

AmpereX[®]

**NORTH AMERICAN PHILIPS
COMPANY**

AmpereX Electronic Corporation
Hicksville, New York 11802

Electron tubes

Book T3

1986

High-power klystrons

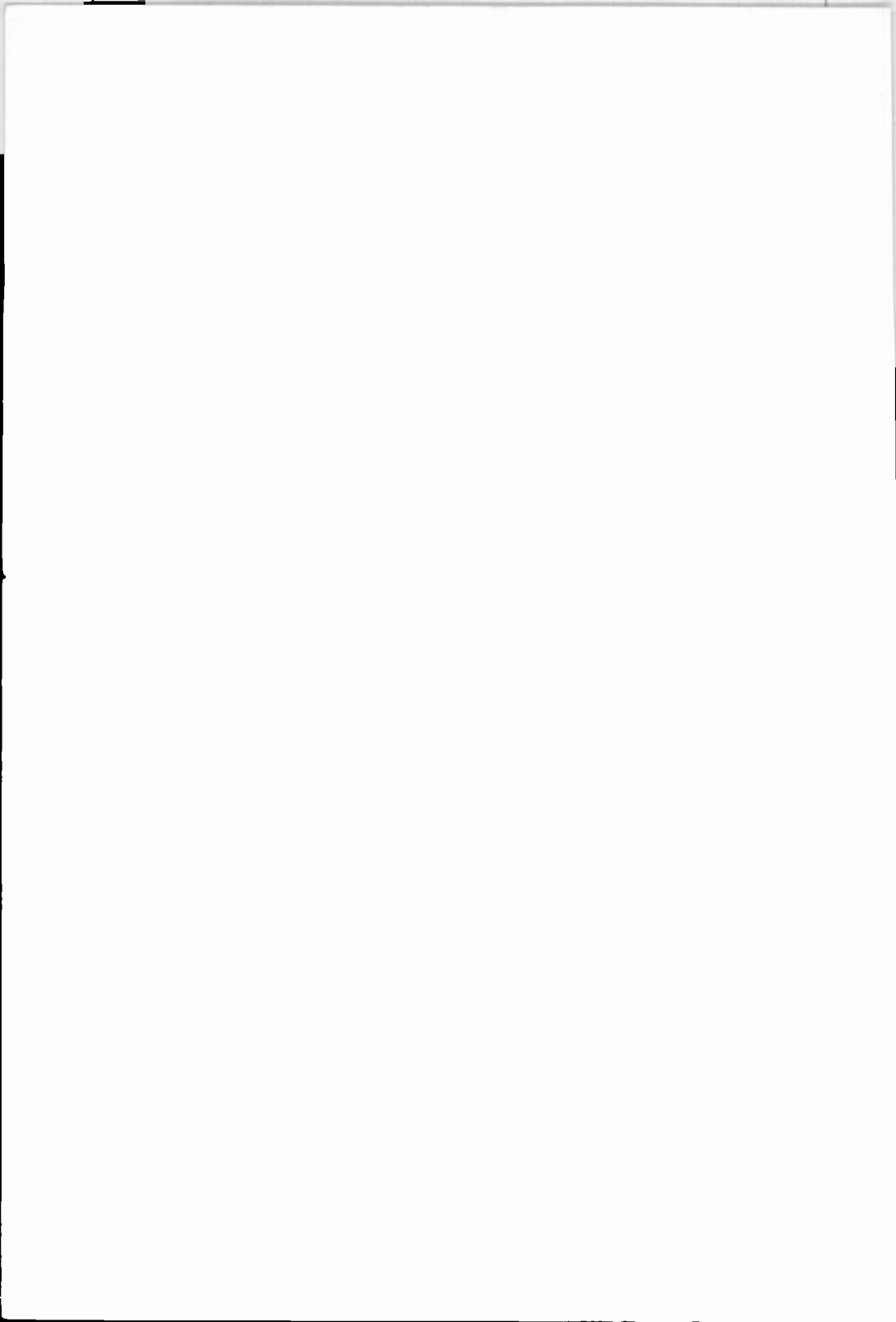

HIGH-POWER KLYSTRONS

page

Selection guide

U.H.F. power klystrons	1
Continuous-wave high-power klystrons	1
Pulsed power klystrons	1
S.H.F. power klystrons	1

General

List of symbols	5
Definitions	8
Waveguide data	9
Flange designations	10
General operational recommendations klystrons	13
Rating system	17

Device data (alpha-numerically)	19
---	----

Index of type numbers	192
---------------------------------	-----



DATA HANDBOOK SYSTEM

Our Data Handbook System comprises more than 60 books with specifications on electronic components, subassemblies and materials. It is made up of four series of handbooks:

ELECTRON TUBES	BLUE
SEMICONDUCTORS	RED
INTEGRATED CIRCUITS	PURPLE
COMPONENTS AND MATERIALS	GREEN

The contents of each series are listed on pages iv to viii.

The data handbooks contain all pertinent data available at the time of publication, and each is revised and reissued periodically.

When ratings or specifications differ from those published in the preceding edition they are indicated with arrows in the page margin. Where application information is given it is advisory and does not form part of the product specification.

Condensed data on the preferred products of Philips Electronic Components and Materials Division is given in our Preferred Type Range catalogue (issued annually).

Information on current Data Handbooks and on how to obtain a subscription for future issues is available from any of the Organizations listed on the back cover.

Product specialists are at your service and enquiries will be answered promptly.

ELECTRON TUBES (BLUE SERIES)

The blue series of data handbooks comprises:

- T1** Tubes for r.f. heating
- T2a** Transmitting tubes for communications, glass types
- T2b** Transmitting tubes for communications, ceramic types
- T3** Klystrons
- T4** Magnetrons for microwave heating
- T5** Cathode-ray tubes
Instrument tubes, monitor and display tubes, C.R. tubes for special applications
- T6** Geiger-Müller tubes
- T8** Colour display systems
Colour TV picture tubes, colour data graphic display tube assemblies, deflection units
- T9** Photo and electron multipliers
- T10** Plumbicon camera tubes and accessories
- T11** Microwave semiconductors and components
- T12** Vidicon and Newvicon camera tubes
- T13** Image intensifiers and infrared detectors
- T15** Dry reed switches
- T16** Monochrome tubes and deflection units
Black and white TV picture tubes, monochrome data graphic display tubes, deflection units

SEMICONDUCTORS (RED SERIES)

The red series of data handbooks comprises:

- S1 Diodes**
Small-signal silicon diodes, voltage regulator diodes (< 1,5 W), voltage reference diodes, tuner diodes, rectifier diodes
- S2a Power diodes**
- S2b Thyristors and triacs**
- S3 Small-signal transistors**
- S4a Low-frequency power transistors and hybrid modules**
- S4b High-voltage and switching power transistors**
- S5 Field-effect transistors**
- S6 R. F. power transistors and modules**
- S7 Surface mounted semiconductors**
- S8a Light-emitting diodes**
- S8b Devices for optoelectronics**
Optocouplers, photosensitive diodes and transistors, infrared light-emitting diodes and infrared sensitive devices, laser and fibre-optic components
- S9 Power MOS transistors**
- S10 Wideband transistors and wideband hybrid IC modules**
- S11 Microwave transistors**
- S12 Surface acoustic wave devices**
- S13 Semiconductor sensors**

INTEGRATED CIRCUITS (PURPLE SERIES)

The purple series of data handbooks comprises:

EXISTING SERIES

Superseded by:

IC1	Bipolar ICs for radio and audio equipment	IC01N
IC2	Bipolar ICs for video equipment	IC02Na and IC02Nb
IC3	ICs for digital systems in radio, audio and video equipment	IC01N, IC02Na and IC02Nb
IC4	Digital integrated circuits CMOS HE4000B family	
IC5	Digital integrated circuits – ECL ECL10 000 (GX family), ECL100 000 (HX family), dedicated designs	IC08N
IC6	Professional analogue integrated circuits	IC03N and Supplement to IC11N
IC7	Signetics bipolar memories	
IC8	Signetics analogue circuits	IC11N
IC9	Signetics TTL logic	IC09N and IC15N
IC10	Signetics Integrated Fuse Logic (IFL)	IC13N
IC11	Microprocessors, microcomputers and peripheral circuitry	IC14N

NEW SERIES

IC01N	Radio, audio and associated systems Bipolar, MOS	(published 1985)
IC02Na	Video and associated systems Bipolar, MOS Types MAB8031AH to TDA1524A	(published 1985)
IC02Nb	Video and associated systems Bipolar, MOS Types TDA2501 to TEA1002	(published 1985)
IC03N	Integrated circuits for telephony	(published 1985)
IC04N	HE4000B logic family CMOS	
IC05N	HE4000B logic family – incased ICs CMOS	(published 1984)
IC06N*	High-speed CMOS; PC74HC/HCT/HCU Logic family	(published 1986)
IC07N	High-speed CMOS; PC54/74HC/HCT/HCU – uncased ICs Logic family	
IC08N	ECL 10K and 100K logic families	(published 1984)
IC09N	TTL logic series	(published 1984)
IC10N	Memories MOS, TTL, ECL	
IC11N	Linear LSI	(published 1985)
Supplement to IC11N	Linear LSI	(published 1986)
IC12N	Semi-custom gate arrays & cell libraries ISL, ECL, CMOS	
IC13N	Semi-custom Integrated Fuse Logic	(published 1985)
IC14N	Microprocessors, microcontrollers & peripherals Bipolar, MOS	(published 1985)
IC15N	FAST TTL logic series	(published 1984)

Note

Books available in the new series are shown with their date of publication.

* Supersedes the IC06N 1985 edition and the Supplement to IC06N issued Autumn 1985.

COMPONENTS AND MATERIALS (GREEN SERIES)

The green series of data handbooks comprises:

- C1 Programmable controller modules**
PLC modules, PC20 modules
- C2 Television tuners, coaxial aerial input assemblies, surface acoustic wave filters**
- C3 Loudspeakers**
- C4 Ferroxcube potcores, square cores and cross cores**
- C5 Ferroxcube for power, audio/video and accelerators**
- C6 Synchronous motors and gearboxes**
- C7 Variable capacitors**
- C8 Variable mains transformers**
- C9 Piezoelectric quartz devices**
- C10 Connectors**
- C11 Varistors, thermistors and sensors**
- C12 Potentiometers, encoders and switches**
- C13 Fixed resistors**
- C14 Electrolytic and solid capacitors**
- C15 Ceramic capacitors**
- C16 Permanent magnet materials**
- C17 Stepping motors and associated electronics**
- C18 Direct current motors**
- C19 Piezoelectric ceramics**
- C20 Wire-wound components for TVs and monitors**
- C21* Assemblies for industrial use**
HNIL FZ/30 series, NORbits 60-, 61-, 90-series, input devices
- C22 Film capacitors**

* To be issued shortly.

U.H.F. POWER KLYSTRONS

type	status	cooling	output power, peak sync. kW	frequency range MHz
YK1001	M	FA	11	470 to 860
YK1002	M	W, FA	11	470 to 860
YK1151	M	FA	25	470 to 860
YK1190	M	V/VC/W	45	470 to 610
YK1191	M	V/VC/W	45	590 to 720
YK1192	M	V/VC/W	45	710 to 860
YK1198	M	V/VC/W, FA	60	c.w. 600 to 800
YK1220	C	V/VC/W, FA	16.5	470 to 860
YK1223	P	V/VC/W, FA	16.5	470 to 860
YK1230	C	V/VC/W, FA	27	470 to 860
YK1233	P	V/VC/W, FA	27	470 to 860
YK1263	P	V/VC/W, FA	58	470 to 810
YK1265	P	V/VC/W, FA	64	470 to 810
YK1295	C	V/VC/W, FA	58	470 to 610
YK1296	C	V/VC/W, FA	58	590 to 720
YK1297	C	V/VC/W, FA	58	710 to 860

HIGH-POWER KLYSTRONS

type	status	cooling	output power		centre frequency MHz
			c.w. kW	pulse kW	
YK1240	P	W	—	330	1300
YK1250	P	W	400	—	999.3
YK1300	P	W	600	—	499.7
YK1301	P	W	800	—	499.7
YK1302	P	V,FA	800	—	508.6
YK1303*	P	V,FA	1000	—	508.6
YK1305	P	W	350	—	499.7
YK1350	P	W	1000	—	352.21

PULSED POWER KLYSTRONS

type	status	cooling	output power kW	gain dB	frequency MHz
YK1110	C	W	6000	30	2998 ± 5
YK1510	P	W	20000	44	S-band
YK1511	P	W	20000	44	S-band
YK1512	P	W	20000	44	S-band
YK1600	N	W	35000	53	2998.5

S.H.F. POWER KLYSTRONS

type	status	cooling	output power kW	gain dB	frequency range MHz
YK1210	C	FA	1.15	50	11800 to 12200

COOLING: FA = forced air; W = water; V = vapour; VC = vapour condensation.

* Data available on request.

CLASSIFICATION

The devices are classified as follows:

- N = New type.** Recommended for new equipment design. Data sheets contain advance information and specifications are subject to change without notice.
- P = Preferred type.** Recommended for equipment design; production quantities available at date of publication.
- C = Current type.** No longer recommended for equipment design; available for equipment production and for use in existing equipment.
- M = Maintenance type.** No longer recommended for equipment production; available for maintenance of existing equipment.
- O = Obsolescent type.** Available until present stocks are exhausted.

Obsolescent types of which all stocks are exhausted are called **obsolete**; any data still published on these types is for reference purposes only.

GENERAL



LIST OF SYMBOLS

1. Symbols denoting electrodes and electrode connections

Anode	a
Accelerator electrode	acc
Collector electrode	coll
Filament or heater	f
Filament or heater tap	f _c
Grid	g
Tube pin which must not be connected externally	i.c.
Cathode	k
Resonator	res
Helical electrode	x

2. Symbols denoting voltages

Remarks

a. In the case of indirectly heated tubes the voltages on the various electrodes are with respect to the cathode; in the case of directly heated, d.c. fed tubes, with respect to the negative side of the filament; and in the case of directly heated, a.c. fed tubes, with respect to the electrical centre of the filament, unless otherwise stated.

b. The symbols quoted below represent the average values of the voltages concerned, unless otherwise stated.

Anode voltage	V_a
Anode voltage in cut-off or in cold condition	V_{ao}
Accelerator voltage	V_{acc}
Supply voltage of tube electrodes	V_b
Collector voltage	V_{coll}
Filament or heater voltage	V_f
Filament or heater starting voltage	V_{fo}
Voltage between focusing electrode and cathode	V_{foc}
Grid voltage	V_g
A.C. input voltage	V_i
Inverse voltage	V_{inv}
Voltage between cathode and heater	V_{kf}
A.C. output voltage	V_o
Peak value of a voltage	V_p
Resonator voltage	V_{res}
Voltage on helical electrode	V_x

3. Symbols denoting currents

Remarks

- a. The positive electrical current is directed opposite to the direction of the electron current.
- b. The symbols quoted below represent the average values of the currents concerned, unless otherwise stated.

Anode current	I_a
Accelerator current	I_{acc}
Collector current	I_{coll}
Filament or heater current	I_f
Filament or heater starting current	I_{fo}
Peak filament or heater starting current	I_{fp}, I_{fsurge}
Grid current	I_g
Cathode current	I_k
Peak value of a current	I_p
Resonator current	I_{res}
Current to helical electrode	I_x

4. Symbols denoting powers

Anode dissipation	W_a
Collector dissipation	W_{coll}
A.C. driving power	W_{dr}
Grid dissipation	W_g
Input power	W_i
D.C. anode supply power	W_{ia}
Peak input power	W_{ip}
Output power	W_o
Peak output power	W_{op}
Resonator dissipation	W_{res}

5. Symbols denoting capacitances

Measured on the cold tubes.

Capacitance between anode and all other elements except control grid	C_a
Capacitance between anode and grid (all other elements being earthed)	C_{ag}
Capacitance between anode and cathode (all other elements being earthed)	C_{ak}
Capacitance between a grid and all other elements except anode	C_g
Capacitance between a grid and cathode (all other elements being earthed)	C_{gk}

6. Symbols denoting resistances

External a.c. resistance in anode lead or matching resistance	R_a
Filament or heater resistance in cold condition	R_{fo}
External resistance in a grid lead	R_g
Internal resistance of a tube	R_i
External resistance in a cathode lead	R_k
External resistance between cathode and heater	R_{kf}

7. Symbols denoting various quantities

Bandwidth	B
Noise factor	F
Frequency	f
Pulse repetition rate	f_{imp}
Power gain	
Magnetic field strength	H
Height above sea level	h
Pressure drop of cooling air or cooling water	Δp
Required air flow or water flow for cooling	q
Transconductance	S
Temperature of anode or anode block	T_a
Ambient temperature	T_{amb}
Averaging time of current or voltage	t_{av}
Inlet temperature of cooling air or cooling water	T_i
Pulse duration	t_{imp}
Outlet temperature of cooling air or cooling water	T_o
Time of rise of voltage	t_{rv}
Cathode preheating time, also called waiting time; the minimum period of time during which the heater or filament voltage should be applied before the application of electrode voltages	t_w
Rate of rise of voltage	$\frac{dV_a}{dt}, \frac{\Delta V}{\Delta t_{rv}}$
Voltage standing-wave ratio	VSWR
Reflection coefficient	σ
Duty factor	δ
Efficiency	η
Wavelength	λ
Amplification factor	μ
Temperature, relative	θ

TUBES FOR MICROWAVE EQUIPMENT DEFINITIONS

- B** Bandwidth.
- $\Delta f/\Delta T$ The temperature coefficient $\Delta f/\Delta T$ is the change of frequency with temperature.
- f_{imp} Pulse repetition rate.
- Δf_p The pulling figure Δf_p is the difference between the maximum and minimum frequencies, reached when the phase angle of the load with a VSWR of 1,5 is varied from 0° to 360° .
- H** Magnetic field strength.
- t_{imp} The pulse duration t_{imp} is defined as the time interval between the two points on the current pulse at which the current is 70% of the smooth peak current (see Fig.1).

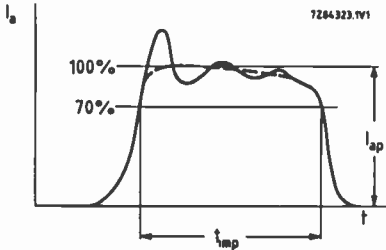

Fig. 1 Current pulse.

The smooth peak is the maximum value of a smooth curve through the average of the fluctuation over the top portion of the pulse.

- t_{rV} The time of rise of voltage t_{rV} is defined as the time interval between points of 10 and 90 per cent of the smooth peak value measured on the leading edge of the voltage pulse.
- T_a Temperature of anode or anode block.
- VSWR The voltage standing-wave ratio in a waveguide is the ratio of the amplitude in the electrical field at a voltage maximum to that at an adjacent minimum.
- dV_a/dt or $\Delta V_a/\Delta t_{rV}$ Unless otherwise stated the rate of rise of voltage dV_a/dt is defined by the steepest tangent to the leading edge of the voltage pulse above 80% of the smooth peak value (see Fig. 2).

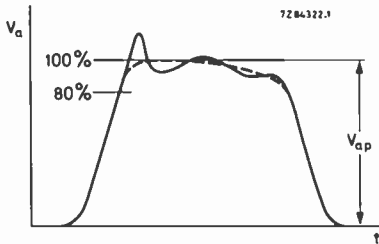

Fig. 2 Voltage pulse.

- δ The duty factor δ is the ratio of the pulse duration to the time between corresponding points of two successive pulses.

RECTANGULAR WAVEGUIDE DATA AND DESIGNATIONS

FREQUENCY RANGE TE mode 153-IEC GHz	WAVEGUIDE DESIGNATION				WAVEGUIDE Inner construction 153-IEC			WAVEGUIDE Outer construction 153-IEC			ATTENUATION in dB/m for copper guide 153-IEC		Theoretical C. W. for lowest to highest frequency MW		
	BRITISH STAND.	RETMA	IAE RC- /U alum.	BAND PREFIX	Width mm	Height mm	Tolerance on width and height ±	Width mm	Height mm	Tolerance on width and height ±	Frequency GHz	Theoretical value		Maximum value	
															153-IEC
1.14 — 1.73	R 14	WG 6	WR 650	69	103	L	165.10	87.55	0.33	0.26	1.36	0.00522	0.007	12.0	— 11.0
1.45 — 2.20	R 18	WG 7	WR 510	—	—	D	129.54	64.77	0.36	0.20	1.74	0.00749	0.010	7.5	— 7.0
1.72 — 2.61	R 22	WG 8	WR 530	104	105	—	109.22	54.61	0.22	0.22	2.06	0.00970	0.013	5.2	— 7.5
2.17 — 3.30	R 26	WG 9A	WR 340	112	113	—	86.36	43.18	0.17	0.17	2.61	0.0138	0.018	3.4	— 4.8
2.60 — 3.95	R 32	WG 10	WR 284	48	75	S	72.14	34.04	0.14	0.14	3.12	0.0189	0.025	2.6	— 3.2
3.22 — 4.90	R 40	WG 11A	WR 229	—	—	A	58.17	29.063	0.12	0.12	3.87	0.0249	0.032	1.6	— 2.2
3.94 — 5.99	R 48	WG 12	WR 187	49	95	G	47.55	22.149	0.09	0.09	4.73	0.0355	0.046	0.94	— 1.32
4.64 — 7.05	R 56	WG 13	WR 159	—	—	C	40.39	20.193	0.08	0.08	5.57	0.0431	0.056	0.79	— 1.0
5.38 — 8.17	R 70	WG 14	WR 137	50	106	I	34.85	15.799	0.070	0.070	6.46	0.0576	0.075	0.56	— 0.71
6.57 — 9.99	R 84	WG 15	WR 112	51	68	H	28.499	12.624	0.057	0.057	7.89	0.0794	0.103	0.35	— 0.46
7.00 — 11.00	—	—	WR 102	—	320	T	25.90	12.95	0.125	0.125	—	—	—	0.33	— 0.43
8.2 — 12.5	R 100	WG 16	WR 90	52	67	X	22.860	10.160	0.046	0.046	9.84	0.110	0.143	0.20	— 0.29
9.84 — 15.0	R 120	WG 17	WR 75	—	—	M	19.050	9.525	0.038	0.038	21.58	12.06	0.133	0.17	— 0.23
11.9 — 18.0	R 140	WG 18	WR 62	91	—	P	15.759	7.859	0.03	0.03	17.83	9.93	0.05	0.12	— 0.16
14.5 — 22.0	R 180	WG 19	WR 51	—	—	—	12.954	6.477	0.024	0.024	14.99	8.51	0.05	0.080	— 0.107
17.6 — 26.7	R 220	WG 20	WR 42	53	121	—	10.668	4.318	0.02	0.02	17.70	6.35	0.05	0.043	— 0.058
21.7 — 33.0	R 260	WG 21	WR 34	—	—	—	8.636	4.318	0.020	0.020	10.67	6.35	0.05	0.034	— 0.048
26.4 — 40.0	R 320	WG 22	WR 28	—	—	—	7.112	3.556	0.020	0.020	9.14	5.59	0.05	0.022	— 0.031
32.9 — 50.1	R 400	WG 23	WR 22	—	—	—	5.680	2.845	0.020	0.020	7.72	4.88	0.05	0.014	— 0.020
39.2 — 59.6	R 500	WG 24	WR 19	—	—	—	4.775	2.388	0.020	0.020	6.81	4.42	0.05	0.011	— 0.015
49.8 — 75.8	R 620	WG 25	WR 15	—	—	—	3.759	1.880	0.020	0.020	5.79	3.91	0.05	0.0063	— 0.0090
60.5 — 91.9	R 740	WG 26	WR 12	—	—	—	3.099	1.549	0.020	0.020	5.13	3.58	0.05	0.0042	— 0.0060
73.8 — 112.0	R 900	WG 27	WR 10	—	—	—	2.540	1.270	0.020	0.020	4.57	3.30	0.05	0.0030	— 0.0041
92.2 — 140.0	R 1200	WG 28	WR 8	—	—	—	2.032	1.016	0.020	0.020	4.06	3.05	0.05	0.0018	— 0.0026
114.0 — 173.0	R 1400	WG 29	WR 7	—	—	—	1.651	0.826	—	—	—	—	—	0.0012	— 0.0017

* IEC Recommendations are obtainable from:
 Central Office of the International Electrotechnical Commission
 1, rue de Varembe
 GENEVA, Switzerland

** based on breakdown of air of 15,000 volts per cm
 (safety factor of approx. 2 at sea level)

FLANGE DESIGNATIONS

FOR WAVEGUIDE 153 - IEC*	FLANGE DESIGNATION					
	PLAIN FLANGE			CHOKE FLANGE		
	154 - IEC	JAN UG /U		154 - IEC	JAN UG /U	
		Brass	Aluminium		Brass	Aluminium
R 14	PDR 14	417A	418A			
R 18	PDR 18					
R 22	PDR 22	435A	437A			
R 26	PDR 26	553	554			
R 32	UER 32 PDR 32 PAR 32 UAR 32	53	584	CAR 32	54A	585A
R 40	UER 40 PDR 40					
R 48	PAR 48 PDR 48 UAR 48 UER 48	149A	407	CAR 48	148C	406B
R 58	PAR 58 PDR 58 UAR 58 UER 58			CAR 58		
R 70	PAR 70 PDR 70 UAR 70 UER 70	344	441	CAR 70	343B	440B
R 84	PBR 84 PDR 84 UBR 84 UER 84	51	138	CBR 84	52B	137B
R 100	PBR 100 PDR 100 UBR 100 UER 100	39	135	CBR 100	40B	136B
R 120						
R 140	PBR 140 UBR 140	419		CBR 140	541A	
R 180						
R 220	PBR 220 UBR 220 PCR 220	595	597	CBR 220	596A	598A
R 280	PCR 260					
R 320	PBR 320 PCR 320 UBR 320	599		CBR 320	600A	
R 400	PCR 400	383				
R 500	PCR 500 PAR 500					
R 620	PCR 620 PFR 620	385				
R 740	PCR 740 PFR 740	387				
R 900	PCR 900 PFR 900					
R 1200	PCR 1200 PFR 1200					









IEC

Waveguide flanges covered by IEC recommendation shall be indicated by a reference number comprising the following information:

- a. the number of the present IEC publication.
- b. the letter "IEC".
- c. a dash.
- d. a letter relating to the basic construction of the flange

P = pressurable
 C = choke, pressurizable
 U = unpressurizable

- e. a letter for the type according to the drawing. Flanges with the same letter and of the same waveguide size can be mated.
- f. the letter and number of the waveguide for which the flange is designed.

UNPRESSURABLE		PRESSURABLE		CHOKE	
 Type E	14	 Type D	14	 Type A	 Type A
	32		32		
	70		70		
	84 100		84 100		
 Type B	120	 Type B	120	 Type B	
	320		 Type C		220
			 Type F		320 500 620 1200

* IEC Recommendations are obtainable from :

Central Office of the
 International Electrotechnical Commission
 1, rue de Varembe
 GENEVA, Switzerland

GENERAL OPERATIONAL RECOMMENDATIONS

KLYSTRONS

1. GENERAL

1.1 Data

The characteristic data, operational data, capacitance values and curves apply to an average tube which is characteristic of the type of tube in question.

1.2 Reference point of the electrode voltages

If not otherwise stated the electrode voltages are given with respect to the cathode.

1.3 Operational data

The operational data stated in the data sheets do not relate to any fixed setting instructions. They should rather be regarded as recommendations for the effective use of the tube. On account of the tolerances prevailing, deviations from the settings stated may occur.

It is also possible to use other settings, for which purpose the graphs can be used for finding the operational data, or for which purpose interpolation between the settings stated can be performed. If one wishes to deviate from the settings recommended in the data sheets, one should take great care not to exceed the permissible limiting values. If appreciable deviations occur, the manufacturer should be consulted.

A general rule for multi-cavity klystrons is that the accelerator electrode voltage and/or the focusing electrode voltage must be adjusted so that the cathode current stated will flow.

1.4 D.C. connections

At all times there should be a d.c. connection between each electrode and the cathode. If necessary, limiting values have been stated for the resistance of these connections.

1.5 Mounting and removal

The instructions relating to each type of tube can be found in the data sheets and the "Instructions for operation and maintenance".

The mounting and removal should be effected with extreme care to avoid damage to the tube. This also applies to rejected tubes, where claims are made under guarantee.

Ferromagnetic parts must not be used in the vicinity of klystrons equipped with a permanent magnet, as this might have a detrimental effect on the operation of the klystron. If necessary, the ceramic insulators and windows must be carefully cleaned, as dirt may damage the klystron on account of local overheating. Naturally the flange of the output cavity must also be thoroughly cleaned so as to prevent arcing.

The "Instructions for operation and maintenance" should in all cases be followed.

1.6 Accessories

Perfect operation of the tubes can only be guaranteed if use is made of the accessories which the manufacturer designed for the tube.

1.7 Supply leads

The supply leads to the connections and terminals must be of such a quality that no mechanical stresses, due to differences in temperature or other causes, can occur.

1.8 Danger of radiation

In general the absorption in the tissues of the body, and hence the danger, is the greater the shorter the wavelength of the h.f. radiation for equal output. The output of klystrons may be so high that injuries (in particular of the eye) can be inflicted.

Klystrons operated at a high voltage (exceeding 16 kV) may, moreover, emit X-rays of appreciable intensity, which call for protection of the operators.

2. LIMITING VALUES

2.1 Absolute limiting values

In all cases the limiting values stated are absolute maximum or minimum values. They apply either to all settings or to the various modes of operation. The values stated should in no case be exceeded, neither on account of mains voltage fluctuations and load variations, nor on account of production tolerances in the various building elements (resistors, capacitors, etc.) and tubes, or as a result of meter tolerances when setting the voltages and currents.

Every limiting value should be regarded as the permissible absolute maximum independent of other values. It is not permitted to exceed one limiting value because another is not reached. For instance, one should not allow the limiting value of the collector current to be surpassed while reducing the collector voltage below the permissible limiting value.

If in special cases it should be necessary to exceed a specific limiting value, it is advisable to consult the tube manufacturer, as otherwise no claims can be made.

2.2 Protective circuit

To prevent the limiting values of voltages, currents, outputs and temperatures from being exceeded, fast-operating protective circuits must be provided.

2.3 Drift current

The limiting value indicated for the drift current is an arithmetical mean value.

3. NOTES ON OPERATION

3.1 Operational data and variations

When developing electrical equipment the spread in the tube data must be taken in to account; if necessary, the tube tolerances can be applied for.

With respect to the spread in the operational data and the average values stated in the data sheets it is recommended that a certain margin be allowed for in the output and input powers when designing equipment intended for series production.

3.2 Input power, required driving power

In the data sheets the power stated is the input power W_{dr} fed to the input cavity and measured between the circulator and this cavity with a 50-ohm resistor serving as a substitute for the load presented by the cavity.

3.3 Output power

As a general principle the effective output power is stated.

3.4 Sequence of application of the electrode voltages

With multi-cavity klystrons the electrode voltages must be connected in the order given in the operating instructions.

3.5 Drift current

When the klystron is driven by an a.m. signal (for instance a video signal), the drift current fluctuates with the modulation. Consequently, the power supply unit must be designed so as to be suitable for the peak values occurring, which may be appreciably higher than the arithmetical mean values stated.

4. HEATING

4.1 Type of current

Klystrons can be heated by means of either standard alternating current or direct current. At other frequencies the tube manufacturer should be consulted.

4.2 Adjusting the heater voltage

The heater voltage generally governs the adjustment of the heating, while the heater current may deviate from its nominal value within fixed tolerances. The heater voltage should be maintained as accurately as possible. For measuring the heater voltage a r.m.s. voltmeter is required. This meter must be directly connected to the filament terminals of the tube and have an inaccuracy $< 1,5\%$ in the voltage range concerned. The indicated measuring value should lie in the uppermost third of the scale.

4.3 Switching on the heater current

If the data sheet does not contain special data concerning the heater current during switch-on, the tube may be switched on at full heater voltage.

If maximum values are stated for the heater current during switch-on, they relate to the absolute maximum instantaneous value under unfavourable conditions. In the case of a.c. supply this value will occur if the tube is switched on at the maximum amplitude of the highest mains voltage. It is possible to calculate the maximum current during switch-on if the cold resistance and the relationship between the heater current and the heater voltage is known. In practice a heater transformer more or less acting as a leakage transformer is mostly used for limiting the starting current, or a choke coil or resistor is connected in series with the primary of the heater transformer. This choke coil or resistor can be short-circuited by a relay whose action is delayed by about 15 seconds. By means of a calibrated oscilloscope it can be checked whether the starting current remains within the permissible limits; the supply lead may, if necessary, be used as measuring resistance.

5. COOLING

5.1 Forced-air cooling

It is essential that the faces of tubes that are to be cooled by an air-blast should be hit as evenly as possible by the air stream, so as to prevent large differences in temperature which may give rise to mechanical stresses. In many cases (in particular with the large types of tubes) an additional air stream must be directed to the metal-to-ceramic seals. The cooling air is usually supplied from a fan via an insulating duct. This air should be filtered, so that all impurities and moisture are removed; in addition to this the radiator must be cleaned at regular intervals. The data concerning the cooling can be found in the data sheets. The cooling must be switched on together with the heating. After the klystron has been switched off cooling air must be supplied for some time; this period depends on the size of the tube and the load. If the cooling of whatever part of the tube is interrupted or if the quantity of cooling air is too small, the collector voltage and the heating must be switched off automatically.

5.2 Water cooling

With water-cooled klystrons the cooling equipment is rigidly attached to the tube. If the equipment should be live, the cooling water must be supplied through insulating pipes, of sufficient length.

The water cooling and air cooling for other parts of the tube must be switched on together with the heating. The cooling-water circuit must be arranged so that the water always enters at the bottom, no matter how the tube is mounted. If the pumps should be out of operation, the water jacket(s) of the tube must always be full. In that case after-cooling may in general be done away with.

In many cases the metal-to-glass or metal-to-ceramic seals require additional cooling by a low-velocity air flow. If the cooling-water supply or additional air cooling should fail, the collector voltage and heating must immediately be switched off. Further cooling data can be found in the data sheets.

The specific resistance of the cooling water must be minimum $20 \text{ k}\Omega\text{-cm}$, the temporary hardness must be maximum 6 German degrees of hardness. In principle distilled water should be used in the circulation cooler; to reduce the corrosive effect of the distilled water about 700 mg of 24% hydrazin hydrate and 700 mg sodium silicate must be added per litre. The pH-value should range from 7 to 9.

If frost is to be expected, a standard glycol based antifreeze for cars, like Glysantin should be added.

5.3 Vapour cooling

The conversion of water of 100°C to steam of 100°C requires an energy of 2256 kJ/l . This energy is extracted from the collector which by this means is cooled very effectively.

The cooling system may be designed as a closed circuit where the steam is ducted upwards or downwards to the applied heat exchanger. Due to a strong deposit of minerals during the continued variation of the aggregate state, the use of distilled water is absolutely necessary. When commencing operation a multiple change of the complete cooling water is recommended to dispose deteriorations of the systems.

The loss of coolant during operation is very low (1 l per week approx).

It is obvious, that a vapour cooling system is advantageous only in stationary assemblies and for high dissipation levels. This, however, yields another advantage of vapour cooling. The energy, generated in the heat exchanger, can be used very effectively i. e. for heating purposes.

6. STORAGE

Klystrons may only be stored in their original packing and according to the instructions, so as to avoid damage. For fitting, the tubes must be removed from the packing and directly inserted into the support. In all cases the "Instructions for operation and maintenance" must be adhered to.

In the case of prolonged storage the vacuum of high-power klystrons should be checked at intervals of about three months and improved if necessary, both being possible with the aid of the built-in getter ion pump and a suitable power supply/test unit. During this operation the heater supply should preferably be turned on slowly.

RATING SYSTEM

(in accordance with IEC Publication 134)

ABSOLUTE MAXIMUM RATING SYSTEM

Absolute maximum ratings are limiting values of operating and environmental conditions applicable to any electronic device of a specified type as defined by its published data, which should not be exceeded under the worst probable conditions.

These values are chosen by the device manufacturer to provide acceptable serviceability of the device, taking no responsibility for equipment variations, environmental variations, and the effects of changes in operating conditions due to variations in the characteristics of the device under consideration and of all other electronic devices in the equipment.

The equipment manufacturer should design so that, initially and throughout life, no absolute maximum value for the intended service is exceeded with any device under the worst probable operating conditions with respect to supply variation, equipment component variation, equipment control adjustment, load variations, signal variation, environmental conditions, and variations in characteristics of the device under consideration and of all other electronic devices in the equipment.

HIGH-POWER KLYSTRONS

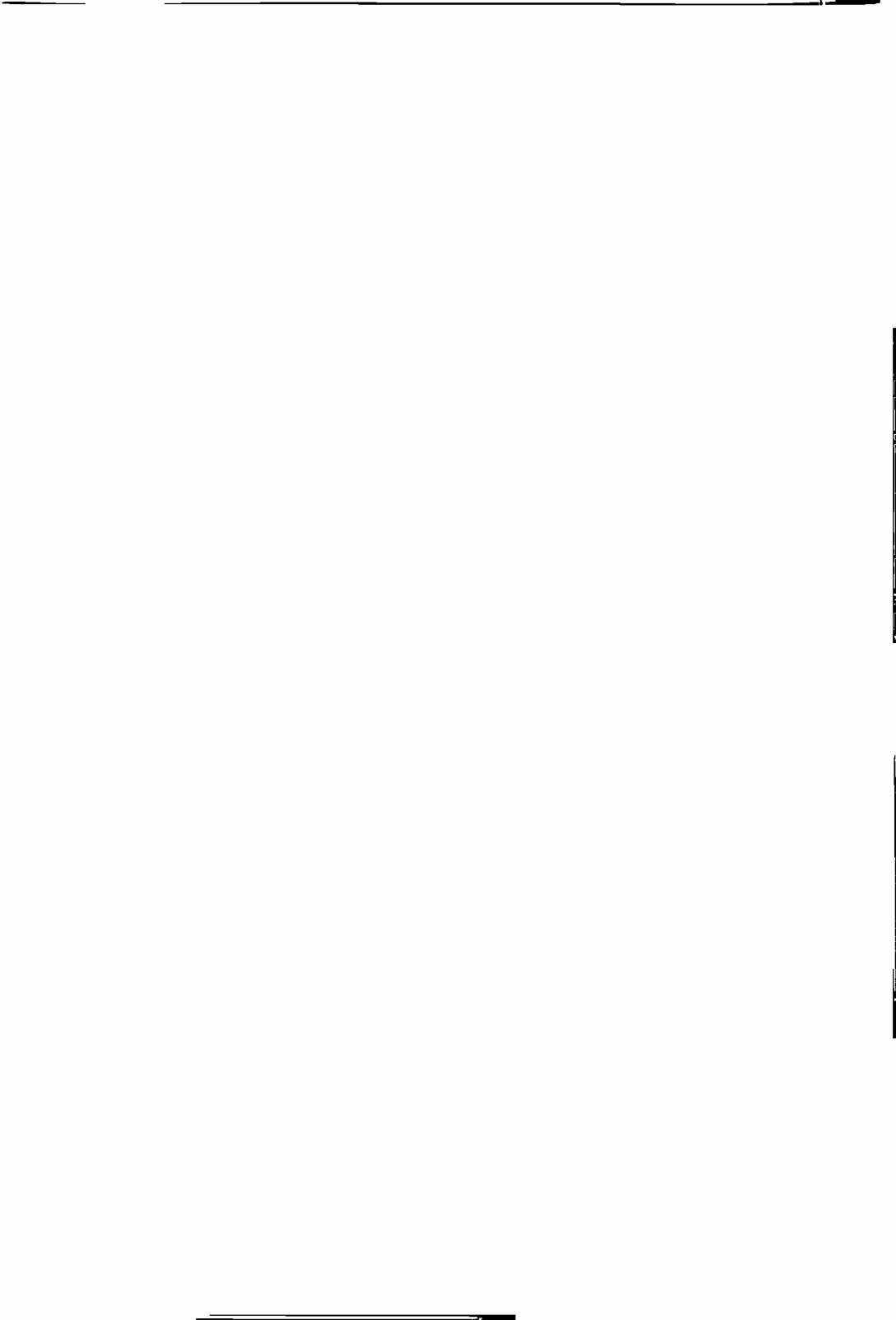

U.H.F. POWER KLYSTRONS

Power amplifier klystrons in metal-ceramic construction for the frequency band 470 MHz to 860 MHz designed for four external resonant cavities, beam focusing by means of permanent magnets, continuously operating getter-ion pump and operation with a depressed collector potential. These klystrons are intended for use as u.h.f. power amplifier in vision and/or sound transmitters for the TV bands IV and V.

QUICK REFERENCE DATA

Frequency range	470 to 860 MHz
Power output	11 kW
Power gain	30 dB
Cooling	
YK1001:	air-cooled drift tubes and air-cooled collector
YK1002:	air-cooled drift tubes and water-cooled collector

This data must be read in conjunction with GENERAL OPERATIONAL RECOMMENDATIONS for KLYSTRONS.

HEATING: indirect by a.c. or d.c.

Cathode	dispenser type
Heater voltage	V_f 7.5 to 8.0 V

During operation the applied heater voltage should not fluctuate more than $\pm 3\%$. It is advised to operate the klystron at 8 to 8.5 V (including mains fluctuations) during the first 300 hours. The heater voltage should then be reduced to 7.5 to 8.0 V.

Heater current	I_f 32 (< 36) A
----------------	-------------------

The heater current should never exceed a peak value of 80 A when applying an a.c. heater voltage or 65 A when applying a d.c. heater voltage.

Cold heater resistance	R_{fo} 28 m Ω
Waiting time	t_w min. 180 s

GETTER-ION PUMP POWER SUPPLY

Pump voltage, unloaded (cathode reference)	4.0 kV
Internal resistance	approx. 300 k Ω

MECHANICAL DATA

Dimensions in mm

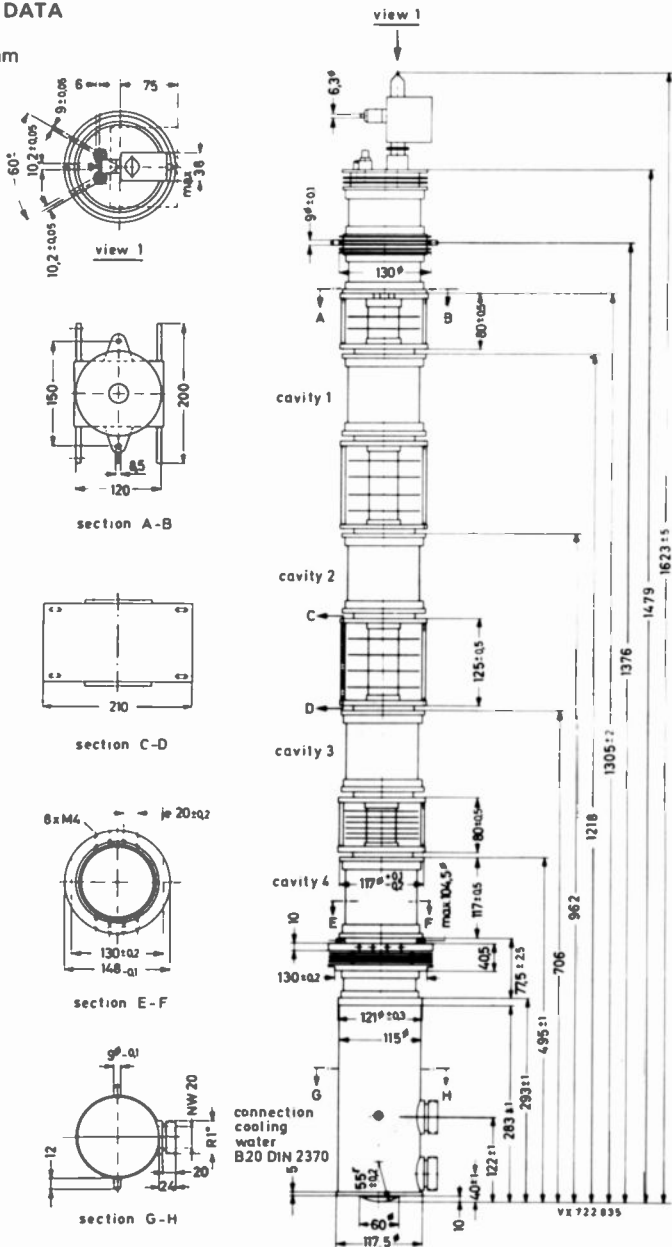

Fig. 2.

MECHANICAL DATA (continued)

Dimensions in mm

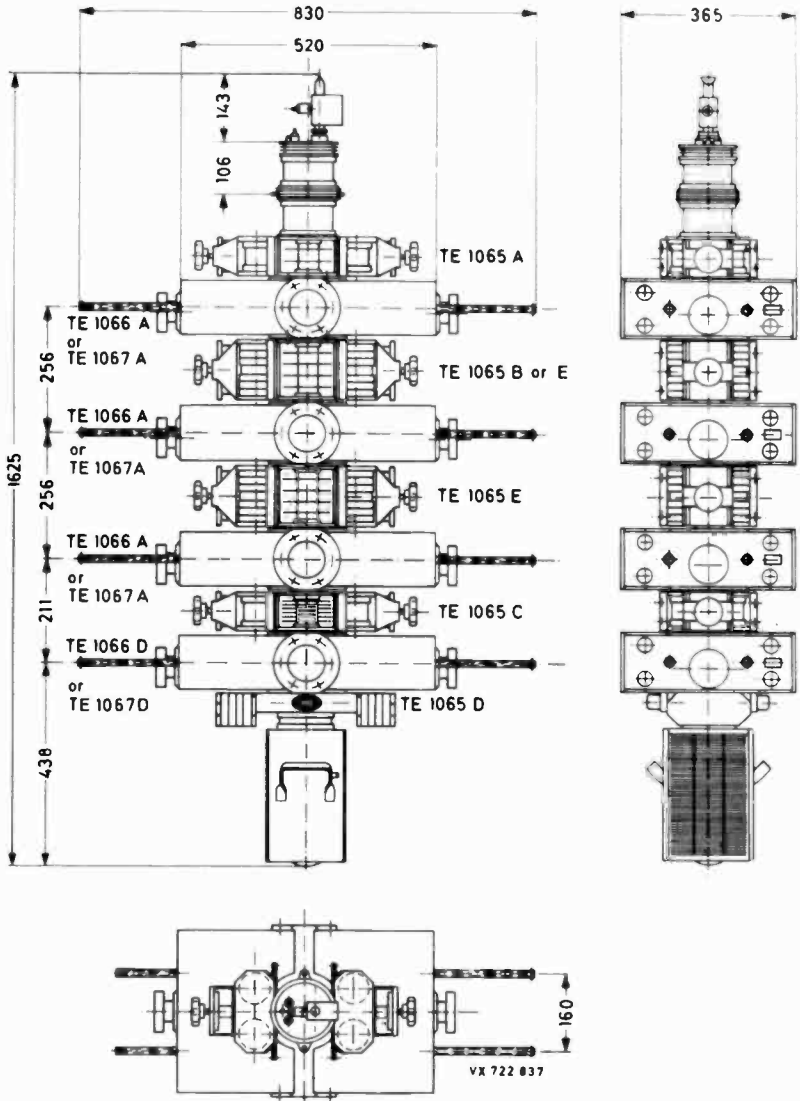

Fig. 3.

COOLING

Except collector, applicable up to an air-inlet temperature T_i of 40 °C and an altitude of 2500 m (values refer to air inlet).

Cathode base	air, $q = \text{approx. } 0.5 \text{ m}^3/\text{min}$
Accelerating electrode	air, $q = \text{approx. } 0.5 \text{ m}^3/\text{min}$
Drift tubes 1, 2 and 3	air, $q = \text{approx. } 1.0 \text{ m}^3/\text{min}$ each
Drift tube 4	air, $q = \text{approx. } 1.5 \text{ m}^3/\text{min}$
Drift tube 5	forced air, $q = \text{approx. } 1.5 \text{ m}^3/\text{min}$ ($\Delta p = 900 \text{ Pa} = 9 \text{ mbar}$)
Cavity TE1066D or TE1067D	forced air, $q = \text{approx. } 2.0 \text{ m}^3/\text{min}$ ($\Delta p = 900 \text{ Pa} = 9 \text{ mbar}$)
Collector YK1001	forced air, see cooling curves Figs 5, 6 and 7
Collector YK1002	water, see cooling curves Figs 9 and 10

MOUNTING

Vertical, cathode up. In order to prevent distortion of the magnetic focusing field ferromagnetic material should not be used within a radius of 35 cm from the tube axis. All connections should be free from strain.

MASS (net)

YK1001	approx. 55 kg
YK1002	approx. 45 kg
Total mass of accessories	approx. 125 kg

PRODUCT SAFETY*1. X-radiation*

Correct operation of the tube can be guaranteed only if a set of accessories, approved by the tube manufacturer, is used.

The operating tube generates X-rays which can penetrate the ceramic parts of the tube envelope. In order to reduce the radiation at any accessible points to an officially acceptable, non-dangerous level the tube must be shielded and any possible radiation path blocked by at least 1 mm of brass or an equivalent depth of non-magnetic X-ray absorbing material. The proper use of accessories will provide the necessary shielding.

2. R.F. radiation

R.F. power may be emitted through apertures other than the normal output coupling (for example r.f. leaks). This r.f. power may be sufficiently intense to cause danger to the human body, particularly to the eyes. Such radiation may be increased if the tube is functioning incorrectly.

ACCESSORIES

Heater connector	type 40649
Heater/cathode connector	type 40649
Focusing electrode connector	type 40634
Accelerating electrode connector	type 40634
Collector connector	type 40634
Getter ion pump connector	type 55351
Magnet unit for ion pump	type TE1053
Set of five pairs of focusing magnets	type TE1065 (2xA, 2xB, 2xC, 2xD, 2xE)*
Set of four cavities for 470 MHz to 790 MHz	type TE1066 (3xA, 1xD)
or	
Set of four cavities for 700 MHz to 860 MHz	type TE1067 (3xA, 1xD)
2 magnet field adaptor plates for collector (YK1001 only)**	type TE1073
Recommended circulators (optional)	
470 to 600 MHz	2722 162 01551 (T100/IV-N)
600 to 800 MHz	2722 162 01561 (T100/V-N)
790 to 1000 MHz	2722 162 03261 (T100/V-3-N)

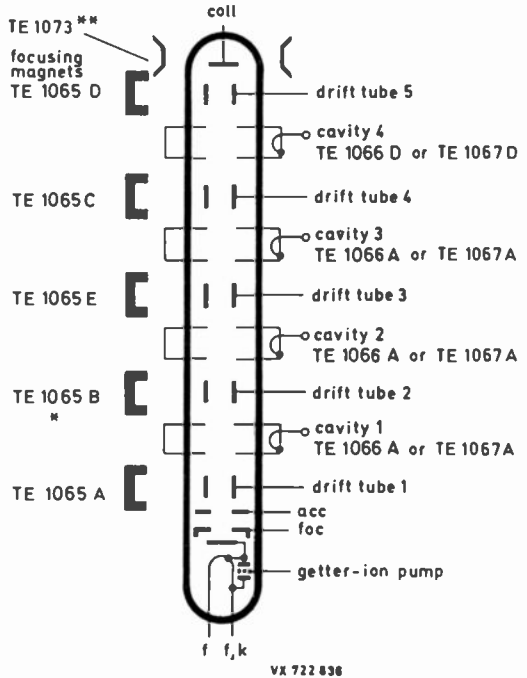

Fig. 4.

- * If the klystron is used under TV transposer conditions replace 2xB by 2xE.
- ** Operation for vision and sound transmitter without depressed collector voltage.

LIMITING VALUES (Absolute maximum rating system)

Heater voltage	max.	8.5	V
Cathode voltage	max.	-22	kV
Cathode voltage at zero current	max.	-25	kV
Depressed collector voltage	max.	7	kV
	min.	0.5	kV
Cathode current	max.	2.3	A
Accelerating electrode voltage	max.	-25	kV
Series resistance in accelerating electrode circuit	max.	20	k Ω
	min.	10	k Ω
Negative focusing electrode voltage*	max.	700	V
	min.	100	V
Drift tube current**			
Collector dissipation	max.	40	kW
Load VSWR	max.	1.5	(14 dB)
Pump voltage	max.	4.5	kV
Pump current (see Fig. 8.)	max.	15	mA
Temperature of			
cathode base and accelerating electrode	max.	125	$^{\circ}$ C
drift tubes 1, 2 and 3	max.	80	$^{\circ}$ C
drift tubes 4 and 5	max.	150	$^{\circ}$ C
resonator 4	max.	125	$^{\circ}$ C
collector seal YK1001	max.	200	$^{\circ}$ C
Collector body YK1001 [▲]	max.	300	$^{\circ}$ C
outlet cooling water YK1002	max.	75	$^{\circ}$ C
inlet cooling air	max.	40	$^{\circ}$ C

* The power supply must be preloaded with min. 10 mA at 500 V.

* For limiting values of various operating conditions see next page and Fig. 11.

▲ In safeguard this temperature limit the air outlet temperature should be measured in at least two places; one 50 mm and one 150 mm from the upper collector plate and 50 mm from the cooling fins; the cooling data of collector are minimum values.

MAXIMUM VALUES of drift tube current

For vision transmitter without level dependent cut-out threshold

without depressed collector voltage	max.	80 mA
with depressed collector voltage	max.	130 mA

For vision transmitter with level dependent cut-out threshold

without depressed collector voltage for 0 to 7 kW output power, peak sync.	max.	40 mA
with depressed collector voltage for 0 to 7 kW output power, peak sync.	max.	60 mA
without depressed collector voltage for full output power	max.	100 mA
with depressed collector voltage for full output power	max.	200 mA

For vision and sound transmitter fed from the same power supply and without level dependent cut-out threshold

without depressed collector voltage	max.	100 mA
with depressed collector voltage	max.	160 mA

For vision and sound transmitter fed from the same power supply and with level dependent cut-out threshold

without depressed collector voltage for 0 to 7 kW output power, peak sync.	max.	60 mA
with depressed collector voltage for 0 to 7 kW output power, peak sync.	max.	80 mA
without depressed collector voltage for full output power	max.	120 mA
with depressed collector voltage for full output power	max.	250 mA

TYPICAL OPERATING CONDITIONS

As 11 kW vision transmitter (CCIR-G standard)
in the frequency range 470 MHz to 790 MHznotes
1, 2

	without depressed collector voltage	with depressed collector voltage		
Cathode voltage	-18.0	-13.5	kV	3
Depressed collector voltage	-0.5	-5.0	kV	
Accelerating electrode voltage	0	0	V	4
Neg. focusing voltage	≈ 400	400	V	5
Drift tube current, static	≈ 25	30	mA	
black level	≈ 40	80	mA	6
Cathode current	1.9	1.9	A	
Output power, peak sync.	11	11	kW	
Drive power see Fig. 12.				
Linearity without compensation	≈ 80	80	%	7
Sync. compression	∧ 45/25	45/25		8
V.S.B. suppression	∧ -20	-20	dB	9
Noise with reference to black level	∧ -46	-46	dB	10
Differential gain	≈ 5	5	deg	11

As 2.2 kW and 4.4 kW TV sound amplifier

Cathode voltage	-18.0	-18.0	-13.5	-13.5	kV	3
Depressed collector voltage	-0.5	-0.5	-5.0	-5.0	kV	
Accelerating electrode voltage	-7.5	-5.5	-7.5	-5.5	kV	4
Neg. focusing voltage	≈ 400	400	400	400	V	5
Drift tube current	≈ 40	50	50	70	mA	6
Cathode current	0.7	1.0	0.7	1.0	A	
Output power	2.2	4.4	2.2	4.4	kW	
Drive power	∧ 0.5	0.5	0.5	0.5	W	

As 2.1 kW amplifier for television
transposer service

Cathode voltage			-15		kV	3
Depressed collector voltage			5.0		kV	
Neg. focusing voltage	≈		400		V	5
Drift tube current	≈		60		mA	6
Cathode current			2.2		A	
Output power, peak sync.			2.1		kW	
Drive power see Fig. 12						
Intermodulation products	∧		-51		dB	12

Notes

1. With the appropriate focusing magnets TE1065, cavities TE1066 and a circulator between the driver and input cavity.
A precorrection of the level dependent frequency response up to 2 dB must be provided.
2. In case of failure the beam voltage must be switched off and made to drop below 5% of its nominal value within 500 ms of the failure.
3. Fluctuations of the beam voltage up to $\pm 3\%$ will not damage the tube; to meet the signal-transfer quality requirements the nominal beam voltage should not vary more than $\pm 1\%$.
4. It is recommended that this voltage be obtained from a voltage divider between cathode and ground, which should carry a quiescent current of minimum 3 mA.
5. The focusing electrode voltage should be adjustable from 100 V to 500 V; a setting range from 100 V to 700 V is recommended.
6. At black level, to be focused for minimum drift tube current. If necessary to obtain the required signal-transfer quality, a deviation of maximum 10% from this minimum current is permitted. The limiting value, see Fig. 11, must however, not be exceeded.
7. Measured with a sawtooth voltage with amplitude between 17 and 75% of the peak sync value, on which is superimposed a 4.43 MHz sinewave with a 10% peak-to-peak value.
8. Calculated from $(1 - V_{\text{black}}/V_{\text{sync}})_{\text{in}} / (1 - V_{\text{black}}/V_{\text{sync}})_{\text{out}}$.
9. Measured with 10 to 75% modulation without compensation; V.S.B. filter between driving stage and klystron.
10. Produced by the klystron itself; without hum from power supplies.
11. Without compensation.
12. Without compensation, see German Bundespost 176 Pfl 2 or ARD-Pflichtenheft 5/2. Three-tone test method (vision carrier -8 dB, sound carrier -7 dB, sideband signal -16 dB with respect to peak sync = 0 dB).

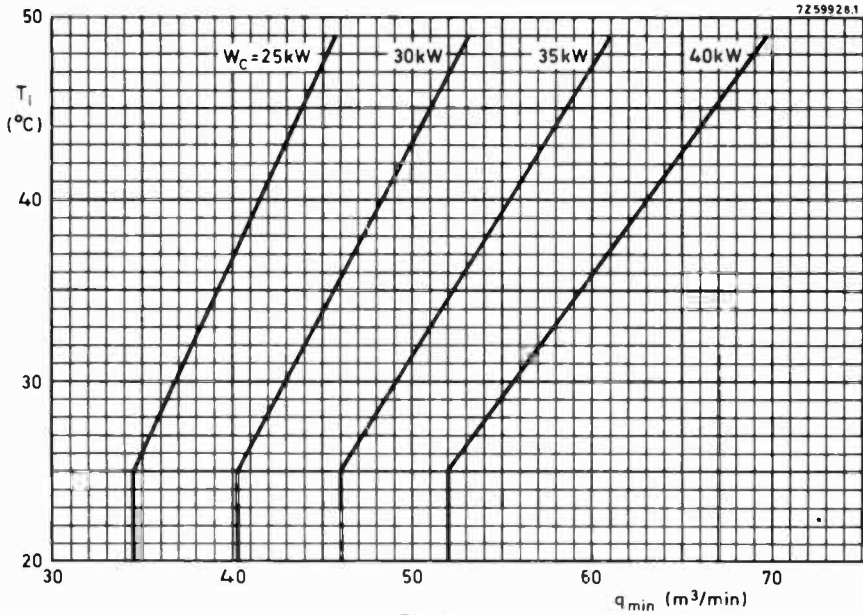

Fig. 5.

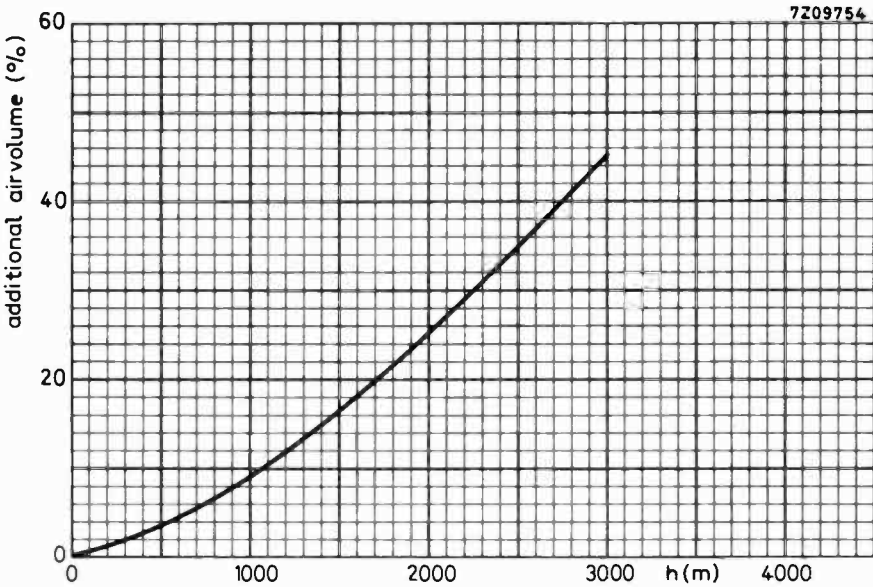

Fig. 6.

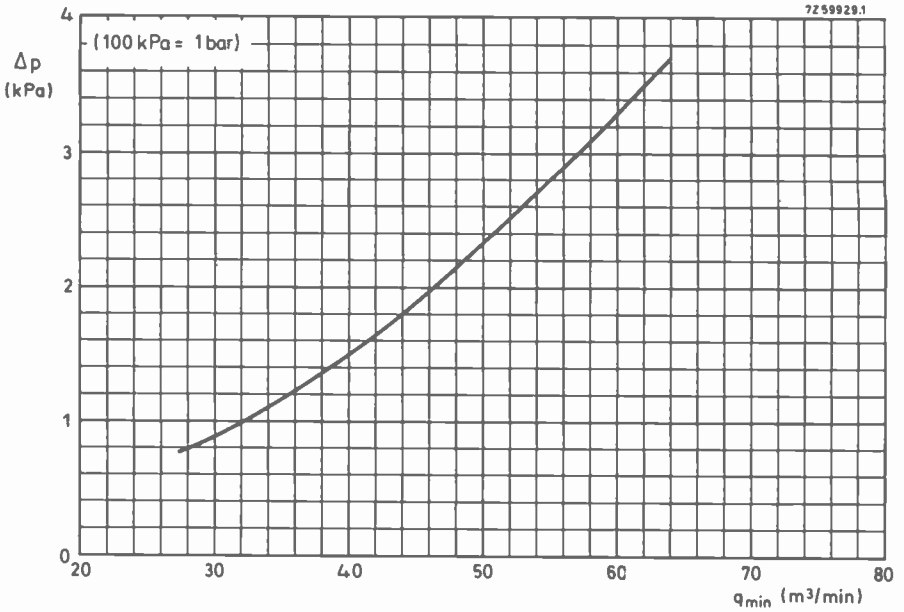

Fig. 7 Ratio of cooling air pressure to cooling air volume of YK1001.

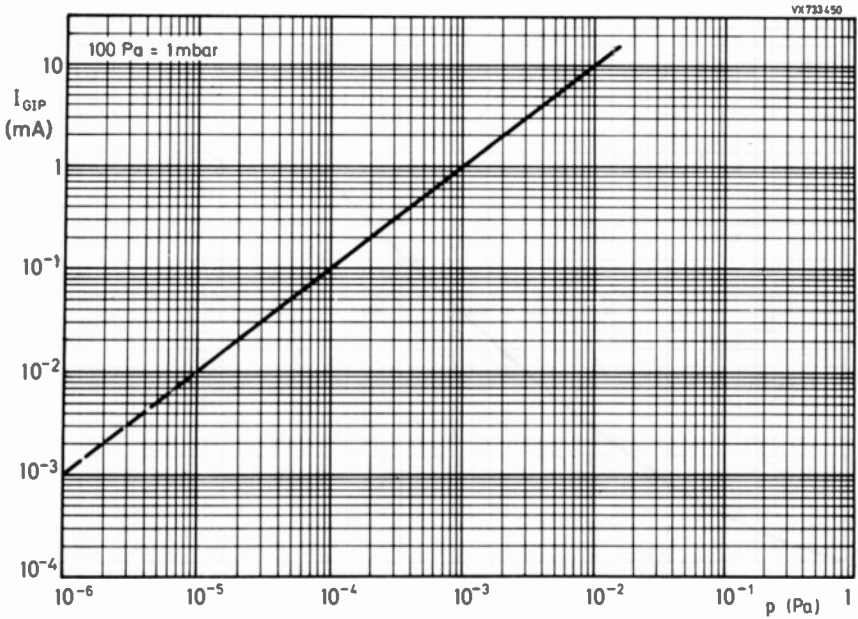

Fig. 8 Ratio of pump current to gas pressure in the klystron.

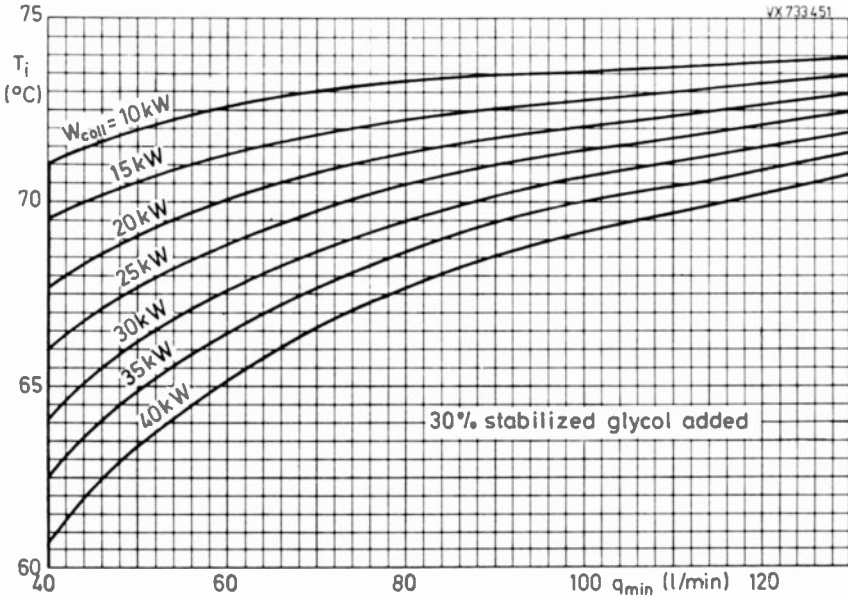

Fig. 9 Cooling curves for closed circuit cooling.

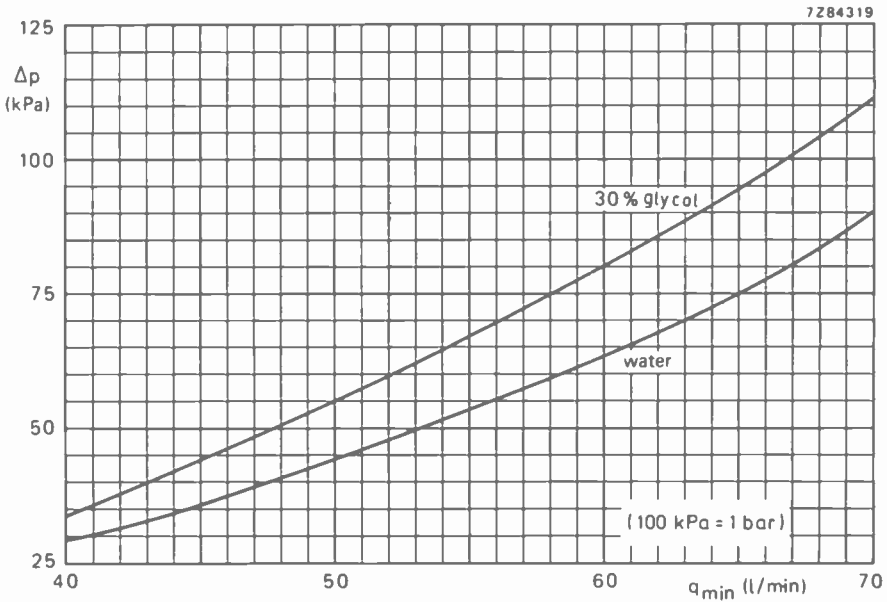

Fig. 10 Ratio of cooling water pressure to cooling water volume.

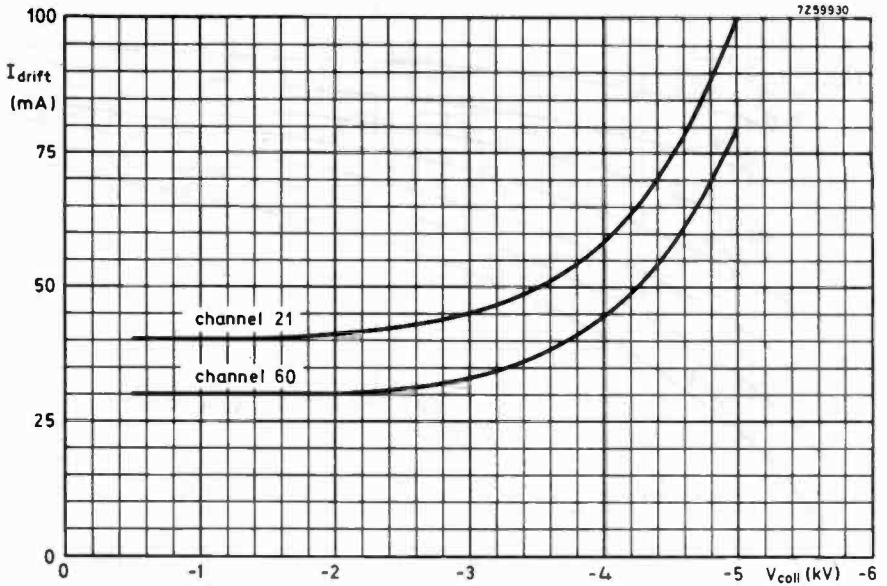

Fig. 11.

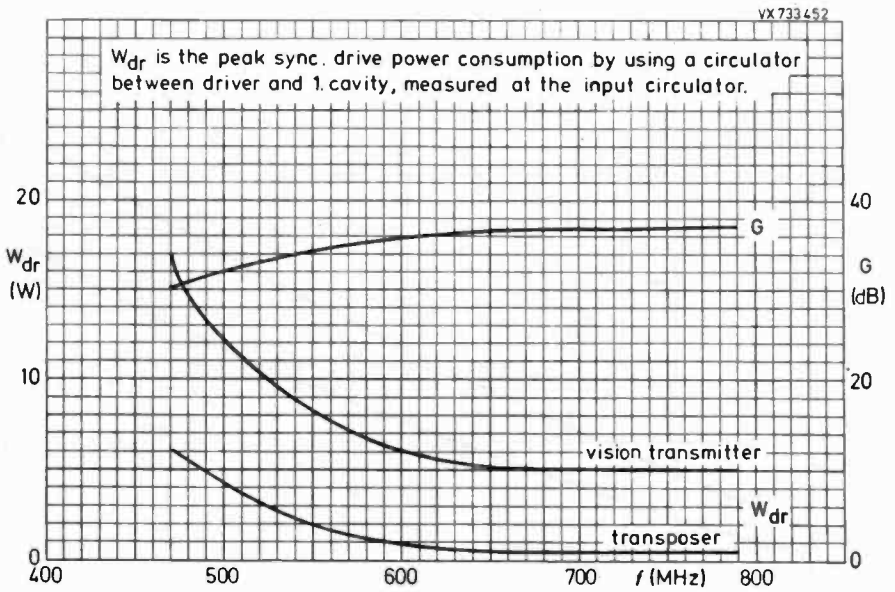

Fig. 12.

PULSED POWER KLYSTRON

Fixed frequency pulsed power klystron in metal-ceramic construction for the range 2998 ± 5 MHz, with 3 internal cavities, electromagnetic focusing, continuously operating getter-ion pump, coaxial input connector and S-band output waveguide, water cooled, intended as amplifier in linear accelerators and similar applications.

QUICK REFERENCE DATA

Frequency range	f	2998 \pm 5 MHz
The klystron is factory tuned to 2998 MHz but can delivered for any frequency within the range 2993 MHz to 3003 MHz. Other frequencies on request.		
Peak power output	W_{op}	6 MW
Power gain	G	30 dB

This data must be read in conjunction with GENERAL OPERATIONAL RECOMMENDATIONS for KLYSTRONS.

HEATING: indirect by a.c. or d.c.

Cathode	oxide coated	
Heater voltage	V_f	3 to 4.6 V
Heater current, marked on each tube	I_f	70 to 82 A

The heater current should never exceed a peak value of 150 A when applying an a.c. heater voltage or 100 A when applying a d.c. heater voltage.

Cold heater resistance	R_{fo}	6 m Ω
Waiting time	t_w min.	45 min

GETTER-ION PUMP POWER SUPPLY

Pump voltage, unloaded		4 kV
Internal resistance	approx.	300 k Ω

COOLING (valid for a pulse repetition rate up to 50 p.p.s.)

Drift tubes and focusing coils	q min.	4 l/min
	p max.	350 Pa *
Collector	q min.	7 l/min
	p max.	350 Pa *

ACCESSORIES

Magnet and housing for getter-ion pump	type TE1053A and TE1053B
--	-----------------------------

MASS (net)	approx.	110 kg
------------	---------	--------

* 350 Pa = 3,5 mbar.

MECHANICAL DATA

Dimensions in mm

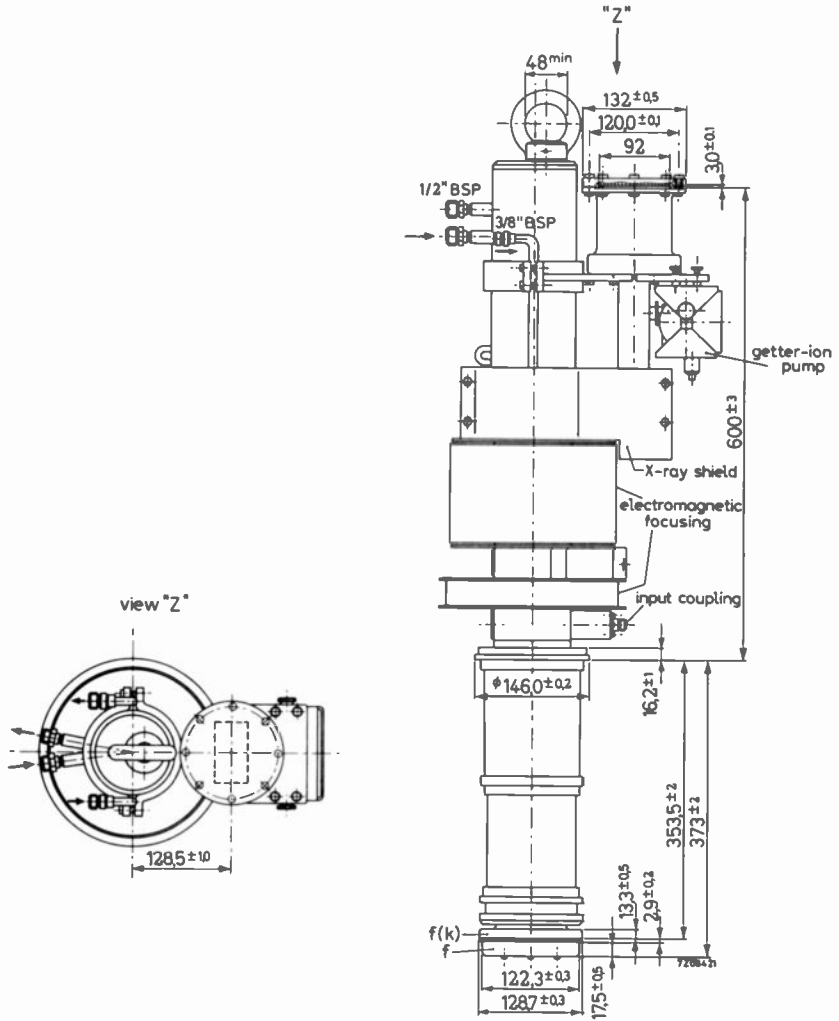

Fig. 1.

MOUNTING Vertical.

To be supported from mounting flange with cathode down. Although the collector and output cavity are provided with a lead shield, adequate additional shielding is required for protection against personal injury due to X-ray radiation.

LIMITING VALUES (Absolute maximum rating system) for pulsed operation.

notes

All voltages are specified with respect to ground.

Cathode voltage, peak	max.	-220 kV
Cathode current, peak	max.	120 A
Beam input power, peak	max.	25 MW
R.F. input power, peak	max.	10 kW
R.F. output power, peak	max.	8 MW
Pulse repetition rate	max.	600 p.p.s.
Pulse duration	max.	3 μ s
Voltage standing-wave ratio of load	max.	1.5
Focusing magnet voltage	max.	50 V
Focusing magnet current	max. min.	32 A 24 A
Pump voltage	max.	4.5 kV
Pump current	max.	15 mA
Water outlet temperature	max.	75 $^{\circ}$ C

OPERATING CONDITIONS

1

Frequency	2998 MHz	
Heater current		2
Cathode voltage, peak	-210 kV	3
Cathode current,		
peak	100 A	
mean	10 mA	
Focusing magnet voltage	40 V	
Focusing magnet current	29 A	4
Pulse repetition rate	50 p.p.s.	5
Pulse duration	2.2 μ s	
R.F. input power	5 kW	
R.F. output power,		
peak	6 MW	
mean	0.66 kW	

Notes

1. When the klystron has not been in operation for some time, conditioning might be required. This should be done by gradually increasing the cathode voltage until in each step stable operation is obtained. Stored tubes require pumping at intervals of approx. 3 months.
2. To be adjusted at the value marked on each tube.
3. For maintaining a minimum output power of 5 MW during life the cathode voltage may be increased to -215 kV.
4. To be adjusted for max. r.f. output power.
5. Data for operation at p.r.r. higher than 50 p.p.s. on request.

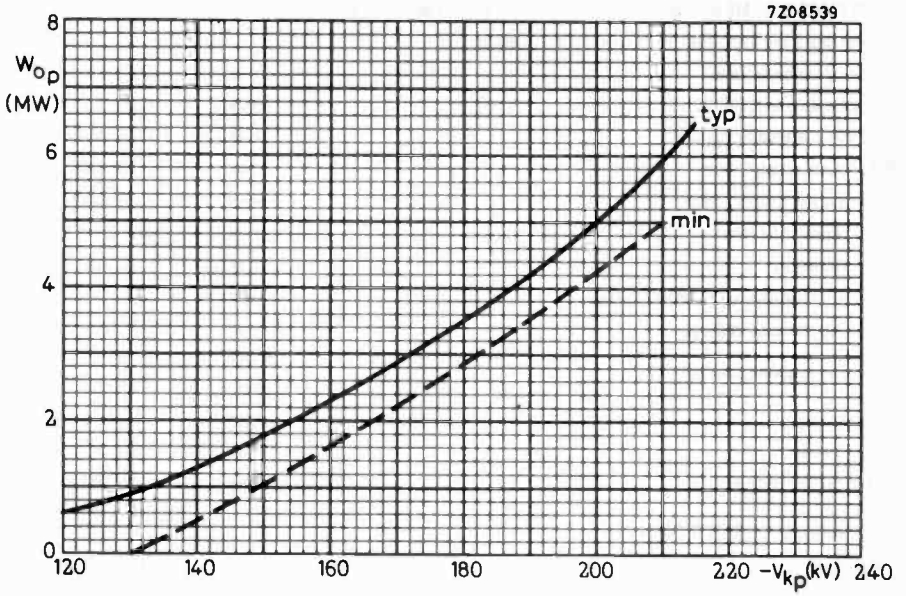

Fig. 2.

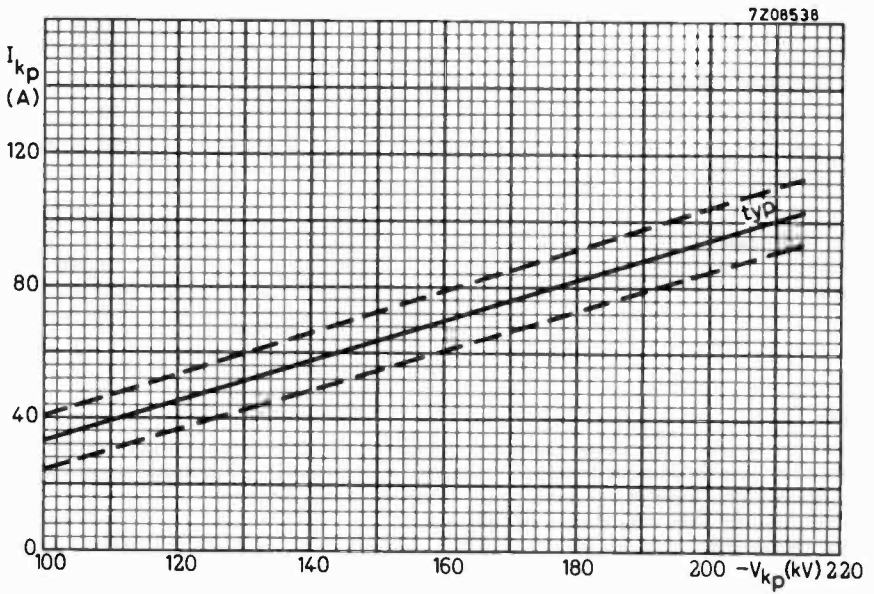

Fig. 3.

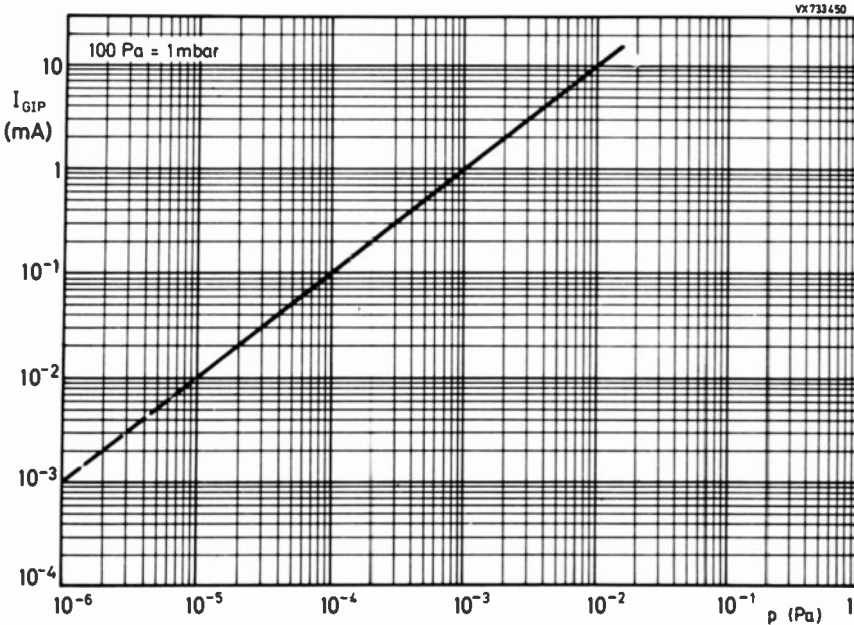

Fig. 4 Ratio of pump current to gas pressure in the klystron.

PRODUCT SAFETY

R.F. radiation

R.F. power may be emitted not only through the normal output coupling but also through other apertures (for example, r.f. leaks). This r.f. power may be sufficiently intense to cause danger to the human body, particularly to the eyes. Such radiation may be increased if the tube is functioning incorrectly.

X-radiation

A highly dangerous intensity of X-rays may be emitted by tubes operating at voltages higher than approximately 5 kV. Adequate protection (X-ray shielding) for the operator is then necessary. The emission intensity of X-rays may correspond to a value of voltage much higher than that expected from the actual value applied to the tube.

Poor focusing may result in excessive X-radiation.

U.H.F. POWER KLYSTRON

U.H.F. TV power klystron in metal-ceramic construction, with four external resonant cavities, integral permanent magnets, and incorporated getter-ion pump. The klystron is intended to be used with depressed collector voltage in 10 kW and 20 kW vision transmitters, in sound transmitters or in high-power transposers in the frequency range 470 to 860 MHz.

QUICK REFERENCE DATA

Frequency range	470 to 860 MHz
Output power, peak sync	25 kW
Cooling	forced air

This data must be read in conjunction with GENERAL OPERATIONAL RECOMMENDATIONS for KLYSTRONS.

HEATING: indirect by d.c.			notes
Cathode	dispenser type		
Heater voltage			
vision transmitter	V_f	7 V	1
sound transmitter	V_f	6.5 V	1
Heater current	$I_f \approx$	30 (26 to 34) A	
Cold heater resistance	$R_{fo} \approx$	28 m Ω	
Waiting time			
a. Heater voltage 7 V	t_w min.	180 s	2
b. Stand-by 6 V vision transmitter	t_w	0 s	2, 3
c. Stand-by 5.5 to 6 V sound transmitter	t_w	0 s	2, 3

FOCUSING

The integral temperature-compensated coaxial permanent magnets are pre-adjusted by the tube manufacturer.

GETTER-ION PUMP SUPPLY

Pump voltage, no load condition	4 kV
Internal resistance	300 k Ω

If it is between 3 kV and 4.5 kV, the collector to body voltage may be used as the pump supply voltage. In this case the pump anode must be connected to body (earth) via a 300 k Ω series resistor.

Notes

1. During operation the heater voltage should not fluctuate more than $\pm 3\%$.
2. The heater current should never exceed a peak value of 65 A.
3. Valid after a waiting time of at least 8 min; as soon as the beam voltage is switched on, the heater voltage must be increased to the nominal value.

MECHANICAL DATA

Dimensions in mm

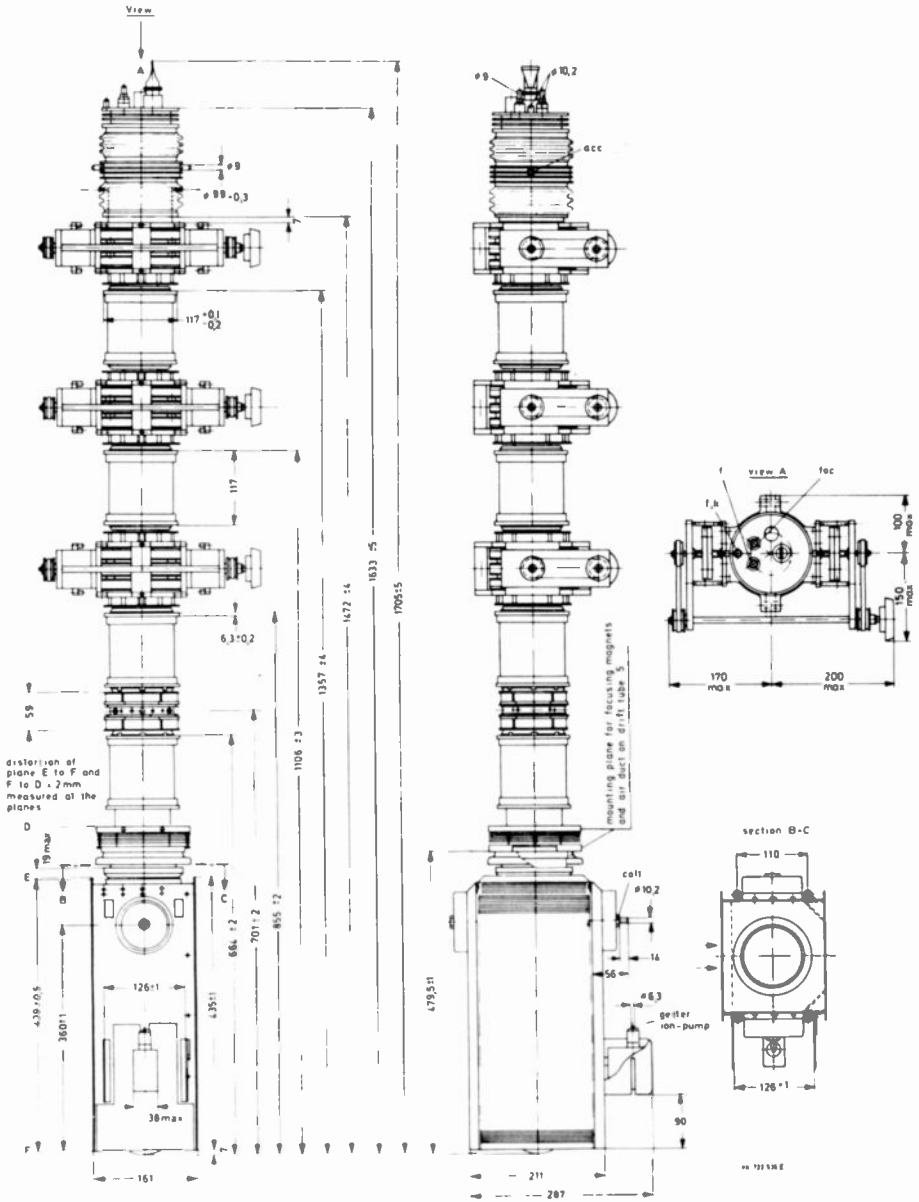

Fig. 1.

MASS AND DIMENSIONS**Klystron**

net	approx. 100 kg
gross	approx. 200 kg
outline dimensions of packing (cm)	205 x 79 x 66

MOUNTING

Mounting position: vertical with collector down.

To remove the tube from the magnet frame a total free height of 2.5 m, excluding hoist, is required.

COOLING**Cooling data, using the trolley TE1081**

Cathode socket, drift tubes, and cavities

forced air, approx. 5 m³/min, $\Delta p = 800$ Pa (8 mbar)

Collector (60 kW dissipation)

forced air, min 55 m³/min.

$\Delta p = 2100$ Pa (21 mbar), see Figs 3, 4 and 5.

PRODUCT SAFETY**1. X-radiation**

Correct operation of the tube can be guaranteed only if a set of accessories, approved by the tube manufacturer, is used.

The operating tube generates X-rays which can penetrate the ceramic parts of the tube envelope. In order to reduce the radiation at any accessible points to an officially acceptable, non-dangerous level the tube must be shielded and any possible radiation path blocked by at least 1 mm of brass or an equivalent depth of non-magnetic X-ray absorbing material. The proper use of accessories will provide the necessary shielding.

2. R.F. radiation

R.F. power may be emitted through apertures other than the normal output coupling (for example r.f. leaks). This r.f. power may be sufficiently intense to cause danger to the human body, particularly to the eyes. Such radiation may be increased if the tube is functioning incorrectly.

Instruction manual

For detailed mounting and tuning instructions see klystron instruction manual, delivered with each tube.

MECHANICAL DATA of the trolley TE1081

Dimension in mm

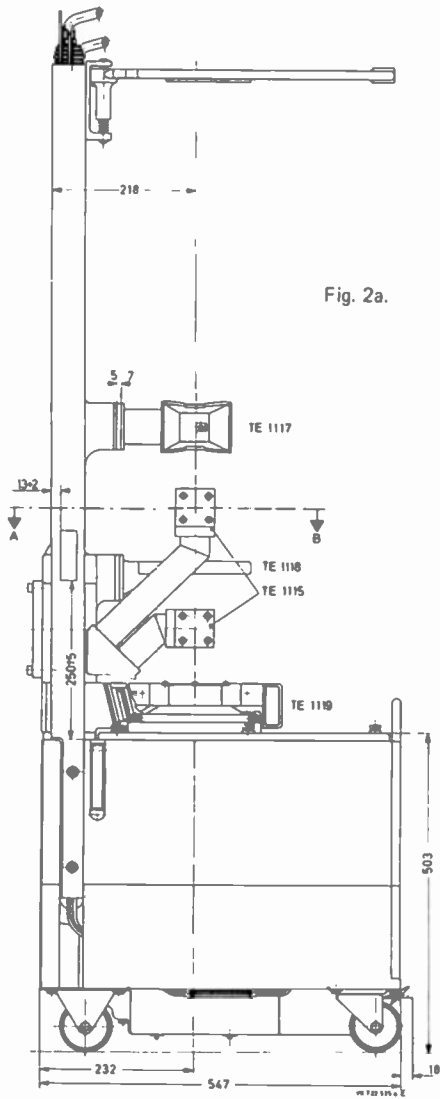
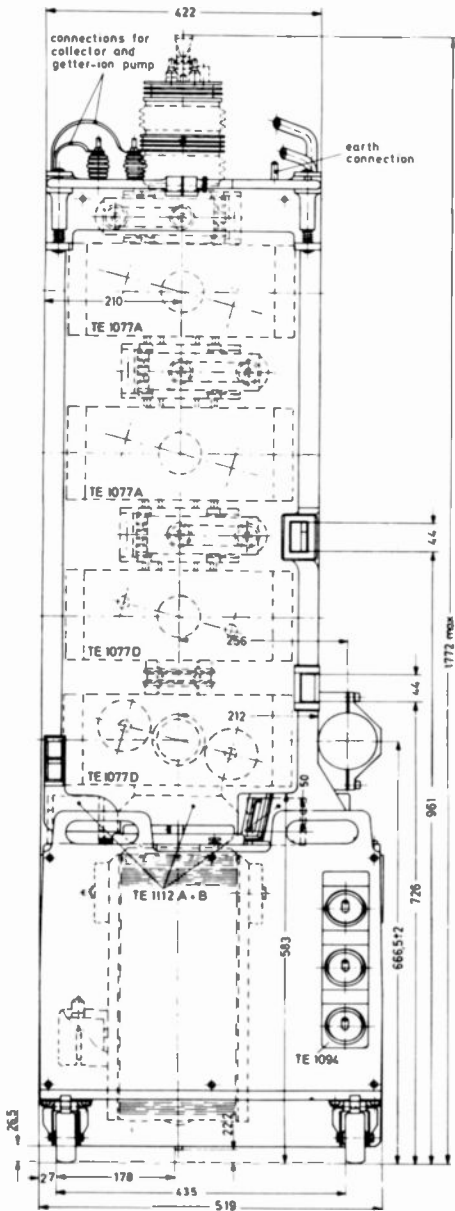

Fig. 2a.

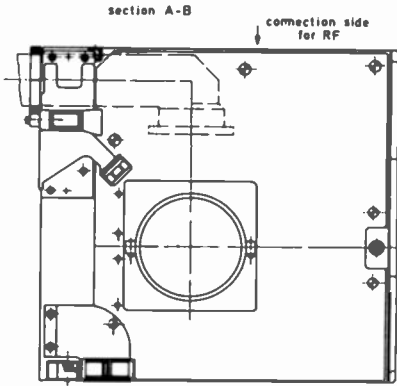
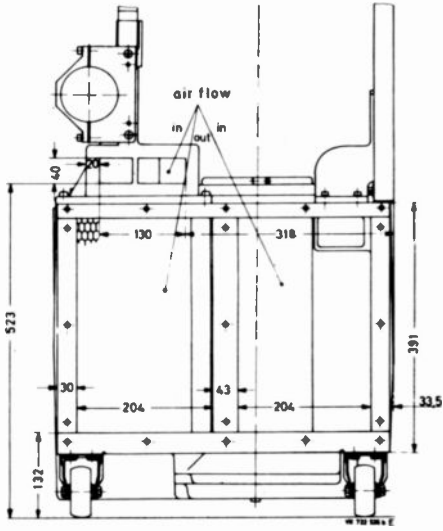

Fig.2b.



ACCESSORIES

Frequency range (MHz) Channel	470 to 637 21 to 41	638 to 860 42 to 68
Stub	TE1089	TE1089
Cavity 1 Input coupling device	TE1077A TE1083	TE1078A TE1084
Cavity 2 Load coupling device	TE1077A TE1085	TE1078A TE1086
Cavity 3 Load coupling device Adaptor flange	TE1077D TE1085 TE1090	TE1078D TE1086 TE1090
Cavity 4 Output coupling device	TE1077D TE1091A	TE1078D TE1092A
Magnet for drift tube 5	TE1112A TE1112B	TE1112A TE1112B
Trolley	TE1081	TE1081
Air duct for cavities	TE1115	TE1115
Air duct for drift tube 3	TE1117	TE1117
Air duct for drift tube 4	TE1118	TE1118
Air duct for drift tube 5	TE1119	TE1119
Magnet for getter-ion pump	TE1053A	TE1053A
Connectors		
Heater	40649	40649
Heater/cathode	40649	40649
Focusing electrode	40634	40634
Accelerating electrode	40634	40634
Collector	40649	40649
Getter-ion pump	40634	40634
Earth	40649	40649

Special parts

Load coupling unit mating TE1077D (instead of TE1091A)	TE1087
Load coupling unit mating TE1078D (instead of TE1092A)	TE1088
Plug connection mating TE1091A and TE1092A	TE1091B
Lifting device	TE1113
Recommended circulators (optional)	
470 to 600 MHz	2722 162 01551 (T100/IV-N)
600 to 800 MHz	2722 162 01561 (T100/V-N)
790 to 1000 MHz	2722 162 03261 (T100/V-3-N)

LIMITING VALUES (Absolute maximum rating system)

	min.	max.	notes
Heater voltage		8.5 V	
Ground to cathode voltage		28 kV	
Ground to the accelerator electrode voltage	0 kV	28 kV	
Ground to collector voltage	0 kV	5 kV	
Cathode to focusing electrode voltage	100 V	600 V	
Cathode current		4 A	
Accelerator electrode current	-0.2 mA	+1.5 mA	
Focusing electrode current	-0.2 mA	+3 mA	
Drift tube current			
static		60 mA	4, 5
dynamic		260 mA	5
Collector dissipation		65 kW	
Series resistor in accelerator electrode circuit	10 k Ω		
Return loss of load at operating frequency	14 dB		
Pump voltage, no load condition	3.0 kV	5.0 kV	
Pump current		15 mA	
Temperature of focusing magnets		70 °C	
Inlet temperature of cooling air		45 °C	
Outlet temperature of cooling air		110 °C	

Notes

4. Static operation (operation without output power) in vision transmitters only with beam currents < 2/3 of given value allowed (see design considerations).
5. A drift tube current cut-out should be provided to protect the klystron. The cut-out should have an automatic action which depends on the drive level, see Figs 6 and 7.

TYPICAL OPERATING CONDITIONS

As 20 kW vision transmitter in accordance with CCIR-G standard,
with depressed collector voltage

notes

Operating conditions

	470 to 640		470 to 790	790 to 860	MHz	
Frequency range	470 to 640		470 to 790	790 to 860	MHz	7
Channel	21 to 41		21 to 60	61 to 68		
Collector to cathode voltage	16.5	18	20.0	20.0	kV	8
Cathode current	3.6	3.3	3.0	3.1	A	
Ground to collector voltage	4.0	4.0	4.0	4.5	kV	
Drift tube current (black level)	120	100	70	70	mA	
Ground to accelerator electrode voltage	0	≈ 3	≈ 6	≈ 6	kV	
D.C. input power	59	59	60	62	kW	
Cathode to focusing electrode voltage	300 (100 to 600)				V	9
Drive power see Fig. 10.						

Performance

	22				
	min.	typ.	max.		
Output power, peak sync	22				kW 10
Sync. compression			40/25		11
V.S.B. suppression	23	25			dB 12
Noise ratio, with reference to black level	48	> 50			dB 13
Linearity 10/75	0.75	0.8			14
Differential gain (10/85 at 4.43 MHz)	0.75	0.85			15
Differential phase (10/85 at 4.43 MHz)		+10/-3	+15/-5		deg 15, 16
Variation in response characteristic as a function of power level in the double-sideband region		0.25	0.5		dB 17
in the single-sideband region		0.4	0.6		dB 18
Ripple of response characteristic (white level 10/20)			0.3		dB
Maximum output power		25			kW 19
Efficiency		37			%

TYPICAL OPERATING CONDITIONS (continued)

As 20 kW vision transmitter in accordance with CCIR-G standard, notes
 without depressed collector voltage 6

Operating conditions 7

Frequency range	470 to 860	MHz	
Channel	21 to 68		
Collector to cathode voltage	19.5 to 23	kV	8
Cathode current	3.05 to 2.6	A	
Ground to collector voltage	0	kV	
Drift tube current (black level)	80 to 40	mA	
Ground to accelerator electrode voltage	1.5 to 6.5	kV	
D.C. input power	60	kW	
Cathode to focusing electrode voltage	300 (100 to 600)	V	9

Drive power see Fig. 10.

Performance

Output power, peak sync 22 kW 10

	min.	typ.	max.		
Sync. compression			52/26		11
V.S.B. suppression	23	25		dB	12
Noise ratio, with reference to black level	48	> 50		dB	13
Linearity 10/75	0.65	0.75			14
Differential gain (10/85 at 4.43 MHz)	0.65	0.75			15
Differential phase (10/85 at 4.43 MHz)		+12/-3	+15/-5	deg	15, 16
Variation in response characteristic as a function of power level in the double-sideband region		0.25	0.5	dB	17
in the single-sideband region		0.4	0.6	dB	18
Ripple of response characteristic (white level 10/20)			0.3	dB	
Maximum output power	22	23		kW	19
Efficiency		37		%	

TYPICAL OPERATING CONDITIONS (continued)

As 10 kW vision transmitter in accordance with CCIR-G standard

notes

Operating conditions

6

7

Frequency range	470 to 640	470 to 790	790 to 860	MHz	
Channel	21 to 41	21 to 60	61 to 68		
Collector to cathode voltage	15.0	16.0	16.0	kV	8
Cathode current	2.2	2.1	2.2	A	
Ground to collector voltage	4.0	4.0	4.5	kV	
Drift tube current (black level)	60	50	50	mA	
Ground accelerator electrode voltage	≈ 4.0	≈ 5.5	≈ 6.0	kV	
D.C. input power	33	33.5	35	kW	
Cathode to focusing electrode voltage	300 (100 to 600)			V	9

Drive power see Fig. 10.

Performance

10

Output power, peak sync

11

kW

	min.	typ.	max.		
Sync. compression			40/25		11
V.S.B. suppression	23	25		dB	12
Noise ratio, with reference to black level	48	> 50		dB	13
Linearity 10/75	0.75	0.8			14
Differential gain (10/85 at 4.43 MHz)	0.75	0.85			15
Differential phase (10/85 at 4.43 MHz)		+10/-3	+15/-5	deg	15, 16
Variation in response characteristic as a function of power level in the double-sideband region		0.25	0.5	dB	17
in the single-sideband region		0.4	0.6	dB	18
Ripple of response characteristic (white level 10/20)			0.3	dB	
Maximum output power		12.5		kW	19
Efficiency		33		%	

TYPICAL OPERATING CONDITIONS (continued)

notes

As sound transmitter in accordance with the CCIR-G standard (one carrier operation)

6

R.F. setting

Cavity 4 on sound carrier frequency
 Cavity 1 on sound carrier frequency -0.5 MHz
 Cavity 2 on sound carrier frequency -0.5 MHz,
 Cavity 3 on sound carrier frequency min. +3 MHz,
 (load coupler and load are not necessary)

Double-humped resonance curve slack ≤ -0.5 dB

Operation with high voltage collector to cathode

with depressed collector voltage

7

Frequency range	470 to 640	470 to 790	790 to 860	MHz	
Channel	21 to 41	21 to 60	61 to 68		
Collector to cathode voltage	16.5 18	20.0	20.0	kV	
Ground to collector voltage	4.0 4.0	4.0	4.5	kV	
Cathode to focusing electrode voltage	100 to 600	100 to 600	100 to 600	V	
Driving power	\leq 0.5	0.5	0.5	W	
Ground to accelerator electrode voltage	\approx 10.5 12.5	14.0 16.0	14.5 16.5	kV	
Cathode current	1.1 0.8	1.0 0.7	1.0 0.7	A	20
Output power	4.4 2.2	4.4 2.2	4.4 2.2	kW	

without depressed collector voltage

Frequency range		470 to 860		MHz	
Channels		21 to 68			
Collector to cathode voltage		19.5 to 23		kV	
Ground to collector voltage		0		kV	
Cathode to focusing electrode voltage		100 to 600		V	
Driving power		\leq 1		W	
Ground to accelerator electrode voltage	11.5 to 15.5		13 to 17	kV	
Cathode current	0.8 to 0.7		0.6 to 0.5	A	20
Output power	2.2		1.1	kW	

TYPICAL OPERATING CONDITIONS (continued)

notes

As sound transmitter (continued)

6

Operation with low voltage collector to cathode

7

with depressed collector voltage

Frequency range	470 to 640	470 to 790	790 to 860	MHz
Channel	21 to 41	21 to 60	61 to 68	
Collector to cathode voltage	15.0	16.0	16.0	kV
Ground to collector voltage	4.0	4.0	4.5	kV
Cathode to focusing electrode voltage	100 to 600	100 to 600	100 to 600	V
Driving power	≤ 0.5	≤ 0.5	≤ 0.5	W
Ground to accelerator electrode voltage	≈ 0.9 ≈ 10.5	≈ 12.5 ≈ 13.5	≈ 13.0 ≈ 14.0	kV
Cathode current	0.8 0.6	0.65 0.5	0.65 0.5	A 20
Output power	2.2 1.1	2.2 1.1	2.2 1.1	kW

Notes

6. With stated accessories; in case of failure the beam voltage must be switched-off and made to drop below 5% of its nominal value within 500 ms of the failure.
7. For optimum performance one of these settings has to be chosen in accordance with the transmitter manual.
8. Fluctuations up to ± 3% will not damage the tube; to obtain a good signal transfer quality the beam voltage should not vary more than ± 1%.
9. To be adjusted for the specified cathode current.
10. The signal transfer quality is measured with matched load (VSWR ≤ 1.05).
11. Calculated from $(1 - V_{black}/V_{sync})_{in} / (1 - V_{black}/V_{sync})_{out}$
12. Measured with 10 to 75% modulation without compensation; V.S.B. filter between driving stage and klystron.
13. Produced by the klystron itself; without hum from power supplies.
14. Measured with a staircase signal of 10 to 75% of the peak sync value.
15. Measured with a sawtooth voltage with an amplitude between 15 and 80% of the peak sync. value on which is superimposed a 4.43 MHz sinewave with a 10% peak to peak value.
16. Phase difference to burst signal.
17. With respect to ± 0.5 MHz about the carrier frequency.
18. With respect to specified tolerance range.
19. With increased driving power under the given operating conditions, without guarantee for signal transfer quality.
20. Cathode current adjusted by accelerating electrode voltage (coarse), and focusing electrode voltage (fine).

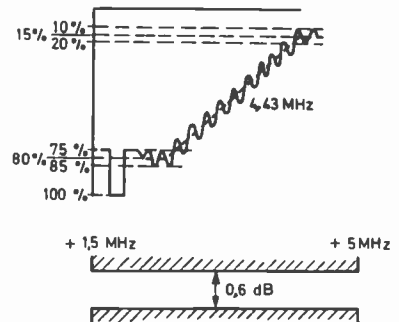

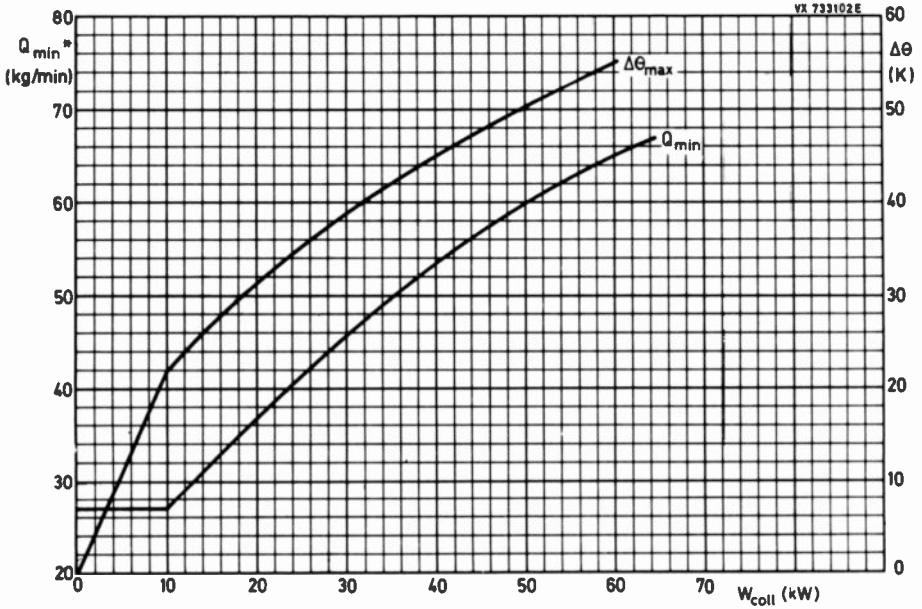

Fig. 3 Required quantity of cooling air Q_{min} for the inlet temperature $T_i = 25^\circ\text{C}$ and relative temperature difference $\Delta\theta$ versus the collector dissipation W_{coll} .

* A normal cubic metre (at 1033 mbar, 15°C) corresponds to 1.226 kg.

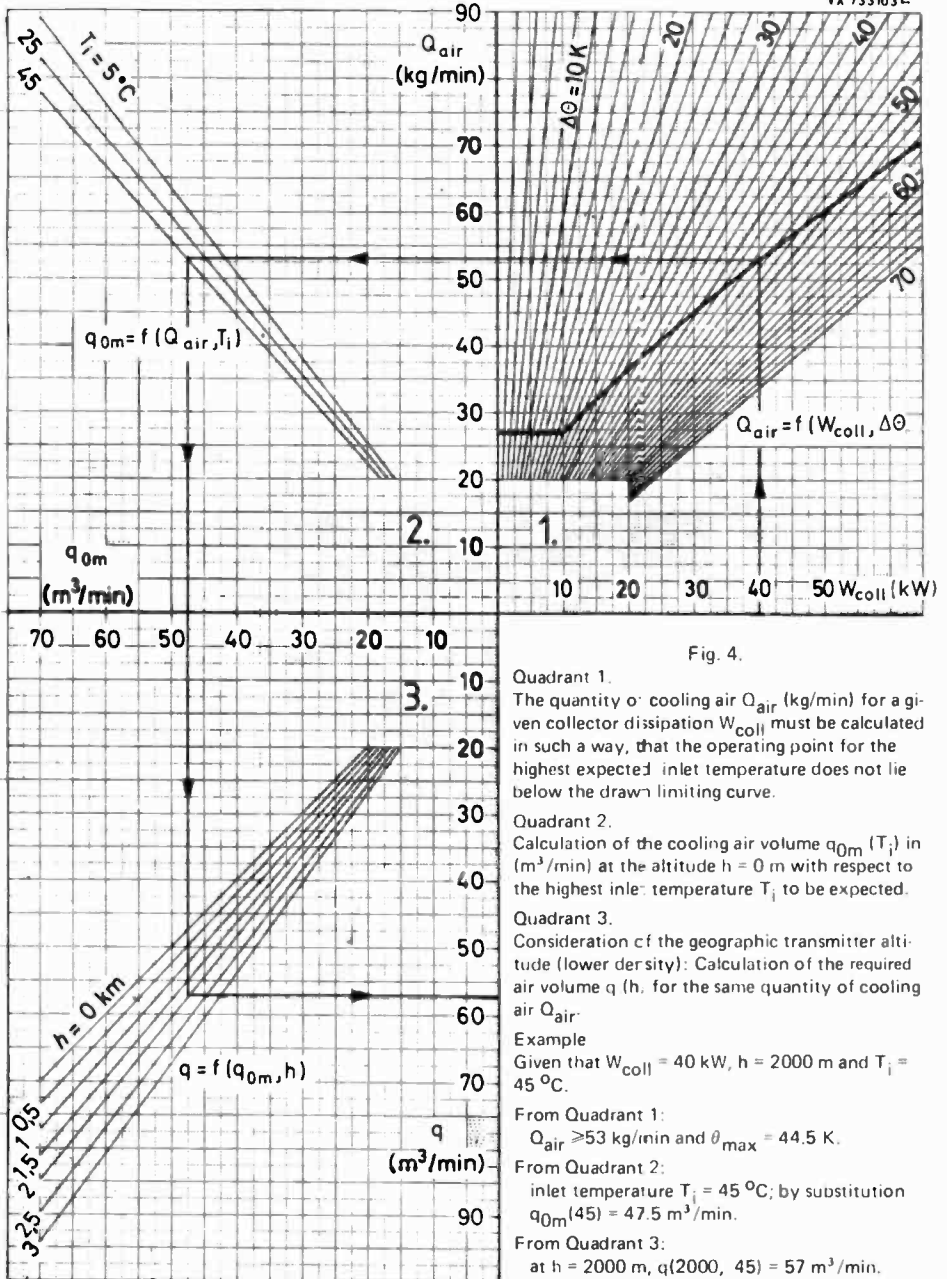

Fig. 4.

Quadrant 1.

The quantity of cooling air Q_{air} (kg/min) for a given collector dissipation W_{coll} must be calculated in such a way, that the operating point for the highest expected inlet temperature does not lie below the drawn limiting curve.

Quadrant 2.

Calculation of the cooling air volume q_{0m} (T_i) in (m^3/min) at the altitude $h = 0$ m with respect to the highest inlet temperature T_i to be expected.

Quadrant 3.

Consideration of the geographic transmitter altitude (lower density): Calculation of the required air volume q (h , for the same quantity of cooling air Q_{air}).

Example

Given that $W_{coll} = 40$ kW, $h = 2000$ m and $T_i = 45$ °C.

From Quadrant 1:

$Q_{air} \geq 53$ kg/min and $\theta_{max} = 44.5$ K.

From Quadrant 2:

inlet temperature $T_i = 45$ °C; by substitution $q_{0m}(45) = 47.5$ m^3/min .

From Quadrant 3:

at $h = 2000$ m, $q(2000, 45) = 57$ m^3/min .

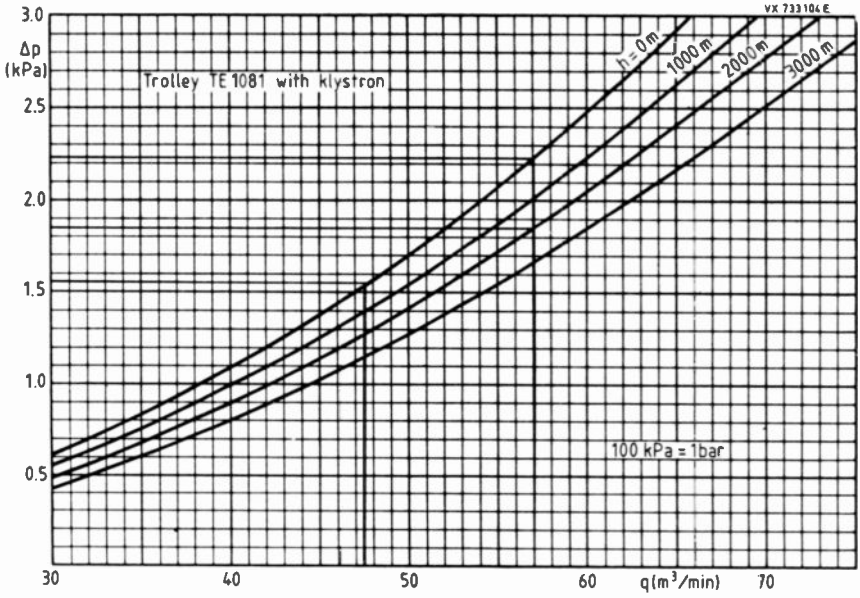

Fig. 5 Calculation of the pressure drop Δp between air inlet and air outlet at the trolley TE1081 as a function of cooling air volume q for selection of the correct blower.

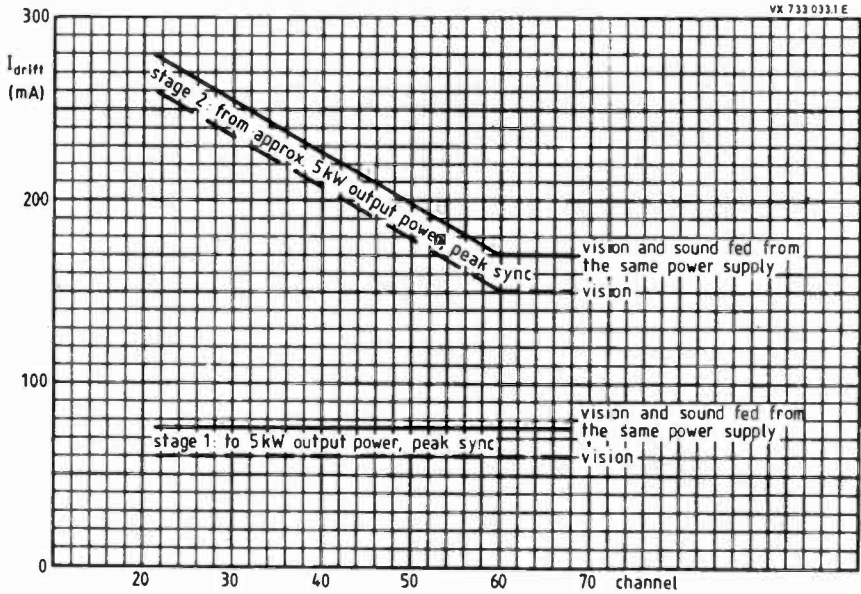

Fig. 6 Drift tube current cut-out at operation with depressed collector voltage for 20 kW transmitter.

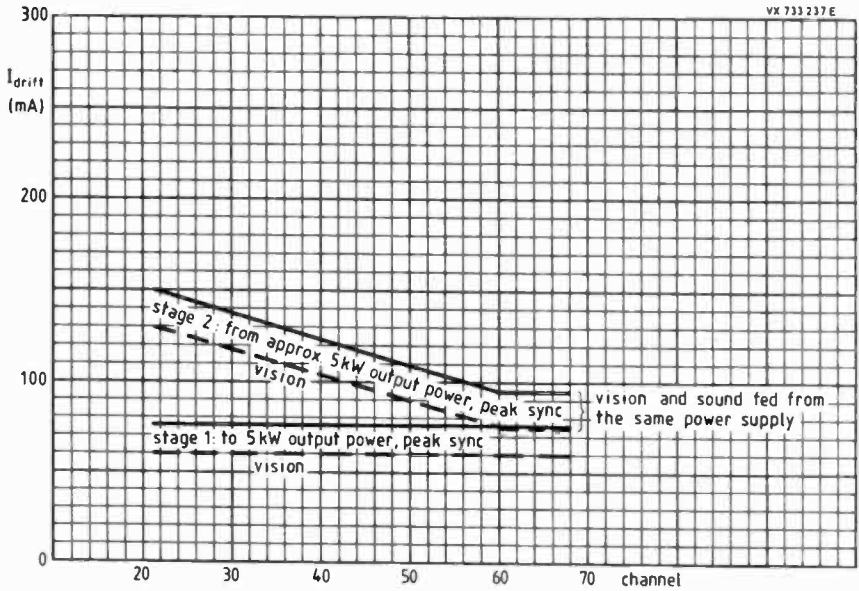

Fig. 7 Drift tube current cut-out at operation without depressed collector voltage for 20 kW transmitter.

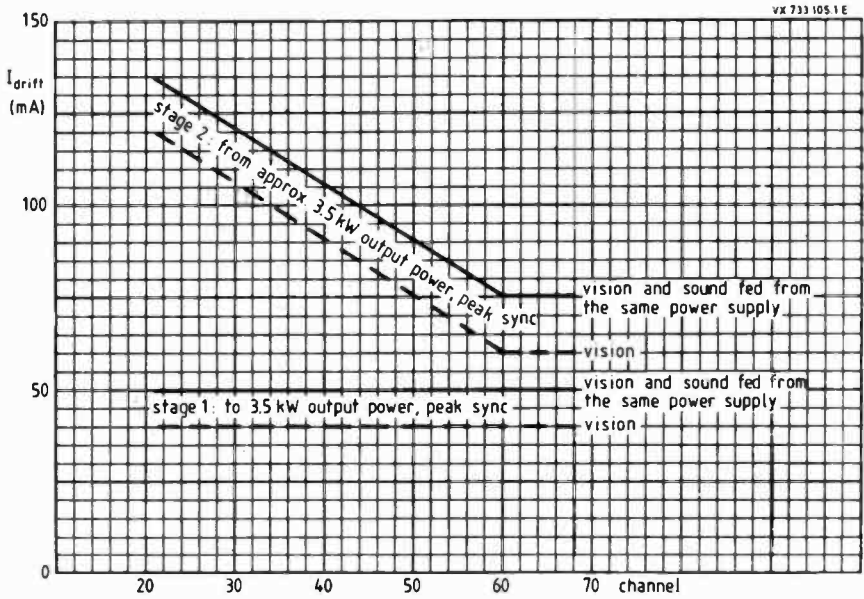

Fig. 8 Drift tube current cut-out at operation with depressed collector voltage for 10 kW transmitter.

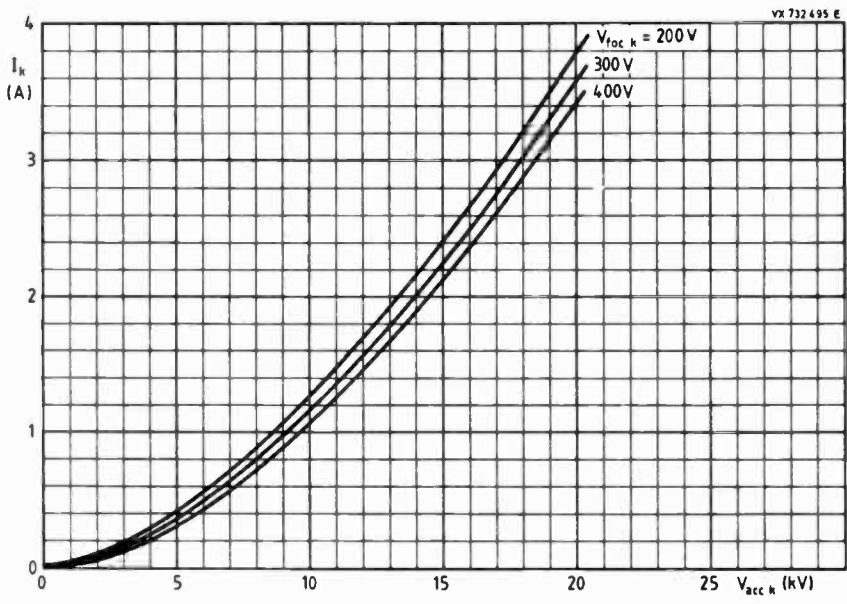

Fig. 9.

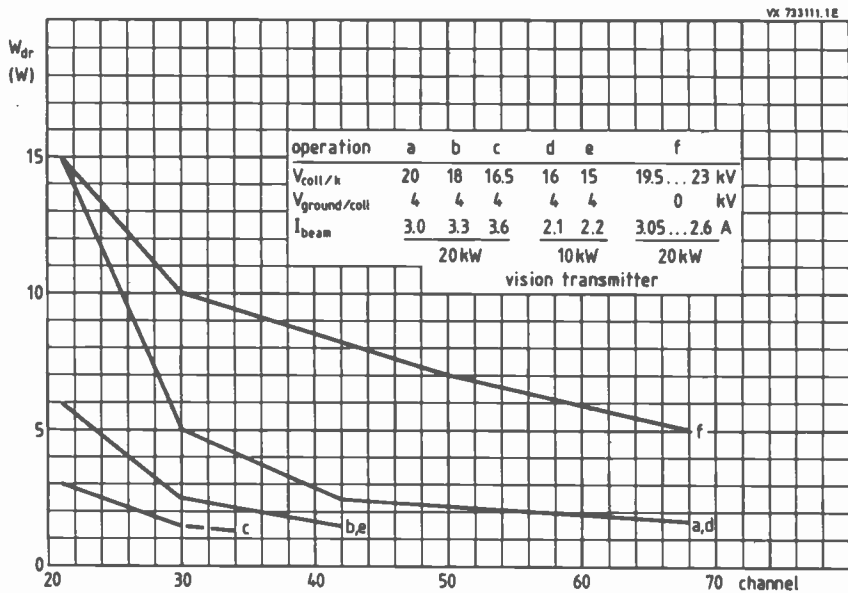

Fig. 10 Max. drive power in dependence on channel and operation mode.

DESIGN CONSIDERATIONS FOR POWER SUPPLIES AND SAFETY CIRCUITS

1. Power supplies

	Range ¹⁾	Internal resistance	Hum
Heater voltage	6.5 to 8.0 V (26 to 36 A)	²⁾	Corresponding to non-smoothed three-phase, full-wave rectifier
Cathode to focusing electrode voltage	100 to 600 V (-0.2 to +3 mA)		< 0.1%
Ground to collector voltage	0 or 4.5/ 4.0/ 3.5 kV ³⁾ (500 mA mean, 1 A peak)	0 or 300 to 600 Ω	< 0.1%
Collector to ⁴⁾ cathode voltage	Operation without depressed collector voltage	Operation with depressed collector voltage	
20 kW operation	19.5 to 23 kV (65 kW)	16.5 kV 18.0 kV (65 kW) 20.0 kV	300 to 600 Ω < 0.1%
10 kW operation		15.0 kV 16.0 kV (35 kW)	
Ground to accelerator electrode voltage	see Fig. 9.		
Getter-ion pump to cathode voltage ⁵⁾	voltage, unloaded 3.5 to 4 kV (load up to 15 mA)	300 kΩ	--

¹⁾ Maximum allowable deviation from nominal or set values:

- a) $\pm 2\%$ during adjustment, if the published performance is to be attained,
- b) $\pm 1\%$ fluctuation of the set values during operation to maintain the performance,
- c) during operation, deviations not exceeding $\pm 3\%$ of the set values will not damage the tube.

²⁾ The heater current should never exceed a peak value of 65 A.

³⁾ At operation with depressed collector voltage a capacitor of 0.5 μF must be installed near the collector connection of the klystron and the trolley between feed line and ground.

⁴⁾ An additional tap for approx. 500 V to the given voltages is recommended.

⁵⁾ Needed for operation without depressed collector voltage.

2. Safety circuits

The safety circuits must operate in any one of the following cases:

- a) The cut-out threshold of the drift tube current is exceeded. Dependent on the peak output power this cut-out should operate in two stages, see Figs 6 and 7.

- b) The set collector or cathode current is exceeded by more than 30 % (max. 400 mA).
- c) The air volume for collector cooling falls below the initial value for a longer period (see data sheet by cooling).
- d) The cooling air for drift tubes 3, 4 and 5, cavity 4, and cathode terminals fails (checked by a vane or equivalent device).
- e) The set max. temperature on the contact thermometers of the klystron is exceeded.

Set temperatures of the probe assemblies are:

	Probe 1 (top)	Probe 2 (middle)	Probe 3 (bottom)
10 kW Vision	80 °C	80 °C	80 °C
10 kW Sound	65 °C	65 °C	65 °C
20 kW Vision	90 °C	110 °C	110 °C
20 kW Sound	65 °C	65 °C	65 °C

- f) The return loss is lower 14 dB (VSWR \geq 1.5).
- g) The pump operating current exceeds 50 μ A.

3. Operation without output power

Static operation (operation without output power) in vision transmitters is not allowed at beam currents $>$ 2/3 of the given value. Without driving signal the beam current must be reduced or the tube switched-off.

4. Switching-on and switching-off procedures

a) Switching-on sequence:

1. accelerating electrode at cathode potential,
2. cooling air,
3. ground to collector voltage,
4. heater voltage and cathode to focusing electrode voltage.

Steps 1 to 4 can be simultaneous.

5. waiting time,
6. collector to cathode voltage,
7. ground to accelerator electrode voltage.

b) Switching-off sequence:

1. accelerating electrode at cathode potential,
2. all other voltages and cooling simultaneously.

c) Switching-off sequence when the safety circuits operate:

1. accelerating electrode at cathode potential,
2. cathode-to-collector voltage.

For repeated switching-on (repeating): see a) 6 and 7.

In case of failure the following voltages must be switched-off and made to drop below 5% of their nominal value:

accelerating electrode-to-body voltage and cathode-to-collector voltage within 500 ms, collector-to-body voltage within 1 s.

It is recommended to start this drop 200 ms after occurrence of the failure.

5. Waiting time after short interruptions of operation

Interruption of the heater voltage	Required waiting time	$\left\{ \begin{array}{l} \text{vision } V_f = 7 \text{ V} \\ \text{sound } V_f = 6.5 \text{ V} \end{array} \right.$
0 to 30 s	0 s	
30 to 60 s	30 s	
60 to 90 s	60 s	
> 90 s	180 s	

6. Focusing

- a) The tube is pre-focused by the tube manufacturer.
- b) For final focusing see manual.

7. Cooling

- a) The cooling of the cathode socket, accelerating electrode, drift tubes, and cavities must be monitored.
- b) The air volume of the collector cooling and, dependent on it, the temperature distribution at the air outlet, must be monitored at minimum three points.
- c) Also during stand-by the cathode socket must be cooled and the getter-ion pump kept in operation.

8. Mounting

- a) The r.f. connectors for operation have the following dimensions:

Stub	7/16
Input coupling device cavity 1	7/16
Output coupling device cavities 2 and 3	7/16
Output coupling device cavity 4	3 1/8"
- b) Forces on klystron terminals max. 10 N. Bending moment max. 1 Nm.
- c) The coaxial magnets must not be removed from the klystron.
- d) In order to prevent distortion of the magnetic focusing field, ferromagnetic material should not be applied within a radius of 35 cm from the tube axis.
Using the trolley TE1081. No parts should be mounted on or within the trolley and ferromagnetic parts in the trolley are not allowed.
- e) Magnetic stray fields, e.g. from transformers, coils, etc., must not exceed $50 \mu\text{T}$ (0.5 gauss) at the surface of the klystron.
- f) It is recommended to use non-magnetic material for doors of cabinets containing output stages, if these doors must be closed after focusing.

9. Storage and transport

- a) In cases of prolonged storage, each klystron must be checked for vacuum at least every 6 months and pumped if necessary.
It is recommended to check every 3 months (the heater voltage need not switched-on).
- b) All klystrons are insured during delivery transportation.
Each tube must be inspected for damage within 7 days of delivery:
 1. Visual inspection of pack and tube.
 2. Vacuum inspection with the getter-ion pump (without heating), the pump current must decrease to less than $10 \mu\text{A}$ within 15 min.



U.H.F. POWER KLYSTRONS

For u.h.f. band IV/V vision transmitters and sound transmitters.
Metal-ceramic construction, four external cavities, electromagnetic focusing and a high-stability dispenser type cathode.
Suitable for vapour, vapour-condensation or water cooling.

QUICK REFERENCE DATA

Frequency range		
YK1190	470 to 610	MHz
YK1191	590 to 720	MHz
YK1192	710 to 860	MHz
Output power as vision transmitter	40	kW
Cooling	vapour, vapour condensation, or water	

This data must be read in conjunction with GENERAL OPERATIONAL RECOMMENDATIONS for KLYSTRONS.

HEATING: indirect by d.c.			notes
Cathode	dispenser type		
Heater voltage	$V_f \approx$	8.5 V \pm 3 %	
Heater current	$I_f \approx$	22 to 27 A	1
Cold heater resistance	$R_{fo} \approx$	30 m Ω	
Waiting time			2
at $V_f = 8.5$ V	t_w min.	300 s	
at $V_f = 6.0$ V (black heat)	t_w min.	0 s	
FOCUSING: electromagnetic			
Focusing coil current	9 to 12 A		
Resistance of focusing coils			
cold (20 °C)		7.2 to 9.5 Ω	
operating at an ambient temperature of 20 °C	<	11 Ω	

BEAM CONTROL

The accelerator electrode voltage allows adjustment of the beam current between 0 and 100%.

GETTER-ION PUMP SUPPLY			3
Pump voltage, no-load condition	3 to 4 kV		
Internal resistance of supply	300 k Ω		

MECHANICAL DATA YK1190

Dimensions in mm

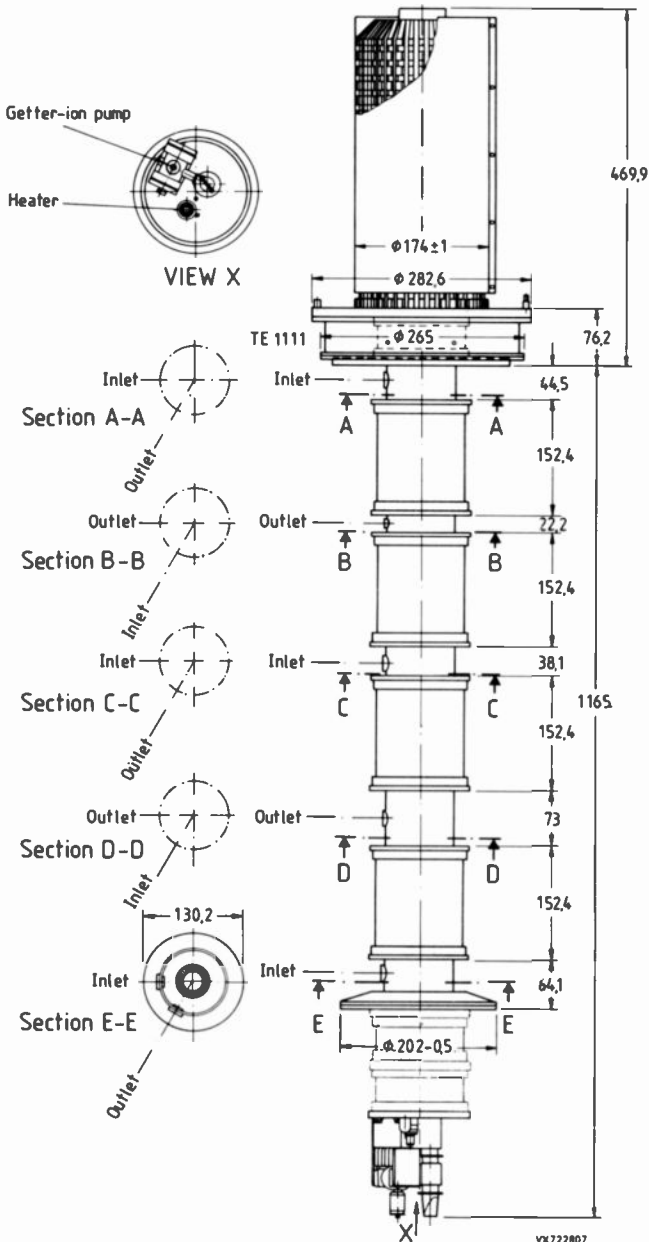

Fig. 1.

YK1191, YK1192

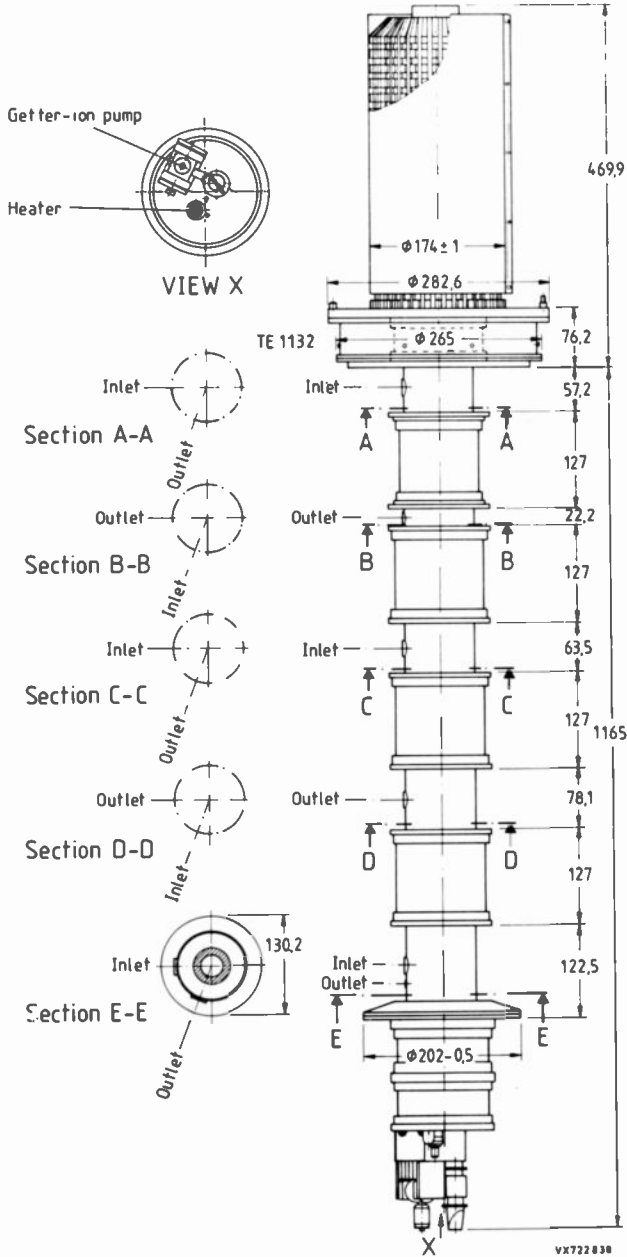

Fig. 2.

YK1190
 YK1191
 YK1192

Mechanical outlines of trolley

Dimensions in mm

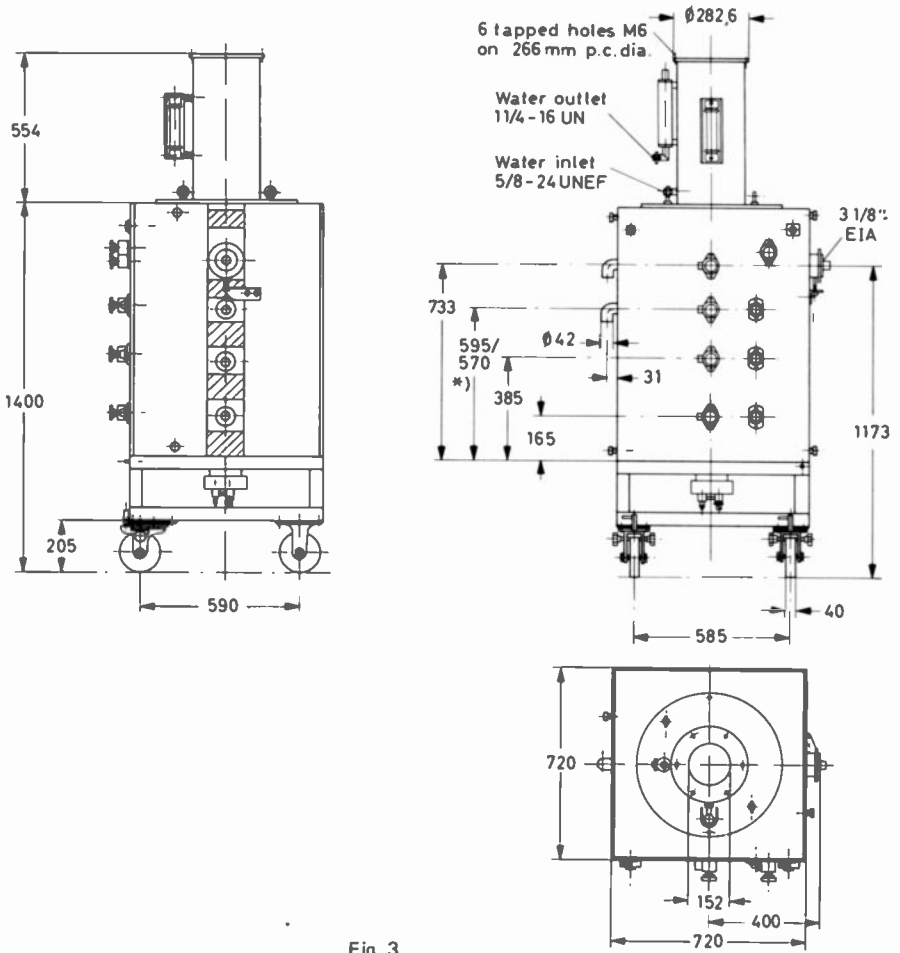

Fig. 3.

VX 722 642 A

- YK 1190 = 570 mm.
- YK 1191/92 = 595 mm.

COOLING

Cathode socket

accelerator electrode

air; $q \approx 0.15 \text{ m}^3/\text{min}$, T_i max. 40°C

Collector

vapour (with boiler TE 1110), note 4
volume of water converted to steam: $27 \text{ cm}^3/\text{min}$
per kW collector dissipation resulting in $43 \text{ l}/\text{min}$
steam per kW collector dissipation
water or vapour condensation (with cooler
TE 1194) $q = 35$ to $60 \text{ l}/\text{min}$, T_o max 80°C ,

Drift tubes

water; rate of flow to drift tubes and collector
connected in series $q \approx 9 \text{ l}/\text{min}$, T_i max. 80°C ,
 $\Delta p = 200 \text{ kPa}$ (2 bar)

Cavities 3 and 4

forced air; $q = 1.5 \text{ m}^3/\text{min}$, $\Delta p = 250 \text{ Pa}$ (2.5 mbar)
 T_i max. 45°C **MASS AND DIMENSIONS**

Klystron

net	approx.	80	kg
gross	approx.	230	kg
outline dimensions of packing (cm)		205 x 75 x 65	
Cavities	approx.	45	kg
Magnet frame with coils	approx.	885	kg

MOUNTING

Mounting position: vertical with collector up.

To remove the tube from the magnet frame a total free height of 3.5 m, excluding hoist, is required.

PRODUCT SAFETY*1. X-radiation*

Correct operation of the tube can be guaranteed only if a set of accessories, approved by the tube manufacturer, is used.

The operating tube generates X-rays which can penetrate the ceramic parts of the tube envelope. In order to reduce the radiation at any accessible points to an officially acceptable, non-dangerous level the tube must be shielded and any possible radiation path blocked by at least 1 mm of brass or an equivalent depth of non-magnetic X-ray absorbing material. The proper use of accessories will provide the necessary shielding.

2. R.F. radiation

R.F. power may be emitted through apertures other than the normal output coupling (for example r.f. leaks). This r.f. power may be sufficiently intense to cause danger to the human body, particularly to the eyes. Such radiation may be increased if the tube is functioning incorrectly.

Instruction manual

For detailed mounting and tuning instructions see klystron instruction manual, delivered with each tube.

ACCESSORIES (note 5)

Each tube is delivered with the following factory fitted accessories:

	YK1190	YK1191	YK1192
Collector radiation suppressor	TE1111	TE1132	TE1195
Accelerator electrode ring	TE1141	TE1141	TE1141
Cathode ring	TE1142	TE1142	TE1142
	or TE1142B	or TE1142B	or TE1142B
Set of sealing rings	TE1147	TE1147	TE1147
A. Accessories to be ordered separately when replacing equivalent other brand types			
Magnet flux ring	TE1138	TE1138	
Spark gap	TE1140	TE1140	
Set of connectors (heater, cathode, acc. electrode, getter-ion pump)	TE1146	TE1146	TE1146
B. Accessories required for first equipment			
Magnet flux ring	TE1138	TE1138	TE1138
Spark gap	TE1140	TE1140	TE1140
Set of connectors (heater, cathode, acc. electrode, getter-ion pump)	TE1146	TE1146	TE1146
Extension pipes for drift tubes	6 x TE1133A 2 x TE1133B	6 x TE1133A 2 x TE1133B	6 x TE1133A 2 x TE1133B
Water interconnecting pipes between drift tubes			
T ₁ - T ₂	TE1134A	TE1135A	TE1135A
T ₂ - T ₃	TE1134B	TE1135B	TE1135B
T ₃ - T ₄	TE1134C	TE1135C	TE1135C
T ₄ - T ₅	TE1134D	TE1135D	TE1135D
Flexible water pipes			
between tube and boiler for vapour cooling	TE1145A	TE1145A	TE1145A
between frame and tube	TE1145B	TE1145B	TE1145B
tube outlet for water cooling	TE1145C	TE1145C	TE1145C
Boiler for vapour cooling	TE1110	TE1110	TE1110
or			
Cooler for water cooling	TE1194	TE1194	TE1194
Cavities	3 x TE1121A 1 x TE1121D	3 x TE1098A 1 x TE1098D	3 x TE1191A 1 x TE1191B
Input coupler	TE1122A	TE1102	TE1102
Load coupler for cavities 2 and 3	2 x TE1122B	2 x TE1102	2 x TE1102
Blanking plates	3 x TE1157	3 x TE1157	3 x TE1157
Output coupler for cavity 4	TE1123	TE1105	TE1196
Arc detector	TE1107	TE1107	TE1107
Magnet frame with coils	TE1108	TE1108	TE1108
Tool set	TE1137	TE1137	TE1137

ACCESSORIES (continued)	YK1290	YK1291	YK1292
C. Spare and optional parts			
Collector radiation suppressor	TE1111	TE1132	TE1195
Accelerator electrode ring	TE1141	TE1141	TE1141
Cathode ring	TE1142	TE1142	TE1142
	or TE1142B	or TE1142B	or TE1142B
Set of connectors (heater, cathode, acc. electrode, getter-ion pump)	TE1146	TE1146	TE1146
Set of sealing rings	TE1147	TE1147	TE1147
Water protection shield	TE1139	TE1139	TE1139
Recommended circulators			
470 to 600 MHz	2722 162 01551 (T100/IV-N)		
600 to 800 MHz	2722 162 01561 (T100/V-N)		
790 to 1000 MHz	2722 162 03261 (T100/V-3-N)		

LIMITING VALUES (Absolute maximum rating system)

Heater voltage	max.	9.5	V	
Beam voltage	max.	23	kV	
Cold cathode voltage	max.	-27	kV	
Beam current	max.	7	A	
Body current	max.	150	mA	
Accelerator electrode current	max.	6	mA	note 7
Collector dissipation	max.	150	kW	
Load VSWR	max.	1.5		
Temperature of tube envelope	max.	175	°C	
Static pressure in the cooling system	max.	600	kPa	{ (6 bar) note 6

YK1190
YK1191
YK1192

TYPICAL OPERATING CONDITIONS: YK1190/YK1191

As 40 kW vision transmitter (CCIR-G standard)

	gain-tuned	efficiency-tuned			
	operation	operation (examples)			
Output power, peak sync.	45	45	45	kW	
Beam voltage	22	20.5	22	kV	
Beam current	6.3	5.7	4.8	A	
Accelerator to cathode voltage	22	20.5	18	kV	
Body current					
without drive	15	15	15	mA	
at 45 kW peak sync., black level	30	40	40	mA	
Focusing coil current	10.5	10.5	10.0	A	
Drive power, peak sync.					
YK1190 - channel 21	2	10	6	W	note 9
channel 38	1.5	7	4	W	note 9
YK1191 - channel 37	1.5	7	4	W	note 9
channel 51	1	5	3	W	note 9
Bandwidth at -1 dB points	8	8	8	MHz	note 10
Differential gain	80	75	70	%	note 11
Differential phase	6	7	10	deg	note 11
Linearity	70	65	60	%	note 12
Operating efficiency	32	38.5	42.5	%	
Saturation output power	55	60	46.5	kW	
Saturation efficiency	40	43	44	%	

As 4 kW/8 kW sound transmitter (CCIR-G standard)

Output power	4.5	9	4.5	9	kW	
Beam voltage	20.5	20.5	22	22	kV	note 6
Beam current	1.25	1.5	1.15	1.4	A	
Accelerator cathode voltage	≈ 7.5	≈ 8.5	≈ 7	≈ 8	kV	note 13
Focusing coil current			9		A	
Drive power			1.5		W	note 9
Bandwidth at -1 dB points			1		MHz	

TYPICAL OPERATING CONDITIONS: YK1192**As 40 kW vision transmitter (CCIR-G standard)**

Output power, peak sync.	45		kW	
Beam voltage	23		kV	note 6
Beam current	4.6		A	note 8
Accelerator to cathode voltage	18		kV	
Body current				
without drive	15		mA	
at 45 kW peak sync., black level	40		mA	
Focusing coil current	10		A	
Drive power, peak sync.	2		W	note 9
Bandwidth at -1 dB points	8		MHz	note 10
Differential gain	70		%	note 11
Differential phase	10		deg	note 11
Linearity	60		%	note 12
Operating efficiency	42.5		%	
Saturation output power	46.5		kW	
Saturation efficiency	44		%	

As 4 kW/8 kW sound transmitter (CCIR-G standard)

Output power	4.5	9		kW	
Beam voltage	23	23		kV	note 6
Beam current	1.1	1.3		A	
Accelerator to cathode voltage	≈ 7	≈ 8		kV	note 13
Focusing coil current		9		A	
Drive power	1.5			W	note 9
Bandwidth at -1 dB points		1		MHz	

Notes

1. When switching on the heater voltage, the heater current must never exceed a peak value of 65 A.
2. In case of a mains failure an interruption up to 30 s can be tolerated without new waiting time. After min. 10 minutes of stand-by heating time at 6 V (black heat), the beam current may be switched on; the heater voltage must be increased to its nominal value of 8.5 V simultaneously. Continuous black heat periods should not exceed two weeks and should be separated by similar periods of rest or full operation.
3. To ensure that the klystron is always ready for operation, operate the ion getter pump at least every 6 months (preferably every 3 months) during storage. For details see klystron instruction manual.
4. In order to avoid corrosion of the cooling system, coolant water must be pure and deionized (resistivity min. 100 k Ω ·cm).
5. Correct operation of the tube can be guaranteed only if a set of accessories, approved by the tube manufacturer, is used. The operating tube generates X-rays which can penetrate the ceramic parts of the tube envelope. In order to reduce the radiation at any accessible points to an officially admissible, non-dangerous level the tube must be shielded and any possible radiation path must be blocked by at least 1 mm of brass or an equivalent portion of non-magnetic X-ray absorbing material. The proper use of our accessory parts will provide the necessary shielding.
6. Static pressure in the body-cooling system and in the water-cooling jacket TE1194.
7. The accelerator electrode voltage must not be positive with respect to the body (ground).
8. If the accelerator electrode is connected to the body (ground) via 10 k Ω resistor, the beam current is within $\pm 5\%$ of the value given in the graph of Fig. 4.
9. The drive power is defined as the power delivered to a matched load.
10. Variation of the signal level between black and white at any sideband frequency may cause a reaction of the peak sync. level. Proper tube design limits this reaction to less than 0.5 dB.
11. Measured with a sawtooth signal from black level to peak white occurring at each line and superimposed colour subcarrier with a 10 % peak to peak amplitude.
12. Measured with a ten-step staircase signal from black level to peak with occurring at each line.
13. A voltage divider for adjusting the beam current should be dimensioned on the basis of an accelerator electrode current of max. 1.5 mA.

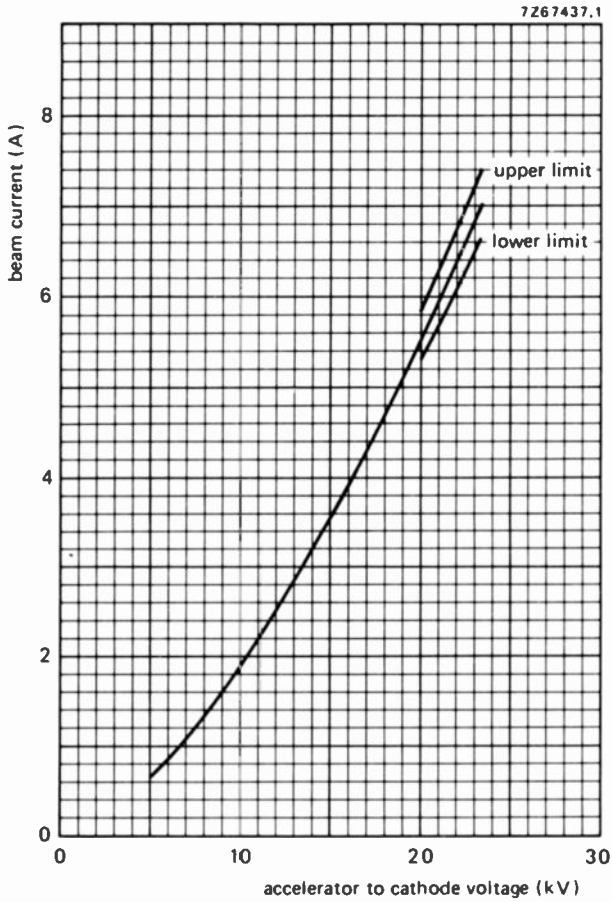

Fig. 4.

U.H.F. POWER KLYSTRON

Optionally vapour, vapour condensation, or water-cooled power klystron in metal-ceramic construction for 60 kW CW amplifiers. The tube has four external cavities, electromagnetic focusing and a high stability dispenser-type cathode.

QUICK REFERENCE DATA

Frequency range	800 MHz
Cooling	vapour, vapour condensation, or water

This data must be read in conjunction with GENERAL OPERATIONAL RECOMMENDATIONS for KLYSTRONS.

HEATING: indirect by d.c.

	dispenser type	notes
Cathode		
Heater voltage	$V_f \approx 8.5 \text{ V} \pm 3\%$	
Heater current	$I_f \approx 22 \text{ to } 27 \text{ A}$	1
Cold heater resistance	$R_{fo} \approx 30 \text{ m}\Omega$	
Waiting time		2
at $V_f = 8.5 \text{ V}$	$t_w \text{ min. } 300 \text{ s}$	
at $V_f = 6.0 \text{ V}$ (black heat)	$t_w \text{ min. } 0 \text{ s}$	

FOCUSING: electromagnetic

Focusing coil current	9 to 12 A
Resistance of focusing coils	
cold (20 °C)	7.2 to 9.5 Ω
operating at an ambient temperature of 20 °C	$\leq 11 \Omega$

BEAM CONTROL

The accelerator electrode voltage allows adjustment of the beam current between 0 and 100%.

GETTER-ION PUMP SUPPLY

Pump voltage, no-load condition	3 to 4 kV	3
Internal resistance of supply	300 k Ω	

MECHANICAL DATA

Dimensions in mm

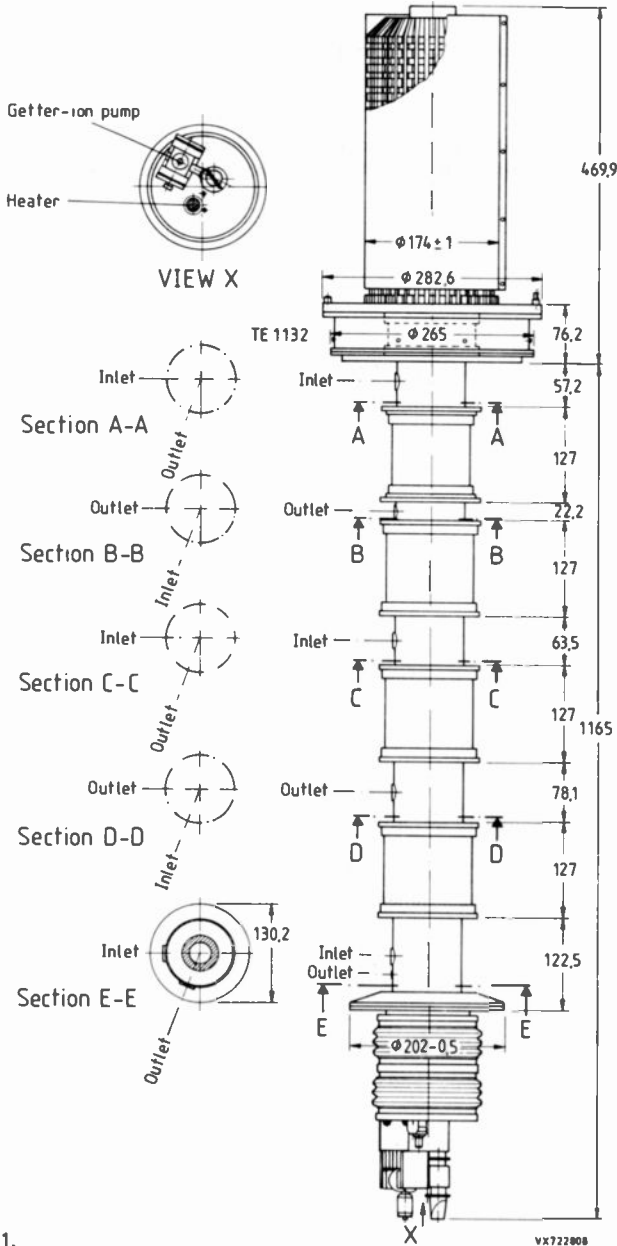
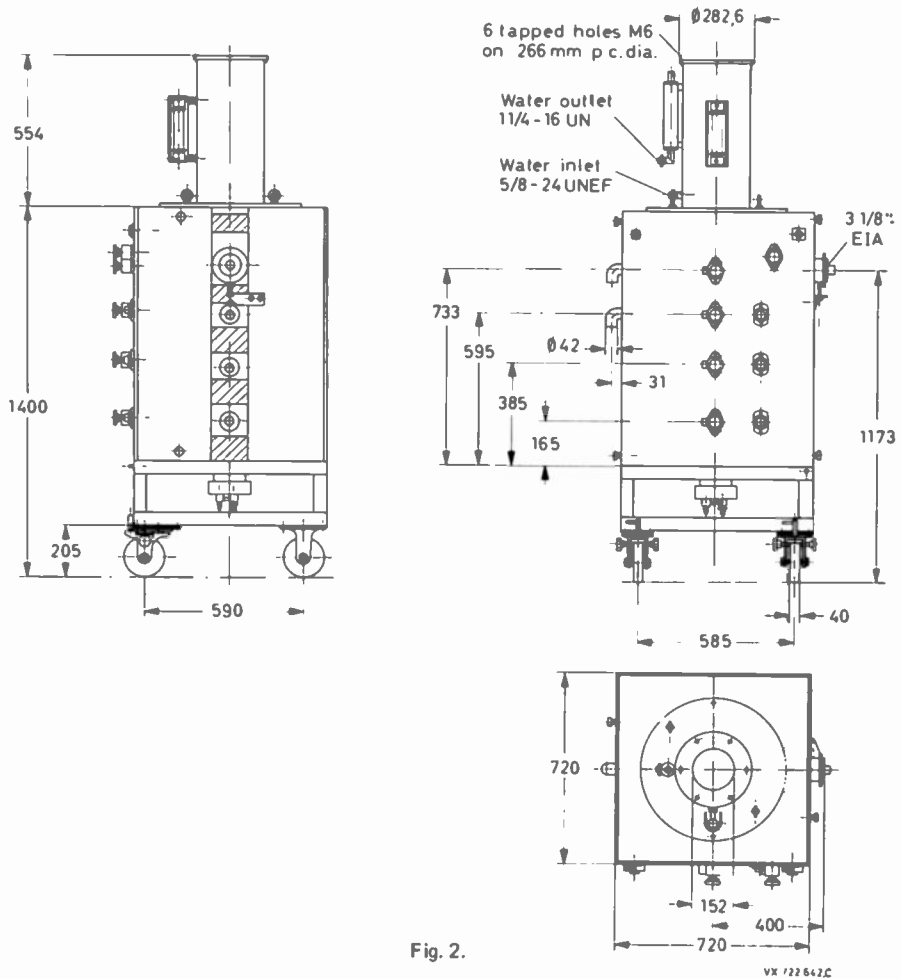

Fig. 1.

Mechanical outlines of trolley

Dimensions in mm



COOLING

Cathode socket

accelerator electrode

Collector

air; $q \approx 0.15 \text{ m}^3/\text{min}$, T_i max. 40°C vapour (with boiler TE1110), note 4
volume of water converted to steam: $27 \text{ cm}^3/\text{min}$
per kW collector dissipation resulting in $43 \text{ l}/\text{min}$
steam per kW collector dissipation
water or vapour condensation (with cooler
TE1194) $q = 35$ to $60 \text{ l}/\text{min}$, T_o max 80°C ,

Drift tubes

water; rate of flow to drift tubes and collector
connected in series $q \approx 9 \text{ l}/\text{min}$, T_i max. 80°C ,
 $\Delta p = 200 \text{ kPa}$ (2 bar)

Cavities 3 and 4

forced air; $q = 1.5 \text{ m}^3/\text{min}$, $\Delta p = 250 \text{ Pa}$ (2.5 mbar)
 T_i max. 45°C **MASS AND DIMENSIONS**

Klystron

net approx. 80 kg

gross approx. 230 kg

outline dimensions
of packing (cm) 205 x 75 x 65

Cavities approx. 45 kg

Magnet frame with coils approx. 885 kg

MOUNTING

Mounting position: vertical with collector up.

To remove the tube from the magnet frame a total free height of 3.5 m, excluding hoist, is required.

PRODUCT SAFETY*1. X-radiation*

Correct operation of the tube can be guaranteed only if a set of accessories, approved by the tube manufacturer, is used.

The operating tube generates X-rays which can penetrate the ceramic parts of the tube envelope. In order to reduce the radiation at any accessible points to an officially acceptable, non-dangerous level the tube must be shielded and any possible radiation path blocked by at least 1 mm of brass or an equivalent depth of non-magnetic X-ray absorbing material. The proper use of accessories will provide the necessary shielding.

2. R.F. radiation

R.F. power may be emitted through apertures other than the normal output coupling (for example r.f. leaks). This r.f. power may be sufficiently intense to cause danger to the human body, particularly to the eyes. Such radiation may be increased if the tube is functioning incorrectly.

Instruction manual

For detailed mounting and tuning instructions see klystron instruction manual, delivered with each tube.

ACCESSORIES

Set of sealing rings	TE1147	
Collector radiation suppressor	TE1195	
Accelerator electrode ring	TE1141	
Cathode ring	TE1142	
Water interconnecting pipes between drift tubes		
T ₁ - T ₂	TE1135A	
T ₂ - T ₃	TE1135B	
T ₃ - T ₄	TE1135C	
T ₄ - T ₅	TE1135D	
Extension pipes for drift tubes	6 x TE1133A 2 x TE1133B	
Flexible water pipes		
between tube and boiler	for vapour cooling	for water cooling
between frame and tube	TE1145A	-
tube outlet	TE1145B	TE1145B TE1145C
	-	
Boiler for vapour cooling or	TE1110	-
Cooler for water cooling	-	TE1194
Magnet flux ring	TE1138	
Water protection shield	TE1139	
Spark gap	TE1140	
Set of connectors (heater, cathode, accelerator electrode, getter-ion pump)	TE1146	
Cavities	3 x TE1191A 1 x TE1191B	
Input coupler	TE1102	
Load coupler for cavities 2 and 3	2 x TE1102	
Blind flanges	3 x TE1157	
Output coupler for cavity 4	TE1192	
Arc detector	TE1107	
Magnet frame with coils	TE1193	
Tool set	TE1137	
Recommended circulator	2722 162 01561 (T100/V-N)	

LIMITING VALUES (Absolute maximum rating system)

Heater voltage	max.	9.5 V	
Beam voltage	max.	28 kV	
Cold cathode voltage	max.	-30 kV	
Beam current	max.	7 A	
Body current	max.	60 mA	
Accelerator electrode current	max.	6 mA	note 5
Collector dissipation	max.	150 kW	
Load VSWR	max.	1.5	
Temperature of envelope	max.	175 °C	
Static pressure in the body cooling system and in the water cooling jacket TE1194	max.	600 kPa	(6 bar)

TYPICAL OPERATING CONDITIONS**As 60 kW CW amplifier**

Output power		60 kW	
Beam voltage		27 kV	
Beam current		4.9 A	note 6
Accelerator to cathode voltage	≈	17 kV	
Body current without drive at 60 kW		10 mA 20 mA	
Focusing coil current	≈	10 A	
Drive power, at 800 MHz	≈	2 W	note 7
Bandwidth at -1 dB points	≈	5 MHz	
Operating efficiency	=	45 %	

Notes

1. When switching on the heater voltage, the heater current must never exceed a peak value of 65 A.
2. In case of a mains failure an interruption up to 30 s can be tolerated without new waiting time. After min. 10 minutes of stand-by heating time at 6 V (black heat), the beam current may be switched on; the heater voltage must be increased to its nominal value of 8.5 V simultaneously. Continuous black heat periods should not exceed two weeks and should be separated by similar periods of rest or full operation.
3. To ensure that the klystron is always ready for operation, operate the ion getter pump at least every 6 months (preferably every 3 months) during storage. For details see klystron instruction manual.
4. In order to avoid corrosion of the cooling system, coolant water must be pure and deionized (resistivity min. 100 kΩ·cm).
5. The accelerator electrode voltage must not be positive with respect to the body (ground).
6. If the accelerator electrode is connected to the body (ground) via 10 kΩ resistor, the beam current is within ± 5% of the value given in the graph of Fig. 3.
7. The drive power is defined as the power delivered to a matched load.

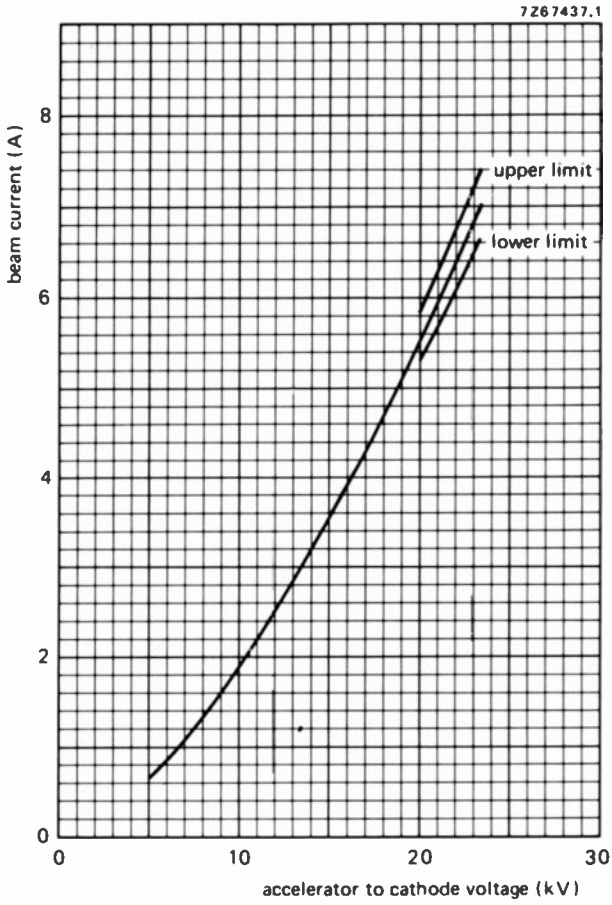

Fig. 3.

S.H.F. POWER KLYSTRON

Forced-air cooled power amplifier klystron in metal-ceramic construction for the frequency band of 11.8 to 12.2 GHz. The tube has internal resonant cavities, beam focusing by means of permanent magnets, and an integral getter-ion pump. The YK1210 is intended to be used in vision and sound transmitters, and transposers. It may be operated with or without depressed collector voltage.

QUICK REFERENCE DATA

Frequency range	11.8 to 12.2 GHz
Output power as vision transmitter	1.15 kW
Gain	50 dB
Cooling	forced air

This data must be read in conjunction with GENERAL OPERATIONAL RECOMMENDATIONS for KLYSTRONS.

HEATING: indirect by d.c.

Cathode	dispenser type	
Heater voltage	V_f	5 to 6 V
Heater current	I_f	4 (\leq 5) A
Heater peak starting current	I_{fp}	max. 8 A
Cold heater resistance	R_{fo}	\approx 20 m Ω
Waiting time	t_w	min. 120 s

COOLING

Cathode socket and accelerating electrode	low-velocity air flow 0.5 m ³ /min, 100 cm ²
Body	forced air, \approx 0.5 m ³ /min $\Delta p < 1000$ kPa (10 bar)
Collector	forced air, \approx 6 m ³ /min $\Delta p < 1000$ kPa (10 bar)

GETTER-ION PUMP SUPPLY

Pump voltage, no-load condition	3 kV
Internal resistance of supply	300 k Ω

MOUNTING

Vertical

Forces on klystron terminals max 10 N. Bending moment max 10 Nm.

To maintain correct focusing, the magnetic system should not be closer than 150 mm to external ferromagnetic materials, and no closer than 300 mm to external magnets.

MECHANICAL DATA

Mass: ≈ 30 kg focusing magnet included

Dimensions in mm

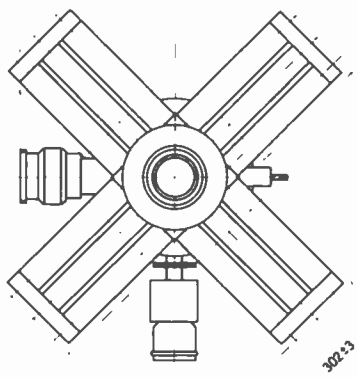
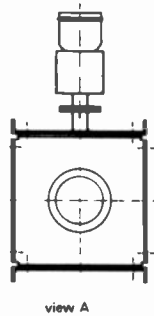
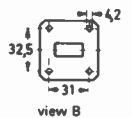
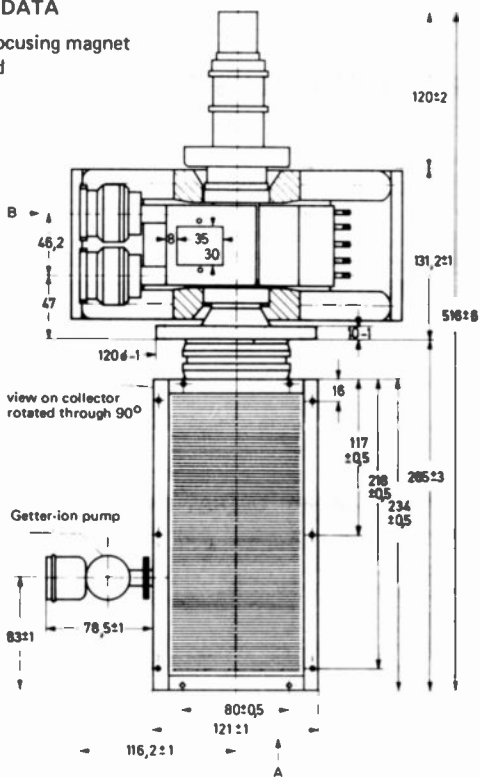

LIMITING VALUES (Absolute maximum rating system)

Collector to cathode voltage	max.	15 kV
Body to collector voltage	max.	4 kV
Body to accelerator voltage	max.	15 kV
Accelerator to cathode voltage	max. min.	10 kV 7.5 kV
Cathode current	max.	650 mA
Collector dissipation	max.	7.5 kW
Drift tube current, static, set value	max.	10 mA
As vision transmitter at $W_{O\ sync} = 1\text{ kW}$		
dynamic, without depressed collector voltage	max.	30 mA
dynamic, with depressed collector voltage	max.	60 mA
as transposer at $W_{O\ sync} = 210\text{ W}$		
dynamic, without depressed collector voltage	max.	20 mA
dynamic, with depressed collector voltage current cut-out region measuring range	max.	20 to 50 mA 60 mA
Getter-ion pump voltage	max. min.	4 kV 2.5 kV
Pump current	max.	15 mA
Internal resistance of the pump supply	min.	300 k Ω
Accelerator current	max.	-0.2 to +2 mA
Series resistor in accelerator circuit	min.	10 k Ω
Temperature of focusing magnets	max.	55 $^{\circ}\text{C}$
Inlet temperature of cooling air	max. min.	45 $^{\circ}\text{C}$ 5 $^{\circ}\text{C}$

TYPICAL OPERATION

Frequency range	11.8 to 12.2	GHz	
Bandwidth (-1 dB)	> 12	MHz	
Power gain	50 (> 49)	dB	
	without depressed collector voltage	with depressed collector voltage	
As vision transmitter			
Collector to cathode voltage	10.5	8.5	kV
Body to collector voltage	0	2	kV
Cathode current	0.4	0.4	A
Output power, sync	1.15	1.15	kW
As sound transmitter			
Collector to cathode voltage	10.5	8.5	kV
Body to collector voltage	0	2	kV
Cathode current	0.4	0.4	A
Output power	1.05	1.05	kW
As transposer (W_O nom. 100 W)			
Collector to cathode voltage	10.5	8.0	kV
Body to collector voltage	0	2.5	kV
Cathode current	0.4	0.4	A
Output power, sync	105	105	W
Intermodulation products	< -57	< -57	dB
As transposer (W_O nom. 200 W)			
Collector to cathode voltage	12	9	kV
Body to collector voltage	0	3	kV
Cathode current	0.5	0.5	A
Output power, sync	210	210	W
Intermodulation products	< -57	< -57	dB

GENERAL NOTES ON POWER SUPPLY DESIGN

	range*	internal resistance	hum
Heater voltage	4.5 to 6.5 V (max. 5 A)	The heater current should not exceed a value of 8 A when switching on the supply	Corresponding to non-smoothed three-phase bridge rectifier
Body to collector voltage	0/2.0/2.5/3.0 kV 100 mA continuous 200 mA peak	< 600 Ω	< 0.1%
Collector to cathode voltage**	8.0/8.5/9.5 kV with depressed collector voltage 10.5/11.5 kV without depressed collector voltage	< 600 Ω	< 0.1%
Body to accelerator voltage	Via potentiometer. Total resistance \approx 5 M Ω and series resistor 10 k Ω (suitable for 15 kV) between accelerator electrode and tap.		

PRODUCT SAFETY

R.F. radiation

R.F. power may be emitted not only through the normal output coupling but also through other apertures (for example, r.f. leaks). This r.f. power may be sufficiently intense to cause danger to the human body, particularly to the eyes. Such radiation may be increased if the tube is functioning incorrectly.

X-radiation

A highly dangerous intensity of X-rays may be emitted by tubes operating at voltages higher than approximately 5 kV. Adequate protection (X-ray shielding) for the operator is then necessary. The emission intensity of X-rays may correspond to a value of voltage much higher than that expected from the actual value applied to the tube.

Poor focusing may result in excessive X-radiation.

* Maximum allowable deviation from nominal or set values:

- a) $\pm 2\%$ during adjustment, if the published performance is to be attained.
- b) $\pm 1\%$ fluctuation of the set values during operation to maintain the performance.

** It is recommended that additional taps be made \approx 500 V above and below the indicated values.

U.H.F. POWER KLYSTRONS

For u.h.f. band IV/V vision transmitters and sound transmitters.

Metal-ceramic construction, four external cavities, electromagnetic focusing and a high-stability dispenser type cathode.

Suitable for vapour, vapour-condensation or water cooling.

YK1223 comprising a non-intercepting annular beam control electrode (ABC) for low-voltage beam modulation.

QUICK REFERENCE DATA

Frequency range	470 to 860 MHz
Output power as vision transmitter	10 and 15 kW
Cooling	vapour, vapour condensation, or water

This data must be read in conjunction with GENERAL OPERATIONAL RECOMMENDATIONS for KLYSTRONS.

HEATING: indirect by d.c. notes

Cathode	dispenser type		
Heater voltage	V_f	5.0	V*
Heater current	$I_f \approx$	19.5 to 22.5	A 1
Cold heater resistance	$R_{fo} \approx$	25	m Ω
Waiting time			2
at $V_f = 5.0$ V	t_w min.	300	s
at $V_f = 4.3$ to 4.5 V (black heat)	t_w min.	0	s

FOCUSING

Focusing coil current	8 to 11	A
Resistance of focusing coils		
cold (20 °C)	7.2 to 9.5	Ω
operating at an ambient temperature of 20 °C	< 11	Ω

BEAM CONTROL for YK1220 6, 7

The accelerator electrode voltage allows adjustment of the beam current between 0 and 100 %.

BEAM CONTROL for YK 1223 6, 7

The klystron comprises a non-intercepting annular beam control electrode (ABC) for low-voltage beam modulation. See Fig. 7.

Additionally the accelerator electrode voltage allows adjustment of the beam current between 0 and 100%.

GETTER-ION PUMP SUPPLY 3

Pump voltage, no-load condition	3 to 4	kV
Internal resistance of supply	300	k Ω

*During operation the heater voltage may not fluctuate more than +1 or -2 %.

YK1220
YK1223

MECHANICAL DATA

Dimensions in mm

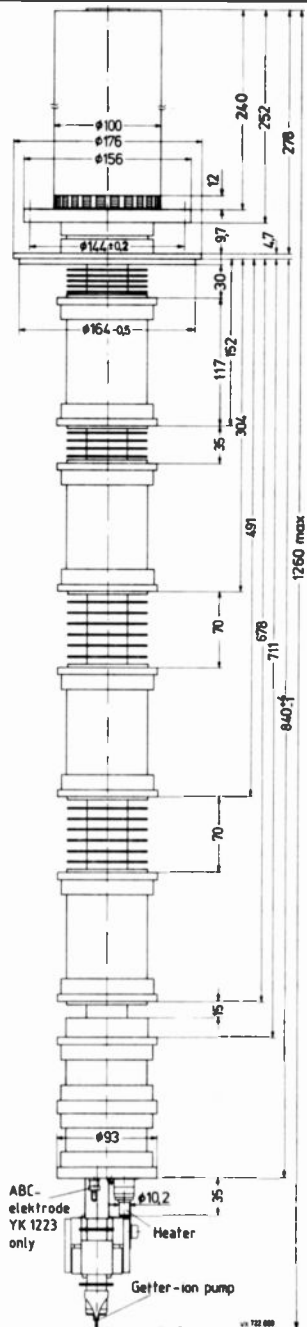

Fig. 1.

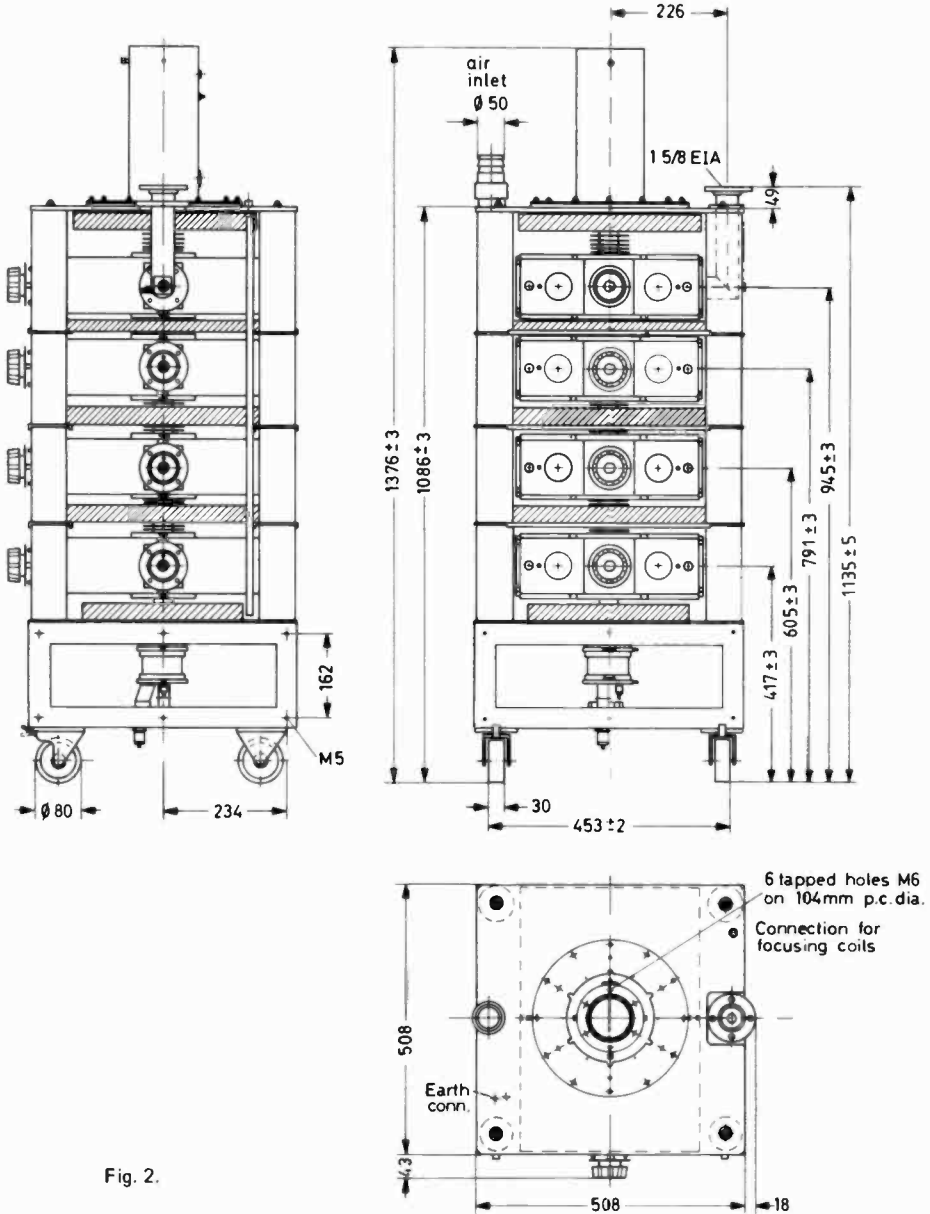

Fig. 2.

VX 722 585.4

MASS AND DIMENSIONS

Klystron

net	approx. 25 kg
gross	approx. 77 kg
outline dimensions of packing (cm)	170 x 45 x 46
Cavities	approx. 45 kg
Magnet frame with coils	approx. 220 kg

MOUNTING

Mounting position: vertical with collector up.

To remove the tube from the magnet frame a total free height of 2.5 m, excluding hoist, is required.

COOLING

Cavities 1, 2, 3 and 4, drift tubes 4 and 5
and cathode socket

forced air, T_i max. 50 °C
 $q \approx 1.2 \text{ m}^3/\text{min}$, $\Delta p = 350 \text{ Pa}$ (3.5 mbar)

Cathode socket only, during black heat

forced air, T_i max. 50 °C, $q \approx 0.15 \text{ m}^3/\text{min}$

Collector

vapour with boiler TE1189C, note 4
volume of water converted to steam: 27 cm³/min
per kW collector dissipation resulting in 43 ℓ/min
steam per kW collector dissipation;

water or vapour condensation (with water jacket
TE1189A) $q = 7$ to 18 ℓ/min, T_o max. 90 °C,
see Fig. 4. For 10 ℓ/min, $\Delta p = 16 \text{ kPa}$ (0.16 bar).

PRODUCT SAFETY

1. X-radiation

Correct operation of the tube can be guaranteed only if a set of accessories, approved by the tube manufacturer, is used.

The operating tube generates X-rays which can penetrate the ceramic parts of the tube envelope. In order to reduce the radiation at any accessible points to an officially acceptable, non-dangerous level the tube must be shielded and any possible radiation path blocked by at least 1 mm of brass or an equivalent depth of non-magnetic X-ray absorbing material. The proper use of accessories will provide the necessary shielding.

2. R.F. radiation

R.F. power may be emitted through apertures other than the normal output coupling (for example r.f. leaks). This r.f. power may be sufficiently intense to cause danger to the human body, particularly to the eyes. Such radiation may be increased if the tube is functioning incorrectly.

Instruction manual

For detailed mounting and tuning instructions see klystron instruction manual, delivered with each tube.

ACCESSORIES

Correct operation can be guaranteed only if approved accessories are used.

notes

Collector radiation suppressor	TE1182B		
Spark gap	TE1183		
Set of connectors (heater, cathode, accelerator electrode, getter-ion pump)	TE1184		
Magnet frame with coils	TE1188		
		water cooling or vapour conden- sation cooling	vapour cooling
Collector cooling jacket	TE1189A		TE1189C
Temperature sensor	—		TE1199
Tool set		TE1190	
Cavities		4 x TE1185	
Inlet coupler and load coupler for cavities 2 and 3		3 x TE1186C	12
Output coupler, 3 1/8 inch, 90°-elbow		TE1187C	13, 14
Arc detector		TE1107B	
Recommended circulators (optional)			
470 to 600 MHz		2722 162 01551 (T100/IV-N)	
600 to 800 MHz		2722 162 01561 (T100/V-N)	
790 to 1000 MHz		2722 162 03261 (T100/V-3-N)	

LIMITING VALUES (Absolute maximum rating system)

Heater voltage	max. 6.5	V	
Beam voltage	max. 21	kV	
Cold cathode voltage	max. -21	kV	
Beam current	max. 3	A	
Body current	max. 100	mA	
Accelerator electrode current	max. 5	mA	5
Collector dissipation	max. 42	kW	
Load VSWR	max. 1.5		
Temperature of tube envelope	max. 175	°C	
Static pressure in the cooling system TE1189A	max. 600	kPa	(6 bar)
Focusing coil current	max. 11.5	A	
ABC-electrode voltage with respect to cathode for YK1223	max. -1	kV	

PERFORMANCE DATA

of ABC-electrode for YK1223	min.	typ.	max.	
Capacity	70	75	85	pF
D.C. current at -1000 V*	—	—	0.5	mA

* The d.c. electrode current may rise up to max. 1 mA during life time. The applied modulator should be designed for an ABC-electrode current of at least 1 mA.

TYPICAL OPERATING CONDITIONS (modulation electrode YK1223 at cathode potential)

As 10 kW vision transmitter

Standard CCIR:	G		I		G		I		G		I		notes
Channel	21		45		68								10
Output power, peak sync.	11		11		11						kW		
Beam voltage	13	13.5	15	15	16	16	kV						
Beam current	1.95	2.05	1.55	1.55	1.5	1.5	A		6				
Accelerator to cathode voltage	≈ 12	≈ 12.5	≈ 10	≈ 10	≈ 10	≈ 10	kV		7				
Body current													
without drive	≈ 10	≈ 10	≈ 7	≈ 7	≈ 7	≈ 7	mA						
at black level	≈ 50	≈ 50	≈ 35	≈ 35	≈ 30	≈ 30	mA						
Focusing coil current	≈ 10	≈ 10	≈ 9	≈ 9	≈ 9	≈ 9	A						
Drive power, peak sync., max.	10	15	6	10	4	8	W		8				
Operating efficiency	43	40	47	47	45	45	%						
Minimum efficiency	42	40	46	44	44	43	%						

Sound transmitter

Output power	1.1		2.2		5.5		kW
Beam voltage	13	16	13	16	18.5		kV
Beam current	0.38	0.3	0.5	0.4	0.8		A 6
Accelerator to cathode voltage	≈ 3.5	≈ 3.0	≈ 4.5	≈ 3.5	≈ 6.0		kV 7
Body current	≈ 15		≈ 15		≈ 15		mA
Focusing coil current	≈ 10		≈ 10		≈ 10		A 9
Drive power,							
channel 21	4		4		4		W 8
channel 45	2		2		2		W 8
channel 68	1		1		1		W 8
Bandwidth at -1 dB points	> 300		> 300		> 300		kHz
Operating efficiency	22		34		37		%

As 15 kW vision transmitter

	G		I		G		I		G		I		notes
Standard CCIR:													10
Channel		21				45				68			
Output power, peak sync.		16.5				16.5				16.5			
Beam voltage	16.5	15.5	17.5	17.5	19	19							kV
Beam current	2.35	2.6	2.0	2.0	1.95	1.95							A 6
Accelerator to cathode voltage	≈ 13.5	≈ 14.5	≈ 12	≈ 12	≈ 12	≈ 12							kV 7
Body current													
without drive	≈ 10	≈ 10	≈ 7	≈ 7	≈ 7	≈ 7							mA
at black level	≈ 50	≈ 70	≈ 45	≈ 45	≈ 40	≈ 40							mA
Focusing coil current	≈ 10	≈ 10	≈ 9	≈ 9	≈ 9	≈ 8							A
Drive power, peak sync. max.	10	15	8	10	6	10							W 8
Operating efficiency	43	43	47	47	45	45							%
Minimum efficiency	42	40	46	44	44	43							%

Sound transmitter

	1.65		3.3		kW	
Output power						
Beam voltage	15.5	19	15.5	19		kV
Beam current	0.37	0.3	0.63	0.5		A 6
Accelerator to cathode voltage	≈ 3.5	≈ 3.0	≈ 5.0	≈ 4.5		kV 7
Body current		≈ 15		≈ 15		mA
Focusing coil current		≈ 10		≈ 10		A 9
Drive power,						
channel 21		4		4		W 8
channel 51		2		2		W 8
channel 68		1		1		W 8
Bandwidth at -1 dB points		> 300		> 300		kHz
Operating efficiency		29		34		%

Notes

1. When switching on the heater voltage, the heater current must never exceed a peak value of 65 A.
2. In case of a mains failure an interruption up to 30 s can be tolerated without new waiting time. After min. 10 minutes of stand-by heating time at 4.3 to 4.5 V (black heat), the beam current may be switched on; the heater voltage must be increased to its nominal value of 5.0 V simultaneously. Continuous black heat periods should not exceed two weeks and should be separated by similar periods of rest or full operation.
3. To ensure that the klystron is always ready for operation, operate the ion getter pump at least every 6 months (preferably every 3 months) during storage. For details see klystron instruction manual.
4. In order to avoid corrosion of the cooling system, coolant water must be pure and deionized (resistivity min. 100 k Ω ·cm).
5. The accelerator electrode voltage must not be positive with respect to the body (ground).
6. For cathode current versus accelerator-to-cathode voltage, see Fig. 5.
7. The accelerator electrode has to be connected to its supply (power supply or voltage divider) via a 10 k Ω resistor.
For adjusting the cathode current a voltage divider should be dimensioned according to an accelerator electrode current of max. 1.5 mA.
8. The drive power is defined as the power delivered to a matched load.
9. Value is not critical. It may be set in accordance to the vision klystron focusing coil current. Operation of one vision and one sound klystron focusing units in series is admitted.
10. Standard CCIR-G: klystron tuned to frequency response according to the specification CCIR-G.
Standard CCIR-I: klystron tuned to frequency response according Fig. 3.

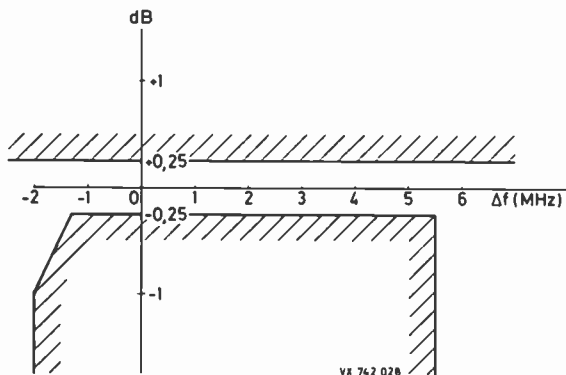

Fig. 3.

11. Optional.
12. Standard equipment is directly controlled on the side of trolley. In case of front panel control TE1186A is available instead of TE1186C.
13. Output coupler 1 5/8" (TE1187B for direct control, TE1187A for front panel control) is also available. Please contact manufacturer.
14. The output couplers comprise a standard loop. For several channels a modified loop is to be used. Please indicate channel when ordering.

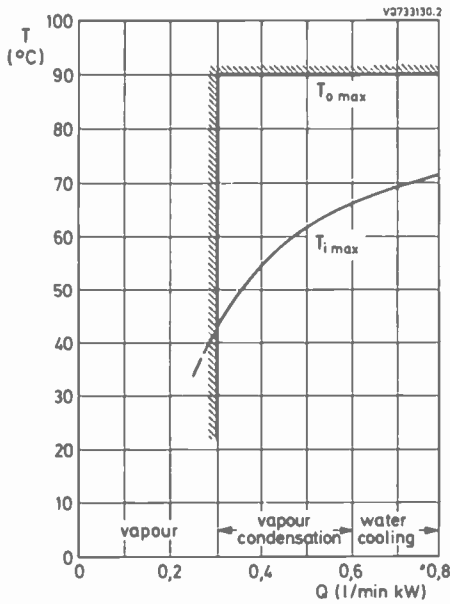

Fig. 4.

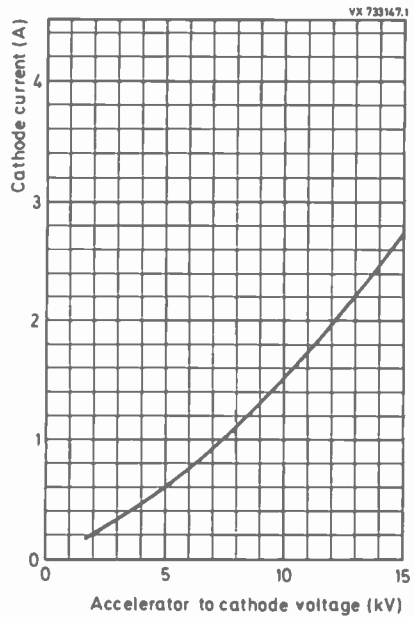

Fig. 5.

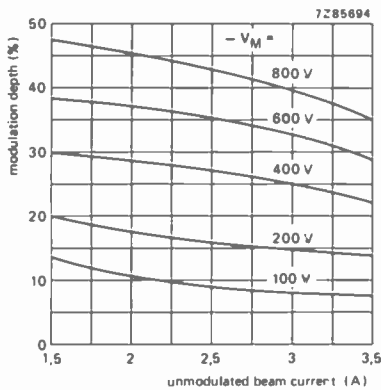

Fig. 6 ABC-operation for YK1223. Parameter: modulation voltage $-V_M$ (with respect to cathode).



U.H.F. POWER KLYSTRONS

For u.h.f. band IV/V vision transmitters and sound transmitters.
Metal-ceramic construction, four external cavities, electromagnetic focusing and a high-stability dispenser type cathode.
Suitable for vapour, vapour-condensation or water cooling.
YK1233 comprising a non-intercepting annular beam control electrode (ABC) for low-voltage beam modulation.

QUICK REFERENCE DATA

Frequency range	470 to 860 MHz
Output power as vision transmitter	20, 25 and 30 kW
Cooling	vapour, vapour condensation, or water

This data must be read in conjunction with GENERAL OPERATIONAL RECOMMENDATIONS for KLYSTRONS.

HEATING, indirect by d.c.

		notes
Cathode	dispenser type	
Heater voltage	V_f 5.0 V*	
Heater current	$I_f \approx 19.5$ to 22.5 A	1
Cold heater resistance	$R_{fo} \approx 25$ m Ω	
Waiting time		2
at $V_f = 5.0$ V	t_w min. 300 s	
at $V_f = 4.3$ to 4.5 V (black heat)	t_w min. 0 s	

FOCUSING

Focusing coil current	8 to 11 A
Resistance of focusing coils	
cold (20 °C)	7.2 to 9.5 Ω
operating at an ambient temperature of 20 °C	< 11 Ω

BEAM CONTROL for YK1230

The accelerator electrode voltage allows adjustment of the beam current between 0 and 100 %.

6, 7

BEAM CONTROL for YK1233

The klystron comprises a non-intercepting annular beam control electrode (ABC) for low-voltage beam modulation. See Fig. 7.
Additionally the accelerator electrode voltage allows adjustment of the beam current between 0 and 100%.

6, 7

GETTER-ION PUMP SUPPLY

Pump voltage, no-load condition	3 to 4 kV	3
Internal resistance of supply	300 k Ω	

*During operation the heater voltage may not fluctuate more than ± 1 or -2 %.

YK1230
YK1233

MECHANICAL DATA

Dimensions in mm

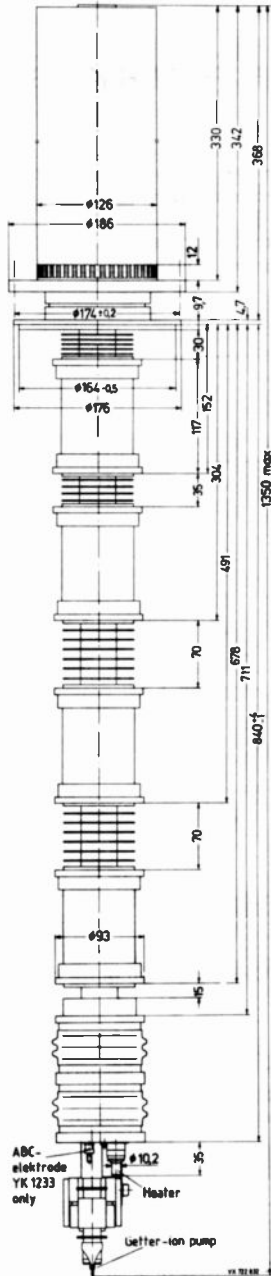

Fig. 1.

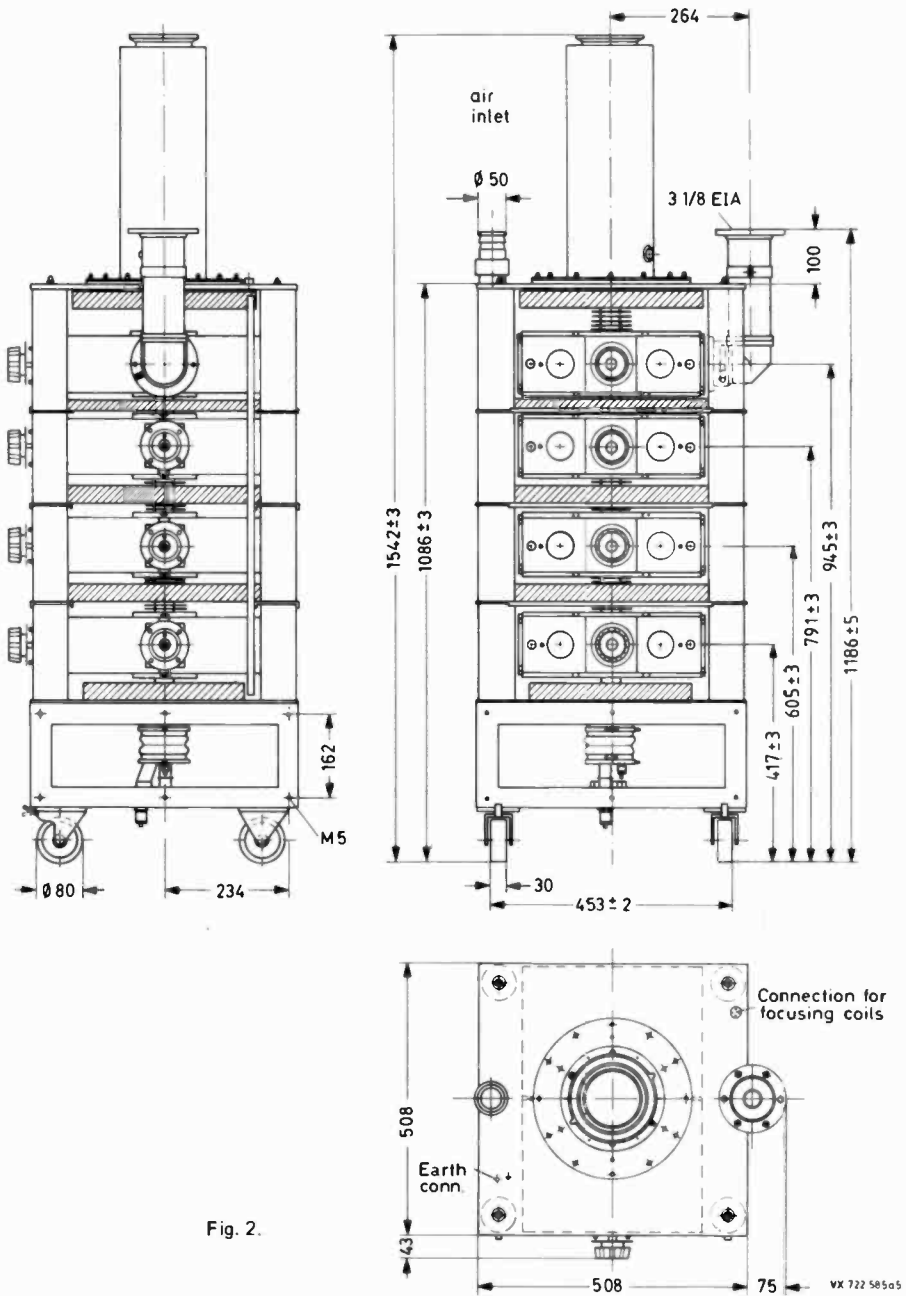

Fig. 2.

MASS AND DIMENSIONS

Klystron

net	approx.	40	kg
gross	approx.	90	kg
outline dimensions of packing (cm)		170 x 45 x 46	
Cavities	approx.	45	kg
Magnet frame with coils	approx.	220	kg

MOUNTING

Mounting position: vertical with collector up.

To remove the tube from the magnet frame a total free height of 2.5 m, excluding hoist, is required.

COOLING

Cavities 1, 2, 3 and 4, drift tubes 4 and 5
and cathode socket

forced air, T_i max. 50 °C
 $q \approx 1.2 \text{ m}^3/\text{min}$, $\Delta p = 350 \text{ Pa}$ (3.5 mbar)

Cathode socket only, during black heat

forced air, T_i max. 50 °C, $q \approx 0,15 \text{ m}^3/\text{min}$

Collector

vapour with boiler TE1189D, note 4
volume of water converted to steam: 27 cm^3/min
per kW collector dissipation resulting in 43 ℓ/min
steam per kW collector dissipation;

water or vapour condensation (with water jacket
TE1189F) $q = 16$ to 36 ℓ/min , T_o max 90 °C,
see Fig. 4. For 10 ℓ/min , $\Delta p = 16 \text{ kPa}$ (0.16 bar).

PRODUCT SAFETY

1. X-radiation

Correct operation of the tube can be guaranteed only if a set of accessories, approved by the tube manufacturer, is used.

The operating tube generates X-rays which can penetrate the ceramic parts of the tube envelope. In order to reduce the radiation at any accessible points to an officially acceptable, non-dangerous level the tube must be shielded and any possible radiation path blocked by at least 1 mm of brass or an equivalent depth of non-magnetic X-ray absorbing material. The proper use of accessories will provide the necessary shielding.

2. R.F. radiation

R.F. power may be emitted through apertures other than the normal output coupling (for example r.f. leaks). This r.f. power may be sufficiently intense to cause danger to the human body, particularly to the eyes. Such radiation may be increased if the tube is functioning incorrectly.

Instruction manual

For detailed mounting and tuning instructions see klystron instruction manual, delivered with each tube.

ACCESSORIES

Correct operation can be guaranteed only if approved accessories are used.

notes

Collector radiation suppressor	TE1182B		
Spark gap	TE1183		
Set of connectors (heater, cathode, accelerator electrode, getter-ion pump)	TE1184		
Magnet frame with coils	TE1188		
		water cooling or vapour conden- sation cooling	vapour cooling
Collector cooling jacket	TE1189F		TE1189D
Temperature sensor	—		TE1199
Tool set	TE1190		11
Cavities	4 x TE1185		
Inlet coupler and load coupler for cavities 2 and 3	3 x TE1186C		12
Output coupler, 3 1/8 inch, 90° elbow	TE1187C		13
Arc detector	TE1107B		14
Recommended circulators (optional)			
470 to 600 MHz	2722 162 01551 (T100/IV-N)		
600 to 800 MHz	2722 162 01561 (T100/V-N)		
790 to 1000 MHz	2722 162 03261 (T100/V-3-N)		

LIMITING VALUES (Absolute maximum rating system)

Heater voltage	max. 6.5 V	
Beam voltage	max. 26 kV	
Cold cathode voltage	max. -26 kV	
Beam current	max. 3.8 A	
Body current	max. 120 mA	
Accelerator electrode current	max. 5 mA	5
Collector dissipation	max. 70 kW	
Load VSWR	max. 1.5	
Temperature of tube envelope	max. 175 °C	
Static pressure in the cooling system TE1189F	max. 600 kPa	(6 bar)
Focusing coil current	max. 11.5 A	
ABC-electrode voltage with respect to cathode for YK1233	max. -1 kV	

PERFORMANCE DATA

of ABC-electrode for YK1233	min.	typ.	max.	
Capacity	70	75	85	pF
D.C. current at -1000 V*	—	—	0.5	mA

* The d.c. electrode current may rise up to max. 1 mA during life time. The applied modulator should be designed for an ABC-electrode current of at least 1 mA.

TYPICAL OPERATING CONDITIONS (modulation electrode YK1233 at cathode potential)

As 20 kW vision transmitter

notes

Standard CCIR-G

9

Channel	21	45	68	
Output power, peak sync.	22	22	22 kW	
Beam voltage	19.5	20	22 kV	
Beam current	2.7	2.45	2.2 A	6
Accelerator to cathode voltage	≈ 15	≈ 14	≈ 13 kV	7
Body current				
without drive	≈ 10	≈ 7	≈ 7 mA	
at black level	≈ 50	≈ 45	≈ 40 mA	
Focusing coil current	≈ 10	≈ 9	≈ 9 A	
Drive power, peak sync.	15	10	10 W	8
Operating efficiency	42	45	45 %	
Minimum efficiency	41	44	44 %	

Sound transmitter

Output power	2.2		4.4		kW
Beam voltage	19.5	22	19.5	22	kV
Beam current	0.4	0.35	0.6	0.55	A
Accelerator to cathode voltage	≈ 3.5	≈ 3.0	≈ 5.0	≈ 4.5	kV
Body current	≈ 15		≈ 15		mA
Focusing coil current	≈ 10		≈ 10		A
Drive power,					
channel 21	4		4		W
channel 45	2		2		W
channel 68	1		1		W
Bandwidth at -1 dB points	≥ 300		≥ 300		kHz
Operating efficiency	28		37		%

As 25 kW vision transmitter

	G		I		G		I		G		I		notes
Standard CCIR:													10
Channel		21				45				68			
Output power, peak sync.		27				27				27			kW
Beam voltage		21		19		21.5		21.5		23.5		23.5	kV
Beam current		3		3.45		2.8		2.8		2.5		2.55	A
Accelerator to cathode voltage		≈ 16		≈ 17.5		≈ 15		≈ 15		≈ 14		≈ 14	kV
Body current													
without drive		≈ 10		≈ 10		≈ 7		≈ 7		≈ 7		≈ 7	mA
at black level		≈ 60		≈ 80		≈ 50		≈ 50		≈ 45		≈ 50	mA
Focusing coil current		≈ 10		≈ 10		≈ 9		≈ 9		≈ 9		≈ 9	A
Drive power, peak sync., max.		15		25		10		20		10		20	W
Operating efficiency		42		41		45		45		46		45	%
Minimum efficiency		41		40		44		44		44		43	%

Sound transmitter

	2.7		5.5			
Output power						kW
Beam voltage		19		23.5		kV
Beam current		0.47		0.38		A
Accelerator to cathode voltage		≈ 4.7		≈ 4.1		kV
Body current		≈ 15		≈ 15		mA
Focusing coil current		≈ 8		≈ 10		A
Drive power,						
channel 21		4		4		W
channel 45		2		2		W
channel 68		1		1		W
Bandwidth at -1 dB points		> 300		> 300		kHz
Operating efficiency		30		41		%

TYPICAL OPERATING CONDITIONS (continued)

modulation electrode YK1233 at cathode potential

As 30 kW vision transmitter

Standard *	G	M	K	G	M	K	G	M	K	notes
Channel	21	14	21	42	42	42	62	69	62	10
Output power, peak sync.	32	32	32		32			32		kW
Beam voltage	23	23	21		24			25		kV
Beam current	3.3	3.3	3.7		2.95			2.85		A 6
Accelerator to cathode voltage	≈ 17.5	17.5	18.5		16.5			16		kV 7
Body current										
without drive	≈ 10	10	10		7			7		mA
at black level	≈ 50	50	50		45			40		mA
Focusing coil current	≈ 9	9	10		8			8		A
Drive power, peak sync., max.	25	25	25		20			20		W 8
Operating efficiency	42	42	41		45			45		%
Minimum efficiency	41	41	40		44			44		%

Sound transmitter

Output power							3.3			kW
Beam voltage							23	25		kV
Beam current							0.42	0.39		A 6
Accelerator to cathode voltage							≈ 4.5	≈ 4.2		kV 7
Body current							≈ 15			mA
Focusing coil current							≈ 8			A 9
Drive power,										
Standard*	M	G,K								
channel	14	21					4			W 8
channel	42	42					2			W 8
channel	69	62					1			W 8
Bandwidth at -1 dB points							≥ 300			kHz
Operating efficiency							34			%

Standards: CCIR-G, RTMA-M, RTMA-M and CCIR-K.

Notes

1. When switching on the heater voltage, the heater current must never exceed a peak value of 65 A.
2. In case of a mains failure an interruption up to 30 s can be tolerated without new waiting time. After min. 10 minutes of stand-by heating time at 4.3 to 4.5 V (black heat), the beam current may be switched on; the heater voltage must be increased to its nominal value of 5.0 V simultaneously. Continuous black heat periods should not exceed two weeks and should be separated by similar periods of rest or full operation.
3. To ensure that the klystron is always ready for operation, operate the ion getter pump at least every 6 months (preferably every 3 months) during storage. For details see klystron instruction manual.
4. In order to avoid corrosion of the cooling system, coolant water must be pure and deionized (resistivity min. 100 k Ω ·cm).
5. The accelerator electrode voltage must not be positive with respect to the body (ground).
6. For cathode current versus accelerator-to-cathode voltage, see Fig. 5.
7. The accelerator electrode has to be connected to its supply (power supply or voltage divider) via a 10 k Ω resistor.

For adjusting the cathode current a voltage divider should be dimensioned according to an accelerator electrode current of max. 1.5 mA.

8. The drive power is defined as the power delivered to a matched load.
9. Value is not critical. It may be set in accordance to the vision klystron focusing coil current. Operation of one vision and one sound klystron focusing unit in series is admitted.
10. Standard CCIR-G: klystron tuned to frequency response according to the specification CCIR-G.
Standard CCIR-I: klystron tuned to frequency response according to Fig. 3.
Standard CCIR-M: klystron tuned to frequency response according to the specification CCIR-M.

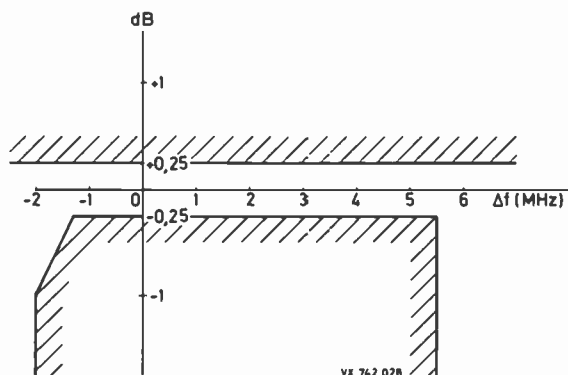

Fig. 3.

11. Optional.
12. Standard equipment is directly controlled on the side of trolley. In case of front panel control TE1186A is available instead of TE1186C.
13. The output couplers comprise a standard loop. For several channels a modified loop is to be used. Please indicate channel when ordering.
14. One arc detector for cavity 4 is required. For output power > 15 kW an additional arc detector for cavity 3 is recommended.

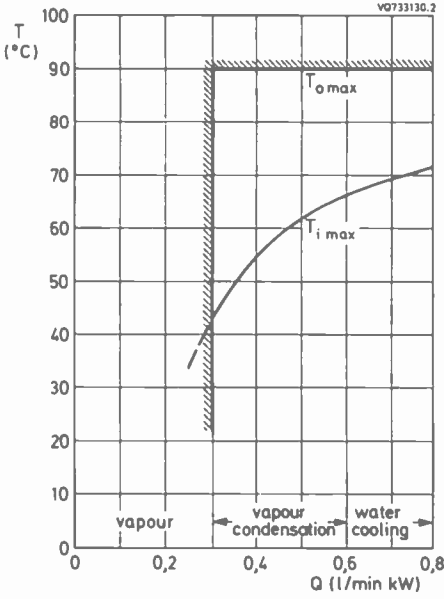

Fig. 4.

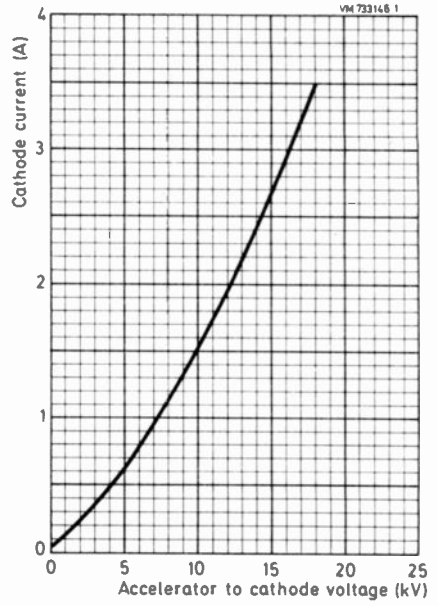

Fig. 5.

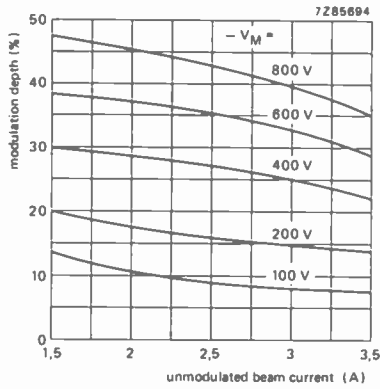

Fig. 6 ABC-operation for YK1233.
Parameter: modulation voltage $-V_M$
(with respect to cathode).

HIGH-POWER KLYSTRONS

Fixed frequency, high-power klystron in metal-ceramic construction, for use in scientific and industrial applications. The tube has internal cavities, solenoid focusing, and a high stability dispenser-type cathode.

QUICK REFERENCE DATA

Centre frequency (fixed tuned)	1300	MHz
Bandwidth		note 1
Pulse output power	330	kW
Cooling		
collector		water
body		air

This data must be read in conjunction with GENERAL OPERATIONAL RECOMMENDATIONS for KLYSTRONS.

HEATING: indirect by a.c.

Cathode	dispenser type			note 2	
	min.	typ.	max.		
Heater voltage	V_f	7	7.8	8.5	V
Heater current	I_f	31	32	33	A
Cold heater resistance	R_{fo}	—	30	—	m Ω
Waiting time	t_w	10	15	—	minutes

FOCUSING: electromagnetic

Solenoid current	11	12	13	A
Solenoid voltage	—	—	200	V

GETTER-ION PUMP SUPPLY

Operating voltage	3	4	5	kV
Operating current	—	$5 \cdot 10^{-3}$	5	mA
Internal resistance of power supply	—	300	—	k Ω

Notes

- Bandwidth, see Fig. 1.
An input signal with an edge of $1 \mu\text{s}$ will be transmitted without discernable overshooting of the output signal.
- Typical values are adjusted at the supplied heater transformer, which is mounted inside of the oil container (primary voltage 220 V).

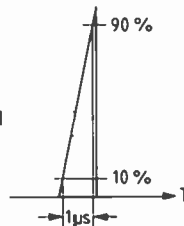

Fig. 1.

MECHANICAL DATA

Dimensions in mm

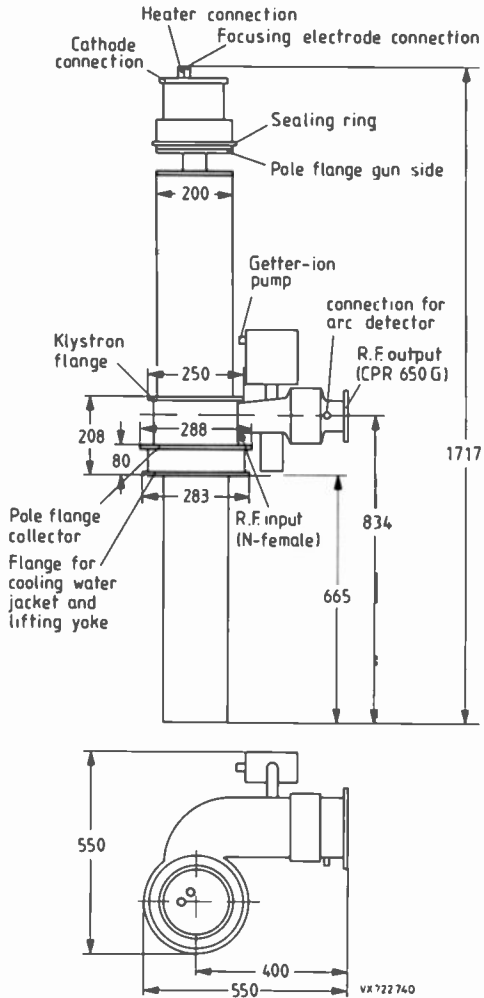

Fig. 2.

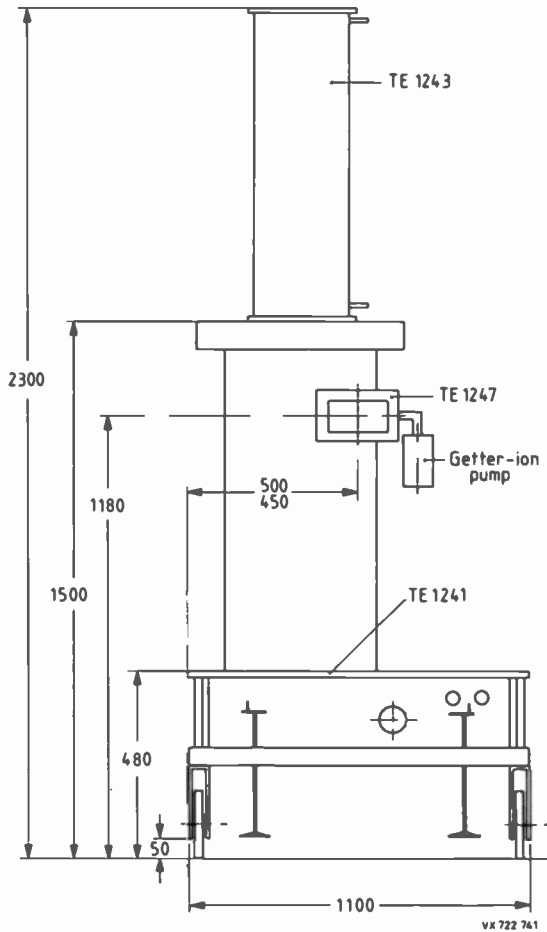

Fig. 3 Complete assembly consisting of tube, trolley, oil tank, focus mount, r.f. transition and operational lead shieldings.

COOLING

Cooling is achieved by demineralized water with 10 % stabilized glycol added

	min.	typ.	max.		
pressure in any cooling water circuit	–	–	900	kPa	(= 9 bar)
pressure drop	–	–	100	kPa	(= 1 bar)
Collector					
cooling water flow rate	8	15	30	ℓ/min	
inlet water temperature	+15	+20	+30	°C	
outlet water temperature	+15	+25	+60	°C	

MASS

Net mass of complete assembly 350 kg

DIMENSIONS

Tube and mounting frame see drawings
 Required ground clearance for lifting hoist min. 450 cm
 Capability of hoist min. 250 kg

MOUNTING

vertical, collector up

R.F. CONNECTORS

Input N-type, female, 50 Ω
 Output waveguide WR650 / CRP650G

OIL CONTAINER, contents

approx. 70 ℓ

ACCESSORIES**A. Tube parts (factory fitted)**

The tube will be shipped without additional factory fitted parts.

B. Operational parts for first equipment

Operational frame, consisting of trolley, oil container, heater transformer, di/dt sensor, focusing coil unit and cathode plug-connections	TE1241
Collector water cooling jacket	TE1243
Temperature sensors for water inlet, -outlet and collector	TE1245
30° waveguide bend (H-plain)	TE1247
Arc detector	TE1249

C. Optional parts

H.V. cable with R3 plugs, length 6 m	TE1159
H.V. dummy plug R3	TE1161

D. Parts for handling

Yoke for lifting klystron vertically	TE1251
Lifting frame for storage and any movement of a burnt-out or spare klystron in any other position than vertical	TE1253

LIMITING VALUES (Absolute maximum rating system)

Heater voltage, a.c.	max.	8.5	V	
Heater current, a.c.	max.	33	A	note 1
Cathode voltage to body	max.	-65	kV	
Cathode current	max.	12	A	
Collector dissipation	max.	650	kW	note 2
Pulse output power	max.	330	kW	
Pulse length	max.	2	s	
Ratio	max.	1/100		
Load VSWR	max.	1.2		
Input power, d.c.	max.	650	kW	

TYPICAL OPERATING CONDITIONS

325 kW pulse output power (VSWR < 1.1)	typ.		
Cathode voltage	-60	kV	
Cathode current	11	A	
Input power, d.c.	600	kW	
Collector dissipation	330	kW	
Efficiency	50	%	
Drive power	27	W	
Pulse length	1.5	s	
Ratio	1/200		

PERFORMANCE DATA

Phase shift to cathode current	< 20	°/A
Phase shift to rel. cathode voltage	< 20	°/%
R.F. output to rel. cathode voltage	< 0.3	dB/%
Harmonic levels to fundamental	< 30	dB
Signal-to-noise ratio	> 50	dB

Notes

1. When switching on the heater voltage, the heater current must never exceed a peak value of 40 A.
2. Maximum dissipation can be tolerated up to 0.5 s.

INSTALLATION AND OPERATION REQUIREMENTS**A. Required interlocks**

1. Fast switch-off of the drive power within 10 ms has to be done if the arc detector and/or r.f. reflection indicator is activated. An arc detector must be provided at the output waveguide.
2. A fast switch-off of the beam supply has to be provided when one of the following situations occurs:
 - a) the beam current increases rapidly,
 - b) the solenoid current deviates by more than $\pm 5\%$ from the adjusted value,
 - c) when the body current exceeds 500 mA.

The switching sensors and the discharge facilities for the power supply must be designed so that a copper wire of 0.35 mm diameter, connected to the power supply instead of the klystron (length approx. 1 cm/kV), will not be destroyed, if the full operating voltage is switched on and applied to the wire.

3. The mains for the beam power supply has to be switched off within 100 ms when one of the following situations occur:
 - a) the collector temperature monitor (with internal thermocouple) is activated (adjusted to maximum temperature),
 - b) the monitored temperature differences between inlet and outlet in the collector and/or body cooling circuits are too high;
max. values permitted: $\Delta\theta = 30\text{ K}$
 - c) the beam current either exceeds the limiting value or increases by more than 30% or max. 2 A above the adjusted value,
 - d) the water flow of the collector and body cooling circuit decreases below the required minimum value.

Restarting is not allowed within 10 s after any interruption.

B. Switching-on and off sequence**Switching-on sequence**

1. Getter-ion pump supply on.
2. Check that the pump current is $< 1\text{ mA}$.
3. Heater voltage supply on.
4. Wait for preheating time (min. 10 minutes).
5. Cooling of focusing.
6. Collector cooling supply on.
7. Solenoid current supply on.
8. R.F. drive on.
9. Beam voltage supply on.

Switching-off sequence

1. Beam voltage supply off.
2. All other supplies and cooling circuits off.

C. Radiation dangers

R.F. radiation

R.F. power may be emitted not only through the normal output coupling but also through other apertures (for example, r.f. leaks). This r.f. power may be sufficiently intense to cause danger to the human body, particularly to the eyes. Such radiation may be increased if the tube is functioning incorrectly.

X-radiation

A highly dangerous intensity of X-rays may be emitted by tubes operating at voltages higher than approximately 5 kV. Adequate protection (X-ray shielding) for the operator is then necessary. The emission intensity of X-rays may correspond to a value of voltage much higher than that expected from the actual value applied to the tube.

Poor focusing may result in excessive X-radiation.

This tube and accessories are equipped with a lead shielding which under normal conditions reduces the radiation values below 0.75 mR/h, measured at a distance of 1 m from the tube assembly.

CONTINUOUS-WAVE HIGH-POWER KLYSTRON

Water cooled, high efficiency, fixed frequency, continuous-wave high-power klystron in metal-ceramic construction, for use in scientific and industrial applications. The tube has internal cavities, solenoid focusing, beam control by accelerator anode and a high stability dispenser-type cathode.

QUICK REFERENCE DATA

Centre frequency (fixed tuned)	999.3 MHz
Bandwidth at saturation (−1 dB points)	4 MHz
Output power	400 kW
Cooling	water

This data must be read in conjunction with GENERAL OPERATIONAL RECOMMENDATIONS for KLYSTRONS.

HEATING: indirect by a.c. or d.c.

		dispenser type			
		min.	typ.	max.	
Heater voltage	V_f	8.0	8.5	9.0	V
Heater current	I_f	24	26	28	A
Cold heater resistance	R_{f0}	—	30	—	m Ω
Waiting time	t_w	10	—	—	minutes

notes 1, 2

FOCUSING: electromagnetic

Solenoid current	—	—	20	A
Solenoid voltage	—	—	200	V
Solenoid resistance	—	10	—	Ω

GETTER-ION PUMP SUPPLY

Operating voltage	3	3.3	4	kV
Operating current	—	10^{-3}	80	mA
Internal resistance of power supply	25	300	—	k Ω

MECHANICAL DATA

Dimensions in mm

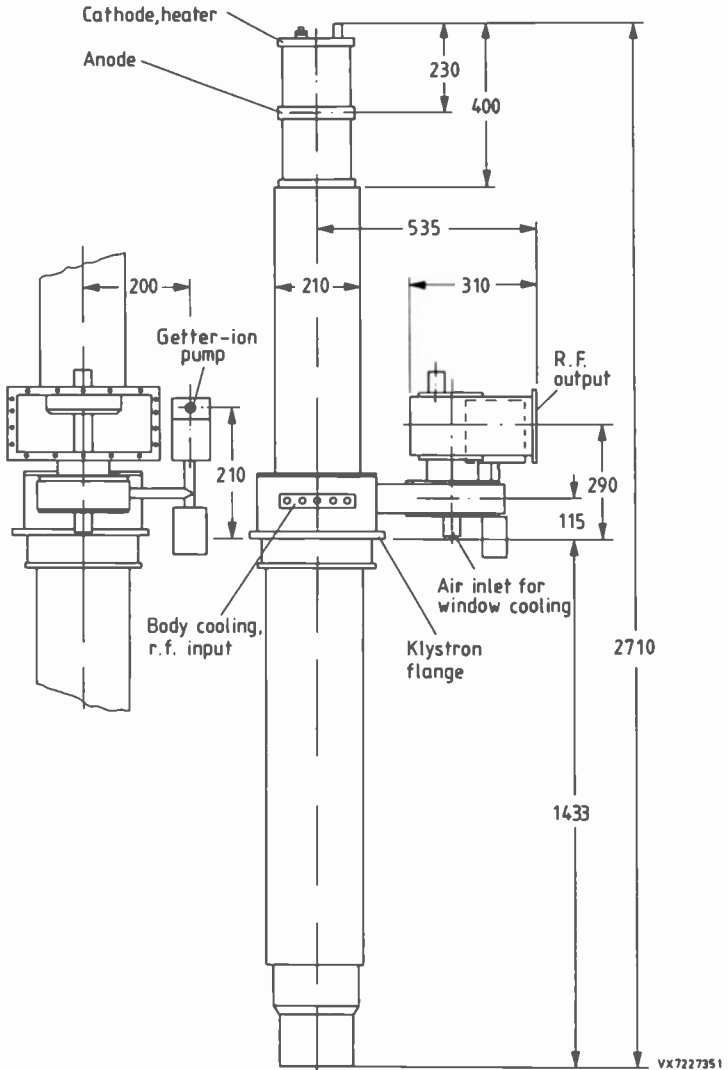

Fig. 1.

Tube mounted in the mounting frame with solenoid.

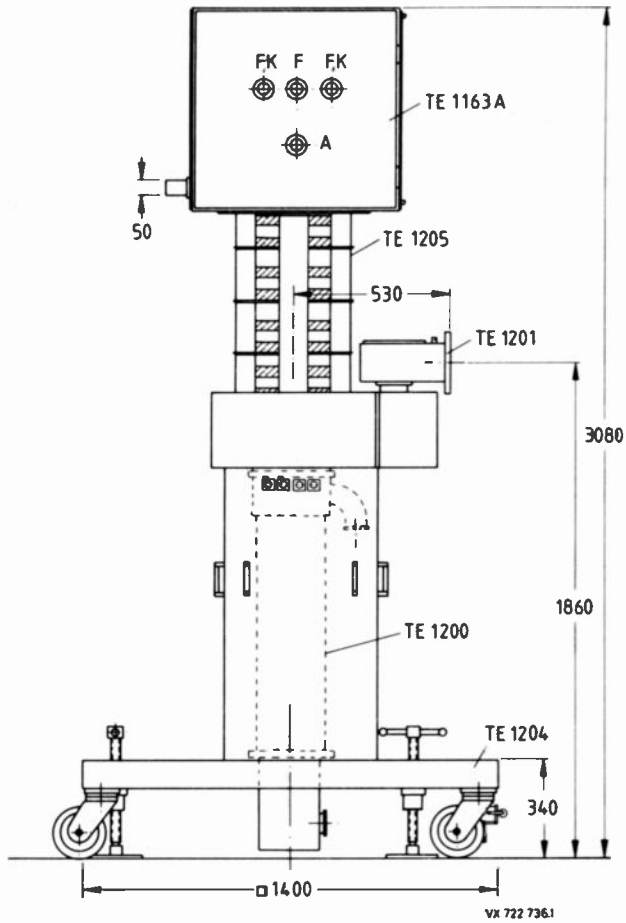

Fig. 2.

	min.	typ.	max.		
COOLING					
Collector					
demineralized or distilled water with 10% stabilized glycol added	350	450	550	ℓ/min	note 3
pressure drop	—	100	—	kPa	(= 1 bar)
Body circuit I					
demineralized or distilled water with 10% stabilized glycol added	5	7	—	ℓ/min	note 3
pressure drop	—	300	—	kPa	(= 3 bar)
Body circuit II					
demineralized or distilled water with 10% stabilized glycol added	7	9	—	ℓ/min	note 3
pressure drop	—	300	—	kPa	(= 3 bar)
Cathode socket and accelerator anode					
air	2	—	—	m ³ /min	
pressure drop	—	—	500	Pa	(= 5 mbar)
Output window					
air	—	2	—	m ³ /min	
pressure drop	—	2	—	kPa	(= 20 mbar)
Inlet water temperature	—	—	+50	°C	
Inlet air temperature	—	—	+45	°C	

MASS

Net mass YK1250	300	kg
Mounting frame with solenoid	750	kg
Capability of hoist	min. 600	kg

DIMENSIONS

Tube and mounting frame	see drawings
Required ground clearance for lifting hoist	min. 450 cm

MOUNTING

vertical, cathode up

R.F. CONNECTORS

Input	N-type, female
Output	waveguide R9 (WR — 975)

ACCESSORIES**A. Tube parts**

Waveguide coupling iris (if required)		note 4
Magnet for getter-ion pump (factory fitted)		

B. Operational parts for first equipment

Collector water cooling jacket	TE1200	
Waveguide transition, R9	TE1201	note 5
Anode ring	TE1202	
Cathode ring	TE1203	
H.V. connection unit with four R3 sockets	TE1163A	note 6
Klystron trolley	TE1204	
Focusing coil unit	TE1205	
Connection cables		
heater/cathode	2 x TE1206A	
heater	1 x TE1206B	
accelerator anode	1 x TE1206C	

C. Parts for handling

Yoke for lifting TE1205 and TE1163	TE1208	note 7
Yoke for lifting and turning a klystron from any position	TE1209	
Supporting frame for storage and any movement of burnt-out or spare klystrons in any position other than vertical	TE1210	
Trolley for transportation of a klystron in horizontal position without lifting gear	TE1211	

LIMITING VALUES (Absolute maximum rating system)

Heater voltage	}	max. 10% above specified values		
Heater current				
Cathode voltage to body (ground)	max.	-61	kV	
Cold cathode voltage to body (ground)	max.	-65	kV	
Cathode current	max.	12	A	
Accelerator anode voltage to cathode	max.	41	kV	note 8
Cold accelerator anode voltage to cathode	max.	45	kV	
Accelerator anode current	max.	10	mA	
Collector dissipation	max.	700	kW	note 9
Dissipation body circuit I	max.	10	kW	
Dissipation body circuit II	max.	10	kW	
C.W. output power	max.	420	kW	
Load VSWR	max.	1.2		note 10
Temperature rise, window cooling air flow	max.	70	K	

TYPICAL OPERATING CONDITIONS

	min.	typ.	max.		
350 kW operation into matched load					
Cathode voltage to body (ground)	-54	-56	-57	kV	
Cathode current	0	10.4	11	A	
Input power, d.c.	-	614	-	kW	
Accelerator anode voltage to cathode	-	31	-	kV	
Accelerator anode current	-	1	5	mA	
C.W. output power, VSWR < 1.1	330	350	-	kW	
Collector dissipation	-	264	500	kW	note 9
Efficiency	55	57	-	%	
C.W. drive power	-	20	40	W	

400 kW operation into matched load

Cathode voltage to body (ground)	-	-60.3	-	kV	
Cathode current	-	11.8	12	A	
Input power, d.c.	-	712	-	kW	
Accelerator anode voltage to cathode	-	34.5	40	kV	
Accelerator anode current	-	0.3	5	mA	
C.W. output power, VSWR < 1.1	-	418	-	kW	
Collector dissipation	-	294	500	kW	note 9
Efficiency	56	58	-	%	
C.W. drive power	-	9	40	W	

PERFORMANCE DATA

Phase shift to cathode current	< 20 °/A
Phase shift to rel. cathode voltage	< 20 °/%
Phase shift to r.f. drive	< 12 °/dB
R.F. output to rel. cathode voltage	< 0.3 dB/%
Spurious noise amplitude	
for f < 300 Hz	< 3 %
for f = 300 to 1000 Hz	< 1 %
for f > 1000 Hz	< 0.5 %

Notes

1. When switching on the heater voltage, the heater current must never exceed a peak value of 60 A.
2. Required values are given with each tube.
3. For further recommendations please contact the tube manufacturer.
4. Separately shipped together with each tube and to be returned together with each burnt-out tube.
5. It is recommended to return the coaxial waveguide transition together with burnt-out tube for inspection.
6. R3 sockets are only usable together with optional R3 plugs.
7. These parts are needed for all handling operations at the site (only one set required).
8. The accelerator anode voltage may never become positive with respect to the body (ground).
9. It must be observed that for operation with reduced r.f. drive the maximum value for collector dissipation is not exceeded.
10. For reflections exceeding this value please contact the tube manufacturer.

INSTALLATION AND OPERATION REQUIREMENTS

A. Required interlocks

1. Fast switch-off of the drive power within 10 ms has to be done if the arc detector and/or r.f. reflection indicator is activated. An arc detector must be provided at the knee of the output waveguide.
2. A fast switch-off of the beam supply has to be provided when one of the following situations occurs:
 - a) the beam current increases rapidly,
 - b) the solenoid current deviates by more than $\pm 5\%$ from the adjusted value.
The switching sensors and the discharge facilities for the power supply must be designed so that a copper wire of 0.35 mm diameter, connected to the power supply instead of the klystron (length approx. 1 cm/kV), will not be destroyed, if the full operating voltage is switched on and applied to the wire.
3. The mains for the beam power supply has to be switched off within 100 ms when one of the following situations occur:
 - a) the beam current either exceeds the limiting value or increases by more than 30% or max. 2 A above the adjusted value,
 - b) the pump current exceeds 10 μA ,
 - c) the collector temperature monitor (with internal thermocouple) is activated (switch-off value adjustable between 30 and 60 K above the water inlet temperature),
 - d) the monitored temperature differences between inlet and outlet in the collector and/or body cooling circuits are too high;

max. values permitted:	collector	$\Delta\theta = 15 \text{ K}$
	body circuit I	$\Delta\theta = 15 \text{ K}$
	body circuit II	$\Delta\theta = 15 \text{ K}$
 - e) the water flow of the collector and body cooling circuits decreases below the required minimum value,
 - f) the air flow for the r.f. window and cathode cooling decreases below the required minimum value.
4. Switch-off the heater voltage for pump current $> 4 \text{ mA}$.
Restarting is not allowed within 10 s after any interruption.

B. Switching-on and off sequence

Switching-on sequence

1. Cathode cooling on.
2. Getter-ion pump supply on.
3. Check that the pump current is $< 10 \mu\text{A}$.
4. Heater voltage supply on.
5. Wait for preheating time (min. 15 minutes).
6. Cooling air r.f. window on.
7. Cooling body circuits I and II on.
8. Collector cooling supply on.
9. Solenoid current supply on.
10. Check that the heater current has reached the adjusted value $\pm 0.5 \text{ A}$.
11. R.F. drive on.
12. Beam voltage supply on.

Switching-off sequence

1. Beam voltage supply off.
2. All other supplies and cooling circuits off.

C. Radiation dangers

R.F. radiation

R.F. power may be emitted not only through the normal output coupling but also through other apertures (for example, r.f. leaks). This r.f. power may be sufficiently intense to cause danger to the human body, particularly to the eyes. Such radiation may be increased if the tube is functioning incorrectly.

X-radiation

A highly dangerous intensity of X-rays may be emitted by tubes operating at voltages higher than approximately 5 kV. Adequate protection (X-ray shielding) for the operator is then necessary. The emission intensity of X-rays may correspond to a value of voltage much higher than that expected from the actual value applied to the tube.

Poor focusing may result in excessive X-radiation.

This tube and accessories are equipped with a lead shielding which under normal conditions reduces the radiation values below 0.75 mR/h, measured at a distance of 1 m from the tube assembly.

U.H.F. POWER KLYSTRONS

For u.h.f. band IV/V vision transmitters and sound transmitters.
Metal-ceramic construction, four external cavities, electromagnetic focusing and a high-stability dispenser type cathode.
Suitable for vapour, vapour-condensation or water cooling.
Comprising a non-intercepting annular beam control electrode (ABC) for low-voltage beam modulation.

QUICK REFERENCE DATA

Frequency range	470 to 810 MHz	note 10
Output power as vision transmitter		
YK1263	40 and 55 kW	
YK1265	40, 55 and 60 kW	
Cooling	vapour, vapour condensation, or water	

This data must be read in conjunction with GENERAL OPERATIONAL RECOMMENDATIONS for KLYSTRONS.

HEATING: indirect by d.c.			notes
Cathode	dispenser type		
Heater voltage	V_f	8.5 V $\pm 3\%$	
Heater current	$I_f \approx$	24 to 28 A	1
Cold heater resistance	$R_{fo} \approx$	30 m Ω	
Waiting time			2
from cold, $V_f = 0$ V	t_w min.	300 s	
from black heat, $V_f = 6$ V	t_w min.	0 s	

FOCUSING

Focusing coil current	10 to 12 A
Resistance of focusing coils	
cold (20 °C)	7.2 to 9.5 Ω
operating at an ambient temperature of 20 °C	\leq 11 Ω

BEAM CONTROL

The klystrons comprise a non-intercepting annular beam control (ABC) electrode for low-voltage beam modulation. See Fig. 7.
Additionally the accelerator electrode voltage allows adjustment of the beam current between 0 and 100%.

GETTER-ION PUMP SUPPLY

Pump voltage, no-load condition	3 to 4 kV	3
Internal resistance of supply	300 k Ω	

YK1263
YK1265

MECHANICAL DATA

Dimensions in mm

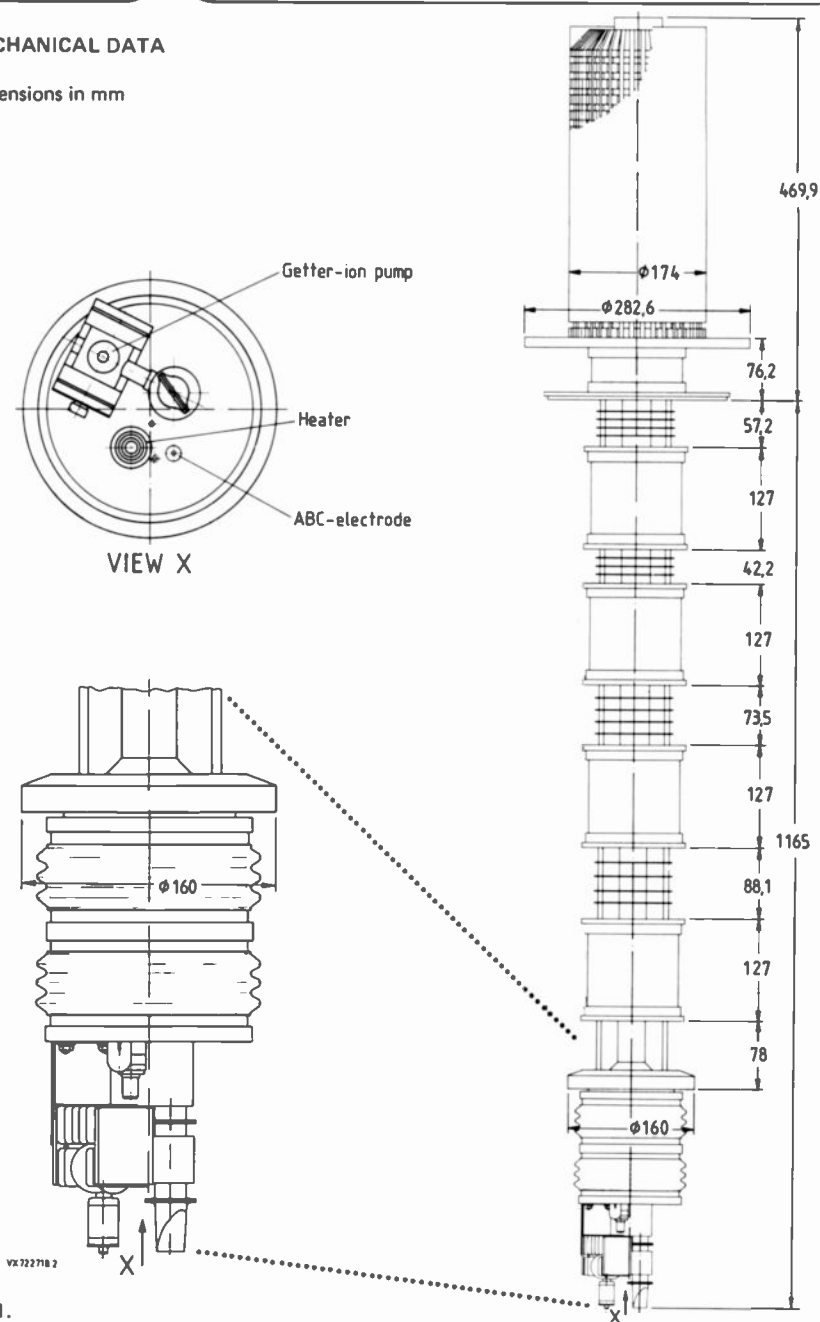

Fig. 1.

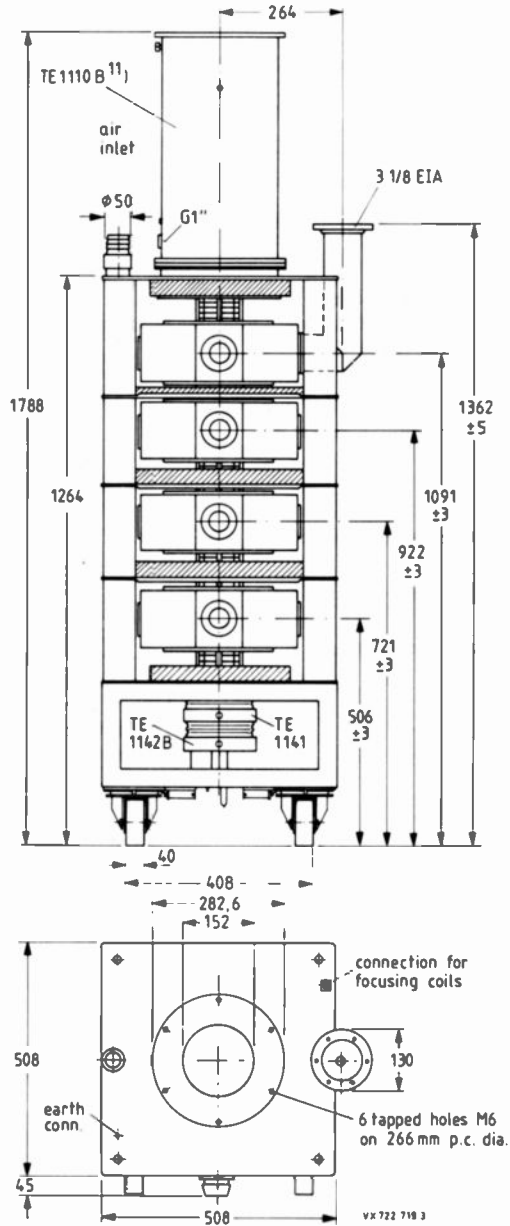

Fig. 2.

MASS AND DIMENSIONS

Klystron

net	approx. 79 kg
gross	approx. 232 kg
outline dimensions of packing (cm)	182 x 75 x 75
Cavities	approx. 45 kg
Magnet frame with coils	approx. 230 kg

MOUNTING

Mounting position: vertical with collector up.

To remove the tube from the magnet frame a total free height of 3 m, excluding hoist, is required.

COOLING

YK1263	Cavities 1, 2, 3 and 4, drift tubes 4 and 5 and cathode socket via manifold	forced air, T_i max. 50 °C $q \approx 2 \text{ m}^3/\text{min}$, $\Delta p = 1600 \text{ Pa}$ (16 mbar)
YK1265	Cavities 1, 2, 3 and 4, drift tube 4 and cathode socket via manifold	forced air, T_i max. 50 °C $q \approx 3 \text{ m}^3/\text{min}$, $\Delta p = 1600 \text{ Pa}$ (16 mbar)
	Drift tube 5, separate cooling	forced air, T_i max. 50 °C, $q \approx 3 \text{ m}^3/\text{min}$, flow area $\approx 50 \text{ cm}^2$
Cathode socket only, during black heat		forced air, T_i max. 50 °C, $q \approx 0.15 \text{ m}^3/\text{min}$
Collector		vapour with boiler TE1110B, note 4 volume of water converted to steam: 27 cm^3/min per kW collector dissipation resulting in 43 ℓ/min steam per kW collector dissipation water or vapour condensation (with water jacket TE1194B) $q = 35 \text{ to } 60 \text{ } \ell/\text{min}$, T_o max 90 °C, see Fig. 3. For 60 ℓ/min , $\Delta p = 100 \text{ kPa}$ (1 bar)

ACCESSORIES

Correct operation can be guaranteed only if approved accessories are used.

Collector radiation suppressor	TE1221
Anode ring	TE1141
Cathode ring	TE1142B
Spark gap	TE1183
Set of connectors (heater, cathode, accelerator electrode, getter-ion pump)	TE1146
Cavities	4 x TE1224

	front panel controlled	direct controlled
Inlet coupler and load coupler for cavities 2 and 3	3 x TE1226 and 3 x TE1226D	3 x TE1226
Output coupler, 3 1/8 inch, 90° elbow	TE1227	
Magnet frame with coils	TE1222	
Collector jacket for water or vapour condensation cooling	TE1194B	note 11
Boiler for vapour cooling	TE1110B	note 11
Tool set	TE1190	
Temperature sensor	TE1199	
Arc detector	TE1107B	
Recommended circulators (optional)		
470 to 600 MHz	2722 162 01551 (T100/IV-N)	
600 to 800 MHz	2722 162 01561 (T100/V-N)	
790 to 1000 MHz	2722 162 03261 (T100/V-3-N)	

LIMITING VALUES (Absolute maximum rating system)

Heater voltage	max. 9.5 V	
Beam voltage	max. 28 kV	
Cold cathode voltage	max. -30 kV	
Beam current	max. 7 A	note 6
Body current	max. 150 mA	
Accelerator electrode current	max. 6 mA	note 5
Collector dissipation	max. 150 kW	
Load VSWR	max. 1.5	
Temperature of tube envelope	max. 175 °C	
Static pressure in the cooling system TE1194B	max. 600 kPa (6 bar)	
ABC-electrode voltage with respect to cathode	max. -1.4 kV	

PERFORMANCE DATA

of ABC-electrode	min.	typ.	max.	
Capacity	80	90	100	pF
D.C. current at -1000 V*	-	-	1	mA

PRODUCT SAFETY

1. X-radiation

Correct operation of the tube can be guaranteed only if a set of accessories, approved by the tube manufacturer, is used.

The operating tube generates X-rays which can penetrate the ceramic parts of the tube envelope. In order to reduce the radiation at any accessible points to an officially acceptable, non-dangerous level the tube must be shielded and any possible radiation path blocked by at least 1 mm of brass or an equivalent depth of non-magnetic X-ray absorbing material. The proper use of accessories will provide the necessary shielding.

2. R.F. radiation

R.F. power may be emitted through apertures other than the normal output coupling (for example r.f. leaks). This r.f. power may be sufficiently intense to cause danger to the human body, particularly to the eyes. Such radiation may be increased if the tube is functioning incorrectly.

Instruction manual

For detailed mounting and tuning instructions see klystron instruction manual, delivered with each tube.

* The d.c. electrode current may rise up to max. 2 mA during life time. The applied modulator should be designed for an ABC-electrode current of at least 2 mA.

TYPICAL OPERATING CONDITIONS (modulation electrode at cathode potential)

As 40 kW vision transmitter

notes

Standard CCIR-G

Channel	21	45	68		
Output power, peak sync.	45	45	45	kW	
Beam voltage	21	22.5	24.5	kV	
Beam current	5.2	4.45	4.15	A	6,7
Accelerator to cathode voltage	19	17.5	16.5	kV	5
Body current					
without drive	8	5	5	mA	
at black level	60	30	30	mA	
Focusing coil current	11	10.5	10	A	
Drive power, peak sync. max.	20	10	10	W	8
Operating efficiency	41	45	44	%	
Bandwidth at -1 dB points	7	7	7	MHz	9

As 55 kW vision transmitter

Standard RTMA-M and RTMA-M*

Channel	14	45	69		
Output power, peak sync.	58	58	58	kW	
Beam voltage	23	25	26	kV	
Beam current	6.0	5.05	4.85	A	6,7
Accelerator to cathode voltage	21.5	19	18.5	kV	5
Body current					
without drive	8	5	5	mA	
at 58 kW peak sync., black level	80	40	40	mA	
Focusing coil current	11.5	11	10.5	A	
Drive power, peak sync.	20	10	10	W	
Operating efficiency	42	46	46	%	
Bandwidth at -1 dB points	7	7	7	MHz	9

YK1263
YK1265

As 60 kW vision transmitter (YK1265 only)

Standard*	M/G	M/G	M/G	notes
Channel	14/21	42/42	69/62	
Output power, peak sync.	64	64	64 kW	
Beam voltage	24.5	25.5	26.5 kV	
Beam current	6.1	5.3	5 A	6,7
Accelerator to cathode voltage	21.5	20	18.5 kV	5
Body current				
without drive	8	7	5 mA	
at 64 kW peak sync., black level	80	60	40 mA	
Focusing coil current	11.5	11	10.5 A	
Drive power, peak sync.	20	10	10 W	8
Operating efficiency	43	47.5	48 %	
Bandwidth at -1 dB points	7	7	7 MHz	9

As 8 kW FM sound transmitter

Output power	9	9	9 kW	
Beam voltage	21	22.5	24.5 kV	
Beam current	1.15	1.0	0.95 A	
Accelerator to cathode voltage	7	6.5	6 kV	5
Focusing coil current	9	9	9 A	
Drive power	5	5	5 W	8
Bandwidth at -1 dB points	1	1	1 MHz	

As 11 kW FM sound transmitter

Output power	12	12	12 kW	
Beam voltage	23	25	26 kV	
Beam current	1.4	1.2	1.1 A	
Accelerator to cathode voltage	8	7.5	7 kV	7
Focusing coil current	9	9	9 A	
Drive power	5	5	5 W	8
Bandwidth at -1 dB points	1	1	1 MHz	

As 12 kW FM sound transmitter

Output power	13	13	13 kW	
Beam voltage	24.5	25.5	26.5 kV	
Beam current	1.4	1.3	1.2 A	
Accelerator to cathode voltage	8	7.5	7.5 kV	7
Focusing coil current	9	9	9 A	
Drive power	5	5	5 W	8
Bandwidth at -1 dB points	1	1	1 MHz	

* Standards: RTMA-M, RTMA-M* and CCIR-G.

As 60 kW vision transmitter (YK 1265 only)

	M/G	M/G	M/G		notes
Standard*					
Channel	14/21	42/42	69/62		
Output power, peak sync.	64	64	64	kW	
Saturated output power	68	68	68	kW	
Beam voltage	25	26	27	kV	
Beam current	6.3	5.5	5.25	A	6, 7
Accelerator to cathode voltage	22	20	19.5	kV	5
Body current					
without drive	8	7	5	mA	
at 64 kW peak sync., black level	80	60	40	mA	
Focusing coil current	11	10.5	10	A	
Drive power, peak sync.	20	10	10	W	8
Saturated efficiency	43	47.5	48	%	
Bandwidth at -1 dB points	7	7	7	MHz	9

As 6 kW FM sound transmitter

Output power	6.4	6.4	6.4	kW	
Beam voltage	25	26	27	kV	
Beam current	0.85	0.77	0.72	A	
Accelerator to cathode voltage	5.3	5.0	4.8	kV	5
Focusing coil current	10	9.5	9	A	
Drive power	5	5	5	W	8

CW operation for synchrotron radiation sources (YK1265 only)

Frequency	≈ 500	≈ 500	MHz	
Output power	52	42	kW	
Beam voltage	23	21	kV	
Beam current	5.6	4.9	A	

Standards: RTMA-M, RTMA-M and CCIR-G.

Notes

1. When switching on the heater voltage, the heater current must never exceed a peak value of 65 A.
2. In case of a mains failure an interruption up to 30 s can be tolerated without new waiting time. After min. 10 minutes of stand-by heating time at 6 V (black heat), the beam current may be switched on; the heater voltage must be increased to its nominal value of 8.5 V simultaneously. Continuous black heat periods should not exceed two weeks and should be separated by similar periods of rest or full operation.
3. To ensure that the klystron is always ready for operation, operate the ion getter pump at least every 6 months (preferably every 3 months) during storage. For details see klystron instruction manual.
4. In order to avoid corrosion of the cooling system, coolant water must be pure and deionized (resistivity min. 100 k Ω ·cm).
5. The accelerator electrode voltage must not be positive with respect to the body (ground).
6. For beam current (tolerance \pm 5%) versus accelerator-to-cathode voltage, see Fig. 4.
7. A voltage divider for adjusting the beam current should be dimensioned on the basis of an accelerator electrode current of max. 1.5 mA.
8. The drive power is defined as the power delivered to a matched load.
9. Variation of the signal level between black and white at any sideband frequency may cause a reaction of the peak sync. level. Proper tube design limits this reaction to less than 0.5 dB.
10. For operation in the frequency range 810 to 860 MHz please contact tube manufacturer.
11. TE1110B with 1" inlet and steam outlet on top. TE1194B with two 1" tube fittings SWAGE LOCK SS-1610-1-16 at one side of the cooling jacket.

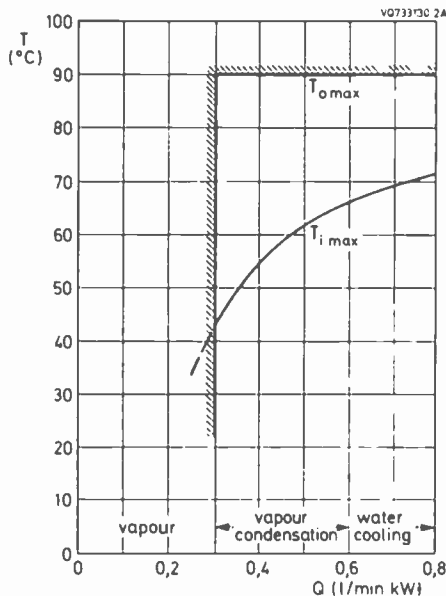

Fig. 3.

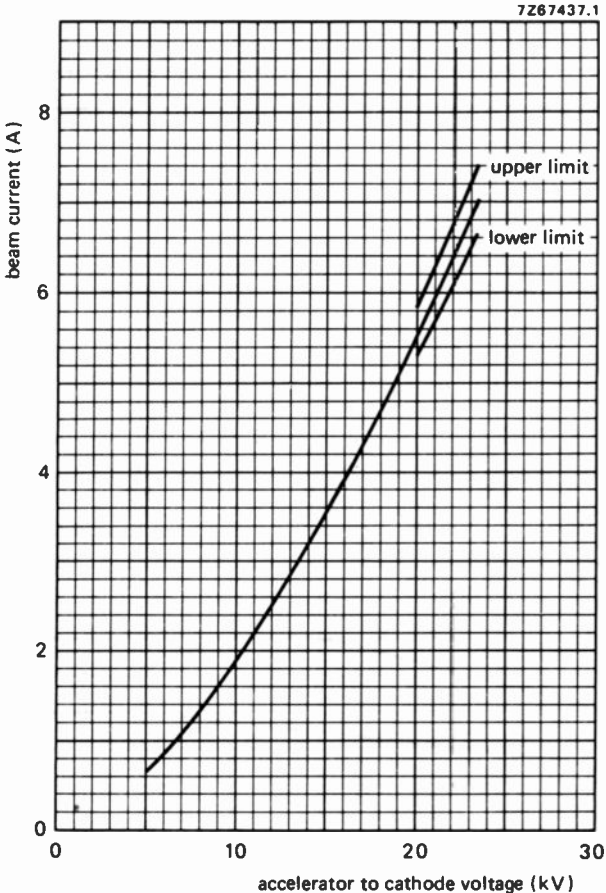

Fig. 4.

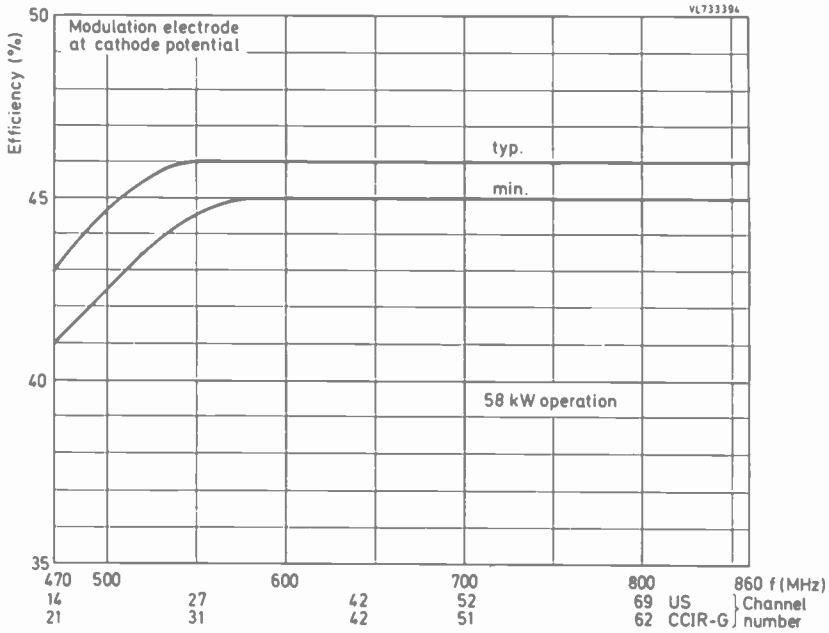

Fig. 5.

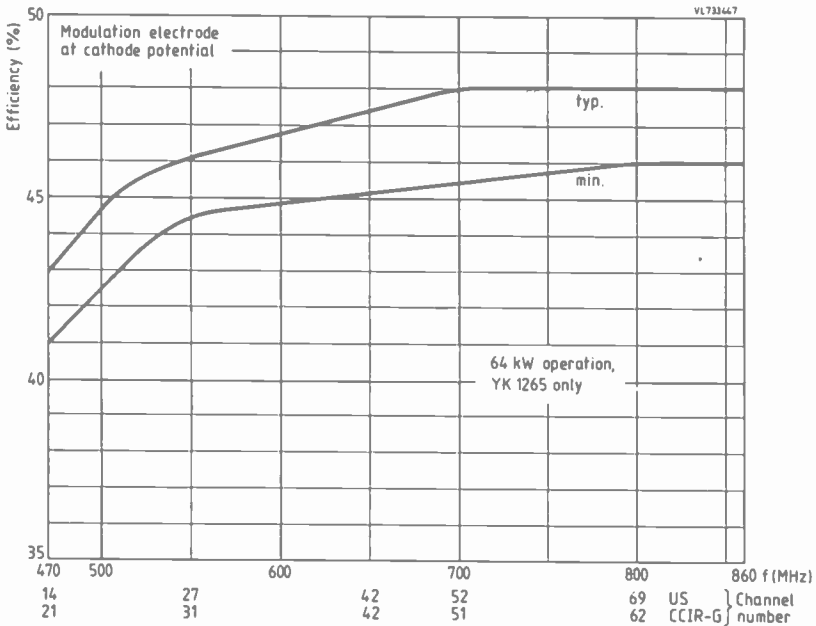

Fig. 6.

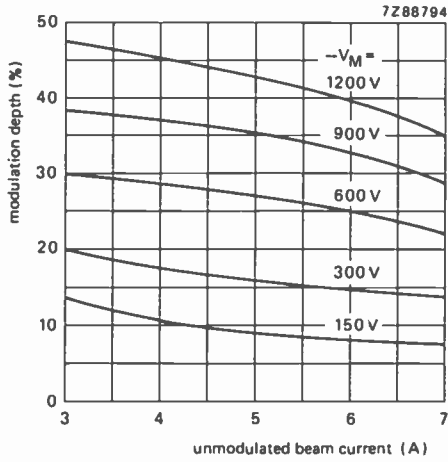

Fig. 7 ABC-operation.
Parameter: modulation voltage $-V_M$
(with respect to cathode).

U.H.F. POWER KLYSTRONS

For u.h.f. band IV/V vision transmitters and sound transmitters.
Metal-ceramic construction, four external cavities, electromagnetic focusing and a high-stability dispenser type cathode.
Suitable for vapour, vapour-condensation or water cooling.
Comprising a non-intercepting annular beam control electrode (ABC) for low-voltage beam modulation.

QUICK REFERENCE DATA

Frequency range	
YK1295	470 to 610 MHz
YK1296	590 to 720 MHz
YK1297	710 to 860 MHz
Output power as vision transmitter	40 and 55 kW
Cooling	vapour, vapour condensation, or water

This data must be read in conjunction with GENERAL OPERATIONAL RECOMMENDATIONS for KLYSTRONS.

HEATING: indirect by d.c.		notes
Cathode	dispenser type	
Heater voltage	$V_f \approx 8.5 \text{ V} \pm 3\%$	
Heater current	$I_f \approx 22 \text{ to } 27 \text{ A}$	1
Cold heater resistance	$R_{fo} \approx 30 \text{ m}\Omega$	
Waiting time		2
at $V_f = 8.5 \text{ V}$	$t_w \text{ min. } 300 \text{ s}$	
at $V_f = 6.0 \text{ V}$ (black heat)	$t_w \text{ min. } 0 \text{ s}$	
FOCUSING: electromagnetic		
Focusing coil current	9 to 12 A	
Resistance of focusing coils	7.2 to 9.5 Ω	
cold (20 °C)		
operating at an ambient temperature of 20 °C	$< 11 \Omega$	

BEAM CONTROL

The klystron comprises a non-intercepting annular beam control (ABC) electrode for low-voltage beam modulation. See Fig. 5.
Additionally the accelerator electrode voltage allows adjustment of the beam current between 0 and 100%.

GETTER-ION PUMP SUPPLY	3
Pump voltage, no-load condition	3 to 4 kV
Internal resistance of supply	300 k Ω

YK1295
 YK1296
 YK1297

MECHANICAL DATA YK1295

Dimensions in mm

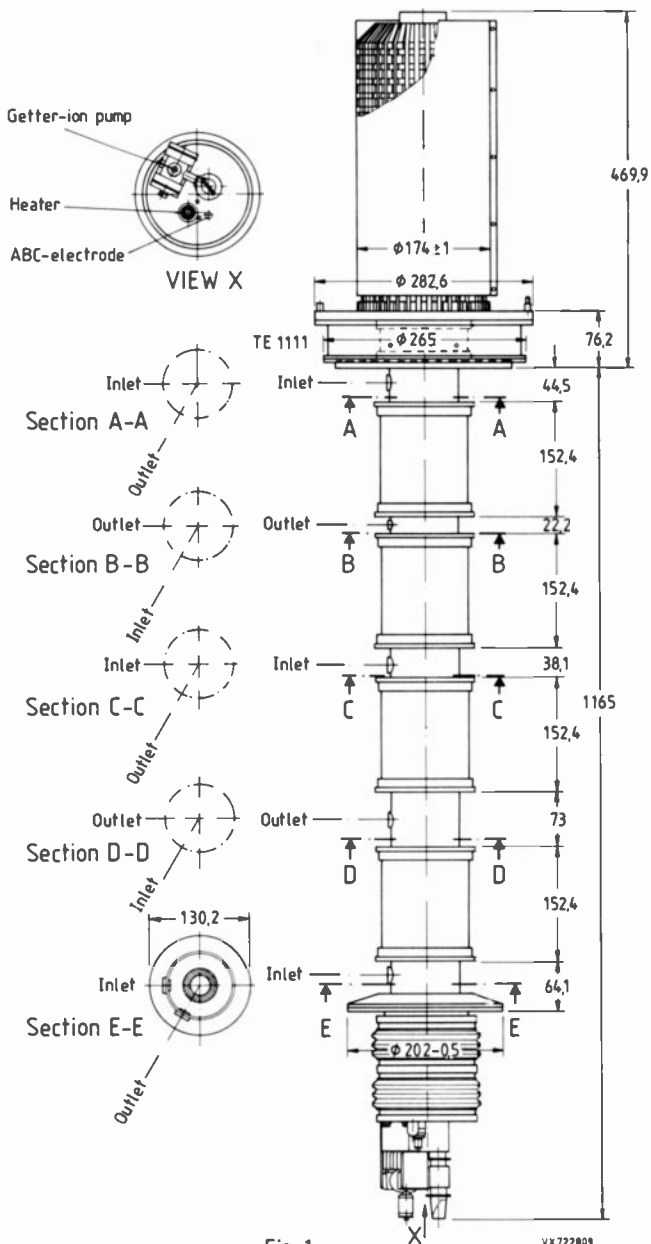

Fig. 1.

YK1296, YK1297

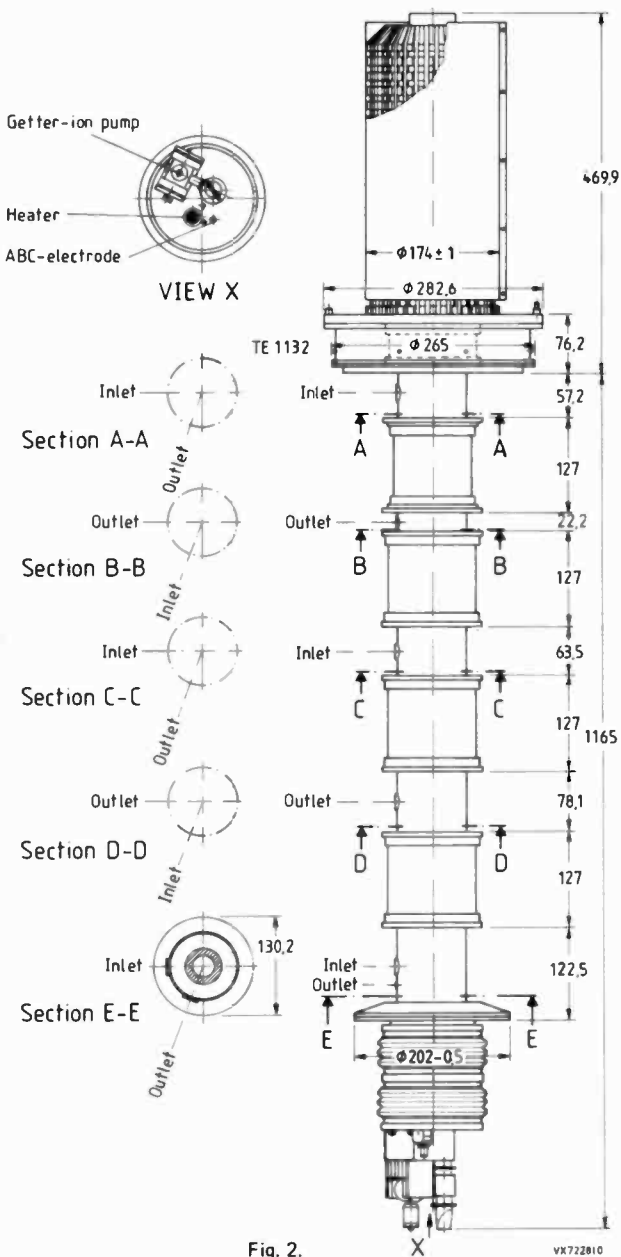

Fig. 2.

YK1295
YK1296
YK1297

Mechanical outlines of trolley

Dimensions in mm

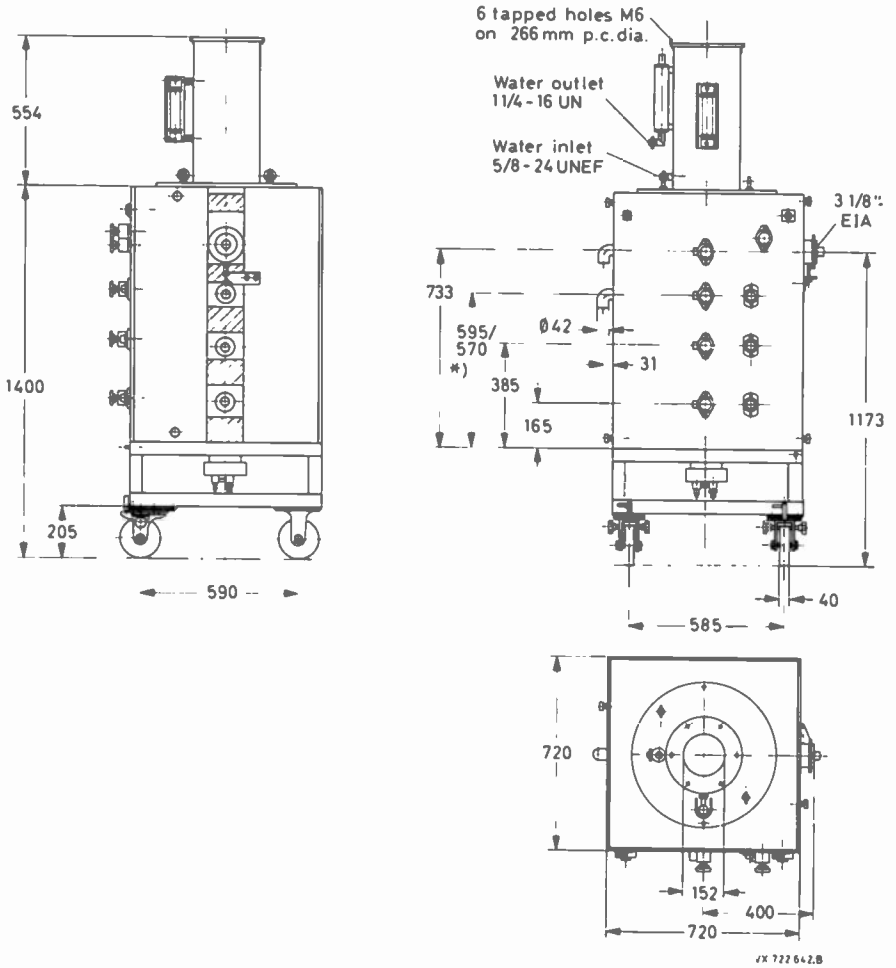

Fig. 3.

* YK1295 = 570 mm.
YK1296/1297 = 595 mm.

COOLING

Cathode socket

accelerator electrode

air; $q \approx 0.15 \text{ m}^3/\text{min}$, T_i max. $40 \text{ }^\circ\text{C}$

Collector

vapour (with boiler TE1110), note 4

volume of water converted to steam: $27 \text{ cm}^3/\text{min}$ per kW collector dissipation resulting in $43 \text{ l}/\text{min}$

steam per kW collector dissipation

water or vapour condensation (with cooler TE1194)

 $q = 35 \text{ to } 60 \text{ l}/\text{min}$, T_o max $80 \text{ }^\circ\text{C}$,

Drift tubes

water; rate of flow to drift tubes and collector

connected in series $q \approx 9 \text{ l}/\text{min}$, T_i max. $80 \text{ }^\circ\text{C}$, $\Delta p = 200 \text{ kPa}$ (2 bar)

Cavities 3 and 4

forced air; $q = 1.5 \text{ m}^3/\text{min}$, $\Delta p = 250 \text{ Pa}$ (2.5 mbar) T_i max. $45 \text{ }^\circ\text{C}$ **MASS AND DIMENSIONS**

Klystron

net

approx. 80 kg

gross

approx. 230 kg

outline dimensions
of packing (cm)

182 x 75 x 75

Cavities

approx. 45 kg

Magnet frame with coils

approx. 885 kg

MOUNTING

Mounting position: vertical with collector up.

To remove the tube from the magnet frame a total free height of 3.5 m, excluding hoist, is required.

PRODUCT SAFETY*1. X-radiation*

Correct operation of the tube can be guaranteed only if a set of accessories, approved by the tube manufacturer, is used.

The operating tube generates X-rays which can penetrate the ceramic parts of the tube envelope. In order to reduce the radiation at any accessible points to an officially acceptable, non-dangerous level the tube must be shielded and any possible radiation path blocked by at least 1 mm of brass or an equivalent depth of non-magnetic X-ray absorbing material. The proper use of accessories will provide the necessary shielding.

2. R.F. radiation

R.F. power may be emitted through apertures other than the normal output coupling (for example r.f. leaks). This r.f. power may be sufficiently intense to cause danger to the human body, particularly to the eyes. Such radiation may be increased if the tube is functioning incorrectly.

Instruction manual

For detailed mounting and tuning instructions see klystron instruction manual, delivered with each tube.

YK1295
YK1296
YK1297

ACCESSORIES (note 5)

A. Accessories required for first equipment

	YK1295	YK1296	YK1297
Collector radiation suppressor	TE1111	TE1132	TE1195
Accelerator electrode ring	TE1141	TE1141	TE1141
Cathode ring	TE1142B	TE1142B	TE1142B
Set of sealing rings	TE1147	TE1147	TE1147
Magnet flux ring	TE1138	TE1138	TE1138
Spark gap	TE1140	TE1140	TE1140
Set of connectors (heater, cathode, acc. electrode, getter-ion pump)	TE1146	TE1146	TE1146
Extension pipes for drift tubes	6x TE1133A 2x TE1133B	6x TE1133A 2x TE1133B	6x TE1133A 2x TE1133B
Water interconnecting pipes between drift tubes			
$T_2 - T_2$	TE1134A	TE1135A	TE1135A
$T_2 - T_3$	TE1134B	TE1135B	TE1135B
$T_3 - T_4$	TE1134C	TE1135C	TE1135C
$T_4 - T_5$	TE1134D	TE1135D	TE1135D
Flexible water pipes between tube and boiler for vapour cooling	TE1145A	TE1145A	TE1145A
between frame and tube	TE1145B	TE1145B	TE1145B
tube outlet for water cooling	TE1145C	TE1145C	TE1145C
Boiler for vapour cooling or Cooler for water cooling	TE1110	TE1110	TE1110
Cavities	3x TE1121D 1x TE1121D	3x TE1098A 1x TE1098D	3x TE1191A 1x TE1191B
Input coupler	TE1122A	TE1102	TE1102
Load coupler for cavities 2 and 3	2x TE1122B	2x TE1102	2x TE1102
Blanking plates	3x TE1157	3x TE1157	3x TE1157
Output coupler for cavity 4	TE1123	TE1105	TE1196
Arc detector	TE1107	TE1107	TE1107
Magnet frame with coils	TE1108	TE1108	TE1108
Tool set	TE1137	TE1137	TE1137

**B. Accessories to be ordered separately when
replacing equivalent other brand types**

Magnet flux ring	TE1138	TE1138	—
Spark gap	TE1140	TE1140	—
Set of connectors (heater, cathode, acc. electrode, getter-ion pump)	TE1146	TE1146	TE1146

C. Spare and optional parts	YK1295	YK1296	YK1297
Set of connectors (heater, cathode, acc. electrode, getter-ion pump)	TE1146	TE1146	TE1146
Set of sealing rings	TE1147	TE1147	TE1147
Water protection shield	TE1139	TE1139	TE1139
Recommended circulators			
470 to 600 MHz	2722 162 01551 (T100/IV-N)		
600 to 800 MHz	2722 162 01561 (T100/V-N)		
790 to 1000 MHz	2722 162 03261 (T100/V-3-N)		

LIMITING VALUES (Absolute maximum rating system)

Heater voltage	max.	9.5	V	
Beam voltage	max.	28	kV	
Cold cathode voltage	max.	-30	kV	
Beam current	max.	7	A	
Body current	max.	150	mA	
Accelerator electrode current	max.	6	mA	note 7
Collector dissipation	max.	150	kW	
Load VSWR	max.	1.5		
Temperature of tube envelope	max.	175	°C	
Static pressure in the cooling system	max.	600	kPa	} (6 bar) note 6
ABC-electrode voltage with respect to cathode	max.	-1.4	kV	

PERFORMANCE DATA

of ABC-electrode	min.	typ.	max.	
Capacity	80	90	100	pF
D.C. current at -1000 V*	-	-	1	mA

* The d.c. electrode current may rise up to max. 2 mA during life time. The applied modulator should be designed for an ABC-electrode current of at least 2 mA.

TYPICAL OPERATING CONDITIONS

As 55 kW/40 kW vision transmitter (standards: RTMA-M, RTMA-M* and CCIR-G)

	YK1295/YK1296			YK1297			
Output power, peak sync.	58	58	45	58	58	45 kW	
Beam voltage	22.5	26	22.5	23.5	27	25.5 kV	
Beam current	6.4	4.85	3.8	5.9	4.9	3.9 A	note 8
Accelerator to cathode voltage	≈22.5	≈18.5	≈16	≈21	≈19	≈16 kV	
Body current							
without drive	15	15	15	15	15	15 mA	
at black level	40	40	40	40	40	40 mA	
Focusing coil current	10.5	10.5	9.5	10.5	10.5	10 A	
Drive power, peak sync.							
Standard*	M	G					
YK1295 - channel	14	21	10	6	6	— W	note 9
channel	37	38	7	4	4	— W	note 9
YK1296 - channel	37	36	7	4	4	— W	note 9
channel	52	51	5	3	3	— W	note 9
YK1297			—	—	—	2 W	note 9
Bandwidth at -1 dB points			8	8	8	8 MHz	note 10
Differential gain			75	70	70	70 %	note 11
Differential phase			6	10	10	10 deg	note 11
Linearity			65	60	60	60 %	note 12
Operating efficiency			40	46	46.5	42 44 45 %	
Saturation output power			63	60	46.5	60 60 46.5 kW	
Saturation efficiency			44	47.5	48	43 45 46.5 %	
As 11 kW/8 kW FM sound transmitter							
Output power			12	12	9	12 12 9 kW	
Beam voltage			22.5	26	25.5	23.5 27 25.5 kV	
Beam current			1.5	1.2	1.3	1.5 1.2 1.3 A	
Accelerator cathode voltage			8.5	7.5	≈ 8	8.5 7.5 ≈ 8 kV	note 13
Focusing coil current			9	9	9	9 9 9 A	
Drive power			1.5	1.5	1.5	1.5 1.5 1.5 W	note 9
Bandwidth at -1 dB points			1	1	1	1 1 1 MHz	

* Standards: RTMA-M, RTMA-M* and CCIR-G.

Notes

1. When switching on the heater voltage, the heater current must never exceed a peak value of 65 A.
2. In case of a mains failure an interruption up to 30 s can be tolerated without new waiting time. After min. 10 minutes of stand-by heating time at 6 V (black heat), the beam current may be switched on; the heater voltage must be increased to its nominal value of 8.5 V simultaneously. Continuous black heat periods should not exceed two weeks and should be separated by similar periods of rest or full operation.
3. To ensure that the klystron is always ready for operation, operate the ion getter pump at least every 6 months (preferably every 3 months) during storage. For details see klystron instruction manual.
4. In order to avoid corrosion of the cooling system, coolant water must be pure and deionized (resistivity min. 100 k Ω ·cm).
5. Correct operation of the tube can be guaranteed only if a set of accessories, approved by the tube manufacturer, is used. The operating tube generates X-rays which can penetrate the ceramic parts of the tube envelope. In order to reduce the radiation at any accessible points to an officially admissible, non-dangerous level the tube must be shielded and any possible radiation path must be blocked by at least 1 mm of brass or an equivalent portion of non-magnetic X-ray absorbing material. The proper use of our accessory parts will provide the necessary shielding.
6. Static pressure in the body-cooling system and in the water-cooling jacket TE1194.
7. The accelerator electrode voltage must not be positive with respect to the body (ground).
8. If the accelerator electrode is connected to the body (ground) via 10 k Ω resistor, the beam current is within $\pm 5\%$ of the value given in the graph of Fig. 4.
9. The drive power is defined as the power delivered to a matched load.
10. Variation of the signal level between black and white at any sideband frequency may cause a reaction of the peak sync. level. Proper tube design limits this reaction to less than 0.5 dB.
11. Measured with a sawtooth signal from black level to peak white occurring at each line and superimposed colour subcarrier with a 10 % peak to peak amplitude.
12. Measured with a ten-step staircase signal from black level to peak with occurring at each line.
13. A voltage divider for adjusting the beam current should be dimensioned on the basis of an accelerator electrode current of max. 1.5 mA.

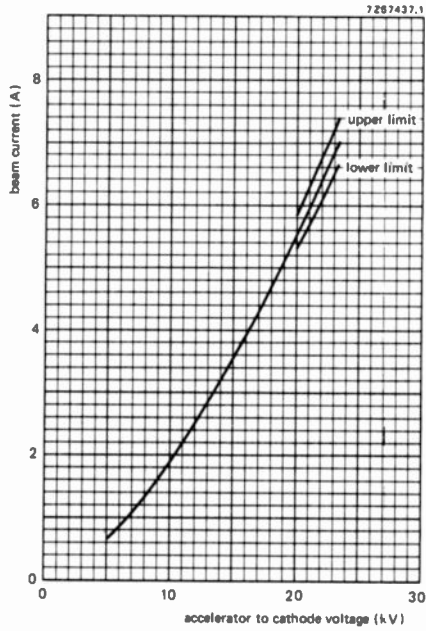

Fig. 4.

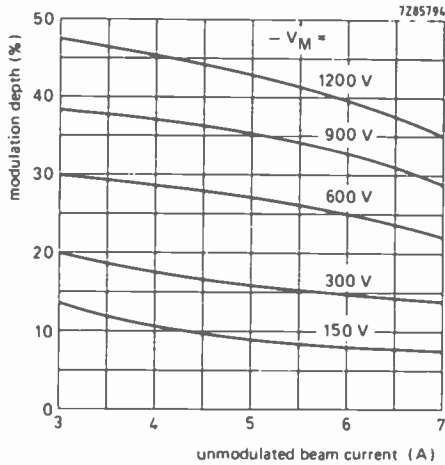

Fig. 5 ABC-operation.
Parameter: modulation voltage $-V_M$
(with respect to cathode).

CONTINUOUS-WAVE HIGH-POWER KLYSTRONS

Water cooled, high efficiency, fixed frequency, continuous-wave high-power klystrons in metal-ceramic construction, for use in scientific and industrial applications. The tubes have internal cavities, solenoid focusing, beam control by accelerator anode and a high stability dispenser-type cathode.

QUICK REFERENCE DATA

Centre frequency (fixed tuned)	499.7	MHz
Bandwidth at saturation (-1 dB points)	2	MHz
Output power		
YK1300	500 to 600	kW
YK1301	600 to 800	kW
YK1305	< 350	kW
Cooling	water	

This data must be read in conjunction with GENERAL OPERATIONAL RECOMMENDATIONS for KLYSTRONS.

HEATING: indirect by a.c. or d.c.

Cathode					dispenser type	
		min.	typ.	max.		
Heater voltage	V_f	22	25	27	V	
Heater current	I_f	20	23	25	A	notes 1, 2
Cold heater resistance	R_{fo}	-	100	-	m Ω	
Waiting time	t_w	15	-	-	minutes	

FOCUSING: electromagnetic

Solenoid current		7	9	15	A
Solenoid voltage		-	140	220	V
Solenoid resistance		-	15	-	Ω

GETTER-ION PUMP SUPPLY

Operating voltage		3	3.3	4	kV
Operating current		-	10^{-3}	80	mA
Internal resistance of power supply		25	300	-	k Ω

YK1300
YK1301
YK1305

MECHANICAL DATA

Dimensions in mm

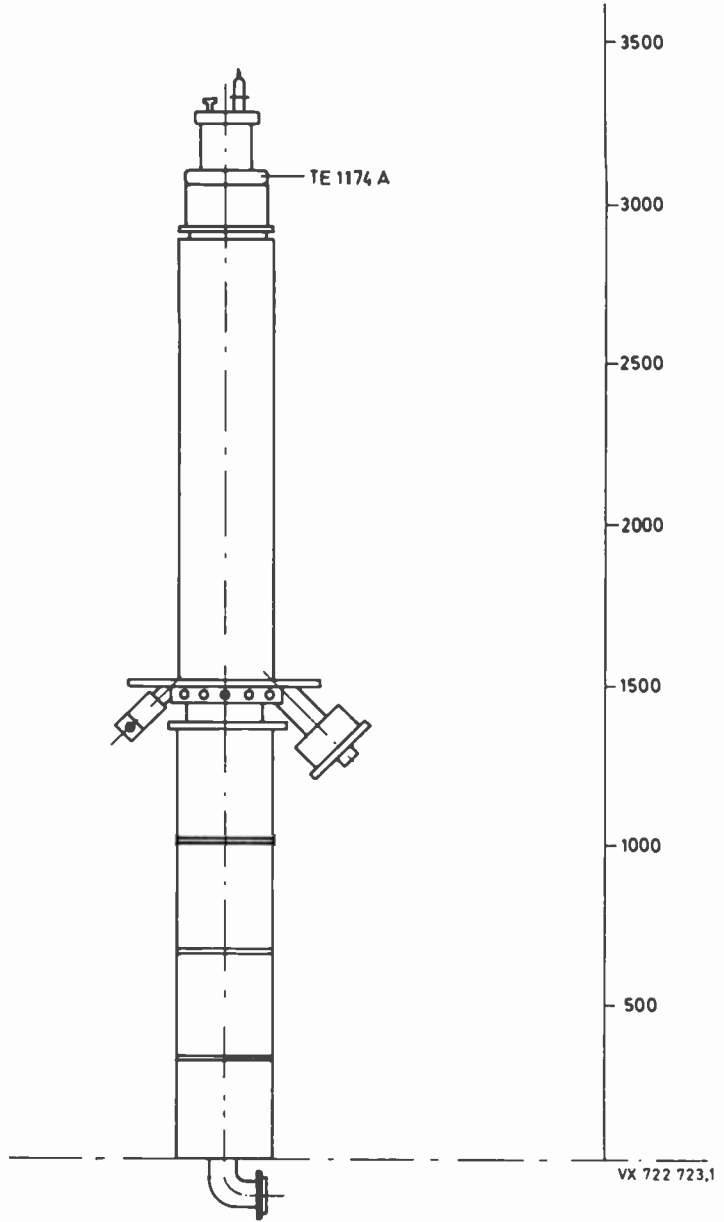

Fig. 1.

Tube mounted in the mounting frame with solenoid.

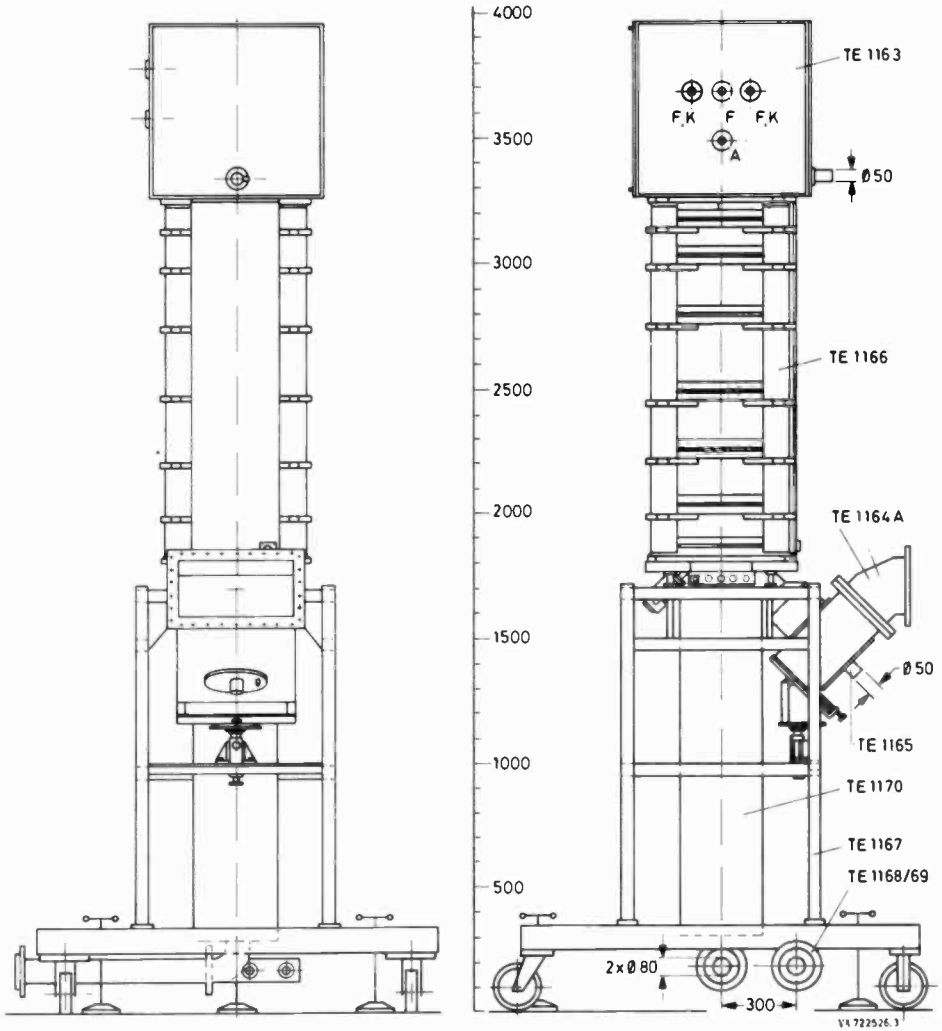

Fig. 2.

MECHANICAL DATA (continued)

Tube mounted in the mounting frame with solenoid.
Dimensions in mm

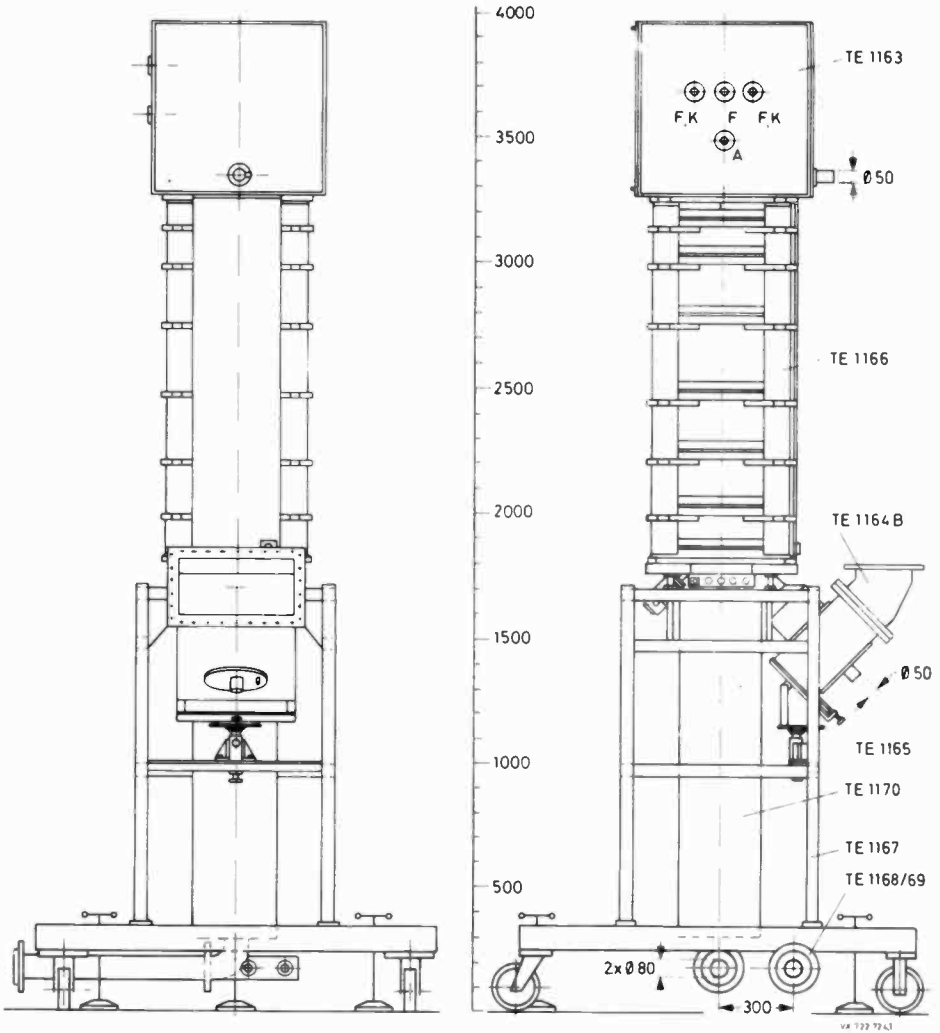

Fig. 3.

Drawing shows klystron and trolley without operational lead-shielding.

COOLING	min.	typ.	max.		
Collector					
demineralized or distilled water with 10% stabilized glycol added YK1300, YK1301	750	900	1000	ℓ/min	note 3
YK1305	200	500	700	ℓ/min	note 3
pressure drop	—	200	—	kPa	(= 2 bar)
Body circuit I					
demineralized or distilled water with 10% stabilized glycol added	7	10	—	ℓ/min	note 3
pressure drop	—	300	—	kPa	(= 3 bar)
Body circuit II					
demineralized or distilled water with 10% stabilized glycol added YK1300, YK1301	20	25	—	ℓ/min	
YK1305	15	18	—	ℓ/min	note 3
pressure drop	—	300	—	kPa	(= 3 bar)
Cathode socket and accelerator anode					
air	2	—	—	m ³ /min	
pressure drop	—	—	500	Pa	(= 5 mbar)
Output window					
air	0.6	1.2	—	m ³ /min	
pressure drop	—	9	—	kPa	(= 90 mbar)
Inlet water temperature	—	—	+50	°C	
Inlet air temperature	—	—	+45	°C	

MASS

Net mass YK1300, YK1301, YK1305	400	kg
Mounting frame with solenoid		
YK1300, YK1305	800	kg
YK1301	900	kg
Capability of hoist	min. 600	kg

DIMENSIONS

Tube and mounting frame	see drawings
Required ground clearance for lifting hoist	min. 580 cm

MOUNTING

vertical, cathode up

R.F. CONNECTORS

Input	N-type, female
Output	waveguide R5 (WR1800) mating flange UDR5

ACCESSORIES

A. Tube parts

Collector water cooling jacket		note 4
Waveguide coupling iris		note 4
Magnet for getter-ion pump (factory fitted)		

B. Operational parts for first equipment

Coaxial/waveguide transition, WR1800 with 45° elbow		
YK1300	TE1164A	note 5
YK1301, YK1305	TE1164B	note 5
Window cooling air inlet	TE1165	
Accelerator anode ring (factory fitted)	TE1173	
Cathode ring	TE1174A	
Corona protector	TE1174B	
H.V. connection unit with R3 sockets		
YK1300	TE1163A	note 6
YK1301, YK1305	TE1163B	note 6
Klystron trolley with waveguide support	TE1167	
Focusing coil unit		
YK1300	TE1166A	
YK1301, YK1305	TE1166B	
Water outlet collecting tube	TE1168	
Set of interconnecting water hoses	TE1169	
Connection cables, heater/cathode heater accelerator anode	2x TE1171A TE1171B TE1171C	

C. Optional parts

H.V. socket R3	4x TE1158	note 7
H.V. cable with R3 plugs, length 6 m	4x TE1159	note 7
length 9 m	4x TE1160	note 7
H.V. dummy plug R3	4x TE1161	note 7
Collector water cooling jacket	TE1170	

D. Parts for handling

Yoke for lifting TE1166 and TE1163	TE1175	note 8
Yoke for lifting and turning a klystron from any position	TE1176	
Supporting frame for storage and any movement of burnt-out or spare klystrons in any position other than vertical	TE1177	
Trolley for transportation of a klystron in horizontal position without lifting gear	TE1178	

LIMITING VALUES (Absolute maximum rating system)

Heater voltage	}	max. 10% above specified values	
Heater current			
Cathode voltage to body (ground)	max.	-65	kV
Cold cathode voltage to body (ground)	max.	-75	kV
Cathode current	max.	18	A
Accelerator anode voltage to cathode	max.	55	kV note 9
Cold accelerator anode voltage to cathode	max.	65	kV
Accelerator anode current	max	10	mA
Collector dissipation	max	850	kW note 10
Dissipation body circuit I	max.	10	kW
Dissipation body circuit II	max.	15	kW
C.W. output power	max.	630	kW
Load VSWR	max.	1.2	note 12
Temperature rise, window cooling air flow	max.	30	K

TYPICAL OPERATING CONDITIONS

	min.	typ.	max.	
500 kW operation into matched load				
Cathode voltage to body (ground)	-60	-62	-63	kV
Cathode current	4	14	15	A note 13
Input power, d.c.	-	867	-	kW
Accelerator anode voltage to cathode	0	43	-	kV note 13
Accelerator anode current	-	1	5	mA
C.W. output power, VSWR ≤ 1.1	500	520	-	kW
Collector dissipation	-	347	850	kW note 10
Efficiency	58	60	-	%
C.W. drive power	-	25	50	W
600 kW operation into matched load				
Cathode voltage to body (ground)	-62	-64	-65	kV
Cathode current	4	15.9	16.5	A note 13
Input power, d.c.	-	1017	-	kW
Accelerator anode voltage to cathode	0	47	-	kV note 13
Accelerator anode current	-	1	5	mA
C.W. output power, VSWR ≤ 1.1	600	610	-	kW
Collector dissipation	-	407	850	kW note 10
Efficiency	57	60	-	%
C.W. drive power	-	25	50	W

LIMITING VALUES (Absolute maximum rating system)

Heater voltage	}	max. 10% above specified values	
Heater current			
Cathode voltage to body (ground)	max.	-77	kV
Cold cathode voltage to body (ground)	max.	-85	kV
Cathode current	max.	18	A
Accelerator anode voltage to cathode	max.	65	kV note 9
Cold accelerator anode voltage to cathode	max.	75	kV
Accelerator anode current	max.	10	mA
Collector dissipation	max.	850	kW note 10
Dissipation body circuit I	max.	10	kW
Dissipation body circuit II	max.	15	kW
C.W. output power	max.	820	kW
Load VSWR	max.	1.2	note 12
Temperature rise, window cooling air flow	max.	30	K

TYPICAL OPERATING CONDITIONS

800 kW operation into matched load	min.	typ.	max.	
Cathode voltage to body (ground)	-75	-76	-77	kV
Cathode current	4	17	18	A note 13
Input power, d.c.	-	1300	-	kW
Accelerator anode voltage to cathode	0	47	50	kV note 13
Accelerator anode current	-	2	5	mA
C.W. output power, VSWR < 1.1	750	800	820	kW
Collector dissipation	-	500	850	kW note 10
Efficiency	60	61	-	%
C.W. drive power	-	40	70	W

LIMITING VALUES (Absolute maximum rating system)

Heater voltage			
Heater current			max. 10% above specified values
Cathode voltage to body (ground)	max.	-50	kV
Cold cathode voltage to body (ground)	max.	-55	kV
Cathode current	max.	15	A
Accelerator anode voltage to cathode	max.	45	kV note 9
Cold accelerator anode voltage to cathode	max.	50	kV
Accelerator anode current	max.	10	mA
Collector dissipation	max.	400	kW note 10
Dissipation body circuit I	max.	6	kW
Dissipation body circuit II	max.	10	kW
C.W. output power	max.	370	kW
Load VSWR	max.	1.2	note 12
Temperature rise, window cooling air flow	max.	30	K

TYPICAL OPERATING CONDITIONS

350 kW operation into matched load	min.	typ.	max.	
Cathode voltage to body (ground)	-47	-48	-49	kV
Cathode current	4	12	13	A note 13
Input power, d.c.	-	580	600	kW
Accelerator anode voltage to cathode	0	36.5	-	kV note 13
Accelerator anode current	-	1	5	mA
C.W. output power, VSWR \leq 1.1	315	330	370	kW
Collector dissipation	-	230	400	kW note 10
Efficiency	55	58	-	%
C.W. drive power	-	16	30	W

PERFORMANCE DATA

Phase shift to cathode current	<	20	°/A
Phase shift to rel. cathode voltage	<	20	°/%
Phase shift to r.f. drive	<	12	°/dB
R.F. output to rel. cathode voltage	<	0.3	dB/%
Spurious noise amplitude			
for f < 300 Hz	<	3	%
for f = 300 to 1000 Hz	<	1	%
for f > 1000 Hz	<	0.5	%

Notes

1. When switching on the heater voltage, the heater current must never exceed a peak value of 65 A.
2. Required values are given with each tube.
3. For further recommendations please contact the tube manufacturer.
4. Separately shipped together with each tube and to be returned together with each burnt-out tube.
5. It is recommended to return the coaxial/waveguide transition together with burnt-out tube for inspection.
6. R3 sockets are only usable together with optional accessories TE1159 and TE1160.
7. Cable with R3 plugs on each end, to be fed into the R3 sockets of the H.V. connection unit TE1163 and into R3 sockets TE1158 applied to the power supply. Dummy plugs are provided for cable termination on H.V. test of the cable set.
8. Parts are needed for all handling operations at the site and are to be ordered once for the site.
9. The accelerator anode voltage may never become positive with respect to the body (ground).
10. It must be observed that for operation with reduced r.f. drive the maximum value for collector dissipation is not exceeded.
11. For reflections exceeding this value please contact the tube manufacturer.
12. The klystron should not be operated with a cathode current below 4 A except for switching purposes.

INSTALLATION AND OPERATION REQUIREMENTS**A. Required interlocks**

1. Fast switch-off of the drive power within 10 ms has to be done if the arc detector and/or r.f. reflection indicator is activated. An arc detector must be provided at the knee of the output waveguide.
2. A fast switch-off of the beam supply has to be provided when one of the following situations occurs:
 - a) the beam current increases rapidly,
 - b) the solenoid current deviates by more than $\pm 5\%$ from the adjusted value.
 The switching sensors and the discharge facilities for the power supply must be designed so that a copper wire of 0.35 mm diameter, connected to the power supply instead of the klystron (length approx. 1 cm/kV), will not be destroyed, if the full operating voltage is switched on and applied to the wire.
3. The mains for the beam power supply has to be switched off within 100 ms when one of the following situations occur:
 - a) the beam current either exceeds the limiting value or increases by more than 30% or max. 2 A above the adjusted value,
 - b) the pump current exceeds 10 μA ,
 - c) the monitored temperature differences between inlet and outlet in the collector and/or body cooling circuits are too high;

max. values permitted:	collector	$\Delta\theta = 15 \text{ K}$
	body circuit I	$\Delta\theta = 15 \text{ K}$
	body circuit II	$\Delta\theta = 15 \text{ K}$
 - d) the water flow of the collector and body cooling circuits decreases below the required minimum value,
 - e) the air flow for the r.f. window and cathode cooling decreases below the required minimum value.
4. Switch-off the heater voltage for pump current $> 4 \text{ mA}$.
Restarting is not allowed within 10 s of any interruption.

B. Switching-on and off sequence**Switching-on sequence**

1. Cathode cooling on.
2. Getter-ion pump supply on.
3. Check that the pump current is $< 10 \mu\text{A}$.
4. Heater voltage supply on.
5. Wait for preheating time (min. 15 minutes).
6. Cooling air r.f. window on.
7. Cooling body circuits I and II on.
8. Collector cooling supply on.
9. Solenoid current supply on.
10. Check that the heater current has reached the adjusted value $\pm 0.5 \text{ A}$.
11. R.F. drive on.
12. Beam supply on.

Switching-off sequence

1. Beam voltage supply off.
2. All other supplies and cooling circuits off.

C. Radiation dangers

R.F. radiation

R.F. power may be emitted not only through the normal output coupling but also through other apertures (for example, r.f. leaks). This r.f. power may be sufficiently intense to cause danger to the human body, particularly to the eyes. Such radiation may be increased if the tube is functioning incorrectly.

X-radiation

A highly dangerous intensity of X-rays may be emitted by tubes operating at voltages higher than approximately 5 kV. Adequate protection (X-ray shielding) for the operator is then necessary. The emission intensity of X-rays may correspond to a value of voltage much higher than that expected from the actual value applied to the tube.

Poor focusing may result in excessive X-radiation.

These tubes and accessories are equipped with a lead shielding which under normal conditions reduces the radiation values below 0.75 mR/h, measured at a distance of 1 m from the tube assembly.

CONTINUOUS-WAVE HIGH-POWER KLYSTRON

Vapour cooled, high efficiency, fixed frequency, continuous-wave high-power klystrons in metal-ceramic construction, for use in scientific and industrial applications. The tubes have internal cavities, solenoid focusing, beam control by accelerator anode and a high stability dispenser-type cathode.

QUICK REFERENCE DATA

Centre frequency (fixed tuned)	508.6 MHz
Bandwidth at saturation (-1 dB points)	2 MHz
Output power	800 kW
Cooling	vapour

This data must be read in conjunction with GENERAL OPERATIONAL RECOMMENDATIONS for KLYSTRONS.

HEATING: indirect by a.c. or d.c.

Cathode	dispenser type				notes	
		min.	typ.	max.		
Heater voltage	V_f	22	25	27	V	
Heater current	I_f	20	23	25	A	1, 2
Cold heater resistance	R_{f0}	—	100	—	m Ω	
Waiting time	t_w	15	—	—	minutes	

FOCUSING: electromagnetic

Main focusing section

Solenoid current	—	7	8	A	2, 3
Solenoid voltage	—	500	600	V	
Solenoid resistance	—	80	—	Ω	

Prefocusing coil

Solenoid current	—	5	7	A	2, 3
Solenoid voltage	—	30	40	V	
Solenoid resistance	—	6	—	Ω	

GETTER-ION PUMP SUPPLY

Operating voltage	3	3.3	4	kV
Operating current	—	$\approx 10^{-3}$	80	mA
Internal resistance of power supply	25	300	—	k Ω

MECHANICAL DATA

Dimensions in mm

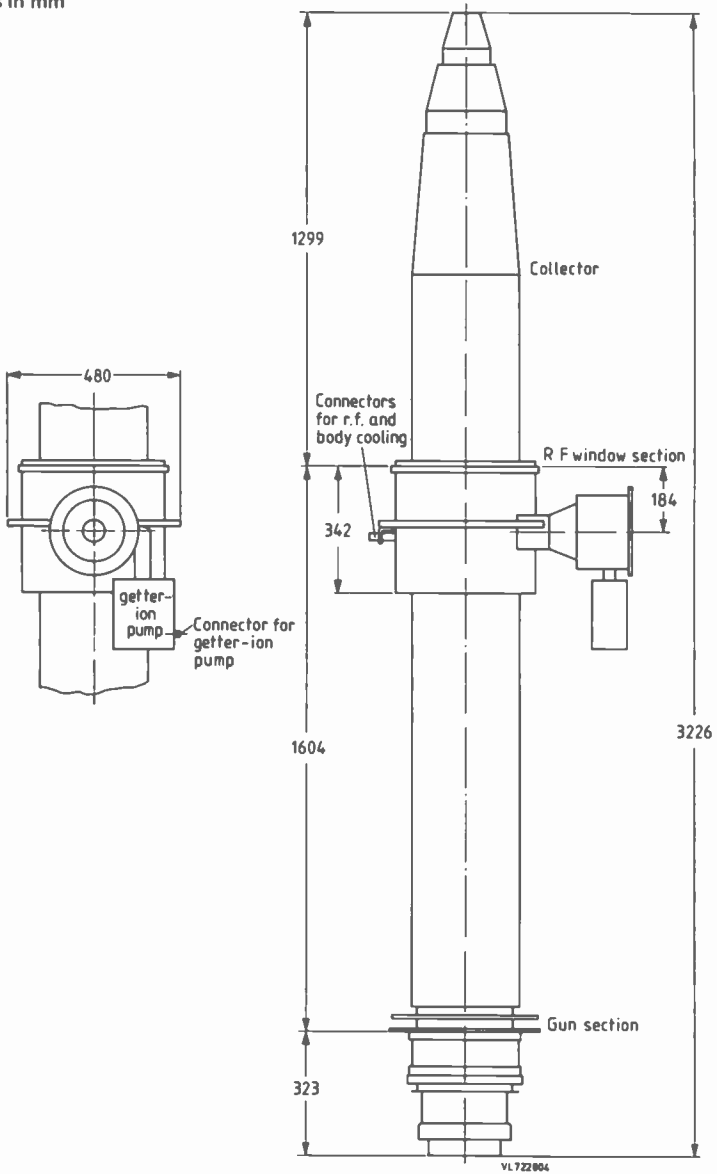

Fig. 1.

Tube mounted in the mounting frame with solenoid.

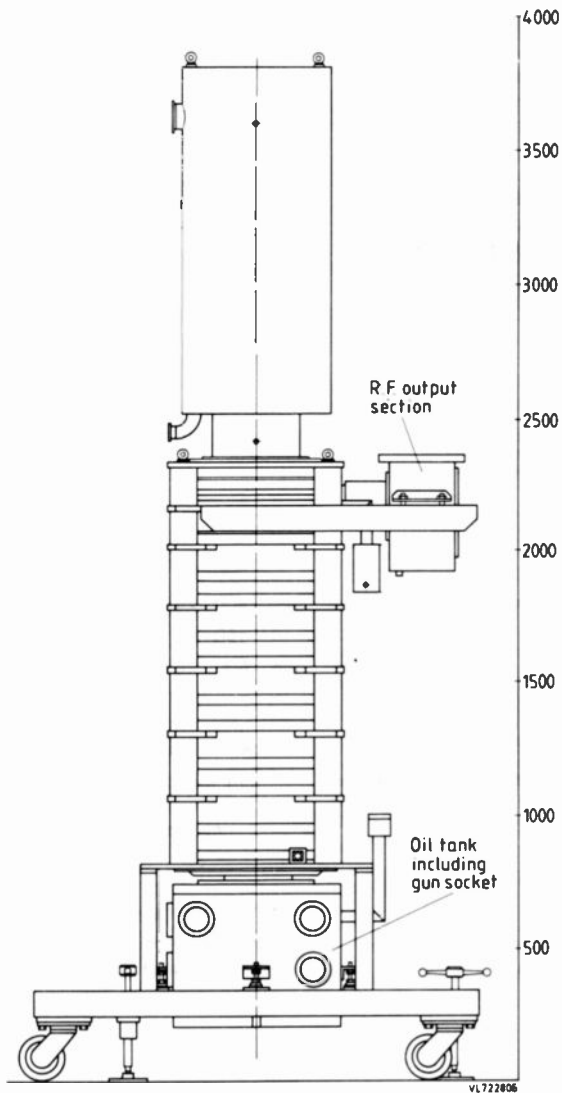

Fig. 2.

Drawing shows klystron and trolley without operational lead shielding.

COOLING	min.	typ.	max.		
Vapour cooling of collector demineralized or distilled water	50	100	—	ℓ/min	note 4, 5
pressure drop at 100 ℓ/min	—	—	20	kPa	(= 200 mbar)
Water cooling of body circuit I demineralized or distilled water with 10% stabilized glycol added	10	14	—	ℓ/min	note 5
pressure drop	—	300	—	kPa	(= 3 bar)
Water cooling of body circuit II demineralized or distilled water with 10% stabilized glycol added	15	20	—	ℓ/min	note 5
pressure drop	—	300	—	kPa	(= 3 bar)
Output window air	0.6	1.2	—	m ³ /min	
pressure drop	—	9	—	kPa	(= 90 mbar)
Inlet water temperature	—	—	+50	°C	
Inlet air temperature	—	—	+45	°C	
Cathode socket and accelerator anode under oil					
MASS					
Net mass YK1302		500		kg	
Mounting frame with solenoid		1400		kg	
Boiler		150		kg	
Capability of hoist	min.	600		kg	
DIMENSIONS					
Tube and mounting frame				see drawings	
Required ground clearance for lifting hoist				min. 650	cm
MOUNTING				vertical, collector up	
R.F. CONNECTORS					
Input				N-type, female	
Output				waveguide R5 (WR1800) mating flange UDR5	

ACCESSORIES

Klystron trolley with waveguide support	TE1312
Focusing coil unit	TE1322
Oil tank	TE1332
Coaxial/waveguide transition, WR1800	TE1342A
Lead shielding	TE1362
Trolley for transportation of a klystron in horizontal position without lifting gear	TE1372A
Supporting frame for storage and any movement of burnt-out or spare klystrons in any position other than vertical	TE1372B
Handling equipment	TE1382
Boiler	TE1392

LIMITING VALUES (Absolute maximum rating system)

Heater voltage	}	max. 10% above specified values		
Heater current				
Cathode voltage to body (ground)	max.	-85	kV	
Cold cathode voltage to body (ground)	max.	-90	kV	
Cathode current	max.	20	A	
Accelerator anode voltage to cathode	max.	65	kV	note 6
Accelerator anode current	max.	5	mA	
Collector dissipation				note 7
output power > 200 kW	max.	750	kW	
output power < 200 kW	max.	500	kW	
Dissipation body circuit I	max.	15	kW	
Dissipation body circuit II	max.	10	kW	
C.W. output power	max.	850	kW	
Load VSWR	max.	1.2		note 8
Temperature rise, window cooling air flow	max.	30	K	

TYPICAL OPERATING CONDITIONS

800 kW operation into matched load	min.	typ.	max.		
Cathode voltage to body (ground)	-76	-80	-	kV	
Cathode current	-	16.5	-	A	note 9
Input power, d.c.	-	1322	-	kW	
Accelerator anode voltage to cathode	-	52	-	kV	note 9
Accelerator anode current	-	1.5	-	mA	
C.W. output power, VSWR ≤ 1.1	-	800	-	kW	
Collector dissipation	-	522	-	kW	note 7
Efficiency	60	60.5	-	%	
C.W. drive power	-	60	80	W	

PERFORMANCE DATA

Harmonic content with respect to fundamental			
2nd order	max.	-25	dB
3rd order	max.	-25	dB
Spurious noise amplitude			
for f < 300 Hz	≪	1	%
for f = 300 to 1000 Hz	≪	1	%
for f > 1000 Hz	≪	0.5	%

Notes

1. When switching on the heater voltage, the heater current must never exceed a peak value of 65 A.
2. Required values are given with each tube.
3. Further adjustment according to operating instructions.
4. Volume of water converted to steam: 27 cm³/min per kW collector dissipation in 43 l/min steam per kW collector dissipation.
5. For further recommendations please contact the tube manufacturer.
6. The accelerator anode voltage may never become positive with respect to the body (ground).
7. It must be observed that for operation with reduced r.f. drive the maximum value for collector dissipation is not exceeded.
8. For reflections exceeding this value please contact the tube manufacturer.
9. The klystron should not be operated with a cathode current below 4 A except for switching purposes.

INSTALLATION AND OPERATION REQUIREMENTS

A. Required interlocks

1. Fast switch-off of the drive power within 30 ms has to be done if the arc detector and/or r.f. reflection indicator is activated. An arc detector must be provided at the knee of the output wave guide.
2. A fast switch-off of the beam supply has to be provided when one of the following situations occurs:
 - a) the beam current increases rapidly,
 - b) the solenoid current deviates by more than $\pm 5\%$ from the adjusted value.
 The switching sensors and the discharge facilities for the power supply must be designed so that a copper wire of 0.35 mm diameter, connected to the power supply instead of the klystron (length approx. 1 cm/kV), will not be destroyed, if the full operating voltage is switched on and applied to the wire.
3. The mains for the beam power supply has to be switched off within 100 ms when one of the following situations occur:
 - a) the collector temperature monitor (with internal thermocouple) is activated ($T = \text{max. } 150^\circ\text{C}$),
 - b) the monitored temperature differences between inlet and outlet in the collector and/or body cooling circuits are too high:

max. values permitted:	body circuit I	$\Delta\theta = 15\text{ K}$
	body circuit II	$\Delta\theta = 15\text{ K}$
 - c) the beam current either exceeds the limiting value or increases by more than 30% or max. 2 A above the adjusted value,
 - d) the water flow of the body cooling circuits decreases below the required minimum value,
 - e) the air flow for the r.f. window cooling decreases below the required minimum value,
 - f) the thermocouple temperature at the inner conductor of the output window exceeds 90°C ,
 - g) the pump current exceeds $10\ \mu\text{A}$.

Restarting is not allowed within 10 s of any interruption.

B. Switching-on and off sequence

Switching-on sequence

1. Getter-ion pump supply on.
2. Check that the pump current is $< 10\ \mu\text{A}$.
3. Heater voltage supply on.
4. Wait for preheating time (min. 15 minutes).
5. Cooling air r.f. window on.
6. Cooling body circuits I and II on.
7. Collector cooling supply on.
8. Solenoid current supply on.
9. Check that the heater current has reached the adjusted value $\pm 0.5\text{ A}$.
10. R.F. drive on.
11. Beam supply on.

Switching-off sequence

1. Beam voltage supply off.
2. All other supplies and cooling circuits off.

C. Radiation dangers

R.F. radiation

R.F. power may be emitted not only through the normal output coupling but also through other apertures (for example, r.f. leaks). This r.f. power may be sufficiently intense to cause danger to the human body, particularly to the eyes. Such radiation may be increased if the tube is functioning incorrectly.

X-radiation

A highly dangerous intensity of X-rays may be emitted by tubes operating at voltages higher than approximately 5 kV. Adequate protection (X-ray shielding) for the operator is then necessary. The emission intensity of X-rays may correspond to a value of voltage much higher than that expected from the actual value applied to the tube.

Poor focusing may result in excessive X-radiation.

This tube and accessories are equipped with a lead shielding which under normal conditions reduces the radiation values below 1 mR/h, measured at a distance of 1 m from the tube assembly.



CONTINUOUS-WAVE HIGH-POWER KLYSTRON

Water cooled, high efficiency, fixed frequency, continuous-wave high-power klystron in metal-ceramic construction, for use in scientific and industrial applications. The tube has internal cavities, solenoid focusing, beam control by modulation anode and a high stability dispenser-type cathode.

QUICK REFERENCE DATA

Centre frequency (fixed tuned)	352.21 MHz
Bandwidth for 1dB drop in output power	± 0.5 MHz
Output power	1 MW
Cooling	water

This data must be in conjunction with GENERAL OPERATIONAL RECOMMENDATIONS for KLYSTRONS.

HEATING: indirect by a.c. or d.c.

Cathode		dispenser type			
		min.	typ.	max.	
Heater voltage	V_f	22	25	27	V
Heater current	I_f	20	23	25	A
Cold heater resistance	R_{fo}	—	100	—	m Ω
Waiting time	t_w	15	—	—	minutes

FOCUSING: electromagnetic

Solenoid current		8	10	12	A
Solenoid voltage		—	200	250	V
Solenoid resistance		—	20	—	Ω

GETTER-ION PUMP SUPPLY *

Operating voltage		3	3.3	4	kV
Operating current		—	10^{-3}	80	mA
Internal resistance of power supply		25	300	—	k Ω

* The tube is equipped with two ion getter pumps which can be operated individually or in a parallel arrangement at one power supply.

MECHANICAL DATA

Tube mounted in the mounting frame with solenoid.
Dimensions in mm

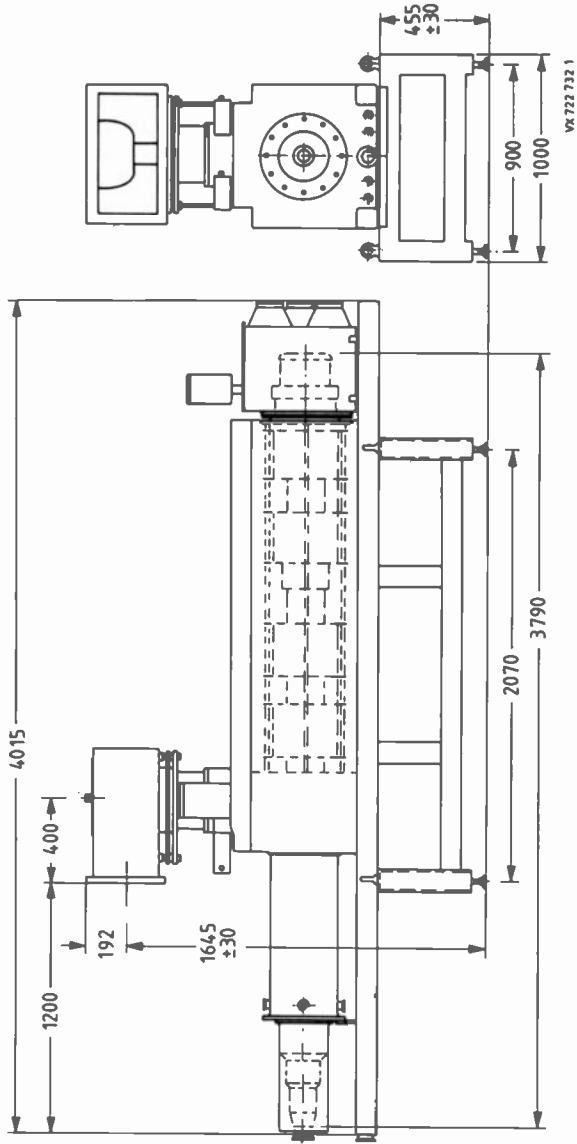

Fig. 1.

COOLING	min.	typ.	max.		
Cooling of collector and any body is achieved by filtered soft water.					
Pressure in any cooling water circuit	—	—	700	kPa	(=7 bar)
Pressure drop	—	—	300	kPa	(=3 bar)
Collector					
cooling water flow rate	800	1000	1200	ℓ/min	
inlet water temperature	—	+20	+75	°C	
outlet water temperature	—	+30	+90	°C	
Body circuit I					
cooling water flow rate	15	20	25	ℓ/min	
inlet water temperature	—	+20	+40	°C	
outlet water temperature	—	+40	+60	°C	
Body circuit II					
cooling water flow rate	15	20	25	ℓ/min	
inlet water temperature	—	+20	+40	°C	
outlet water temperature	—	+40	+60	°C	
Output window					
air	—	1	—	m ³ /min	
pressure drop	—	15	—	kPa	(=150 mbar)

MASS

Mass of complete assembly without demountable X-ray shield max. 3000 kg

DIMENSIONS of complete assembly

Length approx. 4 m
 Height approx. 1.9 m
 Width approx. 1 m

MOUNTING horizontal

COOLING WATER CONNECTORS

Body circuits I and II Walther series 0 - Type 4 (NW12)
 Collector Sandvik FCL-316L-76, 1-S-V

R.F. CONNECTORS

Input female connector, 50 Ω, type N
 Output WR2300 waveguide

ACCESSORIES

Transportation and operation frame	TE1351A
Focusing coil unit I	TE1351B
Focusing coil unit II	TE1351C
Coaxial/waveguide transition, WR2300 (R3)	TE1352
Waveguide support	TE1353
Collector cooling jacket I	TE1354A
Collector cooling jacket II	TE1354B
Cooling water collector	TE1355A
Interconnecting hoses	2 x TE1355B
H.V. oil tank	TE1356
Mounting rack	TE1359

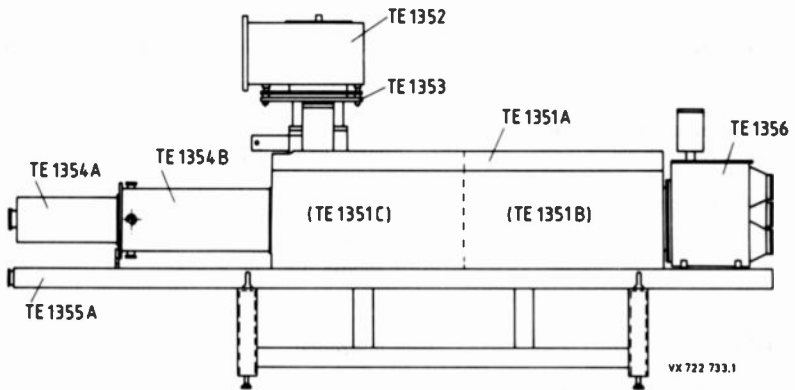

Fig. 2.

LIMITING VALUES (Absolute maximum rating system)

Heater voltage	}	max. 10% above specified values	
Heater current			
Cathode voltage to body (ground)	max.	-95	kV
Cathode current	max.	25	A
Modulation anode current	max.	10	mA
R.F. drive power	max.	150	W
C.W. output power	max.	1.1	MW
Load VSWR	max.	1.3	
Body dissipation	max.	20	kW
Collector dissipation	max.	900	kW *

TYPICAL OPERATING CONDITIONS

1 MW operation into matched load	typ.
Input power, d.c.	1470 kW
R.F. drive power	90 W
Collector dissipation	460 kW
Body dissipation	10 kW
C.W. output power	1000 kW
Efficiency	68 %
Beam voltage	90 kV
Beam current	16.3 A

PERFORMANCE DATA

Phase shift to cathode current	< 15 °/A
Phase shift to rel. cathode voltage	< 15 °/%
Phase shift to r.f. drive	< 10 °/dB
R.F. output to rel. cathode voltage	< 0.2 dB/%
Signal-to-noise ratio at saturation	60 dB
Harmonic levels to fundamental at saturation	30 dB
Ratio of fundamental to other discrete frequencies within bandwidth at saturation	70 dB

* 1600 kW for 1 s. can be tolerated with reduced drive.

INSTALLATION AND OPERATION REQUIREMENTS

A. Required interlocks

1. Fast switch-off of the drive power within 10 ms has to be done if the arc detector and/or r.f. reflection indicator is activated. An arc detector must be provided at the knee of the output waveguide.
2. A fast switch-off of the beam supply has to be provided when one of the following situations occurs:
 - a) the beam current increases rapidly,
 - b) the solenoid current deviates by more than $\pm 5\%$ from the adjusted value.
The switching sensors and the discharge facilities for the power supply must be designed so that a copper wire of 0.35 mm diameter, connected to the power supply instead of the klystron (length approx. 1 cm/kV), will not be destroyed, if the full operating voltage is switched on and applied to the wire.
3. The mains for the beam power supply has to be switched off within 100 ms when one of the following situations occur:
 - a) the beam current either exceeds the limiting value or increases by more than 30% or max. 2 A above the adjusted value,
 - b) the pump current exceeds 10 μA .
 - c) the monitored temperature differences between inlet and outlet in the collector and/or body cooling circuits are too high,
 - d) the collector temperature monitor (with internal thermocouple) is activated (switch-off value adjustable between 30 and 60 K above the water inlet temperature),
 - e) the water flow of the collector and body cooling circuits decreases below the required minimum value,
 - f) the air flow for the r.f. window and cathode cooling decreases below the required minimum value.
4. Switch-off the heater voltage for pump current $> 4 \text{ mA}$.

Restarting is not allowed within 10 s after any interruption.

B. Switching-on and off sequence

Switching-on sequence

1. Getter-ion pump supply on.
2. Check that the pump current is $< 10 \mu\text{A}$.
3. Heater voltage supply on.
4. Wait for preheating time (min. 15 minutes).
5. Cooling air r.f. window on.
6. Cooling body circuits I and II on.
7. Collector cooling supply on.
8. Solenoid current supply on.
9. Check that the heater current has reached the adjusted value $\pm 0.5 \text{ A}$.
10. R. F. drive on.
11. Beam voltage supply on.

Switching-off sequence

1. Beam voltage supply off.
2. All other supplies and cooling circuits off.

C. Radiation dangers*R.F. radiation*

R.F. power may be emitted not only through the normal output coupling but also through other apertures (for example, r.f. leaks). This r.f. power may be sufficiently intense to cause danger to the human body, particularly to the eyes. Such radiation may be increased if the tube is functioning incorrectly.

The r.f. radiation 1 m from any part of the klystron at 1 MW output power is max. 0.1 mW/cm^2 .

X-radiation

Due to the high accelerating voltage, the klystron generates a high level of X-rays which is reduced by the supplied shielding plates of the focus mount and the H.V. oil container. Nevertheless the complete assembly has to be shielded additionally during operation in order to reduce the radiation to a non-dangerous level. The tube manufacturer recommends a "lead garage", as shown in the drawing Fig. 3. Though the overall dimensions are not critical, it is essential, that any possible radiation path is blocked by at least 2 mm of lead sheets.

LEAD GARAGE

Dimensions in mm

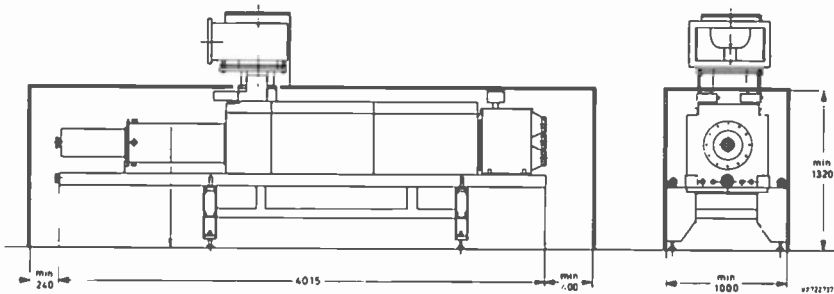

Fig. 3.

The "lead garage" will not be supplied by the tube manufacturer.



PULSED POWER KLYSTRONS

Fixed frequency 20 MW pulsed power amplifier klystrons in metal-ceramic construction with 5 internal cavities, electromagnetic focusing, continuously operating getter-ion pump.
Coaxial input connector and S-band output waveguide fitted with a ceramic window.
Water cooling system for r.f. waveguide and window, collector and body.
Intended for use in long-range radar transmitters.

QUICK REFERENCE DATA

Operating frequency		
YK1510		S-band, the klystrons are factory tuned to the specified frequency range
YK1511		
YK1512		
R.F. output power*		
peak	>	20 MW
average	>	20 KW
Duration of r.f. pulse (-3 dB down)		4 μ s
Gain		44 dB

This data must be read in conjunction with GENERAL OPERATIONAL RECOMMENDATIONS for KLYSTRONS.

HEATING, indirect by a.c. or d.c.

Heater voltage**	V_F	15 to 30 V
Heater current	I_F	20 to 30 A
Heater supply current at switch-on; the surge current must never exceed a peak value of 50 A.		
Resistance of heater		
cold	R_{fo}	> 0.125 Ω
hot	r_f	0.9 to 1.1 Ω
Waiting time	t_w	min. 12 min

* At least one point in the band.

** The exact value is marked on each tube test report. During operation the heater voltage may not fluctuate more than $\pm 5\%$.

YK1510
YK1511
YK1512

MECHANICAL DATA

Dimensions in mm

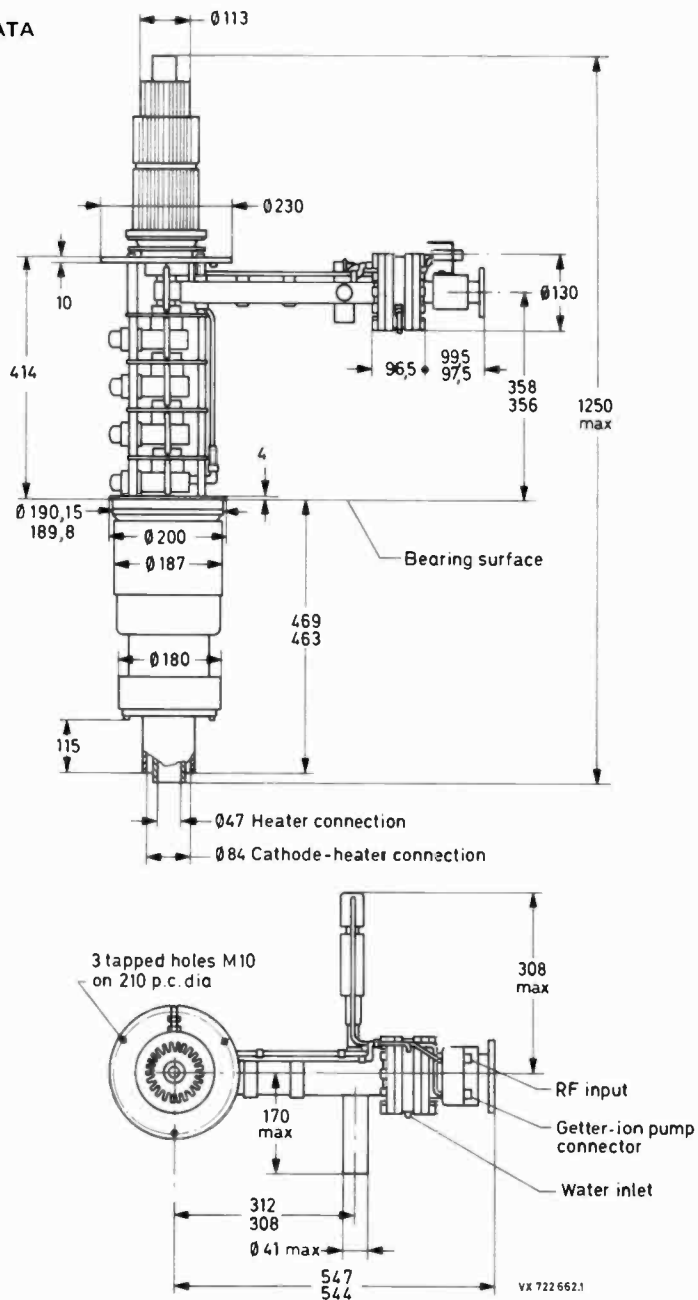

Fig. 1.

MASS (net)	approx.	70	kg
-------------------	---------	----	----

MOUNTING

Mounting position: vertical with collector up

GETTER-ION PUMP POWER SUPPLY

Pump voltage		4.5 to 5.5	kV
--------------	--	------------	----

Supply current

tube operating	max.	50	μ A
tube turned off	max.	200	mA

ELECTROMAGNET

Current I_1, I_2, I_3	max.	175	A
-------------------------	------	-----	---

Impedance of each coil (20 °C)		0.08	Ω
--------------------------------	--	------	----------

COOLING

Collector, body and window*	min.	max.	
Cooling-water inlet temperature	—	60	°C
Cooling-water flow	10	—	ℓ/min
Cooling-water inlet pressure	—	1000	kPa (= 10 bar)
Cooling-circuit pressure drop	—	600	kPa (= 6 bar)
Electromagnet	min.	max.	
Water flow	13	—	ℓ/min
Water inlet pressure	—	1000	kPa (= 10 bar)
Water inlet temperature	—	60	°C

* By means of a single water circuit.

YK1510
YK1511
YK1512

LIMITING VALUES (Absolute maximum rating system)

Beam voltage, peak	max.	270	kV
Beam current, peak	max.	275	A
R.F. input power			
peak	max.	5	kW
average	max.	10	W
R.F. output power			
peak	max.	23	MW
average	max.	23	kW
Load VSWR	max.	1.4	
Collector dissipation	max.	80	kW
Voltage pulse duration (measured at 70 %)	max.	6	μ s
Duty factor	max.	0.003	
Pressure on the output window	max.	1300	kPa (= 13 bar)
	min.	1100	kPa (= 11 bar)

PRODUCT SAFETY

1. X-radiation

Correct operation of the tube can be guaranteed only if a set of accessories, approved by the tube manufacturer, is used.

The operating tube generates X-rays which can penetrate the ceramic parts of the tube envelope. In order to reduce the radiation at any accessible points to an officially acceptable, non-dangerous level the tube must be shielded and any possible radiation path blocked by at least 1 mm of brass or an equivalent depth of non-magnetic X-ray absorbing material. The proper use of our accessories will provide the necessary shielding.

2. R.F. radiation

R.F. power may be emitted through apertures other than the normal output coupling (for example r.f. leaks). This r.f. power may be sufficiently intense to cause danger to the human body, particularly to the eyes. Such radiation may be increased if the tube is functioning incorrectly.

TYPICAL OPERATING CONDITIONS

Measured under matched load conditions (VSWR < 1.1)

Operating frequency*				S-Band
Bandwidth (-1 dB)				100 MHz
Beam voltage				240 kV
Beam current				254 A
R.F. input power, peak				1 kW
Operating mode	A	B	C	
Output power				
peak	20	10	10	MW
average	20	20	10	kW
R.F. pulse duration (-3 dB)	4	4	4	μ s
Pulse repetition rate	250	500	250	Hz
Duty factor	0.001	0.002	0.001	
Gain				44 dB
Efficiency				> 30 %
Perveance				2.0 to 2.3 μ A \cdot V ^{-3/2}

* The tube is tuned to a fixed frequency at the factory.

DEVELOPMENT DATA

This data sheet contains advance information and specifications are subject to change without notice.

YK1600

PULSED POWER KLYSTRON

Fixed frequency, pulsed power klystron in metal-ceramic construction for S-band with 5 internal cavities, electromagnetic focusing, continuously operating getter-ion pump.

Coaxial input connector and r.f. output split into two parallel waveguide arms with two r.f. ceramic windows.

Water cooling systems for r.f. windows, collector and body.

Intended for use for linear particle accelerator applications.

QUICK REFERENCE DATA

Frequency (fixed tuned)	f		2998.5	MHz
R.F. pulse width (at -3 dB)			4.5	μ s
R.F. output power				
peak	W_{op}	>	35	MW
average	W_o	>	15.75	kW
Gain	G	>	52	dB
Efficiency	η	>	45	%

This data must be read in conjunction with GENERAL OPERATIONAL RECOMMENDATIONS for KLYSTRONS.

HEATING: indirect by a.c.

Cathode

long life oxide type

		min.	typ.	max.	
Heater voltage *	V_f	17	20	25	V
Heater current	I_f	18	21	24	A
Cold heater resistance (20 °C)	R_{fo}	—	125	—	m Ω
Waiting time	t_w	15	—	—	minutes

GETTER-ION PUMP SUPPLY

Pump voltage	—	—	5	kV
--------------	---	---	---	----

* The actual value is marked on each tube test report.

MECHANICAL DATA

Dimensions in mm

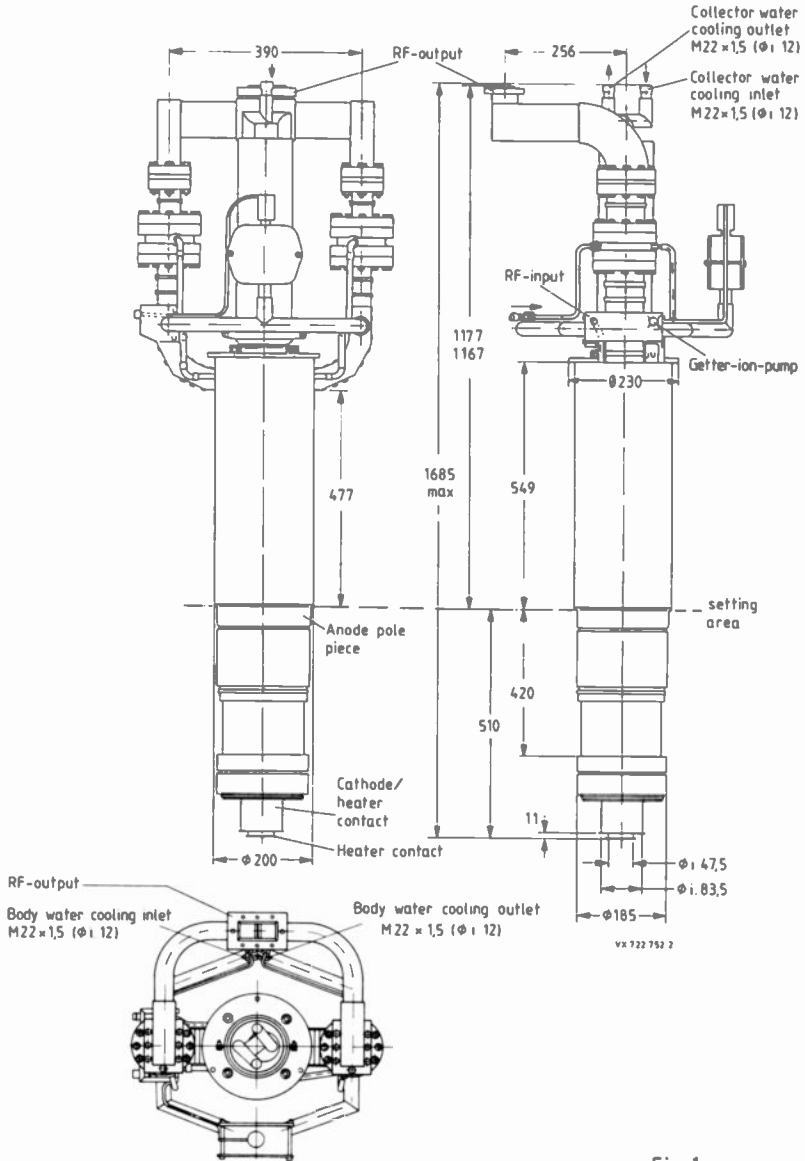

Fig. 1.

COOLING	min.	typ.	max.
Collector			
demineralized or distilled water with 10% stabilized glycol added	—	60	— ℓ/min
pressure drop	—	70	— kPa (= 0.7 bar)
Body circuit			
demineralized or distilled water with 10% stabilized glycol added	—	10	— ℓ/min
pressure drop	—	170	— kPa (= 1.7 bar)
Focusing coils			
demineralized or distilled water with 10 % stabilized glycol added	—	100	— kPa (= 1 bar)

MASS

Net mass YK1600, incl. combiner	120 kg
Magnet trolley	450 kg
X-ray shield collector	170 kg
X-ray shield body	300 kg

DIMENSIONS

Tube and mounting frame see drawing

MOUNTING

vertical, cathode down

R.F. CONNECTORS

Input N-type, female
Output waveguide, LIL-Flange V.W. 31 1240-2

CONNECTOR GETTER-ION PUMP

HN-type, female

ACCESSORIES

R.F. power combiner	TE1610
Focusing magnet	TE1612
Counter coil	TE1613
X-ray shield for body	TE1620
X-ray shield for collector	TE1621
Transport trolley klystron	TE1630
Lifting yoke for klystron	TE1631
Lifting device for collector shield	TE1632
Lifting device for magnet	TE1633
Magnet trolley	TE1634

LIMITING VALUES (Absolute maximum rating system)

Heater voltage	max.	25	V
Heater current	max.	24	A
Cathode voltage, peak	max.	300	kV
Cathode current, peak	max.	300	A
Collector dissipation	max.	80	kW
R.F. drive power			
peak	max.	1000	W
average	max.	10	W
R.F. pulse width	max.	6	μ s
H.V. pulse width	max.	7	μ s
Load VSWR			
for normal operation	max.	1.15	
permissible value *	max.	1.5	
Pressure on r.f. output windows SF ₆	max.	550	kPa (5.5 bar)

* Without destruction of the tube.

TYPICAL OPERATING CONDITIONS

Frequency	2998.5	MHz
Heater current	21	A
Heater power	420	W
Preheating time cathode	15	minutes
Supply voltage of getter-ion pump	5	kV
Load VSWR	<	1.04
Cathode voltage, peak	270	kV
Cathode current peak	280	A
Bandwidth (-1dB)	>	10 MHz
Perveance	2	$\mu\text{A}/\text{V}^{3/2}$
R.F. drive power, peak	175	W
R.F. pulse width at -3 dB	4.5	μs
Pulse repetition rate	100	Hz
Pressure on r.f. output windows SF ₆	550	kPa (5.5 bar)
R.F. output power		
peak	35	MW
average	15.75	kW
Gain	53	dB
Efficiency	>	45 %
Dissipation on klystron body	<	2 kW

DEVELOPMENT DATA

PRODUCT SAFETY

R.F. radiation

R.F. power may be emitted not only through the normal output coupling but also through other apertures (for example, r.f. leaks). This r.f. power may be sufficiently intense to cause danger to the human body, particularly to the eyes. Such radiation may be increased if the tube is functioning incorrectly.

X-radiation

A highly dangerous intensity of X-rays may be emitted by tubes operating at voltages higher than approximately 5 kV. Adequate protection (X-ray shielding) for the operator is then necessary. The emission intensity of X-rays may correspond to a value of voltage much higher than that expected from the actual value applied to the tube.

Poor focusing may result in excessive X-radiation.

This tube and accessories are equipped with a lead shielding which under normal conditions reduces the radiation values below 2.5 mR/h, measured at a distance of 0.4 m from the tube assembly.

INDEX OF TYPE NUMBERS

type	page
YK1001	21
YK1002	21
YK1110	35
YK1151	41
YK1190	63
YK1191	63
YK1192	63
YK1198	75
YK1210	83
YK1220	89
YK1223	89
YK1230	99
YK1233	99
YK1240	109

type	page
YK1250	117
YK1263	127
YK1265	127
YK1295	141
YK1296	141
YK1297	141
YK1300	151
YK1301	151
YK1305	151
YK1302	163
YK1350	173
YK1510	181
YK1511	181
YK1512	181
YK1600	187

NOTES

NOTES

NOTES

NOTES

NOTES

NOTES ✓

NOTES

NOTES

Ask AmpereX

Tomorrow's Thinking in Today's Products[®]

AmpereX Electronic Corporation

A NORTH AMERICAN PHILIPS COMPANY

HICKSVILLE DIVISION

230 Duffy Avenue
P.O. box 560
Hicksville N.Y. 11802

Telephone 516-931-6200
TWX 510-221-1839