

TECHNICAL MANUAL

STEREO 80 CONSOLE

994 6867 001

HARRIS CORPORATION Broadcast Equipment Division

MANUAL PART NO. 888 1515 001
Price: \$15.00

Printed: 1975 Feb.

SAFETY NOTICE

WARNING: THE CURRENTS AND VOLTAGES IN THIS EQUIPMENT ARE DANGEROUS AND UNDER CERTAIN CONDITIONS, COULD BE FATAL.

This manual is intended as general guidance for trained and qualified installation, operating, maintenance and service personnel who are familiar with and aware of the dangers inherent to handling potentially hazardous electrical and/or electronic circuits. It is not intended to contain a complete statement of all safety precautions which should be observed by personnel in using this or other electronic equipment.

THE INSTALLATION, OPERATION, MAINTENANCE AND SERVICING OF THIS EQUIPMENT INVOLVES RISKS TO BOTH PERSONNEL AND EQUIPMENT, AND MUST BE PERFORMED ONLY BY PROPERLY TRAINED AND EXPERIENCED PERSONNEL EXERCISING DUE CARE. PERSONNEL MUST FAMILIARIZE THEMSELVES WITH SAFETY REQUIREMENTS, SAFE HANDLING AND OPERATING PRACTICE, AND RELATED FIRST-AID PROCEDURES (E.G., FOR ELECTRICAL BURNS AND ELECTRICAL SHOCK).

HARRIS CORPORATION Broadcast Equipment Division shall not be responsible for injury or damage resulting from improper installation, operation, maintenance or servicing, or from the use of improperly trained or inexperienced personnel in the performance of such tasks, or from the failure of persons engaged in such tasks to exercise due care.

As with all electronic equipment, care should be taken to avoid electrical shock in all circuits where substantial currents or voltages may be present, either through design or short circuit. Caution should also be observed in lifting and hoisting equipment, especially regarding large structures, during installation.

LIABILITY LIMITATION

The procedures outlined in this Manual are based on the information available at the time of publication and should permit the specified use with minimum risk. However, the manufacturer cannot assume liability with respect to technical application of the contents and shall, under no circumstances, be responsible for damage or injury (whether to person or property) resulting from its use.

The manufacturer is specifically not liable for any damage or injury arising out of failure to follow the instructions in this Manual or failure to exercise due care and caution during installation, operation, maintenance and service of this equipment.

CAUTIONARY NOTICE

Always disconnect power before opening covers, doors, enclosures, gates, panels or shields. Always use grounding sticks and short out high voltage points before servicing. Never make internal adjustments, perform maintenance or service when alone or when tired.

Never remove, short-circuit or tamper with interlock switches on access covers, doors, enclosures, gates, panels or shields. Keep away from live circuits, know your equipment and don't take chances. Proper training of experienced personnel and observing the above guidelines will help assure safe and continued operation of this equipment.

TABLE OF CONTENTS

<u>Paragraph</u>		<u>Page</u>
SECTION I. GENERAL INFORMATION		
1-1.	Introduction	1-1
1-2.	Equipment Supplied	1-1
1-3.	Description	1-1
1-4.	Mixing Channels	1-2
1-5.	Channels 1 and 2	1-2
1-6.	Channel 3	1-2
1-7.	Channels 4, 5, 6, and 7	1-2
1-8.	Channel 8	1-2
1-9.	Program, Audition, and Cue Selection	1-2
1-10.	Program Channels	1-3
1-11.	Monitor Circuit	1-3
1-12.	Cue Circuit	1-3
1-13.	Power Supplies	1-3
1-14.	Muting and Warning Lights	1-3
1-15.	Specifications	1-4
SECTION II. INSTALLATION		
2-1.	Introduction	2-1
2-2.	Initial Inspection	2-1
2-3.	Preparation For Use	2-1
2-4.	Power Requirements	2-1
2-5.	Power Supply Assembly	2-1
2-6.	Power Cable	2-1
2-7.	Operating Environment	2-2
2-8.	Mounting	2-2
2-9.	Input Connections	2-2
2-10.	Microphone Inputs	2-3
2-11.	Modification Procedure for 30/50 ohm Microphones	2-3
2-12.	Medium Level Inputs	2-7
2-13.	Network and Remote Inputs	2-7
2-14.	External Monitor Input	2-7
2-15.	Output Connections	2-7
2-16.	Left Program Channel	2-9
2-17.	Right Program Channel	2-9
2-18.	Audition Outputs	2-9
2-19.	Cue Headphones	2-9
2-20.	Monitor and Intercom Speakers	2-10
2-21.	Warning Lights	2-10
2-22.	Muting	2-10
2-23.	Station Grounding	2-12
SECTION III. OPERATION		
3-1.	Introduction	3-1
3-2.	Controls and Indicators	3-1
3-3.	Control Adjustments	3-1
3-4.	General	3-1

1515

TABLE OF CONTENTS (cont'd)

<u>Paragraph</u>	<u>Page</u>
3-5. Procedure	3-1
3-6. Talk Back to Remote Location	3-9
3-7. Talk Back to Studio A and Studio B	3-9
SECTION IV. PRINCIPLES OF OPERATION	
4-1. Introduction	4-1
4-2. Circuit Description	4-1
4-3. Audio Preamplifier	4-1
4-4. Audio Booster	4-1
4-5. Audio Output	4-2
4-6. Power Supply	4-3
SECTION V. MAINTENANCE	
5-1. Introduction	5-1
5-2. Preventive Maintenance	5-1
5-3. Corrective Maintenance	5-1
5-4. Bias Adjustments	5-1
5-5. Preamplifier	5-1
5-6. Audio Output Amplifier	5-1
5-7. Troubleshooting	5-1
5-8. General Troubleshooting Techniques	5-1
5-9. Fault Location Guide	5-2
SECTION VI. PARTS LIST	
6-1. Introduction	6-1
SECTION VII. DIAGRAMS	
7-1. Introduction	7-1

LIST OF ILLUSTRATIONS

<u>Figure</u>	<u>Page</u>
1-1. Stereo 80 Console	vi
2-1. Power Transformer Connections	2-4
2-2. Input/Output Terminal Boards	2-5
2-3. Loss Pad Chart	2-8
2-4. Monitor and Intercom Speaker Connections	2-11
2-5. Muting Connections	2-12
3-1. Controls and Indicators	3-2
6-1. Location of Major Subassemblies	6-2

LIST OF TABLES

<u>Table</u>	<u>Page</u>
1-1. DC Power Distribution	1-4
1-2. Specifications	1-4
1-3. Supplemental Performance Characteristics	1-6
2-1. Power Connections	2-2
2-2. Input Connections	2-6
2-3. Output Connections	2-9
2-4. Monitor and Intercom Speaker Connections	2-10
3-1. Controls and Indicators	3-3
5-1. DC Circuit Voltages	5-2
5-2. Fault Location Guide	5-3

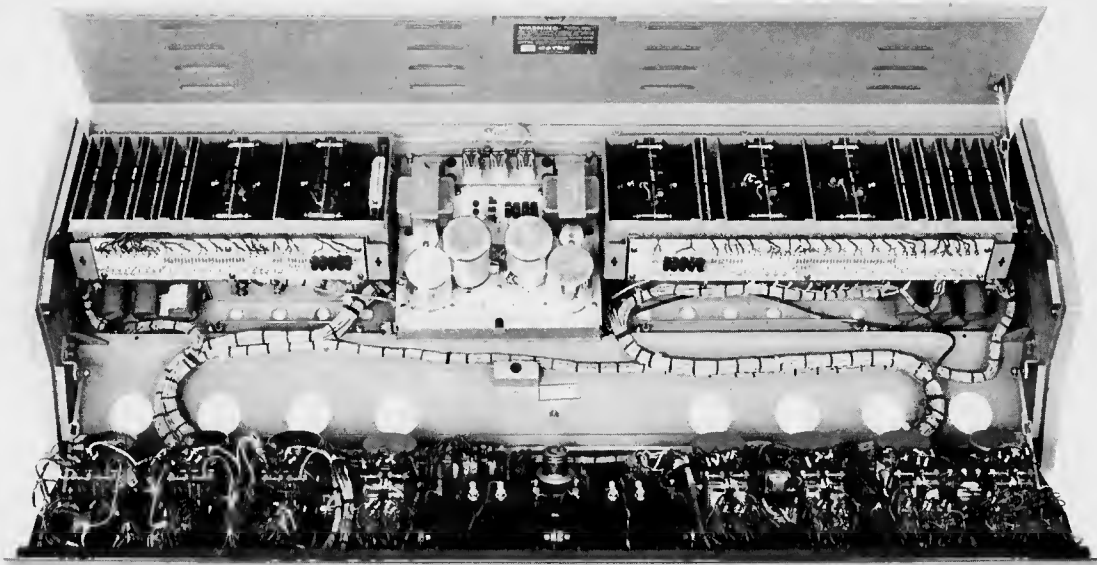
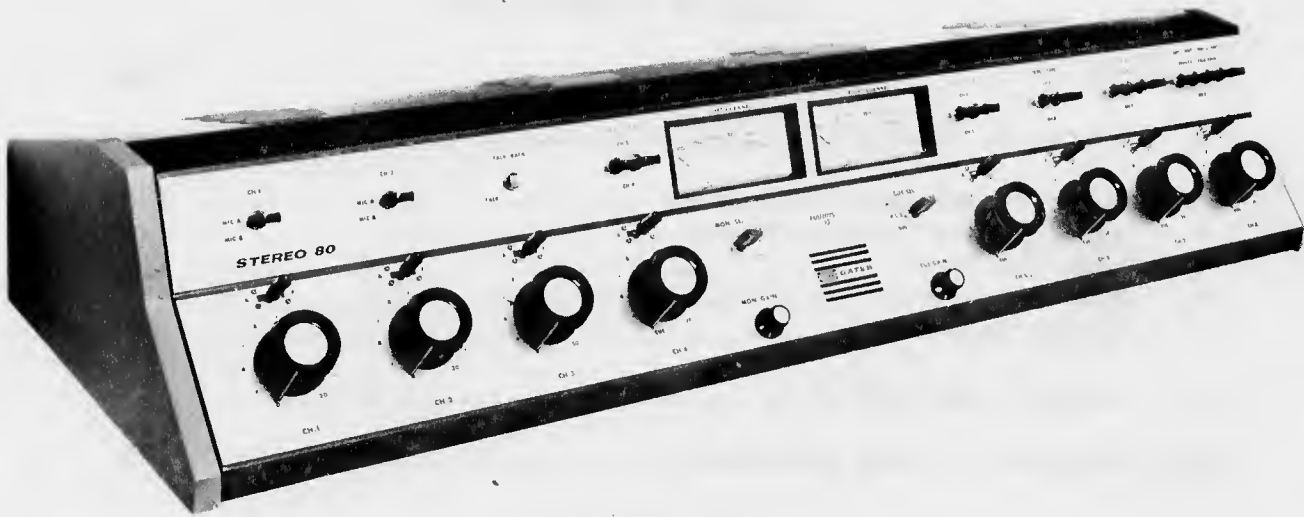

Figure 1-1. Stereo 80 Console

SECTION I

GENERAL INFORMATION

1-1. INTRODUCTION

This manual contains all information necessary to install, operate, and service the Stereo 80 Console, Model No. 994 6867 001. This section covers equipment identification, specifications, and other basic information. Figure 1-1 shows front and interior views of equipment supplied.

The various sections of this manual provide information as follows:

- a. SECTION II, INSTALLATION, provides information relative to incoming inspection, power requirements, input and output connections, and mounting requirements.
- b. SECTION III, OPERATION, provides identification and functions of front panel controls and indicators, and other information relative to operating the unit.
- c. SECTION IV, PRINCIPLES OF OPERATION, provides a description of electrical circuits.
- d. SECTION V, MAINTENANCE, provides information for service and fault location.
- e. SECTION VI, PARTS LISTS, provides information for ordering electrical parts and assemblies.
- f. SECTION VII, DIAGRAMS, provides block and schematic diagrams and other drawings necessary for maintaining the unit.

1-2. EQUIPMENT SUPPLIED

The Stereo 80 Console contains the following printed circuit modules: six preamplifier cards, five audio booster cards, and five audio output cards. All cards of the same type are interchangeable. A power supply assembly with front panel for installation in a standard 19-inch equipment rack is supplied as a separate unit. Also supplied with the console are the following items:

- a. Extender Card
- b. Knob Decal Kit
- c. Cue and Program Phone Jacks

1-3. DESCRIPTION

The Stereo 80 is a stereophonic audio console of solid state design and modular construction utilizing transistor circuitry mounted on printed circuit boards. Featuring eight stereo mixing channels and right and left program channels with monitor and cue capability, the Stereo 80

Console provides all necessary studio functions and facilities for the typical FM station that broadcasts stereophonic programs exclusively. Audition outputs are provided for recording and general production use. Selection of eighteen inputs include: five microphones, four turntables, five tapes (cartridge and reel-to-reel), three remote lines, and a network line.

1-4. Mixing Channels

1-5. Channels 1 and 2. These channels are equipped with low-noise preamplifiers for use with low-impedance, broadcast-type microphones. Each of these channels may select from two different input signals by means of a front panel switch.

1-6. Channel 3. This channel is equipped with a low-noise preamplifier and is also intended to be used with a low-impedance, broadcast-type microphone. Since this channel is assigned to the control room and functions as part of the talkback system, a single input is provided.

1-7. Channels 4, 5, 6, and 7. These channels are designed for medium level inputs and may be used with turntable preamplifiers, cartridge tape machines, or reel-to-reel tape machines. Inputs are selected by means of front panel switches. Input assignments are as follows:

Turntables (TT-1, TT-2, TT-3, TT-4): channel 4 or 5

Tapes (Tape 1, Tape 2): channel 5 or 6

Cartridge Tapes (CT-1, CT-2, CT-3): channel 6 or 7

1-8. Channel 8. This channel is specifically designed to function with network and remote lines as sources. Various combinations of preview, talkback, and program cue are possible using the front panel switches. Switching options for network and remote lines are as follows:

Network: Preview/Talkback or Channel 8 (center position is off)

Remote 1: Preview/Talkback or Program Cue or Channel 8

Remote 2: Preview/Talkback or Program Cue or Channel 8

Remote 3: Preview/Talkback or Program Cue or Channel 8

1-9. Program, Audition, and Cue Selection. Any of the eight Mixing Channels may be switched to either Program or Audition positions to permit independent monitoring or recording of incoming sources without disturbing programming. Channels 4 through 8 have a cue position associated with the channel attenuator which provides signal to the amplified cue system. This signal can be monitored by an internal speaker or external headphones. On Mixing Channels 1 and 2, the center position of the Program-Audition key switch provides a microphone cue signal to the Cue Selector switch. On Mixing Channel 3, this position is used with the control room microphone for talkback. All Mixing Channels include front panel variable attenuators for setting output signal levels.

1-10. Program Channels

The Left and Right Program Channels are identical. Each channel consists of a booster amplifier, audio output amplifier, VU meter, and a master gain control. The master gain control, an internal adjustment, is preset at the factory to remove 16 dB of gain from the circuit which is the optimum setting for providing adequate operating margins of signal-to-noise and "headroom". The VU meter is a standard volume indicator used in conjunction with the mixing channel attenuators to establish a reference volume of 0 VU which is equivalent to an output level of +8 dBm. Left and Right Channel outputs are available on the input/output terminal boards, TB1 and TB2. Provisions for connecting high-impedance headphones are also available on TB1 and TB2.

1-11. Monitor Circuit

The monitor circuit includes Left and Right Channels each consisting of a booster amplifier and an output amplifier. The Monitor Gain control and the Monitor Selector switch which are common to both channels, are available on the front panel. The Monitor Selector switch provides selection of three inputs: Program, Audition, or external source. The amplified output from the monitor circuit is available on terminal boards TB5 and TB6 for connection to Lobby, Studio, and Control Room monitor speakers.

1-12. Cue Circuit

The cue circuit consists of a booster amplifier, audio output amplifier, gain control, input selector switch, and a push-to-talk switch. The Cue Gain control, Cue Select switch and Talkback switch are front panel controls. The Cue Select switch provides selection of three inputs: Channel 1 microphone, Channel 2 microphone, or cue bus. The cue bus includes all medium level inputs and the network-remote lines. The Talkback switch, when placed in the TALK position, connects the Control Room microphone (CH. 3) to the cue circuit input and applies amplified output to studio intercom speakers or remote lines.

1-13. Power Supplies

The Power Supply Assembly contains a power transformer and four regulated dc power supplies which are designated LM (Left Monitor), RM (Right Monitor), LP (Left Program), and RP (Right Program). Distribution of dc voltage to the console is listed in table 1-1.

1-14. Muting and Warning Lights

A protective system of warning lights and speaker muting is provided to prevent acoustic feedback and broadcasting of a cue signal when "live" microphones are nearby.

WARNING: Disconnect primary power prior to servicing.

1-15. SPECIFICATIONS

Equipment specifications are listed in table 1-2. These specifications are the performance standards, or limits against which the equipment may be tested. Table 1-3 lists supplemental performance characteristics. Supplemental characteristics are not specifications but are typical characteristics included as additional information for the user.

Table 1-1. DC Power Distribution

<u>POWER SUPPLY</u>	<u>VOLTAGE</u>	<u>CIRCUIT</u>
Left Monitor	+45Vdc regulated +45Vdc regulated	Left Monitor Booster Amplifier Left Monitor Output Amplifier
Right Monitor	+45Vdc regulated +45Vdc regulated +45Vdc regulated +45Vdc regulated	Right Monitor Booster Amplifier Right Monitor Output Amplifier Cue Booster Amplifier Cue Output Amplifier
Left Program	+45Vdc regulated +45Vdc regulated +45Vdc regulated +64Vdc unregulated	Left Channel 1, 2, and 3 Pre-amplifiers Left Program Booster Amplifier Left Program Output Amplifier Muting Driver Board
Right Program	+64Vdc unregulated +45Vdc regulated +45Vdc regulated +64Vdc unregulated	VU Meter Lights Right Channel 1, 2, and 3 Pre-amplifiers Right Program Booster Amplifier Right Program Output Amplifier VU Meter Lights

Table 1-2. Specifications

MICROPHONE (Channels 1, 2, & 3 to Program Line Out)	
Maximum Gain:	100 ±2 dB
Frequency Response:	±1 dB, 20 to 20,000 Hz
Distortion:	Less than 0.5%, 20 to 20,000 Hz, +24 dBm output
Noise:	More than 75 dB below +18 dBm output with -50 dBm input. Equivalent input noise is better than -125 dBm, 20 to 20,000 Hz

WARNING: Disconnect primary power prior to servicing.

Table 1-2. Specifications (cont'd)

Crosstalk: Less than 10 dB above the Noise, with normal levels and control settings at 15 kHz

Microphone Impedance: 150 ohms, balanced, with C.T.
37.5 ohms, balanced, no C.T.

MEDIUM LEVEL (Channels 4 thru 7 to Program Line Out)

Maximum Gain: 60 \pm 2 dB or 36 \pm 2 dB

Frequency Response: \pm 1 dB, 20 to 20,000 Hz

Distortion: Less than 0.5%, 20 to 20,000 Hz at +24 dBm output

Noise: More than 80 dB below +18 dBm output with -10 dBm input, 20 to 20,000 Hz

Crosstalk: Less than 10 dB above the Noise, normal levels and control settings, at 15 kHz

Input Impedance: 600 ohms, balanced

NETWORK/REMOTES (Channel 8 to Program Line Out)

Maximum Gain: 54 \pm 2 dB

Frequency Response: \pm 1 dB, 20 to 20,000 Hz

Distortion: Less than 0.5%, 20 to 20,000 Hz at +24 dBm output

Noise: More than 80 dB below +18 dBm output with -10 dBm input, 20 to 20,000 Hz

Crosstalk: Less than 10 dB above the Noise, with normal levels and control settings at 15 kHz

Input Impedance: 600 ohms, balanced

AUDITION CIRCUITS

Maximum Gain: Mic to Aud Out 50 dB \pm 2 dB
Med to Aud Out 14 dB \pm 2 dB
Net to Aud Out 4 dB \pm 2 dB

Frequency Response: \pm 1 dB, 20 to 20,000 Hz

1515

Table 1-2. Specifications (cont'd)

Distortion:	Less than 0.5%, 20 to 20,000 Hz
Output Impedance:	600 ohms, balanced
MONITOR CIRCUITS	
Maximum Gain:	Mic Pgm to Mon Out 131 dB \pm 2 dB Mic Aud to Mon Out 116 dB \pm 2 dB Med Pgm to Mon Out 91 dB \pm 2 dB Med Aud to Mon Out 76 dB \pm 2 dB Ext Mon to Mon Out 48 dB \pm 2 dB
Frequency Response:	\pm 1 dB, 30 to 15,000 Hz
Distortion:	Less than 1%, 30 to 15,000 Hz at +40 dBm (10 Watts) output
Noise:	More than 80 dB below +40 dBm (10 Watts) output, 30 to 15,000 Hz
Crosstalk:	Less than 10 dB above the Noise, with normal levels and control settings, at 15 kHz

Table 1-3. Supplemental Performance Characteristics

POWER REQUIREMENTS	
Line Voltage and Frequency:	117V (as supplied)/234V, 50/60 Hz
Power Consumption:	120 Watts Maximum
Output Voltage:	Four (4) outputs, 45Vdc at 2.2 Amps, each, one (1) output 64Vdc unregulated
PHYSICAL SIZE	
Console:	45.0 inches wide (114.3 cm) 15.5 inches deep (39.37 cm) 7.75 inches high (19.685 cm)
Console Weight:	105 lbs. (47.63 kg)
Power Supply Assembly:	7.75 inches deep (19.68 cm) 19.0 inches wide (48.26 cm) 7.0 inches high (17.78 cm)

1515

SECTION II
INSTALLATION

2-1. INTRODUCTION

This section explains how to prepare the Stereo 80 Console for operation. Also included is information relative to power requirements, environmental requirements, input and output connections, etc.

2-2. INITIAL INSPECTION

Upon receipt of the Stereo 80 Console, inspect the shipping container for damage. If damage is evident, the shipping container and cushioning material should be kept until the unit has been checked mechanically and electrically.

The contents of the shipment should be as indicated on the packing list. If the contents are incomplete or if the unit is damaged electrically or mechanically, notify the carrier and Harris Broadcast Equipment Division. Keep the shipping materials for carrier's inspection.

2-3. PREPARATION FOR USE

2-4. Power Requirements

The Stereo 80 Console requires a power source of 117 or 234V ac $\pm 10\%$, 50 to 60 Hz, single phase. Power consumption is approximately 120 watts. The Power Supply Assembly, as delivered from the factory, is connected for operation from 117V ac.

2-5. Power Supply Assembly. The Power Supply Assembly is panel-mounted for installation in a standard 19-inch rack or desk pedestal. The power supply should be located several feet from the console in a position which permits free circulation of air. As shipped from the factory for domestic use, the primary windings of the power transformer are connected in parallel for 117V ac, 50/60 Hz operation. However, the two primary windings are accessible by removing the front panel and the printed circuit board. For 234V ac operation, connect the primary windings in series as illustrated in figure 2-1. Connect the power supply to the console by installing shielded twisted wire, size A.W.G. 22 or larger, from terminal board 2TB1 in the power supply to terminal board TB10 in the console. The two terminal boards are interconnected so that wires connect like terminal numbers (2TB1-1 to TB10-1, etc.) in accordance with information contained in table 2-1. Also, refer to the interconnection drawing, 815 4822 001, contained in section VII. Cable length should not exceed 100 feet.

2-6. Power Cable. In accordance with international safety standards the power supply is equipped with a three-wire power cable. When connected to an appropriate power line outlet, this cable grounds the power supply assembly. The cable includes a standard three-wire plug. In some countries, it may be necessary to obtain a special adapter for operation

from 234V ac service. These adapters are normally available at local electrical supply houses. The console assembly includes a ground stud for connection to the station ground system.

Table 2-1. Power Connections

<u>WIRE NO.</u> <u>(STP)</u>	<u>POWER SUPPLY</u> <u>TERMINAL NO.</u>	<u>CONSOLE</u> <u>TERMINAL NO.</u>
1	2TB1- 1	TB10- 1
	2TB1- 2	TB10- 2
2	2TB1- 3	TB10- 3
	2TB1- 4	TB10- 4
3	2TB1- 5	TB10- 5
	2TB1- 6	TB10- 6
4	2TB1- 7	TB10- 7
	2TB1- 8	TB10- 8
5	2TB1- 9	TB10- 9
	2TB1-10	TB10-10

2-7. Operating Environment

The operating environment should be within the following limitations:

- a. Temperature: 0°C to +55°C
- b. Relative Humidity: 5% to 95%, non-condensing
- c. Altitude: 10,000 feet

2-8. Mounting

As supplied from the factory, the Stereo 80 has seven "bumper" feet for desk-top mounting. These bumpers space the bottom of the console away from the desk surface to provide proper air ventilation. If permanent, desk-top mounting is required, remove the hardware from the "bumper" feet and replace it with longer bolts or screws, but remount the bumpers in their original position to allow the necessary air circulation beneath the console. All cable connections are made through the bottom of the console.

2-9. Input Connections

The input cables should be solder-connected to the terminals of TB1 and TB2 (figure 2-2) which are located along the front surface of the module compartment. These cables should be 2-conductor shielded wire, with an overall vinyl jacket. The vinyl jacket prevents the shield from shorting to other building grounds and resulting in a troublesome ground loop. Tie the input shields to the shield ground-bus provided beside TB1. Input connections are listed in Table 2-2. Also refer to the overall schematic provided in Section VII.

2-2

WARNING: Disconnect primary power prior to servicing.

CAUTION

To prevent unwanted ground loops, all wiring connected to TB1 and TB2 should be free from ground connections in the source equipment (microphones, turntable, pre-amplifiers, tape recorders, etc.). An ohmmeter check is recommended to be certain each wire is not grounded before connecting it to the console input. If this check is made, those sources showing no grounds may exhibit lower noise if the input transformer center tap is grounded. Center taps should not be grounded if the source line is grounded.

2-10. Microphone Inputs. Mic A, Ch 1 and Mic A, Ch 2 inputs are assigned (see Muting Assignments) as Studio A microphone inputs. Mic B, Ch 1 and Mic B, Ch 2 inputs are assigned as Studio B microphone inputs. The inputs for Channel 3 are for the control room microphones. The nominal level to these inputs is -60 dBm at 150 ohms. Microphones with impedances from 100 ohms to 250 ohms may be used. To use 30/50 ohm microphones, an internal modification is necessary.

2-11. Modification Procedure for 30/50 ohm Microphones. To use 30/50 ohm microphones, the following modification is necessary:

- a. Remove all modules from the card guide, noting their location.
- b. Remove the screws which hold the sockets in place in the bottom of the card guide, noting that the sockets "float" in their mountings.
- c. Remove the screws which hold the card guide to the console chassis and tip the card guide forward, toward the rear side of the front panel.
- d. Locate the desired transformer, T1, T2, T3, T4, T5, or T6. Note that the primary leads go to terminals 7 and 12 of the associated socket.
- e. Using a very small, flat screwdriver, insert it into the terminal 7 slot on the rear side of the socket, and pull on the blue wire; it should come out with only a slight amount of effort. If necessary, rock the screwdriver while removing the wire. Apply insulating tape to the terminal of the blue wire and dress it back out of the way.
- f. Attach a new terminal to the white wire of the transformer. Insert the white wire terminal into the No. 7 space of the socket.
- g. Replace the card rack and align the plastic sockets. Fasten the sockets to the card rack and replace the modules.

WARNING: Disconnect primary power prior to servicing.

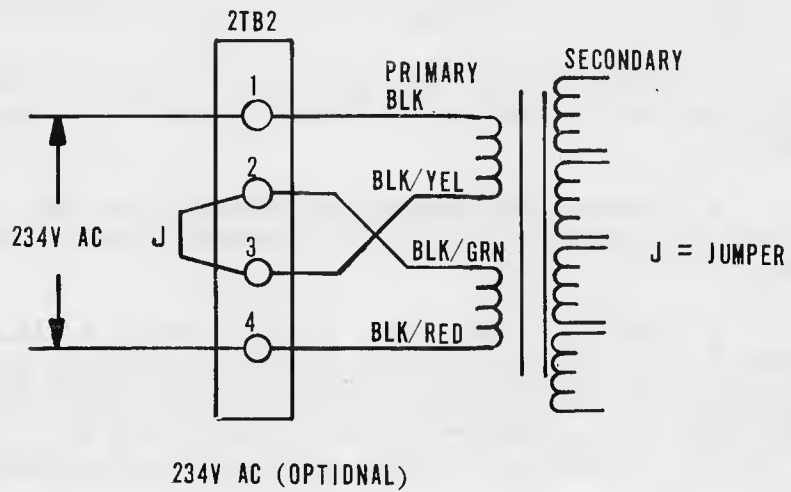
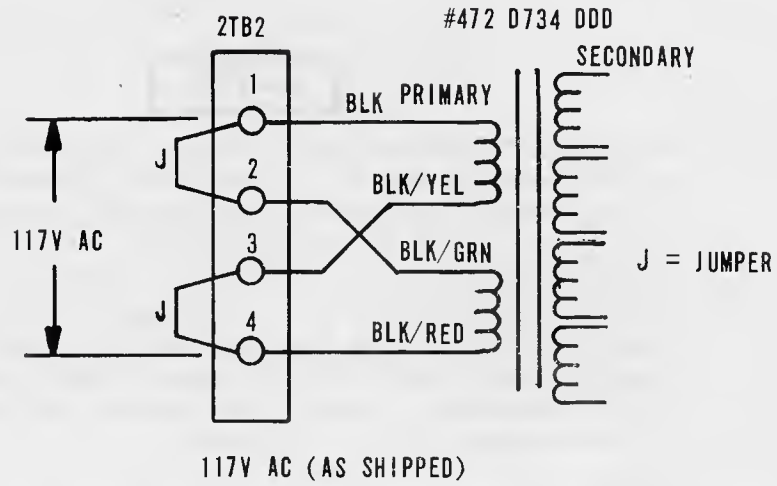
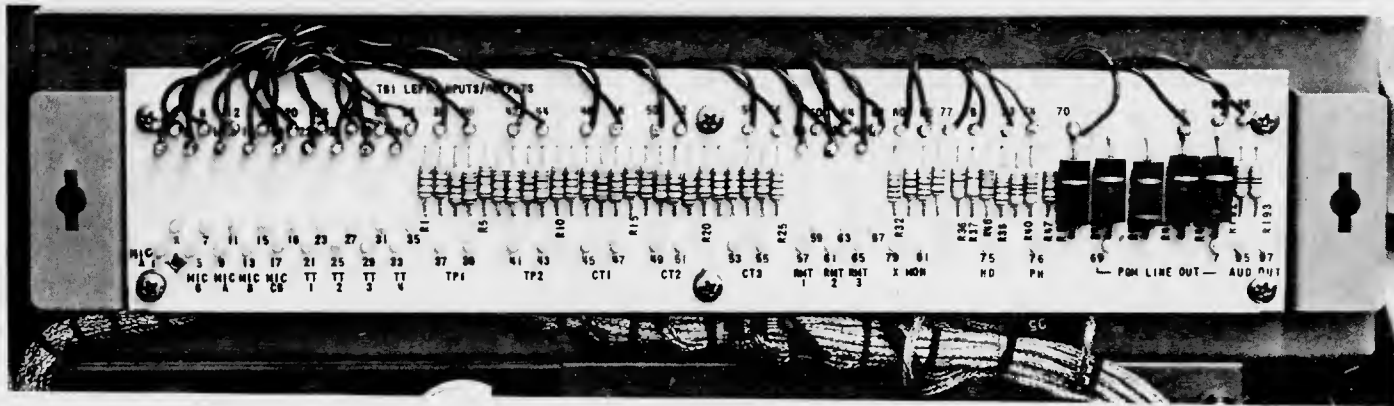
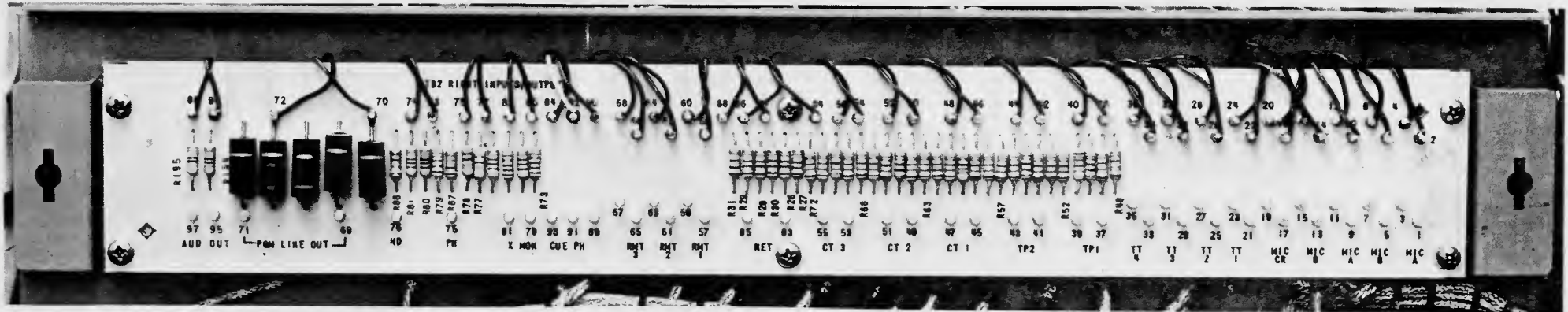

Figure 2-1. Power Transformer Connections



Left I/O Terminal Board, TB1



Right I/O Terminal Board, TB2

Figure 2-2. Input/Output Terminal Boards

Table 2-2. Input Connections

<u>MIXING CHANNEL</u>	<u>INPUT</u>	<u>TERMINAL BOARD CONNECTIONS</u>
1	Mic A Left	TB1- 1 and 3
1	Mic A Right	TB2- 1 and 3
1	Mic B Left	TB1- 5 and 7
1	Mic B Right	TB2- 5 and 7
2	Mic A Left	TB1- 9 and 11
2	Mic A Right	TB2- 9 and 11
2	Mic B Left	TB1-13 and 15
2	Mic B Right	TB2-13 and 15
3	Cont. Rm. Mic Left	TB1-17 and 19
3	Cont. Rm. Mic Right	TB2-17 and 19
4 or 5	TT-1 Left	TB1-21 and 23
4 or 5	TT-1 Right	TB2-21 and 23
4 or 5	TT-2 Left	TB1-25 and 27
4 or 5	TT-2 Right	TB2-25 and 27
4 or 5	TT-3 Left	TB1-29 and 31
4 or 5	TT-3 Right	TB2-29 and 31
4 or 5	TT-4 Left	TB1-33 and 35
4 or 5	TT-4 Right	TB2-33 and 35
5 or 6	Tape 1 Left	TB1-37 and 39
5 or 6	Tape 1 Right	TB2-37 and 39
5 or 6	Tape 2 Left ✓	TB1-41 and 43 ✓
5 or 6	Tape 2 Right ✓	TB2-41 and 43 ✓
6 or 7	CT-1 Left	TB1-45 and 47
6 or 7	CT-1 Right	TB2-45 and 47
6 or 7	CT-2 Left	TB1-49 and 51
6 or 7	CT-2 Right	TB2-49 and 51
6 or 7	CT-3 Left	TB1-53 and 55
6 or 7	CT-3 Right	TB2-53 and 55
8	Network	TB2-83 and 85
8	Remote 1 Left	TB1-57 and 59
8	Remote 1 Right	TB2-57 and 59

1515

Table 2-2. Input Connections (cont'd)

<u>MIXING CHANNEL</u>	<u>INPUT</u>	<u>TERMINAL BOARD CONNECTIONS</u>
8	Remote 2 Left	TB1-61 and 63
8	Remote 2 Right	TB2-61 and 63
8	Remote 3 Left	TB1-65 and 67
8	Remote 3 Right	TB2-65 and 67
	External Monitor Left	TB1-79 and 81
	External Monitor Right	TB2-79 and 81

NOTE

Do not over tighten the screws which hold the plastic sockets. These sockets must "float" in their mountings to allow self-alignment with the modules.

2-12. Medium Level Inputs. All medium level input channels, 4 through 7, present a 600 ohm, balanced input impedance. Nominal input levels are -20 dBm for the turntable inputs and +4 dBm for all tape inputs. The input levels for the various tape inputs can be lowered to -20 dBm by removing the correct pad on TB1 and TB2. (See the overall schematic for resistor numbers.) Only if the specific input sources are free of grounds, may the center taps of the corresponding input transformers be grounded for lowest noise.

2-13. Network and Remote Inputs. The Network/Remote inputs on Channel 8 all present a 600 ohm, balanced input impedance. Nominal input level is -14 dBm for the network line and -20 dBm for the remote line. This level may be raised as needed by installing the appropriate balanced H pad in place of the straight through connection now used. See the Loss Pad Chart (figure 2-3) for resistor values. The pad board is located next to switch S11 on the upper right of the front panel, and the change affects all inputs on Channel 8.

2-14. External Monitor Input. Each external monitor input presents a balanced 600 ohm input to match a 600 ohm source. The nominal input level is 0 dBm. This value may be raised by adjusting the values of R32 and R34 on TB1 and R73 and R75 on TB2. Refer to the overall schematic (852 6795 002) contained in section VII.

2-15. Output Connections

Output connections are provided on the Input/Output terminal boards, TB1 and TB2 (figure 2-2). Refer to table 2-3 and the overall schematic provided in section VII.

WARNING: Disconnect primary power prior to servicing.

600/600 ohms "T" pads			150/150 ohms "T" pads		
dB loss	R1-R2 ohms	R3 ohms	dB loss	R1-R2 ohms	R3 ohms
2	68	2700	2	18	750
4	130	1200	4	36	330
6	200	820	6	51	200
8	270	510	8	62	120
10	330	390	10	82	100
15	430	220	15	110	56
20	470	120	20	120	30
25	510	68	25	130	16

600/150 ohms "T" pads			
dB loss	R1 ohms	R2 ohms	R3 ohms
12(min)	510	6.8	160
15	510	51	110
20	560	100	62
25	560	120	33

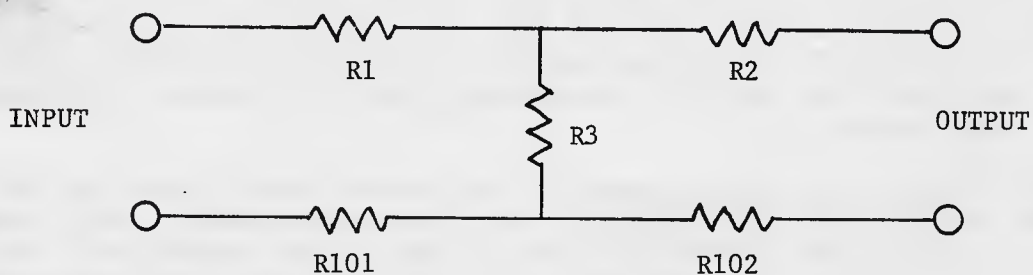

NOTE

This chart may be used for H pads by halving R1 and making R101 equal to half of R1, and by halving R2 and making R102 equal to half of R2. For T pads, simply short out R101 and R102 and use R1 and R2 values directly.

Figure 2-3. Loss Pad Chart

2-16. Left Program Channel. The Left Channel output is 600 ohms balanced, and provides +8 dBm output level when the Left Channel VU meter reads 0 VU. This output appears at terminals 69 and 71 of TB1. When loaded with 600 ohms, the maximum output level obtainable at this point is in excess of +30 dBm. This output level provides an adequate amount of headroom to prevent clipping of the program signal peaks. A high-impedance headphone output is available at terminals 75 and 76 of TB1. This output is bridged across the program output line before the 6-dB line pad and is balanced.

Table 2-3. Output Connections

<u>OUTPUT</u>	<u>TERMINAL BOARD CONNECTION</u>
Left Program Channel	TB1-69 and 71
Headphones, Left Channel	TB1-75 and 76
Left Audition Output	TB1-96 and 97
Right Program Channel	TB2-69 and 71
Headphones, Right Channel	TB2-75 and 76
Right Audition Output	TB2-95 and 97
Cue Headphones	TB2-89, 91, and 93

2-17. Right Program Channel. The Right Channel output is 600 ohms balanced, and provides a +8 dBm output level when the Right Channel VU meter reads 0 VU. This output appears at terminals 69 and 71 of TB2. When loaded with 600 ohms, the maximum output level obtainable at this point is in excess of +30 dBm. This output level provides an adequate amount of headroom to prevent clipping of the program signal peaks. A high-impedance headphone output is available at terminals 75 and 76 of TB2. This output is bridged across the program output line before the 6-dB line pad is balanced.

2-18. Audition Outputs. The left and right audition outputs are 600 ohm, balanced, and provide a -26 dBm output level when the VU Meter indicated "0" VU. The left audition output is available on terminals 95 and 97 of TB1; the right audition output is available on terminals 95 and 97 of TB2. The audition outputs provide a convenient source for recording and may be used for other purposes. This feature, which is independent of the monitor circuitry, permits the operator to record from any channel selected for audition while simultaneously monitoring the channel selected for broadcast.

2-19. Cue Headphones. The cue headphone jack connection points are terminals 89, 91, and 93 of TB2, and are intended for a shorting-switch phone jack. If this type jack is not used, a jumper across terminals 89 and 91 must be used. Using this jumper, however, will not allow the inserted headphones to disable the internal cue speaker, which may be desirable.

2-20. Monitor and Intercom Speakers. The connections for the monitor and intercom speakers are located on terminal boards TB5 and TB6 (figure 2-4), which are below the swing-up transformer deck. Loosening the two thumb screws at the back of the transformer deck will allow it to swing upward toward the front panel, exposing TB5 and TB6. Speaker connections are provided in table 2-4.

Table 2-4. Monitor and Intercom Speaker Connections

<u>SPEAKER</u>	<u>CONNECTION</u>	<u>MUTING</u>
Left Lobby	TB5-1 and 2	Not Muted
Left Studio A	TB5-3 and 4	Muted
Left Studio B	TB5-5 and 6	Muted
Left Control Room	TB5-7 and 8	Muted
Intercom Speaker Studio A	TB5-9 and 10	Muted
Right Lobby	TB6-1 and 2	Not Muted
Right Studio A	TB6-3 and 4	Muted
Right Studio B	TB6-5 and 6	Muted
Right Control Room	TB6-7 and 8	Muted
Intercom Speaker Studio B	TB6-9 and 10	Muted

It is important to make certain that the total load on the amplifier, from all speakers, does not drop below 8 ohms. Load impedance below 8 ohms will cause automatic protection circuitry in the output amplifier to function, causing the output to sound very distorted or garbled. If several 8-ohm speakers are needed, use the accessory 48/8-ohm speaker-matching transformer, part number 478 0291 000. Any combination of speakers is satisfactory if the total load is 8 ohms or greater.

2-21. Warning Lights. The connections for the Warning Lights are on terminal board TB7 which is also located underneath the swing-up transformer deck. Terminals 1 and 2 are for the 117V ac 60 Hz input voltage. If possible, connect the neutral side of the line to terminal 2 and the hot side to terminal 1. Terminals 7 and 8 are for Studio A terminals, 5 and 6 are for Studio B, and terminals 3 and 4 are for the Control Room. The warning lights should not be grounded, except through the power line, and they should not exceed 2 amperes of current.

2-22. Muting

As supplied from the factory, the Stereo 80 is arranged to mute in the following manner: Mic A, Ch 1 and Mic A, Ch 2 will mute the Studio A speakers. Mic B, Ch 1 and Mic B, Ch 2 will mute the Studio B speakers. The microphone on Channel 3 is intended for the Control Room and will mute the Control Room speaker and the Internal Cue speaker in the console.

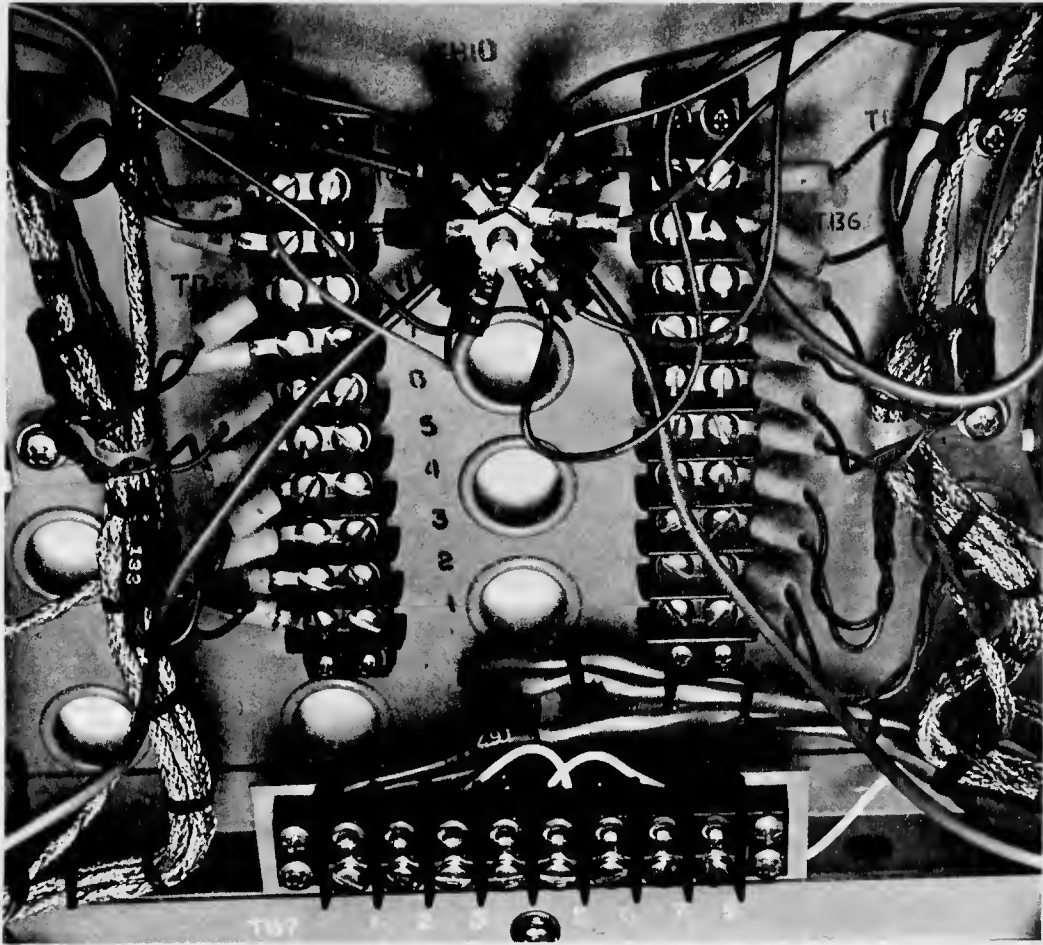

Figure 2-4. Monitor and Intercom Speaker Connections

This assignment is arbitrary for Channels 1 and 2; Channel 3 is fixed and must remain as assigned. It is however, easy to change Channels 1 and 2 if the operation of the muting system is understood. It operates as follows:

A control signal is derived from terminal 1 of the Relay and Muting Driver Board. This signal is fed to each of the Program-Audition switches associated with a microphone (Channels 1, 2, and 3). In the case of Channel 3, if the key switch is placed in either the Program or Audition mode, this signal is then fed back to terminal 11 of the Relay and Muting Driver Boards and mutes the Control Room speakers. (See Muting Assignment Drawing, 815 4821 001, contained in section VII.) In the case of Channels 1 and 2, if the Program Audition key switch is thrown, the drive signal is then fed to the wiper of the appropriate MIC A/MIC B selector switch. Depending upon what position the selector switch is in, the drive signal is then fed to terminals 1, 2, 5, or 6 of TB15, which is located between switches S1 and S2 on the rear of the front panel. Terminal 3 of TB15 represents the receive point for the Studio A muting drive signal and terminal 4 is the Studio B receive point.

1515

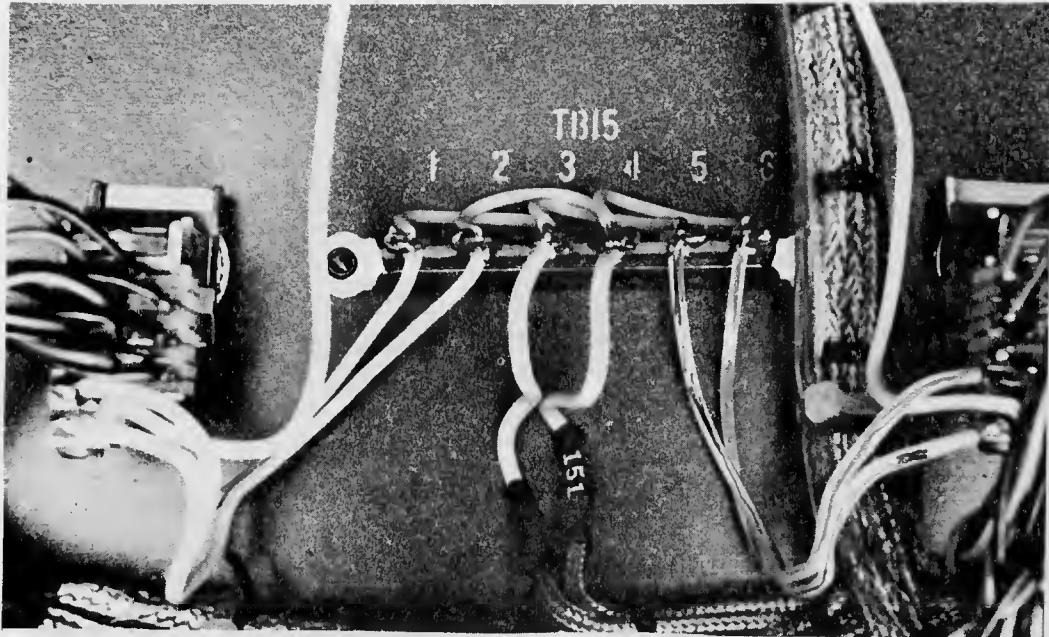

Figure 2-5. Muting Connections

With this information, it is possible to set up any muting configuration by adding or changing several jumpers on TB15 (figure 2-5).

For example:

Mic A/Ch 1, Mic A/Ch 2 to mute Studio A: Jumper 1 to 3 and 5 to 3 on TB15.

Mic A/Ch 1, Mic A/Ch 2 to mute Studio B: Jumper 1 to 4 and 5 to 4 on TB15.

All Mic's to mute Studio A: Jumper 1 to 3, 2 to 3, 5 to 3, and 6 to 3 on TB15.

2-23. Station Grounding

The ground stud, located underneath the transformer deck at the front left corner, should be connected to the station ground by means of a heavy copper wire or strap. This should be the only ground connection to the Stereo 80 Console.

SECTION III

OPERATION

3-1. INTRODUCTION

This section provides operating instructions for the Stereo 80 Console.

3-2. CONTROLS AND INDICATORS

All operating controls are contained on the console front panel. Figure 3-1 shows the front panel controls and indicators and provides reference to table 3-1 which describes the function of each control and indicator.

3-3. CONTROL ADJUSTMENTS

3-4. General

The Master Gain controls for Left Program Channel (AT11) and Right Program Channel (AT12) are internal adjustments. All Mixing Channel gain adjustments should be made with the Left Channel Master Gain and Right Channel Master Gain controls adjusted as delivered from the factory. In this position, the Master Gain controls remove 16 dB of gain from the circuit. This setting provides a good balance in the monitor circuit when switching from Program to Audition and is the best choice in providing adequate operating margins of signal-to-noise and "headroom".

3-5. Procedure

a. Adjust the CUE and MONITOR GAIN controls to mid-range and all channel attenuators to "12" on the dial (about 1:00 o'clock position). Apply power to the console and check to see that the VU meters are illuminated.

b. With a program signal on one of the medium level inputs (for example, TT1), set the TT1 input selector to the CH. 4 position and set the key switch for Channel 4 to the "P" (Program) position. The VU meters should respond to the program level variations. Adjust the program level at the source of the signal (Turntable, etc.) for peaks of 100 indicated on the VU meters.

c. Set the Monitor Selector switch to PGM and adjust the Monitor Gain control for a comfortable level from the Control Room monitor speakers.

d. Set the Channel 4 key switch in the "A" (Audition) position; this removes the signal from the program channel and connects it to the Audition channel. There should be signal present at the Audition Output terminals. Resetting the MON. SEL. switch to AUD position allows monitoring of the Audition channel with the same monitor speaker level as before.

Figure 3-1. Controls and Indicators

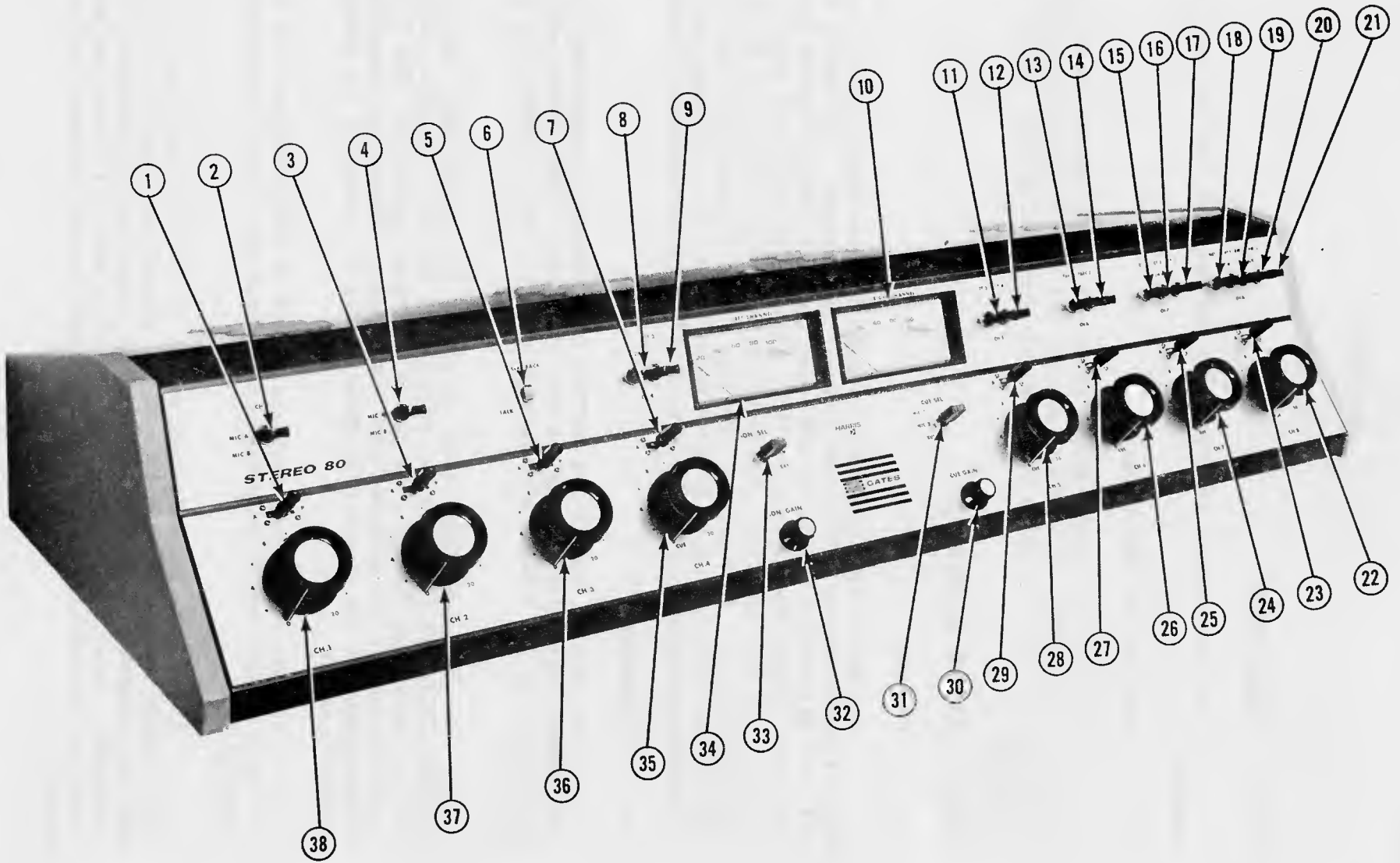

Table 3-1. Controls and Indicators

REF	CONTROL/INDICATOR	FUNCTION
1,3,5	A-P (Audition-Program) Key Switches Mixing Channel 1, S16 Mixing Channel 2, S17 Mixing Channel 3, S18	A position: applies the output of Mixing Channel to the Monitor Select switch and Audition output terminals. Center position: applies the output of Mixing Channel to Cue Select switch. P position: applies the output of Mixing Channel to the Program Channels.
2	CH. 1 MIC A/MIC B Input Select Switch, S1	MIC A position: selects MIC A input for Mixing Channel 1. MIC B position: selects MIC B input for Mixing Channel 1.
4	CH. 2 MIC A/MIC B Input Select Switch, S2	MIC A position: selects MIC A input for Mixing Channel 2. MIC B position: selects MIC B input for Mixing Channel 2.
6	TALKBACK/TALK switch, S25	TALK position: 1. connects Control Room Mic to cue Circuit. 2. applies output from cue circuit to intercom speakers and PREVIEW/TALKBACK position of NET/RMT switches.
8	TT-1 CH. 5/CH. 4 Mixing Channel	CH. 5 position: connects TT-1 (turntable 1) to Mixing Channel 5. Center position: off. CH. 4 position: connects TT-1 to Mixing Channel 4.
9	TT-2 CH. 5/CH. 4 Mixing Channel	CH. 5 position: connects TT-2 to Mixing Channel 5. Center position: off. CH. 4 position: connects TT-2 to Mixing Channel 4.

WARNING: Disconnect primary power prior to servicing.

Table 3-1. Controls and Indicators (cont'd)

REF	CONTROL/INDICATOR	FUNCTION
7	A-P (Audition-Program) Key Switches	A position: applies the output of Mixing Channel to Monitor Select switch and Audition Output terminals.
23	Mixing Channel 4, S19	Center position: off.
25	Mixing Channel 8, S23	P position: applies the output of Mixing Channel to the Program Channel
27	Mixing Channel 7, S22	
29	Mixing Channel 6, S21	
29	Mixing Channel 5, S20	
34	LEFT CHANNEL VU meter, M1	Standard volume indicator used in conjunction with Mixing Channel attenuators to establish a reference volume level of 0 VU which is equivalent to an output level of +8 dBm.
10	RIGHT CHANNEL VU meter, M2	
11	TT-3 CH. 4/CH. 5 Mixing Channel	CH. 4 position: connects TT-3 to Mixing Channel 4. Center position: off. CH. 5 position: connects TT-3 to Mixing Channel 5.
12	TT-4 CH. 4/CH. 5 Mixing Channel	CH. 4 position: connects TT-4 to Mixing Channel 4. Center position: off. CH. 5 position: connects TT-4 to Mixing Channel 5.
13	TAPE 1 CH. 5/CH. 6 Mixing Channel	CH. 5 position: connects tape machine 1 (reel-to-reel) to Mixing Channel 5. Center position: off. CH. 6 position: connects tape machine 1 to Mixing Channel 6.
14	TAPE 2 CH. 5/CH. 6 Mixing Channel	CH. 5 position: connects tape machine 2 to Mixing Channel 5. Center position: off.

WARNING: Disconnect primary power prior to servicing.

Table 3-1. Controls and Indicators (cont'd)

REF	CONTROL/INDICATOR	FUNCTION
15	CT-1 CH. 6/CH. 7 Mixing Channel	CH. 6 position: connects tape machine 2 to Mixing Channel 6. CH. 6 position: connects cartridge tape 1 to Mixing Channel 6. Center position: off. CH. 7 position: connects cartridge tape 1 to Mixing Channel 7.
16	CT-2 CH. 6/CH. 7 Mixing Channel	CH. 6 position: connects cartridge tape 2 to Mixing Channel 6. Center position: off. CH. 7 position: connects cartridge tape 2 to Mixing Channel 7.
17	CT-3 CH. 6/CH. 7 Mixing Channel	CH. 6 position: connects cartridge tape 3 to Mixing Channel 6. Center position: off. CH. 7 position: connects cartridge tape 3 to Mixing Channel 7.
18	NET PREVIEW/TALKBACK/CH. 8 Select Switch, S12	PREVIEW TALKBACK position: applies network input to Cue bus for selection by CUE SEL. switch. Center position: off. CH. 8 position: applies network input to Mixing Channel 8.

WARNING: Disconnect primary power prior to servicing.

Table 3-1. Controls and Indicators (cont'd)

REF	CONTROL/INDICATOR	FUNCTION
19	RMT 1 PREVIEW/TALKBACK/CH. 8 Select Switch, S13	PREVIEW/TALKBACK position: applies remote line 1 input to cue bus for selection by CUE SEL. switch. Center Position: provides Program Cue function by applying output of monitor circuit to remote line 1. CH. 8 position: applies remote line 1 input to Mixing Channel 8.
20	RMT 2 PREVIEW/TALKBACK/CH. 8 Select Switch, S14	PREVIEW/TALKBACK position: applies remote line 2 input to cue bus for selection by CUE SEL. switch. Center position: provides Program Cue functions by applying output of monitor circuit to remote line 2. CH. 8 position: applies remote line 3 input to Mixing Channel 8.
21	RMT 3 PREVIEW/TALKBACK/CH. 8 Select Switch, S15	PREVIEW/TALKBACK position: applies remote line 3 input to cue bus for selection by CUE SEL. switch. Center position: provides Program Cue function by applying output of monitor circuit to remote line 3. CH. 8 position: applies remote line 2 input to Mixing Channel 8.

WARNING: Disconnect primary power prior to servicing.

Table 3-1. Controls and Indicators (cont'd)

REF	CONTROL/INDICATOR	FUNCTION
22 24 26 28 35 36 37 38	Mixing Channel Attenuators CH. 8, AT8 CH. 7, AT7 CH. 6, AT6 CH. 5, AT5 CH. 4, AT4 CH. 3, AT3 CH. 2, AT2 CH. 1, AT1	Provide variable attenuation of selected input signals to establish the desired volume reference level as indicated on the Left and Right Channel VU meters. Attenuators for Mixing Channels 4 thru 8 have a CUE position which provides signal to the amplified cue signal.
30	CUE GAIN control, AT14	Controls gain of Cue circuit and used to establish desired volume level of Cue speaker/headphones after Mixing Channel attenuators have been set for proper indication on VU meter.
31	CUE SEL. switch, S26	Provides selection of the following inputs for Cue system: Mixing Channel 1 microphone, Mixing Channel 2 microphone, or Cue Bus.
32	MON. GAIN control, AT13	Controls gain of Monitor Circuit and is used to establish desired volume level of the Control Room speaker after Mixing Channel attenuators have been set for proper indication on VU meter.
33	MON. SEL switch, S24	Provides selection of the following inputs for the Monitor System: Program, Audition, or External source.

WARNING: Disconnect primary power prior to servicing.

e. Set the TT1 input selector to the CH. 5 position; set the key switch for Channel 5 to the "P" position, and note that the VU meters are indicating program variations which are now controlled by the Channel 5 attenuator. Monitor and Audition operation will be the same as Channel 4, described above.

f. Adjust the Channel 5 attenuator to the CUE position, and adjust the CUE GAIN control for a comfortable level from the cue speaker in the console or headphones.

g. Similarly, set the other medium-level inputs (TT2, TAPE 1, CT1, etc.), adjusting the program level at the source of the signal. This technique allows all channel attenuators to be used in approximately the same position ("12" on the dial) for normal VU meter indications.

h. Set the CH. 1 microphone input selector to MIC A and the CH. 1 key switch to Channel "P" position. Speaking about one foot from the microphone should give a normal indication on the VU meters. The microphone signal may be switched to the Audition channels by setting CH. 1 key switch to "A" position, and monitored in a normal manner. If the muting assignments are correct, the monitoring speakers near the microphone should be muted, and the warning lights in the area should be lit. Similarly, operate Channel 2 and Channel 3 to check levels and muting assignments.

By leaving the Channel 1 and 2 key switches in the center or neutral position, and selecting MIC 1 or MIC 2 on the CUE SEL. switch, you should be able to monitor these microphones through the cue system. The center position of the Channel 3 key switch is associated with the Talk Back system as described below.

The sources feeding Channels 4, 5, 6, and 7 are directed to the correct channel by using the input selector switch on the upper part of the front panel. When a given source selector is set downward, the signal is directed into the channel directly below the switch. When set in the "up" position, it goes to a different channel. Each input is clearly labeled above the input selector switch.

The four input selectors above the Channel 8 attenuator are for the Network feed and the Remote lines. When in the "down" position, all four inputs mix into Channel 8. The center position of the Network switch provides a 600-ohm terminated input for the feed line, while the center position of the three Remote switches provide a program cue to the remote location through the monitor amplifier in the console. In the "up" position, all four inputs can be previewed through the Cue system. The three Remote inputs also use this position for Talk Back.

NOTE

The Network input selector key should never be in the "up" position when the Talk Back feature is used.

3-6. Talk Back to Remote Location

During remote programming, Talk Back to the remote location is accomplished in the following manner:

- a. Place the correct input selector switch, RMT 1, RMT 2, or RMT 3, in the "up" (Preview/Talk Back) position.
- b. Place the CUE SEL. switch in the BUS position.
- c. The Control Room (CH. 3) Program-Audition switch is in the center or neutral position.

The signal coming from the remote location is placed on the cue bus and is heard over the cue speaker or headphones. The level is controlled by the CUE GAIN control. When you wish to talk to the remote location, talk into the Control Room microphone while holding down the white push-to-talk switch, located on the left side of the top front panel. In doing this, the output of the Control Room microphone pre-amplifier is fed directly to the cue amplifier, whose output is then fed down the remote line. The level going to the remote position should be adjusted by using the Channel 3 attenuator. Use the push-to-talk switch only while talking.

3-7. Talk Back to Studio A and Studio B

Talk Back to Studio A and Studio B is accomplished as follows:

- a. Set input selector switches NET, RMT 1, RMT 2, and RMT 3 to center (PROGRAM CUE) or down (mix). This will prevent a studio conversation from going out on the remote or net lines.
- b. Set the CUE SEL. switch to either MIC 1 or MIC 2, depending on the studio microphone assignment. This permits studio conversations to be heard through the console cue system. Use the console CUE GAIN control to adjust the level of the cue speaker.
- c. With the Control Room (CH. 3) Program-Audition key switch in the center position, set the TALK BACK switch in the TALK position and talk into the control room microphone. This conversation will be heard in both studios. Use the channel gain control (CH. 3) to adjust the level going out to the studios.

SECTION IV

PRINCIPLES OF OPERATION

4-1. INTRODUCTION

This section provides a description of the printed circuit modules contained in the card guide. Refer to the overall schematic diagram and the circuit schematic diagrams provided in section VII. Location of modules in the card guide is shown in figure 6-1.

4-2. CIRCUIT DESCRIPTION

4-3. Audio Preamplifier, Schematic 827 9272 001

The audio input signal is derived from the series-fed secondary winding of the associated microphone input transformer, T1, T2, T3, T4, T5, or T6 (refer to overall schematic, section VII). The high side of the secondary winding supplies the audio input signal to the base of transistor Q1 with the dc bias voltage from the decoupled emitter resistor, R14, of transistor Q2. Resistor R4 and capacitor C2 provide a high frequency load for the secondary of the input transformer, thereby preventing a rising response.

The input signal is amplified by transistor Q1 and directly coupled to the base of transistor Q2, where additional amplification takes place. Diodes CR1 and CR2 provide forward bias for the complementary output stage formed by transistors Q3 and Q4. The bias current is adjustable by means of variable resistor R10, which is shunted across CR1 and CR2.

Base resistors R8 and R11 prevent oscillation in output transistors Q3 and Q4. The feedback path from the output of Q3 and Q4 to the emitter of Q1 is through resistors R5 and R6, which set the gain of the preamplifier to 12. Capacitor C9 provides high frequency compensation.

Power supply filtering is provided by resistor R15 and capacitor C7. Additional filtering for transistor Q1 is provided by resistor R1 and capacitor C3.

4-4. Audio Booster, Schematic 828 8000 001

The input signal is supplied to the base of transistor 3Q1 by means of a series-fed secondary winding of an external transformer, T11 or T12 (refer to overall schematic, section VII). The secondary winding also provides the dc bias voltage to the base of transistor 3Q1 from the decoupled emitter resistor 3R10 of transistor 3Q2.

Transistor 3Q1 provides voltage gain to the input signal, which is directly coupled to the base of transistor 3Q2. Transistor 3Q2 supplies additional voltage gain to audio signal and provides the drive signal to

the output stage, transistor 3Q3. The output signal is coupled to the load through capacitor 3C9 and back to the emitter of transistor 3Q1 through capacitor 3R5. The ratio of feedback resistor 3R5 and emitter resistor 3R3 sets the voltage gain of the booster amplifier at 6.8.

Resistors 3R1 and 3R6 and capacitors 3C3, 3C10, and 3C5 provide RFI protection. Resistor 3R9 is a parasitic suppressor; capacitor 3C4 provides high frequency compensation. Capacitor 3C11 is a high frequency load for the secondary winding of the input transformer.

Power supply filtering is provided by resistor 3R11 and capacitor 3C8. Additional filtering for the input stage is provided by resistor 3R4 and capacitor 3C2.

An alternate input is used for the Cue Booster circuit. The input signal is coupled from terminal 9 through capacitor 3C1 to the base of transistor 3Q1. Bias for 3Q1 is provided by an external 1K ohm resistor, R86, connected between terminals 8 and 12 (refer to the overall schematic, section VII).

4-5. Audio Output, Schematic 827 7491 002

The input signal is applied to the base of transistor 2Q1 through blocking capacitor 2C2 and 2R26, a parasitic suppression resistor. The audio signal is amplified by 2Q1 and directly coupled to the base of transistor 2Q3, which also provides voltage gain. Transistor 2Q2 and associated components 2CR1, 2R2, and 2R7, form a constant current source which functions as the collector load for 2Q3.

Diodes 2CR2, 2CR3, and 2CR4 provide forward bias for the NPN driver and output transistors, 2Q4 and 2Q8, and the PNP driver and output transistors, 2Q7 and 2Q9. Transistors 2Q8 and 2Q9 form a complementary-symmetry output circuit. Output bias is adjusted by variable resistor 2R4.

High frequency compensation for the amplifier is provided by capacitor 2C3; capacitors 2C10 and 2C4 provide RFI protection. Power supply decoupling for the first stage, 2Q1, is provided by resistor 2R1 and capacitor 2C1.

Resistor 2R18 and capacitor 2C5 form a high frequency load across the output. The dc feedback path is through resistors 2R19 and 2R20. The ac feedback path is through capacitors 2C7 and 2C6 and resistors 2R21 and 2R20.

The amplifier protection circuit is formed by transistors 2Q5 and 2Q6, capacitors 2C8, 2C9, and 2C11, resistors 2R12, 2R13, 2R14, 2R15, 2R16, and 2R17, and diodes 2CR5, 2CR6, 2CR7, 2CR8, 2CR9, and 2CR10. This reduces drive to the output stage when an abnormal operating condition is present.

4-6. Power Supply, Schematic 842 7179 001

The Power Supply Assembly contains a power transformer (2T25) with four center-tapped secondary windings and four regulated dc power supplies which are identical except for reference designations. The following discussion references the Right Monitor (RM) Power Supply.

Single-phase full-wave rectification is accomplished by diodes 1CR1 and 1CR2 in conjunction with one center-tapped secondary winding of power transformer, 2T25. The rectified voltage is fed to a large filter capacitor, which is external to the pc board, and to the collector of series pass transistor 2Q1 and the collectors of drive transistors Q1 and Q5.

The regulated output voltage appears at the emitter of 2Q1 and flows through current sensing resistors R25 and R26 to the output terminals. This voltage is also applied to resistors R54, R33, R37, R41, and R50 which form a voltage divider, with resistor R37 being variable to provide adjustment of the output voltage.

The variable voltage from resistor R3 is applied to the base of the reference amplifier transistor, Q7. Reference voltage, generated by diodes CR37 and CR41 and resistor R45 which is connected to the regulated output, is applied to the emitter of Q7. Capacitor C9 is a filter across the reference diodes. Regulation is accomplished by varying the amount of current available from the current source (CR3 and CR33) to the base of the current amplifying transistors, Q1 and Q5, in response to variations in dynamic collector impedance of Q7. A foldback current limiting circuit is formed by transistor Q6, diode CR5, and resistors R25, R27, R17, and R21.

Diodes CR3, CR25, CR26, CR4, and CR6 provide reverse voltage protection. Resistors R1, R5, and 2R1 are parasitic suppressors, Thermostat 2S1 provides high temperature protection by activating at 100°C and applying ground to the base of Q5. Capacitors C1 and C5 provide high frequency compensation for the regulator.

WARNING: Disconnect primary power prior to servicing.

SECTION V

MAINTENANCE

5-1. INTRODUCTION

This section provides information for servicing the Stereo 80 Console. Standard testing techniques for semiconductor devices apply to the circuitry contained in this unit.

Measure dc voltages with the same meter that will be used for maintenance. Record these voltages on the schematic for reference should troubleshooting be required.

Do not remove or insert transistors with power applied. The failure time for transistors is measured in microseconds and a momentary short is all that is required to damage them in some circuits. Observe polarities when installing new capacitors and diodes.

5-2. PREVENTIVE MAINTENANCE

Preventive maintenance for this unit is limited to standard good housekeeping practices. Dust and dirt should be removed periodically. Using a soft brush, remove dust and dirt from power transformers, rectifiers, and other components that require heat dissipation for proper operation.

5-3. CORRECTIVE MAINTENANCE

5-4. Bias Adjustments

The following measurements, and other general module testing, may be easily performed by using the PC Extender Board supplied with the console. Remove the module, insert the Extender Board in its place, and plug the module into the Extender Board, maintaining the same orientation as the other modules. Reversed orientation may damage the module. Bias adjustments should be performed whenever circuit components are replaced or component value changes are suspected.

5-5. Preamplifier. Referring to schematic 827 9272 001 contained in section VII, locate and adjust variable resistor R10 to set the no-signal dc voltage across resistor R17 to 25mV \pm 5mV.

5-6. Audio Output Amplifier. Referring to schematic 827 7491 002 contained in section VII, locate and adjust variable resistor 2R4 to set the no-signal dc voltage across resistor 2R15 to 12mV \pm 2.5mV.

5-7. Troubleshooting

5-8. General Troubleshooting Techniques. When a malfunction occurs, the first step is to isolate the problem in a particular channel or amp-

WARNING: Disconnect primary power prior to servicing.

lifier. This is done by noting which signal paths and controls affect the troublesome operation. Possibly, disconnecting certain input or output wiring will stop the malfunction, indicating a bad ground connection or shorted-load condition.

If the trouble is in the console, the next step is to measure the dc circuit voltages. The individual amplifiers are of the direct-coupled type, and proper biasing of each circuit is indicated by a single module measurement at the output of each circuit. These voltages are listed in table 5-1.

Table 5-1. DC Circuit Voltages

<u>MODULE</u>	<u>VOLTAGE</u>	<u>TEST POINT</u>
Preamplifier	21.5 Vdc	positive (+) side of capacitor C8
Booster Amplifier	36.0 Vdc	positive (+) side of capacitor C9
Output Amplifier	22.0 Vdc	junction of resistors 2R14 and 2R15
Power Supply	45.0 Vdc	2TB1-3, 7, 15, and 19

Since all signal circuits are connected to regulated power supply modules, their voltages may be expected to be very constant. However, variations in the power line will cause proportionate variations in the voltages across filter capacitors 2C1, 2C2, 2C3, and 2C4 (64 Vdc), and Muting Relays K1, K2, and K3.

5-9. Fault Location Guide. The information contained in Table 5-2, Fault Location Guide, is presented as an aid to troubleshooting. This table lists the most common trouble symptoms for this type of equipment and includes the probable cause and corrective action required.

Table 5-2. Fault Location Guide (cont'd)

TROUBLE SYMPTOM	PROBABLE CAUSE	CORRECTIVE ACTION
RIGHT MONITOR AND CUE OPERATION IS INTERMITTENT.	1. RM Power Supply overheating.	<p>1e. The faulty module is indicated when 45 Vdc is present at 2TB1-19. Repair or replace module.</p> <p>1a. Check power supply. If it is hot, thermostat switch 2S1 may be operating to protect the power supply. Check wiring for shorts.</p>
RIGHT MONITOR INOPERATIVE.	1. Right Monitor Booster Amplifier.	1a. Check module by substitution or voltage measurement. Repair or replace if defective.
	2. Right Monitor Output Amplifier.	2a. Check module by substitution or voltage measurement. Repair or replace if defective.
CUE INOPERATIVE.	1. Cue Booster Amplifier.	1a. Check module by substitution or voltage measurement. Repair or replace if defective.
	2. Cue Output Amplifier.	2a. Check module by substitution or voltage measurement. Repair or replace if defective.
LEFT MONITOR INOPERATIVE.	1. Left Monitor (LM) Power Supply.	<p>1a. Check power supply capacitor 2C3 for 64 Vdc.</p> <p>1b. Check power supply output at 2TB1-3 for 45 Vdc.</p>

WARNING: Disconnect primary power prior to servicing.

Table 5-2. Fault Location Guide (cont'd)

TROUBLE SYMPTOM	PROBABLE CAUSE	CORRECTIVE ACTION
LEFT MONITOR INTERMITTENT.	<ol style="list-style-type: none"> 1. LM Power Supply overheating. 2. Left Monitor Booster Amplifier. 3. Left Monitor Output. 	<ol style="list-style-type: none"> 1c. If 45 Vdc is not present, remove the connections between the console and 2TB1-2 and 3. Check for 45 Vdc between 2TB1-3 and 4. If 45 Vdc is present with console interconnections removed, the problem is in the console. Restore interconnecting wiring and proceed to next step. 1d. Sequentially remove the following modules while monitoring 2TB1-3 for 45 Vdc. <ol style="list-style-type: none"> a. Left Monitor Booster Amp. b. Left Monitor Output Amp. 1e. The faulty module is indicated when 45 Vdc is present at 2TB1-3. Repair or replace if defective. 2a. Check module by substitution or voltage measurement. Repair or replace if defective. 3a. Check module by substitution or voltage measurement. Repair or replace if defective. 1a. Check power supply. If it is hot, thermostat switch 2S3 may be overheating to protect the

WARNING: Disconnect primary power prior to servicing.

Table 5-2. Fault Location Guide (cont'd)

TROUBLE SYMPTOM	PROBABLE CAUSE	CORRECTIVE ACTION
<p>RIGHT PROGRAM AND MIXING CHANNELS 1, 2, and 3 INOPERATIVE.</p>	<p>1. Right Program (RP) Power Supply.</p>	<p>power supply. Check wiring for shorts.</p> <p>1a. Check power supply capacitor 2C2 for 64 Vdc.</p> <p>1b. Check power supply output at 2TB1-15 for 45 Vdc.</p> <p>1c. If 45 Vdc is not present, remove the connections between the console and 2TB1-15 and 14. Check for 45 Vdc between 2TB1-15 and 16. If 45 Vdc is not present with console interconnections removed, the problem is in the console. Restore interconnecting wiring and proceed to next step.</p> <p>1d. Sequentially remove the following modules while monitoring 2TB1-15 for 45 Vdc:</p> <ul style="list-style-type: none"> a. Ch. 1 Preamplifier b. Ch. 2 Preamplifier c. Ch. 3 Preamplifier d. Right Program Booster Amp. e. Right Program Output Amp. <p>1e. The faulty module is indicated when 45 Vdc is present at 2TB1-15. Repair or replace module.</p>

WARNING: Disconnect primary power prior to servicing.

Table 5-2. Fault Location Guide (cont'd)

TROUBLE SYMPTOM	PROBABLE CAUSE	CORRECTIVE ACTION
RIGHT PROGRAM AND MIXING CHANNELS 1, 2, and 3 INTERMITTENT.	1. RP Power Supply overheating.	1a. Check power supply. If it is hot, thermostat switch 2S2 may be operating to protect the power supply. Check wiring for shorts.
RIGHT PROGRAM INOPERATIVE.	1. Right Program Booster Amplifier. 2. Right Program Output Amplifier.	1a. Check module by substitution or voltage measurement. Repair or replace if defective. 2a. Check module by substitution or voltage measurement. Repair or replace if defective.
RIGHT MIXING CHANNEL 1, 2, or 3 INOPERATIVE.	1. Ch. 1 Preamplifier. 2. Ch. 2 Preamplifier. 3. Ch. 3 Preamplifier.	1a. Check module by substitution or voltage measurement. Repair or replace if defective. 2a. Check module by substitution or voltage measurement. Repair or replace if defective. 3a. Check module by substitution or voltage measurement. Repair or replace if defective.
LEFT PROGRAM, LEFT MIXING CHANNELS 1, 2, and 3, AND MUTING INOPERATIVE.	1. Left Program (LP) Power Supply.	1a. Check power supply capacitor 2C4 for 64 Vdc. 1b. Check power supply output at 2TB1-7 for 45 Vdc.

WARNING: Disconnect primary power prior to servicing.

Table 5-2. Fault Location Guide (cont'd)

TROUBLE SYMPTOM	PROBABLE CAUSE	CORRECTIVE ACTION
<p>LEFT PROGRAM, LEFT MIXING CHANNELS 1, 2, and 3, AND MUTING INTERMITTENT.</p>	<p>1. LP Power Supply overheating.</p>	<p>1c. If 45 Vdc is not present, remove the connections between the console and 2TB1-7 and 6. Check for 45 Vdc between 2TB1-7 and 8. If 45 Vdc is not present with console interconnections removed, the problem is in the console. Restore interconnecting wiring and proceed to next step.</p> <p>1d. Sequentially remove the following modules while monitoring 2TB1-7 for 45 Vdc:</p> <ul style="list-style-type: none"> a. Ch. 1 Preamplifier b. Ch. 2 Preamplifier c. Ch. 3 Preamp ifier d. Left Program Booster Amp. e. Left Program Output Amp. <p>1e. The faulty module is indicated when 45 Vdc is present at 2TB1-7. Repair or replace module.</p> <p>1a. Check power supply. If it is hot, thermostat switch 2S4 may be overheating to protect the power supply. Check wiring for shorts.</p>

WARNING: Disconnect primary power prior to servicing.

Table 5-2. Fault Location Guide (cont'd)

TROUBLE SYMPTOM	PROBABLE CAUSE	CORRECTIVE ACTION
LEFT PROGRAM INOPERATIVE.	<ol style="list-style-type: none"> 1. Left Program Booster Amplifier. 2. Left Program Output Amplifier. 	<ol style="list-style-type: none"> 1a. Check module by substitution or voltage measurement. Repair or replace if defective. 2a. Check module by substitution or voltage measurement. Repair or replace if defective.
LEFT MIXING CHANNEL 1, 2, or 3 INOPERATIVE.	<ol style="list-style-type: none"> 1. Ch. 1 Preamplifier. 2. Ch. 2 Preamplifier. 3. Ch. 3 Preamplifier. 	<ol style="list-style-type: none"> 1a. Check module by substitution or voltage measurement. Repair or replace if defective. 2a. Check module by substitution or voltage measurement. Repair or replace if defective. 3a. Check module by substitution or voltage measurement. Repair or replace if defective.
MUTING INOPERATIVE.	<ol style="list-style-type: none"> 1. Muting Assignment. 2. Relay or Muting Driver Board or relays K1, K2, or K3. 	<ol style="list-style-type: none"> 1a. Check muting assignment. 2a. Check for 64 Vdc on pin 1 of relay and muting driver board. 2b. With all key switches off, measure the voltage at pins 9, 10, and 11 for 63.4 Vdc (0.6 Vdc less than pin 1 reading). The same voltage should be present on terminals 3 and 4 of TB15.

WARNING: Disconnect primary power prior to servicing.

Table 5-2. Fault Location Guide (cont'd)

TROUBLE SYMPTOM	PROBABLE CAUSE	CORRECTIVE ACTION
<p>HIGH FREQUENCY OSCILLATION.</p> <p>METER POINTER NOT AT ZERO.</p>	<p>1. Input or output lines improperly grounded.</p> <p>2. Power improperly grounded.</p> <p>1. Zero adjustment.</p>	<p>2c. Check relays K1, K2, and K3 for proper operation. Check for open relay coil.</p> <p>2d. Check diodes CR2, CR3, and CR4.</p> <p>1a. Check input and output ground connections. Restore connections if required.</p> <p>2a. Check system power ground and input/output devices for ground loops.</p> <p>1a. The pointer adjustment is located on the rear of the meter case between the terminals.</p>

WARNING: Disconnect primary power prior to servicing.

SECTION VI

PARTS LIST

6-1. INTRODUCTION

This section provides a description, reference designation, and order number for replaceable electrical parts and assemblies. Figure 6-1 provides identification of major assemblies.

NOTICE

Actual component values may vary slightly from component values contained in schematics and parts lists. Due to industry-wide shortages of electrical components, it is sometimes necessary to use parts other than those specified. In every case, however, a substitute part is selected for conformance to overall design specifications so that equipment performance is not affected.

WARNING: Disconnect primary power prior to servicing.

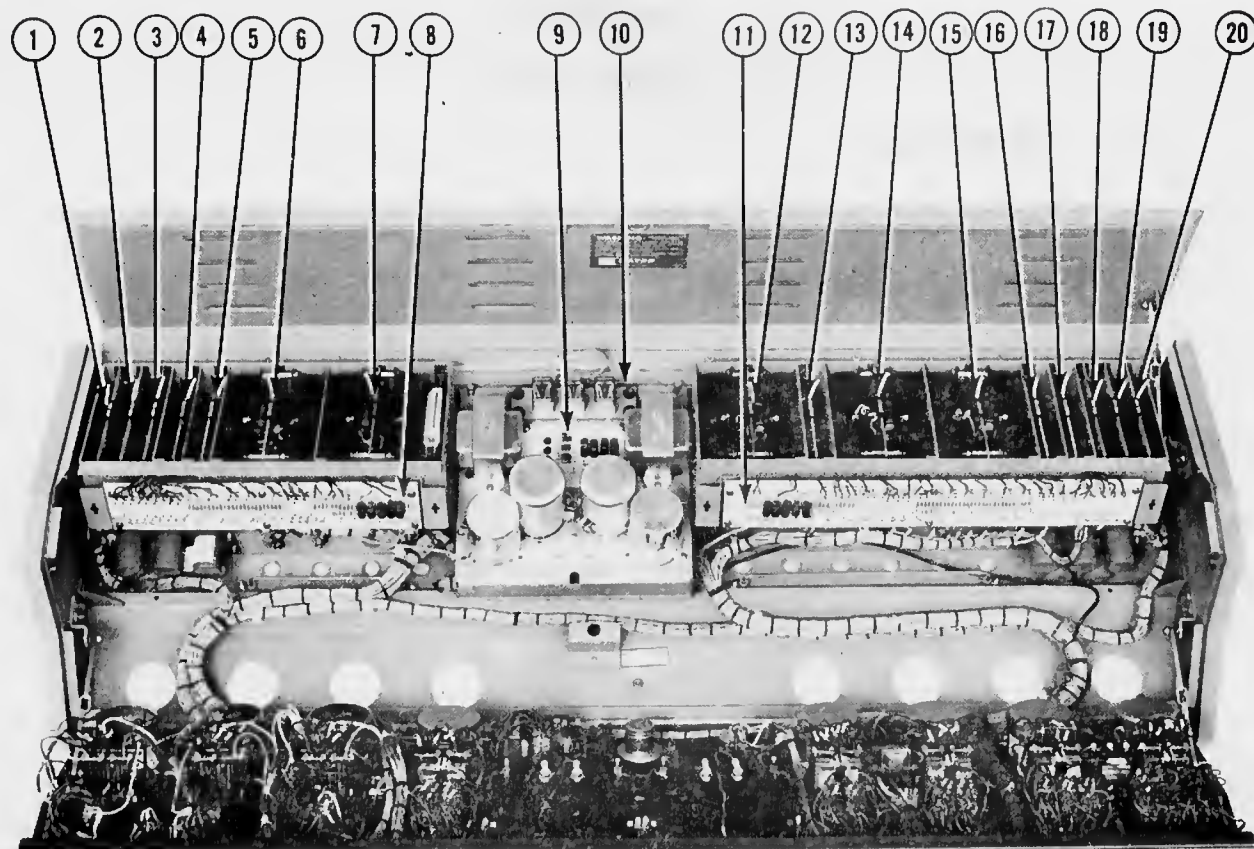

LEFT CARD GUIDE ASSEMBLY

REF. SUBASSEMBLY

1. Left Ch. 1 Preamplifier, J1
2. Left Ch. 2 Preamplifier, J2
3. Left Ch. 3 (Cont. Rm.) Preamplifier, J3
4. Left Program Booster Amplifier, J4
5. Left Monitor Booster Amplifier, J5
6. Left Program Output Amplifier, J6
7. Left Monitor Output Amplifier, J7
8. Left Input/Output Terminal Board, TB1

RIGHT CHANNEL CARD GUIDE ASSEMBLY

REF. SUBASSEMBLY

11. Rt. Input/Output Term. Bd., TB2
12. Cue Output Amplifier, J16
13. Cue Booster Amplifier, J15
14. Right Monitor Output Amp., J14
15. Right Program Output Amp., J13
16. Right Monitor Booster Amplifier, J12
17. Right Program Booster Amplifier, J11
18. Right Ch. 3 (Cont. Rm.) Preamplifier, J10
19. Right Ch. 2 Preamplifier, J9
20. Right Ch. 1 Preamplifier, J8

OUTPUT TRANSFORMER DECK

REF. SUBASSEMBLY

9. Relay Driver PC Board
10. Output Transformer Deck
(Located under Output Transformer Deck)
 - (1) Power Supply Input Terminal Board, TB-10
 - (2) Power Supply Terminal Boards, TB-3 and TB-4
 - (3) Speaker and Warning Lights Terminal Boards, TB-5,6, and 7

Figure 6-1. Location of Major Subassemblies

1515

SECTION VI

ELECTRICAL PARTS LIST

BASIC STEREO 80 CONSOLE

994 6867 003

SYMBOL	DESCRIPTION	GATES PART NO.	SYMBOL	DESCRIPTION	GATES PART NO.
AT1 thru AT3	Attenuator, 150/300, 2 dB, W/O Cue	554 0281 000	M1,M2	Meter, VU "B" Scale	630 0140 000
AT4 thru AT8	Attenuator, 150/300, 2 dB, W/Cue	554 0280 000	R89 thru R108	Res., 620 ohm, 1/2W, 5%, LN	540 1130 000
AT11, AT12	Potentiometer, 10K ohm, Locking	550 0379 000	R109 thru R124	Res., 240 ohm, 1/2W, 5%, LN	540 1190 000
AT13	Potentiometer, Dual 10K ohm	550 0283 000	R125 thru R156	Res., 560 ohm, 1/2W, 5%, LN	540 1191 000
AT14	Potentiometer, 10K ohm	550 0215 000	R157, R158	Res., 75 ohm, 1/2W, 5%, LN	540 1148 000
C10, C11	Cap., 1200 pF, 500V, 5%	500 0913 000	R163 thru R172	Res., 62 ohm, 1/2W, 5%, LN	540 1219 000
C12	Cap., .03 uF, GMV	516 0393 000	R173, R174	Res., 43 ohm, 1/2W, 5%, LN	540 1218 000
C13 thru C20	Cap., .01 uF, 600V	516 0080 000	R175	Res., 240 ohm, 1/2W, 5%, LN	540 1190 000
E5 thru E53	Standoff	614 0347 000	R176	Res., 150 ohm, 1/2W, 5%, LN	540 1117 000
J1 thru J16	Receptacle	612 0432 000	R177	Res., 130 ohm, 1/2W, 5%, LN	540 1220 000
LS1	Speaker, 45 ohm	722 0009 000	R178	Res., 200 ohm, 1/2W, 5%, LN	540 1128 000
			R179	Res., 47 ohm, 1/2W, 5%, LN	540 0579 000

WARNING: Disconnect primary power prior to servicing.

Basic Stereo 80 Console - 994 6867 003 - continued

SYMBOL	DESCRIPTION	GATES	PART NO.	SYMBOL	DESCRIPTION	GATES	PART NO.
R180	Res., 16 ohm, 1/2W, 5%, LN	540	1174 000	T7 thru T16	Transformer, Input, Medium Level	478	0311 000
R181, R182	Res., 5.6K ohm, 1/2W, 5%, LN	540	1183 000	T17	Transformer, Line, Remote	478	0312 000
R183	Res., 1K ohm, 1/2W, 5%, LN (Part of Cable)	540	1116 000	T19 thru T22	Transformer, Input, MIC	928	4841 001
R184	Res., 1K ohm, 1/2W, 5%, LN	540	1116 000	T27 thru T29	Transformer, Input, Medium Level	478	0311 000
R190, R191	Res., 390 ohm, 2W, 5%	540	0601 000	TB1	Terminal Bd., Input, (Left)	992	3424 001
R196, R197	Res., 5.1K ohm, 1/2W, 5%, LN	540	1105 000	TB2	Terminal Bd., Input, (Right)	992	3423 001
S1,S2	Switch, Lever, 2 Pos.	602	0097 000	TB3, TB4	Terminal Bd., Power Supply	992	3407 001
S3 thru S11	Switch, Lever, 3 Pos.	602	0096 000	TB5, TB6	Terminal Bd., 10 Terminals	614	0010 000
S12 thru S15	Switch, Lever, 3 Pos.	602	0099 000	TB7	Terminal Bd., 8 Terminals	614	0030 000
S16 thru S23	Switch, Lever, 3 Pos.	602	0100 000	TB10	Terminal Bd., 27 Terminals	927	8969 001
S24	Switch, Lever, 3 Pos.	602	0098 000	TB15	Terminal Bd., 6 Terminals	614	0162 000
S25	Switch, Lever, 2 Pos.	602	0082 000	TB16	Terminal Bd., 7 Terminals	614	0163 000
S26	Switch, Lever, 3 Pos.	602	0080 000	TB17	Terminal Bd., 6 Terminals	614	0162 000
T1 thru T6	Transformer	928	4841 002	TB18	Terminal Bd., 1 Pos.	614	0129 000

WARNING: Disconnect primary power prior to servicing.

SYMBOL	DESCRIPTION	GATES PART NO.	SYMBOL	DESCRIPTION	GATES PART NO.
TB19, TB20	Terminal Bd.	614 0127 000	TB26	Terminal Bd., 2 Pos.	614 0158 000
TB21 thru TB25	Terminal Bd., 5 Pos.	614 0161 000			

AUDIO OUTPUT CARD

994 6754 002

SYMBOL	DESCRIPTION	GATES PART NO.	SYMBOL	DESCRIPTION	GATES PART NO.
2C1	Cap., 100 uF, 50V	522 0394 000	2CR5, 2CR6	Diode, Zener, 1N4747A	386 0100 000
2C2	Cap., 25 uF, 25V	522 0242 000	2CR7 thru 2CR10	Diode, 1N2071	384 0020 000
2C3	Cap., 56 pF, 500V, 5%	522 0753 000	2Q1	Transistor, 2N5087	380 0112 000
2C4	Cap., 470 pF, 500V, 5%	500 0835 000	2Q2	Transistor, 2N4036	380 0045 000
2C5	Cap., .10 uF, 100V	508 0268 000	2Q3	Transistor, 2N3417	380 0111 000
2C6	Cap., 640 uF, 25V	522 0385 000	2Q4	Transistor, 2N2102	380 0127 000
2C7	Cap., 3.3 uF, 50V, Tantalum	526 0336 000	2Q5	Transistor, 2N5088	380 0115 000
2C8, 2C9	Cap., .05 uF, 100V	508 0266 000	2Q6	Transistor, 2N5087	380 0112 000
2C10	Cap., .001 uF, 1000V, ±10%	516 0054 000	2Q7	Transistor, 2N4036	380 0045 000
2C11	Cap., 1 uF, 35V, ±20%, Tantalum	526 0050 000	2Q8	Transistor, 2N4914	380 0128 000
2CR1, 2CR2	Diode, MZ2361	384 0256 000	2Q9	Transistor, 2N4905	380 0107 000
2CR3, 2CR4	Diode, MZ2360	384 0255 000			

1515

WARNING: Disconnect primary power prior to servicing.

Audio Output Card - 994 6754 002 - continued

SYMBOL	DESCRIPTION	GATES PART NO.	SYMBOL	DESCRIPTION	GATES PART NO.
2R1	Res., 39K ohm, 1/2W, 5%, LN	540 1185 000	2R14, 2R15	Res., .51 ohm, 2W, 5%	542 1072 000
2R2	Res., 10K ohm, 1/2W, 5%, LN	540 1111 000	2R16	Res., 9.1K ohm, 1/2W, 5%, LN	540 1189 000
2R3	Res., 33K ohm, 1/2W, 5%, LN	540 1109 000	2R17	Res., 270 ohm, 1/2W, 5%, LN	540 1188 000
2R4	Potentiometer, 500 ohm, 1/4W	552 0815 000	2R18	Res., 10 ohm, 1W, 5%	540 0563 000
2R5	Res., 33K ohm, 1/2W, 5%, LN	540 1109 000	2R19	Res., 10K ohm, 1/2W, 5%, LN	540 1111 000
2R6	Res., 820 ohm, 1/2W, 5%, LN	540 1127 000	2R20	Res., 51 ohm, 1/2W, 5%, LN	540 1192 000
2R7	Res., 100 ohm, 1/2W, 5%, LN	540 1102 000	2R21	Res., 6.2K ohm, 1/2W, 5%, LN	540 1106 000
2R8, 2R9	Res., 1000 ohm, 1/2W, 5%, LN	540 1116 000	2R22, 2R23	Res., 10 ohm, 1/2W, 5%, LN	540 1151 000
2R10, 2R11	Res., 220 ohm, 1/2W, 5%, LN	540 1118 000	2R24, 2R25	Res., 100 ohm, 1/2W, 5%, LN	540 1102 000
2R12	Res., 270 ohm, 1/2W, 5%, LN	540 1188 000	2R26	Res., 1000 ohm, 1/2W, 5%, LN	540 1116 000
2R13	Res., 9.1K ohm, 1/2W, 5%, LN	540 1189 000	2R27	Res., 200 ohm, 1/2W, 5%, LN	540 1128 000

AUDIO BOOSTER

994 7686 001

SYMBOL	DESCRIPTION	GATES PART NO.	SYMBOL	DESCRIPTION	GATES PART NO.
3C1	Cap., 47 uF, 10V, Tantalum	526 0336 000	3C4	Cap., 10 pF, 500V, ±5%	500 0804 000
3C2	Cap., 10 uF, 35V, Tantalum	526 0318 000	3C5	Cap., 240 pF, 500V, 5%	500 0830 000
3C3	Cap., 470 pF, 1000V	516 0043 000	3C6	Cap., 100 uF, 50V	522 0394 000

WARNING: Disconnect primary power prior to servicing.

Audio Booster - 994 7686 001 - continued

SYMBOL	DESCRIPTION	GATES PART NO.	SYMBOL	DESCRIPTION	GATES PART NO.
3C8, 3C9	Cap., 100 uF, 50V	522 0394 000	3R4	Res., 470K ohm, 1/2W, 5%, LN	540 1198 000
3C10	Cap., 10 pF, 500V, ±5%	500 0804 000	3R5	Res., 6200 ohm, 1/2W, 5%, LN	540 1106 000
3C11	Cap., 300 pF, 500V	500 0784 000	3R6	Res., 150 ohm, 1/2W, 5%, LN	540 1117 000
3Q1, 3Q2	Transistor, TZ-1218	380 0147 000	3R7	Res., 43K ohm, 1/2W, 5%, LN	540 1196 000
3Q3	Transistor, MPS-U45	380 0179 000	3R8	Res., 150 ohm, 1/2W, 5%, LN	540 1117 000
3R1	Res., 150 ohm, 1/2W, 5%, LN	540 1117 000	3R9	Res., 1K ohm, 1/2W, 5%, LN	540 1116 000
3R2	Res., 470K ohm, 1/2W, 5%, LN	540 1198 000	3R10	Res., 56K ohm, 1/2W, 5%, LN	540 1172 000
3R3	Res., 1100 ohm, 1/2W, 5%, LN	540 1315 000	3R11	Res., 1K ohm, 1/2W, 5%, LN	540 1116 000

AUDIO PREAMPLIFIER

994 6911 001

SYMBOL	DESCRIPTION	GATES PART NO.	SYMBOL	DESCRIPTION	GATES PART NO.
C1	Cap., 100 pF	500 0759 000	C9	Cap., 15 pF	500 0806 000
C2	Cap., 240 pF	500 0830 000	CR1, CR2	Diode, MZ2361	384 0256 000
C3	Cap., 10 uF, 35V, Tantalum	526 0318 000	Q1,Q2	Transistor, Selected, TZ1218	380 0147 000
C4,C5, C6	Cap., 47 uF, 10V, Tantalum	526 0336 000	Q3	Transistor, MPS-U45, Darlington	380 0179 000
C7	Cap., 100 uF, 50V	522 0394 000			
C8	Cap., 450 uF, 50V	522 0432 000			

1515

WARNING: Disconnect primary power prior to servicing.

Audio Preamplifier - 994 6911 001 - continued

SYMBOL	DESCRIPTION	GATES	PART NO.	SYMBOL	DESCRIPTION	GATES	PART NO.
Q4	Transistor, MPS-U95, Darlington	380	0183 000	R9	Res., 6.2K ohm, 1/2W, 5%	540	1106 000
R1,R2	Res., 1M ohm, 1/2W, 5%	540	1162 000	R10	Potentiometer, 10K ohm, 1/4W	550	0315 000
R3	Res., 150 ohm, 1/2W, 5%	540	1117 000	R11	Res., 10K ohm, 1/2W, 5%	540	1111 000
R4	Res., 13K ohm, 1/2W, 5%	540	1194 000	R12	Res., 1K ohm, 1/2W, 5%	540	1116 000
R5	Res., 11K ohm, 1/2W, 5%	540	1208 000	R13	Res., 2K ohm, 1/2W, 5%	540	1104 000
R6	Res., 1K ohm, 1/2W, 5%	540	1116 000	R14	Res., 16K ohm, 1/2W, 5%	540	1195 000
R7	Res., 150K ohm, 1/2W, 5%	540	1210 000	R15	Res., 100 ohm, 1/2W, 5%	540	1102 000
R8	Res., 10K ohm, 1/2W, 5%	540	1111 000	R16, R17	Res., 10 ohm, 1/2W, 5%	540	1151 000
				R18	Res., 150 ohm, 1/2W, 5%	540	1117 000

OUTPUT/TRANSFORMER DECK

992 3422 001

SYMBOL	DESCRIPTION	GATES	PART NO.	SYMBOL	DESCRIPTION	GATES	PART NO.
C1,C2	Cap., 6000 uF, 50V, W0/Ins. Case	524	0171 000	R185, R186	Res., 82 ohm, 1/2W, 5%	540	1225 000
C3,C4	Cap., 6000 uF, 50V, W/Ins. Case	524	0150 000	T18	Transformer, Monitor Remote	478	0311 000
E1 thru E4	Standoff	614	0347 000	T23, T24	Transformer, Line	478	0310 000
K1,K2, K3	Relay, 4 PDT, 48V	574	0214 000	TB8	Terminal Bd.	927	8969 001

6-8

WARNING: Disconnect primary power prior to servicing.

Output/Transformer Deck - 992 3422 001 - continued

SYMBOL	DESCRIPTION	GATES PART NO.	SYMBOL	DESCRIPTION	GATES PART NO.
TB11 thru TB14	Terminal Bd., 4 Pos.	614 0160 000			

PRINTED BOARD, RELAY DRIVER

992 3428 001

SYMBOL	DESCRIPTION	GATES PART NO.	SYMBOL	DESCRIPTION	GATES PART NO.
CR1	Diode, Zener, 1N4732A	386 0123 000	R1,R2, R3	Res., 1000 ohm, 1/2W, 5%, LN	540 1116 000
CR2, CR3,CR4	Diode, 1N2071	384 0020 000	R4,R5, R6	Res., 820 ohm, 2W, 5%	540 0609 000
Q1,Q2, Q3	Transistor, 2N4356	380 0151 000	R7	Res., 10K ohm, 2W, 5%	540 0635 000

INPUT TERMINAL BOARD (TB1 LEFT)

992 3424 001

SYMBOL	DESCRIPTION	GATES PART NO.	SYMBOL	DESCRIPTION	GATES PART NO.
R1,R2	Res., 270 ohm, 1/2W, 5%, LN	540 1188 000	R14 thru R17	Res., 270 ohm, 1/2W, 5%, LN	540 1188 000
R3	Res., 75 ohm, 1/2W, 5%, LN	540 1148 000	R18	Res., 75 ohm, 1/2W, 5%, LN	540 1148 000
R4 thru R7	Res., 270 ohm, 1/2W, 5%, LN	540 1188 000	R19 thru R22	Res., 270 ohm, 1/2W, 5%, LN	540 1188 000
R8	Res., 75 ohm, 1/2W, 5%, LN	540 1148 000	R23	Res., 75 ohm, 1/2W, 5%, LN	540 1148 000
R9 thru R12	Res., 270 ohm, 1/2W, 5%, LN	540 1188 000	R24, R25	Res., 270 ohm, 1/2W, 5%, LN	540 1188 000
R13	Res., 75 ohm, 1/2W, 5%, LN	540 1148 000	R32	Res., 220 ohm, 1/2W, 5%, LN	540 1118 000

1515

WARNING: Disconnect primary power prior to servicing.

Input Terminal Board (TB1 Left) - 992 3424 001 - continued

SYMBOL	DESCRIPTION	GATES	PART NO.	SYMBOL	DESCRIPTION	GATES	PART NO.
R33	Res., 150 ohm, 1/2W, 5%, LN	540	1117 000	R41, R42	Res., 100 ohm, 2W, 5%	540	0587 000
R34	Res., 220 ohm, 1/2W, 5%, LN	540	1118 000	R43	Res., 820 ohm, 2W, 5%	540	0609 000
R35	Res., 150 ohm, 1/2W, 5%, LN	540	1117 000	R44, R45	Res., 100 ohm, 2W, 5%	540	0587 000
R36, R37	Res., 4.3K ohm, 1/2W, 5%, LN	540	1207 000	R46, R47	Res., 10K ohm, 1/2W, 5%, LN	540	1111 000
R38	Res., 5.6K ohm, 1/2W, 5%, LN	540	1183 000	R192, R193	Res., 300 ohm, 1/2W, 5%, LN	540	1163 000
R39, R40	Res., 6.2K ohm, 1/2W, 5%, LN	540	1106 000				

INPUT TERMINAL BOARD (TB2 RIGHT)

992 3423 001

SYMBOL	DESCRIPTION	GATES	PART NO.	SYMBOL	DESCRIPTION	GATES	PART NO.
R26 thru R31	Res., 100 ohm, 1/2W, 5%, LN	540	1102 000	R61 thru R64	Res., 270 ohm, 1/2W, 5%, LN	540	1188 000
R48, R49	Res., 270 ohm, 1/2W, 5%, LN	540	1188 000	R65	Res., 75 ohm, 1/2W, 5%, LN	540	1148 000
R50	Res., 75 ohm, 1/2W, 5%, LN	540	1148 000	R66 thru R69	Res., 270 ohm, 1/2W, 5%, LN	540	1188 000
R51 thru R54	Res., 270 ohm, 1/2W, 5%, LN	540	1188 000	R70	Res., 75 ohm, 1/2W, 5%, LN	540	1148 000
R55	Res., 75 ohm, 1/2W, 5%, LN	540	1148 000	R71, R72	Res., 270 ohm, 1/2W, 5%, LN	540	1188 000
R56 thru R59	Res., 270 ohm, 1/2W, 5%, LN	540	1188 000	R73	Res., 220 ohm, 1/2W, 5%, LN	540	1118 000
R60	Res., 75 ohm, 1/2W, 5%, LN	540	1148 000	R74	Res., 150 ohm, 1/2W, 5%, LN	540	1117 000

6-10

WARNING: Disconnect primary power prior to servicing.

Input Terminal Board (TB2 Right) - 992 3423 001 - continued

SYMBOL	DESCRIPTION	GATES PART NO.	SYMBOL	DESCRIPTION	GATES PART NO.
R75	Res., 220 ohm, 1/2W, 5%, LN	540 1118 000	R82, R83	Res., 100 ohm, 2W, 5%	540 0587 000
R76	Res., 150 ohm, 1/2W, 5%, LN	540 1117 000	R84	Res., 820 ohm, 2W, 5%	540 0609 000
R77, R78	Res., 4.3K ohm, 1/2W, 5%, LN	540 1207 000	R85	Res., 100 ohm, 2W, 5%	540 0587 000
R79	Res., 5.6K ohm, 1/2W, 5%, LN	540 1183 000	R87, R88	Res., 10K ohm, 1/2W, 5%, LN	540 1111 000
R80, R81	Res., 6.2K ohm, 1/2W, 5%, LN	540 1106 000			

POWER SUPPLY, PANEL ASSEMBLY

992 3421 001

SYMBOL	DESCRIPTION	GATES PART NO.	SYMBOL	DESCRIPTION	GATES PART NO.
2C1 thru 2C4	Cap., 900 uF, 100V	524 0146 000	2S1 thru 2S4	Thermostat, Close @100°C	442 0021 000
2E1 thru 2E4	Standoff	614 0347 000	2T25	Transformer	472 0734 000
2F1,2F2, 2F3,2F4	Fuse	398 0054 000	2TB1	Terminal Bd.	927 8969 001
2Q1 thru 2Q4	Transistor, 2N4348	380 0157 000	2TB2	Terminal Bd., 4 Terminals	614 0160 000
2R1 thru 2R4	Res., 1 ohm, 1/2W, 5%	540 1101 000	2XF1 thru 2XF4	Fuseholder	402 0119 000
2R5 thru 2R8	Res., 75K ohm, 1/2W, 5%, LN	540 1152 000	2XQ1 thru XQ4	Socket, Transistor	404 0294 000

1515

WARNING: Disconnect primary power prior to servicing.

POWER SUPPLY, P.C. BOARD

992 3588 001

SYMBOL	DESCRIPTION	GATES	PART NO.	SYMBOL	DESCRIPTION	GATES	PART NO.
C1 thru C4	Cap., .001 uF	516	0055 000	Q1 thru Q4	Transistor, 40373	380	0156 000
C5 thru C8	Cap., 100 pF	500	0759 000	Q5 thru Q16	Transistor, 2N5550	380	0158 000
C9 thru C12	Cap., 100 uF 50V	522	0394 000	R1 thru R4	Res., 10 ohm, 1/2W, 5%, LN	540	1151 000
C13 thru C24	Cap., .01 uF	516	0082 000	R5 thru R8	Res., 100 ohm, 1/2W, 5%, LN	540	1102 000
C25	Cap., 300 uF, 100V	522	0436 000	R9 thru R16	Res., 75K ohm, 1/2W, 5%, LN	540	1152 000
C26 thru C29	Cap., 470 pF	516	0043 000	R17 thru R20	Res., 1.3K ohm, 1/2W, 5%, LN	540	1187 000
CR1 thru CR24	Diode, 1N2071	384	0020 000	R21 thru R24	Res., 18K ohm, 1/2W, 5%, LN	540	1113 000
CR25 thru CR32	Diode, 1N3253	384	0282 000	R25 thru R32	Res., 3.0 ohm, 10W, 5%	542	1162 000
CR33 thru CR36	Diode, 1N5286	384	0621 000	R33 thru R36	Res., 27K ohm, 1/2W, 5%, LN	540	1147 000
CR37 thru CR40	Diode, MZ2360	384	0255 000	R37 thru R40	Potentiometer, 10K ohm	550	0315 000
CR41 thru CR44	Diode, 1N4737	386	0106 000	R41 thru R44	Res., 3.3K ohm, 1/2W, 5%, LN	540	1165 000

Power Supply, P.C. Board - 992 3588 001 - continued

SYMBOL	DESCRIPTION	GATES PART NO.	SYMBOL	DESCRIPTION	GATES PART NO.
R45 thru R48	Res., 7.5K ohm, 1/2W, 5%, LN	540 1154 000	R50 thru R53	Res., 10 ohm, 1/2W, 5%, LN	540 1151 000
R49	Res., 12 ohm, 1W, 5%	540 0286 000	R54 thru R57	Res., 36 ohm, 1/2W, 5%, LN	540 1175 000

POWER SUPPLY TERMINAL BOARD

992 3407 001

SYMBOL	DESCRIPTION	GATES PART NO.	SYMBOL	DESCRIPTION	GATES PART NO.
C3	Cap., 100 uF, 50V	522 0394 000	C24, C25	Cap., 450 uF, 50V	522 0432 000

1515

WARNING: Disconnect primary power prior to servicing.

SECTION VII

DIAGRAMS

7-1. INTRODUCTION

This section provides block and schematic diagrams and other drawings necessary for maintaining the Stereo 80 Console. The following diagrams are contained in this section:

1. Stereo 80 Block Diagram	842 6555 002
2. Stereo 80 Schematic	852 6795 002
3. Preamplifier Schematic	827 9272 001
4. Audio Booster Schematic	828 8000 001
5. Audio Output Schematic	827 7491 002
6. Power Supply Schematic	842 7179 001
7. Relay and Muting Driver Board Schematic	815 4265 001
8. Muting Assignment Schematic	815 4821 001
9. Power Supply Interconnecting Cable	815 4822 001
10. Installation Diagram, External Connections	828 0021 001
11. Installation Diagram, Console Layout	815 4830 001
12. Cable Inlet and Mounting Dimensions	839 0728 001

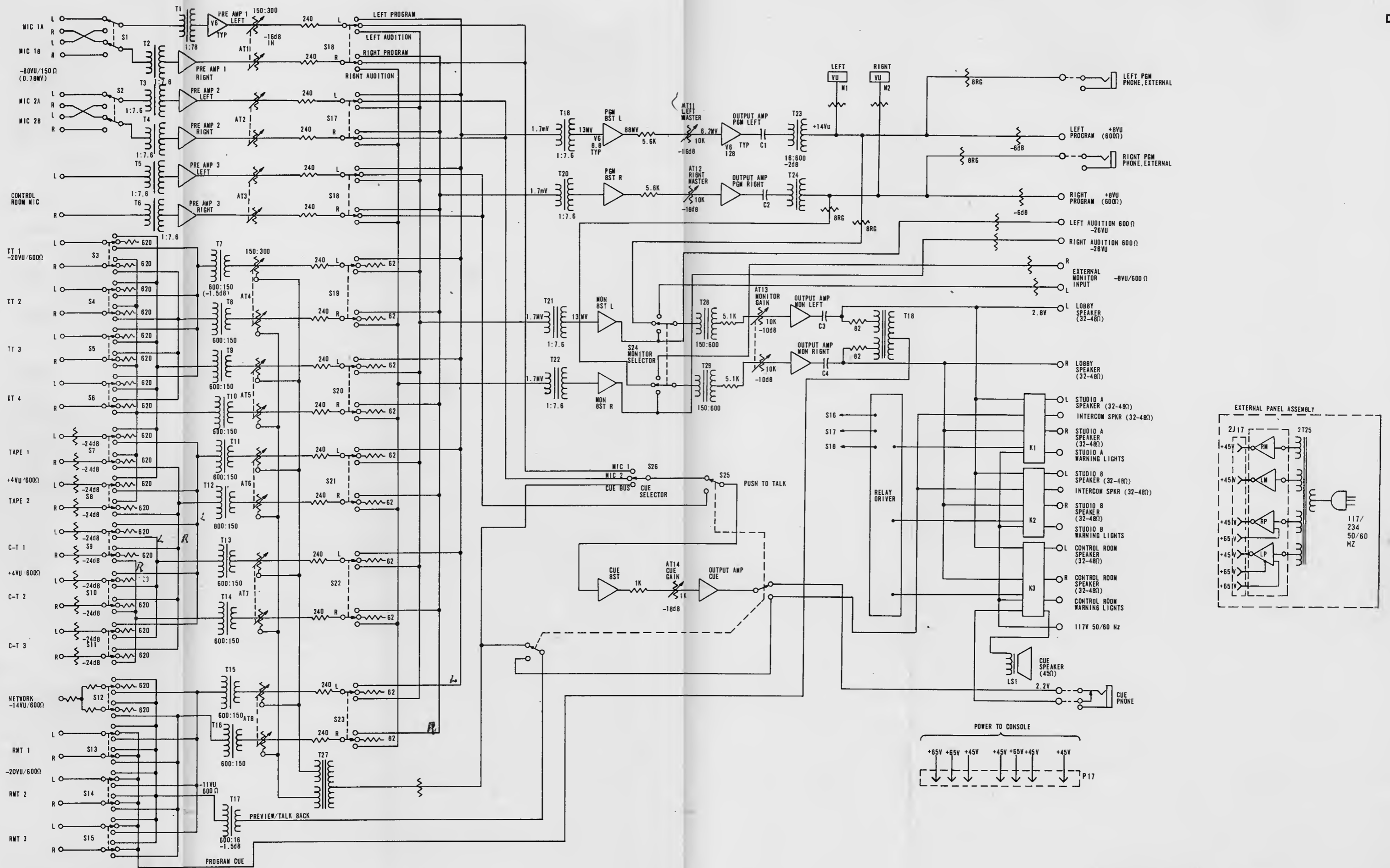

HARRIS CORPORATION Broadcast Products Division
 123 Hampshire Street, Quincy, Illinois 62301

BLOCK DIAGRAM
STEREO 80 CONSOLE
 842 6555 002

WARNING: Disconnect primary power prior to servicing.

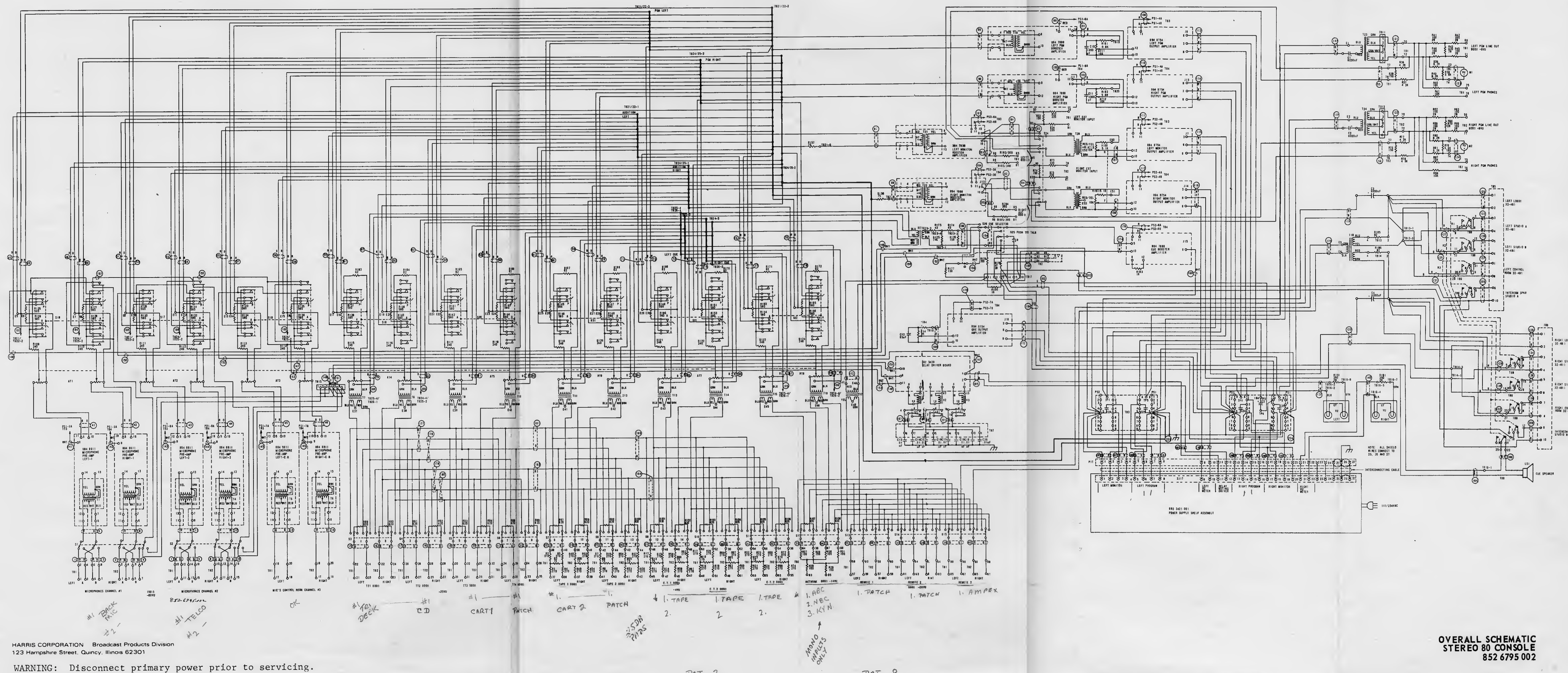

HARRIS CORPORATION Broadcast Products Division
 123 Hampshire Street, Quincy, Illinois 62301

WARNING: Disconnect primary power prior to servicing.

OVERALL SCHEMATIC
 STEREO 80 CONSOLE
 852 6795 002

#1 BACK MIC
 #2 -

#1 TELCO
 #2 -

OK

#1 TAP DECK

CD

#1 CART 1

PATCH

*1. CART 2

PATCH

1. TAPE

1. TAPE

1. TAPE

*1. ABC

2. NBC

3. KYN

MONO IMPEDS ONLY

POT 4

POT 5

POT 6

POT 7

POT 8

www.americanradiohistory.com

WARNING: Disconnect primary power prior to servicing.

HARRIS CORPORATION Broadcast Products Division
123 Hampshire Street, Quincy, Illinois 62301

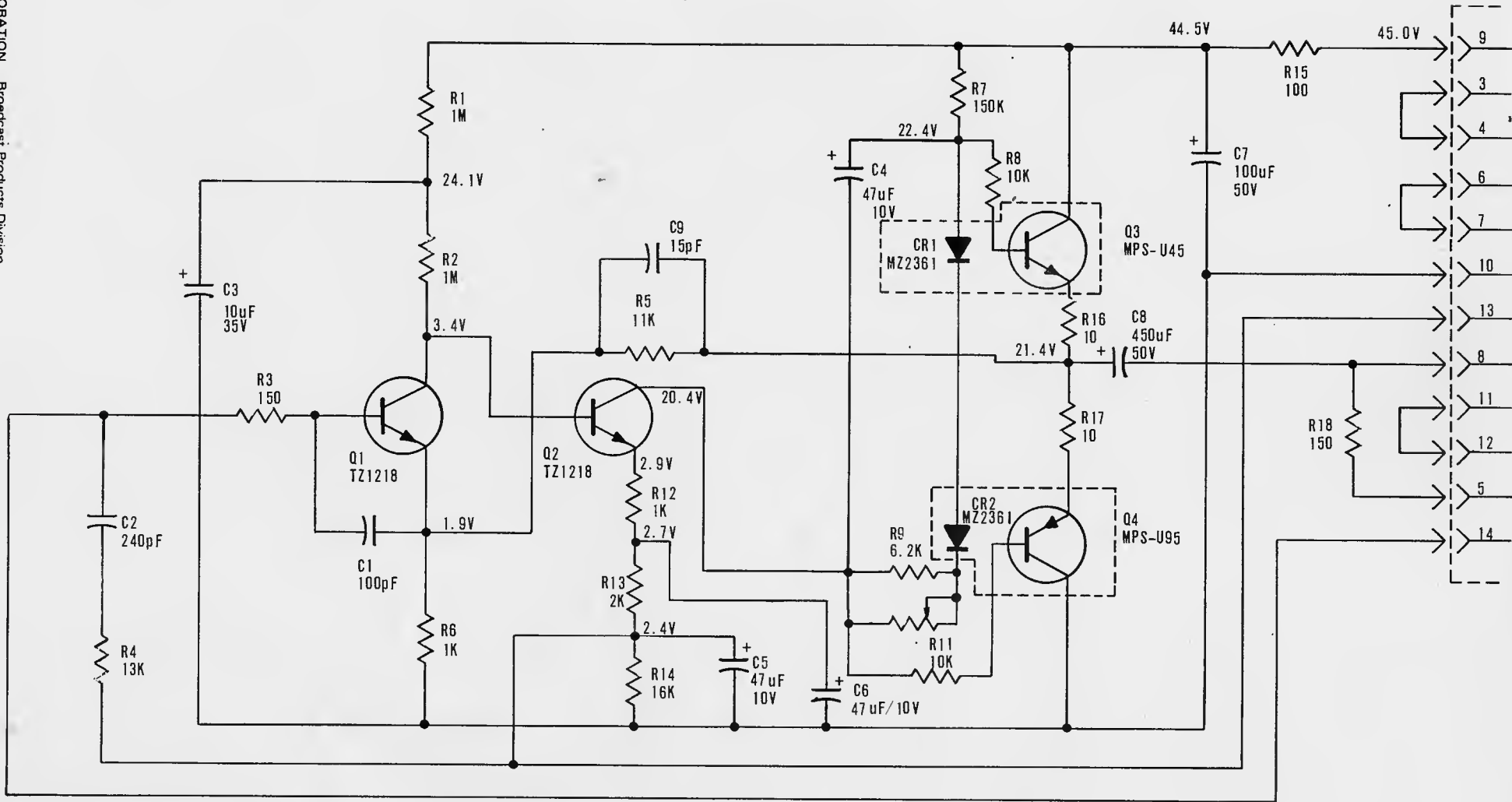

- UNLESS OTHERWISE NOTED:
1. RESISTORS ARE 1/2 WATT 5%
 2. RESISTANCE IN OHMS
 3. D.C. VOLTAGES ARE UNDER NO SIGNAL CONDITIONS

SCHEMATIC
PRE-AMPLIFIER
827 9272 001

HARRIS CORPORATION Broadcast Products Division
 123 Hampshire Street, Quincy, Illinois 62301

WARNING: Disconnect primary power prior to servicing.

**AUDIO BOOSTER AMPLIFIER
 SCHEMATIC**
 828 8000 001

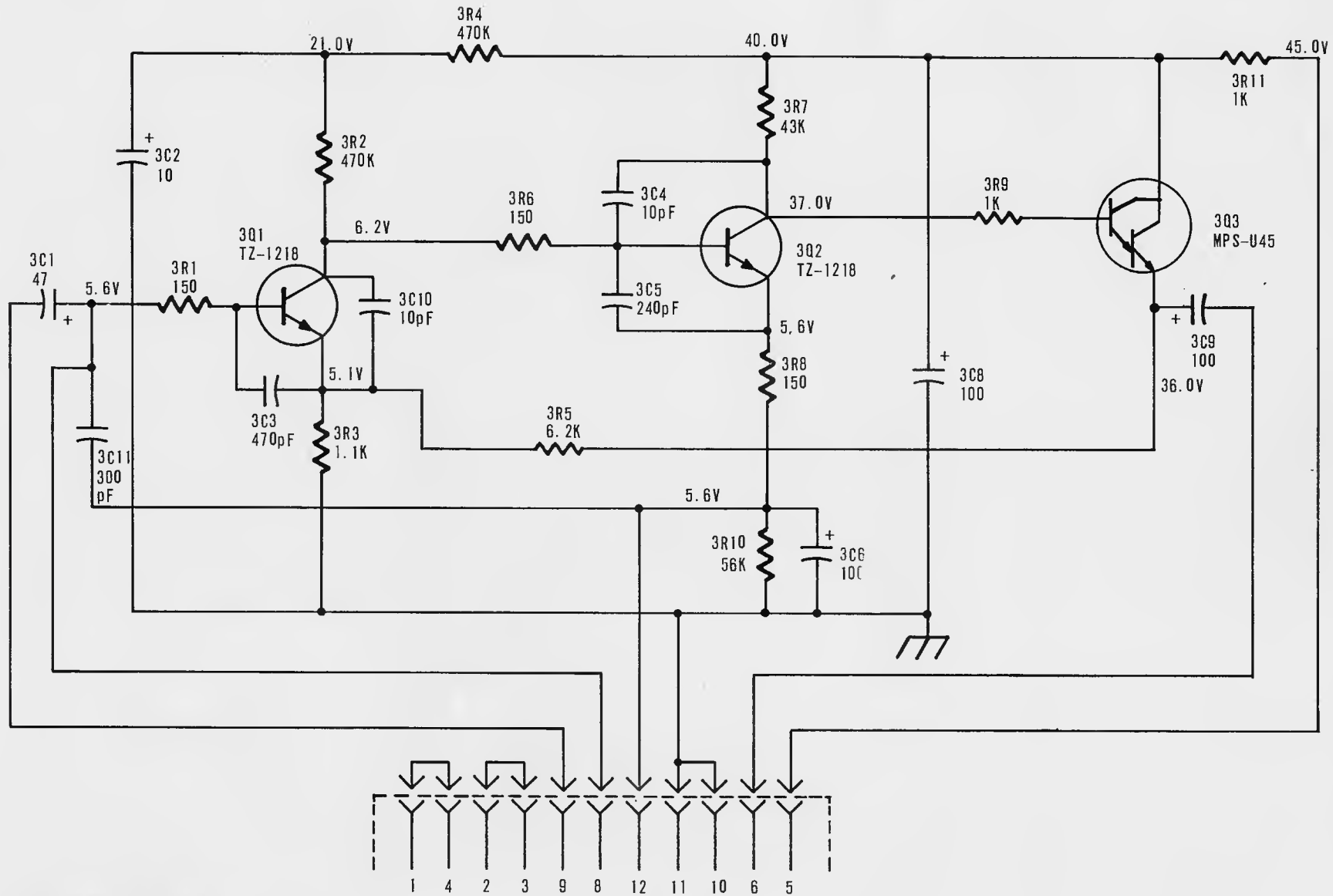

4. VOLTAGE MEASUREMENTS MADE WITH 1K OHM BETWEEN TERMINALS NUMBER 8 AND 12
3. CAPACITANCE IN μ F
2. RESISTANCE IN OHMS
1. RESISTORS ARE 1/2 WATT 5%
- UNLESS OTHERWISE NOTED:

AUDIO BOOSTER

WARNING: Disconnect primary power prior to servicing.

HARRIS CORPORATION Broadcast Products Division
123 Hampshire Street, Quincy, Illinois 62301

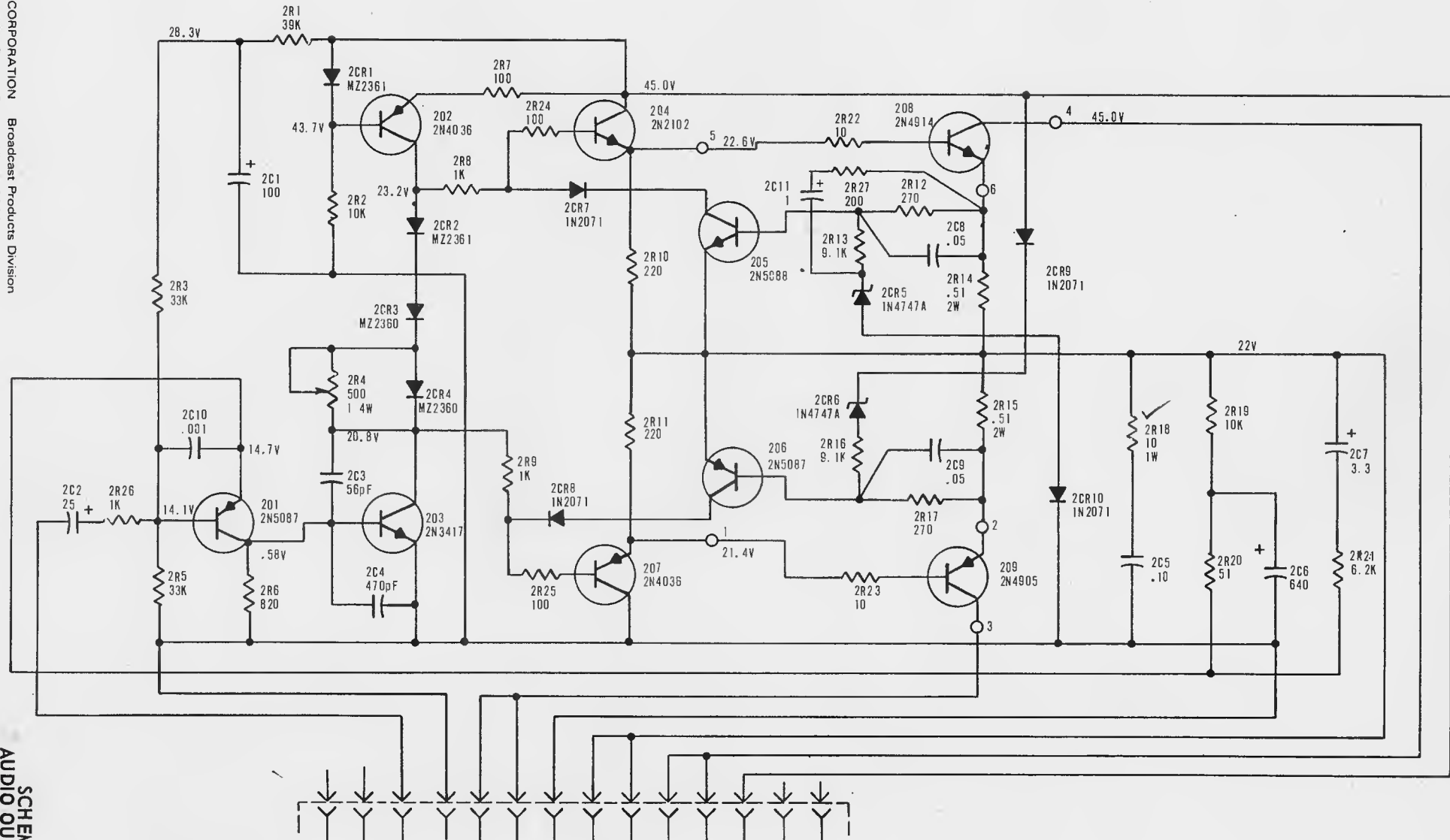

3. CAPACITANCE IN uF
 2. RESISTANCE IN OHMS
 1. RESISTORS ARE 1/2 WATT 5%
 UNLESS OTHERWISE NOTED:

14 13 12 10 8 9 11 3 4 6 7 5 2 1

SCHEMATIC
 AUDIO OUTPUT
 827 7491 002

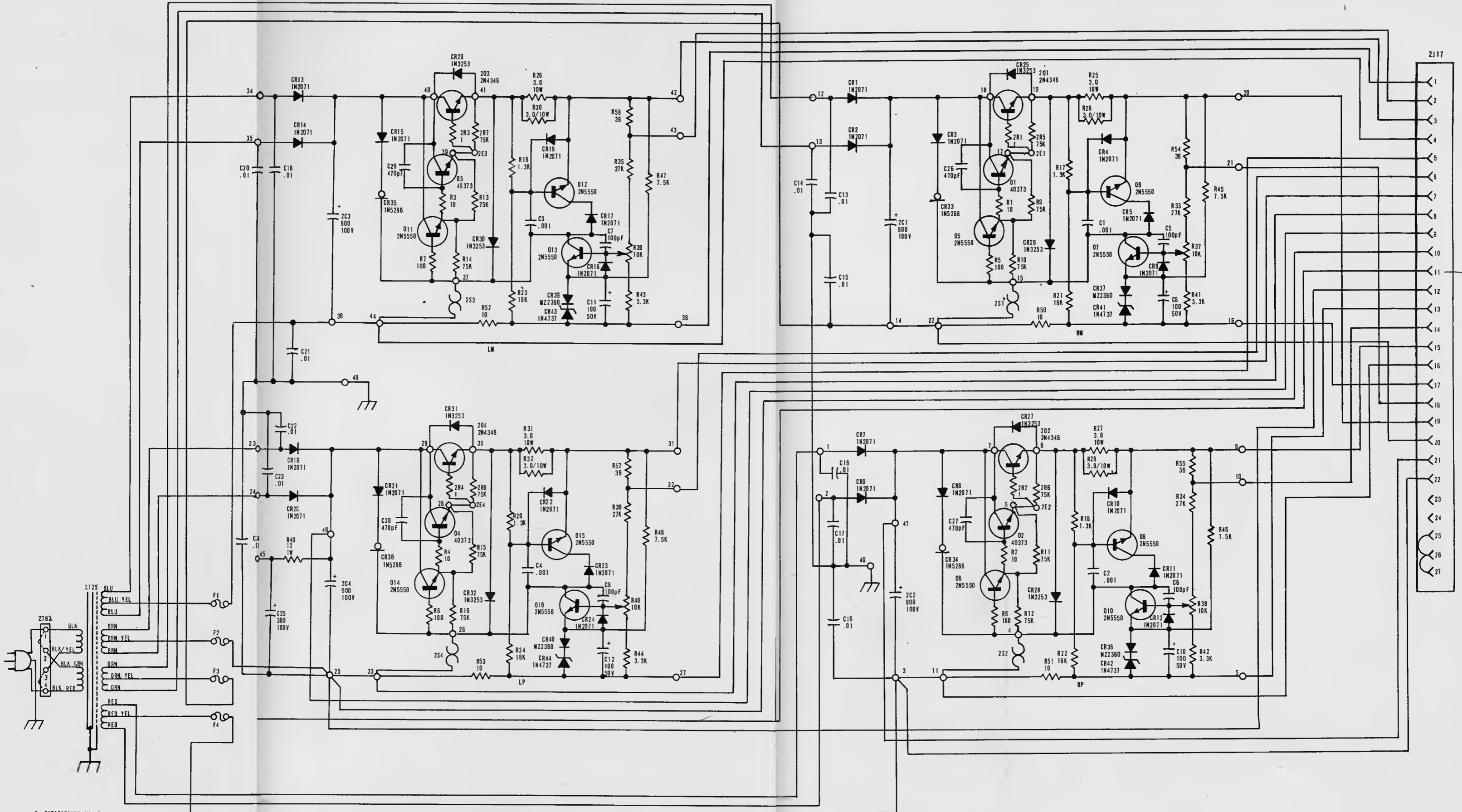

3. CAPACITANCE IN μ F
 2. RESISTANCE IN OHMS
 1. RESISTORS ARE 1/2 WATT 5%

UNLESS OTHERWISE NOTED:

HARRIS CORPORATION Broadcast Products Division
 123 Hampshire Street, Quincy, Illinois 62301

POWER SUPPLY SCHEMATIC
 STEREO 80 CONSOLE
 842 7179 001

WARNING: Disconnect primary power prior to servicing.

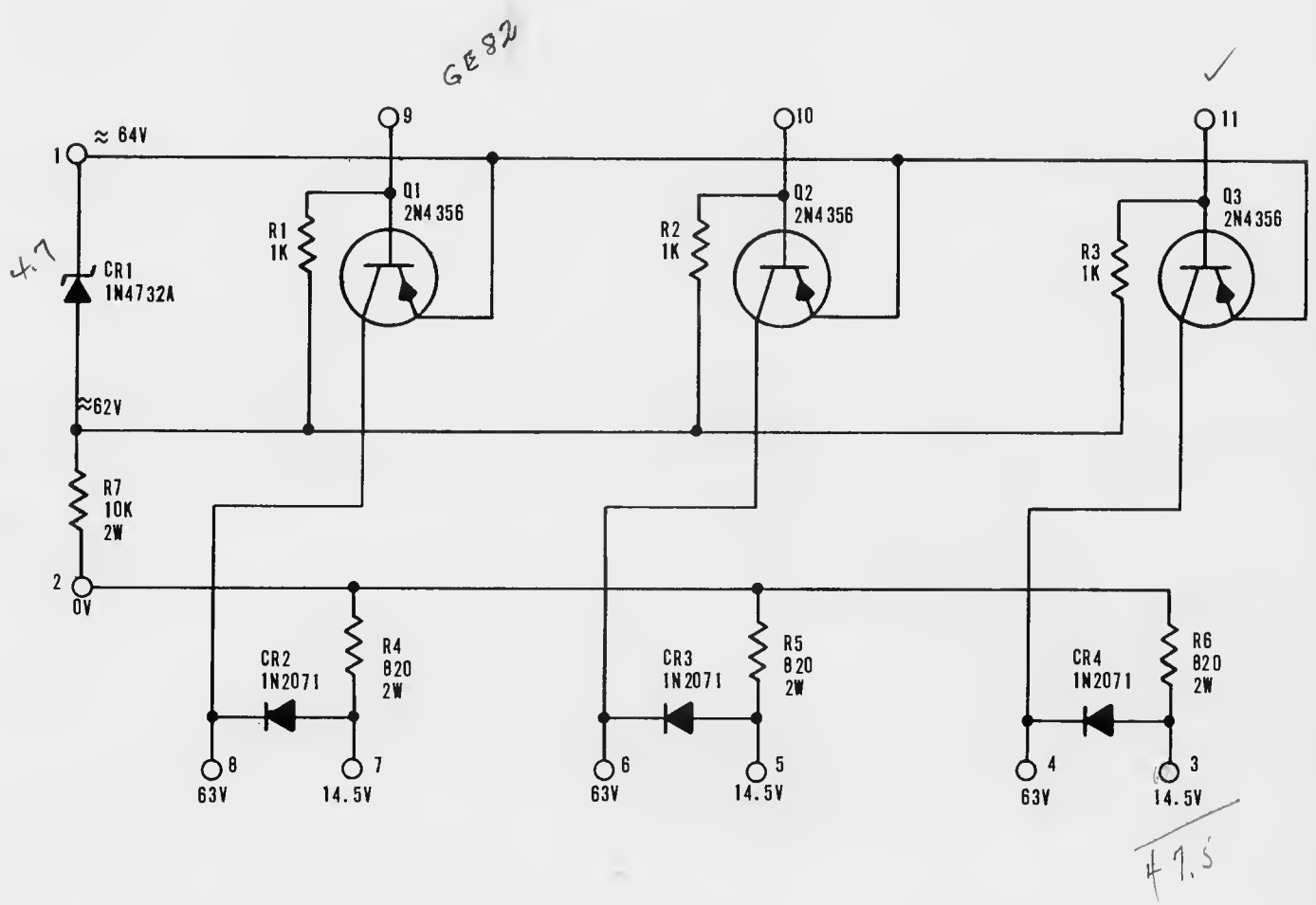

HARRIS CORPORATION Broadcast Products Division
 123 Hampshire Street, Quincy, Illinois 62301

SCHEMATIC
RELAY AND MUTING DRIVER BOARD
 8 15 4265 001

WARNING: Disconnect primary power prior to servicing.

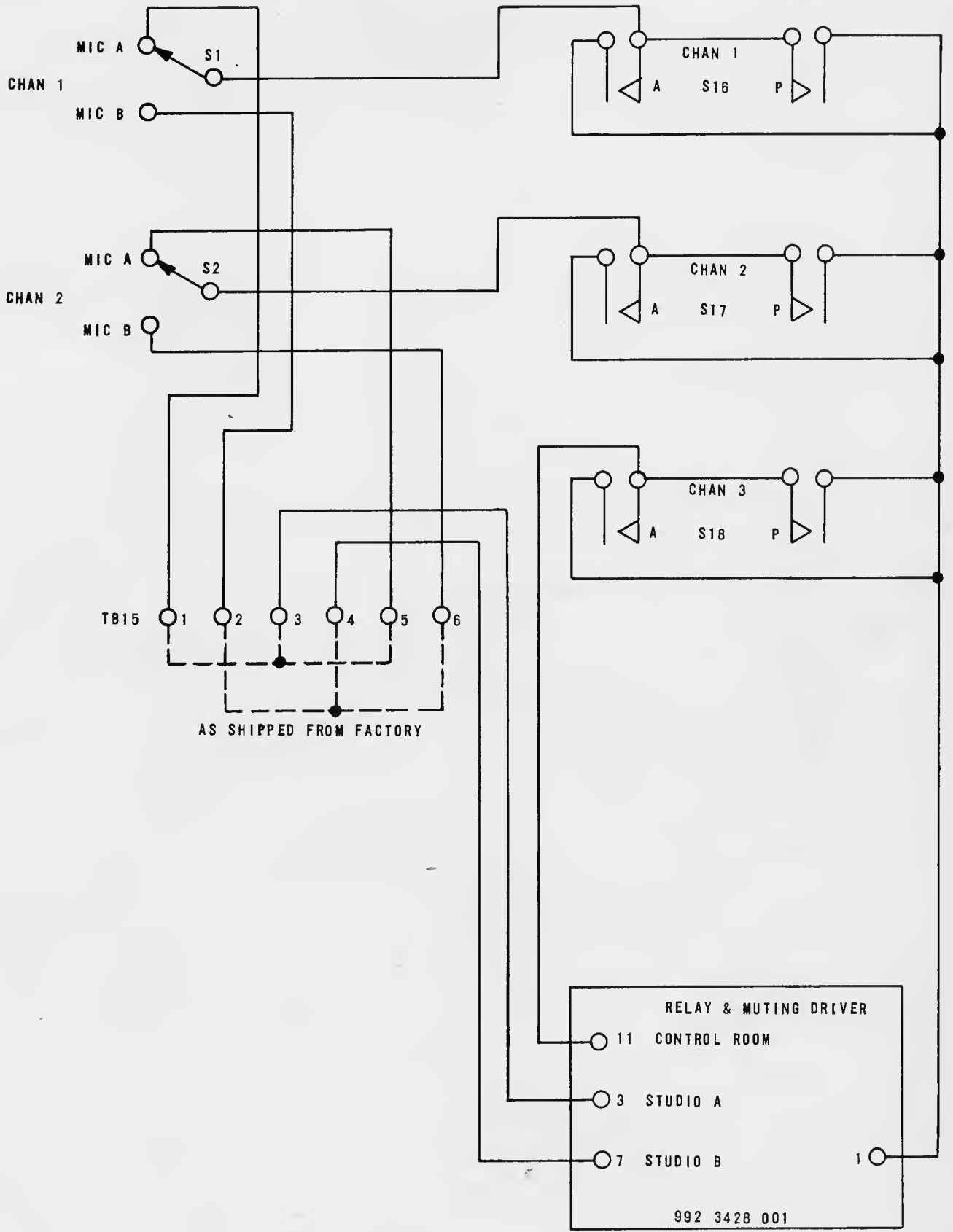

HARRIS CORPORATION Broadcast Products Division
 123 Hampshire Street, Quincy, Illinois 62301

MUTING ASSIGNMENT SCHEMATIC
STEREO 80 CONSOLE
 815 4821 001

WARNING: Disconnect primary power prior to servicing.

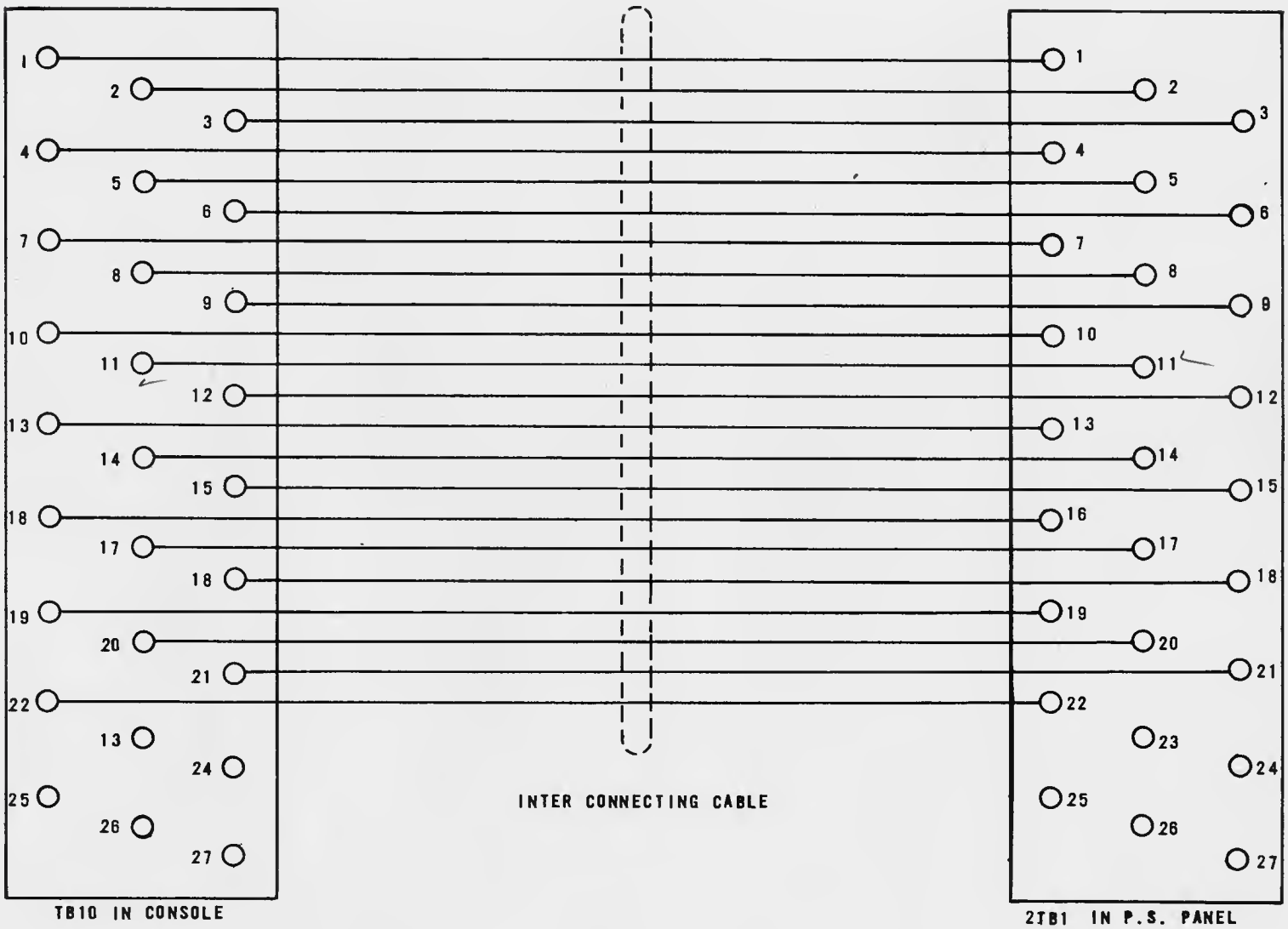

INTER CONNECTING CABLE

TB10 IN CONSOLE

2TB1 IN P.S. PANEL

HARRIS CORPORATION Broadcast Products Division
123 Hampshire Street, Quincy, Illinois 62301

POWER SUPPLY INTERCONNECTING CABLE

STEREO 80 CONSOLE

815 4822 001

WARNING: Disconnect primary power prior to servicing.

WARNING: Disconnect primary power prior to servicing.

HARRIS CORPORATION Broadcast Products Division
123 Hampshire Street, Quincy, Illinois 62301

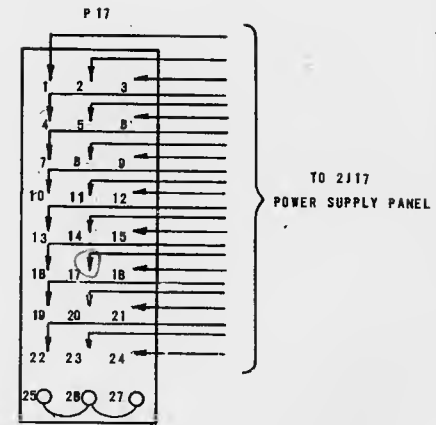
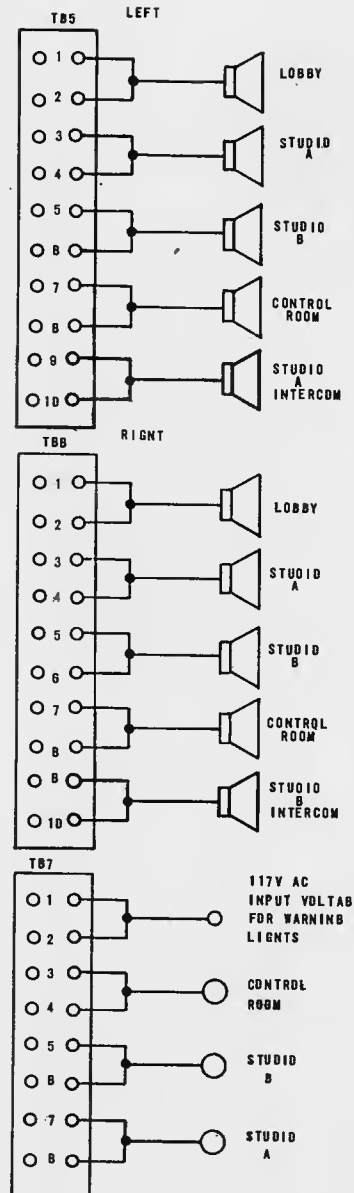
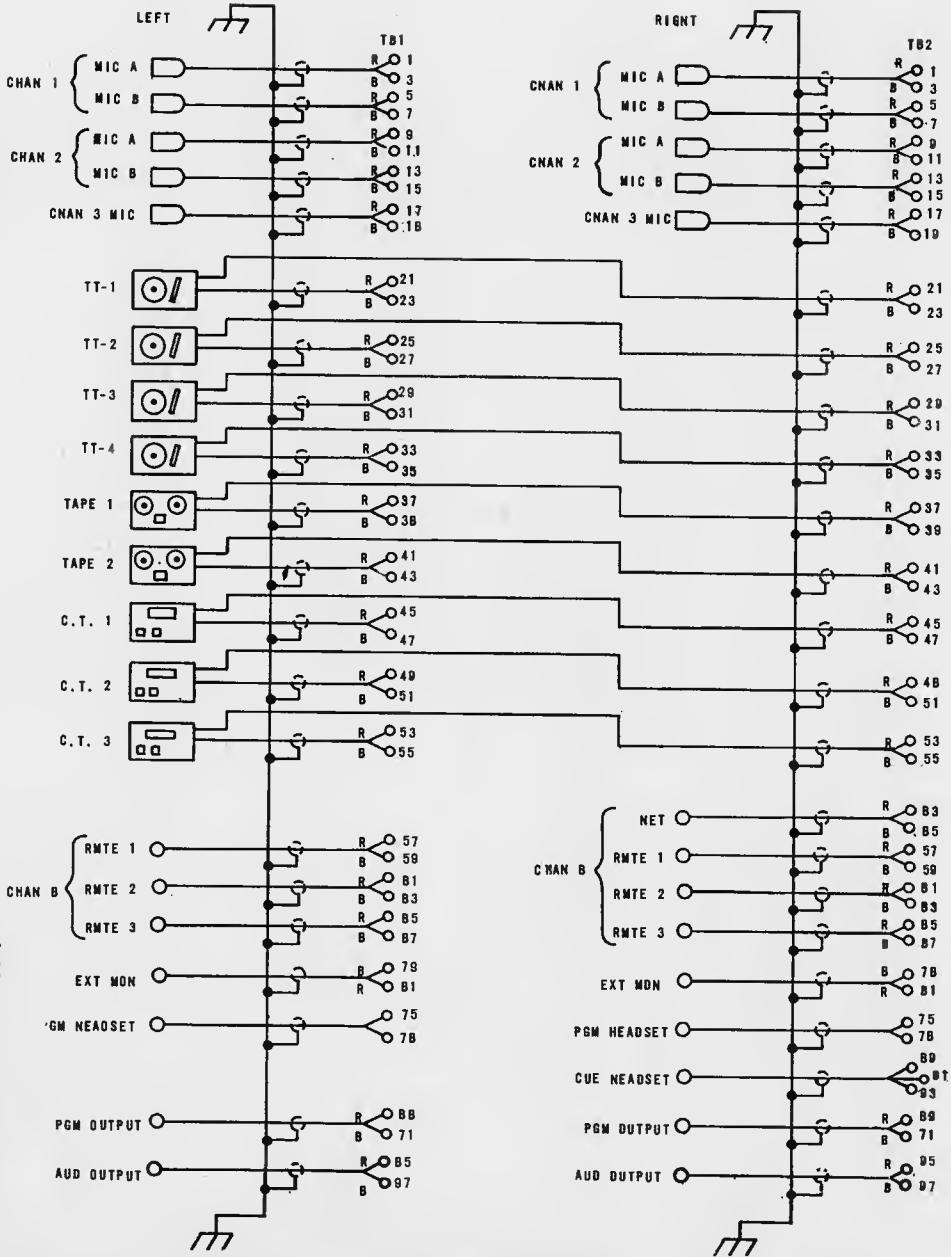

INSTALLATION DWG.
EXTERNAL CONNECTIONS
STEREO 80 CONSOLE
828 0021 001

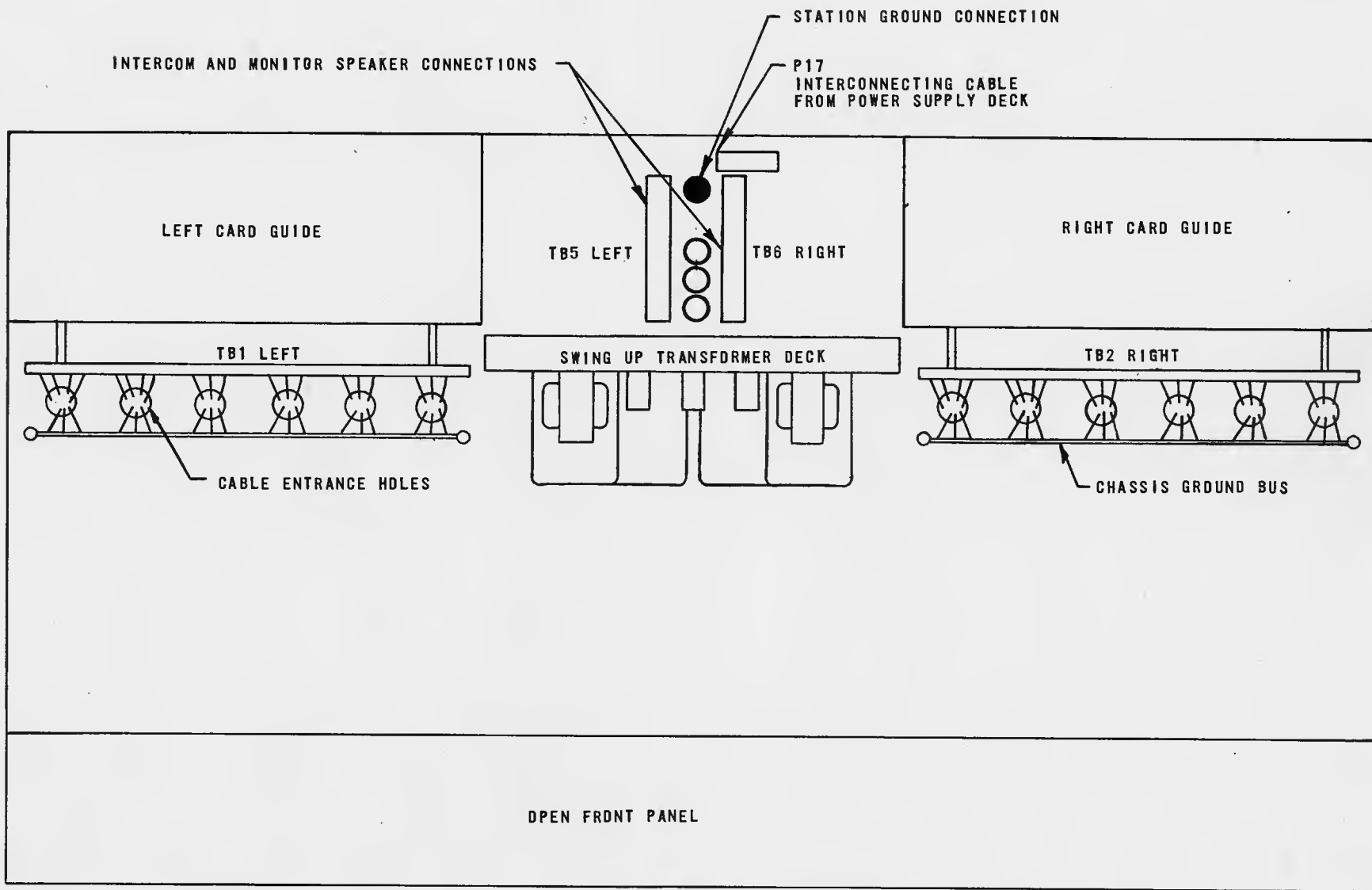

HARRIS CORPORATION Broadcast Products Division
 123 Hampshire Street, Quincy, Illinois 62301

WARNING: Disconnect primary power prior to servicing.

INSTALLATION DIAGRAM
 CONSOLE LAYOUT
 STEREO 80 CONSOLE
 815 4830 001

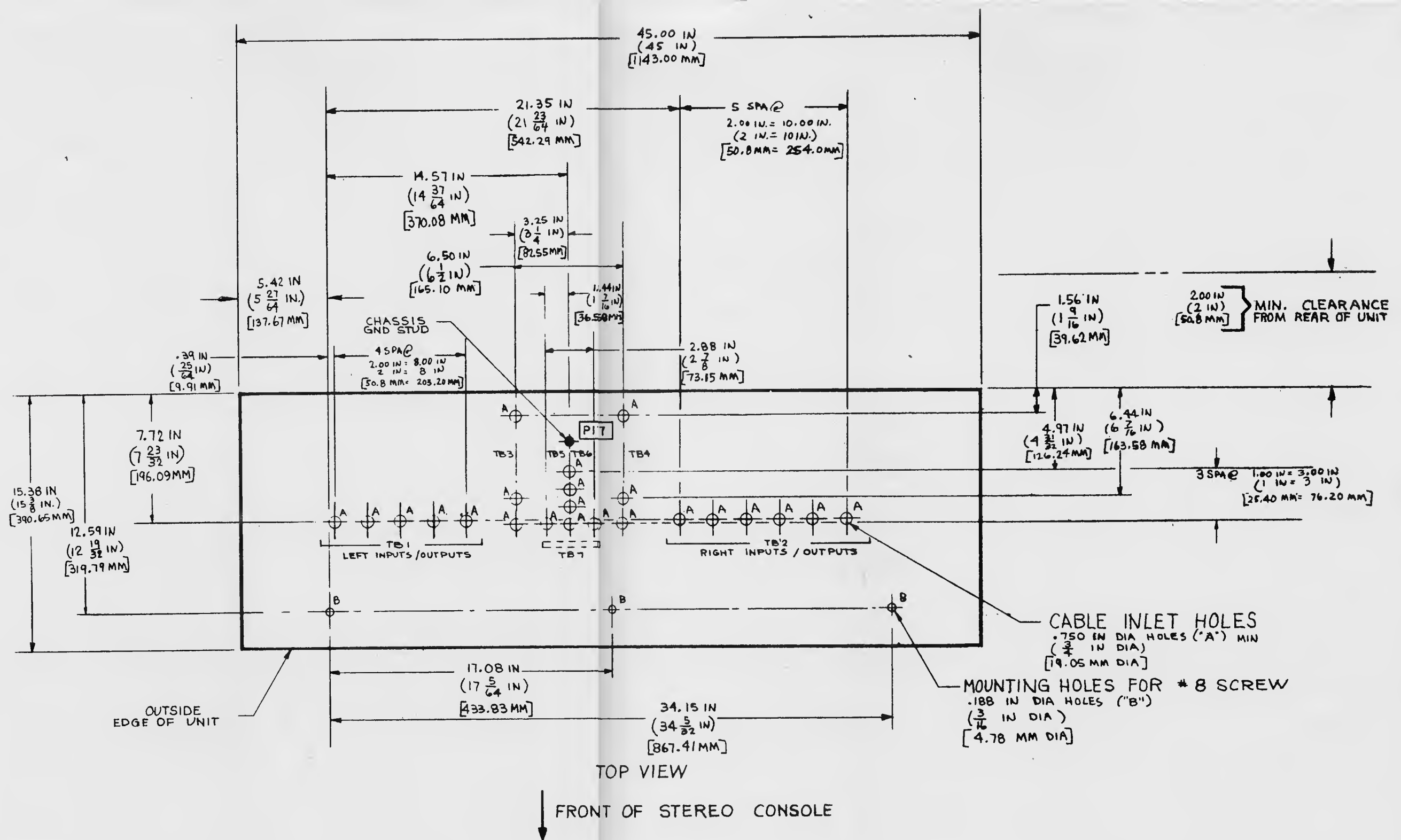

- 3 NOTE: RACK MOUNTED POWER SUPPLY
- 2 SCHEMATIC 828-0021-00X MUST BE USED FOR SYMBOL REFERENCE
- 1 LAYOUT AND DRILL HOLES PER DIMENSIONS ABOVE. MAKE SURE THAT CLEARANCES FROM EDGE OF UNIT (AS SHOWN ABOVE) ARE MAINTAINED.

NOTES:

HARRIS CORPORATION Broadcast Products Division
 123 Hampshire Street, Quincy, Illinois 62301

WARNING: Disconnect primary power prior to servicing.

CABLE INLET AND MOUNTING DIMENSIONS
 STEREO 80 CONSOLE
 839 0728 001