

**GATES
ENGINEERING
REPORT**

**THE PULSE DURATION MODULATOR...
A NEW METHOD OF
HIGH LEVEL MODULATION IN
MEDIUM AND SHORT WAVE
BROADCAST TRANSMITTERS**

**HARRIS
INTERTYPE
CORPORATION**

GATES®
A DIVISION OF HARRIS-INTERTYPE



THE PULSE DURATION MODULATOR... A NEW METHOD OF HIGH LEVEL MODULATION IN BROADCAST TRANSMITTERS

ABSTRACT

A new approach for obtaining the audio power required for high level plate modulation of AM broadcast transmitters is described. The advantages of this system are: lower initial cost, broader frequency response, lower distortion, transmitter output adjustable from zero to full output, lower power consumption, fewer amplifier tubes and lower operating cost.

The new modulation system (Patents Pending), herein called PDM (Pulse Duration Modulation), obtains its improved performance by operating the modulator tube in series with the RF power tube. High efficiency is obtained by operating the modulator tube in a saturated switching mode, or Class D.

CONVENTIONAL TRANSMITTER DESIGN

True innovations in AM broadcast transmitter design have been few. Most of the variations from the conventional high level plate modulated circuit in service today are the result of attempts to improve power conversion efficiency and reduce operating cost. Unfortunately, this has often been at the expense of simplicity and reliability. Performance standards for audio response and distortion have remained relatively unchanged in recent years, being limited primarily by the inherent linearity of available power amplifier tubes.

Utilization of all power amplifier tubes in a "switching" mode eliminates the factors that limit transmitter response, distortion and efficiency. It is significant that this is accomplished without resorting to complicated, hard-to-adjust circuitry. Transmitters utilizing a pulse duration modulator have a single final RF power amplifier tube and a one tube final modulator stage.

**H. A. Swanson
Engineering Department
Gates Radio
Quincy, Ill. 62301 U.S.A.**

JUN 25 1975

The pulse duration modulator is a recent Gates' development and is in no way similar to screen modulation, phase to amplitude (ampliphase), or low level modulation systems. Gates' PDM modulation is a new method of achieving high level plate modulation, resulting in overall transmitter efficiency never achieved before.

BROADCAST TRANSMITTERS WITH PULSE DURATION MODULATOR

Transmitters employing a pulse duration modulator (PDM), such as the Gates' 100 kW medium wave VP-100 and short wave SW-100, are high level plate modulated transmitters that utilize a new type of audio translation technique to generate the high level of audio necessary for plate modulation.

The modulator in a conventional plate modulated transmitter operates in a linear mode similar to an analog computer. In a PDM transmitter the modulator operates in a switching mode as in a digital computer. It should be noted that almost all new computers are digital.

In a PDM transmitter the modulator operates in a manner similar to a switch. It has two conditions—on or off. Audio information is contained in the duration of the "on" pulse. Thus the name Pulse Duration Modulation was adopted by Gates for this new system (for which it has patents pending).

The amplitude of the audio signal is determined by the percentage of time the modulator tube is conducting (duty cycle). A square wave signal of approximately 70 kHz is pulse width modulated by the audio signal. The amplitude of the audio signal causes the symmetry of the kHz square wave to vary. For instance, a large positive signal will cause the square wave to be "on" most of its cycle. A large negative signal will cause the square wave to be "off" most of the time. The frequency of the audio determines the frequency at which the symmetry of the square wave varies. The above described modulation is called pulse duration modulation (PDM).

No new modulation process is involved. Gates' PDM modulation is still high level plate modulation of a Class C RF amplifier. The difference is simply the manner in which the audio signal is translated and applied in series with the RF amplifier plate supply. The audio intelligence is superimposed on a 70 kHz pulse train at a low level. It is then amplified by a series of amplifiers to a level sufficient to modulate the final RF amplifier. The 70 kHz component is then filtered out to leave the amplified audio and a DC component which is the modulated plate voltage for the Class C final amplifier. **This eliminates the need for a modulation transformer and reactor.**

Continuous 100% modulation capability over a wide frequency range is inherent in this system and thus provides exceptionally good trapezoidal modulation capability with no compromise of cost or complexity. Another feature of this high efficiency series type modulator is automatic carrier level control and simple power level change. Another is fast acting crowbar protection from flash arcs, accomplished by opening the high voltage plate line to the power amplifier tube.

The high efficiency modulator provides carrier level control and fast acting crowbar protection because the modulator is in series with the PA, and the voltage applied to the PA tube can be rapidly removed by turning the modulator tube off in case of an arc or other fault, or adjusted to any D.C. level between zero and normal plate voltage. The PA plate voltage is determined by the duty cycle of the PDM. If the duty cycle is zero, there will be zero PA plate voltage. If the duty cycle is 10% the PA plate voltage will be 10% of the H.V. power supply voltage. During normal full power output the duty cycle is about 50%, and the PA plate voltage is about one-half of the H.V. power supply voltage.

THEORY OF OPERATION

How is PDM generated? A PDM pulse train has a constant repetition rate or frequency. It is a pulse train of variable width pulses, the width of the pulses being a function of the audio amplitude. In the Gates' PDM transmitters it is generated by combining a 70 kHz sawtooth with the audio signal at the input of a high gain amplifier. (See Figure 1 below).

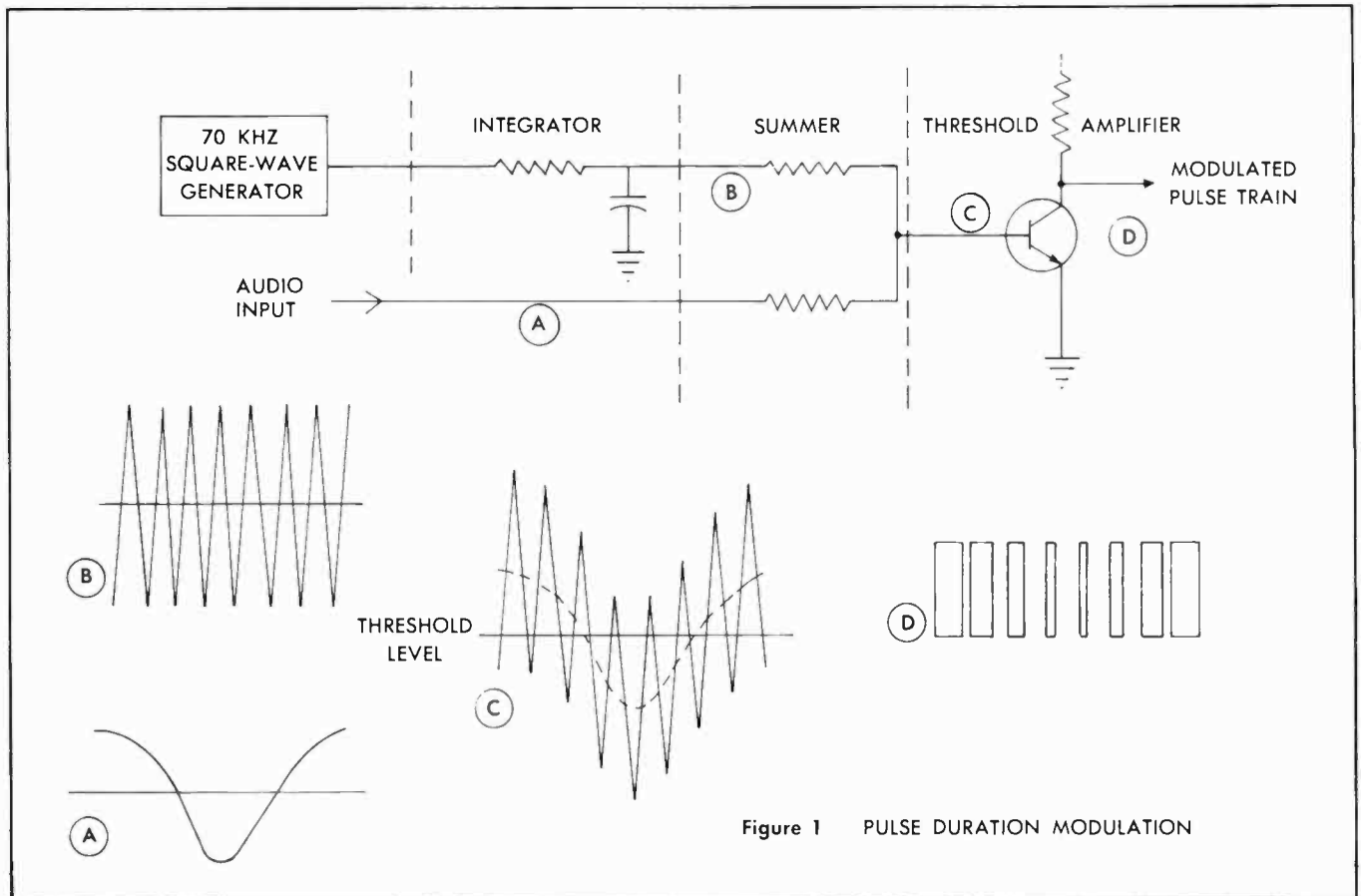

The output of a 70 kHz oscillator is clipped to form a square wave, and integrated to form a ramp or sawtooth voltage. This voltage is summed with the audio signal at the input of a Schmitt trigger threshold amplifier. The output of this amplifier is a modulated rectangular pulse train with a 70 kHz repetition rate pulse width modulated in accordance with the input audio signal. Or, amplitude changes in the audio input signal appear as the duty-cycle change of constant amplitude rectangular waves.

The resulting rectangular pulses are amplified by the driver and modulator stages and applied to the power amplifier cathode through a low pass filter which removes the 70 kHz signal and its sidebands, thereby recovering the original audio. The modulator tube acts like a variable resistor whose resistance varies with the amplitude and frequency of the audio signal. It is connected in series with the cathode of the power amplifier tube to obtain normal amplitude modulation.

As the reader will note, succeeding stages in the modulator chain are simple switches, capable of turning on and off at a 70 kHz repetition rate with not more than one or two microseconds of rise and fall time.

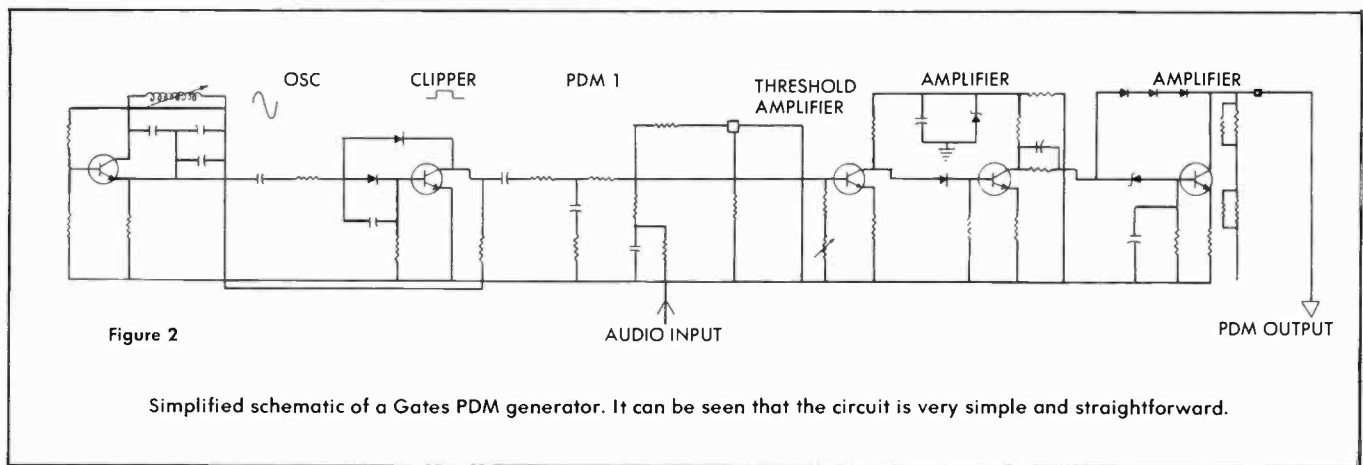

THE PULSE DURATION MODULATOR IN A 100 KW TRANSMITTER

To accomplish 100% modulation of the final amplifier of a 100 kW medium wave transmitter, such as the Gates' Model VP-100, average power in the neighborhood of 50 kilowatts is needed. In the VP-100 the power gain necessary to raise the level of a +10 dBm audio input signal to the level required to modulate the power amplifier is accomplished in four stages: two transistor amplifiers, Q4 and Q5, and two tubes, V1 and V2. The block diagram (Figure 3) indicates the relationship of these and other stages.

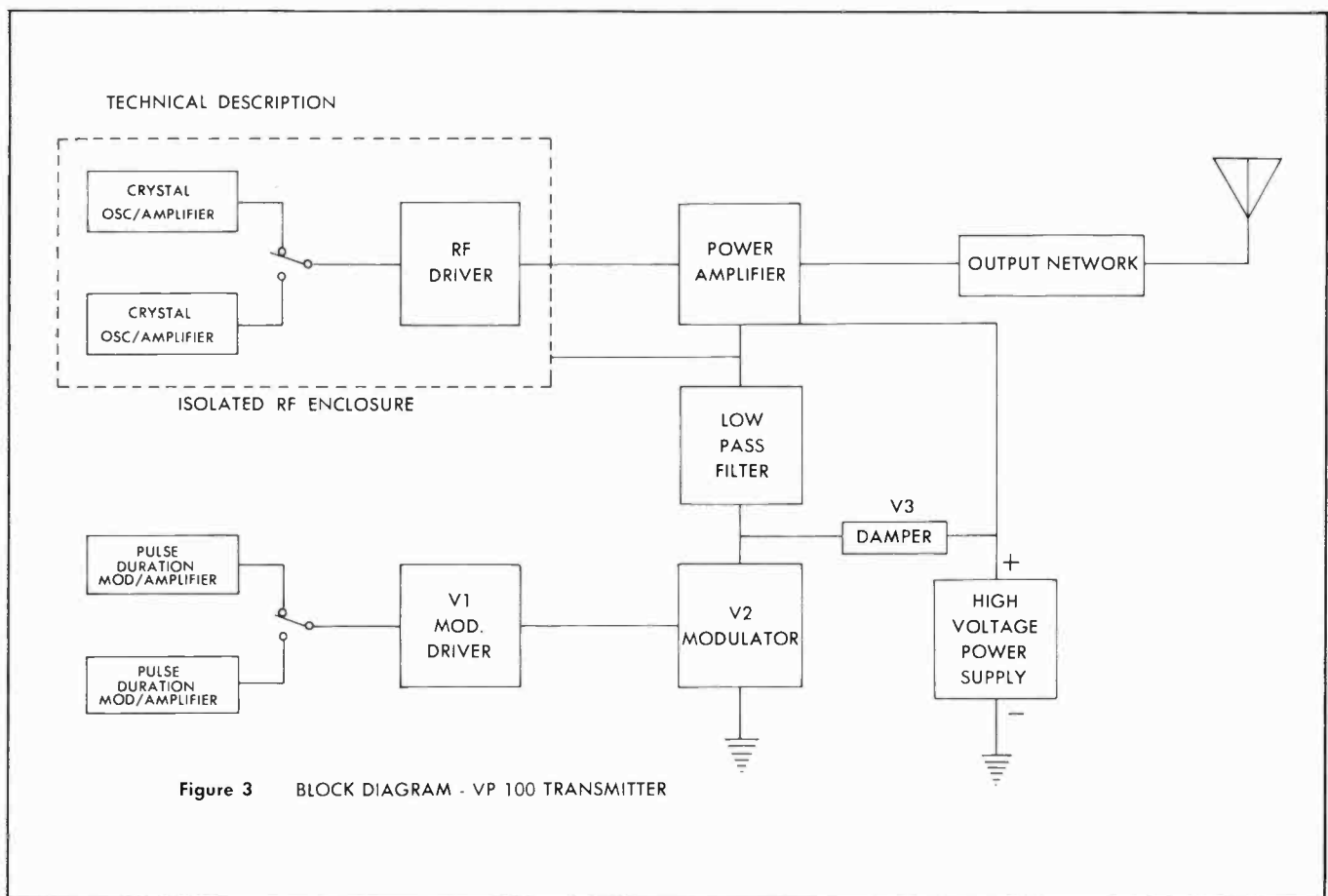

The modulator, V2, is connected through a low pass filter to the cathode of the power amplifier. The low pass filter provides the necessary function of removing the 70 kHz frequency component and the harmonics thereof and of recovering the audio as a modulating signal for the power amplifier. Note that the modulator is in series with the power amplifier.

The damper diode, V3, is connected between the modulator plate and 29 KV+, and conducts alternately with the modulator. That is, at a 70 kHz rate. V3 conducts when the modulator does not, providing a discharge path for the energy stored in the inductors in the low pass filter. This function is necessary in the interest of efficiency and low distortion in the system.

THE AUDIO SIGNAL

How is the audio recovered so that it can be used to modulate the PA tube? The output of the modulator is a train of variable width rectangular pulses of 70 kHz duration. Before this signal can be applied to the PA tube it must be converted to audio. This is accomplished by means of a low pass filter. The filter eliminates all of the 70 kHz switching frequency and leaves the desired audio component.

PEAK VOLTAGES IN GATES' PDM TRANSMITTERS

The peak voltages appearing at the final amplifier stage are of the same magnitude that exists with any plate modulated Class C amplifier. The series type PDM modulator differs only in the location of the common ground point. With no modulation the DC plate to cathode voltage is one-half of the H.V. power supply voltage.

The absence of a modulation reactor greatly reduces the magnitude of the transient peak voltage that can occur in conventional transmitters under certain fault conditions. In a transmitter of conventional design, sudden loss of RF drive to the final amplifier will cause the voltage of the amplifier plate to rise until something flashes over. In the Gates' PDM transmitter the maximum voltage that can appear across the tube is equivalent to only slightly more than during normal modulation.

The PDM transmitters have been designed with a number of simple, reliable fault protection circuits. They operate full time to take care of equipment induced faults, as well as faults caused by operator error. Any fault occurring in the high voltage power supply, or the voltage applied to the final amplifier tube, can exist for only about 10 ms before either the AC input overload or the DC overload circuits turn the transmitter off. All components operate within their design ratings during this period.

To summarize:

1. Under normal operating conditions the peak voltages are the same as for any conventional plate modulated amplifier.
2. Transient voltage peaks are less of a problem in the Gates' PDM design because there is no modulation reactor.
3. Maximum plate voltage is limited to a 10 ms time duration by overload circuits.

SALIENT FEATURES OF PDM

(a) Reliability

The most troublesome components in an AM transmitter, the modulation transformer and reactor,

have been eliminated by use of the pulse duration modulator. Because the modulator stages operate in a highly reliable saturated switching mode, small changes in component characteristics have negligible effect on the modulator performance. Tube and transistor linearity has almost no effect on the modulator performance. The modulator tubes and transistors operate in a manner similar to a switch. All they have to do is turn on and off. Tube life under this mode of operation will be increased greatly.

(b) Ease of Maintenance

Because of the reduced cost of the components and the inherent low failure rate of the saturated switching mode circuit, maintenance costs are lower.

Troubleshooting procedures are simplified by the fact that the modulator stages are inherently either operating properly or not operating at all. Linearity is not important. Most of the modulator is solid state.

(c) Operating Economy

With an overall efficiency of 65% normally achieved, and the lesser number of tubes, transmitter operating cost is greatly reduced from that of transmitters using conventional high level modulation.

(d) Operating Convenience

Power output can be adjusted to almost any power level between zero and rated output and automatically maintained at that level. Day/night power change is very simple.

SUMMARY

Broadcast transmitters utilizing pulse duration modulators provide unique performance and operational advantages over those of conventional design.

COMPARISON OF BROADCAST TRANSMITTERS WITH PULSE DURATION MODULATORS VS. CONVENTIONAL HIGH LEVEL TRANSMITTERS	
GATES PDM DESIGN	CONVENTIONAL AM
<p>EFFICIENCY</p> <p>Limited by tube pulse characteristics</p> <p>Is independent of distortion.</p> <p>Overall efficiency is 60 - 70%.</p>	<p>EFFICIENCY</p> <p>Limited by linear operating conditions.</p> <p>Compromise with distortion.</p> <p>Overall efficiency is 45 - 55%.</p>
<p>ECONOMY</p> <p>Two power tubes.</p> <p>Low cost 70 kHz inductors.</p>	<p>ECONOMY</p> <p>Three power tubes.</p> <p>Expensive modulation transformer and reactor.</p>
<p>PERFORMANCE</p> <p>Response limited by power supply and switching rate.</p> <p>Distortion independent of tube linearity.</p> <p>High performance at high power levels.</p> <p>Carrier shift almost zero.</p> <p>Continuous 100% modulation.</p>	<p>PERFORMANCE</p> <p>Response limited by iron-core components.</p> <p>Distortion dependent upon linear operating conditions.</p> <p>Performance compromise at high power levels.</p> <p>Carrier shift usually 3 - 5%.</p> <p>Usually continuous 50% modulation.</p>

**HARRIS
INTERTYPE
CORPORATION**

GATES®

A DIVISION OF HARRIS-INTERTYPE

QUINCY, ILLINOIS 62301 U.S.A.