

# Bradley

BROADCAST & PRO AUDIO

Catalog 1997-1998

RECEIVED  
JUL 13 1997  
SAC

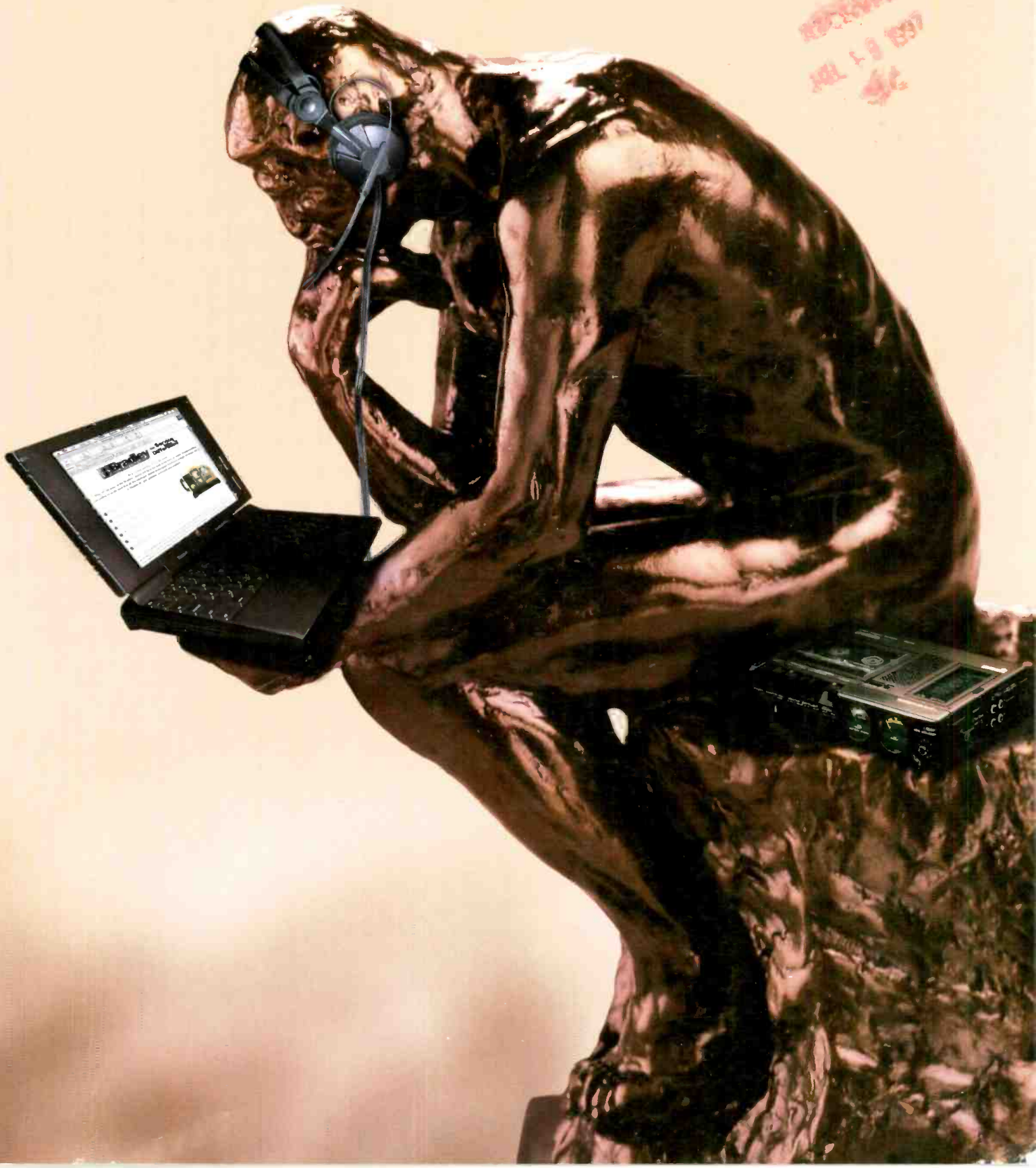

# The First Name In Digital, The First Family In MiniDisc



## MD Cart Series

### Recorders/Players

*The DN-995R/990R recorders and DN-981F player offer all the advantages of MD without the conventional tape cart problems of wow and flutter or drop-outs and tape stretching. These full-function units provide audio and computer interface as well as a multitude of options, including synchronization. Optional "Hot Start" switchbox adds instant playback of any 10 tracks (DN-981F).*



**T**he first name in digital, Denon has also become the premier manufacturer of MiniDisc products for broadcast and post production applications. Even the most demanding tasks of repetitive audio required by fixed installations are made easy and reliable with MiniDisc. Denon not only offers the most comprehensive line of MiniDisc products, they are totally committed to the further development of MD technology.

The MiniDisc format has proved to be the most convenient and reliable medium available. MD can literally be used millions of times without any signal degradation. The sonic quality is equal to Compact Disc and immensely superior to celluloid, while offering unsurpassed portability. More and more digital audio users are turning to MD for archival purposes.

From recording and replication to MD Carts and ENG MD recorders, Denon has a full family of products to integrate MD technology quickly and economically. Contact your favorite distributor and find out why Denon is the "first family in MiniDisc".



**DN-1100R MD Recorder** *The DN-1100R MD recorder offers 74 minutes of stereo recording time with a 44.1 kHz sampling rate, 16-bit linear (A/D converter) quantization and ATRAC compression. The unit also features 10 independent "Hot Start" buttons to which any 10 tracks from a total of 255 can be assigned. This feature is ideal for sound effects libraries, sound bytes and announcements.*

**DN-80R Portable MD Recorder** *The DN-80R is the most advanced ENG recorder on the market, allowing up to 148 minutes recording time in mono and 74 minutes in stereo, per disc. The portable unit provides news gathering personnel and reporters who are on-the-move with shock-proof recording and playback capabilities from a 40 second memory buffer. Further time-saving production features include field editing on a single disc. A standard 23dx video camera battery provides maximum power for a full 148 minutes.*



**DN-045R MD Replicator** *The DN-045R MD replicator performs exact digital-to-digital dubs, up to 3.5 times faster than realtime without the cascade of ATRAC compression. The included Windows™ software also allows fool-proof editing during replication.*

**DENON**  
The First Name In Digital Audio

# **Bradley** BROADCAST & PRO AUDIO

*Our Service Makes The Difference*

## Sound Forge XP

# \$99

See other side for details!

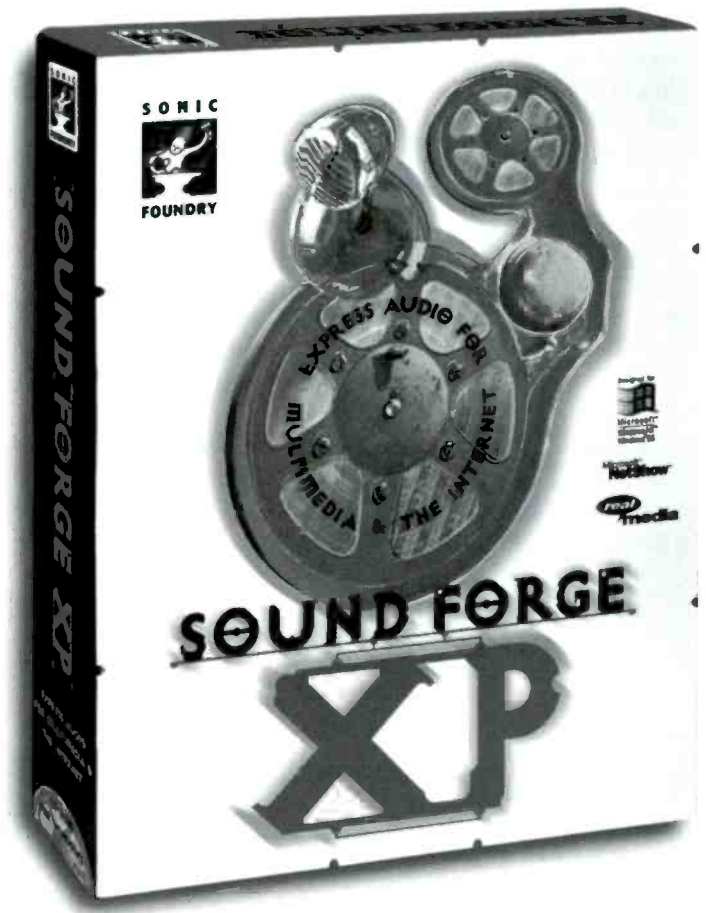

# **Bradley** BROADCAST & PRO AUDIO

BRADLEY BROADCAST SALES INC.  
12401 TWINBROOK PARKWAY • ROCKVILLE, MARYLAND 20852

BULK RATE  
U.S. POSTAGE  
**PAID**

PERMIT NO. 1025  
ROCHESTER, NY

\*\*AUTO\*\*\*\*\*3-DIGIT 571  
571049  
SBC  
DEAN SORENSON  
600 N KIWANIS  
SIOUX FALLS SD 57104-1802



TELEPHONE: TOLL-FREE: 800-732-7665 • Direct: 301-231-7800 • FAX: 301-230-6526

# Don't throw this card away!

## Fax Bradley for this special deal.

### IT DOES A LOT FOR VERY LITTLE!!

Sound Forge XP delivers over 25 powerful digital audio effects and processes within a flexible, familiar Windows environment. Explore the creative potential of audio with this powerful two-track editor, using a full range of effects, including reverb, ten-band EQ, distortion, and fade in/out. Use the mix, paste, and crossfade functions to combine sound files in a single step. Unlimited undo/redo capabilities allow complete editing freedom.

Recording professional-quality audio has never been easier. Sound Forge XP's accurate, responsive record meters hold peak levels to let you choose the "hottest" sound without clipping or distortion. Use the Remote Record feature to record while running other audio applications simultaneously.

Spend less time converting and more time creating. Sound Forge XP supports an extensive set of file formats, including Microsoft WAV, NeXT/Sun Java AU, Video for Windows AVI, Macintosh AIFF, and all known ACM formats. Best of all is this limited time, special offer from Bradley:

\*(Maryland delivery, please add \$4.95 sales tax)  
Shipping additional outside the Continental U.S.

**Sound Forge XP**  
**\$99**  
**Delivered!\***

Please note: Opened software items are not returnable.

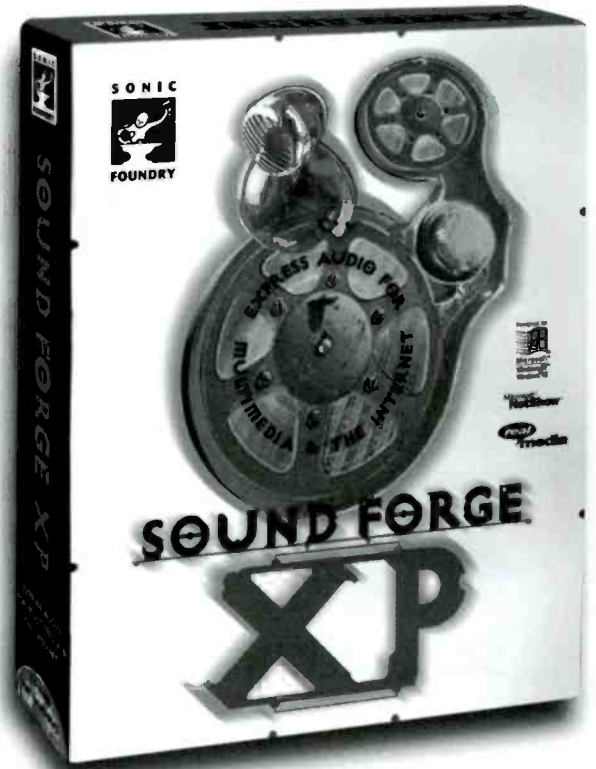

Dear Bradley: Please send me Sound Forge XP. I include a check or credit card authorization.

My Name \_\_\_\_\_

Company Name \_\_\_\_\_

Address (no PO boxes) \_\_\_\_\_

Phone \_\_\_\_\_

Check enclosed  Bill my credit card (circle one: MasterCard VISA Discover)

Card # \_\_\_\_\_ Expiration Date \_\_\_\_\_

Name On The Card \_\_\_\_\_

Billing Address \_\_\_\_\_

Signature \_\_\_\_\_

For this special, we require a check with your order, or you may use MasterCard, VISA, or Discover. Order as many items as you want, but note that these specials expire when our stock is gone or 1/31/98, whichever is sooner. Sorry, no COD or orders on account. Allow 7 days for delivery. Shipping charges to the lower 48 are included (Alaska and Hawaii additional charge).

To place your order, mail this form with your check, or fax it with your credit card information.

FAX to: 1-301-230-6526

Or mail to:  
Bradley Broadcast Sales  
12401 Twinbrook Parkway  
Rockville, MD 20852

## PRICING

Prices marked MFR LIST show the suggested selling price from the manufacturer and are subject to discount. Call us for a current price quotation.

## ORDERING INFORMATION

**Minimum order:** \$25.00 in merchandise and \$7.00 in shipping and handling.

**Ordering by telephone:** Call 800-732-7665 or 301-231-7800 during our office hours, listed on page 1. Net 30 terms are available to qualified buyers, subject to credit limit. We require a firm purchase order signed by an authorized agent of your company for Net 30 purchases. We also welcome MasterCard, Visa, and Discover; credit card orders are authorized in full at the time of purchase.

**Ordering by fax:** Send your order by fax to 301-230-6526, 24 hours a day. Include shipping and invoicing instructions.

**Ordering by mail:** Mail your order, with shipping and invoicing information, to Bradley Broadcast Sales, 12401 Twinbrook Parkway, Rockville, MD 20852. Enclose your purchase order (if you have an account), or payment or credit card information. Remember to include tax if appropriate.

**Shipping charges:** We can quote shipping charges, so you may include them with your prepayment, or we can ship your merchandise freight collect, or charge shipping to your credit card, or ship via the carrier of your choice using your account number. If you have a Bradley account in good standing, shipping charges can be added to your invoice.

**COD shipments:** COD orders are limited to items immediately available from stock. We reserve the right to ship COD only to established clients. Shipments in excess of \$500 may require payment by cash or certified check. We do not ship COD via U.S. Mail.

**Tax:** Maryland customers must add 5% sales tax or provide signed documentation of Maryland sales tax exemption at the time of order.

## DAMAGED, DEFECTIVE, OR INCORRECT MERCHANDISE

If any package shows signs of damage, do not accept it. We will replace the item when the carrier returns it to us, or we will re-ship immediately upon notification of the problem. In the latter case, new merchandise will be separately invoiced or charged, with credit or refund issued upon receipt of defective merchandise. When you receive any merchandise, always inspect it before signing. Under carrier rules, it is YOUR responsibility to report damage or loss. Note damage on any shipping documents, and save all packing material and waybills. Request inspection by the carrier immediately. Claims for defective or incorrect merchandise must be reported to us within five days. When you call us, we will issue you a return authorization (R.A.) number, which MUST appear on our return package or we cannot accept it. If you order the wrong item, you are responsible for shipping charges to return it. If the error is ours, we will pay for shipping. Merchandise returned for any reason other than defects or damage is subject to restock fees. No returns or exchanges after 30 days.

## BRADLEY BROADCAST GUARANTEE

All merchandise is new and fully warranted by the maker. Bradley Broadcast neither offers nor implies any warranty other than that provided by the manufacturer. Bradley does not guarantee the suitability of any product for your intended purpose and is



12401 TWINBROOK PARKWAY • ROCKVILLE, MD 20852 • 800-732-7665  
301-231-7800 • FAX: 301-230-6526

Sales Office Hours 9:00 AM to 5:30 PM Eastern Time, Monday through Friday  
Business Office Hours 9:00 AM to 5:00 PM Eastern Time, Monday through Friday

**B**radley is a dealer of thousands of products from hundreds of manufacturers. Our customers are radio and TV managers, engineers, freelance reporters, oral historians, government buyers, voice-over specialists, librarians, educators, churches, sound crews, archivists, cable TV engineers, studio technicians, and many others whose business is in audio and broadcast. We're pleased to count you among them.

## CONTENTS

1997-98

FIELD PRODUCTION .....	2-10
TELEPHONE INTERFACE & INTERCOM .....	10-19
MICROPHONES .....	20-35
RECORDING & PLAYBACK .....	36-52
MIXERS & CONSOLES .....	53-60
SOUND REINFORCEMENT .....	60-63
MONITORING .....	64-75
AUDIO PROCESSING .....	76-82
AUDIO INTERFACE .....	82-95
RF EQUIPMENT .....	96-99
FURNISHINGS .....	100-107
INDEX .....	108

Visit Bradley on line!

We're at

<http://www.bradleybroadcast.com>

not liable for consequential damages incurred in the use of any product we provide. Product specifications are subject to change without notice.

## ACCOUNT TERMS

Credit terms are Net 30 days. Interest at the rate of 1.5% per month (18% per annum) will be charged to overdue accounts, and further credit privileges suspended at our option. The calculation of due date is based upon the shipment date for each item, or our invoice date, whichever is later. We invoice partial shipments and expect payment within 30 days on each shipment. If your institution or company cannot accept partial billings, we will hold merchandise for complete shipment at one time. Postmark date of your payment must be within 30 days of invoice or ship date to be considered timely.



## PORTABLE RECORDING

### SONY TCD-D8 DAT RECORDER

Sony's portable DAT recorder is the latest version of one of our most popular tools for collecting audio in the field. Now the deck is a sleek charcoal black. You can make 44.1kHz recordings from an analog source. Also, no longer must you hunt for an AC adapter; it comes packed with one.

This lightweight Sony recorder/player runs on four "AA" cells and weighs about a pound. Digital volume limiting, automatic date function, and audible cue are standard. It offers 20-22kHz audio at 48 and 44.1kHz sampling; 32kHz is also supported. Standard DAT tapes give you two hours of the highest fidelity audio, or four hours in long-play mode.

Sony also offers the optional SBM-1, a Super Bit Mapping 20-bit A/D converter for making the most of analog input recording, for use with the TCD-D8 and other digital recorders.

TCD-D8	60SOTCDD8	MFR LIST	\$799.95
SBM-1	60SOSBM1	MFR LIST	\$549.95
Mic Cable for TCD-D8 (feeds mono mic audio to both channels)			
	61WHENG6		only \$12.00
Car Battery Cord	60SODCCE260HG		only \$20.00

CALL 1-800-732-7665 FOR BRADLEY PRICE

### SONY TCD-D10 PRO II PORTABLE DAT RECORDER

Take an imaginary walk around the TCD-D10 Pro II. See the big, easy to read LCD display. Finger the balanced XLR mic/line inputs. Pick it up and gauge the ruggedness of this four-and-a-half pound recording tool.

You will appreciate other features, too: End search to find the position of your last recording. Index and search features for quick cut access. Level attenuator, low cut filter, and peak limiter for the mic inputs. Digital transfer in the AES/EBU and S/PDIF formats. Absolute Time recording and playback for time reference that can be translated to SMPTE. Four direct drive motors for a stable, long life. It comes with two rechargeable battery packs, a recharger, AC power supply, a pistol-grip remote control, and a carrying case.

You end your tour with the realization that the TCD-D10 Pro II will prove a worthwhile companion on the road.

TCD-D10 Pro II	60SOTCDD10PRO	MFR LIST	\$4,000.00
Spare rechargeable battery	60SONP22H	MFR LIST	\$75.00

CALL 1-800-732-7665 FOR BRADLEY PRICE

**Bradley is your field production specialist.**



### DIGITAL BRING IT BACK PACK

To help you with your field recording, we package the popular, portable TCD-D8 Sony DAT recorder with Audio-Technica's great AT822 stereo microphone with cable. An \$1,199.00 value.

Package 9701      Only \$969.00



### TASCAM DA-P1 PORTABLE DAT

Not all professional DAT recorders cost as much as a small car. The DA-P1 from Tascam sports balanced XLR mic/line inputs with phantom power, unbalanced RCA, digital S/PDIF output, and rechargeable battery. You also get selectable sampling rates, a mic limiter, and a 20dB pad. For monitoring, the unit has a TRS headphone jack and level control for any headphones.

The display shows program time, sampling rate, ABS time, and record margin; displaying counter mode is easy, as is counter reset, margin reset, and ID select. A hold switch prevents accidental operation. Standard accessories include a shoulder belt, AC adapter, and one battery.

DA-P1	60TEDAP1	MFR LIST	\$1,899.00
Porta-Brace Case	60PBARDAP1	MFR LIST	\$178.00
Extra battery	60TEBPD1	MFR LIST	\$100.00
Charger	60TECBD1	MFR LIST	\$75.00

CALL 1-800-732-7665 FOR BRADLEY PRICE

### HHB PORTADAT

From Hollywood to Washington, the PORTADAT is on the job. The PDR1000 is built around a rugged direct-drive transport with four heads for confidence recording. The nickel metal hydride rechargeable battery runs the unit for two hours (juice it back up on the charger/12VDC supply, which is included and operates on all international mains voltages).

The unit has XLR balanced inputs, phantom power, AES/EBU and S/PDIF digital I/O, limiter, built-in speaker, and selectable sampling rates. A carrying case comes with it. Weight: 4.4 pounds including battery. This is a most impressive professional effort from HHB.

Ask us about the PDR1000-TC with time code for motion picture and other time-critical work.

PDR1000	60HHPDR1000	MFR LIST	\$3,495.00
Hard aluminum case	60HHCASE	MFR LIST	\$175.00
Porta-Brace case	60PBAR1000	MFR LIST	\$182.00

CALL 1-800-732-7665 FOR BRADLEY PRICE

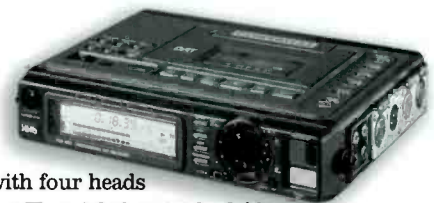

## FIELD PRODUCTION

Bradley Broadcast • 12401 Twinbrook Parkway • Rockville, MD 20852 • 800-732-7665 • 301-231-7800 • Fax: 301-230-6526 • email: info@bradleybroadcast.com

**SONY MINIDISC PORTABLE RECORDERS**

Record on MiniDisc in the field with the MZ-B3. This stereo model has a built-in speaker and mono microphone, plus a mini connector for stereo mic. Since audio capacity doubles in mono, you can use one 74 minute disc to hold 148 minutes, or operate the unit in the normal stereo mode. Note, mono recordings are not compatible with many studio MD machines.



The MD format assures you of pristine, low-noise audio and convenient access functions. The MZ-B3 adds high-speed playback and powerful search features including a system that lets you mark sections of your audio for later retrieval. Weight: 1 lb. with batteries (takes 3 "AA").

The cousin MZ-R3 model has many of the same features but lacks the mic and speaker. Both models have line and headphone outputs on stereo mini jacks; both have SCMS.

MZ-B3 Recorder/Player 60SOMZB3	MFR LIST	\$899.95
MZ-R3 Recorder/Player 60SOMZR3	MFR LIST	\$649.95

CALL 1-800-732-7665 FOR BRADLEY PRICE

**SONY DIGITAL MICRO RECORDER**

Amazing audio quality is the trademark of the NT-2, which records on an ultra-compact digital microcassette tape using its own data reduction scheme. The "mini-DAT" tape is no bigger than a large postage stamp.



The NT-2 weighs less than a half-pound but provides up to two hours of continuous recording without interruption thanks to memory reverse. The large LCD display has a four-digit readout for key operating modes. "Mode select" displays tape counter, remaining time, date, and time. Stereo earphones, stereo mic, lithium battery and AC adapter are included.

Response: 10Hz to 14kHz. Size: only 2-1/2" x 7/8" x 4-3/8".

NT-2	60S0NT2	MFR LIST	\$1,699.95
------	---------	----------	------------

CALL 1-800-732-7665 FOR BRADLEY PRICE

**Accessories:**

60 Minute NT Tape	60S0NTC60	\$9.95	90 Minute NT Tape	60S0NTC90	\$14.95
120 Minute NT Tape	60S0NTC120	\$17.95	NT Cleaning Tape	60S0NTC10CL	\$16.95

**PLUG 'EM! BRADLEY ENG MIC CABLES**



We know what kind of ENG cables you need: durable, high-quality, with a choice of straight or coiled. Our cables are for portable DAT and cassette recorders and will stand up to the rigors of field use. Straight cords are 6 feet long except as noted: coiled cords extend to over ten feet. Need something else? CALL US.

XLR female to XLR male, straight cable	61WHMK406	\$13.25
XLR female to XLR male, coiled cable	61GCENG5	\$35.95
XLR female to XLR male, straight (10')	61WHMK410	\$14.40
XLR female to 1/8" TRS mini, straight cable	61WHENG6	\$12.00
XLR female to 1/4" TS, straight cable	61WHENG4	\$12.00
XLR female to 1/8" TS mini, straight cable	61WHENG	\$12.00
XLR female to 1/4" TS, coiled cable	61WHENG2	\$28.00
XLR female to 1/8" TS mini, coiled cable	61WHENG3	\$28.00

**DIGITAL GET THE STORY PACK**

Superb DAT recording in the field was never easier. Order the Tascam DA-P1 pro DAT recorder, described on the facing page, and add Audio-Technica's AT825 stereo microphone with cable, a total \$2,425.00 value.



Package 9702      Only \$1,865.00



**SONY PORTABLE CASSETTE RECORDERS**



**SONY TCM 5000EV PRESSMAN**

Four alkaline "C" cells provide about 20 hours of recording with this pro, three-head mono cassette deck. A warning signal in your headphones tells you when your tape is running out. Other features include built-in condenser mic, one touch recording, -20% to +40% pitch control, instant edit mode, one touch review, auto shut-off at the end of the tape, locking pause, VU meter/battery life indicator, tape counter, and earphone jack.

In the voice activated mode, the unit will delay recording until the motors get up to speed. The result is gapless VOX operation. Mic input is 1/8" mini TS.

TCM-5000EV 60SOTCM5000EV \$479.00



**SONY TC-D5 PRO II**

Like its DAT brother, it's a broadcast favorite, a stereo cassette recorder with lighted VU meters, battery check, and record limiter. It arrives equipped with carrying case, shoulder strap, and belt, and weighs less than four pounds. Mic inputs are female XLR (ready to rip with your pro mic), line outputs are RCA, and headphone output is 1/4" TRS.

The TC-D5 Pro II runs on just two "D" cells, or an optional AC supply, or external 6 or 12VDC. Frequency response is excellent, and with Dolby B you get a 6dB improvement in signal/noise ratio.

TC-D5 Pro II 60SOTCD5 \$1,099.00

Accessories:  
Porta-Brace deluxe case 60PBARD5 \$175.00

Also available:  
The TC-D5M has all of the features of the Pro II with the exception of the mic inputs, which are 1/4" TS. 60SOTCD5M \$699.00

**BRING IT BACK!**

**MONAURAL PACKAGE**

The "Bring It Back" Mono Pack includes the Marantz PMD-222 cassette recorder with vinyl case, the professional Beyer M58 mic with wind-screen and clip, Sennheiser headphones, a coiled ENG cable, a 25' XLR to XLR cable with Cord-Lox, a 16" Rubberneck gooseneck, and a Rowi clamp. Valued at over \$1,000.00.

Package 9703 \$699.00



**STEREO PACKAGE**

The "Bring It Back" Stereo Pack gives you Audio-Technica's AT822 stereo mic and the Marantz PMD-430 stereo cassette deck. Also included are a windscreen and adapter cables for the mic, a case for the recorder, and a 25' XLR to XLR cable with Cord-Lox. Valued at over \$1,000.00.

Package 9704 \$789.00



**GET THE STORY!**

We wanted to show something else in this space this year but the boss wouldn't let us. Our customers tell us they love the "get the story" packs.

Who are we to argue with success? You get the mono Marantz portable tape deck of your choice from the list on page 5, then we add Shure's indestructible VP64 mic plus one of our coiled ENG mic cables. Very good value indeed.



Package 9705 with PMD-222 \$479.00

Package 9706 with PMD-221 \$449.00

Package 9707 with PMD-201 \$399.00

**EXTRA!**

Bradley's special accessory kit includes a pair of Sennheiser HD445 headphones, Rowi mic clamp, desk tripod mic stand, a 10" rubber gooseneck, 25' XLR-to-XLR mic cable with Cord-Lox strap, and a great Kaces gig bag to hold it all.  
A \$235 value. Package 9708 Only \$139.00



# MARANTZ PORTABLE CASSETTE RECORDERS



News reporters, oral historians, court reporters, and audio people of every stripe reach for Marantz cassette recorders. Their favorite: The PMD-222.

It's a three-head mono deck with a balanced XLR input for your favorite pro mic. These features help you in your work: speaker, VU meter, phone jack, pitch control, built-in electret condenser mic, two speeds, auto-shutoff, cue and review, memory rewind/replay, and 1/4" TRS headphone jack. It also has a switchable limiter, automatic noise-control switch, and metal tape capability. Three "D" cells give you 7-1/2 hours operation; the optional Ni-cad rechargeable provides 5-1/2. We love it.

**60MR222 \$369.00**

The PMD-221 contains all features of the PMD-222, above, but the mic input is 1/8" TS mini.

**60MR221 \$349.00**

The PMD-201 is a two-head version of the PMD-221, without memory rewind/play. Mic input is 1/8" TS mini.

**60MR201 \$295.00**

Marantz on a budget: The PMD-101 is an affordable, two-head mono portable with ±20% pitch control, tape counter, line input/output RCA jacks, and a headphone jack. Use the built-in condenser or plug in your own mic with 1/4" connector. Tone control, low-battery LED, and two speeds are standard.

**60MR101 \$215.00**

The PMD-430 is the stereo big brother in this family, featuring dbx noise reduction and three heads. You also get 6% pitch control, illuminated VU meters, limiter, and Dolby B. Memory rewind, auto shut-off/replay, three step mic attenuator, and headphone jack round out the list of useful functions. Mic inputs are 1/4" TS, line inputs and outputs are RCA phono. Carrying case included.

**60MR430 \$499.00**

**Accessories:**

Kases KEB20 Gig Bag	40KEKB20	\$22.50
Vinyl carrying case for PMD 221 and 201	60MRCLC221	\$35.00
All weather case for all models	60MRWPC221	\$20.00
Porta-Brace deluxe case for all PMD recorders	60PBAR222	\$175.00
Ni-cad battery pack for all PMD recorders	60MRRBD430	\$66.00



## WHIRLWIND MD-1 PORTABLE MIC-TO LINE DRIVER

The MD-1 combines a high quality mic/line input stage with a transformer-isolated line output and independent headphone amplifier. Operating on two 9 volt batteries, and housed in a rugged steel chassis, the MD-1 is designed to withstand rough usage. Use it with boom, parabolic, or interview mics, including those that require phantom power. Input is mic/line selectable, and a separate headphone level control provides a 60db range of adjustment. A headphone line input allows monitoring of other signals while the mic/line stage is in use. Because of its flexibility, the MD-1 is also an ideal piece of test gear for audio signal tracing. Count on Whirlwind come up with great audio problem-solvers.

**61WHMD1 MD-1 Mic/Line Driver \$299.00**

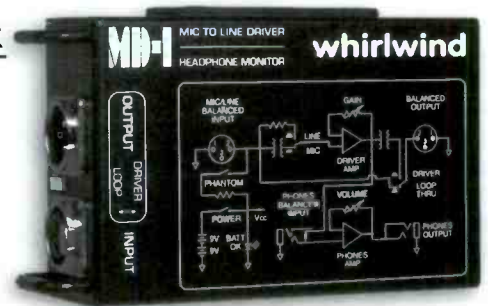

## SHURE FP22

### STEREO HEADPHONE AMP

Monitor your field audio in stereo. Power is by a 9V battery or 12-24VDC. The FP22 weighs 16 ounces and allows a mono signal and a stereo signal to be mixed any way you wish (with either or both signals, in either or both ears). Loop-through chaining, belt clip, XLR and phone jack are standard.

**FP22 60SHFP22 MFR LIST \$395.00**

**CALL 1-800-732-7665 FOR BRADLEY PRICE**

## SHURE FP11

### MIC/LINE AMP

Does your field gear accept mic-level audio? If not, here's a useful mic-to-line amp with adjustable gain of up to 84dB. It runs on a 9V battery and has both a balanced XLR mic input and a 1/8" TS mini input for a high level, high impedance source. The output is transformer balanced and appears on both an XLR connector and a set of spring contact binding posts. A switchable peak limiter and belt clip are included.

**FP11 60SHFP11 MFR LIST \$340.00**

**CALL 1-800-732-7665 FOR BRADLEY PRICE**



## PORTABLE MIXERS

# SHURE FIELD DEVICES

CALL 1-800-732-7665 FOR BRADLEY PRICES ON SHURE MIXERS

### M267

The M267 gives you so much for your money: a compact four-input mono mic mixer, with VU meter, switchable limiter, phantom power, built-in battery pack, muting circuit, and headphone jack with level control. Mic and line switches are provided on inputs and outputs. You also get a tone oscillator, four XLR inputs, one XLR output and a binding post output, mix bus connection, and low cut filters. Works on 120/240 VAC or three 9V batteries.



**Best Seller**

M267 60SHM267 MFR LIST \$625.00

### FP16A

A Bradley Best-Kept Secret, the FP16A is a handy field tool. It's a one-in, six-out audio DA for routing audio feeds, useful as a press bridge, at remote events, any place where you want multiple portable mic/line outputs. Includes phantom power, XLR transformer-balanced I/O (each switchable for mic or line), link jacks for ganging, and screwdriver-set gain controls. Run it on 120/240VAC or three 9V batteries for up to 20 hours. The battery supply automatically cuts in if you lose your AC power. Optional rack mount available.



FP16A 60SHFP16 MFR LIST \$645.00

### FP33

A step up from the popular FP32, this version is a portable stereo mixer with a 30dB reduction in self-noise, making it compatible with the latest digital stuff. Also: recessed panpots to prevent accidental movement; a dynamic range of 100dB; indicators for input levels, limiters, and low battery; and three kinds of phantom power for each input including 48V. The FP33 has three inputs, two outputs, and a cable to connect two mixers. Uses two 9V batteries.



FP33 60SHFP33 MFR LIST \$1,795.00

## JK AUDIO REMOTEMIX 3

Plug Remotemix 3 into any phone line or handset cord, and you have an instant Remote broadcast facility, IFB patch, or live interview station. Featuring two XLR mic inputs, RCA line in/out and two headphone jacks, plus a DTMF dial pad and VU meter, this powerful little mixer really brings it home! Runs on two 9V batteries, or included AC adapter. Functions as a telephone when attached directly to a phone line.



60JKMIX JK Audio Remotemix 3 MFR LIST \$895.00

### M367

The M367 mono mixer inherited quality from the M267 and added to it: it's 25dB quieter and has another two mic/line inputs, for a total of six. Other additions include 12 and 48V phantom, two XLR outputs, input peak LEDs, headphone monitor circuit, adjustable limiter threshold, and full meter illumination. Delayed power-on means no start-up "pop". Takes two 9V batteries.

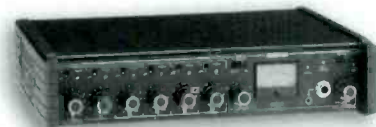

M367 60SHM367 MFR LIST \$795.00

### FP42

The FP42 is a stereo sibling of the mono M267. Four balanced mic/line inputs with pan pots and phantom power are provided. Cue audio is routed to the stereo headphone jacks when a channel control pot is pulled out. Run it for eight hours on three 9V batteries, or plug into 120/240 VAC. Controls include mono/stereo switch, tone oscillator, limiter on/off, and headphone level control.



FP42 60SHFP42 MFR LIST \$1,175.00

### FP32

The FP32 stereo mixer is three mic/line channels with panning. A concentric, clutched master gain control is included. The FP32 has two illuminated VU meters plus battery check, and includes a carry case and shoulder strap. You'll like the slate mic and tone features and built-in simplex or A-B phantom powering. Uses two 9V batteries; a third battery is required for A-B power.



FP32 60SHFP32 MFR LIST \$1,325.00

#### Accessories:

Porta-Brace Mixer Case for FP-31, 32 and 32A	(Specify model)	\$60.00
Rack mount kit for M367	61SHA367R MFR LIST	\$46.50
Rack mount kit for M267	61SHA268R MFR LIST	\$35.00
Rack mount kit for FP42 and FP16A	60SHA16R MFR LIST	\$35.00

## QUICKTAP IFB

This useful device connects to the handset cord of any phone, providing an IFB tap with both 1/8" mono jack with volume control, and a fixed output 600 ohm male XLR output. No batteries or AC are required for operation.



60JKQT JK Audio Quicktap MFR LIST \$59.00



**FIELD PRODUCTION**

Bradley Broadcast • 12401 Twinbrook Parkway • Rockville, MD 20852 • 800-732-7665 • 301-231-7800 • Fax: 301-230-6526 • email: info@bradleybroadcast.com

## KACES III EQUIPMENT CASES

This company wants to prove that they have a soft gig bag for every need. OK, that works for us. Our customers use lots of portable products, and Kaces makes very affordable bags for them. In fact, they're good enough to earn a Bradley Best-Kept Secret. You get sturdy web handles, tear-resistant nylon, thick padding, heavy-duty zippers, and lots of room for microphones, cables, and notepads.

Bags for lots of other products are available; give Bradley a call.

Kaces KEB20	for Marantz Portables, Shure FP31 & 32	40KEKB20	\$22.50
Strap	KEB22 & 20	40KESTRAP	\$5.95
Kaces KEB22	for Mackie 1202	40KEKB22	\$22.50
Kaces KEB29	for Spirit Folio Mixer	40KEKB29	\$39.00
Kaces KEB30	for Mackie 1604 (includes strap)	40KEKB30	\$51.00



## SKB RACKMOUNT CASES

These durable racks are made not of wood but of rigid polyethylene with welded frames, so they're half the weight of wood racks. The removable latching front and rear covers seal tight. You know they travel well because they meet ATA specs. Rackable depth is 17" with cover. Cases have two carrying handles and can be stacked.

SKB Shock Rack Cases are similar and give extra protection with an internal, shock-absorber frame. Three sizes, all 20" usable depth.

One of SKB's best ideas was the Pop-Up rack. Plop it in place, pull off the cover, pop up your gear at any angle. The 12-space frame has heavy-duty slide hinges. The interior is 8"H x 20-5/8"W x 23-1/2"D.

(Here's one that's not a rack: For stashing stuff, the SKB-1713 briefcase case is the way to go. Top lid is hinged at the back. 17" x 13" x 10-1/2".)

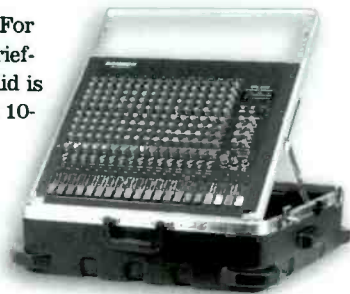
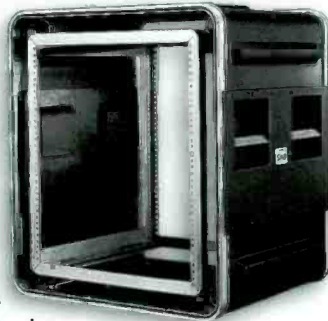

### SHOCK RACK CASES

8 space	77SK908	\$349.00
12 space	77SK912	\$395.00
16 space	77SK916	\$419.00

### POP-UP RACK CASE

77SK19P12 \$139.00



### UTILITY CASE

(not pictured)

77SK1713 \$104.00

### ATA RACKMOUNT CASES

2 space	77SK192	\$99.00	8 space	77SK198	\$169.00
4 space	77SK194	\$109.00	10 space	77SK1910	\$179.00
6 space	77SK196	\$125.00	12 space	77SK1912	\$198.00

## MODERN CASE "RACK BAGS"

Take a rack with you. These lightweight racks from Modern Case are made of sturdy ply wood and surrounded by a half-inch of foam and cordura fabric. Straps let you carry them easily.

Order one space for a single small piece of gear, or go up to six rack spaces and 18" usable depth.



Shell depth	1SP	2SP	3SP	4SP	5SP	6SP
8"	\$51.00	\$54.00	\$57.00	\$61.00	\$69.00	\$78.00
10"	\$58.00	\$61.00	\$64.00	\$69.00	\$76.00	\$87.00
12"	\$66.00	\$69.00	\$72.00	\$76.00	\$85.00	\$94.00
15"	\$75.00	\$78.00	\$82.00	\$87.00	\$94.00	\$103.00
18"	\$87.00	\$90.00	\$93.00	\$98.00	\$106.00	\$115.00

## PORTA BRACE

*Best Seller*

The sturdy Run Bag can be loaded many ways without just dumping one thing on top of another, but it retains the convenience of a lightweight bag. The main compartment has an adjustable divider. Inside walls have large slip pockets. Outside, you get two large zippered compartments for cables, plus two big slip pockets. Stand-up handles with leather grips and a lightweight shoulder strap allow for comfortable use. All sizes have main compartments of approximately 7" wide by 9-1/2" high.



Run Bag, 18" length	60PBRB1	MFR LIST	\$139.00
Run Bag, 21" length	60PBRB2	MFR LIST	\$142.00
Run Bag, 25" length	60PBRB3	MFR LIST	\$147.00

CALL 1-800-732-7665 FOR BRADLEY PRICE

**WHIRLWIND ACTIVE PRESS BOX**

Toiling as we do near Washington, we know something about press events. When a passive mic box isn't enough, we recommend Presspower. It accepts two inputs and feeds 16 transformer-isolated XLR outputs. You can send down a 1kHz tone so everyone can set their levels before the shouting starts. A VU meter and a headphone jack let you keep an eye and an ear on everything.

Presspower can run on AC or just four 9V batteries. It provides phantom power (+48VDC when running on AC, +12 off batteries). Inputs can be mic or line level; both have low cut filters. Twelve outputs are mic level, on XLR and 1/8" connectors, two outputs are line level fixed at 0dB, and two are adjustable line level. The variable outputs also appear on 1/4" TRS connectors. It is supplied with a carrying case and can be rack mounted.

Presspower 61WHPP \$1,349.00



**CONEX CELLJACK FOR CELLULAR PHONE REMOTES**



Feed great remote audio back to the studio with your Motorola bag phone and the new Conex CellJack. It's a compact cellphone adapter that connects to various broadcast devices with its balanced XLR input and line output, both transformer isolated. The XLR's gain is switchable, so it accepts either your dynamic mic or the output of a field mixer. Use the stereo headphone jack to monitor the cellphone; when your radio is plugged into the tuner input, its audio is fed to one side of the headset. Very nice.

An interconnect cable is included with this palm-size problem solver. Call us.

CellJack 60CNJACK only \$225.00

**Package 9711:** Great for cellular recording! Take the CellJack, a VP64 field mic with coiled cable, and Sennheiser's HD445 headphones.

Value: \$505.00. only \$379.00

**ATI PRESSBOX/MIC DISTRIBUTION**



The PB2X8 has phantom power and provides two low-noise mic/line inputs. Eliminate mic clutter with a single or back-up pair of mics. Feed each of eight transformer-isolated channels from either input or both mixed. Drive a high-level XLR and a medium- or low-level TRS line simultaneously from each output. Use as a 2X8 or stereo 1X4 DA, or a two-input mixer. Features include oscillator, low-cut, loop-through expansion, VU meter, and headphone output. Uses XLR, 1/4", and 3.5mm TRS jacks.

PB2X8 60AIPB2X8 MFR LIST \$1,399.00

CALL 1-800-732-7665 FOR BRADLEY PRICE

**MARTI SMARTI**



Marti's new telephone remote codec, the SMARTI, is capable of sending and receiving broadcast quality audio over a standard (POTS) telephone line. The SMARTI has a built-in 4 channel mixer, 2 headphone jacks, 10 number telephone storage and automatic redial, full duplex data connections, a port for attaching 2 computers, and an event timer with LCD display which can count up or down. The SMARTI is remote controllable, has an internal power supply, and supports up to 33 Kbps depending on the phone line. Software upgrades will be available automatically through modem connection to MARTI. Order the SMARTI for broadcast audio quality with phone line convenience.

SMARTI 60MTSMARTI MFR LIST \$3,400.00

CALL 1-800-732-7665 FOR BRADLEY PRICE

**Bradley accepts MasterCard, Visa, and Discover**

**ZERCOM REMOTE CONSOLES**

*Best Seller*

When the shoulder pads are crashing together down below, look for Zercom up above. The MAX-Z mixer makes your sports coverage stand out.

It includes four mic/line inputs with level controls and rear panel trim pots, clock, and timer. Two channels have buttons that divert audio to cue for "spotters". It offers push-button keypad with memory, auto-pause access for PBX and toll service, store, and last number re-dial. Program three favorite numbers into the auto-dialer.

The 15-pound MAX-Z comes with a carrying case, built-in rechargeable battery for 20 hours of operation, and 110/220VAC capability. Size: 13" x 17" x 5".

**MAX-Z                    60ZEMAXZEPS                    MFR LIST                    \$1,225.00**

For simpler field audio on a budget, the MAX-Z II is a mixer with built-in touch pad phone dialer. It weighs just six pounds and comes with a carrying case so it's as road-worthy as you are (well, almost). You get two mic/line inputs (one switchable to cue), plus 1/8" TS tape input, two headset outputs, and 24 hours on one battery charge. Indicators display battery and AC status, power, line active, cue active, and VU. (Photo, page 9)

**MAX-Z II                    60ZEMAXZIIEPS                    MFR LIST                    \$750.00**

**CALL 1-800-732-7665 FOR BRADLEY PRICE**

**Digital or Analog...Bradley has your field gear.**

**COMREX CODEC BUDDY**

Codec Buddy is just that, a field unit designed for use with digital codecs like the ones we offer on pages 10-12. This versatile four-channel mixer is also good for feeding cellular phones, POTS lines, and RPUs. Remotes using codecs require lots of feeds, including main channel to station, headphone audio for several people, PA feed, intercom audio for the engineer, backup feed, and more. With all these mixes, each with its own level, your remote site can look like a wiring nest. Use Buddy instead. Most sites will require only a Buddy and a digital codec with terminal equipment.

Features include four XLR mic inputs (two of which also take line), four headphone outs, spotter input, sophisticated headphone mixer and matrix, a PA feed so local fans can hear talent and callers coming in on the return codec channel, a telco interface with coupler and dial pad, and a single-line frequency extender to enhance program transmission on a standard dial-up line or cellphone. Weight: eight pounds.

**Codec Buddy                    60CCCB                    MFR LIST                    \$1,900.00**

**CALL 1-800-732-7665 FOR BRADLEY PRICE**



**WHIRLWIND MEDUSA PRESS BOXES**



Here come the wolves in the press pack! But you're ready for them with your Medusa Press Box. It accepts a single line-level signal and gives you multiple mic level, 150 ohm output feeds. Designed to hold up under severe treatment, Whirlwind's cold-rolled steel boxes are on the job in punishing environments everywhere.

<b>6 Channel</b>	<b>61WHPB06</b>	<b>\$229.00</b>
<b>12 Channel</b>	<b>61WHPB12</b>	<b>\$449.00</b>
<b>15 Channel</b>	<b>61WHPB16</b>	<b>\$549.00</b>
<b>24 Channel</b>	<b>61WHPB24</b>	<b>\$855.00</b>

**COMREX NEXUS ISDN CODEC**



Now you can produce quality digital audio from the road with ease. Brand new from Comrex, the NEXUS portable ISDN codec is a Turbo G.722 device with built-in bonding terminal adapter and NT-1. Use it for 15kHz or 7.5kHz low delay, bi-directional mono audio. A front-panel keypad and LCD make it easy to use. Other features include auto dial, ten-number memory, switchable mic/line input, ancillary data capability, and audio output that lets the NEXUS return feed be mixed with local program audio.

Compact and built for the road, NEXUS weighs less than four pounds and measures 6.25" x 9.5" x 2".

**NEXUS                    60CCNEXUS                    MFR LIST                    \$2,300.00**

**CALL 1-800-732-7665 FOR BRADLEY PRICE**



## COMREX HOTLINE POTS CODEC

The newest in an expanding line of digital products from Comrex, the HotLine provides wideband two-way audio over a standard dial line. It employs an algorithm especially designed for use over low bit-rate modem connections and, unlike other units, the HotLine will provide quality audio over a wide range of modem connections: from 33.6 kbps down to 12 kbps. The HotLine algorithm adjusts frequency response based upon available bandwidth and runs a setup routine upon connection to determine at what speed a stable connection may be established. At 33.6 kb/s frequency response is 20 Hz - 10kHz. The HotLine is an essential and economical addition to your audio toolbox. ISDN may not always be available or practical for your remote application, but POTS service is always readily available. HotLine provides great audio from anywhere, for the price of a phone call.



60CCHOTLINE	HotLine	MFR LIST	\$2,995.00
60CCHOTLINERM	HotLine Studio Version	MFR LIST	\$3,195.00

CALL 1-800-732-7665 FOR BRADLEY PRICE

## TELOS ZEPHYR DIGITAL TRANSCEIVER

Harness the power of the digital telephone system. The Zephyr codec creates world-class audio for remote broadcasts, sports coverage, voice-overs, distribution of spots, recording studio feeds, ad hoc networks, and backup to microwave and satellite links. It was designed specifically for broadcast applications on ISDN and Switched 56.

Zephyr provides both the superb quality of Layer III and compatibility with installed Layer II-only equipment. With just the push of a button, you select the coding scheme to use.

Each ISDN line has two 64 kb/s channels on a single copper pair. Zephyr, on just one ISDN line, provides bi-directional, 20kHz stereo plus ancillary data transmission.

Layer-III allows 15kHz mono on a single ISDN channel or one SW56 line, reducing your transmission costs when sending mono material.

- Each unit serves as both a transmitter or receiver.
- Versions with ISDN terminal adapter include built-in NT-1. Everything required for the ISDN connection is included.
- Versions with V.35/X.21 port connect to one or two Switched 56 lines. (External CSU/DSU required for Switched 56.) This port also provides compatibility with satellite links and other data paths.
- Full metering, call-duration timer, headphone jack, and straight-forward controls make operation easy.
- 20kHz stereo, duplex audio can be sent on a single dial-up ISDN line or two Switched 56 lines using Layer III or Layer II coding.



## ZEPHYR EXPRESS



Sending live audio from the field via ISDN has never been easier. Meet ZephyrExpress, a full featured codec, ISDN terminal adapter, and audio mixing/monitoring system, all in a rugged road chassis.

Fans of the widely-used studio Zephyr will find the familiar features: MPEG Layers III and II, G.722 for widest compatibility, and G.711 for voice grade calling to any phone. It's brand new from the creative folks at Telos and from Bradley. We've been your Telos supplier longer than any other dealer. No one knows Telos like Bradley does.

60TSZ9302	MFR LIST	\$5,280.00
-----------	----------	------------

CALL 1-800-732-7665 FOR BRADLEY PRICE



- 7kHz transmission using G.722 is included for transmission to and from installed codecs.
- Transmit and receive coding schemes can be individually selected.
- Bi-directional, RS-232 serial data at 9600 bps for communications and control are transmitted simultaneously with the audio. Windows-based software is included at no charge.
- The split channel mode allows individual mono signals to be transmitted to separate sites.
- Four end-to-end parallel "contact-closures" can be used to control recorders and other devices. The first input can be used as a "panic dialer" to automatically connect to a frequently called or emergency number.
- The ISDN Telephone feature (G.711) allows Zephyr to dial any standard analog telephone line for low-grade voice communications.

### Zephyr - Stereo transmit & receive

with ISDN terminal adapter	60TSZ9202	MFR LIST	\$4,980.00
with X.21/V.35 interface	60TSZ9201	MFR LIST	\$4,380.00
with ISDN TA and X.21/V.35	60TSZ9200	MFR LIST	\$5,180.00

### Zephyr - Mono transmit & receive

with ISDN terminal adapter	60TSZ9102	MFR LIST	\$3,980.00
with X.21/V.35 interface	60TSZ9101	MFR LIST	\$3,380.00
with ISDN TA and X.21/V.35	60TSZ9100	MFR LIST	\$4,180.00

CALL 1-800-732-7665 FOR BRADLEY PRICE

COMREX FREQUENCY EXTENDERS

Everyone's talking about digital audio over phone lines, with good reason, but don't forget you can use frequency extension today to upgrade affordably any audio fed over standard phone lines.

One-line systems encode audio by shifting frequencies up by 250Hz. At the decode end, frequencies are downshifted to restore 2-1/2 octaves of program energy to the low end. For single-line encoding, put one LXT/R encoder/decoder at the studio, another in the field. It includes a built-in coupler for direct connection to the phone line.

Ask us about two-line systems (a full 5kHz audio connection), and three line (8kHz).



LXT/R one line encoder/decoder	60CCLXTR	MFR LIST	\$850.00
Rack mount	60CCRATR	MFR LIST	\$30.00

CALL 1-800-732-7665 FOR BRADLEY PRICE

COMREX DIGITAL AUDIO CODECS

Comrex offers several potent choices for sending audio over digital phone lines.

**DXP.1** and **DXR.1** codecs deliver superb bi-directional mono feeds over ISDN or SW56 using the G.722 standard. On a 56 or 64 kb/s circuit, they produce 7.5kHz audio, and they upgrade automatically to 15kHz if the connection is 112 or 128 kb/s. The very low delay makes this an excellent choice for live programming such as talk, news, and sports.

The **DXP.1** is a portable unit with external AC supply, headphone output, and selectable mic/line input. The **DXR.1** is a rack mount unit with balanced line level I/O. Each requires a terminal adapter with **IMUX** (sometimes called "bonding") to send 15kHz on a BRI ISDN line.

The **DX-100** is a full mono/stereo apt-X encoding/decoding system. It's capable of bidirectional audio up to 15kHz and supports data rates from 56 to 256 kb/s. The low-noise, low-delay coding scheme makes it suitable for STL and studio-to-studio work.

The **DX-100** has **IMUX** which adds the data rate of two independent 56 or 64 kb/s data channels. Configure it for ISDN or Switched 56 operation, or for satellite, wireless modem, or fractional T1.

The **DX200 MusicLine** codec is an affordable way to send wide-band, bidirectional stereo audio over ISDN. It uses ISO/MPEG Layer II coding to send full bandwidth stereo over digital paths as low as 112 kb/s. A broadcaster, recording studio, or music service can send stereo using one ISDN or two Switched 56 lines, or send mono 11kHz on a single SW56 or 64 kb/s.

Choose among sampling rates of 24, 32, and 48kHz. The **DX200** encoder is configurable for output data rates (from 56 to 384 kb/s) and it allows full stereo, joint stereo, dual mono, and mono operation. It now also has Turbo G.722 for low-delay work and backwards



compatibility with almost all installed Layer II codecs. The **DX200's** built-in **IMUX** allows it to support transmission rates up to 256 kb/s.

The optional Control Panel is a 1RU unit with control buttons and LCD display to allow changing settings "on the fly."

All Comrex codecs have balanced analog I/O connectors. Data ports are DB25 (EIA-530), with a DB25-to-DB25 cable provided. Optional cables for connecting to X.21 or V.35 are available.

DXP.1	60CCDXP	MFR LIST	\$1,500.00
DXR.1	60CCDXR	MFR LIST	\$1,500.00
DX100	60CCDX100	MFR LIST	\$3,000.00
DX200	60CCDX200	MFR LIST	\$3,000.00
DX200 Control Panel	60CCDX200CP	MFR LIST	\$300.00

CALL 1-800-732-7665 FOR BRADLEY PRICE



## MUSICAM USA CODECS

The CDQ Prima series now incorporate Layer III coding, in addition to Musicam™, a digital audio enhancement to MPEG Layer II that is compatible with other Layer II codecs.

All models in the family are based on a common set of core features, configurable with different options, and you can upgrade any CDQPrima as your needs grow. Common features include an integrated support processor with the power of a high-end personal computer, world power supply, 18-bit AD/DA converters for better signal quality, plug-in communications modules, and AES/EBU so you're ready for the all-digital studio (optional on Model 110). You also get a dial keypad, downloadable software changes, and computer ports for external control. Each codec supports MPEG-I at 32 and 48kHz, and MPEG-II at 16 and 24Hz; each also contains G.722 ADPCM coding and will automatically detect which scheme is in use. No separate terminal adapters needed.

You can customize your codec with psychoacoustic parameter adjustment, multiple interface slots, alarm relay, inverse line multiplexing to use several ISDN lines at once, digital VU meter, SMPTE time code, and more.

**CALL 1-800-732-7665 FOR LITERATURE AND A BRADLEY PRICE QUOTE.**

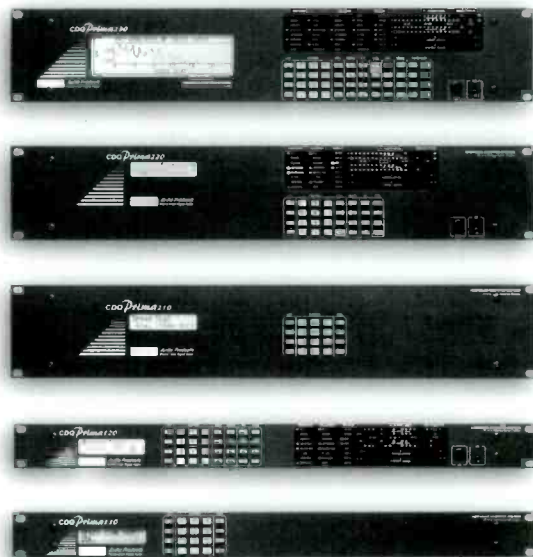

## GENTNER HYBRID COUPLER AND AUTO COUPLER

### GENTNER HYBRID COUPLER

The economical Hybrid Coupler is nice for one-way audio feeds, news, and telemarketing. It connects to a phone line via a modular jack, and provides a loop-through to a telephone set. A three position switch allows it to seize the line, simply tap the circuit, or be turned off. Its hybrid coil provides approximately 10dB of separation between send and receive, adjustable with a trimmer. The coupler is a passive device requiring no power.



Hybrid Coupler	60GEHC	MFR LIST	\$189.00
----------------	--------	----------	----------

**CALL 1-800-732-7665 FOR BRADLEY PRICE**

### GENTNER AUTO COUPLER

Gentner's auto-answer, auto-disconnect units are intended for listen lines and IFB sends. Connect one at each audio source you wish to monitor by phone. They allow simultaneous send and receive upon connection. Balanced 600 ohm connections are provided for both send and receive audio, and a null trimmer pot maximizes isolation. This version hangs up the phone line at loop drop. A special CP version is used on lines where the phone company does not provide the loop drop signal. The decoder disconnects when it hears dial tone, busy signal, recorder signal, or ringback. Units operate on 117VAC from a provided external power supply.



Auto Coupler	60GEAC	MFR LIST	\$329.00
Auto Coupler CP	60GEACP	MFR LIST	\$329.00

**CALL 1-800-732-7665 FOR BRADLEY PRICE**

## GENTNER MICROTEL

Microtel is bristling with connectors to make your job of connecting audio to a phone line easier.

It connects to a phone, replacing the handset with your mic and headphones. Inputs are provided for a mic (XLR) and an aux (1/8" TS mini). An additional input lets you feed the headphone bus with IFB or air monitor. Outputs are provided for headset (1/4" TRS) and high-level (1/8" TS mini), as well as an auxiliary feed jack for tape machines or dedicated loops. It's for IFB, news reporters, salespeople, anyone who needs to record calls or send audio. Battery operated.



Microtel	60GEMICRO	MFR LIST	\$259.00
AC adapter	60GEXFMR	MFR LIST	\$29.00

**CALL 1-800-732-7665 FOR BRADLEY PRICE**

## TAC AUDIO COUPLER

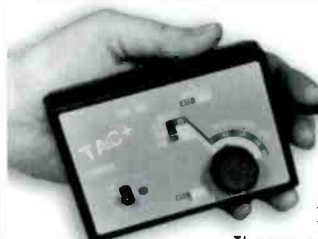

Feed your precious audio from your field recorder into a phone, and listen while you're feeding. TAC, by Sound America, connects in series with the handset and is suitable for feeding news cuts, remotes, and sales demos. Great for Marantz and Sony decks.

It connects with virtually any phone (except those with the dial in the handset). The low impedance input on both models is designed for cassette recorder outputs. TAC+ adds a high/low impedance selector and 60dB attenuator pad.

TAC	60SATAC	\$89.50
TAC+	60SATACP	\$99.95
Carrying Case	60SACASE	\$9.95





**COMREX TELEPHONE COUPLERS**

These couplers provide clean transformer connections between your telephone lines and external audio equipment. Designed for send- or receive-only applications, they have modular telephone jacks for the phone line and for a telephone set.

The TCB-1 Manual Coupler provides a switched hold connection. Unbalanced audio in/out is on a single 1/4" TRS connector. The unit does not require power. The TCB-2 Auto-Answer Coupler answers the telephone line on the first ring and disconnects that line when the caller hangs up. An A/C power supply is included. If your CO does not provide loop drop, order the optional dial tone detect board.



TCB-1 Manual Coupler	60CCTCB1	MFR LIST	\$150.00
TCB-2 Coupler & Pwr Supply	60CCTCB2	MFR LIST	\$250.00
Dial tone detector for TCB-2	60CCDTD	MFR LIST	\$125.00

CALL 1-800-732-7665 FOR BRADLEY PRICE

**EXCALIBUR HC-1 HANDI-COUPLER**

Use the Handi-Coupler on remotes and around the station: on-air, production, the newsroom, the sales office, and in the sports kit. The HC-1 connects in series with the handset of any telephone using modular connectors. Since a connection to the telephone line is not required, the HC-1 can be used with almost any telephone in single or multi-line, modern electronic or older key systems.

Pressing the front panel button disconnects the handset and connects the external audio in/out jacks to the telephone. Releasing the button reconnects the handset, allowing normal use of the phone. External audio is connected via separate in and out jacks. Both inputs and outputs are 1/4" TRS jacks wired so that you may use either balanced or unbalanced connectors.



HC-1	60EXHC1	\$99.00
------	---------	---------

**SOUND AMERICA R/SVP**

News, sales, and PR types will use the "Record/Send Verywell Phone". It's a classic TouchTone™ desk phone with a coupler built in, so you can connect a cassette recorder or other source direct to the phone network with no loss of quality. Feed your audio down the line; use the handset to mix in voice, or switch it to "mute". Also record phone conversations, or make voicemail messages with music added. Mini 1/8" jacks for send and receive are provided. SVP is a send-only version. Want a push-to-talk handset? Order the PT-1 option with either model.



R/SVP	60SARSVP	\$140.00
R/SVP with PT1	60SARSVPPT1	\$166.00
SVP	60SASVP	\$125.00
PT-1 Option	60SAPT1	\$32.80

**HENRY TELESTOR AND DIGISTOR**



The new TeleStor is an unattended digital actuality recorder for phone-fed audio. Your contract weather service or news crew can call into TeleStor and leave their message for later playback by the DJ or automation system.

TouchTone™ passwords ensure that only authorized personnel can get in. TeleStor erases the previous message, and plays the new message back to the caller for confirmation. Choose two recording times, both at 2.5kHz frequency response.

DigiStor does the opposite. It answers a phone line and plays the message you recorded for the caller to hear. Your listeners can call in for concert updates, ski reports, and promotions. Each caller hears the message from the beginning. It's also a useful "message-on-hold" or utility repeater system. It has single and continuous play modes, battery backup to prevent memory loss, and the ability to record from mic or line. Choose from several lengths and responses. We can also configure DigiStor with a call counter.

TeleStor, 2.5kHz, 1:20 min	60HETELESTORS	\$499.00
TeleStor, 2.5kHz, 5:25 min	60HETELESTORX	\$669.00
DigiStor, 2.5kHz, 2:02 min.	60HEDS	\$335.00
DigiStor, 3.5kHz, 1:20 min.	60HEDSHF	\$355.00
DigiStor, 2.5kHz, 8:32 min.	60HEDSXM	\$499.00
DigiStor, 3.5kHz, 5:30 min.	60HEDSXMHF	\$525.00
Counter Option	60HECOUNTER	\$45.00

## INTERFACE AND MESSAGE STORAGE

### SYMETRIX 610 BROADCAST DELAY

Symetrix offers great value in the 610 talk delay, which gradually

builds up 7.5 seconds of 14kHz stereo audio in memory. Push a button to dump the profanity and start the build-up again.

The 610 can be set up so that only half of the 7.5 second memory is deleted, retaining a reserve of 3.75 seconds. This lets the host bring up another caller without having to wait for memory to build from scratch, a feature which will be appreciated on fast-moving talk shows. Push "exit delay" at the end of the show, and the 610 gradually releases memory until you're operating in real time again. Connectors are XLR with switchable +4/+8 nominal level. The unit is bypassed if power is lost or the bypass switch pushed.

A cough button lets the host take a quick break with no dead air, great for taking a quick sip of water. No one will ever know.

610                      60SY610                      MFR LIST                      \$2,695.00

CALL 1-800-732-7665 FOR BRADLEY PRICE



### EVENTIDE BD500 DIGITAL BROADCAST DELAY

Thousands of broadcast users made suggestions for Eventide's next

model, and here's the result, a stereo delay with an enhanced version of their exclusive automatic catch-up circuitry, optional digital I/O, and many conveniences.

When you push DUMP, you no longer create a few moments of unprotected airtime while the delay re-builds. The BD500 lets you divide the delay time into segments. Each time DUMP is pressed, only one segment is dumped. If another naughty word is spoken right away, push it again to dump the next segment of delay. So you might set up three segments, like this: [3 seconds], [3 seconds], [2.5 seconds], each an extra level of protection.

Standard stereo delay is 8.5 seconds, and more can be added. A new "sneeze" button edits audio to your delay, so the host can cough or make an aside without being heard and without a pause. Most front panel switches can now be remoted.

Analog XLR's are standard, with digital AES/EBU available optionally. It's all in one rack unit, and all built around Eventide's great algorithm that catches up quickly without degrading your audio.

BD500                      60EVB500                      MFR LIST                      \$3,395.00

CALL 1-800-732-7665 FOR BRADLEY PRICE



### EVENTIDE CLASSIC BROADCAST DELAYS

Consider Eventide your insurance policy.

When a no-no is uttered by your guest or caller, push Delete on the front panel or via a remote closure to bypass the delay line. It closes a relay contact to start any filler material. The mono delays are available in 6 and 12 second versions, and the stereo units offer 3 or 6 seconds.

These units have balanced inputs and outputs, and specifications that don't compromise audio quality. The mono BD941 and stereo BD942 are full 20kHz bandwidth.

Stereo, 6 sec delay	60EVB09426	MFR LIST	\$2,395.00
Stereo, 3 sec delay	60EVB09423	MFR LIST	\$1,995.00
Mono, 12 sec delay	60EVB094112	MFR LIST	\$2,195.00
Mono, 6 sec delay	60EVB09416	MFR LIST	\$1,795.00

CALL 1-800-732-7665 FOR BRADLEY PRICE



### EXCALIBUR HYBRID ADAPTER



Use your favorite broadcast hybrid with most any phone: old, new, single or multi-line. It hooks up through the handset connector. With the button out, your phone works as normal. With the button in, the handset is disconnected and your hybrid is on line. The performance of the hybrid is the same as though it were connected directly. Connectors are modular phone jacks.

Hybrid Adapter                      60EXHA1                      \$99.00

### RADIO SYSTEMS TI-101 INTERFACE



You'll find this affordable telco interface easy to install and set up. Connections are XLR for audio, banana posts for phone. Popular with smaller stations, this is a solid choice when you're watching the dollars carefully.

Connect pro audio mixers to phone lines and eliminate feedback and gating problems. Caller equalization, send limiter, caller mute, and conference linking are standard. The factory support from the folks at Radio Systems is very good.

TI-101                      60RST1101 MFR LIST                      \$495.00

CALL 1-800-732-7665 FOR BRADLEY PRICE

Don't see what you need?  
Call us!

1-800-732-7665

## TELEPHONE INTERFACE

Bradley Broadcast • 12401 Twinbrook Parkway • Rockville, MD 20852 • 800-732-7665 • 301-231-7800 • Fax: 301-230-6526 • email: info@bradleybroadcast.com

**TELOS ONE-X-SIX TALK SYSTEM**



The ONE-x-Six is a phone system with all of the phone interface gear needed for talk show programming. A compact housing holds both a Telos ONE digital hybrid and a six-line broadcast phone system; a desktop Switch Console is included for one-person system control.

Use the ONE-x-Six to place calls, put callers on hold or on the air, and to conference. The system has sophisticated automatic gain control, super trans-hybrid loss of better than 40dB, program on hold feature, and special functions including control of external recorders and delays.

The ONE-x-Six is ideal for talk shows that seek Telos quality but don't need the even greater sophistication of the Telos Direct and 1A2 Interface Modules.

**ONE-x-Six      60TS1X6      MFR LIST      \$2,180.00**  
**CALL 1-800-732-7665 FOR BRADLEY PRICE**

**TELOS DIRECT INTERFACE AND 1A2 INTERFACE MODULES**

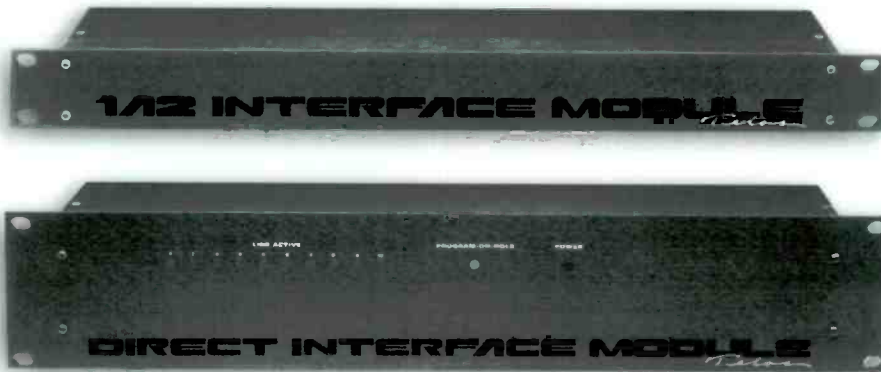

Here are two powerful choices for selection and control of multiple telephone lines in broadcast systems. The Direct Interface allows direct connection of up to 10 phone lines. It functions as a full broadcast phone system including program on hold and caller conferencing.

The 1A2 Interface Module makes use of standard 1A2 key telephone equipment. Each handles 10 phone lines and units can be coupled to handle up to 30 lines. Software upgrades for both interface modules add several functions such as AUTO-ANSWER, which automatically answers incoming calls and places them on hold.

The desktop Switch Console offers extensive line control, remote tape machine start/stop, and a BUSY-ALL mode that is great for clearing all lines before a contest. Other control options include drop-in modules for BE, PR&E, and other popular radio consoles. Screen your callers with phones, or use the powerful Call Screen Manager software, described to the right.

Telos Direct Interface Module	60TS100DI	MFR LIST	\$1,840.00
Telos 1A2 Interface Module	60TS100KSI	MFR LIST	\$1,050.00
Telos Switch Console	60TS100SC	MFR LIST	\$650.00

**CALL 1-800-732-7665 FOR BRADLEY PRICE**

*Bradley Knows Telos*

For longer than any other supplier, Bradley has brought you the power and audio quality of Telos phone interface equipment. From the latest digital codecs, to sophisticated hybrids, to muscular multi-line systems, Telos is in the vanguard, and Bradley knows Telos best! Call us to learn more about the fine products of Telos.

**TELOS CALL SCREEN MANAGER**

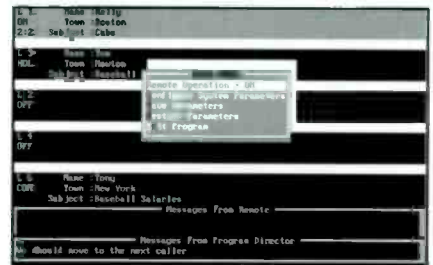

With Call Screen Manager and a properly equipped PC, your screener/director can give your air talent information about each caller as well as special messages. Line status is updated to indicate which callers are on the air, part of a conference, and on hold. Each line has a call timer and programmable duration alarm. Special remote software is available for communicating with your talent via telephone modem. This lets your talent conduct his/her program from virtually anywhere.

If you are using a Telos Direct Interface or Key System Interface, Call Screen Manager is an economical upgrade. If not, contact Bradley for details on the Telos configuration that's right for you.

<b>Host Software</b>	60TS951	MFR LIST	\$350.00
<b>Host and Remote Software</b>	60TS952	MFR LIST	\$450.00

**CALL 1-800-732-7665 FOR BRADLEY PRICE**



## HYBRIDS AND INTERFACE

### TELOS ONE DIGITAL TELEPHONE HYBRIDS

One of the best values in telephone hybrids anywhere, and year after year a customer favorite thanks to automatic adjustment to each call, sophisticated AGC on input and output, an advanced downward expander on the caller audio, and digital processing to reduce dramatically the chances for feedback when monitoring with open speakers.

Telos ONE has two outputs and a switchable mic/line input. Choose between rack mount and "modem case" versions, which can also rack mount with optional hardware.



The ONE plus ONE starts with two Telos ONE digital hybrids in a single rack unit chassis. Each hybrid functions independently. An internal mix-minus matrix cross couples the outputs of the two hybrids. In a dual hybrid application, you need only send the ONE plus ONE a single mix-minus. All of the Telos ONE features are included.



Telos ONE rack mount version	60TS1R	MFR LIST	\$1,050.00
Telos ONE modem case version	60TS1	MFR LIST	\$680.00
Telos ONE plus ONE	60TS11	MFR LIST	\$2,180.00

CALL 1-800-732-7665 FOR BRADLEY PRICE

### TELOS 100 DELTA DIGITAL HYBRID



The digital signal processing of the 100 Delta includes a dynamic digital equalizer that examines the caller audio in three frequency bands within the context of the overall signal. The high and low bands are automatically equalized with reference to the mid band. The 100 Delta also boasts logarithmic (dB) dynamics control and context sensitive AGC. Together these processes offer increased caller intelligibility and matched levels.

The 100 Delta has two mixed inputs (one line level and one mic/line) and two outputs (one with caller audio and the other with a continuously adjustable mix of caller and mix-minus). This simplifies the creation of external mix-minuses. DUPLEX DEPTH can be adjusted for full-duplex, half-duplex, or any point in between. Two DEPTH settings can be stored and remotely selected. This allows remote switching, between a setup requiring more depth for maximum feedback suppression, and one where feedback is not a concern and maximum duplex conversation is desired. The 100 Delta performs well on even the toughest phone lines thanks to its extraordinary trans-hybrid loss and sophisticated processing.

100 Delta	60TS100D	MFR LIST	\$2,180.00
-----------	----------	----------	------------

CALL 1-800-732-7665 FOR BRADLEY PRICE

Best Seller



### TELOS HYBRID ACCESSORIES

The Auto-Answer board has simple line SEIZE and DROP. The Super Auto-Answer features remote control of line SEIZE and DROP, selectable number of rings before answering, dial tone detector for failsafe line drop, DTMF decoder with open collector outputs, and other features. A special Super Auto-Answer version allows users of 1A2 Key Systems to select phone lines using a standard multi-button desk set.

Either can be used with the Telos 100 Delta, ONE, and ONE plus ONE.

Telos Auto-Answer		
60TS1AA	MFR LIST	\$50.00
Telos Super Auto-Answer		
60TS1SAAXX	MFR LIST	\$150.00

CALL 1-800-732-7665 FOR BRADLEY PRICE

### GENTNER TELESWITCH CALL DIRECTOR

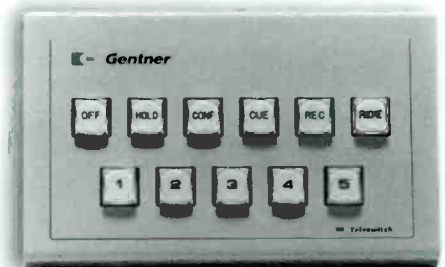

Select multiple phone lines without the cost of a PBX or multi-line system. Up to five lines can be connected, placed on hold, and routed to your hybrid. Connections are on standard RJ-11C jacks. Other features include a conferencing mode, an input for audio-on-hold, and a telephone set connection. It's suited to talk shows and distance learning applications.

An external hybrid is required. An optional connectorized cable is available for use with the Gentner hybrid model you specify.

TeleSwitch	60GETS	MFR LIST	\$995.00
Hybrid cable	61GE830002XXX	MFR LIST	\$26.20

CALL 1-800-732-7665 FOR BRADLEY PRICE



# Use the *HotLine*

...when ISDN doesn't make sense

## One-time remotes just got easier!

Sometimes it's impractical to install a special circuit like ISDN for a one-time remote. However, a plain telephone line is usually available. Wouldn't it be nice if you could have high quality two-way audio on that plain line? That's just what you get with the *HotLine*.



**800-237-1776**

<http://www.comrex.com>

**COMREX**  
We make great connections

**Wideband two-way audio on POTS  
(Plain Old Telephone Service)**

COMREX Corporation, 65 Nonset Path, Acton, MA 01720 USA Tel: 508-263-1800 Fax: 508-635-0401  
Email: [info@comrex.com](mailto:info@comrex.com) Fax-on-Demand: 508-264-9973 Toll-free: 800-237-1776 in North America  
or 0-800-96-2393 in the U.K.

# JK Audio

Remote  
Broadcast Gear

Phone  
Line  
Hybrids



Headphone  
Amplifier



Telephone  
Handset  
Interfaces



Analog

Digital

ISDN

PBX



**GENTNER TS612 MULTI-LINE PHONE SYSTEM**



Gentner's impressive system has two digital hybrids that let you conference up to four callers at once. The TS612 is sophisticated yet requires little training, and lets your operator screen and organize calls with ease. With new optional call-screening software, the screener can control the system right from a PC keyboard, with eight fields to describe each caller.

Choose between six and 12 lines, expandable to several studios and applications. No mix minus is required. A glance at the multi-color indicators shows the status of each line (ringing, in-use here, in-use elsewhere, unscreened-and-holding, screened-and-holding, and on-air). A VIP button puts a guest on a line that cannot be deselected or put on hold.

The control surface is unique and one of the best things about the TS612. It incorporates a phone handset, so you don't need a separate screener's phone. Your screener can talk with a caller while other callers are on the air. If you wish, you can add two more control surfaces to the basic system, to add a second studio and an outside screener.

A NEXT feature selects the call that has been waiting the longest. A REC button allows simple recording of calls by triggering your tape deck.

The system allows direct connection to a PC or digital storage system via RS232. A new, optional network interface provides for expansion to accommodate up to ten studios. Up to ten TS612 systems can be networked using the same six or twelve common lines.

The TS612 is suited to talk shows, contests, business TV, and audience interaction.

TS612 Six-Line System	60GETS612	MFR LIST	\$2,995.00
With ScreenWair Software	60GETS612P1	MFR LIST	\$3,490.00
TS612 Twelve-Line System	60GETS61212	MFR LIST	\$3,990.00
With ScreenWair Software	60GETS612P2	MFR LIST	\$4,485.00
Network Interface	60GE910003220	MFR LIST	\$495.00
Extra Control Surface	60GETS612CS	MFR LIST	\$459.00

CALL 1-800-732-7665 FOR BRADLEY PRICE

**Qualified government buyers, call for our GSA price list.**

**GENTNER DH20 & SPH-10**



Superior audio quality is the hallmark of the professional Gentner hybrid DH-III. Send-AGC provides consistent audio levels for your callers. The CUE button lets you screen calls off air; REC starts your tape recorder.

Automatic re-nulling allows the hybrid to be connected to a multi-line phone instrument used as an on-air selection device. Auto answer/auto disconnect, auto nulling, caller alert tone, and quiet switching on new line selection are also part of the DH-III story.

A simpler, economical alternative is the DH20, which omits the AGC, REC, and CUE functions but retains the performance quality through 16 bit processing with 2x oversampling, 10kHz sampling rate, automatic and continuous nulling, adjustable caller control (ducking), internal test tone generators, remote control capability, and single-space rack mount design.

The DH20 and DH22 are single and dual hybrids with all-new features. No mix-minus is required, as the units generate them internally. Auto-answer/disconnect are standard, as is a monitor amp for caller audio. The DH20 and DH22 automatically adapt to changing telephone line conditions, to provide superior audio quality at all times.

DH-III	60GEDH3	MFR LIST	\$1,895.00
DH-20	60GEDH20	MFR LIST	\$995.00
DH-22	60GEDH22	MFR LIST	\$1,595.00

Also Available: Gentner SPH-10 Telephone Hybrid

A new, affordable analog telephone hybrid from Gentner, the SPH-10 incorporates exclusive audio filtering and equalization to eliminate unwanted noise and hum, while maximizing caller intelligibility. The SPH-10 includes a monitor speaker jack for hands-free call monitoring, and caller-only and caller plus send outputs for recording. I/O is via balanced XLR connectors, with telephone connection and loop-through on RJ-11 connectors. Worldwide compliant, the SPH-10 is CE/CSA approved, and accepts power supply voltages from 100 to 240 volts at 50/60 Hz.

SPH-10	60GESPH10	MFR LIST	\$499.00
--------	-----------	----------	----------

CALL 1-800-732-7665 FOR BRADLEY PRICE

**GENTNER G2500 DIGITAL SUPERHYBRID**



Advanced digital technology from Gentner.

The G2500 does not require a mix-minus feed; it makes its own. Just connect it to your console. Use it for dedicated VIP calls with your other phone equipment (conferencing through the console) or for calls in other studios. Several units link to make a mini conference bridge. Auto answer/disconnect, auto null and re-null, and caller mute are standard.

G2500	60GEG2500	MFR LIST	\$1,995.00
-------	-----------	----------	------------

CALL 1-800-732-7665 FOR BRADLEY PRICE

**TELEPHONE INTERFACE**



## TELEX HEADSETS

Intercom headsets must meet a different standard. They're worn constantly, so they must be lightweight and rugged. The audio needs to be clean and clear, targeting voice frequencies. Yet they can't bust your budget, because you have other things to spend your money on.

The PH-1 is a single-sided, full cushion monoaural headset with dynamic, noise-cancelling boom mic with response of 100Hz-8kHz. Earphone output is 105dB. The PH-2 is a dual-sided version.

If you prefer a lightweight model, choose the PH-4, dual sided headset with 98dB earphone output, or PH-8 single-side version. Mic response is 50Hz-10kHz.

All models listed have earphone impedance of 150 ohms and earphone response of 50Hz-15kHz; all have five foot cable terminated in a female XLR-4 connector. (For male connector, add "R" to the part number.)



PH-1	60TXPH1	MFR LIST	\$140.00	PH-4	60TXPH4	MFR LIST	\$150.00
PH-2	60TXPH2	MFR LIST	\$160.00	PH-8	60TXPH8	MFR LIST	\$140.00

**CALL 1-800-732-7665 FOR BRADLEY PRICE**

## CONEX DT-55 REMOTE CONTROL BY TELEPHONE

If you need to control something remotely, do it by phone. The DT-55 answers a phone line, accepts your access code, then allows control of the SPDT relays and the remote monitoring of ten external switch contacts or logic levels.

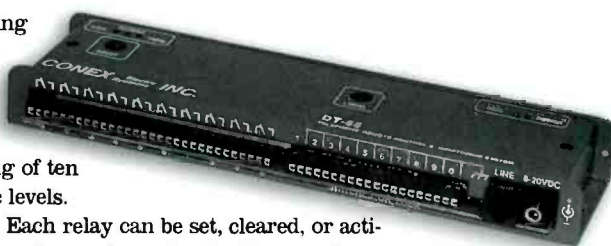

Relays are magnetic latching. Each relay can be set, cleared, or activated momentarily. The DT-55 can also act in an interlocking mode: when a button is pressed, its associated relay is set, and all others are cleared. Tones indicate the status of the external inputs. Holes are provided for mounting to a surface or to a user-supplied, single space rack panel.

DT-55	60CNDT55	MFR LIST	\$339.00
-------	----------	----------	----------

**CALL 1-800-732-7665 FOR BRADLEY PRICE**



## MOTOROLA SPIRIT TWO-WAY RADIOS

Use two-ways when covering news events, rigging up a venue, climbing a tower at any job site. You don't need a base station; they work direct at a range of up to two miles depending on the model and your location. They survive the four-foot drop test. All models include a belt-clip and rechargeable battery. Motorola quality is available to you at a low price.

Here are some popular models, with coded squelch and an audio-accessory jack. Two-channel models include a drop-in charger, otherwise available as an option. We offer many other styles, including open squelch and itinerant frequencies for use beyond 75 miles of your place of business. Call Bradley for the list, plus pricing of cases, chest packs, earpieces, and headset mics.

**CALL 1-800-732-7665 FOR BRADLEY PRICE**

## CLEAR-COM INTERCOM SYSTEMS

Clear-Com likes to say that talk is cheap. They make high-quality intercom systems available at a low price.

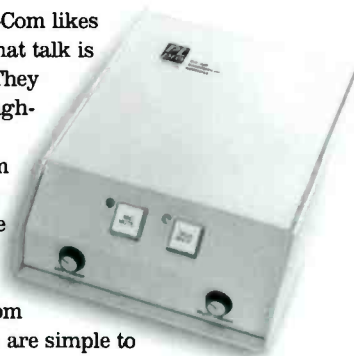

Clear-Com systems are simple to set up, very reliable, and expandable, suitable for churches, theaters, and concert halls. Call us for info on a Clear-Com system for you.

New from Clear-Com is the AB-100 On-Air Announcer's Console, a compact desktop unit designed for sports and live event broadcasting. It integrates all the inputs, outputs, and controls needed at the announce position, including intercom "talkback", IFB, and a mute button. The built-in headphone amp lets the talent hear program audio, IFB, and/or intercom audio. Dual volume controls let the operator set either side of the stereo headphone feed for the best mix of intercom and program levels.

Power it from most intercom and IFB systems, external DC, or the supplied AC adapter. Connect it to virtually any one- or two-channel intercom system.

AB-100	61CMAB100	MFR LIST	\$925.00
--------	-----------	----------	----------

**CALL 1-800-732-7665 FOR BRADLEY PRICE AND CLEAR-COM LITERATURE**



**RTS SERIES 2100  
WIRELESS INTERCOM**



Communicate without wires. The RTS Series 2100 is a complete wireless intercom system that operates in the 150 to 216MHz band, protected from external radio and electrical interference. Four belt pack transceivers can operate with the Model 2105 base station, and when two base stations are chained together, up to eight headset stations can be tied into a full duplex communication network.

The rugged, lightweight Model 2110 belt packs offer up to 24 hour operation on a single battery and numerous operator convenience features. Two belt pack transceivers form a simple, two person link, and the Series 2100 is easily used as an extension to your hard-wired intercom for unlimited possibilities.

2105 base station	60RT2105	MFR LIST	\$1,625.00
2110 transceiver	60RT2110	MFR LIST	\$550.00

CALL 1-800-732-7665 FOR BRADLEY PRICE

**We carry wired RTS Intercom Systems.  
Call Bradley.**

**THE TELOS LINK**

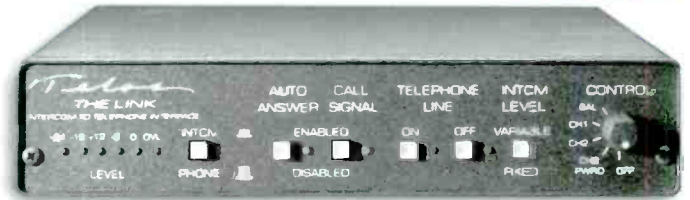

From the Telos factory in Cleveland comes this very useful device to connect intercom systems via phone lines. Your crew can communicate as effortlessly as if they were together, in one location.

The Link allows natural, full-duplex communication without level or feedback problems, thanks to adaptive digital hybrid technology. Both the telco and comm paths use digital auto-nulling hybrids, so neither party misses a syllable. A digital audio processor performs automatic gain control, smart gain switching to enhance hybrid performance, high pass filtering to reduce hum and interference, pitch shifting for feedback reduction, and call signal generation.

The Link has an interface for RTS, Clear-Com, and other intercom systems. Other features include a "wet" single channel operation option to provide power to belt packs and metering for both intercom and telco levels. The auto-answer function lets field personnel simply call in to be connected. Rack mounting kits are available.

Note: The popular Telos ONE phone hybrid is available in versions for interfacing four-wire intercom systems with dial-up phone lines or two-wire intercoms. Call us for info.

The Link	60TS1L	MFR LIST	\$1,680.00
----------	--------	----------	------------

CALL 1-800-732-7665 FOR BRADLEY PRICE

**TELEX INTERCOM SYSTEMS**

You'll see the Telex name on TV every weekend, adorning the heads of coaches who stomp up and down the sidelines, their neck veins bulging as they direct their troops. Telex is built to take the abuse, not only on the field but in broadcast vans, theaters, and lecture halls.

Audiocom is versatile, capable of balanced or unbalanced formats, single or two channel lines, wet or dry operation, even in limited rack space. Components are modular, letting the system grow with you. You can set up simple belt pack party lines, or sophisticated, director-controlled networks with multiple channels, IFB's, and matrix control. Use standard mic cable to connect up to 22 channels of user stations, belt packs, speaker stations, and power supplies.

Radiocom is a wireless alternative to any intercom, performing like a wired system thanks to quality VHF highband companding, full duplex. It has a built in interface for connection to Audiocom balanced line systems, RTS, and other unbalanced systems such as Clear-Com.

CALL 1-800-732-7665 FOR A TELEX INTERCOM SYSTEMS BROCHURE

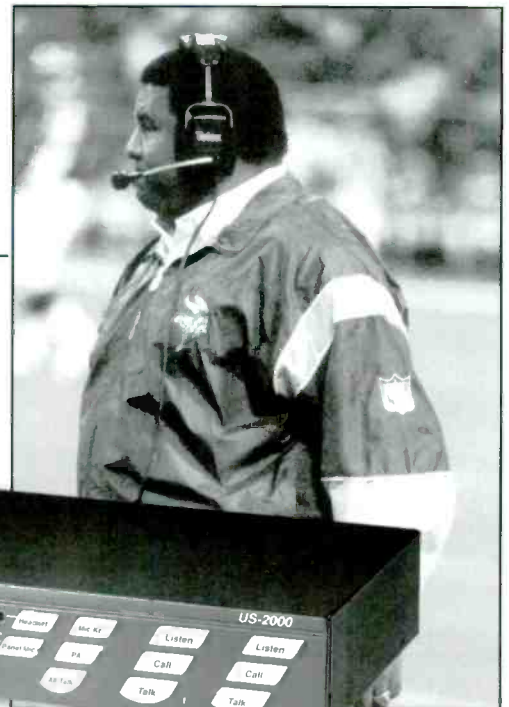

**TELEPHONE INTERFACE / INTERCOM**



## CROWN HS MICROPHONES



Do you use Sony headphones? Crown's broadcast microphones are designed to fit onto the earpiece of your MDR-7506, either side. Turn a classic headphone into a classic headset!

The CM-311HS is suitable when you're covering a sports event, soaring above the city in a traffic chopper, or working a news story. It rejects background and off-axis noise with a highly effective cardioid pattern.

The CM-312HS with hypercardioid pattern is for quieter studio environments, talk shows, and location interviews. The mic is to the side of the mouth, inconspicuous and resistant to pops.

Both models adjust for comfort and come with a belt pack with XLR output connector, battery on/off switch, mute switch, and foam pop filters. Power your mic with phantom or a 9V battery.

*Headphone not included.*

CM-311HS	60CRCM311HS	MFR LIST	\$299.00
CM-312HS	60CRCM312HS	MFR LIST	\$279.00

CALL 1-800-732-7665 FOR BRADLEY PRICE

## BIG EARS PARABOLIC REFLECTOR

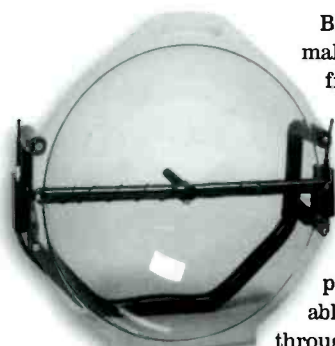

Big Ears is a parabolic reflector that makes possible the pickup of sounds from more than 200 feet away. Attach your mic and you'll hear the result of intensive study into the ideal reflective patterns.

Big Ears can be focused for the best performance. It's lightweight (five pounds) thanks to patented composite plastic. It's available in clear or in one of five see-through colors. Both the shape and thickness are molded to very tight tolerances. Two mounting plates in the handle accommodate wireless equipment. The handle and mic yoke detach for nested storage. The dish is shatter-resistant for the safety of the operator. Big Ears is not a toy: this is a high-end reflector for field use by demanding broadcasters, filmmakers, surveillance agencies, and other professionals. Microphone not included.

Big Ears	62COBE	MFR LIST	\$1,249.00
----------	--------	----------	------------

CALL 1-800-732-7665 FOR BRADLEY PRICE

## HEADSETS

### SHURE SM2

You'll be a hero for finding great headset quality at this price. It's for radio, TV, film, and video. The boom puts the mic on either side of the head. The mic is designed to be used very close to one corner of the mouth; it reduces distant noise effectively. The set is heavy duty but weighs less than 11 ounces and is soft against your ears. Mic response is 50-15kHz, headphones 100-8kHz. The cable is detachable for quick and easy changes between mono, stereo, or split feed headphone functions. Cable is unterminated.



*Best Seller*

SM2	60SHSM2	\$209.00
-----	---------	----------

### BEYERDYNAMIC DT SERIES

Bradley welcomes the DT-290, a new double-sided headset with dynamic mic and five-foot cable. It's part of a new series of low profile, lightweight sets for sports commentating, great on camera. Modular parts make service simple. Single-sided and condenser versions are available.

Always popular, the DT-108 and 109 provide full bandwidth headphone audio; their noise-cancelling mics can handle considerable sound pressure from excitable air talent. The DT-109 is a dual-earmuff model; the DT-108 has one earpiece. Headphones on the 108 and 109 are 400 ohms, on the 290, 80 ohms, and all mics are 200 ohms with other impedances available. Headset cables are unterminated. The 108 and 109 can be ordered with optional coiled cable and in balanced mic versions.



DT-290	60BEDT290	\$209.00
DT-109	60BE422045	\$249.00
DT-108	60BE421790	\$209.00

### TELEX PH-24

The studio-quality electret condenser boom mic includes a windscreen and can disconnect for repair. This lightweight announcer's set also has high fidelity earphone receivers with removable foam cushions, boom swivels for positioning on either side of your head, and an in-line push-to-rough button. Ask about the omni PH-25.

PH-24	60TXPH24	\$179.00
-------	----------	----------

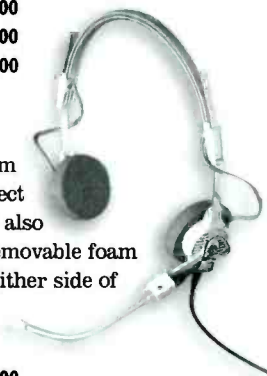

### SENNHEISER HMD 25-1

The HMD 25-1 has comfortable closed supraural earpieces for good isolation, and a supercardioid mic with 50-12kHz response. Headphone response gives that great Sennheiser sound at 30-16kHz. The six-foot cable is unterminated.

HMD 25-1	60SNHMD251	\$379.00
----------	------------	----------

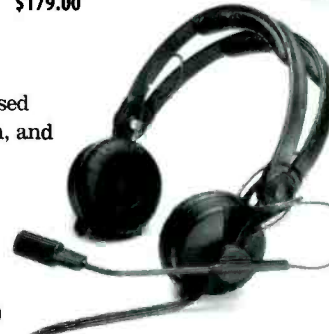

## SENNHEISER K6 MODULAR MIC SYSTEM

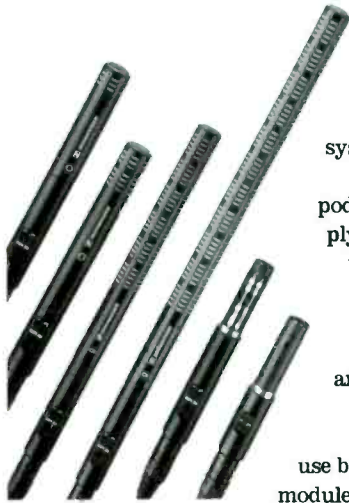

Choose your mic capsule, add the powering module, and you're set with one of the most flexible mic systems around. Choose a lav system, or handheld ENG. Need to switch to a shotgun mic, or a podium style? Switch capsules simply by screwing them off and onto the K6. It runs on 12-45V phantom or for 150 hours on a single "AA" cell, and includes bass rolloff switch. Its output is balanced, low-impedance (200 ohms) and terminates in a 3-pin XLR.

All capsules are black and use back-electret technology. A single module plus a few interchangeable capsules provide you the flexibility you need in your mic kit.

**Popular Systems:**

MKE2-60 omni lavalier and K6 power supply	60SNMKE260C	\$478.00
ME64 ENG handheld and K6 power supply	60SNME64C	\$425.00

**Mic Capsules if bought separately:**

ME65 for ENG, a new supercardioid handheld with high gain before feedback. 50-20kHz.

60SNME65	\$249.00
----------	----------

ME66 Short Shotgun combines supercardioid at low frequencies plus shotgun above 2000Hz. Light weight prevents fatigue in handheld use. 50-20kHz.

60SNME66	\$235.00
----------	----------

ME67 Spot Shotgun combines supercardioid at low frequencies plus shotgun above 2000Hz. An excellent value, great for TV or podium use. 50-20kHz.

60SNME67	\$309.00
----------	----------

ME64 Cardioid, tight pattern, high gain before feedback, good for speech. 50-20kHz.

60SNME64	\$169.00
----------	----------

MKE2-60 Omni Lavalier, less than 1/4" diameter, popular for broadcast or instrument use. 20-20kHz.

60SNMKE260	\$239.00
------------	----------

**Powering Module: K6 (phantom and "AA")**

60SNK6	\$239.00
--------	----------

Other modules available. Call for pricing on mounting hardware and windscreens.

## STEWART BPS-1 BATTERY PHANTOM SUPPLY

This single channel, 48 volt phantom power supply is rated for up to 200 hours using a pair of 9V alkaline batteries. It can deliver up to 4.5 mA at 48VDC, and has locking XLR connectors. The all-aluminum chassis includes a detachable belt clip. A solid value.



BPS-1	60SEBPS1	\$95.00
-------	----------	---------

## LIGHT WAVE SCREENS, MOUNTS & FISHPOLES

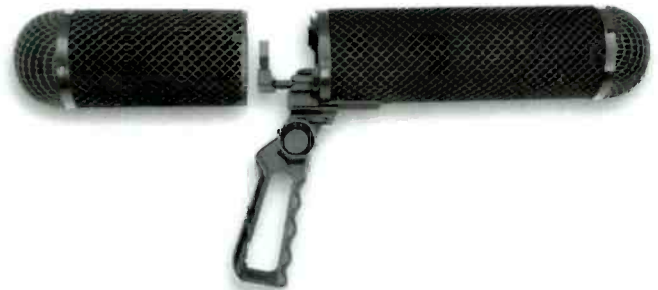

Protect your field shotgun from wind and handling noise. Super Screens provide great wind attenuation; add a Super Mount pistol grip for the best in mic isolation. Models to match mics in this section are listed; we can quote many others.

Light Wave fishpole booms have telescoping cam locks and provisions for internal wiring. Also available: several models of high-wind covers to provide further protection, including the classic Super-Sock, an oversized Super-Sock, and the Windmaster with 3/8" deep fur-like pile.

**Light Wave Super Screens**

For AT815B	60LWSS815	MFR LIST	\$280.00
For AT835B	60LWSS835	MFR LIST	\$270.00
For ECM 672	60LWSS672	MFR LIST	\$260.00
For MKH-416	60LWSS416	MFR LIST	\$260.00

**Light Wave Super Mount Pistol Grips**

For AT815B	60LWSM815	MFR LIST	\$145.00
For AT835B	60LWSM835	MFR LIST	\$140.00
For ECM 672	60LWSM672	MFR LIST	\$150.00
For MKH-416	60LWSM416	MFR LIST	\$140.00

**Popular items include:**

FP12 fishpole 4' to 12'	60LWFP12	MFR LIST	\$210.00
FP6 fishpole 28" to 6'	60LWFP6	MFR LIST	\$195.00
Super-Sock for Super Screen	60LWSSQXXX	MFR LIST	\$50.00
Super-Sock for Mini Screen	60LWMSQXXX	MFR LIST	\$35.00

CALL 1-800-732-7665 FOR BRADLEY PRICES

**SHOTGUN MICROPHONES**

Can't get there from here? Grab a shotgun and listen in anyway. Most can be hand held, camera or boom mounted, or operated from a fishpole.

Power the popular AT815B with either one "AA" cell or phantom 9-52V. At only nine ounces and under 19", this Audio Technica model won't load you down. Or consider the AT835B extended-range condenser. It combines the best attributes of cardioid and shotgun mics. Phantom or internal battery powered, the AT835B has high sensitivity and flat response. It is 14-1/2" long.

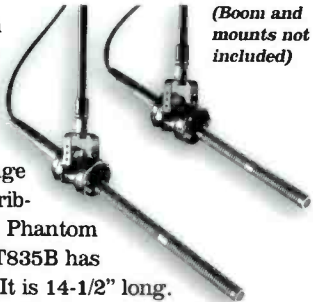

*(Boom and mounts not included)*

Both models include bass rolloff, stand clamp, storage case, and windscreen.

AT815B	60AT815	\$299.00
AT835B	60AT835B	\$229.00

The Sony ECM 672 is a short electret shotgun mic. It mounts on a portable video camera or can be hand held. The lightweight ECM 672 will operate for about 3000 hours on an "AA" cell and run on 48V phantom. Includes two low frequency roll-offs.



ECM 672	60S0672	\$465.00
---------	---------	----------

Electro-Voice uses N/DYM design in a unique, hand held or camera-mounted "short shot". The RE45N/D, right, has the high output of a condenser but it's dynamic, so no batteries are required. This 11-1/2" model is unfazed by humidity levels that can kill a condenser shotgun. Best at 6-8 feet from your audio source.



RE45N/D	60ELRE45	\$419.00
---------	----------	----------



The Sennheiser MKH-416, above, is a specialized directional mic for interviews, podiums, and long-distance video work. It has a supercardioid/lobe shotgun pattern with good feedback rejection and 128dB/SPL. It's 10" long and weighs about six ounces, suitable for boom, fishpole, and cameras. Audio is full bandwidth; use 48V phantom or ask about the 12V A-B version. Also ask us about the MKH-816 ultra-directional, for crowded news conferences, movie and TV sets.

MKH-416 P48U3	60SNMKH416	\$1,219.00
---------------	------------	------------



AKG's C-568EB delivers directivity in a short 10" package. It's an electret condenser that works below 500Hz as a hypercardioid; above that point the interference principle provides an increasing sound power concentration. This model includes built-in impedance converter/preamp and bass roll off switch, and accepts phantom 9-52V. Stand adapter and foam screen included.

C-568EB	60AKC568EB	\$395.00
---------	------------	----------



**HAND HELD MICROPHONES FOR ENG/EFP**

**BEYER M 58**

Your friend with the "golden ears" will tell you how fine this mic sounds. The M 58 is a top-of-the-line hand held with a full 40-20kHz response. Its low mass diaphragm produces superb intelligibility. Shock mounted for low handling noise, the M 58 looks great on camera. The balanced 10" shank has a sweet feel in your palm. You'll find this mic in the field kits of some of the finest in our trade.

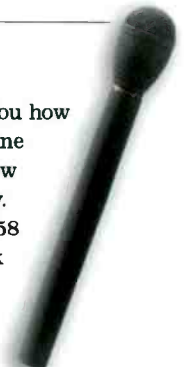

M 58	60BEM58	\$179.00
Mic clamp	61BEMKV8	\$17.95
Windscreen	60BEW558	\$18.00

**SHURE VP64**



Over and over our customers tell us how pleased they are with this simple, affordable, durable field mic. The long handle on the VP64 provides an interviewer with better reach, and its styling looks great on camera. It uses a neodymium magnet for an output up to 6dB higher than competing models. An internal shock mount reduces handling noise. Response: 50-12kHz. The VP64 includes a windscreen and stand adapter.



VP64	60SHVP64	\$89.00
------	----------	---------

**ELECTRO-VOICE 635**

Perhaps the most widely used ENG microphone, the 635 is nicknamed "The Hammer" for good reason. Choose from a variety of configurations including an economical "six pack" without stand adapters. Fans of neodymium can order the 635N/D with greater output and an even more protective metal casing. E-V offers both in fawn beige or sleek black.



All flavors provide 80Hz to 13kHz response. The individual mics are packaged with stand adapter.

635A (beige)	60EL635A	\$105.00
635A/B (black)	60EL635AB	\$105.00
635N/D (beige)	60EL635ND	\$125.00
635N/D-B (black)	60EL635NDB	\$125.00
Windscreen	60EL314E	\$17.00
6-pack/635A	60EL635A6	\$569.00
6-pack/635A/B	60EL635AB6	\$569.00

**EV 635L EXTENDED**

A bigger, better, longer version of the classic 635A. It's 9-1/2". Good for interviews and attaching mic flags.

635L (beige)	60EL635L	\$129.00
635LB (black)	60EL635LB	\$129.00

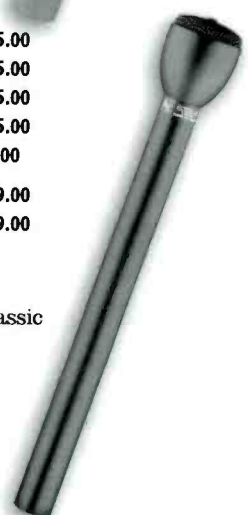

## STEREO MICROPHONES

Suitable for use with pro DAT and cassette machines, the AT825 from Audio Technica has two elements in an X/Y pattern. It produces wonderful stereo recordings and is mono compatible.

Use an "AA" cell or phantom power. Switchable low cut filter and windscreen are included; the cable terminates in XLR's.

AT825                      60AT825                      MFR LIST                      \$525.00



Also Available: The AT822 stereo mic is ideal for use with portable DAT decks like the Sony TCD-D7 and D8. It's similar to the AT825 but is designed for battery use only and outputs are unbalanced. You get two cables: One terminating with a 1/8" stereo mini-plug and the other with dual 1/8" mono mini plugs with 1/4" phone plug adapters. A great field tool, a super value.

AT822                      60AT822                      MFR LIST                      \$399.00

## ELECTRO-VOICE RE50

It's like a mic within a mic.

The omni RE50

has the same tailored response and high output of its cousin the 635A, and its resilient shock mount design gives plenty of isolation. The built-in windscreen is an effective pop filter. Also available in an N/DYM version; call for pricing.

RE50                                      60ELRE50                      \$189.00  
 RE50B                                      60ELRE50B                      \$189.00  
 Windscreen                                      60EL376                      \$24.00

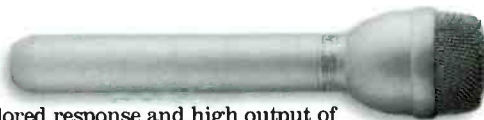

## AUDIO TECHNICA AT804



We're fond of this tough little omni. The hardened steel grille and die-cast case make it a nice choice for your ENG field kit. Frequency response is 50Hz to 15kHz; the mic has high sensitivity to match the input of most recorders and mixers. Windscreen, carrying case, and stand adapter are provided.

AT804                      60AT804                      \$89.00

## AKG D-230

The long handle of this 8-1/2" omni dynamic holds a mic flag nicely; the integrated windscreen rejects wind and pops. The matte, non-reflective finish is perfect on camera. Worth a listen for any field work. Response 40-20kHz, weight 8 oz. Internal shock absorber.

D-230                      60AKD230                      \$159.00



## SHURE SM57 & SM58

*Best Seller*

For hand held or lectern use, the SM57 is a good choice. Presence boost and low end roll-off treat voice frequencies with wondrous care. Non-glare gray is ideal for stage or camera. Also a fine instrument mic. 40Hz to 15kHz.

The next step up is the SM58, used for voiceovers and ENG. It has a spherical windscreen and fixed bass roll-off to prevent popping or boominess close up. Order it with or without on/off switch. Also an outstanding music vocal mic. 50Hz to 15kHz. Both weigh about 10 oz. These dynamic cardioids are truly two of our best sellers.



SM57	60SH57	\$97.00
SM58	60SH58	\$119.00
SM58 with on-off switch	60SH58S	\$125.00
Windscreen for 57	61SHA2WSXX	\$9.95
Windscreen for 58 (ask for color choice)	61SHA58WSXX	\$4.75

## SHURE SM7

Voice-over work and other critical audio calls for the superb SM7. Expect 40Hz to 16kHz response, four selectable curves, symmetrical cardioid pattern, and internal air shock mount. Noise from wind, boom, and breath-pops is dampened by the integral foam windscreen. Weight: 27 oz.



SM7	60SHSM7	MFR LIST	\$566.50
Spare Windscreen	61SH90KR2600	MFR LIST	\$15.50

CALL 1-800-732-7665 FOR BRADLEY PRICE

## SHURE BETA

Bradley is pleased to offer the premium BETA series from Shure. Three supercardioid mics with exceptional audio for demanding work and hardened steel grilles for long life.

BETA 58A: a dynamic mic for live vocal work, ENG, and VO's.  
 BETA 57A: A dynamic for acoustic and electric music or miking a crowd.  
 BETA 87: an electret condenser for studio or performance vocals. The neodymium BETA 57A and 58A are 50-16kHz; BETA 87 is 50-18kHz. All weigh between six and nine ounces.

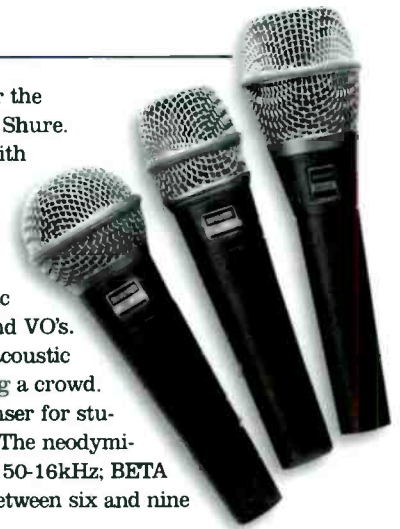

BETA 58A	60SHB58	MFR LIST	\$266.00
BETA 57A	60SHB57	MFR LIST	\$220.00
BETA 87	60SHB87	MFR LIST	\$434.00

CALL 1-800-732-7665 FOR BRADLEY PRICE

# MICROPHONES

## ELECTRO-VOICE SUPERCARDIOID FIELD MICS



RE supercardioids are everywhere! The familiar slotted handle indicates Variable-D design that virtually eliminates unwanted bass boost in close-up work. All are fawn beige.

**(1&2)** Born in a TV studio, the RE15 is a broadcast and production workhorse. It has a built-in pop filter, bass roll-off switch, and hum bucking coil. The supercardioid pattern makes it ideal for on-camera and studio recording. Response: 80-15kHz. The RE10 is a lower-price alternative with many of the same features, at 90-13kHz. Weight 6 oz.

RE15	60ELRE15	\$349.00
RE10	60ELRE10	\$219.00

**(3&4)** An exceptional ENG mic, suitable for the studio, the RE16 has a special screen that retains its shape if dropped. Includes heavy-duty pop filter, hum-bucking coil, and switchable bass roll-off. Response: 80-15kHz. The RE11 is a moderately priced alternative with 90-13kHz response. Weight 8 oz.

RE16	60ELRE16	\$359.00
RE11	60ELRE11	\$239.00

**(5)** RE18 has an integral shock mount for superior hand held performance. This mount also dampens stand or lectern noises. Response: 80 to 15kHz. Weight 8 oz.

RE18	60ELRE18	\$389.00
------	----------	----------

### Accessories:

Replacement clamp for RE series, except RE20/27.

60EL311	\$19.50
---------	---------

Colored windscreen for RE11, RE16, or RE50. Choose black, red, orange, yellow, green, blue, and violet.

Pop filter for RE18	60EL379X	\$14.00
Windscreen for RE18	60EL351	\$16.50
Pop filter for RE11 and RE16	60EL338	\$29.00
	60EL376	\$24.00

Windscreen for RE10 and RE15 mics. Two piece design has zippered rear portion to cover shank of mic. Rear portion can be used on RE11 and RE16.

60EL314	\$32.00
---------	---------

Security damp for RE series, except RE20/27.

60EL340	\$32.00
---------	---------

Call Bradley for other EV accessories.

## AUDIO TECHNICA ATM-63HE

Great for directional miking, the ATM-63HE has a hypercardioid pattern and very flat response of 50Hz-18kHz. It's a neodymium with improved shock mounting. Nice for high-end ENG. Weight 20 oz.

ATM-63HE	60ATM63	MFR LIST	\$210.00	CALL 1-800-732-7665 FOR BRADLEY PRICE
----------	---------	----------	----------	---------------------------------------

## ELECTRO-VOICE RE20

A winner of our best seller award, and still one of the most popular broadcast and voice-over mics in the world. Smooth, extended, clean response. The cardioid RE20 rivals the finest (and most expensive) condenser mics, and it won't break your budget. Internal blast and shock protection, bass roll-off switch. 45Hz to 18kHz. Weight: 26 oz.

This is a career-maker.

RE20	60ELRE20	MFR LIST	\$786.00
------	----------	----------	----------

CALL 1-800-732-7665 FOR BRADLEY PRICE

## ELECTRO-VOICE RE27N/D

A beautiful mic based on the RE20, right, with even more high end thanks to the magnet's neodymium alloy design. It has three switchable filters: one high frequency, two low. It handles high sound pressure levels without breaking a sweat. An integral shock mount and blast filter are provided. 45Hz to 20kHz. Weight: 25 oz.

CALL 1-800-732-7665 FOR BRADLEY PRICE

## SENNHEISER MD421 II

The MD421 II continues the tradition of the MD 421 which has been one of Sennheiser's most popular dynamic mics for over 35 years. The new large diaphragm, dynamic element handles high sound pressure levels, making it a natural for recording. The MD421's full-bodied cardioid pattern, and five-position bass control make it an excellent choice for most instruments, as well as group vocals, or radio broadcast announcers. Frequency response : 30-17kHz. Weight : one pound. One listen and you'll know why it's a classic. Give your career a boost with the MD421 II.

MD421II	60SNMD421II	MFR LIST	\$485.00
---------	-------------	----------	----------

CALL 1-800-732-7665 FOR BRADLEY PRICES

## AUDIO TECHNICA ATM-25

Here's a Bradley Best-Kept Secret. This is a surprisingly sweet mic at the price. The hypercardioid pattern rejects unwanted sounds and it withstands high SPL nicely. With a response that enhances male and female voices, the ATM-25 deserves to make your short list. Response: 30Hz to 15kHz. Weight 20 oz.

ATM-25	60ATATM25	MFR LIST	\$278.00
--------	-----------	----------	----------

CALL 1-800-732-7665 FOR BRADLEY PRICE

# MICROPHONES

## STUDIO CONDENSER MICS

### ELECTRO-VOICE RE2000

Critical recording demands ultra-low self-noise, great sensitivity, and wide dynamic range. Here they are, all in one condenser package: the RE2000. It's compatible with your finest digital audio recording equipment. E-V gives you response of 70-18,000Hz, an integral heating system that controls the heat and humidity of the mic, and its own external power supply so you need not rely on inconsistent power from a console phantom system.

Features include supercardioid pattern, gorgeous mid-size diaphragm for high output with smooth transient response, custom Jensen transformer for clean true 150-ohm output, and 12-dB-per-octave switchable low-frequency roll-off. The RE2000 comes with hard-shell case, external pop filter, power supply, shock mount system, stand adapter, and 20-foot cable. This is an exceptional professional microphone. Weight of mic with mount: 25.3 oz. plus power supply and cable.



RE2000      60ELRE2000      MFR LIST      \$2,042.00

CALL 1-800-732-7665 FOR BRADLEY PRICE

### AUDIO TECHNICA 4050/CM5

Here's a warm, multi-pattern studio mic for demanding uses. Dual gold-plated, large-diaphragm, aged condenser elements provide response of 20-20kHz, dynamic range of 132dB, and SPL handling of 149dB, even more with the switchable 10dB pad. Patterns are cardioid, omni, and figure eight. Low-end roll-off switch, internal windscreen, and external shock mount are included. It operates with any remote phantom or simplex source supplying 48VDC. Weight: 16.9 oz.



AT 4050/CM5      60AT4050CM5      MFR LIST      \$995.00

CALL 1-800-732-7665 FOR BRADLEY PRICE

### AUDIO TECHNICA 4033

The AT4033 is an affordable cardioid condenser mic, well-suited for digital applications. It boasts frequency response of 30Hz to 20kHz. Powered by an external 48V phantom source, the AT4033 can handle up to 140dB SPL (150dB SPL with the switchable 10dB pad) without distorting and has dynamic range of 123dB. It also has an 80Hz hi-pass filter to reduce sensitivity to popping. The mic is also available with a shock mount. Wt: 14.5 oz.



AT4033-SC (w/ stand damp)      60AT4033SC      MFR LIST      \$685.00

AT4033-SM (w/ shock mount)      60AT4033      MFR LIST      \$725.00

CALL 1-800-732-7665 FOR BRADLEY PRICE

### NEUMANN TLM-193 CONDENSER

*Best Seller*

The familiar name, the incredible audio, the famous logo at the bottom... they're all here. The TLM-193 is a cardioid large-diaphragm condenser mic with 130dB dynamic range, 20Hz to 20kHz response, very low self-noise, and the rich Neumann sound. But the price—ay, there's the rub. It's less than half that of other famous Neumann condensers. Let us give you a quotation for this fine audio device. Requires 48V phantom power. Weight 1.08 lb.



TLM-193      60NETLM193      MFR LIST      \$1,495.00

WS-89 Windscreen      60NEWS89      MFR LIST      \$30.00

CALL 1-800-732-7665 FOR BRADLEY PRICE

### AKG C1000S

AKG condenser quality is available in a moderate price range with the C1000S. It includes a pattern converter for cardioid or hypercardioid operation. Powering is via an internal 9V battery or external 12-48V phantom. The C1000S comes with a foam windscreen and stand adapter. Weight 9.7 oz.



C1000S      60AKC1000S      MFR LIST      \$525.00

Also available:

The AKG C414B/ULS Classic studio mic. Call us for all the specs.

60AK414      MFR LIST      \$1,249.00

CALL 1-800-732-7665 FOR BRADLEY PRICE

### AKG C3000

AKG is leading the way at bringing expensive condenser performance within everyone's reach. The C3000 doesn't look like any other mic, but in performance it emulates the best AKG's. It includes a built-in spider shock absorber and the following switchable features: cardioid/hypercardioid pattern, bass roll-off, and -10dB pad for close miking. Takes 9-52V phantom. A super, large-diaphragm performer. Weight 11 oz.



AKG C3000      60AKC3000      MFR LIST      \$749.00

H15/22 Elastic Suspension      60AKH1522      MFR LIST      \$210.00

N62E Phantom Supply (powers 2)      60AKN62E      MFR LIST      \$149.00

CALL 1-800-732-7665 FOR BRADLEY PRICE

## MICROPHONES

### STUDIO CONDENSER MICS

#### AUDIO TECHNICA 4031

A-T quality is affordable thanks to the 4031, a cardioid capacitor microphone, powerable with 9-52V phantom. The response of 30-20kHz has a slight rise in the high frequencies. This model is appropriate for indoor broadcast work. Low self noise, high output, and high SPL characterize a nice performer. High-pass switch, foam windscreen, and quality brass casing are standard. Wt: 4.9 oz. The optional 48V supply can power up to four mics.

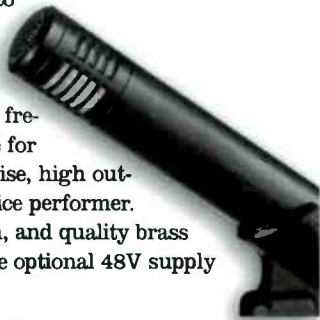

AT4031	60AT4031	MFR LIST	\$350.00
CP8506 48V supply	60ATCP8506	MFR LIST	\$180.00

CALL 1-800-732-7665 FOR BRADLEY PRICE

#### SHURE SM81

For just a few hundred dollars you can enjoy a fine condenser mic. The SM81 is a unidirectional condenser with low distortion of 0.5% and 135dB SPL before clipping; the 10dB attenuator stretches upper limit to 145dB SPL. It also provides a selectable low frequency curve to compensate for proximity effect or disturbances. Weight: 8 oz.



SM81	60SH81	MFR LIST	\$441.50
------	--------	----------	----------

CALL 1-800-732-7665 FOR BRADLEY PRICE

#### STOPPIT

Some of our fine mics come with their own external filters, but for those that don't, pick the Raxxess Stoppit filter. Eliminate the popping caused by hard consonants. Order just the screen, which comes with a sturdy stand mount, or choose the POMT package (pictured) which includes a 6" Stoppit, gooseneck, and steel stand clamp.



POMT Package	61RXPOMT	MFR LIST	\$42.95
6" Stoppit	61RXSTOP6	MFR LIST	\$19.95
8" Stoppit	61RXSTOP8	MFR LIST	\$22.95

CALL 1-800-732-7665 FOR BRADLEY PRICE

### AUDIO TECHNICA PRO 8HE

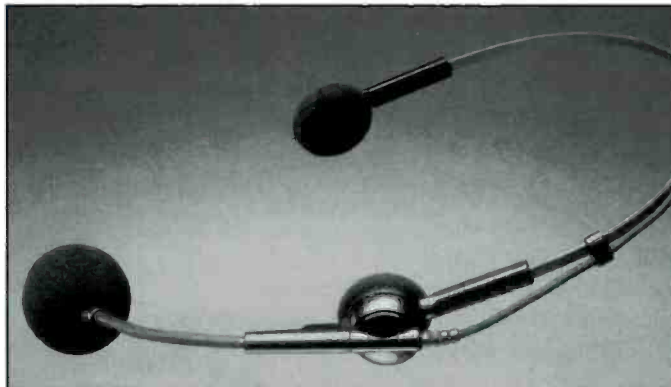

DJs, musicians, and aerobics instructors need hands-free vocal pickup. This new model is a headworn dynamic mic (no powering needed). Rotate the boom to put the mic on either side of your head. The pattern is hypercardioid, response is 200-18kHz, and impedance 600 ohms. It weighs only two ounces and comes with two windscreens, a clothing clip, and 16' cable with XLR. Please note, this is not a headset but a headworn mic with temple pads.

PRO 8HE	60ATPRO8HE	\$85.00
---------	------------	---------

#### AUDIO TECHNICA TALKBACK MIC

The gooseneck on this talkback mic lets you set it where you want it, and the subcardioid pickup pattern reduces noise. The response is 200Hz to 5kHz, great for simple voice communication. A low-Z XLR male connector on the base of the gooseneck plugs into your console.

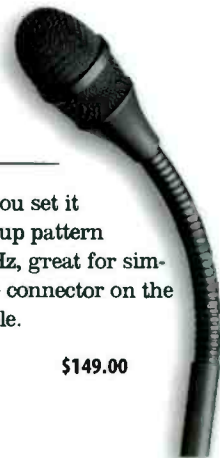

AT808G	60AT808G	MFR LIST	\$149.00
--------	----------	----------	----------

CALL 1-800-732-7665 FOR BRADLEY PRICE

#### AUDIO TECHNICA AT837R

Now you can get UniPoint performance in a superior vocal mic. This handheld has an internal shock mount. The hypercardioid element can be swapped for three other optional patterns. Runs on 48V phantom only. Windscreen included.



AT837R	60AT837R	\$169.00
--------	----------	----------

**Bradley knows fine audio mics.  
Call us for AKG, Sennheiser, EV,  
Sony, Neumann, and more!**

## MICROPHONES

Bradley Broadcast • 12401 Twinbrook Parkway • Rockville, MD 20852 • 800-732-7665 • 301-231-7800 • Fax: 301-230-6526 • email: info@bradleybroadcast.com



**AUDIO TECHNICA BOUNDARY UNIPOINTS**

For demanding surface-mounting situations, choose between omni and uni patterns of A-T's condenser plate mics. Both are about 2.5" wide, both run on either "AA" cell or 5-52V phantom and come with 25' cable. A good match for the SmartMixer on page 69.

AT841a omni	60AT841A	\$219.00
AT851a uni	60AT851A	\$229.00



**CROWN PRESSURE ZONE MICROPHONES**



Crown PZM mics use the pressure zone at an acoustic boundary, such as a floor or table surface, to eliminate distortion and comb filtering problems.

(1) The PCC-160 is for stage floors, lecterns, and TV news desks. The large surface increases sensitivity and prevents phase problems; its supercardioid pattern minimizes background noise. Balanced low impedance output. 15' cable included. Takes 12-48V phantom.

(2) The PZM-185 has a balanced low impedance output. This model is suited to broadcast production, conferences, and recording. It's powered by an internal "N" cell or external phantom power. The male XLR connector is in the handle. No cable.

The Sound Grabber (not pictured) is a very affordable, portable PZM powered by an "AA" cell. It looks like the PZM-180 but has an unbalanced high-impedance output, 10' cable to 1/8" TS plug, and adapters for 1/4" TS phone and 3/32" TS applications. All models listed are black; the PCC-160 can also be ordered in white.

PCC-160	60CRPCC160	MFR LIST	\$309.00
PZM-185	60CR185	MFR LIST	\$199.00
Sound Grabber	60CRSG	MFR LIST	\$99.00

CALL 1-800-732-7665 FOR BRADLEY PRICE

**AUDIO TECHNICA UNIPOINT SERIES**

*Best Seller*

UniPoints are a family of low profile specialty mics with great low frequency response and interchangeable heads for different patterns. They control feedback with exceptional rejection specs.



**1. AT859QML**

It plugs into any XLR jack for swift installation or removal. 9-52V phantom power only.

AT859QML	60AT859	\$129.00
----------	---------	----------

**2 & 3. AT857**

The 857AMa can mount on a mic stand or its own threaded surface mount adapter. It has an on/off/roll-off switch and can run on "AA" cell or phantom. Its brother, the 857QMa, plugs directly into a female XLR connector and operates only on phantom power. Roll-off switch.

AT857AMa	60AT857AM	\$235.00
AT857QMa	60AT857	\$195.00

**4. AT853A**

Hang this one using the plastic coated, stainless steel hanger, or mount it on a stand adapter. It has an on/off/roll-off switch and can operate on "AA" cell or phantom.

AT853a	60AT853	\$189.00
AT853wa (white)	60AT853WA	\$229.00

**SHURE SM11**

Pick this mic when you want a lavalier that doesn't require powering. Get small with the SM11, a tiny dynamic lav with optimized response, natural sound quality and Shure toughness. You also get a lavalier cord, tie bar, and tie tack.

5M11	60SH11	\$85.00
------	--------	---------



**Churches, courtrooms, and teleconferencing... call us for Automatic Mic Mixing products.**



# MICROPHONES

## SONY LAVALIERS

Our customers choose Sony condenser lavs above all others. These mics ignore unwanted noise and give you the convenience of battery operation.

The ECM-77B, a mere 1.5 grams, is Sony's tiniest lavalier, an unobtrusive, high performance omni with the best bandwidth of the four.

The popular ECM-55B has an omni pattern and is recommended for the widest applications. The ECM-66B has a uni pattern ideal for musical instruments.

The economical ECM-44 is omnidirectional; it includes a foam windscreens, while the other models include a metal mesh. All versions are matte black; all conveniently take "AA" cells; all but the 44B accept 48V phantom. Case and clips included. Also available: unterminated versions for wireless systems.

ECM-44B	60S044B	\$165.00
ECM-55B	60S055B	\$269.00
ECM-66B	60S066B	\$299.00
ECM-77B	60S077B	\$299.00

Also available: Colored windscreens, and holder-clip styles including double mic, pencil or safety-pin type, tiepin and necklace types. Call us for assistance.

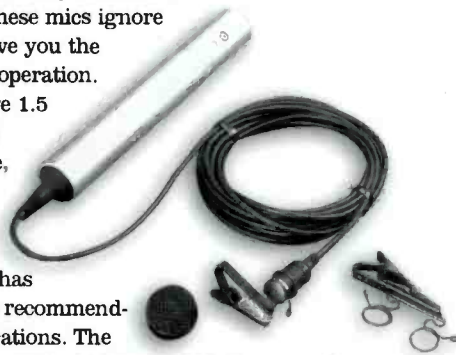

## AUDIO TECHNICA AT831

It's a mini unidirectional condenser, best where feedback or room noise is a problem, and excellent for music instruments. Choose from two versions.

- AT831R 9-52V phantom power only, with 25' cable, 60AT831R \$169.00
- AT831b takes phantom and "AA" cell, with 6' cable, 60AT831B \$142.00



## CROWN GLM

The 100 is a mini omni electret condenser, easily concealed. The black head is approx. 1/3" x 3/4". Wide, smooth response, high SPLs, 8' cable with wired XLR. Use 12-48V phantom. Several mounts and windscreens are included. The 200 is a hypercardioid model with a rising high frequency response for presence.

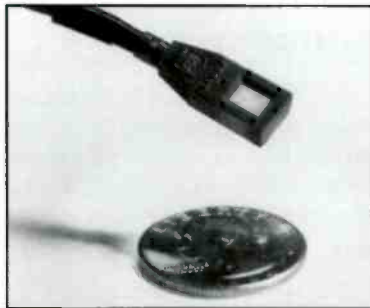

GLM-100	60CRGLM100	\$169.00
GLM-200	60CRGLM200	\$194.00

## SHURE MX SERIES LAVALIER MICROPHONES

The MX184 supercardioid condenser lav solves problems of extraneous sound and gain-before-feedback, so pick it for talk shows and other noisy environs. The cardioid MX185 provides an intermediate pattern for directional use. For less complex applications, the omni MX183 is an excellent choice. Both have a frequency response dip at 730Hz that minimizes the "chest resonance" effect; both include tie clip, cable, and belt-pack preamp that takes phantom power only.

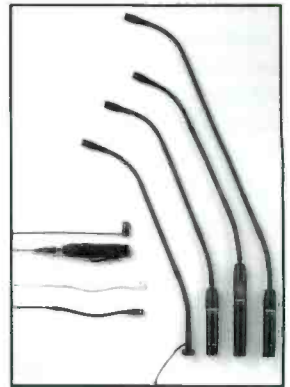

MX185 cardioid	60SHMX185	MFR LIST	\$280.00
MX184 supercardioid	60SHMX184	MFR LIST	\$290.00
MX183 omnidirectional	60SHMX183	MFR LIST	\$260.00

CALL 1-800-732-7665 FOR BRADLEY PRICE

## DESK STANDS

1. The Atlas DS-7 is a heavy duty adjustable desk stand, our most requested, and available in chrome or ebony, both with black base.

Chrome	61ATDS7	\$15.00
Ebony	61ATDS7E	\$15.00

2 & 2A. Two popular collapsible mic tripods for tabletop mounting. Pick the style you like best, and put one in your field kit.

2. K&M	61KM12996	\$19.00
2A. AKG	60AK231	\$14.00

3. The AT8615 stand is metal, with XLR in's and out's for plug-in of podium and desk mics. Also available with on/off switch in the stand.

AT8615	60AT8615	\$49.00
--------	----------	---------



**MICROPHONE STANDS AND BOOMS**

1. AKG KM-251 heavy duty, collapsible floor stand adjustable: 23" to 53".

Chrome	60AKKM251	\$69.00
Black	60AKKM251B	\$69.00

2. Atlas MS-12C basic stand with heavy duty base. Height span: 34"-62"

Chrome	61ATMS12C	\$21.00
Ebony	61ATMS12CE	\$21.00

3. Atlas MS-20 heavy duty mic stand with shock mounting. Height span: 37"-66"

Chrome	61ATMS20	\$54.00
Ebony	61ATMS20E	\$54.00

4. Shure S15 collapsible stand can be adjusted up to 14 feet. It is sturdy and stable enough to hold heavy microphones, yet weighs only five pounds. Easy to transport. Comes with vinyl carrying bag and cable strain relief.

60SHS15	\$169.00
---------	----------

5. ST-201A/2 professional two-section collapsible mic stand. Lightweight, yet stable. 36"-63"

Black	61KM201B	\$33.00
Chrome	61KM201	\$33.00

6. Atlas MS-25 heavy duty mic stand with shock mounting and triangle base so talent can step up close. Height span 38"-67"

61ATMS25	\$82.00
----------	---------

7. Atlas MS-4 three section version of the MS-20. Height span 25"-65"

61ATMS4	\$39.00
---------	---------

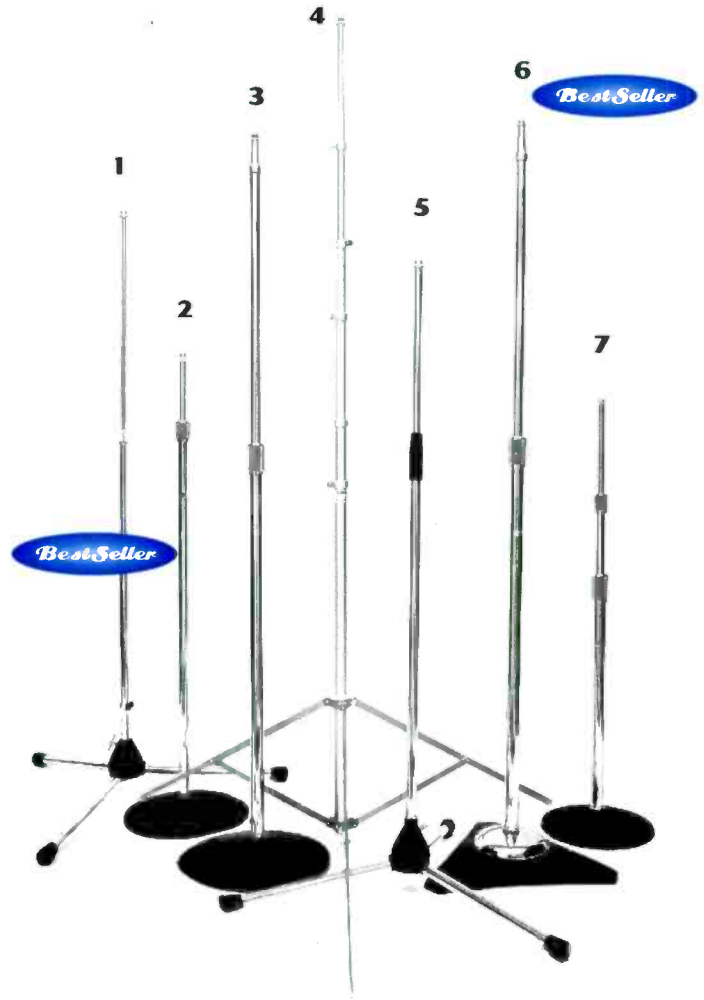

**ATLAS PERFORMER SERIES BOOMS**

We like them for their single hand adjust, swivel/clamp design, smooth positioning, and counterweights for mic balance.

BB77E Basic Boom, 34", black	61ATBB77E	\$16.25 (not shown)
BB77 Basic Boom, 34", chrome	61ATBB77	\$16.25 (not shown)
PB11XE: 16" - 24", black	61ATPB11XE	\$37.00
PB15E: 34", black	61ATPB15E	\$24.50
PB15: 34", chrome	61ATPB15	\$29.50
PB21XE: 25" - 38", black	61ATPB21XE	\$34.00
PB21X: 25" - 38", chrome	61ATPB21X	\$34.00
PB25: 34", heavy duty, chrome	61ATPB25	\$35.00
PB25X: 32" - 51", hvy duty, chrome	61ATPB25X	\$42.00

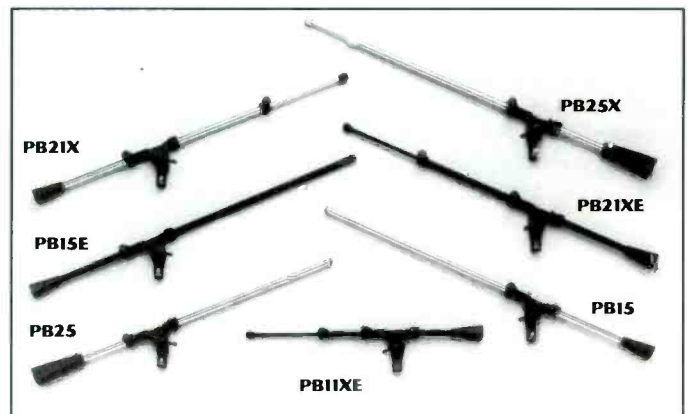

**DON'T FORGET YOUR MIC CABLES! SEE PAGES 93-94.**



**BOOMS, STANDS AND GOOSENECKS**

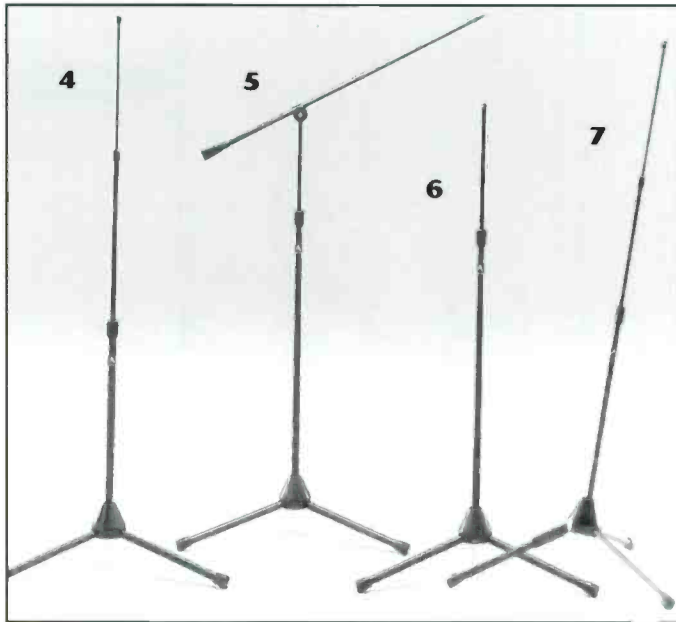

**ATLAS PERFORMER SERIES STANDS**

Metal tripods use Glide-n-Lock legs for secure positioning without knobs and screws. A wearproof clutch, rubber feet, and a flat ebony finish make them popular.

4. 3-section, 26" - 63" high	61ATTL343E	\$65.00
5. Boom version of #6, below	61ATTL34BBE	\$69.00
6. 2-section, 34" - 63" high	61ATTL34E	\$52.00
7. Tilt-leg version of #4, above	61ATTL353E	\$72.00

**ULTIMATE LIBERTY**

The Ultimate Liberty has a unique clutch that makes it the easiest stand to adjust. Height ranges from 34" to 64", and the 10" diameter round base allows six stands to stack. Lifetime guarantee.

61USL \$35.00



**SCH-211/2**

Collapsible boom extends to 38".

Black	61KM2112B	\$22.00
Silver	61KM2112	\$22.00



1. Atlas SB-36 great boom/stand with a grip action clutch and air suspension. Stand extends from 50" to 74", boom length is 62".

w/ casters	61ATSB36W	\$199.00
w/o casters	61ATSB36	\$179.00



2. Beyer GST 400 Boom Stand combo with black finish. Stand adjustable 35"-65". Boom fixed at 33". Tripod style base.

GST 400	60BEGST400	\$69.00
---------	------------	---------

3. K&M Mic Boom Stand. A professional collapsible mic stand with adjustable 31" boom. Tripod base.

KM 271	61KM271	\$37.50
--------	---------	---------

**GOOSENECKS**



1. Atlas Goosenecks

6" Chrome	61ATGN6	\$5.95
6" Black	61ATGN6E	\$5.95
13" Chrome	61ATGN13	\$6.95
13" Black	61ATGN13E	\$6.95
19" Chrome	61ATGN19	\$7.99
19" Black	61ATGN19E	\$7.99

2. Mic-Eze Rubbernecks eliminate the noise. Don't tolerate creaking in your gooseneck! XLR versions are wired.

16" Neck	61ACR16	\$13.95
10" Neck	61ACR10	\$11.50
12" Neck w/XLR	61ACR12X1	\$49.00
18" Neck w/XLR	61ACR18X1	\$49.00

3. Atlas Gooseneck Mounting Flanges

a. AD-11B Female 5/8"-27		
Chrome	61ATAD11B	\$3.75
Ebony	61ATAD11BE	\$3.75
b. AD-12B Male 5/8"-27		
Chrome	61ATAD12B	\$3.75
Ebony	61ATAD12BE	\$3.75
c. AD-18B Heavy Duty Female		
Chrome	61ATAD18B	\$6.69



**DON'T BE SHOCKED!**



(1 & 3) Tensimount spider mounts come in sizes to fit most microphones. Stand adapter required.

TM1 for mics up to 1-3/8" diameter	60AKTM1	\$22.00
TM2 for mics up to 2" diameter	60AKTM2	\$23.00
TM3 for mics up to 2-3/4" diameter	60AKTM3	\$27.00

Accessory: Mic stand adapter for Tensimount

61AKSA40	\$16.00
----------	---------

(2) Audio Technica 8415 shock mount is designed for field production. The elastic suspension accommodates different sized mics.

60AT8415	\$51.00
----------	---------

(4) Audio Technica AT8410 is a universal mount with clothes-pin clamp to fit most mics without extra sleeves or adapters. Special neoprene suspension cords isolate the mic in every direction.

60AT8410A	\$49.00
-----------	---------

(5) Sennheiser MZS100 is the best shock mount we offer. It attaches to any microphone with the mic's own stand adapter. A thumbscrew adjusts tension on the absorbing mechanism so it can be optimized for the weight of the mic.

60SNMZS100	\$89.00
------------	---------

**SHURE A58WS WINDSCREENS**

They fit most mics with ball heads. Choose among black, orange, red, blue, brown, white, green, and yellow.



61SHA58WSXX	\$4.75
-------------	--------

**MIC SPLITTERS AND COMBINERS**

Use Pro Co's MS-2 to split the signal from a low-Z mic to two mixers. Direct output, plus isolated output with ground lift. The MC-2 combines signals from two low-Z balanced mics to one input. One connector has polarity reverse switch. Both units use XLR connectors. (See our Audio Interface section for more accessories!)



MS-2 Splitter	60PCMS2	\$89.00
MC-2 Combiner	60PCMC2	\$89.00

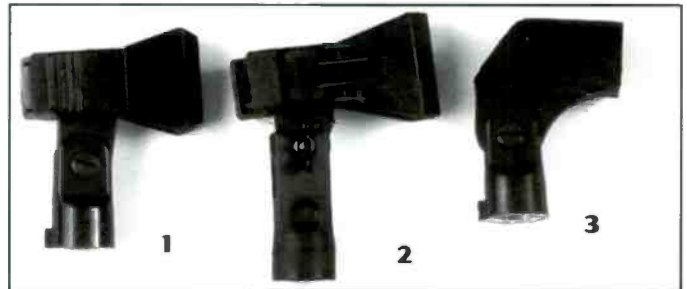

1. This clothes pin style, spring loaded swivel mic adapter fits most mics.

61BEMKV6	\$16.00
----------	---------

2. An unbreakable Mic-Eze holder with locking bolt and non-slip grip.

61ACM4	\$12.95
--------	---------

3. Swivel Adapter fits most Shure mics and many others thanks to its tapered sleeve.

61SF1	\$4.95
-------	--------



**ROWI CLAMP**

If you have a field mic, you need a Rowi Clamp. Attach your microphone to almost any surface. The jaw opens to 1-1/2", and the mic adapter swivels.

Rowi Clamp	60BBRC	\$36.95
------------	--------	---------



**FOR MULTIPLE MIC MOUNTING:**

Atlas TM-1 allows installation of two or three mics on a single stand.

61ATTM1	\$13.95
---------	---------

Shure A27M twin mount allows placing two mics vertically on one stand. Designed for M-S stereo.

61SHA27M	\$64.00
----------	---------



# MICROPHONE ACCESSORIES

**4. AKG KM235/1 twin mount** for horizontal extension or installation of two mics on one stand. Three pivot points allow flexible mic positioning.

60AKKM235 \$15.00

**5. Atlas VM-2 shock mount adapter** reduces vibrations to mic.

61ATVM2 \$16.00

**6. Atlas LO-2B** allows quick disconnect of mic clamp.

Chrome 61ATLO2B \$11.50  
Ebony 61ATLO2BE \$11.50



**8. Atlas CO-1B clamps** to mic stands or booms to allow attaching a second mic.

61ATCO1B \$12.95

**9. MZA-217 5/8" external to 3/8" internal thread adapter.**

61SNMZA217 \$3.00

**10. Atlas SW-1B swivel attachment** makes mic placement more convenient.

61ATSW1B \$19.50

**11. Atlas CH-1B** attaches to mic stand and provides a place to hang the mic cable.

61ATCH1B \$9.95

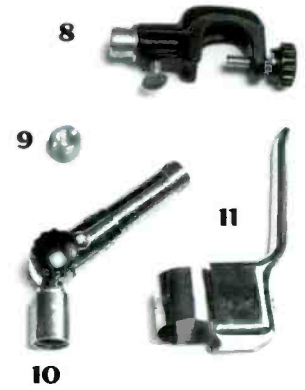

*Best Seller*

## LUXO STUDIO DESK MOUNTING ARMS

### A. LUXO KM-1 MIC ARM

The KM-1 reaches 41" without external springs. Balanced for mics weighing two pounds. Requires mounting bracket or riser.

KM-1 Oyster 61LUKM1 \$59.00  
KM-1 Black 61LUKM1B \$59.00

### B. LUXO LM-1 MIC ARM

Same reach as KM-1 above, but spring-loaded and balanced for mics weighing one pound. Requires mounting bracket or riser.

LM-1 Oyster 61LULM1 \$52.00  
LM-1 Black 61LULM1B \$52.00

Also available: Luxo LM-2 is similar to LM-1 but has a 26" reach.

LM-2 Oyster 61LULM2 \$52.00  
LM-2 Black 61LULM2B \$52.00

### C. PRO RISER

Get a rise from your mic with this 12" metal pedestal, a convenient mount and longer reach for your Luxo arm.

Oyster 61LURISER \$21.00  
Black 61LURISERB \$21.00



## ATLAS MIC ADAPTERS

Useful chrome adapters. If you don't see what you need, give us a hoot.

3/4" long, 5/8"-27M thread (shown)	61ATAD4B	\$3.75
3/8" pipe F to 5/8"-27F	61ATAD3B	\$3.75
Coupling; 5/8"-27F to 5/8"-27F	61ATAD5B	\$3.75
Coupling; 7/8"-27F to 7/8"-27F	61ATAD6B	\$5.25
3" long tube; 5/8"-27M thread each end	61ATAD7B	\$3.75
6" long tube; 5/8"-27M thread each end	61ATAD8B	\$3.75



## O. C. WHITE MIC ARMS

Bradley can accommodate any mic with the right O.C. White arm. Grey, with models in black available by special order.



Single mic arm only

600CSMA	MFR LIST	\$98.00	
Single mic arm with riser	600CSMAR	MFR LIST	\$135.00
Two-joint single mic arm	600CTJSMA	MFR LIST	\$188.25
Triple mic arm with riser	600CTMA	MFR LIST	\$441.00

CALL 1-800-732-7665 FOR BRADLEY PRICE

## D. LUXO MOUNTING BRACKETS

C-clamp Oyster	61LUABR	\$10.50
C-clamp Black	61LUABRB	\$10.50
Table mount Oyster	61LUCBR	\$10.50
Table mount Black	61LUCBRB	\$10.50
Wall mount Oyster	61LUBBR	\$10.50
Wall mount Black	61LUBBRB	\$10.50

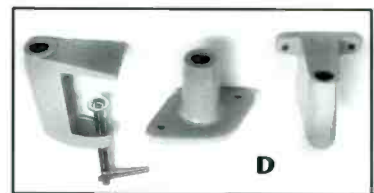

# MICROPHONES

THE  
ONE  
YOU'VE  
BEEN  
WAITING  
FOR



## SHURE UHF WIRELESS

This is as good as it gets.

The new Shure UHF Wireless delivers everything you'd expect from a premium-quality UHF system. And then some.

Like programmable LCD displays on both transmitters and receivers. A generous 191 channels of frequency-agility. The flexibility to perform flawlessly in practically any application. And the built-to-last reliability you expect from Shure. All at a fiercely competitive price. You patiently waited for it. Now it's waiting for you.

To learn more about the new Shure UHF Wireless System, call 800-25-SHURE.

**SHURE**<sup>®</sup>

The Sound of Professionals...Worldwide.<sup>®</sup>



**Lindy Williams**  
V.P. Engineering  
Lotus Communications  
Los Angeles, California

"We've replaced some 'very expensive' condenser microphones with the RE27N/D ...now the GM wants the guest mic replaced, as well as the production studio and the newsroom microphones. You're blowing my engineering budget!"



**Steve Lariviere**  
Chief Engineer  
WSNE

**East Providence, Rhode Island**  
"We replaced six expensive German condenser microphones in favor of the RE27N/D. What a great sound!"

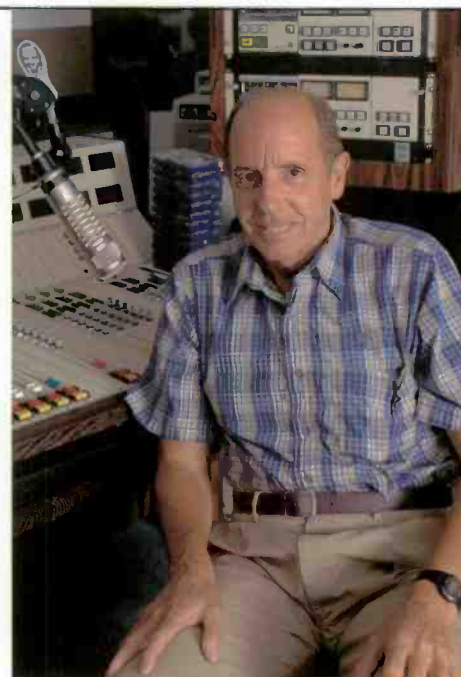

**Marv Collins**  
Chief Engineer  
KFI-KOST-KACE  
Los Angeles, California

"The RE27N/D has the fullness of a ribbon with the punch of a shotgun condenser microphone. The pattern is very good, giving good backside rejection of noise. Congratulations on building such a fine microphone."

# RE27N/D

## Studio Dynamic Microphone

### The new broadcast standard.





## RANE MIC PREAMPS



Rane preamps give you -130dB EIN, better than preamps in most mixers and great for use with condenser mics, digital recorders, workstations, and air consoles. Get the cleanest possible recordings by going direct to tape or disk. Phantom 48V power gives the juice to condensers. A remote power supply keeps the signal quiet.



The DMS22 is a two-channel, rackable mic preamp with three-band equalization, panning, and a built-in stereo mixer. Parametric midband allows precise control in the vocal range. XLR I/O plus TRS Out.

The popular MS-1 is an exceptional preamp for its price, balanced with a cross-coupled output to drive long lines. It measures approximately 2"x5"x4" and has mounting flanges for installation in tight spots. XLR input and output.

DMS 22	60RNDMS22	MFR LIST	\$549.00
MS1	60RNM51	MFR LIST	\$199.00

CALL 1-800-732-7665 FOR BRADLEY PRICE

## APHEX TUBESSENCE THERMIONIC MIC PREAMP



The Model 107 has created a new market: the affordable tube mic preamp.

The solid state front end is transformerless, using the best capacitors. The tube circuit is a new invention which imparts the sonic characteristics of tubes without the high voltages, heat, fragility, and short life span of conventional tube circuitry. Apex dubbed it Tubessence, and it's notable for its presence, detail, openness, and image. Use the 107 in place of your console's preamps, or bypass the mixer and record direct to DAT.

The Model 107 provides two discrete preamps, each with its own controls. Switchable 48V phantom, front panel XLR's, 20dB pad, low cut filter, and switchable +4dBm or -10dBV output with 1/4" TRS phone jacks are provided.

Model 107	60AP107	MFR LIST	\$449.00
-----------	---------	----------	----------

CALL 1-800-732-7665 FOR BRADLEY PRICE

## AZDEN WIRED-TO-WIRELESS CONVERTER

Turn your favorite dynamic wired mic into wireless with the Azden 31XT. This sleek transmitter plugs into the XLR connector of your mic. The unit is powered by a single "AA" cell for ten hours of operation. Adjustable audio level handles a variety of mics. Azden matches it up with four great receivers so you can choose the configuration you want. It's available on 17 different VHF frequencies.

Bradley carries the whole Azden family of wireless products, including headset, handheld, and bodypack systems. Call us for an info packet. Each system shown includes a 31XT transmitter and the appropriate receiver. Optional rack kits are available.

211XT Non-diversity system	60AZ211XT	MFR LIST	\$405.00
111XT Non-diversity system (camera-mount receiver)	60AZ111XT	MFR LIST	\$505.00
311XT Diversity system	60AZ311XT	MFR LIST	\$485.00
221XT Two-channel system with two transmitters	60AZ221XT	MFR LIST	\$755.00

CALL 1-800-732-7665 FOR BRADLEY PRICE

## ATI MIC PREAMPS



The Ultimike is a small preamp that can mount near the audio source and has an unusually quiet, active balanced instrumentation type input stage. Switchable limiter and low-cut filter are built in. Gain is adjustable, and a front jack gives 15dB of gain trim from a remote location with a 10K pot. Features include a phase reversing switch, 48V phantom, and XLR connectors.

The M1000 is a dual preamp for one stereo or two mono mics and a transformer output. Drive a pair of 600-ohm outputs from 50 to 250 ohm impedance mics. It uses XLR connectors. Call us for pricing on rack kits and versions of the M1000 with balanced differential outputs, and/or 48V phantom power.

Ultimike M100	60AIM100	MFR LIST	\$349.00
M1000 transformer output	60AIM10001	MFR LIST	\$429.00

CALL 1-800-732-7665 FOR BRADLEY PRICE

See pages 80-81 for mic and audio processors.



## MIC PREAMPS AND WIRELESS

### SONY UHF SYNTHESIZED WIRELESS

Broadcast, sound reinforcement, Broadway... when you're handling critical wireless audio, ponder Sony UHF.

Synthesized control makes it easy to access up to 94 channels for virtually interference-free wireless operation. The space diversity system offers stable reception

at extended operating distances. Presets are programmed into each tuner for instant configuration of systems using up to 11 channels simultaneously.

Sony wireless keeps getting better. The new WRT-860A68 is a bodypack transmitter that's 1/3 smaller than the popular WRT-820A and adds detachable antenna, higher power, and battery life indicator. The new WRT-867A68 is a hand-held dynamic mic that runs on a single "AA" cell and produces great vocal audio even though it's smaller than other Sony handhelds.

Tuners are one rack space tall and include rack ears. Antennas are purchased separately. Call Bradley for the details and package pricing on these outstanding systems.



#### Tuners

WRR-820A Diversity Tuner	60SOWRR820A	MFR LIST	\$1,600.00
WRR-840A Dual Diversity Tuner	60SOWRR840A	MFR LIST	\$2,400.00
WRR-810A Portable Tuner with antenna (uses two "AA" cells)	60SOWRR810AXX	MFR LIST	\$1,325.00

#### Mics

WRT-810A Handheld Transmitter Mic	60SOWRT810AXX	MFR LIST	\$990.00
WRT-867A68 Handheld Transmitter Mic	60SOWRT867A68	MFR LIST	\$2,125.00
WRT-820A Bodypack Transmitter packages w/ lavalier mic	60SOWRT820AXX	MFR LIST	Call
WRT-860A68 Bodypack Transmitter packages w/ lavalier mic	60SOWRT860AXX	MFR LIST	Call

#### Antennas

AN-820A Antenna with built in amp	60SOAN820A	MFR LIST	\$183.00
WD-820A Antenna Distributor for using two antennas with up to four receivers	60SOWD820A	MFR LIST	\$1,450.00

CALL 1-800-732-7665 FOR BRADLEY PRICE

### STEWART POWER SUPPLIES

Deliver +48V to mics, direct boxes, any device needing phantom power. All versions include a PS-1 power supply, and you can combine models for up to 12 channels on one supply. Isolated outputs protect other equipment.

For field work, use the BPS-1 battery supply which uses two 9V's to produce +48V phantom power for a single mic. Belt clip and low-battery indicator included.

PM-1 one channel	60SEPM1	\$79.00
PM-2 two channel	60SEPM2	\$125.00
PM-4 four channel	60SEPM4	\$149.00
BPS-1 battery powered	60SEBPS1	\$95.00



### SHURE SC SERIES WIRELESS SYSTEMS



The SC Series VHF wireless lets you change frequencies on the spot so you can "dial away" from interference. Choose among eight frequencies (four in traveling models). A battery "fuel gauge" tells you how much life is left in the 9V battery.

Tone Key Squelch lets you power on or off without pops. Each receiver occupies a half-rack space; the hardware to mount one or two units is now included.

#### SC Series Diversity Bodypack Systems

Each includes indicated mic, transmitter, receiver, two 1/4 wave antennas, rack kit. Call for instrument plug-in and stage headworn versions.

SC14/83 with WL83A omni lav	60SHSC1483	MFR LIST	\$948.00
SC14/84 with WL84A uni lav	60SHSC1484	MFR LIST	\$996.00
SC14/93 with WL93 omni micro lav	60SHSC1493	MFR LIST	\$948.00
SC14/98 with WM98 instrument mic	60SHSC1498	MFR LIST	\$1,098.00
SC14/10 with WH10 headworn mic	60SHSC1410	MFR LIST	\$954.00

#### SC Series Diversity Handheld Systems

Each includes handheld transmitter with indicated mic element, receiver, two 1/4 wave antennas, rack kit, swivel adapter, and grip/switch cover.

SC24/58 with SM58 mic	60SHSC2458	MFR LIST	\$1068.00
SC24/87 with SM87 mic	60SHSC2487	MFR LIST	\$1,140.00
SC24/BETA58 with BETA 58 mic	60SHSC24B58	MFR LIST	\$1,164.00
SC24/BETA 87 with BETA 87 mic	60SHSC24B87	MFR LIST	\$1,212.00

#### Accessories:

Front Mount Antenna Kit	60SHWA503	MFR LIST	\$32.40
Heavy Duty Carrying Case	60SHWA525	MFR LIST	\$200.00

CALL 1-800-732-7665 FOR BRADLEY PRICE

Call us for non-diversity versions.



**TELEX VHF WIRELESS**



The new FMR-150 Pro series offers a diversity wireless that is frequency agile without sacrificing quality or range. Multi-crystal tuning allows the use of any three frequencies within a 3.5MHz band. The FMR-150 protects against interfering signals: it gives tone-squelch when the unit is off and an interference safeguard when it's on. Because it uses crystal control, the FMR-150 is 24dB quieter than most synthesized frequency-agile wireless. Up to 14 systems can operate at once.

The FMR-70 is a good choice when your budget is limited: an affordable, non-agile diversity system; up to 12 systems can operate at once. Like the FMR-150, this system is a half-rack design and uses a diversity circuit that keeps both antennas active.

Our packages include receiver, AC wall transformer, and two quarter-wave antennas. All mics are electret/condenser.

**FMR-150C Cardioid Lapel Mic System**, with WT-150 micropack transmitter and ELM-33S mini lapel mic.

60TXFMR150C MFR LIST \$940.00

**FMR-150L Omni Lapel Mic System**, with WT-150 micropack transmitter and ELM-22S mini lapel mic.

60TXFMR150L MFR LIST \$940.00

**FMR-150H Hand-Held Mic System**, with HT-150 hand-held transmitter with 65-ELE mic head.

60TXFMR150H MFR LIST \$975.00

**FMR-70C Cardioid Lapel Mic System**, with WT-55 belt-pack transmitter and WLM-60 lapel mic.

60TXFMR70C MFR LIST \$617.00

**FMR-70L Omni Lapel Mic System**, with WT-55 belt-pack transmitter and WLM-50 lapel mic.

60TXFMR70L MFR LIST \$617.00

**FMR-70H Hand-Held Mic System**, with HT-200/65 hand-held transmitter with 65-ELE mic head.

60TXFMR70H MFR LIST \$720.00

CALL 1-800-732-7665 FOR BRADLEY PRICE

**OTHER TELEX WIRELESS PRODUCTS**

The ENG-1 is an extra small, portable, single channel dockable VHF receiver with balanced output, headphone output, level and squelch controls, rubber antenna, removable belt clip, and more.

60TXENG1 MFR LIST \$295.00

The AD-200 is a wideband 150-234 MHz diversity antenna splitter/combiner with power supply for four FMR series receivers. Combines as many as eight antennas into two. Includes rack mount, (8) 2' cables for receivers, and (4) power hook-up cables. A UHF version is also available.

60TXAD200 MFR LIST \$515.00

**SHURE LX SERIES WIRELESS**

Built on the popular L Series, the new LX VHF wireless features 6dB quieter performance, detachable antennas, front-panel squelch, and rack hardware that can handle single or dual receiver setups. But it's still easy on your budget.

All bodypacks and transmitters have Shure's innovative battery "fuel gauge". Other features include mic/line level switch, 18-20 hour battery life, level meters for RF and audio, and in-line power supply instead of a "wall wart". The heart of LX is the LX4 MAR-CAD diversity receiver, really two radio receivers with exceptional audio and rejection of noise.

Handheld systems are available with a range of interchangeable Shure mic elements including premium BETA mics. Bodypack systems are available in several flavors of lavalier and instrument mics... even a headworn version for DJs and aerobics instructors.

The rack hardware can mount one or two receivers, with antennas in the rear. For front antennas, order the WA503 option, below. Also ask us about antenna splitters, antenna distribution for multiple systems, 1/2 wave antennas, and non-diversity systems.

**LX Series Diversity Bodypack Systems** Each includes indicated microphone, bodypack transmitter, receiver, two 1/4 wave antennas, rack kit. Call for instrument plug-in and stage headworn versions.

LX14/83 with WL83A omni lav	60SHLX1483	MFR LIST	\$750.00
LX14/84 with WL84A uni lav	60SHLX1484	MFR LIST	\$798.00
LX14/93 with WL93 omni microlav	60SHLX1493	MFR LIST	\$750.00
LX14/98 with WL98 instrument mic	60SHLX1498	MFR LIST	\$900.00
LX14/10 with WH10TQG headworn mic	60SHLX1410	MFR LIST	\$756.00

**LX Series Diversity Handheld Systems** Each includes handheld transmitter with indicated mic element, receiver, two 1/4 wave antennas, rack kit, swivel adapter, and grip/switch cover.

LX24/58 with SM58 mic	60SHLX2458	MFR LIST	\$852.00
LX24/87 with SM87 mic	60SHLX2487	MFR LIST	\$924.00
LX24/BETA58 with BETA 58 mic	60SHLX24B58	MFR LIST	\$948.00
LX24/BETA 87 with BETA 87 mic	60SHLX24B87	MFR LIST	\$1,002.00

Accessories:

Front Mount Antenna Kit	60SHWA503	MFR LIST	\$32.40
Heavy Duty Carrying Case	60SHWA525	MFR LIST	\$200.00

CALL 1-800-732-7665 FOR BRADLEY PRICE



**MICROPHONES**

## TASCAM DA-20 DAT RECORDER



Considering the jump to digital and worried about the cost? Looking for an affordable DAT option for a secondary studio? Tascam's new DA-20 may be your answer.

Record and play at all three major sampling frequencies (48, 44.1, and 32), including recording either analog or digital at 32kHz. It connects to the world with unbalanced RCA analog inputs and outputs as well as SPDIF digital I/O. SCMS copy protection can be switched off. The specs, as usual with Tascam, are impeccable. The DA-20 occupies three rack spaces and includes a wireless remote.

DA-20 60TEDA20 MFR LIST \$1,099.00

CALL 1-800-732-7665 FOR BRADLEY PRICE

## TASCAM DA-30MKII DAT RECORDER

Best Seller



Tascam updated its DA-30 last year and the result was a clear success. The MK II features a data/shuttle wheel, standard and long record modes, selectable copy ID provisions, and more. The shuttle wheel lets you find cuts fast, enter program numbers, and trim the ABS time display when setting Start or Skip ID positions.

Features include a parallel port for external control, digital I/O in both the AES/EBU (on XLR) and S/PDIF (coaxial) formats, start ID positioning, and +4dBm and -10dBV analog inputs and outputs. Recording is offered at 48kHz and 44.1kHz sampling frequencies. Ideal for audio track mastering.

DA-30MKII 60TEDA30 MFR LIST \$1,599.00

RCD-30 Wired Remote

60TERCD30 MFR LIST \$90.00

CALL 1-800-732-7665 FOR BRADLEY PRICE

## PANASONIC DAT RECORDING

Panasonic's family tree of DAT machines has a brand-new member, the exciting SV-3800. All three models described here provide analog inputs and outputs on balanced XLR, plus digital I/O in both the AES/EBU and S/PDIF formats. All come with rack kits and Panasonic's exceptional audio performance.

The new SV-3800 inherits the features of its predecessor, the widely-hailed SV-3700, and improves on them with new 20-bit resolution DAC's for the best possible playback. A single-play function plays one cut to the next start ID, then stops (ideal for broadcast and live sound). A front-panel switch lets you choose +4 or -10 operation; attenuation is adjustable. A front-panel display keeps track of drum hours. Multiple digital I/O facilities are provided for connecting to many kinds of gear. And the familiar shuttle wheel is here, plus a shuttle search function that finds your cut and cues up to it. Choose the SV-3800 with confidence.



The SV-3900: This model is configured for sophisticated remote control uses. Control up to 32 machines on an ES-bus LAN. The unit also accepts P2 protocols for single machine/controller combinations.



The optional SH-MK390 remote is for network management of single or multiple decks, allowing event automation, multiple DAT duplication, and assembly editing. RS-422 serial control is available for external computer or editor control.

The SV-4100 (not pictured): Shines in specialized applications. Features include external sync for video post and stereo submix recording, Quick Start memory adjustable with one-frame resolution, synchronized frame-accurate editing, four locate points, and more.

SV-3800	60PASV3800	MFR LIST	\$1,695.00
SV-3900	60PASV3900	MFR LIST	\$2,895.00
SV-4100	60PASV4100	MFR LIST	\$2,950.00
RC410 wired Remote Control for 3800	60PARC410	MFR LIST	\$315.00
SH-MK390 Remote Control for 3900	60PAMK390	MFR LIST	\$495.00

CALL 1-800-732-7665 FOR BRADLEY PRICE

## SONY DTC-790 DAT RECORDER

One of the best values in DAT, anywhere. This model now has a better, quick-load mechanism and a center-mounted transport for reduced vibration. High speed search, automatic track renumbering, fast



and slow audible cue, and auto rewind are standard. Inputs are RCA analog plus optical and coaxial digital. Outputs are analog and optical. A wireless remote and SCMS copy management are included. Need a coaxial digital output? See the DTC-A7 on page 41.

DTC-790 6050DTC790 MFR LIST \$899.95

CALL 1-800-732-7665 FOR BRADLEY PRICE

# Think Twice



Before you buy any other DAT recorder.

**The DA-302 Dual DAT Recorder** doesn't just double your DAT power, it actually multiplies it! Think of the possibilities! Available for the first time – high speed DAT dubs. Dubs that even copy time code. And functions impossible from two single units – like two masters at a pass, and independent or continuous operation for up to 8 hours of record/play power. With TASCAM's Append Dubbing function you can start dubs at any location on the master. Of course it's got dual S/PDIF connections for digital transfers and archiving, plus output selection in either S/PDIF or AES/EBU. To expand its capabilities, there's the optional LA-D302 balanced analog I/O kit and the WR-7000 to interconnect multiple DA-302's. Twice the power. Twice the speed. Twice the value!



60TEDA302

MFR LIST: \$1,999.00

CALL 1-800-732-7665 FOR BRADLEY PRICE

# TASCAM

# 1000 CARTS IN ONE HOT LITTLE BOX

360 Systems INSTANT REPLAY®



Just press a Hot Key  
and get the sound  
you want.

Up to 16 hours  
of true stereo inside.  
Completely  
self contained, no PC!

RECORD, PLAY and ORGANIZE ...  
**INSTANTLY.**

**Test Drive It  
(818) 991-0360**

You're only 24 hours away  
from a free 10-day Test Drive.  
So try it out. We'll understand  
if you don't give it back.

**Drive it Hard**



*360 Systems*

PROFESSIONAL DIGITAL AUDIO

Voice (818) 991.0360 Fax (818) 991.1360 web: 360systems.com, e-mail: sales@360systems.com

**SONY DTC-A8 DAT RECORDER**

The DTC-A8 is an affordable, high quality choice in a DAT machine. It gives you the power of Sony Super Bit Mapping for clearer recordings. The combo of SBM and full 44.1kHz capability make this a good choice for affordable CD mastering. Analog ins and outs are on both RCA and 1/4" connectors. The unit will locate to a program number from the front panel. It will accept an optional foot control. Also of note: The deck uses Sony's new, four-motor direct drive design for better tape stability.



This unit is rackable and incorporate SCMS; a head cleaning roller is built in.

DTC-A8	6050DTCa8	MFR LIST	\$1,475.00
Foot Control for A8	6050FSA8	MFR LIST	\$50.00

CALL 1-800-732-7665 FOR BRADLEY PRICE

**SONY PCM-R500 DAT RECORDER**

With Sony's surprisingly affordable PCM-R500, you can switch in Super Bit Mapping. Signals with an apparent resolution of greater than 16 bits (the product of today's high-bit A/D's) can be recorded on a standard tape. This single-ended noise shaping system can transfer a 20-bit signal to a 16-bit medium without just "chopping off" four bits. The result: your recordings are smoother and clearer, especially at low levels, no matter what machine you play them on. A shuttle/jog wheel is provided for easy system operation of fast forward/rewind and AMS/program number selection.



The PCM-R500 has a robust four motor transport, analog I/O on balanced XLR connectors (adjustable from -12 to +4), digital I/O on both AES/EBU and S/PDIF, and no SCMS to worry about. A digital meter keeps track of head time. A rack kit and wireless remote are supplied; the unit also provides an 8-pin parallel connector for fader start and other control.

PCM-R500	6050PCMR500	MFR LIST	\$1,750.00
----------	-------------	----------	------------

CALL 1-800-732-7665 FOR BRADLEY PRICE

**FORGET OPEN REEL LOGGING**

Record up to 500 hours of your audio on one data-grade DAT tape. Use Eventide's loggers to capture your air signal, phone calls, the competition, just about anything. The VR-204 is a four-channel logger that lets you search your tapes by time, date, or channel. Units are rackable and include a speaker and headphone jack. The recorder can capture audio even while you're playing another tape back.



Normal response is up to 3400Hz. If you need more bandwidth (for delayed broadcast or "Best Of" shows, for example), ask us about the VR240 models, which accommodate up to 24 channels, and their high fidelity option.

VR-204 Record/Play Logger	60EVR204	MFR LIST	\$7,495.00
VP-204 Play Only	60EWP204	MFR LIST	\$6,495.00

CALL 1-800-732-7665 FOR BRADLEY PRICE

**HENRY DIGITAL RECORDER**

Capture network feeds for delayed playback; put one at your translator site for station ID's. Record weather alerts or request-line calls; program "talking signs." DigiCord can hold 16 messages for play in any order without re-cue time (eight are accessible from a front panel switch; all 16 from the remote connector). Features include single or

repeat modes and EOM output to start next event. Other features include battery backup to prevent memory loss, and the ability to record from mic or line.

DigiCord, 5kHz, 5:25 min.	60HEDC	\$595.00
DigiCord, 8kHz, 2:40 min.	60HEDC8	\$595.00



**360 SYSTEMS INSTANT REPLAY HARD DISK SYSTEM**

Listen up, radio stations, stadium scoreboard operators, theater sound technicians, TV audio engineers... this is what you've been asking for: powerful audio storage with instant access. Instant Replay is a digital recorder with the hard disk built in, and is available in 8, 16 and 24 hour versions.

It stores up to 1,000 cuts, long or short, and lets you assign 500 at a time to 10 "banks" of 50 buttons. Jingles, effects, songs, commercials, any audio is at your fingertips.

To play a cut, just push its button. Audio starts instantly. Or create a playlist from the 50 hot keys, and set the list to play through or to cue up after each cut.

The display shows cut name, duration, bank number, and hot key number. The imbedded keyboard lets you name your cuts. Finding cuts is easy with the FIND command. A printer port lets you create copies of your cut or bank lists.

Features include 16 bit stereo audio, +4dBm analog I/O, and AES/EBU and S/PDIF digital I/O. A new GPI port allows remote start. Use the built-in D-NET to transfer audio at high speed to other Instant Replays or DigiCart/IT's.

Instant Replay, 8 hours	60HIR8	MFR LIST \$2,995.00
Instant Replay, 16 hours	60HIR16	MFR LIST \$3,495.00
Instant Replay, 24 hours	60HIR24	MFR LIST \$3,795.00

CALL 1-800-732-7665 FOR BRADLEY PRICE



# MINIDISC MACHINES

## 360 SYSTEMS SHORTCUT PERSONAL AUDIO EDITOR

Designed to replace reel-to-reel tape machines for fast editing of single or dual channel audio, the Shortcut offers digital and analog I/O, 16 bit linear



uncompressed audio, one-touch instant recording, and non-linear editing with random access. Two models are available, 1.5 and 3 hour capacity, with the same feature set.

Designed for easy, intuitive operation, the Shortcut includes built-in speakers and selectable mic/line inputs. A large scrub wheel provides outstanding simulation of tape reel rocking, and is surrounded by large buttons which perform the major functions CUT, COPY, INSERT and ERASE. The front panel also features familiar tape transport controls, a qwerty keyboard for cut location and titling, and HOT KEYS for instant access to predetermined audio segments.

Shortcut is ideal for acquiring and quickly editing voice cuts. It is indispensable for news and call-in shows where speed and accuracy is essential. Operates on 90-250 volts, 50/60hz. for worldwide operation. No battery option is available.

60THSC1801	Shortcut 1.5 hour editor	MFR LIST	\$2,995.00
60THSC1802	Shortcut 3 hour editor	MFR LIST	\$3,495.00
60THSC1803	Shortcut 4 hour editor	MFR LIST	\$3,895.00

CALL 1-800-732-7665 FOR BRADLEY PRICE

## TASCAM MD-801 MINIDISCS



Tascam joins the MD fray with the MD-801, designed for broadcast, industrial production, and conference use. We like it because you can title your MD cuts with a standard PC keyboard. Features include rack mount, +4/-10 inputs and outputs, repeat playback, "jog" dial for editing in fine increments, RS-232 port, and a PC-2 connection for a computer keyboard for titling and cut location. If you record in mono, you double your disc capacity (up to 148 minutes).

Choose between record/play and play-only models. Connections are balanced XLR, unbalanced RCA, AES/EBU, and S/PDIF. SCMS is selectable. An optional RAM buffer allows instant start.

MD-801R Recorder/player	60TEND801R	MFR LIST	\$2,499.00
MD-801P Player	60TEND801P	MFR LIST	\$2,399.00
BU-801 RAM Buffer	60TEBU801	MFR LIST	\$249.00

CALL 1-800-732-7665 FOR BRADLEY PRICE

## DENON MINIDISC FAMILY

Like DAT before it, MiniDisc is now far more popular among professional users than with the general consumer. The pros love the easy digital recording and fast playback access.

### CART STYLE

The DN-990R recorder/player has a look that any broadcaster will find inviting. Rotary selector knob for titles and functions. Instant start. End monitor: hear the end of any cut at the touch of a button. Digital and balanced-analog I/O on XLR connectors. Serial and parallel control ports.

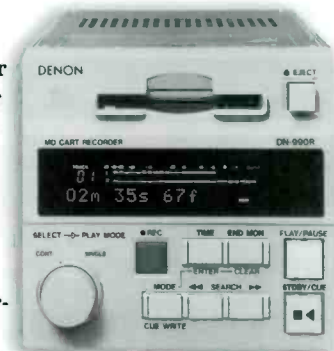

The DN-995R recorder/player adds switchable serial protocol, word clock in and out, time/date stamp, faster cue up, and Windows software for control and digital dubbing (without losing out info). The new DN-981F player has Hot Start memory for instant access to 10 tracks of your choice when you assign them to buttons on the included Windows software.

### STUDIO STYLE



The DN-1100R is an MD recorder with 10 independent Hot Start buttons to which any 10 tracks can be assigned. Designed with theaters and public address in mind, Hot Start is also in demand by DJs and broadcasters for live and post work. Many of the same powerful features of the cart-style Denon machines are included. Call us for details.

### DUPLICATING



Use the new DN-045R to create complete copies of your MiniDiscs. The digital dubbing circuit bypasses the ATRAC compression for the best possible dub. Dubbing occurs at up to 3.5 times normal speed. Windows software, provided, allows editing during replication.

DN-990R Recorder/Player	60DEDN990R	MFR LIST	\$2,800.00
DN-995R Recorder/Player	60DEDN995R	MFR LIST	\$3,800.00
DN-981F Player w/Hot Start	60DEDN981F	MFR LIST	\$2,300.00
DN-1100R Recorder/Player	60DEDN1100R	MFR LIST	\$2,600.00
DN-045R Replicator	60DEDN045R	MFR LIST	\$4,200.00

CALL 1-800-732-7665 FOR BRADLEY PRICE

# RECORDING AND PLAYBACK



## SONY MDS-B5 MINI-DISC RECORDER

The latest generation Sony MD recorder incorporates Direct Duplication Link, which enables high speed copying of the compressed signal on a MiniDisc, avoiding generation loss. This feature is also useful for eliminating fragmentation on heavily edited discs. Multi-access hot start of up to 10 tracks is provided via the supplied remote control, or via IBM® keyboard or parallel remote port. RAM-TOC edit lets you decide whether or not to save your edited recording to a master disc. You can also perform temporary editing of a pre-mastered disc. Monaural recording option allows up to 148 minutes on a disc. A ±12.5% vari-speed control is incorporated, along with next-track selection for playback while listening to the current selection. You may assemble seamless loops, move cuts, or divide and recombine audio with ease. Connectors: S/PDIF digital I/O, and analog +4dBm inputs on XLR.



60S0MDSB5 MFR LIST \$3,295.00  
60S0MDSB6P MFR LIST \$2,300.00

CALL 1-800-732-7665 FOR BRADLEY PRICE

## 360 SYSTEMS DIGICART/II HARD DISK SYSTEM

"Like Fort Knox, with an ATM." If storing and retrieving audio is in your job description, consider DigiCart/II. It's a treasury of accessible audio; a cart machine, a mini-workstation, a hard disk recorder in one package.

DigiCart/II offers access to 10,000 cuts with just a few key-strokes. Make a selection, hit play, and audio is rolling immediately. While one cut plays, cue up the next.

Back to back cuts are seamless, so one machine can replace multiple audio sources. Playback choices include programmed playlists, which can be simple strings of cuts or sophisticated groupings of linear or rotating stacks.

DigiCart/II stores up to 48 hours of stereo audio internally, and now features industry-standard Zip drives for removable media. An upgrade path is available for those who wish to convert their Bernoulli drives to Zip drives.

DigiCart/II provides AES/EBU, AES/SMPTE 75 ohm, and S/PDIF digital I/O ports, as well as balanced analog I/O. It creates 16-bit recordings, either in linear mode or with Dolby AC-2 data reduction for extended recording time. Digital editing of heads, tails, fades, and gain is non-destructive and subframe accurate.

Optional D-NET lets you transfer audio at high speed to other DigiCart/II's or Instant Replays. Comprehensive GPI and serial control interfaces let many broadcast automation systems "talk" to DigiCart/II. Also available: Added storage of up to 80 hours with the companion Hard Disk System.

2710 DigiCart/II With 8 hour, 1-GB hard disk 60TH2710 MFR LIST \$3,995.00  
2720 DigiCart/II With 16 hour, 2-GB hard disk 60TH2720 MFR LIST \$4,395.00  
2730 DigiCart/II With 24 hour 3-GB hard disk 60TH2730 MFR LIST \$4,695.00

CALL 1-800-732-7665 FOR BRADLEY PRICE

## MINIDISC ON A BUDGET



Many customers tell us they would like to use MiniDisc for digital audio recording and playback, but their budget won't let them.

Good news: Sony's MDS-JE510 is priced in the hundreds, not thousands, and includes all the standard MD functions: track naming, divide, combine, move, and erase, including "all track" erase. A jog dial controls editing and titling. You can set the recording level of the analog input. Analog and optical digital I/O are provided, as is a wireless remote.

MDS-JE510 60S0MDSJE510 MFR LIST \$360.00  
CALL 1-800-732-7665 FOR BRADLEY PRICE

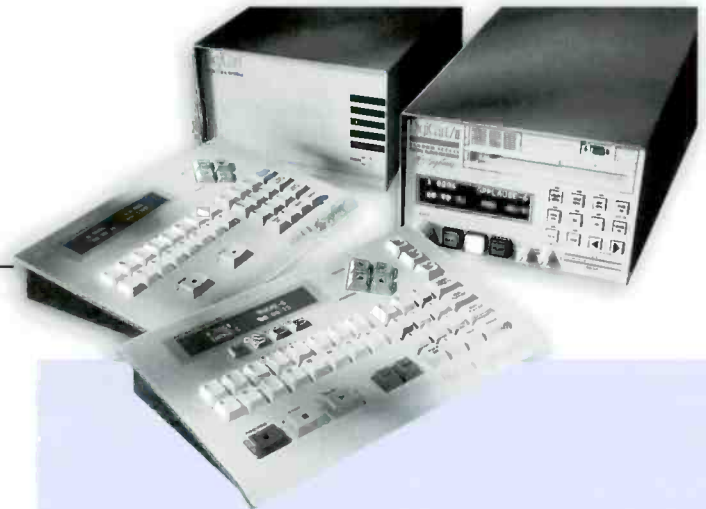

### Accessories

D-NET File Transfer Network, allowing high speed transfer to another DigiCart/II or Instant Replay. Order one per DigiCart/II.

D-NET 60THDNET MFR LIST \$300.00

"On Screen II" is a Windows program that controls up to three DigiCart/II's and helps you print lists of cuts, stacks, and directories. "PC Hot-Keys" is a program that provides access to multiple banks of 50 audio cuts and includes the printing software.

On Screen II 60THONSC2 MFR LIST \$795.00  
PC Hot Keys 60THPCHK2 MFR LIST \$595.00

The RC-220 Remote duplicates the machine's front panel and includes 16 presets for instant playback and a keypad for rapid cut selection. Controls up to four machines. The RC-205 Mini-keyboard Remote is useful for titling directories and files. It maps up to 100 cuts to "hot keys." Both are useful in production. The RC-210 Remote is a simplified control panel, designed for on-air playback.

RC-220 60THRC220 MFR LIST \$745.00  
RC-205 60THRC205 MFR LIST \$130.00  
RC-210 60THRC210 MFR LIST \$595.00

CALL 1-800-732-7665 FOR BRADLEY PRICE

## THE SOFTWARE REVOLUTION

### DIGITAL AUDIO LABS FAST EDDIT

Record voice, music, or any other sound you would normally record on a tape recorder. Then edit your recordings! Rearrange the sounds, change the volume, or mix two sounds together- it's like word processing, but for sound!

Fast EdDIT's Waveform display editor lets you see soundfiles and play them back quickly and easily. Simply tell your PC the name of the soundfile to play, and the name will appear in a button on the screen. Then, any time you click on the button, the soundfile will play. You can also trigger catalog sounds with keys on the computer keyboard, or with MIDI (requires a Windows compatible MIDI card for external MIDI sources). With the playlist editor, you simply make a list, hit the play button, and play back the sounds for quick, precise editing. Features include :

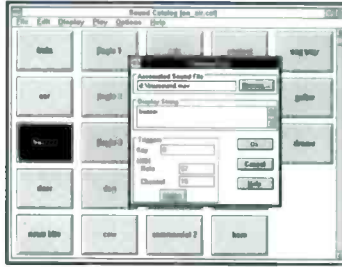

- Ultra-fast cut-and-paste editing
- Overlays
- Custom fades and crossfades
- Multiple undos
- Bass & Treble EQ
- Sample reversal
- Gearshift™
- Drop markers during play & record
- Zoom in/zoom out
- Gain change
- Normalize
- On-line help is always available

Fast EdDit 60DAFEDIT MFR LIST \$199.00 CALL 1-800-732-7665 FOR BRADLEY PRICE

**Package 9713: We bundle the Fast EdDit and CardD Plus sound card. Call.**

### DART AUDIO RESTORATION (FOR PC'S)

Remove clicks, pops, and other evil noises from any audio file. With DART and a 16-bit Windows sound card like the CardD, you can record tapes, records, or other archived audio and remove the noise that comes with age and overuse (and leave the root file intact). DART lets you list your various revisions using different levels of noise reduction, so you can compare and pick the best. Interested? Call us for details.

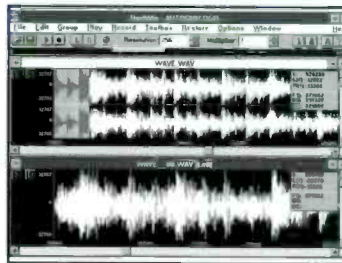

DART 60DTDART MFR LIST \$399.00  
CALL 1-800-732-7665 FOR BRADLEY PRICE

**Package 9715: We bundle the DART and CardD sound card. Call**

### SESSION SOFTWARE 2.0 (FOR MACINTOSH)

This is Digidesign digital multitrack recording, editing, and mixing software for your Mac. It's intended for music recording, multimedia authoring, or teaching on all those schoolroom desktops. This new software provides two-channel recording of 16-bit, 44.1 or 48kHz audio, with 4-16 tracks of playback depending on your computer.

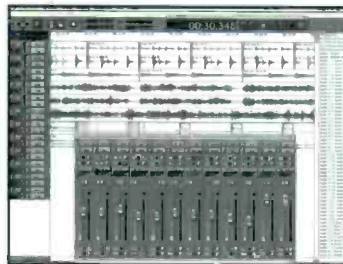

Features include digital parametric EQ, auto punch-in and -out, non-destructive recording, cut/copy/paste, drag-and-drop to assemble track playlists, unlimited digital track bouncing, edit to time (or beats, or SMPTE, or feet and frames), synch with QuickTime, and much more. A Windows version is planned at press time.

Power Mac users, just plug it in and go. Quadra and Mac IICI users, order the companion Audiomedia II sound card, which also includes the popular two-track Sound Designer II software.

Session Software 2.0 60DDMS110 MFR LIST \$199.00  
Audiomedia II sound card 60DDMM005 MFR LIST \$1,295.00

CALL 1-800-732-7665 FOR BRADLEY PRICE

## SOUND CARDS

### THE CARDD PLUS (FOR PC'S)

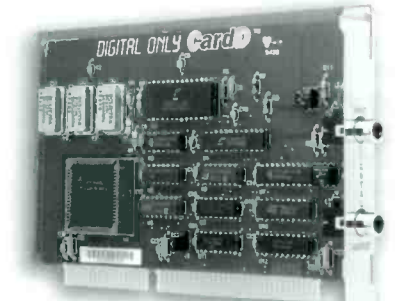

You need a quality sound card to get the most out of digital editing software. The CardD Plus plugs into your PC and provides professional digital audio with simultaneous record and play, selectable sampling rates of 48, 44.1, 32, and 22.05kHz, and real-time audio transfer. Connections are on RCA jacks, with levels selectable by jumper among +4, -10, and consumer. For direct digital I/O capability in the S/PDIF format, add the i/o CardD, which works with the driver in the CardD Plus, or the stand-alone Digital Only CardD, which has its own Windows driver. These cards are compatible with Windows 95 and Windows NT.

CardD Plus 60DATC01 MFR LIST \$795.00  
i/o CardD 60DAIO01 MFR LIST \$295.00  
Digital Only CardD 60DAD001 MFR LIST \$495.00

CALL 1-800-732-7665 FOR BRADLEY PRICE

### ADB MULTI!WAV

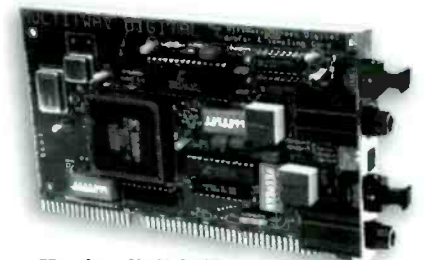

Here's a digital I/O sound card for Windows that handles AES/EBU format as well as S/PDIF. Compatible with SAW and other editing programs. Other important features: real-time digital format conversion, optical as well as coaxial S/PDIF, software-upgradable hardware design (for features such as 24-bit audio), and more.

Multi!WavPro-18 62ABMWPRO MFR LIST \$699.00

CALL 1-800-732-7665 FOR BRADLEY PRICE

## RECORDING AND PLAYBACK

**ROLAND DM-800  
DIGITAL AUDIO WORKSTATION**

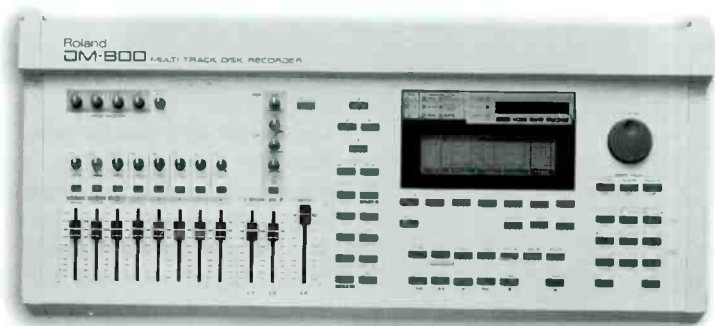

It looks more like a mixer than a DAW, but Roland's DM-800 is deceptive. It's a multitrack disk recorder well-suited to radio production, post work, and music recording.

In a studio setting, plug in any video monitor or even a regular TV set, to see your work. Or take it with you: it weighs only 13 pounds, and it has its own small LCD display so you don't even need a monitor.

Descended from Roland's successful DM-80, the 800 performs all digital mixing operations, including audio recording, EQ, editing, track bouncing, and final mixdown.

The DM-800 has eight digital/analog outputs, six inputs, time compression modes, pitch correction, scrub preview, and 300 virtual tracks. It supports SMPTE and MIDI time codes and has its own Sample Rate Resolver to lock to any time code. Autolocator buttons access 40 marker locations.

Analog I/O is balanced +4dBm on 1/4" jacks; digital I/O is S/PDIF coax. The most popular configuration, shown below, includes two 500-MB drives and provides up to 200 track minutes storage; you can add external drives for up to 24 track hours. Ask about interfaces to ADAT, DA-88, and RS-422.

Consider the cost of competing workstations, then look at the DM-800's price tag. Then give us a call.

<b>DM-800</b>	<b>60RADM800HD</b>	<b>MFR LIST</b>	<b>\$7,595.00</b>
<b>Hard Travel Case</b>	<b>60RADM800TC</b>	<b>MFR LIST</b>	<b>\$100.00</b>
<b>Rollaround Stand</b>	<b>60RADM800RS</b>	<b>MFR LIST</b>	<b>\$120.00</b>

**CALL 1-800-732-7665 FOR BRADLEY PRICE**

**SONIC FOUNDRY**

Sound Forge 4.0 sets the standard for sound editing software on the Windows platform. Providing unparalleled cross platform file format and audio compression support, Sound Forge can be used alone, or as an addition to a multi-track program.

This stereo, professional quality audio editor abounds with processes, effects, and tools, including EQ, compression, Pan/Expand, Time compression/expansion, delay/echo, noise gate, and many more. Sound Forge 4.0 will open AVI files directly to synchronize sound and video with sub-frame accuracy. It can generate, listen to, and be triggered by MIDI/SMPTE time code during both recording and playback.

In addition to the powerful editing program, several "plug-in" programs are available to enhance your recording capabilities. Included in this group are a noise reduction plug in with vinyl restoration and hiss/hum/rumble/click removal capability. The batch converter plug-in allows easy conversion of hundreds or thousands of files, including batching of any process or effect in Sound Forge. Also available are spectrum analysis, and Waves™ and Q-Sound™ Plug ins, to use these popular audio effects systems with Sound Forge.

Each Sonic Foundry product ships with native versions for Windows 95, Windows NT, and Windows 3.1 on a single CD-ROM. Waves WaveShell and AudioTrack plug ins are only available for Windows 95 or Windows NT.

<b>Sound Forge 4.0</b>	<b>MFR LIST</b>	<b>\$495.00</b>
<b>Plug-Ins:</b>		
<b>Noise Reduction</b>	<b>MFR LIST</b>	<b>\$249.00</b>
<b>Batch Converter</b>	<b>MFR LIST</b>	<b>\$199.00</b>
<b>Spectrum Analysis</b>	<b>MFR LIST</b>	<b>\$149.00</b>
<b>Q-Sound</b>	<b>MFR LIST</b>	<b>\$195.00</b>
<b>Waves</b>	<b>Call for availability</b>	

**CALL 1-800-732-7665 FOR BRADLEY PRICE**

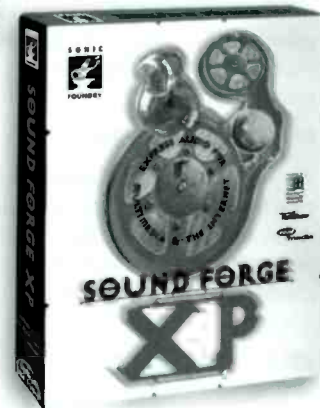
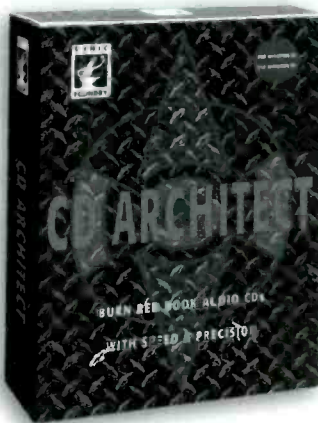
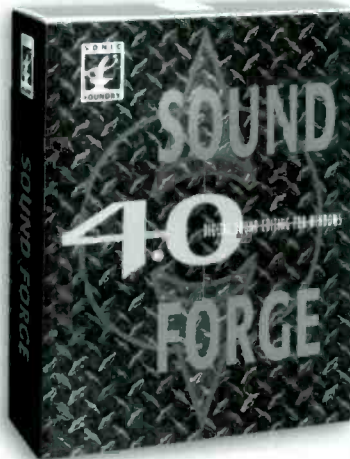

## TASCAM DA-88 DIGITAL MULTITRACK RECORDER

The Tascam DA-88 uses a standard Hi-8 cassette to give 1 hour 48 minutes of stunning digital audio on eight tracks.



The unit's controls, transport jog wheel, and single button punch-in are unintimidating for anyone who knows multitrack. The DA-88's numeric display shows absolute time, memo times, pitch change, SMPTE Time Code and Offset.

Useful features include on the fly arming and front panel controls for cross-fades and track delay. Up to 16 units can lock together for a total of 128 tracks.

The optional remote control can handle six DA-88 transports. With the optional SY-88 Synch Board, the DA-88 will act as either SMPTE Master or Slave and provides video sync, RS-422, and MIDI Machine Control protocols. The DA38 is a lower priced version, without SMPTE.

DA-88	60TEDA88	MFR LIST	\$4,799.00
DA-38	60TEDA38	MFR LIST	\$3,499.00

### Accessories:

RC-848 Multi-Machine Remote Control	60TERC848	MFR LIST	\$1,599.00
RC-808 Single Machine Remote Control	60TERC808	MFR LIST	\$225.00
MU-8824 24-Channel Meter Bridge	61TEMU8824	MFR LIST	\$999.00
SY-88 Sync Board	60TESY88	MFR LIST	\$849.00
PW-885 Sync Cable (three feet)	61TEPW885	MFR LIST	\$90.00

CALL 1-800-732-7665 FOR BRADLEY PRICE

## BRADLEY DIGITAL RECORDING TOOLS

**Spectral Translator Plus** enables 8-channel digital audio transfers between any of several digital formats including AES/EBU (4 pairs). Make digital dubs between Alesis ADAT, Tascam DA-88, Fostex RD-8, Sony PCM-800, or Yamaha DRU8, and monitor the transfers live.

60SPTPLUS	MFR LIST	\$1,495.00
-----------	----------	------------

**Symetrix 488 DYNA-Squeeze** If you record digital audio hot, you risk fatal clipping; if you record too low, you waste bits and risk noise and distortion. The eight-channel 488 squeezes your tracks toward the upper end of the recorder's dynamic range, giving recordings the feel of analog while preserving the clarity of digital.

60SY488	MFR LIST	\$579.00
---------	----------	----------

**Symetrix 620** is an outboard 20-bit A/D converter with selectable dither and noise shape, for a reduction in distortion and increased resolution of low level signals in your 16-bit projects. Great for mixing to DAT or mastering CD's.

60SY620	MFR LIST	\$995.00
---------	----------	----------

CALL 1-800-732-7665 FOR BRADLEY PRICE

## MARANTZ CDR-620 AND CDR-615 COMPACT DISC RECORDERS

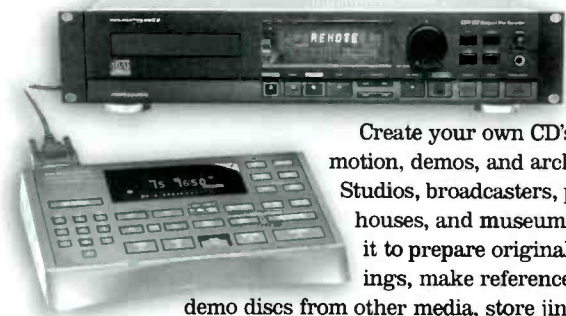

Create your own CD's for promotion, demos, and archiving. Studios, broadcasters, production houses, and museums will use it to prepare original recordings, make reference and demo discs from other media, store jingles and sound bites, and restore older recordings.

The CDR-620 is a write-once recorder with one-bit digital converters, sample rate converting, auto track incrementing and indexing from CD, DAT, DCC, and MD. The SCSI-II interface allows integration into a digital audio workstation system or PC.

The recorder allows you to stop your work and resume it later. Digital I/O includes AES/EBU and SPDIF formats, balanced +4/-10 analog XLR in and +4 out. The wired remote gives full status and control, copy prohibit on/off, and emphasis on/off.

The CDR-615 is a more economical version of the CDR620. It does not have SCSI-II port capability, 2x speed recording, or AES/EBU inputs/outputs. The RC-620 remote is an option for the CDR-615 that allows index recording and playing, defeatable copy prohibit, defeatable emphasis, and other features not addressable from the main unit.

CDR-620	60MRCDR620	MFR LIST	\$3,600.00
CDR-615	60MRCDR615	MFR LIST	\$2,700.00
RC-620	60MRR620CDR	MFR LIST	\$300.00

CALL 1-800-732-7665 FOR BRADLEY PRICE



## ALESIS ADAT XT DIGITAL AUDIO RECORDER

With a staggering number of ADATs in the field, Alesis has received lots of ideas for improving an already winning digital multitrack recorder. The result is ADAT XT.



The transport on this new version of ADAT is four times faster and is under constant software control for faster search and lock. The speed of XT alone will make many ADAT fans happier. Digital editing includes track copy, track delay, auto punch, tape offset, 10-point autolocator, and rehearse mode. Quality is remarkable thanks to 18-bit, 128x oversampling A/D's and 20-bit, 8x oversampling D/A's. It's all compatible with existing ADAT machines and tapes.

Not familiar with ADAT? This format uses S-VHS tapes to record more than an hour of CD-quality audio onto eight tracks. You can link machines to obtain 16 to 128 tracks.

Unbalanced -10dBV 1/4" jacks and balanced +4dBm multi-pin ins and outs are standard. The optional BRC commands up to 128 tracks with locate points, SMPTE/MIDI synch, and more.

ADAT XT occupies three rack spaces.

<b>ADAT XT</b>	<b>60AEADATXT</b>	<b>MFR LIST</b>	<b>\$3,499.00</b>
<b>Accessories:</b>			
AI-1 AES/EBU and S/PDIF Digital Interface/SRC	60AEAI1	MFR LIST	\$899.00
AI-2 Audio/Video Synchronization Interface	60AEAI2	MFR LIST	\$1,299.00
BRC Master Remote Control	60AEBRC	MFR LIST	\$1,499.00
Harness to (8) XLR-M & (8) XLR-F, 4 meter	61HOADX16413		\$159.00
Harness to (16) stereo 1/4" phone, 4 meter	61HOADP16413		\$149.00

CALL 1-800-732-7665 FOR BRADLEY PRICE

**READY TO RIP**  
**Special: We package the fine Technics RS-TR575 dual cassette deck, below, with Excalibur's IHF-to-PRO interface amplifier IA-1 and a Middle Atlantic rack shelf. Value: \$498.00**  
**Package 9716 \$419.00**

## TECHNICS CASSETTE FAMILY

Unlike many dual cassette decks in this price range, the RS-TR575 records in both wells. It allows sequential or simultaneous parallel recording from the same source. You get a dual tape counter, 2X FF/REW speed, motor-driven well doors, and auto tape calibration for fidelity on any brand tape. Play in series for 24 hours. Other features include Dolby B&C noise reduction and Dolby HX-Pro headroom extension. Connectors are -10dBV on RCA phono jacks.

Also available: The RS-TR272 double auto-reverse deck records in one well. It has an electronic counter, series play, balance control, and Dolby B&C and HX-Pro.

The RS-BX501 is a single-well auto-reverse machine with Dolby B&C, HX-Pro, and auto tape calibration.

## TASCAM PROFESSIONAL CASSETTE MACHINES



Bradley offers many choices in audio cassette decks. For the



most critical audio recording we recommend this trio. They are rackable recorders with Dolby B and C noise reduction and Dolby HX Pro for extra headroom. Features include ±12% pitch, three locate markers, 25-pin parallel port, and separate left and right input controls. Signal-to-noise is 78dB using Dolby C, and metal tape response is at least 25Hz to 19kHz.

**122 MKIII:** A three-head cassette deck, well-suited for on-air use. Bias and level calibrations are on the front panel. Input level controls are gear/clutch coupled. The head system features Cobalt Amorphous heads with independent azimuth adjustment. Connectors are balanced (+4 dBm XLR) and unbalanced (-10 dBV, RCA on rear and 1/4" on front).

**112 MKII:** For Tascam pro performance in an economical machine, order the 112 MKII, a two-head deck with unbalanced connectors (-10 dBV, RCA on rear and 1/4" on front). A balancing kit with XLR connectors is optional.

**112R MKII:** (pictured) Choose this auto-reverse, three-head deck when you need extended recording and playback time. The head rotates 180 degrees for accurate playback alignment of both sides of the tape. The 112R MKII has unbalanced connectors like the 112 MKII.

**BONUS!** Get 5 free TDK SA60 cassettes with each purchase of a Tascam Cassette machine.

122 MKIII	60TE122MKIII	MFR LIST	\$1,349.00
112 MKII	60TE112MKII	MFR LIST	\$849.00
112R MKII	60TE112RMKII	MFR LIST	\$1,149.00

CALL 1-800-732-7665 FOR BRADLEY PRICE

**Accessories:**

LA-112 Balancing Kit (for 112 MKII & 112R MKII)	60TELA112	MFR LIST	\$100.00
RC-112R Remote Control (for 112R MKII)	61TERC112R	MFR LIST	\$265.00
RC-134 Remote Control (for 122 MKIII & 112 MKII)	61TERC134	MFR LIST	\$250.00



RS-TR575	60TCRSTR575	MFR LIST	\$269.95
RS-TR272	60TCRSTR272	MFR LIST	\$199.00
RS-BX501	60TCRSBX501	MFR LIST	\$239.95

CALL 1-800-732-7665 FOR BRADLEY PRICE



# CASSETTE MACHINES

## TASCAM DUAL CASSETTE MACHINES



The Tascam 202 MKIII has two auto-reversing wells with simultaneous record on both, and continuous playback capabilities. Built for studio use, the 202 MKIII is enhanced by twice speed dubbing and a headphone jack. This model has one set of line I/O connectors plus front-panel mic inputs.



The exciting Tascam 302 is two independent cassette decks in one chassis. Each is capable of independent recording with its own set of line inputs and outputs, controls, noise reduction, and meters. It too has high speed dubbing and continuous record/play between the wells. Extra features include pitch control, Cascade output (for multiple units in a duplication system), and Control I/O (for continuous recording and playback on multiple machines).

Both models rack mount and include Dolby B, C, & HX-Pro. Synchro Reverse makes two-sided tapes when one is longer than the other. Machines are high impedance, low level, unbalanced on inputs and outputs.

202 MKIII	60TE202MKIII	MFR LIST	\$529.00
302	60TE302	MFR LIST	\$699.00
<b>Accessories:</b>			
RC-302 Wired Remote for 302			
	60TERC302	MFR LIST	\$65.00
WR-7000 Two Machine Synchro Cable for 302			
	60TEWR7000	MFR LIST	\$15.00

CALL 1-800-732-7665 FOR BRADLEY PRICES

## DENON CASSETTE FAMILY

DN-790R Single Well • Three heads • Dolby S Noise Reduction • Dolby B&C and HX-Pro • ±12% pitch control • XLR balanced and RCA unbalanced I/O • Rack mount included

DN-790R	60DEDN790R	MFR LIST	\$1,000.00
---------	------------	----------	------------

DN-720R Single Well • Dolby B&C and HX-Pro • ±12% pitch control • RCA unbalanced I/O • Rack mount included

DN-720R	60DEDN720R	MFR LIST	\$500.00
---------	------------	----------	----------

DN-770R Dual Well with Auto Reverse • Play two cassettes at once; play A while recording B • Record on either well • Relay Record for three hours, Relay Play 5x • Dolby B&C (HX-Pro on Deck B) • RCA unbalanced I/O • Rack mount included

DN-770R	60DEDN770R	MFR LIST	\$700.00
---------	------------	----------	----------

CALL 1-800-732-7665 FOR BRADLEY PRICE

## MARANTZ DUAL CASSETTE MACHINES

*Best Seller*



The PMD-500 and 510 allow simultaneous recording (from a single source on the 500, or separate sources on the 510), playback on one tape while recording on another, and quick auto-reverse. Serial recording gives three hours of continuous material. Standard or high speed dubbing, Dolby B&C Noise Reduction, Dolby HX-Pro, and memory rewind are included.

The PMD-510 is really two machines in one deck. Extra features include ±15% pitch control, cascade circuitry allowing series recording with multiple machines, and separate meters and counters for each well. A switchable headphone jack allows cueing of one well while the other is playing.

Both models are rackable and provide -10dBV on unbalanced RCA connectors. An RC5 port makes serial, IR, or master remote control simple to configure. The optional remote kit works with either model and includes a wall/rack mount controller with hand-held wireless remote. It's handy for duplication projects, since you can operate multiple units in parallel.

PMD-500	60MRS500	MFR LIST	\$639.00
PMD-510	60MRS510	MFR LIST	\$829.00
RCSPMD Remote Accessory Kit	61MRRCSMD	MFR LIST	\$75.00

CALL 1-800-732-7665 FOR BRADLEY PRICE

### DON'T FORGET AN INTERFACE AMP.

Henry Matchbox II (see page 91)

60HEMATCH2	MFR LIST	\$195.00
------------	----------	----------



## RECORDING AND PLAYBACK

## SONY CASSETTE MACHINES WITH DOLBY S

Make stunning recordings with the power of Dolby S type noise reduction. In a single or twin-well deck, Dolby S delivers the very best audio on analog cassettes.

The single-well TC-KE500S is a three-head recorder with sorbothane cassette stabilizer and Sony's 160 khz Super Bias circuitry. The two-motor tape transport and quartz control servo drive make for accurate performance; the 16 segment display and linear tape counter make life easier. Other features include memory with reset switch, multiple AMS track search, and switchable MPX filter.

The TC-WE805S is dual well. Dual recording, dual auto reverse and dual 2-motor transports are featured.

Twin/sequential recording and playback, auto record calibration, high and normal speed dubbing and twin linear time counters are standard features.

In addition to Dolby S, both models have Dolby B & C and Dolby HX-Pro, for increased headroom and low distortion.

TC-KE500S	60SOTCKE500S	MFR LIST	\$ 480.00
TC-WE805S	60SOTCWE805S	MFR LIST	\$ 330.00

CALL 1-800-732-7665 FOR BRADLEY PRICE



## TEAC V-610 CASSETTE DECK



With metal tape, you can expect 25Hz to 19kHz performance from the V-610. Teac's cassette deck has a stable center-mounted transport and a quality bi-polar power supply. Features include electronic counter, Dolby B&C type noise reduction, Dolby HX Pro headroom extension, independent peak level meters with peak hold, auto-tape selector, and a headphone jack. Need auto reverse? Ask us about the Teac R-560.

This model measures 17-1/8"W x 5-11/16"H x 11-3/16"D.

V-610	60TEV610	MFR LIST	\$239.00
-------	----------	----------	----------

CALL 1-800-732-7665 FOR BRADLEY PRICE

**Package 9717: Take the V610 with an Excalibur IA-1 interface amp and a Middle Atlantic rack mount kit. Value: \$475.00 Bradley price: \$369.00**

### DON'T FORGET AN INTERFACE AMP.



Aphex 124A (page 86)	60AP124	MFR LIST	\$229.00
----------------------	---------	----------	----------

CALL 1-800-732-7665 FOR BRADLEY PRICE

## TASCAM MULTITRACK PORTASTUDIO

For the musician or other professional seeking convenient multitrack recording, Tascam has improved its very popular 424 Portastudio. The 424 MKII is a four-track cassette recorder and eight input mixer (four mono, two stereo). Features include three-band EQ with sweepable mid, two tape speeds, balanced XLR mic inputs, two aux sends (one to cue for headphone mix), auto punch/rehearse, and an internal power supply. No external transformers! Dedicated tape outputs allow integration to external mixers.

Need more inputs? Ask us for a quote on Tascam's 464. For eight-track recording, request the 488 MKII.

424 MKII Portastudio	60TE424	MFR LIST	\$599.00
----------------------	---------	----------	----------

CALL 1-800-732-7665 FOR BRADLEY PRICE



## RECORDING AND PLAYBACK



## CASSETTE MACHINES

### TASCAM 102MKII AND 103 CASSETTE RECORDERS



Both the three head 103 and two head 102MKII are single-well decks with Dolby B&C noise reduction, Dolby HX-Pro headroom extension, and tape counter. You'll appreciate the uncluttered front panel with headphone jack and bias fine adjustment. Inputs and outputs are -10dBV on RCA jacks. The 102MKII includes rack mount; the shelf for the 103 is optional.

Tascam 102MKII	60TE102MKII	MFR LIST	\$369.00
Tascam 103	60TE103	MFR LIST	\$569.00
Rack Shelf for 103	61TERMS2	MFR LIST	\$45.00
Excalibur IA-1 interface amp	60EXIA1	MFR LIST	\$180.00

CALL 1-800-732-7665 FOR BRADLEY PRICE

### TELEX CASSETTE DUPLICATORS

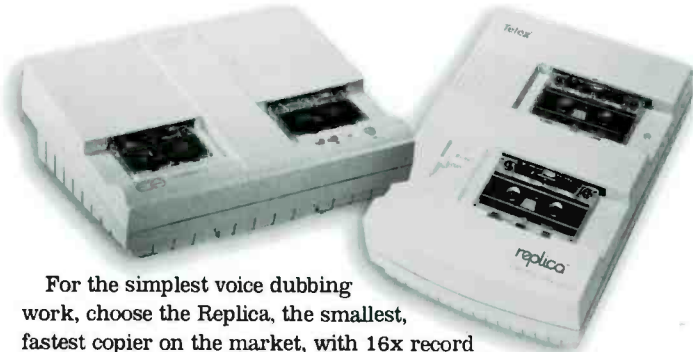

For the simplest voice dubbing work, choose the Replica, the smallest, fastest copier on the market, with 16x record speed and weighing only 7 pounds.

The popular Copyette models are improved: they now have an erase head built right in, so you don't need to bulk erase your tapes. For affordable, portable copying, they're ideal. Dub both sides of a C-60 tape in less than two minutes, all in a ten-to-twelve pound package. The Copyette 1-2-1 makes one dub at a time; the model 1-2-3 makes three copies at once. A protective hard cover is included.

These models dub with response to 6.3kHz mono or 8kHz stereo. For higher fidelity dubbing or if you're handling much larger quantities of cassettes, ask us about the Telex ACC series of expandable tape duplicators.

Replica	60TXREPLICA	MFR LIST	\$425.00
Carry/Storage Vinyl Case	60TXRBB1		\$25.00
Copyette 1-2-1 Mono EH	60TXCOPY121M	MFR LIST	\$550.00
Copyette 1-2-1 Stereo EH	60TXCOPY121S	MFR LIST	\$885.00
Copyette 1-2-3 Mono EH	60TXCOPY123M	MFR LIST	\$1,350.00
Copyette 1-2-3 Stereo EH	60TXCOPY123S	MFR LIST	\$2,150.00

CALL 1-800-732-7665 FOR BRADLEY PRICE

## MARANTZ CASSETTE MACHINES



Churches, aerobics instructors, and corporate A/V professionals enjoy Marantz quality. These are two-head, two-motor single well decks with auto-reverse, Dolby B noise reduction, and rack ears.

The PMD-501 is an affordable, basic deck. The 502 adds  $\pm 15\%$  pitch control, Dolby C and HX-Pro, output level control, an electronic counter, and dual front-panel mic inputs on 1/4" jacks (nice for smaller installations where no mixer is available). A balanced XLR line I/O option is available for this model.

PMD-501	60MR501	MFR LIST	\$329.00
PMD-502	60MR502	MFR LIST	\$499.00
XLR option for 502	60MRXLR502PMD	MFR LIST	\$100.00

CALL 1-800-732-7665 FOR BRADLEY PRICE

Most Bradley items are shown at manufacturer's list.  
Call us for a price quote!

1-800-732-7665

## FOSTEX DIGITAL MULTITRACKER



For all-in-one multitracking and digital quality, Fostex gives us the DMT-8VL, an upscale alternative to the traditional cassette multitracker combo. Here's eight tracks of CD quality (16-bit, 44.1kHz) recording, direct to an internal 540MB hard disk. Forget about tape. Non-destructive editing and jog/shuttle control mean your work is far simpler now.

The eight-channel analog mixer is effectively a 16-input design with in-line monitoring. You get 22 inputs available at mixdown, dual parametric EQ, dual aux sends, and easy integration into MIDI work. Inputs are 1/4" unbalanced at -10dBV; four of them are variable down to -50 for mics. Recording time is about 12-1/2 minutes.

DMT-8VL	60FODMT8VL	MFR LIST	\$1,295.00
---------	------------	----------	------------

CALL 1-800-732-7665 FOR BRADLEY PRICE

## RECORDING AND PLAYBACK



**AUDI-CORD DL SERIES  
CART MACHINES**



Audi-Cord cart decks are newly improved, with LED peak-hold recording meters and a Cue Add/Inhibit feature to allow editing on the fly. These models are a "best buy" for your money, with two cue tones, front panel or remote operation, and high and low frequency EQ. Record models have bias and tone present indicators and automatic record/play meter switching. Engineers will like the modular design, plug-in circuit cards, and heavy construction.

Record units are available with an optional timer, and tertiary tone may be added to any deck. Single transport models are listed here; ask about versions with two record/play units in one deck.

Mono playback	60ACDLP	MFR LIST	\$1,050.00
Stereo playback	60ACDLP	MFR LIST	\$1,150.00
Mono record/play	60ACDLRM	MFR LIST	\$1,550.00
Stereo record/play	60ACDLRS	MFR LIST	\$1,800.00

CALL 1-800-732-7665 FOR BRADLEY PRICE

**INTRACLEAN HEAD CARE  
PRODUCTS**

**S-711 Intraclean** is the solution used by top manufacturers on heads, capstans, and pinch rollers. Made of halogenated hydrocarbons, S-711 removes the toughest oxides. It has no alcohol to dry out pinch rollers; controlled evaporation allows fast drying.



Two ounce bottle	60ICS711	\$7.15
Gallon can	60ICS711G	\$55.00
Quart can	60ICS711Q	\$22.00
Pump dispenser	60ICPD	\$20.00

**Cotton cleaning swabs** with 6" maple stick. The tip is wound tightly and mounted with glue to prevent unraveling. Buy 1000 for best price.

1000 swabs	60BBCS1000	\$18.95
100 swabs	60BBCS100	\$2.95

**D-511S wand-style head demagnetizer** to reach the tightest places. Plastic probe is safe on heads. 110V AC.

60ICD5125	\$50.00
-----------	---------

**K-161D head care kit** is a package that combines the D-511S demagnetizer, a two oz. bottle of S-711, 100 cotton swabs, and a nice carrying bag.

60ICK161D	\$69.95
-----------	---------

**EDITING  
HELPERS**

White grease pencils for marking recording tape. One dozen.  
61EDWP1 \$14.85

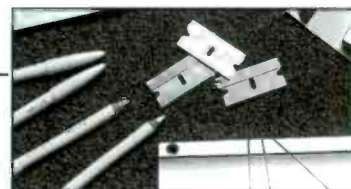

100 single edged razor blades designed for professional splicing.

61EDRB1	\$16.50
---------	---------

Edital pre-cut splicing tabs.

250 1/4" tabs	61EDCX1	\$15.75
250 1/2" tabs	61EDCX6	\$26.50
250 cassette tabs	61EDCX3	\$15.75

Edital splicing blocks with provisions for multitrack and 45-degree cuts. Call for other sizes.

1/4" block	61EDS3	\$52.00
1/4" block with 90-degree and 45-degree cuts	61EDS390	\$49.00
1/4" replacement block for Otari	61EDS30T	\$59.00
1/2" block	61EDS35E	\$55.00
Cassette block	61EDS15	\$49.00

**REEL TAPE HELPERS**

Empty Reels and Boxes

1/4"x 7" plastic reel	60EM7R	\$ .99
Box for 7" plastic reel	60EM7WB	\$ .64
1/4" x 10 1/2" plastic reel	60EM10R	\$3.25
Box for 10 1/2" plastic reel	60EM10WB	\$1.45

**We carry all major  
brands of cart tape and  
test tapes.  
Call us!**



**BULK IT!**

Audiolab's widely-used TD-1B erases carts plus other magnetic media up to 1/4" thickness and reel sizes up to 10-1/2". Pushbutton switch won't let you leave it on by mistake. Eraser duty cycle is one minute on, three off. Or choose the TD-4, which erases up to 14" reels, 1" wide. Includes adjustable "on" cycle, cooling fan, and automatic shut-off. Use for audio, video, computer, and cartridge tape.

Geneva's hand-held PF-211 erases 1/4" reels, cassettes and cartridges.

Erasing other formats? Call us!

TD-1B	60AUTD1B	MFR LIST	\$145.00
TD-4	60AUTD4	MFR LIST	\$950.00
PF-211	61NOPF211	MFR LIST	\$79.99

CALL 1-800-732-7665 FOR BRADLEY PRICE



## MRL TEST TAPES

### CARTRIDGE TEST TAPES

We supply tapes loaded into the type of cart shell that you use. The multi-frequency tapes shown are for reproduce gain, head azimuth, and frequency response calibration. These full track master recordings, with cue track erased, are suitable for mono or stereo players. Specify 160nWb/m or 250nWb/m. Also available are single frequency tapes, fast and slow sweeps, pink and white noise, and cue tone test tapes at the same price.



audiopak shell	60MLS211AP	\$79.00
ITC shell	60MLS211SC	\$79.00
Fidelipac 300 shell	60MLS211FP	\$79.00
Fidelipac Mastercart shell	60MLS211MC	\$79.00
Fidelipac Dynamax Cobalt shell	60MLS211DC	\$79.00

### REEL TO REEL TEST TAPES

These are just our most popular; call for what you need. Spot frequency tapes are for overall frequency response checking. Fast sweep and pink/white noise tapes are for frequency response or phasing verification. Most 1/4" test tapes for 7-1/2 and 15 ips are \$65.00 and most 1/2" tapes at those speeds are \$129.00. Tapes can be ordered with NAB or IEC equalization; for all tape sizes; for various operating levels; and for various speeds.

1/4" Spot Frequency, 7-1/2ips, 250nWb/m, NAB	60ML21T204	\$ 65.00
1/4" Spot Frequency, 15ips, 250nWb/m, NAB	60ML21J205	\$ 65.00
1/2" Spot Frequency, 15ips, 250nWb/m, IEC	60ML31J229	\$129.00

### CASSETTE TAPES

Bradley saves you money on the cassette tapes you need. Get the same low price on any quantity up to 100. When ordering 100 tapes of any mix, take an additional 10% off.

Model	Length	Item Number	Price
Maxell XLII	60 min	61MXXL2C60	\$2.17
Maxell XLII	90 min	61MXXL2C90	\$2.71
Maxell XLII	100 min	61MXXL2C100	\$2.98
Maxell MX-S	60 min	61MXMXS60	\$3.45
Maxell MX-S	90 min	61MXMXS90	\$3.95
Maxell MX-S	100 min	61MXMXS100	\$4.45

#### Tape Types:

Maxell XLII - Type II, high bias for music recording.

Maxell MX-S - Type IV, metal formulation for critical recording.

### UTILITY CASSETTES

These inexpensive, standard-bias cassettes are ideal for sales demos, news actualities, or any general purpose voice recording.

62CMUPL010	5 minutes/side	\$1.29
62CMUPL020	10 minutes/side	\$1.49
62CMCOM30	15 minutes/side	\$1.29
62CMCOM45	22.5 minutes/side	\$1.39
62CMOCM60	30 minutes/side	\$1.49

## REEL TO REEL

### QUANTEGY (FORMERLY AMPEX)

Model	Item No.	Size	Reels/ Ctn.	Carton Price	Single Price
499	61AM499174111	1/4" x 2500' x 10-1/2"	10	\$223.20	\$27.78
499	61AM49917611T	1/4" x 2500' HUB	10	159.00	N/A
456	61AM456151111	1/4" x 1200' x 7"	10	82.98	10.50
456	61AM456173111	1/4" x 2500' x 10-1/2"	10	208.30	26.98
456	61AM45617611T	1/4" x 2500' HUB	10	135.00	N/A
456	61AM456273111	1/2" x 2500' x 10-1/2"	7	286.00	\$51.00
456	61AM456573111	1" x 2500' x 10-1/2"	5	420.00	N/A
456	61AM45697G111	2" x 2500' x 10-1/2"	2	379.00	N/A
406	61AM406151131	1/4" x 1200' x 7"	10	66.30	7.95
406	61AM40617313J	1/4" x 2500' x 10-1/2"	10	166.38	19.95
406	61AM40617613T	1/4" x 2500' HUB	10	105.00	N/A
407	61AM407151131	1/4" x 1800' x 7"	10	86.90	10.42
407	61AM40717313J	1/4" x 3600' x 10-1/2"	10	230.80	27.67
407	61AM40717613T	1/4" x 3600' HUB	10	172.00	N/A

Quantegy Tape Types: 499 Grand Master Gold, 1.5 mil, Backcoated.  
456 Grand Master, 1.5 mil, Backcoated.  
406 Mastering, 1.5 mil, Backcoated.  
407 Mastering, 1.0 mil, Backcoated.

## GENEVA AT-200B CASSETTE ALIGNMENT TAPE

Don't overlook your cassette decks. The AT-200B conforms to IEC/NAB standards. Tests include seven spot frequencies, 400Hz Dolby calibration tone, pink noise and sweep tone for stereo phasing, and 3150Hz pilot tone for wow and flutter measurements.

61N0AT200B \$175.00

## DENON AUDIO TECHNICAL CD

Spot and sweep frequency tones and a variety of other signals allow you to evaluate the THD, channel separation, and other characteristics of CD players and other audio components in your facility.

60DETCO only \$24.95

### CD JEWEL BOXES

High quality replacement boxes at a great low price.

60EUMB .69¢

Purchase 25 or more for only 59¢ each

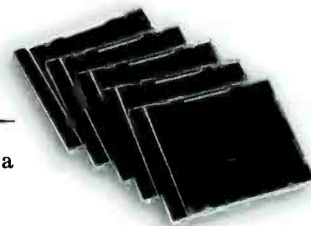

## CD-121A CD CLEANING SYSTEM

Removes contaminants from the encoded data, crosswise to the direction of the data. Includes non-CFC disc cleaning fluid.

CD-121A Cleaning System 60ICCD121 only \$22.95

#### Accessories:

Package of three replacement pads 60ICCD122 only \$4.95  
Spare 1.5 ounce bottle CD-103A cleaning fluid 60ICCD103 only \$6.95



**DIGITAL MEDIA**



**MINIDISC**

Type	Length		Price
Sony	60 minutes	60S0MDW60	\$8.99
Sony	74 minutes	60S0MDW74	\$11.99
Sony Pro	74 minutes	60S0PRMD74	\$12.99
Maxell	60 minutes	61MXMD60	\$11.50
Maxell	74 minutes	61MXMD74	\$12.95

**DAT**

Type	Length		Price
Maxell	46 Minutes	61MXR46DM	\$6.75
Maxell	60 Minutes	61MXR60DM	\$7.50
Maxell	90 Minutes	61MXR90DM	\$8.95
Maxell	120 Minutes	61MXR120DM	\$10.50

**PROFESSIONAL DAT**

Premium DAT tapes with special lengths.

Type	Length		Price
Panasonic	19 minutes	61PARTR19M	\$5.00
Panasonic	34 Minutes	61PARTR34M	\$5.50
Panasonic	64 Minutes	61PARTR64M	\$6.50
Panasonic	94 Minutes	61PARTR94M	\$7.50
Panasonic	124 Minutes	61PARTR124M	\$8.50
Sony	15 Minutes	60S0PDP15	\$5.99
Sony	34 Minutes	60S0PDP34	\$6.99
Sony	48 Minutes	60S0PDP48	\$7.99
Sony	64 Minutes	60S0PDP64	\$9.25
Sony	94 Minutes	60S0PDP94	\$11.25
Sony	124 Minutes	60S0PDP124	\$12.99

**RECORDABLE CD'S**

Sony 74 Minute	60S0CDQ74A	\$8.99
Sony 63 Minute	60S0CDQ63A	\$8.50

**CLEANING TAPES**

Geneva DAT Cleaning Kit	61NOPF390	\$29.00
Denon DAT Cleaning Tape	60DEK10CL	\$9.99

**DISCWASHER**

**CD CLEANER**

The gear drive system ensures complete radial cleaning of the compact disc. Cleaning fluid is formulated to remove debris safely.



CDC	61DICDC	only \$15.00
CD-1 Cleaning fluid refill and pads	61DICD1	only \$6.95

**CD POLISH**

Removes minor scratches and blemishes from CD surfaces. Package includes CD-1 cleaner, CD-2 polish, six applicator swabs and four polishing wipes.

61DICD2	only \$10.95
---------	--------------

**CD LENS CLEANER**

This disc-shaped cleaner uses a dual wet/dry action to ensure thorough lens cleaning.

61DICDL2	only \$21.95
----------	--------------

**TECHNICS CD CHANGER**



Our customers put them in their studios, and our employees like them for family gifts. This Technics multidisc deck has rotary front-load design so you can change any four CD's while a fifth is playing. The mechanism is super quiet. MASH 1-bit DAC system, random access programming, spiral play, and a useful disc location display are standard features.

The SL-PD887 includes a wireless remote control with power button.

SL-PD887      60TCSLPD887      MFR LIST      \$229.95

CALL 1-800-732-7665 FOR BRADLEY PRICE

Don't forget an interface amp...

Excalibur CD-1    60EXCDI    \$99.00



**TECHNICS MEGA CD CHANGER**



Play one, change 60 with the SL-MC60. It sure earns the name "Mega Changer".

Load 60 discs and access them quickly. Program 32 tracks while you listen. An additional slot handles quick play of another single CD, cuts of which can be included in programmed play with the 60. The changer mechanism moves horizontally, taking one disc at a time from the internal storage rack. You can change one disc while another is playing.

Disc grouping lets you put CD's into five memory categories, from which you can program continuous or random play, so you can group discs by format. A liner-notes organizer book lets you find your favorite CD quickly. Size: 17" x 6-3/4" x 15-1/4".

SLMC60	60TCSLMC60	MFR LIST	\$299.00
SLMC410	60TCSLMC410	MFR LIST	\$349.00
Holds 110			

CALL 1-800-732-7665 FOR BRADLEY PRICE

**We appreciate your business. Thank you!**



## CD PLAYERS

### DENON CD CART MACHINES

Play CD's with the convenience of carts on the DN-951FA. Use the rotary track knob to dial the next cut; then hit play for instantaneous audio. Manually search through a track; choose single or continuous play modes; and preview the last several seconds of a track just by pushing a button, a handy feature in the air studio.

Denon's Auto Track Select System reads barcodes you place on the CD. You can set it up to cue only to a specified track, to the exclusion of all others; or cue to a specified track, allowing the operator to select others; or lock out a specific track, allowing the operator to select any of the others.

Three decks mount in a rack with an optional shelf. Remote control uses pull-to-ground logic or RS422. Outputs are balanced analog, adjustable from -20 to +18dBm, and AES/EBU digital. Each CD is protected and stored in a special plastic CD "cart" case even while it's in the machine.

DN-951FA      60DEDN951FA      MFR LIST      \$1,500.00

The DN-961FA is a drawer-loading version for those stations who choose not to use the CD Cart format. No Auto Track Select.

DN-961FA      60DEDN961FA      MFR LIST      \$1,500.00

CALL 1-800-732-7665 FOR BRADLEY PRICE

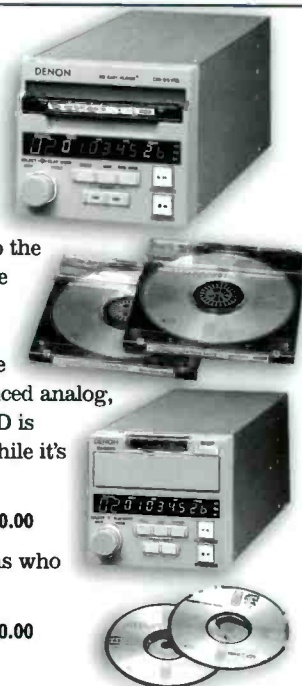

### DENON C680 CD PLAYER

Track search select knob, jog/shuttle wheel, pitch control, rack mount, balanced audio outputs and auto cue are just a few features which make the DENON DN-C680 a "must have" single CD player for studio and broadcast production. You can listen to the end of a track using the End Monitor function, and the End Of Message function provides a warning to the operator that the track will end shortly.

This unit uses 18 bit, 8-times oversampling, and it occupies three rack spaces. Big friendly buttons, parallel remote port, RS-232C/422A switchable serial remotes, digital AES/EBU and SPDIF, and XLR balanced/RCA unbalanced analog outputs are provided. Be sure to call and ask about available add-on options such as the Sampling Rate Converter and SMPTE Kit.

C680      60DEDNC680      MFR LIST      \$900.00

CALL 1-800-732-7665 FOR BRADLEY PRICE



### SONY CDP CD PLAYERS

Sony's high fidelity single-slot CD's are a sure bet. They have direct-access cut selection, peak search, manual fader, music scan, time fade, and four repeat modes. Hybrid pulse D/A

converters and digital servo control assure beautiful audio. The CDP-XE500 adds a wireless remote control with variable output, 10 key cut selector, and digital volume control.

CDP-XE400      60SOCDPXE400      MFR LIST      \$180.00

CDP-XE500      60SOCDPXE500      MFR LIST      \$200.00

U2 Rack Shelf      61MAU2      \$38.00

CALL 1-800-732-7665 FOR BRADLEY PRICE



### DENON CD/CASSETTE COMBO



- Two machines in one
- Record from CD to tape
- Play background music continuously
- Mix from both sources, add mic audio
- Rack mountable

DN-610F    60DEDN610F    MFR LIST    \$700.00

### EXCALIBUR INTERFACE AMPS

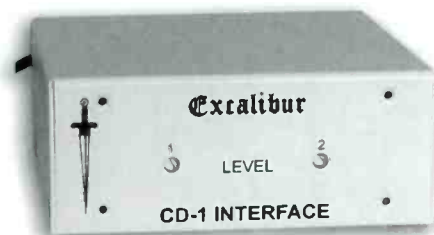

They ain't sexy but they'll make your CD players a lot happier in a professional setting. These one-way amps connect CD and other semi-pro outputs (-10dBV) to pro (+4dBm) equipment. The CD-1 amplifies one stereo source and now uses euro-style block connectors. Rubber feet and angle brackets are included; the optional RM-1 can mount four CD-1's in a rack space.

The CD-2 handles two CD players and connects via barrier strip.

CD-1      60EXCD1      \$99.00  
 CD-2      60EXCD2      \$165.00  
 Rack Kit for CD-1      60EXRM1      \$21.00

**CHECK OUT PAGE 48 FOR  
 CD BOXES AND  
 CLEANING SUPPLIES**

## RECORDING AND PLAYBACK

## SONY CDP-D500 COMPACT DISC PLAYER



The latest professional quality CD player from Sony features precise cueing by CD frame unit, with a rehearsal function. A Jog Dial precisely places the cue point, while the cue/standby button offers back cueing capability. The CDP-D500 operates with a variety of remote interface options, including RS232C, GPI, and supplied wireless remote. Word sync input is provided via BNC connector, and  $\pm 12.5\%$  varispeed may be employed in 0.1% increments.

Sony CDP-D500      6050CDP-D500      MFR LIST      \$1,525.00

CALL 1-800-732-7665 FOR BRADLEY PRICE

## MARANTZ CD PLAYERS



Bradley's menu of CD players continues to grow. Here come our friends at Marantz with two new models to make your selection juicier. Both of these new decks are rack mountable and include  $\pm 12\%$  pitch control, fader start input, S/PDIF digital output, cue-and-review, and optional wired remote. The PMD321 adds balanced XLR outputs and cue-to-music.

These decks will find fans among radio jocks, dance DJs, churches, dance instructors, and other audio professionals. Call us for the lowdown.

PMD320	60MR320	MFR LIST	\$429.00
PMD321	60MR321	MFR LIST	\$529.00
Wired remote	60MRRCSMD	MFR LIST	\$90.00

CALL 1-800-732-7665 FOR BRADLEY PRICE



Store your CD's  
right in your rack.

Middle Atlantic CD holder for 40 discs, 4RU tall  
61MACDSH \$59.00

## TASCAM'S CD FAMILY



The CD-201: Solid CD performance on a budget. You get rack mount, single-play function, and auto-cue with two sensitivity settings for tight starts with no dead air. Other features include fader start ports, RCA unbalanced outputs, and digital S/PDIF. The optional wired remote lets you create a custom playlist of up to 20 tracks, and has a search key to move through a track while you listen. The CD-201 occupies 3RU.



The CD-301 MKII: The same features of the 201, plus balanced XLR analog outputs and a heavier-grade transport. The new 1-bit delta-sigma D/A system in these models produces exceptional audio for your money.



The CD-401 MKII: Broadcast features at a consumer price. It too is rack mounted, and comes with a fader start port and  $\pm 6\%$  pitch control. This fine player has XLR balanced and RCA unbalanced analog outputs, plus digital S/PDIF.

Specs are broadcast standard, with 18 bit, 4x oversampling, a precision three beam pick-up for accurate tracking, and Tascam's "Zero Distortion" circuitry for superb audio. This unit will cue to index. A wired remote is optional.

CD-201	60TECD201	MFR LIST	\$529.00
CD-301 MKII	60TECD301MKII	MFR LIST	\$739.00
CD-401 MKII	60TECD401	MFR LIST	\$1,049.00

Wired remote controls for 201 and 301MKII:	61TERC31	MFR LIST	\$90.00
for 401 MKII:	61TERC401	MFR LIST	\$90.00

CALL 1-800-732-7665 FOR BRADLEY PRICE



# TURNTABLE AND ACCESSORIES

## ATI DISC-PATCHER



The DP100 is a one-way level/impedance interface with UL listing. It rejects common mode interference, which is important in high RF environments. The Disc-Patcher offers 102dB dynamic range, flat (20-20kHz, ±0.25dB) frequency response, and 0.005% THD. A Velcro mount is supplied. Great for CD players. (Ask about the P-1000 turntable amp.)

**DP100**      **60AIDP100** MFR LIST    **\$279.00**  
**Rack Kit Holds one or two Disc-Patchers.**  
                  **60AI20273** MFR LIST    **\$28.00**

CALL 1-800-732-7665 FOR BRADLEY PRICE

See pages 60-61 for club mixers.

## BACK TO THE FUTURE... WITH VINYL!

The warm familiar sound of vinyl is finding new fans and you can make them happy with the best-selling, always popular, still chuggin' along, built-like-a-brick, feels-like-old-times SL-1200MKII turntable from Technics. You'll see it in broadcast studios, clubs, and anywhere people want to get the best from their records.

The massive base and isolation feet keep the rumbles of the world away from the cartridge. Features include quartz lock, slide fader pitch adjustment of ±8%, 0.7 second startup time, stylus illuminator, and speed strobe indicator. The SL-1200MKII comes with tonearm, base, and dust cover. The direct drive mechanism provides the lowest noise and rumble in this price range.

Need a cartridge and preamp? We've got 'em too. Call Bradley today.

**SL-1200MKII**      **60TC1200**      **MFR LIST**      **\$599.95**

CALL 1-800-732-7665 FOR BRADLEY PRICE

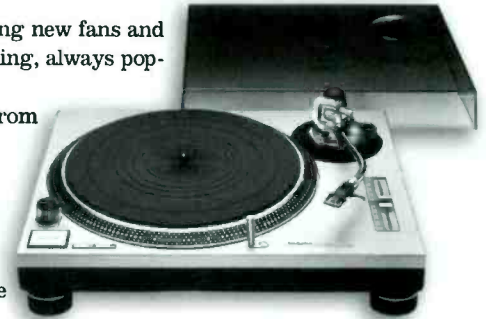

## PHONO CARTRIDGES

Just a sample of the models we carry.

Shure M447X	60SHM447X	\$29.00
Shure M44GX	60SHM44GX	\$29.00
Stanton 500AL	60ST50AL	\$35.00
Stanton 680EL	60ST68EL	\$85.00

Call for other models.



## D4 RECORD CLEANING & SC-2 STYLUS CARE

D4 six ounce refill	61DID4R6	\$7.60
SC-2 fluid 3.5 ounce refill	61DISC2R	\$1.95

## AUDIOARTS R-60

Real modular design and surface mount componentry make the R-60 a great sounding air console that's also easy to service. All components are on modules that can be pulled out while you're on the air. The console comes with an extender ribbon for easy servicing even while your jock continues to work.

Each module provides two inputs. The R-60 comes with many features that are optional in other consoles: six-source input selector, up-timer, cue speaker, P&G faders, start/stop machine control, talkback, white fader knobs, and a preamp card for two mics. Separate modules for control room monitoring, studio monitoring, and output are provided. The Audioarts warranty is three years.

Choose among four configurations, listed here. The two 18-frame models add a clock and a position for a second, optional input selector. The R-60/18 version "short-loaded" with 12 modules is a noteworthy value and earns a Bradley Best-Kept Secret.

Any R-60 can also be equipped with an optional "Simple Phone" module. Want to handle a phone segment? Hit the set-up button for a preliminary chat with the caller; then when it's time to go live or to record the call, just push channel ON to send caller and talent to air or a recorder. The module creates a mix-minus from any of its three bus-select buttons.

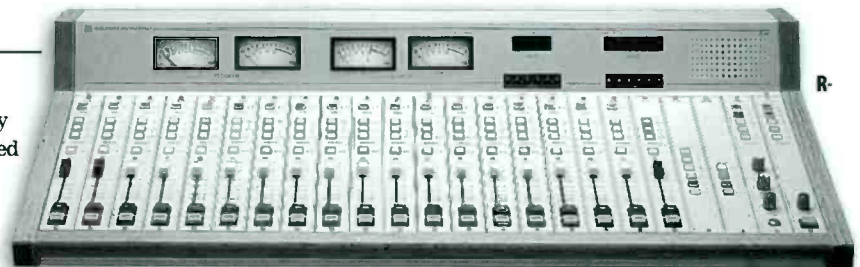

60/18 frame, 18 modules	60WSR6018	MFR LIST	\$9,747.00
R-60/18 frame, 12 modules	60WSR601812	MFR LIST	\$7,203.00
R-60/12 frame, 12 modules	60WSR6012	MFR LIST	\$7,097.00
R-60/12 frame, 8 modules	60WSR608	MFR LIST	\$4,977.00

### Popular Accessories:

CP-60 Sliding Copy Stand	60WSCP60	MFR LIST	\$379.00
Six-Source Line Selector	60WSLS60	MFR LIST	\$292.00
SP-60 Simple Phone Module	60WSSP60	MFR LIST	\$631.00
TR-60-FF 1 Set Full Function Tape Remote Controls	60WSTR60FF	MFR LIST	\$207.00
CF-60 Color Coded Fader Knobs (ships with white)	60WSCF60	MFR LIST	each \$6.00

CALL 1-800-732-7665 FOR BRADLEY PRICE

# RECORDING AND PLAYBACK AND CONSOLES

**AUDIOARTS R-5 CONSOLE**

The R-5 console provides as standard equipment the features most requested by Audioarts console users: two inputs per channel, two mic inputs with A/B selection, talkback feature, full function tape remote, input selector, and simple phone module. Typical high-quality design features include electronic switching throughout, installation without disassembly, and better than 16 bit digital audio performance.

R-5 Console 60WSR5 MFR LIST \$5,795.00

CALL 1-800-732-7665 FOR BRADLEY PRICE



**AUDIOARTS R-16**

The Audioarts R-16 reflects an industry trend toward packaging better and better things in smaller and smaller frames. Well, that's what users want these days: mixers and other products to complement their workstations, remote vans, and live-assist automation or satellite systems.

The R-16 is available with ten inputs (eight line, two mic), or short-loaded with six modules and upgradeable later. It has illuminated start/stop switches and VU meters, conductive plastic faders, and socketed IC's. The board has room for an optional six-input expander and three tape utility modules. At three years, the warranty is exceptional.

R-16	60WSR16	MFR LIST	\$3,973.00
R-16/6	60WSR166	MFR LIST	\$2,749.00
LS-16 Expander	60WSLS16	MFR LIST	\$281.00
TR-16 Tape Remote (Full Function)	60WSFF1	MFR LIST	\$199.00
TR-16 Tape Remote (Start Stop)	60WSSS3	MFR LIST	\$199.00

CALL 1-800-732-7665 FOR BRADLEY PRICE



**FIDELIPAC DYNAMAX MX**

The no-nonsense MX series is for the studio manager looking for an economical way to get on-air performance in a bullet-proof console, and you get your choice of rotary or linear faders. These are modular mixers with active balanced line inputs and outputs, up-timer, internal power supply, and two inputs per channel, one of which may be configured for mic with an optional preamp kit (the console includes one).

Pre-fader patch points, two mono outputs (useful for mix-minus work), VCA design, and all-steel construction are standard. Let us fax you the specs.

Below we list just some of the 14 possible configurations of the MX series, ranging from 6 to 18 channels. Certain sizes offer you a choice between wide and narrow fader modules. Call us for the full list and a price quote.

MX6R	6 channel rotary	60FPMX6R	MFR LIST	\$3,270.00
MX8L	8 channel linear	60FPMX8L	MFR LIST	\$4,370.00
MX10R	10 channel rotary	60FPMX10R	MFR LIST	\$4,400.00
MX12L	12 channel linear	60FPMX12L	MFR LIST	\$5,820.00
MX16E	16 channel linear	60FPMX16E	MFR LIST	\$7,550.00
MX18E	18 channel linear	60FPMX18E	MFR LIST	\$8,210.00

CALL 1-800-732-7665 FOR BRADLEY PRICE.



# RECORDING CONSOLES

## MACKIE 8-BUS SERIES

What's not to like about the 8-BUS? It's a recording and PA board, available in 16, 24, and 32 channels. Features include +48V phantom power, four-band EQ, six stereo assignable AUX returns, stereo solo, and talkback with mic. Double your inputs for mixdown with MIX-B. All channels have high headroom mic preamps.

Two headphone monitoring set-ups allow you to build custom mixes for the talent and the operator. All channels provide patching, direct out, tape returns, balanced mic inputs (XLR), and balanced line inputs (1/4"); the console has balanced XLR's on the main L/R output. The power supply is rack mountable.

Distortion, response, and gain specs are suitable for today's digital sources. An optional tilttable meter bridge provides ladder LED's for each input channel and VU meters for the main outputs. We can also provide pricing on metal stands and a "side car" with rack space for power supplies, patch bays, and more.

32-8	32x8x2	60MD328	MFR LIST	\$4,999.00
24-8	24x8x2	60MD248	MFR LIST	\$3,999.00
16-8	16x8x2	60MD168	MFR LIST	\$3,199.00
MB32	Meter Bridge for 32-8	60MDMB32	MFR LIST	\$899.00
MB24	Meter Bridge for 24-8	60MDMB24	MFR LIST	\$799.00
MB16	Meter Bridge for 16-8	60MDMB16	MFR LIST	\$699.00

CALL 1-800-732-7665 FOR BRADLEY PRICE

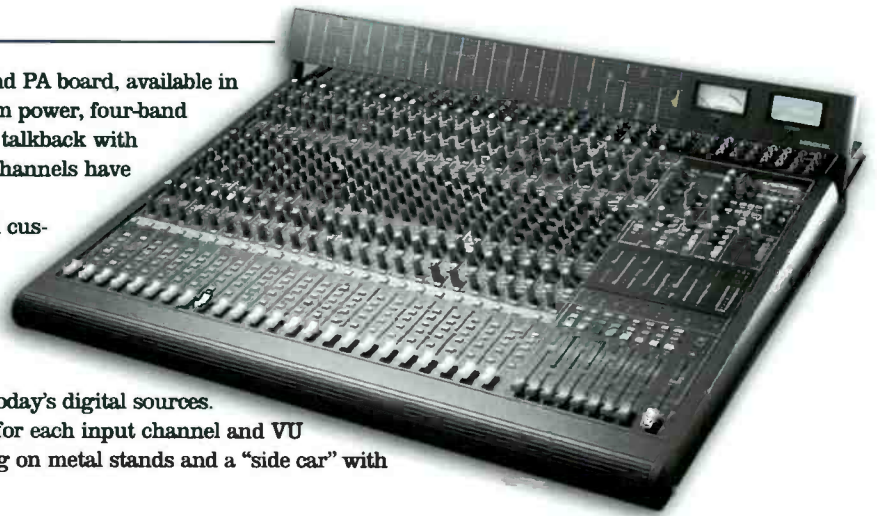

Also available: Ask us about the new OTTO-34 automation system and Ultramix Pro Mac software, for affordable 34-136 channel MIDI automation for the 8-Bus and other boards.

## MACKIE SR SERIES

And lest you think Mackie forgot about four-bus mixers, allow us to introduce you to their SR Series. Great for live sound, also suitable for anyone doing multitrack work. Churches, community centers, and budget-minded broadcasters will want to consider them.

The audio performance, log-taper faders, and high-end preamps are based on Mackie's superb 8-Bus mixers. The 4x2x1 bus design is easy to master. Features include six balanced aux sends with masters, PFL/AFL, sophisticated EQ, LED's on each channel for overload and signal present, 60dB of gain on the mic preamps, "double bussed" sub outs for 8-track recording, phantom power, balanced main outputs on both XLR and TRS plus a separate mono sum, balanced inputs (XLR and 1/4") on every channel, and an internal power supply. These boards weigh only 30-40 pounds.

Mackie brochures are among the most informative and fun in the business. Let us send you a copy about the Mackie board of your choice.

32-4	32x4x2x1	60MDSR324	MFR LIST	\$2,299.00
24-4	24x4x2x1	60MDSR244	MFR LIST	\$1,599.00

CALL 1-800-732-7665 FOR BRADLEY PRICE

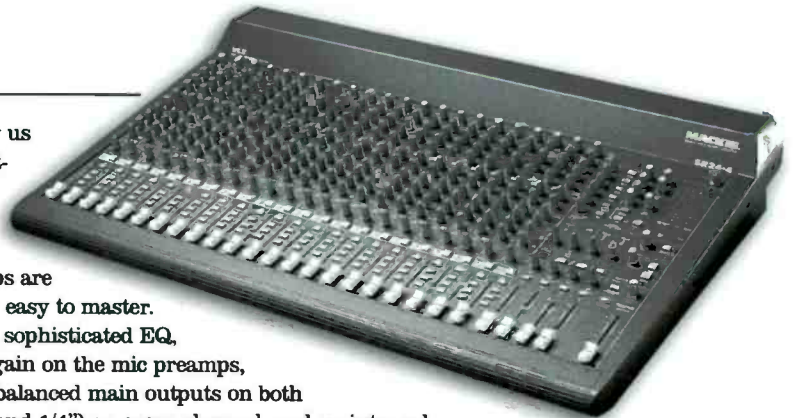

## MACKIE LM-3204

Put 40 inputs into five rack spaces. The LM-3204 line mixer has sixteen stereo inputs (with two patchable XLR mic preamps and four stereo aux returns), squeezed into five rack spaces. It also gives you 3-band EQ, signal-present LED's on every channel, tape inputs and outputs, eight inserts, and Mackie's handy ALT 3/4 bus feature that gives an extra stereo output to which each channel can be assigned. Think of it as a CR-1604 with lots more inputs.

First designed as a tool for keyboardists, this is a useful mixer for many applications including club sound, stage submixing, and main studio mixing. Other features include stereo "in place" solo, sealed rotary pots, tape monitor section, and a built-in power

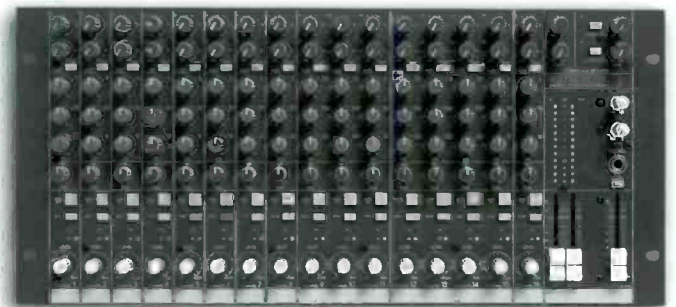

supply. The optional 3204E is a 16 stereo channel expander. Daisy chain up to four.

LM-3204	60MDLM3204	MFR LIST	\$999.00
LM-3204E	60MDLM3204E	MFR LIST	\$899.00

CALL 1-800-732-7665 FOR BRADLEY PRICE

## CONSOLES



## MACKIE MICROSERIES 1202-VLZ

This is the updated version of Mackie's instant classic compact mixer. The improvements aren't just cosmetic. If you go shopping for a mixer, you'll find it very hard to even come close to what this 12-channel mixer does for the money. Use it as a main board in a small studio, as an effects submixer, or as a mic preamp.

Features include: very low impedance design (for better noise specs), 60dB gain and low-cut filter on channels 1-4, three-band EQ on all channels, PFL solo, balanced XLR main outputs (as well as 1/4"), RCA tape interface, a sophisticated control room/phones section, mutes on every channel, and the same ALT 3-4 system used on the big brother CR-1604 mixer, giving you an extra stereo bus when you mute a channel.

Channels 1-4 have XLR mic inputs and 1/4" TS line inputs, while channels 5-12 have 1/4" TRS line inputs configured in four stereo pairs. Input channels have center detent gain and pan controls, two aux sends, and channel inserts on 1-4. The master section includes two stereo aux returns, headphone level control, RCA phono jack tape I/O, and the LED display. The power supply is built in.

MicroSeries 1202 VLZ	60MD1202VLZ	MFR LIST	\$429.00
Rack Mount (7 RU)	60MDRM1202VLZ	MFR LIST	\$12.00
Kaces Soft Carrying Case	40KEKB22	only	\$22.50

CALL 1-800-732-7665 FOR BRADLEY PRICE

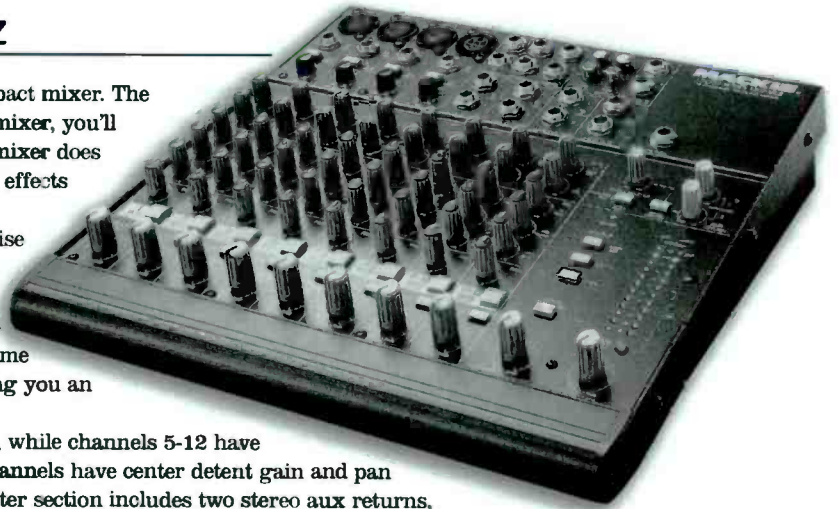

Also new: Mackie's 1402-VLZ with two more channel strips and 60mm volume faders. Retail: \$599.00. Call Bradley for details.

## MACKIE CR-1604 VLZ MIXER

The updated version of the CR1604 mic/line mixer maintains the sound quality and unique five-way mounting configuration of the famous original, and adds a long list of new features.

They include a true four-bus design, with channel assigns to busses 1-2, 3-4, or main L/R,

plus bus assigns to left or right Main Mix. Now you

also get acclaimed Mackie mic preamps on all 16 channels, 60mm log-taper faders, mid-range EQ sweepable down to 100Hz up to 8kHz, inserts on every channel, control room outputs, and a new trim control gain structure to handle everything from hot digital multitrack inputs to quiet vocals.

Other improvements: low cut filter and signal-present LED on every channel, mono output volume control, RCA ins and outs for two-track mixdown, and lots of aux and effects power. And the trim control is accessible no matter how the I/O pod is rotated.

Post-fader direct outputs on channels 1-8 allow split monitoring. If you can't afford an eight-bus console, this is a reasonable alternative for multitrack and mix-down work.

The mixer is rackable. The RotoPod option brings the connectors face-forward. MixerMixer is an active combiner that lets three 1604's act as one; the remote fader option then lets their main output be controlled by one fader. CordPack includes all cables to connect three 1604's with one MixerMixer.

CR1604-VLZ	60MD1604VLZ	MFR LIST	\$1,199.00
Rotopod	60MDRPVLZ	MFR LIST	\$25.00
MixerMixer	60MDMM	MFR LIST	\$229.00
Remote Fader	60MDRF	MFR LIST	\$75.00
CordPack	60MDCP	MFR LIST	\$69.00

CALL 1-800-732-7665 FOR BRADLEY PRICE



## BROADCAST TOOLS CONSOLE CONTROLLER II



This desktop device has three channels of insert switching to help integrate your Mackie mixer or workstation into a broadcast studio. Console insert points or source equipment (mic-preamps) may be turned off or on, as indicated by a red LED on each switch. It has a switch to allow internal/external monitor input switching or monitor amp mute control, and monitor level control.

For more than three channel inserts, cascade multiple CCII's. Connectors are TRS 1/4" jacks, remote control is on a DB-9 (control, tally, and warning light/skimmer), and switches are SPST momentary.

Console Controller II	60BTCCII	MFR LIST	\$299.00
-----------------------	----------	----------	----------

CALL 1-800-732-7665 FOR BRADLEY PRICE



## RECORDING CONSOLES

### YAMAHA PROMIX 01

Among the many features of this smart mixer is its parametric EQ, on every channel plus the main stereo output. The ProMix not only includes "Q" control so you can determine how wide or fine an effect you want, but it also remembers your EQ settings in snapshot memory, and it has 30 standard EQ curves that you can call up and modify.

Snapshot memory also restores the position of faders, channel on/off switches, and send levels. Use it once, and you'll wonder how you ever got along without it. Happy users include broadcasters, theme parks, live venues, and churches.

Dub digitally with 20-bit clarity to DAT or another digital medium. ProMix 01 provides 16 mic/line input channels plus one stereo input, two muscular digital effect processors, and three assignable stereo compressors. A stereo "pair" function allows changes in a left channel, such as EQ and gain, to be mirrored in the right. Dynamic automation lets you create your moves in real time and play them back in conjunction with an outboard MIDI sequencer.

Use the control wheel and cursor keys to set EQ and other functions on the LCD screen. Inputs 1-8 are mic/line, +4dBm, balanced, on XLR, with phantom power. Inputs 9-16 are mic/line, +4dBm, balanced, on 1/4" TRS. Inputs 17/18 form a stereo input, +4dBm, unbalanced, on 1/4" TRS. Both analog and S/PDIF digital outputs are provided.

ProMix 01	60YAPM01	MFR LIST	\$1,199.00
Rack Mount Kit	60YARK01	MFR LIST	\$29.95

CALL 1-800-732-7665 FOR BRADLEY PRICE

### YAMAHA 02R

The Yamaha 02R is a digital recording console that's compatible with Tascam, ADAT, AES/EBU, and Yamaha digital formats. This is a 40-input, 8-bus, fully automated mixing console. Optional interface cards allow integration with any digital recorders, whether tape-based, or non-linear hard disk or magneto-optical. Motorized faders, snapshot memory of settings, two effects processors... an amazing amount of power. Call Bradley for info on Yamaha's latest digital success.

02R	60YA02R	MFR LIST	\$8,699.00
-----	---------	----------	------------

CALL 1-800-732-7665 FOR BRADLEY PRICE

### RANE SM-82 STEREO LINE MIXER



Expand your console by eight inputs without buying a whole new board. The SM-82 combines eight stereo (or 16 mono) inputs to one stereo output, all in a one-space chassis. Each input channel has a level control, aux send, and stereo balance. The aux return and master output sections also have level and balance controls. Unbalanced 1/4" inputs accept levels from -10dBV to +26dBm. When a source is connected to the left channel and the right connector is unused, the signal is routed to both channels. Expansion jacks let you link two units. The SM-82 has S/N of 98dB.

SM-82	60RNSM82	MFR LIST	\$599.00
-------	----------	----------	----------

CALL 1-800-732-7665 FOR BRADLEY PRICE

### SPIRIT FOLIO RAC PAC

Get plenty of mixing power in eight rack spaces with the Rac Pac mixer. It's for sub-mixing, PA mixing, and recording, especially for 4 or 8 tracks. Spirit equips it with 10 mono inputs, two stereo inputs (for up to 28 inputs at mixdown), and four subgroups. The connector panel rotates to the rear or underside. You get direct outputs on each mono channel for recording direct to multitrack, inserts on all mono channels and mix outputs, three band EQ, six aux sends, four stereo returns plus two stereo effects returns, and a high pass filter.

Rac Pac	60SFRW5141	MFR LIST	\$1,199.95
---------	------------	----------	------------

CALL 1-800-732-7665 FOR BRADLEY PRICE



CONSOLES

Bradley Broadcast • 12401 Twinbrook Parkway • Rockville, MD 20852 • 800-732-7665 • 301-231-7800 • Fax: 301-230-6526 • email: info@bradleybroadcast.com

**SPIRIT PRO TRACKER**

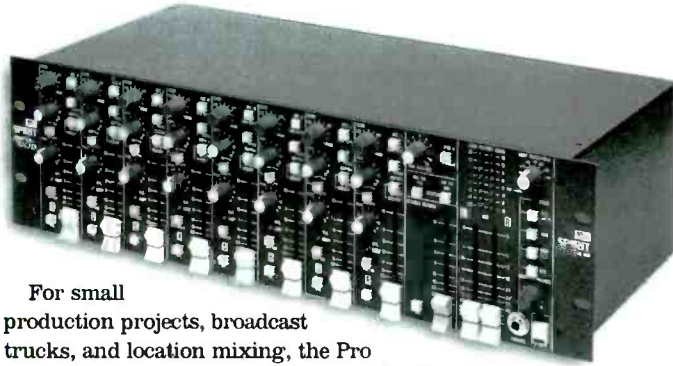

For small production projects, broadcast trucks, and location mixing, the Pro Tracker is an eight-channel in-line rackable mixer with phantom power, limiting, daisy-chain capability, and multination-al power supply. Mix audio to your digital multitrack. It's also good for recording at venues without interfering with the main house board.

All I/O's are balanced: each input has DI capability. Other features include high pass filters, aux (switchable pre- and post-fader), PFL, monitor fade and pan control, and stereo effects return. The mix is routable to Tape Sends 7/8 for two-track recording on a multitrack without affecting multitrack feeds from channels 1-6. The Pro Tracker uses a quality mic preamp for great direct to tape audio.

Pro Tracker 60SFRW5197 MFR LIST \$1,199.95

CALL 1-800-732-7665 FOR BRADLEY PRICE

**SOUNDCRAFT K1 MIXING CONSOLE**

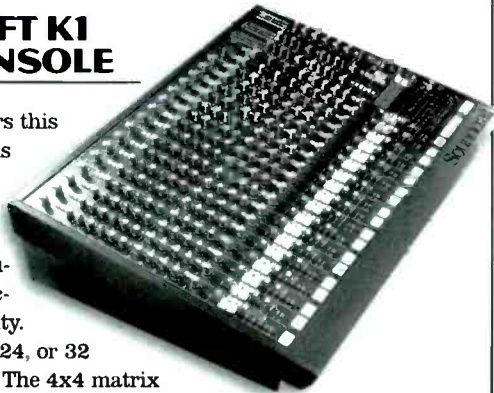

Soundcraft also offers this new, affordable four-bus mixer. You order your inputs in multiples of four, so you save money over fully modular designs without sacrificing a lot of flexibility.

The K1 offers 8, 16, 24, or 32 mono or stereo inputs. The 4x4 matrix allows multiple speaker systems to be set up easily. Stereo inputs can connect to DAT, CD, or tape sources. Four-band EQ, six auxiliaries, and peak-reading bargraph meters make this compact board easy to use.

Mono modules accept any mic or line source via XLR or 1/4". Phantom +48V, polarity reverse, high pass filter, pre-fader insert, and pan are standard. Two stereo input channels are fitted in every board as standard; more can be added in blocks of four. Each stereo channel has two 1/4" inputs, one of which can be set with RIAA curve for phono cartridges.

Faders are 100mm. Power supply is external. Weights range from 30 to 70 pounds. Order one of the pre-loaded setups shown below, or call for other options.

K1 8 channel w/8 mono & 2 stereo	60SFRW5184	MFR LIST	\$2,995.00
K1 8 channel as above, rack mountable	60SFRW5185	MFR LIST	\$2,995.00
K1 16 channel w/16 mono and 2 stereo	60SFRW5186	MFR LIST	\$3,995.00
K1 24 channel w/24 mono and 2 stereo	60SFRW5187	MFR LIST	\$5,495.00
K1 32 channel w/32 mono and 2 stereo	60SFRW5256	MFR LIST	\$7,695.00

CALL 1-800-732-7665 FOR BRADLEY PRICE

**TASCAM UTILITY MIXER**



The ten-pound M-08 gives you 12 inputs (four mono, four stereo), two-band EQ, phantom power, effect returns, mute, PFL, overload indicators, and daisy chain connections. Size: 13" x 3-1/2" x 12-7/16".

M-08	60TEM08	MFR LIST	\$349.00
Rack Kit	60TERM08	MFR LIST	\$15.00

CALL 1-800-732-7665 FOR BRADLEY PRICE

**ASHLY MIXERS**



Ashly's rackable audio mixers have a five-year warranty so you can install them with confidence in studios, remote vehicles, or meeting rooms. The MM-508 is an eight input, stereo output mixer, with low noise and distortion. Each input has XLR mic and 1/4" TRS line connections, level trim with clipping indicator, three-band EQ with sweepable mid, two aux sends, and channel patching. The mixer also has a stereo input on RCA jacks for a tape player or CD.

Phantom power is available for the mic inputs. Ports include a stereo, +24dBm transformer balanced output on XLR's, a balanced stereo output on 1/4" TRS, an independent mono output, a tape output on RCA jacks, and headphone. The master section has pre-master sub in/out patches, two aux sends and returns, and LED metering. For ease of service, this three-space mixer is modular from the rear. A Bradley Best Seller.

MX-508	60ASM508	MFR LIST	\$1,400.00
--------	----------	----------	------------



Also Available:

LM-308—An eight channel line mixer with stereo, unbalanced, line level inputs and outputs. Inputs 1 and 2 may be switched to accept mic level. One rack space high.

LX-308	60ASLX308	MFR LIST	\$499.00
--------	-----------	----------	----------

CALL 1-800-732-7665 FOR BRADLEY PRICE



# RECORDING / UTILITY CONSOLES

## YAMAHA MX200 MIXER

The price of these models demands attention. Available in four sizes, all with stereo and mono output busses, the MX200 is intended primarily as an SR mixer for small concerts, but will find a home in other situations.

All input channels have switchable "A" and "B" inputs: the "A" inputs are balanced XLR with phantom power, the "B" inputs are balanced TRS phone jacks that also accept unbalanced signals. Insert patch points on every channel let you add processing. A -20dB input pad and -16 to -60dB rotary gain control let you match levels with virtually any input source, and a switchable 80Hz high-pass filter cuts out hum and rumble.

Three band EQ, four aux sends, pan pots, on/off switches, and pre-fader listen are provided. Four switchable LED bargraphs monitor your bus signals with peak-reading accuracy. Independent master faders control the left and right stereo busses, as well as the mono bus.

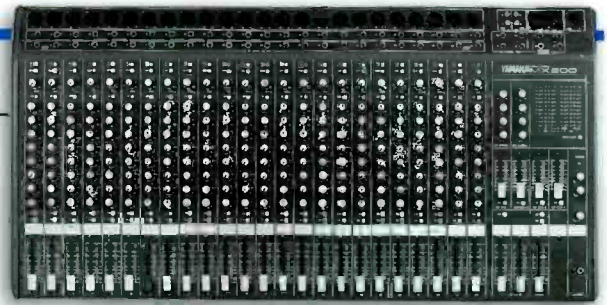

MX200-8	60YAMX2008	MFR LIST	\$749.00
MX200-12	60YAMX20012	MFR LIST	\$949.00
MX200-16	60YAMX20016	MFR LIST	\$1,099.00
MX200-24	60YAMX20024	MFR LIST	\$1,499.00

CALL 1-800-732-7665 FOR BRADLEY PRICE

Also available:

Yamaha's M2000 mixers have eight output groups and stereo and mono busses, and come in frame sizes from 16 to 40 channels. Call us for details.

## RANE SM-26B SPLITTER/MIXER

As we pointed out in this space last year, the SM-26B is unusual because it does so much. Allow us to explain.

First, it's a six-to-two, line level mixer, accepting six balanced or unbalanced line inputs which are applied to six Level and Pan controls. An added master stereo input brings the total inputs to eight. The mix is sent to left and right output jacks.

The unit is also a splitter: it can take one or two line level inputs, and split these to any of the six mono outputs on the rear. In this mode you can control the level from each input bus to each output.

It is also a six in, six out buffer amp, and a -10 to +4 shifter. The



SM-26B may also be used in a combination of modes. One example: inputs 1 through 3 are mixed to the left and/or right output busses, while outputs 4 and 5 are delivering signal originally applied to the left and right master inputs, and output 6 is driven from input 6 straight through. Sorry, it won't do windows.

All ins and outs are 1/4" TRS active balanced.

SM-26B	60RNSM26	MFR LIST	\$429.00
--------	----------	----------	----------

CALL 1-800-732-7665 FOR BRADLEY PRICE

## U.S. AUDIO RACK MOUNT MIXERS

Designed and built in the U.S. by Whirlwind, these mixers are available in a configuration to answer any thorny problem.

The MIX-5S is an all-purpose mixer for sound contracting and similar work. It's a single space, five input device with four input channels (each with XLR and 1/4" TRS balanced connectors for mic or line), LED level indication, phantom power, pan, and an aux channel with RCA for a tuner or CD player. The outputs are XLR and 1/4" TRS. The MIX-5 is the popular mono version and a notable value.

The MIX-6 is a broadcast-quality mixer in one rack space. Inputs 1-4 and the stereo outputs are capable of any combo of line- or mic-level, XLR or 1/4" balanced or unbalanced signal. Input 5 is a stereo RCA pair, input 6 is a stereo 1/4" pair (balanced or unbalanced). This last input is switchable to take it off the output and patch it to the headphone for solo monitoring. This unit has a switchable stereo limiter, phantom power, and internal power supply.

MIX-8 provides eight stereo line level inputs, with headphone monitoring, stereo aux sends on inputs 1-4, and pans on inputs 5-8. Each channel has volume control; output level is set with a single stereo master pot. A foot-switchable circuit can mute the main outputs and allow monitoring of the main mix. A clip LED indicates overload.

MIX-44 is an unusual, two-space device that lets you create four discrete mixes from four separate inputs. It takes four separate

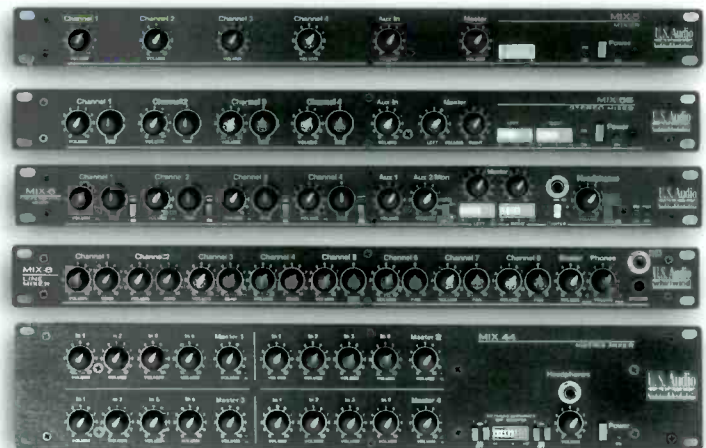

balanced line-level inputs, and applies them to four mixer sections where they are combined through volume controls to four output mixes. Call for the specs on this useful matrix mixer.

MIX-5 Mono	60WHMIX5	MFR LIST	\$399.00
MIX-5 Stereo	60WHMIX5S	MFR LIST	\$499.00
MIX-6 Stereo	60WHMIX6	MFR LIST	\$1,012.00
MIX-8 Stereo	60WHMIX8	MFR LIST	\$645.00
MIX-44 Matrix	60WHMIX44	MFR LIST	\$1,125.00

CALL 1-800-732-7665 FOR BRADLEY PRICE



**ATI NANOAMP MIC/LINE MIXER**

With Nanoamp mixers you can configure your setup as it suits you. The MX100 is a three-input mic/line mixer, while its companion XP100 is a four-input expander. Inputs and outputs are XLR. The expander comes with DC and audio connection cables.

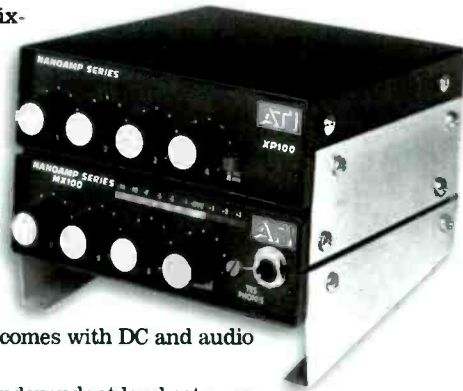

Features include independent level sets, master gain, adjustable headphone output, phantom mic power, balanced inputs, and metered output for balanced or unbalanced lines.

Order the AC/DC wall supply separately. An optional external battery pack runs an MX100 for three hours. Install Nanoamps in a rack with optional hardware, up to three across; various rack and desk mount kits are available.

MX100-XLR Mic/Line Mixer	60AIMX100XLR	MFR LIST	\$359.00
XP100-XLR Expander	60AIXP100XLR	MFR LIST	\$289.00
WA100-1 AC/DC Wall Supply for above (sold separately)			
	60AIWA1001	MFR LIST	\$13.00
BBU100-1 Battery Pack (takes four 9V)	60AIBBU1001	MFR LIST	\$27.00
Single unit rack mount	60AI20604501	MFR LIST	\$22.00
Double unit rack mount	60AI20604502	MFR LIST	\$25.00
Triple unit rack mount	60AI20604503	MFR LIST	\$30.00

CALL 1-800-732-7665 FOR BRADLEY PRICE

**SAMSON MIXPAD 9**

A sassy mixer with superior low noise and distortion, three mic/line inputs and three stereo inputs (for a total of nine channels), two aux sends per channel, two stereo effects returns, two-band EQ,



pan/balance controls, peak LED's on the outputs, balanced stereo output, and a durable aluminum chassis. You also get gain trim for mic and line inputs, phantom power, headphone jack, in-line power supply: all in a package under four pounds.

You can see the uses: Broadcast. Multimedia. Submixing. Monitor mixing. Corporate video. With a Mic EIN of -128dBu, THD of 0.004%, output noise >-83dBu, and S/N of 87dB. And on. Size: 2.5 x 9.375 x 9".

MIXPAD 9	60SSMP9	MFR LIST	\$249.99
----------	---------	----------	----------

CALL 1-800-732-7665 FOR BRADLEY PRICE

**AUDIO TECHNICA AT-MX341A SMARTMIXER**



The SmartMixer is a leading choice for controlling multiple mics automatically. By keeping the number of open channels to a minimum, it allows more gain before feedback and provides transparent switching.

It's improved, too, with a transformerless input design for even less noise, switchable mic/line on inputs and output, master output level, 12V phantom power for each mic, and a manual mode that lets you use it as a conventional mixer.

SmartMixer has priority pre-select switches so you can choose among one-mic-at-a-time operation, all active, or any mix of moderator override. Audio connections are XLR. Each unit accepts four inputs. Any number of mixers can be linked, to accept larger numbers of mics.

A rack adapter is provided. Mount two in a single space with the optional joining plate. Need a good mic? We recommend Audio Technica's AT851a boundary mic.

AT-MX341a	60ATMX341	MFR LIST	\$799.00
AT851a Mic	60AT851A	MFR LIST	\$297.00

Accessory:

AT8628 Joining Plate	60AT8628	MFR LIST	\$25.00
----------------------	----------	----------	---------

CALL 1-800-732-7665 FOR BRADLEY PRICE

**SAMSON MIXER /AMPLIFIERS**

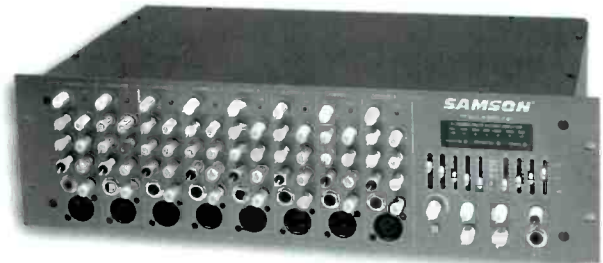

When you need a stand-alone sound system, turn to Samson. These are rack-mountable mixers with EQ and power amps built right in. Both give you XLR mic and 1/4" line inputs on the front panel, plus phantom power, internal reverb, two aux sends, 10-band graphic master EQ, and patch points for preamp out, power amp in, and monitor out. A separate CD/Tape input is routed through the channel EQ.

The S8 has eight inputs, four-band EQ on each channel, and 300 watts/channel (into 4 ohms). You also get peak LED's, headphone jack, and a level meter. The more economical S6 has six inputs, three-band EQ, and 210 watts/channel, and lacks the headphone and metering features.

S8	60SSS8	MFR LIST	\$629.00
S6	60SSS6	MFR LIST	\$499.00

CALL 1-800-732-7665 FOR BRADLEY PRICE



## POWERED MIXERS

### YAMAHA EMX SERIES POWERED MIXERS

Choose between twelve- and sixteen-input configurations of this rugged pro mixing console with built-in stereo amp. The internal digital effect processor has 15 digital effects. The graphic equalizer has nine bands for flexible stereo EQ. The power amp provides up to 200 watts per channel (stereo) into 8 ohms.

Each mixer input provides three-band EQ, two auxiliary sends, a pan control, and 48V phantom power. Large heat sinks and forced air cooling let you run this mixer all day with no headaches.

EMX-3500-12	60YAEMX3500	MFR LIST
\$1,999.00		
EMX-3500-16	60YAEMX350016	MFR LIST
\$2,199.00		

CALL 1-800-732-7665 FOR BRADLEY PRICE

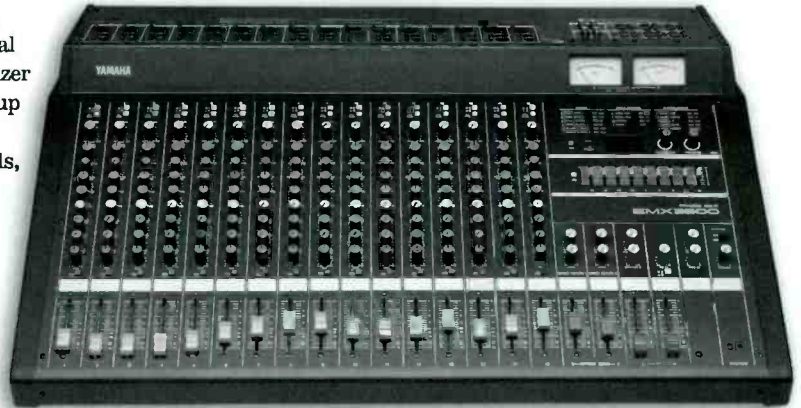

### SHURE AUTOMATIC MIC MIXERS



With multiple mics come multiple headaches. Use too few, and you don't get adequate coverage. Use too many, and you get more background noise, and less gain before feedback on a PA. Ponder two solutions from Shure, one for the studio, one for the field. Both models distinguish between constant background noise and speech. Last-mic lock-on keeps one mic open when no one is talking, so you don't lose ambiance. Both have phantom power, limiter, linking capability, and rack mount.

The FP-410 is Shure's popular, portable automatic mixer, operating off either 120V or two 9V batteries. It has four mic/line inputs and two XLR outputs, one mic/line switchable, the other line level.

The SCM-810 is Shure's latest automatic mic mixer. Like the FP-410, it activates only those mics being addressed, minimizing poor audio caused by open mics. This mixer has eight mic/line channels. Each input has two-band EQ for setup in different mic environs. Logic terminals help with activation of external devices and external mic control. The I/O's are on removable header connectors; an optional adapter converts to XLR. Each channel also has a 1/4" phone jack for use as a direct output, gated channel output, send/receive insert, or external speech gate for mixing consoles.

FP-410	60SHFP410	MFR LIST	\$1,650.00
SCM-810	60SHSCM810	MFR LIST	\$1,650.00
RKC800 XLR adapter	60SHRKC800	MFR LIST	\$250.00

CALL 1-800-732-7665 FOR BRADLEY PRICE

### SPIRIT POWERSTATION



The best portable mixers combine mixing, effects, and power amplification all in one.

Spirit's Powerstation is a powered mixer with renowned Lexicon digital effects available on all inputs via Aux 2. The mixer has eight mono and two stereo inputs, three-band EQ, stereo seven-band graphic EQ to suit any room, PFL, and inserts on every mono input. A high pass filter fights mic pops and stage rumble. Each channel has two aux's.

The custom power amp at 2 x 300W (into 4 ohms) ensures clear, loud audio without distortion all night long. Use the patch-bay to feed external amps with or without the graphic EQ or to plug another mixer into your amp. Powerstation is freestanding and includes a detachable lid.

Powerstation	60SFRW5191	MFR LIST	\$1,599.95
Rack Mount	60SFRW5194	MFR LIST	\$59.95

CALL 1-800-732-7665 FOR BRADLEY PRICE

**Bradley Broadcast and Pro Audio is your expert in Recording and Sound Reinforcement Equipment.**



## THE EV ENTERTAINER II

### 100 LBS. & FITS IN YOUR TRUNK

#### 100M Stereo Mixer:

100w/ch, eight mic/line plus two line inputs, reverb, EQ, phantom, more.

60EL100M MFR LIST \$2,058.00

#### Sx100 Speakers:

Two-way 12" systems, 65x65 degree coverage, constant directivity.

60ELSx100 MFR LIST \$692.00 each

CALL 1-800-732-7665 FOR BRADLEY PRICE



## CROWN CSL AMPLIFIERS

Crown's patented grounded-bridge circuitry generates voltage swings with very low distortion. Output device emulation protects your amplifier even under adverse conditions. Bridge-mono mode provides double output voltage; parallel mono mode gives double output current.

You get a three-year warranty with these muscular amps. Specifications include S/N ratio of 105dB; response 20-20kHz ±0.1dB; harmonic distortion less than 0.1% at rated output into 8 ohms; and IM distortion less than 0.05%. Input connectors are 1/4" TRS jacks and output connectors are binding posts. Need front-panel volume control? Ask us about Crown Power Tech amps.



460 CSL (200 watts/ch into 8)	60CRCSL460	MFR LIST	\$975.00
800 CSL (300 watts)	60CRCSL800	MFR LIST	\$1,075.00
1400 CSL (500 watts)	60CRCSL1400	MFR LIST	\$1,375.00

CALL 1-800-732-7665 FOR BRADLEY PRICE

## JBL'S EON POWER SYSTEM

The EON system includes the MusicMix 10-channel stereo mixer, two 15" two-way powered speakers, two JBL E50S dynamic mics, and all necessary cables. Give us a call for info and individual EON prices.

Power System 60JBEON MFR LIST \$2,177.00

CALL 1-800-732-7665 FOR BRADLEY PRICE



## PA PACKAGES



### BRADLEY PREMIUM PA SYSTEM

#### 300 WATTS OF POWER

Spirit Powerstation Mixer with Lexicon effects plus two EV Sx200A speakers, powered bass modules, crossover controller, and cables. Not for amateurs. A \$6,119 value.

Package 9720 \$3,999.00



### TOA PA SYSTEM

#### FOR SMALLER ROOMS

MX-101 mono mixer with four inputs, plus a pair of SL-122 speakers and cables. Value: \$1,400.00

Package 9721 \$869.00



## P.A. EQUIPMENT

### COMMUNITY CSX SERIES SPEAKERS

Join the community! Classics in their price range, CSX speakers deliver sonic quality every time. Fuseless protection guards your speakers against excessive input. Ferro-fluid cooling of the LF drivers is equal to the rigors of long term use. CSX cabinets are finished in an attractive durable black carpet.

We know these well. If you don't, you should.

The CSX25 is the smallest, with a twelve-inch two-way configuration. 32 pounds, 18.25"H x 15"W x 13.5"D.

The CSX35 is slightly larger and uses a 15" woofer and a larger cabinet to produce a more solid low frequency response. 43 pounds, 23.75"H x 17.25"W x 13.5"D.

The CSX52 has a smooth, three-way design for honest reproduction of the important mid-range, while still using a 15" woofer for pleasing lows. The 52's sound like Hi-Fi speakers, yet they will develop tremendous SPL. 82 pounds, 33.5"H x 18"W x 18"D.

Other Community models are available.

CSX25	60C0CS25	\$299.00
CSX35	60C0CS35	\$309.00
CSX52	60C0CS52	\$549.00



### ANCHOR PORTABLE SOUND

Anchor portable sound systems help you reach audiences between a dozen and 5,000 people. The amp and speaker are built in. You just need to pick the right model. Call us for a free Anchor catalog. Now you can order many Anchor systems outfitted with Shure wireless mics. Call us!



#### EXPLORER

- For crowds up to 250
  - Choose A/C or battery version (50 vs 25 watts)
  - Line and mic inputs, phantom
  - Only 23 pounds
- PA-2500 AC powered  
60ANPA2500 \$549.00
- PB-2500 Battery powered  
60ANPB2500 \$549.00

#### LIBERTY

- For crowds up to 1,000
  - Choose A/C or battery version (70 vs 50 watts)
  - Two XLR mic inputs w/ phantom power
  - CD/tape input
  - Switch for best-projection/best-fidelity
- MPA-4500 AC powered  
60ANMPA4500 \$849.00
- MPB-4500 Battery powered  
60ANMPB4500 \$945.00

#### MINI-VOX

- Over the shoulder five-pound PA
  - Project hundreds of feet, reaches 200+ people
  - Inputs for CD/tape and mic w/phantom
  - Runs 25 hours+ on nine "C" batteries
  - Mic included
- Mini-Vox PB-25  
60ANPB25X \$218.00

### ULTIMATE SUPPORT STANDS

Remotes, concerts, lectures... anywhere you need to support a speaker, these stands are the Ultimate. We can only show our best sellers here; call for info on mix stands, speaker stands, lighting support, and more. Ultimate products carry a lifetime warranty. Let us send you an Ultimate catalog. Ultimate TS-30T can be varied in height from 3'6" to 6'8", and will support up to 100 lbs. Bag included.



Ultimate TS-30T can be varied in height from 3'6" to 6'8", and will support up to 100 lbs. Bag included.

Silver	61USTS30T	\$89.00
Black	61USTS30BT	\$108.00

Ultimate TS-33T will extend to over 9' and support 100 pounds, yet it weighs only eight pounds! (pictured). Bag included.

Silver	61USTS33T	\$107.00
Black	61USTS33BT	\$129.00

#### Accessories:

TAD-138 1-3/8" diameter tripod adapter is used with same sized sockets provided by Community, EV, Toa, and others.

61USTAD138	\$11.50
------------	---------

TMB-400K is a unique two part mounting system that consists of a thin plate (screwed to the bottom of the speaker) and a slide-in bracket (attached to the top of the tripod). Mounting screws included.

61USTMB400	\$22.00
------------	---------

BMB-200K attaches speakers with built-in threaded inserts spaced 4-3/8" to 6" apart, such as those provided by Ramsa and Bose. Mounting screws not included.

61USBMB200	\$19.00
------------	---------

**Ask us about "Utilock" stands for extra-easy and safe load lifting.**

## SOUND REINFORCEMENT



**MEDUSA  
MULTIPAIR SYSTEMS**

These multipair systems are so much nicer than the snake-haired mythical creature whose name they bear. Use them for heavy-duty audio runs. Systems are available in 6 to 52 channel configurations. Each has foil shielding and numbered, color coded fan-outs for easy set up. Medusa systems use cold rolled steel boxes, thick jacketed cable, mil-spec strain reliefs, premium PVC shrink tubing, and Whirlwind connectors.

The Power series, also listed below, is ideal for powered mixers. They incorporate two runs of 14 gauge speaker wire built into, but shielded from, the mic and monitor lines. Call us for pricing on other Medusa cables including versions for multitrack.

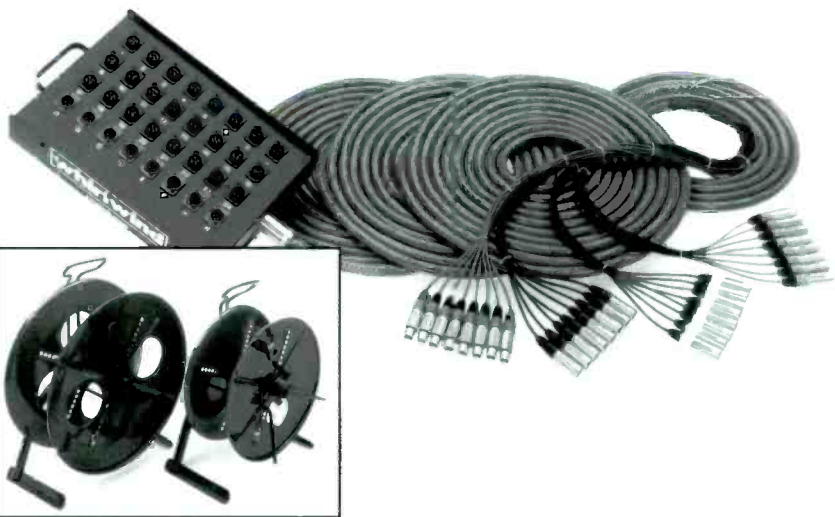

**STANDARD MEDUSA SERIES**

50' - 6 in, 3 out	61WHMS63XL50	\$169.00
100' - 8 in, 4 out	61WHMS84XL100	\$249.00
100' - 12 in, 4 out	61WHMS124XL10	\$295.00
100' - 16 in, 4 out	61WHMS164XL10	\$357.00
100' - 24 in, 8 out	61WHMS248XL10	\$564.00

**MEDUSA POWER SERIES**

100' - 8 mics, 2 speaker, 1 monitor.	61WHMP8100	\$389.00
100' - 12 mics, 2 speaker, 2 monitor.	61WHMP12100	\$479.00

**MEDUSA CABLE REELS**

Carry Medusa cable systems with these windup reels.

Small capacity, 795' of 1/4" OD cable.	61WHMEDWHS	\$101.00
Large capacity, 1150' of 1/4" OD cable.	61WHMEDWHL	\$122.00

**CRICKET TEST SET**



Battery operated receive-and-send test set from Galaxy Audio is an economical polarity and continuity tester, great for people who work on sound systems. Takes 9V. Case included.

Cricket	60GACRICKET	\$309.00
---------	-------------	----------

**TUNNEL TAPE**

Tunnel Tape holds your cables together in a non-sticky tunnel down the middle of the tape. No more gunky cables! Works best on hard surfaces. It's hand-tearable and available in black, or "hazard" yellow and black. Call for case pricing on 4" and 6" widths.

3" wide, black 120'	61SY543	\$13.25 ea	\$190.80 case of 16
3" wide, hazard stripe 120'	61SY563	\$14.02 ea	\$201.89 case of 16



**WHIRLWIND  
CABLE REELS**

Stow your cables quickly with these durable take-up reels. Note: these reels will hold less if the cable's outer diameter is larger. Call us for configuration help.

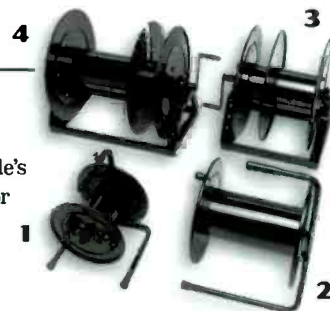

(1) WD-1 Capacity: 640' of 1/4" OD cable	61WHWD1	\$135.00
(2) WD-2 Capacity: 1640' of 1/4" OD cable	61WHWD2	\$176.00
(3) WD-3 Capacity: 2100' of 1/4" OD cable	61WHWD3	\$325.00
(4) WD-3S Capacity: 3675' of 1/4" OD cable	61WHWD3S	\$325.00

**SHURTAPE  
GAFFER'S TAPE**

Tape your cables, carpets, and more with a tape that pulls up cleanly after the job.

2" wide, black 180'	61STBK2	\$13.50 per roll
2" wide, grey 180'	61STGY2	\$13.50 per roll



**SPECIAL! Buy six rolls of Shurtape for only \$64.80.**

**SONIC II HEARING PROTECTORS**

Reduce sound pressure on your ear without reducing highs or lows. Includes box with key chain.

42NOS0N2	\$6.95
----------	--------



## POWERED MONITORS

### DORROUGH AUDIO METERS: DIGITAL OR ANALOG

With digital equipment all around you, monitoring those levels is more and more important. Dorrough's 280/380 series now offers two-channel, AES/EBU-reading audio meters with over-indication and selectable peak hold. They conform to AES 3 1992.

The 280 series is horizontal, the 380 is vertical. Analog versions are also available.

Among the most popular analog Dorrough meters is the Model 40-A2. It has a scale allowing 14dB of headroom in 1dB steps. It's a stand-alone unit with internal power supply. All 40A2 meters include peak hold. For dual (stereo) metering, use two meters and a dual rack kit. Call us for straight line versions.

The display of both peak and average is the trademark of Dorrough's award-winning meters, allowing your operators to make better judgments about your audio.

280-D (40dB)	60DR280D	MFR LIST	\$850.00
280-E (60dB)	60DR280E	MFR LIST	\$850.00
380-D (40dB)	60DR380D	MFR LIST	\$850.00
380-E (60dB)	60DR380E	MFR LIST	\$850.00
40-A2	60DR40A2	MFR LIST	\$475.00

Rack mount kit for 280 Series, specify single, dual, or triple  
60DR280RMX MFR LIST \$45.00

Rack mount kit for 40A/40AP, specify single or dual  
60DR40XX MFR LIST \$45.00

CALL 1-800-732-7665 FOR BRADLEY PRICE

### SONY SMS-1P POWERED NEAR-FIELD MONITOR



This 10cm full range monitor is ideal for desktop music and video editing. Two input channels (XLR, 1/4") with separate input controls, provide additional flexibility. The SMS-1P incorporates both a canceling magnet and large shield, allowing use near video monitors. The built in power amp boasts 15 watts of power in a durable design capable of long hours of use. Bass and treble controls are furnished, as well as mounting threads on the bottom of the main body for simple speaker placement.

60S0SMS1P MFR LIST \$300.00

CALL 1-800-732-7665 FOR BRADLEY PRICE

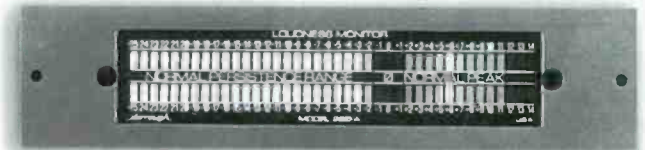

The two-channel AES/EBU meter



Two 40-A analog meters with rack kit

### DORROUGH 1200 TEST SET

Here's the solution to balance your stereo lines, an easy to operate gain set. The 1200 is a stereo signal test device for measurement of balance, level, crosstalk, and S/N over the dynamic range of the system from noise floor to clipping. Use it for L/R polarity and phase compatibility testing in mono and stereo. Rack mountable.

1200 60DR1200 MFR LIST \$1,650.00



### FOSTEX 6301B POWERED MONITOR

What can we say about a powered monitor that our customers ask for above all others? We've banged up ours time and again, and they just keep on pumping out the great nearfield audio. Keep a pair on your equipment shelf for special requirements; take them on remotes with your DJ mixer.

The 6301B takes inputs as low as -10dBV. The 6301B has a 1/4" TS input. The 6301B/EAV adds an active balanced XLR input and special magnetic shielding, so it can be mounted adjacent to video monitors or other sensitive equipment. The 6301B puts out 10 watts RMS power and 80Hz to 13kHz response. Size: 7-3/4" x 4-3/4" x 5".

6301B 60F06301 \$179.00 ea.  
6301B/EAV 60F06301X \$209.00 ea.

Accessories:

Rack kit for single unit 61MA6301RM \$60.00  
Rack kit for two units 61MA6301RMD \$68.00



Qualified government buyers, call for Bradley's GSA price list.



# Today's audio requires careful attention to precise level control...

The consumer now has audio playback systems that stretch the limits of program dynamics. With all this new equipment, the modern listener is able to hear subtle differences in level and distortion within program material and make critical program choices based on the quality of sound.

Now it is more critical for the engineer to obtain the maximum loudness with the

minimum of distortion components in order to fully utilize the dynamic range available. With the dynamic range that digital audio offers, and the bandwidth now available to film and video productions, it has become of paramount importance that there be a new method of monitoring and establishing the maximum safe level at which a system can operate.

Every Dorrough Audio Level meter simultaneously shows three dimensions of program material content. Peak, average power, and compression are displayed on a color-coded 40-segment LED scale. The meters are easily viewed while providing high precision indications of program energy content.

**All Dorrough second generation meters have fully integrated peak-hold functions.**

## Analog Reading Meters

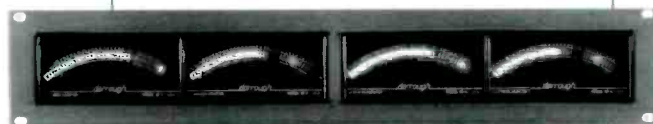

### Loudness Meter Model 40-A2

The standard loudness meter model 40-A2 has a scale allowing 14 db of headroom in 1 db steps. It is a stand alone unit, has an internal power supply, and measures 8 1/2" x 2 7/8" x 6 1/2".

Model 40-A2 \$475.00



### Loudness Meter Model 40-B2

The relative loudness to peak modulation meter model 40-B2 is a scale differentiation of the 40-A2 and is calibrated in percent modulation, with the lower scale in db from +3 to -36.

Model 40-B2 \$475.00

### Loudness Meter Model 40-C2

Also a scale differentiation of the 40-A2 allowing 20 db of headroom

Model 40-C2 \$475.00

### Single and Dual Racks

The 40 series of meters can be optionally mounted in standard single or dual 2 RU racks.

Model 40-S (Single rack) \$45.00  
Model 40-D (Dual rack) \$45.00

### Loudness Meter Model 20-A2

The model 20-A2 is a straight line version of the standard model 40-A2, has an external power supply, and is available with A2, B2, and C2 scales.

Model 20-A/B/C2 \$475.00  
Model 20-S (single rack) \$45.00  
Model 20-D (dual rack) \$45.00

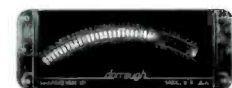

### Loudness Meter Model 10-A2

The model 10-A2 is a smaller version of the standard 40-A2 measuring 5" x 2 1/2", and has an external power supply. Rack mount is required and a triple rack would allow for a center channel sum meter when wired for both right and left channels.

Model 10-A/B/C2 \$475.00  
Model 10-S (single rack) \$45.00  
Model 10-D (dual rack) \$45.00  
Model 10-T (triple rack) \$45.00

### Loudness Meter Model 12-A2

The model 12-A2 is a dual version of the 10-A2. Two of these meters mount into a standard rack for a total of four metering channels.

Model 12-A/B/C2 \$950.00  
Model 12-S (single rack) \$45.00  
Model 12-D (dual rack) \$45.00



### Balance Meter Model 40-P

Parity of signals, both mono and stereo, can be seen on this meter as two indications starting at center scale. A null feature is also provided.

Model 40-P \$595.00

### Surround Sound Meter Single Channel Meter Model 240-A2 and 340-A2

A single channel loudness meter that measures 1 1/2" x 5" and has an external power supply.

Model 240-A/B/C (H) \$475.00  
Model 340-A/B/C (V) \$475.00

### 2-Channel Meter Model 280-A and 380-A

The models 280-A and 380-A feature a single meter with two channels of audio. The meter measures 1 1/2" x 5" and has an external power supply.

Model 280-A/B/C (H) \$850.00  
Model 380-A/B/C (V) \$850.00  
Model 280-S (single rack) \$45.00  
Model 280-D (dual rack) \$45.00  
Model 280-T (triple rack) \$45.00



## LOGITEK BRIGHT VU



Logitek improves their economical VU's with an expanded bargraph that can handle a range of 53dB, digital DSP for extra precision, XLR input connectors, internal multivoltage power supply, and a choice of digital or analog inputs.

The multicolor displays show VU and PPM simultaneously. VU is a solid bar, peak a single dot. Accuracy is  $\pm 0.1\text{dB}$ . Analog sensitivity is adjustable -10 to +24dBu for full scale. Digital models accept AES/EBU and S/PDIF, and have a loop-through for installation convenience.

Available in complete, rack mounting sets that are one rack space high, or as desktop meters. (Also ask about Ultra-VU, with dual analog/digital inputs, high-res "zoom" mode, stereo image/phase, emphasis, and sample rate indication.)

*Specify analog or digital.*

Single stereo meter, desktop	60LTBDTX	MFR LIST	\$470.00
Single stereo meter, rack mount	60LTBV2X	MFR LIST	\$560.00
Dual stereo meter, rack mount	60LTBV4X	MFR LIST	\$795.00
Triple stereo meter, rack mount	60LTBV6X	MFR LIST	\$995.00

CALL 1-800-732-7665 FOR BRADLEY PRICE

## DENON AM/FM TUNER WITH RDS



Denon's tuner has superb audio and the added features of RDS, including program service name (call letters or slogan), program type, radio text, and traffic program ID. The unit can also tune to the type of format you wish to hear. Other features include 40 station presets, auto FM presets, character input to title your presets, RF attenuator, and low impedance output. An AM loop antenna is included.

TU-380RD	60DETU380RD	MFR LIST	\$325.00
----------	-------------	----------	----------

CALL 1-800-732-7665 FOR BRADLEY PRICE

## FURMAN VU-40 STEREO SYSTEM MONITOR

Furman's monitor is an inexpensive dual meter that can keep watch on either line levels or amp power outputs. The scales are set with a positive action, resettable switch matrix on the rear. It has two independent channels with familiar VU meter scales coded in three colors, and lets you switch for peak or average response. Each channel has a line level/power out switch; line level is settable for -10, zero, or +4dBu. Also includes ground lift switch and sixteen power-out choices from 20 to 1260 watts; it also

## BROADCAST TOOLS SILENCE MONITOR

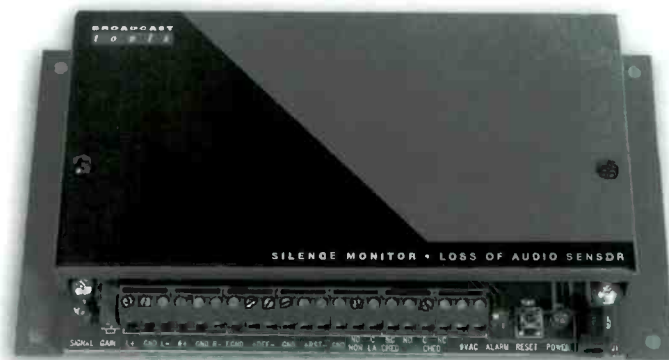

This circuit card monitors any stereo or monaural audio source, including mod monitors, tuners, and automation systems. Set the time-out from two seconds to 8-1/2 minutes with dip switches. One relay is latched for the duration of the audio loss, the other until reset is activated.

Silence Monitor	60BTSIL	MFR LIST	\$199.00
Rack Kit	60BTRM2	MFR LIST	\$49.00

CALL 1-800-732-7665 FOR BRADLEY PRICE

## GENTNER SILENCE SENSOR



Silence Sensor is ideal as a failsafe device when using a dial-up transmitter remote control. On detecting silence, this unit activates an open collector output (capable of sinking 250mA, 48VDC, noninductive). Simultaneously it starts a timer. At the end of the time period, a second open collector output and a relay closure are also activated. Use the first output for an alarm, and the second output for a second, louder alarm while the relay closure starts a backup tape machine. The timer's period is adjustable over a range of 0 to 99 seconds and then up to 99 minutes in one-minute increments.

Silence Sensor	60GESS	MFR LIST	\$539.00
----------------	--------	----------	----------

CALL 1-800-732-7665 FOR BRADLEY PRICE



accommodates 25V and 70.7V lines. The "B" version adds XLR balanced I/O.

VU-40	60FUVU40	MFR LIST	\$249.00
VU-40B	60FUVU40B	MFR LIST	\$299.00

CALL 1-800-732-7665 FOR BRADLEY PRICE

**TECHNICS AM/FM RECEIVERS**



You can get a sweet-sounding radio receiver without spending a whole lot of money. The SA-EX110 provides 100 watts per channel, and specs cut at 40-20kHz, 8 ohms, and 0.8% THD. Class H+ amplifier circuitry gives you high power output with outstanding dynamic headroom. Features include 30-station FM/AM random access presets, four audio inputs plus one for VCR audio, quartz-synthesized digital tuning, and a motor-driven volume knob that's controllable by the 31-key wireless remote. The SA-AX910 ups your power to 120 watts, adds home theater modes, and includes Dolby Pro Logic Surround, sub-woofer signal output, and other performance features. Four audio and two video inputs.

SA-EX110	60TCSAEX110	\$179.95
SA-AX910	60TCSAAX910	\$499.00
Rack Shelf	61MAU3	\$42.00

**ANCHOR POWERED MONITORS**

Use the AN-1000X in a rack, or put it on a speaker stand to address up to 300 people with pleasurable audio fidelity. It has a 50 watt amp, matched two-way speaker system, RCA and 1/4" phone line-level inputs, a mic/line XLR balanced input, and both line-level RCA and external speaker outputs. The AN-1001X is a companion, unpowered speaker with I/O parallel speaker connectors.

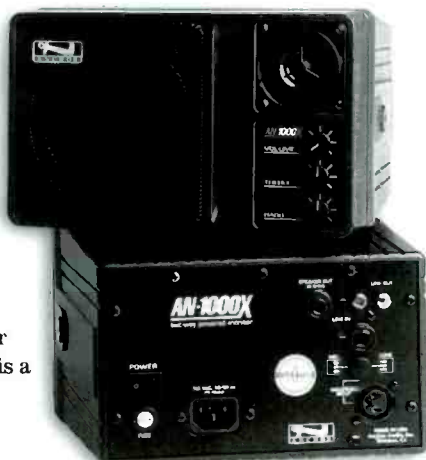

The little-brother AN-100 is suitable for multimedia applications and other work where economy is paramount. It has a 25 watt amp, 1/4" phone mic and instrument inputs, plus two RCA line inputs. Like the AN-1000, it is magnetically shielded.

Anchor has lots of options, including rack kits, speaker stands, and wireless mic versions. Call us.

AN-1000X	60AN1000X	MFR LIST	\$400.00 ea.
AN-1001X unpowered companion	60AN1001	MFR LIST	\$145.00 ea.
AN-100	60AN100	MFR LIST	\$172.00 ea.
Accessories for all models listed:			
Single Rackmount	60ANRM1	MFR LIST	\$55.00
Dual Rackmount	60ANRM12	MFR LIST	\$63.00

CALL 1-800-732-7665 FOR BRADLEY PRICE

**WOHLER POWERED STEREO MONITORS**



A reviewer writing in "Radio World" said Wohler's design "reminds me of those rare pieces that are almost overdesigned to prevent obsolescence." We agree: these monitors sound great and will last a long time.

Wohler's rackable, powered stereo monitors are shielded for installation in TV stations, mobile trucks, flyaway systems, and many other specialty environments. The AMP-1A has response from 100Hz to above 10kHz, at levels loud enough for a busy studio. Mids and highs are reproduced through the left and right speakers, while lows are combined in the center.

For extended response and even more volume, the two rack unit AMP-2 is your choice. It includes LED level meters with VU or PPM ballistics, and visual phase/polarity indication.

Models not already so equipped can be ordered with input switching, phase/polarity indicators, three-state level indications (off, on, over range), surround sound, output volume adjust, headphone output, and more.

AMP-1A	60WOAMP1A	MFR LIST	\$710.00
AMP-2	60WOAMP2	MFR LIST	\$1,095.00

Options: Digi-1 option card allows these models to receive input signals in the AES/EBU or SPDIF digital audio formats. Format and sampling rate are sensed automatically. This version replaces the monitor's analog inputs; call for other configurations.

DIGI 1	60WODIGI1	MFR LIST	
\$485.00			

CALL 1-800-732-7665 FOR BRADLEY PRICE

**CALL US FOR OTHER WOHLER PRODUCTS, INCLUDING:**

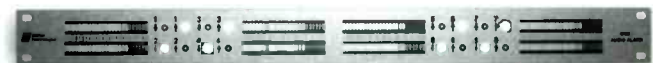

**MSM-1**  
Digital level metering, up to 10 stereo AES/EBU channels



**MSM-2**  
Audible alarm: monitor up to 80 channels in 1RU

## SPEAKERS

### GALAXY HOT SPOT

Solve feedback problems associated with conventional floor monitoring. Put this compact, eight-pound nearfield loudspeaker on a mic stand or atop a keyboard. Because of its small size, it can be positioned readily, allowing more direct and louder audio than a conventional floor monitor. It handles up to 200 watts, with a frequency response of 150Hz-15kHz. The Hot Spot is a 16-ohm cabinet with two 5" drivers, charcoal foam grille, and two 1/4" inputs wired in parallel. The optional stand adapter works with KM series mic stands. Ask about optional straps and wall swivel brackets. Size: 6.75 x 10.94 x 6".

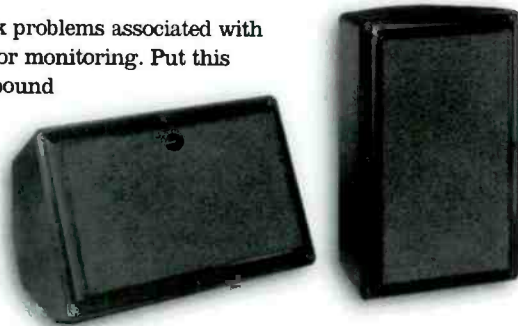

Hot Spot	60GAHS	MFR LIST	\$159.00 ea.
Hot Spot w/volume control	60GAHSVC	MFR LIST	\$169.00 ea.
SA-1 Stand Adapter	60GASA1		\$9.99

CALL 1-800-732-7665 FOR BRADLEY PRICE

### ALESIS MONITOR SPEAKERS

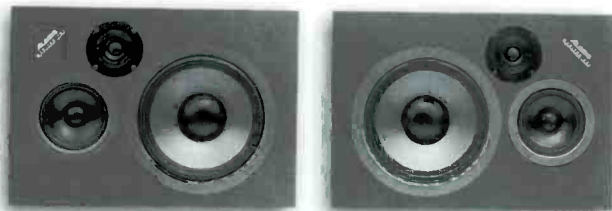

Their award-winning near-field now has a mid-field studio reference monitor in the family.

The three-way Monitor Two will provide the wide image, extended bass, and high power needed to make outstanding mixes. Ten-inch low frequency drivers, 5" mids, and 1" silk-dome tweeters give great audio without causing listener fatigue. They handle 150 watts continuous program (200 watts peak). Like the Monitor One, this box uses SuperPort venting to ensure accurate bass transients. Size: 14 x 20 x 14". Weight: 34 lbs. each.

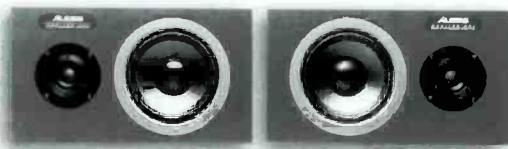

The two-way Monitor One uses similar technology and is ideal for working close. Overall it handles an impressive 120 watts of continuous power. Size: 15 x 9-1/4 x 8-1/2". Weight: 15 lbs. each. Both models use five-way binding posts for solid connection and check in at better than 45-18kHz, +/-3dB. Nominal impedance is 4 ohms.

Monitor Two	60AEMON2	MFR LIST	\$699.00 pair
Monitor One	60AEMON1	MFR LIST	\$399.00 pair

CALL 1-800-732-7665 FOR BRADLEY PRICE

### AURATONE SPEAKERS



Sometimes a traditional speaker isn't right for your situation. Portability and 35 watts power handling make shielded Sound Cubes popular for comparison and final mixes, auditioning, remotes, and as a reference standard speaker. The matching removable fabric grille is included.

You get three Auratone speakers in one package with the unique 5RMC. Only 5-1/4" high, it can live on top of your console or, with optional ears, rack mount. Frequency response is 100Hz to 12.5kHz, +/-3dB. Power handling is 40 watts for each speaker. Use it to monitor the mono sum as well as left and right, or put it at your transmitter site for monitoring your FM and AM.



Sound Cubes, Black	60AA5CB	\$147.00 pr
5RMC	60AA5MC	\$225.00 ea.
Accessory:		
Rack ears for 5RMC	60AA5MCR	\$11.95



For Sound Reinforcement Speakers, turn to page 62.

## MONITORING

**JBL CONTROL SERIES MONITORS**

**1. CONTROL ONE**

The Control One is a small two-way system suited to broadcast and video work. It's made of molded polypropylene. High power handling capacity (150W, pink noise), excellent audio (120Hz to 20kHz, ±3dB), and shielding make it suitable for critical monitoring. Size: 9-1/4 x 6-1/4 x 5-5/8".

Control One    60JBCNTRL1    MFR LIST    \$292.00 pair

**2. CONTROL FIVE**

The spirit and quality audio of James B. Lansing live on in this best selling compact monitor. The Control Five will handle up to 175W and provides 75-20kHz response. The system has a titanium dome tweeter and a 6-1/2" woofer. The dividing network uses protection circuitry against dangerous overloads. High quality components give excellent transient response. Mount with Omnimount 75 series or in a rack with MTC-53 hardware.

Control Five    60JBCNTRL5    MFR LIST    \$502.00 pair

**Accessories:**

MTC-2+ This Universal Mount with ball joint holds a single Control One or Control One Plus monitor on the wall or ceiling and lets you aim it.

60JBMTC2    MFR LIST    \$56.00 ea.

MTC-53 rack mount ear for a Control Five. To mount one monitor, order two; to mount two monitors, order four.

60JBMTC53    MFR LIST    \$46.00 ea.

CALL 1-800-732-7665 FOR BRADLEY PRICE

**JBL MONITOR SPEAKERS**

Proven JBL performance! The 4408A is a two way, 8" woofer system ideal for broadcast and general monitoring applications.

The 4410A is a powerful three way, 10" woofer studio monitor that gives exceptional spatial detail because of its vertical, in-line driver array.

The 4412A is a three way, 12" woofer studio monitor that has superior efficiency, greater power handling capacity, and extended bandwidth.

Power ratings with pink noise are 100, 125, and 150 watts, respectively. All provide at least 50Hz to 20kHz response, ±2dB.

Price shown is per speaker. Add R or L to part number to specify Right or Left when ordering.

*Best Seller*

*New!*

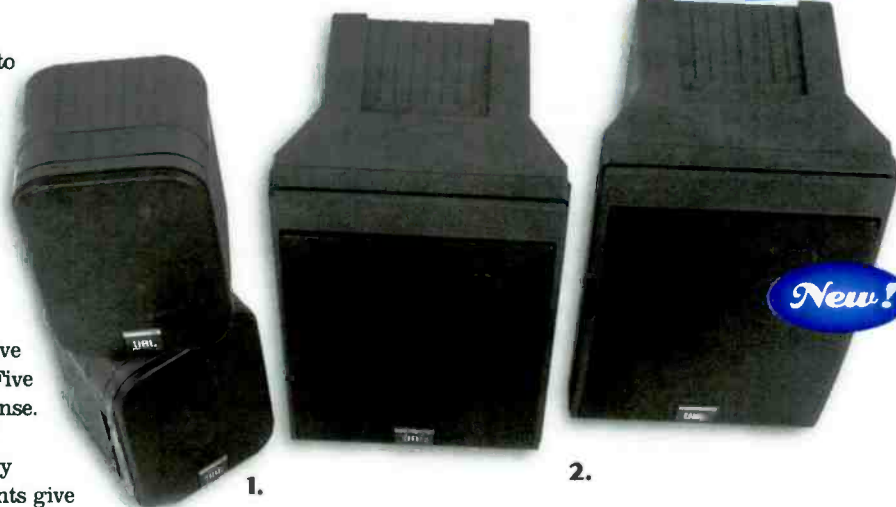

1.

2.

3.



(1) 4408A	60JB440EX	MFR LIST	\$355.00 ea.
(2) 4410A	60JB4410X	MFR LIST	\$492.00 ea.
(3) 4412A	60JB4412X	MFR LIST	\$738.00 ea.

Accessories: Rack mount kit for one 4408A  
60JBMR4408    MFR LIST    \$38.00

CALL 1-800-732-7665 FOR BRADLEY PRICE

**You'll find  
speaker  
mounting  
brackets on  
pages 71-72.**



# SPEAKERS

## TANNOY NEARFIELD MONITORS

Now you can order popular Tannoy monitors with integral power supplies. The Limpet 135-watt amp is included with "LM" versions of the PBM series. Each Limpet system delivers an enhanced stereo image because the channels are fully separated. Limpet offers a balanced or unbalanced "combo" connector for 1/4" and XLR.

Or order the PBM Series without the amplifier. These are small but hearty. For example, the PBM 6.5 has a 6-1/2" woofer, and the PBM 8's is 8", for extended response. Speakers are gray; the black cloth grille is removable. Peak power ratings are 100 and 125 watts respectively, with response of 64-20kHz or better. These units are 13-16" high. Call for information on larger models.

PBM 6.5 LM	60TAPBM65LM	MFR LIST	\$1,075.00 pair
PBM 8 LM	60TAPBM8LM	MFR LIST	\$1,395.00 pair
PBM 6.5 II	60TAPBM65II	MFR LIST	\$475.00 pair
PBM 8 II	60TAPBM8II	MFR LIST	\$795.00 pair

CALL 1-800-732-7665 FOR BRADLEY PRICE



PBM W/  
OPTIONAL  
LIMPET AMP

## YAMAHA NS-10M STUDIO MONITORS



This Yamaha model has found wide acceptance as a production reference monitor. Its 7-1/2" woofer and 1-1/2" soft dome tweeter create smooth 60Hz to 20kHz response, while giving the listener a good feel for how the material will sound when played on a more modest system. The NS-10MC version is intended for installation work. The cabinet accommodates several types of brackets, and a black cloth grille is included.

NS-10M Studio	60YANS10MS	MFR LIST	\$478.00/pr
NS-10MC	60YANS10MC	MFR LIST	\$598.00/pr

CALL 1-800-732-7665 FOR BRADLEY PRICE

## PRO CO MONITOR SELECTORS

Route the outputs of a stereo amplifier to different speakers. Switch between nearfields and main monitors off of one amp; do easy "A-B" comparisons of two speaker pairs. The RMS-1A is a half-rack unit that sends your signal to one of three pairs of speakers. It switches up to 1800 watts (at 8 ohms).

All I/O's are via five-way binding posts. The RMS-2A handles more speakers. It is essentially two of the RMS-1A in a single rackable chassis. Five year warranty.

RMS-1A	60PCRMS1A	MFR LIST	\$222.00
RMS-2A	60PCRMS2A	MFR LIST	\$444.00

CALL 1-800-732-7665 FOR BRADLEY PRICE



## MONITORING



**JBL 4200 SERIES STUDIO MONITORS**



With their curved baffles and sparkling clear audio, these speakers bring a new look and sound to console-top, near field monitoring. The Multi-Radial baffle optimizes stereo imaging between three and five feet from the speakers. Both the 1" titanium high frequency transducer and low frequency components are shielded for use next to video monitors and other sensitive equipment. Woofers are 6-1/2" on the 4206 and 8" on the 4208. The enclosures are covered with gray vinyl and the front baffles are injected molded polypropylene.

4206	60JB4206	MFR LIST	\$204.00 ea.
4208	60JB4208	MFR LIST	\$268.00 ea.

Also available:

JBL is out with a powered near-field reference monitor, the 6208. It's a 50x50 watt bi-amplified monitor that looks like a 4208 and accepts -10 or +4, balanced or unbalanced audio.

6208	60JB6208	MFR LIST	\$499.00 ea.
------	----------	----------	--------------

CALL 1-800-732-7665 FOR BRADLEY PRICE

**OMNIMOUNT UNIVERSAL MOUNTING SYSTEMS**

Hanging a load on a wall or ceiling is serious business. Choose Omnimount to do the job right. The ball and clamp assembly enables full movement. Wiring can be hidden for a dressed installation.

For tiny loads up to five pounds, choose the 25-WBX, suitable for nearfield monitors on racks or walls. The 50 series holds up to 15 pounds, the 75 series is rated for 25 pounds, and the 100 series will hold 55 pounds.

The WB-BC bottom mount has a double bend tube to hold the speaker from its bottom. The WA-BC is of similar design, but has a single bend tube to hold the device from the rear. Also available is the CA-MP ceiling mount, several other configurations, and series with greater load handling. Call us to pick the right model.

25 WBX	600M25WBXBC	\$28.00
50 WA-BC	600M50WA	\$39.00
50 WB-BC	600M50WBBC	\$39.00
50 CA-MP	600M50CAMP	\$39.00
75 WA-BC	600M75WABC	\$59.00
75 WB-BC	600M75WBBC	\$59.00
75 CA-MP	600M75CAMP	\$59.00
100 WA-BC	600M100WA	\$71.00
100 WB-BC	600M100WB	\$71.00
100 CA-MP	600M100CAMP	\$71.00

**ELECTRO-VOICE SENTRY MONITORS**

This model is a mainstay. The Sentry 100A has an 8" woofer; the 1.5" tweeter handles up to 25 watts input power where most tweeters do about five. For 15 years it has been popular in broadcast and video production. Finished in black with a removable gray grille. Response: 45Hz - 18kHz. The Sentry 100EL is a powered version, with XLR balanced and 1/4" phone unbalanced inputs.



100A	60ELSEN100	MFR LIST	\$459.00 ea.
100EL	60ELSEN100EL	MFR LIST	\$909.00 ea.

Accessory: Rack mount kit for Sentry 100A and 100EL			
	60ELSRB7	MFR LIST	\$46.50 ea.

CALL 1-800-732-7665 FOR BRADLEY PRICE

**We have your speaker. Call us!**  
**1-800-732-7665**

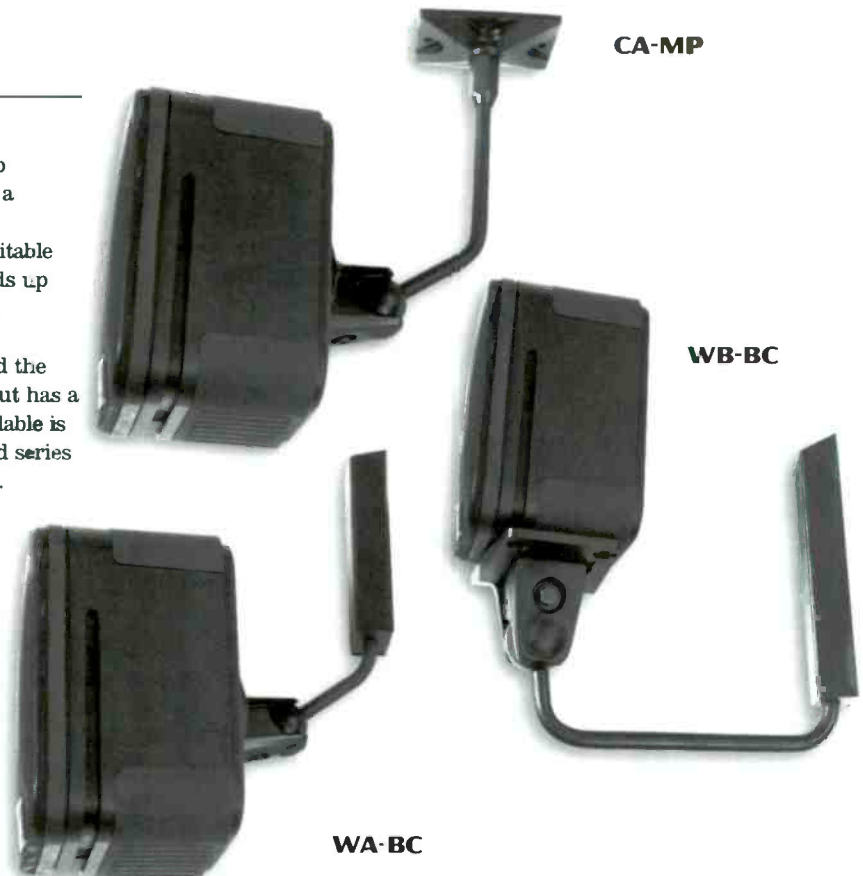

## AMPLIFIERS

### ELECTRO-VOICE S-40 COMPACT MONITOR

Use this in trucks, crowded studios, and other tight spots. It's a wall-mountable nearfield with a 5-1/4" woofer and a 1" ferro-cooled soft dome tweeter in a polystyrene enclosure only 9.8 x 7 x 5.9". The drivers are video shielded. Long term power handling is rated at 160 watts; protection circuits prevent accidental overload. Response: 85Hz to 20kHz. The S-40 comes with threaded inserts for Omnimount Series 25 mount, or use the optional "U" bracket for wall or ceiling.

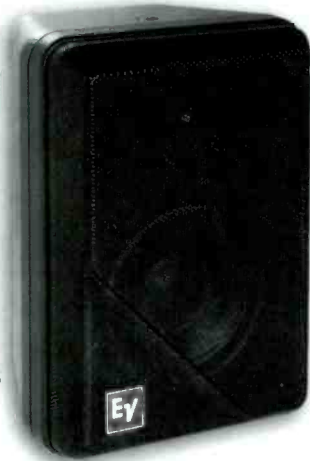

S-40 Black	60ELS40	MFR LIST	\$317.00 pair
S-40 White	60ELS40W	MFR LIST	\$317.00 pair

**Accessories:**

Black U-type bracket	60ELS40MB	MFR LIST	\$34.50 pair
White U-type bracket	60ELS40MBW	MFR LIST	\$34.50 pair
Omnimount WBX Arm Mount (one per speaker)	600M25WBXBC		\$28.00 ea

CALL 1-800-732-7665 FOR BRADLEY PRICE

### PIVOTELLI SPEAKER BRACKETS

Speakers can swing side to side and tilt up and down. The speakers are clamped front and back, and although screw holes are provided on the bottom of the bracket, you need not screw into most speakers. The distance to the wall is also adjustable. Pivotelli brackets have a five year warranty, and come with hardware for installation into wooden wall studs, brick, or concrete. Hold speakers up to 44 pounds and between 4" and 10" deep.

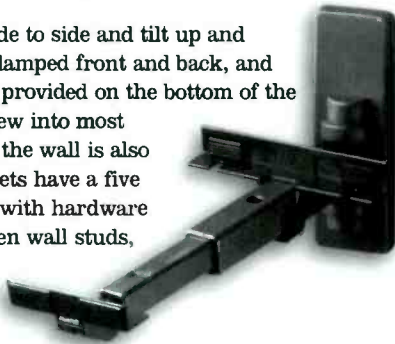

60PV55	MFR LIST	\$99.95 pair
--------	----------	--------------

CALL 1-800-732-7665 FOR BRADLEY PRICE

**Accessory:**

Metal stud kit required for mounting to metal studs. Order one kit per bracket.

60PVMSKS	MFR LIST	\$10.00
----------	----------	---------

### TASCAM PA-20 MKII

With its dual power, switchable stereo/mono design, this amp excels in control room and recording booth situations, running single, paired, or bridged speakers. It's equipped with both XLR balanced and RCA unbalanced inputs, optimized for +4dBm and -10dBV. It pumps 25 watts per side into 8 ohms stereo; throw a switch and you're in bridged BTL mode with 50 watts. Bright LED's tell you when the protection circuits are engaged so you can identify problems.

PA-20 MKII	60TEPA20MKII	MFR LIST	\$250.00	CALL 1-800-732-7665 FOR BRADLEY PRICE
------------	--------------	----------	----------	---------------------------------------

### HAFLER P-1000



The P-1000 brings the quality of Hafler's larger amps to a popular lower price and power range.

Conservatively rated at 50 watts per channel into 8 ohms and 55 into 4, the amp has both balanced XLR and 1/4", and unbalanced RCA, inputs. Outputs are barrier strip. "Trans-ana" design results in very stable, linear operation. The front panel has a power switch, a normal/bridged mono switch, level controls, headphone jack, and LED's for clip, thermal, and signal; the rear panel has a chassis/float ground switch and a balanced/unbalanced 115V/230V power line selector.

Expect response of +/-0.1dB from 20Hz to 20kHz, and +/-3dB from 0.1Hz to 100kHz (can you hear that high?). Convection cooling assures quiet operation. The warranty is five years.

P-1000	60HFP1000	MFR LIST	\$499.00
--------	-----------	----------	----------

CALL 1-800-732-7665 FOR BRADLEY PRICE

### HAFLER P-1500 AMPLIFIER



Hafler drew accolades with the introduction last year of its P-1500, and it deserved the praise. Suitable for studio monitoring and touring sound, it uses patented "Trans-nova" topology (for "transconductance nodal voltage amplifier") to produce a fine sound.

Features include 1dB gain controls with anti-tamper caps, XLR and 1/4" balanced inputs, binding post outputs, electronic fuse, lateral MOSFET output devices, two-channel or bridged mono output, and quiet convection-cooled design. LED indicators allow monitoring each channel. Other indicators include thermal, short, clip, and signal. The P1500 is rated at 75 watts per channel into 8 ohms, 85 into 4. This is a two-space rackable amp with a five-year warranty.

P-1500	60HFP1500	MFR LIST	\$549.00
--------	-----------	----------	----------

CALL 1-800-732-7665 FOR BRADLEY PRICE



## MONITORING

**CROWN D-75A & D-45 POWER AMPLIFIERS**

*Best Seller*



This is the model that pros all over the world specify by name. Rugged, easy to install, and reliable. The D-75A feeds 40 watts into 8 ohms, 55 into 4 ohms. It has detented level controls for each channel, headphone jack, barrier block outputs, and balanced combo XLR and 1/4" inputs, all in a single rack space. A distortion indicator alerts you in the unlikely event that distortion of any kind exceeds 0.05%.

The D-45 is a smaller amp, rated at 25 watts into 8 ohms, 35 into 4. It's identical to the D-75A except in power and price, and is suited to broadcast and recording nearfield monitoring, headphone amps, and small paging systems.

D-75A	60CR75	MFR LIST	\$625.00
D-45	60CR45	MFR LIST	\$475.00

CALL 1-800-732-7665 FOR BRADLEY PRICE

**STEWART HALF RACK POWER AMPLIFIERS**

The chassis of these half-rack amps act as heat sinks and keep them cool. The PA50B provides 25 watts per channel stereo into 8 ohms and 100 watts when bridged mono into 4; the PA100B and the PA200 will supply 50 watts and 200 watts respectively into 8 ohms.



Specs rival much more expensive units, with response of 20Hz to 20kHz, ±0.5dB, S/N of 98dB, and distortion at 1kHz only 0.1%. Inputs are 1/4" balanced, level controls are tamper resistant screwdriver pots on the front panel. The PA200, based on the PA100B, has knobs instead of screwdriver access, 1/4" phone output jacks, and a Stewart IEQ circuit.

We have Stewart amps rated up to 2x650 watts at 4 ohms. Call us!

PA50B	60SEPA50B	MFR LIST	\$299.00
PA100B	60SEPA100B	MFR LIST	\$399.00
PA200	60SEPA200B	MFR LIST	\$429.00

**Accessories:**

Single rack kit for PA	60SERMK1	MFR LIST	\$20.00
Dual rack kit for PA	60SERMK2	MFR LIST	\$30.00

CALL 1-800-732-7665 FOR BRADLEY PRICE

**SYMETRIX 420 POWER AMPLIFIER**



Wipe out powering problems without wiping out your budget. Hook up the 420 to studio monitors, nearfields, and multiple pairs of headphones. It's a handy two-channel amp, with XLR inputs paralleled with TRS 1/4" jacks, and screw terminal outputs. The 420 will drive up to 20 watts per channel stereo into a 4 or 8 ohm load, or 40 watts mono bridged. Typical distortion is less than 0.04%.

The mono sum feature lets you check compatibility of signals, or mix paging and music for commercial installations. Front controls include gangable level knobs, headphone jack with defeatable speaker mute, clip LEDs, and power switch.

420	60SY420	MFR LIST	\$399.00
-----	---------	----------	----------

CALL 1-800-732-7665 FOR BRADLEY PRICE

**U.S. AUDIO P-12 POWER AMPLIFIER**



Here's an ideal economical answer to situations that require low-powered amplification. The P-12 is a single-space unit with 11 watts per channel into 8 ohms. Simple controls include two channel gain, clip LED's, and a switch for speaker-or-headphone operation. Want to feed a headphone network? A special rear-mounted XLR jack interfaces directly to the separate SAT-1, a headphone breakout box with two channels and four outputs.



P-12	60WHP12	MFR LIST	\$269.00
SAT-1	60WHPHSAT	MFR LIST	\$199.00

CALL 1-800-732-7665 FOR BRADLEY PRICE

**RANE HC6 HEADPHONE CONSOLE**



Rack mount is standard on this fine system. A master stereo input drives six stereo headphone amplifiers, which provide both front and rear panel 1/4" TRS outputs. Each amplifier also has a separate mono balanced/unbalanced input, allowing the HC6 to act as six independent amps. The HC6 also has a master level control and mono/stereo push button.

HC6	60RNHC6	MFR LIST	\$479.00
-----	---------	----------	----------

CALL 1-800-732-7665 FOR BRADLEY PRICE



## HEADPHONE AMPLIFIERS

### SYMETRIX SX204 HEADPHONE AMPLIFIER

*Best Seller*



This headphone amp is part of the Symetrix SX series of half-rack products; it is popular with our customers. It's a 1 in, 4 out stereo headphone amplifier. Four independent stereo amps will drive even high-impedance headphones to maximum levels. Controls are master input level, stereo/mono switch, and individual level. Balanced or unbalanced inputs are on 1/4" TRS jacks, outputs also 1/4" TRS.

SX204	60SYSX204	MFR LIST	\$319.00
Accessory: Rack mount kit for one or two SX series units.			
	60SYRM2	MFR LIST	\$39.00

CALL 1-800-732-7665 FOR BRADLEY PRICE

### BENCHMARK HEADPHONE AMPLIFIERS

Put the monitoring right where you need it. You can use stereo headphone amps in your console, at your patch bay, in belpack mic preamps, or anywhere. Capable of driving both low and high impedance headphones, the HPA-1 includes a gain pot adjustable from off to +18dB. Requires ±9 to ±22VDC bipolar power, from a supply like the optional PS-1.

For a self contained headphone amp, we offer the IFA-7. Separate left and right XLR inputs ease installation. Requires PS-1 power supply.



HPA-1	60BMHPA1	MFR LIST	\$70.00
IFA-7	60BMIFA7	MFR LIST	\$195.00
Accessory:			
PS-1 power supply	60BMPS1	MFR LIST	\$35.00

CALL 1-800-732-7665 FOR BRADLEY PRICE

### HEADPHONE BREAKOUT

This passive Whirlwind winner has two stereo ins (for daisy chaining) wired to six resistor bridged outputs. Locking 1/4" TRS jacks prevent accidental disconnection.

61WHBB	\$79.00
--------	---------

### FOSTEX PH-50 HEADPHONE DISTRIBUTION AMPLIFIER

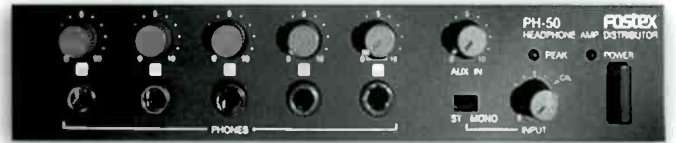

Drive up to five sets of headphones with this handy headphone amp. Each output has its own 100mw amplifier for individual settings. The main input is driven from a headphone output, and an aux input is provided for a second input from a cue system. Units may be cascaded for large ensembles, multimedia presentations, or educational applications.

PH-50	60FOPH50	MFR LIST	\$279.00
CALL 1-800-732-7665 FOR BRADLEY PRICE			

### SONY HEADPHONES

#### MDR-7506

Our all-time headphone champ, the MDR-7506 is widely hailed for its exceptional audio and comfort in a headphone that doesn't run into three figures. The clever collapsible design means they're easy to take with you. Audio from the 40mm drivers is crystal clear with 10Hz to 20kHz response. The closed ear design reduces noise and feedback. Gold 1/8" plug with screw-on 1/4" adapter. 36 ohms.

60SOMDRV6	\$89.00
-----------	---------

#### MDR-7504

The MDR-7504 yields a 15Hz to 18kHz frequency response from its 40mm drivers. Folding construction for compact storage. 45 ohms.

60SOMDR7504	\$84.00
-------------	---------

#### MDR-7502 (NOT PICTURED)

You can enjoy Sony headphone quality at an economy price-point with the 7502. A cost effective headphone with a 30mm driver and 60Hz to 16kHz response. 45 ohms.

60SOMDR7502	\$55.00
-------------	---------



**MONITORING**

Bradley Broadcast • 12401 Twinbrook Parkway • Rockville, MD 20852 • 800-732-7665 • 301-231-7800 • Fax: 301-230-6526 • email: info@bradleybroadcast.com

**SENNHEISER HEADPHONES**

**HD25-SP**

For dramatic isolation from outside noise, wear the HD25-SP. High efficiency drivers, modular parts, and great specs: 16Hz to 22kHz response, 105dB sensitivity, weight only five ounces. 70 ohms.

605NHD25SP  
\$109.95



**HD 445**

A light, high performance Open-Aire headphone with good deep bass, neodymium-ferrous magnets, and single cable entry. Replaceable parts, 1/8"-to-1/4" plug. 18Hz-21kHz, 52 ohms.

605NHD445 \$70.00



**BEYER DT 48**

For ENG and film monitoring, this specialty headphone has a coiled cable and 1/4" stereo jack. It offers flat accurate response and excellent isolation. Not for everybody. Specify 8, 25, or 200 ohms.

60BEDT48 \$269.00



**Skip the cable!**  
**Ask us about Beyer's**  
**IRS-790 infrared headphones.**

**AUDIO TECHNICA HEADPHONES**

**ATH-M40**

These, flat response phones are as comfortable as they look, well worth a listen. They are designed for pro monitoring and mixing. Closed back, neodymium magnet, 5-28,000Hz response, weight less than 9 oz. 60 ohms.

60ATATHM40 \$142.50



**ATH-910 PRO**

Also from A-T: the ATH-910 PRO with closed backs, large 44mm drivers, and an adjustable double headband. Earpads are replaceable. 20-22kHz response, weight about 7 oz. 1/4" plug. 30 ohms.

60ATH910 \$85.00



**KOSS TD61**

This economical, yet rugged headphone is ideal for budget requirements. Frequency response is an impressive 20-20,000 hz and Koss' "no questions asked" lifetime warranty adds even more value to your purchase. Includes 8 foot straight cord with 1/8"-1/4" stereo adaptor.

60KOTD61 \$18.85



**STANTON 101/HB**

DJs take note: Here's an affordable, single-cup headphone with soft vinyl-covered cushions and a 12' cord with 1/4" stereo plug, weighing about 5 oz. Black and pink. 100 ohms.

605T101HB \$59.00



**AKG MONITORS**

**K240 MONITOR**

Critical listening merits an exceptional headphone. This popular circumaural model simulates hearing in natural room conditions with its fine directional sound perspective and distance discrimination. The design combines main transducers and 12 passive diaphragms, with crossover at 200Hz. Weighs 8-1/2 ounces. Ten-foot cable, dual plug (1/4" and 1/8"). 600 ohms.

The DF model is a calibrated version for best reference-monitor performance. Both models are widely used for broadcast.

60AKK240 \$109.00  
60AKK240DF \$125.00



**K141 MONITOR**

Award-winning headphones from AKG. Semi-open back construction, hard gold plated jack plug and contacts, patented self-adjusting headband. Exciting bass, clear defined treble. Great price/performance ratio. 600 ohms.

60AKK141 \$79.00



**MONITORING**



## EQUALIZERS

### SABINE FEEDBACK EXTERMINATORS



Your graphic EQ is fine for shaping sound, but if you use it to control feedback, the width of its filters means you may be removing a lot of good stuff too. An FBX, placed in front of your power amp, senses feedback and, in less than a half-second, places a super-narrow adaptive digital filter on the resonating frequency. It's automatic and v-e-e-r-y precise.

This will help audio pros anywhere. You get feedback control and increased clarity. At last you can crank up those monitors. Connectors are XLR and 1/4" TRS, balanced and unbalanced. The FBX-1802 is a dual mono version with a few extra features thrown in.

The FBX SOLO is a miniature version of the 901, controlling feedback on one input channel. Pack one with your wireless mic setup. Monitor engineers can patch one on any offending channel. Mount up to six in a rack tray. Choose line or mic input versions; the latter has a pre-amp and phantom power.



FBX-901	60SBFBX901	MFR LIST	\$649.95
FBX-901/S 1/5 Octave Version	60SBFBX901S	MFR LIST	\$649.95
FBX-1802	60SBFBX1802	MFR LIST	\$1,299.95
FBX-SOLO Line version	60SBSL620	MFR LIST	\$324.95
FBX-SOLO Mic version	60SBSM620	MFR LIST	\$349.95
Rack Tray (holds 6 SOLOS)	60SBSL6RACK	MFR LIST	\$44.95

CALL 1-800-732-7665 FOR BRADLEY PRICE

### RANE MICRO-GRAPHIC EQUALIZERS

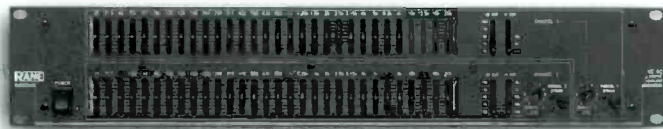

Reliable Rane EQ's are now improved with both balanced XLR and 1/4" TRS connectors. Their filters are constant Q with grounded center-detent controls. The ME-15B is a two-channel, 2/3 octave device in one rack unit; the ME-30B is one-channel, 1/3 octave in one rack unit. Features include overall level control, bypass mode, 20mm sliders, RFI filtering, and  $\pm 6$  or 12dB slider range.

The ME60 is a two-channel, 1/3 octave EQ with sweepable low and high cut, in a two RU chassis. It's like two ME30's in one unit, with some nice extras. It uses XLR, 1/4" TRS, and RCA jack I/O; sliders are 20mm. Need longer sliders? Ask about the GE60.

ME-30B mono 30-band	60RME30B	MFR LIST	\$419.00
ME-15B stereo 15-band	60RME15B	MFR LIST	\$429.00
ME-60 stereo 30-band	60RME60	MFR LIST	\$699.00

CALL 1-800-732-7665 FOR BRADLEY PRICE

### YAMAHA GRAPHIC EQ'S



Submitted for your consideration, three fine graphic EQ's, all with balanced XLR and unbalanced 1/4" connectors, switchable levels (+4/-20), EQ bypass, boost and cut, and peak indicators that warn of near-clipping.

Q2031B is a classy, stereo 31-band graphic EQ in two rack spaces. An automatic circuit mutes the output for 3-5 seconds after power is switched on. You get 6 or 12dB of boost or cut, with points centered at ISO 1/3 octave frequencies from 20-20kHz. Sockets for output transformers are included on the rear panel.

GQ2015 is a compact dual, 2/3 octave, 15-band EQ in one RU. GC1031-BII is a high performance 1/3 octave, 31-band EQ in one RU.

Q2031B	60YAQ2031	MFR LIST	\$749.00
GQ2015	60YAGQ2015	MFR LIST	\$429.00
GQ1031-BII	60YAGQ1031B2	MFR LIST	\$399.00

CALL 1-800-732-7665 FOR BRADLEY PRICE

### RANE GE215 AND GE130 GRAPHIC EQUALIZERS



The GE215 (pictured) is a 2 channel, 15 band, 2/3 octave design, while the GE130 is a single channel, 30 band 1/3 octave version. Both units feature +12/-15db boost/cut range, and rack mount in two rack spaces. Constant-Q design, a Rane innovation, prevents unwarranted interaction between filters, while still producing the types of correction curves demanded by even the most unusual acoustic situations. An overall level control is provided for each channel, as well as overload indicators. A bypass switch is provided, and the rear panel has both XLR and Euroblock terminal connectors for both inputs and outputs.

GE215	60RNGE215	MFR LIST	\$599.00
GE130	60RNGE130	MFR LIST	\$569.00

CALL 1-800-732-7665 FOR BRADLEY PRICE

### ASHLY CL52E DUAL COMP/LIMITER



Place a ceiling on the peak levels of your program material. The CL-52E lets you set the amount of gain reduction, attack/ release times, and output gain. Features include trigger circuit patch, variable threshold, variable ratio from 2:1 to infinity:1, variable attack and release, and LED's to indicate up to 20dB of reduction. The CL52E provides two channels of gain reduction in one compact package, strappable for stereo.

CLX52E	60ASCLX52	MFR LIST	\$499.99
--------	-----------	----------	----------

CALL 1-800-732-7665 FOR BRADLEY PRICE

## AUDIO PROCESSING

Bradley Broadcast • 12401 Twinbrook Parkway • Rockville, MD 20852 • 800-732-7665 • 301-231-7800 • Fax: 301-230-6526 • email: info@bradleybroadcast.com

**DBX 166A DUAL  
COMPRESSOR/LIMITER/GATE**



A compact, high performance tool with two independent channels, each combining OverEasy compression, PeakStop, and a soft knee expander gate. The front panel gives you stereo or dual-mono operation. Connectors: balanced XLR and unbalanced 1/4" inputs and outputs, IEC AC connector.

Prevent transient peaks from overloading your digital recorder; make an intimate vocal stand out in a music mix; use compression for jingles and post production.

**166A          60DB166          MFR LIST          \$419.95**

**CALL 1-800-732-7665 FOR BRADLEY PRICE**

**DBX 160A COMPRESSOR/LIMITER**



Use this classic device to control variation in levels, raise a signal out of a mix, transfer between digital and analog media, prevent tape saturation, and protect speakers. The "A" in the name means a better signal path, single front panel with rack ears, IEC AC connector, ground lift switch for pin 1 of the XLR input, and a stronger chassis.

Choose OverEasy or classic hard knee compression. The 160A gives variable compression ratio from 1:1 through infinity to negative compression, a dual RMS LED display that monitors input or output and gain reduction, up to 60dB of gain reduction, compression threshold from -40dB to +20dB, and balanced and unbalanced outputs that can drive loads simultaneously.

Setup is easy, metering is precise. Two 160A's can be stereo-coupled to process an entire mix or instruments miked in stereo.

**160A          60DB160X          MFR LIST          \$459.95**

**CALL 1-800-732-7665 FOR BRADLEY PRICE**

**RANE DC24 DYNAMIC CONTROLLER**

Take advantage of effective split-band processing in a single, affordable box. The DC24 is a two-channel compressor, limiter, expander gate with controls for compression ratio & threshold, expander/gate ratio & threshold, and limiter threshold. Gain reduction meters keep you up to date.

The internal crossover allows a single audio channel to be divided into two bands, processed separately, and re-combined into one channel. This crossover may also serve as a dividing

**DBX 1066 DUAL  
COMPRESSOR/LIMITER/GATE**



It's new and it's packed: OverEasy soft knee compression, zero-attack PeakStopPlus limiter, 70dB expander/gate, 12-segment gain reduction meters, over/under LED's, and peak-reading I/O meters. Vary the ratio to select anywhere from gentle downward expansion to gating. Link both channels for stereo compression. Adjust your attack and release times or let the unit do it.

Monitor input or output. You can A/B your audio with or without sidechain processing. Work in the dark thanks to illuminated switches. Use either the balanced XLR or unbalanced 1/4" TRS connectors; convert semi-pro -10dBV audio to the internal +4dBu. Forget "Y" cables; sidechain sends and returns are on separate jacks. The internal supply lets you use this box all over the world.

Each channel has the following controls: expander/gate threshold & ratio, compression threshold & ratio, compression attack & release times, output gain, and limiter threshold.

**1066          60DB1066          MFR LIST          \$549.95**

**CALL 1-800-732-7665 FOR BRADLEY PRICE**

**SYMETRIX 501 PEAK-RMS  
COMPRESSOR/LIMITER**



Capture your audio at the highest resolution without overshoot or distortion with this fine single-channel compressor/limiter. Radio stations will use it for voiceovers and recording music because it ensures consistent program levels. Protect PA amps and speakers from spikes. It's also a good companion for your cassette or DAT machine, helping you get the most from your audio.

RMS and interactive peak control, manual or automatic attack/release, and stereo link port are included. Input/output connectors are balanced XLR and unbalanced 1/4" TRS. The compressor is RMS responding, like the human ear, so your sound is more consistent and enjoyable.

**501          60SY501          MFR LIST          \$379.00**

**CALL 1-800-732-7665 FOR BRADLEY PRICE**



network allowing all processing functions for each band. Connections are XLR and 1/4", with gain switches for -10/+4; RFI filtering is built in. Individual channel hard wire bypass switches are also provided.

**DC24          60RND24          MFR LIST          \$599.00**

**CALL 1-800-732-7665 FOR BRADLEY PRICE**



## LEVELERS / DELAYS / EFFECTS

### SYMETRIX AGC/LEVELERS



A Symetrix AGC/Leveler is the solution for inconsistent levels. Unlike a compressor/limiter, it not only pushes "down from the top" but also makes your quiet sounds louder, with finesse.

Got a walkaway automation system? Pick the stereo 422 to feed your air chain processing a steady diet. Got loud commercials on your cable TV system? Not any more. Use it to convert "all-over-the-place" audio to a smooth, constant level. This model is also handy in theaters, tape duplication work, and music mixdown.

Set up is easy; just set your target level and let the unit gently boost low levels and compress hot ones. Peak limiter, I/O metering, and remote bypass port are standard. The 422 handles line-level audio. Connectors are balanced XLR and 1/4" TRS.

Working with mics? The Symetrix 421m may be the better



choice. It's a single-channel AGC/Leveler with many of the same features as its sibling. It also has both a line input (1/4" TRS and screw terminals) and mic input (XLR with phantom), and provides selectable speech curve filters to get the most out of voices. A downward expander keeps the output quiet when audio is absent. Good for churches, paging systems, auditoriums. It's linkable for stereo and can also be used on program material. Both models are UL approved.

422	60SY422	MFR LIST	\$595.00
421m	60SY421M	MFR LIST	\$569.00

CALL 1-800-732-7665 FOR BRADLEY PRICE

### APHEX DOMINATOR II LIMITERS



Limiting is important but you want to avoid dullness and "hole punching" in your audio. Apex designed the Dominators to reduce the audible side effects of limiting. This means greater limiting depth for higher loudness without sacrificing audio quality. As a peak overshoot protection limiter, the Dominator is undetectable while it prevents peak levels from exceeding the level you set. The result is greater density and punch.

The 720 is a stereo, three-band peak limiter with a 104dB dynamic range, compatible with your digital equipment. Model 722 adds pre-emphasis (either 50 or 75  $\mu$ sec) before the limiters. A de-emphasis circuit appears after the final limiter. Both pre-emphasis and de-emphasis are switchable. The 722 is designed for use in broadcast, satellite, and transmission links.

720 Dominator II	60AP720	MFR LIST	\$1,350.00
722 Dominator II	60AP722	MFR LIST	\$1,495.00

CALL 1-800-732-7665 FOR BRADLEY PRICE

### RANE AUDIO DELAYS



Rane has several delay models for your situation. The AVA-22 is for A/V synchronizing, providing two channels of audio delay in video increments, up to 9.5 NTSC frames and 8.0 PAL/SECAM frames. Features include half-frame increments, remote memory recall, two memories per channel, and front-panel lockout. Suitable for TV and video post.



The AD-22 is a balanced, two in/two out audio delay with a range of 0.011 to 327.68 milliseconds on each output. The delay is adjustable in 10 microsecond and 1 millisecond increments. Each output has two non-volatile memories of delay values. Quality is assured with Dolby Time Link 1-bit delta-sigma circuitry. Features include front panel lockout and fail-safe bypass in case of power loss.

The AVA-22 and AD-22B use XLR connectors; the AD-22 has terminal strips.

AVA-22	60RNAVA22	MFR LIST	\$899.00
AD-22	60RNAD22	MFR LIST	\$849.00
AD-22B	60RNAD22B	MFR LIST	\$849.00

CALL 1-800-732-7665 FOR BRADLEY PRICE

### EVENTIDE DSP-4000B ULTRA-HARMONIZER®



The software on board this digital-ready effects processor was created especially for radio, TV, and post-production. Push a button, you're the voice of a computer. Push another, you're talking through a car phone. Yet again, and we hear you talking from the cabin of an airplane. Choose from dozens of environments.

You also get sound effects and audio backgrounds: thunder and rain, the surf, a passing plane. You can be on a mountaintop or at the bottom of the ocean. Reverbs, choruses, flanging, and pitch change are here, along with TimeSqueeze™ time compression. Store your creations on internal memory or removable PCMCIA card. Create a cast of characters and settings for your morning show or any special production. XLR and 1/4" analog. MIDI in/out/thru and PA422 serial port data connectors are provided.

An available option for the DSP-4000B is an AES/EBU and S/PDIF digital I/O for an all-digital path, plus an optional sampler board adds more power.

DSP-4000B	60EV4000B	MFR LIST	\$3,995.00
ES/EBU Option	60EVAESOPT	MFR LIST	\$1,000.00

CALL 1-800-732-7665 FOR BRADLEY PRICE

## AUDIO PROCESSING



**DBX PROJECT 1  
AUDIO PROCESSORS**

Project 1 processors capitalize on today's technology to give you dbx audio performance at low cost. All four models shown are rack mountable.



The 266 is a compressor/gate with two channels of compression, program-adaptive expander/gates, and AutoDynamic attack and release controls. Balanced inputs and unbalanced outputs are on 1/4" TRS connectors. Side chain insert is standard. Set it for stereo or dual mono operation.



The 296 Spectral Enhancer makes your vocal and instrument tracks sparkle. It's a dual channel processor for detailing and cleaning up mixes or individual tracks. Separate controls let you set the amount of high frequency and low frequency enhancement. Hiss Reduction circuitry removes hiss instead of adding it, a common problem in HF equalization. LF Detail adds mass to the bottom end and reduces muddiness. LED metering of filter activity and clip indicators are standard. The 296 uses 1/4" TRS connectors, balanced in, unbalanced out (balanced output in bypass mode).



The 286 is an all-in-one mic processor with preamp, OverEasy compression, de-essing, spectral enhancement, and expander/gate. Phantom power, high-pass filtering, and input gain control are provided. The XLR mic input accepts balanced or unbalanced inputs; a 1/4" TRS jack takes line signals. Use the insert jack to add external gear between the preamp and processors.



The 290 stereo reverb has six reverbs in one rack space: room, hall, chamber, plate, cathedral, and gate. Select dark, medium, or bright ambiance. This is a stereo device with balanced I/O on 1/4", footswitch port, and MIDI in.

266	60DB266	MFR LIST	\$249.95
296	60DB296	MFR LIST	\$349.95
286	60DB286	MFR LIST	\$349.95
290	60DB290	MFR LIST	\$399.95

CALL 1-800-732-7665 FOR BRADLEY PRICE

**DBX PERFORMER & PRODUCTION  
SERIES PROCESSORS**

Half-rack signal processors from one of the most famous names in processing. The 140X and 150X have electronically balanced inputs and outputs on 1/4" TRS jacks, and are designed to operate at +4dBm. All other models have unbalanced 1/4" TS inputs and outputs on their rear panels. All include hardware to mount one or two units.

**163A COMPRESSOR/LIMITER**

Famous dbx

OverEasy compression is controlled by a single slide control. An LED display indicates the amount of compression and two units may be strapped for stereo. Front panel 1/4" instrument input.



163A	60DB163X	MFR LIST	\$169.95
------	----------	----------	----------

**263A DE-ESSER**

The 263A has a single slider for adjusting sibilance reduction, plus a knob for sensitivity to specific sibilance frequencies and a push button for selecting bandwidth. Even if the input levels vary as much as 45dB, patented circuitry delivers the exact de-essing required. Front panel 1/4" mic input.



263A	60DB263X	MFR LIST	\$169.95
------	----------	----------	----------

**363X DUAL CHANNEL NOISE GATE**

A dual-channel noise gate with individual control of threshold, hold, and release. The 363X has Key Engage and Key Monitor for each channel, plus separate channel bypass switches. Strappable for stereo.

363X	60DB363X	MFR LIST	\$269.95
------	----------	----------	----------

**140X AND 150X NOISE REDUCTION**

Get more than 40dB of extra dynamic range from your audio systems. For limited bandwidth devices (telco, cart decks, STL's, certain digital gear), use Type II noise reduction with the 140X. For full bandwidth systems (studio open reel recorders, digital systems sampled at more than 40kHz), use Type I with the 150X. Both are two channels of encode/decode with bypass switches for each circuit.

140X	60DB140X	MFR LIST	\$319.95
150X	60DB150X	MFR LIST	\$319.95

CALL 1-800-732-7665 FOR BRADLEY PRICES ON ALL OF THESE DBX PRODUCTS

**Bradley carries the Alesis family  
of processors, too. Call for details.**



# PROCESSORS

## YAMAHA EFFECTS PROCESSORS

The SPX-990 has 80 great preset effects and 100 memory locations into which you can store your own versions. The 990's two-in/two-out setup allows stereo sources to be processed without disrupting the original stereo image. Effects include natural reverb, tempo-based delays, and various pitch change and combination effects. Inputs and outputs are analog, electronically balanced, with XLR and TRS 1/4" connectors. A/D-D/A are 20 bits.

The classic SPX-1000 provides 40 preset programs including pitch change, distortion, natural reverberation and early reflections, delay and echo, and various combinations. Presets can be edited, retitled, and stored in user-defined memories; each program has a range of parameters and EQ to tailor the effect. Program five effects at the same time. Other features include MIDI implementation, 1/4" unbalanced analog I/O connectors, and Yamaha-format digital I/O. A/D-D/A are 16 bits.

Both models provide switchable stereo -20dBV and +4dBm I/O.



SPX-990	60YASPX990	MFR LIST	\$1,179.00
SPX-1000	60YASPX1000	MFR LIST	\$1,829.00

CALL 1-800-732-7665 FOR BRADLEY PRICE

## BOSS VT-1

Put this in the hands of a good air talent, and watch the crowds flock to your next remote. The VT-1 is a little box with simple controls that let you alter incoming mic audio and produce hilarious results: women sound like Barry White, men sound like leprechauns, kids sound like robots. Take a couple to your next remote, wire in some mics, and let the listeners play. Or use it for your morning show and production guru. Presets let you switch between effects quickly.

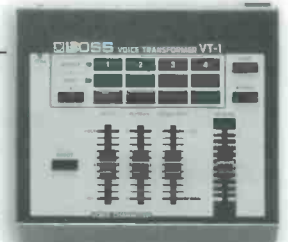

VT-1	60RAVT1	MFR LIST	\$395.00
------	---------	----------	----------

CALL 1-800-732-7665 FOR BRADLEY PRICE

## RANE VPI2 VOICE PROCESSOR



The VP12 incorporates a studio grade mic preamp, balanced line input, low and hi cut filters, de-esser, gate/compressor, and two channel parametric EQ. Mic and line inputs may be summed through the subsequent processor stages, allowing input from other outboard mic preamps, or from wireless mic receivers.

VP12	60RNVPI2	MFR LIST	\$599.00
------	----------	----------	----------

CALL 1-800-732-7665 FOR BRADLEY PRICE

# A BETTER

# VP12

BETTER DE-ESSER  
with ratio control.



BETTER input section with both mic and line (wireless) inputs that can be summed together



BETTER Signal-To-Noise Ratio : 97dB.

VOICE PROCESSOR

BETTER mic preamp  
utilizing the SSM 2017 chip

**APHEX 320A COMPELLOR**



Ride gain like a cowpoke rides a bronco: quickly and intelligently. The Compellor compresses, levels, and limits peaks. These functions were designed to work together. The leveler provides a platform based on long term average audio levels. The compressor readily handles short term gain changes. A process balance control varies the ratio of these two functions. A fast peak limiter follows, to catch any overshoots and hold them to an absolute peak value. A silence gate prevents gain pumping during slow fades. You decide how much the lowest level signal will be brought up and the proportion of leveling to compression, and trim the output for unity gain.

The transparent audio path is servo-balanced (XLR) inputs and outputs and the Aphex VCA 1001. The unit works in dual mono or one of two stereo link modes. A Bradley Best Seller.

320A Compellor 60AP320 MFR LIST \$1,350.00

CALL 1-800-732-7665 FOR BRADLEY PRICE

**YAMAHA REV100 DIGITAL REVERB**

With 99 editable presets, the, affordable REV100 reverberates with standard reverb, stereo reverb, "gated" reverb for warmth or ambiance, mono and stereo delay for repeats or bouncing effects, delay/reverb combinations, and reverb/modulation effects including flange, chorus, and symphonic.

**SYMETRIX 528E VOICE PROCESSOR**



Use it for announce mics, voice-over studios, and PA systems. More than a preamp, it's a self-contained voice processor. It enhances intelligibility, reduces off-mic noise, and increases perceived presence. It performs six functions: mic preamplification, de-essing, downward expansion, compression/limiting, voice symmetry alignment, and parametric EQ.

Preamp gain is variable up to 60dB; 48V phantom power is provided for your condenser mics. A switchable 15dB pad, mic/line input switch, RFI protection, and variable EQ bandwidth are standard. Mic and line inputs and the balanced output are XLR; the unbalanced out and other connections are 1/4".

528E 60SY528E MFR LIST \$699.00

CALL 1-800-732-7665 FOR BRADLEY PRICE



The simple controls include input level, mix balance (wet/dry), decay, delay, and level. Connectors are analog 1/4" I/O and a MIDI port. This unit uses an external A/C adapter.

REV100 60YAREV100 MFR LIST \$299.00

CALL 1-800-732-7665 FOR BRADLEY PRICE

**MOU T H T R A P**

BETTER EQ section with each band covering 20-20K with filters in series.

BETTER output section with main and aux to feed 2 devices or a stereo input.

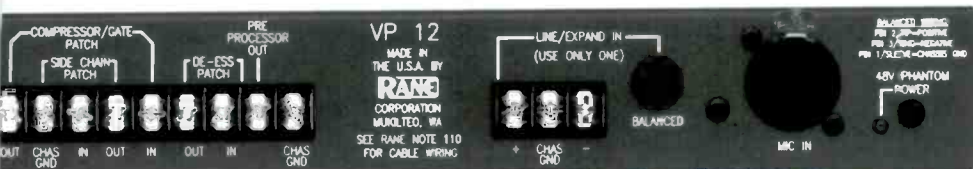

RANE CORPORATION

Phone: 206-355-6000

Fax: 206-347-7757

Home Page: <http://www.rane.com>

BETTER THD+Noise spec: 0.009%

BETTER Equivalent Input Noise spec: -130 dBu.

BETTER Price (Really!)

BETTER contact your local RANE dealer and check one out!



## PROCESSORS/ SAMPLE RATE CONVERTERS

### LEXICON EFFECTS PROCESSORS



Fans of the classic Lexicon PCM-70 will be delighted with the PCM-80 digital effects processor, with classic and new effects, 200 programs, and digital I/O for use with ADAT and other popular devices. All programs are discrete stereo; all programs incorporate multi-voice delay effects AND reverb (not either/or). You get RAM or ROM storage with PCMCIA data card for future software upgrades. It uses balanced analog 1/4" jacks and S/PDIF digital coax connectors.

PCM-80                      60LEPCM80                      MFR LIST                      \$2,745.00

CALL 1-800-732-7665 FOR BRADLEY PRICE

### ALESIS QUADRAVERB 2



The Q2 is like eight effects units, interconnected with an automated mixer/patch bay that can route signals between the inputs and outputs of each. Since you have eight simultaneous effects available to be combined, layered, or split between two input and two output channels, your capabilities go up exponentially. Each of eight blocks can act as a stereo or mono chorus or flanger, EQ, pitch shifter, five second delay (mono, stereo, ping-pong, or multi-tap), or multiple reverb.

The LCD display shows routings as "digital patch cords" between blocks. Each block can receive a mix of inputs from other blocks or from the input jacks. Besides balanced and unbalanced analog ports, the Q2 connects to ADAT via digital optical.

QuadraVerb 2                      60AEQV2                      MFR LIST                      \$799.00

CALL 1-800-732-7665 FOR BRADLEY PRICE

### ART FXR SIGNAL PROCESSORS

These two-channel units have reverb, gated reverb, panning, chorusing, flanging, and multiple types of delay. Inputs and outputs are on unbalanced 1/4" connectors.

The FXR processor provides 250 preset combinations, up to four effects at once, and random access memory for complex reverbs. It works mono in/out, stereo in/out, or as two independent processors in one chassis. Run vocals through one channel, instruments through the other.

The FXR Elite II is a programmable version, allowing the user to vary parameters and store the changes. It's responsive to MIDI patch change protocol, and offers foot-switching through the MIDI program table.



FXR 423                      60MX423                      MFR LIST                      \$259.00

FXR Elite II 434                      60MX434                      MFR LIST                      \$345.00

CALL 1-800-732-7665 FOR BRADLEY PRICE

### ATI MULTIPLE AMPLIFIER ARRAYS



ATI's UL-listed arrays can be used alone or in sets to create a mic distribution amp, headphone amp, consumer-to-pro interface, press box, or simple mixer. They combine gain control, distribution, and mixing in a single rack space. They're available in four or eight channels of line-to-line (to 42dB) amplification.

Rear panel jumpers let you create combinations of distribution amplifiers, mono summing networks, or sum and difference networks. Call us if you prefer XLR termination strips or for info on mic-to-line versions.

4 channel line amp, transformer outputs                      60AIMLA4001                      MFR LIST                      \$515.00

4 channel line amp, differential outputs                      60AIMLA4002                      MFR LIST                      \$389.00

8 channel line amp, transformer outputs                      60AIMLA8001                      MFR LIST                      \$799.00

8 channel line amp, differential outputs                      60AIMLA8002                      MFR LIST                      \$599.00

CALL 1-800-732-7665 FOR BRADLEY PRICE

### Z-SYSTEMS SAMPLE RATE CONVERTERS



The Z-2SRC Sample Rate Converter is an uncommonly good way to convert from one digital audio rate to another. The digital design provides the best audio conversion for CD to DAT, visperseed to 44.1, DAW to digital mixer, and other uses. Features include jitter reduction, format conversion, and external sync. Ins and outs are AES/EBU, S/PDIF, coax, optical, and XLR.

Get the same audio quality in a smaller, economical package with "Z-Link". It's built on the Analog Devices AD1890 asynchronous chip and puts out 44.1 and 48kHz using precise crystal references. You get switch-selectable AES/EBU and S/PDIF output flags on transformer-isolated RCA or BNC connectors, with 20-bit resolution, 120dB dynamic range, and -106dB THD+N. Yes the specs are impressive, and that's what you want when your audio is at stake. The "plus" version adds AES sync input and loop-through for sync to other sample rates and sources.

Z-1SRC                      60ZS2SRC                      MFR LIST                      \$1,200.00

Z-Link                      60ZS2LINK                      MFR LIST                      \$430.00

Z-Link+                      60ZS2LINKP                      MFR LIST                      \$599.00

CALL 1-800-732-7665 FOR BRADLEY PRICE

## AUDIO PROCESSING AND INTERFACE

Bradley Broadcast • 12401 Twinbrook Parkway • Rockville, MD 20852 • 800-732-7665 • 301-231-7800 • Fax: 301-230-6526 • email: info@bradleybroadcast.com

Rack-Ups™ are small studio problem solvers that operate on 24 volt DC (don't forget to order the power supply). Several units can run on a single supply, up to its current limits.

Any module can mount using the tenacious adhesive strips provided, or order the optional rack kit to mount up to three side-by-side. Other options allow under-counter or flush mounting; or choose a one-rack-space universal chassis that holds up to five Rack-Ups and eight Stick-Ons. Call Bradley for a pamphlet that describes all of the hardware in detail.

**AUDIO DA**

Distribute line-level signals. The DA-4D handles one stereo in to four out, or one mono in to eight out. Recessed level controls and audio presence indicators are provided. Connect balanced or unbalanced, high or low impedance lines on the rear-panel barrier blocks.



RU-DA4D \*      60RDRUDA4D      MFR LIST      \$231.00

**AUDIO DA WITH XLR**

This DA uses XLR connectors to distribute line-level audio. Plug your source into the front panel XLR or wire it to the rear panel barrier block. The 150 ohm balanced outputs appear on XLR's on the front panel. An input gain trim is provided; inputs are RF filtered. Inputs may be strapped to provide phantom power. An unbalanced DA with phono connectors is also available.

RU-BDA3 \*      60RDRUBDA3      MFR LIST      \$223.00

**IHF-PRO INTERFACE**

Balanced and unbalanced devices can "talk" to each other. This connectorized audio interface provides gain trim on both channels, gain adjustments in both directions. Unbalanced connections are on phono jacks, balanced are XLR and/or barrier block.

LA2D \*      60RDRULA2D      MFR LIST      \$266.00

**MIC/LINE MIXER**

Here you get five channels of audio mixing, with all connections on barrier blocks. Four of the inputs accept mic or line level; the fifth is line only. A rear panel jumper connects 24VDC phantom voltage to any or all of the mic inputs. Output level indication and channel controls are provided.



RU-MX5 \*      60RDRUMX5      MFR LIST      \$248.00

**(\*) POWER SUPPLY**

For use with Rack-Ups and Stick-Ons. 24V single ended DC, 400ma. UL Listed.

PS-24A      60RDXFMR      MFR LIST      \$17.00

**CALL 1-800-732-7665 FOR BRADLEY PRICE**

**STEREO LINE AMP**

This unit has two separate, isolated line amplifiers. Use it for stereo or as two individual monaural amps. Inputs are balanced bridging and enter the front via XLR. Outputs are on XLR and are low impedance balanced, for short or long balanced lines. Gain trim controls for each channel are provided.

RU-BLA2 \*      60RDRUBLA2      MFR LIST      \$238.00

**MICROPHONE DA**

Use it to distribute connectorized mic-level audio. Drive short or long balanced lines.



Front-panel XLR outputs, front (XLR) and rear (barrier) inputs, input gain trim, and selectable phantom on input.

RU-MDA3 \*      60RDRUMDA3      MFR LIST      \$226.00

**DUAL MIC PREAMP**

RDL's connectorized mic-to-line audio preamplifier features two isolated preamps, for stereo or dual mono operation. Inputs may be strapped to provide phantom power through the standard XLR connectors. Outputs are driven through front XLR's and rear barrier block. Gain trim from 35 to 65dB. (RDL mic preamps can operate on 12VDC with a loss of 6dB headroom.)

RU-MP2 \*      60RDRUMP2      MFR LIST      \$299.00

**DUAL AUDIO METER**

Large LED's let you see this meter across the room. Features include two separate line-level inputs, selectable peak or average metering, selectable L+R/L-R, channel calibration controls, and write-on label area.

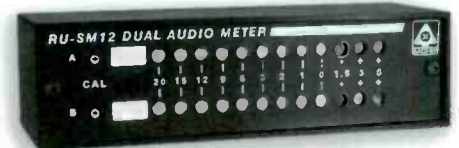

RU-SM12 \*      60RDRUSM12      MFR LIST      \$213.00

**TRIPLE RACK MOUNT**

Mounting for three Rack-Ups in a single rack space. Order RU-FP1 fillers for unused slots or to reverse-mount any Rack-Up. Choose the JP-1 Universal Jack Panel for custom mounting of your own connectors.

RU-RAJ Triple Rack Mount      60RDRURA3      MFR LIST      \$29.00  
 RU-FP1 Filler      60RDRUFF1      MFR LIST      \$10.00  
 JP-1 Jack Panel      60RDJP1      MFR LIST      \$15.00

**AUDIO INTERFACE**



*Best Seller*

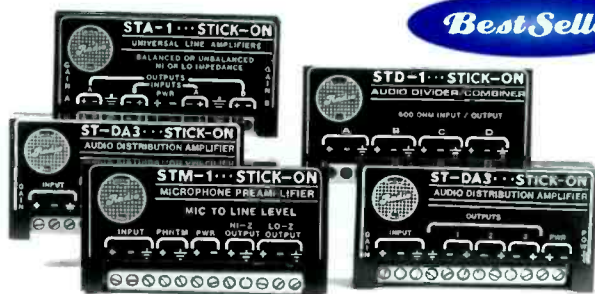

What are Stick-Ons? They fit in your hand. They're simple to install, and provide super audio despite their size. What do they do? Well: most anything.

Stick a module onto any surface by attaching its stiff adhesive strip to an edge or side.

All modules marked (\*) require a power supply, purchased separately. The PS-24A can power any Stick-On, and sometimes more than one depending on the mix.

**ST-AMC3 Active Mic Combiner** lets you expand a mic input on your mixer. Combines three mic-level inputs, with gain settings, to one mic-level output.

**ST-AMC3 \*      60RDSTAMC3      MFR LIST      \$114.00**

**STM-1 Mic Preamp** is a Hi or Lo Z preamp for commercial sound and broadcast. It provides a fixed 50dB gain to bring a mic signal up to the range of nearly any line input. Balanced or unbalanced output; internal/external phantom capability. For intercom use, the input will operate directly from a speaker.



**STM-1 \*      60RDSTM1      MFR LIST      \$96.00**

**STM-2 Mic Preamp** is extra low noise and has gain adjustment from "off" to 65dB, two balanced or unbalanced outputs, and more. If you need even more gain, ask about the STM-3. RDL mic pre-amps can operate on 12VDC with a loss of 6dB headroom.

**STM-2 \*      60RDSTM2      MFR LIST      \$132.00**

**ST-MPA2 Mic Phantom Adapter** allows you to add phantom-powered mics to standard inputs. Power two mics with one module. Full response; trim-pot adjustable voltage.

**ST-MPA2 \*      60RDSTMPA2      MFR LIST      \$83.00**

**ST-MX3 Mixer** has three adjustable line level inputs and a single output. It allows you to combine signals of different levels, impedances, or balanced/unbalanced configurations. The ST-MMX3 is similar, but inputs are at mic level, output is line.

**ST-MX3 \*      60RDSTMX3      MFR LIST      \$120.00**

**ST-MMX3 \*      60RDSTMMX3      MFR LIST      \$126.00**

**CALL 1-800-732-7665 FOR BRADLEY PRICE**

**STA-1M Audio Line Amplifier** has a gain range of -14dB to +7dB when using the balanced I/O. When using the unbalanced I/O, the gain range is -7dB to +14dB. Single channel.

**STA-1M \*      60RDSTA1M      MFR LIST      \$100.00**

**ST-TC1 Telephone System Coupler** connects to your phone system KSU, simulating a telco CO line and letting you add radio control or paging. When the line is seized, the ST-TC1 provides a relay closure to control the equipment of your choice. An audio feed is available for input to or output from the KSU.



**ST-TC1 \*      60RDSTTC1 \*      MFR LIST      \$120.00**

**STP-1 Attenuator** is useful for reducing input levels to improve headroom. Each STP-1 has two variable modified "H" pads providing up to 85dB attenuation. A 15 turn trim pot allows adjustment of levels.

**STP-1      60RDSTP1      MFR LIST      \$55.00**

**ST-DA3 Distribution Amplifier** has one input, three outputs. Use two for 2x6 stereo output. Master gain adjustment provides up to 20dB gain. Inputs and outputs are RF bypassed. If the source is mic level, choose the STM-DA3 mic DA, feeding one 150 ohm signal to three isolated outputs.



**ST-DA3 \*      60RDSTDA3      MFR LIST      \$126.00**

**STM-DA3 \*      60RDSTMDA3      MFR LIST      \$126.00**

**STA-1 Electronic Transformer Pair** combines an electronic line transformer and adjustable 20dB gain amplifier. There are two circuits in each unit for stereo operation. Typical applications include: balanced to unbalanced interface, unbalanced to balanced bridging amp, monaural combiner, stereo splitter, and Hi-Z amplifier.

**STA-1 \*      60RDSTA1      MFR LIST      \$136.00**

**STD-1 Divider/Combiner** is a passive, four channel device where any channel may be an input or output. Branch a 600 ohm line to three inputs, combine stereo signals to a mono input, branch or combine 150 ohm mic signals, or divide a mono signal to apply stereo inputs.

**For 150-ohm      60RDSTD1150      MFR LIST      \$49.00**

**For 600-ohm      60RDSTD1600      MFR LIST      \$49.00**

**For 10K-ohm      60RDSTD10K      MFR LIST      \$49.00**

**\* Modules with a \* require a power supply, sold separately. See page 83.**

**AUDIO INTERFACE**

**MORE RADIO DESIGN LABS**

**ST-ACR** Audio Controlled Relays let you control switching from any audio signal. Multi-turn adjustments cover the range from mic to line level. Relay release can be adjusted from 1/2 to 5 seconds on the ACR1, and from 5 to 50 seconds on the ACR2. Double-pole, double-throw switching contacts are provided. A "slave" terminal connects Stick-On logic controlled relays (see below).

ST-ACR1 *	60RDSTACR1	MFR LIST	\$90.00
ST-ACR2 *	60RDSTACR2	MFR LIST	\$90.00

**ST-LCR1/ST-LCR2** Logic Controlled Relays provide double-pole, double-throw switching contacts, open-collector outputs, and an LED indicator of relay closure. Dual inputs

ST-LCR1 * momentary action	60RDSTLCR1	MFR LIST	\$70.00
ST-LCR2 * alternate action	60RDSTLCR2	MFR LIST	\$103.00



**Also Available:**

ST-MXL3 *Mixer: 3 Line to 1 Mic (new)	60RDSTMXL3	MFR LIST	\$120.00
ST-MLX3 *Mixer: 1 Mic/2 Line to 1 Line	60RDSTMLX3	MFR LIST	\$120.00
ST-SX4 *Four-input Audio Switcher	60RDSTSX4	MFR LIST	\$95.00
ST-PH1 *Stereo Phono Preamp	60RDSTPH1	MFR LIST	\$126.00
ST-OSC2A *Dual Oscillator, 1 and 10kHz	60RDSTOSC2A	MFR LIST	\$98.00
ST-OSC2B *Dual Oscillator, 100 and 400Hz	60RDSTOSC2B	MFR LIST	\$98.00
ST-PA6 *6-watt Power Amplifier	60RDSTPA6	MFR LIST	\$88.00
ST-SSR1 *Solid State Audio Relay	60RDSTSSR1	MFR LIST	\$98.00
ST-VCA1 *Voltage Controlled Amplifier	60RDSTVCA1	MFR LIST	\$113.00
ST-SH1 *Stereo Headphone Amp	60RDSTSH1	MFR LIST	\$114.00

**Mounting Options**

Use the flat SMK-12 for detachable mounting of Stick-Ons inside your console or rack (up to 15 edge-mounted, or six flat-mounted). Use the RC-1U rack chassis for the greatest flexibility in mounting Rack-Ups and Stick-Ons (6 and 12 respectively, but mixing is OK).

60RDSMK12	MFR LIST	\$23.00
60RDRC1U	MFR LIST	\$131.00

**STR-19 Racking System**

This 3RU steel hinged panel holds and hides multiple Stick-Ons, which snap into place. Swing open to access your adjustments.

60RDSTR19	MFR LIST	\$123.00
-----------	----------	----------

\* Modules with a \* require a power supply, sold separately. See page 83.

**CALL 1-800-732-7665 FOR BRADLEY PRICE**

**SHURE PROBLEM SOLVERS AND IMPEDANCE TRANSFORMERS**



Read this list and keep it in the back of your mind the next time you have an audio problem. Use these devices "in line" thanks to their XLR connectors and small size. They are 4-1/2" long and 3/4" in diameter. Except as noted, they are designed to be used with 150 ohm low level equipment. Color coded.

**Line input adapter** converts low impedance microphone input to bridging line-level input. May be driven from source of up to 50 kilohms and 24dBm.

61SHA15LA	MFR LIST	\$39.00
-----------	----------	---------

**Bridging transformer** matches balanced or unbalanced devices of different impedances (33 kilohm primary, 600 or 7500 ohm secondary).

61SHA15BT	MFR LIST	\$50.25
-----------	----------	---------

**Tone generator** produces a continuous 700Hz signal capable of driving low impedance balanced lines. Battery operated.

61SHA15TG	MFR LIST	\$83.50
-----------	----------	---------

**High pass filter** provides a low frequency cutoff to reduce unwanted LF noise.

61SHA15HP	MFR LIST	\$48.00
-----------	----------	---------

**Mic attenuator** provides 15, 20, or 25dB attenuation to prevent preamp overload. Switchable.

61SHA15AS	MFR LIST	\$41.75
-----------	----------	---------

**Phase reverser** instantly reverses phase of a balanced line of any level. Switchable and can be used in either direction.

61SHA15PRS	MFR LIST	\$48.00
------------	----------	---------

**Bradley accepts Visa, MasterCard and Discover Cards**

## AUDIO INTERFACE

### WHIRLWIND AUDIO ACCESSORIES

(1) The Hot Box active direct box runs for 500 hours on two 9V batteries, and also takes 48V phantom. It provides super-clean audio through super-clean circuitry. It has a ground-lift switch, useful for eliminating hum problems. Includes an LED "on" indicator and a +15dB, Flat, -40dB switch.

Hot Box 61WHHB \$131.00



(2) IMP 2 is an economical direct box that converts a line or instrument unbalanced signal to a low impedance balanced one. Hi-Z bridging input and ground lift on output.

IMP 2 61WHIMP2 \$42.00



(3) Director direct box combines road durability with great studio performance and no power required. Loading, distortion, and signal loss are eliminated by the TRHL-M transformer and custom circuitry. Mumetal shielding is included for EM and RF isolation.

Director 61WHDIR \$70.00

(4) IMP Splitter allows a single input to be split into two or three signals. Low impedance.

1x2 61WHMS2 \$56.50

1x3 61WHMS3 \$69.00



(5) IMP Combiner combines two low impedance signals into one low impedance output. Features phase reverse switch to match phase or to throw mics out of phase for special effects.

IMP Combiner 61WHCOMB \$64.00



(6) Phase Reverse is a handy "back pocket" adapter for reversing phase on low impedance lines. XLR connectors.

Phase Reverse 61WHPR \$19.00



(7) IMP Pads provide fixed attenuation on low impedance lines. XLR connectors.

10dB pad 61WHPAD10 \$23.25

20dB pad 61WHPAD20 \$23.25

30dB pad 61WHPAD30 \$23.25

40dB pad 61WHPAD40 \$23.25

(8) Lifter is a handy in-line device for ground lift at pin-1 on an XLR line.

Lifter 61WHGL \$17.00



(9) Whirlwind Little IMP in-line impedance matching transformer with female XLR connector to male 1/4" connector.

61WHLI \$12.60



### SHURE IMPEDANCE TRANSFORMERS

A95U in-line impedance matching transformer with male XLR connector. Male and female 1/4" adapters supplied.

61SHA95U  
MFR LIST \$34.50



A95UF in-line impedance matching transformer with female XLR connector. Male and female 1/4" adapters supplied.

61SHA95UF  
MFR LIST \$43.50

CALL 1-800-732-7665  
FOR BRADLEY PRICE

### APHEX 124A AUDIO LEVEL INTERFACE



Match 'em Dan-o. The Aphex 124A is a two-way buffer that lets you connect -10dBV semi-pro and consumer audio products with +4 or +8dBm pro systems. It allows both to operate at their best by matching impedances and operating levels. Inputs and outputs are transformerless for wide, flat frequency response and perfect square waves to preserve transients. Hum and noise rejection are high, while noise and distortion are almost non-existent. A switchable 600 ohm load allows input line termination.

IHF connectors are RCA; balanced I/O's are XLR. The optional rack kit holds one or two units in a single rack space.

124A 60AP124 MFR LIST \$229.00  
Rack Kit 60AP44008 MFR LIST \$29.95

CALL 1-800-732-7665 FOR BRADLEY PRICE





**EXCALIBUR IA-1  
INTERFACE AMPLIFIER**



Use the IA-1 to connect consumer type equipment to pro broadcast gear. It's a newly-improved two-way stereo box with unbalanced RCA jacks and balanced, removable Euro-style wire capture blocks. I/O levels are adjustable. Rubber feet let you mount it on a flat surface; angle brackets attach it to the wall or under a counter. The optional rack mount puts one or two IA-1's in a single RU. Power is via the attached, UL-approved plug transformer.

Use it with DAT decks, workstations, ENG gear, and more. Response is DC-25kHz  $\pm 0.2$ dB, with distortion better than 0.006% and common mode rejection of an impressive 75dB at 1kHz. It's DC coupled and uses no audio transformers. Phase, response, and RF rejection are superior. As always, Excalibur gives great audio for your money.

IA-1	60EXIA1	\$180.00
Rack Kit	60EXRM1	\$21.00

**ATI MATCHMAKER**

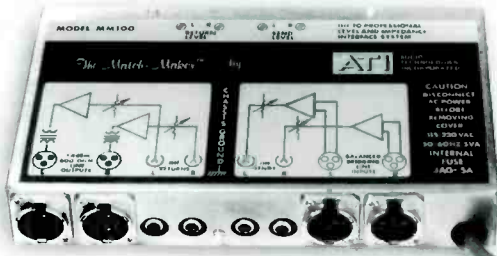

Keep your audio crisp and clean even while matching up consumer and pro equipment. Forget problems with loading, distortion, hum loops, RF pickup, and high frequency roll off. The Matchmaker solves these problems with less than 0.02% THD, 20Hz to 20kHz with  $\pm 0/0.25$ dB response, and over 98dB of dynamic range. The Matchmaker performs exceptionally thanks to design features including its transformer balanced outputs. It's UL listed. Choose the rack kit to hold one or two in 1RU.

Matchmaker	60AIMM100	MFR LIST	\$299.00
Rack Kit	60AI20273	MFR LIST	\$28.00

CALL 1-800-732-7665 FOR BRADLEY PRICE

**EXCALIBUR "H" PADS**

If you're a techie like the folks at Excalibur, you'll know what to do with these. "H" pads save you the trouble of brewing at home. 1% metal film resistors assure accurate losses and low noise. A threaded stud allows easy mounting. "H" pads are available in 6, 10, 20, and 50dB losses, and to use as a blank PC board for making your own. Custom values are also available. Prices are per pad. Order in multiples of five.

6dB 600 ohm	60EX6H	\$2.40	50dB 600 ohm in/150 ohm out	60EX50H	\$2.40
10dB 600 ohm	60EX10H	\$2.40	Blank pad	60EXBH	\$2.20
20dB 600 ohm	60EX20H	\$2.40			

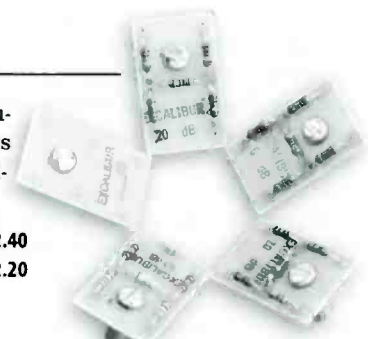

**EXCALIBUR DISTRIBUTION  
AMPLIFIERS**

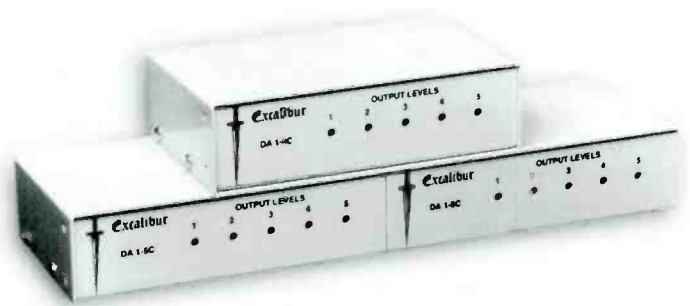

That familiar sword logo means you can count on audio quality inside. Excalibur DA's use barrier strip I/O's. The DA1-5C has one input and five outputs, while the DA2-5C has two 1 by 5 DAs. Their size allows you to hide them almost anywhere. Optional rack ears mount either DA in one RU. SN >80dB at unity gain, input common mode rejection is greater than 75dB at 1kHz, and THD is less than 0.01%. Maximum gain is 18dB and maximum input and output levels are  $\pm 22$ dBm.

DA1-5C	1x5	60EXDA15	\$165.00
DA2-5C	Dual 1x5	60EXDA25C	\$270.00

Accessories:

Rack ears for DA1-5C	60EXDA15R	\$15.00
Rack ears for DA2-5C	60EXDA25CR	\$15.00

**EXCALIBUR APA-1  
ALL PURPOSE AMPLIFIER**

Use it as a stereo line amp, 1 by 2 splitter, 2 to 1 summer, mix-minus amp, level and impedance interface, active phase inverter, or headphone amp. Summing, splitting, matching, interfacing: the APA-1 does it all. The dip switches let you set it quickly, and its clean audio puts it at home in the highest quality facilities. Inputs and outputs are on barrier strips.

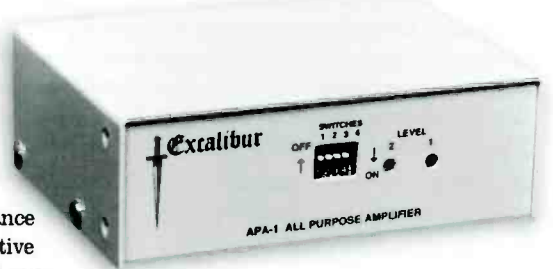

APA-1	60EXAPA1	\$149.00
Rack Mount Kit	60EXAPA1R	\$15.00

## RIXX PAM-1 PASSIVE ATTENUATOR/MIXER

The RIXX PAM-1 is a simple passive device which can be used for independent, variable attenuation of two unbalanced audio channels. It can also be used to sum the channels into a mono signal, with resistors incorporated to prevent output driver damage. Continuously variable attenuators are internally located to prevent tampering.



Typical uses include reducing levels between "pro" and "semi-pro" audio gear, or between broadcast and consumer VTR's; mixing channels for mono dubs, padding outputs from digital workstations and recorders or to feed a mono monitoring device (such as a video monitor speaker).

PAM-1 60RIPAM1 \$39.95

## RADIO SYSTEMS DISTRIBUTION AMPLIFIERS

Best Seller



This New Jersey company has been making quality audio products for two decades, and their DA's are among our most popular. Front panel independent level adjusts, balanced bridging inputs, balanced low impedance outputs, barrier strip connectors, and super low noise and distortion combine to make them a sure fire investment.

Response is within a tenth of a dB of 20Hz-20kHz, gain is up to +26dB without pad, and distortion is below 0.01%.

DA-8 (8 Mono)	60RSDA8	MFR LIST	\$340.00
DA-16 (8 Stereo/16 Mono)	60RSDA16	MFR LIST	\$425.00

CALL 1-800-732-7665 FOR BRADLEY PRICE

## AUDIOARTS MODEL 8400 DISTRIBUTION AMPLIFIER



Euro-style, plug-in connector blocks make this DA easy to wire. It's also one of the more flexible you can buy: use it as an eight output stereo DA, or as four 1x4 DA's, set with rear panel jumpers. That's 16 total outputs, each with its own front panel recessed gain trim. All inputs and outputs are on separate connectors. The three-conductor connectors come with mating plugs. No pinching or stray strand shorting.

Expect flat response from 20Hz to 20kHz (within one tenth of a dB), THD+N typically under 0.002%, and a 121dB dynamic range.

8400	60WSDA8400	MFR LIST	\$499.00
------	------------	----------	----------

CALL 1-800-732-7665 FOR BRADLEY PRICE

## ATI ENCORE DISTRIBUTION AMPS



ATI offers more flavors than an ice cream truck. Their distribution amplifiers are available in so many configurations, you're certain to find one to solve your specific wiring problem. We like the Encore Series, even more now that ATI offers versions with XLR's.

The DA206 and DA412 offer six or twelve balanced outputs divided among two or four independent, 1-in to 3-out channels. Internal jumper plugs parallel inputs for 1x6, 2x6, or 1x12 operation. These DA's have master input controls plus programmable gain for various nominal inputs; output taper controls are adjustable from +8 to -10dBm. Max gain is 40dB. These models use XLR connectors.

The DA208 and DA416 offer eight or sixteen balanced outputs divided among two or four independent, 1-in to 4-out channels. Parallel inputs on rear connectors allow 1x8, 2x8, or 1x16 operation. Audio taper output controls adjust from +8 to -10dBm. LED indicators warn of overdriven shorted output. Max gain is 20dB. These models use barrier block connectors.

All are UL Listed. Call us for the impressive audio specs.

DA206	60AIDA206	MFR LIST	\$479.00
DA412	60AIDA412	MFR LIST	\$669.00
DA208	60AIDA208	MFR LIST	\$379.00
DA416	60AIDA416	MFR LIST	\$549.00

CALL 1-800-732-7665 FOR BRADLEY PRICE

## TASCAM FOUR CHANNEL INTERFACE AMP



Like other audio interfaces, the LA-40 MKII lets you use balanced XLR equipment with unbalanced RCA gear. Unlike others, this rackable unit offers four channels in each direction.

All I/O connectors are located on the back panel. Ground lift switches for each channel and a universal "all-lift" minimize unwanted noise. Front-panel dials let you fine tune the amplification by ±6dB. Under the chassis, switches toggle between +4 and -20dBm nominal outputs.

The LA-40 MKII lets you assign the signal of a single input to multiple outputs. Flip one switch to assign it to all the channels above it (assuming they are of the same I/O conversion type). The system also accommodates the "multing" of multiple inputs or stereo input pairs.

LA-40 MKII	60TELA40	MFR LIST	\$475.00
------------	----------	----------	----------

CALL 1-800-732-7665 FOR BRADLEY PRICE



**ATI MICROAMP DISTRIBUTION AMPLIFIERS**

These high-quality devices aren't for everybody but they might be for you. Each has headphone jack, LED metering with switchable calibration and input overload indicators. Set your levels with individual output adjustments. RF rejection of all models is excellent. Distortion is typically 0.005%. For the absolute best RF rejection, choose transformer outputs; for maximum output, specify balanced differential outputs. Microamp DAs are uncommon. Let us fax you the specs.



Single 1x8 w/transformer outputs	60AIDA10081	MFR LIST	\$949.00
Single 1x8 w/differential outputs	60AIDA10082	MFR LIST	\$829.00
Dual 1x8 w/transformer outputs	60AIDA20161	MFR LIST	\$1,399.00
Dual 1x8 w/differential outputs	60AIDA20162	MFR LIST	\$1,149.00

CALL 1-800-732-7665 FOR BRADLEY PRICE

**APHEX 120 DISTRIBUTION AMPLIFIER**

The 120 boasts THD 0.002% at +4dBm and hum and noise better than -90dBm at unity gain. XLR I/O's and maximum RF shielding make it suitable for both studio and field. The 120 is a half-rack DA with one input, four outputs with level controls, and one unity gain direct output. Aphex publishes an aggressive response spec (5Hz to 100kHz, +0, -0.5dB) which makes it suitable for critical applications, as well as distributing SMPTE time code. The optional rack kit holds one or two in a single RU.



120	60AP120	MFR LIST	\$319.00
Rack mount	60AP44008	MFR LIST	\$29.95

CALL 1-800-732-7665 FOR BRADLEY PRICE

**BURK LX-1 SIX-INPUT STEREO SELECTOR**

Integrate numerous sources—studios, feeds, players—through one master control unit. The transition is smooth and levels remain constant. The LX-1 can connect to your remote control system for remote program switching. It matches -10 IHF to +4 PRO inputs, so you need no external matching equipment. The LX-1 also allows mixing of two studio sources, or lockout of all audio sources. Tally indications are provided for each source, making clear which is active. Individual start and stop pulses are available for each source, a feature which lets you use the LX-1 to start a fill tape or reset automation.



LX-1	60AVLX1	MFR LIST	\$1,295.00
------	---------	----------	------------

CALL 1-800-732-7665 FOR BRADLEY PRICE

**360 SYSTEMS AM-16/B ROUTING SWITCHER**

*Best Seller*



Let Bradley and 360 Systems save you a lot of trouble and time. You can configure the AM-16/B as a 16 x 16 mono or 8 x 8 stereo matrix. The companion AM-16/E slave unit operates in parallel to provide more simultaneous inputs. Combine one master and one slave unit for 16 x 16 stereo operation. Use additional slaves for multi-channel applications or for custom matrices.

Replace patch panels and cumbersome switchers with this expandable system. Store your configurations in 100 memory locations, and easily recall individual patches or complex "salvos."

All inputs and outputs are electronically balanced. The switcher has both RS-422 and MIDI remote control facilities. The front panel includes single ended jacks with the input and output of two mono channels or one stereo pair, to serve as test points or for an emergency patch. Specifications are impeccable. Frequency response is ± 0.5dB, 20Hz to 20kHz. Distortion is less than 0.008% THD+N, DC to 20kHz @ +22dBm. Signal to noise is 105dB unweighted, and crosstalk is 99dB at 1kHz and 83dB at 20kHz, any channel to any other.

The optional AM-16/R is a single space remote control station that operates on the EIA-485 control bus for X-Y and salvo switching. It controls up to four AM-16/B's or may be used in multi-drop configurations.

AM-16/B Switcher	60TH16B	MFR LIST	\$1,495.00
AM-16/E Expander	60TH16E	MFR LIST	\$995.00
AM-16/R Remote Station	60TH16R	MFR LIST	\$695.00

CALL 1-800-732-7665 FOR BRADLEY PRICE

**LOGITEK SWITCHERS**



Quietly doing their job in racks everywhere, these passive Logitek switchers are proven performers. The Pre-10 is a 10x2 stereo routing switcher with barrier strip terminations. The Mon-10 is a 10x1 stereo switcher with wire-capture terminal blocks and front panel switching to look at Left, Right, L+R, or L-R and feed the selected signal to the VU meter and internal monitor amp. Meter sensitivity may be selected over a 50dB range in 10dB steps. The monitor amp feeds the front panel speaker, a front panel headphone jack, and rear panel speaker connections.

Pre-10	60LTPRE10S	MFR LIST	\$560.00
Mon-10	60LTMON10	MFR LIST	\$855.00

CALL 1-800-732-7665 FOR BRADLEY PRICE

**Most prices shown in our catalog are manufacturer's list. Call for a current quote.**



## AUDIO INTERFACE

### Z-SYSTEMS DIGITAL AUDIO ROUTER



The Z-8.8 is a digital audio patchbay, router, and DA. With eight lines in and eight out (for eight stereo pairs of AES/EBU or SPDIF), it's ready to detangle your audio kluge. It handles XLR, coax, or optical ins and outs. Separate I/O modules let you convert one connector to another, and match impedances and levels. Call for 16- and 32-line versions.

Z-8.8 (all AES/EBU)

60ZS88A MFR LIST \$980.00

Z-8.8 (4 AES, 2 BNC, 2 Optical)

60ZS88M MFR LIST \$1,080.00

CALL 1-800-732-7665 FOR BRADLEY PRICE

### BROADCAST TOOLS ACTIVE AUDIO SWITCHER



The 8X2 dual audio switcher accepts eight stereo inputs, switchable to two stereo outs via switches with LED indicators. Inputs can either overlap or interlock any source. Inputs are balanced bridging and take balanced or unbalanced sources, and can be configured to allow up to 10dB dimming. Trimmers adjust the inputs -10 to +8dBm. Output and dimming level settings are provided. Other features: power-up input select, switch disable mode, mono outputs, mute input, and output selectable silence sensor. Parallel and RS-232 ports are provided for remote control and status.

8X2 Active Dual Stereo Audio Switcher

60BT8X2AEV MFR LIST \$629.00

CALL 1-800-732-7665 FOR BRADLEY PRICE

### BROADCAST TOOLS THE TALKING DUCK

The Talking Duck is an audio circuit identifier. Press the button to record a 15-second message. On playback, it runs a five-second, 1kHz tone along with your message. Connect to a telco loop and identify a circuit readily. The Duck feeds the circuit until a 1/4" TRS plug is inserted into its jack. The source gear is then switched back. Takes 9V battery or its wall transformer.



Talking Duck 60BTDUCK MFR LIST \$139.00

CALL 1-800-732-7665 FOR BRADLEY PRICE

### BROADCAST TOOLS PASSIVE SWITCHER/ROUTER

The 6X1A is a passive, six-input switcher/router that can select up to six stereo balanced inputs to one stereo out. Sealed gold contact relays make for transparent audio. Switches with LED's provide interlocked source selection and status. A "D" connector allows remote control and status. Remote inputs can be momentary or maintained TTL/CMOS, open collector or contact closure. Program the 6X1A to power up on any of the six inputs. I/O's are wire-captive terminal strips. This half-rack device can mount on a desktop or, with the optional shelf, in a rack.



6X1A Passive Stereo Switcher/Router 60BT6X1 MFR LIST \$399.00

Shelf Option (holds two) 60BTRM1 MFR LIST 49.00

Filler Panel 60BTFP1 MFR LIST \$39.00

CALL 1-800-732-7665 FOR BRADLEY PRICE

### BROADCAST TOOLS DTMF CONTROLLER

The DC-8 connects to a dial-up phone line, allowing you to control eight SPDT relays and monitor eight digital inputs via any standard Touch-Tone™ phone. Relays can be set for momentary, latching, interlocking, or group latch/unlatch. Pager Alert dials a digital pager and displays a programmed phone number. A tone generator is built in.

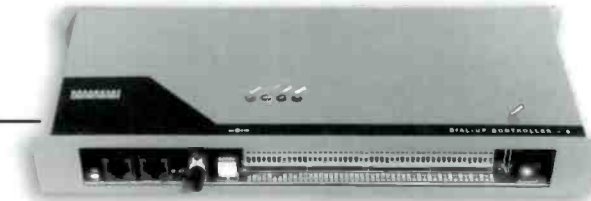

DC-8 Dial-Up DTMF Controller 60BTDC8 MFR LIST \$399.00

RM-2 Rack Kit 60BTRM2 \$49.00

CALL 1-800-732-7665 FOR BRADLEY PRICE

### BROADCAST TOOLS SATELLITE TOOLS

Here are two tools for satellite system users. The SCC-16 is a satellite channel controller, providing remote channel selection for DAT-SEDAT digital audio decoder cards installed in Scientific Atlanta, Comtech/Fairchild, and Ariel receivers. Program it to select eight channels and subchannels on each decoder card. The XP-3 provides remote transponder selection for the same three brands of receivers, allowing selection of the three transponder channels. Call us for more info.

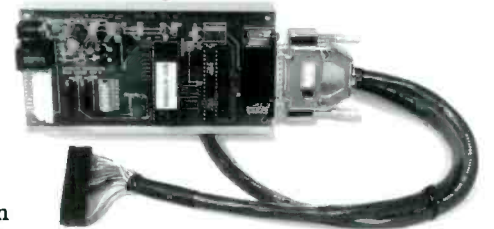

SCC-16 Satellite Channel Controller 60BTSCC16 MFR LIST \$299.00

XP-3 Satellite Transponder Controller 60BTXP3 MFR LIST \$299.00

CALL 1-800-732-7665 FOR BRADLEY PRICE

## AUDIO INTERFACE

# HENRY ENGINEERING

## MATCHBOX II & TWINMATCH

Everyone's heard of the Matchbox, Henry's bi-directional device for marrying pro gear to equipment with consumer levels and impedances. Use the improved Matchbox II with DAT machines, CD players, cassette decks, and digital editors.

The average noise floor is reduced by 8dB for more dynamic range. A high-gain mode brings very low levels from digital editor sound cards up to +4dBm. Gold-plated RCA jacks extend the life of the unit. And all outputs, both balanced and unbalanced, are now adjustable. (You won't overdrive the inputs of those sound cards.) The AC cord is three-wire, and AC ground is isolated from audio ground to reduce noise.

TwinMatch is a four-channel, one way model bringing -10 to +4, great for two stereo consumer sources like CD players.

Matchbox II	60HEMATCH2	MFR LIST	\$195.00
TwinMatch	60HETM	MFR LIST	\$195.00

CALL 1-800-732-7665 FOR BRADLEY PRICE

## MIXMINUS PLUS

If your console manufacturer won't put Mix-Minus in your board, do it yourself. Use this box to add a mix-minus output suitable for feeding the send input of a telephone hybrid. One input of this unit is fed with the mixer output, the other takes hybrid receive audio. These two signals are subtracted using phase reversal to create a program mix, minus the receive audio. Initial null adjustment will provide 40dB rejection of the receive audio signal. Very handy.

MixMinus Plus	60HEMMP	MFR LIST	\$195.00
---------------	---------	----------	----------

CALL 1-800-732-7665 FOR BRADLEY PRICE

## STEREOSWITCH

Hank's products are simple and reliable. They have that undefinable "good feel" in your hand. This one is an audio switcher that takes three stereo balanced sources, selects the one you indicate, and routes it to the stereo balanced output.

Program it internally to select one input when AC power comes up. Tally outputs will drive remote status indicators. Use it as a line selector or for auto source selection under the control of an automation system.

It uses sealed relays with gold-plated contacts, and is "transparent" since it puts no circuitry in the audio path. Control it with any momentary or maintained contact closure, open collector, TTL/CMOS logic, or DC voltage from 5-24 volts. Audio connections are barrier strip.

StereoSwitch	60HESTS	MFR LIST	\$250.00
--------------	---------	----------	----------

CALL 1-800-732-7665 FOR BRADLEY PRICE

## STEREOMIXER

StereoMixer is an eight-input stereo line mixer that lets you mix four stereo or eight mono sources (or a combo of both). It has three outputs: L, R, and Mono. Inputs and outputs are balanced barrier strip; bus inputs allow linking. The power supply is internal, and the StereoMixer is built with the same ruggedness and audio quality as all Henry products.

StereoMixer	60HESM	MFR LIST	\$250.00
-------------	--------	----------	----------

CALL 1-800-732-7665 FOR BRADLEY PRICE

*Best Seller*



## U.S.D.A. & MICROMIXER



Henry's U.S.D.A. lets you combine, as well as split, audio signals. The Universal Summing and Distribution Amplifier has two inputs (one stereo pair) and four outputs (two stereo pairs). While it can be used as a conventional 1x4 or 2x2 distribution amp, you get the added ability of either stereo input to be combined into dual mono without affecting the other output. Up to 20dB of gain is available, adjustable individually on each output.

The MicroMixer has four balanced inputs that can be individually assigned to its two balanced outputs. Used alone, or with the U.S.D.A., the MicroMixer is a good way to combine stereo to mono, create mix-minus or monitor busses, and numerous other uses. Each unit's balanced outputs are isolated and will drive a 600 ohm load to +25dBm with less than 0.01% THD. The bridging inputs accept a wide range of balanced and unbalanced sources.

U.S.D.A.	60HEUSDA	MFR LIST	\$195.00
MicroMixer	60HEMM	MFR LIST	\$195.00

CALL 1-800-732-7665 FOR BRADLEY PRICE



## AUDIO INTERFACE

### CONEX AS-101 ROUTING SWITCHER

Bradley clients use the AS-101 to expand mixer inputs, set up simple automation systems, and fix other studio problems. This 10x1 stereo routing switcher can be programmed for "overlap" switching, which prevents the source from turning off until the trailing edge of the command strobe turns on the new source. Inputs may be individually switched for 10K bridging or 600 ohm terminating. Audio connections are via plug in screw clamp terminal blocks, and all audio paths are transformerless balanced. The control format is four-level BCD plus strobe, ground, and 12VDC. Several control heads may be operated in parallel.



You can do more, too: An auxiliary rack mount chassis accepts option boards for relay-based machine control, RS-232/422 interface, and a system controller board which allows the unit to function as a simple automation system when controlled by a PC. Call for the list of Conex options.

AS-101 Switcher	60CNAS101	MFR LIST	\$962.00
Single unit remote control	60CNAS401	MFR LIST	\$161.00

CALL 1-800-732-7665 FOR BRADLEY PRICE

### HARKEN SPECIALTY ADAPTERS



**Inline Switchable Audio Pad with XLR connectors** Allows attenuation from 10dB to 40dB in 2dB steps.

600/600 ohm pad	60HK1126	\$63.25
150/150 ohm pad	60HK1121	\$63.25
600/150 ohm pad	60HK11261	\$63.25

**XLR Universal Two-Fer Connect** any two cables regardless of the gender of their XLR connectors. The Two-Fer is the adapter in the center of our photo, with two barrels and a connecting cable.

60HK115 \$41.00

**Telephone Interface** The HK128X will interface a phone instrument to your audio system with a handset cord and XLR connectors.

60HK128X \$42.75

**Phase Reversal & Ground Lifter** A single inline unit with XLR connectors.

60HK113 \$51.75

**Polarity Tester** Uses LEDs to show polarity of the DC voltage on pins 2 and 3 of an XLR.

60HK125 \$33.00

**XLR Monitoring Device** Allows you to monitor moderate to high level audio. The TS mini-jack allows you to connect an ear piece or headphone.

60HK111 \$25.50

XLR Adapters:		
XLR to: (adapter termination)		Price
Phono (RCA) jack (female)	60HK107X	\$14.50
Phono (RCA) plug (male)	60HK110X	14.50
1/4" tip sleeve	60HK108X	48.75
Mini-plug (TS wired to pins 2 & 3)	60HK121X	14.50
Mini-jack (TS wired to pins 2 & 3)	60HK122X	14.50
Three terminal barrier strip	60HK104X	17.25
Mini quick connect wire capture	60HK118X	16.00
Triple binding posts, side mounted	60HK119X	25.50
Triple binding posts, rear mounted	60HK103X	25.50
<i>Replace "X" with "M" or "F" to specify gender of XLR</i>		
XLR to: (adapter termination)		Price
Bantam patch field jack	60HK109B	\$32.50
BNC (coax shield & XLR body isolated)	60HK106X	15.10
RJ11C Modular telco 6 pin jack	60HK116X	16.25
RJ11C Modular telco 6 pin plug	60HK126X	18.75
RJ9 Modular telco handset 4 pin jack-transmit		
	60HK117TX	16.25
RJ9 Modular telco handset 4 pin jack-receive		
	60HK117RX	16.25
RJ9 Modular telco 4 pin plug-transmit	60HK127TX	18.75
RJ9 Modular telco 4 pin plug-receive	60HK127RX	18.75
<i>Replace "X" with "M" or "F" to specify gender of XLR</i>		

### SWITCHCRAFT CONNECTORS AND ADAPTERS

#### Connectors (Solder type)

Inline TS 1/4" phone M	61WHSW280	\$1.89
Inline TRS 1/4" phone M	61WHSW297	\$3.99
Inline Phono (RCA) M	61WHSW3502	\$1.29
Inline 1/8" TS MINI M	61WHSW780	\$3.55
Philmore Inline 1/8" TRS/Mini M	61WHSW502M	\$2.05

#### Adapters (User assembly required)

XLR M to XLR M	61WHSW390	\$11.50
XLR M to XLR F	61WHSW53FM	\$9.95
XLR F to 1/4" TRS F	61WHSW383A	\$14.90
XLR M to 1/4" TRS F	61WHSW384A	\$13.90
XLR F to 1/4" TRS M	61WHSW386A	\$14.50
XLR M to 1/4" TRS M	61WHSW387A	\$12.75
XLR F to XLR F	61WHSW389	\$12.90
1/8" TS F to 1/4" TS M	61WHSW364	\$6.60

M=Male, F=Female



## AUDIO INTERFACE

# TOUGH PROBLEMS? SIMPLE SOLUTIONS!

## CG-25A 25 Hz Tone Generator And High-Pass Filter

The Conex CG-25A tone generator provides a simple, economical method for adding 25 Hz cue tones to satellite systems, translators and audio tape recordings. The CG-25A is a self-contained desktop unit or you can rack mount 1 or 2 units with the optional rack-mount kit.



## CJ-20 CellJack Cell-Phone Interface

The Conex CJ-20 CellJack is a compact cell-phone adaptor that allows easy remote broadcasts via your cellular phone. It interfaces various broadcast audio devices and is designed to work with the popular Motorola 'bag phones'. Use the CellJack with your own remote mixers, tape recorders, studio microphones, headphones, etc. for immediate, simple and cost effective remotes.



## RX-11 ToneJack A Portable Audio Generator

The RX-11 is a very compact audio frequency generator providing sine and square wave signals with precise frequencies from 1 Hz to 29,999 Hz. Built-in functions include audio sweep, tone burst, auto-step through 10 user-assigned frequencies and more. Operates from a 9-V battery or external power. The RX-11 can also be controlled by any computer with a serial port.

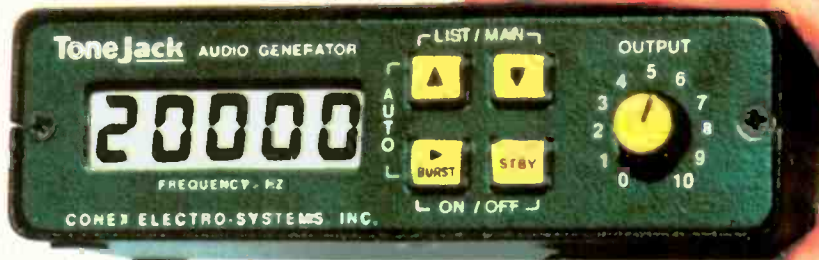

## AS-101 10 Channel Audio Switcher

The Conex AS-101 Audio Switcher allows any one of 10 stereo sources to be switched to the stereo output channel. Switching is accomplished by pressing one of the illuminated buttons on the front panel, or remotely, via the remote control connector on the rear panel. Several optional AS-401 remote control devices may be connected in parallel, and all will indicate the selected channel. The AS-101 can also be controlled by a computer via an optional RS-232/422 interface.



## DT-55 Telephone Remote Control

The DT-55 answers a phone line, accepts a user determined access code, then allows remote control of ten SPDT relays, and the remote monitoring of ten external switch contacts or logic levels. Each relay can be set and cleared, activated momentarily (for the duration of the push-button actuation on the calling telephone), or all relays can be interlocked.

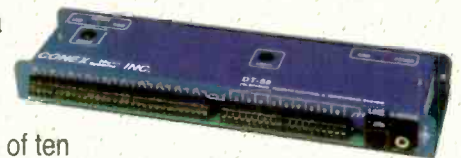

**Something missing in your studio?**



# The MultiDesk™ System

A new concept in configurable studio furniture



**MB-4**  
MultiBridge



**MR-14S**  
MultiRack



**MD-48**  
MultiDesk



**MR-14W**  
MultiRack



**MB-6**  
MultiBridge



**Middle Atlantic Products, Inc.**

**5 easy to assemble pieces fit together  
in any combination!**



**ZERCOM PATCH SWITCH**

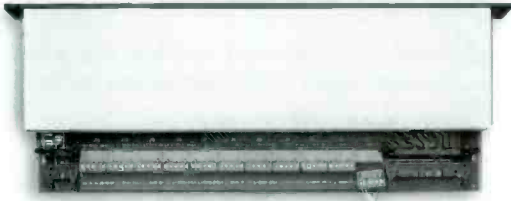

Zercom's patch switch is back at a lower price. This is a convenient replacement for traditional patch bays. It functions as either a stereo "10-in/1-out" or "1-in/10-out" switcher and router. Any number of units can be bussed together to handle unlimited inputs. The new design also features summing of multiple sources and all signals off. Connections are pluggable terminal blocks, making wiring changes a snap. Also included: Phase reversal, stereo/mono selection, and a PCB for easy installation of audio pads.

A small radio station with three consoles can be interconnected on up to 10 input sources with four Patch Switches.

PS-2      60ZEPS      MFR LIST      \$379.00

CALL 1-800-732-7665 FOR BRADLEY PRICE

**FURMAN PATCH BAYS**

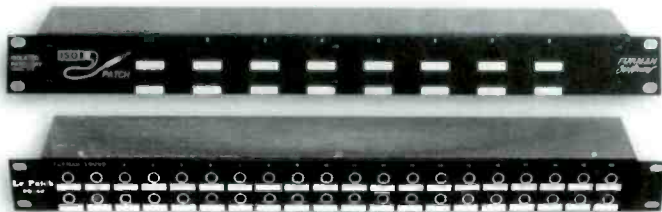

The PB Series provides patching at an affordable price. Choose from three 40-point configurations, each housed in a solid, single-space steel chassis. Models come assembled with standard 1/4" phone jacks with either tip-sleeve (TS) or tip-ring-sleeve (TRS) front and rear, or with 1/4" TS in front and RCA jacks in the rear. Top to bottom normalization is standard. A normal can be defeated by snipping a wire on a circuit board.

PB-40 TS	60FUPB40P	MFR LIST	\$165.00
PB-40 TRS	60FUPB40T	MFR LIST	\$180.00
PB-40 RCA back to TS front	60FUPB40R	MFR LIST	\$155.00

**Accessories:**

Patch cords are 30" long. Ask us for 72" lengths. Prices are for packs of 10.

Patch-T 1/4" TRS connectors	60FUPATCHT	MFR LIST	\$22.00/pk
Patch-P 1/4" TS connectors	60FUPATCHP	MFR LIST	\$18.00/pk
Patch-R RCA connectors	60FUPATCHR	MFR LIST	\$18.00/pk

CALL 1-800-732-7665 FOR BRADLEY PRICE

**GOTHAM CT-1 CABLE TIES**

Bag of 100. They're reusable! 7-1/4" long.

61NECT1      \$59.00/Bag



**BRADLEY CORD-LOX**

Cord-Lox stay with your cable, helping you store or coil. Each strap makes two loops: a cable holder to keep the strap on the line, and a larger loop to hold the coil. Three sizes delivered from stock. Black only. (Call us about custom imprints and colors.)



3/4" x 5"	With cable holder closed at both sides. For shorter cables.	60CL205C	\$1.20
1" x 7"	With cable holder closed at both sides. For medium cables.	60CL307C	\$1.29
1-1/2" x 18"	for snakes	60CL4180	\$3.48

**RAXXESS CABLE ORGANIZER**

Steel fingers hold your cables, nice and neat. Maximum cable diameter: 0.25".

61RXDEPOT      \$15.95



**WHIRLWIND XLR CONNECTORS**

Whirlwind's WI series features one-piece die cast housings. The special cable grip provides 100% strain relief on diameters of 0.11" to 0.31". Strain relief boots are black, with red, blue, and white available by special order.

**Male inline XLR**

61WHWI3MXX ea: \$2.25  
Box of 100      \$180.00

**Female inline XLR**

61WHWI3FFX ea: \$2.40  
Box of 100      \$192.00



**BRADLEY MIC CABLES**

Some of the most widely-heard audio in the world runs through Bradley assembled mic cables, featuring Neutrik XLR's.



3' cable	61WHMK403	\$12.58	25' cable	61WHMKS20	\$14.50
6' cable	61WHMK406	\$13.25	50' cable	61WHMKS50	\$22.00
10' cable	61WHMK410	\$14.00			

**BRADLEY BULK MIC CABLE**

Make your own! You save money when you buy this rugged, low-impedance mic cable in bulk.      60AT8300      35¢ per foot

# AUDIO INTERFACE

## NEUTRIK CONNECTORS

X series connectors have only four parts. They have no set screw, and crimping during assembly is not required. One piece unbreakable die cast housing, bellows-style polyurethane flex relief, and chuck-type, snap on cable clamp provide secure strain relief.



The C series are right angle connectors that swivel at 45-degree intervals when assembled for maximum packing density. Both XLR types are available in nickel shell with silver contacts or black shell with gold contacts.

3 Pin XLR Type	Shell	Part#	Price
Female Cable	Nickel	61NT3FX	\$2.60
Female Cable	Black	61NT3FXB	\$3.16
Female Panel	Nickel	61NT3FP	\$2.77
Female Right Angle	Nickel	61NT3FRC	\$6.75
Male Cable	Nickel	61NT3MX	\$2.42
Male Cable	Black	61NT3MXB	\$3.34
Male Panel	Nickel	61NT3MP	\$2.71
Male Right Angle	Nickel	61NT3MRC	\$6.95

### Other Neutrik Connectors

1/4" TS phone plug	61NTNP2C	\$2.56
1/4" TRS phone plug	61NTNP3C	\$3.23
1/4" TRS lockable chassis jack	61NTNJ3FP6C	\$4.96

## CANARE STAR QUAD MIC CABLE



An excellent low-noise bulk cable, designed for mics but excellent for any audio. It gets its name from the four conductor-style construction that minimizes the "loop area" between twists of the conductors, reducing noise. Buy it by the foot, in two reel sizes, or assembled.

Bulk Star Quad	per foot	60CAL4E6BK	\$57
	656' (200m) reel	60CAL4E605XX	\$335.00
	1000' (305m) reel	60CAL4E610XX	\$509.00

Black is the only color offered by the foot. Reels are available from stock in black. Special order blue, brown, gray, green, orange, purple, red, white, and yellow. Call for pricing on multipair setups.

### Canare Star Quad Assembled Mic Cables

5 feet	60CAEC005FBXX	\$23.50
15 feet	60CAEC015FBXX	\$29.00
25 feet	60CAEC025FBXX	\$35.25
50 feet	60CAEC050FBXX	\$51.50

These cables come with Neutrik XLR connectors. Black is available from stock. Other colors are special order. Cables may be special ordered in any length, with a minimum order of 10 cables in any mix of colors and lengths.

## WHIRLWIND WALL MOUNTING PLATES

Whirlwind's stainless steel plates fit standard single or double gang electrical junction boxes. Mounting screws are included.

	Part #	Price
<b>Single:</b>		
One female XLR	61WHWP1FW	\$9.84
One male XLR	61WHWP1MW	\$9.84
One 1/4" TRS jack	61WHWP1QW	\$12.50
Two female XLR's	61WHWP2FW	\$15.60
Two male XLR's	61WHWP2MW	\$14.95
Two 1/4" TRS jacks	61WHWP2QW	\$14.95
<b>Double:</b>		
Four female XLR's	61WHWP4FW	\$28.00
Four male XLR's	61WHWP4MW	\$28.00
Four 1/4" TRS jacks	61WHWP4QW	\$33.00



## WIRE AND CABLES

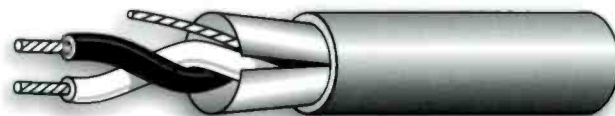

**West Penn 291** Most useful for audio connections, a popular alternative to 8451. A two-conductor shielded cable with drain wire and foil shield. Signal conductors are 22 gauge stranded, and the drain conductor is 24 gauge stranded. 1000' spools are available in black, blue, red, white, yellow, brown, green, violet, orange, and gray.

60WP291XX \$95.00

**West Penn 510** Wiring stereo signals? Use this two-pair individually foil shielded cable with common drain wire and overall shield. 1000' reels.

60WP510 \$175.00

### Assembled Speaker Cables

50 feet of 16 gauge speaker wire with chrome plated plugs.

42ME500 \$15.95

### Bulk Speaker Cable

Our heavy duty speaker cable has a black, polypropylene jacket. Minimum order is 50 feet.

14 ga, 2 conductor	61WHW14GA	37¢ per foot
12 ga, 2 conductor	61WHW12GA	55¢ per foot

### Whirlwind Multipair Cable

Each pair of this heavy duty cable is individually twisted and shielded and has its own drain wire. Sold in multiples of 50'. Price is for a 50' length.

6 pair	61WHW06PR	\$56.00	16 pair	61WHW16PR	\$100.50
9 pair	61WHW09PR	\$65.00	20 pair	61WHW20PR	\$131.00
12 pair	61WHW12PR	\$78.50	32 pair	61WHW32PR	\$199.50

### Shrink Sleeving

Shrunk size is approximately half of original diameter. Available in black, red, blue, white, and clear. Minimum order is 50' of any one length and color. Other sizes available.

3/16" diameter	61WHPT316	32¢ per foot
3/8" diameter	61WHPT38	45¢ per foot

# AUDIO INTERFACE

**CORD-LOX COIL 'N CARRY**

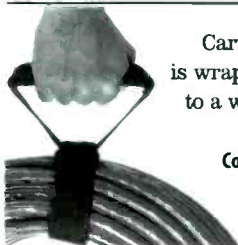

Carry large cable spools conveniently. Webbing is wrapped around a doweled handle and attached to a wide Cord-Lox strap.

Coil 'n Carry    60CL419WHP    \$13.50

**WHIRLWIND CABLE TESTER**

Slip it in your pocket. This versatile tester checks most varieties of cables with any combo of XLR, 1/4", or RCA plugs for shorts, opens, and phase. The hands-free design lets you play with your cables to find the intermittents. Belt clip included.

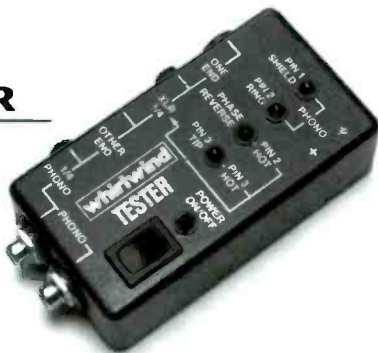

Cable Tester    61WHTR    \$62.00

**PROGOLD**

ProGold from CAIG Laboratories is a must-try treatment for your audio connections. It's an environmentally safe conditioner, preservative, and lubricant for critical edge connectors, IC's, sockets, and relays. It will improve conductivity, prevent degradation of your signals, and fight RFI and intermittents.



The 5% solution is an excellent all-purpose spray for connectors. Use solvent-free 100% ProGold where more cleaning and lubrication is called for, particularly on carbon pots.

ProGold 5% Spray, 6 oz can	60CGG556	\$14.00
ProGold 100% Spray, 2 oz can	60CGG10052	\$22.00
ProGold 100% Liquid, brush applicator	60CGG100L2DB	\$16.00
ProGold Wipes, 100% (50)	60CGKG50W	\$17.00

**FOSTEX TT-15 TONE GENERATOR**

"Quick, give me a tone!" No problem when you have the battery-operated TT-15. Generate your choice of five at the push of a button: 40Hz, 400Hz, 1kHz, 10kHz, and 15kHz, with distortion typically less than 0.02%. An attenuator provides output levels of 0dBV, -10dBV, and -30dBV with insignificant level shift when changing from a bridging load to a 150 ohm load. An internal 9V battery provides reliable operation of this rugged, metal device.



TT-15    60F0TT15    \$55.00

**CRL REAL TIME EVENT SEQUENCER**



You could stand there and do it yourself—over, and over, and over—or you could let the Sequencer do it.

Automate repetitious tasks, such as firing an audio source, turning on your outdoor lighting, just about anything. The starting time of an event can be programmed to the second; the sequencer can control each month's weekly sequences of events for the next 12 months.

The unit can trigger up to 255 events. Outputs are selectable to either latch on or provide a half or full second contact closure. The standard output mode allows any combination of eight outputs to fire at any one time; a binary encoded mode fires one of 255 external devices. Software lets you back up your programs to computer disk. Security keylock and battery backup are included.

CRL Sequencer    60CUES    MFR LIST \$895.00

CALL 1-800-732-7665 FOR BRADLEY PRICE

**CONEX CG-25A TONE GENERATOR**

The Conex CG-25A tone generator is used with reel tape systems to record 25Hz on either or both audio channels between selections. It also finds applications in translators, satellite systems, and cable



broadcasting. Two front panel switches allow pre-set timed or manually timed tones. Front panel LED's indicate duration of tone and silence intervals. One or two units can be rack mounted in a single rack space with an optional rack kit.

Conex CG-25A	60CNCG25	MFR LIST	\$451.50
RMK Rack Kit	60CNRMK	MFR LIST	\$27.00

CALL 1-800-732-7665 FOR BRADLEY PRICE

**THE TIME-TEMP THING**



Sine Systems gets the prize for descriptive nomenclature. They also deserve a salute for this clever automation tool. It's a rack-mounted device that speaks the time, the temperature, or both on command from your automation system. Very important information to radio listeners!

The unit comes with a small sensor that you install where you like (you supply the cable). Then give the Thing a contact closure or open collector to make it speak; when it's done, it gives a momentary contact closure back to your automation. It also automatically changes the way it speaks, so it doesn't sound like a machine.

Time-Temp Thing    62SITTT1    MFR LIST    \$599.00

CALL 1-800-732-7665 FOR BRADLEY PRICE



## AUDIO CONTROL INDUSTRIAL REAL TIME ANALYZER



You've seen this model in Bradley's pages before. Year after year it's one of our best sellers, a remarkable value and an important audio tool.

For sound reinforcement, the SA3051 is used to test acoustically and adjust frequency response by using its calibrated microphone and pink noise generator. It can also test the response of an electrical audio source like a console, tape deck, or telco program circuit with its balanced, bridging, wide level range line input. For critical, intra-circuit measurements, a 1 megohm BNC input, also with a wide level range, is included.

The LED display simultaneously shows the amplitude of each of the 30 ISO third octave frequencies between 20Hz and 20kHz. Three response times let you analyze transient, average, or integrated response. Results of acoustical or electrical response tests using the digital pink noise generator, whose response is flat to within 0.25dB, can be viewed instantly. An individual response curve can be frozen on the display, and the unit stores six response curves in memory.

A back-up battery maintains memory for a year. Acoustical noise spectral distribution and absolute sound pressure level measurements are also in a day's work. The SA3051 is available as a basic unit or loaded with both an internal, rechargeable battery with five hour life and a parallel printer interface for use with your printer.

Basic unit	60AOSA3051	MFR LIST	\$995.00
Deluxe unit with rechargeable battery and case (printer not included.)	60AOSA3052	MFR LIST	\$1,300.00
<b>Accessories:</b>			
RM-10 rack mount adapter requires three rack spaces (5.25").	60AORM10	MFR LIST	\$55.00
SC-10 soft carrying case with pocket for mic and cables.	60AOSC10	MFR LIST	\$59.00
AC-10 in line filter for "A" weighted measurements.	60AOAC10	MFR LIST	\$44.00

CALL 1-800-732-7665 FOR BRADLEY PRICE

## EXCALIBUR CDA-1 COMPOSITE DA

The one-in/three-out CDA-1 adds flexibility to your transmission facility. Use it to feed auxiliary STL systems, test equipment, and back up transmitters. Each output has its own 20 turn level control, and can drive up to 75 feet of RG-58 coax. A ground lift switch and transient protection on the power supply are provided. Other uses include distributing modulation monitor outputs and subcarrier generator outputs. Frequency response is DC to



100kHz  $\pm 0.2$ dB (less than 0.05dB down at 53kHz), THD is less than 0.01%, and noise is greater than 90dB below 4V at unity gain.

CDA-1                      60EXCDA1                      MFR LIST                      \$420.00

CALL 1-800-732-7665 FOR BRADLEY PRICE

## CROWN FM TRANSMITTERS AND TRANSLATORS

Crown's innovation is an integrated FM system that combines audio process-

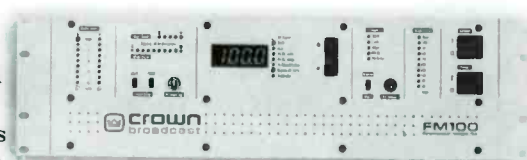

ing, stereo generation, and RF in one easy-to-ship unit, in power ranges up to 2000 watts. This approach provides an economical, flexible system well-suited as a translator (satellite or terrestrial-fed), or a back-up or main low-power transmitter. Installation and set-up are simple, even by non-techies.

Select the frequency of the transmitter yourself using the internal dial switches. A built-in remote I/O interface supports remote control and monitoring. Automatic control circuitry provides proportional foldback protection. The DC power hookup can provide uninterrupted service when AC power is lost.

All integrated models include digital metering and diagnostics, 100/120 VAC, 220/240 VAC, and DC operation. Translator versions, providing RF in and out, also include an integrated FM receiver and FSK ID-er.

### FM Transmitter Systems with exciter, stereo generator, audio processor, RF amp and low pass filter

30 watt	62CRFM30T	MFR LIST	\$3,995.00
100 watt	62CRFM100T	MFR LIST	\$5,995.00
250 watt	62CRFM250T	MFR LIST	\$7,295.00
500 watt	62CRFM500T	MFR LIST	\$9,495.00
2000 watt	62CRFM2000	MFR LIST	\$19,995.00

### FM Translator Systems (RF in/out) with receiver, FSK ID-er, RF amp and low pass filter

30 watt	62CRFM30R	MFR LIST	\$4,290.00
100 watt	62CRFM100R	MFR LIST	\$6,290.00
250 watt	62CRFM250R	MFR LIST	\$7,590.00
500 watt	62CRFM500R	MFR LIST	\$9,790.00

CALL 1-800-732-7665 FOR BRADLEY PRICE

## BRADLEY BACK-UP RF PACKAGE

Here's a special Bradley package, ideal as a back-up FM system. You'll have a low-power transmission system ready to go on short notice. It includes a tunable 500-watt Crown transmitter with processor and stereo generator, three-bay Shively antenna, and 150' of coax cable with connectors. We can also configure it other ways to fit your situation. The system works nicely on your studio roof, at a temporary tower, or at any emergency location. Power it with a portable generator or battery-driven inverter.

Package 9725                      MFR LIST                      \$12,800.00

CALL FOR BRADLEY PRICE.

## RF EQUIPMENT

**SINE SYSTEMS  
REMOTE CONTROL**

Bradley customers can now benefit from the cost-effective approach to remote control espoused by Sine Systems of Nashville. The RFC-1 lets you control and monitor your transmitter from any phone. It speaks to you with a human voice and can phone you to report out-of-tolerance conditions and automate power/pattern changes. The control unit itself is only as large as a modem.



The typical basic system is one RFC-1/B and one rackable RP-8 eight-channel relay panel. Add RP-8's for more channels. We recommend you also add an SP-8 heavy-duty surge protector. If you do, Sine Systems will include lightning damage coverage in your one-year warranty. Available options include room temperature monitor, a serial option for logging, and a current monitor for tower-light confirmation.

RFC-1/B	62SIRFC1BHV3	MFR LIST	\$1,199.00
RP-8 Relay Panel	62SIRP8	MFR LIST	\$399.00
Rack Kit for RFC	62SIRK3	MFR LIST	\$35.00
SP-8 Surge Protector	62SISP8	MFR LIST	\$129.00

CALL 1-800-732-7665 FOR BRADLEY PRICE

**GENTNER VRC-2000 REMOTE CONTROL**

This popular transmitter control now comes with PC software for Windows<sup>®</sup> that lets you see your meter readings, check all status channels at a glance, and control up to six sites, all with point-and-click ease.



The VRC-2000 is a powerful 16-channel, voice-response remote control system. It provides transmitter control via any bi-directional audio link, whether dial-up, dedicated phone line, or radio link (such as STL/TSL/SCA). When it's operated as a stand-alone unit, you can control your transmitter from any telephone that has a DTMF keypad. The VRC-2000 responds with a synthesized voice. The Command Relay Unit provides relay isolation between the VRC-2000 and your equipment. Handles eight raise and eight lower commands. The most popular system is shown below. Call us for configuration assistance. Also available: Special purpose accessories including a failsafe unit, temperature sensor, and UPS.

VRC-2000 System (with Windows software, data interface, command relay, and two barrier strips)

60GFVRC2000P1 MFR LIST \$3,499.00

VRC-2000 Unit only

60GF910072201 MFR LIST \$2,995.00

CALL 1-800-732-7665 FOR BRADLEY PRICE

**BURK TC-8 REMOTE CONTROL**

This straight-forward control is ideal for attended AM or FM facilities with limited requirements, college stations, translators, and satellite and ENG sites. It gives you eight analog metering channels, eight status, and 16 control outputs. Fail-safe output assures positive transmitter control.



Communication between sites uses dedicated lines, STL subcarriers, FM SCA, 450MHz TRL, or digital links. The required subcarrier generators are built in at no extra cost. This system is not hard to learn or calibrate. The optional IP-8 interface panel brings all connections out to screw-type barrier strips and isolates the control logic with plug-in 10 amp form-C relay contacts.

TC-8	60AVTC8	MFR LIST	\$2,495.00
IP-8 Interface Panel	60AVIP8	MFR LIST	\$495.00

CALL 1-800-732-7665 FOR BRADLEY PRICE

**GENTNER GSC3000  
SITE CONTROL**



Here's a site-expandable transmitter remote control system that can run from one to 256 sites, with 8 to 256 channels of metering, status, and command per site! Thanks to networking protocol and a modular approach, the GSC3000 is ideal for radio and TV station owners, duopolies, LMA's, and other complex transmitter combos, as well as single-site users. A powerful Windows<sup>™</sup> application makes setup and operation of multiple sites a breeze. However, the GSC3000 does not require the dedicated use of a computer in order to control sites. All functions necessary to operate, change, or correct transmitter parameters are performed by local hardware at each site. This means your reliable transmitter operation is not dependent upon a PC.

The GSC3000 is plug-compatible with VRC-2000 accessories, making upgrade, or parallel operation simple to implement. Multiple security level capability allows restricted access to users who are not qualified to alter commands or change parameters. And the GSC3000 can communicate over telephone, RF or Direct PC connection. Call Bradley to find out how advanced site control can enhance your station's reliability AND your peace of mind.

GSC I/O 16 CHANNEL	60GF910085100	\$2,495.00
GSC I/O 8 CHANNEL	60GF910085101	\$1,495.00
GSC MODEM/2 WIRE	60GF910085103	\$225.00
GSC PACKAGE	60GF910085104	\$3,605.00
GSC V.3400 MODEM	60GF910085108	\$775.00
WIRING INTERFACE UNIT		
	60GF910085110	\$195.00
GSC COMMAND RELAY UNIT		
	60GF910085120	\$ 495.00

CALL 1-800-732-7665 FOR BRADLEY PRICE



## BURK ARC-16 REMOTE CONTROL



The ARC-16 Two-Unit Transmitter Remote Control System allows you to rectify problems instantly. Clear text display and simple controls are "talent friendly". The system includes a studio unit for monitoring and alarms, and a transmitter unit with the same functions that lets you calibrate your system on-site. Unlike many remote controls, it offers control and metering of studio equipment including automation, EAS, and security. It provides full-time studio control, dial-up control, or both. It has 16 metering channels, 16 raise/lower outputs, and 16 status channels. (Ask us about the single-unit system that allows control from any phone with a DTMF keypad.)

The Enhanced Speech Interface option allows control or readings from a Touch Tone phone; the caller is greeted with a human voice and prompted. The ESI lets you listen to program audio; it also will call a series of phone numbers to announce an alarm, and it can be enhanced with optional CDL software to interface with a computer directly or via modem. Call for info on other systems options.

ARC-16 two-unit system includes modems to connect by telco, STL, SCA, or TRL (specify).

60AVARC16DU MFR LIST \$3,895.00

**Accessories:**

ESI Enhanced Speech Interface 60AVESI MFR LIST \$895.00

CDL Software 60AVCDL MFR LIST \$295.00

IP-8 Interface panel (see description under TC-8) 60AVIP8 MFR LIST \$495.00

Autopilot, a program for IBM-compatible PC's, gives your ARC-16 better record keeping and the ability to operate unattended. Autopilot will take care of routine and emergency operation. Requires CDL software, above.

60AVAP MFR LIST \$595.00

CALL 1-800-732-7665 FOR BRADLEY PRICE

## MARTI RPU



The new Marti SR-10 base station receiver is designed for broadcast remote pickup and ENG. Its frequency agility and fine selectivity will help you find your way through the high interference levels in today's RPU work. Features include front-panel selection of channels, six programmable priority channels, backlit LCD display, built-in monitor speaker with headphone jack, and double balanced mixers. Options include remote channel selection and display, and subaudible tone detection for signaling and automatic repeater applications.

Marti has mono and stereo RPU systems in configurations starting at about \$3200. Call or fax Bradley for a Marti catalog.

## CIRCUIT WERKES DR-10



The DR10 is a microprocessor based remote control that allow operation of station equipment over any phone line, via touch-tone. The DR-10 auto answers, provides password protection, and allows any of the 16 DTMF tones to activate any of the ten relays in the DR-10. Each relay can be programmed for momentary, latching, or interlocked operation. Additionally, relays can return a beep tone to acknowledge activation.

The DR-10 also features four logic-level inputs that will activate one of its relays, or call out to any of four phone numbers (one per logic input), and tell you which channel caused the alarm with a series of beeps.

Applications include EBS monitoring, remote audio switching, RPU control, or automatic tape recording. When used with its companion "silencer" option, the DR10 can share the audio channel from your remote broadcast to deliver commands without interrupting program audio.

CircuitWerkes DR-10 Dial Up Controller 60CTDR10 \$449.00  
 CircuitWerkes Silencer Option 60CTSIL \$159.00

## WILL-BURT HURRY-UP

The Hurry-Up is a 25' telescoping mast designed for fast, easy deployment. It's ideal for small ENG microwave antennas, Marti antennas, and weather instruments weighing up to 20 pounds. You extend it manually by pushing up the six nested aluminum sections and fixing them with quick release collars. You can pop it up in less than a minute even if you're wearing thick gloves, and it's easy to adjust and lock the direction of your antenna.

No guy wires to worry about; you just lock the mast into the holding tube on the mounting stand, and drive your vehicle onto the plate to keep everything in place. With a typical load, it'll survive winds well over 50 mph. The mast itself weighs 28 pounds and is 6' high when nested. The base weighs 36 pounds.

Hurry-Up 60WB903220 \$1,450.00



## RF EQUIPMENT

## OPTIMOD ON AIR PROCESSORS

### Optimod-FM 2200

The newest FM processor from Orban



combines the best elements of architecture and design of the 8100A and 8200 Optimod processors, and combines them with full digital circuitry to produce an audio processor with excellent control, consistency and versatility, at a modest price. Eight factory presets allow you to install and go on-air with confidence. You can then develop your own signature sound, starting with the pre-programmed settings, and save the results in eight different user areas. The 2200 can be connected to your remote control system, to change from one processing setting to another. And, with digital I/O, the 2200 may be connected to digital STLs and exciters.

Digital processing provides consistency over time, and precise control, in addition to a clean and quieter sound across the full dynamic range of your audio. Even the stereo composite signal is generated digitally, producing a clean and drift-free composite waveform.

Your air signal is your most important product. Assure that your listeners get the quality they deserve with the Orban 2200.

2200/U	600B2200U	MFR LIST	\$3,950.00
2200/D	600B2200UD	MFR LIST	\$4,350.00

### Optimod-FM 8200 Digital Processor

Digital technology and Optimod quality are a powerful combo. Remote PC software is included for control from anywhere.



The 8200 has automatic gain control, compression, peak modulation control, and stereo encoding. Processing setups are changed with one button thanks to Modular Variable Processing (MVP). Two-band MVP processing offers an improved version of the open, natural Optimod sound. The optional five-band MVP provides competitive major-market processing with selectable speeds for any format.

Adjust factory presets easily. Create custom sounds, and store 32 in memory. The computer interface allows modem control. Auto switching is ideal for dayparting or multiple formats.

Digital I/O is available for feeding a digital system, such as a digital STL, without the unneeded conversions and their inherent distortions. Ask us for details.

8200 with two-band MVP	600B8200U2S	MFR LIST	\$7,400.00
8200 with five-band MVP	600B8200U3S	MFR LIST	\$10,400.00

### Orban Optimod-AM 9100B

Optimod is great on the AM band too. Three characteristic slopes are available on plug-in modules to optimize your unit for low-fi or high-fi receivers, or to split the difference. The system provides "EQ" adjustments to tune out transmitter deficiencies precisely. Mono systems can be upgraded to stereo at a later date. Meets the NRSC pre-emphasis and low pass filtering standards.

9100B1/U10 Mono	600B9100B1	MFR LIST	\$4,550.00
9100B2/U10 Stereo	600B9100B2	MFR LIST	\$6,350.00

CALL 1-800-732-7665 FOR BRADLEY PRICE ON ALL OF THESE OPTIMOD PRODUCTS

## CUTTING EDGE OMNIA

Omnia.fm represents a completely new approach to FM processor architecture, and, most importantly, brings you full digital control of your air signal, without the harsh digital "grunge" often heard in other digital processors. The omnia.fm uses PCM-CIA card technology to configure all processing resources, including fundamental rearrangements of system architecture. Remote operation and control of the unit is accomplished via web browser, a universally available interface.

Software driven features include daypart automation, format presets, and two levels of processing control for novice or expert users. A front panel headphone jack is provided on the front panel for monitoring in noisy environments.



The topology of the Omnia consists of six audio processing sections, followed by a digital stereo generator, and selectable composite clipper. Unique sections include the "Thunder Boost" EQ section, which provides an unusually clean and powerful low end, without sacrificing loudness, and a Dynamic Peak Limiter that produces a more natural, musical sound, with lower I.M. distortion.

Call Bradley to learn more about the amazing Omnia FM processor. Available later this year.

Omnia	60CEOMNIA	MFR LIST	\$7,895.00
-------	-----------	----------	------------

CALL 1-800-732-7665 FOR BRADLEY PRICE

## OPTIMOD 9200



The wait is over! Orban has just introduced the Optimod-AM Digital 9200. Now monaural AM stations will be able to upgrade to digital processing with a true five-band mono processor. The unit offers DSP digital processing, and comes standard with Windows-based PC remote control software, transmitter EQ, gated AGC, built-in sine and square wave test tone and bypass, high and low pass filtering, and dual analog outputs. Eight factory presets are provided for formats ranging from classical music to hard rock to news/talk and sports programming. The drift-free nature of digital processing can mean lower long-term maintenance costs.

AES/EBU digital I/O is available with an optional plug-in board, which enables the unit to accept and produce sampling rates of 32, 44.1 or 48 kHz. The 9200 is not upgradeable to stereo. For those seeking a stereo AM Optimod, the analog 9100B is still available in both mono and stereo.

9200U	600B9200U	MFR LIST	\$3,950.00
9200U/D	600B9200UD	MFR LIST	\$4,395.00

CALL 1-800-732-7665 FOR BRADLEY PRICE



## WARNING LIGHTS

### 1. BE Studio Warning Light

This classic light comes with a 25 watt red bulb and an attention grabbing flasher. The silk-screened globe housing fastens to a steel mounting plate. Available legends are ON AIR, AUDITION, REHEARSAL, and RECORD. Specify vertical or horizontal lettering. Also available in other languages, or blank so you can label your own.



60BR83500X MFR LIST \$60.00

### 2. Titus Warning Lights

Titus ON AIR and RECORDING lights are beautiful and practical ways of indicating that a studio is in use. Four internal lamps are wired in parallel, and use 24VDC, eliminating the need for relay interface boxes. The mounting base is of solid oiled oak. Size: 8-11/16" x 4-3/4" x 2-1/2" (W/H/D). Lettering is on a smoked glass window that is available with either a horizontal or vertical orientation with a silver or a gold frame.



60TIOALXX MFR LIST \$125.00

### 3. Fidelipac Warning Lights

Red lettering on a black background provides a highly visible warning that microphones are live. ON AIR or RECORDING legends are available in English. The ON AIR legend is also available in Spanish, French, German, Japanese, and four other languages. Lights are 5" x 10" x 2-1/2" (H/W/D).



ON AIR 60FP340 MFR LIST \$80.00  
RECORDING 60FP340REC MFR LIST \$80.00

CALL 1-800-732-7665 FOR BRADLEY PRICE

## ESE 60-MINUTE UP-TIMERS

A large LED display makes the ES520 readable in all room conditions. Control it from its start, stop, and reset controls or via two remote options. A momentary short to ground or 5V logic "O" can activate any function; four triggers reset the timer using a momentary or continuous signal. The serial output can drive 100 remote slaves. The new LX version has a slim, modern appearance.



ESE 520 60ES520 MFR LIST \$185.00  
Rack Option for above 60ESP MFR LIST \$50.00  
LX 520 60ESLX520 MFR LIST \$285.00

CALL 1-800-732-7665 FOR BRADLEY PRICE

## THE INFORMER

Best Seller

How hot or cold is it outside? What's the temperature in your transmitter room or garage? Bradley offers two versions of this specialized thermometer. The digital readout version reads from -40 degrees to 120 degrees Fahrenheit, and has high and low temp memories. Includes 50' cable and probe; runs on "AA" cell.



Designed for transmitter remote control use, the voltage Informer provides an output of 10mV/degree (100°F equals one volt). Its 18' cable lets you install the probe anywhere, including the transmitter's exhaust ducts. You must provide 5-12VDC to power the voltage version.

Digital readout 60TKI MFR LIST \$57.95  
Voltage output 60TKITX MFR LIST \$58.95

CALL 1-800-732-7665 FOR BRADLEY PRICE

## ETA POWER DISTRIBUTION

Best Seller

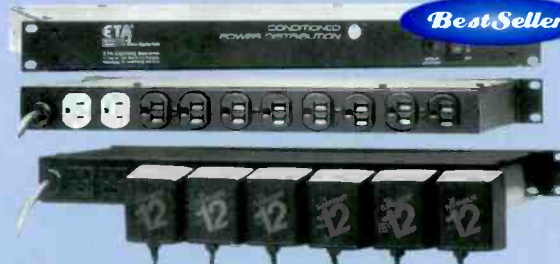

ETA Audio Conditioned Power units: spike and surge protected, EMI/RFI filtered. They are rated for 1800 watts, 15 amps, and have a master power switch, reset circuit breaker, and Edison AC outlets. All are 1 RU high and 7-3/4" deep.

PD10 with 8 rear protected outlets plus 2 always on  
60ARPD10 \$119.00  
PD10V same as PD10 plus a digital voltmeter display  
60ARPD10V \$199.00  
PD11L same as PD10 plus two retractable rack lamps and a front-panel outlet.  
60AR614 \$169.00  
PD11LV same as PD10 plus the digital voltmeter, lamps, and front-panel outlet.  
60AR615 \$249.00  
PD9 with 8 rear protected (mounted to accept power transformers!) and 1 front  
60ARPD9 \$149.00

## WHIRLWIND AC6R

This rackable power strip has six AC outlets, on/off switch, and resettable circuit breaker. 15 amps. The "SP" version adds surge protection. The "2R" version has six outlets on the rear, two in the front.



AC6R 61WHPC1 \$44.00  
AC6R/SP 61WHAC6RSP \$69.00  
AC6/2R 61WHAC62R \$43.00



**FURMAN POWER PRODUCTS**

Lower your noise floor and stop lifting grounds, too. The new Furman Isolation Transformer will change the way you look at studio hum problems. Designed for critical, low-noise installations, the IT1220 can supply 20 amps of balanced AC power. The goal: drastically reduce hum and buzz caused by ground currents from power supply filtering and by radiation from supply cables into sensitive signal sources. You can install it yourself for clean, safe power.



It typically gives a 16dB improvement in background noise floor in systemwide installations. This 3RU chassis has 12 isolated outlets on the back and two more on the front.

IT-1220                      60FUIT1220                      \$1,079.00

Furman's PL-Plus has eight switched outlets, a ten foot power cord, a front panel LED voltage monitor, and RF filtering. Protect your gear from spikes and surges. Outlets are rated at 15 amps. The two



slide-out lamps have a dimmer control. The PM-8 has the power conditioning features of the PL-Plus, without lights, but adds an AC ammeter and front-panel unswitched outlet.

PL Plus                      60FUPLPLUS                      \$175.00  
PM-8                      60FUPM8                      \$169.00

**AR-1215 AC line voltage regulator**

Protects equipment from problems caused by brownouts and overvoltages. It accepts voltages from 97 to 141 volts, and converts them to US standard 117 volts. The "J" version of the AR-1215 provides switch selectable 100VAC output. Input capacity 15 amps; output 12 to 15 amps. Unit instantly shuts down to protect your gear should an extreme overvoltage situation occur.



AR-1215                      60FUAR1215                      \$439.00  
AR1215J                      60FUAR1215J                      \$439.00

**AR-PRO** is a 30 amp line voltage regulator for use overseas and at home. Supply clean, regulated power for an entire studio or stage. It delivers 120V AC with capture ranges of 88 to 134 volts and 172 to 264 volts, 50/60 Hz. Because the AR-PRO works automatically, it can protect against a catastrophic error. Includes fourteen regulated, conditioned outlets, input voltmeter, output ammeter, and adjustable rack ears. Height: 3.5".

AR-PRO                      60FUARPRO                      \$1,649.00

**AC-CETERA CLAMP ON LIGHTS**

These Lumin-Eze lights will clamp and lock to any horizontal or vertical surface. The shade is directable. The 12" extension arm swings and bends. A detachable power supply is included to plug into any 110V outlet; or you can choose battery versions.

LE-15 Standard	61ACLE15	\$39.00
LE-25 Adds on/off switch	61ACLE25	\$49.00
LE-35 Adds on/off, halogen bulb, and dimmer	61ACLE35	\$65.00
LE-45 Battery version of LE-15 (two "AA") plus on/off	61ACLE45	\$55.00
LE-5D Dual lamp arms with three-way on/off switch	61ACLE5D	\$69.00
LE-6D Dual lamp battery version of above (four "AA")	61ACLE6D	\$75.00



*Best Seller*

**LITTLITE LAMPS**

Littlite makes: yes: little lights. Illuminate the dark corners of your job.

The popular L-3 Series has a mounting base with attached gooseneck, a dimmer, and a high intensity tungsten-halogen bulb in a finned hood. The L-2 Series has a mounting base with attached gooseneck, dimmer, and a low intensity incandescent bulb in an unobtrusive tubular hood. Optional AC adapter is a 120V transformer. Euro transformer also available.

L-3 Series, 12"	61LL312A	\$41.00
with AC adapter	61LL312	\$51.00
L-3 Series, 18"	61LL318A	\$41.00
with AC adapter	61LL318	\$51.00
L-2 Series, 12"	61LL212A	\$33.00
with AC adapter	61LL212	\$43.00
L-2 Series, 18"	61LL218A	\$33.00
with AC adapter	61LL218	\$43.00

The G Series has a swivel BNC-style connector, useful in applications requiring easy removal. They mate with panel sockets on your equipment.

G-Series, 12"	61LL12G	\$23.00
G-Series, 12" High Intensity	61LL12GHI	\$32.00
G-Series, 18"	61LL18G	\$25.00
G-Series, 18" High Intensity	61LL18GHI	\$34.00

The X Series has a 3-pin male XLR connector with isolated lamp circuit. Useful where a detachable, non-swiveling connection is desired.

X-Series, 12"	61LL12X	\$28.00
X-Series, 12" High Intensity	61LL12XHI	\$37.00
X-Series, 18"	61LL18X	\$29.00
X-Series, 18" High Intensity	61LL18XHI	\$39.00

**Spare Bulbs**

Q5 High Intensity Bulb	61LLQ5	\$7.50
1815 Low Intensity Bulb	61LL1815	\$2.50



# FURNISHINGS

## PERFECTDATA COPY STANDS

We use these copy stands next to many of our computer terminals. They're great in your air studio because they pivot out of the way easily on their "C" clamp. They are available in letter size with two weight capacities. Use the optional extender to hold computer printouts or open books. Almond color.

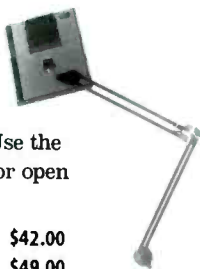

Letter size 1lb capacity	61LU16007	\$42.00
Letter size 3lb capacity	61LU16008P	\$49.00
Extender	61LUEK	\$15.00

## CUTTING WEDGE

These charcoal gray acoustic tiles control noise, slap, echo, and standing waves. The tiles come in convenient 12" by 12" squares. They can be shipped via UPS in any quantity, so you save on shipping. Order by the case and save even more.

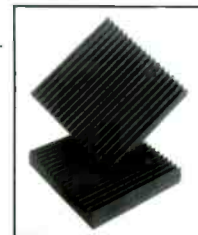

2" thick square	60CW1	\$3.25 ea.	\$2.92 ea./case of 56
3" thick square	60CW3	\$4.25 ea.	\$3.82 ea./case of 36
4" thick square	60CW4	\$5.90 ea.	\$5.31 ea./case of 28

Note: Minimum order is 10 squares; shipping charges are additional.

## MIDDLE ATLANTIC MULTI-DESK SYSTEM

Like all Middle Atlantic products, their new Multi-Desk System of configurable studio furniture is well built and affordable, and ships via UPS to save money. Design your setup around the MD-48, a 48" x 30" grey laminated tabletop with steel tube legs. "Quick-Lok" construction lets you assemble it in minutes. Simply lift the legs into place from their folded shipping position.

Then add your choice of optional Multi-Bridges and side Multi-Racks, both with rails. You assemble the tabletop Multi-Bridge as an open work space or as a rack with one or two bays. The rolling Multi-Racks provide added counter and rack space; one face is sloped, one is vertical, for maximum flexibility.

The standard system shown here includes an MD-48 desk, two MR-14W side racks, and an MB-6 overbridge that you can also set up as two six-space bays. We can also quote other configurations and tell you about optional modesty panels, cable management kits, and drawers. Call us to order or ask for an info pamphlet.



## NIGEL B. FURNISHINGS

### DESKTOP RACK STAND

Handle up to 13 rack units of equipment in an adjustable, lockable frame that goes from vertical to horizontal. Good for recorders and mixers. Size: 26"H x 21"W x 18"D.

60NBPLDERS	\$179.00
------------	----------



### RECORDER STAND

Sturdy and movable, with heavy-duty construction and smooth rolling casters. Has 13 rack units of space plus eight additional units between its uprights.

60NBPLRS	\$429.00
----------	----------

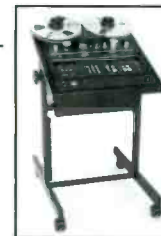

**We carry the full line of Murphy Studio and Nigel B computer and video furniture. Call us!**

## MIXRAK

MIXRAK is an affordable, no-frills line of modular furniture. The design makes assembly and expansion easy. Board surfaces are protected by melaface and high pressure laminate. The desk is edged with 1-1/2" solid oak, the other edges are protected by T-molding. Heavy threaded rack rails ensure proper mounting of equipment.

DT72 30" x 72" Top	60MIDT72	\$169.00
DT22 22" x 30" Top	60MIDT22	\$87.00
FDT Desk Top Rack/Organizer	60MIFDT	\$179.00
HDT Desk Top Rack/Organizer	60MIHDT	\$85.00
RB Rack Base (14 space)	60MIRB	\$159.00
SR Angled Rack	60MISR	\$249.00
R2 Rack (2 space)	60MIR2	\$59.00
R4 Rack (4 space)	60MIR4	\$74.00
R8 Rack (8 space)	60MIR8	\$103.00
R12 Rack (12 space)	60MIR12	\$125.00
R16 Rack (16 space)	60MIR16	\$145.00

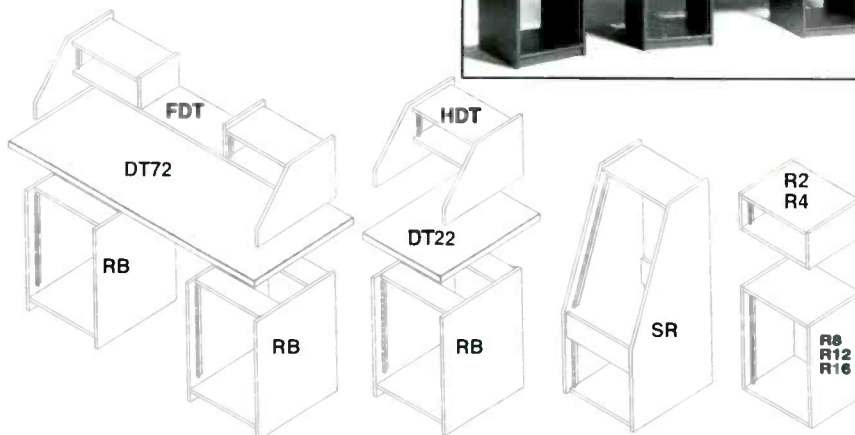
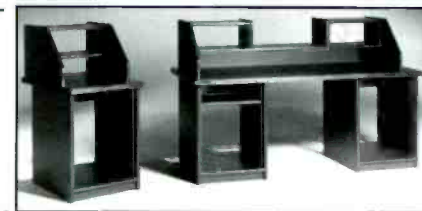

# FURNISHINGS



**MIDDLE ATLANTIC RACKS**

Build them yourself and save. Wood racks look nice and set up easily with the supplied Allen key and hardware. The surface is black laminate over 5/8" high density

particle board. Rails are drilled and tapped to fit all equipment. Each rack ships knocked

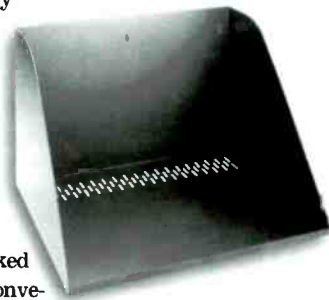

down for convenient UPS delivery. An optional caster set lets you roll your rack away. Other sizes are available by special order.

You can wall mount these economically with the WMS-20 shelf (inset), which holds up to 200 pounds.

2 space, 16" deep	61MARK2	\$55.00
4 space, 16" deep	61MARK4	\$59.00
8 space, 18" deep	61MARK8B	\$89.00
12 space, 18" deep	61MARK12B	\$92.00
16 space, 18" deep	61MARK16B	\$99.00
20 space, 18" deep	61MARK20B	\$109.00
Wheel kit	61MARKW	\$36.00
WMS-20 Wall Shelf	61MAWMS20	\$65.00

**PANASCHEME RACKS**

For fine furniture enclosures, look no farther than Panascheme, a Bradley Broadcast exclusive. They ship assembled, ready to install. We offer two series.

**Oak Trim Racks** are made of high density, 3/4" Domtar Melamine panels, with edges finished in a custom-milled red oak cap, treated with lemon oil. Standard color is black; other colors are available optionally.

**Oak Ply/Solid Wood Racks** have a beautiful all oak exterior surface constructed of 3/4" multi-ply, cabinet-grade panels. Edges are finished in red oak cap.

Both models include a lightweight removable back panel, and pass-through holes in the bottom rear.

Prices shown are for 18" usable depth models; call for other depths, glass doors, rear rail, locks, carpeting, and any other features you need. Racks may ship via truck. For a quality oak knock-down alternative that ships UPS, see below.



Total Height	Rack Units	18" Deep Oak Trim		18" Oak Ply/Solid Wood	
		Part #	Price	Part #	Price
10-3/4"	4	61PSER04M018	\$183.00	61PSERC40018	\$215.00
17-3/4"	8	61PSER08M018	\$203.00	61PSERC80018	\$242.00
24-3/4"	12	61PSER12M018	\$226.00	61PSER120018	\$265.00
31-3/4"	16	61PSER16M018	\$245.00	61PSER160018	\$296.00
38-3/4"	20	61PSER20M018	\$265.00	61PSER200018	\$326.00
45-3/4"	24	61PSER24M018	\$290.00	61PSER240018	\$358.00
56-1/4"	30	61PSER30M018	\$308.00	61PSER300018	\$425.00
63-1/4"	34	61PSER34M018	\$336.00	61PSER340018	\$504.00
73-3/4"	40	61PSER40M018	\$398.00	61PSER400018	\$575.00

Outside Dimensions: Width: 22-1/8", Depth: 19-1/2"

**Options:**

Casters, 2"	61PSCASTERS	\$109.00
Swivel Base	61PSSWIVEL	\$109.00

**PANASCHEME OAK KNOCK-DOWN RACKS**

These oak racks come ready for assembly, so you get a fine wood enclosure yet minimize your shipping expense. These are a step up from inexpensive particle-board knock-downs. The barrel-nut and through-bolt hardware doesn't strip even after multiple assemblies. The enclosures are made of multi-ply, cabinet-grade red oak and treated with tung oil for a durable finish. Edges are capped in solid oak.

Choose from four standard sizes, all with 17-1/4" usable inside depth and packed with hex key and hardware. Available options include other sizes and depths, doors, locks, rear rail, sloped front, and casters.

8 Space	61PS08KD	\$179.00	20 Space	61PS20KD	\$209.00
12 Space	61PS12KD	\$189.00	Casters	61PSCASTERS	\$109.00
16 Space	61PS16KD	\$199.00			

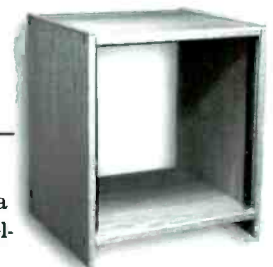

**RAXXESS SECURE RACK STORAGE**

Store and secure tapes, tools, CD's, and detritus that can clutter up your life. The Rak-Vault is a steel, rack-mount enclosure with a hinged front panel and keyed lock. Black, baked enamel finish. 9" deep.

RKV-3 (5-1/4" high)	61RX3V	\$59.00
RKV-4 (7" high)	61RX4V	\$69.00



# FURNISHINGS

## SOUNDOLIER EQUIPMENT RACKS

Soundolier's industry standard metal utility cabinets have been re-designed for better ventilation, wire management, and overall appearance. They are complete with base, top panel, vented side panels, vented rear locking door, knockouts, one pair of fixed rails, mounting screws, and hardware. The rear door is removable and can hinge right or left.

Series 100 is shipped knocked down (K.D.) to save you money on shipping. Series WA100 is welded and pending UL approval. Both have new, easy wiring access through openings in the top and bottom. You can leave the openings for access and ventilation, or cover them with an optional panel. The top opening can



accept exhaust fan ES195-22. Call us for optional solid or acrylic

Total Height	Rack Units	Welded		Knocked Down	
		Part #	Price	Part #	Price
41"	21	60SDWA10036	\$324.00	60SD10036	\$289.00
46-1/4"	24	60SDWA10042	\$339.00	60SD10042	\$299.00
65-1/2"	35	60SDWA10061	\$389.00	60SD10061	\$355.00
74-1/4"	40	60SDWA10070	\$429.00	60SD10070	\$399.00
81-1/4"	44	60SDWA10077	\$439.00	60SD10077	\$415.00

front doors, or WA200 series racks with front doors, adjustable rails, and available extra depth.

The racks above are stocked in black textured enamel; other colors by special order. Inside usable depth is 17-1/4".

Caster truck (4 swivel casters, 1 pr locking)	60SDCT502	\$120.00
Top/Bottom Panel	60SDS195	\$19.00
Dual Exhaust Fan System	60SDES195122	\$326.95

## MIDDLE ATLANTIC RACK SHELVES

Quick and easy rack mounting in one, two, or three spaces. Steel is 16 gauge with durable black powder coat finish. Depths: 11" for U1, and 14-3/4" for U2 and U3. Inside left to right dimension on all shelves is 17 3/8". Need a lot of U2 shelves? Ask about the master pack of 50.



One space, holds 35 lbs	61MAU1	\$29.00
Two space, holds 50 lbs	61MAU2	\$38.00
Three space, holds 85 lbs	61MAU3	\$42.00

## MIDDLE ATLANTIC CLAMPING RACK SHELVES

Adjustable rubber-lined clamps secure your unit from the top, "L" brackets grab it from the rear. Steel construction, vented bottom. These sizes are one-piece with 14-3/4" depth. Taller, knock-down models are available.

2RU	61MARC2	\$45.00	4RU	61MARC4	\$54.00
3RU	61MARC3	\$49.00			

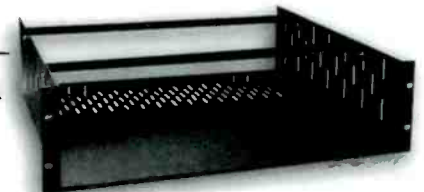

## MIDDLE ATLANTIC GANGABLE RACKS

Slim 5 is a knock-down metal enclosure that ships via UPS to save you money. Buy just the frame, or add removable vented side panels. These racks can be ganged together for versatility.

The patented corner joint provides great strength and helps in your setup. Slim 5 comes with substantial top and bottom panels; the bottom is open for cable access and pre-punched for optional casters and leveling feet. Electrical knockouts are provided.

Ask about optional split rear rack rails, cable chases, and front and rear doors. Usable depth 20".

Skirted Caster Base	61MACB55	\$105.00
Leveling Feet (4)	61MALF	\$19.00



Total Height	Rack Units	Enclosure		Side Panel (Pair)	
		Part #	Price	Part #	Price
17-3/4"	8	61MA58	\$145.00	61MASP58	\$80.00
28-1/4"	14	61MA514	\$165.00	61MASP514	\$96.00
40-1/2"	21	61MA521	\$185.00	61MASP521	\$127.00
54-1/2"	29	61MA529	\$205.00	61MASP529	\$156.00
68-1/2"	37	61MA537	\$215.00	61MASP537	\$185.00
79"	43	61MA543	\$225.00	61MASP543	\$209.00

## MIDDLE ATLANTIC SLIDING SHELVES

The SSL is a new, low-profile sliding shelf that occupies one rack space and provides a black laminate slide-out surface with positive lockout and 11" reach. It supports up to 35 pounds. The universal telescopic rear support fits all racks. The popular SS version holds up to 50 pounds, extends 14", and now latches in both open and closed positions. The SS occupies slightly more than one rack space, usually not a problem due to the equipment being placed on top.

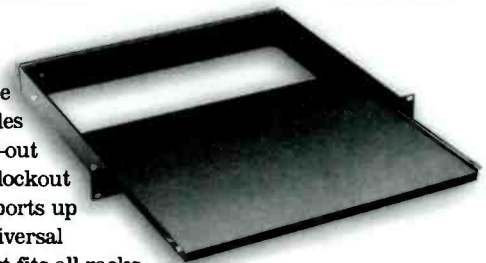

SSL	61MASSL	\$55.00
SS	61MASS	\$99.00

# FURNISHINGS



**THE RACK RULER**

We love it. This steel tape measure with belt clip pulls out to eight feet and is incremented in both rack spaces and inches. Bonus: the back of the tape has great formulas and engineering info.

61MARULER \$12.95

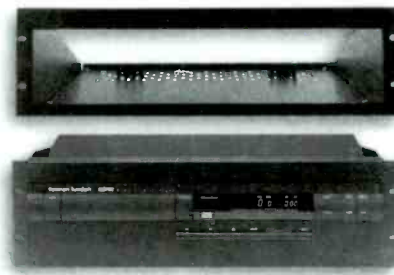

**CUSTOM RACK SHELVES**

Rack mount your non-rackable equipment, without unsightly gaps. Custom rack mounts are more than shelves. They bring your unit up to the next full rack space, and prevent it from sliding back with rear brackets. Custom cut-outs are made for your equipment, and the complete shelf is shipped to you in two to three weeks. Many patterns are already on file, so call us to review. Some assembly is required. These shelves accept units up to 17-3/8" wide.

Brushed and black anodized aluminum  
61MARSH4A \$125.00  
Textured black enamel on steel  
61MARSH4S \$109.00



**BLANK PANELS**

Our best selling blank panels, flanged for strength and made of black brushed and anodized aluminum. Easy to machine.

1 space 61MABL1 \$12.50  
2 spaces 61MABL2 \$13.75  
3 spaces 61MABL3 \$16.75  
4 spaces 61MABL4 \$18.75

**ECONO-BLANKS**

They're now flanged for strength. Black powder coat on steel. Less expensive but heavier to ship. Need a lot? Save with master packs.

EB-1 1 space 61MAEB1 \$6.25  
EB-2 2 spaces 61MAEB2 \$7.95  
EB-3 3 spaces 61MAEB3 \$8.95  
EB-4 4 spaces 61MAEB4 \$10.95  
EB-5 5 spaces 61MAEB5 \$12.95  
EB-6 6 spaces 61MAEB6 \$14.25  
EB-1 Master Pack (100) 61MAEB1MP \$219.00  
EB-2 Master Pack (50) 61MAEB2MP \$269.00

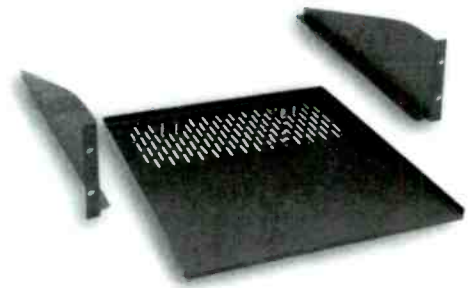

**KD SHELVES**

KD means knock-down. When you assemble them, you save on shipping. Flush studs are provided with bottoms for easy assembly. KD shelves are 16 gauge steel painted with black baked enamel, and can be used with equipment up to 17-3/8" wide. Ears come packaged in pairs. Call for extra-tall ears and extra-deep bottoms.

**Important: For a complete shelf, purchase both a bottom section and a set of ears.**

**Bottom Section, 15-1/2" deep**

61MAKDB \$17.00  
Matching Ears, 3-1/2" tall 61MAKDE2 \$28.00  
Matching Ears, 5-1/4" tall 61MAKDE3 \$30.00  
Matching Ears, 7" tall 61MAKDE4 \$31.00  
Matching Ears, 8-3/4" tall 61MAKDE5 \$32.00  
Matching Ears, 10-1/2" tall 61MAKDE6 \$33.00  
Matching Ears, 12-1/4" tall 61MAKDE7 \$35.00

**Bottom Section, 11-1/2" deep**

61MAKDBS \$17.00  
Matching Ears, 3-1/2" tall 61MAKDE2S \$27.00  
Matching Ears, 5-1/4" tall 61MAKDE3S \$29.00  
Matching Ears, 7" tall 61MAKDE4S \$31.00



**HALF RACK UNIVERSAL SHELF**

Mount one or two half-rack devices horizontally in one rack space. Mounting hardware is included and the shelf is drilled with universal holes. 10" deep. Need lots? Ask about the 50-piece master pack.

61MAUTR1 \$19.95

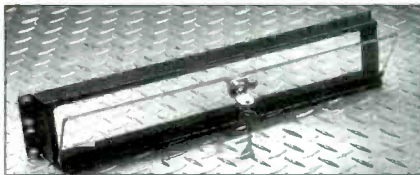

**PLEXIGLAS SECURITY COVERS**

A lightly smoked Plexiglas door protects your equipment behind a keylock. An immediate hit when we first showed them at NAB last year. Depth of covers is 1 1/2".

2 spaces 61MASECL2 \$36.50  
4 spaces 61MASECL4 \$37.00  
8 spaces 61MASECL8 \$53.00



**SECURITY COVERS**

Ideal for providing both security and protection, these perforated steel covers are 1" deep and allow easy viewing of control settings. Screw notches let you remove them without unmounting the gear. Use with tamper-proof screws.

1 space 61MASEC1 \$20.00  
2 spaces 61MASEC2 \$24.00  
3 spaces 61MASEC3 \$26.00

**REAR HANGING BRACKET**

To support amps and other gear with rear ears. Each is a pair.



RH-2 2 Space 61MARH2 \$8.00  
RH-3 3 Space 61MARH3 \$9.00  
RH-4 4 Space 61MARH4 \$10.00

## MIDDLE ATLANTIC, CONT...



### RACK CHASSIS

For your custom electronics. Flush face is easily removed for punching and the rear panel is full height and removable. Face and rear are black anodized aluminum, while the top, bottom, and sides are steel. These chassis are 10" deep and ship assembled.

1 space	61MACH1	\$59.00
2 spaces	61MACH2	\$69.00
3 spaces	61MACH3	\$74.00



### RACK DRAWERS

- Enclosed top
- Ball bearing slides extend 14"
- Flush slam latch keeps drawer closed
- Keylock option is factory installed
- Storage height is 1/2" less than rack-ing height
- Larger sizes available, including hanging file kit
- Models shown are anodized aluminum. Steel models available
- Ask about partitions for CD, DAT, LP, Cassette, VHS

2 spaces	61MADWR2	\$98.00
2 spaces w/lock	61MADWR2L	\$123.00
3 spaces	61MADWR3	\$119.00
3 spaces w/lock	61MADWR3L	\$144.00
4 spaces	61MADWR4	\$143.00
4 spaces w/lock	61MADWR4L	\$168.00

### RACK RAILS

Our best 1/8" thick galvanized steel rails are punched and tapped for 10-32 screws. Side mounting holes are 9/32" diameter. Sold in pairs. Shorter lengths available.

8 spaces (14")	61MARR8	\$14.00
10 spaces (17-1/2")	61MARR10	\$16.00
12 spaces (21")	61MARR12	\$19.00
14 spaces (24-1/2")	61MARR14	\$21.00
16 spaces (28")	61MARR16	\$23.00
18 spaces (31-1/2")	61MARR18	\$26.00
21 spaces (36-3/4")	61MARR21	\$30.00
27 spaces (48-1/4")	61MARR27	\$36.00
45 spaces (78-3/4")	61MARR45	\$52.00



### VENT PANELS

Middle Atlantic's 16 gauge steel panels have one piece construction and are perforated with 5/32" diameter holes yielding 68% open area.

1 space	61MAVT1	\$9.35
2 spaces	61MAVT2	\$11.25
3 spaces	61MAVT3	\$13.20
4 spaces	61MAVT4	\$14.40
6 spaces	61MAVT6	\$15.30



### FANS AND FAN PANELS

Three-space fan panels include grilles and are punched for 4-1/2" diameter fans. The quiet, 100 CFM fans, sold separately, are designed for long life. Line cord supplied; user must install plug. Black anodized aluminum shown; also available in steel with black enamel.

Panel for 1 fan	61MAFP1	\$29.00
Panel for 2 fans	61MAFP2	\$32.00
Panel for 3 fans	61MAFP3	\$34.00
Fan	61MAFAN	\$38.00
Fan Guard	61MAGUARD	\$4.25
Filter Kit with washable filter keeps dust out of your gear. Can be fit over fan panels or used alone. Three RU.	61MAFILTER	\$29.00

### RACK HARDWARE

Each package contains 10-32 x 3/4" black machine screws and flat nylon washers. Choose Phillips, square drive, or a special tamper-proof star post for security. Phillips hardware is now heat treated to reduce stripping, and is available in a master pack.

Phillips 100 ea	61MAHDWEP	\$16.50
Master Pack (50 bags of 100)	61MAHPMP	\$375.00
Torx Post Screws 50 ea	61MAHDWET	\$13.00
Torx Post for above	61MATBIT	\$10.25
Square Drive 100 ea	61MAHDWES	\$22.80
Square Drive for above	61GIMABIT	\$2.29

Shoulder washers are non-conductive and are used with standard washers to isolate equipment from the rails.

100 ea	61MASW	\$7.50
--------	--------	--------

### UCP PUNCHED PANELS

Design and assemble your own custom panels out of stock modules. The completed panels look professional with no gaps; all hardware is flush, and all visible parts have an aesthetic brushed and black anodized finish.

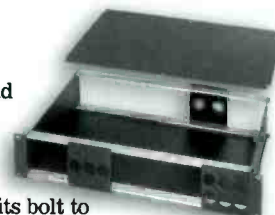
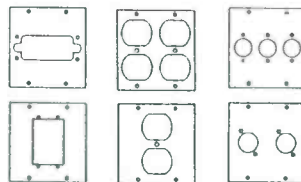
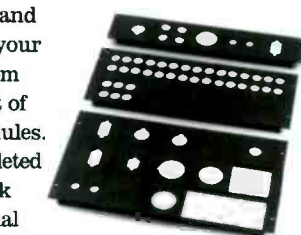

Frame kits bolt to their ears with included hardware; then you fit up to five modules across a two-rack-space frame, or ten modules in a four space frame, or 15 modules in a six spacer. Modules are prepunched for your choice of connectors. Middle Atlantic has a hundred modules with cutouts for XLR, data multipin, phone, BNC, RCA, LEDs, duplex receptacles, twistlocks, and many specialty types of connectors. These are just a sample. A loaded two space frame is less than \$60. Call us!

All punched UCP's	\$11.00
The UCP-CH chassis fits UCP modules on front and rear	61MAUCPCH \$39.00
Adapt any single UCP module to a standard 1900 electrical box	61MAUCPADP \$9.00

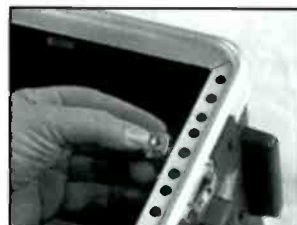

SKB's Nut Retainer Clips make life so much easier when you're mounting things in a rack. They clip onto your rail so you have one less thing to hold. Bag of 22.

SKB Rack Pack	775K19AC1	\$9.95
---------------	-----------	--------

## MEDIA STORAGE

**A.** CD clutter got you down? Each ART wire tower holds 31 single CD's plus two doubles in a free-standing, tabletop, or wall configuration.

61AR1209 \$17.00

**B.** Ruslang racks accept CD's and Denon shells. Available in walnut, oak, black, and other colors.

Wall Unit (holds 96) 60RLCD96 \$116.00  
 Lazy Susan (128) 60RLCD128LS \$329.00  
 Lazy Susan (256) 60RLCD256LS \$455.00

**C.** The mobile Fidelipac MR-200 holds 200 carts in eight removable modules mounted on a caster base. Or order each module separately for use as a 25-cart wall rack.

MR-200 complete 60FPMR200 \$395.00  
 WR-25 rack only 60FPWR25 \$42.00

**D.** Ruslang's CD storage systems are made up of three modules and a base (our photo shows two). Bolt them together and screw them to the wall. Height: 78-1/4".

612 CDs Package 9722 \$584.00  
 960 CDs Package 9723 \$646.00  
 1,322 CDs Package 9724 \$708.00

**E.** Simpac Cart Racks let you configure your own storage on any vertical surface. Each black plastic unit holds 10 carts.

60SICRBK \$6.30 ea  
 12 or more \$5.75 ea

**F.** ABCO carousels store CD's and carts. All stand six feet and include casters. Each consists of removable wire modules that can be purchased separately for wall mounting.

280 CDs 60AB280 \$375.00  
 560 CDs 60AB560 \$679.00  
 300 Carts 60AB300 \$419.00  
 500 Carts 60AB500 \$649.00  
 70 CD Wire Rack 60AB70 \$71.00  
 50 Cart Wire Rack 60AB50 \$55.00

**G.** Nigel B's storage drawers are fitted with compartments for discs and tapes.

CD Drawer holds 69; 4RU high 60NBCDD \$173.00  
 DAT Drawer holds 76; 2RU high 60NBDDAT \$165.00  
 Cassette Drawer holds 64; 3RU high 60NBAC3D \$157.46  
 Cover and lock option for any drawer 60NBDCI \$34.96

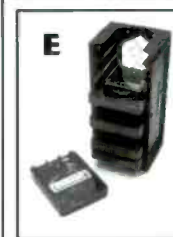
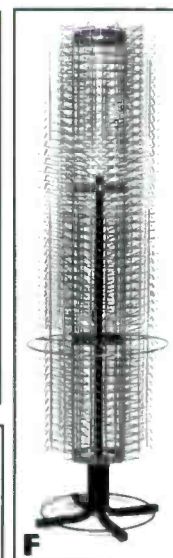
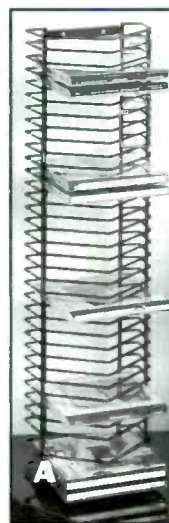

## MIDDLE ATLANTIC MEDIA HOLDERS

Rack mount media holders from Middle Atlantic are anodized aluminum. Call us for steel versions.

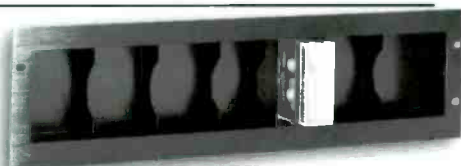

Compact disc holder for 40 CD's; 4RU tall 61MACDSH \$59.00  
 Cassette holder for 33 audio cassettes; 3RU tall 61MACS \$55.00  
 DAT holder for 27 digital audio tapes; 3RU tall 61MADAT \$57.00  
 LP, 10-1/2" reel tape, or binder holder; 8RU tall 61MALP \$125.00

## MIDDLE ATLANTIC CD-1



Stick your empty CD cases in the CD-1 to keep them off your studio counter. One RU tall, brushed and black anodized finish. Holds six.

CD-1 61MACD1 \$35.00

## ALPS MEDIA STORAGE CABINETS

Look to the Alps when you have a lot of media to store, whether it's CD, DAT, reel, cassettes, or video. Each has a foot-print of only 2 x 4', and look how much they hold. Partitions can be mixed among drawers in a single unit. Cabinets come in white, almond, and gray laminates. These are typical CD models. We have similar pricing for other media. Prices do not include truck freight.

Five drawer floor unit for 2120 CD's, 42" H 60ALCBA605CD \$1,670.00  
 Eight drawer floor unit for 3392 CD's, 60" H 60ALCBA908CD \$1,439.00  
 Six drawer top unit for 1836 CD's, 45" H 60ALCBU466CD \$1,385.10



Best Seller

New!

Alps Mini-storage cabinet for any media. This compact cabinet provides the same safety and security for your media as its larger brothers, at a great price!

Alps Mini Media Cabinet 60ALMMSK \$649.00  
 Lock for MMSK 60ALMINILOCK \$80.00

Manufacturers are listed in bold.

<b>360 Systems</b> . . . . . 37-39, 89	<b>CCS</b> . . . . . See Musicam USA	<b>Focal Press</b> . . . . . Call Bradley	<b>Wireless</b> . . . . . 33-35	<b>Compact Disc</b> . . . . . 42	<b>Tascam</b> . . . . . 2, 36, 38, 42-46, 57, 72, 100
<b>ABCO</b> . . . . . 107	<b>Cellcast</b> . . . . . Call Bradley	<b>Fostex</b> . . . . . 46, 64, 74, 95	<b>Microtech Gefell</b> . . . . . Call Bradley	<b>DAT</b> . . . . . 2, 3, 36-37	<b>Teac</b> . . . . . 43, 49, 52, 100
<b>Accetera</b> . . . . . 101	<b>Cellular Interface</b> . . . . . 8	<b>Frequency Extension</b> . . . . . 11	<b>Middle Atlantic</b> . . . . . 51, 102-107	<b>Hard Disk</b> . . . . . 37, 39	<b>Technics</b> . . . . . 43, 49, 52, 100
<b>Acoustic Treatment</b> . . . . . 102	<b>CircuitWerkes</b> . . . . . 96	<b>Furman</b> . . . . . 66, 93, 101	<b>MiniDisc Machines</b> . . . . . 3, 38-39	<b>MiniDisc</b> . . . . . 3, 38, 39	<b>Telephone &amp; Teleconference</b>
<b>A/D Converters</b> . . . . . 42	<b>Cleaners</b> . . . . . 47, 95	<b>Furniture</b> . . . . . 102, 107	<b>Blank MD Discs</b> . . . . . 49	<b>Multi-track</b> . . . . . 42-43, 45-46	<b>Cellular Interface</b>
<b>ADAT</b> . . . . . 43	<b>Clear-Com</b> . . . . . 18	<b>Gaffer's Tape</b> . . . . . 63	<b>Mix Minus</b> . . . . . 91	<b>Open Reel</b> . . . . . Call Bradley	<b>Codecs</b>
<b>ADB</b> . . . . . 40	<b>Coaxial Cable</b> . . . . . Call Bradley	<b>Gates</b> . . . . . See Processing	<b>Mixers &amp; Consoles</b>	<b>Other</b> . . . . . 3, 13, 37	<b>Couplers</b> . . . . . 6, 12-13
<b>ADC</b> . . . . . Call Bradley	<b>Coaxial Dynamics</b> . . . . . Call Bradley	<b>Galaxy</b> . . . . . 63, 68	<b>Auto Mic Mixers</b> . . . . . 59-60	<b>Stands</b> . . . . . 102	<b>DTMF</b> . . . . . 1
<b>Adtran</b> . . . . . Call Bradley	<b>Codecs</b>	<b>Gemini</b> . . . . . Call Bradley	<b>Broadcast On-Air</b> . . . . . 52-53, 57	<b>Reel to Reel</b> . . . . . See Recorders	<b>Frequency Extension</b> . . . . . 1
<b>AEQ</b> . . . . . Call Bradley	<b>ISDN</b> . . . . . 10-12	<b>Geneva</b> . . . . . 48-49	<b>Digital</b> . . . . . 56	<b>Relays</b> . . . . . 85	<b>Hybrids &amp; Delays</b> . . . . . 12, 14-15
<b>Air Corp</b> . . . . . Call Bradley	<b>POTS</b> . . . . . 8, 10	<b>Genfer</b> . . . . . 12, 16-17, 66, 97	<b>Mic/Utility 6, 8, 9, 56-59, 83-85, 91</b>	<b>Remote Control, Transmitter</b> . . . . . 97-78	<b>ISDN &amp; Switched</b> . . . . . 9-10
<b>Akai</b> . . . . . Call Bradley	<b>Comark</b> . . . . . Call Bradley	<b>Gorman Redlich</b> . . . . . Call Bradley	<b>Mixer/Recorder Combos</b> . . . . . 45-46	<b>Remote Control, via phone</b> . . . . . 18, 97-98	<b>Message Storage</b> . . . . . 13, 6
<b>AKG</b> . . . . . 22, 23, 25, 29, 31, 32, 75	<b>Community</b> . . . . . 62	<b>Gotham</b> . . . . . 93	<b>Multitrack</b> . . . . . 42	<b>Remote Pickup Equipment (RPU)</b>	<b>Mix Minus</b> . . . . . 6
<b>Altesis</b> . . . . . 43, 68, 82	<b>Compact Disc</b>	<b>Hafler</b> . . . . . 72	<b>Portable</b> . . . . . 6, 8-9, 55-57, 59-61	<b>RF</b> . . . . . 98	<b>Remote Equipment</b> . . . . . 6, 8-10
<b>Alps</b> . . . . . 107	<b>Accessories</b> . . . . . 48-49	<b>Halland</b> . . . . . Call Bradley	<b>Powered</b> . . . . . 60-61	<b>Telephone</b> . . . . . 6, 8-9, 13	<b>Telex</b> . . . . . 18, 20, 35, 4
<b>Ampex</b> . . . . . See Quantegy	<b>Blank Discs</b> . . . . . 49	<b>Har-Ken</b> . . . . . 92	<b>Production</b> . . . . . 54-59	<b>Reverb</b> . . . . . See Processing	<b>Telos</b> . . . . . 10, 15-16, 1
<b>Amplifiers</b>	<b>Players</b> . . . . . 49-51	<b>Hard Disk Systems</b> . . . . . 37-39	<b>MixRak</b> . . . . . 102	<b>Roland</b> . . . . . 41, 80	<b>Test</b> . . . . . 48, 63, 85, 90, 95-9
<b>Composite</b> . . . . . 96	<b>Recorders</b> . . . . . 42	<b>Head Cleaners</b> . . . . . 47	<b>Modern Case</b> . . . . . 7	<b>Routing Switchers</b> . . . . . 89-92	<b>TFT</b> . . . . . Call Bradley
<b>Distribution</b> . . . . . 82-84, 87-89, 91	<b>Storage</b> . . . . . 51, 107	<b>Headphones</b> . . . . . 74-75	<b>Modulation Sciences</b> . . . . . Call Bradley	<b>Rowi</b> . . . . . 31	<b>Thermometers</b> . . . . . 10
<b>Headphone</b> . . . . . 5, 72-74, 85	<b>Test CD's</b> . . . . . 48	<b>Headsets</b> . . . . . 18, 20	<b>Monitors</b>	<b>RTA</b> . . . . . 96	<b>Timers</b> . . . . . 10
<b>IHF/Pro</b> . . . . . 50, 82-83, 86-88, 91	<b>Compressors</b> . . . . . See Processing	<b>Henry</b> . . . . . 13, 37, 44, 91	<b>Meters</b> . . . . . 64, 66, 83	<b>RTS</b> . . . . . 19	<b>Titus</b> . . . . . 10
<b>Line</b> . . . . . 82-84	<b>Comrex</b> . . . . . 9-11, 13	<b>HNB</b> . . . . . 2, 42	<b>Modulation</b> . . . . . Call Bradley	<b>Ruslang</b> . . . . . 107	<b>Toa</b> . . . . . 6
<b>Mic &amp; Press</b> . . . . . 5, 8, 33, 83, 84	<b>Conex</b> . . . . . 8, 18, 92, 95	<b>Hosa</b> . . . . . Call Bradley	<b>Phase</b> . . . . . 67	<b>Sabine</b> . . . . . 76	<b>Tone Generators &amp; Decoders</b> . . . . . 85, 9
<b>Phono</b> . . . . . 85	<b>Connectors &amp; Adapters</b> . . . . . 92-94	<b>Hybrids</b> . . . . . 14-16	<b>Selectors</b> . . . . . 70	<b>Sample Rate Converters</b> . . . . . 82	<b>Tracer</b> . . . . . 98
<b>Power/Monitor</b> . . . . . 72-73	<b>Consoles</b> . . . . . See Mixers	<b>INC</b> . . . . . Call Bradley	<b>Signal</b> . . . . . 66-67	<b>Samson</b> . . . . . 59	<b>Transformers</b> . . . . . 84-8
<b>Analizers</b> . . . . . 96	<b>Copy Stands</b> . . . . . 102	<b>Informer</b> . . . . . 100	<b>Speakers</b> . . . . . See Speakers	<b>Satellite Tools</b> . . . . . 90	<b>Transmitters, FM</b> . . . . . 9
<b>Anchor</b> . . . . . 62, 67	<b>Cord-Lox</b> . . . . . 93, 95	<b>Inovonics</b> . . . . . Call Bradley	<b>Motorola</b> . . . . . 18	<b>Scala</b> . . . . . Call Bradley	<b>Tuners &amp; Receivers</b> . . . . . 66-67
<b>Antennas</b> . . . . . Call Bradley	<b>Cotton Swabs</b> . . . . . 47	<b>Intercom &amp; IFB</b> . . . . . 18-19	<b>Mounting Hardware</b> . . . . . 106	<b>Security Covers</b> . . . . . 105-5	<b>Tunnel Tape</b> . . . . . 63
<b>Anvil</b> . . . . . Call Bradley	<b>Couplers</b> . . . . . See Telephone	<b>Interface Amps</b> . . . . . See Amplifiers	<b>MRL</b> . . . . . 48	<b>Sennheiser</b> . . . . . 20-22, 24, 31, 75	<b>Turntables</b> . . . . . 52
<b>Aphex</b> . . . . . 33, 45, 78, 81, 86, 89	<b>CRL</b> . . . . . 95	<b>Intraclean</b> . . . . . 47-48	<b>Multitrack Editors</b> . . . . . 40-41, 45-46	<b>Sequencers, Event</b> . . . . . 95	<b>Two-Way Radios</b> . . . . . 10
<b>ART</b> . . . . . 82	<b>Crown</b> . . . . . 20, 27-28, 61, 73, 96	<b>ITC carts</b> . . . . . Call Bradley	<b>Multitrack Recorders</b> . . . . . See Recorders	<b>Shelves</b> . . . . . See Racks	<b>Ultimate</b> . . . . . 31, 62
<b>Ashly</b> . . . . . 57, 76	<b>Crystal Partners</b> . . . . . 20	<b>JBL</b> . . . . . 61, 69, 71	<b>Murphy</b> . . . . . Call Bradley	<b>Shively</b> . . . . . Call Bradley	<b>UPS</b> . . . . . Call Bradley
<b>ATI</b> . . . . . 8, 33, 52, 59, 82, 87-89	<b>Cutting Edge</b> . . . . . 99	<b>Kaces</b> . . . . . 7	<b>Music Libraries</b> . . . . . Call Bradley	<b>Shure</b> . . . . . 4-6, 20, 23, 26-28, 31, 34-35, 52, 60, 85-86	<b>US Audio</b> . . . . . 58, 73
<b>Atlas</b> . . . . . 28-32	<b>Cutting Wedge</b> . . . . . 102	<b>Kintronics</b> . . . . . Call Bradley	<b>Musicam USA</b> . . . . . 12	<b>Shurtape</b> . . . . . 63	<b>Warning Lights</b> . . . . . 100
<b>Attenuators</b> . . . . . 84-88	<b>DAT</b>	<b>Konig &amp; Meyer</b> . . . . . 28-30	<b>Neumann</b> . . . . . 25	<b>Silence Sensors</b> . . . . . 66	<b>West Penn</b> . . . . . 94
<b>Audi-Cord</b> . . . . . 47	<b>Loggers</b> . . . . . 37	<b>Koss</b> . . . . . 75	<b>Neutrik</b> . . . . . 94	<b>Simpac</b> . . . . . 107	<b>Whirlwind</b> . . . . . 5, 8-9, 63, 74, 86, 93-95, 100
<b>Audio Control</b> . . . . . 96	<b>Recorders, Portable</b> . . . . . 2	<b>Lamps &amp; Lights</b>	<b>Nigel B.</b> . . . . . 102, 107	<b>Sine Systems</b> . . . . . 95, 97	<b>Will-Burt</b> . . . . . 98
<b>Audio Restoration</b> . . . . . 40	<b>Recorders, Studio</b> . . . . . 36	<b>Goose-neck</b> . . . . . 101	<b>Noise Reduction</b> . . . . . See Processing	<b>SKB</b> . . . . . 7, 106	<b>Wire</b> . . . . . See Cables
<b>Audioarts</b> . . . . . 52-53, 88	<b>Storage</b> . . . . . 107	<b>On-Air</b> . . . . . 100	<b>Numark</b> . . . . . Call Bradley	<b>Snakes</b> . . . . . 63	<b>Wire Ties</b> . . . . . 93
<b>Audiolab</b> . . . . . 47	<b>Tape &amp; Accessories</b> . . . . . 49	<b>Lexicon</b> . . . . . 82	<b>O.C. White</b> . . . . . 32	<b>Software, Audio Editing</b> . . . . . 40-41	<b>Wireless Microphones</b> . . . . . 33-35
<b>audiopak</b> . . . . . Call Bradley	<b>dbx</b> . . . . . 77, 79	<b>Light Wave</b> . . . . . 21	<b>Omnimount</b> . . . . . 71	<b>Somich/MicroCon</b> . . . . . Call Bradley	<b>Wohler</b> . . . . . 67
<b>Audio Technica</b> . . . . . 22-28, 31, 59, 75	<b>De-essers</b> . . . . . See Processing	<b>Limiters</b> . . . . . See Processing	<b>On-Air/Recording Lights</b> . . . . . 100	<b>Sonic Foundry</b> . . . . . Call Bradley	<b>Workstations</b> . . . . . 40-41
<b>Audix</b> . . . . . Call Bradley	<b>Degaussers</b> . . . . . 47	<b>Littlite</b> . . . . . 101	<b>Orban</b> . . . . . 99	<b>Sony</b> . . . . . 2-4, 22, 28, 34, 36-37, 39, 45, 49-51, 64, 74	<b>XLR's</b> . . . . . See Connectors
<b>Auralone</b> . . . . . 68	<b>Delays</b>	<b>Loggers</b> . . . . . 37	<b>OSC</b> . . . . . Call Bradley	<b>Sound America</b> . . . . . 12-13	<b>Yamaha</b> . . . . . 56, 58, 60, 70, 76, 80-81
<b>Autogram</b> . . . . . Call Bradley	<b>Profanity</b> . . . . . 14	<b>Logitek</b> . . . . . 66, 89	<b>OTari</b> . . . . . Call Bradley	<b>Sound Cards</b> . . . . . 40	<b>Z-Systems</b> . . . . . 82, 90
<b>Automation Tools</b> . . . . . 66	<b>Studio &amp; Alignment</b> . . . . . 78	<b>Luxo</b> . . . . . 32	<b>PA Systems</b> . . . . . 61-62	<b>Sound Cards</b> . . . . . 40	<b>Zercom</b> . . . . . 9, 93
<b>Azden</b> . . . . . 33	<b>Delta</b> . . . . . Call Bradley	<b>Mackie</b> . . . . . 54-55	<b>Panascheme</b> . . . . . 103	<b>Sound Reinforcement</b> . . . . . 54, 60-62	
<b>Bags, Equipment</b> . . . . . 7	<b>Denon</b> . . . . . 38, 44, 48-50, 66	<b>Marantz</b> . . . . . 4, 5, 42, 44, 51	<b>Panasonic</b> . . . . . 36, 49	<b>Soundcraft</b> . . . . . 56-57	
<b>Behringer</b> . . . . . Call Bradley	<b>Digidesign</b> . . . . . 40-41	<b>Martini</b> . . . . . 8, 98	<b>Parabolic Mic Reflector</b> . . . . . 20	<b>Soundolier</b> . . . . . 104	
<b>Belar</b> . . . . . Call Bradley	<b>Digital Audio Labs</b> . . . . . 40	<b>Masts</b> . . . . . 98	<b>Patching</b> . . . . . 93	<b>Speakers</b> . . . . . 62, 64, 67-72	
<b>Benchmark</b> . . . . . 74	<b>Digital Storage</b> . . . . . See Recorders	<b>Maxell</b> . . . . . 48-49	<b>PerfectData</b> . . . . . 102	<b>Mounting Hardware</b> . . . . . 62, 68, 71-72	
<b>Beyerdynamic</b> . . . . . 20, 22, 30, 31, 75	<b>Digital Transfer Tools</b> . . . . . 82, 90	<b>Medusa</b> . . . . . 63	<b>Phono Cartridges</b> . . . . . Call Bradley	<b>Spectral</b> . . . . . 42	
<b>BGW</b> . . . . . Call Bradley	<b>Digitech</b> . . . . . Call Bradley	<b>Meters, Audio</b> . . . . . 64, 83	<b>Pivotelli</b> . . . . . 72	<b>Spirit</b> . . . . . 56-57, 60	
<b>Broadcast Electronics</b> . . . . . 100	<b>Direct Boxes</b> . . . . . 86	<b>Mic-Eze</b> . . . . . 30	<b>Pop Filters</b> . . . . . 31	<b>Splicing Supplies</b> . . . . . 47	
<b>Broadcast Tools</b> . . . . . 55, 66, 90	<b>Discwasher</b> . . . . . 49, 52	<b>Microphones</b>	<b>Porta Brace</b> . . . . . 7	<b>Sports Mixers</b> . . . . . 6, 8	
<b>BSS</b> . . . . . Call Bradley	<b>Distribution Amps</b> . . . . . See Amplifiers	<b>Boundary</b> . . . . . 26, 28-32	<b>Potomac</b> . . . . . Call Bradley	<b>Stands</b> . . . . . 28-30, 62	
<b>Bullfrog</b> . . . . . See MixRak	<b>DOD</b> . . . . . Call Bradley	<b>Cable</b> . . . . . 93	<b>Power Dist &amp; Protection</b> . . . . . 100-101	<b>Stanton</b> . . . . . 75	
<b>Burk</b> . . . . . 89, 97-98	<b>Dorrough</b> . . . . . 64-65	<b>Combiners</b> . . . . . 84, 86	<b>Press Boxes</b> . . . . . 8-9	<b>Stereo Generators</b> . . . . . 99	
<b>Cabinetry</b> . . . . . 102, 107	<b>Dr Ferd</b> . . . . . Call Bradley	<b>Condensers, Studio</b> . . . . . 21, 25-26	<b>Processing</b>	<b>Stewart</b> . . . . . 21, 34, 73	
<b>Cables &amp; Accessories</b> . . . . . 3, 63, 93, 94	<b>Drawers</b> . . . . . 106-107	<b>Dynamic</b> . . . . . 22-24	<b>Audio</b> . . . . . 42, 76-82	<b>STL/TSL</b> . . . . . Call Bradley	
<b>Cablewave</b> . . . . . Call Bradley	<b>DTMF Controllers</b> . . . . . 90	<b>Goose-neck</b> . . . . . 26-27	<b>Broadcast</b> . . . . . 77-81, 99	<b>Storage, Media</b> . . . . . 106-107	
<b>Caig</b> . . . . . 95	<b>Duplicators, Cassette &amp; MD</b> . . . . . 38, 46	<b>Headsets</b> . . . . . 20, 26	<b>QEI</b> . . . . . Call Bradley	<b>Studer</b> . . . . . Call Bradley	
<b>Canare</b> . . . . . 94	<b>Dynamax</b> . . . . . see Fidelipac	<b>Headworn</b> . . . . . 20, 26	<b>Quantegy</b> . . . . . 48	<b>Stylli</b> . . . . . Call Bradley	
<b>Cart Machines</b> . . . . . 47	<b>EAS</b> . . . . . Call Bradley	<b>Lavaliers</b> . . . . . 27, 28	<b>Rack Bags</b> . . . . . 7	<b>Surge Protection</b> . . . . . 100-101	
<b>Accessories</b> . . . . . Call Bradley	<b>Editall</b> . . . . . 47	<b>Mixers</b> . . . . . See Mixers	<b>Racks &amp; Hardware</b> . . . . . 103-106	<b>Switchcraft</b> . . . . . 92	
<b>Carts &amp; Tape</b> . . . . . Call Bradley	<b>Editing Software</b> . . . . . 40-41	<b>Phantom Supplies</b> . . . . . 21, 34	<b>Ruler</b> . . . . . 105	<b>Switchers</b> . . . . . 89	
<b>Splice Finders</b> . . . . . Call Bradley	<b>Editing Supplies</b> . . . . . 47	<b>Preamps</b> . . . . . 84	<b>Storage</b> . . . . . 103-104, 106	<b>Symetrix</b> . . . . . 42, 73-74, 77-78, 81	
<b>Storage Racks</b> . . . . . 107	<b>Editors, Digital</b> . . . . . 38, 40-41	<b>Processors</b> . . . . . 80-81	<b>Radio Design Labs</b> . . . . . 83-85	<b>Tannoy</b> . . . . . 70	
<b>Cartridges, Phono</b> . . . . . Call Bradley	<b>Effects Processors</b> . . . . . See Processing	<b>Shotgun</b> . . . . . 21-22	<b>Radio Systems</b> . . . . . 14, 88	<b>Tape &amp; Tape Supplies</b>	
<b>Carver</b> . . . . . Call Bradley	<b>Electro-Impulse</b> . . . . . Call Bradley	<b>Special Purpose</b> . . . . . 20, 23	<b>Radios, Receivers</b> . . . . . 66-67	<b>ADAT/SVHS</b> . . . . . Call Bradley	
<b>Cases, Equipment</b> . . . . . 5, 7	<b>Electro-Voice</b> . . . . . 22-25, 61, 71-72	<b>Splitters</b> . . . . . 84, 86	<b>Radios, Two-Way</b> . . . . . 18	<b>Cartridge</b> . . . . . Call Bradley	
<b>Cassette</b>	<b>Enberg</b> . . . . . Call Bradley	<b>Stands &amp; Booms</b> . . . . . 28, 32	<b>Ramsa</b> . . . . . Call Bradley	<b>Cassette</b> . . . . . 48	
<b>Accessories</b> . . . . . 47-48	<b>Equalizers</b> . . . . . See Processing	<b>Stereo</b> . . . . . 2, 23	<b>Rane</b> . . . . . 33, 56, 58, 73, 76-78, 80	<b>DAT</b> . . . . . 49	
<b>Duplicators</b> . . . . . 46	<b>Erasers</b> . . . . . 47	<b>Talkback</b> . . . . . 26	<b>Raxxess</b> . . . . . 26, 93, 103	<b>Erasers/Degaussers</b> . . . . . 47	
<b>Mixer/Recorder Combos</b> . . . . . 45	<b>ESE</b> . . . . . 100	<b>Wireless</b> . . . . . 33-35	<b>Razor Blades</b> . . . . . 47	<b>Gaffer's</b> . . . . . 63	
<b>Portable Recorders</b> . . . . . 4-5	<b>ETA</b> . . . . . 100	<b>Microtech Gefell</b> . . . . . Call Bradley	<b>RDS/RBDS</b> . . . . . Call Bradley	<b>Head Demagnetizers</b> . . . . . 47	
<b>Storage</b> . . . . . 107	<b>Eventide</b> . . . . . 14, 37, 78	<b>Middle Atlantic</b> . . . . . 51, 102-107	<b>Receivers &amp; Tuners</b> . . . . . 66-67	<b>Hi-8</b> . . . . . Call Bradley	
<b>Studio Recorders</b> . . . . . 43-46	<b>Excalibur</b> . . . . . 13-14, 50, 87, 96	<b>MiniDisc Machines</b> . . . . . 3, 38-39	<b>Recorders</b>	<b>Open Reel</b> . . . . . 48	
<b>Tapes 48</b>	<b>Exciters, FM</b> . . . . . Call Bradley	<b>Blank MD Discs</b> . . . . . 49	<b>ADAT &amp; Hi-8</b> . . . . . 42-43	<b>Storage</b> . . . . . 107	
<b>Catel</b> . . . . . Call Bradley	<b>Fans</b> . . . . . 106	<b>Mix Minus</b> . . . . . 91	<b>Cartridge</b> . . . . . 47	<b>Test</b> . . . . . 48	
	<b>Feedback Control</b> . . . . . 76	<b>Mixers &amp; Consoles</b>	<b>Cassette</b> . . . . . 4-5, 43-46	<b>Tape Recorders</b> . . . . . See Recorders	
	<b>Fidelipac</b> . . . . . 53, 100, 107	<b>Auto Mic Mixers</b> . . . . . 59-60			

Copyright © 1997 Bradley Broadcast Sales, Inc.

Reproduction or transmittal is prohibited. Every effort is made to ensure the accuracy of the information contained here, but Bradley is not responsible for typographical errors. Specifications and prices are subject to change without notice.

General Manager  
Art Reed

LAYOUT  
The Concept Company  
Original Photography  
Ed Castle & Bob Martin  
& Marc Laur

Printing/Prepress

Preptech, Rochester, NY  
Cohber Press, Rochester, NY



# U.S. Audio Mixers Put Broadcast Quality in Your Rack.



**MIX-8** • 8 stereo line inputs. Inputs 1-4 have aux send, 5-8 have pan. Headphone Out.



**MIX-6** • 6 stereo inputs. Inputs 1-4 are XLR/TRS mic/line, 5 is aux RCA, 6 is aux TRS.



**MIX-61** • 6 stereo mic/line inputs. Broadcast quality in a basic mixer.



**MIX-5S** • 5 stereo inputs. Inputs 1-4 are mic/line, 5 is aux RCA.



**MIX-5** • Mono version of the MIX-5S.



**MIX-44** • 4x4 line level matrix mixer. Inputs 1-4 through four mixes to four outputs.

.....➔ **Our “Black Boxes” Put it in Your Toolkit.**

The new Whirlwind MD-1 is a perfect example: It combines a high quality mic/line input stage with a transformer-isolated line driver and independent headphone amplifier. It's ideal for boom, parabolic and interview mics, providing phantom power, local monitoring and a line-level balanced output for noise immunity over long cable runs.

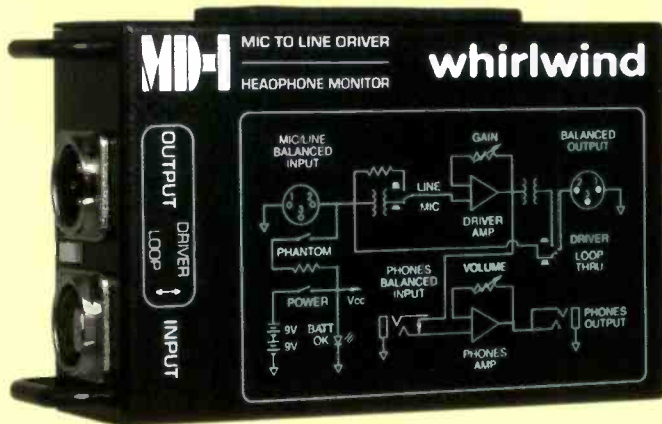

Housed in a rugged steel chassis designed to easily withstand the wear of daily professional use, the MD-1 is provided with a belt clip and



is powered by two standard 9V alkaline batteries accessed through press-latch trays in the side of the unit (changing batteries does not require opening the case). The headphone circuit has its own level control and an additional direct input. It's a great addition for any toolkit.

# whirlwind

# How Many Buttons Do You Need To Push Before ISDN Works For You?



## Just One.

### **Telos Zephyr: The Best Way to Hear from There™**

**You don't have the time or the resources to suffer over complex menus and heavy manuals. You need something with fast setup, practical features, and reliable operation. You need Zephyr.**

Zephyr is the best sounding, lowest cost way to send high-quality audio over ISDN. Once programmed, anyone can Auto Dial ISDN calls. Not sure what to do next? Press the help button for simple instructions.

Zephyr is full-duplex for two-way transmission. And you don't have to worry about what codec is on the other side – with Layer III, Layer II, and G.722, Zephyr can handle whatever is thrown at it. Let Zephyr make your job less complicated. And you may get fewer blisters on your fingers.



- The ideal solution for remote broadcasts, ad hoc networks, voiceovers, distribution of commercials, backup to satellite and microwave links, and many other applications.
- Designed by Telos System for audio applications over ISDN.
- Optional AES/EBU digital audio input/output module with sample rate conversion.
- Clean, uncluttered front panel for simple operation. Full metering, call duration timer, headphone jack, and mic/line inputs.
- Built-in input protection limiter. When your talent screams, your audio doesn't distort.
- Zephyr has an integrated ISDN terminal adapter designed for the non-technical operator. You can even place a standard voice-grade call to a Plain Old Telephone Service (POTS) telephone.

