

CB

AN ARGUS SPECIALIST PUBLICATION

CITIZENS' BAND

FOR BRITAIN'S 250,000 CBUSERS

OHM SWEET OHM

Aerials explained



MONITOR OF THE MONTH Lady Linda

FILM FUN DIY dummy load, TVI filter and adaptor projects

Latest equipment, clubs and QSL news

The THUNDERPOLE RIDGE

Out of this World!

THUNDERPOLES ARE GO!

The Ever Popular Mk II (Base Loaded)

Base loaded ribbed coil design on a single radiating element 1.5m long. Doubly encapsulated windings for maximum performance and all weather protection.

Pre-tuned and requiring no S.W.R. adjustment.

Precision machined alloy base with 3 angled ground planes each 2.67m long with cross bracing, designed for maximum performance.

Power handling 500w, frequency 27mhz, S.W.R. 1:15 or less.

Base for 1 1/4" diameter. Pole mounting.

The Amazing Mk III (Centre Loaded)

Centre loaded helically wound coil with low radiation angle shrink wrapped for all weather protection and that amazing extra performance you would expect from the world famous Thunderpole range.

Bigger diameter, radiating element 1.65m long, making the most of the latest H.O. specifications.

Power handling 500w wide frequency band covering 120 channels, low S.W.R.

Suitable for all models — AM, FM, SSB.

Base for 1 1/4" diameter Pole mounting.

New Thunderflash Mobile (Centre Loaded)

Centre loaded helically wound solid copper winding on fibre glass shrink wrapped for maximum protection — strength.

The whip is 17.7 p.h. stainless steel and all fittings are chrome brass with stainless steel screws.

Slim elegant coil. Overall length of the Thunderflash 1.65 long.

Fully compatible for use on 27FM and new CEPT frequencies.

To obtain maximum performance insist on:-

THUNDERPOLE HATCHBACK/BOOT MOUNT

No drilling or soldering necessary. Standard 1/2" UNE Thread mounting adjustable angle with positive non-slip action.

THUNDERPOLE STRIKES AGAIN! Citizens Band magazine on the fantastic Thunderpole range.

Thunderpole II

The Thunderpole was the best all round base station antenna tested.

A well constructed easily assembled and erected excellent performance legal antenna with the added bonus that it is pre-tuned.

Thunderpole III

On test the Thunderpole Mk III performed very well and contact was maintained even when the mobile test vehicle encountered a strong signal on the next channel in our notorious blackspot. In conclusion we consider the Thunderpole III to be a strong well constructed, top performance antenna.

Thunderflash Mobile

Firstly it is a very slim and neat looking aerial. The whip is 17.7 p.h. Swedish stainless steel and the centre loaded copper coil is wound on fibre glass for added strength and rigidity.

The screws themselves are stainless steel and all fittings are chromed brass. A very elegant antenna indeed. Reported TX was excellent.

It is strong and very well constructed and excellent value for money at around £16.00.

THUNDERPOLE ANTENNA U.K. LTD.

A subsidiary of Freeman & Pardoe Ltd.,
17thing Road,
Ardén Forest Industrial Estate,
Alcester, Warks B49 6ES

Tel: 04781 722572

Ask for Thunderpole at your local stockist

The Thunderpole design and name are registered trade marks of Freeman & Pardoe Limited.

© Copyright 1984, 1989

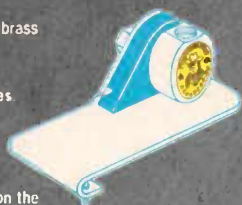



CB CITIZENS' BAND

CONTENTS

Editor Eamonn Percival
Group Editor Chris Adam Smith
Ad Manager Cass Gilroy
Copy Control Alistair Carnell
Design Heather Hopkinson

Update	All the news printed to fit	4
Back Chat	Your news, view and opinions – and your chance to see your name in print.	8
Ohm Sweet Ohm	A look into the complexities of the vertical antenna.	10
Over the Air	Shepherd Man, in a reflective mood, looks back over the years.	14
QSL	David Shepherdson reports on his latest mailbag.	17
Lady Breakers	Filly plays Sherlock Homes this month.	21
Q&A	We attempt to sort out some of your problems.	22
Truck Stop	Brandybird bids a tentative farewell.	25
Film Fun	Four ideas for empty film cannisters – and none of them rude.	28
A Radio Celebration	Captain Sparx takes a trip to Chicago to visit a radio museum.	32
Monitor of the Month	The lovely Lady Linda tells us about her work as a monitor.	38
CB Bench	An expanded rig brings problems for our resident rig doctors.	40

Citizens' Band Magazine A.S.P. Ltd., 1 Golden Square, London W1R 3AB.
 Telephone 01-437 0626. Typesetting by Multiform Photosetting Ltd., PO
 Box 88, University Place, Splot, Cardiff Tel: (0222) 462320.
 Printed by Chesham Press Ltd., 16-18 Germain Street, Chesham, Bucks. HP5
 1LH. U.K. newstrade distribution by SM Distribution Ltd., 6 Leigham Court
 Road, Streatham, London SW16 2PG. Telephone 01-677 8111.

Overseas sales and non newstrade sales by Magazine Sales Department, No.
 1 Golden Square, London W1R 3AB. Tel: 01-437 0626

Subscription Department: Irifonet Ltd., 5 River Park Estate, Berkhamsted, Herts
 HP4 1HL. Tel: 04427 76661-4. U.S.A. Subscription Agent: Wise Owl Worldwide
 Publications, 4314 West 238th Street, TORRANCE, CA90505, U.S.A.

UPDATE



No Let Up In Pirate Crackdown

No let up in Pirate Crackdown

There will be no let-up in the Government's crackdown on

pirate radio stations following a record year of raids against illegal broadcasters, Industry Minister Robert Atkins said at

a recent press conference.

The Department's Radio Investigation Service (RIS) made nearly 450 raids last year. More than 100 people were prosecuted – a rise of over 50 per cent on 1987.

And the Minister announced that the Government is to seek more powers to prosecute people who advertise on or support the pirate stations.

Mr Atkins told a London press conference that interference from uncontrolled radio broadcasts can threaten: vital communications for emergency services like fire and police; important radio links for businesses; legitimate radio and TV services.

"The RIS are not killjoys," said Mr Atkins. "The content of broadcasts is not their concern. But they have a vital job to do in keeping the airwaves clear.

"I must warn pirates that there will be no let up. The RIS will continue to keep up the pressure to make certain that interference is removed."

He outlined powers which the Government will be seeking, which would make it an offence: to supply goods

and services for the operation of an unlicensed station; to advertise on an unlicensed station, or to solicit others to do so; to engage in the operation of an unlicensed station.

These proposals would need legislation to put them into effect.

"This shows the determination of the Government to make sure that all those involved in the running of pirate stations are discouraged from illegally," the Minister continued.

"But the Government is using the carrot as well as the stick. There are positive incentives for those interested in community-based local radio to stay within the law, with 20 licences for community stations available to the most suitable applicants this year.

"But the rub for the pirates is that anyone with a conviction for a piracy committed from 1 January 1989 onwards will be barred for five years from applying for a community radio licence. So there is even less reason to risk fines of up to £2000 and three months in jail by staying on the wrong side of the law."



Editorial

I recently attended the latest user group meeting with representatives from the Department of Trade and Industry at Waterloo Bridge House. Unfortunately, due to publishing schedules, I had to leave two thirds of the way through. However, my good buddy Ian Oliver was able to stay until the end and will report on the happenings in the next issue.

My personal observation was that an awful lot of time

was wasted through various groups arguing with whatever other groups were trying to say, people spouting off about subjects they clearly had little knowledge of, and the agenda almost petering to a standstill because of various user group representatives repeatedly trying to go back to a subject which had already been covered.

I wonder if it would be possible for the groups concerned to organise a kind of 'pre-meeting' meeting amongst themselves at a mutually decided venue. That way, they could get together and sort out what points they would like to discuss *before* the meeting with the DTI. It would save squabbling and time-wasting, although the difficulties involved in getting these groups from all over the country together in one place are obvious and harmonisation between these organisations is sometimes sadly lacking. Why not think about it, ladies and gents, and let me know your feelings.

Cameron Beval



New Scanner

Nevada Communications recently announced the introduction into the UK of a new mobile/base scanning receiver from Uniden Bearcat – the model 950XLT.

This unit is the latest release from the Bearcat stable and has 100 programmable memories in five 20 channel banks.

The 95XLT has extended frequency coverage including the 900MHz UHF band. The set has a retail price of £269.00. Full technical details are as follows:



Frequency Coverage:

29-54MHz
118-174MHz
406-512MHz
806-952MHz

Features:

- Scan speed 15 channels per second
- Memory lock-out facility

- Programmable frequency search facility
- Programmable memory delay
- Back lighted controls for

- night use
- Included with the set are DC cord and plug-in whip
- Compact size: 2in (H) x 7in (D)

Balloon Boob

An amateur radio enthusiast who worked for the Ministry of Defence admitted breaking into police frequencies and helping another radio ham interfere with United Navy signals.

Michael Holland, of Norbury, was also said, at Croydon Magistrates Court to have attached a radio transmitter to a balloon.

Holland, 24, an electronics engineer, pleaded guilty to seven charges under the Wireless Telegraphy Act.

Mr Jonathan Davies, prosecuting, said Holland had worked for a weapons research establishment, and a massive investigation costing £48,000 had been mounted by the police and the MoD.

He had used frequencies of an extremely sensitive nature, including some that were not published. He had frequencies for many police stations. He had also failed to give and acknowledge a callsign and not logged his conversations.

He also admitted attaching a transmitter to a helium balloon, obtaining and giving information, and aiding and abetting a member of his radio group to interfere with United States Navy signals.

Many of the frequencies have now had to be changed. When spoken to in the course of the investigation, Holland said "I have tuned around."

Miss Debra Gold, defending, said that Holland did have a licence for using his radio equipment. He was an amateur radio enthusiast, in fact his social life revolved

around shortwave radio.

"He had no ulterior motives, and failed to see the harm his actions could have caused," she said.

He started off keeping to all the rules, but became lax as time went by. He was in a group of about five people who communicated with each other through the airways. They did not use a callsign amongst themselves, which they should have done, and failed to log conversations.

Regarding the balloon with the transmitter, this was for meteorological research. This idea was to monitor atmospheric temperature changes for the group's own interest.

The information received and given was purely of social interest. They did listen to police calls and discussed them amongst themselves.

He had admitted aiding and abetting a broadcast on United States Navy lines, but had not done it himself. He should have known better than to have had anything to do with it. It was not the most sensitive of the United States frequencies.

Prosecution had a very serious effect on his life, and he no longer had the chance of being employed on security work.

"There has been no breach of security and no allegation that he used information from the MoD" she said.

Magistrates said they took a very serious view of the fact that Holland was employed by the Ministry of Defence and the potential for abuse of sensitive material.

He was fined a total of £2,500 and ordered to pay £500 towards costs.

Youngest Breaker

Little Kimberley Bolger must surely be the world's youngest breaker. She made her first transmission when she was just minutes old. And that was after mum Alison had delivered her herself!

Alison, 21, whose handle is 'Learner,' was at home in

Kegworth, Nottingham with her toddler Jason, when she began to get stomach pains. Already four days overdue, she called her mother on her rig to complain about the pains. As there was no sign of the baby, her mother suggested she call back in half an hour.

The birth started minutes

later. Within 15 minutes she was cradling the new arrival in her arms. She struggled downstairs and finally reached the CB to break the news.

"I shouted to mum on the radio 'I've had it.' She said 'Had what?' So I held the mike to let her hear Kimberley crying.

After calling the midwife and Alison's husband Gary, the happy grandparents arrived. Mum and baby were taken for a medical checkup, where Kimberley weighed in at a healthy 7lb 9oz.

Our thanks to David Lazell and to the Nottingham Evening Post for this heartwarming story.

New from Cirkit

A range of Toko miniature push-button switches for use in audio, radio, video and consumer electronics equipment is now supplied by Cirkit Distribution. Featuring short travel distance of 2mm and terminal pitch of 2.5mm x 2.5mm, the switches have sliding contacts for low operating force and are supplied with shorting or non-shorting timing.

Self-locking, non-locking and interlocking formats are all available as standard and 2-pole and 4-pole structures have key pitches of 10, 12.5mm or 15mm. Where round or square F series buttons are attached, a new purpose-designed adaptor must be used.

Rated at 30V DC/0.1A, TM series switches have a maximum contact resistance of 20mΩ maximum and a minimum insulation resistance of 100mΩ. Dielectric strength is 500V AC for one minute. Dip-soldering is the recommended method for board mounting the switches, which have a solder heat resistance of 260°C ±5°C for 5 ±1 second. They are particularly suitable for use in amplifiers, radio cassettes, car stereos, music centres and for signal selection in televisions, video-related equipment and other consumer electronics apparatus.

These switches offer excellent durability (50,000 cycles operating life without load; 30,000 cycles operating life with 30V DC/0.1A resistive load) and are proof against temperatures as low as -25°C and as high as +85°C for 96 hours. They are also capable of withstanding 90-95% relative humidity at +40°C for 96 hours.

Toko TM series miniature push-button switches complement a comprehensive selection of switches for a wide variety of applications, all held in stock at Cirkit's Broxbourne and Portsmouth facilities for immediate dispatch.

For further information contact: Cirkit Distribution Ltd, Park Lane, Broxbourne, Hertfordshire, EN10 8NQ. Tel: (0992) 444111.

Telepoint's Travelling Telephones

As further promises of our instant communication future blossomed in the early weeks of 1989, the 'pirate menace' was given a passing mention in respect of the Broadcasting Bill. There have been broad hints that penalties for running such operations, advertising on one, or even delivering groceries to any gent with an illicit microphone could result in awesome penalties, including removal of one's football club admission card (possibly in some new public humiliation ceremony).

However, best buy of the imminent future promises to be an advance of the Telephone Plan, placing of base stations in public areas, within range of which consumers can use their own mobile Telephone telephones, cost of calls being only marginally higher than conventional callboxes. One clear advantage of this innovation is the ease of making calls without pressing one's nose against the glass of any kiosk occupied by a gent calling up his spouse at considerable length. On the

other hand, the Telepoint idea does require use of one's personal instrument. Thus, you would need to have one in your briefcase, back pocket, handbag or sandwich tin. One idea of our innovative government is the granting of probably four licences for systems that need not be compatible, initially, in order to 'test' which system works best for the consumer. Of course, this would lead into a compatible system, covering the nation, and probably owned by one or maybe two operators.

This reminds telephone buffs of the early days of the land-line system, when high above the streets of the metropolis, gangs representing the two competing telephone systems fought each other, and did their best to sabotage each other's efforts to link the general public. Could this sort of thing happen again, in the name of entrepreneurial competition?

Asked their opinion of the Telepoint idea, various experts have sniffed that useful as it is, callboxes are so much better these days, that carrying your own callphone would be superfluous, though it would

make a nice status symbol. In some parts of the City these days, you can hardly walk the dog without colliding with some eager gent calling up his broker, or the Samaritans (things being what they are in some brokerage houses). As in the early and some would say romantic days of Citizens Band, a large amount of pleasure was involved merely in holding the gear, whether or not you were actually involved in conversation. Thus, some Telepoint 'dummy stations' could be set up for people who merely wanted to look as though they were making important calls but in fact have no actual cash in the bank to pay for the cost of the same. Talking into a cordless telephone is maybe stale cheese for power mike veterans who reckon they can reach Mars on a clear night. But, as a wise old college professor said, the one great feature that separates man from the animal kingdom is man's desire to talk into a microphone. He wasn't referring Citizens Band, of course – but was he thinking of Telepoint?

David Lazell



Reader of the Month

Our thanks to Lyn Morris, of Wareham, Dorset, who sent us this charming photo, simply captioned: "Toby, looking over a CB fanatic's shoulder – just to prove that not only humans find your magazine interesting."

Stanley Eyeball Coach

Any London QSLers/breakers interested in going up in a bus to the Stanley Eyeball (April 16th) please ring Brian on 01-340-5601. Brian is hoping to organise a coach for the trip which will leave London early that morning.

EVERYTHING!

For the CB & Amateur Radio Enthusiast from Zetagi

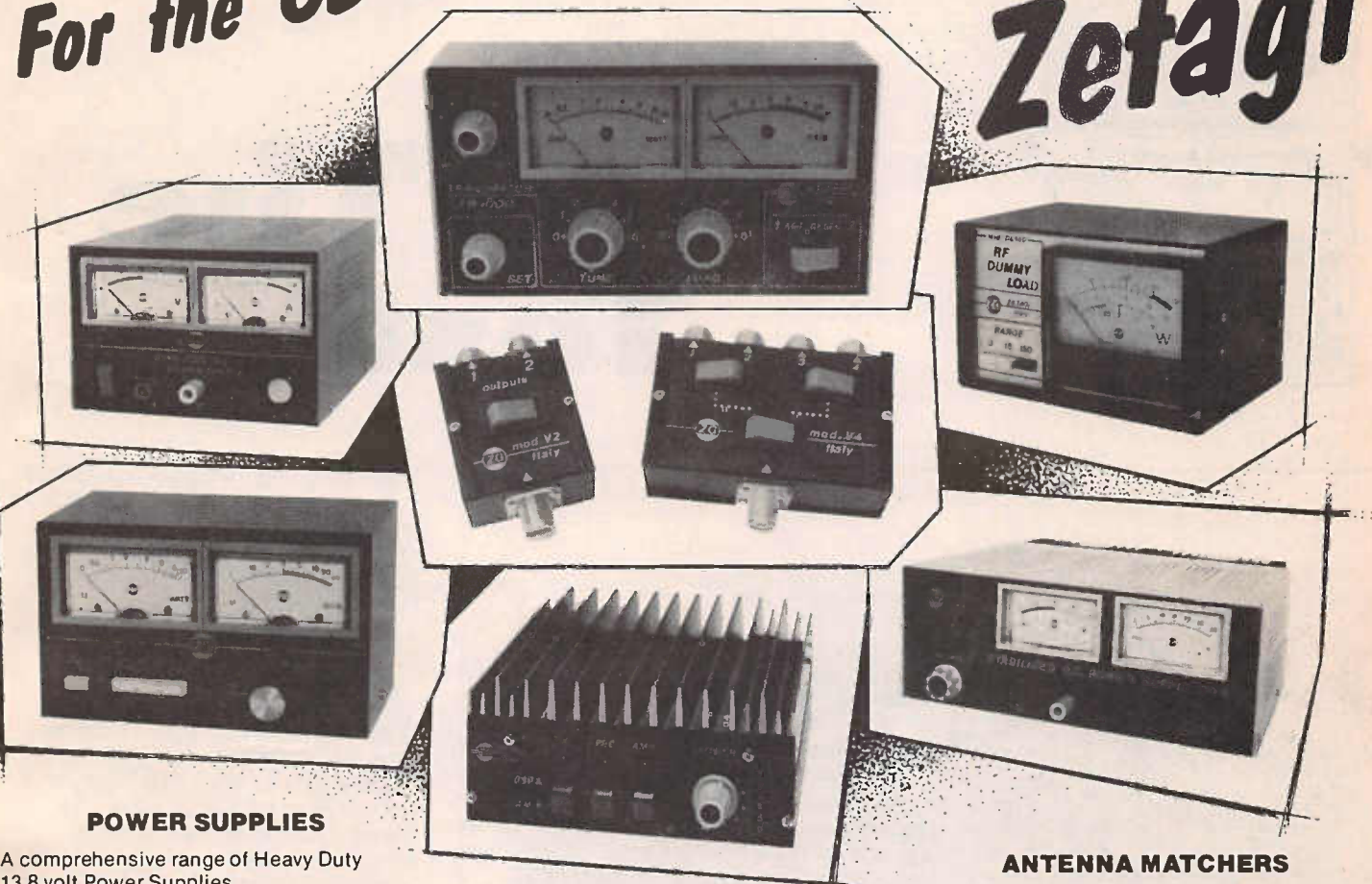

POWER SUPPLIES

A comprehensive range of Heavy Duty 13.8 volt Power Supplies

- MODEL 1210/1 10 Amp (No Meter)..... £69.95
- MODEL 1210/S 12 Amp (W/Meter)..... £89.95
- MODEL 1220/S 25 Amp (W/Meter)..... £149.95
- MODEL 1220/1 25 Amp (No Meter)... £125.00
- MODEL 1240/S 40 Amp (W/Meter).... £199.00

SWR/POWER METERS

Superb High Specifications for the discerning enthusiast. Just released.

- MODEL HP201 (3-300MHz) 1Kw Max . £29.95
- MODEL HP202 (26-30MHz) 1Kw Max . £39.95

PRE-AMPLIFIERS

Low noise · High Performance to improve reception on even the best receivers in the 26-30MHz range.

- MODEL HP28 Deluxe V/Gain..... £34.95
- MODEL P27-1 Base Station Pre-Amp . £25.69
- MODEL P27-M Mobile Pre-Amp £19.99

SWITCHES

A selection of Heavy Duty Low Loss Switches for frequencies up to 500MHz.

- MODEL V2 2 Way 500 Watt..... £6.99
- MODEL V3 3 Way 1Kw £15.00
- MODEL V4 4 Way 500 Watt..... £11.52

ZETAGI Products are available from specially selected dealers throughout the U.K. or direct from UK Importers:—

MOBILE AMPLIFIERS

ZETAGI are famous for their range of reliable and high specification Amplifiers — note these are for use by radio amateurs only and are not legal for CB use.

- MODEL B150 150 Watt (26-30MHz) £54.95
- MODEL B300 400 Watt (3-30MHz) .. £145.95
- MODEL B550 500 Watt (3-30MHz) .. £237.00

BASE AMPLIFIERS

Two popular models for use by radio amateurs. These are not legal for use on CB radio.

- MODEL BV131
A valve Amplifier covering (26-30MHz) and delivering 100 Watt output £115
- MODEL BV132
A Solid State Broadband (3-30MHz) Amplifier delivery 100 Watts £125

FREQUENCY COUNTERS

- C45 5 Digit Compact counter
Ideal for use up to 50MHz £59.95
- C357 7 Digit Top of the range
For use up to 350MHz £99.00

ANTENNA MATCHERS

- MM27 100 Watt (26-30MHz)..... £11.95
- M27 500 Watt (26-30MHz) £19.95
- TM1000 1Kw matcher and 2 way switch with SWR/PWR meter £67.00

DUMMY LOADS

- DL150 A superb precision Dummy Load and Power meter.
Freq: 3-500MHz
Power: 1Kw £88.00
- DL50 50 Watt 500MHz Load..... £13.50

METERS

- Top Class Precision Instruments for the Service Dept. or Radio Amateur.
- MODEL 430 A VHF SWR and Power Meter
Freq: 120-500MHz. Power 1Kw £69.50
- MODEL 700 A combined VHF and UHF Precision Meter. Freq: 120-500MHz
Freq: 120-150MHz Power: 1Kw (Max) £99.95

We also carry the complete range of Zetagi Spares.

CATALOGUES

SEND IN NOW £2 FOR OUR BUMPER PACK OF CATALOGUES AND RECEIVE £20 WORTH OF VOUCHERS. PACKED FULL OF USEFUL TECHNICAL INFO AND DETAILS OF ALL OUR PRODUCT RANGES

NEVADA

189 LONDON ROAD NORTH END PORTSMOUTH PO2 9AE

HOTLINE (0705) 662145

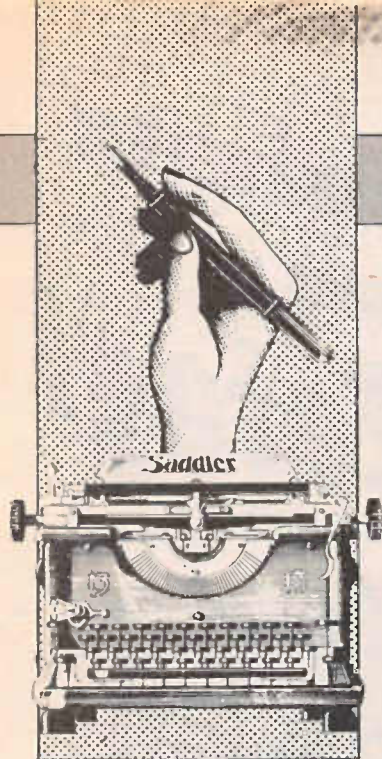

Pass The Test



Whilst taking the RAE course, I learned a few facts on procedures and practices and how a radio works. More importantly, how not to cause interference and some of the steps to take if I did. But the course made me, an ex-CB operator, realise how little I knew before.

Being an ex-CB operator, I have never had a refusal from anyone to speak to me. Having a good location, I have many hundreds of log entries.

Many stations enjoy SSB legally and are ex-CB on ham radio. What I do resent is knocks on my door from people who have TVI and, on investigation, finding CB the problem. By monitoring on my HF receiver, I find harmonics and all sorts of spurious emissions – a good many from 11 metre SSB operation.

So, good buddies, pass the test and then give me and thousands of ex-CBers (and some who still operate) a call. To the whiners: if you can't stand the time, don't do the crime!

PS. Now for the cw test.

**M Charlton (G1 P7L),
Notts**

Open Channel

Rumours, rumours, rumours. Are we about to lose 934MHz? Are about to lose the original 27MHz frequencies in favour of CEPT? Are we likely to get SSB in the near future? Will AM ever be legal in this country? If we don't lose the old frequencies, will we be allowed rigs which contain both 'old' and 'new' frequencies? Will the DTI (or whoever) introduce a 'novice' licence?

In six years as a CB operator – and a responsible one, albeit sometimes not

exactly legal – I am sick to death of this to-ing and fro-ing from the DTI. "We'll look into the situation in xxx years' time" is a quote I am more than tired of hearing.

CB used to be 'open channel'. What happened to free speech in this country? There are countless people in this country who would dearly love to see *real* open channel communication.

The same goes for pirate radio, outlawed from the start and still, I hear, the DTI are spending a fortune locating people whose sole interest is in

broadcasting decent music, not doing any harm to others, in fact giving thousands of people a great deal of pleasure.

I know the old chestnut about causing interference to emergency services, but I would dearly like to see the figures when this has been a real problem. Again, it's just another feeble excuse from the DTI. I'm voting Labour next time!

**J Sindell,
Warrington,
Cheshire**



Old Man Blues

I am writing in reply to J Halsey's smug letter in your November 1988 issue. In the first place, what does he mean by "idle chatter" and "communication in the proper sense of the word"? Anyone who has ever had the misfortune to listen to two hams talking will realise that they are probably the most boring bunch of self-satisfied prats in existence.

Who really wants to call another station "Old Man" in this day and age anyway? I thought that went out with Tony Hancock. And he's right about the test being easy - if a cretin who couldn't pass the 11-plus can pass the RAE, then why have one?

As for CB not being for DX, we seem to be the only country in Europe who think so. Ask him how many radio hams are ex-sidebanders.

The reason why people want to "play radio ham" is because we can't all afford £1000 to set up a station. Perhaps the knowledge that 108,000 CB licences as opposed to 58,000 ham ones were issue last year might change his ideas a bit.

I agree that 27MHz isn't the most ideal band but it's the same one as the rest of Europe uses, and surely *that's* what "communication in the proper sense of the word" is supposed to be about?

Stick to 10 metres Halsey 'Old Man,' you were made for each other.

**G Wilkie,
Bannockburn**

Hogging by Taxi

I am writing to you about a local taxi firm and would be grateful for any other readers' views on the subject. I have had a CB licence for about four or five years and I recently wrote to the DTI about them.

On a couple of occasions I came across them - this was about three months ago. Once, on channel 14, I met in with another breaker and moved onto channel 5 to speak. This channel was clear so my friend and I began a conversation but were soon told: "Breakers who are on channel 5, move up or down because we've been here all day."

On another occasion, a friend of mine asked if I would drive him to a nearby hill to chase skip. He went round the channels and paused for a while on channel 5. We had the strongest skip that day and started to call QSK from the North East of Scotland but once again we were told to move on.

Trying to keep the peace, I have made a point of keeping clear of channel 5. Recently, I've been modulating with a breaker I used to speak to regularly, although each of us

were in different 'circles.' We call each other on channel 14 and, if clear, move onto his regular channel which is 31. Now we have got the same folk coming back telling us to move to another channel.

The thing that bugs me most is why can't the taxis go through 14 as well? Why can't the DTI give taxis permission to use one channel and one channel only (for example, truckers use channel 19)? The taxi firm is about eight or nine miles away from me.

**Frustrated CBer,
Aberdeenshire.**

Cree Valley Eyeball

May I say thank you for publishing my previous letters about the Cree Valley Breakers. I would now like to let you know about our annual eyeball at Auchenlarie Holiday Farm, Gatehouse of Fleet, Kircudbrightshire, on Friday 28th to Sunday 30th of April.

Events include stage shows, dance, darts, dominoes, Junior Miss Eyeball, Miss Eyeball, Glamorous Granny, Club Quiz and country and western.

Caravans are available at £13 per night, sites for caravans and tents at £3.50 per night.

Please send SAE to: Mass Eyeball, PO Box 1, Wigtown DG8 9HA.

**Saltire,
Scotland**

Tie Breaker Boobs

May I point out some circuit faults in the pcb layout in Fig 4 on page 30 of the January magazine - 'Tie Breaker' by David Cox.

1. Four copper track breaks underneath IC1 not shown by the usual sign (a small 'x' within a circle).
2. Capacitor C8 apparently missing. It is, in fact, the right-hand one of the two capacitors, each designated as C6 in the right-hand pcb.
3. R8 label missing on left-hand side of left-hand pcb.
4. Right-hand side of R4 is wrongly terminated on pcb copper track intended for pin 13 of IC2. It should go to the track for pin 12 thereof.

I haven't made up this unit but I write so that you can enlighten readers in your next available issue.

PS. I'm a musician and not an electronics man!

**C Spinks,
Address not supplied**

Thank you very much, Mr Spinks, for taking the time and trouble to write and point these errors out. Your points appear to be quite correct and we can only apologise for any trouble caused to DIY enthusiasts with this project. From time to time, with DIY projects, one or two mistakes can occur between the translation of the author's artwork and the finished design, although we concede that, in this case, there were more than one or two!

SSB please!

I would like to refer to a recent article by Brandybird. I am a regular reader of your magazine and, on reading your honours list for 1989, came to my eye a handle, which Peter has chosen to use.

I first went on the air when I was 33 years old. I was active for four years and operated AM and SSB. Then I went QRT for about four years and returned to the airwaves late last year (1988).

I would like to see SSB legalised and am convinced that the government are very 'lax daisy' (sic) on this issue for, if SSB were to be legalised, a lot of people who abuse the airwaves would have their rigs lifted by the DTI. Less rigs = less trade = less revenue.

If genuine radio operators were allowed to use SSB, it would boost the economy no end. What with buying postage stamps, envelopes, QSL and picture-postcards of various cities and towns, the licence fees etc would amount to millions of pounds. Our airwaves would be a lot cleaner as the bucketmouth would be driven off by more detection, financed by revenue which I have just mentioned and we would all be better ambassadors for our country.

I am all for the phone patching suggestion and channel 9 for emergencies should be taken a lot more seriously. Let's get rid of the bucketmouths and clean up the airwaves. Then let us put pressure on the government to legalise SSB.

It's the only way.

**Honky Tonk,
Newtownards,
Co Down**

OHM SWEET OHM

In this, the first of a new series,

Brian Kendal looks at the

complexities of the vertical aerial

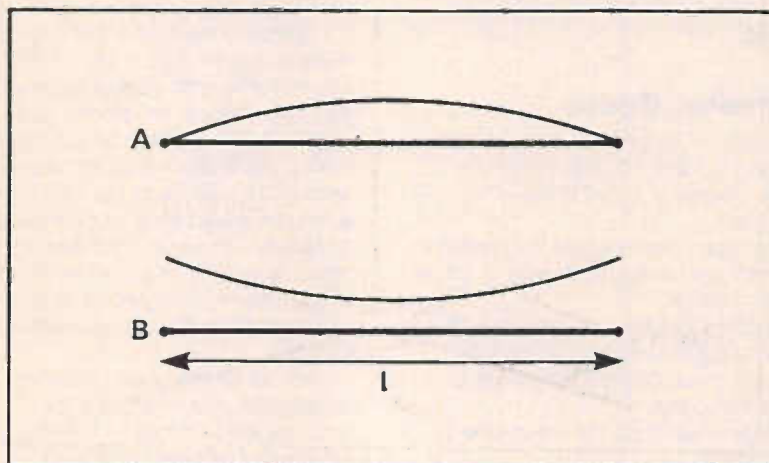

Figure 1. Current (A) and voltage (B) distribution on an aerial whose length (l) corresponds to half a wavelength at the frequency of operation.

The most important single factor in determining the effective range of any radio transmission is the aerial. The terms of the CB licence, however, severely limit the design of aerials which may be used. Consequently the breaker has to make a choice between a number of very similar aerials constructed by competing manufacturers.

Specifications for the different types of aerial can be obtained, but even these can be confusing. For example, how would a choice be made between an aerial claiming 1dBi gain with another claiming -1dBd. Furthermore, how important is a low VSWR and what advantage would be gained by replacing UR43 feeder with UR69 costing twice as much.

Without engineering knowledge such comparisons are difficult, but within this short series, it is hoped not only to give the reader sufficient information to make valid comparisons between rival products and systems, but also to make most effective use of their installation.

Perhaps the most appropriate place to start would be to describe the way in which an aerial operates.

The Simple Aerial

When a radio frequency signal is induced into any short piece of wire, a standing wave pattern is set up. The highest voltage appears at the open end(s) and the lowest either at the centre or at any point where it is earthed.

As any signal must have power, if voltage has been induced into the system, so must current for, in any circuit, power is equal to the voltage multiplied by the current.

With both voltage and current present at any and every point along the wire,

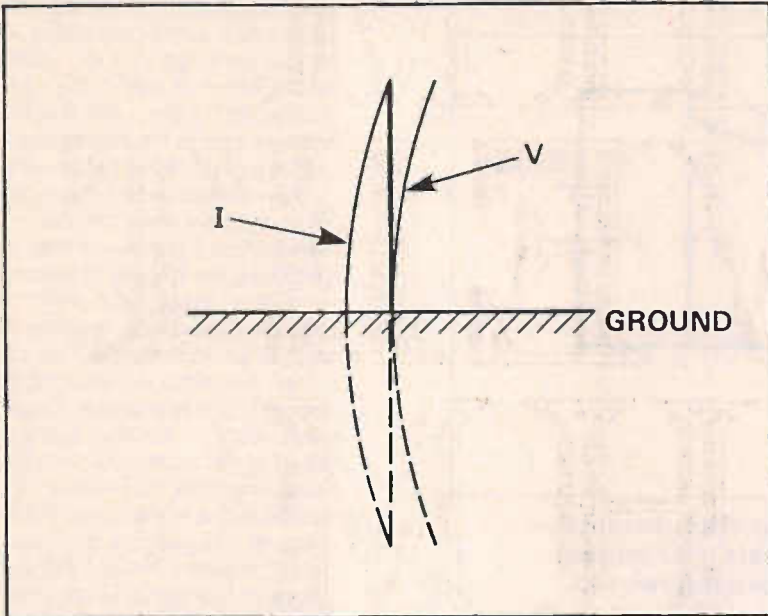

Figure 2. Diagrammatic representation of the voltage (V) and current (I) distribution on a quarter wave aerial mirrored against ground.

then each point must have resistance, for Ohm's Law tells us that resistance is equal to the voltage divided by the current.

Thus, as the voltage at the ends is high, for a given power, the current must be low and the resistance must be high. At the point of minimum voltage, for the same power, the current must be much higher and consequently the resistance will be much lower.

If the aerial is to be used for transmitting, we must now consider the power transfer theorem which tells us that, to transfer maximum power, the output impedance (which is the term for resistance to alternating currents such as radio signals) of the generator must match the impedance of the load.

All this means is that, to radiate effectively, the output impedance of the transmitter must match the impedance of the aerial at the point at which the feeder is attached. This can vary between many thousands of ohms, if the aerial is fed at the end, down to a fraction of an ohm for some types of current fed aerials.

The Half Wave Dipole

When the length of the aerial is increased to about half a wavelength, it then assumes specific characteristics. As may be expected, either end of the wire develops high voltage and the centre, high current, but the impedance at the centre is about 70 ohms.

If the wire is increased still further in length, this impedance increases until, when a full wavelength long, it becomes very high. As further half wavelengths

are added, the impedance at the centre becomes alternately high and low, but never as low as for a single half wavelength.

A half wavelength is therefore the basic aerial length.

Such an aerial may be mounted either horizontally or vertically and the characteristics are similar in each case.

The Quarter Wave Vertical

It is a characteristic of the earth that it will act like a mirror to radio frequency

energy, reflecting any signals which impinge on it.

This has a considerable influence on the vertical angle at which the aerial radiates the majority of its signal, as we shall see in a future article, but it can also be used to reduce the size of a vertical aerial.

If, instead of a half wavelength of wire, a quarter of a wavelength is now mounted vertically directly above the earth, this will be reflected in the earth and the whole will act similarly to a vertical half wave aerial.

The main difference in the characteristics which will be noticed is that the impedance at the centre, instead of being about 70 ohms like a dipole, will now be considerably less.

For many years, text books quoted the impedance of a vertical quarter wave aerial against earth as 36 ohms, but in practice this never seemed to be realised. Many workers (including the author) now believe this figure to be in error and that the correct figure is something in the order of 18 ohms.

It obviously would be very inconvenient if all vertical quarterwave aerials had to be mounted at ground level, but fortunately the effect of the ground can be synthesised by use of an artificial earth system.

In its simplest form an artificial earth comprises a disc of conducting material of at least half a wavelength in diameter under the base of the aerial. Obviously such a groundplane would be highly inconvenient, but again technology comes to the rescue, for this in turn can be replaced by three or four rods, each just over a quarter of a wave in length. For optimum performance, these should be mounted symmetrically around the base of the aerial.

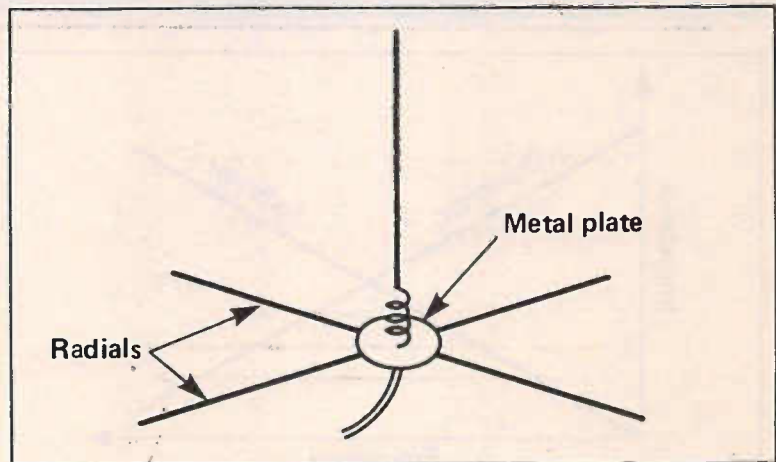

Figure 3. Practical loft aerial installation. The radials should measure about 9ft from the aerial base. They may be of any gauge wire and need not be straight although this would be more effective.

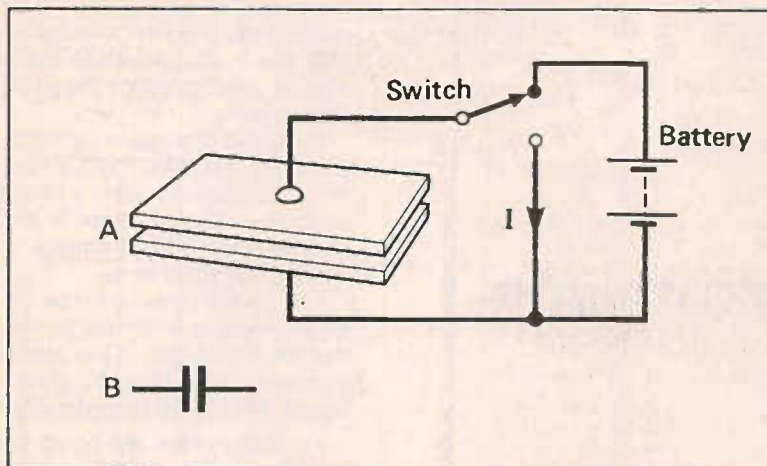

Figure 4. (A) The basic form of a capacitor. In practice there will be many plates with alternate ones coupled together (B) The symbol used in circuit diagrams to represent a capacitor.

When this is not possible, such as in mobile installations, the body of the car makes a reasonable substitute. The most effective radiation will be achieved if the aerial is mounted in the centre of the roof. If it is not, directional effects may be noticed.

I have heard of several breakers on 27Mhz, who have used a mag-mount whip mounted on a biscuit tin lid in the loft as a base station aerial. Although this may work to a degree, it will not be as effective as a full size ground plane.

In such circumstances, considerable advantage would be gained if four 9ft lengths of wire were soldered to the biscuit tin lid and laid across the rafters.

The Loaded Whip

So far we have considered a vertical aerial of a quarter wave in length which, on 27MHz, corresponds to about 8ft 6in. Unfortunately, the licence conditions for this band limit the length to 1.62 metres ie 5ft 4in. Some means have to be found whereby the missing 3ft can be replaced. This is achieved by a technique known as 'loading.'

Capacitance and Inductance

Before going further into loading techniques, we have to understand the concepts of capacitance and inductance.

Let us first suppose that two flat plates are mounted very close to each other but not touching. When a battery is connected across the plates, electrons will be attracted from the plate attached to the negative side of the battery to that connected to the positive side until the voltage across the two plates is the same as that of the battery. If the battery is then disconnected, that potential difference between the plates will remain. If the plates are then short circuited, the excess of electrons will flow (ie an electrical current) from the positive plate to the negative until equilibrium is restored. This ability to 'store' electrons is known as the property of capacitance. Capacitance is dependent on the area and distance apart of the plates and the properties of insulating material between. The unit of capacitance is the Farad but this is very large and capacitors are usually quoted in micro (one millionth), nano (one thousand millionth) or pico (one million millionth) farads.

It is well known that if a current is passed through a coil or wire, a magnetic field will be set up. If the current is switched off, the field will collapse and in doing so will induce a current into the coil, this being known as the back EMF (Electro Motive Force).

From the fact that an EMF is induced into the coil, the property is known as "inductance" and is measured in "Henries." Coils are normally referred to as "inductors." Though not as inconveniently large as the Farad, nevertheless, units of milli (thousandth) and micro (millionth) henries are frequently used.

Now, both inductors and capacitors have the ability to pass alternating currents such as audio or radio frequency signals but have opposing characteristics, for as the frequency rises, the impedance of an inductance is greater whilst that of a capacitor decreases.

For reasons of which there is not room to describe here, capacitance and inductance tend to oppose each other, but if brought into a circuit together, there will be one frequency at which the impedance of each is equal. At this frequency, the circuit will accept signals but reject all other frequencies, ie it forms a tuned circuit.

Now, as we have seen that a length of wire a half wavelength long, or a quarter wavelength operated against earth, by virtue of its length, acts as a tune circuit, it therefore follows that the aerial must possess the properties of both capacitance and inductance.

It further follows that if either the capacitance or inductance can be increased without lengthening the wire, the natural frequency of the system will be artificially lowered. This is the principle of "loading" which will be covered in next month's article.

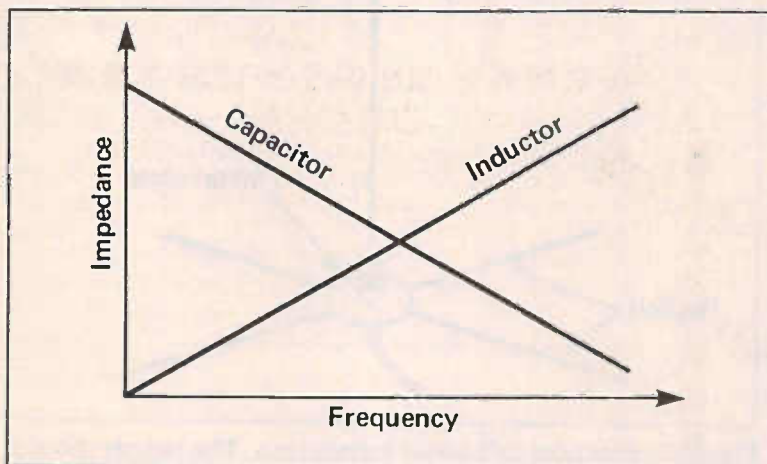
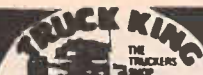

Figure 5. Graphical representation of how the impedance of a capacitor and an inductor changes with frequency.



U.K.'S No. 1 TRUCK & CB STORE



Our 3rd edition catalogue is still available at £2.00 and features over 2,000 truck and CB items. The 4th edition will now appear early in the New Year. If you would like to order this now, please send £2.00 along with your details on a separate piece of paper and this will be sent on as soon as available.

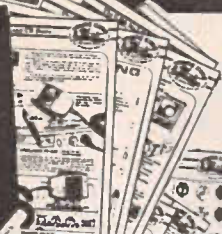

Off Junction 5 M.L.

TEL (0923) 35943
320 St. Albans Road, Watford, Herts. W1P 5PQ

CREDIT CARDS AND CARRIER DELIVERY

To make your purchase fast and efficient we take Access, Visa and Amex for both phone and mail order sales. Your new radio will normally be on its way within 24 hours of receipt of order and we even have a carrier service. Just £6.00 for any parcel, within the U.K. mainland, which will ensure swift delivery (within 2 days for most regions). Just the job for those urgent requirements.

AS ONE OF THE UK'S OLDEST ESTABLISHED CB SPECIALISTS TRADING SINCE 1979 WE HAVE THE WIDEST RANGE OF CB'S AND ACCESSORIES IN THE COUNTRY.

ALL MAIL ORDER ITEMS ARE CHECKED & TESTED BEFORE DESPATCH WHEREVER POSSIBLE AND FULLY GUARANTEED.

DISCOUNT PRICES ON CB RADIOS



MOBILE RADIOS

UNIDEN 200 — £86.00 + £2.00 p&p
JESAN 303 — £49.00 + £2.00 p&p
MAXCOM 30E. £79.00 + £2.00 p&p

PR 27 GB MOBILE RADIOS

DNT. CONTACT 40 £49.00 + £2.00 p&p

DNT. CONTACT 40 W/SCAN MIKE £59.00 + £2.00 p&p

HAND HELD RADIOS

JESAN CB 950 — £59.00 + £2.00 p&p
MIDLANO 77-805 £79.00 + £2.00 p&p

PR 27 GB HAND HELD RADIOS

DNT 4000 FM £59.00 + £2.00 p&p



PRO 450E

Just Type Approved for PR 27GB, features volume, squelch, mike and RF gain, PA, tone switch, LED dimmer, S, RF and Modulation meter with new style LED chain meter. A nice quality unit, offered at the UK's lowest price.

£110 + £2.00 p&p



DNT SCANNER 40

This unit has just received type approval — RTD No. 3715 — and features Volume, Squelch, Ch. 9, and I9 switch, variable power output, PA scan mike, Channel free indicator, Noise blanker and electronic scan search.

SPECIAL INTRODUCTORY PRICE £110 + £2.00 p&p

HOME BASE ANTENNA PRICE BLITZ

We've reduced our prices considerably on some top selling base aerials.

- THUNDERPOLE 3 (LEGAL) £18.00 + £1.50 p&p
- LEMM MINI GP (LEGAL) £16.50 + £1.50 p&p
- TAGRA BT — 104 SIGMA 4 £72.00 + £3.00 p&p
- VIKING 777/ANTRON 99 £55.00 + £2.00 p&p
- SIRIO 2012 £70.00 + £3.00 p&p
- SIRIO TORNADO £36.00 + £2.00 p&p
- SHAKESPEARE SUPER BIG STICK £75.00 + £3.00 p&p

To comply with recent legislation we wish to point out unless a base antenna is marked legal in our advertisement it should only be used for the 10 meter amateur band frequency (28.00-29.70 MHz).

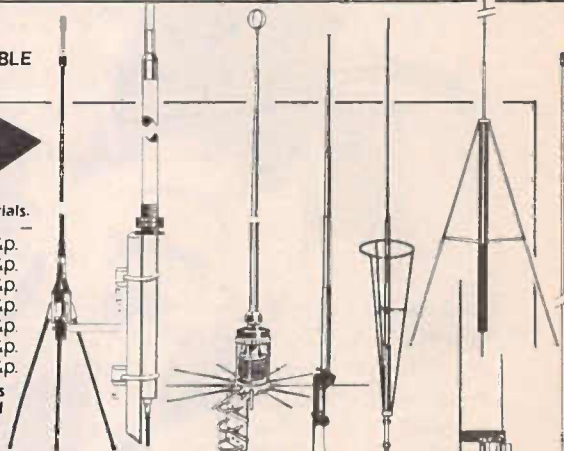

NEW UNIDEN BC 200XLT NEW SCANNER

Covering
29 — 54 MHz
118 — 174 MHz
406 — 512 MHz
806 — 956 MHz

With 200 memory channels, scan, priority search and many more up to the minute features from the No. 1 scanner manufacturers.

£245.00 + £2.00 p&p

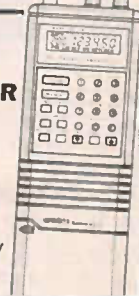

UNIDEN BC 100 XLT Also in Stock £175.00 + £2.00 p&p

DON'T FORGET OUR UNIQUE HUSTLER DCX DISCONE is available at

£26.00

incl. p&p and covers 40-999 MHz GET THE MOST OUT OF YOUR SCANNERS & RECEIVERS!



AV-801 Astro Scan Base Station

Multiply your scanner power with this patented high performance antenna. Co-inductive 5/8 wave design for low band; full 1/2 wave dipole design for high band; and 1 1/2 wave collinear design for UHF/800 MHz. Weighs only 2.25lb. Cable not included.

£39.00 + £2.00 p&p



AVANTI, AV-140 MOONRAKER 4 4 DUAL ELEMENT BOOM

Boom Length 16'5" gain 14.5 Db.



PDL 2 QUAD

Original Avanti stock purchased by us recently in the USA (repackaged by Antenna specialists) gives a shattering db gain. LIMITED QUANTITY — PLEASE RESERVE BY PHONE.

£149.00 + £3.00 p&p

DOWN IN PRICE! FC 250 FREQUENCY COUNTER

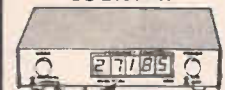

£45.00 + £1.00 p&p
Covers up to 250 MHz requires 12v supply.

CB CITY LIBRARY SPECIAL PACKAGE

If you're not familiar with this excellent series of books we've put together a really good value deal on all 5 titles if purchased at the same time.

- SCREWDRIVERS GUIDE £6.95
- PLL DATA BOOK £6.95
- CYBERNET EXPORT MANUAL £6.00
- UNIDEN EXPORT MANUAL £6.00
- and the NEW-UNDERSTANDING AND REPAIRING CB RADIOS £12.50
- USUAL TOTAL COST £38.40

JUST PURCHASED AT ONE TIME £29.95 inc. p&p

Of course you may still order one or more title from the package at the usual price. Above prices inc. p&p.



MAIL ORDER

To: TRUCK KING, Dept CB3/89
320 ST. ALBANS ROAD, WATFORD WD2 5PQ
Enquiries, ACCESS • VISA • AMEX orders phone (0923) 35943

All prices quoted include post & packing. Overseas orders add 20% (E Sterling only please)

QTY	ITEM	£

Name _____
Address _____

I enclose Cheque/PO. for £ _____ payable to Truck King

I wish to pay by ACCESS VISA AMEX (Tick)

Card No. _____

ACCESS
VISA
AMEX
phone
orders
0923 35943

PLEASE USE A SEPARATE SHEET OF PAPER IF YOU NEED MORE ROOM

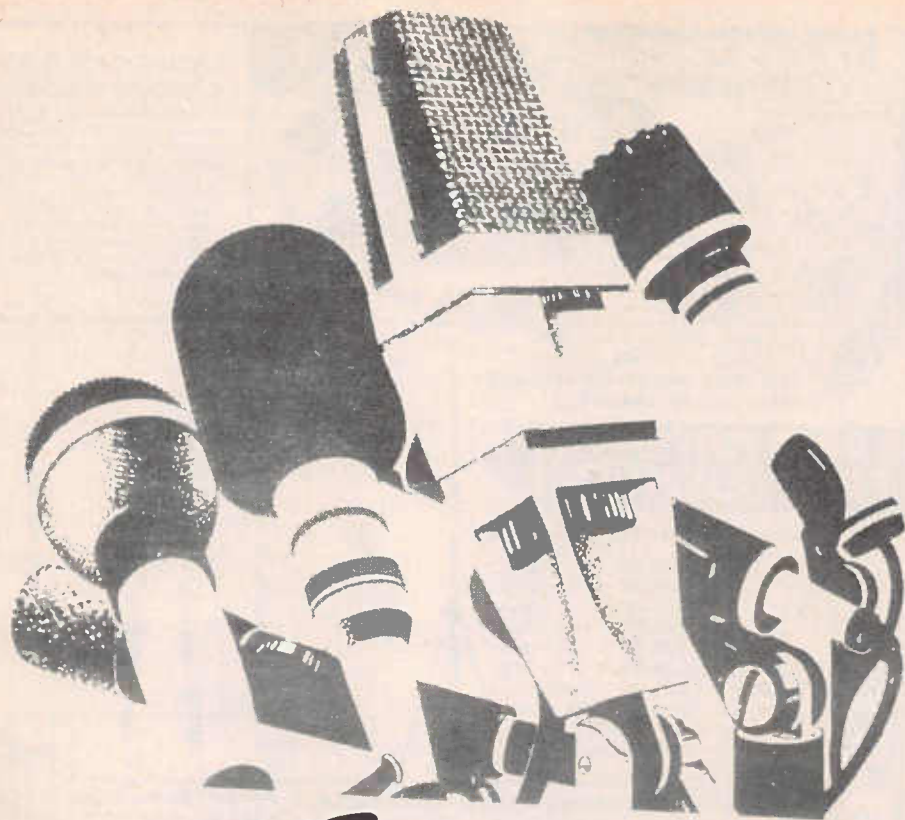

OVER THE AIR

I feel sure that there must be many of you who can, at this very moment, lay your hands on back issues of this prestigious magazine. Some can, I am sure, even go back to copies of those printed in 1981 or before. The earliest that I have is a copy dated Summer '79, when it was special publication put together by the staff from *Hobby Electronics*. At that time they made the following quote in the Introduction. "This publication is aimed at those who are supporting the various campaigns to legalise CB in Britain. It is not intended as any form of encouragement to acquire and operate a rig. The present operators are all breaking the law and face heavy fines, confiscation of equipment and, theoretically at least, imprisonment. We are saying this not as some legal 'get out'; in fact we would advise strongly against becoming involved in this activity, not only from a legal point of view but from a practical one. We believe CB will be allowed but

probably on quite different frequencies making the smuggled rigs redundant and therefore a waste of money."

That statement was made by Halvor Moorshead one of the two 'then' Editors of HE (*Hobby Electronics*). The other Co-Editor, Rick Maybury, went on to become the editor of Citizens' Band . . .

Back in 1981 the competition was fierce with other publications such as *Breaker*, *CB Radio* and *What CB*. All of which aimed or claimed to serve the 'new legal market' of CB users. Even prior to legal use *What CB* in its very first issue (October 81) made the following statement on page 5 after they had gone to great lengths to explain what the magazine's aims were. "When is CB going to become legalised?" That's the question a lot of people would like answered - manufacturers, importers and shops as well as CB users. October 16th has been an oft-quoted date, other rumours make it the end of October. Yet others have it that CB will not be legal until November - or is it going to be December? Some people in the trade think it may be as far away as next March! Our bet is November."

Amnesty

After going on to explain that the Home Office is keeping tight-lipped about revealing the legalisation day, the following piece is printed under the same article. "At the very least, some sort of amnesty would seem fairest (*the writer is talking about AM users*), and would be likely to result in a more rapid acceptance of the legal service. We fear, however, that fairness will not come into it and many breakers will feel cheated and disgruntled. There is much talk of boycotting the FM system."

"This, surely, must be the last thing the Government wants. That the legal FM system will be successful is certain, with or without the existing AM users' support, but if there is a self-perpetuating, anti-FM faction the Home Office will have achieved the worst of both worlds. Government departments tend to be rather good at that."

Moving on to page 6 of the same magazine (*What CB* October 1981) they go on to explain about 22 channel, ½ watt output system recommended by CEPT (yes, *CEPT*).

Then they went on to explain about how hard it would be to take a non-CEPT (the UK system) into most of Europe, and vice-versa for those bringing sets into the UK. They sum the European end up as follows: "Over much of Europe therefore, visitors using CB equipment which does not conform in all respects to the CEPT Specification would not be allowed to enter the country." So, even in 1981, the CEPT Specification was there for a European standard, and even then the European sets had to reach a 'type-approved' standard.

Concern

One thing that has always given me cause for concern is the fact that CB very rarely (almost bloody never) gets good press. So, I was pleased to see on page 11 (*What CB* October 1981) that someone had taken the time to report three of four extracts from national newspapers such as *The Daily Telegraph* and *The Daily Mail*. But, then almost without warning, the writer ends up with a piece about someone called Adrian Page (a lecturer in English) who wrote a "very strange piece" for *The Sunday Times* Opinion Page. It seems that the writer claims that Mr Page "puts forward an argument that, far from contributing to personal freedom as its supporters put forward, CB could be contributing to the 'creation of a rigorously controlled society' etc." This is how the writer describes Mr Page's rendition of CB and those who use it . . . "Frankly, I can't really understand what his piece of writing is all about, but I think what he's getting at is that talking to people on CB brings communication down to a lowest common denominator, making it more difficult for people to talk, rather than just speak, to each other. The trouble is he uses, for examples, acronyms such as Gestapo and compares the use of CB to the societies in Orwell's *1984* and *Brave New World*. A slight touch of overkill I would say."

"The sting, as always, comes in the tail. The whole piece would be of no consequence and could be dismissed as so much academic drivel were it not for the fact that at the end - and out of the blue - he speaks out against the legalisation of CB. His last three paragraphs verbatim give the tone of the entire piece."

These are the three following quotes from Mr Page's piece: "Like the obsession of Space Invaders, this activity (CB) will breed its own social problems without offering a solution" . . . "Articulatory is not a question of snobbery, it is increasingly essential in order to survive" . . . "Would this Government consider legalising anything which would enable us to challenge its authority" . . .

In *CB Radio* January 1982 issue it would seem at that time some people had a problem with trying to determine what was legal and what was going to be legal. Even then the rumours of 'legal AM' were causing problems. They printed an article on page 54 entitled "Absolute Rumours" and stated the following facts: "The new British CB system, legalised on November 2nd, is already in the balance.

"According to reports we have received, a Member of the House of Lords and Home Minister has said that it is the Government's intention to legalise the FCC frequencies in due course. The fate of the UK system is clearly in the balance." *CB Radio* claim that this was a comment made in another "certain" CB publication, and with the help of Amstrad Consumer Electronics Ltd they try and squash the rumours. The story went on with the following quotes: "This piece of irresponsible journalism has created much confusion from both the CB'ing public and the trade.

We have approached the publication who ran the article on their front page to ascertain the facts on which it was based. As they are refusing to comment and sounding very embarrassed, we can only assume that this piece of sensationalism was based on nothing more than speculation."

"The official statement from the Home Office is that 'AM CB will not be legalised in this country.' If we were intending to make AM FCC equipment legal we wouldn't be hiding the fact."

CB Radio went on to say: "The CB trade have not been amused. Millions of pounds have been committed to the purchase and importations of FM rigs over a long period of time. To be informed that all the work, time and money spent on the development of FM CB may have been wasted is regarded by the trade as some kind of sick and untimely joke. One major wholesaler talked to us about facing bankruptcy as all his money was tied up in FM rigs."

Sticker

It seems that in those days some people had been misled by a sticker that someone was placing on the back of AM sets. It read: THIS RADIO IS ILLEGAL TO USE BEFORE THE 1ST APRIL 1982. No one within the trade would claim responsibility for the stickers, but it was known that a certain

distributor had done this to sell off most of his AM stock. That was also around the time that a certain person was flooding the market with 27/81 stickers and breakers were being conned into believing that, by sticking one of these onto an illegal set, would make it legal.

Breaker magazine published by Link House in and around 1981 felt the need to use young ladies in various states of undress and in various sexual poses to catch the eye of the male population of readers. How many can remember the old 'Firestik' advert - with a young lady holding a mobile antenna to her lips with the caption "you can't lik a stik"? That seemed to offend a lot of people so they then came out with the advert in which a young lady wearing a thin top (and it must have been cold!) is standing with a Firestik in her hand and the antenna is dressed in a sort of doll's dress and a hat. The advert claimed: "For those we offended with our "lik A Stik" ad, we have now dressed the nude."

They seemed to carry many pages of letters from readers, pages of colour adverts from CB distributors, pictures of very big American trucks and lots of details about the teams that monitored the 09. REACT, Suffolk EARS, BEST, NESS and THAMES (good to read about my old friend George again). The thing that I liked most of all in this magazine was the good and funny drawings that accompanied many articles.

This leads me back to Citizens' Band and, as I have said before, the Editor in 1981 was Rick Maybury, with the ever present features such as 'Update' and 'Back Chat' and even then we were delighted with articles from 'Mack The Hack.' He was in those days extolling the virtues of FM, as well as informing us that some 2½ years previously he had been talking to 'Viking' and 'Herman The German' who turned out to be two people involved with the production of this magazine (Cit' Band).

So, after all this, what have we learned? *Citizens' Band* is the only national monthly magazine left from the old days. In fact, if you go back to the '79 issue - they were, as far as I know, the first to publish for the UK in this market. The ladies in less than covering clothes have gone. Many of those who advertised have now become a memory and, to the surprise of many, FM is still going.

However, it still remains that the DTI keep very tight-lipped on certain things, AM is still something for the future, distributors are still trying to con users into buying certain items by making out they 'may' become legal and, last but not least, we still believe in rumours! So as Jimmy Greaves might say . . . "It's a funny ol' game" . . .

Birthday

If you class the Americans as being the first to use a legal CB system (and I do),

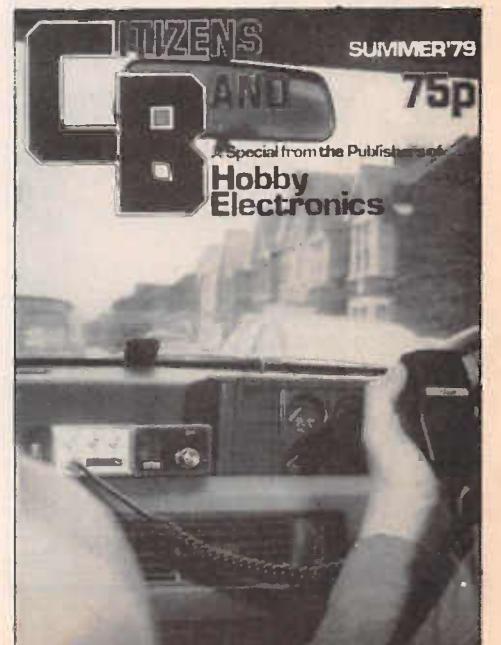

then you may like to know that CB celebrates its 42nd birthday on the 10th of April this year, because that is the day that the first 'legal' transmission was made in the USA. So, the use of Single Side Bands (SSB) must be classed as the first by-product of our favourite pastime. To many, the use of SSB (still illegal – at present in the UK) has turned into a way of life, to some even an obsession. Many still like to keep these activities under wraps and some even treat it like a secret society. However, you do have to be dedicated. The sort of dedication that gets you to stay up until all hours, listen in on faint contacts, drive out in search of vantage points for lift etc. Maybe even learn other languages. Many of these people are the diehards of CB who have been around since or before legalisation. Then you have those who DX on 'legal frequencies,' these are also dedicated users. Much of what applies to the SSBer also goes for this type of DXer. It is very clear to me that these people get a fantastic buzz from their activities – and they are the true CBers.

So, November the 2nd 1981 was "the day." Well, thinking back to that day I can't remember much about those who I spoke to, except that many are now no longer on channel, or have gone 'up-market' to join the ranks of 'the Amateur.' The one thing that I do remember is that it was damn cold sitting in my old van throughout the night. But just how far have we gone since the beginning, just how much has CB changed, is the equipment any better now? Yes, I think that we have (in many respects) gone far – bloody backwards! CB is its own worst enemy, with the breeding of the animal known as the *Muppet-annotominus* or the *Wally-vegatateamous*. They have done more harm in seven years to CB, than a



herd of elephants would do to a flower show. But then some blame must be put down to the DTI and the Government! Yes, CB has changed! Since 1981 we have seen an increase in the licence fees, new frequencies and changes governing the use of CB as well as restrictions on certain equipment. Some may even say that the laws are not strict enough, whilst many do say that the DTI don't do enough. But, after thumbing through the back issues of some of our then specialist magazines it does seem that the moans and groans of present users are about the same as they were in 1981. We still haven't got AM or SSB, or many of the other things that were required then. The only thing that has changed is that nowadays, the specialist press (Cit' Band being the only one left) doesn't indulge in speculation and rumours because that is where most of the rumours started in the early legal days.

Visits

A couple of months ago, I stated that a number of CB emporiums were being visited by the RIS. It seems that now their attention has turned towards breakers. A number have had a visit and many more can expect one at some stage in the future. It is unfortunate that some well-behaved good buddies are on the receiving end along with those who deserve to get caught.

However, the fact remains that, if you are in any way illegal, and get caught – then you must take what is coming. I feel sorry for those decent ones that get caught out, including those who, although illegal, still don't cause problems. And I can't claim to be 100% legal so I have no doubt that I will get 'the knock on the door' (that could make a good story!)

Well done to Uncle Stan, CBers and the Army for helping to raise £2,353 for PHAB. The cheque was presented to the PHAB treasurer Yvonne Humphries by the Newport Mayor, Councillor Veronica Brydon. The money was raised through a 50-mile sponsored walk from Newport to Yatton and back.

BDX Print are putting together an up-to-date CB Directory with PO Box details of clubs, groups and organisations. If you would like to be included in the lists or would like to know more please contact: PO Box 4, Coatbridge, Lanarkshire, Scotland ML5 2QA. Please include a SAE for A4-size paper.

We have already received a number of replies on the channel problems (CEPT) caused by 'Pagers' but we do still need more information. So please keep your letters coming in and ask your friends for information. Send them to 'Paging Problems,' Citizens' Band Magazine, ASP Ltd, 1 Golden Square, London W1R 3AB.

I have been sent some copies of a CB publication called "The Monitor." It is put together by MSGB (Monitoring Service of Great Britain) and supplies information about clubs etc, news and eyeball reports as well as information from the DTI. It is published every quarter and is *free of charge*. The only thing you pay for is £1 per year towards printing and postage. If you would like a copy without further obligation send an SAE to: The Monitor, School House, Meadway School, Littleton Street, London, SW18 3SZ.

If you have any news, views, dates of events or would like a mention for someone who does good things for CBers, please let me have them c/o Shepherd Man, PO Box 429, London SW19 2UU.



COMMUNICATION THE

QSL WAY



More names and addresses from QSLers all over the world, courtesy of David Shepherdson

Well, this month I've quite a bit of news to get through so I'll get right down to business with some details of some forthcoming events.

If you are planning any such meetings that you feel would benefit from a mention here, please put pen to paper and let me have clear details as soon as possible! Don't send the information a week or so before the actual day, as that is far too late for the publishing deadlines and whatever you do *do not* send anything via the magazine; please send direct to me at 3 Tarn Villas, Cowpasture Road, Ilkley, West Yorkshire, LS29 8RH.

Well, the good news is that I've finally got the date for the 1989 Big Meeting at Co Durham. This year the meeting will be held on April 16th between 11.00am and 4.00pm, once again in the Stanley Youth Centre, Stanley, Co Durham. As usual it will be well signposted from the A1 (Chester-le-Street turnoff). There will be many QSL clubs, radio traders and other CB organisations in attendance. Maps and accommodation leaflets are now available for a SASE to PO Box 5, Consett, Co Durham, DH8 8NG. This is one of those I hope to attend, so perhaps see you there! Incidentally, there is talk of a coach from London being arranged (to leave early on the Sunday morning). Anyone interested should call Brian on (01-340-5601).

The week before this meeting, the Cutty Sark Club is holding their 1989 Swap Meeting over the weekend of 8th & 9th April at the Falcon Hotel, Ethelbert Road, Cliftonville, Margate, Kent, admission 50p per day. This meeting is organised jointly with the WBC. In May,

the Tango Papa's are again holding their Charity Eyeball at the Floral Hall, Southport on the 20th.

In June, I've details (so far) of three. On the 10th & 11th the Sea Smugglers have their second International Card Swap meeting at the Granville Hotel, Sea Road, Bexhill on Sea. Admission 50p per day, Saturday 10-4, and Sunday 10-2. There is also Saturday Night Ents, admission £1. On June 18th, the Sheffield Charity Eyeball is to be held

once more at the British Steel Sports Ground, Bawtry Road, Tinsley, while on June 24th & 25th the Kilo Mike Club is holding their 1989 Eyeball at the Kirby Muxloe Sports Ground, Ratby Lane, Kirby Muxloe.

Looking ahead to August, I've some early details of the Tripe City Breakers 1989 Eyeball which will be held at the Barton Village Hall, on the A6, near Preston in Lancs. Opening times are 10am 'til 5pm on Saturday 19th August,

ZZIP SLIDER

VI

P.O. BOX 139 BEXHILL SUSSEX

1000

L'AMOUREUX.

ZOO KEEPER

QSL Club Addresses:

GBQDC	PO Box 5, Consett, Co Durham, DH8 8NG.
Cutty Sark	16 Bradenham Ave, Welling, Kent, DA16 2JG.
Tango Papa	PO Box 13, Southport, Lancs.
Sea Smugglers	PO Box 139, Bexhill on Sea, E Sussex, TN40 2AF.
Sheffield Charity	PO Box 275, Sheffield, S2 5HY.
Kilo Mike Eyeball	PO Box 1, Kirby Muxloe, Leicester, LE9 9DP.
Tripe City Breakers	PO Box 14, Accrington, Lancs, BB5 6JL.
Berliner Bear/Super	PO Box 2923, D-6750 Kaiserslautern, West Germany.
Stinky	PO Box 156, Wolverhampton, WV6 9DX.
Boomerang Radio	PO Box 98, Hastings, East Sussex, TN34 3QQ.
Cherokee Spirit	

When writing to any QSL Club or Firm, always include return postage to assist with their reply, it does help. Please also mention that you saw their name in the CB Mag, thanks.

and admission is 50p. Club and trade stalls a-plenty, £3 for a 6-foot table for any club interested in attending.

Right, in recent issues I've mentioned a couple of people who have been in touch with some updated info. The first is Knut (*Berliner Bear*) of West Germany who has been in and out of hospital for much of 1988, and will be spending some more time in the same place this year! He was able to spend a little time in England before Christmas. He has arranged for his post to be diverted to his hospital room so anyone who writes to him should not have such a long delay in receiving a reply from him. For Currie Card Collectors, I have a number of his 813 cards to swop on his behalf so if your collection lacks one of these cards drop me a line, with your card(s), needs list and return postage and I'll send you one and any help I can offer.

Another person who was mentioned a while back was Dennis (*Applejack*) who used to run the Currie Card Bank and Currie Card Collectors Clubs. I was informed by the new president of the two

Enlight Cards Currie Collector No 808

CRAFTY COCKNEY & CHANTILY
KEITH & KATHY
 6 HAIG STREET, SELBY N YORKS YO8 0B2 ENGLAND U.K

SUPER STINKY

INT. QSL COLLECTORS CLUB

Currie Collector No 813



We swap QSL cards all over the world!!

President: **KNUT MITTELSTÄDT**
 POSTBOX 2923, D-6750 KAISERSLAUTERN, WEST GERMANY

QSL from

ROADMENDER

clubs that Dennis had passed on the clubs due to ill-health and I was given the impression that Dennis had also ceased QSLing. I have since received a letter from Dennis to the effect that I got the wrong impression and he is, in fact, still very active in QSLing and his collecting of the Currie series of QSL cards. Sorry Dennis! He also has a new address which I'll include in the usual place.

Someone else who has been having a lot of bad luck is Roger (*Boomerang Radio*) in Wolverhampton. That's PO Box 156, Wolverhampton, WV6 9DX. Let's see if that gets printed correctly as Roger says I've been putting an incorrect address in before!

For anyone who has been waiting for a reply from Roger or the club, Roger sends his apologies and assures me he will be clearing the backlog as soon as possible. Roger has given me permission to explain the delay so here is a brief outline. About two years ago, Roger became a grandfather with the birth of Gaenor who, regrettably, died five weeks later due to a heart defect. In August last year, a second grandchild was born and young Steven has also been discovered to have the same heart defect. Roger has been told that this is a million-to-one chance, but at the time of writing, Roger and family have been spending most of the time at the hospital following a sophisticated transplant operation. Best wishes, of course, go to Roger and family. Anyone who has been waiting for a reply or a BR package, please bear with him, or drop him a line, with return postage, and ask about your package as the club has had a couple go astray in the post of late.

Also whilst mentioning post going astray, don't forget that during November last year, the Birmingham Main Sorting Office suffered a number of fires which destroyed thousands of letters and packages so if your post went through Birmingham at that time, and you are still awaiting a reply, it is possible that either your letter or any reply may have been one of those destroyed. All you can do there is write again and see if you have any better luck this time.

Continuing with this month's apparent theme of illness and accidents, I've been asked to tell you that Nan (*Homebird*) on the Isle of Lewis has been in hospital following an injury so she is also behind in answering her post. Another lady who has asked me to pass on her message about her delay in replying to her post is Alice (*Blue Eyes*) who says: "Sorry to all my friends out there but I have been sick and in hospital so have not been able to answer any mail since August 1988. I will answer all of you but please be patient. It will take time for me to reply to everyone, Alice."

After all the above, there's just about sufficient room for a few names from the

QSL Service Addresses:

Charlie Cards	26 Edward St, Hartshorne, Burton-on-Trent, Staffs, DE11 7HG.
Currie Cards	89 Derwent St, Blackhill, Consett, Co Durham.
Ensign Cards	58b Market St, Ashby-de-la-Zouch, Leics.
Impact Graphics	57 Moor Street, Earlsdon, Coventry, CV5 6ER.
POMA (Ray-UK Rep)	PO Box 106, Canterbury, Kent, CT1 3YN.
Raymac Display	No. 2 Showfield Ind. Units, Pasture Lane Ind. Est., Morton, North Yorks. (Send £2 for Sample pack & £4 credit towards order).
Vine Lodge Products (Labels)	11 Mill Lane, Butterwick, Boston, Lincs, PE22 0JE.
Scottish CB Newsheet	C/o 'Arnail', Patison, Neilston, Glasgow, G78 3AT. One year's subscription £2.70.



QSLer Addresses:

Dennis (<i>Applejack</i>)	PO Box 5, Consett, Co Durham, DH8 8NG.
Nan (<i>Homebird</i>)	PO Box 11, Stornoway, Isle of Lewis.
Alice (<i>Blue Eyes</i>)	WM 97, PO Box 23, Brentford, Middlesex, TW8 9NF, UK.
Robert (<i>Iron Man</i>)	28 Madras Rd, Auchtermuchty, Fife, KY14 7BW.
Keith & Kathy (<i>Crafty Cockney</i>)	6 Haig Street, Selby, N Yorks, YO8 0BX.
Martin (<i>Zipslider</i>)	PO Box 139, Bexhill, Sussex.
Mike (<i>RB 01</i>)	PO Box 279, Newcastle, Staffs, ST5 1PA.

PO Box 98. Hastings. East Sussex. TN34 3QQ.

Cherokee Spirit
QSL Club



Star Rider Designs 106

DX Call

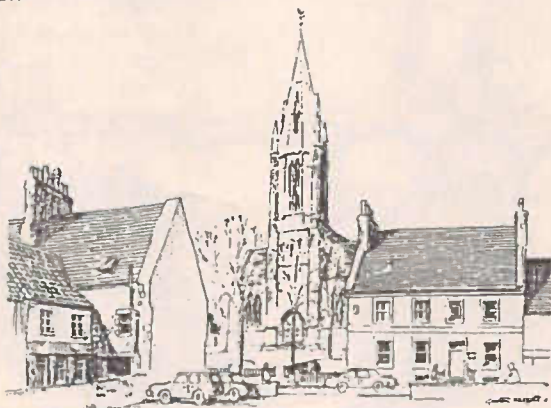

St John's Church Cupar
P.O. Box 16 Cupar, Fife, Scotland.

Forthcoming Events:

April 8th/9th – Cutty Sark/WBC Meeting, The Falcon Hotel, Ethelbert Road, Cliftonville, Margate, Kent. 50p admission per day.

April 16th – Stanley "Big Meeting," Stanley Youth Centre, Stanley, Co Durham.

May 20th – Tango Papa Charity Eyeball, The Floral Hall, Southport. Contact: Eyeball 89, PO Box 13, Southport.

June 10th & 11th – Sea Smugglers 2nd Int. Card Swap at Granville Hotel, Sea Road, Bexhill on Sea.

June 18th – Sheffield Charity Gala, British Steel Sports Ground, Tinsley, Sheffield.

June 25th – Kilo Mike Eyeball, Kirby Muxloe Sports Ground, Ratby Lane, Kirby Muxloe, Leicester.

August 19th – Tripe City Breakers, Barton Village Hall, Nr Preston, Lancs.

Contact addresses shown in clubs section!

pile, starting off with Robert (*Ironman*), of Auchtermuchty. From Selby in North Yorkshire hails Keith & Kathy (*Crafty Cockney* and *Chantily*) and from Bexhill comes Martin (*Zipslider*) who is a new QSLer and has a set of Star Rider Cards, while from Staffs cometh a massive package from Mike (*RB91*) who asks, in addition for a mention, if anyone can help him to find the whereabouts of Midas cards, or more accurately, the plate for his Midas card. He is now using Ensign cards with great success.

Midas cards, for those who may not know or who are new to QSLing, were a hot foil card firm, like Charlie and Engsign, but Midas was taken over some time back and apparently have collapsed. I say 'apparently' as both addresses I have are no longer valid and I have not heard of them for some 18 months and know of no-one who has! I will be pleased to pass on any correction or update on this topic!

I've just been informed that due to a typing error somewhere along the line the other month, I gave a slightly incorrect address for the Cherokee Spirit QSL Club of Hastings. The correct post code should have been TN34 3QQ but I gave it as TF34 3QQ which meant that at least one letter ended up in Telford of all places! Apologies to anyone who ended up with a re-directed letter or their application returned not known, put it down to the old excuse of computer error, better known as Brain Fade!

Just enough room, I think, to let you know that my own Dragonrider QSL Club has, in addition to the very popular "Warrior" series of cards, a limited number of the "Legend of Arthur" series of cards still available. These cards are available for £20 for 1,000 (UK Post Paid). They are single-colour of ink artist-drawn cards and are printed as "four-ups", linked in the centre of the card by the DR logo. Each part is swapped by the individual member and both series are proving very popular. The Club also has a new set of Club cards available in addition to the five full-colour ones. For further details, order form etc, please drop me a line, enclosing return postage and I'll get back to you as quickly as possible.

Well, once again that's it, no more room so I'll close with a reminder that if you want a mention, either for yourself, or for your club, please drop me a line. For yourself, don't send a bit of paper asking for a mention, send me your usual QSL package which will give you a far better chance of a mention. For a club, please let me have some details of the club and *please, please* do include an up-to-date membership application form so I can see what you offer and for how much. If you have a query which I might be able to help with, or you require a reply, please do remember to include suitable return postage.

I had burglars the other week. The miserable thieving ratbags – I could think of a better name but this is a family magazine – (OK, so no more *Dallas* and *Eastenders*, probably did me a favour), my video recorder (well, can't use it without a television, can I?), and my hi-fi (well, it is possible to live without Dire Straits – I suppose).

But that wasn't all. They also took my CB base station.

Now, I can cope with the temporary loss of TV, video recorder and hi-fi. Everything was insured, after all. But the base station was different. It was my eyes and ears. It was how I stayed in touch. After all, how can you be the local CB celebrity without a CB radio?

Now you might say to yourself, So what? What's to stop the stupid female simply going out and buying another rig? Because it wouldn't be the same, that's why. It was *my* rig. I had had it ever since I was introduced to Citizens' Band, almost seven – well, never mind how long ago. I couldn't tolerate another rig in its place. If it was secondhand, I wouldn't know where it had *been*. If it was new, it wouldn't have roots. A history. It wouldn't be *mine*.

I had to have my rig back, it was as simple as that.

I thought about it. The police had commented that my burglars seemed a pretty slick, professional outfit. So what would experienced burglars do with a CB base station that was practically, although I say it myself, a collector's piece? Let's not mince words, my base station is a classic of its kind, an antique. Serious collectors and those in the know would sell their houses for my base station. Particularly if they knew it had belonged to a 'celebrity.'

Obviously, the burglars would try and sell it, stands to reason. They might, of course, try to flog it abroad – for all I knew there was an international market in antique rigs like mine, although the police didn't seem to think so. However, it seemed more likely that the burglars would not be aware of its real worth and would try and dispose of it locally. The police had promised to alert CB dealers in the area, but after all, what do the police know about CB? I decided this was too important to be left to the police. I would talk to a few people myself.

'Someone's pinched your base station? Hard luck,' said Geronimo at the *Thrifty Truckstop*. 'You'll need a new one then. Can I interest you in the latest

Lady Breakers

CB

Thieves

**After a burglary,
Filly sets off
on her own
detective mission**

model from (well known CB manufacturer)?'

Of course I might have known the shark would only see the commercial opportunities to himself.

'I don't want any sophisticated modern rubbish,' I snapped. 'I want my rig back. Will you keep a look out for it, and put the word out? You know everyone, after all.'

'Oh, don't worry old girl, no one would touch your old kit with a bargepole,' he said cheerfully.

'What, you mean it's too well known? Too – er – hot?' I queried.

'You could put it that way,' he agreed with a smirk. 'Sure, I'll look out for it. Have you tried the flea market in town?'

Obviously, this man was not worthy of my attention, far less of my custom. I couldn't understand how he had come to be considered an authority in all matters pertaining to radio. Suggesting I look for my matchless base station in a *flea market* – I departed in a huff.

The next dealer I tried was little better. He suggested I tour the local car-boot sales. The third simply fell about laughing when I asked if my rig might have been exported abroad to crown the collection of some foreign CB aficionado.

Moodily, I made my way home, thinking that what our area needed were a few CB dealers who knew their stuff. Mooching about the house, it struck me that the police might have missed a few clues. They hadn't spent a very long time investigating the scene of the crime, it seemed to me. I had a good look round, carefully examining the ground outside for footprints and tyre marks. I couldn't see any. Idly, I walked up the road, peering into ditches and hedges. You never knew, the criminals might have thrown a cigarette stub – perhaps some exotic foreign brand – out of the window as they raced away. Something that would infallibly identify them . . .

I stopped, heart pounding. At the end of the road there is a large pond, and there was something in it. I could just see a metallic corner sticking out of the water, winking in the sun.

The getaway car? No, don't be stupid. The pond is only two feet deep. What, then? Excited, I waded in and found –

My base station. My base station, hurled ignominiously out of the getaway car as it roared from the scene of the crime. I was affronted. The fools had rejected it, deeming it worthless! They must have been misled by its deceptively aged and scruffy appearance. Well, it was their loss. Little did they know what a prize had escaped them.

Clutching my treasure, I dripped my way homewards to call the police. True, after its dunking in the stagnant pond, it would probably never work again, but who cared. Antiques don't have to work to be priceless, do they?

Now, how much was that ultra-sophisticated, all-singing, all-dancing modern rubbish Geronimo had mentioned – ?



MARINE MUDDLE

Need some advice? Our resident CB doctor, Saul Wright, tries his best

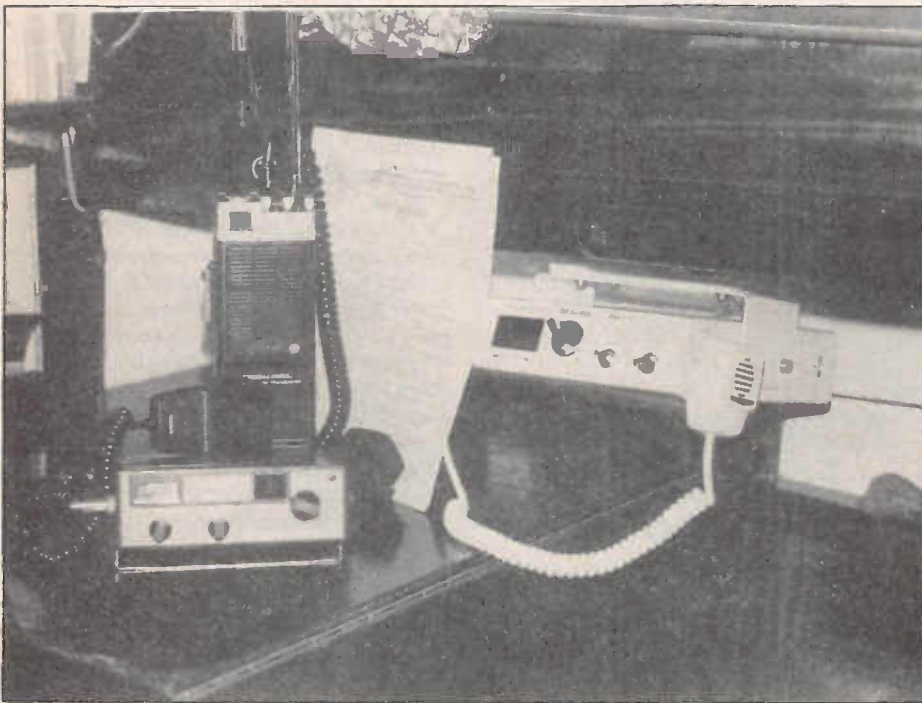

several years ago, and probably was brought for use on a boat or launch. Our information is that this type of CB/marine combination was (and still is) illegal, so be warned. Our friends down at Truck King, who have a better memory than us regarding this rig reckon it was based on the Uniden 200 chassis, so it shouldn't pose too many problems for rig-doctors.

Marine muddle

Q Can you help me? About a year back a friend gave me a rig. Neither he or I are sure of its origins. I have a sneaking suspicion that it has come from a yacht or boat; I say this because it has two odd features - it's white, instead of the normal black. There is also a marine channel switch. Please can you tell me if my theory is correct. The rig is marked Quasar ME B400 and I have enclosed a drawing

of the front panel.
Robbie Cave
Enfield,
Middlesex

A Thanks for the very clear sketch - you even drew on the CB 27/81 logo, which should have told you something... The B400 was a hybrid with normal 40 channel CB FM operation and additional receive only marine channels. The rig was imported in limited numbers by the marine specialists Ladyline

More telly troubles

Q I wonder if I'm the first reader to write in with a problem on a CEPT rig. I've got an Alpha 4002 - incidentally I brought the first one in the shop, nearly three months ago - and apart from the problem which I will describe, is working fine. I'm using the rig as a home base, feeding an Antron 99 antenna (brought at the same time), and powered by a SW mains power supply. The trouble concerns our Ferguson TV which mysteriously changes channels virtually every time I key the mike on channels 35 to 40. It's not a random change either, it always goes to the next channel. For instance, if the family is watching ITV on channel 2, the TV will go to channel 3. What's the answer - it's driving the family nuts?
Charlie Drew
Manchester

Vexing video

Q I would be grateful if you could help me with a case of VRI (video recorder interference). One of my neighbours recently purchased a new VCR; the problem is, every time I key the mike his picture changes from colour to black and white.

It only happens when the TV is used via the video recorder. I run a York CB6 864 feeding a LEMM 1/4-wave antenna. I have an antenna switch and Ham Inter low pass filter in the antenna line. My neighbour lives about 60 metres away, some of my other neighbours who live closer have experienced no problems with TV!! HELP!

'Cavalier'
Carrbridge



would well be that it's turned up higher than it needs to be. Lastly, take another look at your low-pass filter, is it working

correctly? If it's one of those cheap-and-cheerful items you might think about buying a better quality one.

Homebase horror

Q My Wagner 506 homebase has been messing me about at odd times lately. Suddenly, for no apparent reason volume will drop by over 50%, regardless of signal strength. (No problem with transmission). Whether it's a S1 or S2 copy from 80 to 90 miles away in Cornwall - easy from 900ft on the side of Dartmoor - or local transmissions just down the road. It is just as if the radio has gone off-frequency. In fact local stations are very often clearer one channel up (never down), than the one they are on. The local rig Doc had the Wagner for three weeks and it never missed a beat. New silver rod and coax, SWR of 1.5:1 and no trouble from the car or tractor rigs when used indoors points to the Wagner. Hope you can help.
V C Pierce
Devon

A Congratulations - your Wagner is suffering from every serviceperson's nightmare - the intermittent fault. For the non technical amongst you this means that the equipment will always work perfectly when it's on the bench, but the fault will return as soon as it's back in the customer's hands. Unfortunately they are swines to track down, the fault could be triggered in a number of ways, including mechanical shock, or even a sudden change in temperature; that's why every rig doctor worth his or her salt should have a hair-drier in their tool kit. It's not for part-time hairdressing either, it's used in conjunction with a tin of 'freezer' aerosol and a 'tapping' stick to try and recreate the fault condition. The problem you describe sounds like it might be centered around the receiver front end - ask your Doc to concentrate his fire around the Rx crystal or synthesiser chip - they've both been known to develop this type of instability.



A The problem is undoubtedly straightforward TVI, caused by the additional amplification, and possible lack of efficient filtering in the VCRs tuner section.

First, and most obvious is to buy your neighbour an early Christmas present and give him a good quality TV filter to put in between his VCR and TV aerial. Second, ask him if his VCR has a local/distant adjustment on the aerial input of his VCR. This is effectively a gain control for the aerial pre-amplifier. It

A My guess is the Ferguson TV is a fairly old design, probably one of their 3000 or 4000 series models which had ultrasonic remote control systems. Unlike modern infra-red systems they were notoriously prone to interference - some models even responded to the high frequency notes produced by jangling keys! The remote control circuitry in the TV is almost certainly responding to an odd harmonic produced by your rig - it's probably getting in through the small transformer used to produce the high voltages needed by the ultrasonic transducers. You could try putting a high-pass filter in the antenna line. If that doesn't work there's probably not a lot you can do - unless you're an experienced TV engineer. The offending circuitry needs screening - and this isn't the type of job you could do for yourself. Why not have a word with your local Ferguson dealer, they may have come across this problem before. By the way, yes you are the first with a CEPT problem - congratulations...

Pama & Co

WHOLESALE ONLY

OPEN MONDAY - SATURDAY

NEW THIS MONTH ★

Now Available:-

**UNIDEN PC450E
HAS AT LAST
GOT APPROVAL
Phone Us For
Details**

Pama SUPA TRI

EXCEPTIONAL PERFORMANCE FROM THIS TRIPLE LOADED HIGH QUALITY ANTENNAE SIMPLY ... THE BEST!

INTRODUCTORY OFFER PRICE

£19.95

Also Available:-

The original PAMA TRI our No. 1 best selling aerial is still available made from the highest quality materials, the PAMA TRI has a performance unequalled by any antennae in it's price range.

£14.95

**FOR WHOLESALE ORDERS
PLEASE PHONE: 061-445 8918
AND WE WILL GIVE YOU OUR
IMMEDIATE ATTENTION**

ALL ORDERS DESPATCHED WITHIN 24HRS

Wholesalers for:-

CTE - ZETAGI - **maxcom** **lemi**
MIDLAND - **NEVDA**
HEMBRO - **Pama** **antler**
SADELTA - **uniden** **BREMI**
THUNDERPOLE - SIRIO

LOOK FOR THE PAMA DEALER
STICKERS



MIDLAND 77-805



Exceptional performance from this dual-purpose hand portable. Can be mounted under the dash and when away from the car - hiking, walking, fishing etc. - it will keep you in touch.

MIDLAND 77-104



It doesn't need to be big! The Mini Mobile is the smallest rig available but don't be deceived; it has exceptional performance for it's size.

JESAN KR200
JESAN CB950
Handheld
JESAN KR303:
The small budget priced rig.



DNT CONTACT 40
Now with Scanning Microphone

CEPT frequencies, 40 channels, F.M. Mobile superb performance, excellent sensitivity, Channel 9 indicator T/X indicator - unbeatable value.



uniden 100



One of the most popular Mobile Rigs around. It has excellent sensitivity and anti 'bleed over' facility of the 200.

uniden 200



One of the best mobiles around with R.F. gain, tone control and other features, it has a good sensitive RX section with low 'bleed over'.

uniden 300



Undoubtedly the 300 is the best selling base station in the U.K. It's features includes mic gain, R.F. gain, power and tone controls and S meter. Value for money? It's unbeatable.

uniden 400



The first available rig for CEPT frequencies manufactured to the highest standards. Features include the mic gain, R.F. gain, squelch, 40 channels and a low 'bleed over'.

**"WHEN YOU BUY UNIDEN"
YOU BUY RELIABILITY**

Pama & Co

Pama House, 433 Wilmslow Road,
Withington, Manchester M20 9AF.
(3 minutes from M56)

Telephone: 061-445 8918 061-434 5701
061-446 2437 Telex: 666762 Pamaco G
Fax: 061-445 0978



Truck Stop

**Brandybird bids
a tentative farewell
to her faithful
big-wheelers**

Hello again. By now, you should all have finished eating turkey, and all be back doing what you're normally found doing.

Hopefully, the weather won't be too bad. As I'm writing this, at the beginning of December, we've already had a motorway pile-up that will be remembered for years - one of the worst in my area for many years, so please, let me remind you if you're driving on a motorway and there is light drizzle, twilight, or a light mist, please forget that you've got sidelights and for God's sake, get those dipped headlights on! I drive to work past junction three on the M6 and it really is unbelievable the amount of people driving on sidelights or, worse still, no lights at all. Even in that really foggy spell at the end of November, people just didn't bother to switch their lights on. It's nothing short of suicidal. And whilst I'm at it, please drop back from that vehicle in front of you. Whatever speed you are both doing, if he stops - well - one crunched cab or car. It never ceases to amaze me the stupid idiotic things that people do whilst they are driving. Please don't be a moron.

As you've probably all realised over the past few months, I've been looking for a proper job. I did get one, in a garage, but after two months we both realised we weren't suited and so parted company. Now I'm lucky enough to have been given a chance with a pump hire company. Unfortunately, it doesn't give me much chance to get onto the rig to listen to all your gossip. Sorry fellas, just don't get the chance to get on the rig to talk to you any more - and they won't let me have one on the desk at work (not for want of trying). So, it looks very much as if I'm going to have to stop writing Truckstop in a short while. So, is there anyone out there who thinks they are capable of writing a page of nonsense about trucks and truckdrivers, either a driver themselves or someone who, like myself, spends (or used to) a lot of their time talking to the truckers? Someone who is interested in trucks and their workings and therefore willing to write

just a bit of technical stuff? (It's easy enough, if you write to the makers, they'll send you all their press releases.)

Then all you need is a typewriter and a sense of humour . . . If anyone is interested, then please drop me a line, preferably with a sample page, or write to the Editor at the mag. I don't want to go, but . . . C'est la vie.

Don't forget your letters to: Truckstop, PO Box 158, Coventry CV6 6BD. I'd like to take this opportunity of thanking everyone for reading my page and supporting my madness. Also thanks for all the letters that I've received in my time with the mag. Until someone volunteers, I suppose I shall continue so, if you want to see the back of me, then volunteer . . .

That's all for this month folks, stay lucky and keep on truckin'.

*Farewell
Truckers*

Brandybird



SHARMAN'S WHOLESALE



CHALLENGER BJ 200

5 Band
programmable
hand held scanner
26.0/29.995 MHz
50/88 MHz
115/178 MHz
200/280 MHz
360/520 MHz



MAXCOM 30E

Most popular UK 81 CB
now back in the UK.



OPEK 437
POWER MIKE



OPEK 436
DYNAMIC MIKE



OPEK 452
POWER ECHO MIKE

FANTASTIC NEW RANGE OF MIKES NOW AVAILABLE!

If you would like further details of the full range of CB equipment, telephones, In Car entertainment, portable TV and radio and all the benefits of dealing with one of the country's major wholesalers, then please phone 061-834-9571 for immediate attention.

3 BURY NEW ROAD, MANCHESTER M8 8FW
TEL: 061-834 9571 TELEX 665446 Sharma G FAX 061 835 3679

SHARMAN'S WHOLESALE

SHARMAN'S WHOLESALE

**Dial-a-Match
540 48"**

**Dial-a-Match
530 24"**

Half Breed

**Dominator
D2505
base loaded
open coil**

NEW



NEW

**Dial-a-Match
530C
cellular
look alike**

**Dominator
D2500
centre loaded**

NEW

NEW

**Dial-a-Match
512 12"**

NEW

**Enterprise ET6
24" cellular
look alike
mag mount**

**Enterprise
ET7
24" cellular
look alike
mirror mount**

NEW

VALOR'S UK Distributor since 1981

All available at the best prices

SHARMAN'S WHOLESALE

These four useful assets to the CBER use empty 35mm film cannisters which most breakers are familiar with. Each unit uses easily obtainable components, and the total cost of all four will be under £5.00 so the finances shouldn't be over-stretched.

Dummy Load

This uses 2 watt resistors, (not wire-wound as these can create problems by acting as inductances and varying impedance of the load). The drawing will give an idea as to the placing of the resistors, and the method of connecting the short length of 50 ohm coax to load. This unit has taken loads in excess of its wattage, up to 50 watts for *short periods* while checking out power on amplifiers, but it would normally be used on CB at an average of 15 watts. This can be exceeded if a longer coax is fitted and the resistors are immersed in a jar of engine oil, as this greatly reduces the heat factor. The value of the paralleled resistors is derived by the following "formula":

$$\frac{390}{55.7 \times 560} = 55.7.$$

$$\frac{7}{55.7 + 560} = \frac{31192}{615.7} = 50.66 \text{ ohms,}$$

near enough for the 50 ohms impedance required.

TVI Filter

Many of these have been made over the years and are quite effective in helping to clear TVI. It is a high-pass unit, which plugs into the TV between the antenna and the set. Neither the capacitors nor the wire gauge is critical, but the sizes shown have proved quite effective. The insertion loss is low so it should not degrade the picture, except for very weak areas. This is not a "cure-all TVI problems" filter but it has completely eliminated interference in some cases, and reduced it considerably in others. If the signal strength for TV is strong in your area, it is possible to use two boards in series to possibly reduce the TVI further. The wire for the coils can often be removed from an old output transformer or coil taken from an old radio etc.

Microphone Adaptor

This is a useful unit in that it enables a Cybernet mike to be used in a Uniden rig, or a Uniden mike in a Cybernet rig. This helps when either a mike or an

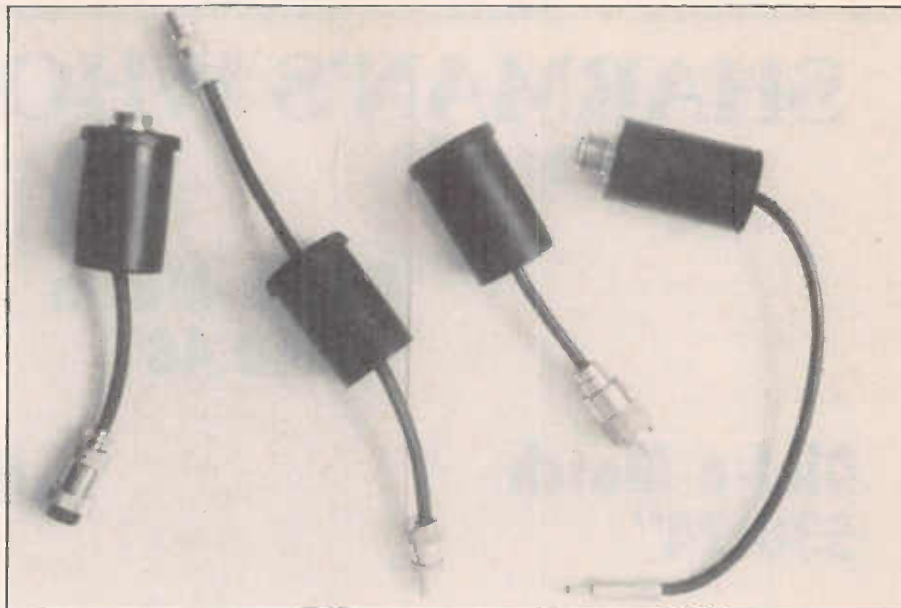

echo unit or processor etc is to be tried out on another set, when normally it would entail changing the connector. As the majority of rigs are either Cybernet or Uniden, it will cover a large number of rigs most commonly used.

Hand-held Antenna Adaptor

This unit is not in the photograph as it was an afterthought, but as I have found that it is useful, I have included it for the following reason. I have a Harvard 410 handheld and, as I sometimes use it on the main antenna, I purchased one of the commercial adaptors which was a single unit in that the rig plug and the antenna socket was a solid unit. As the writer uses RG8 heavy duty cable, this made it awkward to use the handheld, as the cable kept pulling the set about, and it was also heavy to hold when talking into the built-in microphone.

I used a cannister and fitted an SO239 threaded socket which requires a hole the same diameter as the 4-pin chassis plug as used on the microphone adaptor. A length of 50 ohm coax and the necessary plug to suit the hand held socket, plus the usual film cassette

case, complete the 'bits & pieces' required, and its construction is basically as for the adaptor previously mentioned. This enables the rig to be moved around without any hassle.

I hope that at least one of these units will be useful to you, and the following are some construction details to help you along.

Dummy Load Construction

The resistors as shown in the photo are some of the older type, and are physically larger than their modern counterparts, but if the larger sizes are available then I suggest that you use these. However, if only the modern '2-watters' are available, then you have the opportunity to increase the wattage, as you can use 11 at 560 ohms which will give you around 51 ohms at 22 watts. Also you will find that you have more room in the case to manipulate the resistors, but the following advice holds for whatever size you use.

First put the resistors together in a bunch to make sure that they will fit into the cannister, and then fold the wires of each individual resistor at right angles to

Film Fun

**Ever wondered what to do with those old film cannisters?
Vic Brown has four suggestions for a start**

the body as shown on the diagram, but leaving one register out to fit into the centre. Bunch the resistors in a circle around the centre one, with the wires facing the centre and twist all the wires together and solder them, cutting off the surplus after you are sure that you have all the wires firmly soldered. Cut off the surplus wire, leaving just sufficient to make connection to the coax cable, and make sure again that the resistors will fit into the case. Do the same to the other end of the resistors, again leaving sufficient for connection. Take 150mm of 50 ohm coax cable and strip off 50mm of outer covering, and peel out the braid leaving the centre and the braid as two separate wires. Push the inner wire through the centre of the resistors until the braid at the other end touches the connection and cut the braid and solder it to the connection it is resting on.

Trim the top wire to a suitable length and strip off a small amount of insulation and solder to the other connection. Take the cannister and make a hole in the centre of the base to enable the coax to be pushed through fairly tightly, and feed the cable through and push the resistor bank into the case while pulling the slack through. Clip the lid on, and then strip the other end of the cable and fit to the PL529, thus completing the project. It is possible to test the dummy load by replacing your antenna connection with the DL and you should get a reading through your SWR meter of almost 1 to 1, but this will only be apparent if your SWR meter is a good quality unit, as the majority of meters use a pcb for the wiring, and are useless as a reliable means of testing.

To prove this point, if yours is a unit without a matcher or any other additions, then use the meter as stated with the DL and take a reading and then reverse the rig connection with the DL and again take a reading with the forward and reverse readings on the switch being reversed. (ie for forward read ref and for ref read forward, and the reading should, in both instances, be 1 to 1, or at least the same either way round). If not, don't rely on its readings, they are probably incorrect.

TVI Filter Construction

A small piece of verboard .15 matrix is needed, 25mm x 12mm, with the tracks running across the 12mm width, this giving around six tracks. Obtain a short length of 26 swg enamelled wire and make two small coils of four turns each 6mm inside diameter by winding them on a 6mm drill, leaving 3mm at right-angles as shown in diagram.

One coil is soldered between strips 2 & 5, the other between 3 & 4 on opposite edges of the board, on the copper track side. On the plain side, take one capacitor and thread the wires through the holes of one of the coils so that the

capacitor & coil are wired in parallel, and repeat this with the other coil/capacitor. Still on the plain side, take the 1 meg resistor and push through holes 2 & 5 and solder it.

Now take two pieces of TV coax around 125mm each and strip one end of each as shown. Solder the braid of one piece to track 5 on the track side, with the inner soldered to track 4, and the other piece the braid to track 2, and the inner to track 3.

Now make a hole in the centre of the cannister base, just sufficient to accept the coax, and do the same by making a

similar hole in the lid. Thread one cable through the lid outwards, and the other lead through the base outwards.

Fit a coax plug on either end of the cable (the filter is reversible) and a coax line socket onto the other lead. The filter should now be pushed into the case the lid fitted.

This completes the filter.

Microphone Adaptor Construction

Firstly fit the 4-pin chassis mounting plug into the lid of the cannister by

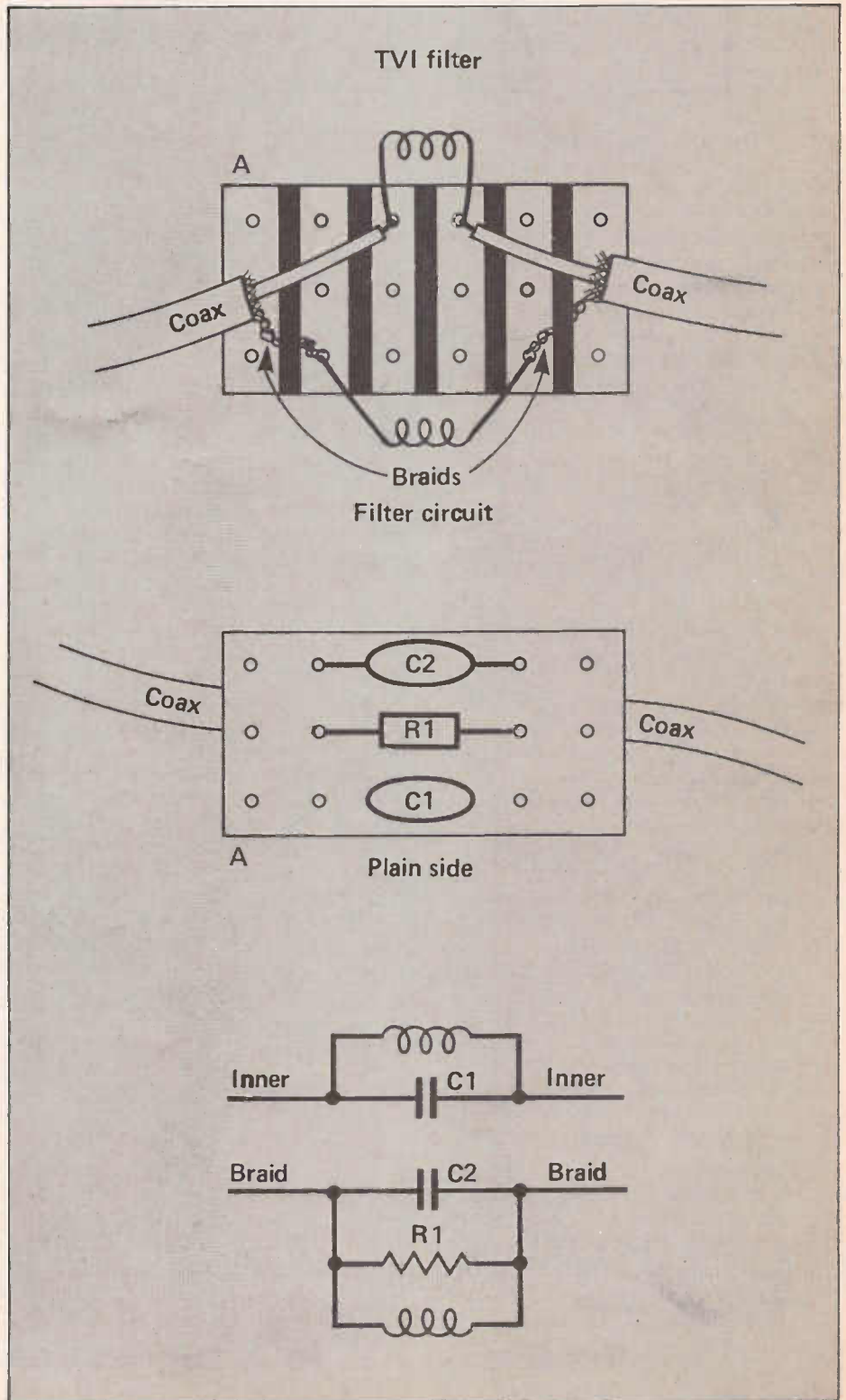

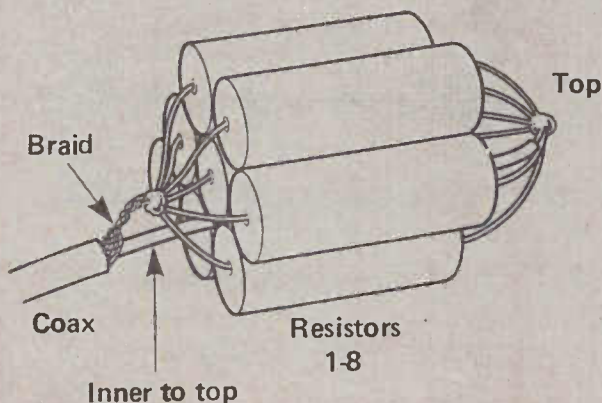
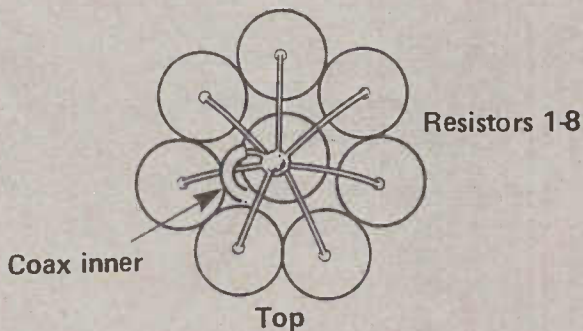
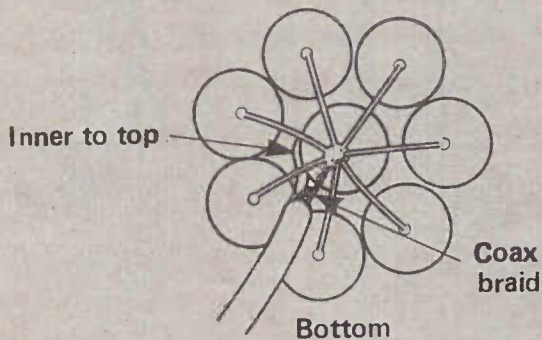
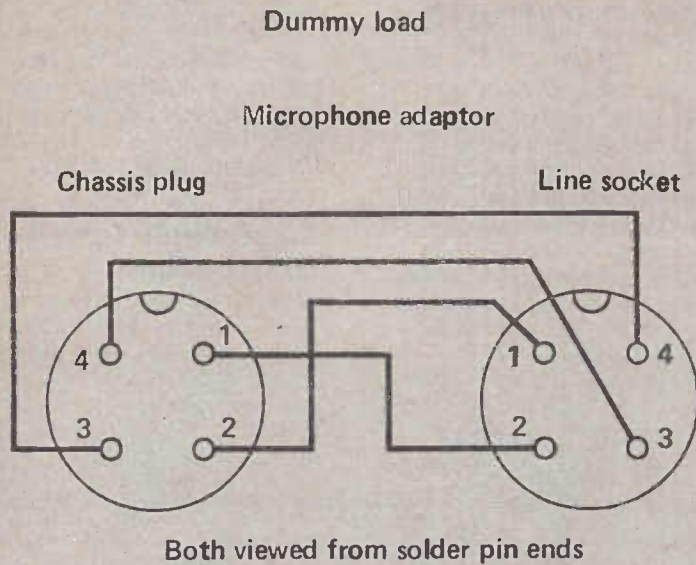

cutting out a suitable hole with a modelling or Stanley knife. The plastic is easily cut so try to make the plug a snug fit. When completed, fit the plug from the outside and then put the locking washer and the nut on the inside and tighten the nut firmly.

Make a hole centrally in the base of the cannister so that the 4-core cable you use fits tightly to act as a cord grip, and feed one end of about 400mm of either 4-core cable (screened cable is not necessary and two pieces of twin flex can be used) and pull sufficient through to enable you to solder to the plug comfortably. It does not matter what colour goes to what as the important thing is to use the numbers on both plug and line socket to get the wiring correct. Wire up the plug and socket as per diagram, and then ease the lid on to the cannister and snap it on.

This completes the adaptor.

Base Antenna Adaptor Construction

This is straightforward and basically consists of fitting the socket to the case as for the mike adaptor, soldering the coax to the centre connection and the braid to the large solder tag under the nut, and fitting the correct plug to the other end after passing the cable through a hole in the base of the cannister.

Components

Dummy Load

- 1 piece of 50 ohm coax.
- 1 PL529 plug.
- 7 390 ohm 2 watt resistors.
- 1 560 ohm 2 watt resistor.
- 1 film cassette case.

TVI filter

- 1 piece v/board .15 matrix 6 strip x 12mm.
- 2 5.6pf disc or similar capacitors. (C1-C2).
- 1 1 meg ¼ watt resistor. (R1).
- 1 length of 26 swg enamelled wire.
- 250mm of TV cable (coax).
- 1 standard coax plug.
- 1 coax line socket.
- 1 film cassette case.

Microphone Adaptor

- 1 4 pin chassis mounting plug.
- 1 pin line socket cable entry.
- 150mm of 4 core cable (see text).
- 1 film cassette case.

Base Antenna Adaptor

- 1 SO 239 threaded socket.
- 1 metre 50 ohm RG 58 or similar.
- 1 film cassette case.
- 1 plug to suit hand held rig.

All components are available from the usual stockists and are standard stock.

**Pama
& Co****FOR****WHOLESALE ONLY****Pama
& Co**

THE PAMA SALES TEAM



IGAL



EDI

**NEW
FREEFONE
ORDER LINE
FOR
ORDERS
ONLY****FREEFONE
(0800)
262963**

JACK



LEN

DO THE PRODUCTS YOU STOCK SELL FAST?

Pama's Do!

Pama realise that being a C.B. retailer is not easy, we understand your problems and how important it is that you have the products that sell on your shelves fast, thats why Pama's is probably the biggest independent C.B. wholesaler in the country.

10 GOOD REASONS FOR CALLING Pama

- ★ EXTENSIVE STOCK RANGES
- ★ DISTRIBUTOR OF ALL LEADING BRANDS
- ★ ALL ORDERS DESPATCHED WITHIN 1 HOUR OF PLACEMENT
- ★ HIGHLY COMPETITIVE PRICES
- ★ FULL SERVICE AND SALES BACK-UP
- ★ FRIENDLY - PROFESSIONAL SALES TEAM
- ★ THE FASTEST DELIVERY IN THE U.K.
- ★ EVERYTHING FROM A - Z IN C.B. IN ONE PLACE
- ★ DELIVERY EVERYWHERE NATIONWIDE & EUROPE
- ★ TRADE-ONLY, OPEN 7 DAYS A WEEK.

To set up an account with Pama is easy, just pick up the phone and call one of the sales team **ON THE HOTLINE (061-446 2437) 3 LINES AVAILABLE** and they will be pleased to answer all your questions and send any information, you require.

***WE ARE CELEBRATING 10 YEARS OF PAMA
SO THERE ARE MANY CELEBRATORY OFFERS***

**PAMA HOUSE, 433 WILMSLOW ROAD,
WITHINGTON, MANCHESTER M20 9AF.**

**Pama
& Co****TEL:** 061-445 8918
061-434 5701
061-446 2437
Telex 666762 PAMA CO G
Fax 061 445 0978**Pama
& Co**

THE BROADCAST MUSEUM

A radio celebration in the Windy City

Despite the plan to transform Britain into a national museum of industry and disappearing crafts, so far there has been remarkably little thrust towards creating showplaces of radio and communication history. In the USA in contrast, the colourful era of early radio broadcasting is being re-lived in a number of museums and exhibitions, a recent addition being The Museum of Broadcast Communications in Chicago, assembled in new offices close to The Loop (at 800 S Wells Street) last year (1987). As is usually the way in such cheerful enterprises, radio industry professionals, business companies and radio communication enthusiasts are pitching in with help, ideas, equipment, financial help and so on. It is, to say the least, good reason for any radio-minded Brit to save up for a fast trip to America's second city.



Media

Chicago's Museum of Broadcast Communications covers a wide media

field, including radio, television, audio and video recording. Of course, the city, whilst owning a prohibition, crook-chasing image, was much involved in radio and television output. Studs Terkel, a present day social historian, developed vox populi radio reporting for his excellent work – almost as well known in Britain as the USA Chicago was, and remains, something of a pace-setter in base-to-mobile police communication, its Radio Control Centre being the subject of admiring radio magazine coverage in Britain during the early 1930s. Contemporary press coverage refers to the loudspeakers mounted in the roof of police cars, an American formula for migraine one might think – the radio cops were said to leap from their saloons, guns blazing. They were perhaps auditioning for a part in a Warner Brothers picture! By the mid 1980s, Chicago's police communications centre – opened in 1961 – was reckoned to be 'second to none,' with around 50 satellite receiver stations, two dozen base stations and some 150 long distance telephone lines. Some 50 UHF and VHF frequencies were used, with ten 'new' frequencies on 800MHz. Computer directed frequency use is taken for granted in such a facility. Radio veterans will reflect that Chicago always had a distinct radio flair: its short wave station, W9Xf, operating on 49.18 meters, using 10 kilowatts, was considered a favourite catchphrase by British amateurs in the 1930s.

Among those especially credited with the creation of The Museum of Broadcast Communications, Bruce DuMont gained some inspiration by a visit to The Museum of Broadcasting in New York, which is especially concerned with the care of video history and broadcasting archives. However, the New York Museum had been facilitated by the generosity of William S Paley, who aided its launch with \$1.5 million. It seemed unlikely that a similar financial endowment would be available for a similar venture in Chicago. Yet, Bruce DuMont felt impelled to help Chicago move towards such a facility: he was, in any case, aware of the importance of maintaining a library of broadcast and video history material (a sentiment not always shared in the fast-moving and highly competitive electronics and broadcasting industries).

Especially involved in presenting political analysis programming, and producer of 'The Lee Phillip Show' on Channel 2 of the Chicago TV station WBBM-TV, during the late 1970s, Bruce DuMont knew that valuable if almost forgotten documentary/reportage material was stored in the WBBM-TV library. But even with a well-managed and enlightened station, history if not exactly 'bunk' is hardly likely to be seen as good for the balance sheet. It was whilst musing on the archive issue, that

Bruce DuMont visited New York's Museum of Broadcasting. As they say in all the best novels, all the rest is history – kept in airtight cans and nicely labelled.



Founder

The story of this hard working broadcaster and his campaign on behalf of broadcasting history could itself make a stirring TV or radio programme. In August 1987 press coverage of the Museum's opening, 'This Week' recalled that Bruce DuMont's uncle, Allen B DuMont, was founder of the DuMont Television network (1947 to 1956) and that Bruce DuMont was therefore born 'with the broadcast bug in his veins, and he eats, lives and breathes the business.' A board member of the local branch of the National Academy of Television Arts and Sciences, Bruce DuMont presented his proposal for a Chicago-based broadcasting museum at a meeting in 1982. His fellow members were interested, even sympathetic but were unstandably uncertain as to the next steps to take (this sort of thing happens to the best committees!) However, the wise fellows decided to give Bruce DuMont initial expenses of \$250, and proposed that he become a sort of one-man research team and commission of enquiry.

Given the clutter that accumulates in any radio shack (all too often, erroneously described as 'junk' by spouses obsessed by spring cleaning and salvage drives) it might be assumed that media coverage would at once provoke interest and support. A major – perhaps the priority – problem was that of securing a site. Some broadcasting museums in the USA have been initiated as sub-sections of more generalised industrial and/or community-based museums, which (notwithstanding Britain's Museum of Film and Photography at Bradford and London's Museum of the Moving Image) would seem the most likely move forward in Britain. Bruce DuMont at last seemingly secured his first objective in 1983 by persuading city officials to allocate a display and storage area in a new public library on South State Street – a transformation job on a well-known



Robert De Niro as Al Capone in "The Untouchables."

city hall policy, partly to do with re-elections to the library board and, in all probability, obsessions arising from a plan to organise a new World's Fair in Chicago. All this was rather like a radio ham trying to get local planning permission to raise a radio antenna, and being told he really ought to be re-building The Crystal Palace.



Support

Meanwhile, in a painstaking though personal publicity avoiding manner, Bruce DuMont continued to build local interest and support beyond the vague and possibly noisy expression of good wishes. In one sense, there was a 'working against the clock element,' as rapid changes overtook the broadcasting media. During 1983, too, Fahey Flynn – a well known Chicago

“... like a radio ham trying to get local planning permission to raise a radio antenna”

department store. However, these high hopes were modified by a turn around in

broadcaster – died, reminding Museum supporters that a well managed archive



along could secure the work of a disappearing generation of radio pioneers. Honouring Fahey Flynn's work, and that of an ABC News anchor-man, Frank Reynolds, who had died earlier that year, WLS-TV donated \$5,000 to the Museum fund, as did local publisher, Rance Crain.

Money in useful rather than large sums continued to arrive, some of this initial financing being assigned to basic market research – that is, to gain further insight into likely public use, preferred interests and required services. Still avoiding the civic brouhaha on a world's

brother, television(!) have wide popular appeal in terms of development and early history.



Attraction

The Museum opened on June 13th 1987 (prior to that, some 500 people had signed up as members). A major

“... a mouth-watering example of what might be done here in Britain”

fair (which did not materialise) the Museum's board of directors in 1984 secured the services of Arthur C Nielsen Jr as chairman, a most fortunate choice. Mr Nielsen, former chief executive and chairman of the Nielsen market research organisation, has been a generous and wise advocate for the cause. At last, the *firm* promise of accommodation came following a September 1985 celebration at the Chicago studios of WBBM-TV. This celebrated the 25th anniversary of the televised debates between John F Kennedy and Richard M Nixon, held at Chicago when both men were US Presidential candidates, whilst a gala event celebrated the work of well-known broadcasters who began and/or developed their careers in Chicago. Total sum raised was around \$150,000, permitting the embryonic Museum to take an option for a fourteen thousand square feet area at the River City development at 700 S Wells Street.

Now, really substantial gifts began to arrive, including \$400,000 from Kraft Foods Inc; \$200,000 from the MacArthur Foundation; \$130,000 from Arthur Nielsen (personal gift); \$100,000 from Paul Harvey; \$75,000 from The Chicago Community Trust. Corporations linked with radio-related business in the Chicago area, also support the venture, these including Zenith Electronics and the A C Nielsen Company.

The Museum's annual budget, as a non profit making facility is around half a million dollars, about a third of this coming from admission fees, which are modest (\$3 adults; \$2 students; \$1 senior citizens and children). An initial projection of Museum attendance made in 1987 was some 35,000 per year, modest indeed compared to the four million visitors who every year 'oh and ah' at Chicago's celebrated Museum of Science and Industry. However, radio veterans will probably think this a considerable under-estimate, for even in these days of computer screens and video razzamatazz, radio and its lesser

attraction is the A C Nielsen Research Centre, a library containing a vast resource of radio and television programme tapes. Visitors can listen to radio, or look at and listen to vintage programmes on request in special booths, reminiscent of the listening booths found in up-market record shops a few decades ago. Kraft Foods Inc, a company which has been especially generous to the Museum, has donated tapes from its network programmes, including the Kraft Television Theatre, Kraft Mystery Theatre, Kraft Suspense Theatre. Incidentally, the Kraft Music Hall, a 60-minute radio programme launched on NBC radio in 1934, was later moved to television format. Among its many stars, Penny Singleton – the hard-pressed housewife, 'Blondie' of the popular 'Blondie and Dagwood' movies – made her radio debut on the programme in 1937.

The Kraft Show on Radio Luxembourg during the late 1930s, had a similar format, and included Billy Cotton and his Band (the band leader also being known as a racing car driver). Incidentally, Kraft donated a 99-seat theatre to the Museum, for special exhibitions, events and presentations. A working radio station has been donated by the local station, WGN, and there are plans to encourage educational parties, etc to develop their own programme making



skills. Roy Leonard, staff member of WGN, hosted a broadcast from the Museum studio on its opening day. Chuck Schaden, who gave his personal collection of 45,000 hours of 'golden oldie' radio shows to the Museum, has broadcast his 8pm to 10pm weekend record-and-recollections programme from the Museum.



Phenomenon

Another broadcaster who has given welcome and enthusiastic support to the venture is Ed Herlihy, well known in the world of American broadcasting as host of the Kraft Suspense Theatre.

Interviewed by 'The Chicago Sun-Times' (June 12th 1987) Ed Herlihy noted a phenomenon certainly true of the USA and in my view, increasingly in Britain, namely a growing interest on the part of young people in the early days of the electronic media. The period displays, showing the evolution of broadcasting and receiver design, etc - a popular feature of museums of this kind in the USA - are a mouth-watering example of what might be done here in Britain, given similar flair to that bouncing

around in Chicago.

Although the Museum has a limited budget - and space - it is already seen as a valuable 'school for broadcasting.' Bruce DuMont, more recently political correspondent for WTTW-TV Channel 11, and a host of a radio programme, 'Inside Politics' on WBEZ-FM, plans to develop Museum events saluting achievements in broadcasting, ie by personalities and organisations. Advertising men - of which fraternity I was a member in an affluent long ago - are also recommended to 'hot foot' it to Chicago. The Museum has a large collection of commercials, TV and radio. Amateur radio has at this stage only modest attention, though it should be remembered that radio broadcasting in the USA was originated by the hams. As the Museum develops, it will provide increasing reasons for radio minded people to pop over to Chicago.

Attempting to cover all that's afoot in the Chicago Museum of Broadcast Communications is a bit like trying to make a satellite dish out of plasticine. I hope I've shown the value of perseverance, as Horatio Alger would have said, had he thought of opening a similar centre of honest virtue. Horatio Alger wrote about many American heroes, but like they say in Chicago, if you want to know what stickability really means, try launching a Museum of Broadcast Communication.

DON'T MISS OUT!

Fill in your name and address and give this form to your newsagent.

Please order me a copy of *CITIZENS' BAND* and reserve/deliver me a copy every month.

NAME

ADDRESS

.....

.....

.....

Newsagent:

This magazine is made available to your wholesaler through:-

S.M. Distribution Ltd
6 Leigham Court Road
Streatham
LONDON
SW6 2PG

Tel. No: 01 677 8111

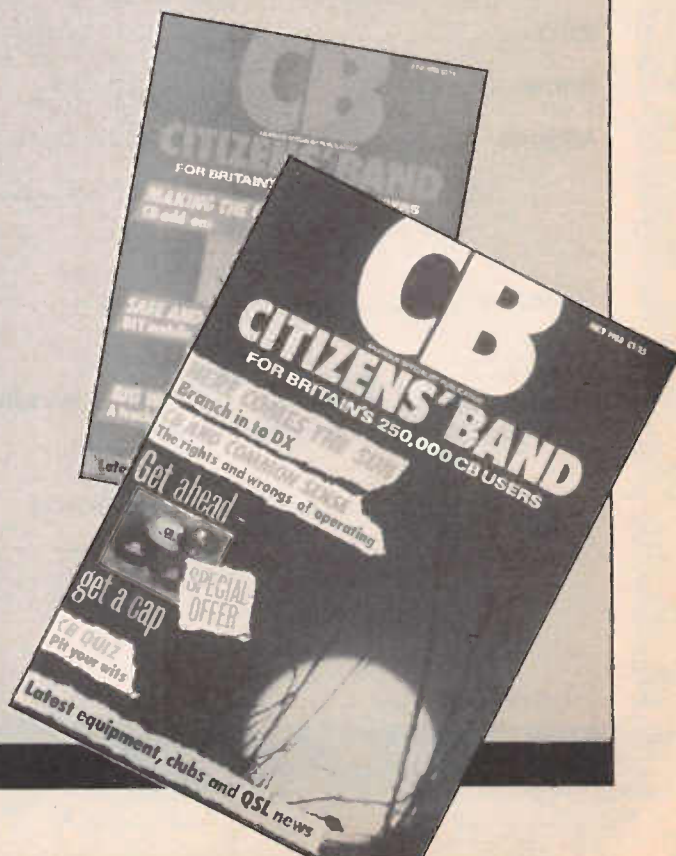

PLEASE ALLOW 28 DAYS FOR DELIVERY
 Back numbers of *Citizens' Band* are available for the last 12 months only. Each magazine will cost £1.90 including postage. Past features have included:

- October 1987:**
Zodiac CEPT sets; Taxis and CB; Starline Voice Controller
- November 1987:**
QSL Guide; DIY signal injector; Great Radio Firsts
- December 1987:**
DNT CEPT sets; DIY signal tracer
- January 1988:**
BCB in Scotland; MSGB monitors; Akigawa FS117d review
- February 1988:**
Satcom 40F review; DIY voltage dropper
- March 1988:**
CB in Ireland; FM in Depth; Roger Bleeps
- April 1988:**
DIY alarm system; CB in Norway
- May 1988:**
DIY Base Mike; Mike Fright
- June 1988:**
CB accessories; DIY mobile mike; Truckers' guide
- July 1988:**
DX for beginners; CB common sense
- August 1988:**
Team CEPT reviewed; Community radio
- September 1988:**
Bleedover Cures; DIY DX compressor
- October 1988:**
Mike connections; Introduction to QSLing

Readers SERVICES



Cut out and send to:
 Citizens' Band,
 Infonet Ltd,
 5 River Park Estate,
 Berkhamsted,
 Herts HP4 1HL
 Tel: (0442) 876661/4



Please commence my annual subscription to *Citizens' Band* with the issue. I enclose a cheque/postal order for £..... made payable to 'ASP Ltd' or debit from my Barclaycard/Access No

valid to

Name

Address

Signature

UK £16.80 Far East £22.35
 Europe £20.70 Rest of the World £21.10 or USA \$36.00
 Middle East £20.85 Airmail rates on request.

Please send the following back issues of *Citizens' Band* at £1.90 per copy

.....

Total cost of order £.....

CB1

Write with cheque or PO to:
 ASP Readers Services Dept.
 PO Box 35,
 Wolsey House,
 Wolsey Road,
 Hemel Hempstead,
 Herts HP2 4SS.



Please send... *Citizens' Band* binders at £5.95 each.

Delete as appropriate:
 I enclose cheque/postal order/money order for the above amount payable to '*Citizens' Band*'. Please debit my Access/Visa account number:

Signature

Name

Address

.....



Corley - well in control

I have been a monitor of channel 19 since Day One when FM rigs went legal - years of giving road reports, weather conditions, directions and any other help possible. I cover one of the busiest stretches of motorway around Coventry which includes the M6, M69 and M42 as well as several A-roads in the area. My base station is about half a mile from Corley services on the M6 and I am usually known as *Corley Control* or *Lady Linda*.

I get most of my information from truckers who are always willing to give you an update on their 'backdoor.' Information on roadworks are sent to me every week and I also have a good liaison with local police and Warwickshire Police Headquarters at Leek Wooton.

I find that most 10-33's that happen on the roads come over on channel 19 and I can then take the breaker to channel 9 (that's if it's clean of wallies!) and phone the message straight to the motorway control room at Leek Wooton who, in turn, can almost immediately send out the emergency services

required and put speed limit lights flashing to slow down oncoming traffic. If possible, I also try to get in touch

with Orange Control, who can help by warning drivers of what's up ahead and any possible diversions they could take.

For some truckers, an early warning can save hours of sitting in square-wheeled traffic and if they are on route insurance means that they can stop at the nearest services, 'phone their company and get permission to leave the stipulated route.

There are many different types of hazards to deal with, some funny, some serious and others just as plain stupidity on the part of various individuals. I have witnessed people trying to cross six lanes of motorway just to take a short cut, children riding bicycles on the motorway or throwing stones off the bridges at passing vehicles. Please, mums and dads reading this, I know when there have been times when we have said "Oh, why don't you go play on the motorway?" Yes, it may sound funny but for a few parents, it has had tragic results.

One real emergency came over on channel 19 one afternoon. A trucker had split his trousers while loading at the local pit which is only about 200 yards away from my home. It was no sooner mentioned when I sent a needle and thread up to him and no doubt saved a few embarrassing moments.

Other hazards can be anything from a 'cat's-eye' which has come loose, spare wheels, chains, ropes, tarpaulins; in fact, just about anything that could come loose from a load.

Monitor of the Month

Lady Linda, from Corley, gives us an insight into the daily workings of a dedicated monitor

When weather conditions are very bad, I have been known to give up 18 hours a day to channel 19 because, in freezing conditions, it is absolutely vital that drivers are warned of roads blocked



Orange Control's headquarters

and told where the nearest truckstop or cafe is. During the blizzards last year, I was in touch with the two local

truckstops who let me know if there was still room and also that they would provide meals after normal hours. I was able to phone various wives etc and put their minds at rest and also call out garages to defrost frozen brake pipes and replace waxed-up filters.

Although I have had offers of money for phone calls, in addition to the help I have given, I make a point of not giving my address out and normally just say that to be thanked is quite enough. I don't do it for any gain, I do it simply to help.

When I wanted some help one day to start my diesel car, a trucker came round within 10 minutes to start it. When I was on Corley Services last year for the Children in Need Appeal, hundreds of drivers who I have spoken with for years called in and made a donation and I was able to make a payment of over £600 to the Appeal – for that, incidentally, I should like to thank everyone concerned. I used the caravan that day and also used my 'wind-up'

handle, *Pink Suspenders*, to lure breakers but it backfired on me since they were not content with seeing the underwear on a hanger but I had to put them on and give them a flash! In fact, one driver called in three times and put money in the box each time for another 'flash!' I often wonder how he explained away his tachograph sheet for that day.

Over the years I have come to consider many of the breakers as friends even though we have never met and if I took up all the offers to go out for the night, I would be fully booked up to the year dot.

Many people ask me what equipment I use because I put out such a lovely clear signal. Well, it's a Cybernet Beta 3000 and an RA201 echo box with an Avanti Astroplane antenna.

The photos were taken on Corley Services when I did the Appeal by Charlie Kilo, a local breaker, and if the truckers who posed with me would like to contact me on channel 19, I have some spare copies for them.



Linda, hard at work

The winter snow was slowly melting in the gutters, and a ray of sunlight broke through an overcast sky. Inside the workshop Danny and Ritchie sat at their benches, each busy with a radio. The usual noises filled the room: the occasional clatter of a soldering iron being returned to its rest, a few hisses and crackles from radios on test, and odd grunts of satisfaction from the pair as they homed-in on the faults.

Suddenly there came an exasperated groan from the general direction of Ritchie's bench. Danny was lost in his own world of non-functioning transmit mixer stages – the fault on the radio currently open on his testbench.

"Hey, Danny!" No reply. "Danny!" Still no reply. "DANNY!" bellowed Ritchie, so loud that Danny nearly fell off his chair.

"Hey, I'm not deaf you know!" he replied, somewhat shaken.

"Oh yeah? Could've fooled me!"

"Sorry, Ritchie. Once I get stuck in a repair job I sometimes tend to switch off everything around me. Kinda like I'm one one frequency and you're on another! What's the problem?"

"This radio; it's weird," replied Ritchie, indicating the little Uniden transceiver in front of him. "It seems to be working on the wrong frequencies."

"Show me," said Danny, sliding his chair over to Ritchie's bench.

"I have a frequency meter on the transmitter output, coupled through the low-level sampler," Ritchie told his friend, "and it seems to be showing the correct values."

He picked-up the microphone and held the PTT bar firmly in. The display on the counter flickered for a second or two, and then settled at 26.964950MHz. Danny glanced at the channel selector on the radio, noticing that it was set to channel 1.

"Well, there's nothing wrong there," he agreed. "The exact frequency should be 26.965, but that figure's well within the limits."

"Now get this," said Ritchie, releasing the microphone switch and changing a few connections to the test equipment. "I have the signal generator set on 26.965, but there's nothing coming through on the receiver."

"So how do you figure the thing's on the wrong frequency? Maybe the receiver's just gone faulty."

"Ah, but watch this!" Ritchie slowly tuned the generator output upward to around 27.4MHz. The S-meter on the radio started to swing across to full scale, and the continuous note from the modulated generator signal became audible. Ritchie reduced the output of the generator and zeroed-in on the receiver. Danny looked carefully at the generator's frequency readout, which indicated 27.420MHz. A look of slight concentration passed over his face as he performed some quick mental arithmetic.

"Hmmm," he said quietly to himself, thinking over the possibilities. "Have you tried the set on different channels?"

"Yep. It's the same each time: fine on transmit, but too high on receive."

"Give it a try on channel 40," ordered Danny, with all the authority of an army sergeant. There was a few moments of quiet as Ritchie found the radio to be correctly transmitting, but once again receiving on too high a frequency. Danny examined the generator readout; it was a shade under 27.86MHz. Again Danny did some quick arithmetic. Ritchie was now becoming eager as to what Danny was running through his mind.

"You look as if you've solved the problem already," said Ritchie, observing the smile on Danny's face.

"Possibly," came the reply. "Have you got the service manual out yet?"

Ritchie passed it over to Danny who turned straight to the schematic diagram.

"This is the part we're interested in,"

Danny stated. He indicated an area of the diagram to his assistant (fig 1). "Just to see if my idea is correct, take your voltmeter and clip it between ground and pin 8 of that PLL IC." Ritchie pulled his testmeter toward him, adjusted the range switches and clipped the test prods to the appropriate places on the circuit board. The needle swung across the scale to almost nine volts. Danny, seeing this, gave a satisfied smile. He thought again for a moment, and examined the schematic lying in front of him. A trace of concern passed over his face.

"What are we doing Danny?" inquired Ritchie, waiting anxiously for the next move.

"We're looking at the transmit/receive switching pin," replied Danny, still looking at the open book on his lap. "Try keying the mike and keep an eye on that meter." Ritchie did so, noting that the meter showed exactly the same reading as before. "Interesting . . ." responded Danny, his voice trailing off as he once more considered the symptoms carefully.

"What exactly are we looking for?" asked Ritchie. "I'm getting a little lost here!" Danny paused for a moment, then looked up.

"What's the first IF in this radio?" he asked in return.

"10.695," replied his assistant.

"Right. And during reception what frequency does the VCO run at?"

"Well, somewhere around 16MHz."

"Correct. To be exact, it's 10.695MHz below the frequency we want. Now what happens when we switch the set to transmit?" Ritchie thought for a few seconds before replying.

"Am I right in assuming that this radio uses the 10.240 reference oscillator to mix with the VCO to get the final output?"

"You are."

"So the transmit/receive pin shifts the VCO up by 455kHz to make up for the difference!" he said, pleased.

"You got it. So what would happen if there's no signal on transmit to shift the

Danny and Ritchie tackle the usual problem of an 'expanded' rig

CB BENCH

PLL up by 455kHz?"

"The radio would transmit 455kHz below the required frequency. Hold on though! This thing's working on transmit; it's receive that's wrong!"

"Okay, so what would happen if the signal is somehow stuck on transmit all the time?" Ritchie thought hard for a moment.

"Ah! The receiver would run 455kHz too high."

"That's it. Those figures we got earlier from the generator are all 455kHz higher than they should be. That's why I wanted you to look at pin 8 to see what voltages were there on receive and transmit - it's the switching pin."

At that moment the telephone on the far end of the bench rang. Ritchie turned around quickly to answer it, not realizing he had managed to wrap a couple of test leads around his arm. As he turned away, the transceiver was pulled up on end, catching several of the switches on the front panel. Ritchie turned back, and untangled himself while Danny walked behind him to get the phone.

A couple of minutes later, the call having been dealt with, the pair returned to the radio on Ritchie's bench.

"Right, where were we?" asked Danny.

"455kHz higher than we should be," replied Ritchie, grinning.

"Oh, yeah. If you went right around the band you'd find all 40 channels perfectly all right on transmit, but all 455kHz high on receive, because of the high input to pin 8 all the time."

As Danny talked, Ritchie casually tuned the generator around the CB band, observing the radio. He gave a puzzled look, first at the transceiver, then at the generator, and finally at Danny.

"Whatever's wrong Ritchie?"

"This set's what's wrong - look!"

Danny peered over his assistant's shoulder to see the generator set at 26.965MHz, and the radio switched to channel 1 happily receiving the signal as it should.

"Now isn't that interesting?" said Danny, with an air of a detective uncovering an important lead in a case. "Try switching over to transmit."

Ritchie pulled the microphone toward him, and keyed it. The frequency meter on the output of the radio flickered to 26.50996MHz.

"Mmm, 26.51," mumbled Danny to himself. "By my reckoning that's 455kHz below channel one," he continued in a louder voice.

Ritchie nodded in agreement.

"See what voltages you've got on pin 8 now, Ritchie." Ritchie busied himself on the test prods once again.

"Zero on both receive and transmit," he finally announced. "What do you make of this Danny? I'm totally lost!"

"I must admit I'm having to think hard on this one," replied Danny. "It's normal to get a broken PC foil trace or an open

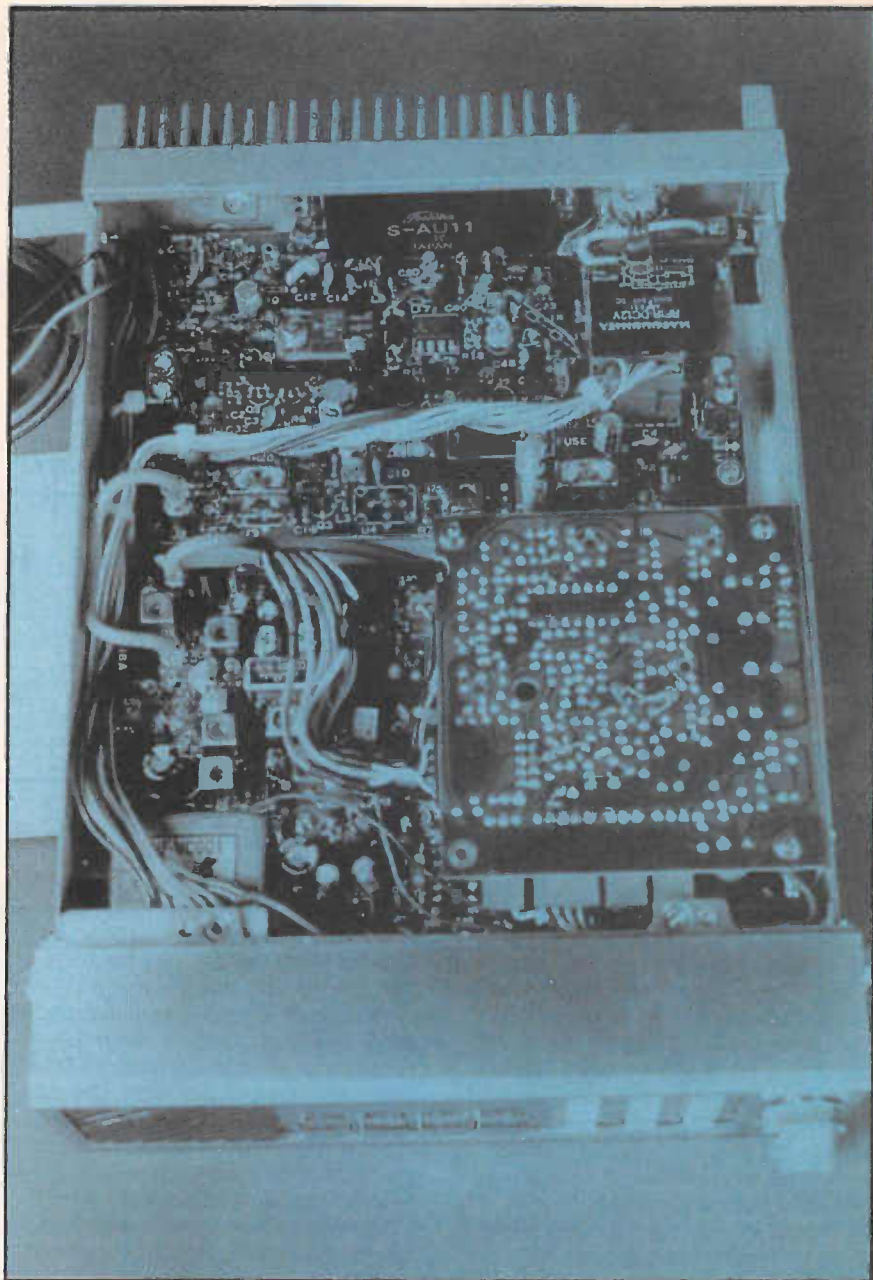

diode, or something like that. In those cases the set would stay in one condition or the other. Even with an intermittent, if it came back it would work properly, not go from one extreme to the other." He stopped and started at the schematic diagram yet again.

"Here, let me take a good look inside that set," he said finally.

Ritchie moved his chair over to enable Danny to move closer to the radio.

Danny carefully examined the interior wiring and then frowned. He traced a wire from the main board up to a front panel switch, and then looked at the panel marking for the switch: Tone. Holding the PTT bar of the microphone in, he flicked the tone switch. The frequency meter jumped to the correct reading. He returned the switch to its previous position, and once more the meter showed a signal 455kHz lower than it should have been. Smiling happily at having found the trouble, he

then quickly traced the remaining two wires from the switch. Sure enough, it was as he suspected.

"What's going on?" asked Ritchie. "How does the tone switch make the radio work on the wrong frequency?"

"Elementary, my dear Ritchie!" replied Danny, with an exaggerated English accent. "Someone has tried to expand the range of this radio to more than 40 channels and made a complete mess of it."

Ritchie looked a little puzzled, so Danny continued his explanation. "What's probably happened is that someone read or heard that you can sometimes use the transmit/receive switching pin to get an additional 40 channels. You see, on some radios the manufacturers used a PLL device having T/R switching like this one, but didn't actually connect the switching pin. They could use a separate 10.695MHz crystal oscillator on transmit, so the

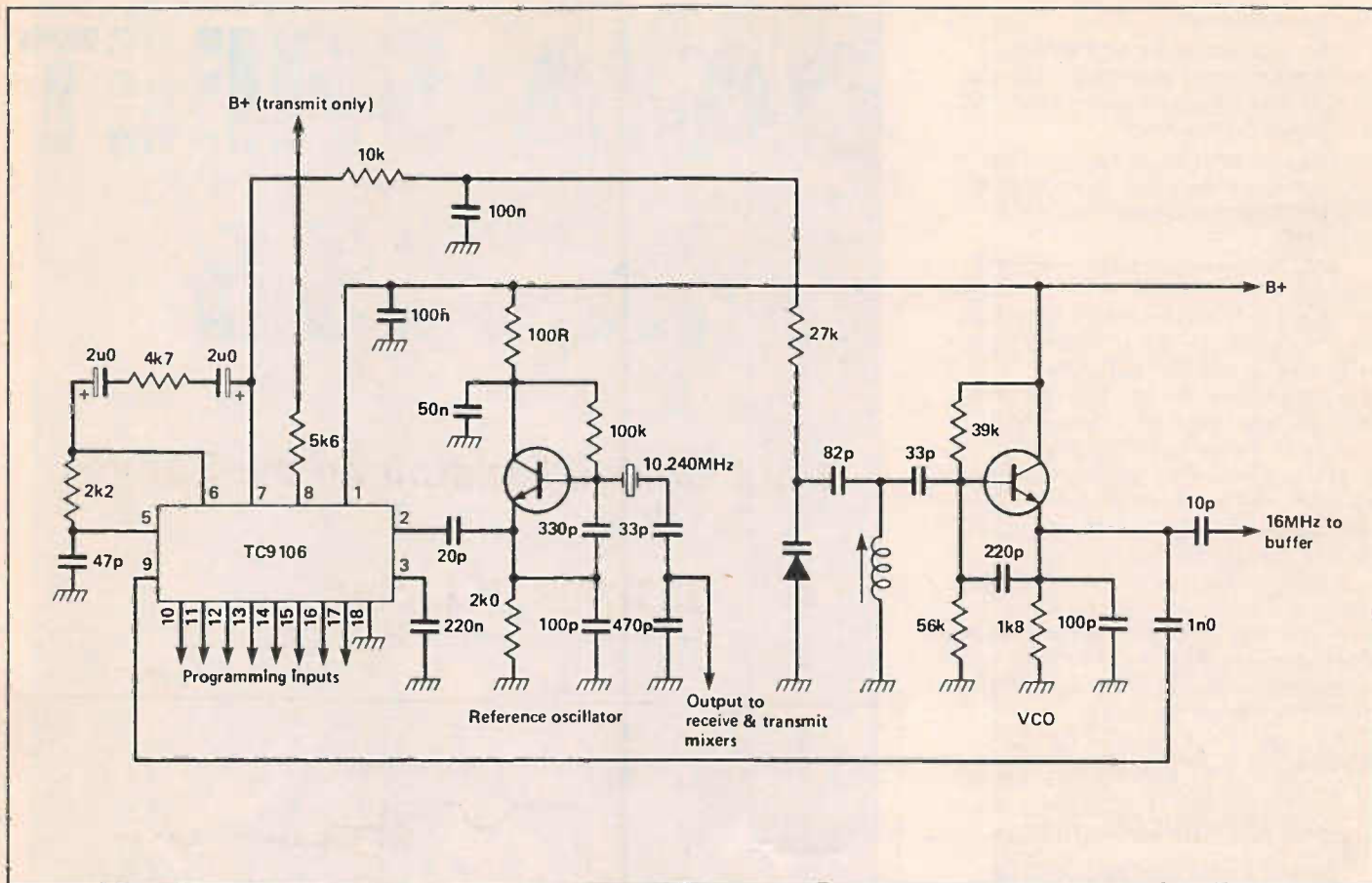

VCO would run at the same frequency during reception and transmission. The 455kHz shift wouldn't be needed."

"So on those sets," interrupted Ritchie, "you can switch that pin to shift the whole radio up or down by 455kHz."

"Correct. If you try to do it on a radio that uses the switching already though, you wind up receiving and transmitting on different frequencies. With the TC9106 in this chassis, the pin is taken high on transmit to shift upward by 455kHz."

"Let me see if I've got this right then," said Ritchie, a little cautiously. "If the pin is wired permanently high, the radio will function normally on transmit because the pin should be high anyway, yes?"

"Yes."

"But on receive, the set's running 455kHz higher than normal because of that pin not going low."

"Right so far."

"If the pin is wired permanently low then, the set receives on its regular channels okay, because the pin *should* be low, but on transmit the output is

455kHz lower than normal because of the lack of upshift."

"By jove Watson, I do believe you've got it!" retorted Danny, in his mock accent again. "In a way you get 80 extra channels. The only trouble is you can only transmit on the lower block and receive on the upper block. And as for the regular channels in the middle, well, you've seen what happens to them!"

"So you reckon someone's tried to modify the set and hashed it up?"

"I do. Can you get the bottom cover off and see where that orange wire goes? That's what's been added and wired to the tone switch. The red and black to the switch have been wired to the stabilised supply and ground. You'll find that the orange is connected to pin 8 on the 9106 underneath."

Ritchie quickly removed the four screws holding the cover in place. Sure enough, as Danny had predicted, the orange wire had been joined to pin 8 on the PLL device. The PC board trace leading away from the pin had also been cut.

"Aha! There's the problem. What you'll have to do is remove that extra wiring, then bridge the track to reconnect the transmit/receive pin to its proper point in the circuit. The soldering doesn't look too good there, which isn't surprising. If someone doesn't know enough to at least leave well alone when they don't understand, I suppose we can't really expect great soldering."

"Gee, thanks Danny. I'd never have thought that anyone would have done something as silly as that."

"Like they say, a little knowledge . . ." replied Danny as he pushed himself and his chair back to his own bench. The workshop returned to its previous state of silence as Ritchie repaired the 'expanded' radio, and Danny continued with the faulty mixer stage on his bench.

So ended another technical discussion in the workshop as the afternoon sun slowly started to disappear behind the office block opposite.

DATA SHEET

LC7136

Paul Coxwell examines the Sanyo

LC7136 PLL chip

The Sanyo LC7136/7137 PLL chip is a modern type, designed especially for the British "CB 27/81" channels, and found in a very large percentage of such British sets (eg Rotel, Maxcom, Amstrad etc). At first glance it appears very similar to the 7130/7131 device (see Data Sheet No 2), and indeed the pin connections are identical. The only difference between the chips as far as the IC manufacturers are concerned are the different N-codes in the ROM.

The VCO runs 10.695MHz below the required channel frequency during reception, and can directly feed the first mixer in the receiver, just as with the 7130 device. On switching to transmit however, the 7136/7 lowers the VCO to around 13/14MHz, ie half the desired channel carrier frequency. The VCO output then feeds a doubler stage in the transmit chain. (Its 7130 cousin raises the VCO by 455kHz allowing mixture with 10.240MHz to obtain 27MHz).

Programming is 6-pin BCD (see last month's data sheet), and channel 9 and 19 pins allow instant selection of the emergency and calling/traveller's channels. Table 1 shows the N-codes for receive and transmit. There are no "gaps," as the British channels run with 10kHz spacing all the way across the band. The basic reference to the phase detector is 5kHz, so the receive N-codes increment by two each channel to get a 10kHz channel spacing. Note, however, that on transmit the N-codes increment by one each time. The VCO output therefore increases by 5kHz, but when the signal has passed through the doubler it will have increased by 10kHz for each channel step. The partial table of N-codes also shows the corresponding VCO frequencies. Because the VCO has to shift by such a considerable amount, it is usual for the transmit/receive switching to introduce some additional capacitance to the oscillator circuit on transmit, to help it regain lock at the lower frequency.

The 7136/7137 has an internal reference oscillator, requiring just a crystal and trimming components to be provided. An active low-pass filter is included for insertion between the phase detector output and VCO input, as with the 7130. The lock detector signals an out-of-lock condition by pulling pin 14 to ground and a miscode on the program pins is indicated by a low on pin 10. These are often tied together and used to remove bias on a transmit amplifier to prevent off-channel transmission from taking place.

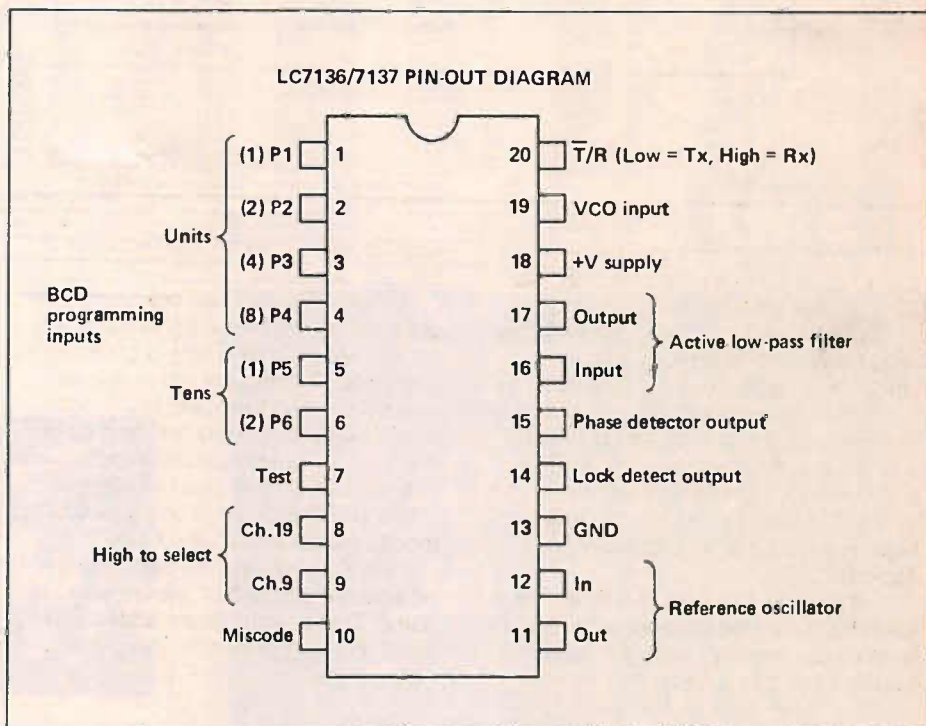

Table 1 N-codes in ROM and VCO frequencies

Channel	N-Code		VCO Frequency	
	Rx	Tx	Rx	Tx
1	3381	2760	16.905	13.800
2	3383	2761	16.915	13.805
3	3385	2762	16.925	13.810
.
38	3455	2797	17.275	13.985
39	3457	2798	17.285	13.990
40	3459	2799	17.295	13.995

Figures shown above assume a 5kHz reference and result in channels ranging from 27.600 to 27.990MHz. By making the 10.240MHz very slightly higher in frequency, the reference rises to a minute fraction above 5kHz and gives the required 1.25kHz extra on each channel.

SMJ ELECTRONICS

EDINBURGH
EH11 1PB

SPECIALISTS IN SEMICONDUCTORS AND MUCH, MUCH MORE

TEL: 031-337-6950. TEL/FAX 031-337-2446

TRANSISTORS	BD244C	.36	MRF237	3.36	2SC1306	1.21	2SK33	.40	LA4460	1.47	NE567	52	FC	
AC128	29	BD245C	84	MRF238	13.64	2SC1312	09	2SK192	25	LA4461	1.47	NE645	1.37	FOR
AC178	20	BD246C	75	MRF450	13.50	2SC1318	10	3N201	1.11	LA4500	1.65	NE646	1.23	synthesiser
AC187/B	22	BD317	1.78	MRF450A	13.80	2SC1359	13	3SK40	1.27	LB1405	2.24	PLL02	5.70	we can supply a conversion board to
AD149	75	BD318	1.79	MRF454	22.94	2SC1384	23	3SK48	2.71	S042	2.50	RC4558	5.71	allow operation on both the sets of 40 channels.
AD161	40	BD507	65	MRF455	19.80	2SC1398	60	3SK88	45	TA7061	78	TA7217	1.19	Technical help is available.
AD162	40	BD508	87	TIP29C	.26	2SC1413	3.50	3SK97	1.66	TA7120	58	TA7222	1.24	
AF124	42	BD529	54	TIP30C	29	2SC1674	15	40673	1.30	TA7130	46	TA7227	2.07	
AF127	33	BD530	99	TIP31C	28	2SC1675	13			TA7137	61	TA7240/1	1.98	
AF239	32	BD901	46	TIP32C	33	2SC1678	1.07	IC'S		TA7204	3.18	TA7270/1	1.86	
8C107	11	BD902	49	TIP33C	67	2SC1815	10	AN240	1.13	TA7205	96	TA7280	2.31	
8C108	07	8F115	38	TIP34C	67	2SC1909	91	AN6551	73	TA7208	1.40	TA7280	91	
8C109	13	8F173	26	TIP41C	27	2SC1923	13	AN7131	1.37	LC7120	2.75	TA7310	91	
8C114	09	8F180	12	TIP42C	27	2SC1942	1.98	AN7140	1.18	LC7130	3.28	TA76902	97	
8C141	28	8F184	32	TIP47	52	2SC1945	3.63	AN7178	2.47	LC7131	2.88	TBA8107	1.38	
8C142	19	8F185	24	TIP120	38	2SC1946	12.62	8A402	59	LC7132	2.89	TC9106	4.31	
8C147	11	8F194	11	2N3065	28	2SC1947	3.78	8A521	1.35	LC7137	3.16	TC9109	5.46	
8C170	11	8F195	08	2N3064	96	2SC1957	56	8A858	92	LM301	35	TD41010	1.10	
8C182/L	06	8F196	08	2N3055	42	2SC1989	1.68	CA3089	91	LM311N	68	TD41011	1.37	
8C183/L	07	8F197	16	2N3771	1.16	2SC1970	1.48	CA3089	2.45	LM317T	78	TD41020	1.99	
8C184/L	10	8F198	02	2N3772	3.11	2SC1971	2.82	CA3240	1.39	LM324	41	TD41510	3.18	
8C212/L	07	8F199	09	2N3773	1.40	2SC1972	8.25	HA1319	2.16	LM329	48	TD41512	3.12	
8C213/L	10	8F200	21	2N3818	35	2SC1973	58	HA1322	1.82	LM380N	1.32	TD41515	3.71	
8C214/L	08	8F244	39	2N3888	1.10	2SC2002	25	HA1338	2.31	LM383	3.50	TD41903	.82	
8C238	06	8F245	29	2SA473	46	2SC2028	1.25	HA1339A	3.80	LM384N	2.90	TD42002	.63	
8C308	06	8F255	05	2SA564	10	2SC2029	1.12	HA1342A	3.80	LM386	1.16	TD42003	.76	
8C327	06	8F256	31	2SA608	11	2SC2078	55	HA1366W/WR	1.72	LM387	2.10	TD42005	1.40	
8C328	11	8F259	25	2SA673	13	2SC2085	49	HA1367	2.64	LM390CN	78	TD42006	.76	
8C546	05	8F324	02	2SA678	38	2SC2092	1.32	HA1368/R	1.63	M51102	1.85	TD42006	.76	
8C547	05	8F337	28	2SA683	20	2SC2097	21.09	HA1374	2.11	M51513	1.86	TD42020	1.81	
8C548	05	8F422	23	2SA684	28	2SC2099	19.25	HA1377	1.73	M51514	1.12	TD42030	1.06	
8C550	14	8F423	23	2SA699	68	2SC2168	.83	HA1388	2.77	M51515	1.94	TD42611A	.86	
8C558	06	8F469	18	2SA733	13	2SC2236	.26	HA1389	1.39	M51516	2.22	UPC1032	.73	
8C639	11	8F470	45	2SA966	28	2SC2290	23.61	HA1392	1.90	M51517	2.06	UPC1156	2.05	
8C640	14	8FR90A	60	2SA999	10	2SC2312	2.85	HA1394	2.72	MB3712	1.22	UPC1181/2	.89	
BD124P	.50	8F950	25	2SA1012	67	2SC2314	.30	HA1397	2.55	MB3730	2.06	UPC1185	1.75	
BD131	38	8F951	24	2SA1015	08	2SC2320	10	HA1398	2.57	MB3731	2.15	UPC1186	.71	
BD132	38	8F950	50	2SB626	25	2SC2395	16.20	HA13001	1.60	MB3756	1.83	UPC1230	1.49	
BD135	22	8F951	24	2SC380	09	2SC2539	10.79	LA1201	.73	MB8719	4.12	UPC576	.78	
BD136	23	8F950	50	2SC495	40	2SC3020	12.90	LA1230	1.27	MC1310	6.65	UPD858	1.65	
BD137	23	8U205	74	2SC538	10	2SD234	46	LA4032	1.99	MC1350	1.41	UPD2816	5.34	
BD138	28	8Y208A	89	2SC710	10	2SD235	68	LA4102	.84	MC1723	.30			
BD139	21	8U208D	103	2SC711	.09	2SD235	68	LA4112	.94	MC3357	1.54	V REGS		
BD140	25	8U326A	99	2SC730	3.67	2SD313	41	LA4140	.58	MC3359	2.54	7805	.27	
BD201	33	8U405	63	2SC828	10	2SD325	36	LA4201	1.15	MC13002	3.05	7808	.34	
BD235	28	8U406D	129	2SC900	27	2SD330	46	LA4220	1.41	MC145106P	4.19	7812	.27	
BD237	27	8U426A	89	2SC930	17	2SD380	4.28	LA4250	2.23	MM55108	3.00	7816	.35	
BD238	31	8U508A	.96	2SC945	.08	2SD471	26	LA4400	2.59	NE545	2.38	7905	.49	
BD241	34	8U508D	1.11	2SC1060	59	2SD837	79	LA4420	1.32	NE555	.16	7908	.49	
BD242	33	8U526	1.11	2SC1061	57	2SD880	37	LA4422	1.02	NE556	.56	7912	.49	
BD243C	34	8U536	1.40	2SC1098	.71	2SK30	.36	LA4445	1.35	NE565	1.01	7915	.49	

SMJ

VAT AT 15% MUST BE ADDED TO THE ABOVE PRICES
We have listed only a small percentage of the devices available. We stock over a thousand different Semiconductors along with TV and Video spares, including idlers, Clutch Assemblies, Video Heads etc. Trade customers are welcome to use our account service for ease of ordering. Retail customers may send a Cheque/Postal order or just call us and use your Access card. We welcome your telephone enquiries so if the device you require is not listed just phone us and we will either be able to supply or at least tell you where it can be obtained.

If an advertisement is wrong we're here to put it right.

If you see an advertisement in the press, in print, on posters or in the cinema which you find unacceptable, write to us at the address below.

The Advertising Standards Authority.

ASA Ltd, Dept 3 Brook House, Torrington Place, London WC1E 7HN

THAT WAS THEN BUT THIS IS NOW



GIVE AS TOM GAVE
TOM SERVED IN THE ROYAL AIR FORCE
TOM FOUGHT FOR HIS COUNTRY
NOW IT'S OUR TURN TO CARE FOR HIS NEEDS

Please help by giving all you can for an emblem during Wings Week or send a donation to:
THE ROYAL AIR FORCES ASSOCIATION APPEALS DEPT., (D S)
PORTLAND ROAD, MALVERN, WORCESTERSHIRE WR14 2TA

I enclose a donation of _____ for the Wings Appeal
Please debit my Access/Barclaycard (delete as applicable)
Credit Card No. _____
Name _____
Address _____

Please tick if receipt required or information on RAFA Membership Space donated by _____

ACCESSORIES

WHOLESALE

CB radios, aerials and accessories delivered to your shop. Contact for price list.

Pama House, 433 Wilmslow Road, Manchester M20 9AF. only 3 minutes from M56



OPEN EVERY DAY, SUNDAY 10-2

NATIONWIDE DELIVERY DEALERS

contact us today for very fast, friendly service, competitive prices, widest range and latest CB products.

Tel: 061-446 2437 061-445 8918
061-434 5701
Telex: 666762 PAMAGO G
Fax: 061-445 0978
Order Line: 0800 262963



BREAKER BASES

CAMBRIDGESHIRE

Tower Communication

Everything for the 27MHz & 934MHz CBer, Radio Amateur or SWL

★ First Class Sales & Service ★
11 High Street, Haddenham, Cambs.
Tel: Ely (0353) 740306



CORNWALL

CHAT BACK CB CENTRE

FULL STOCKS OF 934MHZ & 27MHZ AMATEUR RADIO — PMR & NEW CEPT CORDLESS PHONES — REPAIRS

Opening Hours: Mon-Fri 9am-5pm
Sat 9am-1pm

Easthill, Tuckingmill, Camborne, Cornwall TR14 8QL.
Tel: 0209-715773

DORSET

DO YOU OWN A CB SHOP IN DORSET? IF SO ADVERTISE HERE.

HAMPSHIRE

BREAKER'S WORLD

2 High Street, Bordon, Hants. We are the experts in communication. Full range of CB and accessories in stock. Fully equipped workshop for repairs. Open 7 days a week
Mon-Sat 10am-6pm
Sun 10am-1pm. 04203-4684

CHESHIRE

PENKETH ELECTRONICS & CB SUPPLIES

5 Chapel Road, Penketh, Warrington We are the CB stockists for the Cheshire/Merseyside area. Sales & Service, Audio & Hi-Fi Accessories. Secondhand Hi-Fi bought and sold. Telephone 092 572 3282
Open 9.30-5 (except Wed & Sun)

DEVON

CB Sales

We guarantee that if we have it in stock + you can find it cheaper locally, we'll match/better the price.

Full repairs, modifications, services.

CB SALES. Stidson, South Brent, Devon TQ10 9JT
Tel: 03647 3292
Open: 8.30-9.30 Monday to Sunday
Mail Order; telephone enquiries welcome.

ESSEX

WOODFORD CB CENTRE
528 Chigwell Road, Woodford Bridge, Woodford Green.
Tel: 01-504 9652

We offer a full repair service and rig conversions. We will match any genuine advertised price.

LARGE RANGE OF CB EQUIPMENT
Open Tues-Sat 10am-5pm

HAMPSHIRE

P. SQUIRE (ANDOVER) LTD.
19 Bridge Street, ANDOVER, Hants
Tel: 0264-52623

SPECIALISTS IN CB SALES AND SERVICE
Very large selection of Rigs and Accessories.
Repairs, and Services Reasonable prices. Expert Advice — Free.
Open 8.30 to 5.30 (excl Wed & Sun.)

CHESHIRE



LARGEST STOCKIST OF NEW ANDS/HAND CB EQUIPMENT IN THE CREWE AREA

CB37
15 Middlewich Street
Crewe CW1 4BS
Tel: 0270 588440 anytime

DEVON

MAGGIE'S C.B. CENTRE

Open: 10am-5pm. Closed Wednesdays and Sundays. Full repair service for all electronic equipment including both old/new frequency/rigs. Scanners, aerials, rigs etc. for sale.

63 Fleet Street, Keyham, Plymouth Nr. HMS Drake PL2 2BU
Tel: Plymouth (0752) 563222 or workshop/answerphone (0752) 569237

GLOUCESTERSHIRE



DES ELECTRONICS
CB SALES & SERVICE
COMPREHENSIVE RANGE. COMPETITIVE PRICES.
OPEN: MON.-FRI. 9am-6pm
TELEPHONE & MAIL ORDER WELCOME
TEL: 045382 6710
SEND £1.00 FOR LATEST ILLUSTRATED CATALOGUE
UNIT 38, UPPER MILLS, STONEHOUSE, GLOS.
JUNCTION 13 - M5
FIRST RIGHT PAST THE SHIP INN.

HERTFORSHIRE

934MHz 27MHz
Largest selection of CB Equipment
Mail Order Service
Rickmansworth
C Communications Centre
37-39 Station Road, Rickmansworth, Herts WD3 1QP
Tel: (0923) 775577/770634
Mon.-Sat. 9am-6pm
Wed 9am-1pm and 3pm-6pm

CORNWALL

RON'S SHOP

46 Lower Bore Street, Bodmin Cornwall PL31 2JY.
Tel: Bodmin 0208 74569
CB RADIOs and all ACCESSORIES
CORDLESS TELEPHONES and ANSWERING MACHINES, RADIOS, ELECTRICAL GOODS ETC.
Open: Mon.-Sat. 9am-6pm

DEVON

AGRIMOTORS

Merton CB & Radio Centre
Merton Garage & Post Office, Merton, Nr. Oakhampton EX20 3DZ
Open 6 days 9-6 (Sundays by appointment)
Specialists in 934MHz Suppliers of all 27Mhz and 934Mhz equipment
Tel: 08053-200

WE HAVE RATES TO SUIT ALL ADVERTISERS NEEDS

KENT

R G ELECTRONICS

For all your C.B. equipment
Established seven years
Open six days Mon — Sat
HP Terms available
For Mail Order Catalogue send two 19p stamps to 66 Oxford Street, Whitstable, Kent CT5 1DG.
Tel: 0227 262319

ACCESSORIES



WHOLESALE DISTRIBUTORS OF CB

Giant range of CBs and accessories, contact us today for very fast, friendly service, competitive prices, widest range and latest CB products.

Tel: 061-445 8918 061-434 5701
Telex: 666762 PAMACO G
Fax: 061-445 0978
Order Line: 0800 262963

WE DELIVER NATIONWIDE OPEN EVERY DAY, SUNDAY 10-2
Pama House, 433 Wilmslow Road, Manchester M20 9AF Only 3 minutes from M56



BREAKER BASES

KENT

CQ SHOP
1 St. James's Road, Gravesend, Kent DA11 0HF
Gravesend 567171
FOR ALL YOUR
COMMUNICATION REQUIREMENTS
CB. RADIOS, AMATEUR RADIO
ACCESSORIES
Installation & repairs
★ METAL DETECTORS ★
MAIL ORDER SERVICE
"communicate with confidence"

MIDDLESEX

CB EXCHANGE
For rigs, accessories,
sales and service
Part exchange welcome

*Tandy authorised
dealers*
475 STAINES RD.,
BEDFORD, MIDDLESEX
(Nr. Barclays Bank) TW14 BBL
01-890 0900
WE RARELY CLOSE

NORTHAMPTON

EARLS BARTON CB SHOP
S.M.R. Engineers
FULL RANGE CB EQUIPMENT
SERVICE AND REPAIRS
Open Monday - Friday 9-6
Saturday 9-5
Sunday 10.30-12.30
38a DODDINGTON ROAD
(STD 0604) 810000

SURREY

The Mad Baron
The CB Specialist
Rigs - Twigs and other Bits
Supplied and Repaired
Phone BOB on (0932) 336010
(24 Hour Answer phone)
WILL MAIL AT COST.
ACCESS AND VISA CARDS WELCOME
SOUTHERN U.K. AK3 SUPPLIER
PO Box 88, WEYBRIDGE, KT13 0RT

LONDON

ALPHA'S CB CENTRES
224 Balaam Street, London E13
Tel: 01-471 5589
Open: Mon-Sat 9am-7pm:
Sunday 10am-2pm
ALSO
EX ZULU/ONE/FOUR,
132 Leytonstone High Road, E15.
Tel: 01-555 8045. Open: Mon-Sat
9am-5.30pm.
T/A Balaam St, Motors

NOTTINGHAM

MADHAWK ONE CB CENTRE

For all your CB requirements.
New and used equipment always
in stock. Repairs and service.

**75 Ratcliffe Gate,
Mansfield, Notts.**
Tel: 0623 651113

OXFORDSHIRE

**MODULATIONS
COMMUNICATIONS**
62 Wootton Road,
Abingdon, Oxon.
OX14 1JD
Tel: 0235 - 21400
Open: 6 days Mon-Sat
9-5.30
Instant credit facilities. Agents for
934 MHZ. Wholesale, Retail and
NEW CEPT CB NOW AVAILABLE

SURREY

**GUILDFORD
CB**
Surrey's biggest
stockists of CB
equipment and
accessories.
Low prices, technical know-how.
Repairs, 934 and Amateur.
Cobras and Yaesu wanted.
34 Aldershot Rd., Guildford GU1 4JL

HENRY'S

934MHz and 27MHz
CB and accessories
catalogue S.A.E.
404 Edgware Road,
London W2 1ED
01-724-0323
Open 6 days a week

NORFOLK

BA YEOMANS + SON

ESTABLISHED 1965
Lowest prices in UK or refund difference
Mobile Aerials from £2.99
Base Aerials from £9.99
3 amp Power Supply from £9.99
Used CB from £19.99
New CB from £46.00
Scanners from £49.99
CB Aerial Plugs 40p
CB Microphones from £4.50
65 North Walsham Road, Norwich.
Tel: 426294

SHROPSHIRE

LES EVANS ELECTRICAL CB CENTRE

Unit 7, The Brewery, Wem.
Tel: (0939) 32090 (24 hours)
New and Used CB's
Large stocks of Ariels
+ Accessories
Prompt Repair Service

TERMS AND CONDITIONS

CLASSIFIED ADVERTISING TERMS & CONDITIONS

Our terms for new advertisers (semi-display and lineage) are strictly pro-forma payments until satisfactory reference can be taken up (excluding recognised advertising agencies). Cheques and P.O.'s should be crossed and made payable to ARGUS SPECIALIST PUBLICATIONS LTD and sent together with the advertisements to:

The Classified Dept.,
No. 1 Golden Square,
London W1R 3AB.

There are no reimbursements for cancellations. Advertisements arriving too late for a particular issue will be inserted in the following issue unless accompanied by instructions to the contrary. It is the responsibility of the advertiser to ensure that the first insertion of every series is published correctly, and corrections must be notified in time for the second insertion, otherwise the publishers will not accept liability or offer any reduction in charges. All advertising sales are subject to Government Regulations concerning VAT. Advertisers are responsible for complying with the various legal requirements in force e.g. The Trade Description Act, sex discrimination act & the business advertisements (disclosure) order 1977. Full Terms & Conditions of Advertising available on request.

LANCASHIRE

**TIGERS CAGE
CB SUPPLIES**
FOR ALL YOUR CB NEEDS
MAILORDER WELCOME
Open: Mon-Sat 9am-6pm
Sun 9am-4pm
343, Chorley New Road,
Horwich, Lancs. Tel: 0204 68218

NORTH HUMBERSIDE

BREAKER ONE NINE CB CENTRE

414 BEVERLEY ROAD, HULL
Tel (0482) 447560
LARGE SELECTION OF NEW AND
SECONDHAND CB EQUIPMENT.
FULL RANGE OF C.E.P.T. RIGS
AVAILABLE
EXCELLENT
REPAIR
SERVICE

SUFFOLK

**"THE BEST
STOCKED CB
SHOP FOR
MILES"**
RADIOCARE
PHONE OR CALL IN FOR BEST PRICES
NORMAL SHOP HOURS (Closed Thurs.)
18 OUT WESTGATE
BURY, ST. EDMUNDS
0284 701823

ACCESSORIES



WHOLESALE DISTRIBUTORS OF CB

Giant range of CBs and accessories, contact us today for very fast, friendly service, competitive prices, widest range and latest CB products.

Tel: 061-445 8918 061-434 5701
Telex: 666762 PAMACO G
Fax: 061-445 0978
Order Line: 0800 262963

WE DELIVER NATIONWIDE OPEN EVERY DAY, SUNDAY 10-2
Pama House, 433 Wilmslow Road, Manchester M20 9AF Only 3 minutes from M56



BREAKER BASES

SOMERSET

TRAVELLING LIGHT C.B. RADIO SPECIALISTS

Largest stocks in the area.
Repairs/Sales and Service.
2nd Hand Rigs Bought and Sold ...
Also phones, I.C.E. and much more.
Travelling Light, 19 King Street,
Frome, BA11 1BH. Tel: 0373 66281

WEST MIDLANDS

HEWARD'S HOME STORES LTD (Established 1963)

822/4 Kingstanding Road,
Birmingham B44 9RT.
Tel: 021-354 2083
G4RJM with 38 years in The Radio
Trade Ham Equipment urgently
wanted Open: Mon-Sat 9-6
WE WELCOME ALL CB'ers

YORKSHIRE

LEN BERRY ELECTRONICS LTD.

We monitor channel
0723-373914
or eyeball at:
**147 VICTORIA ROAD,
SCARBOROUGH,
YORKSHIRE**

WEST YORKSHIRE

SUPERSLAB CB CENTRE

John A. Dobbins Ltd
Bradford Road, A650,
East Ardsley, Nr. Wakefield
Tel: 0532 524586
**LARGEST STOCKIST OF CB
EQUIPMENT IN THE NORTH**
(Trade and Retail)
Full Repairs Service
Mail Order

SUSSEX

The C.B. Centre

Inrange Ltd, 8 Marine Court,
St. Leonards on Sea.
Tel: Hastings (0424) 443185/442025
Open: Monday to Saturday 9.30-5.30
Retail & Wholesale



YORKSHIRE

EMPRESS TRADING CO. THE No. 1 C.B. SHOP

**WIDE RANGE OF RIGS & TWIGS
ALL ACCESSORIES AVAILABLE,
"PART EXCHANGE WELCOME"**
ALSO, 2 WAY TAXI AND T.V.
AERIALS, TELEPHONES, IN CAR
RADIOS AND ELECTRICAL GOODS.
ANY ENQUIRIES WELCOME.
TEL: (0274) 499340
564 Thornton Road, Bradford BD8 9NF

SOUTH YORKSHIRE

North Saturn Communications

The Communication Specialists
CB - PMR - CORDLESS PHONES
IN-CAR TELEPHONES
Mobile Phones, Cellnet/Vodafone
5 Odeon Arcade, Hallgate, Doncaster
South Yorkshire DN1 3LZ
Tel: (0302) 66352 & 65991
Mobile Phone 0836 608111

**THIS SPACE
COULD BE
YOURS
TELEPHONE
RACHAEL PHILLIPS
ON 01-437-0626
TO ADVERTISE**

ADVERTISING COUPON

CLASSIFIED COUPON

CITIZENS' BAND, CLASSIFIED ADVERTISEMENT
DEPARTMENT, No. 1 GOLDEN SQUARE, LONDON W1R 3AB.

PLEASE DEBIT MY ACCESS/BARCLAYCARD No.

EXPIRY DATE



Private and Trade rate 58p per word (VAT inclusive) minimum 15 words.
Display box rate £9.15 (+ VAT) per single column centimetre (minimum 2.5cm).
NO CLASSIFIED REIMBURSEMENTS. ALL ADS MUST BE PRE-PAID.

Name

Address

Daytime Tel. No.

Signature Date

FOR SALE QSLs WANTED KITS ACCESSORIES OTHERWISE STATE

IF YOU DO NOT WISH TO CUT UP YOUR MAGAZINE PLEASE PHOTOCOPY THIS COUPON

ACCESSORIES



Tel: 061-445 8918 061-434 5701
Telex: 666762 PAMACO G
Fax: 061-445 0978
Order Line: 0800 262963

WHOLESALE
DISTRIBUTORS
OF CB

WE DELIVER NATIONWIDE OPEN EVERY DAY, SUNDAY 10-2
Pama House, 433 Wilmslow Road, Manchester M20 9AF Only 3 minutes from M56

Giant range of CBs and accessories, contact us today for very fast, friendly service, competitive prices, widest range and latest CB products.

Tel: 061-446 2437

CLASSIFIED

CB
CITIZENS' BAND
01
437
0699



Lineage: 58p per word including VAT
Minimum 15 words
Semi Display: £9.15 per single column centimetre
Minimum 2.5 centimetres
CB Classified Department,
Argus Specialist Publications Ltd.,
1 Golden Square, London W1R 3AB

ACCESSORIES

NEW! from FCC SYSTEMS
REPLACEMENT PLL'S FOR UNIDEN & CYBERNET
FCC80U TO REPLACE TC9119 TC9106 TC9109
UNIDEN 100 - 400 AND AUDIOLINE RIGS
PRICE INC. VAT, P/P £13.85
FCC80C TO REPLACE LC7137 - LC7136
CYBERNET, MIDLAND, HARIER, AMSTRAD ETC.
PRICE INC. VAT, P/P £12.85
Quantity discounts available. Make cheques, P/O payable to:
FCC SYSTEMS, 71 STATION ROAD, SEAHAM,
Co DURHAM, SR7 0AQ. TEL: 0642 603875

★ STOP PRESS ★ STOP PRESS ★ STOP PRESS ★
"THE SHACK"
New appointed Piranha Car Burglar Alarm Distributor.
★ Special - Trunkers 4 1/2" screen TV's & Omni Directional
Vehicle TV Aerials ★
Specialist components, IC's transistors, Cybernet & Uniden
spares, car radios, speakers, intercoms, new C.B. radios from
£46. Accessories all at discount prices. All repairs tested on
Marcom 2955 test set by Derby's leading rig doctor.
Ring Paul (03321) 780363 (anytime)
THE SHACK, 231 Caxton Street,
Sunnyhill, Derby OE3 7RB.

TO ADVERTISE
HERE
TELEPHONE
01-437-0626

ATTENTION

NORTHCOTT ELECTRONICS

NORTHERN IRELANDS LARGEST
CITIZENS' BAND RADIO SPECIALIST

LINEAR AMPLIFIERS	£17.00 - £269.00
MOBILE ANTENNAS	£6.00 - £53.00
BASE ANTENNAS	£12.00 - £86.00
MICROPHONES	£5.00 - £69.00
RIGS 27/81 + C.E.P.T.	£47.00 - £260.00
S.W.R./POWER METERS	£6.00 - £99.00

Plus Books : Magazines : S/H Rigs : Speakers : Masts : Repairs : Etc.

VISIT US NOW AT UNIT 21, IN-SHOPS,
NORTHCOTT SHOPPING CENTRE, GLENGORMLEY.
TEL: BELFAST (0232) 342552

OPEN: Mon.-Tues. 9.30am-5.30pm. Wed.-Thurs.-Fri. 9.30am-9.00pm.
Saturday 9.00am-5.30pm.

WE HAVE RATES TO SUIT
ALL ADVERTISERS NEEDS
CALL RACHAEL PHILLIPS
FOR MORE DETAILS

NATIONAL ORGANISATIONS

A.B.C.B.
(Association for British Citizens' Band)
The National Organisation
Representing
Licensed Breakers
and Clubs
Large SAE for details to:
ABCB, PO Box 13, North PDO,
Nottingham NG5 7DU

QSLs

GLOSSY QSL and Eyeball
Cards. Many colours with gold/
silver/coloured lettering. S.a.e.
order form and samples. Sharp
Graphics, P.O. Box 3, Grange-
mouth FK3 9BD. (0324)
473432.

Full Colour QSLs 1000 £55
● Personalised QSLs 1000 £16.50
● Eyeball Cards 1000 £11
● Embroidered Patches 100 £100
(sample £2) ● Club Stamps -
Mounted 50 £50 ● Patches 3" dia. in
up to 9 colours. Club stamps 1" dia.
DIY QSLs 100 £2.50
Eyeball Cards 100 £1.10
DIY Bargain Pack 100 of each: £3
SAFE for details: CURRIE QSLs
Room 2, 89 Derwent St., Consett,
Co. Durham, DH8 8LT, England.

EQUIPMENT

C.B. EXCHANGE

Buy (Working or not) cash by return. Sell
fully serviced and aligned S.A.E. for
availability or Tel: (0253) 886632
North West House, Poulton-le-Fylde,
Blackpool, Lancs. FY6 8BN.

SPECTRUM COMMUNICATIONS

CB radios, accessories, spares and
possibly the most professional and
experienced service department in
the UK. Suppliers of kits and add on
modules. Send SAE for kits list to:
United B6, Marabout Ind. Estate,
Dorchester, Dorset.
Tel: 0305 62250
Open: 9-1, 2-5pm Tues.-Fri. 9-1, 2-4pm Sat.

PERSONALISED LEISUREWEAR

T-SHIRTS & SWEATSHIRTS

by
Interprint

MINIMUM ORDER - ONLY 12
FREE DESIGN SERVICE

Other Top Quality
Personalised Products

Sports Shirts, Ties, Hats, Lighters, Bags,
Stickers, Badges, Aprons, Tea-Towels

Write for free colour brochure to:

INTERPRINT Dept. CB
CRAVEN ARMS,
SHROPSHIRE SY7 9NY.



TEL: (05882) 2703 & 2502

FOR SALE

- MULTI-BAND -
ACTION RECEIVER
ICN-8032s

THE ENTIRE LISTENING POST
★ HI/LO AIR
★ VHF 53-180MHz
★ CB 27/81 + CEPT - 100 CH's
★ SIGNALS OF: TOTAL CB,
HAM-RADIO, UTILITIES +
AIRCRAFT, EMERGENCY
CALLS, MARINE, LOCAL
2-WAY, TAXIS & MORE!
★ SOULCH, RUBBER 'DUCK'
ANTENNA, EXTERNAL AUDIO
& DC JACKS
★ SUPER SENSITIVE + HAND
COMPACT
FREE CONFIDENTIAL
FREQUENCY BULLETIN.
24 HOUR C.O.D.
0388 763323
C/W BATTERIES £27.50 INCL. P+P
EARPHONE
CWO/COD
Direct from: TAYLOR RADIO (Dept. CB3)
8 Emmons Street, Crook, Co. Durham, U.K.

DO YOU
HAVE ANY
PRODUCTS OR
SERVICES TO
OFFER CB
ENTHUSIASTS?
IF SO ADVERTISE
HERE.

ACCESSORIES

WHOLESALE

CB radios, aerials and accessories delivered to your shop. Contact for price list.

Pama House, 433 Wilmslow Road, Manchester M20 9AF.
only 3 minutes from M56



OPEN EVERY DAY, SUNDAY 10-2

NATIONWIDE DELIVERY DEALERS contact us today for very fast, friendly service, competitive prices, widest range and latest CB products.

Tel: 061-446 2437 061-445 8918
061-434 5701
Telex: 666762 PAMAGO G
Fax: 061-445 0978

CRYSTALS

QUARTZ CRYSTALS and FILTERS

Large numbers of standard frequencies in stock for amateur, CB, professional and industrial applications.
Stock crystals £5.50 each (inc. VAT and UK post)
Any frequency or type made-to-order from £6.50
Phone or SAE for lists

COLLEGE ELECTRONICS
Merriott, Somerset, TA16 5NS. Tel: (0450) 73718

SERVICE MANUALS

C.B. CIRCUITS MANUAL

Giant Collection of C.B. Circuits covers over 100 different makes/models.
Only £5.00 POST FREE
Plus FREE catalogue Unique Repair and Data Guides. Most equipment service manuals supplied.
MAURITRON (CB), 8 Cherry Tree Road, Chinnor, Oxon OX9 4QY.

FAX US DETAILS OF YOUR ADVERT
01-437-1006

PLANS

SURVEILLANCE DEVICES, Bug Detectors, Voice, Scrambler, Directional Microphone, Many others. SAE for list, Plans Centre, Unit 7, Old Wharf, Dymack Road, Ledbury HR8 2DS.

BEREAVEMENT

PEACOCK: MARIA ANNA "TIA MARIA"

WE ALL WOULD LIKE TO EXPRESS OUR APPRECIATION TO ALL WHO PAID TRIBUTE TO OUR LATE MUM, FOR THE CARDS, FLOWERS AND HEARTFELT DONATIONS. WE ARE ALSO OVERWHELMED FOR THE LOVE SHOWN FOR OUR MUM. WORDS CANNOT SAY ENOUGH. ONCE AGAIN - FROM THE BOTTOM OF ALL OUR HEARTS WE THANK YOU ALL.
THE PEACOCK FAMILY,
BERKSHIRE

EQUIPMENT

TRAVELLING LIGHT

ALL YOUR C.B. REQUIREMENTS
CONTACT US NOW!

RIGS INCLUDING MIDLAND, UNIDEN ETC. . . .
BASE ANTENNAE INCLUDING SIRIO
MOBILE ANTENNAE INCLUDING THOROBRED, C.T.E., SIRIO, MODULATOR, T-POLE, OSCAR, ETC., ETC. . . .
ALL ACCESSORIES . . .

**TRAVELLING LIGHT, 19 KING STREET,
FROME, SOMERSET BA11 1BH.
PHONE TED ON (0373) 66281**

**COPY DEADLINE FOR THE JUNE
ISSUE IS 6th APRIL**

Please mention

CB Citizens' Band

when replying to all Adverts

NEVADA

If its advice you need on any aspect of CB radio, then these are the people to talk to.

Your nearest Nevada Main Dealer below has been especially selected for his expertise. Call him now and he will be pleased to advise you. He also stocks the new TRX 404 Transceiver and Selective Calling Unit . . . naturally!

**RETAILERS!
MAIN DEALERSHIP
STILL AVAILABLE IN
SOME AREAS.
CONTACT NEVADA
FOR FURTHER
DETAILS**

**BROOMKNOLL ELECTRONICS
(AIRDRIE)
0236-54580**

**PAMA & CO
(MANCHESTER)
061-445-8918**

**T. HALL
(ASHFORDBY)
0664-812061**

**J FISHLOCK
(BATH)
0225-27718**

**AGRIMOTORS
(MERTON)
08053-200**

**CHATBACK CB
(CAMBORNE)
0209-715773**

**UK DISTRIBUTORS
NEVADA COMMUNICATIONS
PORTSMOUTH
0705-662145**

**AXDON TELEVISION
(PERTH)
0738-23753**

**IAN FISHER
(STANHOPE)
0388-528464**

**KNIGHTS
(KIRTON IN LINDSEY)
0652-648378**

**RILEYS TV
(BOLSOVER)
0246-826578**

**B. A. YEOMAN & SON
(NORWICH)
0603 426294**

**CB EXCHANGE
(BEDFORD)
01-890-0900**

**THE AERIAL SHOP
(SIDCUP)
01-300-5588**

**O.T.S.
(LEIGH-ON-SEA)
0702-714330**

**HENRY'S
(LONDON)
01-724-0323**

**MM ENTERPRISES
(ASHFORD)
0233-620877**

**INRANGE
(HASTINGS)
0424-715709**

maxon

ADVANCING THE ART OF
COMMUNICATION

MX 1000

CEPT TYPE APPROVED. COMPACT DESIGN.
NIGHT ILLUMINATION. LAST CHANNEL
MEMORY RETENTION. SCANNING MIKE
(OPTIONAL). SPECIAL FEATURES ON REAR
PANEL INCLUDE: 2.5mm 'S' METER JACK, 3.5mm
PA SPEAKER JACK & 3.5mm EXTERNAL
SPEAKER JACK. LED S/RF METER.
VOLUME CONTROL INCLUDES
POWER ON/OFF. SQUELCH
CONTROL WITH PA



MX 2000
AWAITING
TYPE
APPROVAL.
SPECIAL
FEATURES AS
MX 1000, PLUS:
INSTANT CHANNEL 9
SWITCH. SCANNING
SWITCH. CB/PA SWITCH.
LO/DX PUSH SWITCH

IMPORTED & DISTRIBUTED IN THE UK BY
SHARMAN'S WHOLESALE
3 BURY NEW ROAD, MANCHESTER M8 8FW
TEL: 061-834 9571 TELEX: 665446 Sharma G FAX: 061 835 3679