

# CEED

COMMUNICATIONS ENGINEERING & DESIGN  
THE PREMIER MAGAZINE OF BROADBAND COMMUNICATIONS



**Home  
improvement:  
looking for solutions**

***WHAT DO PCS,  
INTERNET ACCESS  
AND BROADBAND  
TELEPHONY  
HAVE IN COMMON  
WITH PIZZA  
AND BALLOON GRAMS?***

OCTOBER 1995

CEED

Construction practices

Test gear

Designing interactive TV



**Now you can deliver them all in a  
single vehicle.  
With the super-reliable AT&T 5ESS-2000  
switch and our new 5E10 software.**

When you're adding telephony and data services to your cable system, you need the most versatile, most reliable switch and software on the market.

The AT&T 5ESS®-2000 Switch. And our new 5E10 software.

Only the 5ESS Switch lets you combine landline and wireless on the same switching platform. So you can offer landline features to wireless customers.

It also has Advanced Intelligent Network capabilities. Which gives you the advantage of offering "follow-me" numbers to your PCS customers.

Plus, our new 5E10 software allows fast, easy provisioning of high-speed Internet access. And adds residence features like enhanced Call Waiting, which identifies the calling party before customers interrupt their current call.

And with the 5ESS switch and software your investment is always protected. New services can be offered without upgrading hardware or waiting for a new software release.

All this on the most reliable digital switch in the world. Whose nearest competitor, according to FCC data, had over four times more downtime.

The 5ESS-2000 Switch and 5E10 Software Release are available now.

Call your AT&T Network Systems representative for more information.

**Everything you need. To do everything you want.**

 **AT&T Network Systems**

Circle Reader Service No. 1

**C**able system operators today stand on a precipice, overlooking the opportunities that lay before them. Perhaps never in its short but illustrious history has the cable industry had so many doors to ponder: high-speed data delivery and Internet access; telephony; interactive services; and expansion of pay-per-view toward a near video-on-demand environment.



## A model for reliability built in Alexandria

Choosing which applications and services to pursue first isn't easy, but that's the marketing department's challenge. What the engineering community has to ensure is that the infrastructure is in place to support such services—and today, it's doubtful. Tree-and-branch cable systems have too many single points of failure, active electronics have mean times before failure that are less than acceptable, there's little in the way of backup electronics in most headends and there are problems in the power grid that takes service down much too often. Clearly, there's a lot of work to be done.

Jones Intercable just fired up its newest headend facility in Alexandria, Va. It could be argued that Jones chose that high-profile system to be its flagship, based on dense housing, great demographics and probably because of its proximity to the nation's capital and lawmakers. But it's also under attack from Bell Atlantic, the local telephone provider, which has targeted the area as one of its beachheads in the battle for marketshare. In response, Jones had to build a highly reliable network in order to compete.

The point is that Jones' new headend is an impressive facility and will likely serve as a model for the rest of the industry. Everything in the 750-MHz system is new, of course, but that's not what makes it unique. It's the level and amount of quality and redundancy that the Jones engineers have designed into the headend and the plant that make one stand up and take notice. Clearly, Jones is making

a statement to Bell Atlantic that it has built a network that is survivable and capable of being more reliable than the incumbent's.

The reliability message is driven home in several places, including:

- ✓ In the plant, where 10 counter-rotating rings of fiber serve the 28-square-mile community.
- ✓ In the bank of Scientific-Atlanta frequency agile modulators that have hot standby units ready and waiting to step in if a failure occurs.
- ✓ Within the fiber nodes themselves, each of which is outfitted with standby power supplies and status monitoring.
- ✓ In the headend, where Barco has installed its ROSA software system that monitors the performance of the satellite receivers.
- ✓ In the fiber optic management system designed by Fiber Optic Network Solutions that terminates nearly 3,000 fiber strands in the headend.

What Jones has done in Alexandria is carry out the exact steps most MSOs are simply giving lip service to. Yes, it's more expensive, but Jones believes it can't cut corners in the race to provide multimedia and telephony services to its subscribers.

In the words of Roger Seefeldt, a fund engineer from Jones' corporate headquarters who helped with the project, the headend in Alexandria is the headend of the future. It's hard not to agree with him.

*Roger J. Brown*

Roger Brown  
Editor

## CED MAGAZINE

### VP Group Publisher

William McGorry

### Publisher

Robert C. Stuehrk

### Editor

Roger Brown, Rbrowner@aol.com

### Managing Editor

Dana Cervenka

### Contributing Editors

Leslie Ellis, Ellis299@aol.com

Fred Dawson

### CONSULTING ENGINEERS

#### Chairman

Wendell H. Bailey, NCTA VP,  
Science and Technology

#### MEMBERS

Jim Chiddix, Senior VP, Engineering and  
Technology, Time Warner Cable

Stephen D. Dukes, VP, Technology, TCI  
Technology Ventures

David Fellows, Sr. VP, Engineering and  
Technology, Continental Cablevision

Tom Jokerst, Sr. VP, Engineering, Charter  
Communications

Earl Langenberg, Executive Director, Growth  
Division, US West Communications

Dave Large, Principal, Media Connections  
Group

Robert Luff, Chief Technical Officer,  
Broadband Division, Scientific-Atlanta

Pete Smith, VP Engineering, Rifkin &  
Associates

Joe Van Loan, Sr. VP, Engineering, CableVision  
Industries

#### National Sales Manager

Cathy Wilson

#### Advertising/Marketing Manager

Scott C. Snyder, SSnyderCED@aol.com

#### Classified Sales Manager

Tim Reeder  
800/866-0206

#### Assistant to the Publisher

Michelle Pazar

#### Production Manager

Elaine Callahan

#### Art Director

Don Ruth

#### Address

600 S. Cherry St., Suite 400  
Denver, CO 80222  
303/393-7449

#### Circulation Director

Maria Gottlieb (212) 887-8565

#### Fulfillment Manager

Shawn Green (212) 887-8564

#### Subscriber services

CE  
P.O. Box 10728  
Riverton, NJ 08076-0728  
Telephone: 609/786-0501  
Fax: 212/887-8493

#### CHILTON PUBLICATIONS

Leon C. Hufnagel, Jr., President  
Donald W. Chestnut, Sr. VP, Ops/Admin.  
Christopher M. Savine, Sr. VP Finance  
Bill O'Brien, Sr. VP Communications Group



**New!**

# Take The Heat Off System Testing

*Troubleshooting with Sencore's NEW line of signal level meters will help you take the heat off testing all your system parameters.*



**The SL754 "CHANNELIZER" Features:**

- All Freq./Channel Tuning from 5-810 MHz
- Extended Measuring Range from -35 to +60 dBmV
- Channel Planning Capabilities for custom channel planning or choose from 8 pre-set channel plans
- Automatic Pass/Fail Testing of all system parameters including:
  - Tilt Max A/V Ratio
  - P/V Min. C/N Level
  - Flatness Max. Hum
  - Ch. to Ch. Variation All Ch. to Ch. Variation
- Rugged Design for use in all types of weather conditions

Circle Reader Service No. 2

**The SL753 "CHANNELIZER" Installer's Meter Features:**

- All Freq./Channel Tuning from 50 to 810 MHz (5-810 MHz with sub-band option)
- Extended Measuring Range from -35 to +60 dBmV
- Signal Quality Tests includes video and audio carrier, plus "on channel" % of Hum
- Channel Planning Capabilities for custom channel planning or choose from 8 pre-set channel plans
- Rugged Design for use in all types of weather conditions

Both the SL753 and SL754 are covered by Sencore's **New 3 Year** Extended Warranty

**For More Information, Call 1-800-SENCORE!  
(736-2673)**

# Meeting The Worldwide Demand For Excellence



The introduction of unique MC<sup>2</sup> coaxial cable by Trilogy Communications clearly opened a new era of excellence in CATV development and construction. Trilogy proved that an air-dielectric cable could be designed to maintain a 93% velocity of propagation, while assuring greater strength and flexibility than traditional foamcore cable. The 100% bonding and hermetically-sealed compartments of MC<sup>2</sup> reduce moisture ingress and migration to the lowest incidence and degree ever encountered in the field.

To date, over 1.5 billion feet of MC<sup>2</sup> have been installed worldwide.

The 93% velocity of propagation and superior attenuation of MC<sup>2</sup> provide much more than the purest signals over the longest distances. MC<sup>2</sup> provides great savings as well: about 20% fewer amplifiers; less cable waste over long distances; use of one size smaller than would be required for foamed trunk and feeder, meaning more cables per duct, longer lengths per reel — with 30% less shipping weight than foam.

Whatever your drop cable requirements may be, Trilogy's "Total Quality" manufacturing program assures the highest levels of performance and durability.

And the Trilogy tradition of excellence continues straight through to service and delivery, with the absolute best guarantees in the CATV industry.

From innovation to installation and beyond, Trilogy greets the world with the confidence of a true leader.



## Sending The Right Signal

**Trilogy**   
COMMUNICATIONS INC.

Call or write for free sample and brochure: Trilogy Communications, Inc.,  
2910 Highway 80 East, Pearl, MS 39208 (601) 932-4461 Fax (601) 939-6637

Circle Reader Service No. 3



## 36 A break in the chain

*By John Grothendick, Antec Corporation*

In the quest to forge a plant worthy of interactive digital services, the subscriber drop remains the weakest link.



*CED magazine is recognized by the Society of Cable Telecommunications Engineers.*

## FEATURES

### 42 Prepping the project

*By Jeff Michaud, Cable Constructors Inc.*

A cable contractor advises operators on managing joint construction projects.

### 48 Singing off the same sheet

*By Dana Cervenka*

The SCTE's Basic Construction Working Group is busy hammering out recommended construction guidelines for the cable industry.

### 50 VOD in the U.K.

*By Alec Livingstone, BT*

BT's Kesgrave video-on-demand trial is the real thing: it's running in a real telephone exchange, it uses existing cabling infrastructures, and it's impressing real customers.

### 1A 20th Anniversary special

*By Roger Brown and CED staff*

What was the most important technological development of the past 20 years? Who were the men for all seasons? And most importantly, how did engineering executives from top MSOs dispose of their '70s-era, plaid leisure suits? *CED* takes a fond look back in celebration of its 20th year.

### 58 The road to Geneva

*By Leslie Ellis*

For cable operators and telecommunications vendors, it's all about seeing, and being seen, at Telecom '95 in Geneva.

### 64 Designing for interactivity

*By Mark Myslinski, GI Communications Division, General Instrument Corp.*

Interactive broadband networks will demand an architecture that can manage the onslaught of new applications and services.

### 80 Telecom Perspective

*By Fred Dawson*

Bellcore has added a number of programs designed to test and develop specifications for HFC.

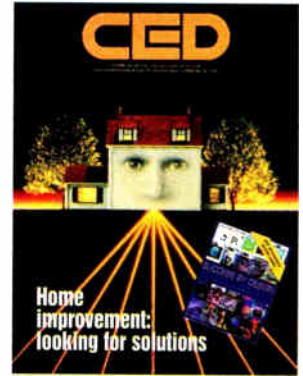

## About the Cover

*Photo by Peter Angelo Simon, The Stock Market.*

## DEPARTMENTS

5 In Perspective

12 Color Bursts

16 Spotlight

18 Frontline

20 Farmer's Market

22 Capital Currents

24 Ciciora's Corner

26 FiberLine

74 Back to Basics

78 Product Showcase

84 Ad Index

85 What's Ahead

86 Literature Guide

95 Return Path

97 People

98 New Products

100 In the News

101 Classifieds

108 My View

©1995 Capital Cities Media, Inc. All rights reserved. CED is a registered trademark of Capital Cities Media, Inc. CED (USPS 330-510) (ISSN 1044-2871) is published monthly except twice in May by Chilton Publications, A Capital Cities/ABC Publishing Group, 825 7th Ave., New York, NY 10019. Volume 21, Number 11. U.S. domestic subscriptions are \$48. Outside USA, subscriptions are \$69 for surface delivery or \$96 for air speed delivery, prepaid in U.S. funds drawn on a U.S. branch bank. Second-class postage paid at New York, NY 10019 and additional mailing offices. CED is published on behalf of the cable television and broadband communications industries. POSTMASTER: Please send address changes to CED Circulation, P.O. Box 10728, Riverton, NJ 08076-0728. MEMBERS OF THE BPA. Canada Post International Publications Mail Product (Canadian distribution) Sales Agreement No. 649945. Printed in U.S.A.

## Standard and the FCC offer the perfect plan to improve your cash flow.

By now, the FCC's "Going Forward" rules are old news. But this unique opportunity to improve your cash flow, by adding up to 6 new channels, is as fresh as ever.

Here's the easiest way to take full advantage.

### Plug in a channel today, cash in tomorrow.

Since the inception of our receivers and modulators, Standard has consistently advanced frequency-agile headend technology. With our any-channel-in, any-channel-out convenience, plus a whole host of options, you can be up and running in no time, to cash in on "Going Forward."

### The easy way.

Start with our Agile IRD II, an RS 250 broadcast certified integrated receiver/descrambler that offers all the features you'll need: an industry

standard dual conversion 70 MHz IF with TI loop, factory pre-calibrated video and audio controls and a fully synthesized PLL tuning circuit accurate to 100 KHz. And because the internal 950-1450 MHz active loop thru eliminates splitters and signal loss, adding multiple receivers is no problem. The IRD II is the receiver of choice when adding a channel.

Next, add our TVM550 series frequency agile modulator to achieve noise and spurious free performance, coupled with ultra-stable, artifact-free PLL synthesized tuning throughout the spectrum from 54 to 550 MHz. You want stereo? The TVM550S has stereo, eliminating the need for separate components, hassling with calibration, and additional rack space.

### It makes sense.

Whether you add a single channel or

the maximum six, generate the cash flow you need to upgrade your head-end to the highest level of performance – Standard's Agile IRD II receiver and TVM550 series modulator.

Add a channel... the easy way. Call Standard today and go forward while it's still to your advantage.

*The right technology... for right now.*

 **Standard  
Communications**

**SATELLITE & BROADBAND  
PRODUCTS DIVISION**

P.O. Box 92151 • Los Angeles, CA 90009-2151  
310/532-5300 ext. 280 • Toll Free 800/745-2445  
Fax: 800/722-2329 (Toll Free) • 310/532-0397 (CA & Int'l Only)

Canadian Address: 41 Industrial Pkwy S., Units 5 & 6  
Aurora, Ontario Canada L4G-3Y5  
905/841-7557 Main • Fax: 905/841-3693  
Sales: 800/638-4741

# Return on investment.

Circle Reader Service No. 4





## ***A Natural Migration***

Leadership and vision. That's what sets us apart in today's environment of converging technologies. ADC Video Systems is leading the migration to advanced video and telephony network services with a clear vision and solution for your future – all while meeting your most demanding requirements today.

ADC Video Systems offers complete end-to-end solutions in hybrid fiber/coax video/telephony transport and distribution, high speed digital fiber backbone transport, distance learning,

Px64 multipoint videoconferencing, TV1 broadcast quality video and cellular telephone transport.

The flexibility to meet the needs of today's market will ultimately determine tomorrow's success. Whether you're migrating to digital video and telephony services, rebuilding your CATV network, installing state-of-the-art distance learning facilities or building videoconferencing networks, ADC Video Systems has the technology you need. Call us to find out why the future is real. We'll help keep you flying in the right direction.

**ADC Video Systems**

*Formerly American Lightwave Systems, Inc.*

999 Research Parkway Meriden, CT 06450 (800) 504-4443 • FAX (203) 630-5701



# THE FUTURE IS REAL



## The ADC Family of Products

- Homeworx™ 750 MHz Hybrid Fiber/Coax Transmission System
- DV6000™ Digital Video Transmission System
- PixlNet™ Multipoint Videoconferencing System
- Network Monitoring and Control System
- FiberFrame™ Fiber Management System
- Soneplex™ DS1/DS3 Transport System
- CityCell™ Cellular Telephone Transport
- FN6000™ TV1 Broadcast Quality Video

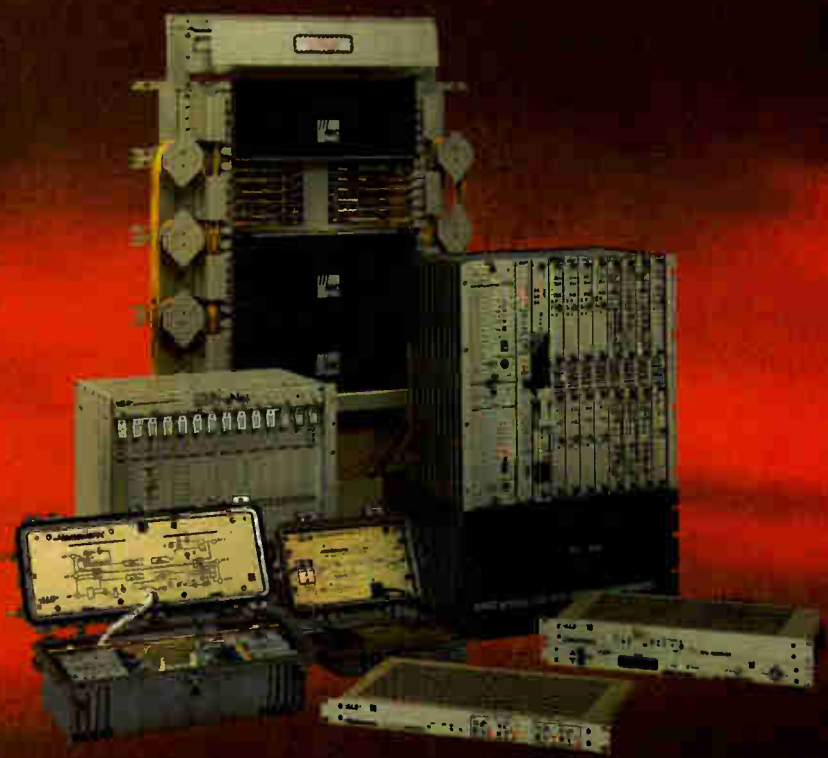

Circle Reader Service No. 5

U.S. Sales Offices in California, Colorado, Connecticut, Florida, Georgia, Illinois, Massachusetts, Minnesota, Texas and Virginia. International Sales Offices in Australia, Belgium, Canada, China, Mexico, Singapore, South Korea, United Kingdom and Venezuela.

# Jones fires up nation's first passive HFC network in Alexandria, Va.

Engineers from Jones Intercable fired up the MSO's new, state-of-the-art headend and cable plant late last month in Alexandria Va., firing the first salvo in what could be a long and bitter war for customers between Jones and Bell Atlantic—if Bell Atlantic ever gets started, that is.

The Jones plant is newsworthy in many respects. It is the first HFC network that was built without using any active electronics beyond the node, where optical signals are converted to RF and sent out over coaxial distribution runs that are, on average, about 1,000 feet long. Each node serves an average of 158 passings. The plant's backbone consists of 10 fiber loops of counter-rotating signals, making it extremely reliable. And the new headend features redundancy and backup virtually everywhere, as well.

Jones officials are the first to admit the unusual architecture doesn't make economic sense everywhere, but is justified in Alexandria because of high housing densities and positive demographics. Being located just outside of Washington, D.C., where it can be shown off to members of Congress, doesn't hurt either.

For example, even though the plant covers an area of just 28 square miles, it passes 73,000 homes, MDUs and businesses. Roughly 40,000 customers are actually served by the system.

Within that small area, Jones will eventually deploy 10 fiber rings and more than 500 fiber nodes (each of which is status monitored and

has its own standby power supply). Within each fiber ring, there are between 120 and 180 fibers, resulting in nearly 3,000 fiber terminations at the headend. There are a total of 216 fiber sheath miles, but more than 14,000 fiber miles, 92 percent of which are route diverse.

While the Alexandria topology may not be repeated elsewhere soon, the philosophy behind the headend plays virtually anywhere. "I'm constantly being asked what the headend of the future looks like," noted Roger Seefeldt, fund engineering director at Jones' corporate office. "I think this is it."

Although the Jones system will one day go head-to-head with Bell Atlantic, company officials say that was not the primary reason the system was rebuilt. Instead, it was built because competition will soon dictate that Jones will need a highly reliable network to stay the market leader.

## Set-tops cranking out, but have nowhere to go?

In what could qualify as two of the most oddly timed news releases of the year, Philips and CLI jointly announced volume production of digital set-tops, like the one being used by Bell Atlantic in its switched digital network in Dover Township, N.J., while Bell Atlantic announced a delay in deploying services over that very same network.

But first things first. Philips Digital Videocommunications Systems and Compression Labs Inc. announced that the two companies are "producing thousands of interactive digital set-top decoders per month" which will soon be used by FutureVision, the video information provider working with Bell Atlantic to offer interactive services in New Jersey.

Philips and CLI say the set-tops are the first mass produced decoders to comply with the MPEG-2 standard for digital video compression and transport.

Meanwhile, Bell Atlantic said it has delayed the 200-home technical trial in Dover Township because of problems with the network's video administration and operational support system software. Services were slated to be rolled out to 38,000 homes there after a six- to eight-week technical trial.

FutureVision's compliance testing was deemed successful, and the company will be working with the regional Bell operating company to resolve the software problems. Commercial service will be delayed until the tests are completed, which could push initial rollout into 1996. After that, Bell Atlantic expects to begin adding about 2,000 homes per month to the network.

## ADC pens agreements with OSI and Optivision

Further evidence that ADC Telecommunications seeks to be a major player as a supplier of equipment to hybrid fiber/coax network operators came in late August when the company announced two new business relationships.

First, the company announced it is working with Objective Systems Integrators to jointly develop a set of element manager systems for ADC's Homeworx HFC access platform. The two companies will jointly market "OSWorx" element manager systems that are based on OSI's NetExpert software, beginning in the third quarter of 1995.

The element manager will feature open interfaces, such as Transactional Language 1 (TL1) and the CMISE standard. As such, it will provide management of voice, video and data services. Further, it will be compliant with Bellcore's TR-008 and TR-303 standards.

The new element manager system will provide a number of critical functions, including configuration management, such as inventory and provisioning; fault management, including testing, alarming and alarm correlation; performance management; and security management.

In addition, ADC announced its intentions

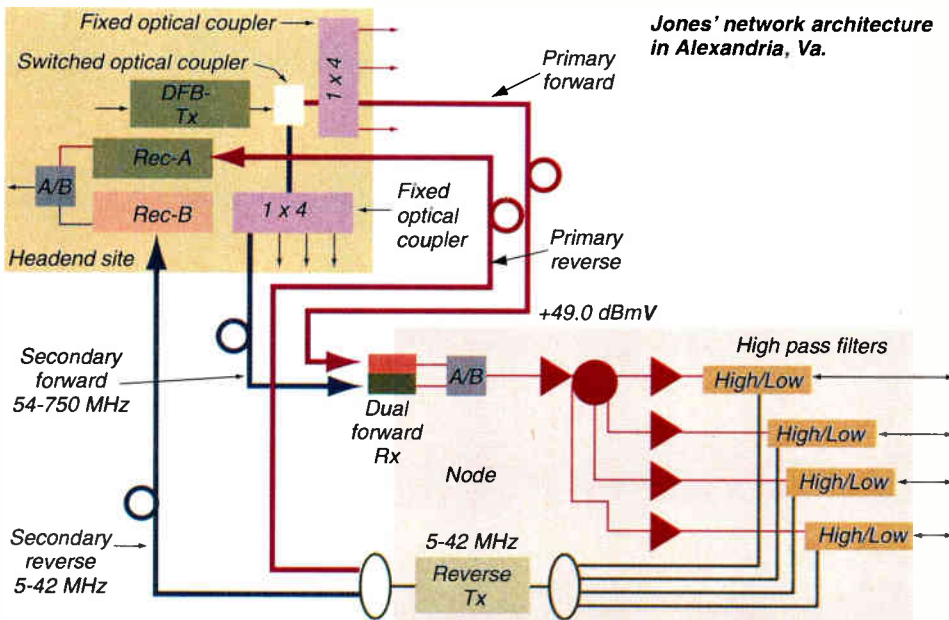

# Bill Winslow's Up On The Latest Ways To Avoid Downtime



*Bill Winslow  
Manager  
Materials Management Services*



In your business, downtime is deadly. It drains productivity and your cash flow. But Bill Winslow can give you materials management solutions to make your techs and installers more productive. You'll get just the right amount of equipment, just when you need it. You'll meet industry service mandates, and your customers will be satisfied. And that's where Bill Winslow and Sprint/North Supply can help.

At Sprint/North Supply, we have years of experience creating a full range of materials management solutions that save time and money. Solutions for building, upgrading or re-building systems. Solutions for drop installation orders to hook up your new customers. And solutions for any type of plant maintenance — including emergency repairs. We take care of your materials needs, so you can focus on productivity and service. We'll manage your materials quickly and accurately — all orders are filled in 24 hours and shipped overnight.

Effective, efficient materials management is easy with our network of 11 distribution centers. We have 30,000 products from 1,200 leading manufacturers. Located throughout the United States, our distribution centers cover 1,067,107 sq. ft. of space. They're linked by computer to deliver the materials and equipment you need to keep your productivity on target and your customer service on track.

With one toll-free call, you'll have instant access to the broadband and telecommunications solutions you need. At Sprint/North Supply, we're your full-line national distributor. Call and let us tell you how to keep your downtime down.

FREE CATV/BROADBAND CATALOG. Call and order your FREE 296-page catalog, featuring thousands of products. NO OBLIGATION.



**1-800-639-CATV**

Circle Reader Service No. 6

On Line, On Call, On Time



## ◆ COLOR BURSTS

to invest \$6 million in Optivision, a Palo Alto, Calif.-based company developing MPEG digital video compression technology.

Optivision is working on a complete line of OPTIVideo MPEG-1 and MPEG-2 encoders and decoders for video transmission and video-on-demand applications. Optivision already has a close working relationship with C-Cube, a supplier of integrated chips for MPEG codecs.

### AlphaStar picks Samsung to build its DBS set-tops

AlphaStar Digital Television has announced that Samsung Electro-Mechanics Co. will manufacture digital television set-top receiver boxes as part of the AlphaStar digital direct-to-home satellite television system. The receivers will be among the first to use MPEG-2 DVB compliant technology for the highest quality picture available. The AlphaStar Digital DTH satellite television system is scheduled to launch in December 1995.

"Samsung brings outstanding manufacturing and consumer electronics distribution expertise that is an ideal match for AlphaStar's world standard digital system," commented Murray Klippenstein, president and CEO of AlphaStar.

AlphaStar is the first digital satellite television service in America to use TV/COM's open world standard MPEG-2 digital video broadcast (DVB) compliant system.

SEM Co. is a leading manufacturer of electronic components used in consumer electronics, of cable television and satellite receiving equipment, and of advanced computer components. As a \$1.5 billion unit of the Korean multinational Samsung Group, which has total worldwide revenues of over \$50 billion, SEM Co. has access to the D-RAM memory chips that are essential to the production of the set-top satellite-TV receivers.

AlphaStar is a wholly-owned subsidiary of Tee-Comm Electronics Inc., a digital satellite communications company. By December, the company plans to offer more than 100 channels of video and audio services via an AT&T 402R satellite using a small dish and a set-top digital receiver manufactured by Tee-Comm Electronics.

### IVDS coming to the Midwest; testing to begin

In what promises to be one of the first uses of the Interactive Video and Data Services spectrum, Welcome To The Future Inc. (WTF) announced it has been contracted by Dispatch

Interactive Television Inc. (DITV) to provide turnkey interactive television hardware, software and network services to the Columbus, Ohio and Indianapolis, Ind. markets.

WTF and DITV are scheduled to deliver interactive television service to Columbus and Indianapolis beginning late October 1995, starting with several hundred test homes located in both cities. Based on the results of the control test, a gradual roll-out of the system will commence approximately six months thereafter. The wireless, real-time interactive response system is called HEAT—Home Entertainment Advanced Technology.

The remote control will allow viewers to "point-and-click" at their own TV screen and "interact" with informational and transactional services provided, as well as control normal TV set broadcast, cable and VCR functions. The home viewer's interactive response is then transmitted back on the IVDS (Interactive Video and Data Services) broadcast spectrum, which was authorized by the FCC last year.

A sampling of the interactive services that will be tested will not only be personalized news and information services—such as sports, weather, horoscopes, classifieds, restaurant and entertainment directories—but viewers will also be able to easily conduct transactions including home shopping, home banking, electronic bill paying, reservation and ticket purchases for airline, theater and movies, as well as be able to order home delivery of groceries and fast food, or control and monitor home appliances and utilities, assuring lower operating costs.

### AT&T, Motorola chosen to supply PCS PrimeCo

PCS PrimeCo, L.P., the consortium of telcos girding to provide PCS in a number of major markets, announced its intention to award separate multi-million dollar provisioning contracts to AT&T Network Systems and Motorola to supply PrimeCo with the hardware and software for a complete, end-to-end wireless communications system, including base stations and switching equipment.

These agreements are believed to be among the first between a United States PCS carrier and any Code Division Multiple Access (CDMA) technology supplier, and have a combined total of as much as \$1 billion. Definitive agreements are subject to terms and conditions, which were not disclosed, and could take up to one month to finalize and close.

Both Motorola and AT&T will provide the equipment to build out specific geographic areas, or MTAs, that PrimeCo serves. PrimeCo

owns PCS licenses in 11 Major Trading Areas across the U.S., covering 57 million potential customers.

Under the agreements, AT&T Network Systems would provide equipment for the Houston, Jacksonville, Miami, New Orleans, Richmond and Tampa MTAs. Motorola's Cellular Infrastructure Group would supply complete PCS systems for customers in Chicago, Dallas, Honolulu, Milwaukee and San Antonio MTAs.

PrimeCo plans to have the first customers on its network by the end of next year, and these suppliers have committed to delivering equipment in time for PrimeCo to meet that goal. Delivery date milestones were not disclosed.

PrimeCo, the four-way partnership of AirTouch Communications, Bell Atlantic, Nynex and US West, announced in June that it will deploy CDMA technology throughout its PCS network because it is a cost-effective way to offer wireless services in its own markets and also provide national interoperability with the company's owners' cellular systems.

### Jottings

France Telecom has chosen to use equipment supplied by **BroadBand Technologies and Groupe Sagem (SAT)**, a French telecom equipment supplier, to build a fiber-to-the-curb trial network that will provide broadband interactive multimedia services. The companies will work together to provide telephony, video and data to up to 20,000 homes, and France Telecom will incorporate the BBT/SAT system into its \$100 million Fiber Optic Information Superhighway initiative, an extension of the national fiber optic business network, which was launched in 1992 . . .  **DirecTV**, the national DBS provider, has reached agreement with famed film director Francis Ford Coppola and his Zoetrope Corp. to transmit the original theatrical version of "Apocalypse Now" in widescreen, 16x9 format. This marks the first time a film has been digitally broadcast in this format. Of course, viewers will need a widescreen TV to see the film without it being letterboxed . . . Viewers in Omaha will have one more choice of a provider for TV. **Sky Cable of Omaha** announced it will use digital compression gear from **Decathlon Communications** when it gets up and running this autumn. Sky leases four wireless cable channels presently and is negotiating for four more. With 10-to-1 compression, the MMDS provider could offer up to 80 channels of video. Sky will compete with Cox Cable and US West, both of which have built state-of-the-art interactive video systems in that city . . .  **CED**

# In network monitoring, it's the A.M. of a new age.

AM Communications offers a decade of experience in cable network monitoring. More than 400 AM systems are at work today, under our own name or within the products of some pretty famous strategic allies.

Our new products include not only Echo, a low-cost end-of-line monitor, but also a truly exciting second generation cable network monitoring system featuring easy-to-use OmniVu software. It's a Windows-based, open architecture system that's powerful, rich in

features, and distinctly affordable in price.

AM's total monitoring solutions include hardware, software, and technical service that's in-depth and on time. Please call (215-536-1354, 1-800-248-9004), fax (215-536-1475), or write (1900 AM Drive, Quakertown, PA 18951-9004). And give us the opportunity to do a little crowing

about what we  
can do for you.



**COMMUNICATIONS**

GUARDRAILS FOR THE INFORMATION SUPERHIGHWAY



Echo™ and OmniVu™ are trademarks of AM Communications, Inc.  
Windows™ is a trademark of Microsoft® Corp.

Circle Reader Service No. 7



# Electronic warrior tackles return path



Louis D. Williamson

**C**alm. Mellow. Easy-going. All apt words to describe Louis Williamson, senior project engineer, Time Warner Cable Engineering & Technology. And it's a good thing, too, because his very first project out of college, for Martin Marietta Aerospace, was a real nail-biter: designing a detection system to prevent nuclear missile silos from exploding. His pet project, actually a microwave vapor analyzer, detected minute amounts of rocket fuel leakage in the silos.

Maybe because he was exposed to such responsibility so early, Williamson's career took on the flavor of looking beyond the stress of the moment to the thrill of the engineering challenge. As an example, he cites another of his favorite projects at Martin. "Electronic warfare was actually fairly fun. Like the reverse plant today," says Williamson. "You never know if your message is going to get through."

In fact, one of Williamson's personal challenges today is trying to perfect two-way communication over the cable plant to ensure that applications like telephony and interactive entertainment will really work. "When I first started analyzing it, the return path kind of looked like an electronic warfare scenario," he reflects. "There is a lot of [garbage] floating around in there, it comes and goes, and it tries to jam you from communicating."

The comparison between the two eventually struck a familiar chord, and as Williamson called to mind his previous work up in the microwave frequencies for Martin, he hit upon the idea of using the high-end return path for Time Warner's Full Service Network in Orlando. While acknowledging that the high-end is definitely more expensive to operate in, requiring more amplifiers to overcome higher signal loss, Williamson found it to be blessedly clean. "We know that it works, and is usable now," he notes. "It's just a matter of when we are going to need it."

Other projects Williamson is currently working on for Time Warner include stabilizing the platform for new analog convertor launches, which will offer on-screen guides and "virtual channels."

When Williamson first joined the MSO (then American Television & Communications) in 1983, the connection between his research and real-world applications was not quite so clear-cut. He started off by working on distributed subscriber terminals, characterized by having most of their "smarts" located outside of the house. "Unfortunately, that was about the time of the cable-ready set evolution," he notes wryly, "so off-premise convertors never really made it."

It wasn't too long before ATC reorganized its R&D

department into the engineering and technology group, somewhere around 1986, and Williamson suddenly found himself in the role of fiber guru. At a time when no one really knew what AM was, he had the task of convincing laser manufacturers and others that it would be a good idea to make the equipment the MSO needed.

"Finally, we found one company that did understand analog," recalls Williamson. "They were doing high-frequency analog lasers. We got them to bring in one of their systems and plug the matrix into it, and [this produced] some really lousy pictures. But the pictures came through, so we were excited."

With the successful implementation of fiber down to smaller and smaller nodes, the engineering and technology team began searching for the next step in network evolution. At that point, Williamson and his colleagues began "trolling" for new ideas, a process that's a big portion of his job. "You have to figure out where the fish are," he notes, "and you throw a line out to them—sometimes, you even get a little bite." As it turns out, they reeled in a whopper: the FSN.

"Compression was coming together, we felt that the price of storage was coming down, and we were comfortable with digital transport, digital audio, and those types of trials," Williamson explains. "So it was really, how could we combine them all to make a system, and leverage all of those to make a business out of them?"

## Another career determined by prerequisites

Did Williamson have any idea as a young student that he would one day be involved in engineering the premier interactive cable network? His parents may have had a clue, as their 16-year-old son was fond of taking electrical devices apart—sometimes even putting them back together—or rewiring his room just for fun. ("I don't understand it, dear. When I use the toaster, the TV in Louis' room comes on.") Originally, Williamson had wanted to become the next Jacques Cousteau, until he found out that one of the prerequisite courses for his chosen career was a bit out of his realm. "I couldn't swim, so I decided that oceanography was probably not the job to have," he notes. And thus, in 1980, Williamson graduated with a BSEE from Virginia Polytechnic Institute and State University.

Today, his love for nature has translated into a love for house plants, which grow with abandon throughout his 85-year-old Denver home. He also enjoys bike riding, woodworking and photography, and looks forward to resuming his hobbies, now that things have calmed down in Orlando.

Given that much of the interactive infrastructure is well on the way to becoming a reality, as in Orlando, Williamson sees the emphasis shifting from hardware, to software and applications. "We are no longer going to be worried as much about set-tops and amplifiers," he predicts. "There's going to be a big thrust on interactive shopping and games and those types of things. That's really what is going to make the business grow. It's not going to be saving a dollar on a set-top." 

# THE BEST JUST GOT BETTER

## Better

The GC12V75's improved run time and competitive price make it an exceptional value.



## Best

The GC12V100 offers the industry's longest run time and an unprecedented 2-year warranty.



**A**lpha offers two new choices for improved system reliability: the Dynasty GC12V75 and GC12V100 float-service broadband batteries. These new Dynasty gel/cell® batteries offer the *longest* run time of any battery sold in the industry.

Dynasty broadband gel/cells® are also the only batteries that share the features and reliability found in telecommunication battery designs. There is simply no better battery for reliable cable system performance.

And there's no better or more convenient battery service than the Alpha Advantage<sup>SM</sup> program.

- ▶ **The Longest Run Time Available**  
*These new broadband gel/cells® provide the industry's longest run time.*
- ▶ **The First 2-Year Warranty**  
*The new GC12V100 offers the industry's first full 2-year warranty.*
- ▶ **The Most Complete Battery Service**  
*Fast delivery and complete recycling with the Alpha Advantage<sup>SM</sup> program.*



The Alpha XM Series CableUPS® and the Johnson Controls Dynasty gel/cell® battery.

▶ For more information, on the Alpha Advantage<sup>SM</sup> battery program call: **1-800-421-8089**

**United States**  
Alpha Technologies  
3767 Alpha Way  
Bellingham, WA 98226  
Tel: (360) 647-2360  
Fax: (360) 671-4936

**Canada**  
Alpha Technologies  
5700 Sidley Street  
Burnaby, B.C. V5J 5E5  
Tel: (604) 430-1476  
Fax: (604) 430-8908

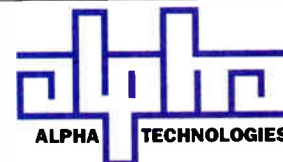

# The computer ate my homework



By Wendell Bailey,  
VP of Science  
and Technology, NCTA

When I was a lot younger (Hey! I was actually young once) the big excuse for not having your homework done was the famous "the dog ate it" line. This was in the same league, if not the style, as "a bully took it away from me," or "I lost it on the bike ride to school, and it blew away before I could catch it." I think I would be safe in saying that few, if any, of my teachers (or fellow students for that matter) believed any of these pearls.

The world certainly has changed, however, when it can be said that the single most popular individual personal catastrophe is: "The computer crashed," or whatever you were working on is "somewhere in computer hell and no one can get it out."

The funny thing is that I don't know of any dogs actually eating homework assignments, and while there may have been the odd one or two "bullies," I think the excuse was used perhaps a bit too often. And while sick cars and sick relatives are possibilities that we all have to live with, I think this, too, may be a bit overused.

## Major reliability problem

But no one, literally, *no one* in today's society finds anything unusual about saying that the computer ate it, or

that it disappeared and that it can't be resurrected, or that the printer wouldn't print, or that the word processor delivered a document that was all fouled up and they are working to correct it. Indeed, everyone thinks that these are so normal and so regular that they never blink an eyelash at what may in fact be fraudulent excuses.

If we think deeper about this, we come to an amazing realization: In today's society, we put up with a device, the computer, that is crucial to our day-to-day business activities, but which has a major reliability problem. Is there anyone who does not, at least once a day, have something weird happen to or on their computer? I'm not talking about minor weird, like mistyped words. I'm talking about locking up weird; I'm talking about saved to the wrong file weird; I'm talking about flashing screens; I'm talking about the dreaded "windows closing now, good-bye."

And woe to the person who buys a new printer or a new CD player, or even a sound card, and attempts to get them working correctly on the first attempt. Indeed, if you have the nerve to try to install these things yourself, you'll be sure to have a load of fun with the less-than-clear instructions, and the cryptic choices that can quickly have you pulling your hair and gnashing your teeth.

Some of you, especially the assembly language gifted, may find this complaint to be unfair. After all, not everyone pays attention to all of the instructions that come on the latest goodies box from the computer store. But even at times when professionals come in to install things like modems, they don't just stick them in a slot and press the "go" button, either. They fiddle with the software, they fool with the interrupts and play around with the DMA lines and the interrupt addresses.

They get the printer working (though not necessarily all of the fonts, and now, the modem doesn't work). They get the modem working, and the sound card doesn't work. They get the sound card working, but then the CD doesn't work, and on and on and on. Eventually, they get it all sorted out, and frankly, compared to what the average computer user can do, they seem to get it done in fairly short order.

But if this were a car or a television set, we would not tolerate this level of flakiness in any way, shape or form. What if we had to put up with this level of functional reliability in something like an airplane or a heart pacemaker?

Should you be so bold as to buy a new software package to install on your computer, all the while expecting and looking forward to the increases in productivity that it will bring you, what's the likelihood that it will be installed hassle-free? What's the likelihood that it will work the way it is supposed to work? Not much.

Even the computers that are advertised as being "plug-and-play" do not solve all of these problems. They do a grand job of taking care of those printer start-up blues, but they seem just as likely as anything else to give you another problem that requires the application of the "Three Finger Salute."

Why do we, as a society, tolerate this level of uncertainty in our daily lives? Especially when this uncertainty has a direct effect on the so-called productivity increases that the computer was meant to bring to society? Is it that we have not been able to separate the self-inflicted problems from the computer-generated glitches, and have therefore decided not to take notice? I don't believe that is the complete answer, but it may be part of it.

## Multiple combinations and permutations

It just may be that the technology and capabilities of the computer have moved too fast for anyone, even the designers, to think of all the possible ways that multiple elements can be put together in a system. The inevitable result of this has been the birth of an essential tool that is not above eating our homework.

Some day, we may all look on this excuse with the same level of jaundiced disbelief as we do on that old saw about the dog and the bully. May the day arrive soon. "I have a report due, but you know, my computer..." **CED**





# Nobody carries a more durable, dependable & versatile line of batteries.

For any climate, for virtually any application, POWER GUARD offers a complete line of maintenance-free, fully accessorized batteries to meet your needs.

**Handles and Hardware Included.** POWER GUARD Premium Gel Cell, AGM Sealed and Flooded batteries are manufactured to the highest quality standards in the industry. And only POWER GUARD batteries come equipped with convenient carrying handles and hardware for safer, easier transportation and installation.

**Maintenance-Free and Recyclable.** Our batteries are exclusively designed

for longer cycle life and maintenance-free operation. And all POWER GUARD batteries are 100% recyclable. Simply call our convenient 800 number; and we'll pick up your spent batteries.

**In Stock for Immediate Delivery.** In a bind? As part of our commitment to meet customer needs, POWER GUARD has batteries in-stock and available for immediate delivery. Call POWER GUARD and have your batteries shipped when and where you need them. POWER GUARD, your single source for all the power you need.



 **POWER GUARD**™

A n A N T E C C o m p a n y

Circle Reader Service No. 9

**1-800-288-1507**

506 WALKER STREET, OPELIKA, ALABAMA 36801 FAX: 334-742-0058



# Revolution is in our midst

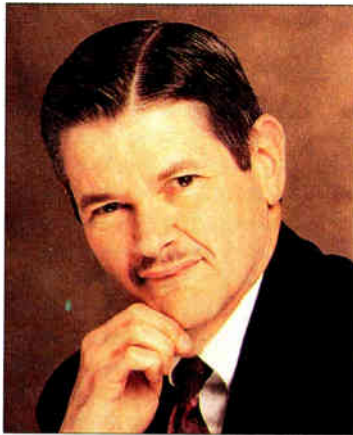

By Jim Farmer,  
Chief Technical Officer,  
Antec Technology Center

We are in one of those periods that rarely comes to an industry, during which the word "revolution" is apropos. Revolutionary times are fraught with danger.

Formerly big players must manage change properly, or they become bit players. New entrants succeed if they take advantage of changes the entrenched folks don't see coming. On the other hand, revolutionary times provide incredible opportunities to lose money, if one errs.

The problem is to separate the real players from the Future Failures of America. Having spent my entire career on the supply side of the industry, I used to find myself impatient with customers who tested me to see if I was real or not. One time, I found myself specifying a system we were purchasing and felt the uncontrolled fear that I would wind up with something that didn't do the job. I realized how career limiting that could be. So here are a few tips to help determine what is real, and what is made of nonexistium.

### Healthy skepticism

We see many operators who, when faced with buying new systems, use the, "Get your stuff working in my plant by such and such (unrealistic) date, or you're out," approach. It puts

you and your potential supplier in a lose-lose situation. When you deal with new systems, delays are not only likely, they are inevitable. If a supplier has an unrealistic drop dead date, he is likely to put out a system that has flaws he would have found with a few more weeks of testing. In the end, this is going to inconvenience you, and possibly cause you subscriber or regulatory problems.

A preferred approach is to take what the supplier says skeptically. Challenge your supplier to show why his dates are reasonable. Take the attitude, "I hear what you are saying, but I don't believe you can do it. Prove me wrong if you can."

Sit down with the engineers doing the work and understand how they see the schedule. Ask where the risks are (they always exist, regardless of what the salesman says), and how they are being mitigated. Especially in the earlier portions of a development program, don't be alarmed if something doesn't work, and the engineers are not sure how to fix it. This is a normal part of any product development process. As long as you can come back later and see progress, there is no cause for alarm. Similarly, when the first equipment is put in the field, there will be problems that will take time to overcome. Again, this is normal and not cause for alarm if the engineers are making progress.

Take time to understand how the system works,

what it can and what it can't do. Written specifications, whether generated by you or the supplier, are important. They should detail how something will work, what specifications it will meet, and what else has to happen for the system to work within your network. Again, don't be alarmed if specifications change somewhat during development, but make sure every change still specifies something that does the intended job. Also, it's okay to include a phrase that says the equipment shall perform the intended purpose, even if that requires it to meet something not in the specification.

Think about what you are being told about cost, performance, maintenance requirements, physical space, plant requirements, how your subscribers will react, etc. Are the answers reasonable based on your past experience? Take time to learn about the system. Of course, take time on your own to learn the background information, so your potential supplier's people are not unduly called upon to start from Ohm's law and work up.

### Development costs

Honor any nondisclosure agreements you sign. A supplier realizes that you are (or at least should be) talking to everyone developing similar products. Remember that your supplier is spending literally millions of dollars to develop something new, and he has a right to not have information handed to a competitor. To get an idea of the magnitude of R&D costs, an incremental set of improvements in a product can cost maybe \$50,000 to \$200,000. Something really new, such as compression to the home, will cost hundreds of millions by the time you install the first one, and before anyone knows for sure that there is a market for it.

### Proven in the real world

Finally, be prepared to work with a supplier in field testing. This is crucial, because a manufacturer can't possibly simulate all of the variables that will affect equipment in the real world. He needs to get prototypes out quickly, so that when you and he find improvements (you will), he has time to make changes before he commits to final product.

An MSO for whom I have a lot of respect is hosting a number of experimental systems in his plants now. Sure, he is spending a few bucks, and some of the new stuff he's looking at may not make it. But when it comes time to deploy on a large scale, he'll have first-hand knowledge of what is real, what is hyperbole, and what just doesn't work.

Watch your commitments and carefully manage expectations (yours, those of your boss, and those of your customers). New things must still obey that most fundamental law of electronics, Murphy's: "Nothing is as easy as it looks, everything takes longer than expected, and if anything can go wrong, it will, at the worst possible moment." Healthy skepticism is still better than unbridled optimism for something new. **CED**

### Have a comment?

Contact Jim via e-mail at:  
jfarmer@ix.netcom.com

Telecom '95  
in Geneva  
French Pavilion  
Stand 5222

**NEW  
Low Price!**



# THE HANDHELD FLASH MINI OTDR



## Portability & Performance

Enjoy true field portability with the handheld *FLASH* fiber optic cable tester. It's small (6 1/2" by 8") . . . lightweight (less than 3 1/2 lbs.) . . . easy to use . . . and performs flash maintenance, fault location, fault analysis, and verifies repairs with the touch of a button.

The field based OTDR *FLASH* is the solution for all your construction and maintenance applications with flexible software tailored to your needs for all stages of test operation. The *FLASH* provides instantaneous link evaluation to reduce repair time and improve efficiency.

## Engineered for full OTDR functionally:

- Dual wavelength capabilities - 1310, 1550 or 1310/1550 nm
- Fast acquisition time to analyze attenuation and reflectance
- Automatic injection level analysis
- Automatic ghost detection and cancellation
- Real-time analysis (less than a second)
- Splice location down to 0.05 dB
- PCMCIA memory storage to analyze each trace
- Choose between manual or an auto measurement
- Flexible software solutions for specific applications
- Low power consumption for over 8 hours of field operation
- Simple user interface guides you through the test process
- PC software for data analysis

You'll wonder how we squeezed in so much capability. The *FLASH* provides all the accuracy, speed, and features you'd expect from Wavetek. Get the Wavetek *FLASH*.

**Winner**



**Winner**

*Wavetek...partners in productivity for over 25 years.*

Circle Reader Service No. 10

**Call 1-800-622-5515**

**WAVETEK**

©Wavetek Corp., 1995

# Putting fiber to the test

## Practical field testing guidelines

By Todd Jennings,  
Product Manager,  
Siecor Corporation

Practical cost-effective guidelines for testing new and previously installed optical fiber cables are needed to ensure proper installation and long-term system performance. Straight-forward test procedures and guidelines have been established based on 17 years of field experience and over 4,000 fiber optic installations. This article summarizes up-to-date information on common test practice and documentation, available test equipment, and field effects and limitations for testing in cable TV applications.

### Why test?

As the deployment of fiber optic systems accelerates in cable TV applications, so do the demands for extending headend to node lengths, increasing channel loading, and improving carrier-to-noise ratio. To meet these demands, new installations are routinely pushing the limits for low attenuation, reflectance, and dispersion—specifying maximum fiber attenuation of 0.35/0.25 dB/km at 1310/1550 nm, non-reflective fusion splices averaging less than 0.05 dB, and high-performance connectors with maximum loss of 0.50 dB and return loss less than -55 dB.

- Establishing minimum levels of testing is crucial to:
- ✓ ensuring the installed quality meets the demanding goals for current and future use
  - ✓ documenting initial performance as a benchmark for future maintenance, upgrades, and reconfiguration, and
  - ✓ minimizing downtime should a system go down.

Implementing simple field-proven test procedures provides solid proof of system integrity, prevents rework, and ensures reliable system operation.

use of fusion splicing and factory-terminated connectors minimizes the need to field test and document component reflectances. For troubleshooting and acceptance testing of mechanical splices or field-installed connectors, the OTDR should be used to measure individual component reflectance.

Although dispersion is an important system design concern, it is not necessary to test in the field if the guaranteed cable specifications are documented.

To make cost-effective decisions, it is important to know what present and future value is added by both specifying guaranteed component performance and field testing installed performance. The following sections detail the purpose, procedure and field considerations for testing end-to-end attenuation, OTDR analysis, reflectance and dispersion. In addition, tools and procedures for troubleshooting, upgrades and reconfigurations are summarized.

The most basic and essential test of an installed link is end-to-end attenuation, the total optical loss between the fiber's endpoints. Acceptable loss values are dependent upon the fiber quality, system length, wavelength and number and type of connectors, splices and splitters. The end-to-end loss should always be less than the link loss budget calculated in the system design. Because of the stress and bending that cables can be subjected to during installation, *the attenuation of each link should be measured after installation.*

### Attenuation test procedure

The attenuation of installed cable systems is tested by the *insertion loss* method, as shown in Figure 1. An optical source and optical meter are used to measure the relative drop in the optical level (dB) between entering and exiting the fiber.

*Each connectorized fiber should be tested from headend to node at 1310 and 1550 nm to account for wavelength-dependent attenuation differences. If return path transmission is planned, bi-directional attenuation measurement should be performed.*

#### Insertion loss test procedure:

**Step 1: Reference.** Connect a short test jumper between the optical source and the optical meter. Record the reading as the reference power  $P_{\text{reference}}$  in dBm. This power level is simply the output power of the light source coupled into the test jumper (see Figure 1a).

*Note: Never disconnect or adjust the jumper connection at the optical source after recording the reference value. This will probably change the value and cause final test results to be inaccurate.*

**Step 2: Check.** Disconnect test jumper #1 at the power meter and insert a second test jumper. Verify that the two test jumpers are good by ensuring that the power  $P_{\text{check}}$  is within the guaranteed maximum mated pair connector loss, typically 0.5 dB, of  $P_{\text{reference}}$ . If this criterion is met, continue to Step 3. Otherwise, clean the connectors and adapter and repeat Step 2. If the loss is still greater than 0.5 dB, replace the test jumpers as appropriate and repeat (see Figure 1b).

Figure 1a: Insertion loss test procedure; reference

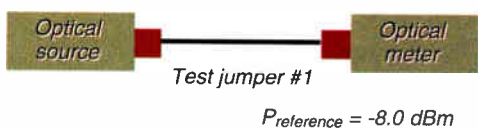
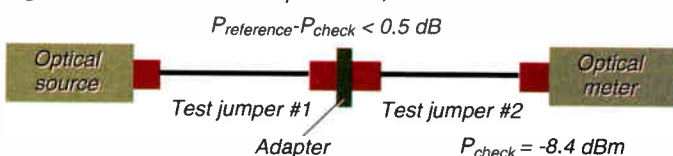

Figure 1b: Insertion loss test procedure; check



### What to test

Today's analog cable TV transmission systems require stringent attenuation, reflectance and dispersion limits. The primary focus of field testing is attenuation—measured as end-to-end system attenuation and as discrete OTDR component losses.

In many new installations, the

**The world's newest, fastest OTDR  
can test 500 fibers in less than a day.  
It's probably taking you all week.**

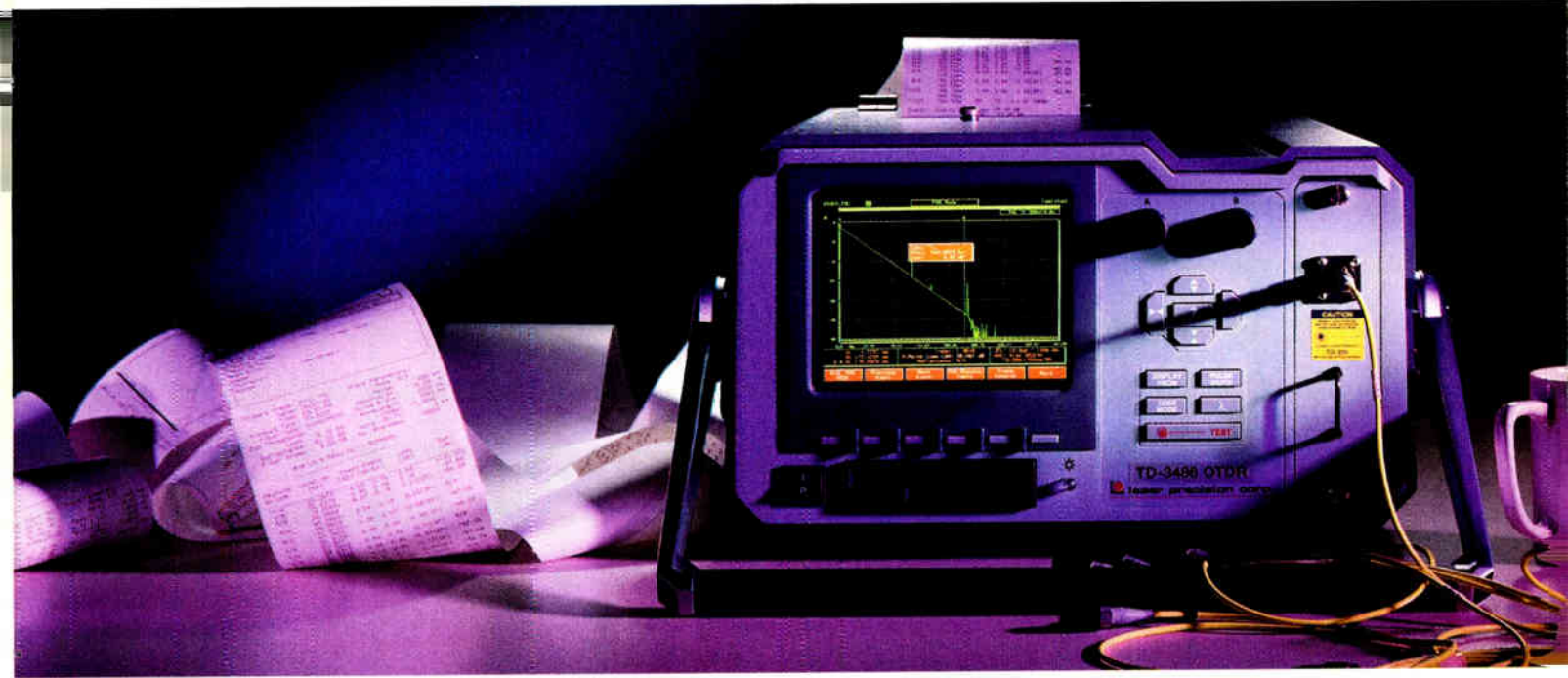

Our new TD-3486 modular OTDR is loaded with a 486 processor, governed by our exclusive software, and reduces fiber optic cable test time significantly. What now takes three minutes to test on an ordinary OTDR takes only 22 seconds on the 3486. Which means your technicians can do a lot more testing in a lot less time, and you'll save a lot of money. And the 3486 does it with better resolution and clearer, more accurate traces which are easily seen in your choice of colors on its VGA display. Restoration time is dramatically accelerated, too.

The world's fastest OTDR brings new meaning to "one-button testing." Plus, it's so incredibly easy to operate, you're really going to reduce training time.



**The dynamic range is nothing short of extraordinary.**

The TD-3486 can go from 32 dB all the way up to 40 dB. Special modules let us give you precisely what you need whether you're testing 2 km of cable or 200 km. But the next thing you need is more information about the newest OTDR from the company that makes nothing but fiber optic test equipment: Laser Precision. Call us toll-free, or write, and we'll tell you more in no time at all.

**GNI** **Nettest**  
**laser precision division**

We're easy to work with.

109 N. Genesee St., Utica, NY 13502 315/797-4449 or **1-800/443-6154** Fax: 315/797-5847

Circle Reader Service No. 13

Figure 1c: Insertion loss test procedure; test

System attenuation (dB) =  $P_{reference} - P_{test}$

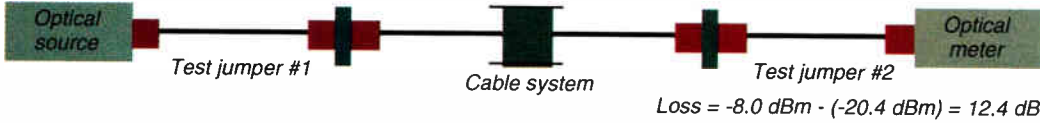

Step 3: Test. Leave the two test jumpers attached to the optical source and optical meter. Disconnect the two jumpers at the adapter. Attach the optical source/test jumper #1 to fiber under test at the headend and the power meter/test jumper #2 to same fiber at the node. Record the power level in dBm as  $P_{test}$  and calculate the loss in dB. Repeat this step for each fiber to be tested (see Figure 1c).

**Attenuation test guidelines**

To ensure accurate test results, follow these guidelines for the test jumpers, test equipment and system under test:

- ✓ *Test jumpers*—the fiber and connectors should be of the same type and grade as the cable system.
- ✓ *Test equipment*—optical sources should be stabilized lasers operating within  $\pm 20$  nm of the 1310 and 1550 nm operating wavelengths; optical meters should provide linear measurements up to +20 dBm and be traceable to the National Institute of Standards and Technology (NIST) calibration standard.
- ✓ *System under test*—all system connectors and adapters should be clean prior to measurement.

**OTDR testing**

Although attenuation testing measures the total lump sum loss between two endpoints, an Optical Time Domain Reflectometer (OTDR) can measure the distance, loss and reflectance of each component in the cable system from one end. The OTDR works like a radar, sending pulses of laser light out through the fiber, measuring the level and time delay of the return signal, and displaying this information in a graphical format. A single “signature trace” of each fiber provides an overview of the entire cable system (see Figure 2).

As shown in Figure 2, the OTDR plots the optical power level in dB on the vertical scale vs. distance (in meters or feet) on the horizontal scale. The trace declines from left to right, indicating that light is being attenuated by the fiber, connectors and splices as it travels down the length of cable. Linear sections represent continuous spans of cable, with their slope indicating distributed loss over a section of fiber. Steeper slopes indicate higher fiber loss in dB/km.

Vertical drops (seen at points B, C, and D) represent point losses, such as connectors, splices and faults. Spikes indicate

reflective events such as connectors (B) or mechanical splices (C) where the continuity of glass is interrupted; the higher the spike, the greater the reflection. A fusion splice (D) exhibits a point drop but no reflective spike. The final spike (E) on the trace indicates the fiber end, beyond which the trace drops off to the

OTDR’s noise floor.

**OTDR test procedure**

Prior to installing a cable reel, an OTDR can quickly and easily verify the length and attenuation of each fiber. It can also detect point faults or discontinuities caused by shipping and handling. This inspection can provide important protection against liability when multiple parties are involved.

When fusion splicing is performed, splice loss estimates from LID-based (Local Injection and Detection) splicers should be documented. *After installation and termination, OTDR signature traces should be documented on each fiber at 1310 and 1550 nm, verifying fusion splice loss and location.* If field-terminated connectors or mechanical splices are used, the loss and reflectance of each one should be tested with an OTDR.

Signature trace documentation can be provided in either printout or file form. A benefit of saving OTDR traces in file form is the ability to perform more detailed off-line analysis and comparison, often saving time and retesting.

**OTDR field effects**

*Loss measurement:* In general, fiber attenuation decreases with increasing wavelength. A typical single-mode fiber has an attenuation specification of 0.35 dB/km at 1310 nm and 0.25 dB/km at 1550 nm. Lower fiber attenuation is indicated on the OTDR as a shallower slope.

Actual splice and connector loss are practically independent of wavelength. However, fiber becomes more bend sensitive at longer wavelengths. For example, a tight bend in a fiber undetectable at 1310 nm may cause a significant loss when measured at 1550 nm. If apparent splice loss is noticeably higher at 1550 nm, suspect bending problems at or near the splice point. It is beneficial to isolate 1550 nm bending effects and correct them.

Detectable bends can affect transmission problems at the longer wavelength and degrade the fiber’s physical longevity. For this reason, most system operators perform OTDR testing at 1310 nm (normally the transmission wavelength) and 1550 nm (to detect bending effects).

Apparent OTDR splice loss measurements can exhibit directional differences due to small-scale differences in the geometry (mode field diameter) and backscatter characteristics of the two fibers. Occasionally, the OTDR may indicate a small increase

**A single signature trace of each fiber provides an overview of the entire system**

Figure 2: OTDR signature trace

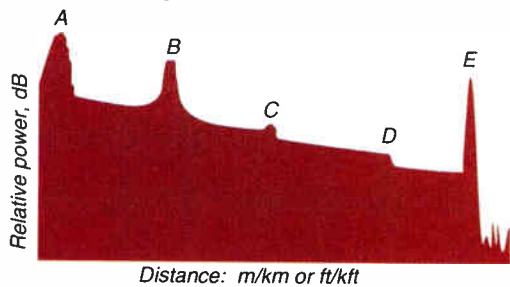



**“I’ve got  
my bases  
covered  
with  
CED”**

*John Rigas*

John J. Rigas  
President  
Adelphia Cable  
Communications

**CED**

THE PREMIER MAGAZINE OF  
BROADBAND COMMUNICATIONS

in the backscatter level at a splice point as shown in Figure 3, an anomaly commonly referred to as a "gainer." Testing the same splice in the opposite direction will indicate an exaggerated loss.

The best measurement is achieved by averaging the results from both directions. If a gainer is encountered, the splicer should always attempt to maximize the gain.

*Length measurements:* Although the fiber

distance accuracy of OTDRs is typically on the order of  $\pm 0.01\%$ , both fiber overlength and index of refraction limit the fault-finding accuracy of OTDRs. It is important to remember that the OTDR measures fiber length, somewhat different than sheath length for cables with a designed fiber overlength to prevent mechanical or thermal stress from being coupled to the

Figure 3: Apparent splice loss "gainer"

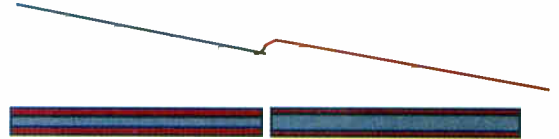

fibers. During fault location, consider that the actual sheath length will be shorter than the fiber length measured by the OTDR. With a cable route diagram of known sheath lengths, a cable/fiber ratio can be calculated to a known point, e.g. a splice point, and a corresponding cable distance and sequential mark to a fault estimated.

In addition, since the OTDR measures distance based on actual round-trip transit time, it is necessary to supply the OTDR with the most accurate index of refraction (to define the velocity of propagation) when making crucial distance measurements. Differing fiber suppliers and designs have slightly different indices, directly impacting OTDR distance measurements. Consult the fiber or cable supplier for the best values to use for a given fiber type and wavelength, and remain consistent in use of that index.

### OTDR limitations

One limitation of the OTDR becomes evident when looking at closely spaced events or points close in proximity to the OTDR. The width of the reflective spikes represents an OTDR's dead zone, a blind spot immediately following each reflective event as the OTDR recovers from receiver saturation caused by a reflection. To allow measurement of the connection loss, a test fiber box is used to connect between the OTDR output and the connecting hardware.

A second weakness of OTDRs is seen when attempting to measure through splitters and branching components. The apparent OTDR loss and reflectance values are erroneous and confusing as the OTDR displays the cumulative backscatter from multiple fiber paths on one trace. When test access is not available at the splitter output, the OTDR can be used from the opposite end or, on a limited basis, to identify and locate faulty branches.

### Optical reflections

Analog systems commonly used in cable TV are inherently more sensitive to reflections than digital systems. Consequently, new installations normally specify fusion splicing and physical contact (PC) connectors with reflectance less than -55 dB, provided by either an Ultra PC or angled PC polish. When this is the case, field testing of reflectance is

Lindsay Electronics

## Acknowledging the growth of Lindsay's Electronics Division



# LINDSAY ELECTRONICS

A new era of  
1 GHz communications equipment is created ...

HARD LINE PASSIVES

SUBSCRIBER AMPLIFIERS

APARTMENT AMPLIFIERS

DISTRIBUTOR AMPLIFIERS

POWER PASSING MULTITAPS



# LINDSAY ELECTRONICS

Going the extra mile ... for the last mile  
Since 1953

50 Mary Street West, Lindsay, Ontario, Canada K9V 4S7  
Tel: (705) 324 2196. Fax: (705) 324 5474. Tel: (800) 465 7046 (U.S. only)

Circle Reader Service No. 14



## THE FEARS OF *Roger Wallace*, CATV NETWORK TECHNICIAN

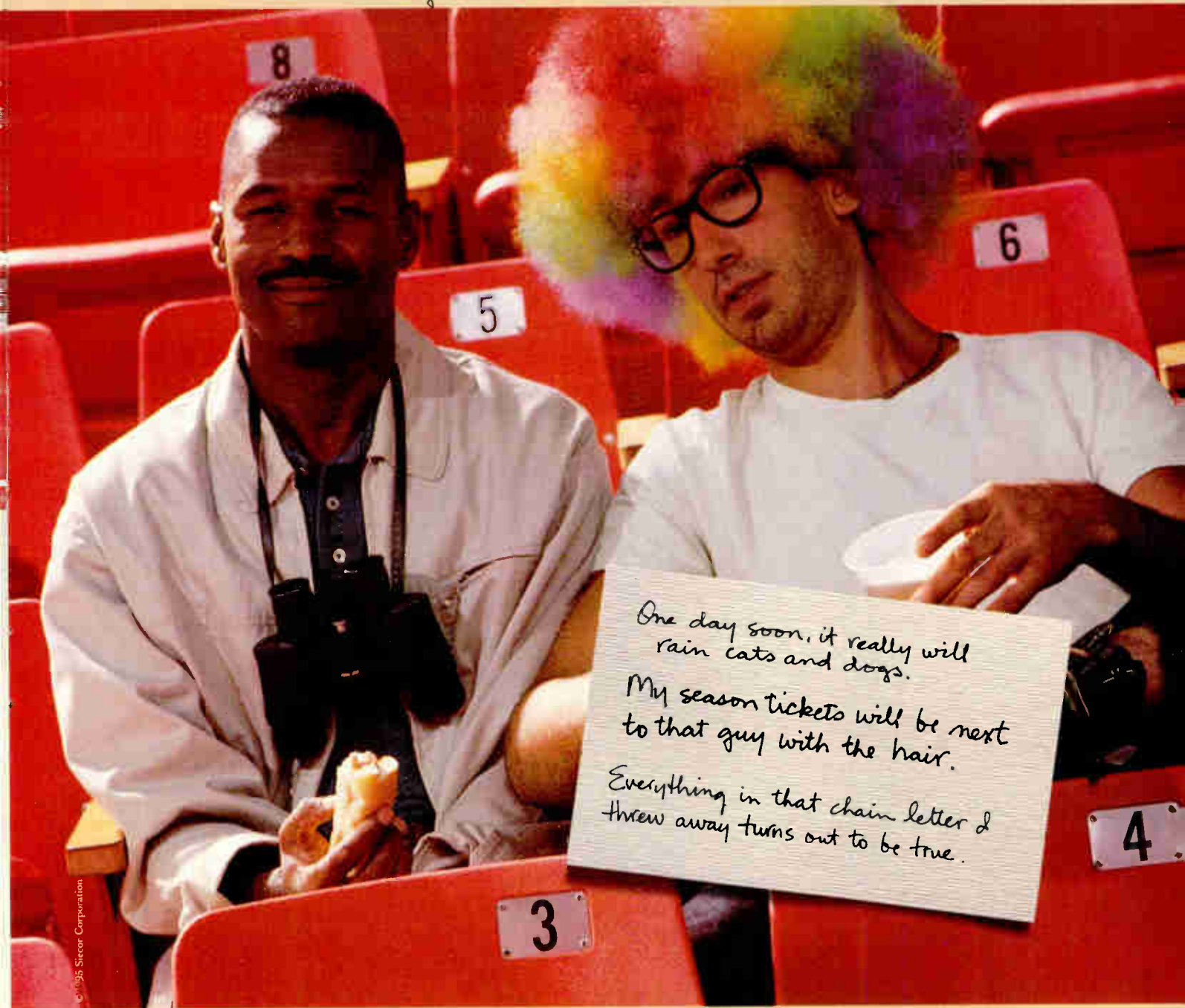

© 1995 Siecor Corporation

### NOTICE HOW HE ISN'T WORRIED ONE BIT ABOUT KEEPING HIS NETWORK RUNNING SMOOTHLY.

The fact is, Roger would be wiggling out if he wasn't using Siecor to help tackle his CATV network. Because Siecor gives him tailored solutions. Not just cookie-cutter solutions originally designed for other applications.

For instance, when Roger needed his cable jackets striped so they wouldn't be confused with other cables, Siecor started striping. When he requested a 19-inch



fiber distribution frame instead of a standard 23-inch frame, Siecor began building. And when Roger sought an easier way to control his network, Siecor supplied him with network management software that gives detailed information on every component in his network. Basically, Siecor has come up with every tailored solution Roger could hope for.

Except maybe, some good-sized hair clippers.

# SIECOR

What can we do for you?

HAVE NO FEAR. CALL 1-800-SIECOR-4 FOR MORE INFORMATION.

Circle Reader Service No. 15

not required as long as the guaranteed connector reflectance is documented.

Reflectance values of mechanical splices or field-terminated connectors should be measured using an OTDR, which calculates a component's reflectance based on the height of its reflective spike relative to the fiber backscatter level, as shown in Figure 4. Most recent OTDRs provide this measurement automatically.

### Dispersion

Optical fiber cables are specified for a maximum dispersion coefficient (ps/nm-km) within an operating wavelength window. Actual system dispersion is a function of the fiber quality, length and transmitter characteristics. *Since dispersion is not adversely affected by installation, field testing is not required.* Instead, the cable manufacturer's guaranteed dispersion performance should be documented for use in system design calculations, reconfigurations and upgrades.

Figure 4: OTDR reflectance measurement

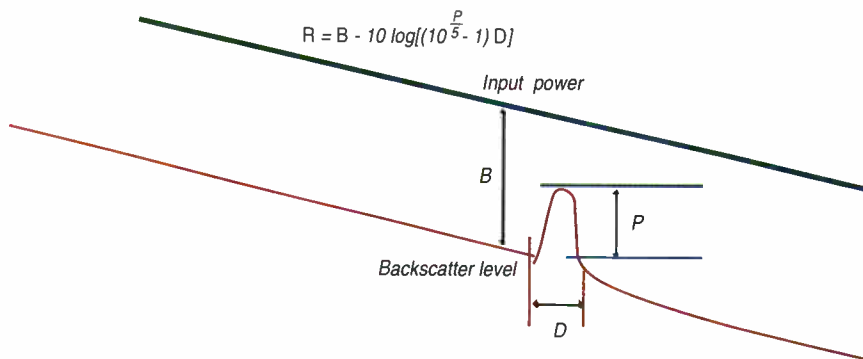

When documentation on an existing system is not available, the cable manufacturer can measure or estimate the installed cable's dispersion performance.

Documentation plays a vital role in the long-term success of any cabling system with regard to system reconfiguration, upgrades and maintenance. End-to-end test results establish the initial integrity and performance of a system. Documents of work performed on the fiber plant can be used for liability protection in the event that multiple vendors are involved. Equally important, these documents establish "as-built records" and can be compared to current conditions when troubleshooting.

Careful planning and accessible documentation also help to avoid costly retesting or cable plant replacement when subsequent upgrades or reconfigurations are undertaken. *The following test results and cable records should be documented and maintained in a systematic and accessible format:*

#### Test results:

- ✓ End-to-end attenuation data—considered the primary confirmation of system performance.
- ✓ OTDR signature traces—computer files or printouts of OTDR traces provide a graphical summary of the location, loss and reflectance of mid-span components.

- ✓ Certificate of Compliance—completed by a contracted installer to confirm test performance, compliance with stated requirements, and applicable warranty coverage for all individual connectors and splices.

#### Cable records:

- ✓ Cable specifications—specification sheet can be provided by the supplier and defines the minimum optical and mechanical performance guaranteed for the cable.
- ✓ Cable route diagram—cable route information provided by the installer defines the location, route and connectivity of the "as-built" cable plant and should include:

- a) fiber routing and location information
- b) fiber connectivity information
- c) splice point locations
- d) patch panel locations
- e) cable lengths
- f) cable part numbers

### Troubleshooting and maintenance

Because of the quality and importance of information transmitted over fiber optic systems, ongoing service is critical. A properly installed and tested system requires minimal routine maintenance. Ensuring proper connector care and cleanliness, and checking the routing and protection of system jumpers are simple safeguards that are central to preventing possible service interruptions.

In the case of system error or failure, troubleshooting and service restoration can be performed quickly and easily. There are three key components required for efficient troubleshooting.

**Documentation:** Initial test results and cable records are essential to effective maintenance and troubleshooting. Contrasting current test results with the original documentation quickly and clearly identifies changes and potential trouble spots.

**Test equipment:** Using a simple power meter and initial attenuation test results to isolate faults will eliminate unnecessary service calls and minimize downtime. If the fault lies within the cable plant, an OTDR can be used to pinpoint its exact location.

**Troubleshooting plan:** A simple but effective flow-chart or procedure can be used to quickly isolate a fault to either a network transmitter, receiver, patch cord or cable segment. The first step requires only a power meter, test jumper and the "as-built" documentation.

### Troubleshooting

*A logical troubleshooting sequence quickly and effectively isolates and locates faults.* First, the received power level is measured and compared to the received sensitivity specification. If the received power is normal, the receive electronics should be diagnosed to identify the problem. If, on the other hand, the received power level is low, the transmitter output power should be measured next. A low transmitter output indicates a problem with the transmitter output or

**A properly installed and tested system requires minimal routine maintenance**

Now's not the time to be scratching your head with questions.



*HP CaLan 8310211P  
for systems  
status and load  
measurement.*

Sixty feet up with your hands full. Less hope you understand the test and only of your cable test equipment—so that your equipment is from HP CaLan.

Our easy-to-use, one button measurements give you accurate and repeatable results every time you take a reading. Plus, its abundant data storage capacity lets you

©2002 Hewlett-Packard Co. T3802-60001-01

capture the results of tough tests—measurements for in-depth analysis in the comfort of your office.

So the only thing hard about these instruments is the case that surrounds them.

What's more, on those rare occasions our help menus don't have the answers you're looking for, our instant on-line assistance will.

Providing you will.



*HP CaLan 83312A  
for how fast video  
quality assurance.*



*HP CaLan 83311P  
for all RF and video  
measurements.*

quick answers wherever and whenever you need them most.

To find out how HP CaLan can improve your cable TV testing ability (and maybe even get you home faster) call HP CaLan at 1-800-452-4514, Ext. 9514\*.

\*For assistance, please call 1-800-452-4514.

There is a better way.



Figure 5: Cable system testing summary

Application	Test procedure	Equipment required
<b>Pre-installation</b> Component specification	Specify maximum loss and reflectance of connectors, splices and fiber.	none
Cable reel inspection	OTDR inspection of each fiber for length, attenuation and discontinuities (1310 or 1550 nm).	OTDR, 1310 or 1550 nm using reenterable mechanical splice or bare fiber adapter
<b>Installation &amp; acceptance</b> Fusion splicing	Document LID-based splice loss estimates	Fusion splicer with LID
Attenuation test	Document insertion loss of each connectorized fiber at 1310 and 1550 nm from headend to node. Perform bi-directional testing for return path transmission.	Optical source, 1310/1550 nm laser Optical meter 2 test jumpers 1 adapter
OTDR analysis	Signature trace documentation of each fiber at 1310 and 1550 nm, verifying fusion splice loss. Measure loss and reflectance of each field-terminated connector and mechanical splice.	OTDR with dual 1310/1550 nm Test fiber box
<b>Troubleshooting</b>	Optical meter to measure power levels, isolate faults to transmitter, receiver, patch cords or cable plant. If isolated to the cable plant, use an OTDR to locate breaks, high losses or high reflections.	Optical power meter OTDR Visual fault locator
<b>Other applications</b> Upgrade/reconfiguration	Fiber identifier to confirm fiber and direction for mid-span reconfiguration. Fiber identifier with integral power meter for continuity checks on splitters and in-line components.	Fiber identifier
Communication	Fiber communication during installation, testing and restoration.	Fiber talkset

**Other test equipment**

An optical power meter is used to perform the first step in troubleshooting. Once a fault is isolated to the installed cable link, an OTDR is normally used to locate the fault within the cable.

In cases where a fault is near an endpoint or inside the connecting hardware, a visual fault locator can pinpoint attenuation problems within an OTDR's dead zone. Visual fault locators utilize a visible wavelength (approximately 650 nm) laser that glows red at points of high loss such as tight bends or crimps, faulty connectors or splices, damaged components or pigtailed, and fiber breaks.

For reconfigurations or upgrades, fiber identifiers can passively detect the presence and direction of signal traffic and a 2 kHz test tone mid-span, useful in positively identifying fibers targeted for use. Some units incorporate a power meter that displays the relative core power when clipped on to the fiber. The detected power level is dependent upon the coupling efficiency as well as the optical and geometric properties of the fiber, coating, and coloring. Although they provide only an approximation, measurements on either side of splitters and hard-wired components can be used for basic troubleshooting.

*Fiber talk sets* provide simple point-to-point communication over

the installed cable during installation, testing, maintenance and restoration. Unlike walkie-talkies, they do not create error-causing RF interference that can disturb test equipment.

**Conclusion**

Simple end-to-end attenuation testing and OTDR analysis ensure installed quality and document performance for future upgrades and reconfiguration. The same equipment, the optical meter and OTDR, are primary tools for inspection and troubleshooting. Other more specialized tools provide effective troubleshooting ability for a variety of system configurations.

Figure 5 summarizes the test procedure and equipment required for pre-installation inspection, installation and acceptance testing, and troubleshooting and maintenance. **CED**

©NCTA. Reprinted with permission from the 1995 NCTA Technical Papers.

electronics. In these cases, follow the procedure in diagnosing the electronics or call the appropriate vendor for assistance.

If the transmitter output is normal and the received power is low, excessive loss is occurring in the cable plant. A power meter with a test jumper is then used to confirm whether or not there is a problem with the system jumper.

If the system jumpers have acceptable loss, then the fault probably lies within the terminated cable plant itself. Losses in the cable plant are most often caused by damaged connectors, and cut or damaged cable.

Once a problem is isolated to the cable plant, a high resolution OTDR is used to locate the fault. A comparison of the original signature trace to the current OTDR trace can easily identify and locate a fault or break. If the fault is determined to be near an endpoint, a visual fault can be used to pinpoint a problem within splice trays, interconnect hardware and patch cords.

# About the only thing it doesn't deliver is pizza.

Encrypted data  
communications  
*from addressable controller  
to subscriber.*

Extensive  
on-screen display  
*with display and  
graphics capability.*

Multiple  
program guides  
*Interactive Electronic Program  
Guide with grid-type presentation.*



Dynamic picture  
shift encoding  
*for the ultimate in enhanced  
signal security.*

Near-video-on-demand  
*field-proven technology  
with display schedule and enhanced  
pause, resume and  
review instructions.*

Virtual data channels  
*for additional revenue generation.*

As you can see, the BA-V1000 Command Station comes with the works. From its on-screen display capabilities to the security of dynamic picture shift encoding, the Command Station delivers great cable service. It's this kind of vision that keeps your customers happy. And hungry for more. When you're ready to order, just call your Pioneer regional sales manager.

**PIONEER**<sup>®</sup>  
Pioneer New Media Technologies, Inc.

Northeast, 201-236-4186; Southeast, 614-777-7260; Mid-Atlantic, 614-777-7258; Central, 614-777-7257; West, 310-952-3063.

# Preparing the drop for digital services

Is the weakest  
link ready to  
handle digital?

By John Grothendick,  
Product Development  
Manager,  
Antec Corp.

**D**espite new technological advances in all parts of the cable network, the subscriber drop remains the weakest link. The drop, which is the most labor intensive and costly part of the network, is probably the least equipped to deliver interactive digital services. Today, even with more forgiving analog signals, problems with the drop generate seven out of 10 service calls. If today's drop generates so many problems, imagine the failure rate if operators attempt to use today's drop for tomorrow's more demanding digital services. Customers will demand high quality, interactive digital services, or they'll go elsewhere.

## What's emerging

Most advanced cable architectures today have driven fiber optics deep into the plant, transitioning networks from a tree-and-branch beginning to star architectures that rely on coaxial cable with no more than two amplifiers feeding each home. Optical node sizes have shrunk from the original 10,000 or 5,000 homes to 2,000, and now, to 500 homes or less. The fewer homes served by a single fiber, the greater the spectrum availability, and the lower the level of maintenance required. Operators positioning their systems in this way are future-proofing their networks for interactive services and two-way digital communications.

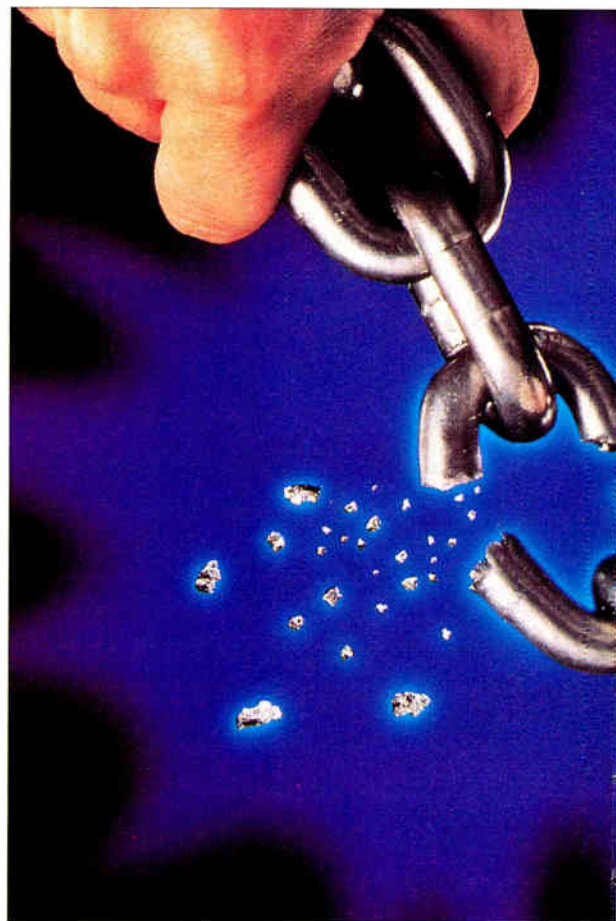

Yet, coaxial cable continues to provide the most robust medium to the home in the delivery of voice, video and data services. A good, high quality drop, installed and maintained correctly, could, theoretically, download the entire Library of Congress in just 15 minutes (experts suggest that normal twisted pair transmission would take more than two years).

New modulation techniques are emerging that are moving the industry toward digital transmission. In today's analog world, amplitude modulation (AM) provides the most basic form of electronic signal delivery. New advancements in Quadrature Phase Shift Keying (QPSK), Quadrature Amplitude Modulation (QAM) and Vestigial Side Band (VSB) are beginning to emerge. Each has been developed by a different manufacturer for the purpose of squeezing more digital information into a single 6-MHz analog channel. This results in brand new considerations for cable operators in establishing a drop system that will remain transparent despite the type of modulation technique used.

In order to provide a reliable, seamless transmission path for video, voice and data services, the drop system must successfully pass a 1 GHz spectrum, digitally compressed signals and two-way interactive services.

Most industry experts agree that a 5 MHz to 1000 MHz spectrum is required to provide all the services



PHOTO BY MYRON J. DORF/THE STOCK MARKET

realized. These thresholds become lower and lower as the modulation format becomes more sophisticated.

Once the bit error rate threshold is reached, the signal becomes virtually unrecoverable. Where an analog signal will simply grow snowy or look "ghosty," bit errors will create a tiling or checkerboarding effect or incorporate other artifacts that will virtually ruin a digital picture.

Of the advanced modulation formats, QPSK is the least sophisticated and the most robust. It offers a failure threshold of  $3 \times 10^{-6}$ . That means signals can experience no more than three bit errors per 1 million bits (as tested by a bit error rate detector). Thresholds for QAM and 16 VSB modulation are in the  $10^{-7}$  or  $10^{-8}$  range (three bit errors per 10 million to 100 million bits).

Antec has tested drop systems using the QPSK digital modulation format at speeds of up to 2.3 megabits per second. Components tested in the drop included cable connectors, splitters, passives, amplifiers and hardware. In a test comparing standardized, high quality drop components against non-standardized, off-the-shelf devices, the low-quality components consistently performed more poorly. The reasons primarily rest in a lack of proper shielding, impedance matching problems, high attenuation, and substandard environmental protection.

Tests of 16 and 256 QAM as well as 16 VSB will be performed within the next four months. These tests will be done with a variety of payloads and in different bands of the spectrum. The performance parameters detailed in the remainder of this article are the results from data collected when testing with the QPSK modulation technique.

The proper selection of drop cable, connectors, passive devices, house amplifiers, and related hardware is critical to the long-term viability of a drop. Proper installation and maintenance of each component can mean the difference between a high quality drop and one that will need to be modified, or at worst, completely reinstalled when digital services become more prevalent.

### Recommended performance parameters

**Drop cable:** In selecting drop cable, operators should use cable no smaller than RG-6 for systems over 550 MHz. For drops spanning over 150 feet, operators should rely on RG-7 or RG-11 coaxial drop cable. Each drop cable should be sweep tested to 1 GHz to ensure that the cable can handle signals from 5 MHz up to 1 GHz.

Operators should select drop cable offering a  $75 \pm 2$  ohms or better impedance level. Impedance is determined by the distance between the center conductor of the cable and the outer conductor, and is related to structural return loss. This distance must remain consistent throughout the cable, from its installation at the tap through its connection to the home. For this reason, installers shouldn't bend cable more than 10 times its diameter. Crimping the cable, bending it too tightly, even stepping on it can make the cable oval in spots that will impact its impedance and thus, deliver lower levels of performance into the home.

Structural return loss is specified at 23 dB. Flexing of the aerial drop will impact this structural return loss

subscribers will be looking for over the next 10 to 15 years. Allocation of the 1 GHz platform varies only slightly among the major multiple system operators (MSOs) involved in hybrid fiber/coax network deployment. A typical spectrum allocation may look like this:

- ✓ The traditional sub-low band has been expanded to cover 5 MHz to 40 MHz and will provide the return path for telephony and other related smaller payload deliveries in a QPSK modulation format.
- ✓ The traditional 50 MHz to 550 MHz band will be reserved for forward analog signal transmission to accommodate traditional receiving devices.
- ✓ The spectrum area from 550 MHz to 750 MHz would be used for digitally compressed video, digital music, interactive games, advertising, etc. The modulation scheme for these services would primarily be 64 and 256 QAM and 16 VSB, and will handle higher bit payloads of up to 45 Mbps or better.
- ✓ The upper end of the 1 GHz platform would be reserved for high-speed, two-way digital services and PCN, with various payloads and modulation formats of different "bit to hertz" ratios.

AM analog signals degrade on a graduated scale before a failure threshold is reached. Digitally delivered signals, with their associated modulation formats, will perform at optimal level until their failure threshold is

**Of the  
advanced  
modulation  
formats, QPSK  
is the least  
sophisticated  
and the most  
robust**

**Installers  
shouldn't bend  
cable more  
than 10 times  
its diameter**

specification, sometimes by as much as 10 to 15 percent. Poor structural return losses are the result of impedance mismatching and can cause microreflections. In turn, this can cause bit errors and damage to digital signal integrity.

For aerial applications, operators should use a messenger cable so the "messenger" provides the support and removes strain from the coaxial cable itself. For underground applications, a flooded, polyethylene jacketed cable is recommended for weather and water protection.

Shielding on drop cable is equally important. In addition to the aluminum tape, drop cable should have a minimum of 60 percent braid coverage to reduce the impact of ingress (signals getting into the system) or egress (signals getting out of the system).

Connectors: Connectors should offer shield effectiveness at 80 dB or better within the 5 MHz to 1 GHz spectrum. This type of shielding will again prevent ingress/egress problems. A circumferential seal at the port/connector interface is necessary in outdoor cable applications, and the author's company recommends using a 360-degree compression connection at both the tap and home connections (a hex fitting may reduce the impedance or drop cable return loss by crimping the cable). For the F-connections, use torque specifications outlined by the manufacturer or tighten the connection

with an extra quarter turn to ensure a tight fit. Seal all connections at the connector/cable interface to provide effective weather protection and prevent ingress/egress.

Passives: Splitters and other passive devices should effectively pass 5 MHz to 1 GHz and provide 110 dB EMI shielding. Each passive should include a 1/2 long mechanical F-port to accommodate the deep threading used for many premium connectors. Each passive should also provide a minimum of 15 dB input/output return loss.

Select passives with a rugged housing and backplate (stainless steel or zinc with tongue and groove construction). Many of today's passive devices use printed circuit boards which can radically improve electrical performance, since PCBs standardize the manufacturing process. Check to see that the PCB is properly mounted and grounded on standoffs that are well connected to the housing. Poor grounding, as well as sub-standard components, will act as a source of increased return loss in a splitting device.

The primary problems during installation rest in installer abuse of passives. In many cases, splitters and the like are tossed into a box to jostle around during transport, damaging the components.

It's important that passive devices be treated with the same care as optical transmitters. While much less expensive, passives perform an important network task and

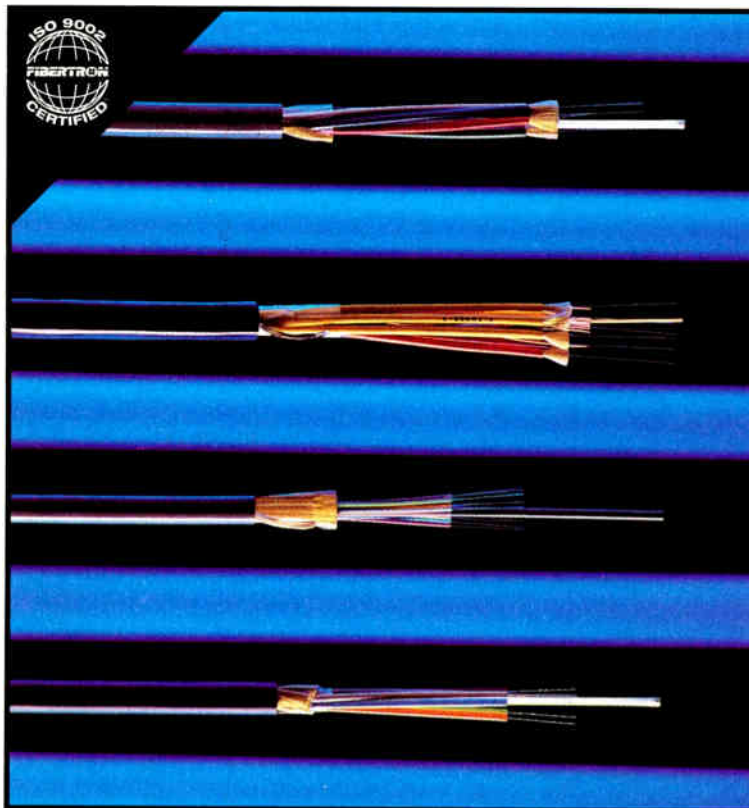

**We Know Cable...  
Inside And Out!**

Inside. Outside. Overhead. Buried. How do you select the right fiber optic cable for the application? From our comprehensive line of Chromatic Technologies fiber optic cable, Fibertron takes the guesswork out of cable selection with qualified, experienced applications assistance. We'll recommend, prepare and provide a Chromatic Technologies cable that's perfect for the job...both inside and out!

Like XP™ and RLT™ loose tube fiber optic cables with ChromaTek™ jacketing. These cables can be used indoors and outdoors - so you no longer need to splice or terminate at a given distance inside or outside a facility. You save time, money, and headaches. And that's just the beginning. We carry standard and specialty fiber optic cable to suit virtually any application, including: tight buffered breakout and multiple application (MAC) cable; loose tube cable in standard, heavy duty, and armored styles; low-smoke, zero halogen; tactical, field deployable; shipboard and more.

When it comes to cable, where you buy can be as important as what you buy. At Fibertron, you always get the right cable for the right price. And our immediate, off-the-shelf delivery of both single-mode and multimode cable, with 1 to 216 fibers, helps keep you on schedule. What's more, we provide value-added services like terminations, custom assemblies, packaging, staging, and palletizing for orders of all sizes and shapes.

So before you design, specify, buy, or install...give us a call.



XP™, RLT™, and ChromaTek are trademarks of Chromatic Technologies, Inc.

**FIBERTRON**  
Your Link with Fiberoptics

Northwest  
(510) 635-1970

Southwest  
(714) 871-3344

Northeast  
(717) 652-6565

Southeast  
(404) 409-1700



# A Proven Winner.

## NetExpert is a sure thing for your OSS requirements.

In a close race, choosing the right horse can be tricky business. You need an edge – a proven winner. In the race to bring new services to market – only **NetExpert** from OSI is a sure thing. Whether your business is deploying new technologies or bringing new services online to your customers – **NetExpert** has

the power, speed, and durability to get you to the finish ahead of your competition.

Gaining the edge with **NetExpert**

will ensure that the time required to **provision** and **activate** new services and customers sets new track records – **every time**. So, when time is money and it's time to place your bet – bet on a proven winner – **NetExpert** software from **OSI** – the company that gets you there first.

For information call 916-353-2400 and ask for your regional sales representative.

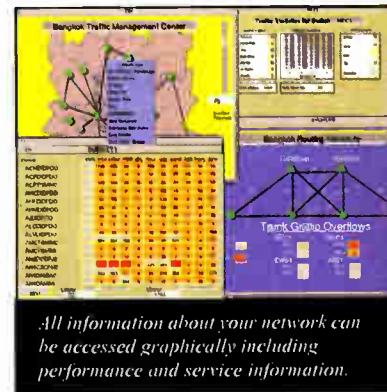

All information about your network can be accessed graphically including performance and service information.

Set track records when deploying new services with **NetExpert**.



OBJECTIVE SYSTEMS INTEGRATORS

When Time is Money.

**TULSAT**

**AD-1 AGILE  
DEMODULATOR**

**\$399**

- \* Nyquist SAW Filter
- \* 4.5 Sub Carrier Output
- \* PLL Synthesized Tuning
- \* UHF, VHF & Cable Input
- \* Synchronous Video Detector
- \* Optional T-Channel Input

**BLONDER  
TONGUE**

**800-331-5997**

**TULSAT**

**VCRS PLUS**

(Call for Latest Price)

**\$139.00  
HALFSIZE VCII CHASSIS**

**THERMOSTAT CONTROLLED FAN  
SAVES RACK SPACE**

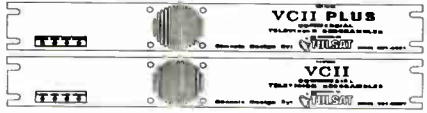

**(800) 331-5997**

**TULSAT**

**LARGE INVENTORY  
CONNECTORS**

Popular & Hard to Find Sizes

Gilbert LRC  
Pyramid PPC Others

**TAPs DCs LEQs**

Magnavox SA Millenium  
Regal Eagle Jerrold Others

**TRAPs**

Positive Negative Tiering  
Eagle Arcom  
Pico Intercept Others

**800-331-5997**

◆ **COVER STORY**

won't perform as specified if they are damaged.

During the installation process, installers should assess which passive should be used for individual subscribers. For instance, one home may have three TVs, two located in roughly the same area; a third may be a significant distance away. In this case, a balanced splitter may impair the level of signals delivered to each TV. While the closest two will have a proper signal level, the third may not. An unbalanced splitter then can compensate for changes in the distance of each TV's location.

House amplifiers: Select a two-way compatible amplifier that can use the 5-40 MHz return path without modification. The amplifiers should be sweep tested to 1 GHz, deliver less than 7 dB of noise and provide a minimum of 13 dB of return loss. Pay attention to CSO figures; some manufacturers of house amplifiers often do not provide this information directly.

The Society of Telecommunication Engineers' Interface Practices Committee is studying CTB and CSO parameters for house amplifiers and will likely have specifications soon.

Hardware: Select hardware that is Underwriters' Laboratories listed and which meets ASTM galvanizing specifications. Do not purchase hardware that contains staples, clips, or anything else that requires use of a hammer. Hammers are the worst enemies of good drop installers; typically a hammer will hit the cable (even inadvertently) and result in the impedance or structural return loss that leads to a less than perfect drop installation.

Surge protection: Protection from surges in the form of lightning or other "rapid rise time transients" remains another critical concern in the drop. As new devices are added to the network-telephony interfaces, broadband modems, etc.—inadequate surge protection may prove to be life-threatening to a subscriber. It may no longer be acceptable to show that the drop was properly bonded to alleviate the system operators from surge damage liability. Not only may a customer be lost to the competition, but costly legal problems may also result.

Bonding the drop still remains the primary surge protection method for the drop system. It's wise to check the National Electrical Code and local ordinances on bonding to ensure that your system is effectively bonded. If possible, attach a short #12 or larger bond wire to the grounding devices installed by the local power utility company. Avoid severe bends in the bonding wire that would present extra impedance to the surge going to ground.

In-home wiring: Operators are extremely concerned that homeowners can cable their own additional outlets. Operators are responsible to the FCC for the disposition of the signal up to the subscriber terminal device. Although totally controlling home wiring will be impossible, there are still some measures that the operator can take to ensure its quality. Public service announcements and bill stuffers can educate subscribers as to the importance of using system recommended equipment and procedures.

Subscriber drops still comprise up to 75 percent of the investment made in the broadband infrastructure. By installing non-compatible, poor performing drop components—or failing to properly train installers on how those components should be installed—the network operator, who is otherwise building a reliable and high-quality system, will suffer from lower network performance at the subscriber's home. Without effectively training personnel on proper installation, operators face increased operational costs for drop servicing, potentially lower revenues from consumers dissatisfied with the quality of services, and added capital costs as new drops must be installed to handle future services.

Drops require quality components and a specialized, well-trained staff that can ensure that each drop is installed correctly and performs effectively—at every single home. **CED**

WHEN YOU COMPARE CABLE SUPPLIERS,  
WE'RE THE **best** CHOICE.



WHEN YOU NEED IMMEDIATE DELIVERY,  
WE'RE THE **only** CHOICE.

WHEN THERE IS A PLENTIFUL SUPPLY OF CABLE, YOU CAN TAKE THE TIME TO COMPARE SUPPLIERS. YOU'LL DISCOVER THAT TFC IS THE **best** CHOICE BECAUSE OF OUR QUALITY, PROVEN RELIABILITY AND ENVIABLE RECORD FOR ON TIME DELIVERY. BUT WHEN CABLE IS IN SHORT SUPPLY, YOU'LL FIND TFC IS THE **only** CHOICE FOR IMMEDIATE DELIVERY; WE MANAGE OUR CAPACITY TO MAKE IT SO. TO FIND OUT HOW TFC CAN MEET YOUR CABLE NEEDS RIGHT NOW, MAKE THE SMART CHOICE AND CALL **1-800-677-CATV**



# Construction from a contractor's point of view

## Avoiding potential trouble spots

By Jeff Michaud, Director of Marketing,  
Cable Constructors Inc.

With the advances in technology that have bombarded the industry over the past few years, the hype (and reality) of the information superhighway and the inevitable merger of two industries, the amount of construction that is currently taking place seems to be at a record-setting pace. A sales representative of a major industry vendor told me recently that his company had just set an all-time high for yearly sales. That means contractors will be an

integral part of many operators' projects. This article will review the basic components of a construction project from the perspective of the contractor and highlight areas that tend to cause problems in the average project. By noting these potential trouble spots, many of these issues can be avoided or minimized on upcoming projects.

### Project components

The average construction project breaks down into the following components. The milestones are mapping, design, permitting,

materials ordering, inventory control, construction commencement, quality control and system acceptance. Examining each will reveal some interesting points.

Mapping takes on two forms: strand mapping required for newbuild construction and system rebuilds, and asbuilt mapping required for electronic upgrades (utilizing existing cable and replacing electronics only). Existing system maps can be used in place of strand maps or asbuilt maps, assuming the existing system maps are up to date. This assumption can be a costly mistake if the design is based on what turn out to be inaccurate or outdated system maps. The inaccuracy usually is not noticed until the construction phase, which often results in an inefficient redesign and additional labor costs.

System design can be a trying experience today. What is the best architecture for this system (the \$64,000 question)? Once someone has answered that, and assuming they have specified what equipment vendors to use, the design team can start system design. Ideally, enough design is required to allow timely ordering of material in sufficient quantity to support the number of construction personnel as dictated by the construction schedule build rate. More on that under materials ordering.

Permitting is a frequently underestimated step in the process. This represents the one area of the project over which we have the least control. Once the paperwork has been filed in the required format, and the fee(s) have been paid, it's necessary to wait until the governing authority grants approval. In some cases that means starting all over from scratch. Inquiring if there are ways of speeding up the process to produce a quicker turnaround time can have one of three effects. The desired outcome, obviously, is for the turnaround time to improve, a seemingly rare result. More likely, there'll be no change, or worse, somehow the official has become alienated, and now it takes longer than normal. In any case, two out of the three result in no improvement. It is best to plan ahead and allocate sufficient time, if possible.

Permitting is also an area where, in most cases, the local system personnel have a thorough understanding of the requirements of the different governing bodies. Introducing a new party into the picture by having the contractor handle permitting may prove counter productive.

Two types of permits tend to be overlooked in rebuilds or upgrades: they are power supplies and pole permits. More power is required of today's 750 MHz systems. Where once, approximately 0.25 power supplies per mile of plant were common, today, 0.45 is not uncommon. Thus, for a 1,000 mile system, roughly

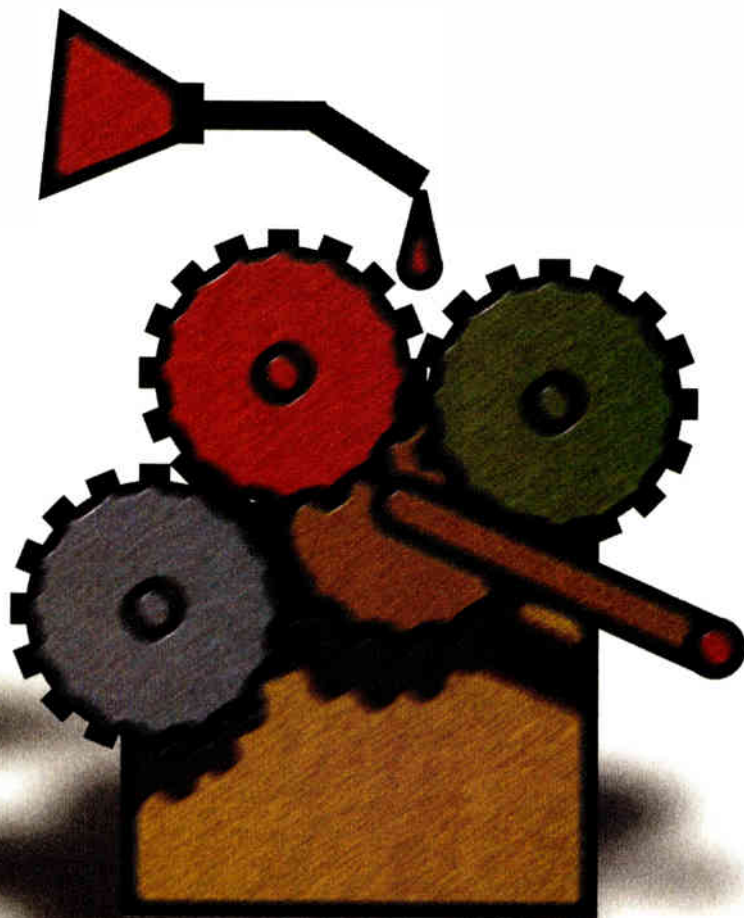

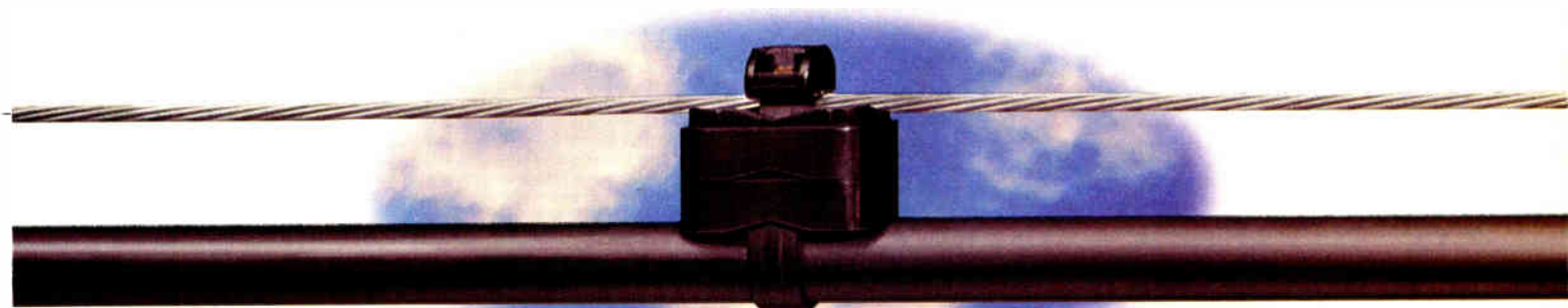

[ IT TAKES THE "STALL" OUT OF "INSTALL." ]

The Deltec® Cable Support System from Thomas & Betts can make a real difference in your installation time. It installs with just a single wrap. Saving you time *and* money.

Here's another difference -- it's not metal, it's homopolymer acetal. A material that has more than proven itself in 20 years of harsh outside plant testing.

What's more, the Deltec System has no sharp edges or points. So it's easy on your hands. Easy to hold on to. And

easy on coaxial, fiber optic, and twisted pair cable. All of which makes the Deltec System easy to work with. And of course, it's fast, too.

Last but not least, the Deltec System is versatile. It supports cable either horizontally or vertically.

For more information, just call 800-685-9452. We'll try to keep it brief, because we know how valuable your time is. **Deltec®**

ISO 9000 Registered

**Thomas & Betts**

## ◆ PREPPING THE SYSTEM

200 new power supplies will need to be added. The other type of permit often overlooked is pole permits. New pole attachments are often associated with new subscribers; however, that's not necessarily the case anymore. In rebuilds or upgrades, fiber optics and system mergers justify connecting neighboring systems via a fiber link, frequently requiring new pole attachments in non-residential areas. Some of these cannot be identified until fiber design has been completed. Timing can be critical if construction is right on the heels of design. Don't forget that with new pole attachments comes a makeready assessment.

Materials ordering can be handled one of three ways. The operator orders all material, the contractor orders all material, or a combination. An example of this would be the operator orders the electronics, cable, connectors, power supplies and pedestals, while the contractor provides all of the strand, hardware, lashing, bonding and grounding material. Generally the electronics, cable, connectors and power supplies are ordered off of a bill of material (BOM) that is produced during design. Blanket orders for many of these items

will permit ordering prior to the existence of a BOM, but a reconciliation should be conducted as soon as a BOM is available, to ensure the proper amount of material is on site allowing timely completion of the project. Other material such as pole hardware, lashing, bonding and grounding is normally not specified on a BOM, and ordering is accomplished on an as needed basis. This, however, requires close communication with the job site to ensure proper quantities are on hand.

Inventory control is becoming a key component in the construction project, and material delivery is one aspect of inventory control. It is not a major issue on a small project, but on larger projects, receiving materials can be a major undertaking. Keep in mind that a small project, based on mileage, becomes a major project at accelerated build rates. Several options exist to handle this task: one is to have a construction warehouse which may be at a separate site from the system warehouse. This is worth considering, especially if current warehouse facilities would have a hard time handling the congestion of re-stocking the contractor periodically. Another option is to have the

contractor supply the warehouse and ship material to that warehouse either out of the operator's facility, or drop ship directly to the contractor. Yet another option is to have a turnkey contractor who is responsible for all aspects of the material process. With proper safeguards to protect the operator from material overages, this can be a very effective alternative and may eliminate the need for temporary staffing to manage inventory. Inventory control also means monitoring shrinkage, waste, equipment failures and goods damaged in shipping, which when combined, can have a significant impact on the timely completion of the project.

Construction is a multifaceted process. The preliminary stages involve establishing lines of communication for all situations, review of construction standards, review of staffing requirements as they relate to the available resources outlined above, coordinating paperwork and reporting procedures and material logistics to cover the main points. Rarely are all of the prerequisite components complete prior to the commencement of construction; rather, they are in various phases of completion. This requires the on-site management of

## Growing plant specialists

*As far as installers and linemen are concerned, Roger Kennedy's new philosophy is: if you can't find them, create them. As owner of Kennedy Cable Construction, a telecom contractor firm, Kennedy had no desire to re-visit what he experienced last year—serious shortages of skilled personnel who had training in coaxial splicing, and even basic construction safety practices. To remedy the problem and head off further labor shortages, he has teamed up with his local tech school, Southeastern Technical Institute, to offer training and a Technical Certificate of Credit called "Telecommunication Outside Plant Specialist."*

*The increased level of construction activity on the part of both cable companies and telcos has certainly exacerbated the labor shortage, says Kennedy, and there's no end in sight.*

*"I think that '96 will definitely be a big year for cable contractors," he explains. "We have some new projects that we are starting, [including one] in Atlanta."*

*Kennedy already has big plans for the first crop of graduates: "I feel job placement can be readily available for the first 100 students to complete the training," he notes.*

*Those who enroll in the new certification program can look forward to training in four separate disciplines: outside plant construction safety, pole climbing and operations, map reading and underground cable operations. To a lesser degree, some training in advanced technologies will also be incorporated into the series, including instruction in new fiber optic/coaxial architectures: everything from 450 MHz systems to 750 MHz systems with 500 homes per node. All*

*totaled, the series is worth 15 credit hours.*

*But instructors will hit the basics first, and hard. "A lot of kids out there who have worked in the industry," notes Kennedy, "have not even had any basic training in CPR, first-aid and defensive driving skills."*

*The method of instruction will be a mix of hands-on and classroom training. Kennedy is generously giving the course a good head-start by donating tools, climbing gear, poles, line trucks and even space to conduct the outside training.*

*The program has already been approved by the Georgia Board of Technical and Adult Education for a launch this fall quarter, and eventually, once the program is established, Kennedy plans to seek SCTE recognition for the course.*

*The contractor has been hard at work developing the project with Joe Woodruff, STI's vice president for Instructional Services. Woodruff is eager to get the word out that financial assistance is available for full-time residents of Georgia who sign up for the courses. A state scholarship, funded by the state lottery, pays 100 percent of all the fees that students would incur, explains Woodruff, including the cost of tuition and books.*

*"This is a good opportunity for [students] to get training that's short and sweet," adds Woodruff. "And something they can go to work with almost immediately."*

*Classes for the fall quarter will begin October 2; the winter quarter starts in January; and the spring quarter will begin next April.*

*-D.C.*

# TAKE A GOOD LOOK AT OUR NEW POLYETHYLENE ENCLOSURES.

**FREE  
Channell  
Padlock with  
first 50,000  
EPH Enclosures  
sold!**

Channell Commercial's high quality ABS plastic enclosures are well known in the industry and are used extensively throughout the world. Now, we've added a new series of enclosures to meet the needs of our economy-minded customers: The Economy Pedestal Housing (EPH™) Series of high production, injection-molded polyethylene enclosures for housing taps and splitters. They're engineered and manufactured to our usual high standards in our own facilities, but designed for applications where security is not a major concern.

EPH Series enclosures feature consistent wall thicknesses and include many of the other features found on our most popular Signature Series (SPH™) enclosures. These cost-competitive polyethylene enclosures have the highest possible UV protection and are far superior in design to any existing polyethylene enclosures found in the industry today.

When economy is a factor and security is not a major concern, take a good look at Channell's EPH Series of polyethylene enclosures. Call toll-free today for complete information.

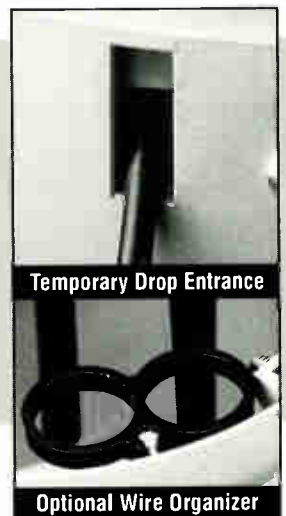
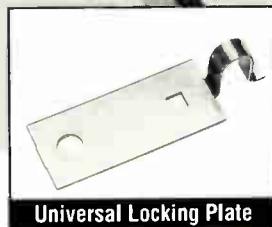
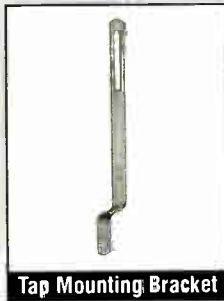

**U.S.A.** 800/423-1863 • 909/694-9160 • FAX: 909/694-9170  
**CANADA** 800/387-8332 • 905/567-6751 • FAX: 905/567-6756  
**U.K.** +1 44 171 589 3304 • FAX: +1 44 171 589 1021  
**ISRAEL** 972 4 341329 • FAX: 972 4 341387

**CHANNELL**  
COMMERCIAL CORPORATION

## ◆ PREPPING THE SYSTEM

both the operator and the contractor to coordinate their efforts to direct the available resources of design, material and manpower to areas that will be of most benefit. This is where the team concept must come through. A lack of communication is like having the quarterback run a play without telling the offense what play he is running. A quality control (QC) program will save both the operator and contractor time and money. It identifies sub-standard work and

requires the crew(s) to correct such work within days of the inspection and subsequent notification. A timely re-inspection has a self-correcting effect. It sends a message to the crew that it will be accountable for the quality of its work. For example, when correcting previously claimed production, the crew is not financially productive, which it would be had the task been performed correctly the first time. In the case of work paid by the piece, the crew is

not paid for the corrective work conducted on previously claimed piece(s). In the case of hourly paid crews, the corrective work results in no claimable production for the hours turned in. This detracts from the total production applied toward a bonus program. In either case, the message is delivered loud and clear. Any crew that goes through that procedure will soon realize it definitely pays to make sure the job is done right the first time.

The alternative is to fall behind with the QC inspection. Chances are the crew(s) responsible for the substandard work are on to another job site. There will be more substandard work because a priority was not placed on quality work. Now, another crew may have to complete all of the corrective work. It will not have the chance for a bonus, or would be making more money on pieces in a normal production environment. Under certain circumstances, this can lead to difficulty in completing the corrective work, possibly delaying the completion of the job. A delayed completion costs the operator money, perhaps through lost revenue from postponement of additional channel launches requiring the increased bandwidth brought by the project. From the contractor's perspective, by the end of the job most or all of the total job revenue has been realized, meaning there is no income available to offset the expense of the corrective work. That means all of this work expense comes directly off the bottom line of the project. Assuming a fully equipped crew costs \$1,000/day, 20 crew days of cleanup at the end of the job is a 2 percent reduction in gross profit of a \$1 million job, not to mention the money lost by that crew not completing billable work on another job.

System acceptance completes the project and signifies the end of the job. A good QC program should translate into swift system acceptance, assuming that the operator, throughout the course of the project, has taken the necessary steps to have assurance it is getting what it paid for. If the operator waits until the end of the job to gain that assurance, it ends up costing the contractor money by tying up his receivable account. This also means a higher corrective work cost since it is more time-consuming to correct work that was completed months before.

The service oriented nature of the contracting business means customer satisfaction is of paramount importance to survival. That translates to completing a project on schedule, under budget and with minimum subscriber complaints. By identifying potential problem areas ahead of time, the contractor and operator together can successfully complete the project within the prescribed requirements. **CED**



**ARROW**  
MODEL T59™

**The all steel  
WIRING TACKER  
that shoots  
Insulated  
Staples**

**UL**

The Arrow T59™ is a hard hitting all steel tool. It incorporates the same rugged construction, easy compression span handle and patented jam-proof mechanism of the Arrow's world-renowned T50™ Tacker. The T59 is finished in durable chrome to withstand the bumps and scratches of professional use.

**A WIRING TACKER FOR EVERY JOB**  
There is always a need for tackers that shoot non-insulated staples. As one of America's oldest and most respected names in the fastening business, Arrow has an extensive range of wiring tackers for just about every assignment:

**T18™ - For wires up to 3/16" dia.**  
**T25™ - For wires up to 1/4" dia.**  
**T37™ - For wires up to 5/16" dia.**  
**T75™ - For wires up to 1/2" dia.**

**NEW! FOR NM SHEATHED CABLE.** The Arrow 7514S staple, made exclusively for our T75 tacker, has been awarded a UL listing for installing NM Sheathed Cable: 12/2, 12/3, 14/2, 14/3, 16/2, 16/3. This important addition to every electrician's and cable installer's inventory is specially coated for extra long holding power.

Perfect for RG59 and RG6.  
Whatever your wire or cable installation task — TV, HiFi, Alarm System, Plastic, Wire Conduit, Computer, Multi-Conductor, Control Wiring, Hollow Tubing, or any NM Sheathed Cable — there is a reliable Arrow Tacker and Arrow Staple to make your job easier, faster and more secure.

**All Arrow Tackers and staples are built in the U.S.A. under the strictest standards of quality assurance. It's been that way for over half a century!**

**ARROW FASTENER COMPANY, INC.**  
271 MAYHILL STREET, SADDLE BROOK, NEW JERSEY 07663  
IN UNITED KINGDOM: ARROW FASTENER (U.K.) LTD., 14 BARCLAY ROAD, CROYDON, SURREY CR0 1JN  
IN CANADA: JARDEL DISTRIBUTORS, INC., 6505 METROPOLITAN BLVD. EAST, MONTREAL, QUEBEC H1P 1A9

**See your Arrow rep now for all new dealer friendly profit opportunities.**

©1995, ARROW FASTENER CO., INC.



# SystemSelect™

FOR INTELLIGENT SOLUTIONS

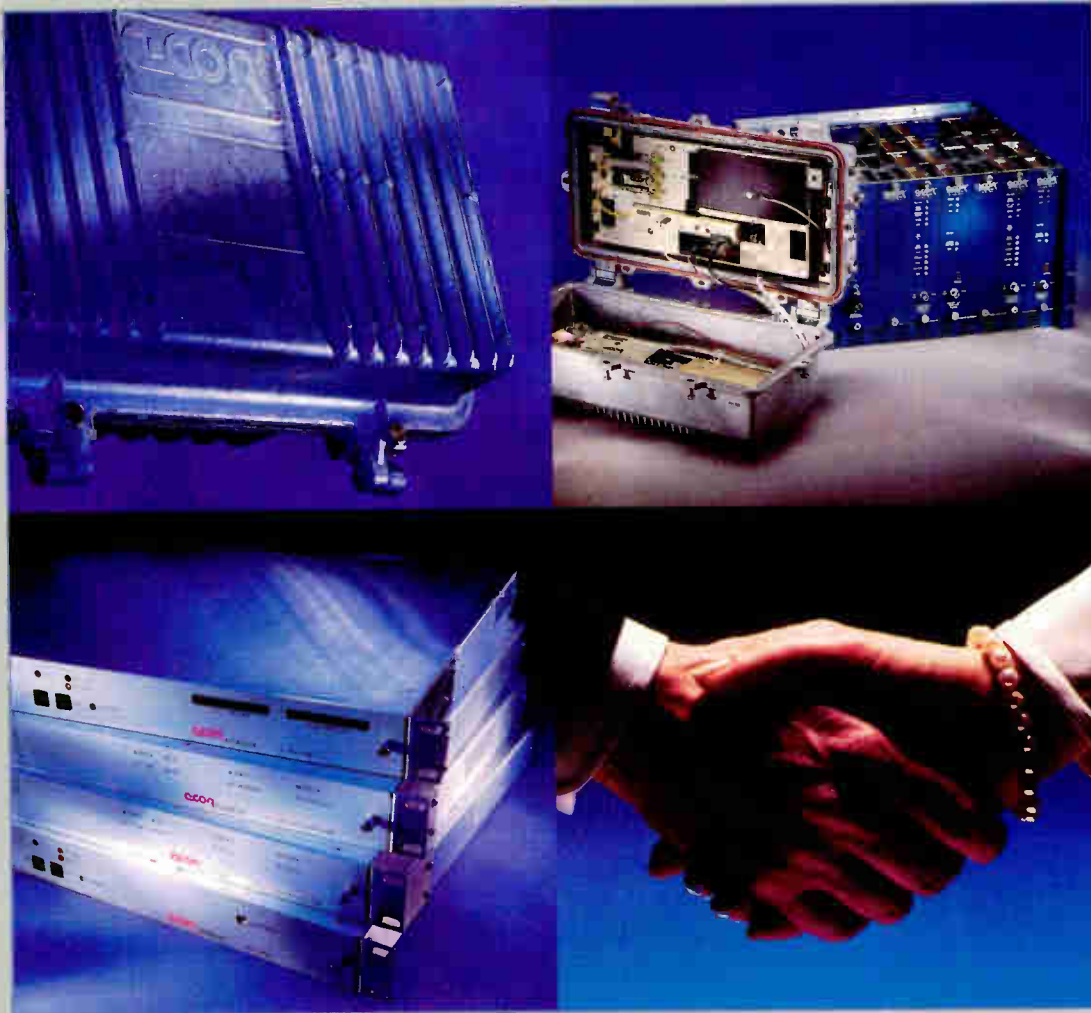

*SystemSelect™, C-COR's platform for a full range of network solutions for the cable television, telephone, and broadcast industries.*

Call now,  
**800-233-2267,**

for more  
information  
about

SystemSelect™.

C-COR's fiber optic and RF products offer advanced networking capabilities for today's hybrid fiber/coax architectures.

**POWERFUL**...LinkNet™ AM fiber optic equipment offers 750 MHz capability on single or dual fibers: redundant optical backup; a flexible, modular, upgradable platform; and the network management option.

**FLEXIBLE**...FlexNet™ RF amplifiers offer cost-effective, flexible capability from basic service to interactive multimedia. FlexNet™ 750 MHz amplifiers come in a 1 GHz housing and are backed by C-COR's extended warranty.

**RELIABLE**...Multi and single channel uncompressed digital video fiber optic systems provide highly-reliable, cost-effective delivery of video, audio, and data over long distances with no signal degradation.

Network analysis, design, installation and maintenance assistance, repair, training, and a 24-hour technical support hotline are also part of SystemSelect™.

**For Intelligent Solutions!**



60 Decibel Road  
State College, PA 16801  
814-238-2461  
800-233-2267  
Fax 814-238-4065

**CALIFORNIA OFFICE**  
47323 Warm Springs Boulevard  
Fremont, CA 94539-7462  
510-440-0330  
Fax 510-440-0218

**DENVER OFFICE**  
12742 East Caley Ave. / Suite A  
Englewood, CO 80111  
303-799-1100  
Fax 303-643-1743

**INTERNATIONAL OFFICE**  
P.O. Box 10,265, 1301 AG Almere  
The Netherlands  
31-36-536 4199  
Fax 31-36-536 4255

**CANADIAN OFFICE**  
377 MacKenzie Avenue, Unit 5  
Ajax, Ontario L1S 2G2, Canada  
905-427-0366 / 800-427-2559  
Fax 905-428-0927

# SCTE group drafts construction guidelines

## Singing off the same sheet

By Dana Cervenka, Managing Editor

The SCTE's Basic Construction Working Group, part of the Society's Construction and Design Subcommittee, is forging full-speed ahead to develop recommended construction guidelines for the cable industry.

"What the SCTE wants to do, is to get, more or less, one sheet of music that we all follow," explains Gene Coll, working group leader and VP sales/engineering with Diamond Communications. While emphasizing that the guidelines being developed are recommendations only, Coll notes that the project was born out of a pervasive lack of construction standards throughout the industry. More than 20 years of diverse construction practices in different systems, motivated by economics and other factors, have left a legacy of systems that adhere to their own standard, but not a common one.

Keith Burkley, chairperson for the Construction and Design Subcommittee, and vice president of construction with Time Warner, developed the initial goals for the Subcommittee back in 1992 at the SCTE Expo in San Antonio. Those goals included drafting a recommended construction practices manual for the cable industry that is as generic as possible (and which can be used as an addendum to a contract); and developing standards that "are consistent with the training and objectives of the industry and the SCTE." The manual should go a long way toward establishing industry wide quality standards, consistent practices and self-policing methods. As Burkley noted in his original committee guidelines, "Self regulation—If we don't do it, someone else might."

The new construction manual will cover project management, cable handling and equipment, aerial cable placement, buried and underground cable placement, enclosures/pedestals, bonding and grounding, splicing and connectors, and activation and testing.

The chapter on activation and testing should provide operators with help in dealing with new technologies such as digital. A representative from H-P Calan and an engineer with C-COR are putting their heads together to come up with that one. It's a big job. As Coll notes, "They are addressing every new type of equipment, every method out there."

At present, all of the chapters are between 80 to 100 percent complete.

### Honing splicing practices

Burkley says that of all the construction-related issues, coax splicing is the one that cries out for the most fine-tuning. In fact, the issue warranted so much attention that the working group formed a separate subgroup to study it. That group includes three major connector manufacturers, and two coax suppliers. At the Working

**"A slip of the knife which just took off a couple of shavings of copper is significant"**

Group's Las Vegas meeting, the emphasis was on trying to ensure compatibility.

"We are really trying to come up with a set of specifications based on the variables: connectors, cable types and different vendors," notes Burkley. "In this exercise in Vegas, we were putting a fair amount of effort into trying to genericize types of connectors with types of entries into different electronic equipment and cable types. But it gets difficult because you have so many options."

The working group has also outlined several alternatives for grounding practices.

Marvin Nelson, director of certification programs for the SCTE, has responsibility for editing and supervising the production of the

construction guidelines. Like Burkley, he feels that it was critical for the working group to tackle splicing issues, especially with the advent of increased technical demands on the cable plant.

"Knowing that an inadvertent slip of the knife which just took off a couple of shavings of copper is significant," he explains, "when we start talking about 750 MHz. You can get by with it at 400, but you aren't going to be able to at 750 or 1 GHz."

Digital transmission, in particular, will be acutely sensitive to less-than-perfect construction practices.

With that in mind, Nelson also cites the need to educate people in the trenches about the proper way to handle cable overall, and that starts with the right way to unload a reel of cable from a truck.

"A lot of people don't have forklifts or a loading dock to unload it from, so they just roll it out of the back and let it drop," says Nelson. "That does severe damage to the cable."

Overall, the new guidelines should be a better fit for the cable industry than the Bellcore Bluebook, which is heavily referenced for construction practices, but which doesn't necessarily directly apply to handling coax plant, adds Nelson. "When you are on the pole, the Bluebook would apply quite well. But when you are talking about hanging and handling techniques, then coax has a whole different set of requirements—different from the way you would handle twisted pair."

### Converging industries

Eventually, the recommended practices which the group drafts could have a good chance of evolving into a de facto standard. That prospect is enhanced by the broad, multi-industry participation which SCTE committees enjoy. All of the association's committees are open to representatives from other industries, including telcos and utilities.

For those who'd like to participate in the working group's efforts, the group's next meeting will be held at the Atlantic Cable Show, this month, and Coll is urging both operators and manufacturers to attend.

"Basic construction does not have the glamour of fiber," notes Coll, which has dampened participation, and consequently, has hampered completion of the construction manual. The goal is to have the manual ready for engineering committee review by the end of the year.

If all goes according to schedule, then the document should be in print and available for purchase sometime next summer. **CED**

# Picture Perfect



*ComSonics' Revolutionary New WindowLite Installer... The First Meter Built for Installers Out-Performs Any Other Installer's Meter Available Anywhere.*

## Unprecedented Technology

**Accurate and reliable ...** Delivers frequency range, level measurement range, and accuracy levels that match more expensive, full-service signal level meters.

**Optimal performance ...** The only installer's meter that can automatically select and set six video carriers from the full tuning range available.

**Rugged, shockproof, waterproof ...** The Installer stands up to the most grueling and demanding conditions faced by cable installers anywhere.

**Worldwide adaptability ...** Outperforms any other installer's meter available anywhere ... with full programmability and international channel selection.

**Affordable ...** Best of all, the price is right. You get more than your money's worth with the WindowLite Installer. For the first time, you can put *affordable* breakthrough technology into the hands of all your installers.



**COMSONICS, INC.** An Employee Owned Corporation

**We set the standards.**

1350 Port Republic Road / P.O. Box 1106  
Harrisonburg, VA 22801 USA

Phone: (703) 434-5965  
In USA: (800) 336-9681  
Fax: (703) 432-9794

# BT's video-on-demand technology trial

Video over copper, fiber and radio



By Alec Livingstone,  
Lead Delivery Manager, BT

According to the *Sunday Times* of April 21, the information superhighway is alive and well, not in North America, but in Kesgrave, a "picturesque village" in rural East Anglia. The event described by the *Sunday Times* was, according to Larry Ellison, chief executive of Oracle, "BT snatching its place in history by being the first company to connect interactive television to the information superhighway."

They were both referring to the launch on March 1 of BT's video-on-demand technology trial: a trial which set out to answer the technical issues surrounding the viability of a number of technologies key to the development of interactive multimedia services. In the dark days at the beginning of 1994, there were several developments which needed to be put in place in order to make the first steps toward a

A family takes part in BT's trial in Kesgrave.  
Photo by BT pictures.

truly interactive, one-to-one video service.

1. Video encoding at two megabytes per second.

2. Picture quality transmission at 2 megabytes per second over a number of transmission media including twisted copper pairs.

3. Good picture quality decoding and control from a set-top box.

But there was another overriding consideration, which was to run a trial service, not a demonstrator. There have been a great many demonstrations of video-on-demand technology from BT and a number of suppliers over the years; how-

ever, our intention was to run a trial service in a real telephone exchange, using existing cabling infrastructures, and using as many as practical of the operational processes which would go to run a real service. Those include producing the user handbooks and providing helpdesk facilities within a normal customer support environment.

The trial is based in Kesgrave, with a video server comprised of an nCube parallel processing computer playing video stored on a magnetic disk. The value of the parallel processing computer software as implemented by Oracle is in the ability of each processor to reconstruct a movie from a large number of segments distributed across the total disk array. By breaking up the movie in this way and taking advantage of the disk controllers' ability to manage a relatively small number of simultaneous disk accesses, one copy of a movie can be viewed simultaneously by many customers all rewinding, pausing and playing the movie without interfering with each other, and never watching exactly the same segment as anyone else.

Movies are encoded in real time at 2 megabytes per second using MPEG-1 coding and converted to E-1 streams for transmission to the home by optical fiber, ADSL on copper, or 29 GHz line-of-sight radio.

Currently, there are around 60 customers connected; three using radio distribution, two demonstration sites in London connected by megastream links to Kesgrave, one demonstration site located at BT Laboratories, and the remainder of the customers served equally by fiber or copper using ADSL. The technical aspects of the ADSL distribution have been described elsewhere; however, some of the operational aspects of the service are worth repeating.

Prior to the trial, besides concern over the picture quality which could be delivered by ADSL, there was considerable concern over the possible impact on normal voice telephony. Indeed, as part of the trial planning

Figure 1: Video-on-demand

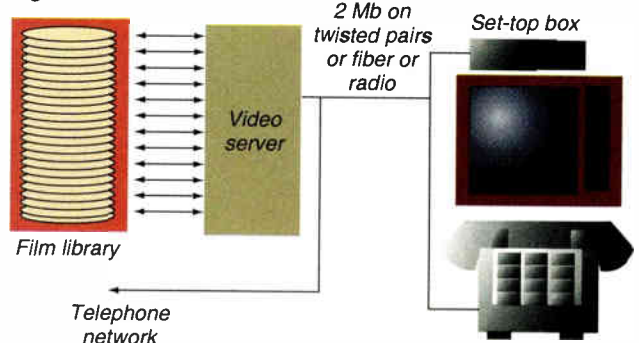



## How many headend channels are enough?

Perhaps 80 or 100 channels still sound impressive. Until you realize GI's next-generation COMMANDER® 6 Modulators and Upconverters use 1 GHz bandwidth to push the head-end performance envelope to 161 channels (much greater with digitally compressed services). It's the new standard for giving subscribers more programming, entertainment, and information services.

What's more, GI's COMMANDER 6 Modulators and Upconverters offer you all the benefits of frequency agility without sacrificing high performance.

### What about digital?

If it seems far off, think again. GI's frequency-agile upconverters handle both analog and digital signals right now. So, you won't have to replace them when you implement our industry-leading DigiCipher® and DigiCable™ technology. Now that's smart.

### What about space?

GI engineers solve physical space problems at your headend or

central office, too. As an example, our new COMMANDER upconverters handle two standard channels instead of one.

That means you can effectively double the number of channels you offer in the same physical space.

### What about services?

GI provides the full range of signal origination, reception and processing products for the emerging technologies— analog and digital video broadcast, digital audio, games, data, and other interactive services. Consider our headend prepackaging service—GI's total system solution, custom-designed, assembled, tested, and delivered using GI expertise.

So, if you're looking for headend solutions with a future, look to General Instrument—the worldwide leader in end-to-end analog and digital communications systems. Call to learn more about GI's next-generation headend systems— advanced enough to be their own replacement.

New GI COMMANDER 6 Upconverter

**GI** General Instrument

(215) 674-4800 (worldwide) • (800) 523-6678 (toll-free in U.S.) • (215) 956-6497 (fax worldwide)

©1995 General Instrument Corporation

Circle Reader Service No. 27

## ◆ INTERACTIVE TV IN THE UK

Figure 2: Technology trial

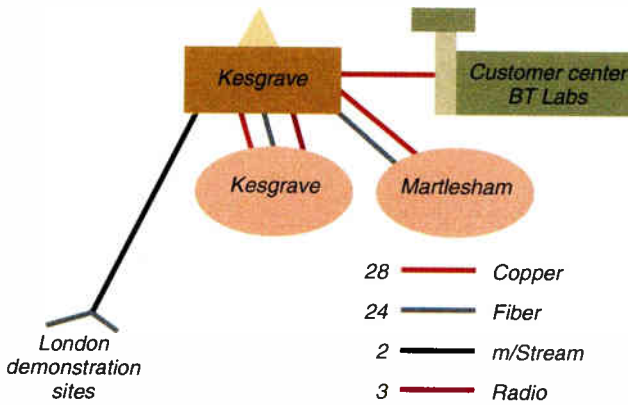

process, there were contingency plans prepared should ADSL cause customers problems. The chosen ADSL technology was DMT-based from Amati, supplied in the U.K. by Nortel. This technology is still relatively new and has not benefited from some of the integration work which has now been carried out on the older CAP-based equipment. Nor is the network matching quite so refined, and the equipment installed in the trials is optimized

for the U.S. network, not the U.K. one.

Despite misgivings about the technology, most of the results have been extremely encouraging. Installation of the customer equipment is relatively simple; the only failures we have seen have been obviously catastrophic ones with no need for any complicated alignment or tuning, as one might expect with a technology which is stretching twisted pair distribution into entirely new areas of our experience. The only minor complication encountered is due to the size of the present generation of ADSL equipment, which requires that in most cases, it be installed out of sight, usually some distance from the TV receiver. However the video signal can be driven up to 30 meters, and there are no practical problems in finding suitable domestic installations.

Picture quality on the trial system is excellent in the eyes of the most discerning cus-

tomers, the content providers. Certainly the quality is comparable with the best VHS quality, and very much better than that which most domestic equipment delivers. It is worth reiterating that to the homeowner, the picture quality on ADSL is exactly the same as that delivered over fiber. There are still disbelievers in the industry, and principally for that reason, the customer demonstration suite at BT Laboratories is delivered from Kesgrave by ADSL over copper, despite the fact that the sites are five kilometers apart.

There is one word of caution on transmission quality. Pictures, or more accurately the human brain, are remarkably tolerant of errors, and the odd bit of information lost in transmission may not affect the customer's viewing of the movie. However, it is not yet clear what the long-term error characteristics of the medium will be, nor how tolerant some other applications may be. For example, the movie application is loaded into the set-top box when the customer first connects to the server. That application of course cannot tolerate errors and is delivered using error correction which currently takes around 20 seconds. That may well

# This Optical Power Meter Is So Smart, It Talks to Your PC.

The New Model OPM 5 Series optical power meters operate at 850, 1310 and 1550nm for use in all singlemode and multimode applications. When connected to a PC, the versatile OPM 5 serves as a lab meter providing real-time readings and hard copy output for documentation.

- Stand-alone unit stores 250 loss readings in the field
- Connects to PC or printer
- Ideal for batch and stability testing
- Auto-zero
- Use AC or 9V battery

Call for a Product Catalog detailing the OPM 5 and the entire family of Noyes fiber optic test equipment.

**1-800-321-5298**

Noyes Fiber Systems  
P.O. Box 398 • Laconia, NH 03247 • PHONE 603-528-7780 • FAX 603-528-2025



**NOYES**  
FIBER SYSTEMS

# All the right ingredients!

**Strong, cost effective  
Christy Grade Level Boxes...  
now available from Channell.**

Christy Concrete Products, Inc. has been manufacturing boxes for underground construction of water systems and utilities for nearly four decades. Now, they've teamed up with Channell Commercial to provide their concrete and Fibrelyte™ products to the telecommunications and broadband communications industries.

Christy uses an automated "dry tamp" process to manufacture its concrete boxes. To provide additional strength, fibers are added to the concrete mix. Additionally, a unique, thermoplastic ring assures proper fit of the non-skid lid and also protects the top edge of the box from chipping. The result is less breakage during shipment and reduced liability problems with installed boxes.



Christy's Fibrelyte boxes and lids complement the concrete product line. Constructed of proprietary composite materials, these lightweight and high strength Fibrelyte boxes offer many advantages over precast concrete.

In many applications, Christy's concrete and Fibrelyte boxes and lids can be intermingled, providing numerous combinations for added strength while providing low cost product solutions.

Christy quality concrete and tough Fibrelyte grade level boxes—the right ingredients for your underground plant requirements. Call Channell toll free today for complete information.

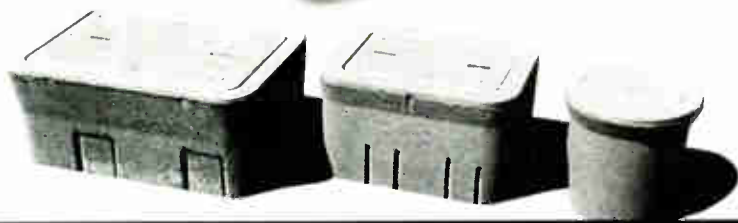

**Christy Concrete Products, Inc.**  
44100 Christy Street, Fremont, CA 94538

**Marketed exclusively by Channell Commercial Corporation**

**U.S.A.** 800/423-1863 • 909/694-9160 FAX: 909/694-9170  
**CANADA** 800/387-8332 • 905/567-6751 FAX: 905/567-6756  
**U. K.** +1 44 171 589 3304 FAX: +1 44 171 589 1021  
**ISRAEL** 972 4 341329 FAX: 972 4 341387

## ◆ INTERACTIVE TV IN THE UK

change as the error characteristics of the media are better understood.

The other gratifying observation immediately after the first customers were connected was that ADSL did not adversely affect the associated telephony to any great degree. As mentioned above, the ADSL equipment is optimized for the U.S. network, and it does affect performance in the U.K. The manifestation of the problem is a higher than normal feedback

of the customer's own voice through the telephone handset, which leads customers to talk more softly than they would normally. In the vast majority of cases, this is not a problem, although it may be in certain situations where, for example, there is a high level of background noise.

In summing up the performance of the technology trial to date, there are two major observations:

1. Picture quality is excellent. Although difficult to quantify, it is clearly much better than VHS, and certainly in the ability to deliver excellent picture quality using PAUSE, there is no comparison. Qualitatively, the picture quality that can be delivered is probably better than can be displayed by a large number of domestic television sets. Of course, there are limitations. Extraordinarily busy frames are difficult for the technology to cope with, but most action sequences, including sports, are coped with adequately.

2. The installation is as near to that which will be encountered in real life as possible; a 25-year-old telephone exchange, existing copper pairs, a "low-tech" environment for the server and normal domestic telephone equipment.

For the future, there are, of course, enormous possibilities for the technology, but refinements are necessary. What the video-on-demand technology trial has demonstrated is some key components which move us much nearer universal access to the information superhighway. The trial has established that high quality moving picture distribution is possible over copper, fiber and radio access methods. It has delivered that by effectively associating a PC with every television set. A computer in every home connected by a 2 megabyte channel to limitless disk storage is a mouth-watering prospect for application developers. Moreover, the access to those applications can be very simple.

The future for ADSL has to be one of cost reduction and increased bandwidth. The technology trial currently uses DMT technology, which is still very expensive. The next steps in the evolution of this program may well be to take a backward step in technology to CAP, where there may be benefits to be derived in cost and size, because the technology is more mature. Also, in terms of performance, although 2 megabytes in one direction with 16 kilobytes the other way is an astonishing achievement, long term, we may well need six megabytes downstream if only to support more than one television set, and anything up to 1 megabyte on the back channel to support interactive games.

In conclusion, we have a technology trial which has been running for six months providing a truly interactive video-on-demand service. The next steps will require further advances in servers, set-top boxes, and transmission and switching. The achievements of March 1 were a major step forward; however, in retrospect they were merely the first small steps toward universal access to the information superhighway which will totally change our lives. **CED**

# F I L T E R S DELIVERED QUICK

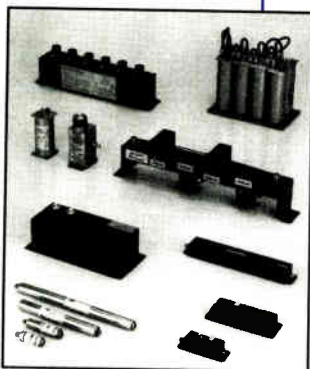

- The most highly selective bandpass filters.
- Notch filters which do not interrupt adjacent channels.
- Pay-TV traps shipped overnight.
- The broadest selection of terrestrial interference filters to improve C-band reception.
- Custom filters designed to your specifications.

### ASK FOR OUR CATALOGS:

**C/91** for CATV filters.

**Fastrap/90** for pay-TV traps.

**Supernotcher/90** for notch filters.

**MTV/91** for terrestrial interference filters.

## MFC

MICROWAVE FILTER COMPANY

6743 KINNE STREET  
EAST SYRACUSE, NY 13057  
800-448-1666 • 315-437-3953  
FAX: 315-463-1467

Circle Reader Service No. 30



# QUICK CHANGE ARTIST

HCP2550 HETERODYNE CHANNEL PROCESSOR  
CHANGE CHANNEL TO CHANNEL



**T**he R.L. Drake Company now offers you greater flexibility in meeting the needs of your headend with the HCP2550 Heterodyne Channel Processor. Drake, long recognized for manufacturing communication equipment of enduring quality, has designed the HCP2550 to be an extremely versatile heterodyne channel processor surpassing the most demanding engineering requirements.

- Capable of converting any standard VHF, UHF, HRC, IRC, or cable TV input signal to HRC, IRC, or any standard cable TV output channel.
- Output frequency coverage from 54 MHz to 550 MHz.
- Selectable offsets, A/V ratio adjustment, and RF output adjustment offer exceptional flexibility.
- SAW filtering eliminates adjacent channel interference.
- Programming of input and output channels is accessible via front panel DIP switches.
- IF loop-thru connections.
- High output power to +60 dBmV.



R.L. Drake Company  
P.O. Box 3006  
Miamisburg, OH 45343  
U.S.A.

Sales Office: 513-866-2421  
Fax: 513-866-0806  
Service & Parts: 513-746-6990  
In Canada: 705-742-3122

*Made in America by  
Drake...A trusted, world  
leader in communications  
equipment since 1943.*

Circle Reader Service No. 31

**DRAKE**

# If you like this...

# ...You'll LOVE this!

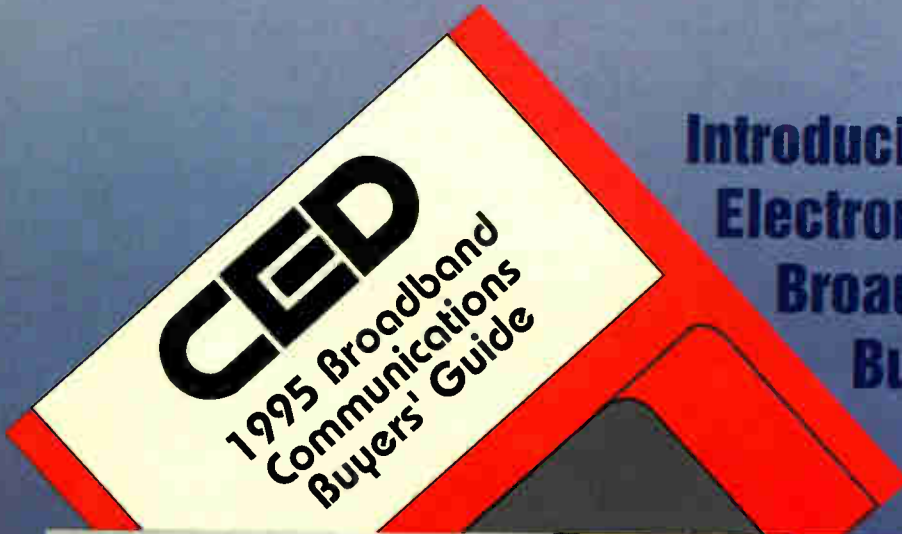
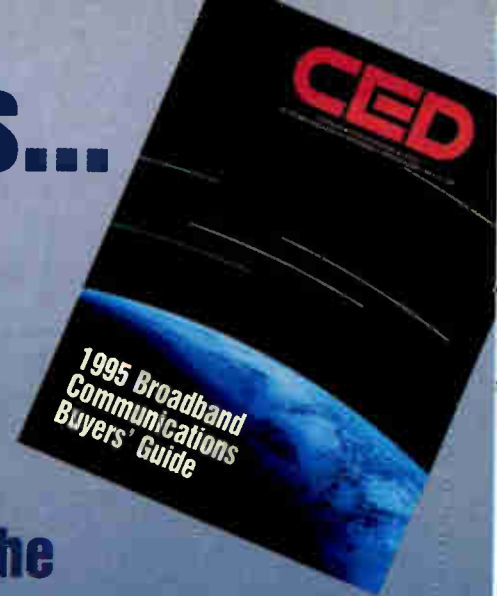

## Introducing the Electronic 1995 CED Broadband Communications Buyers' Guide

Windows  
format

### Your Key to Purchasing Power!

**NEW**



The CED Buyers' Guide has long been recognized as the most comprehensive listing of broadband communications products and services in the industry. Now this powerful resource is even better!

Available for the first time in Windows format, the "Electronic" Buyers' Guide gives you:

- Access to hundreds of companies and thousands of products
- An easy-to-use, searchable format
- Easy installation
- Printing capability for information that you select
- A resource you can depend on!

Special  
Introductory  
Price

# \$29.95

(Visa, Mastercard, American Express Accepted)

Order your copy today!

Call (303) 393-7449 Ext. #218

communications/engineering digest

communications/engineering digest

communications/engineering digest

CED

CED



Technical Regulatory Standards federal/state/local

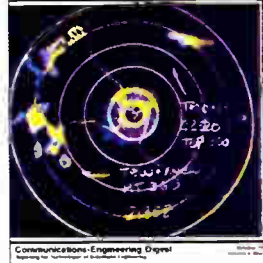
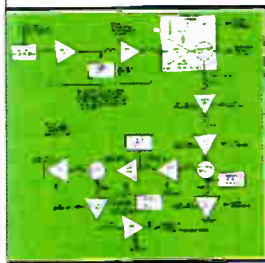

CED

CED

CED

CED

CED

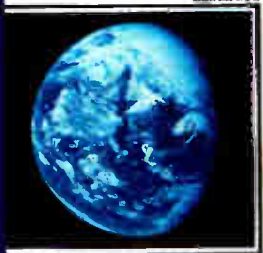

Communications-Engineering Digest

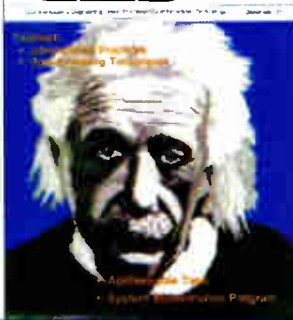

# SUCCESS BY DESIGN

## A retrospective of broadband technology

### Special 20th Anniversary Section

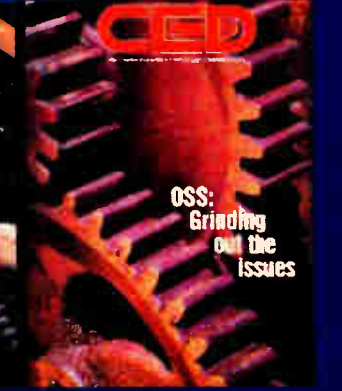
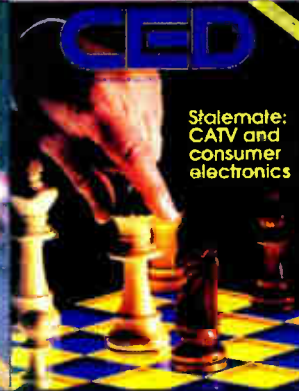
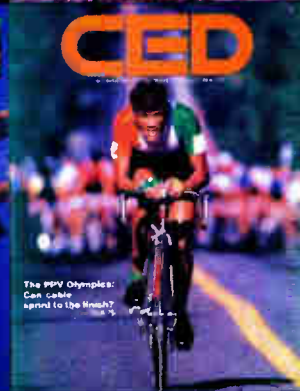
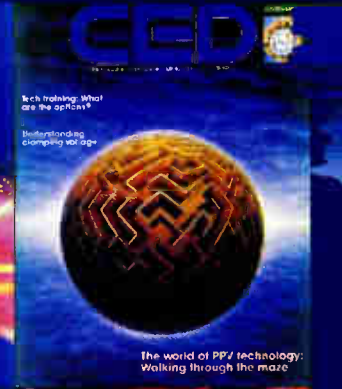
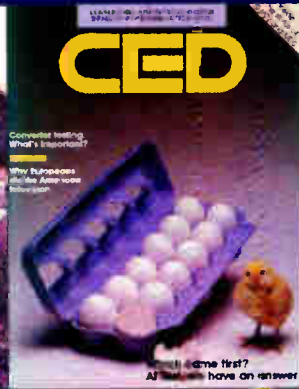
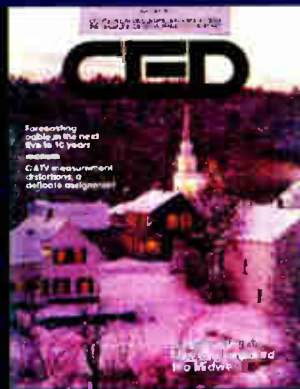
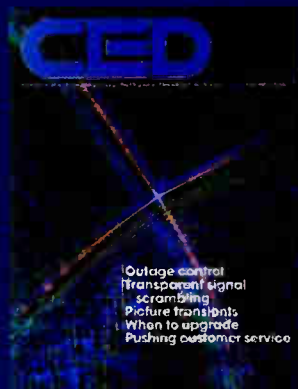

# Only One Sweep System Leads a Double Life!



**Stealth Sweep...**

**Stealth Reverse Sweep...**

## STEALTH REVERSE SWEEP



### PUT REVERSE SWEEP CAPABILITY INTO YOUR HAND

**The Stealth Reverse Sweep...** The latest sweep technology has been enhanced to meet your reverse sweep testing needs. Forward and reverse path alignment can now be done simultaneously – and by one person – with one instrument – the handheld Stealth.

Engineered for the interactive revolution, the Stealth 3SR handheld unit with the reverse sweep option both receives and transmits sweep for fast, precise, and accurate measurement of **both** the forward and reverse paths.

Eliminating awkward, complicated equipment setup results in simplified testing, reduced fatigue, and less time maintaining your system. You'll wonder how we squeezed in so much capability.

### Features include:

- Built-in sweep transmitter
- Simple, user interface
- Sweep any reverse band from 5 - 1,000 MHz
- Fast, continuous reference sweep
- Stealth Sweep ... a Wavetek exclusive, tests without interrupting viewer reception
- Signal analyzer for carrier levels, C/N, hum, tilt, and spectrum display
- Automated FCC 24-hour test capability

The Stealth Reverse Sweep provides all the accuracy, speed, and features you'd expect from the leader.

So, get the smallest, fastest, lowest priced, most capable sweep on the market. Get the Wavetek Stealth. **Call 1-800-622-5515.**

*Wavetek... partners in productivity for over 25 years.*

**Congratulations CED on your 20th Anniversary!**

Telecom '95  
in Geneva  
French Pavilion  
Stand 5222

# channel surfing



**New**

## MicroStealth Multi-Channel Testing -- for under \$900



**The Faster, Easier,  
Comprehensive signal level meter  
for cable TV installers.**

**Multi-Featured...** For the first time, installers can check all channels quickly and accurately- ensuring FCC compliance and reducing subscriber callbacks. MicroStealth's scan mode displays multiple channels simultaneously on a single screen. Plus, measure up to 890 MHz for today's high bandwidth cable systems.

**Easy Viewing...** View the signal levels on a detailed, high resolution LCD display -- a feature, up until now, only available on higher priced signal level meters.

**Easy to Use...** With the press of a single button, cable installers can easily get a snapshot of the system's performance. There is even a one button *Go/No-Go* function so you can be sure you are within FCC compliance on every installation. MicroStealths are lightweight, rugged and water resistant, to withstand the abuse of every-day field use.

**MicroPriced...** The new MicroStealths are yours at unbelievably low prices. Even the enhanced MicroStealth MS1200 with 890 MHz frequency extensions, full scan mode, FCC *Go/No-Go*, and printer driver capability, is about half the price you would expect.

All the accuracy, speed and ease of use at a price you expect from a leader.

**Call 1-800-622-5515**

**WAVETEK**

*Wavetek...partners in productivity for over 25 years.*

©Wavetek Corp., 1995



# Saluting the Pioneers

R O G E R B R O W N

**AFTER** spending the past few weeks poring over every issue of CED that exists in our extensive library, I've come away with a new and profound sense of the technical issues that have shaped this burgeoning broadcast entertainment video industry for the past 20 years. Risking patronization of the pioneers, I salute the engineering visionaries who were bold enough to take risks and help transform what was then a simple signal regeneration service using primitive technology into a new source of differentiated programming and information.

Looking back at some early prognostications, it's clear the engineers of the mid-'70s were pragmatic about the future. In a 1976 commentary, NCTA VP of Engineering Delmer Ports showed clear vision and thinking when he noted that fiber optics would be attractive for major trunks, express trunks, rural extensions and shared services. It would have been easy to either dismiss the technology altogether or get caught up in the hype that surrounds new technology. He did neither. Israel "Sruki" Switzer was also correct when he said HDTV would take several years to manifest itself—and that the world had yet to see a high-quality 525-line picture. We're still working on both of those.

Along the way came new and better technologies to provide more channels and clearer pictures, but more importantly, the cable TV industry has become an integral part of the American culture. Nearly two-thirds of all households can't live without their MTV, their CNN or The Weather Channel. Others tune in to The Discovery Channel, C-SPAN, ESPN, Nickelodeon and USA Network to be informed and entertained. Where once it was the big three networks that dictated what Americans watched, the cable industry has allowed viewers to tune into what *they* wanted to watch. And in some cases, cable programs have actually been more daring, more provocative and more successful than the fare offered by CBS, ABC or NBC.

One needs to go no further than the day Home Box Office beamed the Ali-Frazier

fight by satellite to the world (which occurred, ironically, the day before CED's first issue was published). That singular occurrence, often recognized as the watershed event in the industry, set cable TV apart from all other broadcast services. It allowed cable operators to affordably add new, unique programming sources to their channel lineups. This ability to give viewers product they had never seen before allowed MSOs to penetrate into urban areas where the broadcasters owned the TV turf. I wonder if the engineers at HBO had any idea of the magnitude of their efforts and wisdom. I suspect not.

It's this and other examples of that "can-do" attitude that scream from the pages of CED over the years that leave me with such a sense of awe. Prior to the cable industry's adoption of satellite services, there were only a handful of earth station antennas. It could be argued that it was the cable industry that made satellite communications possible



**Cable TV has become part of the American culture**

for the rest of the world, by driving down the cost of the hardware.

And while they're often a sore subject, it was cable equipment manufacturers who built set-top convertors so that viewers could have access to more than 12 channels of video. Inside those boxes were high-quality tuners that were later joined with other features such as timers, audio controls, and on-screen messages—features that cost subscribers a

few dollars a month and didn't require a brand-new TV receiver.

Later, people would scoff at the thought that HBO and other programmers could effectively scramble their services to protect their revenue streams—before it happened. Similarly, before engineers from the industry insisted that video could, in fact, be transported over linear analog lasers, the experts said it couldn't be done. Then it was high definition TV and digital compression—and General Instrument turned the world on its ear.

Each of these tumultuous events are recognized throughout the pages of CED. Early issues of the magazine were devoted to helping system technicians and engineers pass the FCC's proof of performance and technical standards tests. From there, content was devoted to helping the technical community understand new technologies as well as do their jobs better.

As new and more breakthroughs occurred, CED covered them and explained their meanings, as you'll see from the following pages, which attempt to encapsulate the most memorable technical occurrences since 1975. Along the way, we've highlighted and recognized those pioneers and visionaries who helped mold the industry into what it is today. From Warren Braun, Delmer Ports, Gayheart Kleykamp, Ken Simons, Tom Smith and Glenn Chambers, the first persons highlighted in CED, to Louis Williamson, whom we throw our Spotlight upon this month, you've read about them here, first.

Never has the future seemed so bright—or so daunting—for MSOs. The business is about to change (yet again), and only the strong will survive, but if history is any teacher, it can be safely argued the industry will soon take its place as a respected player in the global communications marketplace. And CED will be there.

We're proud of our 20-year track record, just as the MSOs should be proud of the steps they've taken along the way to become part of the American culture. Let's see what the next 20 years bring.

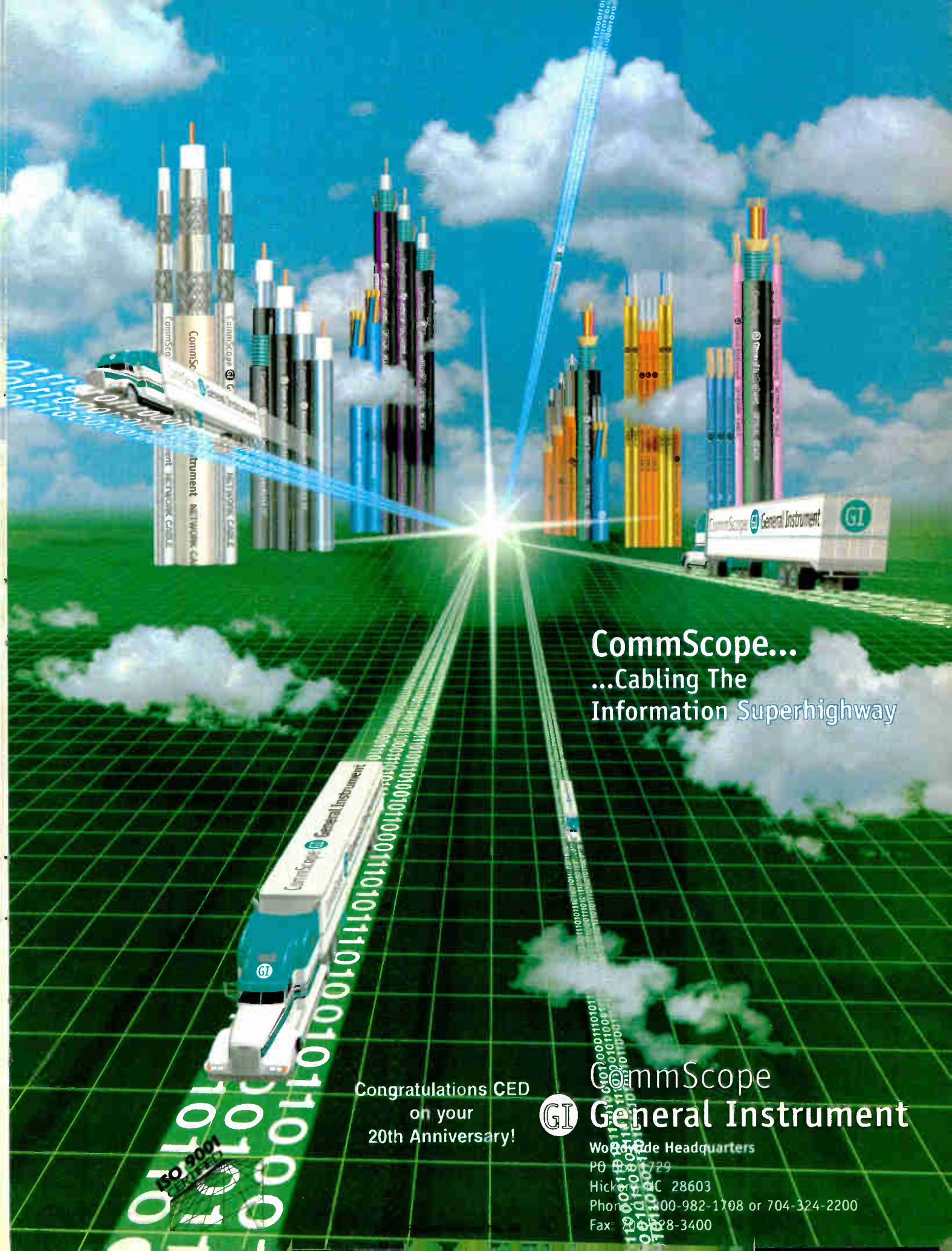

CommScope...  
...Cabling The  
Information Superhighway

Congratulations CED  
on your  
20th Anniversary!



CommScope  
General Instrument

Worldwide Headquarters  
PO Box 11729  
Hickory, NC 28603  
Phone: 704-324-2200 or 800-982-1708  
Fax: 704-324-3400



# 1975-1976

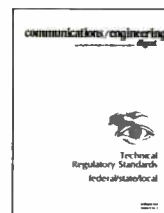

## A P R O F I L E

Glenn Chambers of ATC in Appleton, Wis. is named SCTE Man of the Year during its convention in Dallas. He's cited for his work on FCC Proof of Performance Requirements.

Len Ecker was named a member of Jerrold's headquarters sales staff, reporting directly to Jack Forde, manager of headquarters sales in Jerrold's CATV Systems Division.

NCTA Vice President of Engineering Delmer Ports shows great insight into the future in a column he writes, called "Fiber optics: A treat or a threat?" He notes that the new technology will be useful for long trunk runs and extensions into rural areas, but it "won't replace coaxial cable for house-to-house connections."

Sid Topol, president of Scientific-Atlanta, says his company's sales volume is scheduled at \$45 million for the fiscal year ending June 30, 1976.

Frank Drendel buys Comm/Scope (the first time) from Superior Continental Corp. for about \$5 million and is named president of the company.

By the time "communications/engineering digest" was presented to the cable TV industry's technical community, the Society of Cable Television Engineers was already six years old. It's first meeting, on a Sunday back in 1969, was a success, and a short while later some 200 people were members of the SCTE, at \$20 per year dues. The purpose of the Society was not to form a union, as some surmised, but to foster education in the burgeoning cable industry. The Society remained focused on organizational issues and keeping itself afloat in the early years.

By the time 1975 rolled around, cable TV was gaining favor and growing fast. Keeping up with regulations and new technology was beginning to be a challenge. Although the SCTE began publishing a newsletter in early 1975 to report on its internal growth, SCTE President Robert Bilodeau and others believed there was a need for another outlet. This one would be for more technical discourse. It was launched in October 1975—ironically just one day after HBO carried its first satellite-delivered program, a watershed technical event.

"C/ED will be an outlet for technical exploration, examination and problem solving," Bilodeau wrote in the first issue. "It will also be a communications vehicle between readers in the technical aspects of our industry. In addition, it will provide current information on our regulatory requirements relating to measurements, proof of performance and system operations as they relate to the everyday system technician. In a broad

sense, it will be an encyclopedia of personalities involved in technical and related aspects of the cable television industry."

That first issue was focused on regulations, with several reports related to the status of important technical committees and groups, including: the



One of the first ads to appear in CED

NCTA; the Cable Television Technical Advisory Committee; the FCC; and the New York and New Jersey state regulations as they related to cable TV.

**Estimated 1975 revenues for the industry: \$770 million, according to the NCTA**

HBO subscription numbers grow from 60,000 to 275,000 in more than 100 systems. Service is transmitted to 12 earth stations that serve 14 cable systems.

**According to the NCTA, the cable industry consists of 3,450 systems serving 7,700**

**communities and passing 10.8 million homes. Nearly 190,000 miles of plant are in place. Construction costs range from \$3,500 per mile to \$10,000 per mile. Pennsylvania boasts the most systems (301), while California has the most subscribers (1.5 million).**

Top 10 cable operators: TelePrompTer, Telecommunications Inc., Warner, ATC, Cox, Viacom, Sammons, CPI, United and Cablecom-General.

**The first Canadian high-power AML system was installed by the Alberta Government Telephone Co. The equipment was purchased from Theta-Com, a subsidiary of Hughes Aircraft. It was installed and energized less than five days after clearing customs. Meanwhile, Cablevision Systems in Jericho, N.Y. installs the 100th AML system in the U.S.**

Technical sessions at the NCTA convention include discussions of system reliability, two-way cable systems, satellite transmission and earth stations, and FCC rules and regulations, proving the old axiom that what goes around, comes around.

**Starting in August, C/ED is published by Titsch Publishing Inc., which also publishes CableVision magazine. Associate Publisher Judy Baer says little will change: "C/ED will be the best. I promise. I would settle for nothing less."**

The first transcontinental, two-way, live Congressional testimony was delivered from Santa Monica, Calif. to Washington, D.C. for House Communications Subcommittee hearings, on a 3.2-meter horn antenna.

**The cable TV signal leakage issue gains the attention of the Office of Telecommunications Policy and the FCC when the "Harrisburg Affair" occurs. Two planes narrowly miss each other, and the cable TV system is blamed for causing interference in the mid-band frequencies that are shared with the Federal Aviation Administration. The incident sparks a lengthy debate and series of discussions between several government entities to avoid similar problems in the future. The FCC releases docket 21006, which calls for cable TV operators to offset their frequencies by Jan. 1, 1979. It's a pain, but the FAA wanted cable to abandon the mid-band altogether.**



From the People Who Invented Leakage Detection . . .  
*ComSonics Introduces*

**SNIFFER**<sup>®</sup>

**SLEUTH**<sup>™</sup>



*THE  
Most Complete  
Leakage Control  
Package Available  
Anywhere!*

- Detects leaks more than 500 feet away!
- Self contained:
  - Near-Field Probe, Far-Field Probe, Dipole Antenna
- Detects both:
  - Standard Sniffer Transmitter and TV Carrier Signal
- Sniffer I.D. Signal Discrimination
- Frequency Agile (2 Ranges)
- Tunable in 1kHz increments
- Full function LCD
- External Antenna connection
- GeoSNIFFER compatible
- Nickel-cadmium battery (user replaceable)
- Custom-made Holster available
- Docking Station accessory

*Celebrating...  
CED's 20 Year Anniversary and  
ComSonics' 20 Years of  
Cable Test Equipment Excellence!*

**COMSONICS, INC.**

**We set the standards.**

1350 Port Republic Road, P.O. Box 1106  
Harrisonburg, VA 22801 USA

(703) 434-5965, In USA: (800) 336-9681 Fax: (703) 434-9847

Circle Reading Device No. 22



# 1977-1978

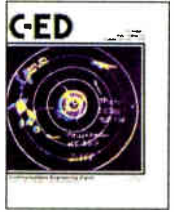

A P R O F I L E

**The Society of Cable Television Engineers announces plans to move its headquarters from Ridgefield, Conn. to Washington, D.C. effective April 1, 1977.**

Award winners: Frank Bias, VP of engineering of Tele-Vue, was named SCTE Man of the Year, while Communications Properties Inc.'s Jim Stelwell and Scientific-Atlanta's Alex Best were honored with NCTA Technical Achievement Awards for their engineering expertise by FCC Chairman Richard Wiley.

**As of June 1977, SCTE membership stood at 833 members, including technicians, engineers, managers and manufacturers. In addition, there are 17 "sustaining member" companies on the books.**

By the end of 1977, SCTE has 1,115 members and an annual budget of \$33,000, according to SCTE President Bob Bilodeau. Membership dues are \$20 per year. The SCTE estimates there are about 8,000 technical personnel in the industry.

**In 1978, Jim Grabenstein, the chief engineer at Potomac Valley TV in Cumberland, Md., receives the SCTE "Member of the Year" award. Meanwhile, Cliff Paul of the New Jersey Cable Commission is hired as the sole engineer in the FCC's microwave division.**

Membership in the SCTE tops 1,500 when Tom Townsend of Fox Cities Communications in Appleton, Wis. joins the organization.

Bell announces that a fiber optics total communication system will be in operation in Chicago by the middle of 1977. The system uses 12 fibers and delivers voice, data and Picturephone between central offices.

**The cable industry rallies to fight the Consumer Communications Reform Act, also known as the Bell Bill. The bill would preclude cable companies from competing with other communications facilities or creating "redundant" circuits for services that are already available or proposed. The bill maintains that the Bell company can provide services such as security, fire alarms, home banking and library access more competitively than anyone else.**

After a six-month search for a new vice president of engineering following Delmer Ports' untimely death, the NCTA taps Robert Luff to take his place. The 30-year-old Luff comes from the FCC, where he was engineering assistant to Chairman Richard Wiley. After his stint at the NCTA, Luff goes on to similar positions at cable MSOs and is presently chief technical officer of Scientific-Atlanta's Broadband Division.

**Following a wave of interest in light-wave technology, Irving Kahn announces the formation of General Optronics Corp., which will manufacture and sell gallium arsenide lasers, LEDs and related systems. Kahn says the lasers will have a lifespan of about 100,000 hours, or 10 times the lifespan of equipment built then.**

Tele-Communications Inc. selects Scientific-Atlanta to supply about 60 earth stations over the next 30 months. The first place TCI plans to place a dish is in Corpus Christi, Texas.

**The New Jersey Office of Cable Television announced a plan to interconnect the state's 270,000 subscribers with a CARS band microwave system that would supply a one-way broadcast feed to more than 90 percent of the subscribers in the state. The action is important because it opens up larger areas for advertisers, creating another source of income for operators.**

It's a subtle thing, but CE/D becomes C-ED. The letters still mean the same thing: Communications Engineering Digest, but the magazine gets a new graphic look. Toni Barnett, formerly of Jerrold, is named managing editor and Ron Cotten of Cablecom General becomes technical editor.

**At the 1977 Western Show, Sen. Ernest Hollings says a subcommittee plans a "major legislative initiative" on cable TV to free the industry from "needless bureaucratic restraints."**

Interest in addressability begins to show up in 1978. Delta-Benco-Cascade debuts its Intelligent Tap System, which is a remote descrambling system. The system was invented by Stern Telecommunications and licensed to DBC. Other systems include Access-1 from Merrill Cable Equipment and the Magnavox MX 4000 addressable tap.

**SCTE President Bob Bilodeau (who is also Suburban Cablevision's engineering VP and a company founder) and HBO Director of Engineering Development Robert Tenten are awarded by the NCTA for Outstanding Engineering Achievement. More than 6,000 people attend the show in New Orleans, where nine inches of rain fall in one day.**

There is great debate over the definition of a "small" cable system in regards to regulation. Bob Bilodeau suggests it should depend on the size of the amplifier cascade; the FCC finally settles on the 1,000 subscriber benchmark.

**Milton Shapp, governor of Pennsylvania, but best known to cable industry pioneers as the founder of Jerrold Electronics, received the first honorary SCTE membership during a meeting of the New Jersey Cable TV Association.**

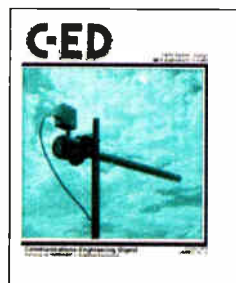

The industry moves closer to deregulation when the FCC eliminates the time-consuming certificate of compliance process, allowing cable systems to begin providing service to customers after filing some basic identification paperwork with the Commission. Prior to the action, the FCC had more than 1,500 certificates pending.



# Our Standard for Reliable Performance

**F**or more than 20 years, Alpha Technologies has set the standard for reliable communications power. Like the next sunrise, it's a standard our customers have come to rely on. And while our power may not yet match the certainty of the sun, we're getting closer all the time.



*Reliable Power. Nothing Less Will Do.*

---

*Sales & service offices throughout the world. For more information, call: 1-800-421-8089 or 360-647-2360*



Broadband Power Systems



Batteries



XM CableUPS®



UPS Systems



Argus DC Systems

***Congratulations CED on your 20th Anniversary!***

Circle Reader Service No. 57



**CABLETOWN, USA**

**POP. 232,175**

**THE FUTURE IS HERE**

# Talk Is Cheap.

COMING TO  
A TOWN  
NEAR YOU.

## CABLESPAN™

While others continue to promise, the tried and true **CABLESPAN™** telephony-over-cable system delivers.

While others talked, we listened. While others still promise, we deliver today. We deliver an advanced telecommunication system that provides basic and advanced telephony services over your broadband cable network.

The CABLESPAN system provides the flexibility to economically serve a wide range of residential and business applications. It integrates seamlessly with your existing CATV architecture while offering one of the lowest start-up costs in the industry. It provides incremental growth space with your subscriber penetration rate – with a host of unmatched options to keep per-subscriber-cost low.

All of this and more. To assure quality service, the CABLESPAN system provides robust fault recovery and comprehensive monitoring, maintenance and diagnostic capabilities. To meet the future needs of your subscribers, the CABLESPAN system provides a platform supporting tomorrow's multitude of advanced telephony services.

Twenty-first century communications technology is here. For a glimpse at the future of your network, see us at:

Alts Booth #40  
Western Cable Booth #3130  
Or call 1.800.445.6501

*Just what you'd want from*  
YOUR NETWORKING PARTNER®

**tellabs®**

Circle Reader Service No. 58



At the beginning of 1979, there are 1,100 approved receive-only earth stations in the cable TV industry, and the number is growing at a rate of about four per business day. As of the same date, there are 552 approved CARS band microwave stations, and the number is increasing by one every other business day.

RCA Americom announces that it will launch a third satellite by the end of 1979. The new bird will be used exclusively by cable TV programmers.

Times Wire and Cable, since renamed Times Fiber, introduces a complete fiber optic earth station link consisting of 100 meters of fiber cable, an optical transmitter and receiver, and all necessary connectors. It's priced at "under \$8,500."

Scientific-Atlanta hooks up with Homesat Inc. to sell and install earth stations at large rural farms and ranches in 10 western states. The announcement marks the first legal direct satellite-to-home distribution of TV programming in the U.S. The system, consisting of a 4.6-meter dish, installation and service, costs about \$20,000.

# 1979-1980



## A P R O F I L E

In 1979, the average cost of a subscription to basic cable service is \$7.69.

The NCTA Engineering Department begins publishing TechLine, a newsletter focusing on engineering and technical issues. The newsletter is still published under the same name.

State-of-the-art cable TV amplifiers feature feedforward technology covering the entire 45 MHz to 300 MHz band. Brand new set-top descrambling convertors pass 30 channels and feature push-button or dial controls and hard-wired remotes.

Channel capacity becomes a huge issue as programming ideas outpace the industry's ability to add bandwidth. Ted Turner scraps his plans for a 24-hour, all-news channel because there aren't enough operators who have room to add the channel. Of course, a short time later, Cable News Network is launched and the rest, as they say, is history.

After a five-year stint as president of the SCTE, Bob Bilodeau of Suburban Cable, wanting to become less involved in the everyday business of the Society, is kept on as chairman of the organization because of his expertise, but passes the president's gavel to Harold Null of Storer Cable TV. The action marks the beginning of a trend where there's a new president chosen nearly every year.

The Cable Satellite Public Affairs Network (C-SPAN) begins daily coverage of the proceedings of the House of Representatives. Brian Lamb, formerly a Washington Bureau Chief for C-ED, is president of C-SPAN.

Paul Levine is named publisher of C-ED and Cathy Wilson joins the staff as an ad sales executive.

Interest in providing "non-entertainment services" over cable TV systems rises, especially in the areas of teletext, education and load management information.

Comm/Scope is awarded a patent for bonded laminated dropwire, which eliminates "tigerstripping," or minute cracks that occur when the coaxial cable is bent too far.

Because of increased usage by cable

systems, the FCC expands the number of frequencies available for use in the Cable Television Relay Service (CARS) band to include the spectrum from 12.7 GHz to 13.2 GHz, putting it on a shared, co-equal and primary basis with TV auxiliaries.

During the NCTA convention, Frank Bias, VP of science and technology at Viacom International, is given the engineering award for Outstanding Achievement in Operations, while Mike Jeffers of Jerrold is given an award for Outstanding Achievement in Development.

Oak introduces its "Total Control" addressable system at the National Show, heralding the beginning of the addressable set-top era. Meanwhile, Jerrold unveils PlayCable, an education/game system that uses a terminal made by Mattel and an adapter built by Jerrold.

The Community Antenna Television Association (CATA) holds its annual meeting away from its home base of Oklahoma for the first time. The organization appears to gear up for a heavy lobbying effort on telephone issues and copyright.

Qube, the nation's first real-time interactive cable system, comes on line in Warner's system in Columbus, Ohio and a few other cities. The technology captures the attention of the news media everywhere, but a lack of suitable programming, combined with the high cost, keeps the system from catching on elsewhere.

Comm/Scope President Frank Drendel announces the company has completed construction of its new 80,000-square-foot coaxial cable production facility after yet another year of record-breaking sales.

Chris Weaver becomes vice president of the NCTA's newly renamed science and technology department, replacing Bob Luff. The 28-year-old Weaver comes to NCTA from ABC, where he was responsible for technology assessment.

In rare cooperation between cable and broadcasters, NBC's Prime Time Sunday program switches to Warner's Qube system to get immediate feedback on President Carter's energy w address.



# The History of Satellite

## LAUNCHING THE BIRD

Perhaps no other single event in the history of cable television contributed to the medium's explosive growth as much as Home Box Office's decision to put its service up on a satellite in 1975.

It took awhile, though, for satellite to find its niche in cable. Prior to '75, the media had been toying with satellite technology, primarily using it to transmit live news feeds and events. It was around the same time that HBO was searching for a solution to its distribution problem.

The programmer was forced to build or rent space on towers, and obtain service from common carriers in order to establish a microwave network capable of carrying its services from one point of origin out to many around the country. "What would have been involved," recalls Bob Zitter, senior vice president, technology operations, HBO, "was essentially replicating what AT&T had already built for the three broadcast networks." An expensive proposition, to be sure.

Enter Time Inc.'s Gerald Levin, who proposed a revolutionary idea to his board of directors: invest in a satellite transponder that would cover the entire country, so that cable systems everywhere could receive HBO's programming simply by utilizing a satellite receive antenna. Though the investment was significant, the board went for it, and soon, HBO was renting transponder time on a Western Union satellite, eventually migrating to RCA's Satcom I.

But there was at least one more roadblock to realizing the programmer's dream of nationwide coverage. And that was convincing operators to install a TVRO antenna that was a whopping 10 meters in diameter, with a price tag to match: about \$120,000. At that time, no one in the cable industry was even looking at satellite. Though HBO was able to convince some ops to make the expenditure, the number of 10-meter antennas deployed grew to only about 100.

Realizing that the service had a better chance if the size—and price—of the dishes could be shrunken, HBO, in concert with Scientific-Atlanta, set about trying to convince the FCC that more than adequate signal quality could still be delivered with receive antennas that measured only five meters in diameter. Fortunately, the Commission changed the regulations to allow the use of the smaller dish.

The next step was educating operators about satellite in general, and then establishing a leasing program, again in conjunc-

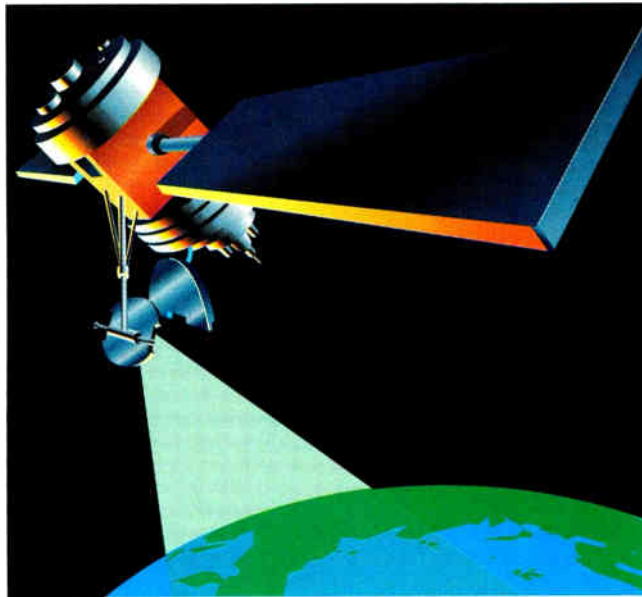

tion with S-A, to make dishes affordable.

HBO's new service was so successful, that it became very attractive to cable pirates, as the cost and size of satellite dishes dropped. Zitter, who joined the company in '81 as director of network operations, and later became vice president, network planning, thus found himself faced with the task of acquiring a satellite encryption system and then rolling it out.

This would turn out to be no easy task, as "no one manufactured anything that would securely scramble satellite signals," says Zitter. Eventually, after working with a number of companies in the early '80s, the programmer selected a company called Linkabit, which would later be purchased

by M/A-Com, a manufacturer with experience both in encryption technology for the government and with satellite transmissions from deep space probes. The contract with M/A-Com was for the provision of encoders for HBO's network origination facility, as well as commercial decoders for its affiliates, and consumer decoders for the growing number of people who were potential C-band dish subscribers.

Once the VideoCipher encryption technology had been deployed, HBO began scrambling its networks on January 1, 1986. Other programmers enthusiastically followed suit, and soon, VideoCipher became the de facto standard for the cable industry.

Unfortunately, it quickly became apparent that the VideoCipher II system was being pirated, and it took some time for VideoCipher to deal with the problem. "Our biggest concern was that during this time period, there were hundreds of thousands, mounting into, we believe, millions of boxes that continued to be manufactured and sold to pirates," says Zitter.

The problem was later inherited by General Instrument, when the manufacturer purchased M/A-Com. "Ultimately, GI stood up in a way that we are pleased that they did," notes Zitter. The manufacturer

devised VideoCipher II Plus, and more importantly, a different incarnation of the technology: VideoCipher Recoverable Security, or VCRS. While VCRS utilized VideoCipher II Plus, which remains secure to the present, it offered something more to capture HBO's interest. That was the ability to upgrade security in the future without having to replace every decoder in the field, by utilizing "a replaceable security module based on smart card technology," says Zitter.

"As a matter of policy, HBO has decided, from that point forward, that we would only use anywhere in the world a satellite encryption technology that is able to be restored through the changing of a card."



# 1981-1982

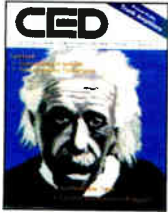

A P R O F I L E

Wendell Bailey steps in as vice president of engineering at the NCTA, filling the spot formerly occupied by Chris Weaver for 18 months. Weaver resigned "at the request of NCTA President Tom Wheeler" because he testified without permission, according to press reports.

**For the first time, incompatibilities between "cable-ready" TVs and cable systems rear their ugly heads. NCTA President Tom Wheeler contacts TV manufacturers to try to solve the problem**

Jerrold restructures its engineering organization to focus more resources on developing DBS terminals. Mike Jeffers is put in charge of advanced development; Frank Ragone heads distribution products; and Tony Aukstikalnis is put in charge of the subscriber terminal systems group.

**As pay services gain popularity, so does addressability. Tom Polis, VP of engineering at Comcast, notes that installing and maintaining an addressable system over 15 years averages \$37,000 per mile, or four times the cost of the cable. Meanwhile, Gary Tjaden of Cox Cable reports that subscribers have learned they can have free access to pay services simply by cutting a single wire inside their set-tops. He estimates that 20 percent of his subscribers tamper with the set-top.**

**Set-tops struggle to keep up with ever-expanding bandwidth demands. Oak introduces a 400 MHz home terminal with a touch-sensitive keyboard, favorite channel memory, optional parental control, infrared remote control and electronic A/B switch for dual cable systems.**

Comsat and Satellite Television Corp. file a plan with the FCC to spend \$600 million to provide at least three channels of premium television direct to homes via small aperture satellite dishes as early as 1985. It's the first formal application for direct broadcast satellite (DBS) service filed with the Commission. Receivers would cost \$300 to \$400, and the three-channel service would be \$25 per month.

**The FCC authorizes the launch of 20 new satellites and grants construction permits for 25 more. It also begins exploring the feasibility of spacing satellites within 3 degrees of one another.**

Scientific-Atlanta begins making coaxial cable and touts the fact it is the "only full-line manufacturer of distribution systems for the CATV industry."

**According to statistics compiled by the NCTA, in 1981, the average monthly basic cable rate is \$7.99; there are 38 programmers; and the industry employs roughly 45,000 people in roughly 4,375 systems. A.C. Nielsen says there were 23.2 million subscribers, making cable TV 28 percent penetrated.**

Magnavox rolls out its "mobile laboratory and training center" for the first time. The 46-foot trailer houses \$500,000 worth of 440 MHz distribution equipment, including a 16-amp cascade. Since then, the Magnavox (now Philips Broadband Systems) truck has logged hundreds of thousands of miles and offered training around the country.

**Zenith introduces a new 54-channel addressable convertor with a secure scrambling system, plus a remote control. It's called the Z-Tac. Rogers Cablesystems in Minnesota becomes the first customer a few months later.**

Hughes Communications announces it has developed a method for a single earth station antenna to simultaneously receive programming from two satellites. Hughes officials say the break-

through will be particularly important in 1983, when Galaxy 1 and RCA's Satcom III-R will be located just four degrees apart.

**CBS and NHK demonstrate high definition TV around the country. Because it's a bandwidth hog, however, there is considerable debate where the 25 MHz-wide signals can reside.**

According to a CED construction survey, the cable industry spent \$1.4 billion in construction in 1981 and was projected to spend \$1.8 billion in 1982. In 1981, the industry installed nearly 72,000 new miles of plant, the survey notes.

**Industry pundits, including CED's own editorial staff, predict that "home security will be the first of the non-entertainment two-way cable services to become a separate profit-making business." Consequently, at least seven manufacturers announce products. What can't be forecast, however, is the fact that many of the systems aren't reliable, and consumers never embrace the new service.**

MDS service becomes MMDS as Microband Corp. details its plan to offer a multi-channel microwave, or "wireless cable" service. Microband offers "Urbanet," a system of pay-TV, teletext, two-way interactive and other services.

**Times Fiber is chosen by Caltec Cablevision of Baltimore County, Md. to supply a fiber optic system to tie three headends together. The 32.5 miles of fiber make the system the largest fiber cable system. Only 13 repeaters will be needed, instead of 47 amps, if it were an RF system. The cost? Roughly \$750,000.**

United Cable of Scottsdale, Ariz. is the first cable system to deploy Jerrold 450 MHz distribution gear. GI was chosen to supply more than 500 miles of dual-trunk, single feeder equipment, including a two-way I-net.

**In what is arguably the largest contract ever written for cable TV electronics, TCI chooses Jerrold to supply \$100 million worth of addressable set-tops and head-end gear, to be supplied over the next three years. The contracts call for 750,000 400- and 450-MHz convertors that can deliver up to 66 channels each.**





Scientific  
Atlanta

*Thanks to  
CED for  
20 Years  
of Great  
Technical  
Editorial.*



Atlanta 1996

TM, © 1992 ACOG

Official Sponsor of the  
1996 Atlanta Olympic Games



# 1983-1984



A P R O F I L E

American Television and Communications (ATC) announces an agreement with Toshiba Corp. to develop and produce the Distributed Subscriber Terminal system, an outside-the-home addressable system. A similar agreement is penned with Matsushita for the development of a teletext decoder. Time Video Group VP Gerald Levin says, "It makes great sense for us to become an aggressive developer of hardware." Company executives say they expect sales of \$40 million per year. A short while later, those deals are dead and ATC (Time Warner) learns a lesson about being in the hardware market. Meanwhile, the industry learns that off-premise addressable gear is expensive.

**Taking an opportunity to toot its own horn, Jerrold announces it has supplied more than half of the addressable systems currently deployed. According to "an independent report," Jerrold led the pack with 68 Starcom systems deployed, while Oak was second with 41 systems installed. They were followed by Zenith (with 39 systems), Tocom, Pioneer and Octagon-Scientific (a company formed by former Magnavox executives), respectively.**

But not everyone is enamored with addressability. Ken Gunter of Rogers/UA Systems said addressability "has all the earmarks of being the most expensive and unforgiving equipment buy yet." And Bob Rogers of TCA Cable notes that subscribers don't want the unsightly, complicated boxes in their homes. Gunter urges manufacturers to keep working on off-premise solutions.

**Just a few companies that were displaying cable TV set-tops in 1983: Kanematsu-Gosho, Magnavox, Telease, Tocom, RCA, Texscan, Hamlin, Cabletenna and Eagle.**

Following three years of research, HBO selects the M/A-COM Linkabit technology to scramble its uplink feeds, thereby thwarting millions of individual TVRO owners from receiving HBO programs without paying for them. Headend descrambling units cost about \$2,000 each. According to a CED news item, "the new technology, while not foolproof, is believed to provide a level of security that will make any attempt at piracy unprofitable."

**General Optronics develops the Atmospheric Optical Communications System as an alternative to microwave transport. The line-of-sight system can transmit up to eight channels of video, plus voice and data, up to 10 miles. The first commercial user is Mitre Corp. in its McLean, Va. facilities.**

After years of exponential growth, the construction market softens in 1983, signaling a slowdown of the heady franchising days that dominated the industry for several years.

**The SCTE hosts its first Cable-Tec Expo in Dallas—and it's a success. Nearly 900 techs and engineers turn out for the workshops, and 1,300 people visited the 22,000-square-foot exhibit floor, where 115 companies were displaying their wares.**

Jerrold introduces the Starcom V addressable baseband descrambler, which tunes the entire 550 MHz bandwidth.

**Texscan purchases the Sylvania Division of GTE Communications Products for \$16.5 million. The acquisition immediately gives the combined company an estimated 26 percent marketshare in distribution gear. Jerrold responds by purchasing Century III Electronics International to protect its identity as the leading supplier of distribution gear.**

A 1983 study from International Resource Development predicts that utilities will begin stringing fiber to offer cable TV, telephone and other services. The report said the utilities will likely lease the capacity of the network, making "both cable and phone plant obsolete by the end of the century."

**Magnavox introduces power doubling and parallel power doubling techniques for cable TV amplifiers. The invention dramatically increases the signal strength coming out of the amps.**

Judy Baer, executive VP of the SCTE, resigns from the organization, and President Tom Poliss moves the group's headquarters to West Chester, Pa. Just three months earlier, the SCTE announced its 1982 revenues were \$325,700, and that the Society's deficit had been trimmed to about \$17,000.

**Coincidental with the rapid decline of video games, General Instrument and Mattel pull the plug on PlayCable, the industry's first game channel, which had found only 20 systems and 5,000 subscribers willing to ante up \$12 to \$15 a month for 20 games.**

United Cable's grand fiber optic experiment—the Times Fiber Mini-Hub network it installed in Alameda, Calif.—nears completion, after a six-month delay. Oddly, the system uses fiber for the drop portion of the network and coaxial cable for the trunk runs. The system is fraught with technical problems and is scrapped a short time later.

**A report from Strategic Inc. says that as of the middle of 1984, there were only 20 activated two-way cable TV systems, but predicts that by 1990, nearly 25 percent of all cable systems will be two-way active.**

The cable industry's top 50 MSOs had an estimated 3.4 million addressable subscribers at the end of March 1984, according to Paul Kagan Assoc. Today, that number stands at more than 30 million subs, or 52 percent of all cable subscribers.

**After much hoopla surrounding its launch, DBS in the '80s never gets off the launch pad. CBS bows out, leaving Satellite Television Corp. looking for a partner, and two weeks later, Western Union follows suit.**

Gary Kim becomes editor and publisher of CED magazine, following a three-year period of time when George Sell, Fred Dawson and Peter Evanow held similar posts.

**Bill Riker leaves his post as director of engineering at the NCTA to take the post of executive vice president of the SCTE.**

# **THE FCC IS NOT THE ONLY GROUP REDUCING YOUR PROFITS...**



**Your MDU  
“customers” are  
stealing millions  
from you. This is  
money you can no  
longer afford to  
lose.**

**Call the industry  
leader in high  
security enclosures  
and let us show you  
how to stop MDU  
theft and improve  
your bottom line!**

**Congratulations CED  
on your 20th Anniversary!**



**Cable Security**



# Memorable

## LONG LASTING IMPRESSIONS

They say you only get one chance to make a first impression. Never is that more true than in the world of product advertising, where the delicate balance between “eye-catching appeal” and “information value” often determine an ad’s (and sometimes, the actual product’s) long-term success. And while the rules of political correctness have changed, along with the use of color, type styles, photography and computer generated effects, advertising has always had a special relationship with CED readers. Here are a few of the more “memorable” ads seen throughout the pages of CED over the last two decades. Enjoy.



Pioneer: 1990

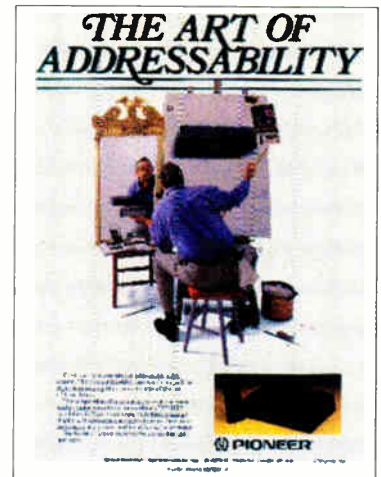

Pirelli Fiber Optic Cables: 1994



Pico Products: 1981



M/A-Com: 1985

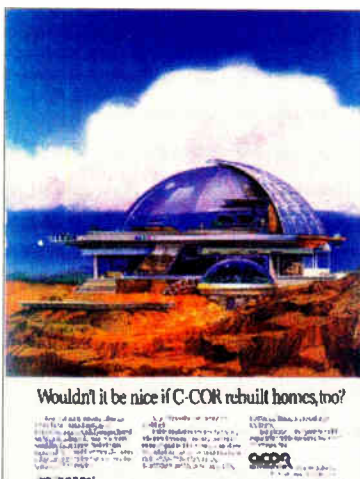

C-Cor Electronics: 1985



Northern Telecom: 1994

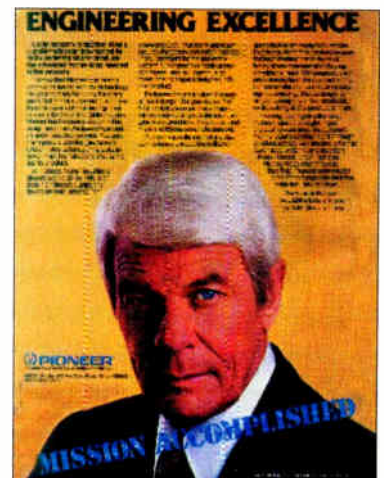

Pioneer: 1980

# Advertising

THAT HAVE LASTED 20 YEARS

**If you haven't complied with the FCC by July 1, they may arrange an extension.**

**Don't worry.**

**Be happy.**

WAVETEK

Wavetek: 1990

introducing PAYMATE

**Tocom**

Tocom: 1976

**Laser By The Foot.**  
Only From General Instrument.

General Instrument

General Instrument: 1994

**The fiber for people who don't know their own strength.**

**CORNING**

Corning: 1990

Interactive video games. So we can connect by video. Right in San Diego at Eonix. The Holograph.

**AT&T Network Systems**

AT&T Network Systems: 1995

# Reliable Netw

Lectro Products' ZTT-UPS series modular units with its ferroresonant technology and "no break/no data loss" transferring capabilities provide rugged, reliable network powering. It's technician friendly and field serviceable. And because it's totally modular, the Lectro line of cabinetry offers a wide range of installation possibilities to meet even the most complex network demands.

## **Ferroresonant Technology**

*Rugged, reliable system of network powering...Minimal active components...2000:1 spike attenuation protects against input utility spikes and transient voltages.*



## **No Break/No Data Loss**

*Provides clean, no break transfer to inverter mode... No Data Loss, high-speed AC detector circuit senses loss of AC within a 1/4 wave cycle...Absolutely no break in the output wave form.*

## **Looks Good**

*All aluminum construction for corrosion proof cabinets...Powder coat paint available...Modular design enhances neighborhood aesthetics.*

## **Field Selectable Output Voltage**

*60 VAC or 90 VAC field selectable outputs...Rated at 15 amps...Compatible with today's CATV and Telephony applications.*

# Work Powering



*The doors have been removed for photographic purposes.*

## **Modular Powering**

*Reliable 24, 36 or 48 VDC units... You choose the proper standby reserve... Load matching available.*

## **Multiple Cabinet Configurations**

*Cabinet size optimized for location... Separate generator cabinet available... Separate fiber optics electronics cabinet... Compact design power node.*

## **Technician Friendly**

*All electronics located on one, 2 lb. pull-out module... Design allows the user to replace inverter module without disturbing output waveform in the AC mode... Easy access test points on outside, front panel... No exposed points of electrocution.*

**Congratulations CED on your 20th Anniversary!**

**POWER** *When It's All On The Line*

**LECTRO**

*Lectro Products, Inc. 420 Athena Drive Athens, Georgia 30603*

**800-551-3790**

Circle Reader Service No. 61



Easily the biggest issue of the year is signal scrambling, which takes a lead role at every major convention discussion. The cable industry wants programming scrambled because millions of backyard dishes are being sold to people who want cable programming without paying a fee. The cable industry even proposes to stop carriage of any satellite programming that isn't scrambled. In fact, the NCTA issues an RFP on a scrambling system to help spur programmers along, and eight firms reply, including: General Instrument, Scientific-Atlanta, Telease, TRW, Eagle, M/A-Com, Oak and CableData. The programmers are unhappy because they are denied representation in the consortium and try to form their own group, but that effort fails when Turner announces its intention to use VideoCipher gear. In the end, the NCTA scraps the consortium because scrambling begins to happen anyway.

General Instrument acquires M/A-Com's cable/home communications unit for \$220 million. The unit is the same one that supplies the VideoCipher satellite scrambling and descrambling equipment to the cable industry. With the acquisition, GI also gets Frank Drendel, who comes to the company as president and CEO of the Broadband Communications Group, which includes Jerrold and Tocom.

# 1985-1986

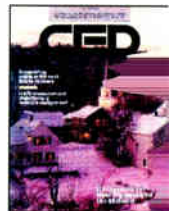

## A P R O F I L E

The NCTA and MSOs are buoyed by a new law that for the first time provides a comprehensive national cable TV policy. The main provisions allow cable systems to raise their rates five percent per year and require them to set aside some channels for leased access. Rate regulation would end if cable systems have "effective competition," a term later defined to be areas where there are three broadcast stations. That definition effectively frees 80 percent of the industry from regulation. The deregulation is set to occur at the end of 1986.

According to estimates from Paul Kagan Assoc., the top 50 cable MSOs are expected to construct about 51,000 miles of new and rebuilt plant by the end of 1985, down about 10 percent from the previous year. The news comes as little surprise to the industry, which is experiencing a general slowdown in growth. Kagan further estimates that 3.9 million addressable boxes will be sold in 1985, down from 4.4 million in '84.

One-time cable TV equipment market leader Oak Communications struggles to ward off bankruptcy as a result of losses associated with its subscription TV service called ON TV of Los Angeles. The company mulls whether it should sell off its hardware business, in which it expects to lose \$9 million on \$50 million in sales during the year. The company was plagued with high failure rates in its TC-56 set-top, beginning in 1982.

Scientific-Atlanta jumps back into the backyard market, re-starting the "Homesat" service it had to suspend back in 1980 because of legal questions surrounding the service. The good news is that the price has dropped to about \$3,000 for a 2.8-meter system.

Though not completely dead yet, DBS service suffered a major blow when United Satellite Communications Inc. went off the air because it couldn't make a payment for uplink services. TCI, which had been negotiating to buy into the venture, walked away from those discussions, but outlined a cooperative venture the cable industry could enter to get into the DBS business.

Yes, it's true cable operators recognized a long time ago that their connections need to improve. That's why Raychem and Anixter introduced the EZF connector during the 1985 National Cable Show in Las Vegas. The new connectors were designed

to reduce RF leakage and moisture ingress. The connectors' average cost is about 40 cents apiece.

General Electric debuts the Control Central programmable universal remote control. The device can be programmed to operate a VCR, TV, CD player and a cable set-top. The units are slated to carry a \$150 retail price tag.

John Sie, senior VP at TCI, notes that cable operators should adopt "VCR friendly" installation practices to help slow the growth of the industry's key enemy. Sie said systems should be encouraged to help consumers hook up their VCRs so that cable subscribers will be encouraged to tape movies off cable. He further predicts that the popularity of video rental stores will wane in 15 to 24 months.

The popularity of VCRs, combined with the complexity of hooking them up with TVs and cable boxes, lead manufacturers to develop VCR switchers, a valiant attempt to simplify connection and clarify VCR recording off cable. The switchers fail to catch on with consumers, however.

A federal court in Camden, N.J. sentences a man to nine months in prison for stealing services from NYT Cable in Cherry Hill. The action represents the first imprisonment imposed under the 1984 federal cable law, which made it a federal offense to steal cable TV service.

HBO transmission is interrupted by a self-proclaimed "Captain Midnight" who jammed the pay service's satellite feed for about five minutes during a midnight movie to show his displeasure over HBO's scrambling practices. The high-quality message read: "Good evening HBO, from Captain Midnight. \$12.95 a month? No way! (Showtime/Movie Channel Beware)." Federal investigators get involved because of the ramifications the action has on all satellite communications. A few months later, John MacDougall, a disgruntled satellite dish dealer in Ocala, Fla., confessed to the crime and was fined \$5,000 for his actions. MacDougall did the deed during a part-time stint at the Central Florida Teleport.

Scientific-Atlanta and Times Fiber agree to merge their two cable manufacturing units, following a similar deal between M/A-Com and General Instrument.



# About the only thing it doesn't deliver is pizza.

***Congratulations CED on your 20th Anniversary!***

**Encrypted data  
communications**  
*from addressable controller  
to subscriber.*

**Extensive  
on-screen display**  
*with display and  
graphics capability.*

**Multiple  
program guides**  
*Interactive Electronic Program  
Guide with grid-type presentation.*



**Dynamic picture  
shift encoding**  
*for the ultimate in enhanced  
signal security.*

**Near-video-on-demand**  
*field-proven technology  
with display schedule and enhanced  
pause, resume and  
review instructions.*

**Virtual data channels**  
*for additional revenue generation.*

As you can see, the BA-V1000 Command Station comes with the works. From its on-screen display capabilities to the security of dynamic picture shift encoding, the Command Station delivers great cable service. It's this kind of vision that keeps your customers happy. And hungry for more. When you're ready to order, just call your Pioneer regional sales manager.

**PIONEER®**  
Pioneer New Media Technologies, Inc.

Northeast, 201-236-4186; Southeast, 614-777-7260; Mid-Atlantic, 614-777-7258; Central, 614-777-7257; West, 310-952-3063.



# Engineer's Roundtable

P A S T , P R E S E N T & F U T U R E I S S U E S

*No retrospective would be complete without getting comments from the engineers who made it all happen. Over the next three pages, you'll get a glimpse of today's most influential engineers as they appeared roughly 20 years ago as well as their thoughts about the most tumultuous events since 1975. Then, just to put them on the spot, we asked for their predictions of the future.*

## Wendell Bailey, NCTA:

### What was the most important technological development of the past 20 years?

It was probably what happened in fiber optics. The main thing was that it was cable engineers who figured out how to do this in analog. Fiber had been there, but our industry's grasp of what it took to make fiber work for us [is the important point]. What we've discovered is that the architecture which we've used is positioning us well for digital, also.

### Looking around the network, is there any one invention that you need that is not in existence yet?

If there was a really good way to splice multiple fibers simultaneously, that would be very useful. If someone digs up a cable with 240 fibers in it, you are looking at 48 hours to splice it. And that's assuming that you have everyone sitting right there on the edge of the hole. Imagine doing that in a hole, when there are 250 of them, and both ends are mangled.

### What will the industry look like in 10 to 20 years?

In 10 years, we will be the pervasive entertainment and information delivery medium. We will have a variety of services to choose from. I think by the end of 20 years, it's entirely possible that the affiliate TV system will no longer exist, because networks will find that their best, brightest future is in programming channels on a satellite. And they will seek to have affiliations with cable systems, like they currently have with broadcast. And all that frequency that broadcasters are using will be given over to its proper, most best use, which is for portable communications.

## Alex Best, Cox Communications:

If you ask me what's been the most important technological event a few years from now, I would have two items that I would have a hard debate between. One would be the linear laser, and the other would be the development of digital TV. But digital is still yet to come. Linear lasers are what enabled us to fiberize our systems. Lasers have been around for a number of years, but they were not adequate, from a tech-



**Best: "In 1975, I was with Scientific-Atlanta. My title was staff engineer, and my responsibilities were developing headend equipment and set-top converters."**

where, look at the pictures and decide whether the problem is *at* that point, or *after* that point. Once all signals are digital, I'm not sure what they are going to grab and plug into the tap to assess the health of the system.

As for the future, in 10 years, you will see most of the big cable operators still carrying a number of analog television channels. You will see us carrying lots of channels of digitally compressed television. Therefore, from a television product offering, we will replicate or be able to offer more channels than a DirecTV. A typical cable system might have a couple hundred channels, probably 50 or 60 of them analog, and 150 of them digital.

In addition, we will be offering a high-speed LAN service and a cablephone telephone service. A big part of our business will be wireless telephony.

In 20 years, I think we will be almost all digital. I'm not sure there will be any analog services left on our cable. Video-on-demand will be commonplace. You will see a PC data service that not only offers access to all the online services at high speeds, but also provides video telephony capability. It will be just as commonplace that you make a video phone call over a cable plant, as you do a voice phone call today.

## Ed Callahan, Callahan Associates

The most important technological develop-

ment was addressability, because until then it was awkward to offer multi-tiered services. Every change of service required a truck roll. It was very labor-intensive to make any changes. I think it was impressive to customers that they could call a customer service rep and request a new service, and with an addressable scrambling convertor, they could be authorized almost while they were on the phone.

As for inventions I need, once we go to digital television, there will be a lack of cost-effective test equipment that we can give to our service techs to be able to determine where a problem is occurring. For example, today we can throw a TV set in the truck, plug it in some-

where, look at the pictures and decide whether the problem is *at* that point, or *after* that point.

Once all signals are digital, I'm not sure what they are going to grab and plug into the tap to assess the health of the system.

As for the future, in 10 years, you will see most of the big cable operators still carrying a number of analog television channels. You will see us carrying lots of channels of digitally compressed television. Therefore, from a television product offering, we will replicate or be able to offer more channels than a DirecTV. A typical cable system might have a couple hundred channels, probably 50 or 60 of them analog, and 150 of them digital.

In addition, we will be offering a high-speed LAN service and a cablephone telephone service. A big part of our business will be wireless telephony.

In 20 years, I think we will be almost all digital. I'm not sure there will be any analog services left on our cable. Video-on-demand will be commonplace. You will see a PC data service that not only offers access to all the online services at high speeds, but also provides video telephony capability. It will be just as commonplace that you make a video phone call over a cable plant, as you do a voice phone call today.

ment was addressability, because until then it was awkward to offer multi-tiered services. Every change of service required a truck roll. It was very labor-intensive to make any changes. I think it was impressive to customers that they could call a customer service rep and request a new service, and with an addressable scrambling convertor, they could be authorized almost while they were on the phone.

As for inventions, I think it's a reasonably-priced, hybrid digital/analog set-top box. We are hearing some astronomical prices quoted these days. The pricing is so high, that it's going to be very tough to find sufficient revenue to support the cost of a box, let alone make additional revenues.

If we look out 10 years, there will be more consolidation. There are going to be very large companies; there are going to be multimedia companies that are offering services. And it's going to be hard to tell if they are a cable company, a telecommunications company, a computer company, or a media company.



**Callahan: "In 1975, I was director of engineering with ATC. I was responsible for engineering and design of the cable systems that ATC was building, and for equipment selection for those systems. Also, I directed technical activities for some interactive experiments that we were doing. We actually did something in Orlando in '71-'72 called the Polycom interactive experiment, where we were demonstrating pay-per-view through the use of addressable interdiction."**

## Jim Chiddix, Time Warner Cable:

It may be a little myopic of me, but in terms of technology affecting cable television, I would have to say it was the development of broadband fiber that was the most important development. That is a fundamental technology allowing us to transform our networks from our traditional business to a whole array of new busi-

Now's not the time to be scratching your head with questions.



*HP CalLab 88100118  
for accurate  
surge and level  
measurements.*

Don't test up with your hands full. Test down. You understand the importance of your cable test equipment. It's not that your equipment is from HP CalLab.

Our easy-to-use, one button measurements give you accurate and repeatable results every time you take a reading. Plus, its abundant data storage capacity lets you

©2001 Hewlett-Packard Co. T38022001.02.02

capture the results of tough wire experiences for in-depth analysis by the comfort of your office.

So the only thing hard about these instruments is the cash that surrounds them.

What's more, our these time instruments our help them find the answers you're looking for, our instant on-line analysis will.

Providing you with



*HP CalLab 88844  
for fast and reliable  
quality assurance.*



*HP CalLab 88844  
for all HP and other  
connections.*

quick answers wherever and whenever you need them most.

To find out how HP CalLab can improve your cable TV testing ability (and maybe even get you home faster) call HP CalLab at 1-800-452-4844, Ext. 88144.

©2001 Hewlett-Packard Co. T38022001.02.02

There is a better way.



**HEWLETT®  
PACKARD**

nesses and I think it's going to prove to be central to our business strategy as an industry in the coming years. "

As for inventions, I fully expect innovation and invention will continue and cable will continue to adapt new technologies in a creative and entrepreneurial way. But I think we have all the fundamental technological tools we need to transform our network from a tree-and-branch video delivery system to a multiple network transport structure carrying broadband analog and a variety of switched digital services.



**Chiddix: "I was GM of Cablevision in Waianae, Hawaii. We had 3,500 subs. I was also chief tech and bench tech—I rebuilt the amps by myself. I also had started a video tape playback automation business, which I eventually sold to Texscan."**

In 10 years we'll be well on our way and in 20 years we'll be firmly established as a major piece of the communications infrastructure globally. While the traditional business of multichannel video delivery will be highly competitive, we will have a piece of a great many other businesses and in sum total will be in a business position that will dwarf where we are today. There are enormous opportunities between here and there. In addition to providing a powerful array of entertainment and video services, both scheduled and on-demand, I think we'll be in the business of delivering any information that can be put in digital form.

**Walt Ciciora, consultant:**

For me, the most important technological development of the past 20 years was the remote control. It is the first technological development that recognized that human beings are meant to use this stuff. And it makes choice accessible. Without the remote control, nothing that followed would be of any use, or of any interest, and we would be nowhere.

I think we need what I call a television integrating device that is microcomputer controlled. You plug in your TV, your VCR and all of your consumer electronics equipment, and the TVID knows what you like, and what you want to do, and it makes sure that everything is hooked up in the right way, turns on at the right time. And it sets the clock.

In 10 years the industry will look just like it looks now in Fairfield, Conn. There'll be two coaxial cables into the house. Both will be providing phone, data and video. And the total price will be less than what we pay now. However, both companies will be more profitable,



**Ciciora: "I was with Zenith as director of circuits and systems research and development. I was working for Zenith research and development on Teletext when the information superhighway was made of gravel."**

due to productivity improvements and greater efficiencies. I believe that computers will outsell TVs. The computer penetration will exceed 75 percent of homes; however, most people will still not know how to use most of what is there. Computers will respond to voice, so that people who can't type are not handicapped, and I believe that television sets will evolve to modular units which plug into a comprehensive bus. And microcomputer control will take care of making sure that all the correct gozintas and gozoutas are properly aligned. Adults will stop having children, because they can program VCRs themselves. The decoder interface standard will almost be finished. And Arthur C. Clark's dictum will apply. He said that any truly advanced technology is indistinguishable from magic. Cable will be like magic because it will finally be easy to use.

**David Fellows, Continental Cablevision**

The most important technological development has to be TVROs. The ability to receive satellite programming allowed cable to differentiate itself from a community antenna system and allowed the penetration of the major metropolitan areas. I keep reminding people that Bev (broadcast entertainment video) is the girl we brought to the dance and we ought not forget her in our fantasies over these good-looking businesses like telephony and high-speed data.

What I need is something that integrates wireless and wired technology so that if I happen to have a wire I plug it in and all these services come pouring out the wire into my PC, TV, telephone or home game system. But when I'm not near a wire, I transition to a version of these services that is wireless.

Ten years from now there will be a whole bunch of giants. There will be at most three MSOs or groups of MSOs worth talking about. One is the Sprint consortium and another is Time Warner/US West. Maybe there's room for a third one. And then there will be lots of little companies just like there are lots of little telephone companies.

As for applications, I believe in the analogy that early TV was just radio with a camera stuck in front of it. As we shift to programming becoming more interactive, I don't know what

that means. To start with, we'll take phone books and encyclopedias and put them on line. But then we'll add QuickTime movies.

**Dave Large, Media Connections Group:**

There are two important developments, and they go together. One, of course, was the development of highly linear fiber optics, and the second was advances in digital compression. There is a relationship between system size, bandwidth, noise and distortion, and fiber optics let us break out of that box. That gave us the ability to do telephony and interactive services, which is obviously where we are all headed in the future.



**Large: "I was with Avantek in 1975 as a senior member of technical staff, responsible for the line of cable TV test equipment."**

What digital compression let us do is provide six to 10 times as many video streams as we otherwise could in that bandwidth. That, combined with the small node size, is what makes the effective bandwidth per customer usable for switched services.

We need interoperability standards. We've got five or six different things that think they are going to use the upstream part of the network, two-way services, and what we know from the studies that we have done is that there are tremendous problems with ingress. And probably the only way to manage that ingress is to bring the upstream transmitter out to the wall of the house.

And there's going to need to be a higher degree of standardization in digital video compression. All the levels of that, from the modulation to the error correction to the compression to the enabling part of it. I don't know that it has to be totally standardized, but we certainly need to move in that direction.

The future is going to be driven by regulation rather than technology, and that makes it very hard to predict. Do Republicans win the next election, or do Democrats? What happens to the makeup of the FCC?

**Bob Luff, Scientific-Atlanta**

I think the hybrid fiber/coax architecture was real important. It really began to tackle the

# A Proven Winner.

**NetExpert is a sure thing for your OSS requirements.**

In a close race, choosing the right horse can be tricky business. You need an edge – a proven winner. In the race to bring new services to market – only **NetExpert** from OSI is a sure thing. Whether your business is deploying new technologies or bringing new services online to your customers – **NetExpert** has

the power, speed, and durability to get you to the finish ahead of your competition.

Gaining the edge with **NetExpert**

will ensure that the time required to **provision** and **activate** new services and customers sets new track records – **every time**. So, when time is money and it's time to place your bet – bet on a proven winner – **NetExpert** software from **OSI** – the company that gets you there first.

For information call 916-353-2400 and ask for your regional sales representative.

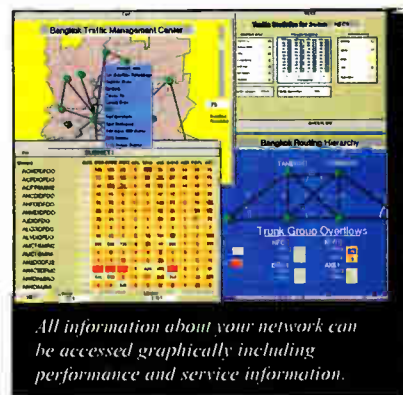

*All information about your network can be accessed graphically including performance and service information.*

Set track records when deploying new services with **NetExpert**.



OBJECTIVE SYSTEMS INTEGRATORS

**When Time is Money.**

Circle Reader Service No. 63

number-one technical issue facing the industry, which was reliability. And hybrid fiber/coax was the key element that allowed us to break through the 550 MHz barrier, and look to 750 MHz. It has expanded the capabilities of our core networks to provide a whole new tier or generation of new products and services that are clearly going to be key in a more competitive environment.

As for things we need, the issue is standards. We went from these independent, entrepreneurial systems of the past, to MSOs, to full, interconnected two-way networks which traverse MSOs, even traverse industries. We need to connect to the computer industry, the telephony industry, and a lot more interconnection with our own video entertainment industry.



**In 1975, Luff was vice president of science and technology for NCTA, where he was chief spokesman on all technology, safety and technical regulation issues. "I was Wendell Bailey before Wendell Bailey was Wendell Bailey."**

today. We still, as an industry, haven't mastered the set-top, VCR and advanced TV set without a maze of wires and a stack of remote controls on the coffee table.

But 20 years from now, there's got to be seamless connections to their computers, printers and telephony systems. The wireless folks will want to be able to get access to this while they are mobile and while they are traveling. People have to feel confident of the major investments they are making in stereo, large screen TVs, HDTV, and computers.

**Bill Riker, SCTE**

From my experience, the most important development was satellite delivery of cable services. That made it possible for pay services to be rolled out on a wide scale and reduce the responsibilities of cable operators providing those services to nothing beyond maintaining the earth station.

The one invention I need is how to clone

myself. I'm sure that's true of a lot of people in our industry who are just well overworked and can't delegate a lot of responsibilities.

In the future, telephone services may or may not really be economically viable but the delivery of high-speed data could be more lucrative than all the pay services combined. Monthly fees of \$30 or more is something we could conceivably charge and something people would conceivably pay. I question whether going head-to-head with the phone company in telephony is important as something that isn't being used out there—like a broadband data conduit.

**Geoff Roman, General Instrument**

Digital video compression is the most important technological development in the last 20 years. It will propel the integration of video, voice and data services and dramatically increase the capacity of the networks and minimize the degradation of signals in storage or transmission.

The missing invention is a means of providing a "bullet-proof" return path. This issue is the remaining hurdle to making the cable television platform a true telecommunications highway.

In 10 years, digital television will be widespread. Cable television will have made inroads into the telephony market using both wired and wireless platforms. It will be difficult to classify an operator as a cable or telco as the range of services offered by both will overlap. Wideband delivery of data to PCs will be a significant revenue source and will lead to the development of true, interactive multimedia programming, as well as support a host of business and educational applications.

Within 20 years, HDTV will become a major component of the service offering and the transition of television from a broadcast oriented delivery system to a switched-on-demand will be well underway.

**Archer Taylor, Malarkey-Taylor Associates:**

I think three things were critically important. Number one is when satellite happened. That opened the door to passing nearly every TV home, and we couldn't do it before. Secondly, analog optical fiber was another important thing that really changed the industry architecture and the capabilities. And the final one was compressed digital, video and digital modulation. QAM and VSB. A combination of MPEG QAM and VSB. All of these things are certainly the wave of the future, and they happened in that 20-year period.

As for inventions, I think we need to eliminate the set-top convertor. From about 1970, I called it a necessary evil. And it still is. We can't do without it, but it has created all kinds of problems. The joint committee of EIA and NCTA are working on the set-back device, and this may be



**Bill Riker (on the right) was headend engineer of Suburban Cablevision of Essex and Union counties in New Jersey, where he oversaw the construction of several AML hub sites.**

an answer, but I think it is only a partial answer.

We also need a way to navigate in a consumer-friendly manner. And the final thing we need is a good drop connector. It has to be craft-friendly, foolproof, leakproof, have long life and be a good impedance match. I am talking about the F connector. F-connectors are the Achilles Heel of reliability.

In the future, mergers and consolidation are going to continue. Standard definition television is going to replace HDTV because I think HDTV is probably approaching death. We'll have multiple programs on each television channel. And of course, we are going to have competitive video and local telephone delivery. And finally, and this may be in the 20-year category, rather than 10-year, is we are going to have combined video and PC displays that will be used for both entertainment and PC operations.

**Joe Van Loan, Cablevision Industries:**

The thing that made cable mature was the arrival of satellites. It opened up new sources of programming and put living images in place that had been occupied by character generators.

I think we need a reliable F-fitting, because it's the Achille's Heel in our search for improvement in network reliability. You only have to look in the Dumpster in any cable system to know it's the one thing that gives them the most trouble. Certainly the glamour applications like telephony and data transport will follow if we fix our reliability problems.

We need to harness the VCR so people can see programs they missed. A more user-friendly and intelligent user interface is needed. We're coming along with advanced technology that will deliver more programming, but unless people can easily find it, they won't watch it and won't pay for it.

HFC networks will continue. Telephony will be commonplace. In 10-20 years, there may be even fiber to the curb. Digital processing will be largely in use. Primestar and DSS have shown the public believes they recognize quality pictures. Whether that means millions of new channels remains to be seen, but the trend toward more diversity and freedom of choice probably continues.



# 1987-1988



## A P R O F I L E

Following a few years of discussion and experimentation, 1987 is seen as the year in which pay-per-view is finally implemented widely. New equipment is introduced by Business Systems Inc., Melita Electronic Labs, Scientific-Atlanta and Zenith to enable PPV ordering.

Technically, the big focus at the National Show is hardware that allows impulse pay-per-view ordering. Jerrold announces a huge price reduction (Starfone sidecars reduced to \$20 each, Starvue drops to \$15) in an attempt to stimulate the market.

Jerrold introduces its Starcom 7000 addressable set-top, which integrates the functions of the impulse PPV sidecar into the unit. Other features include a VCR timer, last channel recall and more functionality via the remote control. Jerrold VP and GM Hal Krisbergh, who helped spur the market by starting Cable Video Store, a PPV programming service, predicts a majority of set-top orders will call for that capability.

Inspired by the Massachusetts Institute of Technology's \$45 million Media Laboratory, Jerrold sets up an Applied Media Lab to help the industry investigate consumer reaction to new services like impulse PPV, advanced TV systems and data delivery. It also announces its intention to develop and sell a linear AM fiber optic trunking system. A short while later, Catel and Arister make similar announcements.

Bowing to pressures created by incompatibilities between cable service and consumer electronics gear, Denver's Mile High Cable system stops scrambling every channel and instead offers a standard basic tier of non-scrambled channels, preserving scrambling for premium channels only.

In 1987, the average monthly rate for basic cable is \$12.18, according to Paul Kagan estimates. There are 73 cable programmers, and the industry spends \$2.3 billion to acquire programming to fill the 7,900 cable systems located across the country.

By now, connecting a TV and a VCR to a cable TV descrambling convertor can become quite complicated, depending upon the functions a homeowner wants to perform. To help, the NCTA Engineering Committee publishes a document that illustrates 27 different ways to interconnect the devices. Consumers are confused, upset and often blame the cable system when their new, fully-featured TVs don't work the way they were advertised.

The SCTE opens its new national headquarters in Exton, Pa. It's just a short time later when the organization buys the building and retires the debt.

More than 1,100 people attend the SCTE's Cable-Tec Expo in Orlando in 1987, where Rex Porter is named the Society's Member of the Year.

**VCR technology adds a new wrinkle: Super-VHS quality. The pictures are indeed better, and some cable engineers fear that consumers will begin complaining about poor cable quality. But consumers prove again that they don't pay for quality, and Super-VHS is a non-factor.**

In a rare miss, Archer Taylor predicts we'll see widescreen TV in showrooms by 1993—with most artifacts scrubbed out and scan lines virtually invisible at close range. His prediction doesn't seem far-fetched, based on the pace of technological development, but what no one could have predicted is how the broadcasters have retreated from HDTV since then. In fact, widescreen TVs have been introduced, but only in limited quantities.



Fiber optic innovation continued at a breakneck pace. Catel Telecommunications announces an FM

system that converts signals to analog for about \$1,000 per channel (an 80 percent reduction in price). Ortel showed its first AM laser, which launched video through 6.5 kilometers of fiber. Larry Stark of Ortel says his company is working on a system that will carry 42 channels of video over 15 kilometers with a carrier-to-noise ratio of 56 dB and CTB greater than -65 dB.

The FCC rules that cable operators must offer viewers the option of installing a high-isolation A/B switch as part of the must-carry rules.

Scientific-Atlanta debuts two new set-tops, the 8590 and 8570 models. The 8590 features audio volume control with visual level indicators via LEDs so that TV viewers can locate the "optimum" level for stereo separation. Other features include improved scrambling, audio control even when the convertor is turned off, parental control and a VCR timer.

The formation of Cable Television Laboratories begins as the cable industry sees the need for research and development to occur outside of the manufacturers' and MSOs' domains. NCTA's Wendell Bailey, in his monthly CED column, writes: "As cable's identity comes more into public consciousness, as the benefits and services which we bring to consumers begin to be recognized by public policy thinkers as well as our subscribers, the time to pay attention to what part technology plays in our daily activities, as well as our future, is now."



**CED's first annual salary survey found engineers and techs consumed by three major thoughts: low wages, a lack of adequate training and looming competition.**

John Goddard, president of Viacom Cable, made a few predictions at the 1988 Cable-Tec Expo. He said that by 1993, basic cable penetration would exceed 70 percent; telcos would be offering video, but only outside their telephony territories; and 15 percent of the cable plant in the U.S. would be fiber-based.

Roger Brown is named editor of CED magazine after Gary Kim departs to help start Cable World magazine. Rob Stuehrk comes to CED as publisher from Communications Technology.



# 1989-1990



## A P R O F I L E

**Interest in fiber optics reaches a new summit as traditional equipment suppliers Jerrold and Scientific-Atlanta were touting their new fiber optic systems, along with smaller fiber companies like Catel Telecommunications, American Lightwave Systems and Synchronous Communications.**

Jones Intercable announces its plans to upgrade Broward County with TransHub III, a fiber optic system manufactured by Catel. Jones engineers design a new architecture, dubbed the Cable Area Network, that actually keeps the existing coax in place for back-up, which can be used in the event of a fiber failure. Although the CAN architecture gains interest, few systems outside of Jones in Augusta and Broward deploy it. And Catel has problems meeting Jones' timetable and never becomes a major player in the market.

**During the 1989 Atlantic Cable Show, Scientific-Atlanta announces that in less than six months, cable operators have ordered more than 100 AM fiber systems. Earlier, Anixter announced its sales volume had already exceeded 100 systems.**

Marking a watershed event in the development of fiber optic gear specifically for cable TV systems, Jerrold and Ortel Corp. announce an agreement where the Calif.-based Ortel will offer high-power distributed feedback lasers exclusively to Jerrold, beginning in mid-1990. The devices will be guaranteed to provide a 7 dB loss budget over 15 kilometers.

TCI jumps on the fiber bandwagon, announcing that it has committed to purchase half of the AT&T Laser Link product the supplier has in stock as the MSO deploys fiber throughout its systems in 1989. Anixter Cable President John Egan says his company will produce 1,000 AM fiber systems in 1989. Fiber links cost \$30,000 each, but the price falls quickly as laser yields improve.

**The FCC floats the idea of telephone companies to operate as programmers and cable operators over their own facilities. The concept later becomes known as "video dialtone." The cable industry erupts in dissension, noting that it would be impossible to guard against cross-subsidization. And without that protection, the NCTA argues, the cable industry is at risk of being swallowed whole.**

Compact-disc quality audio over cable TV systems comes about. The three major players hoping to find customers: International Cablecasting Technologies, Digital Radio Labs and Digital Cable Radio (Jerrold). Digital Radio Labs becomes the odd man out as ICT hooks up with Scientific-Atlanta to produce Digital Music Express.

**The cable industry's nose is bloodied in the cable/consumer electronics interface battle. After TV makers commit to build millions of TVs with the MultiPort decoder plug built in, cable equipment vendors are reluctant to build the decoders, and operators stubbornly refuse to part with the revenue they've built over remote control rentals. The decoder interface debate continues to this day, and Congress has gotten involved.**

In spite of an effort by HBO and some others to get the cable industry to switch to Ku-band satellites, the industry re-commits its fortunes to the C-band, citing reliability as a key issue.

**Another bandwidth jump is made as nearly all major suppliers of distribution amplifiers show 750 MHz versions, while debate over the merits of 1 GHz gear swirls throughout the technical community.**

According to CED's annual salary survey, the average manager makes \$52,500 a year, the typical engineer makes \$37,500 a year, and the average tech made \$27,000 per annum.

**The countdown clock toward signal leakage compliance begins as operators have until July 1, 1990 to comply with strict new leakage testing and monitoring guidelines issued by the FCC.**

Richard Wiley, chairman of the FCC's Advisory Committee on Advanced Television Service, announces that testing of all nine proposed and accepted HDTV systems will commence June 4, 1990 and be completed by September 3, 1991. By March 1990, consolidation brings the number of proponents to six.

**This time, DBS does take off. A consortium of nine cable operators, including TCI, ATC, Comcast, Continental, Cox, Newhouse, United Artists, Viacom and Warner, hatch a plan to distribute cable programming directly to homes via a Ku-band satellite. The group is known as K Prime Partners. It later becomes PrimeStar.**

TCI almost singlehandedly starts an industry recession by suspending all capital spending in response to cable TV operations being classified as highly leveraged transactions. The recession will last for nearly two years, until those HLT restrictions are relaxed, and MSOs get access to cheaper money.

**Meanwhile, the telcos get busy learning about video, announcing several domestic tests of fiber-to-the-curb. In addition, they're majority partners, with cable operators in some cases, in the United Kingdom, where cable franchising begins to accelerate.**

General Instrument raises everyone's eyebrows with an 11th-hour proposal for an HDTV system that's based on digital signal processing and compression. The DigiCipher system becomes the foundation for video compression in general, and TCI later announces its plans to deploy millions of digital set-tops that will offer 500 channels. We're still waiting for HDTV and for those digital set-tops.

**Fueled by demand for more bandwidth and better pictures, the industry finds itself in the middle of a banner construction year. Equipment manufacturers report record sales and backlogs, while operators scramble to upgrade and extend their plants.**



# SystemSelect™

FOR INTELLIGENT SOLUTIONS



Call now,  
**800-233-2267**,  
 for more  
 information  
 about  
 SystemSelect™.

SystemSelect™, C-COR's full range of network solutions for the cable television, telephone, and broadcast industries.

**Sales Engineers** help analyze your specific network needs and offer innovative solutions.

Experienced **Network Designers** provide highly-reliable, cost-effective maps, including a complete bill-of-materials.

**Field Engineers**, on-site or on-call, provide customer-focused network services, including a 24-hour emergency hotline (814-238-0427) for technical support.

Talented **Applications and Training Engineers** offer a full series of Broadband and CATV seminars, covering hybrid fiber/coax applications.

**Equipment Repair Technicians** provide maximum customer satisfaction when repairing or testing amplifiers and fiber optic equipment.

SystemSelect™...For Intelligent Solutions!



**C-COR**  
 ELECTRONICS INC  
 The Network Company

60 Decibel Road  
 State College, PA 16801  
 814-238-2461  
 800-233-2267  
 Fax 814-238-4065

**CALIFORNIA OFFICE**  
 47323 Warm Springs Boulevard  
 Fremont, CA 94539-7462  
 510-440-0330  
 Fax 510-440-0218

**DENVER OFFICE**  
 12742 East Caley Ave. / Suite A  
 Englewood, CO 80111  
 303-799-1100  
 Fax 303-643-1743

**INTERNATIONAL OFFICE**  
 P.O. Box 10.265, 1301 AG Alincze  
 The Netherlands  
 31-36-536 4199  
 Fax 31-36-536 4255

**CANADIAN OFFICE**  
 377 MacKenzie Avenue, Unit 5  
 Ajax, Ontario L1S 2G2, Canada  
 905-427-0366 / 800-427-2559  
 Fax 905-428-0927



Interest in wireless telephony soars as the idea of personal communications services works its way through the FCC notice of inquiry stage. PCS is viewed as another way cable can compete with telcos in that market.

The FCC tries to leverage the development of interactive TV when, in response to a proposal from TV Answer, it issues a notice of proposed rulemaking establishing an interactive video and data service band between 218 MHz and 218.5 MHz. Later, the FCC hosts an auction, several winners are disqualified and little has happened to date. TV Answer become Eon and became an answer in search of a question.

Cox Cable in San Diego hosted a historical event when James Kennedy, Cox chairman and CEO, placed a call to FCC Chairman Al Sikes in Washington, D.C. via a PCS handset. The call was picked up by a microcell receiver and backhauled over the HFC cable plant to the local telephone switch.

With everyone looking forward to possibly transporting PCS over cable networks, a new focus is placed on the return portion of the cable plant. Will it be reliable? Is it too noisy? Can it be used for telecommunications services? All are open questions that remain open today.

# 1991-1992

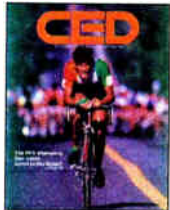

## A P R O F I L E

Testing of proposed HDTV systems slips from the fourth quarter of 1990 to April 1991 as final preparation of the Advanced Television Test Center in Alexandria, Va. takes longer than anticipated.

**Jerrold unveils DigiCable, a digital compression and transmission system specifically designed for the cable TV plant. The system can compress five movie channels or two live-action NTSC channels into a single 6-MHz channel slot.**

By early 1991, the cable TV segment is the fastest growing portion of the fiber cable market, according to Corning Inc. At that time cable TV accounted for just 5 percent of the North American market, but was growing 100 percent per year.

**Live compressed video feeds were the rage throughout 1991. Scientific-Atlanta was touting the benefits of vector quantization over discrete cosine transform (DCT eventually won out with better pictures). Skypix, which had just received a financial shot in the arm from Home Shopping Network, struck a deal with Glenn Jones to test a new analog/digital receiver by early 1992. The test never happened.**

The technical side of the industry wrestles with the logistics surrounding the 1992 Olympics Triplecast, which relies on traps to control the pay-per-view event. While the technology apparently works, the Triplecast is a bust.

**TCI gives up on "on-premise" and interdiction systems because of the impending Triplecast as well as a trend toward "pay-per-event" businesses. The company throws out a ton of money to roll out Jerrold addressability in nearly every system to capitalize on the Triplecast. The Olympics are a bust, and Mike Tyson will soon go to jail. Snakebit again?**

According to the NCTA, the cable industry loses \$3 billion a year to cable pirates, mostly to those who are in the business of supplying illegal decoders. A couple of years later, that number is amended to \$5 billion a year in losses.

**The NCTA and a group of organizations that represent the nation's cities reach an 11th hour accord on technical standards. Among the key agreements: MSOs will**

**improve carrier-to-noise to 43 dB, signal levels shall be no less than 3 dBmV at the end of a 100-foot drop or less than 0 dBmV at the terminal, and new testing procedures will be carried out twice yearly. The agreement comes just before the FCC would have crafted its own policy.**

In 1992, the average monthly price for basic cable jumped over the \$20 mark for the first time, according to Paul Kagan Associates estimates. By then, the industry is spending nearly \$4 billion per year to acquire programming, and the number of systems in existence tops 11,000 as the penetration rate exceeds 61 percent.

**A bill introduced by Vermont Senator Patrick Leahy mandates the use of a MultiPort-like device to get rid of set-top decoders in the house. Leahy wrote the bill after purchasing a high-end TV for his mother, then discovering most of the features won't work after a cable box is plugged into it. Leahy's legislation is adopted in modified form as part of the re-regulation bill that eventually passes through Congress.**

Antec announces its network vision of the future, dubbing it the Cable Integrated Services Network. The 10-year evolutionary plan builds upon a 1-GHz network with a flexible method for controlling a digital portion of the bandwidth. The concept embraces the Synchronous Optical Network (Sonet) standard. Jerrold also touts the benefits of a 1-GHz platform, dubbing it "System 2000." The company rolls out a spate of hardware capable of handling increased bandwidths.

**Ortel Corp. executive Larry Stark boldly predicts that it will be routine for DFB lasers to have transmit powers of 25 milliwatts within the next two years. He also pronounces the 1550 nm wavelength "dead" for cable TV use, noting that any advantages gained through better attenuation and amplification at 1550 nm can be overcome with better 1310 nm devices.**

The most upbeat show in years is the 1992 Cable-Tec Expo, where manufacturers began believing the MSOs were starting to spend money on capital improvements again. During that show, ATC's Ron Wolfe is named Member of the Year, while ATC also took home the President's Award for technological leadership.



# The History of Fiber

## F I B E R I N C A B L E T V

The history books may reflect that the fiber optic era in cable TV began in 1987 and 1988 when Jim Chiddix and Dave Pangrac, two engineers from American Television and Communications, began pressuring equipment manufacturers for a fiber optic solution to reduce long amplifier cascades; but in truth the process was started long before that.

It really all started in 1970, when Corning Glass Works (as it was then known) was finally successful in reducing fiber attenuation to less than 20 dB. "This technology is moving out of the laboratories into manufacturing, into the plants and into the field," said Dr. David Duke of Corning in 1977. "It's becoming a practical reality."

At about the same time, Delmer Ports, then the vice president of engineering at the NCTA, wrote: "Just as microwave technology was the center of attention in the '40s, and as transistors erupted in the '50s; then satellite communications in the '60s, now fiber optics has emerged as the glamour technology of the 1970s."

What had happened? The military had installed several fiber links in aircraft and on naval ships to transport data and video over short distances. AT&T installed a 144-fiber trunk in Atlanta to test the technology. And TelePrompTer Manhattan Cable put in a short trunk run as a test. Fiber attenuation had actually improved to 1 dB to 2 dB per kilometer, which offered hope, but still required signal regeneration for runs of any reasonable length.

For several years thereafter, there were numerous experiments with fiber, but always the same dilemma remained: to launch video via laser meant it had to be either an FM or digital signal, and the cost of converting from FM to AM or from digital to analog was simply too high to make fiber affordable for anything beyond trunking and point-to-point applications.

Early pioneers included TelePrompTer in Manhattan and Lompoc, Calif.; and

Cablecom in Joplin, Mo. and other systems. Irving Kahn of TelePrompTer was absolutely convinced of fiber's potential. In addition to using the technology, he invested in companies that manufactured the gear.

In one twist that today seems odd, but which made perfect sense at the time, Times Fiber designed a system that utilized light emitting diodes (LEDs) which could transport video in analog form. But LEDs aren't as powerful as lasers, so Times engineered a system that did exactly the opposite of what MSOs are doing

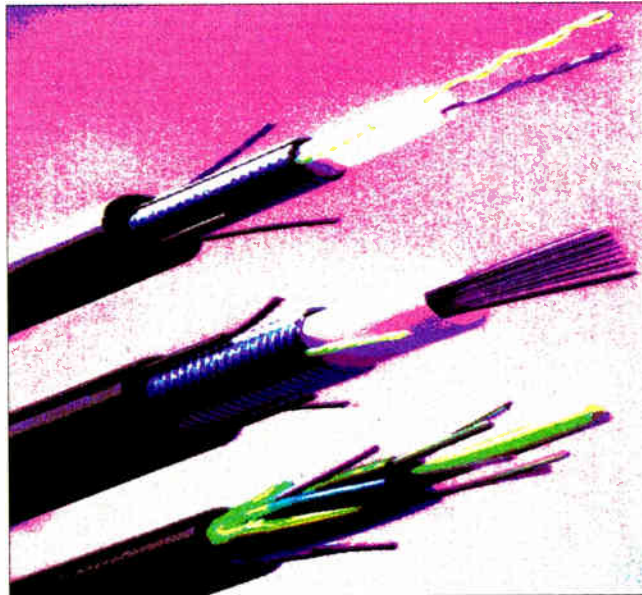

today. Relying on a coaxial trunk run, the Mini Hub system converted signals to light at hub sites and transported them over fiber to the home, where they were detected and converted back to AM format for the TV and VCR.

Fiber optics was so tantalizing, yet so elusive back in 1987, according to Chiddix. The promise was there—enormous bandwidth, attenuation of just a few tenths of a decibel, small, easy-to-use cables that are immune to leakage or RF interference—but linearity wasn't. "Today's laser and photodiode technology can be compared to fairly poor oscillators and untuned detectors," he wrote back then. "In the next few years, it may make sense to construct fiber backbones . . ."

By late 1987, ATC engineers are testing the concept of fiber backbones and suggest they could build one for about \$27 per subscriber within the next two years. But they need devices that can deliver a minimum of 42 channels as far as 15 kilometers.

With that as a goal, manufacturers set out on a mission. Lasers are built by AT&T and Ortel to achieve those early minimum specs. Chiddix and Pangrac continue to pound for better performance and lower prices. Other MSOs join in the cacophony and say they, too, would deploy fiber networks because they offer better pictures, increase bandwidth and reduce maintenance costs.

As devices are made available, operators begin installing trunk runs, primarily to replace high-power microwave links. By eliminating these AML sites, operators can save money on equipment, real estate and maintenance. Names for these new topologies appear: ATC calls its the fiber backbone; Jones develops the Cable Area Network that keeps the old coax in place and adds a switch for redundancy; and Rogers Cablesystems in Canada has its urban transmission topology, complete with rings for survivability.

In 1990, fiber is pushed deeper into the network after MSOs discover they can optically repeat signals and passively split them to node locations in neighborhoods. This "fiber trunk and feeder" concept (other terms then were all fiber trunk and fiber to the brider—today, it's "hybrid fiber/coax") eliminates trunk and brider amplifiers (thus making the investment in more fiber possible) and reduces the number of active components.

The concept, of course, becomes the method of choice for MSOs. While other options and operating wavelengths exist, cable systems are all following the same path, albeit at different speeds. As device performance improves, the size of the areas served by the nodes has gotten smaller—typical applications drive fiber to nodes serving 500 homes or fewer.

# Congratulations CED on

**Adelphia**  
extends its congratulations  
to  
**CED Magazine**  
a pillar  
of the  
engineering community  
for 20 years



**A Continental  
Congratulations  
to**

**CED**

**for 20 years  
of excellence**



**CONGRATULATIONS**

**CED**

*Connecting the  
cable communications  
industry for  
twenty years*



★ The technical wizards of  
★ the NCTA Engineering  
★ Committee congratulate

**CED**

★ on helping us make magic  
★ over the last 20 years.

★ From all your friends  
★ on the Committee



# two decades of success!

**Congratulations**

**CED**

*on building a  
quality publication  
over the last 20 years!*

**COX**  
COMMUNICATIONS

**CONGRATULATIONS**  
**CED**

ON YOUR  
20TH ANNIVERSARY  
FROM ALL YOUR FRIENDS AT



**Congratulations**

**CED**

*on 20 years of  
editorial leadership.  
We look forward to  
you leading us into the  
21st century.*

 **CENTURY  
COMMUNICATIONS**

**Congratulations**

**CED**

*on 20 Years  
of  
Editorial Excellence*



**THE LENFEST GROUP**

202 SHOEMAKER ROAD • POTTSTOWN, PA 19464 • 215/327-0965



# The Man of the Year

## A LOOK BACK AT CED HONOREES

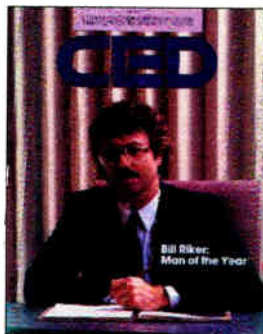

**1986: Bill Riker, SCTE**

After taking over the reins of the financially strapped, poorly-organized Society of Cable Television Engineers, Riker brought organization and an air of professionalism to the group and has

guided the transformation of the Society into a hugely influential organization. His efforts have paid off big: the SCTE just went over the 14,000 member benchmark and is planning to move into a brand new headquarters this fall.

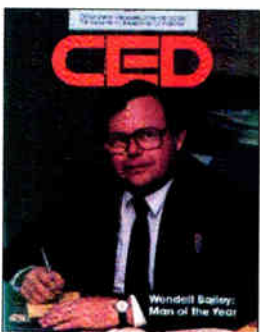

**1987: Wendell Bailey, NCTA**

Often referred to as "the engineer's man in Washington," Bailey combines his quick wit with tremendous diplomatic skills to solve a wide variety of technological conundrums.

While he obviously seeks active participation from engineering executives of member companies, Bailey is often the industry's point man when it comes to thorny issues like signal leakage, the consumer electronics interface and dealing with Congress and the FCC.

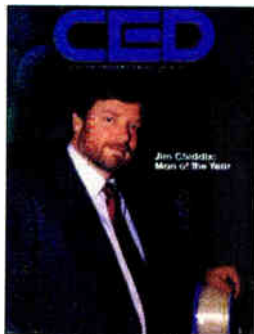

**1988: Jim Chiddix, ATC**

When Jim Chiddix and Dave Pangrac advanced the notion that cable systems could use analog distributed feedback lasers to transport video signals over fiber optic cable, the

experts called them nuts. After all, AT&T Bell Labs said it couldn't be done. After proving it could be done, and done well, Chiddix has to be considered one of the brightest and most visionary minds the industry has. Chiddix went on to oversee the construction of the Full Service Network in Orlando.



**1989: Nick Hamilton-Piercy, Rogers Cablesystems**

A visionary who isn't afraid to roll up his sleeves and get to work, Hamilton-Piercy leads a

team of respected engineers and researchers north of the border. His stated goals—quality, service and innovation—led Hamilton-Piercy and his Rogers team to develop a new fiber optic architecture, an advanced signal leakage detection system and perform key work related to high definition television.

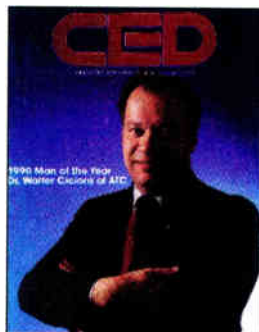

**1990: Dr. Walt Ciciora, ATC**

Imagine spending a year in which you log 100,000 air miles and keep in touch with countless

skunkworks building technology that one day may have an impact, all the while staying focused as the industry's leading expert on consumer electronics compatibility issues. As VP of technology at American Television and Communications, Walt did all that and more.

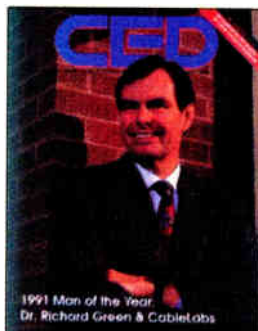

**1991: Dr. Richard Green and CableLabs**

Green and the rest of Cable Television Laboratories have been extremely

successful at building consensus within the industry and presenting a unified voice on networked video issues. And the timing couldn't have been better as competition in the video marketplace is heating up, and worldwide standards bodies have turned their attention to networked video. CableLabs has focused its sights on helping its member companies understand the technical issues surrounding new businesses.

**1992: Tom Elliot, TCI; Ed Horowitz, Viacom; and Howard Miller, PBS**

This triumvirate of widely different personalities and businesses were able to come together and help define the coming digital revolution. Although the rollout has taken much longer than anyone dreamed, the potential for digital techniques to alter the course of how television is created and consumed remains. These three shared the vision and came together to shape the groundbreaking CableLabs RFP on digital compression.

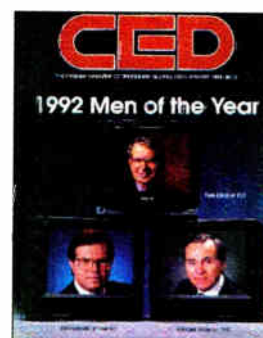

**1993: Dr. Walt Ciciora, Time Warner Cable**

By forging an agreement with the Electronic Industries Association over consumer electronics compatibility guidelines. Ciciora's colleagues argue that he singlehandedly saved the industry millions of dollars. While the negotiations are still ongoing and sometimes get testy, Ciciora's diplomatic acumen is beyond reproach. Today, Ciciora is a consultant and counts the NCTA and Pioneer as clients.

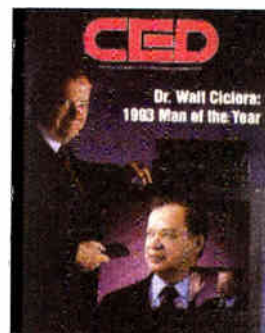

**1994: Nick Worth, TeleCable**

The consummate "nice guy," Worth worked his way up through TeleCable's ranks to serve as the entrepreneurial company's top engineer for several years. His commitment to building quality systems while maintaining the bottom line caught the attention of his colleagues at other MSOs. After TCI acquired TeleCable, he has since gone off to enter an MBA program.

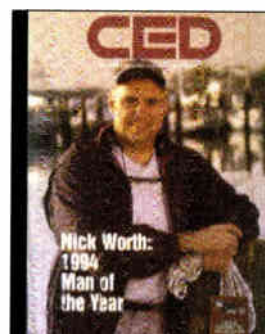



Scientific-Atlanta completes the acquisition of Nexus Engineering Corp., one of its chief competitors in the headend hardware arena. The deal calls for Nexus principles Basil Peters and Peter van der Gracht to become part of the S-A management team.

Bell Atlantic and TCI stun the world by announcing a plan to merge their two companies. TCI chief John Malone and BA's Ray Smith get along famously, but Wall Street reacts negatively, sending stock prices too low to support the deal. A few months later, the deal is off and the cable vs. telco war of words resumes. Battlegrounds take shape in California and in Omaha.

Meanwhile, a number of companies begin working on systems that can deliver telephony over cable systems. MSOs want to test the gear and are itching to get into the business. CableLabs issues a telecom RFP, promising that the cable industry will spend \$2 billion on infrastructure over the next several years. In the meantime, telephone companies begin talking of competing with one another as well as with the long distance companies, and vice versa. Odd alliances are announced regularly (some work out and some don't). It's a confusing and exciting time because few will be able to accurately predict the future.

# 1993-1994

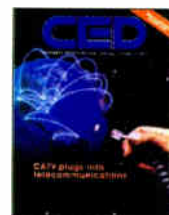

## A P R O F I L E

At the close of 1992, the cable industry suffers a huge blow when it is re-regulated, against the wishes of President George Bush, who had vetoed the legislation only to have it overridden by a Democratically controlled Congress. The industry is somber, but realistic, having seen the legislation coming. Indeed, capital spending continues to increase, in spite of unclear rate rules.

**The great "cable vs. telco" debate is muddled when Sammons announces it plans to lease fiber capacity from New Jersey Bell's video dialtone system in Morris County. The system is slated to use a fiber-to-the-curb system from Broadband Technologies. However, the agreement falls apart several months later after Sammons tires of waiting for the FCC to approve the plan.**

Philips becomes the real Ghostbuster after its ghost canceling reference signal is chosen as the North American standard to eliminate those annoying TV ghosts. The Vector system transmits a signal in the VBI and compares the received signal with it to remove ghosts. The invention is named "grand winner" of Popular Science magazine's Best of What's New awards.

**In addition to announcing its plans to roll out digital compression in its systems beginning in 1994, TCI says it will offer a slate of digital programs to other operators from its national uplink center outside Denver. The concept becomes known as the "Headend in the Sky" and is primarily aimed at small systems that cannot afford to buy all the digital gear they would need on a standalone basis. To carry this out, TCI says it will spend upwards of \$750 million per year over the next four years.**

Tom Staniec of NewChannels is awarded the industry's first Polaris Award, which recognizes the "next-generation" engineer who has shown innovation in his use of fiber optic technology. The award is presented by Corning Inc., the SCTE and CED magazine. In 1994, Jim Ludington of Time Warner Cable wins the award.

**Time Warner Cable announces its intention to construct a Full Service Network in Orlando, and have it up and running by the end of 1993. The two-way interactive network will integrate ATM and Sonet technology with traditional cable TV and**

**will include a host of interactive services, including cablephone. The project turns out to be a massively complex job of integration, and Time Warner suffers in the popular press because of delays that push the launch to the end of 1994.**

Meanwhile, several of the seven regional Bell operating companies announce comprehensive (and expensive) plans to rebuild their networks with broadband equipment in an effort to deliver video and interactive services. US West, for example, says it will spend \$13 billion to deploy broadband throughout its 14-state territory. Two years later, the telcos tire of waiting for FCC approval and retrench as they search for just the right technology to deploy.

**Faced with apparent impending competition from the telcos, the cable industry realizes it must change if it hopes to survive. Suddenly, there's renewed interest in system reliability, network and workforce management, operational support systems, making the return path work and understanding switching technology as interactivity becomes the new buzzword.**

After all is said and done, the battle to develop a standard for HDTV comes down to a melding of the best of the best. The "Grand Alliance," a cooperative agreement between AT&T, General Instrument, Sarnoff Research, MIT, Philips Electronics, Thomson and Zenith, is charged with developing a single system. It is presently being tested. The group selects Zenith's VSB modulation format.

**For the first time, high-power direct broadcast satellite service commences when DirecTv, a service offered by Hughes and partners, begins beaming 150 channels to 18-inch satellite dishes. The first million units sell like hotcakes despite a retail pricetag that can approach \$1,000. The cable industry loses a few subscribers, but it's not an epidemic.**

Set-tops of the future are slowly being defined. GI and Microsoft decide to build an operating system, while the DAVID system from Microware is chosen by a consortium of Compression Labs, Zenith and Philips. Hewlett-Packard licenses DigiCipher II technology. Scientific-Atlanta hires several engineers from the Apple/IBM venture known as Kaleida to construct its own OS, called PowerTV.



# Congratulations

A R C H E R T A Y L O R

**1975** was a very good year! CED was born, the first trade magazine dedicated primarily to the technical side of the burgeoning telecommunications industry, once known as CATV—Community Antenna Television.

Judy Baer called it “*Communications Engineering Digest*” when she began to solicit articles and advertising. Judy had been working at Phasecom with Bert Rosenblum and Arie Zimmerman in 1972 when the FCC adopted the *Cable Television Report and Order*, establishing for the first time a set of technical standards for the still rather young cable television industry. In Paragraph 170 of its Report, the FCC called for assistance in developing standards in several areas the Report and Order had not covered: receivers designed for use with cable TV; cross-modulation, ghosting and hum; envelope delay, differential phase and gain; and audio quality.

The Cable Television Technical Advisory Committee (CTAC) was established by the FCC to provide expertise from the industry. Hubert “Hub” Schlafly was elected industry chairman. Judy Baer applied for, and was hired as administrative assistant to Armig Kandoian, who had been named CTAC executive secretary. The Final CTAC Report was issued on May 30, 1975, and the advisory committee was disbanded. By this time, Judy had already begun to lay the groundwork for her new magazine.

On October 1, 1975, HBO leased a satellite transponder to relay coverage of the Ali-Frazier heavyweight prize fight from Manila (the “Thrilla from Manila”) in the Philippine Islands to CATV headends in Jackson, Miss., and Kissimmee, Fla. With that one, single trailblazing event, doors began to swing open. Pay-TV would no longer have to depend on bicycling video tapes from city to city. Programs would no longer have to be filtered through broadcast TV stations. Program networks would no longer be confined within the scarce spectrum limits of terrestrial broadcasting.

Most provocative of all, the viability of

cable TV would no longer depend on how many “distant signals” the FCC would allow. With nine million subscribers, representing only 13 percent of TV households, the industry could contemplate a staggering seven-fold growth in the years to come.

But 1975 was not all roses. Cable TV growth had stagnated. Cable had already been introduced in the small towns and cities, generally remote from the big cities, and wherever it could offer at least some television programming not otherwise available. It was not generally perceived as viable in most of the major metropolitan areas where terrestrial broadcasting stations already provided essentially all of



**TelePrompTer  
was the  
largest MSO  
in the U.S.**

the programming available from three commercial networks, the public broadcasting network and a number of unaffiliated TV stations. Growth stagnation resulting from saturation of the feasible market had only slight impact on system operating revenue. Subscribers continued to pay their monthly charges. But highly leveraged operators relying on growth to service heavy debt obligations were hit especially hard. Equipment sales and new construction dropped drastically. Brokers, consultants and other service firms were forced into layoffs and downsizing. System sales, mergers and acquisitions fell off sharply, as investors waited to see how the situation might develop. It did not help a bit that the U.S. economy was in a recession in the 1974-75 period. What a terrible time to start a new magazine!

During the decade of the 1960s, Irving Kahn had become a particularly articulate and effective spokesman for the cable TV industry in the financial community. He had left 20th Century Fox to establish a new company to manufacture and market a device, patented by “Hub” Schlafly, that would enable a speaker to read from a prepared scroll without looking away from the audience. The company he formed prospered as the TelePrompTer became a nearly standard fixture at conventions and rallies everywhere. Intrigued by the possibility of distributing pay-TV on CATV coaxial networks, he acquired the franchise for Johnstown, Pa., and constructed the first of many systems across the country. By 1975, TelePrompTer was the largest multiple system operator in the U.S., with over a million subscribers.

However, trouble arose in 1970 over renewal of the Johnstown franchise. The mayor pleaded guilty to extortion and testified against Kahn, who was then convicted of bribery. By 1975, he had served out his three-year sentence and re-entered the cable business in New Jersey. However, the impact of the adverse publicity on the largest MSO in the business could do little to enhance confidence in the industry.

Kahn was forced to sell his interest in TelePrompTer, ironically at the top of the market, and once grinned that here he was, sitting in jail with \$10 million in cash, and nowhere to spend it.

Shortly after he had completed his term, Irving Kahn was asked to address a cable TV convention in Dallas. After the introduction, he walked to the podium, looked out over the audience and started to speak: “As I was saying when I was so rudely interrupted . . .”. All is not lost when we can retain a sense of humor.

1975 must be perceived as a watershed year. By 1980, the growth foreshadowed by that HBO satellite demonstration was in full swing. The dark side of that year has long since become history. We can say with Charles Dickens as he opened his *A Tale of Two Cities*: “It was the best of times. It was the worst of times.” And CED was there.





Congratulations CED  
on your 20th Anniversary.

# Finally, a Spectrum Analyzer for the End-of-Line

*Cheetah PC-1000 Performs In-Service Distortion Tests*

## COMPLIANCE TESTING

A true end-of-line spectrum analyzer, the PC-1000 performs remote diagnostics, alarm monitoring and FCC compliance testing. You save the time and hassle of carting "portable" spectrum analyzers to the field to perform tests manually.

Place the PC-1000 at required FCC test points and other strategic locations for automated compliance testing. It completes non-interfering distortion tests including CSO, C/N, Hum and In-Channel Frequency Response. This provides you the ability to continuously monitor and alarm on distortion parameters without disrupting service.

Make the PC-1000 part of your status monitoring and performance measurement plans!

For more information, call (813) 756-6000.

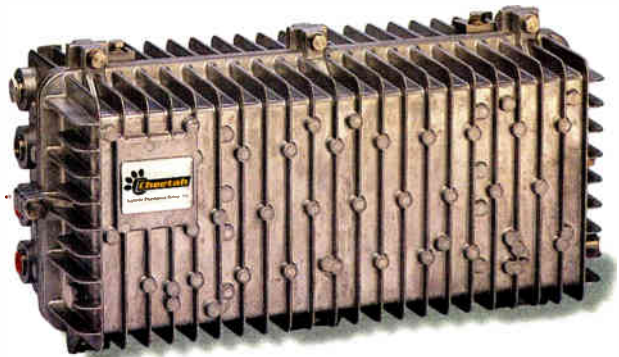

Full spectrum analysis capabilities

5 MHz-1 GHz operation

Frequency agile RF data modems

Automatic corrections for scrambled channels

S U P E R I O R E L E C T R O N I C S G R O U P , I N C .

6432 Parkland Drive ▲ Sarasota, Florida 34243 ▲ Phone (813) 756-6000 ▲ Fax (813) 758-3800

To CED on your  
20th Anniversary.  
Your readers have  
benefited from  
your twenty years  
of dedication to  
the industry.  
We wish you  
continued success.

*A Tribute*

**ANTEC**

CONVERGENCE '95™

# CONVERGENCE TECHNOLOGY

DEALING WITH THE CHALLENGES

*A must conference in a dual-track format for engineering and non-engineering communications professionals needing to broaden their understanding of convergence issues and stay abreast of emerging technologies.*

IN CONJUNCTION WITH THE  
**USTA CONVENTION**

Coming November 8—9, 1995 to  
Marriott's Orlando World Center

From broadband switched digital networks to enhanced wireless services, technology is serving up communications opportunities never before possible — along with matching challenges. Far from being of the commercial, off-the-shelf variety, convergence technology is proving to be more complex, slower to implement, and more expensive than anticipated.

With technological breakthroughs and architectural enhancements being announced on a daily basis, there is a tremendous need among all communications professionals to broaden their understanding of the technology issues, and stay abreast of developments. The content providers, original equipment manufacturers and network operators who are best at exploiting merging and emerging technologies will have the competitive advantage.

The *Convergence '95™ Conference, Convergence Technology: Dealing With the Challenges*, offers a collaborative, dual-track environment addressing the key areas of technological development. For non-engineers the **Strategic Track**: a strategic grounding in the technology issues of the day to better understand the implications and spot the opportunities technology provides their companies. The **Engineering Track**: a detailed look at today's engineering solutions and tomorrow's technology challenges.

## SESSION TOPICS INCLUDE:

- Architectures for Convergence
- Compelling Content
- Defining Utopia: What's True/What's False About Convergence?
- Strategic Look at Network Capabilities
- Network Challenges — Loops, Links and Interfaces
- Advancing Technology — New and Available
- Taking Broadband Beyond Entertainment: Strategic Implications
- Meet the Wizard — Systems, Standards and Software
- Internetworking for Fun and Profit
- The A,B,Cs of Research & Development: Alliances, Bellcore and CableLabs
- The Convergence Solution: Trials, Deployments and Avoiding Deadends

SESSION TOPICS  
SUBJECT TO CHANGE  
WITHOUT NOTICE.

Call 1-800-488-1396 to immediately receive full conference and registration information by fax!

To receive information by mail, please complete all information below and mail or fax to **CommPerspectives**, Attn: Gary, 600 S. Cherry St. #400, Denver, CO 80222, 800-888-4824 • 303-393-7449 (ext. 225) • Fax 303-329-3453

Name \_\_\_\_\_

Title \_\_\_\_\_

Company \_\_\_\_\_

Address \_\_\_\_\_

City \_\_\_\_\_

State/Province \_\_\_\_\_

ZIP/Postal Code \_\_\_\_\_ Country \_\_\_\_\_

Office Phone \_\_\_\_\_ Fax \_\_\_\_\_

C4-95-3

## SPONSORED BY:

**ANTEC**



**cable data**

**digital**

**GI**  
General Instrument

**NORTEL**  
A World of Networks



## OFFICIAL PUBLICATIONS:

**CONVERGENCE**

**CED**

**Multichannel News**

## CONFERENCE PRODUCER:

**CommPerspectives**

CONFERENCE MANAGEMENT  
PROVIDED BY  
PITTELLI & PARTNERS, INC.



# Panning for gold in Geneva

Vendors eager to attend Telecom '95

By Leslie Ellis, Contributing Editor

It isn't often the case, but domestic cable TV operators might learn a few things from the world's largest telecommunications show, Telecom '95, scheduled to run Oct. 3-11 in Geneva, Switzerland. Telecom '95, often dubbed "the Olympics of communications," is hosted by the International Telecommunications Union and held every four years. It promises an astonishing amount of expense and vastness in the vendor displays—with several measuring multiple stories in height.

There are many reasons for the manufacturers to be there: To chase the international dollar, to show their muster in the telecommunications arena, and to capture the interest of the telcos.

There's a similar logistical load, considering that the event, in attendance alone, is an order of magnitude larger than the National Show, with an estimated 200,000 people and 900-plus exhibitors planning to descend on

Geneva. Indeed, the population of Geneva will more than double when the Telecom '95 bunch hits town. "This is a city where there's about 18,000 rooms, and 200,000 people who need rooms," laments one hardware executive, who says he's staying about 45 miles away in the foothills of France.

Alcatel Network Systems Inc., for example, is sending 11 divisions to the show, and is keeping its technology plans under heavy guard, so as to break new product news there; AT&T is setting up six booths, a spokesman said.

What's it all about? "Defining new boundaries for the 21st century marketplace," noted Sarah Parkes, a spokesperson for the ITU, who described Telecom '95 as a networking powerhub for international regulatory frameworks, emerging technologies and market opportunities.

It is the enormity of Telecom '95 that excites traditional cable suppliers, many of whom are planning a first, whopping push of their wares into the international telecommuni-

cations marketplace. The vendors largely view Telecom '95 as nirvana for broadband opportunities, mostly because the "Connect!" theme centers on global interconnect and convergence issues—their specialty.

## What's hot: cable telephony

At the top of the convergence list: the delivery of telephony signals over cable plant, with several manufacturers scheduled to make a major product thrust in that area. Notably, executives with Motorola Inc., Tellabs Operations Inc. and ADC Telecommunications—all of which are building gear that allows phone signals to pass over HFC networks—point to an increasing international interest in "integrated" equipment, where video, voice and data signals ride together on one physical network.

That trend supplants existing "overlay" configurations, particularly in the U.K., where network operators build a wholly separate distribution plant to carry different types of telecommunications information. "Right now, everyone wants an integrated solution. The only reason they haven't done it earlier is because the technology didn't exist," says Jim Phillips, VP and GM of Motorola's Multimedia Group.

Interest in HFC networks over perhaps more costly but more stalwart fiber-to-the-curb and related switched digital video designs is also on the move, the vendors say. "In general, we're seeing a definite switch in interest toward HFC networks, over fiber-to-the-curb topologies,"

## Navigating the Summits

*Exhibitors and attendees in Geneva who need to rest their feet or get out of show mode will likely want to take in the promised flood of high-profile news announcements, strategic and technical sessions at Telecom '95.*

*On the news front, expect big splashes from France Telecom, MFS Communications, Tandem Computers, Sony Corp., and others. Or, there are two "Summits" — one for strategy and one for convergence issues.*

*The Strategies Summit will address regulatory, legal, economic and policy issues, carrying a theme of "Breaking Down Barriers toward the Global Information Society."*

*Topics scheduled for discussion:*

- ✓ Global Markets: Characterizing the Opportunities and Challenges;
- ✓ Evolving Structures: Regulator for Growth and Change;
- ✓ Resourcing for Growth: Capital Formation and Human Resources;
- ✓ Telecom Futures;

- ✓ Strategies in Challenge; and
- ✓ A New Agenda For International Cooperation.

*In the Technology Summit, the focus will be "Convergence of Technologies, Services and Applications," with a fleet of individual sessions.*

*Some of the highlights will include:*

- ✓ Broadband Communication Services,
- ✓ Implications of Convergence for the Telecom Industry,
- ✓ ATM Deployment Experiences,
- ✓ Digital TV, Interactivity and Multimedia for the Consumer,
- ✓ Residential Broadband Architectures, and
- ✓ Technical Standards and Global Standardization, to name just a few.

*Telecom '95 will also shine as a beacon for bookworms—because of a far-reaching "World Book and Audio-Visual Fair" on telecom and electronics, located at the entrance of Hall 4 of the exhibition.*

—L.E.

# Our Tools Won't Leave Your Signal Stranded On The Information Super Highway.

Signal

## Coring Tools

- Precise Cable Preparation
- Beveled Edge Safeguards O-Rings
- Color Coded to Cable Sizes



## Jacket Strippers

- Score-Free Jacket Removal
- Color Coded to Cable Sizes
- Plastic Guide Sleeve Protects Aluminum

INFORMATION

## ShortCut

- Removes Messenger Evenly
- Eliminates Need for Knife
- Leaves Cable Ready for Jacket Removal



## Drop Stripping Tools

- Consistent One-Step Cable Preparation
- Precision Cutting Edge Eliminates Nicks and Shorts



1GHz

## Crimping Tools

- Ensures Full Crimp
- Field Adjustable
- Avoid Signal Leakage



Return Path

## TerminX

- Guarantees Full Compression
- 360° Support Ensures Consistency
- Easy to Use Ergonomic Pistol Grip Speeds Termination



Build It With...  
**CablePrep**

Tools You Trust.

CablePrep A Ben Hughes Communication Products Company  
207 Middlesex Avenue, P.O. Box 373, Chester Connecticut Phone: 203-526-4337 Toll Free: 1-800-394-4046 Fax: 203-526-2291

## ◆ TELECOM '95 PREVIEW

notes ADC's Rich Henkemeyer, pointing to areas like Belgium, South Africa, France and Italy as hot spots for HFC deployment.

And, says Motorola's Phillips: "We're seeing a universal shift to HFC, because network operators are starting to realize that [with HFC] they have access to four to six new revenue streams—like voice, video, interactivity, high-speed data, and picture phone—over one, more affordable network."

Motorola will also use Telecom '95 as a way to show the international marketplace its commitment to the converging telecommunications and computing industries. Specifically, Motorola plans to show off its Cablecomm cablephone gear, in the works for the last three years and currently being tested within Tele-Communications Inc.'s Arlington Heights, Ill. franchise area.

"This is our chance to formally launch [the equipment] in Europe, which we haven't done yet—it's like our coming out party," says Phillips, noting that "primarily, our interest outside the U.S. is in Europe and Asia."

"We're the last of the big guys to get into the cable phone equipment marketplace, and

when we entered, we were slightly behind the other players," Phillips says, adding that "right now, we believe we're ahead of everybody."

Other manufacturers working on cable phone equipment: Tellabs Operations Inc., ADC, AT&T Network Systems, Philips Broadband Networks Inc., Scientific Atlanta/Siemens, and General Instrument Corp., through an almost defunct relationship with DSC Communications.

All of those companies will be showing off their wares in Geneva, with the exception of General Instrument Corp., which is sending personnel but not setting up a booth, nor exhibiting with DSC.

The two hardware suppliers are in the middle of some complicated litigation, in a sort of hardware love triangle configuration, where DSC is in the midst of suing competitor Next Level Communications, which General Instrument recently purchased. The acquisition may well sink GI's and DSC's co-development efforts, executive sources say.

Ronald Tapp, managing partner of Andersen Consulting Inc.'s Communications Industries Multimedia Group in Chicago, points to con-

vergence issues as another hot topic for this year's event. "There's a massive amount of change being imposed on the communications industry, driven by regulations and the coming about of technology that enables convergence," Tapp says, adding that the past year has ushered in a sort of global reality check on technology, for cost and performance reasons.

Manufacturers headed for the event—many of which have been toiling on their exhibits for over a year—call Telecom '95 a "can't miss" opportunity for touting an international telecommunications presence.

"[Telecom '95] is mainly a showcase—people notice if you're not here," noted Michael Tyler, managing director of Eloquence Ltd., a Berkshire, England-based manufacturer of digital multiplexers, exhibiting at the event.

Going into the show, most manufacturers, including hardware heavyweights like Sony Corp., Nokia Telecommunications, ArianeSpace, Motorola Inc. and Racal Electronics Inc., were leery of disclosing specifics about their new product wares, opting instead to save their news for delivery at press conferences [see sidebar].

# WE'VE GOT THE POWER ⚡

**We offer the most  
complete line of application  
specific and standard  
fixed attenuators and terminations  
in the industry.**

**JFW... The Power Leader**

For more information or for a free catalog, contact:

**JFW Industries, Inc.**

5134 Commerce Square Drive

Indianapolis, Indiana 46237

Tele. (317) 887-1340 Fax (317) 881-6790

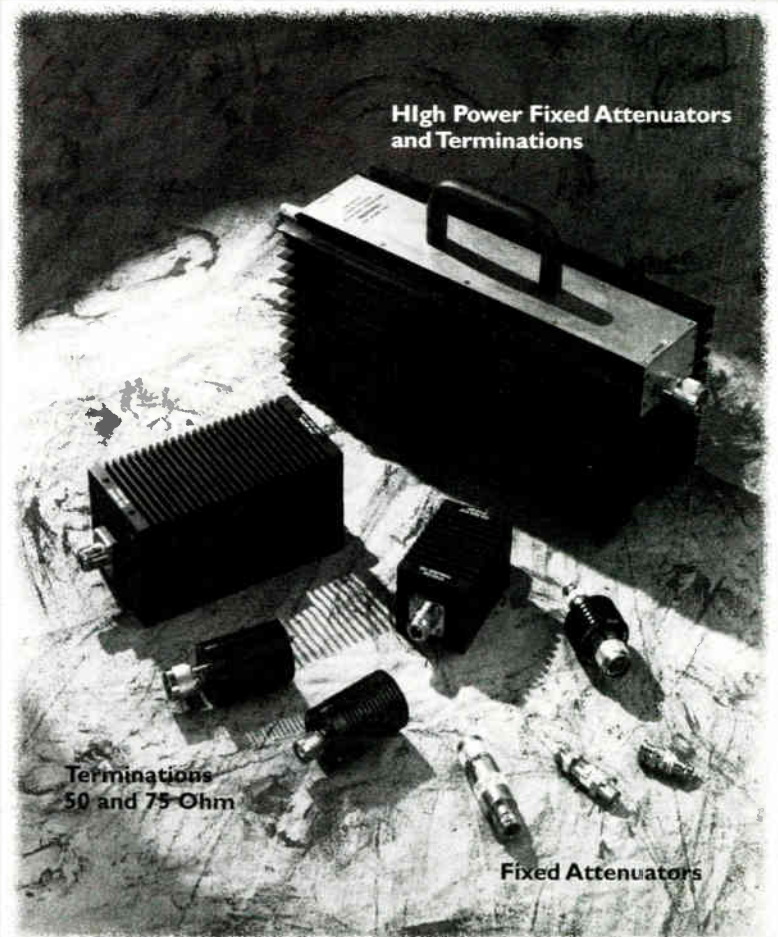

# It's Only A Good Wave... If You're Using The Right Board.

In a sea of video technology, you could sink or swim based on the choices you make. Our engineers and scientists know the right equipment makes a big difference when it comes to performance. In a business where speed and efficiency mean money, you'll appreciate how we've revolutionized the MPEG-2 decoder environment. Our single board, audio/video decoders are designed for a wide range of television entertainment, broadcast, cable, telco and video production applications. Computer platforms from Mac's to mainframes can now become multimedia servers...with products from Vela that address the PCI, EISA, VME and SCSI architectures.

Versatile, flexible MPEG-2 decoder boards from Vela Research.  
The right boards...for the wave of the future.

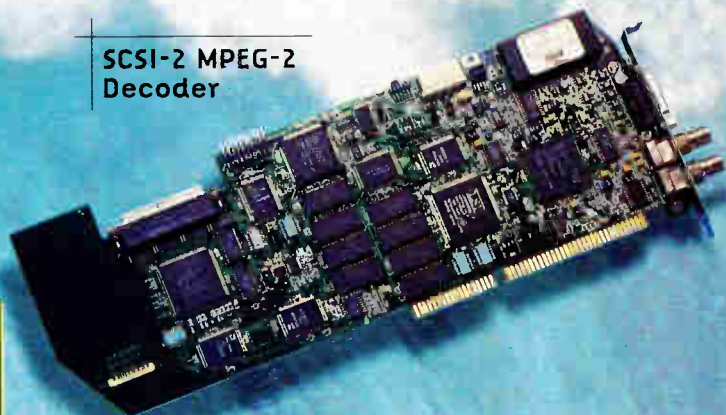

SCSI-2 MPEG-2  
Decoder

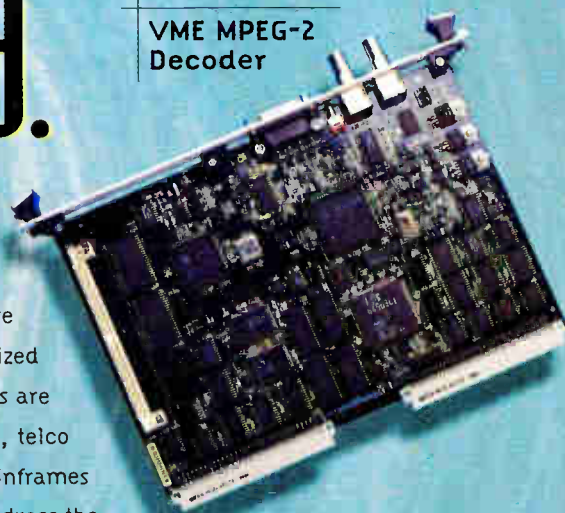

VME MPEG-2  
Decoder



EISA MPEG-2  
Decoder

The Wave Of The Future.<sup>™</sup>

**Vela Research**<sup>™</sup>  
The Wave Of The Future.<sup>™</sup>

1-813-572-1230

To get all the facts, call Rick Chile, Director of Sales.  
2501 118th Avenue North • St. Petersburg, Florida 33716

## ◆ TELECOM '95 PREVIEW

But others, including the troupe of U.S.-based manufacturers headed for Geneva, were anxious to get as much visibility as possible, even if that means showcasing their wares with other, more established international players, like Scientific-Atlanta Inc. will do with Siemens Stromberg/Carlson, and ADC Telecommunications Corp. will do with Nokia Telecommunications.

ADC signed a deal with Nokia earlier this

year to cooperatively design and market cable phone products for hybrid fiber/coax (HFC) networks, and will use Telecom '95 to hammer that message home, says Henkemeyer.

"What we'll be showing is the ability of Nokia's 2 Megabit ACM-2 transport system to integrate with our HomeWorx HFC platform," Henkemeyer says.

On the software side, Microsoft Corp. plans to show how its far-reaching software products

"slice through the telecommunications marketplace," says Bill Snyder, marketing manager of advanced technology sales for the Redmond, Wash.-based software giant. Specifically, Microsoft plans to focus on Windows '95, its backoffice suite of products, its Windows NT server, and "everything that connects as a platform for building out public network services," says Snyder.

"I think people are starting to understand that the traditional public network model will have to change—product life cycles are shortening," Snyder explains, noting the "Moore's Law" of computing that dictates a quantum leap in semiconductor processing capacity every 18 months.

"For example, if you look at how quickly perceptions change about the World Wide Web and the Internet, you see an incredible acceleration of development and opportunity," Snyder says.

Microsoft will also discuss its "MITV" interactive set-top operating system, being tested within the company's headquarters, and its Microsoft Network service, including a presentation during an online services forum session during the 11-day confab, Snyder said.

### Not all rosy

Several vendors, familiar with Show logistics domestically, call the move into Telecom '95 a mind-boggler. At the top of the gripes list: finding lodging, and the costs of making last-minute booth changes. "It's a real pain," notes one executive, adding that "this event has been growing and growing since 1971, but it has yet to graduate to a better-suited city than Geneva."

To illustrate the hugeness, consider the ITU's food estimates: 9,000 meals per day served (up 3,000 from 1991), consisting of 150,000 rolls, 9,000 kg of meat, 1,000 kg of fish, 18,000 kg of vegetables, 2,000 kg of cheese, 70,000 sandwiches, and, perhaps mercifully, 15,500 bottles of wine.

One executive expended about 100 hours just trying to find places for her company's staff to sleep, bathe and change clothes, and admits to checking out youth hostels and campsites.

Most vendors say their staffs will be sprinkled throughout Switzerland and France. "My one-way commute to Telecom '95 is double what my drive from home to work is, round trip," laughs DSC's Adams.

Still, most of the battleweary call the logistics "a real learning experience," which they plan to document carefully and remember for their return to Telecom '99, which will also take place in Geneva. "We're holding fast to the fact that this is a good learning experience, and that we'll know what to do and what not to do in four years," laughs Snyder. **CED**

# MEET MINIMAX!

## Peak Performance in the Palm of Your Hand

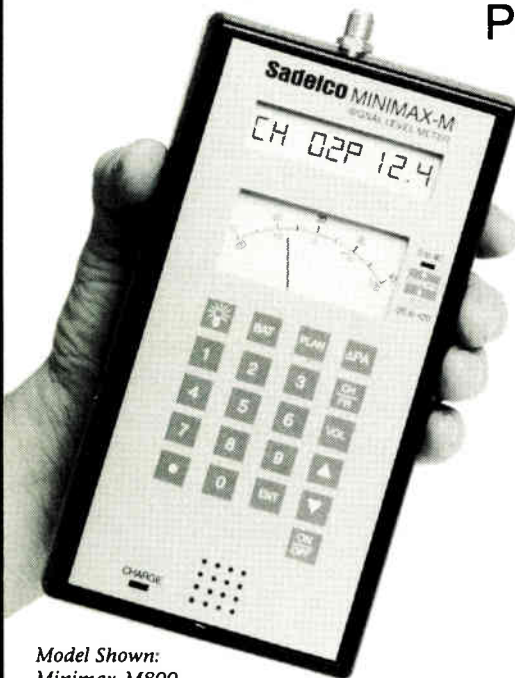

Model Shown:  
Minimax-M800

**Accurate, lightweight, rugged, easy to operate, and low cost —**

**Sadelco's new MINIMAX Signal Level Meters come in two versions to meet your special needs —**

#### CATV versions feature:

- Digital dB Readout
- 30 to +50 dBmV range
- Autoranging Attenuator

#### MMDS versions feature:

- Real-time Microammeter and Digital dB Readout
- 20 to +40 dB range
- MMDS down-converter power supply

#### All Models Feature:

- Fast Digital Tuning with 1 dB accuracy
- Frequency ranges from 5 - 862 MHz available

**Call today to find out what MINIMAX can do for you!**

# 1-800-569-6299

Worldwide call 201-569-3323  
European Distributor Inquiries Welcome!

# Sadelco®

75 West Forest Ave. • Englewood, NJ 07631 USA  
(201)569-3323 • Fax(201)569-6285



# WHEN IT COMES TO OPTICAL FIBER WE'VE GOT YOUR NUMBER.

## NOW HERE'S OURS.

Cable TV technicians and engineers  
already know that Corning's consistent and  
field-friendly fiber provides the industry's  
lowest splice loss numbers.

Now, when it comes to timely information  
for cable TV fiber applications, here's the  
only number you'll need.

Call the Corning  
Optical Fiber  
Information Center  
800-525-2524  
Ext. 534

Everything you want to know  
about optical fiber.  
All from the most extensive fiber  
reference source in cable television.

**CORNING**

*Specify Corning. Fiber you can count on.*

Circle Reader Service No. 36

Corning Optical Fiber

Count on Corning Fiber

# Designing an interactive services architecture

## Making the pieces of the puzzle fit

By Mark M. Myslinski, Associate Product Manager, GI Communications Division, General Instrument Corp.

The interactive landscape consists of at least a dozen identifiable service types, and the list is growing by the day. Market research is being performed on many aspects of interactive services, covering everything from the potential business and the customer's attitude and willingness to "interact" with the TV, to the appearance of the TV and the remote, and

even how much a typical arcade enthusiast spends annually. Although primary efforts to develop interactive broadband networks target near-video-on-demand (NVOD) and video-on-demand (VOD), the relative utility of those types of services will immediately provide the basic functionality and resources for a wide variety of other interactive services.

To support this, broadband network developers are designing networks that can connect thousands of service providers to hundreds of thousands of subscribers, and which can run,

collectively, thousands of applications. This creates a complex network that must be carefully designed, configured and managed to prevent service blockage and provide consistently acceptable service to the subscribers.

These new interactive broadband networks will require an interactive services architecture to manage the onslaught of new applications and services. This interactive services architecture must provide a defined structure that provides application developers with a defined set of resources for interactive service applications, as well as a means for service developers to define service operation and application operations. This will assure that service performance, such as availability and latency, is acceptable and guaranteed.

Such an architecture can then make interactive network deployment successful, and transform the condition of "interacting with the network" into network transparency. Thus, a sound interactive services architecture will erase such conditions as "connecting to the service" or "waiting for download" from the minds of the subscribers.

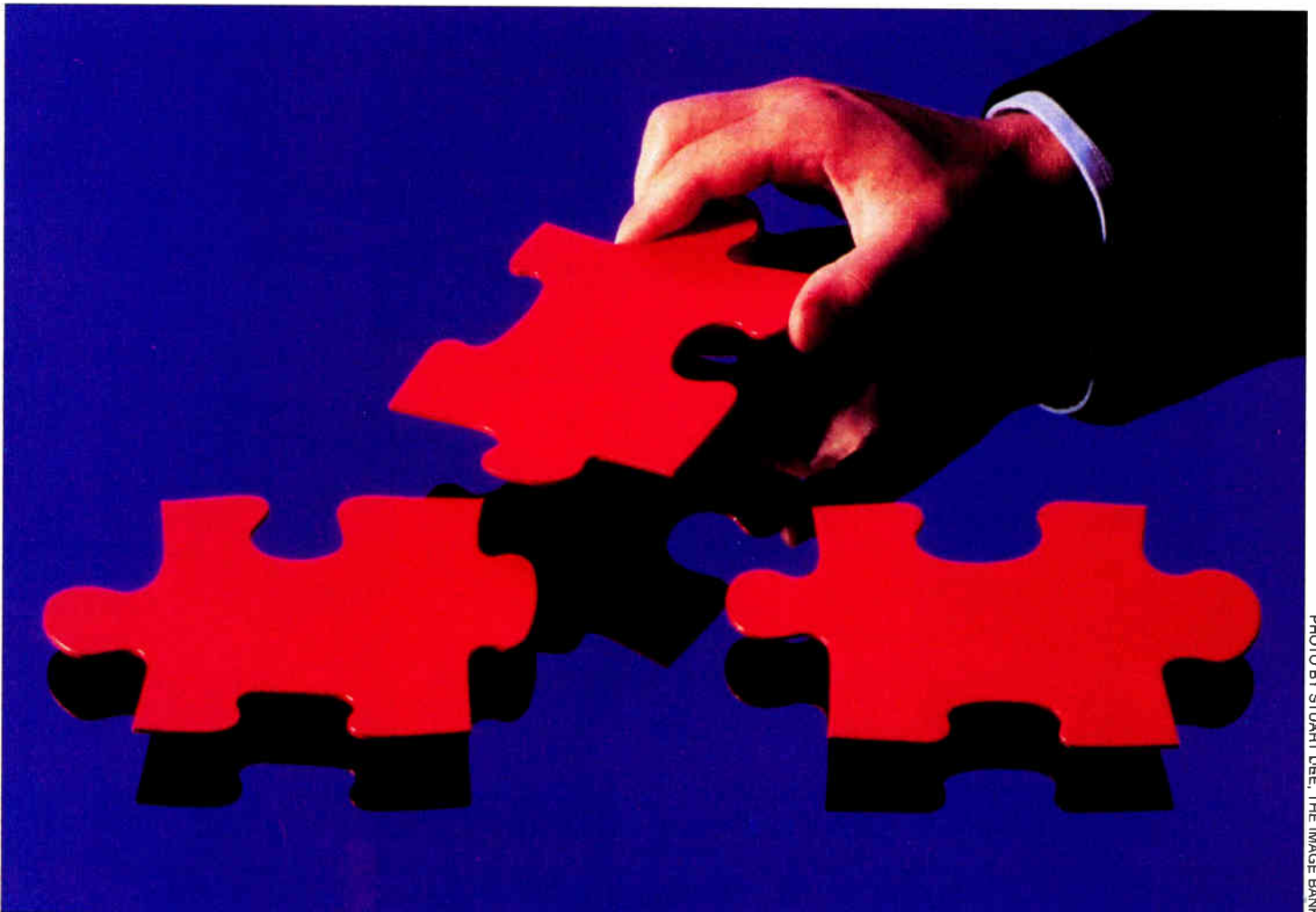

PHOTO BY STUART DEE, THE IMAGE BANK

# A Bright New Light in the Headend Universe

## PULSAR

BARCO introduces PULSAR, a revolutionary modulator for CATV headend applications requiring high quality RF signal and automatic provisioning. PULSAR offers remote monitoring and control of all modulator functions. An intelligent "white limiter" and video AGC prevent overmodulation and automatically optimize video input signal levels.

### Remote or Local Control

Easy-to-use front panel keys allow direct control of video and audio RF levels, modulation depth, frequency deviation, and input switching. An RS-485 interface allows remote control of the unit.

### Maximum Flexibility

PULSAR operates with 110 Vac or -48 Vdc, making it compatible with both conventional CATV or Telco powering schemes. The modulators feature IF substitution and are compatible with all major scrambling techniques.

### Find Out More!

PULSAR gives CATV operators and Telcos an entirely new dimension in signal and service delivery. To find out why PULSAR will transform the future of headend modulators, call 770/590-7900.



- High RF Output Over the Entire Frequency Range
- White Limiter and Video AGC
- Auto Set-Up, Auto Alignment
- Complete Software Control for Monitoring and Backup
- Fixed Frequency and Tunable Versions
- 110 VAC and -48 VDC Powering
- Unique In-Channel Tilt Control

## BARCO

1000 Cobb Place Boulevard  
Kennesaw, GA 30144

Tel: 770/590-7900

Fax: 770/590-8836

Circle Reader Service No. 37



## ◆ INTERACTIVE ARCHITECTURE

This article suggests a concept for an interactive services architecture (ISA) that defines logical views to provide the needed definition and structure for complex interactive networks. Some examples of how the network and application functions may be broken down, assessed and managed accompany these logical views. From this effort, the reader can begin to see how broadband interactive network developers might bring some common structure and logical sense to the myriad technological advancements and complexities being created and brought to market.

The ISA will include definition of the "users" of this network, the resources available to them, classification of services, and the performance expected for a given level of service. Ultimately, the ISA should define and use a "network within the network" for each of the interactive services. It should make the broadband networks a viable reality by providing the performance necessary to make all the interactive services a true, personal experience.

### How can this be done?

One major goal of the ISA should be to support VOD at a minimum—and provide this

as a basic utility of other services. With the advent of digital video compression and evolution toward smaller service areas, the ISA must facilitate VOD capacities to satisfy virtually any demand success scenario.<sup>1</sup>

The development of the ISA must also support the challenges of today's cable industry as it deploys broadband interactive networks.

These are:

- ✓ interconnection of headends
- ✓ standard interfaces to switching systems
- ✓ interconnection between various servers
- ✓ preparation for becoming broadband network providers
- ✓ automated service provisioning and transaction billing.<sup>2</sup>

The ISA should also note the change in the way these new services are offered, operated and billed. These changes will occur over time, and will be based on the availability of the detailed, accurate connectivity, control and usage information. The ISA must enable billing systems to receive information based on any combination of subscription, time, per-use, resource usage and application activity. The availability of this information will fast become a requirement for the suc-

cess of many new services that require flexibility in specifying how they are offered and purchased.

The ISA can meet these goals by promoting the uniform use of the content and signaling bandwidth in the networks. This would include use of the available bandwidth for secondary on-line services such as initialization, PPV data collection and program guide download. It will be necessary to combine transport multiplexes and the distributed databases to uniformly address the available resources for all interactive services. Examples of these resources, which include performance parameters, are the bandwidth, datalink performance, database storage, database access time and latency. The ISA requirements for performance should prevent conditions such as set-top "boot up," because consumers simply will not tolerate latency.<sup>3</sup>

By creating a solid set of requirements on the available system resources, the ISA could prevent inconsistent use of the network by various applications to avoid performance and capacity problems. As the requirements address the resource-related performance parameters, the ISA can address two main figures of merit: network efficiency based on how much network capacity is devoted to data transmission; and access efficiency, or the time between the queuing and the transmission of a packet. These requirements will enable the ISA to meet its goals through:

- ✓ optimizing network performance
- ✓ enabling incremental investments toward expanded or additional services
- ✓ providing an end-to-end solution that is not optimized strictly toward a specific service or application.<sup>4</sup>

While meeting these goals, the ISA must have direct implication into broad design issues, such as provision of the digital broadband services themselves. Further out, it should have the ability to provide dynamic connectivity between servers and fiber nodes to match traffic and service demand patterns. Applications such as movies-on-demand may require support of a variety of data rates to allow different types of source material, encoded at different rates, to achieve a consistent level of subjective video quality. Furthermore, the parameters of communications sessions must be dynamically adjustable, so that the shared digital bandwidth used for point-to-point services can be allocated to various types of services as needed.<sup>5</sup>

Included in the interconnection requirements, the ISA must support standard interfaces and configurations that will interface to an ATM switch, a Sonet backbone or other

# QINTAR®

Quality



1 GHz splitters



1 GHz taps



1 GHz 2-way amps



1 GHz A/B switches

In stock • Low cost • 5 year warranty

Qintar, Inc. • 700 Jefferson Ave.  
Ashland, OR 97520-3703 • U.S.A.

Ph. (503) 488-5500 • Fax (503) 488-5567

# Introducing Zenith MultiMedia. Power your way to new cable revenues. Today.



Zenith Network Systems has developed the first real-time, two-way interactive analog system that offers you nearly every revenue-generating service associated with digital.

And, since it's analog, you can install it at a fraction of the cost.

What's more, it's technology that's here, technology you understand, technology that's ready to install. Today.

## The MM2500™ Set-Top

Our MM2500 set-top is an addressable, broadband, stereo-compatible unit that offers you two distinct advantages.

It is the only fully-downloadable, software-driven set-top, so you get full, diverse control from the headend.

And the MM2500 set-top is the only analog unit that supports revenue-generating real-time, two-way interactive services...the unregulated sources of revenue so essential to your growth and survival in today's competitive environment.



## The ScreenPlay™ Authoring Tool

The ScreenPlay Authoring Tool is an easy-to-learn, easy-to-use Windows™ based system that lets



you creatively customize on-screen displays downloaded to the MM2500 set-top.

It comes with a wide variety of characters and other graphic devices built-in, while allowing you to scan in virtually any graphic you might choose.

## Real Revenues Today. And Tomorrow.

While getting ready for the digital future, the MM2500 set-top can begin to generate new sources of real revenues today.

- Expanded promotion of PPV
- Interactive program guides
- Bulletin boards and messaging
- Interactive shopping and games
- New advertising options
- Near video-on-demand

Equally important, the MM2500 set-top can be a pathway for you — and your customers — to the digital future.

## Plug In To The Power.™

New technologies make way for new ways of making profits. And leading the way in technological advancements is, of course, something Zenith has been doing for over 75 years — another reason to plug in to the power of Zenith.

To learn more and to receive our free information kit, just call us today at 1-800-239-0900.



Circle Reader Service No. 39

## ◆ INTERACTIVE ARCHITECTURE

network configuration.

Before finalizing all this, the individual operators—the ones who actually assign the specific channels to various services and the service mix—must help decide which paths the operations data will take. This will permit them to offer multiple services and assure proper allocation of resources for such services.

### External factors

The ISA, as currently imagined, would be a manifestation of existing industry standards, emerging requirements for open systems and interoperability, and the need for logical management of a complex network. The ISA would enhance the network platform by throttling the use of various services on the network to the point each individual service and its transactions are met with the same performance and integrity as any other. This could only be accomplished if applications and services developed for the network are definable relative to the resource burden they can potentially place on the network.

This definition, which can be structured by actually classifying services, can help predict

how network resources will be affected. This can provide application developers with a modeling tool that will enable them to develop their applications to fit a specific classification, and optimize its performance relative to the allocated network resources.

There are several levels of service and application which could be defined, and which service classifications may be included in their structure. Starting with the type of service it represents, this categorization would arrange the services relative to whether they are communication-based (i.e., point-to-point), data download, or transaction-based. This level of scrutiny is important because the operator needs to know if a service generates bursty or consistent traffic on the network. An example of this categorization would be as follows<sup>6</sup>:

- ✓ Entertainment, including broadcast TV, pay-per-event, VOD, video games, program guides, NVOD and interactive TV.
- ✓ Education, including interactive training and distance learning.
- ✓ Public Network Communications, including IXC access, Internet WWW, LEC/CAP phone service and videophone/teleconferencing.

- ✓ Transactions and information, including home shopping, travel reservations, bulletin board access, banking, yellow pages and advertising.
- ✓ Private network communications, such as remote access to office LANs, FX to PABX, group work and telemedicine.
- ✓ Building automation, including security monitoring, automatic meter reading and energy management.

The category attribute could be used in conjunction with the actual service type definition, which could be defined as either data broadcast, data-on-demand or video- and data-on-demand.

This level of definition will help determine whether the traffic generated is broadcast to multiple end points (set-tops), and whether it must be simultaneously or even program synchronous. As the definition is studied in more detail, the implementation of the applications transfer of video or data will be an important factor to its classification.

Examples of this next level of definition are store and forward, message-oriented immediate, or connection-oriented immediate.

To be complete, the classification must include the type of media that a service can require to be transferred. This media definition should be broken down as far as possible, to optimize network performance. The appropriate and minimal bandwidth can then be allocated for the appropriate media. Examples of these are:

- ✓ Voice
- ✓ Music/sound
- ✓ Line drawings/artwork
- ✓ Still pictures
- ✓ Motion video
- ✓ Text.

The realm of applications and services to be classified must include commercial insertion subsystems and addressable commercial insertion.<sup>7</sup> This consideration protects hidden resource burdens such as operations that require data return to the servers for detection of cue tone, confirmation and flow control information that regulates the rate at which the server sends out the data.

### Resources, resources, resources

The performance guarantee can only be provided through diligent definition of resources, and judicious use of them. The ISA should provide a set of constructs that will be used to define the network, its performance and its attributes.

Primarily, the ISA should provide element definition for variable bandwidth for content and interactive signaling, and definition of

**PEAK PERFORMANCE.**

**Belden®  
Drop Cable.**  
**The Clearest Signals  
In Cable TV.**

Only Belden's unmatched shielding capability provides the signal integrity needed for the clearest pictures. An only our sweep tests are guaranteed at 1 GHz with 20 dB SRL – the lowest values published.

Demand Belden – The Drop Cable Specialist. For more information call:  
**1-800-BELDEN-4**

**20dB**

**Belden**

© Copyright 1994, Belden Inc.

Circle Reader Service No. 40



# Making The Right Connections. . . . . .Sending Strong, Clear Signals

## RMS Quality ✓

Simply put, RMS products last longer and perform better. We're committed to delivering unsurpassed product excellence to our global network.

## RMS Pricing ✓

Our ability to compete and win in world markets is based upon sharp pricing and our creative promotions.

## RMS Experience ✓

Our appetite for learning and our desire to serve has not diminished over the past 50 years. We're happy to share information with our customers.

## Quality CATV Products

- Taps ■ Splitters ■ Filters ■ Connectors ■ Couplers
- Standby Power Supplies ■ Headend Equipment
- Transformers ■ Security Products ■ Pedestals
- Coaxial Cable ■ Installation Supplies
- Regulated Power Supplies



5500 SERIES  
DIRECTIONAL TAPS

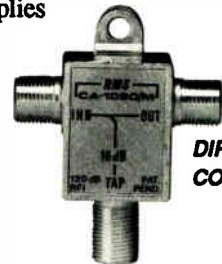

DIRECTIONAL  
COUPLERS



16 WAY SPLITTERS

Circle Reader Service No. 41



Call Or  
Write Today  
For Our  
New Catalog

International  
Distributor  
Inquiries  
Are Welcome

United Kingdom  
RMS, U.K.  
Phone: (0256) 881-525  
FAX: (0256) 882-8666

Switzerland  
Erivision  
Phone: 062/71 11 34  
FAX: 062/71 48 19

Argentina  
Super Cable S.R.L.  
Phone: (541) 433-2427  
FAX: (541) 433-0297

Israel  
Rotal Telecommunication  
Phone: +972 3 5569480/1/2/3  
FAX: +972 3 5569484

Rumania  
TVS Holding  
Phone/FAX: 40-991-35319

**RMS ELECTRONICS, INC., 41-51 Hartz Way, Secaucus, NJ 07094**  
Phone: (201) 601-9191 FAX: (201) 601-0011 Toll Free: (800) 223-8312

## Make Your Quality Cable Connection With Pirelli.

As an ISO 9001 registered company, Pirelli manufactures a full range of fiber optic cables for the cable television industry. Make your quality cable connection by calling these Pirelli representatives:

**Communications Supply Group**  
680 Industrial Cir S  
Shakopee MN 55379  
1-800-451-9032 · FAX 612-445-8423  
CO, IA, MN, ND, NE, NM, SD, WI, WY

**dB Communications**  
4007 Skippack Pike  
PO Box 1268  
Skippack PA 19474  
1-800-526-2332 · FAX 610-584-7875  
CT, DE, MA, MD, ME, NH, NJ,  
NY, PA, RI, VA, VT, WV

**B.E. Duval Company**  
347 W 6th St  
PO Box 5255  
San Pedro CA 90733  
310-833-0951 · FAX 310-832-9970  
AZ, CA, HI, NV

**Glade Communication Equipment Company**  
2691 151st Place NE  
Redmond WA 98052  
1-800-347-0048 · FAX 206-869-4119  
AK, ID, MT, OR, UT, WA

**MicroSat**  
4343 Shallowford Rd Ste F3  
Marietta GA 30062  
1-800-438-0812 · FAX 404-643-0899  
AL, AR, FL, GA, KS, LA, MS, NC, OK,  
SC, TN, TX

**W. Whitaker & Associates**  
120 Professional Park Ste 1  
PO Box 6327  
Lafayette IN 47903  
1-800-433-8775 · FAX 317-447-5064  
IL, IN, KY, MI, MO, OH

**PIRELLI**  
FIBER OPTIC CABLES

1-800-669-0808 · 803-951-4800

## ◆ INTERACTIVE ARCHITECTURE

fixed latency. Secondly, the resource definition should include parameters that affect performance, such as capacity, latency and cost. By understanding what each application (or service class) requires of the network, and what flexibility it has in operating the network, the ISA configuration can optimize network configurations. The ISA will enable the network capability and performance to be defined because each element in the network will be identified relative to the resources it provides. By defining the individual transport multiplexes, the ISA can define the specific bandwidth allocated for video, data and signaling associated with a specific service classification.

Through this definition of available resources, the requirements of the applications and the level of interactivity required, the ISA will provide a model to promote compatibility of interactive services over different types of network configurations. The ISA should even define an open system standard and suggest others to promote for a maximum interoperability scenario. The interoperability efforts will include promotion of standard interfaces for the content providers (VIPs), operators, the WAN interface and the application interface at the set-top. Standards could also facilitate headend interconnection, which might include a standard service layer interface, server interconnection and service provisioning and transaction billing automation mechanisms.

Control functions must also be supported, which requires access to, and interaction with, networks, databases and other processors external to the network, including those located in regional or national distribution centers. The real-time access will include actions not communicated by the subscriber, such as access control, security, metering and billing. For example, a video server may need to give a set-top unit permission and access codes to decrypt a movie or ask it to tune to a new digital channel for a different type of service.

### A configurable aspect of the network

A server may also need to access external databases or service bureaus to verify a credit card number or determine whether a particular type of merchandise is in stock and available for immediate shipping. The implications of all the real-time and interactive service activities cross all aspects of the network, and must include actions taken by the application, as well as the content of the real-time signaling and the control messages sent to the subscriber.

The service providers, operators and application developers will all have to be supported

in their drive toward interactive services with networks designed to deploy mass amounts of content and interactive signaling without bogging down the user or service provider with network idiosyncrasies or delays. The infrastructure and performance of the architecture can be made transparent, if modeled properly.

The modeling of the network, and its build-out, must be based on key components of the network. This could be accomplished through definition of operative points that are key to the access and use of the system resources or service facility. Examples of these components are:

- ✓ Provision for flexible resources (i.e. bandwidth) that can be provided dynamically and in real-time
- ✓ Common application interfaces at the service provider, the local server, and at the set-top/network demarcation
- ✓ Service classification and resource allocation budgets
- ✓ Service mix/network modeling techniques for network design and performance guarantee (i.e. latencies).

These key components can be maintained and optimized by deriving configuration and build-out tables for a network and its associated service model and taking into consideration take rates vs. load balancing for the network. The rules-based table will use the performance guarantee as the threshold for addition of resources via components in the network, and will make extendible use of TDMA and other dynamic bandwidth mechanisms to provide adequate resources. Once saturation is reached, the ISA build-out will use space division multiplexing and frequency division multiplexing to provide a logical path to maintain the performance guarantee, all based on the number of subscribers on the network and the service mix offered.

The ISA must take into consideration the migratory aspects of the subscribers and interactive services. For example, as next-generation analog set-tops roll out, interactive services (more than just enhanced program guides) will be tested on significant numbers of subscribers for the first time. These set-tops will provide new ways of using the VBI for data transport, as well as out-of-band (OOB) channels that facilitate more interactive applications and the flexibility to download more information than previously available. And the new set-tops will also facilitate a two-way, real-time OOB channel for interactive services. The platforms provided by the interactive analog networks will invoke special forms of interactive services tailored to these networks, with initial focus on broadcasting



# Our Inserters have a head start, before they get to your headend.



Testing our systems is something we take very seriously at SDI. That's why every StarNet Digital Inserter runs and verifies thousands of spots—before they're shipped. Our quality control department loads each system with commercials and connects it to the live tone feed. And the

testing is not done until the system verifies insertions at over 99% accuracy.

We think our testing and quality control is the best in the industry. If you don't believe us, just ask our customers. With over 35 systems installed, SDI is a leader in the digital insertion market.



404 W. Ironwood Drive, Salt Lake City, UT 84115  
(801) 464-1600 · Fax (801) 464-1699

Circle Reader Service No. 43

## ◆ INTERACTIVE ARCHITECTURE

applications to the set-tops.

The new digital networks will take the concepts and capabilities of interactive services to levels beyond those of the analog networks because compression technology will enable advances in bandwidth utilization to overcome analog network bandwidth constraints. The new digital networks and high-end digital set-tops will also offer advanced processing, higher quality graphics, significant application memory (4 to 6 megabits) and a dedicated real-time OS. These platform advancements, in conjunction with an all digital network which is optimized for support of interactive services, will lead to more complex applications development. The ISA must evolve with these technologies and constraints.

### The need for documentation

Once the network resource definition is complete, a user's guide for various network topologies and technologies can be provided by the network vendors that uniformly describes network resources, regardless of the vendor used.

The Application Developers Manual will

enable such developers to understand the network capabilities and the resources and performance available for each of the application classifications. Application developers can then make note of network features which are different across vendors and make those parts of their applications modular and portable. The operators can also gain a comfort level from the use of these manuals, in that they can be sure that the network is being used correctly and uniformly across the available services and applications.

### In conclusion

The ISA is proposed as a logical concept and structure that can be nurtured and collectively developed to bring consistency in the development, operation, use and enhancement of broadband networks. The benefits of collectively defining and using the ISA could enable these networks to become more viable because of portability of services, and to maintain a layer for the growth of future applications and services. This type of infrastructure could also provide a means for facilitating undefined service technologies. **CED**

### References

1. D.E. Robinson, "Video-on-Demand: The Cable Advantage," Jerrold Communications.
2. R. Hajbandeh, Ph.D., "Multimedia Services Through CATV and Telco Networks," TDS Telecom.
3. D.M. Moloney, "In-Home Intelligence For Interactivity," General Instrument Corp.
4. R. Safadi, "An Optimal Approach To A Full-Service Broadband Communications Network," General Instrument Corp.
5. H.J. Kafka, "Video Servers—Moving Trials to the Interactive Mainstream," AT&T Bell Laboratories.
6. S. Lipoff, "Multimedia Applications and their Bandwidth Needs," Arthur D. Little, SCTE 1995 Conference on Emerging Technologies.
7. J. Farmer, "Advertising Insertion: Analog vs. Digital Systems," Digital Video, a division of Antec.
8. J. Richardson, D. Williams, R. Adams, "Interoperability Requirements for Interactive Cable," Intel Corp., 1994 NCTA Technical Papers.

# Work Ready TELSTA A-28 LIFTS . . . In Stock and . . .

## READY—to

# ROLL



- One phone call does it all.
- TELSTA A-28's equipped for cable Construction and Maintenance.
- Your choice of utility body or van mounted.
- Factory direct pricing. No dealers, no third party, no hassle.
- Super lease deals available.
- Backed by the best warranty and service program in the industry.

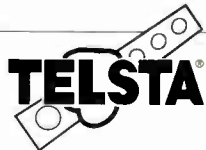

Mobile Tool International, Inc.  
5600 W. 88th Ave.  
Westminster, Colorado 80030  
Phone: (303) 427-3700

An Employee Owned Company

## Call — 303-657-2557 to start your TELSTA ROLLING

# CEB IS instrumental to me



**James A. Haag**  
**Access Network Architect**  
**Time Warner**  
**Communications**



**CEB**

THE PREMIER MAGAZINE OF BROADBAND COMMUNICATIONS

# Five ways to enhance the life of test gear

Simple tips for reducing downtime

By Michael McCaffery,  
President, CTV Inc.

**W**ith the rising cost and complexity of test equipment, don't you think it's worth a little extra effort to maintain your test gear?

You have confidence in your test equipment and the technicians who use it, but do you wonder why there is so much downtime due to equipment failure? Featured in the following article are five easy ways to enhance the life of your equipment and reduce possible downtime, as well as tips on how to find the right service facility.

## General maintenance

On all field portable battery operated equipment, the number-one failure is the battery. To get maximum use out of your equipment, taking care of your battery is crucial.

✓ When using nickel-cadmium batteries, i.e., field strength meters, run the battery down until the unit shuts down and recharge as soon as possible. Do not let it sit for more than four hours. With NiCd batteries, the sooner you get them on the charger, the better.

✓ For equipment using lead acid batteries, i.e., sweep receivers and analyzers, deep discharges cause more damage than anything else. When the unit shuts down, do not reuse it until the battery has been completely

recharged. Since most shut-down circuits monitor the battery voltage, they assume a fully charged battery is being used. Batteries recover voltage without recovering capacity. Recharging your battery every night should become standard practice.

✓ It is essential to keep display lenses and coverings free of scratches and nicks. Most lenses are hard coated, but can only withstand "normal" usage. I have seen equipment with severely scratched lenses used by technicians who think the equipment can "double" as a worktable (they place tools or beverages on the lens). This can lead to misinterpreted readings and eventual breakage.

✓ Typical portable test equipment is water "resistant." Ultraviolet rays, however, attack many of the plastic and rubber products used to resist water. To help prevent this, keep the

equipment out of direct sunlight when not in use. Close the lid (if provided) or store the unit in a truck or a shaded area whenever possible.

✓ The penetration of dirt into the seals is also a major concern. Keep the equipment as clean as possible.

After each day's use, carefully brush off the front panel area of the unit. If the area is muddy, use a wet cloth and wipe off the lens, then follow with

**Even with proper care, field test equipment, after all, is only machinery**

any type of window cleaner (do not apply directly onto the lens). This will keep dust and dirt from being forced into the seals.

General maintenance will not prevent all equipment failures, but it can eliminate some minor problems that could create major repairs and downtime. Your primary reason for owning test equipment is to help serve your customers. Keeping equipment in good repair not only makes your job easier, but helps save money, too.

## Shopping for a service facility

Even with proper care, field test equipment, after all, is only machinery. At some point in time, it will require service, whether it's just wear and tear, a scheduled calibration or a major repair. When looking for a repair facility, make sure that it provides "full service."

A full service facility should be able to repair and calibrate all equipment and be N.I.S.T. (National Institute of Standards & Technology) traceable. This ensures that your equipment is also N.I.S.T. traceable. Some manufacturers of test equipment do not authorize outside repair facilities to calibrate their test gear. This should not "force" you to their service center. There are



Keeping test gear in good repair makes your job easier and saves money, too.

# Cable Professionals Only:

## Leader Makes Your Wish List A Reality

### Spectrum Analyzer

Covers 5 to 1030 MHz from narrow bandwidth to full span. A variable marker indicates digital readout of designated frequency and level.



### Multi-Channel Display

Auto Channel Search sets up to 128 channel bargraphs. A variable marker has digital readouts of designated channel, frequency and level.



### Single Channel Display

Digital readouts include CH number, visual or sound carrier, assigned frequency, signal level and dual analog bargraphs.



### C/N Measurement

Measures the RF carrier level to system noise ratio to 50 dB range.



### HUM Measurement

Verifies FCC POP does not exceed 3% p-p of visual signal level.



### FCC 24-Hour Tests

Unattended tests can be set for recall, measurement, data-logging and storage.



### Stability Mode

Measures the min/max visual signal level to insure it doesn't exceed the FCC limit.



- Digital AC/DC Voltmeter
- Visual to Sound Ratio
- Visual to NICAM Ratio
- Display on PC via RS-232C
- Printouts Graphic and/or List
- Speaker with Volume Control
- Field Replaceable F Connector
- 50 Customized Preset Program Memories
- 512 Data Memories Maximum
- EPROM lookup charts include Std HIS, Std EIA, HRC EIA and IRC EIA
- dBmV, dBmW, dBuV, dBuVEMF Eng Units
- Full Duplex Remote Control
- Peak or Average Detection and Max Hold Mode
- Switchable Backlight Display
- 12.5 and 25 kHz Offsets
- Sleep Modes

**NEW**

Cable TV  
Spectrum Meter  
Model 953

Optional Printer



Call toll-free

**1 800 645-5104**

In NY State

**516 231-6900**

**LEADER**  
FOR PROFESSIONALS WHO KNOW  
THE DIFFERENCE

Leader Instruments Corporation, 380 Oser Avenue, Hauppauge, New York 11788  
Regional Offices: Chicago, Dallas, Los Angeles, Atlanta. In Canada call Omnitronix Ltd., 416 828-6221

Give Leader Service No. 36

UNITED STATES TELEPHONE ASSOCIATION  
98<sup>th</sup> Annual Convention  
in **ORLANDO**



See you November 5-8 as we convene to explore “Dimensions of New Reality.” Members, associate members and interested professionals from all segments of the communications landscape are welcome! Special feature – a Wednesday morning combined general session with the start of the Convergence '95™ Conference.

Call the USTA Convention Office  
(202/326-7282) for additional information  
about special pricing for registrants of Convergence '95.

In conjunction with the  
Convergence Technology Conference

## BACK TO BASICS ♦

many repair facilities that provide "equal or better" service, lower cost and less downtime than the original manufacturer.

The most important criteria to be aware of when selecting a service facility are: environmental testing (be sure your equipment is tested and calibrated at the maximum and minimum temperature specs), turn-around time, customer support, cost and warranty.

Environmental testing consists of heat soaking for 60 minutes at a high end temperature, followed by cold soaking for 60 minutes at a low end temperature. Environmental testing enables the technician to locate any components on the verge of failure and ensures proper operation of the unit through extreme temperature changes.

Past experience in manufacturing and servicing portable test equipment used in temperature extremes has shown that most failures occur in the worst weather, at the most inconvenient time. Environmental testing has proven effective in ensuring the equipment is ready for any condition.

A reasonable turnaround time is crucial. The facility should be flexible in meeting your needs. If you require immediate service, can they accommodate you? If your equipment is out of circulation for any extended period of time, you lose money, and possibly customers.

Turnaround times may vary due to different factors. If your equipment has an intermittent problem, it may take some time before the source of the problem can be pinpointed. Availability of replacement parts may also cause a

delay in the return of the equipment. Should this happen, that's where customer support becomes a crucial issue. The service facility should contact you immediately with any unforeseen problems so you can adjust your schedule or make arrangements to fulfill your customers' needs.

On the other hand, if the equipment only needs calibration and does not require any repair, the return time should be minimal (one week or less).

Cost may be a deciding factor in the service facility that you choose. Some facilities do complete module replacement, as opposed to component-level repair. This can get very expensive—not only will you be charged for these parts, but you may also be paying for parts that are often repairable. Look for a company that charges a flat fee for the service you need.

Does the service facility offer you any type of warranty on the completed work? If not, look for someone who offers warranty on parts and labor.

Remember, when looking for a service facility, to check out their testing procedures.

Make sure you have a contact person who will answer any and all questions you may have. When you call for any reason, you should be able to speak to a "live person." And don't forget turnaround time. Do not settle for second-rate service. If the service facility you use now cannot or will not accommodate all of the criteria, find another service facility! Even if the new facility is not the least expensive, if you feel confident that it will give you the best service, then your money will be well spent. **CED**

**Look for a  
company that  
charges a  
flat fee for  
the service  
you need**

### OVERSTOCK SPECIALS

#### TAPs & DCs

Scientific Atlanta

	NEW	USED
DCs	\$18.50	\$8-\$12
2-Ways	CALL	\$8-\$12
3-Ways	\$22.50	\$8-\$12
Taps	CALL	\$3-\$10

#### TRAPs

Used Neg Ch 2,5,6,A	\$1.50	All Swept 100 Min
New Neg Ch C,E,G	\$2.50	100 Min
Tiering Trap Ch AB	\$2.85	NEW USED \$1.95

**800-331-5997**

### SUB-BAND

#### Modulators DeModulators

T-Channels, 4.5mhz & Agiles

**BT-2001 IRD'S**

**BT-6185 IRD'S**

Standard, Plus, VCRS or No Card Available

### BLONDER TONGUE

**800-331-5997**

### NEW COMMERCIAL

950-1450 mhz

#### Satellite Receiver

**\$249.00**

Crystal Synthesizer  
Narrow/Wide Band Audio  
3-Year Warranty

### BLONDER TONGUE

**800-331-5997**

**TULSAT**

**TULSAT**

**TULSAT**

Circle Reader Service No. 47

3 IN 1 REMOTES

**Creature Comforts**

**The ProMote III offers your subscribers a 3-in-1 that's exceptionally easy to use.**

**Creature Features Include:**

- Easy set-up for CATV, TV's and VCR's.
- Complete converter functions.
- LED identifies successful programming and operation
- Only requires 2-AAA batteries.

**Whatever kind of creature your subscriber is, the ProMote 3-in-1 will make watching TV comfortable.**

**ABC**  
CABLE PRODUCTS INC.  
800-777-2259

Circle Product Reference No. 102

CATV TRAPS

**EAGLE**  
COMTRONICS INC.

.....AVAILABLE.....

## 1 GHz NEGATIVE and POSITIVE TRAPS

**FEATURES:**

- For systems which may go to 1GHz in the future
- Higher channel capability
- Improved L.A.S. characteristics
- Temperature stable

**EAGLE COMTRONICS INC.**

4562 Waterhouse Road, Clay, New York 13041  
(315) 622-3402 (800) 448-7474  
Telex #937361 Fax#(315) 622-3800

Circle Product Reference No. 103

ANTENNAS

**Downlink High Quality and Low Prices with DH Satellite's Complete Line of Antenna's and Mounts.**

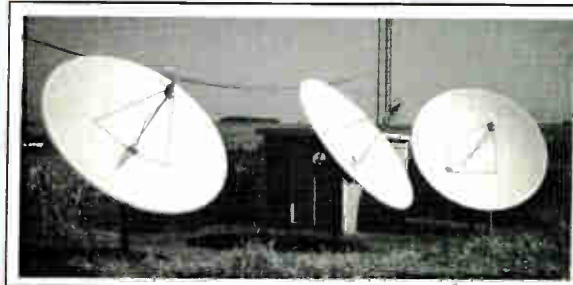

The DH 3.7m Spun Aluminum one piece antenna gives you high performance gain, easy assembly with outstanding stability and delivery to your installation site.

**CALL FOR PRICING  
OR NEAREST DIST.**

**(800) 627-9443**

**DH Satellite**

600 N. Marquette Rd.  
Prairie du Chien, WI USA 53821

**Phone (608) 326-8406**

**Fax (608) 326-4233**



Circle Product Reference No. 101

DESIGN & DRAFTING

**Program Manager**

File Options Window Help

**Lode Data Drafting and Design**

**Lode for Windows.**

The most popular broadband engineering software is now available for:

Windows, 3.1x  
Windows, NT  
Windows, '95

**New Drafting Assistant Import Features:**

- ▷ EOL signals
- ▷ Power supplies
- ▷ Device-to-device footages
- ▷ Housing and self terminators

Call now for details!

All versions are available to current customers for immediate download on the Lode Data BBS

**Lode Data Corporation**  
7120 E. Hampden Avenue  
Denver, CO 80224  
Tel: (303)759-0100 Fax: (303)759-0214

Circle Product Reference No. 103



# QUALITY FIBER OPTIC ASSEMBLIES

SINGLEMODE/MULTIMODE

- PC/APC >65 dB
- FDDI
- ESCON
- SMA
- BICONIC
- FC
- SC
- ST

MULTI-FIBER DESIGN/TERMINATION

## SAME DAY DELIVERY

Custom designed fiber optic cables for CATV, Telecomm and Datacomm applications.

**ARIA** TECHNOLOGIES, INC.

5309 Randall Place  
Fremont, CA 94538

Ph: 510-226-6222 Fax: 510-226-6242

Circle Reader Service No. 104

How many times in life do you have a chance to get it right the *first* time?

Not many, when you consider the odds. So today we want to be sure you don't make a poor choice that will haunt you for the next 10 years.

Soon, you may be having to select power supplies for your system. Like many others, you are caught in the dilemma of which way your system is going to go over the next several years. Why not choose power supplies that leave all options open with the simple switching of a tap? The PERFORMANCE retrofit *Flexi-Power*™ allows you the choice of three separate voltages from one power supply. Select either 60V, 72V or 90V RMS, whatever suits your needs. Both ferro & inverter versions are now available.

CALL JUD WILLIAMS AT 800-279-6330

(INTERNET) jud.williams@industry.net

*Performance* CABLE TV PRODUCTS

P.O. BOX 947, ROSWELL, GA 30077

AN EDWIN-ROSS COMMUNICATIONS COMPANY

Circle Reader Service No. 105

## Tricorder III: Trunk Meter Capability

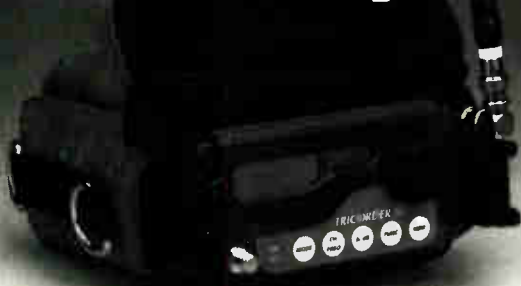

### Distribution Meter Price

**T**he newest member in the popular Tricorder family, the Tricorder III measures signal levels, carrier-to-noise and hum, and monitors leakage - all of the tests needed to maintain a CATV trunk or active distribution system. A new bag-mounted antenna offers as much as four times the leakage sensitivity as earlier Tricorders. You can even option up to calibrated leakage measurement with our new CLI option pack.

Trilithic  
9202 East 33rd Street  
Indianapolis, In 46236  
800/344-2412  
Fax 317/895-3613



Circle Reader Service No. 106

## Tempo Beats the Competition Three Tones to One!



MADE IN USA

The TR-3 multi-tone generator delivers three distinct tones all at the same time from a single unit. Tempo's TR-3 multi-toner saves you time and money by combining three tone generators into one! The TR-3 also includes the standard features of the average single-tone generator. Optional TR-3 adapter allows multiple test connection combinations. For additional information call your local distributor or Tempo Research at (800) 642-2155.



Also available: TR-4 for RJ45 & Data applications

1221 Liberty Way • Vista, CA 92083 • (619) 598-8900 • Fax (619) 598-5634

Circle Reader Service No. 107

# Bellcore delves into HFC amid support for FITL

## Juggling topologies

By Fred Dawson,  
Contributing Editor

**B**ell Communications Research, in an effort to expand understanding of hybrid fiber/coaxial network technology, is generating data which appears to underscore long-standing in-house preferences for more traditional telephone industry topologies.

The RBOC-owned organization, now in limbo as the Bell companies decide how to go about finding its new owners, has added a wide range of programs devoted to testing and developing specifications for HFC, responding in part to telco interest in the technology, and in part to a perceived opportunity to broaden its customer base in the cable industry. But, despite confirmation of many claims made by manufacturers for the flexibility and expandability of HFC, leading staff members remain ambivalent about the

long-term advantages of the cable-derived network owing to the noise sensitivities of digital modulation techniques, ingress in sub-band upstream communications and the vulnerability of system electronics to power surges.

"Not all the problems are obvious, and we're certainly not the only ones pointing them out," said Paul Shumate, executive director for broad-

band local access and premises networks, who served as guide to CED representatives in a recent tour of three Bellcore sites in New Jersey. "For example, CableLabs discovered things nobody realized about coax," he said. "It turns out the least little imperfection in the electronic components generates impulse noise. This hasn't been a problem in the downstream, where the frequencies are relatively noise-free, but it is a serious phenomenon in terms of impact on the upstream signal."

There are problems for downstream digital signals as well. In one of several labs devoted to testing HFC, Tom Chapuran, a staff technician, offered demonstrations of the impact of microreflections on downstream signals, showing how failure to use 75 ohm terminators at end points in household wiring can defeat digital sig-

nals. For example, in one instance the reflected impulse from a wall-plate terminated branch of coax knocked out a 16 QAM-modulated digital signal delivered in the downstream channel at 180 MHz.

"It's ridiculous not to sell 75 ohm terminators as part of a multiport device," Shumate said. "It wasn't seen as sufficiently important in the analog environment to require it, but, with digital, it's a different story."

All the problems shown in the demonstration could be cured through adaptive equalization, Chapuran said. But at 64 and 256 QAM, the problems are more acute, and the going also gets tougher in the upstream environment, he noted. "You can't solve all the possible problems with electronics," he commented.

Adaptive equalization also carries a price beyond basic costs, Chapuran noted. "The equalization changes at different frequencies," he said. "It can take time to acquire the equalization state when you're switching channels, which can be frustrating to the viewer."

It's too early to say what the typical range of premise wiring conditions is, or what their impacts are on the various approaches to distributing signals in the home, Chapuran added. "That's what we're finding out here," he said.

In all their testing, officials were cautious when it came to generalizing about real-world conditions, saying that much data remains to be collected before a full range of specifications and recommendations can be developed.

But the yellow flag is up, even when it comes to using coax at the end of fiber-to-the-curb networks.

"As soon as you put coax in for broadband distribution, even at a curbside ONU (optical network unit), you have new concerns about reliability," Shumate said.

Bellcore is looking at a variety of alternatives to coax drops in the star/star fiber environment, including twisted pair copper, fiber and wireless. Its longest experience, of course, is with twisted pair, and here, the findings continue to support the long-held Bellcore thesis that there is much still to be mined from the telcos' copper plant, though maybe not as much as some telcos would like.

"We believe ADSL (asymmetrical digital subscriber line) is much more amenable to interactive services than HFC," said David Waring, director of business development. ADSL, which originated several years ago at Bellcore, delivers video and data at up to 8 megabits per second in the downstream, together with bi-directional ISDN (integrated services digital network) and POTS (plain old telephone service) over standard telephone lines.

A lot of testing now is focused on the technical variant of ADSL known as VDSL or BDSL (very high speed or broadband digital subscriber line), which uses similar but lower-level modulation techniques, such as 16 QAM versus 64 QAM, to generate much higher bit rates over shorter strands of distribution copper. The technology, supporting broadband digital service distribution to approximately 24 single dwelling households

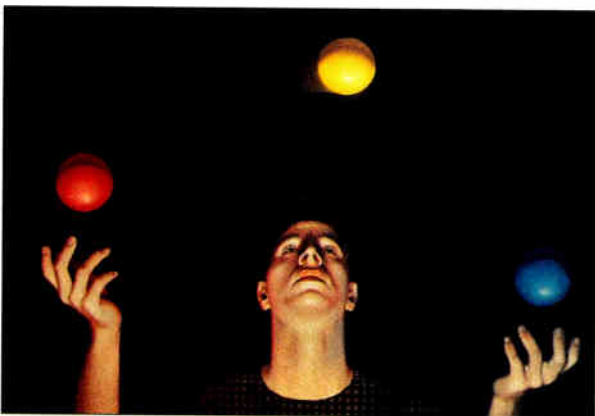

PHOTO: JAMES TENNISON/THE IMAGE BANK

# How to fit Dallas, Texas into a six-foot space.



## Introducing Diamond Transport™ - The Most Space Efficient Universal HFC System Available, Featuring Fan-Less Thermal Vent Design.



Imagine. With one 6-foot Diamond Transport™ system in your HFC network, you can reach up to 200,000 households, or the subscriber base of a city about the size of Dallas. Or Atlanta. Or San Francisco.

Diamond Transport™ features true universal shelving with front panel access that allows you to configure transmitters and receivers any way you choose, up to 91 transmitters per rack! Plus, Diamond Transport™ gives you the flexibility of pre-wired racking as an option and you choose the rack. You asked for better space efficiency, reliability and superior optical performance – so we gave it to you. Diamond Transport™. Now there are no limitations.

**For a complete capabilities portfolio on Diamond Transport™, contact your Philips representative today.**

Circle Reader Service No. 48



# PHILIPS

Philips Broadband Networks, Inc. 100 Fairgrounds Drive Manlius, NY (315) 682-9105, (800) 448-5171 FAX (315) 682-9006

from an ONU, vastly reduces the number of ONUs in the FTTC design while making use of existing distribution plant.

But there's a potential problem which Bellcore officials decline to be very specific about. Known as "far end crosstalk" or "FEXT," the interference occurs across lines over the first 100 feet or so in the transmission path when too many VDSL transmitters are put together in a single bank at the ONU. There are

three ways to solve the problem, said Craig Valenti, another technical staff member: shorten the range, which can cut the number of households served per ONU by a substantial margin; use coax or shielded twisted pair at the drop end, which keeps the signal-to-noise ratio up by reducing attenuation, or "shape" the spectrum using discrete multitone or wavelet modulation.

Valenti declined to discuss details of perfor-

mance of VDSL, including what the distance limits are for 24 gauge shielded twisted pair at 51 megabits per second, which is the ATM-compatible speed many telco engineers appear to favor. But with regard to the impact of FEXT on overall advantages of VDSL, he said, "It could be serious."

The upshot of the findings concerning use of coax or copper at the end of fiber links, whether in FTTC or HFC constructs, is that Bellcore experts continue to see fiber to the home as a desirable option, especially if the cost curve continues to fall relative to the other options.

"When we looked at FTTH costs a couple of years ago with respect to conformity to our TR 909 (fiber in the loop) specifications, we found a difference of \$330 per household over FTTC for narrowband, and about \$500 for broadband," Shumate said. "Today, there's been so much progress in loop lasers and other areas that the difference now looks more like \$460 for broadband and \$220 for narrowband."

On further investigation, factoring in life cycle costs, the cost difference virtually disappears, Shumate added. For example, by moving the powering to the customer premises with backup power supplied by batteries, the FTTH life cycle savings is about \$200 per household, he said.

"Maintenance and provisioning savings on metallic drops add another \$200 savings over the 20-year lifespan," he noted. "The result is, there's really not much difference now, and the numbers will only get better going forward."

Chinlon Lin, director of broadband light-wave systems research, made a similar point. "When you look at the delays that have pushed deployment back by at least a year and take into account the progress on FTTH, it starts to look very good for FTTH," he said.

Meanwhile, FTTC is clearly back in the ascendancy, albeit with a delay tied to unresolved technical issues and uncertainties about broadband. With Bell Atlantic, Southwestern Bell, BellSouth, Nynex and US West signaling their preferences for FTTC, the question suppliers and engineers face is whether this position will hold before deployment begins in earnest, or whether, once again, there will be a massive shift in telco agendas.

If FTTC stays strong, and a lot will depend on the powering issue (see sidebar), the telcos' evolutionary path to FTTH would be strengthened.

"Stay tuned," Shumate said. "There's still a lot to learn."

## CommScope GI General Instrument

CommScope, the world's leading coaxial cable manufacturer, is pleased to present a three day training experience—entitled

### "Introduction to CATV and Broadband Technologies"

This educational opportunity is scheduled to be held from October 17 - 19, 1995 in Charlotte, North Carolina. The course consists of two days of classroom style hands-on training and a one day plant tour of our manufacturing facility, located in beautiful Catawba, NC. You will have the opportunity to connectorize various trunk, distribution and drop products and also see our manufacturing process for both coax and fiber optic cables.

**Hurry, don't miss this opportunity!** There is limited seating. All registrations should be received by October 6, 1995. To receive more information, please contact Susan McAlister at (800) 982-1708.

# Bellcore makes headway on powering for FITL

Concern over the downsides of HFC amid the improving cost parameters for FTTH may lead to greater telco interest in all-optical networks, but first the carriers must solve the powering problem.

While the issue has slowed FTTC deployment, it appears to be more nettlesome for FTTH. In FTTC networks, as opposed to FTTH, power design alternatives to trenching copper with fiber, such as coaxial-delivered AC or DC to ONUs (optical network units), represent options that maintain the telco tradition of powering the premises telephone.

For FTTH, the obvious alternative to running copper with fiber everywhere is customer-supplied power backed up by network-supplied batteries. Tough as this might be to accept, given the many drawbacks associated with today's battery technology, Bellcore and others are working on ways to make backup support for lifeline service more palatable.

One approach now under manufacturing development in Henderson, Nev., Madison, Wis., and four other places is the lithium manganese battery technology developed and licensed by Bellcore for use in many markets, including laptop PCs and other consumer devices. "We think this technology will dominate the laptop computer battery market," said Frough Shokoohi, a Bellcore specialist in solid state chemistry research.

Shokoohi said network backup power is another potential application for the malleable, cloth-like battery material, which can be folded into compact packaging without losing its current-generating capacity. The technology meets telco needs for long-life rechargeable batteries in non-temperature controlled housings, she said, noting that the lithium manganese batteries have two-and-a-half times the longevity of nickel cadmium, and 12 times that of lead acid batteries, while generating nearly twice the energy per kilogram of nickel cadmium, and three times that of lead acid.

"We think it is the lowest cost alternative as well," she said.

Whether such performance capabilities, due in the marketplace from Bellcore-licensed manufacturers within two years, will overcome telco resistance to maintaining batteries in non-network powered FTTH systems remains to be seen. But Bellcore technical directors Paul Shumate and Chinlon Lin believe the benefits of eliminating metallic lines from the network could prove persuasive once new backup power options become available.

Meanwhile, the issue for telcos remains

whether to implement broadband via HFC or via FTTC, and, here again, powering the network is a critical issue. If FTTC can't be powered to everyone's satisfaction, the platform for evolving to FTTH won't be implemented, which would strengthen the HFC option.

Coax has emerged as a strong contender for

powering optical network units in FTTC systems. This evolutionary path eliminates the need to trench twisted pair copper in FTTC networks for powering purposes while supplying a pipeline over which to deliver analog TV signals during the transition to digital media.

"Coax offers an elegant powering solution,



## An NCTI Certificate of Graduation

is recognized throughout the industry as a solid indicator that your technical and non-technical employees have what it takes to excel in the rapidly changing CATV/broadband communications industry.



The most comprehensive cable training available anywhere!

Call, fax or write for your FREE NCTI Training Kit today.

CED 10/95



National Cable Television Institute  
801 W. Mineral Ave.  
Littleton, CO 80120-4501

(303) 797-9393 fax: (303) 797-9394

Circle Reader Service No. 50

**Telcos would have to add a lot of surge protection over what cable already uses in order to prevent ONU outages**

given its analog service transmission capability," Shumate said. "But it also serves as a conductor for power surges, which is the primary cause of amplifier outages." A Bellcore study of CATV networks found amplifiers go out for an average of 25 minutes per unit each year, which means telcos would have to add a lot of surge protection over what the cable industry already uses in order to prevent ONU outages, Shumate noted.

One alternative for powering ONUs now under intensive study at Bellcore and BellSouth involves use of solar power panels. Bellcore has spearheaded solar powering of curbside ONUs in narrowband FTTC arrays at a variety of sites, including two pedestals operating commercially over BellSouth Telecommunications facilities in Charleston, S.C. for the past two years.

"Since we started, we've had only one power failure, and that was because of electronics in a line card rather than lack of sunlight," said Bryant Davis, digital electronics support specialist at BellSouth's regional office in Charleston. "I'd term the trial a success."

BellSouth, with the most aggressive fiber-to-the-curb (FTTC) deployment in the U.S., is looking for a way to avoid running copper lines in the trenches with fiber, Davis said. "We're looking at AC and DC distributed powering over twisted pair and coaxial as other options," he added, noting that BellSouth just began a year-long test of coaxial powering of FTTC in conjunction with extension of a cable TV overlay.

The two solar-powered ONUs are part of a 44-ONU network segment serving the Dunes West residential subdivision. The panels supply 840 volts of reserve power to a lead-acid battery at the pedestal. Sun power in the area is rated at about 425 watts per day per square foot.

Officials said an ONU uses about 3.4 watts on average, requiring about 81 watt hours per day, which means the stored power in the battery can last through 10 days without recharging from the sun. Bryant said the trial has access to backup power from the network in the event of an outage but that, in any widescale deployment, the ONUs would be completely solar dependent. **CED**

**Ad Index**

	<b>Reader Svc. #</b>	<b>Page #</b>
ADC Video Systems	5	10-11
Adelphia Cable Communications		34A
Alpha Technologies	8, 57	17, 9A
AM Communications	7	15
ANTEC		40A
Arrow Fastener	24	46
AT&T Network Systems	1	2, 3, 4
Barco	37	65
Belden	40	68
C-COR Electronics	25, 51, 64	47, 85, 31A
Cable Prep	32	59
Cable Security	60	17A
Century Communications		35A
Channell Commercial Corp.	23	45
Charter Communications		34A
Christy Concrete Products Inc.	29	53
Comm/Scope/G.I.	49, 56	82, 5A
Comsonics	26, 55	49, 7A
Continental Cablevision		34A
Corning	36	63
Cox Cable Communications		35A
Drake, R.L. Co.	31	55
Fibertron	18	38
General Instrument	27	51
Hewlett Packard	16, 59	33, 25A
JFW Industries	33	60
Jones Intercable		35A
Laser Precision Corp.	13	27
Leader Instruments	46	75
Lectro Products	61	20A-21A
Lenfest Group		35A
Lindsay Electronics	14	30
Line Ward Corp.		Card Insert
Microwave Filter	30	54
Mobile Tool Int'l Inc.	44	72
NCTA Engineering Committee		34A
NCTI	50	83
Noyes Fiber Systems	28	52
Objective Systems Integrators	19, 63	39, 27A
Philips Broadband	48	81
Pioneer New Media Tech., Inc.	17, 62	35, 23A
Pirelli Cables North America-Communications Division	42	70
Power Guard	9	19
Qintar	38	66
RMS Electronics	41	69
Sadlecio	35	62
Scientific-Atlanta	11	23, 15A
Sencore	2	6
Siecor	15	31
Sprint/North Supply	6	13
Standard Communications	4	9
Starnet Development	43	71
Superior Electronics	52, 65	109, 39A
Tektronix Inc.	12	25
Telesupply	53	110
Tellabs	58	10A-11A
Thomas & Betts	22	43
Times Fiber	21	41
Trilogy	3	7
Tulsat	20, 47	40, 77
Vela Research	34	61
Wavetek	10, 54, 45	21, 2A, 3A
Zenith Electronics Corp.	39	67

**Product Showcase**

ABC Cable Products	100	78
Aria Technologies	104	79

	<b>Reader Svc. #</b>	<b>Page #</b>
DH Satellite	101	78
Eagle Comtronics	102	78
Lode Data	103	78
Performance Cable TV Products	105	79
Tempo Research	107	79
Trilithic	106	79

**Literature Guide**

ABC Cable Products	167	92
ADC Telecommunications	152	90
ADC Video Systems	165	91
AEL Industries	188	94
ANTEC	129, 130, 131	87
ATx Telecom Systems	168	92
AXSYS	170	92
BARCO	181, 182	93
Budco	186	94
C-COR Electronics	123, 124	86
CUO, Inc.	175	93
Cable Leakage Technologies	164	91
Cable Prep	134	87
Cable Security	148	89
Cable Technologies	149, 150	89
Channell Master	169	92
Comm/Scope/G.I.	180	93
Comm/net Systems Inc.	172	92
Corning	132	87
CSG Systems	171	92
Drake, R.L. Co.	161, 162	91
EXFO	187	94
Fujitsu Network Trans. Sys. Inc.	189	94
GeoKlein Industries, Inc.	122	86
Harris Corp./Dracon Div.	142	88
Hennessy	176	93
Integral	185	94
Kennedy Construction	174	92
Lectro Products	173	92
Mega Hertz	179	93
Microwave Filter	183	94
Monroe Electronics	178	93
NCTI	139	88
Nortel	153	90
Noyes Fiber Systems	145	89
Panasonic	140	88
Performance Cable TV Products	128	87
Philips Broadband	127	87
Power Guard	147	89
Quality RF	166	91
Quazite	141	88
Raibow Satellite	163	91
The Remarkable Company	158	90
Ripley Company	138	88
RMS Electronics	133	87
Reliance Comm/Tec	156	90
Scientific-Atlanta	159	91
Sea Change Technology	190	94
Sprint North/Supply	146	89
Starnet Development	177	93
Sunset Enterprises	184	94
Superior Electronics Group, Inc.	125	86
Tech Electronics	121	86
TG Annlift	143	89
Tellabs	144	89
Time Mfg.	151	90
Trilithic	154	90
Triple Crown Electronics	155	90
Vela Research	126	86
Viewsonics	157	90
Wavetek	160	91
Zenith	135, 136, 137	88

## OCTOBER

## Trade shows

**3 Southeast Texas SCTE Chapter, Testing Session.** BCT/E and Installer Certification exams to be administered. Location: Houston, Texas. Call Richard Grahn (713) 579-6319 for more information.

**3-4 Introduction to Cable TV Passive Fiber Optic System Design.** Produced by Siecor Corp. Location: Keller, Texas. For more information, call Siecor at (800) 743-2671, ext. 5539 or 5560.

**3-5 Advanced Broadband Applications Engineering Training.** Produced by General Instrument. Location: Phoenix, Ariz. Call Lisa Nagel (215) 830-5678.

**3-6 7th Annual Digital Video Workshop.** Presented by the Electronic Industries Association with the participation of the Consumer Electronics Society of the IEEE. Location: The Philadelphia Marriott. Call Maxine Stone, EIA/CEG Engineering Department (703) 907-7660.

**5 Great Plains SCTE Chapter, Testing Session.** BCT/E and Installer Certification exams to be administered. Location: Bellevue, Neb. Call Randy Parker (402) 292-4049.

**5 Greater Chicago SCTE Chapter, Technical Seminar.** Topic: Signal Processing and Headends, with speakers TBA. Location: Ramada Inn, Palatine, Ill. Call Bill Cohn (800) 544-5368.

**7 Cactus SCTE Chapter, Technical Seminar.** Location: Dimension Cable Office, Phoenix, Ariz. Topic: Transportation Systems—Part 2, with Ron Hranac of Coaxial International. Call Harold Mackey (602) 352-5860, ext. 135.

## October

**10-12 Atlantic Cable Show.** SCTE-sponsored technical sessions. Location: Atlantic City Convention Center, Atlantic City, N.J. Call Atlantic Cable Show registration manager (609) 848-1000, ext. 213.

**10-12 Mid-America Cable Show.** Location: Overland Park International Trade Center, Overland Park, Kan. Call the Mid-America Cable TV Association at (913) 841-9241.

**9-10 Fundamentals of the Digital Network.** Produced by Nortel. Location: New York City. To sign up, call: (800) NT-TRAIN (select option 1).

**10-12 Philips Mobile Training '95.** Location: Washington, D.C. Call (800) 448-5171 to register by phone (800-522-7464 in New York State).

**10-12 Wheat State SCTE Chapter, Testing Session.** BCT/E certification exams to be administered. Location: Great Bend, Kan. Call Jim Fronk (316) 792-2574.

**11 Inland Empire SCTE Chapter, Testing Session.** BCT/E

and Installer Certification exams to be administered. Location: Moscow, Idaho. Call Roger Paul (509) 484-4931, ext. 230.

**11 Mid-South SCTE Chapter, Testing Session.** BCT/E and Installer Certification exams to be administered. Location: Time Warner office, Memphis, Tenn. Call Kathy Andrews (901) 365-1770, ext. 4110.

**12 Music City SCTE Chapter, Testing Session.** BCT/E exams to be administered. Location: Nashville, Tenn. Call Kenny Long (615) 244-7462, ext. 392.

**12 SCTE Satellite Tele-Seminar Program.** Topic: What's New with Safety in Telecommunications, from Expo '94 in St. Louis. To be transmitted on Galaxy 1R, Transponder 14, 2:30-3:30 p.m. eastern time. Call SCTE National Headquarters (610) 363-6888.

**15-19 NCF95/ProForums.** Produced by the International Engineering Consortium. Location: Hyatt Regency O'Hare, Chicago. Call IEC Customer Support Group (312) 938-3500.

**17-19 Digital Video and Fiber Optic Networking.** Produced by C-COR Electronics Inc. Location: State College, Pa. Call C-COR Technical Customer Services (800) 233-2267, ext. 4422.

**17-19 Introduction to CATV and Broadband Technologies.** Produced by CommScope. Location: Charlotte, N.C. Includes hands-on training and plant tour. Call Susan McAlister (800) 982-1708.

**18-19 Antec Fiberworks Compressed Video: Concepts and Transmission (CVCT).** Location: Denver, Colo. Call Karen Olheiser (800) FIBER-ME for more information.

**18-19 Understanding Hybrid Fiber/Coax Design.** Produced by Scientific-Atlanta Institute. Location: San Francisco. For further information and to register, call Bridget Lanham (800) 722-2009, press 3.

**24 Milestones and Mirages on the Road to Convergence.** Produced by Datapro Information Services Group. Location: Omni Shoreham Hotel, Washington, D.C. Call Catherine Scheimreif (800) DATAPRO, ext. 2257 to reserve a seat.

**24-25 Introduction to Cable TV Passive Fiber Optic System Design.** Produced by Siecor Corp. Location: Tampa, Fla. Call Siecor at (800) 743-2671, ext. 5539 or 5560.

**25-26 Fundamentals of the Digital Network.** Produced by Nortel. Location: Chicago. Call (800) NT-TRAIN (select option 1).



**C-COR**  
ELECTRONICS INC.

**TECHNICAL SEMINARS**

September 26 - 28 / Dallas, TX  
October 24 - 26 / State College, PA

3 days of informative, cost-effective, up-to-date instruction for cable tv technicians.

Call **800-233-2267**  
ext. 4422 for more information.

60 Decibel Road / State College, PA 16801

# CED

## Literature & Source Guide—Fall '95

### Unattended/Automated Playback for Local Origination

For over a decade, **TECH Electronics** has set the standard for highly reliable and cost effective controllers for unattended/automated playback. The PVC Family of Controllers offers full functional control for up to 16 VCRs with three channel output. With the only Windows™-based scheduling software in the industry, creating and composing playback schedules has never been easier. **TECH Electronics** can save your LO operation time and money: Call (800) 572-4935, (770) 446-1416, or FAX (770) 448-5724.



Circle Reader Service No. 121

### Anti-Icing System "Turns Up the Heat"

**GeoKlein Industries'** SteadyState anti-icing system prevents the accumulation of ice and snow on satellite dish reflectors. SteadyState uses a heating element that is a continuous core of semiconductive polymer which regulates its own heat output as the ambient temperature changes. The heater strip is supplied on reels ready to be cut in length and is easy to install, using pressure sensitive adhesives supplied with the SteadyState kit. For more information, circle the Reader Service Number, or call **GeoKlein Industries** 303-440-7770.

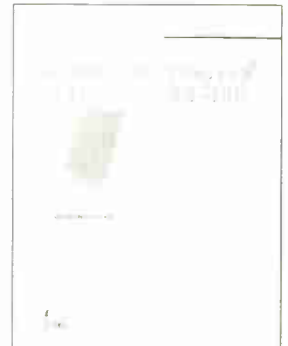

Circle Reader Service No. 122

### Cable Network Manager™

**C-COR's** Cable Network Manager (CNM)™ is the complete network management system for the complex communication systems of the 1990s. The new challenges of network management include managing hybrid fiber/coax systems, redundancy/fail-safe control and inventory management. CNM manages all of these and even records any accessories that are installed. Call **C-COR, the Network Company**, at 1-800-233-2267.

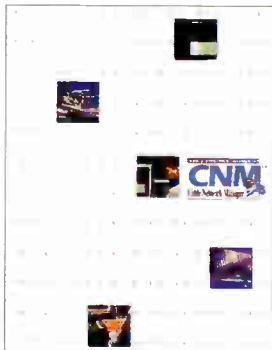

Circle Reader Service No. 123

### SystemSelect™...Strength in Service

**C-COR's** comprehensive service organization provides the support you need to plan, design, build and maintain today's complex communication networks. Whether it's network maps, a bill of materials, installation assistance, training programs or more, **C-COR's** customer driven approach is designed to serve you diligently, creatively and promptly. Service is **C-COR's** strength. Call **C-COR, the Network Company**, at 1-800-233-2267.



Circle Reader Service No. 124

### 10 FREE Answers from Superior

**Cheetah™** provides an integrated network management solution that is designed to evolve with your network requirements. This solution offers flexibility, reliability and the ability to integrate equipment from multiple vendors. **Cheetah** provides status monitoring of headends, fiber nodes, power supplies, amplifiers and end-of-lines. For the **FREE "10 Questions You Need To Ask Before Ordering A Status Monitoring System,"** call **Superior Electronics** at (813) 756-6000.



Circle Reader Service No. 125

### Vela Research for Video Servers, Encoders and Decoders

**Vela Research Inc.** designs and manufactures video servers, encoders and decoders. Their Perspective 2000 video server stores digitized video (movies, video clips, commercials, etc.) in a compressed digital format (MPEG-1, MPEG-1+ and MPEG-2) and can deliver multiple NTSC or PAL video outputs. **Vela's** MPEG Encoder can compress and multiplex audio and video signals into MPEG compliant data streams. **Vela's** MPEG decoder boards are designed for a wide range of video applications. Contact **Vela Research** at (813) 572-1230.

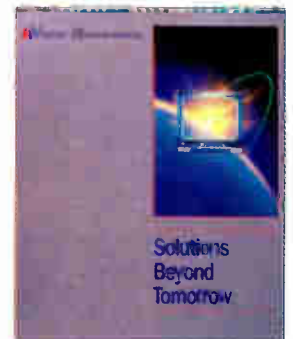

Circle Reader Service No. 126



## New Package Describes End-to-End Network Solutions

Philips Broadband Networks, Inc., now offers a package of product literature. ISO 9001-certified, Philips designs, manufactures and distributes equipment and systems to transport cable and data signals. The package covers Philips' Diamond Net™ and Diamond Transport™ systems, Net Prophet™ monitoring system, Spectrum 2000™ 1 GHz amplifier and the forthcoming BCG™ (Broadband Communications Gateway) and specialty pre-rack service. Call 1-800-448-5171 (in NYS: 1-800-522-7464).



Circle Reader Service No. 127

## FREE Handbook

The FREE pocket size Cable TV Power Supply and Battery Handbook contains 125 pages of information for installers, maintenance technicians, system designers and cable TV engineers. Subjects such as power supply evaluation, plant layout, installation, maintenance and common problems encountered in the field are fully covered. Included is a special section on battery selection, management and testing. **Performance Cable TV Products**, Roswell, GA 30077-0947 (800) 279-6330 e-mail to: jud.williams@industry.net



Circle Reader Service No. 128

## IDS Brings Two-Way Interactivity & Expanded Bandwidth

Marketplace needs are pushing the communications industry towards the convergence of video, voice and data. ANTEC's Integrated Drop System (IDS) has established exacting drop specifications, fully compatible components and proven installation practices to help radically improve the quality, reliability and performance of signals delivered through broadband network subscriber drops. **Find out how IDS performance benefits you and your customers. Call 1-800-TO-ANTEC x-2666 for a free brochure.**

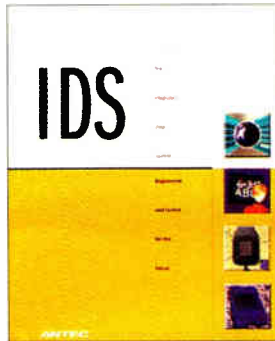

Circle Reader Service No. 129

## Capitalize on Your Network Potential

ANTEC Corporation is an international communications technology company that specializes in the design and engineering of Hybrid Fiber/Coaxial (HFC) based networks and the manufacturing, materials management and integration of products for these networks. From the headend (signal acquisition and distribution point) to the home, ANTEC provides all of the network elements needed to plan, build, rebuild, upgrade and maintain a broadband communications system. **Call 1-800-TO-ANTEC x-2666 for a free capabilities**

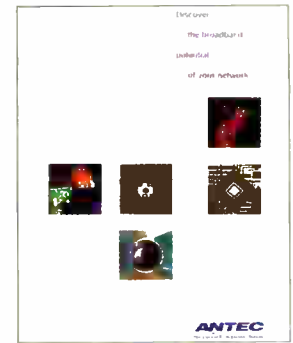

Circle Reader Service No. 130

## Does Your EAS Equipment Meet New FCC Requirements?

The FCC has ruled that by July 1, 1997, cable systems must have installed and operating all necessary Emergency Alert System (EAS) equipment to receive, decode and encode the new digital emergency information, and to transmit the required information across all cable channels. ANTEC has the technology to meet EAS requirements. **Get the facts on the NEW Emergency Alert System...Call 1-800-TO-ANTEC x-2666 for a free brochure.**

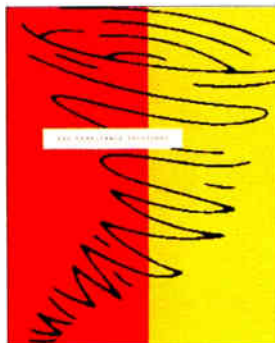

Circle Reader Service No. 131

## The Fiber You Choose Makes a Difference!

To learn more, order the FREE "Corning Fiber Advantage" brochure. Cable TV operators, here's your chance to get the facts about Corning optical fiber. Discover why your choice of fiber is critical and how fiber geometry—the physical dimensions of the glass—can result in low-loss splices, the first time, virtually every time. **Corning** wrote the book on optical fiber. Now it's available by calling 1-800-525-2524 ext. 543. Ask for the "Corning Fiber Advantage" brochure.



Circle Reader Service No. 132

## FREE Cable Catalog From RMS

RMS Electronics is a leading manufacturer/supplier of cable equipment with over 50 years of experience. We have been serving the cable industry for over thirty years and are quickly becoming the fastest growing supplier of cable components in the world. The new RMS American catalog contains an extensive line of over 400 products which are used in the construction or rebuilding of cable television systems. Call for catalog.

**RMS Electronics Inc. (800) 223-8312**

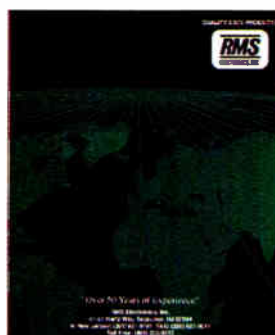

Circle Reader Service No. 133

## FREE information on our tools!

Since 1979 **Ben Hughes Communication Products** has been manufacturing a full line of Cable Prep® tools for the cable industry. The hex crimp tool line includes those made for fiber optic cables, CATV, MATV, STV and standard RF connector applications. A complete line of coring, stripping/coring and jacket stripper tools are available. Special tools can be made to order. For more information call (203) 526-4337 or Fax (203) 526-2291.

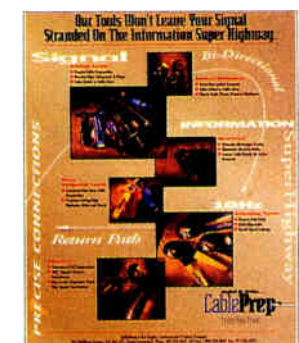

Circle Reader Service No. 134

## Revenue-Generating MM2500 Set-top

Zenith Electronics Corporation's MM2500 set-top unit features real-time, two-way interaction, in-band transmission of conditional access data, baseband SSAVI scrambling and unlimited pay-per-view control. The MM2500 is a powerful, all-purpose analog set-top device that gives network providers full and diverse control from the headend. For more information, call 1-800-788-7244.



Circle Reader Service No. 135

## A Serious Revenue Generator

Zenith Electronics Corporation's new ScreenPlay™ authoring tool is an innovative approach that combines speed, flexibility, customized on-screen displays and interactive capabilities with set-top device technology. ScreenPlay is the only analog, PC-based dialogue authoring tool that offers the ability to quickly generate, modify and edit on-screen displays and applications. For more information, call 1-800-788-7244.



Circle Reader Service No. 136

## Zenith's MetroAccess™ System

MetroAccess is a complete, cost-efficient family of RF data communication products from Zenith Electronics Corporation. It uses proven, high-speed technology for hybrid fiber/coax systems linking businesses, communities, schools and residences for a wide range of applications including work-at-home, distance learning, real-time videoconferencing, Internet access and on-line services. For more information, call 1-800-788-7244.



Circle Reader Service No. 137

## The Cable Tool Innovators

Ripley Company's Cablematic Division offers a complete catalog in cable preparation tools. The catalog displays tools for jacket and sheath stripping, simultaneous coring and stripping, hex and round full-cycle crimping, plus many specialty tools including fiberoptic tools and cable expanding kits. Using proper tools promotes system reliability and assures safe, fast, accurate cable preparation. Call now 1-800-528-8665 for your free catalog. Ripley Company, Cablematic Division, Phone (203) 635-2200, Fax (203) 635-3631

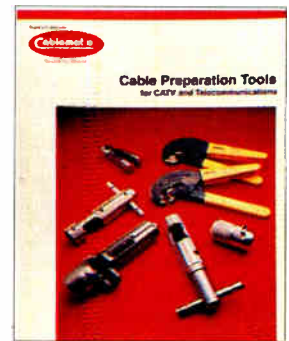

Circle Reader Service No. 138

## NCTI Spanish/English CATV Illustrated Dictionary

The National Cable Television Institute (NCTI) offers a new Spanish/English illustrated dictionary of cable television and broadband technology terms. The first section presents English terms with Spanish translation and Spanish definition. The second section offers Spanish terms with English translation and English definition. Cost \$29.95 plus S/H; quantity discounts. Please contact: NCTI, 801 West Mineral Ave., Littleton, CO 80120-4501, (303) 797-9393, Fax (303) 797-9394.



Circle Reader Service No. 139

## Panasonic Full Line Product Guide

This Product Guide is for Panasonic's Audio/Video product line that includes; Cameras, VTR's and Monitors. Explanations are given on advantages, and facts for features and specifications of D-3, M II and S-VHS products. Includes all new products such as Supercam and the AG-DS850, S-VHS. HI-FI, Editing, Recorder-Player with Digital Slow. Panasonic Broadcast & Television Systems Company Phone (201) 392-4709 Fax (201) 392-6821

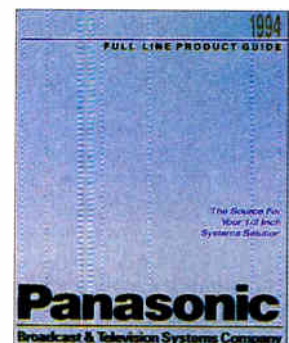

Circle Reader Service No. 140

## New Catalog for Underground Utility Products

Lenoir City, TN—COMPOSOLITE® polymer concrete underground utility products by Quazite are lightweight (for reduced installation costs), strong and reliable. Proven performance in servicing CATV, telephone and electrical facilities, install it and forget it. A wide range of splice/pull boxes with light and heavy duty designs are available. Call 1-800-346-3062 for our FREE catalog. QUAZITE 3621 Industrial Park Dr., Lenoir City, TN 37771

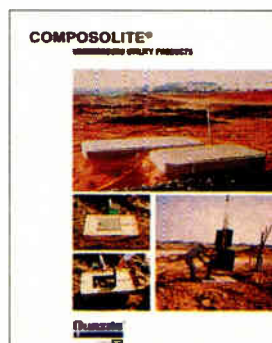

Circle Reader Service No. 141

## Harris/Dracon Tools, Test Sets, and Wiring Devices

The accepted standard of the telco industry, Harris tools and test sets have been used by technicians for over a quarter century. This 20-page brochure details over 50 products for installing, repairing and maintaining telecommunications wiring. Also included are popular items from the Harris Portable Test Equipment line of test sets. Harris/Dracon is an ISO 9001 registered company. For more information call 1-800-4-HARRIS, Ext. 3111



Circle Reader Service No. 142

## Up in the air about aerial lifts

ARMLIFT. The aerial lift that provides you with years of dependable service — lifts built tailored to your needs. With up to 34' working height, Armlift offers a variety of power sources, two speed operation on all units, gravity or hydraulic bucket leveling, choice of buckets and 720 degree non-continuous rotation. Truck or van mounts with a full line of equipment options. **Armlift, Div. of TG Industries, Inc.** Call (712) 864-3737.



Circle Reader Service No. 143

## New CABLESPAN™ Brochure from Tellabs

A new, full-color brochure from Tellabs describes the benefits of the company's CABLESPAN 2300 Universal Telephony Distribution System, which allows cable television operators to provide telephone and data services using the existing CATV infrastructure. Alternate-access providers will also find the CABLESPAN system to be a unique, innovative approach to providing business and residential telecommunications services Around the world. To receive a copy of the brochure, call 1-800-445-6501.

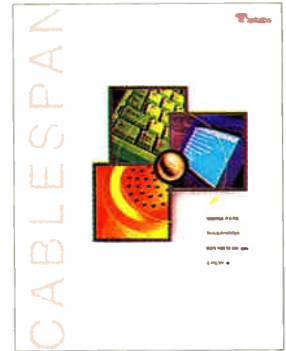

Circle Reader Service No. 144

## FREE 1996 Fiber Optic Test Equipment Catalog

Noyes Fiber Systems announces its new FREE 1996 Fiber Optic Test Equipment Catalog. The full color catalog provides an overview of the products and services offered by Noyes Fiber Systems including Optical Power Meters, Light Sources, Loss Test Sets, Return Loss Test Sets, OTDR's, Fiber Scopes, and Fiber Identifiers. Call **Noyes Fiber Systems**, PO Box 398, Laconia, NH 03247 (603) 528-7780, (800) 321-5298 or FAX (603) 528-2025



Circle Reader Service No. 145

## Free Sprint/North Supply CATV Catalogs

**Sprint/North Supply** is a leading nationwide provider of integrated solutions for voice, data, teleconferencing and CATV product needs through its 11 strategically located distribution centers. We offer more than 30,000 products from over 1,200 manufacturers. Let us show you a sample. Ask for our new broadband catalog containing thousands of products from 97 suppliers. Ask, too, about the following catalogs: Fiber Optics, Outside Plant, Tools, Test and Supplies, and Security Products. 800-639-CATV, FAX 800-755-0556.



Circle Reader Service No. 146

## FREE Catalog for Powering Broadband Networks

**Power Guard** is the leader in providing powering solutions for advanced broadband networks. If you're building a CATV plant or an advanced broadband network carrying voice, video and data we have a power supply to meet your requirements. Power Guard can offer the most technically advanced, cost-effective systems on the market, because we have invested more toward research and development than all of our competitors combined. For a free catalog and to see how we can help call **1-800-288-1507**.



Circle Reader Service No. 147

## Cable Security™ provides Ultimate MDU Security Package

Cable Security manufacturers of the Beast™ box and distributors of Cable Ready™ ultra high security steel molding has merged the products together for the ultimate MDU security application. When these product groups are used together they will supply the Telecommunication Industry with the highest security level for multiple dwelling units available today. Please call 1-800-288-1507.



Circle Reader Service No. 148

## Fiber Optics—Special Applications

Education, Business, Voice/Data, CATV, and Fiber Optics, 6 terms not often thought of at the same time,—**UNTIL NOW**. Selecting the most cost-effective products for these unique fiber applications is essential for their success. If you are in the various stages of implementation, it's not too late to call for the most cost-effective products for these unique applications. **GUARANTEED!** Call for your free copy of our white paper on these applications. **Cable Technologies International**, (215) 657-3300, FAX (215) 657-9578.



Circle Reader Service No. 149

## The Clicker Family

**The Clicker Family**, a unique, simple to use 2, 3 and 4 function family of universal remotes that includes the most extensive library of cable codes on the market today. Are you suffering from: Sagging revenue streams? Confused subscribers? Too many different remotes? Complex remote operation? Too many buttons? Then your solution is...**The Clicker Family**. A family of universal remotes for your video and cable needs. Available for immediate delivery only from **Cable Technologies Int'l, Inc.** (215) 657-3300, Fax (215) 657-9578



Circle Reader Service No. 150

## Versalift boom-tip-mounted bucket

Put your operator two feet closer to that hard-to-reach splice. And it provides line access from 3 sides of the bucket, eliminating expensive rotators. Positive hydraulic bucket leveling gives a solid, stable work platform, leading to increased productivity and greater worker satisfaction. The VERSALIFT TEL-29NE. For more information, contact Time Mfg., P O Box 20368, Waco, TX 76702-0368 Phone: (817) 776-0900, Telex: (910) 894-5218, Fax: (817) 776-7531.



Circle Reader Service No. 151

## ADC Homeworx Access Platform Overview

This overview discusses ADC's Homeworx platform, a fully integrated loop access and transport system with telephony and video subsystems. With the Homeworx platform, the subsystems can be installed separately or simultaneously, depending on the service provider's needs. The platform accommodates basic and premium cable TV services, and allows service providers to gradually add more sophisticated services, such as video-on-demand and interactive television. ADC Telecommunications (800) 366-3891.

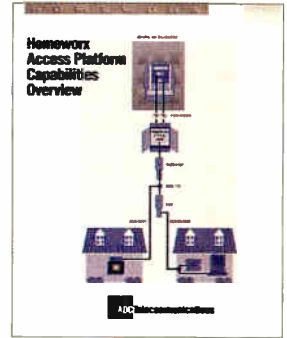

Circle Reader Service No. 152

## Nortel's Telephony 101

Telephony is an attractive new revenue opportunity for cable operators. But with new opportunities come challenges, including the challenge of understanding an industry long dominated by a few companies. Nortel, a supplier to the industry for nearly 100 years, has prepared Telephony 101 as a primer for new entrants on the business and technology of Telephony and Telco Talk, a glossary of acronyms and definitions. For your FREE copy call 1-800-667-8437.



Circle Reader Service No. 153

## New Catalog from TRILITHIC

From signal level meters to leakage detectors, from frequency counters to calibration equipment, the new Instruments Catalog from TRILITHIC has all of the products you need to test and maintain your CATV/broadband distribution system. Updated in September, the catalog now includes such popular new instruments as the TRICORDER II and III and the SUPER PLUS leak/ingress locator, and the current price list. Trilithic Inc., 9202 E. 33rd St., Indianapolis, IN 46236 Phone (800) 344-2412



Circle Reader Service No. 154

## Products . . . flexible, reliable and affordable

Triple Crown manufactures the Titan Series trunk/bridget amplifiers, AM fiber transmitters and receivers, Minex Series indoor/outdoor distribution amplifiers, LA Series dual hybrid line extenders and subscriber drop amplifiers. All amplifiers are available in a wide range of gains and bandwidths, in all international powering formats. Hotel, hospital pay-per-view systems, with interactive services. For more information call (905) 629-1111.

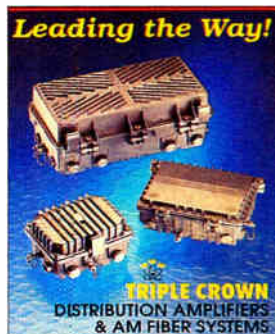

Circle Reader Service No. 155

## Broadband Products Catalog

A 108-page catalog, divided into five sections, covers the Reliable Electric Division offerings of Pedestal Closures, Multi-dwelling Unit Closures, Fiber Node Cabinetry, Fiber Optic Products and Accessories. The catalog features specifications sheets with applications, dimensions and ordering information. Highlights include the new Slam Lock series of enclosures as well as the Access 360° metallic and non-metallic pedestals. Reliance Comm/Tec, 11333 Addison, Franklin Park, IL 60131 (708) 455-8010

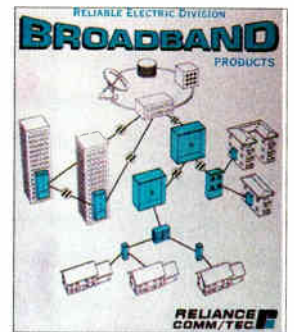

Circle Reader Service No. 156

## NEW! Amplifier Catalog

Viewsonics Inc. full color amplifiers catalog contains photos and specifications of all their amplifiers, including the newest mini tubular amps with 10dB and 15dB gain, the mini 2-way amp, and the 35dB amp with a noise figure at 3.5dB. You'll find their amps all over the world including places you've never heard of, so call and/or fax for your free Viewsonics Amplifier Catalog today.

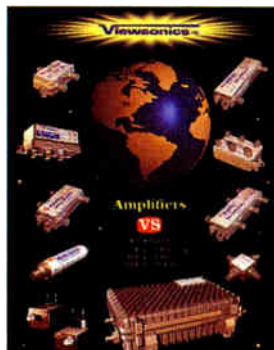

Circle Reader Service No. 157

## Full Line Coax/Wire Stripping Tools

The Remarcable Co. manufactures a full line of COAX/WIRE stripping tools starting with our durable and precise Model #26 Cutter Head that attaches to any of the following powered tools. The Model 824 Battery Powered Hand-Held Portable Tool lasts up to 200 strips per charge. The Hand-Held Tool can also be powered by the Model 827 A/C Power Supply. Our Model 1246 top of the line Production Tool is designed to deliver the highest in quality and quantity. Call 315-461-8161 for more information.



Circle Reader Service No. 158

## Scientific-Atlanta's complete line of broadband systems

Scientific-Atlanta's 1994 Broadband Communications Products Catalog is available from your local Scientific-Atlanta sales representative, by calling 800-722-2009 or writing Bill Brobst at 4261 Communications Drive, Norcross, GA 30093. The catalog carries up-to-date information on Scientific-Atlanta's complete line of broadband systems and cable TV equipment. There's digital compression, telephony over cable, head-end, distribution and fiber optics electronics as well as subscriber products including home communications terminals and management systems. We have what you need.

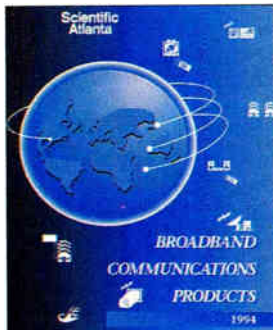

Circle Reader Service No. 159

## FREE: New Wavetek 1995 CATV Selection Guide

This NEW 20 page color guide presents a full line of sophisticated test equipment designed to fit the evolving needs of the cable television industry. Products include the *Stealth Sweep* & new Reverse Sweep Option, the *Stealth SAM*, the new *FLASH Mini OTDR*, signal level & analysis meters, frequency agile leakage detection, and bench sweep gear. Call 800-622-5515

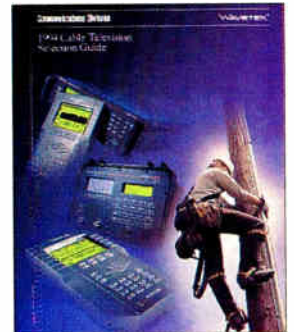

Circle Reader Service No. 160

## DRAKE VM2552 Stereo Video Modulator

Bring stereo audio into your cable system at an affordable cost. The Drake VM2552 modulator incorporates BTSC stereo encoding, providing a significant cost savings when compared to purchasing separate components. Professional noise reduction circuitry reproduces the BTSC signal with good stereo separation and audio fidelity. The frequency-agile VM2552 features frequency coverage up to 550 MHz with a powerful output of +60 dBmV. Contact Mr. Phillip Hawkins, R.L. Drake Company, (513) 847-4523.

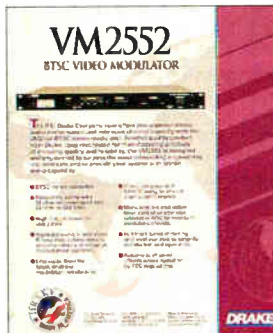

Circle Reader Service No. 161

## ESR1260 IRD Earth Station Receiver

The Drake ESR1260 IRD is a high quality commercial integrated receiver descrambler with synthesized frequency tuning of IF and subcarrier audio frequency. The VideoCipher® RS module can be accessed directly through the front panel, providing added convenience for the operator. Major operating functions are also selected via the front panel and programming is simplified with liquid crystal displays of operating parameters. The ESR1260 IRD's compact design optimizes valuable rack space. R.L. Drake Co. (513) 847-4523.



Circle Reader Service No. 162

## Free Info: Multiple Beam Satellite Feeds

To what degree are you ready? Rainbow Satellite manufacturer of multiple beam feeds for satellite antennas can answer and solve your needs. We have developed a feed for receiving C1, C4, G1, C3, and G5 utilizing antennas manufactured by all the major companies. Rainbow Satellite, PO Box 490395, Leesburg, FL 34749-0395. Call Brian Wilkes today at 904-326-8030 or FAX (904) 326-8058.



Circle Reader Service No. 163

## Cable Leakage Technologies, Inc.

CABLE LEAKAGE TECHNOLOGIES (1-800-783-8878) offers a new family of WAVETRACKER products. The WAVETRACKER system has undergone major enhancements, with a new compact size, a VGA quality LCD display, and a NEW LOW PRICE. CLT's new Windows™ based A.P.L.A.S. Software offers ONE STEP data processing, using the newest, most current mapping product available. The DELTA WAVE Differential G.P.S. Base Station now offers 2 to 5 meters accuracy.



Circle Reader Service No. 164

## Complete End-to-End Solutions

ADC Video Systems offers hybrid fiber/coax video/telephony transport and distribution, high speed digital fiber backbone transport, distance learning, Px64 multipoint videoconferencing, TV1 broadcast quality video and cellular telephone transport. ADC Video System's Family of products include: Homeworx™, DV6000™, PixlNet™, Network Monitoring and Control System, FiberFrame™, Sonplex™, CityCell™, and FN6000™. ADC Video has the technology you need. Call us at (800) 504-4443 or Fax (203) 630-5701.



Circle Reader Service No. 165

## Free Repair Component Catalog from QRF

Quality RF Services, Inc. is a leading distributor of CATV repair components. We have a large selection of CATV hybrid IC's, electrolytic capacitors, resistors, pots, trimmers, transformers, transistors, diodes and much, much more. If you use it to repair a CATV amplifier or power pack, QRF usually has it in stock for same day delivery.

Also receive  
Confidential Hybrid price list!!  
For more information call (800) 327-9767 or FAX: 407-744-4618

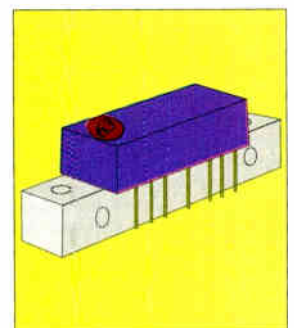

Circle Reader Service No. 166

## Optical Links and "Simple to Use" Remotes

Call ABC Cable Products now for information on the CBLinX fiber optic transmitters and receivers that transport point-to-point video, audio, and data where high performance is required. Also, our latest addition to our CATV remote family of products. The **ProMote II and III** Universal remotes have the capability of operating CATV converters, TVs and VCRs. Call now and let ABC make your job simpler and more cost effective!  
1-800-777-2259.



Circle Reader Service No. 167

## FREE Brochure on Javelin Series

ATx Telecom Systems, Inc., is a leading manufacturer of broadband video transport equipment. The Javelin 1550 Series includes the 1550-nm optical fiber amplifier featuring dual pumps and redundant power supplies for high reliability. With output power of +21 dBm, the amplifier enables architectures which consolidate headends and distribute signals more economically. For a brochure on the Javelin Series, please contact ATx at (708) 778-2900; fax (708) 369-4299.

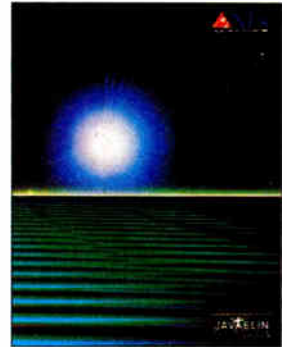

Circle Reader Service No. 168

## Free Microwave Catalogue

**Point-to-point 13 GHz & 18 GHz Systems.** Channel Master® manufactures a complete line of 13 GHz and 18 GHz point-to-point microwave equipment for franchised CATV, private and wireless cable. For a free catalog, write to **Channel Master, MICRO-BEAM®** Division, 1315 Industrial Park Drive, Smithfield NC 27577 or call MICRO-BEAM® Sales Manager Glenn Martin at 919-989-2234.



Circle Reader Service No. 169

## Free Literature From Axsys—The Install Experts

AXSYS is a woman-owned business that specializes in the design and installation of high performance fiber optic networks for voice, video and data. Applications have included telephone, cable TV, 802 networks, process control and security. Our services include: system design, aerial & underground cable installation, premises wiring, splicing/termination, project management, testing, activation, training, emergency services, system maintenance & upgrades. Call (860) 774-4102 for information.

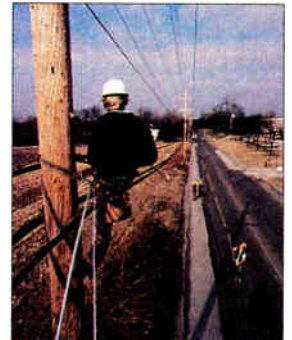

Circle Reader Service No. 170

## Solutions for a Converging World

**CSG Systems, Inc.**, is a premier provider of customer and transaction management systems and related services to the cable, telephony and wireless industries. The company serves many of the nation's largest MSOs representing more than 17 million subscribers. CSG also provides services to two video-dial-tone providers, a major on-line service provider and two direct broadcast satellite system providers. In addition, CSG provides marketing and print and mail services to its customers. Call 800-366-2744 for more info.

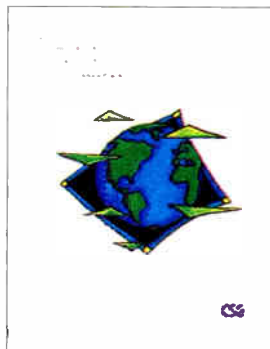

Circle Reader Service No. 171

## Free Broadband Powering Catalog

Call today for **Comm/net Systems Inc.** Powering Product catalog. Included in the catalog is technical information and pricing for: Generator and UPS systems, Headend power system design templates, DC to AC inverters, Rack mount and bench-top AC power sources, Lab power sources, Integrated power sources and load boxes, Outdoor OTN and power node cabinets, Standby and non-standby power supplies and accessories. Call today (206) 623-8670 or FAX (206) 623-8684.

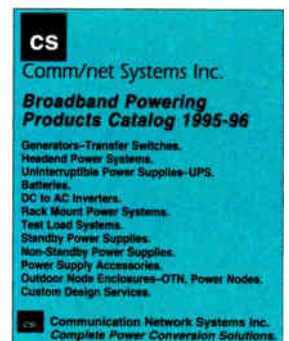

Circle Reader Service No. 172

## Lectro's Zero Transfer Time Power Supplies

Lectro's no break, no data loss ZTT/UPS power supplies are designed to meet all your network requirements. Our reliable 24, 36, & 48 VDC units are available in 6, 9, 12, & 15 amp models. All units provide a highly regulated 60 Hz over a wide load range in AC and DC modes and are status monitoring capable. For information on our full line of products, please contact:

**Lectro Products**  
P.O. Box 567, Athens, GA 30603  
1-800-551-3790 Phone  
1-706-548-5493 Fax.



Circle Reader Service No. 173

## Kennedy Cable Construction for All Your Building Needs

**Kennedy Cable Construction, Inc.**, for aerial and underground line construction of CATV, LANs, telecommunications and fiber optic systems. Splicing, upgrades, rebuild, new extensions of system, balance, sweep and proof system. Call our office for more information on your building needs: Phone: (912) 557-4751, WATS: (800) 673-7322, FAX: (912) 557-6545

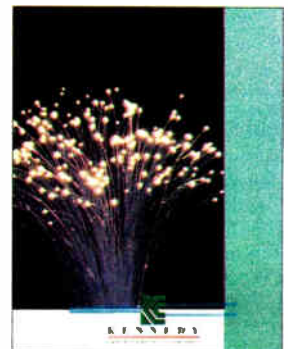

Circle Reader Service No. 174

## Subscriber Management, Billing and Pay-Per-View System

*CableWorks*™ from CUO, Inc. is an easy-to-use subscriber management, billing and pay-per-view system that is ideal for small to medium operations. A flexible, global product, *CableWorks* features national language support for quick foreign language conversion. In addition to enhanced reporting and standard applications integration, *CableWorks* expands readily to accommodate more stations or more subscribers. For a free demonstration disk, circle this reader service number or call (800) 541-8825.

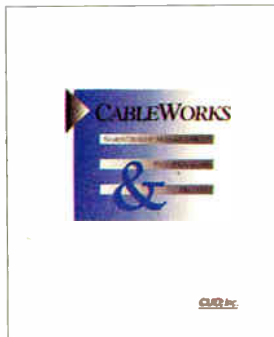

Circle Reader Service No. 175

## Free Catalog Hennessy Outdoor Enclosures

Hennessy designs and manufactures quality aluminum and stainless outdoor enclosures/cabinets ideal for hub sites, mini-headends and other electronic equipment that requires protection. Wide range of sizes available. Options include: air conditioning, insulation, heaters, receptacles, breakers, lights, etc. Equipment can be 19" or 24" rack, shelf, panel or custom mounted, 76 page catalog, application photos and product demo available. For more information call **Hennessy**, (800) 950-7146.

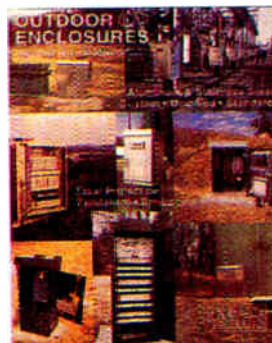

Circle Reader Service No. 176

## Free Information on Digital Insertion Equipment

Testing our systems is something we take very seriously at SDI. Every StarNet Digital Inserter runs and verifies thousands of spots—before they're shipped. Our quality control department loads each system with commercials and connects it to the live video feed. And the testing is not done until the system verifies insertions at over 99% accuracy. We think our testing and quality control is the best in the industry. With over 35 systems installed, SDI is a leader in the digital insertion market. Call (801) 464-1600 for more info.



Circle Reader Service No. 177

## Switching and Control Products for Cable Companies

For 15 years Monroe Electronics has provided the CATV industry with timed and DTMF A/V switching and control equipment. Our Series 3000 products have a proven record of reliability. Monroe Electronics has quality products to meet your switching needs. For a FREE catalog phone 1-800-821-6001 or FAX (716) 765-9330.

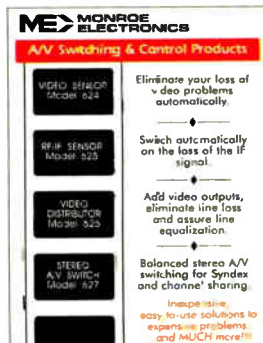

Circle Reader Service No. 178

## "Unique" Products for the 21st Century!

The Mega Hertz, 470 page, catalog provides "unique" product solutions for your changing 21st century equipment requirements. Mega Hertz, a leading national supplier for 20 years, can guide you through your choices of Character Generator solutions, Commercial Insertion systems, Emergency Alert (EAS) compliance, sizing a Stand-by Generator or automating channel switching in your headend. **Mega Hertz** 800-525-8386 (CO); 800-821-6800 (MO); 800-962-5966 (GA); 800-922-9200 (FL).



Circle Reader Service No. 179

## Cable Construction Manual for CATV Broadband Systems

CommScope is now making available a revised and updated edition of its widely distributed and used Cable Construction Manual for CATV and Broadband Systems. The new manual includes sections on storage, testing and construction procedures for coaxial trunk and distribution cables in aerial and subsurface applications, fiber optic cables as well as safety procedures. For more information, call **CommScope/GI** (800) 982-1708.

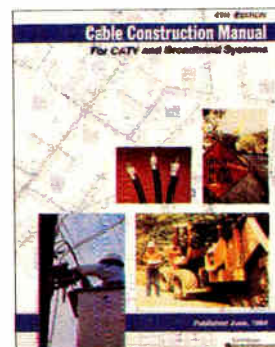

Circle Reader Service No. 180

## BARCO PULSAR CATV Modulator

PULSAR is a unique microprocessor-controlled modulator for CATV headend applications requiring high output RF signal quality, remote monitoring, and automatic provisioning/alignment. Complete software control enables alternative signal routing and remote configuration for back-up modulators to quickly restore programming without the expense or delay of dispatching a technician to the headend. Call **BARCO** at (770) 590-7900 or Fax (770) 590-8836 for more information.

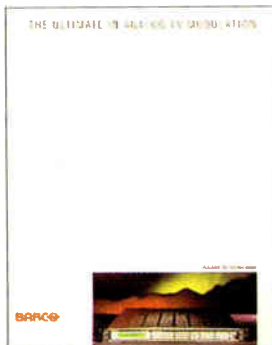

Circle Reader Service No. 181

## BARCO ROSA CATV Network Monitoring System

ROSA is a Remote Control and Diagnostic System (RCDS) for headend and network performance monitoring and automatic service restoral. The RCDS Open System Architecture (ROSA) provides network-wide monitoring and control through an easy-to-use Windows graphical environment, controls both BARCO and non-BARCO network equipment, and interfaces to most leading data base packages. Call **BARCO** at (770) 590-7900 or Fax (770) 590-8836 for more information.



Circle Reader Service No. 182

## Free Catalog—Filters/Traps for Broadband Systems

Catalog Vol. 1 No. 4 describes a complete line of filters and traps for CATV featuring the full line of "brickwall" filters deleting single or multiple channels without sacrificing adjacent channels while passing up to 1 GHz. A selective line of bandpass filters is also described which suppress adjacent channel, off air interference while maintaining low loss in the passband. Other products are: notch and bandpass filters, co-channel eliminators, pay-TV traps, bandsplitters, CARS band filters and terrestrial interference filters. Call **Microwave Filter Co.** (315) 437-3953.

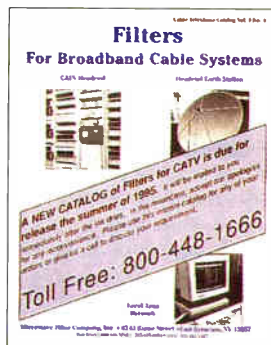

Circle Reader Service No. 183

## New Tyton Catalog From Sunset Enterprises

Sunset Enterprises, a leading distributor of TYTON Cable Management Products is proud to introduce the new Tyton Product Line Catalog containing Cable Ties, Identification Cable Ties, El-Ty Aerial Support Spacer Ties, Mount Bases, Nail Clips, Masonry Clips, Siding Clips, T Clamp, Wire Duct, Lightguide Fiber Optic Enclosure, Surface Raceway, Laser Tag, Fiber Optic Cable Markers, Markable Taplock, Barricade Tape and Surge Protection Products. Call for FREE catalog. 800-900-9879. Fax 609-478-0516.



Circle Reader Service No. 184

## FREE Catalog on Pre-assembled Cable-In-Conduit

For over thirty years the Integral Corporation has been the leader in pre-assembled cable-in-conduit (HDPE). Integral produces a wide variety of conduit products which are described in our literature catalog; such as coax cable-in-conduit, fiber optic cable-in-conduit, rope or pull tape-in-duct, service drop-in-duct, or aerial messenger-on-duct, "Lubaduk" pulling lubricant. For catalog or information, call **Integral Corporation** at (800) 527-2168.



Circle Reader Service No. 185

## 1995 FREE Budco Catalog

The 1995 Budco Catalog is packed with more products than ever before from fine names like: • Brady • Cable Pro • Diamond • F-Conn • Klein • Times Fiber • Ben Hughes Cable Prep • Cable Ready • Engineerig Unlimited • Jameson • Ripley Cablematic • Tyton • and many more. We will ship your stock orders within 24 hours. Call **Budco** at 1-800-331-2246 for your free catalog today.



Circle Reader Service No. 186

## Fiber Optic Test Equipment Catalog 1995-1996

The new Catalog covers all EXFO's products including OTDRs, power meters, light sources, visual fault locators, talk sets, etc. EXFO manufactures fiber optic test equipment for different industries and application such as LAN, Telco, CATV, Lab, and military. Call us to receive a free copy at 1-800-663-EXFO.

**EXFO E.O. Engineering Inc.**  
465 Godin Avenue  
Vanier, Québec, Canada, G1M 3G7  
Phone: (418) 683-0211  
Fax: (418) 683-2170



Circle Reader Service No. 187

## Optical Links Literature

**AEL Industries, Inc.** offers a full set of product data sheets on their AELINK family of products entitled High Performance Optical Links for the Cable and Cellular Industries. Line performance information, power requirements, and physical characteristics are described in detail. AEL Industries, Inc., 305 Richardson Road, Lansdale, PA 19446-1485.



Circle Reader Service No. 188

## Fujitsu's Broadway™ Full-Service Network Video Tape

Voice, data and video. You can do it all. Fujitsu's Broadway line of products and services builds the end-to-end broadband network that allows you to make your customers' dreams come true. Our Broadway video shows you how we can help you deliver the most reliable video, data and voice services available today. **Fujitsu-800-777-FAST** (ask for "Broadway")



Circle Reader Service No. 189

## Digital Insertion Systems From SeaChange

**SeaChange Technology** provides a dramatic transformation in the way video is delivered. Through advances in data networking, software engineering and service performance, SeaChange Technology has become the leader in digital insertion systems. Its open system architecture, based on standard components and the Windows NT platform, provides a fault-tolerant system that is scaleable and modular to meet future demands and emerging applications. Call (508) 287-4499, ext. 275. *SeaChange delivers.*



Circle Reader Service No. 190



# The issue: Signal theft

One of the biggest operational headaches cable operators have to deal with is signal theft. The National Cable Television Association has estimated that the cable industry loses about \$5 billion every year to

unauthorized viewers of cable signals—a whopping 20 percent piracy rate. What do you think about signal security?



## The questions:

1. What is your system's current penetration rate for basic subscription services?

- Below 35%     35%-55%     56%-75%     Over 75%

2. What would you guess is the current level of basic service theft in your system?

- Less than 5%     5%-15%     16%-25%     Over 25%

3. What is your system's current penetration rate for premium services (of all basic subs)?

- Less than 50%     50%-75%     75%-100%

4. What would you guess is the current level of premium service theft among basic subscribers in your system?

- Less than 5%     5%-15%     16%-25%     Over 25%

5. How much revenue does your system expect to lose to signal theft during 1994?

- Less than \$20,000     \$20K-\$35K  
 \$36K-\$50K     Over \$50K

6. What recent steps has your system taken to reduce signal theft?

- None     Regular audits     Offer amnesty  
 Started security program     Other

7. How concerned is your system's management about local signal theft?

- Very concerned     Somewhat     Not concerned

8. Has your system filed charges against anyone for service theft over the past year or so?

- Yes     No     Don't know

9. What hardware do you have in place to battle piracy?

- Scrambling     Traps     Locking pedestals  
 Set-top descramblers     None

10. Do you think set-top manufacturers could do more to make their scrambling systems more secure?

- Yes     No     Don't know

11. How much would you be willing to pay, per set-top, for a vastly improved security system?

- Less than \$10     \$10-\$25     \$26-\$40     \$41-\$50

Your comments:

Fax us at:

**303-393-6654**

Make a copy of this page and fax it back to us at the number above, or mail it to CED, 600 South Cherry Street, Suite 400, Denver, Colo. 80222.

\*Every month, we'll pick one response from those we receive and award \$50. See official rules below.

Names won't be published if you request your name to be withheld, but fill out the name and job information to ensure that only one response per person is tabulated.

Your name and title

---



---



---

System name:

---

Location:

---

Your MSO:

---

Your job function:

---

Daytime phone #:

**Official rules:** No survey response necessary. Enter by returning the completed survey via fax or mail to the locations indicated above, or print the words "CED Return Path" on a 3"x5" card and mail it along with your name, address, daytime phone number and signature. To be eligible for the drawing, entry forms must be received by 5 p.m. on November 30, 1995. CED is not responsible for lost or misdirected mail. One entry per person. Forms mutilated, illegible or not in compliance with these rules shall be considered ineligible in the sole discretion of the judges. Odds of winning depend on the number of entries received. A random drawing from eligible entries will be held on or about December 1, 1995. Winner will be required to provide his/her social security number and proof of identification and is solely responsible for all federal, state and local taxes incurred. Prize is not transferable to any other person. Sweepstakes participants agree

to waive any and all claims of liability against CED magazine, Capital Cities Media Inc., Capital Cities/ABC Inc. and its affiliated and independent contractors for any injury or loss which may occur from participation in this sweepstakes or receipt of the prize. Winner consents to publication of his/her name for publicity purposes without further compensation. Participants must be 18 years of age or older. Employees of CED magazine, Capital Cities Media Inc., Capital Cities/ABC Inc. and its affiliated and subsidiary companies, and their respective employees, agents and independent contractors, and their immediate families are not eligible to participate. Void wherever prohibited, license required, restricted or taxed by law. Sweepstakes sponsors reserve the right to change or modify the sweepstakes rules while the sweepstakes is in progress. Participation in the sweepstakes constitutes acceptance of all sweepstakes rules.

**RESULTS**

Three-quarters of those responding to the set-top survey said it will be at least two years—and maybe longer—before they expect to deploy new digital set-tops in their systems that will take advantage of digitally compressed signals and dramatically increase the number of programming choices available to consumers.

In the meantime, operators will be deploying new, “advanced analog” boxes to offer new features to consumers. MSOs are split, however, when it comes to speculating about which of those features are most important to viewers.

Interestingly, most respondents said the government should not standardize digital set-tops and offer them for sale at retail outlets, but a majority said that would be OK for analog products. When it comes to the standardization process, it appears interest in the process is low, based on the small numbers who said they were familiar with VESA and DAVIC, for instance.

Finally, an overwhelming number of respondents said they welcome the addition of new set-top manufacturers, and they also believe that more companies translates into cheaper set-tops because of competition.

*Congratulations to Rocky Nelson of Time Warner Cable in Memphis, Tenn., who won \$50 last month just for filling out this survey. To enter your name in an upcoming drawing for \$50 cash, fill out the questionnaire on the previous page and send it in!*

# The issue: Set-tops

Congress wants to standardize them, and consumers often dislike them, yet cable systems are preparing to deploy millions of new analog and digital set-tops to

act as gateways to new services. Yet there are myriad issues related to their deployment. This survey explored what you think about set-tops.

## The results:

1. Does your system presently use addressable set-top descramblers?

Yes <b>80%</b>	No <b>20%</b>	Don't know <b>0%</b>
-------------------	------------------	-------------------------

2. How old are the set-tops you presently use in your system, on average?

Less than 1 year <b>0%</b>	1-3 years <b>36%</b>	4-7 years <b>32%</b>	7+ years <b>33%</b>
-------------------------------	-------------------------	-------------------------	------------------------

3. Is your system going to use the new “advanced analog” set-tops (such as GI’s CFT2200 or S-A’s 8600x)?

Yes <b>28%</b>	No <b>20%</b>	Don't know <b>52%</b>
-------------------	------------------	--------------------------

4. If so, what new features do you think are most important to consumers?

Program guides <b>28%</b>	On-screen messaging <b>36%</b>
Virtual channels <b>20%</b>	Other <b>16%</b>

5. Do you think Congress should standardize digital set-tops so that consumers can buy them at retail outlets?

Yes <b>36%</b>	No <b>56%</b>	Don't know <b>8%</b>
-------------------	------------------	-------------------------

6. Do you think a similar standard should apply to analog set-tops as well?

Yes <b>52%</b>	No <b>40%</b>	Don't know <b>8%</b>
-------------------	------------------	-------------------------

7. How familiar are you with the VESA and DAVIC organizations, which are both developing standards that will impact your system in the future?

Very <b>0%</b>	Somewhat <b>12%</b>	Little <b>52%</b>	Not at all <b>32%</b>
-------------------	------------------------	----------------------	--------------------------

8. How soon do you expect to begin deploying new digital set-tops to subscribers on your system?

In next 6 months <b>0%</b>	Next year <b>20%</b>	1997 or later <b>72%</b>
-------------------------------	-------------------------	-----------------------------

9. Mitsubishi, NEC and Sony are just three new companies that expect to build set-tops for cable and telephone companies. Do you welcome new vendors to the market?

Yes <b>76%</b>	No <b>4%</b>	Don't know <b>16%</b>
-------------------	-----------------	--------------------------

10. Do you think the addition of these companies will help reduce the cost of digital set-tops?

Yes <b>72%</b>	No <b>8%</b>	Don't know <b>16%</b>
-------------------	-----------------	--------------------------

**Your comments:**

“In three years, I have upgraded my PC four times. How long will a digital set-top last before processing speed or RAM becomes an issue? Applications always seem to outpace hardware capability.”  
– Stephen Whitlock, Sammons Comm., Petersburg, Va.

“I cannot believe the government can justify placing [set-tops] into the hands of individuals. You don't mandate locks and then pass out keys to everyone.”  
– Bob Baker, TCA Cable TV, Clovis, N.M.

“The only real way we can compete with DBS will be with digital quality and national ads advertising that fact.”  
– Celio Da Costa, Comcast, Burlington, N.J.

# People on the move

**Jones Futurex Inc.**, a manufacturer and marketer of data and facsimile encryption devices, has named **Christopher Bowick** as president. Bowick will continue in his role as group vice president/technology and chief technical officer for **Jones Intercable Inc.** Bowick, who joined Jones Intercable in 1991, previously served as vice president of engineering for Scientific-Atlanta's Transmission Systems Business Division. Bowick's monthly column, "From the Headend," had been featured in *CED* for eight years.

**ADC Telecommunications Inc.** has named **Carleton Brown** as president of ADC Video Systems (formerly American Lightwave Systems). Prior to joining ADC, Brown was president of ATx Telecom.

Also, **James Granger** has been named by ADC as vice president and general manager, Access Platform Systems Division. Granger joined ADC from Sprint/United Telephone of Florida, where he was vice president of consumer markets.

**Jerry Conn Associates Inc. (JCA)** has promoted **Dave Showalter** to president. With that promotion, Showalter will be taking on all the operational responsibilities as the key facilitator to the management team and associates. He succeeds former President Tom Carbaugh, who will remain as chairman of the JCA board of directors, and will concentrate on the creation of new business opportunities.

**Keith Schneck** has joined **AM Communications Inc.** as president, COO and CFO. Prior to joining the company, Schneck spent eight years at Integrated Circuit Systems in positions including executive vice president and COO, and senior vice president, finance.

In a related announcement, **Alvin Hoffman**, a significant investor in the company, has been elected as a director.

**United International Holdings Inc. (UIH)** has announced that **Robert McRann** and

**John Porter** have joined UIH as managing director, and COO, respectively, of the company's multi-channel television ventures in Australia. McRann comes on board from Cox Cable Communications, where he was a senior vice president, and for the last 13 years, general manager of a large cable system located in San Diego, Calif. Porter joins UIH from Time Warner Cable, where he was a division president in Columbus, Ohio.

UIH also announced that **Donald Hagans**, a regional development executive for the company, will be appointed chairman of the board of the Ventures.

**Dynatech** has appointed **Craig Soderquist** as president of the Dynatech Video Group. Soderquist joins the company from General Instrument Corp., where he served as vice president, new business development.

**The R.L. Drake Company** has named **Michael Brubaker** as senior vice president of marketing and sales. Brubaker will work as a contributor in research and development of products that meet market demands, and will oversee all domestic sales and marketing efforts. He will also oversee sales and marketing operations at Drake's sales offices in Barcelona, Spain and Peterborough, Ontario. Brubaker has been with Drake for 22 years, most recently serving as vice president of sales and marketing.

**William D. Wilson** has been named vice president-video services for **GTE Telephone Operations**. He replaces Robert Calafell, who was recently named senior vice president-corporate planning and development for GTE Corp. Wilson, who currently serves as vice president and controller for GTE, returns to Telephone Operations to implement a strategy he helped formulate while he was vice president-business planning for the telephone operating group from 1989 to 1993.

**Bryan Ollila** has been named as vice president of sales, **Zenith Network Systems**. Ollila will be responsible for directing the company's sales activities for analog and digital set-top units and data communications products serving traditional cable operators, wireless cable systems and telephone companies, as well as future DBS products. He will also oversee Network Systems sales operations, customer service and field service. Most recently, Ollila had served as regional manager, South America for Comunicaciones Broadband, a Scientific-Atlanta/Antec joint venture serving

the Latin American telecommunications marketplace.

**Superior Electronics Group Inc.** has named **David**



**Frankfield** to the position of vice president of sales. In this position, Frankfield will be responsible for managing the national sales force for the Cheetah product line. He will also direct support and sales to MSOs and telephone companies. Prior to joining Superior, Frankfield was national sales manager, broadband products at Alpha Technologies.

And **Jim Schulz** has been named as the director of technical services for **Superior Electronics Group**. Schulz is now responsible for customer service, applications engineering, field installation and support groups for the Cheetah product line. He has more than 17 years of experience in the cable industry as a manager, engineer and cable technician. He was most recently chief engineer for Paragon Cable in Minneapolis.

**Sheri Stinchcomb** has been named to the position of director of network planning for **Cox Communications**. Prior to joining Cox, Stinchcomb gained eight years of experience on the technical side of the business with Southwestern Bell in Dallas, Oklahoma City, and most recently, in St. Louis. In her new position at Cox, she will be responsible for directing and coordinating the company's entry into wireless and wireline telephony, as well as new business development.

**Randall J. Larsen** has been promoted to technical director, Cable Integration for Cox California PCS. In his new role, Larsen will provide various engineering and project management functions associated with providing PCS over hybrid fiber/coax. He will also serve as a liaison between the technical and operations departments within Cox California PCS and local cable operators in southern California and Nevada.

**Amphenol RF/Microwave Operations** has named **Maurice Covino** to the newly-created position of business unit manager—CATV Connectors for Amphenol's CATV Connector Group. Covino will be responsible for leading the engineering, manufacturing, product management, and sales and marketing activities for CATV connector products. He joins Amphenol from Gilbert Engineering, where he was recently the president director general for its French subsidiary. **CED**



C. Bowick



Dave Showalter

## Dual tuner/dual decoder

LONG BEACH, Calif.—The Cable and Broadcast Systems Group of Pioneer New Media Technologies Inc. has announced the Dual Tune/Dual Decode DoubleVision Command Station home terminal. The new terminal fulfills FCC regulations for simultaneous viewing and recording capabilities and provides the capability for intuitive on-screen menus.



*Pioneer New Media Technologies' DoubleVision Command Station*

The Command Station has two separate tuner/descrambler combinations—one for the television, and one for the VCR. The terminal also features a built-in output switch, which allows users to watch a program without disturbing the VCR tuner. Display and programming features of the Command Station include: an on-screen control display which shows what channels are selected and what programs are scheduled to be recorded; the VCR tuner is made without an on-screen display, so there is no danger of interference with recording; program timers allow viewers to program the VCR and order pay-per-view at the same time; an on-screen prompt notifies subscribers if there is a charge for a program they have selected for viewing or recording; automatic loading of program times from on-screen electronic program guides eases the programming procedures for viewers; the VCR controller automatically prompts the VCR to record a selected program at the appropriate start time, so users no longer need to set record times on both the set-top box and the VCR. And finally, the time of day can be displayed on the front panel of the terminal, to ensure taping at the correct time.

Circle Reader Service number 67

## Fiber cabinet

ATLANTA, Ga.—GC Technologies is offering a preterminated wall-mount cabinet designed for fast, easy cable installation. With "on-location" installation, end-to-end factory

## Handheld signal level meters

testing and pre-splicing of external fiber, GCT converts a full day, three-person job into a one-person, three-hour task.

In addition, with environment-controlled factory conditions, each termination is guaranteed to be reliable and free from operator errors, according to GCT. This ensures greater life expectancy and peak performance with return losses available at better than 65 dB on premium polish terminations.

Circle Reader Service number 68

## TNC connectors

MINNEAPOLIS, Minn.—ADC Telecommunications Inc. has announced new-generation TNC connectors.

The connectors feature several improvements over traditional TNC connectors, according to ADC. First, to ensure proper alignment during termination, the connectors feature a gold-plated locking center conductor. Second, the center insulator design gives the connectors a true 75-ohm impedance. This improves transmission reliability in digital applications by eliminating any impedance mismatch in the network. Third, the connectors feature half-inch crimp ferrules with the cable size clearly marked on each one. And

finally, ADC's family of TNC connectors can be terminated with industry-standard crimp tool and die sets, eliminating the need to purchase new tools and dies.

Circle Reader Service number 69

## Duct lubrication

ELYRIA, Ohio—ARNCO Corp. has announced Perma-Lube, permanent duct lubrication.

The Perma-Lube process instills a proprietary lubricant throughout the entire length of the inner wall as the duct is being co-extruded with a color-coded jacket. The process is employable on all types of duct: smoothwall, ribbed, wave ribbed and corrugated types.

The ducts are safe for all types of cable; the lubrication is dry, so it won't attract dirt or other foreign material in the duct, and won't lose its effectiveness in wet conditions. The lubricant is also environmentally-friendly. For extreme pulls, a



*ARNCO Corp.'s Perma-Lube*

### **The SL754 Handheld Channelizer Signal Level Meter**

SIOUX FALLS, S.D.—Sencore Inc. has announced the new SL754 Handheld Channelizer Signal Level Meters. The SL754 is designed to be an affordable answer to equipping the service tech, according to Sencore. The new line of signal level meters provides users with the ability to tune to any cable TV channel in the spectrum 5 to 810 MHz, including sub-band channels.

In addition, frequency tuning allows the user to tune to any frequency to measure pilots, DMX carriers, convertor control signals or other carriers used in today's systems. The SL754 also allows switching between FCC standard, HRC, IRC, VHF/UHF, PAL A, PAL B/G, PAL I, Japan, Israel, Germany and Belgium channel plans, or building a custom channel plan from the keyboard.

The large, two-line LCD display is easy to read, even in extremes of bright sunlight to cold weather. Attenuator functions are automatic and provide direct signal level readings from -35 dBmV to +60 dBmV.

The SL754 also allows users to make CNR and A/V measurements.

Circle Reader Service number 66

compatible supplementary Hydralube cable lubricant formulation is available from ARNCO.

Circle Reader Service number 70

### **High-security MDU enclosure**

AURORA, Colo.—Electronic Metal Products has developed the Max line of high security enclosures. Depending on a cable company's particular security needs, the Max box is available in two styles: Max, the maximum security MDU for areas requiring stringent security; and Econo-Max, a medium security MDU for installations that do not require maximum security. The Diversified Locking System prevents lock-picking, is recessed for maximum protection and can be customized for each cable system.

Circle Reader Service number 71

### **Low pass filter**

EAST SYRACUSE, N.Y.—Microwave Filter Company Inc. has introduced the Model 3322-806/860(40) low pass filter, used to protect UHF off-air antenna reception from cellular telephone and mobile communications interference.

The unit has a passband from 50-806 MHz and an insertion loss that is typically less than 1 dB. A minimum of 40 dB rejection is achieved for signals in the 860 to 1000 MHz band. Type "F" female connectors are standard. Special configurations can be quoted directly from the factory. Dimensions for this model are approximately 1 x 1.5 x 4 inches.

Circle Reader Service number 72

### **Patchcord attenuator**

ORISKANY, N.Y.—New to Fiber Instrument Sales' line of fiber optic products is the Patchcord Attenuator, for use in optimizing equipment's detector performance.

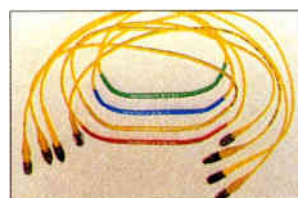

**FIS Patchcord Attenuators**

The FIS Patchcord Attenuator is built to meet low reflection attenuation requirements in 5 dB, 10 dB, 15 dB

and 20 dB versions. Typically, 5 dB and 10 dB versions hold a +0.5 dB tolerance, and 15 dB and 20 dB versions, a 1 dB tolerance. APC and Ultra versions are available, achieving -60 dBm back reflection.

The attenuator is custom-built, allowing user choice of fiber length, style and connector type. Custom attenuation is available upon request.

Circle Reader Service number 73

### **SAW filtered modulator**

VENTURA, Calif.—Holland Electronics Corp. has introduced a new, fixed frequency, SAW filtered modulator, model SAWM, for use in systems with up to 60 channels.

The new SAWM takes advantage of the fixed frequency approach to provide good S/N stability and reliability, while providing SAW filtering to maintain flatness and a 60 dB spurious harmonic rejection up to 450 MHz. The SAWM provides a 50 dB output and is a good balance of performance and price for those systems requiring 60-channel operation, according to the company.

Circle Reader Service number 74

### **Lightwave receiver**

WEST TRENTON, N.J.—EPITAXX Optoelectronic Devices Inc. has announced the development and production of a pigtailed receiver module characterized by extremely low-noise equivalent power.

The receiver circuitry consists of an InGaAs pin photodiode and pre-amplifier and is pack-

aged in a 14-pin dual-in-line package with a 200  $\mu$ m step-index fiber pigtail. A high optical coupling efficiency of greater than 95 percent is achieved by coupling the large core fiber to a 120  $\mu$ m diameter InGaAs photodiode by a proprietary lensing technique.

A hybrid pre-amplifier circuit, consisting of discrete transistors, was developed for extremely low noise performance. The pre-amplifier has a transimpedance gain of 2 Gigaohms, an integrating frequency response and power dissipation of less than 100mW. When cooled to -50 degrees C, the receiver module has an NEP of less than 7fW/rt Hz at 1300 nm, over an operating bandwidth of 85 KHz.

The receiver module can be customized for the particular application. Various types and sizes of fiber can be utilized, as well as different sizes of InGaAs photodiode active diameters. The pre-amplifier circuit can be modified, depending on NEP, bandwidth, gain and dynamic range requirements. EPITAXX can also develop additional analog circuitry such as equalization, amplification, filtering and variable gain control. The receiver can be used as a discrete device or multiple receivers can be configured into a one- or two-dimensional array.

Circle Reader Service number 75

### **7-880 MHz RF preselector**

INDIANAPOLIS, Ind.—Trilithic Inc. has introduced a preselector that offers return path filtering in addition to the industry standard range of 55 to 880 MHz, according to the company. Band 1 has six individual fixed filters which are channels T-7 through T-12. Bands 2 through 5 are tunable filters; 55 to 110 MHz, 110 to 220 MHz, 220 to 440 MHz, and 440 to 880 MHz, respectively. Each filter, whether tunable or fixed, has a high selectivity shape factor of 2.2:1 for 30 dB to 3 dB.

The portable field case houses all six filter bands, as well as an optional 20 dB preamplifier powered by a rechargeable NiCad battery pack. Included with each VF-5 at no additional cost is a complete 75 ohm BNC and F connector set.

Also new from Trilithic is the EVS-30, a compact, cost-effective solution to EBS switching (FCC Part 73.G). Each 5.25-inch rack enclosure provides 30 independent A/B-type video/RF switches, all toggling on the closure of a single TTL contact. Several EVS-30s may be chained together to switch as many channels as may be required. Each switch may be connected to one alternate source or to separate sources, and may be configured to default to either the primary or EBS source on loss of power.

Circle Reader Service number 76

### Exide Electronics forms growth group

RALEIGH, N.C.—Exide Electronics Group Inc. has announced the formation of its Emerging Technologies Group. The company formed the group to more aggressively position itself in newly emerging, high-growth technology markets. Initially, the group will focus primarily on converging interactive communications markets.

Exide Electronics recently strengthened its position in the communications industry with its acquisition of Lectro Products Inc., a company specializing in power protection for both cable TV and telecommunications applications.

The primary market sectors served by the communications unit of Exide Electronics' new Emerging Technologies Group include cable TV service providers, telephone broadband service networks, telecom powerboard system providers, and selected computer and data communications equipment manufacturers.

Including revenues from the newly-acquired Lectro, the communications business unit alone is expected to have sales in excess of \$20 million in 1996.

Warren Johnson will now assume leadership of the company's Emerging Technologies Group. During his 17-year tenure with Exide, Johnson has held senior management positions in operations, corporate development and finance. The Emerging Technologies Group will be headquartered in Raleigh, N.C., and will share Exide Electronics' facilities and support resources. In addition to Lectro Products, the Emerging Technologies Group will integrate operations that manufacture rectifiers and inverters marketed under Lortec, Exide Electronics and private-label brand names.

### GI to provide digital satellite network

SAN DIEGO, Calif.—Educational Management Group (EMG), a unit of Simon & Schuster which delivers live, interactive television services to schools nationwide, has selected General Instrument Corp. to provide a digital, interactive educational network. Scheduled to launch digital service last month, EMG will ultimately provide 30 to 40 original programs daily to more than 1 million students in 3,500 U.S. schools via the digital satellite system.

Teachers use EMG as an "electronic background," fully integrated with their lesson plans. Classrooms can communicate with educational experts, and journey on electronic field trips to places of interest throughout the world. Through EMG's programming, students have traveled electronically to the Amazon to study rain forest species; to Hong Kong to observe world cultures; and to New Zealand to interview Antarctic researchers. Students also view live presenta-

tions given by professors and experts complete with live Q&A sessions.

EMG will deploy GI's DigiCipher satellite uplink system. GI's DigiCipher Multiple Channel Per Carrier (MCPC) system will provide a total of 20 channels, transmitting 13 hours of regular programming per day to the Continental U.S. and Hawaii. After-hours transmissions will feature rebroadcasts of programs shown earlier in the day. EMG can be viewed on Spacenet 424 in the clear.

### S-A, YTT sign \$16 million contract

ATLANTA—Scientific-Atlanta Inc. has signed a contract to supply China's nationwide satellite communications network to Yunnan King Modle Tobacco Telecom Corp. (YTT), the telecommunications subsidiary of Yunnan Provincial Tobacco Company, China's largest manufacturer of tobacco products.

The \$16 million network calls for the installation of a Scientific-Atlanta SkyRelay VSAT (Very Small Aperture Terminal) network to connect more than 2,200 manufacturing, distribution and retail locations throughout China to coordinate the purchase of raw materials, to conduct tobacco auctions via the network, and to monitor processing and production of tobacco products for delivery to a massive network of retail outlets. The companies have agreed to cooperate to provide after-sales service for S-A's other customers in China, and to conduct other joint activities related to Scientific-Atlanta's range of products and technologies.

While the network will be used primarily for data and voice communications, the contract also includes some S-A MPEG-based digital video compression encoding and decoding equipment for YTT to use in exploring the use of video and videoconferencing within the network. In addition to providing comm services to Yunnan Provincial Tobacco Company, YTT plans to offer network communications services to other businesses throughout China.

### PFI begins construction of fiber network

FOLSOM, Calif.—Competitive Access Provider PFI (Phoenix FiberLink Inc.) has broken ground for the construction of a fiber optic telecom network in Salt Lake City, Utah to provide telephone service to business customers.

The \$9-10 million metropolitan area network uses fiber optic cable to provide high-speed telephone and computer data transmission service. The initial phase is scheduled to be completed by the end of 1995. The system will be built in a ring architecture and utilize Sonet (Synchronous Optical Network) technology to provide 99.99 percent reliability. It will support voice, video, data, ATM and frame relay.

### Continental launches Aussie digital system

SYDNEY, Australia—Optus Vision, a joint venture between Continental Cablevision Inc., Optus Communications, the Nine Network and the Seven Network of Australia, was expected to activate its cable television service last month.

"Optus Vision will be the first commercially available cable television service in Australia," said Martin Hannes, managing director of Continental Cablevision Asia Pacific, in a prepared statement.

"Deployment of the digital broadband network, which will have full two-way capability for video and telephone, is well ahead of schedule and is now expected to pass 250,000 homes by the end of this year, a 150 percent increase over earlier estimates," added Hannes, who also noted that the HFC network will pass more than 3 million homes in major Australian cities by the end of 1998.

### Apple picks C-Cube's MPEG video decoder

MILPITAS, Calif.—C-Cube Microsystems Inc. has announced that Apple Computer has selected the company to provide the core digital video technology for Apple's new MPEG Media System, introduced in mid-July. The user-installable MPEG Media System card uses C-Cube's CL450 MPEG decoder to deliver full-screen, full-motion video and CD-quality sound to the Apple Macintosh for the first time.

Apple's MPEG Media System offers users real-time MPEG stereo audio. The card will work with the Macintosh Performa 630, 5200 and 6200 systems and will be incorporated into the Performa 6230CD. The MPEG Media System will enable Macintosh Performa users to play-back interactive games, entertainment, educational titles, reference works and interactive training titles.

### Reliance Comm/Tec sale finalized

SEAL BEACH, Calif.—Rockwell International Corp. and K-Tec Holdings Inc., an affiliate of Kohlberg Kravis Roberts & Co. (KKR), have finalized the sale of Reliance Comm/Tec, a wholly-owned subsidiary of Reliance Electric Company, to KKR's K-Tec affiliate and the management of Comm/Tec for \$475 million.

Under the terms of the sale, Comm/Tec will become an independent, privately-held company focused on the telecom business worldwide. The company provides power, connection, protection, enclosure, transmission and loop test products, systems and turnkey service support to telecom companies serving the local subscriber loop.

Comm/Tec became part of Rockwell as a result of Rockwell's acquisition of Reliance Electric last year. **CED**

PRODUCTS, SERVICES & EQUIPMENT DIRECTORY

**White Sands**

**1-800-Jumpers**  
 CUSTOM MADE CABLE ASSEMBLIES INCLUDING  
 F to F, N to N. BNC, RCA, F-81

Gilbert AHS	RG-56	Belden
LRC	RG-59	Times
Off Shore	RG-11	Comm/Scope
Amphenol	RG-213	Intercomp
	RG-214	

We will make any cable assembly. Quick delivery on all colors and lengths.  
 Fax: (602) 582-2915. Ph (602) 581-0331  
**335 W. Melinda Drive, Phoenix, Az 85027**

**LEMCO**

**TOOLS:**  
**CONSTRUCTION  
 SPLICING  
 DROP INSTALLATION**

717-494-0620  
 CATALOG: 800-233-8713

**COMMUNICATIONS & ENERGY CORPORATION**

**FILTERS & ANTENNAS FOR CATV / SMATV / MMDS / LPTV**

*Manufacturer specializing in fast delivery of Filters for CATV and other video systems, MMDS & LPTV Transmitter Channel Combiners and other broadcast filters and Terrestrial Interference filters for TVRO systems.*

7395 Taft Park Drive East Syracuse, NY 13057  
 Tel 315-452-0709 Fax 315-452-0732 US/CAN 800-882-1587

Contact: Steve Shafer or Vince Cupples

**TKR** Quality Repair at Competitive Pricing

REPAIR CENTER REPAIRS & SALES

- ☐ In Warranty Repair
- ☐ Jerrold Addressable Repair Specialist
- ☐ DP5, DP7 & DPV7 / Panasonic 1402, 1403
- ☐ Remote Repair (URC 450, 550)

For more information contact: TKR Repair Center  
 Tel: (908) 583-2026 • Fax: (908) 290-1677  
 25 Industrial Drive • Cliffwood Beach, NJ 07735

Free delivery & pickup in certain areas

TCI AFFIL.

**COMMERCIAL ELECTRONICS & SUPPLY**

► Your complete electronics source ◀

HYBRIDS ♦ SEMICONDUCTORS ♦ WIRE ♦ CABLE

FUSES • CONNECTORS • HAND TOOLS  
 TRANSFORMERS • SURGE PROTECTORS  
 UNINTERRUPTIBLE POWER SUPPLIES

**MULTIMETERS AND OTHER TEST INSTRUMENTS**

**800-247-5883**

A Division of CEI

**GTS GTS ENTERPRISES, INC.**

- Fiber Fusion Splicing Specialists
- Optoelectronic Equipment Installation
- CW Proofs to 750MHz
- Upgrade/Rebuild Construction
- Computer Drafting and Design

508 Industrial Drive • Woodstock, GA 30188  
 PH (404) 591-1670 • FX (404) 591-1484

**Professional Installation & Technical Services, Inc.** *Since 1986*

An Engineering Services Company dedicated to:

- SWEEP - BALANCE - PROOF
- CALAN EQUIPPED - 1GHZ
- COMPUTERIZED REPORTING
- ELECTRONIC UPGRADES - RESPLICE
- SPLICING & ACTIVATION
- SYSTEM MAINTENANCE & REPAIR
- 750 MHz SWEEP EXPERIENCE

CINCINNATI, OHIO  
 FAX: 513-583-1140  
**800-457-4569**

**DESIGN EXTENDER**  
 THE MAPPING INNOVATORS

A Division of GLA International *Est. 1982*

Strand Mapping	FTF-FTSA Design
As Built Mapping	Fiber Optic Design
Rebuild Mapping	Lode Data - AutoCad
Fiber Optic Routing	Lynx, Focus, CableView
MDU Surveys	Microstation (DGN) Experts
Map Digitizing	File Conversions DWG - DGN - DXF
System Design	CAD System Sales & Training

625 Woods Mill Rd. South Ste. 300 Town & Country, Mo. 63017  
 Phone: 314-579-6627 or 800-875-8786 Fax: 314-579-6628

PRODUCTS, SERVICES & EQUIPMENT DIRECTORY

**NETWORK SPECIALISTS**

**INS Inc.**  
Integrated Network Services, Inc.

**SCTE Member**

Covering North and South America

**ENGINEERING, DRAFTING & DESIGN**

- Consulting
- Base & Strand Mapping
- As-Built Mapping
- Design & CADD Drafting
- Xact Software
- Novell Authorized
- Premise Wiring

*Se Habla Espanol*

Offices in Alpharetta, GA and Santiago, Chile, S.A.

Contact: Bruce Lane **404-442-8738**  
2001 Westside Drive, Bldg. 100, Suite 100 Alpharetta, GA 30201

**MIDWEST CABLE SERVICES**



- NATIONWIDE BUYERS -  
**CATV SCRAP CABLE AND USED LINE GEAR**  
**800-852-6276**

P.O. Box 96, Argos, IN 46501  
Phone: (219) 892-5537 • FAX: (219) 892-5624

**NATIONWIDE INSTALLATIONS**

NaCom a contractor with over 24 years experience offering outstanding customer service for:

- Residential Premise Wiring
- MDU's
- Drop Buries
- DBS

Call (800) 669-8765 Ext. 3046

**NaCom**

Building Communication Systems Throughout America



Mapping and Engineering Solutions

**"Mapping the 21st Century's Information Super Highway"**

Cable TV • Power • Gas • Telephone • Water/Waste Water

**Services include:**  
Consulting • Data Conversion • GIS/Facility Mapping  
Data Base Design • Field Walkout • Fiber/Coaxial Design  
CADDSTAR™ (Applications software for AutoCad™ and MicroStation™)



**For more information contact:**  
405 N. Reo Street • P.O. Box 20112 • Tampa, FL 33622-0112  
Telephone: (813) 289-4119 • Facsimile: (813) 287-3674

**MFC**  
MICROWAVE FILTER COMPANY

Filters for CATV, Wireless Cable, LPTV, TVRO

- Super Selective Bandpass Filters
- Channel Deletion/Reinsertion Filters
- Pay-TV Traps
- Channel Combiners
- Antennas
- Terrestrial Interface Filters

Contact Terry Owens, Sales Manager  
6743 Kinne St., East Syracuse, NY 13057  
800-448-1666 • (315) 437-3953 • FAX (315) 463-1467 or 437-3893

**CCI CABLE CONSTRUCTORS, INC.**  
COMPLETE TURNKEY CONSTRUCTION 1-800-338-9299

- Coaxial and Fiber
- Mapping and Design
- Make Ready
- Splicing and Activation
- Fusion Splicing
- Material Supply
- Aerial, Underground & Fiber Construction
- Emergency Fiber Restoration
- System Sweep
- Proof of Performance
- Turnkey Headend
- Complete Turnkey Project Management

quality service performed on a timely basis

**FCC PROOF OF PERFORMANCE TESTING**



**1-800-292-0126**  
**605-426-6140**  
IPSWICH, SD

- **Headend Services**
  - COMPLETE HEADEND RELOCATION SERVICE
  - RERACK AND REWIRE
  - OPTIMIZE
  - PROOF
- **FCC Proof Performance**
  - RF PROOFS
  - VIDEO TRIANUAL PROOFS
- **On Site Training**
- **Design and Drafting**
  - STRAND MAPPING
  - AS BUILT MAPPING
  - SYSTEM DESIGN
  - MAP MANAGEMENT & SYSTEM UPDATES

 Call Tim Reeder to reserve space in the next available issue of CED! 800-866-0206



**C.O. Finder!™ For Windows**

**Telecommunications Network Information**

Keep up on thousands of North American Number Plan changes every month!

Use the database ALL Telco's use for network management & design.



**NPA, NXX, Exchange, LATA CLLI, Telco, Mileage, SMDS, Frame Relay, + 150 More!**

\$75 One-Time, \$240 Quarterly, \$495 Monthly

Official FCC NECA #4 Compliant

Stuff Software 407-290-2301, Fax: 290-0079

Home Page & Working Sample Software: <http://www.gdi.net/stuff/stuff.html>

Base Mapping • Strand Mapping • As-Builds • Make Ready • Digitizing • Broadband Network Design • Fiber Optic Network Design  
New England Distributor of American Digital Cartography Maps



AutoCAD  
Lode CADD  
Lode DATA

MicroStation  
Lynx CADD  
FOCUS

P.O. Box 365 • North Springfield, Vermont 05150  
Voice: (802) 885-9317 Fax/Modem: (802) 885-9328



- Door to Door Sales
- System Audits
- Converter Placement Campaigns

**609-786-1701**

301 Route 130 South / Cinnaminson, NJ 08077  
Fax 609-786-0121

*Serving the industry since 1977*

**RCH  
CABLE**

**GEN-COMM COMMUNICATIONS INC.**

SURVEY      DESIGN  
AUTOCAD

FIBER      C.A.T.V.  
CABLE NETWORKING      COAX

**"GLOBAL COMMUNICATION DESIGN"**

CALL: 1-800-819-6939

# Quality Cable & Electronics Inc.

1950 N.W. 44TH Street Pompano Beach, Florida 33064



**CONVERTERS  
HEADENDS  
DROP MATERIAL  
LINE EQUIPMENT**

*New / Used All Equipment / Competitive Prices*

**Phone: 305•978•8845 Toll Free: 800-978-8845 Fax: 305•978•8831**

**CALL OR FAX US TODAY WITH YOUR REQUEST! CREDIT TERMS AVAILABLE UPON APPROVAL!**

**CED MEANS BUSINESS!**

Call Tim Reeder  
to place an ad:  
800-866-0206



## PRODUCTS, SERVICES & EQUIPMENT DIRECTORY

**TEST EQUIPMENT**  
 Reconditioned Wavetek, HP, Tektronix and more. Signal Level Meters, Sweep Systems, TDR's, Power Meters, Spectrum Analyzers, Frequency Counters and Fiber Test Equipment. Guaranteed to meet/exceed manufacturers specs. 90 day warranty standard.

**SATELLITE ANTENNAS**  
 Used Scientific Atlanta, Andrews, Vertex, RSI and others. 7 meter & up.

**PTL Cable Service, Inc., USA**  
 Phone (407) 747-3647 Fax (407) 575-4635  
**BUY-SELL-TRADE**

Industry Service Since 1966  **ROCKY MOUNTAIN JUMPER CABLES**  
 P.O. BOX 9707 • HELENA, MT 59604

**Custom Made Jumper Assemblies All Brands Fittings/Cable**

- F Male
- RG - 59
- PL
- F Female
- BNC
- RG - 11
- Other

Our jumpers never leave our plant during construction, insuring inspection of each phase of construction. Our quality control insures you the lowest RF leakage possible. Call for pricing and free sample. (406) 458-6563

**The Splice is Right.** *AFL Fiber Optic Field Services*

Splicing by Alcoa Fujikura Ltd., whether Mass Fusion or Single Fusion, is accomplished with state-of-the-art Fujikura equipment. Our field forces are equipped with high quality OTDR's for final test measurements. Service is on time, meeting your specifications. And the splice is right ... the first time.

**1-800-552-5688**  
 INFORMATION • SCHEDULING • PRICING

 **Alcoa Fujikura Ltd.**  
 Telecommunications Division  
 Spartanburg Operations

150 Ridgeview Circle  
 Duncan, SC 29334

**EMERGENCY ALERT SYSTEMS**  
 By **Idea/onics**

- up to 90 channels
- 14 day delivery
- compatible with all headends

**-AFFORDABLE-**

Tel: 701-786-3904 Fax: 701-786-4294  
**Video Units Also Available**

**ASK ABOUT COMPLETE SYSTEMS TO MEET THE NEW FCC MANDATE**

**WINTER LINEMENS BOOT**



- Rubber Foot/Leather Top
- Thick Felt Liner
- Dual Shanks
- Extra Tall Heel
- Air Claw Sole
- Steel Toe Available

Call for free catalog

**HOFFMANS BOOTS**  
 100 E. Riverside  
 Kellogg, ID 83837

**1-800-925-1599**  
 Fax (208) 786-4301

**WE BUY & SELL SURPLUS NEW & USED**

CONNECTORS, TAPS, HEADEND, LINEGEAR, MISC.

**TM BROKERS**  
 5402 HIGHWAY 95 - COCOLALLA, ID 83813  
 TEL: 208-683-2797 OR 208-683-2019  
 FAX: 208-683-2374



**When it's Time To Advertise... Call Tim at 610-964-4982**

**dB-tronics**  
 Cable Television Equipment Sales & Service Center

**Check Us Out For Scientific Atlanta**  
 Parts & Services

- ✓ Genuine S-A Parts In Stock
- ✓ Factory Trained Repair
- ✓ Sales of New & RMF Equipment
- ✓ Purchase of Wreck-Out & Excess Equipment
- ✓ 450 & 750 MHz Equalizers

**CALL OR FAX US FIRST**

Telephone: 803-574-0155  
 USA Toll Free: 800-356-2730  
 Fax: 803-574-0383

 **Scientific Atlanta**  
 Parts & Services



dB-tronics, Inc.  
 145 Tradd Street  
 Spartanburg, SC 29301  
 USA

get converted!

## CAREER OPPORTUNITIES

**JOIN THE LEADER!!**

- Cellular / Wireless / RF / Microwave
- Switch Maintenance / Translations / Testing Techs
- Central Office Switch Installers • Former Military Tech Controllers
- Central Office Engineers • Outside Plant Technicians & Engineers

<b>ATLANTA</b> 800-733-9783	<b>BALTIMORE</b> 800-927-8090	<b>BOSTON</b> 800-775-2905	<b>CHARLOTTE</b> 800-669-3681	<b>CHICAGO</b> 800-676-7955
<b>CINCINNATI</b> 800-578-4110	<b>CLEVELAND</b> 800-767-0775	<b>DALLAS</b> 800-729-0969	<b>DENVER</b> 800-786-6898	<b>FT LAUDERDALE</b> 800-497-1322
<b>HOUSTON</b> 800-786-6588	<b>INDIANAPOLIS</b> 800-653-6586	<b>KANSAS CITY</b> 800-497-7250	<b>LOS ANGELES</b> 800-487-6927	<b>MEMPHIS</b> 800-696-8574
<b>MILWAUKEE</b> 800-726-7899	<b>MINNEAPOLIS</b> 800-827-5251	<b>NEW ORLEANS</b> 800-669-3690	<b>NEW YORK</b> 800-726-2245	<b>ORLANDO</b> 800-859-3101
<b>NEW JERSEY</b> 800-767-1948	<b>PHILADELPHIA</b> 800-829-5692	<b>PHOENIX</b> 800-455-0017	<b>PITTSBURGH</b> 800-642-0008	<b>PORTLAND</b> 800-366-2304
<b>RALEIGH, NC</b> 800-827-9985	<b>RESTON, VA</b> 800-786-5211	<b>SACRAMENTO</b> 800-669-3682	<b>SAN DIEGO</b> 800-477-1352	<b>SANTA CLARA</b> 800-398-1277
<b>SEATTLE</b> 800-767-9350	<b>ST. LOUIS</b> 800-708-0729	<b>SHELTON, CT</b> 800-546-6447	<b>TAMPA</b> 800-643-7142	<b>WARREN, MI</b> 800-745-2544

**FOR NATIONAL AVAILABILITIES CONTACT: TELECOM NAT'L RECRUITER 800-729-0969 FAX 214-644-8681**

**NORTHERN TELECOM:** DMS 10 / 100 / 200 / 250 SL-100 / SL-1 Meridian

**ATT:** 4.5 ESS, D4 DDM-1000, 2000

**DSC:** DEX 400 / 600

**ERICSSON:** AXE, 882

**SIEMENS:** EWSD, DOO

**FUJITSU:** FLM 150, 600

  
**AEROTEK**  
 Telecommunications Services

AeroteK Telecommunications Services is the fastest growing contract services company in the industry. We stress quality, service and caring of our contract employees. AeroteK is in search of talented technical personnel in all aspects of Telecommunications. Above are some of our immediate needs on a national and international basis. Please call your nearest office above or our national contact today.

Openings for Telecommunications personnel with **Engineering, Installation and Data** experience for work throughout the United States. Please contact John Taylor of Wolters Communications at 918-473-2611 or FAX resume to 918-473-1121.

*Since 1975* we have served professionals in the CABLE-TV industry by matching talent with opportunity. Below is a sampling of the talents we are seeking to match with the many opportunities that are currently available.

- SWEEP TECHNICIANS
- DESIGNERS
- LINE TECHNICIANS
- BROADCAST/L.O. TECHS
- CHIEF ENGINEERS
- CHIEF TECHNICIANS
- SERVICE TECHNICIANS
- LEAD TECHNICIANS
- HEADEND TECHS
- PLANT MANAGERS

SCTE Sustaining Member

**Peter Froehlich & Co.**  
*executive search*

P.O. Box 339 Weatherford, TX 76086  
(800) 742-4947 FAX (817) 594-1337

**All levels of Technical Positions - Corporate to Hourly. Positions Available Nationwide. Call or Write. Fees Paid.**

**JY JIM YOUNG & ASSOCIATES**  
One Young Plaza - 1235 Ranger Highway - Weatherford, Texas 76086  
Call Toll Free (800) 433-2160 or Fax (817) 599-4483

Friendship Cable, a subsidiary of Buford Television, Inc. has the following openings in our cable systems in Texas, Arkansas, Missouri and Louisiana.

- **Service Technicians**-Must have 2 years of cable television technical experience with background in troubleshooting, and knowledge of line amplifiers and headends (all states listed).
- **Installer/Technicians**-Must have 1 year cable installation technical experience with some knowledge of service related work (Arkansas and Texas).

Applicants must have a valid drivers license and good driving record. Employees will be required to live within the system; therefore, relocation may be necessary. We offer a competitive salary and generous benefits package. Drug screen required. Please send resume or call for an application to:

**Human Resources Manager**  
Buford Television, Inc.  
P.O. Box 9090  
Tyler, TX 75711  
(903)561-4411  
EOE

**CDI**®  
CDI Telecommunications, Inc  
*is hiring experienced people for the following positions:*

**DESIGN ENGINEERS**  
Design Fiber & Coax Broadband Routes.

**TECHNICIANS**  
Installation, Cut-over, Testing, Upgrades

**Call: (800) 669-1890**  
**Ext. 895**  
**Fax: 800-875-1904**  
**Attn. CB895**

Mail resume to:  
P.O. Box 4056, Dept. 95  
Scottsdale, Arizona 85261-4056

Engineering

**PLUG INTO THE FUTURE**

Begin an exciting new career with Ameritech New Media Enterprises, where our trend of rapid expansion encourages boundless growth and opportunities. We currently seek talented professionals to boost this breakthrough venture.

**RF Engineers**  
Qualified candidates will be responsible for designing our coax cable network. 3+ years of experience in RF coaxial design and a BS in Engineering or equivalent technical field experience. Cable industry experience a plus.

**Fiber Engineers**  
Qualified candidates will be responsible for designing our fiber cable network. 3+ years of experience in Fiber design and a BS in Engineering or equivalent technical field experience. Cable industry experience a plus.

**Right of Way Engineer**  
Qualified candidates will be responsible for negotiating and procuring use of public private rights of way to construct cable network to provide customer service in a five state area. 5+ years of experience in Right of Way management and support liaison between federal, state and local governments, finance, law, regulatory, construction, engineering and customer service departments.

If you have the qualifications for any of these positions and want to be a part of a new and exciting business venture with a well established organization, submit your resume with salary requirements to: **Ameritech New Media Enterprises, Staffing - PUBENGCD, 300 S. Riverside Plaza, Ste. 1800, Chicago, IL 60606. EOE**

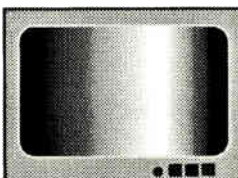

**Ameritech**

**New Media Enterprises**

Providing our customers of today with tomorrow's technologies.



## CAREER OPPORTUNITIES



the nation's fastest growing HFC network design contractor, is presently accepting applications for the following positions:

- > BROADBANDS/RF DESRS.
- > CADD DRAFTERS
- > DATA ENTRY PERSONNEL
- > SYSTEM PROOF/SWEEP & BALANCE TECHNICIANS
- > FIBER SPLICERS
- > FIELD ENGINEERS
- > FIELD MAPPERS

Excellent Compensation & Benefits

*Mail Resume to:*  
**DIGITEL NETWORK SERVICES**  
 470 N. Clayton Street NW, Atlanta, GA 30245  
 or fax to: (404)682-4500

### START AN EXCITING CAREER IN TELECOMMUNICATIONS

Continental Cablevision is seeking career oriented people to become team members of the #1 Telecommunications Service provider in South Florida. Positions are available for:

#### CUSTOMER SERVICE TECHNICIANS

Universal Technician capable of servicing the customer from Installation to Outage Management. A valid Florida driver's license and good driving record are required. Drug screen/background check. EOE M/F/D/V.

Apply in person at:

141 NW 16th Street, Pompano Beach, Florida 33060

To Fax resume (305) 783-6665

or

Mail resume to address above Attn: Bill Shaw or Carolyn Thorpe.

### US WEST International, Inc. Director - Construction Engineering

#### Ideal candidate will have:

- 5 years experience plus technical degree.
- Extensive background in the technical basis of various network OSP technologies, and to include experience in modeling tools, analysis techniques and telecommunications engineering.
- Experience with Hybrid Fibrid Coax Construction techniques.
- Must be knowledgeable in strategic planning, contract negotiations, financial management.
- Strong Interpersonal and Management skills.
- Outstanding Communications Skills.

50% or more International Travel required.

Candidate will be initially Denver-based. After a period of 12 to within 18 months must be willing to relocate overseas to support a US WEST International joint venture.

For consideration, please send resume to:

**US WEST International, Inc.**

ATTN: L. Harris

P.O. Box 6540

Englewood, CO 80155-6540

Equal Opportunity Employer

### US WEST International, Inc. Director - Engineering Projects

#### Ideal candidate will have:

- 5 years experience, to include extensive background in the technical basis of various network technologies, plus a technical degree.
- Experience with Cable Engineering-all aspects and constructions, to include CATV Hybrid Fibrid Coax Construction and technical resource (consultants/contractors) management, must.
- Experience with modeling tools, analysis techniques and telecommunications engineering; and must be knowledgeable in strategic planning, contract negotiations and financial management.
- Engineering management experience.
- Experience in international and domestic business development, desirable.

50% or more International Travel required.

Candidate will be initially Denver-based. After a period of 12 months to within 18 months must be willing to relocate overseas to support a US WEST International joint venture.

For consideration, please send resume to:

**US WEST International, Inc.**

ATTN: L. Harris

P.O. Box 6540

Englewood, CO 80155-6540

Equal Opportunity Employer

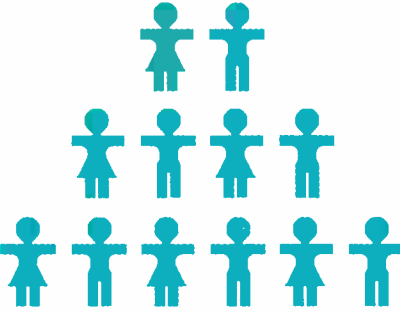

**FINDING A NEEDLE IN  
 A HAYSTACK IS EASY WHEN  
 YOU PLACE YOUR CAREER  
 OPPORTUNITIES ADVERTISEMENT  
 IN THE  
 CED Career Marketplace**

To Place An Ad Call Tim: 800-866-0206

**TECHNICIANS**

Experienced Cable TV Technicians – all levels for service and field maintenance in large MSO system located in San Jose, CA. Send resume and work experience to: **Sherry Hyde, TCI Cablevision of CA, Box 114, San Jose, CA 95103-0114**

**Chief Technician Wanted**

Multimedia Development Corp. is seeking a self motivated individual to assume the position of chief technician. Must have 5 years experience in the cable television business. Must be able to perform FCC testing and proof of performance. SCTE Certification a plus. MDC is an aggressive, fast moving cable and wireless cable operator. Send resume to : Bill Simons, P.O. Box 878, Sandia Park, NM 87047

**Need some Help?  
Let CED Classified's**

**CAREER MARKETPLACE**

**recruit it for you!**

With a circulation to over 18,000 cable television professionals, reaching the right candidate is as easy as...

**CED.**

To reserve classified space in the next available issue of CED, please call

Tim Reeder at:

800-866-0206, 610-964-4982 or

Fax to 610-964-4663.

**BROADBAND SERVICES ENGINEER**

A progressive Southeast based independent telephone company with 40,000 customers is seeking a Broadband Service Engineer. This individual will help guide the company's transition from copper based to fiber optic based facilities that will permit the company to offer video and entertainment services. This individual will assist in the research and development of network based broadband products and services, conduct field trials of broadband equipment and lead internal company training on broadband technology.

Candidates will have a bachelor's degree in electrical engineering and a minimum of 10 years experience to include: design of fiber optic facilities (async. and sonet); frame relay, SMDs, and ATM, CATV systems; and fiber hybrid coax systems. Engineering experience with an operating telephone company a plus. Send resume with position history, experience, and salary requirements to CED Classifieds Box # 650, 1 Chilton Way (4th Floor), Radnor PA 19089

We are an Equal Opportunity Employer

**Construction Supervisor**

Time Warner Cable is the second largest cable operator and leader in the telecommunications revolution. Our Bakersfield division is currently looking for a Construction Supervisor who will be responsible for all of the existing system's construction which is primarily line extensions. The position is also responsible for administering the company safety program. Candidates must have at least three years of cable construction experience and supervisory or lead experience. Must also be able to obtain a valid California drivers license.

If interested, please send resume to:

Time Warner Cable  
Human Resources, (RE: CED Construction)  
3600 N. Sillect, Bakersfield, CA 93308



**T I M E W A R N E R  
C A B L E**

**RESIDENTIAL TECHNICAL  
SALES MANAGER/DIRECTOR**

Digital Music Express is seeking a qualified candidate to fill a Technical Sales Manager/Director position based in New York. This residential division position requires a thorough technical knowledge of digital audio. A college degree in electronics or related field and experience in a cable system is preferred.

The Technical Sales Manager/Director will manage a multi-state territory and assist the residential field staff with respect to the technical delivery of DMX. A working knowledge of headend equipment and cable band-width is essential.

Please mail a resume and salary requirements to:

Digital Music Express  
342 Madison Avenue, Suite 902  
New York, NY 10173-0002

Attn.: Vice President, Eastern Region

DMX offers a competitive salary and benefits package and is an EEOC employer.





# The ubiquitous cable box



By Archer S. Taylor,  
Director and Senior  
Engineering Consultant,  
Malarkey-Taylor Associates

Since July 25, 1967, when U.S. Patent No. 3,333,198 was issued to Ronald C. Mandell and George Brownstein, the dual heterodyne set-top convertor has been indelibly associated with cable television. The limitations imposed by the convertor interface on the normal use of TV receivers for over-the-air reception are a major source of public irritation and political antagonism. If we were able to connect the cable TV service drop directly to the antenna terminals of a "cable-ready" TV set, with only a passive interface, probably half of our political troubles would evaporate.

Technologically, of course, it could be done, and the Joint Engineering Committee (JEC) has made great progress toward an analog interface to be plugged into the back of "cable-ready" TV sets. The "set-back" interface would have no viewer operated controls, and operation of the TV set when connected to cable would be the same as for off-air reception. The analog characteristics of TV sets qualified to be identified as "cable-ready" would be compatible with the agreed characteristics of the "set-back" interface box. The characteristics for digital reception, whether off-air or by cable, are still under intense study. However, at last report, the most difficult issues regarding the command set apparently remain unresolved. At issue is how much control of the consumer's in-home electronics should be confined to the TV or VCR, against allowing at least some control in the interface (decoder) box. At the May 1995 NCTA Convention in Dallas, Walt Ciciora made the following observation based on months of hard negotiation with representatives of the consumer electronics industry: *"Their ultimate fear is that if too much control is lost, the TV becomes a mere monitor."*

The Bell segment of the telephone industry has made it clear that the traditional telephone switched architecture is strongly preferred over the hybrid fiber/coaxial (HFC) architecture for video and interactive voice and data distribution. In place for many decades, it provides dual transmission paths for each subscriber line between the central office (CO) of a local exchange carrier (LEC) and each subscriber terminal. Concentrators are commonly distributed throughout the service area to enable a group of subscriber lines to share a higher capacity trunk line connected to the central office, or switching center.

Cable TV has experimented with mostly one-way versions of such a switched system; e.g. TRACS, SCAT, Mini-Hub, Discade, Redifusion (U.K.), and most recently, Cabletime (U.K.). Most have been discontinued, because of high cost and incompatibility. In its simplest form, the switched architecture provides one 6-MHz band per outlet (e.g. channel 3). The pro-

gram content is remotely selected at the central office, or headend, according to commands transmitted upstream from some sort of keyboard by means of either an RF modem connected to the cable network, or a data modem connected to the POTS (plain old telephone service). Thus, the switched architecture is at least as incompatible with conventional analog TV sets as the customary cable box.

Telephone companies, like the cable TV suppliers that promoted switched architecture, propose a variety of technological approaches to improve compatibility. Clearly, any function provided in the TV set that can be controlled with an infrared remote transmitter, could equally well be controlled at the switching center. Features normally provided in the TV set, such as favorite channel recall, parental control, sound volume control and mute, could easily be provided at the switching center. By multiplexing two to six subscriber lines to each subscriber outlet, PIP and simultaneous viewing and recording of separate programs could be provided.

## A simple video monitor

The ideal subscriber display device for use with a switched network architecture would be a simple video monitor. It could be arranged to accommodate either 4:3 or 16:9 aspect ratios; 2:1 interlace or progressive scan; or various frame and horizontal scanning rates to accommodate HDTV and multi-media programming. The display device could be direct view or projection CRT, or it might be active matrix, LCD, micro-mirrors, plasma, or any other flat panel arrangement. The power supply and electronic drive components could be self-contained, or in separate cabinets.

In the mid-1980s, the FCC adopted rules for a "Video Display Device," capable of being tuned only to channel 3 or 4. It was intended primarily as a display device for games or as a computer monitor. Sanyo and Toshiba had petitioned the FCC for such a device to avoid the expense of providing UHF tuning capability as required by the All-Channel rules. The consumer electronics industry vigorously opposed the idea. As far as I know, no such device was ever marketed.

The telephone companies might attempt to market display features including PIP and simultaneous recording as being more convenient and easy to use with a video monitor display than built in to the TV set. The Carterfone precedent probably inhibits telco ownership of the display terminal. Vigorous and contentious efforts have been committed by the consumer electronics industry to protect and defend its control of the potentially marketable features of enhanced television receivers and video recording equipment. It would be most extraordinary if consumer electronics could be compelled to surrender the lifeblood of its market strategy, and sell video monitors to telephone customers.

While the RHCs have enormous financial resources, the consumer electronics industry is no paper tiger. The RHCs surely have a lot of work to do, and not just in technology. **CED**



# See it big... Keep it simple.

**L**ooking at the "big picture," Cheetah™ came up with a simple idea: a network management system that is designed to evolve and adapt to changing technologies.

As new products for signal distribution and alternative services come into the market, the Cheetah System architecture will be compatible. This system was designed by the Cheetah development team, which includes the best hardware and software engineers from around the world. Simply put, their job is to develop an open system that offers compatibility and flexibility.

The Cheetah System allows you to grow from a few line monitors for FCC testing to a network management system that meets your evolving requirements for network reliability and deployment of new services.

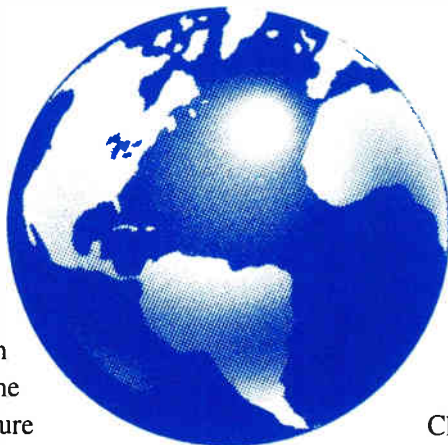

By integrating equipment from multiple vendors into one global network management system, Cheetah provides a flexible solution that offers seamless interconnections. In addition, as you add services like interactive video, telephony and data transmission, be assured that you can expand your Cheetah System to provide one integrated management tool.

From this big picture perspective, we offer you a simple network solution. This is what has made the Cheetah System a standard around the world. From the Pacific Rim to Europe and North America, the Cheetah System has been selected to monitor the world's broadband networks.

**Network Management. Performance Measurements. Status Monitoring.** The Cheetah solution will work for you now and in the future.

SUPERIOR ELECTRONICS GROUP, INC.

6432 Parkland Drive • Sarasota, Florida 34243 • (813) 756-6000 • (813) 758-3800

# The Milenium™ Tap You Install Today Is The Tap You'll Need Tomorrow



Network powered, interactive services are coming. That means you'll have to replace your conventional taps with those that pass power. Unless you install Milenium 2000™ today.

Milenium taps can be easily converted to pass power with a simple face plate change. Upgrading is faster, easier and more economical than replacing an entire tap. All Milenium taps are backward/forward compatible and upgradeable to uninterruptible signal and power passing (USP) with faceplate removed.

*Make today's investment pay off tomorrow.*

\*Milenium 2000 is a registered trademark of Antronix

*Call your TeleWire representative*



*Our success depends on your satisfaction*

**TeleWire** SUPPLY

EASTERN 800-532-2288 • SOUTHWESTERN 800-421-4334 • NORTHEASTERN 800-458-4524 • CENTRAL 800-428-7596  
SOUTHEASTERN 800-433-3765 • WESTERN 800-232-9378

Circle Reader Service No. 53