

MARCH 1982 \$3.00

# BME

BROADCAST MANAGEMENT/ENGINEERING

# NAB PREVIEW

# It's Showtime in Dallas

KUDD 0038278 X M AD  
F. W. DENBROOK DIR OF ENG  
KUDW RADIO OF WASHINGTON  
325 CMU-D OF WASHINGTON  
SEATTLE WA 98195 DIR

# What makes a champion at Indy?

It's a finely balanced combination of human skills, technical superiority, endurance, performance, dependability and teamwork. On the track, or off it, these are the elements that build a champion.

When you join the radio audience for the big event, you are part of the Indianapolis Motor Speedway Radio Network's world wide coverage reaching 700 stations throughout the 50 states and many more around the globe.

And you'll appreciate why the network chose Ward-Beck's R2000 Production Console to process feeds from a score of individual audio sources and transform them into championship action for all the world to hear.

The R2000. The champion's champion!



First by Design



Ward-Beck Systems Ltd., 841 Progress Avenue, Scarborough, Ontario, Canada M1H 2X4.  
Tel:(416)438-6550.

Ward-Beck Systems Inc., 6900 East Camelback Road, Suite 1010, Scottsdale, Arizona 85251.



## Does the Revox PR99 remind you of something?

It should.

It's inexpensive to buy, easy to maintain, practical, reliable, made in West Germany, and built to keep on going through years of demanding use.

No gadgets, no frills. Merely a solid machine equipped with everything a professional needs to get the job done efficiently—and with high quality results.

What's more, the PR99 now comes in three versions: all-steel console, transport case

with snap-off cover, and rack mount. All three may be ordered with the new monitor panel: speaker, amp, volume control, and track selector.

Other features include: • Die-cast chassis • Precision machined headblock • Balanced line in and out switchable for calibrated or uncalibrated mode • Servo-controlled capstan motor • Edit mode switch • Tape dump • Self-sync • Choice of 3.75/7.5 or 7.5/15 ips • Remote control and vari-speed available.

In short, the PR99 is so versatile, so dependable, and so downright sensible that you could almost call it a "volksorder."

Except, well...the shape isn't quite right.

### STUDER REVOX

Studer Revox America, Inc.  
1425 Elm Hill Pike, Nashville, TN 37210 (615) 254-5651  
Offices: Los Angeles (213) 780-4234  
New York (212) 255-4462  
Canada: Studer Revox Canada, Ltd.

Circle 184 on Reader Service Card

Place  
Postage  
Here



*Broadband Information Services, Inc.*  
*P.O. BOX 6058*  
*Duluth, Minnesota 55806*

Place  
Postage  
Here



*Broadband Information Services, Inc.*  
*P.O. BOX 6058*  
*Duluth, Minnesota 55806*

Place  
Postage  
Here



*Broadband Information Services, Inc.*  
*P. O. BOX 6056*  
*Duluth, Minnesota 55806*

## BM/E READER SERVICE CARD May 1982 Issue

NAME \_\_\_\_\_  
 TITLE \_\_\_\_\_  
 STATION OR COMPANY \_\_\_\_\_  
 ADDRESS \_\_\_\_\_  
 CITY \_\_\_\_\_ STATE \_\_\_\_\_ ZIP \_\_\_\_\_  
 PHONE # ( ) \_\_\_\_\_

GREAT IDEA BALLOT: Circle your favorite solution								
SOLUTION A	SOLUTION B	SOLUTION C						

100-249: ADS					250-399: EDITORIAL														
100	101	102	103	104	105	106	107	108	109	110	111	112	113	114	115	116	117	118	119
120	121	122	123	124	125	126	127	128	129	130	131	132	133	134	135	136	137	138	139
140	141	142	143	144	145	146	147	148	149	150	151	152	153	154	155	156	157	158	159
160	161	162	163	164	165	166	167	168	169	170	171	172	173	174	175	176	177	178	179
180	181	182	183	184	185	186	187	188	189	190	191	192	193	194	195	196	197	198	199
200	201	202	203	204	205	206	207	208	209	210	211	212	213	214	215	216	217	218	219
220	221	222	223	224	225	226	227	228	229	230	231	232	233	234	235	236	237	238	239
240	241	242	243	244	245	246	247	248	249	250	251	252	253	254	255	256	257	258	259
260	261	262	263	264	265	266	267	268	269	270	271	272	273	274	275	276	277	278	279
280	281	282	283	284	285	286	287	288	289	290	291	292	293	294	295	296	297	298	299

**What are your comments on AM stereo?**  
 \_\_\_\_\_  
 \_\_\_\_\_  
 \_\_\_\_\_  
 \_\_\_\_\_

AM STEREO READER POLL			
Circle the system you currently favor:			
Belar	Harris	Kahn	Motorola
No plans for AM stereo		Magnavox Don't know	

**Use until August 31, 1982**

## BM/E READER SERVICE CARD May 1982 Issue

NAME \_\_\_\_\_  
 TITLE \_\_\_\_\_  
 STATION OR COMPANY \_\_\_\_\_  
 ADDRESS \_\_\_\_\_  
 CITY \_\_\_\_\_ STATE \_\_\_\_\_ ZIP \_\_\_\_\_  
 PHONE # ( ) \_\_\_\_\_

GREAT IDEA BALLOT: Circle your favorite solution								
SOLUTION A	SOLUTION B	SOLUTION C						

100-249: ADS					250-399: EDITORIAL														
100	101	102	103	104	105	106	107	108	109	110	111	112	113	114	115	116	117	118	119
120	121	122	123	124	125	126	127	128	129	130	131	132	133	134	135	136	137	138	139
140	141	142	143	144	145	146	147	148	149	150	151	152	153	154	155	156	157	158	159
160	161	162	163	164	165	166	167	168	169	170	171	172	173	174	175	176	177	178	179
180	181	182	183	184	185	186	187	188	189	190	191	192	193	194	195	196	197	198	199
200	201	202	203	204	205	206	207	208	209	210	211	212	213	214	215	216	217	218	219
220	221	222	223	224	225	226	227	228	229	230	231	232	233	234	235	236	237	238	239
240	241	242	243	244	245	246	247	248	249	250	251	252	253	254	255	256	257	258	259
260	261	262	263	264	265	266	267	268	269	270	271	272	273	274	275	276	277	278	279
280	281	282	283	284	285	286	287	288	289	290	291	292	293	294	295	296	297	298	299

**What are your comments on AM stereo?**  
 \_\_\_\_\_  
 \_\_\_\_\_  
 \_\_\_\_\_  
 \_\_\_\_\_

AM STEREO READER POLL			
Circle the system you currently favor:			
Belar	Harris	Kahn	Motorola
No plans for AM stereo		Magnavox Don't know	

**Use until August 31, 1982**

## COMPLIMENTARY SUBSCRIPTION QUALIFICATION CARD

1. I would like to receive BM/E (Broadcast Management/Engineering)  
 YES       NO
2. Please check your business classifications
 

<input type="checkbox"/> AM Station/Network Group <input type="checkbox"/> FM Station/Network Group <input type="checkbox"/> TV Station/Network Group <input type="checkbox"/> Non-broadcast TV <input type="checkbox"/> Campus Limited Radio <input type="checkbox"/> CATV Facilities <input type="checkbox"/> Microwave Telephone <input type="checkbox"/> Satellite Company	<input type="checkbox"/> Recording Studio <input type="checkbox"/> Teleproduction Facility <input type="checkbox"/> Government <input type="checkbox"/> Consultant <input type="checkbox"/> Lawyer <input type="checkbox"/> Manufacturer/Distributor/Dealer <input type="checkbox"/> Other (please specify) _____
---	---
3. Are you responsible for more than one station or facility?  
 YES       NO
4. My primary area of responsibility is (please check one)
 

<input type="checkbox"/> Corporate Management  <input type="checkbox"/> Technical Management & Engineering  <input type="checkbox"/> Operations & Station Management/Production & Programming	Board Chairman, President, Owner, Partner, Director and VP or General Manager (other than in charge of engineering or station operations management)  VP Engineering, technical engineering director, chief engineer, engineering supervisor, other engineering or technical titles  VP operations, operation manager, director, general manager, station manager, production manager, program manager, news director, and other operations titles
---	--

5. Signature \_\_\_\_\_ Date \_\_\_\_\_

Name \_\_\_\_\_

Title \_\_\_\_\_

Station Call Letters or Company \_\_\_\_\_

Street \_\_\_\_\_

City \_\_\_\_\_ State \_\_\_\_\_ Zip \_\_\_\_\_

Is this your business address?       YES       NO

If not, please give us your business address below so that we can avoid sending duplicate copies

Name \_\_\_\_\_

Station Call Letters or Company \_\_\_\_\_

Street \_\_\_\_\_

City \_\_\_\_\_ State \_\_\_\_\_ Zip \_\_\_\_\_

# ADVERTISER'S INDEX

ADM Technology .....	13	ESE .....	107	Moseley Assoc. ....	34
Alexander Manufacturing .....	33	Excalibur Industries .....	99	Motorola .....	65
Ampex-AVSD .....	55	Fernseh .....	77	NEC America .....	35
Ampex-MTD .....	23	Frezzolini Electronics .....	26	Nortronics .....	116
Anton/Bauer .....	90	Fuji Photo Film .....	81	Nurad .....	19
Belar Electronics Lab., Inc .....	118	General Electric Video .....	100	Pacific Recorders & Engineering ....	C2
Broadcast Electronics .....	88	Grass Valley Group .....	7	Potomac Instruments .....	89
Broadcast Video Systems .....	118	Harris Corp .....	15, 18, 110	QSI Systems, Inc .....	114
Canon USA .....	47	Harris Video .....	50	RCA Broadcast .....	68-69
Capitol Magnetic Products .....	57	Harrison .....	9	RCA/EO .....	93
Central Dynamics .....	28	Hitachi Denshi .....	95	Rohde & Schwarz .....	84-85
Cine 60 .....	92	Hughes Helicopters .....	45	Sennheiser .....	82
CMX/Orox .....	3	IGM Trillium .....	114	Shure Bros .....	62
Comark Communications .....	94	Ikegami .....	17, 73, 98, 106	Sony Broadcast .....	4-5, 60-61
Continental Electronics .....	25, 94	International Tapetronics .....	24	Spectrasonics .....	111
Convergence .....	58-59	Japan Broadcast Show .....	113	Stainless .....	16
Countryman .....	89	US JVC .....	75	Stanton Magnetics .....	117
Crosspoint Latch .....	102	Kahn Communications .....	67	Studer Revox .....	C3
Data Communications .....	48-49	Leader Instruments .....	108	Swiderski Electronics .....	25
Datametrics .....	112	Lerro .....	21, 70	Telex Communications .....	27
Datatronix .....	117	LPB .....	104	Thomson-CSF Broadcast .....	22
dbx .....	26	3M/Scotch Cart .....	10-11	Time & Frequency Technology .....	32
Delta Electronics .....	20	3M/Audio-Visual .....	78	Videotek .....	116
Digital Communications .....	86	Marconi Electronics .....	96	Viscount Industries .....	82
EECO .....	30	Maxell .....	38	Vital Industries .....	43
EEV .....	105	MCI/Quantel .....	41, 109	Ward Beck Systems .....	C4
Electro-Voice .....	14, 87	McMichael .....	103	Weathermation .....	83
Emcee Broadcast .....	52	Monroe Electronics .....	99		

**When accuracy Counts...Count on Belar  
for AM/FM/TV MONITORS**



**BELAR** CALL ARNO MEYER (215) 687-5550  
**ELECTRONICS LABORATORY, INC.**  
LANCASTER AVENUE AT DORSET, DEVON, PA. 19333 • 80X 826 • (215) 687-5550

Circle 182 on Reader Service Card

**SALES OFFICES**

**BM/E**

**Broadcast Management/Engineering**

295 Madison Ave.  
New York, New York 10017  
Telex: 64-4001  
National Sales Manager  
James C. Maywalt

**Eastern & Midwestern States**

295 Madison Avenue  
New York, New York 10017  
212-685-5320  
James C. Maywalt  
Denis J. O'Malley

**Western States**

300 Broadway  
Suite 20  
San Francisco, CA 94133  
415-421-7330  
William J. Healey  
Sandy Fibish  
18998 Skypark Circle, Suite 260  
Irvine, CA 92714  
714-556-6480  
Bob Hubbard

**United Kingdom/Europe**

Chiberton House  
Doods Road  
Reigate, Surrey, England  
Telephone, Reigate 43521  
Bronwyn Holmes  
Derek Hopkins

**Japan/Far East**

Eiraku Building  
1-13-9, Ginza,  
Chuo-Ku, Tokyo 104 Japan  
03 (562) 4781  
S. Yasui  
K. Yamamoto

## A VERSATILE ADD-ON VMA-400 DUAL VIDEO MIX AMP



- Two independent, stand alone video mix amps complete with remote control panel and tally outputs
- Add two levels of mix to any video system: production switcher, routing switcher, edit suite
- Optional auto-mix and audio-follow

**broadcast video systems ltd.**

1050 McNICOLL AVE., UNIT 15, AGINCOURT, ONTARIO M1W 2L8 TEL.(416) 497-1020 TLX.065-25329

*for those who attended  
the NAB Convention...*

*for those who missed  
this year's show...*

# an important announcement

*It's the BM/E June Show in Print issue featuring coverage of all that was new and exciting at the NAB.*

*If you tried to get through the big show you know that it takes a team like the six editors BM/E brought to Dallas to cover all the important developments. The Show in Print report gives you much-needed perspective on the whole show.*

*If you did not make it to Dallas, the June issue provides you a thorough review of the video and audio products on display at the exhibits.*

*And that's not all. The July issue of BM/E will continue NAB coverage with reports on mobile equipment, transmitters and RF equipment.*

*We assigned six full time editors to NAB because there's no other way to cover it. Read all about NAB starting in this issue with the report on satellites and continuing in June and July.*

**BM/E**  
BROADCAST MANAGEMENT ENGINEERING

# TELEVISION DEMODULATOR QSI DEMOD 400



The Demod 400 off-air demodulator helps you clean up your act. Now you can stabilize off-air signals

without tying up an expensive proc-amp. The Demod 400 gives you the choice of straight off-air signals or replacement sync, burst and blanking at the flip of a switch.



UNPROCESSED

PROCESSED

Plus you have control over sync and burst amplitudes, burst phasing, and set-up level during processing. There's even a built in speaker to make life easier. All this at a price that won't deflate your budget.



For more information about the Demod 400 call (617) 938-1403, or write to us.

**QSI® Systems, Inc.**  
12 Linscott Road, Woburn, Massachusetts 01888

Circle 176 on Reader Service Card

## LOWEST PER CARTRIDGE COST\* THE LATEST MICROPROCESSOR TECHNOLOGY

WHY WOULD YOU BUY ANYTHING BUT **IGM GO-CART**

In 24, 42 or 78-cartridge\* capacity

Use 2 or more Go-Carts for back to back play of all programming, including music

OR

Add one to your existing system to handle all the commercials, ID's, and public affairs, leaving the music on reels or disks. Easily interfaced to most automation systems, ours or "theirs".

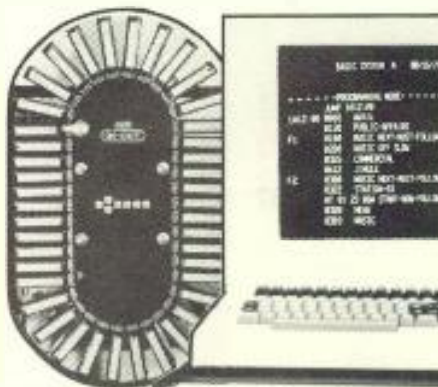

**FAST!** Worst access time is 8 seconds.

**HUMAN ENGINEERED.** Whole unit swings open for maintenance, even while on air.

# IGM COMMUNICATIONS

4041 HOME ROAD, BELLINGHAM, WA 98226 (206) 733-4567

Circle 177 on Reader Service Card

## EQUIPMENT

### Gould Power Line Conditioner 289

The new 5KVA ac power line conditioner, Model GSC 5060, provides both isolation and regulation of 120 V ac power for sensitive electronic loads.

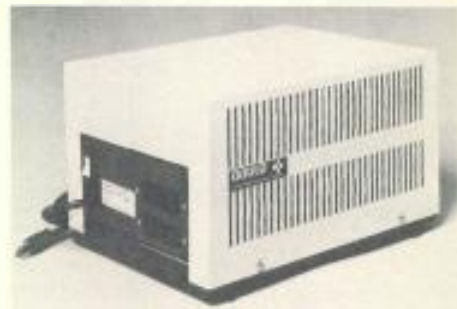

It has applications in computer automation systems.

### Applied Digital Technology Controller 290

The Relacon remote level controller is used for level and switch settings for most standard video processing, including color correctors, time base correctors, and proc amps. It is frame accurate with updates keyed to SMPTE time code, and is capable of storing hundreds of scenes.

### M/A-COM Mixer Preamps 291

Three new series of double balanced mixer preamps are coupled with low-noise preamps and have standard IF frequencies from 10 to 240 MHz. They feature SMA connectors, and all have a broadband frequency range of 2 to 18 GHz.

### Record-cleaning Machine from VPI 292

The semi-automatic wet-wash record-cleaning machine uses distilled water to





# BROADCAST EQUIPMENT



card frame to deliver a second independent 20 kHz audio channel for various transmission purposes. The module set electronically modulates a wideband audio channel on an FM subcarrier that is multiplexed above the video baseband signal, and demodulates the signal down to baseband audio at the receive end. The set delivers greater than 70 dB audio S/N with less than 0.1 percent THD. The audio frequency response is flat ( $\pm 0.2$  dB) from 20 Hz to 20 kHz. Alarm outputs are provided for detecting loss of carrier.

## VG Electronics' Zone Plate Generator 288

The new VGE1032 zone plate generator, in addition to the familiar test signals, also offers sinewave, squarewave, or triangular gratings of varying pitch and varying speeds.

The generator is switchable between NTSC 525 lines and PAL 625 lines. Signals are produced digitally by using a read only memory whose inputs represent the phase of the signal at each sampling point.

neered with laser interferometry and features the company's diamond surround pattern. Power capacity is 70 W continuous program at 800 Hz, 12 dB/octave slope. Sensitivity is 110 dB SPL, with a frequency range from 800 Hz to 20 kHz. Price is \$210.

## ProTech Intercom Station 286

The PL Amp 3, a new intercom station, features two-channel operation switchable between A and B, 600 ohm balanced transformer isolated PL bus, and high-gain amplifier circuitry. The unit



can be powered by single or multiple power supply locations, and will operate off 9 to 24 V dc. Price is \$225.

## Audio Capability Fiberoptics from Artel 287

The new SL-2000 is now, according to the manufacturer, the only fiberoptic system capable of simultaneously transmitting broadcast-quality audio over a single optical fiber. The T-2121/R-2121 audio subcarrier module set plugs directly into the SL-2000



PLAN TO BE AT

# JAPAN



Inter BEE

# BROADCAST SHOW

JAPAN WELCOMES U.S.

- EXHIBIT AT Inter BEE
- ATTEND TECHNICAL STUDY TOUR
- JOIN U.S. DELEGATES TOUR

TOKYO — NOV 7-14, 1982

FOR FURTHER INFORMATION RETURN COUPON TO:

C.T.I., INC.

870 MARKET ST SUITE 740  
SAN FRANCISCO, CA 94102  
TEL 415) 433 3072

Inter BEE/U.S. REPRESENTATIVE

NAME \_\_\_\_\_

EXHIBITION SPACE

COMPANY \_\_\_\_\_

TECHNICAL SYMPOSIUM

ADDRESS \_\_\_\_\_

U.S. DELEGATES  
TOUR PACKAGE

CITY \_\_\_\_\_ STATE \_\_\_\_\_ ZIP \_\_\_\_\_

# Perfect Timing Perfect Price

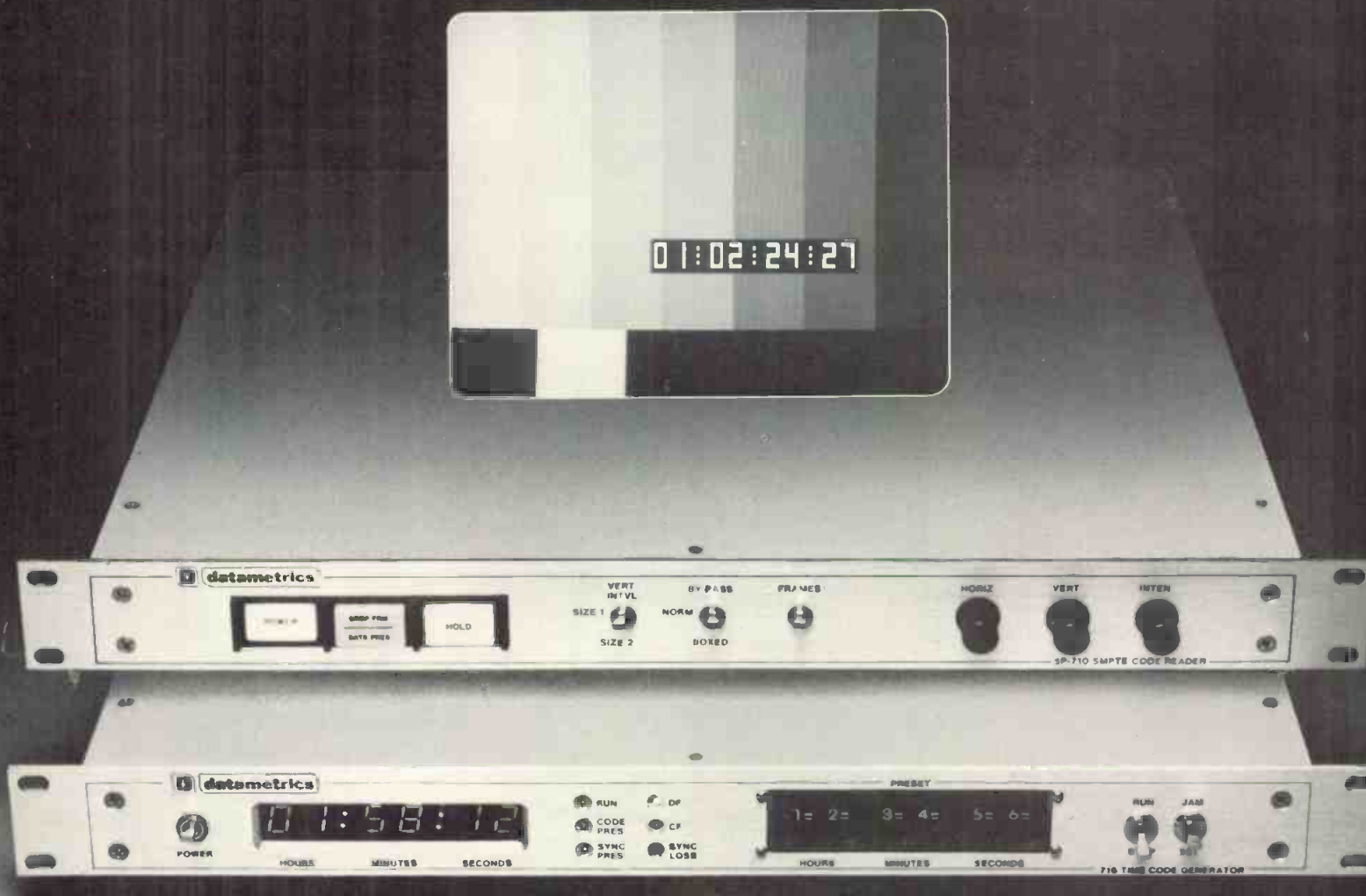

Datametrics, the quality leader in SMPTE Time Code equipment, now offers a low-profile system that meets all your time code needs perfectly...at a very low-profile price.

The Model 710 SMPTE Time Code Reader is a versatile instrument designed to perform in studio and production environments. Features include wide shuttle speed, frame accurate decoding from 1/20 to 60X normal play speed, a built-in character generator for monitor

display and code burn-in, complete remote control capabilities, plus optional data outputs for computer editing interface.

The Model 716 SMPTE Time Code Generator produces reliable, accurate time code and can be used with the Model 710 Code Reader as a complete time code system. Standard features of the 716 include jam/sync capabilities, frame rates selectable for film or video, and compatibility to the RS-170A color frame standard.

**\$ 2280.**

Available from stock at \$2280. each, these SMPTE

Time Code Units, with built-in Datametrics quality, will give you the perfect time code system...at the perfect price.

For full details, call your Datametrics dealer or contact Datametrics directly.

**datametrics**

**DRESSER**

Datametrics • Dresser Industries, Inc.  
340 Fordham Road, Wilmington, Mass 01887  
Tel. (617) 658-5410 TWX: 710-347-7672

Circle 175 on Reader Service Card

# BROADCAST EQUIPMENT

ulation, high modulation, and over modulation simultaneously to help establish desired conditions. The audio input and output circuits are 600 ohms balanced, with the frequency response at 20 to 80,000 Hz, and audio adjustment range is  $\pm 8$  dB maximum.

## Custom Console from Winsted 281

The two new modular units are specially designed for Sony's 800 and Type 5 video equipment, and for Panasonic's new VHS editing system. This console from the System 85 series features welded and bolted construction, assembles easily in different configurations, and has standard 1-inch racks.

## Transmitter Combiners from Phelps Dodge 282

Two new series of cavity-ferrite transmitter combiners are designed to satisfy the requirements of four 800 MHz trunked systems. These modular five-channel combiners use new six-inch diameter, three-quarter wavelength copper cavity. Each channel uses a dual isolator to provide a minimum of 60 dB isolation between transmitter inputs.

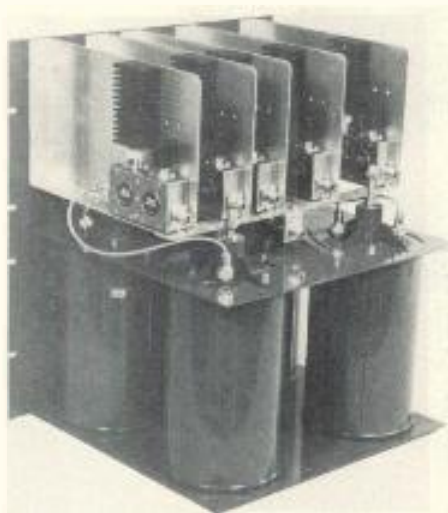

Units are also available in 10- or 20-channel versions.

## Delay Line/Flanger from Loft 283

The new Loft 450 has a maximum bandwidth of 18 kHz and comes standard with up to 160 milliseconds delay. With the addition of the EM-450



the unit provides up to 320 ms delay. It includes a musical instrument input with up to 20 dB of gain and a rear panel foot pedal jack. The unit's S/N ratio is -90 dB and comes in a 19-inch steel rack mount casing that occupies 1 3/4 inches of rack space.

## Microcontroller from Kavco 284

Kavtrol is used for real-time control and management of master control systems, commercial insertions, automated program delay, and routing switcher management. Three levels of processing control are offered by this system, including various external



computer peripherals for different traffic densities and features.

## New Driver from JBL 285

The 2425 compression driver is a new high-frequency component with improved dynamic range equipped with a pure titanium diaphragm. It was engi-

## The SPECTRA SOUND Model 1500

# Performance You Can't Hear

The SPECTRA SOUND Model 1500 Twenty-Seven Band Graphic Equalizer is the result of nearly two decades of engineering excellence. The Model 1500 represents a significant improvement over current equalizer technology.

### The Lowest Distortion

The Model 1500 has the lowest distortion of any equalizer available. The THD and the IM distortion of the Model 1500 are below .0018%, test equipment residual, 20Hz to 20kHz, +18dBv.

### The Lowest Noise

The Model 1500 is the quietest equalizer available. The signal-to-noise-ratio is 104dB below +4dBv, unweighted, 20Hz to 20 kHz.

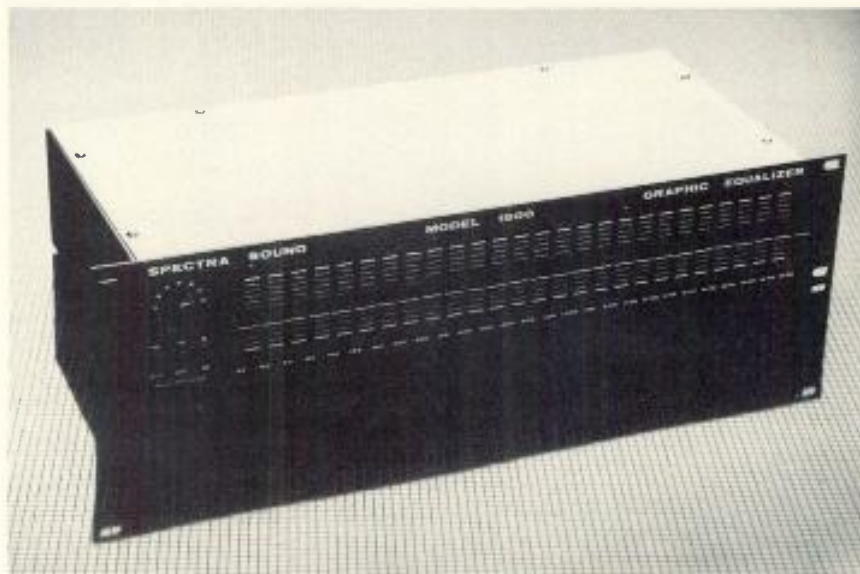

**Spectra Sound** 

3750 Airport Road  
Ogden, Utah 84403  
(801) 392-7531

Spectra Sound is a wholly owned subsidiary of Spectra Sonics

Circle 174 on Reader Service Card

# Harris' New SX Series of All-Solid-State AM Transmitters

Now a high technology blend of broadcast and computer science has created the SX-1 (1000 watts), SX-2.5 (2500 watts), and SX-5 (5000 watts)—Harris' new family of all-solid-state high performance, high reliability AM transmitters!

Harris' solid-state experience brings you energy-saving efficiency. A typical SX-5 equipped station can expect an annual power bill reduction of 15 to 36%.

Exciting new technology is employed throughout the line, including Polyphase Pulse Duration Modulation\* for exceptional audio performance. Plus microprocessor control and status monitoring, sophisticated diagnostic techniques, and a unique cooling system that protects components from dirt build-up. All SX transmitters are designed for AM Stereo operation.

Find out what this new generation of Harris transmitters can do for you. Contact **Harris Corporation, Broadcast Division, P.O. Box 4290, Quincy, Illinois 62305-4290. 217-222-8200.**



\*Polyphase PDM — Patented.



## HARRIS

Circle 173 on Reader Service Card

[www.americanradiohistory.com](http://www.americanradiohistory.com)

# broadcast EQUIPMENT

## Radio Case from K and H Products 276

The new case manufactured by Porta-Brace is specially designed to carry and protect two Vega I receivers and transmitters. The Radio Mike Case is a padded, nylon carrier that secures to the side of Porta-Brace recorder carriers or attaches to the company's Video Belt.



It can be used as a permanent storage for two receivers and a pouch for two transmitters, or other similar-sized equipment.

## Phoenix Computer Announces Graphics Terminal 277

Phoenix Computer Systems, Inc., of Lafayette, LA, has announced its entry into the broadcast television market with the introduction of a color graphics terminal combining its Raster 640 raster-scan color terminal with the Phoenix NTSC encoder. The terminal provides pixel-addressable graphics display with resolution of 640 x 256 pixels, eight colors for both foreground and background, and three refresh memory planes permitting up to 36 colors. The software package offered allows users to define up to 256 symbols. The hardware includes detachable keyboard, digitizing pad, and disk drives.

## Four-speed ATR from Nagra 278

The newly designed twin-capstan, four-speed studio and remote audio recorder is offered in both two-track and stereo versions. The recorder, now marketed in the U.S., features a detachable individually controlled keyboard, including remote calibrations of speed and tape type. With the interchangeable head assembly the unit is capable of high-speed copying with 10 msec

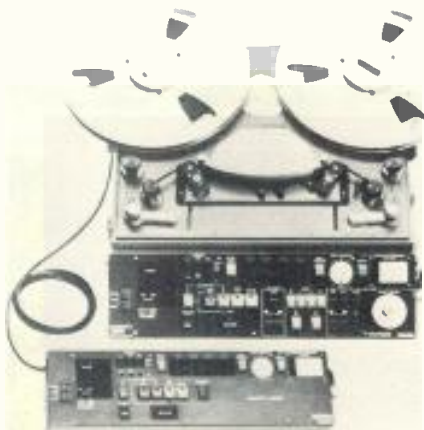

spooling characteristics. Among the other features are servo-controlled editing plus a built-in cutter.

## New Transmitter Package from Marcom 279

The Synergistic FM transmitter update system is intended to yield new performance from older FM transmitters. It contains a programmable audio processor with five remotely selectable processing regimes, the Rood/Marcom



stereo generator with 70 dB stereo separation, and the HPA-4635 FM exciter with modulator.

## FM Controllers from Delta 280

The FMC-1S is a single-channel unit for monaural FM or TV applications, and the FMC-1D is a dual-channel unit for stereo FM frequency modulation control. The FMC-1 series compares modulation threshold, minimum mod-

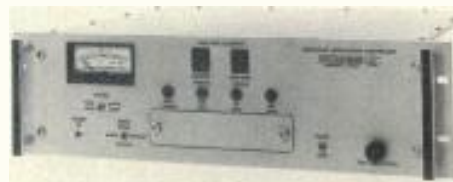

## BROADCAST ENGINEERS/ TECHNICIANS

MCI/Quantel, world's leading supplier of digital video equipment and Emmy award winner for technology, has several outstanding career opportunities for engineers and technicians.

Immediate openings exist for a technical services engineer to be based in the New York metropolitan area, and test engineers, installation engineers, and technicians to be based at corporate headquarters in Palo Alto, California. Some travel required.

Your background ideally would include experience with digital video systems, but a background in computers/peripherals may suffice.

We offer an excellent starting salary, good benefits package, and plenty of room for advancement. Plus the prestige of being associated with the top company in an exciting industry.

Send your resume now to MCI/Quantel, Broadcast Group, PO Box 50810, Palo Alto, CA 94303. Or call Marsha Verse at (415) 856-6226. An equal opportunity employer.

**MCI/QUANTEL**  
The digital video people

# Leader announces the brightest idea in Vectorscopes. CRT-generated targets.



## The Leader Vectorscope is unique.

Only the Leader LVS-5850 NTSC Vectorscope offers CRT-generated phase/amplitude targets that are as bright and clear as the vectors themselves. And electronically generating the targets eliminates non-linearity errors caused by CRT aging, so you can be confident that what you see is what you've got.

The LVS-5850 fits directly into your present vectorscope rack. It provides a test circle pattern—75% or 100% saturation—and lets you select the reference phase from either of two video signals or a subcarrier.

## Precise NTSC sync/test pattern generators.

Leader's LCG-400 series provides accurate reference signals for any off-the-air broadcast or non-broadcast use. Available in multiburst or sweep marker configurations, they provide EIA and full-field color bars as well as staircase, raster (in eight colors), window,



LCG-400 Sync/Test Generator.

convergence and cross-hatch test signals... plus gen-lock capabilities and a host of auxiliary outputs. As a matter of fact, Leader's sync/test generators do virtually everything the \$4,000 generators do... except cost as much.

## A network-proven 50 MHz oscilloscope.

The Leader LBO-517 oscilloscope gives you all the features most needed by video engineers. Waveform monitor-like displays of composite video at V or H rates with 1 mV sensitivity. Plus alternate time base for viewing entire frames and individual lines simultaneously. Two auxiliary channels for monitoring Hd, Vd, blanking, and more... a total of 4 channels. The 20 kV CRT gives you very

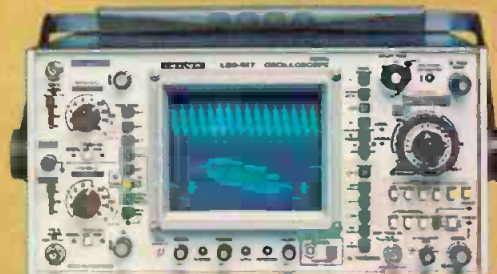

LBO-517 50 MHz Oscilloscope.

bright, sharp displays at all sweep rates,

## Two-year warranty. Evaluation units.

High reliability permits Leader to provide a generous two-year warranty (even on the CRT) ... backed by factory service depots on both Coasts. Evaluation units are available to all qualified customers.

Call toll-free (800) 645-5104 to request:

an evaluation unit, our 1981/82 catalog, the name of your nearest "Select" distributor and additional information.

For video engineers who know the difference.

**LEADER**  
Instruments Corporation

380 Oser Avenue  
Hauppauge, N.Y. 11788 (516) 231-6900  
Regional Offices:  
Chicago, Los Angeles, Dallas.

## GREAT IDEAS

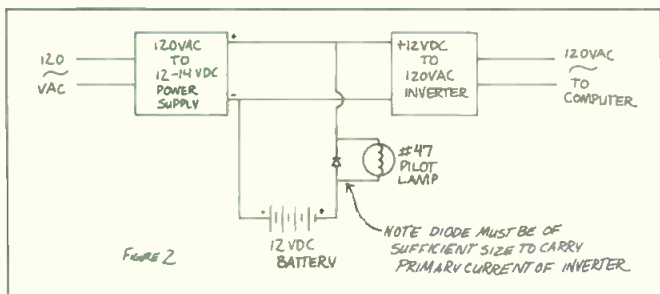

When the main power is cut off, the diode becomes forward-biased and the batteries supply power to the computer system. Note that there are no moving parts or contacts to become dirty. Power transfer is instantaneous, with no glitches.

The second powering scheme is similar in operation, except a 120 V ac inverter is used to supply power to the computer system. Although a standard resistor could be used to supply the charging current as in Figure 1, it has been replaced with a #47 pilot lamp to allow a simple method of monitoring the charging current. The voltage of the commercially powered supply is adjusted so that the #47 lamp glows dimly. Charging and switchover is exactly the same as in Figure 1. When the commercial power fails, the diode becomes forward-biased and keeps the inverter going.

The above systems are presently in use on computer graphics displays for a TV studio and with data-handling systems. This allows the computer to continue running during transfer to an emergency generator. Without the battery backup the memory contents would be lost. The computer system can remain completely operational for several hours with no commercial or emergency power. It is limited only by the amp/hour rating of the batteries.

### SOLUTION C

Joseph H. Petit, Audio/Visual Dept.  
Quaker Dats Co., Chicago, Ill

As illustrated in the diagram, a battery charger supplies power to a voltage regulator which reduces it to the needed levels. During a power failure the regulator starts drawing power from the storage batteries, and the external circuits are undisturbed. Switchover is complete and automatic without any complex circuitry. **BM/E**

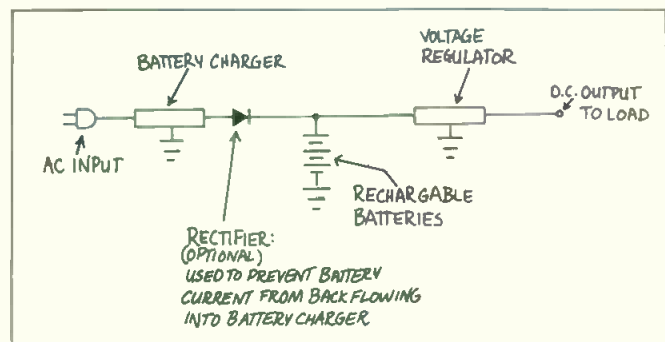

**VOTE NOW!**  
**BALLOT ON READER SERVICE CARD**

# Perfect Timing SMPTTE

## TIME CODE READERS THAT YOU CAN AFFORD

**ES251**-Six digit SMPTE Time Code Reader displaying Hours, Minutes and Seconds. Reads at play back speed.

Momentary hold switch permits "freezing" of time displayed.

Releasing hold switch updates display to correct time. **\$295**



**ES252**-Exactly like ES251, but displays Minutes, Seconds and Frames. **\$300**

**ES253**-Eight digit reader, displays Hours, Minutes, Seconds and Frames.



Reads at play back speed, has "freeze" control. **\$454**

**ES254**-BI-DIRECTIONAL, MULTI-SPEED

(1/20 to 20 times), eight digit reader with "freeze" control. On loss of code, displays last valid code read. **\$675**

## AND FOR OFF-LINE EDITING ES255 SMPTTE IN/VIDEO OUT

ES255 is an eight digit, multi-speed, bi-directional SMPTE reader which adds the SMPTE input to your video. You can now "burn" the time code into the video portion of your tape, or feed a monitor directly. **\$995**



Write, Wire or Call: (213) 322-2136  
142 Sierra Street, El Segundo, CA 90245



# No excuses

In EFP or ENG, getting the shot is everything.

And, a growing number of networks, major stations and independent producers are consistently getting everything with the Ikegami HL-79. They've become so confident with their HL-79's that the need for a "backup" no longer exists.

The more than 2,000 HL-79's in service today have set new industry standards for low light level performance, well-balanced handling and unprecedented reliability. But Ikegami never rests. Now, the best ENG camera is even better. The improved HL-79D Series features an advanced FET preamp that (depending on your choice of tubes) will deliver a 2 to 3 dB gain in signal-to-noise ratio. The HL-79D Series is avail-

able in four new, application-matched configurations that include high resolution diode-gun or low capacitance diode gun tubes.

In EFP and studio production, the new HL-79D will deliver excellent results. In fact, if you don't have an Ikegami studio camera, chances are that the HL-79D will produce a better picture than whatever camera you've got on the floor.

Contact Ikegami and ask for a side-by-side comparison. Then you'll see why an Ikegami HL-79 crew can leave the excuses—and the backup—at the station.

## Ikegami HL-79D

Ikegami Electronics (USA) Inc., 37 Brook Avenue, Maywood, NJ 07607; (201) 368-9171  
Northeast: (201) 368-9171  West Coast: (213) 534-0050  Southwest: (713) 445-0100  Southeast: (912) 924-0061  Canada: (201) 368-9179

Circle 170 on Reader Service Card

[www.americanradiohistory.com](http://www.americanradiohistory.com)



# WHY ARE LEDDICONS® WORLD LEADERS?

Higher resolution is an important reason, but did you know that EEV 30mm Advanced P8400 series Leddicons feature all these advantages?

- \* Integral, variable light bias for minimal picture smearing under low light conditions
- \* Unique anti-microphony mesh
- \* Direct plug in replacements - no camera modifications

**LEDDICONS are BETTER LONGER**  
Proven everyday throughout the world.  
Specify Leddicons for replacements and  
your new camera - Available NOW.

Please send me my free World Broadcast Systems Map, Brochure and full technical details of Leddicons for my application.

Name .....

Position .....

Company .....

Address .....

Application .....



**EEV, INC.**

7 Westchester Plaza, Elmsford, NY 10523, Tel: 914-592-6050, Telex: 646180

In Canada: EEV Canada Ltd., 67 Westmore Drive, Rexdale, Ontario M9V 3Y6, 416-745-9494, Telex 06-989363

In Europe: English Electric Valve Co. Ltd., Chelmsford, Essex CM1 2QU, England, Tel. 0245 61777, Telex 851-99103

® Registered Trademark for Leddicon Camera Tubes

Circle 169 on Reader Service Card

# GREAT IDEAS

## SOLUTION B

John Yurek, Assistant Chief Engineer  
Eastern Tekcom, Monroeville, PA

The following describes two means of black-out protection for computer/terminals. The first was made for use with a TRS-80 model 1 computer but could be adapted to almost any system, as the voltages used are compatible with many other systems. The second system is usable with any device that requires an uninterruptable power source, as it supplies a constant 120 V ac regardless of commercial power status.

In Figure 1, three battery systems are bridged across the +12, +5, and -5 volt power buss *before* the respective regulators. What is unique is the charging switchover system. The respective battery supply is trickle-charged from the host power system through the 470, 68, or 1k resistors. The diode is reversed-biased during charging.

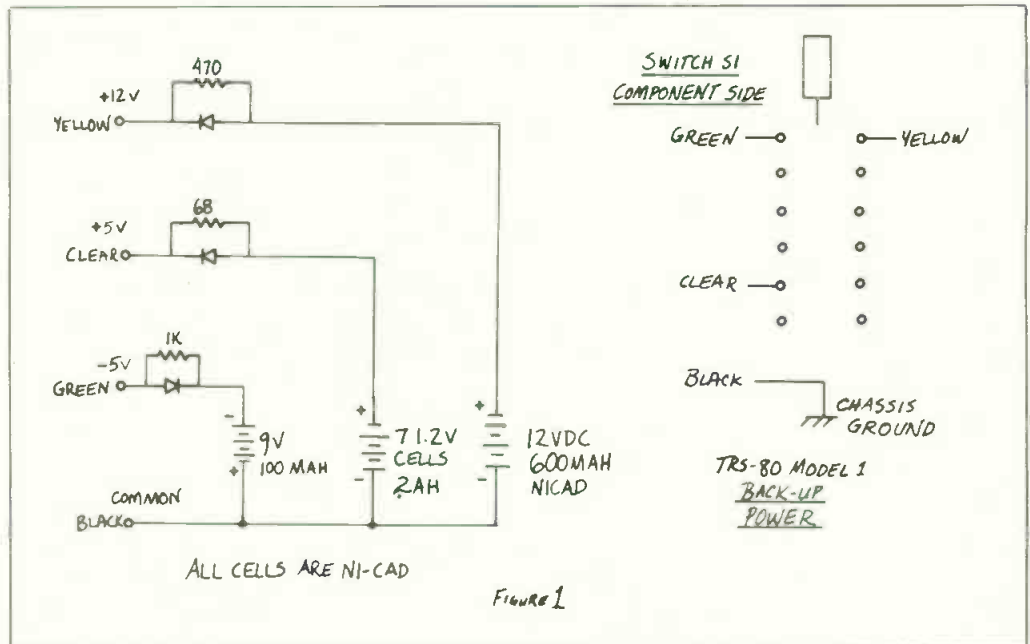

# VOTE NOW!

## BALLOT ON READER SERVICE CARD

**4 Models—8 and 10 mixer dual stereo with rotary or linear faders • Transformer Balanced Inputs and Outputs • 3 Inputs Per Mixer—internal pads allows mic/line selection on the same mixer • Two 4-Input Auxiliary Input Selectors—may be assigned to any mixer • Pre-fader Pushbutton Cue—in addition to normal CCW fader cue position • LED Status Indicators—color coded to aid in instant identification of function selectors • Momentary or Continuous Remote Control Contacts—internally selectable, also controls optional digital timer reset/start • Full Metering Capability—two meters standard, up to four meters and/or digital clocks and timers optionally available, all meters provided with LED peak indicators • Gain Selectable Microphone Preamps—provided with center tap access for phantom condenser microphone power, processor input/output port with buffer amplifier for outboard compressors, limiters, etc. • Programmable Muting Logic—internal pin-programmed matrix allows any selection of monitor and cue muting for the first five mixer positions • Pushbutton Aural Phase Test • Announcer's Microphone Intercom-Air Selector • Full Dual Channel Operation—-independent program and audition assignment push-buttons • Five Monitor Driver Outputs—four muted, one non-muted • All Mixers Switch-Selectable to Mono or Stereo • Ground-Plane Techniques Used Throughout for Increased RF Immunity • Selectable Internal or External Master Level Controls • Accessories and Options—mono mixdown, high impedance (cassette) line input plug-ins, reference oscillator/line input plug-in, additional microphone input plug-ins, digital clock, digital timer, linear faders.**

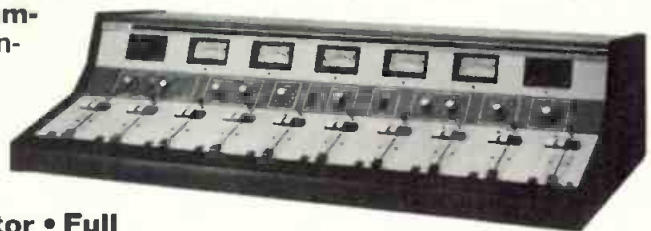

**LPB®**

**citation series** Everything you want in an audio console

LPB Inc. • 28 Bacton Hill Road • Frazer, PA 19355 • (215) 644-1123

Manufacturers and Distributors of Broadcast Equipment since 1960

© 1981 LPB Inc.



# McMICHAEL ACE CONVERTER

## the best in Standards Conversion

### McMICHAEL ACE FOUR FIELD CONVERTER

is the world's most sophisticated and accurate standards converter and is the accepted new standard for the industry.

- ★ Only converter in the world with four fields of digital storage
- ★ Bi-directional conversion between PAL, SECAM, NTSC and PAL-M and any other internationally recognized TV standards
- ★ No flicker on horizontal edges
- ★ Virtually transparent conversion
- ★ Minimum judder on vertical and horizontal motion
- ★ No loss of detail on pans
- ★ Significant noise reduction
- ★ Accepts and repairs signals that are out of specification
- ★ Soft failure modes
- ★ Price competitive to all other similar but less sophisticated systems

ACE is manufactured under license from the BBC who use ACE exclusively for standards conversion

McMichael Limited is an advanced electronics company with over 60 years' experience in the development and manufacture of state-of-the-art electronics.

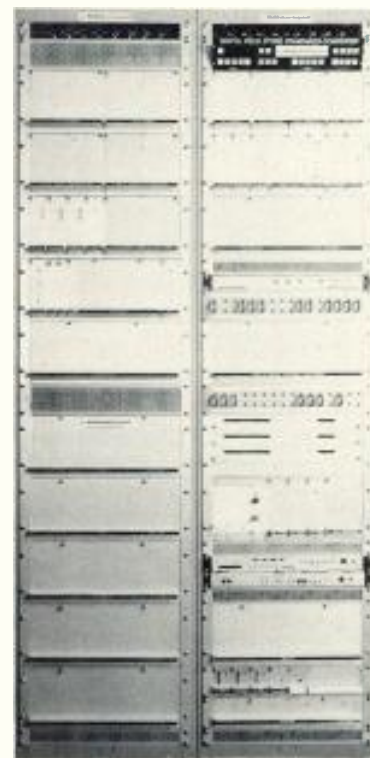
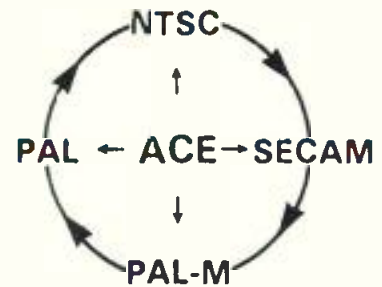

# McMICHAEL ACE CONVERTER

Marketing Dept.

McMichael Limited, Wexham Road, Slough, Berks SL2 5EL, England  
Tel (0753) 21610 Telex 849212

# GREAT IDEAS

## SOLUTIONS to problem 4: Black-Out Protector

One of the greatest fears among microprocessor users is that the system will crash during blackouts or brownouts, resulting in a loss of memory or actual system damage. *BM/E's* readers were asked to design a simple circuit that will sense line voltage drop and automatically supply standby voltage to the appropriate circuits. Here are three solutions to this problem.

### SOLUTION A

Myles H. Marks, Technical Director  
WPXI-TV, Pittsburgh, PA

A standby battery pack, no more than 0.7 volts higher than the internal power supply's output voltage, can be paralleled to the main power supply of the critical circuitry via a series silicon diode (see drawing). As long as the output voltage of the main power supply remains on, no current will flow through the diode. As soon as the power supply's voltage drops below 0.7 volts lower than the standby battery pack, the diode will conduct and supply power from the battery pack.

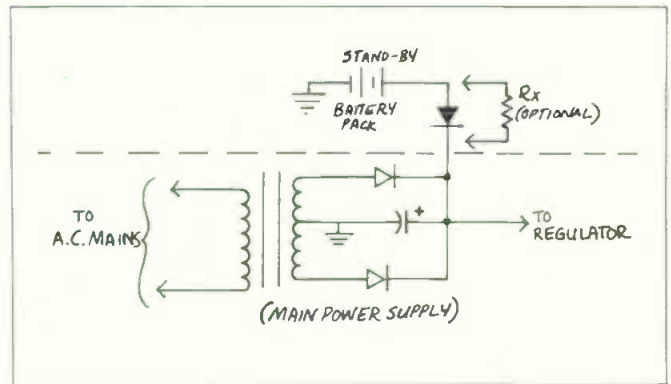

Moreover, using this simple method (and if rechargeable batteries are used), by connecting an appropriate-size resistor across the diode it is possible to keep the batteries trickle-charged while the main power supply remains operating.

It should be noted that the diode should be connected to the output of the power supply *before* going into the regulator circuitry of the critical circuitry.

## VOTE NOW!

BALLOT ON READER SERVICE CARD

# IT SERVES THEM RIGHT!

## CREATIVE PRODUCERS DESERVE A VERSATILE SWITCHER

WIPE BEHIND A CHROMA KEY  
WIPE OVER A CHROMA KEY  
INDEPENDENTLY POSITIONABLE INSERTS  
TWO MIX EFFECTS SYSTEMS  
DOWNSTREAM KEYER  
MASTER FADE TO BLACK

The 6124 production switcher affords a great degree of flexibility. Its two fully independent cascaded mix-effects systems each with a keyer, enable a large number of complex functions to be performed; from simple cuts to the most complicated multiple re-entries.

**AUTO DRIVE™** with its S-100 bus computer is a plug compatible option, which may be added at any time, to upgrade the 6124 to a programmable switcher with 255 events. Each event may be set from one frame to 99 minutes. **AUTO DRIVE™** controls all switcher functions simultaneously.

Model 6124

Price N.T.S.C. \$13,700.

P.A.L. \$14,700.

Encoded Chroma Keyer Not Available in P.A.L.

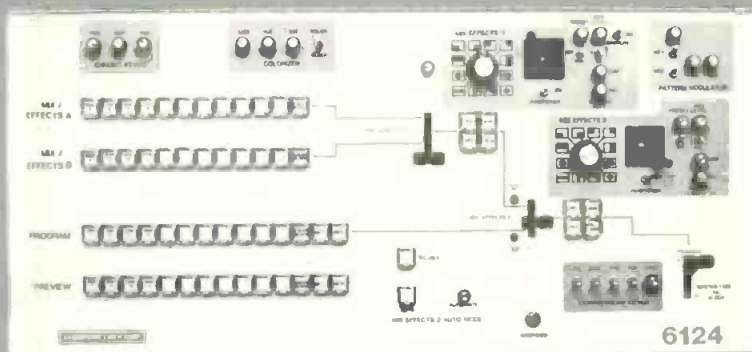

### CROSSPOINT LATCH CORP.

95 Progress Street, Union, N.J. 07083

Tel. (201) 688-1510 Telex: 181160

# GREAT IDEA CONTEST

Here's a chance to share your own personal solutions to some of broadcasting's most vexing engineering needs . . .

Each month, *BM/E* presents two engineering problems and invites you to submit solutions complete with diagrams. *BM/E*'s editors will read the entries and select the best for publication—giving readers an opportunity to vote for the idea they consider best by using the ballot area on the Reader Service Card.

We will pay \$10 for each entry printed. In addition, the solution in each month's competition receiving the most votes on our Reader Service Card will win an engineering slide rule calculator. So put on your thinking cap and submit an answer to either of the problems outlined below . . . and be sure to watch this section for the solutions.

## Problem 6: Automatic Switchover to Back-up Transmitter

Most modern dual transmitters include automatic switchover to a back-up unit if the on-air unit fails, or automatic transfer of the load to one transmitter if both are ordinarily combined. However, broadcasters buying a new transmitter will often keep a serviceable older transmitter as a back-up. And, in such cases, a system is needed to cut automatically to the old transmitter if the new one fails. This circuit may include repeated trials of the new transmitter, with some time limits, and also warning signals activated by a failure. What would be your proposed design for such a system?

**Solutions to Problem 6  
must be received by  
May 15, 1982 and will be  
printed in the July, 1982 issue.**

## Problem 7: Intercom/IFB in the On-Air Console

Both radio and TV stations frequently need to communicate with on-air talent before or during transmission. Though separate intercom/IFB systems are available, do you have a plan for one which can be incorporated within an audio mixer so that program audio and communications can be simply integrated?

**Solutions to Problem 7  
must be received by  
June 15, 1982 and will be  
printed in the August, 1982 issue.**

### CONTEST RULES

- 1. How to Enter:** Submit your ideas on how to solve the problems, together with any schematic diagrams, photographs, or other supporting material. Entries should be roughly 500 words long. Mail the entries to *BM/E*'s Great Ideas Contest, 295 Madison Avenue, New York, NY 10017. Use the official entry form or a separate piece of paper with your name, station or facility, address, and telephone number.
- 2. Voting and Prizes:** *BM/E*'s editors will read all entries and select some for publication; the decision of the editors is final. Those selected for publication will receive a \$10 honorarium. Each month, readers will have an opportunity to vote for the solution they consider the best by using the Reader Service Card. *BM/E* will announce the solution receiving the most votes and will award the winner of each month's competition an engineering slide rule calculator.
- 3. Eligibility:** All station and production facility personnel are eligible to enter solutions based on equipment already built or on ideas of how the problem should be solved. Consultants are welcome to submit ideas if they indicate at which facility the idea is in use. Manufacturers of equipment are not eligible to enter. Those submitting solutions are urged to think through their ideas carefully to be certain ideas conform to FCC specs and are in line with manufacturers' warranty guidelines.

Mail Official Entry Form to:

#### **BM/E's Great Ideas Contest**

295 Madison Avenue, New York, NY 10017

*Solution to Problem #* \_\_\_\_\_

Your Name: \_\_\_\_\_

Title: \_\_\_\_\_

Station or Facility: \_\_\_\_\_

Address: \_\_\_\_\_  
\_\_\_\_\_

Telephone: (\_\_\_\_\_) \_\_\_\_\_

I assert that, to the best of my knowledge, the idea submitted is original with this station or facility, and I hereby give *BM/E* permission to publish the material.

Signed \_\_\_\_\_

Date \_\_\_\_\_

# The brightness you need to show it big

## General Electric Professional Large Screen Video Projection

With General Electric's exclusive sealed light valve and sealed Xenon lamp system, in both color and monochrome General Electric Professional Large Screen Video Projectors, you can depend on sharp pictures from 2 to 25 feet wide. New high brightness models allow the room lighting viewers need to take notes and refer to written material.

The color projectors reproduce every color accurately, with the convenience of inherent color registration. General Electric's exclusive single gun, single optical path light valve system eliminates the need for manual color convergence.

Portable and flexible, the projectors are being used for a wide variety of applications, including front and rear projection. Our applications experts will tell you whether yours can be added to the growing list, which includes:

**Education:** Medical, dental, engineering, computer science instruction.

**Business:** Sales meetings, industrial training, product presentations, real-time display of computer-generated data, teleconferences.

**Aerospace and Defense:** Situation displays, simulator training.

**Entertainment:** Theatre television, closed-circuit TV events, overflow crowds, special effects.

**Television Production:** Backgrounds for news programs, special effects, data display, program previewing.

Call or write: General Electric Company, Video Display Equipment Operation, Electronics Park 6-206, Syracuse, NY 13221. Phone: (315) 456-2152.



**NEWS BACKGROUND** at WTMJ-TV, Milwaukee, is displayed rear screen by General Electric projector.



**SELL-OUT CROWDS** at Fiske Planetarium, Boulder, watched live NASA transmission presented by General Electric projector.

### GE Professional Large Screen Television Projector Specifications

COLOR PROJECTORS									
Model	Light Output in Lumens			Resolution* in TV Lines per Picture Height		Input Power Req.		Scan Standards***	Video Input**
	Open Gate, Min.	Modulated TV, Min.	Modulated TV, Typ.	Min. Horiz.	Min. Vert.	Watts	Volt-Amps.		
PJ 5000	550	220	280	750	300	1200	1600	525 li./60 fps; 625 li./50 fps	(1)
PJ 5050	1250	500	650	750	300	1600	2150	525 li./60 fps; 625 li./50 fps	(1)
PJ 5800	550	200	280	750	600	1200	1600	875 lines, 60 fps	(2)
PJ 5850	1250	500	650	750	600	1600	2150	875 lines, 60 fps	(2)
PJ 5100	550	200	280	750	650	1200	1600	1023 lines, 60 fps	(2)
PJ 5150	1250	500	650	750	650	1600	2150	1023 lines, 60 fps	(2)
MONOCHROME PROJECTORS									
PJ 7000	1000	600	750	800	400	1000	1350	525 li./60 fps; 625 li./50 fps	(3)
PJ 7050	1700	1000	1250	800	400	1000	1350	525 li./60 fps; 625 li./50 fps	(3)
PJ 7055	3300	2000	2400	800	400	1500	2000	525 li./60 fps; 625 li./50 fps	(3)
PJ 7800	1000	600	750	800	650	1000	1350	875 lines, 60 fps	(3)
PJ 7850	1700	1000	1250	800	650	1000	1350	875 lines, 60 fps	(3)
PJ 7855	3300	2000	2400	800	650	1500	2000	875 lines, 60 fps	(3)
PJ 7100	1000	600	750	800	750	1000	1350	1023 lines, 60 fps	(3)
PJ 7150	1700	1000	1250	800	750	1000	1350	1023 lines, 60 fps	(3)
PJ 7155	3300	2000	2400	800	750	1500	2000	1023 lines, 60 fps	(3)

Line Power. All Projectors 117 or 240 v., ± 10%, 50/60 Hz

\*Resolution measurements made with wide-band video input

\*\*Video Input Key: (1) NTSC or RGB. (2) RGB. (3) Wide-Band

\*\*\*For use at other scanning rates, contact General Electric (VDEO) for special application/model information



Circle 165 on Reader Service Card

## TAX TIPS

Naturally, the liberalized rule does not completely eliminate the requirement under the basic tax law that the lessor must have some minimum investment unconditionally at risk in the leased property. The lessor is also required to contribute 10 percent of the cost of the leased property either in cash or in amounts borrowed with recourse.

Furthermore, the lessor will have to continue to have at least 10 percent of the original cost of the leased property unconditionally at risk throughout the duration of the lease. In addition, the lease may not have a term that exceeds more than 70 percent of the economic useful life of the property nor will these modified leasing rules apply to property that is used by the lessee for personal purposes.

The virtual elimination of the criteria by which transactions are evaluated to determine whether they are leases or not, combined with the pass-through of depreciation allowances and tax credit, appears to be a boon to every broadcaster. Not only should these provisions have an impact on the equipment leasing industry, but many financially distressed companies should also benefit.

Because cash-shy or troubled firms often have little or no tax liability, they cannot take full advantage of even the minimal tax breaks for purchased equipment under the old rules, let alone the greatly increased tax benefits under the new tax law. But under these new leasing provisions, they are permitted to take advantage of the new write-offs, at least partially, in the form of reduced leasing costs.

These rules, in effect, permit a company to rent capital assets instead of buying them while, at the same time, gaining at least part of the tax benefits normally accruing to buyers. The law shifts the normal tax advantage of buying to the lessor, with the hope that the lessor in turn will agree to lower rental payments from the tenant or lessee. It is this "selling of tax credits" that has recently received so much attention in the press.

On a somewhat negative note, what at first looks like a break for small or cash-short companies may, in reality, turn out to be of little actual benefit to them. The new law contains still another provision that is likely to make lessors more, rather than less, demanding in the future. The old tax rules stated that the residual, or trade-in, value of leased property would revert to the lessor; the new law leaves this open to negotiation. With the lessors losing one of their major advantages, this may prompt them to drive much harder bargains in the future.

The door is now open for everyone in the broadcasting business to begin thinking about leases. An awareness of these rules should enable you to acquire the equipment or property you need at a rental value below what you formerly paid. Or, if you are the one planning on using your excess equipment to earn rental income, you will benefit because the restrictions have been eased.

With either approach it is imperative that you seek the assistance of your tax adviser. There is talk in Washington of repealing some of the leasing provisions, particularly the so-called selling of tax credits. Senator Robert Dole, chairman of the Senate Finance Committee, has, in fact, threatened to introduce legislation making any repeal retroactive to the beginning of February 1982. The new tax laws are still on the books, however, and with the help of your tax adviser, it is still possible to benefit from them.

BM/E

## NEVER MISS ANOTHER COMMERCIAL BREAK!



... thanks to  
**Monroe Electronics**  
**MODEL 3000R-14**

### VIDEO RECORDER CONTROL UNIT!

The new Video Recorder Control Unit from Monroe Electronics lets you automatically insert commercials from an unattended video cassette recorder. The Model 3000R-14 can be programmed to switch directly to the commercial tape or to include a short message or station ID from another source. A telephone interface lets you override the entire operation from any Touch Tone\* telephone at any remote location.

**Two important features highlight Monroe's 3000R-14 Video Control Unit.**

- A diagnostic SELF-TEST MODE enables you to check out the entire sequence of operation without actually starting up the machine.
- A DTMF decoder allows use of STOP, REWIND or LENGTH-OF-NEXT-COMMERCIAL cues independent of the program source cues.

**If you've been losing income because of missed commercials, call or write today for literature and prices.**



**MONROE ELECTRONICS, INC.**

100 Housel Avenue, Lyndonville, NY 14098 Phone: 716/765-2254

\*Touch Tone is a registered trade mark of AT&T

Circle 163 on Reader Service Card

## VCR IN-CASE OPERATION



**SPEED UP YOUR SET-UP...  
OPERATE YOUR VCR IN THE CASE!**

- SLIDE-OFF LIDS, GROOVED TRACKS
- REAR CABLE ACCESS
- ETHAFOAM SOUND PROOFING
- VENT SPACE UNDERNEATH
- AIR FLOW THROUGH REAR

**THE INCASE BY EXCALIBUR.**

CALL FOR INFO  
**213/899-2547**

**EXCALIBUR INDUSTRIES**

12427 Foothill Blvd., Lake View Terrace, CA 91342 · (213) 899-2547

Circle 164 on Reader Service Card

# Outstanding Outdoors

Camera location 3 behind home plate is no place to tear down a camera. Especially if the director wants to punch it up on air to catch the next pitch. That's just one reason why the rock-steady, works-every-time HK-357A is an outstanding choice for production in the field.

Beyond its reputation for legendary Ikegami reliability, the HK-357A has a lot more to recommend it as the ideal field camera. For example, its crisp, high resolution picture, signal-to-noise ratio of better than 53 dB, and superb colorimetry.

What's more the camera really shows off when it's time to set up. Use of the optional microproces-

sor control brings into play Ikegami's Emmy award winning digital techniques for automatic setup. Simply press one button and the computer automatically refreshes all set up and registration adjustments in about 45 seconds. No chip charts blowing in the wind, no tweaking. Just unpack, plug-in, auto-setup, and shoot.

Hook up is a simple matter too. Choose the triax option and you can position the camera as far as a mile from the van with absolutely no compromise in picture quality as compared to multicore. And for versatility, our triax camera interfaces with TV-81 multicore at the flip of a switch.

Field test an HK-357A to see why Ikegami is the choice of so many networks, major market stations, and independent producers.



NATAS ATAS

## Ikegami HK357A

Ikegami Electronics (USA) Inc., 37 Brook Avenue  
Maywood, NJ 07607, (201) 368-9171

Northeast: (201) 368-9171  West Coast: (213) 534-0050

Southwest: (713) 445-0100  Southeast: (912) 924-0061

Canada: (201) 368-9179



Circle 162 on Reader Service Card



## New Opportunities for Leasing

by Mark E. Battersby

THE ECONOMIC RECOVERY ACT of 1981 is going to change the way a lot of broadcasters do business. In fact, if you are among those who are involved with or have been thinking about leased equipment, the new tax rules may prove quite rewarding.

Now that leasing companies are free to pass along the tax benefits normally associated with property ownership, the way has been cleared for an expansion of equipment leasing activities. And, thanks to those same new rules, you are likely to find that the former restrictions governing just what does or doesn't constitute a lease for tax purposes have been eased.

Under the old tax law, only the so-called owner of property could claim the investment tax credit and the depreciation deductions for the property or equipment. When the user of the equipment or the property didn't have sufficient tax liability to fully utilize the accompanying tax benefits, quite often a "leveraged" lease was arranged. With a leveraged lease, a person or entity that needed tax deductions or credits actually purchased the desired equipment and leased it to either the leasing company for releasing or directly to the end user. With this type of arrangement, the end user usually profited from lower rental charges.

Until now, however, the IRS has limited the extent to which leveraged leasing could be used as a means of transferring tax benefits. Specifically, in order to obtain a ruling that a three-party financing transaction purporting to be a lease would be accepted as such for tax purposes, the Internal Revenue required (among other things) that: (1) the lessor's minimum at risk investment in the property be at least 20 percent of cost; (2) the lessor have a positive cash flow and a profit from the lease independent of the tax benefits; (3) the lessee not have the right to purchase the property at less than its fair market value; (4) the lessee not have investment in the lease and not lend any of the purchase costs of the owner; and (5) use of the property at the end of the lease term by a person other than the lessee be commercially feasible.

Quite obviously these guidelines permitted only a very few transactions to qualify as legitimate "leveraged"

leases or even as leases of any kind. Equally obvious, leases drafted within these guidelines could not hope to provide enough opportunities to distribute the increased tax benefits generated under the new depreciation and tax credit rules.

As a means of facilitating the use of leasing transactions in order to help enhance absorption of both the new depreciation deductions under the cost recovery system and the liberalized new investment tax credit, the new law includes a unique "safe harbor" from the Internal Revenue's old administrative leasing guidelines. This safe harbor is limited to leasing transactions involving corporate lessors (other than personal holding companies and Subchapter 'S' corporations).

As part of the safe harbor, the initial and continuing minimum at risk investment required of the lessor will be reduced from 20 percent of a 10 percent minimum; and, in determining the lessor's expected cash flow and profit from the lease, the tax benefits of ownership may now be taken into account. The new rules, it should be noted, are intended simply as a safe harbor from the IRS's administrative guidelines, although it is anticipated by lawmakers that they will greatly increase the other effects of the Economic Recovery Act.

The safe harbor rules will apply only in the case of property or equipment that is Section 38 (investment tax credit) property and only if the property is leased within three months after its acquisition by the lessor. If the lessor leases the property back to the person from whom the lessor acquired it (our familiar sale-leaseback transaction), the rules will apply only if the lessor acquired the property within three months after acquisition by the transferor/lessee and at a price no greater than the price paid by that transferor/lessee.

Property or equipment placed in service after 1980 and before the date of enactment of the new law is considered by lawmakers to meet the three-month requirement so long as it is leased within three months of this enactment date. Otherwise, the safe harbor rules are considered to be effective after June 25, 1981—with no expiration date, as many of the Economic Recovery Act's provisions have.

# It deserves an Oscar

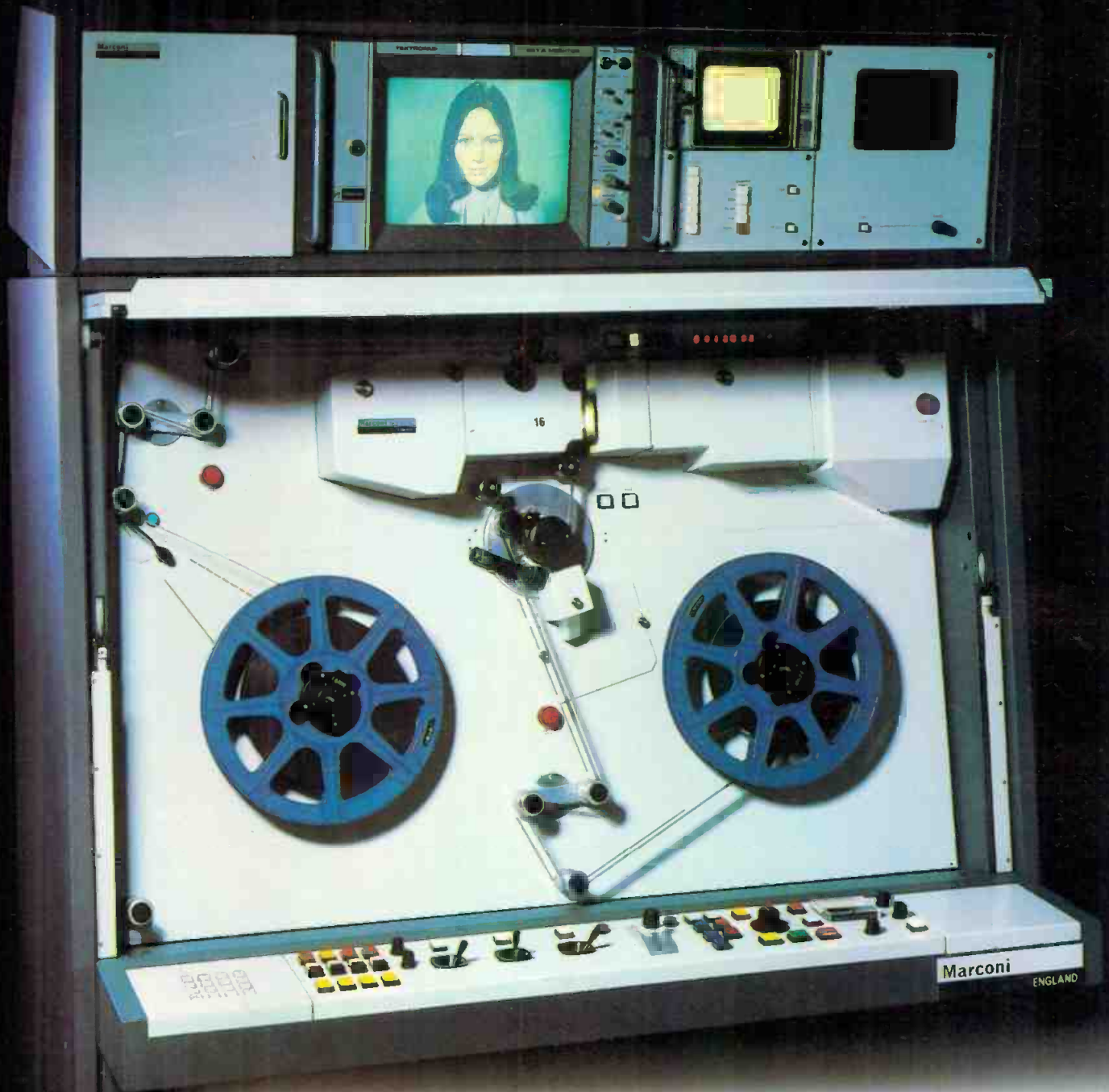

## The New Marconi Line Array Telecine B3410

For a remarkable contribution to film in TV, Marconi's new Line Array Telecine B3410 fully deserves its great reputation.

The unique combination of full digital processing with micro-processor control and CCD sensors means exceptional picture quality, shorter set-up times, rapid change of TV standards, long life and minimum maintenance. No tubes, no replacements!

Also offering fast change of film gauge and full resolution Cinemascope, this most outstanding newcomer is available for swift delivery at a highly competitive price.

For full details contact: Marconi Electronics Inc. (John White or Simon Frazer)

Tel: (201) 767-7250 or A.F. Associates  
Inc. (Richard V. Lunniss or Bill Ebell)  
Tel: (201) 767-1000.

**Marconi**  
Electronics Inc.



100 Stonehurst Court, Northvale, New Jersey 07647. U.S.A. Tel: 767-7250, Telex:  
710-991-9752.

Circle 161 on Reader Service Card

[www.americanradiohistory.com](http://www.americanradiohistory.com)



**“I want the world.  
Consistent .05% corner registration  
and full auto-setup of up to 96  
cameras on computer command.”**

**HITACHI HEARD YOU.**

**AUTO  
SETUP**

Don't want much, do you?

Dynamic registration not just at dead center but at all four corners.  
Plus 2-minute auto-setup of all those cameras.

You're asking for some smart camera system, networks  
of the world and top-drawer video production companies.

Well, Hitachi heard you, and has created an outright *genius*—  
the Hitachi SK-110 Camera System.

The computer registration capabilities of this camera system  
produce pictures of a  
clarity and resolution  
previously unheard of.

And you get auto-setup  
at the push of just one but-  
ton, and zero reference,  
too, where the computer  
sets the green channel and  
compares blue and red to  
it with absolute precision.

The SK-110 is not only self-correcting, but self-diagnostic  
as well. It gives both video screen display and hard copy print-  
out; can be hooked into the CRT for control room monitoring.

There's a high-performance contour corrector;  
5 automatic setup modes including quick check;  
5 data files; so many other unique features an ad  
can't begin to tell you about them.

The ultimate Hitachi SK-110. Contact the  
broadcast video division at any of the offices  
listed below. Hitachi Denshi America Ltd.,  
175 Crossways Park West, Woodbury, NY  
11797 (516) 921-7200. Offices also in  
Chicago (312) 344-4020; Los Angeles  
(213) 538-4880; Atlanta (404)  
451-9453; Cincinnati (513) 489-6500;  
Dallas (214) 233-7623; Denver  
(303) 344-3156; Seattle,  
(206) 575-1690; and Washington,  
D.C. (301) 459-8262.

Circle 160 on Reader Service Card

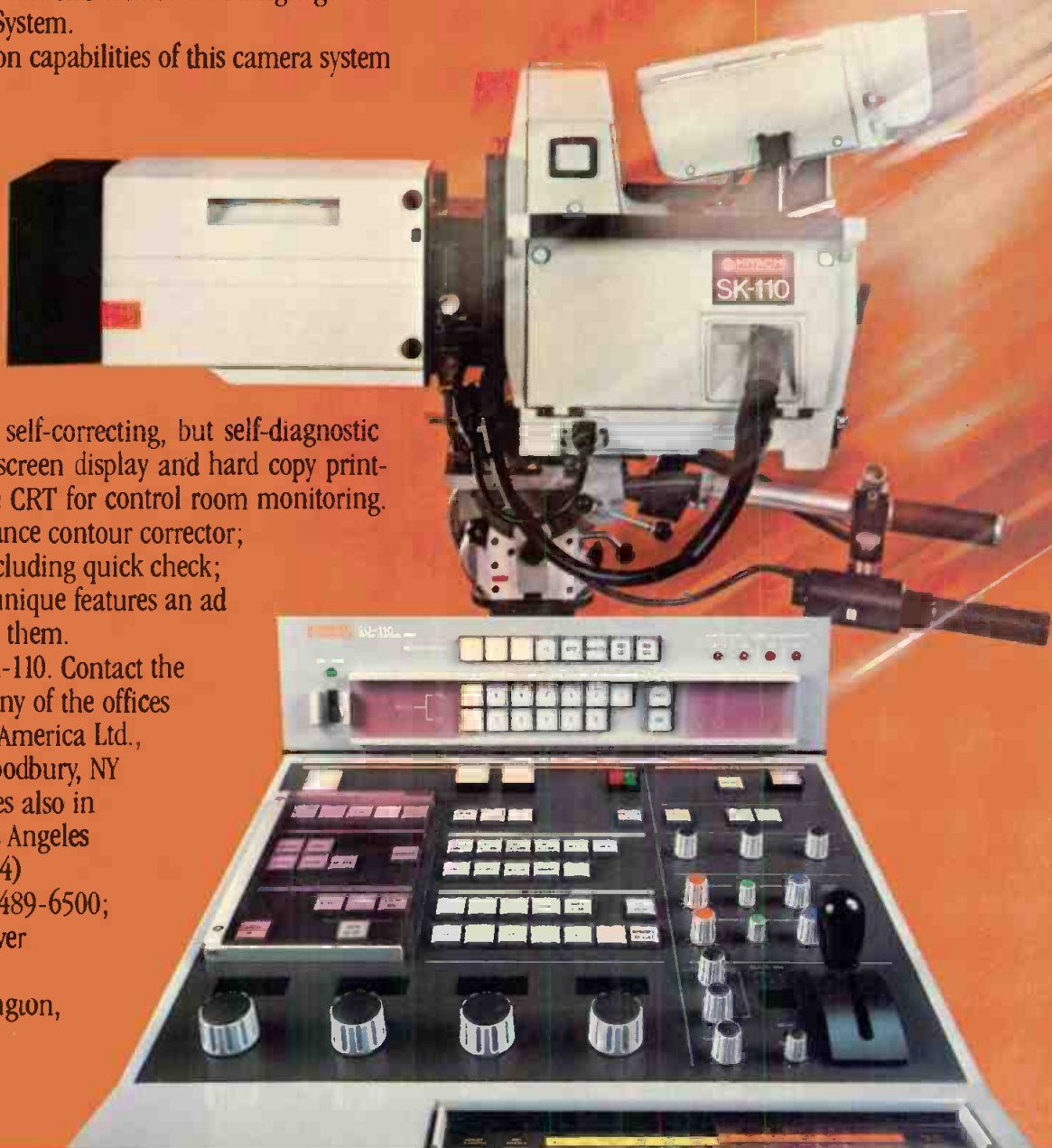

# FCC RULES & REGULATIONS

certain terms that it thinks everyone could get along quite well, for instance, without the Fairness Doctrine.

With such support growing, it appears to be only a matter of time before some congressional action will be taken. If and when it happens, however, it is likely to demonstrate the truth of the time-honored observation that, indeed, there is no such thing as a free lunch. For example, one of the FCC's suggested changes—repeal of Section 307(b) of the act, requiring allocation of radio frequencies in a "fair, efficient, and equitable" manner "among the several States and communities"—is suggested as a "substantial quid pro quo" to reflect the substantial deregulatory proposals. However, repeal of Section 307(b) can be viewed as an antibroadcast move; the current law's language suggests a congressional preference for use of RF spectrum on a local basis to serve local needs. This supports broadcast stations, licensed as they are to particular communities, while developing technologies based on distant program reception, such as cable television and direct broadcast satellites (DBS), are disfavored. Since many observers believe that the broadcast industry could be facing a serious threat from cable and DBS, Section 307(b) is being clung to as a protective measure for broadcasters, and its repeal could lead to new emphases, and possibly new definitions, within the broad universe of communications industries.

The possible reorganization of the Commission itself as it confronts the once distinguishable but increasingly overlapping areas within its jurisdiction should also be ex-

amined. As is apparent from the satellites report in this issue of *BM/E*, new satellite technology is growing into areas once reserved for broadcasting. The most obvious example of this, direct broadcast satellites, could be operational before the end of the decade; a number of specific proposals are even now under active consideration at the Commission. However, the FCC's internal organization—with a Broadcast Bureau, Cable TV Bureau, Common Carrier Bureau, and so forth—is not set up to deal with the policy questions created by the services that straddle traditional definitions.

To adjust itself to the communications industry of the 1980s and 1990s, the Commission is considering a variety of restructuring options. While no details have been released, it is a good guess that one option involves the creation of a "Mass Media Bureau" to handle all matters relating to media. This would include broadcasting, of course, and also such services as DBS and multipoint distribution systems, both of which are currently handled in the Common Carrier Bureau. Cable TV could conceivably fall in this category as well. Combining all of these services in one bureau might seem a cumbersome process likely to result in confusion and inefficiency. But it would enable the Commission to take into account all of the mass communications needs of the American public and all of the available technological means of meeting those needs. From it might come a coherent and consistent set of policies designed to offer to the public and the industry the maximum benefits possible.

BM/E

## Look, no hands!

Just push a button. That's how easily you can switch your transmission system to any mode or alignment without the inconvenience of manual patch links. Comark automatic switches are available for all coaxial and waveguide systems and can be fully operated by remote control. For a free brochure return the coupon below or call (413) 569-5939.

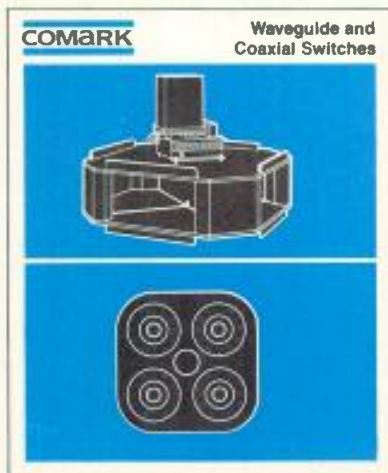

Comark Industries, Inc.  
P.O. Box 229  
Southwick, MA 01077

Send me more information about  
Transmission Switches.

Name

Company

Address

City  State

Zip  Phone

Visit us at NAB Booth 1709  
Join our treasure hunt  
where everyone is a winner

**COMARK**

Circle 159 on Reader Service Card

## 24-HR. PROFESSIONAL SERVICE FOR COLLINS & CONTINENTAL AM & FM TRANSMITTERS

Continental Electronics offers parts and engineering service for all Collins AM & FM transmitters.

Whenever you want parts or service for your Collins or Continental equipment, phone our service numbers day or night,

**(214) 327-4532 parts**  
**(214) 327-4533 service**

Continental Electronics Mfg. Co.  
Box 270879; Dallas, Texas 75227

Phone (214) 381-7161

1 kW thru 50 kW AM & FM transmitters and related equipment.

Continental   
Electronics

"A New Strength in Radio Broadcasting Equipment"

Circle 158 on Reader Service Card

# RCA FM power tubes. 15 to 55kW outputs at high efficiency.

RCA is now in the FM power tube business with a series of four tubes and cavities designed specifically for high-gain, high-efficiency broadcast service:

Tube Type	Output	Gain	Efficiency	Cavity Model
8986	15kW	20db	80%	Y1393D-V1
8985	25kW	20db	80%	Y1393D-V2
9011	30kW	21db	80%	Y1393D-V3
8984	55kW	16db	78%	Y1369

There's a very persuasive reason for using a tube with high efficiency: lower operating costs. Over the lifetime of a transmitter this can mean considerable savings.

And RCA tubes are designed for long life.

Our cavities complement our tubes. They provide high-gain, grid-driven circuits which take full advantage of the tubes' high Gm electron optics, high efficiency, ease of neutralization and ease of cooling.

Along with our power tubes, and the cavities that bring out their best performance, we also supply service and application engineering. Find out more today. Contact RCA Power Tube Marketing, New Holland Avenue, Lancaster, PA 17604. Call (717) 397-7661. Or get in touch with RCA, Brussels, Belgium. Sao Paulo, Brazil. Sunbury-on-Thames, Middlesex, England. Paris, France. Munich, West Germany. Mexico 16 D.F., Mexico. Hong Kong.



We supply both the power tube and the cavity. In our pictured Y1393 cavity, the 9011 tube delivers a measured gain of 20 db with an efficiency of 80%.

# RCA

## FCC RULES & REGULATIONS

action, i.e., such items as the maximum amount of commercial time permitted to be broadcast.

However, what distinguishes the recent auxiliary broadcast revision from the 1981 radio deregulation action is that the recent revision relates to actual spectrum use and avoidance of technical interference through private cooperation and coordination. The sanctity of the spectrum, and the perceived need to impose restrictions on its use in order to assure interference-free service, are among the most basic justifications offered in support of the Commission's existence. Indeed, governmental regulation of broadcasting was first deemed necessary back in the 1920s because competing stations, then subject to virtually no technical regulation, sought to drown out one another.

In light of this history, the Commission's present willingness to rely on competitive pressure to assure technically acceptable use of auxiliary frequencies is somewhat surprising, and reflects the extent of the current Commission's belief in the "miracle of the marketplace." It is, of course, something of a risk, a risk that could increase substantially if the experiment is extended to other areas. For example, while the "no license, no log" approach has not been adopted yet with respect to any other types of service, it appears that some Commission staffers may have given thought to applying a variation of this approach to low power television operations. Exactly how this might have worked is not clear.

There are, then, some possibly important develop-

ments on the horizon at the Commission. However, the *real* action to watch for will occur, if at all, on Capitol Hill. After all, the source of all of the Commission's regulatory power is none other than the Communications Act, which only Congress can change. In particular, the "public interest" standard—the vague catch-all rubric with which the Commission justifies its every action—is a creation not of the Commission but of the Congress, which included it in the act. Further, the act itself contains several provisions that, in and of themselves, impose fairly dramatic governmental restrictions on broadcasters' rights. These include, for example, the political broadcasting rules requiring that equal time, at lowest unit rates, be provided to political candidates, and that candidates for federal offices be guaranteed "reasonable access" to all stations.

From time to time there have been assaults mounted on various aspects of the act, most to no avail. Now, however, there is growing support, both inside and outside Congress, for serious overhaul of most, if not all, of the broadcast-related provisions of the act. Voices from various sectors have been heard advocating codification of the deregulatory steps already taken by the Commission, as well as elimination of the Fairness Doctrine and the political broadcasting rules, the possibility of comparative challenges to renewal applicants, and other burdensome aspects of the act. Probably the most impressive advocate of legislative pruning is none other than the Commission itself, which has let Congress know in no un-



# The Total VTR Battery System

- Power-packed, higher performance Nicad<sup>®</sup> Cells deliver more VTR running time, longer life, never need maintenance, fast charge in one hour.
- Exclusive electronic circuitry and quality construction provides the identical total reliability of Cine 60 Powerbelts... standard of the industry.
- "Total Charge Capability, anywhere..."
- On location, fast charge from any 12 Volt car system — unattended, in one hour, with our 3 lb. Car Fast Charger — no heavy inverter needed.
- From A.C., one hour fast-charge with our 3 lb. Universal Model 9400 or BP 2500.
- Fast Charge four batteries — automatically and unattended — with our new, multiple, High Frequency, Regulated Fast Charger, one per hour, four in 4 hours.
- Standard charge 2 batteries overnight, with our two channel, regular Charger.
- Directly replaces original VTR batteries — Sony BP-20, BP-20A, BP-50, BP-60, BP-80, BP-90 and JVC/Panasonic PBP-1.
- See your local authorized Cine 60 Dealer. Ask about the Total VTR Battery System you need.

There's Always Something New From Cine 60

## CINE 60

530 Ninth Ave.  
New York, N.Y. 10036  
(212) 586-8782  
TWX: 710-581; TELEX: 645-647

6430 Sunset Blvd.  
Hollywood, Ca. 90028  
(213) 481-3046

Circle 156 on Reader Service Card

# interpreting the FCC rules & regulations

## Deregulation 1982 and Beyond: Relaxations, Repeals, and Redefinitions

by Harry Cole

IN LOOKING FORWARD to the next big step in deregulation, one should probably anticipate that first noncommercial radio, and later television, licensees will be given the freedoms that commercial radio already enjoys under deregulation. Those include elimination of program logging and ascertainment requirements as well as elimination of guidelines concerning nonentertainment and (for commercial TV licensees) commercial programming.

The freeing up of *all* noncommercial licensees from logging and ascertainment rules, together with a general relaxation of the overall programming obligation to which they are also subject, is already in the works; it was proposed last summer and is ready for action as of this writing. Commercial television may not be far behind, as some reports have indicated that the Commission may soon be prepared to consider for television the same types of deregulation that it has extended to radio.

However, as was noted last month, the deregulatory changes effected thus far have not fundamentally altered the regulatory environment. Those changes have made life somewhat easier, at least in the short run, but they have not created the freewheeling atmosphere that some associate with the notion of "deregulation." Other

changes of this ilk include the recent elimination of the annual financial report requirement and the possible relaxation of some of the filing requirements involved in the Commission-imposed equal employment opportunity program. Both of these have been under discussion for some time.

One other interesting area to which deregulation may spread was hinted at in February, when the Commission created a type of blanket authorization permitting broadcasters to use certain auxiliary frequencies on a temporary basis without having to obtain a separate license. Under this new system, broadcasters may use the auxiliary frequencies involved for up to 30 days (720 hours) without any prior approval from the FCC, and without even having to keep logs concerning the operation. While licensees taking advantage of this option are expected to contact local frequency coordination committees or the like to assure any particular frequency's availability, this is no more than courtesy.

It is beyond question that this approach is but an extension of the already well-established philosophy of deregulation. The governing concept is that broadcasters will act in their own best competitive interests, which, the theory goes, will impose more efficient and effective restraints on broadcasters than does governmental regulation. In many respects this is probably a sound theory. And, in any event, it can't hurt to try it out on the types of regulations covered in the commercial radio deregulation

---

Harry Cole is a partner in the Washington, DC, law firm of Farmer, Wells, McGuinn, Flood and Bechtel. Cole was also on staff for a year and a half at the Broadcast Bureau of the FCC.



# BRILLIANT

## The New Anton/Bauer LG-30 Lighting Head

Anton/Bauer, the recognized leader in portable battery systems, has done it again with their new LG-30 "Black Beauty" Lighting Head, the ultimate in portable lighting.

This unique unit offers professional features not found in any other light — a spring loaded, captive, swing-away dichroic filter; integral one hand on-off and focusing; extra heavy duty



The perfect companion for the LB-300 Battery Belt.

cable and strain relief; a standard handle with spare bulb storage (removable for camera mounting); brackets for custom mounting on all ENG cameras; and an improved lamp socket that accepts standard 12v and 30v bulbs. The LG-30 "Black Beauty", the first truly heavy duty professional portable light.

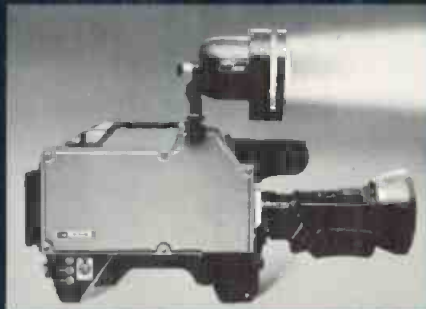

The LG-30 mounts easily to any ENG camera.



For further information:

**NEW ADDRESS: ANTON/BAUER, INC. One Controls Drive Shelton, CT 06484 (203) 929-1100**  
**DEALER INQUIRIES INVITED**

Circle 155 on Reader Service Card





New from McMartin was an FM demodulator for satellite service.

kHz bandwidth maintained throughout the transmission path. United Stations says it is using SCPC analog at the present time but is configuring the system for ready shift to digital audio at a later date. The company offers to give detailed advice to any subscriber on getting a proper earth terminal.

The United Press, in the process of building a sat net to serve about 5000 subscribers, had excellent material on hand to explain the system and give help to radio stations looking toward an earth terminal. The UPI terminals, as reported last year, are being made and installed by Harris Corporation. Harris will also maintain them under contract to UPI. UPI subscribers can get terminals with several different financial arrangements, including long-term part payments through UPI.

Three firms, Comsearch, Compucon, and Spectrum Planning, Inc., were at the show to offer frequency analysis and coordination of prospective earth terminal sites. Although the FCC has removed the absolute requirement of licensing for small aperture terminals, many in the industry point to the danger of being "bumped" if the frequency coordination and licensing are not carried out.

Described in a companion satellite story in this issue and in earlier stories, and very much present at the show, (largely in hospitality suites) were several of the most significant satellite operations. ABC's TalkRadio and Superradio were both displayed strongly to the industry. So was Satellite Music Network, the first full-format programmer. Bonneville Broadcast Consultants, the first Beautiful Music programmer on a satellite, brought a large orchestra to its reception to entertain friends and prospects. There was a universal sense that satellite distribution will more than come up to its billing as a great new power source for broadcasting. **BM/E**

For more information: Scientific Atlanta, 250; Bell System, 251; Broadcast Electronics, 252; Cetec, 253; Harris Corp., 254; Sono-Mag, 255; UMC, 256; Andrew Corp., 257; Anixter-Mark, 258; Antenna Technology Corp., 259; Calstar, 260; ComTech Data Corp., 261; M/A-Com, 262; McMartin, 263; Microdyne, 264; NEC, 265; Pinzone, 266; RCA, 267; Satellite Transmission Systems, 268; United Satellite Systems, 269; Modulation Assoc., 270; Audio & Design Recording, 271; Video Data Systems, 272; Associated Press, 273; United Stations, 274; United Press, 275.

## THE NEW STANDARD COVERS AM BAND PLUS HARMONICS TO 5 MHz



The Model FIM-41 Field Strength Meter has many more features —

- Measures Harmonics to -80 dB
- High Adjacent Channel Rejection
- Ganged Oscillator/Receiver Tuning
- Stable Operation over wide Temperature Range
- Low Battery Drain Circuits
- Front Panel Speaker
- Large illuminated Meter and Tuning Dial
- Indicates field strength accurately down to 10  $\mu$  volts/M
- RF input jack for tuned voltmeter applications

CONTACT US NOW FOR COMPLETE DETAILS  
ON OUR LINE OF FIELD STRENGTH METERS

# POTOMAC INSTRUMENTS

932 PHILADELPHIA AVE.  
SILVER SPRING, MARYLAND 20910 (301) 589-2662

Circle 153 on Reader Service Card

**REVOLUTIONARY  
NEW**

# ISOMAX™

**MICROPHONE**

**IMPROVES:**

- ↑ "on mike" sound
- ↑ available gain without feedback
- ↑ isolation for conferences & interviews
- ↑ matte black finish looks great on camera

**REDUCES:**

- ↓ room rumble & echo
- ↓ clothing noise
- ↓ camera noise
- ↓ paper shuffle noise

**ISOMAX PRO**  
for balanced line battery  
or phantom operation.

**ISOMAX W**  
for use with all wireless  
battery pack transmitters.

## COUNTRYMAN ASSOCIATES INC.

417 STANFORD AVE.-REDWOOD CITY, CA. 94063-PHONE 415-364-9988

Circle 154 on Reader Service Card

## Design Engineering Service/Test Engineers

Excellent career opportunities are immediately available with fast growing Broadcast Electronics. You will find state of the art design tasks exceptionally challenging and the working environment in a 70,000 square foot headquarters complex pleasant and stimulating. Excellent company benefits, including Profit Sharing Plan.

### Section Manager RF Products

Lead a creative group of RF Design Engineers through the development of a new line of innovative RF broadcast products. Position requires a strong background in design of RF power amplifiers or in AM or FM transmitting equipment along with skills in supervisory and project management. BSEE with 3-5 years' experience.

### Section Manager Audio Products

We need an experienced audio engineer with some project management experience to head up development team to design audio tape cartridge machines and audio control consoles. Individual should have BSEE.

### Radio Automation Service Engineer

If you enjoy working with program automation equipment and have a technical background with a good command of digital electronics, you could be the person for this challenging position. The overwhelming success of our "Control 16" Program Control System has resulted in an opening for a Customer Service Engineer.

### Transmitter Test Technician

Must possess experience or skill to test, align and troubleshoot RF amplifiers or broadcast transmitters up to 30KW power output.

### Also, Challenging Opportunities For Design Engineers

We are seeking talented designers for the RF, audio, microprocessor hardware and mechanical engineering sections. Applicants should have BSEE or BSME degree with one to three years' experience.

Candidates are invited to send resume, in strict confidence, to Personnel Department.

An Equal Opportunity Employer

**BE** BROADCAST  
ELECTRONICS INC.

4100 NORTH 24TH STREET, P.O. BOX 3806  
QUINCY, IL 62305, PHONE (217) 224-9600

## NEWS FEATURE

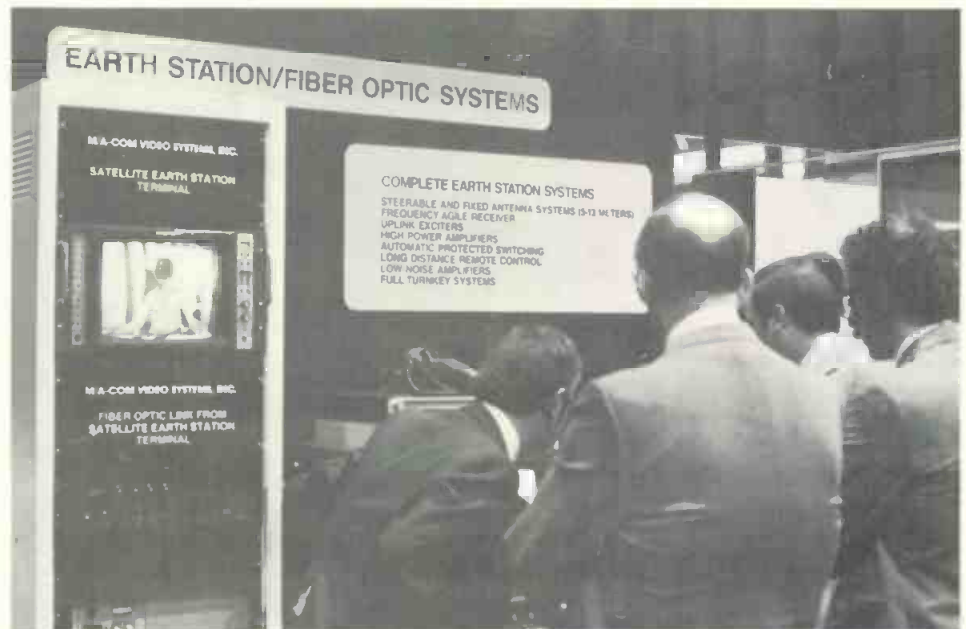

MIA-Com's satellite terminal equipment is compatible with Bell's T1 digital service.

terminal cost. USS had a complete terminal in operation on the lot with a 3.8-meter antenna and remote control system. The "sat hopping" was most successful with good quality video from all U.S. satellites, and from others such as the Mexico City transmission now opening that country to satellite service.

Modulation Associates described its "affordable" radio earth terminals with antennas of two, three, and 3.7-meter diameter. The firm makes a variety of electronic units for the systems, among them the "Economy-Sat," described as a member of a new generation of small aperture terminal units of low cost but good quality. With these or other electronics units in the line, Modulation Associates will assemble and deliver complete earth stations.

Audio & Design Recording introduced a new audio processing system, the F601 super-dynamic limiter (described in detail in next month's account of audio processing at the show), aimed primarily at audio-line performance in radio stations. However, the ability of the processor to handling PCM digital signals gives it relevance for reception of satellite digital signals. The unit has very great dynamic range (100 dB) and other characteristics to match.

Video Data Systems introduced the VITL (vertical interval transmission link) system, primarily for sending data on a standard video signal encoded in the vertical interval. It will be covered in detail in the Show-In-Print issue, but should be noted here as a possible data channel for satellite video transmission.

### Services and programming

New satellite service and new satellite programming were both in evidence at the show. The whole industry, of course, is alive with organizations aiming toward the creation of new sat nets for software production. Only a part of this activity came up at the show, but what was there indicated strongly the directions the industry is taking.

In a bold shift, the Associated Press announced a music service, which was available starting April 1, bringing to AP affiliates and others live country music every night, all night. The program, to run from 10:00 PM to 5:00 AM, will originate in studios built for it at WSM in Nashville and will air the performances of the country music stars who are so often on hand in "Grand Old Opry" land. Host from 10:00 to 2:00 will be Chuck Mangione; others of similar renown will take over for the later period.

The program is being fed to the AP's earth terminals and can be subscribed to on a one-to-a-market basis, with AP affiliates getting first crack in each market. With about 500 of the earth terminals already in place, and with the number to reach 900 by the end of this year, virtually every medium to large market in the country now has or will soon have at least one AP earth terminal.

United Stations, a New York-based software producer, will also put out country music, in this case 24 hours a day. The programming will originate in the firm's studios in New York and go by T1 digital landlines to the sat uplink for Westar 2 in Verne Valley, NJ. Programming will be in stereo, with 15

# NEWS FEATURE

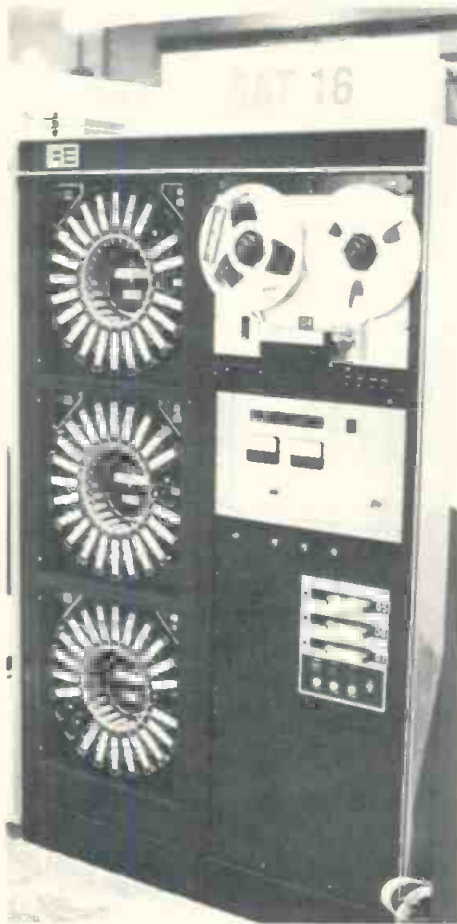

BE's Sat 16 automation unit decodes satellite cue tones.

keyboard to return the antenna to any position that has been entered in the memory.

NEC introduced a new Series 204 TVRO electronics system consisting of the 4417 low noise converter and the 4420 demodulator. The signal is sent from the LNC to the demodulator at UHF so a small coaxial cable can be used. A 10-key touchpad on the demodulator allows instant choice of any satellite frequency. NEC had a complete earth terminal in operation on the lot, with a five-meter 4 GHz antenna made by Alcoa.

Pinzone, based in Newbury, OH, showed a new 24-channel receiver for satellite systems with 7 dB true dynamic C/N threshold, 11 dB noise figure, full 30 MHz IF bandwidth and 8.4 MHz video band. The company offers complete earth terminals using Prodelin antennas, Dexcel low-noise amplifiers, and Cablewave feed lines and coax.

RCA had a separate demonstration of the ADDS digital audio system with a special listening room. The programming came from Scientific-Atlanta (also using it in the S-A demo described above); RCA will build only the uplink part of the system. RCA was also emphasizing the "OVT" equalization system, which reduces the ef-

fects of noise in satellite transmission. OVT was introduced at earlier NAB conventions.

**Satellite Transmission Systems.** This wholly owned subsidiary of California Microwave, builder of a considerable number of large uplink stations around the world (including the AT&T uplink in Coram, NY, mentioned earlier) brought a new video companding system, the VP-100T and 100R (transmitter and receiver). The stated benefit is a 6 dB minimum in-

crease in signal-to-noise ratio. The capability includes the video signal and two 15 kHz audio channels, with simple addition of a scrambling system (also made by STS).

**United Satellite Systems.** This firm, based in St. Hilaire, MN, makes antennas of 3.8 and five-meter diameter and combines them with electronics from other firms for complete TVRO earth stations. The pitch is strongly toward the backyarder, but also to TV stations looking for reasonable earth



When I first described to Electro-Voice engineers what I knew the Sentry 100 had to be, I felt like a "kid in a candy store." I told them that size was critical. Because broadcast environment working space is often limited, the Sentry 100 had to fit in a standard 19" rack, and it had to fit *from the front, not the back*. But the mounting hardware had to be optional so that broadcasters who didn't want it wouldn't have to pay for it.

The Sentry 100 also had to be both efficient and accurate. It had to be able to be driven to sound pressure levels a rock 'n roll D.J. could be happy with by the low output available from a console's internal monitor amplifier.

The Sentry 100 also had to have a tweeter that wouldn't go up in smoke the first time someone accidentally shifted into fast forward with the tape heads engaged and the monitor amp on. This meant high-frequency power handling capability on the order of five times that of conventional high-frequency drivers.

Plus it had to have a 3-dB-down point of 45 Hz, and response that extended to 18,000 Hz with no more than a 3-dB variation.

Since it's just not practical for the engineer

## Electro-Voice's Greg Silsby talks about the Sentry 100 studio monitor

to always be directly on-axis of the tweeter, the Sentry 100 must have a uniform polar response. The engineer has to be able to hear exactly the same sound 30° off-axis as he does directly in front of the system.

I wanted the Sentry 100 equipped with a high-frequency control that offered boost as well as cut, and it had to be mounted on the front of the loudspeaker where it not only could be seen but was accessible with the grille on or off.

I also didn't feel broadcasters should have to pay for form at the expense of function. The Sentry 100 had to be attractive, but another furniture-styled cabinet with a

fancy polyester or die-cut foam grille wasn't the answer to the broadcast industry's real needs.

And for a close I told E-V's engineers that a studio had to be able to purchase the Sentry 100 for essentially the same money as the current best-selling monitor system.

I'm happy to report that we've achieved all our objectives.

Market Development Manager, Professional Markets



**EV** Electro-Voice  
a gulton company

600 Cecil Street, Buchanan, Michigan 49107  
In Canada: Electro-Voice, Div of Gulton Industries (Canada) Ltd.,  
345 Herbert St., Ganoaque, Ontario K7G 2V1.

Circle 150 on Reader Service Card

**M/A-COM DCC proudly announces digital audio satellite receivers for the radio networks.** Our MAESTRO™ (M/A-COM Earth Stations for Receive-Only) terminal is a complete 3-meter earth station system which receives high quality 15 KHz and 7.5 KHz digital audio signals. Each complete system includes: 3-meter antenna, low-noise amplifier, down-converter, digital program terminal, and installation cables and materials.

Uplink transmission equipment and complete earth stations can also be provided for private networking and common carrier applications.

**Selected by AT&T/Bell Laboratories**

MAESTRO™ is the result of combining the latest in earth station technology with digital program audio. The M/A-COM DCC design has been chosen for the AT&T audio network from among other approaches because of

superb technical performance and our broad-based experience in providing digital earth stations and audio equipment for international and domestic satellite needs, such as telephony, TV-sound, and broadcast program distribution.

**Remote Uplink Capability**

MAESTRO™ can accommodate multiple uplinks from remote locations within the same satellite transponder. This supports special broadcasting situations without requiring additional equipment for multiple transponder operation. The flexibility in this approach means graceful network expansion and implementation independent of other services.

**Multiple Channel Selection**

In larger networks, multiple T1 carriers can be received, and selection of carriers and audio circuits is done by simple thumbwheel selection or under external computer control.

Within a single transponder, up to twenty 15 KHz audio channels can be selected.

**Affordable**

MAESTRO™ terminals are available on lease terms, or can be purchased directly. Installation can be completed in less than one day using simple step-by-step instructions, and without the use of heavy equipment, extensive ground preparation, or technical know-how.

**Don't delay! Let M/A-COM DCC show you how satellite program distribution can increase your AM or FM listening audience by offering the finest in audio quality.**



Leading the Way in Satellite Communications Technology

**PRESENTING THE MAESTRO™**

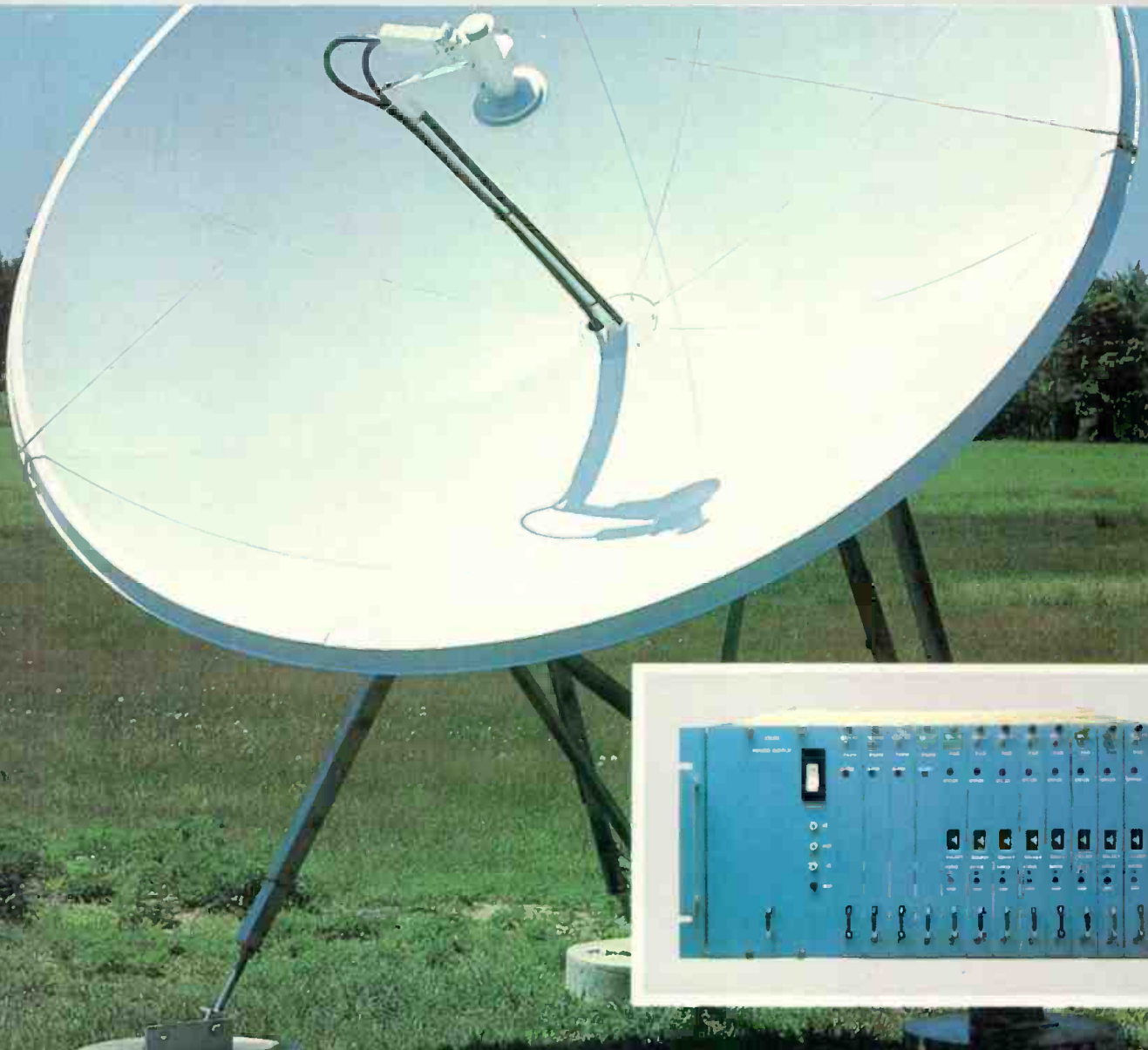

U.S.: M/A-COM DCC Inc., 11717 Exploration Lane, Germantown, MD 20874, Phone (301) 428-5532  
 Canada: DCC, 1290 Airco Blvd., Mississauga, Ontario, L4W1B2, Canada, Phone (416) 674-1810  
 Europe: DCC LTD, Humphreys Rd., Dunstable Woodside Estates, Dunstable, Bedfordshire LU5 4SX, England  
 Phone (0582) 666616

Circle 149 on Reader Service Card

**Prices on  
BARCO  
monitors  
reduced  
substantially**

**Order now  
while the  
devaluation of  
the Belgian  
Franc is in  
your favor.**

**Call your local  
rep. or our  
toll free number  
for these new  
low prices.  
(800)-526-2270**

**Rohde & Schwarz  
Sales Co. (U.S.A.) Inc.**  
14 Gloria Lane  
Fairfield, N.J. 07006

## NEWS FEATURE

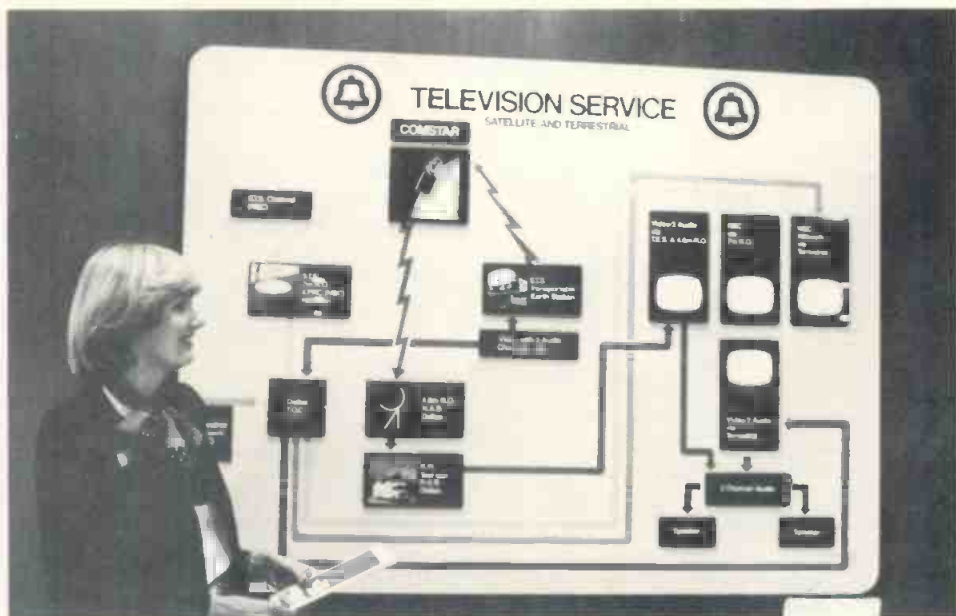

The Bell System promoted its satellite and terrestrial television services, also demonstrating digital audio transmission for radio.

firm, had information on many large uplink installations made around the world and on an extensive line of high-power and control equipment for microwave service.

M/A-Com DCC, recently the absorber of the long-established Microwave Associates, introduced a new line of three-meter earth terminals for digital audio compatible with the Bell T1 digital service. Called the "Maestro" series, the terminals work with 15:11:15 companding and have the high audio quality of the Bell digital system. The firm also said it is prepared to build uplinks for the system. M/A-Com had a full earth terminal on the lot with a five-meter remote-controllable antenna for video service and showed control from the exhibit booth in the

hall, with a closed-circuit TV view of the moving antenna.

McMartin introduced a new FM demodulator for satellite service, which can be used with other electronic units. McMartin says the demodulator, with top-grade characteristics, is a less expensive choice than many combined systems.

Microdyne announced a new 12-foot antenna and complete electronics for SCPC analog or digital audio service. Minimum gain is put at 41 dB; the pedestal gives 360-degree azimuth positioning and 10 degrees to 65 degrees in elevation. Also introduced was the "MAPS" programmable antenna remote control and positioning system. As do a number of other antenna control systems, the Microdyne unit uses a

Earth station dishes in the convention center parking lot included models from NEC (far left), Scientific-Atlanta (right foreground), and SatCom Technologies (right rear).

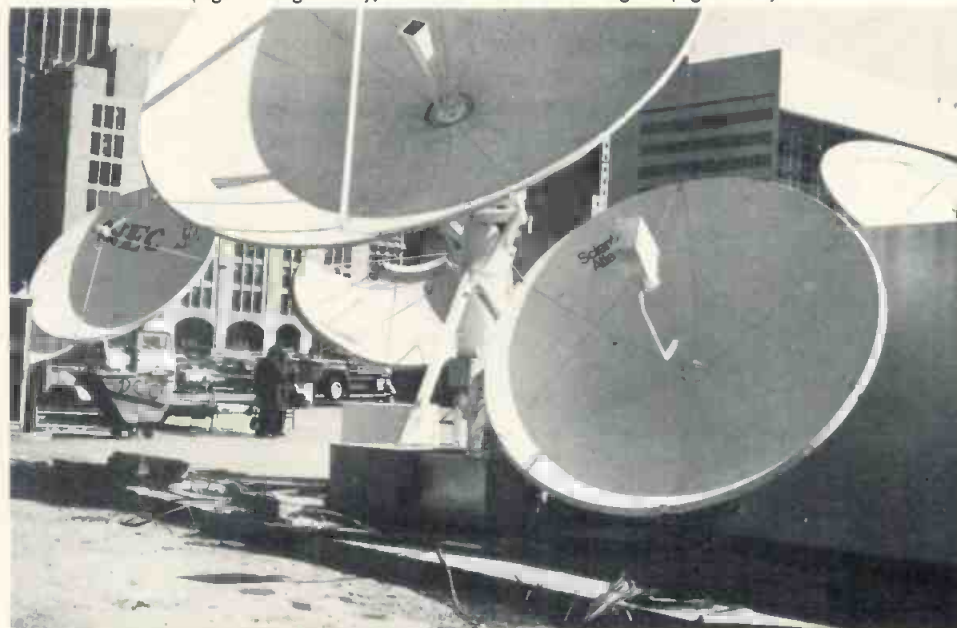

# RAMSA

## The Recording Specialist: Ramsa WR-8816

The WR-8816 recording console includes the same modular construction, input modules, power supplies, and faders as the WR-8716 plus many important recording advantages. Like direct outputs for 4, 8, or 16 track recording and peak-reading LED meters that let you monitor any 4 out of 24 signals with clear, quick response.

You'll command a variable frequency EQ section with 3 frequency settings for the high and low frequencies plus continuously variable

midrange. Stereo echo send replaces the separate mono controls you'll find on competitive boards. And you get two independent stereo monitor controls—one for musician's headphones, one for control room monitors—a special feature for any mixer in this class. And there are other important features

like low noise electronically balanced mic inputs with new high-speed IC's, 16 switchable post-fader solo controls and XLR-type mic connectors.

Ramsa offers a full line of specialty mixers including the more compact WR-8210 recording mixer and WR-130 sound reinforcement mixer. So don't hold down your professional sound, call (201) 348-7470, because you're ready for Ramsa.



See us at NAB Booth 1621

**Panasonic**  
PROFESSIONAL AUDIO DIVISION

Circle 102 on Reader Service Card

www.americanradiohistory.com

# BM/E

BROADCAST MANAGEMENT/ENGINEERING

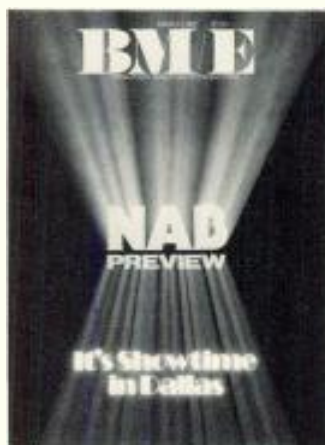

The NAB is coming to Dallas, as this month's cover proclaims. Our preview contains an overview of all the new products to be introduced at the big show. Cover art was designed by Mark Rogan.

Art direction for the March issue by Saija Osis.

Publisher  
**Charles C. Lenz, Jr.**  
Editorial Director  
**Gerald M. Walker**  
Editor Emeritus  
**James A. Lippke**

Editor  
**Robert Rivlin**  
Senior Editor  
**Robin Lanier**  
Managing Editor  
**Janet E. Smith**  
Associate Editor  
**Eva J. Blinder**  
Assistant Editor  
**Tim E. Wetmore**  
Editorial Assistant  
**Douglas Damoth**  
Editorial Assistant  
**Toria Smith**  
Special Assignments Editor  
**C. Robert Paulson**

Associate Publisher  
**Djuna Van Vort**  
Production Manager  
**David Rose**  
Circulation  
**Robert Crawford**  
Sales & Marketing Assistant  
**Charles Read**  
Reader Service  
**Sharon Porges**

Comptroller  
**Michael J. Lanni**

## MARCH 1982/VOLUME 18/NUMBER 3

### 8 Editorial

*Go slow on technical deregulation*

### 12 Broadcast Industry News

*Sony Corp. acquires MCI, Inc.; Radio Nets unite to form trade association; FCC voids RCA's auction*

### 23 Radio Programming & Production for Profit

*KFWB advances audio quality for RENG*

### 24 BM/E's Program Marketplace

*Syndicators Revisited—The Musicworks*

### 29 Television Programming & Production for Profit

*Tic Tac Dough: winning the syndication game*

## 35 NAB 1982: Dallas—the Sky's the Limit

### 38 It's Show Time In Dallas

*With over 460 exhibitors, there will truly be something for everyone*

### 43 What's Hot In Radio Products?

*Some important new technology for radio equipment buyers*

### 58 Radio Equipment Exhibitors Listing

### 87 What's Hot In TV Products?

*Manufacturers to emphasize product performance and equipment life*

### 113 TV Equipment Exhibitors Listing

### 176 Succeeding with ENG/EFP Microwave

*Learning how to use production microwave requires careful planning*

### 191 The 5 mm Difference

*What's behind RCA's new 1/2-in. tubes for the Hawkeye camera/VCR?*

### 199 Radio Programming: the Shape of Things to Come

*New developments could change the character of programming substantially over the next few years*

### 215 New Transmitter Design for the '80s

*Digital technology hits transmission*

### 229 Putting the Telephone to Work

*Bell's Dial-It goes beyond opinion polling and into market research*

### 237 Extending Transmitter Tube Life

*Help keep operating costs low with a program of filament voltage management*

### 249 LPTV '82: Getting the Lowdown on Low-Power

*Feelings of hope and concern mingled at LPTV '82 session*

### 261 Tax Tips for Stations

*Keeping the Business in the Family*

### 267 FCC Rules & Regulations

*Unraveling Unregulation*

### 237 Great Idea Contest

*Vote for this month's winner—enter next month's contest!*

### 238 Broadcast Equipment

*BM/E's survey of new products*

### Coming In April . . .

EFP: What you need to know when gearing up for field productions.

### BROADBAND INFORMATION SERVICES, INC.

295 Madison Ave., New York, N.Y. 10017, 212-685-5320, Telex: 644-001

Publishers: **BM/E—Broadcast Management Engineering**

**BM/E's World Broadcast News**



BM/E BROADCAST MANAGEMENT ENGINEERING (ISSN 0005-3201) is published monthly by Broadband Information Services Inc. All notices pertaining to undeliverable mail or subscriptions should be addressed to 295 Madison Ave., New York, NY 10017. BM/E is circulated without charge to those responsible for station operation and for specifying and authorizing the purchase of equipment used in broadcast facilities in the U.S. and Canada. These facilities include AM, FM and TV broadcast stations, CATV systems, ETV stations, networks and studios, audio and video recording studios consultants, etc. Subscription prices to others \$24.00 one year, \$36.00 two years, Foreign \$30.00 one year, \$48.00 two years. Air Mail rates on request. Copyright 1982 by Broadband Information Services, Inc., New York City. Second class postage paid, N.Y., N.Y. and additional mailing offices.

# NEWSMAKER

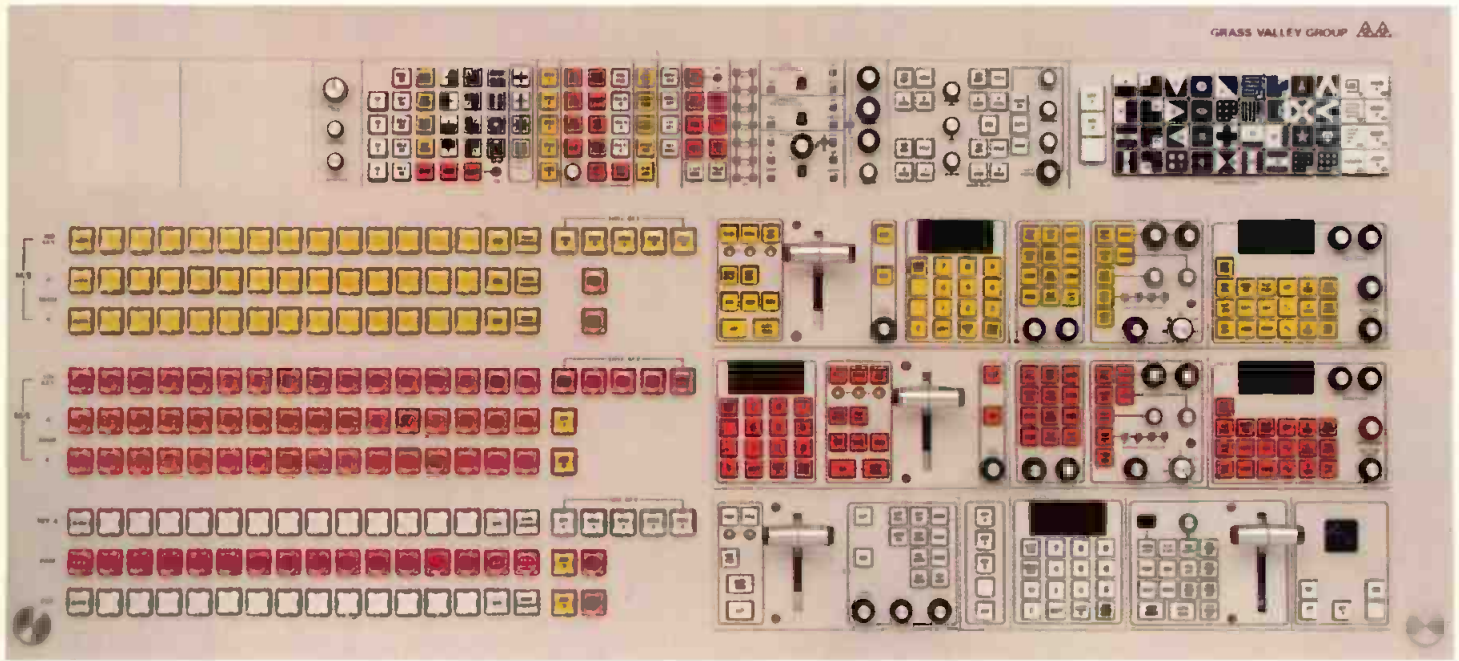

## New 300-2 Production Switcher Is Good News For Local Broadcasters!

### More Than 100 In Service

Over 100 broadcasters and production houses are now enjoying the versatile 300 Switcher in the industry's most demanding production environments. Now, local broadcasters can have the power of the 300 in a size more suited to local needs and budgets. With two full featured mix/effects systems, a program/preset mixer, downstream keyer, and optional MkII Digital Video Effects, the 300-2 is the answer to your news director's most ambitious plans to improve that air look.

### New Standard Features:

Each 300 Switcher includes a powerful E-MEM effects memory system, with *Effects Dissolve and Sequencing*, in each mix/effects system. With E-MEM storage you can preset effects for a tight news format and use sequences to recall your openings and bumpers at the push of a button. Other standard features, such as automatic external key selection, chroma key memory, independent lever and title auto transitions, look-ahead preview and up/down unlimited re-entry make the 300 very responsive to fast paced production.

### An Integrated System:

The 300 Switcher and optional MkII Digital Video Effects were designed as a total system. The DVE interface, including *automated input switching buses, tracking chroma key, wipe follow, microprocessor communication and camera tally*, is fully implemented in the system. For post production needs, a field proven serial interface is available for use with most premium grade computer editing systems. Your "News Switcher" can do double duty for commercial and promotion production, keeping down costs of outside services while attracting new clients.

### Grass Valley Group Reliability

Separate microprocessors per mix/effects, wire-per-function backup on critical control panel functions and carefully thought out fail-safe modes assure maximum on-air confidence. Of course, GVG service support and training courses are available.

Production power, straightforward operation, unique standard features and Grass Valley reliability — a *total system*. Why not make news in your market with a 300 Production System?

## THE GRASS VALLEY GROUP, INC.®

P.O. BOX 1114 GRASS VALLEY CALIFORNIA 95945 USA • TEL: (916) 273-8421 TWX: 910-530-8280

A TEKTRONIX COMPANY

Offices: **Eastern Regional:** 499 Thornall St, Edison, NJ 08817, (201) 549-9600 • **Southeastern District:** 1644 Tullie Circle N.E., Ste 102, Atlanta, GA 30329 (404) 321-4318 • **Midwestern Regional:** 810 West Bristol St, Elkhart, IN 46514 (219) 264-0931 • **Northwestern District:** 3585 North Lexington Ave, Ste 238, Arden Hills, MN 55112 (612) 483-2594 • **Southwestern District:** 316 Seminary South Office Bldg, Fort Worth, TX 76115 (817) 921-9411 • **Western District:** 1032 Elwell Court, Ste 244, Palo Alto, CA 94303 (415) 968-6680 • **Western Regional:** 21243 Ventura Blvd, Ste 206, Woodland Hills, CA 91364 (213) 999-2303

Circle 103 on Reader Service Card

[www.americanradiohistory.com](http://www.americanradiohistory.com)



# EDITORIAL

## Go slow on technical deregulation

REAGANOMICS (or, more technically, supply-side economics) has a strangely ambivalent meaning for broadcasters. On the one hand, broadcasting seems to be about to break free of the regulatory shackles—primarily those imposed by the FCC—that have held it in check almost since its inception. On the other, unregulation may mean the kind of neo-“Wild West” mentality—almost a state of anarchy, if you will—in which it’s every broadcaster for himself and may the best station (or the one with the most capital) win.

Herb Korte, VP of engineering for Broad Street Communications, writes: “One of my AM chief engineers sent me a letter from a listener. While not too great a distance from the transmitter, the listener loses the station in the evening because of spectrum crowding. Why can’t he continue to receive us, he wants to know? And yet the last line of the listener’s letter also makes this request: ‘Please pass along to the FCC my support of your efforts to have your burdensome regulations relaxed.’”

Nowhere is the dichotomy of unregulation more apparent. Without restrictions, the station would undoubtedly raise its power levels, theoretically putting more signal into the listener’s home; but then, so would the other stations in the area. The net result would be a lot more power, but little benefit to the listener.

The potential for technical deregulation has already been broached with the relaxation of the first class licensing rule. More may be on the way—removal of type requirements for modulation monitors, for instance, or abandonment of mandatory proof of performance procedures.

Many broadcasters, it seems, are heartily applauding the FCC’s efforts in these directions. Too long, they argue, has broadcasting lived under the shadow of the FCC’s “Big Brother” attitude. No government authority, they feel, has the right to legislate what is simply taste, nor, in fact, to regulate either what is broadcast or how it is accomplished.

But is technical unregulation really in the best interest of broadcasting or broadcasters? Should technology be considered in the same breath with network/affiliate relations? Has all broadcast equipment actually reached the stage when federal standards of performance are no longer required? Can industry committees be relied on to police the industry and set, by mutual consent, industry-wide standards and practices?

We fear the answer is “no” when it comes to technical regulation, and that concepts of supply-side economics and a completely free-market economy do not apply when the supply of a commodity—such as spectrum allocations—is so narrow. Nor do we accept the view that an industry left to its own devices will evolve a “natural sense of law and order” when such large profits are at stake, especially when it comes to matters of standards and practices and technical performance.

The situation is a little analogous to what might happen if speed limits and stop signs were removed from the highways. Initially, traffic might move a little faster; but the inevitable result would be chaos.

# "In terms of operation, it's magic."

## Harrison

Bill Varney is a supervising rerecording mixer at Warner Hollywood's Samuel Goldwyn Sound Facilities. He works exclusively in "Room D." Bill's credits include such films as *Raiders of the Lost Ark*, *Ordinary People*, and *The Empire Strikes Back*. Goldwyn's first Harrison PP-1 was installed in "Room D" in August, and a second console is slated for installation when Goldwyn opens its new dubbing stage later this year. What does Bill Varney have to say about his Harrison console?

"In terms of operation, it's magic. And one thing we notice about this console, more than any other we've worked behind, is that we don't 'sense' its presence. It may be hard for anyone to think that's very important unless they sit behind one of these for 9, 10, 12 hours a day. But, with the Harrison console, we never feel it's there. The design of it has been done so well that it just sort of sits there, and you do your thing and never sense that it's around."

Bill Varney,  
Warner Hollywood Studios



Harrison Systems is known for its music recording consoles, but for the past couple of years we've been quietly building a reputation as a major supplier of sound post-production consoles. Warner Hollywood, Walt Disney Productions, Compact Video, and others are using our PP-1 for motion-picture sound.

Now we are introducing two new consoles: PP-3 for film-sound facilities, and TV-3 for video-sound production and post-production.

**If your sound goes with pictures,  
we have what you need.**



HARRISON SYSTEMS, INC./P.O. Box 22964, Nashville, Tennessee 37202/(615) 834-1184, Telex 555133

Circle 104 on Reader Service Card

[www.americanradiohistory.com](http://www.americanradiohistory.com)

# IF IT WERE YOUR JOB TO GET THIS ON TAPE, WHAT TAPE WOULD YOU GET IT ON?

It's a complete mismatch. A collection of college amateurs together for only a couple of months against the equivalent of the Russian professional all-stars, a team that has dominated world hockey for a decade or more, a team that has recently embarrassed the NHL All-Stars with a 7-2 exhibition victory. But in the end, the amateurs win in a dramatic showdown for all the world to see at a time in world politics when a victory really counts.

America, like most of the world, will see the game on tape. In fact, many of the events at Lake Placid will be broadcast and rebroadcast to the world on tape under the most demanding time and temperature conditions. It's a one-chance situation all the way and the stakes are always high.

That's why Scotch® Video Tape was there when the U.S.-Russia Hockey Game was first recorded. And again when the Moon Walk was first recorded.

And again when the Space Shuttle Landing was first recorded.

The Papal Tour of America. The Return of the Hostages. The Eruption of Mount St. Helens. Whenever there was one chance to get it, chances are they got it on Scotch Video Tape.

So whether your production is important to the world or just important to you, why take chances? Get it on the one tape you know will get it right.

Magnetic A/V Products Division/3M.





**HISTORY IS RECORDED ON SCOTCH VIDEO TAPE.**

3M hears you...

**3M**

# BROADCAST INDUSTRY NEWS

## Sony Corp. Acquires MCI, Inc.

Sony Corp. of America has gained its fourth U.S. manufacturing operation with the purchase last month of MCI, Inc., of Fort Lauderdale, FL. The move gives Sony a strong foothold in the professional recording equipment industry. MCI, formerly privately held, manufactures and sells a range of multi-track recorders and studio mixing consoles. Its net sales for 1981 totaled approximately \$15 million.

Officials of the two companies said they looked forward to mutual benefit and increased growth for MCI, described as the U.S. leader in its area. MCI will operate as an independent division within Sony; company founder G.C. (Jeep) Harned will continue as president and chief executive officer of the division. Michael Schulhof, a director of Sony Corp. of America, has been named chairman.

Schulhof explained that the acquisition "further strengthens Sony's capacity for the launch of the compact digital audio disc later this year."

## Radio Nets Unite to Form News Trade Association

In a move aimed directly at increasing advertiser understanding of and use of radio networks, the major networks have joined forces for an industry-wide education and promotion effort through a new organization, the Radio Network Association Inc. (RNA). The RNA was launched as a public entity at a press conference in New York on February 9, with top personnel of the founding networks—ABC, CBS, NBC, and RKO—on hand to explain the purposes of the association.

Chairing RNA is Edward F. McLaughlin, president of ABC

Radio Networks; vice chairman is Thomas F. Burchill, president of RKO. Richard Brescia, vice president and general manager of CBS Radio Network will serve as secretary/treasurer, Richard Penn, vice president and general manager of NBC Radio Network, is director.

McLaughlin and his associates in the group affirmed that they were in active negotiation with the managements of a number of other radio nets, to invite them to become members of RNA, which hopes to encompass all nets of national scope. In answer to a question from the floor, McLaughlin said RNA was eager to extend membership to syndicators via satellite, such as Satellite Music Network.

The RNA operations, not yet planned in detail, will include many forms of information and promotion, such as advertising, press releases, exhibits, and programs on the air.

## U.K. Videotex Establishes Boston Computer Center

Commercial Prestel videotex service has hit the U.S. with the inauguration of a Boston computer center that gives users access to a 210,000-page database. The service, in operation in the U.K. since the fall of 1979, provides business users with two-way interactive information transmission and reception. Companies may also establish their own databases for closed, internal use.

British Telecom (formerly with the British Post Office) runs the service, designing the software along with Aragon and Logica. Hardware is built by GEC Computers of the U.K. A floppy disk that converts an Apple II home computer to Prestel has recently become available to U.S. users for \$85; a Zenith Prestel terminal runs \$1250.

In a separate development, Times Mirror Videotex Services, Inc., a division of Times Mirror Co., has joined with Infomart of Toronto to form a joint venture company that will market commercial Telidon videotex systems in the



The Prestel computer, known as "Jefferson," in its Boston home. As of January, over 15,000 Prestel sets in 25 countries were in service.

U.S. The two companies will own equal shares in the new firm. First order of business for the joint venture has been to supply the system for an ambitious field trial of Telidon that Times Mirror begins this month in southern California. The trial will include, information retrieval, such on-line transactional services as telebanking and Ticketron ticket reservations.

## FCC Voids RCA's Auction

RCA Americom's auction of seven Satcom 4 transponders (see *BM/E*, December, 1981, p. 10) has been voided by the FCC, which ruled that the variation in price for the individual transponders constituted discrimination. The Commission cited section 202(a) of the Communications Act, which prohibits common carriers from charging customers varying amounts for like services without reasonable justification.

An RCA Americom spokesman told *BM/E* at press time that the company was at work on an alternate tariff structure that it hoped would "meet the needs of the Commission." The new structure was expected to be ready by the end of February.

Although it rejected RCA's particular auction method, the FCC said it would give consideration to "non-discriminatory rates for satellite transponders developed by auction or some other way reflecting supply-and-demand rather than cost."

The Commission also had critical words for RCA Americom's plan to

**Neve**  
A WORLD OF EXCELLENCE



5100 Range  
TV Audio Consoles

## NEW BROADCAST AUDIO TECHNOLOGY

### TV AUDIO CONSOLES

Neve is proud to introduce the 5100 Range of Television Audio Consoles, specifically designed for North American requirements. From 16 in/4 out to 48 in/16 out, this new technology range leaves competition again far behind, through superior performance, ease of operation, high quality construction, and the ultimate in reliability as well as serviceability. Delivery is generally from stock to 60 days, including most options. Why wait for old technology when you can get new technology right away?

### RADIO CONSOLES

The new 5322 Radio Console is designed for the discriminating radio station. If you desire a premium radio console, the Neve 5322 is the answer.

### BROADCAST INTERCOM

Neve's NECOMM is a technically advanced and cost effective family of intercom systems for broadcast facilities. The microprocessor based NECOMM system features virtually unlimited capability for user modification and future expansion. Standard software programs for various broadcast applications are available now, field proven in many television facilities over the past 3 years. NECOMM is easily and economically configured in systems from 16 x 16 to 256 x 256 with a full range of terminals, from cost effective passive panels to intelligent stations. NECOMM is easy and inexpensive to install, in existing as well as new broadcast facilities, occupying much smaller physical space compared with other systems of lesser capabilities. NECOMM can fit into your facilities and budget!



5300 Range  
Radio Consoles



NECOMM Range  
Broadcast Intercom

**Neve**

Rupert Neve Incorporated Berkshire Industrial Park, Bethel, Connecticut 06801 Tel: (203)744-6230 Telex: 969638

Rupert Neve Incorporated 7533 Sunset Blvd., Hollywood, California 90046 Tel: (213)874-8124 Telex: 194942

Rupert Neve Incorporated P.O. Box 120907, Nashville, Tennessee 37212 Tel: (615)385-2090

Rupert Neve of Canada, Ltd. 2721 Rena Road, Malton, Ontario L4T 3K1, Canada Tel: (416)677-6611 Telex: 983502

Neve Electronics International, Ltd. Cambridge House, Melbourn, Royston, Hertfordshire, SG8 6AU England Tel: (0763)60776

Rupert Neve GmbH 6100 Darmstadt Bisnarckstrasse 114, West Germany Tel: (06151)81764

[www.americanradiohistory.com](http://www.americanradiohistory.com)

# You'll save time, trouble, testing -and money- with ADC Custom Jackfields.

Standard Longframe Jackfields

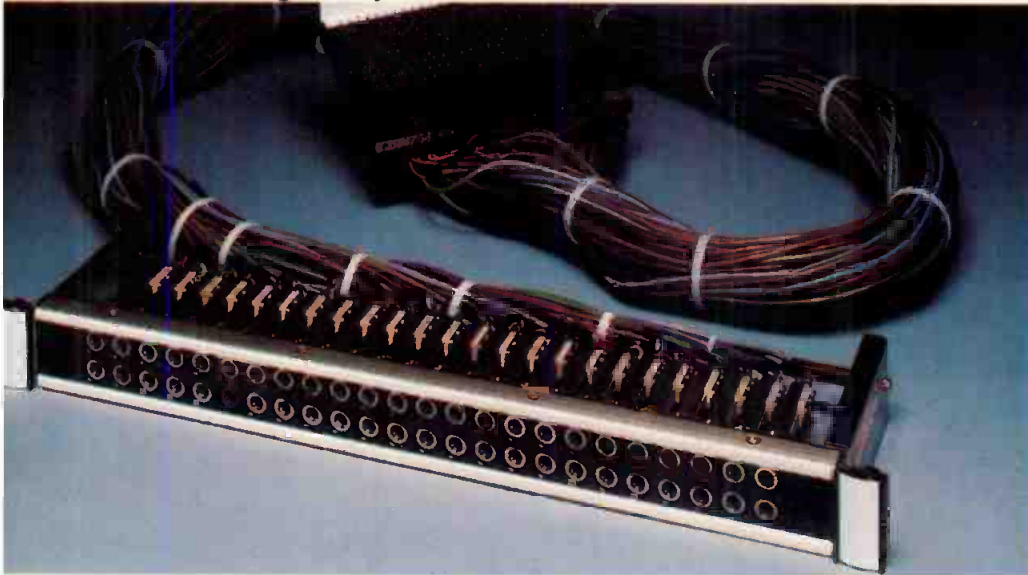

ADC Pro-Patch Video Jackfields

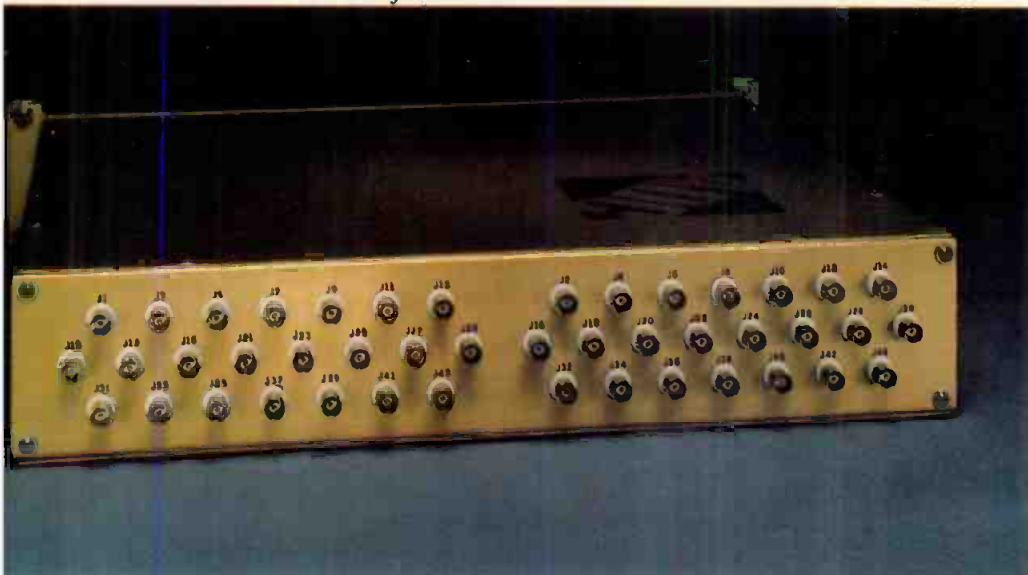

ADC Pro-Patch Audio Jackfields

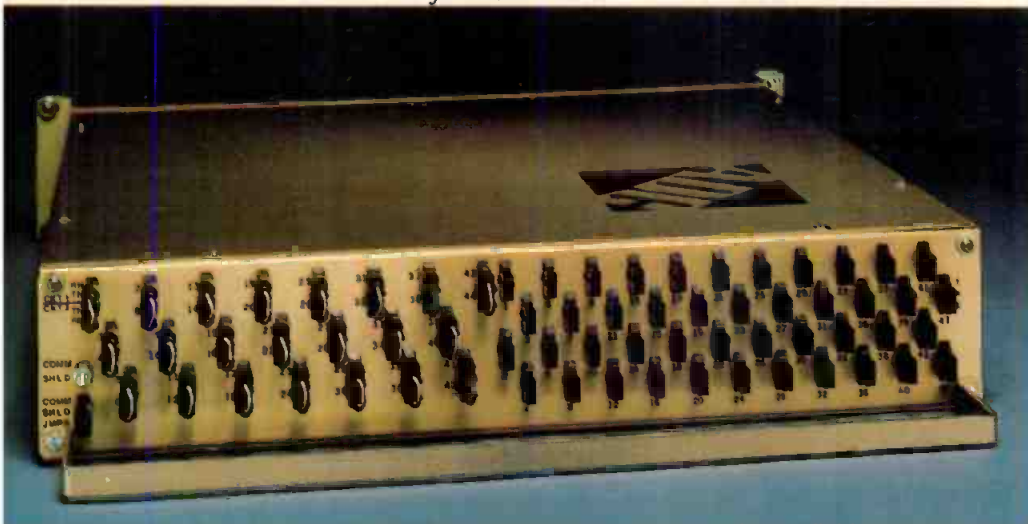

If you consider the cost of your time, building your own jackfields is expensive. ADC can deliver pre-wired, pre-tested custom jackfields in just 2 to 4 weeks. And they're priced from 20% to 50% below your do-it-yourself costs.

We offer various configurations including your choice of options such as: choice of panel size, longframe (1/4"), or bantam jacks, wire wrap or solder assembly, variable cable lengths, choice of normalling configuration and types of terminations.

When complete, we thoroughly inspect and computer-test every circuit, every connection to make sure the unit operates to specification. That's why we can back every unit we produce with a five year warranty. And our 40-plus years' experience in building jackfields for the telephone industry helps us make these reliable units:

**Standard Longframe Jackfield**—One of our most popular jackfields shown here with jacks mounted in a 1 3/4" panel. This unit shows normals, tip, ring and sleeve wired out to a terminal block. We also offer 240 other low-cost configurations.

**ADC Pro-Patch Video Jackfield** is the newest offering in our broadcast jackfield line. Shown here in rear view, this unit features self-normalling loops that are internal to the jackfield. Loops are color phase compensated for cross-patching. No phase shift occurs between self normal and patch cord.

**ADC Pro-Patch Audio Jackfield** is another new member of the family. This configuration incorporates pin and socket termination that allows instant making or breaking of normals, and eliminates soldering at the patch bay, thus reducing installation labor costs.

For more information about ADC Custom Jackfields call our toll-free hotline today. 1-800-328-6188. In Minnesota, call (612) 835-6800.



Circle 105 on Reader Service Card

## News

sell seven other Satcom 4 transponders on a non-common carrier basis, saying it would have to determine "whether such private use is in the public interest." It initiated a rulemaking to decide if domestic satellite licensees should be allowed to modify their licenses for varying uses; in the interim, it said, RCA must stick with its current tariffs.

The FCC's disagreement provided the only flaw (albeit a major one) in Satcom 4's otherwise smooth debut. The bird lifted off from Cape Canaveral one day later than its original launch date because of bad high-altitude wind conditions, and went into its geosynchronous orbit four days after launch. Once all systems are tested out, the new satellite will become RCA's second all-cable orbiter. Eight of the 24 transponders have been assigned to RCA customers who have been bidding their time on Comstar D-1 and D-2. Two other transponders have been reserved for occasional use. The satellite carries four spare transponders and a 10-year fuel supply.

Looking to the future, RCA has asked the FCC for permission to launch a sixth in-orbit satellite in January, 1985. Its request cited the large demand for satellite services, saying that requests for service since it filed for its fifth satellite last summer have exceeded 175—far more than it can fill with the present system.

### 10 PTV Stations Fingered for Advertising Experiment

The FCC's Temporary Commission on Alternative Financing for Public Broadcasting has given the go-ahead to 10 public television stations to begin an 18-month advertising experiment. The stations are WNET, New York; WTTW, Chicago; WHYY, Philadelphia; WQED, Pittsburgh; WPBT, Miami; WYES, New Orleans; WQCN, Erie, PA; WKPC, Louisville, KY; WSKG, Binghamton, NY; and WIPB, Muncie, IN.

At the same time, the Temporary Commission—which is headed by commissioner James Quello—declined to allow radio broadcasters to participate in the trial. One of its concerns was that since NPR, a major producer of programming for public radio, is presently the exclusive negotiator with the unions, radio stations might run too great a risk in trying to negotiate individual contracts.

Although the participating TV stations will be permitted to run ads similar to those seen on commercial television, not all plan to do so.

WNET, for example, immediately issued a statement saying it would limit itself to seeking "expanded corporation-underwriting grants" to be acknowledged by televised credits.

### CBS's Hour-News Plan: Affiliates Not Convinced

CBS television network affiliates remain skeptical about the net's latest push for a partial waiver of the prime-time access rule, designed to allow an expansion of the nightly national news to one hour.

Although the network is proposing to turn some commercial time in the extra half-hour back to the affiliates as compensation, not all affiliates are mollified. The *New York Times* quoted affiliate board head Jim Babb as saying, "The compensation they are offering isn't close to satisfactory" for most affiliates. He cited a recent, informal telephone poll in which 83 of the 114 affiliates questioned said they opposed the expanded news.

Also steamed up about the proposal was NATPE, which lost no time

**Delivery 30 Days or Less!**

**MONOMAX BY AMPRO**

**When you go music on cart, don't make your mono listeners turn to someone else.**

AM Stereo is coming and FM Stereo is here. Your rich, clear stereophonic sound can lose a lot of its punch when heard on a monaural receiver. Phase cancellation, response holes and peaks can make it sound downright dull and lifeless. And that turns off listeners. That's bad business for you because the majority of your prime time audience consists of mono receivers.

To give your mono listeners the sound quality they demand, you need Monomax... the new stereo tape matrixing system from Ampro. Monomax helps your signal come across strong and clear because it totally prevents phase cancellation problems. Now your mono as well as stereo listeners can enjoy the full lively sound you transmit.

Don't settle for less than Ampro perfection.

Take a closer look for yourself. Send for our FREE brochure on MONOMAX.

Dealer Inquiries invited. Fight inflation with Ampro/Scully

**AMPRO  Scully**

Professional Equipment for Broadcasting Professionals  
2693 PHILMONT AVENUE, HUNTINGDON VALLEY, PA 19006  
(215) 947-7000 • TWX: 510-665-5010 • CABLE: AMPROSCUL HVAL

**NAB  
Booth  
#3307**



in registering its indignation with the FCC.

CBS, asking the FCC to move swiftly on its request, told the Commission that only 13 of its affiliates required a waiver to air the hour-long news program. This is because the show would go into prime time only in the Eastern time zone—and PTAR applies only to top-50 markets. The markets it seeks the waiver for are Buffalo, Charleston, WV, Cincinnati, Cleveland, Columbus, OH, Dayton, Kalamazoo, Louisville, Miami, Norfolk, Orlando, Providence, and Spartanburg.

The expansion plan calls for the news to run 6:30-7:30 p.m. in the Eastern time zone, 5:00-6:00 p.m. in the Mountain and Central zones, and 6:00-7:00 p.m. in the Pacific zone.

### Lear Perenchio Form New Entertainment Consortium

Programming kingpins Jerry Perenchio and Norman Lear have formed a jointly owned entertainment consortium, Embassy Communications, which will combine the recently purchased Avco Embassy Pictures and their T.A.T. Communications Co.

Embassy Communications will consist of three divisions: Embassy Television, Embassy Pictures, and Embassy Telecommunications. In addition, it will manage Tandem Productions, Inc., and its cable arm, Communication Services, Inc. (CSI), owned by Lear and Bud Yorkin.

Alan Horn, formerly president and chief operating officer of T.A.T. and Tandem, has been named chairman and CEO of Embassy Communications and Tandem. Michael Grade will be president of Embassy Television. Both Lear and Perenchio will be "significantly involved" in developing TV programs and motion pictures for the new company, which will be headquartered in Century City, CA.

### DC Talk Outlet WRC-AM Computerizes Newsroom

WRC, AM news/talk station in Washington, DC, recently installed a newsroom computer purchased from Integrated Technology, Inc., of Kansas City, MO. The system consists of a central processing unit that holds two megabytes of RAM, eight terminals with CRTs, and two word processors. Each intelligent terminal contains 32K bytes of memory, and the system will operate without disk drive, though bulk memory drives are

present for backup.

WRC's system is designed for managing news information, rather than for financial management. All scripts are prepared on the word processors and the data is accessed directly by the talk show host or on-air personality. For example, if a call-in show's host is asked a question regarding what had been said on a previous show, the host can access that information by computer and respond properly to the caller, all while the show is on the air.

The computer monitors all incoming wire service information (AP, APTV, UPI, and Reuters). Electronic mail functions are among its other ca-

pabilities and it can be expanded to many times its present capacity. According to a station spokesman, the investment for the entire WRC unit was \$175,000.

### MPR Digital Studio Eyes Standard-Setting Quality

A flotilla of advanced equipment, including a just-installed 3M digital audio mastering system and digital editor, has Minnesota Public Radio hoping that its new state of the art 24-track production studio will set new standards in the technical quality of national satellite-distributed radio programming.

# FOLLOW THE LEADER

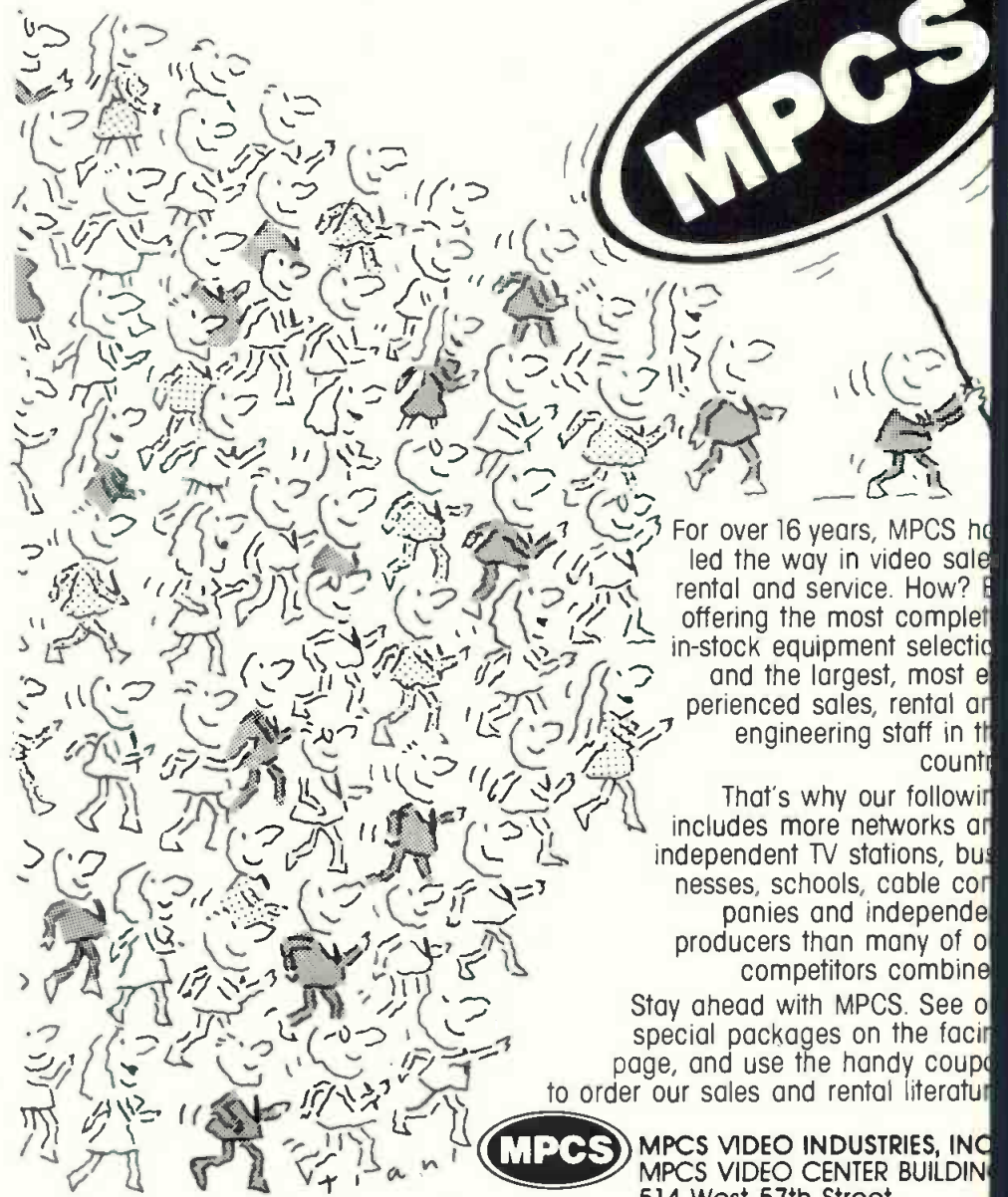

For over 16 years, MPCS has led the way in video sales, rental and service. How? By offering the most complete in-stock equipment selection and the largest, most experienced sales, rental and engineering staff in the country.

That's why our following includes more networks and independent TV stations, businesses, schools, cable companies and independent producers than many of our competitors combine.

Stay ahead with MPCS. See our special packages on the facing page, and use the handy coupon to order our sales and rental literature.

**MPCS** MPCS VIDEO INDUSTRIES, INC.  
MPCS VIDEO CENTER BUILDING  
514 West 57th Street  
New York, New York 10019

The new MPR studio has already hosted post-production for *Star Wars for Radio* and the mixing of the new Columbia recording of Lucasfilm's *Raiders of the Lost Ark*. It features six broadcast studios and four fully equipped control rooms. The Maud Moon Wyerhaeuser 24-track digitally equipped production studio and a record library housing over 30,000 discs have aided MPR in producing more programming for National Public Radio than any other station-based organization. In addition to a newsroom with seven editing booths, connected to the major wire services and the National Weather Service, the

station has satellite uplink and dual downlink facilities, plus a completely computerized typesetting system.

MPR, often referred to as the "flagship of the national system," has earned a reputation for its quality productions, having won three Peabody Awards in the last four years. The addition of the 3M digital equipment should help it continue its tradition of superb-quality audio production.

### New Oak Subsidiary Will Stress Satellite Activities

Intending "to make Oak a major entity in the business of satellite com-

munications," Oak Industries has formed Oak Satellite Corp. as a new subsidiary. The new company will work at developing and consolidating the companies activities in the satellite field.

E.A. Carter, Oak's chairman and CEO, described the significance of the move as follows: "By consolidating our current satellite operations into a unified integrated unit and providing experienced senior management, we expect to accelerate the establishment of Oak as a leading participant in an activity with exciting potential."

One likely area of focus for Oak Satellite Corp. is DBS, Carter noted. Oak's Satellite Systems and VideoNet divisions are being transferred to the new company. Satellite Systems markets the Orion encoding/decoding system for satellite-delivered pay-per-view TV programming, while VideoNet is a leading producer of video-conference services and programming.

Gary T. Barbera, executive VP of Oak Industries, a member of the company's board of directors, and president of Oak Technology, Inc., also will serve as president and CEO of Oak Satellite. The new company will be headquartered in Rancho Bernardo, CA.

### Sports, Entertainment Fill Two New Cable Services

The Entertainment Channel, a joint venture of Rockefeller Center Cable and RCA Cable, will launch a brand-new pay television program service on June 4, 1982. The service has reached an exclusive agreement with RKO/Nederlander to supply a multi-play package of Broadway productions encompassing at least 10 plays. The long-term contract also includes over 5000 hours of original BBC programming. Arrangements have been made to lease two transponders on Satcom 4.

In another cable development, boxing promoter Don King announced the formation of a cable network that will provide prime-time sporting events, shows, and concerts via satellite and cable television. The Don King Sports and Entertainment Network plans a "pay-for-view" format with regional interconnects and advertising support. With the recent development of a digital decoder, the programs can be monitored and the customer billed later.

Michael Downs, VP of operations, says the marketing strategy allows for "windows" for broadcast and syndication television. The debut of the network, presently scheduled for April 21, will feature a world-class championship boxing match; contenders are still to be announced.

# FOR VIDEO SALES, RENTAL, & SERVICE

LISTEN TO SOME OF THE MANY REASONS TO FOLLOW THE LEADER TO MPC'S:

#### INDUSTRIAL 'ENG' SYSTEM

- (1) Sony DCX1800K—color camera
  - (1) Sony VO4800—3/4" recorder
  - (2) Sony BP60—batteries
  - (1) Quickset 4730107—tripod
  - (1) Quickset 4728523—fluid head
  - (2) Sony ECM50PS—microphone
  - (1) Sony CCJ10—33' VTR ext. cable
- Reg. \$11,350 NOW ONLY \$7,382

#### STUDIO SYSTEM

- (1) Ikegami ITC350—EFP color camera w/ind. saticon tubes, Canon 10X power zoom lens, Camera control unit & 49' cable
  - (1) ITE H9/T12/D7/H9T47CB—tripod, fluid head & legs
  - (1) set of cable drives
  - (1) Sony PVM1900—monitor
  - (1) JVC CR8200—editor
- Reg. \$26,100 NOW ONLY \$16,995

#### EXTRAORDINARY CAMERA SALE

Ikegami ITC350—ENG Camera w/Plumbicon tubes, 10X zoom lens, & professional tripod

Reg. \$12,000

NOW UNDER \$9,000

#### 1/2" BETA EDITING SYSTEM

- (1) Sony SLP303—1/2" player
  - (1) Sony RM440—editor controller
  - (1) Sony SLO383—1/2" editor
  - (1) Sony RCC5E—cable
  - (1) Sony RCC5F—cable
  - (2) Sony KV-1207—12" receiver
  - (1) Sony VDC5—video dubbing cable
- Reg. \$8,800 NOW ONLY \$5,729

#### 1/2" VHS EDITING SYSTEM

- (1) JVC BP5300—1/2" player
  - (1) JVC BR6400—1/2" editor
  - (1) JVC RM88 editor controller
  - (2) JVC 7280 UM
- Reg. \$9,685 NOW ONLY \$6,295

#### TODAY'S BUSINESSMAN'S COMPUTER PACKAGE

- 1 Bell & Howell / Apple Computer
- 1 Disc Drive w/ controller
- 1 Panasonic TR930 monitor
- 1 Visicalc—electronic calculator

Reg. \$2,495 NOW ONLY \$1,895

To order the above, or for sales inquiries, call 212-586-3690. Out of NYS, 800-223-0622.

Please include my name on your mail and forward your catalog(s) at no charge. Sales  Rental

Name \_\_\_\_\_

Company Name \_\_\_\_\_

Company Address \_\_\_\_\_

City \_\_\_\_\_ State \_\_\_\_\_ Zip \_\_\_\_\_

I saw this ad in \_\_\_\_\_



MPC VIDEO INDUSTRIES, INC.  
3 VIDEO CENTER BUILDING  
West 57th Street  
York, New York 10019

## News Briefs

Katz Broadcasting Co., a subsidiary of Katz Communications, Inc., has agreed to purchase **WDBO-AM/FM**, Orlando, FL, for \$9.5 million from the Outlet Co. Katz already owns **D 95 FM**, Tulsa, and has received FCC approval for the purchase of the four park City Communications stations, including **WEZN-FM**, Bridgeport, CT; **WAAF-FM/WFTQ-AM**, Worcester, MA, and **WZZK-FM**, Birmingham, AL . . . . A U.S. District

Court in San Juan has named Spanish International Network buyer for American Colonial Broadcasting Corp. and its two outlets, **WKBM-TV**, San Juan, and **WSUR-TV**, Ponce. Purchase bid was \$10 million . . . . **WRBC-TV**, New Jersey's first minority-owned television station, has gone into receivership after just a few months on the air. Donald C. McMeans, president of the station's licensee, Renaissance Broadcasting Corp., said that the station's plight stemmed from the refusal of local cable systems to carry the station; he suggested that racism

was involved.

Storer Broadcasting, Group W, and King Broadcasting are just a few of the users of Bonneville Satellite Corp.'s new **Electronic Journalism Center**, across the street from the Capitol in Washington, DC. The new live/tape origination center, complete with a news editing system, provides full-time dedicated microwave and uplink facilities for domestic and international satellite distribution . . . . **CNN2**, Turner Broadcasting's second all-news cable net, met its startup date with nearly one million subscribers . . . . **WMHT**, Schenectady, NY, has become the second PBS TV station in the country to offer 24-hour programming. **WTVS**, Detroit, was the pioneer last June.

NAB has asked the U.S. Supreme Court to strike down a Massachusetts law closing trials of minors on sex-offense charges. ABC, CBS, PBS, and RTNDA were among those joining NAB in its friend of the court brief . . . . The Connecticut Supreme Court will conduct a one-year trial, beginning April 12, to allow TV cameras, VTRs, and still cameras to cover its proceedings . . . . NAB's Executive Committee has established a task force on **public broadcasting funding**, to be chaired by Thomas E. Bolger, president of **WMTV**, Madison, WI . . . . NAB will honor Julius Barnathan, president of broadcast operations and engineering for ABC, New York, with its **1982 Engineering Award** at the association's engineering conference luncheon, scheduled for April 6.

**WCVB-TV**, Boston, made off with top honors in the recent **New England Emmy Awards**, walking away with 18 of the coveted citations. Also in the limelight were **WBZ-TV**, Boston, with six; and **WNAC-TV**, Boston, with five. Other award winners included **WFSB**, Hartford, **WJAR**, Providence, **WVIT**, Hartford, and **WSBK**, Boston . . . . **WNAC** also won two certificates of merit in the 1981 Odyssey Institute's Media Awards for the Concerns of Children . . . . **RKO Radio Networks** have given permission to the American Forces Radio and Television Services (AFRTS) to re-broadcast RKO news, information, and sports. AFRTS operates 300 radio stations and 118 television stations, which broadcast to U.S. servicemen overseas and in Alaska . . . . This is the **thirtieth anniversary year** of broadcasting for the Christophers, the New York-based producer of religious television programming.

## McMartin industries, inc.



"Many people think McMartin Industries only makes transmitters. But in our 25 years in business we've grown into a full-line broadcast equipment manufacturer. Not only do we manufacture a complete line of AM and FM transmitters, we also produce audio consoles, monitors and amplifiers, FM/SCA equipment, and satellite receivers. Over 300 products in all. So, think of us for transmitters...and remember McMartin Industries for all your broadcast needs."



*Ray B. McMartin*

Ray B. McMartin  
President  
McMartin Industries, Inc.

TR-55D, FM/SCA Tuner  
MS-252, 25 Watt Amplifier

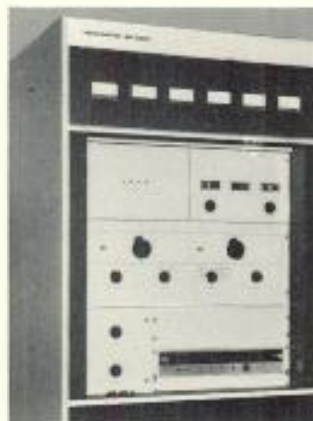
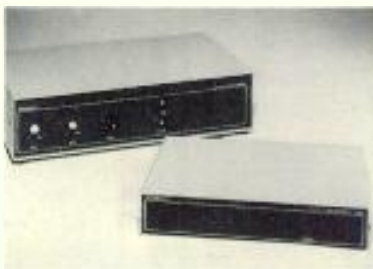

BF-3.5M, 3,500 Watt FM Transmitter

Visit our booth at NAB

4500 South 76th Street • Omaha, Nebraska 68127-1880 • (402) 331-2000 • Telex 484485

Circle No. 110 on Reader Service Card

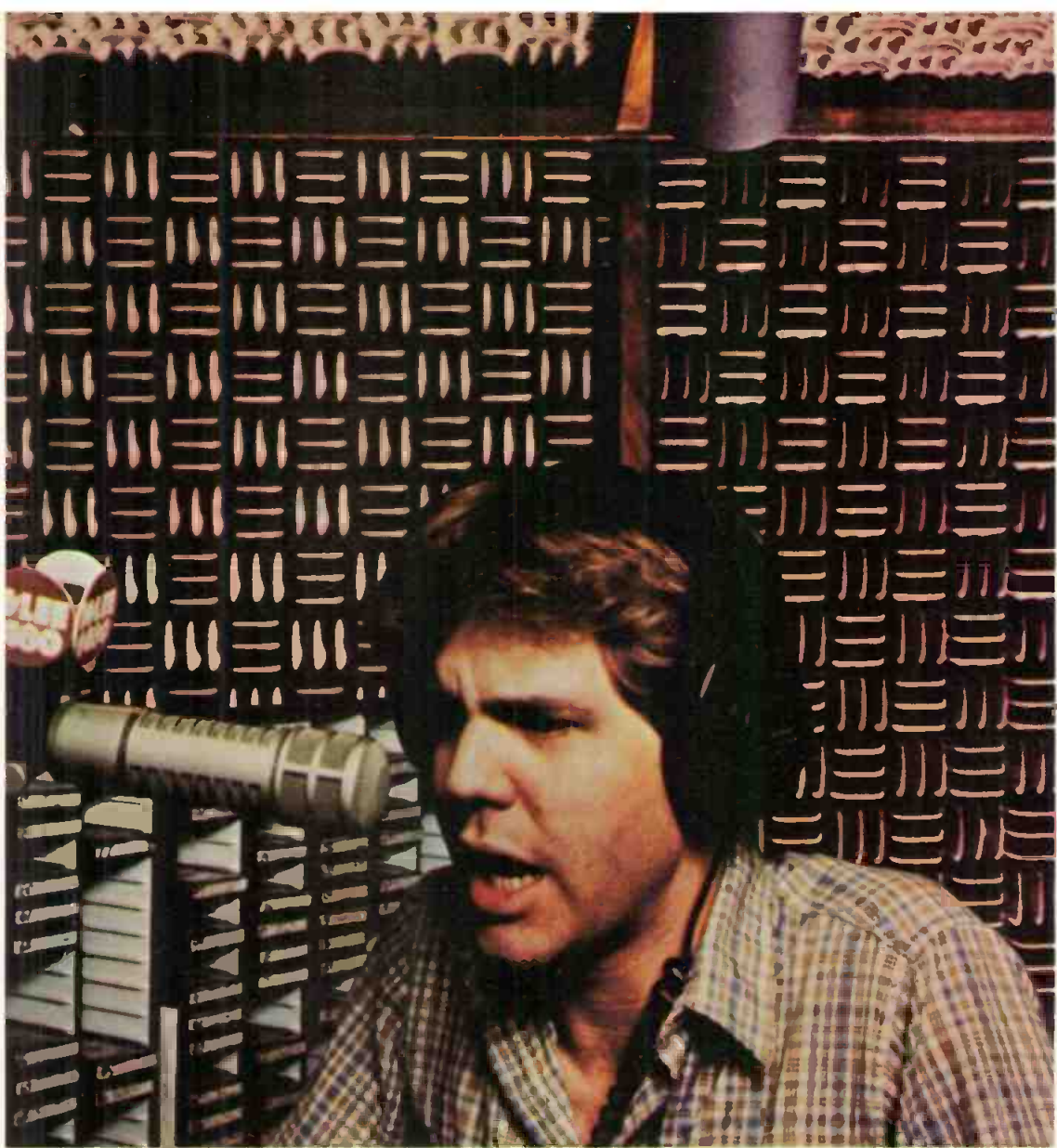

# SONEX

## FOR CLEAN SOUND

After WLEE installed SONEX, people called about the "clean, new sound!" Was it new equipment?

No. The answer is simple and inexpensive:

SONEX kills all the stray reflections, so the mike processes a clean signal of the announcer's voice. The announcer hears himself in a warm environment, and there's

less clutter to waste watts. The result is a noiseless, clear signal and greater market penetration.

Get the facts today. SONEX is available in five colors, in three thicknesses, and in standard four-ft. square panels. Use it in broadcasting, recording, videotaping or performing areas for really pure, clean sound.

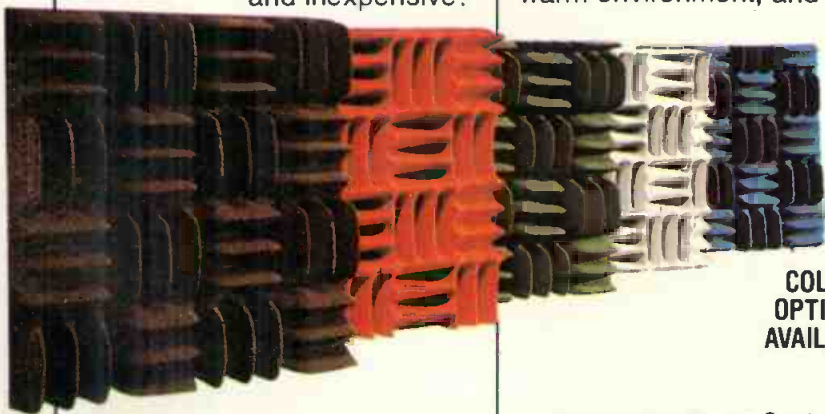

COLOR  
OPTIONS  
AVAILABLE

**Alpha  
Audio**

2049 West Broad Street  
Richmond, Virginia 23220 (804) 358-3852  
*Acoustic Products for the Audio Industry*

Circle 107 on Reader Service Card

[www.americanradiohistory.com](http://www.americanradiohistory.com)

***The Performance  
a Broadcaster Expects,  
The Features and  
Reliability He Demands.***



## THE NEW OTARI MTR-10 SERIES PRODUCTION RECORDERS

We engineered them to be the ultimate in broadcast production. They embody the innovative technology and the highest reliability that has made us The New Workhorse in audio production.

### THE ULTIMATE IN PRODUCTION EFFICIENCY

- Three speeds: 3 $\frac{3}{4}$ , 7 $\frac{1}{2}$ , 15 or 7 $\frac{1}{2}$ , 15, 30 ips.
- Full, two and four track formats.
- Flexibility in cabinet choice: desk type, overbridge or rack mount for custom installation.
- Full servo, D.C. PLL transport governed by an on-board microprocessor—an industry first.
- $\pm 20\%$  vari-speed with ips or percentage display.
- Built-in, no overshoot return-to-zero with optional 10 memory/one stroke and keycard access autolocator.
- Internal multi-frequency square/sine wave generator.
- Preset master bias switching.
- Electronically balanced I/O with direct-coupled, high current outputs.
- Automatic reel size sensing with single hand, bi-directional tape rocking.
- Cue control with lifter defeat and controlled wind.
- Dump edit and shuttle edit control.
- Integral, precision splicing block.
- Cue speaker and headphone monitoring.
- Direct access playback head.
- Modular, single card electronics with high slew-rate integrated circuits.

### THE ULTIMATE IN ANALOG AUDIO

- Dynamic Range: 75dB measured from noise floor to 3% THD (30 ips,  $\approx 226$  tape).
- Frequency Response: 0 VU (+4) 35Hz-29kHz, +1.0, -3.0dB @ 30 ips.

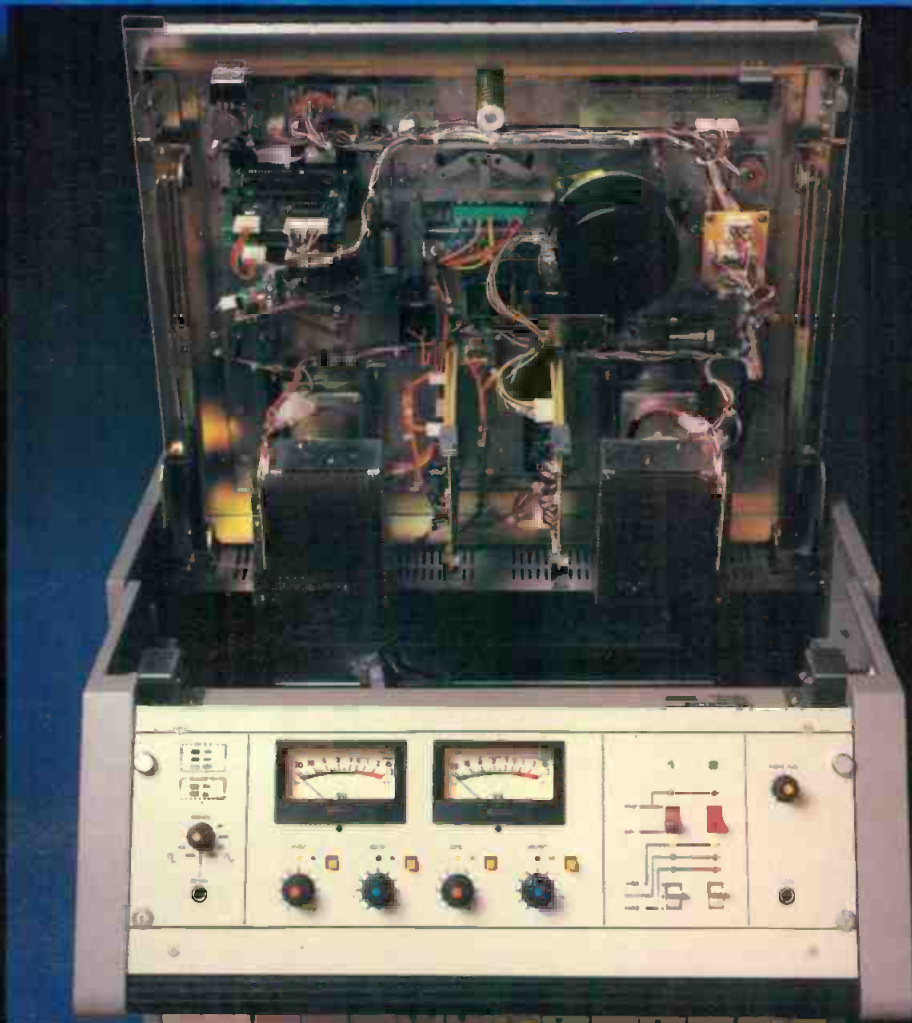

- Wow & Flutter: Less than 0.04%, DIN 45507
- Distortion: Less than 0.1% @ 1kHz, 250nWb/m.
- Maximum Output: +28 dBm.
- Adjustable record phase compensation.

These features and more will allow you to do your job faster while delivering every last dB of performance. It's the productive and efficient solution to the demanding new realities of the contemporary broadcast facility.

### ENGINEERED TO BE EASILY SERVICED

Access to all components makes maintenance straightforward. The audio, transport, master CPU and power supply electronics are all of modular, card frame design: the entire transport assembly is top-hinged to allow wide-open access while the deck is in operation.

### ENGINEERED TO THE HIGHEST STANDARD OF RELIABILITY

Reliability is paramount in Otari's approach to doing business. We've earned an enviable reputation for quality and value that has made us the

world leader in broadcast automation (Model ARS-1000) and compact production recorders (the 5050 Series). With the new MTR-10, we have successfully bridged the gap between the new technology and reliability.

Evaluate the MTR-10 recorder for yourself by contacting your authorized MTR-10 Series professional audio dealer. It will become evident that Otari is several steps ahead of the competition—again. Audition the performance, features and engineered reliability that will meet the needs of all broadcasters for years to come.

If you're really thinking of buying broadcast precision, there's only one logical decision.

THE NEW WORKHORSE

**OTARI**

2 Davis Drive  
Belmont, California 94002  
(415) 592-8311  
Telex: 910-376-4890

© 1982 Otari Corp

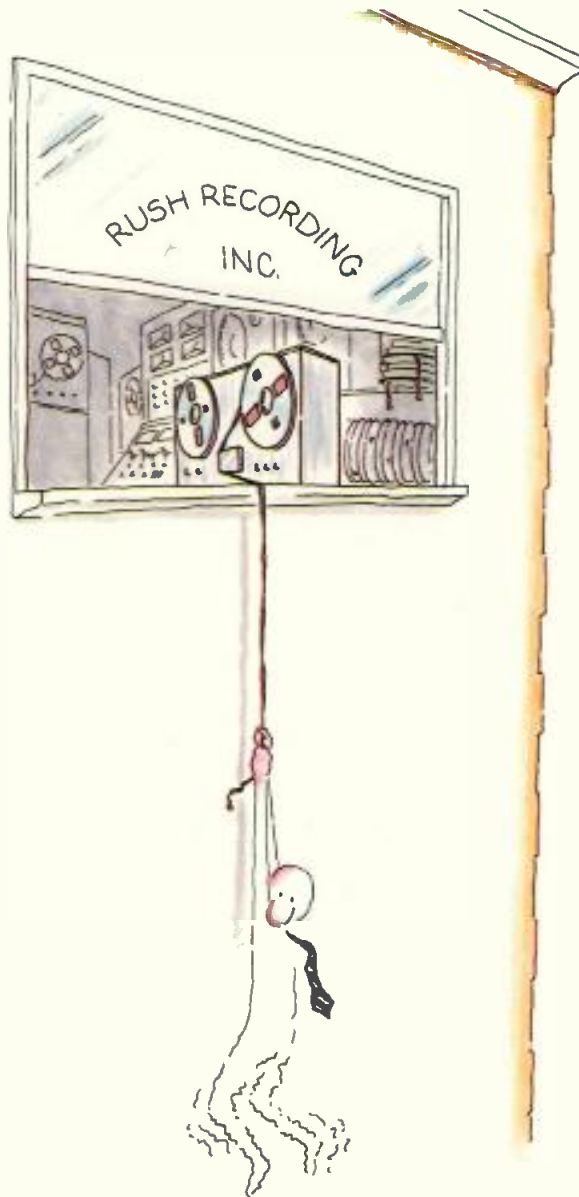

## Audio engineers who try Maxell won't let go.

Maxell quality saves a lot of recording situations. Maxell meets your 1/4" open reel and audio cassette needs, no matter how demanding you are. Because we're more demanding. We've developed a name that means unique quality all around the world. For example, Maxell cassettes give you a productivity boosting four-function leader with A/B side indications, directional arrows, non-abrasive head cleaner and five-second cue to set timing and level.

You can see Maxell excellence in the cassette construction and on the 'scope or meter. The physical construction is strong enough to meet all professional requirements. Maxell open reel tape and cassettes give you quality you can hear. And your clients can hear as well.

We'll give you all the technical information you need to form your own opinions. But if you're like just about every audio professional that tries Maxell, you won't let go. Remember, we warned you!



# maxell®

PROFESSIONAL/INDUSTRIAL DIVISION

Our success is magnetic.

Maxell Corporation of America, 60 Oxford Dr., Moonachie, N.J. 07074 (201) 440-8020

Circle 113 on Reader Service Card

[www.americanradiohistory.com](http://www.americanradiohistory.com)

# RADIO

PROGRAMMING & PRODUCTION FOR PROFIT

## KFWB Advances Audio Quality for RENG

DELIVERING "HI-FI" quality audio from remote pickup units in the hostile RF environment of the Los Angeles area has prompted Richard Rudman, chief engineer of KFWB News, to come up with some high-grade solutions to land mobile radio's problems. The results of this venture have been impressive.

"The feeling was that there was a need for all-news reporters to sound as if they were really there at the scene of the news, as it was happening," says Rudman. The main concern was to give clarity and a sense of immediacy to the great number of live reports. KFWB combines the resources of 11 mobile units feeding to four repeater sites, making the live remotes the main reason for the existence of the upgraded system.

Although so-called "hi-fi" quality mobile systems had been used previously, Rudman went to j-engineering, an electronics engineering firm in Canoga Park, CA, to consult with design engineer Jim Noble. Modifications were made to the Motorola equipment with striking results.

According to Rudman, the Motorola Micor mobile units were chosen because of their durability and dependability. The units spend all their time bouncing around in cars in the hot California sun and the engineers knew the radios could be relied upon to take the punishment. As Noble says, "You can almost run a truck over these radios and they still work."

Another attractive feature of the Motorola transmitters was the direct FM modulation. The modifications on these units consisted of widening the audio response of the transmitter down to 20 Hz and changing the pre-emphasis to 50  $\mu$ s. Peak limiting followed by a six-pole low-pass filter at 8 kHz round out the modifications while maintaining the standards set by the FCC.

Rudman submitted his modified acceptance to the FCC in January, 1979, and went on the air with the mobiles after getting the Special Temporary Authorization in May, 1979.

Though he had approval for his



*Four-wheel-drive vehicle can be used to originate live programming from locations inaccessible to sedans.*

mobiles, Rudman relied on telephone lines for feeds from the receivers until 1981. "Because we are a news station, and with the southern California area's susceptibility to earthquakes, we did not want to be dependent on audio lines back from the receivers,"

states Rudman.

On May 12, 1981, the FCC granted KFWB a composite type acceptance for the new modifications on its repeaters. This allowed the station to convert more completely into a wireless system.

Repeaters are necessary in the Los Angeles area because of the terrain. The improved audio quality not only allows the station to enhance the "feel" of its live remotes, but also offers communications quality equipment that is impervious to the very difficult RF environment.

In addition to the Micors and Motorola repeaters, KFWB used the Motorola Spectra Tac voting receivers, again modified by j-engineering. The receiver modifications include an entirely new IF section with new crystal filters that exhibit the broader passband necessary to accommodate the wider audio resonance, and sharper skirts to retain selectivity. Improved matching networks insure accurate filter response. The crystal discriminator is replaced with a quadrature detector that provides greater linearity and is capable of excellent frequency response.

In subsequent receiver audio stages, deemphasis is changed to 50  $\mu$ s and the squelch circuit is modified to "look" for noise around 25 kHz by moving the squelch circuit away from

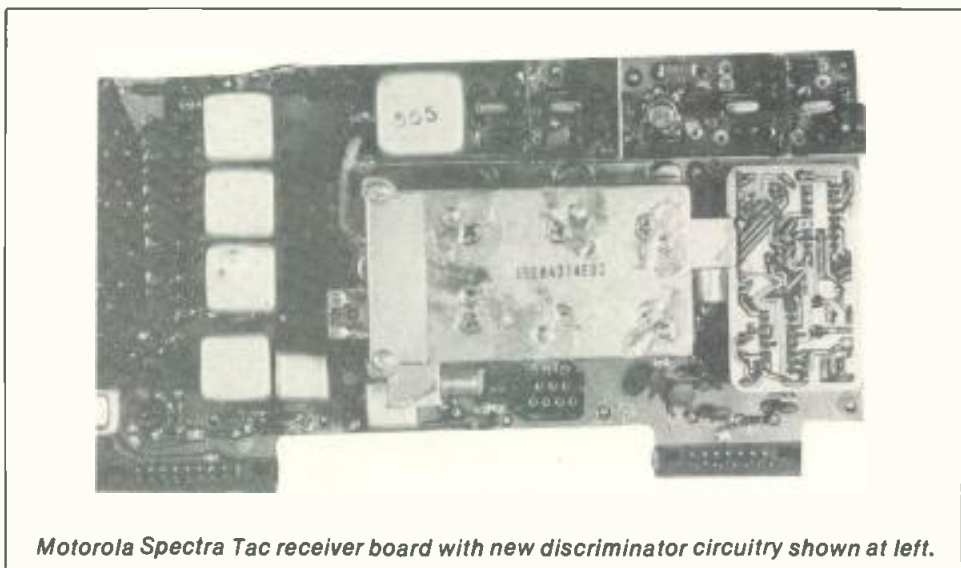

*Motorola Spectra Tac receiver board with new discriminator circuitry shown at left.*



# studio-proven pickups

## ON THE AIR

Don't compromise true hi-fi phono cartridge performance to get the ruggedness required for professional use. Shure offers four cartridges designed to take the use and abuse to which professional phono cartridges are regularly subjected. These cartridges are designed specifically for professional studio, broadcast, disco and mobile sound use.



### SC39 Series

(SC39ED, SC39EJ, SC39B)

Three cartridges engineered to provide undistorted playback on even the "hottest" records, with enough durability for the most demanding backcuing and slip-cuing operations. Features include: SIDE-GUARD stylus deflector to prevent accidental damage to the shank assembly; MASAR™ stylus tip to minimize noise build-up and cue-burn on lacquer masters, often-played records, or 45's pressed on sub-standard vinyl; lever-operated STYLUS GUARD for unparalleled stylus protection when not in use; and incredibly flat frequency response through the mid-high bands.



### SC35C

A proven, durable performer designed for use on the heaviest and most rugged tone arms which require a tracking force of 4 to 5 grams. Easily visible stylus aids cuing. Rigid stylus shank stands up to abuse.



Shure Brothers Inc., 222 Hartrey Ave., Evanston, IL 60204  
In Canada: A. C. Simmonds & Sons Limited  
Manufacturer of high fidelity components, microphones, loudspeakers, sound systems, and related circuitry.

Circle No. 114 on Reader Service Card

## Radio Programming

the 4-5 kHz range. If it is not moved, the response to wideband audio is to see it as noise and to squelch off.

The impressive final results are that the modified system achieves flat response from 20 to 5000 Hz and goes down 3 dB at 7500 Hz. Harmonic and IM distortion are at 1% and noise is down 50 dB. These specifications are surprisingly pertinent to a 25 kHz N<sub>2</sub> channel.

According to Marc Wiskoff of Motorola, broadcasters who depend more on the hand-held than the mobile units can use the Motorola MX-300, which has already been modified and achieves the same results as the Motorola Micors.

This is encouraging to those broadcasters who depend on remote pickups for news. For stations such as KFVB, this type of audio quality is essential. "Our station covers over 7000 square miles and our reporters need to file reports at all times, day or night. With the modified system, we can do it," says Rudman.

Since the j-engineering system has the added benefit of operating within



Mobile equipment plays cassette sound as part of live report; from left, cassette deck, control head, Motorola control.

the N<sub>2</sub>, 16F3 mode, many licensees in similarly problem-ridden RF terrains may find that this kind of system is the only way to get reasonable quality audio back to the studios from the field. **BM/E**

## BM/E's Program Marketplace

# Syndicators Revisited

The Musicworks of Nashville  
Box 111390, Nashville, TN 37211  
Tel.: (615) 790-1200

WHEN BILL ROBINSON launched The Musicworks in early 1977, he had more than 20 years of experience in programming radio stations and a long list of awards for his skill with Country music. *BM/E* first reported on The Musicworks in May, 1978. The operation then boasted three formats and 21 subscribers, and offered client stations a close study of their markets and a detailed programming layout.

Three and a half years later, Robinson's subscriber list passed 50—with Number 50 an Australian station that is the first overseas subscriber for Musicworks. Robinson's brand of Country music has brought the subscribing station a substantial audience increase. The tapes, which reach Australia in seven days by air mail, must include a certain proportion of Australian-originated material, requiring special preparation.

Along with the subscriber list, the

programming has grown and diversified. *Alive Country*, the original format, is still very much alive. On tap since the beginning are veteran Country announcers Lee Shannon and Gary Havens, along with Charley Douglas and Robinson himself. Subscribers may choose one, two, or three announcers.

Each subscriber starts with 36 reels of music in each series—if he takes all three, as some do, he gets 108 reels or 162 hours. The Musicworks also sends four monthly update reels.

*Casual Country*, another of the original formats, is a "foreground" music that Robinson has found effective in markets saturated with Beautiful Music.

Music and talk for both these formats come on separate reels; the user can transfer the talk segments to carts, allowing talk to be inserted into the music sequences at the right points by an automation system. This arrangement also lets the talk include localized material such as PSAs, IDs, and promos. The system further supports station localism by never referring to the format name or source of the music. The announcers become

members of the station's own staff, as far as listeners are concerned.

The new, unannounced *Country 80* format has become popular with stations that want a body of Country music for live or live-assist operation. Also new is *Pop Adult Lifestyle*, Adult Contemporary music aimed for the 25 to 50 audience, mixing hits, recurrenents, and some outstanding oldies.

Slated to go this month are several new ventures, including what Robinson believes to be the first radio syndication directed toward Hispanic listeners. Gustavo Valadez, a widely known figure in Hispanic culture in the Western United States, will act as the permanent consultant. The announcers will be Hispanics with a strong background of radio experience.

Also nearly ready is *Light and Easy*, a Beautiful Music format with a decidedly foreground character.

#### Something different

An entirely different new program series is *Question Mark*, which consists of 2½-minute vignettes about Country music stars. The Musicworks will issue 10 of these each week, to be used as the subscriber station wishes.

"We work long and hard on each of our program series, make sure with careful testing that we have the act together before we put it on stage," Robinson told *BM/E*. "That is a main factor in our success."

He might have added that his own proven skill in choosing the music and putting it into valid sequences is another indispensable factor in the success of the operation. The staff of The Musicworks now numbers 19, with specialists in various music styles. But Robinson himself is still the guiding spirit in the choice and arrangement of music.

Robinson points to satellite delivery as potentially a transforming force on the syndication scene. The rigid time schedule of satellite delivery, however, can be an obstacle to station localism, he cautioned. Tape, Robinson says, offers more flexibility to the programmer; thus, he sees the satellites as a threat to some syndicators.

The Musicworks left Indianapolis in September, 1980, after three years there, for Nashville, the capital of Country. This has worked out well, with The Musicworks the only full-format syndicator on the scene, and thus early on the list for recording companies putting out Country music. Being timely is, of course, necessary for success with popular music, and The Musicworks now has timeliness more than ever. **BM/E**

# Feast your ears with HIGH-COM<sup>®</sup>

High-com<sup>®</sup> is the new standard for tape and STL noise reduction systems developed by AEG Telefunken. This system, with a 12dB level set window, **outperforms all others** in transient performance, breathing effects and frequency response errors.

High-com<sup>®</sup> **assures perfect dynamic tracking ... every time.**

Available from **Straight-Wire Audio, Inc.**, 2523 Wilson Boulevard, Arlington, Virginia 22201, 703-522-7780

## SWA

When quality talks, everybody listens.

HEAR US AT  
BOOTH 1724  
NAB DALLAS  
CONVENTION

MFG. OF  
PH-2 PHONO PREAMPLIFIERS  
UA-2 UNIVERSAL AMPLIFIERS  
MTX ACTIVE MATRIX  
UPS POWER SUPPLY  
IN KITS OR FULLY ASSEMBLED

Circle No. 115 on Reader Service Card

## LIGHTNING FAST YET PAMPERED

That unique combination of  
**20-minute Burp Charger** and  
camera mounted, slide-lock,  
super ni-cad battery.



See us at NAB Booth 1623

Circle No. 116 on Reader Service Card

# THE NEW OF VIDEO.

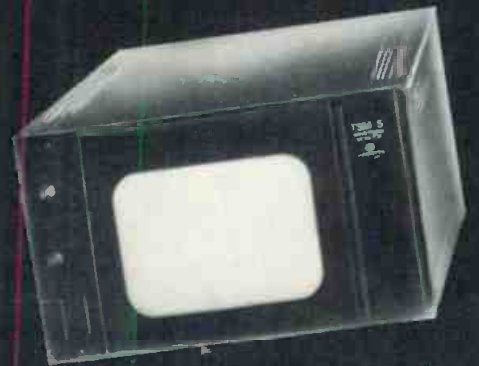
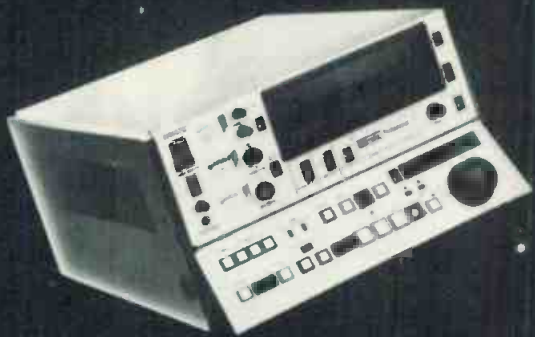

**See us at NAB Booth 2010**

# WORLD

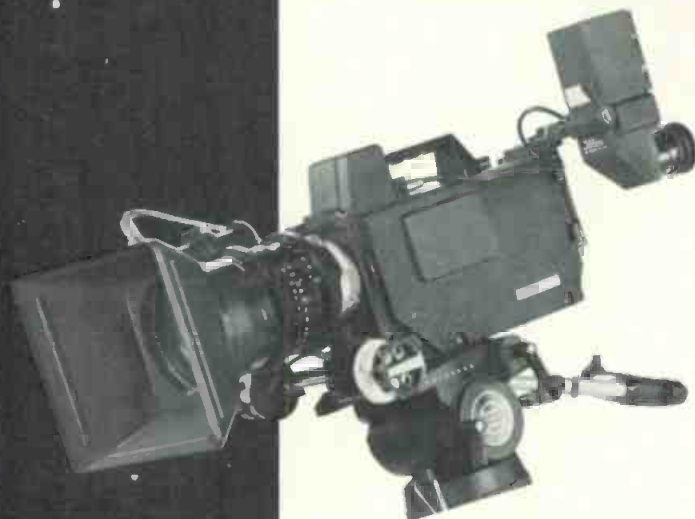

## **CAMERA MART, THE SOURCE FOR EVERYTHING IN TODAY'S NEW WORLD OF VIDEO TECHNOLOGY.**

At Camera Mart, we're keeping pace with the rapidly advancing science of video technology to give you the most sophisticated state-of-the-art equipment available.

In the new world of video, equipment is more flexible, more versatile, more accurate than ever before, with capabilities far ahead of just a year ago.

At Camera Mart we can give you entire video systems: cameras, sound, lighting, editing...plus the expertise of our trained technical staff to help you put together the system that's exactly right for your needs, TV broadcasting, field production, fixed or mobile installations, ENG/electronic cinematography, you name it.

Whether you want to buy, rent or lease, see what's been happening in video research and development. See how much more you can have with the latest advanced video systems at Camera Mart.

*Products Shown:  
Sony BVU-800 Broadcast Cassette VTR, Ikegami HL-79 ENG/EFP Camera, Videotek TSM-5 Wave Form Monitor, Videotek VSM-5 Vectorscope, Ikegami EC-35 Electronic Cinematography Camera, Quantel DPE 5000 Digital Effects System, Panasonic NV-8500 VHS Editing Recorder, Microtime T-120 Time Base Corrector.*

**The Camera Mart, Inc.**  
456 W. 55th St., New York 10019 • (212) 757-6977/Telex: 1-2078  
Video Department: 800 Tenth Ave.  
Sales • Service • Rental

Circle 117 on Reader Service Card

Announcing...the all new  
**Philips LDK6**  
automatic camera.

A revolutionary design...it's a 'thinking' camera  
that is a generation beyond the smart cameras.



Think about that...  
then step into the future at  
NAB when the LDK6 joins the  
other world famous members  
of the Philips camera family.

See the LDK6 at the Central Dynamics  
Exhibit plus new CDL and American Data  
switching equipment.



**CENTRAL DYNAMICS  
CORPORATION**

*The U.S. Broadcast Company for* ■ **CDL** ■ **PHILIPS** ■ **American Data**

900 Corporate Drive, Mahwah, NJ 07430 201-529-1550

Circle 118 on Reader Service Card

# TELEVISION

PROGRAMMING & PRODUCTION FOR PROFIT

## Tic Tac Dough: Winning the Syndication Game

PROGRAM SYNDICATORS, recognizing the salability of excitement, have long made game shows a standard part of their repertory. With their inherent competition and challenge, contests have built-in audience appeal.

This is amply illustrated by the success of *Tic Tac Dough*, now in its fourth year of syndication. Barry & Enright Productions of Los Angeles purchased the show from NBC, where it premiered in 1956. The show's executive producer, Dan Enright, boasts that *Tic Tac Dough* presently runs in some 70 markets, including "all the major markets." Evidently a hit with network affiliates, the show has cleared 13 CBS affiliates, 23 NBC affiliates, and 15 ABC affiliates. Sales are handled by Colbert Television Sales, also in L.A.

Chris Craft Video Tape Center, a subsidiary of KCOP-TV, Ch. 13 in Los Angeles, handles *Tic Tac Dough's* busy production schedule. KCOP, an independent station owned by Chris Craft Industries Stations, uses its production facility for a number of syndicated shows, including *The Joker is Wild*, another Barry & Enright production. Several game shows for cable companies



Centerpiece of the *Tic Tac Dough* set is the game-board, which displays the questions. Because the set is so bright, lighting must be held to about 150 fc.

such as CBS Cable (*Quiz Kids*) and Showtime are also produced there. Chris Craft Video General Manager John E. Braislin described the studio's schedule as "extremely busy."

The *Tic Tac Dough* crew works two days every other week, producing 10 shows—two weeks' supply for subscribing stations. (A total of 195 episodes—39 weeks' worth—are produced each year; stations use reruns for the remaining 13 weeks.) The crew numbers over 20, including a technical director, lighting director, and operators for the four

RCA TK-46 cameras. Richard Klein is the director. The 7000-square-foot studio was once a motion picture facility and can hold an audience of 200 people. Seating is modular, allowing flexibility for the various shows and also allowing Chris Craft Video to rent it out as "four walls" to producers. Each working day, one audience watches the taping of three shows, with a new audience coming in for the other two.

### The one-inch "look"

One of the TK-46s is always focused on the elaborate game board;

## DA'S FOR AUDIO

**Highest Performance • Excellent Reliability • Low Cost**

Select Neve's DA-90 Audio Distribution Amplifier Range as your DA standard and get peace of mind. Rack cage is 3.5" tall and can take up to ten (10) DA Output Cards and/or Input Mixing Cards, plus PSU module. Each output card has nine (9) resistive split outputs. Specify 75, 150 or 600 ohms.

Delivery is generally stock to 30 days.

Model		Price
PL70426	19" Rack Cage, Empty	\$ 465
BA-569	Power Supply Module	\$ 490
BA-567	DA Card - 9 Outputs	\$ 220
BA-568	Input Mixing Card - 4 Inputs	\$ 195

(Prices subject to change)

 **Neve**

Rupert Neve Incorporated  
Berkshire Industrial Park  
Bethel, CT 06801

Please Call:  
(203) 744-6230

# Telemet pride is in our AV Routing Switchers and in America's Space Shuttle.

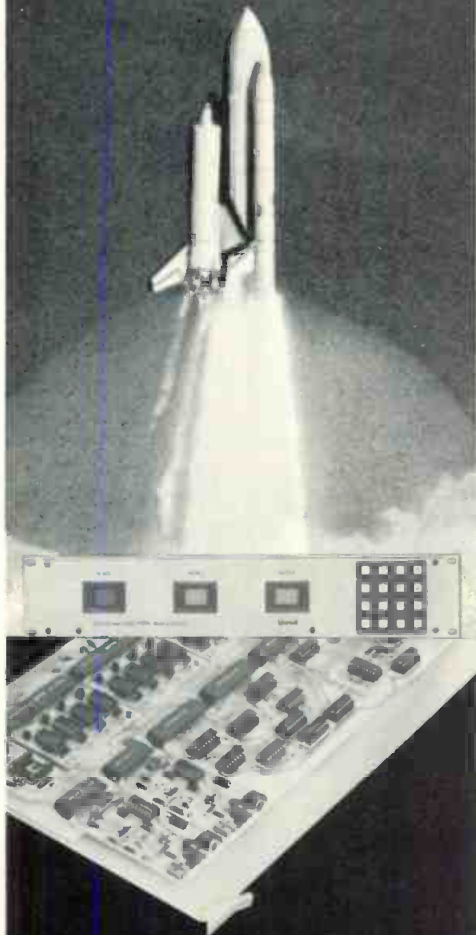

We make Wideband Equalizers  
for NASA at the Cape.  
And, the latest, most advanced  
AV Routing Switchers for  
the Broadcast Industry.  
Guaranteed quality and quick  
delivery from the source —  
that America trusts.

## Telemet

A Geotel Company  
185 Dixon Ave. Amityville, NY 11701  
(516) 842-2300  
Eastern Area Office — (914) 279-3231

Circle No. 120 on Reader Service Card

30 BM/E MARCH, 1982

## TV Programming

another picks up the host, with the other two taping the players. All cameras are equipped with Q-TV teleprompters. The show is recorded on Ampex VPR-2 one-inch machines, two for record and one for playback. (The facility itself offers seven cameras, seven VTRs, and CMX editing.) Director of engineering Win Korabell says that *Tic Tac Dough* went to one-inch (with SMPTE time code) this season (taping started last summer) when Barry & Enright opted for one-inch's "better look and ease of editing." The show was previously produced on quad.

Most editing for the show takes place at Compact Video, which Korabell describes as "in my opinion probably one of the top five post-production facilities in the U.S." Very little editing for *Tic Tac Dough* is done at Chris Craft Video, with the exception of audio sweetening. This is accomplished with an Audio & Design Recording 32 x 4 stereo-capable audio board and four stacked McKenzie 1/4-inch endless-loop machines, giving 20 tracks of audio sweetening for laugh tracks and applause.

A Central Dynamics 480/8 switcher with "all the bells and whistles" provides special effects for *Tic Tac Dough*. Its capabilities, including stars, wipes, and mosaic patterns, are used throughout the show for segues, intros, and wraparounds.

The game board's nine monitors, plus the numerous flashing lights used in the show, mean that overall studio lighting has to be carefully controlled against excessive brightness. Korabell says that the show is lit at about 150 fc overall.

### Computer games

The physical setup for the game itself is complex, with 10 computers controlling the rotation of questions for the contestants. The game, based on the venerable tic-tac-toe, requires players to answer questions that appear in the nine boxes of a tic-tac-toe grid. Questions fall into 90 categories, which rotate among all the boxes in a computer-directed "random" shuffle.

"Of course, with computers there are no random shuffles," Enright admits, "but we devised as best we could a random shuffle so that the same category does not appear again in the same box. It runs like a cycle." The contestant selects a box, then must correctly answer a question in the designated category before



Two of the four RCA TK-46s used for the show focus on the contestants. All cameras are equipped with Q-TV teleprompters.

putting his or her mark in the box. Enright explains that each box has its own computer to present the questions, while the tenth computer performs the "shuffle."

Prospective players must go through a three-stage screening process, involving a 90-question examination, two interviews, and a test playing of the game. "You don't necessarily look for the pretty types or the handsome types," Enright explains. "You do look for someone who is pleasing and articulate, and of course someone who knows how to play the game."

### Bye-bye PTAR?

The prime-time access rule has been instrumental in helping syndicators sell their shows to network stations. Now, deregulation may present syndicators with the prospect of no more PTAR. What would Enright's strategy be if PTAR were abolished?

"To make a graceful retreat," laughs Enright. Becoming serious, he adds, "You intensify efforts to sell to networks. You see, independent stations do not have an easy time competing. By and large, the networks control things, so you have to intensify your efforts to make your syndicated product better in order to make it more appealing to a station to program in the daytime. On the other hand," Enright points out, "it is not a foregone conclusion that the Commission will indeed give that time back to the networks."

The seriousness of the situation is hardly lost on him: "The reason for the proliferation of shows into syndication is the prime-time access rule. If that time were returned to the networks, it would be a hard thing for syndicators."

Until and if that happens—and even after, if Enright's determination is any indication—Barry & Enright have a winner with *Tic Tac Dough*. **BM/E**

**What  
the Shadow  
doesn't know  
...it learns.**

**The BTX Shadow System:**

- synchronizes and controls ATRs and VTRs to sprocket-lock, subframe accuracy
- learns each recorder's dynamic characteristics to optimize machine control
- maintains minimal offset during GO TO and CHASE functions
- runs independently, allowing hands-off synchronization in all control modes
- uses standard RS 232C interface to permit present and future computer automation, including electronic editing
- available with optional control console, which displays time and status data and allows keypad entries of destinations, GO TO and FOLLOW commands, and data storage/retrieval
- priced to permit each transport to have its own Shadow

To learn what the Shadow knows, call  
1 (800) 225-2253

The BTX Corporation, 12 Huron Drive, Natick, MA 01760

**btx**  
**SHADOW**

Circle 121 on Reader Service Card



# WORDS & PICTURES

Introducing Vidifont® Graphics V. The character/graphics system with unique technological innovations.

Everything you need to combine operator ease with artistic beauty. Total creative freedom. A rainbow of colors. An infinite variety of animated effects. Plus multi-user access.

Graphics V.™ Sophisticated. Easy to use. Practical. Flexible. Everything you'd expect from the great Vidifont tradition.

## THE FACTS SPEAK FOR THEMSELVES

- Eight full-set fonts. Up to 48 in resident memory.
- 256 automatic kerning combinations of intercharacter spacing.
- 4,096 colors in resident collection.
- 16 color "quads" instantly on-line.
- Backgrounds. Created independently of foreground character plane and enlarged or reduced.
- Capability to mix italics and conventional characters on the same row.
- Edge types include border, shadow and outline.
- Edging may be extended in any direction. Up to 256 scan lines.
- Compact component design for mobile applications, built-ins, or custom console.
- User stations and disk storage may be located hundreds of feet from main electronics.
- Up to 8 keyboards can operate simultaneously.
- Simultaneous on-line accessibility provided by two independent, full-function, high resolution channels.
- Over 35 pages instantly accessed on-line.
- Unlimited additions from disk.

- Character appearance enhanced by edge polishing to eliminate objectionable effects of aliasing.
- Exclusive area composition permits composing and editing in one section of the display without disturbing adjacent items.
- Free-form manipulation through double-buffered frame store. Character placement not limited by row-structured page.
- Margins can be released in any or all directions. Displays can "bleed" or run off the edge of the screen.
- "Cut and paste" capabilities.
- Multi-planar character and row stacking.
- Unique restore function permits examination of sequenced displays. Graphics V steps back and restores previous display for comparison.

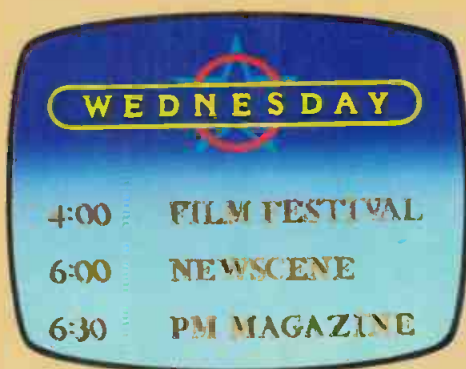

## THE WIDEST ARRAY OF DYNAMICS

- Rolls/crawls. 196 speed/direction combinations.
- Up to four displays may be moved in any direction simultaneously.
- Ripple-on/ripple-off. Character-by-character appearance or removal at any of 127 rates.
- Timing relationships may be examined event-by-event, re-arranged, re-timed or otherwise adjusted.

## EASY TO USE

- Operator-oriented design. Prompted and menued entries. Logically laid out keyboard.
- Independent color edit outputs for each channel.
- Standard setup always available. When a different, often-used format is required, operator loads in a "user environment." Fonts, colors, channels, levels, tabs, margins, etc. are automatically configured and placed on-line.
- Self-test and diagnostics.



## FONT COMPOSE

□ Plug-in module allows in-house creation of fonts, logos, and graphics. Generated from artwork or electronically synthesized. Full range of composition, editing, and creative aids available directly on keyboard.



Vidifont® IVA. With Vidivote™ and Viditext.™ The cost-effective champ of character generators. Includes so many of the capabilities of Vidifont Graphics V.

For complete information about the new Vidifont Graphics V, send for our brochure. Thomson-CSF Broadcast, Inc., 37 Brownhouse Road, Stamford, CT 06902. Tel. (203) 327-7700.

West Coast Sales & Service,  
1919 West Magnolia Boulevard,  
Burbank, CA 91056. Tel. (213) 849-2188.

 THOMSON-CSF BROADCAST, INC.

See us at NAB Booth 3201

# KCST-TV SAVES

**“RCA TK-47 cameras cut set-up time and lighting costs, made troubleshooting easy, and increased our commercial production”**

... Tom Wimberly, Chief Engineer  
KCST-TV, San Diego, California

KCST-TV went through some painstaking steps before they added four new TK-47 studio cameras. They even set up a side-by-side comparison study with six other cameras.

According to Tom Wimberly, Chief Engineer, it was no contest. A technical committee judged the TK-47 to be far and away the best studio camera available. Best in automatics, best in picture quality, best in cost effectiveness and best in all around performance.

That was “before”. What about on-air performance after a year of operation? Here’s what Tom Wimberly has to say:

“The TK-47 cameras have resulted in substantial cost and manpower savings. We’ve cut camera set-up time from an hour to less than ten minutes. Our studio lighting costs have dropped \$400 per month.

Camera maintenance is cut a whopping 48 hours a week. We were concerned initially about the complexity of the TK-47, but we worried needlessly. The camera is extremely reliable. When we experience an occasional problem we find that the microprocessor control makes the TK-47 easier to troubleshoot than any other camera. But best of all, we’re getting unmatched picture quality, and that’s helping us build our audience and double our commercial production.”

Find out how the TK-47 can give you a new “look” in cost-saving, time-saving, and picture quality. TK-47 — it’s automatic, versatile and now available in Triax. Call your RCA Representative and ask for a showing of a tape in which six top engineering professionals tell how they are using TK-47’s in their broadcast and teleproduction operations. You’ll see why the TK-47 is first choice for savings and performance. RCA Broadcast Systems, Building 2-2, Camden, NJ 08102.





# NAB: 1982

## THE SKY'S THE LIMIT

INTRODUCTION, PROGRAM	37
WHAT'S HOT IN RADIO PRODUCTS?	43
RADIO EQUIPMENT EXHIBITORS LISTING	61
WHAT'S HOT IN TV PRODUCTS?	87
TV EQUIPMENT EXHIBITORS LISTING	113

# Profitable in-house production starts with the right system.

## Designed by MCI.

Time was when you could get by on in-house production with a couple of beat-up tape recorders and a turntable. But audiences and advertisers of today are demanding more. And that means a total production system that allows you to do everything from overdubbing and track bouncing to live multitrack recording. Now the company that has equipped more award winning studios than any other has designed a Total Production Package priced within your budget. You get an 8-track recorder, 2-track recorder and a studio quality console with

10 microphone and 5 stereo line inputs. Plus remote control, an accurate spot timer, 10 programmable "search and find" memories, variable speed and dozens of other features designed to make your job easier and your product better. MCI even offers a comprehensive user training program in the creative use and the maintenance of this system.

Contact your nearest MCI dealer today about the quality design (and current price advantages) of MCI's new Total Production Package. Your advertisers will love you for it.

You can see it at booth 1615 NAB Dallas.

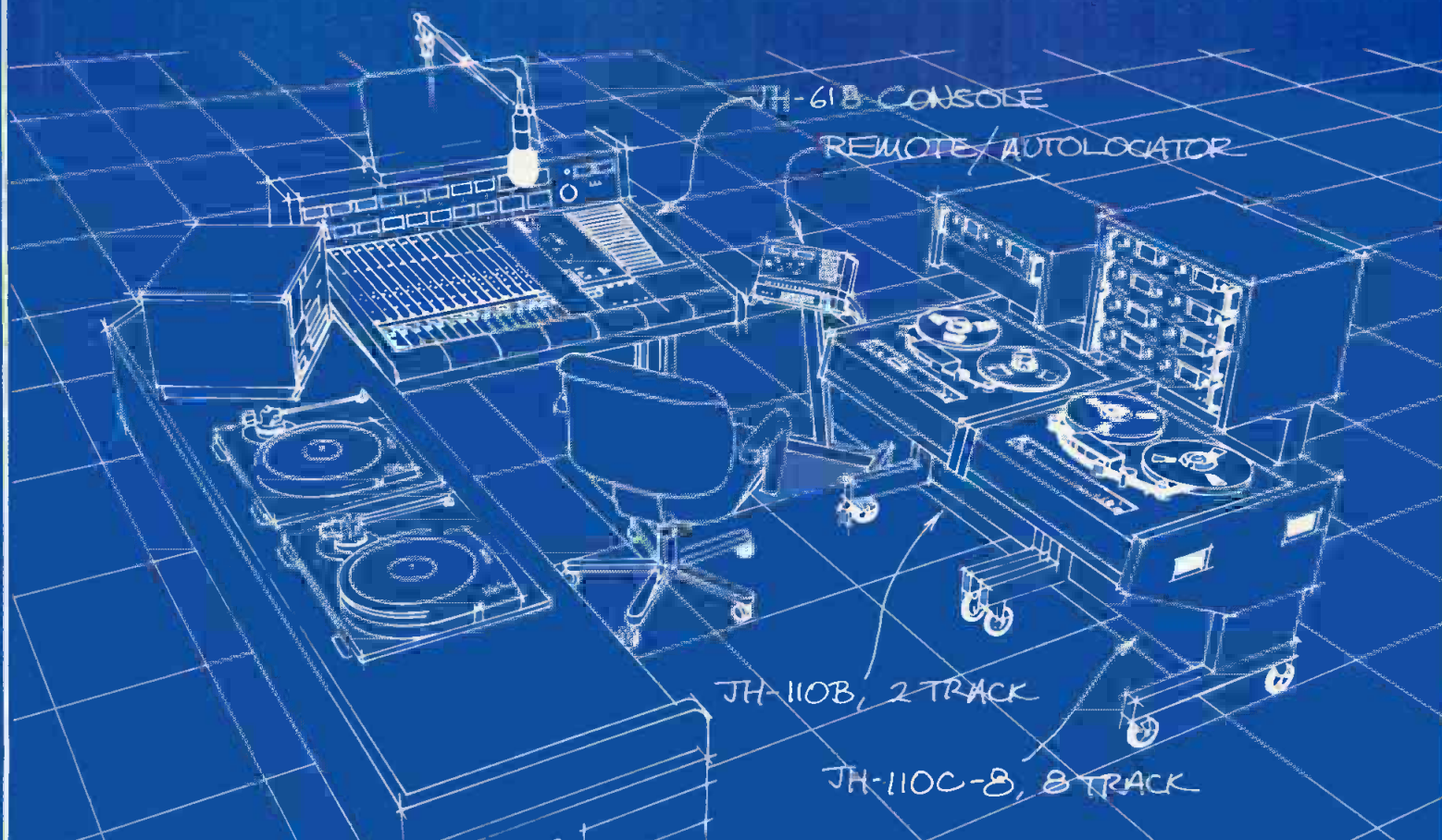

SPECIFICATION		CONTROL		DWG.		
 A division of Sony Corporation of America		TITLE BROADCAST AUDIO PRODUCTION SYSTEM				REV B
		DRAWN A.H.	DATE	SHT 1 OF 3	DWG. SIZE A	
CHECKED D.M.		APPROVED J.L.				

# IT'S SHOW TIME IN DALLAS

OVER 460 EXHIBITORS . . . over 200,000 square feet of exhibit space . . . four days of intense workshops and discussions . . . guest speakers such as Walter Cronkite and Mark Fowler . . . at the NAB convention in Dallas, April 4 - 7 at the Dallas Convention Center, the sky's the limit!

There truly will be something for everyone, especially in the exhibit area, open 9:00 a.m. to 6:00 p.m. Sunday through Tuesday, and 9:00 a.m. to 2:00 p.m. on Wednesday. A booth-by-booth description and analysis of equipment trends, broken down into Radio and TV equipment sections, follows this introduction.

The program kicks off on Sunday at 3:00 p.m. with ceremonies marking NAB's sixtieth year and the president's "state of the industry" address. Glen Campbell entertains.

Another general session for all attendees will be on Monday at 2:30, when the topic is, "Washington: What's Next?" Speakers will include FCC Chairman Fowler, other commissioners and legislators in what is billed as "a unique forum with all the snap and pace of a theatrical production . . . as entertaining as it is informative." Audience participation is strongly welcomed.

Wednesday is also shaping up as a day of major general-interest activities. Having adopted "The Year of the First Amendment" as its second overall conference theme, the NAB will present a major discussion on broadcasters' First Amendment rights. Beginning at 9:30 a.m., a panel of high-powered experts will tackle political broadcast time and rates, editorializing, illegal searches, censorship, fairness, gag orders, reporters threatened with jail, station records threatened with confiscation, and other issues affecting broadcasting's rights.

This will be followed by a unique opportunity to meet new Commissioners Mimi Weyforth Dawson and Henry Rivera in an unrehearsed, frank, no-holds-barred discussion moderated by NAB's VP and GM, John Summers.

Wednesday's activities will climax with an address by Chairman Fowler at the NAB's closing luncheon,

which will also feature entertainment by comic Steve Allen. Walter Cronkite will accept the NAB's prestigious Distinguished Service Award.

## ENGINEERING SESSIONS

The four-day conference will be marked by some major engineering workshops, though the full schedule has not yet been released. Some of the topics geared for TV broadcasters are:

- ☆ Direct Broadcast Satellites
- ☆ ENG Frequency Coordination—including the L.A. Coordinating Committee plan as an example
- ☆ HDTV
- ☆ UHF Transmitter Improvements
- ☆ Half-inch VTR Standards—including results of the SMPTE committee meetings
- ☆ Multichannel Sound—featuring a report on the EIA BTS Multichannel Sound committee
- ☆ Receiver Technology
- ☆ The SMPTE Workshop—featuring papers on digital techniques, digital VTRs, and digital transmission

- Sessions of interest to radio engineers will include:
- ☆ Radio STL Problems—including going stereo with a remote AM transmitter
  - ☆ Radio Allocation Report—based on the recent ITU Region 2 Conference
  - ☆ The Elimination of Hum and Noise in the Baseband Audio Channel
  - ☆ Telephone Talk Shows—including information on telco equipment and broadcast interfaces
  - ☆ AM Transmitter ICPM
  - ☆ Satellite Technology
  - ☆ AM Antenna Systems

- General engineering sessions include:
- ☆ Operator or Technician Certification—with members of NAB and the Society of Broadcast Engineers
  - ☆ Audio Modulation Monitors—discussing changes in the FCC's type acceptance and monitoring requirements

In the hands of a professional, an equalizer can work wonders. For the person who owns a UREI equalizer,

miracles are often made.

In the studio, sound reinforcement systems, in broadcast radio and television production, a good engineer relies upon his talent and expertise. And, the UREI reputation for unparalleled professional performance and quality.

Whether to correct or create, UREI offers a complete line of the most effective audio frequency shaping instruments available:

**The Model 535 Dual Graphic Equalizer**  
Two channels of ten calibrated, stepless, vertical adjustment controls with  $\pm 12$ dB boost or attenuation. Also available in a single channel version-Model 533.

**The Model 537 One-Third Octave Graphic Equalizer**  
A single channel device, it provides  $\pm 12$ dB of boost or cut in 27 ISO 1/3 octave increments from 40Hz to 16kHz.

**The Model 539 Room Equalization Filter Set**  
Specifically designed for room equalization, it offers 27 ISO 1/3 octave calibrated adjustments from 0 to  $-15$  dB attenuation plus band-end tunable high and low-pass filters.

**The Model 546 Dual Parametric Equalizer**  
Two independent channels. Each has four sections of continuously variable bandwidth, frequency, boost or cut; bypass for each filter section and channel; tunable end-cut filters; and 0dB gain. Also available in a single channel version-Model 545.

From One Pro To Another-trust all our toughest signal processing needs to UREI.

# The UREI Equalizers

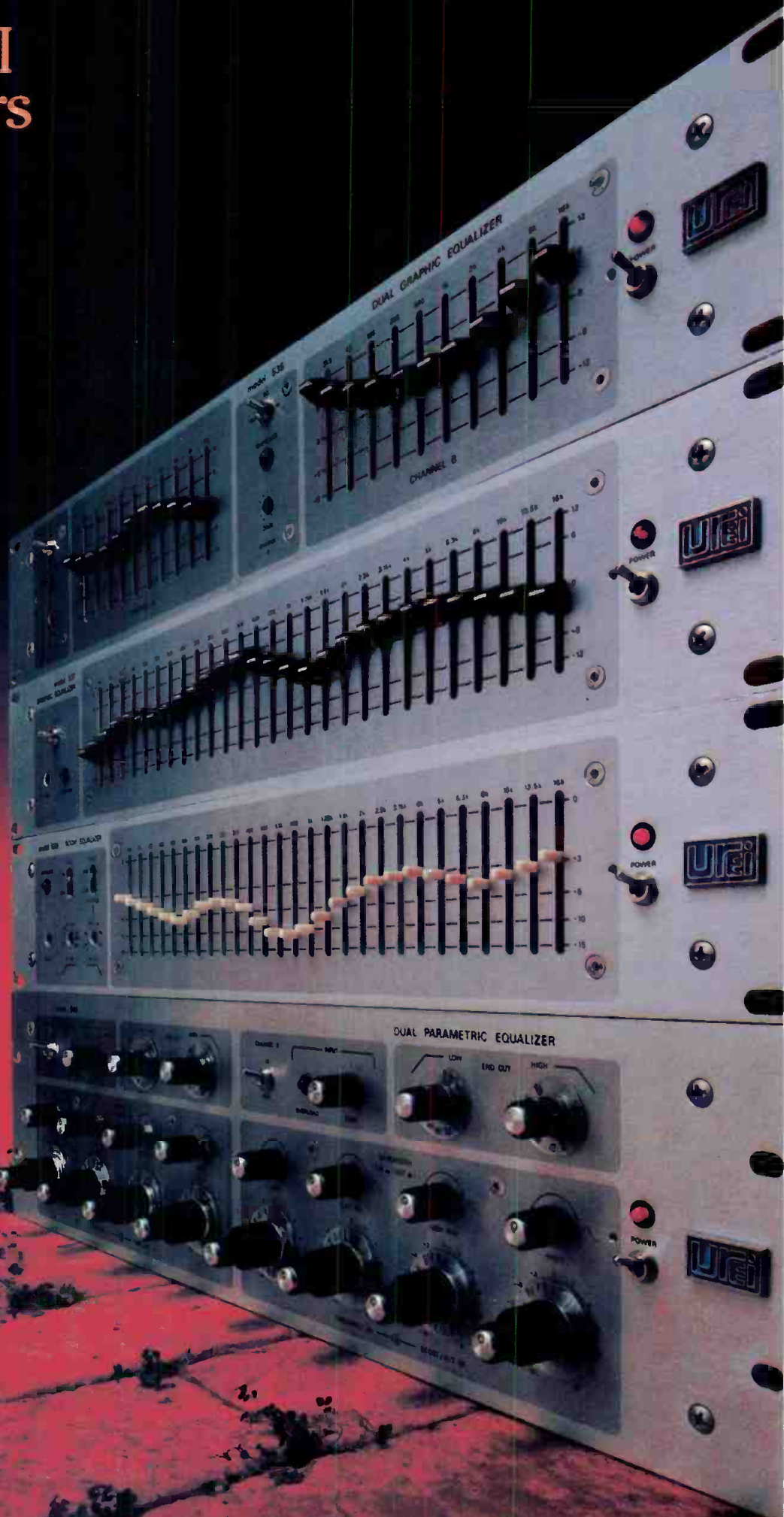

**UREI** From One Pro To Another

United Recording Electronics Industries  
1460 San Fernando Road, Sun Valley, California 91352 (213) 767-1000 Telex: 65-1389 UREI SNVY  
Worldwide: Gotham Export Corporation, New York; Canada: E.S. Gould Marketing, Montreal

See your professional audio product dealer for full technical information.

# ★ NAB: 1982 ★

☆ Apart from the engineering sessions, there will also be a full program for both television and radio management.

For TV, featured topics will include:

☆ **The Emerging Technologies**—a rundown on the trends and significance of cable and home video growth, cable viewing patterns, satellite delivery services, DBS proposals, pay TV revenues, and other new technologies. Will feature demonstrations of videotex/teletext, HDTV, digital special effects, and automation equipment.

☆ **Management by Strengths**—a workshop on management techniques that yield better productivity through setting and accomplishing goals within a company.

☆ **Financing the New Technologies**—a hard look at the dollars and cents involved in moving into new markets.

## TELEVISION

### NAB SCHEDULE

#### SUNDAY

3:00 - 5:00 p.m. *General Session:*  
Doors open with musical entertainment, followed by the presentation of the State of the Industry Message, and entertainment with Glen Campbell

#### MONDAY

9:30 - 11:30 a.m. *Opening Session:*  
The Emerging Technologies

Noon - 2:15 p.m. *Television Luncheon,*  
Speaker: Senator Bob Packwood

2:30 - 3:45 p.m. *Workshops:*  
The Information Explosion — Part I  
The Future of Broadcast Automation  
Competing for Sales in Markets 100 +  
Management by Strengths — Part I

2:30 - 5:00 p.m. *Government Relations Special Seminars*

4:00 - 5:00 p.m. *Workshops:*  
The Information Explosion — Part II  
Independent Local Programming  
Marketing & Promotions  
Management by Strengths — Part II

#### TUESDAY

9:30 - 11:00 a.m. *General Session:*  
TvB Presentation

11:00 a.m. - 12:15 p.m. *Workshops:*  
Financing the New Technologies  
Regional Interconnections  
Tomorrow's Newsroom Today

#### WEDNESDAY

9:30 - 10:30 a.m. *General Session:*  
First Amendment Seminar

10:30 a.m. - Noon *FCC Panel*

Noon - 3:00 p.m. *Closing Luncheon:*  
Speaker: FCC chairman Mark Fowler,  
followed by the Distinguished  
Service Award and entertainment  
with Steve Allen

## FOUR IMPORTANT THINGS ABOUT SIGNAL PROCESSING:

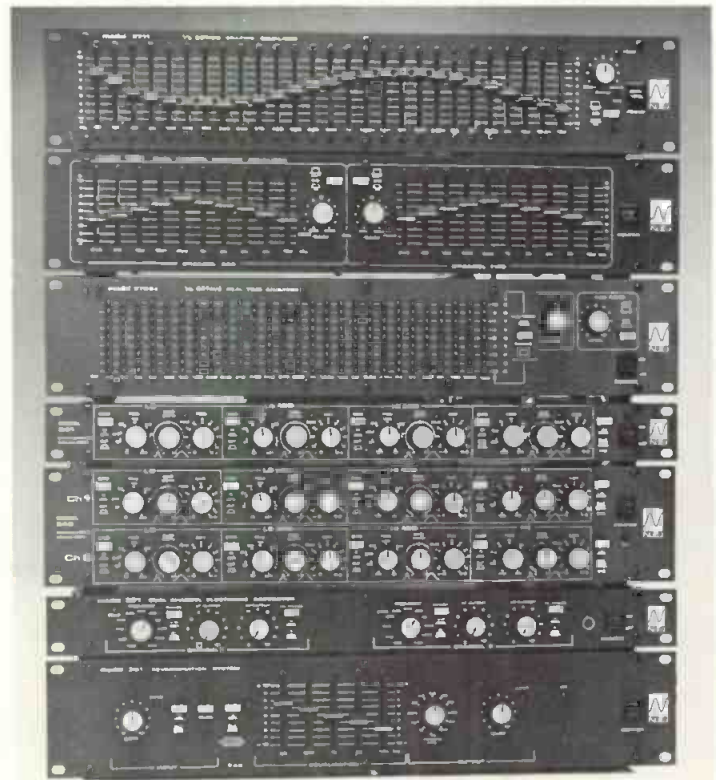

- Performance
- Quality
- Value
- ... NEI!

Now performance, quality, and value have been distilled into an extensive line of signal processing components for the audio professional, by the audio professionals at NEI. No matter which member of NEI's Signal Processing family is chosen for the job, the musician or sound engineer can count on shared excellence in design and construction that makes each ideal for a host of critical, demanding applications found in the studio, in broadcasting, and on stage. Plus, NEI offers all this performance and quality to those that need the creative control signal processing provides, but have to do it on a budget: price tags that won't break your bank, just equipment that gives you really great sound!

When it comes to signal processing, remember four important things: performance, quality, value, and NEI! For complete information on the new 1010 Graphic EQ/RTA, or other members of NEI family of fine, signal processing components, see your authorized NEI dealer.

**DESIGN YOUR SOUND WITH THE AUDIO PROFESSIONALS: YOUR PRO SOUND DEALER AND NEI!**



934 N.E. 25th Avenue  
Portland, Oregon 97232  
Telephone (503) 232-4445

Circle No. 126 on Reader Service Card



# ★ NAB: 1982 ★

☆ **Regional Interconnections**—a workshop on setting up ad hoc networks for news, sports, and other kinds of programming.

☆ **Tomorrow's Newsroom Today**—featuring members of RTNDA discussing various newsroom computer options.

☆ **The Future of Broadcast Automation**—a panel discussing the operational benefits of a network to link station groups, rep firms, ad agencies, research groups, and database sources, and also some of the problems.

☆ **TvB's General Session**—new upscale customers and how to sell to them.

☆ **The Information Explosion**—how will today's broadcaster be involved in the new communications technologies?

☆ **The TV Luncheon speaker** will be Senator Bob Packwood (R-OR), chairman of the Senate Commerce Committee.

Radio management will enjoy 16 special, hands-on clinics covering virtually every aspect of station management. They include:

☆ **Cash Flow/Credit and Collections**—a 75-minute clinic on cash management techniques.

☆ **The Great American Arbitron Shoot-Out**—what is, what is not, and what should be happening in audience measurement.

☆ **Home Computers in Small Markets**—how to put small computers to work for everything from traffic to avails.

☆ **Radio Research and Market Segmentation**—a mini-course in the business strategy of building numbers and therefore the future.

☆ **You Called the FCC?**—or, what not to do when you have a problem.

☆ **Leasing a Cable Channel**—the economics and programming possibilities for radio stations that lease CATV channels.

☆ **The Art of Negotiating**—how to get more for less of everything from office supplies to equipment and capital. A practical, how-to course on saving money.

☆ **What the FCC Didn't Deregulate**—how to save money, time, and perhaps your license under the new rules and guidelines.

☆ **The New Tax Law and You**—examining cash, depreciation, estates, and the various changes that are involved in the economic recovery plan.

☆ **1982 is an Election Year**—how to find your way through the political reporting maze.

In addition to the clinics, the NAB will present several in-depth forums on topics of interest to radio broadcasters. They are:

☆ **People Management, with Jim Newman**—management, sales, and motivation through a proven method of healthy, high-performance human behavior. How to be a better, more productive radio manager.

☆ **Sales, Sales, Sales—1982**—a full day devoted to anything and everything about sales in an updated version of last year's most popular convention event.

## RADIO

### NAB SCHEDULE

#### SUNDAY

3:00 - 5:00 p.m. *General Session:*  
Doors open with musical entertainment followed by the presentation of the State of the Industry Message, and entertainment with Glen Campbell

#### MONDAY

9:30 - 10:45 a.m. *Clinics:*  
Sales Motivation - Pam Lontos  
What the FCC Didn't Deregulate  
Leasing a Cable Channel  
Small Market is a State of Mind\*

9:30 a.m. - 12:30 p.m. *Forum:*  
People Management with Jim Newman

11 a.m. - 12:15 p.m. *Clinics:*  
Sales — AM in the 80's  
Management - Jim Hooker & Chris Lytle  
1982 is an Election Year  
The Great American Arbitron Shoot-Out

1:30 - 4:30 p.m. *Forum:*  
Spanish Language Radio

2:30 - 5:00 p.m. Government Relations Special Seminars

#### TUESDAY

9:30 - 10:45 a.m. *Clinics:*  
Minority Programming for Profit & Progress  
Radio Research & Market Segmentation  
Cash Flow/Credit & Collections  
Home Computers in Small Markets\*

9:30 a.m. - Noon *Forum:*  
Sales, Sales, Sales — Part I

11:00 a.m. - 12:15 p.m. *Clinics:*  
The Art of Negotiating  
The New Tax Law & You  
You Called the FCC?  
Home Computers in Small Markets\*

12:30 - 2:00 p.m. *Radio Luncheon:*  
Radio's World is Exploding!

2:30 - 5:00 p.m. *Forums:*  
Sales, Sales, Sales — Part II  
(split into small\* and large market sessions)  
People Management with Jim Newman  
Satellite Programming

#### WEDNESDAY

9:30 - 10:30 a.m. *General Sessions:*  
First Amendment Seminar

10:30 a.m. - Noon FCC Panel

Noon - 3:00 p.m. *Closing Luncheon:*  
Speaker: FCC chairman Mark Fowler followed by the Distinguished Service Award and entertainment with Steve Allen

\*Of special interest to Small Market Broadcasters

☆ **Programming for the Birds**—some of the very latest developments in satellite-distributed programming, including vital information about how to motivate your own staff in this direction. Both the dos and the don'ts.  
☆ **Spanish-Language Radio**—the challenge of special-language programming.



# BRILLIANT

## The New Anton/Bauer LG-30 Lighting Head

Anton/Bauer, the recognized leader in portable battery systems, has done it again with their new LG-30 "Black Beauty" Lighting Head, the ultimate in portable lighting.

This unique unit offers professional features not found in any other light — a spring loaded, captive, swing-away dichroic filter; integral one hand on-off and focusing; extra heavy duty



The perfect companion for the LB-300 Battery Bell.

cable and strain relief; a standard handle with spare bulb storage (removable for camera mounting); brackets for custom mounting on all ENG cameras; and an improved lamp socket that accepts standard 12v and 30v bulbs. The LG-30 "Black Beauty", the first truly heavy duty professional portable light.



The LG-30 mounts easily to any ENG camera.



For further information:

**NEW ADDRESS: ANTON/BAUER, INC. One Controls Drive Shelton, CT 06484 (203) 929-1100**  
DEALER INQUIRIES INVITED

Circle 127 on Reader Service Card

# INTRODUCING OPTIMOD-TV

## A TV Audio Revolution.

There's a revolution going on. TV broadcasters are competing with VCR, videodisc, premium cable, and other services for the eyes *and ears* of a mass audience that's becoming more aware of good sound. In this audio war, '60's processing technology doesn't cut it.

Enter OPTIMOD-TV. It's the same second generation OPTIMOD-FM sound that's sweeping the country, with enhancements to adapt it to the specific needs of TV broadcasters. Smooth multiband compression teams up with our patented "Smart Clipper"<sup>TM</sup> and FCS overshoot corrector to create a tightly bandlimited, peak-controlled output that stays out of the video and is ready for TV stereo. And stereo processing is supplied standard.

The processor rides gain and peak-limits with remarkable subtlety, achieving superior consistency, openness, and naturalness on the finest master-quality audio or the poorest 16mm optical film.

OPTIMOD-TV gives you the potential to bring your audio up to the same quality as your state-of-the-art picture. Processing is no longer the limiting factor. So plan your audio strategy for the great war of the '80's around OPTIMOD-TV Mode 8108A. Your Orban broadcast dealer can tell you more. Or contact us Toll Free (800) 227-4498. In California (415) 957-1067 for more information. Hear the OPTIMODs *live* at NAB Booth 1812.

### orban

Orban Associates Inc.  
645 Bryant St.  
San Francisco, CA  
94107



Circle 128 on Reader Service Card

# ***WHAT'S HOT IN RADIO PRODUCTS ?***

**FIND IT FAST**

AUDIO PROCESSING	44
NOISE REDUCTION	44
CONSOLES	46
TAPE MACHINES	49
CART MACHINES AND CARTS	49
SATELLITE SYSTEMS	51
TRANSMITTERS	51
REMOTE CONTROL AND STL	52
AUDIO PRODUCTION EQUIPMENT	54
TEST AND MEASUREMENT	56
INTERCOMS	56
TELEPHONE/STUDIO COUPLING	56
PROGRAM AUTOMATION	57
SYNDICATORS	57

# ★ NAB: 1982 ★

YOU ASKED FOR IT, so come and get it—that is the message for radio managements in the advance information on the 60th NAB conference. What radio managements asked for most in *BM/E's* "Survey of Broadcast Industry Needs" (February, 1982)—audio processors, tape machines, consoles, cart machines, test equipment, and satellite receiving equipment—will be on display in a number of state-of-the-art versions, some bringing important new technology.

For example, Neve will have the first all-digital consoles, a big step toward the all-digital studio the experts have long been hailing as a crucial future development. Broadcast Electronics and Harris will have the first automation software designed specifically to integrate local automation with satellite formal programming, in response to the just-born technology of syndication via satellite.

Digital products will be on view everywhere. Studer's new tape recorder, the A810, uses digital control in a highly innovative way, although the signal is kept in analog form. Apparently there will be no all-new digital tape machine at the show; but 3M will be demonstrating its multitrack digital machine, in use for several years.

There will be consoles from Sphere with digital control. Eventide will have a digital special effects system using plug-in program modules that take programmable operation beyond earlier limits. Tape machines, too, continue their development. ITC will have a new version, the "B" model, of the Series 99 cart machines. The Ampex ATR-800 is a new analog recorder, using the same basic technology as the ATR-100 but designed specifically for broadcast use.

## AUDIO PROCESSORS

The 1982 NAB show, in short, promises to deliver on its theme: the Sky's the Limit! The makers of audio processors keep refining the product, pushed forward by the tension between the industry desire for a "loud" signal and that for a clean signal. There is also a competitive "battle of special effects", an effort to bring in

new special effects systems that go farther into the startling and "new" than anybody has before.

Eventide's SP-2016 programmable special effects system, shown at the AES in November but new to the NAB, uses plug-in program modules that can give it almost any conceivable capability. Eventide has a number of modules ready, and is developing more. The user can develop his own programs, and record the modules in the field.

Some other special effects systems on display are also spectacularly capable. Lexicon's new Model 97 special effects and reverb system would seem to be in this category, with 40 storage registers for effects or reverb programs. Ursa Major, another highly experienced special effects and reverb designer, will bring a new computer interface for its 8 x 32 digital system, introduced earlier.

Audio and Design will add a new limiter with digital memory to its very extensive line of processing systems. Advanced Music Systems, new in this field, will show a digital reverb system. Both Broadcast Technology and UREI will have equalizers on plug-in cards.

Other amplitude control and special effects systems of great variety will be on tap, including the widely used systems of Orban and Gregg Laboratories, both bringing refined versions of earlier models.

Aphex Systems will introduce the Model II Aural Exciter, intended to give the exciter "lift" to broadcast material. Aphex will also have the new Model EQF-1, a modular equalizer/filter.

Thomson-CSF Broadcast will have its full line of audio processing units, including the Volumax, Audimax, and related gear. Datatronic will show its new Model 8160 10-band graphic equalizer, with modules that can be plugged in to enhance the voice quality of each on-air personality.

Orban will also have its new Optimod 8180A, applying the Optimod technique to audio for television. The unit omits a stereo generator, of course, but adds preemphasis and deemphasis to raise the S/N. Gregg is showing the Model 2560, similarly directed to television audio. These units, along with a number of the consoles on display, are a response to the sharply increased interest in audio among television engineers and producers.

## NOISE REDUCTION

MicMix will bring something that sounds new—a noise reduction system, the Dynafex, claimed to reduce the noise already on a recording by up to 30 dB without coding or decoding. A more usual, coded noise reduction pattern is the AEG-Telefunken High-Com

Eventide's Model SP 2016 signal processor.

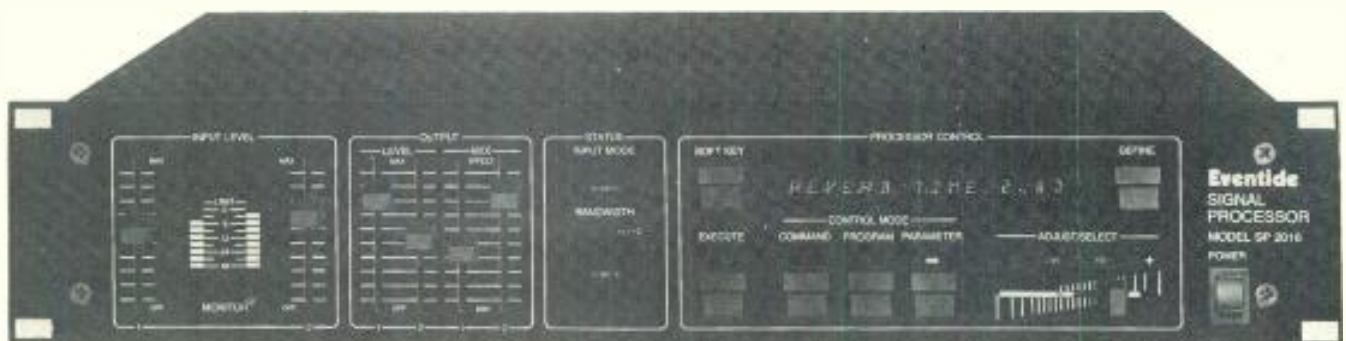

If you're looking for low-cost TV programming with broadcast quality...

## There's a Harris earth station system to fit your needs

The Harris SSL\* family offers a variety of satellite earth stations *specifically designed for broadcasters*. Whatever your system requirement—large or small, downlink or uplink—Harris has the complete package for you, including total planning, rapid reposition antennas, video receivers, exciter-high power amplifiers, microwave links, remote control and complete installation. All backed by Harris 24-hour-a-day service—the most responsive in the broadcast industry.

The high-speed drive system of the Harris kingpost pedestal allows rapid and accurate repositioning of the antenna, so that it can be rotated automatically between any domestic com-



6.1 meter



9.0 meter

munications satellites in less time than a normal commercial break.

The Harris 9.0 meter SSL provides the industry's most advanced feed horn antenna design, with video receive S/N (signal-to-noise) in the high 50s for network quality broadcasting. This antenna is also designed for uplink service, *where specifications and price outperform 10 meter designs!*

The 6.1 meter SSL provides *highly cost effective* TV receive only (TVRO) service for broadcasters, with S/N performance in the mid-50s.

Set your sights on a whole new universe of TV program sources. Contact Harris Corporation, Broadcast Products Division, Quincy, Illinois 62305-4290. 217-222-8200.

\*Satellite to Studio Link

Visit the Harris TV and radio equipment display at the 1982 NAB, Dallas.



# HARRIS

Circle 129 on Reader Service Card

[www.americanradiohistory.com](http://www.americanradiohistory.com)

# ★ NAB: 1982 ★

system, much used in Europe, to be seen in the Straight Wire Audio booth. Dolby promises a new audio replacement Type "A" noise reduction module for Ampex VTRs to go with the previously introduced module for Sony decks, as well as a new rack system holding 24 Type "A" cards in a compact space.

## CONSOLES

As at every NAB show for years, the number of console exhibitors on the floor will be bigger than the year before. The largest technical innovation, according to the advance information available to *BM/E*, will arrive with the Neve all-digital series, noted above. At each input on these consoles an A/D converter puts the signal into digital form, with selectable sampling rates of 48 kHz and 41.1 kHz, apparently on the way to becoming world standards. After conversion, the signal stays digital through all control, switching, and

*Dolby will introduce a new audio replacement Type "A" noise reduction module.*



*One of Neve's new consoles from the 51 Series.*

processing in the console, with the gains in precision and flexibility the experts have been promising for a long time. Called the "DSP" series, the consoles also have memory for settings on all control paths.

A sizeable number of other console makers are bringing new models, with many aimed for television audio, as noted. Microtrak will have a 10-channel model. Howe Audio has the new 7500 Series. ADM will introduce a teleproduction audio console, a post-production audio console, and an on-air console. The ADM teleproduction audio console can handle 160 inputs, has 32 mix modules, and outputs up to eight tracks.

Some other firms filling the console cornucopia will be MCI, with a new general purpose mixer; and LPB, with its new "Benchmark" series, to add to the Citation and Signature series. McCurdy will bring two new production consoles and a new on-air console. Ward-Beck will unveil two new TV audio consoles, and an array of others for production and on-air radio work. Quad Eight is bringing the new Series 248 consoles. Meanwhile, Harris continues to improve its Micro-Mac microprocessor-controlled modular console.

Harrison, long eminent in large consoles for the recording industry, is making a strong move toward broadcasting with the new TV-3, designed specifically for handling audio in television. It has full multitrack ATR capability, with eight, 16, or 24 tracks, and puts emphasis on capability for stereo sound with television images. Signal peak levels are indicated with vertical LED arrays.

Trident, a British firm, will show the Series 80 recording and production console. Shure Brothers has two new portable mixers, models M267 and M268; Shure says it has improved characteristics over earlier models. Logitek has mixers designed for ENG, with six inputs, two outputs, and built-in monitoring and intercom. Interface also has an ENG mixer, this one with eight inputs and two out.

Pacific Recorders brings its well-known BMX series of consoles, and Studer will have the 900 Series consoles, introduced last year.

Long familiar is the habit of successful hardware makers, no matter what their original products were, to add audio consoles to the line. Both Gregg Laboratories, which made its reputation in audio processing,

# HARNESSING SOUND AT THE SPEED OF LIGHT



SEE  
US AT  
N.A.B.  
BOOTH  
1505

Now you can lock into a 7 dimension in post production with the advanced proven Q-LOCK System by Audio Kinetics. Q-LOCK enables you, for the first time, to precisely synchronize control an audio/video/film machine matrix. Among the numerous features designed for maximum efficiency with minimum operational complexity are:

- SOFT dedicated software packages tailored to your individual requirements and readily upgradable without the need to replace hardware.
- Integral multi-standard SMPTE jam sync code generator with NEW Q-LOCK option for regenerating code.
- Sequence of tach pulses in 'Wind,' and time code in 'Parking' and 'Play,' eliminates the need for machine modifications.
- Optional hi-speed readers.
- Hierarchy of control assigns machine commands to any combination of, or any individual machine without complex cabling.
- Manual or automatic record entry and exit.
- Complete system locator with ten cue point memories.
- Cycle (looping) facility for sound to picture repeat.
- Variable time code events.
- Can be integrated with external computers utilizing RS232 / 422 protocols.



- User orientated design by graduates of post production.
- Supplied complete with generator, readers, machine interfaces and all necessary cabling and connectors.

Effectively combining any three machines, be it video, audio or film, the Q-LOCK System controls the whole machine matrix as a

single piece of equipment, giving you greater flexibility, easier sound editing and improved accuracy. More machines can be added on a chase basis.

**AK** To find out how Q-LOCK can streamline your existing facilities, simply use the coupon or contact Audio Kinetics direct.

## AUDIO KINETICS

4721 Laurel Canyon Boulevard, Suite 209  
North Hollywood, California 91607  
Tel: 213/980-5717. Telex: 194781. **Toll Free 1-800-423-3666**

Please send me full details on Q-LOCK

Name .....

Company .....

Address ..... Zip Code .....

Telephone No. ....

Type of business Audio Video Film Broadcasting



# LIMIT TO THE LIMIT.



## HERE ARE THE INDUSTRY'S MOST DYNAMIC PERFORMERS.

OF COURSE, THEY ALSO COMPRESS, EXPAND, GATE AND DUCK. THAT'S WHY RECORDING AND BROADCAST ENGINEERS ALIKE APPRECIATE THE EXTREME DEPENDABILITY AND MAXIMUM FLEXIBILITY OF AUDIO & DESIGN'S COMPLETE LINE OF COMPRESSOR/LIMITERS. NO OTHER MANUFACTURER IN THE WORLD CAN MATCH THIS SELECTION OF LOW DISTORTION LEVEL CONTROLLERS.

1. THE GEMINI EASY RIDER OFFERS TWO FULL FUNCTION CHANNELS AT A MODEST PRICE.
2. THE EX-PRESS LIMITER IS IDEAL FOR CONTROLLING STEREO MIXES, PLUS IT CAN BE CONFIGURED FOR FM BROADCAST OPERATIONS.
3. KNOWN THE WORLD OVER, THE VOCAL STRESSER COMBINES A COMPLEX LIMITER WITH FOUR BANDS OF SWEEP EQ.
4. THE ORIGINAL COMPLEX LIMITER FEATURES SEPARATE COMPRESSION, LIMITING AND EXPANSION FACILITIES.
5. FOR SPECIAL APPLICATIONS, THE VOICE-OVER LIMITER AUTOMATICALLY MAINTAINS A PRE-ESTABLISHED MUSIC TO VOICE RATIO.
6. AND, THE UNIQUE SELECTIVE LIMITER CONTROLS LEVEL IN ONE FREQUENCY REGION WITHOUT MODULATING THE REST OF THE PROGRAM.

WITH FEATURES LIKE ADJUSTABLE ATTACK, RELEASE AND RATIO AS WELL AS STEREO COUPLING, "SIDE CHAIN" ACCESS AND "SOFT KNEE" SLOPES AT THE THRESHOLD OF COMPRESSION, THESE EXCEPTIONAL LIMITERS ARE THE MOST PROFESSIONAL CHOICE FOR EFFICIENT, LOW DISTORTION LEVEL CONTROL. CALL TOLL FREE, 800-426-6170 FOR DETAILS ON THESE AND OTHER FINE AUDIO PROCESSORS FROM AUDIO & DESIGN.

AUDIO & DESIGN RECORDING, INC. • P. O. BOX 786 • BREMERTON, WASHINGTON 98310  
TELEPHONE (206) 275-5009 • TELEX 15-2426

AUDIO & DESIGN RECORDING, LTD. • NORTH STREET • READING RG1 4DA • BERKSHIRE, ENGLAND  
TELEPHONE (0734) 53411 • UK TELEX 848722

Copyright 1981 by Audio & Design Recording, Inc.



## Audio + Design

THE HIT SOUND IN AUDIO SCIENCE

Circle 131 on Reader Service Card

www.americanradiohistory.com

★ **NAB: 1982** ★



*The ATR-800 audio recorder from Ampex.*

and Audio-Technica, known for phono pickups and microphones, are joining the party at this NAB with their first consoles. The makers' competence in broadcast equipment design indicates that attendees will examine these consoles with care.

**TAPE MACHINES**

The digital tape recorder has been stirring the waters mightily for years, but, largely because its cost is still well beyond radio budget limits, the digital machine is not yet near a take-over in radio. That take-over is sure to come in the future, but in the meantime analog tape machine design keeps moving ahead.

As noted above, according to the advance information there will not be a single new digital open-reel tape machine at the show. Of the digital machines al-

ready in use, we will see the 3M multi-track system. Sony will apparently not bring any of the widely-used digital recording systems in its line. However, Gotham Audio will show the EMT system for recording short bits (commercials, songs, etc.) on digital disc packs.

Of the analog machines, the new Studer A810 continues the emphasis on great precision in control that Studer embodied in the A800. The new machine uses a microprocessor to adjust all amplifiers with digitally controlled pad networks, eliminating trim pots. Signal control is thus linked directly to the microprocessor. The system has a memory that will hold all parameters for four different tapes, for instant recall. Meanwhile, Studer also plans to introduce an all-digital tape recorder at the AES Convention in Montreux, Switzerland, in March; presumably we will see it in this country not too long from now.

The new Ampex ATR-800, with advanced characteristics on a par with those of the ATR-100 and ATR-124, is meant to make the job of the tape operator in a broadcast station as precise and error-free as possible. At a price in the neighborhood of \$6000, it seems sure to be welcomed by the radio industry.

Otari will have new versions of several of its two-track and four-track machines, which broadcasters have adopted in increasing numbers lately. Nagra will have the new T-Audio, a servo-controlled, studio-size ATR transport.

Fostex will display its new A 8 reel-to-reel recorder, with eight tracks. Also on display will be multi-track mixers and digital delay equipment.

**CART MACHINES AND CARTS**

Making a first public appearance as a subsidiary of 3M, International Tapetronics is bringing a new version of the extremely popular Series 99 cart machines, the B Series. The ITC Series 99 and the Pacific Recorders Tomcat cart machines together have radically raised the level of cart performance in the last two years. The Tomcat cart series will also be demonstrated, as it was at last year's NAB.

Aptly timed to coincide with the opening of its new partnership with ITC, 3M is bringing a new "Scotch Cart," with revisions of both the mechanical and the magnetic tape design aimed for a higher performance level. 3M demonstrated the new cart in New York on February 26 and thus definitely ended the unhappy saga of "Centracart," the radically new cart system 3M struggled to get to market for three years and then abandoned.

Another new cart for which the maker claims improved performance is coming from veteran cart maker Fidelipac. Called "Master Cart," it is intended to make

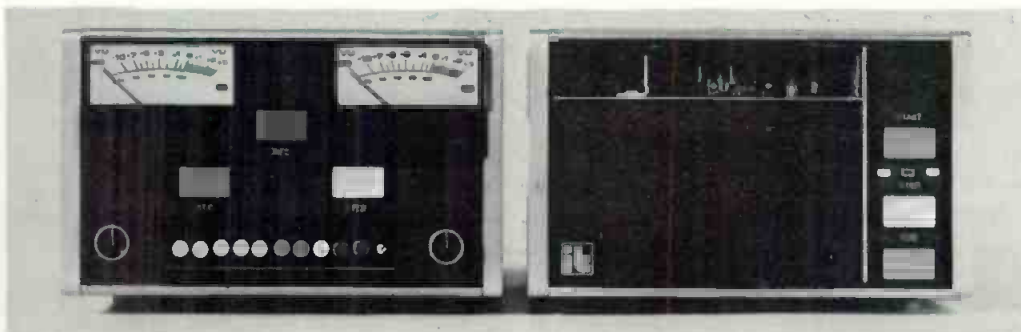

*ITC's Series 99 cart machine.*



# the trendsetters

Unquestionably the industry's standard of excellence in broadcast equipment

Most manufacturers meet industry standards; we exceed them. Our TOMCAT cartridge recorders/reproducers and BMX series of broadcast consoles deliver trendsetting on-line performance in broadcasting systems worldwide, from Boston to L.A., Australia to Great Britain.

TOMCAT: simply the world's finest. Innovative design assures superb sound quality, reliability, and low noise operation. Our Maxtrax™ wide-track fixed azimuth heads yield more signal, lowest phase error.

BMX, Series II: the ultimate in high performance mixing consoles. These compact units feature proven RF immunity and CMOS remote control flexibility plus a choice of 10, 14, 22,

and 26 input mainframe configurations. A new mix module is now available to offer two mix-minus busses for telephone talk shows. All this in a no-nonsense panel layout! See why TOMCAT and BMX series have made us the industry trademark. Call or write today for free information on our complete line of equipment.



pacific recorders &  
engineering  
corporation

1100 roselle street  
san diego, california 92121  
telephone 714 453-3255

★ **NAB: 1982** ★



*Scientific Atlanta will be breaking into radio earth stations.*

cart performance more reliable as well as higher in fidelity. Procart is bringing its full line of carts.

**SATELLITE SYSTEMS**

The satellites, of course, will have a strong presence at the show, almost certainly even stronger than last year's splendid appearance. AT&T will demonstrate program distribution via satellite for both television and radio, as prefigured at last year's NAB. Bell will also show satellite/terrestrial transmission for automated newsroom management and for other services for the radio broadcaster.

Turner Broadcasting will have full information on the CNN radio service network, another satellite-mediated operation. UPI, jointly with Harris Corp., which is building earth stations for the UPI satellite net, will demonstrate the various news services that UPI affiliates can get via satellite. World Communications will describe its extensive satellite services for both radio and television. M/A-Com DCC plans to demonstrate digital satellite gear, including a receive-only terminal for radio networks.

Several companies have announced new electronics for earth stations. McMartin is bringing new modulators and demodulators. California Microwave, with several hundred radio earth stations hanging from its belt, has revised and improved the complete electronic chain for the radio earth station. Scientific-Atlanta, which until recently made mostly television satellite gear, will demonstrate a complete radio earth station, antenna through receiver, for digital satellite signals. Harris also has a complete earth station with a new control system, Model 9165, which has 24 prepro-

grammed antenna positions instantly recallable, and all corresponding controls for the electronics section. The control center can be at the antenna or remote. Thus California Microwave, Harris, and Scientific-Atlanta will be among those with dishes on the lot outside the convention hall. There are likely to be a score or more of others crowding the lot, as there were last year at Las Vegas.

Related to the latest in satellite technology are the automation software systems of Broadcast Electronics and Harris mentioned at the beginning. As described in the article on the future of radio programming elsewhere in this issue, several of the satellite nets, initially ABC and the Satellite Music Network, are using cue tones, sent out along with the programming, to control automated switching at the local station. The cues are intended to cut in local material set up on carts.

The new Broadcast Electronics and Harris software, designed for the respective automation systems of the two companies, incorporate into the local automation precise response to the cue tones being used by the satellite nets. This integrates the satellite switching completely into the station's program automation. Other program automation system designers may well have similar software by the time they get to the NAB exhibit floor.

**TRANSMITTERS**

Six years ago the all-solid state transmitter, both FM and AM, seemed about to come in like a spring flood, at

**END STV PIRACY**

low cost Dynacom system

Whether you're going into STV for the first time or you have an existing system that's letting you be robbed blind, check out the new, secure Dynacom system.

We have provided "ticket module" decoders to small market clients and fully addressable systems to larger markets.

Call Robert Payne today at (404) 428-3100, and start STV paying off for you.



Dynacom Electronics Limited  
590 Commerce Park Dr./Marietta, Ga. 30066

Circle No. 354 on Reader Service Card

★ **NAB: 1982** ★

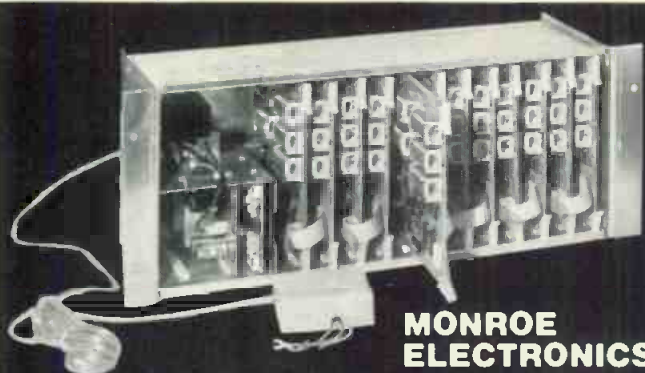

**MONROE ELECTRONICS**  
**MULTI-FUNCTION DUAL-TONE TELEPHONE REMOTE CONTROL RECEIVER SYSTEMS**

Single function or expandable systems respond to DTMF codes to provide latching or momentary relay outputs. Verification and status information is conveyed by audible tones.

- Magnetically latching or momentary relay outputs.
- Responds to DTMF codes from standard dial-up telephone.
- Microwave or radio link audio input.
- Operates from 24 VDC or 117 VAC.
- Expandable up to 60 relay outputs.

**\$1,825**

**OPTIONAL:** contact status monitor with alarm, voltage limit status monitor with alarm and auto dialer.

**ALSO AVAILABLE:** Radio-telephone interconnect systems, FSK Remote Monitor and alarm systems.

Write for brochure on Tone Signal Products

**M E MONROE ELECTRONICS, INC.**  
 212 Housel Avenue, Lyndonville, NY 14098  
 Phone: (716) 765-2254

Circle No. 167 on Reader Service Card

**Winsted**

THE PERFECT MATCH  
 for your video equipment



MODEL 85-20

**SYSTEM/85**  
 MODULAR VIDEO CONSOLES

A new generation of professional modular systems, developed by Winsted for use with the Sony "800 and Type 5" series video equipment.

These rugged 19" EIA modular units offer easily assembled welded and bolted stability. Units assemble in any configuration to suit your needs. The basic module is expandable to any size system with add-on-units.

**FOR FULL-LINE CATALOG** of the most complete line of customized videoproduction equipment, call or write:

**THE WINSTED CORPORATION**

8127 Pleasant Ave. So., Minneapolis, MN 55420 • 612-888-1957

PHONE TOLL-FREE **1-800-328-2962**

Telex: 910576-2740

See us at NAB Booth 1703

least up to medium-high power levels. But that flood subsided to a trickle, and the excitement about solid state transmitters almost disappeared.

This year it is clear that the proponents of the solid state transmitter were simply gathering strength for a steadier attack. Harris is leading with a new series of all solid state AM transmitters, the SX series, with models at 1 kW, 2.5 kW, and 5 kW. Harris claims important gains in power economy (one of the gains solid state design promised in the beginning), in reliability, and in fidelity of performance. The series is fully ready for AM stereo, using Polyphase Pulse Duration Modulation, according to Harris.

Other transmitter makers are joining the solid state march, making it a respectable procession. McMartin is bringing a new solid state 300 W FM unit. Singer has a new solid state 1 kW FM unit. RCA will put fresh emphasis on the solid state 5 kW AM transmitter, the BTA-5FF, introduced last year. Bayly Engineering will describe new models in the AEG-Telefunken line of solid state FM transmitters, with models up through 3 kW. Elcom-Bauer has two new all solid state FM transmitters, at 250 W and 1 kW respectively, as well as the new Model 690B PLL FM exciter.

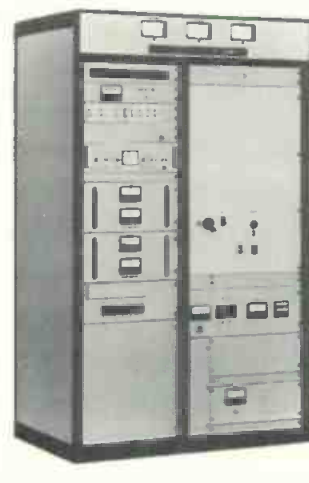

A 25-kW FM transmitter from Larcan.

**REMOTE CONTROL AND STL**

The companies long serving us well with gear for remote control, STL, and remote pickup will be strongly in evidence, most with new gear. Marti has a new line of STLs of improved characteristics. Moseley will bring its latest microprocessor-controlled remote

Marti's RPT2.



# MAGNECORD MC-II

## Modern Performance with Traditional Quality

The Magnecord MC-II is a rugged, precision tool for the broadcast control room—be it fully automated or D.J. assisted. The MC-II is made that way, by design, in the Magnecord tradition. Of course, it meets or exceeds NAB standards with IEC equalization on request.

### Superior dc Servo Drive

The dc servo, Hall effect motor with flutter-filter belt drive, provides exceptional speed stability (to 0.05%), totally unaffected by line voltage or frequency fluctuations. And it runs so cool, no ventilation is required.

### Full Broadcasting Features

Unlike some other cart machines, the Magnecord MC-II comes with the extra features broadcasters desire at no added cost. Built-in full remote control capability. Automation compatible cue tones (stop, secondary, tertiary) with LED indicators and contacts for external cue switching. Cue track input and output access for FSK logging. A universal mic/line input and front panel headphone jack to "preview" or time new carts and for servicing convenience.

### Flexible Broadcast Use

The MC-II is so flexible it virtually defies obsolescence. You can choose mono or stereo models, play only, or with record capability. Best of all, play models are field-convertible to record/play. The record electronics come in a separate housing for convenient, space-saving installations.

### Rugged Magnecord Design

As with all Magnecords, the MC-II is designed to work long and reliably. For example, the woven polyester drive belt and polyurethane pressure roller are virtually indestructible. The regulated dc

power supply has universal line capability (100-140V, 200-280V, 45-65Hz), consumes nominal power and is brown-out proof. Computer grade push buttons are rated at 10 million operations. A single piece chassis and machined base plate assure positive alignment of all tape transport parts. Hard core, long life heads are mounted on unique, glass-filled Lexan® head brackets with precision, phase-locked tape guides. Carefully designed circuit boards and a Mu-metal shield make the MC-II immune to RFI, even when operated directly under a transmitting tower.

### Convenient Service Access

When a Magnecord MC-II needs service, downtime is minimized. The covers and front panels are hinged for convenient access. All solid state circuitry is on plug-in

epoxy boards. Plug-in ribbon cables eliminate point-to-point wiring. And, of course, the Magnecord MC-II is made in the U.S.A. so parts are readily available.

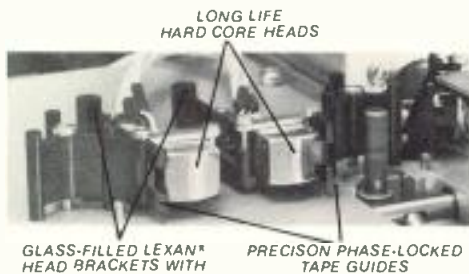

LONG LIFE  
HARD CORE HEADS

GLASS-FILLED LEXAN®  
HEAD BRACKETS WITH  
POSITIVE ADJUSTMENTS

PRECISION PHASE-LOCKED  
TAPE GUIDES

### HEAD ASSEMBLY

When you compare performance, reliability, and cost, the MC-II is indeed a modern tool worthy of the name Magnecord, because it's made in the tradition of rugged excellence.

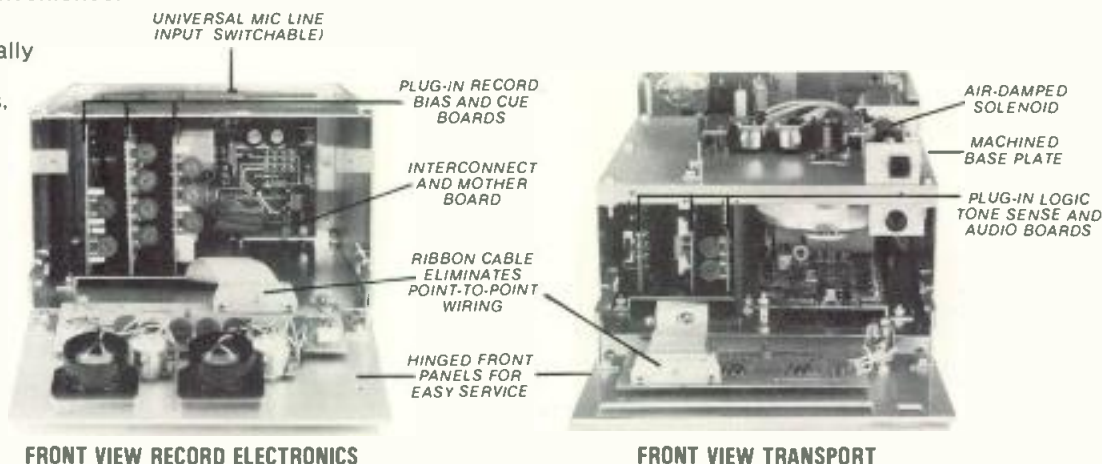

UNIVERSAL MIC LINE  
INPUT (SWITCHABLE)

PLUG-IN RECORD  
BIAS AND CUE  
BOARDS

INTERCONNECT  
AND MOTHER  
BOARD

RIBBON CABLE  
ELIMINATES  
POINT-TO-POINT  
WIRING

HINGED FRONT  
PANELS FOR  
EASY SERVICE

AIR-DAMPED  
SOLENOID

MACHINED  
BASE PLATE

PLUG-IN LOGIC  
TONE SENSE AND  
AUDIO BOARDS

FRONT VIEW RECORD ELECTRONICS

FRONT VIEW TRANSPORT

Quality products for the audio professional



# TELEX® MAGNECORD®

TELEX COMMUNICATIONS, INC.

9600 Aldrich Ave. So., Minneapolis, MN 55420 U.S.A.  
Europe: 22, rue de la Légion-d'Honneur, 93200 St. Denis, France

Circle 133 on Reader Service Card

www.americanradiohistory.com

★ **NAB: 1982** ★

control system, the MRC-2. Time and Frequency Technology also has new STLs. Micro Control Associates will bring new remote pickup equipment, and Motorola has a redesigned two-way communications system. All the firms noted, of course, and McMartin too, all important in these fields, will have their extensive lines of other related gear. Hallikainen will have the PCC process control computer for handling transmitter remote equipment.

**AUDIO PRODUCTION EQUIPMENT**

Other gear for studio operation will also be super-plentiful, and the highest interest seems to attach now to microphones, among these classes. The emphasis on microphone quality, and use, seems likely to keep rising as sources of distortion are brought lower and lower in other parts of the sound-handling chain. AKG will have new, refined condenser mics. Audio-Technica will bring a new shotgun condenser model, and Crown has new versions of the pressure-zone microphones designed specifically for use in broadcasting. Some other important suppliers of microphones on the floor will be Electro-Voice, Sony, Shure, Gotham (Neumann), and

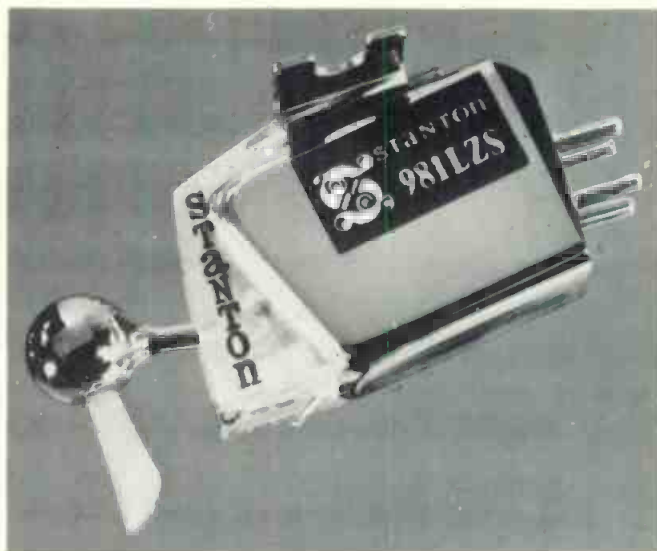

Stanton will introduce a new magnetic series for phono pickup.

Beyer. Wireless mics will come from Cetec Vega, Sony Telex, Swintek, Comrex, HM Electronics.

Another studio basic, the turntable, will appear on the floor in many versions, most of them the crystal-controlled variety that has brought enormous improvement in speed regularity. Russco Electronics will join the crystal-control ranks with a new model, the Mark IV. Audio Technology is bringing the new "Encore" turntable, which it describes as a low-cost, high-performance unit.

Another studio basic, the phono pickup, will be on

**Nobody's perfect . . . but we'll help you get close.**

Phase errors in stereo cart machines, stereo reel-to-reel machines, stereo-to-mono dubs, and more can now be corrected inexpensively and effectively.

The revolutionary Howe Series 2000 Phase Chaser™ is one neat little package that can be placed in the audio chain in any of several locations to correct phase error between left and right channels.

**The Howe Series 2000 Phase Chaser™ is not expensive, just essential.**

*Get your facility in phase for as low as \$800.*

Phase Chaser™ is a trademark of Howe Audio

For further information contact:  
**Howe Audio Marketing**  
 3085-A Bluff Street  
 Boulder, CO 80301  
 (800) 525-7520 or (303) 442-3231

**Howe Series 2000 Phase Chaser™**

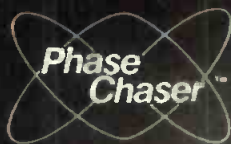

OP2005



OP2020



OP2022



OP2023

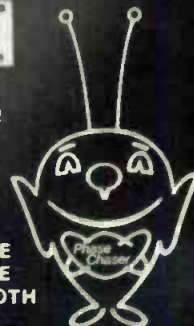

SEE ME AT THE NAB BOOTH 2744



**howe audio productions, inc.**

P.O. Box 383, Boulder, CO 80306

# Take it Off... Take it All Off



Bell & Howell's new Model TD-500 Bulk Eraser takes all recorded signals off your high-energy magnetic tapes. Quickly, easily, automatically. So they record like new each time you reuse them.

The compact Model TD-500 offers unmatched versatility for erasing various magnetic media. Reels up to 16 inches in diameter, with 1-inch or 2-inch tape. Cassettes. Cartridges. Floppy disks. A full complement of adapters lets you choose just those you need for the media you use.

Compare our specs and prices with other bulk erasers on the market. We think you'll choose Model TD-500 by Bell & Howell.

For more information on how to make the most of your magnetic media, write or phone

#### DATATAPE DIVISION

300 Sierra Madre Villa, Pasadena, CA 91109  
(213) 796-9381, ext. 2591, Warren Vaughan, for  
technical data, or ext. 2383, Charlotte Heftman, for  
ordering information.

 **BELL & HOWELL**

See the versatile Model TD-500 at the NAB conference in Dallas,  
April 3-7, 1982.

GERMANY Friedberg/Hessen, West Germany 3441  
UNITED KINGDOM Basingstoke, Hants, England 20244

©1982 Bell & Howell Co.

Circle 135 on Reader Service Card

www.americanradiohistory.com



THE SKY'S THE LIMIT

# ★ NAB: 1982 ★

the shelves of at least three of the prime suppliers, Shure, Stanton, and Audio-Technica. Stanton will introduce a new magnetic series, the 981, with frequency response beyond 50 kHz.

## TEST AND MEASUREMENT

Many items of radio test gear of the highest precision and ease of use will be on the floor, since this technology has been advancing at tremendous speed in the last five years. Tektronix, Sound Technology, Amber and Hewlett-Packard, are just four of the exhibitors we can count on for excellent test gear. Potomac Instruments, another in this category, will bring a new "intelligent" monitor which keeps track of antenna and transmitter parameters for logging purposes and for warning if any parameter is outside tolerance. Belar Electronics will have the new, high-precision FM modulation monitors promised some months ago.

## INTERCOMS

Clear-Com is bringing no less than eight new intercom systems, plus additions to existing hard-wired



*Clear-Com will be showing at least eight new intercom systems.*

systems. ROH Corp. has designed new support modules for the Series 300 system to interface the system with telephone lines. Other advances in intercom design are coming from RTS and Farrtronics.

## TELEPHONE / STUDIO COUPLING

Easing the rough spots in the telephone-studio or telephone-remote pickup is still a prime objective of hardware makers. Russco has a new remote mixer,

### Weather \*

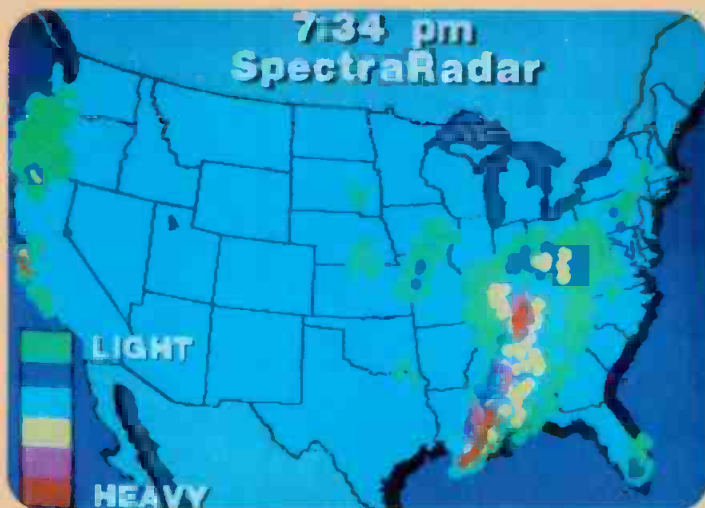

### Public Service\*

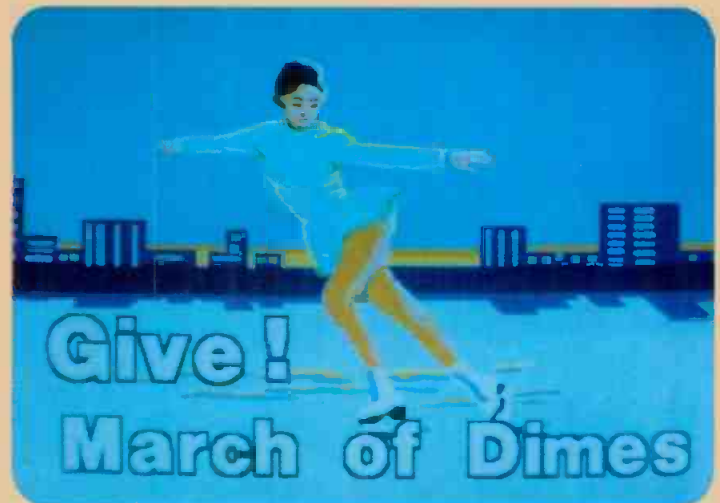

# The Best Fonts.

\*Actual Raster Photograph



SPECTRA COMPUTER SYSTEMS

391 CHIPETA WAY—RESEARCH PARK SALT LAKE CITY, UTAH 84108

801-581-5478

Model T-411, to interface remote gear with a dial-up telephone. Another Russco item is the T-112, an equalizer to improve telco line quality.

Telefax will have a system that connects to a dial-up phone, and will plug in headphones, tape recorders, and microphones, as needed, as well as receive incoming calls.

### PROGRAM AUTOMATION

Program automation seems to be a mature branch of the industry, in the sense that there are very few newcomers trying to break in; the field is held firmly by four or five companies that have been dominant for some time. Broadcast Electronics, Harris, Sono-Mag, IGM, and Cetec are among the long-standing automators who will all be on hand with highly refined program automation systems of various capacities and capabilities.

Business automation, in contrast, keeps getting new recruits, and the old firms keep introducing changes and additions to their systems. This field is too complex for advance capsulizing, but there will be systems at all price levels and capacities on the floor, and *BM/E* will cover them in detail in the June Show-In-Print issue.

### SYNDICATORS

A number of the successful syndicators will be on the exhibit floor. Radio station operators interested in syndicated programming should sample as many new

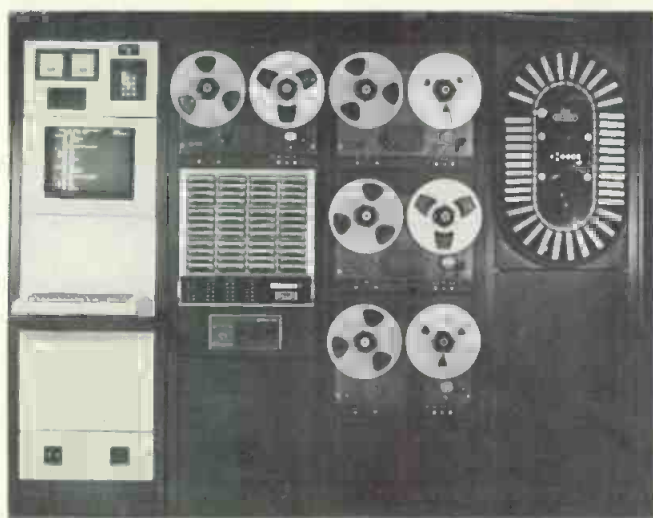

*IGM will be among the exhibitors of program automation systems.*

formats from established firms as possible. The reason for careful comparison shopping in this case is that most syndicators operating on a national scale have grown substantially in the last five years or so in the skill with which they choose the music and assemble it into programs. They also have generally increased their knowledge of the various audience groups and of shifts in taste: quite a few syndicators today do intensive audience research of their own.

In sum, for every function radio managements put on their shopping lists, there will be top-grade gear. Thus, the shopper will have a hard time seeing and hearing it all. **BM/E**

News\*



Sports\*



# ***The Best Graphics and Booth 2415.***

Circle No. 136 on Reader Service Card

If we had set out to give you only  
the features our competition gives you,  
this is where we'd be today.



---

Most VTR units give you only a fraction of the features you might want from a video tape recorder. So we didn't stop where our competition did. We kept on adding features. Until we developed the most versatile 1" machine on the market.

Compare the 3M TT-7000 VTR and NTC-10 Time Base Corrector to the competition. Nobody puts together more of the features you want than 3M. And once you see our unit, we think you'll agree that buying anything else is like getting half a machine.

The 3M TT-7000 Video Tape Recorder gives you:

- Autotrack following (ATF), with multipoint sampling, ¼ reverse through 2X forward, plus preset slo-mo speeds and direction (optional).
- Video and sync confidence heads.
- Three channel audio confidence heads.
- Video sync channel.
- All DC motor and servo tape transport.
- Play start after scanner lock.
- Spot peels in any combination.
- 19" rack mountable with full dust cover.
- Front panel plug-in modules.
- Frame accurate insert and assemble editing.
- Dual tape timer with zero memory.
- Tape speed override on front panel.
- Stop tone and cue-up (0, 3, 5, 7 sec. preroll).
- Contact closure and TTL external interface.
- Variable speed forward/reverse shuttle.
- Still frame jog.
- Autochroma and color framing.
- Audio 3 record in play mode (built-in speaker).
- Instant stop action from play or slo-mo (with ATF option).
- Instant audio bias level adjust.
- Video level calibrate marker.
- Preset/Manual tracking select on front panel.
- Fixed precision rabbited drum tape guide.

- And low RF, high temperature and low voltage alarms.

Our Time Base Corrector comes complete with its own list of standard features:

- Sixteen line correction window.
- Ten bit quantizing.
- Four times subcarrier sampling.
- 65 dB signal-to-noise ratio.
- Velocity compensation.
- Digital one line drop out compensator.
- Compact size (8¾" high by 17½" deep by 18½" wide).
- 45 pounds total weight.
- Portable cabinet or rack mountable.

- And front panel plug-in modules.

Add it all up, and you've got the most complete VTR/TBC package on the market. For a free demonstration, call (612) 733-7914 or write 3M Professional Audio/Video Equipment, Bldg. 223-5S, 3M Center, St. Paul, MN 55144. Get the picture.



**3M means business.  
And the time  
to act is now.**

3M hears you...

**3M**



# EIMAC cavities cover 54 to 970 MHz at power levels to 30 kW —our design or yours

Varian EIMAC has complete cavity design and production capability. We make sure that tube and cavity are compatible. If it isn't an off-the-shelf-item, we have the designers and engineers for any specific job.

EIMAC has expertise in all disciplines including pulse, CW, FM, and TV. We match tube, power,

bandwidth and operating mode to achieve optimum performance.

More information on EIMAC cavities and tubes is available in our Cavity Capability brochure from Varian EIMAC. Or for prompt consideration of your special design requirements, contact Product Manager, Var-

ian EIMAC, or the nearest Varian Electron Device Group sales office. Call or write today.

Electron Device Group  
Varian EIMAC  
301 Industrial Way  
San Carlos, California 94070  
415-592-1221

Varian A.G.  
Steinhauserstrasse  
CH-6300 Zug, Switzerland  
Tel: (042) 23 25 75  
Telex: 78 841

EIMAC Cavity	Matching EIMAC Tube	Tuning Range (MHz)	Power Output
CV-2200	4CX20,000A	86-108	30 kW
CV-2220	3CX1500A7	86-108	1.5 kW
CV-2225	4CX3500A	86-108	5 kW
CV-2240	3CX10,000U7	54-88	10 kW†
CV-2250	3CX10,000U7	170-227	10 kW†
CV-2400	8874	420-450	300/1250 W*
CV-2800	3CX400U7	850-970	225 W
CV-2810	3CX400U7	910-970	190 W

\* pulsed power

† peak sync, or 2.5 kW combined in translator service



Circle 140 on Reader Service Card

# RADIO EQUIPMENT EXHIBITORS LISTING

**ACCURATE SOUND / 1610**  
Information not available.**ADM TECHNOLOGY / 1714**

Will bring the new ST 100 Series III on-air radio control room package, consisting of audio console, cabinetry, cart machines, tape recorders, and turntables in a variety of configurations. Construction is modular. Also, the ST 160 II radio production console. (Also see listing in TV section.)

**ADVANCED MUSIC SYSTEMS / 2904**

Will show the new RMX 16 digital reverb system, with nine reverb programs and up to 99 memory locations, all non-volatile. Also, the DMX 15-80 digital delay and DMX 15-80S stereo digital delay. (Also see listing in TV section.)

**AEG-TELEFUNKEN (DIV. BAYLY ENGINEERING) / 2536**

Will unveil the N Plus 1 changeover unit, 100 W and 300 W FM transmitters, the all solid state Tele-Watt transmitter, and a stereo encoder for FM transmitters. Will also exhibit its line of wattmeters, digital paging equipment, and two-way radios.

**AKG ACOUSTICS / 2629A**

Will feature the new C-414 EB/P48 condenser mic, the new C-535 EB hand-held vocal condenser mic, the new C-567 E condenser lavalier mic, and the new D-130 rugged omni-field mic. Also, the full line of mics and headphones, stands, accessories, and reverbs.

**ALLIED BROADCAST EQUIPMENT / 2920**

Will show its lines of audio distribution amps, preamps, and studio cabinets.

**ALLSOP / 2718**

Will bring the new Orbitrac record cleaning system and new Ultraline

cassette deck cleaner in new improved auto reverse style.

**ALPHA AUDIO / 2309**

Will show Sonex, an open-cell urethane plastic foam designed to control reverberation time, eliminate stray reflections, and kill standing waves.

**AMBER ELECTRO DESIGN / 2016**

Will have Model 4500 Automatic Distortion Measuring System with fully balanced input and output and comprehensive noise filtering. Options include the IEEE-488 bus interface and sweeping capability for distortion and frequency response plots. Also, Model 3501 measurement system with IMD capability, and Model 4400A Multipurpose Test Set.

**AMERICAN IMAGE PRODUCTIONS / 2735**

Will bring new "Plays it Country" promotional campaign, along with its five sales/production library services. (Also see listing in TV section.)

**AMPEX / 3002**

Will feature the new ATR-800 audio recorder, specifically designed for broadcast applications with 10 percent variable speed, cue point memory, and microprocessor control. Also, the ATR-100 studio ATR and ATR-124 24-track ATR, and the full line of MM multi-track recorders, audio processors, and audio recording tape. (Also see listing in TV section.)

**AMPRO / SCULLY / 3307**

Will show the full line of Scully reel-to-reel tape recorders, the Model 8300 triple-deck cart machine, Ampro single-deck cart equipment, and Ampro consoles.

**APHEX SYSTEMS / 2704**

Will introduce the Aphex II aural exciter and the EQF-1 modular

equalizer/filter. Also CX-1 modular compressor/expander and rack-mountable stereo versions of these products. Many new VCA products will also be on exhibit.

**TOBY ARNOLD & ASSOC. / 2018**

Will have production music libraries with big band programming, MOR, and jingles.

**ARRAKIS SYSTEMS / 1824**

Will introduce the 100-RS audio routing switcher, several new varieties of its 2000 console, and the 150-SC five-channel console. Will also exhibit its full audio line, including audio amps, consoles, and audio routing switchers.

**ASSOCIATED PRESS / 3204**

Information not available.

**AT&T / 1504**

Will demonstrate program distribution for TV and radio, satellite/terrestrial transmission for automated newsroom management with data equipment, sales management systems, and other services.

**AUDICO / 2501**

Will show audio tape loaders, audio cassette timers, rewinders, and labels. (Also see listing in TV section.)

**AUDI-CORD CORP. / 1510**

Is showing a line of cart players/recorders, including the "A" Series and the 100 Series, at two cost levels.

**AUDIO & DESIGN / 1514**

Will bring the new F601 Series limiter with digital switching facilities and last-use memory. Also, the Transdynamic Tri-band processor, Ex-press Limiter, Complex-Limiter, Easy-Rider compressor/limiter, paragraphic equalizer, Scamp card modulator system including compressor/limiter, expander gates, dynamic noise filters, de-esser, equalizers, and DA.

# Better listening through better design—Series 99B

...Crisp, Clean, Brilliant Sound

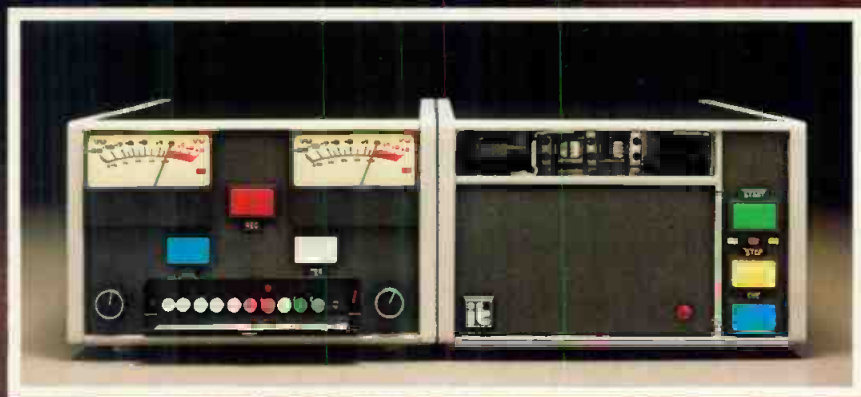

## Superior features!

"ELSA" (Patent 4,142,221) the only Cartridge Preparation System that automatically erases the cartridge, eliminates azimuth error and locates the splice. "ELSA" combines with:

- Crystal-referenced DC Brushless Servo Motor
- Standard High-Speed Cue
- Micro-adjust, center pivot head module
- Exclusive ITC open-face head design (Patent 4,193,103)
- Exceptional Frequency Response
- Improved headroom, transient response and square wave performance
- Distortion-free cartridge positioning system
- Multi-turn Calibration Controls
- Multi-function Test-Tone Generator
- Dramatically reduced heat allows for sealed case
- Microprocessor controlled

Series 99B—a combination of performance features that meets even the highest standards.



**International Tapetronics Corporation**

2425 South Main Street, P.O. Box 241, Bloomington, Illinois 61701

Call Toll-Free 800-447-0414 to learn more about Series 99B and to receive our new, complete brochure.  
Call Collect from Alaska, Hawaii or Illinois (309) 828-1381.

Circle 141 on Reader Service Card

# NAB: 1982

**AUDIO-TECHNICA /2923**

Will bring the new AT-815R phantom-powered shotgun microphone. Will also display its line of mics, headphones, tonearms, and phono cartridges.

**AUDIO TECHNOLOGY /2728**

The new P-100 from the Encore Series of low-cost, high-performance turntables and preamps, will be introduced. Also new is the DA-2008 dual 1 x 4 distribution amp. Other products include the Emphasizer mic audio processor and the Microamp Series of mic, line, phono, monitor, and distribution amps.

**AUDITRONICS /3124**

Showing consoles Models 206 (six inputs), 212 (12 inputs), and 218 (18 inputs), all mono or stereo, line or mic level. Also introducing the 1000-DA6 distribution amplifiers with one-in/six-out, or two-in/12-out. Introducing a complete line of broadcast control room furniture. Also on exhibit: 110 series of pro-

duction consoles with up to 26 inputs.

**AUTOGRAM /2748**

Will show its IC-10 10-channel console, AC-8 eight-channel console, AC-6 six-channel console, and T-8 frequency response test set.

**2B SYSTEMS CORP. /2739**

Manufacturer and marketer of plastic card promos.

**BASYS /2940**

Will show full Fury newsroom computer system. Also Cart Fury, Clip Fury, and archival-type setup.

**BAYLY ENGINEERING /2536**

Products include a fully transistorized stereo encoder used for the conversion of two AF signals into a multiplex signal, and an automatic change-over unit. Standard equipment will include wattmeters and dummy loads, a digital paging system, and portable and mobile two-way radios.

**BELAR ELECTRONICS /2715**

Will introduce new FM modulation and stereo monitors. Other products include FM modulation and stereo monitors and FM and TV SCA monitors.

**BEST AUDIO /2707**

Will show their custom audio remote pickup truck. Also showing audio cabling systems.

**BEYER DYNAMIC /2915**

Will show new MCE 5 miniature microphone, only 18 mm in length. The M500 and 600 mics will also be on display, as well as stands and booms. The MC715 dynamic and condenser mics will be exhibited along with various headphone models.

**BGW SYSTEMS /2841**

New equipment includes power amp Models 75, 150, 6000, and 7000. Also displayed will be the new SRM 10B Tannoy PA and also the SRM12B. Other equipment will be Models 10 and 20 electronic crossovers, and Models 250E and 750B professional power amplifiers.

**BIRD ELECTRONIC CORP. /3204A**

Will introduce the 8630-601 Series Moduload RF calorimeter/load system in 10, 25, and 50 kW versions; the 4391 RF Power Analyst wattmeter with peak envelope, pulse, and CW power; the 4388 (panel) and 4384 (portable) RF Power Analyst wattmeters for TV; and the 8730-677 dolly-mounted, water-cooled load resistor, 10 kW-80 kW. Will also show

## Telemetry Problems?

Many subcarrier and telco telemetry circuits are shakey, making telemetry return the weakest link in broadcasting. The Marti TSL-15 is solving these problems.



TSL-15

This link consists of a 15 watt type accepted transmitter, a narrow band receiver and Yagi Antennas designed for 450-456 MHz. group P channels. This system will provide continuous-duty operation, and can handle data and voice in a 20Hz.-3000Hz. band. Test meters are provided on both transmitter and receiver. Automatic station identification is available and external DC operation is provided for.

**MARTI** MARTI Electronics, Inc.  
1501 N. Main • P.O. Box 661  
Cleburne, Texas 76031  
(817) 645-9163 • Telex 794 835

See us at NAB Booth 3109

Circle 160 on Reader Service Card

Serving your industry creatively.  
Visit us at NAB . . . booth 2844.



**Rees Architects  
Associates Planners  
Inc Engineers**

4200 Perimeter Center Drive  
Oklahoma City, Oklahoma 73112  
Telephone 405/946-9800

Circle 162 on Reader Service Card



# STILL TO COME IN BM/E

## APRIL

### Field Production— a Special Report.

All the latest developments in Radio and TV EFP including mobile vans, intercoms, microprocessor-controlled field cameras.

## MAY

### Satellites and Broadcasting.

Exclusive coverage of the hottest topics in satellite technology, including Radio network distribution and DBS. Plus late-breaking developments from NAB.

## JUNE

### NAB Show-in-Print.

The most comprehensive report on all the major NAB developments in print. Overviews, plus detailed product-by-product analysis.

PLEASE  
STAY  
TUNED

THE SKY'S THE LIMIT

# NAB: 1982



*Broadcast Audio will show monitor amplifiers.*

self-cooled line terminations, water-cooled load resistors, RF power monitor/alarm, the high-speed transmission line monitor/alarm, and RF wattmeters.

### **BOSCH BLAUPUNKT / 3330**

Will unveil a line of new products for radio broadcasters.

### **BROADCAST AUDIO / 1920A**

New lines displayed will be the System 14 digital audio console, low profile monitor amplifier, distribution amp and phono amp, System 5 mono audio console for news and production, and a 1 3/4-inch rack or table enclosure with all amps on plug-in cards. Other stereo audio consoles and control room furniture will be seen.

### **BROADCAST CARTRIDGE SERVICE / 2316**

Showing the Fone Box, and Aristocart, Capitol Audiopak, and Fidelipak audio cartridges. Storage systems, alignment tools, and accessories as well as cartridge reloading service.

### **BROADCAST ELECTRONICS / 3104**

Will show SAT-16, satellite format program automation systems. Also on display will be FM transmitters, stereo generator, SCA generator, FM exciter, single and multi-deck stereo/mono record/playback cartridge equipment, mono/stereo audio consoles with linear rotary faders, and turntables, as well as phono preamps and AM/FM accessories.

### **BROADCAST MUSIC / 1612**

Information not available.

### **BROADCAST PROGRAMMING INTERNATIONAL / 1512**

Showing full-length Classical selections in a format which includes block to full-time programming. Also other Rock, Country, MOR, Easy Listening programs.

### **BROADCAST SYSTEMS / 2803**

Distributor of video and audio distribution equipment, including cables, connectors, etc.

### **BROADCAST TECHNOLOGY / 2115**

To show the new Model CF-9105 card frame, which holds up to five cards in BTI 3000 series. Will also introduce the EG-3501 and EG-3502 dc-controlled graphic equalizers on plug-in cards. Each is a five-band graphic with 12 dB boost or cut at the center frequencies (31, 125, 500, 2 kHz and 8 kHz for the 3501 and 62, 250, 1 kHz, 4 kHz and 16 kHz for the 3502). Will also show the line of preamplifiers, line amplifiers, and power amplifiers on plug-in cards.

### **BRYSTON VERMONT / 2910**

Will show a new 25 W cue and foldback amplifier. Also showing the line of other audio amplifiers, from 50 to 200 W.

### **CABLEWAVE SYSTEMS / 3206**

On display will be high power and low loss coaxial transmission line. Also coaxial and elliptical waveguide transmission line systems, parabolic antennas, RF connectors, pressurization equipment, mounting hardware, and accessories.

### **CALIFORNIA MICROWAVE / 2105**

Along with full new lines of down converters, the Mod70 modulator, and the Demod70, two up converters will also be on display. The Sat10 radio program receive-only earth station will be exhibited, as well as a complete line of SCPC demods to receive satellite-delivered programming. (Also see listing in TV section.)

### **CANFORD AUDIO / 2817**

Will introduce a new range of microphone cables in seven colors, plus multicore cable brackets.

### **CAPITOL MAGNETIC PRODUCTS / 3127**

Will show its A-2 broadcast cartridge for mono/music and the AA-3, especially designed for music broadcasting.

### **CBS RADIO STATION NEWS SERVICE / 3131**

A new package of news features, formerly prepared for CBS stations only, will be on display as a full syndication package called "Byline Magazine."

### **CELESTIAL MECHANIX / 2616**

Will have promotional campaigns in TV and print media for all Radio formats. "Country Dreams" campaign and a premiere rock pro-



Production Studio, WRBR.FM, South Bend, Indiana.

## Electro-Voice's Greg Silsby talks about the SENTRY 100 studio monitor

When I first described to Electro-Voice engineers what I knew the SENTRY 100 had to be, I felt like a "kid in a candy store." I told them that size was critical. Because broadcast environment working space is often limited, the SENTRY 100 had to fit in a standard 19" rack, and it had to fit *from the front, not the back*. But the mounting hardware had to be optional so that broadcasters who didn't want it wouldn't have to pay for it.

The SENTRY 100 also had to be both efficient and accurate. It had to be able to be driven to sound pressure levels a rock 'n roll D.J. could be happy with by the low output available from a console's internal monitor amplifier.

The SENTRY 100 also had to have a tweeter that wouldn't go up in smoke the first time someone accidentally shifted

into fast forward with the tape heads engaged and the monitor amp on. This meant high-frequency power handling capability on the order of five times that of conventional high-frequency drivers. Plus it had to have a 3-dB-down point of 45 Hz, and response that extended to 18,000 Hz with no more than a 3-dB variation.

Since it's just not practical for the engineer to always be directly on-axis of the tweeter, the SENTRY 100 must have a uniform polar response. The engineer has to be able to hear exactly the same sound 30° off-axis as he does directly in front of the system.

I wanted the SENTRY 100 equipped with a high-frequency control that offered boost as well as cut, and it had to be mounted on the front of the loudspeaker where it not only could be seen but was accessible with the grille on or off.

I also didn't feel broadcasters should have to pay for form at the expense of function. The SENTRY 100 had to be attractive, but another furniture-styled cabinet with a fancy polyester or die-cut foam grille wasn't the answer to the broadcast industry's real needs.

And for a close I told E-V's engineers that a studio had to be able to purchase the SENTRY 100 for essentially the same money as the current best-selling monitor system.

I'm happy to report that we've achieved *all* our objectives.

Market Development Manager,  
Professional Markets



**EV** **Electro-Voice**  
a gulton company

600 Cecil Street, Buchanan, Michigan 49107

In Canada:  
Electro-Voice, Div. of Gulton Industries (Canada) Ltd.,  
345 Herbert St., Gananoque, Ontario K7G 2V1.

# NAB: 1982

motion feature sophisticated animation techniques.

## CENTURY 21 PROGRAMMING / 1503

Will introduce new programming series on Big Bands and MOR/Beautiful Music. Will also emphasize engineering services to subscribers.

## CETEC BROADCAST GROUP / 3136

Will introduce the 7000 GLS program automation system for satellite and programming services. Single rack automated system complete with audiofile and random access playback machine, CRT terminal, memory, and program software found in the Cetec 7000 system will also be on display. Also Cetec 7000 level II and the 8000 Series studio control room consoles, 2000 Series eight-mix stereo console, and five-mix stereo console.

## CETEC VEGA / 3129

Will show new Model QX-1 wireless intercom master station for use with wired systems, allowing single-person full duplex connection with a wired system. Also introducing the QX-2 multichannel wireless master station, which allows up to six persons full duplex interface with wired system. Will also show its full line of RF microphone systems.

## CHASE MEDIA / 1912

Business automation systems for radio broadcasting, covering traffic/billing/financial/music. (Also see listing in TV section.)

## COLUMBINE SYSTEMS / 2716

Will show new business automation systems for media inventory, production billing, music inventory and rotation, and studio automation interface. Also showing the complete in-house traffic system, covering general accounting and payroll. (Also see listing in TV section.)

## COMEX / 2829

Will feature the Shively FM transmitter antenna. (Also see listing in TV section.)

## COMPUTER CONCEPTS CORP. / 2022

Will introduce the Music Management System, a computer system which supplies a music library inventory, playlist scheduler, airplay historian and research tool. Also introducing a word processing system designed for broadcasters, for writing past-due reminders, general correspondence, advertising and news copy.

## CONCEPT PRODUCTIONS / 2107

Will show a new version of the Voice/Music synchronizer, which maintains synchronization between music tapes and voice tapes in syndicated programming. Also describing syndicated formats: Adult Contemporary, Adult Rock, Album Rock, and Country.

## OTIS CONNOR PRODUCTIONS / 1507

Introducing two new syndicated radio formats with Adult Contemporary music. Also showing seven other program packages, with Adult Contemporary, Rock, and Country music.

## CONTINENTAL ELECTRONICS / 3134

Will show its line of AM and FM transmitters in latest versions, including 1, 5, 10 and 50 kW AM; and 2.5, 20 and 50 kW FM. Will also show the Audio Rock 10 and Mark 8 audio consoles.

# Some broadcasters just don't believe what we say about ARISTOCART

They're the ones who haven't switched yet!

In a way we can't blame them. For example, that statement of ours about checking every Aristocart cartridge for phase stability and frequency response. Every one? Or the bit about guaranteeing performance on any properly aligned cart machine to AM/FM sound standards unmatched by any other commercial cartridge. Pretty tall claim! Fortunately, a lot of discriminating broadcasters have discovered we mean exactly what we say. They've made Aristocart one of the best selling NAB cartridges in the world. Why should you settle for less?

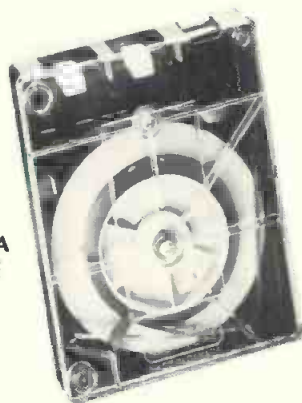

NAB  
TYPE A & AA  
CARTRIDGE

MANUFACTURED BY ARISTOCART DIV. WESTERN BROADCASTING LTD., 505 BURRARD ST., VANCOUVER, B.C., CANADA V7X 1M6 TEL: (604) 687-2844 TELEX: 04-54639

Circle No. 143 on Reader Service Card

### CONTINENTAL RECORDINGS / 2800A

Will show radio station ID packages and commercial jingles. Formats include Adult Contemporary, Country, Beautiful Music, Oldies, news and information.

### CRL SYSTEMS / 2827

Among the products to be displayed are the AM 4 audio control systems as well as the FM 2, 4, and 4C audio control systems.

### CROWN INTERNATIONAL / 1921

Showing new pressure-zone microphones (PZM) specifically for broadcasting—the 2LV clip-on and 3LV tie-bar. Also, the new BDP-2 microcomputer-based spectrum analyzer; and new power amplifiers for broadcast use. Showing the RTA-2 real-time analyzer and EQ-2 equalizer.

### CSI ELECTRONICS / 1606

Showing the new Model T-25-A1 25 kW AM transmitter using RF and modulation circuits. The RF power amplifier is a single 3CX20000A3 operating class "C." The high-level modulators are 4CX5000A tetrodes offering the high-power AM broadcaster improvements over the T-25-A. Also on hand will be the T-2.5-A and T-10-A AM transmitters and T-1-F, FM-3000E, FM-12000E, and T-25-F FM transmitters and EX-20-F FM exciter.

### CUSTOM BUSINESS SYSTEMS / 2017

Will show for the first time a stand alone co-op billing system that produces ANA/RAB affidavits, with actual copy broadcast; and a music library system that tracks up to 10,000 records per category, with 21 different characteristics. Also showing complete business automation systems for radio.

### PETER DAHL CORP. / 2101A

Will show heavy-duty plate, power, filament, and modulation transformers and reactors.

### DATA COMMUNICATIONS / 3318

Will demonstrate the Master Control Automation System for on-air control; also describing the line of business automation systems for radio. (Also see listing in TV section.)

### DATATRONIX / 1927

Showing new Model 8160 personal 10-band graphic equalizer with concealed modular plug-ins that can be preset for each personality's voice. Also 300-PR power equipment enclosure, plus full line of audio production consoles, equalizers,

compressor/limiters, 7000 Series monitor, and preamplifiers.

### D-B ELECTRONICS / 2024

A new tape winder programmable self-timer for cart, reel-to-reel, and cassette recorders will be introduced. Other equipment will be the DB-TEL telephone answering interface units, the mono/stereo turntable preamp, and cart machines in one-, two-, and three-deck configurations.

### dbx / 2113

The model 907 noise reducer features user-defined stereo gating param-

eters. Also newly introduced Model 610 completely microprocessor-controlled equalization system for monitor systems. Other units include the 900 Series modular signal processors, 160 Series compressor/limiters, 500 Series signal enhancers, and Type I and Type II noise reduction systems.

### DELTA ELECTRONICS / 3112

Will announce its FMC-1 frequency modulation controller. Other equipment shown will be RF ameters, operating impedance bridges, RCS-1V remote control systems, co-

## NOW...from ECHOlub A sophisticated, computer-controlled PRODUCTION SWITCHER

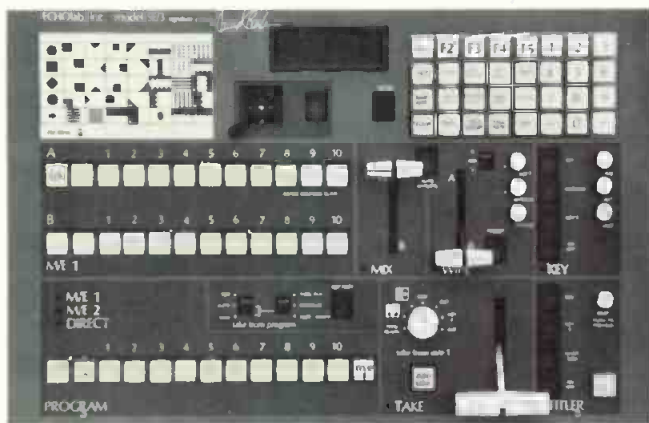

The SE/3 is a new-generation, programmable Switcher/Special Effects Generator that offers extremely sophisticated control, editing and effects capabilities at an astonishingly low price. The secret of both price and performance lies in a powerful microcomputer that replaces most of the digital logic found in other switchers, and in an innovative, transition-centered approach to the system architecture. Providing full computer control of all switching and effects, the SE/3 has 12 inputs, full BC crosstalk and distortion specifications and an RS-449 port for editing. Two-and-a-half separate pattern generators and

three mix/effects amplifiers can simultaneously air five different sources and three wipe patterns without lock-outs. It provides for the programming, storage (of up to 200 shots) and instant re-creation of any desired sequence of patterns, pictures and transitions.

A contact-closure editing interface is available for initiating any pre-programmed event. The slim-profile control panel (only 1 3/4" deep) can be installed remotely from the main chassis for maximum flexibility. Yet the SE/3 costs only \$14,000.

Send for complete details.

An ECHOlub Signature Instrument

# ECHOlub, Inc.

175 Bedford Road  
Burlington, MA 01803 (617) 273-1512



# #1 SELLER



Sound technology and time-proven performance have made the PCL-505/C Aural Studio-Transmitter Link the work horse of the Moseley STL line. The PCL-505/C has been the world's Number 1 selling composite aural STL since its introduction in late 1974. Taking the technology used in the PCL-505/C a step further, the PCL-505A/C was specifically designed for the dense metropolitan RF environments. Excellent adjacent-channel rejection is achieved in the PCL-505A/C, through the use of a Surface Acoustic Wave (SAW) first I.F. filter, in conjunction with a phase-linearized second I.F. filter.

The PCL-505/C and PCL-505A/C feature on-frequency RF amplifiers and micro-strip line techniques. Excellent frequency stability is achieved by referencing the low-noise, frequency-modulated oscillator output to a crystal-controlled reference oscillator. Composite stereo waveforms allow the stereo generator to be located in the studio, far from strong RF fields, and the wideband input carries both the stereo waveform plus two subcarriers as well.

Both versions are ruggedly constructed for continuous duty, with extensive multimetering and excellent serviceability. A built-in remote connector allows remote control, or optional automatic transfer panels for switching operation to standby units.



So, whether your STL requirement is for a ruggedized, economical work horse; or, if your market has grown to the point of crowded STL spectrum, Moseley's PCL-505 series of STL will accommodate your needs.

## PCL-505/C and PCL-505A/C

- TRUE COMPOSITE STEREO FM
- CARRIES STEREO WAVEFORM PLUS TWO SUBCARRIERS
- ON-FREQUENCY RF AMPLIFIER

- EXTENSIVE MULTIMETERING
- PCL-505A/C RECEIVER FOR HIGH DENSITY RF AREAS

For further information,  
please contact our Marketing Department



**MOSELEY ASSOCIATES, INC.**  
A Flow General Company · Santa Barbara Research Park

111 Castilian Drive . . . Goleta, California 93117  
(805) 968-9621 · Telex: 658-448 · Cable: MOSELEY

Circle No. 145 on Reader Service Card

THE SKY'S THE LIMIT

# NAB: 1982

axial transfer switches, and antenna monitors.

**DeWOLF MUSIC LIBRARY/2610**  
Information not available.

**DICTAPHONE CORP./2020**  
Will exhibit its Veritrac 5000 and 5600 multi-channel loggers. The 5000 is a microprocessor-controlled high capacity voice logger for users who need more than four channels.

**DOLBY LABS/2405**  
Will show multi-track noise reduction unit that provides up to 24 tracks of Dolby A noise reduction with separate regulated power supplies and electronically controlled output protection. (Also see listing in TV section.)

**DRAKE-CHENAULT/1516**  
Will show program services, including Hit Parade for the 40+ affluent market, as well as special features and program management.

**EIMAC/3119**  
Will introduce a line of graphite grid tetrodes with 40, 100, and 300 kW, as well as 50 kW FM transmitting cavity. The CV2225 FM cavity from the established line will also be shown. (Also see listing in TV section.)

**EG&G, ELECTRO-OPTICS/1820**  
A new LS-162, 155MM self-contained beacon (dc operated) temporary obstruction light will be on exhibit. Also, FAA-approved high intensity obstruction lights for towers.

**ELCOM BAUER/1908**  
Will introduce the new Model 690B PLL FM exciter. Other new products include 250 W and 1000 W solid state FM transmitters, and the 610B 10 kW single-tube grounded grid transmitter. Also the Viva 5 Series of audio consoles, the Seville Series of tape cartridge machines, and the AP-50B Insta-Peak III peak limiter. From the established line, formerly Cetec Broadcast Products, are AM transmitters, AGC Level Guard, and Model WBL wide band composite limiter.

**ELECTRO IMPULSE/1805**  
Will show the DPTC 50 kW dummy load with 3/8-inch connector with dielectric meter, plus 5, 10, 25, 30 and 300 kW dummy loads.



Eventide's Timesqueeze Jr.™

#### ELECTRO-VOICE / 1905

Will introduce a new studio audio monitor, the Century 500. Will also unveil a larger version of the Century 100A. Plus full professional microphone line including modular and shotgun systems.

#### EVENTIDE CLOCKWORKS / 2934

Will feature new model of Time-Squeeze digital time compressor/expander for regulating pitch changes during VTR/ATR speed-up and slow-down. Also new SP 206 digital reverb/signal processor. Other digital audio processing products will include Harmonizer and broadcast audio delay lines.

#### FARRTRONICS / 2517

New equipment consists of the M82 eight-channel party line communications system. Also M81 intercom with individual power supplies, amplifiers, and control switching, and new M70 audio consoles. Other products will be the M76 distribution amplifiers and the M750 audio patchfields.

#### FIDELIPAC / 3132

New Master Cart II will be shown at the exhibit. Also to be seen are complete audio tape cartridge lines, studio warning lights, and cart storage racks. A wow and flutter meter will be on display with various Audio-Technica phono cartridges and microphones.

#### FIRSTCOM / 2414

Will show an extensive commercial advertising and production library for radio.

#### FITZCO SOUND / 2540

No information available prior to show.

#### FORT WORTH TOWER CO. / 3326

Will show towers, earth stations, and prefabricated equipment buildings.

#### FOSTEX / 1911

Will introduce the A8 reel-to-reel eight-track recorder/reproducer. Also on display will be multi-track mixing desks, the Multi-Tracker cassette deck with built-in mixer, and the line of digital delay equipment.

#### GARNER INDUSTRIES / 2304

Will feature its bulk audio tape erasers and 1/4-inch open-reel duplicators. (Also see listing in TV section.)

# #1 PERFORMER

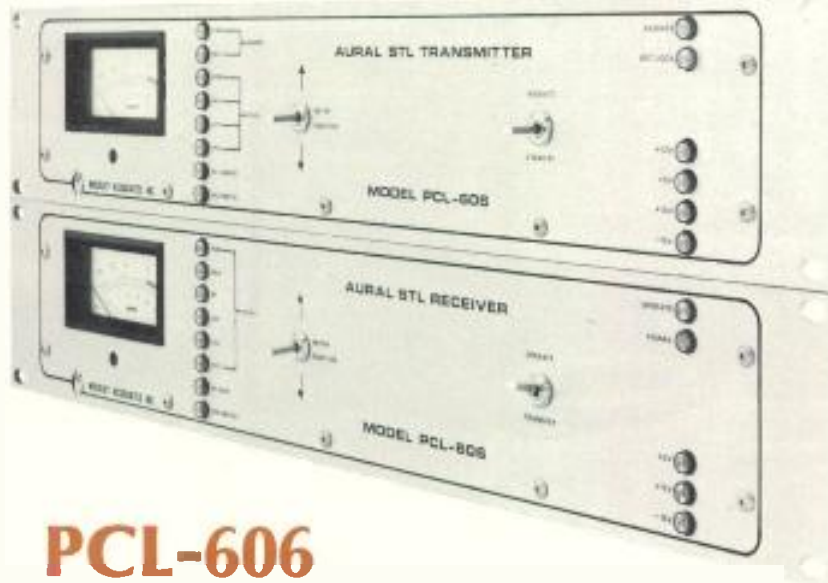

## PCL-606 and PCL-606/C

- ULTRA LOW NOISE AND DISTORTION
- EXCELLENT SELECTIVITY
- OUTSTANDING FREQUENCY STABILITY

Topping the Moseley line of aural studio-transmitter links, the PCL-606 and PCL-606/C are tailor-made for the broadcaster who demands the very finest in performance and engineering. Extremely congested, high-density RF environments are no problem for broadcasters using these all-new, state-of-the-art systems. Either the monaural (PCL-606) or stereo composite (PCL-606/C) provide today's broadcaster with the highest quality program interconnect available in an aural STL. Both are designed for maximum performance and reliability, with easy service features to minimize maintenance down time.

The dynamic range of both systems can be optimized as a function of

- SELECTABLE IF BANDWIDTH
- BUILT-IN DIAGNOSTIC METERING

signal strength, by a pin diode attenuator circuit in the receiver. Superior frequency stability is achieved in the PCL-606 and PCL-606/C Transmitters by locking phase and frequency to a synthesized AFC. Ultra-phase linear I.F. filters, and a broadband, extended digital demodulator provide surprisingly low noise and distortion, while the balance between distortion and selectivity can be tailored to user needs by adjusting I.F. bandwidth. A compensated, linear, baseband response maximizes both monaural and stereo transmission. Both the PCL-606 and PCL-606/C have switch-selectable signal metering functions to measure the incoming RF signal over its entire range. Internal system performance metering functions are built into both transmitter and receiver. All normal service adjustments are easily accessible through the top cover, and brass-enclosed module construction makes PC board servicing easier than ever. Should there be a failure or abnormality shutdown; the receiver is equipped to switch internally and automatically to a standby unit for continuous performance.

Continuing the legacy of the PCL-505, the PCL-606 and PCL-606/C are revolutionizing the state of the art in the aural STL marketplace.

For further information,  
please contact our Marketing Department



## MOSELEY ASSOCIATES, INC.

A Flow General Company · Santa Barbara Research Park

111 Castilian Drive · Goleta, California 93117  
(805) 968-9621 · Telex: 658-448 · Cable: MOSELEY

Circle No. 146 on Reader Service Card

# BEHIND THE LENS OR IN FRONT,



## TIFFEN FILTERS ARE THE INDUSTRY'S FIRST CHOICE.

Most major manufacturers of video cameras install Tiffen filters as original equipment in the filter wheel behind the lens.

Most major TV stations and studios use Tiffen filters in front of the lens.

Why? Because cameras are only as good as their components. When quality components are required Tiffen filters meet all the requirements.

They're rugged, reliable, precision-made. And the performance is always outstanding.

Superior technology and quality craftsmanship combine to make Tiffen filters the industry's first choice.

Tiffen Makes Filters For:

Ampex	Harris	Rank Taylor Hobson
Angenieux	Ikegami	RCA
Canon	IVC	Schneider
Fernseh	Marconi	Thompson
Fujinon	Norelco	And Many Others
GE	Phillips	

Write Dept. BM/E for FREE  
Professional Brochure and Price List.

# TIFFEN®

90 Oser Avenue, Hauppauge, N.Y. 11788  
(516) 273-2500 Telex 96-7748

See us at NAB Booth 2509  
Circle No. 147 on Reader Service Card

THE SKY'S THE LIMIT

# NAB: 1982

### GENERIC COMPUTER / 2317

Will show new computer automation system for traffic control using the Apple and the Polymorphic computers.

### GOLDEN IMAGE NETWORK / 1800A

Will be presenting TV commercials for radio station promotions.

### GORMAN-REDLICH MFG. / 2307

Will show its EBS equipment, weather radios, and digital antenna monitors.

### GOTHAM AUDIO / 2919

Will introduce the EMT digital disc recorder and the TMS 84 microphone. The EMT 266 transient limiter and the EMT 948 turntable will also be on display.

### DAVID GREEN CONSULTANTS / 2014

Will show the IBM System 23 Dexcel program software for small-market radio stations. Also Sperry weather radar system for small-market radio, and outdoor radio ads.

### GREGG LABORATORIES / 2009

Will introduce the 2020 eight-channel and 2040 14-channel control room audio consoles. Also showing the 2540 AM audio processing system and Telemix hands-free telephone interface system. (Also see listing in TV section.)

### HALLIKAINEN & FRIENDS / 1618

Will introduce the production form of the PCC 180 prototype process control computers for handling remote transmitter facilities. TEL series of digital telemetry adapters for Mosely TRC 15A and TVA series

*The MR-3 can be seen at Harrison's booth.*



audio equipment are other lines to be shown.

### HARRIS CORP. / 3101

Will introduce several new products, including a totally new solid-state AM transmitter line in 1, 2.5, and 5 kW models (see story elsewhere in this issue); for facility control, an earth station controller system with 24 repositionable antenna and earth station configurations; and, for automation, a new addition to the Autotron Star business automation system permitting word processing, script preparation, etc. Other radio highlights will be the Harris AM stereo system, modulation monitors, AM and FM transmitters, the Micro-Mac microprocessor-controlled mixing console, and the 9003 program automation system. (Also see listing in TV section.)

### HARRISON SYSTEMS / 1910

Will display the MR-3 24-track recording console, for scoring, featuring input modules containing all circuitry for one channel of input, one multitrack feed, and one monitor channel. The unit can accommodate up to 36 input modules and three master modules. Additional space is reserved for optional console-mounted automation controls. Also on display will be a live console for live performances or OB remotes. (Also see listing in TV section.)

### HOWE AUDIO (BCP) / 2744

Will exhibit new Phase-Chaser, an electronically controlled precision time-delay network, and a new Series 7500 audio console. The 7000 console and turntable preamps, along with other accessories, will also be displayed.

### IGM COMMUNICATIONS / 3122

Updates on the basic "A" automation system will be revealed, such as version 3.0 software, CRT remote station, and CRT encoder system. Other items to be included are Insta-Cart and Go-Cart, and the CBSI business system.

### INTEGRATED SOUND SYSTEMS / 2924

Will demonstrate a stereo version of the TDM-8000 audio time compressor. The unit alters program time without change in pitch.

### INTERNATIONAL TAPETRONICS / 3145

Now under 3M banner, will unveil the Series 99 "B" audio cartridge machine. Also, complete line of audio cart equipment including ITC's SP, RP, 3D, and WRA Series of repro-



Lexicon's Model 1200 time compressor/expander will be introduced at NAB.

audio delay processor for special effects, digital reverb, etc. with 40 storage resistors (32 user-programmable). Also showing the line of digital reverberation systems.

**LIGHTNING ELIMINATION ASSOC./1616**

Will show new "Perfect Power Source" incorporating protection from surges, lightning, transients, noise. Also showing dissipation arrays, surge eliminators, transient eliminators, filtering systems.

ducers and recorder/reproducers. The PD-II Series reproducers, ESL-IV eraser/splice locator, and the 770 Series reel-to-reel reproducers/recorders will also be exhibited.

**JAM CREATIVE PRODUCTIONS/1728**

Will feature many brand-new station ID jingle packages, plus "The Answer," its recently completed commercial production library.

**JEFFERSON DATA/1710**

Will show sales and traffic, general accounting, and station operated interface computer system for radio called System 90. It uses an IBM computer and operates completely within the station. The ENP Electronic News Processor is an integrated computer system for broadcast news.

**JENEL CONSULTANTS CORP./2314**

Will show new audio integral jack-fields and terminal blocks with quick connections and describe expanded engineering and design services.

**KAMAN SCIENCES (BCS)/3216**

Will have in-house demographics/sales proposal computer package. Also displayed will be complete traffic/billing systems with inventory control, news, accounting and amortization programs, and computerized interface to auto switchers.

**LARCAN COMMUNICATIONS EQUIPMENT, INC./2736**

Will introduce new 25 kW FM broadcast transmitter with only one tube. Other equipment includes UHF and VHF TV and FM broadcast transmitters and antennas of various ratings.

**LEXICON/2019**

Will introduce to the NAB the Model 1200 time compressor/expander, which allows all recordings to be played faster or slower than the original without changing pitch. Will also introduce the Model 97 digital

**Delivery 30 Days or Less!**

**THE SCULLY 280B SERIES**

... consider our constant tension feature which minimizes tape stretch to reduce wow, flutter and phasing problems. This is standard on the Scully 280B Series, available in up to 8-track, 8-channel record/play models. Each is built with the famous Scully reliability, dependability and uncompromising quality. Engineered for long trouble-free performance.

Dealer inquiries invited. Fight inflation with Ampro/Scully

**AMPRO  Scully**

Professional Equipment for Broadcasting Professionals  
2693 PHILMONT AVENUE, HUNTINGOON VALLEY, PA 19006  
(215) 947-7000 • TWX: 510-665-5010 • CABLE: AMPROSCUL HVAL

*Quality*

it's a matter of record with Scully

**NAB Booth #3307**



Circle No. 148 on Reader Service Card



# LISTEN TO THE DIFFERENCE.

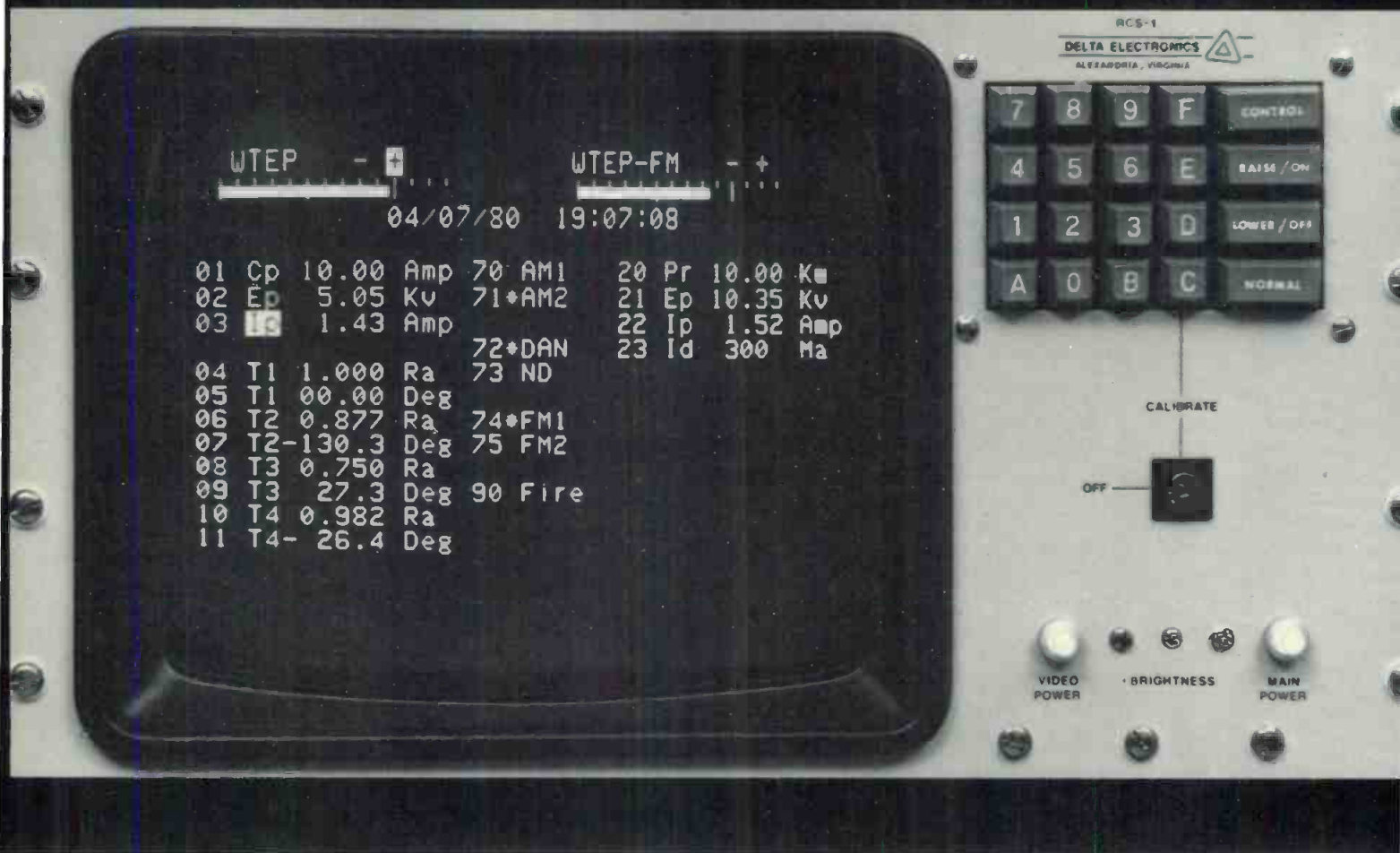

## THE DELTA RCS-1 REMOTE CONTROL SYSTEM

*A simple, yet sophisticated approach to AM, FM and TV Remote Control*

### SIMPLE.

- All parameters are displayed for the operator.
- Hands-off operation until an actual control function is required.
  - Automatic logging option ends the nightmare of forgotten or incorrect log entries.

### SOPHISTICATED.

- Features not found on other remote control systems:
- Modulation bargraph with peak flashers.
  - Direct antenna monitor interface.
  - Telephone coupler with speech synthesizer providing telephone interrogation.

The RCS-1 is designed to grow with your plant. Additional control, input, and alarm boards can be added to the systems, thereby meeting any new station requirements. In addition, the RCS-1 contains the fundamental building blocks for ATS, permitting conversion to a combination Remote Control/ATS System at a later date.

Write or call for a descriptive data sheet and pricing.

**DELTA ELECTRONICS**



5730 General Washington Drive, Alexandria, VA 22312 703-354-3350 TWX 710-832-0273

Circle 149 on Reader Service Card

# NAB: 1982

## LIVE SOUND/1726

Will feature the "Big Country" voice-tracked format for automated radio stations, and the "Country Beautiful" format.

## LOGITEK ELECTRONIC SYSTEMS/2015

Will exhibit a new audio mixing board for ENG mobile units and for editing facilities with six inputs, two outputs, built-in intercom, and Hall effect solid-state switching. Capability for audio-follow mode. Also introducing the potless audio console system designed for all-talk stations, with level control by outboard noise gates and compressors. Has switching for cart sequencing, mic and phono inputs, cart talk-over capability.

## LPB/3114

Will introduce the Benchmark series of modular audio consoles with equalization and limiting compression. B-2000 has up to 16 stereo inputs, B-3000 up to 24 inputs, both with mono, stereo, four track output. Also showing regular line of consoles and AM low power transmitters.

## 3M, MAGNETIC A/V PRODUCTS DIV./3133

Will show a brand new Scotch audio cart featuring new tape formulation in compatible tape format. The new design, incorporating a tape tension control arm that maintains correct tape-to-head tension, helps eliminate phase errors, and improve overall performance. Also showing full line of audio tapes and cassettes. In booth 3006, look for demonstration of 3M digital audio recorders. Also see separate listing for International Tape-ronics, a new 3M company. (Also see listing in TV section.)

## M/A COM DCC/3303

Will show digital satellite communication products, including a demonstration of a receive-only audio program terminal for radio networks.

## MAGNUM TOWERS/2005

Will show its tower sections in varying sizes from 18 to 60 meters.

## MARTI ELECTRONICS/3109

Will introduce four new products: Model STL-10 new studio-transmitter link; Model TSL-15 transmitter-studio data link with



The TSL-15 transmitter-studio link will be just one of Marti's new products.

identifier; Model ARS-15 automatic relay station; and Model TR-15 base station transmitter-receiver. Will also show its line of remote pickup handheld and portable transmitter/receivers, portable relay stations, STLs, and remote control systems.

## MCCURDY RADIO/3106

Will present the new SS 8816 air console along with the SS 8670 air/production console. Another new item on display will be the SS 8720 production console. The company also produces a line of studio cabi-

## Delivery 30 Days or Less!

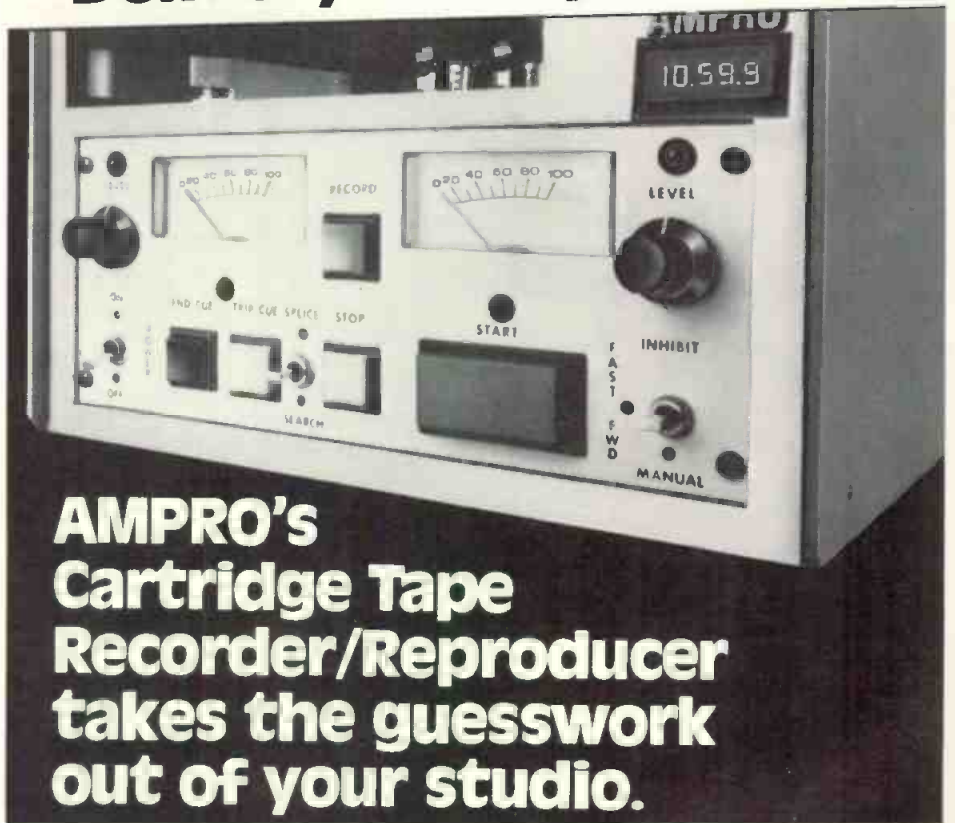

## AMPRO's Cartridge Tape Recorder/Reproducer takes the guesswork out of your studio.

1. **DIGITAL MESSAGE TIMER** gives a continuous 5-digit LED display of elapsed playing time to the tenth of a second.
2. **RELOAD INDICATOR** flashes ready light after play until cartridge is reloaded.
3. **LED PEAK LEVEL INDICATOR** warns of excessive record level.
4. **SELF ALIGNING PINCH ROLLER** improves stereo phasing.
5. **ELECTRONIC SPLICE FINDER** positions splice between play head and capstan.

Available in 34 different mono and stereo models to suit your studio's exact needs. Built for long, trouble-free life. Don't settle for less than Ampro perfection. Take a closer look for yourself. Send for a **FREE** brochure on CARTRIDGE TAPE RECORDER/REPRODUCERS.

Dealer inquiries invited. Fight inflation with Ampro/Scully

# AMPRO Scully

Professional Equipment for Broadcasting Professionals  
2693 PHILMONT AVENUE, HUNTINGDON VALLEY, PA 19006  
(215) 947-7000 • TWX: 510-665-5010 • CABLE: AMPROSCUL HVAL

**NAB  
Booth  
#3307**

Act Now\*

DIGITAL AUDIO DELAY

BLEEPMATE™ 675

Now you can end the bother and uncertainty of tape audio delays and save thousands of bucks.

You can buy this new solid-state simplicity for just \$1,940.—hundreds less than many tape delays cost.



Comex's new Bleepmate™ 675, a simple yet sophisticated 6-second solid-state delay, has no moving parts (so technical and on-air talent aren't bothered by endless tape/head upkeep). And the 675 has a broad +/- 1dB, 20Hz to 7.5KHz response. Its low price makes systems redundancy practical too.

Contact us today:  
Comex Systems  
2 Columbia Drive  
Amherst, N.H. 03031  
(603) 889-8564

Distributor inquiries are welcome of course.

\*Introductory offer expires April 30. After April 30 price increases to \$2,480.

COMEX  
SYSTEMS

Circle No. 151 on Reader Service Card

THE SKY'S THE LIMIT

NAB: 1982

netry, with desks, turntable mounts, console mounts, and an announce turret with inputs and controls for microphones for connection to on-air and production consoles.

#### MCI/1615

Will have new audio production package with mixing console, tape recorders, and accessories. Also on hand will be the new JH-800 general-purpose audio console, and a complete line of audio tape recorders and audio mixing consoles.

#### McMARTIN INDUSTRIES/3102

Introducing the new FM-2001 SCA generator and the TR-2001 SCA receiver; the all solid state 300 W FM transmitter, Model BFM-300; the 30 kW FM transmitter, BF-30M; and the four-channel satellite mod/demod, SMR-4 and SDR-4. Will also show the complete line of other transmitters, AM and FM; audio consoles; and remote pickup ENG equipment.

#### MICMIX AUDIO PRODUCTS/3142

A noise reduction system—Dynafex—is the new unit to be introduced, designed for use on-line in the production room, or anywhere in the signal chain. Also on exhibit will be the entire series of Master-Room reverb systems, including the XL-515, XL-305, XL-210, and the XL-121.

#### MICRO CONTROL ASSOC./1813

Will probably show RTS-20 remote pickup unit rated at 20 W; standard frequency ranges cover 140-180, 200-250, 300-350, 440-480 MHz. Also a line of aural studio-to-transmitter links.

#### MICRODYNE CORP./2618

The seven-meter antenna motor drive with controller and SCPC radio terminals are among the new equipment to be shown. Also to be introduced at the show will be audio subcarrier receive terminals and the 1100 TVR X-24 B-2 satellite broadcast receiver. Other equipment includes the five- and 3.6-meter satellite antennas.

#### MICRO-TRAK CORP./3115

Will introduce 10-channel audio console Model 6510, available in mono or stereo. A new phono preamp, the 6411-CX equipped for playback of encoded discs, will be on display. Telefile, a news gathering and production portable console with cas-



Moseley will be showing the new MRC-2.

ette tape recorder for TV and radio reporters, is also new. Full line of audio consoles, remote telecommunications consoles, and remote audio system packages will also be on display.

#### KEITH MONKS AUDIO/2833

Will show the CR501 full-service record cleaning machine for radio stations.

#### MOSELEY ASSOCIATES/3103

New MRC-2 microprocessor remote control system will be unveiled, as well as the PCL-606 and 606/C aural STLs. The MRC-2, with fully automated supervisory control of remote transmitters and earth stations, includes "smart" terminals at all sites, digital operation, up to 99 remote sites. Also showing the RPL-3 and RPL-4 mobile links, telemetry return links, and audio limiters and gain control systems.

#### MOTOROLA C & E/1508

Will show new portable base/repeater two-way radio with auto-patch, full-channel remote control, and studio RF communication system. MX 300 synthesized UHF and VHF radios and the Syntor mobile radios will also be on display. Wideband audio mod for handhelds and mobiles and Mitrek mobile radio can be seen, along with the Spectra Tac voting system. The R2001 communications analyzer, paging products, and cueing receivers round out the line.

#### MUSIC DIRECTOR PROGRAMMING SERVICE/1503D

Will have new reels added to the "Basic Golden Oldies" programming package. Also available will be the weekly playlist for Adult Contemporary formats.

#### THE MUSICWORKS/1914

Programming of all forms of Hispanic music with Country and Pop-Adult formats also available. Will also show Solid State Logic's Master Studio System, featuring integrated



Otari's MTR 10/2 quarter-inch two-channel recorder.

computer control centralized in the 4000 E console. Also on display will be SSL's Real Time Mixing System, which does not rely on a time code, but instead is based on a preset function that remembers static fader levels.

**NADY SYSTEMS / 2711**

Will feature its 610 Series VHF transmit/receive RF microphone system and also hand-held RF mics, diversity receivers, and other wireless systems.

**NAGRA MAGNETIC RECORDERS / 3146**

Will introduce the T-Audio servo-controlled studio size ATR transport with SMPTE time code. Also on display will be the 4.2, 4S, and IV-SL stereo recorder/playback units. The TRVP logging machine series will be exhibited, as will the Nagrafax weather facsimile printer. (Also see listing in TV section.)

**NETWORK PRODUCTION MUSIC LIBRARY / 2412**

Will detail new production music library releases.

**NORTRONICS / 3108**

Will bring the new PF 710/420 alignment gauges, PF 380 broadcast cartridge head degausser, PF 707 lapping kit, PF 702/703/704 lapping film, and PF 601 magview tape track developer. Will also bring its full line of professional tape care products.

**FRED A. NUDD CORP. / 2021**

Will display its line of self-supporting towers and monopoles, including a monopole for mounting FM antennas and an angle-braced guyed tower with hardware.

**ORBAN ASSOCIATES / 1812**

Will introduce the new Optimod 8180A compressor/limiter expressly for TV audio, incorporating FM Optimod design system. Also bringing to

the NAB for the first time the Model 424A two-channel compressor/limiter and de-esser. Will show full line of other processors, including AM and FM Optimods, Model IIIB spring reverb, Model 245E stereo synthesizers, equalizers. (Also see listing in TV section.)

**OTARI / 1611 and 2214A**

New products on display will be the 5050 MK III compact production recorders in 1/4-inch two track and 1/2-inch four-track tabletop cabinet configurations. The MTR 90-8 one-inch eight-track version of 16/24 channel MTR 90, the MTR 10 full-track version, with new cabinet and

mounting options to entire series including desk, overbridge, and rack configurations, are also new. Also VL 500/600 fully automated videocassette loading product line (VHS and Beta).

**PACE, INC. / 2723**

Introducing the MP-1 portable circuit board repair system and other systems for circuit board repair.

**PACIFIC RECORDERS AND ENGINEERING / 1608**

Will show the Tomcat cart recorder/players, and the BMX audio consoles. Also on display will be audio distribution amplifiers, routing

**Delivery 30 Days or Less!**

**There are consoles, and then there are AMPRO CONSOLES... in a class by themselves.**

Dollar for dollar no other console offers you as many operational features as AMPRO. And that means your job is easier because you can control a myriad of functions right at your fingertips. Standard features included in 6 to 12 mixer models...

1. **FOUR INTERLOCKED PUSHBUTTON SWITCHES** per input channel allows selection of up to 48 individual sources.
2. **FOUR-LEVEL LED "STRETCHED PEAK" INDICATORS** on each output channel in addition to two standard VU meters.
3. **REMOTE START SWITCHING** for all high level inputs.
4. **PHASE TEST SWITCH** for immediate audible check of monosum signal.
5. **BALANCED TRANSFORMER** preamps on all mic and high level inputs.

Don't settle for less than Ampro perfection. Take a closer look for yourself. Send for a FREE brochure on CONSOLES today!

**NAB Booth #3307**

Dealer Inquiries Invited. Fight Inflation with Ampro/Scully

**AMPRO Scully**

Professional Equipment for Broadcasting Professionals  
2693 PHILMONT AVENUE, HUNTINGDON VALLEY, PA 19006  
(215) 947-7000 • TWX: 510-665-5010 • CABLE: AMPROSCUL HVAL

Circle No. 152 on Reader Service Card

**Slow Motion  
Sync Roll Coincidence Disk  
Splits Math Tag Comments  
S O n t e B E d i n s S y n c M o l n S a g P a d O R T**

**HELP**

**is available at**

**NAB**

**Booth #3327**

**datatron, inc.**

**VIDEO SYSTEMS DIVISION**

2942 Dow Avenue, Tustin, California 92680 (714) 544-9970 • TWX 910-595-1589

Circle 153 on Reader Service Card

[www.americanradiohistory.com](http://www.americanradiohistory.com)

# NAB: 1982

switchers and systems, as well as control room and studio cabinetry.

## PANASONIC PROFESSIONAL AUDIO/1621

Information not available.

## PETERS PRODUCTIONS/1619

Will debut two new **music formats**, including Rock and MOR orientations. Seven music formats for comprehensive campaigns will also be demonstrated.

## PHELPS DODGE COMMUNICATIONS/3116

Will have on display its line of **FM antennas**, coaxial transmission line components, harmonic filters, and **directional couplers**.

## POTOMAC INSTRUMENTS/3111

Will introduce the **DAP-11 intelligent monitor/logger**, which continuously monitors antennas and transmitters and provides alarm signals and log printouts. Also new is an **AM monitor receiver**. A UHF field strength meter will also be exhibited.

## PROCART/1816

Will show full line of Procart **NAB type AA cartridges**, which assure superior phase and phase flutter stability.

## QEI CORP./1919

Will show its new **FM 3.5 GAL transmitter**, which incorporates the QEI solid state exciter and driver modules with the 3CX3000A7 triode transmitting tube. The FM 3.5 GAL includes automatic power controls and remote control/ATS as standard features.

## QUAD EIGHT ELECTRONICS/2705A

Will introduce the 248 component series **audio console**. The System 5 **digital reverb processor** will also be on

*The 691 FM modulation monitor from QEI.*

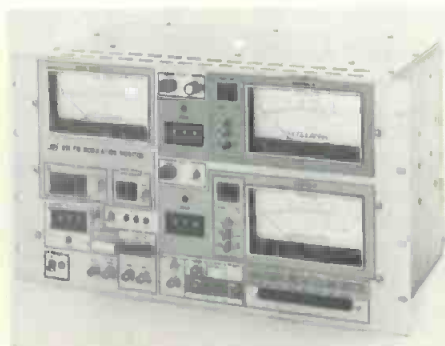

display—a high speed processing unit with 103 dB dynamic range and approximately 96,000 different settings. Other products in the company's line include the **Model 24 automated console** with 32 mixing channels and floppy disk editing unit, and **SMPTE interface to VTRs**.

## RADIO COMPUTING SERVICES/2830

Will demonstrate the **Traffic 2000 computerized business automation system**. Also on hand will be a music selection system.

## RAMKO RESEARCH/1909

Featured unit will be the **Phasemaster cart machine**. Also on hand will be full lines of studio consoles, audio router, distribution amps, and mic and turntable preamps. Line amps, monitor amps, as well as solid state **VU meters** and the **Technics professional series** can be seen.

## RCA/3001

Several models of **CP antennas** will be shown and the **BTA-5FF solid state 5 kW AM transmitter** will be exhibited. (Also see listing in TV section.)

# Delivery 30 Days or Less!

## THE SCULLY 250 RECORDER REPRODUCER SERIES

No assignment is too tough for the Scully 250. Moderately priced... you can use this compact unit for direct news and sports feeds, as well as professional field recordings. Options include full or half track mono; two or quarter track stereo. Built with the famous Scully reliability, dependability, and uncompromising quality. Engineered for long trouble-free performance.

**Dealer inquiries invited. Fight inflation with Ampro/Scully**

# AMPRO Scully

*Professional Equipment for Broadcasting Professionals*  
2693 PHILMONT AVENUE, HUNTINGTON VALLEY, PA 19006  
(215) 947-7000 • TWX: 510-665-5010 • CABLE: AMPROSCUL HVAL

# Quality

it's a matter of record with Scully

**NAB Booth #3307**



# We've got you covered!

## Cetec CP Antennas mean superior signal coverage throughout your service area!

Television Antennas, both circularly and horizontally polarized, including The Spiral omnidirectional CP/TV and ring-panel directional CP/TV; horizontally polarized slot antennas, and corner reflectors.

FM/CP Radio Antennas of every type and power, including very low and very high-power antennas, the all-purpose JSCP Series B, and many others, all customized to your specifications.

JSCP Series B

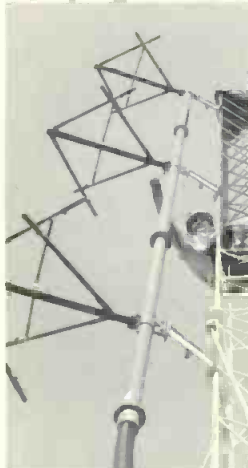

Slot HP/TV

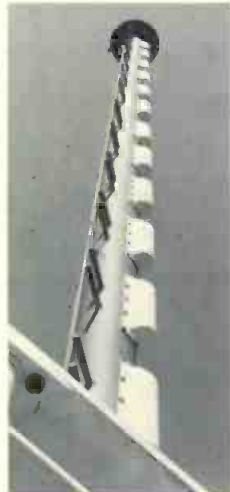

Ring Panel CP/TV



JHCP High Power

# Cetec Antennas

6939 Power Inn Rd, Sacramento, CA 95828  
(916) 383-1177 Telex: 377321

Circle No. 155 on Reader Service Card

78 BM/E MARCH, 1982

THE SKY'S THE LIMIT

# NAB: 1982

## R—COLUMBIA PRODUCTS/2612

New unit will be the System 40 base station interface for interconnecting RF intercom headsets and existing hardwired intercom systems. Another new line will be the FM wireless intercom headphones. Intercom headphones and microphones for broadcast use will also be shown.

## REES ASSOCIATES/2844

Offers architectural and engineering services for planning of broadcast facilities.

## ROH CORP./2303

Will introduce intercom system support modules for the Series 300 communications system to interface telephone, two-way radio, page systems, and IFB equipment; all can be controlled by one common-use panel. Also audio monitors and audio terminal equipment.

## RTNDA/3205A

Will have members and officers present to discuss the Radio and Television News Directors Association as well as videotapes of award-winning news.

## RUSSCO ELECTRONICS/1806

A new remote mixer designed to interface with a dial telephone and an equalizer/coupler designed to improve audio quality on any telephone line will be introduced. A mic-line driver and a new Mark VI turntable are two other new units to be displayed. A full line of turntables, consoles, phono preamps and tone amps, along with monitor amplifiers will be exhibited.

Among R-Columbia's products, the Model T-50/2B transmit wireless base station.



The MKE 40-3 will be Sennheiser's first directional lavalier microphone.

## SAKI MAGNETICS/1722

Will introduce long life replacement heads for Studer Revox and Otari quarter-inch tape recorders. Other products on display include long life replacement heads for Ampex 350 and 440 tape recorders as well as all models of Scully machines. (Also see listing in TV section.)

## SCIENTIFIC-ATLANTA/1602

Will show new digital audio earth station for radio stations. Includes three-meter earth station antenna, 120 degrees K LNA, digital receiver, and audio channel units. Also full line of earth stations and equipment for TV applications.

## SENNHEISER ELECTRONIC CORP./2101

Will introduce the first directional lavalier microphone, the MKE 40-3. The company's lightest weight (two ounces) monitoring headphone, the HD 40, will also be on display together with its full range of other mics.

## SESCOM/1700

Will introduce four portable battery-operated test units in compact cases: AVM-1, ac voltmeter for audio; AFM-1, frequency meter, 0-100 kHz; PAG-1, portable audio generator; and THD-1, portable distortion meter, at prices near \$100 each. Will also show ENG portable mic mixer and mic/line driver.

## SHIVELY LABS/1718

New product is the FM Broadband Panel Antenna, a modular system, which can be assembled to handle a number of stations on one system. Will also show other FM antennas for low, medium and high power, coax transmission line and accessories.



A new microphone mixer, the M267, from Shure Brothers.

**SHURE BROTHERS, INC. / 3110**

Is showing two new microphone mixers: Model M267, four channels plus master control with level meter and tone oscillator; and M268, a simplified model. Also introducing the Model R104A omnidirectional cartridge for the SM81 condenser microphone.

**SINGER BROADCAST PRODUCTS / 3120**

Will show a new solid-state 1 kW FM transmitter. Also on display will be a 1200 W AM transmitter with solid state low-level stages and RF amplifier. A line of transmitters, including a single-tube 25 kW FM transmitter, will be on hand.

**SONO-MAG CORP. / 3107**

Will exhibit the line of program automation systems, the Carousel, cart players, and live-assist systems.

**SONY / 3200**

Will show new digital audio delay line in addition to a sampling of other professional audio products such as RF mics. (Also see listing in TV section.)

**SOUND GENESIS / 2026**

Information not available.

**SOUND TECHNOLOGY / 2636**

Will bring a new computer interface, Model GPIB, for the 1500A test set. Will also be emphasizing the Model 1020A FM stereo generator-test set.

**SPHERE ELECTRONICS / 2604**

Will show for the first time the new digital attenuator for audio consoles.

Stanton's Model 310 phono preamplifier/equalizer.



Also introducing the Model 1604 mixer for satellite signals, with 16 inputs and four outputs.

**STANTON MAGNETICS / 3125**

Will show the new Professional Series phono pickups, Models 980 and 981; and the new Dynaphase 55/600 ohm headphones. Also showing the line of other phono pickups, headphones, preamplifiers.

**STANTRON / 2420**

Will be displaying cabinets and desks from its new delivery program which

**Delivery 30 Days or Less!**

*Quality*

it's a matter of record with Scully

**THE SCULLY 8300 SERIES**

... the premier three deck cartridge tape reproducer on the market today. Outstanding Scully features: all three decks are removable, not just two; the upper bearing is permanently aligned, assuring long trouble-free operation; decks and the crystal controlled D.C. servo motor are secured to a bulkhead for mechanical stability; modular design for ease of service.

Dealer Inquiries Invited. Fight Inflation with Ampro/Scully

**AMPRO  Scully**

Professional Equipment for Broadcasting Professionals  
2693 PHILMONT AVENUE, HUNTINGDON VALLEY, PA 19006  
(215) 947-7000 • TWX: 510-665-5010 • CABLE: AMPROSCUL HVAL

**NAB Booth #3307**

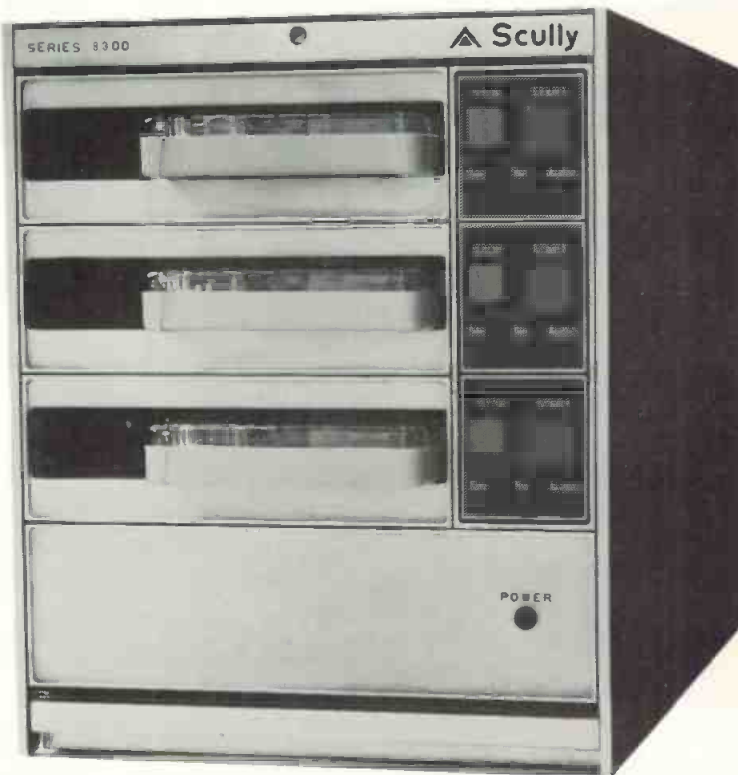

Circle No. 156 on Reader Service Card



DYNAPHASE 55/600 Ohms



## A New 600 Ohm Headphone From Stanton—The Choice of the Professionals

Now the great performance enjoyed by recording professionals worldwide in the Stanton 881S cartridge is also available in a brand new, lightweight headphone... the Stanton Dynaphase 55/600 ohms. Professional quality sound is the result of superior Stanton driver design that includes 1½" dynamic high velocity elements with a specially formulated synthetic film diaphragm assembly (Pat. Pend.) and samarium cobalt magnets... allowing for low distortion and

exceptionally wide frequency bandwidth.

The tuning of the air cavities behind and in front of the diaphragm is a unique design of Dynaphase 55/600 ohms. It results in the flattest response and finest acoustical behavior of the driving element. Includes adapter plug.

*For further information, contact Stanton Magnetics, 200 Terminal Drive, Plainview, N.Y. 11803*

**See us at NAB Booth 3125**



**STANTON**  
THE CHOICE OF THE PROFESSIONALS™

Circle 157 on Reader Service Card

[www.americanradiohistory.com](http://www.americanradiohistory.com)

# NAB: 1982

includes rack, console, turret, and bench cabinets, as well as "knockdown" terminal desks and accessories.

## STATION BUSINESS SYSTEMS / 3302

Will show the BAT-1700 **business accounting and traffic systems**, using an in-house minicomputer with options such as Music Play list and inventory, program package inventory, and media cartridge inventory programs. Also Newscom **newsroom computer system**.

## STEPHENS ELECTRONICS / 2511A

Will introduce its new 821-B104A-24C 24-track portable tape recorder.

## STRAIGHT WIRE AUDIO / 1724

Will introduce High-Com noise reduction system. **Power supply boards** for op-amps will also be introduced, as will the UA-2 **universal amplifier card**.

## STUDER REVOX / 3123

Will show prototype of new A810 **audio recorder** with microprocessor-controlled transport and elimination of all trim pots in favor of D/A converters under microprocessor control. Memory stores alignment for four tapes. Unveiling new 900 Series **Consoles**. Also exhibiting the line of other tape recorders, consoles, tape editing system, telephone hybrid interface, and SMPTE synchronizing system.

## SWINTEK ENTERPRISES / 1702

Will show a new line of hand-held **RF microphones**, with self-contained antenna system. System also can include a 1W base station for use in broadcast **EFP**. Will also have line of **ENG** wireless microphone systems, lavaliere microphones, and intercom systems.

*Some of Stantron's cabinet line.*



## SYMETRIX / 2511

Will introduce a new **telephone interface box** for audio. Also on display will be the 501 peak RMS compressor/limiter and a full line of signal processing products.

## SYSTEM ASSOCIATES / 2411

Will describe its brokerage service for used broadcast equipment, buying and selling items through free listing in company's flyer sent to users across the country. Listing is held until needs are met.

## WILLIAM B. TANNER / 1720

Information not available.

## TEAC (TASCAM) / 2734

Will introduce the new M-16 24-input, eight-output **production console**; the new Model 85-16B 16-track **recorder-reproducer**; the Series 30 transports, half-inch eight-track, quarter-inch four-track and two-track; the new M-30 and M-15 **mixers**; and the new **portable mixer**, Portastudio Model 244. Also showing the line of other recorder/reproducers and consoles.

## TDK / 2726

Will feature its full line of audio cassettes, including D-L leaderless cassettes and test tapes. (Also see listing in TV section.)



**The ultimate in cost effective, state-of-the-art, compact console design.**

Trouble-free by design—MICROTOUCH bus switching eliminates lever key switches, inputs and outputs are transformer isolated to block RF pick-up, ground plane shielding protects circuitry. LED's and self-indicating switches provide operator feedback.

Up to 21 inputs in 5 channel (21" wide) and 8 channel (26" wide) rotary and linear fader configurations with dual mono and dual stereo outputs.

Send for a Free brochure on MICROTOUCH consoles.

**Dealer Inquiries invited. Fight inflation with Ampro/Scully**

**NAB  
Booth  
#3307**

# AMPRO Scully

Professional Equipment for Broadcasting Professionals  
2693 PHILMONT AVENUE, HUNTINGDON VALLEY, PA 19006  
(215) 947-7000 • TWX: 510-665-5010 • CABLE: AMPROSCUL HVAL

# NAB: 1982



Telex will be showing wireless microphone systems.

## TEKTRONIX/3005

Will feature its Model 496 1 kHz to 1800 MHz portable spectrum analyzer. (Also see listing in TV section.)

## TELFAX COMMUNICATIONS/2735

Will show a telephone unit for gathering audio for radio or TV at a remote site and phoning back to station. Can plug in mic, headphones, or tape recorder to unit, receive incoming calls, or dial on the unit to station.

## TELEX COMMUNICATIONS/3130

New equipment to be displayed will include hand-held RF microphones. Also on view will be reel-to-reel recorders/reproducers, intercom systems, and professional microphones. Reel-to-reel loggers and headsets round out the equipment line.

## TENNAPLEX SYSTEMS/2111

Will show the Elcom network analyzer system for complex impedance and group delay. Also broadband UHF log periodic receive antennas.

## TFT, INC./2838

New equipment includes the Model 8100 transmitter-to-studio-link and the 7700 studio-transmitter link. Also on display will be aural STL for FM, AM, stereo, and intercity relay service. Telemetry return links for remote control, data acquisition, and automatic logging systems will be exhibited.

## THOMSON-CSF BROADCAST/3201

Full line of audio processing products, including FM Volumax, automatic peak controller, AM Volumax, dual audio DA, and Audimax automatic level controller. (Also see listing in TV section.)

## TURNER BROADCASTING/2917

Will feature the CNN radio service network. (Also see listing in TV section.)

## UMC ELECTRONICS/1814

Will bring its line of broadcast cart recorder/reproducers for A, B, and C carts; System 8 for automatic recording from satellite receivers or phone lines; and the BC-16 broadcast consoles.

## UNIDYNE TECHNOLOGIES/1620

Will show direct mail advertising promotions for Radio stations.

## UNITED RECORDING ELECTRONICS IND./2530

UREI will show power amps for stereo monitoring that are new to the broadcast industry. Also new are the 811-A and 813-A time align sound monitors. The line of parametric equalizers will also be on display. A full line of limiter/compressors will be on hand, featuring the LA-4, the 1176-LN peak limiter, and BL-40 modu-limiter. Other products include the 200/2000 XY recorder/test system and the Mod-1 modular audio console.

## UNR-ROHN/3138

Showing line of towers and accessories for TV, radio and microwave antennas, both guyed and self supporting.

## UPI/3139

Will show satellite package in conjunction with Harris Corp. for news services such as Audio Network, Broadcast Wire, Highspeed DataneWS, plus services delivered by conventional transmission.

## URSA MAJOR/1913

The remote unit of the 8X 32 digital reverberator will be shown for the first

*Ursa Major will introduce the remote unit of the 8X32 digital reverberator.*



*A sampling from Valentino's production music library.*

time at the exhibit. Also shown will be the SST-282 digital reverberation and special effects system.

## US TAPE AND LABEL/1506

Line of tapes and labels.

## VALENTINO, INC./1716

Will present a new Valentino production music library as well as the sound effects library and the video stock shots library.

## V & B TOWER CORP./1918

Showing full line of antenna towers for radio, TV, microwave systems.

## WARD-BECK SYSTEMS/3301

Will feature television audio consoles, the L2042 and the L3242. The M1204B production console and the M2484B broadcast/multi-track audio consoles will also be on hand. Also displayed will be the T1202 transportable mixer and the Microcom intercom system.

## WILKINSON ELECTRONICS/ TELEVISION TECHNOLOGY/3117

A new FM exciter will be on display as well as a new stereo generator. Other products include AM and FM transmitters, line surge protectors, and silicon rectifiers. Studio-transmitter link equipment will also be on hand. (Also see listing in TV section)

## WIREWOKS/2916

Will feature its TE-2 microphone cable tester, plus a full line of professional mic cables, multicable component groups, and Bandits cable marking system.

## WOLD COMMUNICATIONS/2729

Will discuss its satellite network for both TV and radio. TVROs will be on hand, along with information on company's transportable earth stations.

## WORLD TOWER/2811

Will show the regular line of towers for radio and television antennas.

# THE PERFORMER

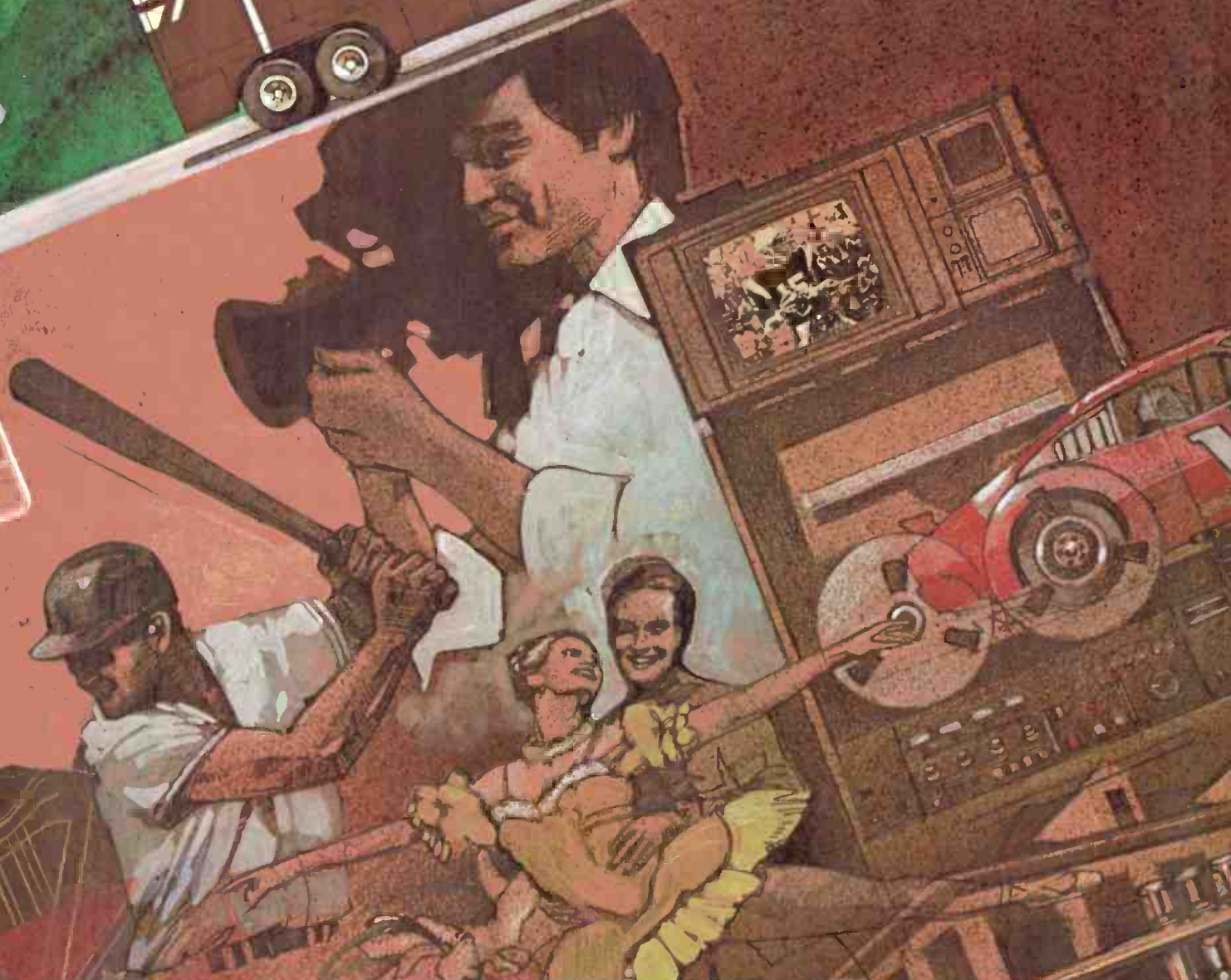
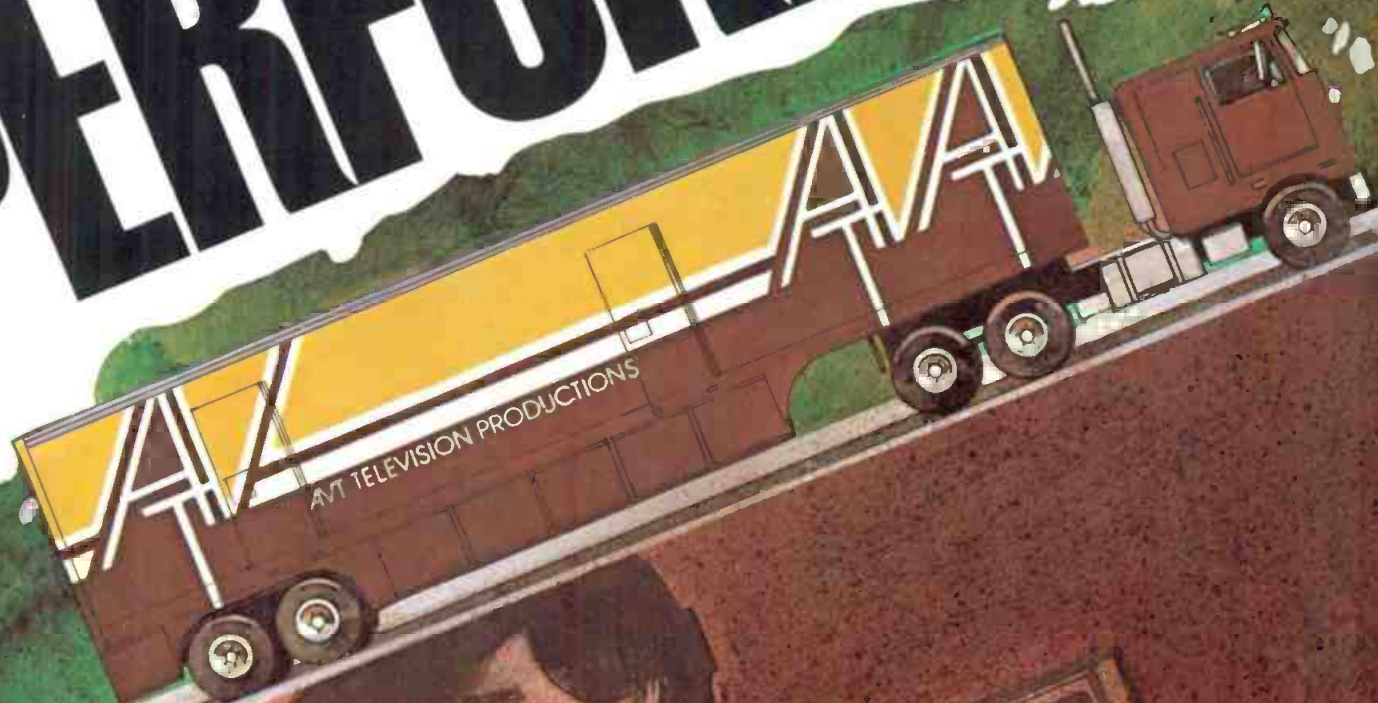

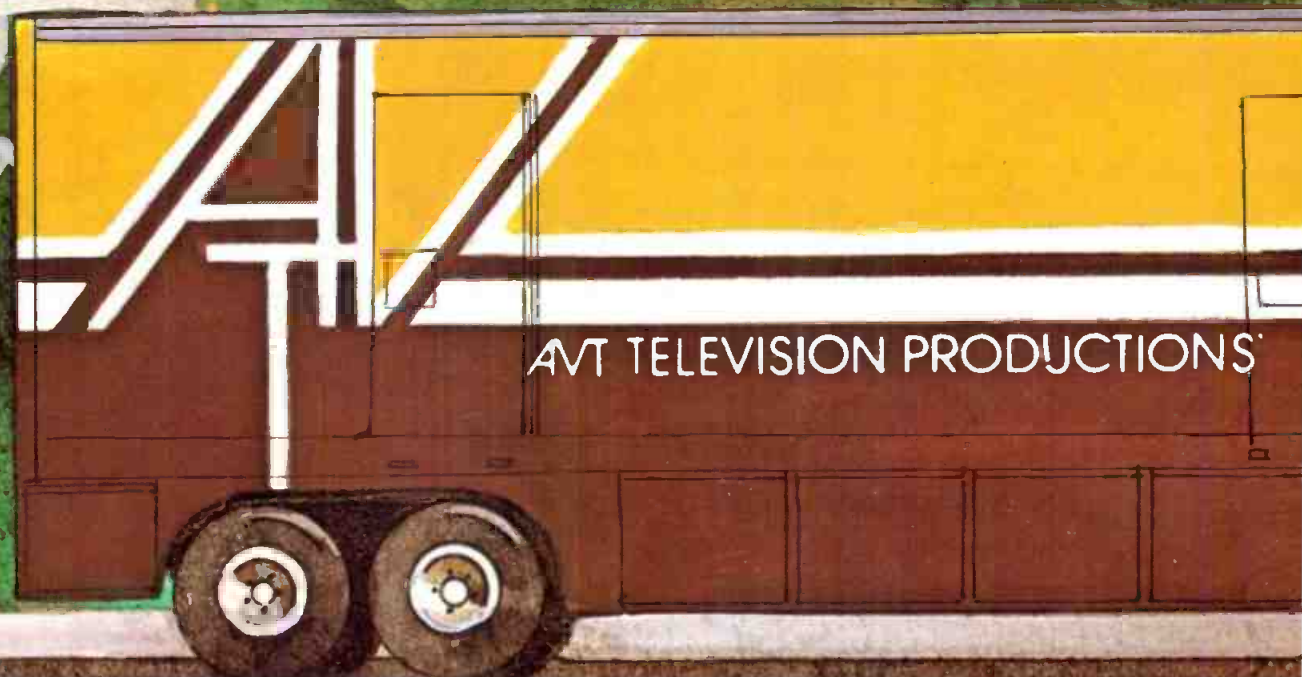

**The Lerro Organization of Philadelphia  
is proud to be a part of putting together  
“THE PERFORMER”  
45 feet of technical excellence.**

AVT Television Productions’ “THE PERFORMER” defines the state of the art in television production facilities. Forty-five feet of technical excellence and human comfort for the sophisticated user. From shot organization through post-production, you have available the full range of digital video effects plus stereo. Sports event to entertainment spectacular, “THE PERFORMER” goes one step beyond your production requirements.

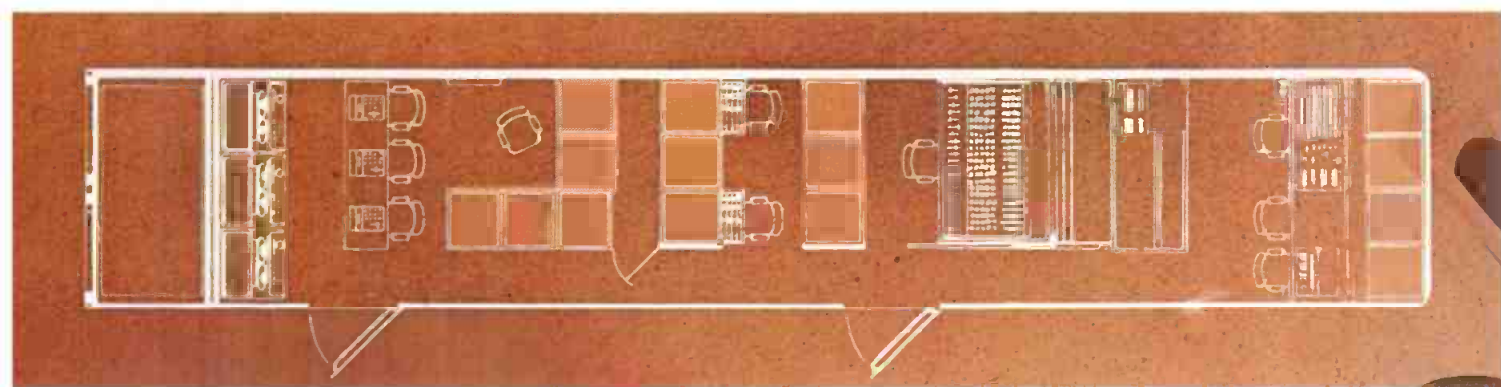
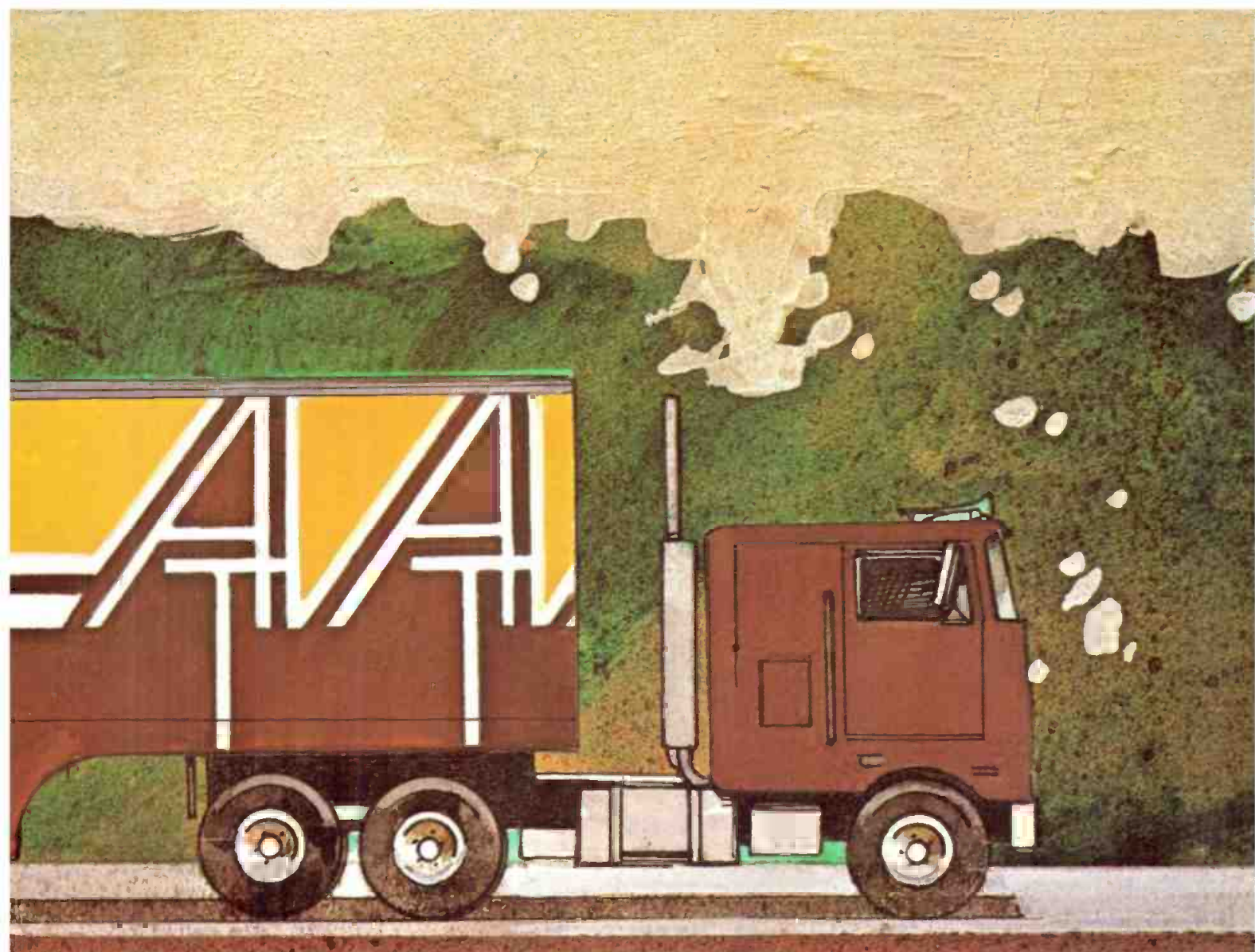

## EQUIPMENT LIST

### CAMERAS

- 5 Hitachi SK-96 Hard Cameras
- 2 Hitachi SK-96 Soft Cameras
- 5 30 x 1 Lens Fujinon
- 2 17 x 9 Lens Fujinon
- 1 Hitachi SK-91 Camera
- All cameras are triax with Plumbicon tubes.

### VIDEO

- 3 Hitachi HR-200 1" video tape machines with waveform, vectorscope, & SMPTE time code
- 3 Slo-Mo controllers
- 1 Hitachi HR-100 1" portable tape machine

### PRODUCTION SWITCHER

- Grass Valley 1600 7-K
- 24-inputs with quad split, analog & digital boarderline

### TERMINAL EQUIPMENT

- Grass Valley Dual Sync System
- Fernseh Video D/As
- Fernseh 20 x 20 Routing Switcher
- 2 DPS-1 Frame Synchronizers
- Complete Tektronix Monitoring Facilities

### INTERCOM

- RTS System, 6 channel
- 12 channels IFB

### DIGITAL VIDEO EFFECTS

- Quantel DPE-5010 Plus
- Infinite compression; zoom expansion to 4X normal size
- Variable positioning of picture
- Picture reversal and tumble
- Auto sequence

### GRAPHICS

- 2 channel Chyron IV with remote keyboard capability

### AUDIO

- Yamaha PM 2000
- 32 inputs with complete patching capabilities plus
- 15 input pre-mixer with stereo kill and direct to air capabilities, Otari
- 2 channel reel-to-reel recorder
- 3 Stereo Cart Machines with all cues & tones
- Time code output for multi-truck feeds

### EDITING SYSTEM

- Convergence Editor ECS-104-S with dual channel (stereo) edit capability

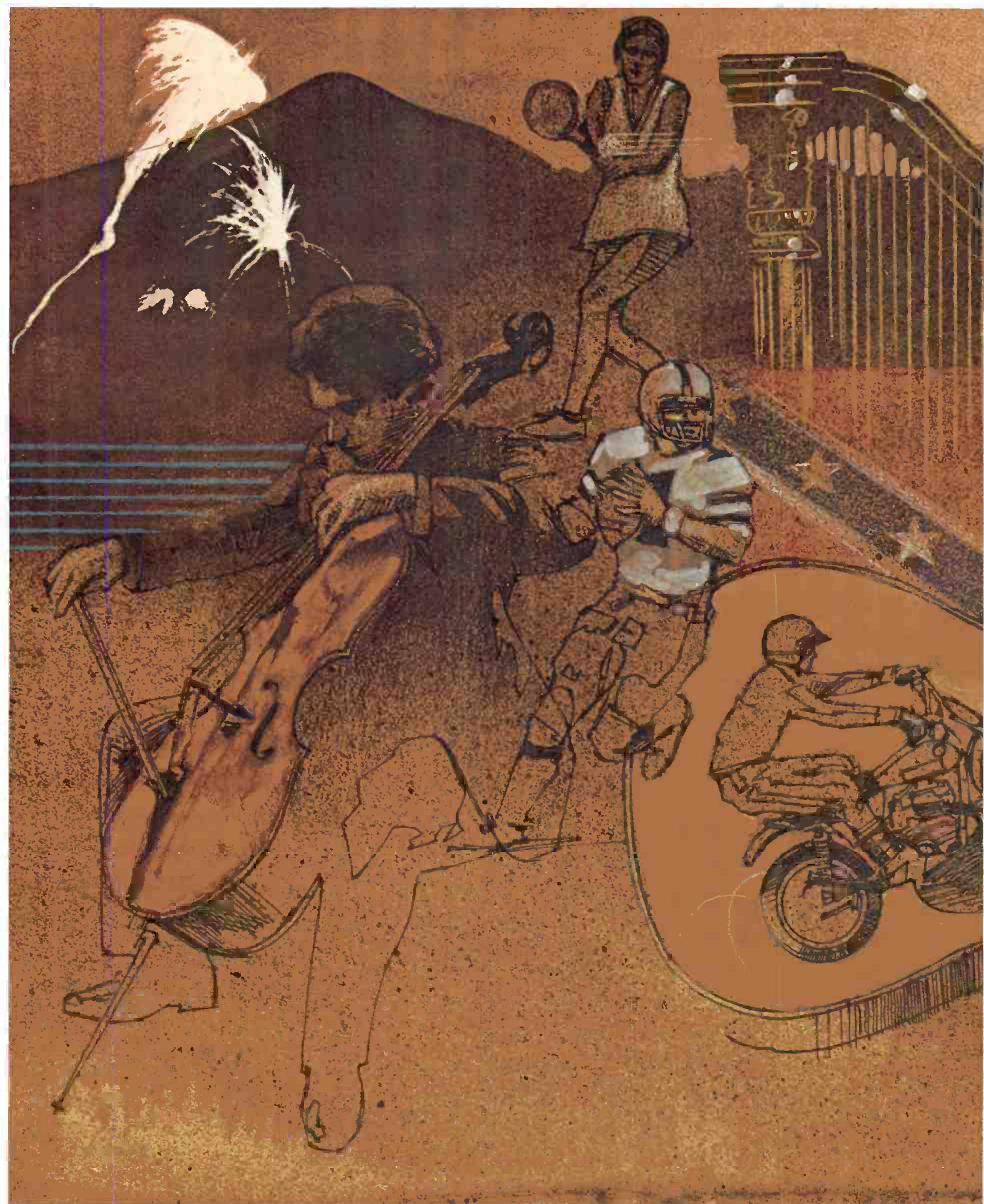

**AVT TELEVISION  
PRODUCTIONS**

1466 Amherst Road  
Knoxville, Tennessee 37919  
(615) 584-2166

**LERRO**

ELECTRICAL CORPORATION

Design, Engineering and Installation  
3125 N. Broad Street, Philadelphia, PA 19132  
(215) 223-8200

# **WHAT'S HOT IN TV PRODUCTS?**

## **FIND IT FAST**

DIGITAL ART AND GRAPHICS	88
CHARACTER GENERATORS	88
DIGITAL EFFECTS	89
VTRs/VCRs	90
VIDEOTAPE, FILM, ACCESSORIES	90
CAMERA/VCR COMBOS	91
CAMERAS	92
PICKUP TUBES	93
LENSES AND FILTERS	93
TELECINES	94
STILL STORES, SLOW MOTION, ANIMATION	94
PRODUCTION SWITCHERS	95
ROUTING SWITCHERS AND MACHINE CONTROL	96
BUSINESS AND NEWS AUTOMATION	97
POST-PRODUCTION	97
SIGNAL PROCESSING AND DISTRIBUTION	99
AUDIO FOR TV	100
LIGHTING AND POWER	101
CASES, FURNITURE, CAMERA SUPPORT, PROMPTING	102
TEST AND MEASUREMENT, MONITORS	106
SATELLITE SYSTEMS, TRANSMITTERS, ANTENNAS, MICROWAVE	106



# ★ NAB: 1982 ★

EVEN BEFORE THE COMMITMENT had been made to return the NAB show to Dallas in 1982, it was plain that the show had outgrown the available exhibit space. Nonetheless, it's off to Dallas we go for what will certainly be one of the most exciting shows in recent history. Over 460 manufacturers will crowd into (and around) the Dallas Convention Center—at least as many as last year, but in even less space than was available in Las Vegas. So expect a more intimate, perhaps even crowded show, with many exhibitors having surrendered some booth space to the greater impact of the show itself.

Our research and phone conversations with many of the manufacturers indicates that broadcasters should *not* expect a large number of new product introductions this year. Manufacturers have tuned into the apparent trend among equipment purchasers to look less at flashy new products with many thousands of dollars worth of “bells and whistles” and more at how the equipment will perform, how long it will last, what its price/performance specifications will be. In our Survey of Broadcast Industry Needs (see last month's issue), broadcasters revealed that they will spend the same or slightly more on capital purchases during the coming year, despite the recession. But management's voice of economic caution is reflected in the careful evaluation being given each new purchase.

Several new areas of growth will, of course, be evident. Any product with digital processing will be bound to attract attention—both equipment for digital imaging and for digital control.

## DIGITAL ART AND GRAPHICS

Especially watch for companies with digital art and graphics products, which include the digital art systems at booths such as MCI/Quantel (DPB-7000), Aurora (Digital Videographics), Computer Graphics Lab (IMAGES), McInnis-Skinner (Weathergraphics), Spectra Computer/Weathercaster (S-1010), Colorgraphics (new Live Line III), Logica (Flair), plus, undoubtedly, some surprises.

Quantel's Digital Paint Box may be among the hottest items at the show, since its software is ex-

*Quantel's Digital Paint Box will draw many a viewer.*



*New developments for 3-M's D-8800 are expected.*

tremely advanced and offers painting programs such as smear, poster paints, finger paints, etc., as well as an extra bit of processing in the stylus that increases the flow of the electronic “paint” as the stylus is pressed down harder.

All products for improving image production value will be popular.

Don't forget the less costly Interand Telestrator system, which draws directly into microprocessor memory through an interactive stylus, or the extremely low-cost For-A Video Writer. Comprehensive Video's new Video Scribe is probably along the same lines. Another extremely low-cost system is the Video Associates Labs encoder module, which allows Apple II computer graphics to be re-synchronized for broadcast use.

## CHARACTER GENERATORS

Besides these actual art/graphics systems, look for significant developments in character generators, beginning to flex their muscles as full graphics systems. Thomson-CSF was the first to lead the way last year with Graphics V, which incorporates a multi-level framestore together with more standard character generator features. This year it will apparently be Chyron's turn, with the company promising brand-new software to permit the multi-plane, multi-color, multi-directional composition only a framestore can deliver. The Dubner CBG offers a combination character generator, framestore, and drawing tablet, plus the ability to digitize external sources.

3M, meanwhile, is promising developments for its D-8800 system, introducing a camera-based font compose that presumably also will increase the animation capabilities of this system. Fernseh appears to be holding off any significant new developments with its Compositor I, which already has an advanced drawing tablet-based font compose program and computer-created animation programs.

Other developments in character generators will be on a more modest scale.

As promised last year, System Concepts will introduce a new font loadable Quantafont Model Q-8 teleproduction titler. This new unit offers multiple type faces and multiple font sizes in a given resident mode (floppy disk). Its features include 26.1 ns resolution and many options, such as dual-channel operation and font composing. Video Data Systems will introduce several new generators in a low price range. Shintron will show the Model 515 Fortex Graphics

Titler. This unit includes a downstream matte keyer. Knox will add a color box to complement its K-128 system, described last year but never acutally introduced. BEI will offer its high-resolution Marquee titler with "Chroma Stick" joystick color control and font compose. Laird Telemidia promises some new models. QSI will have user-programmable alphanumeric characters in its SID identifier for microwave feeds.

Several teletext options will be shown, primarily from overseas manufacturers trying to sway the American market. The Canadian Telidon and the French Antiope are the two main contenders. Unitex Video Graphic Systems will offer teletext editing equipment such as keyboards and computer disks, either standalone or with another computer. Zenith's Z-text will also be on hand.

Encoders will also be of interest, with Datum offering a new VI system with 48 bits per line. EEG's line 21 encoder is already well known.

### DIGITAL EFFECTS

Products to improve the image production value of television will be evident throughout the show. Digital effects processors are still evolving, now largely due to programming efforts in the framestores that make them more and more versatile. A significant new development will be NEC's brand-new bubble memory-based effects processor, which may prove once and for all if solid state bubble memories can find a place in broadcasting—as they promised to do several years ago. NEC will also, of course, bring along its DME, and ActionTrak digital effects system, which, by controlling the variable decay and recording rates of an image, provides exciting records of the motion of an object through the frame—such as a ball or a gymnast.

Toshiba will debut two new products into the U.S. market—a DPE II Digital Picture Effects unit and a digital video synthesizer.

Other impressive effects processors will be evident throughout the show. Last year Ampex caused a stir with its ADO's ability to perform three-dimensional compression—and the system will likely put on a repeat performance this year since it will be among the very first products shown with the new 13.5 MHz digital sampling frequency. ADO may also be available in a four-channel version with either multiple keyboards or multi-channel effects. MCI/Quantel seldom comes to NAB without some new capability for its DPE effects processors—whether the

*Ampex's ADO may have some surprises over last year.*

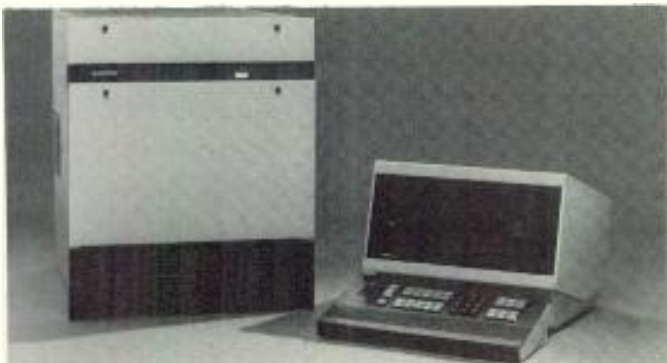

# WE'LL GIVE YOU SOUND AS CLASSIC AS THE MUSIC.



Imagine a new broadcast cartridge that delivers musical sound like reel-to-reel. Sound impossible? Listen for yourself at **BOOTH 3133** of the NAB Show.

Magnetic A/V Products Division/3M

3M hears you. . .

## 3M

Word is getting around  
about ECHOlabs

# SE/3

An  
**Outrageously  
Good Switcher**

SEE IT FOR YOURSELF  
AT **NAB** IN DALLAS

**BOOTH #2932**  
OR CONTACT

## ECHOlabs, Inc.

175 Bedford Road, Burlington, MA 01803  
(617) 273-1512

Circle No. 161 on Reader Service Card

# ★ NAB: 1982 ★

5000+ five-channel system, the newly introduced 5000/SP single-channel, low-cost unit and a "shot box" memory; this year it may have additional effects capabilities beyond the now-standard rolls, tumbles, flips, card shuffles, and modulated patterns. Vital will almost certainly be demonstrating SqueeZoom's new comet tail and mosaic effects.

More on other digital imaging developments later in the discussion of production tools—switchers, still stores, and the like.

Using non-additive analog mixing, the Ultimatte chroma keyer will be shown in a slimmed-down version for news applications at the Vlahos-Gottschalk and Comex booths.

## VTRs/VCRs

One surprise at the NAB will be the sudden emergence of new VTR developments, led off by the promised introduction by Cezar International of an all-digital VTR, the first for under \$50,000. Based around the transport mechanism of the IVC one-inch deck (Cezar and IVC are in the midst of merger negotiations), the deck uses Anabit digital processing to deliver signal performance specifications "equivalent to standard eight-bit processing"—such as S/N in excess of 70 dB. NEC, too, promises the industry's first Type C-based one-inch digital VTR, though it's not clear if it will be introduced as a product or simply a prototype.

Other digital recorder developments have apparently been dropped for the moment, with manufacturers holding back until the CCIR has actually adopted the 4:2:2 13.5 MHz sampling frequency and further discussions have taken place within industry study groups. Sony will almost certainly *not* make any demos of digital recorders—either audio or video. The only remote possibility is still Ampex, though this remains highly unlikely.

Sony will, however, lift the curtain on its brand-new Type C one-inch VTR—model BVH-2000—touted by new Sony Broadcast president Neil Vanderdeusen as "smaller, lighter, more flexible, and with more operational features." It's not simply a retooled BHV-1100, but apparently a brand-new machine.

The same goes for 3M, which will also introduce Model TT-8000, its brand-new Type C machine; no details available yet, except that it will have "enhanced operational features, including more sophisticated editing capabilities" and will be accompanied by a new TBC that should aid in editing.

There's also major work underway on videocassette recorders, with Sony leading the way with its BVU-800 and 820 U-Matic decks—front loading models ideally suited for editing suites, with newly designed transports that keep the tape engaged on the head during shuttle, permitting high-speed search with visible picture; the 820 features track following for broadcastable slow motion effects.

JVC and Panasonic will, of course, have their 3/4-



A full tape line will be available from Fuji.

inch decks on hand. Both are promoting, however, the capabilities of their half-inch professional recorder lines, particularly for news and the early stages of post-production.

## VIDEOTAPE, FILM, ACCESSORIES

Because of growing interest in high definition television, Merlin will show its ME-258 VTR. This is described as an untramaster wideband VTR based on the Bosch BCN Series, and was used during the Compact Video Imagevision demonstration at the fall SMPTE show. Another product used during the demonstration, the Faroudja Labs Image System, will be shown in a new version to improve bandwidth and reduce noise. Faroudja will also offer its low-cost Record-Ex enhancer/booster for use with half- and 3/4-inch VCRs. Recortec, early leader in the move to improve bandwidth on the U-format VCR, will also show its ultra-wideband modifications.

Extended-play version of Type C decks are also becoming popular, particularly among cable broadcasters. Merlin offers a modification for Sony units. Hitachi, RCA, 3M, Sony and others also have their own three-hour versions available.

At least one new 1/4-inch VCR will make its appearance, promised by a new company called Techtran International.

Delcom will show its modified Sony VO-2850 with features such as two-channel audio mixing, countdown generator, and pulse cross output.

Saki and Videomagnetism will demonstrate quad head refurbishing services.

In the videotape area itself, Fuji Photo Film says it will introduce a super high-grade VHS videocassette available in seven lengths. Fuji will also offer several new head cleaner cassettes. TDK reports it will show a professional half-inch videocassette, predicting that half-inch VCRs will soon replace the 3/4-inch format. Maxell, already in the field, will offer several new VHS tapes.

Full tape lines can also be obtained from Fuji, Ampex, Sony, and 3M among several others.

Film should not be forgotten, with Kodak introducing both a daylight-balanced high speed reversal film and a new high-speed negative film that can be force-processed to 1000 ASA, making available-light photography possible even in relative darkness.

Tape accessories will abound, including a new leader generator from CMC Technology that provides instant identification for a station or facility's material. A.F. Associates will introduce an electronic

"slate camera" for identification in both mobile and studio environments. BEI, QSI, and ESE offer similar countdown products.

Several new tape cleaners and evaluators will be shown. TEA will offer the Elecon-254 for one-inch tapes, Recortec will have a new one-inch unit, and Asaca has a new cleaner system. RTI will show cleaners and evaluators for both one- and 3/4-inch tapes and Chyron will feature its cassette cleaner/evaluator. Lipsner-Smith has ultrasonic cleaners for film.

N.O.V.A. will show its sapphire-based tape cleaner. Garner will have tape erasers. And Audico will have its videotape loader, now able to spool both bulk tape and shorter lengths from prespooled cassettes.

### CAMERA / VCR COMBOS

All these recorder developments may, of course, be eclipsed by the arrival of a brand-new member of the broadcast equipment family—the single-piece camera/VCR combo with its integral half-inch format VCR. The debate over which format is best—the Matsushita/RCA-developed ChromaTrak three-channel encoding used in conjunction with VHS-type cassettes, or the Sony-developed two-channel encoding used in conjunction with its Beta-type cassettes—heated up considerably in a SMPTE group studying the formats. The recorder format issue is somewhat clouded by a substantial difference in the types of cameras used with the single-piece combos. RCA has gone with three brand-new half-inch tubes, while Sony has gone with a single one-inch three-stripe tube. The Panasonic version uses three 2/3-inch tubes. The difference seems to profoundly affect the overall weight of the camera/VCR combo.

As of press time, all three manufacturers had announced plans to feature heavily their single-piece systems at NAB. RCA will show the Hawkeye in a version very slightly changed from what has been seen previously, with the body slightly re-tooled. Sony will make the bold step of unveiling a three-tube version of the Betacam using the same detachable recorder as the single tri-stripe tube; it's uncertain if the new camera will be a working model or a prototype. Panasonic will show its combo, possibly re-named ReCam.

The recorder on Sony's Betacam is now detachable.



## NOW YOU CAN KEEP IT FROM SOUNDING FLAT.



We can show you a new broadcast cartridge with the brightest, fullest sound ever. Just stop in to **BOOTH 3133** of the NAB Show.

Magnetic A/V Products Division/3M

3M hears you...

# 3M

## CUSTOM & STANDARD BROADCAST EQUIPMENT

- Master Control Switchers
- Machine Assignment Systems
- Audio/Video Routing Switchers (10 x 1 up to 250 x 250)
- Custom Automated Systems
- Master Control Automation



Custom-designed Master Control

Modular design  
Readily available  
components  
Easy maintenance  
Microprocessor  
control for large  
systems

We can design a system  
for your specific requirements

SEE US AT NAB'82—BOOTH 2600



### IMAGE VIDEO LIMITED

700 Progress Avenue, Scarborough, Ontario, Canada M1H 2Z7  
Telephone: (416) 438-3940 Telex: 065-25392

Circle No. 163 on Reader Service Card

THE SKY'S THE LIMIT

# ★ NAB: 1982 ★

But others are not far behind. Ikegami will definitely enter the ring with its HL-83, the single-piece camera shown at SMPTE, but now with a broadcast-quality half-inch recorder (as opposed to the 1/4-inch recorder demonstrated earlier). It hasn't announced which format yet, but speculation is it will be the RCA-Matsushita version.

The same may also be true for Toshiba, though details are even sketchier. Neither is it likely that Hitachi will take the opportunity to show a camera/VCR combo, though again there are absolutely no details except that "a brand-new ENG camera will be introduced."

## CAMERAS

While Philips Broadcast (Central Dynamics Corp.) has given no indication of offering a single-piece system, it will have a brand-new camera, the LDK-6, described as automatic studio/field camera "with total intelligence."

Sharp's new XC-800 ENG/EFP camera has an extensive DBO range, up to 18 dB gain, auto white and black balancing, and remote control.

There will be considerable emphasis on automatic cameras at this year's NAB. RCA will offer some advanced features in the TK-47 line, including a TK-47T

triax camera and a brand-new remote control unit. Ikegami will be offering the HK-322 as a full-sized computer setup camera, replacing the HK-312. Toshiba has announced a new version of its studio camera, PK-40B, though no further details are available. Also showing automatic cameras introduced earlier will be Ampex (the BCC-21 Digicam), Harris, and Hitachi. Hitachi's latest model is the SK110, a version of the SK-100 originally modified for CBS.

In the lower priced camera range, Ikegami will have a new ITC-730 series for ENG/EFP use featuring prism optics. This unit presumably replaces the ITC-

*Ikegami's EC-35 is still in a field by itself.*



# CASSETTE CLEANER/EVALUATOR

Elcon EA 750 — For 3/4" Cassettes

## Television Equipment

U.S. Distributor of

Matthey Video and Pulse Delays

Matthey Video Filters

Elcon Tape Cleaners and Evaluators for 2",  
1" and 3/4" Tape

Racal Headsets for Intercom/Sportscaster  
Applications

BCA Intercom/Interphone Systems

Link Video DA-s

For information, please contact:

**Television Equipment Associates, Inc.**  
BOX 393, SOUTH SALEM, N.Y. 105900393  
914-763-8893 in Calif. 213-271-9570  
TWX 710-575-2600



- \*85% of tapes discarded for drop-out restored to service after cleaning.
- \*Three front panel illuminating LED displays identifies the location of video dropout, upper edge and lower edge damage.
- \*Quick and accurate tape grading into categories such as "Master Stock," "Standard Quality," "Dub Quality," achieved with user calibrated push buttons.
- \*Electronic evaluation—essential for dropout evaluation.
- \*Bring a test cassette to N.A.B.

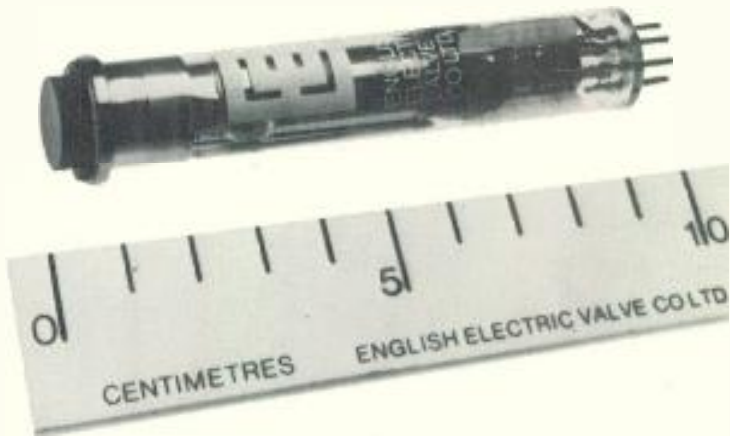

Expect some advances in Leddicons from EEV.

350 and will be fully competitive with the JVC KY-2700, the Hitachi FP-21/22 series and the Sharp XC-700. Toshiba will continue to show the PK-60. JVC may have something new this year, but it will not be announced until showtime. (The Hitachi FP-22 is a computer setup camera priced under \$14,000. At this price, it has been something a benchmark for 1982.)

Still in a field by itself will be the Ikegami EC-35 electronic cinematography camera. This unit is now available for immediate delivery through dealers such as Camera Mart and Cinema Products. No other manufacturer offers anything quite like it, except for the Panacam—a combination of the CEI-310 camera's electronics plus Panavision lenses—which will probably be shown in a hospitality suite.

The EC-35 itself will also be shown by Camera Mart and Cinema Products, the latter offering several accessories for the EC-35 such as matte boxes, follow focus systems, and a J-4 zoom control. Other items by Cinema Products will be the coaxial digital remote control system, now available for the Sharp XC-700 camera.

### PICKUP TUBES

One can't have camera advances without tube advances. While Amperex appears to be standing pat with what has been announced before—"diode gun Plumbicons ranging from half-inch to 30 mm, and high resolution diode-gun frogheads," English Electric Valve indicates it is now in the half-inch tube game with a new half-inch Leddicon. EEV says it will show other advances in one-inch and 2/3-inch Leddicons. The RCA Electro Optics Group will, of course, promote its new half-inch Saticon tube and will show a complete line of Saticons, Visticons and Vidicons.

### LENSES AND FILTERS

In the camera lens field, *BM/E* received word from several manufacturers indicating that there will be more lenses available for the half-inch tube format cameras and more lenses for automatic cameras. Angenieux says it will have a new fast zoom lens for half-inch tube cameras rated at *f*/1.4. Also new from Angenieux will be four new lenses for automatic cameras: a 15X *f*/1.5 and a 25X *f*/1.4 for automatic ENG/EPF cameras, a high-quality 12X zoom, and a

## WE'VE PUT AN END TO STALE SOUNDING JINGLES.



We've developed a new cartridge with sound so bright and fresh, it'll give new dimension to your music programming. See what we mean at **BOOTH 3133** of the NAB Show.

Magnetic A/V Products Division/3M

3M hears you...

# 3M

## VCR IN-CASE OPERATION

See Us At  
NAB  
Booth 2103



**SPEED UP YOUR SET-UP...  
OPERATE YOUR VCR IN THE CASE!**

- SLIDE-OFF LIDS, GROOVED TRACKS
- REAR CABLE ACCESS
- ETHAFOAM SOUND PROOFING
- VENT SPACE UNDERNEATH
- AIR FLOW THROUGH REAR

**THE INCASE BY EXCALIBUR.**

CALL FOR INFO  
213/899-2547

**EXCALIBUR INDUSTRIES**

12427 Foothill Blvd., Lake View Terrace, CA 91342 • (213) 899-2547

Circle No. 166 on Reader Service Card

# ★ NAB: 1982 ★

new 42X wide-angle zoom for automatic studio cameras.

New Fujinon lenses will be for larger-format cameras. A 16.5 280 mm f/2.1 servo adaptable lens is available for 1¼-inch cameras. An 11–310mm f/1.6 studio/EFP lens and a 12.5–212mm f/2.1 studio lens are available for one-inch cameras. The company may also demonstrate some of its pioneering work with lenses for the NHK HDTV system.

Canon will announce a new EFP camera lens, the PV-40X13.5 BIE. This f/1.7 unit is designed for one-inch tube cameras. Other new lenses include two 15X zooms for ⅔-inch ENG cameras, one rated at f/1.6 and the other at f/1.8.



Two new Schneider lenses will be shown by TeleCine.

TeleCine Corp. will show two new Schneider lenses, a lightweight 14X zoom available for either half-inch or ⅔-inch tubes, and a new 15X studio all-purpose lens with built-in diascope for automatic cameras.

Tiffen and Belden/Lee will both be showing new lines of color correction filters, with Tiffen offering attractive stackable filter holder cases and a new rotatable matte box. Spectra Tek Star and other special effects filters will be shown at the Alan Gordon Enterprises booth.

## TELECINES

The telecine arena will be lively this year at the Marconi and A.F. Associates booths. Marconi will be showing the B-3410 solid state line array telecine (introduced last year at Montreux), putting it in direct competition with the Fernseh FDL-60. New for the FDL-60 CCD system is a pan/scan program and black stretch circuit. Rank Cintel, now getting competition from both Fernseh and Marconi, continues to make advances in the Mark III flying spot scanner system, “keeping it even further ahead of the rest.” New this year will be a Varispeed option enabling time compression and expansion at varying film speeds with no loss of light in the flying spot scan. The new development supplements X/Y cursor-controlled pan/scan and TOPSY scene-by-scene color correction. Nytone, too, will demonstrate its flying spot scanner 35 mm slide chain.

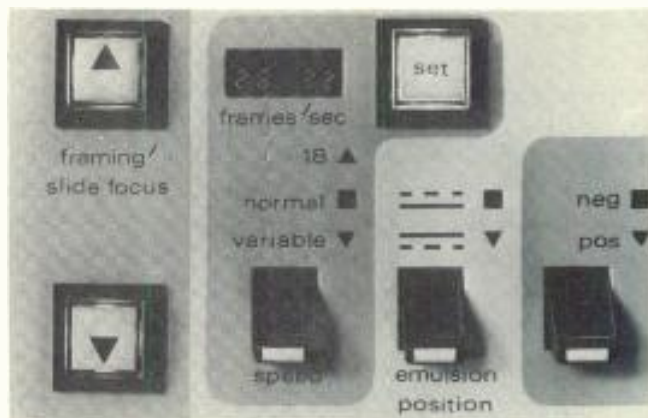

This Varispeed option is another advance for Rank Cintel's Mark III flying spot scanner.

In image tube telecines, Ikegami is coming out with a new model, TKC-990, that incorporates completely automatic setup. Magnasync/Moviola will show a new V-500 telecine, patterned, presumably, on its basic Videola design. RCA will feature its TK-29C telecine system with “advanced color corrector” permitting pan/scan and scene-by-scene correction. Meanwhile, also look to L-W International for new developments in the Athena telecine projector line, and to Cohu and Laird for multiplexers.

Watch for color corrector developments from Corporate Communications with its FDL-60 system as well as new standalone telecine and tape-to-tape models.

## STILL STORES, SLOW MOTION, ANIMATION

It's almost certain new production equipment will draw NAB crowds wherever it's displayed. Interest should be extremely high in still stores—both digital varieties such as the new Harris IRIS II, now offering library control of 10,000 entries with six user stations, MCI/Quantel DLS-6030 with browse program, ADDA ESP with the new VIP digital compressor/positioner, and the Ampex ESS-2, and also in disk-based recorders such as the Eigen and Echo Science (Image Maker) systems.

Grove Video does promise a new digital graphics storage and animation device, which is presumably some form of single-frame recorder. Fernseh will probably show its new single-frame storage system for the BCN recorder offering massive still storage capacity within tollerable recall times. Almost every other company with one-inch decks will be showing slow motion controllers.

Slow-motion recorders such as the systems from Eigen and Echo Science (the Imager Maker) are finding ever-increasing applications. Arvin/Di-

*New production equipment can be expected from companies like MCI/Quantel.*



among, of course, will bring its satellite weather system, also based on a disk recorder.

Single-frame recorders are also becoming popular for video animation. Both the Lyon Lamb and AniVid systems will be demonstrated, with the former offering a new animation stand and the latter a computerized zoom lens control. A new company, Computer-Computer Operations, Inc., will be offering a real-time video animation system, presumably similar to animatics-type animation stands currently used to produce test commercials. These systems record on VTRs. 3M's single-frame animation controller, which interfaces with the TT-7000 track-following capability may also be on hand.

Computer graphics animation will be shown interfaced with the AniVid and also the Eigen disk recorder to produce frame-by-frame computer animation with the computer rather than reflective art as the input.

### PRODUCTION SWITCHERS

Digital effects systems were discussed earlier. The production switchers they interface with have already reached their zenith, with some of the technology spilling backwards into smaller, more compact units for post-production suites and mobile vans. Grass Valley will have a two-M/E version of the 300 Series "Rolls Royce" on hand, plus new features for the full system. Central Dynamics Corp. will be showing switchers from both the American Data and CDL lines; ADC will have new chroma and downstream keyers and a new single-M/E 20-input model, while CDL will present a new single-bus quadruplexer/digital signal generator and a new model CD-480-65 switcher. Vital will show both its 250 P/N digital switcher and also the four-M/E Saturn switcher, which is now probably the largest on the market. Ikegami promises a brand-new production switcher line, though details are unavailable. Will NEC also bring its switcher line? Ampex will feature its digitally controlled ADC switchers, up to three M/Es.

Switcher automation will again be popular, with the Grass Valley E-MEM, CDL CAP, Vital PSAS, and ADC ACTS systems in full operation. Crosspoint

*ISI will be among the exhibitors showing production switchers.*



## OUR NEW CART CAN GIVE IT MORE LIFE.



Stop by **BOOTH 3133** of the NAB Show and we'll show you a new broadcast cartridge with sound so good, it'll bring any commercial alive.

Magnetic A/V Products Division/3M

3M hears you...

## CONGRATULATIONS!!!

WE CONGRATULATE THE  
NATION'S BROADCASTERS  
ON THEIR CONTRIBUTIONS AND  
ACCOMPLISHMENTS TOWARD MAKING...

THE 1980's  
"A DECADE  
OF  
DEREGULATION!"

PLEASE VISIT BOOTH NO. 1808  
(Lower Level) AT THE SHOW IN DALLAS.

 LAIRD TELEMEDIA INC.®  
2424 SOUTH 2570 WEST • 801 972-5900  
SALT LAKE CITY, UTAH 84119

Circle No. 170 on Reader Service Card



★ **NAB: 1982** ★

Latch will show its automation control system on a brand-new three-M/E switcher with six buses, the largest in its line. Ross Video, too, will be adding a scene store memory to its switcher line that will remember up to 200 switcher crosspoint and key mode settings. ISI will also have its APE automation system on hand, and will be showing two new switchers.

Beaveronics will show a standalone downstream keyer specifically designed for character generator inserts; a dual selector permits choice of either channel from a two-channel generator or the simultaneous selection of six generator inputs for multiple keying situations. Echolab will feature its 10-input digital switcher with edit controller interface.

**ROUTING SWITCHERS AND MACHINE CONTROL**

In routing switchers, one of the most interesting developments in recent years promises to be a new system from Hughes Electronic Devices Corp. (HEDCO), which is introducing a brand-new 100 x 100 audio-follow-video switcher in an extremely compact unit. The size reduction is made possible by a three-stage design, somewhat similar to tele-

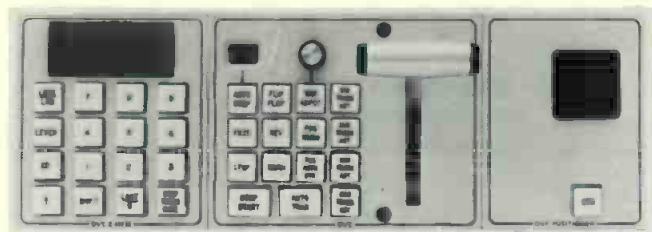

*Among Grass Valley's introductions will be this Mk II digital video effects real time system.*

phone company switching circuits except that it is non-blocking, which substantially reduces the number of crosspoints and yields a unit one-quarter to one-fifth the size of other systems.

Grass Valley will have a new 10 x 1 utility routing switcher, new M-200 modular automation switching system and the 440 routing switcher. 3M will show the 6500 machine control/automation system and 20X and 40X routing switchers. Also look for routing switcher developments from Utah Scientific with its PLMC-1, which also incorporates machine control.

Compact Video reports it will bring a brand-new computer-assisted video playback system for automated TV station operations, "designed to eliminate errors associated with most commercial and news segments during typical operations." Kavco, too, will show VTR playback and commercial insertion programmers. A new modular machine control system is promised by Dynair, supplementing its routing switcher equipment.

CDL, too, is entering the ranks of machine control/



automation system manufacturers with the brand-new APC-920, heralded as a true-time automation system with logging capabilities. Don't forget other established companies in the field such as ADC, Fernseh's TVS/TAS and Automax system, and Vital's Vimax's.

NEC will show its digital, four-channel multiplexed audio routing switcher. Other routing switcher manufacturers that should be closely tracked for developments include Datatek with a new source identifier, Di-Tech with a new automatic logging device for its routing switcher systems, Image Video with a new broadcast routing switcher, and Telemet with a computer-controlled switching system.

## BUSINESS AND NEWS AUTOMATION

With several stations around the country having installed newsroom computer systems recently, interest should be high at NAB to hear reports from the field. Companies offering news and business automation systems will include Basys with its Fury system for data as well as cart and film clip management; Chase Media's business automation system for traffic/billing/financial/music inventory; Data Communications's business automation systems; the Kaman Sciences program for sales, traffic, accounting, and inventory management, with MC switcher interface; the McInnis-Skinner Newscom newsroom computer system with Weatherscan weather services; the System Concepts QuantaNews van-based newsroom computer system; Mead Data's computer-based business

machines including terminals and printers; the Station Business Systems accounting, traffic, and inventory system, and also Newscom newsroom computer program; the Generic Computer business automation system using Apple or Polymorphic computers; Jefferson Data's sales, traffic, and accounting system, and also Electronic Newsroom Computer (ENP) system; the Spectra Computer/Weathercaster computerized forecasting system; and the Colorgraphics weather system for forecasting with Weather Service International and satellite weather data.

## POST-PRODUCTION

The most exciting development in electronic post-production has been finger-controlled computer peripherals applied to editing systems. Last year, Ampex stole the show with ACE, primarily used for edit decision list-type control. This year, the same peripheral will be put into service by Control Video with its Lightfinger screen, which displays the VTR controls in prompted displays. This is the system said to be favored by Francis Ford Coppola, who is looking for a "no knobs" video editing approach for his film-oriented editors.

Systems for film editing will also be featured, led by the Convergence ECS-104 and the Harris EPIC, both of which use their EDL programs to provide film-style cut logs that enable the video cut to be matched with the original film frames. CMX was unclear about whether it would bring its FLM-1 system, which interfaces film transports with a video editor and EDL



**We  
put it all  
together.**

*From Emmy award-winning coverage of the 1980 Winter Olympics to historic coverage of the Space Shuttle, and in hundreds of Network and Independent feature productions, Convergence video editing systems are the number one choice because of their speed, reliability and ease of operation.*

*Since 1975, Convergence has led the way with numerous product innovations. We produced the first ENG editor and were the first to incorporate Joystick Control. Most recently we pioneered the modular editing system design concept.*

*Today we're working on further innovations to assure that you'll always find more functions and features for your editing investment.*

 **CONVERGENCE  
CORPORATION**  
Convergence Corporation... The modern art of video editing systems.

1641 McGaw, Irvine, CA 92714 Tel: (714) 549-3146, Tlx: (910) 595-2573 • 250 W. 57th Street, Fisk Building, Suite 815, New York City, NY 10019  
1 Lochaline Street, London W6 9SJ U.K. Tel: 01-741 7211, Tlx: 851-27950 MONREF G

Circle No. 171 on Reader Service Card

BM/E MARCH, 1982 97

THE SKY'S THE LIMIT

# ★ NAB: 1982 ★

program to provide video rough cuts based on actual film footage.

Regular video editing systems will also, of course, be plentiful, many offering new options and interface capabilities for all the latest VTRs and VCRs. The ECS-104 can now accept more source VTRs while the ECS-90 has an EDL option. Both the 340X and The Edge have new features. Developments in the Fernseh Mach One or EPIC systems were not specified.

There are some new products, however, in low and midrange systems. United Media has two new audio editors to work alongside its Commander I and II video editing systems. Jatex will again bring out its A/B roll system with list maintenance. Datatron, featuring the Editt/Plus low-cost controller and the Vanguard system, promises new editing peripherals using LSI and VLSI circuitry.

Among the VTR manufacturers there will be a number of recently introduced systems such as the Sony BVE Series in five-machine and three-machine configurations, the JVC RM-88U two-machine ENG setup, and the Panasonic 700 B-2 two-machine time code editor. There may also be developments in the Videomedia Z-6 editors.

Perhaps the most innovative editing product intro-



Control Video will be showing its Lightfinger screen.

duction will come from Cezar International, adding to its Decision Maker, Editing Center, Controller, and other products. The Collator is "the ultimate editor because it doesn't make edits." Instead, it controls eight or more VTRs that contain alternating scenes of a program, rolling them to air and making actual editing unnecessary. Seeking to capture a segment of the movies-for-TV market, Cezar is also introducing the Preface, for previsualizing and then assembling various program segments.

A brand-new ATR/VTR synchronizer, on the way from Ampex, is capable of linking up 16 machines with one synchronizer required per transport. Other

# A NEW SUNRISE FOR FILM

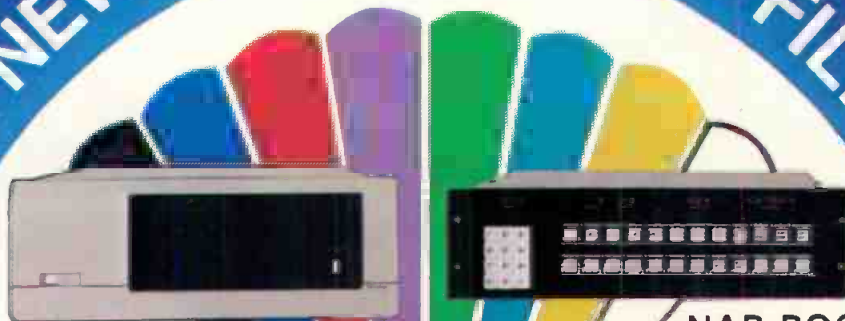

U.S. PAT. 4,096,523  
and others

NAB BOOTH  
#2413



## The System 60 XL<sup>tm</sup>

not a silent partner<sup>®</sup>

### FILM to TAPE and TAPE to TAPE

COLOR CORRECTORS BY: CORPORATE COMMUNICATIONS CONSULTANTS, INC.

4250 Veterans Memorial Highway • Holbrook, N. Y. 11714 • (516) 737-0903

Circle No. 172 on Reader Service Card

synchronizers from BTX (The Shadow), EECO, Control Video, Audio Kinetics (Q-Lock), and Adams-Smith will round out the editing controller lines.

There are several new developments in time code systems, particularly now that the technology of Vertical Interval Time Code has become widespread. Datametrics will show VITC generator/readers and character generators. BTX will introduce a new line of microprocessor-based units, RS-232 controlled and compatible with most editing systems. Adams-Smith (exhibiting at the Glentronix booth) also has a new VITC system capable of reading code up to 45X play speed and providing an output in longitudinal code format for editing interface. EECO will show combination VITC/longitudinal generators and readers. Skotel will offer a new character generator option for its longitudinal and VITC systems, as well as its popular hand-held unit. And look to For-A, Shintron, and ESE for additional time code developments.

### SIGNAL PROCESSING AND DISTRIBUTION

The list of companies offering digital signal processing equipment is quite impressive, with several now interested in capturing the market for small, low-cost systems. Harris will unveil the 690 digital TBC frame synchronizer, which promises "ultra-high performance and low cost." A new dual-channel digital TBC is on the way from ADDA, designed specifically for A/B roll editing. A new digital TBC will also be shown by For-A.

Microtime is already in the field, having previously



NEC's FS-16 offers proc-amp functions and frame synchronization.

introduced the T-120 low-cost digital TBC to supplement its 2525 and other processing products. Both NEC (the FS-15) and MCI/Quantel (the DFS-1750) introduced extremely compact framestore synchronizers at last year's show, rounding out more extensive TBC/synchronizer/framestore product lines.

Two companies that will undoubtedly have new digital processing products—Digital Video Systems and Fortel (the renamed Edutron)—had few details at presstime. The former, of course, carries the popular Phaser line of TBC/framestore synchronizers, the latter the CCD and Y-688 "Total Error Corrector" TBC/frame synchronizer/image enhancers.

Oki will show its portable digital standards converter. The Faroudja Image System for boosting VTR specifications has already been discussed.

Color correctors are becoming extremely popular, especially as the use of telecines grows, but also for tape dubbing. Applied Digital Technology will premiere a new Relecon microprocessor-based color corrector for tape dubs. Both Corporate Communications and Dubner offer this kind of product also, the Corporate Communications system designed to in-

## For maintenance technicians, no practice is perfect!

Too much routine studio maintenance is enough to turn off any good technician. They'd prefer to spend their time on more pressing problems, rather than just practicing their skills on routine chores. And that's what makes the AVL Digital Routing Switcher perfect for busy maintenance departments. It's routine-maintenance free. No practice is necessary!

With AVL Digital, constant fine-tuning and regular adjustments are chores of the past. That can save time and money for the department. The system is reliable and simple... just install it and turn it on for dependable control switching performance.

AVS 100 switchers are available from stock in standard configurations such as 10 x 10 and 20 x 20, or virtually any size, made to order. There's a full range of 'audio

follow video', 'video only' and 'audio only' systems available.

Building an AVL system to meet specific needs is as simple as it is to maintain!

Give your technicians a break from the regular maintenance practice. The AVL Digital Routing Switcher is a perfect start.

For more details on AVS 100 Switchers, options, sizes and other quality AVL Digital products, please contact ...



**AVL DIGITAL LTD.**  
70 Milner Avenue, Unit 5  
Scarborough, Ontario Canada M1S 3P8  
Telephone: (416) 298-6220  
Tlx: 06-963533 Twx: 610-4923219  
See us at N.A.B. — booth #3106



Circle No. 173 on Reader Service Card



**LEADER**

- \* Studio systems & accoustical design
- \* Installation, construction & turnkey facilities regardless of location
- \* Dependable technology & equipment from world class manufacturers
- \* Talk to us about your specific broadcast problems (Large or Small) or objectives. You'll discover so many good reasons why

**WE ARE THE:**



**LEADER**

**FOR BETTER AUDIO**

Leader Broadcast Systems Inc.  
15707 2nd Place West  
Alderwood Manor, WA. 98036

195 West 7th Avenue  
Vancouver, B.C.  
V5Y 1L8  
(604) 685-6043  
CABLE: Leadertape VCR.

Circle No. 174 on Reader Service Card

## TECHNICAL MAINTENANCE SEMINARS

### FOR VIDEO EDITING SYSTEMS

Convergence Corporation prides itself on the quality of its editing products, and we realize the importance of regular maintenance to keep editing equipment at peak operating efficiency.

These Technical Seminars teach you to perform routine preventive maintenance on your Convergence equipment, so you can virtually eliminate any costly down-time that might result from lack of attention to equipment upkeep. Contact Training Coordinator for further details.

Editing Model	City	Dates
ECS-103 & 104	New York, NY	March 2-5
ECS-103 & 104	Los Angeles, CA	April 27-30
ECS-90	Los Angeles, CA	May 12
ECS-103 & 104	Miami, FL	June 1-4
ECS-103 & 104	Chicago, IL	July 13-16
ECS-90	New York, NY	August 11



1641 McGaw Avenue, Irvine, California USA 92714  
For further details contact: Training Coordinator - Convergence Corp.  
Ph. (714) 549-3146

Circle No. 175 on Reader Service Card

THE SKY'S THE LIMIT

★ **NAB: 1982** ★

terface with the Sony BVX-30 multiprocessor, which includes image enhancement and noise reduction features.

Thomson-CSF will also feature a digital multiprocessor, combining digital noise reduction with image enhancement, color correction, and error correction. A new Thomson Vidimax system will add two f-stops of sensitivity with an easily installed camera modification and a new model of the 9100 processor. Composite Video describes a new TV-425 "processing center" it will bring, consisting of proc amp, noise reducer, and image enhancer. Apat Herzog says it will have a brand-new digital video processor.

Manufacturers of almost all the Type C machines with track scanning or track following also offer their own TBCs. There is a new unit for the Sony BVU-800, and also for the new 3M one-inch decks.

Pulse processing and distribution equipment will also be available for inspection. Grass Valley, Di-Tech, Leitch, and Datatek are some of the industry leaders. New products will be forthcoming from Shintron with a modular distribution amp system, and from Allen Avionics which will have a complete series of video and pulse delay lines. Sigma Electronics will have new SCH and black burst plug-in cards for its modular distribution system.

### AUDIO FOR TV

Our separate report on radio equipment at the NAB contains vital information for all interested in exploring quality audio for TV. Some companies, however, manufacture audio products designed only for TV applications that would not be appropriately listed in the radio section.

In consoles, Ward-Beck will feature both its production and broadcast models, custom-designed to suit specific applications. Neve is continuing advances made in previous years' in digital audio consoles and will show its full range of production and broadcast models, which use completely digital signal processing as well as control. ADM will have a new Series II television production console as well as an equivalent model for post-production. Quad Eight also makes large-scale post-production audio consoles. Harrison will bring its TV-3 mixer in configurations for both post-production and live mixing, the former fully equipped for editing system interface; the consoles feature novel graphic VU meters.

Smaller mixers, designed for portable ENG production, will also be abundant. Micro-Trak will introduce Telefile, which incorporates both a mixer and a cassette recorder. Interface has a new 8 x 2 portable mixer. Comprehensive Video's belt-worn mixer will also be shown.

Intercom and IFB is another major area of interest to TV broadcasters. The hot new development here is toward RF systems. R-Columbia will show a new interface unit for interconnecting its RF headphone/mic units with existing hardwire systems. Cetec Vega will



Developments in intercoms are promised by RTS.

take much the same approach with an RF intercom master station allowing full duplex interface between wired and wireless units. HME, Comrex, Sony, Swintek, Nady, and several others will show RF microphones that can be adapted for use as intercom systems.

Hardwired intercom leaders RTS and Clear-Com both promise developments, with Clear-Com featuring four-channel intercom and IFB systems. ROH plans to introduce intercom system support modules for its Series 300 to permit telephone, two-way radio, and other interfacing. TEA will show the BCA intercom system and headsets. Farrtronics will also show an intercom system.

Finally, don't forget the Ward-Beck Microcom intercom system, which offers advanced features for applications such as mobile vehicle installation.

Microphones and tape recorders are fully discussed in the radio equipment section. Of particular note for TV applications are Electro-Voice, Sony, Beyer Dynamic, and Sennheiser mics, and Otari, Nagra, and Ampex ATRs. Look for a major demonstration of digital audio recording at the 3M booth.

ATR/VTR synchronizers were discussed earlier in post-production. A system for synchronizing sprocketed film transports with VTRs and ATRs through the use of SMPTE time code shaft encoders will be demonstrated by Multi-Track Magnetics.

Processing is becoming increasingly important as TV audio improves. Dolby, a leader in the field with its plug-in modules for Sony Type C VTRs, will bring a brand-new module for Ampex VTRs incorporating noise reduction and an improved audio section for both A and B tracks. Gregg Laboratories will introduce a new TV audio processing system with six-octave range. Orban, a leader in radio compressor/limiters, will show a brand-new Optimod for TV, based on its FM processing system. Broadcast Technology, dbx, Lexicon, and Eventide Clockworks are some of the other companies with impressive processing systems that have TV application potentials. Comrex low frequency extenders have uses in TV audio in addition to their popular applications in radio.

### LIGHTING AND POWER

There are not a great number of product developments in this area, but a few are worth mentioning.

TM

# RECORD EX

## Improves any cassette VTR



Actual unretouched monitor images.

The picture quality of  $\frac{3}{4}$ " or  $\frac{1}{2}$ " VTRs can be improved by RecordEx™, a revolutionary device from Faroudja Laboratories. RecordEx pre-processes video prior to recording to boost, and therefore preserves in play-back, picture details normally lost in color-under formats.

Color-under pictures pre-processed through RecordEx look natural, life-like and rich in all the nuances and detail that previously only film and expensive tape formats could preserve. Broadcasters like the elimination of the "cartoon" effect or plastic appearance caused by loss of details. Because large outlines are not modified by RecordEx, the picture does not look enhanced. It looks as if it came from a better VTR.

RecordEx is an add-on device available in a portable battery-operated configuration. Connections are easy and no adjustment is required in daily use. An AC adapter is available.

Send for detailed information on how RecordEx can work for you.

## FAROUDJA Laboratories

Faroudja Laboratories Inc.  
946 Benicia Avenue  
Sunnyvale, California 94086  
Telephone 408/245-1492

See us at NAB Booth 2814

Circle No. 176 on Reader Service Card

BM/E MARCH 1982 101

# ★ NAB: 1982 ★

Perhaps the most interesting is a fiberoptic system from LTM which can pipe light around corners for hard-to-reach locations or in tight for close-ups. LTM is also among the companies with new lighting units for the 6000 W HMI bulbs. Arriflex and Strand Century will also introduce a 6K unit to supplement its other lights, including handheld HMIs. Arri will also show a new fluid head tripod. Frezzolini will have a new dc-powered camera-mounting lighthouse as well as a new on-board ac power pack/battery unit and fast-charging systems. Anton/Bauer will feature lighting heads, and also new fast chargers and a new microcharger for many battery types. Comprehensive Video will have a new line of quartz location lights, as well as a nicad battery fast-charging system.

Matthews has packed a number of essential lighting accessories into a handy suitcase format. It will also be showing the Tulip Crane—a transportable crane system that rides either on its own dolly tracks or on the back of a truck. Lowel Light, Cool Light, Cinema Products, and Colortran will feature various location lighting kits based on quartz lighting units.

Studio lighting control systems have gone the way of most broadcast equipment, now often featuring solid state dimmers and microprocessor control. One of the leaders here is the Strand Century Mantrix dimmer. Electro Controls will have a new advanced control system for TV studio lighting. Kliegl will also introduce a new K95 SCR "intelligent" digital dimmer to supplement its Performer line. Skirpan, a Compact Video company, also offers similar systems.

Sylvania will feature its Bright Beam, a new daylight fill lamp, presumably to compete with the various Osram HMI and CID daylight-balanced bulbs that have become so popular. G.E. will bring good things to light with its Quartzline series of professional lamps. Rosco will show a complete line of color control materials for lights, as will Belden/Lee. Full lines of studio lighting units can be found at such manufacturers as Mole-Richardson and Colortran, the latter also offering lighting control systems. The Phoebus Corp. will have a new quartz light follow spot. Great American Market promises more special lighting effects units in addition to its growing line of HMIs.

Other NAB exhibitors will be concerned with large-scale lighting and studio installations. Theatrical Services will show new electronic distribution systems

*Strand Century's Mantrix for lighting control.*

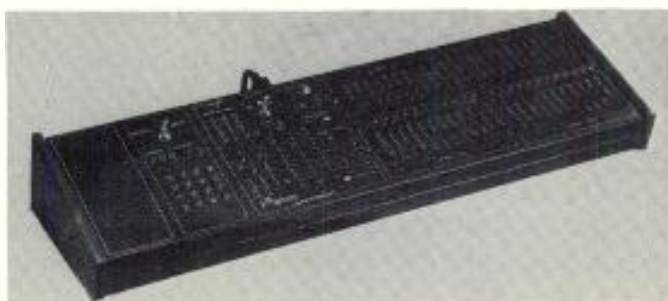

*Winsted will be offering a selection of cabinets and racks.*

and electronic patching. Theater Service & Supply can be turned to for products such as artificial snow. Theater Vision has a modular studio system complete with lights, background, grid, etc. Peter Albrecht Corp. will feature microprocessor-controlled winches and lighting positioners. Gagnon LaForest's Vertilift system is a similar electronically controlled lighting positioner.

There have also been some developments in power supplies in addition to those mentioned above. Cine 60 will be introducing a new ac adaptor for cameras and VTRs, and also extremely lightweight lithium emergency batteries for ENG equipment. From PEP will be a new line of nicad battery chargers and battery systems ranging from 12 V camera batteries to 30 V lighting systems. Christie Electric will be coming to the show with a new version of its 20-minute fast-charging Reflex 20 system in a miniaturized camera-mounting package for Hawkeye and other single-piece units. Alternative energy sources are offered by both Perrott Engineering Labs, which is continuing to make advances with its silver/zinc lightweight battery line, now affordable again since silver prices have dropped, and Film/Video Equipment Services with its sealed lead/acid ENG batteries.

## CASES, FURNITURE, CAMERA SUPPORT, PROMPTING

With so much production being done in the field, cases have become a major item of concern. One new development is shipping cases that incorporate a standard 19-inch rack so equipment need not be removed from the case once it reaches its destination. Anvil has a full line of cases of this type, constructed of heavy-duty metal and wood. Thermodyne's approach is to use high-impact molded plastic. Excalibur will show a case containing a VTR that can be field operated without unpacking. A new line of Fiberbilt molded plastic cases also incorporates the rack-mount design. Both Parsons Manufacturing and William Bal Co. will also show lines of shipping cases.

# Ampex Announces the Practical End of Video Jitters.



Video Jitters can drive you up a wall.

It happens when you've repeated an edit over and over.

You want it perfect. Now, everything's cued up just right. You hit the edit button, and what do you get? A glitch. A shaky picture. A sour stomach. Video Jitters.

The culprit is stiction—friction build-up so bad that the tape actually jerks across the heads and scanner. Humid conditions can make it worse.

But not if you use Ampex 196 One-Inch Broadcast Video Tape.

Every batch of Ampex 196 has to pass the toughest test in the industry—stiction-free operation at the extreme environments of 90% RH and 90° F, to guarantee that you have consistent stiction-free operation under all conditions.

Ampex 196. Less friction, because who needs it?

**Ampex 196 One-Inch Video Tape.**

## AMPEX

Ampex Corporation • One of The Signal Companies 

**SPECIAL OFFER  
FREE \$400 1" REFERENCE TAPE**

Send me the details on how to get my free \$400 reference tape for buying 10 hours of Ampex 196 One-Inch Broadcast Video Tape.

NAME \_\_\_\_\_  
TITLE \_\_\_\_\_  
COMPANY \_\_\_\_\_  
ADDRESS \_\_\_\_\_  
CITY \_\_\_\_\_ STATE \_\_\_\_\_ ZIP \_\_\_\_\_  
PHONE (\_\_\_\_) \_\_\_\_\_

Offer expires May 31, 1982.

Send to: Ampex Corporation, Magnetic Tape Division,  
401 Broadway MS 22-02, Redwood City, CA 94063

BME

See all the new Ampex products at the NAB, Booth 3002



# ★ NAB: 1982 ★

As has been pointed out again and again, a TV station is nothing without the proper selection of cabinets and racks—the theme of Winsted's exhibit. Amtel will show a new RF interference-free cabinet in addition to its other cabinets and rack systems. Em-Cor and Environment Containers also have product lines in this area.

The ever-popular Uni-Set will be on hand with its modular studio design setup. It will be joined this year by the line of Leben modular set equipment, shown by Argen Design.

Camera support equipment will find its champions in manufacturers such as O'Connor Engineering, which will introduce metal tripods in addition to its Hydroped and larger studio pedestals. ITE will show new tripods and a new pneumatic studio pedestal. Listec will show a new Vinten lightweight studio pedestal, as well as a microprocessor-controlled remote pan/tilt head. Power Optics has a similar device, along with the Scene-Sync for matching the movements of a camera in a chromakey setup. Bogen Photo and Karl Heitz will both exhibit lines of tripods and heads. Quick-Set will show both camera and microwave equipment mounts.

Camera prompting systems have definitely moved into the digital era, with the Digivision prompter being shown by Listec, a digital prompter system from Telescript, and a monitor-based system from Q-TV. BEI will demonstrate the capabilities of its Dataprompter character-based system. Cinema Products will show the Camraprompter, mounted on an ENG/EFP camera for field operation.

## TEST AND MEASUREMENT, MONITORS

Leading off companies with brand-new T&M products will be Tektronix, which will be introducing a new transmitter test set for its computer-based ANSWER signal analyzer. The software is completely user-programmable to perform virtually every testing procedure that a station could want, including remote transmitter monitoring. Also brand-new is the three-in-one Model 380 test monitor—a unique waveform monitor/vectorscope/oscilloscope in a portable package.

New products from Asaca will be an automatic distortion analyzer and a color bar generator with ID. The company will also feature its line of I/Q decoding color monitors.

Lenco will show new monochrome monitors, a demodulator, and its line of color monitors. Rohde & Schwarz, too, will have its demodulator on view, together with a group delay measuring set and a video noise meter, plus Barco monitors. Marconi has been at work on its automatic insertion signal analyzer, which will be featured along with the television interval timer for making blanking measurements.

Last year Lenco introduced the Vectorscope, enabling non-technical operators to make SCH measurements. This year, Amtron offers a similar, non-tech-



*Model 380 test monitor from Tektronix is a portable monitor/vectorscope/oscilloscope.*

nical approach in the form of its safe area/safe title generator; the reticule that is generated for precise title alignment can also be supered over a pulse cross display and the timing measurements counted off. Belar will show a new TV frequency monitor.

For physical setup and alignment of cameras, Porta-Pattern will again offer such products as grey scale charts and the standard BBC flesh-tone references, in addition to slides for telecine alignment and balancing. Tentel will display its Tentelometer for adjusting tape tension, and spindle height alignment gauge for VCRs.

Image Video will have a dc voltage panel that can measure up to 128 dc voltages.

Some monitors have already been mentioned. Both Conrac and Ikegami will bring their lines of high-resolution broadcast monitors, including a model for display of computer graphics from Conrac. Sony, too, will bring professional color monitors. Other monitor lines will be on hand from Panasonic, JVC, and Sharp. Elector meanwhile promises both medium-resolution color monitors (the Barco industrial line) and a new video projector.

Videotek's lines of waveform monitors and vectorscopes are becoming increasingly popular; both feature internally generated graticules for more precise alignment. The company will also introduce a new eight-input program monitor. Broadcast Video Systems will feature a new combination waveform monitor/vectorscope. Leader Instruments will bring a new vectorscope with internally generated graticule, plus a companion waveform monitor in prototype form. Don't forget that Hitachi, too, has product offerings in this area.

## SATELLITE SYSTEMS, TRANSMITTERS, ANTENNAS, MICROWAVE

New equipment and services for satellites will be high on the list of "must see" products for many broadcasters. California Microwave will offer such products as a dual-frequency down converter and earth station monitors and controls. Microdyne will introduce a new video uplink modulator as well as earth station antennas. Leitch has a new audio/video satellite scrambling system. Harris, RCA, Scientific

**If you've pledged allegiance to the American red, white and blue...**

Barco can give them to you, brilliantly. Thanks to our new **American Standard Phosphors**, we can also give you increased compatability with broadcast network colorimetry and precise color reproduction to tolerances of  $\pm 0.005$ . But Barco also gives you freedom of choice because we can still offer you E.B.U. chromaticity coordinates, if you prefer.

Whatever Barco unit you choose, rest assured you'll get all the versatile Barco features you've heard about. Features like modular construction, delta and inline tubes, as well as different screen sizes and resolutions to choose from. And those are just some of the reasons why Barco has become the standard of the industry, there are plenty more.

**Check out our numbers.**

AMERICAN STANDARD PHOSPHORS			E.B.U. PHOSPHORS		
Delta	X	Y	Delta	X	Y
Red	0.630	0.340	Red	0.640	0.330
Green	0.310	0.595	Green	0.290	0.600
Blue	0.155	0.070	Blue	0.150	0.060

Best of all, when you buy Barco you're buying one of the most comprehensive customer support programs in the industry, backed by Rohde & Schwarz.

Barco Color Monitors. When it has to be right on the money. For complete details, contact us at 14 Gloria Lane, Fairfield, N.J. 07006. Phone (201) 575-0750. Telex 13310.

**BARCO HELPS YOU REMAIN TRUE TO YOUR COLORS.**

See us at NAB Booth 3213

**Rohde & Schwarz Sales Co. (U.S.A.) Inc.**



Circle 178 on Reader Service Card

# Vital Industries has instituted a cost-saving manufacturer-financing program - applicable to any Vital equipment purchase.

In accordance with our longterm commitment to more responsive television industry service, equipment purchases are being directly financed by Vital Industries itself **at 10% interest.**

Recognizing the barriers raised by prohibitively high interest rates, this financing program is offered well below prime — to permit prompt acquisition, without delay, of the advanced programming and operational systems so essential to productivity and profitability.

This bottom-line economy adds to the special advantage Vital offers TV management: **a complete line of switching, video effects and station automation equipment, available from one single source** — 25 sophisticated system options, totally line compatible. Including production and post-

production mixers and switchers, plus our exclusive digital video manipulation system, the versatile Squeezoom®. All are state-of-the-art products of Vital's innovative technology; and all are now available with Vital 10% financing.

**This low-interest opportunity** is made possible by Vital Industries' unique financial strengths, solidly established by nearly two decade's stable performance and continuing growth. Now the largest U.S. independently-owned manufacturer of TV switching, effects and distribution systems, Vital can draw on corporate resources available from few other suppliers.

For full program details, contact our Finance Department:

**(800) 874-7875 Toll Free**



## VITAL INDUSTRIES, INC.

3700 N.E. 53rd Street  
Gainesville, Florida 32601, USA

Circle 179 on Reader Service Card

# ★ NAB: 1982 ★

Atlanta, Andrew Corp., and several others offer various satellite systems.

Satellite consulting services, such as frequency coordination and site selection, will be discussed by Compucon, Comsearch, and Wold Communications, among others. Wold will provide information on its transportable earth station, as will Compact Video. And companies such as AT&T, Western Union, RCA, and UPI will discuss their various satellite services.

In the TV transmitter category, Harris says it will show a complete new line of UHF transmitters including 30, 55, 110, and 220 kW models. Also on exhibit will be the TV-50H, a VHF transmitter ideally suited for circularly polarized applications.

RCA has added a new 10 kW G-line transmitter. In the UHF band, RCA will be showing the 55 kW UHF-TV 55 model. RCA will also be promoting CP antennas.

Larcan Communications, which recently acquired Canadian GE, will unveil a new 30 kW low-band VHF transmitter with only two tubes. Bayly Engineering will bring 300 W and 1 kW VHF transmitters and the AEG-Telefunken stereo audio system.

Acrodyne will show a new 12.5 kW VHF transmitter that combines to make a fully redundant 25 kW system. A new version of a 1 kW UHF amplifier will be on exhibit, as will some low power modules suited for LPTV.

In somewhat of a specialty area, EMCEE will show a totally solid state MDS transmitter and a single-bay TVH-1000C 1 kW amplifier for translators. Television Technology Corp. will show a new 1 kW UHF transmitter or translator.

Eimac promises several new developments in TV transmitter tubes and cavity amplifiers.

The Andrew Corp. reports that it will have a new UHF TV transmitter antenna on hand, as will Bogner Broadcast Equipment Corp. If you have to measure any of the above, Bird Electronic plans to have on hand several new RF Power Analyzers. Bird will also show an RF calorimeter load/synthesizer.

Cablewave Systems will show a new type high-power, low-loss coaxial transmission line. Showing something new in waveguides will be Micro Communications; both circular and rectangular waveguides for UHF TV will be on exhibit.

Power dividers, waveguides, coaxial switches, and so forth can be seen at the Comark booth and will also be displayed by Wilkinson Electronics. A new series of power tubes and klystrons will be shown by Thomson-CSF's Electron Tubes division.

Encoding and decoding equipment for STV and LPTV systems, now becoming quite popular, can be viewed at the Blonder-Tongue and Oak Communications booths. Oak will also have an encoder/decoder system for satellite distribution.

Encoder/decoder systems for slow-scan weather and sports information retrieval are available from Colorado Video, Enterprise Electronics, and also Nagra.



*Oak Communications will show encoder/decoder equipment for STV and LPTV systems.*

Fiber optics is in the future for many broadcasters. BIW has fiber optic transmission cable as well as triax. A fiber system from Artel is used to interconnect cameras in a multi-camera EFP setup. Grass Valley will also show its fiber optic links.

Production microwave systems are still, of course, the preferred means for getting signals around. Ikegami is promising a complete new line of ENG microwave systems, presumably the system that has been in use in Japan for some time. Both NEC and Hitachi have similar systems available.

Harris Farinon will, of course, make a strong impact at the show with its Global microwave transmitter and other portable and helicopter-mounting systems. RF Technology will have a new 12 W transmitter and 7 GHz amplifier as well as its popular camera-mounting system. M/A-Com will introduce a new helicopter and camera-mounted transmitter along with lightweight fiberglass antennas, a high-gain microwave interferometer, and new point-to-point microwave systems. Tayburn will again be featuring its helicopter-based system with automatic tracking antenna. Nurad, in addition to its full line of microwave antennas, will feature its helicopter-mounted self-contained transmitting and antenna packages.

Microwave-equipped and production vehicles will also be popular at the show—either on the exhibit floor or outside in the parking lots. Hughes, for instance, will have its 300C helicopter on hand. Wolf Coach has a new Ford Supervan modification for ENG/EFP applications. Television Engineering Corp. will show its production van. Philips will have a 23-foot production van outfitted with a complete array of Philips and other CDC equipment. Look for Shook's 22-foot van with its 14-foot production area. Also on hand will be the newly improved M-20 production van and standard ENG van from Midwest Corp. Centro, too, will discuss its mobile vehicle construction capabilities, as will Gerstenslager and A.F. Associates. E-N-G Corp. will unveil a new ENG vehicle with a 6.2-liter diesel engine.

Tower manufacturers will also abound, among them Allied, Fort Worth, LeBlanc and Boyle, Unarco-Rohn, World, Utility, V&B, and Magnum. Flash Technology will feature its obstruction and tower lighting systems. Lightning Elimination will demonstrate surge protection devices. Philadelphia Resin will present non-metallic antenna guys. **BM/E**

**TO FIND OUT  
WHAT EVERYONE  
ELSE WILL BE  
STRIVING FOR  
NEXT YEAR,  
COME SEE SONY  
THIS YEAR.**

**SONY UNVEILS TECHNOLOGY SO  
ADVANCED IT MAY NEVER FIND ITS WAY INTO  
OUR COMPETITORS' PRODUCTS.**

If by chance you visit all the other exhibits at NAB before coming to Sony, you'll get two things: sore feet, and a clear understanding of just how far ahead of the rest of the industry Sony really is.

After all, where else will you find the future of 1" recording—the BVH 2000? It contains virtually every technological innovation in 1" Type C video recording known to man. And we've arranged no fewer than 14 of them for you to come and play with.

And what other exhibit features the most sophisticated and cost-effective editors and peripherals in the business? All plug-compatible, all based on Sony's total system approach, and all technologically superior.

And where else will you find the incredible Betacam™ system? The most compact, the most lightweight, and the highest performance combination of recorder and cameras (one-tube and three-tube) of its kind anywhere. And most important of all, it's the greatest value for your money in the industry.

The answer: only at Sony.

So after wading through an endless array of ordinary exhibits, come watch Sony turn up the lights on the most significant broadcast innovations of 1982.

**SONY**

Broadcast

Sony is a registered trademark of Sony Corp.



Circle 180 on Reader Service Card

# STUDIO OR STADIUM, FUJINON'S NEW BCTV LENSES PLAY ALL THE ANGLES.

From super-wide to ultra-tele, in the studio or the stadium, Fujinon BCTV lenses are the clear winners . . . from any angle.

**NEW.** Fujinon's P28x15 ESM — the super studio lens. It gives you a wall-to-wall 15mm wide angle and a maximum aperture of F/2.2 which is maintained out to ten times. Even at 420mm, the F/4.2 allows you to keep your lighting levels reasonable. And for the tightest shots, the built-in 1.7X extender takes you to 714mm. Naturally, it has a built-in diascope for near instant computer setup. But range and speed do not reveal the incredibly sharp, bright, high contrast image the new 28X delivers. Its superior resolution and color performance place it ahead of any lens in its class.

**NEW.** Fujinon's P17x16.5 ESM — the standard studio lens. With a zoom range from 16.5 to 280mm, an aperture which will remain flat at F/2.1 out to 217mm and built-in 1.5X and 2X extenders, here's the lens destined to be the industry workhorse for years to come. Simply put, it offers virtually every performance and operating feature — including built-in diascope — you're likely to need.

**Not new.** Fujinon's P30x20 ESM — the super field lens. Whether picking up the clearest shot of the space shuttle lifting off or a concert stage from the back of the top balcony, it goes out farther and flatter to deliver outstanding images . . . especially under lighting conditions that leave other lenses in the dark. Total zoom range, with the built-in 2X extender

is an incredible 20 to 1240mm. The F/2.2 aperture remains flat from 20 to 418mm — and at 620mm is giving you F/3.2. No wonder the 30X lens is acknowledged by the industry as the finest field zoom available.

For more information on the newest

and finest BCTV lenses, and why they are the best performance investment for your new or existing cameras, contact Fujinon. Large format zoom lenses are another reason why the world sees itself more clearly through the eyes of Fujinon.

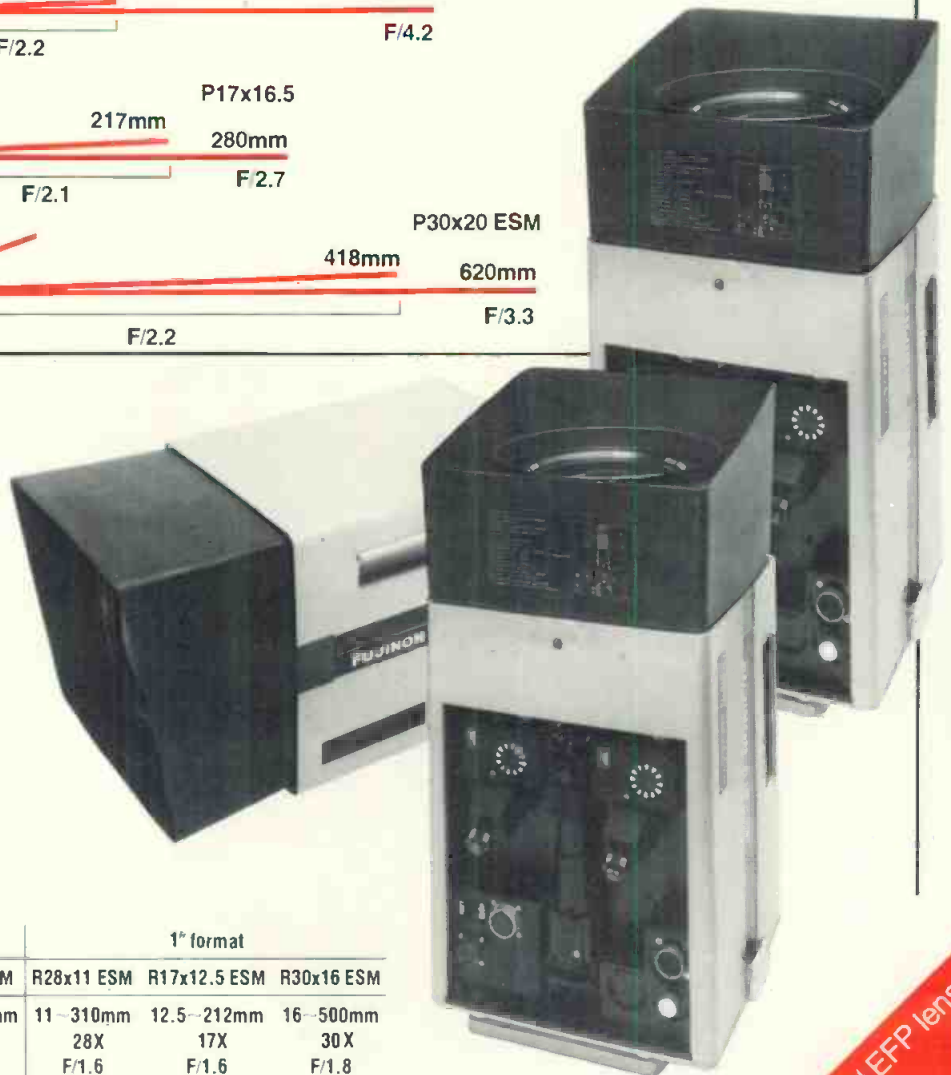
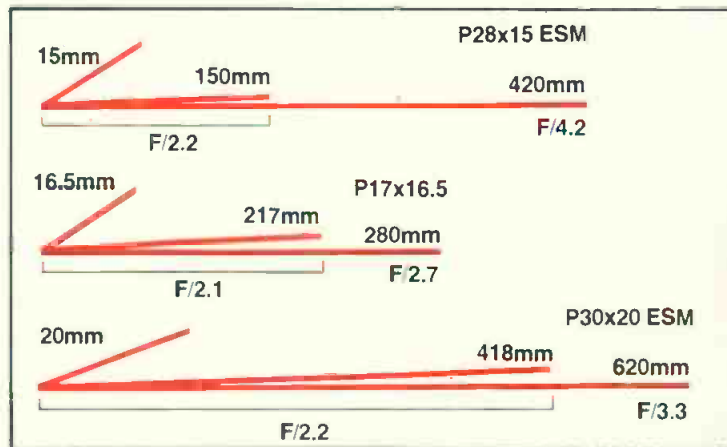

Specifications:	1 1/4" format			1" format		
	P28x15 ESM	17x16.5 ESM	30x20 ESM	R28x11 ESM	R17x12.5 ESM	R30x16 ESM
Focal Length	15-420mm	16.5-280mm	20-620mm	11-310mm	12.5-212mm	16-500mm
Zoom Ratio	28X	17X	30X	28X	17X	30X
Max. Aperture	F/2.2	F/2.1	F/2.2	F/1.6	F/1.6	F/1.8
M.O.D.	.95m	.75m	2.5m	.95m	.75m	2.5m
Range Extender	1.7X	1.5X, 2X	2X	1.7X	1.5X, 2X	2X



FUJINON INC. 672 White Plains Road, Scarsdale, New York 10583  
(914)472-9800 Telex: 131642

118 Savaróna Way, Carson, California 90746  
(213)532-2861 Telex: 194978

Circle 182 on Reader Service Card  
www.americanradiohistory.com

See all the newest BCTV, ENG and EFP lenses  
at NAB . . . visit  
**FUJINON  
BOOTH  
3314.**

# TV EQUIPMENT EXHIBITORS LISTING

**ACRODYNE/3315**

Will introduce the TT 3500 VH 12.5 kW VHF transmitter, which can be combined to function as a fully redundant 25 kW transmitter. A new, smaller version of the 1 kW UHF amplifier assembly will also be unveiled, compatible with the UHF/VHF driver portion of the transmitter and translator line. The 5 kW UHF TT 3480U is also new. Also, a full line of UHF/VHF new transmitters and translators.

**ADAMS-SMITH/2008**

Will show new Model 2602 vertical interval time code system with continuous code reading from freeze-frame and slow-mo to 45X play speed; editor interface provides fully-compatible code plus velocity information. Also on display will be the TS-605 tape synchronizer, the TS-1605 television sound editor, and the TS-2605 modular tape synchronizer.

**ADC PRODUCTS/1923**

Will introduce new right-angle male and female XLR connectors and 1/4-inch audio jacks. New designs in both audio and video jackfields will be introduced along with new capability for custom jackfields.

**ADDA CORP./1712**

Will introduce new DTBC digital dual-channel TBC, designed espe-

cially for A/B roll editing, that also allows some simple transitions without the need of an additional switcher. Also new VIP video compressor/positioner for use in conjunction with ESP electronic still store to permit compression and positioning of stored stills. Also featured will be VW-1 and VW-2 digital TBC/frame synchronizers.

**ADM TECHNOLOGY/1714**

Will have the new 3232 Series II teleproduction audio console, with up to 160 input sources and full 32-input mixing modules, and the new 800/1200 Series II post-production audio console, with eight- or 12-input main-frame and VCA capability on all input modules. Also, the 2400 and 1600 Series II television production audio consoles. (Also see listing in Radio section.)

**ADVANCED MUSIC SYSTEMS/2904**

Will introduce the DMX 15 SYNC audio delay compensator, for use with video field or framestore synchronizers. (See also listing in Radio section.)

**A.F. ASSOCIATES/3320**

Will show the new electronic slate camera system for use in both mobile and studio operations—self-contained unit available as a console or rack mount. Two Marconi CCD film

chains will be on display as well as two MR 2B one-inch VTRs. A remote control for Ikegami HL-79 and 357 cameras will also be exhibited.

**AGFA-GEVAERT/1920**

Will show its line of audio tape and videotape; information on new products not available at press time.

**PETER ALBRECHT CORP./2319**

Will demonstrate a new TV studio lighting and scenery machinery control using a microprocessor with memory for up to 240 separate motorized winches with 99-cue memory.

**ALLEN AVIONICS, INC./2318**

Brand-new this year is a complete rack-mountable series of video and pulse delay lines capable of replacing up to 1450 feet of cable, available with total delays of 255, 637.5, 1275, and 2275 ns.

**ALLIED TOWER CO./3141**

Will show microwave and broadcast transmitting towers.

**AMERICAN IMAGE PRODUCTIONS/2735**

Will bring new "Watch What We're Doing Now" promotional campaign for TV stations. (Also see Radio section.)



# NAB: 1982

## ANIMATION VIDEO/2818

Will demonstrate the new video controller, which will interface a computer graphics system to a one- or 3/4-inch VTR, for frame-by-frame video animation. Will also introduce the Intelens, a programmable zoom lens assembly with microprocessor control of zoom and iris in 1/100-inch increments.

## ANTIOPE/TELEMATICS CORP./2110

New encoding and decoding teletext equipment complying with most recent teletext specifications will be displayed. On the air, real time, teletext displays with text and graphics presentations.

## ANTON/BAUER/1802A

Will introduce a wide-range (90-250 V) one-hour fast charger without need to switch ac input. Also, new microcharger capable of overnight charge of any snap-on battery. Other products includes snap-on Nicad batteries, Black Beauty lighting

head, lighting battery belt, and car fast charger.

## ANVIL CASES/2410

Will bring its line of ATA 300 Category 1 cases and containers for the television market, including a line of EIA standard rackmount case designs. Also full line of equipment transport cases.

## APAT HERZOG/2929

This brand-new company will introduce the Model A digital video processor. Also, test equipment for digital video and digital information functions. The TDAC traveling digital/analog converter allows technicians to look at and address information or signal at any point during processing.

## APPLIED DIGITAL TECHNOLOGY/1925

Will introduce the Relecon, a new microprocessor-based video tape-to-tape color corrector based on SMPTE time code addressing.

## ARBEN DESIGN/2112A

Will introduce the Leben Set Plus, modular set equipment for TV studio backup. Also showing the line of other set parts for TV studios.

## ARRIFLEX/2109

Will introduce the Arriflex fluid head tripod. Also new 6000 W addition to the HMI lighting line. Other products on display include full HMI lighting line, the Image Stabilizer, and a sampling of its line of motion picture cameras such as the 16 mm BL and SR.

## ARTEL COMMUNICATIONS/2624

New to NAB will be the battery-powered EFP-1000 fiber optic transmission system for multi-camera EFP systems, which connects cameras to control center up to two miles away with program audio and video, intercom, IFB, genlock, etc. Also, a full line of fiber optic broadcast-quality video/audio transmission systems.

## ARVIN/DIAMOND/2901

Will show satellite weather display systems that feature automatic receive, store, color, and display functions for over 1400 satellite weather pictures per month with variable-speed multi-playback capabilities.

## ASACA/SHIBASOKU/3308

New products include Model 725 automatic distortion analyzer and the Model CB53A1 color bar generator with ID. The CMM-20-11 and full CMM line of color monitors with color decoding on the I/Q axis will be introduced at the show. Also on

## Simply Sophisticated ... and then some

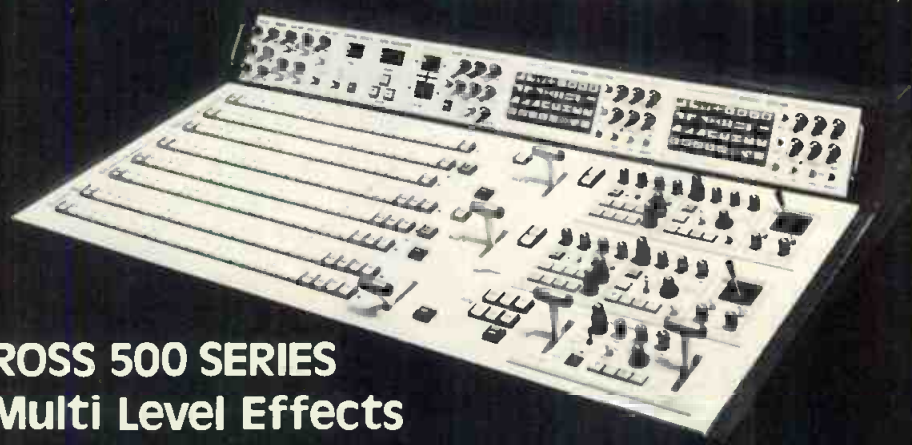

## ROSS 500 SERIES Multi Level Effects Switchers ... are

Simply Sophisticated  
... and then some

Ross 500 series video production switchers offer the tremendous production capability of the Multi Level Effects system along with simplicity of operation.

Choose from a full range of models that can be equipped with options to match almost any need including quad, split screen, spin, rotary and matrix wipes, auto transitions, interfaces for edit systems and digital effects and analog key borders.

... AT NAB BOOTH 2310

introducing ... the **NEW!**  
Ross Scene Store memory system

— combining versatility with ease of operation at an affordable price.

For your new mobile, studio or editing suite, let us introduce you to the whole Ross Video family.

Ross Video Limited  
9 Plaza Drive, PO Box 220  
Iroquois, Ont. Canada K0E 1K0  
613 652 4889 Telex 05-811579

U.S.A.  
Ross Video Inc.  
P.O. Box 6700  
Ogdensburg, N.Y. 13669



# It deserves an Oscar

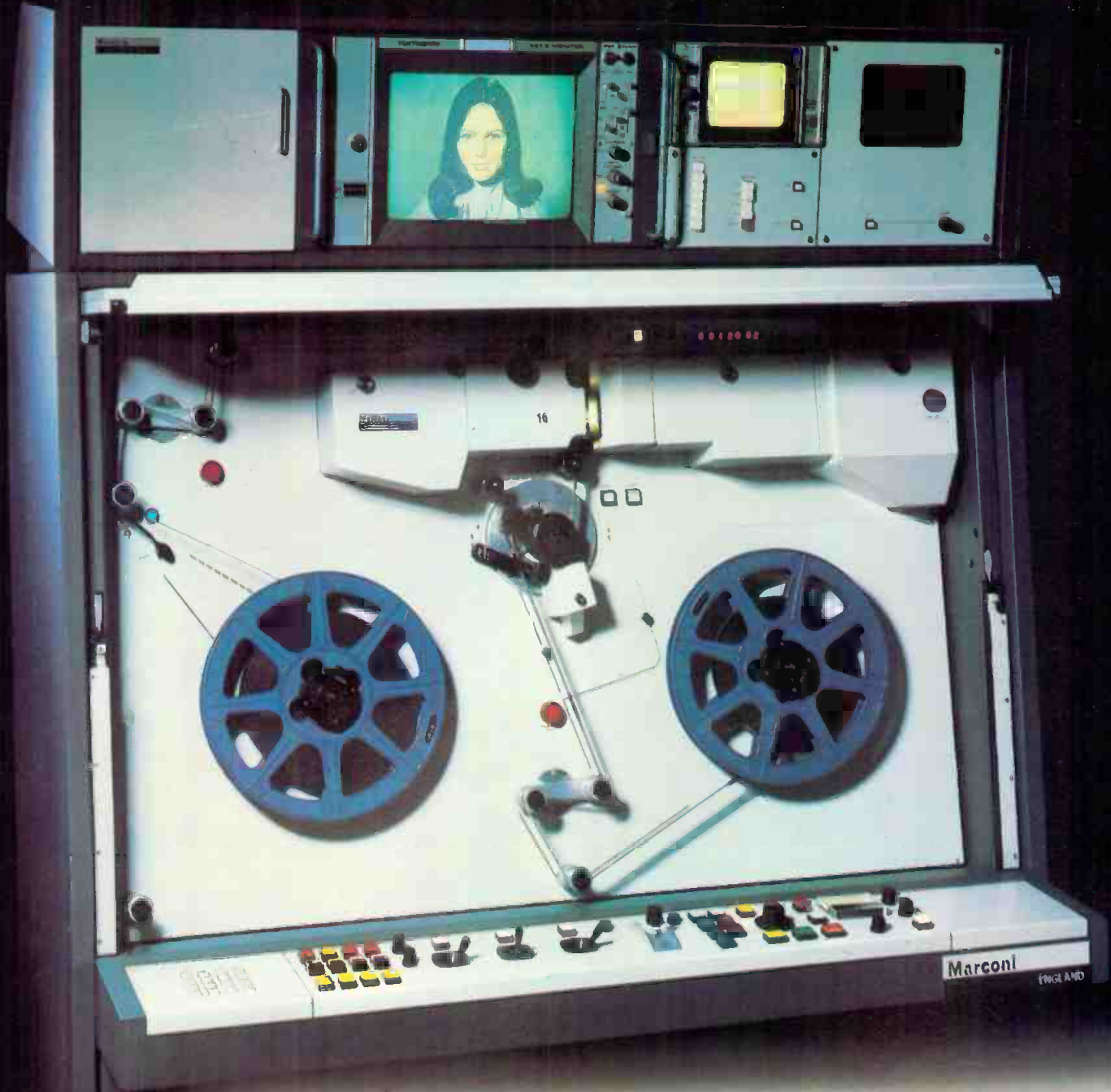

## The New Marconi Line Array Telecine B3410

For a remarkable contribution to film in TV, Marconi's new Line Array Telecine B3410 fully deserves its great reputation.

The unique combination of full digital processing with micro-processor control and CCD sensors means exceptional picture quality, shorter set-up times, rapid change of TV standards, long life and minimum maintenance. No tubes, no replacements!

Also offering fast change of film gauge and full resolution Cinemascope, this most outstanding newcomer is available for swift delivery at a highly competitive price.

For full details contact: Marconi Electronics Inc. (John White or Simon Frazer)

Tel: (201) 767-7250 or A. F. Associates  
Inc. (Lou Siracusanu or Bill Ebell)  
Tel: (201) 767-1000.

**Marconi**  
Electronics Inc.



100 Stonehurst Court, Northvale, New Jersey 07647. U.S.A. Tel: 767-7250, Telex:  
710-991-9752. See it at NAB Dallas Booth 3320

Circle 186 on Reader Service Card

# NAB: 1982

display will be video test equipment such as video sweep generator, TV test signal generator, portable production system, and the magnetic tape cleaner/evaluator.

**ASSOCIATED PRESS/3204**  
Information not available.

**AT&T/1504**

Will demonstrate program distribution for TV and radio, satellite/terrestrial transmission for automated newsroom management with data equipment, sales management systems, and other services.

**AUBURN INSTRUMENTS/2311**

Will introduce a new two-wire machine control system, along with a new digital blanking meter.

**AUDICO/2501**

Will bring the new U-Matic Pay-off Module for its videotape loading system, allowing users to spool new tape from 60-minute cassettes and reload kit reels directly into other cassette shells; also a new videotape splicer for 3/4-inch and half-inch. (Also see listing in Radio section.)

**AUDIO KINETICS LTD./1505**

Will show custom designed operating software for audio post-production, ADR/looping, sound effects assembly, and audio editing. Telecine production will also be in evidence.

**AURORA SYSTEMS/2806**

Will show its Aurora 100 Digital Videographics digital art/paint system, which features multiple user stations and independent design and display stations. Thirty-two out of 256 colors are presented per palette, with a 512 x 486 pixel resolution. Features include color matching, cut and paste, and scan-in of external artwork.

**2B SYSTEMS CORP./2739**

Manufacturer and marketer of plastic card promos.

**WILLIAM BAL CORP./2200**

Will show new molded plastic shipping cases for TV equipment.

**BAYLY ENGINEERING/2536**

Two new VHF transmitters will be shown in 300 W and 1 kW models. Other new products include a fully transistorized stereo encoder used for the conversion of two AF signals

into a multiplex signal, and an automatic changeover unit. Standard equipment will include wattmeters and dummy loads, a digital paging system, and portable and mobile two-way radios. (Also see listing in Radio section.)

**BEAVERONICS/2306**

Will introduce the new Model DSK-6-DL downstream keyer for character generator inserts into its production switcher, accepting video and key signals from up to six character generators. It features selection of borders, automatic fade in and out at se-

lectable rates, and preview capability. Will also exhibit line of video switchers and master clock systems.

**BELAR ELECTRONICS/2715**

A TV frequency monitor will also be displayed for the first time. Other products include FM modulation and stereo monitors and FM and TV SCA monitors.

**BELDEN COMMUNICATIONS/2737**

A complete line of Lee color effect and color correction filters will be shown.



## TransPath I

**The Littlest Big Router at the Dallas NAB**

A TransPath I (video or audio) 100 x 100 system is entirely housed in 29RU of standard rack space. Imagine! Replace your existing switcher with a system many times more powerful without increasing costly rack space.

Design your own central routing system using TransPath building blocks. Initial systems of 50 x 50 are expandable to 400 x 600 with as many as three channels of audio.

TransPath uses a new 3-stage design in three dimensions to eliminate wiring and crosstalk between modules. Consequently, crosspoints are reduced by 43%, and the multiple paths available for assignment provide path redundancy not found in conventional routing systems.

TransPath is the largest router ever displayed at an NAB. See it!

See and Operate TransPath I at Dallas NAB  
EXHIBIT 2214



**HUGHES ELECTRONIC DEVICES CORP.**  
P. O. Box 1985, Grass Valley, CA 95945 • 916/273-9524

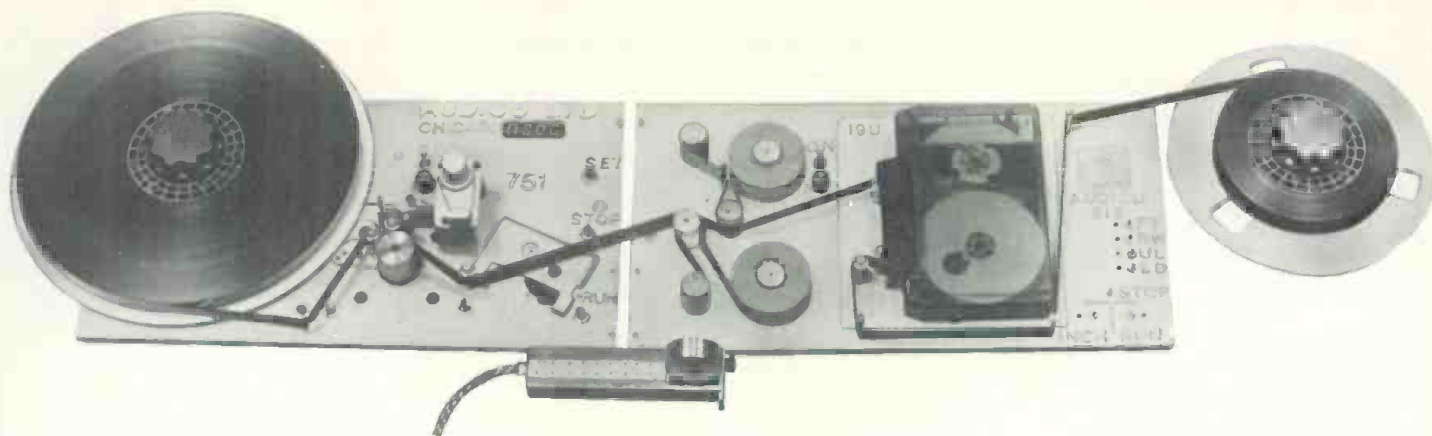

This video cassette loader/reloader from Audico has new attachment.

# TransPath I

## Your Door to a Revolutionary Routing System



TransPath I is the first routing system to condense a switching matrix using the 3-stage concept. Central processing, using state-of-the-art components, allows unheard-of flexibility. A master terminal provides bus control or diagnostic information in parallel with individual remote panels. The system is equipped for either numeric or alpha-numeric displays.

TransPath offers multiple level switching with both AFV and breakaway operation, and all paths are virtually transparent. Input and output monitoring and redundant central processing are unique features incorporated in each 100 x 100 basic matrix, all contained in 29RU.

With sources constantly increasing and rack space at a premium, TransPath offers an innovative approach. Think about it, then see us.

See and Operate TransPath I at Dallas NAB  
EXHIBIT 2214

**HUGHES ELECTRONIC DEVICES CORP.**  
P. O. Box 1985, Grass Valley, CA 95945 • 916/273-9524



Circle No. 187 on Reader Service Card

### BELL HELICOPTER /2400

Will feature its JetRanger helicopter, with ENG equipment from various manufacturers and videotapes of ENG scenes at the booth.

### BESTON ELECTRONICS, INC. /3207

Will display its Marquee 3000 high resolution character generator with "chromastick" variable color adjustment, font loading, font compose, and other advanced features. Also shown will be the Marquee 2000, Data-Prompter titler-based teleprompter, and Fumeo projector.

### BIRD ELECTRONIC CORP. /3204A

Will introduce the 8630-601 Series Moduload RF calorimeter/load system in 10, 25, and 50 kW versions; the 4391 RF Power Analyst wattmeter with peak envelope, pulse, and CW power; the 4388 (panel) and 4384 (portable) RF Power Analyst wattmeters for TV; and the 8730-677 dolly-mounted, water-cooled load resistor, 10 kW-80 kW. Will also show self-cooled line terminations, water-cooled load resistors, RF power monitor/alarm, the high-speed transmission line monitor/alarm, and RF wattmeters.

### BIW CABLE SYSTEMS /3017

Showing fiber optic cables for video transmission. Also introduced will be triaxial cable for broadcast cameras. In-line and panel mount connectors and complete cable assemblies round out the line.

### BLONDER-TONGUE LABORATORIES /2312

Encoding and decoding equipment for low-power applications. A complete line of accessories for low-power signal reception locations.

### BOGEN PHOTO CORP. /2918

Will show its line of camera support equipment, including tripods, heads, dollies, etc.

# Space, For The Future.



## High resolution digital weather satellite data from **Environmental Satellite Data Inc.**

It's the data source of the future — clean, crisp pictures — precise color enhancements — your choice of regional or national pictures from GOES east or west\* ESD data is wowing

viewers now in Dallas — Kansas City — Des Moines — Toledo — Detroit — Cleveland — and many other markets, large and small.

## **ColorGraphics Liveline Display**

Over 85% of initial purchasers are receiving ESD data on ColorGraphics' displays . . . and now we are pleased to

formally announce that ESD has named our display "**The Preferred Terminal**" for broadcast television, and will market it as such!



SuperRadar by WSI



High Resolution GRAPHICS

At one low price, the same display also provides national and regional remote radar — and exciting full-color GRAPHICS!

**NOW—HIGHEST RESOLUTION IN THE INDUSTRY—760 × 480!**

# ColorGraphics Weather Systems, Inc.

5727 Tokay Blvd. • Madison, Wisconsin 53705 • (608) 274-5786

SEE US AT BOOTH 2913, NAB

Circle 188 on Reader Service Card

\*January 1982

# NAB: 1982

**BOGNER BROADCAST EQUIPMENT / 1711**

Will show high-power UHF TV transmitting antennas (to 220 kW), low and medium-power VHF/UHF slot and dipole transmitting antennas, circularly polarized FM transmitting antennas, and MDS & ITFS transmitting and receiving antennas.

**BROADCAST MARKETING / 2925**  
Information not available.

**BROADCAST SYSTEMS / 2803**

Distributor of video and audio distribution equipment, including cables, connectors, etc.

**BROADCAST TECHNOLOGY / 2115**

Will show models EG 3501 and 3502 dc-controlled five-band graphic equalizers with 12 dB of boost or cut. Also Model CF 9105 card frame with integral barrier strip connectors, and Model PS 3400 power supply.

**BROADCAST VIDEO SYSTEMS / 2706**

Will introduce the Model EV-4060 color signal monitor, switchable from waveform to vector display. Also new is the BVS-BB-1200 "Bang Box" passive video switcher. Other products on display will be BVS video and pulse delay lines, BVS low pass video filters and CCIR noise measurement filters, Cox 203 NTSC encoder, and Cox 339 color balance corrector.

**THE BTX CORPORATION / 2301**

Will introduce new line of microprocessor-based SMPTE and VITC time code products featuring modular construction, allowing units to be upgraded with the addition of field-installable PC boards. A complete RS-232 interface makes the unit compatible with all editing computers. Also full line of ATR/VTR synchronizers including The Shadow.

**CALIFORNIA MICROWAVE / 2105**

Will introduce the AD2A dual-frequency down converter for SCPC and digital data transmission, the DEQ700 delay equalizer, the Mod70 modulator, Demod70 demodulator, RLO100 restoral local oscillator, UC14000 and UC6000 up converters, DC11000 and DC4000 down converters, FLS/MC earth station monitor and control, VP100T and VP100R video signal processors, and

## Look, no hands!

Just push a button. That's how easily you can switch your transmission system to any mode or alignment without the inconvenience of manual patch links. Comark automatic switches are available for all coaxial and waveguide systems and can be fully operated by remote control. For a free brochure return the coupon below or call (413) 569-5939.

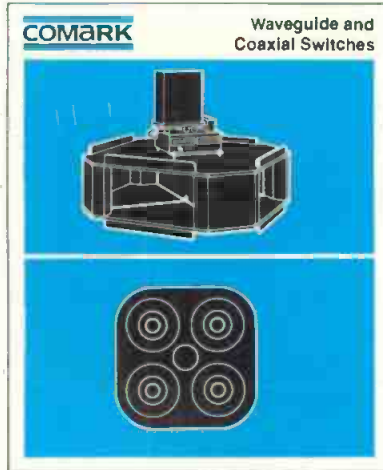

Comark Industries, Inc.  
P.O. Box 229  
Southwick, MA 01077

Send me more information about Transmission Switches.

Name \_\_\_\_\_

Company \_\_\_\_\_

Address \_\_\_\_\_

City \_\_\_\_\_ State \_\_\_\_\_

Zip \_\_\_\_\_ Phone \_\_\_\_\_

Visit us at NAB Booth 1709.  
Join our treasure hunt  
where everyone is a winner.

**COMARK**

Circle No. 189 on Reader Service Card

## For FM Wireless Intercom... It's NAB Booth 2612!

Superb, interference free, intercom up to 1/4 mile! FCC certified and license free. Five channels available. Comfortable, lightweight, and only 11 ounces without standard 9 volt batteries. Soft, foam-filled, vinyl ear cushions provide excellent acoustic seal, reducing ambient noise. Interface capability with "hard-wired" systems. VOX



accessory available for "Hands Free" operation. The TR-50 is available in hard hat.



- TV & Film cameramen, producers, directors.
  - Theatre crews.
  - Football coaches, assistants, spotters.
  - Language translators.
  - Manufacturing personnel.
  - Tour directors.
  - Security personnel.
- Request Bulletin 4V for TR-50 and other FM wireless models.  
INTERCOM MODEL TR-50 **\$297.**

**R-COLUMBIA PRODUCTS CO., INC.**  
2008 St. Johns Avenue  
Highland Park, Illinois 60035  
(312) 432-7915 TWX:910-692-2160

Circle No. 190 on Reader Service Card

# NAB: 1982

a video compander. Will also describe its line of satellite earth stations.

**CAMBRIDGE PRODUCTS / 1916**  
Will introduce new fast-fit BNC right-angle connector.

**CAMERA MART / 2010**  
Will show Ikegami's new EC-35 electronic cinematography camera. Other

products include lines from Ikegami, Sony, Sharp, JVC, Videotek, Microtime, O'Connor, and many others. Also on display will be test and processing equipment.

**CANADIAN GENERAL ELECTRIC / 2736**  
See listings in TV and radio sections under ARCAN Communications.

**CECO COMMUNICATIONS / 1804**  
Showing the full line of electron tubes for transmitters and receivers, CRTs, camera tubes. Also its line of broadcast accessories.

**C.E.I. / 3321**  
Will show current product line of broadcast cameras for studio, mobile vans, EFP, telecine islands, and animation systems. Featured will be the CEI 310, 330, and 340, plus Americam.

**CENTRAL DYNAMICS CORP. / 3208**  
**Philips Broadcast Group** will show a brand new studio/field camera, the LDK-6, with full microprocessor-based setup and control. Also new to NAB will be the LDK-44 modular camera system, easily convertible for ENG, EFP and studio operation. Also the 23-foot mobile production van with Philips equipment. Other products will include LDK-25B multi-conductor and LDK-5 triax studio/field cameras; LDK-14S ENG/EFP portable camera; LDM-3001 digital noise reducer; and line of UHF and VHF transmitters.

**American Data Corp.** will offer a brand new downstream keyer and chroma keyer for its production switchers, plus the new 3101-20 single multichannel mix effects and mix key switcher with 20 inputs. Other products include large and small production switchers, including models for post-production and ENG/EFP vans.

**Central Dynamics Ltd.** will introduce the APC-920 "true time" broadcast automation system with full logging capability, including clock interface and machine control. For its line of production switchers, a single-bus quadruplexer/digital test signal generator, plus CD-480-65 switcher. Other products include full range of production switchers including compact models, plus machine control switching systems. Switchers feature CAP2XL switching automation.

**CENTRO CORP. / 2204**  
New concepts for TV remote production vehicles. Also a display of remote and fixed facilities completed in 1981.

**CETEC VEGA / 3129**  
Will show new Model QX-1 wireless intercom master station for use with wired systems, allowing single-person full duplex connection with a wired system. Also introducing the QX-2 multichannel wireless master station, which allows up to six persons full duplex interface with wired system. Will also show its full line of RF microphone systems.

**CEZAR INTERNATIONAL / 1701**  
Most important new product introduction will be an all-digital VTR, modeled around an IVC one-inch tape transport and said to be the in-

## VALUE-PACKED MODULAR DESIGN

From 104mm input faders to stereo/mono combining networks, Quantum now offers modular production/on-air series broadcast consoles fully equipped with professional features found previously only on those consoles priced beyond your budget.



60th Annual Convention  
& International Exposition  
April 4 - 7, 1982  
Dallas, Texas

QUANTUM will be shown  
at NAB Booth 2006

Please send me further details and full technical specifications.

Name \_\_\_\_\_ Position: \_\_\_\_\_

Studio/Company \_\_\_\_\_

Address \_\_\_\_\_

Phone: (\_\_\_\_) \_\_\_\_\_



**QUANTUM**  
AUDIO LABS, INC.

1905 RIVERSIDE DRIVE  
GLENDALE, CALIFORNIA 91201  
PHONE: (213) 841-0970

# The Quantel DLS 6030.

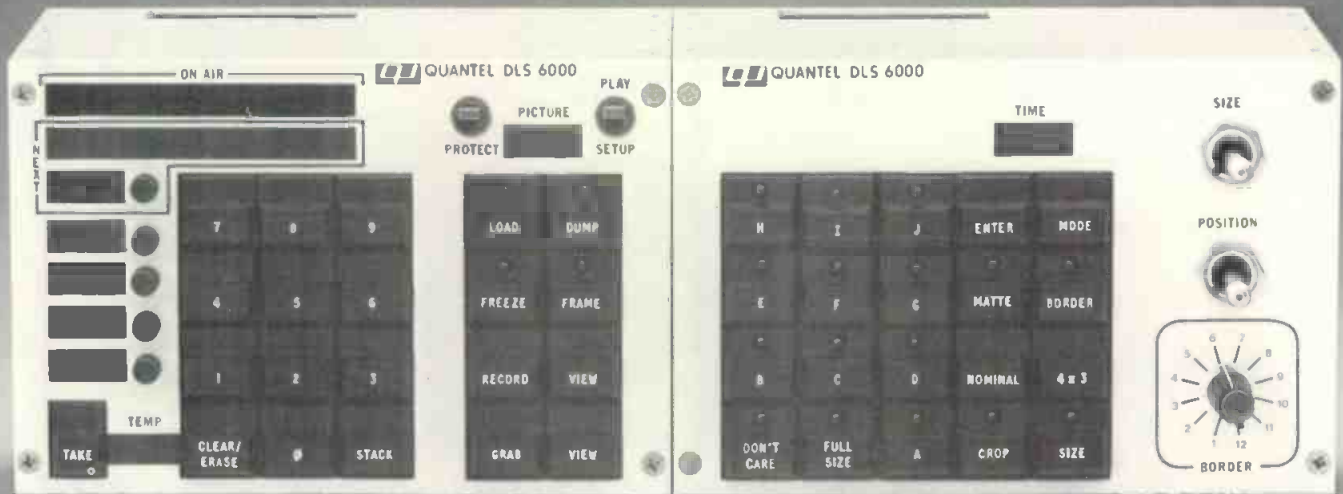

## Every other way to store stills is obsolete.

Introducing the state-of-the-art in electronic still-storage—the Quantel DLS 6030 digital library system.

Obviously it stores still pictures. Up to 800 on each small Winchester disk drive. And with the quality that is a hallmark of Quantel. But the DLS 6030 goes far beyond still-storage.

It is the only electronic still-store with production effects capabilities. So now you can compress still pictures to any size. Crop them to remove unwanted material. Position them anywhere you want. Put borders around them. And dissolve from one shot to the next.

You can even build up totally new pictures—composites or montages—from existing material.

And you can always retain your "originals" in their pristine state.

The DLS 6030 lets you browse through its disk library to select the pictures you need, and gives you unprecedented facilities for on-air editing, previewing, and presentation.

Off-loading? You can dump all the pictures—in digital form—onto

standard videotape. Then reload at the remote site via any VTR. The transfer is digital, so there's no generation loss.

Because Quantel's technology is leading-edge, the DLS 6030 is small—about one-quarter the size of still-stores using older technology—and draws far less power. So it's ideal for mobile operations as well as the studio.

There's nothing else like it. See for yourself. Call your local MCI/Quantel representative. Or get in touch with us directly at 415/856-6226. Micro Consultants, Inc., P.O. Box 50810, Palo Alto, California 94303.



**MCI/QUANTEL**  
The digital video people.



# WHY BUY TWO LENSES WHEN THIS ONE WILL DO?



## Schneider 14X ENG/EFP lens zooms from super wide angle to long telephoto.

Changing lenses to handle changing conditions could cost you a once-in-a-lifetime shot. And that's why you should know about the Schneider 14X ENG/EFP lens. It gives you two-lens versatility in an economical one-lens package.

It can power zoom from 9mm–126mm. Or with the built-in 2X extender from 18mm–252mm. With the 6.3mm–9mm aspheric lens attachment, it can power zoom on the super wide angle shots. And, when the action calls for close and tight, it's got macro focusing.

The Schneider 14X is designed to bring out the best in Ampex, CEI, Fernseh, Hitachi, Ikegami, JVC, NEC, Panasonic, Philips, RCA, Sharp, Sony, Thomson and Toshiba  $\frac{2}{3}$ " cameras. Lightweight, compact, ruggedly constructed, and weather resistant, it comes with a complete line of accessories. Superb European optics combined with excellent f/1.7 sensitivity bring back crisp, clear pictures even under low light level conditions.

In addition, Schneider offers the 14X lens in a  $\frac{1}{2}$ -inch format for the new one-piece VCR cameras such as RCA Hawkeye, Panasonic and Sony. Schneider broadcast lenses are available throughout the United States and Canada from: **TELE-CINE CORP.**, 400 Crossways Park Drive, Woodbury, NY 11797; (516) 496-8500.

## Schneider 14X ENG/EFP

Tele-Cine Corp. is a subsidiary of Schneider Corporation of America.

Circle No. 193 on Reader Service Card

See us at NAB Booth 3016

[www.americanradiohistory.com](http://www.americanradiohistory.com)

THE SKY'S THE LIMIT

# NAB: 1982

dustry's "first digital VTR under \$5000." Also, several new products to supplement editing line, including Preface word processor-like program, enabling previsualization of script and scene elements, and the Collator VTR synchronizer for eight or more decks with alternating scenes to create editless programs. Full line of other editing systems including Controller, Decision Maker, and Edit Center. Editors now feature interfaces for all types of VTRs including BVU-800.

### CHASE MEDIA / 1912

Business automation systems for TV broadcasting, covering traffic/billing/financial/music inventory. (Also see listing in Radio section.)

### CHRISTIE ELECTRIC CORP. / 1623

Will show a new miniaturized camera-mounted power supply (ac adaptors) for RCA Hawkeye and other cameras. Also new is a nicad battery replacement for Sony BP60, and mount adaptors for on-board batteries for Ikegami HL-83, Hitachi FP-21 and FP-22. Other products include the Reflex-20 20-minute charger, and super nicad battery packs for ENG/EFP. Also on display will be an automatic sequencer for one to eight reflex-20 batteries.

### CHYRON / 3329

Will premiere a brand new software program for the Chyron IV graphics system designed to give it substantially increased graphics capability. New features will include 512 color choices, multicolor characters, diagonal typing, and a built-in programmable fader. Other additions to the system include additional memory planes (up to four) and a digitizing tablet, enabling the system to be used as a digital art unit. The new multimode graphics module replaces the existing font compose module. Also shown will be a new version of the RGU remote graphics unit, now with GH color choices, full-feature auto display, and operator prompts, and the CGE cassette cleaner/evaluator, now with optional tape damage recorder.

### CINEMA PRODUCTS CORP. / 3144

Will show the new Ikegami EC-35 video camera with Cinema Products accessories such as matte boxes, follow focus system, zoom control,

etc. Also introducing the CP Co-Ax digital remote control for the Sharp XC-700 camera; new Zip-Pak portable regulated power supply for 12-14 volt ENG cameras; and the GSMO 16 mm camera with 100-foot quick change film cassette magazine. Will also show regular line of cameras and accessories, including the Steadicam camera support system and location lighting kits.

#### CINE 60/1704

Will introduce new ac adapters for cameras and VTRs, lightweight lithium emergency batteries for ENG equipment, new battery chargers and snap mounting systems for on-camera batteries, fast charger for all cameras and VTRs, and fast charge nicad batteries for sunglasses. Also showing battery belts, other accessories.

#### CLEAR-COM/2807

Will feature new intercom and IFB products, including SB-412 IFB switchboard-operated main station with two PL, two IFB channels; MS/RM-400 four-channel master/remote intercom stations; and CH-41/42 cameraman's headsets. Other products include many models of multi-channel remote and main stations, portable belt-worn stations, power supplies, and remote speakers.

#### CMC TECHNOLOGY CORP./1802

Is introducing new videotape leader generator which puts complete identification data at the beginning of tape. Also describing quad headwheel refurbishment services.

#### CMX SYSTEMS/3304

Will show the CMX 340X computer assisted editing system with new interfaces and additional software features to simplify and speed up post-production. The Edge, microprocessor-assisted editing system with several new features, will be shown with both external switcher control and built-in audio/video dissolver options.

#### COLORADO VIDEO/3140

Will introduce the new Model 250 slow-scan television transceiver for telephone line transmission services such as weather. Also showing the Model 274D digital memory for the transceiver system.

#### COLORGRAPHICS WEATHER SYSTEMS/2913

Will bring the new Live Line III Computer System, combining weather computer and high-resolution graphics with more than 4000 colors for display of weather information from Weather Services International and satellite data.

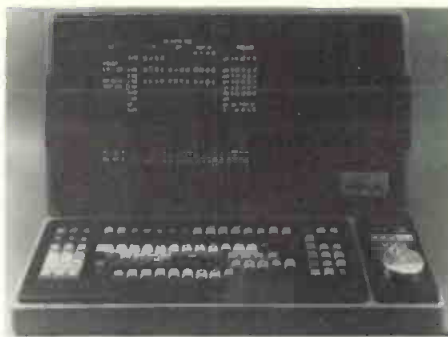

CMX's 340X computer-assisted editing system.

#### COLORTRAN/3317

Will introduce a new line of high performance spotlights and new lighting control system. A new high density dimmer rack for studio applications that permits three-phase distribution and eliminates the need for patch panels will also be on display. Other products include control and dimming systems for TV lighting.

#### COLUMBINE SYSTEMS/2716

Will show new systems for film management and inventory, business automation media inventory, production billing, music inventory and rotation, and studio automation interface. Also complete in-house system for traffic general accounting and payroll. (Also see listing in Radio section.)

#### COMARK COMMUNICATIONS/1709

Will show new patch panels, power dividers, waveguide and coaxial switches, cabinets for UHF transmitters, accessories. Also showing line of TV RF facilities, antennas, couplers.

#### COMEX/2829

Will show new Ultimatte units for enhanced chromakey effects. (Also see listing in Radio section.)

#### COMPACT VIDEO/1604

Will introduce the CTS 800 computer assisted videotape playback system offering a viable alternative to two-inch quad cassette VTRs. It is designed to eliminate operational errors associated with most commercial and news segments during typical operating day and to offer longer random access programming.

#### COMPOSITE VIDEO/2115

New is the Model TC-425 processing center, consisting of processing amplifier/sync generator, image enhancer, and noise reducer. Also Model VC-460 image enhancer, and BG-600 new black burst generator. Also on hand will be audio/video distribution amplifiers, processing amps, and audio enhancer/noise reducers.

# FACT!

## No one can match The Complete Lightning Protection Systems from LEA.

- ANTENNA DISSIPATION ARRAYS FOR AM, FM, TV, MICROWAVE TOWERS
- SURGE ELIMINATORS FOR MAIN POWER LINES TO HANDLE ENERGY LEVELS OF > 8800 JOULES PER PHASE
- COAXIAL TRANSMISSION LINE SURGE ELIMINATORS 1 Kw to 25 Kw
- KLEANLINE ELECTRONIC FILTERING SYSTEMS TO PROTECT AGAINST LIGHTNING STRIKES AT > 8800 JOULES PER PHASE PLUS AN RFI/EMI FILTER TO HANDLE RF INTERFERENCE FOR SENSITIVE SOLID STATE EQUIPMENT.
- TRANSIENT ELIMINATORS FOR DATA LINES, PHONE LINES, COMMUNICATIONS EQUIPMENT WITH A FREQUENCY RESPONSE FROM D.C. TO 1 GIGAHERTZ.
- LIGHTNING WARNING SYSTEMS PROVIDING 1/2 HOUR ADVANCE WARNING OF AN APPROACHING STORM.
- SURGE AND TRANSIENT GENERATORS
- GROUND SYSTEMS
- CONSULTING SERVICES
- PERFECT POWER VOLTAGE REGULATION

**LIGHTNING ELIMINATION ASSOCIATES**



12516 Lakeland Road  
Santa Fe Springs, CA 90670  
(213) 944-0916  
TWX: 910-586-1381

Perfect Power Source  
See us at NAB Booth 1616

Circle No. 194 on Reader Service Card

# NAB: 1982

## COMPREHENSIVE VIDEO SUPPLY/2322

Will introduce Video Scribe, new low-cost character and animation graphics generator. Quartz location lighting is also new. Also, PAG Nicad fast charger and video test center system with test signal generator and video distribution amplifier. The standard line of Unicol,

PAG, and Bilora products will also be shown.

## COMPUCON/2513

Will show engineering services for communications planning such as satellite and terrestrial microwave frequency studies, LPTV engineering, and FCC application preparation.

## COMPUTER GRAPHICS LAB./2933

Will feature the IMAGES digital art/paint system, developed by New York Institute of Technology. Features include full 256-color palette, airbrushing, cut and paste, characters,

edging, digitizing external artwork, and full 512X487 pixel resolution.

## COMPUTER OPERATIONS/2403

Will introduce a real-time video animation system.

## COMPUTER VIDEO SYSTEMS/2305

Information not available.

## COMREX CORP./1613

Will introduce new models of low-frequency extension systems as well as new ENG communications equipment. Other products include talk show systems including wireless microphones.

## COMSEARCH/2416

Will introduce new services for low-power TV testing, FCC check-outs. Also showing services for frequency coordination of satellite earth stations and microwave point-to-point systems, including field services and frequency protection.

## CONRAC/3009

Its line of computer graphic color monitors will be displayed. Also on view will be a complete line of professional color monitors, including the 6142 19-inch modular master monitor with comb filter separator, the 5322 moderately priced 19 V professional broadcast monitor, and 5742 compact high-resolution 13 V color monitor with comb filter.

## CONTROL VIDEO CORP./2324

Will introduce the "Lightfinger Editor," a computerized, touch-activated CRT-controlled videotape editing system. Will also show new Super-Sync video/audio synchronizer that locks to incoming tach pulse, control track, or SMPTE. The device permits locking to any source machine in any editing system for A/B rolls.

## CONVERGENCE CORP./1902

Will show its ECS-104 list management editing system with a newly expanded chassis to allow for more source VTRs. New software enhancements are added features such as slow motion on one-inch VTRs will be shown. Also a brand-new complete post-production video-assisted film editing system will be shown, allowing film editing on video with logging and referencing of cuts through computer interface with the ECS-104.

## COOL LIGHT/2201

Will show the A14-003 nine-light and the A21-003, -006 tri-light units. Also on display will be the Single Handy, 2000 W Star Light, and Mini-Cool for video.

## The Wireless Intercom System designed for your specific needs

The Cetec Vega Q System fulfills the demanding applications of motion picture, broadcasting and stage production communications. Sound and camera crew cuing, stunt coordination, sound program monitoring, etc. can be achieved easily without running cables.

### Features

- Can interface with wired intercom systems such as RTS, Clear-Com, David Clark, four wire, etc.
- Operates simplex or duplex with up to 6 walking units plus 1 plug-in unit (at the base station, which can include a wired-intercom interface).
- Operates in the VHF high band, 150 to 216 MHz, for minimal interference.
- Usable with commonly available headsets (electret or magnetic).



**Cetec Vega**

Division of Cetec Corporation

P.O. Box 5348/EI Monte, CA 91731/(213) 442-0782/TWX 910-587-3539  
In Canada: A. C. Simmonds & Sons Ltd.

Circle No. 195 on Reader Service Card

**A GREAT NEW  
PRODUCT SHOW  
IS COMING TO  
NAB IN APRIL**

**BOOTH 1707**  
**JVC**<sup>®</sup>  
US JVC CORP.

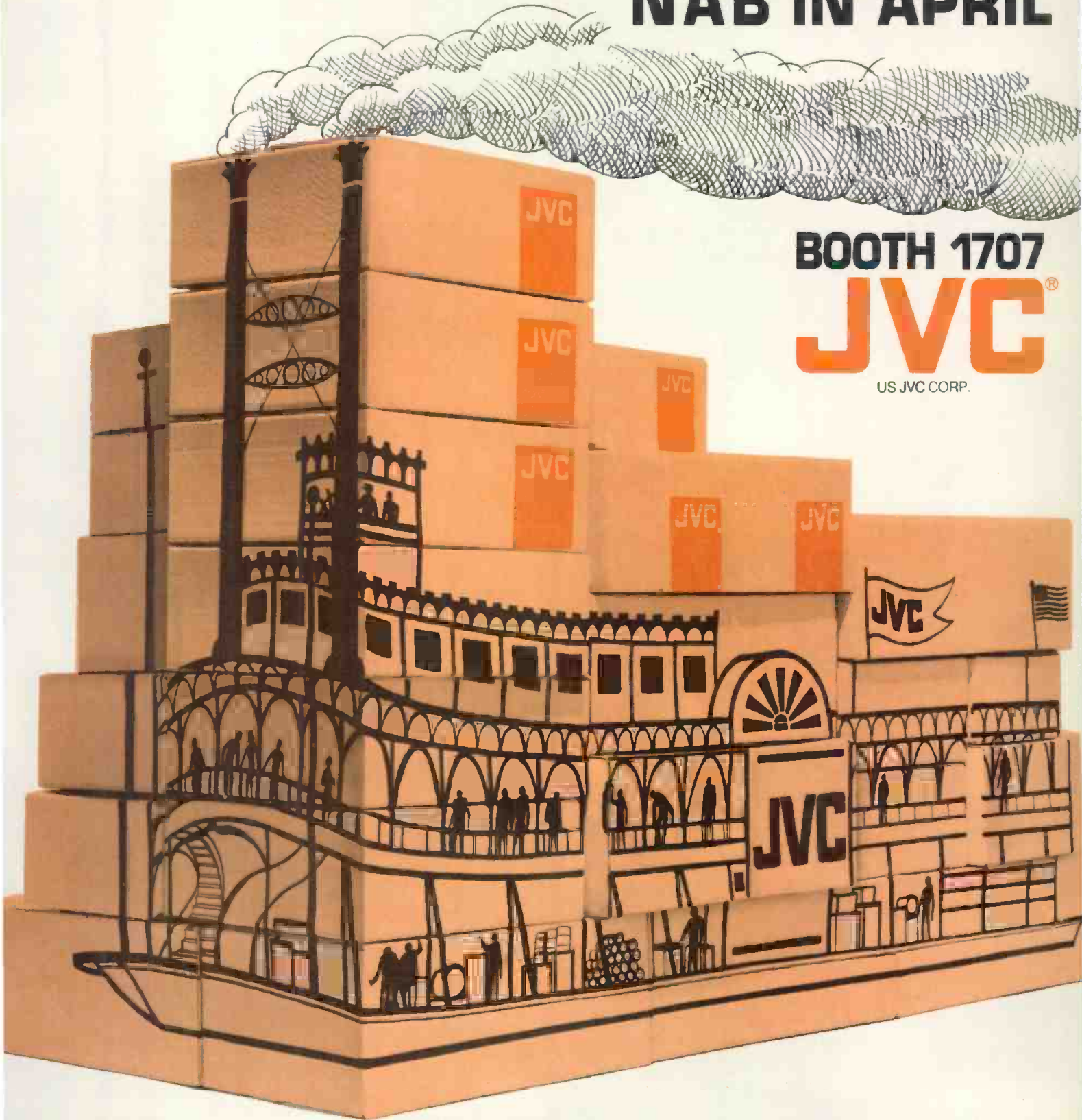

**GET ON BOARD WITH JVC**

© 1982 US JVC CORP.

Circle 196 on Reader Service Card

# NAB: 1982

## CORPORATE COMMUNICATIONS CONSULTANTS/2413

Will bring four new color corrector systems: Model 30 is for tape-to-tape correction using Sony multiprocessor BVX-30; Model L-100 is for correction of positive and negative films transferred on Videola scanners; Model 608 is for the Fernseh FDL-

60A2 CCD telecine; and Model CXL is for NTSC correction of prerecorded video tapes. Will also show the Model 60XL for film-to-tape transfer with optional prerecorded videotape color correction.

## CROSSPOINT LATCH/2408

Will introduce new six-bus, eight-input, three-M/E production switcher, Model 6139A; also the 6139C with self-contained switcher automation control or interface with editors. Also showing line of other switchers, switcher editor interface, and "switcher in a suitcase" portable video and audio production system.

## BILL DANIELS CO./2813

Will show its trade reference book for broadcast equipment which contains technical reference information and a products section.

## DATA COMMUNICATIONS CORP./3318

Will display fully integrated master control automation system to automate on-air switching and machine assignment, verify machine delegation, automatically generate five alternative schedule logs, and aid in materials identification program. (Also see listing in Radio section.)

## DATAMETRICS INC./1500

New equipment includes Model 700 multi-keyer character generator for time code, and Models 760 and 766 vertical interval time code generators. Other products will be the 710 code reader/video character inserter/jam sync code generator. Also, portable code reader and Model 722A code generator/reader/character inserter.

## DATATEK/3138A

New routing switcher unit will identify source system through decoding of original video signal. Also two video routing switchers, the D-701 TV transmitter color phase equalizer, and video and time code amplifiers. Distribution amplifiers for video pulse, subcarrier, audio, and SMPTE time code will be shown as well as audio preamplifiers, line amplifiers, and monitor amps.

## DATATRON/3327

Will feature Editt/Plus, an advanced off-line editing system that controls 3/4 or half-inch VTRs with no VTR modifications. A complete new line of videotape editing peripherals will be introduced using microprocessors, LSI and VLSI circuitry. Also displayed will be newly upgraded models of Vanguard editing controller, a microprocessor-based SMPTE time code editing system.

## DATUM/2409

Will introduce the Model 9400-930 vertical interval encoder/decoder with 48 bits per line and outputs for printout and display. Also new is a two-inch high, seven-second LED time display, the largest on the market. Other equipment will be character generators and the Model 9241 time code-based videotape cue searcher.

## dbx/2113

Featuring Model 907 user-defined stereo gating parameters. Also newly introduced Model 610 completely mi-

# When you cover the action from the source...



# the source for mobile studios should be Gerstenslager.

In a van or trailer, your most modern, best equipped studio could be your Gerstenslager. It all starts when you tell us what you need. The job to be done. Then we'll work with your engineers and principal equipment suppliers. Develop the plans. Detail placement of every piece of equipment, generators, wiring, climate control, consoles. Exactly as you want it. Then, build the unit from the frame up. A studio on wheels that is actually a dependable broadcasting station comparable to conventional studio systems.



How we do it with examples of work we have done for others is included in this brochure. It's yours for the asking. Write or call: (216) 262-2015.



## GERSTENSLAGER

The Gerstenslager Company, Wooster, Ohio 44691

Circle No. 197 on Reader Service Card

# di-tech Gives You A *REAL* Choice Of Controllers With Our Matrix Switchers...

## We're Tuned Into Your Needs!



**MODEL 975**  
Numerical, Master X-Y Serial Controller



**MODEL 993**  
Alphanumeric, Single Buss Controller



**MODEL 915B**  
Numerical, Single Buss Controller



**MODEL 917**  
Numerical, Master X-Y Parallel Controller



**MODEL 940**  
Numerical, Single Buss Controller



**MODEL 915A**  
Numerical, Single Buss Controller



**MODEL 911**  
Numerical, Single Buss Controller



**MODEL 998**  
Alphanumeric, Single Buss Controller, with 4 Pre-Set Inputs



**MODEL 997**  
Alphanumeric, Single Buss Controller, with Match Feature



**MODEL 991-2**  
Alphanumeric, 2 Buss Controller



**MODEL 910-3**  
Numerical, 3 Buss Controller

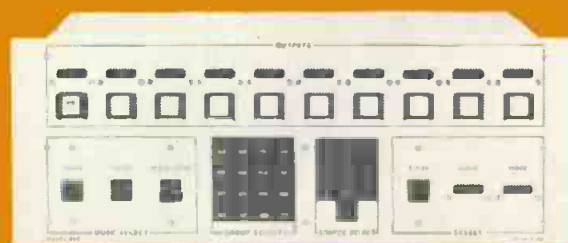

**MODEL 996**  
Alphanumeric, 10 Buss Controller

**di-tech** has developed an entire line of versatile control panels with every variation you might ever need. Each alphanumeric or numerical panel represents state of the art quality, unsurpassed reliability and ease of operation, allowing you total flexibility and freedom for audio only, video only or audio-follow-video with 1, 2 or 3 channels of audio per input. Select your exact matrix and controller from **di-tech's** surprisingly affordable line.

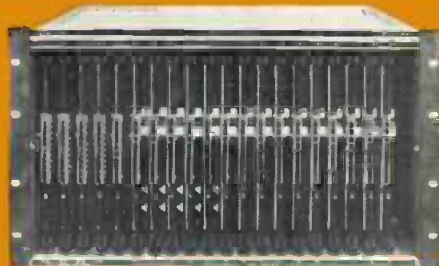

**MODEL 5841**  
Video Assembly Expandable Beyond 40 X 15

### Models 5800 and 5840 feature:

- up to 3 channels of audio per input within the same frame
- expandable inputs and outputs beyond the stated matrix
- audio only, video only or AFV; V.I. switching

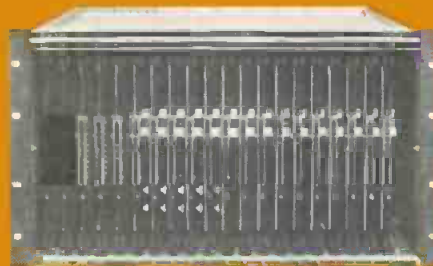

**MODEL 5842**  
Audio Assembly Expandable Beyond 40 X 15

Discover for yourself why industry leaders are switching to **di-tech**!



# di-tech

our *NEW*, bigger location:  
**48 JEFRYN BOULEVARD**  
**DEER PARK, N.Y. 11729**  
**TEL. # (516) 667-6300**

Circle 198 on Reader Service Card

# THE SYSTEM EVERY SOUND ENGINEER WOULD BUY IF HE CONTROLLED THE PURSE STRINGS.



If your engineers could be heard, there's no doubt which wireless microphone system they'd choose for sound, quality and design. A Sony. How do we know? We've asked them.

But we've also heard that because they cost more than ordinary systems, some people have been reluctant to buy them. Well, take a moment to see why it's penny-wise and pound-foolish to settle for anything less.

First, the modular combination of Sony receivers and diversity units makes it the most flexible system you can buy. The portable rack can be used with either three receivers as shown above or two receivers and a diversity unit. So it satisfies virtually any production requirement. Second, it's the *only* modular system. Not a hodgepodge like competitive systems. Which means it can be set up and rearranged in a mere fraction of the time it takes to set up other systems. And finally, because it's a Sony, you're assured of something else: superior sound quality and worry-free operation.

So if you're in the market for a wireless microphone system, remember, if it costs less than a Sony, you're getting exactly what you bargained for. For the facts about the state of the art in wireless microphone systems, including 19" rack mounting for studio installation, con-

**SONY.**  
Professional Audio

sult our dealer listing. © 1982 Sony Corp. of America, 9 W. 57th St., New York, NY 10019. Sony is a registered trademark of the Sony Corp.

Circle 199 on Reader Service Card

# WHERE TO FIND SONY WIRELESS SYSTEMS.

AUDIO VIDEO RECORDERS/ARIZONA  
Phoenix  
Floyd Ramsey (602) 277-4723

ROH'S INC.  
Tucson  
Bill Roh (602) 795-8573

AMERICAN ELECTRONIC SUPPLY/CALIFORNIA  
Hollywood  
Maury Rosenthal (213) 464-1144

AUDIO SERVICES CO.  
N. Hollywood  
Mark Chatinsky (213) 980-9891

HOFFMAN VIDEO SYSTEMS  
Los Angeles  
Ken Williamson (213) 749-3311

SOUND GENESIS  
San Francisco  
Dave Angress (415) 285-8900

FIDELITY SOUND CO./DISTRICT OF COLUMBIA  
Washington, DC  
Ed Lacomis (202) 296-9110

HARRIS AUDIO SYSTEMS/FLORIDA  
No. Miami  
Mike Harris (305) 944-4448

FALCONE INTERNATIONAL INC./GEORGIA  
Marietta  
Fred Orton (404) 427-9496

ROSCOR CORP./ILLINOIS  
Morton Grove  
Lee Ruber (312) 966-3010

NICHOLS ELECTRONICS/KANSAS  
Overland Park  
Ned Soseman (913) 492-2151

PIERCE PHELPS/MARYLAND  
Bethesda  
Fred Bergstrasser (301) 984-7979

TECHNIARTS  
Silver Springs  
Bill Moore (301) 585-1118

CRAMER VIDEO INC./MASSACHUSETTS  
Needham Heights  
Dan Mulhern (617) 449-2100

GENERAL TV NETWORK/MICHIGAN  
Oak Park  
Doug Mumley (313) 548-2500

HY JAMES ENTERPRISES  
Ann Arbor  
Henry Root (313) 994-0934

WESTERN MEDIA ENTERPRISES/NEVADA  
Las Vegas  
Pete San Filipino (702) 362-4170

ALTEL SOUND/NEW YORK  
New York  
Ozzy Reiter (212) 889-9700

CAMERA MART  
New York  
Jeff Wohl (212) 757-6977

MARTIN AUDIO VIDEO  
New York  
Mike Bogen (212) 541-5900

MASQUE SOUND  
New York  
Jack Shearing (212) 245-4623

PIERCE PHELPS/PENNSYLVANIA  
Philadelphia  
Frank Brady (215) 879-7000

RIO RADIO/TEXAS  
McAllen  
Mark Garcia (512) 682-5224

AVEC ELECTRONICS CORP./VIRGINIA  
Richmond  
Lee Merritt (804) 359-6071

CUSTOM VIDEO SYSTEMS/WASHINGTON  
Seattle  
Al Harwood (206) 365-5400

FULL COMPASS INC./WISCONSIN  
Madison  
Jonathan Lipp (608) 271-1100

## SONY

© 1982 Sony Corp. of America, 9 W. 57th St., New York, NY 10019. Sony is a registered trademark of Sony Corp.

THE SKY'S THE LIMIT

# NAB: 1982

**croprocessor-controlled equalization system** for monitor systems. Other units include the 900 Series modular signal processors, 160 Series compressor/limiters, 500 Series signal enhancers, and Type I and Type II noise reduction systems.

### DELCOM/2710

Introducing improved version of Delcom/Sony Model VO-850D **pneumatic VTR**, with playback audio mixer, dual tone generator, countdown generator, blackburst generator, optional pulse cross output. Also showing AE-3 interface unit for Convergence editor and ISI switcher.

### DIGITAL VIDEO SYSTEMS/1904

New products to be introduced include the low-cost Phaser V **framestore synchronizer** with full frame memory, designed for applications such as synchronizing network feeds, studio-to-studio interface and satellite and remote links. Also featuring **Phaser IV new adaptive digital comb filter** to provide perfect chroma inverted pictures with freeze frame/field capability. Also on display will be the DPS-100 series low-cost component digital TBCs, designed to work with VCRs. Other products on display will be sync generators and digital test calibration generator.

### DI-TECH/2203

Model 2100 is a new **automatic logging device** used with audio/video routing switcher systems. Audio/video routing switchers, audio/video pulse distribution amplifiers and video detectors will be among other equipment shown. Also, Touch-Tone controls and audio monitor amplifiers.

### DOLBY LABS/2405

Will show **multi-track noise reduction unit** that provides up to 24 tracks of Dolby A noise reduction with separate regulated power supplies and electronically controlled output protection. Also, Dolby A noise reduction module that plugs directly into the Sony BVH-1000 and 1100 VTRs, providing at least 10 dB of noise reduction.

### DUBNER COMPUTER/2702

Will bring a new model of its **character background generator**, CBG-2.

Highly sophisticated character generator with memory planes, diagonal typing, three-dimensional lettering, and now a **drawing tablet** for computer-created smooth curved lines and limited "paint" capabilities. Also showing computer-assisted color corrector for telecine and dubbing operations.

### VICTOR DUNCAN, INC./2404

Will be demonstrating a full line of professional and industrial video equipment for rental and sale.

### DYNACOM/2424

Will show **addressable STV system** and low power TV scrambling devices.

### DYNAIR ELECTRONICS/3135

New System 23 **modular machine control**, and the new System 23 **control and data routing switcher**, will be displayed. The system 21 and Series 10 routing switchers will also be shown, as well as the Series 5300 precision distribution equipment.

### ECHOLAB, INC./2932

Will display the SE/3 computer-controlled special effects switcher, which accommodates 10 synchronous or asynchronous video sources and is expandable to interface with editing systems via an RS-449 channel.

### ECHO SCIENCE CORP/3319

Will introduce the ESS-1B, the latest in **framestore disc recorders/reproducers** from Echo. The ESS-2 Image Maker recorder/reproducer will also be on display.

### ECCO/1819

Will introduce the VIG-850 longitudinal/vertical **time code generator** and VIR-950 vertical interval **time code reader**. Also, VCG-750 video character generator; MTG-550 time code generator, which supplies continuous serial time code; and TCR-650 time code reader with user bits.

### EEG ENTERPRISES/2507

Three new items will be line 21 **smart encoding system** with intelligent terminal, including custom software, easy text preparation, time scheduling and newswire processing; **vertical interval keyer** for insertion of digital information; and line 21 **video decoder** with data recovery port. Turnkey closed captioning systems and simple encoders will be on hand as well as video decoders.

### EEV, INC./2216

Improved one-inch HOP high resolution **Leddicon tubes**, 2/3-inch diode



# NAB: 1982

gun Leddicons, half-inch Leddicons, high brightness character display tubes, and monochrome CCD camera. Vidicons, power tubes, and travelling wave tubes will also be displayed.

## EIGEN VIDEO/1902A

Will introduce its new Frame Grabber, DSR Series, for interfacing

computer graphics systems with its disc recorders for animation effects in a variety of applications. The 10 MHz disc recorder is also new, as is the 18-10 frame recorder for color stills.

## EIMAC/3119

New products include 40, 100, and 300 kW graphite grid tetrodes, the Y-730—100 kW UHF TV triode, and the Y-831 200 kW model. The new equipment from the Microwave Tube Division includes a high efficiency external cavity UHF-TV klystron, and the A-1200 high efficiency aural coupler, along with the

VCP-7858 high efficiency visual coupler. Other equipment includes full lines of tetrodes and VHF-TV cavities, klystrons, a high-power klystron amp, and a 500 W combined KU-band medium power TWT amp. (Also see listing in Radio section.)

## ELECTOR/2104

Will introduce new medium resolution color monitors with .43 mm pitch tube for high brightness. Will also show for the first time a hi-beam video projector, made by Vidi-Pro. Will show the line of other video color monitors.

## ELECTRO CONTROLS/1915

Will show new Lite Cue with advanced control panel and memory system for TV studio lighting control. Also present will be Plexus 1000 and 2000; Lite Patch dimmer-to-circuit electronic patching system.

## ELECTRO-VOICE/1905

Will introduce a new studio audio monitor, the Century 500. Will also unveil a larger version of the Century 100A. Plus full professional microphone line, including modular and shotgun systems.

## EMCEE BROADCAST

### PRODUCTS/3331

New products include a totally solid state MDS transmitter and new single-bay TUA-1000C amplifier for translator and LPTV applications. Other transmitters, down-converters, and a LPTV transmitter equipped with the tone-activated TD-100 remote auto interrogator.

## EMCOR PRODUCTS/1901

Showing the Ten Series cabinets and consoles, featuring vertical cabinets.

## E-N-G CORP./1501

Will unveil a new ENG vehicle equipped with a 6.2 liter diesel engine. Other ENG/EFP vans will be present.

## ENTERPRISE ELECTRONICS/1822

Will display color weather radar equipment.

## ENVIRONMENTAL CONTAINERS/2907

Will show its line of cases and cabinets for broadcast equipment.

## ESE/2305

Will introduce the Model 260 SMPTE time code generator. Established products will include a line of digital clocks, master clocks, and timers. Will be demonstrating full SMPTE time code product line.

## INTRODUCING

# TEN-X

The *TEN-X* is an all-new economically priced 10x1 utility switcher. Housed in a one-RU rackmounting package, it is available in both video-only and AFV versions, with or without local control panels. The *TEN-X* features:

- Vertical interval video switching
- DC-restored video inputs
- +24dBu audio input/output
- Wire-per-crosspoint control
- Audio breakaway capability
- Full broadcast performance specs

Best of all, it's from Grass Valley Group—  
World Leader in Television Switching.

**THE GRASS VALLEY GROUP, INC.®**

P.O. BOX 1114 GRASS VALLEY CALIFORNIA 95945 USA

Circle 200 on Reader Service Card

# Storeel is dedicated to conserving energy. Yours.

Energy conservation is much in the news these days. Like the weather, many talk about it but few do anything about it. We haven't figured how to change the weather, but we do have several systems specifically

engineered for broadcasters that both conserve energy and add efficiency. The very latest (shown installed) is called STOR-MAX.™

Save energy (yours) by converting your overcrowded film and VTR libraries to the new "Instant Access" high-density systems engineered and distributed only by Storeel. Modular Rapid Transit Storage™ maximizes units stored per square foot of floor space, minimizes retrieval time, optimizes energy efficiency.

Our many years of design and engineering pay off in solutions to your storage problems.

Call or write "The Railriders" at Storeel today for free estimate. No obligation, of course.

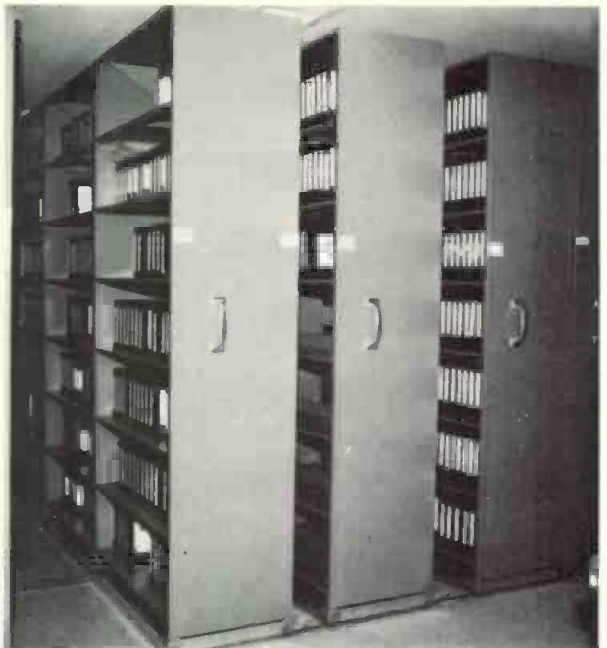

*Illustrated catalog of Storeel's "confusion eliminators" available upon request. Write on your letterhead or telephone for your free copy.*

# STORROOL CORP.

2050-C Carroll Avenue • Atlanta, Georgia 30341 • Telephone (404) 458-3280

**The  
Space-Saving  
Engineers**



Circle 191 on Reader Service Card

[www.americanradiohistory.com](http://www.americanradiohistory.com)

# NAB: 1982

## EVENTIDE CLOCKWORKS/2934A

Will feature new model of Time-Squeeze digital time compressor/expander for regulating pitch changes during VTR/ATR speed up and slow down. Also new SP 206 digital reverb/signal processor. Other digital audio processing products will include the Harmonizer and broadcast audio delay lines.

## EXCALIBUR INDUSTRIES/2103

Will show new case allowing VTR operation in field. Also showing full line of cases for audio and video equipment as well as monitor and rack cases.

## FAROUDJA LABORATORIES/2814

Will debut new version of Image System with improved bandwidth and noise reduction capabilities. Also new enhancer/booster combination to operate with 3/4- and half-inch VCRs. A new comb filter with cross-talk suppression will also be introduced.

## FERNSEH, INC./3323

Will highlight new graphics capability for the Compositor I character generator/graphics system, and new black stretch circuit and pan/scan feature for the FDL-60 CCD telecine. Other products will include the BCN line of Type B VTRs; KCA-100 ENG/EFP camera; KCP-60 studio camera; Mach One multisource editing system; Automax machine control and switching system; TVSTAS-1000 video/audio distribution switching system; and a line of professional color monitors.

## FIBERBILT/1801

Will introduce a new molded case featuring strong, recessed hardware. "Supertrunk" will be shown in various rack-mount configurations and different sizes. Printed circuit board cases, micro-computer cases, other original equipment cases will be on display.

## FILM/VIDEO EQUIPMENT SERVICE CO./2422

Introducing new wide-angle adaptors for video lenses. Will also introduce a sealed lead acid battery, for 0.8 hours running time of a 250 W light. Will also demonstrate complete lens repair service, and lines of rental and sales stands and other accessories.

## FLASH TECHNOLOGY CORP./1708

Will display obstruction warning lighting systems and lighting controls.

## FOR-A CORP./2210

Will show new NTSC digital time base corrector and VTW-600 character generator with its CU-600 color adder unit and the DU-600 character, design unit. Also WU-300 wipe unit. Other equipment includes CCS-4200 color corrector, TSG-5000 sync pulse generator, and FM-60 frame memory unit.

## FORTEL/2106A

Will introduce a new series of digital processing products (details at the show). Also showing the current line of processors: CCD-1H timing corrector; CCD-2H Modular TBC/Image enhancer system; Y-688 Total Error Corrector; Faroudja automatic image correction, (exclusive to Fortel in N. America).

## FORT WORTH TOWER/3326

Will show towers, earth stations, and pre-fabricated equipment buildings.

## FREZZOLINI ELECTRONICS/1817

New ac/dc portable lighthead with accessories and a new on-board ac adapter/battery eliminator for ENG

# Introducing "RIDE BEHIND" Alexander's New

## Battery System for Portable Cameras and VTR's

Alexander's new 7600 Ride Behind is a rechargeable nickel-cadmium 14.4v, 4AH replacement battery pack. But the big news — the pack comes with three studs for snap-on mounting on any camera equipped with a keyhole mounting bracket. Just attach a standard or short power cable for camera or VTR connection.

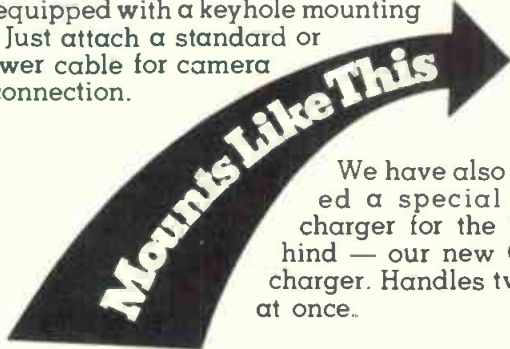

We have also developed a special 10-hour charger for the Ride Behind — our new CR7600-2 charger. Handles two packs at once.



## And Look at our Deal!

7600 Ride Behind Battery Pack just **\$175** CR7600-2 10-hour charger, just **\$60**

Freight prepaid on orders of \$100 or more



**ALEXANDER**  
ALEXANDER MANUFACTURING CO.  
1511 So. Garfield Pl. Box 1645  
Mason City, IA 50401/515-423-8955

In Canada contact G.E. Irving Industries, 2209A Dunwin Dr., Mississauga, Ontario L5L 1x1

Circle No. 201 on Reader Service Card

cameras will be introduced. Complete line of nicad on-board batteries and portable lighting and power systems will be available. Also complete line of fast charge systems.

#### **FUJINON/3314**

Will introduce several new lenses for larger-format cameras. P17X16.5ESM is a 16.5 to 280mm f/2.1 servo-adaptable zoom for 1 1/4-inch formats; P28X111ESM is an 11 to 310 mm f/1.6 zoom for studio/field cameras with one-inch tubes; R17X12.5ESM is a 12.5 to 212mm f/2.1 zoom for studio-type one-inch format cameras. Also shown will be full line of lenses including models for 1/2-inch format cameras, EC cameras, and ENG/EFP/studio cameras.

#### **FUJI PHOTO FILM/3313**

Introducing the Super HG VHS videocassettes in seven lengths; and also the new video head cleaning cassettes for half-inch VCRs, designed to extend life of the VCR. Also full lines of half-, 3/4-, one-, and two-inch tapes.

#### **GAGNON LaFOREST/2800**

Will show the Vertilift and rigging equipment with hydraulic and electronic controls for precise positioning.

#### **GANON/3305**

Will introduce an all-new lens for one-inch tube cameras, PV40X13.5 BIE with maximum aperture of f/1.7. Also two brand-new 15X zooms for 2/3-inch format cameras with f/1.6 and f/1.8 respectively. Also featuring complete line of lenses for all camera formats and lens remote control system.

#### **GARNER INDUSTRIES/2304**

Will feature its videotape erasers. (Also see listing in Radio section.)

#### **GENERAL ELECTRIC/2500**

Will show its line of incandescent, Quartzline, and tungsten-halogen lamps for TV and film.

#### **GENERIC COMPUTER/2317**

Will show new computer automation system for traffic control using the Apple and the Polymorphic computers.

#### **THE GERSTENSLAGER CO./2630**

Will discuss its custom-built mobile television vans and trailers.

#### **GLETRONIX/2008**

New item is the PC-12 pulse clock. Will also show full line of time code generators, readers/character gener-

ators, and hand-held generator/readers. Digital and analog clocks, clock drivers, machine control, and time and temperature displays will be displayed. Lines of T&M equipment and monitors from various manufacturers will also be shown.

#### **ALAN GORDON ENTERPRISES/2406**

Will introduce a new line of filters for special effects by Spectra Tek. The Elemack camera dolly and the MAC video animation system will also be on display along with the line of audio and video systems and ac-

cessories, including Swintek wireless mic systems and Spectra light meters.

#### **THE GREAT AMERICAN MARKET/2103**

Will introduce Colormax, a computerized rolling lighting color changer; Instaset vacuum-formed scenic elements; and RDS/Fresnels, new line of studio lighting fixtures. Also showing the Great American Pattern, 2000 W Scene Machine, Lighthesizer, Starstroke, RDS/HMI lights, Excalibur custom cases, and more special effects.

THE LATEST LINE FROM ITT JENNINGS:

# HIGH POWER "TITANATE" CERAMIC CAPACITORS

At last here's an answer for those applications that require a high power capacitor providing high KVA ratings, long life, and extremely high reliability over a wide frequency and temperature range.

It's our "titanate formulation" ceramic capacitors.

They exhibit a high dielectric constant, low loss characteristics, and can be produced in smaller sizes than most other types of capacitors with similar ratings.

These capacitors offer capacitance ranges from 5 to 5,000 pF or more, and voltage ranges from 5 to 40 KV.

They are ideal for transmitters, power supplies, induction heaters, voltage grading for circuit breakers, CRT computer interfaces, lightning arrestors or practically any application that requires a high power ceramic capacitor.

Do you have an unusual requirement? If so, our modern production facility and our 30 years of high power test experience can assist you with specialized ceramic capacitors in a variety of shapes, sizes and formulations—even water cooled types.

Check with our applications department at 970 McLaughlin Avenue, Dept. TF1, San Jose, CA 95122, or call us at (408) 292-4025 and let us tell you more about our high power titanate ceramic capacitors.



## JENNINGS ITT

DIVISION OF INTERNATIONAL TELEPHONE AND TELEGRAPH CORPORATION

# NAB: 1982

## THE GRASS VALLEY GROUP/3010

Will feature new post-production options for the 300 Series production switchers, plus the new 300-2 two M/E switcher, a scaled-down version of the 300 Series. The Mark II digital video effects system will have new effects capabilities. Also new will be a video status display system and full-function X-Y control panel for the 440 Series routing switchers, a 10X1 utility routing switcher, new features and operational levels for the M200 automation system, and the new "Wavelink" fiber optic audio and video communications system. Also on view will be the 440 Series routing switchers, 1600-4S MC switcher, M200 automation system, 3240-41 video proc amps, 3400 Series video DAs, 3250 Series SCH generators, 1600 Series production switchers, and 1600-1X post-production switchers with E-MEM.

## GREGG LABORATORIES/2009

Will introduce the 2560 television audio processing system with six-octave loudness controller, multi-band gain controller, and multi-band peak limiter. (Also see Radio section.)

## GROVE VIDEO CORP./2701

Will introduce the Imager II, a new digital graphics storage and animation device. The Imager I will also be exhibited.

## HARRIS CORP./3101

Many new products from different divisions will be introduced, including: a complete new line of UHF transmitters in 30, 55, 110, and 220 kW models featuring a new exciter and improved efficiency; for facility control, an earth station controller system with 24 preprogrammed antenna positions and earth station configurations; for production, a new version of the IRIS still store, now capable of handling 10,000 title entries in a library management program; and in signal processing, the new 690 digital TBC/frame synchronizer for both direct and heterodyne VTRs in a low-cost package. Other TV products will include a full line of VHF and UHF transmitters, CP antennas, the TC-85 microprocessor setup studio camera, the Epic multisource editor, and microwave systems from Harris Farinon. (Also see listing in Radio section.)

## HARRISON SYSTEMS/1910

Will introduce new TV-3 series TV production mixers for live production or post-production in mini configurations for both studio and remote. Also new DS-1 graphic display audio level indicator (VU or PPM or both) and equipment for automation level indication and spectrum analysis.

## KARL HEITZ/2515

Will show Fluid Head 3 with both fluid tilting and panning, and rapid adapter for video/cine cameras up to 20 pounds. Tripods with spring balanced heads and soft grips. Full array of Arriflex lenses will also be available.

## HITACHI DENSHI/3202

Promises a "brand-new hand-held ENG camera," but no further details available yet. Unconfirmed speculation points to a single-piece camera/VCR combo. CMOS solid-state b&w camera will definitely be displayed, and possibly an industrial-grade color CMOS camera. Also being shown widely for the first time, will be SK-110, the computer setup version of the SK-100, adapted for use by CBS and now available as a product. Also full complement of ENG cameras including SK-81, SK-91, and FP-22 computer setup camera for under \$14,000. Full complement of one-inch VTRs including three-hour version and a four-machine editing setup.

## HM ELECTRONICS/2402

New MB-150 remote base station for communication between remote transceivers, and new hand-held RF mic featuring concealed antenna. Full line of HME wireless mics and intercom systems will also be shown.

## HUGHES ELECTRONIC DEVICES CORP. (HEDCO)/2214

Major new product introduction will be a 100 x 100 routing switcher, dubbed TransPath. Most significant feature is a three-stage, non-blocking switching matrix that permits reduction of crosspoints to only 5700 and consequent size reduction to one-fifth of comparable units. Configurations include audio, video, AFV, or breakaway. Video frame is only 22 rack units high. Other products include dual 8 x 1 audio switcher, clamping distribution amplifier, and full line of audio distribution equipment.

## HUGHES HELICOPTERS/2611

Will display fully equipped Hughes 300C ENG helicopter with all accessories.



Hitachi will be showing a full line of ENG cameras.

## IKEGAMI ELECTRONICS/3209

Promises several "hot" new product introductions. Leading the list is Ikegami's HL-83 single-piece camera/VCR combo with half-inch recorder (Mitsubishi/RCA format). Also new HK-322 full-scale automatic setup studio/field camera. Complete new lines of both ENG microwave and production switchers. Production models of the EC-35 electronic cinematography camera. Production models of the ITC-730 low-cost ENG/EFP camera. New generation TKC-990 automatic setup telecine camera. Plus full line of other cameras including HL-79DAL, HL-790 studio/field convertible, and HK-357 auto setup studio field camera with triax. Full line of Series 8 standard and RH high resolution color monitors.

## IMAGE VIDEO/2600

A new broadcast routing switcher and the new VMP-1 voltage monitor panel will be on display. The VMP-1 monitors up to 128 dc voltages and includes digital circuitry throughout. It also offers adjustable display rate and software-adjusted alarm tolerances.

## INDUSTRIAL SCIENCE INC./1600

Will introduce two new models of production switchers, the 210 and the 910. Other equipment on display will be Models 904 and 200-3 video production switchers, terminal equipment, plus options for the different switchers, including APE automation system.

**Y-688<sup>32</sup>**  
Total Error Corrector

# CLOSE THE GENERATION GAP

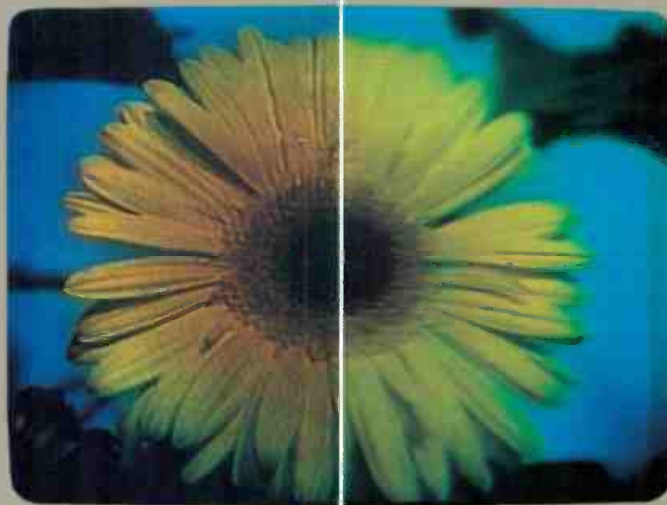

4th generation, Y-688<sup>32</sup> Total Error Corrector

4th generation, conventional TBC

*Y-688<sup>32</sup> Total Error Corrector...simply the most powerful tool available for extending multi-generation quality of color-under video tape recorders.*

*Professional teleproducers and broadcasters can now produce*

*third and fourth generation video tapes of quality close to first generation playback through conventional systems.*

*More than just a time base corrector, and more than an image processor or noise re-*

*ducer, the Y-688<sup>32</sup> is a Total Error Corrector. No single device or system of components, at any price, can match the performance of the Y-688<sup>32</sup> TEC for correcting multi-generation video signal errors.*

**FORTEL**

**FORTEL**

**Y-688<sup>32</sup>** Total Error Corrector



## Specifications

Digital Sampling	Luma: 8 bits at 14.3MHz Chroma: 8 bits at 7.2MHz (R-Y at 3.58MHz and B-Y at 3.58MHz)
Window of Correction Signal to Noise Ratio	32 Horizontal Lines 57dB Encoded Mode (Combs Off) 60dB Dub Mode (Combs Off)
Differential Phase (Residual Error)	Dub In/Dub Out (Y-688) 0.5°
Differential Gain (Residual Error)	Encoded In/Encoded Out 1.5°
Bandwidth	Dub In/Dub Out (Y-688) 0.5%
K Factor (2T)	Encoded In/Encoded Out 1.5%
White Clip	5.0MHz (-3dB)
Power	Dub (Y-688) 1.5%
Ambient Temperature	Direct 1.5%
Ambient Humidity	Heterodyne 3%
Weight	110 IRE Nominal (Internally Adjustable)
Dimensions	87-130VAC or 200-260VAC, 50 or 60Hz, 235W 10°C to 40°C (50°F to 104°F)
	10% to 90%
	18.2kg (40 lbs.)
	48.3cm (19") W
	8.9cm (3.5") H
	60.3cm (23.75") D
	54.6cm (21.5") D into rack

## Inputs

Dub In  
Video In (Encoded)  
DOC RF  
Genlock/Sync (Loop)  
Subcarrier (Loop)

## Outputs

Dub Out  
Video 1 (Encoded)  
Video 2 (Encoded)  
VTR Advanced Sync  
VTR Subcarrier  
Blackburst  
Y  
R-Y  
B-Y  
Sync  
Subcarrier  
Blanking  
7.2MHz Color Video

## Controls and Indicators

Power	2 position switch (on or off)
Program Out	2 position switch bypasses unit circuitry in program video path, monitor video path is always activated.
Input Mode	2 position switch selects Y-688 (dub) video input signal or encoded video input signal.
Image Processing	2 position switch turns the image processing and en- hancement portion of the Y-688 <sup>32</sup> Total Error Corrector on or off.
Video Gain	± 3dB
Chroma Gain	± 3dB
Setup	± 20 IRE
Hue	± 30°
Video Position	± 1 usec (with respect to sync)
Horizontal Phase	± 4 usec
Chroma Phase	360°
Vertical Image	0-100% Boost of vertical detail
Horizontal Image	0-100% Boost of horizontal detail
Noise Reduction	0-6dB compression in auto position and adjusts the level of coring in the manual mode.
Auto Position	Allows automatic boost compensation when Faroudja Laboratories Record 1™ pilot tone is present in input video signal.
Power On	Green LED
Image Pilot	Amber LED (indicates Record 1™ pilot tone present in input video)
Genlock	Green LED
Video	Green LED (indicates input video present)

Fortel Incorporated  
6649 Peachtree Industrial Boulevard  
Norcross, Georgia 30092-9990  
Telephone (404) 447-4422  
Telex 804822

**FORTEL**

<sup>32</sup>Y-688<sup>32</sup> Total Error Corrector is a trademark of Fortel Incorporated.  
™Record 1 is a trademark of Faroudja Laboratories, Inc.  
All specifications are subject to change without notice.

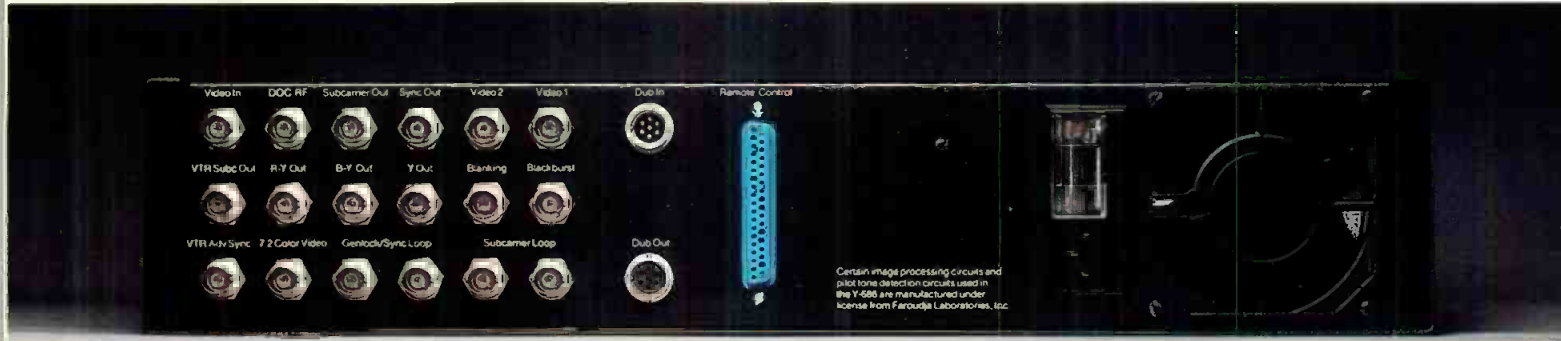

Certain image processing circuits and  
pilot tone detection circuits used in  
the Y-688 are manufactured under  
license from Faroudja Laboratories, Inc.

**NAB: 1982****INTERFACE/1620A**

Introducing a new 200-B 8 x 2 portable mixer, which operates on ac or dc and is especially designed for ENG. Also on display will be a new broadcast audio console.

**INNOVATIVE TELEVISION EQUIPMENT/3309**

Will show new T2A, T8, and T13 tripods. Other new equipment includes P2 and P8 pneumatic studio pedestals, H9A, H10 and H16 fluid heads with adjustable counter-balance, and P9 lowboy camera dolly mount. Complete line of camera support dollies, tripods, and pedestals.

**INTERAND CORP./TELESTRATOR/1807**

New equipment includes the Telestrator 440, a real-time, stylus-controlled video art system, and Telestrator 100 compact unit for live supering of simple line art and symbols. The Telestrator 880, a powerful video art and animation system is another new unit to be shown. The telestrator auto probe, which expands power of existing character generators and graphic systems, completes the new equipment to be exhibited.

**JATEX/2505**

New this year will be the VSEC-62TMX A/B roll editing control system with computer assist, list management, status display, dual disk drive, printer, and SMPTE operation. Also, new options for the VSEC-42TDX editing controller and VGEN IV. Other items on display will include the VSEC-42T and VSEC-42TD editing controllers, VGEN VI generator/reader/display, and VTIM video/audio timer.

**JENEL CONSULTANTS CORP./2314**

Will show new video integral jack-fields and terminal blocks with quick connections. Will also describe expanded engineering and design services.

**JENSEN TOOLS/2719**

Will bring new tool kits for cable TV installers and field engineers. Will also show full line of tool kits and test equipment.

**JEFFERSON DATA/1710**

Will show sales and traffic, general accounting, and station-operated in-

terface computer system for TV called System 90. It uses an IBM computer and operates completely within the station. The ENP Electronic News Processor is an integrated computer system for broadcast news.

**US JVC/1707**

New products to be announced. Other equipment to be seen includes the KY-2700 three-tube ENG/EFP camera and KY-1900U ENG camera. Also 1/2-inch professional VHS units will be on display. In post-production, the RM-88U two-machine editor/controller for VCRs will be on hand. Also shown will be 3/4-inch recorders/players and full line of color monitors and accessories.

**KAMAN SCIENCES (BCS)/3216**

Will have in-house demographics/sales proposal computer package. Also displayed will be complete traffic/billing systems for TV and radio stations, with inventory control, news, accounting and amortization programs, and computerized interface to auto switchers.

**KAVCO/2733**

Will show a computer-controlled video playback system, as well as a full line of edit controllers. Will have photo display of systems design and installation capabilities. Also on hand will be a commercials insertion system.

**KINGS ELECTRONICS/1907**

Will display assorted RF coaxial and triaxial connectors. Video patch panels and patch cord will also be exhibited.

**KLIEGL BROS./3014**

Will introduce the K96 SCR intelligent digital dimmers for lighting control systems. Will also display Kliegpac 9, Performer II, and Command Performance controllers, plus fresnels, scoops, and 1550 Series Klieglights.

**KNOX VIDEO/1900A**

Will show new color box for variable color backgrounds and characters plus full edging for the K128 generator. Also on display will be the K128B high resolution alphanumeric character generator. The KD128 400 page floppy disk programmable memory for the K128B will be exhibited, along with the KX50 low cost titler with four-page memory.

**EASTMAN KODAK/3212**

Will unveil two new film stocks. 7251 is a high-speed 16 mm reversal film with an ASA of 400 and balanced for

**TRIDENT****Lexicon****Urei****SONY***Wireless Microphone*

Professional

*Eastern Acoustic Works,  
Inc.*

**MAIN DEALER IN THESE  
AND MANY OTHER  
FINE LINES  
COMPLETE SYSTEM DESIGN  
AND INSTALLATION.**

---

**HARRIS AUDIO  
SYSTEMS, Inc.**

---

1962 N.E. 149 St., N. Miami, Florida 33181

(305) 944-4448 **SOUND EAST**

Michael Harris



# NAB: 1982

against lightning and surges, transients, and noise. Also showing dissipation arrays, surge eliminators, transient eliminators, filtering systems.

## LIPSNER-SMITH/1903

Featuring the Model CF-100 film cleaning system, using ultrasonic energy. Also showing the CF-200 ultrasonic film cleaning system.

## LISTEC TELEVISION EQUIPMENT/3325

Will show new Vinten lightweight studio pedestal for 2/3-inch color cameras; new Vinten microwave support equipment; new microprocessor-controlled remote pan and tilt head and zoom controls; and new Chroma I color monitors. Also showing full line of Vinten camera support units and Digivision monitor prompters.

## LOGICA/1502

Will introduce Flair, a video art/paint system featuring extended pseudo-animation capabilities, 256-color palette

and 768 x 757 pixel resolution. Also showing Context teletext system.

## LOWEL-LIGHT/2302

Will show regular line of lighting equipment; including Lowel Lite, D Kit, Tota Lite, and Soft Lite location lighting kits. Also full range of lighting stands and accessories.

## LTM/2721

Will premiere its new fiberoptic system for lighting control, in which the source illumination is pumped in for close-ups, lighting miniature sets, commercial product shots, etc. Also, new 6 kW HMI light to supplement full line of HMIs and controls.

## L-W INTERNATIONAL/1601

Will feature its latest-model Athena 6000 and 4000 flickerless telecine projectors incorporating freeze frame and slow motion "real time" effects capabilities.

## LYON LAMB VIDEO/2832

Will introduce Model 3300 Video Animation Camera Stand, which features compound with N/S/E/W moves, 360-degree rotation, and top and bottom peg bars with opening for underlight. Trol System that automates compound and camera movements will be exhibited with VAS IV Video Animation System for frame-by-frame recording onto one-inch tape.

## 3M, MAGNETIC A/V PRODUCTS DIV./3133

Will show full line of Scotch videotape and videocassettes. (Also see listing in Radio section.)

## 3M, PROFESSIONAL AUDIO/VIDEO DIV./3006

Major product introduction will be TT-8000 brand-new one-inch Type C VTR with greatly enhanced editing and operating features over TT-7000. Also, accompanying NTC-10B heterodyne TBC for slow motion with track following. D-8800 character generator/graphics system will be on hand with newly introduced camera font compose option. Also look for major digital audio recording demonstration. Other products will include 20X and 40X routing switchers and Model 6500 machine control system.

## M/A-COM VIDEO SYSTEMS/3303

Will introduce a new helicopter and camera-mounted ENG microwave system. Fiberglass ENG antennas with interchangeable feeds and a 2.5 GHz/2.5 MX ENG transmitter/receiver will be announced along with high gain interferometer antenna systems. Also new is 40 GHz mi-

# STROBEGUARD®

HIGH INTENSITY  
OBSTRUCTION  
LIGHTING SYSTEMS\*  
FOR TELEVISION AND  
RADIO TOWERS AND  
SIMILAR SKELETAL  
STRUCTURES.



TECHNICAL PRODUCTS GROUP — BEDFORD DIVISION  
35 CONGRESS ST., SALEM, MASSACHUSETTS 01970  
TEL: (617) 745-3200

ATTENTION: GEORGE MANDEVILLE, PRODUCT MANAGER

\*FAA APPROVED as meeting or exceeding the requirements of Advisory Circular AC 150/5345-43 and FAA/DoD Specifications L-856 plus FAA AC 70/7460-1

# WHY ARE LEDDICONS® WORLD LEADERS?



Higher resolution is an important reason, but did you know that EEV 1-inch P8022 series Leddicons feature all these advantages?

- \* Light bias even on standard tubes
- \* Unique anti-microphony mesh
- \* Direct plug-in replacements

Also, P8145 series for HOP(ACT) operation

**LEDDICONS are BETTER LONGER**  
Proven every day throughout the world.  
Specify Leddicons for replacements and  
your new camera - Available NOW.

Please send me my free World Broadcast Systems Map, Brochure and full technical details of Leddicons for my application.

Name .....

Position .....

Company .....

Address .....

.....

Application .....

1098



**EEV, INC.**

7 Westchester Plaza, Elmsford, NY 10523, Tel: 914-592-6050, Telex: 646180

In Canada: EEV Canada Ltd., 67 Westmore Drive, Rexdale, Ontario M9V 3Y6, 416-745-9494, Telex 06-989363

In Europe: English Electric Valve Co. Ltd., Chelmsford, Essex CM1 2QU, England, Tel. 0245 61777, Telex 851-99103

® Registered Trademark for Leddicon Camera Tubes

See us at NAB Booth 2216

Circle 208 on Reader Service Card

[www.americanradiohistory.com](http://www.americanradiohistory.com)

# NAB: 1982

crowave and 23 GHz point-to-point microwave systems. Also interference-free ENG and fixed link fiber optic transmission systems. Other products are high efficiency 7M/9.2M steerable satellite systems; Sky Scan auto track ENG central receive system; and 2, 7, and 12 GHz intercity microwave systems.

## MAGNASYNC/MOVIOLA/2108

Will introduce the V-500 telecine for 16/35 mm, with 6000-foot capacity. Also on display will be the Videola V-1000 with hollow prism optical system makes for variable speed transfers independent of TV synchronization constraints.

## MARCONI ELECTRONICS/3320

Main exhibit will be the new B3410 CCD telecine, with solid state line array and digital video processing. Also on display will be the MR2B one-inch C format VTR. Will also introduce reconfigured versions of the Model 2914A TV insertion signal analyzer with new interfaces for automatic operation using instrument

controllers. Also newly revised Model 2920 TV interval timer, and new S1100 automatic audio transmission test system.

## MATTHEWS STUDIO EQUIPMENT/2626

Introducing new Video Matth Pak, an array of Matthews' equipment stored in a custom-designed case for ENG/EFP; contains accessories, adaptors, reflectors, etc. Also on display will be the transportable Tulip Crane system with a number of accessories for a wider range of applications. Stands, high rollers, and the Mini-Jib will also be on hand.

## MAXELL CORP./2212

Will introduce VHS T-150 tape for the duplicator market; and also a new one-inch videotape on open reels. Will also show the line of half-inch and 3/4-inch videotape, in cassettes and in bulk.

## MCI/QUANTEL/3306

Major product introduction will be DPB 7000 Digital Paint Box art/paint system featuring unlimited color selection, color mixing and blending, choice of line and brush thicknesses from one-quarter of a TV line to one inch, painting modes including poster paint, water colors, gels, etc., and

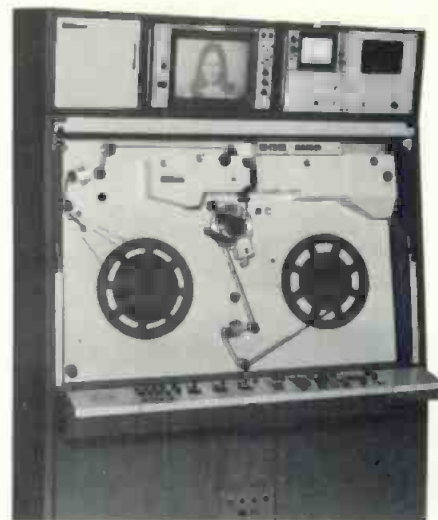

Marconi's B3410 Live Array Telecine.

stylus responsive to touch of artist. System will be shown interfaced with DLS-6030 digital still store. Other products will include DPE-5000 and DPE-5000+ extended digital effects systems; DPE-5000SP single-channel low-cost digital effects; DFS-1750 digital framestore synchronizer; DFS-1550 digital TBC/synchronizer; and DSC-4000 digital standards converter.

## MEAD DATA CENTRAL/2801

Will show computer-based machines, including a deluxe terminal and a printer.

# NOW, ONE MICROPHONE CAPTURES IT ALL.

The Sennheiser Telemike Electret Microphone System.

Its unique modular design provides all the flexibility and precision of a collection of separates—from omni to super cardioid, spot to shotgun, telescopic boom to tie-clip lavalier.

All, at a fraction of the price of comparable separates.

And all, with the most advanced electret technology available: our unique back-electret.

See your Sennheiser dealer for details. And capture it all.

All components available separately or as a package.



## SENNHEISER

ELECTRONIC CORPORATION  
10 West 37th Street, New York, N.Y. 10018  
(212) 239-0190

© 1981, Sennheiser Electronic Corporation (N.Y.)

# NOW! CONTINENTAL'S 1 KW AM



**Pulse width modulation** in an efficient 1 kW package; efficiency and reliability of a tube-powered final; clear, crisp sound of transformerless modulation; ready for AM stereo. Switch-mod system allows maximum modulation level at all power levels while providing cost-effective operation.

Write for brochure on 314R-1:  
Continental Electronics Mfg. Co.  
Box 270879 Dallas, TX 75227  
(214) 381-7161

See us at NAB Booth 3134

Continental  
Electronics

# WHY ARE LEDDICONS® WORLD LEADERS?



Higher resolution is an important reason, but did you know that EEV  $\frac{2}{3}$  inch P8160 series Leddicons feature all these advantages?

- \* Precision geometry and registration
- \* Unique anti-microphony mesh
- \* Direct plug-in replacements
- \* Designed specifically for ENG/EFP cameras such as TK76, TK760, HL77, 78, 79, BVP300 and LDK14, CE1300 series etc.

**LEDDICONS are BETTER LONGER**  
**Proven everyday throughout the world.**  
**Specify Leddicons for replacements and**  
**your new camera - Available NOW.**

Please send me my free World Broadcast Systems Map, Brochure and full technical details on Leddicons for my application.

Name .....

Position .....

Company .....

Address .....

Application .....

109C

PHOTO BY TIM STONE



7 Westchester Plaza, Elmsford, NY 10523, Tel: 914-592-6050, Telex: 646180

In Canada: EEV Canada Ltd., 67 Westmore Drive, Rexdale, Ontario M9V 3Y6, 416-745-9494, Telex 06-989363

In Europe: English Electric Valve Co. Ltd., Chelmsford, Essex CM1 2QU, England, Tel. 0245 61777, Telex 851-99103

® Registered Trademark for Leddicon Camera Tubes

See us at NAB Booth 2216

Circle 213 on Reader Service Card

[www.americanradiohistory.com](http://www.americanradiohistory.com)

# NAB: 1982

## MERLIN/1706

Will introduce the ME 258 wideband VTR based on Fernseh BCN Type B VTR, and the ME 238 extended-play conversions for Type C one-inch VTRs. Also will present work on HOTV project undertaken with Compact Video.

## MICRO COMMUNICATIONS, INC./3312

New equipment will include circular and rectangular waveguide units for UHF-TV, as well as microwave antennas and interferometers for 2 GHz, 7 GHz, MDS and ITFS diplexers. Waveguide and coax RF systems, LPTV antennas, VHF and FM antennas are among the other equipment to be shown. Also line of coax and waveguide switches, diplexers, filterplexers, and combiners.

## MICRODYNE CORP./2618

Will introduce the 100 TV video uplink modulator and the 1100 TVE

video uplink 6 GHz exciter. Different sized satellite antennas will also be present.

## MICROTIME, INC./3322

Will feature its compact, low-cost T120 digital TBC and "smart proc amp" option for its 2525 digital synchronizer/image enhancer permitting connection of up to eight sources with automatic setup memory for each. Also full range of other TVCs, synchronizers, image enhancers, noise reducers, plus new products to be announced.

## MICRO-TRAK/3115

Will introduce Telefile, a portable news gathering and production console with cassette tape recorder for TV and radio reporters. (Also see listing in Radio section.)

## MIDWEST CORP./2518

New improved M-20 production vehicle and a standard ENG vehicle will be exhibited. Both vehicles will be shown completely equipped.

## MOLE-RICHARDSON/3203

Will show a full line of both incandescent and HMI lights in styles ranging from spots and floods and fresnels to arc lamps and soft lights.

## MULTI-TRACK MAGNETICS/2922

Will show the Video Avex System, an audio system for production of sound with video. It consists of R 106/ECS master pickup recorder and a D106/DCS horizontally mounted reproducer with complete remote controls. Also on display will be the MST-100 "Hardlock" totally modular synchronizer.

## NADY/1815

Will show its digital video test signal generator.

## NAGRA MAGNETIC RECORDERS/3146

Will introduce the T-Audio servo-controlled studio size ATR transport with SMPTE time code. Also on display will be the 4.2, 4S, and IV-SL stereo recorder/playback units. The TPVR logging machine series will be exhibited, as will the Nagrafax weather facsimile printer. (Also see Radio listing.)

## NEC AMERICA, INC./2528

One of the most promising "new generation" exhibits of the show. New products expected to be introduced include a new digital effects unit with bubble memory; what may be an actual working model of a digital VTR; a CCD color camera billed as

## VIDEO PRODUCTION CONSOLE



8 Inputs 4 Out - Stereo Capabilities  
 Rack Mountable  
 Transformer Balanced Outputs (+24dBm)  
 XLR Mic and XLR Line Connectors  
 E.Q. Defeat - Channel Mutes  
 Built-in Phantom Power (for condenser mics)  
 Dealer Inquiries Invited

*Audiomaster Inc.* 1365-C Dynamics St.  
 No. Anaheim, Calif. 92806, 714-528-4930

Circle 211 on Reader Service Card

RUSSCO'S MARK V VARI-SPEED TURNTABLES MOVE THAT HEAVY 6½LB. PLATTER SO QUICK SMOOTH & QUIET!.. AND YOU'VE GOT DEPENDABILITY AT A LOW PRICE!

YES, DEAR, I THINK IT'S PRETTY.



Write for Catalog with full specs.

**RUSSCO**

ELECTRONICS INCORPORATED  
 See us at NAB Booth 1806

5690 E. Shields Ave., Fresno, Calif.  
 U.S.A. 93727 Phone (209) 291-5591

Circle 214 on Reader Service Card

# EEV high efficiency UHF klystrons pay for themselves...in 1 to 3 years!

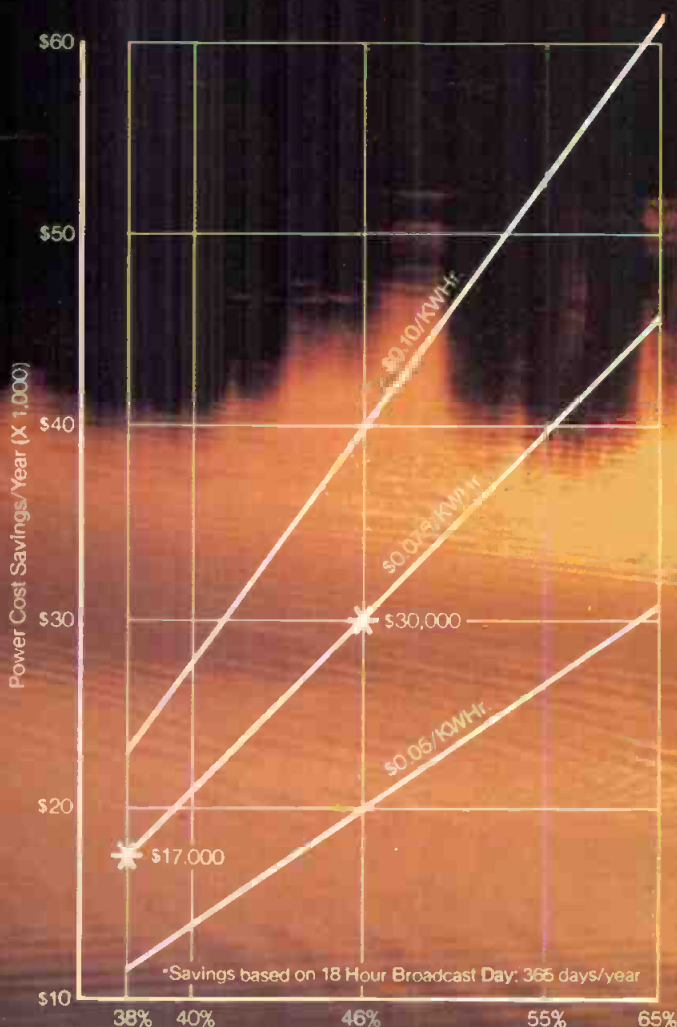

Annual Power Cost Savings using EEV 55KW high efficiency klystron vs. older generation 30% efficiency klystron



## These are the facts.

- Over 70 EEV 55KW high efficiency external cavity klystron installations made during the past three years.
  - These klystrons are operating from 38% to 46% efficiency vs. average of 30% efficiency for older generation klystrons.
  - Annual power cost savings from \$17,000 to \$30,000 for single tube installations.\*
  - Existing transmitters upgraded with new EEV klystrons operating from 38% to 40% Eff.
  - New transmitter installations with EEV klystrons operating from 40% to 46% Eff.
  - Life and reliability proven by 1400 installations worldwide logging over 9,000,000 hours/year.
  - EEV 55KW high efficiency klystrons available for UHF channels 14 to 78.
  - Development work being completed to attain 55%-65% efficiencies for external cavity klystrons with modulating anode or grid pulsing vs. klystron's intrinsic 46% efficiency.
- With these facts you can predict your power cost savings when you install EEV's 55KW high efficiency external cavity klystron.

### Start now.

Specify EEV for your existing or new transmitter, or...

Convert and upgrade your internal cavity klystron system to EEV's external cavity klystron.

Every week you delay installing an EEV 55KW high efficiency klystron can represent an additional 4400KW to 7500KW on your power bill.

\*Based on an 18 Hour Broadcast Day and \$0.75/KWHr.



**EEV, INC.**

7 Westchester Plaza, Elmsford, NY 10523, 914-592-6050, Telex 646180

In Canada: EEV CANADA, LTD., 67 Westmore Drive, Rexdale, Ontario, M9V 3Y6, 416-745-9494, Telex 06-989363

In Europe: English Electric Valve Co. Ltd., Chelmsford, England CM1 2QU Tel: 0245 61777, Telex 851-99103

See us at NAB Booth 2216

Circle 216 on Reader Service Card

**We just  
made it  
worth  
\$3,000  
to visit  
booth  
3207.**



We're Beston Electronics, Inc., BEI. And when you visit us at the NAB Show you're going to be in for a \$3,000 surprise. Because, for the NAB Show only, we've reduced the price of our Marquee 2000 Character Generator with Font Compose \$3,000! You pay only \$28,500.

**MARQUEE 2000 FEATURES:**

- "user" designed keyboard
- self-diagnostics board standard
- computer aided design
- italics
- true character overlap
- economical operation
- formats own discs
- uses only 250 watts
- "camera" font compose

See it demonstrated at NAB Booth 3207. And see all the advantages and capabilities of operating your very own Marquee 2000 with Font Compose. Discuss our convenient leasing options with one of our experienced sales representatives. Call Rod Herring, Jim Sherry or Jim Shaw today Toll-free at 1-800-255-6226, they'll save you that \$3,000 before NAB. A video-tape demo of Marquee 2000 is available, just ask about it when you call.

**IT'S WORTH \$3,000 TO VISIT BOOTH 3207!**



Toll-free 1-800-255-6226  
 In Kansas 913-764-1900  
 TWX 910-749-6410  
 P.O. Box 937 Olathe, Kansas 66061



**MULTIFONT DISPLAY** Up to four fonts from the font library can be loaded from the disc and mixed on a character by character basis.



**KEY OUTPUTS R,G,B** and keying outputs are supplied from the Marquee-2000 so the output may be downstream keyed with the surrounding or drop shadow edging.

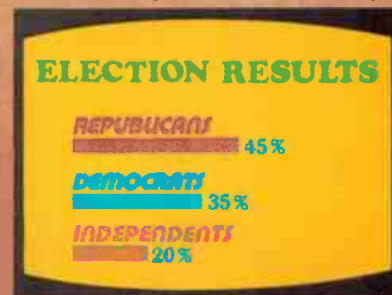

**ITALICS** Any row of text can be made to instantly assume a 13-degree slope at the touch of a key.



**PROPORTIONAL SPACING** Proportional spacing, true character overlap and variable inter-row spacing help produce captions of correct density and weight



**DOUBLE-HEIGHT LOGOS** Large station or client logos can be displayed alongside two rows of text when using the double-height logo capability.



# NAB: 1982

"professional" and perhaps offering broadcast quality; a new generation **Type C one-inch VTR**; and a new 12 GHz **TVRO antenna**. Also featured will be the **LDME digital effects processor**, **MNC-81 ENG/EFP camera**, **TKA-105 routing switcher**, **DV-10 dual video transmission system**, **TMC-105 machine control**, **VHF and UHF transmitters**, and the **Actiontrak effects unit**.

**RUPERT NEVE/3118**

Under the theme, "The Magic of Neve," will introduce the **DSP digital audio production console** for TV, film, and music recording; the **51 Series completely redesigned production consoles**, including a **24-track multi-track version for TV post-production**; the **53 Series stereo broadcast production consoles**, suitable for on-air use; and the **81 Series, a completely new multi-track audio console range** for TV post-production. Will also highlight the **Necam II TV post-production system**, the **542 range of consoles**, and

the **33000 Series limiter/compressors and ancillary equipment**.

**NEWSCAN/MCINNIS-SKINNER & ASSOC./2502A**

Will exhibit its **NewsScan family of newsroom computer systems**, **Weathergraphics high-performance weather graphics system**, and **Weatherscan weather information services**.

**N.O.V.A. CORP./2411**

Will introduce a **universal sapphire tape cleaning device** for videotape.

**NURAD/1607**

Will introduce a number of new **microwave RF and antenna units**: **20PR2 Dualrod with power amplifier**; **NU45R 2 and 7 GHz agile tuner**; **NU20R. 2 GHz frequency agile tuner**; **NU225R 2 and 2.5 GHz frequency agile tuner**; **NU70TA 7 GHz transmitter**; **NU713T 7 and 13 GHz transmitter**; and **NU130T 13 GHz transmitter**. Also showing its full line of other antennas and transmitters for microwaves.

**NYTONE ELECTRONICS/2725**

Will feature **flying spot scanner systems with broadcast quality color slide reproduction**, **80 slide capacity**, **standalone operation**, and **random access capability**.

**OAK COMMUNICATIONS/2206**

Orion satellite **encode/decode system** and **Sigma (advanced) multiple-channel, high security addressable STV decoder** are two new systems to be introduced. Also new **Frontier decoder**. Other units are the **Alpha addressable single channel STV decoder** and additional **Sigma and Orion systems**.

**O'CONNOR ENGINEERING/2001**

Will introduce new **metal tripods and adjustable side-loading platform** for **Model 50-D. Mechanical pedestal, adjustable spreaders for tripods, and adjustable spreaders with wheels** for tripods are among other new items to be shown. Also **Hydroped**. Full line of **fluid camera heads and wooden tripods and accessories** will be on display.

**OKI/2218**

Will show its **LT-1200 portable digital TV standards converter**, totally automatic for **NTSC, PAL, SECAM, or PAL-M operation**.

**OLESEN/2012**

Will bring its line of **television lighting equipment, TV studio layouts, dimming and distribution equipment, track rigging for cycloramas and cyc**

## Weather and News without the **BLUES**



**No blue tint or edging—all hair detail intact!\***

These same results are possible in **your newscasts and other live broadcast situations**. Operating on a new principle, detail from the foreground camera comes through perfectly in the composite—including each strand of hair, smoke, liquid, shadows, transparent objects—the works! **No blue tint, blue edging or edge crawl—no "cut-out" look; no soft edges on hard objects—no hard edges on soft objects.**

**NEWSMATTE** needs no encoder and is simple to operate with its one knob control. It will integrate into your switcher or can stand alone. **NEWSMATTE** marks a breakthrough for live broadcast just as the Emmy award winning **ULTIMATE-4** was a breakthrough for commercials and TV production. Call or write **now** for more information or a demonstration.

### See **ULTIMATE'S NEWSMATTE!**

**ULTIMATE CORPORATION** 18607 Topham St., Reseda, California 91335 USA • (213) 345-5525

\*Actual photo from BARCO CTVM MONITOR

Circle 218 on Reader Service Card

See us at booth 2738 at NAB



**Another step ahead.**

**In synchronizers.  
In TBC's.**

See us at the show.  
NAB Booth #3322  
NTCA Booth #1613



Circle 219 on Reader Service Card

[www.americanradiohistory.com](http://www.americanradiohistory.com)

THE SKY'S THE LIMIT

# NAB: 1982

screens, studio fabrics and lighting grids, and studio flooring.

### ORBAN ASSOCIATES/1812

Will introduce the new Optimod 8180A **compressor/limiter** expressly for TV audio, incorporating FM Optimod design system. Also bringing to the NAB for the first time the Model 424A **two-channel compressor/limiter and de-esser**.

### OTARI/1611 and 2214A

New products on display will be the 5050 MK III **compact production recorders** in quarter-inch two-track and half-inch four-track tabletop cabinet configurations. Also the MTR 90-8 one-inch eight-track version of 16/24 channel MTR 90, the MTR 10 full track version, with new **cabinet and mounting options** to entire series including desk, overbridge, and rack configurations are also new. Also VL 500/600 **fully automated videocassette loading product line** (VHS and Beta).

### PACE, INC./2723

Will introduce the new MP-1 **portable circuit board repair system** and regular line of printed circuit board repair systems.

### PANASONIC VIDEO SYSTEMS DIV./3217

Will highlight its **single-piece camera/VCR combo** with standard 2/3-inch tube camera and Matshushita/RCA three-track recorder format; camera may have been renamed ReCam. Also showing broadcast cameras,

*The LDK-5 triax repeater, new from Philips, for use with the LDK-5 and 5B cameras.*



plus 700 B-2 Series time code VCR editors interfaced with AU-700 VCRs. May also bring line of monitors.

### PARSONS MFG./2023

New equipment includes **recessed wheels and recessed handle cases**. Also shown will be carrying cases for portable audio/visual equipment.

### PEP, DIV. OF ELECTRONIC APPL./3211

To introduce a new line of nicad **ENG battery charger systems** including battery charging stations, portable 12 and 30 V dc lighting, and camera mounted ac adapters. Also on display will be the Christie Reflex-20 system of super fast-charging batteries.

### PERROTT ENGINEERING LABS/2011

Will exhibit battery packs and chargers for both nickel-cadmium and silver-zinc batteries.

### PHILADELPHIA RESINS/1715

Will show non-metallic antenna guys.

### PHILIPS TEST & MEASUREMENT/3215

Will exhibit a full line of test gear such as waveform monitors, vectorscopes, modulators, demodulators, signal generators, and signal analyzers.

# 8000 FROM CETEC

Cetec's new 8000 Series console was designed and built especially for broadcasters. You get all the features you need without paying for things you don't use. This means you get a luxury console — including precision Penney and Giles faders — at a moderate price. Features include five

lighted meters, two peak indicators, five advisory enuciators, and a built-in LCD timer. In addition to the 25-watt RMS monitor amp, there is a separate headphone amp with enough gain to keep

everyone happy. Just pull the monitor control knob and you get instant mono sum for quick A/B comparison. You can even feed all

three stereo busses and the mono

buss at the same time without interaction. Great specs include low distortion and noise, with plenty of head-room. Strong RF fields do not affect the 8000. Broadcasters helped us design the 8000, and the results are just outstanding.

Isn't it time you talked to Cetec?



See for yourself  
at NAB Booth 3136

Circle 215 on Reader Service Card



# THE FUTURE IS IN CONTROL.

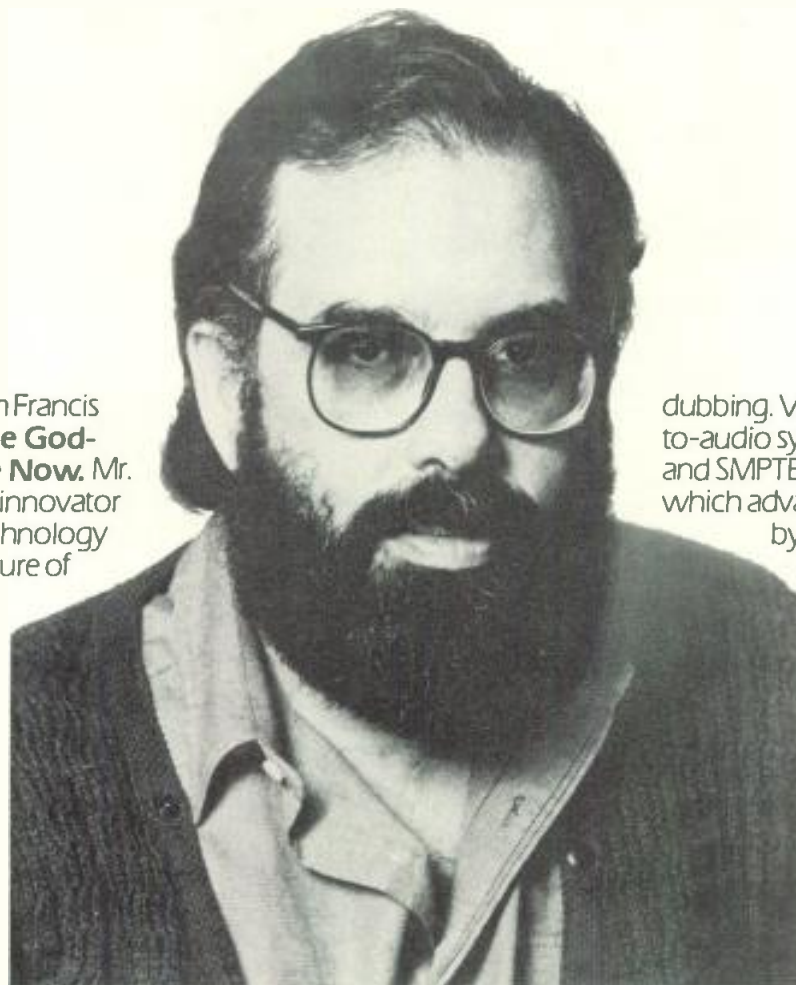

That's the message from Francis Coppola, film father of **The Godfather** and **Apocalypse Now**. Mr. Coppola, the preeminent innovator in applying electronics technology to cinema, believes the future of filmmaking lies in the use of "thinking machines," computers and communication devices that give him precise control over all the elements of film production.

Control Video Corporation is helping Francis Coppola translate vision into reality, right now. Because at the heart of his "electronic cinema" concept is our microprocessor - and software-based Intelligent Controller.™ Says Coppola: "We back up every foot of film with video tape, then do all the work edits in the lower cost medium. The Control Video system allows us to code reels, scenes, and takes, do the edits quickly and accurately, and then conform them back to film. It's a tremendous help."

Francis Coppola's message is as relevant for broadcasters, production and post-production specialists as it is for filmmakers. Because the Intelligent Controller's modular concept allows you to plug in card options that put you in control. Computerized tape editing, of course. Multiple machine control. Automatic window

dubbing. Video-to-video and video-to-audio synchronization. A real-time and SMPTE time clock. A "Stroker,"™ which advances a VTR by one frame by passing your finger over a pad. And now, the "Lightfinger"™ option that controls the entire editing system by simply touching a CRT-displayed menu.

Control Video also makes The Sequencer,™ which provides complete automation for cable TV systems, broadcast stations, and closed-circuit video operators.

If you're involved in video editing, like Francis Coppola - or like Lucasfilm, Hanna-Barbera, Teletronics, Warner-Amex, and other users of our products - you know that control means convenience, flexibility, cost savings, and a better product. And control, in the end, means Control Video Corporation.

Call or write today for complete information on the Intelligent Controller, or other Control Video products. Start building for the future now.



See us at NAB Booth 2324

  
**Control Video**

Control Video, 578 Division Street, Campbell, CA 95008, (408) 866-7447

Circle 222 on Reader Service Card

[www.americanradiohistory.com](http://www.americanradiohistory.com)

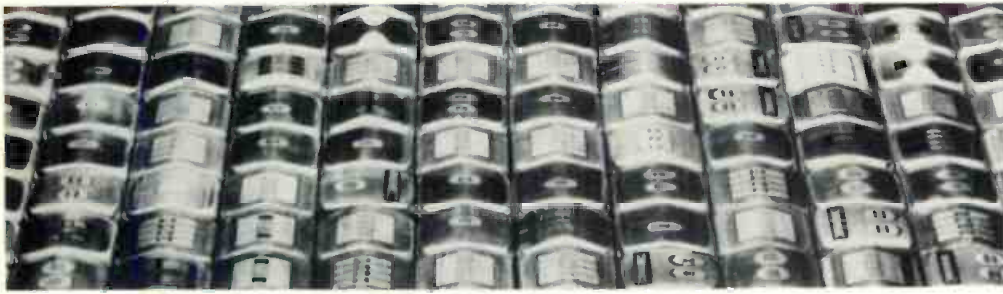

**FOR 27 YEARS WE'VE  
BEEN THE LEADER IN  
MAGNETIC HEAD PERFORMANCE.  
THIS YEAR IT'S  
ACCESSORY PERFORMANCE.**

Recording equipment designed to tolerances for professional applications requires state-of-the-art accessories and maintenance products. Since 1965 when Nortronic pioneered the first all-metal-faced broadcast recording heads, we've understood the critical need for keeping those heads as good as we've built them.

Nortronic Performance Series for the professional. From head cleaners to degaussers, the finest accessories are now available through your distributor. Or call Nortronic at 1-800-328-5640 for the distributor nearest you.

Nortronic Co., Inc.  
8101 Tenth Avenue North,  
Minneapolis, MN 55427

**NORTRONICS**  
People, Performance, Pride

Circle No. 220 on Reader Service Card

**BOOTH  
3311**

**See PERVEAC**  
(Perv-e-ac)

A breakthrough in UHF klystron  
efficiency control.

**TOWNSEND**  
INNOVATORS IN TELEVISION TRANSMISSION SYSTEMS.

Townsend Associates, Inc. • P.O. Box 1122 • Mainline Drive Industrial Park  
Westfield, MA 01086 • Tel. 413-562-5055 • TWX #710-356-1521

Circle No. 221 on Reader Service Card

THE SKY'S THE LIMIT

**NAB: 1982**

**THE PHOEBUS CORP./1713**

Will have a new Ultra Quartz follow spotlight, and also the Ultra Arc with long and short throw.

**PORTA-PATTERN  
TELECOMMUNICATIONS/1803**

New equipment on display includes 11-step log gray scale chart, 16 mm BBC color flesh tone reference film loop, and 35 mm black and white chess board aspect ratio transfer alignment film. All with telecine alignment applications.

**POWER-OPTICS/3113**

Will show its line of remote control pan/tilt systems for video cameras, and instruments for color monitor set-up and antenna positioning. Also Scene-Sync camera/art stand synchronizer for in-camera matched chroma-keying.

**QUAD EIGHT  
ELECTRONICS/2705A**

Will introduce the 248 component series audio console. The System 5 digital reverb processor will also be on display—a high speed processing unit with 103 dB dynamic range, and approximately 96,000 different settings. Other products in the company's line include the Model 24 automated console with 32 mixing channels and floppy disk editing unit, and SMPTE interface to VTRs.

**QSI SYSTEMS/1502**

Will introduce two color bar identifiers and the DEMOD-400, featuring replacement sync, burst, and blanking. The VSID-Tally is new, and a character generator which adds alphanumeric characters to television video source can be seen. Also on display will be the VT-7 countdown generator and the CB-7000 and CB-7100 color bar identifiers.

**Q-TV/3011**

Exhibiting video prompter cueing equipment with studio and on-location prompters available.

**QUICK-SET/3008**

Will show line of video camera heads, tripods, pedestals, and dollies.

**RANK CINTEL/2516**

Will unveil the brand-new Mark IIIC flying spot scanner telecine with new Varispeed module to permit time compression/expansion without loss

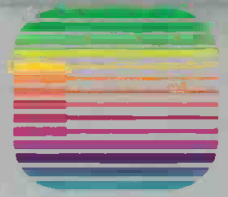

## INNER VIEW: A closer look at Conrac Monitors

### Active Convergence: Registration made simple.

Conrac's Active Convergence System gives you complete control over color registration adjustments and greatly streamlines convergence checks.

It uses 36 independent controls to individually adjust nine separate areas on the CRT screen—including corners!

You spend less time on convergence checks—and the adjustments you make will be much more accurate.

Conrac's system uses 24 operational amplifiers to independently control red, green, and blue in each screen area. Vertical and horizontal waveforms are referenced for shaping the signals that excite the convergence yoke assembly. Dynamic blue lateral convergence is achieved with operational amplifiers.

### Beam Current Feedback: The Ultimate in Black Level Stability.

Conrac's unique Beam Current Feedback system maintains a more stable picture for a longer period of time.

It automatically maintains black level stability—regardless of CRT aging or component drift. In fact, black level is held to within 1% of peak luminance level between 10% and 90% APL (Average Picture Level).

Conrac's unique system uses a keyed back porch video amplifier and beam current sensing that occurs during the vertical interval.

The video signal is ac coupled to the video amplifier, thus eliminating the dc component and retaining the level between black and white. It is then amplified and applied to G1 of the CRT. The feedback loop is completed when a sample cathode current (gated by the brightness pulse) is applied to a sample and hold circuit.

If the cathode current changes for any reason, the video amplifier's dc level is automatically adjusted. Result: reference black level will remain constant.

### Conrac Technology: 30 years of leadership.

Conrac's track record of technical innovation stretches back nearly three decades.

And what we've learned since then goes into every monitor we make today. That's important to you. Because the more technology we pack into each monitor, the more performance you'll receive from it.

Active Convergence and Beam Current Feedback are just two ways Conrac technology can save you time and money.

For the complete inner view of Conrac technology, call or write us today: Conrac Division, Conrac Corporation, 600 North Rimsdale Ave., Covina, CA 91722, Telephone: (213) 966-3511, Telex: 67-0437

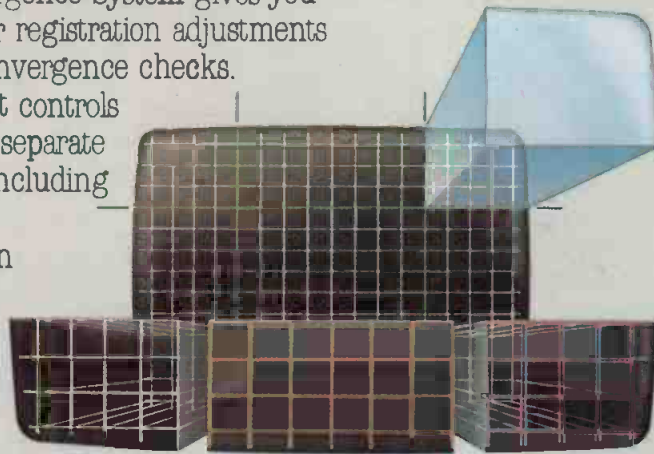

Conrac's Active Convergence system lets you adjust color registration on nine separate areas of the CRT.

Conrac's exclusive Beam Current Feedback system automatically maintains black level stability.

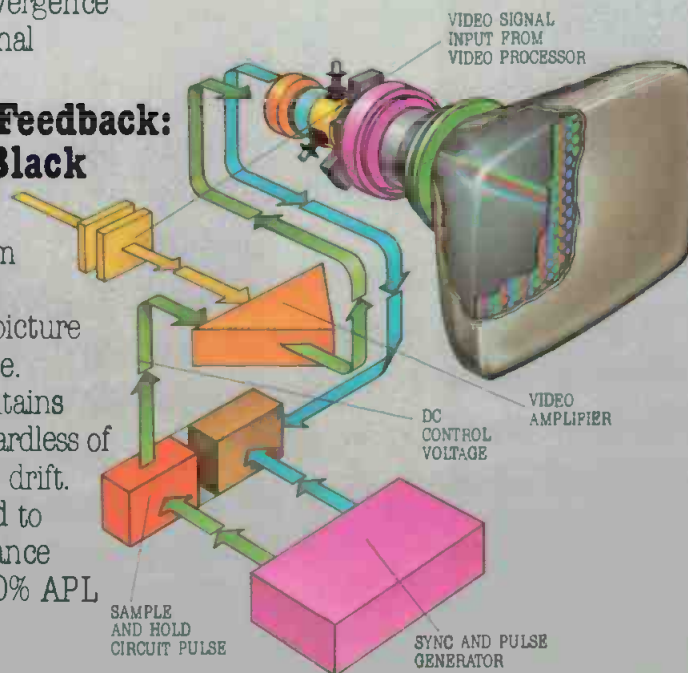

Quality you can take for granted.

# NAB: 1982

of light. Also TOPSY scene-by-scene color correction and X/Y Curser controlled pan/scan during transfers.

## RCA/3001

Will show the Hawkeye system, including the HCR-1 recording camera, HR-2 studio recorder, and the new HE-1 edit controller. The TK-47T triax and TK-47 automatic cameras will also be on hand, with new remote control options. Other equipment is the TK-29 telecine system, operating with Colorist system for color correction application, and the TR-800 one-inch VTRs (with CMX computer controlled editor.) Along with a complete line of visticons, Saticons, and vidicon tubes will be two G-line VHF transmitters and a 55 kW UHF TT-55. (Also see listing in Radio section.)

## R-COLUMBIA PRODUCTS/2612

New unit will be the System 40 base station interface for interconnecting RF intercom headsets and existing hardwired intercom systems. Another new line will be the FM wireless in-

tercom headphones. Intercom headphones and microphones for broadcast use will also be shown.

## RECORTEC/3137

Will show one-inch tape cleaner/evaluator. Also the LPA long play attachment for nine-hour play/record time on standard 3/4-inch VCRs and three-hour record time on Recortec high-band modified U-Matic VCRs. Also in the company's line is the HBU-4400 portable U-format recorder, and tape timer for quad machines.

## REES ASSOCIATES/2844

Offers architectural and engineering services for planning of broadcast facilities.

## RESEARCH TECHNOLOGY INTERNATIONAL/1903

Featured will be the 3/4-inch videocassette evaluator/cleaner, which operates at 25X normal play speed. Cinescan, a high-speed 16 mm film viewer and the TV-120 film care system designed for previewing, editing, and inspecting films quickly will also be seen.

## RF TECHNOLOGY/2720

New microwave equipment on display will be the RF 212 12 W trans-



A half-inch Saticon with coil from RCA.

mitter and the RF 710 7 GHz power amplifier. Other products on hand will be the camera-mounted wireless microwave system, including RF 203 200 mW transmitter, RF 200 2 GHz receiver, and RF QA6 camera-mounted antenna.

## ROHDE & SCHWARZ/ BARCO/3213

A group-delay measuring set and the UPSF2 video noise meter, along with the EKF2/D precision TV demodulator, will be the new equipment on display. Also to be seen are the video signal generators, noise generators and stereo decoders. TV mod and demod and b/w and color monitors will also be shown.

## ROSCO LABS/2000

Will introduce a kit for color correction of video or film, and four new

# PUZZLED?

## WITH THE PIECES IN A SYSTEM?

We're the most complete systems Company you've ever seen.

- Video Equipment
- System Design
- Turnkey Installations
- Remote Trucks

## WE MAKE THE PIECES TOO!

- AE-3 Automated A/B Rolls
- VO-5850D — A VTR with extras.

# delcom

The leading edge in television  
Tulsa 918-494-9500

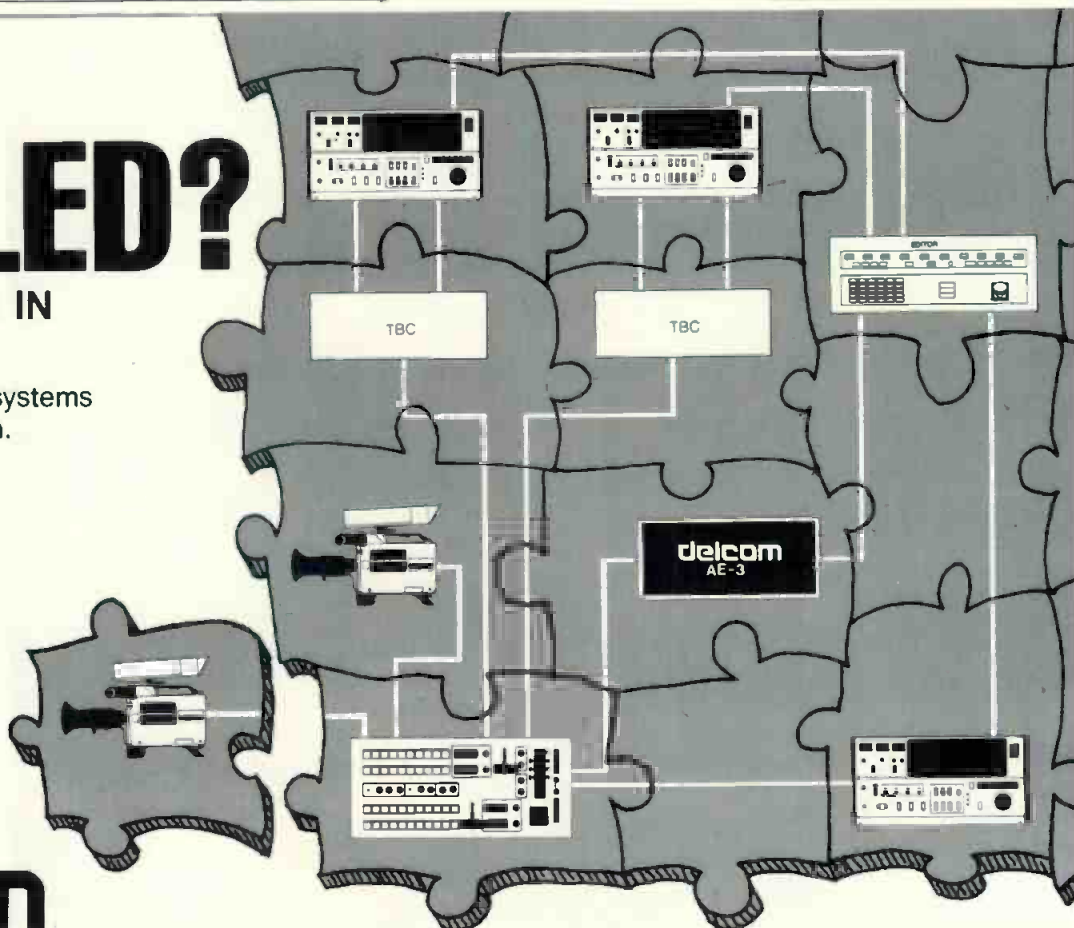

CHECK US OUT AT NAB BOOTH 2710 LOWER LEVEL — NORTH  
St. Louis 314-432-1164 Oklahoma City 405-942-1339

# Progress by Design

Videotek's philosophy is to progressively design & refine the quality, function, and reliability of our products, and to provide equally aggressive service-after-the-sale.

Videotek's state-of-the-art TSM-5A Waveform Monitor and VSM-5A Vectorscope reflect this on-going commitment, with such innovative features as Internal Graticule CRT for precise parallax-free signal analysis, and Non-Glare Shields to eliminate distracting ambient light. TSM-5A also includes selectable 1H mode for easy one-line viewing, and 0.5  $\mu$ s/div. scan rate for the most accurate time-base measurements.

Our popular Studio 12 picture monitor includes, as standard equipment, the features found on monitors costing twice as much: A-B Split Screen, Selective H-AFC, High Voltage Regulation, ACC-Defeat, Preset Controls, Pulse Cross, Underscan, External Sync plus more.

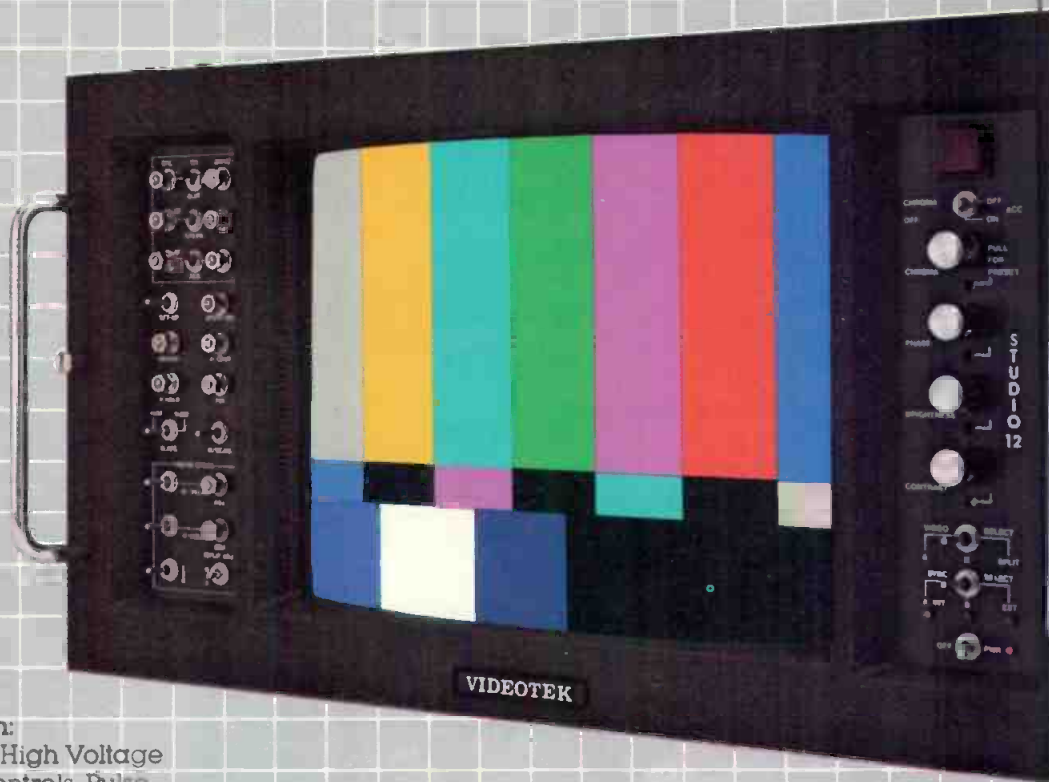

(all available in AL standard)

In only 7 years, Videotek has become an industry leader. We design and build more sizes and configurations of color monitors than anyone—worldwide! And our 1981 "Distinguished Video Industries Service Award" stands as a testimonial to our commitment to your needs.

**Now that's Progress...by Design.**



**VIDEOTEK  
INC.**





# McMICHAEL ACE CONVERTER

## the best in Standards Conversion

### McMICHAEL ACE FOUR FIELD CONVERTER

is the world's most sophisticated and accurate standards converter and is the accepted new standard for the industry.

- ★ Only converter in the world with four fields of digital storage
- ★ Bi-directional conversion between PAL, SECAM, NTSC and PAL-M and any other internationally recognized TV standards
- ★ No flicker on horizontal edges
- ★ Virtually transparent conversion
- ★ Minimum judder on vertical and horizontal motion
- ★ No loss of detail on pans
- ★ Significant noise reduction
- ★ Accepts and repairs signals that are out of specification
- ★ Soft failure modes
- ★ Price competitive to all other similar but less sophisticated systems

ACE is manufactured under license from the BBC who use ACE exclusively for standards conversion

McMichael Limited is an advanced electronics company with over 60 years' experience in the development and manufacture of state-of-the-art electronics.

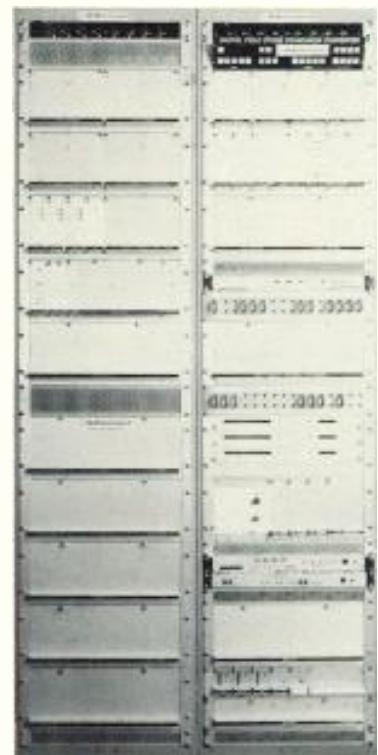
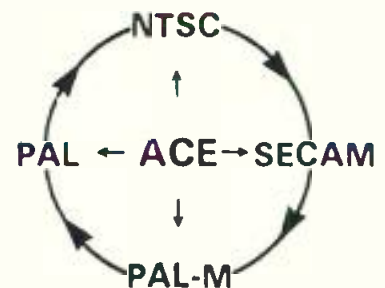

# McMICHAEL ACE CONVERTER

Marketing Dept.

McMichael Limited, Wexham Road, Slough, Berks SL2 5EL, England  
Tel (0753) 21610 Telex 849212

Circle 228 on Reader Service Card

# NAB: 1982

materials for balancing lights. The full Cinegel line of correction filters will be displayed, as well as cyc and rear screen materials.

## ROSS VIDEO/2310

Will introduce a scene store memory system for its production switcher which provides recall of switcher set-up information. Also on display will be Models 514 and 508 video production switchers, with multi-level effects (MLE) and transition preview system.

## RTNDA/3205A

Members and officers will be present to discuss the Radio and Television News Directors Association; will also show videotapes of award winning news.

## RTS SYSTEMS/1604

Will show its full line of intercom and IFB systems with conference line, multi-function, one-way, and point-to-point capabilities.

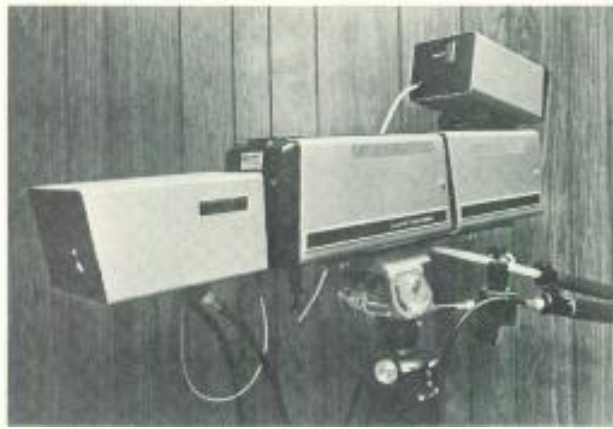

One from the color camera line of Sharp Electronics.

## SAKI MAGNETICS/1722

Will introduce new audio posts for one-inch and 3/4-inch Ampex and Sony VTRs. Long-life replacement heads for Studer Revox and Otari quarter-inch tape recorders will also be announced. (Also see listing in Radio Section.)

## HOWARD W. SAMS & CO./2703

Distribute audio/video catalogues and electronic, microcomputer, and video books and publications.

## SCIENTIFIC-ATLANTA/1602

Will show new digital audio earth station for radio stations. Includes three-meter earth station antenna, 120 degrees K LNA, digital receiver, and audio channel units. Also full line

of earth stations and equipment for TV applications.

## SENNHEISER ELECTRONIC CORP./2101

Will introduce the first directional lavalier microphone, the MKE 40-3. The company's lightest weight (2 oz.) monitoring headphone, the HD40, will also be on display, together with its full range of other mics.

## SHARP ELECTRONICS/1906

Will exhibit for the first time the Model XC-800 color camera for ENG/EFP, which has 9/18 dB gain, 16 times DBO range, auto white and black balancing, genlock, remote control with 300 meter range. Will also show the XC-700 ENG/EFP

# GET YOUR SIGNALS STRAIGHT!

The VCA-2 Clamping Amplifier.

You've got a problem — 1000 feet or more of remote video cable that's adding frequency distortion, hum and bounce to your video signal. But, don't worry — we've got the solution! AVL Digital solves cable length problems and more, with the VCA-2 Clamping Amplifier.

The VCA-2 equalizes frequency response loss caused by cable length. At the same time, it also reduces hum and bounce by using back porch and sync tip clamping without affecting the reference burst.

Versatility, at a low cost and in a minimum of space, is another feature of the VCA-2. It allows complete restoration of the sync pulse signal and maintains it at proper levels despite video level changes of up to 10 db. Other functions include differential phase and gain distortion compensation, adjustable white level clipping for both colour and monochrome signals and input circuitry which allows common mode hum rejection up to 40 db.

AVL's Clamping Amplifier is available in six configurations through combinations of the basic unit with a cable equalizer option, differential phase and gain equalizer option or a high gain amplifier option. No matter which variation you require, the result is distortion-free, more accurate video. Get your signals straight with AVL Digital!

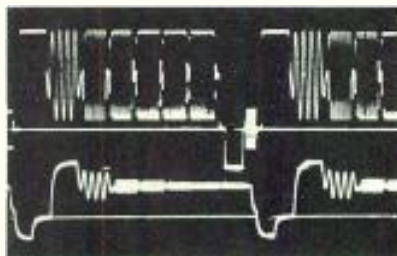

4.2 MHz MULTIBURST signal shown as the input and output of a VCA-2. These represent the equalization after being fed through one mile of 724 cable.

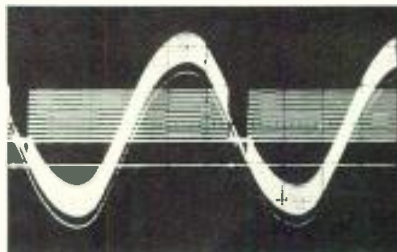

STAIRCASE signal shown as the input and output of a VCA-2. A 5 volt p-p hum superimposed onto the staircase signal at the input has been removed by the VCA-2 to restore the original Staircase signal.



**AVL DIGITAL LTD.**  
70 Milner Avenue, Unit 5  
Scarborough, Ontario Canada M1S 3P8  
Telephone: (416) 298-6220  
Tlx: 06-963533 Twx: 610-4923219

See us at N.A.B. — booth #3106

Circle No. 225 on Reader Service Card

BME MARCH, 1982 159



**"Confidentially...  
*registration* is a  
big pain in the neck."**

Not so confidentially ... there is an incredibly small solution for this big problem. It's called a Microprocessor and it can be slipped into most CEI cameras, **old or new**, at little cost.

What this compact little brain does is continually register your camera, invisibly and without fuss, throughout a shoot. It uses picture detail instead of a cumbersome diascope. Make sense?

Furthermore, if your camera is out of registration because of non-use, maintenance, or shock, the friendly microprocessor instantly diagnoses the problem and tells you, in English, on your viewfinder, what to do.

Black or white balance off? Same quick solution. The helpful microprocessor fixes it or spells out the correction in your viewfinder.

Also, the versatile microprocessor will control the iris, measure the light level, tell you the lens-opening, recognize specific colors, generate time code ... we could go on and on.

Each camera has its own friendly microprocessor. A neat touch, if you don't want to use it, simply flip a switch, do it yourself and let the little fella rest.

Suggestion: Rap with CEI's microprocessor at the NAB. MAIN LEVEL, BOOTH 3321.



**CEI**

880 Maude Avenue  
Mountain View, CA 94043-4089  
415/969-1910 Telex: 348-436

Circle 230 on Reader Service Card

THE SKY'S THE LIMIT  
**NAB: 1982**

color camera and the line of monitor/receivers.

**SHINTRON/1603**

Will show for the first time the Model 200 Series **modular distribution amplifiers**. Also introducing the Model 515 Fortex **graphic titler**, with downstream matte keyer and genlock sync generator. Showing line of video switchers, character generators, time code generators and readers.

**SHOOK ELECTRONIC ENTERPRISES/2628**

Will unveil a new 22-foot mobile **television production system** with a 14-foot production area. The unit is a self-contained, self-powered vehicle suitable for exterior remote productions or as a control facility for interior or studio productions.

**SIGMA ELECTRONICS/2614**

will introduce the BBG-550 plug-in module for **modular distribution system** to add SCH adjustable black burst signal; and the BBG-144 stand-

alone **black burst module** with four phase adjustable black burst outputs. Also will show line of sync generators and distribution system.

**SKIRPAN LIGHTING SYSTEMS/1604**

Will show lighting control systems for all broadcast studio applications.

**SKOTEL/2816**

New character generator option for the TCR-TCG **time code reader/generator series** will be introduced. VITC time code reader and generator,

*Expect more advances for Sony's Betacam.*



digital metronome, and portable time code readers and generators will also be shown.

**SONY/3200**

Major new product introductions will be made in several areas. A brand-new **three-tube version of the Betacam** will be shown, interchangeable with the single-tube version and using the same, separable recorder. Also brand-new will be BVH-2000 **Type C one-inch VTR**, described as lighter, smaller, and having more features and operational conveniences than the previous generation. Also showing the BVX-30 digital multiprocessor; full line of ENG cameras including BVP-110, 300, and 330 with new features such as **triax operation**; BVE line of editors including three-machine and multisource systems; new BVU-800 and 820 front loading cassette decks including track following capability; and line of professional audio products. (Also see listing in Radio section.)

**SPECTRA COMPUTER SYSTEMS/2415**

Will introduce the new S-1010 **fine arts graphic computer**, with weather and graphics software options including digital paint programs. The company also has the Weathercaster

# BUILT TO MAKE IT!

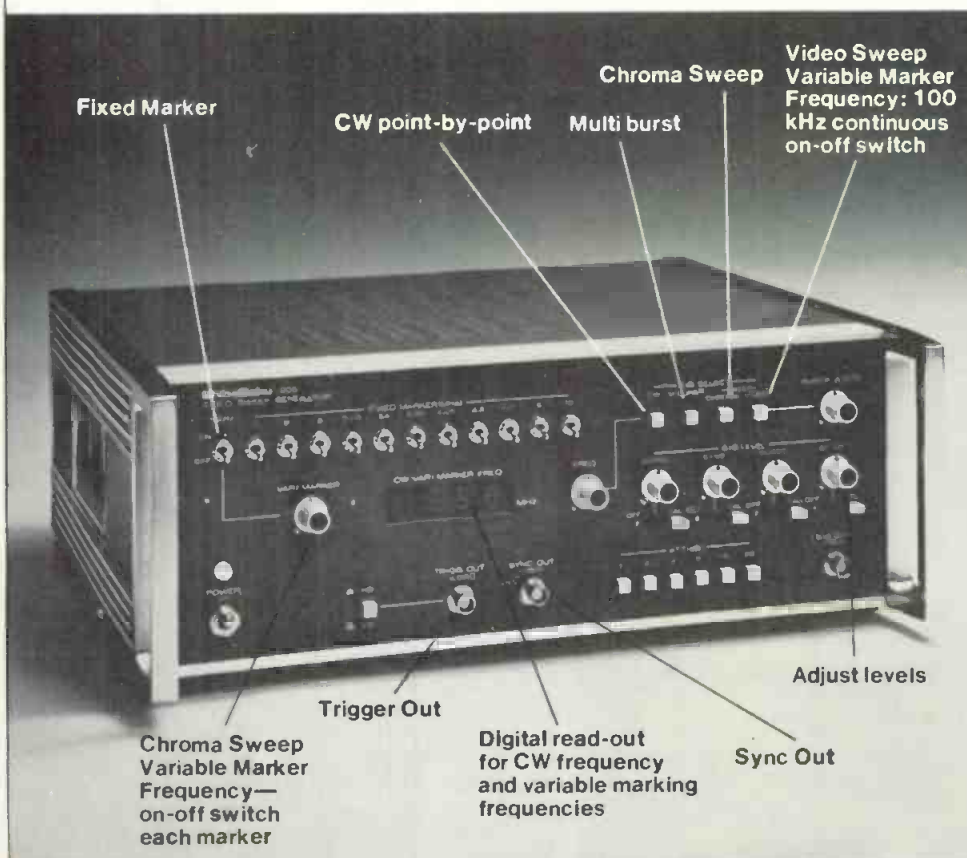

**AND MAINTAIN IT!!** Measures frequency response on TVs, VTRs and other video equipment.

The Asaca Video Sweep Generator 205 contains a built-in standard color sync signal generator. The color burst can be switched on and off so the 205 is ideal for oscillator comparisons to measure frequency response of color equipment.

There is a selection of output signals: video sweep (0.1 - 10 MHz), chroma sweep (sub carrier  $\pm 2$  MHz), CW and multi-burst.

Also, the 205 features facilities for composite sync signal outputs and trigger pulse outputs (H. D/V. D. Selectable) and so it can be used for oscilloscope triggering. Digital read out for CW frequency and variable marking.

Contact your Asaca distributor for details or demonstration. Or write to:



ASACA CORPORATION OF AMERICA  
 1289 Rand Road, Des Plaines, Ill. 60016  
 (312) 298-4380

# Crosstown or cross country, call Calvert first.

You'll get the lowest price in America *and* overnight delivery.

## TRANSMITTING TUBES

3B28	14.00	4CX1000A	370.00	673	45.00	6146A	8.95
3CW2000A3	1375.00	4CX1000K	502.00	805	55.00	6146B	8.95
3CW2000A7	1507.00	4CX1500A	584.00	807	8.50	6155	75.00
3CX1000A7	527.00	4CX1500B	470.00	810	55.00	6156	90.00
3CX1500A7	465.00	4CX3000A	871.00	813	45.00	6161	550.00
3CX2500A3	432.00	4CX5000A	1025.00	816	5.75	6166A (7007)	2640.00
3CX2500F3	469.00	4CX10000D	1069.00	828	88.00	6696A	2850.00
3CX3000A1	432.00	4CX15000A	1430.00	833A	85.00	6697A	3000.00
3CX3000A7	601.00	4CX20000A	1520.00	836	8.75	ML7007A	3750.00
3CX3000F1	516.00	4CX35000C	5525.00	866A	7.25	7237A	553.00
3CX3000F7	610.00	4CX40000G	7075.00	866AX	38.00	7527	130.00
3CX10000A3	1130.00	4X150A	50.00	872A	17.00	7527A	165.00
3CX10000A7	1382.00	4X500A	320.00	880	2034.00	8008	16.00
3CX15000A3	1260.00	4-65A	65.00	889RA	1800.00	8122	88.00
3CX15000A7	1340.00	4-125A	75.00	891	1790.00	8791VI	387.00
3CX20000A7	1837.00	4-250A	90.00	891R	2395.00	8792VI	690.00
3-400Z	90.00	4-400A	105.00	892	1925.00	8806	2500.00
3-500Z	99.00	4-400AX	165.00	892R	2240.00	8807	2660.00
4CV35000A	2500.00	4-400B	130.00	4055VI	119.00	8873	191.00
4CX250B	57.00	4-400C	95.00	5762	545.00	8874	191.00
4CX250BC	71.00	4-500A	221.00	5867A	135.00	8875	191.00
4CX250K	120.00	4-1000A	420.00	5879	4.80	8890	2500.00
4CX250R	95.00	5CX1500A	650.00	5924A	825.00	8891	3375.00
4CX300A	161.00	5CX3000A	1055.00	5933	19.00	8916	3375.00
4CX350A	90.00	5-500A	260.00	6076	560.00	8985	1650.00
4CX350F	118.00	575A	29.00	6076A	695.00	8986	1275.00

## RCA CAMERA TUBES

PART NO.	PRICE	PART NO.	PRICE	PART NO.	PRICE	PART NO.	PRICE
BC4390 series	1955.00	BC4593R	2444.00	BC4992 series	2350.00	BC7735	240.00
BC4391 series	2222.00	BC4594 series	2444.00	BC4993R	2555.00	BC8134	766.00
BC4392 series	2350.00	BC4809	750.00	BC4994 series	2555.00	BC8134B	766.00
BC4393R	2555.00	BC4809B	750.00	5820A/L	3295.00	8480	1161.00
BC4394 series	2555.00	BC4908 series	1955.00	7295C	2950.00	BC8480	1905.00
BC4532U	1375.00	BC4909	2050.00	7389C	3050.00	BC8507	275.00
BC4592 series	2238.00					BC8541	275.00

NEW CUSTOMERS—we accept telephone orders. Inquire about our convenient Net 30 terms.  
Prices and items subject to change or withdrawal without prior notice.

TOLL FREE 800-526-6362

7 DAYS—24 HOUR  
EMERGENCY PHONE SERVICE

TOLL FREE 800-526-6362



## SPECIAL NAB DISCOUNT

All Items This Ad.

Calvert offers you  
Significant Discounts  
on telephone orders.

CALL TOLL FREE FOR DETAILS

Offer expires April 15, 1982

# CALVERT ELECTRONICS, INC.



ONE BRANCA ROAD, EAST RUTHERFORD, NJ 07073

800-526-6362 • 201-460-8800 • TWX 710-989-0116/ERFD • TELEX 4754059

West Coast: 1355 Redondo Avenue, Suite 6, Long Beach, CA 90804 ■ 213-498-3504/3184

England: Imperial House, Victoria Rd., Chelmsford, Essex CM1 1NY ■ Telephone: 0245 358585 ■ Telex: 995849

# NAB: 1982

**CT-100 weather forecasting computer system** with animated weather presentations for broadcasting.

**STAINLESS/2418**

Will show its line of antenna towers for radio, TV and microwave applications.

**STATION BUSINESS SYSTEMS/3302**

Will show the **BAT-1700 business accounting and traffic systems** using an in-house mini computer with options such as Music Play list and inventory, program package inventory, media cartridge inventory programs. Also newscom **newsroom computer system**.

**STOREEL CORP./3205**

Will highlight space-saving storage systems for the television and radio industries, including a new **double-entry setup truck** to be introduced at NAB. Also on exhibit will be high-density storage systems for TCR-100 RCA carts and ACR25 Ampex cas-

ettes and multiple-purpose mobile storage systems with horizontal or vertical bases.

**STRAND CENTURY/3328**

Two new fresnels in six- and eight-inch sizes will be introduced. The 6000 W Ianiro HMI 14-inch fresnel, one of the smallest and lightest 6Ks available, will also be on display. Also lighting control systems.

**STUDER/REVOX/3123**

Will show prototype of new **A810 audio recorder** with microprocessor-controlled transport and elimination of all trimpots in favor of D/A converters under microprocessor control. Memory stores alignment for four tapes. Unveiling new **900 Series Consoles**. Also exhibiting the line of other tape recorders, consoles, tape editing system, telephone hybrid interface, SMPTE synchronizing system.

**SYLVANIA/GTE/3013**

Introducing the New Brite Beam Lamp, a **daylight fill lamp** of high efficiency. Also will have line of other lamps for television applications.

**SYSTEM CONCEPTS/1705**

Will debut the **QuantaFont Model Q-8 teleproduction titler**. Features include

font library loadable from floppy disk, multiple type faces and font sizes per resident load, and multi-row logos. Also featured are 26.1 ns resolution, proportional space characters, borderline and shadow edging, eight background and character colors, and multiple remote keyboard capability. Other products on display are the **QuantaFont Q-7A, Q-7A/R, and Q-6** titlers, and the **QST** subtitling system, as well as the **QuantaNews** computer assisted broadcast newsroom system.

**SYSTEM ASSOCIATES/2411**

Will describe brokerage service for used broadcast equipment, through which they buy and sell items through free listing in flyer sent to users across the country. Listing is held until needs are met.

**TAYBURN ELECTRONICS/2308**

Will introduce the new computer-controlled **ENG microwave news gathering systems**; and a new **frequency-agile portable helicopter microwave electronic system**. Also showing the line of microwave antennas, transmitters, and receivers.

**TDK/2726**

Will bring its complete line of video-tape and video cassettes, including the

## MEASURES GROUP DELAY IN TRANSMISSION SYSTEMS & LINES

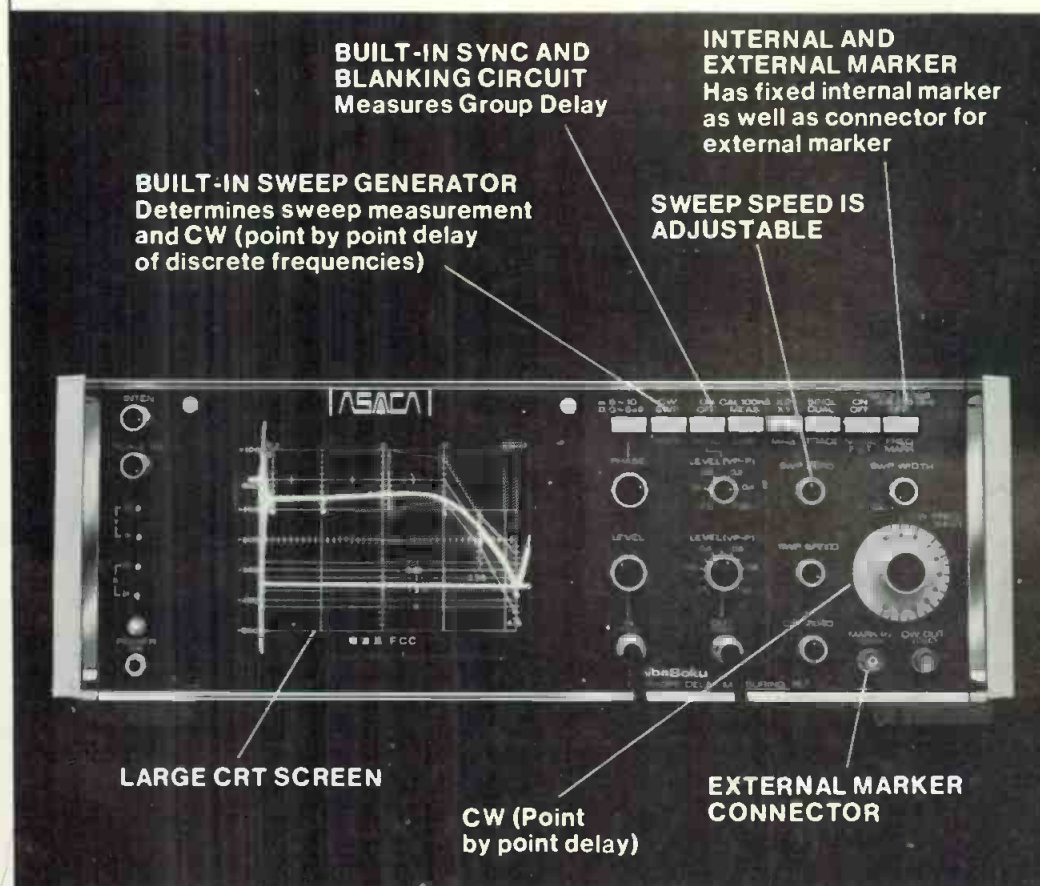

At last! The Envelope Delay Measuring Set You've Always Wanted—But Which Technology Couldn't Develop Until now! Compare

Our envelope Delay Measuring Instruments\* feature large CRT screens, built-in sweep generators and allow spot frequency delay measurements from 200 KHz to 10 MHz. Check out Models 763 NA and the new 201-1. Both are NTSC or PAL compatible. The 201-1 adds a built-in sync generator and blanking mixer.

Don't you delay in getting full information. Write.

We create change



ASACA CORPORATION OF AMERICA  
1289 Rand Road, Des Plaines, Ill. 60016  
Phone (312) 298-4380

\*Product of SHIBASOKU—sister company of ASACA

# NAB: 1982

new PT-120 half-inch professional cassette in the Super Avilyn formulation. (Also see listing in Radio section.)

**TECHTRAN INTERNATIONAL/2835**  
Will introduce 1/4-inch portable video unit and VTR with monitor in five-inch suitcase.

**TEKTRONIX/3005**  
Will introduce several new products for test and measurement, headed by Model 280 portable three-in-one test monitor. Modes include waveform monitor with flat response, vectorscope, and oscilloscope. The scope itself weighs about 12 pounds and an optional rechargeable battery pack another 12 pounds. The unit is a product of Sony/Tektronix, Japan, and has been marketed successfully overseas for some time. Also new will be Option 3 for the ANSWER microprocessor-based automatic video signal analyzer. New software package is a transmitter set, permitting complete measuring and monitoring of signals

in any cycle determined by the engineer, with automatic printouts, alarms, computer graphics presentations as required. RS-232 interfacing permits remote transmitter monitoring under new FCC proposals. Other new and featured TV products will include the 650HR color reference picture monitors, 1420/1424 Series waveform monitors and vectorscopes, 1470 Series NTSC test signal generator, and 528A waveform monitor. (Also see listing in Radio section.)

**TELE-CINE CORP./3016**  
New Schneider lightweight 14X ENG/EFP camera lens with built-in 2X extender. Also new is the 15X

studio/all purpose lens with built-in diascope and 2X range extender. Other products include complete line of Schneider zoom lenses, servo control lens accessories, rentals, and service.

**TELFAX COMMUNICATIONS/2735**  
Will show a telephone unit for gathering audio for radio or TV at a remote site and phoning back to station. Can plug in mic, headphones, or tape recorder to unit, receive incoming calls, or dial on the unit to station.

**TELEMET, DIV. OF GEOTEL/3007**  
Will introduce the Model 7934 routing switcher with computer-



A new Option 3 will be shown for Tektronix's Answer system.

## TELEVISION DEMODULATOR QSI DEMOD 400



The Demod 400 off-air demodulator helps you clean up your act. Now you can stabilize off-air signals

without tying up an expensive proc-amp. The Demod 400 gives you the choice of straight off-air signals or replacement sync, burst and blanking at the flip of a switch.

Plus you have control over sync and burst amplitudes, burst phasing, and set-up level during processing. There's even a built in speaker to make life easier. All this at a price that won't deflate your budget.



UNPROCESSED PROCESSED



For more information about the Demod 400 call [617] 938-1403, or write to us.

**QSI® Systems, Inc.**  
12 Linscott Road, Woburn, Massachusetts 01888

## athena 6000

The Most Cost-Effective Telecine Projector Available

The ATHENA 6000 is designed to meet professional requirements in NTSC, PAL and SECAM countries.

- Automatically phase-locks to NTSC, PAL or SECAM field rates
- Unlimited hold time in still frame mode
- 1-2-4-6-8-12-24 frames per second, forward or reverse, totally without flicker
- Remote control option
- Two-year parts and workmanship warranty
- Modular assembly/easy maintenance



For more information contact:

L-W INTERNATIONAL 6416 Variel Avenue,  
Woodland Hills, California 91367 U.S.A.  
Telephone: 213/348-8614

See QSI in Dallas at NAB '82 — Booth #1502.

Circle 234 on Reader Service Card

# Tele-Measurements Mobile Vans Take You Where the Action Is



When it comes to building mobile vans that meet the needs of TV broadcasters or cable operators, Tele-Measurements delivers. In fact, Tele-Measurements, a leader in the design and construction of customized field production vehicles, has delivered a total of 17 vans this year, which are now in use all over the United States.

Typical of the wide range of mobile vans produced by Tele-Measurements are the two units shown above. At the left is an electronic news-gathering vehicle especially designed for use by a major network. It features full microwave transmission and receiving facilities on both 2 and 7 GHz frequencies and is equipped with Sony broadcast video recorders, Dynair audio/video switching, and a 6.5 continuous-duty generator.

At the right is the cable field production van custom-built for Cross Country Cable in Bound Brook, New Jersey. This vehicle is powered with two 6.5 KW generators and mounts a shooting platform on the roof. Electronic equipment includes four Hitachi FP40SS color cameras, a JVC 3/4-inch editing system, a Systems Concepts character generator, and a broadcast production switcher.

In addition, Tele-Measurements produces the CAV-1 "portable portable" van, a compact Econoline-type vehicle which is rapidly becoming the standard for economy and efficiency in remote pickup for cable systems.

For more information about Tele-Measurements field production vans designed to meet your specific needs, call or write:



## TELE-MEASUREMENTS INC.

Headquarters: 145 Main Avenue, Clifton, N.J. 07014  
201-473-8822 212-581-9020  
Atlantic City Office: 1616 Pacific Avenue, 08401  
609-345-2670

Circle 236 on Reader Service Card



# NAB: 1982

control option; and the new Model 3711 RF synthesizer. Will also show line of chroma keyers, video and pulse distribution amplifiers, equalizers, demodulators, video test and measurement equipment.

### TELESCRIPT/3015

will feature digital monitor-based prompting system with 15-inch, 1000-line monitor, contrast enhancer, full line of mounting supports. Also standard, transport-based prompters and support equipment.

### TELEVISION ENGINEERING CORP./2114

New model TEC24B remote van includes cameras, video switcher, audio console, video recorders, and all terminal equipment.

### TELEVISION EQUIPMENT ASSOCIATES/3324

Will introduce the Elcon videotape cleaner/evaluator Model 254, for one-inch tape, with display pin-

pointing edge damage and dropouts. Also introducing the Matthey digital video delay, with infinitely variable 10-165 ns delay; the TEA Sports-caster headset; the Link pulse and video distribution amplifier; and the BCA 0 929 modular intercom.

### TELIDON VIDEOTEXT/2824

Will show broadcast teletext and interactive video text systems for TV or able distribution.

### TENTEL/1605

On display will be the Tentelometer tape tension gauges, and Tentel spindle height gauges for Beta, U-Matic, and VHS recorders.

### THEATRICAL SERVICES/2705

Will show new electronic distribution system for studio lighting with plug-in switches for instruments. Also a new modular patching system. Will discuss custom installation of a studio lighting control system.

### THEATER SERVICE & SUPPLY/1900

Will show theater and studio supplies such as lighting, fabrics and hardware.

### THEATRE VISION/1800

Will show turnkey studio lighting installation with lights, dimmers,

control, headphones, scrims, and backdrop.

### THERMODYNE INTERNATIONAL/2407

Will show new Rack-Pack instrument transportation case incorporating standard EIA rack mount in heights to 25 inches. Also full line of equipment transportation cases, transportable editing consoles, etc., all of molded plastic with aircraft latches.

### THOMSON-CSF BROADCAST/3201

Will introduce new Vidimax system for adding two f/stops sensitivity to cameras consisting of simple camera modification and updated version of Model 9100 digital video processor. Other TV products include complete line of Microcam cameras, the TTV-1525 studio camera, the Vidifont IVA character generator, Vidifont Graphics V character generator/art system, Model 9100 digital video processor, and Vidiplex digital signal multiplexer. (Also see listing in Radio section.)

### THOMSON-CSF ELECTRON TUBE DIV./1609

Introducing a new series of power tubes and klystrons, including TH-



## Choose from two new recording electronics packages from Inovonics.

Model 380 is the upgraded successor to our well-known 375, used in hundreds of studios and stations around the world. With your tape transport and our 380, you have the ultimate analog recorder. Features of the 380 include:

- Advanced circuitry to reduce the effects of tape compression and phase distortions.
- Unprecedented signal and bias headroom for

full compatibility with highest-coercivity tapes.

- Two "workhorse" EQ and bias settings, plus an optimized mode with separate setup for best performance from "super" tapes.
- Compatibility with virtually any combination of transports and heads.
- SYNC reproduce, "pick-up" record and exclusive auto mute.
- Remote control of all functions.

## The perfect pair.

Use the 380 to create new, ultimate-performance recording equipment, or to give your old tape or mag-film recorder a sound so clean you must hear it to believe it. \$820.00

Model 370 is intended for routine replacement use. It is compatible with most studio transports and a wide variety of original and replacement heads. The 370 will make "new" machines out of your older studio recorders, delivering superior performance and great reliability. \$580.00

For more information, see your distributor or contact us today.

### Inovonics Inc.

503-B Vandell Way  
Campbell, CA 95008

Telephone  
(408) 374-8300

See us at NAB Booth 1610-A



# TV test equipment from the inventors of the Plumbicon® tube.

At long last a new, reliable source of TV test equipment. One that offers fast, predictable delivery. One with a name all the world trusts—Philips. Four quick examples:

## PM5565 Waveform Monitor

Enjoy the luxury of examining one line and one field at a time. On top of this, there's a convenient front probe input so you can use the monitor as a troubleshooting oscilloscope.

## PM5567 Vectorscope

If you want more accurate decoding and the ability to have an external reference from composite video signals, choose our vectorscope.

Both waveform monitor and vectorscope mount side by side, fit all existing hardware and use less power than the competition.

## PM5539 Color Analyzer

Take it on a quick trip through your studio or control room and adjust all monitors to the same color temperature in a matter of minutes.

With four different memories, there's no problem in quickly calibrating four different phosphors.

Variable full-scale, from less than set up to more than reference white, allows measurement of color tracking as a function of APL.

## PM5534 Color Pattern Generator

Our universal pattern contains all the signals needed to verify overall system operation—directly from the picture. No wonder virtually every set manufacturer uses our pattern for their TV set alignment.

Of course our TV test equipment line doesn't end here. Today Philips offers a wide range of equipment including sync and pattern generators, VITS generators and analyzers, and TV modulators and demodulators.

For nationwide sales and service information call 800-631-7172, except in Hawaii, Alaska and New Jersey. In New Jersey call collect (201) 529-3800, or contact Philips Test and Measuring Instruments, Inc., 85 McKee Drive, Mahwah, New Jersey 07430.



# Philips, of course.



Test & Measuring  
Instruments

# PHILIPS

Circle 238 on Reader Service Card

# NAB: 1982

347, 1 kW TV; TH-18363, cavity for 1 kW TV; TH-382, 6 kW tetrode for aural UHF; TH-582, 13.5 kW tetrode for aural UHF; TH-3591B, 600 W KU band for satellite ground station; TH-3640, 3 kW C band for satellite station; TH-2416 3 kW C band klystron for satellite station; and THX-1130, CCD for miniature TV cameras. Also showing line of other power tetrodes.

## TIFFEN / 2509

will show new rotating matte box and lens adapters and high-impact filter case. SoFnet filters in black, white, red and skin tone are new, as are the Soft contrast and sepia effect filters.

## TOSHIBA / 2106

Will introduce new version of PD-0 studio camera, PK-40B. Also new DPE II Digital Picture Effects generators, VS-IV digital video synchronizer, and new digital audio delay. Also showing PK-60 ENG/EFP camera with digital setup through removable setup unit.

## TOWNSEND ASSOCIATES / 3311

Will introduce the new 10 kW high-channel VHF transmitter with 1 tube, and the combined transmitter/antenna, 100 W rating for LPTV, Phasestar model. Also introducing the Perveac, device for improving the efficiency of UHF transmitters.

## TROMPETER ELECTRONICS / 3310

Will show full line of products, including patch panels, cable assemblies, and connectors.

## TURNER BROADCASTING / 2917

Will show the CNN2 TV service network and the different programs it provides. (Also see Radio listing.)

## UNIDYNE TECHNOLOGIES / 1620

Will show newly developed TV promotions package.

## UNI-SET CORP. / 2503

Will preview new systems for the studio construction such as modular studio staging systems, rear screen/chromakey module, and graphic design chart. A line of riser blocks, tops, and ramps can also be seen.

## UNITED MEDIA / 2504

Will show two new audio systems, the Translator and the Director, designed for use with its video editors. Ex-



Toshiba will be showing the PK-60 ENG/EFP camera as well as other new models.

pandable version of the modular Commander II editing system is now available with a standalone audio router/dissolver or as a rack mounted unit. The Commander II has eight inputs, automatic or manual routing with stereo possibility.

## UNITED RESEARCH LABORATORY / 3128

Will show new Auto-Sense, an electronic tape motion sensing device for machines lacking this feature.

## UNITEX VIDEOGRAPHIC SYSTEMS / 2110

Will have its full line of videotex and teletext editing equipment, with keyboards, monitors, and disks for standalone use or with computer.

# Your image is on the line.

Barco's broadcast color monitors put your image on the line—clearly.

With the CM-33B 13" and CM-51B 19" monitors you can choose from a medium, standard, or high resolution delta dot tube. Your choice. But all three assure the broadcaster a color critical picture that lets you know exactly what is going out on line.

The medium resolution CM-33B offers a phosphor

triad pitch of .43 millimeters and the CM-51B .47 millimeters. Other features include • Switchable underscan/overscan. • RG off switch for easy set-up. • Color temperature switch.

All models are fully modular and are designed for general purpose applications. The CM-33B is ideal for ENG/EFP applications and the CM-51B is perfect for studio use.

We know your image is on the line. Barco's worldwide reputation for quality is sure to enhance your image.

Available from Elector, U.S. distributor of Barco communications products.

In the U.S.  
Elector U.S.  
5128 Calle del Sol,  
Santa Clara, CA 95050  
Phone: 408 / 727-1506  
Telex: 0236 / 0172335

In Canada  
Electro & Optical Systems Ltd.  
31 Progress Court,  
Scarborough  
Ontario M 16 3V5  
Phone: 416 / 439-9333  
Telex: 021 / 06525431



Circle No. 237 on Reader Service Card

“I want the world.  
Consistent .05% corner registration  
and full auto-setup of up to 96  
cameras on computer command.”

## HITACHI HEARD YOU.

### AUTO SETUP

Don't want much, do you?

Dynamic registration not just at dead center but at all four corners.  
Plus 2-minute auto-setup of all those cameras.

You're asking for some smart camera system, networks  
of the world and top-drawer video production companies.

Well, Hitachi heard you, and has created an outright *genius*—  
the Hitachi SK-110 Camera System.

The computer registration capabilities of this camera system  
produce pictures of a  
clarity and resolution  
previously unheard of.

And you get auto-setup  
at the push of just one but-  
ton, and zero reference,  
too, where the computer  
sets the green channel and  
compares blue and red to  
it with absolute precision.

The SK-110 is not only self-correcting, but self-diagnostic  
as well. It gives both video screen display and hard copy print-  
out; can be hooked into the CRT for control room monitoring.

There's a high-performance contour corrector;  
5 automatic setup modes including quick check;  
5 data files; so many other unique features an ad  
can't begin to tell you about them.

The ultimate Hitachi SK-110. Contact the  
broadcast video division at any of the offices  
listed below. Hitachi Denshi America Ltd.,  
175 Crossways Park West, Woodbury, NY  
11797 (516) 921-7200. Offices also in  
Chicago (312) 344-4020; Los Angeles  
(213) 538-4880; Atlanta (404)  
451-9453; Cincinnati (513) 489-6500;  
Dallas (214) 233-7623; Denver  
(303) 344-3156; Seattle,  
(206) 575-1690; and Washington,  
D.C. (301) 459-8262.

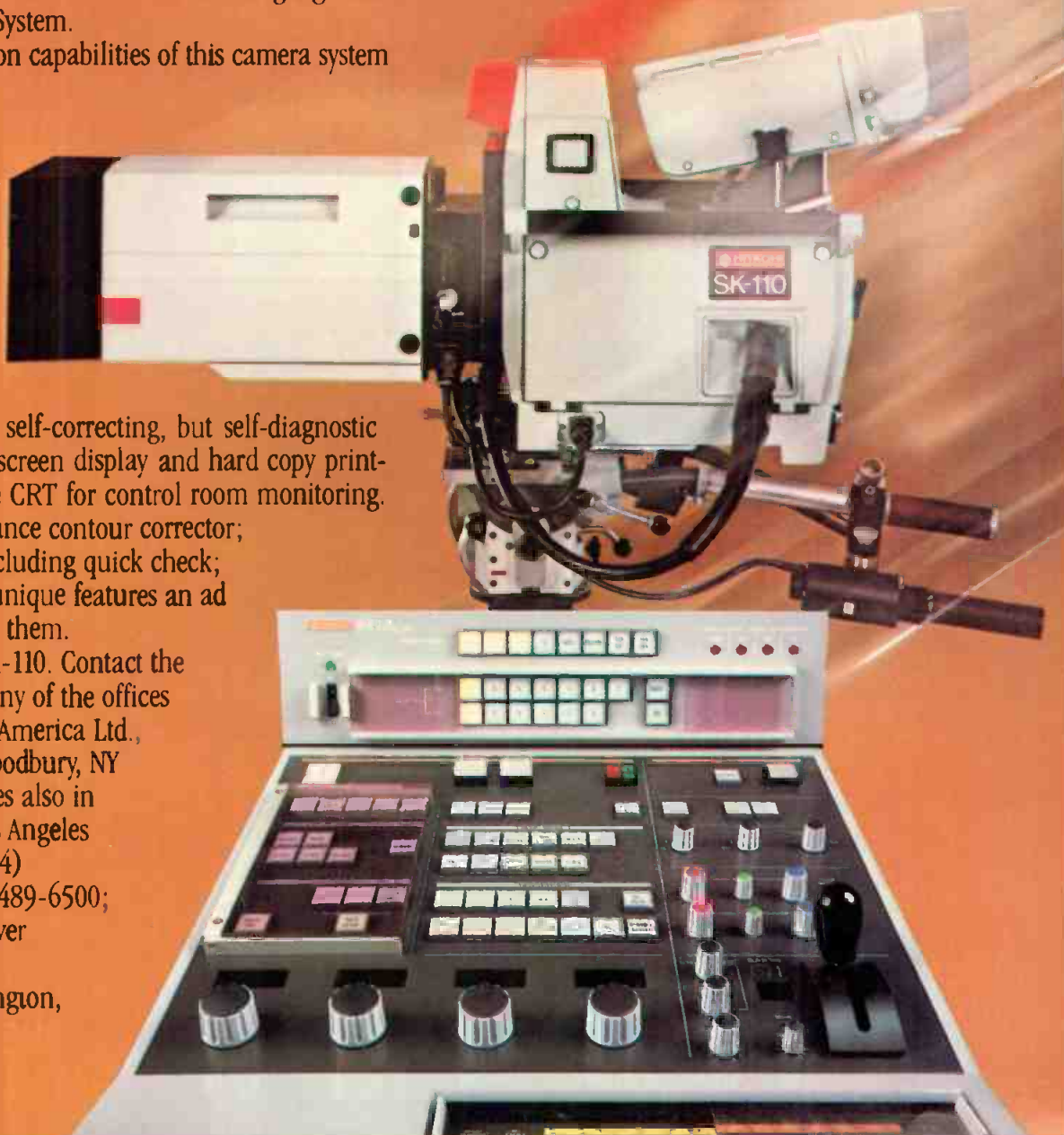

Circle 240 on Reader Service Card

# NAB: 1982

**UNR-ROHN / 3138**

Are showing the line of towers and accessories for TV, radio and microwave antennas, both guyed and self supporting.

**UPI / 3139**

Will show satellite package in conjunction with Harris Corp. for news services such as Audio Network, Broadcast Wire, Highspeed DataneWS, plus services delivered by conventional transmission.

**UTAH SCIENTIFIC / 2602**

Will introduce the new PLMC-1 machine control system using standard AVS-1 party line for connection. Other products on display will be the AVS-routing switcher system and alphanumeric display devices and control panels.

**UTILITY TOWER COMPANY / 3105**

New equipment to be displayed will include such items as tower sections, lighting equipment, and galvanized hardware.

**V & B TOWER CORP. / 1918**

Showing full line of antenna towers and accessories for radio, TV and microwave systems.

**VIDEO ASSOCIATES LABS / 1917**

Will introduce the new BV-3 NTSC Module to convert Apple computer graphics for use in broadcast systems. Will also show the VB-1 and other modification units for VTRs.

**VIDEO DATA SYSTEMS / 2502**

Will show several new character generators (details at show). Will also show its full line of other character generators and production titlers.

**VIDEOMAGNETICS / 2320**

Will show full line of refurbished ferrite and metal heads for most major VTR models.

**VIDEO MEDIA / 2300**

Will show Z-6000A editor, which features SMPTE time code, control track, or proprietary Micro-Loc time code operation. Also Z-6000A-E with four-event internal memory. The editor will also interface with a production switcher to key preprogrammed events. The highlight of the line is the multisource Z-6E with full edit decision list capabilities.

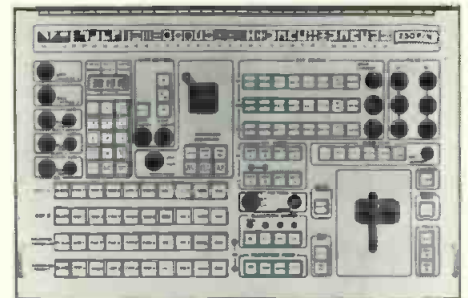

New from Vital the 250 P/N small production switcher.

**VIDEOTEK / 2208**

Will introduce the new TSM-5A waveform monitor, the new VSM-5A waveform monitor, and the new VSM-5A vectorscope, with internal reticule for more precise and parallax-free measurements. Also new audio program monitor with eight inputs. Full line of professional rack-mounted color monitors in various sizes will be on display.

**VITAL INDUSTRIES / 3018**

Will feature the new 250 P/N small production switcher with 10 inputs and five levels of video with switching, automation, and preview capability. The new Saturn Series will also be featured, a microprocessor based production switcher with four M/E—one of the largest production switchers ever built. The SqueeZoom

**API**

Back and Better Than Ever . . .

## AUTOMATED PROCESSES, INC.

### Recording Consoles

Manufactured and Marketed by

**DATATRONIX INC**  
A subsidiary of ATLANTIC RESEARCH CORPORATION

**SEE US AT NAB BOOTH 1927**

2100 Reston Ave.  
Reston, VA 22091  
(703) 620-5300

Distributed by

Los Angeles Raata Audio Systems (213) 469-9593	New York Studio Consultants, Inc. (212) 586-7376	Japan Nissho Electronics (03) 544-8395
--	--	--

# RENT IT!

Now . . . you can rent equipment for

Proof-of-Performance, field strength measurement and portable broadcast studios with PA systems from the largest fleet of broadcast rental gear in America. Call for your copy of our rental equipment catalog.

**davidgreen**  
broadcast consultants corporation

Box 590/Leesburg, Virginia 22075  
Phone 703-777-8660

# 40 to 1

## Canon PV40 x 13.5B IE: THE OLYMPIAN

Canon moves you a giant step forward with a 40X broadcast quality zoom lens. An incredible new lens that allows you to cover a stadium at wide angle or fill the frame with the quarterback's eyes.



Never before has a single lens provided this much flexibility and sensitivity, with remarkably little change in effective aperture throughout its entire 13.5mm-540mm\* range. Built-in extenders let you go all the way to 1080mm and each lens is diascoped-equipped for modern microprocessor-



controlled cameras.

We call it The Olympian. Not only because it is ideally suited for sports coverage but also because of the dedication and team effort required of our optical and electronic engineers in making this lens a reality.

Enlarge a dollar bill forty times and it covers an area twenty feet long and eight feet wide. Now think about what you could do with the Canon PV 40 x 13.5B IE!

\*1" cameras. Also available in 30mm plumbicon.



# Canon®

Optics Division

Canon USA, Inc., Head Office: One Canon Plaza, Lake Success, N.Y. 11042 (516) 488-6700

Dallas Office: 11311 Stemmons Freeway, Suite 1, Dallas, Texas 75229 (214) 620-2641 Chicago Office: 140 Industrial Drive, Elmhurst, Ill. 60126 (312) 833-3070

West Coast Office: 123 Paularino Avenue East, Costa Mesa, Ca. 92626 (714) 979-6000

Canon Canada, Inc., 3245 American Drive, Mississauga, Ontario L4V1B8, Canada (416) 678-2730

© 1982 Canon U.S.A., Inc.

### See the Canon 40 to 1 at NAB Booth # 3305

Circle 243 on Reader Service Card

[www.americanradiohistory.com](http://www.americanradiohistory.com)

# NAB: 1982

will have a new option adding a great number of new multi-channel effects. Other equipment includes the 114-4A with PSAS II automation, production switcher with triple reentry and over 65 wipes.

## VLACHOS-GOTTSCHALK RESEARCH/2738

Will unveil the new Newsmatte version of the Ultimatte composing device for live broadcasts. Also on display will be the Ultimatte IV for production and commercial applications using non-additive keying for enhance chromakey effects.

## WARD-BECK SYSTEMS/3301

Will feature two television audio consoles, the L2042 and the L3242. The M1204B production console and the M2484B broadcast/multitrack audio consoles will also be on hand. Also with the T1202 transportable mixer, and the Microcom intercom system.

## WEATHERMATION/2722

Will show fully digital system for receiving satellite weather information

with user-selectable background colors and maps. Will introduce new features for color remote radar system: pan and zoom, two-color underlays, pseudo-sweep, and eight-frame storage capacity.

## WESTERN UNION/2202

Will be exhibiting the Westar Satellite system as related to the radio, television, and program/commercial syndication aspects of the broadcast industry.

## WILKINSON ELECTRONICS/TV TECHNOLOGY/3117

Will display UHF and VHF transmitters, translators and transmission equipment, including power dividers. (Also see listing in Radio section.)

## WINSTED CORP./1703

Showing new line of modular console-cabinets for TV units in standard 19-inch rack space. Also will show full line of editing consoles, tape and film storage systems, tape and film trucks, dubbing racks, and post-production consoles.

## WIREWOKS/2916

Will introduce a new line of hardwired video multicables incorporating one or two video lines in the

same cable with one, three, or five audio pairs.

## WOLD COMMUNICATIONS/2729

Will discuss its satellite network for both TV and radio. TVROs will be on hand, along with information on company's transportable earth stations.

## WOLF COACH/2100

Will introduce the V-118, a new vehicle design developed for basic ENG/EFM applications consisting of a Ford Supervan modified to include a 42-foot pneumatic mast, 6.5 kW generator, power distributor system, and roll-out electronics racks.

## FRANK WOOLEY & CO./2930

The new Motionmaster color tinting sheets for video transparencies used in the Polurmotion pseudo-animation process will be on display with 32 colors on polyester material with a water-clear, pressure sensitive adhesive.

## WORLD TOWER/2811

Will show regular line of towers for radio and television antennas.

## ZENITH RADIO/2802

Will show multi-channel STV and the Z-Text teletext system.

# TENTEL GAGES

DO THINGS EVEN THE  
FACTORY GAGES DON'T DO!

FOR U-MATIC, BETA, VHS AND 1" TYPE "C" RECORDERS...  
TENTEL GAGES ARE SO EASY TO USE EVEN NON-TECHNICAL  
PERSONS CAN DIAGNOSE PENDING PROBLEMS.

The TENTELOMETER Tape Tension Gage will help if you want to prevent problems with:

- Interchange
- Hooking and flagging
- Tape destruction

The TENTEL Spindle Height (TSH) Gage will help if you want to prevent problems with:

- Tape edge damage
- Cassette binding
- Tape destruction

TENTEL is ready to help with your video recorder service needs. Thousands of service engineers rely on TENTEL daily!

Send for the TENTEL Tape Tips Guide or call us TOLL FREE (800) 538-6894. In California call (408) 379-1884.



**TENTEL**  
1506 Dell Avenue  
Campbell, CA 95008

Circle No. 242 on Reader Service Card

# NEW! Book VIDEOTAPE EDITING

*Videotape Editing-Communications With Pictures And Sound answers every videotape editing question:*  
When to edit? When to (and when not to) use a dissolve or wipe? How to cut? How to use complex sync role editing and audio sweetening? How to affect the mood and pace of a show? Why and how to perform computer editing without losing creative control? It even takes the mystery out of time code and user bits.  
Beginning editors, experience pros, film editors, and media managers will all appreciate Videotape Editing. This new book is your guide through the world of computer assisted videotape editing.  
*Videotape Editing-Communications With Pictures And Sound* By Michael D. Shetter  
• 165 pp. • 144 illus. • 6"X9" • Hardbound  
\$31.00 (\$33.00 in IL)

Order Today!

Brochure Available

(312) 364-1900 Ext. 825

Major Credit Cards Accepted

**SE Swiderski Electronics Inc.**  
Audio/Video Engineers  
1200 Greenleaf Ave. • Box 16 • Elk Grove Village IL 60007

Circle 244 on Reader Service Card

# CB-9000

## Color Bar Identifier



The new QSI CB-9000 is designed to provide a self-contained identified video source with several key features. Combining a SMPTE bar pattern generator with an eight character ID produces not only an identified source but a useful test pattern as well. The ID program is easily changed by the user for multiple purposes, and includes the standard 64 upper case ASCII characters.

Along with the video source, the CB-9000 also features a built-in 1000Hz tone generator, a microphone preamp

and an audio amp with a 600 ohm balanced output. Audio is switch selectable between microphone and tone from the front panel. The microphone input jack and gain control are also front mounted to make the CB-9000's audio easy to use. Audio and video by pass, either switched or on power-down, plus the single rack unit height round out the user oriented features of the QSI CB-9000.

For more information about the CB-9000 call or write to us today.



**QSI** systems, inc.

12 Linscott Road, Woburn, Massachusetts 01888

(617) 938-1403

See us in Dallas  
at NAB '82  
Booth #1502

Circle 245 on Reader Service Card

[www.americanradiohistory.com](http://www.americanradiohistory.com)



# PROVEN PE

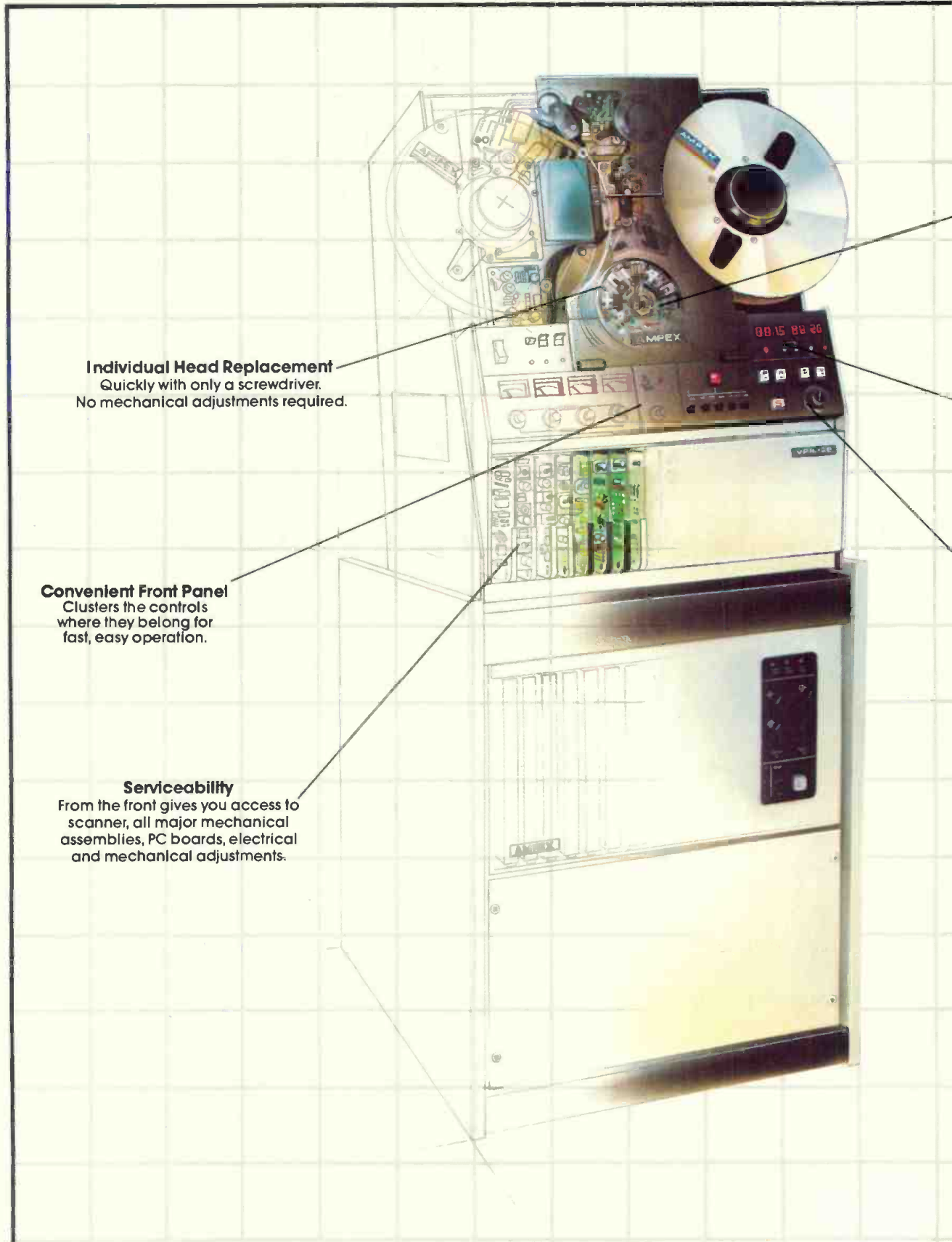

**Individual Head Replacement**  
Quickly with only a screwdriver.  
No mechanical adjustments required.

**Convenient Front Panel**  
Clusters the controls  
where they belong for  
fast, easy operation.

**Serviceability**  
From the front gives you access to  
scanner, all major mechanical  
assemblies, PC boards, electrical  
and mechanical adjustments.

# PERFORMANCE

## Why the Ampex VPR-2B is the world's most popular video tape recorder.

With over 4000 machines in use, the Ampex VPR-2 Series is without question the most widely acclaimed line of VTRs in broadcasting history. Outstanding performance and simple operating features, backed by a global network of parts, service and training, are just a few of the reasons why.

Ampex leadership began with technical innovation. You'll find the highest standards of design, production and quality control in every VPR-2B. And today, after more than 25 years of dedicated service to the television industry, Ampex continues to lead the way in providing high quality, reliable tools to the video marketplace.

As Ampex leadership started with outstanding products, it continues with the strongest worldwide service

support. With Field Engineers on call and an extensive computerized parts network, you get immediate answers to all your video questions. And each year, more than 2000 students throughout the world go through comprehensive product training at Ampex centers. There are more people skilled on Ampex VTRs than on any other video recorder in the world.

But the VPR-2B is more than just the dominant force in the video business. It's a part of the Ampex tradition. A tradition born of technical innovation, product reliability and proven product performance. And it's a name you can count on. Call your Ampex representative, or write Ampex Corporation, Audio-Video Systems Division, 401 Broadway, Redwood City, CA 94063 (415) 367-2011. Sales, spares and service worldwide.



**AST® Automatic Scan Tracking**  
Delivers disturbance-free transitions between play, slow motion and still frame modes.

**Frame-Accurate Editing**  
Results from the VPR-2B's precise tape timer and search systems, AST® and simple edit controls.

**Operational Convenience**  
With continuously variable slow motion instantly available.

## AMPEX TOOLS FOR TOMORROW

Ampex Corporation • One of The Signal Companies 

See all the new Ampex products at the NAB, Booth 3002

Circle 246 on Reader Service Card

[www.americanradiohistory.com](http://www.americanradiohistory.com)

# The most elegant still store yet.



Designed around the Z-8000 microprocessor, and the HVS 632 Frame Synchronizer, IRIS II brings new sophistication to the storage, manipulation and retrieval of digital video stills.

Up to six simultaneous users have on-line access to as many as 7,900 stills. The system uses standard SMD drives, and removable disk packs provide unlimited off-line storage.

To keep track of your off-line stills, an optional Winchester disk-based library lets you list up to 90,000 entries in a fully indexed electronic "card catalog."

You can also divide disk packs into as many as 10 sub-sections, allowing all users to store on the same disk at the same time.

This expands system use without added hardware.

In addition, a digital keyer lets you combine and manipulate images digitally, to create effects with first generation quality.

So, before you make any still store decision, see the IRIS II.

For a demonstration, call or write.

**Harris Corporation, Harris Video Systems,  
P.O. Box 523, 1255 E. Arques Avenue, Sunnyvale CA 94086  
Telephone 408/737-2100 Telex 35-2028**



## HARRIS

Circle 184 on Reader Service Card

# SUCCESSING WITH ENG/EFP MICROWAVE

By Bebe F. McClain

*Most TV broadcasters currently use some form of production microwave. Learning how to use it effectively, however, requires some careful planning.*

AS IF RECALLING his first date, Rod Robinson, chief engineer at Houston's KHOU, remembers vividly how the station took its newly acquired "live eye" truck outfitted with permanent 2 GHz and portable 13 GHz microwave systems to Houston's airport to cover President Ford's arrival. To his dismay, a tall building stood between the truck and the receive tower. "The only solution," recalls Robinson, "was to inaugurate both the 2 GHz and the 13 GHz systems. The truck was moved a quarter of a mile away until the 2 GHz antenna had a line of sight to the receiver. Then we used the 13 GHz to beam the camera signal to the truck. Back at the station the image was crystal clear. We couldn't believe it!"

Robinson is not the only one with vivid "first time" memories. Bill Canora of WVIT in Hartford, CT, while prepared to encounter equipment problems, was

**Bebe F. McClain**, head of her own production and equipment company, B.F. McClain Productions, Asheville, NC, is also a writer specializing in television-related subjects.

unprepared to find himself unable to reach the site of a hostage situation that occurred late one evening. Undaunted, he set the equipment up as close to the scene as the truck could get, and the reporter, with lights shining on him in the darkness, went on live, for the first time, just "a few blocks from the actual site."

George St. Andre, engineering manager at WBZ-TV, Boston, will never forget the first time WBZ went airborne. It was for the Boston Marathon. "The microwave equipment worked but we sure learned a lot about helicopters," St Andre relates. "It is difficult to hover over one spot for long periods, as I originally thought you could. Instead, you have to fly around in a circle and while you're circling your direction of transmission is changing constantly. You need a good combination of antennas. Now we use Omnex antennas on the copter and steerable antennas for reception."

*Aiming toward good ENG: WWLP, Springfield, MA, often utilizes a platform atop its ENG van (left); WCVB-Boston's Winnebago ENG vehicle.*



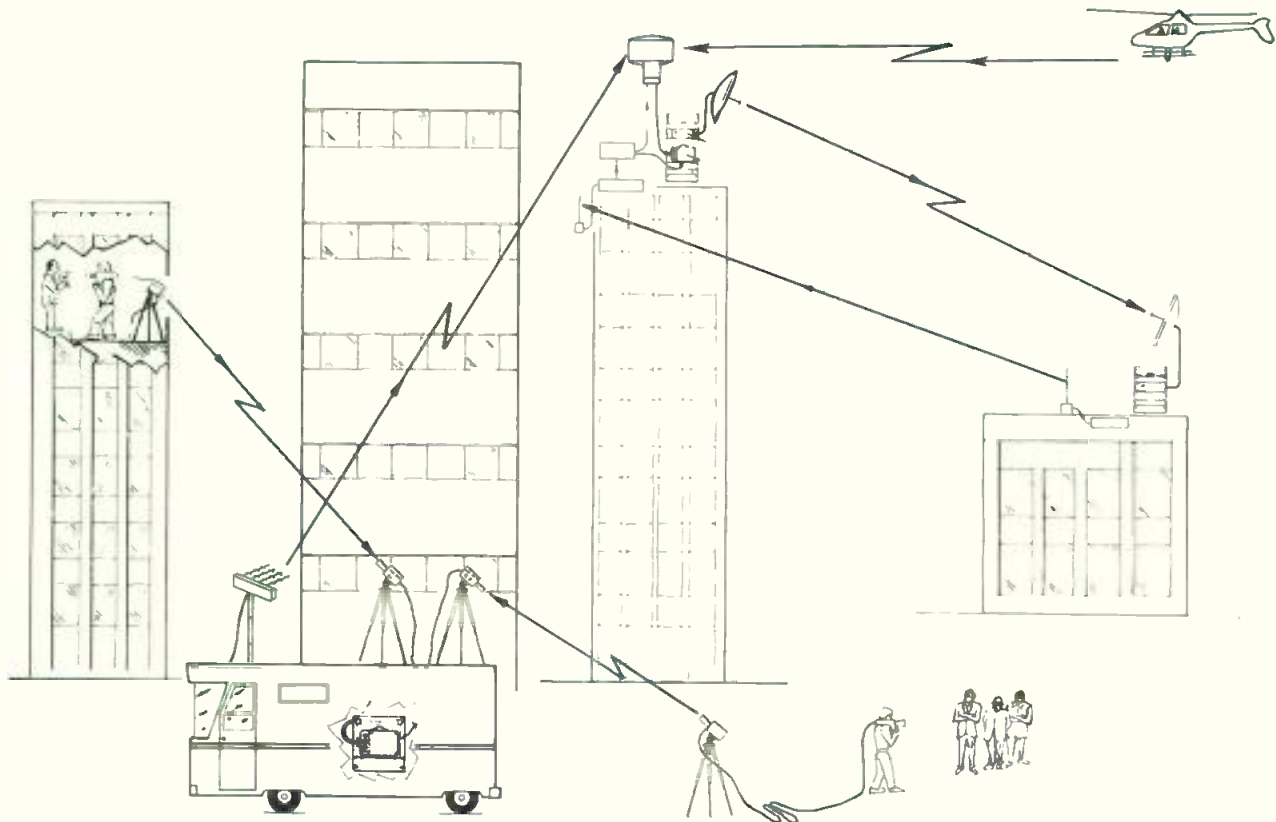

Artist's rendering of an ENG system in an urban setting.

It seems there as many "first time" stories as there are stations using microwave, and one thing is clear: without microwave and the ability it brings to go live from the scene of the action, news broadcasting would simply not be the same today. But discussions with stations of every size and description around the country make it clear that learning to use microwave properly and effectively takes some practice. Going live simply because the opportunity is there wins neither respect for the news team nor viewer loyalty. On the other hand, missing valuable opportunities to go live from important events because of poor planning or faulty equipment is a certain signal to viewers to spin the dial. Learning to use ENG/EFP microwave properly can be one of the greatest benefits a station can employ.

### Why microwave?

One of the strongest success stories with microwave is WWLP, the NBC affiliate in Springfield, MA. The station has a rather unusual news format in that live stories that are covered at 6:00 can be updated, still "live," at 7:00. The famous "Gasoline Alley" fire is a classic example. Not only did WWLP break into a network program at 4:00 p.m. with live footage when the fire began, but it gave updates at both 6:00 p.m. and 7:00 p.m., plus other updates every hour. Without microwave equipment this would have been impossible.

Microwave equipment enables news departments to react fast and air very late-breaking stories, as WWLP did after a murder occurred in Chicopee, MA, and the police chief, who had previously given absolutely no

information, suddenly announced at 4:00 p.m. that he would hold a 6:00 p.m. news conference. WWLP was able to set up microwave equipment and cover the conference live. According to John Fergie, director of engineering at WWLP, news stories, at least in Springfield, don't often wait until 6:00 p.m. to happen, but when they do, ENG microwave equipment allows the station to take the home viewer right into the midst of the event. The audience becomes literally the first person on the scene.

At WBZ-TV, there are so many demands by the news department for live coverage that the station's microwave equipment is used for little else. One special application is the daily "soft news" program, which usually has one of the two news anchors at some remote location while the other broadcasts from the studio. (In addition, a live ENG camera is used for segments from the newsroom.) Each day the theme is different, determined by the location chosen for the remote—such as a local health club, the Museum of Fine Arts, or the scene of the major news story of the day. The co-anchor not only gives information about that place, but also introduces other stories from the remote location. The constant back-and-forth from location to studio makes this news program fast-paced while taking the audience into community establishments for an in-depth look.

KHOU, Houston, and WESH, Daytona Beach/Orlando, give their microwave equipment a workout covering the events at nearby NASA facilities. So much ENG microwave gear is utilized at these sites that frequency coordination and cooperation among those covering an event is imperative if anyone is to

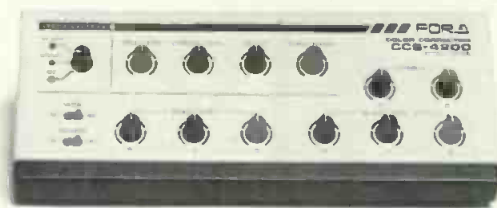
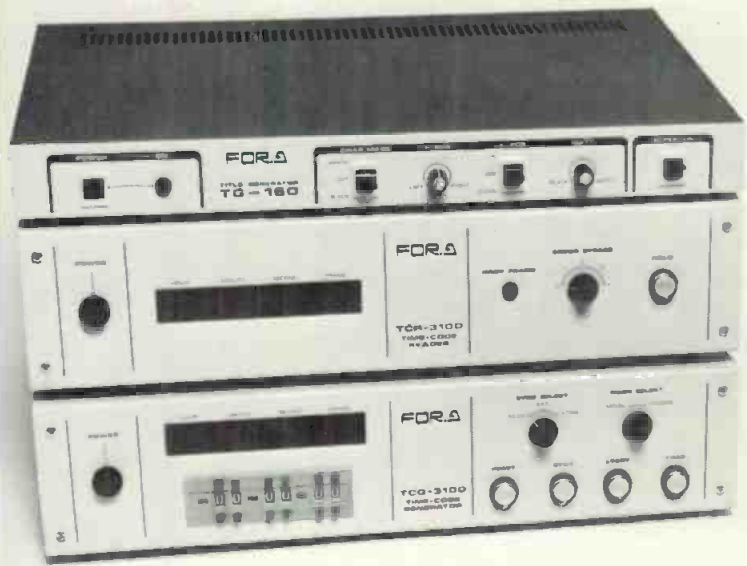

# Introducing the Budget Balancers

If the ever-increasing costs of broadcast engineering equipment has you seeing red these days, you owe it to yourself to look into the Budget Balancers from FOR-A CORP.

You'll like what you see — no nonsense, no compromise, state-of-the-broadcasting-art engineering gear — at prices that simply defy the economic index.

Our SMPTE Time Code Generators, Time Code Readers and Title Generators are up to spec in every sense of the word. And they're incredibly reliable. In fact, the major differences between SMPTE Time Code components from FOR-A CORP. and those from the competition, are updated features and a surprisingly lower price.

The VTW-600 Professional Video Typewriter gives you fea-

tures and performance unmatched by other character generators, regardless of price. And the CCS-4200 Color Corrector provides crucial color and video signal adjustments essential to professional video editing and field production.

You'll also find dozens of other innovative broadcast video products from FOR-A CORP. Each one designed to put your engineering budget back in the black.

# FOR.A

## Innovations in Video

FOR-A CORP. of AMERICA, 1680 N. Vine Street, Los Angeles, CA 90028 (213)467-8412

**See the Budget Balancers at NAB Booth #2210**

Circle 247 on Reader Service Card

[www.americanradiohistory.com](http://www.americanradiohistory.com)

## Succeeding With ENG/EFP Microwave



WVIT, Hartford, captures a live news remote.



Technicians at Boston's WBZ-TV line up ENG stories for the evening newscast.

succeed. The three affiliates in this area meet often and work closely.

Live news coverage is not the only way to utilize microwave equipment, however. More and more local stations are offering live sports. Some, like WVIT, Hartford, now have the ability to cover regular events such as the Hartford Whalers hockey games live. In other instances, microwave gives the ability to provide coverage that truly borders on original programming—such as WCVB's presentation of the Boston Marathon. WCVB deployed six cameras—three at the finish line, one at "Heartbreak Hill," one roving camera that was set up at various locations, and one in a helicopter.

### EFP goes live

Realizing that ENG microwave equipment could be put to use even outside news and sports, many stations have begun producing original programs either completely live or featuring live segments. For example, WWLP's "Chalice of Salvation" mass was moved out of the studio and telecast live from various churches in the community since the station purchased microwave equipment.

Microwave equipment allows stations to beam program video and audio from a remote location to a central recording facility for editing and rebroadcast. This capability is particularly useful to stations like WVIT, Hartford, and WWLP, Springfield, that must gather news over a large area. Instead of bringing back each story, WWLP often dispatches its "live eye" van to some midway rendezvous point where news crews in cars drop off their tapes for subsequent transmission to the station.

Stations are finding hundreds of applications for their microwave equipment—and fortunately, the equipment works well. Ross Kauffman, director of operations and engineering at WCVB, where three vans and a helicopter are outfitted with Microwave Associates ENG equipment, says, "The microwave gear is the least of our worries. The tape equipment gives us the most concern."

WBZ's St. Andre muses, "Maybe we've done too good a job with this microwave equipment. A few years ago the news department was happy to be able to go a few miles out and get a good picture. Now they want to go 100 miles. The next step, I guess, will be relaying our live news stories off a satellite."

## SID Helps Washington Station Overcome Microwave Crunch

In crowded microwave areas such as Washington, DC, New York City, and other major cities, stations not only compete for microwave channels but occasionally have difficulty deciphering which microwave feeds are theirs. In such circumstances, signal source identifiers (SID's) are essential tools.

According to Andy Haas, chief engineer of the ABC Washington News Bureau, the station has been using QSI equipment to help eliminate the problem of crowded microwave space. "There are two reasons for using the SIDs; one is to identify your own feed, and the other is that it's a simple way of complying with FCC ID regulations," says Haas.

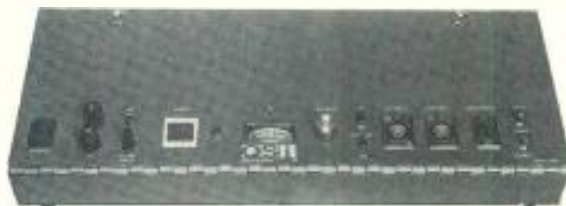

At ABC, he uses the QSI CB 7300 color bar generator/digital identifier, programmed with the call sign of the particular transmitter unit to which it is assigned. Haas uses the color bar generator for every transmitter and keys it in on every transmission.

For quick dispatch, Haas sends the cameras and the microwave equipment to the sites separately, so it becomes imperative that he be able to identify which transmitter is sending the feed.

Haas is working in conjunction with QSI to help develop an additional card for the CB 7300 to make the SID user-programmable, offering eight characters that enable the engineers to identify not only the call sign but also the specific site origination of the remote signal.

# "JUST PLUG IT IN AND IT MAKES MONEY"



It's not just how it works. But how long it works.

That's one General Manager's comment about his station's new EMCEE® translator. He's not far off the mark, either.

EMCEE 1, 100 and 1,000 watt UHF and VHF translators do install easily and require virtually no maintenance. EMCEE can even provide complete translator turnkey packages. Including system design, documentation and construction.

The result is fringe areas turn solid. Brand new markets open. Numbers and billing increase. And your dependence on local cable systems ends for good.

EMCEE translators could create one additional expense for your station, though. Overtime in accounts receivable.



(EMCEE TU-100)  
100 watt UHF translator

## EMCEE

### BROADCAST® PRODUCTS

a division of  
ELECTRONICS, MISSILES  
& COMMUNICATIONS, INC.

P.O. Box 68  
White Haven, PA 18661  
Phone toll free: 800-233-6193  
(In PA, call collect: 717-443-9575)  
TWX: 510-655-7088  
Ans: EMCEE WHHV

Equipment manufactured in U.S.A.

® EMCEE Broadcast Products  
© 1982 EMCEE Broadcast Products



Make sure your tapes are thoroughly erased!!



## TABERASER

completely erases all audio, video, instrumentation tapes and magnetic films.

**Model 409**

designed for high coercivity tape

## TABER

Manufacturing & Engineering Company

2081 Edison Ave. • San Leandro, CA 94577 • (415)635-3831

Circle No. 249 on Reader Service Card

# FitzCo SOUND, INC.

AAE "Concept One" AUTOMATION

AKG

LEXICON

AMPEX

SENNHEISER

BGW/TANNOY

TECHNICS

HANNAY

VEGA

EVENTIDE

NEUTRIK

IVIE

WIREWOKS

AUDIOARTS ENGINEERING

FitzCo  
SOUND, INC.

204 N. Midkiff, Midland, Texas 79701

Phone: (915) 684-0861

Circle No. 250 on Reader Service Card

## Succeeding With ENG/EFP Microwave

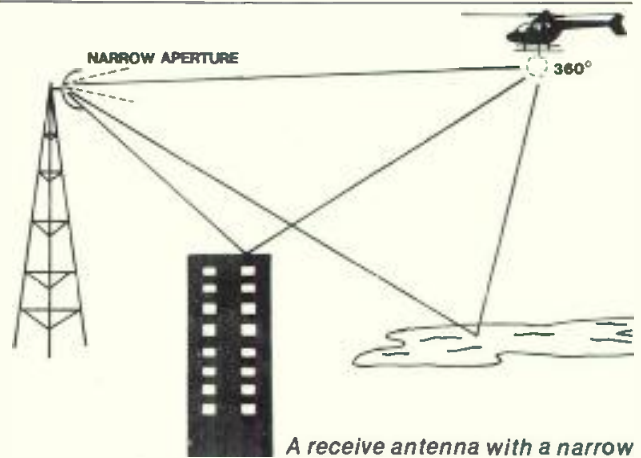

A receive antenna with a narrow aperture is one way to avoid a multi-path problem in areas surrounded by water.

### Staffing up

Live programming has created the need for additional staff at many stations and has added responsibilities and new dimensions to existing jobs at others. Selecting the proper staff is vital if microwave is to succeed.

At WBZ-TV, the station's ENG microwave receiving equipment is manned 16 hours a day. One member of the news staff informs the receive technician of the locations of the live vans and the order of the stories for the night's newscast. Shortly before air time, the technician will "bring them in" one by one, making sure he is getting good, clear video and audio.

Joe Blake, assistant engineering manager at WBZ-TV, explains that these technicians "have to be not only very competent but very calm and unexcitable. When it gets down to the wire and problems occur like loss of audio, and the worried director starts calling for audio, it's easy to panic. One has to stay calm to do this."

Erik van der Kaay, president of Microwave Associates Communications, points out that the equipment is often blamed when, in truth, the problem could lie in the transmission technique. "It would be great to gather together a lot of the receive technicians from the really successful ENG users and have them tell how they brought in the hard ones. Some of them have done very ingenious things. Bouncing signals is a technique that often comes in

Inside WWLP's ENG van.



# BROADCAST PRECISION

## Introducing the Ampex ATR-800. More features than ever before in a broadcast audio recorder.

In a busy broadcast environment, every minute counts. That's why Ampex designed the ATR-800 with saving time in mind. With more standard features than any other recorder in its class, the ATR-800 is the perfect choice for broadcast professionals. And recording studio engineers? Take note.

The ATR-800 was designed for tape editing. The wide open head assembly gives you fast, accurate tape access. Recessed head gate and transport controls prevent tape snag. And a continuously variable shuttle, under control of the microprocessor, regulates tape speed and direction.

But the features don't stop there. You'll find a standard cue amplifier that allows monitoring of any or all channels, a quick change head assembly, a digital tape timer with single-point search-to-cue, three tape speeds

with built-in vari-speed, fader start for remote control from a console and much, much more. All standard. And with a switchable NAB/IEC setup, the ATR-800 is a true international recorder in every sense of the word.

Look around, no other audio recorder offers you more standard features than the ATR-800. Whether you need rack mount, console or pedestal versions, call your Ampex dealer or write Ampex Corporation, Audio-Video Systems Division, 401 Broadway, Redwood City, CA 94063 (415) 367-2011. Sales, spares and service worldwide.

## AMPEX TOOLS FOR TOMORROW

Ampex Corporation • One of The Signal Companies

**Serviceability**  
Plug-In assemblies are easily accessible from the front of the recorder, even when rack mounted.

**Quick Change Head Assembly**  
Converts from one to two to four channels, or back quickly with no mechanical re-alignment.

**Three Speeds with Variable Speed Operation**  
Machines are shipped with three speeds, 7½, 15 and 30 in/sec. Field convertible to 3¾, 7½ and 15 in/sec.

**Digital Tape Timer with Single-Point Search-To-Cue**  
For accurate timing in hours, minutes and seconds.

**Switchable NAB/IEC Setup**  
Converts between NAB and IEC setup, including bias as well as equalization.

**Microprocessor Control**  
Microprocessor system ensures safe, gentle and foolproof tape handling.

**Designed For Editing**  
Head assembly is wide open for unequalled accessibility. Dump edit and hands-on-reel editing modes included.

**See all the new Ampex products at the NAB, Booth 3002**

Circle 251 on Reader Service Card

[www.americanradiohistory.com](http://www.americanradiohistory.com)

FINALLY OFF THE SHELF  
SCR PROOF CABLE IN 10 COLORS

# CANARE CABLE

FROM JAPAN

CANARE 4 CONDUCTOR MICROPHONE CABLE

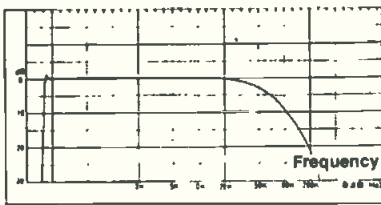

Static noise Characteristic (5 m / 16.5 ft) Frequency response (100 m / 330 ft)



Its flexibility eliminates kinking and splitting—the small diameter facilitates handling and coiling.

CANARE 4 conductor microphone cable eliminates 90% of SCR & magnetically coupled noise.

Because of its unique design, frequency response is not affected even over long runs.

The outer covering is made of smog proof polyethylene, of a new type that closely resembles rubber.

Flexibility is maintained to  $-56^{\circ}$  F.

For catalog and further information contact:  
YAGI INTERNATIONAL CANARE DIVISION  
4506 Saugus Ave. #6 Sherman Oaks, Ca. 91403

Circle No. 252 on Reader Service Card

## Succeeding With ENG/EFP Microwave



WVIT's ENG van at the cemetery during coverage of Governor Grasso's funeral.

handy." Receive operators who are not getting clear pictures will often tell the transmitting operator, "Turn around and see if there's a building behind you to bounce this signal."

At many stations the receive operator also handles the VTR playback during the newscast, while at others the microwave operator monitors air transmission. The latter is true of KHOU and WESH. All of them depend on their two-way communication systems. If that goes down, they're lost.

Technical personnel are not the only people needed for success with live programming. As WVIT station manager Paul Hughes explains, "You can have live capability and if you don't have reporters and news directors, it's only hardware." Hughes goes on to state that special skills are needed for a reporter to do live segments. Having to do it on the first pass is difficult, and lengthy live special events are even more demanding. "Live remote reporting is very different from reading a script in the studio," he points out. "There is a certain amount of presence a talent needs. A few minutes is one thing—but hour after hour is another." They have to not only gather the news, but they have to deliver it well.

"Reporters on live segments live in fear of some drunk walking up in the midst of the transmission and asking for a cigarette," declares Dave Cote, ENG supervisor at WWLP. It actually happened there in Springfield—but he asked for a cup of coffee.

Worse things have happened—and did when

Whatever you do  
at NAB...

DON'T MISS ECHOlalab's

# SE/3

An  
Outrageously  
Good Switcher

SEE IT AT BOOTH # 2932  
OR CONTACT

## ECHOlalab, Inc.

175 Bedford Road, Burlington, MA 01803  
(617) 273-1512

Circle No. 253 on Reader Service Card

# Where You Need It, When You Need It.

Oki Portable Digital TV  
Standards Converter  
**LT1200**



The need for TV standards conversion doesn't stop at the studio door. That's why Oki developed the port-

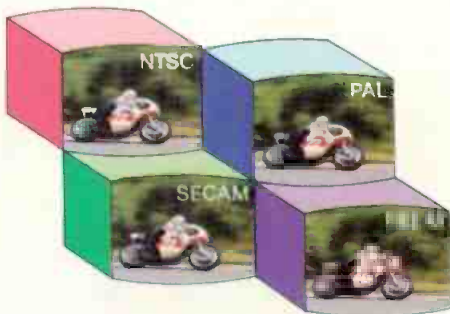

able LT 1200 Digital TV Standards Converter. The cost performance of this system sets the industry standard. And its reliability in the field as well as in rugged use in broadcast stations has earned the LT 1200 a reputation for dependable performance. Operation is totally automatic and totally simple. For converting NTSC, PAL, SECAM, or PAL-M, leave it to the LT 1200. Wherever you are.

Oki also produces the high-end LT 1015Σ and LT 1100Σ Digital TV Standards Converters.



See us at NAB. Booth 2218.

*In the U.S.A. and Canada, contact:*

Oki Electric Overseas Corp.  
One University Plaza,  
Hackensack, New Jersey  
07601 U.S.A.  
Tel: 201-646-0011—0015  
TWX: 7109905004 OKI ELEC HAK

*In Europe, contact:*

Technology Resources S.A.  
27-29 Rue Des Poissonniers  
92200 Neuilly-sur-Seine, France  
Tel: 747-4717, 747-7051  
Telex: 42610657 TERES

Head Office:  
Overseas Marketing & Sales  
10-3, Shibaura 4-chome,  
Minato-ku, Tokyo 108, Japan  
Tel: (03) 454-2111  
Telex: J22627  
Cable: OKIDENKI TOKYO

**OKI**  
electric  
industry  
company, Ltd.

Agent or Distributor inquiries invited.

Circle 254 on Reader Service Card

www.americanradiohistory.com

# PEIRCE-PHELPS. FOR EVERYTHING FROM MINI-VANS TO MAXI-STUDIOS



We just supplied a compact news van to Warner Amex in Mesquite, Texas. And an on-air production studio to WWAC-TV in Atlantic City. Now we'd like to do something for you. Call or write and tell us what you need.

## PEIRCE-PHELPS, INC. VIDEO SYSTEMS DIVISION

2000 N. 59th Street, Philadelphia, Pa. 19131, 800-523-4682. In Pennsylvania, call 215-879-7171.

Circle 241 on Reader Service Card

## Succeeding With ENG/EFP Microwave

WCVB covered "First Night," Boston's version of New York's Times Square New Year's Eve celebration. Shortly after setting up their van on the Boston Common, site of "First Night," the crew realized that the city had forgotten to provide the promised lighting. Not only was WCVB going live in almost complete darkness, but the crew had to stop people from climbing onto the van while the talent dodged a barrage of snowballs.

Concerning live talent, St. Andre of WBZ explains, "You either have the ability to do it live or you don't. A whole different talent is needed for this." He adds that special skills are also needed by production people who must set up multi-camera operations, including local switching at remote locations. News directors also need skill and instinct in deciding where to deploy limited amounts of equipment and what stories to cover live.

### Common pitfalls and experiences

According to Les Bruce of Microwave Associates Communication's customer service department, "One of the most common pitfalls is trying to install all the equipment yourself when you don't have the time or the expertise to do so. Interfacing the antenna control system with the receiver can be particularly difficult." Other key steps in the installation of a system include doing a survey to suggest where to erect a tower, erecting the tower, installing the antenna, the waveguide run to the receiver, the equipment itself, the remote control in the studio, plus testing out the system.

The choice of vehicles is also important, with most stations turning to companies such as Wolf Coach,

Centro, E-N-G Corp., and others to outfit the van with the mast, air compressor racks, and special warning lights indicating the mast is up.

A big exception to this is KHOU. Chief engineer Robinson needed more engineers at the station and also to accompany the cameramen as the station increased its number of "live eye" trucks. Not having the funds to hire additional personnel, Robinson decided that if he could design and build an ENG van that could be completely operated by the cameraman, he would eliminate the need for an engineer to be on board. He did exactly that, bringing four engineers back to the station. Chief cameraman Don Benskin at KHOU comments, "Robinson built the van so fool-proof that all the cameraman has to do is plug the cable from the transmitter in the van into the camera, turn on the power, and raise the mast. The studio operator tells him how to orient the antenna. It's so straightforward and simple."

Robinson completely customized four such vans. He bought Chevrolet Suburbans, installed Microwave Associates MA-2CP 2 GHz transmitters, racks, air compressor, and mast plus all the signal lights. His total investment was about \$32,000, less than half what it might have cost if done outside.

Experience is a dear teacher when it comes to ENG/EFP production. Stations soon learn that there are some places that "they just can't get out of." They either avoid these spots or set up 13 GHz relays. For instance, downtown Providence sits in a dip in the terrain, making it impossible to transmit directly back to the station. WVIT in Hartford has found that the nearby town of Waterbury "sits in such a hole we have to use a double hop to go live out of there."

Multipath, created when signals reflect off water (and elsewhere) and interface with the main signal being sent, is a real problem in cities surrounded by

## Microwave Gets a Lift from Hydraulics

Hydraulic equipment is found all over in such common items as television camera pedestals and barber chairs. Nevertheless, complains N-Pro Co. president Norm Herman, the hydraulic mast has an undeserved bad reputation. Herman is quick to dispel broadcasters' fears that hydraulic masts drip or pose a threat because of high pressure, and points out that hydraulics provides several advantages over air-operated systems.

A special seep-proof design keeps N-Pro's masts drip-free, the company states. Also, the low-pressure, high-volume systems never operate at pressures higher than 80 PSI, about the same as a turned-off garden hose—insuring complete safety.

On the plus side, N-Pro says no maintenance is ever needed for its masts. Oil is the hydraulic medium for the tubular, telescoping masts, and lubrication never needs to be replenished. The masts will smoothly raise equipment to any desired height and hold it there as long as needed—and adjustments of as little as 1/4 inch up or down are accomplished without sudden jolts. The masts will lift up to 350 pounds, depending on model.

Masts are available in a variety of configurations for TV and radio broadcast use, with a wide range of options allowing a high degree of customizing. One example is the RBTV 1, in four- or five-section models that extend to 22 and 27 feet, respectively. Designed to mount atop a TV mobile van, these masts will support 250 pounds, rising to their full extension in one minute and 45 seconds. The RB-1 range, for radio, is designed to elevate and support a 164 MHz antenna and easily fits a standard 125-inch wheelbase vehicle.



*Chevy van recently completed for KIRO, Seattle, utilizes an RF Technology microwave system on a 21-foot N-Pro mast.*

## Succeeding With ENG/EPF Microwave

water, especially when using a helicopter. The best way to eliminate this is to use a receive antenna with a narrow aperture that won't receive reflected signals.

Communications can also be a problem. Chief engineer Nile Hunt of WESH, Daytona Beach/Orlando, solved his two-way communication problem with a hint he picked up watching an episode of *Emergency One* on TV. Plagued with problems of poor audio communications when his ENG crews went indoors, he saw on the program a medical team using a walkie-talkie to communicate with a hospital miles away. Intrigued, he called local medical authorities, who explained that the low-watt walkie-talkies triggered a relay on a more powerful amplifier in the nearby emergency vehicle, which then broadcast to the hospital.

Antenna placement has taught many lessons to many stations. John Fergie of Springfield's WWLP advises. "Everyone starting off assumes that the best place to put their ENG antenna is downtown. This is not always the best place. We would have been better off putting it on our station's tower. The next one will go there. We would have had a much wider range if we had done so."

WBZ-TV put its first receiver on the John Hancock building, Boston's tallest building at the time. But the station soon found that if it tried to go live out of the heart of downtown (a good distance from the John Hancock building), the van became engulfed in a



Physical fitness is the subject of this live news remote from WWLP, Springfield.

jungle of buildings and often had no line-of-sight to the antenna. Another antenna had to be put on top of One Boston Place.

Neither was biggest the best for WPRI, whose competition had secured the tallest building in Providence for its antenna, forcing WPRI to use a shorter, tiered building. WPRI soon discovered this was a blessing in disguise since it could bounce its signal off the smooth glass of the taller building when line-of-sight couldn't be attained. The competition, however, had no such option since WPRI's tiered building would scatter the signal.

Two pieces of advice may prove helpful. One from WWLP: "Do not drive your van into the garage after installing a four-foot dish on top. It will 'reshape' the

## Why Your Radio Station Should Own An Eventide H949 Harmonizer®

### • IT'S A COMPLETE AUDIO TIME COMPRESSION SYSTEM AT A FRACTION OF THE PRICE

The \$3500\* H949 gives you the same audio time compression and expansion capabilities of competitive single-purpose units costing well over twice as much. You get the power to control time itself...with no editing, no program material deleted and no abnormal pitch effects.

### • IT'S A COMPLETE SPECIAL EFFECTS DEPARTMENT

The Eventide H949 Harmonizer® special effects unit gives you an almost endless variety of effects. There's variable delay, echo and reverb. Feedback level and equalization controls let you "custom-tune" the audio. Pitch change capability can create new voices. Mix input with pitch-changed output for chorus and harmony effects. Want the distinctive sound of flanging? The H949 offers the best flanging ever. There's time reversal and repeat too. For even more versatility, many more effects can be created from combinations of the basic effects.

### WHAT CAN THIS MEAN FOR YOUR STATION?

#### • IT CAN HELP YOU MAKE MORE MONEY

Go after those co-op dollars! The H949 can easily compress an existing national spot to accommodate a local retailer tag. Local advertisers who deliver their own ad copy will love what the H949 can do. Endless retakes to correct

\*List price in domestic U.S.



the non-professional's timing errors are eliminated. Use pitch-change to make that local retailer sound more like an announcer (He'll love that!) Time compression with the H949 can bring order out of chaos when running back-to-back religious or political programs which are often mistimed. And, you'll find yourself doing more and better station-produced local spots—with those special audio effects that make for a more professional custom production. Your advertisers will notice and appreciate the difference.

### • IT CAN GIVE YOUR STATION A MORE DISTINCTIVE, TIGHTER SOUND

The H949 Harmonizer can really make a difference. Use its special effects capabilities to produce really distinctive promos, intros and custom jingles. For a brighter, fast-paced sound, some stations choose to speed up their music by a few percent, utilizing the Harmonizer to maintain normal pitch. Using pitch-change, you can even create new voices to populate your air.

**MOST EVENTIDE DEALERS HAVE EVALUATION UNITS AVAILABLE. CALL EVENTIDE TODAY FOR THE DEALER NEAREST YOU.**

**Eventide**  
the next step

265 West 54th Street  
New York, N.Y. 10019  
(212) 581-9290

dish and make it unusable." And another from KHOU: "Do not try to drive underneath a highway overpass with your mast extended. Something's got to give and it will probably be your mast."

### The competitive edge

According to Arnold Klinsky, news director of WVIT, "The home viewer expects live news coverage." But does the person at home really understand live as opposed to tape? Kauffman of WCVB has found that as news directors and producers change at his station, so does the attitude concerning the importance of live segments. But, he feels, "you need it to be complete." St. Andre of WBZ goes further: "If you are going to consider yourself in the live news business, you must have airborne ENG microwave capability."

Even outside the top 25 markets, the ranks, almost without exception, are armed with 2 GHz and 13 GHz gear—and they use it constantly. WESH in Daytona

Beach/Orlando (market 33) wouldn't give it up. And WNDU in South Bend, IN (market 77), is a devoted ENG user.

WPRI in Providence admits that when it saw the reaction to its competition going live every night, it had to jump in, too. The final straw came in 1978 when a terrible snowstorm paralyzed the city. The competition was able to broadcast live from the Civil Defense headquarters and give emergency information. This impressed WPRI with the importance of being able to give information to the public.

ENG microwave can also be instrumental in helping a UHF station succeed in a VHF market. Before 1979, WVIT, Ch. 30 in Hartford, had a small news department of five people, which was not at all competitive. The station increased the news department to over 30 people and bought ENG microwave equipment. Every week now sees a number of live segments, plus special live programming such as the coverage of the Pope's U.S. visit and Governor Grasso's funeral. The station is now considered so proficient at live ENG/EFP that it was the only television station invited inside the cathedral to cover Grasso's funeral mass. WVIT provided pool coverage to networks and local stations using 13 live cameras from three remote locations to cover four hours of memorial events. Does WVIT think that this capability to do live coverage helps it in the market? It must, because two years ago the station received an Emmy Award for the best news coverage in New England, beating out VHF stations in Boston and Providence. This past year it was nominated again.

BM/E

The following stations provided information for this story:

WVIT, Hartford, CT (Ch. 30, NBC)  
 WWLP, Springfield, MA (Ch. 22, NBC)  
 WPRI, Providence, RI (Ch. 12, ABC)  
 WHOU, Houston, TX (Ch. 11, CBS)  
 WESH, Orlando/Daytona Beach, FL (Ch. 2, NBC)  
 WBZ, Boston, MA (Ch. 4, NBC)  
 WCVB, Boston, MA (Ch. 5, ABC)

## Now There's An Eventide Timesqueeze™ Time Compression System Priced For Every Television Facility.

### • EVENTIDE'S NEWEST VIDEO TIMESQUEEZE SYSTEM COSTS JUST \$5000\* COMPLETE

That's thousands less than any other T.V. time compression system. Eventide's Timesqueeze Jr.™ interfaces with virtually every variable-speed-capable VTR or film chain (and audio recorders too.) Compress or expand the running time of program material with no editing, no program material deleted and no abnormal pitch effects.

### • WE CUT THE PRICE BY SIMPLIFYING THE CONTROLS

We've kept operating controls to a minimum. Just set the desired percentage change on four thumb-wheel switches. The resulting time change can easily be calculated to the fraction of a second.



### • WE DIDN'T CUT BACK ON PERFORMANCE

Pitch normalization is the key to successful time compression. That's why the heart of every Eventide Timesqueeze System—regardless of price—is Eventide's fabulous H949 Harmonizer.® Eventide Harmonizers are the best selling, most trusted pitch changers in the world. Both Timesqueeze and Timesqueeze Jr. deliver the superior specs of the H949 Harmonizer—15kHz frequency response; 96dB dynamic range. And our modular approach gives you greater flexibility and economy. For stereo or multitrack operation for example, just add additional H949 Harmonizers at \$3500\* each. No other time compression system can be expanded as economically.

\*List price in domestic U.S.

### • DOUBLE DUTY FOR GREATER VALUE

When not being used for time compression, Eventide Timesqueeze Systems can provide all the audio production effects that made the H949 Harmonizer an industry standard. You can read about all these effects on the facing page. Remember, only Eventide Timesqueeze Systems provide this versatility.

### • EVENTIDE'S SUPER AUTOMATED SYSTEM



Now that you've read about the capabilities of our \$5000\* economy Timesqueeze Jr., just imagine what our top-of-the-line system (shown here) can do. Incorporating

a Hewlett Packard HP-85 (included in the \$8500\* price,) this system offers totally automated control of all calculations and operations. There's a C.R.T. readout to keep you fully informed as to tape machine status, running speed, pitch ratio and other operational data. It's so smart it can even print out how-to-use info and interconnect diagrams.

**SEE BOTH EVENTIDE TIMESQUEEZE SYSTEMS NOW. CALL EVENTIDE OR YOUR DEALER TO ARRANGE A DEMONSTRATION.**

**Eventide**  
the next step

265 West 54th Street,  
New York, N.Y. 10019  
(212) 581-9290



# Think of us as your mike expert.



## The 635A – Perfect design from the start

The Electro-Voice 635A is probably the most widely used broadcast microphone currently available. Yet it was introduced back in 1967! There are microphone companies that haven't been around as long as the 635A! What makes a microphone continue to be the broadcasters' favorite after 15 years in the field?

The 635A was designed to be used anywhere. Its screw-machined steel case and mechanically nested parts set standards for durability and ruggedness that the competition still strives for. It was the first omnidirectional microphone designed to have a shaped, rather than flat, frequency response. A rolled off bass response combined with a slightly rising high end make it perfect for vocal reproduction. And it was the first microphone of its type to feature an elastomer

encased head capsule for reduced handling noise and additional protection from severe mechanical shock.

Despite all the technological advances in the broadcast, recording and sound reinforcement industries, the 635A continues to be the "audio man's screwdriver" – a microphone tool that can be used anytime, anywhere, for almost anything. When a product is designed right to start with, there's no need for it to become obsolete. All Electro-Voice professional microphones are designed with the same goal in mind. That's why people think of Electro-Voice as their microphone expert.

**EV** **Electro-Voice**<sup>®</sup>  
a **gulton** company

600 Cecil Street, Buchanan, Michigan 49107

In Canada:  
Electro-Voice, Div. of Gulton Industries (Canada) Ltd.,  
345 Herbert St., Gananoque, Ontario K7G 2V1.

Circle 257 on Reader Service Card

[www.americanradiohistory.com](http://www.americanradiohistory.com)

# THE 5mm DIFFERENCE

By Robert G. Neuhauser

---

*The newly developed 1/2-in. tubes for RCA's Hawkeye camera/VCR are 5 mm smaller than their 2/3-in. counterparts, contributing significantly to Hawkeye's lighter weight and lower power consumption. Behind the development are a new type of photosensitive material and other technological advances.*

---

THE HEART OF THE NEW RCA Hawkeye recording camera is its three 1/2-in. diameter Saticon\* pickup tubes, which allow the single-piece camera/VCR combination to be about the same weight and utilize about the same amount of power as standard, camera-only ENG/EJ systems while delivering excellent signal performance.

The task originally faced by Hawkeye's designers was to make a smaller and lighter camera without sacrificing resolution, sensitivity, registration, or any other factors that contribute to making a broadcast-quality color image. The choice of pickup tube was therefore of paramount importance, and RCA's designers naturally turned to the basic Saticon type because of its high resolution characteristics, excellent lifespan and reliability,

---

**Robert G. Neuhauser** is senior member, technical staff, applications engineering for RCA's Electro-Optics and Devices Division.

\*Used with permission of trademark owner.



*A new deflection coil design in the RCA-developed tube requires no additional clamps or hardware.*

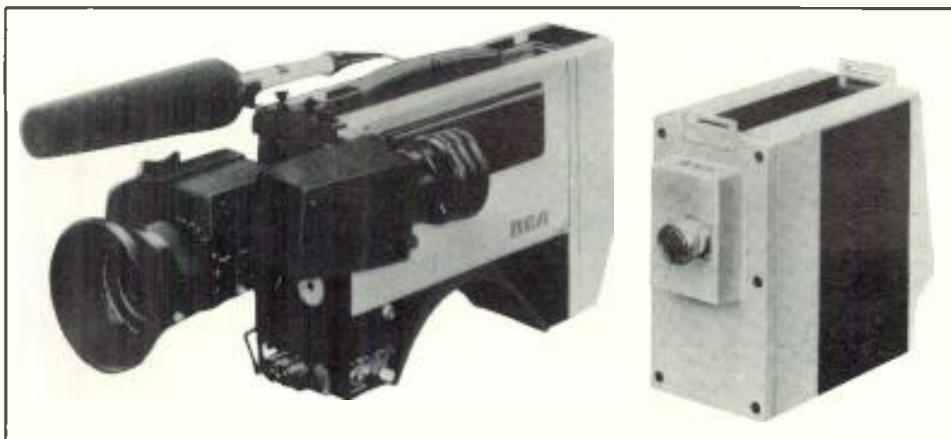

*RCA's Hawkeye camera/VCR system weighs 23 lbs. with lens and detachable recorder—made possible by new 1/2-inch tube developments.*

## The 5mm Difference

and well-known ability to handle the kind of high-contrast scenes that are typically encountered in ENG applications.

Fortunately, the scaling-down process was considerably simplified by the nature of the Saticon tube's amorphous solid-state photoconductor, whose resolution is virtually independent of the size of the tube or the optical image size that is focused on it. The glassy structure of the photoconductor absorbs light very strongly, preventing light scattering in the photolayer. (Typical lead oxide tubes have a photoconductive layer that is microcrystalline in structure, which can cause light scattering and resulting loss of resolution. This makes them less practical for downscaling to the 1/2-in. format.) The Saticon photoconductor's high resistance

to scattering also stores image changes with little loss of resolution.

Actual resolution for the BC4398 13 mm (1/2-in.) Saticon tube is only slightly less than the resolution of the 18 mm (2/3-in.) Saticon tube; resolution and resolution uniformity are slightly greater than 18 mm lead oxide diode gun tubes. The high resolution of the smaller tube is maintained because, as mentioned, the photoconductor does not restrict the tube's resolution and also because high magnetic fields are used with the shorter tube, helping restrict the diameter of the scanning beam.

Making the tube smaller also improves the tube and camera performances in other respects. The smaller tubes obviously contribute to a smaller and lighter camera since they take up less space. Their smaller diameter also means, however, that smaller and lighter deflecting focusing coils, internal optics, and lenses can

## Tape Format is the Secret to VTR Quality

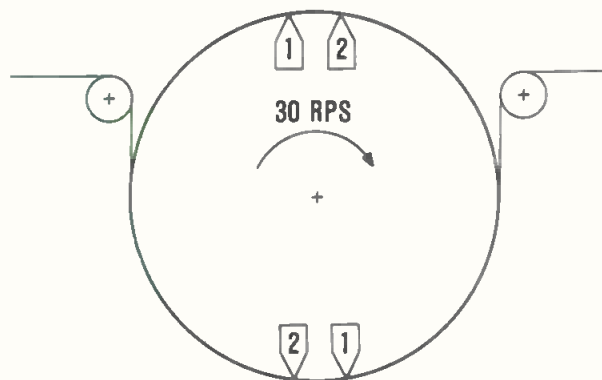

TAPE WRAPS 180° AROUND DRUM

Fig. A. The tape wraps 180° around the recorder drum. The two sets of tape heads record Channel 1 and Channel 2 shown in Figure 1 below.

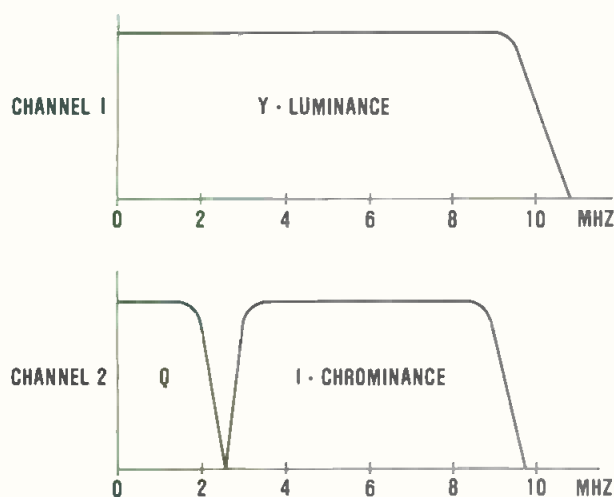

Fig. 1. FM recording was chosen over direct and AM recording as the best way to produce broadcast-quality picture. The FM spectrum allocation is shown above.

To achieve the quality and size objectives of the Hawkeye, RCA had to provide a broadcast-quality camera mated to a compact VHS cassette recorder. But it was not an easy task to design this system. Advancement in the state of the art in magnetic recording was required.

Results of a program carried out at RCA's David Sarnoff Research Center in Princeton, NJ, pointed toward analog, FM recording using the rotary head, helical scan method. Researchers rejected longitudinal recording due to its inherent difficulties in achieving pictures in the search mode—a mandatory requirement for rapid newsroom editing. Direct recording and AM recording were rejected on the grounds of poor picture quality.

Having established these parameters, an in-depth survey of VTR suppliers led to a joint development project in 1979 with Matsushita Electric's Central Research Laboratory in Osaka, Japan. (Matsushita has been RCA's supplier of the consumer VHS recorder as well.) Subsequently, Matsushita undertook a design program and is now in production with the recorder section of Hawkeye.

Figure 1 shows the FM spectrum allocation for the baseband analog components. Two recording channels are used simultaneously as follows: Uncontaminated luminance comes directly from the camera matrix and is recorded on Channel 1, occupying the FM band from 1 to 10 MHz. (The upper deviation is near 6 MHz.) Uncontaminated chrominance also comes directly from the camera and is recorded on Channel 2—the Q signal occupies the FM band up to 2 MHz, the I signal occupies the FM band from just over 2 MHz to 9 MHz. This FM spectrum allocation is a key to the picture quality achieved by Hawkeye.

Perhaps the most dramatic development to come out of the Hawkeye project is a new tape format that RCA calls Chroma Trak. In this format the tape is wrapped 180 degrees around the drum—the upper portion of the drum rotates at exactly 29.97 rps—and records exactly one TV frame per revolution, or one TV field per scan of 180 degrees. The two parallel channels described above are recorded simultaneously—Channel 1 on Head 1 and Channel 2 on Head 2. The drum diameter is 2.44 inches.

be used, reducing the power requirements of the camera.

Each tube weighs only 195 g, measures 8.8 cm, and requires 1.3 W for operation—0.6 W for the tube heaters and 0.7 W for the focusing power (the tube electronics and deflecting coil use only negligible amounts of power). This compares with a 260 g weight and 11.0 cm overall length of a typical 18 mm tube.

#### Extremely low lag

One of the tube's most important performance characteristics is its extremely low lag—the lowest, in fact, of any comparable pickup tube at low light levels.

One of the major factors in this achievement is that the BC4398 has an 8 mm image diagonal as compared to the 11 mm diagonal of an 18 mm tube. This reduction in the scanned area cuts the photoconductor capacitance in half, reducing the lag and effectively in-

creasing the camera's sensitivity in low-light conditions. The smaller capacitance of the target to ground (2.3 pF) also improves the signal-to-noise performance of the camera. Since less signal current is shunted to ground through the reduced capacitance, more signal is available for the video amplifier.

The electron gun is a magnetically focused type that historically has the best reliability and ruggedness. The new technology of a low impedance/low lag triode gun is incorporated into its design.

The camera circuitry also contributes to its overall low lag performance. CTS (comet tail suppression) control, which is independently generated for each tube, sets the beam current at the lowest possible value for normal scene content and automatically increases it as soon as highlights are encountered. The low beam current that can be used for normal scene content substantially reduces low light level lag of the tube.

Figure 2 provides detail on the Chroma Trak tape format. The numbers to the left are in thousandths of an inch; thus, the tape is 500 thousandths, or one-half in, nominal width. There are four separate longitudinal tracks—two for audio, one for VTR control, and one for time code. Because the video tracks do not step on top of the time code track, it can be edited independently. With longitudinal tape speed of eight inches per second, the drum diameter and rotational

rate results in a head-to-tape speed of 225 ips. Hawkeye uses helical scan recording, originally patented by Earl Masterson at RCA in 1956.

In order to satisfy the requirements for high picture quality and small size, the recording density of the Hawkeye was more than doubled over the previous 3/4-inch format. As a result, RCA considers Hawkeye's recording wavelength of 27,000 cycles per inch the new state of the art.

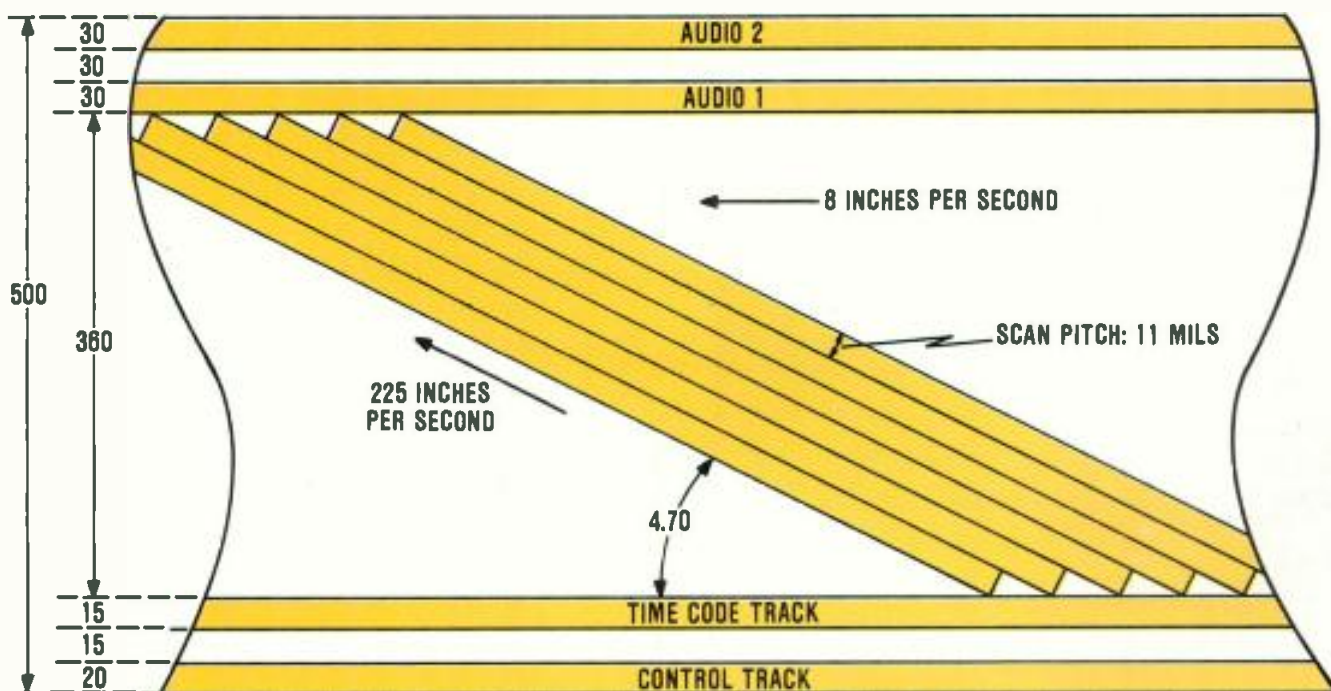

Fig. 2. In the Chroma Trak tape format depicted above, chrominance resolution and S/N, as well as chrominance-to-luminance registration, have been improved compared with 3/4-inch systems.

# ADDA

# CORPORATION



## ESP Digital Still Store System.

On-line previewing and editing; automatic sequencing; the instant creation of multi-layer graphics.

Today a concept we helped pioneer—the electronic storage and retrieval of video images for graphic production and preprogrammed on-air use—is becoming an industry standard for the technological leaders in television and video production.

Now we've put our years of experience into a new generation of still store systems. And from the 150C for mobile applications to the large, multiple drive 750C, our microprocessor-controlled, expandable systems have a production versatility that can't be beat.

With a price/performance ratio to match.

### The Basic System.

Our ESP 750C Digital Graphics System consists of an Analog/Digital Processor, a Master Control Panel, and standard computer industry disk drives. But the built in flexibility of our system makes it easy to expand. Each Analog/Digital Processor can accommodate up to four drives. You can add up to a total of fifteen remote production panels. And more off-line

storage with up to 99 separately identified disk packs.

Our dual channel output and front end synchronization allow you a choice of inputs and a wider range of capabilities.



And the 750's second generation digital electronics give you a production-oriented sequence and memory system that lets you perform last minute editing. Add or delete within a sequence. Create multiple generation graphics with virtually no degradation in the quality of your original image.

### Smart Control.

ESP's intelligent controls make the C Series a production tool that goes easy on everyone in your operation: Technical directors, graphic artists, and production staff alike.



Our standards include:

- A built-in operator prompter.
- Single function keys.
- A rapid-access sequence and memory system.
- Built-in safety features.

### Great Optional Features.

The ADDA ESP C Series offers you some important optional features, too. Time-saving production tools like our Multipix "electronic storyboard." A Multiple Access Controller for simple modular expansion. A Digital Interface Board with programmable electronic interfaces that permits our system to be linked with station automation systems.

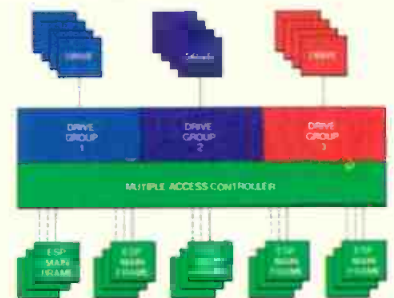

At ADDA Corporation, we pioneered the concept of economical, efficient, electronic graphics generation. And we think we're the best in the business. A lot of other people think so, too. Nearly 80% of the digital still store systems in use today are ours.

But don't take our word for it. Give us a call and let us show you what our years in this industry have produced.

Affordable Excellence.

**ADDA CORPORATION**

1671 Dell Avenue  
Campbell, California 95008  
(408) 379-1500

## The 5mm Difference

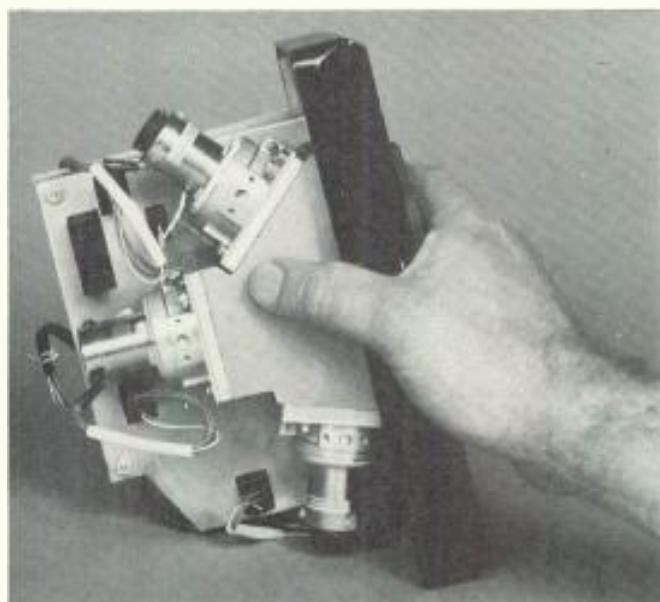

The three-tube sealed optical system is accurate to within 0.0001 inches.

### New deflection coil design

A new concept for the coil assembly was also introduced in the new tubes. This involves a precision diameter bulb precisely concentric with the axis of the tube gun. A precision bore coil system was developed to slip-fit to the bulb, making a monolithic tube coil structure that does not require clamps or fixtures to hold it in position and that will position the axis of the tube precisely on the optical axis of the camera. This avoids added complications of hardware and adjustments in the camera, and further reduces its weight and complexity.

Additional features improve color performance of the BC4398. The tube was designed with all new precision parts to insure registration accuracy and close filtering tolerances. A more rugged construction prevents movement of the tubes because of shock or vibration.

A faceplate extender improves the resolution of the optical image by incorporating enough glass of the proper index in the optical path. An added bonus of this feature is that any dust that may settle on the faceplate will be substantially out of focus and will not appear in the picture, a plus since small dust particles appear very large in the television picture from small-format systems. (Dust, of course, is a minimal problem in the sealed optical system of the Hawkeye camera.) The reliable and versatile indium faceplate seal, allows the faceplate to be sealed to the bulb with a tilt tolerance in the range of 0.0001-in. This is important in small-format optical systems with wide apertures where the depth of focus of the image is in the order of several thousandths of an inch.

While RCA has been marketing Saticon tubes for the past four years, the BC4398 is its first entry into Saticon tube manufacturing. This new tube is now in factory pilot production and will be available in quantity before the end of the year to supply the needs for the RCA Hawkeye and other cameras being designed for small-format tubes.

BM/E

# Perfect Timing

# SMPTTE

## TIME CODE READERS THAT YOU CAN AFFORD

**ES251**-Six digit SMPTTE Time Code Reader displaying Hours, Minutes and Seconds. Reads at play back speed. Momentary hold switch permits "freezing" of time displayed. Releasing hold switch updates display to correct time.



**\$295**

**ES252**-Exactly like ES251, but displays Minutes, Seconds and Frames. **\$300**



**ES253**-Eight digit reader, displays Hours, Minutes, Seconds and Frames.

Reads at play back speed, has "freeze" control. **\$454**

**ES254**-BI-DIRECTIONAL, MULTI-SPEED (1/20 to 20 times), eight digit reader with "freeze" control. On loss of code, displays last valid code read. **\$675**

## AND FOR OFF-LINE EDITING ES255 SMPTTE IN/VIDEO OUT

ES255 is an eight digit, multi-speed, bi-directional SMPTTE reader which adds the SMPTTE input to your video. You can now "burn" the time code into the video portion of your tape, or feed a monitor directly. **\$995**



Write, Wire or Call: (213) 322-2136  
142 Sierra Street, El Segundo, CA 90245

Circle 259 on Reader Service Card



## Introducing the only $\frac{3}{4}$ " time code editing system that performs 20 automatic edits from multiple sources. The Panasonic 700 B-2 Series Time Code Editing System.

**700  
B-2  
SERIES**

Now Panasonic adds a new dimension to the speed and accuracy of time code editing with our new 700 B-2 Series Time Code Editing System. The AU-700 editing recorder, the AU-A70 programmable editing controller, and the AU-J10 multiple source adapter. Together they let you do what other time code editing systems don't: Perform up to 20 automatic, multiple-source insert and assembly edits. And the 700 B-2 Series is packed

with outstanding performance features.

The precision of direct drive.



Check out the excellent stability and precision of the AU-700's direct-drive video head cylinder and capstan servo motor. The superb performance and durability of our crystal-oriented HPF™ heads. All combine to produce an outstanding picture with horizontal resolution of 260 lines color, 330 lines

monochrome and S/N ratio of 46 dB color, 50 dB monochrome. You'll also get an edit with less video noise because video head switching has been moved to the vertical interval so it never shows up in the picture. At the same time, we incorporated DUB IN and DUB OUT connectors with separate Y/C signals and a flying erase head. And to keep that good-looking picture looking good, all circuitry is mounted in a durable annealed aluminum die-cast chassis.

The speed of microprocessors.

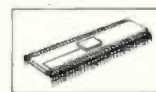

Another touch of ingenuity is the AU-700's microprocessor controls. Designed to work perfectly with the AU-A70 editing controller, they give you the speed, accuracy and versatility of full-logic, mode-to-mode switching. The AU-700 will accept SMPTE time code on a separate track or on audio track one as well as standard CTL pulses. And its electronic



Shown from left AU-700 editing recorder, AU-A70 programmable editing controller.

digital tape counter displays LED readouts of CTL pulses in minutes and seconds—even in fast forward and rewind.

#### Multiple source versatility.

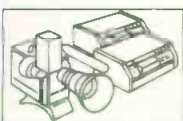

With our AU-A70 editing controller

not only can you generate and read time code pulses, microprocessors let it perform up to 20 time code edits automatically. Add an AU-J10 multiple source adapter and it will accept inputs

from two source decks and one live line plus perform A/B rolls. Microprocessors also let you automatically go to specific tape locations. You can also search both ways at speeds of 1/20X, 1/5X, 1X, 2X, 5X plus pause with picture. Other features include program check, program exchange, insert programming and overflow indication. For editing convenience, separate address time and lap time indicators are included. The AU-A70's error codes pinpoint any procedural

errors to avoid incorrectly programmed edits. The AU-A70 can also be used with any Panasonic solenoid-operated 3/4" and 1/2" VHS™ decks. For worldwide versatility, there is a built-in voltage selector that is compatible with 100V / 120V / 220V / 240V AC, at either 60 Hz or 50 Hz.

#### Total service capability.

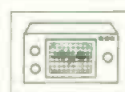

When it comes to servicing and maintaining the 700 B-2 Series, Panasonic backs you with a full net-

work of B-2 dealers, equipped with total service capability. Each has the parts and technical expertise that professionals require. For further information, call your nearest Panasonic office: Northeast—(201) 348-7620 Southeast—(404) 923-9700 Midwest—(312) 364-7936 Southwest—(214) 258-6400 West Coast—(213) 655-1111 The new 700 B-2 Series Time Code Editing System. Only from Panasonic.

**Panasonic**  
VIDEO SYSTEMS DIVISION





**THE SOLID STATE LOGIC MASTER STUDIO SYSTEM:  
It Can Help More Broadcasters In More Ways Than Any Other Console**

Shown here at the American Broadcasting Company's newest audio sweetening room in New York, the SSL-4000 E Series integrates computerised mixing, switching and machine control to provide a much needed audio counterpart to state-of-the-art video capabilities.

Extensive master logic, comprehensive I/O module functions and the industry's most advanced software enable the same SSL Series to easily handle elaborate live and multi-track music mixing, while superior ergonomics and compact design have made SSL the leading choice for outside broadcast production.

And now, Solid State Logic introduces the SSL Real Time System, an uncommonly sensible innovation which brings the full advantages of computer mixing to the demands of live teleproduction, with total On-Air editing flexibility and reliability. Witness the future of broadcast audio production at the Dallas NAB, or contact us for complete details.

**UK & Europe**  
Solid State Logic  
Churchfields, Stonesfield  
Oxford, England OX7 2PQ  
(099 389) 8282  
Telex 837 400

**Solid State Logic**  
**Master Studio Systems**

**North & South America**  
Musicworks International  
2352 Wisconsin Avenue  
Washington, D.C. 20007  
(202) 333-1500  
Telex 440 519

Circle 261 on Reader Service Card

[www.americanradiohistory.com](http://www.americanradiohistory.com)

# RADIO PROGRAMMING: THE SHAPE OF THINGS TO COME

*Many pressures are coming to bear on radio programming, and they will change its character substantially over the next few years. What are the opportunities and the dangers for the radio programmer in the light of the new developments; particularly satellite technology?*



EVERY MANAGER of a radio station today knows that powerful currents of change are flowing through the industry. These forces for change are developing in an industry that is already at its highest level of profit and influence, levels well above the peaks in the pre-television era when radio ruled the living room alone. So why big changes when the game is being won hands down?

The answer is that history, the sweep of technology and economics, is not going to let radio alone. For one thing, satellite distribution of programming is laying the basis for large shifts in the way local radio stations are operated. The satellites are so powerful because they bring higher economic efficiency and more attractive programming than many local stations can develop themselves—even more important as local radio gets more and more competitive. The intensification of competition is itself one of the large forces for change.

Another major change that will affect planning of radio programming strongly is the spread of radio listening to periods throughout the day. Richard Foreman, programming consultant to the ABC radio nets and to a number of group owners of radio stations, points to audience studies that show the number of listeners in the 10 am to 3 pm period to be the largest of the day. Both morning and evening drive times are, of course, still very big. But the radio programmer must think of his audience through the midday as a major target, one of his important potential income sources.

## **Satellites transforming radio**

The satellite revolution is highly visible today, but its full flowering is still ahead. The main result of that flowering is clear: the amount and variety of centrally

produced programming of high finish available to local radio stations will be many times what it was in the past. Moreover, the new programming will reach the station more easily, more cheaply, with higher technical quality than the pre-satellite network programs.

A list of all the programs now available on the satellites is out of date by the time it gets to the printer. Most radio managers today are familiar with the recent program listings of Mutual and RKO, for example, both now almost completely on the satellites. We can multiply such a list by perhaps 10 to get a rough idea of what is coming, if we allow considerable space for the very new kinds of programming that software producers are working to develop. The next two years will see a heavy influx of new styles of programming.

The technology of the satellites is also favorable to the development of a great number of new network operations. But most software executives do not believe the industry can support as many as, say, 20 national nets. A national net runs on national advertising, and no one yet knows how much support national advertisers are going to give the new satellite nets. So far, the response of advertisers has been positive, so there is a lot of expansion to go. But some in the industry believe that the limit might be around 10.

Even with that limit, radio programmers will be in a new world. For quite a while, nearly all local stations will go to one net for programming, in the traditional

## Radio Programming

fashion of the network affiliate. The ultimate satellite revolution will come, however, when some stations will "satellite hop," with steerable or multiple-signal antennas and the electronics to match.

The diversity of the satellite programming will also aid and abet an already developing trend, that toward audience segmentation, the service of audience segments that are more definitely and separately defined than in the past. This is the direction that many stations must take to survive in local competition. The satellite programming will help segmentation to go farther than it has, and most see this as a necessary and healthy movement.



One of first stations to take 24-hour programming via satellite is KIOU, Corpus Christi, Texas, using Bonneville's *Beautiful Music*. Left and right, Jeff Mattieu, Frank Murphy of Bonneville; center, Steve De Walt, president, KIOU.

Agreeing with that assessment, Richard Carr, program director for Mutual, nevertheless pointed out that segmentation will go *too* far if it reduces the size of the audience below economic viability. He does not see this anywhere in sight yet, but considers it a danger of the longer future.

### Localism is still basic

Before going on to examine the satellite revolution, we must first re-state a fact of radio life emphasized in many recent studies (the November, 1981 issue of *BM/E* was devoted to the topic): everyone in the industry agrees that strong localism will continue to be essential to radio success in nearly all markets. The job of the programmer, therefore, must be to find the right mix of outside and local programming, and each must be strong.

Combining localism with effective use of the satellite riches is easiest when the satellite material is short-form, designed to fill out certain parts of the programming day but not to take over large proportions. Up to now most of the satellite programming has been short-form. The creators of short-form programming see themselves as active supporters of localism. As reported in *BM/E*'s October issue, Martin Rubenstein,

president of Mutual, views his material as supplying many important kinds of programming the stations can't produce themselves; but he endorses positively the concept of localism as basic. The same assignment of roles to satellite and local material guides most other software producers.

A more difficult situation develops with long-form programming, with the satellite programmer aiming to supply a large part, or nearly all, of the day's programming. An example is the fast developing distributions of syndicated programming by satellite. Many are concerned with this problem, and some solutions are developing.

### New importance for talk

Prominent among the "new" things the satellite programmers will do is a great enlargement of the role of talk in radio programming. A number of factors are pushing talk to center stage. Audience research has lately shown an upsurge in response to talk material. (The program choices and innovations of the very large satellite nets are being based on extensive and thorough audience research.)

Another new strength for talk comes from the necessity to find a new life for many stations, particularly the AM stations that are suffering from the loss of AM's traditional position as the main purveyor of popular music. The success of FM has created a kind of no man's land for a lot of AM stations. There is a lot of industry sentiment for a new assignment of roles: FM for music, AM for information.

The ABC radio network is preparing a long-form talk series that looks to be one of the most important new ventures in satellite programming. Rick Sklar, ABC vice president for radio programming, describes its aim to be able to fill daily the space from 10 am to 4 pm, leaving the drive-time programming to the station's local efforts. It will be called "TalkRadio."

The mix will include news, interviews with experts on public affairs and other fields, celebrity interviews with hosts who have national experience, self-help material, and call-in segments. The mix is to some extent familiar; what is really new is the quantity of the material, the intent to make it a central part of the local station's programming. Sklar says that talk can win a lot of rating points, but only if it is very expertly done. Local stations in small and medium markets cannot afford the personnel needed for a high-finish talk operation. ABC is about ready to go with such material; launching is set for April. It will be distributed over telephone lines at first, completely on the satellite by late in the year or early 1983.

Part of the ABC plan is a system to help the local station carry out the switching from local to net, etc., when the talk programs are in progress. Along with the program, ABC sends out a series of cue tones which can be used at the station, with a decoding system, to start carts with a variety of material: ID's for the station and the net, news breaks, local spots, PSA's and other material. The idea is not new; Mutual has been developing a similar plan for some time. And Satellite Music Network is also using a cue-tone system, as described presently. In every case the main objective is to make transitions from network to local very smooth; they come several times in an hour and raggedness would destroy the program's hard-won image of high-finish

# It Stands Alone

The Rohde & Schwarz Precision TV Demodulator  
Type EKF2/D



- 20 mV-1.5V Input For Precision Transmitter-Site Monitoring
- Off-Air Monitoring Receiver EKF2 also available (250  $\mu$ V-150 mV)
- Unique 2-Way Tuning:  
PLL Tuning Across The Complete Broadcast Range (Channels 2-83)  
plus  
One Crystal (Any Channel) For High-Accuracy  
(All included! No plug-ins or modifications necessary!)
- All Demodulation Modes:  
Switchable Envelope/Synchronous Demodulation  
Switchable Sound-Trap  
Zero-Reference Pulse
- Built In Speaker For Direct Audio Monitoring  
Available From Stock

The EKF2/D is the world's new standard for precision TV Demodulators ... price/performance is unequalled ... because it's from ROHDE & SCHWARZ — leaders in precision, quality video products.

*Write For New 6 Page Brochure*



See us at NAB Booth 3213

**ROHDE & SCHWARZ**

14 Gloria Lane, Fairfield, N.J. 07006 ■ (201) 575-0750 ■ Telex 133310

Circle 262 on Reader Service Card

[www.americanradiohistory.com](http://www.americanradiohistory.com)

## Radio Programming

and attractiveness.

Talk is also one of the large elements on the crowded new-programming roster of RKO. "America Overnight" is RKO's nightly all-night interview and call-in program, running from midnight to 6 AM, live, in stereo. And that in turn is a little like the long-running success of Mutual, the Larry King show, which runs overnight five nights a week and reaches well over 200 stations.

Although many talk programs are pulling large audiences, they are not displacing news and sports coverage, the old network standbys, as central to network operation. Frank Miller, vice president for programming, CBS Radio, says that the news and sports are the biggest pullers with the net's affiliates. He gives much of the credit for the growth of the net from about 250 affiliates to over 400, in a few years, to the CBS radio broadcasts of major national sports events. But CBS has many other kinds of talk now operative or in the works. These have been developing, says Miller, in direct response to needs expressed by affiliates.

The new CBS net operation, RadioRadio (see *BM/E*, November, 1981), is also responding to the stronger interest in talk. Aimed for a young group, the 18-34 year olds, RadioRadio will use a lot of talk in addition to music entertainment designed specifically for the young listener. Among the talk plans described by Leslie Corn, the RadioRadio program director, is a national call-in program with callers connected directly to national entertainment and political personages, whom each caller can question directly. A toll-free number will encourage callers from every part of the country to join in. Other talk segments will include self-help material, news and news commentary, and a really fresh category—live comedy material.

### Drama's chance for comeback

The emphasis on talk and the overriding need for new kinds of radio programming so that stations can distinguish themselves from one another are beginning to stir new attitudes toward radio drama. Many net executives say that they are thinking seriously about drama, although none are ready to announce definite



*RKO is delivering via satellite a number of fresh-minted talk and music programs, but like other nets finds regular news also an essential for affiliates. In photo News Director Dave Cook and newsman Charles Martin prepare a broadcast.*

plans. The *CBS Mystery Theater*, nine years old, will naturally go on—it has been a fine success for the net and for the nearly 300 stations that use it.

Tom Rounds, president of Watermark, Los Angeles syndicator, says he is trying hard to find a way to get good radio drama written; he deplors the almost total disappearance of the pool of drama talent that flourished in the old radio network era and he points to the success of National Public Radio in the Los Angeles area with innovative kinds of talk programs, including drama. Rounds believes that syndicators must start looking ahead to radically new kinds of programming that will succeed in the coming era of great audience segmentation, of intense local market competition, and of rising competition from alternate media. He thinks expertly-written drama, thoroughly up to date and designed for today's audiences, might be one such new audience grabber.



*The satellite repertoire covers an extreme range of entertainment material, including classic chamber music with world-famous violinist Pinchas Zukerman, often on National Public Radio's "St. Paul Sunday Morning."*

# BETTER ENG/EFP THRU FIBER OPTICS

Take your live ENG/EFP places you could never go until now. Artel's EN-1000 portable fiber optic system gives your crew a two mile camera-to-van range ... around any corners or obstacles.

- BROADCAST QUALITY VIDEO/AUDIO
- FASTER SET UP
- FIELD PROVEN ON NETWORK NEWS
- ULTRA-LIGHT WEIGHT
- HALF THE COST OF MICROWAVE
- LONGER DISTANCE



Call us to discover how the EN-1000 can improve your ENG/EFP operations, while saving time and money. Also ask about the Artel SL-2000 video/audio/data system for STL and entrance links.

SEE US AT NAB BOOTH #2624

**ARTEL** COMMUNICATIONS CORPORATION

P.O. Box 100, West Side Station,  
Worcester, Massachusetts 01602 (617) 752-5690

THE SYSTEM THAT BROUGHT YOU THE SPACE SHUTTLE LANDING.

Circle 263 on Reader Service Card

www.americanradiohistory.com

## Radio Programming

Good talk can even supply radio managements with a way to link forces with competitive media—at least that is the goal of an original plan developed by Pat Whitley, program director of WITS in Boston. WITS is an all-talk station and has locked in a solid segment of the Boston audience with news, sports, and tremendous emphasis on every kind of community interest. The big issues in the area are routinely attacked by inviting into the WITS interview room the experts in each field, the politicians responsible for action, the interested citizens groups. The station's upscale audience shows great approval.

Whitley some time ago got the idea that cable TV companies in the area could use the cream of the WITS issue-oriented material to fill empty channels, programs too expensive for the cable operators to produce themselves. Whitley's idea will shortly become real: video cameras in the WITS interview room will pick up the programs, and the signal will be carried to cable headends in Maine, New Hampshire, and Vermont, as well as Massachusetts. The large increase in the WITS audience for those programs will bring large increases in the station's income.

The WITS story shows again the wide acceptance of good, serious talk by today's audiences. It also shows another fact of the satellite revolution: stations in the biggest markets are not likely to be the major customers for the satellite nets, because in many cases they are already producing highly successful, high-finish pro-



Mutual's long-running overnight talk show, the "Larry King Show," brings to the late-hour listener a parade of statesmen, artists, sports stars, celebrities of every kind. Here King interviews Christie Heffner of Playboy.

gramming themselves, and making a lot of money with it. The satellites *can* lift small-market and medium-market radio stations to new heights, particularly those now in the doldrums. How the satellites might affect big-city stations that are falling behind is not at all clear at the moment; it will be one of the more interesting questions of the next few years.

The crossing of the media boundaries by radio programmers may become fairly common, if plans now

## NEW One Inch Video Tape Evaluator \$9850



- Full Cycle Clean & Evaluate 2.7 minutes
- Fast Clean & Rewind Cycle 1.8 minutes
- Ruggedized for 24 Hour Operation
- Proven Safety and Reliability for Tapes

Recortec installed its first Video Tape Evaluator (VTE) over 12 years ago! Now, we have combined all our industry experience and customer feedback into a new design with all the desirable features at an unbeatable price.

The new VTE-101 provides a built-in diagnostic panel for ease of calibration and a microprocessor controlled printer to provide more meaningful outputs. Our VTE's have been known to pay for themselves faster than originally estimated. Why not order yours now? Satisfaction guaranteed! To find out more, call Sid McCollum, our National Sales Manager.

# RECORTEC

475 Ellis Street Mtn. View, CA 94043  
Tel (415) 962-0220 TWX 910 339 5022

Circle No. 264 on Reader Service Card

***There is new  
time code  
technology  
on the horizon.***

***Datametrics,  
the #1 supplier of  
time code products,  
invites you to preview  
recent advances in  
videotape indexing.***

***Booth 1500  
at NAB***

***Mal Green***  
General Manager

***Brian Parke***  
Sales Manager

***Walter Hickman***  
Product Manager

***Milan Merhar***  
Sr. Engineer

**datametrics**

**DRESSER**

Datametrics • Dresser Industries, Inc.  
340 Fordham Road, Wilmington, MA 01887, (617) 658-5410

*At NAB, Datametrics is at Booth 1500.*

Circle 265 on Reader Service Card

[www.americanradiohistory.com](http://www.americanradiohistory.com)



## Radio Programming

under development by CBS set a pattern. Corn of RadioRadio says that the organization is studying the feasibility of producing programming jointly with major cable systems, in order to spread the cost. The CBS analysts do not see the appearance of the programs on cable as competitive with them. Details on what kinds of programs might be made this way, and how they might serve both radio and cable (both sight and sound on cable?) are not yet available.

### Music, short-form and long

Music, every kind of music, will be abundant on the satellites. So far, most of the music programs have been the "weekend specials" developed by RKO, Mutual, and others. The music specials run from an hour to several hours long. They bring to the local station nationally-known popular musicians in live concerts, or recordings of such musicians with nationally-known music hosts to introduce the records, and often to interview the musicians.

The specials have been enormously popular for both Mutual and RKO, the principal satellite purveyors to date. They attract very large audiences because they can be promoted as events, happenings that stir up old listeners and bring in new ones, some of whom hopefully will stay with the station. Local advertisers in many cases are strong for the specials too, and gladly pay special rates. The success of such programs has stimulated many radio operators to ask for more.

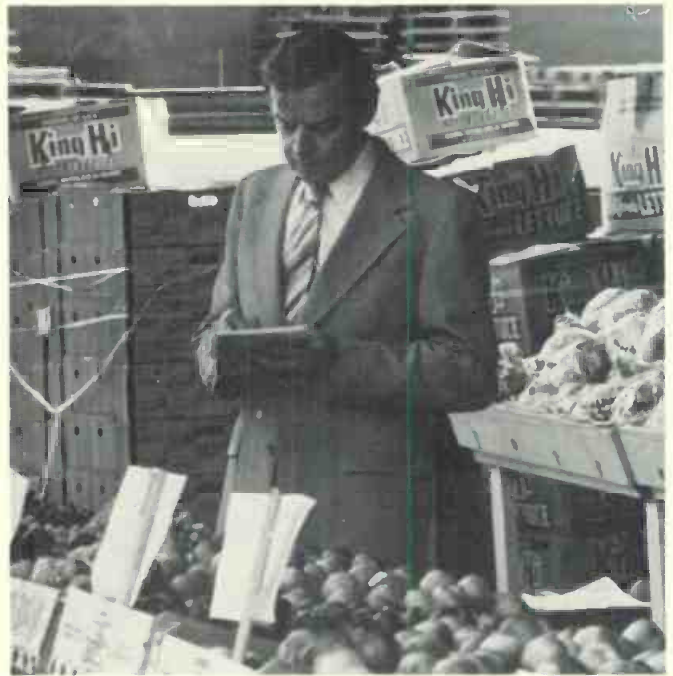

A talk-show category likely to spread in the new nets is well represented by Mutual's "Elmer Dapron's Grocery List," daily food buying guide. Here Dapron does his comparison shopping for an upcoming show.

But what about the standard formats that have been the meat and potatoes of radio programming for decades? Opinion among the software producers is mostly to the effect that the old formats have plenty of staying power. There are some shifts, caused mostly by changes in the demographic groups. For example, some producers see the young adults, grown up from the

# THE CHOICE IS YOURS!



## THE AUDIOPAK A-2 OR THE STEREO PHASED AA-3 BROADCAST CARTRIDGE

**Capitol Audiopak Broadcast Cartridges—  
for stations who care how they sound.**

Both Audiopak carts offer extremely low wow and flutter; a positive brake system which stops the tape, not the hub, assuring accurate cueing. Unsurpassed reliability is assured because we manufacture the tape and all other components in the cartridge. Moreover, all carts are 100% tested before shipping.

The AA-3 offers excellent stereo phase stability. It's loaded with Capitol's own Q17 HOLN tape which extends frequency response and headroom to provide studio sound quality.

CAPITOL MAGNETIC PRODUCTS  
A Division of Capitol Records, Inc.  
6902 Sunset Blvd.  
Hollywood, California 90028



See us at NAB Booth 3127

© 1980 CAPITOL RECORDS, INC.

Circle No. 266 on Reader Service Card

# Specialists in News and Sports Microwave



## Suppliers of

- Truck and Helicopter News Systems
- Portable and Fixed Antennas
- Portable Microwave Links for News Trucks, Helicopters, and News Cars



Helicopter and Truck Microwave Systems  
available for Short Term Lease

Engineering assistance in News System  
Design

Exclusive distributor of—

- Tayburn Portable Microwave Products
- Microwave Specialties Broadcast Antennas



**Broadcast  
Microwave  
Services, Inc.**

**NAB Booth #2308**

**7316 Convoy Court  
San Diego, CA 92111  
Phone (714) 560-8601**

## Radio Programming

post-war baby boom, now in their 20s and 30s, as not interested in Beautiful Music because they never listened to it as teenagers. On the other hand, the group that is 45 years and older is getting much more attention, with startling success for program producers who do go after the group.

An important point is that none of the old formats is dominant. All are there, and each can work in proper setting. There is no one kind of music that is a panacea for radio problems; there is no Super-Disco, no Super Country, that is going to lift every station to the heights. The industry has absorbed fully the lesson of Disco's precipitate fall from the mountain top three years ago.

Most radio programmers now know that every radio station has its own marketing problem, and must find the music that works best in that particular market, with that audience, and that competition. Jim Kefford of Drake-Chenault makes this point vivid by noting that no two of the several hundred subscribers to that veteran syndicator are doing exactly the same programming. Richard Foreman reinforces this: he told *BM/E* that his group finds it necessary to study in great detail the situation of every single station before developing a programming plan. Most of the syndicators described in *BM/E*'s long series of *profiles* also spend a lot of time with each subscriber, to find the right mix for the station's particular needs.

One thing this means is that a station taking its main music from a satellite net should have some options as to

the character of the music. The multiple-channel capability of satellite delivery makes this technically straightforward, and it seems likely to be common in the future.

That particular future is making a strong first entry in the operation of Satellite Music Network, the first full-format music syndicator to go actually on line with satellite delivery. At the time this was written Kent Burkhart, president and one of the founders, said that 75 stations across the country were getting the SMN programming via the space hop, with new ones filling the pipeline: he expects to be programming 150 stations by August.

SMN has five different formats on tap: Album rock, Country, MOR, a black format, and Beautiful Music, the last produced by Bonneville Broadcast Consultants and marketed jointly by Bonneville and by SMN. Burkhart said that station choices so far were split quite evenly between the Album Rock and the Country (the first two formats available) and furthermore that the subscribers were AM and FM in about the same numbers. This suggests a broad appeal: the fate of SMN will tell us a lot about syndication by satellite, because Burkhart and his associates, the creators of the network and the programming, as described in earlier issues of *BM/E*, are highly experienced and successful in software production for radio.

Some observers in the industry believe that, even with a wide choice of formats, full-format satellite delivery will be by its nature too rigid in time-slotting for many local stations, hindering them from timing program elements to fit their needs for localization. The

## Standardize your color monitors to a true D<sub>65</sub> at all luminance levels, with **GRAFIKON** instruments



TV Light Meter for rapid, precise check of luminance.



Optical Color Comparator for setting color temperature at all luminance levels, to D<sub>65</sub> or other standards.



Electronic Color Analyzer for transferring color temperature readings from a master to other monitors. Digital pre-settable compensation for phosphor batches.



**POWER-OPTICS, INC.**

1055 WEST GERMANTOWN PIKE

FAIRVIEW VILLAGE

PENNSYLVANIA 19409

TELEPHONE 215-539-5300

TELEX 84-6314

Circle No. 268 on Reader Service Card

See us at NAB Booth # 3113

# Introducing the New CHYRON® IV.

## The New CHYRON Adds True Graphic Capabilities To The World's Leading Character Generator.

The latest Chyron is the system that the broadcast industry has been waiting for. You have known the Chyron IV as a powerful character generator that's easy to use.

Now, utilizing advanced computer graphics, it has become a flexible graphics tool, as well. The result: a truly versatile graphics generator that provides virtually all of the electronic functions you need. And, it's still easy to use!

### More Artistic Freedom

CHYRON IV's digitizing tablet provides full flexibility for the artist to draw, change select colors and fill. He has,

in effect, a true electronic paint system. *Background graphics* can be created and displayed or stored for later use. In addition to the digitizing tablet, graphic information can be entered with a black and white camera in the font compose mode.

This new background graphics capability gets the artist away from plain text into the generation of "pictures": graphic images, representa-

tions, vignettes with as many as 16 colors or gray scale values, etc.

*Multicolor characters* are available, too. Full color or halftone artwork is digitized and displayed with up to seven different color values per character. The display can be changed from *gray scale values* to *psuedo-color* for ease of trim and area identification. This means that multicolor logos or other artwork can be displayed and treated as a single character to take advantage of all the CHYRON IV animation and character manipulation features.

### New Board is the Key

A state-of-the-art multimode graphics module is the heart of the new capabilities. It replaces the existing font compose module and operates in several differing modes.

In its basic operation, the new module provides an advanced means of camera font compose. A built in A/D converter samples incoming camera video at 10 times sub-carrier and digitizes each sample with four-bit accuracy (thus, the 16-level gray scale). Software then analyzes the data to produce extremely smooth curves and slopes for virtually perfect capture and the elimination of trimming in most cases.

### Many Other Features

Other CHYRON IV features provide even more flexibility. Up to four "vignettes" may be created and independently positioned or animated. Text can be moved out of the safe title area, the color palette has been expanded to 512 choices, character edging can be any color and diagonal typing has been provided. The roll and crawl modes have been improved to allow smooth motion through horizontal and vertical blanking. And there's more. Call or write for all the details.

# The CHYRON® COURIER

An Occasional Newsletter  
Dedicated to the Latest  
Chyron Developments.

Vol. 1, No. 1

## Earlier CHYRON IV's Can Be Retrofitted for New Features

The new CHYRON still carries the model number IV. It will not obsolete the many earlier CHYRON IV's still serving nobly out in the field.

Your current CHYRON IV can be retrofitted to provide all of the newly-developed features. Return your IV to the factory, and we will replace the unit's present font compose module with the new multimode graphics module and add the necessary systems modifications to accept the new features. It will convert your old CHYRON IV into a true graphics generator, with all of the many advantages of the new model.

Updated training sessions will be available, too. Classes for operators may be scheduled at Chyron headquarters in Melville, N.Y. or at your place of business.

For details on the retrofitting of your earlier CHYRON IV and on the latest operator training, call or write today.



## Highlights of the New System

In brief review, these are the main features of the new CHYRON IV.

- Background graphics plane
- Advanced font compose with 16 levels of gray scale
- Multicolor characters (7 colors each)
- Digitizing Tablet
- Winchester disc
- 512 color choices
- Four-level animation plane
- Blanking-to-blanking display capability
- Colored edge
- Fader provides 256 levels, with gamma correction (pre-programmable)
- Diagonal typing
- Software-based for future enhancements.

Circle 269 on Reader Service Card

Follow the Leaders with

# CHYRON

TELESYSTEMS

A DIVISION OF CHYRON CORPORATION  
265 Spagnoli Road, Melville, New York 11747  
• 516-249-3296 • Telex: 144522 Chyron Melv  
Ampex International is exclusive distributor for  
Chyron Graphics Systems outside the U.S.A.

When **YOU** want  
**NICKEL CADMIUM**

20 years of dependability



Belts and Packs for All Cameras and VTRs

**YOU** want  
**PERROTT**  
ENGINEERING LABS, INC.

7201 Lee Highway, Falls Church, Virginia 22046 703-528-5861

Circle No. 270 on Reader Service Card

**THE ONE - SHOT!**

Functional & Attractively Designed!!



☆ **SOURCE IDENTIFIER**  
+ **VIDEO SWITCHER**  
+ **AUDIO MIXER**

**FEATURES**

- NTSC Color bars
- Field programmable characters • Black generator
- Audio mixer, transformers on inputs & outputs
  - 1 KHz test tone
- Video switcher
- BNC & XLR connectors • Optional 110 VAC - 28 VDC - 12 VDC Power supplies • Portable or rack mount

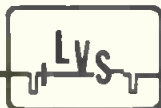

**LANG VIDEO SYSTEMS**

2405 De La Cruz Blvd., Santa Clara, CA 95050  
(408) 988-2311

Circle No. 271 on Reader Service Card

**Radio Programming**

requirement for split-second cut ins and cutaways is seen as a tricky operating burden.

To make the switching easy and sure, SMN is using switching cue tones in much the same way as the ABC net is, as described in the foregoing. The cue tones are multiplexed onto the program carrier. Tom Keenze of United Video, the SMN partner which takes the programs up to the satellite from its uplink near Chicago, said that at the present time six cue tones have been developed. The subscriber can use a simple decoding system to start and stop carts, cut the satellite feed in and out. If the subscriber has an automation system, the software can be enlarged to include use of the cue tones in the exact way intended.

Both Kent Burkhart and Marlin Taylor, president of Bonneville, describe their subscribers as delighted with the "windows" the format gives them for localization. Taylor said that Bonneville is developing a second form of its satellite delivery, in which Bonneville will send out a main body of programming for recording by the subscriber during the late night hours. The subscriber will then undertake the time slotting during the programming day.

It is manifestly too early to assess full format satellite delivery with confidence. It may be that some radio managements have created a special on-air character that is hard to fit into the satellite frame, whereas other radio operations do fit and get a total lift from satellite delivery. There is agreement that, in the case of SMN, the programming itself is splendid and will have a strong positive influence on radio programming in general. It seems most likely that the developers will refine the operation to remove any difficulties of this early period.

**Technical finish is not an "extra"**

Another most important influence on the future of radio programming is the much higher technical quality that is possible with satellite delivery, as compared with older delivery methods. Wayne Hetrick of National Public Radio says that when the NPR satellite net was going into operation, many of the local station personnel were disturbed by the inadequacy of their equipment to handle the signal coming in from the satellite. The same reaction will become more common as satellite feeds spread, and will undoubtedly lead to a lot of equipment upgrading.

The fact that listener standards of acceptability for reproduced sound can be drastically altered by experience is shown by some events at CKLW, in Windsor, Ontario. They were described by chief engineer E. R. Butterbaugh at a recent NRBA meeting.

In the past, CKLW had been very successful in the ratings with what Butterbaugh describes as a hard, very strong sound. The implication was that distortion in the sound was moderate, but present. But then the station started doing much less well in the ratings. Butterbaugh undertook careful audience studies to find out why people did not like the station's sound any more. Because listeners in the area had acquired an ear for high-grade FM sound they began to describe the CKLW signal as "too hard," "distorted," "unpleasant." There was a wide-spread tendency to tune the station out

# Don't let your station sound like a phone booth.



Every broadcaster knows the problems of on-air telephone links. The garbling when announce-feeds go out simultaneously through the board and the phone. Or the mysterious cutoffs in the middle of an important interview when line noise or sibilants generate 2600 Hz for a disconnect signal.

A lot of stations—network flagships and others—who've had to face the problems have also found the answer: the Studer Telephone Hybrid.

With sidetone attenuation of up to 40dB, producing maximum isolation between send and receive circuits through an active self adjusting bridge network, and a 12-Henry choke on the input to ensure positive exchange lock-in, the Studer Telephone Hybrid is simply designed to do the job right. 30dB/octave receive and 12dB/octave transmit filters eliminate unwanted signals that would muddy the on-air clarity you've built into your station. All phone line requirements are automatically matched, and a built-in limiter

and white-noise generator are included to give you adjustable overload protection and privacy. All in a 1¾ inch rack mount unit.

Studer can ensure a clean link for all your console feeds. The Telephone Hybrid maintains air quality on telephone talk shows, news feeds, and phone interviews. And our active-circuit Stereo Balancing Unit couples balanced ins and outs to single-ended recorders, equalizers, limiter/compressors or other unbalanced gear.

For more information on how to keep your station from sounding like a "wrong number," call or write today.

## STUDER REVOX

Studer Revox America, Inc.  
1425 Elm Hill Pike, Nashville, TN 37210, (615) 254-5651  
Offices: Los Angeles (213) 780-4234 / New York (212) 255-4462  
In Canada: Studer Revox Canada, Ltd.

# MUCH MORE FLEXIBILITY.

Presenting Yamaha speaker components. Some have been available only in Yamaha-designed enclosures. The rest are brand new. All are designed to deliver outstanding performance, reliability and durability.

And now, with this full range of Yamaha speaker components to choose from, you have the flexibility to design a sound system that meets your specific needs.

**Low frequency drivers: JA3882 & JA3881** The new JA3882 low frequency driver is specifically designed for high-efficiency sound systems. Its very high sensitivity level enables it to produce high SPL with less amplifier power. With large edgewound copper voice coil, durable cone assembly and stiff compliance, the JA3882 produces clean, powerful low frequencies.

- 15" diameter cone
- 102dB SPL/1 meter/ 1 watt sensitivity
- 30Hz to 4kHz Frequency Range (maximum recommended crossover, 800Hz)

The new JA3881 is an excellent choice for use in stage monitors, keyboard speaker systems, or for 2-way systems. Its flexible suspension and lightweight edgewound aluminum coil give a usable frequency response of 40Hz to 5kHz.

- 15" diameter cone
- 97dB SPL/1 meter/1watt sensitivity

**High frequency compression driver: JA6681B**

With high sensitivity and high power handling

capacity, the JA6681B compression driver makes an excellent mid to high frequency reproducer for use in 2- or 3-way full-range, high-level sound reinforcement or monitor speaker systems. Its unique S-shaped beryllium/copper diaphragm suspension system and precision construction ensure long life.

- 145dB SPL reference sensitivity, 1 watt, using 1 inch plane wave tube
- 108dB SPL at 1 meter, 1 watt (using Yamaha H1230 horn)
- Nominal 800Hz-12kHz, usable down to 500Hz

**Combination high frequency horn & driver: JA4280B/H1400**

This high frequency reproducer's versatility enables it to be used as the mid and high frequency reproducer in a full-range stage monitor, keyboard monitor, or general sound reinforcement system.

- 90° H x 40° V dispersion
- 106dB SPL at 1 meter, 1 watt
- Aluminum horn with damping
- Nominal 1,500Hz-16kHz, usable down to 800Hz.

**Compression tweeter: JA4281B**

This new tweeter is a high-sensitivity, integral horn/driver unit designed to handle the uppermost portion of the frequency spectrum. It is an excellent super-tweeter for use in 3-way or 4-way full-range, high-level sound reinforcement systems. Its superb on/off axis response and absence of diaphragm resonances also make it a fine choice for studio monitor systems.

- 120° dispersion pattern at 10kHz
- 108dB SPL at 1 meter, 1 watt
- Nominal 7kHz-20kHz

**High frequency radial horn and throat adaptors: H1230, AD3500 & AD3502**

The new H1230 aluminum radial horn is designed to provide controlled dispersion (90° H x 40° V) of high frequencies in high-level, wide-range systems. The AD3500 throat adaptor is used to couple the horn to the JA6681B driver. Use the AD3502 throat adaptor to connect two drivers for greater output.

That's the lineup of Yamaha speaker components that leave the system design up to you. So now, with Yamaha mixers, power amps, signal processors, and separate speaker components, you've got the total flexibility you always wanted. From the people who know what music sounds like — Yamaha.

For complete information, write:  
P.O. Box 6600, Buena Park, CA 90622.  
(In Canada, write: 135 Milner Ave.,  
Scarb. Ont. M1S3R1)

Because you're serious.



Circle 315 on Reader Service Card



## Radio Programming

when music went on the air. An intensive clean-up of the station's processing equipment, and development of a new, low-distortion signal, opened the way for re-capture of the audience.

High technical quality in the radio station is therefore not just a pleasant "extra," but one of the keys to survival. And the same applies to the programming itself. In the future, high technical quality in the programs will be more important than ever before. Many software producers have accepted this necessity. Corn of RadioRadio tells of the intense effort made in producing the net's music specials to insure technical quality far above that formerly common.

Bob Adams, program director at WHDH in Boston, points out another good reason for technical upgrading. In addition to equipping the station to compete with others in the market, a refurbished plant can give a tremendous boost to employee morale.

### Pressure from outside

Luckily for radio operators, "competing media" means mostly cable and pay television, the videocassette and videodisc, which are directly competitive with broadcast television but not so directly with radio. Few radio executives foresee noticeable loss of radio audience to these competitors within the near future. Cable television, which seems closest to being a menace, was ruled out by several informants on the grounds that it cannot be portable or car-borne.

Over the long run, though, the competing media *can* damage radio if the material they present is much more interesting and takes over more and more of the listener's time, because the radio product seems less desirable. This pressure from the outside in the longer future will likely be the major influence affecting the shape of radio programming.

Leaders in the industry have in general accepted this as the long-range fact of their situation, and there is widespread activity to develop new, more varied, more interesting programming for the future of radio. It will take two to three years for the fruits of this activity to become evident on any large scale; the big nets are moving ahead, but very carefully, using a lot of audience research as noted earlier.

Jo Interrante and Rob Sisco of IS, Inc., two veteran radio programmers who recently set up as consultants and concept originators for the new nets, reinforced the idea that innovation is a necessity of the future. Sisco noted that the radio listener, when questioned, will admit to liking apples, and has been getting apples for years. But if offered something else also attractive, the listener is sure to welcome the change and have his attention to radio reinvigorated.

Interrante and Sisco also emphasized what is implicit in this sketch of the future, that the local radio programmer must become more influential, more skilled than in the past because in the end the nets are going to produce what he wants, as satellite operations become more and more competitive. And this in turn focuses on the radio listener of the future. There are many imponderables at the moment but we can be sure the listener is going to get a far more varied and interesting radio fare than ever in radio history. **BM/E**

## THE Synergistic\* FM Transmitter Update!



Components: Programmable audio processor  
MARCOM/ROOD stereo generator  
HPA-4536B exciter

Features: Competitive sounds from your transmitter at much lower cost than a new transmitter.

*"Cooperative action of discrete devices such that the total effect is greater than the sum of the effects of the devices taken separately." Webster*

**MARCOM**

P.O. Box 66507, Scotts Valley, CA 95066  
(408) 438-4273

Circle No. 273 on Reader Service Card

## When YOU want NICKEL CADMIUM

20 years of dependability



Belts and Packs for All Cameras and VTRs

YOU want  
**PERROTT**  
ENGINEERING LABS, INC.

7201 Lee Highway, Falls Church, Virginia 22046

703-528-5861

Circle No. 274 on Reader Service Card



# On the other hand, our routing switchers handle channel growth very nicely.

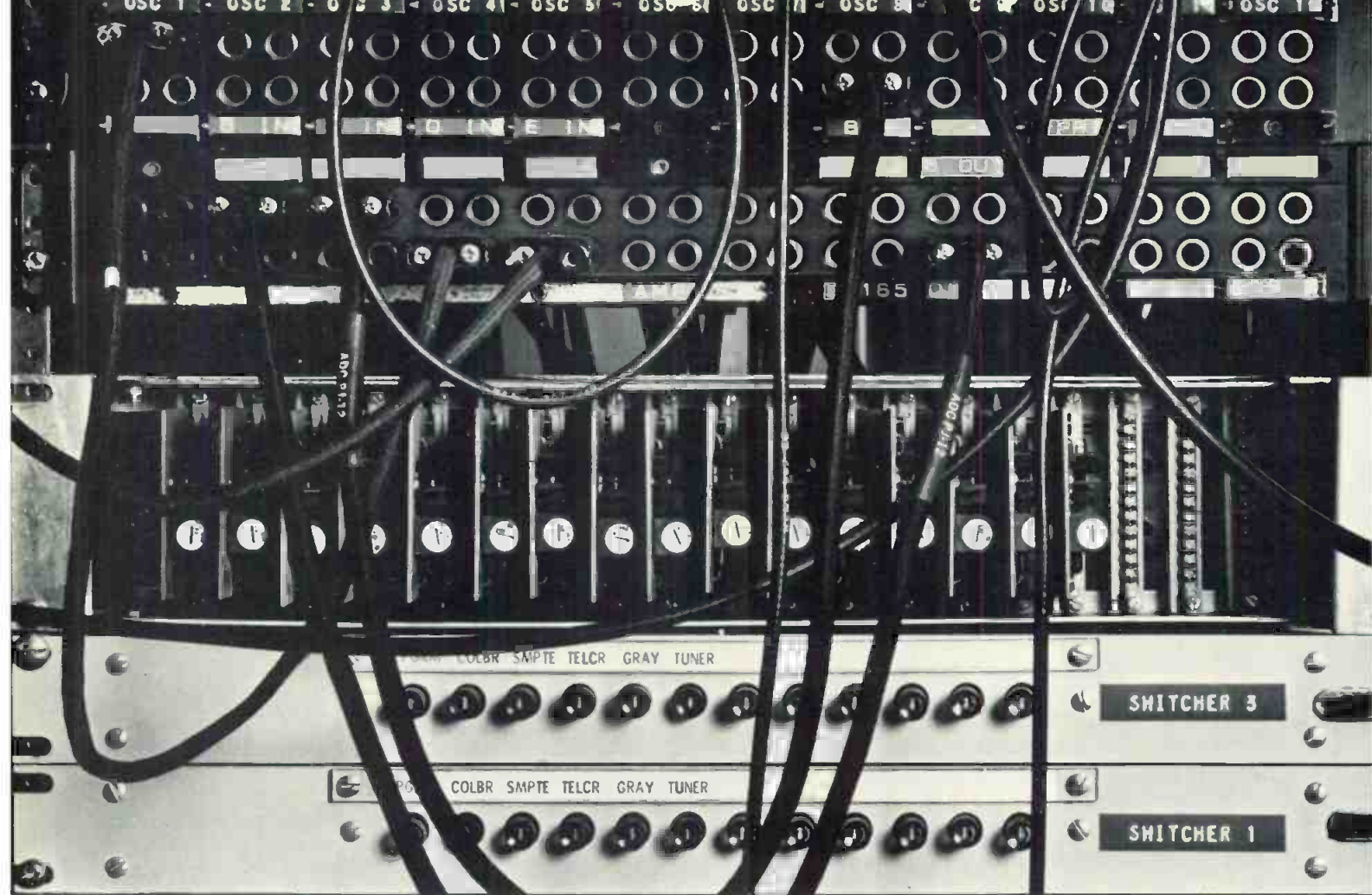

A patch panel will work just fine in your system. If you plan to limit yourself to only ten channels.

But in the fast moving world of cable-vision, more than likely you'll be programming a lot more than ten.

That's where 3M Routing Switchers come in.

Because our switchers allow you to start small, and expand gradually. As your needs grow.

Without the bulky wire mess and inconvenience of a patchwork routing system.

They allow for more VTR's, quick and easy switching, as well as multi-channel programming.

**The routing switchers that grow as your needs grow.**

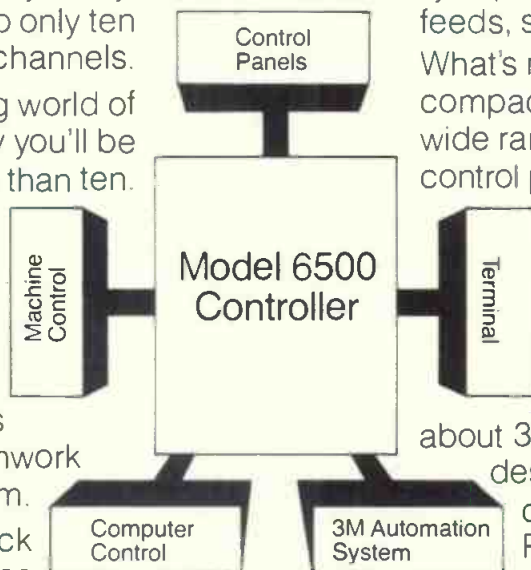

And they're perfect for switching in network feeds, satellite relays, and live remotes. What's more, 3M Routing Switchers are compact and fully electronic. They offer a wide range of capabilities. From simple control panels like thumbwheel, touchpad, universal pushbutton, and LED pushbutton, to completely automated, computer-controlled systems. From 15 x 12 to 40 x 40 and larger.

For more information about 3M Routing Switchers, or a custom design consultation for your studio, call collect 612-736-1032. Or write: Professional Audio Video Equipment/3M, Building 223-5E/ 3M Center, St. Paul, MN 55144.

**3M hears you . . .**



# NEW TRANSMITTER DESIGN FOR THE '80s

By Joe De Angelo

*Digital technology has affected every aspect of broadcasting—including transmission. The 1982 NAB show will mark the introduction of a brand-new AM transmitter from Harris, a second-generation system.*

THE 1982 NAB CONVENTION will see the formal introduction of Harris's brand-new SX Series of all solid state AM transmitters, consisting of the SX-1 (1000 W), SX-2.5 (2500 W), and SX-5 (5000 W). Offering broadcasters up to a 36 percent savings on yearly power bills, in addition to stability and reduced maintenance requirements, they're just what the doctor ordered for stations looking to make long-term capital investments that deliver the highest possible cost/performance ratio.

The SX Series is actually Harris's second generation of all solid state medium wave transmitters, the first generation having been introduced in 1975. The MW-1/1A was the industry's first all solid state 1 kW AM transmitter and is now used by over 750 broadcasters around the world. Since the introduction of the MW-1, Harris has been monitoring transistor technology advances and waiting for the right time to start development on the new high-power SX Series. The past two years of R & D have provided

**Joe De Angelo** is product marketing supervisor—radio with Harris Corp.'s Broadcast Products Division.

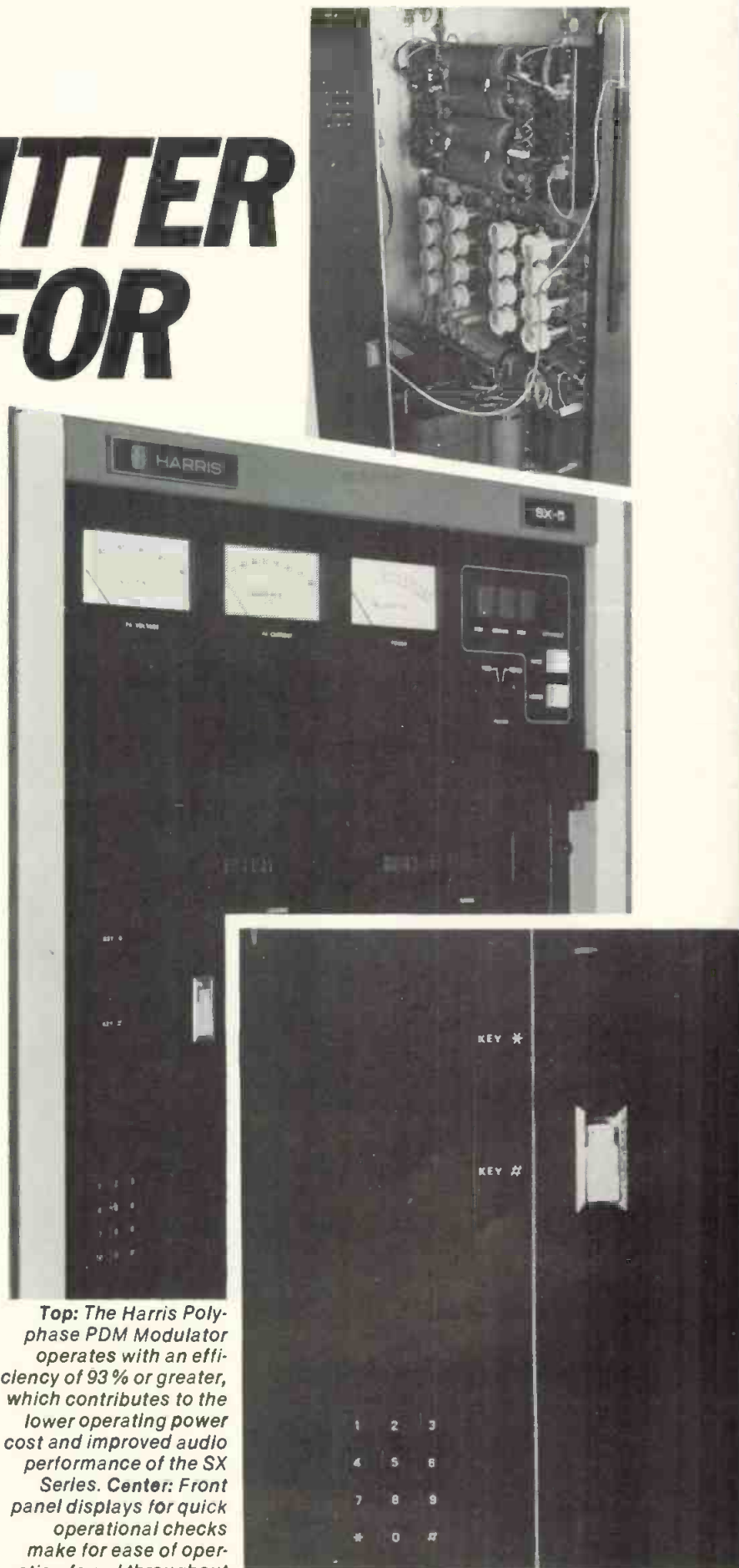

*Top: The Harris Polyphase PDM Modulator operates with an efficiency of 93% or greater, which contributes to the lower operating power cost and improved audio performance of the SX Series. Center: Front panel displays for quick operational checks make for ease of operation found throughout the SX transmitter. Inset: The touchpad keyboard integrates the factory programmed microprocessor for diagnostic assistance. The dual digital display, shown here in a test mode, can display two related parameters or measurements to track down failures.*

## New Transmitter Design for the '80s

*Left: A close-up of two of the four SX-5 high efficiency PA modules shows the quick disconnect connectors. The PA module printed circuit board is removed for servicing purposes while the heavier heat sink remains in the transmitter chimney wall. Right: The pull-out low-level circuitry drawer can be opened and serviced while the transmitter is operating. All boards are hinged for quick and easy front/back access—reducing service and maintenance time.*

some exciting new technological breakthroughs.

One of these is the recent successful introduction of high-power MOSFETs devices, which are used both in the PA and modulator section of the transmitter. MOSFETs (metal oxide semiconductor field effect transistors) represent a second generation of power devices that offer significant benefits over bipolar transistor technology. Combined with the circuits used in the SX transmitters, MOSFETs prove to be extremely efficient.

### Highly efficient PA stage

Figure 1 shows an overall block diagram of the SX-5 5 kW transmitter. Four PA modules develop a total output power of 5600 W. The SX-2.5, on the other hand, employs only two modules to yield a total output power of 2750 W, with the SX-1's one module producing 1100 W. The PA modules, like all the other modules in the transmitters, are common to all three models. Only the number of modules, such as the PA and modulator and the main power supply, varies with power, with low level circuits being identical.

Each PA module contains 16 MOSFET devices arranged in groups of four. Each group operates in a "balanced quad" circuit, with each of the devices in the quad delivering its power to the primary of a toroidal transformer. The secondaries of the four MOSFET quads

are all connected in series, which in turn are in series with the remaining modules. Figure 2 of the SX-5 output network shows this configuration in more detail.

The high efficiency of the SX Series is due in part to the PA stage, which operates Class D and achieves an efficiency factor of greater than 90 percent.

### New polyphase pulse duration modulation

Back in the late 1960s, Harris pioneered the development of pulse duration modulation (PDM). PDM introduced, and continues to offer, a modulation system that yields high efficiency, elimination of large, costly components, and new levels of audio per-

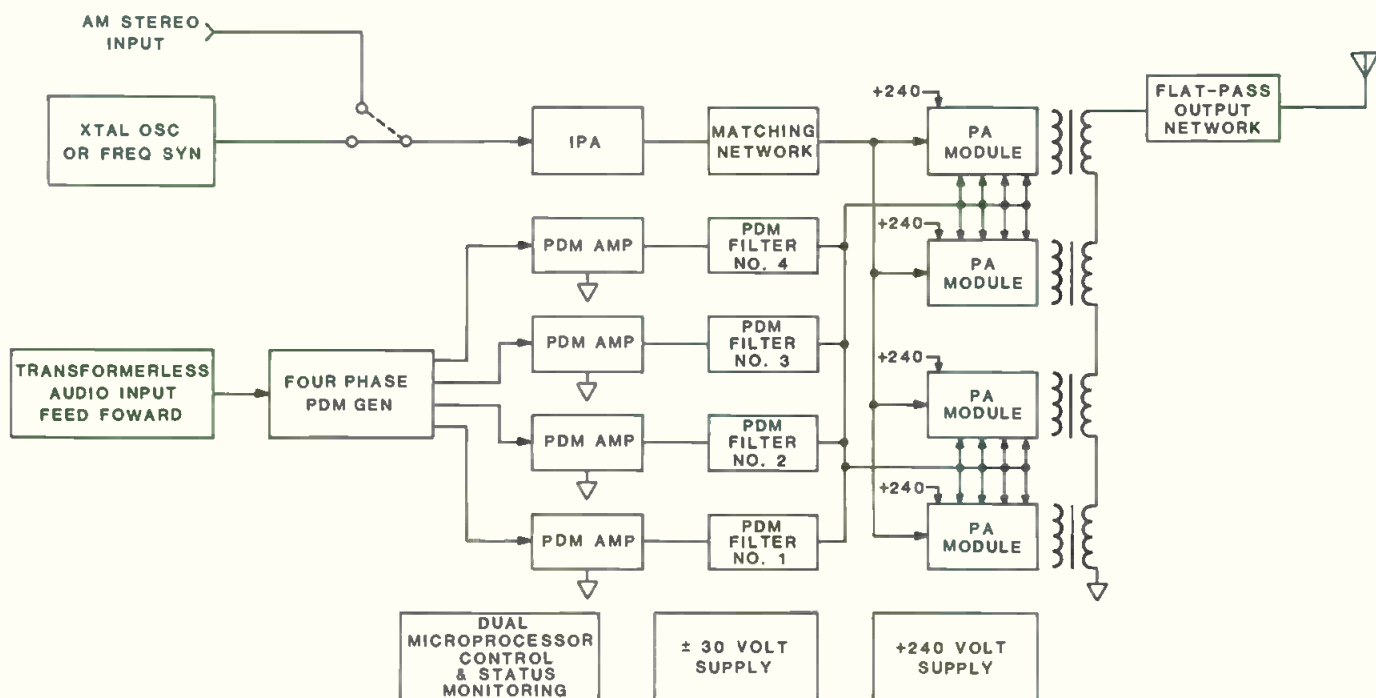

Figure 1. Block diagram of Harris SX-5.

# The first 8-days-a-week logger.



## The Dictaphone Veritrac SL.

Whether charting the hits or checking the spots, Dictaphone's new Veritrac SL voice communications recording system is practically indispensable. Here, in a package you can lease for as little as \$99 a month, is recorded testimony to what you've aired. Uninterrupted by tape changes. 24 hours a day.

What's more, the Veritrac SL is modular. It can be configured to meet your station's specific needs. Providing recording time of up to 8 days. And it has something else going for it. Dictaphone reliability and service.

 **Dictaphone**

A Pitney Bowes Company

For more information on the Dictaphone Veritrac SL system, fill in the coupon or call toll-free:

**800-431-1708**

Except in Hawaii and Alaska  
(in New York call 914-967-2249)

Name

Title  Phone

Station

Address

City  State  Zip

**Mail to: Dictaphone Corporation  
120 Old Post Road  
Rye, New York 10580**

Dictaphone and Veritrac  
are trademarks of Dictaphone Corp., Rye, N.Y. PBME-32

Circle 276 on Reader Service Card

# New Transmitter Design for the '80s

performance.

In the single-phase pulse duration modulator (Figure 3) a 70 kHz square wave is generated that is width modulated by the incoming audio information. The square wave width change is linear with respect to the amplitude of the audio wave. A 10 percent duty cycle change in pulse width will change the PA voltage by 10 percent of the supply voltage; the pulse width rate of change is equal to the audio input frequency. The 70 kHz pulses, after being generated in low level circuits, are amplified to the required power level and then filtered by a 70 kHz low-pass filter. This filter removes the 70 kHz switching content, leaving a dc voltage that varies at an audio rate which in turn modulates the PA stage.

The new polyphase PDM (PPDM) represents significant enhancements

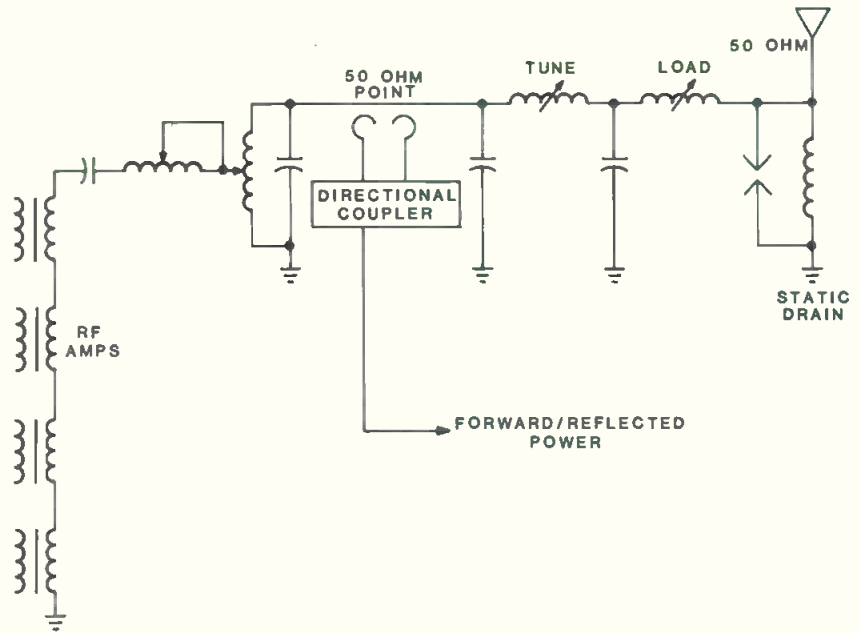

Figure 2. Harris flat-pass output network.

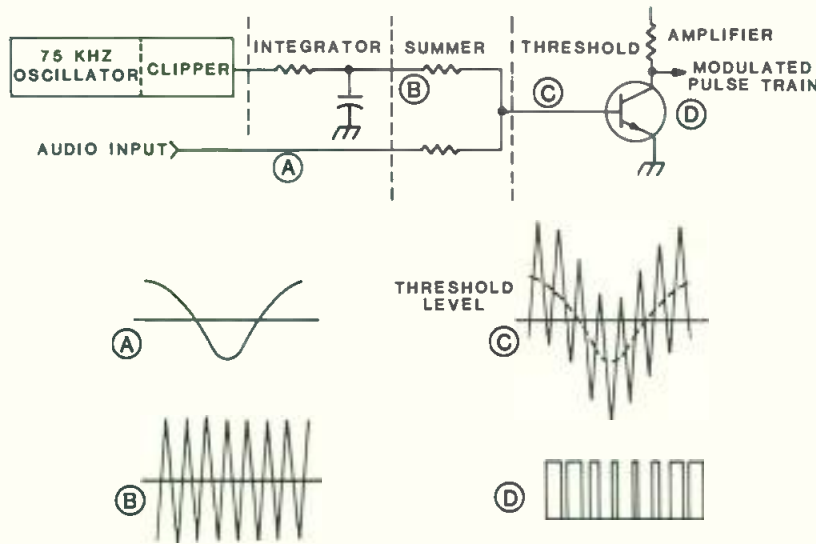

Figure 3A. Single-phase PDM modulator, low-level signal generation.

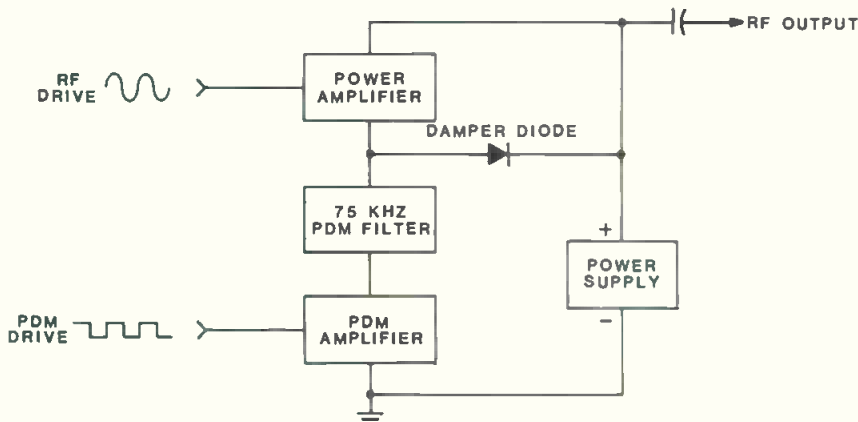

Figure 3B. High-level single-phase PDM modulator (tube or solid state amplifiers).

to the original PDM system, including higher operating efficiency—approaching 94 percent; improvements in audio performance, lower THD and lower IM levels; and built-in off-the-air protection—one section of the modulator could fail, but stations stay on air at reduced power.

As noted, two of the design objectives of the SX line were to increase the modulator efficiency and enhance audio performance. At first glance, it appeared that the means to accomplish both objectives were at odds. To increase modulator efficiency Harris needed to lower the PDM switching frequency; but enhancing audio performance required increasing the PDM switching frequency. After much research and design efforts, both objectives were simultaneously achieved in the new polyphase PDM modulator.

As its name indicates, the polyphase PDM consists of many PDM pulse trains that sample the incoming audio. The SX Series employs a four-phase modulator (Figure 4) in which audio is applied to a transformerless input stage. A feed forward power supply dc sample, plus ripple content, are also applied in this first audio stage. Next, the audio is sampled in a low level stage by each of the four PDM phases, all of which operate at 60 kHz, but offset from each other by 90 degrees. The resulting signals are pulse trains comprised of periodic

# DIAGONALABLE.

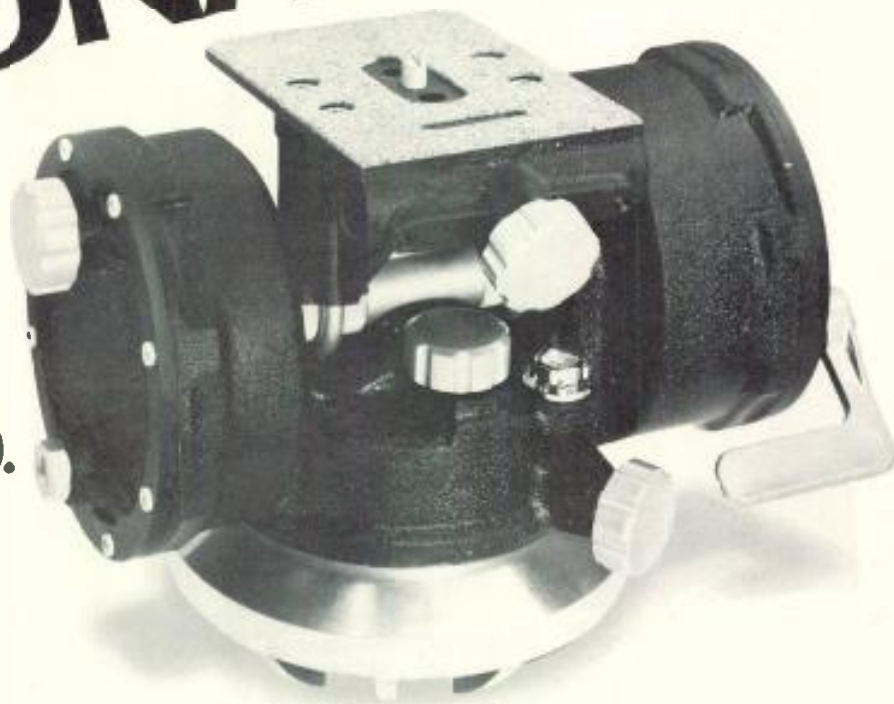

**O'Connor Model 100.**  
Fluid smooth control  
to follow the action  
in any direction.

## SIMULTANEOUS PAN AND TILT CONTROL.

Unlike cumbersome gear heads that require tremendous coordination to operate the separate pan and tilt controls, the O'Connor 100 follows the action at any speed in any direction with the gentle touch of your hand. Panning and tilting are simultaneous, so the camera obeys your every command.

## OUR NEW SIDEMOUNTING PLATFORM.

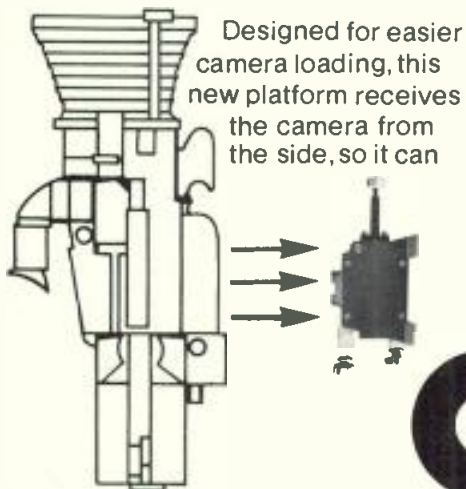

Designed for easier camera loading, this new platform receives the camera from the side, so it can

be lifted more comfortably at the lens and the rear of the body. The mounting plate can be ordered to any length providing support for those extra long and heavy lenses. Plus, the platform is made adjustable to balance the camera on the head and it's a quick release type with a built in safety feature.

## FILM OR TELEVISION.

For decades, the Model 100 has been *the* camera head for feature film production. But today, television crews are discovering their creative potential with O'Connor fluid heads. To accommodate a wide range of cameras and accessories, the 100 is available with a 300, 500 (standard) and 700 in-lb springs to assure that your camera is

properly counterbalanced at all times. Double handles are also available for video users.

## O'CONNOR PRECISION THROUGHOUT.

Built of magnesium and aluminum alloy castings, this low profile head weighs only 16 lbs. Separate controls for the pan drag, pan lock, tilt drag and tilt lock all improve the flexibility and repeatability of camera movement. The tilt range is  $\pm 60^\circ$  with a  $360^\circ$  pan.

## ASK THE MAN WHO OWNS ONE.

There must be a reason why so many of the world's greatest cinematographers insist on the O'Connor Model 100. Maybe because it's diagonalable.

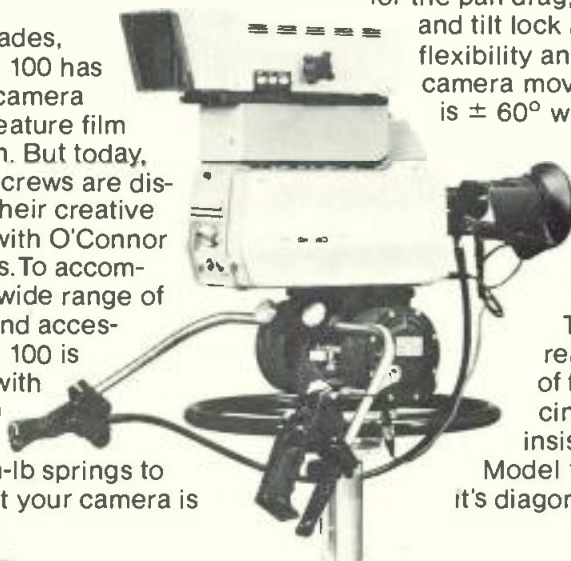

# O'Connor

FLUID CAMERA HEADS

O'Connor Engineering Labs., Inc., 100 Kalmus Drive, Costa Mesa, CA 92626 • (714) 979-3993 • TELEX 685 641  
O'Connor Engineering Ltd., 14 Av. Industrielle, 1227 Carouge, Geneva, Switzerland • Phone (022) 42 79 38 • TELEX 28 449

Circle 277 on Reader Service Card

www.americanradiohistory.com

Discover  
the ~~best~~ *worst*  
kept secret in  
wireless mic's



**The word is out!**

After only a few years on the market, Nady wireless mic's are already the only choice of the top pop and rock entertainers. Now the expanded Nady line is rapidly becoming the choice in wireless in video and film production. What's the secret? Nady Systems' U.S. Patent #4,215,431 — the biggest breakthrough in wireless mic performance ever. Sure, others claim to be the best, but only Nady Systems delivers the proof so obviously in any A-B comparison. Discover for yourself Nady Systems' full line of superior wireless mic's and wireless intercom systems. Discover for yourself matchless performance that is surprisingly affordable.



Nady Lo-Noise circuitry is covered by U.S. Patent 4,215,431.  
NADY SYSTEMS, INC. • 1145 65th ST. • OAKLAND, CA 94608

Circle No. 278 on Reader Service Card

## New Transmitter Design for the '80s

pulses whose duration is modulated by the incoming audio. Since the four reference PDM signals are phase displaced from one another, the modulated PDM signals will be similarly phase displaced by 90 degrees.

After the four phases are amplified, they are first capacitively coupled together, then individually filtered through the PDM filter. Each phase then is series connected to one of the four MOSFET quads on the PA modules. By coupling the four phases together, the majority of the 60 kHz sampling pulse trains cancel one another, leaving a partially recovered amplified signal that no longer contains a high content of the fundamental 60 kHz PDM frequency, but instead contains a highly attenuated 240 kHz ripple frequency that is a product of combining the four phases. ( $4 \times 60 \text{ kHz} = 240 \text{ kHz}$ ). Any residual 60 kHz signal that has not been attenuated earlier by coupling the four out-of-phase PDM pulse trains will be canceled in the PA stage. RF that is modulated by residual 60 kHz signal appears at the output of each of the PA MOSFET quads; but when the RF from the module's quads is added together, the out-of-phase 60 kHz RF sidebands cancel one another.

With both PDM and polyphase PDM, the modulator output filter must be capable of removing the frequency component corresponding to the switching signal without significantly affecting the frequency spectrum of the audio component. In single-phase PDM systems, this meant that the PDM filter had to have a very high level of attenuation of the 70 kHz signal while essentially being transparent to a 10 kHz signal. These single-phase filters introduced phase shift in the audio signal that caused distortion and overshoot. With the Harris four-phase PPDM system, however, the 240 kHz ripple frequency is easier to remove without affecting audio response to 12,500 Hz. Consequently, overshoot is greatly reduced, with harmonic distortion typically 1.0 percent and IM distortion typically 2.5 percent using the SMPTE 4:1 60, 7 kHz tone test.

The Harris Polyphase PDM Modulator, similar to the original PDM system, is a series modulator in which the modulator section is in series with the RF power amplifier and the power supply. The modulator essentially turns on and off at an audio rate, which in turn varies the supply voltage applied across the PA. Other operational features found in PDM transmitters are also present in polyphase PDM transmitters, such as low-level control of power output from zero to full output.

As previously discussed, each of the PA modules used in the SX transmitters contains 16 devices grouped in four quad configurations. Each of these quads is connected in series with one of the four polyphase modulators. The added benefit that the Harris Polyphase Modulator offers is that if a station loses a modulator phase it remains on the air at reduced power. This built-in feature allows broadcasters to stay on the air should one or more PA or modulator modules fail.

### "Flat-pass" output network

After examining various output networks in past and current transmitters, Harris chose an output network/



ANOTHER  
NEW  
FACE

## GRAHAM-PATTEN SYSTEMS

INTRODUCES  
THE MODEL 9402

A Versatile New DA Featuring  
Differential Input  
Switchable Clamping  
Optional Cable Equalization  
(fixed or variable)

And, like our already popular 9401 video/pulse DA, it fits in any Grass Valley Group, inc. standard 900 tray.

**GPS** GRAHAM-PATTEN SYSTEMS, INC.  
P. O. BOX 1960, GRASS VALLEY, CA 95945  
**(916) 273-8412**

Circle No. 279 on Reader Service Card

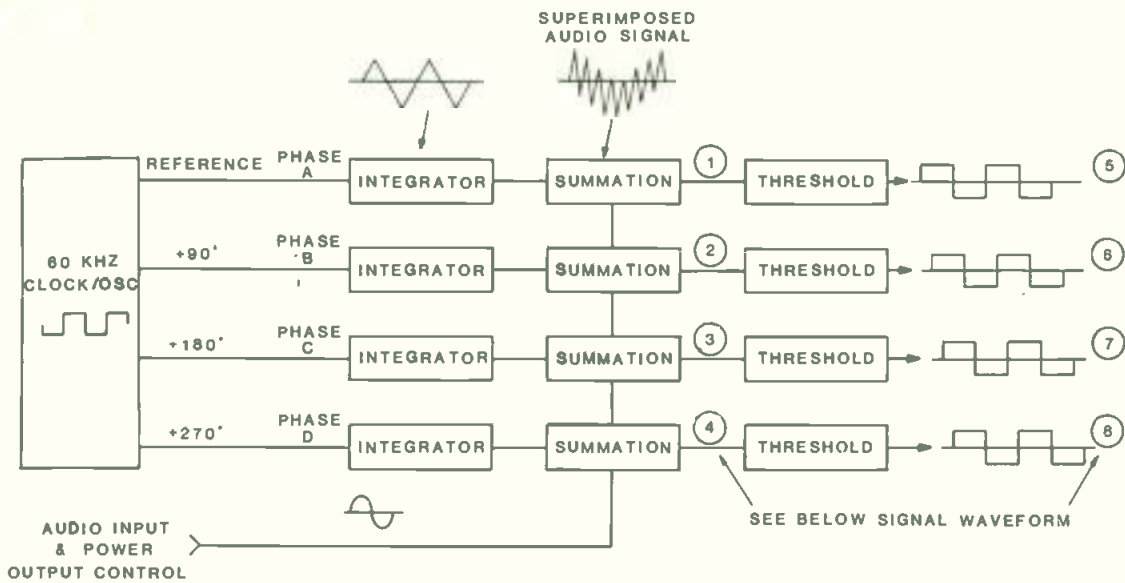

▲ **Figure 4A.** Four-phase PDM modulator, low-level signal generation.

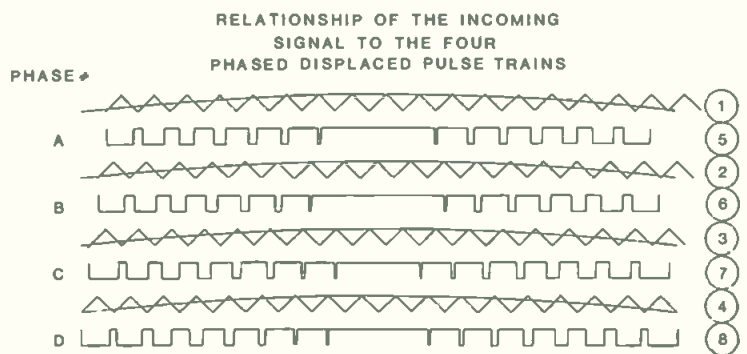

▶ **Figure 4B.** Relationship of the incoming signal to the four phased displaced pulse trains.

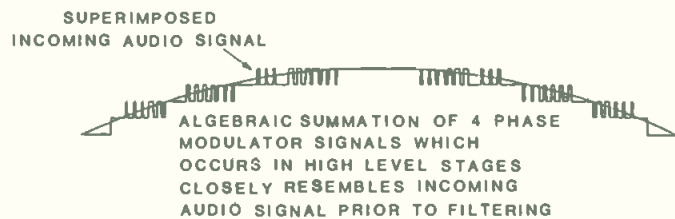

▼ **Figure 4C.** High level four-phase PDM modulator.

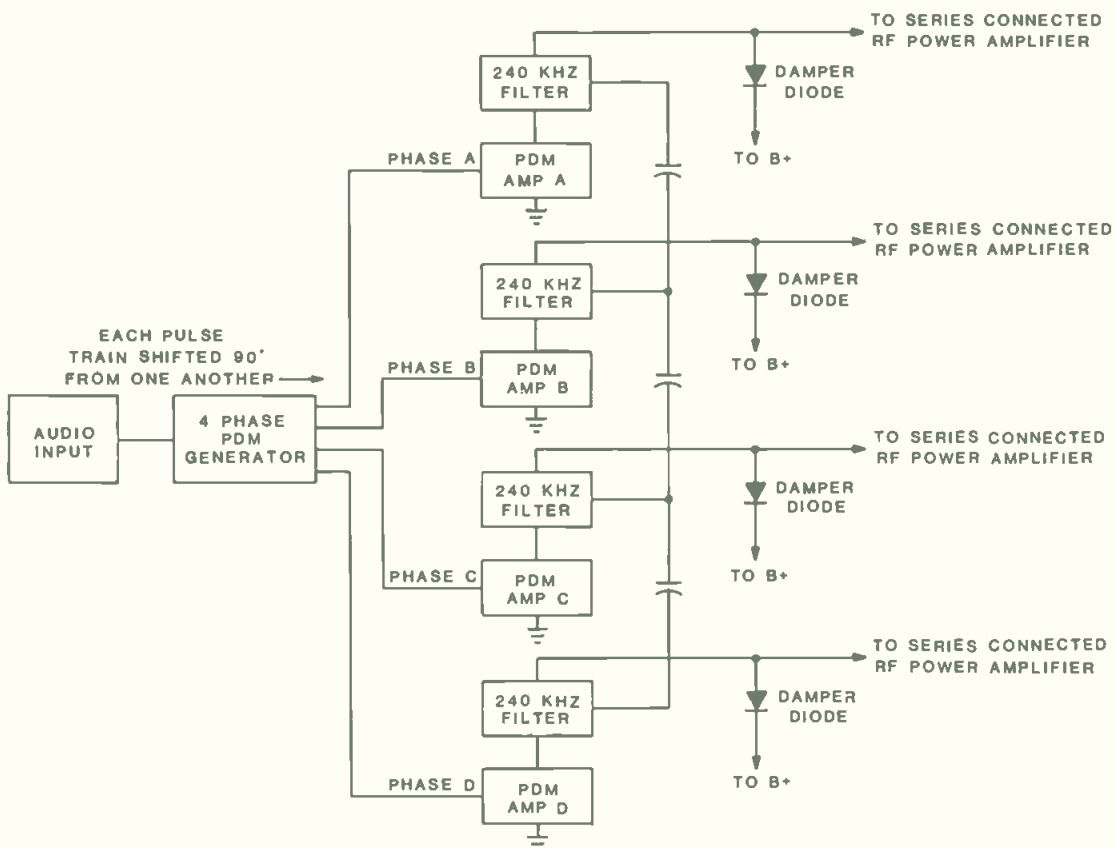



## New Transmitter Design for the '80s

bandpass filter consistent with the design objectives of the entire SX transmitter line. The computer-designed flat-pass output network is a Butterworth bandpass filter that yields super phase and amplitude linearity, two critical requirements for optimum AM stereo performance.

In the Harris flat-pass output network, all the secondaries of the toroidal transformers contained on each of the four modules are connected in series. Unlike other solid state transmitter designs using parallel combiners, the Harris configuration applies equal stress on each of the module quds contributing power to the load. Should a MOSFET quad fail, it simply stops contributing the same amount of power to the series load. The remaining active modules continue contributing power, with their total now being less than 100 percent.

The components prior to the variable tuning coil comprise the Butterworth bandpass filter. As shown in the spectrum analyzer sweep (Figure 5), the response of the entire network is impressive. With each horizontal division representing 50 kHz, the spectrum analyzer demonstrates the  $-3$  dB points located at  $\pm 150$  kHz from carrier.

Knowing that transmitter loads are not always 50 ohms  $\pm j0$ , the flat-pass output network was designed to match a wide range of loads. This is accomplished by the tee section that comprises the last part of the flat-pass network. The tee network allows the SX transmitters to match a load within a VSWR of 1.5:1 from 50 ohms. The Smith chart in Figure 6 shows this broad

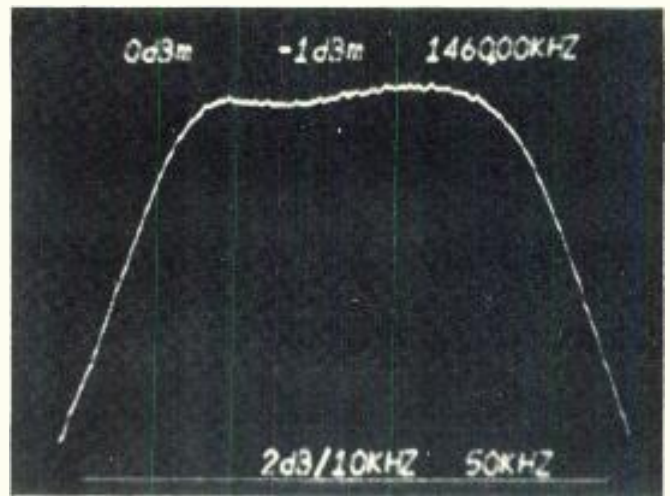

Figure 5. A spectrum analyzer sweep showing the response of the flat-pass network.

tuning window. The resistive component can vary from 35 to 75 ohms with the reactive component range being  $\pm 35$  ohms. Note that this practical network allows the transmitter to match these resistive and reactive extremes independently, but not necessarily together. The best way to indicate the numerous load combinations the SX transmitters will match is to display them on the Smith chart.

Another design goal of the flat-pass network was to place the directional coupler at a constant impedance point. As Figure 2 illustrates, this was easily accomplished by positioning the directional coupler prior to the tee section, which always presents a 50 ohm load to the bandpass section. The directional coupler now gives an accurate reading of forward and reflective power regardless of the load presented to the transmitter.

### Dual microprocessor control and status monitoring

Harris's experience in both transmitter technology and digitally based products such as program automation has allowed incorporation of powerful control and monitoring features into the three SX transmitters.

Recognizing that some stations are not equipped to troubleshoot microprocessors, high reliability with automatic backup was a major design goal. In the several hundred microprocessor-based products Harris has operating in the field, the microprocessor maintains a 99.999 percent reliability factor; the same reliability factor can also be found in the SX Series. Reliability is further enhanced with a full backup processor. A closer look at the dual SX transmitter system shows the transmitter's control and status functions are shared by two microprocessor/IOP controller boards working in tandem. During normal operation, each microprocessor

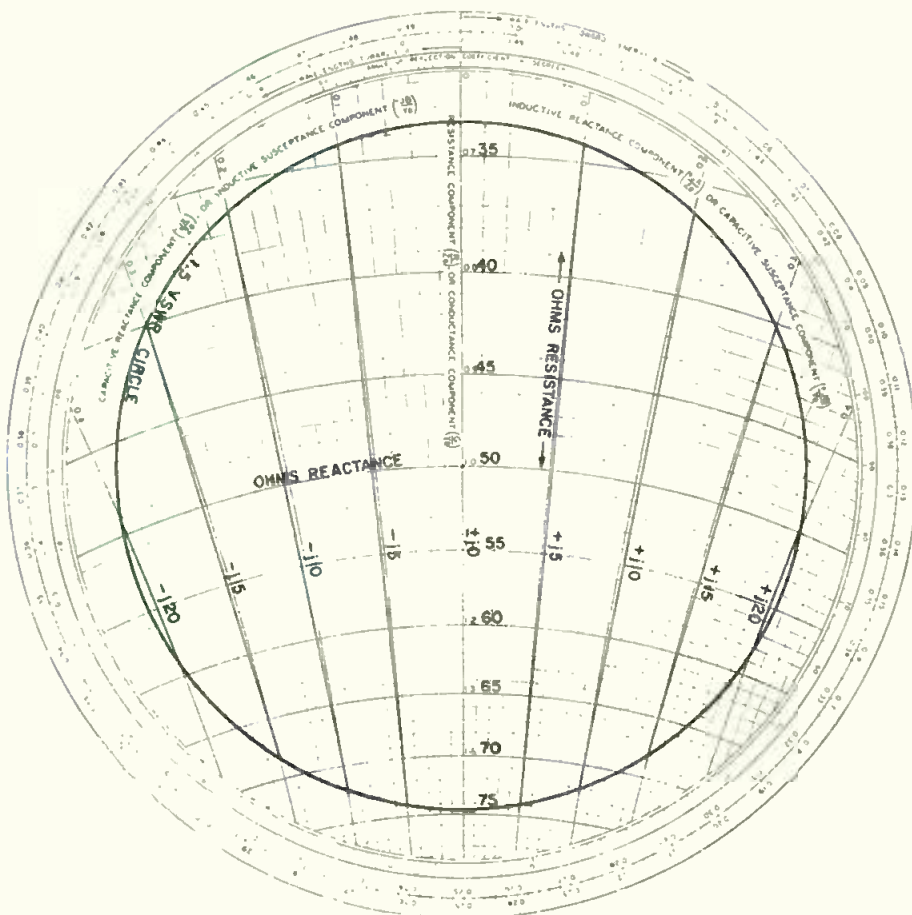

Figure 6. The SX transmitter's load window.



# Increase your live coverage, and you increase your news ratings.

Our new versatile 2 MX ENG system offers you much greater flexibility in news quality live coverage.

This exclusive frequency agile package is so small and lightweight that it easily mounts on any helicopter, van, or news car. It's also available in a compact suitcase to provide more flexibility and faster coverage. You'll be first "on air" with that important news story.

And because MVS provides the most advanced technology in this field, our engineers have the experience to give you exactly what you need. To give you the most cost effective system available.

In addition, our package is compatible with the news gathering equipment you already have. So your investment in our new highly flexible equipment expands the capability of



Dimensions: 4¾" x 2½" x 5¾", Weight: 3½ lbs. Power output: 12 watt, high stability 21-channel synthesizer, internal VSWR and thermal protection, dual audio channels.

your entire news gathering system. As well as increase the ratings for your news programming.

In fact, all of MVS's news gathering systems are designed with your ratings in mind. So whether you want to increase live coverage on the street, the roof, in the mobile unit, or in the

helicopter, MVS can help you do it cost effectively.

And our single-source accountability means faster and better service for your news gathering teams.

MVS is a worldwide leader in ENG/EFP, terrestrial airborne and satellite microwave systems.

If you'd like the facts and figures on how this live coverage can improve your news programming, contact your Regional Sales Manager or Macom Video Systems, Inc., 63 Third Avenue, Burlington, MA 01803, U.S.A. (617) 272-3100, ext. 1872. TWX 710-332-1716, Telex 94-9464.

**MACOM**  
Video Systems, Inc.

See M/A-Com at Booth 3303 and in the Satellite Exhibit Area

Circle 280 on Reader Service Card

[www.americanradiohistory.com](http://www.americanradiohistory.com)

## New Transmitter Design for the '80s

has assigned tasks to perform. One microprocessor is assigned control and associated monitoring tasks, while the other provides data to the front-panel LED display. Under normal operation, both units are constantly checking and monitoring one another. Should one unit fail, however, the other microprocessor automatically assumes that unit's functions without disruption of service. All signal interface with the microprocessor boards is simple high-low TTL logic which can be checked with a logic probe included with each transmitter.

Besides the normal transmitter functional controls found on the front meter panel (ON/OFF, HIGH/MEDIUM/LOW POWER, and RAISE/LOWER POWER), the SX transmitters have a conveniently located dual digital display that formats the wealth of service information available from the controller. The dual display can be used to look at two parameters simultaneously in order to show the interaction between various stages.

Selection of the two displays is made with a touchpad. A conveniently located chart lists the various parameters an operator can display, including individual power amplifier current, individual power amplifier voltage, imbalance between individual power amplifier module voltages, faulty RF power amplifier module, faulty PDM amplifier module, power amplifier dissipation, power amplifier efficiency, main power supply voltage, main power supply current, PDM amplifier dissipation, RF drive level, reflected

power and calculate load VSWR, and temperature of nine strategic heat sinks inside the cabinet.

In addition, the SX microprocessor controller assists in the following tasks: step-start sequence while monitoring power supply parameters during start up; automatically adjusting power output due to fluctuation in line voltage; preventing transistor failure by lowering power output in the event of excessive temperature on any of the nine heat sinks; and detecting up to eight overloads, which are presented to the controller, and acting according to the preprogrammed action assigned to each fault.

Inside the low level pull-out cabinet drawer are eight fault LEDs that indicate overload conditions. Any one of the fault lights will also illuminate the combination off/fault pushbutton on the front panel, immediately notifying an operator that a fault has occurred and that further interrogation is needed.

The new Harris SX line has no VSWR shutdown or trip overload. The only time the transmitter will take action is when long-term operational parameters have been exceeded. Then, and only then, will programmed controller action be initiated. In the case of most 1-5 kW installations, VSWR trips are caused primarily by environmental factors such as lightning noise or antenna guy wire insulator static discharge, not by antenna system component problems. Every effort has been made to have the controller keep the transmitter on the air during a fault condition at some safe power in order to minimize off-air time.

In addition, a customer interface panel provides the user with a centrally located point for connection of all

## Versatile, Affordable Titlers

### TM-1024B

Combines titler & message generator in one small package at one low price.



- Choice of 8 color backgrounds in stand-alone mode
  - Switchable for downstream keying applications
  - 16 page resident memory
  - Character insert & delete
  - Manual & auto sequencing with variable dwell
  - 10x14 character matrix
  - Auto line centering
- Titler and message generator combined for \$2795

### T-1000A

Advanced character enhancements.



- Black and white characters in 2 heights
  - Drop shadow and border in both black and white
  - "See-thru" characters
- Plus: Roll, Crawl, Off-line editing, and 16 page resident memory
- All these features for \$3995.
- For more information, call or write today.



**VIDEO DATA SYSTEMS™**

Corporate: Hauppauge, New York 516-231-4400  
National Sales: Salt Lake City, Utah 801-566-3635

Circle No. 281 on Reader Service Card

# The telecine without tubes.

## Digital CCD technology means better pictures.

Advanced technology in the new Bosch FDL 60 "U.S. Series" with PanScan and black stretch gives you tremendous advantages over conventional film scanners.

And the most important of these is superb picture quality with high resolution, excellent signal-to-noise ratio, and brilliant color rendition with negative or positive film.

### CCDs make the difference

The use of solid-state CCDs—charge-coupled devices—completely

eliminates electro-optical problems inherent to pickup or scanning tubes.

You don't have to worry about burn-in, afterglow, or field lag because there's no photoconductive or phosphor layer to cause these effects.

You can forget about shrinkage, flicker, vertical deflection, horizontal misregistration, and positioning errors of all kinds.

And never again will you be subjected to the expensive ordeal of tube changes.

### New operational modes

Thanks to the FDL 60's capstan drive and digital signal processing, you can operate slow motion, fast motion, forward, reverse, and freeze frame—all in full broadcast quality. You can start and stop instantly, and with frame accuracy. You can search for scenes or frames either with variable programmable search or frame jogging, both with full format color pictures.

### Low operating costs

The solid-state devices used in the FDL 60, including the CCD sensors, need no maintenance. They have all the reliability and long operating life typical of semiconductors. So besides giving you a better picture, the FDL 60 saves you money on maintenance.

### Operational flexibility

The FDL 60 gives you operational flexibility you'd expect only in a modern videotape recorder. You control it like a VTR, too. The servo deck with continuous capstan drive and microcomputer control ensures gentle film handling. And it's totally insensitive to perforation damage.

A keyboard that lets you enter time code cue points and a changeover switch give you disturbance-free transitions between two machines in parallel operation.

You can even integrate the FDL 60 into your VTR editing and film-to-tape transfer systems.

A quick-switch optical block lets you run either 35mm or 16mm film in combination with all the usual types of sound track.

Find out for yourself how high technology can mean better pictures. Call your local Fernseh office. Or get in touch with Fernseh Inc., the Video Corporation of Bell & Howell and Robert Bosch, P.O. Box 15608, Salt Lake City, Utah 84115, (801) 972-8000.

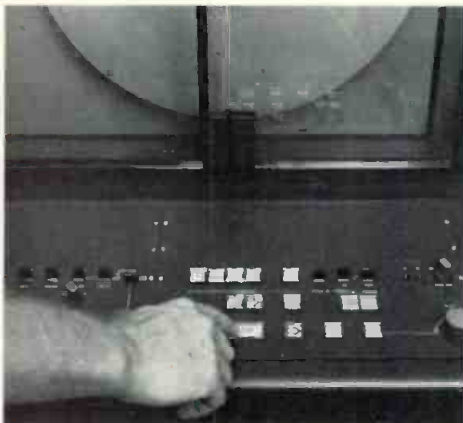

*Convenient film deck controls include speed, mode, direction, format, framing, and focus. Adjacent decks control audio, video, and color correction.*

From now on,  
look to Fernseh.

## **FERNSEH**

© 1982 Fernseh Inc. All rights reserved.

Circle 282 on Reader Service Card

## New Transmitter Design for the '80s

external interface equipment such as remote control, facility control, or audio input.

In designing the SX transmitter line for AM stereo, Harris paid special attention to incidental phase modulation, audio input to RF envelope output phase linearity, and RF channel phase response. The standard high-stability crystal oscillator or optional frequency synthesizer are both equipped to accept external AM stereo RF oscillator signals.

### Innovative cooling system

The cooling system, similar to the other functional areas of the SX transmitter, also offers innovative features new to broadcast transmitters. All three transmitters incorporate a computer-modeled convection cooling technique that not only reduces routine maintenance requirements but also has eliminated blowers and fans in the SX-1 and SX-2.5 altogether, with the SX-5 needing only a small, quiet 150 CFM fan.

The cabinet sidewalls of the transmitter form chimneys to which the power amplifier modules are attached. Convection air enters through a filtered rear entrance and rises through the cabinet walls, cooling the power module's heat sink. The majority of the convection cooling air passes through the isolated chimneys, with only a small amount of air required to flush the inside of the cabinet. Since the majority of the

air does not come in contact with the electronic components, routine cleaning maintenance is greatly reduced.

The high-power MOSFET devices have also allowed Harris to reduce the necessary component size of the SX transmitters. The additional room afforded has allowed 36 3/4 inches of shielded front-panel 19-inch rack space, permitting stations to house most equipment typically found in a 1 kW transmitter installation. Typical configurations may include modulation monitor, remote or facilities control, or audio processing equipment. Separated low-level and power wiring to this equipment is available through the top, bottom, and sides.

Novel electronic packaging new to broadcast transmitter products results in excellent service accessibility. For example, all low-level circuit cards, such as the RF oscillator, control logic, and polyphase PDM generator cards, are located in a pull-out drawer, permitting all critical low-level tests to be made while on the air. In addition, all captive hardware has been used, which significantly aids maintenance. The majority of low-level PC cards are hinged for access to both sides without disconnecting or removing them.

Exceptionally high overall efficiency, maximum reliability, improved audio performance, full service microprocessor control and status monitoring, field upgradability to higher powers, and AM stereo compatibility are just a few of the operator features offered by the new Harris SX Series transmitters, the result of powerful new technological developments. **BM/E**

## sachtler video 25

the state-of-the-art  
video fluid head  
designed to supporting your  
ENG- and EFP-cameras

Now ready to go into operation.

### sachtler video 25

featuring:

Center of Gravity Compensation  
4 step Dynamic Counterbalancing Control  
2 times 7-step on/off drag control for pan and tilt  
Touch & Go wedge plate

The rock-steady, silky-smooth cameramen's fluid head, doing everything in news gathering and field-production.

The all-in-one-piece camera support system.

Call or write:

**Sachtler Corporation of America**

400 Oser Ave., Hauppauge NY 11788

Phone: (516) 231 0033

a subsidiary of

**Sachtler gmbh, Dieselstraße 16, D-8046 Garching**

Phone: (089) 320 4041, Telex: 5215 340

or your nearest sachtler-distributor.

AMPEX - BOSCH -  
HITACHI - IKEGAMI  
- IVC - JVC - LINK -  
MARCONI - NEC - PANASONICS -  
PHILIPS - RCA - SHARP - SONY -  
THOMSON - TOSHIBA  
...and other fine makes  
of professional cameras.



Circle No. 283 on Reader Service Card

# GIANTS COME IN ALL SIZES.

Model Shown: 3106 in the new American Data Gold. Just one in a complete line of quality multi-level video production systems. Simple to operate, yet advanced in design and reasonable in price.



**Central Dynamics** presents at **NAB '82**  
The Broadcast Company for  
**CDL • PHILIPS • American Data**  
**New American Data and CDL switching equipment.**  
**New Philips LDK6...the 'thinking' camera.**  
**2 stages...2 live presentations.**

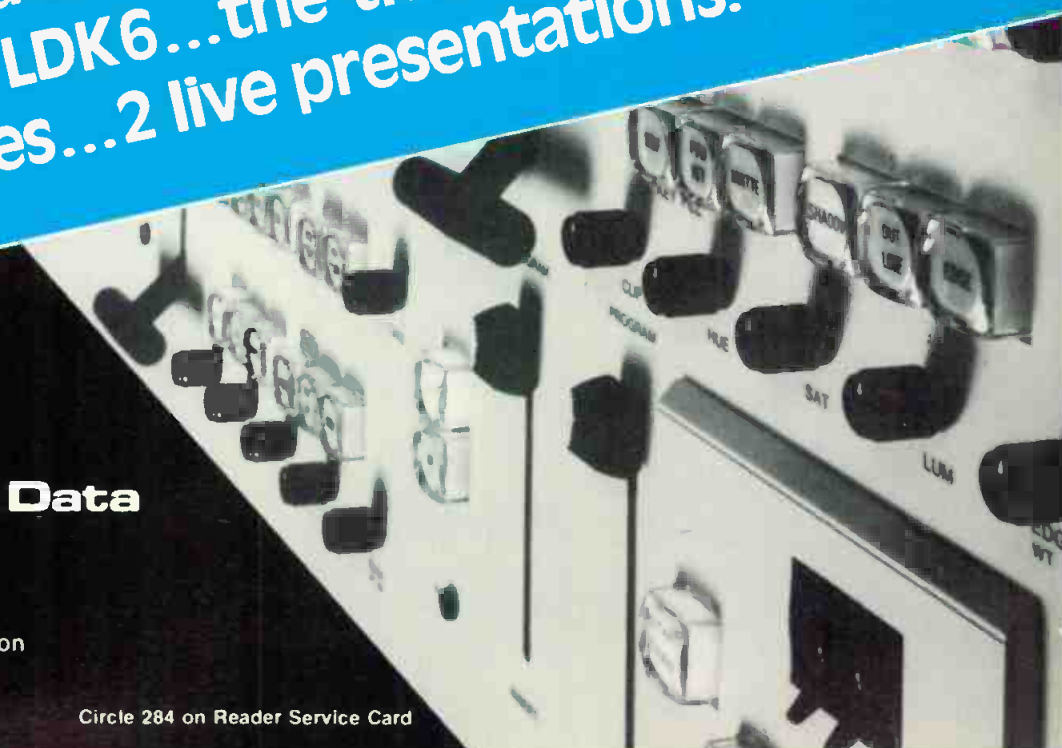

 **American Data**

401 Wynn Dr • Research Park  
Huntsville, Alabama 35805  
Telephone (205) 837-5180  
TWX 810 726-2125  
A Division of Central Dynamics Corporation

Circle 284 on Reader Service Card

[www.americanradiohistory.com](http://www.americanradiohistory.com)

# CMX computer-assisted time code editing for \$13,250?

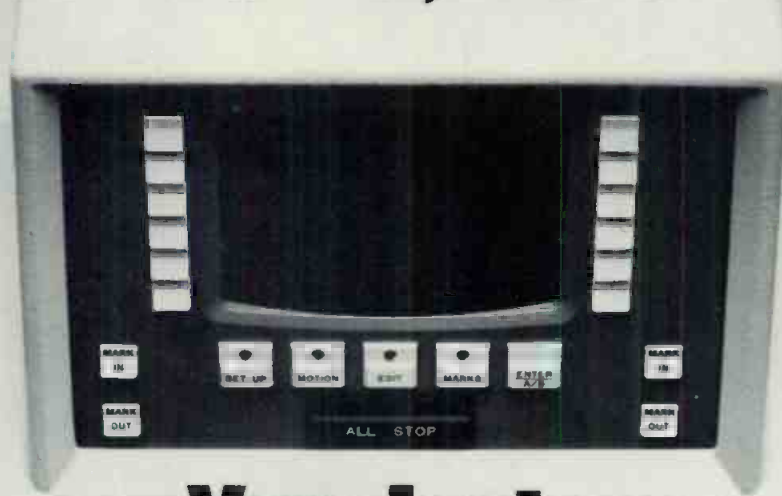

## You bet.

THE EDGE™ from CMX. Now a proven standout when it comes to features and performance in videotape editing.

But wait. Look at that price.

You can get a complete EDGE time code-based editing system including control and display console, electronics frame, cuts-only switcher, two-event GPI, plus interface for two VTR's, for \$13,250. (U.S.)

A three-machine system, including Edit Decision List I/O module, floppy disk drive and A/V dissolver sells for \$23,450. (U.S.)

And, in addition to the dollar EDGE remember that our SMART KEYS™ and layered screens let you set your own editing pace. Our plug-in modules allow you to make the change from two to three machines as well as incorporating product updates quickly and easily. Also we output a 340X Edit Decision List. And remember, we've been talking to VTRs for a long time at CMX. Our smooth-as-silk interface results in extremely reliable operation.

We mean it when we say price, performance and features give you the reasons why THE EDGE is the **only** system you should own.

See your CMX representative for more details or give us a call.

**THE EDGE**  
Winner 1981  
Industrial Design  
Excellence Award  
Industrial Designers  
Society of America

THE EDGE™

CMX

3303 Scott Blvd., Santa Clara, CA 95050. (408) 988-2000

TM Orrox Corp.

Circle 285 on Reader Service Card

**CMX**  
**ORROX**

# PUTTING THE TELEPHONE TO WORK

By Bill Newbrough

***Bell's nationwide Dial-It system provides radio and TV stations with a handy public opinion polling device—but it can also be used as an effective, inexpensive market research tool.***

BELL'S DIAL-IT SYSTEM got started back in the 1970s primarily as a service for telephone company customers. The service generally consists of a prerecorded message that can easily be changed or updated and played back to the caller through the telephone company equipment. Dial-It National Sports, for example, provides sports news updated each quarter hour. Originally considered by Bell as a "seed" service, it has now developed a regular audience, drawing 1,000,000 calls per month. Its promotion via national television advertising has proved that public response to the Dial-It system can be stimulated effectively.

**Bill Newbrough** is a communications consultant working with KRNA, Inc., which provides consulting services to Dial-It sponsors. He was involved in the first applications of Dial-It in the 1970s while supervisor of Bell's Network Management Center.

*One of the first uses of Dial-It for opinion sampling was during the Carter/Reagan debate. ABC asked viewers to call the 900 number corresponding to the candidate they thought had won. The percentage on the night of the debate was almost identical with Reagan's actual victory percentage.*

Each call completed to a Dial-It number (except Dial-It information) costs the caller 50 cents and is logged in computer memory that records when the call was made and to which specific number. Dial-It numbers use Area Code 900.

## **New uses for public opinion polling**

For the 1980 televised debate between presidential candidates Reagan and Carter, ABC-TV inaugurated a brand-new use of the Dial-It service. Responding to announcements made before and after the debate, and to telephone numbers displayed on the screen, millions of viewers dialed in to indicate which of the two candidates they felt had won the debate. Since a separate Dial-It number was established for each candidate, the computer could provide a minute-by-minute analysis and totals for each candidate. As it turned out, Reagan's victory percentage on the night of the debate

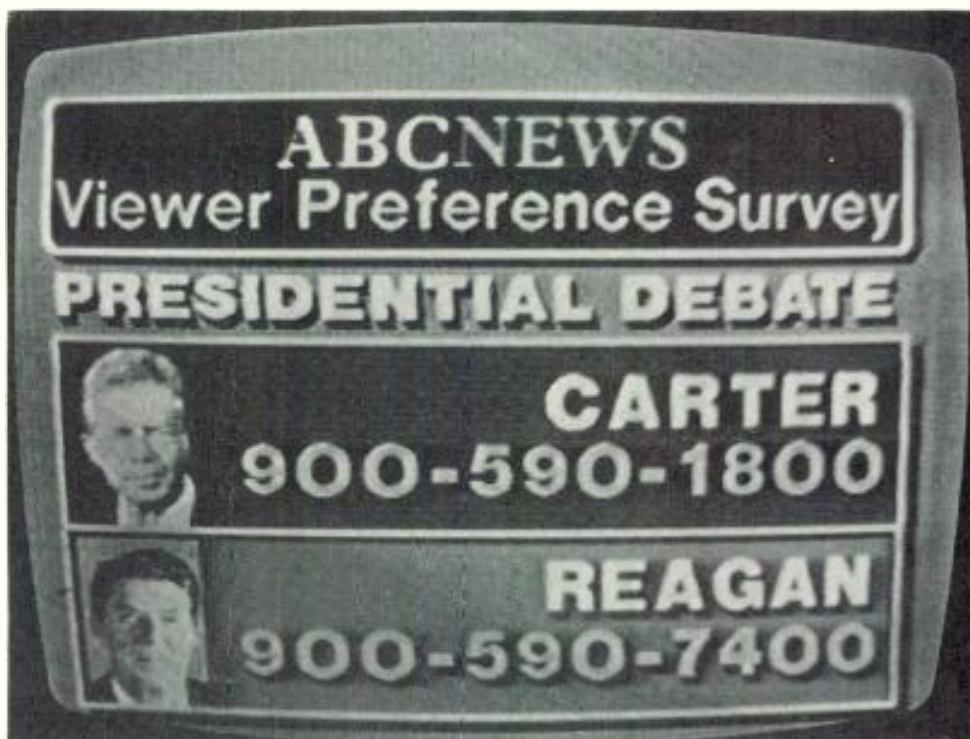



## Putting the Telephone to Work

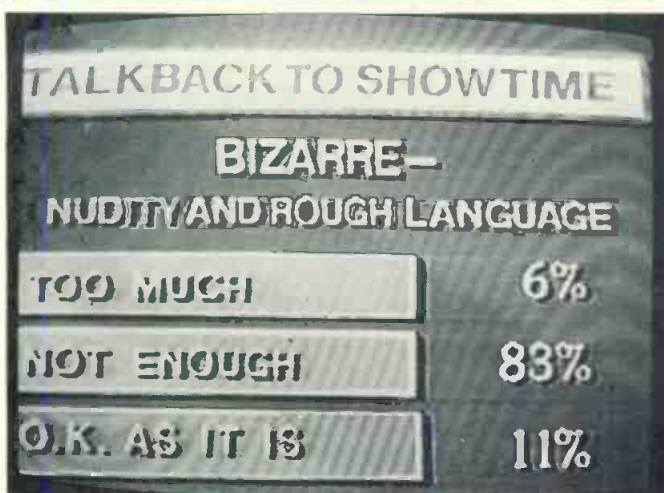

was virtually identical with his victory percentage in the election seven days later.

Now, some recent changes made by Bell in Dial-It tariffs make its use practical even by local broadcasters. For less than \$100 in clerical time (and graphics for the TV station), a broadcaster in a single time zone can use the system to provide instant viewer interaction. A yes/no question asked at the beginning of an hour-long news program, with two telephone voting numbers to call, can be sub-totaled and reported half way through the newscast and totaled up and announced at the end. The results are not only immediate, but the cost of the poll is born by the callers.

To test this new capability, two Denver stations, KBTU and KMGH-TV, began using Dial-It in October, 1981. Both stations announced questions to be polled and began soliciting calls on their 5:00 p.m. news programs. Partial results of the polling were announced during the hour-long programs, and viewers continued responding through the 10:00 p.m. newscasts. Additional promotions of the polling and solicitations for viewer responses were made during several breaks in prime-time programming during the evening.

For example, on October 13 KBTU asked viewers whether American troops should be used in the Middle East if necessary. A total of 2813 viewer responses were recorded by the Bell computerized switching machines; 58 percent were to the "yes" number. As is usually the case with Dial-It polls, the percentages remained fairly constant throughout the evening. For instance, approximately 30 minutes into the polling, when 400 responses had been recorded, the percentage was 60 percent "yes."

KMGH-TV asked viewers of its October 13 6:00 p.m. newscast whether a local high school football coach should be fired (the coach had received substantial media coverage and had been suspended from coaching for requiring a player to run the gauntlet—involving the player's being struck physically by the other team members). Approximately 3600 responses had been recorded by the beginning of the station's 10:00 p.m. newscast. The final results of the poll, announced at the end of the newscast, were 57 percent in favor of firing the coach. Approximately 4300 responses had been recorded by that time.

The cost savings to stations currently doing standard telephone calling to sample public opinion can be enormous. The system also allows stations lacking sufficient staff and resources for standard polling to conduct original research integrated with the local newscasts.

### What about bias?

Some of the main advantages of the Dial-It polling process are the elimination of certain biases that are inherent in standard call-out procedures. The unlisted telephone number bias is eliminated since any telephone can call into the system and geographical bias is reduced since the 50-cent charge is the same no matter where the call originates. The sampling universe that is

*Showtime asked its viewers to decide whether the program Bizarre had too much, not enough, or the correct amount of nudity and rough language, then announced the Dial-It results on-air.*

# NEC unveils E-FLEX Digital Video Effects<sup>®</sup> System.

**"C" format VTR, Dual Video Transmission System, other technology also revealed.**

Visitors to NEC Booth #2528 at the NAB show will see newest addition to the DVE<sup>®</sup> family... plus other major technology innovations from NEC America, Inc.

★★★★

## NEC/NAB NEWS

Final  
Edition

### E-FLEX system puts Emphasis on Flexibility.

NEC adds to its string of successes in digital special effects with the introduction of the E-FLEX system.

This new generation DVE<sup>®</sup> brings many NEC optional digital effects into one package with "user friendly" control parameters and some special surprises.

Pocketable digital effects become a reality through the application of Bubble Memory technology. Special demonstrations of the E-FLEX system have been scheduled during the four days of NAB with deliveries of the first units to commence June 1.



**The real show in Dallas is at BOOTH #2528 lower level. Well worth looking for. NEC AT NAB.**

### TT-8000/NTC-10B improve tape handling characteristics.

This new Type "C" 1-inch VTR and TBC combination is designed to handle a wide range of production, studio and post-production applications.

Improved performance, simplified operator controls, and new tape handling characteristics combine with optional hetrodyne capabilities in the NTC-10B to make the TT-8000 the ideal investment in 1-inch recording.

### 3-chip CCD, Digital VTR prototypes demonstrated.

NEC will demonstrate its world leadership in communications technology design and manufacture through exhibition of the industry's first professional 3-chip CCD color

DV-10 Multiplexed signal horizontally compresses two images into a single picture.



camera and completely digital 1-inch VTR prototypes.

Both systems are at the forefront of the broadcast technology revolution.

### DV-10 doubles video capacity.

Unlike systems that restrict you to one signal per channel, the new DV-10 Dual Channel Video Transmission system accommodates two full video signals on each video path.

Broadcasters, users of CATV, security systems or satellite transponders can now double signal capacity without increasing present video channel space.

ENG field crews can feed two live cameras, camera and VTR, or any other combination of two signals into a single channel microwave link or other interconnect with the DV-10. Built-in U-Matic TBC is an additional feature of the system.

The multiplexer is modularized in a compact package for full field flexibility. The demultiplexer and power supply rack-mount in just 12 inches of space.

### NEC RF Group shows TVRO system/VHF Transmitter.

Visitors to the outside exhibit area at the Convention Center will have the first opportunity to see a new 4GH<sub>z</sub> TVRO earth station with NEC electronics and an ALCOA aluminum antenna. This system is a complete 4.5 meter satellite antenna and receiver for broadcast downlink applications. An NEC 20 kW VHF TV transmitter will provide a centerpiece for RF Group functions within the Convention Center in booth 2528.

**NEC** NEC America, Inc.  
Broadcast Equipment Division  
130 Martin Lane  
Elk Grove Village, IL 60007

Circle 286 on Reader Service Card

**“I need three waveform monitors that can be rack mounted. And they’ve got to be portable, too.”**



**HITACHI  
HEARD YOU.**



You want three waveform monitors that fit side by side in a standard 19" rack mount.

But you also want to be able to slip one out easily when you need to go on location.

Well, Hitachi heard you. And is out front once again in meeting your needs with our new V-099 waveform monitor.

The cost? You can get three of these monitors for about what you'd expect to pay for two of our competition's monitors with this one's features.

And look at these features. The V-099 has a bright (2 kV) 3½" rectangular CRT. It can be operated on AC or from an external DC source, with optional battery pack, when you want to go on the road.

For more information on the V-099 and the rest of the broadest and most advanced line of broadcast and professional video equipment in the business, you know who to get a hold of. Hitachi Denshi America, Ltd., 175 Crossways Park West, Woodbury, NY 11797. (516) 921-7200. Offices also in Chicago, Los Angeles, Atlanta, Cincinnati, Dallas, Denver, Seattle and Washington, D.C.

Circle No. 287 on Reader Service Card

## Putting the Telephone to Work

established is essentially defined by the real-time audience of the station soliciting the audience response.

Although the bias effect of the 50-cent charge has not yet been investigated fully, Bell feels that the charge is so small that there should be no significant economic bias introduced. If anything, Bell says, the charge reduces the biasing effect of people responding to a question in which they have no interest or no significant opinion. Most public opinion research gives people an opportunity to express "no opinion," but it has long been known that some people will provide an opinion even when they have none simply so the interviewer doesn't think they are uninformed or uninterested in a matter of public importance.

Dial-It is able to measure the intensity of audience opinion because a person who feels strongly about responding can respond more than once. The 50 cents per completed response charge may help assure a direct relationship between the intensity of feeling and the number of responses an individual or household will make.

Because the charge to respond is the same from all telephones, Dial-It gives people outside a local calling area the same opportunity to be sampled as those who live within the toll-free calling area. Many opinion-sampling techniques using call-out methods base their universe on listed telephone numbers in the local calling areas, which biases the results by excluding from the samples those outside the local calling area or those with unlisted numbers. If the opinion research is of the type in which a station's normal telephone numbers are used for audience call-ins, the response may be skewed by the varying phone rates incurred by the audience, with some able to respond free and others paying long distance charges. Dial-It eliminates these problems.

Theoretically, everyone with access to a telephone has the same opportunity to express an opinion through Dial-It. Even if the response is massive enough to exhaust the capacity of the Dial-It system, the callers whose responses are measured should be statistically identical to those whose responses are blocked in the telephone system before they can be measured. Each telephone in the country has approximately the same chance of originating a measured response.

### Additional applications for Dial-It

Besides replacing or supplementing existing public opinion research methods, Dial-It can be useful in programming research, radio station music research, and radio listener response lines. Many of these applications make use of Dial-It's capability of forwarding a selected number of calls to another telephone number. The forwarded calls are answered live, rather than routed to the recorded announcement.

For promotional purposes, stations might arrange to obtain a short "personal" message from a celebrity and run it as a Dial-It announcement promoting the station. It would then be possible to promise a certain number of callers, selected randomly by Dial-It equipment, an opportunity to talk directly with the celebrity.

Another alternative is for a station to find a cooperative advertiser to provide prizes to randomly selected callers in exchange for the advertiser's message being on

**OUR  
PICTURE**

**VS.**

**THEIR  
PICTURE**

**LENCO'S  
NEW PCE-462  
COLOR ENCODER  
WILL SHOW  
YOU THE BEST  
RGB TO NTSC  
IN THE BUSINESS  
— FOR  
BROADCAST  
AND COLOR  
COMPUTER  
GRAPHICS.**

Now give yourself a clear advantage — with a picture that's clearly better. Not just visually, but cost-wise, too.

Lenco's new PCE-462 takes RGB sync, blanking, sub carrier and optional luminance and gives you NTSC out — with such high resolution superiority that we'll be glad to compare it against anybody else's.

Now you can upgrade picture quality at a fraction of the cost of other equipment. And enjoy enhanced results from compatible graphics computers with RGB out.

**Frequency response.** Compare this Lenco at  $\pm 0.3$  db to 6.5 MHz, to -3 db at 7.5 MHz. Truly outstanding performance.

**Enhancement.** Compare Lenco sharpness with signal boost of +8.3 db at 3.5 MHz.

**Non-composite RGB or composite green.** This Lenco video input processor accepts either without modification.

**Luminance channel input optional with plug-in circuit board.** Now you can up-date your older 4-tube cameras instantly. All the hardware is here — BNC coax connectors, internal wiring, etc. Just plug in for your clearest color ever.



**LENCO**

Circle 288 on Reader Service Card

**LENCO'S FREE OFFER**



It will improve your picture right now.

Write or call us today. We'll send you a spec sheet on the PCE-462 and give you a side-by-side comparison spec check with all other units now available: the answers you want — direct from our engineers.

Call 314-243-3147

Have your sales representative call me.  Send literature and comparison.

Name (please print) \_\_\_\_\_  
Title \_\_\_\_\_  
Firm or station \_\_\_\_\_  
City \_\_\_\_\_ State \_\_\_\_\_ Zip \_\_\_\_\_  
Telephone \_\_\_\_\_

Lenco, Inc., Electronics Division, 300 N. Maryland St.,  
Jackson, MO 63755 (314) 243-3147

# SAVE THE BUCKS!

Follow the herd  
into NAB Booth 1618  
and check out our new  
Broadcast Control Computer.



H&F has done it again: developed the industry's most versatile control computer in a package that doesn't require big bucks. Our new PCC Broadcast Control is easily programmed to provide everything from simple FCC logging to full ATS, and for up to seven transmitter sites! Get all the details at the NAB show or contact us directly now.

## \$7495

### Hallikainen & Friends

101 SUBURBAN ROAD SAN LUIS OBISPO  
CALIFORNIA 93401 805/541-0200

Circle No. 289 on Reader Service Card

# 40 FOOT MOBILE BROADCAST PRODUCTION FACILITY FOR SALE.

## TERMS AVAILABLE.

## (714) 720-0151

Circle No. 290 on Reader Service Card

## Putting the Telephone to Work

the Dial-It announcement. Traditional radio station call-in contests might provide a Dial-It message to callers who are not winners, rather than subjecting them to annoying busy signals. Automatic, completely random selection of winners by Dial-It is another possibility. Still another possibility is to sell commercial messages on a Dial-It announcement used for contests, thus helping a contest generate revenue as well as listeners.

Perhaps the most significant new application of Dial-It is in the area of audience research. As in a typical radio station call-in contest, data about call volume can be used to project audience size. For instance, the numbers of calls a contest draws during certain day-parts during a ratings sweep can help predict actual audience size between rating sweeps. To do this, variables such as times, prizes, and solicitation techniques must be kept constant so that variations in response as indicated by call volumes relate directly to actual audience size. This allows the effects of programming changes to be measured and evaluated, and additional programming changes made prior to the actual ratings period.

Radio station call-out audience research can also be replaced after a significant Dial-It contest data base is established for a particular station or market. The costs of obtaining Dial-It certainly are substantially less than the costs of the call-out research many stations currently employ. In addition, as already discussed, Dial-It data is probably subject to fewer biases.

One of the most effective examples of this type of programming research was demonstrated last September by Showtime, the cable television programming movie and entertainment service. Showtime generated 32,000 Dial-It responses from subscriber households in 1100 nationwide cable television systems. Viewers were asked to indicate their favorite comedy stars during a comedy night. They were also asked about the amount of nudity and adult language in the program *Bizarre*. Eighty-two percent of the responses indicated that there was not enough of either.

Mike Weinblatt, president of Showtime, called the audience research "an extraordinary opportunity for Showtime people to sample a wide range of opinions on Showtime programming and pay television in general. It also reinforced our belief in the value of direct viewer feedback and interaction."

Showtime also took advantage of Dial-It's capability to divert random calls to another telephone number and used its New York City telephone facilities to sample viewer's specific comments concerning its programming. Another Dial-It application to programming research is planned by Showtime later this month.

Besides Showtime and ABC-TV, national users of Dial-It have included NBC-TV Sports and ESPN, which have given viewers the opportunity to act as referees in their living rooms. While this may not lead to better officiating, it certainly can supplement viewer involvement in sports programming—and increasing audience involvement in any type of programming is perhaps the most important application of Dial-It in the broadcast industry.

BM/E

# Never build an editor that can become obsolete...



## And it goes for every Z editor ever built.

Considering all the advancements made in videotape editing systems in just the last three years, you might think your Mini-Z or Z-6 editing system is becoming obsolete. Well, it's not.

In fact, even though we're introducing a whole new line of Z6000 editors, the very first Z editor we ever built can be fully upgraded to Z6000 capability for less than \$4,500!

So, if you own a Videomedia editing system, hang on to it. For a surprisingly low cost, you can expand its capabilities whenever you want.

## Frame accurate editing, for under \$11,000.

Don't buy a system with more features than you need. If you do, you're paying for "extras" before you can use them. Instead, invest in a system that can grow with you.

For example, start with a Z6000-A, a cuts-only editor with four-way split edits, auto extend and tag, four-event swap/recall, printer output, and the ability to select in and out points on the fly. Like all Z6000 editors, it has distributed intelligence, which controls each transport with an

individual microprocessor, thus eliminating timing discrepancies... all for less than \$11,000!

What's more, you'll be able to add features, such as our new KR6000 character generator for integrated graphics control, when you need them, at a fraction of the cost of a new system with the same capabilities.

## Keep up to date at your own pace.

Whenever we build a new product or add a new capability, we make sure that it adapts to all our previous systems.

That's why, when you buy any Videomedia product, you're investing in a system with a future.

For complete details on our entire line of editing systems, post-production equipment, and a copy of our exclusive No-Obsolescence Policy, call or write today.

**Videomedia**  
Professional Television Systems

250 North Wolfe Road  
Sunnyvale, CA 94086  
Telephone: (408) 733-6500

Circle 291 on Reader Service Card





# No surprises.

Available in 2", 1", 3/4" and 1/2" Beta and VHS.

See us at NAB Booth 3313

Circle 292 on Reader Service Card

[www.americanradiohistory.com](http://www.americanradiohistory.com)



# ***EXTENDING TRANSMITTER TUBE LIFE***

By Robert Artigo

---

*A carefully followed program of filament voltage management can substantially increase the life expectancy of transmitter power grid tubes. With today's rising operating costs, such a program makes good financial sense.*

---

IN RECENT YEARS station managers have seen a substantial increase in replacement costs for power grid tubes. The blame can be placed on higher manufacturing costs due to inflation, volatile precious metal prices, and an uncertain supply of some exotic metals. The current outlook for the future holds little promise for a reversal in this trend toward higher prices.

One way to offset higher operating costs is to prolong tube life. For years station engineers have used various tricks to get longer operating life, with greater and lesser degrees of success. Success can be maximized, however, by understanding the various

---

**Robert Artigo** is senior application engineer for Varian Eimac, San Carlos, CA.





## Extending Transmitter Tube Life

factors that affect tube life and implementing a program of filament voltage management.

A number of factors can aid maximum tube life in your transmitter. For example, are the maximum ratings given on the tube manufacturer's data sheet being exceeded? Data sheets are available upon request from most companies. Most tube manufacturers have an application engineering department to assist in evaluating tube performance for a given application. Make use of these services!

### Headroom

Is the final power tube of the transmitter capable of delivering power in excess of the desired operating level? Or is the demand for performance so great that minimum output power levels can only be met at rated nominal filament voltage?

Figure 1 can be used as a basic guide to determine if a given transmitter and tube combination has a good probability of giving extended life service. Extended life service is defined as useful operating life beyond that normally achieved by operating at rated nominal filament voltage. The amperes/watt ratio is obtained by dividing average plate current by the product of filament voltage and filament current. If the amperes/watt ratio falls in the "good" to "excellent" range, excess emission is sufficient to permit filament voltage derating. At a lower filament voltage, the filament temperature is lowered, thus extending life. A typical FM transmitter on the market today may have an amperes/watt filament ratio of 0.002 to 0.003. This equipment would be considered an excellent choice to achieve extended tube life. On the other hand, if the amperes/watt ratio falls in the "poor" range, it is unlikely that filament derating is possible due to limited

emission. Note that this guideline should be used for thoriated tungsten emitters only, and does not apply to oxide cathode-type tubes.

### Instrumentation

Are all tube elements metered in the transmitter? Elements should be metered for both voltage and current, and meters should be redlined to define operation within safe limits. More modern transmitters may incorporate a microprocessor-controlled circuit to monitor all pertinent parameters.

In addition, the following controls are necessary if an effective filament voltage management program is to be undertaken: power output metering for an FM transmitter or a distortion level meter for AM equipment; *accurate* filament voltage metering (an iron-vane instrument is preferred over the more common average responding RMS calibrated type; the filament voltage measurement must be made at the tube socket terminals); filament voltage control, capable of being adjusted to 0.1 V secondary voltage change; and a filament current meter—desirable but optional.

A means must be provided to hold filament voltage constant. If the filament voltage is permitted to vary in accordance with primary line voltage fluctuation, the effect on tube life can be devastating. An acceptable solution is the use of a ferroresonant transformer or line regulator. This accessory is offered by some transmitter manufacturers as an option and should be seriously considered if a tube life extension program is planned.

### Transmitter housekeeping

Once the transmitter has been placed in operation, tube life is in the hands of the chief engineer. The first action to prolong tube life falls into the category of routine maintenance. Most transmitter manufac-

**Fig. 1. Probability of extended life service can be determined from this graph. Divide the average p.a. plate current in amperes by the product of filament voltage and current. The resulting amperes/watt ratio (Y-axis) is projected horizontally to the appropriate curve. The vertical projection to the X-axis indicate the life extension probability.**

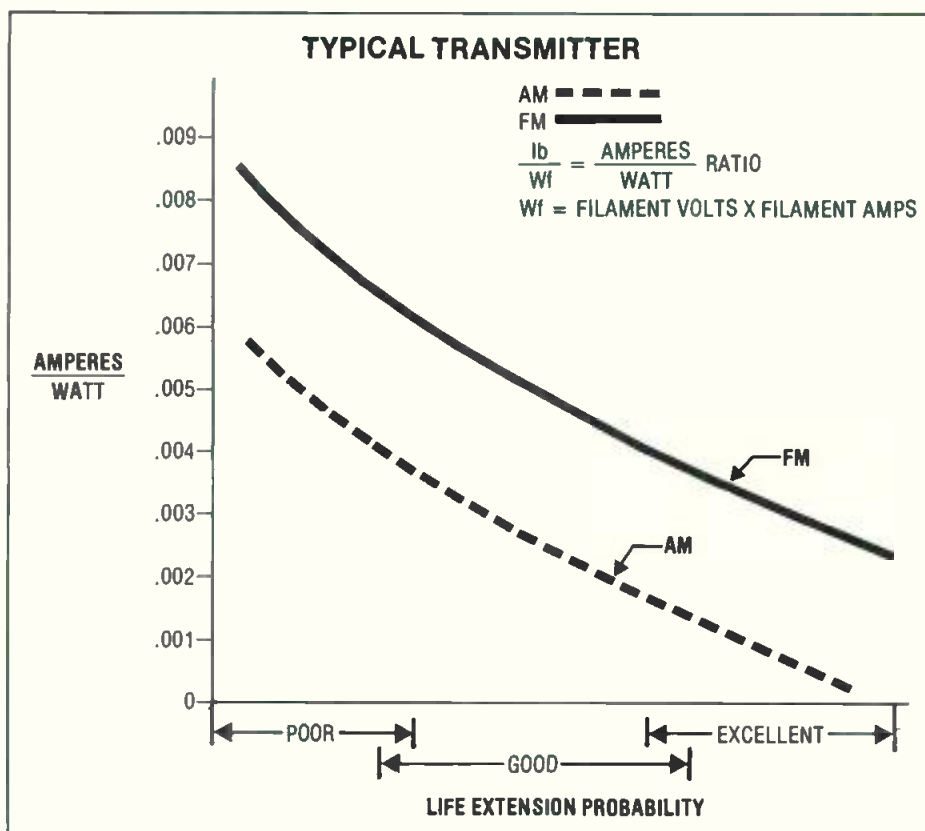

# INTRODUCING

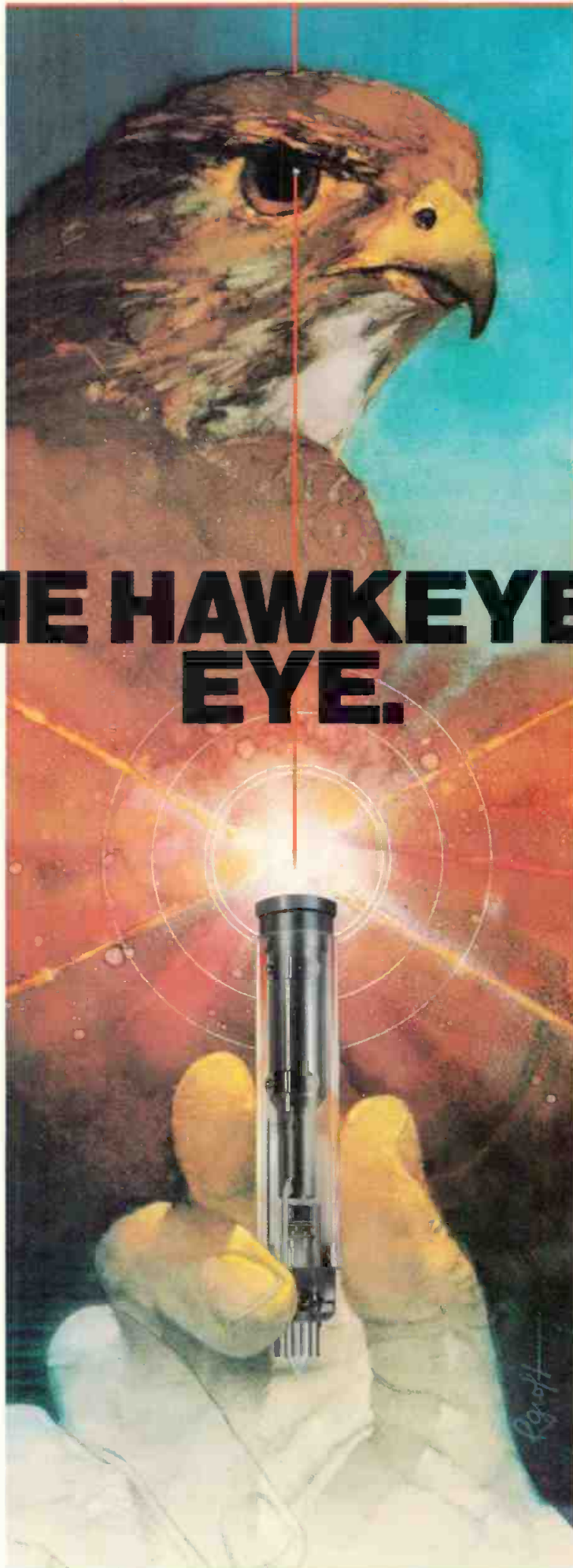

## THE HAWKEYE'S EYE.

RCA's revolutionary new handheld HAWKEYE ENG camera was built around a revolutionary new RCA tube—the ½ inch SATICON\*. Its superior performance is the direct result of enlightened design techniques and the inherent characteristics of the Selenium-Arsenic-Tellurium photoconductor.

The SATICON tube offers outstanding resolution, and handles high-contrast scenes without unpleasant distortion or discoloration. Color pictures come through spot-free, without flare. For these and many other reasons, SATICON tubes are now used in over 50% of the new color cameras sold in North America and Japan.

On the basis of performance, reliability and general user acceptance, they

will soon predominate in color television cameras worldwide.

SATICON tubes are now available as new or replacement equipment for most ENG, studio and remote cameras. For more information, please write RCA Camera Tube Marketing, New Holland Avenue, Lancaster, PA 17604. Telephone: (717) 397-7661. Or RCA Brussels, Belgium. Sao Paulo, Brazil. Sunbury - on - Thames, Middlesex, England. Paris, France. Munich, W. Germany. Hong Kong. Mexico 16 D.F., Mexico.

# RCA

\*Used by permission of trademark owner.

Circle 293 on Reader Service Card

[www.americanradiohistory.com](http://www.americanradiohistory.com)

## Extending Transmitter Tube Life



Figure 2



Figure 3



Figure 4



Figure 5

turers have a routine maintenance schedule established in the equipment manual. This procedure must be followed carefully if operating costs are to be held to a minimum. During routine maintenance it is very important to look for tube and socket discoloration, either of which can indicate overheating.

Look for discoloration around the top of the cooler near the anode core and at the bottom of the tube stem where the filament contacts are made. Review Figures 2 and 3 for examples of a tube operating with inadequate cooling. It is possible for discoloration to appear in the areas mentioned if the transmitter has to operate in a dirty environment. If this is the case, the tube should be removed and cleaned with a mild detergent. After cleaning, the tube should be rinsed thoroughly to remove any detergent residue and blown dry with compressed air. If the discoloration remains, this is an indication that the tube has operated at too high a temperature. Check inlet and outlet air ducting and filters for possible air restriction. It may also be necessary to verify that the air blower is large enough to do the job in the present environment and that it is operating at rated capacity.

With the tube removed, the socket should be blown or wiped clean and carefully inspected. Any discoloration in the socket finger stock caused by overheating could contribute to early tube failure. A finger stock that loses its temper through prolonged operation at high temperature will no longer make contact to the tube elements (Figure 4). A well-maintained socket will score the tube contacts when the tube is inserted. If all fingers are not making contact, more current flows through fewer contacting fingers, causing additional overheating and possible burnout (Figure 5).

### Filament voltage management

The useful operating life of a thoriated tungsten emitter can vary widely with filament voltage. Figure 6 describes the relative life expectancy with various filament voltage levels. Obviously, a well-managed filament voltage program will result in longer life expectancy. Improper management, on the other hand, can be very costly.

For a better understanding of this sensitive aging mechanism, the filament itself must be understood. Most filaments in high-power, gridded tubes are a mixture of tungsten and thoria with a chemical com-

*Fig. 2. Improper cooling means short tube life (left). Discoloration of metal around inner filament stem and anode fins indicates poor cooling or improper operation of tube. Properly cooled and operated tube (right) shows no discoloration after many hours of use. In both cases, good socketing is indicated by scoring on circular connector rings.*

*Fig. 3. Dirty and discolored cooler of amplifier tube at left indicates combination of discoloration due to heating and lack of cleaning. Tube has operated too hot and dust has collected in anode louvers.*

*Fig. 4. Minute scoring in base contact rings indicates that socket finger stock has made good, low-resistance contact to tube elements. Well-maintained socket will score the tube contacts when tube is inserted. If all fingers do not make contact, more current will flow through fewer contact fingers, causing additional overheating and burning, as shown in Fig. 5.*

*Fig. 5. High resistance socket contacts has caused severe burning of contact area in the base. Overheated base caused early demise of tube.*

# Arvin's new Sat-Weather 3 System

The only system that delivers over 1400 pictures per month and provides a unique digital disc editing function for high-speed, multi-image, multi-sequencing replay

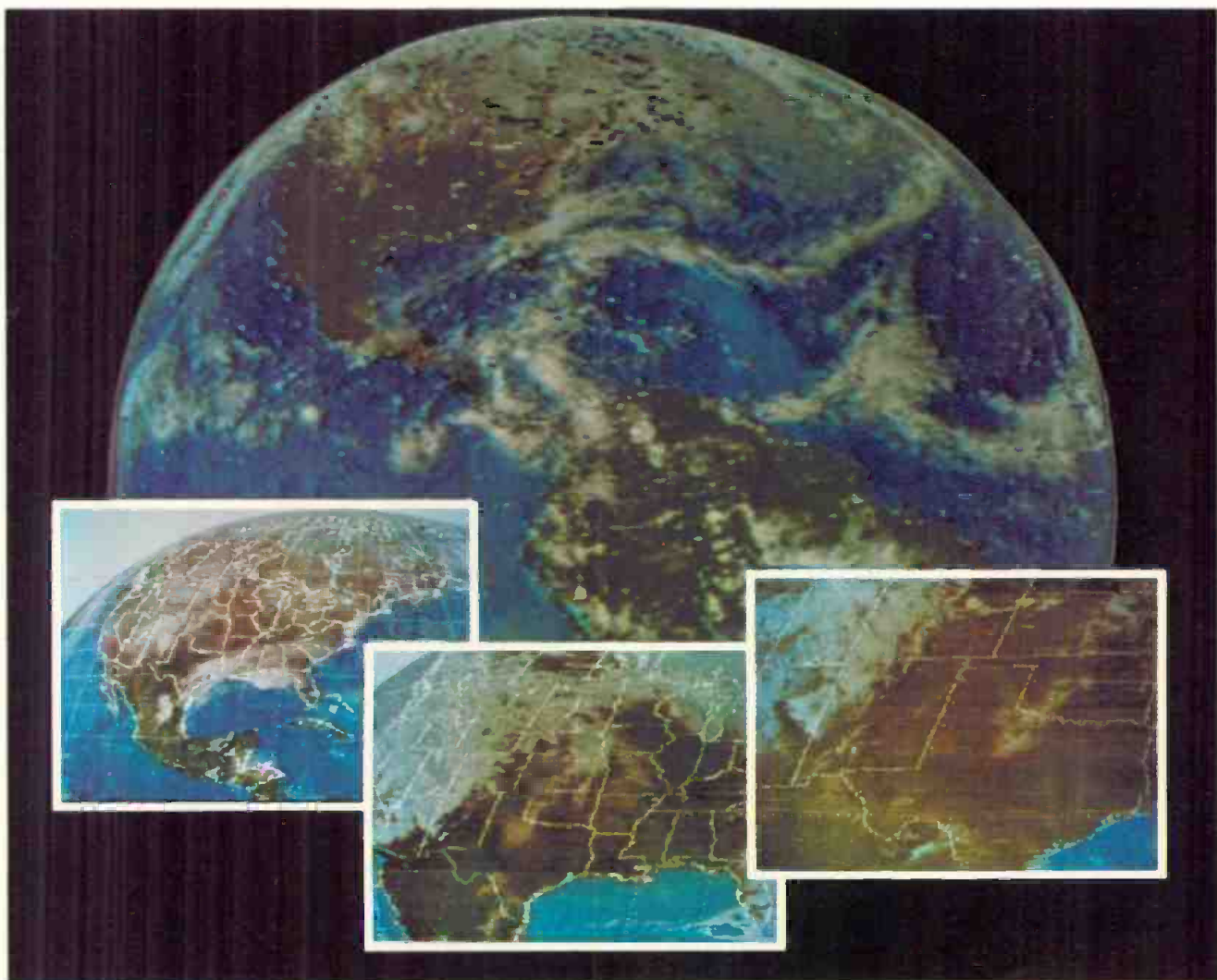

Our new Sat-Weather System provides direct conversion of weather data to color video, including satellite generated infrared signals. It combines this advantage with many other features that give you the potential to provide more colorful, more comprehensive, more creative and exciting weather presentations.

This new, more advanced system can help you to:

- Stimulate greater audience participation.
- Enhance the professionalism of your weather reporting.
- Gain a larger share of audience, or improve a dominant leadership position, in your market.

**ARVIN/DIAMOND®**

P.O. Box 200, Lancaster, Ohio 43130 (614) 756-9222 TELEX 245-344

*Visit our booth No. 2901 at the NAB show for an exciting hands-on demonstration*

Circle 294 on Reader Service Card

## Extending Transmitter Tube Life

position of  $W + ThO_2$ . A filament made of this wire is not a suitable electron emitter for extended life applications until it is processed. Once the filament is formed into the desired shape and mounted, it is heated to approximately  $2100^{\circ}C$  in the presence of a hydrocarbon. The resulting thermochemical reaction forms di-tungsten carbide on the filament's surface. Life is proportional to the degree of carburization. If the filament is overcarburized, however, it will be brittle and easily broken during handling and transporting. Therefore, only approximately 25% of the cross-sectional area of the wire is converted to di-tungsten carbide. Di-tungsten carbide has a higher resistance than tungsten; thus, the reaction can be carefully monitored by observing the reduction in filament current as the carburizing process proceeds.

As the tube is used the filament slowly decarburizes. At some point in life, all of the di-tungsten carbide layer is depleted and the reduction of thoria to free

thorium stops. The filament is now decarburized and is no longer an effective electron emitter.

The key to extending the life of a thoriated tungsten filament emitter is to control operating temperature. Emitter temperature is a function of the total RMS power applied to the filament. Thus, filament voltage control is temperature control. Temperature varies directly with voltage. As the emitter temperature rises the de-carburizing process is accelerated and tube life shortened. Figure 6 shows that useful tube life can vary significantly with only a 5% change in filament voltage. *If the filament voltage cannot be regulated to within  $\pm 3\%$ , the filament should always be operated at the rated nominal voltage.* The danger of operating on the "cold" temperature side is that the emitter may be "poisoned." A cold filament acts as a getter; that is, it attracts contaminants. When a contaminant becomes attached to the surface of the emitter, that area is rendered inactive and loss of emission results. Operation of the filament at slightly below rated nominal voltage, however, can extend tube life if done properly.

### FILAMENT VOLTAGE MANAGEMENT (Figure 6)

Filament voltage management allows extended tube life when accompanied by a continuing housekeeping program. When filament voltage is too high (dashes), power tube loses emission rapidly and normal operating life is not achieved. When filament is operated at rated voltage (black curve) normal tube life is achieved in a majority of cases. With a filament voltage management program (bullets), extended tube life may be achieved. When the minimum required output power level is finally reached (right-hand portion of curve), the filament voltage may be raised to rated value, or above, to achieve additional useful operating life. If filament is run "cool" (stars), extremely short life will result. Note that filament voltage management program does not take effect until about 200 hours of operating time have passed.

If voltage management program is not undertaken, tube should be run at rated filament voltage.

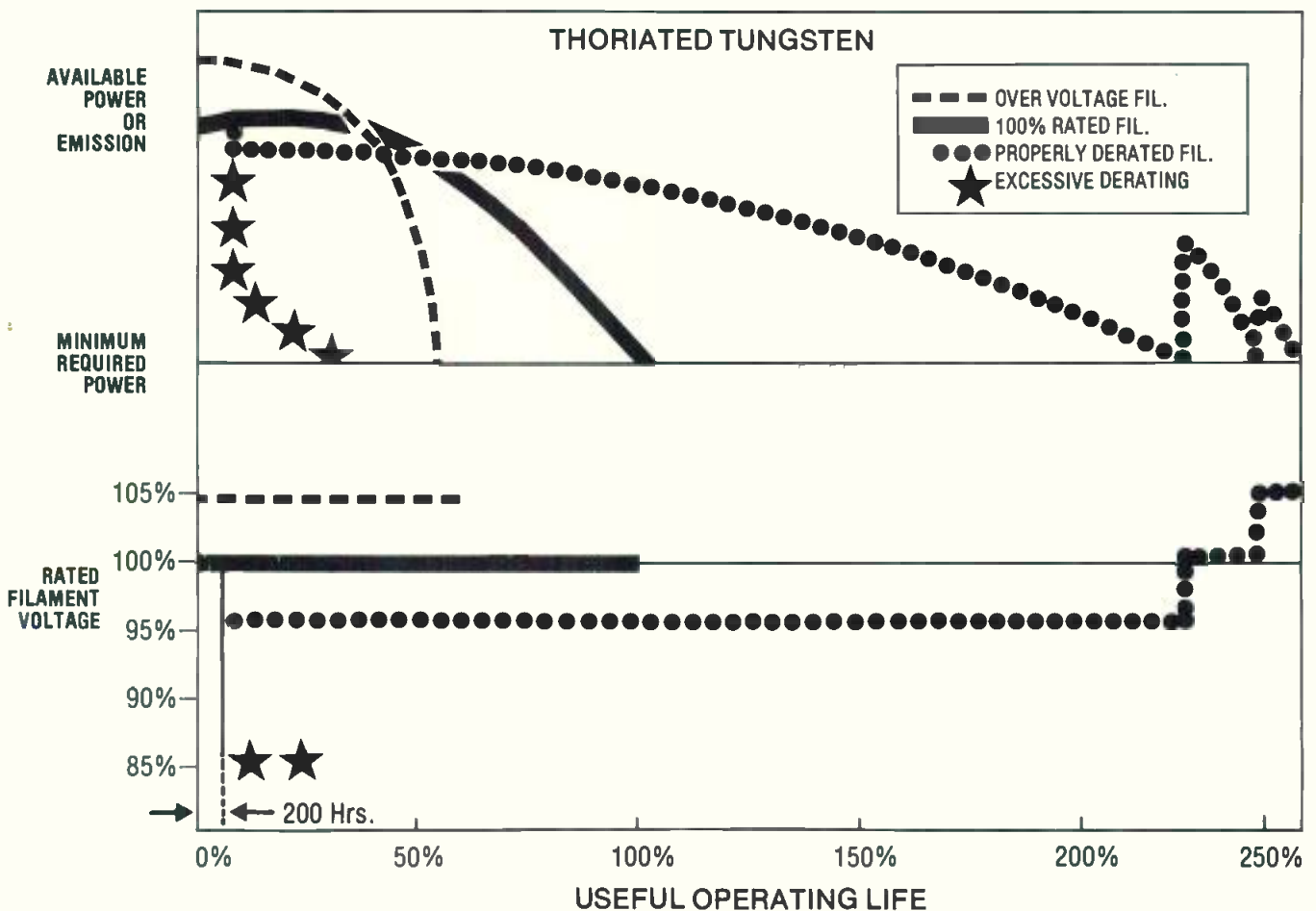



# Two SATICON\* Tubes That Pick Up Exactly What You Pick Out.

Because of their superior performance, Hitachi SATICON pickup tubes have long been used in television broadcasting. But even excellence can be improved. That's why Hitachi researchers are constantly seeking innovations to provide ever clearer and more realistic pictures. Two of Hitachi's latest developments are these:

## SATICON-III

Developed by using Hitachi's own techniques for high precision evaporation and doping that allows only infinitesimal amounts of impurities, this new generation of SATICON tubes provides minimal highlight sticking and low-lag characteristics. Best suited for use in studio cameras.

## New Diode Gun SATICON

This product incorporates the SATICON series' first electron gun, activated by an innovative "five-electrode" diode-operated gun. It will pioneer a new generation in TV cameras by breaking the resolution performance limits posed by conventional camera tubes.

The H9379A SATICON-III and H9386 new Diode Gun SATICON-III will be demonstrated at the 1982 NAB Show. Drop by booth No. 3202 and see what a state-of-the-art picture can be.

\*US Registration No. 1047050

Specifications	H9379A 1-inch SATICON-III	H9386 2/3-inch New Diode Gun SATICON-III
Focusing method	Magnetic	Magnetic
Deflection method	Magnetic	Magnetic
Maximum diameter	28.9 mm	19.8 mm
Overall length	163 mm max.	105 mm max.
Rated heater voltage	6.3 V, 95 mA	6.3 V, 95 mA
Amplitude response (at the center of screen, 400 TV lines)	70%	60%
Limiting resolution (TV lines)	1,200 lines	1,000 lines
Lag (50 msec after, 5 nA equivalent bias light)	1.5%	0.8%
Applications	Studio cameras	ENG and EFP cameras



Head Office: Hitachi, Ltd. Electronic Devices Group, 6-2, Otemachi 2-chome, Chiyoda-ku, Tokyo 100, Japan  
 Tel: Tokyo (03) 270-2111 Cable: HITACHY TOKYO Telex: J22395, J22432, J24491, J26375 (HITACHY)  
 For more information contact: Hitachi America, Ltd. Chicago Office 500 Park Boulevard, Suite 805 Itasca, Illinois 60143 Tel: (312) 773-0700

Circle 295 on Reader Service Card

## Extending Transmitter Tube Life

Of great importance to long tube life is the temperature of the elements and the ceramic-to-metal seals. Element temperature can be held within proper limits by observing the maximum dissipation ratings listed in the data sheet. Seal temperature should be limited to 200°C at the lower anode seal under worst-case conditions. As element temperature rises beyond 200°C, the release of contaminants locked in the materials used in tube manufacturing increases rapidly. These contaminants cause a rapid depletion of the di-tungsten carbide layer of the filament.

When a new power tube is installed in a transmitter, it must be operated at rated nominal filament voltage for the first 200 hours. This procedure is very important for two reasons. First, operation at normal temperature allows the getter to be more effective during the early period of tube life when contaminants are more prevalent. This break-in period conditions the tube for operation at lower filament voltage to obtain longer filament life. Secondly, during the first 200 hours of operation filament emission increases. It is necessary for the life extension program to start at the peak emission point.

A chart recorder or other device should be used to monitor variations in primary line voltage for several days of transmitter operation. The history of line voltage variations during on-air time must be reviewed prior to derating filament voltage. Plan to establish

the derated voltage during the time period of historically low line voltage, as this is the worst-case condition. If line variation is greater than  $\pm 3\%$ , filament voltage must be regulated.

Record output power (FM) or distortion level (AM) with the tube operating at rated nominal filament voltage. Next, reduce filament voltage in increments of 0.1 V and record power or distortion levels at each increment. Allow one minute between each increment for the filament emission to stabilize.

When a noticeable change occurs in output power or the distortion level changes, the derating procedure must stop. Obviously, operation at this point is unwise since there is no margin for a drop in line voltage. It is safer to raise the voltage 0.2 V above the critical voltage at which changes are observed to occur. If this new filament voltage setting is more than 5% below the nominal rated level, filament voltage must be raised to the 95% level. Operation below this point is unpredictable and life expectancy is uncertain. Finally, recheck power output or distortion to see if they are acceptable at the chosen filament voltage level. Recheck again after 24 hours to determine if emission is stable and that the desired performance is maintained. If performance is not repeatable, the derating procedure must be repeated.

### Continuing the program

The filament voltage should be held at the properly derated level as long as minimum power or maximum distortion requirements are met. Filament voltage can

## "The Originators"



Come and join us at the 1982  
**N A B** Convention. It's happening  
at **BOOTH 1701** of the Dallas  
Convention Center, April 4th to the 7th.  
See you there!

**Cezar** International, LTD.

1026 W. Maude Ave., Sunnyvale, CA 94086  
Telephone (408) 733-1436

"The Originators"

Circle No. 296 on Reader Service Card

Research shows . . .

# Increased market shares for stations after switching to Harris CP\* TV antennas

TV stations broadcasting with Harris circularly polarized (CP) transmitting systems have shown steady market share gains, relative to competition, in all parts of the day, according to a recent research study.

Only TV stations that had been on air for at least four successive rating periods with Harris CP systems were analyzed, to compensate for seasonal variations. The average of four Nielsen market shares, in each time slot, for the four successive periods prior to CP were compared to the average of four successive periods after CP. The performance of each CP station was then compared with the performance of its competitors over the same time periods.

The figures speak for themselves—and show a pattern of improved shares after switching to CP *regardless of the time period studied*. The stations' locations ranged from flat to mountainous areas—and again, there was share improvement *regardless of terrain*.

\*Circularly Polarized

Changes in market shares relative to competition, averaged from four successive rating periods prior to installation of Harris CP systems, and four successive periods after installation, for three different markets.

Station/Location	Early News	Prime Time	Late News	9 a.m.—Midnight
Network affiliate, top 40 market	↑ 2.9	↑ 4.5	↑ 6.0	↑ 4.2
Independent, top 20 market	↑ 2.8	↑ 1.3	↑ 2.4	↑ 1.2
Network affiliate, top 50 market	↑ .25	↑ 6.9	↑ 9.6	↑ 2.8

Based on Nielsen VIP® reports 1979-1981, subject to qualifications in said analyses.

When you consider that one market share point is worth about \$100,000 in the 100th ranked market, and over \$3,000,000 in the top ranked market, you can see that Harris CP can be one of the smartest investments you ever made. And you can see why the number of U.S. TV stations broadcasting a CP signal has grown from one to approximately forty-five in just six years.

For more information, contact Harris Corporation, Broadcast Products Division, Quincy, IL 62305-4290. 217-222-8200.



## HARRIS

Visit the Harris TV and Radio Equipment Display at the 1982 NAB, Dallas.

Circle 297 on Reader Service Card



## Extending Transmitter Tube Life

be raised to reestablish minimum requirements as necessary. This procedure will yield results similar to those shown in the illustration, to achieve as much as 10% to 15% additional life extension. When it becomes necessary to increase filament voltage, it is a good time to order a new tube. Filament voltage can be increased as long as the increase results in maintaining minimum level requirements.

When an increase fails to result in meeting a level requirement, filament emission must be considered inadequate and the tube should be replaced. Don't discard it or sell it for scrap! Put it on the shelf and

save it. It will serve as a good emergency spare and may come in very handy some day. Also, in AM transmitters, a low-emission RF amplifier tube can be shifted to modulator use where the peak filament emission requirement is not as severe.

Start planning for longer tube life now! Review the following steps you can take:

- Investigate the manufacturer's ratings on the power tubes in your present equipment, or the transmitter you plan to buy.
- Check that your transmitter has sufficient headroom. Is there a margin of safety in tube operation?
- Look for important instrumentation in the next transmitter you buy. Are all tube elements monitored for voltage and current in the transmitter?
- Whether your transmitter is new or old, start a filament life extension program.

Remember that each time you replace a power tube, the recommended derating procedure must be rerun. Voltage levels required with one tube do not apply to a replacement tube.

When purchasing a tube, insist on a new tube that carries the full, original manufacturer's warranty. Only tubes manufactured by the company of origin have to perform to published data. This is the important reason that transmitter manufacturers buy new, warranted tubes from the original manufacturer.

BM/E

### Bibliography

1. Ayer, R.B., "Use of Thoriated-Tungsten Filaments in High Power Transmitting Tubes," *Proceedings of the I.R.E.*, page 591, May, 1952.
2. Kohl, Walter H., *Materials and Techniques for Electron Tubes*, Reinhold Publishing Corp., N.Y., 1960.
3. Horsting, C.W., "Carbide Structures in Carburized Thoriated-Tungsten Filaments," *Journal of Applied Physics*, Volume 18, Jan., 1947.
4. Langmuir, I., "The Electron Emission from Thoriated Tungsten Filaments," *Physical Review*, 1923, Page 357.
5. Walker, H.S., "High Power Transmitting Valves With Thoriated Filaments for Use in Broadcasting," The Institution of Electrical Engineers, Paper No. 3200E, March, 1960.

Thanks to William Barkley, William Orr, William Sain, and Bob Torno, all of Varian EIMAC, for their help and suggestions in preparing this paper.

### LOWEST PER CARTRIDGE COST\* THE LATEST MICROPROCESSOR TECHNOLOGY

## WHY WOULD YOU BUY ANYTHING BUT IGM GO-CART

In 24, 42 or 78-cartridge\* capacity

Use 2 or more Go-Carts for back to back play of all programming, including music

OR

Add one to your existing system to handle all the commercials, ID's, and public affairs, leaving the music on reels or disks. Easily interfaced to most automation systems, ours or "theirs".

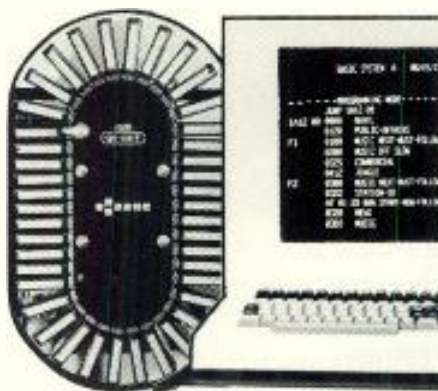

**FAST!** Worst access time is 8 seconds.

**HUMAN ENGINEERED.** Whole unit swings open for maintenance, even while on air.

## IGM COMMUNICATIONS

4041 HOME ROAD, BELLINGHAM, WA 98226 [206] 733-4567

Circle No. 298 on Reader Service Card

**PORTA-BRACE™**  
**VIDEO CASES** carried with shoulder strap & waist belt.

**CALL FOR CATALOG OF CARTS, CASES, & BACKPACKS**

 K and H Products, Ltd.  
Box 246, North Bennington  
Vermont 05257 802-442-9118

Circle 344 on Reader Service Card

# A RANGE OF COMPACT SWITCHERS

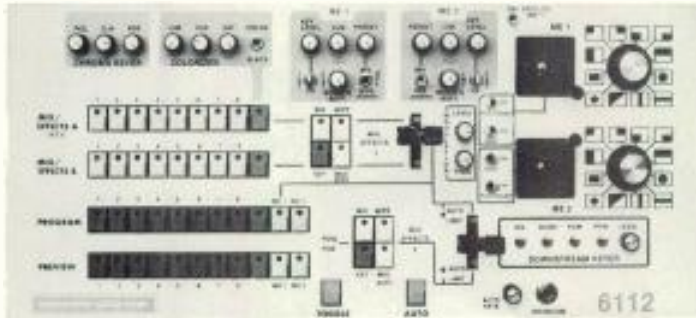

**6112**  
The only switcher in its class to offer two fully independent MIX EFFECTS systems, with each M/E having its own pattern generator and positioner. This nine input, four bus unit includes the following standard features: downstream keyer, pattern modulator, spot-lite, colorizer, toggle or "take preview", automatic or manual mix and wipe operations, variable soft wipes, adjustable borders, internal or external keying on each M/E, intercom, loop-thru video inputs, preset of mix or wipes, black burst output, and a blanking processor. There is also a plug-in optional chroma keyer available. All inputs accept synchronous, non-synchronous, composite, non-composite, monochrome or color signals and go thru dual back porch clamping.  
**Price \$7,950.00 PAL \$8,950.00**

<b>Options</b>	
Encoded chroma keyer (plug-in board)	<b>\$1,050.00</b>
RGB chroma keyer (plug in board)	<b>\$1,050.00</b>
Slimline control panel (4 inches)	<b>\$250.00</b>

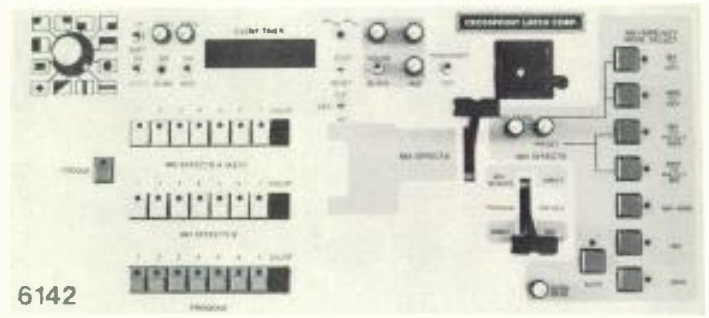

**6142**  
The 6142 is a three bus, eight input completely self-contained switcher. This unit features dual fader handles which permits the operator to dissolve to an effect. The mix effects system features double re-entry along with 12 patterns, variable soft, 24 hour event timer, internal or external keying, pattern modulator, blink key, colorizer, toggle, spot lite, positioner, mix or wipe to key, preset of mix and wipes, blanking processor, loop thru video inputs, dual back porch clamps and black burst output.  
**Price: \$5,245.00**

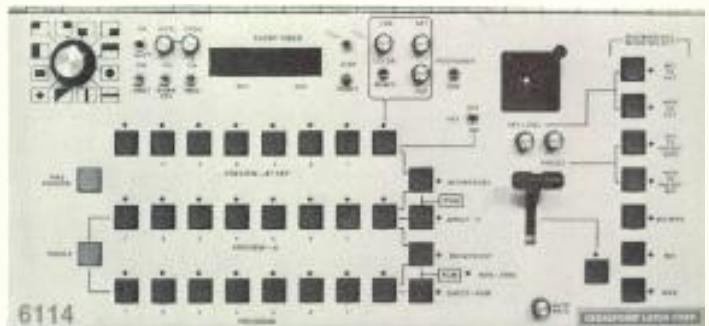

**6114**  
The 6114 is a broadcast quality, eight input, three bus video switcher. It features 12 patterns, positioner, event timer, pattern modulator, soft wipe, spot lite, blink key, toggle, take preview, automatic or manual mix and wipe blanking processor, non-sync lamp, loop through video inputs and a blackburst output.  
**Price: \$4,680 PAL \$5,680**



**6118**  
The 6118 is a three bus, six input production switcher. This self-contained unit genlocks to input #1, then distributes all six drive outputs as well as black burst, so an external sync generator is not needed. The unit also features 12 patterns, soft wipes, colorizer, positioner, key super, input clamps, blanking processor, intercom, and loop thru video inputs. The optional automatic camera lock module operates with the Sony 1610 and 1640 color camera with direct plug compatibility and no need for a CMA-6. The JVC G71US also operates with the automatic camera lock module with no internal camera modification needed, just a special cable. With the automatic camera lock module camera timing is automatic regardless of the differences in camera cable length.

**Price \$2,995.00**  
**Automatic Camera Lock Module \$850.00**

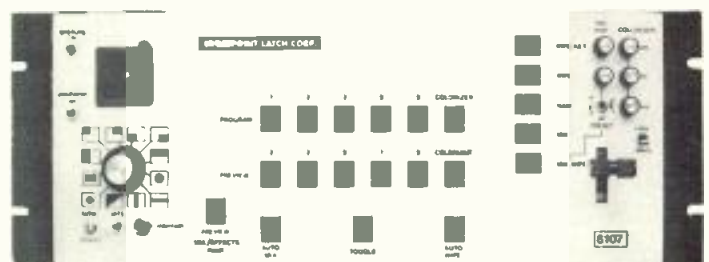

**6107**  
The 6107 is a broadcast quality switcher. Though there are only 2 buses it is possible to preview and/or preset a mix or effect without disturbing the program output. The special mix-wipe function provides a combination mix and wipe (for instance, a dissolve within a circle pattern), which normally requires at least three buses. It also features 12 patterns, soft wipes, built-in intercom amplifiers, and colorizer, toggle and blackburst output.  
**Price: \$3,800. PAL \$4,800.**

**CROSSPOINT LATCH CORP.**

95 Progress Street • Union, N.J. 07083 • Tel. (201) 688-1510 • Telex: 181160

Circle 299 on Reader Service Card  
www.americanradiohistory.com

# Everything you want in an audio console:

**4 Models**—8 and 10 mixer dual stereo with rotary or linear faders • **Transformer Balanced Inputs and Outputs** • **3 Inputs Per Mixer**—internal pads allows mic/line selection on the same mixer • **Two 4-Input Auxiliary Input Selectors**—may be assigned to any mixer • **Pre-fader Pushbutton Cue**—in addition to normal CCW fader cue position • **LED Status Indicators**—color coded to aid in instant identification of function selectors • **Momentary or Continuous Remote Control Contacts**—internally selectable, also controls optional digital timer reset/start • **Full Metering Capability**—two meters standard, up to four meters and/or digital clocks and timers optionally available, all meters provided with LED peak indicators • **Gain Selectable Microphone Preamps**—provided with center tap access for phantom condenser microphone power, processor input/output port with buffer amplifier for outboard compressors, limiters, etc. • **Programmable Muting Logic**—internal pin-programmed matrix allows any selection of monitor and cue muting for the first five mixer positions • **Pushbutton Aural Phase Test** • **Announcer's Microphone Intercom-Air Selector** • **Full Dual Channel Operation**—independent program and audition assignment pushbuttons • **Five Monitor Driver Outputs**—four muted, one non-muted • **All Mixers Switch Selectable to Mono or Stereo** • **Ground-Plane Techniques Used Throughout for Increased RF Immunity** • **Selectable Internal or External Master Level Controls** • **Accessories and Options**—mono mixdown, high impedance (cassette) line input plug-ins, reference oscillator/line input plug-in, additional microphone input plug-ins, digital clock, digital timer, linear faders.

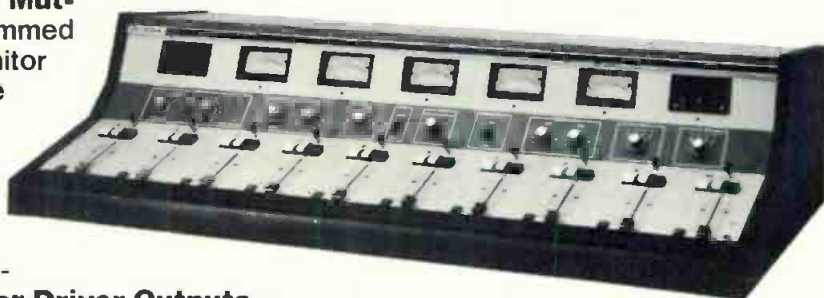

See us at Booth 3114 NAB, Dallas

**LPB**<sup>®</sup> **citation** series

LPB Inc. • 28 Bacton Hill Road • Frazer, PA 19355 • (215) 644-1123  
Manufacturers and Distributors of Broadcast Equipment since 1960

© 1981 LPB Inc.

Circle 300 on Reader Service Card

## LPTV '82: Getting the Lowdown on Low-Power

The 1200 attendees who converged on the Washington Sheraton Hotel January 28-30 for LPTV '82 came away with mixed feelings of hope and concern for the future.

In her opening keynote address Thursday, FCC commissioner Anne Jones delivered a sobering timetable to hopeful LPTV operators. The current freeze on LPTV applications—imposed after the FCC had been inundated with over 6000—will probably not be lifted before 1985 or 1986, Jones predicted. She outlined the rather tedious regulatory process still facing the rulemaking, saying that delays caused by petitions to reconsider the LPTV order could cause “considerable” delay and hold up regular processing of applications until “late this year at the earliest.”

The budget outlook for LPTV has brightened somewhat, Jones said,



Addressing attendees in the exhibit hall, FCC commissioner Anne Jones warned of lengthy processing ahead.

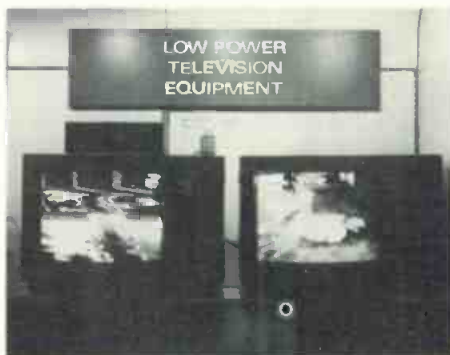

Blonder-Tongue was one of several companies exhibiting equipment for STV, an attractive option for many LPTV operators.

with the recent allocation of over half a million dollars especially for the service by the Office of Management and Budget. This money will go toward a minicomputer for processing applications and an “LPTV task force” of 15 persons. Still, the general budget squeeze at the FCC “has already caused delays in low power,” Jones noted.

On the sunny side, Jones told the audience that the Broadcast Bureau had started processing to final grant some LPTV applications that had passed the cutoff process, and was also processing those translator applications exempted under the freeze. At press time, seven LPTV applications had been granted as part of a larger batch of translator applications. “The low power proceeding is moving,” she emphasized.

Several problems remain for LPTV, Jones commented, including “the vagaries of the budget process,” the extent of coverage protection for existing full-power stations (some are requesting protection beyond their Grade B contours), and ownership regulations. Ownership

### HYDRAULIC ENG MASTS

SMOOTH • SAFE • SURE

6 to 60 FT.

- ▣ STOPS AND STAYS AT ANY LEVEL • WITH PUMP OFF.
- ▣ 150 to 350 LB. LIFT WITH SINGLE MAST.
- ▣ INSIDE OR OUTSIDE MOUNTS SMALL OR LARGE VANS.
- ▣ MICRO ADJUSTABLE • TO THE FRACTION OF AN INCH.
  
- ▣ CONTINUOUS ROTABILITY
- ▣ 1, 2 or 3 SPEED PUMPS.
- ▣ 12, 24 vdc / 120 vac
- ▣ CLEAN AND DRY
- ▣ NO MAINTENANCE.
  
- ▣ NO SUDDEN STARTS OR SLAMMING STOPS.
- ▣ ALL ALUMINUM
- ▣ REMOTE CONTROLLABLE TRAILER MODELS FOR STAKE OUT.
- ▣ CUSTOM DESIGN WELCOME

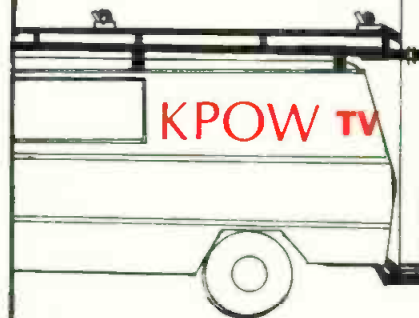

**N .PRO**  
▣ CALL OR WRITE.

1022 Hazelwood Dr.  
or P.O. BOX 604  
OREGON CITY, OR. 97045

(503) 656-5500  
657-5800

## NEWS FEATURE

limits are unnecessary, Jones said, citing "at least a general sentiment" on the FCC that "all ownership limits, both existing and proposed, should be reexamined." She might support "a possible *temporary* limitation to allow initial processing for as many different owners as possible," however. Jones also came out against any LPTV ownership limitations on current broadcasters. She said she supports the proposed pref-

erence for minority applicants, but would like to see preferences dropped for nonprofit applicants and first-received applications.

### Ferris blasts cuts

Friday's keynote speaker was Charles D. Ferris, immediate past chairman of the FCC, who many have dubbed "the father of low-power television." Ferris was quick to disclaim total responsibility for creation of the service, saying, "My role and the role of the FCC is insignificant when compared to the role to be played by thousands of you in the video marketplace . . . You and



Sony's compact, low-cost production console got plenty of attention at the show, according to a company spokesperson.

thousands like you are responsible" for the growth of LPTV.

Ferris praised the Commission and its staff for acting "with confidence and commitment" on LPTV in the face of "grave challenges." He reserved his barbs for Administration budget-trimming, charging, "Indiscriminate budget-cutting does not make sense—is, in fact fiscal nonsense." Drawing a parallel between funding for the FCC and funding for food stamps and school lunches, Ferris remarked, "The FCC is about as overstuffed as the poor and the schoolchildren of this country are overfed."

Severe cuts in the FCC's budget are "an invitation to administrative disaster," Ferris warned. The FCC's role, he said, should be to encourage the movement of broadcasting into the marketplace, not retard it because it lacks the funds to do its job. He urged potential LPTV broadcasters to "make your voices heard in Congress," where budget decisions are made.

Turning to unregulation, Ferris reiterated his support for removing unnecessary regulations, but insisted that the first step must be to remove the *reasons* for regulation. The marketplace must be fully competitive before deregulation can be complete, he declared. One way to achieve this, he said, is to encourage new video technologies. The government's apparent "refusal to invest in the future of this sector of the economy" should not deprive citizens of the benefits of the new technologies.

### Crystal-ball gazing

The scenario for LPTV's future was a popular topic at the convention, with several other speakers addressing it. Molly Pauker, the FCC lawyer who has been placed in charge of the LPTV proceeding, also spoke of a tedious process to get LPTV on the air. She suggested that competing applicants try to resolve their conflicts without waiting for the FCC to do it for them. Agreeing with her were Richard M. Neustadt, David Hilliard, and other communi-

## Advanced RF Technology...

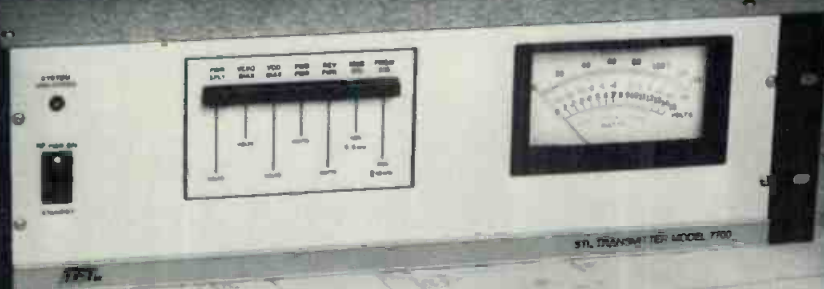

# THE INNOVATIVE APPROACH

That has helped make TFT a performance leader in Studio-Transmitter-Links.

The full-fidelity performance of today's Hi-Fi receivers has put new requirements on broadcast equipment — particularly in the area of STL. TFT has again proven equal to the task.

TFT's innovations include:

- IF modulated transmitter improves S/N
- Pulse counting discriminator in receivers reduces audio distortion
- Automatic switch over on redundant hot stand-by systems maximize on-air time
- Frequency synthesized transmitters improve frequency stability
- Phase linear filters improve stereo performance
- Extended audio headroom provides wider dynamic range

They all add up to better engineering for better performance. Call or write us today for full specifications or an STL applications guide. TFT now has regional service facilities to better serve our customers' needs.



3090 OAKMEAD VILLAGE DR.  
SANTA CLARA, CA 95051  
(408) 727-7272 TWX 910-338-0584

Circle No. 302 on Reader Service Card



# LISTEC TELEVISION EQUIPMENT CORP.

- VINTEN CAMERA MOUNTING
- DIGIVISION MONITOR PROMPTING
- REMOTE AUDIO MIXING CONSOLE

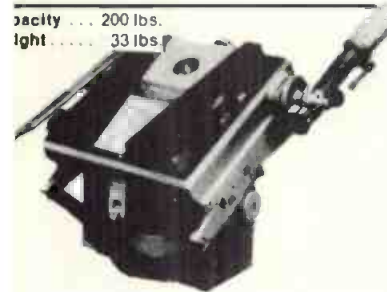

Capacity ... 200 lbs.  
Weight ... 33 lbs.

084 Mark VII L.F. Cam Head shown with optional 3084/14 Female Wedge Adaptor

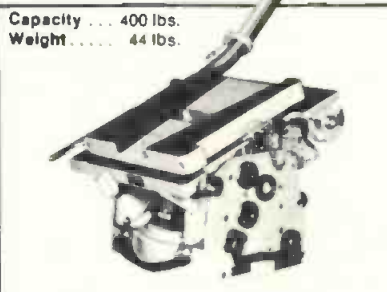

Capacity ... 400 lbs.  
Weight ... 44 lbs.

717 Mark IIIA Cam Head with 506/6A optional Female Wedge Adaptor Assembly

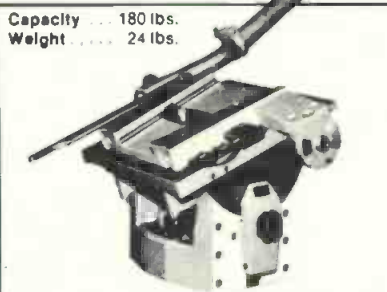

Capacity ... 180 lbs.  
Weight ... 24 lbs.

716 Mark V Cam Head with 716/13 optional Female Wedge Adaptor Assembly

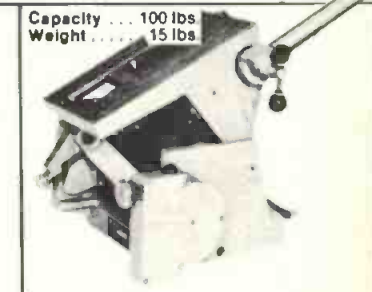

Capacity ... 100 lbs.  
Weight ... 15 lbs.

76 Petrel Mark II L.F. Pan and Tilt Head



Capacity ... 50 lbs.  
Weight ... 20 lbs.

78/3C Post Pan and Tilt Head shown with bracket and Quick Release Wedge Adaptor

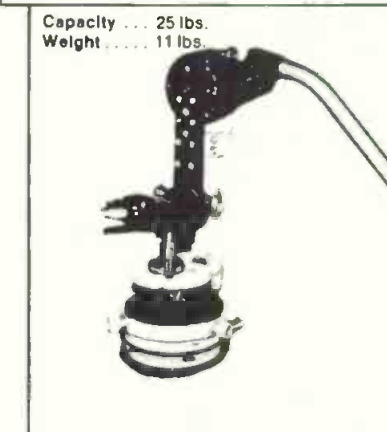

Capacity ... 25 lbs.  
Weight ... 11 lbs.

3089 Cygnet L.F. Mini-Post shown with optional Female Wedge Adaptor Assembly



## MONITOR PROMPTING

DIGIVISION MONITOR PROMPTING SYSTEM offers lightweight, through the lens prompting with high readability and easy mounting to all Vinten heads and simple adaptation to other heads. System is also available with dramatic enhancement keyer with reverse polarity.

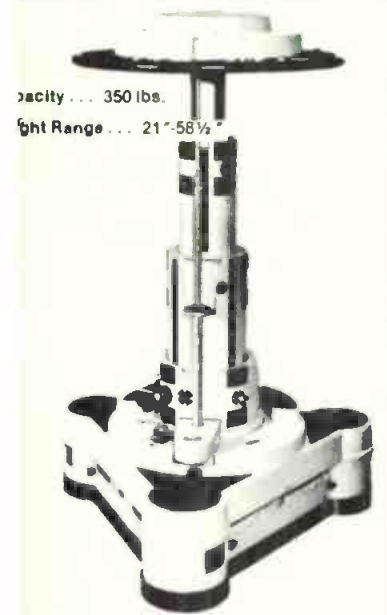

Capacity ... 350 lbs.  
Height Range ... 21"-58 1/2"

2 FULMAR EXTENDED RANGE PNEUMATIC PEDESTAL supplied with single combined lifting steering ring, pedal-operated change over from crab to tricycle steering, adjustable cable guards, dual wheels, 15lb. total trim weights, pressure gauge and wheel cuts for visual inspection

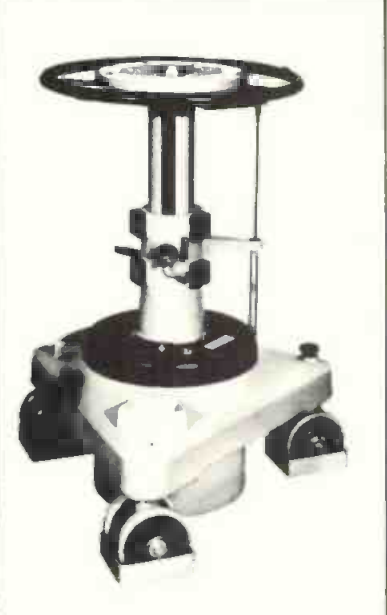

741 TERN PNEUMATIC PEDESTAL supplied with single lifting steering ring, pedal-operated change over from crab to tricycle steering, adjustable cable guards, 7" dual duthane wheels. 20lb. total trim weights.

Capacity ... 290 lbs. Height Range ... 33"-54"



3068 THE PLOVER THREE STAGE TRANSPORTABLE PEDESTAL allows wide range elevation with a "break down" into two parts for easy transport. 50-200 lbs. can be counterbalanced without changing gas pressure with Vinten's multi-ram system.



Capacity ... 110 lbs.  
Height Range To Pan Head Mounting  
Low Level (Legs Horizontal) ... 27"-45"  
High Level (Legs In Tripod Mode) ... 37"-55"

56 PortaPed PORTABLE PNEUMATIC PEDESTAL supplied complete with Pro Jr. Top, "THREE WAY" Adjustable legs for both height and direction, lifting ring, carrying handle, column lock and adjustable drag controls. Options include simple Type 71 PortaSkid castoring Dolly or Type 64 TriTrack Crabbing Base.

WE STOCK AND SERVICE A COMPLETE INVENTORY OF EQUIPMENT OFFERING PROMPT, ACCURATE DELIVERY.



## LISTEC TELEVISION EQUIPMENT CORP.

39 CAIN DRIVE / PLAINVIEW, NEW YORK 11803 / (516) 694-8963 / Telex: 640470

1619 COSMIC WAY / GLENDALE, CALIFORNIA 91201 / (213) 247-9247 / Telex: 182686

★ SEE US AT NAB BOOTH # 3325 ★

Circle 303 on Reader Service Card

## NEWS FEATURE

cations lawyers at a session entitled, "The Crystal Ball: What Will the FCC Do and When?" They pointed out the dangers of lengthy, costly comparative hearings for the low-budget LPTV applicant.

Other sessions ran the gamut of concerns for the infant industry. They included several sessions on hardware (Thomson-CSF introduced its LGT transmitters; Gardiner Communications and Microdyne ran down satellite gear;

Shure explained mics and mixers, and Microwave Associates discussed antennas and transmitters). One session, led by producer Skip Winitsky, Ron Suttle of JVC, and Vince Walisko of the American University, discussed what will be involved in setting up a low-power television studio.

### Filling the air

Programming was another big concern, and several sessions were devoted to looking at the programming possibilities for LPTV. Robert C. Fransen, vice president of



Thomson-CSF brought the only LPTV transmitter actually on display. The LGT EUHF-1000S all solid state 1 kW UHF model, FCC-type-accepted, was described by a spokesperson as "the Rolls-Royce of low-power transmitters."

## HARRIS HAS THE RF NETWORK YOU NEED!

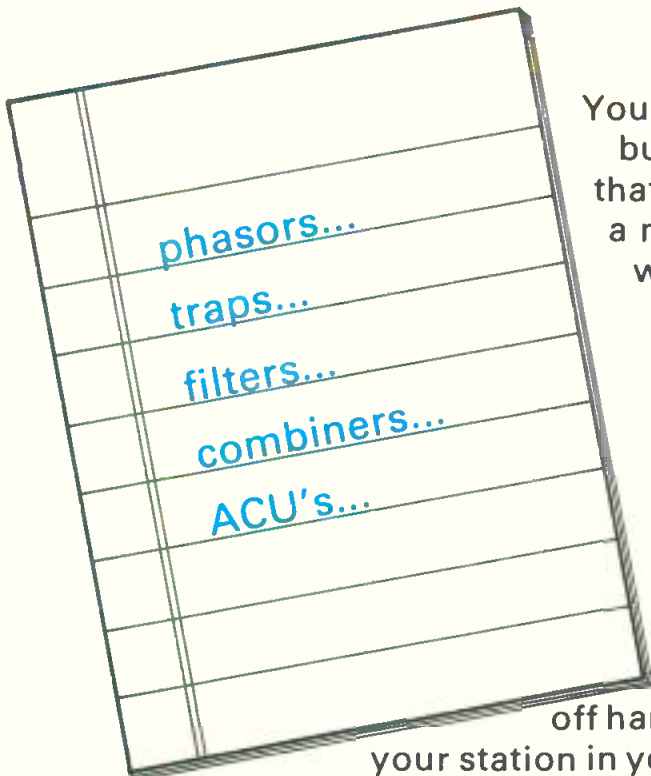

You can afford to buy the quality that comes from a manufacturer with nearly 60 years of broadcast experience. Harris' design capability and experience is an investment that will pay off handsomely for your station in years to come.

Harris can supply any type of RF network needed by AM broadcasters. First we analyze your special needs. Then we design and build the equipment for peak performance and reliability at a competitive price.

For more information, contact **Harris Corporation, Broadcast Products Division, P.O. Box 4290, Quincy, Illinois 62305-4290. 217-222-8200.**

Visit the Harris TV and radio equipment display at the 1982 NAB, Dallas.



# HARRIS

Circle No. 304 on Reader Service Card

the U.S. Satellite Broadcasting Co., the Hubbard Broadcasting subsidiary that is a current DBS applicant, conducted a seminar on USSB's plans for satellite programming for LPTV stations. Hubbard's experience in local broadcasting makes it a natural for DBS service, Fransen claimed, calling his company "the only grassroots broadcaster that has applied for a DBS license." USSB's program, he said, involves bringing local broadcasters in on the production and innovations for the planned 24 hours of entertainment, sports, news, public affairs, and educational programming. Other programming-related sessions discussed teletext, STV, free programming opportunities (hosted by Modern Talking Picture Service), "Cheap TV News," and "Programming for Peanuts."

The last three topics shed some light on an important question for LPTV applicants: how much will it cost? Small stations will tend to have small budgets, and financial considerations of various kinds were discussed at the sessions.

### Bemidji: high-power low-power

A special Friday-evening session featured John Boler, operator of the only commercial LPTV station presently on the air. His Ch. 26, in Bemidji, MN, is far from a typical low-power outlet, Boler is quick to point out. He employs 18 full-time staffers and six part-timers, several of whom are involved in a busy commercial-production operation for local ad-

# MARCONI HAS BROADCAST TRANSMISSION TEST UNDER CONTROL

**QUICKLY IDENTIFY VIDEO DISTORTIONS**  
in your transmitter, studio or tape production facility!



MARCONI 2914A INSERTION SIGNAL ANALYZER

SEE US AT  
NAB  
BOOTH 3320



**TRACE AUDIO TRANSMISSION FAULTS**  
end to end, in seconds!

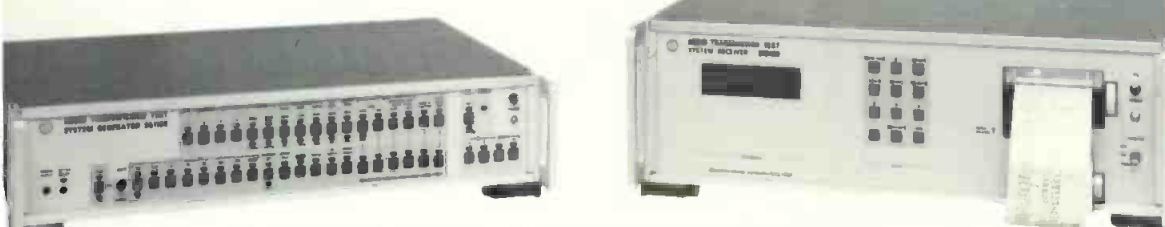

AWA S1100 AUDIO TRANSMISSION TEST SYSTEM



**CATCH EXCESSIVE H & V BLANKING**  
before transmission!

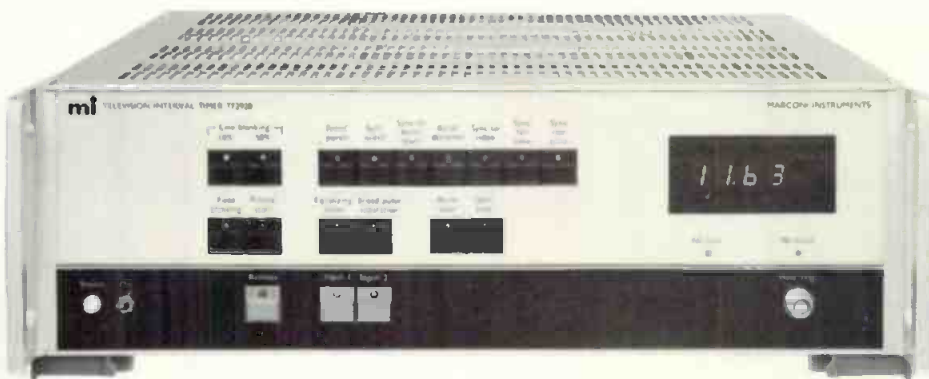

MARCONI 2920 TELEVISION INTERVAL TIMER



**marconi**  
instruments

100 STONEHURST COURT, NORTHVALE, NEW JERSEY 07647 • (201) 767-7250  
P.O. BOX 16577, IRVINE, CALIFORNIA 92713 • (714) 857-2326

Circle 305 on Reader Service Card



## NEWS FEATURE

vertisers. "Once you decide to go commercial, your costs skyrocket," Boler cautioned. He spent over \$640,000 to set up his station, far more than many LPTV operators have envisioned. Because of its location in a relatively remote but well-peopled resort area, however, the station has a potential audience larger than many LPTV stations could hope to reach. Boler says that his 1 kW EMCEE transmitter and

Bogner high-gain antenna, located at a high altitude, enable the station's coverage to extend 45-50 miles.

Boler's main sources of income are advertising and the STV operation he runs in the evenings, with programming provided by SelecTV. His accountant, he said, is projecting a slim profit for this year, with a net income expected to be around \$447,000. Ads are selling well: the 5:30-6:00 p.m. newscast is entirely sold ("We sold it too cheap") and local college hockey games are going for \$2000 (the first one was sold for \$1000, "but we learned our lesson

from that"). One of Boler's larger investments was for a mobile van to pick up the hockey games and local high school basketball games, which are aired live. The local CATV operator carries the channel ("he came to us," Boler commented), and Boler has arranged to sell STV to cable subscribers.

### Exhibitors meet LPTV

With attendees in a cautious mood, traffic was light on the exhibit floor. Most manufacturers had come to the show not to sell, but rather to greet and educate their prospective customers, many of whom had little knowledge of broadcast equipment. Exhibitors tended to bring their lower-end equipment, appealing to the budget-conscious crowd, and most of what they showed was already familiar to broadcasters.

A good sampling of production gear was on hand, designed to show would-be LPTVs that quality production can be affordable. Sony, a last-minute entry, displayed a variety of field and studio production equipment, including a studio/field production package with an SEG-2000, two CCU-1800s, a VO-5850 U-Matic recorder, and two DXC-1800 single-tube cameras. The whole package, including the cameras, goes for less than \$30,000. The BVP-250 three-tube camera and RM-440 editing controller were also on view.

U.S. JVC devoted a large booth to its recent three-tube Saticon cameras, the KY-1900U and KY-2700U. JVC also brought a 3/4-inch editing system and player with remote control, its professional VHS cassette recorders, and a general-purpose monitor.

Panasonic, the only other camera manufacturer at LPTV '82, brought two ENG/EFP models, the AK-710 and AK-760. The company also featured its broadcast 3/4-inch editing system, consisting of the AU-700 editing recorder, AU-A70 programmable editing controller, and AU-J10 multiple source adaptor. Backing up the camera makers was Amperex, with its line of Plumbicon pickup tubes.

A sprinkling of character generators was present, with System Concepts featuring its low-cost (\$2995 plus options) Microgen system. This broadcast-quality system has an internal memory of 192 rows and full editing features. The company also showed its Electronic Video Press display system, aimed mainly at cable TV users. Other character generators were shown by Portac (with the KBD-2) and Texscan.

High-powered art/graphics systems will be beyond the reach of

## When accuracy Counts...Count on Belar for AM/FM/TV MONITORS



**BELAR**  
AM MODULATION MONITOR

**BELAR** CALL ARNO MEYER (215) 687-5550  
**ELECTRONICS LABORATORY, INC.**

LANCASTER AVENUE AT DORSET, DEVON, PA. 19333 • BOX 826 • (215) 687-5550

Circle No. 353 on Reader Service Card

A revolution in portable power—  
this new PEP sealed lead-acid battery  
drives

# TWO ON ONE



PEP SLA 14100 (14w/10ah) belt with RCA TK-76 and 100 w sun-gun. Running time: 45 min., camera and light; 2 1/2 to 3 hours, camera only. Model SLA 12100 (12w/10ah) available for 12 volt systems.

No other system can offer this unique ability: a video camera and sun-gun run by one portable battery unit. Think of the advantages. Eliminate the need for two battery units, reducing the news cameraman's weight load, increasing maneuverability in news conference and other low light situations.

Plus all the other advantages of the sealed lead-acid battery—no "memory effect," excellent voltage regulation even in extreme temperatures, low self-discharge, increased reliability with fewer cells for power supply. And all the practical PEP extras—built-in meter, a charger that won't overcharge, crack resistant naughahyde belts with convenient velcro closure and more.

Send us the make and model number(s) of your equipment for a free two week trial of this revolutionary new portable power source.

**PEP sealed lead-acid batteries—  
"The Problem Solvers."** Battery packs and belts for all film and video cameras and 30 volt lights.

# PEP

PORTABLE ENERGY PRODUCTS, INC.

1875 South Pearl Street  
Denver, Colorado  
303-778-8618

Circle No. 306 on Reader Service Card



## Master Control Automation™ takes the "excitement" out of Broadcasting. But it adds reliability.

From the people who brought you BIAS™ now comes Master Control Automation. It insures an accurate flow of event activity while simultaneously listing reports, reconciling aired spots, and preparing the log for subsequent billing.

And it's all possible through the most sophisticated software system on the market for on-air switching. Master Control Automation will control any on-air switcher regardless of manufacturer. It receives the program log and manages switching activity without

operator intervention. You monitor the entire process at one or more control terminals with a minimum of effort. And you know it's working right.

Master Control Automation™ is a part of the total system umbrella . . . . Network Control System™ Complete broadcast automation with BIAS™, BUY LINE™ (Avail Submission and Electronic Mail), Feature Film™ (Inventory and Amortization), and Financial Accounting Packages. Available together or separately. Call us today for a demonstration at (901) 345-3544.

The simplest, most efficient way to run a television station.

**dhc**™  
 BROADCAST DIVISION  
 DATA COMMUNICATIONS CORPORATION  
 3000 DIRECTORS ROW  
 MEMPHIS, TENNESSEE 38131

Circle 307 on Reader Service Card

SEE US AT NAB, BOOTH #3318.

# NEWS FEATURE

most LPTVers, but Terry Kelly, president of Colorgraphics Weather Systems, says he expects his system, which combines radar, satellite, and surface weather data with high-resolution graphics, to be an LPTV natural. Kelly told *BM/E* that he had already been approached by several prospective LPTV operators who said they intended to program nothing but weather information. A full system is \$36,000, but smaller models start at \$16,000.

## Look on the light side

Lighting equipment makers included Colortran, which displayed a lighting production kit especially for the LPTV market, and Kliegl, which brought an array of its well-known lighting gear and dimming systems. Theatre Service & Supply and Vox-Cam Assoc./R&R Lighting also featured lighting equipment.

Audio equipment made itself heard at the show also, with Audiotronics bringing its 200 Series on-air broadcast mixing console (available with up to 24 channels) and Datatronix showing its API broadcast and recording consoles. Electro-



The modules that make up this API console from Datatronix can be fitted into a standard 19-inch rack in a variety of configurations suited to LPTV operations.

Voice and Shure had their lines of microphones. E-V's CO94 miniature electret condenser mic was one of the newer models on view, and Shure demonstrated a variety of broadcast models.

For production-minded LPTV operators, ISI brought its 900 Series switchers, including the 902 video production switcher and 931 master control switcher. The company also showed its top-of-the-line 200 series. Di-Tech displayed its line of routing switchers and controllers.

## Test gear

Test equipment is essential for any television operation, and test equipment makers were on hand to show their wares. Rohde & Schwarz Sales Co. brought a variety of items, including the SPF 2 digital video test signal generator and the EKF2/D precision TV demodulator, plus a series of Barco monitors and demodulators. Philips Test & Measuring Instruments highlighted its comprehensive PM3263X system, and also showed waveform monitors, vectorscopes, modulators, demodulators, color pattern generators, and signal generators.

Asaca had information on its line of TV signal generators, pattern generators, and sync generators, and Lenco showed its terminal distribution equipment, sync generators, test pulse generators, and monitors. Also bringing test equipment was Wavetek Indiana.

Station Business Systems brought its complete broadcast computer systems, which include business functions and newsroom functions. The systems vary widely in complexity and price, and at first glance seem a bit sophisticated for low-power operations; a company spokesperson pointed out, however, that multiple LPTV operators might find such a system right up their alleys.

For LPTV stations considering teletext programming, British Videotex and Teletext displayed teletext editorial and transmission systems.

Big monitors up here, little meters down there . . . with the production personnel's visual preoccupation, is it any wonder audio quality suffers?

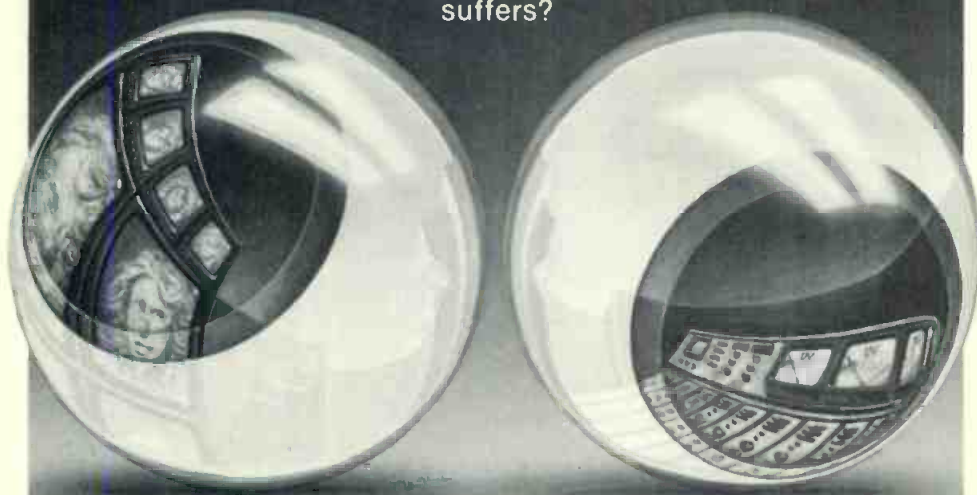

# The <sup>uni</sup>VUer puts it all together!

*Dynamic bar graph display over monitor video!*

- 2-channel for stereo monitoring
- Display size and position variable
- Selectable PPM/VU ballistics
- Peak flasher
- Adjustable silence sense
- Transparent to monitor video
- **RACK MOUNT OR PORTABLE**
- Compatible with European standards
- Master control monitoring
- Editing suites
- Production control rooms
- VTR bridges
- Boss' office
- Anywhere in the program monitoring chain
- **ENG/EFP - in line with monitor video return provides camera operator with audio CONFIDENCE**

See you in Dallas NAB booth 2621

## THE REAL WORLD TECHNOLOGIES GROUP, INC.

Santa Ana, CA (714) 957-1061  
Technology Development Services by  
Microsystems Institute



# Bogner vs RCA®

Bogner is less famous than RCA. But in the twenty years since we innovated a remarkable slot array design we have succeeded to a leadership role in broadcast antennas. We had to be better than competition. And we still are. As proof, compare two typical Bogner and RCA slot antennas. Both are equal in gain, beam tilt and smooth null fill, (for Ch. 40).

A look at the chart shows that the Bogner antenna is superior in every item listed. Furthermore, from all known data, there is *no* other significant characteristic in which the Bogner antenna does not also clearly excel.

Bogner offers uncomplicated, highly efficient, low cost slot antennas with a long history of trouble free performance and unequalled coverage. In the past four years alone, we have put into broadcast use over forty 30 kw to 200 kw UHF slot antennas.

Wouldn't it be good sense to call us before you make a buying decision? Bogner Broadcast Equipment Corp., 401 Railroad Avenue, Westbury, NY 11590, (516) 997-7800.

**A Bogner  
UHF TV antenna  
has to be better!**

	<b>BOGNER</b>	<b>RCA</b>
<b>Model No.</b>	<b>BUH24N*</b>	<b>TFU25G**</b>
<b>Power Handling</b>	<b>134.7 kw</b>	<b>114 kw</b>
<b>Height</b>	<b>58.2 ft.</b>	<b>52.3 ft.</b>
<b>Weight</b>	<b>1.5 tons</b>	<b>2.8 tons</b>
<b>Wind shear</b>	<b>1715 lbs.</b>	<b>2377 lbs.</b>
<b>Moment</b>	<b>32,800 ft. lbs.</b>	<b>65,843 ft. lbs.</b>
<b>Climbing Provision</b>	<b>Full steel ladder</b>	<b>Pole steps</b>
<b>Horizontal Pattern</b>	<b>Omnidirectional, plus eight standard directive patterns and over 100 special ones.</b>	<b>Omnidirectional</b>
<b>Convertibility of Horizontal Pattern in the field</b>	<b>Yes</b>	<b>No</b>
<b>Testing</b>	<b>Gain is measured directly against a precision reference standard.</b>	<b>Gain is calculated from the vertical pattern and from estimates of feed system and radome losses.</b>
<b>List Price</b>	<b>\$149,800</b>	<b>—————</b>
	<b>Bogner Catalog 201A</b>	<b>** RCA Catalog T.9200B</b>

**BOGNER®**  
WE MAKE THEM SMARTER

VISIT US AT NAB BOOTH 1711

Circle 309 on Reader Service Card

www.americanradiohistory.com

## Tax Tips for Stations

planning. Specifically, the new law allows an unlimited marital deduction for both estate and gift tax purposes. This will permit a radio or television station owner to make lifetime and deathtime transfers, no matter how large, to his or her spouse without incurring any taxes.

Furthermore, one half of the value of all property owned by a husband and wife as joint tenants will be includable in the estate of the first spouse to die. This will significantly simplify the law and virtually eliminate the burdensome task of determining how much each spouse contributed to the property.

The bottom line effect of the unlimited marital deduction is to postpone the payment of any estate taxes until the death of both marriage partners. But, remember, it is a deferral, not a relief.

The temptation, of course, is to draft your will in such a way as to leave everything to your spouse; but that is not always a good idea. If the wife has a larger estate than the husband, the tax bill could end up higher. At the very least, the \$600,000 exemption should be used. The estate won't pay tax on it anyway, so why not transfer at least that portion directly on to the next generation or to other heirs?

The new tax law not only eases the problem of estate distributions, it also makes it less costly to make gifts while you are alive. Although many people ignored the law requiring payment of a tax on any gift exceeding \$3000, it was on the books and occasionally enforced.

That rule allowed an annual \$3000 per donee ex-

clusion from the gift tax. Or, a husband and wife could consent to split their gift so that a couple could transfer up to \$6000 per donee each year free of tax. Surprisingly, this annual exclusion has remained unchanged since enactment in 1942. Even the U.S. Treasury Department admits that the purchasing power of a dollar has decreased to less than one third of its 1942 value.

Beginning next year, the annual gift tax exclusion will increase to \$10,000 per donee, thus permitting a husband and wife to consent to transfer up to \$20,000 per donee each year without being subjected to the gift tax.

Finally, further helping reduce the onerous burden of our gift and estate taxes is a little-discussed provision that may well prove quite beneficial to the estate of every business person.

Ordinarily, for estate tax purposes, all property must generally be included in an estate at its fair market value. What's more, the law clearly states that that fair market value should be based on its highest and best use. That means a farmer's estate might find the farmland priced as a housing tract and a station's property valued as land best suited for a skyscraper.

Fortunately, if certain circumstances are met, our old tax law allowed farm property and all real property used in a closely-held business to be included in the estate at its current use value. The only drawback is that the difference in those two values under present law cannot exceed \$500,000.

Many a broadcaster's estate has been able to successfully reduce the value of business property by using the special use valuation method. Combining this special use valuation system with the new tax law simply means

# ROHN

## Broadcast Towers

Write For Free  
Broadcast Tower  
Catalog and Price List.



UNR-Rohn

Division of UNR, Inc.  
6718 West Plank Road, P.O. Box 2000  
Peoria, Illinois 61656  
U.S.A.

Circle No. 313 on Reader Service Card

# swintek

The Leading Name In  
Cordless Microphone Systems



Transmitters small enough to be hidden almost anywhere, tiny microphones that are so unobtrusive that they probably won't even be noticed, hand-held microphones without the encumbrances of hundreds of feet of wire — that's what cordless microphone systems are all about. But there's one more factor of prime importance — reliability. If you're in television, radio or film and you want a cordless microphone system that not only offers the most advanced state-of-the-art electronics but the highest reliability rating in the industry, Swintek is the answer. There's a Swintek transmitter and receiver to fit your specific needs, no matter what your requirements. Check with us today about the greatest name in cordless microphone systems — Swintek.

**alan gordon enterprises inc.**

1430 N. Cahuenga Blvd., Hollywood, CA 90028  
Telephone: (213) 466-3561 • (213) 985-5500  
TWX: 910-321-4526 • Cable: GORDENT

Circle No. 314 on Reader Service Card



Dual channel mix

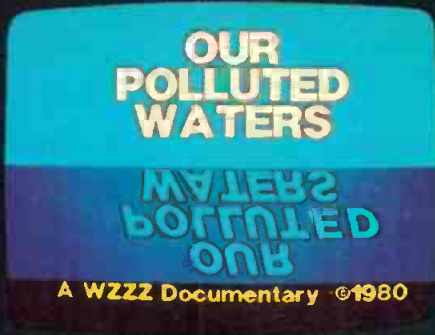

Character Flip/Rotation

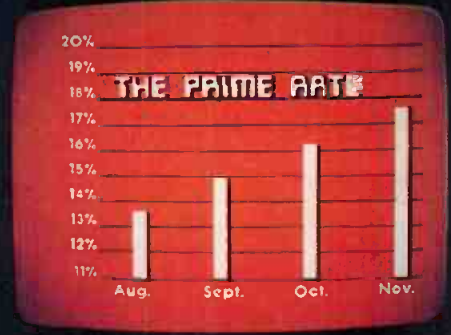

Charting capability

Team	W	L
Philadelphia	15	3
New York	12	4
Boston	10	5
New Jersey	8	11
Washington	7	11

Static headline, changing copy



Keyboard logo compose



Left and right italics



25% and 50% character reduction

State Senate 5th District 20% Pcts.			
*****			
✓Ward	D	99,876	39%
Roberts	R	84,756	34%
Jameson	I	67,543	27%

WEZY-TV Channel 6

Computer Election Interface

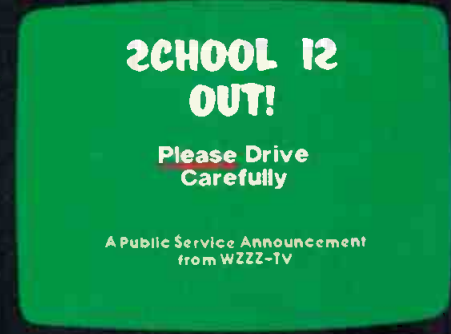

Character reversal

## Many of our capabilities aren't even options on other graphic generators.

Which is the do-all, top-of-the-line graphics generator?

It may not be the one you think it is. Unless you specify the D-8800 Graphics Generator System from 3M.

It's the graphics system that gives you almost every creative capability you could want.

Such as the features you see above, photographed from a monitor using graphics generated from the D-8800 keyboard with no external hardware. Including dual channel mix. Ten roll and crawl speeds. Eight mask positions. Both horizontal and vertical autocentering. Character reduction and



italics that give you hundreds of fonts to create and store.

And much more.

Plus the D-8800 talks to you in plain English, at the keyboard. Not in codes that so often take weeks, even months to learn to decipher.

Call 3M today at 612-733-8132 and ask for a demonstration. You'll quickly discover the D-8800 is your only real option. Or write on your letterhead to: Professional Audio Video Equipment/ 3M, Bldg. 223-5E/3M Center, St. Paul, MN 55144. In Canada contact 3M Canada, Inc., P.O. Box 5757, London, Ontario, N6A-4T1.

3M hears you . . .

## Tax Tips for Stations

that if the assets are not passed tax free to the spouse, if the \$600,000 exemption isn't sufficient to eliminate estate taxes, then the assets used in the closely-held business may be valued at their special use valuation rather than fair market value to reduce the size of—and the taxes on—the estate.

Even though the valuation differential of \$500,000 has only increased to \$750,000 under the new law, it still means that if a studio building used in the business is worth a million dollars on the open market but worth only \$250,000 in its present use, this difference will be acceptable to the Internal Revenue Service.

Still other changes in this area may make the "special use valuation" rules even more profitable for the estates of many broadcasters to use. Specifically, the new tax law provides for an increase in the limitation in the reduction from fair market value allowable for qualifying real property from the current \$500,000 figure to \$750,000. This increase is to be phased in over a three-year period, beginning with the estates of decedents dying after 1980, as follows:

Year of Death	Limitation Amount
1981	\$600,000
1982	700,000
1983	750,000

Under our old tax laws, property qualifying for special use valuation had to be used as closely-held business or farm property (in other words, a "qualified" use) on the date of the decedent's death and for at

least five of the eight years preceding death. The old rule also demanded that the decedent or a family member materially participate in the closely-held business or farm for a period aggregating five of the eight years prior to the decedent's death.

The qualified use requirement was particularly difficult if the principal suffered through a period of illness. Fortunately, under the new law, this requirement is satisfied if either the decedent *or any member of his or her family* used the property for the required period prior to the death.

The Economic Recovery Act also provides an alternative to the material participation requirement for qualification of real property for special use valuation. Under the new law, active management by a surviving spouse who acquired the property from a decedent in whose estate it was included at its special use valuation will satisfy the material participation requirement. Active management simply means the making of business decisions other than the daily operating decisions of the closely-held business. Thus, the new rules demand less activity than actual material participation.

Although the changes in the special use valuation rules are retroactive to the beginning of 1981, the balance of new estate tax rules and rates didn't take effect until early 1982. In fact, it will be 1985 or 1986 before the full benefit of these estate tax changes will be in place.

This makes estate planning more important than ever, and now would be an excellent time to review your estate, your will, and your insurance requirements.

BM/E

## COLOR PRODUCTION SWITCHERS

FOR MORE DETAILS  
CALL OR WRITE

105 EAST 69th AVENUE  
VANCOUVER, B.C.  
CANADA V5X 2W9  
PHONE (604) 327-9446  
TELEX 04-508605

MODEL  
1107  
AC OR DC POWERED

ISCOUNT  
INDUSTRIES Ltd

Circle No. 316 on Reader Service Card

## VIDEO L-C DELAY LINES

A complete line of passive switchable and strappable Variable Delay Lines manufactured specifically for the video industry. Finest specifications available anywhere. Lowest pricing. Delivery from stock.

Request Video Catalog of New  
Rack Mountable Series of  
Video & Pulse Delay Lines

## VIDEO L-C FILTERS

We manufacture a wide range of Linear Phase Lowpass & Bandpass, as well as the sharpest Lowpass, Highpass & Bandpass Filters available in the entire industry. NTSC Lowpass, Band Reject & Bandpass Filters are our specialties. Fastest delivery of prototypes. Introducing a new line of Sub-Miniature Filters: 5 to 500MHz.

SEE US AT NAB - BOOTH 2318

ALLEN AVIONICS, INC.  
224 E. 2nd St., Mineola, NY 11501  
Phone: (516) 248-8080

Circle No. 317 on Reader Service Card

# Freedom of Expression

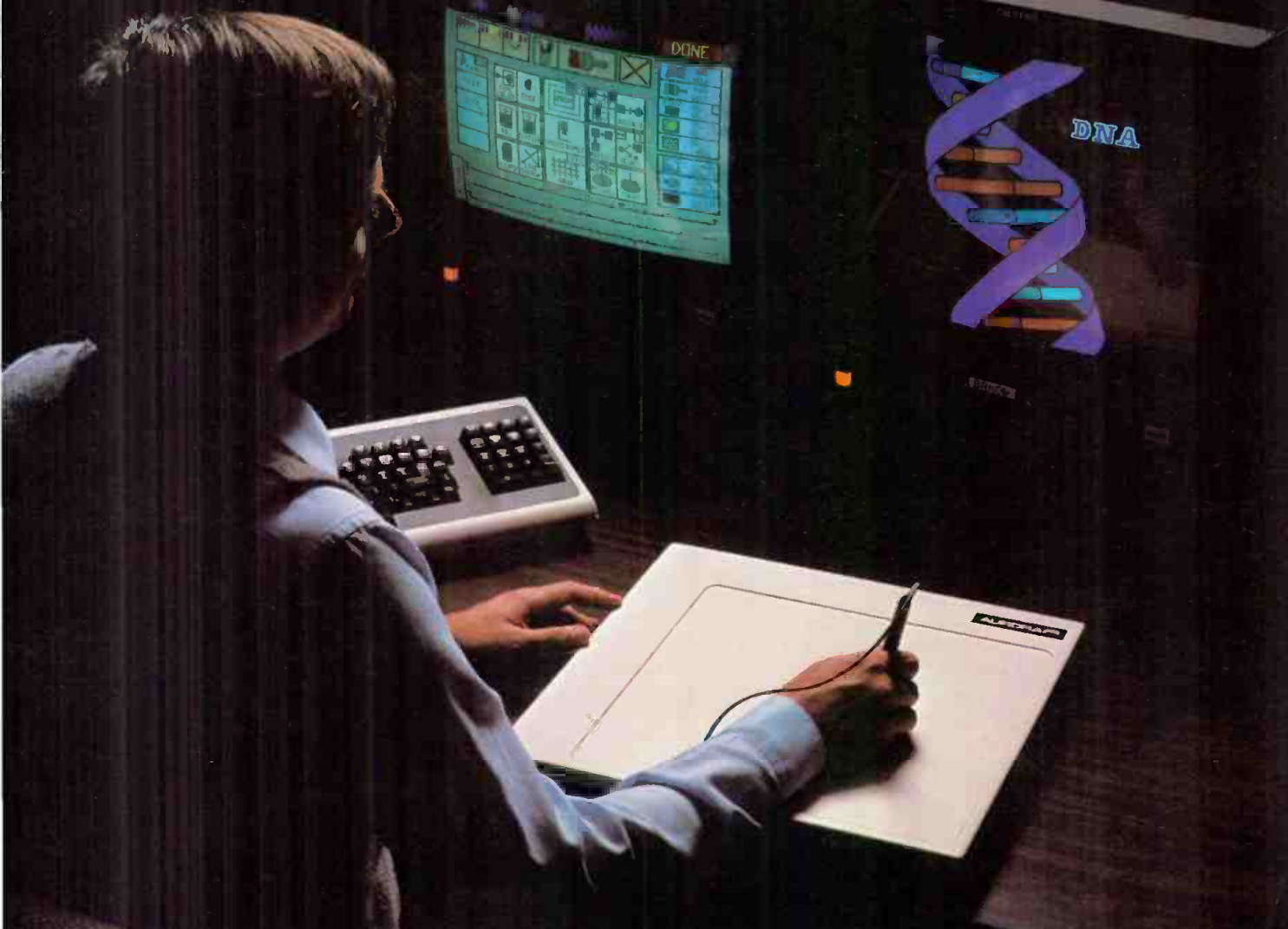

*The Aurora/100 digital videographic and animation system.  
Creativity limited only by your imagination.*

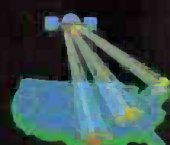
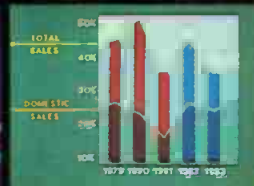
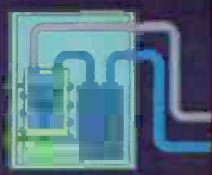

The Aurora/100 is the most powerful television artist's tool ever developed. We've taken the time to do it right. In fact, our people pioneered in the design and application of digital videographic and animation systems starting in the early 70's.

The Aurora/100 was designed first and foremost to permit real artistic flexibility. It's not just an extended character generator but a complete graphic and animation system built from the ground up by creative people for creative people.

This is an extraordinarily powerful system. Yet it is simple to learn. Easy to use. And it requires absolutely no computer experience.

You will be amazed at the speed with which ideas and concepts can be transformed into exciting, colorful visual images.

The Aurora/100 features real-time animation, freehand painting, powerful graphic editing tools, character generation, video input and many other capabilities.

Digital videographics has come of age. Aurora systems are already in use in NTSC and SECAM broadcast, post production and industrial applications in the U.S., France, Japan and Canada.

The Aurora/100. Limited only by your imagination.

**AURORA** 

See us at NAB booth #2806.

Circle 318 on Reader Service Card

Aurora Systems, 185 Berry St., San Francisco, CA 94107 (415) 777-2288



# We wrote the book on Time Code.



**Time Code Pioneers.** Before we wrote The Time Code Book, we helped establish SMPTE Time Code standards and engineered the first SMPTE Time Code Generators and Readers. The first to make SMPTE Code really work, our leadership has been recognized and awarded.

**Innovation, A Way Of Life.** Now, we've introduced the first microprocessor-based equipment enabling you to utilize Vertical Interval Time Code (VITC). Because it's one thing to earn a reputation, it's another to maintain it.

And again, we're contributing to a standard. Further participation with SMPTE helped establish a proposed recommended practice for VITC, and our equipment is designed to make the most of its capabilities. With VITC every field/frame is identified and the code is in the video picture, permitting you to read the code in still frame while freeing the audio track normally used for time code.

**At Technology's Leading Edge.** Like all EECO Video Products, our VITC Generators and

# And now it's yours free.

Readers are innovated for performance, providing quality, reliability and precision at competitive prices. And our Readers allow you to extract VITC at wind speeds.

#### 15 Years Of Industry Involvement.

Supported and serviced by our factory, EECO Video Products are distributed worldwide by Ampex Corporation and in the Southwest by Hoffman Video Systems.

#### Ask For Our Free Time Code Booklet.

For the whole time code picture—Serial and VITC—ask for The Time Code Book, from the people who wrote the book. Write or call, EECO Incorporated, 1601 East Chestnut Ave., P.O. Box 659, Santa Ana, CA 92702-0659. Phone: 714/835-6000.

**EECO**  
Incorporated

See us at NAB  
booth #1819

Circle 319 on Reader Service Card

www.americanradiohistory.com

# INTERPRETING THE **FCC** RULES & REGULATIONS

## Unraveling Unregulation

THE CURRENT ADMINISTRATION could well be called "The Marketplace Administration" because of its strong stance in favor of letting a "free market" control the U.S. economy. The benefit to broadcasters is clear—"deregulation" (or "unregulation," as FCC chairman Mark S. Fowler would have it) has become the catchword for reformers at the FCC.

The unregulatory process faces a harder fight in Congress than it does at the FCC, however. The Senate has already passed S. 1629, its deregulation bill aiming to "encourage and develop marketplace competition in the provision of certain broadcast services and to provide certain deregulation of such broadcast services." Some influential House members, however, especially John Dingell (D-MI), chairman of the Committee on Energy and Commerce, and Timothy D. Wirth (D-CO), chairman of the Telecommunications Subcommittee, staunchly oppose some of its deregulatory measures. Referring to the stalemate, commissioner Abbott Washburn said in a recent speech, "It's uncertain as to whether there will be any broadcast legislation passed this year."

Legislative obstacles do not seem to be stopping the FCC or its broadcast constituents, who are working hard to bring about unregulation. A broad coalition of broadcasters has been meeting in Washington to discuss the possibility of joining forces to work for deregulation legislation. Included are representatives from NAB, NRBA, RTNDA, the National Association of Public Television Stations, the Daytime Broadcasters Association, the National Religious Broadcasters, the National Association of Farm Broadcasters, the Broadcast Financial Management Association, and National Public Radio. Chairman Fowler has also met with industry groups to discuss how best to persuade Congress to eliminate the prime-time access rule.

Although limited by Congress, the FCC itself does have a good deal of room to "unregulate" on its own. And it is taking unregulation very seriously. In a recent interview, Broadcast Bureau chief Laurence E. (Larry) Harris told *BM/E* that the bureau was embarking on a careful review of all rules and regulations that affect broadcasters, to determine which have outlived their usefulness, make no sense, or are burdensome. Necessary regulations will stand, Harris said; many others will be modified or eliminated. New technologies will be encouraged, Harris noted, stating that this FCC will not enact measures designed solely to protect existing technologies from new ones. Exemplifying this phi-

losophy is the FCC's clear push to get LPTV and DBS off the ground.

With so many issues involved, unraveling unregulation can be a confusing pastime. The following status report on FCC activities may help clarify the situation. In general, unregulation of radio has proceeded faster than for television; as one FCC spokesperson put it, full TV deregulation is "down the pike." Things are moving, though, and a quick review shows that broadcasters have more reason to cheer than to weep.

**AM Stereo.** Had been on the FCC's agenda in January, but was pulled by the Chairman's office for unspecified reasons and had not reappeared by press time. Some observers believe the problem to be a conflict between the Commission staff, which has once again come out in favor of choosing a single system, and the commissioners, the majority of whom favor a free-market approach. If a single system is named, it will most likely be the Harris system, though the Chairman's strong support for a marketplace approach makes this unsure. Nevertheless, the item remains high on the priority list at the Commission.

**Low-Power Television.** Action is imminent on this top-priority item at the FCC. The Commission staff was due to submit a draft of a final report and order on LPTV to the Commission by March 1 (after *BM/E*'s press time), and one in-the-know observer—Commissioner Anne Jones—has predicted "there is an excellent chance that the Commission will approve establishment of this new service." Meanwhile, in February the commission issued the first seven LPTV licenses, as part of a larger group of translator applications granted under exemptions to the freeze, and also issued a cutoff list with over 300 LPTV applications. The budgetary outlook for LPTV was eased somewhat when the Office of Management and Budget earmarked an additional half-million dollars for the service last year; this should brighten the prospects for getting through the enormous backlog of applications. The FCC surprised observers early last month by rejecting Congress's suggestion to decide conflicting applications with a lottery, with only commissioner Fogarty dissenting. According to the Commission, Congress's insistence that it continue to establish applicants' qualifications and give a preference to minority applicants would negate any time saving from the lottery.

**Direct Broadcasting Satellites.** No firm authorizations can be made for this new service until spectrum



streamlined application procedures for commercial and noncommercial licenses and substantially shortened and revised Form 301, the application for construction permits. As mentioned earlier, the FCC nixed a proposal to decide mutually exclusive license applications by lottery rather than by the present comparative hearing procedure.

The Commission is also considering changes in its license renewal procedures, and has been urged by broadcasters to cease granting comparative renewal hearings to competing applicants if the incumbent is doing a good job. Deregulation bills S. 1629 and H.R. 5242 include a provision prohibiting the FCC from accepting rival applications unless the incumbent has been judged not to merit renewal; pending passage, the FCC could effect this change by amending its rules. Rep. Al Swift (D-WA) was expected to introduce a bill to this effect in the House last month (after press time), as noted above.

**Equal Employment Opportunity.** A relaxation of affirmative action rules seems possible and has clear support from the Broadcast Bureau. The bureau has recommended that the Commission issue a rulemaking incorporating an OMB proposal that broadcasters no longer be required routinely to file affirmative action reports, unless it had been previously determined that the licensee was discriminating. The Broadcast Bureau also wants to include a proposal to require broadcasters to file Form 395, the annual employment report, only once every two years. The rulemaking may also propose dropping EEO rules for stations with fewer than 15 employees. Some opposition is already shaping

up on the Commission itself; commissioner Henry Rivera wants the FCC to reject the OMB recommendation. Lame-duck commissioner Washburn (whose term expires June 30) also opposes changes in the FCC's EEO rules. The item had been on the FCC's agenda early in the year, but was pulled for further study and is not expected to appear again until midyear.

**Logging Requirements, Financial Reports.** Logging requirements for commercial radio have already been dropped; the FCC has proposed the same for noncommercial radio. Similar proposals will be made for television later this year, according to an FCC spokesperson. In addition, a notice of proposed rulemaking is expected sometime this year on technical logging requirements. A report and order on financial reports is due this month.

**Ascertainment.** Formal ascertainment procedures have been dropped for radio stations and for small-market television stations (those serving populations of 10,000 or less and outside of a Standard Metropolitan Statistical Area). A rulemaking seeking to eliminate ascertainment requirements for public television is now before the FCC.

**Public Broadcasting.** Most prominent on the FCC's agenda in this area is action on financing rules for public radio and television—chiefly aimed at easing the restrictions so that public broadcasters can increase their access to corporate funding. Last year, the Commission relaxed its funding rules to allow public television stations to air the logos of corporate contributors; previously, they had only been permitted to show company names. The Temporary Commission on Al-

### Omni-Q™ Cue & Monitor System

OMNI-Q is a stereo 8 channel in, one channel out general purpose cue, monitor, & line amplifier. Easy, compact, and inexpensive way of handling the common monitoring, cueing, amplifying & switching problems.

#### Typical uses of OMNI-Q:

- Network monitor and amplifier
- Transmitter input selector and monitor
- Automation cue amplifier
- Tape recorder input selector
- Telephone line source selector
- Headphone amplifier
- Console input expander



#### OMNI-Q Special Features:

- 8 balanced bridging stereo inputs
- 600 Ohm and direct switched outputs
- Stereo LED VU meters
- Amplifier drives external speakers
- Contains 2 built-in speakers
- Front panel jack and speaker switch
- Built-in 3 frequency test oscillator
- 1 1/4" rack mounting package

**ONLY \$450.**

**CONEX** ELECTRO SYSTEMS **IIII** INC.

P.O. Box 1342, Bellingham, WA 98227  
(206) 734-4323

Circle No. 322 on Reader Service Card

## MATER ARTIUM NECESSITAS\*

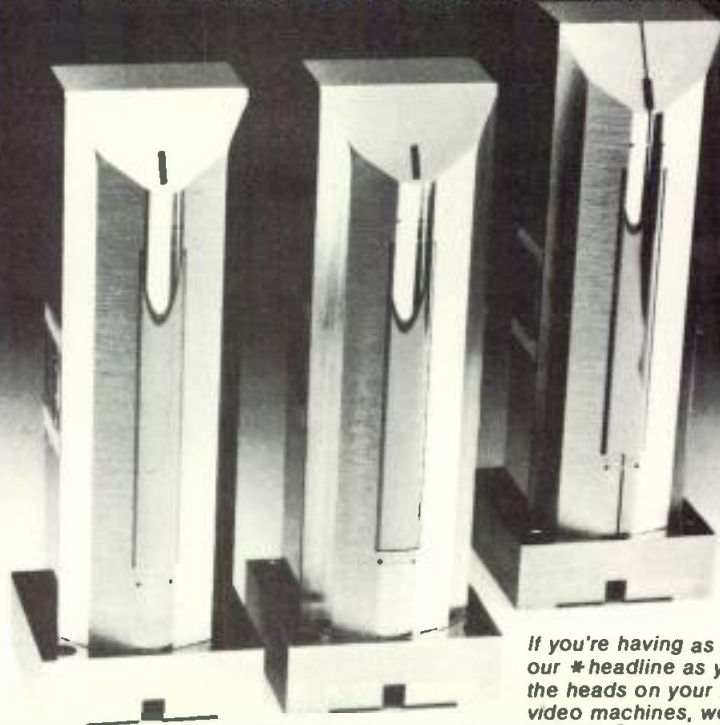

**SAKI**  
SAKI MAGNETICS

If you're having as much trouble with our \*headline as you're having with the heads on your RCA or Ampex 2" video machines, we've got the solution. Our Premium Quality Sakalloy® audio posts last 3 to 4 times longer than standard heads. We've become the world's leading manufacturer of premium audio heads by providing remarkable solutions to demanding industry needs. After all, \*Necessity is the mother of invention. Call us today!

SAKI MAGNETICS, INC. A California Corporation. 8650 Hayden Place, Culver City, California 90230. (213) 559-6704 TWX 910-328-6100. See us at NAB Booth 1722.

Circle No. 323 on Reader Service Card

## FCC Rules and Regulations

ternative Financing for Public Broadcasting has authorized an experiment in which 10 public TV stations will run advertising; radio stations were excluded from participation. Commissioner Quello, chairman of the Temporary Commission, explained that radio representation "was not quite right" since four radio applicants were joint licensees with TV stations involved in the experiment. (See story on p. 14.)

**Children's Television.** A 1979 rulemaking includes a wide range of options, including mandatory per-week minimums; it seems extremely unlikely that any such rules will be enacted, however, because of strong opposition by chairman Fowler to regulating program content. Active lobbying by public-interest groups such as Action for Children's Television is likely to keep the issue in the forefront; commissioner Washburn recently opined "that the Commission and the industry will both continue to recognize the importance and the uniqueness of this audience." Late last year, the Federal Trade Commission dropped its four-year-old rulemaking on advertising on children's television, citing "other important enforcement priorities." Congress had previously told the FTC that it could not regulate advertising solely on the grounds on "unfairness," but only if actual deception was involved.

**Teletext.** A rulemaking now before the FCC outlines a market approach to teletext standards-setting—giving broadcasters discretion to select any standard for broadcast on lines 14–18, 20, and 21 of the vertical

blanking interval. Several teletext experiments have been authorized, most using the Telidon (Canadian) and Antiope (French) systems; both of these systems are compatible with the unified U.S. teletext standard recently proposed by AT&T.

**Subscription Television.** STV got a major boost in 1979 when the FCC eliminated the one-to-a-market rule. The rulemaking currently before the Commission proposes deleting the complement-of-four rule (allowing STV outlets only in areas within the Grade A contours of at least four advertiser-supported stations) and the 28-hour rule (setting a minimum weekly amount of free programming). This issue is of particular interest to prospective LPTV operators, many of whom look to STV as a means of increasing their revenues.

**Technical Issues.** The major technical issue now before the FCC is a rulemaking that would delete the requirement for type acceptance of modulation monitors. Currently, all AM, FM, and TV aural transmitters are required to be equipped with modulation monitors that meet the characteristics specified by the Commission. If the change is approved, stations could use any method they saw fit to monitor their modulation. The rulemaking also asks for comments on a proposal to delete the requirement that modulation monitor indications be continuously available to the operator at the station. The FCC has already dropped its rule requiring TV stations to continuously transmit VITS and has eliminated its first and second class radio-telephone operators licenses, replacing them with a general license. **BM/E**

## CASES BUILT FOR THE FUTURE (OF YOUR EQUIPMENT)

Star  
Case



When you pack for the ultimate show whether it be across town or across the universe your equipment will land safely with Star Case.

Before your next close encounter on the road call or write:

Star Case  
Manufacturing Company, Inc.  
15525 South 70th Court  
Orland Park, Illinois 60462  
312-429-6200

Circle No. 324 on Reader Service Card

## STABLE — RELIABLE AFFORDABLE

### COX 203 ENCODER

- Switchable 3 or 4 channel operation
  - Self-contained color bar generator
  - All set-up controls on front panel
  - Adjustable pedestal
  - Ideal for use with flying spot telecine, character generator color or updating older cameras
- See us at NAB Booth 2706  
Available in NTSC, PAL (B,M,N) or SECAM. Also dual standard (PAL/NTSC).

**broadcast video systems ltd.**

1050 McNicoll Avenue  
Agincourt, Ont. M1W 2L8  
(416) 497-1020

Circle No. 325 on Reader Service Card

# Great announcer mics should be heard and not seen.

You won't see the MCE 5, but you will hear the rich full frequency sound that tells you it's a Beyer. Now the top quality and reliability for which Beyer is famous has been packaged into the world's smallest broadcast microphone – the MCE 5 – the announcer's mic.

The MCE 5 is an omni-directional electret condenser microphone with 20Hz-20kHz  $\pm$  3dB frequency response, 62dB signal-to-noise ratio and a maximum rated SPL at 1kHz of

116dB. Its matte black finish will not reflect light, so it goes unnoticed on camera. And Beyer's unique floating element eliminates pick-up of clothes rustle and body movement. Wind and air noises are reduced by up to 20dB, with the (removable) windscreen. You get only the announcer's voice.

Unlike conventional mini mics that are subject to breakdown from temperature and humidity, the MCE 5 is specially designed to withstand the elements.

The Beyer MCE 5 is available in a variety of configurations and connectors including: balanced, unbalanced, XLR, 1/4-inch and open end; as well as phantom and self-powered with its own battery.

You may not find the Beyer MCE 5 on our announcer, but you'll find it at your local Beyer dealer, today.



**Beyer**   
**Dynamic**

**BEYER DYNAMIC, INC.**

5-05 Burns Avenue, Hicksville, NY 11801  
(516) 935-8000 • In Canada, H. Roy Gray, Ltd.

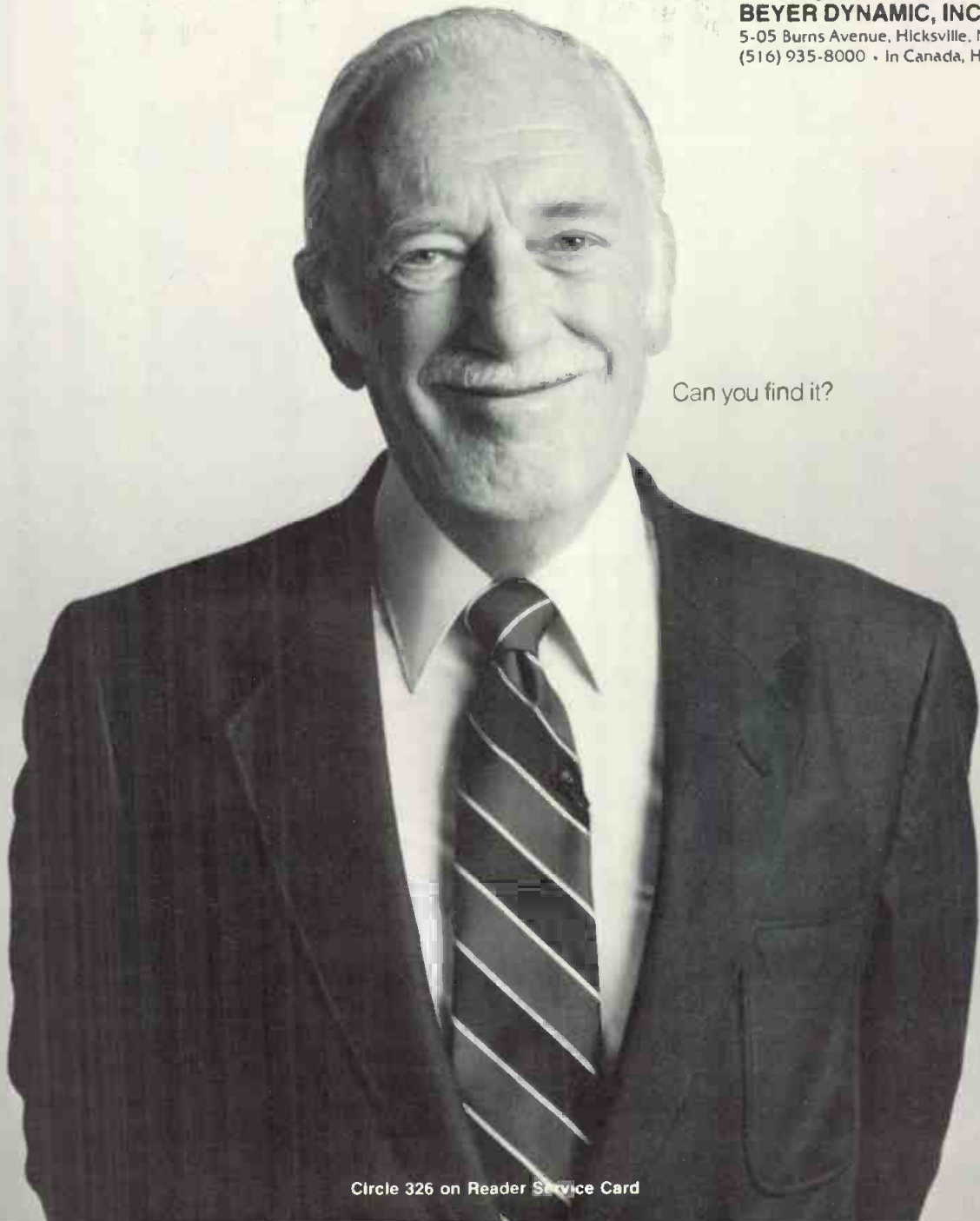

Can you find it?

Circle 326 on Reader Service Card

[www.americanradiohistory.com](http://www.americanradiohistory.com)

# UHF Systems? You're in capable hands with Comark.

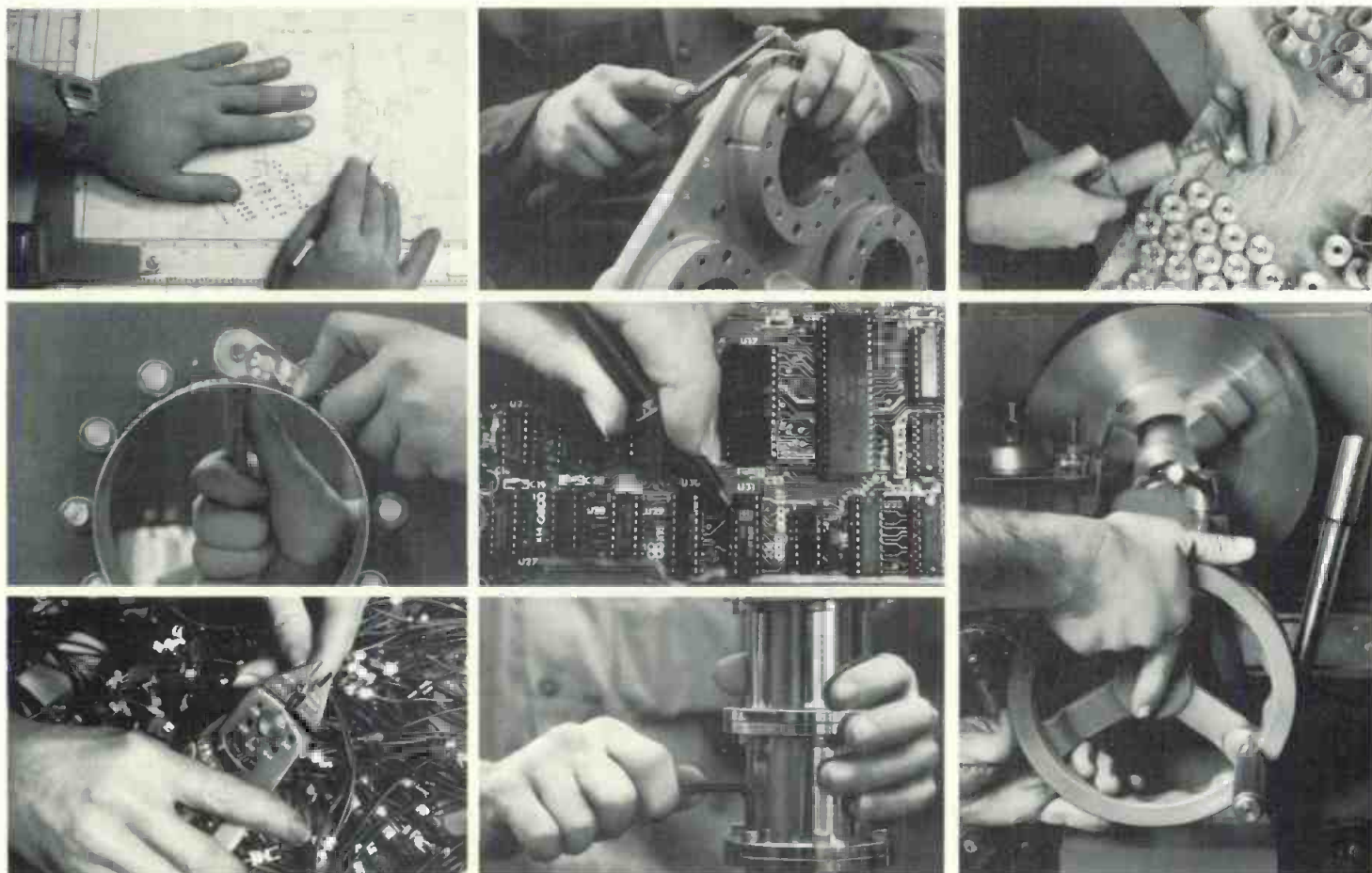

At Comark we manufacture more of the components that make up a total UHF TV transmission system than any other name in the business. Experienced technicians with skillful hands measure, fit, connect, test, check and re-check. But that's only part of the reason you should be looking at Comark.

We are in the forefront in creative engineering and practical implementation. We pioneered the concept of maximum transmitter plant efficiency. From initial planning, to total service, our hands-on policy assures you that we live up to our word and workmanship. And because we're in charge we're able to bring our products to you more economically.

Whether you're looking for a turn-key system, or a transmitter or just components, you place yourself in capable hands the moment you contact Comark. Call us at (413) 569-5939 or write: Comark Communications Inc., PO Box 267, Southwick, Mass., 01077. Telex: 955 329.

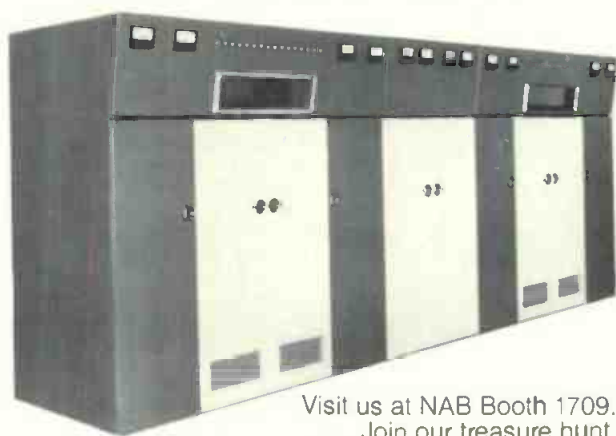

Visit us at NAB Booth 1709.  
Join our treasure hunt  
where everyone is a winner.

## COMARK

MAKING UHF BETTER. SOONER

Circle 327 on Reader Service Card

# GREAT IDEA CONTEST

Here's a chance to share your own personal solutions to some of broadcasting's most vexing engineering needs: end-of-tape sensing . . . cart deck synchronization . . . on/off-air indication on the mixing board . . . distributing timing pulses . . . and the like.

Each month we will present a specific engineering problem and invite you to submit ideas on how to solve it. Send in descriptions and diagrams of equipment you have already built, or ideas on how you think the problem ought to be solved. *BM/E's* editors will read the entries and select the best for publication — giving readers an opportunity to vote for the idea they consider best. Solutions to Problem 1 appear on p. 111; you can place your vote for the winning solution by using the ballot area on the Reader Service Card.

To attract the most original solutions possible, we will pay \$10 for each entry we print. In addition, the winner of each month's competition — the one voted for most often on our Reader Service Card — will receive an engineering slide rule calculator as a prize.

So put on your thinking cap and submit an answer to either of the problems outlined below. Solutions to Problem 4 must be received by March 15, 1982, and will be printed in the May, 1982 issue. Solutions to Problem 5 must be received by April 15, 1982, and will be printed in the June, 1982 issue.

## Problem 4:

### BLACK-OUT PROTECTOR

One of the greatest fears among microprocessor users is that the system will crash during blackouts or brownouts, resulting in a loss of memory or actual system damage. Can you design a simple circuit that will sense line voltage drop and automatically supply standby voltage to the appropriate circuits?

*Solutions to Problem 4  
must be received by  
March 15, 1982 and will be printed  
in the May, 1982 issue.*

## Problem 5:

### RF PROTECTION\*

Recording of miscellaneous RF signals on the audio tracks of VTRs and ATRs is a frequently-encountered problem, particularly in crowded urban environments and when news crews are operating in high-rises. What is your solution for keeping RF interference out of portable recorders?

*Solutions to Problem 5  
must be received by  
April 15, 1982 and will be printed  
in the June, 1982 issue.*

\*Suggested by Greg Lafevre, news director, KSEE-TV, Fresno, CA. If you have an unsolved problem, let us know.

### CONTEST RULES

- How to Enter:** Submit your ideas on how to solve the problems, together with any schematic diagrams, photographs, or other supporting material. Entries should be roughly 500 words long. Mail the entries to *BM/E's* Great Ideas Contest, 295 Madison Avenue, New York, NY 10017. Use the official entry form or a separate piece of paper with your name, station or facility, address, and telephone number.
- Voting and Prizes:** *BM/E's* editors will read all entries and select some for publication; the decision of the editors is final. Those selected for publication will receive a \$10 honorarium. Each month, readers will have an opportunity to vote for the solution they consider the best by using the Reader Service Card. *BM/E* will announce the solution receiving the most votes and will award the winner of each month's competition an engineering slide rule calculator.
- Eligibility:** All station and production facility personnel are eligible to enter solutions based on equipment already built or on ideas of how the problem should be solved. Consultants are welcome to submit ideas if they indicate at which facility the idea is in use. Manufacturers of equipment are not eligible to enter. Those submitting solutions are urged to think through their ideas carefully to be certain ideas conform to FCC specs and are in line with manufacturers' warranty guidelines.

Mail Official Entry Form to:

#### BM/E's Great Ideas Contest

295 Madison Avenue, New York, NY 10017

Solution to Problem # \_\_\_\_\_

Your Name: \_\_\_\_\_

Title: \_\_\_\_\_

Station or Facility: \_\_\_\_\_

Address: \_\_\_\_\_

\_\_\_\_\_

Telephone: ( ) \_\_\_\_\_

I assert that, to the best of my knowledge, the idea submitted is original with this station or facility, and I hereby give *BM/E* permission to publish the material.

Signed \_\_\_\_\_

Date \_\_\_\_\_



# RCA FM power tubes. 15 to 55kW outputs at high efficiency.

RCA is now in the FM power tube business with a series of four tubes and cavities designed specifically for high-gain, high-efficiency broadcast service:

Tube Type	Output	Gain	Efficiency	Cavity Model
8986	15kW	20db	80%	Y1393D-V1
8985	25kW	20db	80%	Y1393D-V2
9011	30kW	21db	80%	Y1393D-V3
8984	55kW	16db	78%	Y1369

There's a very persuasive reason for using a tube with high efficiency: lower operating costs. Over the lifetime of a transmitter this can mean considerable savings.

And RCA tubes are designed for long life.

Our cavities complement our tubes. They provide high-gain, grid-driven circuits which take full advantage of the tubes' high Gm electron optics, high efficiency, ease of neutralization and ease of cooling.

Along with our power tubes, and the cavities that bring out their best performance, we also supply service and application engineering. Find out more today. Contact RCA Power Tube Marketing, New Holland Avenue, Lancaster, PA 17604. Call (717) 397-7661. Or get in touch with RCA, Brussels, Belgium. Sao Paulo, Brazil. Sunbury-on-Thames, Middlesex, England. Paris, France. Munich, West Germany. Mexico 16 D.F., Mexico. Hong Kong.



We supply both the power tube and the cavity. In our pictured Y1393 cavity, the 9011 tube delivers a measured gain of 20 db with an efficiency of 80%.

# RCA

# Solution to Problem 2: AUTOMATIC RECORDING

Facilities equipped with satellite receiving loops often have incoming feeds on an irregular basis. To avoid having an operator standing by 24 hours a day, is there a device or circuit that will automatically switch on a recorder and at the same time alert a technician that a recording is being made? Here are three solutions to this problem, submitted by *BM/E's* readers.

## Solution A

Lee Barrett, Chief Engineer  
KOJMI/KPQX-FM, Havre, MT

Most feeds are preceded by some sort of countdown, tone, or descriptive chatter that serves as the basis of the automatic record circuit shown in Figure 1. The line audios (assumed to be near 0 dBm in level) are bridged—in phase—by transformers T1 and T2. Operational amplifier U1 sums the two channels and amplifies the resulting signal 47 times. The output audio is rectified and fed to the Schmitt trigger, U2. When the voltage at pin 2 of U2 exceeds about 5 V, the output of U2 will switch low, causing Q1 to cut off. Q2 will saturate, causing the tape deck RECORD circuit to

energize. The START signal from Q5 is slightly delayed over the RECORD signal for proper timing. Q3, Q6, and U3 form a retriggerable one-shot to hold the circuit in RECORD during "quiet periods" in the feed. R3 may be increased to lengthen the time delay. (Do not increase the capacitor, C1.) Q7 holds on the "recording" LED while recording is taking place. The Sonalert keyed by Q7 alerts the operator that a feed is being received.

Lack of input audio for a period longer than the time constant of U3 will cause Q8 to cut off. Q9 then saturates, firing one-shot U4, which exhibits a short time period. The STOP pulse generated by Q4 briefly saturates Q10, causing the recording deck to STOP.

Q9 also sets the R-S latch, U5. When set, Q11 will saturate and illuminate the "recording completed" LED. If the operator is away while recording takes place, a brief glance will tell him if the feeds have been received. The RESET button enables the "recording completed" signal to register again. Q12 causes the "recording completed" LED to blank during subsequent recordings.

Transformer T2 and associated circuitry may be eliminated if only mono feeds are taken. (R1 would then be a single section potentiometer.) R1 is adjusted until the circuit starts the recording device with program audio applied. R1 is then further increased over the trip voltage at pin 2 of U2 by 2-3 V. If more gain is needed, R2 may be increased in the U1 circuitry.

It may be necessary to buffer the control signals

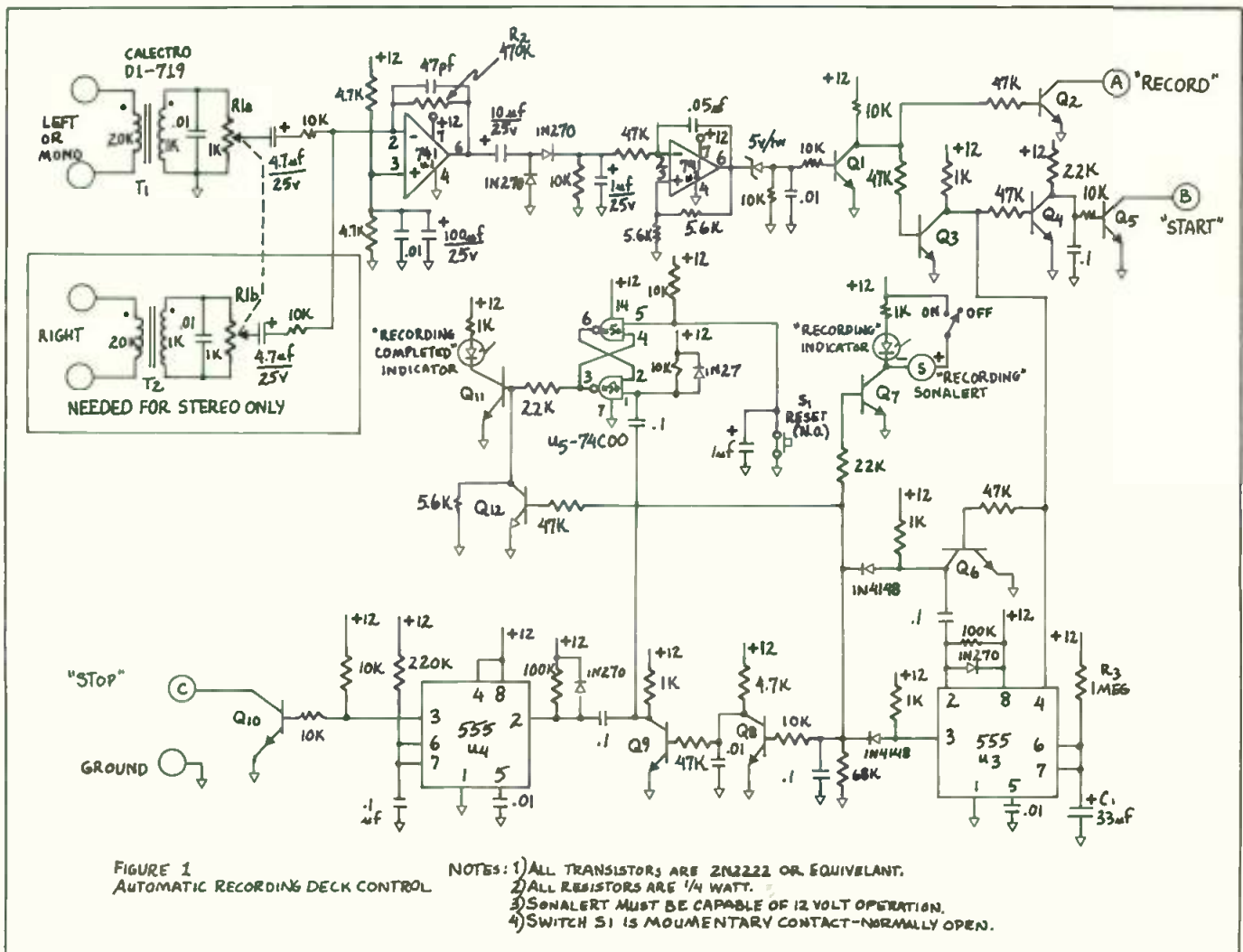

# Easy does it... and fast, too!

High speed, quality previewing  
and editing with

## CineScan™

The most advanced high speed viewer in the world! Lets you run film in forward and reverse at up to 10 times sound speed. Big 44 square-inch screen. Electronic, fingertip controls. One-hand threading for fast, easy loading.



**CineScan** High Speed Previewer

Ideal for editing, timing, VTR promos

For full-color literature,  
write or call toll-free:

Research Technology International

4700 Chase • Lincolnwood, IL 60646 • 800/323-7520\*

\*In Illinois. Call 312/677-3000.



NAB Booth 1903

Circle No. 329 on Reader Service Card

## Service Engineers

The Sony Broadcast Company currently has highly visible career opportunities available in its Atlanta, Ga. and NY/NJ offices for two (2) Service Engineers.

The selected candidates will possess 5 years experience with emphasis on installing, maintaining and servicing broadcast/digital electronics equipment. A BSEE or relevant experience is preferred.

Sony offers a competitive starting salary and comprehensive benefits which include company-paid dental, pension and profit sharing. For prompt consideration, please forward your resume to: Mr. Carlo Severo, Manager, Eastern Region-Broadcast Service Engineering

Sony Corporation of America  
Sony Broadcast Company  
47-47 Van Dam Street  
Long Island City, N.Y. 11101  
An Equal Opportunity Employer m/f/h/v

# SONY®

## Great Ideas

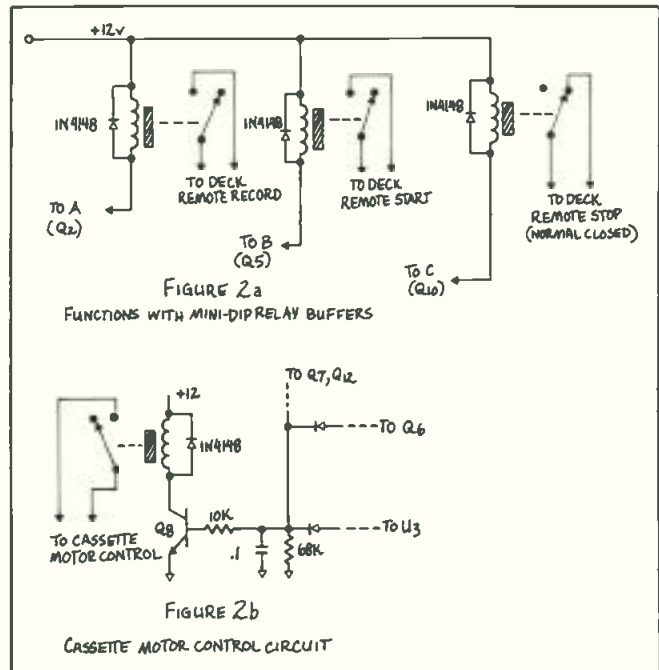

with mini-dip relays or further solid state circuitry if the recording deck does not operate the START, STOP, and RECORD functions against ground. (It is assumed the recording device uses internal latching of these functions.) Figure 2a illustrates the mini-dip configuration.

If a cassette recorder with a motor control is used, transistors Q2, Q4, Q5, Q9, and Q10, along with U4, may be eliminated. A mini-dip relay in the collector of Q8 is used for motor control as shown in Figure 2b. The recorder is left in the RECORD mode.

As a final option, a seven-segment display with associated counting and driving circuitry may be added to display the number of feeds received from the previous RESET. Attention to the voltages is a must when interfacing the counter.

### Solution B

James Sensenbach, Chief Engineer  
KMWU, Wichita, KS

When National Public Radio went to satellite distribution, we had to find a way to record some 25 hours of programs each week. Since we use student operators, it had to be as simple as possible as well as "tamper-proof."

To fill this need, I took an alarm clock module and wired it to emphasize the alarm function. The alarm logic was turned into a short pulse and buffered to provide tape machine remote starting. I used all solid state for long-term reliability and to keep electrical noise to a minimum. These units have been performing flawlessly for two years now. Battery backup of the timekeeping functions came with the clock as a bonus

**VOTE NOW!**

**Ballot On Reader Service Card**

# SAM82

Dimensions: 17.5 x 13.2 x 3.2"  
Weight: 17.6 lbs



# STUDIO AUDIO MIXERS

# SAM42

Dimensions: 11.3 x 10.4 x 3.1"  
Weight: 8.5 lbs

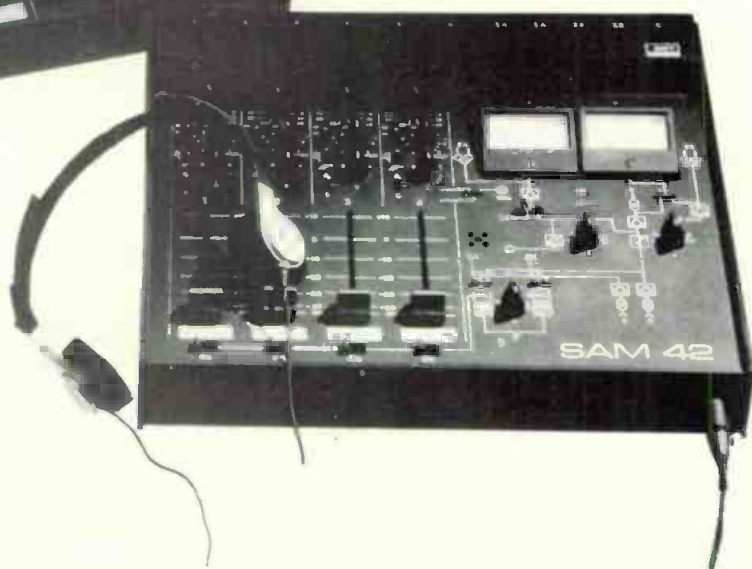

**SAM 82/SAM 42  
will be shown at**



60th Annual Convention  
& International Exposition  
April 4 - 7, 1982  
Dallas, Texas

See us in Booth No. 2903!

Let us show you how to get top audio  
quality — at reasonable cost — also in  
remote broadcasting.

Made in Sweden by

**SATT**  
**Electronics**

P.O. Box 32006  
S-126 11 Stockholm/Sweden  
Phone: +46 (8) 81 01 00 Telex: 10884 SATTEL S

**International distribution:**

Australia: G.E. Direct Marketing, Melbourne    Benelux: Transtec BV,  
Rotterdam    Denmark: AEG Dansk Elektricitets A/S, Copenhagen  
Finland: Sähköliikkeiden OY, Vantaa    France: Publison Audio Pro-  
fessional, Paris    Japan: Hoei Sangyo Co. Ltd., Tokyo    Norway: Siv-  
ing Benum A/S, Oslo    United Kingdom: AKG Acoustics Ltd., London  
West Germany: BFE KG, Mainz.

For additional information mail coupon to:  
SATT, 19th floor, 295 Madison Avenue, New York,  
NY 10017

**I am interested in SAM 82/SAM 42**

Company \_\_\_\_\_

Name \_\_\_\_\_

Address \_\_\_\_\_

Postal code \_\_\_\_\_

Country \_\_\_\_\_

Telephone \_\_\_\_\_

BM/E 3-82

Circle 331 on Reader Service Card

## Great Ideas

feature. To use the clock, an operator sets the alarm time to the time the program starts (the clocks are set 45 seconds fast) and pushes the enable switch to arm the system. She then loads the tape to be recorded on the proper machine and checks for proper recording levels. As soon as the machine starts, the clock is no longer needed and can be set up for the next recording, if necessary.

The heart of the clock is the MA1023 clock module from Digikey in Thief River Falls, MN. It is a self-contained alarm clock that needs only a power transformer and a few switches to be completely functional. A normally closed momentary switch on the alarm display input forces the clock to work in the alarm mode all the time. The set switch is conventional, but the enable switch serves a dual function: it turns the alarm on and off, and controls the display brightness. The display is fully bright when the alarm is on and dimmed when the alarm is off. The alarm logic output is connected to a capacitor/NAND gate combination that functions as a rising edge-triggered one-shot. The output is buffered by transistors that furnish momentary shorts to ground for an essentially TTL-level output. The 5 Mohm pot and the battery are for the backup clock circuits. When the power fails, the clock and the tape machines shuts down, but the time-

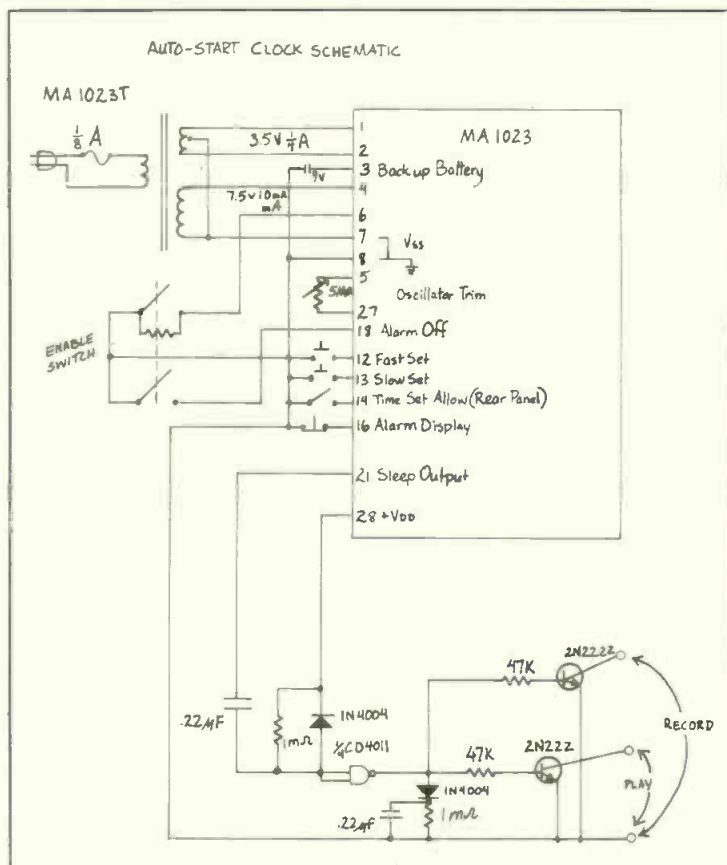

keeping circuits are kept up-to-date using an internal oscillator. The clock time is checked by pressing the momentary display switch. Setting the time requires holding the display switch in the time position, manipulating the set switch, and

## HME Professional Wireless Microphones

**New Looks/New Choices/  
Performance Plus!**

- Concealed Antenna
- Optional Matte Black Finish
- Choice of Five Popular Professional Microphone Elements by Shure, Electro-Voice, Audio Technica and Beyer



**hme**  
HM ELECTRONICS, INC.

HM ELECTRONICS, INC. 6151 Fairmount Ave., San Diego, CA 92120 (714) 280-6050 Telex: 697-122

See us at NAB Booth 2402

Circle No. 332 on Reader Service Card

278 BM/E MARCH, 1982

## NOW, A COST-EFFECTIVE CHROMA DECODER



### RGB-100

A high-quality, economically priced NTSC Chroma Decoder. Composite video signals are decoded to R, G, B and Sync. Models are available in PAL, SECAM, PAL-M and PAL-N.

### Canter-Redman Technologies Corp.

321 West 44th Street  
New York, N.Y. 10036  
(212) 245-5505  
Telex No. 420205 CRT C

Circle No. 333 on Reader Service Card

# Why 4 out of 5 earth stations for TV broadcasting are from Scientific-Atlanta

Model 8010 7-Meter Antenna. Designed specifically for television broadcasting. Exceeds all broadcast earth station requirements.

Full geostationary satellite arc coverage.

Highly reliable GaAs Fet low noise amplifier. Fully enclosed for weather protection.

Factory-installed de-icing systems available for severe weather conditions.

Easy to install. Minimal space requirements.

Scientific-Atlanta has designed, built, and delivered more broadcast earth stations than any other company in the world. A lot more. Here are some reasons why.

## SCIENTIFIC-ATLANTA MAKES THE ENTIRE SYSTEM

Scientific-Atlanta builds complete satellite earth station systems for the television industry. Our earth station packages give you everything you need to turn satellite signals into programming revenues. Antennas, receivers, low noise amplifiers, and installation and service.

## THE RIGHT SYSTEM FOR YOUR NEEDS

As the industry's largest manufacturer, we offer a wider choice in complete system packages. And we have the practical, *total systems* experience to help you put together the earth station to fit your technical requirements. *And your budget.*

A broadcast earth station can be as simple as our Model 8501 Basic Receive-only system. It consists of an antenna assembly, a low-noise amplifier (LNA), and a video receiver.

This is the basic downlink system. It's perfect for operations such as taping satellite programming for future broadcast.

For added flexibility as well as improved reliability, many broadcasters choose our Model 8502 Receive-Only Earth Station. It includes a second set of electronics to give simultaneous reception on two different satellite channels—a significant increase in signal receiving ability.

What's more, the additional electronics serve as back-up units for the primary

set, giving full station redundancy.

Should a malfunction occur in your primary on-line components, protection switching devices are included in the Model 8502 package which will automatically switch those functions over to the redundant stand-by units without interrupting on-line reception.

## SUPPLY YOUR OWN PROGRAMMING

Scientific-Atlanta has supplied 97% of all the satellite uplinks currently in use by commercial TV broadcasters.

When you buy a Scientific-Atlanta uplink, you get the entire package, from the initial site planning advice to the final proof of performance procedure.

If you prefer, the uplink package can include frequency coordination, FCC licensing, and supervision for pouring of the foundation (using local construction crews for minimum cost).

## MORE SATELLITE COVERAGE MEANS MORE PROGRAMMING

Scientific-Atlanta broadcast earth stations are available with full geostation-

ary satellite arc coverage. Your system can "see" all current and future domestic communications satellites from anywhere in the continental United States.

No other antenna system offers more satellite coverage.

Pre-programmable motor-drive systems are available for 7- and 10-meter antennas. You can switch from one satellite to another in 60 seconds or less.

For example, by entering a simple two-digit code into our remote-control antenna positioning unit, your antenna can be switched to a different satellite during a commercial break.

## WRITE OR CALL FOR INFORMATION

Clip this coupon for more information on the most advanced satellite earth station systems available for the television broadcast industry. Or call or write Lou Durham at (404) 449-2362.

BME 3/82

## Scientific Atlanta Communications

Attn: Lou Durham, ATL-20  
3845 Pleasantdale Rd.  
Atlanta, Georgia 30340

Please send more information on satellite earth stations for television broadcasting.

NAME \_\_\_\_\_

TITLE \_\_\_\_\_

COMPANY \_\_\_\_\_

ADDRESS \_\_\_\_\_

CITY \_\_\_\_\_

STATE \_\_\_\_\_ ZIP \_\_\_\_\_

BUSINESS TELEPHONE ( ) \_\_\_\_\_

United States: One Technology Parkway, Box 105600, Atlanta, Georgia 30348. Telephone 404-441-4000. TWX 810-766-4912, Telex 0542898  
Canada: 1640 Bonhill Road, Unit 6, Mississauga, Ontario L5T 1C8, Canada. Telephone 416-677-6555, Telex 06983600  
Europe: Horton Manor, Stanwell Road, Horton, Slough SL3 9PA, England. Telephone Colnbrook (02182) 3211, Telex 849406

## Great Ideas

flipping the time set enable switch on the rear panel. This last switch prevents unauthorized or unintentional resetting of the clock time.

An operator alert can be added by adding another transistor to drive a small lamp, a relay, or even a Sonalert.

## Solution C

*Richard J.C. Miller, Assistant Chief Engineer,  
WNEW-TV, Metromedia, New York, NY*

It is easy to start a tape recorder upon receipt of an input signal, as is evidenced by the plethora of "bussing" devices that start a tape recorder when a signal is detected on a phone line or in a room. One could also use a VOX circuit with a suitable timeout delay to start and stop the recorder. These solutions use readily available commercial products, but both can create problems for broadcasters, for whom quality is of greater importance. Starting a recorder concurrently with the arrival of a signal will cut off the first few syllables, and will probably add some wow while the recorder is starting up.

An elegant solution to this problem incorporates an Eventide Model BD955 digital delay line for delay of all signals to be recorded. The BD955 is in common use in radio stations for the policing of obscenity

during talk shows and provides a 6.4-second broadcast-quality delay. By detecting the signal *before* the delay, and having the recorder monitor the signal *after* the delay, the recorder has the full delay time of the BD955 (up to 6.4 seconds) during which it can come up to speed. The operator can be alerted by any number of means. If the noise of the recorder starting isn't enough, one can easily attach a Mallory Sonalert to an additional set of relay contacts. Other Rube Goldbergish schemes suggest themselves as well.

This solution can take advantage of another feature of the BD955. In normal operation, it starts at zero delay and "catches up" to full delay during pauses in the output audio, which it detects and lengthens. The circuitry used to do this is exactly what is required for a signal detector! There is even an internal relay, which could be used to control the recorder (although it should probably drive an additional relay to handle a non-logic-controlled tape recorder.) The BD955 need be modified only slightly to take advantage of the signal detection circuitry. First, one would disconnect the pause detector input from the output of the delay line and connect it to the input (after the low-pass filter.) Next, the relay driver should be connected to the output of the pause detector. Since the relay driver has a time constant circuit (fast attack, slow release,) it can be used as is, with only the addition of a larger capacitor to increase the dropout time. The modifications required are so few that a front-panel switch could be added to restore the unit to normal operation. Both NC and NO relay contacts are available on the rear panel for control of the recorder. **BM/E**

# DON'T GET CAUGHT WITHOUT ONE

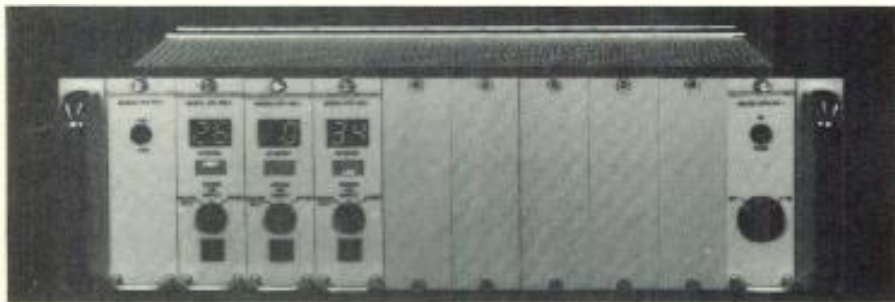

## CODE PHASE CORRECTOR CPC-700 SERIES

Have you ever experienced the trauma of having your editing computer refuse to edit due to the SMPTE Cue Code being out of phase with the video? Fear no longer, as the CPC-700 equipment automatically re-phases and transmits a corrected code for computer acceptance and happiness.



504 W. CHAPMAN AVE.  
SUITE P  
ORANGE, CA 92668  
714-997-4151

Circle 335 on Reader Service Card

## MONEY For . . .

EQUIPMENT LEASING  
ACCOUNTS RECEIVABLES  
PURCHASES/MERGERS  
NEW VENTURES  
CABLE SYSTEMS  
LPTV  
MULTIPOINT DISTRIBUTION  
VIDEO & AUDIO PRODUCTION  
PROGRAMING  
SATELLITE NETWORKS

PGA FINANCIAL SERVICES, LTD.  
BOX 4078 DEPT. BME  
BROOKINGS, OR 97415  
(503) 469-6296

U.S. 800-854-2003 EXT. 5128  
CA. 800-522-1500 EXT. 5128

Circle No. 336 on Reader Service Card

**“At half CMX’s price,  
how good can the Commander be?”**

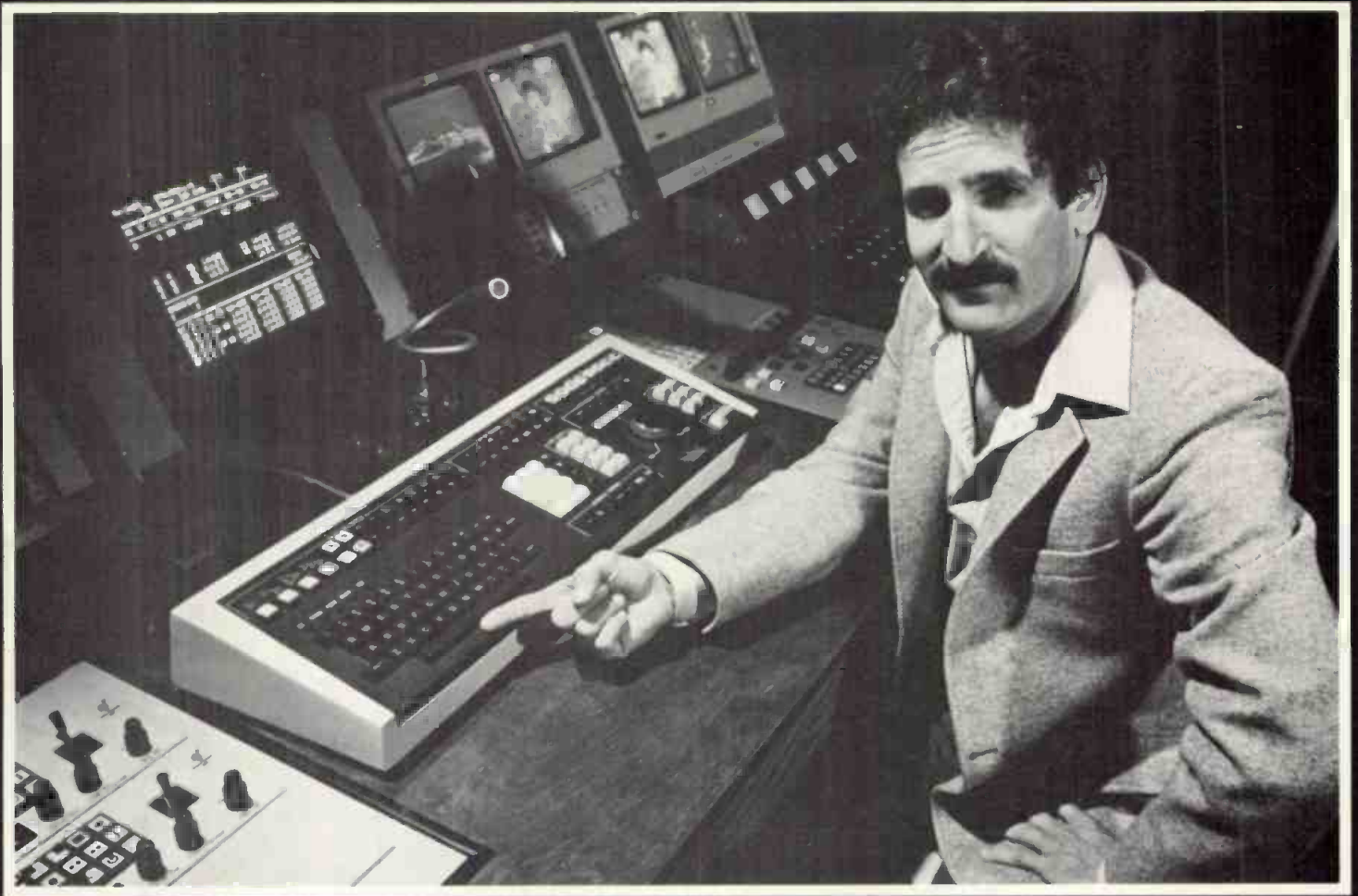

**“Better!”**

**says Andy Maisner, owner of the American Film Factory,  
Venice, California**

"I was prepared to pay whatever it took to bring American Film Factory's facilities up to state-of-the-art standards. But I wasn't willing to just sign a blank check—so we thoroughly evaluated all the leading computer-assisted videotape editing systems on the market. I was really surprised to discover the United Media's new Commander II was capable of everything CMX could do and more—and at half the price. Half the price!

"Let me get specific—the biggest Commander advantage is complete computer control of multiple mix-effect banks for double re-entries. Sure, CMX can do that with a Grass Valley Switcher, but equipping it with E-MEM costs almost as much as the entire Commander II system.

"The other big advantage is Commander's tremendously flexible list management. Everybody has it, but

Commander's degree of sophistication far exceeds the others.

"Commander offers a lot of useful features—like sync step, independent audio and video dissolve, and split audio/video edits in and out in one pass. Again, most other systems can cope with these editing needs somehow, but Commander handles them with true automation.

"Reliability is excellent—in a year of operation, we've never had a hardware failure. In fact, we've already bought our second Commander II system. Commander II is fully CMX-compatible, which reassures my clients—and it's easier to use and much more versatile, which excites my editors.

"With the Commander's built-in total capability and realistic price, it's certainly the *best* system you can buy."

**COMMANDER II**

**United  
Media**

4075 Leaverton Court, Anaheim,

CA 92807 • 714/630-8020

Circle 337 on Reader Service Card

[www.americanradiohistory.com](http://www.americanradiohistory.com)



# THE ELECTRONIC NEWS ROOM BEGINS WITH DATA-PROMPTER™



Tools to enhance creativity are a must with the major focus on local news. Data-Prompter simplifies writing and eases rewriting. Take the first modular step towards an electronic news room ...for under \$10,000...with Data-Prompter.

Find out about leasing options and a video-tape demo of Data-Prompter in action. Call Rod Herring, Jim Sherry or Jim Shaw today Toll-free at 1-800-255-6226.

#### **DATA-PROMPTER:**

Full "news room" word processing:

- simplifies writing
- eases rewriting
- speeds editing

A slug line menu allows:

- precise review
- stacking freedom

Data-Prompter generates:

- hard copy script
- character generated prompting
- closed captioning to the hearing impaired

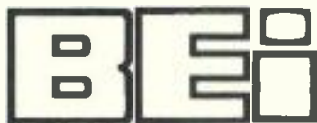

Toll-free 1-800-255-6226  
In Kansas 913 764-1900  
TWX 910-749-6410  
P.O. Box 937 Olathe, Kansas 66061

---

**SEE DATA-PROMPTER AT NAB...BOOTH 3207**

# BROADCAST EQUIPMENT

## Fluke adds DMM Accessories 355

Four new accessories to Fluke's line of digital multimeters include two high-frequency ac probes, a 6 kW high-voltage probe, and a touch-hold probe that saves DMM readings. The 83RF and 85RF RF probes provide a dc output for high-frequency ac inputs from 0.25 V to 30 V rms. Rated bandwidth is 100 kHz to 100 MHz for the 83RF and 500 MHz for the 85RF. The 80K-6 high-voltage probe allows high-voltage measurements to 6000 V, with accuracy of  $\pm 1.0\%$ , dc to 500 Hz and  $\pm 2.0\%$ , 500 Hz to 1 kHz.



Pressing a button near the tip of the 80T-H touch-hold probe, for use with the D810, D811, 8010A, 8012A, and 8050A DMMs, saves a reading for later observation. 83RF, \$49; 85RF, \$85; 80K-6, \$45; 80T-H, \$45. JOHN FLUKE MFG. CO.

## QSI Offers Signal Source ID 356

This new television color bar identifier, the CB-7005, has a memory load that can store up to 80 IDs with instant recall. The front-panel reprogrammable unit combines a color bar generator with an eight-character alphanumeric display and audio signal



source. It is rack-mountable and incorporates a standard 525/60 NTSC color sync generator, EIA FS-189 split field color bar generator, and eight-digit ASCII character generator. \$2395. QSI SYSTEMS, INC.

## Bonneville Offers Audio DA 357

The DA-6 audio distribution amplifier features the 990 op-amp an Jensen transformers, offering studio performance specifications with the flexibility of transformer isolation. Specs include + 24 dB headroom, 30



dB of available gain, and over 80 dB S/N. The one-in, six-out unit is expandable to 10 outputs. BONNEVILLE PRODUCTIONS.

## Grove Announces Animation Option 358

A software option for Grove Video's Imager I digital image storage device allows certain real-time animation of key images, permitting sequences of images to be programmed ahead of time, then aired in real time at frame rates. An adaption of the redundancy techniques of film animation allows the programming of continuous motion of moving images. Effects include horizontal and vertical motion, zoom, and scaling. Other options include a preview channel card, a second floppy disc drive, and a multi-color downstream keyer/colorizer.



The Imager II, combining the Imager I with its animation software options, a second drive unit, and preview card, lists for \$10,900. GROVE VIDEO CORP.

## Dorrough Announces Audio Processor 359

The 610B digital audio processor is unconditionally stable, needing no technical alignments. All controls are accessible from the front panel and are provided, the company says, as "pleasure controls." Processor transfer characteristics are programmed into the digital software. This real-time processor induces no additional distortion during compression up to the threshold point of the peak controller, which is configured to tend to generate primarily even harmonics during limiting, thereby avoiding harshness. Other features include a five-position

## SHIVELY LABORATORIES CIRCULARLY POLARIZED OMNIDIRECTIONAL AND DIRECTIONAL FM ANTENNAS



MODEL 6010 PB PANEL  
BROADBAND 88-108 MHZ



MODEL 6814 25KW PER BAY



MODEL 6810 10KW PER BAY



MODEL 6813 3KW PER BAY

PATTERN STUDIES AND  
OPTIMIZATIONS AVAILABLE

WRITE OR CALL FOR INFORMATION ON

ANTENNAS  
TRANSMISSION LINE  
FILTERS  
PATCHING SYSTEM  
COAXIAL SWITCHES  
POWER COMBINERS

SHIVELY LABORATORIES  
A DIVISION OF HOWELL LABORATORIES  
85 HARRISON ROAD  
BRIDGTON, MAINE 04009  
(207) 647-3327

Circle No. 339 on Reader Service Card

# NURAD

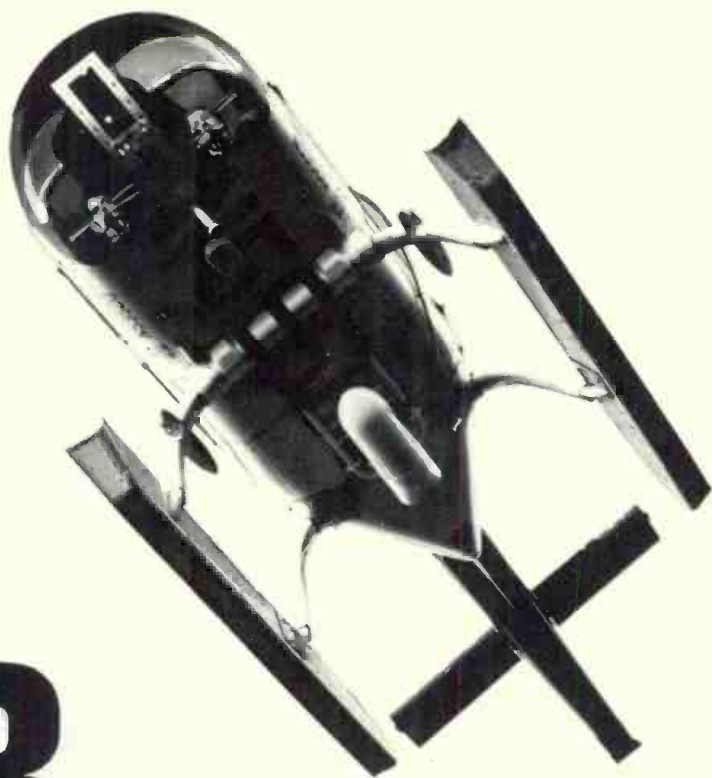

# YOUR MICROWAVE COMPANY

**Nurad now offers the TV broadcaster more than ever before. See our exciting array of new products and systems at NAB, Booth 1607.**

Nurad, Inc., 2165 Druid Park Drive, Baltimore, MD 21211, Telephone (301)462-1700, TWX/Telex (710)235-1071

Circle 340 on Reader Service Card

[www.americanradiohistory.com](http://www.americanradiohistory.com)

## Broadcast Equipment

equalizer, a power VMOS 10 W line amplifier, LED real-time compression ratio meters, and an LED VU meter. DORROUGH ELECTRONICS.

### Console, Case for Revox Recorder 360

A new roll-around console, rugged transportation case, and monitor panel are designed for use with the Revox PR 99 compact professional recorder. The heavy steel console frame has three operating positions; the recorder housing accepts the standard rack-mount PR 99 with no modifications. Rear-panel openings



allow quick connections and the front panel is easily removable for access to electronic alignment controls. The transportation case has the same housing as the console, plus a snap-on front cover and heavy-duty, flush-mounted handles. It may be placed in the console frame. The 19-inch rack-mount monitor panel, which may be fitted in a 3½-inch space at the top of the cabinet console housing, includes an amp card, 6-inch oval speaker, volume control, and track selector switch. Console, \$330; utility shelf, \$65; transportation case, \$225; monitor panel, \$130. STUDER REVOK AMERICA, INC.

### Monitor Test Option from World Video 361

A new option for World Video's line of color video monitors is TSG-1, a built-in combination color bar/audio tone generator that allows the user to check such parameters as color phasing and saturation with the screen display, and the audio section with a 1 kHz audio tone. These

# NICAD BATTERY POWER

Come to Booth 1704,  
NAB and See  
What's New from  
Cine 60...

- Lithium, Expedition Battery Systems.
- New, Universal Fast Charger.
- New, Snap-Mount, On Camera Battery Systems.
- New, Compact (AC Adapter) Power Supply.



# FROM CINE 60

The Original

There's Always Something New From Cine 60.  
630 Ninth Ave., New York, NY 10036 (212) 586-8782  
6430 Sunset Blvd., Hollywood, CA 90028 (213) 461-3046  
TWX: 710-581; TELEX: 645-647

Circle No. 341 on Reader Service Card

**OUR** Now you can choose from a whole family  
**FAMILY** of dbx compressor/limiters to match  
**PLAN.** your budget and application. All  
**\$210 TO** feature our Over Easy® compres-  
**\$650.\*** sion curve for inaudible transition  
into compression. True RMS detec-  
tion for the most natural sound.  
Patented VCAs for precise  
low distortion control of audio levels.  
That's the plan. Now join the family.

See your dbx Pro dealer, or write for information.

\*Manufacturer's suggested retail price.



Over Easy® Compressor/Limiters

dbx, Incorporated, Professional Products Division,  
71 Chapel St., Newton, Mass. 02195 U.S.A.  
Tel. (617) 964-3210, Telex: 92-2522. Distributed in  
Canada by BSR (Canada) Ltd., Rexdale, Ontario.

# dbx®

Circle No. 342 on Reader Service Card

## Broadcast Equipment

signals are also supplied to the standard eight-pin VTR connector on the rear connector panel as well as both BNC and RCA jacks for simultaneous feeding to other equipment. The eight-pin connector allows the test signals to be recorded on the leader of a videotape for later adjustment of the playback system. The color bar generator is not designed for broadcast-quality accuracy, but may be helpful in verifying encoder accuracy of less expensive color cameras, World Video says. \$225. WORLD VIDEO, INC.

## Fidelipac has new Audio Cart

362

Master Cart II, an all-new NAB type AA audio tape cartridge, features an upper and lower tape guide limiting



device that permits it to be used in older cart machines lacking precision tape guides. Other features include wider pressure pads for long wear and better tape-to-head contact, a new bearing-supported one-piece reel assembly for longer tape life and less wow and flutter. Factory-loaded carts are supplied with Fidelipac HOT tape as a standard load at no additional charge. FIDELIPAC CORP.

## Optimod Chassis from Orban

363

Model 8100A/ST is a studio chassis assembly for the Optimod-FM 8100A signal processor that allows the system to be split into compressor and limiter sections. The accessory chassis accepts three cards removed from the main Optimod-FM chassis, and is placed on the studio side of the STL (dual microwave or phone lines), preventing STL overload. This configuration also makes most operating controls available at the studio. Two

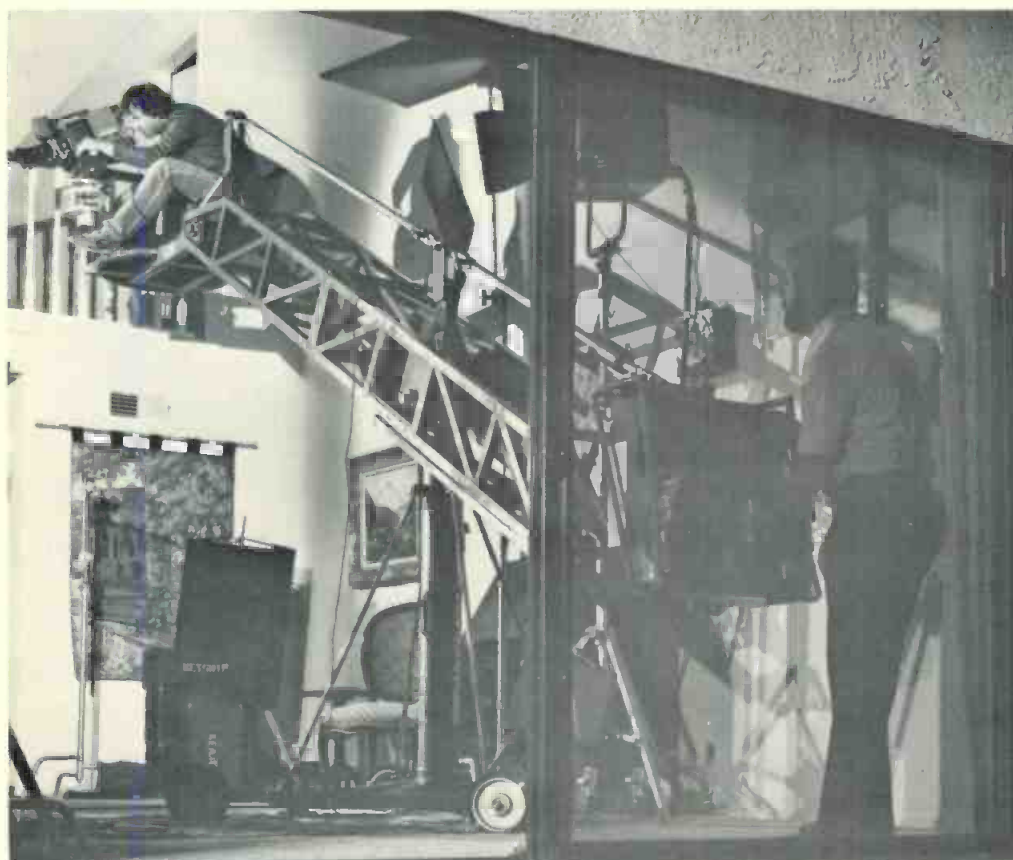

## CHALLENGING THE TULIP

### The Living Proof

The **TULIP CRANE** A camera crane so portable, so lightweight, so creatively versatile, you can carry it right through your front door without scratching the woodwork.

Fast set-up and strike time. Weighs 600 lbs. Folds to 8 feet for easy transport. Lens height of 16 feet plus. Negative drop of minus 3 feet.

Next time, try the **TULIP** on for size and add that creative touch you've been searching for.

EUROPEAN OFFICE:  
Middenweg 49b, 1394 Ad Nederhorst  
Den Berg, Netherlands  
(2945) 3988; Telex: 10254 (GRIMA NL)



EAST COAST:  
143 West 20th Street  
New York, New York 10011  
(212) 937-7454

HEAD OFFICE: 2405 Empire Avenue, Burbank, California 91504  
(213) 843-6715 or 849-6811, Telex: 691599 (MATTHEW)

Photo:  
Tri-Tronics, Inc.

Visit us at NAB  
Booth #2626

Circle 343 on Reader Service Card

## TECHNICAL SERVICES ENGINEER

MCI/Quantel, world's leading supplier of digital video equipment and Emmy award winner for technology, has an outstanding career opportunity for a technical services engineer.

We offer an excellent starting salary, good benefits package, and plenty of room for advancement. Plus the prestige of being associated with the top company in an exciting industry.

You will be based in the New York metropolitan area. Your background should include experience in installation and repair of digital video systems or computers/peripherals.

Contact Marsha Verse, MCI/Quantel, P.O. Box 50810, Palo Alto, CA 94303, (415) 856-6226. An equal opportunity employer.

## MCI/QUANTEL

The digital video people

## Broadcast Equipment

buffer cards are installed in the main chassis at the transmitter, which then performs only the peak limiter, high frequency limiting, and stereo generating functions. Installation and adjustment require only a 1 kHz oscillator. \$795. ORBAN ASSOCIATES, INC.

### Time Code Corrector from Gray 364

When time code on the cue track becomes out of phase with the video, the CPC-700 Series code phase corrector automatically re-phases and transmits a corrected code to specification and computer acceptance. It

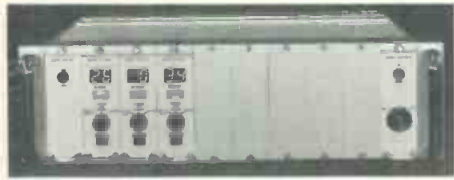

will also measure and display the phase difference in code bits and indicate an early or late condition with respect to the video. One to eight modules fit in an equipment rack, one for each playback VTR machine in the edit bay. Basic equipment rack, including power supply modules and frame pulse generator modules, \$1395; CPC-703-1 front module, \$878; CPC-703-2 input/output rear module, \$117. GRAY ENGINEERING LABORATORIES, INC.

### Basic Offers TVRO

#### Dish Positioner 365

This new control system for positioning TVRO satellite antennas up to 12 feet in diameter consists of a heavy-duty telescoping actuator, a totally enclosed gear motor, a limit switch assembly, and a control panel containing all the indicators and controls. Designed to work with polar-type antenna mounts, the actuator, gear motor, and limit switch are located at the antenna site, with the control panel at a remote location. A



three-digit LED display on the control box shows relative antenna position; an indicator light shows when the actuator is at its upper and lower limits. Antenna position is controlled by a center-off type rocker switch on the front panel. With the actuator installed on an 18-inch radius arm, the antenna can scan ap-

**REVOLUTIONARY  
NEW  
ISOMAX™  
MICROPHONE**

**IMPROVES:**

- ↑ "on mike" sound
- ↑ available gain without feedback
- ↑ isolation for conferences & interviews
- ↑ matte black finish looks great on camera

**REDUCES:**

- ↓ room rumble & echo
- ↓ clothing noise
- ↓ camera noise
- ↓ paper shuffle noise

**ISOMAX PRO**  
for balanced line battery  
or phantom operation.

**ISOMAX W**  
for use with all wireless  
body pack transmitters.

**COUNTRYMAN ASSOCIATES INC.**  
417 STANFORD AVE.-REDWOOD CITY, CA. 94063-PHONE 415-364-9988

Circle No. 345 on Reader Service Card

# "It's about time."



## TDM-8000 Audio Time Compressor

The TDM 8000 allows recorded audio material to be played back at faster rates than at which it was recorded, with the original pitch remaining unchanged. Its patented technology allows the TDM 8000 to handle the most complex program material, with the lowest possible distortion and minimum listening fatigue.

You'll find the TDM 8000 will be invaluable for

compressing video taped segments, first run movies, records, commercials, interviews, etc., to fit pre-determined time frames. And audience retention will actually be improved.

If you've been thinking that it's about time someone produced a truly workable and practical time compressor, the time has come for you to look into the TDM 8000.

## INTEGRATED SOUND SYSTEMS, INC.

29-50 Northern Blvd., Long Island City, N.Y. 11101 (212) 729-8400

A Subsidiary of The VSC Corporation

Dealer/Distributor Inquiries Invited

Circle No. 346 on Reader Service Card

# Beyond P.L.\*



**Broadcast Intercoms limited only by your creativity, imagine:**

- Live Remote P.L. and Cue Systems
- Battery Operated ENG/EFP Systems
- 4 Channel Studio and Post Production P.L. Systems
- Mobile Van P.L. Systems
- Cameraman's Headsets

**All NEW from Clear-Com**

Send for our catalog on more ideas and technical information.

\*A closed circuit hardwired intercom system.

**Clear-Com**  
intercom systems

1111 17th Street  
San Francisco, CA 94107  
(415) 861-6666 EXPORT DIVISION:  
P.O. Box 302  
Walnut Creek, CA 94596  
(415) 932-8134  
TWX: 920-372-1087

Circle No. 347 on Reader Service Card

## NEW-SYSTEM 14



Broadcast Audio Corporation introduces the SYSTEM 14 Digitally Controlled Stereo Audio Console. A digital slide fader and CMOS digitally controlled high resolution logarithmic audio attenuator significantly reduce signal paths, without the numerous disadvantages associated with VCA's.

Options include 5-frequency EQ on each mixer, Pan Pots, Remote Line Selectors, Talkback and Test Oscillators. Standard features include separate mic/line preamps on each mixer and 3 stereo mixing busses.

Base price for a complete 8 mixer SYSTEM 14 is \$11,500.00. Delivery is 60 days ARO.

See us at NAB Booth 1920A

11306 SUNCO DRIVE  
RANCHO CORDOVA, CA 95670  
(916) 635-1048

**BROADCAST  
AUDIO CORPORATION**

Circle No. 348 on Reader Service Card

## Broadcast Equipment

proximately 90° and will reach all existing and planned satellites, the maker says. \$518. BASIC SYSTEMS.

### Keith Monks Unveils

#### Record Cleaner 366

The CR 501 record cleaning machine is designed for maintenance of radio stations' record libraries. This new



model completely and harmlessly removes all residue from the grooves of the record, allowing the stylus to track the modulations instead of riding on dirt deposits that can affect reproduction. KEITH MONKS AUDIO (U.S.A.), INC.

### New Lens

#### from Tele-Cine 367

Schneider's new 14× ENG/EFP lens combines wide-angle and long-telephoto capabilities in a single lens, enabling camera operators to adapt to changing conditions. The 14× lens is lightweight, compact, weather-resistant, and comes with a complete line of accessories. It is designed for all major 2/3-inch tube cameras and is also compatible with the new single-piece VCR/camera combinations.



The lens can zoom from 9-126 mm (from 18-252 mm with the integral 2× extender). Power zoom on wide-angle shots is possible with the 6.3-9 mm aspheric lens attachment. TELE-CINE CORP.

**Lenco Announces New Genlock Unit** 375

The PGL-413 genlock unit is designed to work in conjunction with Lenco's 312 Master Sync System. It will lock



the RS-170A sync generator to any stable composite video signal, whether the input video is RS-170 or RS-170A. The new unit will also genlock to monochrome signals. The PGL-413 locks the 312 system in less than four seconds and follows a vertical, horizontal, color frame, and subcarrier lock sequence. Four front-panel LEDs indicate video presence, system lock, "A" conversion, and color field errors. The unit measures 19 x 1 3/4 x 10 inches and weighs approximately 10 pounds. \$2,500 Lenco, Inc.

**Microphone Mixer from Edcor** 376

The new AM-400 automatic microphone mixer is designed for use with up to four low impedance mics. Multiple units may be strapped together to provide 28 inputs with individual gain controls. Each channel has two adjustable sensitivity controls to accommodate mics of varying sensitivity and frequency response, providing a means of setting the gain of the input channel when that channel is not activated and allowing adjustable



muting. The AM-400 uses FET input and heavy duty CMOS logic circuitry, offering fast turn-on capability that eliminates cut-off of the first word spoken. Each circuit also has a logic circuit for speaker or other external control. All units have balanced 600 ohm line level or 150 ohm mic level outputs, plus unbalanced 600 ohm output. \$743. EDCOR.

**AFA Develops New Slate Camera System** 377

A new title card camera from A.F. Associates can be utilized in both mobile and studio operations. The SC-300 is a compact, self-contained device available as a console or rack-mount unit. With this device, the title card is simply placed into a slot with no adjustment at all required. The SC-300 has an adjustable timer, a cool light source, and is noise free. It has a 19-inch slide mount and is 8 3/4 inches high x 20 inches deep. A.F. ASSOC.

Using Sony  
BVU 50 VCR?  
BVU 110 VCR?  
BVH 500 VTR?

then you need . . .



**Model V90 premium VTR battery!**

The V90 is a direct replacement for the BP90 battery and provides:

- Longer operating time (greater capacity)
- Sturdy plastic case, easily replaceable fuse
- Tailored design for high charge/discharge rates

**Introductory Offer!**

Send in this ad with your order and receive a 20% discount on your initial purchase of the PEP premium "Best Buy" replacement VTR batteries.

Order from:

PEP / EAST  
25 West 54th St.  
New York, NY 10019  
(212) 246-2490

PEP / WEST  
213 North Cedar  
Inglewood, CA 90301  
(213) 419-0309

NOW SHIPPING FROM STOCK

BETTER BATTERIES AT LOWER COST

Circle No. 349 on Reader Service Card



Our Monitor and Distribution Amplifiers are designed expressly for broadcast service. All amplifier circuits are on *plug-in cards* — not hard wired like consumer equipment. Up to four 35 watt cards per Monitor Amplifier, with separate torroid power supplies for each pair of amplifiers. Up to 5 cards per DA, each with 4 transformer balanced outputs. Spectacular performance, in 1 3/4 inch rack or table mount. Brochure on request.

See us at NAB Booth 1920A

11306 SUNCO DRIVE  
RANCHO CORDOVA, CA 95670  
(916) 635-1048



Circle No. 350 on Reader Service Card



# Advertisers Index

ABC	290
ADC	14
ADDA	194
ADM Technology	C-2
Alexander Manufacturing	134
Alpha Audio	19
Ampex-AVSD	174-179,183
Ampex-MTD	103-104,105
Ampro/Scully	15,71,73,75,77,79,81
Animation Video	141
Anton/Bauer	41
Aristocart	66
Artel	203
Arvin-Diamond	241
Asaca Corp of America	161,163
Audio & Design (Recording)	48
Aurora	265
AVL	99,159
Belar Electronics Lab.	254
Bell & Howell	55
Beston	148-149,282
Beyer Dynamics	271
Bogner	257
Broadcast Audio	288,289
Broadcast Microwave	207
Broadcast Video Systems	270
BTX Corp	31
Calvert	162
Camera Mart	26-27
Canon USA	171
Cantor Redman	278
Capitol Magnetic Products	206
CEI	160
Central Dynamics	28,227
Cetec Antennas	78
Cetec Broadcast Group	152
Cetec Vega	126
Cezar International	244
Christie Electric	25
Chyron	209
Cine 60	285
Cinema Products	115
Clear-Com Intercom Systems	288
CMX/Orox	228
Color Graphics	120
Comark Communications	121,272
Comex	74
Comprehensive Video Supply	140
Computer Video	246
Conex	269
Conrac	155
Continental Electronics Mfg	144
Control Video	153
Convergence	96-97,100
Corporate Communications	98
Countryman	287
Crosspoint Latch	247
Data Communications	255
Datametrics	205
Datatron	76,170
dbx	285
Delcom	156
Delta Electronics	72
Dictaphone	217
DiTech	129
Dynacom	51
EchoLabs	67,89,184
Edutron	137-138
EECO	266
EEV	143,145,147
EG & G	142
Elector	168
Electro-Voice	65,190
Emcee Broadcast Products	181
ESE	195
Eventide Clockworks	188-189
Excaltibur Industries	93
Faroudja Labs	101

Fernseh	225
Fitzco Sound	182
For-A Corp	179
Fujinon Optical	112
Fuji Photo Film USA	236
Gerstenslager	128
Alan Gordon Enterprises	264
Grass Valley Group	7,132
Graham Patten Systems	220
Gray Engineering Labs	280
David Green Broadcast Consultants	170
Haliikainen & Friends	234
Harris Audio	139
Harris	45,176,245,252
Harrison	9
Hitachi Denshi American	243
Hitachi Video	169,232
HM Electronics	278
Howe Audio Productions	54
Hughes Electronic Devices Corp/HEDCO	118-119
Hughes Helicopters	259
IGM Trillium	283
Image Video	91
Inovonics	166
International Sound Systems	287
International Tapetronics	62
ITT Jennings	135
US JVC	127
K & H	246
Laird Telemedia	95
Laing	210
Leader	100
Lenco	233
Lerro Electrical	83-86
Lightning Elimination Assoc.	125
Listec Television Equip	251
LPB	248
L-W International	164
3M/Magnetic Tape Div	10-11,58-59,89,91,93,95,214
Marcom	213
Marconi Electronics	117
Marconi Instruments	253
Marti	63
Mathews	286
Maxell Corp of America	22
MCI	36,123,286
McMartin Industries	18
McMichael	158
Microtime	151
Microwave Assoc Communications	223
Monroe Electronics	52
Moseley Assoc	68,69
MPCS	16-17
Nady Systems	220
NEC America	231
Neptune	39
Rupert Neve	13,29
Nortronics	154
N-Pro	249
Nurad	284
O'Connor Engineering Labs	219
Oki	185
Orange Coast	234
Orban Associates	42
Otari Corp	20-21
Pacific Recorders & Engineering	50
Panasonic Matsushita	4-5,196-197
PEP Inc	289
Perrott Engineering	210,213
PGA	268
Philips Test & Measuring Instruments	167
Pierce-Phelps	186
Portable Energy Products	254
Potomac Instruments	268
Power Optics	208
QSI Systems	164,173
Quantum Audio	122
RCA Broadcast Systems	34
RCA EO	239,274

R-Columbia	121
Real World	256
Recortec	204
Rees	63
Research Technology	276
Rohde & Schwarz	107,201
Ross Video	116
Russco Electronics	146
Sachtler	226
Saki Magnetics	269
SATT	277
Scientific-Atlanta	279
Schneider TV Lenses	124
Sennheiser	144
Shivley	283
Shure Bros.	24
Sintronic	258
Solid-State Logic	198
Sony Broadcast	110-111,130-131,276
Spectra Computer	56-57
Stanton Magnetics	80
Star Case	270
Storeel	133
Straight Wire	25
Studer Revox America	211,C-3
Studio Master	146
Swiderski	172
System Concepts	3
Taber Mfg & Eng.	182
Telemeasure	165
Telemet	30
Telex Communications	53
Tentel	172
Thomson-CSF Broadcast	32-33
Tiffen Filters	70
Time & Frequency Technology	250
Townsend Assoc.	154
TVRO	280
Ultimate	150
United Media	281
UNR Rohn	262
UREI	38
Varian, Eimac Div.	60
Videodata	224
Videomedia	235
Videotek	157
Vital Industries	108
Ward Beck Systems	C-4
Winsted	52
Yagi	184
Yamaha	212
ZRC Chemical Products	114

## SALES OFFICES



### Broadcast Management/Engineering

295 Madison Ave.  
New York, New York 10017  
Telex: 64-4001

### Eastern & Midwestern States

295 Madison Avenue  
New York, New York 10017  
212-685-5320  
**James C. Maywalt**  
**Denis J. O'Malley**

### Western States

300 Broadway  
Suite 20  
San Francisco, CA 94133  
415-421-7330  
**William J. Healey**

18008 Skypark Circle, Suite 260  
Irvine, CA 92714  
714-556-6480  
**Bob Hubbard**

### United Kingdom/Europe

Chilberton House  
Doods Road  
Reigate, Surrey, England  
Telephone: Reigate 43521  
**Bronwyn Holmes**  
**Derek Hopkins**

### Japan/Far East

Eiraku Building  
1-13-9, Ginza,  
Chuo-Ku, Tokyo 104 Japan  
03 (562) 4781  
**S. Yasui**  
**K. Yamamoto**

A southern California major market radio station is accepting resumes for employment in two engineering areas:(1) Studio & transmitter maintenance (2) Production & board operations.

Maintenance persons must have experience with modern AM/FM transmitters and solid state studio equipment. General F.C.C. license is preferred.

Operational persons must have experience with all types of studio equipment, including cart and tape machines, consoles, editing and remote broadcast. General F.C.C. license is preferred.

Please send resume and salary history to:



**Doug Rotatori**  
**ABC- Personnel**  
**2420 Avenue of the Stars**  
**Century City, CA 90067**  
EOE M/F

NAME \_\_\_\_\_  
 TITLE \_\_\_\_\_  
 STATION OR COMPANY \_\_\_\_\_  
 ADDRESS \_\_\_\_\_  
 CITY \_\_\_\_\_ STATE \_\_\_\_\_ ZIP \_\_\_\_\_  
 PHONE # ( ) \_\_\_\_\_

GREAT IDEA BALLOT: Circle your favorite solution											
SOLUTION A				SOLUTION B				SOLUTION C			

Tell us what you like or dislike about the issue  
 \_\_\_\_\_  
 \_\_\_\_\_  
 \_\_\_\_\_

What articles would you like to see?  
 \_\_\_\_\_  
 \_\_\_\_\_  
 \_\_\_\_\_

100	101	102	103	104	105	106	107	108	109	110	111	112	113	114	115	116	117	118	119
120	121	122	123	124	125	126	127	128	129	130	131	132	133	134	135	136	137	138	139
140	141	142	143	144	145	146	147	148	149	150	151	152	153	154	155	156	157	158	159
160	161	162	163	164	165	166	167	168	169	170	171	172	173	174	175	176	177	178	179
180	181	182	183	184	185	186	187	188	189	190	191	192	193	194	195	196	197	198	199
200	201	202	203	204	205	206	207	208	209	210	211	212	213	214	215	216	217	218	219
220	221	222	223	224	225	226	227	228	229	230	231	232	233	234	235	236	237	238	239
240	241	242	243	244	245	246	247	248	249	250	251	252	253	254	255	256	257	258	259
260	261	262	263	264	265	266	267	268	269	270	271	272	273	274	275	276	277	278	279
280	281	282	283	284	285	286	287	288	289	290	291	292	293	294	295	296	297	298	299
300	301	302	303	304	305	306	307	308	309	310	311	312	313	314	315	316	317	318	319
320	321	322	323	324	325	326	327	328	329	330	331	332	333	334	335	336	337	338	339
340	341	342	343	344	345	346	347	348	349	350	351	352	353	354	355	356	357	358	359
360	361	362	363	364	365	366	367	368	369	370	371	372	373	374	375	376	377	378	379
380	381	382	383	384	385	386	387	388	389	390	391	392	393	394	395	396	397	398	399

Use until June 30, 1982

## BM/E READER SERVICE CARD March 1982 Issue

NAME \_\_\_\_\_  
 TITLE \_\_\_\_\_  
 STATION OR COMPANY \_\_\_\_\_  
 ADDRESS \_\_\_\_\_  
 CITY \_\_\_\_\_ STATE \_\_\_\_\_ ZIP \_\_\_\_\_  
 PHONE # ( ) \_\_\_\_\_

GREAT IDEA BALLOT: Circle your favorite solution											
SOLUTION A				SOLUTION B				SOLUTION C			

Tell us what you like or dislike about the issue  
 \_\_\_\_\_  
 \_\_\_\_\_  
 \_\_\_\_\_

What articles would you like to see?  
 \_\_\_\_\_  
 \_\_\_\_\_  
 \_\_\_\_\_

100	101	102	103	104	105	106	107	108	109	110	111	112	113	114	115	116	117	118	119
120	121	122	123	124	125	126	127	128	129	130	131	132	133	134	135	136	137	138	139
140	141	142	143	144	145	146	147	148	149	150	151	152	153	154	155	156	157	158	159
160	161	162	163	164	165	166	167	168	169	170	171	172	173	174	175	176	177	178	179
180	181	182	183	184	185	186	187	188	189	190	191	192	193	194	195	196	197	198	199
200	201	202	203	204	205	206	207	208	209	210	211	212	213	214	215	216	217	218	219
220	221	222	223	224	225	226	227	228	229	230	231	232	233	234	235	236	237	238	239
240	241	242	243	244	245	246	247	248	249	250	251	252	253	254	255	256	257	258	259
260	261	262	263	264	265	266	267	268	269	270	271	272	273	274	275	276	277	278	279
280	281	282	283	284	285	286	287	288	289	290	291	292	293	294	295	296	297	298	299
300	301	302	303	304	305	306	307	308	309	310	311	312	313	314	315	316	317	318	319
320	321	322	323	324	325	326	327	328	329	330	331	332	333	334	335	336	337	338	339
340	341	342	343	344	345	346	347	348	349	350	351	352	353	354	355	356	357	358	359
360	361	362	363	364	365	366	367	368	369	370	371	372	373	374	375	376	377	378	379
380	381	382	383	384	385	386	387	388	389	390	391	392	393	394	395	396	397	398	399

Use until June 30, 1982

## COMPLIMENTARY SUBSCRIPTION QUALIFICATION CARD

- I would like to receive BM/E (Broadcast Management/Engineering)  
 YES  NO
- Please check your business classifications  
 AM Station/Network/Group  Recording Studio  
 FM Station/Network/Group  Teleproduction Facility  
 TV Station/Network/Group  Government  
 Non-broadcast TV  Consultant  
 Campus Limited Radio  Lawyer  
 CATV Facilities  Manufacturer/Distributor/Dealer  
 Microwave Telephone, Satellite Company  Other (please specify) \_\_\_\_\_
- Are you responsible for more than one station or facility?  
 YES  NO
- My primary area of responsibility is (please check one)  
 Corporate Management Board Chairman, President, Owner, Partner, Director and VP or General Manager (other than in charge of engineering or station operations management)  
 Technical Management & Engineering VP Engineering, technical engineering director, chief engineer engineering supervisor, other engineering or technical titles  
 Operations & Station Management Production & Programming VP operations, operation manager director general manager, station manager, production manager, program manager, news director, and other operations titles

5. Signature \_\_\_\_\_ Date \_\_\_\_\_  
 Name \_\_\_\_\_  
 Title \_\_\_\_\_  
 Station Call Letters or Company \_\_\_\_\_  
 Street \_\_\_\_\_  
 City \_\_\_\_\_ State \_\_\_\_\_ Zip \_\_\_\_\_  
 Is this your business address?  YES  NO  
 If not, please give us your business address below so that we can avoid sending duplicate copies  
 Name \_\_\_\_\_  
 Station Call Letters or Company \_\_\_\_\_  
 Street \_\_\_\_\_  
 City \_\_\_\_\_ State \_\_\_\_\_ Zip \_\_\_\_\_

Place  
Postage  
Here



*Broadband Information Services, Inc.*  
*P.O. BOX 6058*  
*Duluth, Minnesota 55806*

Place  
Postage  
Here



*Broadband Information Services, Inc.*  
*P.O. BOX 6058*  
*Duluth, Minnesota 55806*

Place  
Postage  
Here



*Broadband Information Services, Inc.*  
*P. O. BOX 6056*  
*Duluth, Minnesota 55806*

# Familiarity breeds respect.

You'll appreciate the Studer B67 MKII from the day it arrives at the station. After several years of hard use, your appreciation will turn to deep respect.

From the beginning, you'll appreciate Studer performance. You'll notice the solidity of the transport, the smoothness of the tape-handling, and the positive feel of the control mechanisms. And you'll hear the sonic clarity you expect from a Studer.

Soon you'll grow accustomed to the features: three speed (15/7.5/3.75 or 30/15/7.5 ips) operation, quartz PLL capstan drive, servo controlled spooling motors, real time counter with plus or minus readout, fader start, dump edit, and auto repeat. Improvements on the B67 MKII include locking tension sensor arms and better head access for easier edits. Full remote and vari-speed available as options.

Finally, as the months turn to years, you'll gain great respect for the B67 MKII's thoughtful design and meticulous Swiss craftsmanship.

Studer professional recorders. Respected worldwide for exceptional reliability and unmatched quality.



**STUDER** REVOX

Studer Revox America, Inc. / 1425 Elm Hill Pike, Nashville, TN 37210 (615) 254-5651  
Offices: Los Angeles (213) 780-4234 / New York (212) 255-4462 • Canada: Studer Revox Canada, Ltd.

Circle 352 on Reader Service Card

[www.americanradiohistory.com](http://www.americanradiohistory.com)

# The dawning of a new era in wide screen sound technology by Ward-Beck

Ward-Beck goes to virtually unlimited lengths to provide the ultimate in custom audio control systems for today's imaginative film producer.

Tomorrow's needs are fully accommodated in this highly sophisticated console at the PATHE Film Studios in Toronto.

For final mixing it accepts the creative talents of up to three sound engineers working together as one.



First by Design.

Ward-Beck Systems Ltd., 841 Progress Avenue, Scarborough, Ontario, Canada M1H 2X4.  
Tel: (416) 438-6550.

Ward-Beck Systems Inc., 6900 East Camelback Road, Suite 1010, Scottsdale, Arizona 85251.