

BROADCAST[®] ENGINEERING

May 1987/\$3

Transmission systems special report



100-----M YE757000 0 XXXXX BE0
J101870000000 26 A 001
RAYMOND MEYER FS
BENCHMARK COMMUNICATION CORP BE
4700 SW 75TH AVE
MIAMI FL 33155

Seeing
between
the lines
pg. 116

AL never met a tape he didn't like.

AL'S is an Automated Library System where all tapes are welcome. Beta, Beta SP, M, M2, U-matic or Digital 19mm formats -- you name it. AL'S can handle it. And in numbers enough to make even a station manager smile. 500, 1000, 1500. How big is your library? AL'S can handle it.

You want to mix formats? AL mixes it up with the best of them. Any combination of tape formats is a piece of cake for AL. Full length programming or commercials -- you mix them up any way you want to. AL'S never been one to play favorites. AL'S will even play news tapes quickly along with all your others.*

AL is top drawer, high tech digital technology -- but he's no snob. Plain and simple, out of the box, stock VTRs suit AL just fine. Why take a chance on prima donna machinery?

Why take a chance, period? Your tape library couldn't be in hands more capable than AL's.

For more information -- or, for an audience with AL himself, call us at: (617) 244-6881. Optional

**Automated
Library
System**
LaKart Division
287 Grove Street
Newton, MA 02116

LAKE
The Systems Company

Circle (7) on Reply Card

www.americanradiohistory.com

Cross-Country Communication

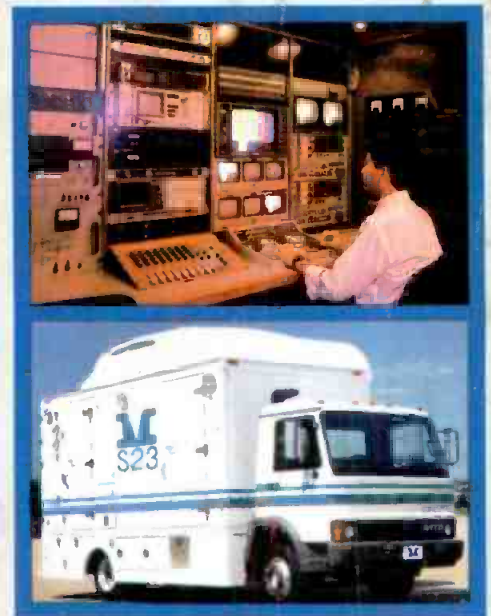

With the antenna
that works!

In Brownsville,

In Seattle,

In Miami,

Everywhere!

Midwest combines its mobile production unit experience with the latest antenna technology to bring you the S-23, a satellite news vehicle that enables you to uplink a story from virtually anywhere.

The S-23 incorporates a Vertex 2.6M antenna with 50db gain into a unit that is spacious enough for full production capability, yet has excellent weight distribution and a wide GVW safety margin.

An integral deployment and positioning system ensures antenna

accuracy, even in heavy weather. You can choose from a variety of equipment configurations and several domestic and foreign chassis models.

Call for specifications and antenna patterns on the S-23, S-18, S-1 Fly-away or any of our mobile satellite news systems.

The Midwest S-23. The mobile satellite news system that works. Everywhere.

2.6M Vertex Antenna

- >50db Gain at 14.25 GHz
- >35db Cross Polar Isolation
- Meets 29-25_{log}θ FCC 2° Spacing Curves



MIDWEST
Communications Corp.

One Sperti Drive
Edgewood, KY 41017
606-331-8990

Circle (3) on Reply Card

Contents

May 1987 • Volume 29 • Number 5



Page 26

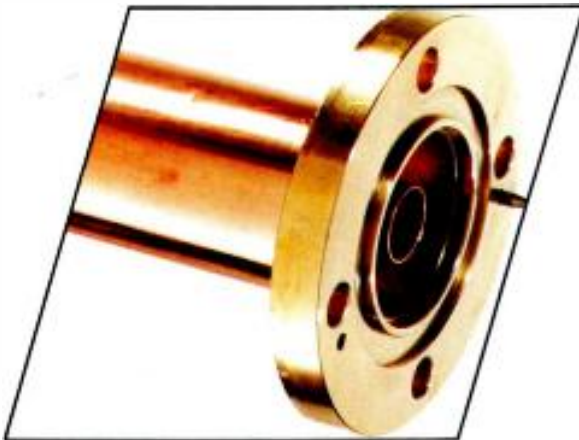

Page 64



Page 93

BROADCAST ENGINEERING

TRANSMISSION SYSTEMS SPECIAL REPORT:

The transmission plant is the heart of any radio or TV facility. The most basic requirement of the engineering department is to keep the transmission system—from the STL to the antenna—in good working order. We examine this critical area of station operation in our Transmission Systems Special Report:

22 Introduction

By Ned Soseman, TV technical editor

26 Inside FM Power Amplifiers

By Jerry Whitaker, editorial director, and Clarence Daugherty, Harris Corporation
To get the most out of a cavity PA FM transmitter, you need to know how it works.

46 Fine-Tuning FM Final Stages

By Geoffrey N. Mendenhall, Broadcast Electronics
Tuning the output stage of an FM transmitter is more than a *peak* and a *dip* process.

64 The Evolution of Broadcast Transmission Lines

By Geza Dienes, Andrew Corporation
The transfer of RF energy is an art and a science, with a little plumbing tossed in.

78 Curve-Fitting Program for Transmission Lines

By Dane Ericksen, Hammett & Edison, consulting engineers
Use your computer to select the best transmission line for the job.

93 Building and Operating a Tower Facility

By Ray Upsahl, Skilling Ward Rogers Barkshire
Understanding tower dynamics and maintenance can add to the service life of your tower.

OTHER FEATURES:

116 Seeing Between the Lines

By Carl Bentz, special projects editor
To see is to believe, but when your video monitor isn't truthful, what then?

134 Show Preview: Montreux '87

By Carl Bentz, special projects editor
The premier international broadcast trade show for 1987 will be held next month in Montreux, Switzerland.

ON THE COVER

Power tubes are the heart of high-power broadcast transmitters. They provide high gain, power-dissipation capability and reliability in a single package. The industry's need for devices capable of higher output and greater reliability is being met with new processes and materials. Shown is a 3CX12,000U7 power tube, designed for VHF-TV applications. (Photograph by Doug Schwartz, Flightspeed Graphics, Santa Clara, CA. Tube provided by Varian Eimac.)

DEPARTMENTS

4 News	18 Troubleshooting
6 Editorial	20 Management for Engineers
8 FCC Update	136 Field Report: Orban 275-A Synthesizer
10 Strictly TV	146 SBE Update
12 re: Radio	148 People
14 Satellite Technology	152 Business
16 Circuits	156 New Products

HOW THE SK-110D PUTS AN END TO THE REIGN OF ERROR.

With the SK-110D, Hitachi has created a studio broadcast camera with microprocessor technology so accurate that registration errors and time-consuming setup are things of the past.

Using a single button, now you can automatically set up RGB, color balance, and analog and digital registration—along with complete fault diagnosis—for up to 42 cameras simultaneously in just two minutes. And while you're shooting, the SK-110D keeps correcting realtime zoom and focusing errors, as well as registration changes caused by fluctuating prism temperatures.

The SK-110D performs magnificently.

Here's why: The 30-mm LOC diode gun Plumbicons and electronics yield 750 lines horizontal resolution, and greater than -56dB S/N. Dynamic focus provides for superb corner resolution. And detail signals are generated from both red and green.

The SK-110D is also today's most technologically advanced and versatile camera system. It offers iris and auto-setup by external chart. It has a high-resolution viewfinder with electronic markers.

The battery-backed head and CCU store up to four full-function files, eight lens files and 64 scene files. And add a smart RCU that controls those files, and you've got a camera that can precisely remember the "look" of every production shot you'll take.

Put an end to the reign of error in your studio today. And usher in a new era of image quality with the Hitachi SK-110D. For a demonstration in your studio contact Hitachi Denshi America Ltd., Broadcast and Professional

Division, 175 Crossways Park West, Woodbury, NY 11797; (516) 921-7200 or (800) 645-7510. Canada: Hitachi Denshi, Ltd. (Canada), 65 Melford Drive, Scarborough, Ontario M1B 2G6; (416) 299-5900.

 **HITACHI**

Circle (4) on Reply Card



Lanesborough acquires Ampex

Allied-Signal and Lanesborough Corporation have announced that they have signed an agreement for the sale of Allied-Signal's Ampex unit to Lanesborough for \$479 million, plus the assumption of certain liabilities.

Lanesborough intends to finance the transaction through a combination of its own equity and an offering of debt or equity securities. In the interim, Lanesborough has arranged for credit facilities with commitments of up to \$475 million from a major New York bank.

Under the agreement, Ampex will be acquired by a newly formed subsidiary of Lanesborough, which plans to operate Ampex with its present management and organizational structure. The transaction was expected to be completed by the end of May, pending regulatory and other approvals.

Lanesborough, which is privately held, manufactures a variety of specialty

chemical products for sale in the United States and abroad.

Allied-Signal (an advanced technology company focused on aerospace, automotive products and engineered materials) announced last December that it was selling Ampex and six other units in its Electronics & Instrumentation sector.

USC/SMPTE seminar telecast via satellite

The Hollywood section of the Society of Motion Picture and Television Engineers and the Continuing Education Division of the School of Cinema-Television, University of Southern California, are sponsoring a 1-day spring tutorial seminar titled, *Electronic Post-Production for Film and Videotape: The 'New Wave' in Electronic Post-Production—An Update*.

The seminar will be held on the USC campus on Saturday, May 16, from 8:45 a.m. to 3:30 p.m. (Pacific Daylight Time). It will be telecast via satellite to universities and colleges coast-to-coast.

Escalating production costs have refocused attention on electronic post-production as an effective technology that might yield cost savings as well as creative flexibility. More than two dozen TV series have been post-produced electronically during this past 1986-87 season, with new techniques being developed and redefined daily.

Seminar attendance is open to industry professionals, students and interested individuals. There is a \$50 registration fee for SMPTE members, \$60 for non-members and \$30 for students. Lunch is included in the registration fee. Due to space limitations, early registration is required.

To register in the Los Angeles area, and for additional information on other schools participating in the telecast of the SMPTE/USC spring tutorial seminar on electronic post-production, call the Continuing Education Division of the USC School of Cinema-Television at 213-743-7469, extension 6.

Continued on page 164

BROADCAST engineering

EDITORIAL

Jerry Whitaker, *Editorial Director*
Brad Dick, *Radio Technical Editor*
Ned Soseman, *TV Technical Editor*
Carl Bentz, *Special Projects Editor*
Paula Janicke, *Associate Editor*
Dawn Hightower, *Associate Editor*
Dan Torchia, *Group Managing Editor*
Ailsa Carter, *Editorial Assistant*
Ramona Vassar, *Group Editorial Assistant*
Pat Blanton, *Directory Editor*

ART

Kristi Sherman, *Graphic Designer*

EDITORIAL CONSULTANTS

Fred Ampel, *Audio*
Nils Conrad Persson, *Electronics*
Tom Cook, *Video*
Mel Lambert, *Professional Audio*

BUSINESS

Cameron Bishop, *Group Vice President*
Duane N. Hefner, *Publisher*
Stephanie Fagan, *Promotions Manager*
Cynthia Sedler, *Promotions Coordinator*
Dee Unger, *Advertising Supervisor*
Mary Birnbaum, *Advertising Coordinator*

ADMINISTRATION

R. J. Hancock, *President*
Doug Riemer, *Circulation Director*
JoAnn DeSmet, *Circulation Manager*
Dee Manies, *Reader Correspondent*
Kevin Callahan, *Art Director*

Editorial and advertising correspondence should be addressed to: P.O. Box 12901, Overland Park, KS 66212-9981 (a suburb of Kansas City, MO); (913) 888-4664. Telex: 42-4156 Intertec OLPK. Circulation correspondence should be sent to the above address, under P.O. Box 12937.

TECHNICAL CONSULTANTS

Eric Neil Angevine, *Broadcast Acoustics*
John H. Battison, *Antennas/Radiation*
Blair Benson, *TV Technology*
Dennis Ciapura, *Radio Technology*
Dane E. Ericksen, *Systems Design*
Howard T. Head, *European Correspondent*
Wallace Johnson, *FCC/Bdct. Engineering*
John Kean, *Subcarrier Technology*
Donald L. Markley, *Transmission Facilities*
Harry C. Martin, *Legal*
Robert J. Nissen, *Studio/Communications*
Hugh R. Paul, *International Engineering*
Art Schneider, *A.C.E., Post-production*
Elmer Smalling III, *Cable/Satellite Systems*
Vincent Wasilewski, *Communications Law*

MEMBER ORGANIZATIONS

Acoustical Society of America
Society of Broadcast Engineers

Member,
Association of Business Publishers
Member,
Business Publications
Audit of Circulation



SUBSCRIPTIONS: BROADCAST ENGINEERING is mailed free to qualified persons within the United States and Canada in occupations described above. Non-qualified persons may subscribe at the following rates: United States and Canada: one year, \$25.00. Qualified and non-qualified persons in all other countries: one-year, \$30.00 (surface mail); \$108.00 (air mail). Back issue rates, \$5, except for the Buyers' Guide/Spec Book, which is \$20. Rates include postage. Adjustments necessitated by subscription termination at single copy rate. Allow 6-8 weeks for new subscriptions or for change of address. Second class postage paid at Shawnee Mission, KS.

BROADCAST ENGINEERING Volume 29, No. 5 (USPS 338-130) is published monthly (except in the fall, when two issues are published) by Intertec Publishing Corporation, 9221 Quivira Road, P.O. Box 12901, Overland Park, KS 66212. Second Class Postage paid at Shawnee Mission, KS and additional mailing offices. **POSTMASTER:** Send address changes to BROADCAST ENGINEERING, P.O. Box 12983, Overland Park, KS 66212.

Photocopy rights: Permission to photocopy for internal or personal use is granted by Intertec Publishing Corporation for libraries and others registered with Copyright Clearance Center (CCC), provided the base fee of \$2.00 per copy of article is paid directly to CCC, 21 Congress St., Salem, MA 01970. Special requests should be addressed to Cameron Bishop, group vice president. ISSN 0007 1794 \$2.00 + \$0.00.

©1987. All rights reserved.

Advertising offices listed on page 167.



LEADER



Once-in-a-lifetime events don't happen twice!

This 8-lb EFP/ENG Monitor confirms your field productions are perfect, first time, every time!

The LVM-5863A Color/Audio Waveform Monitor confidence tests camera and VCR performance anywhere. Shows you the overall production quality immediately... with full color (NTSC) and sound. LVM-5863A lets you be sure all your productions are technically and artistically correct *before* you leave the location. The LVM-5863A confirms white balance, sync and burst levels. Its 2H and 2V waveforms show both line and field rate signals. A switchable IRE filter makes it easy to check peak video. And for



LVM-5863A

accurate verification of setup and black balance, switch on the 4x magnifier. With all this, the LVM-5863A is easy to use since controls are kept to a minimum.

It goes anywhere.

Lightweight and small, the LVM-5863A is easy to hand carry or to mount in trucks, vans or helicopters. Requiring only 12 Vdc, it can use a readily available, self-contained battery (Sony NP-1 or equivalent) or

external power sources such as vehicles and EFP battery belts.

Quickly pays for itself.

The LVM-5863A eliminates the risk of time-wasting, cost-increasing, missed or poor-quality shots.

For Product Demonstration Circle (5) on Reply Card

For Product Information Circle (6) on Reply Card

Call toll-free
(800) 645-5104

In NY State
(516) 231-6900

Request an evaluation sample, our latest Test Instrument Catalog with over 100 outstanding products, the name and address of your nearest "Select" Leader Distributor, or additional information.

For professionals

who know the difference.

LEADER
Instruments Corporation

380 Oser Avenue, Hauppauge, New York 11788

Regional Offices:

Chicago, Dallas, Los Angeles, Boston, Atlanta
In Canada call Omnitronix Ltd. (514) 337-9500

QUALITY CONTROLLER.

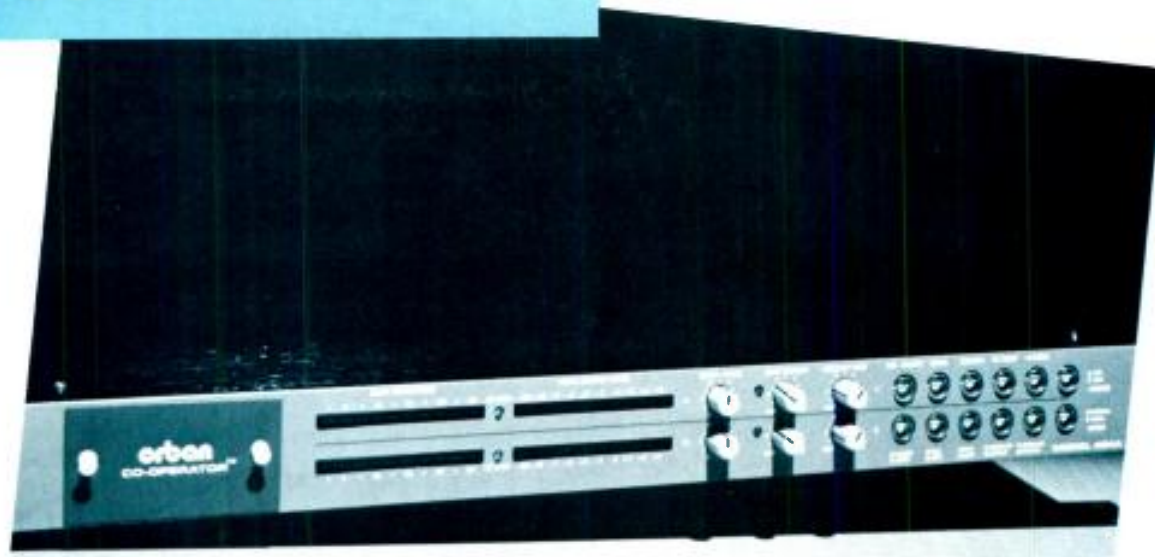

THE NEW ORBAN CO-OPERATOR™ AGC SYSTEM

Introducing the *Co-Operator*: an integrated, easy-to-use Gated Stereo Leveler/Compressor/HF Limiter/Peak Clipper in a powerful and economical dual-channel package. The Co-Operator automatically rides gain, controls excessive high frequency levels, and limits peaks while protecting audio and video tape recorders, broadcast cart machines, mic channels, STL microwave links, and SCA's.

Its simplified controls ensure top results—even from non-technical operators. Yet there is sufficient versatility so that you are never locked into a single "sound".

The Co-Operator rides gain subtly and intelligently—the way *you* would—to preserve the dynamic "feel" of the program material while effectively controlling levels. Or, if gain-riding is not desired, use it as a transparent, no-compromise safety limiter. Either way, it's always alert to safeguard audio quality. It contains a:

- Smooth leveler for transparent gain riding—without long-term distortion-producing overshoots
- Fast compressor and/or peak clipper can be activated to protect against short-term transients. Adjustable release time and release shape let you optimize processing for music or voice
- "Silence Gate" and compressor/leveler crosscoupling team up to prevent pumping and noise breathing
- HF Limiter with six switchable pre-emphasis curves from 25 to 150 us allow you to match the medium being protected and guard against sibilance overload

Ask your Dealer about Orban's new Model 464A Co-Operator—your subtle, automatic quality controller.



Orban Associates Inc.

645 Bryant St., San Francisco, CA 94107 (415) 957-1067 Telex: 17-1480

Circle (118) on Reply Card

Audits discourage false financial certification

By Harry C. Martin

The FCC is making random checks of the backup financial documentation required of construction permit applicants who have certified their financial qualifications. The checks are being conducted as part of prehearing processing. In cases where an applicant has a large number of pending broadcast applications, the commission is authorized to question the validity of the applicant's financial certification. Each applicant selected for audit, whether at random or as a result of an actual question about the validity of a certification, will have to submit all of the documentation on which it relies to support its certification.

The commission eliminated the requirement for detailed financial showings as part of its deregulation program. The certification procedure was designed to conserve commission resources by eliminating the need for analysis of financial documentation, especially from the thousands of applicants who do not become commission licensees. By replacing the documentation requirement with financial certification, however, the commission was careful to emphasize that it was not modifying the basic requirement that applicants have sufficient net liquid assets on hand or available to construct and operate a proposed station for three months without revenue.

Based on the commission's experience over the past five years, a number of broadcast applicants have certified their financial qualifications without any basis or justification. The audit procedure is intended to discourage false financial certifications while preserving the deregulatory benefits of the certification procedure. If a financial certification check reveals that an applicant's certification is false, hearing issues will be designated to determine whether the applicant is financially qualified and whether the applicant is guilty of misrepresentation.

New ownership reporting requirements

The commission has issued a new ownership reporting form (Form 323), which



has been mailed to all commercial broadcast licensees. Most stations must file the report by Aug. 3. Beginning Feb. 1, 1988, non-exempt licensees must annually update their ownership reports on the anniversary date of the filing of the station's license renewal application. Licensees of multiple broadcast stations with different renewal anniversary filing dates may select a single date on which to submit their annual ownership reports, but those reports may not be submitted more than one year apart. After the initial Aug. 3 filing, licensees may submit a certification that no changes have occurred, in lieu of filing a new ownership report.

The only commercial licensees exempt from these filing requirements are partnerships entirely composed of natural persons and sole proprietorships.

FM reclassification procedures

In a public notice issued in late March, the commission outlined how its reclassification of FM facilities pursuant to Docket 80-90 will be implemented now that the March 2 deadline for upgrade applications has passed. The commission accepted applications up to March 2 by Class B and C stations seeking to meet minimum power and height requirements in order to avoid reclassification to a lower class.

This example shows how the reclassification system is being implemented.

Station WXYZ operates on a Class C channel currently allocated to Center City. Center City and the channel are listed in the Table of Allotments. WXYZ operates on this channel with facilities of 20kW at 100m above average terrain. The station also has a construction permit to modify its facilities to increase power to 100kW at 100m. An application was filed by the close of business on March 2, to modify the WXYZ construction permit to operate with facilities of 100kW at 400m. The reclassification procedures affect station WXYZ and its allotment in the following ways:

- The existing license is reclassified to C2.
- The construction permit is reclassified to C1.

- The application is classified as C.
- The class of this channel on the Table of Allotments is not reclassified because the application requesting full Class C facilities was on file by the close of business on March 2.

Any other applicant will have to protect WXYZ's licensed site as a C2, the site of its construction permit as a C1 and the proposed site in its application as a C. The eventual grant of a license to WXYZ for the proposed facilities will cause the Class C channel to be retained in the Table of Allotments and the station will continue to operate as a full Class C facility. However, if the application is returned later or dismissed, the class of this channel in the Table of Allotments will be reclassified to C1 to reflect the class of the construction permit. Other applicants would then only have to protect the station's licensed site as a C2 and the site of its construction permit as a C1. If the construction permit expires, the class of the channel on the Table of Allotments will be classified as C2 to reflect the class of the existing license. Other applicants will then only have to protect WXYZ's licensed site as a C2.

The commission made special provisions to protect the classification rights of applicants in hearing status who are not eligible to amend specifications for minimum facilities for their classes. Also protected are stations that do not fit into any particular class under the current rules. Such stations will not be reclassified until after the commission completes its pending rulemaking in Docket 86-144, which proposes an index method of classification. Furthermore, Class B stations with their transmitters located in Zone 1 or 1A are being reclassified as B or B1.

If an upgrade application filed by an existing station before the March 2 deadline is found insufficient, the applicant will be given one opportunity to correct all deficiencies before the application is returned. Such applicants will be given 30 days to correct noted deficiencies and any other deficiencies that may exist in the application. If, after this 30-day period, the application still contains deficiencies, it will be returned and the allotment reclassified.

! : ? -)))

Martin is a partner with the legal firm of Reddy, Begley & Martin, Washington, DC.



Introducing the Model 200.

A powerful production switcher
that won't wipe you out.

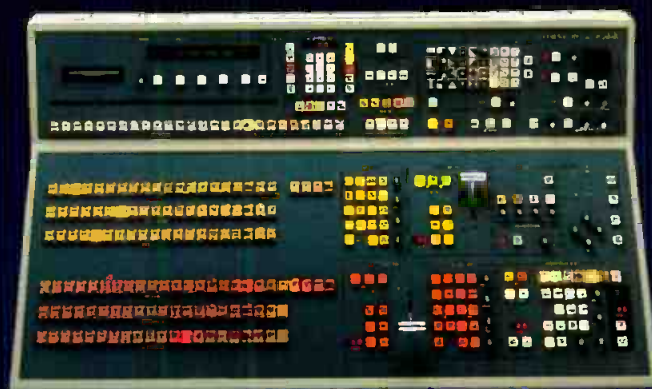

The new Model 200 Production Switcher.

Two mix-effects, 20 inputs, five powerful keyers, an incredibly innovative wipe system,
nine color matte generators and an E-MEM® Effects Memory System.
More power than you ever thought possible for less than \$40,000.

Grass Valley Group®

Circle (8) on Reply Card

THE GRASS VALLEY GROUP, INC. — P.O. Box 1114 - Grass Valley, CA 95945 USA - Telephone (916) 478-3000 - TRT: 160432
New York (212) 845-7988; District of Columbia (301) 612-6313; Atlanta (404) 493-1255; Chicago (312) 264-0931; Minneapolis (612) 483-2594; Dallas-Fort Worth (817) 984-7447;
Los Angeles (818) 999-2303; San Francisco (415) 968-6680.

A TEATRONIX COMPANY

www.americanradiohistory.com

The Klystrode stirs interest at NAB

By Don Markley

The Varian Klystrode was shown again at this year's NAB Convention in Dallas. As expected, it was found in the Varian booth and in a transmitter shown by Comark.

The Klystrodes displayed were models X2253 and X2252. The X2253 is used for channels 14 through 35 and the X2252 is used for channels 36 through 69. This is a 60kW peak visual power amplifier tube that is furnished in a transmitter using a 500W driver.

The transmitter on display had been in operation for several weeks at the Comark factory and had operated with an overall plant efficiency of 71% (60kW peak visual power and 6kW aural power). This plant efficiency could be compared to a 60kW klystron transmitter, which would provide a plant efficiency of 51%. Plant efficiency relates the visual and aural power output to the actual electrical service consumed from the ac power lines.

The first Klystrode transmitter is expected to be installed this fall at WBFF in Baltimore. The unit will be a super-power transmitter that will use six Klystrodes in parallel to produce 360kW of

Markley, BE's consultant on transmission facilities, operates D. L. Markley & Associates, a consulting firm in Peoria, IL.



visual power and 36kW of aural power. That transmitter currently is under development.

Trade-offs

It appears that the price for a Klystrode transmitter will be slightly higher than that for a comparable klystron-equipped system. The Klystrode transmitter will exceed the klystron transmitter price by about \$70,000 per visual power amplifier. A 120kW transmitter using Klystrodes would cost about \$120,000 more than the comparable transmitter with klystrons. However, the power savings should recover this cost over the life of the system.

Two primary factors enter into the increased price. First, the Klystrode transmitter requires a 500W driver stage that is not needed in the klystron. Second, the Klystrode uses a 30kV regulated beam supply. Obviously, this piece of hardware is more expensive than the unregulated supplies used in klystron assemblies.

The Klystrode uses water to cool the collector. The remainder of the tube is cooled by forced air.

The plant efficiency also is assisted by the fact that the magnet-focusing power is less than 300W for the Klystrode. This greatly reduces the size of the magnet-

power-supply system and eliminates the need for water-cooled coils.

Work is proceeding at the 60kW level and the 30kW transmitter should come along later. This appears to be a highly desirable development, based upon the current UHF transmitter market. In addition, the real efficiencies of the Klystrode come into play when the higher power levels are considered. It is in the 220kW and above ranges that the efficiency advantages become overwhelming for a Klystrode amplifier system.

Operating considerations

Both Comark and Varian believe that the life expectancy of the Klystrode will be about the same as that of the klystron. The filament assemblies are roughly comparable and there is no reason to assume any significant difference in life expectancy. The price of the 60kW Klystrode is about equal to the price of a 60kW external cavity klystron.

Varian will furnish the magnetic frame, magnet coil, input cavity, double-tuned output cavity and input and RF couplers. In short, the complete box, ready to roll, is supplied by the company. It is only necessary to provide the normal operating voltages and RF drive to obtain what promises to be the highest efficiency visual amplifier on the market.

Other than Comark, manufacturers appear to be taking a *wait-and-see* attitude concerning this new device.

The general consensus seems to be that the Klystrode sounds like a wonderful box and engineers will look at it again when a few of the Klystrodes have 20,000 hours of field use. Unfortunately, this is a penalty that any new product must pay before its final acceptance in the marketplace.

Hopefully the actual introduction of the device into an on-the-air TV facility will boost the Klystrode in the broadcast industry.

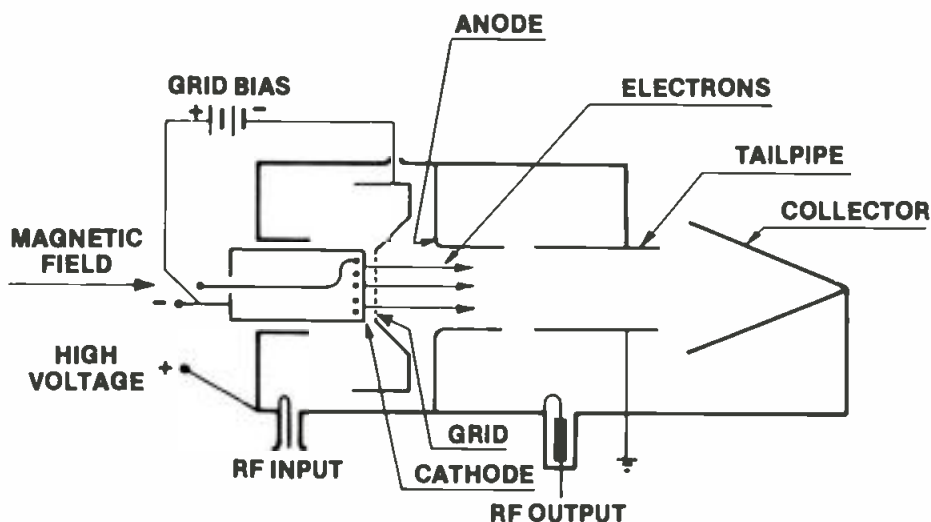

Figure 1. Schematic representation of the Klystrode device, which combines the features of a klystron and a tetrode.

||:~(-)]]]]



The mic mixer you would have designed yourself—The Shure M267.

In the space of just two years, the Shure M267 has become one of the most well-known and widely used mixers in the broadcast industry. One look at it will tell you why.

The M267 gives you the improvements you've told us were most important. Every channel has a mic line level switch for maximum flexibility. There's also a built-in limiter to keep the M267 from overloading at critical moments. The unit contains a built-in battery pack that utilizes three standard 9-volt batteries.

Simplex (phantom) power and a peak LED are standard, too.

The M267 oscillator provides a clean 1 kHz tone, and is located on the front of the unit for simple access. The headphone output is also on the front and includes a level control. IC design, along with active gain controls, provides greater headroom and quieter operation.

For location work or even studio post-production, the M267 carries on Shure's reputation for reliability and ruggedness.

For more information on Shure's complete line of mixers, call or write Shure Brothers, Inc., 222 Hartrey Avenue, Evanston, IL 60202, (312) 866-2553.

SHURE[®]

BREAKING SOUND BARRIERS

Circle (9) on Reply Card

Reviewing FCC field-strength rules

By John Battison, P.E.

Several years ago, the FCC repealed the requirement for a complete annual audio proof-of-performance. From my conversations at many stations, it appears that one important element left in the rules has gone unnoticed. Although it is no longer a rigid rule that an audio proof be performed, it still is necessary to make an annual brief equipment performance measurement.

In the good old days, most of the rules pertaining to AM and FM technical matters were contained in neat little compartments. For instance, the AM rules were listed in 73.1-199 and FM rules were listed in 73.200. Now, Part 73 rules number in the thousands. References contained within this document are complex, but critical to a station's operation. A lack of knowledge about these regulations could lead to disaster. The material in Part 73.44 is a perfect example.

Current requirements

Part 73.44 lists the requirements that must be met by AM transmitters. The allowable transmitter tolerances are based on the date the transmitter entered serv-

Battison, BE's consultant on antennas and radiation, owns John H. Battison & Associates, a consulting engineering company in Columbus, OH.



ice. A casual reading of the rules might give the impression that there is no requirement that an annual emission check be made or that annual records are unnecessary. However, this is not the case.

Section 73.1590, *Equipment Performance Measurements*, details when the equipment measurements must be made. An abbreviated list of the conditions that trigger the need for the tests is shown below (see the FCC rules for exact wording):

- upon initial installation of a new/replacement transmitter;
- modification of existing transmitter or system;
- installation of AM stereo transmission equipment;
- installation of FM stereo transmission equipment;
- as required by other provisions of the rules or license; and
- annually for AM and FM stations, with no more than 14 months between measurements.

A close reading shows that only AM stations have to make annual measurements. FM and TV (aural) stations must provide data showing compliance by the attenuation of spurious and harmonic radiation if any changes in the transmitter or associated equipment have taken

place. The specific requirements for FM spurious emissions are listed in 73.317.

Apparently, the tests for FM stations do not have to be performed annually as required for AM stations. However, in the event of an inspection, you must be able to demonstrate that your equipment complies with the above specifications.

The commission recently modified the rules concerning interference. The new rules eliminate the need to refer to 73.1590. This change points up the importance of keeping abreast of any changes.

Report form

Last month I promised to provide an example of an AM emission report form, which has worked well for me. The form, shown in Table 1, makes it relatively easy to properly record all of the pertinent data. The form can be modified as necessary to fit your particular needs.

Complete the form for each measurement location. When all of the required measurements have been made, properly file the data. The information may be requested by an FCC inspector. Perhaps even more important, the data can be a valuable source of information in the coming years as you need to adjust the antenna array.

ANNUAL EQUIPMENT PERFORMANCE REPORT	
STATION _____	DATE: _____
FREQUENCY _____ kHz.	
POWER _____ kW.	MODE: DA/NON DA _____
PLACE OF MEASUREMENT _____	
DISTANCE _____ MI. (_____ KM)	
FUNDAMENTAL _____ kHz. FS.	MV/M
2nd HARMONIC _____ kHz. FS.	MV/M
3rd HARMONIC _____ kHz. FS.	MV/M
F TO ± 30kHz. BETTER THAN - 25dB.	_____
F TO ± 75kHz. BETTER THAN - 35dB.	_____
F TO MORE THAN ± 75kHz. BETTER THAN - 89.99dB.	_____
BETTER THAN - 80dB.	_____
TRANSMITTER INSTALLATION DATE: _____	
COMMENTS:	
SIGNED: _____	

Table 1. An equipment performance report form such as this can ensure that all of the required data is available for inspection or maintenance purposes.

MTS PROCESSING and A SUPERIOR GENERATOR FOR LESS



THAN MOST OTHER GENERATORS

The TVS-3002 Limiter/generator combines a state-of-the-art digitally synthesized MTS generator with new generation limiter-AGC circuitry to provide a complete, stand-alone stereo television audio system.

Through the use of unique circuit designs and packaging concepts, this one box system contains all that's needed to get you on the air in stereo quickly and easily.

The heart of the TVS-3002 is a time proven digitally synthesized subcarrier modulator that develops a digital approximation of the subcarrier and pilot frequencies. This system greatly relieves the filter requirements following the modulator, significantly improving the stereo separation specification.

To complete the system, the TVS-3002 includes the following additional features.

- L/R or L + R/L - R Inputs
- > 20 dB Levelling AGC Range
- Unique Program Controlled Stereo Sound Field Enhancement circuitry
- CRL's Exclusive Variable Transfer Function Pre-emphasis Limiting
- Factory dbx® Encoding
- Improved dbx® Noise Reduction that reduces noise floor transmission by up to 20 dB over other existing generators
- On-Board Bessel Tone Calibration Generator
- Add the TVS-3002 Multiband Audio Controller for the ultimate in audio control and stereo generation.

Before you spend more and get less, we encourage you to contact CRL for further information and arrange for a demonstration of the NEW GENERATION MTS systems.

**A
GENERATION
AHEAD**



CRL Systems

2522 West Geneva Drive
Tempe, Arizona 85282
(800) 535-7648 (602) 438-0888
TELEX: 350464 CRL TMPE. UD.

Circle (10) on Reply Card

dbx is a registered trademark of dbx, Inc.

www.americanradiohistory.com

Traveling Wave Tube basics

By Elmer Smalling III

Although TWTs are used extensively as power amplifiers in satellite communications, few people are familiar with their operation. The traveling wave tube amplifier operates in a fashion similar to the klystron. That is, an electron beam is velocity (current) modulated by a radio signal. A microwave radio wave is made to travel along a helix that is concentric with an electron beam generated by a hot cathode.

As the electron beam travels along the helix (known as a slow-wave circuit), the radio energy input to the TWT causes bunching of the electrons, which then decelerate, losing energy to the radio wave. In this fashion, power from the electron beam is added to the radio frequency energy providing amplification of the radio signal. The amplified radio signal is delivered to a matched load (transmission line) at the end of the helix. The electron beam is absorbed by a collector at the end of its trip.

There is a version of the TWT where the microwave energy travels in the opposite direction to the electron beam. This is called a backward-wave tube and is used primarily as a microwave oscillator. Traveling wave tubes may have a bandwidth as great as 100% at the fundamental operating frequency.

Efficiency

Early traveling wave tubes had about

Smalling, BE's consultant on cable/satellite systems, is president of Jenel Systems and Design, Dallas.



10% efficiency. Although this seems rather small, the tubes were operated at relatively high power (1,000W to 500,000W) so that the 100W to 50,000W output signal was still much greater than most klystrons or magnetrons could provide at the time.

TWT efficiency may be increased in two basic ways. First, the electron beam that travels down the center of the helix tends to slow as it gives up energy to the radio signal. This causes the two beams (radio and electron) to get out of step. The favorable bunching that takes place between the two beams is destroyed and the TWT loses its efficiency. Increasing the electron beam operating voltage will help improve the phase coherence and operation.

Second, additional energy may be collected from the electron beam by a specially constructed collector that has a series of depressions off-axis to collect unused electrons from the spent beam. Efficiencies of 45% to 50% are attainable.

Intermodulation distortion

TWTs are susceptible to intermodulation distortion when multiple carriers are introduced as in doubly illuminated or multiple SCPC transponders. These IM products may be found at frequencies that are displaced from the fundamental carriers by the difference in frequency between them. It is easy to see that, when there are multiple carriers present, the potential for very severe IM exists.

The best fix for IM is to operate the TWT below saturation. The power must be reduced (backed off) in proportion to the number of carriers and their relative power. It is important to adjust TWT back off according to the manufacturer's recommendations as transponder loading conditions change.

Harmonics

Because of the wide bandwidth and non-linear operating characteristics under saturation conditions, TWTs become excellent second harmonic generators. It is not uncommon to have -10dB second harmonics at the output of a TWT. The range of the harmonic generation is the fundamental frequency and bandwidth.

A fix for harmonic generation requires injecting a coherent harmonic signal with a controlled phase and amplitude along with the fundamental carrier so that they interact and the total effects of the harmonics are minimized. Harmonics may be measured by using a spectrum analyzer.

AM/PM conversion

AM/PM conversion is the change in phase angle between the input and output signal as the input signal varies in amplitude. The cause of this distortion in TWTs is a reduction of the electron beam velocity as the input signal level increases. This causes a greater energy exchange between the electron beam and the RF wave. At a level -20dB below the input power required for saturation, AM/PM conversion is negligible. Below this point, AM/PM distortion sharply increases.

Phase sensitivity

When the velocity of the electron beam in the TWT is changed by any one or a number of factors, the phase of the output signal will change. The primary causes of beam velocity changes are variations in: cathode temperature, grid voltage, anode voltage and cathode voltage. It is important that the TWT power supply be extremely well regulated (less than 0.2%) to prevent beam velocity changes and, in turn, output signal phase changes.

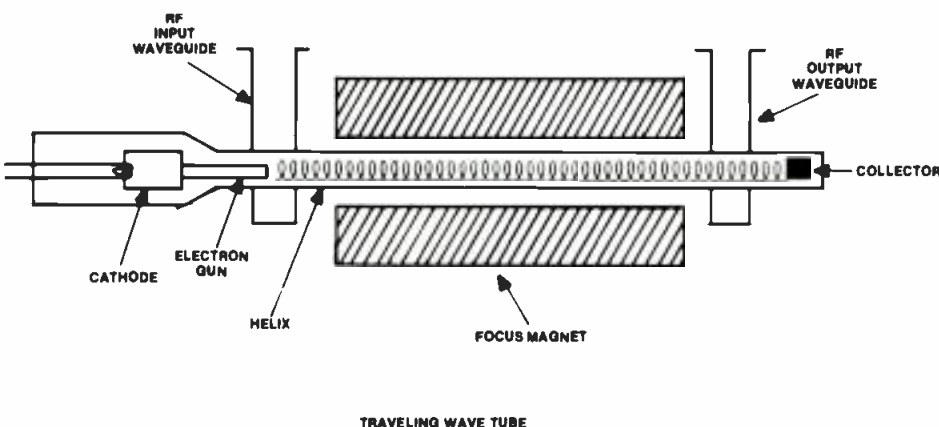

Figure 1. The traveling wave tube (TWT) adds power from the electron beam to RF energy, amplifying the RF signal.

CTM-10 CARTRIDGE RECORDER



SAFE DEPOSIT BOX.

Finally, a cart machine you can bank on. ■ No jams, no repeats and no make goods. ■ Our new CTM-10 cart machine has the same famous reliability that is built into our 5050 BII, ■ plus many new features like Hx-Pro,* ■ so 7.5 ips sounds like 15 ips and your listeners don't tune-out when you shift from CD to cart.

So call us for Technology You Can Trust. ■ Otari Corporation, 2 Davis Drive, Belmont, CA 94002 (415) 592-8311 TWX 9103764890. **OTARI**

*Trademark Dolby Laboratories Licensing Corporation

Circle (11) on Reply Card

www.americanradiohistory.com

Inside digital technology

By Gerry Kaufhold II

Flip-flops and gates can be combined into digital counter circuits. Some of these original counter circuits were developed using vacuum tubes.

Kaufhold is an independent consultant located in Tempe, AZ.

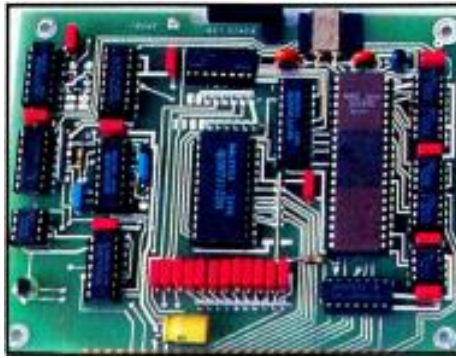

FLIP-FLOP	HEX	DECIMAL	AND GATE
D B C A	CODE	CODE	OUTPUT
0 0 0 0	0	0	0
0 0 0 1	1	1	0
0 0 1 0	2	2	0
0 0 1 1	3	3	0
0 1 0 0	4	4	0
0 1 0 1	5	5	0
0 1 1 0	6	6	0
0 1 1 1	7	7	0
1 0 0 0	8	8	0
1 0 0 1	9	9	0
1 0 1 0	A	10	1
1 0 1 1	B	11	0
1 1 0 0	C	12	0
1 1 0 1	D	13	0
1 1 1 0	E	14	0
1 1 1 1	F	15	0

Figure 1. The truth table for possible states of four flip-flops and AND gate of a 1-in-10 counter shows the short transition back to 0000 at the AND gate output during condition 1010.

The operation of counter circuits expands on the action of a simple flip-flop. A "clock" signal causes the first flip-flop to toggle. The next "clock" signal causes the first flip-flop to toggle again, but this time, the output of the first flip-flop causes a second flip-flop to toggle. This basic circuit can be chained almost indefinitely, creating a series of circuits that divide by two. The 4020 binary ripple counter is an excellent example of the divide-by-two digital counter.

The reason the word "clock" is set off by quotation marks is this: The counting circuit is accepting an edge-triggered signal, and performing an operation. Because the counting circuit is a flip-flop, the term "clock" means any edge-triggered signal that satisfies the voltage-level and timing constraints required to make the flip-flop toggle the states of its outputs. Manufacturers' data sheets label this input pin of the counting device as "clock". A counting circuit is not necessarily using the master clock signal of the digital bus.

Count-to-10 circuit

Because very little usefulness can be derived from dividing anything continually by two, a practical circuit might be one that counts to 10, 100, 1,000 and 10,000 (just as the old frequency counters did).

The circuit in Figure 2 uses a 4-input

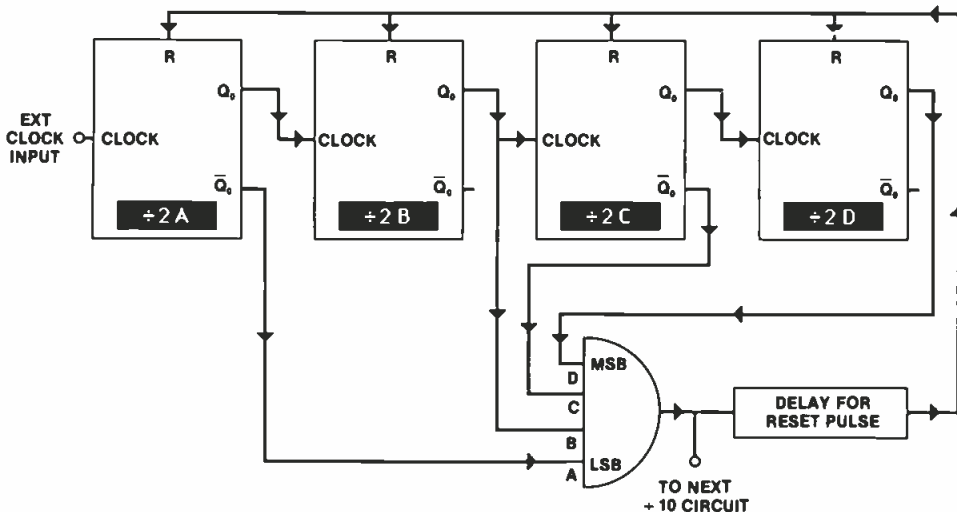

Figure 2. A count-to-10 circuit using flip-flops and one AND gate receives its drive from an external clock at logic level.

AND gate, connected to the outputs of four cascaded flip-flops. Notice the organization of the four inputs to the AND gate. These four bits create a nibble, which has 16 possible unique states from 0000 through 1111 (0 through 15 decimal).

When you look at figure 1, observe that the 10th combination of bits (1001) represents a decimal nine. As long as the inputs to the AND gate range from 0000 through 1001, the output of the AND gate is LO. As soon as the combination (1010) for decimal 10 occurs, the output of the AND gate goes HI, which resets all four flip-flops, and the output of the AND gate returns LO. If this LO-to-HI-to-LO pulse is sufficient to toggle the input stage of the next 4-bit count-to-10 circuit, then the counting can go on accumulating from tens to hundreds to thousands.

The transition that takes place when the AND gate toggles loads 0000 into the flip-flops. The next "clock" input begins counting at 0001 again. The 0000 combination and the 1010 combination actually overlap each other, so the circuit counts to 10, even though it appears as though it is going through 11 transitions. The possible states above 1010 never occur.

Because the succeeding count-to-10 circuit is being "clocked" by the output of the preceding count-to-10 circuit, the second circuit is actually a count-to-100 circuit. By repeating this circuit four times, a count-to-10,000 circuit can be accomplished.

The duration of the pulse from the AND gate must be great enough to both toggle the next counter stage and to effect a complete reset of the four counting flip-flops. This is accomplished with circuitry found onboard a counter chip.

Once designers solved the problem of making circuits count digitally, they applied this discovery to make circuits that add or subtract. These preliminary add or subtract circuits were first called *accumulators* and this term has carried over into use with microprocessors, which all have at least one accumulator register that is used for simple add/subtract operations.

DENSITY determines the input drive level to the Six-Band Limiter. Lets you have it your way—open and transparent, or solid and dense.

CLIPPING adjusts the drive level into the multi-band clippers, determining the loudness/distortion tradeoff.

BASS EQ provides peaking boost at 65Hz, making it easy to get the solid punch you need for many contemporary music formats.

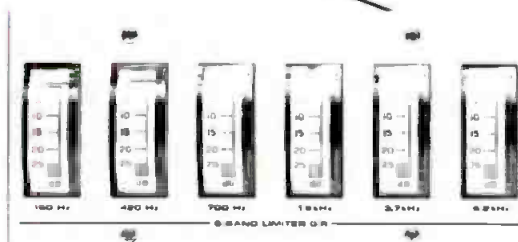

Gain reduction meters for each band: they provide the information you need for accurate setup.

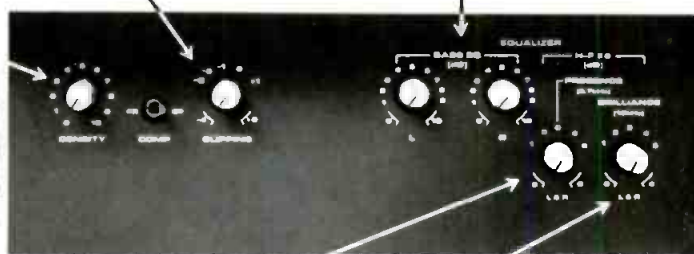

PRESENCE boosts the 3.7kHz band to achieve midrange balances right for your format.

BRILLIANCE boosts the 10kHz band. Use it to increase the sense of "air" and "transparency" in your music.

THE NEW ORBAN 6-BAND FM LIMITER. (WE LISTENED.)

Many FM stations perpetually seek "the perfect sound". OPTIMOD-FM alone does it for many. The OPTIMOD XT Accessory Chassis improved results for some. Still, some seek even more from OPTIMOD-FM.

We listened.

Our **NEW 8100A/XT2 Six-Band Limiter Accessory Chassis** (which works with any 8100A OPTIMOD-FM) features two new high-frequency equalizer controls: PRESENCE and BRILLIANCE. They complement the original 8100A/XT's bass EQ controls, and give you *twice the flexibility* of the single HF EQ control typical of other add-on multiband processors.

With an XT2, your OPTIMOD-FM system is totally immune to operator gain-riding errors because the dual-band compressor in the main unit is converted into a smooth, slow AGC to ride gain ahead of the XT2. Any reasonable input level operates the XT2 in its "sweet spot," so there's never any need to add external, potentially incompatible compression.

This is good news because the time-constants and other processing parameters in a pure, integrated Orban system have been carefully harmonized to achieve an overall sound that's *loud and bright*, yet remarkably *open* and free from audible side-effects.

The XT2 also excels in the most difficult of processing tradeoffs—delivering loudness on music while keeping speech free from clipping distortion. Credit this uniquely capable performance to Orban's patented multiband distortion-cancelled clipping system—which we were able to implement in the XT2 system because the XT's circuitry is fully *integrated* into the processing system, not just tacked onto the front.

The XT2 lets you have it all: natural sound, source-to-source consistency, loudness, clean voice, and adjustability that lets you tailor bass and treble to your taste and format requirements. And thanks to its efficient single-chassis construction and its use of the main 8100A power supply, it lets you have the next step in Optimod processing at an exceptionally reasonable price: \$2075 (suggested list).

We listen to our customers. Listen to our new XT2. We think you'll like what you hear.

Orban Associates Inc.

645 Bryant Street, San Francisco, CA 94107
(800) 227-4498 or (415) 957-1067 Telex 17-1480

orban

Circle (12) on Reply Card

www.americanradiohistory.com

Prevent problems by planning ahead

By Mark A. Bunker

During the life of a tower, antenna systems and transmission-line installations are constantly changed.

Simple techniques can be employed for sharing new or existing tower resources. When it comes to antennas, the single most efficient way to save money is to share transmission lines for multiple applications. If one transmission line is shared by just two RF systems, windloading is cut considerably. Because a second line is no longer required, installation time and costs also are reduced. The more sharing, the lower the windloading and installation costs.

Crossband couplers

Crossband couplers are commonly available for the purpose of combining and separating several RF systems and antennas into the same transmission line. Although only a few square inches in size, units suitable for tower use can handle up to several hundred watts with only a fraction of 1dB loss per channel.

The most common crossband couplers take the form of a Y or T, where a single common connector is the combination or split between two filter sections or ports. The higher-frequency port is a multisection bandpass filter, flat over the band covered. The low-frequency port is a low-pass filter with a response from dc to the maximum bandpass frequency, and

Bunker is an engineering supervisor at KSHB-TV, Kansas City, MO.

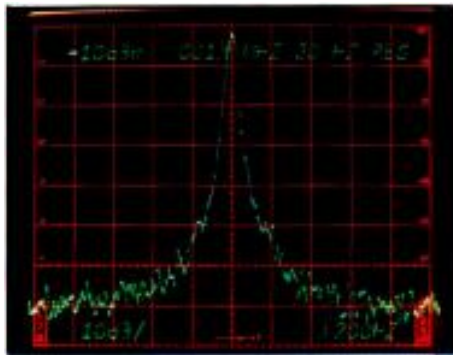

maximum cutoff at the high-frequency port band. Multiband operation is accomplished by stacking a second coupler's common port onto the low-pass port.

Typical ENG installation

Consider a new ENG system, to be installed on a 1,100-foot TV tower. The 2GHz microwave horns are to be installed at the 1,000-foot level along with a UHF (450MHz band) dispatching 2-way. In addition, an existing VHF (150MHz band) paging system antenna is to be replaced and added to the system. An additional 200 feet of transmission line is required between the tower base and the equipment, bringing the total to 1,200 feet. Table 1 shows a comparison of a 3-line system and two alternate installations using a single line and two crossband couplers at each end.

Although the material cost of 1 5/8-inch line is slightly higher, lower installation labor costs tend to even out the overall expense. Although the price of 1 5/8-inch shared line is not as attractive, loading factors are less critical than those of their 3-line counterparts. The system also is open to a future expansion on the 900MHz band by the simple addition of an antenna and two crossband couplers.

Inband combining

Inband combining is accomplished with off-the-shelf combiners containing an arrangement of sharp bandpass reso-

nant cavities and one or two port isolators. It brings with it special problems. Power from multiple transmitters must be reduced to microvolt levels at the outputs of companion transmitters in order to eliminate first-order intermodulation products.

The idea behind inband transmit combiners is that most combining losses and isolation can be accomplished with shape cavity filters. Remaining energies are blocked from the other transmitter outputs by an isolator in each of the outputs, which acts as a "check valve" for the RF of that transmitter. In cases in which frequencies are within a few kilohertz, the cavities are replaced with hybrid couplers, providing a total combination loss of at least -4dB, with -70dB isolation for a 2-channel system.

Inband receiver coupling presents a different problem. Relative loss can be minimized by an amplifier/splitter arrangement, but any inband transmitters also must be isolated from receiver inputs. Additional cavity filters in transmit-and-receive lines will resolve most simple combining combinations. However, if an additional transmission line is available for band sharing, a second receive-only antenna will greatly simplify receiver requirements through isolation by sheer separation of transmit-and-receive antennas.

Cellular and trunking 2-way systems typically use the 2-line, 2-antenna concept. Vertical separation of transmit-receive antennas provides the major receive isolation, while transmit combiners handle transmit isolation. Combining eight to 16 individual systems with little degradation is quite practical with this arrangement.

The separate receive antenna performs the added benefit of eliminating receive-line losses. A tower-mounted pre-amp boosts the signal at the antenna, lowering transmission-line loss by at least the gain of the pre-amp. Pre-amp power is fed down the transmission line itself, eliminating the need for extra cabling. Pre-amp redundancy is provided by either bypassing the pre-amp when power is removed, or by using a switchable backup amplifier. [:-?>)]]

Frequency	150	450	2GHz	150	450	2GHz	150	450	2GHz
Foam Line Size	1/2"	7/8"	7/8"	Shared 7/8"			Shared 1-5/8"		
Line Weight	164	378	378	---	378	---	---	378	---
Coupler Loss dB	---	---	---	-1.4	-1.4	-0.8	-1.4	-1.4	-0.8
Total Loss dB	-8.1	-10.5	-24.6	-6.8	-11.9	-25.4	-4.8	-7.9	-17.6
Total Weight	920 lbs.			378 lbs.			920 lbs.		
Total Area	19.91 sq.ft.			7.73 sq ft.			13.94 sq ft.		

Table 1. Comparison of 3-line system and alternative single-line systems. Figures are typical, and do not allow for connectors, patch cables, line supports and their mounts.

**Precision motion control...
from start
to finish.**

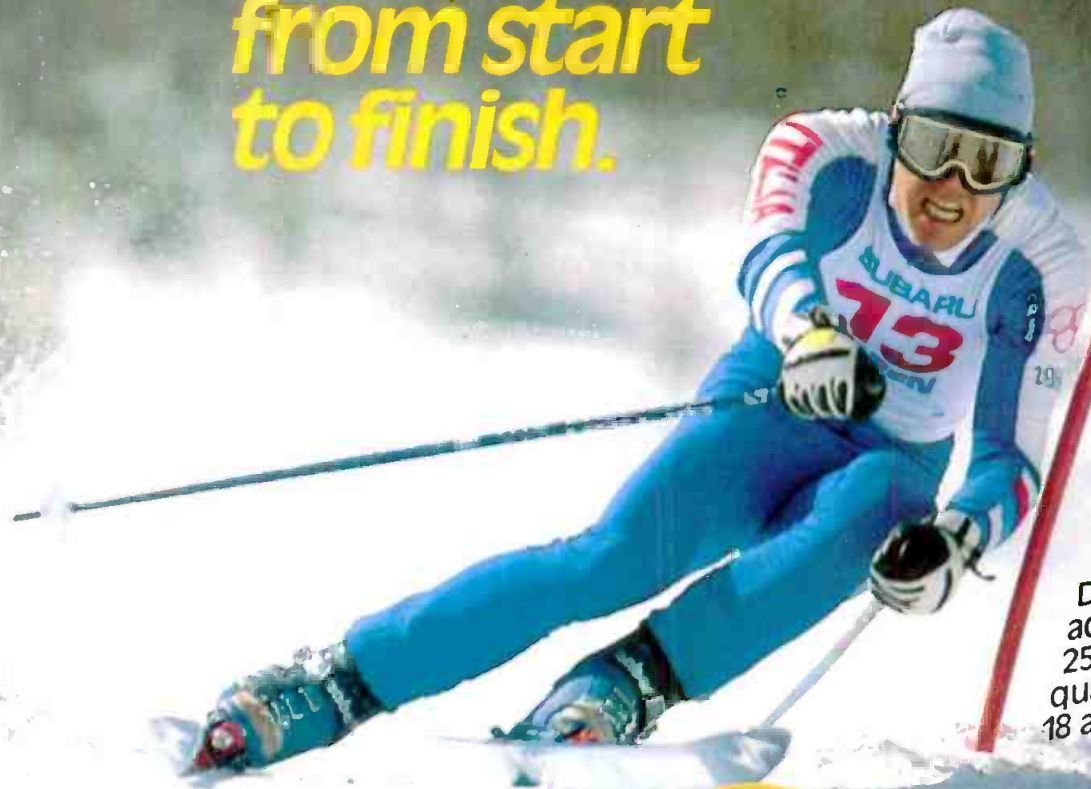

New!

**MultiController
is available with
the New HS-110P
Studio Camera
Pan/Tilt Head.**

Designed for cameras and accessories weighing up to 250 lbs. Provides broadcast quality motion control with 18 arc second repeatability.



**Practice, learn, fine tune,
recall and execute!**

- MultiController operates the programmable high speed HS-100P head and will accurately and repeatedly execute your most creative camera shots... adding new artistic dimensions to your productions.
- The controls are carefully placed and designed to provide the proper feel and responsiveness. When a shot is recalled, the camera is positioned to its new location with all the skill and finesse of an experienced camera operator.
 - Stored camera motions are "learned" through the manual controls which remain "live" so motions may be fine tuned (edited) in either the rehearse or recall modes.
- MultiController operates up to 4 cameras (from a single panel) and up to 5 miles from the HS-100P head.
- Discover how MultiController can expand your production capabilities. Call or write for complete details.

Circle (13) on Reply Card



**TOTAL SPECTRUM
MANUFACTURING INC.**
20 Virginia Avenue, West Nyack, NY 10994
(914) 358-8820

Management for engineers

Bring about change, not a tug of war

By Brad Dick, radio technical editor

By its nature, the broadcast industry is constantly changing. Just when you think you've mastered the latest piece of equipment, something new comes along. For some people, the change brought about by new technology is exciting and challenging. For others, it's frightening. Perhaps the most alarming aspect of new technology is the prospect of it changing the way we do our jobs.

Many stations are struggling between the desire for change and the disappointment that results from problems in implementing these changes. Improperly handled, new technology in the workplace can become a tug of war that everyone loses. Let's look at a real-world example—the use of automation.

Friend or foe?

Jim was both excited and worried about the company's decision to proceed with the plan to install automation equipment. He believed that, in the long run, automating the spot playback and program recording would be beneficial. But, as director of engineering, he also worried about the effect the new technology might have on his staff.

The station planned to purchase the spot player and other automation equipment within the next quarter. He would then have a couple of months to install it and work out the bugs. At most, he had six months to have everything working properly.

It wasn't the hardware installation that caused him so much concern. Jim had to convince the operating staff that the equipment would not mean unemployment. He had already obtained a commitment from the company that no one would lose a job as a result of the installation of the automation equipment. Still, Jim wondered how some of the operators would adapt to the new way they would be expected to perform their jobs. He also wondered how he should go about introducing them to the changes that were about to take place.

The employee's perspective

Changes in station operations and methods are seldom confined to the technical aspects. They require that em-



ployees modify not only how they perform tasks, but even more important, how they view their jobs. The new methods must be feasible and efficient from an objective standpoint. Even more important, the changes must be acceptable to the employees who must implement them.

The added factor of employee acceptance makes the problem of introducing changes different from purely technical problems in several ways. For example, the quality of the solution—in this case, automation—and its acceptability are different characteristics, and do not necessarily go together. A second complication stems from the fact that although management can control solution quality by handling the decision-making, employee acceptance is inherently voluntary. Acceptance of the changes is not subject to the will of management. This factor is often overlooked. In most cases, however, it is impossible to implement even the best technical solution without cooperation by the employees.

It's not uncommon for management to attempt to force change upon employees, with predictable consequences. Failure to obtain employee acceptance of the changes merely aggravates the problem. In some instances, employee resistance is expressed directly in the form of grievances, work stoppages and open hostility toward management. In technical areas, resistance can be expressed in ways such as restriction of output, waste, low-quality work and even sabotage.

Management's responsibility

An effective manager recognizes the potential for these types of problems long before announcing plans for significant changes in the workplace. The avenue typically used by management to prevent the problems is education. Facts and arguments are presented to the staff with the expectation that, given the same information, the employees will take a similarly favorable view toward the desired change.

To the extent that resistance is based on incorrect or insufficient information, this tactic may help. However, resistance to change usually is rooted in feelings of

insecurity, distrust of management's motives and anxiety about the future. In these instances, information does little to reduce the employees' anxiety.

Lack of success with the "selling" approach has led to research into other methods. A common tactic involves the "Y" management approach discussed last month. Typically, the supervisors meet with the employees to discuss the current problems and proposed changes. On the surface, the process appears to be an exchange of information, or a consultation.

The method used to develop this exchange of information varies greatly. However, it is essential that an attempt be made to identify the employees' feelings and ideas. The bottom line is that management always reserves the right to accept or reject the employee contributions as it sees fit. However, if that position is overemphasized during the preliminary discussion phase, it can cause a great deal of damage to the communication process.

The two methods of obtaining acceptance are quite different. The selling approach emphasizes the presentation of management's point of view, while the consultative approach is designed to solicit an expression of employee opinions. In this sense, the latter method is a further step toward consideration for the welfare of employees. The two methods are alike in that both reserve the decision-making function for management with the intent to protect the quality of the decision.

The automation example is typical of the changes being faced by many stations today. As automation becomes more prevalent, people must change the way they do their jobs. The real issue is not the loss of jobs, although that may happen in some cases. The greater issue is how to help the worker adapt to a new way of completing a task.

! : ? - :)))

NEW FROM ARRAKIS SYSTEMS

5000 SERIES

The First No-Compromise
Modular Radio Console...



...At A Down-To-Earth Price: 16 Channels, Under \$10,000.

THE FEATURES YOU WANT —

- 16 Modular Stereo Channels.
- Program, Audition and Mono Mixdown Balanced Outputs.
- Telephone Mix-Minus Buss.
- Full Monitoring Facilities.
- Remote Equipment Start/Stop.
- Remote Module Control.
- Standard Digital Clock and Timer.
- Optional EQ and Effects Modules.

THE DEPENDABILITY YOU NEED —

- DC Controlled — No Audio On Pots.
- Rugged Modular Construction.
- Penny & Giles Slide Faders.
- ITT Schadow Switches.
- NE5532 IC Module Design.
- External Regulated Power Supply.
- Superb Audio Performance Specs.
- Most Important, Arrakis Systems Designed-in Ultra Reliability!

For features, performance, price and reliability,

NOBODY BUILDS CONSOLES LIKE ARRAKIS.

Call (303) 224-2248

Circle (14) on Reply Card

ARRAKIS SYSTEMS INC. 2609 RIVERBEND COURT FORT COLLINS, CO 80525



Transmission systems special report

The RF chain is the link between programming and your audience.

The process of broadcasting pictures and/or sound requires the interfacing of several systems. Relatively minuscule electrical signals generated by the pickup device are amplified and sent through a switching/mixing device, then through processing gear to ultimately modulate an exciter, producing a small amount of RF energy. This energy is amplified and directed through a feedline to a transmitting antenna. At the other end, the signal is picked out of the air by a receiving antenna, detected, amplified and sent to the screen and/or speaker(s).

Each system in this process presents the opportunity to constrain the overall technical quality of a received program. The performance of any subsystem, such as media storage, tape editing and production, also will be restricted by any system in the chain between the subsystem and the antenna.

The high visibility of tape formats, pickup devices and myriad other hairsplitting pros and cons of production technology makes it easy to overlook the foundation of broadcasting:

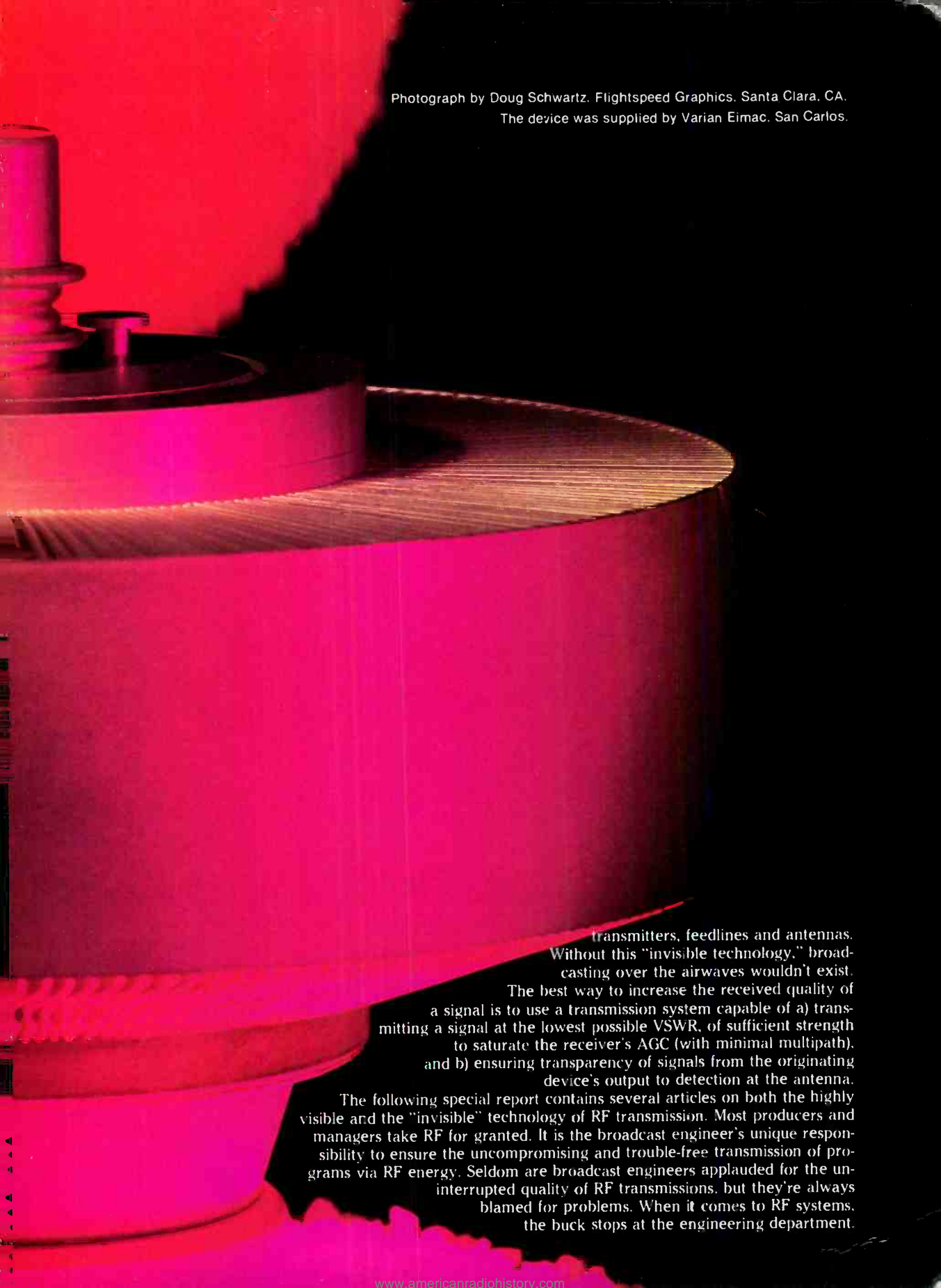

Photograph by Doug Schwartz. Flightspeed Graphics, Santa Clara, CA.
The device was supplied by Varian Eimac, San Carlos.

transmitters, feedlines and antennas. Without this "invisible technology," broadcasting over the airwaves wouldn't exist.

The best way to increase the received quality of a signal is to use a transmission system capable of a) transmitting a signal at the lowest possible VSWR, of sufficient strength to saturate the receiver's AGC (with minimal multipath), and b) ensuring transparency of signals from the originating device's output to detection at the antenna.

The following special report contains several articles on both the highly visible and the "invisible" technology of RF transmission. Most producers and managers take RF for granted. It is the broadcast engineer's unique responsibility to ensure the uncompromising and trouble-free transmission of programs via RF energy. Seldom are broadcast engineers applauded for the uninterrupted quality of RF transmissions, but they're always blamed for problems. When it comes to RF systems, the buck stops at the engineering department.

Meet our b

Half-inch has just advanced a mile. Your suggestions and our experience were combined to create a superior form of Betacam.[®] Betacam SP.[™]

It delivers improved picture signal-to-noise. Four channels of high quality audio. And choices.

For great performance choose economical oxide tape. For superior performance choose metal particle tape.

Sony Communications Products Company, Broadcast Products Division, 1600 Queen Anne Rd., Teaneck NJ 07666. © 1987 Sony Corporation of America.



etter half.

And if you already own Betacam, you have the option of upgrading at your own speed. Because Betacam and Betacam SP are compatible. And that's a choice even your accountant will love.

For more information on the new line of Betacam products, contact your Sony Broadcast representative. Or call Sony at (201) 833-5231.

SONY
BROADCAST



Circle (15) on Reply Card

Sony and Betacam are registered trademarks and Betacam SP a trademark of Sony Corporation.





Inside FM power amplifiers

By Jerry Whitaker, editorial director,
and Clarence Daugherty

**To get the most out of a cavity PA FM transmitter,
you need to know how it works.**

Cavity amplifiers for FM service are viewed by many users as just so much black magic. You know that they work, and how to make them work when a problem occurs, but you're not quite sure *why* they work. The theory of operation,

Daugherty is a senior broadcast technology instructor at Harris Corporation, Quincy, IL. Additional information for this article was contributed by the engineering staff of Broadcast Electronics, Quincy, IL.

however, is fairly straightforward. And like most things in electronics, cavity amplifiers are easy to understand, once you understand them.

Two basic types of cavity amplifiers are used for FM service: $\frac{1}{2}$ -wavelength and $\frac{1}{4}$ -wavelength systems.

The $\frac{1}{4}$ -wavelength cavity

The $\frac{1}{4}$ -wavelength PA cavity is com-

mon in today's FM transmitting equipment. The design is simple and straightforward. A number of variations can be found in different transmitters, but the underlying theory of operation is the same.

A typical $\frac{1}{4}$ -wave cavity is shown in Figure 1. The plate of the tube connects directly to the inner section (tube) of the plate-blocking capacitor. The blocking capacitor can be formed in one of several ways. In at least one design, it is made by wrapping the outside surface of the inner tube conductor with multiple layers of 8-inch-wide and 0.005-inch-thick polyimide (Kapton) film. The exhaust chimney/inner conductor forms the other plate of the blocking capacitor. The cavity walls form the outer conductor of the $\frac{1}{4}$ -wave transmission line circuit. The dc-plate voltage is applied to the PA tube by a cable routed inside the exhaust chimney and inner tube conductor.

In the design shown in Figure 1, the screen-contact fingerstock ring mounts on a metal plate that is insulated from the grounded-cavity deck by a Kapton blocker. This hardware makes up the screen-blocker assembly. The dc-screen voltage feeds to the fingerstock ring from underneath the cavity deck through an insulated feedthrough assembly.

Some transmitters that use the $\frac{1}{4}$ -wave cavity design use a grounded-screen configuration in which the screen-contact fingerstock ring is connected directly to the grounded cavity deck. The PA cathode then operates at below ground po-

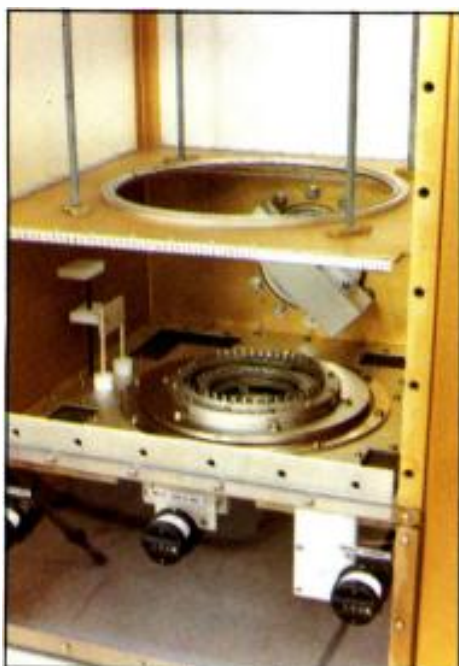

At left, an interior view of a cavity designed for FM applications of up to 50kW output power. This cavity uses the 4CX40,000G tube, shown at right. A movable anode plate resonates the cavity at the chosen frequency. The loading loop can be seen on the back cavity wall.

B E A U T Y

Classic beauty is unmistakable. You know it when you see it.

Like the beauty you get with Ampex 196. Clean, clear pictures that capture every sparkling moment of your production.

No other video tape delivers such consistent low-dropout performance. Or such dynamic picture quality.

By focusing on critical drop-outs, especially in the area not compensated for by your VTR, we developed a video tape you can rely on for all your applications.

The secret behind our success is Ampex Process Management. APM is a unique manufacturing concept enabling us to control the consistency of the entire production process. From raw materials to finished products.

So you always get the cleanest, sharpest pictures time after time, reel after reel, carton after carton. That's why top professionals around the world specify Ampex 196.

If you'd like to know more about how APM contributes to beautiful pictures, call or write Ampex today for a free brochure.



AMPEX

Ampex Corporation, Magnetic Tape Division,
401 Broadway, Redwood City, CA 94063, 415/367-3809.

Circle (16) on Reply Card

www.americanradiohistory.com

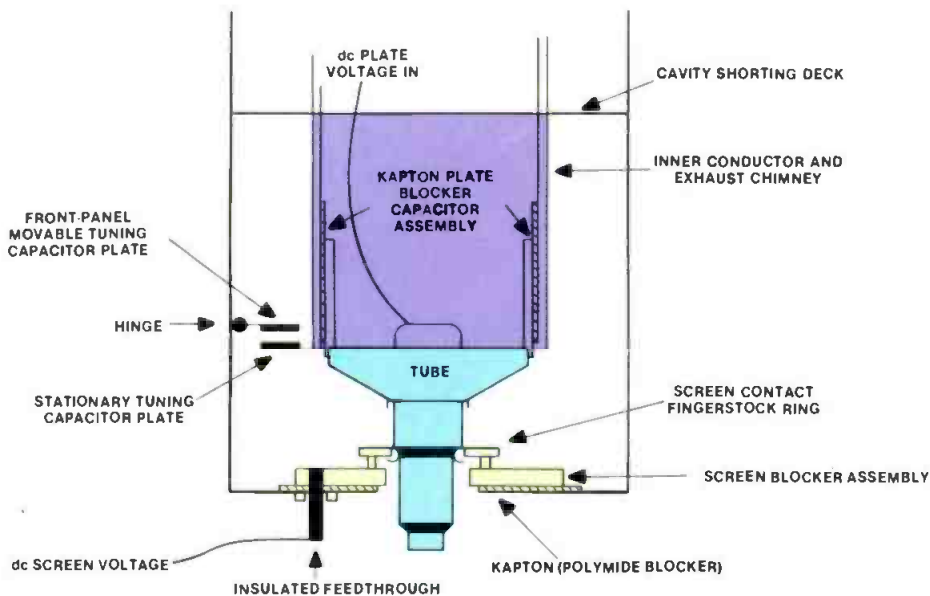

Figure 1. The layout of a common type of 1/4-wavelength PA cavity.

tential (in other words, at a negative voltage), establishing the required screen voltage to the tube.

The cavity design shown in Figure 1 is set up to be slightly shorter than a full 1/4-wavelength at the operating frequency. This makes the load inductive and resonates the tube's output capacity. Thus, the physically foreshortened shorted transmission line is resonated and electrically lengthened to 1/4-wavelength.

Figure 2 illustrates the paths taken by the RF-circulating currents in the circuit.

RF energy flows from the plate, through the plate-blocking capacitor, along the inside surface of the chimney/inner conductor (because of the skin effect), across the top of the cavity, down the inside surface of the cavity box, across the cavity deck, through the screen-blocking capacitor, over the screen-contact fingerstock and into the screen grid.

Figure 3 shows a graph of RF current, voltage and impedance for a 1/4-wavelength coaxial transmission line. It shows that infinite impedance, zero RF current

and maximum RF voltage occur at the feed point. This would not be suitable for a practical PA circuit because arcing would result from the high RF voltage, and poor efficiency would be caused by the mismatch between the tube and the load.

Notice, however, the point on the graph marked at slightly less than 1/4-wavelength. This length yields an impedance of 600Ω to 800Ω and is ideal for the PA-plate circuit. It is necessary, therefore, to physically foreshorten the shorted coaxial transmission-line cavity to provide the correct plate impedance. Shortening the line also is a requirement for resonating the tube's output capacity, because the capacity shunts the transmission line and electrically lengthens it.

Figure 4 shows a graph of the RF current, voltage and impedance presented to the plate of the tube as a result of the physically foreshortened line. This plate impedance is now closer to the ideal 600Ω to 800Ω value required by the tube's anode.

Tuning the cavity

Coarse tuning of the cavity is accomplished by adjusting the cavity length. The top of the cavity (the cavity shorting deck) is fastened by screws or clamps

MONITOR, DECODE, TEST

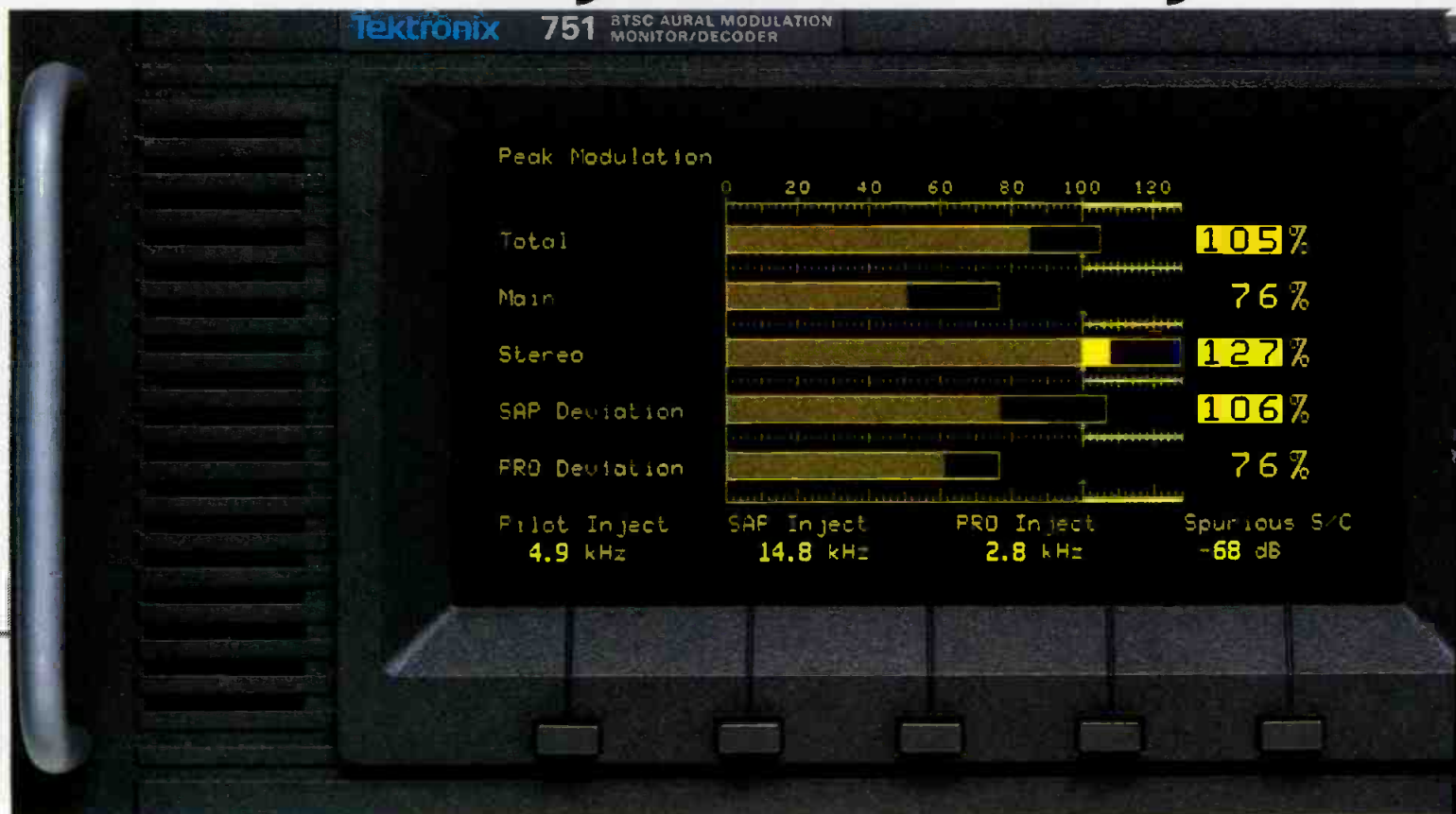

and can be raised or lowered to set the length of the cavity for the particular operating frequency.

Fine tuning is accomplished by the variable-capacity plate-tuning control that is built into the cavity. In the example shown in Figure 1, one plate of this capacitor, the stationary plate, is fastened to the inner conductor just above the plate-blocking capacitor. The movable tuning plate is fastened to the cavity box, the outer conductor, and is mechanically linked to the front-panel tuning control. This capacity shunts the inner conductor to the outer conductor and can vary the electrical length and resonant frequency of the cavity.

The $\frac{1}{4}$ -wavelength cavity is inductively coupled to the output port. This coupling is usually on the side opposite the cavity access door. The inductive pickup loop can take several forms.

In one design, it consists of a half-loop of flat copper bar stock that terminates in the loading capacitor at one end and feeds the output transmission-line inner conductor at the other end. The inductive pickup ideally would be placed at the maximum current point in the $\frac{1}{4}$ -wavelength cavity. However, this point is located at the cavity shorting deck and when the deck is moved for

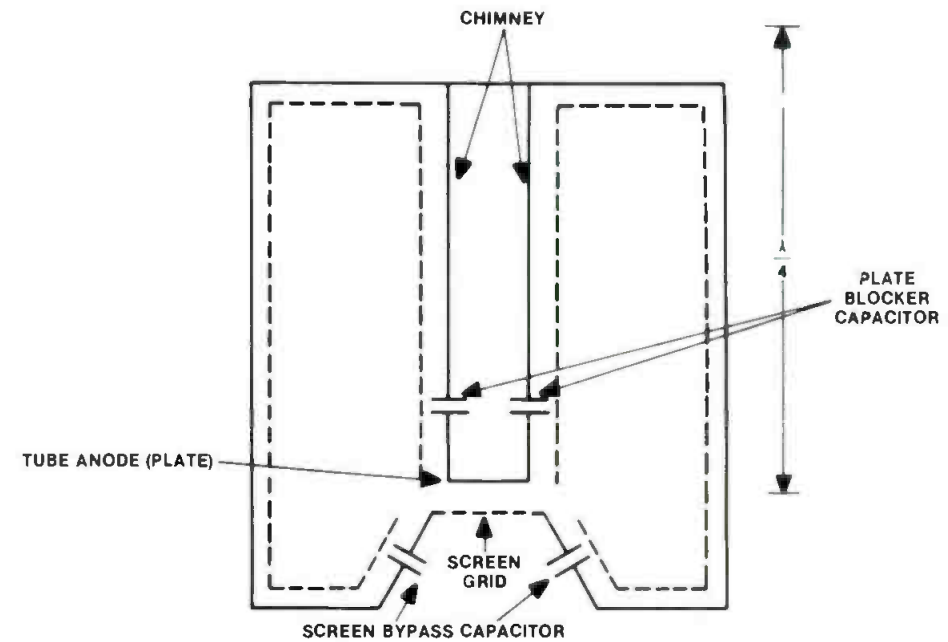

Figure 2. The RF circulating current paths for the $\frac{1}{4}$ -wavelength cavity shown in Figure 1.

coarse tuning, the magnetic coupling will be changed. A compromise in positioning, therefore, must be made. The use of a broad, flat copper bar for the coupling loop adds some capacitive coupling to augment the reduced magnetic coupling.

Adjustment of the loading capacitor matches the 50Ω transmission-line impedance to the impedance of the cavity. Heavy loading lowers the plate impe-

dance presented to the tube by the cavity. Light loading reflects a much higher load impedance to the amplifier's plate.

The $\frac{1}{2}$ -wavelength cavity

The $\frac{1}{2}$ -wavelength PA cavity has been used extensively in FM transmitting equipment. The design can take a number of forms, but the underlying theory of operation remains the same.

T, MEASURE: SEE YOUR STEREO SOUND.



Now, your top choice in a precision modulation monitor for stereo audio couldn't be more clear... or readily available. Look at the Tek 751 and see it all at the touch of a button. Call your Tek Television Sales Manager for full details and a demonstration.

Tektronix
COMMITTED TO EXCELLENCE

Circle (17) on Reply Card

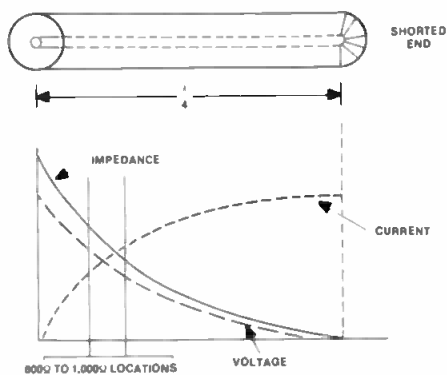

Figure 3. A graph of the RF current (...), RF voltage (---) and RF impedance (—) for a 1/4-wavelength shorted transmission line. At the feed point RF current is zero, RF voltage is maximum and RF impedance is infinite.

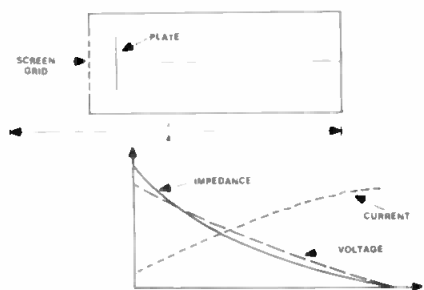

Figure 4. A graph of the RF current (...), RF voltage (---) and RF impedance (—) produced by the physically foreshortened coaxial transmission-line cavity.

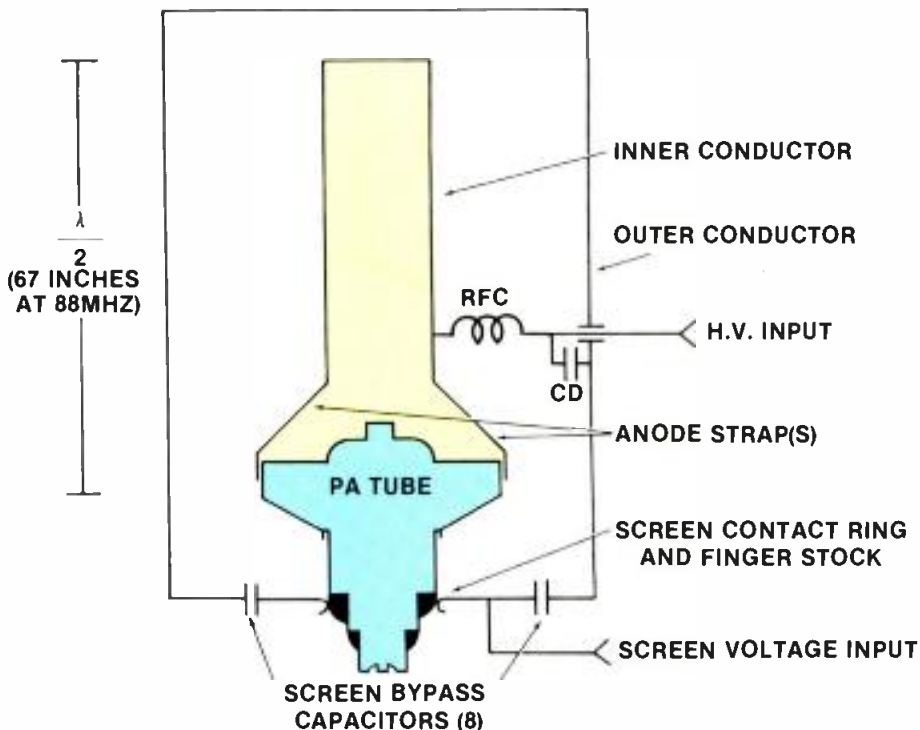

Figure 5. The 1/2-wavelength PA cavity in its basic form.

The design of a basic 1/2-wavelength PA cavity is shown in Figure 5. The tube anode and a silver-plated brass pipe serve as the inner conductor of the 1/2-wave transmission line, and the cavity box serves as the outer conductor. The transmission line is open at the far end

and repeats this condition at the plate of the tube. The line is, in effect, a parallel resonant circuit for the PA tube.

The physical height of the circuit shown in Figure 5 (67 inches) was calculated to operate at 88MHz. To allow adequate clearance at the top of the trans-

Vanguard Series™

Broadcast Audio Consoles

Performance, Value and Reliability through Innovative Technology



- Raised, tactile feel, lighted membrane switch panel-digitally scanned
- 12 stereo inputs plus optional expander
- VCA controls, rotary and linear
- Analog and fluorescent meters
- Modular, plug in electronics
- Easy punch block installation
- Effective RF protection

**BC8DS
8 Mixer
Dual Stereo**
only **\$3,195**

**AUDIO
TECHNOLOGIES
INCORPORATED**



328 Maple Avenue, Horsham, PA 19044 • (215) 443-0330

Circle (18) on Reply Card

PHASE TRAK 90TM

The Stereo Solution for Every Cartridge



Continuous
Electronic
Phase
Correction



The PHASE TRAK 90's LED "phase eye" display shows phase correction activity as it happens.

Just imagine: A cartridge machine that could automatically correct phase errors in the playback audio of any cartridge—regardless of what equipment was used to record it originally. No encoding. No matrixing. Just instant, accurate phase correction every time a cartridge is played.

Sound impossible? Then meet the new PHASE TRAK 90 from Broadcast Electronics!

At the heart of the PHASE TRAK 90 is a revolutionary non-encoding phase correction circuit. (Patent pending.) Whenever a cartridge is played it continuously checks and corrects the phase relationship of the right and left channel playback audio.

But phase correction is only one of the unique features of this new machine. The PHASE TRAK 90 also offers built-in, non-encoding noise reduction, an FSK decoder, digital cue detection, automatic "hot tape" sensing, an optional timer and more. Its superb signal to noise and frequency response characteristics ensure audiophile performance with every cartridge.

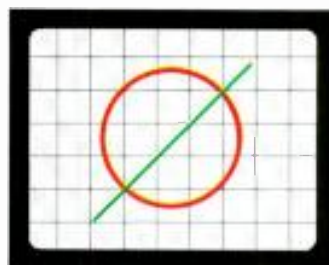

Red circle: Typical Lissajous pattern, right and left channel audio 90 degrees out of phase.

Green diagonal: Typical Lissajous pattern after PHASE TRAK 90 phase correction. Right and left channel audio in perfect phase.

Contact your Broadcast Electronics distributor today or call:

217-224-9600

PHASE TRAK 90TM is a trademark of Broadcast Electronics

BE BROADCAST
ELECTRONICS INC.

4100 N. 24th ST., P.O. BOX 3606, QUINCY, IL 62305-3606, (217) 224-9600, TELEX: 250142

Circle (19) on Reply Card
www.americanradiohistory.com

mission line and space for input circuitry at the bottom of the assembly, the complete cavity box would have to be almost 8 feet tall. This is too large for any practical transmitter.

Figure 6 shows RF voltage, current and impedance for the inner conductor of the transmission line and the anode of the tube. The load impedance at the plate is thousands of ohms. The RF current is, therefore, extremely small and the RF voltage is extremely large. In the application of such a circuit, arcing would become a problem. The high plate impedance would also make amplifier operation inefficient.

Figure 6 also shows an area between the anode and the $\frac{1}{4}$ -wavelength location where the impedance of the circuit is 600Ω to 800Ω . As noted previously, this value is ideal for the anode of the PA tube. To achieve this plate impedance, the inner conductor must be less than a full $\frac{1}{2}$ -wavelength. The physically foreshortened transmission-line circuit must, however, be electrically resonated (lengthened) to $\frac{1}{2}$ -wavelength for proper operation.

If the line length were changed to operate at a different frequency, the plate impedance also would change because of the new distribution of RF voltage and current on the new length of line. The problem of frequency change, therefore, is twofold: The length of the line must be adjusted for resonance and the plate impedance of the tube must be kept constant for good efficiency.

A practical cavity

To accommodate operation of the transmitter at different frequencies while keeping the plate impedance constant, two forms of coarse tuning and one form of fine tuning are built into the $\frac{1}{2}$ -wave PA cavity.

Figure 7 shows the tube and its plate line (inner conductor). The inner conductor is U-shaped to reduce the cavity height.

With the movable section (the plate tune control) fully extended, the inner conductor measures 38 inches and the anode strap measures 7 inches. The RF path from the anode strap to the inside of the tube plate (along the surface because of the skin effect) is estimated to be about 8 inches. This makes the inner conductor's maximum length about 53 inches.

This is too short to be a $\frac{1}{2}$ -wavelength at any FM frequency. The full length of a $\frac{1}{2}$ -wave line is 54.7 inches at 108MHz and 67.1 inches at 88MHz.

The coarse-tuning and fine-tuning provisions of the cavity, coupled with the PA tube's output capacity, resonate the plate line to the exact operating frequency. In effect, they electrically lengthen the physically foreshortened line. This process, along with proper loading, deter-

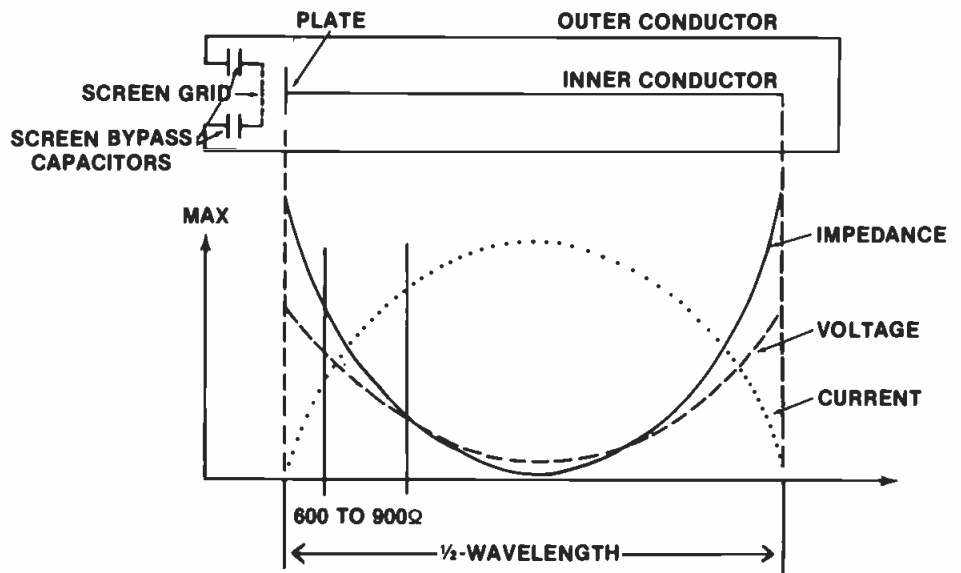

Figure 6. The distribution of RF voltage, current and impedance along the inner conductor of a $\frac{1}{2}$ -wavelength cavity.

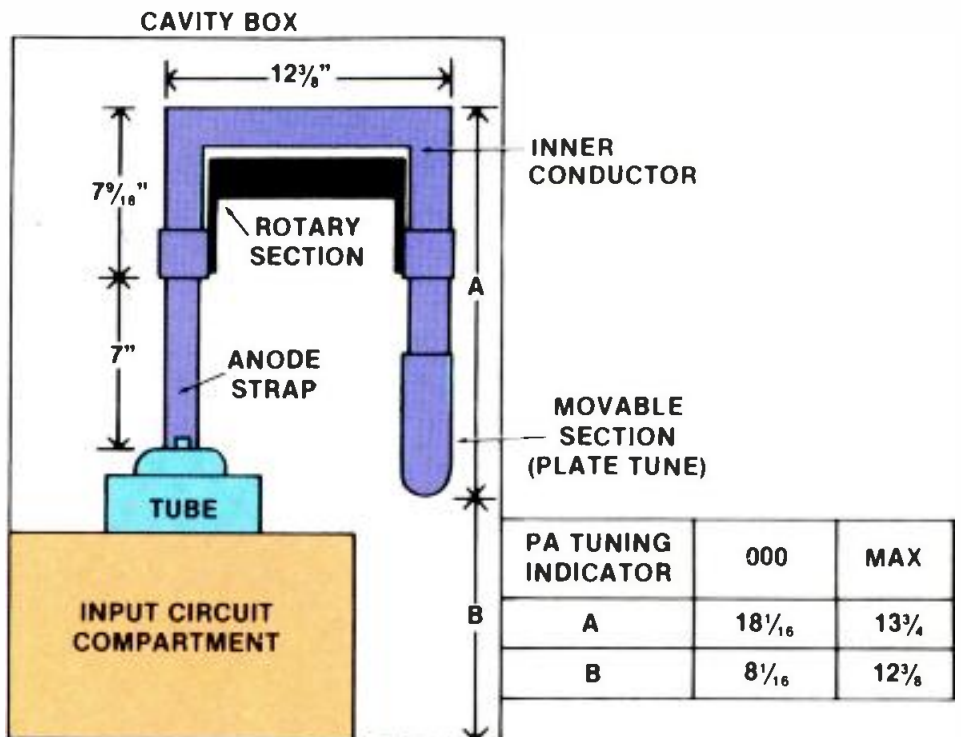

Figure 7. The configuration of a practical $\frac{1}{2}$ -wavelength PA cavity.

mines the plate impedance and, therefore, the efficiency.

Lengthening the plate line

The output capacity of the tube is the first element that electrically lengthens the plate line. A $\frac{1}{2}$ -wave transmission line that is too short offers a high impedance that is both resistive and inductive. The tube's output capacity resonates this inductance. The detrimental effects of the tube's output capacity are, therefore, eliminated.

The anode strap and the cavity inner-conductor rotary section provide two methods of coarse frequency adjustment for resonance.

The anode strap (shown in Figure 7) has less of a cross-sectional area than the

inner conductor of the transmission line. It, therefore, has more inductance than an equal length of the inner conductor. The anode-coupling strap acts as a series inductance and electrically lengthens the plate circuit.

At low frequencies one narrow anode strap is used. At mid-FM frequencies one wide strap is used. The wide strap exhibits less inductance than the narrow strap and does not electrically lengthen the plate circuit as much.

At the upper end of the FM band, two anode straps are used. The parallel arrangement lowers the total inductance of the strap connection and electrically lengthens the plate circuit only a small amount.

The main section of the plate resonant



OVER
5 DECADES
OF



EXCELLENCE



EIMAC
1934-1987

Supporting Broadcasting for over 50 years

Decades of quality and dependability from Varian EIMAC.

EIMAC's tradition of high quality and dependability was firmly established in 1934 and continues on in 1987. Stringent manufacturing standards and controls, plus EIMAC's exclusive, long-term warranty reduces transmitter downtime and eliminates excessive operating overhead.

EIMAC backs its quality products with the industry's most comprehensive warranty program:

Warranty time for each EIMAC tube type is specified in writing and runs from the industry standard of 1,000 hours or 12 months to as high as 10,000 hours and 24 months.

Specific warranties for some popular tube types are:

4CX5000A 10,000 hours/24 months
4CX10,000D 10,000 hours/24 months

4CX15,000A 10,000 hours/24 months
4CX35,000C 10,000 hours/24 months
3CX2500A3 5,000 hours/12 months
4CX1500A 5,000 hours/12 months
5CX3000A 5,000 hours/12 months

Fourteen other EIMAC types have these extended use-time warranties. Specific warranties for each tube type are available from the Varian EIMAC worldwide sales organizations.

In all cases, EIMAC tubes are 100% warranted to be free of manufacturing defects. And, don't forget, EIMAC has a "carcass credit" return program for real savings on replacement tubes.

Compare EIMAC's long record of outstanding performance. We guarantee EIMAC products will be here tomorrow for today's applications.

More information is available on EIMAC tubes and warranty program from Varian EIMAC, or any Electron Device Group worldwide sales organization. See your distributor or contact Varian EIMAC today.

Varian EIMAC
301 Industrial Way
San Carlos, California 94070
Telephone: 415-592-1221

Varian EIMAC
1678 S. Pioneer Road
Salt Lake City, Utah 84104
Telephone: 801-972-5000



Circle (21) on Reply Card

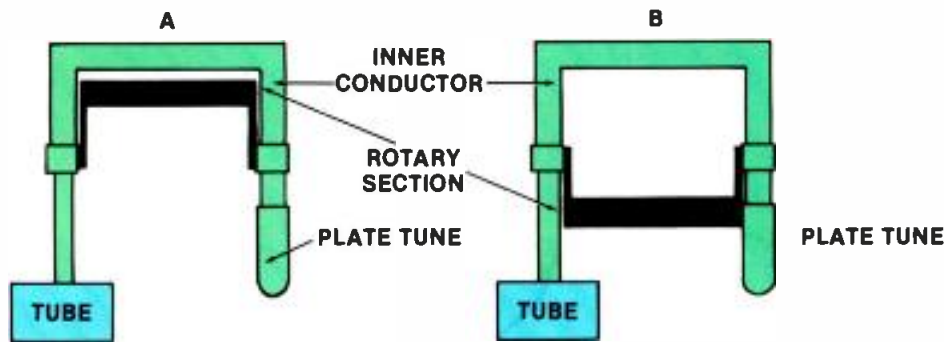

Figure 8. Using the cavity's movable section to adjust for resonance. Diagram (A) shows the rotary section at maximum height and (B) shows the rotary section at minimum height.

- NOTES:
 1. TUNING OPERATED AT ZERO RF AND dc POTENTIAL.
 2. NO PLATE BLOCKING CAPACITOR.

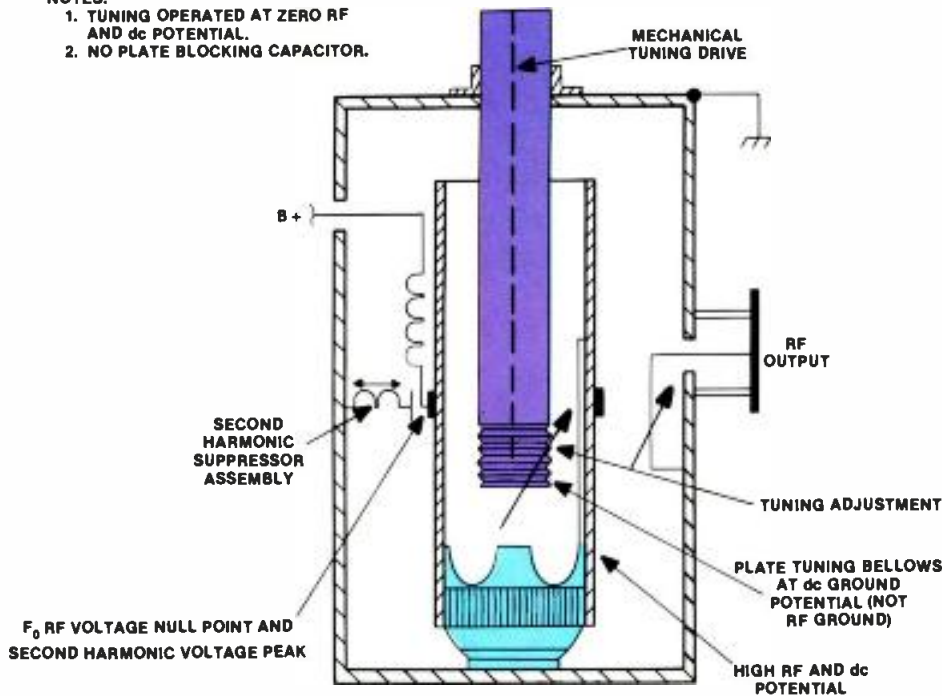

Figure 9. The basic design of a folded 1/2-wavelength cavity.

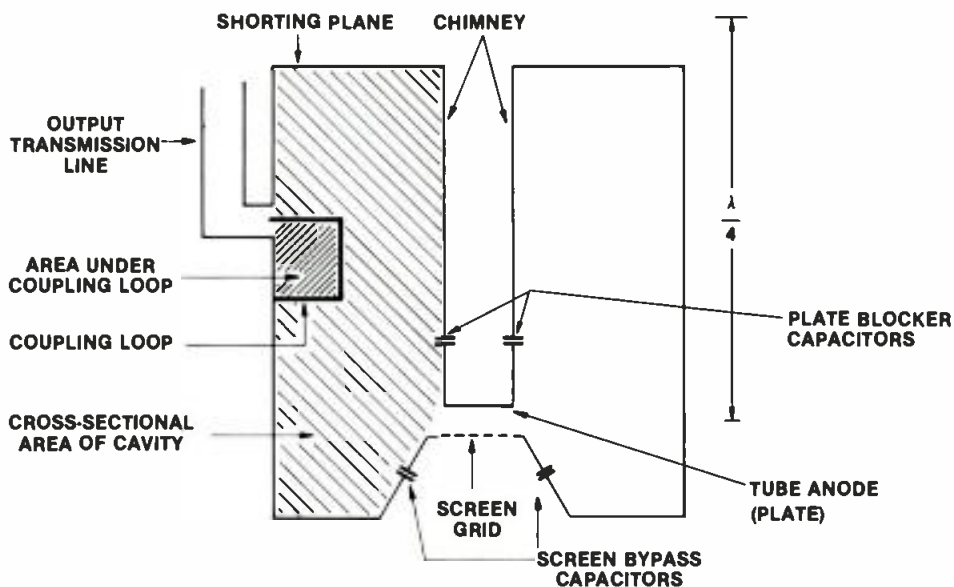

Figure 10. The use of inductive coupling in a 1/4-wavelength PA stage.

line, together with the rotary section, function as a parallel inductance. RF current flows in the same direction through the transmission line and the rotary section. Therefore, the magnetic fields of the two paths add.

When the rotary section is at maximum height, the magnetic coupling between the main section of the transmission line and the rotary assembly is maximum. Because of the relatively large mutual inductance provided by this close

coupling, the total inductance of these parallel inductors increases. This electrically lengthens the transmission line and lowers the resonant frequency. The concept is illustrated in Figure 8(A).

When the rotary section is at minimum height, the magnetic coupling between the two parts of the inner conductor is minimum. This reduced coupling lowers the mutual inductance, which lowers the total inductance of the parallel combination. The reduced inductance allows operation at a higher resonant frequency. This condition is illustrated in Figure 8(B).

The rotary section provides an infinite number of coarse settings for the various operating frequencies.

The movable plate-tune assembly is located at the end of the inner-plate transmission line. It can be moved up and down to change the physical length of the inner conductor by about 4 11/16 inches. This assembly is linked to the front-panel plate-tuning knob, providing a fine adjustment for cavity resonance.

The folded 1/2-wave cavity

A special case of the 1/2-wavelength PA cavity is shown in Figure 9. The design employs a folded 1/2-wave resonator constructed with coaxial aluminum and copper tubing. This cavity arrangement eliminates the high-voltage blocking capacitor and high-current shorting contacts of conventional designs by connecting the main transmission-line resonant circuit conductor directly to the anode of the power tube. A grounded, concentric transmission-line center conductor tunes the cavity with a variable re-entrant length inserted into the end of the main conductor opposite the tube.

The main conductor (the fixed portion of the plate line) is insulated from ground and carries the anode dc potential. High-voltage power is fed at the fundamental frequency RF-voltage null point, approximately 1/4-wavelength from the anode, for easy RF decoupling. A large surface area without sliding contacts results in minimal loss.

Incorporated into the tank design is a second-harmonic suppressor. Rather than attenuating the second harmonic after the signal has been generated and amplified, this design essentially eliminates formation of second-harmonic energy by series-LC trapping the second-harmonic waveform at the point where the wave exhibits a high impedance (approximately 1/4-wavelength from the anode). The basic LC circuit placed here will essentially eliminate the second-harmonic component in the plate-current waveform. The second harmonic will peak in voltage at the same point that the dc-plate potential is applied.

Plate tuning is accomplished by an adjustable bellows on the center portion of

Tired of excuses from "third party" synchronizer companies? Studer, the world's premier tape transport maker, now offers two new intelligent SMPTE/EBU bus controllers.

SC 4008: Dedicated and Expandable – The basic SC 4008 system controls four audio, video or film machine transports via Studer TLS 4000 synchronizers. For more sophisticated applications, an optional expansion board extends SC 4008 control to as many as eight machines. The operating panel has a full array of dedicated keys logically grouped according to function.

Optional features include take count-down unit, VITC reader/translator, video character inserter, and event controller with outputs to trigger up to 10 additional non-synchronous sources.

SC 4016: Soft Alternative to Hard Production Tasks– The SC 4016 top panel shows a radical departure from the SC 4008 concept. Instead of dedicated keys, the SC 4016 employs eight "soft keys" with internal alphanumeric LED

displays. The software menu assigns functions to the keys according to selected system mode, and keys are automatically re-labelled to indicate currently assigned function.

The SC 4016 controls up to 16 synchronous transports, providing complete control (including shuttle and cue functions where applicable) as well as comprehensive machine status displays. Master and slave machine designations may be re-programmed at any time. And, for advance EDL preparation, the SC 4016 provides floppy disc data exchange with personal computers.

In Sync with Swiss Timing – Studer system controllers are made in Switzerland, the country famous for being in control and precisely on time. Every time. For more information on Studer system controllers, please contact your nearest Studer office.

STUDER REVOX

STUDER REVOX AMERICA, INC.
1425 Elm Hill Pike, Nashville, TN 37210, (615) 254-5651

Offices: Los Angeles (818) 780-4234/New York (212) 244-4462/
Chicago (312) 526-1660/Dallas (214) 943-2239
San Francisco (415) 930-9866

Machine Control from a Machine Maker



SC 4008



SC 4016

STUDER SMPTE BUS CONTROLLERS



Synchronizing complex, Austrian Broadcasting Center, Vienna. Studer SC 4016 system controller, Studer mixing console, Studer tape machines.

Circle (22) on Reply Card

www.americanradiohistory.com



**WHEN LOOKING FOR THE LATEST TECHNOLOGY
IN UHF AND VHF TRANSMITTERS...**

Comark's recent track record of technological innovations is unmatched by any other US manufacturer. This impressive history of recognized advancements demonstrates our commitment to the future. A commitment backed by continuing substantial investments in research and product development activities.

Incorporating new technology into today's products is your assurance that the Comark transmitter purchased now will still be current in the year 2000.

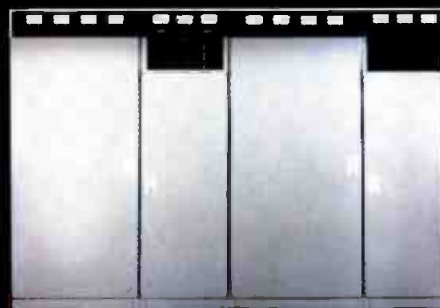

COMARK COMMUNICATIONS, INC.
A Thomson-CSF Company

Route 309 & Advance Lane • Colmar, PA 18915
(215) 822-0777 • Telex 846075

Circle 23 on Reply Card
www.americanradiohistory.com

BROADCASTING

Aug. 18, 1986

"Both COMARK and Thomson-LGT made news at the NAB..."
"COMARK introduced a 60 kw UHF transmitter with a KLYSTRODE..."

"...Thomson-LGT introduced a 30 kw SOLID-STATE VHF Transmitter..."

"Comark... first domestic source for BCD/ABC beam current pulsing systems..."

COMARK

LEADING THE INDUSTRY IN TECHNICAL INNOVATIONS

BM/E June 1986

NAB Show-In-Print

"...the principal advance reported at this NAB was the long-awaited commercial realization of the KLYSTRODE TUBE design in a production transmitter from COMARK..."

"COMARK is first US manufacturer to build production transmitters specifically designed for and featuring wide band external cavity KLYSTRON amplifiers."

BROADCAST ENGINEERING-
May 1986 Transmission
Systems Special Issue

"High-performance Klystrons, Klystrodes and solid-state RF amplifiers are reducing operating costs and improving broadcast transmitter quality..."

"COMARK was the 1st domestic manufacturer to design and produce no-tuning solid-state exciter/driver for use with Klystron transmitting systems..."

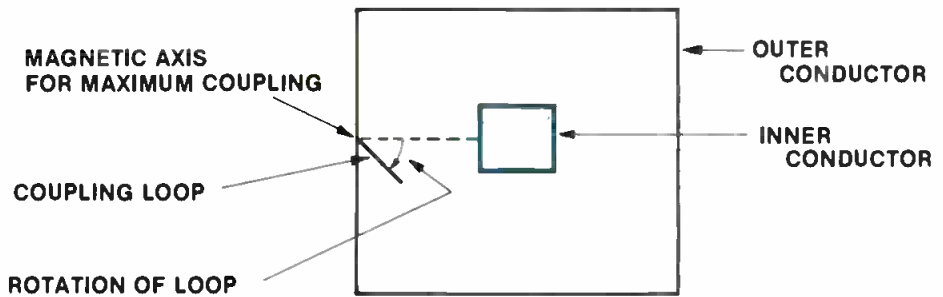

Figure 11. The top view of a cavity showing the inductive coupling loop rotated away from the axis of the magnetic field of the cavity.

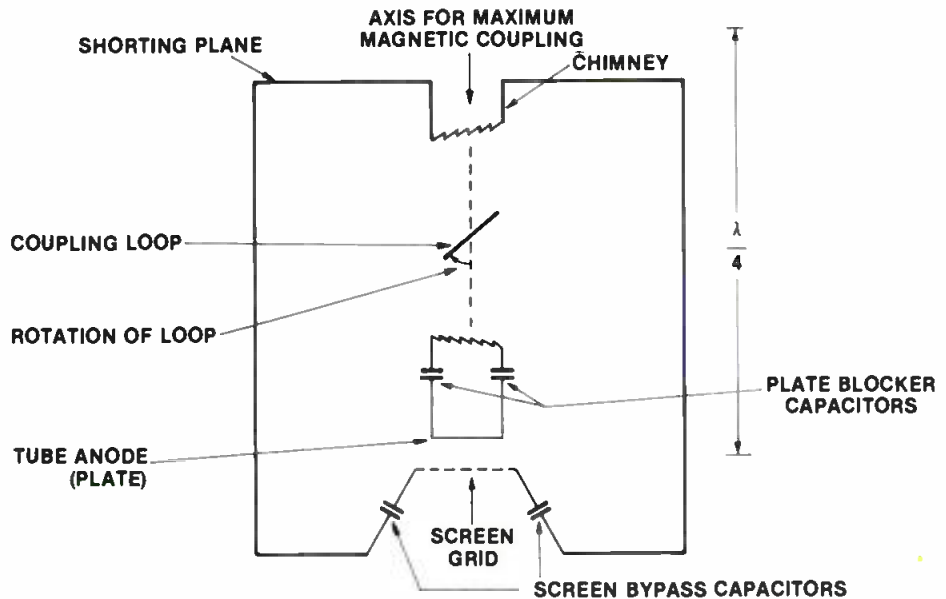

Figure 12. A cutaway view of the cavity showing the coupling loop rotated away from the axis of the magnetic field.

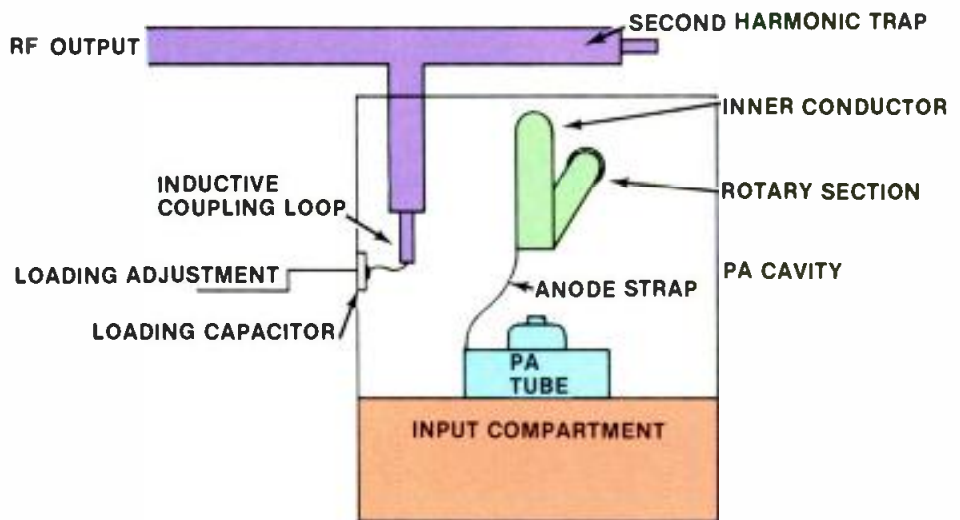

Figure 13. The location of the inductive coupling loop and loading capacitor in a $\frac{1}{2}$ -wavelength FM PA stage.

the plate line, which is maintained at chassis ground potential.

Output coupling is accomplished with an untuned loop intercepting the magnetic field concentration at the voltage null (maximum RF current) point of the main line. The PA-loading control varies the angular position of the plane of the loop with respect to the plate line, changing the amount of magnetic field that it

intercepts. Multiple phosphor-bronze leaves connect one side of the output loop to ground and the other side to the center conductor of the output transmission line. This allows for mechanical movement of the loop by the PA-loading control without using sliding contacts. The grounded loop improves immunity to lightning and static build-up on the antenna.

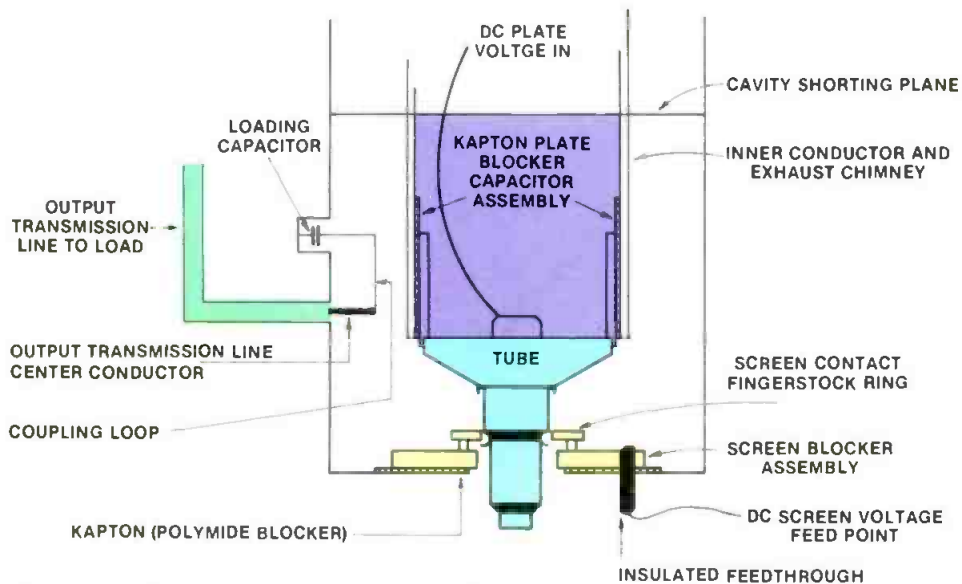

Figure 14. The position of the inductive coupling loop in a 1/4-wavelength FM cavity amplifier. Note that the loop is located away from the points of maximum RF voltage and current.

Circulating currents

When current flows on one conductor of a transmission line cavity circuit, an equal magnitude current flows in the opposite direction on the other conductor. This means that a large value of RF-circulating current is flowing in a cavity amplifier's outer conductor (the cavity box). All of the outer conductor's circulating currents start at and return to the screen grid.

The front or back access panel (door)

of the cavity is part of the outer conductor and large values of circulating current flow through it, into it and out of it. The amplifier must never be operated with the back panel removed or with any loose or damaged fasteners.

A mesh contact strap electrically connects the back panel to the rest of the cavity. If a fastener is loose or damaged, the back panel is loose or the mesh contact strap is damaged or defective, arcs will develop between the cavity box and

the affected area of the back panel.

Once an arc occurs, the pitted surface forms an insulator that restricts the flow of RF current. The damaged surfaces can be cleaned, but the surface must be flat to ensure a good electrical contact. Any pit mark on or under the mesh will cause a recurrence of the arc.

Output coupling

Coupling is the process by which RF energy is transferred from the amplifier cavity to the output transmission line. Both capacitive (electrostatic) and inductive (magnetic) coupling methods are used in cavity RF amplifiers, and in some designs, combinations of the two are used.

Magnetic coupling

Magnetic coupling employs the principles of transformer action. The efficiency of the coupling depends upon three conditions:

- (1) The cross-sectional area under the coupling loop, compared to the cross-sectional area of the cavity. (See Figure 10.) This effect can be compared to the turns ratio principle of the transformer.
- (2) The orientation of the coupling loop to the axis of the magnetic field. The

Continued on page 42

DPTC-25 KFM
GREATLY IMPROVED ALWAYS IN STOCK



Electro Impulse New Dry FM Loads

Rugged & Reliable

- Greatly Improved 25 and 50KW Dry Loads; new 75KW load
- Reduced Load and RF Connector Temperatures
- More Efficient Air Flow Pattern
- Inexpensive Field Mod Kits Available for DPTC 25KFM and 50KFM Loads already in service



Electro Impulse Lab
116 Chestnut Street
Red Bank, NJ 07701
201-741-0404

DPTC-75 KFM
75 KW DRY FM

NEW!

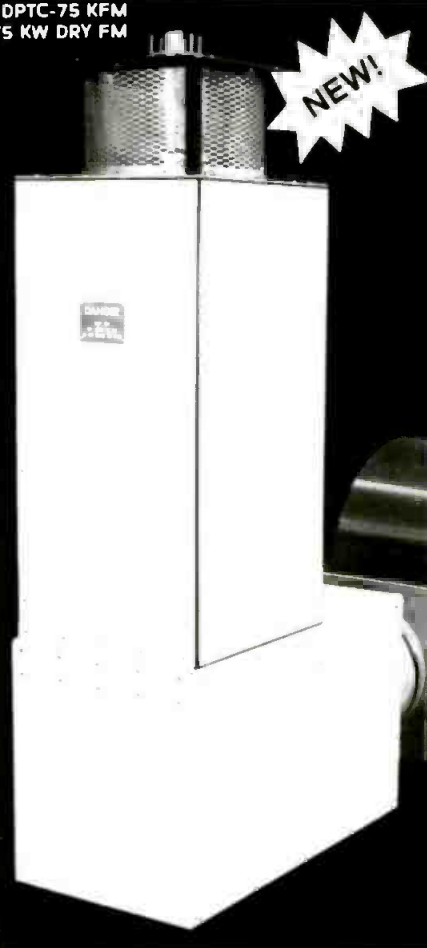

Circle (24) on Reply Card

WE PUT SOMETHING VERY SPECIAL INTO OUR NEW TV-80 ZOOM....



A LOT OF THOUGHT.

We got inside the heads of professionals like you before we designed a single component inside the new Schneider TV-80.

The result is a 17X studio zoom that's picture perfect. One that's easy to use. Easy to service. And one that delivers uncompromising image quality. Truly, the ideal mate for the new generation of 2/3-inch studio/OB cameras.

Our advanced servo module with digital feedback and built-in microprocessor typifies the innovative thinking that's gone into this lens. The servos align themselves automatically whenever you power up, and the easily removable module is interchangeable with flexible cable drives for control flexibility.

The built-in pattern projector employs a unique color mixing system that insures correct color temperature and illumination. Full servo zoom is under one second, and when

used with its built-in 2X range extender, the servo iris automatically compensates for light loss, producing constant video level at all times.

The TV-80 is rugged and compact. All adjustment points are grouped together for easy access. An optional diagnostic digital test unit is available for quick analysis of all electronic functions via one simple connector. And plug-in electronic components make service a snap.

The new Schneider TV-80 Zoom. We put a lot of thought into it, so you'll never think twice before buying it. For more information or a demo, contact: Schneider Corporation of America, 400 Crossways Park Drive, Woodbury, NY 11797, (516) 496-8500.

Western U.S.A. Service: 861 Production Place, Newport Beach, CA 92663, (714) 631-7430.



 **Schneider**
KREUZNACH
SHOOT FOR THE BEST.

Circle (25) on Reply Card

www.americanradiohistory.com

"Digital has final



Sony Communications Products Company, Professional Audio Division,
1600 Queen Anne Rd., Teaneck, NJ 07666. © 1987 Sony Corporation of America.
Sony is a registered trademark of Sony Corporation.

y adapted to me."

Sit down at a Sony PCM-3202 2-channel digital recorder and you'll notice something strange.

Mainly, that it's *not* strange.

You can rock its reels, splice the tape, in fact, you can do everything you're used to doing with a studio-quality analog recorder. But still get great digital sound.

And since it's Sony digital, you'll find that it's not only easier to work with, it's also easier to master with. Because the 3202 makes *direct* digital transfers to the world standard PCM-1630 CD mastering system.

So if you've been waiting for a great tape machine that happens to be digital; don't wait. Contact your Sony Pro-Audio representative for a demonstration.

For more information on the PCM-3202 and the PCM-3102 (7½ ips version) call the Leader in Digital Audio at (201) 833-5231.

SONY
PRO AUDIO

Circle (26) on Reply Card



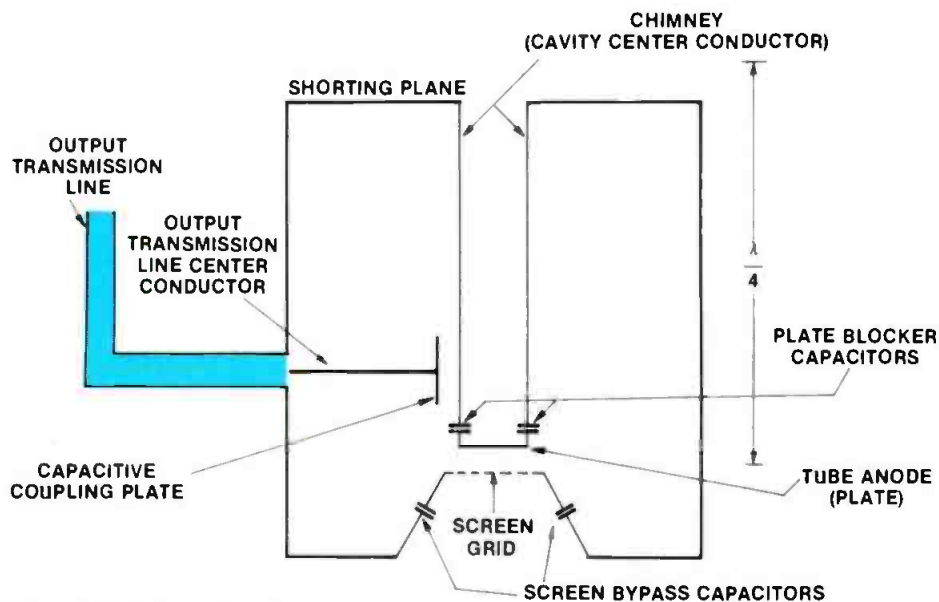

Figure 15. A $\frac{1}{4}$ -wavelength cavity with capacitive coupling to the output load.

Continued from page 38

coupling from the cavity is proportional to the cosine of the angle at which the coupling loop is rotated away from the axis of the magnetic field. (See Figures 11 and 12.)

(3) The amount of magnetic field that the coupling loop intercepts. The strongest magnetic field will be found at the point of maximum RF current in the cavity. This is the area where maximum inductive coupling is obtained. Greater

magnetic field strength also is found closer to the center conductor of the cavity. Coupling, therefore, is inversely proportional to the distance of the coupling loop from the center conductor.

In both $\frac{1}{2}$ - and $\frac{1}{4}$ -wavelength cavities, the coupling loop feeds a 50Ω transmission line (the load). The loop is in series with the load and has considerable inductance at VHF frequencies. The inductance will reduce the RF current that flows into the load, thus reducing the

power output. This effect can be overcome by placing a variable capacitor in series with the output coupling loop, as shown in Figures 13 and 14. The load is connected to one end of the coupling loop and the variable capacitor ties the other end of the loop to ground. The variable capacitor cancels some or all of the loop inductance. It functions as the PA-stage loading control.

Maximum loop current and output power occurs when the loading capacitor cancels all of the inductance of the loading loop. This lowers the plate impedance and results in heavier loading.

Light loading results if the loading capacitance does not cancel all of the loop inductance. The loop inductance that is not canceled causes a decrease in load current and power output, and an increase in plate impedance.

Capacitive coupling

Capacitive coupling, which physically appears to be straightforward, often baffles the technician because of its unique characteristics. Figure 15 shows a cavity amplifier with a capacitive-coupling plate positioned near its center conductor. This coupling plate is connected to the output load, which can be a transmission line or a secondary cavity (for TV serv-

A NEW GENERATION IN SATELLITE UPLINKING/DOWNLINKING

The future needs in satellite communications is the primary focus of a new line of products introduced by MICRO PHASE COMMUNICATIONS.

The MP-1080 Series Modulators are high performance satellite uplink products. These Modulators offer Low Distortion FM Modulation coupled with Low Idle Noise, with an output frequency range of 43 to 97MHz, synthesized in 5kHz steps.

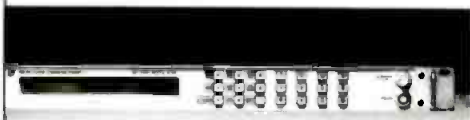

The MP-1080S and the MP-1080P are top-of-the-line models, which feature LCD Displays and TALK MODE entry guidance.*



The MP-2000 Series Demodulators, built to accommodate various user needs and configurations, provide high end-to-end performance in the final link of Audio Distribution.

All MICRO PHASE COMMUNICATIONS products, are designed with as many features and functions as possible.

Advanced micro-processor controls add a new level of sophistication and control to these products.



MICRO PHASE COMMUNICATIONS products can be controlled as a system via the RS232C and RS422 Ports which are incorporated into appropriate products.

Call us today to discuss your specific needs: MICRO PHASE COMMUNICATIONS 415 368-3869.

Factory stock available on some items, custom order lead time as short as one week, typical lead time three/four weeks.

*The MP-1080T is the thumbwheel version.

MICRO PHASE COMMUNICATIONS INC.

999 C Edgewater Blvd., Suite 138
Foster City, CA 94404 415 368-3869

Circle (29) on Reply Card

Task:

Copy a few cassettes today, a thousand tomorrow and ten thousand next week. *BK*



Problem:

Find a one-stop source for tape duplicating equipment that accomplishes the small tasks and the big ones—profitably.

Solution:

Telex—unquestionably the company with the widest, most versatile line of tape duplicating products in the industry.

Telex has a duplicator that fits your needs—today, tomorrow and next week.

Whether it's a new suit for yourself or electronics for your business, it makes sense to shop where you have the widest selection. And, if your purchase is as crucial to the profit line as a high speed tape duplicator, you shouldn't settle for a model that almost fits your needs.

Telex has models that copy as few as one cassette at a time or as many as twenty-three. Telex models are available in mono or stereo and also offer a wide variety of copying configurations such as cassette to cassette, reel to cassette, cassette to reel or reel to reel. For small to medium run cassette duplication, choose one of the new Telex CD Series, but if you need open reel capability plus larger cassette production, one of the Model 6120 configurations is probably best for you. At Telex, you can find the right duplicator at the right price, and you'll find it faster. For more information and detailed specifications, write to Telex Communications, Inc., 9600 Aldrich Ave. So., Minneapolis, Minnesota 55420, Telephone: 612-887-5531.

Call Toll Free in U.S. 800-828-6107

For small to medium production runs...



The NEW CD Series

TELEX®

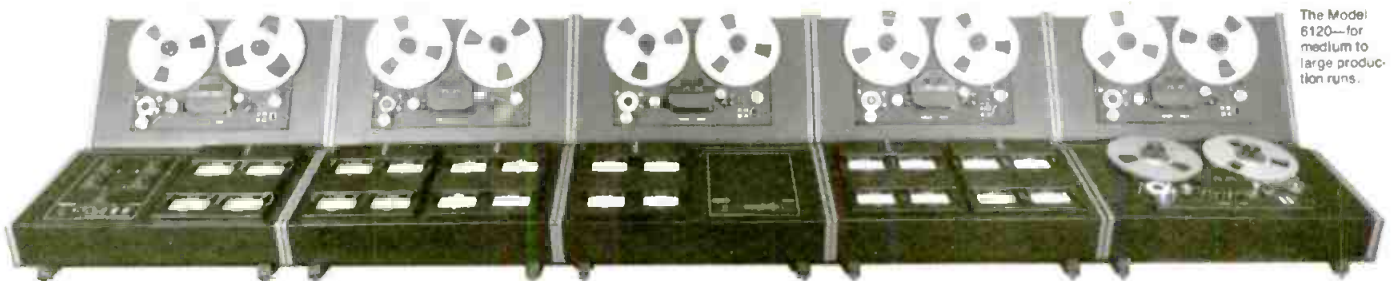

The Model 6120—for medium to large production runs.

Ask a participating dealer about special payment terms available only with the Telex 6120!

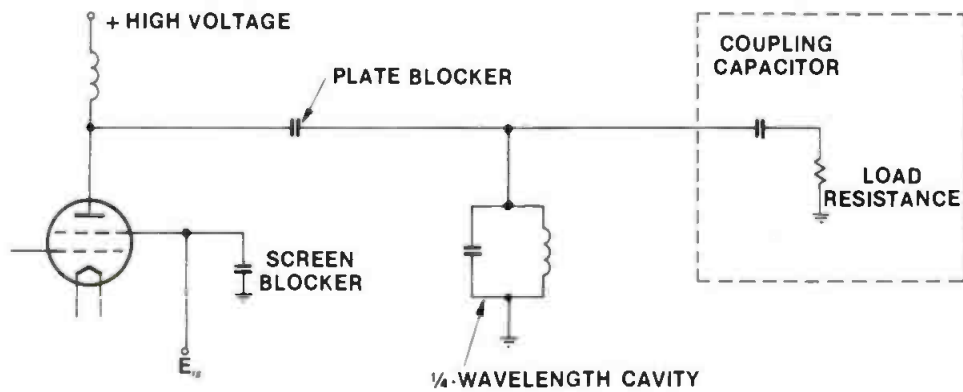

Figure 16. The equivalent circuit of a 1/4-wavelength cavity amplifier with capacitive coupling.

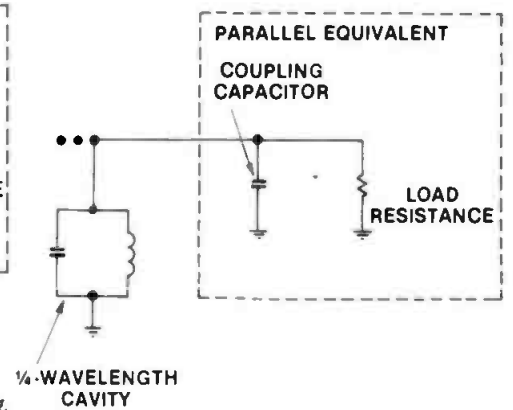
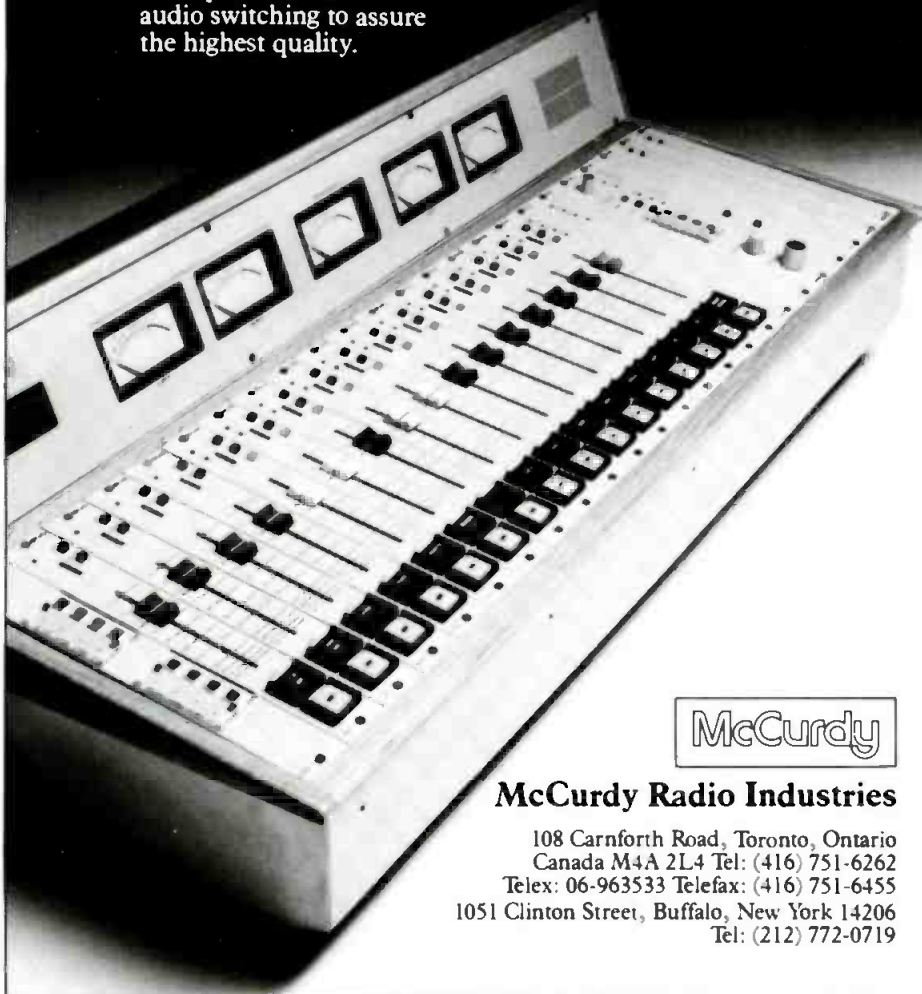

Figure 17. The equivalent circuit of a 1/4-wavelength cavity amplifier showing how the series capacitive coupling appears electrically as a parallel circuit to the PA tube.

INEXPENSIVE BY DESIGN

Here is audio engineering at its affordable best. The McCurdy Series 'S' Console can be tailored for any size budget and broadcast requirement to provide precise audio mixing, monitoring and control. The very latest in analog and digital electronics is coupled with full electronic audio switching to assure the highest quality.

As complete or as basic your budget allows, the Series 'S' offers McCurdy's unsurpassed audio quality and ultra-reliability. Available in a wide choice of modules in three sizes to accommodate up to 26 input mixing modules.



McCurdy

McCurdy Radio Industries

108 Carnforth Road, Toronto, Ontario
Canada M4A 2L4 Tel: (416) 751-6262
Telex: 06-963533 Telefax: (416) 751-6455
1051 Clinton Street, Buffalo, New York 14206
Tel: (212) 772-0719

ice). The parameters that control the amount of capacitive coupling are: the area of the coupling-capacitor plate (the larger the area, the greater the coupling) and the distance from the coupling plate to the center conductor (the greater the distance, the lighter the coupling). Maximum capacitive coupling occurs when the coupling plate is at the maximum voltage point on the cavity center conductor.

To understand the effects of the capacitive coupling, the equivalent circuit of the cavity must be observed. Figure 16 shows the PA tube, cavity (functioning as a parallel resonant circuit) and output section. The plate-blocking capacitor isolates the tube's dc voltage from the cavity. The coupling capacitor and output load are physically in series, but electrically they appear to be in parallel, as shown in Figure 17. The resistive component of the equivalent parallel circuit is increased by the coupling reactance. The equivalent parallel coupling reactance is absorbed into the parallel resonant circuit, thus, the necessity to retune after changing the PA stage coupling (loading). The coupling reactance can be a series capacitor or inductor.

The series-to-parallel transformations are explained by the following formula:

$$R_p = \frac{R_s^2 + X_s^2}{R_s} \text{ and } X_p = \frac{R_s^2 + X_s^2}{X_s}$$

Where R_p = effective parallel resistance;

R_s = actual series resistance;

X_s = actual series reactance; and

X_p = effective parallel reactance.

Although there are many similarities among various cavity designs, each one imposes its own set of operational requirements and limitations. No two cavity systems will tune up in exactly the same fashion. Therefore, closely follow the manufacturer's instructions on tuning. Given proper maintenance, a cavity amplifier will provide years of reliable service.

! : ? =)))

Circle (140) on Reply Card

SEEK PROFESSIONAL HELP.



42B 2-Track Recorder/Reproducer



Hour after hour in a padded room can drive you a little close to the edge. And you don't need any extra trauma from your 1/2-track.

Tascam's new 42B 2-channel, 2-speed, 2-track recorder/reproducer will take your day-in, day-out, all-

day, all-night schedule in stride. And features like +4 dBm XLR in and out, balanced mic inputs for field use, 250/320 nWb/m, and front-panel controls reduce stress in even the most harried engineer.

Call or write TASCAM for the full story on the 42B. Because it's a

crazy world out there. And there's no shame in seeking professional help.

TASCAM
TEAC Professional Division

7733 Telegraph Rd. • Montebello, CA 90640
Telephone: (213) 726-0303

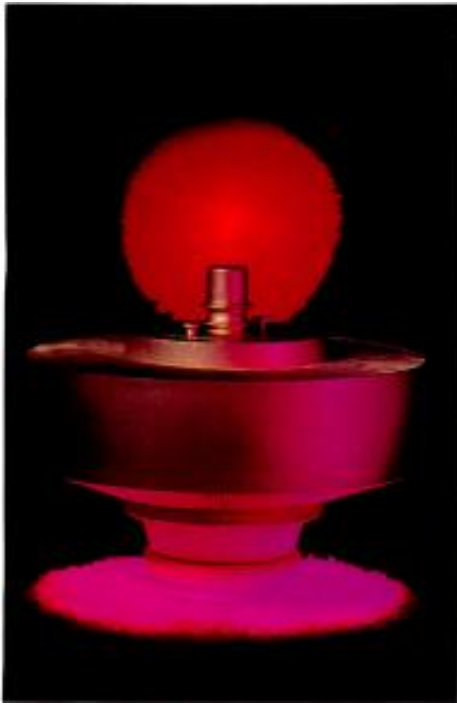

Fine tuning FM final stages

By Geoffrey N. Mendenhall, P.E.

Tuning the output stage of an FM transmitter is more than a peak and a dip process.

Some engineers, even after several years of work, still don't understand the proper procedure for final-stage tuning. Many engineers simply tune for a peak in output and a dip in current, assuming that is all that is required. Improper tuning can affect both a transmitter's efficiency and its audio performance. Be-

cause the tuning of each transmitter is slightly different, understanding how the tuning controls affect the transmitter may enable you to improve your transmitter's performance.

Importance of tuning

Tuning the tube-type power amplifier output stage usually involves several different interacting adjustments. The output circuit's resonant frequency is adjusted to minimize plate current by a control

called *output tuning*. The power output level is adjusted by a control called *output loading*. A third kind of adjustment called *screen voltage* is related to the setting of the output-loading control in amplifiers that use a tetrode tube.

Tuning the power-amplifier input stage generally involves two kinds of adjustments. The grid-circuit resonant frequency is set by the *input-tuning* control. The input-impedance match is set by the *input-matching* control. Some newer transmitter designs eliminate the input-matching control by incorporating broadband-matching networks.

Correct adjustment of these controls is essential not only in achieving peak efficiency, but also in making the passband of the amplifier as transparent as possible to the wideband FM signal that must pass through it. When automatic power control (APC) is used with tetrode amplifiers, you also must provide headroom in the tuning procedure. Providing sufficient headroom is important if screen overloads are to be avoided.

Achieving peak efficiency, adequate APC headroom and a centered passband all simultaneously generally is not possible. A reasonable compromise is the best objective when tuning the final stage.

FM modulation theory

The radio frequency FM signal consists of pairs of sidebands spaced from the carrier frequency by multiples of the modulating frequency. Theoretically, the RF output spectrum contains an infinite number of these sideband components. When the modulation index M (frequency deviation divided by modulating frequency) is small (0.5), the amplitude of

Mendenhall is vice president of engineering for Broadcast Electronics, Quincy, IL.

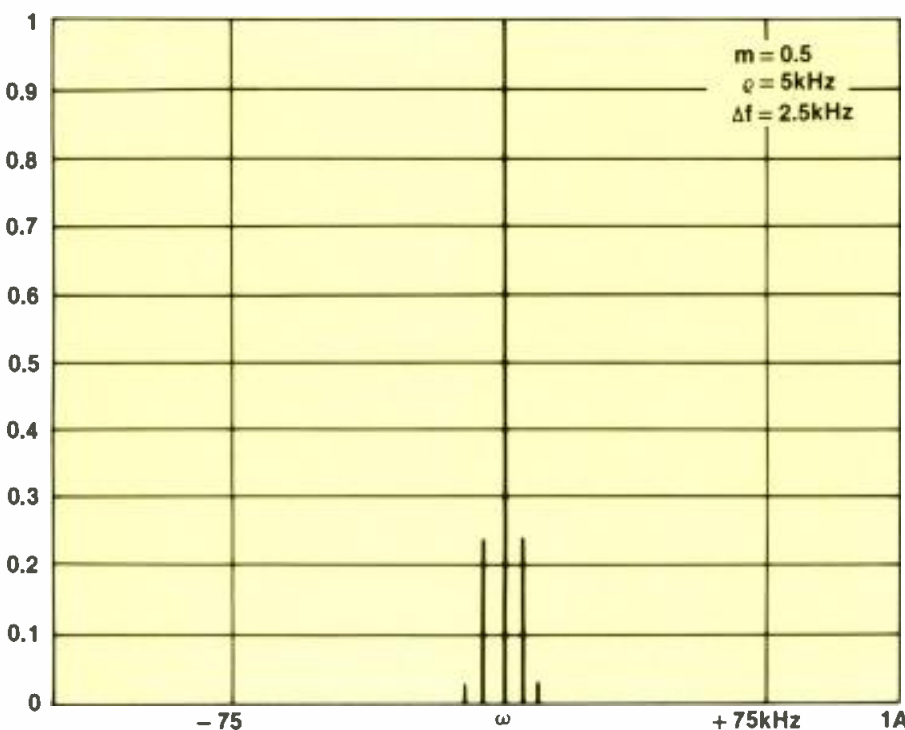

Figure 1. As the modulation index increases, so does the number of sidebands. Shown here is the RF spectrum with a modulation index of 0.5.

Q

Ever
Wonder
Why We
Paint **QEI** FM
Transmitter
Cabinets
Red?



Model FMQ-20/30,000

A

It's Simple.
QEI
transmitters
are **so reliable**, if
we didn't paint
the cabinet red,
you might forget
it was there!

Case in point: Our new 20/30KW FM Transmitter. One of the QEI "New Reliables." Everything about it is designed for maximum efficiency and ultra-dependability. Its single tube design uses a grounded grid triode for greater stability.

QEI FM transmitters employ no troublesome sliding contacts. And to go a step further toward perfect reliability, we found a way to eliminate the conventional plate blocker, along with all the problems it can cause.

The QEI 20/30KW units back you up in another important way, too. Their drivers can be operated as self-contained transmitters, and can go directly to air in minutes.

QEI includes the directional coupler and a 100% semi-conductor spares kit with every transmitter. And our ARC-27 Automatic Remote Control system (including studio control unit) is the envy of the industry.

Our 15,000 hour tube warranty is enviable too. No one else offers anything like it.

Whether your station's power level is 1KW or 60 KW — or anywhere in between — QEI has a "New Reliable" FM transmitter you can count on.

One Airport Drive P.O. Box D
Williamstown, NJ 08094
Phone: 609-728-2020
Toll Free: 800-334-9154
Telex: 510-686-9402

QEI Corporation

The New Reliables

Circle (31) on Reply Card

www.americanradiohistory.com

15000
HOUR
TUBE
WARRANTY

$E(t) =$	total RF output voltage
$A[J_0(M)\sin \omega c(t)]$	carrier amplitude
$+ [J_1(M)\sin (\omega c + \omega m)t]$	first-order upper sideband
$- [J_1(M)\sin (\omega c - \omega m)t]$	first-order lower sideband
$+ [J_2(M)\sin (\omega c + 2\omega m)t]$	second-order upper sideband
$+ [J_2(M)\sin (\omega c - 2\omega m)t]$	second-order lower sideband
$+ [J_3(M)\sin (\omega c + 3\omega m)t]$	third-order upper sideband
$- [J_3(M)\sin (\omega c - 3\omega m)t]$	third-order lower sideband
$\pm [J_n(M)\sin (\omega c \pm n\omega m)t]$	higher-order sidebands

Where:

- A = the unmodulated carrier amplitude constant
- J_n = the modulated carrier amplitude
- $J_1, J_2, J_3, \dots, J_n$ = the amplitudes of the nth-order sidebands
- M = the modulation index
- $\omega c = 2\pi F_c$, the carrier frequency
- $\omega m = 2\pi F_m$, the modulating frequency

Table 1. Carrier and sideband amplitude and phase can be described by the equations shown here.

the second- and higher-order sidebands also is small. The output consists mainly of the carrier and the pair of first-order sidebands. This is illustrated in Figure 1.

The total transmitter RF output power remains constant with modulation, but the distribution of that power into the sidebands varies with the modulation index. This means that the power at the carrier frequency is reduced by the amount of power added to the sidebands.

As the modulation index is increased, as in wide-deviation FM broadcasting, the higher-order sidebands become more prominent. The carrier amplitude and phase (J_0) as well as the sidebands (J_1 through J_n) can be expressed mathematically by making the modulation index (M) the argument of a simplified Bessel function. The general expression is shown in Table 1.

The numeric values of the Bessel functions (J_0 through J_n), which express the amplitudes of the various frequency components, can be found in mathematical tables.

Figures 2 and 3 illustrate the frequency components present for modulation indexes of five and 15, respectively. Note that the number of significant sideband components becomes quite large with a high-modulation index. Depending upon the modulating frequency, the total bandwidth occupied can extend beyond $\pm 75\text{kHz}$ from the carrier.

This single-tone modulating frequency analysis is useful in understanding the general nature of FM, and for making tests and measurements. When program modulation is applied, there are many more sideband components present. These components also vary so much that sideband energy becomes distributed over the entire occupied bandwidth rather than appearing at discrete frequencies. A graphical representation of how the Bessel function values for the carrier and the first eight pairs of sidebands vary with the modulation index is shown in Figure 4.

After examining the Bessel function and the resulting spectra, it becomes clear that an FM signal's occupied bandwidth is far greater than the amount of deviation from the carrier. In fact, the occupied bandwidth is infinite if all the sidebands are taken into account. This means that for perfect information demodulation, a frequency-modulation system would require the transmission of an infinite number of sidebands. In practice, an acceptable quality signal can be transmitted within the limited bandwidth assigned to an FM channel.

Continued on page 52



MF Radio



AM BROADCASTERS CHOOSE FIELD PROVEN

AMPFET SERIES

TOTALLY SOLID STATE MODULAR

ALL POWERS

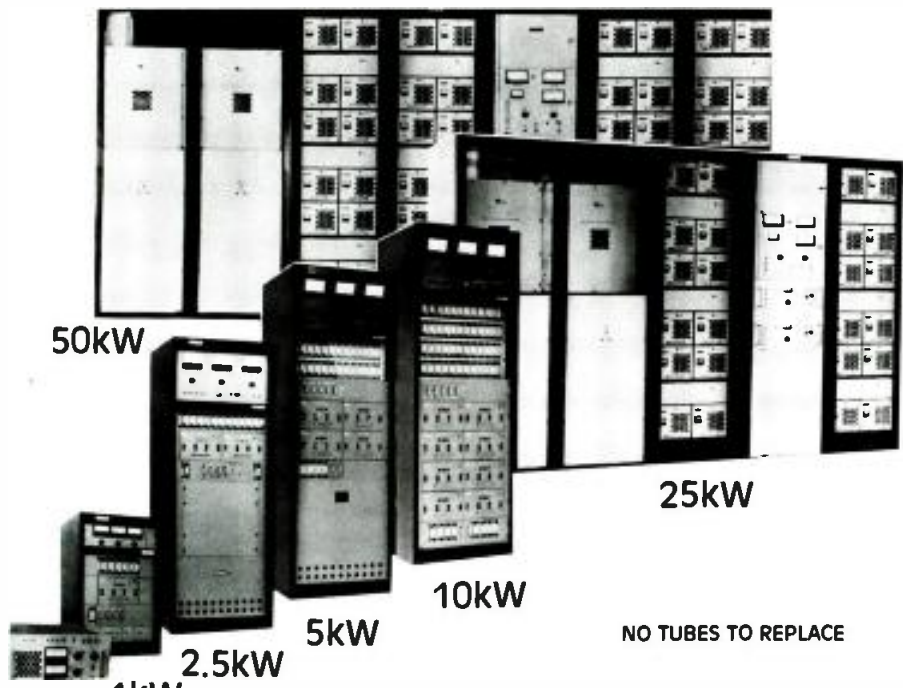

50kW

25kW

10kW

5kW

2.5kW

1kW

400 WATTS

NO TUBES TO REPLACE

MUCH LOWER POWER CONSUMPTION

SUPERIOR PERFORMANCE MONO-STEREO

MODULAR RESERVE & REDUNDANCY

totally solid state AM



NAUTEL
(Nautical Electronic Laboratories Limited)
R.R. #1, Tantallon, Halifax County,
Nova Scotia, Canada B0J 3J0

Phone (902) 823-2233
Telex: 019-22552

Nautel Maine Inc.
201 Target Industrial Circle
Bangor, Maine 04401 U.S.A.

Phone (207) 947-8200
Telex: 944466



Circle (32) on Reply Card

THOMSON-CSF

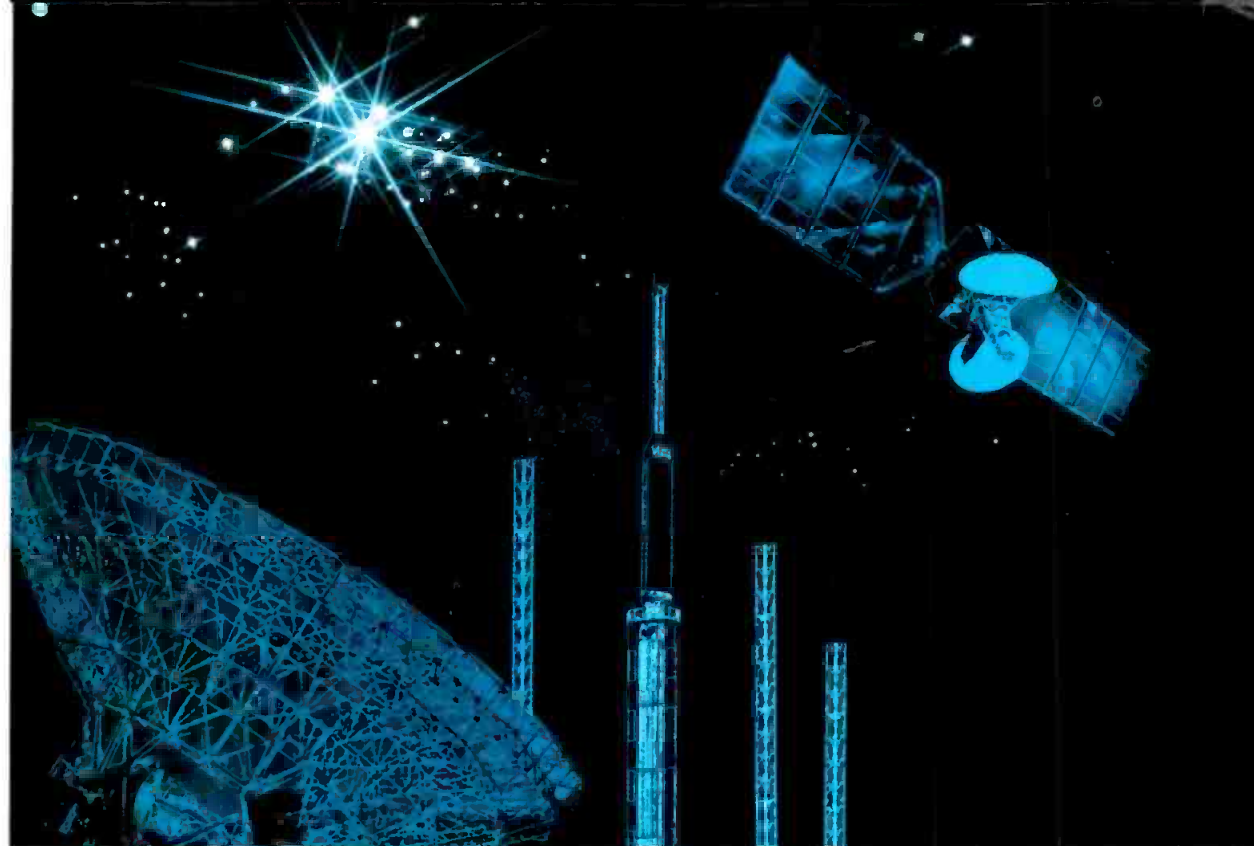

THE FURTHER WE GO, THE FURTHER YOU GO.

At Thomson-CSF we've been pioneers in developing the use of high-power tetrodes in transmitters for more than 70 years.

Over the years we've stayed ahead with such developments as Pyrobloc[®] grids and the Hypervapotron[®] cooling system.

We offer: A complete line of tubes for radio broadcasting applications from FM to the most powerful SW and LW transmitters - the quality of our 500-600 kW tubes has been amply demonstrated in 15 years of service in over forty transmitters worldwide.

A complete line of power grid tubes and their associated cavities for UHF/VHF TV transmitters. Thanks to their efficiency, reliability and tight tolerances, systems makers can offer their customers substantially more cost-effective products.

Earth station tubes up to 18 GHz (1.5 kW) or to 3.35 kW (6 GHz).

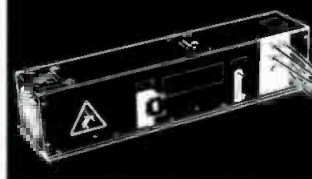

High efficiency space TWTs (including 50 W and 100 W Ku-band for next generation DBS Satellites).



High power radio broadcasting tetrodes up to 1.2 MW.



A complete line of klystrons and TWTs for ground stations and space TWTs for direct broadcasting satellites (DBS) designed to last for at least a decade.

And we also produce high-resolution image pick-up tubes and devices (CCDs), and high-luminosity CRTs for top range professional applications.

In radio and television, telecommunications, military and civil aviation, as well as in a wide range of scientific and medical applications, Thomson-CSF know-how gets your systems moving. Fast.

The world's most powerful tubes for radio and TV broadcasting.

Circle (33) on Reply Card



UHF and VHF tetrodes up to 50 kW. FM tetrodes up to 100 kW.

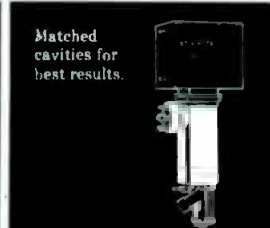

Matched cavities for best results.

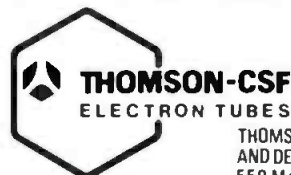

THOMSON-CSF
ELECTRON TUBES

THOMSON ELECTRON TUBES AND DEVICES CORPORATION
550 Mount Pleasant Avenue
P.O. Box 6500
DOVER, NEW JERSEY 07801
Tel.: (201) 328-1400. TWX: 710987 7901.

Belgique - BRUXELLES
Tel: (32-2) 648 64 85
Tx: 23 113 TMBXL B

Brazil - SAO PAULO
Tel: (55-11) 542 47 72
Tx: (011) 24 226 TCSF BR

Canada - MONTREAL QUEBEC
Tel: (1-514) 288 41 46
Tx: 5 560 246 TESAFI MTL

Deutschland - MÜNCHEN
Tel: (49-89) 74 79 0
Tx: 572 916 CSF D

España - MADRID
Tel: (34-1) 405 16 15
Tx: 46 033 TCCE E

France - BOULOGNE-BILLANCOURT
Tel: (33-3) 46 04 81 75
Tx: THOMFUT 200 772 F

Italia - ROMA
Tel: (39-6) 639 02 48
Tx: 670 683 THOMTE I

Japan - TOKYO
Tel: (81-3) 264 63 46
Tx: 2 324 241 THCSF J

Sverige - TYRESÖ
Tel: (46-8) 742 02 10

United-Kingdom - BASINGSTOKE
Tel: (+44 256) 29155
Tx: 858 865 TESAFI G

U.S.A. - DOVER
Tel: (1201) 328 1400
TWX 710987 7901

Gotcha.

If the price doesn't grab you the features will. But first, let's talk price.

The new Sony BVH-3000 costs about a third less than its predecessor, the BVH-2000. So now you can get true one-inch quality without breaking the bank.

One of the ways we did it was by using Sony-developed LSIs. A breakthrough that not only cuts the number of parts but helps make room for new innovations.



Like a revolutionary air threading system that automatically takes the @#!\$#! out of tape handling. An easy to use color framer. And a built-in TBC with a choice of two low-cost, high-performance processor boards.



Of course there's more, but the big news is that you pay less. For the full story, get a hold of your Sony Broadcast representative. Or call Sony at (201) 833-5231.

SONY
BROADCAST

Circle (34) on Reply Card

SONY

NY

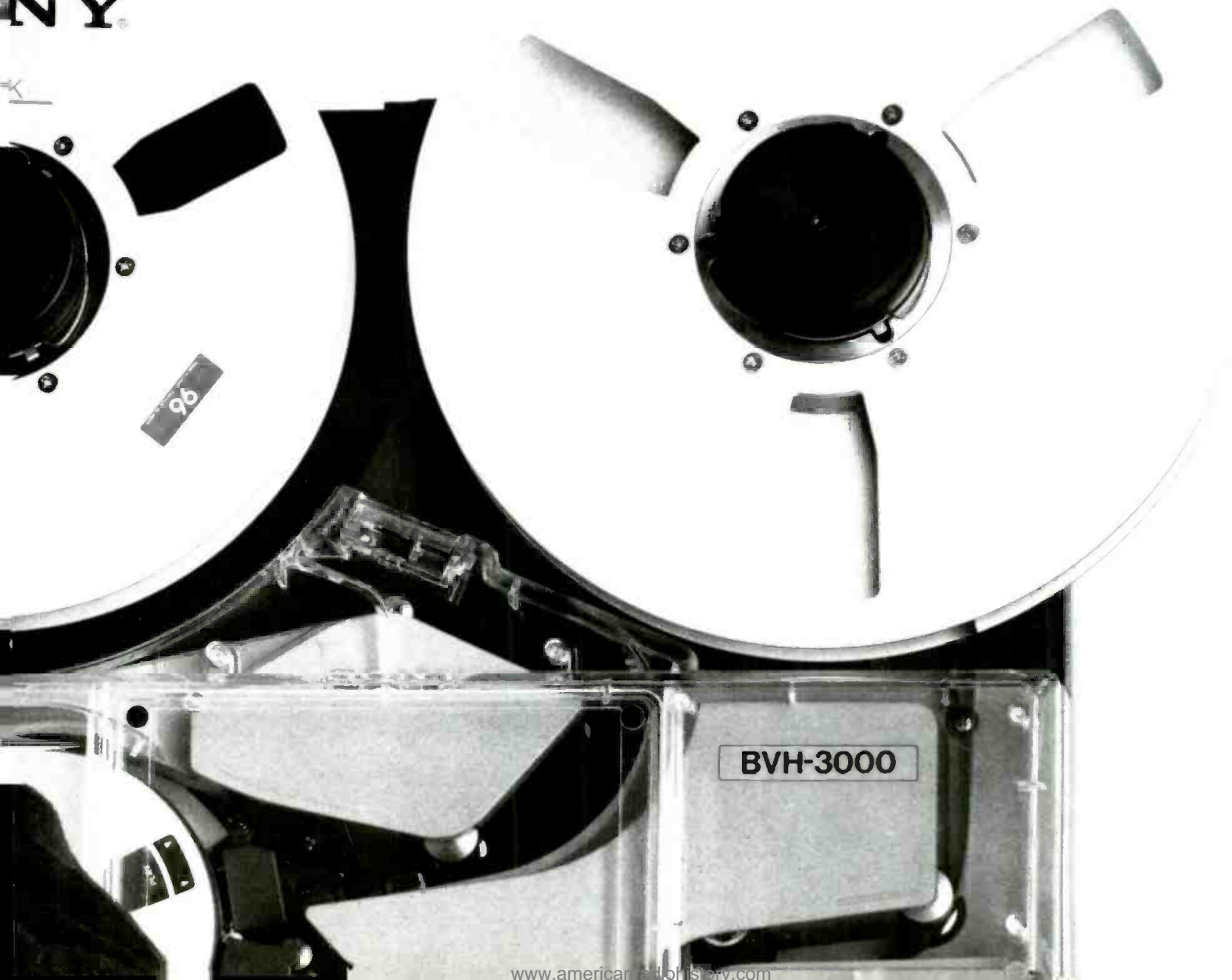

NEW DIGITAL BELTPACK

featuring R.M.K.*



- ▶ Smaller
- ▶ Lighter
- ▶ Higher Output
- ▶ Electronic Switching
- ▶ Compatible with existing Clear-Com

**Kills all open mics
from any remote location.**

For more features and models, contact your local dealer or:



Clear-Com
Intercom Systems

1111 17th Street
San Francisco, CA 94107 • 415-861-6666
Export Division: P.O. Box 302
Walnut Creek, CA 94596 • 415-932-8134
Telex: 176340 CLEAR-COM WNCK

Circle (35) on Reply Card

Comprehensive...

standards, diversity of industry practice and the flexibility required in the lab can overtax most audio analyzers. Add to this the higher performance demands of the new digital audio techniques and you clearly need a lot of horsepower.

The Amber 5500 Programmable Audio Measurement System answers the call. With the most comprehensive facilities, state-of-the-art performance, computer interface and ATE speed, the 5500 meets the challenge. Whether you test communication receivers, studio broadcast equipment, Hi-Fi pre-amplifiers or telephone channels, the Amber 5500 is a winner.

The 5500 measures absolute and relative level, three kinds of distortion, weighted and unweighted noise, frequency and crosstalk - and 3 to 10 times faster than other systems. Distortion below 0.001% and noise lower than 1uV are typical of its performance capabilities.

Ask for our "comprehensive" technical brochure and meet the challenge.

Amber also makes one of the most popular portable high performance audio measurement systems - the 3501. Half the weight and size of comparable instruments, the 3501 has one of the best reliability records in the industry.

amber

Amber Electro Design Inc.
4810 Jean Talon West
Montreal Canada H4P 2N5
Telephone (514) 735 4105
Telex 05-827598
US Toll free 800-361 3697

Circle (36) on Reply Card

Continued from page 48

Bandwidth vs. distortion

Figure 5 depicts a perfect FM modulator connected to a perfect demodulator via a wide-bandwidth RF path. The resulting demodulated baseband (see Figure 6) contains no distortion components.

The effects of an RF bandpass filter on the RF spectrum of a composite baseband signal are shown in Figure 7. The signal consists of a stereophonic baseband modulated at 4.5kHz with only one channel of audio and an unmodulated 67kHz SCA subcarrier. The only distortion evident on the RF spectrogram is the attenuation of sidebands greater than 200kHz from the center frequency and the amplitude differences between the lower and upper sideband pairs.

The corresponding effects observed on the demodulated baseband spectrum for the same signal are shown in Figure 8. Note the creation of many undesired intermodulation terms that will cause crosstalk into subcarrier bands. The distortion shown in this FM system is a result of the limited bandwidth available for the modulation index being used.

Tuning affects sidebands

In a transmitter, the higher-order FM sidebands will be slightly attenuated in amplitude and shifted in phase as they pass through the final amplifier stage. These alterations in the sideband structure are introduced by the amplifier passband and produce distortion in the receiver. The amount of distortion is dependent on the available bandwidth vs. the signal's modulation index.

For a given bandwidth limitation, the distortion usually can be minimized by centering the amplifier's passband on the signal being transmitted. This causes the amplitude and phase errors to equally and symmetrically affect both the upper and lower sidebands.

Tuning an amplifier for maximum power output or best efficiency does not necessarily result in a centered passband. One way to center the passband is to tune the amplifier for minimum synchronous AM modulation while applying FM modulation to the transmitter.

Types of AM modulation

The perfect FM transmitter has an absolutely constant output, regardless of FM modulation or power-supply variations. In practice, there is always some residual amplitude modulation of the FM transmitter output. There are two types of AM modulation that are of interest to the FM broadcast engineer:

- Asynchronous AM modulation is measured without FM modulation and is primarily related to power-supply ripple.
- Synchronous AM modulation (inciden-

Our VPR-80 type "C" is just about the lowest cost VTR you can buy without making quality compromises. That's why top level broadcasters, post-production facilities and corporate teleproduction studios depend on it for "workhorse" reliability and virtually transparent video quality. And why smaller, but quality conscious facilities use the VPR-80 for their most important video productions.

It also makes good business sense

to consider the VPR-80 when you're ready to phase out your 3/4" or quad machines. You won't believe the improvement this small but mighty VTR can make!

You'll find VPR-80s in hundreds of record, playback and duplicating applications, and also teamed up with our ADO™ systems, ACE™ editors, and Ampex switchers in complete post-production editing systems. So whether you're on a tight budget, but need the best — or just need a "work-

horse" that can *match* your best, call your nearest Ampex Sales Engineer for a demonstration. And remember, the Ampex product support team backs you up, everywhere.

Atlanta (404) 491-7112 Chicago (312) 593-6000
Dallas (214) 960-1162 Los Angeles (818) 365-8627
New Jersey (201) 825-9600
(In New York (212) 947-8633)
San Francisco (415) 367-2202
Washington, D.C. (301) 530-8800
Canada (416) 821-8840

AMPEX

For those at the top



...or on the way up.



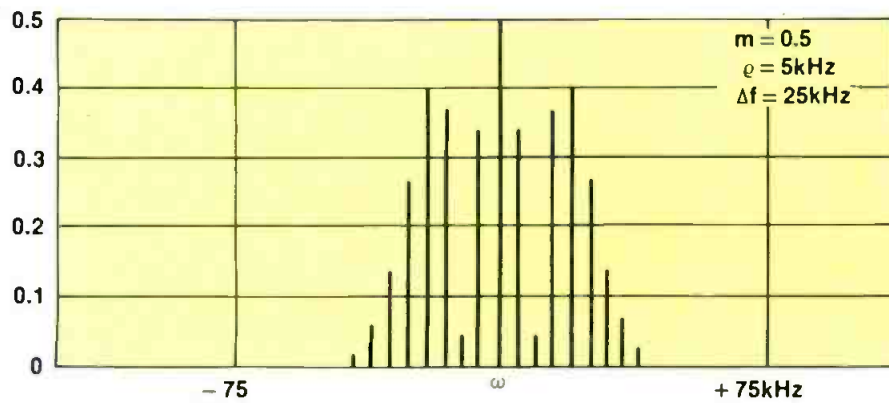

Figure 2. RF spectrum with a modulation index of 0.5.

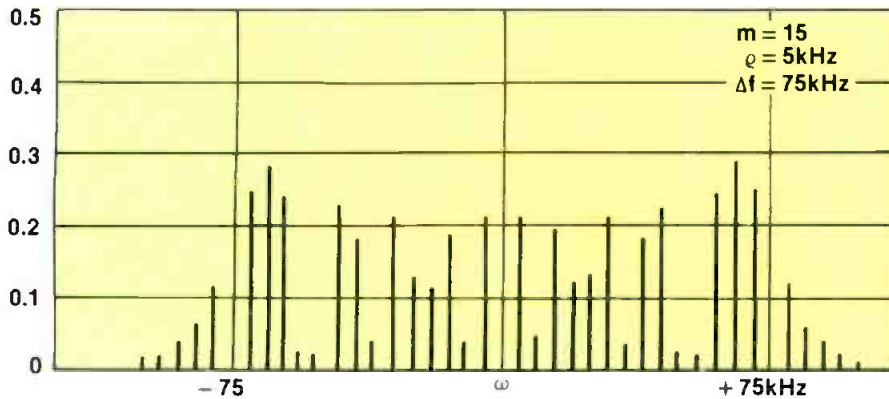

Figure 3. RF spectrum with a modulation index of 15. Note the dramatic increase in occupied bandwidth, as compared with Figures 1 and 2.

tal AM), which is measured with FM modulation, is related to the tuning and overall system bandwidth.

Asynchronous modulation

Residual amplitude modulation of the transmitter output, primarily due to power-supply ripple, is measured with an AM envelope detector. Most FM modulation monitors include an AM detector for this purpose. This detector should include $75\mu\text{s}$ de-emphasis in its output. The residual AM noise in a properly operating FM transmitter will be at least 50dB below the level that represents 100% amplitude modulation of the carrier. If the transmitter is unable to meet the 50dB requirement, the problem usually can be traced to a power-supply component or to a line imbalance in a 3-phase system.

Synchronous AM

Synchronous AM is a measure of the incidental amplitude modulation introduced onto the carrier by the presence of FM modulation. This measurement is useful for determining the proper transmitter tuning. Because all transmitters have limited bandwidth, there is a slight drop-off in power output as the carrier frequency is swept to either side of the

Continued on page 58

This new portable UHF Field Strength Meter gives you accurate readings across the entire band.

Someone once said that "Certainty is Security." That is the main idea behind field strength measurements. They verify the signal level and rf environment at the point of reception. You know for certain what's out there.

It is now easy for UHF stations to achieve this certainty. With the new FIM-72 from Potomac Instruments.

Tune the entire UHF band

From 470 to 960 MHz. The received signal strength is shown in volts and dB, with a 140 dB measurement range. Select peak or averaging detection; wide or narrow IF bandwidth. Seven 20dB logarithmic ranges assures precise readings. Internal demodulators (AM and FM) provide audio monitoring of the selected signal.

It is easy to use

Find the desired signal on the spiral dial. Calibrate the meter using the internal generator, then read the signal strength from the mirrored meter. The field strength is easily determined from the supplied calibration data.

Laboratory applications

The FIM-72 includes a precision rf generator that tracks the tuned frequency. Typical measurements include insertion loss, VSWR, and filter response.

Call Potomac Today

Place your order for this new UHF field intensity meter. Put it to work. And then you will know for certain.

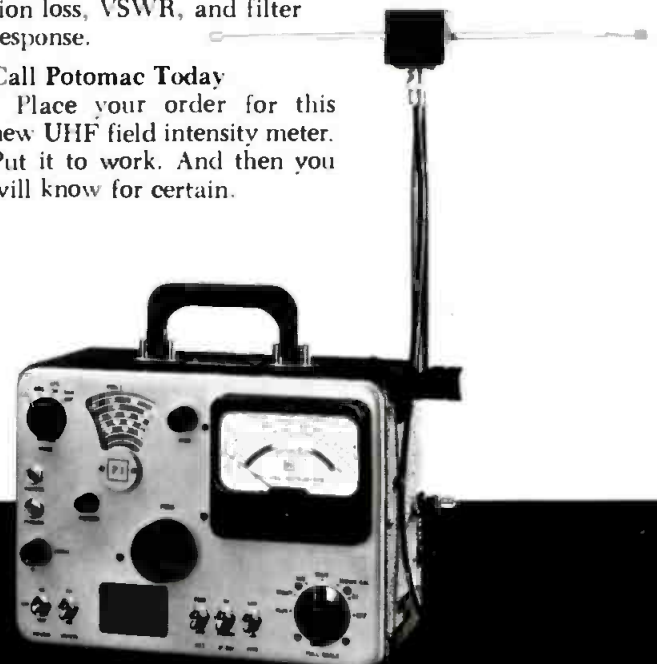

POTOMAC INSTRUMENTS
932 PHILADELPHIA AVE. SILVER SPRING, MD 20910
(301) 589-2662

Circle (38) on Reply Card

“Auditronics’ 310 does everything we need to do, and didn’t kill my budget,”



says Orlando's Jim Doyas.*

“Our new WOFL-TV 35 production facility at Lake Mary, Florida requires the use of 10 mike channels and between 12 and 15 VTR inputs in stereo on a regular basis to handle eight 1” machines plus our quads and other line-level sources.

To get this kind of flexibility, I bought the largest 310 mainframe Auditronics makes, which gives me several blank positions for future expansion and still fits within our audio control room. The 310 is versatile enough that we were able to get all the functions we needed just by picking standard modules. No custom or engineering-built items were needed, which kept our cost down.

In fact, we looked at several other boards that cost \$80,000 and up, but I found the Auditronics 310 would do all that they would do, and for less money.

One reason I leaned toward Auditronics on this purchase was that I had one of their old 110 production boards 10 years ago when I was with the ABC affiliate in Phoenix. Since that was a great board and very reliable, it was natural to go back to Auditronics a second time.

Another factor was the assistance of their dealer, Control Technology, in Fort Lauderdale. Mike Quinn really came through for us with good service, and they treated us right as well.

Our 310 has required no maintenance at all thus far, and I don't expect it will require any. We depreciate our equipment over seven years, but I expect to get at least twice that number of years of useful life out of our Auditronics 310”.

If you'd like to know more about why Meredith Broadcasting's Jim Doyas chose the 310 for his WOFL-TV showcase production facility, call Auditronics toll-free at 800-638-0977 for complete information and a demonstration near you.



3750 Old Getwell Road, Memphis, TN 38118
901 362-1350

*Jim Doyas, Director of Engineering
WOFL Channel 35 Orlando

Circle (39) on Reply Card

THE
HARRIS CONNECTION
WILL KEEP YOU ...



Here's What Broadcasters Say About THE HARRIS CONNECTION:

VHF-TV

Joseph A. Carriere, President
Caprock Telecasting, Roswell, NM/Lubbock, TX:

“When a studio fire wiped us out, our Harris sales manager was on the scene in six hours and we were back on the air in 10 days!

Our VHF equipment from Harris gives us the best quality money can buy. And Harris really stands behind its products.

Over the years, Harris has treated us very well. Other manufacturers may make good equipment, but not all can give the kind of support we get from Harris.”

KNOB, FM-RADIO

John R. Banoczi, General Manager
Anaheim, CA:

“When it came time to buy a 35 kW transmitter, we found that Harris had the right product with the right features at the right price — so we went with the Harris FM-35K.

Besides — Harris has an excellent reputation for backing and servicing the products it sells.”

KCOB, AM-RADIO

John Carl, General Manager
Newton, IA:

“Our SX-1A, 1 kW AM transmitter performs as advertised. It gives us a stand-out presence on the dial — especially in our fringe areas.

And Harris's SunWatch has completely solved our PSA/PSSA power scheduling problems. I don't know how a station could do it otherwise.

When we've needed service, Harris has always come through.”

WEAT, AM-RADIO

Bert Brown, Chief Engineer
West Palm Beach, FL:

“Most AM broadcasters who have upgraded their facilities in this part of the state have gone with Harris SX transmitters. As you are well aware, this is a lightning prone area of the country, and our SX-5A has performed well above our expectations in the area of maintenance and downtime.

We chose Harris for its professional service and support. I have a good rapport with Harris people.”

WSTQ, FM-RADIO

Al Moll, General Manager
Streator, IL:

“Before we switched to Harris, we were barely on the air with a poor signal. Our FM-3.5K, 3.5 kW transmitter makes us a stand-out on the dial.”

KHBS, UHF-TV

Don Vest, Director of Engineering
Sigma Broadcasting, Fort Smith, AR:

“KHBS is our first Harris installation, and I'm very glad I did it.

What impresses me most about Harris is the service and parts support. In 19 years of broadcasting, it's the most cooperative and helpful in the industry.

Harris knows how to treat its customers. Harris is going to win!”

WOMA, FM-RADIO

Dale Eggert, General Manager
Algoma, WI:

“Our FM-3.5K, 3.5 kW transmitter has operated flawlessly since our sign-on last November.

And our Harris representative not only helped us put our equipment package together, but stayed on duty after the sale to see that we met our critical air date!”

WKNO, VHF-TV

Pat Lane, Chief Engineer
Memphis, TN:

“Before I ordered our two new transmitters, I tested three service departments. Harris was the only one with an engineer on duty at 10:30 p.m., the Fourth of July. With the others I got a recording and an answering service.

What impresses me most about Harris is the attitude and the people.”

Find out today how The Harris Connection can keep your station ON THE AIR . . .

. . . and we'll send you your free, full-color ON THE AIR poster. An up-to-the-minute symbol of our industry's rich tradition.

Just call us TOLL FREE at 1-800-4-HARRIS, ext. 3002. Or write: Harris Corporation, Broadcast Division, Marketing Department, P.O. Box 4290, Quincy, IL 62305. Our poster supply is limited, so act today.



Circle (40) on Reply Card



For Excellence In Antennas

- A complete line of TV and FM Broadcast Antennas
- Modern 7,000 ft. test range facilities
- Innovative Engineering Careful construction
- Two Year Warranty on Product and Workmanship

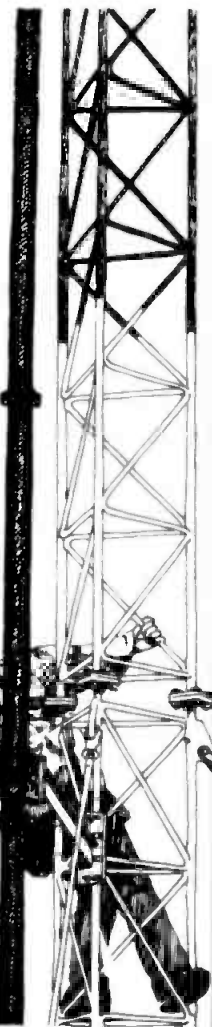

With over 1500 delivered, we've helped more stations penetrate their market.

FCC Directionals
Pattern Studies
Multi-Station Arrays
Full Scale Measurement

JAMPRO ANTENNAS, Inc.
6939 Power Inn Road
Sacramento, CA 95828

(916) 383-1177 TELEX 377321

Circle (41) on Reply Card

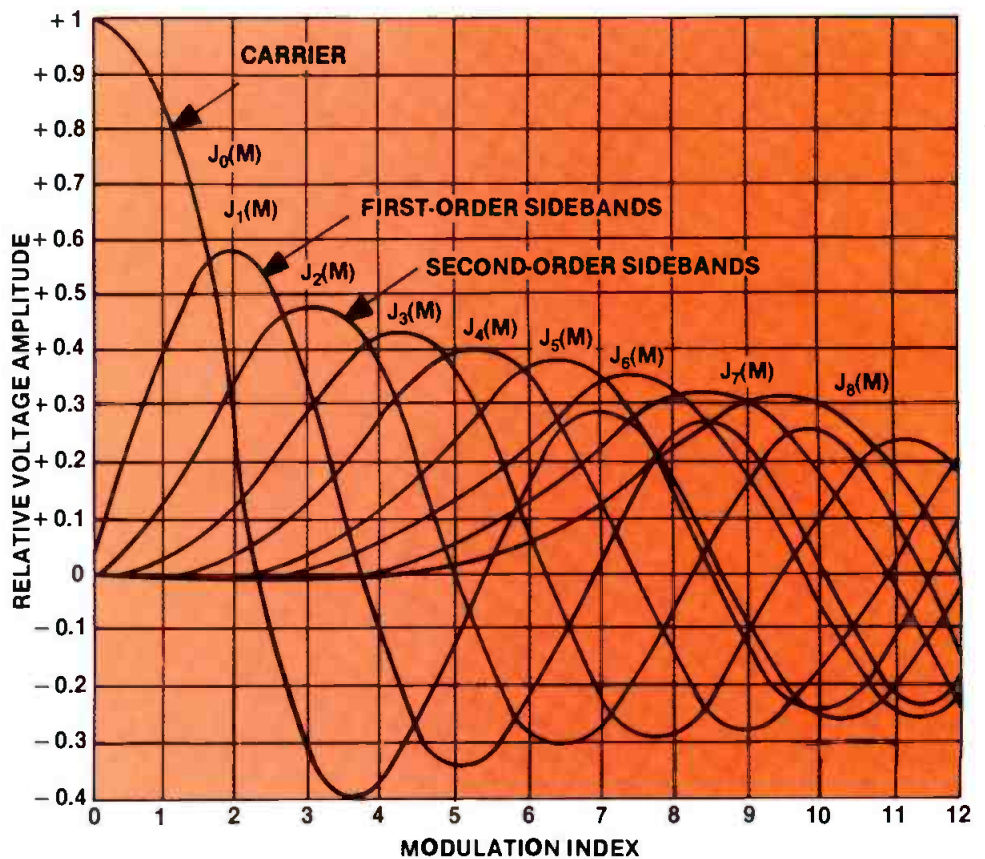

Figure 4. The Bessel function graph illustrates the relationship between the carrier and sideband amplitudes to modulation index.

Continued from page 54

center frequency. This slight change in RF output level follows the waveform of the signal being applied to the FM modulator. The result is AM modulation produced in synchronization with the FM modulation. The concept is similar to the slope detection of an FM signal by an AM detector and a tuned circuit.

Both types of AM noise measurements are made directly at the transmitter output (or an accurate output sample). No amplifying or limiting equipment can be used between the transmitter output and the AM detector because non-linearities in this equipment can actually modify the AM noise level.

Because the transmitter cannot be fully amplitude-modulated, an equivalent reference level must be established indirectly by first measuring the RF-carrier voltage. Refer to the instructions provided by the detector manufacturer to determine this reference level. Generally, the reference level is determined by setting a carrier-level meter to a specified reading or obtaining a specific dc-voltage level without modulation at the detector diode's output.

Measuring synchronous AM gives the station engineer an idea of the system's overall bandwidth and whether the passband is positioned correctly. Tuning for minimum synchronous AM will assure that the transmitter passband is properly centered on the FM channel.

A synchronous AM measurement of 40dB or more below equivalent 100% AM is acceptable. Some of the newer

single-tube transmitters can be adjusted for 50dB or more synchronous AM suppression. Table 2 approximates the overall system bandwidth for a given AM noise measurement.

Tuning for peak performance

All transmitter optimization should be done with the automatic power control system disabled. This prevents the APC from chasing the tuning adjustments in an attempt to keep the output power constant. The transmitter should be connected to the normal antenna system, rather than to a dummy load. Because the antenna resistance and reactance will be different from the dummy load, the optimum tuning point of the transmitter will be different for the two different loads.

The transmitter should be tuned for normal output power and proper efficiency according to the manufacturer's instruction manual. The meter readings should closely agree with those listed on the manufacturer's final test data sheet if the transmitter is being operated on the same frequency at the same power level into a proper load.

Input tuning and matching

The input-tuning control should be adjusted for maximum grid current and then fine-tuned interactively with the input-matching control for minimum reflected power to the driver stage. Note that the point of maximum grid current may not coincide with the minimum reflected power to a solid-state driver. This

UPGRADE YOUR ENG SYSTEM WITH MII

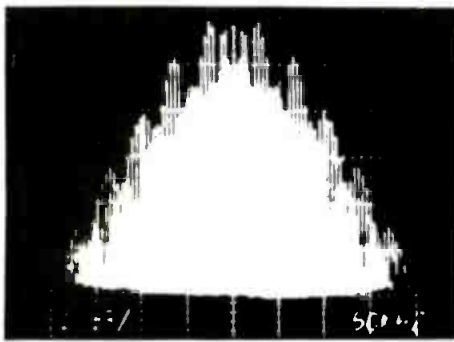

Figure 5. This wideband RF spectrum acts as the test signal for the comparisons.

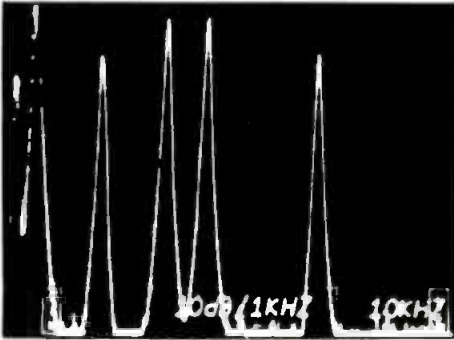

Figure 6. Note the lack of distortion products after the signal has passed through a perfect FM demodulator and wide-bandwidth RF path.

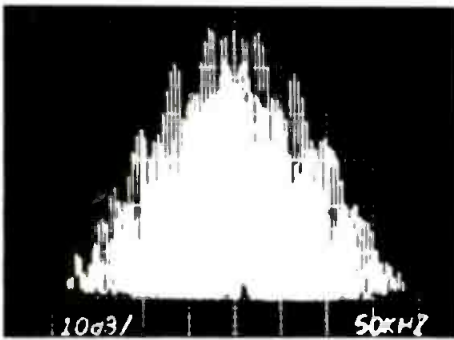

Figure 7. The original signal has now been passed through a bandwidth-limited system. The only visible distortion is for signals greater than 200kHz removed from the carrier.

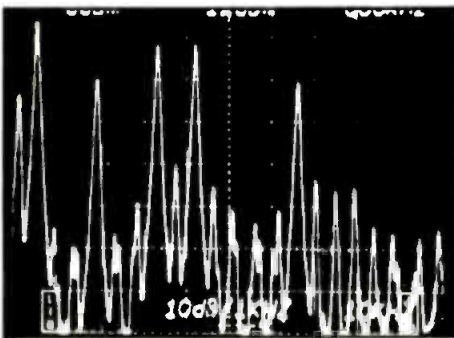

Figure 8. The resulting baseband signal shows intermodulation distortion products.

is because a solid-state driver actually may deliver more power at certain complex load impedance than into a 50Ω resistive load.

The main objective during input tuning is to obtain adequate grid current while



If you use 1/2", 3/4" or any combination, switch to MII and get high performance and overall cost reductions.

The MII Broadcast System is designed to enhance your ENG operations. With product like the AU-400 Camera Recorder that offers a combination of performance and capabilities never before available on 1/2".

Like multi-generation capability, playback through the view-finder, 4-channel audio, on-board time code generator/reader with selectable user bits and over 20 minutes of recording time on a compatible compact cassette. Even 90 minutes of operation with the MII Field Recorder, Field Editing and Studio VTR's. Plus performance of such high quality it can be used as an alternative to 1" C.

And with MII you have low maintenance and training costs. Tape consumption is dramatically reduced. Units are small and lightweight. Cassettes and parts inventory are interchangeable. And MII equipment is 100 percent compatible, so you can interface MII with your present system.

What's more, product is available now.

Find out how you can improve your production quality and cut your overall costs with the Panasonic MII Broadcast System.

For more information call (201) 348-7671.



Panasonic
Broadcast Systems

Circle (42) on Reply Card

LOG AROUND THE CLOCK.



One, two, three o'clock, four o'clock log. The Dictaphone 5600 Veritrac® logger lets you log . . . log . . . log around the clock.

It's a complete broadcast recording retrieval system that lets your radio station keep its entire broadcast day on the record. In one dependable unit you get around-the-clock verification that you're running your advertisers' spots on schedule and meeting all your FCC requirements. Should you require proof, just play back your log around the clock. And it's all there on tape.

The 5600 Veritrac logger. A classic from Dictaphone.

For more information, fill in the coupon, or call toll-free:

1-800-342-8439

Mail to: Dictaphone Corporation,
120 Old Post Road, Rye, NY 10580-0648

Name _____

Title _____ Phone: _____

Company _____

Address _____

City _____ State _____ Zip _____

DICTAPHONE® and Veritrac® are registered trademarks of Dictaphone Corporation, Rye, N.Y. © 1987 Dictaphone Corporation

QBE-57



A Pitney Bowes Company
Circle (43) on Reply Card

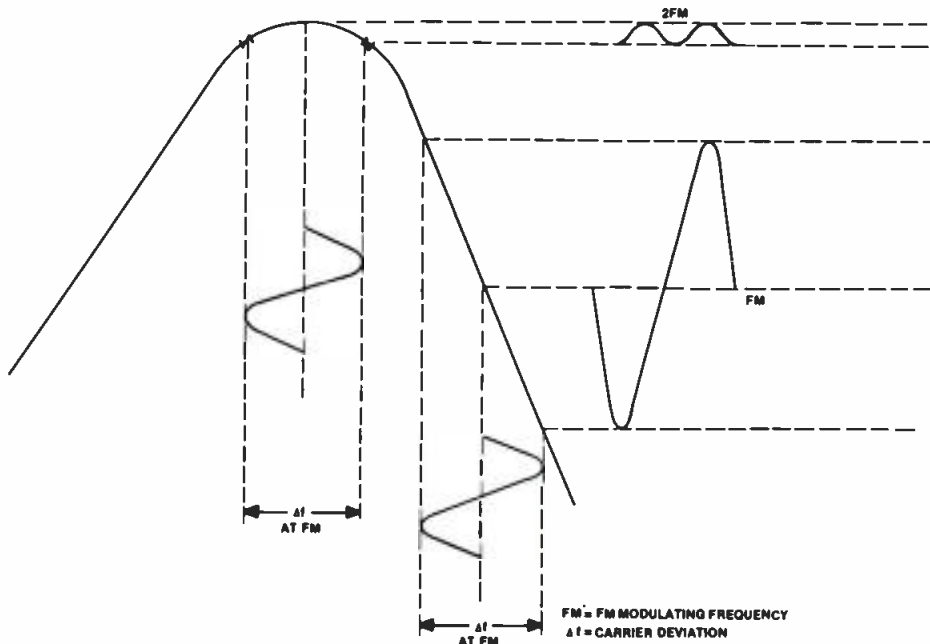

Figure 9. At the point of minimum synchronous AM, the demodulated output from the AM detector will double in frequency.

PEAK-TO-PEAK SYNCHRONOUS AM (BELOW EQUIVALENT 100% AM) (WITH ± 75kHz AT 400Hz FM)	APPROXIMATE BANDWIDTH (- 3dB)
- 40dB	1.1MHz
- 45dB	1.4MHz
- 50dB	2 MHz
- 55dB	2.5MHz
- 60dB	3.4MHz

Table 2. The RF amplifier bandwidth can be estimated by first measuring the peak-to-peak synchronous AM noise. Using that result, obtain the approximate bandwidth from the chart.

providing a good match (minimum reflected power) to the coaxial transmission line from the driver. In the case of an older transmitter with a tube driver, the driver-plate tuning and the final grid tuning combine into one control, which is adjusted for maximum grid current.

Output tuning

The output-tuning control adjusts the resonant frequency of the output circuit to match the carrier frequency. As resonance is reached, the plate current will drop while both the output power and screen current rise together. Under heavily loaded conditions this dip in plate current is not very pronounced, so tuning for a peak in screen current is often a more sensitive resonance indicator.

Amplifiers using a folded ½-wave cavity display little interaction between output tuning and output loading. This is because the output-coupling loop is located at the RF voltage null point on the resonant line. Interactive adjustment of output tuning and output-loading controls is required for ¼-wave cavities because changes in loading also affect the frequency of the resonant line.

Output loading

There is a delicate balance between screen voltage and output loading for amplifiers using a tetrode tube. Generally there is one combination of screen voltage and output loading at which peak efficiency occurs. At a given screen voltage, increasing the amplifier loading will result in a decrease in screen current, while a decrease in loading will result in an increase in screen current. As the screen voltage is increased to get more output power, the loading also must be increased to prevent the screen current from reaching excessive levels. Further increases in screen voltage without increased loading will result in a screen overload without an increase in output power.

APC headroom

APC feedback systems used in many transmitters regulate the power output around a predetermined set point. The selected set point accommodates typical variations in ac-line voltage or changes in other operating parameters.

Most modern FM broadcast transmitters use a single high-gain tetrode as the

STANDARDIZE YOUR EFP SYSTEM WITH MII

final amplifier stage. In these transmitters, adjusting the screen voltage provides a fine adjustment of the output power.

For each power output level there is one unique combination of screen voltage and output loading that provides peak operating efficiency. If the screen voltage is raised above this point without a corresponding increase in loading, there will be no further increase in power output with increasing screen voltage and screen current. If the screen voltage is increased without sufficient loading, a screen current overload will occur before the upward adjustment in power output is obtained.

To avoid this problem, it is a good idea to tune the transmitter with slightly heavier loading than necessary. This practice allows the transmitter to achieve the desired power output level and still provide approximately 5% of headroom in the adjustment range.

The output loading can be adjusted for a peak in output power 5% over the desired level. After this point is reached, the screen voltage can then be reduced enough to return to the desired power level. This procedure will allow sufficient headroom for a screen-voltage APC system. Although the result is a small compromise in efficiency, the practice permits the transmitter power output to increase by up to 5% without encountering a screen overload.

Minimizing synchronous AM

After the correct loading point has been set, FM modulate the transmitter 100% ($\pm 75\text{kHz}$) at 400Hz. Carefully adjust the transmitter's input and output tuning controls for minimum 400Hz AM modulation as detected by a wideband envelope detector (diode and line probe). The input matching and output-loading controls should not need any further adjustment. It is helpful to display the demodulated output from the AM detector on an oscilloscope while making this adjustment.

Note that as the point of minimum synchronous AM is reached, the demodulated output from the AM detector will double in frequency from 400Hz to 800Hz. This is caused by the reduction in output power, which is symmetrical about the center frequency. The effect causes the amplitude variations to go through two complete cycles for every one FM sweep cycle (see Figure 9). It should be possible to minimize synchronous AM while maintaining output power and sacrificing only a small amount of efficiency in a properly operating power amplifier.

A precision envelope detector

Care must be taken when making these measurements to ensure that the test setup does not introduce synchro-



**If you use 1/2", 1" or any combination,
switch to MII and get high performance
and overall cost reductions.**

The MII Broadcast System was designed to enhance your EFP operations. With product like the AU-500 Field Recorder that offers a combination of performance and capabilities never before available on 1/2".

Like over 90 minutes of recording time even in the field, multi-generation capability, field color playback, 4-channel audio, on-board time code generator/reader with selectable user bits and TBC connection. The Field Recorder also accepts compact cassettes from the MII Camera Recorder. Plus MII's performance is of such high quality it can be used as an alternative to 1" C.

And with MII you have low maintenance and training costs. Tape consumption is dramatically reduced. Units are small and lightweight. Cassettes and parts inventory are interchangeable. And MII equipment is 100 percent compatible, so you can interface MII with your present system.

What's more, product is available now.

Find out how you can improve your production quality and cut your overall costs with the Panasonic MII Broadcast System.

For more information call
(201) 348-7671.



Panasonic
Broadcast Systems

Circle (44) on Reply Card

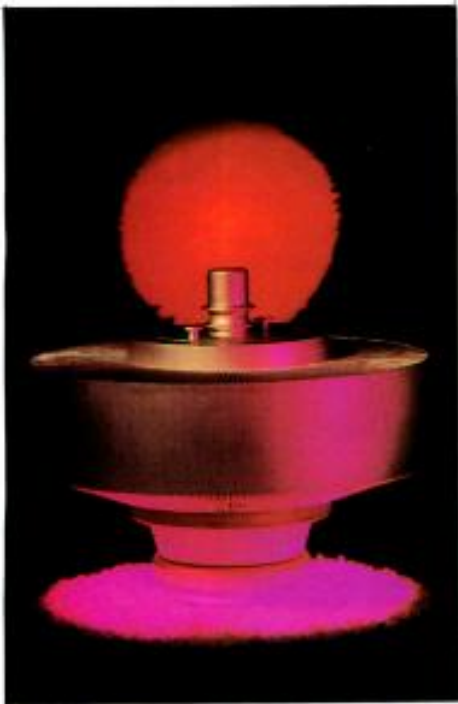

Evolution of broadcast transmission lines

By Geza Dienes

The transfer of RF energy is an art and a science, with a little plumbing tossed in.

Today's sophisticated circular waveguide represents great strides in the development of broadcast transmission-line technology. We have come a long way since the days of 2-wire line. How did we get here? The answer to that question lies in the evolution of broadcast transmission-line technology.

The early days

In the early days of dc it was obvious that a pipeline must be provided for the electrons moving from the source of supply (the negative side of a battery) to the load, and then to a place of disposal (the positive side of a battery). Two metallic wires connected one side of the load to

each pole of the battery. The wires did not need to be of equal length, nor was their relative position important. Remember the lab experiments with scattered wires, connections and switches you performed during Electronics 101 class in college?

Soon, however, came *wireless*, working on the principle that alternating current flow creates an alternating electromagnetic field, which travels through space and is detectable from far away. A new means of information transfer and communication was born. Because wireless transmission is similar to seeds thrown into the wind, the concept of *broadcasting* was applied to generating time-varying electromagnetic fields throughout a large region in space. The industry had a name.

Dienes is senior research engineer with Andrew Corporation, Orland Park, IL.

The 2-wire line

The efficient and controlled conversion of energy from alternating current to electromagnetic fields is performed by the antenna. For convenience (among other reasons) the antenna typically is located some distance away from the RF generator. Transferring the energy from the generator to the antenna requires some type of transmission line. One solution was the 2-wire line.

The behavior of transmission lines is described by the so-called *telegrapher's equation* developed circa 1897. The equation is based on Maxwell's description of electromagnetic propagation and provides solutions for various parameters of transmission lines, including the velocity of propagation, impedance and attenuation. Simplified versions of this equation were adapted and developed for specific transmission line configurations, such as the 2-wire coaxial lines and various types of waveguide.

The 2-wire term refers to a transmission line that consists of two parallel wires separated by a constant distance that is small compared to a wavelength. All alternating current flow causes radiation, but because the current flow in the two wires is in opposite directions, the electromagnetic field generated by one wire tends to oppose and cancel the field generated by the other wire. As long as the distance between the wires of the 2-wire line is small in relation to a wavelength, the net radiation from the transmission line is negligible.

The 2-wire transmission line was extensively employed in the early days because of its many attractive features. The frequencies used for broadcasting were generally less than 30MHz, so a wire

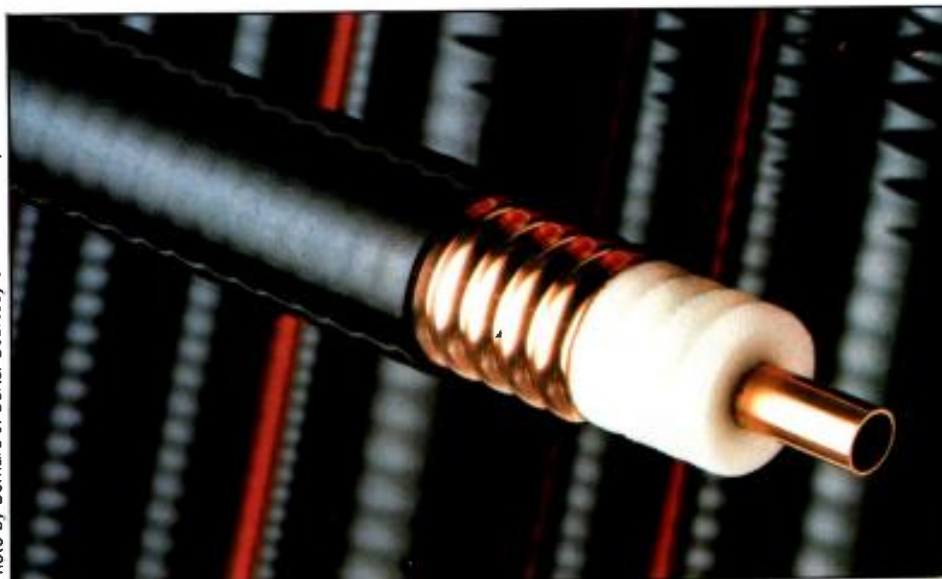

Photo by Bernard J. Surtz. Courtesy of Andrew Corporation.

Foam dielectric coaxial cable allows optimal selection of feedlines.



Hector Munoz,
Distribution Services
Manager

“Our purpose is to keep you on the air.”

Our extensive inventory of broadcast tubes, RF transistors and related components ensures delivery of the product to you on time — even if I have to run the package to the airport myself. Last year our company made over 7500 overnight deliveries, so we take emergencies seriously!”



**\$30 Million Inventory—Over
90% Same Day Shipment**



**Technical knowledge to
help you save time and
money by choosing the
right component.**

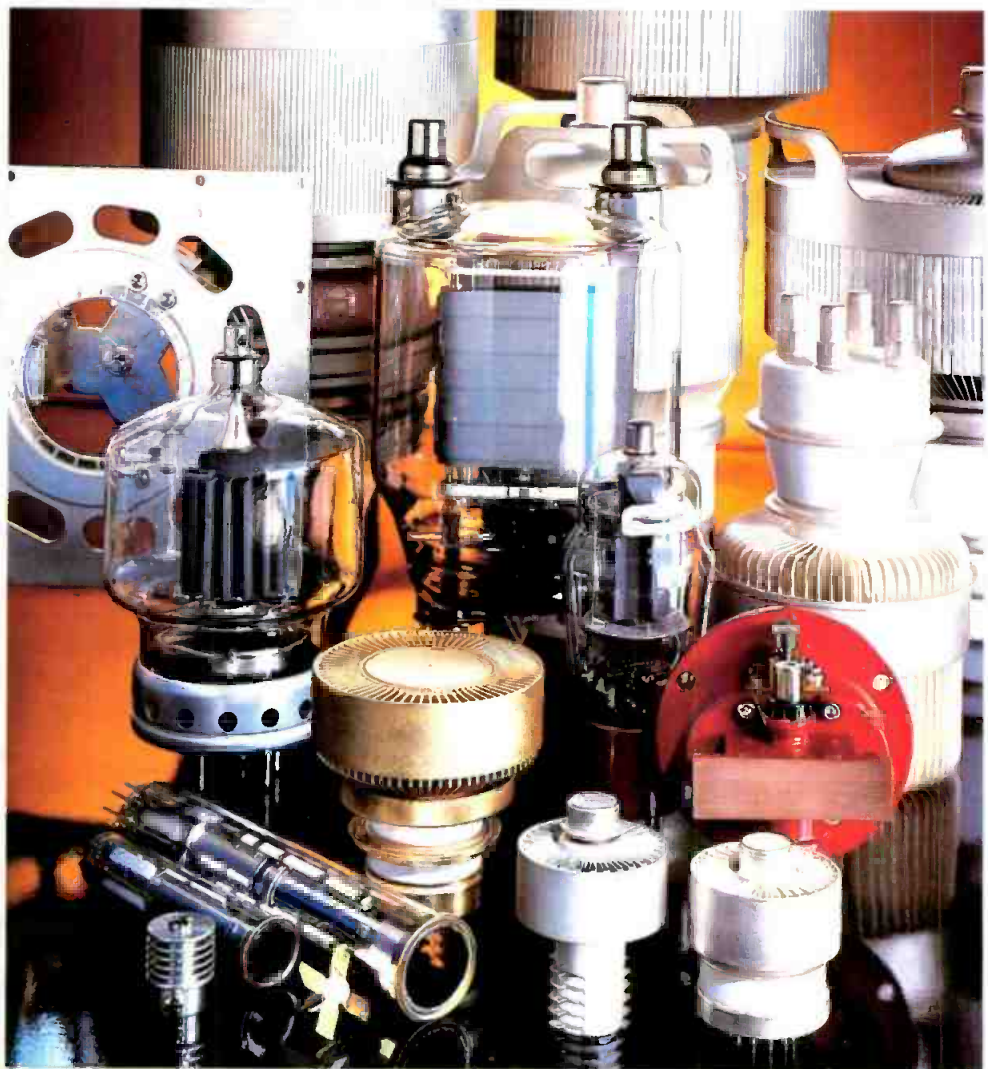

PRODUCTS: Cathode Ray Tubes ■ Diodes ■ Klystrons ■ Monitor Tubes ■
Plumbicon® Tubes ■ Receiving Tubes ■ RF Ceramic Capacitors ■ RF Transistors ■
Saticons ■ Solid State Replacements ■ Transmitter/Power Tubes ■ Tube Sockets ■
Accessories ■ TV Linear Devices ■ Vacuum Capacitors ■ Vidicons ■ Vistacons
MANUFACTURERS: Acrian ■ Amperex ■ Cetron ■ EEV ■ Eimac ■ GE ■ Hitachi ■
ITT ■ Jennings ■ Machlett ■ National ■ Philips ■ RCA ■ Raytheon ■ Thomson CSF ■
Varian ■ Westinghouse

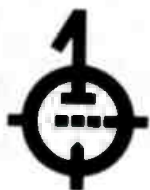

800-323-1770

Richardson Electronics, Ltd.

Convenient Sales Offices: La Fox, IL ■ Woodland Hills, CA ■ Belmont, CA ■ Dallas, TX ■
Norwell, MA ■ Rockville Centre, NY ■ Brooklyn, NY ■ Winter Park, FL ■ Brampton, Ontario,
Canada ■ Lincoln, England ■ Gennevilliers, France

Circle (47) on Reply Card

www.americanradiohistory.com

spacing of 6 to 8 inches was small enough to prevent unwanted radiation and, at the same time, large enough to avoid voltage breakdown. The line could be homemade with a minimum of equipment and the materials required were readily available.

The advantages of this transmission line, such as simplicity, low cost, ease of manufacture and high-power handling capability, were designed to offset some of its deficiencies, which included environmental exposure, general vulnerability and personnel safety considerations.

The need for a better transmission line

By the early 1930s, radio had taken over the land. As the number of transmitting stations mushroomed, so did the potential for interference. To minimize the possibility of one station interfering with others, rules governing radiation were developed. These requirements often included the need for specialized antenna patterns and a change in radiation patterns during nighttime operation. To fill the need, multitower AM broadcast arrays were developed.

These multi-element or multitower AM arrays produced the correct antenna pattern only when the proper phase and amplitude relationship was maintained

among the tower members. Delivering the RF energy to each tower in the proper manner was the task of the transmission line. Precisely preset conditions must be maintained over time, regardless of changes in the environment surrounding the antenna system.

Because the typical 2-wire line was exposed to the elements and there was some interaction among the multiple 2-wire lines, it was not surprising that difficulties were encountered in producing an electrically stable transmission-line system for feeding multi-element AM arrays. The environment, snow, ice and intercoupling tended to change the preset phase and amplitude delivered to each element of the array from day to night and from season to season. A more stable, environmentally tolerant transmission line was needed to improve control of RF transmissions.

During this same time, the telephone communication industry also needed a better transmission line. The desire to lay undersea cable to provide telephone communications among continents created the need for a transmission line that could withstand extreme outside pressures, could be electrically shielded and sealed against the elements, and would exhibit a reasonably low attenuation. Coaxial line was the natural candidate.

Coaxial transmission line

The coaxial transmission line consists of two concentrically arranged cylinders. The shielding is provided by the outer cylinder or outer conductor. Because all electrical fields are confined between the two cylinders, current does not flow on the outside of the outer cylinder. The entire line can be made to withstand large pressures from within or from outside the cable.

The first coaxial transmission-line sections for broadcast application were manufactured by hand. Tubes used in the manufacturing of these early coaxial-line segments generally were in sizes developed for the plumbing industry— $\frac{7}{8}$ inches, $1\frac{5}{8}$ inches, $3\frac{1}{8}$ inches and $6\frac{1}{8}$ inches.

The impedance of a coaxial line is related to the relative diameters of the inner and outer conductors and is easily controlled. Coaxial lines with a large variety of impedances were developed over the years for diverse applications. The 50Ω impedance, a compromise between power-carrying capability and attenuation, became the industry standard. Up until the mid-1950s, a combination of two impedances, 51.5Ω (because of the available commercial tubing) and 50Ω (because of the newly established industry standard) was used. The 75Ω coaxial

OVERVOLTAGE

OR

UNDERVOLTAGE

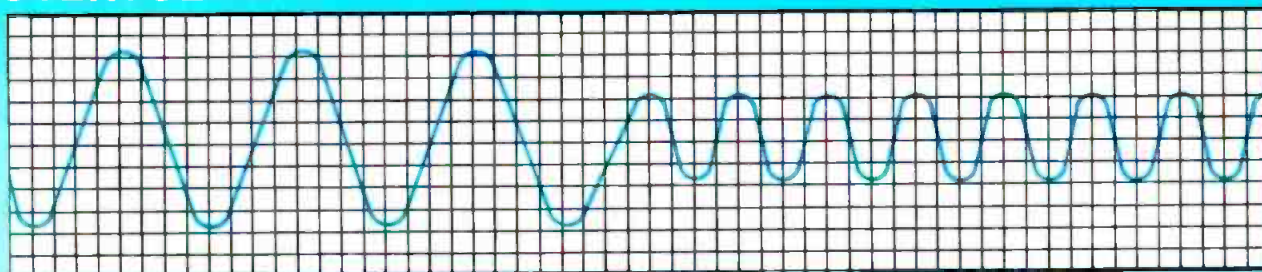

**THE SOLUTION —
THE PESCHEL
AUTOMATIC
VOLTAGE
REGULATOR™
(PAVR)**



**MEETS YOUR SERVICE LINE REQUIREMENTS
FROM 40A TO 2000A, 240 V TO 13.8 kV**
KEEPS YOUR PLANT RUNNING WHILE:

- INCREASING EFFICIENCY
- INCREASING PRODUCTIVITY
- REDUCING MAINTENANCE COSTS

The Peschel Automatic Voltage Regulator is designed for loads that do not require instantaneous voltage correction. The regulator that corrects for line voltage variations instantly sacrifices efficiency, size, weight, output accuracy, serviceability, produces wave form distortion and is expensive. Most applications, even most computer applications, do not require a line voltage correction to be made instantly to within $\pm 1\%$ of the nominal voltage. Why pay extra for a regulator that corrects instantly, like an electronic tap changer or a saturating core type, when your equipment does not need it?

A PAVR, often equipped with a transient suppressor, will provide the protection you need. If you're going to buy an electromechanical type, don't buy an antiquated, induction voltage regulator. There is an alternative.

The PAVR is an electromechanical regulator (easy to understand and service) that is designed specifically for medium to high power loads. It is efficient, reliable and economical.

From the World Leader in High Voltage Technology



POWER PRODUCTS DIVISION

P.O. Drawer W, Route 22, Millerton, New York 12546 Phone (914) 279-8091 TWX 710-574-2420 FAX 518-789-4866

Circle (48) on Reply Card

line, typically used by the TV industry, was chosen because it provided the lowest attenuation.

Commercial availability of coaxial transmission line dates to the mid-1930s. Victor J. Andrew (founder of Andrew Corporation) handmade his first coaxial line components in January 1937. These were coaxial components with flanges, hand-soldered onto each end of the outer conductor tubing with the center conductor supported on ceramic beads. The entire ceramic bead and center conductor assembly was then pulled into the outer conductor.

The proliferation of AM stations between 1930 and 1940 provided a growing market for commercial coaxial-line components. The majority of transmitters tended to be low power by today's standards, with power outputs typically less than 5kW. FM broadcasting appeared in the mid-1930s and later proved to be commercially viable.

The 1940s brought about major advancements in transmission-line technology. World War II, the development of television and the frequency change for FM broadcasting from 50MHz to the 88MHz to 108MHz frequency band all motivated this research and development effort.

The requirements of military operations and the invention of radar prompted a great deal of research, most of it by MIT, into both coaxial and waveguide transmission lines for high power and high frequency. The frequency change of FM broadcast from the 50MHz to 100MHz band was significant because the 2-wire transmission line had either too much extraneous radiation or was too closely spaced for power breakdown at these frequencies. Also, it was just too vulnerable to the elements.

The industry developed standards covering the power levels and frequency bands of various sizes of coaxial lines. These standards included a 75Ω 6-inch-diameter coaxial line for TV use, a 180Ω 3-inch-diameter line for radar use and a 50Ω line for general-purpose use.

Over the years a wide range of coaxial lines became available, ranging from 1/16 inch to 9 inches in diameter. The largest known coax (14 inches in diameter) was manufactured in 1961 for a cyclotron carrying 50MW of RF power. The flexible, continuous-length coaxial cable using a solid dielectric material for insulation and a braided outer conductor also dates to that time period.

Flexible coaxial cable for broadcast

One of the most significant advances in coax manufacturing technology was the development of a manufacturing technique that allowed the production of long, continuous lengths of large coaxial cables. Two types of cables were devel-

oped over the years. One had a smooth outer conductor and the other had a corrugated outer conductor for greater flexibility.

This meant cables could be manufactured in sizes up to 9 inches in diameter. These flexible cables could be installed in continuous lengths up to several hundred feet, and required only one connection to the mating equipment at each end. The cable could be shipped on reels in a compact manner, reducing both shipping and installation costs. An outer jacket of a plastic material protected the

cable from the elements. This was a boon to the broadcast industry because the cable provided high reliability, reduced maintenance and installation costs and also made direct burial possible.

These cables are marketed under a variety of trade names. The typical manufacturing technique for such cable includes continuous seam welding of thin copper strips to form the inner and outer conductors, with a continuous dielectric material and annular or helical corrugations to provide flexibility.

During World War II, the FCC stopped

WE HAVE SOME OF THE BEST CONNECTIONS IN THE COMMUNICATIONS BUSINESS

If you're in the telecommunications, audio or video broadcast industry, you should get to know Trimm. We have a complete line of audio telephone jacks, plugs, jack panels, patch cords, terminal blocks, as well as a broad line of coaxial jacks, plugs, fuse panels and related components. Connect up with Trimm. Call or write for our catalog.

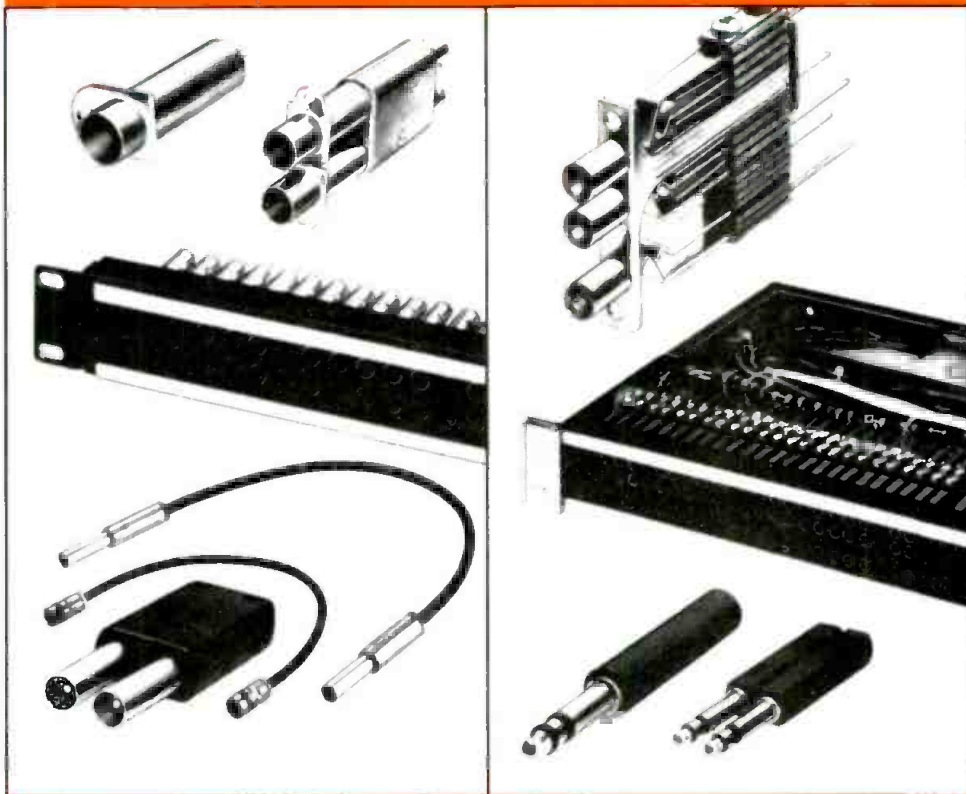

TRIMM INC.

A DIVISION OF NEWTON INSTRUMENT COMPANY

400 West Lake St., P.O. Box 489, Libertyville, Illinois 60048
Phone 312-362-3700, Telex 728452, Fax 312-680-3888

Circle (49) on Reply Card

MILLER

EQUIPPED TO WIN!



MILLER 20
with counterbalancing
Lightweight ENG



COMPACT TRIPOD
with spreader
ENG



MILLER 30
with counterbalancing
multi-step drag control
ENG



MIDI TRIPOD
with spreader
ENG/EFP



MILLER 50
with counterbalancing
multi-step drag control
ENG/EFP

see us at
Montreux
Stand 866

MILLER FLUID HEADS (USA) INC.
2819 W. OLIVE AVE.
BURBANK, CA 91505
Tel: (818) 841-6262

Circle (20) on Reply Card

issuing construction permits for new broadcast stations. The pent-up demand caused explosive growth after the war when hundreds of AM, FM and TV stations mushroomed all over the United States. The public accepted television with open arms and the number of TV receiving sets increased from 10,000 in 1946 to more than 12 million by 1951.

The growth of the TV broadcast industry became so vigorous that in 1948 the commission was forced to freeze the issuance of TV construction permits pending implementation of interference regulations. Subsequently, competing stations covering the same market were vying with one another to provide better-quality sound, picture and reception. This placed demands on the performance of the transmission line. To improve performance, the manufacturers responded with more sophisticated coaxial-line designs that included polyethylene inner conductor supports instead of ceramic bead supports, improved inner connector (bullet) designs, pressurization equipment to protect the large and expensive transmission-line installations and grounding systems to protect against lightning.

Power levels also were increasing to provide better coverage and greater signal strength to the user. The increasing output of transmitters required larger coaxial transmission lines to handle the higher powers and more precisely controlled manufacturing techniques to better control the propagation parameters.

Coaxial line for UHF television

By the mid-1950s, many of the major markets were using all the available VHF TV channels. In order to enter one of these TV markets, the broadcaster had to apply for one of the UHF channels. UHF TV frequencies, being much higher than VHF frequencies, have three disadvantages. First, the propagation of UHF frequencies is not as favorable as VHF frequencies, especially over the horizon. Second, TV sets are not as sensitive to UHF frequencies as they are to VHF frequencies. Third, the free-space attenuation, the apparent loss of signal as a function of distance, is greater for the UHF frequencies than for VHF. In order to provide comparable performance, the commission allowed a greater effective radiated power (ERP) for the UHF stations. In fact, the ratio is almost 20 to 1.

Some of the allowable increased ERP may be generated by using a higher-gain antenna. However, the antenna alone cannot offset this large difference, so still higher-power transmitters were developed for the UHF frequencies. Thus, while transmitter powers for a typical VHF station are in the 30kW to 60kW range, the power output for a UHF station is in the 50kW to 220kW range. Car-

rying the output of such high-power transmitters to the antenna places tremendous demands on the transmission line.

The limitation of coaxial line

The designer of a coaxial transmission line was caught between the jaws of a vise. To produce a coaxial transmission line with a 75Ω impedance, typically used for UHF broadcasting, the inner conductor diameter is 3.6 times smaller than the diameter of the outer conductor. That, of course, means that the resistance of the inner conductor is 3.6 times higher than the resistance of the outer conductor. However, both conductors have to carry the same current. The heat generated by this current, or the I²R losses, are, therefore, nearly four times higher on the center conductor than on the outer conductor. The center conductor thus tends to heat up. The coaxial line is like a vacuum thermos bottle in the sense that there basically is only one means of heat escape from the center conductor, and that is radiation.

Radiation, however, is a very inefficient means of heat transfer and the center conductor needs to be reasonably hot for the transfer to take place at all. If the center conductor gets too hot, oxidation occurs. A softening of the insulating material that supports the center conductor also may take place. Limits, therefore, must be placed on the amount of power that may be carried by a coaxial line.

The natural response to this problem would be to manufacture a larger-diameter line that would have a larger-diameter inner conductor and, therefore, less I²R heat loss. Unfortunately, if the outer and inner diameters of the coax are increased too much, a new mode of propagation may exist in the coaxial line, which is highly undesirable. The designer must carefully select the size of a high-power coaxial line to be as large as possible but not to exceed that dimension that allows an unwanted mode of propagation.

Once the proper coaxial transmission-line size has been determined, one more serious problem remains, which also is the result of heat developed on the center conductor. Because the center conductor runs at a temperature that is typically as much as 65.55°C to 104.4°C hotter than the outer conductor, there will be relative length change between the two conductors. The center conductor will grow in length as a result of its higher temperature.

To accommodate the expansion at each junction point between consecutive coaxial-line segments, a sliding center conductor contact must be provided. This sliding contact allows the center conductor to expand and contract as its temperature varies while providing con-



David Peters, Assistant Engineer KGLT Radio Station, Bozeman, Montana.

THE EIMAC 5CX1500B FOR LONG LIFE, QUALITY AND ECONOMY

Varian EIMAC has been in the business of broadcasting for over 50 years, producing durable, reliable and long-lasting tubes that a non-profit radio station like KGLT in Bozeman, Montana, can afford.

Longevity

KGLT engineers use the EIMAC 5CX1500B tube in their transmitter, reporting a life span of 18-19 months—approximately 13,000 hours of service!

Quality and Savings

This would be impressive under ideal conditions, but KGLT operates under rugged and adverse mountain-top conditions. Just as important is the 40% cost

savings attributable to the 5CX1500B's extended life.

In FM broadcasting, EIMAC tubes are customer-proven.



EIMAC's 5CX1500B broadcasting tube in KGLT radio station's transmitter.

Varian EIMAC offers a 5,000-hour warranty on 5CX1500B tubes.

For more information, contact:

Varian EIMAC
1678 South Pioneer Road
Salt Lake City, Utah 84104
Telephone: 801-972-5000



Circle (50) on Reply Card



Coaxial transmission line consists of two concentric cylinders aligned on a single axis, insulated from each other.

These metal shavings fall on the insulators and, if enough accumulates, provide a current path across the support insulator. The result will be a flashover and a destroyed transmission line. Also, the increased contact resistance caused by the roughed-up sliding surfaces will generate extra heat, which could eventually result in a portion of the center conductor melting, another threat to the line. Most major high-power transmission-line failures occur due to one or both of these conditions.

Coaxial line for UHF television

To provide a coaxial transmission line with the highest possible reliability, development is under way for a coaxial line without sliding contacts. The result is a new series of coaxial line. This line uses an inner connector (bullet) similar to the traditional sliding inner connector, but the new connector, once inserted into the mating section, has a contact pressure high enough to prevent sliding. Center conductor growth and shrinkage is accommodated by a built-in bellows. The bellows segment acts like an accordion, stretching and compressing as needed. This design eliminates the sliding action that is the root cause of most transmission-line failures. To date, thousands of feet of 6 1/8-inch line has been installed in

tinuity from one segment to another.

The inner conductor temperature is not constant with time, but varies as a function of transmitter power output. When the station goes off the air the inner conductor cools off, and when power is applied again it heats up and expands. This causes a cyclic variation of the inner conductor length and causes the end of

the center conductor to slide back and forth on the stationary center conductor (often referred to as a bullet), which is caught between the mating section flanges.

Unfortunately, the periodic sliding action can cause metal shavings to flake off both the center conductor and the connector and roughen the sliding surfaces.

SOLUTIONS

MODULA, MINI MODULA, AND SUPPORT EQUIPMENT from BSM Broadcast Systems

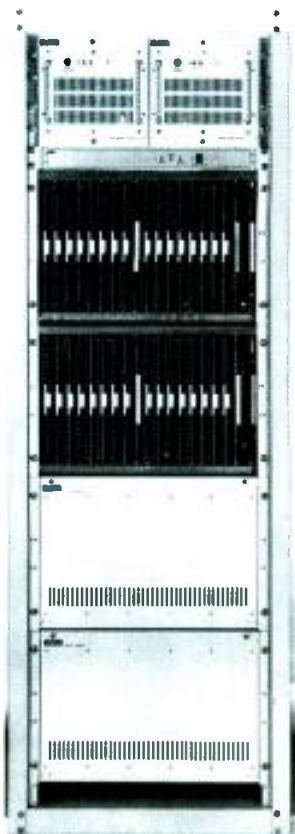

MODULA

PROBLEMS:

- 1 Expandability
- 2 Programming
- 3 Cost

1 BSM Broadcast Systems solves your expansion planning problems for video and audio signal routing with **MINI MODULA**, in matrix sizes from 8 x 8 to 24 x 32, and **MODULA**, for matrices as large as 256 x 256. Both products use the same circuit cards to preserve your initial investment in an expandable system.

2 Both **MODULA** and **MINI MODULA** solve your custom programming needs because the systems are software driven. You re-program to the matrix without sending equipment back to the manufacturer.



MINI MODULA

3 You can see that BSM system costs are highly competitive—user programming, no hybrids, virtually maintenance free. **MODULA** and **MINI MODULA** expandability enhances your initial investment through growth phases of your development.

BSM also offers a complete line of distribution amplifiers and smaller video or audio switchers to complete your system.

Phone BSM today and discuss the **SOLUTIONS** for your signal handling requirements. Our engineers and managers want to work with you from the start.



BROADCAST SYSTEMS, INC.

SOLUTIONS:
(509) 838-0110
 P.O. Box 19007
 Spokane, WA 99219

Circle (62) on Reply Card

FAST BREAKING EVENTS DON'T BREAK MUCH FASTER THAN THIS.

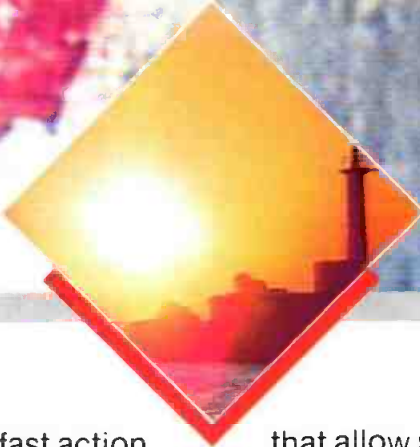

SP-3A
CCD Camera

Conventional
Tube Camera

So if you need to stop or slow down fast action, there's really no other choice.

There's only the one-of-a-kind SP-3A from NEC. A well-known camera with a hot new feature — an electronic shutter. A camera so advanced, it lets you catch action you could only capture before on film.

This camera stops the action at 1/60th to 1/2000th of a second, giving you precise, clear cut images.

And you're in control, selecting the shutter speed with one finger, because the shutter's built right into the camera.

The secret? CCD chips made by NEC. Chips

that allow shuttering to take place through drive pulses rather than optical interruption.

But it's the same hardworking, rugged SP-3A it always was.

And it's as versatile as it ever was. It can be used with Beta[®] M-II or 8mm format integral VTRs, as well as 3/4" VTRs. Options are available for multi-core or triax remote control.

The new SP-3A. Fast action with detail. Durability. And dependability.

If you want all three, it's the only shot you can take.

(Photographs appearing above are actual unretouched photographs of video images.)
Beta[®] is a registered trademark of Sony Corporation.

NEC NEC America, Inc.

NEC America, Inc., Broadcast Equipment Division, 1255 Michael Drive, Wood Dale, IL 60191 Toll Free 1-800-323-6656 In Illinois 312/860-7600

Circle (52) on Reply Card

www.americanradiohistory.com

Good Reasons To Call RTS When You're Talking To Talent.



The time spent talking to on-air talent should be time well spent. We can help improve that critical link.

Since communication with on-air talent is in real-time, an IFB system must not interrupt the talent's concentration. Our Series 4000 IFB System does just that—and more.

We think you (and the talent) will be impressed. Please call or write for literature.

PROFESSIONAL INTERCOMMUNICATIONS • PROFESSIONAL AUDIO PRODUCTS

RTS SYSTEMS

INCORPORATED

1100 West Chestnut Street • Burbank, California 91506 • Telephone 818 840 7119 • Telex 194855 • Telefax 818 842 4921

Circle (53) on Reply Card

high-power UHF installations up to 80kW without a single reported failure.

Rectangular waveguide

At the turn of the century, several investigators predicted the possibility of guiding electromagnetic waves inside hollow metallic pipes. The cross-sectional dimension of the pipe would have to be about $\frac{1}{2}$ -wavelength. For low frequencies (long wavelengths) the pipe size would have to be enormous, on the order of tens or even hundreds of feet. This simply was not practical.

During World War II, much emphasis was placed on the development of high-frequency generating equipment to be used for radar. The study and development of transmission lines for the guiding of high frequencies was a by-product of radar development. MIT and other research centers conducted theoretical studies as well as practical experiments with waveguides of various shapes and types. By 1945, there was sufficient theoretical and practical know-how available to apply these newly developed transmission-line technologies in the commercial field.

Waveguides provide low attenuation and exceptionally high power capability. They do not have a center conductor so the problem of cooling the center conductor is eliminated. All resistive heat loss is developed on the surface of the hollow pipe, which is in direct contact with the outside environment. Heat transfer may take place from the hollow pipe to the environment via both convection and radiation, so cooling is quite efficient. In addition, the attenuation of waveguide is much lower than the attenuation of coaxial line for a given frequency. Therefore, less heat is developed on the waveguide conductor itself. Waveguide appeared to be an ideal transmission line.

As the power output of UHF TV stations increased to the 110kW and 220kW levels, waveguide, as a reliable alternative to coaxial transmission line, became more attractive. Rectangular waveguide with a cross-section of roughly 15" x 7.5", although much larger than a 6- or 8-inch-diameter coaxial line, could provide reliable service with low attenuation. In the late 1950s and early 1960s several UHF TV stations were using rectangular waveguide. To date, these stations report high reliability.

Typically, the waveguide is manufactured from welded aluminum sheet metal. It is somewhat more expensive than coaxial line, but produces greater reliability, especially at high power levels.

VHF/UHF TV competition

The 1960s and '70s saw a proliferation of UHF TV stations. Many of these stations were constructed in markets domi-

WMMS

* WMMS-FM, Cleveland: The No. 1 Large Market Radio Station

KSHE

* KSHE-FM, St. Louis: The No. 1 Medium Market Radio Station

KPWR

** KPWR-FM: The No. 1 Station in the Los Angeles Market

These top stations use Harrison's

AIR-7

on air audio console

People listen when it sounds good.

imagine  Harrison

Harrison Systems, Inc., P.O. Box 22964, Nashville, TN, 37202, Phone (615) 834-1184, Telex 555133

* as determined by the readers of Rolling Stone Magazine

** as determined by Arbitron.

Circle (54) on Reply Card

May 1987 *Broadcast Engineering* 73

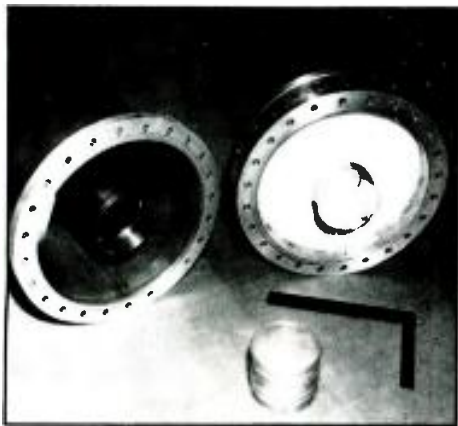

The world's largest known coax. 14 inches in diameter. was designed for a cyclotron.

nated by long-established VHF stations. In order to compete, the UHF stations had to offset the disadvantages of broadcasting at the higher frequency. Owners of these stations began to realize that successful competition required excellence in coverage and that superior coverage was the result of the proper balance among several important performance requirements.

First, it is desirable to radiate the maximum practical ERP. In some cases, emitting the maximum legal ERP of 5MW

(mean) is essential. Second, it is mandatory that the antenna system be designed to provide the optimum coverage. This requirement implies the use of UHF TV antennas with moderate but never high elevation directivity, and a great deal of null-fill. Because ERP is a product of power input to the antenna and antenna gain, which is limited by the requirement to provide optimum coverage, the only way to achieve a high ERP is to use more RF power. So, in the final analysis, the UHF TV station owner was forced to use a very high-power transmitter to be successful in the major markets.

The choice of transmission line had become limited. A coaxial line of the largest possible diameter, typically 8 or 9 inches, was only marginally adequate at these power levels. The other choice was waveguide. After considering the cost of being off the air for transmission-line repairs, more and more high-power stations opted for rectangular waveguide.

One additional factor also influenced the choice. The effectiveness of TV coverage, especially that of UHF, is significantly increased with antenna height. Realizing this, many stations not blessed with nearby mountains built tall towers, up to 2,200 feet in height. This, of course, required long transmission lines. The at-

tenuation of the transmission line became significant and rectangular waveguide, having a much lower attenuation, offered an additional advantage over coaxial line.

Circular waveguide

Although rectangular waveguide seemed to be a panacea for all transmission-line problems, it is not without disadvantages. The most disturbing one is the inability of rectangular waveguide to retain its shape under internal pressure. Pressurizing a transmission line is done to prevent the entry of moisture and is considered essential to long-term reliability.

These large metal waveguide sections tend to bow outward as a result of internal pressure, and assume a slightly rounded shape. Flanges and flange connections are much stronger than the sheet metal waveguide body and will retain their rectangular cross-section even under considerable internal forces. As the rectangular waveguide is pressurized, the cross-section of the rectangular waveguide body will change from an essentially perfect rectangle at the flange joints to a slightly rounded shape, change back again at the next flange joint and so on.



FM Antennas
FCC Directionals • Multistations
Rigid Transmission Line
Pattern Studies
Combiners

Shively Labs

a division of Howell Laboratories, Inc.

51 Harrison Rd
Bridgton, ME 04009
(207) 647-3327

TWX-710-223-8910 SHIVELY BRGT
call or write for more information

Circle (55) on Reply Card

Nothing Comes Remotely Close

SPECTRUM RPU LINKS

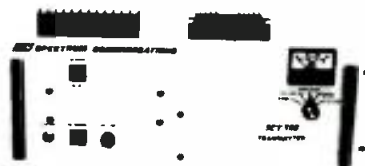

SCT500 RPU Transmitter

TX FEATURES

- VHF & UHF Units
- 2-75 Watts
- Direct FM
- Front Panel Metering & Indicators
- Built-in AC Supply
- 12VDC Input or "Battery Backup"
- 19" Rack Mt. - Cabinets Available
- FCC Type Accepted. Parts 74, 90

The Spectrum SCR500 & SCT500 are a series of high performance broadcast quality RPU Receivers and Transmitters. They incorporate the latest advances in solid state technology—brought about by Spectrum's more than a decade of experience in the two way radio field. These rugged units use the highest quality components & construction for high reliability in either fixed or mobile applications.

RX FEATURES

- VHF & UHF Units
- High Sensitivity & Selectivity
- High Rejection of IMs & strong local signals
- 4 IF Bandwidths Available
- Very Low Distortion
- Full Panel Metering
- Built-in AC Supply
- Many Advanced Features



SCR500M RPU Receiver

Call or Write for Details



SPECTRUM COMMUNICATIONS CORP.

1055 W. Germantown Pk., Norristown, PA 19403
(215) 631-1710 • Telex: 846-211

Circle (56) on Reply Card

The Abekas A53-D Digital Special Effects System

The innovative tradition of Abekas continues with the A53-D—the most cost-effective, high-quality three-dimensional effects system available today.

In single or dual channel configuration, the A53-D gives you a full array of three-dimensional features. This includes: perspective and 3D rotation, variable rotation axes and 3D locate, field/frame freeze and full manipulation of frozen pictures, variable border and background, crop and aspect change, A/B switch-

ing and GPI control, and smooth linear motion and trajectory with variable tension.

The A53-D makes good sense for both live broadcast and post-production applications. For broadcasting, the A53-D offers a simple-to-use control panel with fast access to 24 on-line effects. For post-production, the system's extensive programming features and precise control let you create intricate effects limited only by your imagination.

You can digitally interface the A53-D to the highly acclaimed Abekas A62 digital disk recorder.

This unique duo gives you the ability to composite unlimited layers of manipulated video without generation loss.

Let the A53-D add a whole new dimension to your bottom line, with unmatched price and performance. For details, contact: Abekas Video Systems, Inc., 101 Galveston Drive, Redwood City, CA 94063. (415) 369-5111.

Abekas

Video Systems, Inc.

Now Anything is Possible

ADD NEW DIMENSION TO YOUR BOTTOM LINE

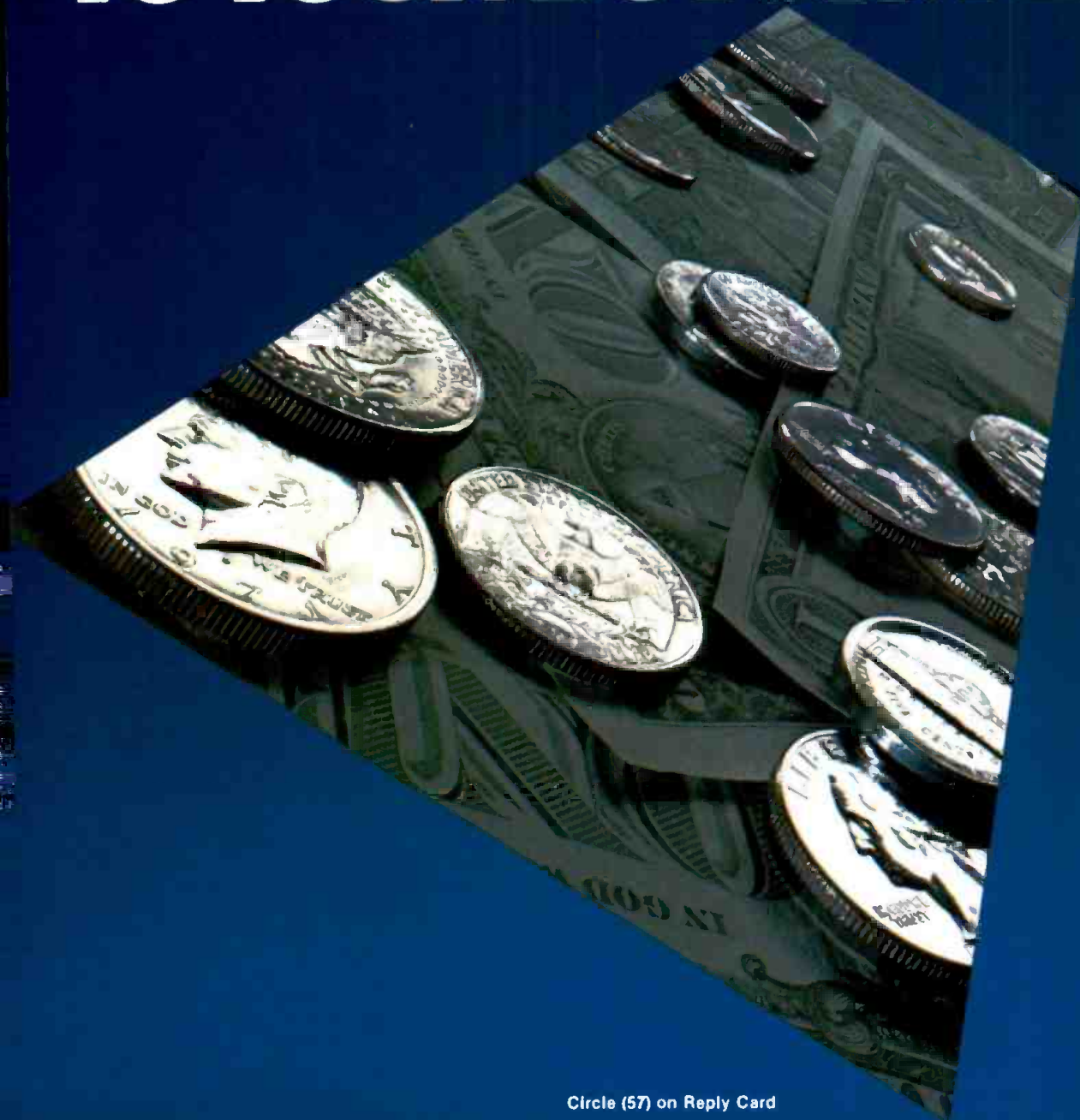

Circle (57) on Reply Card

www.americanradiohistory.com



The 90° circular bend made it possible to use circular waveguide from the transmitter to the antenna.

The net result is that periodic discontinuities develop along the line, causing high VSWR and ghosting. This phenomenon occurs even at fairly low pressures, on the order of 11b/in² or less, so sophisticated pressurization systems had to be developed with dump valves to prevent excessive pressure in the line. Without a dump system, excessive pressure could develop, due simply to rising ambient temperature.

The rectangular cross-section also is less than an ideal aerodynamic shape. The windload produced by rectangular waveguide is much larger than for coaxial line, because it is larger and because of its rectangular shape. As a result, waveguide requires stronger and more expensive towers to support it. In addition, the associated slightly loose supporting system could allow the rectangular waveguide to develop excessive lateral movement, causing severe vibrations on the tower.

Circular waveguide, developed to address some of these problems, is simply a cylindrical tube of sufficiently large diameter to allow the propagation of electromagnetic waves. The advantage of circular waveguide is its round cross-section, which provides for a smoother airflow around it, causing a far lower

AT LAST! STEREO FIELD MIXING COMES OF AGE!

Until you try the new AT4462, you'll never fully realize what other mixers put you through, just to get a stereo signal on tape, on film, or on the air. Because simply adding pan pots or another output to a mono mixer is not enough for today's stereo.

Field Tested and Refined

We went to network and independent broadcast engineers, and leading film and A/V audio people to learn your problems and needs first-hand. And we returned again and again to test our solutions. These tough critics agree that the new AT4462 sets up far faster, provides better signal control, and results in better audio...even in the hands of inexperienced personnel.

**NEW AT4462
STEREO FIELD MIXER
WITH EXCLUSIVE
MODU-COMM™**

Introducing Modu-Comm™

The AT4462 is designed for the real world. For instance, let's assume you're doing a simple sports remote. You set up microphones for the sportscaster and the color announcer, plus a stereo mike for the ambient crowd noise. Normally you would also have to run a

For name of
nearest A-T Sound Specialist
CALL 1-800-992-ATUS (2887)

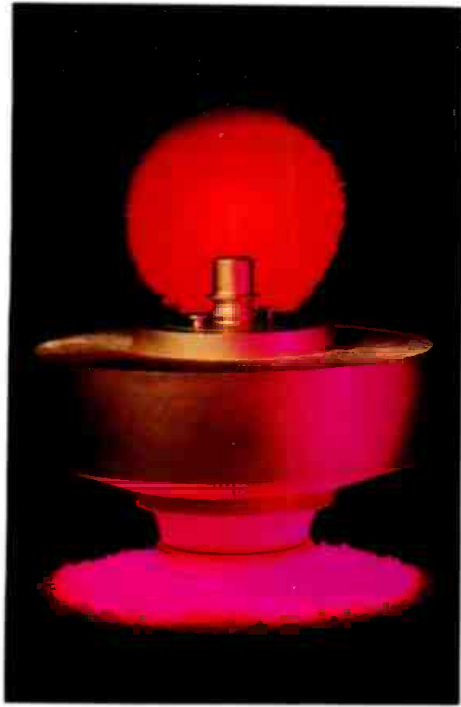

Curve-fitting program for transmission lines

By Dane E. Ericksen, P.E.

Use your computer to select the best transmission line.

A recurring task for the RF engineer is to determine losses for various types of transmission lines. This article will de-

scribe a truly universal curve-fitting program that will determine the loss at any frequency, for all types of commonly

used transmission lines such as foam dielectric cables, flexible and rigid air dielectric cables and circular, rectangular and elliptical waveguide.

The program allows the transmission-line type to be specified by the manufacturer's model number rather than by an arbitrarily assigned number. The curve fits are highly accurate, typically within 1% of the manufacturer's data.

Curve types

Early literature¹ for coaxial transmission lines suggested an equation of the form $Y = a \cdot F^{1/2}$, where F is the frequency in megahertz and Y is the specific attenuation in decibels per 100 feet. Current reference works² use a more refined form, $Y = a \cdot F + b \cdot F^{1/2}$.

This article introduces a Hoerl function curve as a universal transmission line curve-fitting equation. A Hoerl function takes the form $Y = a \cdot b^F \cdot F^c$, where F is the frequency in megahertz, Y is the specific attenuation and a , b and c are constants. It will be shown that a Hoerl function generally is a better fit to manufacturer's data for coaxial cables, and additionally, accurately models waveguide losses.

Least squares curve fitting

A *least squares curve-fitting* technique is used to determine the optimum coefficients for the curve fit. The general approach of this is to assume a particular equation type, then derive the coeffi-

Ericksen is an engineer with Hammett & Edison, consulting engineers, Alameda, CA.

LINE TYPE	A	B	C
DIELECTRIC DC-375 3 1/8" RIGID LINE	1.004E-2	1.000183961	4.893E-1
ANDREW ACX675 6 1/8" RIGID LINE	3.552E-3	1.000128943	5.542E-1
ANDREW LDF4 1/2" HELIAX	2.519E4	6.599E-2	...
ANDREW LDF5 7/8" HELIAX	2.051E-4	3.491E-2	...
BELDEN 8240 RG-58/U	3.372E-1	1.000020485	5.650E-1
BELDEN 8241 RG-59/U	9.867E-4	3.332E-1	...
BELDEN 9273 RG-223/U	4.510E-1	1.000142553	4.938E-1
ANDREW WC1500 CIRCULAR WAVEGUIDE	1.214E13	1.006424244	-5.772E0
ANDREW EW127 ELLIPTICAL WAVEGUIDE	5.908E14	1.000254204	-3.815E0
TIMES FIBER TX656 0.565" FEEDER CABLE	6.818E-2	1.000135259	4.850E-1

Table 1. Curve-fit coefficients for some commonly used cables and transmission lines. Where only two coefficients are given, the best fit is a coax function rather than a Hoerl function.



Make Great News. Hot Pod.

For on-the-spot news reporting, here is the action tripod you can set up in seconds and be ready to shoot while others are still setting up. Release the central lock lever and the legs extend automatically into a stable position, even on steps, a ramp, or any uneven surface. Level the camera in seconds with the fine-adjustment lever. You can also raise the quick-locking center-column to 6.6 feet, to put your image right up front, even when you are in the back. Tear down is just as fast as set up. Grab the centrally located handle for easy carrying. The Hot Pod. It's quick, reliable and professional, the perfect complement to the guaranteed leakproof Sachtler Panorama and Video 20 fluid heads.

That's what we are known for. World-wide. For further information, please contact us.

Sachtler. The System.



Sachtler Corp.
55 North Main Street
Freeport, N.Y. 11520
Phone (516) 867-4900

3316 W. Victory Blvd.
Burbank, CA 91505
Phone (818) 845-4446

Sachtler GmbH Dieselstr. 16,
D-8046 Garching/München,
West Germany.

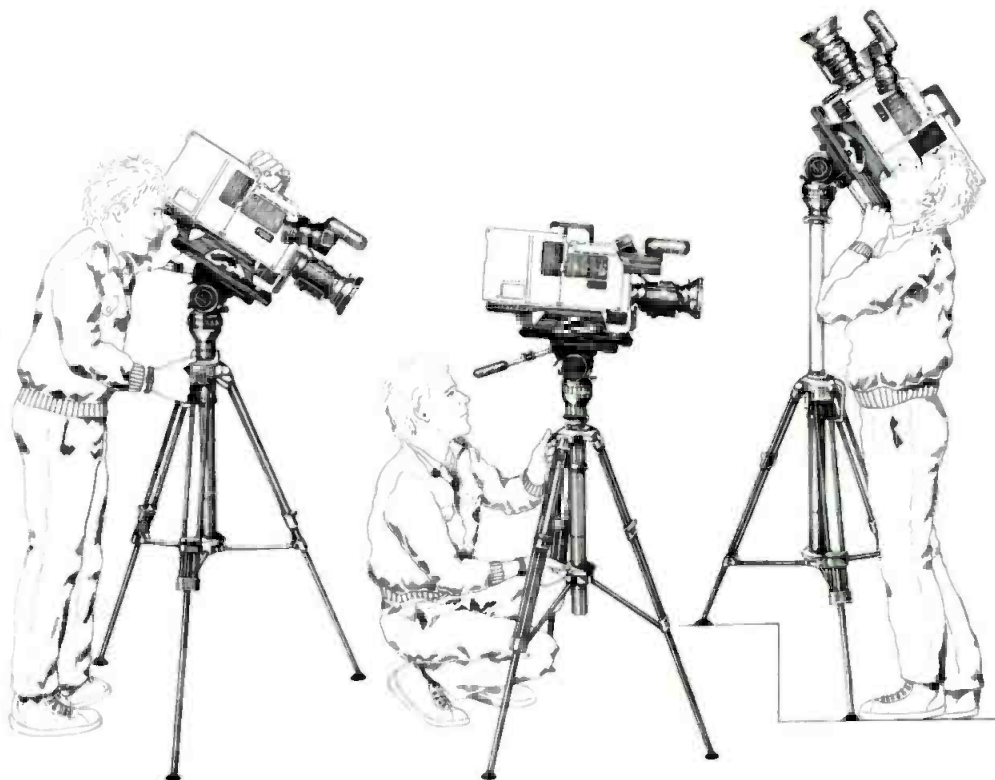

Circle (59) on Reply Card

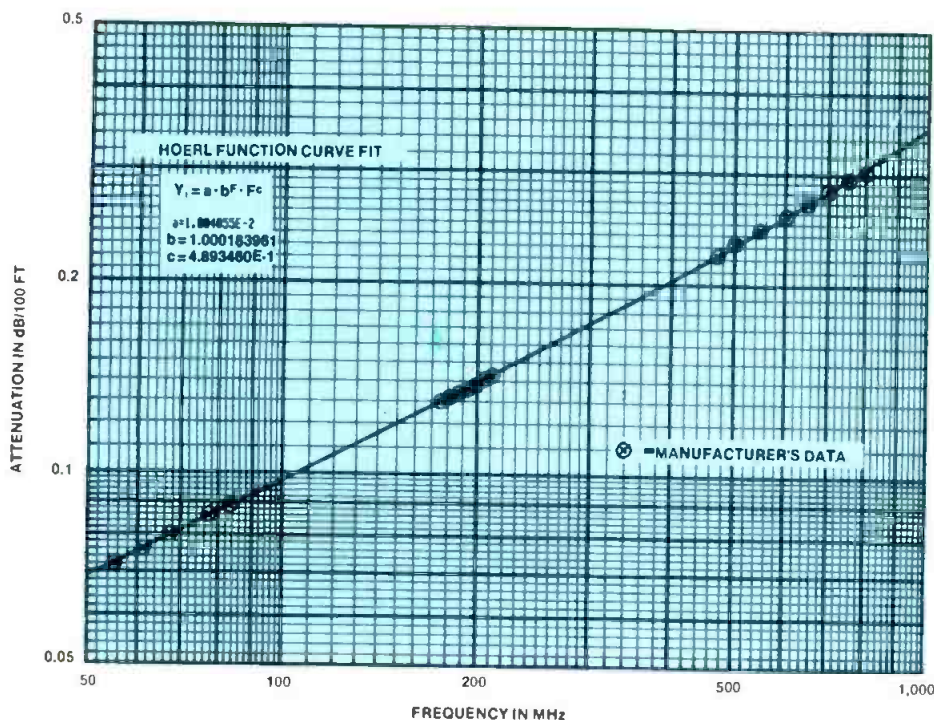

Figure 1. Plot of Hoerl function curve fit to manufacturer's data for 3 1/8" air dielectric rigid coaxial line.

cients that give the smallest sum of the squares of the errors between the originally given points and the corresponding points generated by the mathematical expression being used to model the data. This is accomplished by writing the equation for the sum of the squares of the errors, taking the partial derivations to zero to define the minimum error, and finally solving for these constants. A related article, "The Coax Function," shows the derivation for the $Y = a \cdot F + b \cdot F^c$ curve type, hereafter referred to as a *coax* function.

Modern programmable calculators and personal computers are good at performing summations and algebraic manipulations. This is fortunate, because the solutions for the constants a , b and c for the Hoerl function curve fit are much more involved. Because of their complexity, the solutions are not given here. For information about obtaining detailed documentation, see the "Editor's note" at the end of this article.

Application of formulas

Two computer programs were written by the author for the Hewlett-Packard HP41CX programmable calculator. The first program, COEFFICIENT, is used to enter specific attenuation vs. frequency

How to get your transmitter to phone home.

Now your transmitter can alert you to problems by phone—anywhere, anytime with the VRC-1000 Remote Control. A pre-programmed, synthesized voice quotes parameters; you make adjustments right on your Touch Tone® phone. Or you can dial from anywhere with complete remote control capabilities.

- VDT and printer options
- Full automatic commands
- Fully secure
- Automatic alarm reporting and correction

Patent Pending



GENTNER™
RF PRODUCTS DIVISION

P.O. Box 32550 • San Jose, California, 95152 • (408) 926-3400 • Telex 11 510-600-1445 GENTNER RF PRDVT

Circle (60) on Reply Card

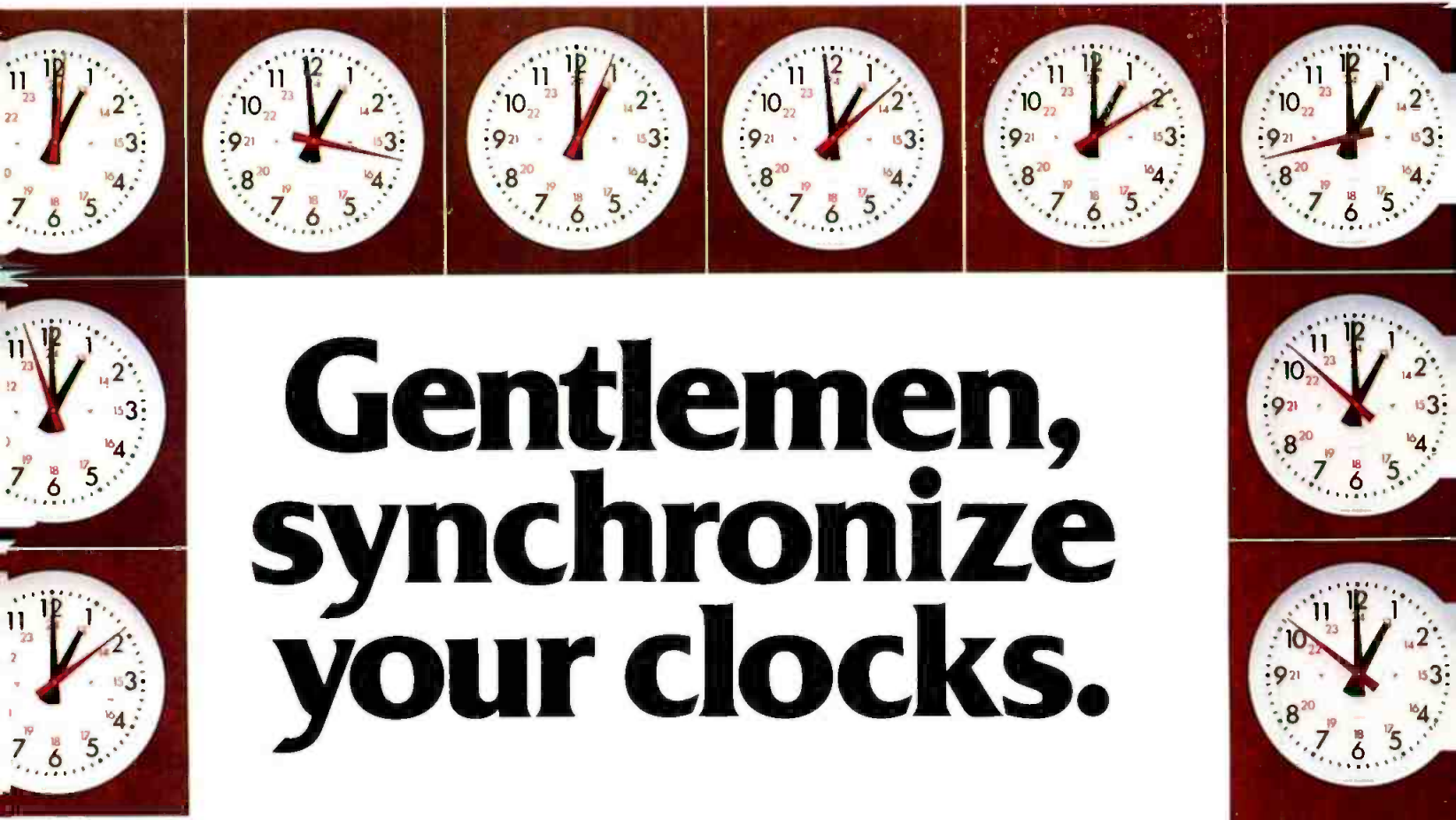

Gentlemen, synchronize your clocks.



The new Leitch CSD-5300
keeps clocks milliseconds accurate
across the city, across the country.
Automatically.

If time synchronization is one of the keys to your business, look into the new Leitch Master Clock System Driver - the CSD-5300.*

Under this one control, a multitude of clocks, digital or impulse, will move in astounding unison. These clocks can be in the same location or thousands of miles apart in different time zones. The new Leitch CSD-5300 also interfaces

with video terminals and computers. What's more, you get time setting accuracy within one millisecond. Using the telephone, the Leitch CSD-5300 calls a number connected with the ultimate reference for time in the land and adjusts itself when necessary.

Clock driving technology just Leitch ahead.

LEITCH

Leitch Video International Inc., 10 Dyas Rd., Don Mills, Ont., Canada M3B 1V5 - Tel: (800) 387-0233 Fax: (416) 445-0595 Telex: 06 986 241

Leitch Video of America, Inc., 825K Greenbrier Circle, Chesapeake VA 23320 - Tel: (804) 424-7920 or (800) 231-9673 Fax: (804) 424-0639

*Generates SMPTE. EBU Time Code.

Circle (61) on Reply Card

May 1987 *Broadcast Engineering* 81

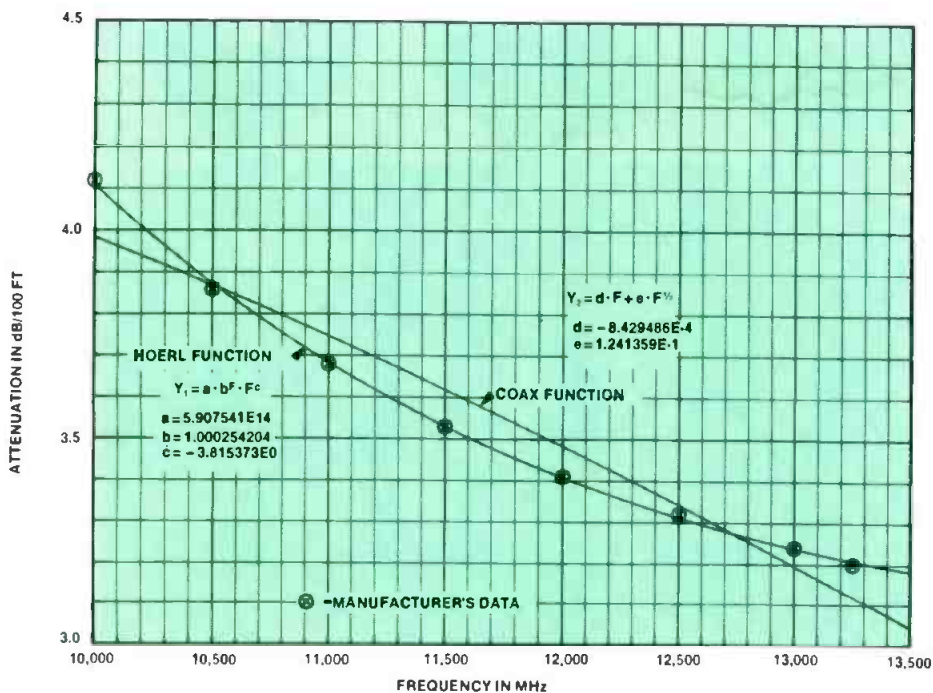

Figure 2. Comparison of Hoerl function and coax function curve fits to the manufacturer's data for Andrew type EW-127 elliptical waveguide.

from the manufacturer's data. After all (F, y) pairs have been entered, the program calculates the coefficients for the coax function and the Hoerl function curves. The program then goes back to each F value, calculates the corresponding y value, and compares the calculated y value to the given y value.

The *rms error* (the square root of the mean of the errors squared) in percent is then determined for both curves, as well as the largest percentage error for each curve. This allows a quick evaluation of the best curve type for a given set of data. For waveguides and coaxial cables below 30MHz, the Hoerl function curve fit has proved to be significantly more accurate than the coax curve fit. For coaxial cables above 30MHz, the Hoerl function is generally more accurate, but not always; the error tabulations must be examined to see which curve gives the best curve fit.

Accuracy

For the 46 transmission-line types curve-fitted by the author, 35 had rms errors of less than 1%, 43 had rms errors of less than 1.5%, and all had rms errors of less than 2%. Greater accuracy generally is possible only if the manufacturer has tabulated the specific attenuation at the

PACO Ni-Cad BATTERY PACK

POWER UP! NEW PACO DP-11 (13.2V 1.7Ah)

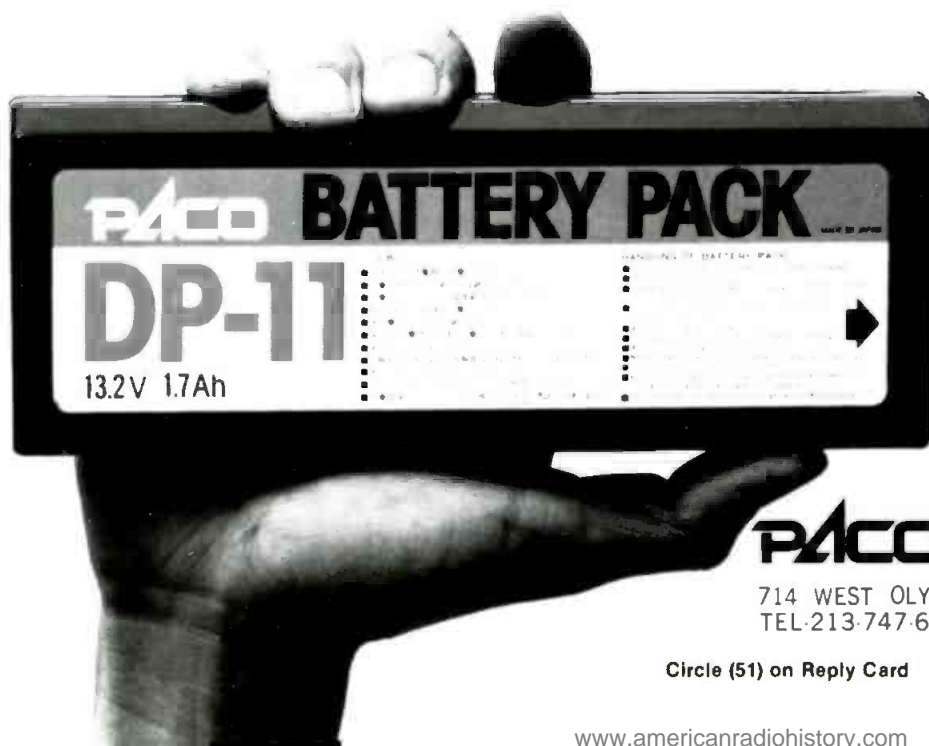

- NEW HIGH POWER CELLS ENABLE 1.7AH(0.2C Discharge Rate)
- THE MAINTENANCE FREE THERMAL PROTECTOR IS BUILT-IN, AS OTHER PACO BATTERY PACKS.
- THIS IS THE DIRECT REPLACEMENT FOR SONY NP-1.

PACO ELECTRONICS U.S.A., INC.

714 WEST OLYMPIC BLVD., SUITE 706, LOS ANGELES, CA 90015
TEL:213-747-6540 / TLX:756923 / FAX:213-747-3731

Circle (51) on Reply Card

**NOW!
25 Inputs**

25 x 1 Video/Stereo Audio Switcher



DATATEK

Datatek's new D-4325 Video/Stereo Audio Switcher Features:

- Program line quality video and audio performance
- Two Video and two full performance audio outputs per channel
- Wide Video bandwidth; high audio output level capability
- Video cable equalizing and vertical interval video switching
- Only two rack units utilize optimum space
- Local or remote control panels provide unsurpassed flexibility—remote control over coax line
- RS-232/422 control standard
- Wire per crosspoint and binary parallel port control available
- All control arrangements are fully operable in parallel
- Expansion provisions are included

*For a descriptive
brochure and
further information
call or write:*

DATATEK
CORP.

1121 Bristol Road, Mountainside, NJ 07092
1-800-882-9100 • 201-654-8100 • TELEX 833-541

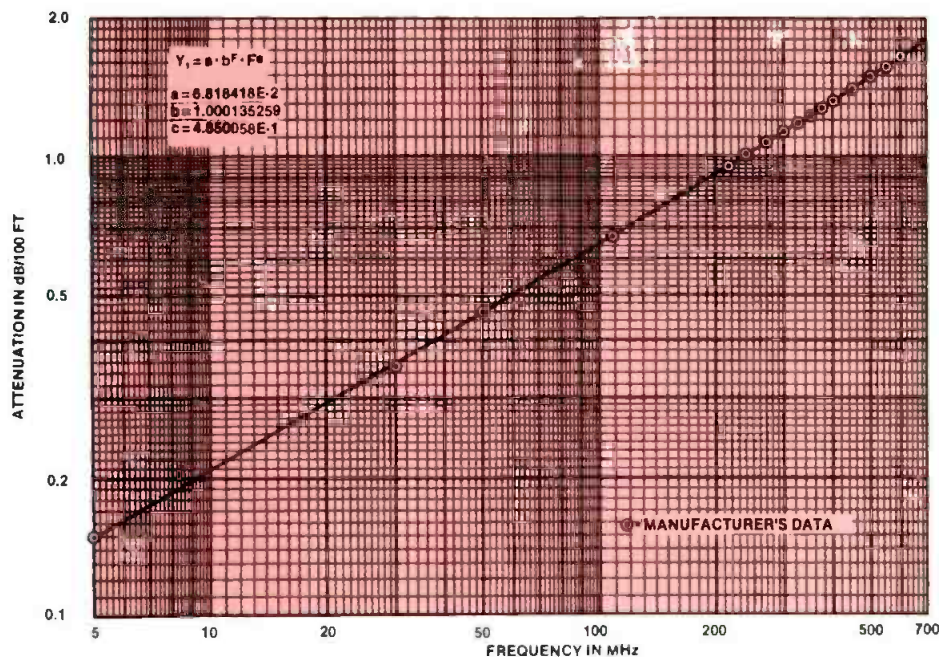

Figure 3. Hoerl function curve fit to Times Fiber type TX565 feeder cable. The curve accurately models specific attenuation over 5MHz to 30MHz, as well as over the higher frequencies.

frequency of interest. In any case, 1% to 2% accuracy usually is sufficient for practical purposes. Thus, the curve-fitting procedure is essentially transparent; that is, the errors introduced by the curve-fitting technique generally are less than normal manufacturing tolerances.

Examples

Consider a curve fit to 3/8-inch rigid line. The Hoerl function rms error is 0.49% and the maximum error, at 801MHz, is 1.22%. The coax function rms error is 1.15% and the maximum error, at 67MHz, is -2.28%. A plot of the Hoerl function curve fit against the manufacturer's data is shown in Figure 1.

Now consider a curve fit to 1/2-inch foam dielectric coaxial cable. The Hoerl function rms error is 0.42% and the maximum error, at 1,500MHz, is 1.24%. The coax function rms error is 0.14% and the maximum error at 1MHz is 0.36%. In this case, the traditional coax function curve fit is slightly superior to the Hoerl function curve fit, but the Hoerl function would be acceptable for practical purposes. (See Table 1.)

Waveguide applications

The Hoerl function also can be used to accurately model waveguide losses. For

Winsted®

FREE CATALOG



Winsted Matchmaker Systems

Big, full color catalog includes complete descriptions, pricing and ordering information on:

- Editing Consoles ● Video Consoles
- Production Consoles ● Dubbing Racks
- Equipment Cabinets ● Micro Computer Stations
- Computer Graphic & Newsroom Consoles
- Tape & Film Storage Systems

Winsted Matchmaker Systems... *the Perfect Match for all professional Video Equipment*

THE WINSTED CORPORATION

9801 James Circle • Minneapolis, MN 55431

Call for your nearest dealer **(800) 447-2257**

Phone Toll Free

TELEX: 510-601-0887

Circle (64) on Reply Card

AIRPORT & HAZARD

LIGHTS



SEND FOR THE MOST COMPLETE CATALOG

HUGHEY & PHILLIPS

Hughey & Phillips, Inc., 8511 Lankershim Blvd.,
Sun Valley, CA 91352, (818) 768-4811

TELEX 182900 TWX-910-498-2252

Circle (65) on Reply Card

TYPE RG8 CABLE		F=50.00 MHZ
F IN MHZ		Y1=1.1935 dB/100 FT
Y IN dB/100 FT		ERR=-0.54%
F, ENTR, Y, R/S		Y2=1.2603 dB/100 FT
F1=50.00		ERR=5.02%
Y1=1.200		
F2=100.00		F=100.00 MHZ
Y2=1.800		Y1=1.8067 dB/100 FT
F3=200.00		ERR=0.37%
Y3=2.700		Y2=1.8424 dB/100 FT
F4=400.00		ERR=2.36%
Y4=4.200		F=200.00 MHZ
F5=700.00		Y1=2.7351 dB/100 FT
Y5=5.800		ERR=1.30%
F6=900.00		Y2=2.7257 dB/100 FT
Y6=6.700		ERR=0.95%
F7=700.00 MHZ		F=400.00 MHZ
Y7=5.800		Y1=4.1413 dB/100 FT
F8=900.00 MHZ		ERR=-1.40%
Y8=6.700		Y2=4.0951 dB/100 FT
F9=700.00 MHZ		ERR=-2.50%
Y9=5.800		F=700.00 MHZ
F10=900.00 MHZ		Y1=5.7900 dB/100 FT
Y10=6.700		ERR=-0.17%
F11=700.00 MHZ		Y2=5.7677 dB/100 FT
Y11=5.800		ERR=-0.56%
F12=900.00 MHZ		F=900.00 MHZ
Y12=6.700		Y1=6.7310 dB/100 FT
F13=700.00 MHZ		ERR=0.46%
Y13=5.800		Y2=6.7500 dB/100 FT
F14=900.00 MHZ		ERR=0.87%
Y14=6.700		
F15=700.00 MHZ		
Y15=5.800		
F16=900.00 MHZ		
Y16=6.700		
F17=700.00 MHZ		
Y17=5.800		
F18=900.00 MHZ		
Y18=6.700		
F19=700.00 MHZ		
Y19=5.800		
F20=900.00 MHZ		
Y20=6.700		
F21=700.00 MHZ		
Y21=5.800		
F22=900.00 MHZ		
Y22=6.700		
F23=700.00 MHZ		
Y23=5.800		
F24=900.00 MHZ		
Y24=6.700		
F25=700.00 MHZ		
Y25=5.800		
F26=900.00 MHZ		
Y26=6.700		
F27=700.00 MHZ		
Y27=5.800		
F28=900.00 MHZ		
Y28=6.700		
F29=700.00 MHZ		
Y29=5.800		
F30=900.00 MHZ		
Y30=6.700		
F31=700.00 MHZ		
Y31=5.800		
F32=900.00 MHZ		
Y32=6.700		
F33=700.00 MHZ		
Y33=5.800		
F34=900.00 MHZ		
Y34=6.700		
F35=700.00 MHZ		
Y35=5.800		
F36=900.00 MHZ		
Y36=6.700		
F37=700.00 MHZ		
Y37=5.800		
F38=900.00 MHZ		
Y38=6.700		
F39=700.00 MHZ		
Y39=5.800		
F40=900.00 MHZ		
Y40=6.700		
F41=700.00 MHZ		
Y41=5.800		
F42=900.00 MHZ		
Y42=6.700		
F43=700.00 MHZ		
Y43=5.800		
F44=900.00 MHZ		
Y44=6.700		
F45=700.00 MHZ		
Y45=5.800		
F46=900.00 MHZ		
Y46=6.700		
F47=700.00 MHZ		
Y47=5.800		
F48=900.00 MHZ		
Y48=6.700		
F49=700.00 MHZ		
Y49=5.800		
F50=900.00 MHZ		
Y50=6.700		
F51=700.00 MHZ		
Y51=5.800		
F52=900.00 MHZ		
Y52=6.700		
F53=700.00 MHZ		
Y53=5.800		
F54=900.00 MHZ		
Y54=6.700		
F55=700.00 MHZ		
Y55=5.800		
F56=900.00 MHZ		
Y56=6.700		
F57=700.00 MHZ		
Y57=5.800		
F58=900.00 MHZ		
Y58=6.700		
F59=700.00 MHZ		
Y59=5.800		
F60=900.00 MHZ		
Y60=6.700		
F61=700.00 MHZ		
Y61=5.800		
F62=900.00 MHZ		
Y62=6.700		
F63=700.00 MHZ		
Y63=5.800		
F64=900.00 MHZ		
Y64=6.700		
F65=700.00 MHZ		
Y65=5.800		
F66=900.00 MHZ		
Y66=6.700		
F67=700.00 MHZ		
Y67=5.800		
F68=900.00 MHZ		
Y68=6.700		
F69=700.00 MHZ		
Y69=5.800		
F70=900.00 MHZ		
Y70=6.700		
F71=700.00 MHZ		
Y71=5.800		
F72=900.00 MHZ		
Y72=6.700		
F73=700.00 MHZ		
Y73=5.800		
F74=900.00 MHZ		
Y74=6.700		
F75=700.00 MHZ		
Y75=5.800		
F76=900.00 MHZ		
Y76=6.700		
F77=700.00 MHZ		
Y77=5.800		
F78=900.00 MHZ		
Y78=6.700		
F79=700.00 MHZ		
Y79=5.800		
F80=900.00 MHZ		
Y80=6.700		
F81=700.00 MHZ		
Y81=5.800		
F82=900.00 MHZ		
Y82=6.700		
F83=700.00 MHZ		
Y83=5.800		
F84=900.00 MHZ		
Y84=6.700		
F85=700.00 MHZ		
Y85=5.800		
F86=900.00 MHZ		
Y86=6.700		
F87=700.00 MHZ		
Y87=5.800		
F88=900.00 MHZ		
Y88=6.700		
F89=700.00 MHZ		
Y89=5.800		
F90=900.00 MHZ		
Y90=6.700		
F91=700.00 MHZ		
Y91=5.800		
F92=900.00 MHZ		
Y92=6.700		
F93=700.00 MHZ		
Y93=5.800		
F94=900.00 MHZ		
Y94=6.700		
F95=700.00 MHZ		
Y95=5.800		
F96=900.00 MHZ		
Y96=6.700		
F97=700.00 MHZ		
Y97=5.800		
F98=900.00 MHZ		
Y98=6.700		
F99=700.00 MHZ		
Y99=5.800		
F100=900.00 MHZ		
Y100=6.700		
F101=700.00 MHZ		
Y101=5.800		
F102=900.00 MHZ		
Y102=6.700		
F103=700.00 MHZ		
Y103=5.800		
F104=900.00 MHZ		
Y104=6.700		
F105=700.00 MHZ		
Y105=5.800		
F106=900.00 MHZ		
Y106=6.700		
F107=700.00 MHZ		
Y107=5.800		
F108=900.00 MHZ		
Y108=6.700		
F109=700.00 MHZ		
Y109=5.800		
F110=900.00 MHZ		
Y110=6.700		
F111=700.00 MHZ		
Y111=5.800		
F112=900.00 MHZ		
Y112=6.700		
F113=700.00 MHZ		
Y113=5.800		
F114=900.00 MHZ		
Y114=6.700		
F115=700.00 MHZ		
Y115=5.800		
F116=900.00 MHZ		
Y116=6.700		
F117=700.00 MHZ		
Y117=5.800		
F118=900.00 MHZ		
Y118=6.700		
F119=700.00 MHZ		
Y119=5.800		
F120=900.00 MHZ		
Y120=6.700		
F121=700.00 MHZ		
Y121=5.800		
F122=900.00 MHZ		
Y122=6.700		
F123=700.00 MHZ		
Y123=5.800		
F124=900.00 MHZ		
Y124=6.700		
F125=700.00 MHZ		
Y125=5.800		
F126=900.00 MHZ		
Y126=6.700		
F127=700.00 MHZ		
Y127=5.800		
F128=900.00 MHZ		
Y128=6.700		
F129=700.00 MHZ		
Y129=5.800		
F130=900.00 MHZ		
Y130=6.700		
F131=700.00 MHZ		
Y131=5.800		
F132=900.00 MHZ		
Y132=6.700		
F133=700.00 MHZ		
Y133=5.800		
F134=900.00 MHZ		
Y134=6.700		
F135=700.00 MHZ		
Y135=5.800		
F136=900.00 MHZ		
Y136=6.700		
F137=700.00 MHZ		
Y137=5.800		
F138=900.00 MHZ		
Y138=6.700		
F139=700.00 MHZ		
Y139=5.800		
F140=900.00 MHZ		
Y140=6.700		
F141=700.00 MHZ		
Y141=5.800		
F142=900.00 MHZ		
Y142=6.700		
F143=700.00 MHZ		
Y143=5.800		
F144=900.00 MHZ		
Y144=6.700		
F145=700.00 MHZ		
Y145=5.800		
F146=900.00 MHZ		
Y146=6.700		
F147=700.00 MHZ		
Y147=5.800		
F148=900.00 MHZ		
Y148=6.700		
F149=700.00 MHZ		
Y149=5.800		
F150=900.00 MHZ		
Y150=6.700		
F151=700.00 MHZ		
Y151=5.800		
F152=900.00 MHZ		
Y152=6.700		
F153=700.00 MHZ		
Y153=5.800		
F154=900.00 MHZ		
Y154=6.700		
F155=700.00 MHZ		
Y155=5.800		
F156=900.00 MHZ		
Y156=6.700		
F157=700.00 MHZ		
Y157=5.800		
F158=900.00 MHZ		
Y158=6.700		
F159=700.00 MHZ		
Y159=5.800		
F160=900.00 MHZ		
Y160=6.700		
F161=700.00 MHZ		
Y161=5.800		
F162=900.00 MHZ		
Y162=6.700		
F163=700.00 MHZ		
Y163=5.800		
F164=900.00 MHZ		
Y164=6.700		
F165=700.00 MHZ		
Y165=5.800		
F166=900.00 MHZ		
Y166=6.700		
F167=700.00 MHZ		
Y167=5.800		
F168=900.00 MHZ		
Y168=6.700		
F169=700.00 MHZ		
Y169=5.800		
F170=900.00 MHZ		
Y170=6.700		
F171=700.00 MHZ		
Y171=5.800		
F172=900.00 MHZ		
Y172=6.700		
F173=700.00 MHZ		
Y173=5.800		
F174=900.00 MHZ		
Y174=6.700		
F175=700.00 MHZ		
Y175=5.800		
F176=900.00 MHZ		
Y176=6.700		
F177=700.00 MHZ		
Y177=5.800		
F178=900.00 MHZ		
Y178=6.700		
F179=700.00 MHZ		
Y179=5.800		
F180=900.00 MHZ		
Y180=6.700		
F181=700.00 MHZ		
Y181=5.800		
F182=900.00 MHZ		
Y182=6.700		
F183=700.00 MHZ		
Y183=5.800		
F184=900.00 MHZ		
Y184=6.700		
F185=700.00 MHZ		
Y185=5.800		
F186=900.00 MHZ		
Y186=6.700		
F187=700.00 MHZ		

The coax function

The normal or matched-line attenuation in decibels per 100 feet is:

$$A_{100} = 4.34R/Z_0 + 2.78f\epsilon^{1/2}F_p$$

$$R_p = 0.1(1/d + 1/D)f^{1/2}$$

D = diameter of inner surface of outer coaxial conductor in inches

d = diameter of center conductor in inches

f = frequency in megahertz

ϵ = dielectric constant relative to air

F_p = power factor of dielectric at frequency f

This equation can be rewritten in the form $Y = a \cdot X + b \cdot X^{1/2}$. A least-squares curve fit gives the following equations for a and b:

$$a = \frac{\sum X \cdot \sum X \cdot Y - \sum X^{3/2} \cdot \sum X^{1/2} \cdot Y}{\sum X \cdot \sum X^2 - \sum^2(X^{3/2})}$$

$$b = \frac{\sum X^2 \cdot \sum X^{1/2} \cdot Y - \sum X^{3/2} \cdot \sum X \cdot Y}{\sum X \cdot \sum X^2 - \sum^2(X^{3/2})}$$

ble TV systems using the 5MHz to 30MHz subplit frequencies (channels T-7 through T-10). For example, consider a typical 0.565-inch foam dielectric feeder cable designed for cable TV applications: At 5MHz, the Hoerl function curve-fit error is only -0.71% and the overall, or rms, error is 0.56%. In contrast, the coax function curve-fit error at 5MHz is -6.33%, and the rms error over the entire frequency range is 1.70%. Clearly, the Hoerl function curve fit does the better job, as shown in Figure 3.

Applying the results

Figure 4 demonstrates the COEFFICIENT program for curve fitting to RG-8 cable. This same program has been run for all transmission lines of interest and a second program, COAX, is used to apply the results. The COAX program is a *working* program that is retained in RAM, whereas COEFFICIENT is loaded and run only when coefficients for a new transmission-line type are needed. There are three simple prompts for COAX:

- the cable type, which is normally the manufacturer's type number such as LDF-5, HJ7 or EW20;
 - the frequency in megahertz; and
 - the transmission-line length in feet.
- The COAX program then applies the

appropriate curve type and coefficients, using the transmission-line type as a global label. The program outputs are a readback of the transmission-line type; a 1-line description of the cable type (for example, "1/2-inch foam," "1 1/8-inch air" and "6 1/8-inch rigid"); a readback of the frequency and line length; and the line attenuation in decibels. Sample printouts are shown in Figure 5.

The decision whether the Hoerl function or the coax function best fits the manufacturer's data over the frequency range of interest is left to the user. When performing the 1-time entry of coefficients for a particular transmission-line type, an internal flag is used to let the COAX program know whether the coefficients pertain to a Hoerl function or to a coax function.

Let the program do the walking

This program provides a convenient and accurate means for the RF engineer to answer such common questions as "What is the attenuation of 153 feet of 7/8-inch foam dielectric cable at 951MHz?" or "What is the loss for 582 feet of 3 1/8-inch rigid line at 103.9MHz?" The accuracy is quite sufficient for use in preparing FCC filings.

Because of the capability of the HP cal-

STOP GROUND-LOOP HUM!

VIDEO HUM STOP COIL...HSC 1

Will ELIMINATE HUM and other INTERFERENCE in Video Lines caused by differences in Ground Potential.

- For Color and Black and White.
- FLAT-DC to 6.5 MHz.
- No Low-Freq or Hi-Freq. Roll-off.
- No Differential Phase Distortion.
- No Differential Gain Distortion.
- No Envelope Delay.
- Passive Device - Failure Free-Low Price.
- Small Compact Package 4" x 4" x 2-1/4".

ELIMINATES HUM AND INTERFERENCE:

IN STUDIO

- Between Buildings
- On long runs in Buildings
- Between Studio and Transmitter
- On Incoming Telco circuits
- On Outgoing Telco circuits

IN FIELD

- Betw. Remote Truck and Telco
- Betw. Remote Truck and Microwave
- For Intertruck Hookup
- For VTR Units
- For Monitoring Lines

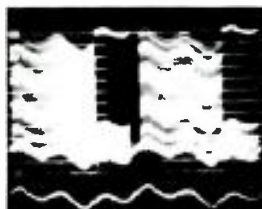

NEW!

\$190
F.O.B.
N.Y.



Available on
10 day free trial

AUDIO-VIDEO ENGINEERING COMPANY
65 Nancy Blvd., Merrick, N.Y. 11566
Tel. (516) 546-4239

Circle (67) on Reply Card

TIMECODE EQUIPMENT ONE-STOP SHOPPING FROM THE LEADER



690 ET Timecode Reader/Generator

- Longitudinal Reader/Generator
- VITC Reader/Generator
- Multifont Programmable Character Generator
- ORANGE Bus Compatible (RS-422)



640 Portable SMPTE
Timecode Generator



641 Portable SMPTE
or EBU Timecode Generator

- 650 Combination SMPTE/EBU LTC Reader/Generator
- 646 SMPTE/EBU Reader/Raster Display
- 647 Rackmount SMPTE or EBU Timecode Generator



SHINTRON

144 Rogers Street, Cambridge, MA 02142
(617) 491-8700

A CARING COMPANY

Circle (150) on Reply Card

EEV KLYSTRONS

SO MUCH MORE TO OFFER

The most comprehensive range of External Cavity UHF TV Klystrons

	Transmitter output power	Frequency range	Typical Sync efficiency
WIDEBAND SERIES			
K3672BCD	55-60 kW	470-810 MHz	44% to 48%
K3572BCD	40-55 kW	470-810 MHz	43% to 46%
K3272WBCD	40-55 kW	470-860 MHz	42% to 45%
K3271BCD	15-30 kW	470-860 MHz	42% to 47%
K3270BCD	5-15 kW	470-860 MHz	42% to 47%

STANDARD SERIES			
Low Band			
K3276HBCD	40-55 kW	470-596 MHz	38% to 43%
K3382BCD	40-55 kW	470-590 MHz	38% to 42%
K3217HBCD	30-45 kW	470-590 MHz	40% to 42%
K3282BCD	30-45 kW	470-610 MHz	30% to 40%
K3230BCD	10-30 kW	470-596 MHz	40% to 42%
K376L	10-30 kW	470-610 MHz	34% to 40%
K370/W series	5-10 kW	470-606 MHz	29% to 35%
Mid Band			
K3277HBCD	40-55 kW	590-710 MHz	38% to 43%
K3383BCD	40-55 kW	590-702 MHz	38% to 42%
K3218HBCD	30-45 kW	590-702 MHz	40% to 42%
K3283BCD	30-45 kW	590-720 MHz	30% to 40%
K3231BCD	10-30 kW	590-704 MHz	40% to 42%
K377L	10-30 kW	590-720 MHz	38% to 45%
K371/W series	5-10 kW	606-742 MHz	32% to 35%
High Band			
K3278HBCD	40-55 kW	702-860 MHz	38% to 43%
K3384BCD	40-55 kW	702-860 MHz	38% to 42%
K3219HBCD	30-45 kW	702-860 MHz	40% to 42%
K3284BCD	30-45 kW	700-860 MHz	30% to 40%
K372/W series	5-10 kW	740-860 MHz	32% to 35%

AVAILABLE TODAY

EEV Klystrons

USA: EEV Inc., 4 Westchester Plaza, Elmsford, NY 10523, USA Telephone: 914 592 6060 Telex: 6818096 Fax: 914 592 8342
 UK: EEV, Waterhouse Lane, Chelmsford, Essex CM1 2QU, England Telephone: (0245) 261777 Telex: 99103 Fax: (0245) 50424
 CANADA: EEV Canada Ltd, 67 Westmore Drive, Rexdale, Ontario M9V 3Y6 Telephone: 416 745 9494 Telex: 06 989363 Fax: 416 745 0618

Circle (69) on Reply Card

www.americanradiohistory.com

XEQ "COAX"			XEQ "COAX"		
CABLE TYPE?			CABLE TYPE?		
LDF5	RUN		LDF7	RUN	
F, MHZ?			F, MHZ?		
	450.2125	RUN		951.50	RUN
L, FT?			L, FT?		
	350.00	RUN		185.00	RUN
LDF5			LDF7		
7/8 FOAM			1 5/8 FOAM		
F=450.21 MHZ			F=951.50 MHZ		
L=350. FT			L=185. FT		
LOSS=2.92 dB			LOSS=1.47 dB		
XEQ "COAX"			XEQ "COAX"		
CABLE TYPE?			CABLE TYPE?		
DC375	RUN		EW127	RUN	
F, MHZ?			F, MHZ?		
	103.90	RUN		12,700.00	RUN
L, FT?			L, FT?		
	582.00	RUN		85.00	RUN
DC375			EW127		
3 1/8 RIGID			F=12,700.00 MHZ		
F=103.90 MHZ			L=85. FT		
L=582. FT			LOSS=2.79 dB		
LOSS=0.58 dB					

Figure 5. Example printouts for the COAX program.

culator to accept alphanumeric designators for global label subroutines containing the appropriate coefficients, the program does not require inconvenient arbitrary designators for familiar cable types. Just key in the manufacturer's designator, frequency and length, and let the COAX program do the walking through those hard-to-read graphs with umpteen closely spaced, easily misread curves.

Footnotes:

1. "Coaxial Cable Communications." The Lenkurt Demodulator, Vol. 6, No. 6, June 1967.
2. Reference Data for Radio Engineers, Fifth Edition, 22-13.

Bibliography:

- Haid, A. "Statistical Theory with Engineering Applications." Chapter 4, Sections 4.4 and 4.8, John Wiley & Sons, London, 1952.
- Kolb, William M. "Curve Fitting For Programmable Calculators." Third Edition, IMTEK, Bowie, MD.

Editor's note: Space does not permit printing the equations for the Hoerl function coefficients a, b and c or the full program listing and documentation. The complete program and documentation is available via the CompuServe Broadcast Professionals Forum at no cost beyond standard connect time charges. At any prompt (!), type GO BPFORUM. The program and documentation will be in data library DL4 under the name CRVFIT.BAS and CRVFIT.DOC, respectively. Because the program was written for a Hewlett-Packard HP41 computer, CRVFIT.BAS is an ASCII file. You will need to re-enter it in your computer's resident language. (=:~)))))

DELTA DOLLY

THE DELTA PEDESTAL

TAKE THE STUDIO ON LOCATION

MATTHEWS
 (818) 843-6715 * (212) 691-4720
 2405 EMPIRE AVE., BURBANK, CA 91504
 TELEX 691599 MATTHEW.

EGRIPMENT
 MACHINEWEG 22 * PHONE - (2945) - 3988
 1394 AV NEDERHORST DEN BERG, HOLLAND.
 TELEX: 10254 GRIMA NL.

matthews
STUDIO EQUIPMENT, INC.

CORNELL DUBILIER

Mica Capacitors

LARGE

STOCK

VACUUM CAPACITORS

JENNINGS

SURCOM ASSOCIATES, INC.

305 Wisconsin Avenue
 Oceanside, California 92054
 (619) 722-6162

Circle (71) on Reply Card



Building and operating a tower facility

By Ray Upsahl

Understanding tower dynamics and maintenance can add to the service life of your tower.

The tower is an important component in the delivery of a broadcaster's signal to the market. Towers often support many antennas in addition to those needed to transmit signals to a station's listeners or viewers. Other antennas may be used for transmitting and receiving 2-way communications for private and public agencies. The tower's important service to the community is often taken

for granted by all but the station's engineering staff.

A tower represents a significant economic investment, and is often a potential liability. The cost of an untimely tower replacement, in terms of lost income and the effort required for planning, designing, dealing with environmental concerns, use permits and public involvement, could be greater than the tower's construction cost. In addition, a tower failure in a populated area could result in a pernicious catastrophe.

Although most broadcasters have emergency plans to remain on the air during the period of time when the tower might be out of service, maintenance of a station's tower structure is a concern of the highest priority.

A review of tower design and conventional code analysis methods shows variations between actual windloads and member forces and stresses associated with the different codes governing tower design. New analysis procedures for determining design wind-speed loads

Upsahl is a consulting and structural engineer with Skilling Ward Rogers Barkshire, in Seattle.



The failure of this tower was caused by either poor design, poor maintenance, or both. This problem could have been avoided.

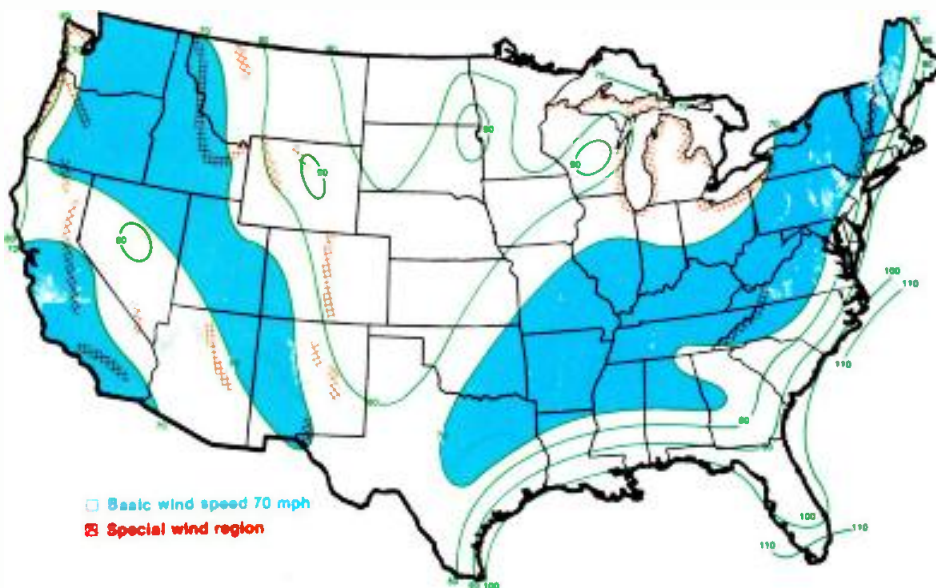

Figure 1. A map of the United States shows contours of 50-year wind speeds, measured at a distance of 33 feet from open, level terrain. The map, using National Weather Service statistical data, is the basis of standardized design wind speeds. (Information supplied by EIA.)

and member forces in dynamically responsive tower structures are based on recent findings from wind-tunnel research. Comparisons of safety factors from these analysis procedures show the differences in conventional code analysis and computed values using rigorous dynamic analysis for certain portions of example towers.

Engineering management program

The first step in an engineering management program for tower safety is to develop a tower evaluation procedure. This procedure will evaluate and document the current condition and structural adequacy of an existing tower. Evaluation is divided into three activities: field inspection, measurement of dynamic properties and load rating. The first two activities are completed in the field on the tower itself, while load rating consists of an office analysis.

A professional tower field inspection may be completed in varying levels of detail. It consists of, at least, a top-to-bottom, hands-on visual inspection combined with measurement of the tower's dynamic properties.

To conduct an effective tower inspection, a qualified structural engineer, familiar with tower structural systems, is required. The inspector that a tower owner hires must be more than a quality-control inspector who is typically concerned only with paint and corrosion protection. The professional tower inspector must have the proper training, experience, attitude, motivation, skills and the physical climbing ability to collect the necessary information. The inspector can assess the need for additional detailed inspection following an initial

reconnaissance. Only then can a proper tower evaluation be completed and long-range considerations be formulated by the owner.

The duties of the tower inspector include detailed planning and preparation. The inspector will acquire and study existing drawings of the tower, if available; will establish methods for recording information in a logical fashion; and will make a permanent record of the inspection as it is accomplished, with the use of field notes, photographs and, perhaps, videotape. Although photographs provide sharper resolution than video, videotape offers the option to record valuable audio comments to accompany the visual data.

Careful planning is critical to an efficient and effective inspection procedure. The ascent of a tower can be time-consuming, particularly when equipment is carried. The inspector must be knowledgeable about tower structures and be able to safely reach each member and connection. The physical demand on the inspector limits the amount of time that can be spent on each inspection trip.

Tower inspection procedures

Professional inspectors will use the historical information such as plans, specs, shop drawings and previous inspection reports to assist in the verification of the as-built configuration. Member size and length, bolt size, cable characteristics and material properties also must be verified. The inspector will check material properties whenever possible. A low-stressed member can be removed and replaced with a new member. The mechanical and chemical properties of the low-stressed member, such

as ultimate strength and weldability, can then be determined in the laboratory.

The professional inspector will use a thorough, systematic approach to inspect the foundation, structural members, connections and corrosion protection (paint). The inspector will:

- Check all joints and members for deterioration and missing, loose or corroding bolts.
- Check all guy cables for corrosion. Corrosion reduces the load capacity of the cable. Continued corrosion can cause individual strand failure, leading to reduced cable section and ultimate guy failure. The loss of one guy means the collapse of the tower.
- Inspect all welds. Ultrasonic testing is recommended in full-penetration butt welds to check for any cracks that may have developed over time.
- Check vertical members for bowing and corrosion. Look for stress concentrations as evidenced by flaking paint on the inside leg where a tower transits from one framing system to another.
- Check horizontal members for bowing, corrosion, and loose, deteriorating or missing fasteners.
- Check angle bracing and tension rod bracing. Note whether members have a bowed appearance, which may indicate insufficient compression capability for member length or tension members taking compression.
- Check for member misalignments. Misalignments may be the result of a serious problem and should be studied to determine the cause.

A continuing scheduled inspection procedure as part of a preventive maintenance program following an initial thorough field inspection will help increase the life of the tower. Establish a permanent log of inspection reports.

Tower diagnostics

The single most important factor that an owner should be concerned with is the *stiffness* of a tower. In the case of a tower structure responding to windload conditions, the less flexible the tower, the more desirable. Loose bracing and/or slack guy wires can be characteristics of overly flexible towers. Another obvious clue to overflexing is any area on a tower that continually develops paint chips.

A measure of tower stiffness is decided by determining the tower's *period of vibration* as it is deflected by applied loads. The period of vibration is the time in seconds for the tower to deflect from vertical, recover and swing past vertical, and return (or cycle) back to vertical again. For a freestanding or guyed tower with a typical height of 500 to 1,000 feet, a period of two seconds is good, while a period of five seconds is not good. A

Continued on page 98

Stations looking to automate, look to IGM.

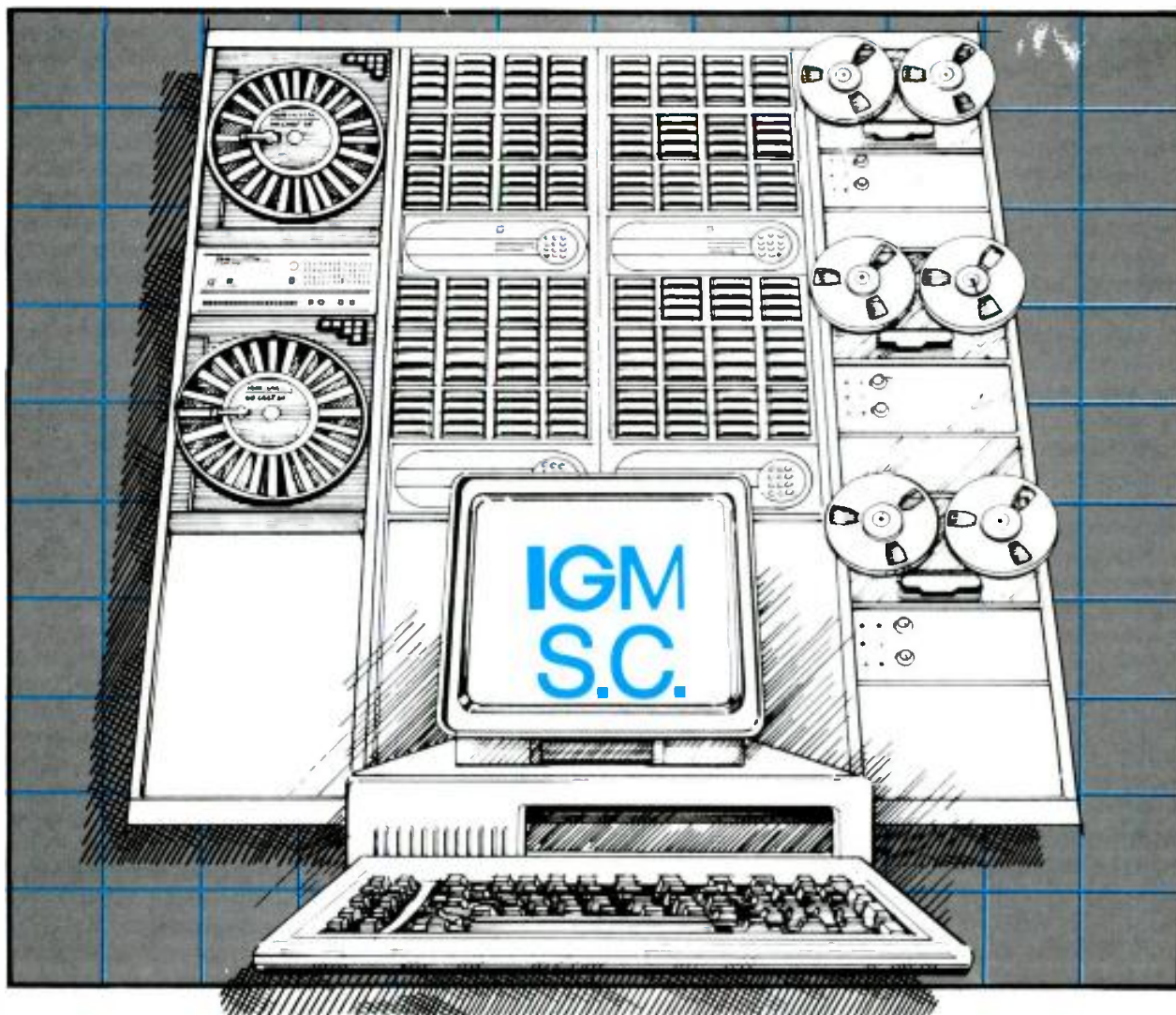

When you are thinking of using a program automation system, a number of questions come to mind. How do I handle network news? How many events of memory do I need to handle any format? How will this work with my billing system? With over 20 years of experience, IGM can help you determine how best to add automation to your operation. The broadcast industry has counted on IGM to build automation systems for all kinds of operations, from small radio stations to network operations.

We can build a program automation system for your station using an IBM-PC or compatible as the brain to

control the IGM-SC or IGM-EC automation controllers. Depending on your specific application, you can add the IGM GoCart and Instacart to handle your commercials and announcements or, if you need reel-to-reel machines or other cart machines, we can include the Studer-Revox PR-99 and Fidelipac cart machines in your system.

For information on how you can use automation successfully, call

800-628-2828 Ext. 578

IGM COMMUNICATIONS

282 West Kellogg Road

Bellingham, Washington 98226

(206) 733-4567

Circle (73) on Reply Card

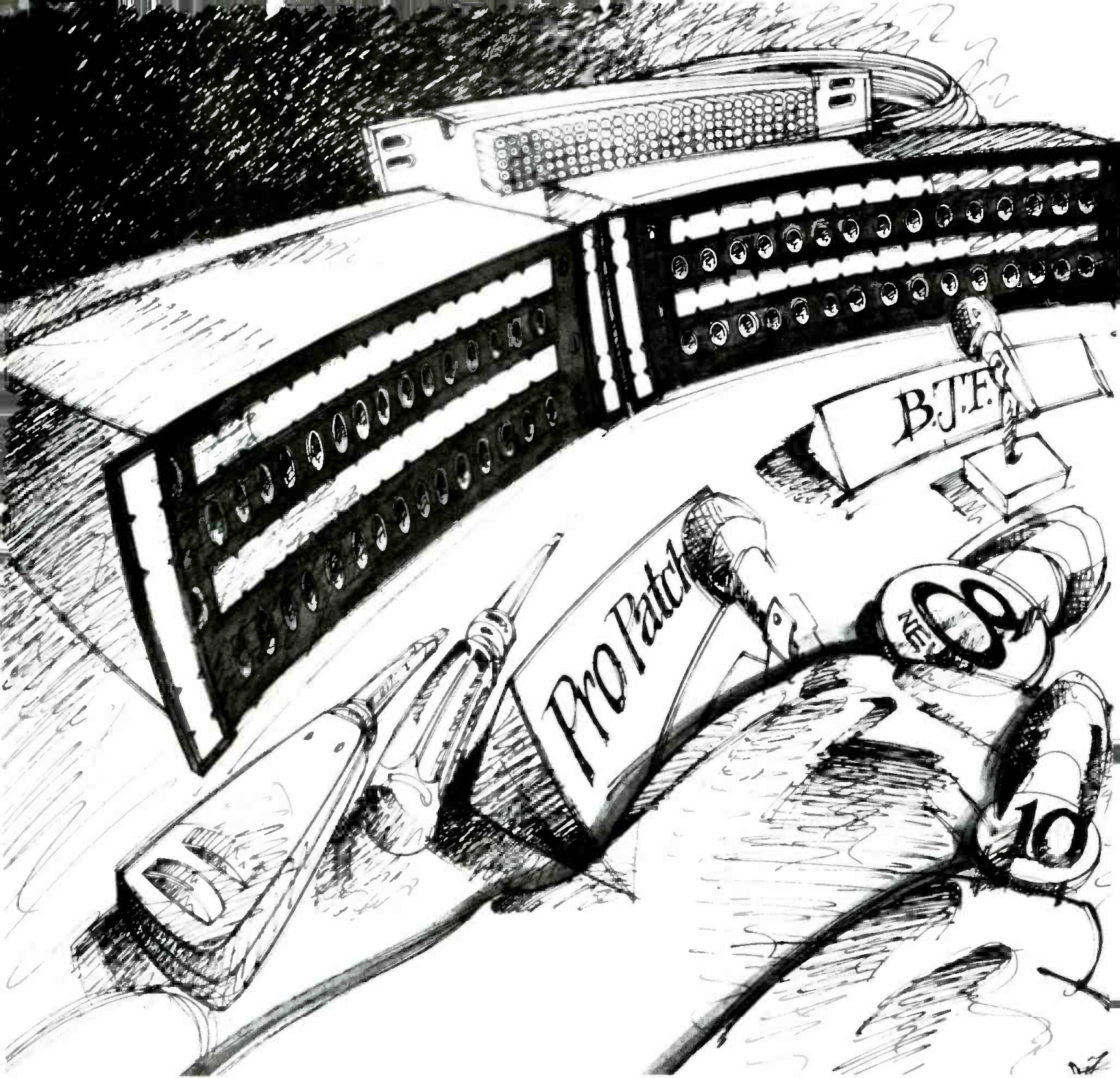

NO PATCHING QUESTION IS TOO TOUGH FOR ADC'S "PANEL OF EXPERTS."

MODERATOR: "Thank you, and welcome. First question, please — don't hesitate to give us your best shot."

QUESTION #1: "OK, Panel, I need patchbays that keep my racks neat and tidy, without a lot of cabling clutter. And I need to install them quickly and securely. Any suggestions?"

PROPATCH: "Sure — try ADC ProPatch Mark II patchbays. They're fully enclosed, and all the terminations are QCP punchdowns on the back of the box. Fast installation is one reason we're the panel of experts."

QUESTION #2: "This one's tougher, Panel. I need to terminate

my patchbays in the bottom of the rack, but I want my jacks protected."

BJF: "No problem. ADC's Broadcast Jackfield (BJF) Mark II series gives you the best of both worlds. They feature Ultra Patch termination panels with QCP punchdowns on the end of a harness. So you can terminate your cabling wherever it's most convenient. The patchbay chassis supports the cable harness and covers the jacks."

QUESTION #3: "What about when your budget's tight? I need quality patchbays, but I've got a small facility and I can't spend a lot of money."

PATCH KIT: "Our Patch Kit is

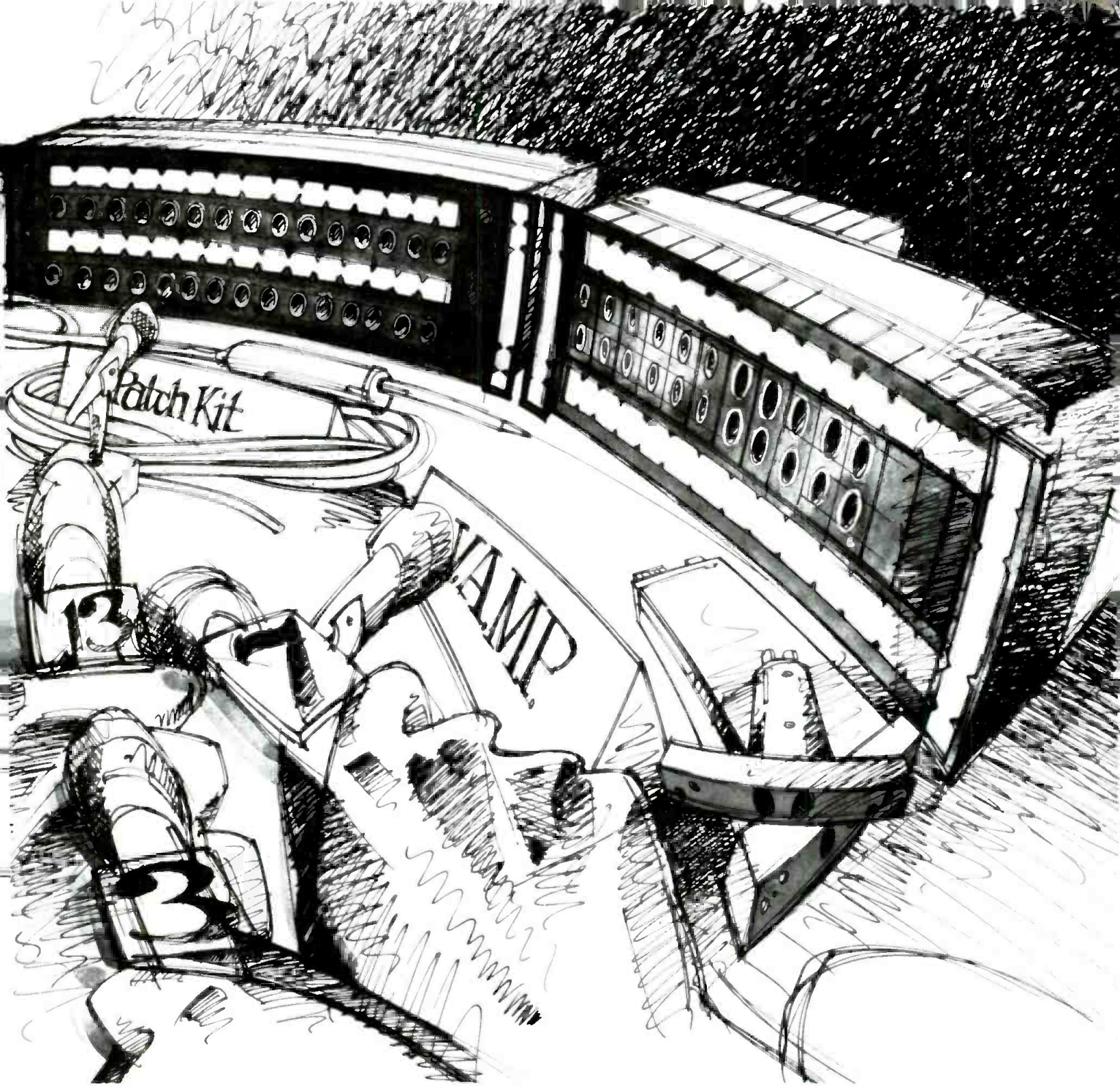

exactly what you're looking for. It's a Broadcast Jackfield Mark II chassis without the cabling. Just add your own cable and you'll have it made. And you'll save money by doing it yourself."

QUESTION #4:

"Let's see you answer this one, Panel. I have a small off-line suite and I need to patch a few audio circuits AND a few video circuits. If you want me to buy two dozen circuits at a time, forget it."

VAMP: "Don't buy more patching than you need. Buy an ADC Video/Audio Modular Patchbay (VAMP)

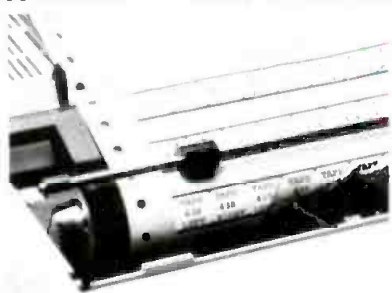

instead. Because it's modular, you can install the number of video and/or audio modules you need—no more, no less. And it's expandable."

QUESTION #5:

"I'm convinced, Panel. You're great patchbays. But doing designation strips drives me crazy."

MODERATOR:

"We've got the answer—our Self Adhesive Identification Labeling System (SAILS for short). It's a special computer-printable, adhesive-backed polyester label.

SAILS won't discolor, smear or tear, and they're removable. You don't even need special software to print on them. You'll find SAILS on every ADC patchbay. Any more questions?"

QUESTION #6: "Just one. Where can I buy ADC patchbays in a hurry?"

MODERATOR: "Call us at (612) 893-3010, and we'll give you the name of your nearest ADC stocking distributor. Like everyone on our panel of experts, he really delivers."



ADC Telecommunications, Inc. 4900 West 78th Street
Minneapolis, Minnesota 55435 (612) 893-3010



GLOBAL SUPPORT FOR GLOBAL COMMUNICATIONS

C-Band and Ku-Band High Power TWT Amplifier Systems

For Video, Voice
and Digital
Communications
50-3000 Watt



To meet expanding needs of the video, voice and data markets, MCL offers a host of C-Band and Ku-Band High Power TWT Amplifier Systems, 50-3000 Watt, with flexibility in configuration and consistently reliable power output. MCL is dedicated to manufacturing amplifiers of the highest quality, yet at competitive prices. The amplifiers are recognized and accepted worldwide for incomparable performance. They are designed to withstand interference from EMI-radiation/RFI-susceptibility, electrical (power source), mechanical stress, environment (temperature/humidity), or general maintenance and transportation.

MCL's C-Band and Ku-Band High Power TWT Amplifier Systems are designed with state-of-the-art engineering concepts, and options are available for customized applications. The C-Band units (5.850-6.425 GHz) operate at 50-3000 Watt power levels; and the Ku-Band units (14.0-14.5 GHz) operate at 50-2500 Watt power levels.

MCL is a primary source of amplifiers and allied equipment for satellite communications worldwide. Commonality in operation, design, and mechanical layout of all MCL equipment provides for interchangeability and keeps maintenance and repair time at a minimum, performance at a maximum.

Write for your FREE copy of MCL's New Brochure #6008 for additional details and technical specifications on the complete line of MCL High Power TWT Amplifier Systems.

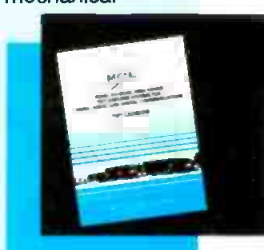

MCL

MCL, INC.
501 S. Woodcreek Road
Bolingbrook, IL 60439
312-759-9500 TWX 910-683-1899

Manufacturers of TWT and Klystron Amplifiers for Satellite Communications.
24-Hour Sales and Technical Support for Immediate Service Worldwide.

Circle (75) on Reply Card

Continued from page 94

tower with a longer period of vibration builds greater stresses in certain members as it sways back and forth in the wind. In fact, a 10% change in the period of vibration will result in a 20% change in dynamic stresses.

The period of vibration for a tower can be calculated if you know the structural system configuration and member properties, or it can be measured in the field. Measurement of the tower's actual period of vibration is preferable to calculation, which assumes a perfect structural system. The comparison of these two measurements can yield valuable information regarding the actual dynamic performance of the tower. One relatively simple method to measure the tower's period in the field is to observe the movement of the tower during a strong windstorm by videotaping it.

Use of accelerometers is a more scientific technique for determining the period of vibration. It is reliable, accurate and provides other useful information. Accelerometers are mounted at various levels of the tower in triplets, to record all directional and torsional periods. Data from each accelerometer can be transmitted and plotted on the ground. A print-out chart allows an accurate determination of primary periods along with damping properties. This information quickly indicates a number of maladies, such as a tower that is too flexible, loose guy wires and loose and/or inadequate bracing.

The load rating of a tower is accomplished by office analysis using information acquired in the field. Analysis uses the as-built characteristics of the tower's structural system, its current condition and the actual or calculated period of vibration. The tower's structural system geometry and member properties are modeled on a computer. Any weak links (or limiting members) of the overall structural system can be identified. The capacity these members should carry is determined to enable the overall system to meet the required capacity of the design loads.

Upgrading or repair

Initiate an upgrading or repair program as soon as possible to correct deficiencies identified in the field inspection or load-rating analysis, such as corrosion or structural problems. Touch-up for general corrosion problems or complete rehabilitation of the protective-coating system can be accomplished by painting contractors, particularly bridge painters.

Structural repairs that require replacement of members or connections and/or extensive retrofitting activities necessitate the hiring of a specialized tower contractor. A limited number of qualified

Continued on page 102

PERFECT FIT, ANY FORMAT.

Tek know-how at work in component television!

When it comes to maintaining performance and enhancing signal quality—in a world of changing formats—Tektronix is your one *complete* solution for test and measurement needs. Tek has what you need, when you need it.

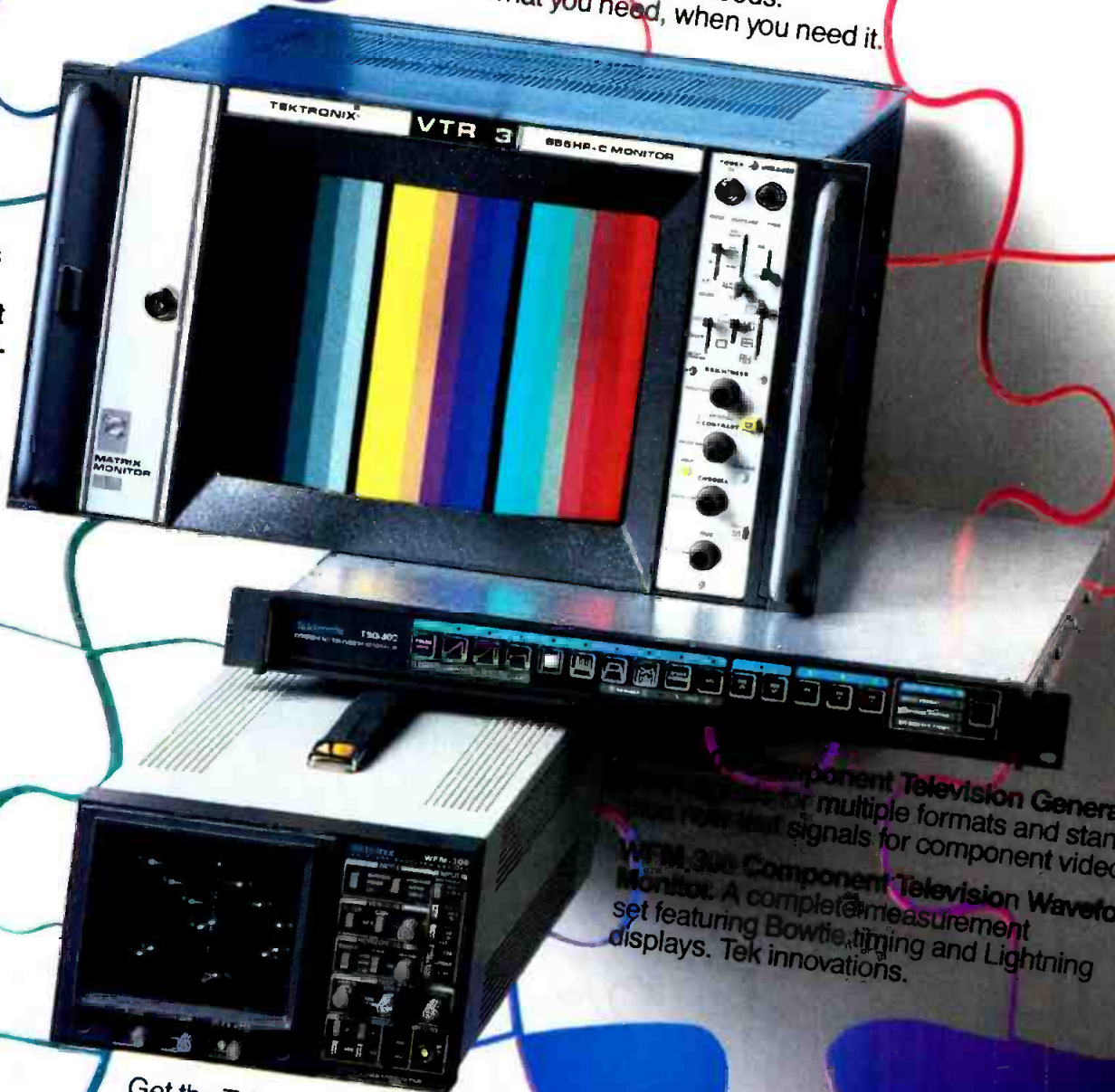

650HR-C Series Component/Composite Input Picture Monitors. Multiple formats with direct analog component inputs — competitively priced.

TSG-400 Component Television Generator. Generates multiple formats and standards, and provides test signals for component video.
WFM-100 Component Television Waveform Monitor. A complete measurement set featuring Bowtie, timing and Lightning displays. Tek innovations.

Get the Tek solution now. For complete details and fast delivery contact your Tektronix Sales Manager today.

Behind the scenes in quality component television

Tektronix
COMMITTED TO EXCELLENCE

Circle (76) on Reply Card

These products available for SMPTE/EBU, M, M1, BetaCam and GB. BetaCam® is a registered trademark of Sony Corporation. Copyright ©1987, Tektronix, Inc. All rights reserved. TVG-076

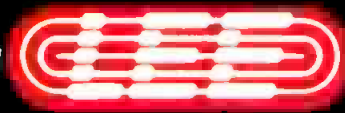

INTERNATIONAL PLC

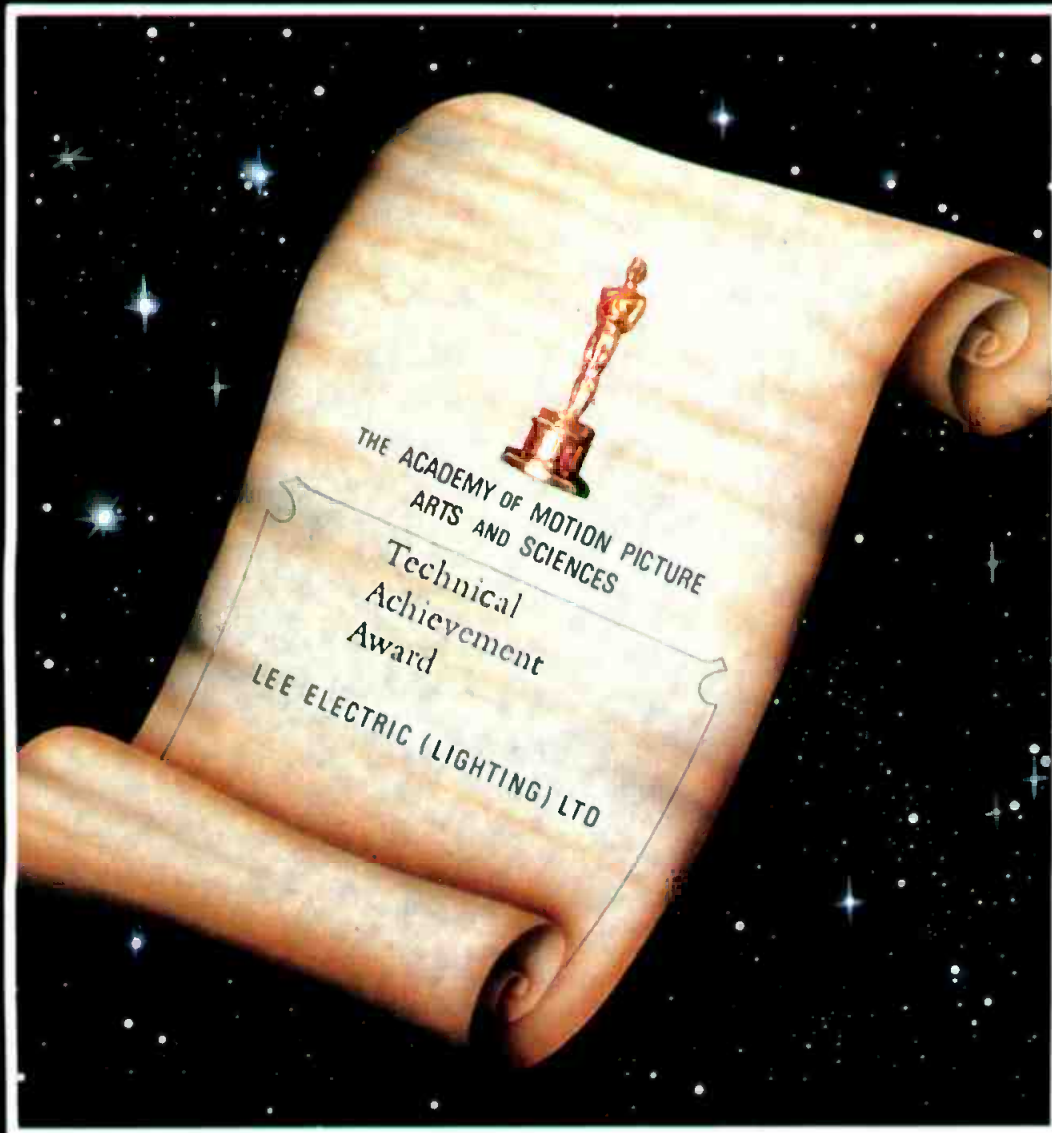

To Lee Electric (Lighting) Limited for the design and development of an electronic, flicker-free, discharge lamp control system. March 22, 1987.

**Researched and Developed by LEE ELECTRIC LIGHTING
Manufactured and Distributed by LEE COLORTAN**

Lee International – Light years ahead.

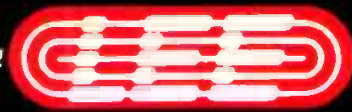

INTERNATIONAL PLC

"The Brightest Star" gets the Technical Achievement Award for 1987.

Lee's award winning DMI 8kw lamp with its all electronic control gear weighing only 74lbs is a fraction of the weight and size of any comparable lighting system available and gives more light.

Lee have the full range of "flicker free" Discharge lighting systems from 200w to 12kw.

All units are of "square wave" format which eliminate "strobing" enabling the film camera to operate at any camera speed or shutter angle required.



By overcoming the electrical supply frequency problem this range of Lee systems can be used with confidence in any film or video location situations or special effects shoot requiring high or low speed photography.

As the result of many years research and development it is now "the state of art" in Discharge lighting technology.

Marketing and Sales by Lee Colortran.
Tel: 01 968 7000.

LEE IN AMERICA

Lee Lighting America Ltd.,
534 West 25th Street,
New York, N.Y. 10001 USA.
Tel: (212) 691 1910.
Belden Communications Inc.,
Tel: (212) 691 1910.
Lee America West Ltd., Tel: (818) 848 1111.
Lee Colortran Inc., Tel: (818) 843 1200.

Lee International, Ladbroke Hall,
85 Earlby Road, London W10 5HH.
Tel: 01-960 2111.

RENTAL, UK & EUROPE

PARIS, Mole-Richardson S.A.

Tel: (010-33-14) 735 3217.

NICE, Mole-Richardson (Cote D'Azur) S.A.

Tel: (010-33-93) 3178 50.

VIENNA, Mole-Richardson G.m.b.h.

Tel: (010-43-222) 82 83 21.

MADRID, Mole-Richardson (H.H.) S.A.

Tel: (010-34-1) 314 7254.

ROME, Lee Italia, Tel: (010-39-6) 79 11 90.

GERMANY, Lee Colortran G.m.b.h.

KOBALD

Tel: (01049 - 81) 717081.

Lee Electric (Lighting) Ltd., Tel: 01-960 2111.

Lee Electric (Northern) Ltd., Tel: (0204) 73375.

Telefilm Lighting Services Ltd.,

Tel: 01-749 7305/6.

Continued from page 98

contractors are available. Consequently, it is difficult to openly bid retrofitting work. Tower owners generally must negotiate with a select group of specialized contractors who are invited to submit proposals. Requests for proposals must be carefully scheduled. Qualified contractors are perpetually busy—often too busy to respond.

The report documenting tower evaluation, including field inspection, dynamic monitoring and load rating, will list any deficiencies and will make recommenda-

tions for necessary action. Routine problems such as painting, member or connection repair, bolt replacement and antenna-mounting adjustments can be corrected by contractors without further engineering effort. Owner participation, other than construction surveillance or a call for third-party inspection, is limited.

If overstressed conditions are found, further engineering efforts are required to design needed improvements and prepare contract documents. Upon discovery of an overstressed condition, complete a thorough analysis of the con-

dition and develop alternative methods of correction. A cost-effective evaluation of various alternatives will allow the tower's owner and the structural engineer to establish a plan of action and priorities. Prepare contract documents and select a contractor to complete the retrofitting work.

The majority of deficiencies discovered during tower evaluation that require correction fall into two basic categories: needed maintenance and repairs (corrosion, loose or damaged parts), and structural inadequacy of the tower at design wind speed.

The most significant problem found on some towers is an overstressed condition existing in the top portion of the tower. The conventional static analysis used in most existing and new tower designs produces towers that lack stiffness and strength in the top portions. These overly flexible towers have long periods of vibration with attendant higher stress in the structural members than was allowed for in the original design, because dynamics were not considered.

Towers with overstressed conditions exhibit flexibility for several reasons including the use of high-strength steel in the design, or the use of a wider-spaced bracing system in the top portion of the tower. These factors allow a tower to meet static load conditions, but cause a lack of stiffness for high dynamic loads.

Several alternatives are available to correct this compressive-buckling overstressed condition. Material can be added to structural members to increase capability and/or to reduce stress. The tower also can be stiffened to reduce the period of vibration, the dynamic loads, member forces and stress.

Good designs usually involve an optimization process of adding a cross-sectional area to key structural members and stiffening the structural system by adding bracing. Other methods of stiffening include tightening existing bracing and connections. In guyed towers, recalculating forces and retensioning cables also may increase stiffness.

The preferred technique to analyze different combinations of methods is to use a computer model for evaluation of design efficiency. The model takes into consideration the aerodynamics of the added materials and icing as it re-analyzes tower stiffness and dynamic stresses. The construction cost of each method also is determined by computer to obtain the most efficient and least-cost alternative.

Tower structure is a function of materials, fabrication, erection, protective coating, mobilization and general conditions. Tower costs are relatively sensitive to labor. Simple solutions using fewer, easily fabricated and erected material additions or changes are usually

BSW

STUDER REVOX



Model PR 99 MKII

Solid Choice For Quality
And Cost Effective Performance

Solid Choice For
Broadcast - Recording Studios
- Remote Recording -

CALL BSW FOR BEST PRICE & SERVICE
TOLL FREE
1-800-426-8434



Broadcast Supply West • 7012 - 27th St. West • Tacoma, WA 98466

Circle (78) on Reply Card

MAPS

4



The Only Antenna Positioner That Does The Whole Job.

The trouble with most satellite antenna positioners is that they only do half the job.

But our new MAPS 4 not only provides you with over 260 satellites and polarity presets for virtually unlimited programming access, it finishes the job that other systems only start.

Exclusive automatic peaking

The MAPS 4 not only drives the antenna to the correct position, our exclusive auto-peaking fine-tunes the alignment, so you are assured of optimum reception every time you reposition. Accuracy like this is only possible with the Microdyne MAPS 4. Once you've seen it work, you'll wonder how you ever got along without it.

There are other great features too, such as our non-volatile memory that protects you from power outages and interrupts, our remote control capability, and the alarm that lets you know about a problem with an audible tone as well as a warning light.

Rock-solid performance and stability

Of course the MAPS 4 system includes the Microdyne/AFC reflectors known worldwide for their superior design and performance characteristics. Their rugged construction ensures the stability you need when the weather turns rough—times when lesser equipment shows its weakness.

The mounts are also fast. The MAPS 4 system scans the entire satellite arc in less than two minutes, putting any satellite

within your reach. The system is compatible with either C- or Ku-band satellites, and is available with either a polar or elevation-over-azimuth mount.

Competitive price

The Microdyne MAPS 4 is the most advanced satellite antenna positioning system available, yet it is very affordable. Especially when you consider that you're getting the time-tested Microdyne name for quality and reliability. So, don't settle for a positioning system that does only half the job. Call us today at (904) 687-4633 and get one that does the whole job.



Microdyne Corporation

491 Oak Road • P.O. Box 7213
Ocala, FL 32672 • TWX: 810-858-0307

Circle (79) on Reply Card

May 1987 *Broadcast Engineering* 103

the most cost-effective. Typically, the cost of strengthening the top portion of a tower runs from 5% to 15% of the existing tower value.

Retrofit programs have often successfully returned tired towers to full capability in meeting their design capacity. These same programs also can develop additional capacity to meet the requirements for additional transmission equipment. Analysis, as a side benefit, yields information on the best location for these facilities relative to the strength and minimum antenna displacements.

Other alternatives worth mentioning that can increase stiffness include: adding guys, widening the distance across the faces of the tower, adding tuned mass dampers and spreading the tower legs. These methods are effective, but may not always be practical.

The replacement of antennas with lighter-weight antennas may seem expensive, but it can prove remarkably effective in reducing dynamic stress in the upper portions of towers. In one case, reduction of antenna weight by 2.6 tons resulted in a 60% to 80% reduction in

dynamic stress in the upper portion of a guyed tower.

Preventive maintenance program

Tower maintenance is necessary for the continued operation of the tower structural system and the mounting system for additional specialized equipment such as antennas and cables. In general, the term *maintenance* can be divided into corrective maintenance and preventive maintenance.

A carefully considered and implemented preventive maintenance program consists of an initial professional tower evaluation including field inspection, measurement of dynamic characteristics and load rating, plus completion of any necessary repairs or upgrading. This should be followed by execution of a regularly scheduled inspection and maintenance program at the station level (see Table 1). Do not depend on station personnel to accurately assess the structural condition of a tower.

New equipment additions

A continuing demand exists for installations of new equipment on towers. Many times, permitting agencies are reluctant to allow mounting of additional equipment on existing towers without further analysis. Once a tower is load rated and a computer model exists, an analysis can easily be provided showing additional capacity, if it exists.

When making new equipment additions to towers, reduction in tower member loads and stresses may be realized by using lightweight equipment. Reduction in the weight of main TV antennas allows substantial reduction of stresses in existing towers and more economical designs of new towers.

Tower analysis practices

In tower design, the structural engineer designs a structural system capable of resisting the vertical gravity loads (dead loads) of the structure, such as structure weight, equipment, antennas and ice, and lateral loads (live loads), such as wind and seismic loads. In the case of tower structure, the wind-induced loads are much greater than the self weight or seismic loads and, therefore, control in the design.

The design procedure is relatively simple. The designer enters the design code, obtains a design wind pressure for a particular geographic location and applies it against the exposed frame of the structure, including icing. The cantilever movements and shears are then determined for the freestanding tower. For the guyed tower, the multiple or continuous span movements and shears are computed. A structure is then designed to resist these forces.

The accuracy with which the loads are

Hearing out of focus?



Solved: stereo phase errors

How? By using the Howe Audio 2300 Phase Chaser you can correct phase errors in stereo signals which cause problems in mono compatibility and stereo imaging.

The 2300 Phase Chaser detects and corrects phase inversion, time delay and channel dropout. Additional features include a clip indicator, 180° phase inversion

indicator, phase error indicator scaled in millisecond, bypass switch, XLR input/output connections and 1 1/4" X 19" rack mount.

For more information contact Howe Audio, 2300 Central Avenue, Suite E, Boulder, Colorado, 80301, (800) 525-7520.

See us at NAB, booth #2832.

 **HOWE**

Circle (80) on Reply Card

The World's First
4:2:2 Telecine

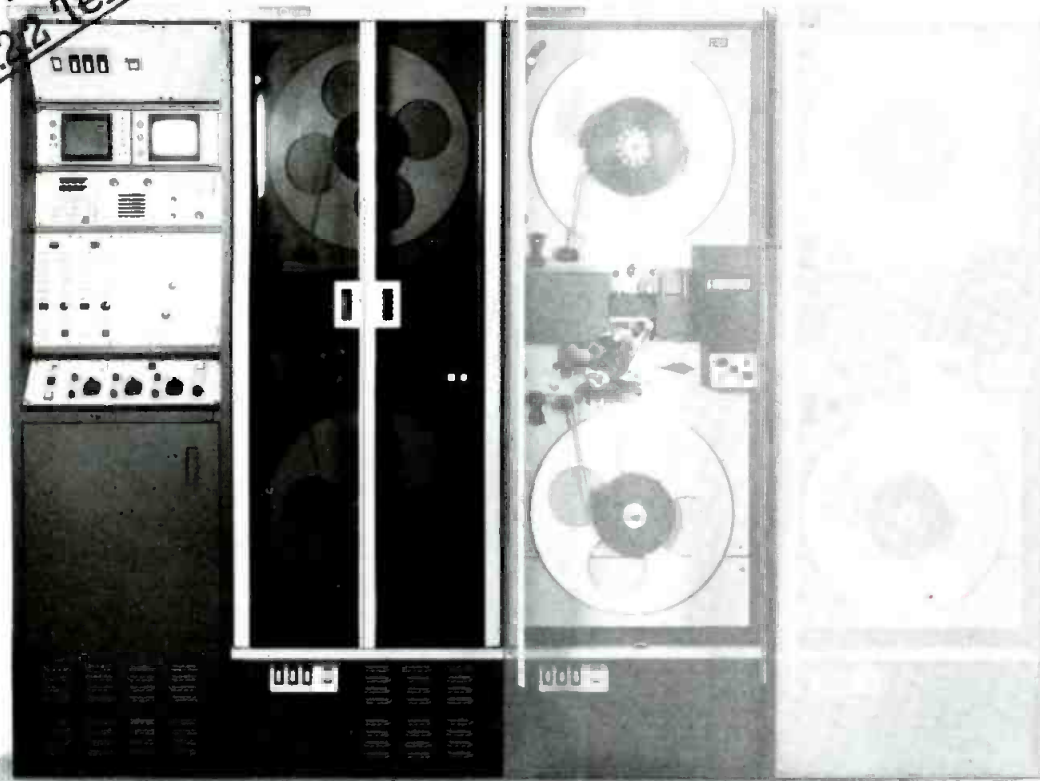

The no hassle broadcast telecine

ADS 1 Advanced Digital Scanner

With ADS 1, Rank Cintel has applied its unique film-scanning experience to the specific needs of the broadcaster.

Developed in close co-operation with the British Broadcasting Corporation (BBC), this CCD multiplexed broadcast-telecine is designed for easy 'on-air' operation and transfer of film to tape prior to transmission.

The incorporation of solid-state imaging technology is an example of Cintel's continuing development philosophy.

Latest component technology, cost-conscious design and modern manufacturing techniques have been

exploited, without compromising performance and reliability. The result is a telecine system which is technically advanced while at the same time being economical to operate. That is not all, ADS 1 also features a unique electronic dirt and scratch concealment system. Add all this together and you have the ideal broadcast-telecine package.

**Take the hassle out of film
broadcasting — call us at
914-353-1914.**



Rank Cintel Inc. East Coast
New York 10994, U.S.A.
260 North Route 303, West Nyack,
Tel: 914-353 1914 Telex: 726441



Rank Cintel

Rank Precision Industries Inc. 411 East Jarvis Avenue, Des Plaines, Chicago, Illinois 60018, U.S.A. Tel: 312-297 7720 Telex: 646998 Fax: 312-6990581

West Coast
13340 Satcoy Street, North Hollywood,
California 91605, U.S.A.
Tel: 818-765 7265 Telex: 182694 RPI LSA
Fax: 818-765 3315

Circle (81) on Reply Card

ITEM	PERIOD	ITEM	PERIOD
STRUCTURE		FOUNDATIONS	
Alignment	Y A	Base Details	Y
Paint	Y A	Guy Anchors	Y
Corrosion	Y	Insulators	Y
Members	Y A	OPERATIONAL	
Connections	Y A	Safety Devices	D
Vibration	Y	Ladders	D
GUYS		Elevators	M S
Tensions	Y A	Antenna	
Strands	Y A	Mountings	Y A
Corrosion	Y	Conduits &	
Sockets	Y A	Waveguides	Y A
Pins	Y	Lighting &	
Insulators	Y	Fixtures	D A S
Y = YEARLY		A = AFTER STORMS	
M = MONTHLY		S = MFGR'S SPECS	
D = DAILY			

Table 1. Once a tower has received its initial professional inspection, implement a station-level inspection program. Schedule a complete cleaning and painting every seven to 10 years. Consider replacing guy lines if they are corroded or if tensioning records show a decrease in tension per manufacturer's recommendations.

known plays an important role in the analysis and design of tower structures. Some loads, such as gravity, can be determined with extreme accuracy, while other loads, such as the wind, are not well known. Wind-induced loads do not have a constant value that can be entered into a static structural analysis. The variability of the load placed upon a tower structure by the wind is defined by its turbulent properties and probability of strength and occurrence. Additionally, variable windloads cause tower structures to exhibit dynamic behavior, which introduces additional bending load due to swaying motion and complicates further analysis.

Until recently, a complete understanding of how the wind acts upon a structure had not been developed. Also, designers did not have the means to accomplish the required sophisticated analysis. As a result, designers, manufacturers and public agencies charged with tower construction responsibilities incorporated into the design codes what was thought, at the time, to be the most prudent approach to determining wind-induced loads. In part, this amounted to a standardized method for approximating wind-pressure envelopes on structures that, with any luck, developed a design value greater than actual design wind pressures for designed wind speeds.

Suggested design wind pressures for

geographic areas of the United States were mapped. Dynamic effects, if recognized by a code, were usually handled by a globally applied load increase. Designers could only hope that when a tower experienced its design wind speed, the allowance for the wind-loading on a member was at least as great as what was actually imposed.

Code authorities and the industry continue to monitor tower failures and the success of the overall system. Historically, the number of factors used to determine windloads has increased with each new edition of the various design codes. The latest additions, although allowing conventional analysis, recognize the importance of dynamic behavior and recommend a more rigorous approach to analysis, especially in the case of towers.

Wind speed and exceedence frequencies

Wind-speed or wind-pressure criteria for tower design are well documented. Figure 1 shows the Electronic Industries Association (EIA) standard ANSI/EIA-222-D map of basic wind speed. The map geographically defines fastest-mile wind speed, 50-year contours and special wind regions. The wind speeds are measured at a distance of 33 feet above ground level. An exposure coefficient is used to include tower height in computations.

EIA standards take into account one set of standards, scaled up by a factor of approximately 2, to compensate for dynamic loads. Although EIA-222-D (which becomes effective June 1) is an improvement over EIA-222-C, it still is not perfect. The dynamic windload factor is a compromise, not accounting for the true dynamics of heavy loads on top of a tower. As a result, the bottom is somewhat overdesigned, and the top of the tower is underdesigned. Dynamic mast weight distribution typically requires strength improvements by a factor of 3 in the top section of a tower compared with static designs.

In several sections of the purchaser check list in the appendix of EIA-222-D, buyers of new towers are alerted to the fact that it is their responsibility to verify and specify windload and iceload requirements. In the real world of dynamic interaction with static loads, any set of standards based on static measurements alone provide only a starting point for tower design.

The American National Standards Institute (ANSI) standards use the same basic wind-speed map. The Uniform Building Code (UBC) is more primitive, and adopts the ANSI code for wind-speed contours. However, the 1985 UBC has shown some increases in wind speed for various locations.

Wind-speed data and wind-speed probability or exceedence frequencies are compiled from decades of records by the National Weather Service (NWS) at more than 129 locations in the United States. Wind information for these locations includes various wind-speed rates by definition, wind-speed probability of occurrence, directional probability and magnitude.

One of three wind-speed measurements appears as the statistical wind speed. The *fastest-mile wind* is the highest recorded average speed at which a mile of wind passed the station. The *fastest-minute wind* is the highest recorded wind velocity sustained for one minute. The *peak gust* is the highest recorded instantaneous wind speed. The fastest-mile and fastest-minute wind speeds average out to approximately the same value, and peak gust values are typically 1.3 times the fastest-minute wind.

Previous studies for extreme wind analysis and structure design have established the annual fastest-minute wind as the most appropriate design value. Newspapers usually report peak gust speeds during storms. Design wind speeds are sustained values and normally would be less dramatic.

When determining a design wind speed, the structural engineer, as directed by the design code, acknowledges a risk factor. This risk factor is defined as

You said,

"I NEED A VIDEO TRANSMISSION SYSTEM THAT MEETS RS-250B SHORT HAUL SPECS, WITH BETTER LINEARITY, SUPERIOR PICTURE AND LARGER LINK BUDGET..."

and we said,

"YOU'RE ON."

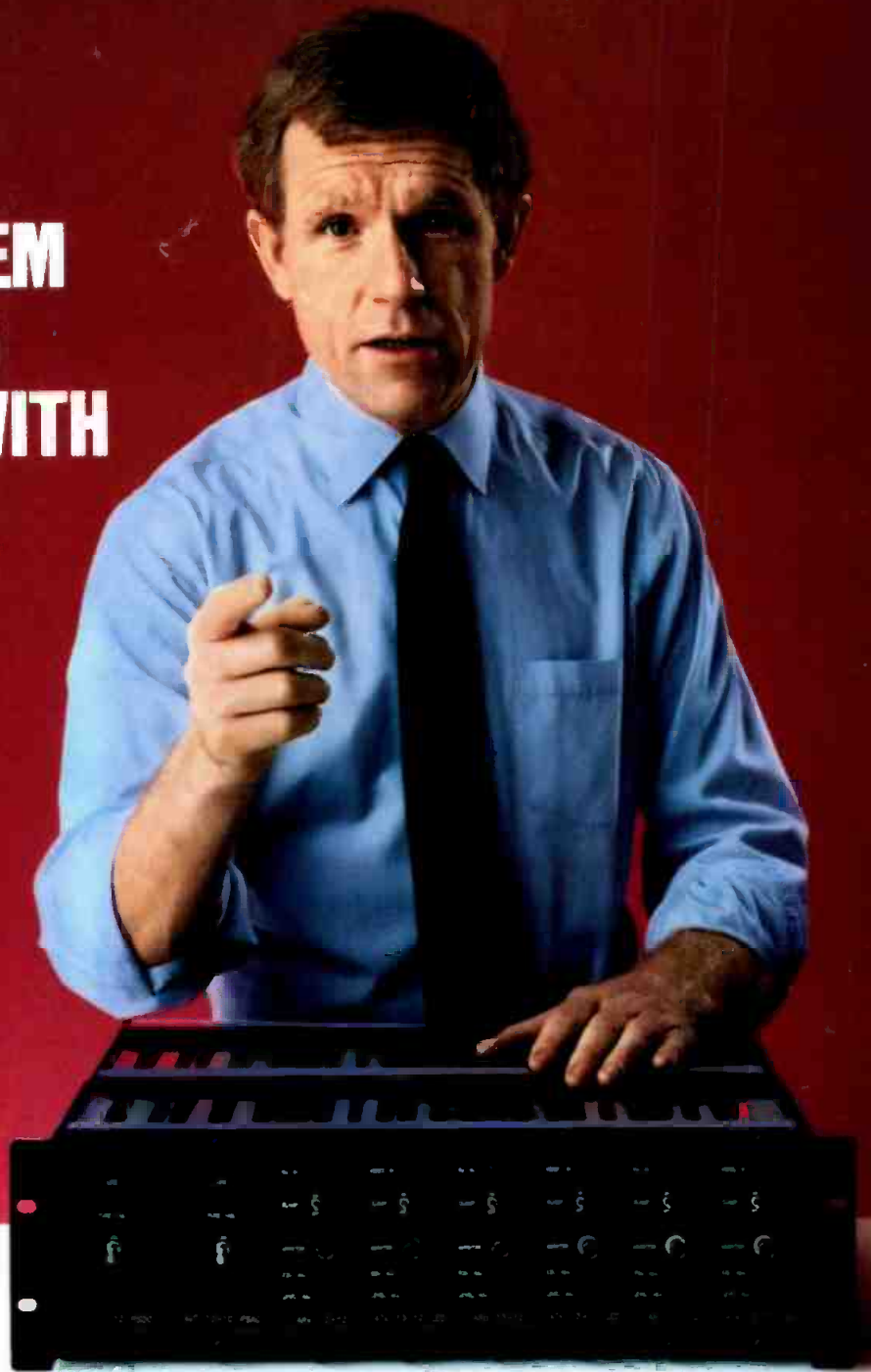

There are some things that just don't belong on live TV. Static in the picture from EMI or RFI contamination. Fuzzy electronic glitches. Or maybe you're having trouble tele-reporting the signal to other locations and you can't tell why.

If you want to eliminate problems like these, we have a suggestion. Get rid of that outdated coaxial or microwave equipment. And then get PlessCor's fiber optic analog video transmission system.

It's got everything you need for on-location broadcasts, with performance and features

that come across loud and clear. Features like a user friendly front panel that give you total control over cable equalization and system gain adjustments. Front panel clamps for easy formatted or unformatted selection. Add to that 75 ohm and 124 ohm simultaneous outputs and it's easy to see why this is the video transmission system that really puts out.

Additional performance is available when you specify our optional upgrade cards including 4 simultaneous outputs, 2 high fidelity audio channels, and redundant AC or DC

power supply, just to name a few. Available with both multimode and single mode light emitting diode and/or laser sources, repeaterless link distances up to 60 kilometers may be supported in current cable plants.

PlessCor's AVT-13-10. Because in a business where your image is everything to us, we make the choice crystal clear. And you'll see the difference as soon as you hear the words, "You're On!"

For more information on this and our other analog video system products contact us at 818/700-0841.

MADE IN THE USA.

PCO

PCO, Inc. Formerly PlessCor Optronics Inc., 20200 Sunburst Street, Chatsworth, CA 91311-6289
Tel: (818) 700-1233 Tlx: 650 239 8651 Fax: (818) 700-9047

Circle (82) on Reply Card

www.americanradiohistory.com

IMAGINE . . .

WHAT YOU COULD DO IF YOU
HAD A DOLLY IN A BRIEFCASE . . .



IMAGINE . . .

IF YOU HAD TRACK
ROLLED UP IN A BAG . . .



**DON'T IMAGINE ANYMORE
IT'S HERE!**

**MATTHEWS BRIEFCASE
DOLLY AND FDCUSTRAK**



**(818) 843-6715
(212) 691-4720**

2405 Empire Ave., Burbank, CA 91504
Capitol Bldg., 236 W. 26th St., NY, NY 10001

Circle (83) on Reply Card

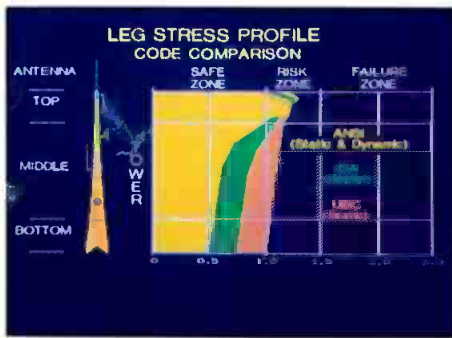

Figure 2. A leg-stress profile compares computed stress on the compression leg (the leg away from the direction of the wind) for three freestanding towers of like geometry, designed using wind pressures defined by different codes. The horizontal axis represents allowable stress, where 1=100%.

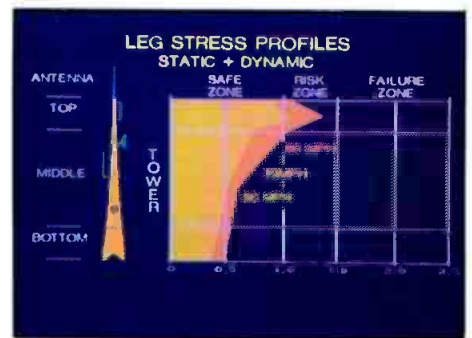

Figure 3. The differences in the static and dynamic leg stress on the same towers as in Figure 2, based on different static design wind speeds.

the probability or acceptability that a windstorm exceeding the design wind speed could occur during the scheduled lifetime of the structure. Most codes require this to be at least the 50-year windstorm or event.

Unfortunately, the 50-year windstorm commonly is thought of as a wind speed exceeded once every 50 years and not likely to occur for another 50 years. Statistically, however, a 50-year event is defined as one that has a 2% probability each year of being exceeded. This

establishes the level of risk that a wind speed exceeding the design wind speed has a 2% chance of occurring during each year of the scheduled lifetime of the structure.

Findings from advanced analysis

Figure 2 shows the comparison of leg stress resulting from a load-rating analysis of freestanding generic towers of like geometry, but designed using wind pressures (same design wind speed) as defined by each of the codes shown. The leg described is the compression leg of a 3-legged freestanding tower. It is located on the side *away* from the direc-

PROVEN PRODUCTS.

FOR SATELLITE UPLINKING AND DOWNLINKING

MICRO PHASE COMMUNICATIONS is a newly formed company bringing together a line of existing and new products.

Over 200 Modulators and 1000 Demodulators are currently in the field from the existing product line. These products are now under the names of MP-1040 Modulator and MP-1010 Demodulator.

The MP-1010 Demodulator is a high quality, low cost retrofit for existing systems using CMI/MAI type shelves. Optionally available in wide band and narrow band configurations, and various audio bandwidths.

Priced at \$2750 for the MP-1040 Modulator, and \$750* for the MP-1010 Demodulator. Delivery as short as one week, typical lead time three/four weeks.

*2: 1 compander included, 3: 1 additional. See the MICRO PHASE COMMUNICATIONS ad in this issue for an introduction of their new products.

MICRO PHASE COMMUNICATIONS INC.

999 C Edgewater Blvd., Suite 138
Foster City, CA 94404 415 368-3869

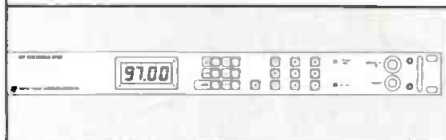

The MP-1040 Modulator is equipped with the basic functions essential for satellite uplinking. Synthesized in 10kHz steps across a 43 to 97MHz band, settings are made via a keypad and monitored on the four digit LED Display.



Circle (84) on Reply Card



Freeze. Frame.

Introducing the fastest, easiest way to get quality prints and slides from video.

Now you can capture the moment, freeze it, and frame it. All with the touch of a button. With the new Freeze-Frame Video Image Recorder from Polaroid.

FreezeFrame produces sharp, instant color prints and color or black and white 35mm slides from virtually any video source. And it delivers a finished picture that is far superior in quality and resolution to direct screen photography or thermal video



System includes Video Image Recorder, control console, and print film camera/adaptor. 35mm camera/adaptor optional.

image recorders.

FreezeFrame can be used in broadcast, production and advertising to proof, edit, storyboard, or reference.

It can also be used to pull a print off a just-breaking news story.

The FreezeFrame system includes a Video Image Recorder, control console, and print film camera/adaptor. And the system connects easily to video cameras, professional VCR's, laser disc players and computer graphics systems.

New FreezeFrame from Polaroid. It's fast, easy and at \$1,899* very affordable.

To find out how Freeze-Frame can help you, call toll-free 800-343-5000 8 a.m. to 8 p.m. Eastern Time.

Or fill out and return the coupon. We'll give you the full picture and show

you just how easy it can be to capture the moment on FreezeFrame.

For more information, mail this coupon to Polaroid Corporation, Dept. 678, P.O. Box 5011, Clifton, NJ 07015.

Please send more information.

I'd like a demonstration.

BE5 1

Name _____

Title _____

Company/Institution _____

Address _____

City _____ State _____ Zip _____

Telephone _____

Video Source _____

Application _____

tion of the wind and is most vulnerable to buckling. The horizontal axis represents the level of stress computed by means of rigorous analysis in this leg at each vertical elevation of the tower (vertical axis) using the loads and resulting characteristics of the tower as would be designed by means of each code.

The leg stress (horizontal axis) is represented by a ratio of the computed load in the tower leg divided by the allowable load. A factor of 1 on the horizontal axis represents 100% of allowable stress in the leg and 0.5 represents 50% of allow-

able leg stress. The horizontal axis also is divided into zones of risk.

The profile shown in Figure 2 is what is believed to be the actual stress occurring in the leg at each elevation. The conventional static analysis and individual code standards that defined each of the generic towers predicted that the leg stress at each elevation would be at 100% of allowable. The actual stress (as computed) shows that the example UBC-complied tower actually is overstressed throughout its entire height. The ANSI and EIA codes generally produce towers

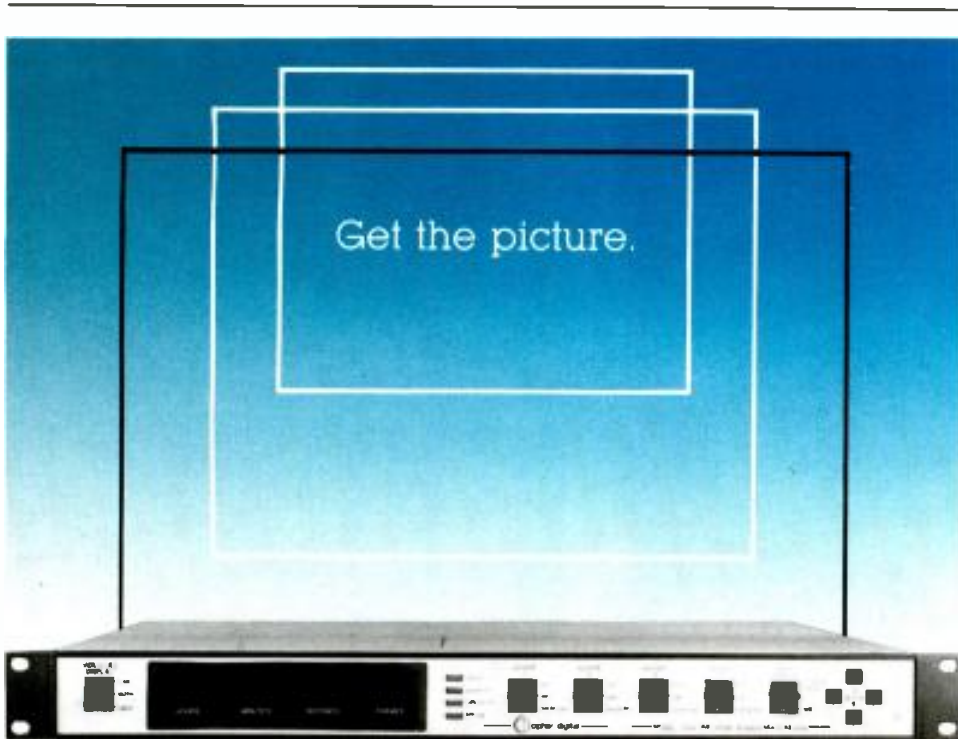

The CDI-700A Time Code Reader, with Quad Video Character Insertor, is easy to operate and brings affordability to video production and post production editing, and it's backed by Cipher Digital's reputation for dependability and 3 year warranty.

An important advantage of this micro-processor-based Time Code Reader is its ability to generate burned-in work prints for production from multiple synchronous video sources, thereby minimizing error by precisely identifying every video frame.

For more details contact Cipher Digital today. Call (800) 331-9066.



cipher digital, inc.
P.O. BOX 170 FREDERICK, MD 21701
(301) 695-0200 TELEX 272065

Timely today, consistent with tomorrow.

Circle (72) on Reply Card

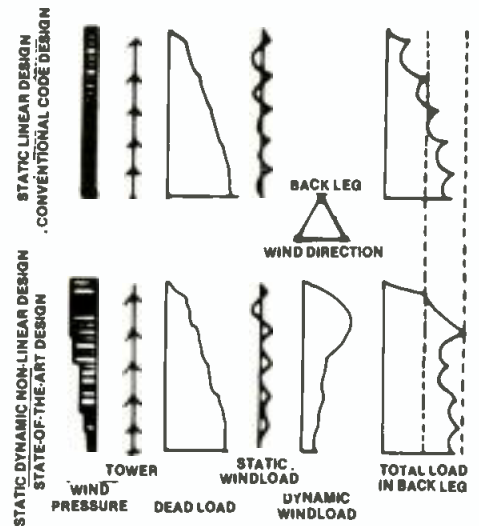

Figure 4. When dynamic forces are considered, some guyed towers may be at more of a risk than owners may realize.

understressed in the bottom portion, while all codes produce towers overstressed in the top portion.

This condition of overstress has been determined to exist in many towers. One indication of physical distress in a system is paint that has flaked off members following a severe windstorm. Towers displaying this symptom must be strengthened.

The goal in designing a new tower or retrofitting an existing tower is to determine the actual windloads with a high degree of accuracy based on a particular wind-design speed. Then, a new tower structure can be designed or an existing tower strengthened so that the allowable leg stresses (horizontal and diagonal member stresses) achieve exactly 100% of allowable stress at every elevation in the tower. This profile would be represented as a vertical line at 1 in Figure 2.

Figure 3 illustrates the differences in leg stress (static and dynamic) for the same freestanding generic towers based on different wind-design speeds. For an 80mph design wind speed, the leg stresses are in the risk zone, while for a 50mph wind speed, stresses are only 50% of allowable. Many tower owners might say "But my tower has stood up for so many years!" They should note, however, that in many parts of the country, the design wind speed has not been experienced since a tower was erected.

Static and dynamic stresses increase rapidly with increasing wind speeds. The static stress increases by the square of the velocity (a doubling of wind speed increases the stress fourfold), and the dynamic stress increases by even a higher factor of approximately the power of 2.5.

Guyed towers

Guyed towers display non-linear behavior that makes their evaluation much

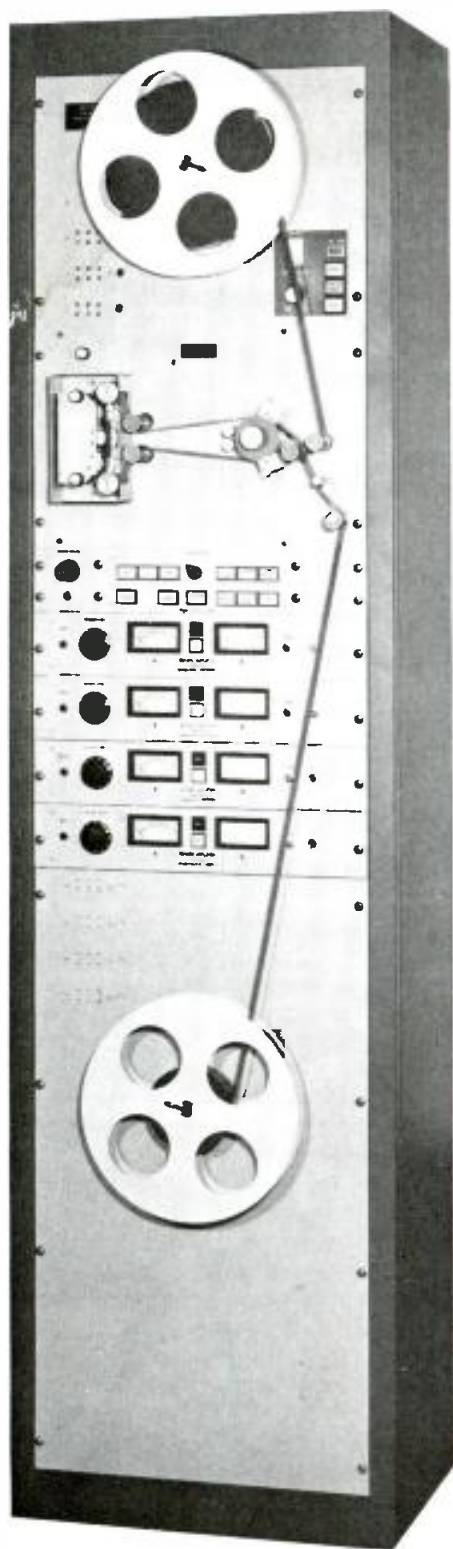

MAGNA-TECH

THE SOUND HEARD AROUND THE WORLD

Magnetic Film
Recorders and Reproducers
for Television and Film
Sound Post-Production

HIGH SPEED

Telecine Magnetic Followers
Video Tape-Film Interlock
Electronic Looping
Dubbing Systems
16 and 35mm Electronic Projectors
Total Facility Engineering

WORLDWIDE SALES OFFICES

Paris
Hi-Fidelity Services
4 Rue Semard
75009 Paris, France

Sydney
Magna-Techtronics (Aust.)
PO Box 150
Crows Nest NSW 2064
Australia — Telex 24655

Johannesburg
General Optical Co., Ltd.
15 Hulbert Road
Johannesburg 2001,
South Africa

Rome
Alberto Sciarretta
Via Siria 24
Rome 00179
Telephone 7943618

Brussels
A.R.C.
Rue de Boisdre Linthout 45
1200 Brussels Belgium

Hong Kong
Paul Yang and Associates
901 Star House
3 Salisbury Road
Kowloon, Hong Kong

Bombay
Capt. P.K. Vishwanath
234/4 Rama Baug,
Deodhar Road
Bombay 400 019, India

Kehl West Germany
Zenon GMBH
Postfach 1743
Hauptstrasse 128
Kehl am Rhein
Tel: 07851/2991
Telex: 753537

London
Branch & Appleby
42 High Street
Harrow-on-the-Hill
Middlesex HA1 3LL,
England

Kuala Lumpur
Kinematronika Sdn. Bhd.
2852, Jalan Selangor/
Persekutuan,
Federal Hill
Kuala Lumpur, Malaysia

Caracas
Cine Materiales sri
Apartado Postal 61.098
Caracas 106 Venezuela

MAGNA-TECH ELECTRONIC CO., INC.

630 Ninth Avenue, New York, N.Y. 10036

Telephone (212) 586-7240

Telex 126191

Cables "Magtech"

Circle (88) on Reply Card

FREE!

TV CAMERA CABLE AND CONNECTORS INFORMATION KIT



Your
one-stop source for
broadcast-quality
camera cable

- Hundreds of types and styles in stock
- Slimline camera cables
- Waterproof connectors
- Three-piece connector design
- Field repairable
- High-strength, black-anodized aluminum connectors
- Boot molded directly to cable
- Quick response to all cable and connector orders

Call or write today for your free order kit.

MOHAWK
WIRE & CABLE CORPORATION

9 Mohawk Drive
Leominster, MA 01453
1-800-422-9961
In Massachusetts, 1-800-642-9961

Circle (89) on Reply Card

up to **55%** OFF
Manufacturer's List Price

Ask for current specials and save even more!

Call Toll-Free: 1-800-426-3938
(In Iowa, 1-800-272-6459)

- More than 400 stage, studio and projector lamps from G.E., Sylvania and Wiko in stock
- 12-hour turnaround guaranteed.

For free price list write: Box 10,
702 E. Washington, Washington, IA 52353
Since 1964

Sittler's

Circle (90) on Reply Card

more complex than for freestanding towers. Figure 4 compares the total load on the back tower leg determined by the conventional analysis procedure of static linear design, to the static-dynamic, non-linear approach. The back leg is vulnerable to compression buckling.

The conventional approach determines a wind pressure that is applied to a tower structure. The total load in the back leg is determined by combining the dead load with the static windload. In the static-dynamic procedure, a wind pressure also is applied to the tower. The total load on the back leg is determined by combining the dead load, plus the static windload, plus the dynamic windload.

Note the differences between the load curves for static windload because of the variability in guy forces, which are treated as springs. The most important comparison is that of total load determined between the two procedures. The static-dynamic procedure defines a much greater load than the conventional static procedure.

Wind-engineering technology

Wind-tunnel research since the 1960s has provided a considerable amount of knowledge about fundamental mechanisms of wind characteristics and wind-loading effects. The design and construction of such structures as the 110-story World Trade Center in New York and the 1,800-foot freestanding CN Tower in Toronto have assisted in the development of wind-engineering technology. It is well known that structure loads, specifically loads in structural members induced by winds, primarily depend on: a) the probabilities that certain wind speeds are reached; b) the turbulent properties of the wind; and c) the dynamic properties of the structure.

Turbulent wind characteristics include wind speed, direction, turbulence and correlation, local effects and special conditions. Most design codes recognize the variation in wind speed relative to the probability of exceedence, and also with height above ground level.

The static velocity profile of wind (velocity relative to the distance from the ground) is not uniform, but increases approximately with a parabolic relationship from ground level up to 1,000 or 2,000 feet. This elevation also is called the *wind gradient*. Velocity up to the gradient level is dependent upon surface conditions. Trees and houses slow the velocity down so that it approaches zero at ground level. However, up to some heights, the velocity increases and approaches its uniform maximum value, not changing above that level.

The wind also is directional. In any geographic location, the probability of high winds usually is far greater from one particular direction than other direc-

tions. Most codes disregard directional effects, which are best handled by wind-tunnel tests.

The turbulence of wind dominates the response of flexible structures such as radio and TV towers. These big wind eddies may be thought of as wind impulses randomly thrown at the structure. Wind impulses can load the tower at different levels, at regular or irregular time intervals with varying energy, causing the tower to sway.

Any combination of these parameters is possible, and certain turbulent patterns will affect a structure more severely than others. These patterns depend on a structure's drag coefficient and surface shape. Fortunately, these impulses are not very well correlated. When a big wind hits a part of the structure, it is likely that smaller winds simultaneously hit on other parts of the tower. This correlation is taken into account as well as the turbulence in dynamic analysis.

Geographic location, topography and upstream exposure can be important. A 10% sloping hill can increase wind speed by 20% as it passes over, resulting in 50% higher loads on a structure placed on top of the hill. If logic is based solely upon this parameter, then hilltops make better locations for windmills than towers.

A tower has a natural mode of vibration in every direction. The individual mode-shape functions are geometric descriptions of a structure's natural response to external stimuli. They are affected by the design, the masses and their distribution, and the properties of the members within the structure.

The fundamental mode is the shape the tower assumes as it sways back and forth, with the horizontal deflection measured from the vertical axis and varying as it proceeds up the tower. The greatest deflection is at the top for the first (fundamental) mode. Higher modes may have the maximum displacement at other elevations. An infinite number of higher mode shapes exists, variable with different geometry or mass distribution.

Building designers must be careful in controlling the sway or drift of buildings. Uninhabited towers, however, sway more and act differently than buildings. However, towers are often designed by the same codes used by building designers or by industry codes that do not take into account the differences between towers and buildings.

A delicate relationship exists between a structure's mass and its stiffness. Stiffness describes the amount of force needed to move a structure a given distance. High stiffness in a structure is desirable, but expensive, if achieved with large amounts of material. Heavy mass also is less easily moved by the wind. However, as the mass of a structure increases, its

SYSTEM TIMING & SC/H PHASING CAN BE E A S Y OR D I F F I C U L T

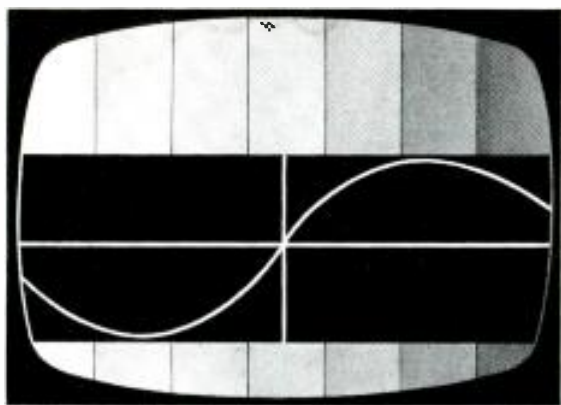

LENCO VIDEOSCOPE



WAVEFORM, VECTORSCOPE, SYNC GENERATOR & OSCILLOSCOPE

LENCO now provides you PAL and NTSC VIDEOSCOPES. These VIDEOSCOPES transform a complicated task into an easy, convenient one!

Until now detection of timing and SC/H phasing problems has required some very expensive and complex measuring equipment. The equipment was so complex that it required extensive knowledge and training to operate.

Now at a single glance of a standard video monitor, system timing and phasing problems and errors can be quickly detected, and both problems can be easily and accurately corrected without the need of complicated and expensive test equipment.

The VIDEOSCOPE'S "on screen" graphics system and LED readout provide critical sync to subcarrier phase information in a simple to understand, accurate video display — on a standard color or monochrome monitor. SC/H relationship is easily and accurately displayed in degrees by an LED readout — not by complicated test equipment.

Locating time base error, sync to subcarrier jitter, system crosstalk problems as well as referencing network subcarrier may be difficult with other equipment. But not with the Lenco VIDEOSCOPE. It was designed for ease of operation and accuracy!

Take the time and guesswork out of your SC/H and system timing problems! *Go the easy and efficient way with the Lenco VIDEOSCOPE.*



CONTACT: Lenco International Sales Manager

300 N. Maryland • P.O. Box 348 • Jackson, MO 63755 USA • TWX 910/760-1382 • Telephone: 314/243-3147

Circle (91) on Reply Card

period of vibration also increases, leading to less desirable higher stresses in resisting members.

Mass must be increased somewhat to increase stiffness, because stiffness depends primarily on the size and geometric spacing of member elements. Large masses, therefore, are acceptable, provided they are accompanied by adequate stiffness. Simply adding dead weight to increase mass (such as heavy antennas), is detrimental because it lengthens the period and does not add stiffness. Modern structures use fewer and fewer materials for economic reasons. Stiffness must be achieved through ingenious framing systems.

Structural damping is the capability of a structure to resist dynamic motion and to return to a static, stationary state. During an ongoing dynamic event, a structural system's damping capability limits it from entering a continuously increasing state of excitation. With zero damping, the structure would sway more and more with each cycle from energy added by the wind. Thus, the same amount of energy must be removed from the system as added, to prevent destruction of the system. Radio and TV towers have little damping, perhaps 0.5% of critical. Unfortunately, this is a low value that makes them dynamically sensitive.

Aerodynamics represents the remaining property of turbulent wind. Fortunately, towers do not normally exhibit serious problems, unlike the infamous Tacoma Narrows Bridge, the suspension bridge that destroyed itself in the wind. However, aerodynamics must be assessed if vortex shedding could occur where a structure has large movements in the crosswind direction. Other aerodynamic properties such as drag coefficients for members are defined by their shape and angle to the wind.

Many of the basics of wind engineering were learned in wind-tunnel testing, which is the most realistic method of evaluation. Unfortunately, these tests are complex, and relatively expensive for a structure that costs less than \$10 million. In a wind-tunnel test, all the surrounding terrain, including buildings and neighboring towers, would be modeled.

Advanced computer analysis

Computer analysis allows towers to be observed the way they act in the real world. Computer methods go to greater lengths to accurately determine wind-induced loads by considering the characteristics of turbulent wind and the dynamic properties of tower structures, than do conventional design-code-governed static analyses. Once structural

loads are defined, finite element analysis of the tower's structural system determines member forces and stress values. Computers can be used to analyze and load rate existing towers as well as design new towers.

A tower owner's obligation

A structural engineering review of radio and TV towers shows that most towers can benefit from an engineering management program. Once a professional tower evaluation program is completed and the tower is on a regularly scheduled preventive maintenance program, an owner should have an excellent understanding of the structural adequacy of the facility, and confidence in obtaining full use of the facility during its expected service life.

It will behoove the owners of existing towers to thoroughly review their present management programs and initiate necessary changes without delay. If you are considering erecting a new tower, a close working relationship with your structural engineer can assure that you will get the most for your investment.

Editor's note: This article was adapted with permission from a presentation by R.D. Upsahl at the 1986 NAB engineering conference.

Computer analysis of tower structures

Computer analysis procedures for flexible tower structures consider the tower as being subjected to two parts of windload: static load due to a leaning away from a roughly steady wind, and dynamic load due to a fluctuating about the static position because of turbulence in the wind. Once determined, these two load parts can be combined to obtain the various total windloading cases. Many load cases exist because the various dynamic mode shapes of the structure are produced by windloads.

Static windload analysis determines the average leaning position of the tower for the average wind speed encountered during a design wind-speed storm, usually the 50-year event. Drag coefficients of structural members exposed to the wind used in determining the windloads at each level of the tower are obtained from charts produced by the International Association for Shell and Spatial Structures¹. These coefficients probably will be universally adopted by future design codes for lattice structures. The dynamic compo-

nents or displacements of the tower then move around this mean position.

Dynamic windloads are determined by a computer program that calculates the dynamic displacements occurring at each level of the tower through integration techniques. These techniques consider the basic components of the structure's mass, period of vibration, damping, turbulence and correlation.

The original research and concepts of dynamic response in structures used in computer analysis were developed by A.G. Davenport². Ongoing wind-tunnel research by Davenport, director of the Boundary Layer Wind Tunnel Laboratory at the University of Western Ontario, Canada, and others on individual parameters, has defined them more accurately.

ANSI recognizes the procedure by providing simplified charts applicable to buildings. Current tower analysis procedures follow the same intent, except in a much more detailed method, specifically designed for towers.

Once static and dynamic windloads are determined, the information is input into a mainframe computer that uses an enhanced version of STRUDL (structural design language) to model the entire structural system of the tower. Tower computer models often contain more than 3,000 members. STRUDL's finite element analysis procedures determine forces and stresses

for all of the many load cases in each structural member of the tower.

Non-linear behavior, as observed in guyed towers, requires several iterations of this procedure. Conventional static analysis of guyed towers treats the system as a multiple-supported beam. Guys are considered as fixed supports where they connect to the tower.

Analysis recognizes guy connections or supports as exerting variable levels of load. When the tower moves away from the wind, force in front guys increases, but at a variable rate depending on guy inclination and size. Force in the back guy decreases in a similar manner. The force in the guy is a function of windload and distance displaced, much like a spring. In fact, some computer-analysis programs treat these supporting guys as springs.

Analysis of non-linear systems requires many iterations by a computer, which results in more of a tuning process. Guyed towers still need much research to be fully understood.

Bibliography

1. "Recommendations for Guyed Masts," The Working Group on Guyed Masts of the International Association of Shell and Spatial Structures, Madrid, Spain, 1981.
2. Davenport, A.G., "The Response of Slender Line-Like Structures to a Gustly Wind," *Journal of the Structural Division ASCE*, December, 1983.



Technology So Advanced



We Created A Dynasty of 30, 40, 60, and 100 MHz. Switches

DYNASTY. The only switches that make obsolescence a thing of the past. Now, ask yourself, "Why"?

- Why can DYNASTY offer 30 MHz performance at 10 MHz prices?
- Why does DYNASTY offer backward compatibility?
- Why does DYNASTY have unique "Adjustment Free" modules?
- Why can DYNASTY upgrade my existing system to 100 MHz?
- Why can you field upgrade DYNASTY without special tools?
- Why does DYNASTY use custom PCB Baluns?
- Why can DYNASTY expand to 1000 x 1000?

- Why does DYNASTY use proprietary Laser Trimmed Hybrids?
- Why does DYNASTY require no special ventilation?
- Why can DYNASTY switch Computer Graphics signals?
- Why does DYNASTY reduce maintenance costs and system down-time?
- Why does DYNASTY grow with my future switching needs?
- Why can DYNASTY offer 100 MHz performance at about only twice the price of 10 MHz switches?
- Why is DYNASTY the only switch for you?

DYNAIR challenges you to get the answers to the questions that

will decide your switching future. DYNASTY meets your switching needs, for today AND tomorrow. Take the DYNAIR challenge and get the answers that you need to hear. Only from DYNAIR.

DYNAIR. Celebrating 30 years of "Value-Innovation" in switching technology.

NATIONALLY CALL
1-800-854-2831
IN CALIFORNIA CALL
1-619-263-7711

DYNAIR
Signals The Start of an Era
DYNAIR Electronics, Inc.

5275 Market Street
San Diego, CA 92114

Circle (135) on Reply Card

Seeing between the lines

By Carl Bentz, special projects editor

To see is to believe, but when your video monitor isn't truthful, what then?

You cannot deny the need for calibrated and well-maintained waveform monitors and vectorscopes at a video facility. Without these test instruments, you have no real assurance of your signal quality. Relative levels of various parts of component and composite formats play essential roles in producing signals that meet FCC guidelines. Relative phases of the chroma elements determine how color will appear in the final product.

In the last analysis, however, you base your judgment of equipment adjustment and overall picture quality on another instrument—the video picture monitor. As you make the assessment, you place a good deal of faith in that monitor, in its capabilities and in its setup. You expect *what you see* to be *what you get*.

It's not surprising that video monitors are everywhere in TV stations and production facilities. They appear in master

control, in technical and recording areas, in the studio, in editing suites, in previewing rooms, in offices and in graphics production areas. For each application, you want the best, most truthful picture possible. It would be nice if you could use a top-of-the-line monitor at every viewing location. However, financial practicality suggests that utility or grade II units will satisfy most of the viewing needs. Master control or grade I monitors should be reserved for areas of critical evaluation, such as master control and production studio control rooms.

Reliability requisites

Differences between grade I and II monitors occur in design characteristics and features. Both are of more concern in critical evaluation and observation applications than for other viewing needs. No matter what type of monitor you plan to use, you want reliability. In this respect, a master-control monitor outshines the utility monitor and accounts

for the added cost of master-control units.

Active components—transistors, ICs and tubes—require operating voltages within specified ranges to perform their interrelated duties. The power supply must develop the correct initial potentials to bias numerous network voltage dividers. The power supply, in turn, depends upon an external ac-voltage source, and, as a result, is vulnerable to the anomalies of the external source. For a reliable power supply, the design must account for and cope with possible problems inherent in the ac-power system.

One method of increasing reliability of the power supply is to conservatively select circuit elements with specifications that exceed the expected conditions. Design goals call for all components to have at least a 50% safety factor overhead. If a design calls for a resistor to dissipate 0.5W of energy, then the component should be rated for 0.75W minimum.

Because 1W resistors are the next power rating step above 0.5W, a 100% overhead results. Other components of the power supply also should meet or exceed similar desired overhead ratings.

Operating electrical components generate heat. Reducing the local build-up of heat calls for ventilation around heat-generating and heat-sensitive components. Heat sinks provide more efficient transfers of heat to the surrounding air by effectively increasing the surface areas of components.

A reliable power-supply design also introduces protection against external forces. Fuses or circuit breakers primarily protect the power supply and internal circuitry from itself, in case a component fails and causes excess current to flow. Power-supply regulator circuits clamp the voltage and current levels that are applied to different sections of the system. In addition, regulators try to maintain constant levels as the power source varies over a reasonable range.

If the 110Vac drops by a few volts, the

Acknowledgments: Barco, Conrac, Lenco, Tektronix and Videotek assisted in the preparation of this article.



Courtesy of Tektronix

An extreme close-up of the screen shows how groups of dots are illuminated by a convergence pattern.

ADD 4 NEW STUDIOS FOR DIGITAL AUDIO POST-PRODUCTION... WITHOUT BUILDING A SINGLE WALL



A Foley Stage

Foley-style sound effect creation and editing in real time to picture, with thousands of effects on-line and instantly available.

An ADR Studio

Automatic Dialogue Replacement and editing with advanced mouse-controlled software.

A Multi-Track Recording Studio

Score to picture with a 200-track digital recorder and the most complete library of musical instruments available anywhere.

A Film-Style Mixing Studio

Up to 200 tracks of music, effects and dialogue can be independently locked to picture and controlled at a single terminal.



The Tapeless Studio™

Featuring the Synclavier® Digital Audio System and Direct-to-Disk™ Multi-Track Recorder

The single workstation solution for today's demanding stereo post-production audio requirements.

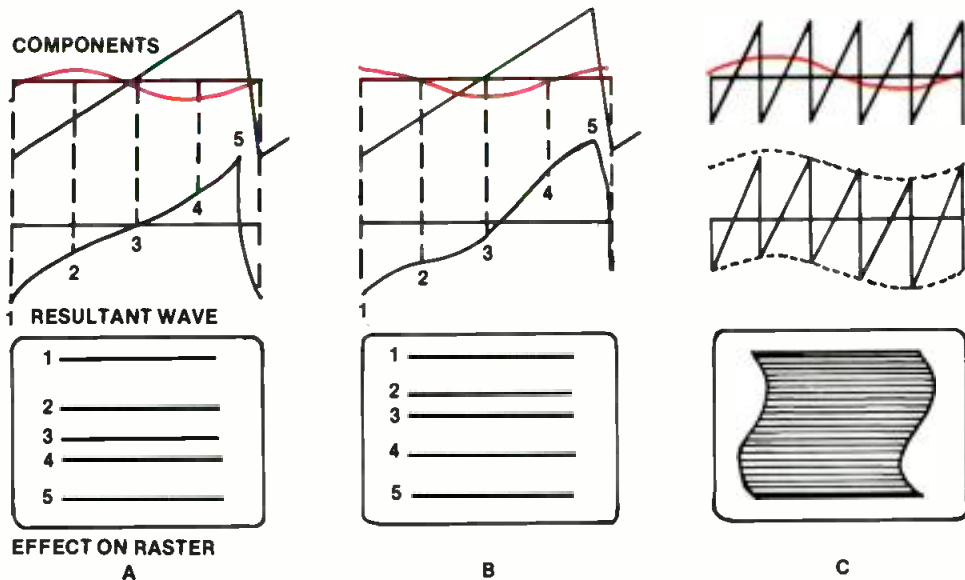

Figure 1. The effects of 60Hz hum on vertical (A and B) and horizontal (C) scan linearity.

first noticeable effect with an unregulated supply is normally in the vertical height of the picture. Regulation in the power supply tends to maintain a specified B+ voltage and to reduce size variation within reasonable ac-line variations.

Although relatively small voltage variations can result in some undesirable effects, large variations can cause failure.

The equipment in a broadcast station needs help to survive voltage transients. Ideally, a studio has a regulation system on incoming mains to trim off large spikes. Transient-reducing devices can be placed in the power-supply input circuit for added protection.

Operating linearity in monitor functions also contributes to reliability.

Video amplifiers are designed for specific amounts of gain. If a stage becomes unstable with respect to gain, following stages may be overdriven or moved to a point on bias characteristics that causes non-linear action. Picture highlights or blacks become compressed or expanded with changing bias. The display does not reliably represent the input signal.

Monitor spec sheets relate image size and picture brightness. The specification rates performance from 10% to 90% of average picture level (APL). As the picture brightness increases, size tends to increase. The increase in beam current as the image becomes brighter causes a related reduction in magnetic sweep field effectiveness.

Sweep circuits demand linearity. Interlaced scanning places special demands upon horizontal and vertical deflection voltages and currents. Non-linearities in the long vertical sawtooth ramp waveform quickly become more obvious than similar errors in horizontal sawtooth ramps. For lines of field 2 to fall exactly between those of field 1, the ramp should be as straight as possible, even though it involves non-linear characteristics of RLC time constants. Figure 1 illustrates the effects of 60Hz hum interacting with vertical and horizontal components of



WHATCHA-MA COLLET.

What the heck's a COLLET? Just the best designed, most dependable and stylish general purpose knob in the world. That's what.

If you want a knob that will never break, melt, corrode, or shake loose; a knob with exquisite tactile feel; a balanced, sculptural, classic knob, then you want Selco's COLLET knobs.

Let us impress you. Our COLLET'S matte-finish, precision-molded 94V-2 nylon body is permanently bonded to a solid brass collar. This retains a machined, split-base threaded bushing, also solid brass, that slips over your control shaft and

tightens from the front with a special brass nut. Finally, a nylon cap in one of seven decorator colors snaps on the front.

Simply superior. Not even a set screw mars its elegant exterior. And Selco's COLLETS come in a full range of sizes and types, with all the accessories, too.

If you're a discriminating designer who wants the respect of his most demanding customers, then

furnish your equipment with Selco's COLLETS. The only thing modest about them is the price. As low as 39 cents each in OEM quantities.

Send for our full-color catalog and a sample knob today. You'll collet fantastic!

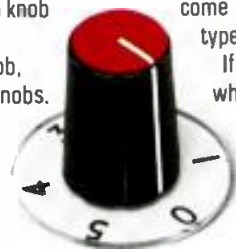

selco
PRODUCTS CO.

7580 Stage Rd. • Buena Park, CA 90621 • Phone (213) 921-0681, (800) 25-SELCO • Telex 655457.

Circle (86) on Reply Card

TUBES
FAST,
LOW COST,
ALWAYS IN STOCK
Types You Need,
When You Need Them.
800-221-5802



**ALPHA
ELECTRONICS**

More than 50,000 different types of electron tubes are always in stock...Eimac, Sylvania, General Electric, Amperex, RCA, and all the other major brands. Just a toll free call away.

Send for a **FREE** Tube/ID Source Guide

To: ALPHA ELECTRONICS, INC. Box A
136E 39th STREET, BROOKLYN, NY 11218
PHONE: (718) 633-2800 TELEX: 232463
FAX: 718-633-4375
CABLE: ALPHATRANS New York

COMPANY _____

NAME _____

ADDRESS _____

CITY _____ STATE _____ ZIP _____

Circle (87) on Reply Card

**“Our videotapes are sharper, crisper—
they’re the best in the NFL because
of our Angenieux lenses.”**

Nate Fine
Director of Photography, Washington Redskins NFL

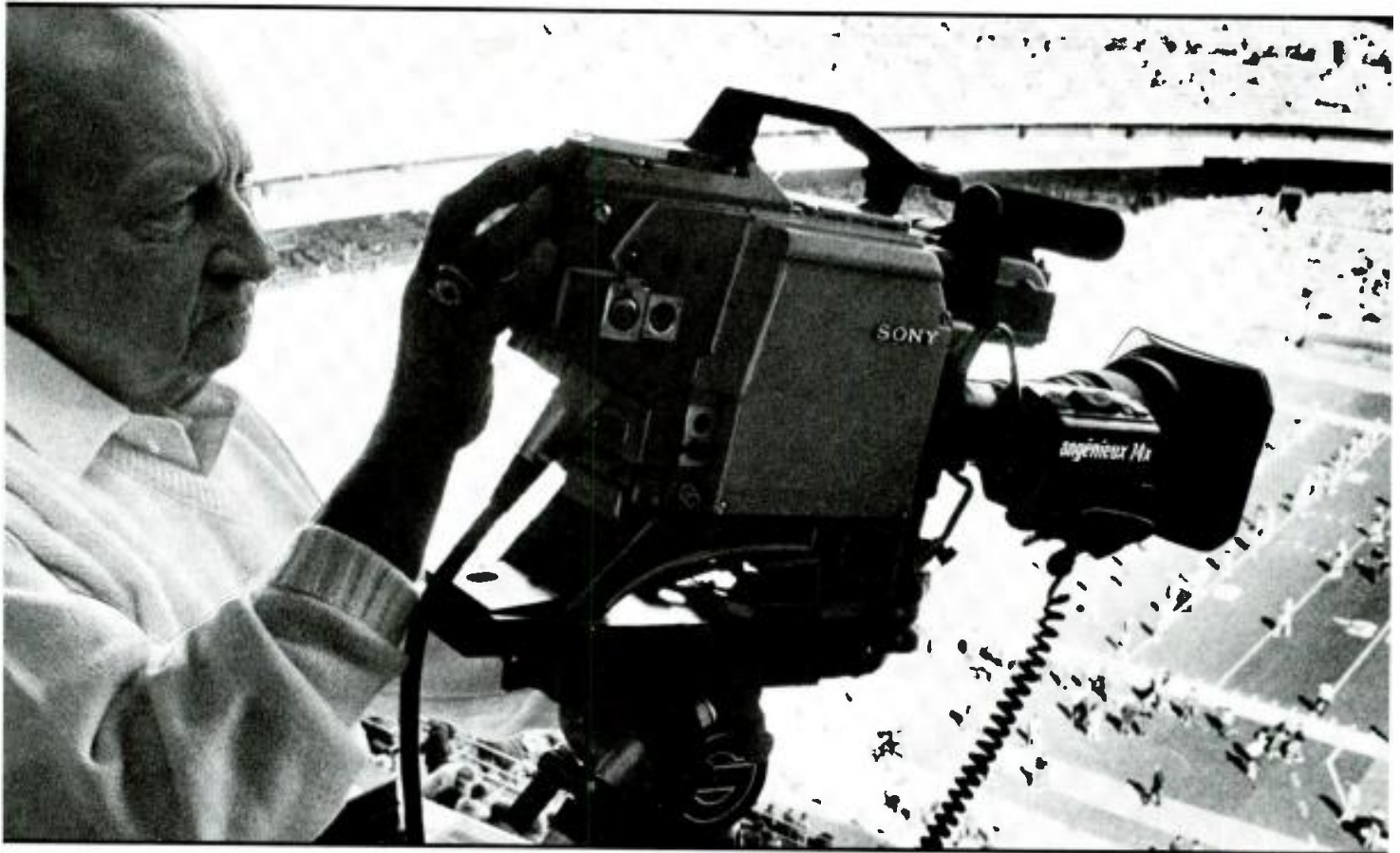

Your camera* can now be dramatically better with the new Angenieux 14x ENG/EFP lenses

The Washington Redskins use three Sony BVW-3 Betacams, each equipped with an Angenieux 14x8, to videotape every game. Nate Fine chose the new Angenieux 14x8 because of its very wide angle, 8mm to 112mm zoom, with the industry's fastest f1.6 maximum aperture. The 8mm wide angle is a must for their style of shooting. Nate Fine has been using Angenieux lenses for nearly 20 years with outstanding results.

What makes the Angenieux 14x8 so outstanding?

Weighs only 3.8 pounds, macro focusing to 0mm, 58° horizontal angle of view, non-rotating front focusing element and HEC coated. Built-in 2x range extender, available with tripod kits and a new servo focus. As a hand held, it feels significantly lighter because the center of gravity has been shifted closer to the camera. The zoom mechanism features exclusive rod construction, stronger and better able to withstand shock. It's part of the new Angenieux 14x generation... 14x9, 14x8, 14x7.

* Angenieux lenses available for Ikegami, Sony, JVC, Ampex, Hitachi, Thomson, Philips, Panasonic and NEC cameras.

For an actual demonstration, see your local Angenieux dealer or write:

angenieux

Corp. of America 7700 No. Kendall Dr., Miami, FL 33156 • Tel: (305) 595-1144 • New York (516) 735-2454

Opticom SA, Case postale 91, 1211-Geneva-17, Switzerland • Tel: 22-36-22-66 • Telex: 27670 Optic CH • FAX: 22-86-12-49

Circle (98) on Reply Card

May 1987 **Broadcast Engineering** 119

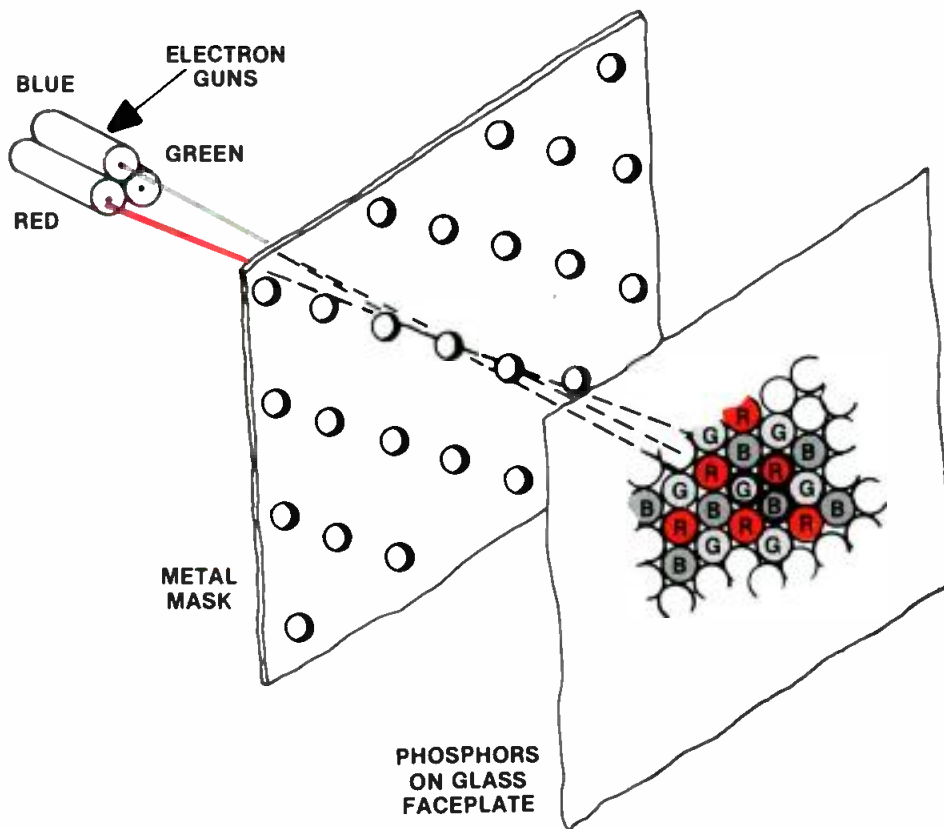

Figure 2. The delta-delta CRT structure produces a more precise image than other types, but requires more care in static and dynamic convergence. This type is common in higher-resolution monitors.

the video signal. The difference between 60Hz and the 59.94Hz scanning frequency causes the signal degradation (Figure 1C) to move upward through the picture.

Adding to sweep linearity problems is the need for corrective variations to be added to the waveforms for each color. For convergence, a high degree of linear control of the non-linear corrective adjustments, such as pincushions and tilts, is essential.

Composite chroma decoders also require linear control. Circuits that mix and separate signals are technically non-linear, but their operation should not be altered by signal or power-level changes.

In component input monitors, decoding accuracy may be less critical, but linearity of multiple channels is a must. Producing a consistent gray scale requires that color-channel gains in RGB monitors must remain constant, relative to one another. R-Y/B-Y, U/V and other color-difference component systems need stable decoding or rematrixing circuits to drive the red, green and blue circuits.

Grade I monitors require more tightly controlled color phosphor specifications. Standard phosphors are selected to produce their greatest light output at specified wavelengths of red, green and blue, and to display a particular color temper-

- Free-floating column
- Adjustable counterbalance
- Position readout
- 120 lb. capacity

A E R O P E D

State-of-the-art...portable studio pedestal designed and manufactured by the people who created the first true fluid head over 35 years ago.

O'Connor Engineering Labs
100 Kalmus Drive • Costa Mesa, CA 92626 • (714) 979-3993

Circle (99) on Reply Card

The art of shaping sound.

SONEX is a high-performance acoustical foam that upgrades your studio inexpensively. Ideal for a temporary isolation booth, it can also eliminate slap echo and harsh resonances in the main room or silence noisy tape equipment in the control booth.

Write for our color brochure today.



Alpha Audio

2049 West Broad Street
Richmond, Virginia 23220 USA
(804) 358-3852
FAX: (804) 358-9496
Telex: 469037 (ALPHAUD C1)

Acoustic Products for the Audio Industry

Circle (100) on Reply Card

N A B R E V I E W

VOL 1

THURSDAY APRIL 16, 1987

FINAL

INTERGROUP'S NEW PRODUCTION SWITCHER THE TALK OF THE SHOW !

9600 VPS A TREMENDOUS SUCCESS!

IT WAS CLEAR FROM THE OPENING OF THE SHOW THAT INTERGROUP'S NEW 9600 SERIES WAS A HUGE SUCCESS. THE BOOTH WAS CONSISTENTLY CROWDED AS PEOPLE TRIED TO ACQUIRE MORE INFORMATION ABOUT THE SWITCHER EVERYONE WAS TALKING ABOUT. YOU CAN BE SURE, "IF YOU MISSED IT, YOU REALLY MISSED IT".

9600 ON THE AIR IN EARLY SUMMER!

IN THE RACE TO BE THE "FIRST 9600 FACILITY", WIFR TELEVISION, ROCKFORD, IL, CONSUMED THE PURCHASE OF THEIR 9600 RIGHT ON THE CONVENTION FLOOR. JIM BRADY, WIFR'S CHIEF ENGINEER, STATES, "WE KNEW THERE WERE GOING TO BE EXCITING ANNOUNCEMENTS FROM SEVERAL SWITCHER COMPANIES. WE HAVE LOOKED AT ALL OF THEM, AND ARE GOING WITH THE 9600." MR. BRADY WENT ON TO CITE THE "ON-AIR" ARCHITECTURE, AND THE COST-EFFECTIVENESS OF THE 9600 AS MAJOR ELEMENTS OF THE DECISION.

M4 KEY SYSTEM HIGHLIGHTED

PERHAPS ONE OF THE MOST UNIQUE AND USEFUL FEATURES ON THE 9600 SERIES PRODUCTION SWITCHER IS THE STANDARD M4 KEYING SYSTEM. M4 KEY STANDS FOR MULTI-ELEMENT, MULTI-PLANE, MULTI-LEVEL, MEMORY KEY, WHICH AUTOMATICALLY STORES ALL KEY MODIFIERS. CONTACT INTERGROUP FOR MORE INFORMATION.



"Creativity You Can Depend On"



NEW MODEL 9600 SERIES PRODUCTION SWITCHER

EUROPEAN CUSTOMERS EAGERLY AWAITING THE 9600 INTRODUCTION AT MONTREUX

EUROPEAN BROADCASTERS AND DEALERS PRESENT AT NAB WERE EAGER TO RETURN HOME AND RELATE THE NEWS ABOUT THE 9600 VPS. THE ENTIRE EUROPEAN BROADCAST COMMUNITY IS AWAITING THE ARRIVAL OF THE 9600 AT MONTREUX IN JUNE. THE INTERGROUP STAND IS NUMBER 134. JUST LOOK FOR THE CROWD.

RECORD SALES AT NAB '87

INTERGROUP VIDEO SYSTEMS MARKED ITS FOURTH NAB APPEARANCE WITH RECORD-BREAKING SUPPORT FROM ITS CLIENTS. THE 9300/9400-SERIES PRODUCTION SWITCHERS, AND THE MASTER CONTROL / ROUTING PORTION OF THE LINE ENJOYED BRISK, AT-THE-SHOW SALES ACTION, A REFLECTION OF THE CONTINUING ENGINEERING AND PRODUCT IMPROVEMENT PROGRAM AT INTERGROUP.

INTERGROUP: A LONG WAY IN A SHORT TIME

WITH THE INTRODUCTION OF THE 9600-SERIES VIDEO PRODUCTION SWITCHER, INTERGROUP VIDEO SYSTEMS HAS ENTERED THE ARENA PREVIOUSLY RESERVED FOR THE MOST EXOTIC OF THE SWITCHER MARQUES. WHAT CAN ONLY BE HAILED AS THE MOST EXCITING PRODUCTION SWITCHER IN THE MID-SIZED MARKET, THE 9600 IS PROOF OF THE TECHNICAL ADVANCES MADE BY INTERGROUP OVER THE SPACE OF FOUR SHORT YEARS.

MOST FEATURES ARE STANDARD

IT HAS LONG BEEN A GIVEN IN THE VIDEO EQUIPMENT WORLD THAT SOME DEGREE OF 'HOMEWORK' IS NECESSARY WHEN COMPARING SPEC'S AND FEATURES OF COMPETITIVE PRODUCTS. FOR THAT REASON, INTERGROUP HAS BEEN QUICK TO POINT OUT THE LONG LIST OF STANDARD FEATURES OF THE NEW 9600: FIVE LINEAR KEYERS, TWO AUX BUSES, FORTY-TWO WIPE PATTERNS, PATTERN SPIN, REFLEX, M4-KEY, THE LIST GOES ON AND ON."

FOR MORE INFORMATION CONTACT : INTERGROUP VIDEO SYSTEM 2040 NW 67TH PLACE, GAINESVILLE, FLORIDA 32606
1-800-874-7590 OR (904) 335-0901

Circle (101) on Reply Card

ature. U.S. and European grade I monitors use different color specifications.

CRTs for utility and grade II monitors have less stringent phosphor purity requirements. The phosphors may produce light colors of a broader bandwidth with a result of less precise color-temperature control and a reduction in CRT price.

The construction of picture tubes follows one of four different gun/mask configurations. The *delta-delta plan* (see Figure 2) originated with NTSC color. It remains a popular configuration although it needs more attention to convergence adjustments.

Medium-resolution CRTs usually use a spacing of 0.43mm between the centers of the phosphor dots. High-resolution models, particularly useful with graphics equipment, use a dot-pitch of 0.31mm and reduced horizontal column-to-column spacing of 0.22mm. The beamwidth could be narrowed to a 0.5mm diameter, close to that of monochrome CRTs. However, cathode loading increases as beam diameter is reduced, decreasing the useful life of the cathode. Normally, the beam illuminates four or five openings in the shadow mask for acceptable brightness performance. A broader beam reduces moire effects when repetitive patterns result in *beats* beat with the spatial

Clean screen for keen greens

With home appliances, the single most common repair during a service call is to plug the appliance into the power outlet. With video display devices, one of the most common complaints is a picture that appears blurry, hazy or dim. A number of electronic reasons can be given for such problems, but often the repair is as simple as a diluted ammonia and water solution on a soft cloth.

The high-voltage potential ($\approx +24\text{kV}$) applied to the HV anode connection of the tube creates a static electric field. Dust, smoke and other airborne particles are attracted by the field to the glass.

Cleaning the monitor screen with any liquid solution should be carefully done. Although there should be no problem in the liquid becoming an electrical conductor, the possibility always exists. Remove power before servicing.

Inside the monitor, various potentials form an efficient dust precipitator. An excessive build-up of dirt can cause an arcing of high voltage, which can lead to eventual failure. If the build-up becomes too heavy, it also is possible that ventilation is affected, causing overheating to occur.

Dust in the monitor cabinet can provide a home for a variety of insects. Cockroaches, common residents in TV stations, can be the cause of monitor failure and even circuit damage, if they move among the components when the power is on. Points of heat would make them more likely to move. One reason for the problem is that monitors are often mounted in ways that make regular cleaning inside the cabinet inconvenient.

In the final analysis, it's easy to keep your monitor operating at its peak and producing the best possible picture with the input signal available.

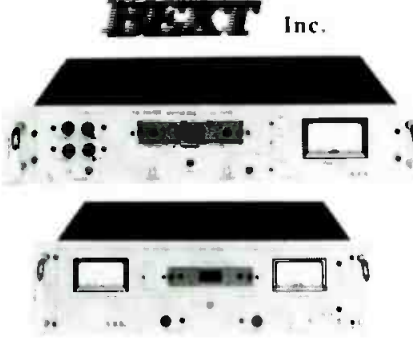

BENT Inc.

- * Reliability, high performance, easy handling, unbeatable prices
- * 15, 30 and 80W excitors
- * 100, 200, 250, 400, 500 and 1000W amplifiers
- All front panel programmable/broadband
- * 2, 10 and 20W composite STL's
- * 24 hrs. technical support on call

739 Fifth Ave.
San Diego, CA 92101
619-239-8462
Telex 229882 LJM UR

Circle (103) on Reply Card

Reconfirm your involvement
in the
broadcast industry!
Renew your subscription
today.

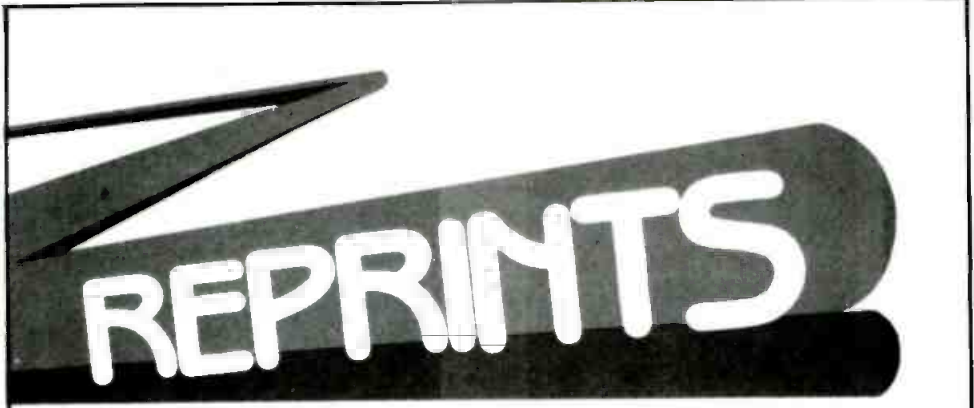

Interested in ordering article reprints out of this or another issue? * Reprints can be excellent learning tools for your technical staff and great marketing tools for your sales staff. Call or write Cynthia Sedler at Intertec Publishing Corp., P.O. Box 12901, Overland Park, KS 66212; (913) 888-4664.

*Minimum order 1,000 copies

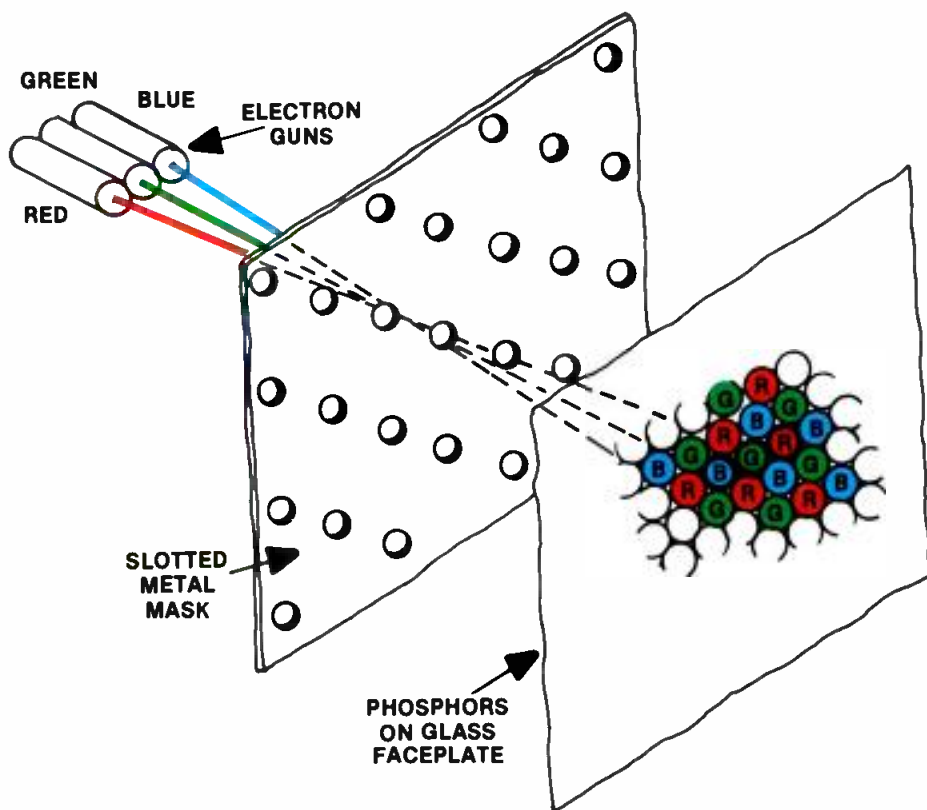

Figure 3. A PIL dot CRT is self-converging. Because all three beams can be made to originate at the same vertical angle, fewer convergence problems exist.

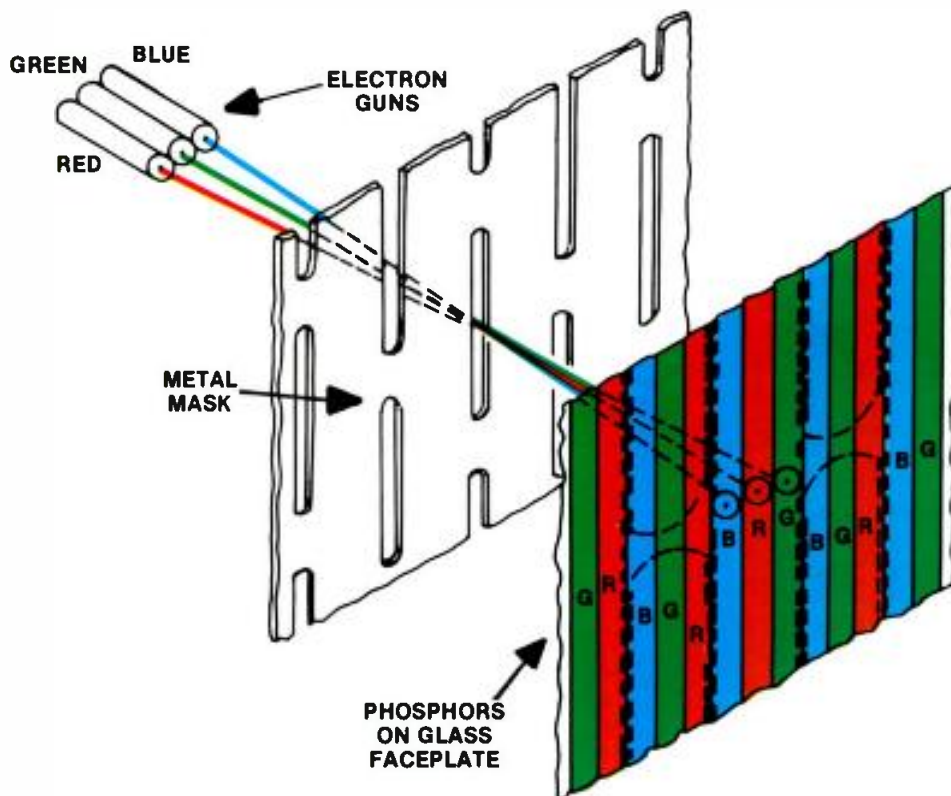

Figure 4. An in-line-slot CRT introduces greater separation among the slots of the shadow mask for more support, thus reducing resolution. As a result, the beam is larger, but more electrons reach the phosphors, producing a brighter picture.



Use of the cross-pulse mode allows the structure of the blanking interval contents to be seen.

Courtesy of Tektronix

frequency of the holes in the shadow mask.

The PIL dot structure avoids some of the delta-delta problems with the precision in-line arrangement shown in Figure 3. The three side-by-side guns, rather than a triangular arrangement, direct the beam through a normal dot mask to illuminate a linear array of dots, rather than a delta format. Although the beam is actually oval in shape, the holes in the mask and the phosphor dots essentially remain circular as in the delta type.

The PIL design brings a self-converging nature to the tube, reducing the amount of convergence circuitry in the monitor. The differences between the two types of CRTs and their convergence systems reduce the compatibility. In other words, although a PIL tube probably will work in a delta monitor with reasonable success, the opposite replacement would be less successful. Deflection parameters of the two types differ considerably and the necessary convergence circuitry is lacking.

Preceding the PIL CRT was the in-line/slot mask design (see Figure 4). For structural stability, the mask slots are separated more than a dot format with the horizontal pitch of the phosphor stripes from 0.7mm to 1mm. This type of display requires a larger beam spot size. Illumination of the screen is more efficient, because fewer beam electrons are blocked by the mask. This format is not suggested for critical viewing, but it serves non-critical imaging well. Convergence concerns are reduced, compared with delta-gun formats.

Another in-line CRT, the *single-gun* form (see Figure 5), combines three beam-forming structures into the single gun. Vertical strips, supported from their ends behind a cylindrical faceplate, form the mask structure. (Other CRT types use a spherical shape.) Vertical resolution approaches infinity, but a more limited horizontal specification results from the practical width of the strips. Phosphors for this CRT are arranged as stripes, similar to the in-line/slot.

An advantage of this tube structure is

The image displays five different models of Pacific Recorders & Engineering mixing consoles arranged on a light-colored surface with colorful paint splatters. Each console is shown from a top-down perspective, highlighting its various knobs, sliders, and buttons. The models are labeled as follows: ABX (top left), AMX (top right), BMX-III (middle left), NEWSMIXER (bottom left), and BMX-II (bottom right). Each label is in a yellow box with a blue border.

ABX

AMX

BMX-III

BMX-II

NEWSMIXER

THERE'S AN IDEAL MIX FOR YOUR STATION.

For many top rated radio broadcasters, Pacific Recorders & Engineering consoles are essential to their operations. Our family of consoles was designed from the same set of functional and operational specifications, with each ascending model adding capabilities without giving up features or performance in the process.

Since their introduction, more than 750 of our BMX on-air consoles have been installed. There's now two models in the BMX family; the legendary Series II, and the new Series III (which offers many more features with the same reliability and performance as the original BMX-II).

A workhorse for production, our flexible, AMX console offers a powerful combination of sophisticated stereo production and advanced on-air features.

Because high quality multitrack capability has become a top priority for more competitive production, we designed the ABX—a serious

multichannel, multi-featured production console which retains the control features of the BMX and AMX.

And, because it was high-time to improve a dismal equipment situation in news/edit rooms, we've built the compact and versatile Newsmixer.

Five consoles. Five different systems designed to help solve your station's unique operational problems—including the problem of operational ease since all our consoles have similar ergonomic designs.

You'll need more technical information of course, and we'll be happy to rush it to you. Just pick-up the phone.

Hands Down, The #1 Choice.

Pacific Recorders & Engineering Corporation
2070 Las Palmas Drive
Carlsbad, California 92009
(719) 438-3911 Telex: 181777 MCI Mail: 285 0799



that it requires a single electronic lens to bring the three beams into focus as they pass through slots in the mask. Fewer convergence requirements and a bright image make this CRT useful in less critical viewing environments. Some engineers advise against the single-gun CRT in grade I monitors because they think that signal disparities are not sufficiently apparent.

Some monitor systems include *beam current feedback*. Beam feedback stabilizes overall picture color and quality by maintaining a more constant color black.

Variations in black level usually display images with some discoloration.

Extended-life CRTs use a different design for the surface in the cathode for an enhanced electron output. (See Figure 6.) Tube cathodes include a coating of a mixture of barium and strontium oxides to produce more electrons than a normal cathode structure. Extended-life cathodes have a special chamber with a reserve of barium oxides.

Test features

Many features provided in monitors

are more useful in technical areas. One of the most common is the *delayed sweep or cross-pulse display*. Delayed horizontal and vertical sweep settings allow the operator to see the H and V blanking intervals. Although these portions of the picture are of limited importance for a viewing room, delayed vertical might be of interest in the tape room to aid in VCR skew adjustments.

By combining the two delays, a cross is formed on the screen that shows the virtual intersection of the two blanking intervals. With appropriate adjustment of brightness and contrast, the structure of the sync intervals becomes apparent. This information is useful during maintenance, to observe the skew error in a VCR playback deck without time base correction. This feature is not required for normal non-technical viewing.

Many engineers request a *blue gun only* display. The blue gun test allows the VTR operator to monitor noise that is generated in the blue channel during playback. The blue channel is of interest because blue chroma requires more gain to be visible than the other two channels throughout the video chain.

Another function served by the blue gun test is to aid in monitor setup. With a standard color-bar pattern displayed and the blue gun test on, the operator can adjust chroma level and phase controls alternately until the four blue bars appear equally luminant. At that point, both chroma level and phase are properly adjusted.

Some monitors include an *NTSC matrix function*, a switched function that changes how color information is decoded for display. The test introduces an RC matrix to compensate for CRTs with non-standard phosphors. At one time, this feature was suggested by several industry organizations to standardize display characteristics. Today, it is seldom included in a standard monitor package.

Aperture correction controls on monitors offer image enhancement by changing the time constant in the video circuitry. The feature typically provides from $\pm 3\text{dB}$ to $\pm 10\text{dB}$ gain at the higher frequencies of the video bandpass for sharpness adjustment. Along with image sharpness you may notice increased noise.

A *time-constant selection* on the monitor is important in the viewing room where a VCR may be used for playback of promos or programs. With a fast time-constant setting, monitor sync will be more affected by skew in sync from VCRs. Stable video from the production area is easily displayed on either time constant, as would be the case for a VCR output with time base correction.

To view edges of the raster, enable switchable *underscan*. The feature is useful in production areas where you must

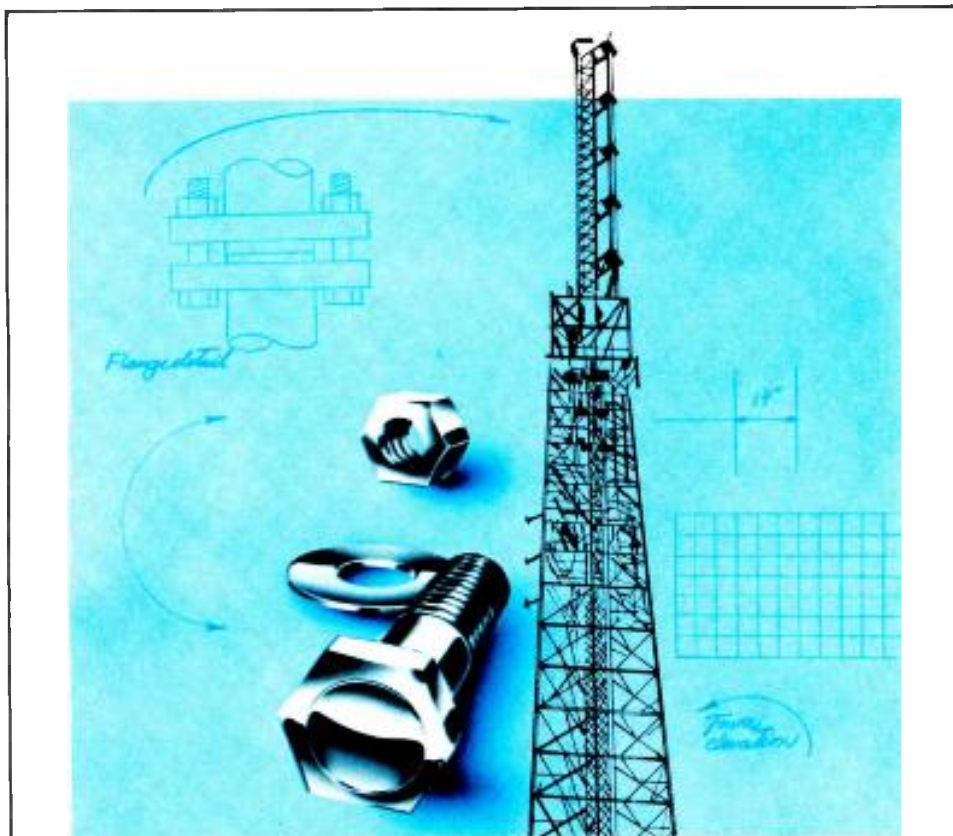

When you build major towers there are no minor details.

At Stainless, Inc., our exceptional track record has earned us the reputation of a company who specializes in detail.

Whether it's dealing with unusual equipment loading conditions or unique terrace conditions, we do whatever it takes to construct a quality Stainless tower to meet your specifications.

As a result of our high standards, we've been commissioned to design and build more than 6,500 towers of all heights and sizes worldwide. We've conquered all types of building challenges. And we've been doing it for 40 years.



Stainless, inc.

North Wales, PA • USA 19454
Phone: (215) 699-4871 Telex: 510-661-8097

Now celebrating our 40th Anniversary.

Circle (105) on Reply Card

Not-So-Big News

The news is out. Studer's new 963 is big on features, performance and reliability. And not-so-big on size.

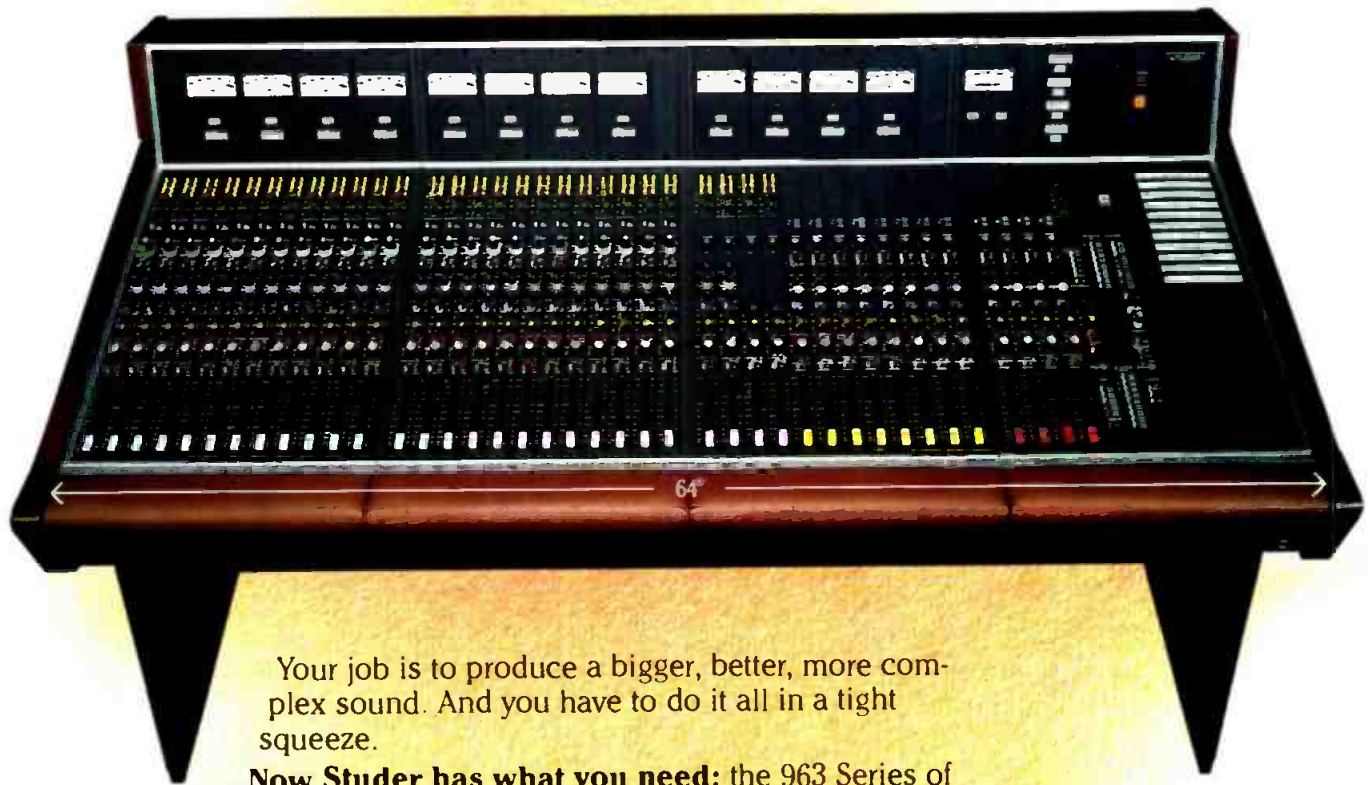

Your job is to produce a bigger, better, more complex sound. And you have to do it all in a tight squeeze.

Now Studer has what you need: the 963 Series of compact production consoles. A 963 is ideal for video post-production, video editing, broadcast production, EFP vehicles, smaller recording studios—anyplace where quality and reliability are critical but space is at a premium.

Based on a standard 30 mm module width, the 963 is available in configurations from 16 to 40 inputs. A 28 input console, with 28 direct outputs plus 4 stereo subgroups and 2 stereo masters, is barely more than 5 feet long. A 40 input console, is barely more than 6 feet long.

Standard features on the 963 include balanced insert points, direct outputs, a bantam jack patch bay, and external mute interface for video switchers. A wide variety of module options lets you custom configure your 963 for practically any specialized application.

When it comes to audio performance, the 963 goes head-to-head with the bulkiest of the big-name boards. Noise levels are digital compatible in “real world” conditions with many open faders. Studer engineers gave special attention to mix bus design and reference grounding to assure consistently superior specifications regardless of frame size. For extra reliability, solid state switching is used in all critical audio paths. As with all Studer products, the 963 is manufactured and assembled to the highest standards of Swiss craftsmanship.

For more information, call your nearest Studer representative. Find out how the 963 can give you big console capabilities in a not-so-big package.

STUDER REVOX AMERICA, INC.
1425 Elm Hill Pike, Nashville, TN 37210, (615) 254-5651

Offices: Los Angeles (818) 780-4234/New York (212) 255-4462/Chicago (312) 526-1660
Dallas (214) 943-2239/San Francisco (415) 930-9866

Circle (137) on Reply Card

STUDER REVOX

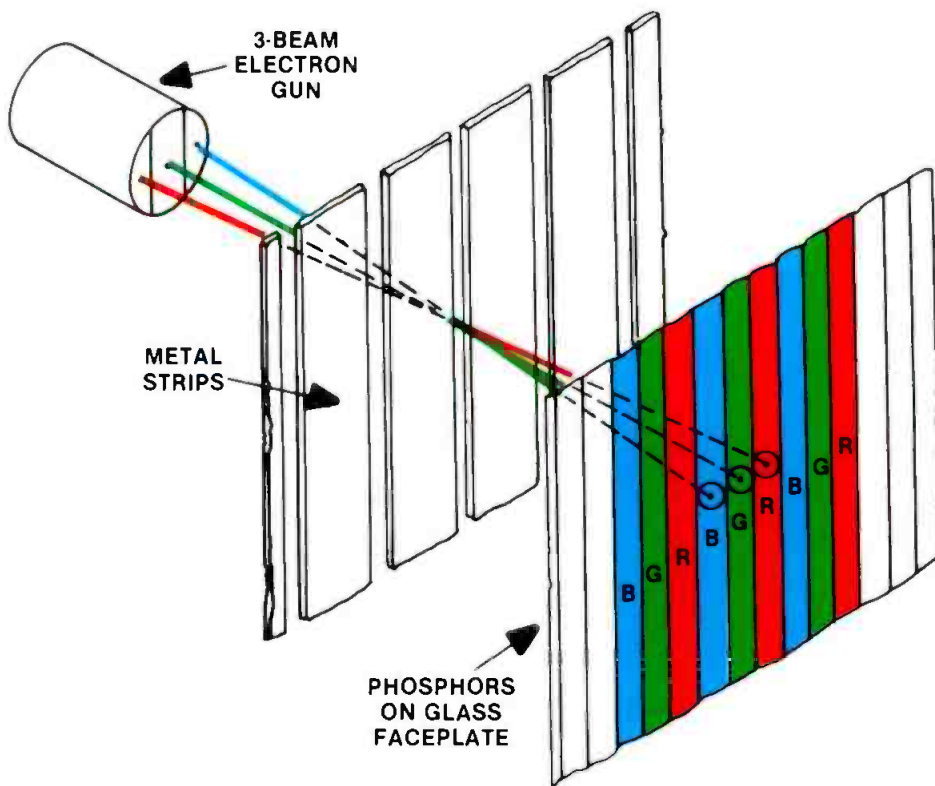

Figure 5. A single-gun CRT has a flat faceplate and produces the fewest convergence problems because all three beams are handled by a single electronic lens. The picture is bright, but signal degradation may be less visible than with a dot-type CRT.

determine if important objects will be seen by most viewers. Objects too near the edge of the raster may be off-screen.

How much overscanning occurs on a CRT screen? In the home receiver, the amount varies. Typically, the underscan amount is approximately 5% to compensate for an overscan of about 5% in normal viewing mode. A safe-area generator helps keep essential picture material in a viewable area on most screens.

Most recent in monitor design innovations is microprocessor setup and control. Operator controls use up/down buttons to signal the microprocessor circuit digitally. In some cases, the screen can be switched to show brightness, contrast, chroma levels and phase values currently stored in the control system memory as normalized values (between 0 and 255). Bar patterns with cursors visually indicate the settings of the parameter. If a permanent change is not desired, then a reset button takes all parameters back to preset conditions. This allows momentary setup changes for special purposes with instantaneous return to standard values.

Setting of parameters during maintenance can be done with an attachment

Beam control

A cross-sectional sketch of a CRT can be used to understand how the electron beam is controlled. The beam originates in the gun as the filament heats a nickel cylinder that has been coated with barium and strontium oxides. At the operating temperature, nickel loses its magnetic properties and does not interfere with electron beam formation.

Electrons leave the cathode with nearly zero velocity and begin their journey to the faceplate along principal paths or rays. The density of each beam (RGB) is controlled by the video signal applied to the cathode terminals of the tube.

As the electrons move, they are forced by the negative charge on the control grid to move into a tightly formed beam. The effect of the control grid is due partly to its potential and partly because of its cylindrical shape, eventually causing the stream of electrons to converge much like light rays in an optical system. From this crossover point, the positive accelerating anode increases the speed of the negative particles and causes some divergence. Immediately, a focusing-field (magnetic or electrostatic) again forces it to remain in a beamlike form.

By the time the beam has reached the point where the neck expands into the tube bulb, horizontal and vertical deflection coils cause the stream to swing from side to side and top to bottom, effectively painting the picture on the faceplate. In order for the beam

The basic design of a conventional CRT.

to converge again at the dot mask, the focus, acceleration and deflection fields must be balanced through potential and spatial separations. Although a light beam is controlled by variations in the refractive indexes of the material through which the light passes, the electron beam can be effectively shaped and guided through regions of controlled electrical and magnetic fields.

The vertical deflection coils can be farther from the center of the electron beam because the deflection distance is shorter and the rate of vertical scan is slower.



Beat the traffic.

M/A-COM opens up a new lane for broadcasters with our new 18GHz microwave system.

If you've been looking for an open frequency at 7 or 13GHz, you're not alone. In many areas, they simply aren't available: there's too much traffic and not enough spectrum.

M/A-COM's new 18GHz microwave system gives you another option: a wide-open band which the FCC has assigned to broadcast. It gives you 50% better link availability (or 40% longer range) than 23 GHz, and none of the congestion of the lower frequencies.

The MA-18CC is a fully-featured microwave system, designed to meet or exceed all RS-250B short-haul performance

specifications. It is field tunable, and a single gunn oscillator covers a wide selection of frequencies so spare parts can be kept to a minimum.

For over 20 years M/A-COM MAC has specialized in providing microwave radio equipment to broadcasters. Every unit with our name on it is built in our own factory, so we not only control the quality, but we know how to service it.

For more information on how you can streamline your microwave needs, contact M/A-COM MAC, Inc., 5 Omni Way, Chelmsford, MA 01824, (617) 272-3100.

Product cannot be offered for sale pending FCC notification.



Circle (107) on Reply Card

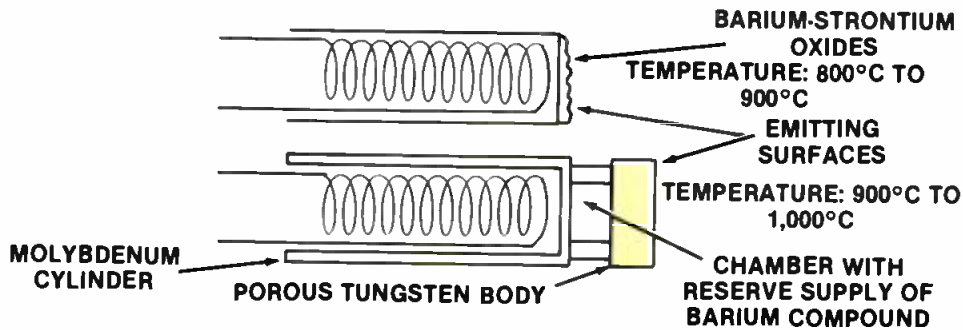

Figure 6. Conventional cathode compared with extended-life cathode (lower drawing).

that senses the color white on the screen. Because the detachable sensor plugs into a microprocessor control circuit, it can perform an automatic adjustment of color balance controls. In some models, memories in the attachment retain settings for one or more specific monitors or for specific color temperature, allowing a quick setup to a particular standard.

A number of parameters can be controlled through microprocessor design. By electing a standards choice, the operator steps through different color modes, such as RGB component and NTSC, PAL or SECAM composite formats.

Making connections

The video inputs accepted by the mon-

itor should be considered before the purchase is made. Most composite monitors offer a sync input, while switchable composite/component units may suggest that sync may be in green or on a separate input. Changes occurring in broadcast technology suggest that color-difference components are growing in popularity, particularly in production, where 1/2-inch formats must interface to other equipment. This means that you could interface among various signal formats, including RGB and composite. Although few monitors include all the possibilities, it is a subject worth discussing with manufacturers' representatives.

How important is an integral audio system? The master-control system presu-

ably includes an audio monitor that follows video selected to the monitor. From a practical point of view, an operator assigned to master control should not be watching outside video sources. The same rule applies in the videotape room, where a utility routing switcher usually selects video and audio sources.

In the viewing rooms, however, an integral audio amplifier and speaker simplifies the system operation for the less-technically oriented. You can drop your cassette into the VCR, turn on one switch and be in business, rather than worry about separate audio controls.

Also designed for less-technical viewing areas, rather than engineering, the combo receiver/monitor connects quickly to a VCR. The receiver/monitor not only lets one coaxial cable connect the playback unit to the display for operation on an unused RF cable, it often includes an 8- or 10-pin connector to link audio and video direct from the VCR. The operator selects VCR to observe playbacks, then presses TV or RF for off-air local channels. The receiver/monitor is for use on various staff desks when an in-house RF-distribution system is used. Not only is direct video capability available for tape, the RF tuner gives instant access to any of 12 (fewer if there are local

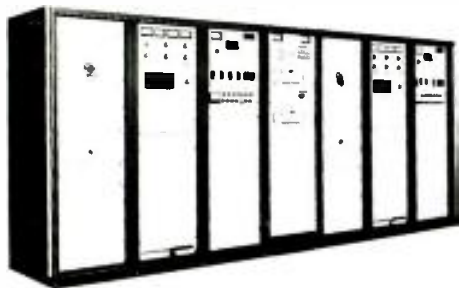

**A First
For The
Industry**

70,000 watts FM

Continental's new 817R-5 combines two proven 816R-5 35 kW transmitters to offer broadcasters many operating advantages. The 817R-5 uses husky components and is built to give many years of dependable service. The first 817R-5 has been shipped to KABL, San Francisco. For product data, call your local Continental Sales Manager.

- SCR power control
- Automatic RF power output control
- Automatic SWR circuit protection
- SWR output power foldback
- Remote control interface
- AC power failure recycle
- Grounded screen amplifier
- 802A exciter

Transmitters 1 to 50 kW AM and to 70 kW FM, antennas, studio & RF equipment © 1986 Continental Electronics 0322



Continental Electronics



a Division of Varian Associates, Inc. PO Box 270479 Dallas, Texas 75227 Ph (214) 341-7161 Telex 73 398

Circle (108) on Reply Card

Interested in ordering article reprints out of this or another issue? * Reprints can be excellent learning tools for your technical staff and great marketing tools for your sales staff. Call or write Cynthia Sedler at Intertec Publishing Corp., P.O. Box 12901, Overland Park, KS 66212; (913) 888-4664. * Minimum order 1,000 copies

Perfect Control

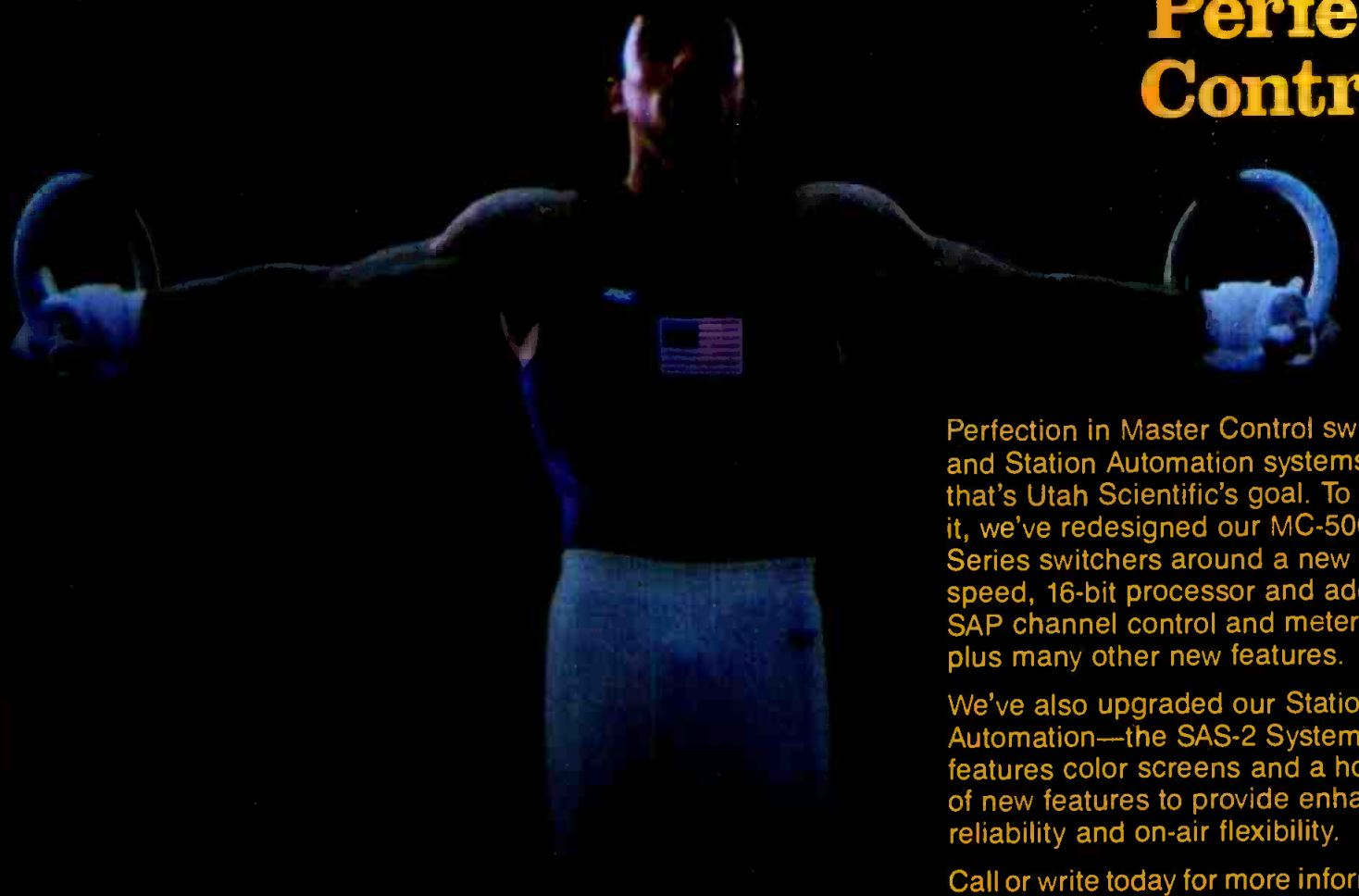

Perfection in Master Control switching and Station Automation systems—that's Utah Scientific's goal. To reach it, we've redesigned our MC-500 Series switchers around a new high-speed, 16-bit processor and added SAP channel control and metering, plus many other new features.

We've also upgraded our Station Automation—the SAS-2 System features color screens and a host of new features to provide enhanced reliability and on-air flexibility.

Call or write today for more information.



US UTAH SCIENTIFIC, INC.
DYNATECH Broadcast Group

1685 West 2200 South, Salt Lake City, Utah 84119

(801) 973-6840 • Toll Free 1-800-453-8782 • TLX: 269-916 • FAX: 801-973-0255

Circle (136) on Reply Card



Current parameters controlling the monitor display are shown in the screen. Menus direct push-button selections and parameter changes, so the user doesn't have to search for a proper adjustment tool.

channels that may cause interference) different signals to be viewed.

A look at graphics

Most computer graphics systems designed for TV applications include standard RS-170/170A sync. Any monitor probably will suffice with these systems, although some systems require two displays for complete implementation.

You might select one for the output image to be a high-resolution unit. For the menu screen, a lower-resolution monochromatic CRT produces a readable operating menu image.

Graphics hardware that was designed for CAD applications may present a problem within the TV environment. Many are designed for significantly different horizontal and vertical scan rates. To successfully integrate them with standard video requires a video encoder, keyer and format interchange device

(frame buffer). For the CAD-type systems, a typical TV monitor may not work properly, its success determined by scan rates and resolution.

The interest in improving video quality is increasing. The need for high-quality video monitors to support that interest is obvious. Selecting the right monitor for use in your facility is a matter of sorting through the available products and matching available features with your particular requirements.

1-7-88



The choice of the professionals...



310B
PROFESSIONAL
PHONO PREAMP/EQUALIZER
... Interfaces magnetic phono cartridges for optimum calibration of audio systems. Available with balanced or unbalanced output.



680EL ... Delivers sound excellence and stands up to backcueing, vibrations and mishandling.



PBR ANNOUNCER'S EARPHONE ...
Ideal for on camera studio work
and remote coverage.

Stanton is the company with a total commitment to quality and reliability—producing products for the Recording Industry, the Broadcast Industry and the Professionals in Audio.

STANTON
THE CHOICE OF THE PROFESSIONALS™

200 Terminal Dr., Plainview, NY 11803



The
Dynaphase
30M/SR is a shoulder rest single cup
headphone that provides the ultimate in
convenience, comfort and superb sound
quality. Made to rest on either your left
or right shoulder, or shoulder rest can
be detached and used as a single cup
hand-held monitor.



500AL ... For heavy duty on-the-air use with wide tracking force range.

Circle (110) on Reply Card



EIDOPHOR,[®] **because big pictures mean big impact.**

Professionally organized conventions require a professional audio visual medium. EIDOPHOR TV projectors deliver pictures up to 12 x 16 meters or 40 by 50 ft. and vividly portray even the fine detail

for every participant. The pictures are so bright, there's no problem with note-taking.

EIDOPHOR —
A very visible difference in quality.



Althardstrasse 70, CH-8105 Regensdorf/Zürich, Switzerland, Phone (01) 842 11 11, Telex 825 853, Telefax (01) 842 21 00

Circle (111) on Reply Card

May 1987 *Broadcast Engineering* 133

Symposium to attract international attendees

By Carl Bentz, special projects editor

If you decide to attend the 15th International TV Symposium and Technical Exhibit, June 11 to 17, in Montreux, Switzerland, you will not be participating in just another trade show. This biennial event, sponsored by the Telecommunications Department of the Swiss PTT (Posts, Telephones and Telegraphs), concentrates on television as a medium served by terrestrial broadcast, satellite broadcast and non-broadcast, broadband CATV technologies. The event is more international than any broadcast convention in the United States, with participants from many countries around the world.

The hardware show

In the exhibit hall at the Montreux Palace Hotel and Convention Center, you should see a number of familiar faces from U.S. companies. You should recognize a number of familiar names as well. Many European manufacturers are well represented at NAB and SMPTE events by their U.S. branches or distributors, but at Montreux, the headquarter organizations are in charge. With these organizations will be a number of manufacturers who rarely exhibit in the United States.

The most recent exhibitor list includes more than 190 different companies that have requested space in the enlarged facilities. Since the 1985 Montreux Symposium, an additional 3,000 square meters of space have been constructed. An improved air-conditioning system has also been added to the entire 12,000-square-meter area.

The majority of European countries will be represented in the exhibit hall, including Austria, Belgium, Denmark, Finland, France, Great Britain, Italy, the Netherlands, Norway, Spain, Switzerland and West Germany. Contingents from non-European countries will include: Canada, Japan, Singapore and the United States.

Many of the products on display at Montreux will be in PAL or SECAM forms, rather than in NTSC, made possible through an encoder at the output of the system. Many designs that embrace analog and digital component technologies will drive the encoders.



Exhibit hours will be from 10 a.m. to 6 p.m., June 12 to 16.

The symposium schedule

The symposium will open Thursday morning, June 11, with welcoming addresses by symposium organization officials, the Mayor of Montreux and the Swiss PTT patron organization. The presentation of the Montreux 1987 Achievement Gold Award will be followed by a presentation of *Technology Trends* by industry leaders from around the world.

A reception will follow the opening ceremonies.

The afternoon session on *High-Definition Television* will examine picture, sound and RF aspects, as they relate to TV and film applications. The HDTV session will conclude, as will nearly all seminar groups, with a round table discussion for the experts and participants to exchange views on the evolution of television for tomorrow.

Friday morning, June 12, the schedule will include concurrent sessions on *Television Production Systems* and *Terrestrial Broadcast Systems and Equipment*. The production group will explore analog and digital developments from around the world, and the trends in studio and OB production and signal processing. The broadcast systems session will consider equipment innovation and topics such as digital multichannel sound and the future extension of terrestrial television to enhance HDTV use. Both sessions will end with a discussion between speakers and attendees.

Friday afternoon's schedule will present concurrent sessions for *Direct Broadcast Satellite Systems* and *TV Origination and Processing*. Participants will learn from the experience of European and Japanese DBS operations that were recently initiated. Topics of medium-vs.-high power, hybrid DBS-communications satellites and DBS economics should present insight into the transmission medium. The origination and processing session will stress innovations in cameras, switching, processing and effects equipment. Advancements in CCD technology also is scheduled.

Saturday morning, June 13, concu-

rent sessions will focus on *Lightweight TV Production Systems* and *Signal Distribution via Satellite and Terrestrial Means*. The production systems session will review small-format analog composite and component equipment and consider their future in high-quality production. Signal distribution topics will compare the economics of satellite operation vs. terrestrial methods with an emphasis on international program distribution for broadcast and CATV.

Saturday afternoon, concurrent sessions on *Video Recording Equipment* and *Approaches in Marketing and Planning of Cable Television* will be hosted. The explosive growth of video recording in digital and analog formats and their applications into advanced post-production techniques should lead to an interesting round table discussion.

A single session is scheduled for Sunday, June 14. *The Entertaining Screen* session will examine the effects of technical advances in the process of entertaining the viewer, but from the producer's perspective. Some previews of new material presented on a wide electronic screen will provide illustrations of the changing nature of production and entertainment values.

The general broadcast sessions will conclude on Monday morning, June 15, with *Broadcasting—The Cold Wind of Change!* This highlight session, spotlighted by a keynote speech that will view both sides of the issue, will focus on new forms of electronic entertainment now available that are eroding the effects of traditional broadcasting. Concurrent with the session will be the topic, *Progress in CATV Network Technologies*.

Monday afternoon will include two sessions of interest to both broadcast and CATV. *Satellite News Gathering* will be of interest to traditional broadcasters, as will the concurrent meeting that will discuss *Home Terminals*, a look at applications for data, text and interactive activities made possible through microelectronics.

Tuesday, June 16 and Wednesday, June 17, will be given over to topics of interest primarily to CATV participants. *Fiber-optic Trunk and Distribution Net-*

Orban 275A stereo synthesizer

By James Radmann

MTS stereo television and stereo synthesis are going hand-in-hand in TV stations across the country. When WXGZ-TV began investigating the conversion, stereo programming was not, and still is not, readily available. There are a number of isolated network or syndicated stereo audio feeds. But, for the majority of TV programming, monaural audio is the norm. Because our station wanted to broadcast in stereo at all times, we needed a stereo synthesizer. We selected the Orban 275A. A block diagram of the unit is shown in Figure 1.

Important features

Our needs are probably similar to those of other stations across the country. The synthesizer had to automatically detect and synthesize monaural programming. Automatic operation is critical to our operation because the transmitter is located 17 air miles from the studio.

Two other important features were also needed in the synthesizer. Because most of the receivers are monaural, and will be for many years, the summed stereo left and right channels have to add back to the original mono to ensure mono compatibility. Generating a pseudo-stereo signal from a monaural signal is not difficult. However, it is more difficult to do so while keeping full mono compatibility.

The other required feature centered on reversed polarity signals. As stereo FM stations learned the hard way, reversing the phase of one audio channel (from a pair of monaural channels) destroys the monaural signal. When combined in the viewer's receiver, a feed's reversed polarization effectively nulls the monaural listener. Automatic detection and correction of reverse polarity is, therefore, desirable. The stereo synthesizer provides these features and many other useful ones.

Noise reduction

Many TV stations use little audio processing. Noise reduction equipment is even less common. The synthesizer pro-

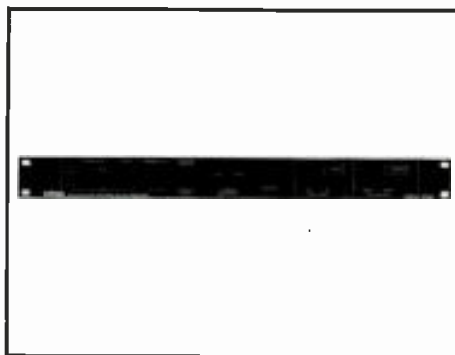

Performance at a glance

- Simple installation with barrier strip connections
- Frequency response of $\pm 0.5\text{dB}$ 30Hz to 15kHz in the bypass mode; $\pm 1\text{dB}$ 30Hz to 15kHz in the synthesize mode
- Fully automatic operation
- Mono receiver compatibility in synthesize mode
- Smooth crossfade between modes
- Automatically corrects for switched polarity lines
- Single-ended noise reduction provides a 10dB improvement in S/N
- Single-channel and equal dual-channel detection and synthesis modes

vides user-selectable, single-ended noise reduction. The noise reduction operates only on synthesized mono material. The circuits apply a combination of program-controlled, high-frequency filtering and broadband expansion. The device typically provides up to 10dB of noise reduction on most signals. Because the noise reduction is single-ended, no encoding and decoding is required.

The synthesizer was initially installed and operated with the noise reduction turned on. It was only after the feature was manually turned off that the noise, buzz and hum produced by our projector's optical sound system became obvious. At one point, an oscillation developed in the film projector's audio exciter lamp. The oscillation produced an annoying buzz in the audio just prior to the lamp failure. Fortunately, with the synthesizer, the failure was detected in-house without the undesirable buzz being transmitted to the viewer.

Most of the noise-reduction circuitry is contained within one chip, the major elements of which are shown in Figure 2. The complex IC provides optimum signal control without operator intervention.

The dynamic filtering begins rolling off the highs at about 1kHz, unless enough highs are detected in the signal to cover the noise floor in the mid- and high-frequency range. As additional high-frequency material is detected, the filter

opens to pass more of the full-range audio.

Stereo/mono detection

Detecting whether a signal is stereo or monaural is difficult. There are two basic ways that synthesizers decide whether the incoming material is stereo or monaural.

In the single-channel mode, it is relatively easy for the device to know what to do. If one incoming channel lacks audio, the synthesizer switches to stereo synthesis. In this mode, if both input channels contain audio, the device considers the material stereo and the synthesizer is bypassed. Because this method is quite reliable, many stations elect to use this operational mode.

The second detection mode can be added to supplement the single channel mode. This mode uses special circuitry to monitor the incoming channels. If the material is true stereo, or even hard-center dialogue with a low-level stereo music or audience noise background, the synthesizer recognizes it as stereo and the stereo synthesis circuits are bypassed. Because no TV facility is perfect, minor phase and level differences between the channels are ignored. An internal trimmer allows the user to determine the point at which the detection circuitry switches to stereo synthesis.

When lightning caused the loss of our regular mono (left) STL transmission channel, the automatic detection/synthesis feature really proved valuable. After the STL failed, the synthesizer automatically switched to synthesized stereo using the one good STL audio channel as the monaural source. After the defective STL channel was repaired, we switched over to the repaired channel and performed checks on the right channel. Once all of the checks were completed, one touch of the button returned the device to the automatic program-controlled operational mode.

In addition to the capability to recognize a dual/mono signal at the synthesizer's inputs, it is equally important to perform a gentle, smooth crossfade from a true stereo source to the synthesis mode. The ½-hour children's programs

Radmann is chief engineer at WXGZ-TV, Appleton, WI.

NEW The Standard Of The Industry...Townsend

Townsend Broadcast Systems stunned TV broadcasters with the unveiling of a totally new line of products at the 1987 NAB.

Not only new looks . . . but technology with a purpose . . . to improve the on-air performance of your station. Transmitters with on-board digital control with status panels to check overall operation at a glance. Video cart automation with foolproof controls for non-technical operators. All new products built with American technology and backed by 24 years of proven support.



TB-30TL 30 KW VHF Low Band Transmitter

Single tube type.
Triode simplicity.
Quick look status.
Memory of last 16 faults.
Redundancy throughout.
On-air reliability.



DC-80 Video Cart Automation System

Up to 24 transports.
Anti head-clog system.
Software controlled, with host computer.
Eliminates operator errors.
Improves on-air video and audio.
Stereo audio standard.

TOWNSEND

BROADCAST SYSTEMS INC.

79 Mainline Drive, Westfield, MA 01085
Tel. 413-568-9581 TELEX #710-356-1521

8222 Jamestown Dr., Suite C-131, Austin, TX 78758
Tel. 512-836-6011 or 800-252-9792
in Texas or 800-531-5232

Circle(113) on Reply Card

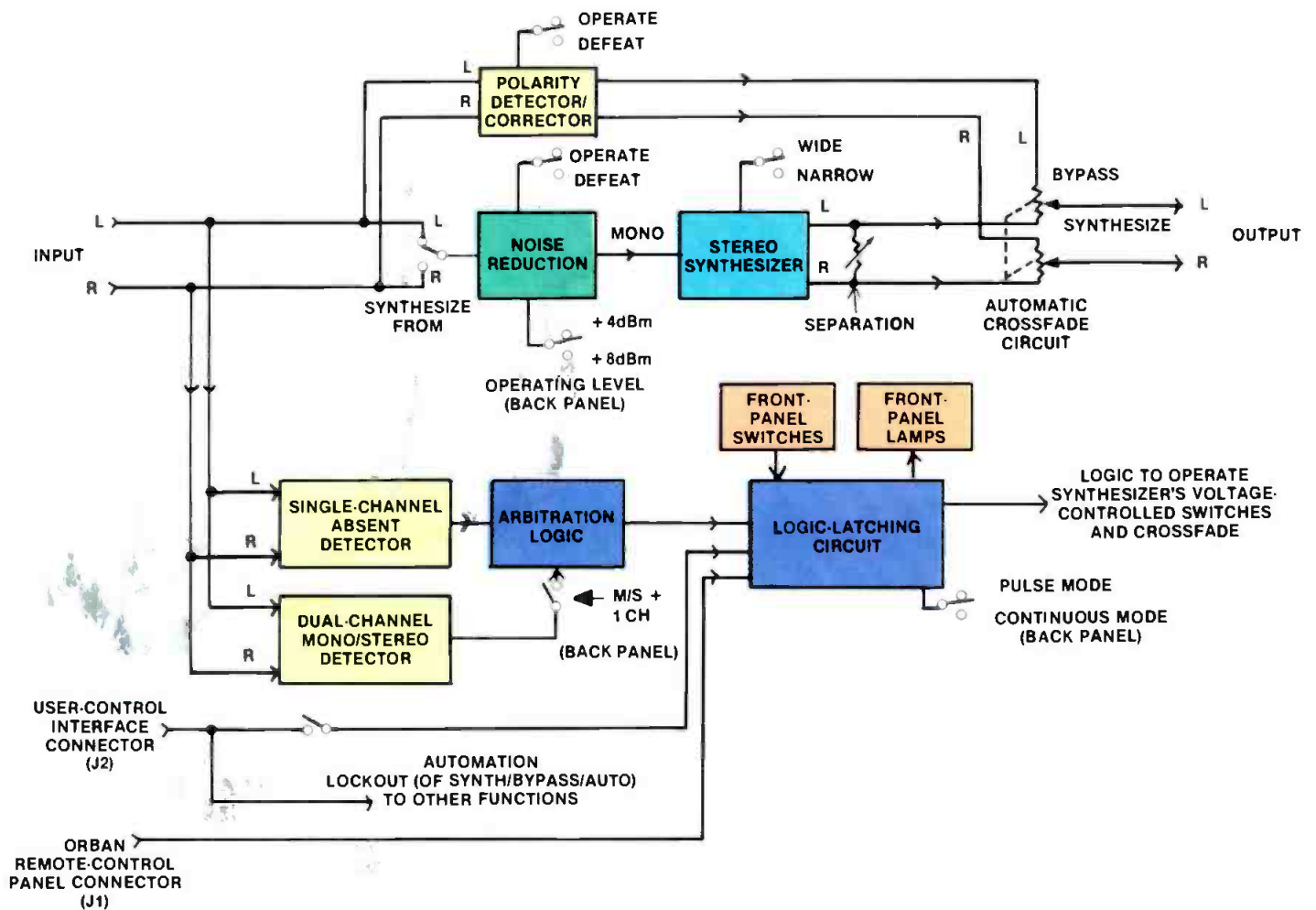

Figure 1. Block diagram of the Orban 275A stereo synthesizer.

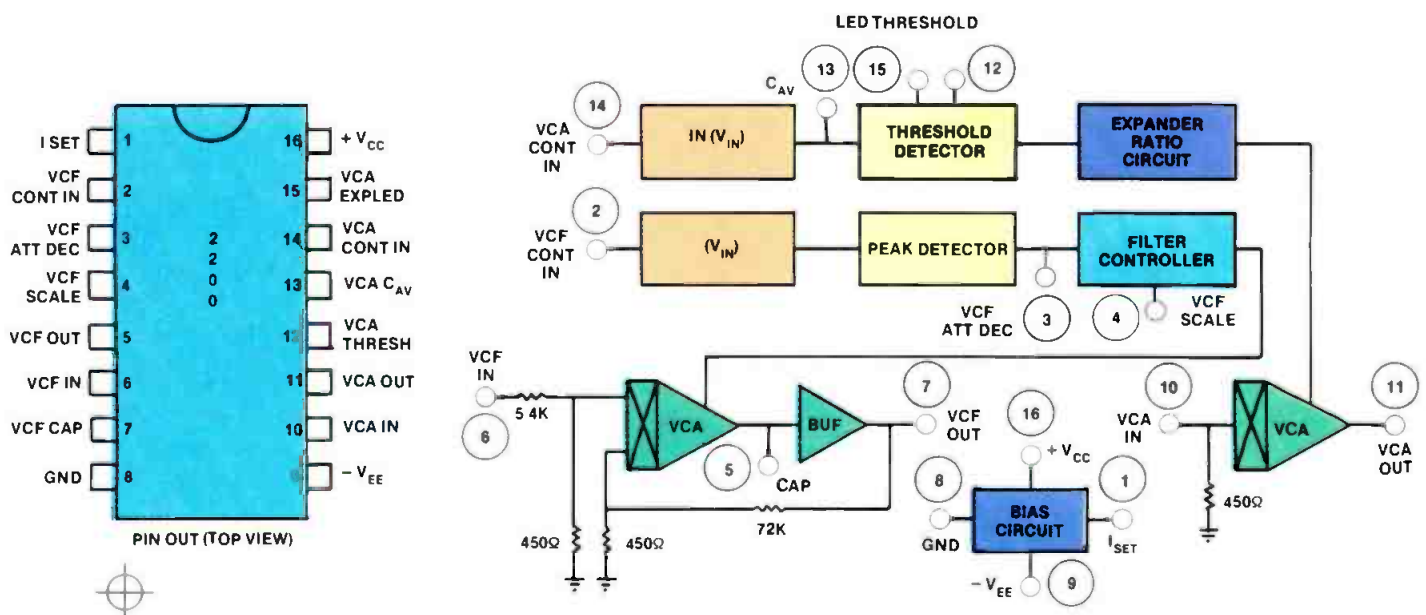

Figure 2. The single-ended noise-reduction circuit relies on an AGC and filter chip.

and 1-hour Fox Broadcasting programming forces the synthesizer to repeatedly detect one missing channel. Then, just as fast, the device will have to switch to the bypass mode to direct the stereo feed

straight to the stereo generator. The synthesizer also detects dual-channel mono commercials. It is not fooled by minor phase differences that may exist on the tape machine. We have been quite pleased

by the unit's consistency in recognizing monaural programming and switching to stereo synthesis when required.

The synthesizer creates a pseudo-stereo effect from the monaural signal by di-

viding the audio spectrum into several frequency bands as shown in Figure 3. Each of these bands is used to develop the left and right channels. The net effect is a complementary comb filter. The ear perceives the resulting signal as a stereo-like effect with substantial depth and relatively wide spatial perspective.

To generate the artificial L-R signal, the mono audio is first passed through a chain of phase shifters. The resulting L-R signal is then added to the mono signal to create the synthesized left channel. The L-R signal is subtracted from the mono signal to create the right channel. The sum of the two synthesized channels remains equal to the original mono signal, thus ensuring mono compatibility.

Two modes are provided in the synthesis mode: wideband and narrowband. The narrow mode creates many narrow frequency bands and is better suited for programs containing a great deal of dialogue. Because much of our station's programming falls into this class, we use the narrow mode most of the time.

The wide mode is suited for musical programming. This mode of operation creates only a few wide frequency bands and results in a dramatic sense of stereo space on music and effects.

A front-mounted separation control allows adjustment of the relative width of the stereo image. Once adjusted, it needs no further attention.

Remote control

All of the unit's functions can be accessed by an optional remote-control panel or an external automation system. The remote-control panel can be located up to 5,000 feet away.

If used with an automatic system, the control signals can be either continuous voltages or pulses. A back-panel switch selects the desired mode. In the pulse mode, the automation system duplicates the front-panel buttons. In the continuous mode, a continuous voltage is required to override the manual controls. The synthesizer's logic reverts to its former standby state when the voltage is removed.

Because our transmitter does not lend itself to this type of operation, we depend on the transmitter remote control for switching functions. Even so, we do not find this to be a limitation in our operation.

Maintenance

Although our station supports a stringent maintenance program, no adjustments are required on the synthesizer. At most, the unit is dusted off once a month.

The unit was opened for inspection upon delivery. Since then, the covers have not been removed. The mainte-

'A vital link'

Brian Sanderson, Sound Designer
Chanhasen Dinner Theatres

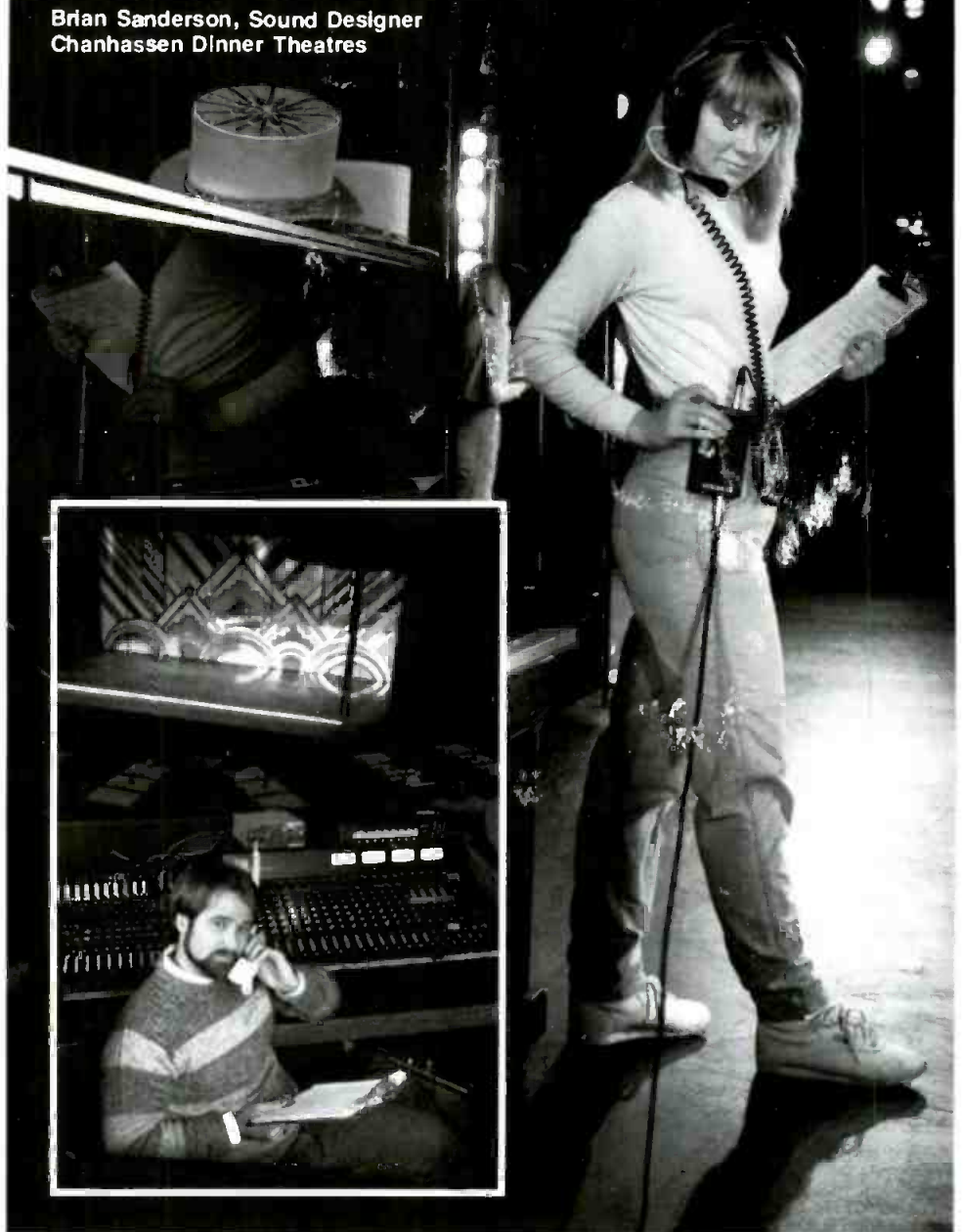

Brian Sanderson has been using Telex intercom equipment in each of the four theatres at the nationally acclaimed CHANHASSEN DINNER THEATRES complex for several years now. When "A Chorus Line", with hundreds of difficult stage and lighting cues, was recently added to its main theatre, Chanhasen upgraded the system to include a multi-channel master switchboard. "I can't imagine doing the show without the Telex Audiocom", Brian said, adding "I depend on it to provide a vital link between the house board and backstage".

The new Phase 2 Telex Intercom systems are uniquely flexible. You can start with the simplest two-party communication system and expand easily to a director controlled multi-channel network.

For complete details telephone or write to: Telex Communications, Inc.
9600 Aldrich Ave. So., Minneapolis, MN 55420 □ Telephone (612) 887-5550



AUDIOCOM

TELEX

Circle (114) on Reply Card

May 1987 *Broadcast Engineering* 139



PESA

The "NEW SWAT PLUS"

Best Stations and Production Houses Assistant

automatic analysis of all sync parameters of the video signal * video monitor output * local liquid crystal display * two independent video inputs * manual/automatic testing modes * alarm indicators for parameters out of tolerance * self-test software * RS 232 output to feed printer or PC * PAL/NTSC version.

Standard Measurements

Watcher-Analyzer:

- * sync and burst amplitude
- * horizontal sync width
- * number of cycles in burst
- * breezeway
- * number of vertical sync pulses
- * equalizer width
- * vertical pulse width
- * SC/H phase up to two degrees
- * SC frequency error up to 0.2 Hz

PLUS

- New * Horizontal Blanking Width
- New * Vertical Blanking Width
- New * Front Porch Width
- New * Amplitude in mV (PAL) IRE Units (NTSC) measurements also
- New * VITS Information detection

Timer:

- * H and V lock
- * PAL lock
- * H delay and SC phase delay between Inputs A and B
- * S ync
- * W atcher
- * A nalyzer
- * T imer

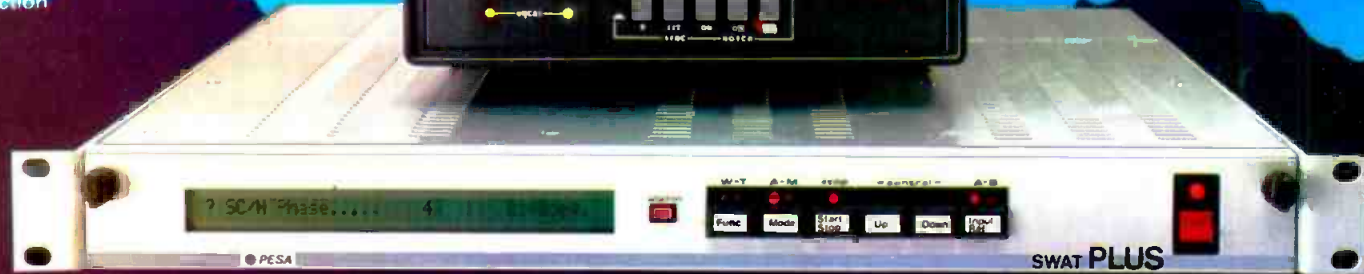

Pesa Electrónica, S.A.

Albalá, 12 - 28037 Madrid (Spain) - Telex 48449 PESAE E - Tel.: 754 00 78

Pesa America Inc. 6073 NW 167th St.-Unit C-4 Miami FL 33015 (USA) - Telex: 6712435 PESAM - Tel. (305) 556 - 9638 - Toll Free: 1-800-USA-PESA (USA, Canada, South America, Caribbean)

Pesa International Ltd. The Paddocks 347 Cherry Hinton Road, Cambridge CB1 4DJ (U.K.) - Telex: 81678 PESAI G - Tel.: (223) 24 26 42 (UK, Europe, Middle East, Africa, Far East, Australasia)

The affordable hi-tech.

Circle (117) on Reply Card

www.americanradiohistory.com



What SBE is doing for you

By Bob Van Buhler

The old question, *What have you done for me lately?*, probably has been asked of most professional organizations. Every once in a while it's a good idea to stop and remind ourselves what the national SBE office does on behalf of its members.

Certification

One important task, undertaken years ago by the SBE, has been the development and promotion of the certification program. The SBE certification program has done more to enhance the credibility and salaries earned by broadcast engineers than any project ever undertaken. SBE certification provides a way for an engineer to add distinction to a career in a visible and profitable way.

Certification also provides avenues for advancement and proof of one's competence in a field that is otherwise blurred by FCC deregulation. The SBE certification program is the industry's only universally recognized "stamp of competence." If you doubt this fact, check out the BE annual salary survey. The survey graphically and indisputably bears out that SBE certification is recognized by and valuable to employers. This recognition typically shows up as increased salaries to SBE certified engineers.

Further evidence of the industry's view of certification is available in the classified employment advertisements. Pick up any trade publication and examine the help wanted advertisements. Every month you see more and more references to "SBE certification preferred." Some job notices now even state that SBE certification is required. For the engineer willing to make the effort, certification provides the path to better recognition, rewards and the opportunity for higher salaries.

Other membership services

The SBE job bank is another project that can help engineers who want to improve their lots. These job bank listings will soon be posted on CompuServe in a double-blind format. The postings help

serve the needs of both employers and engineers across the country. Once implemented, the information will be available 24 hours a day.

The job bank listings currently are available only through the national office and SBE *Shortcircuits*. The list of jobs continues to grow and there are more openings than applicants.

The SBE also offers a comprehensive group life insurance plan. As a part of the Engineering Associations Insurance Trust, inexpensive term life insurance is available to all SBE members. Because of the program's success, premium discounts and coverage-upgrade offers regularly are provided. Engineers working in small stations or as independent contractors often find the program as an attractive means of providing financial security to their families.

Need to rent a car? SBE members are provided discount car rental rates with at least one agency. These rates are comparable to those provided to large corporations. The latest discount rental card was issued with the membership dues notices.

The Ennes scholarship fund provides assistance to individuals studying broadcast-related technology. This assistance also is available to SBE members and their families. If you have a son or daughter or know of someone needing assistance to complete a technical education, contact the national office.

These items are but a small part of what the society does for its members. Additional information will be presented in a later column.

CompuServe forum

Although the discussion was friendly and interactive, the turnout for the CompuServe bylaws forum was sparse. Less than 20 users signed-on to the forum to talk about the proposal to amend the bylaws.

The whole issue of changing the bylaws has been around for several years. However, because of the issue's importance, everyone should thoroughly understand what the changes mean to the society. Each member should be familiar with the language and treat each

proposal as a separate matter. Each proposal will be voted on individually and must stand on its own merit.

According to the SBE's attorney, the only way the bylaws can be changed is through a separate vote for each proposal. The numerous proposed revisions cannot be tied together under a single yes or no vote.

The proposed changes will appear in the next issue of the SBE *Signal*. The entire text also is available in the SBENET area of CompuServe. If neither of these methods is satisfactory, contact the national office for assistance.

Certification guides

Ready to move up to the next certification level? Study guides, which are mentioned in the certification booklet, are now available from the national office. Study guides are available for the following categories: broadcast technologist, broadcast engineer AM/FM, broadcast engineer TV, senior broadcast engineer AM/FM and senior broadcast engineer TV.

The guides can be ordered by prepayment of \$4.95 or charged to a Visa or MasterCard number. Contact the SBE certification secretary at 7002 Graham Road, Suite 118, Indianapolis, IN 46220. Credit card orders can be placed by calling 317-842-0836. Be sure to specify the desired study guide when placing your order.

New officer and board member

On a roll-call vote, the SBE board of directors appointed Bill Harris as the new SBE treasurer. The appointment will continue until a new treasurer is elected this fall. Harris was an elected SBE board member and is technical director for KMJI-FM and KRZN-AM, Denver. He replaces Wally Dudash, who recently retired.

The resulting board vacancy will be filled by Stephen R. Brown, WLTE-FM, Minneapolis. Brown is chapter chairman for Chapter 17 and a certified broadcast engineer.

Van Buhler is chief engineer for WBAL-AM and WIYY-FM, Baltimore.

HOW WILL YOU TEST BTSC AUDIO?

Your old audio test gear won't hack it. Here are key points when evaluating new audio test equipment:

BZZ-BEATS: Buzz beats are not harmonically related to the signal. THD + N measurements spot them by removing the fundamental, measuring everything else. Instruments that measure 2nd or 3rd harmonic at spot frequencies may not.

ABSOLUTE ACCURACY: Setup of BTSC generators for maximum separation requires measurement accuracy of 0.1 dB, channel matching to 0.02 dB, phase accuracy of 1 degree. Instruments with 0.1 dB resolution can't do it; Audio Precision's System One can.

DEVIATION SETTING: BTSC tracking demands that your stereo generator's reference level produces exactly 25 kHz deviation. Set System One's oscillator to the reference level with 0.01 dB settability. Use its 10,396 Hz frequency (0.03% accuracy) and Bessel null techniques for precise deviation setting.

BROAD TESTING CAPABILITIES: High-quality audio testers sell for \$6,000 to \$12,000. At that price, they should test everything in the station-VTRs, ATRs, consoles, processors, distribution amplifiers, routing switchers, full station proofs. They should measure IMD, wow and flutter, phase, frequency, THD + N, broadband and selective amplitude and noise. Audio Precision's System One does.

PERFORMANCE LEVELS: In 5 to 10 years, much of your audio chain will be digital. That puts tough demands on test equipment. Today, some VTRs have PCM audio channel distortion below 0.01%. Your audio test set distortion should approach 0.001%. System One guarantees <0.001%.

AUTOMATION: Automated testing is the economical alternate to increasing staff. System One saves setups, graphs and stores data, prints output. You concentrate on results instead of how to make the measurement.

PROPER PROOFS: Recommended practices call for proofs at constant deviation percentage. That requires data flow from analyzer to oscillator, software that adjusts oscillator amplitude for constant deviation, then measures and graphs oscillator output. Standard with Audio Precision System One.

DAILY PROOFS: Skeleton proofs (even split site) run in 60 seconds at normal operating settings of stereo generator and mod monitor. Daily proofs at sign-on or sign-off help you exercise tight control over audio quality.

If an audio test set doesn't meet these requirements, it's not a complete BTSC tester regardless of its name. System One is used by the leading manufacturers of BTSC stereo generators.

For more information on our complete BTSC testing package consisting of filters and software, call or write Audio Precision today.

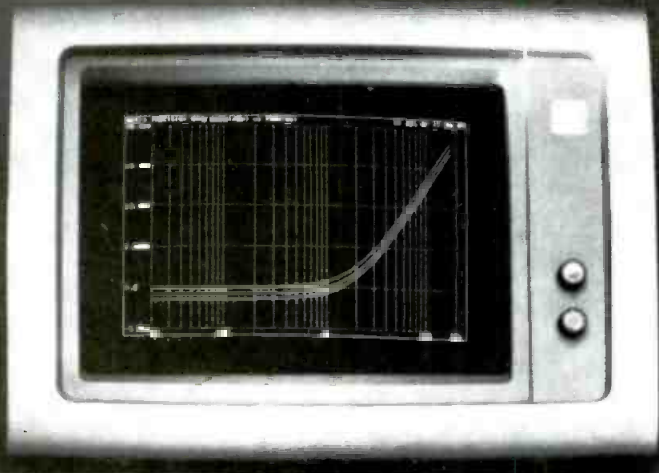

Audio precision

P.O. Box 2209, Beaverton, OR 97075
503/627-0832 1-800/231-7350

Circle (109) on Reply Card



Paul D. Gerlach has been appointed to the position of vice president and general manager at Lenco Electronics Division, Jackson, MO. He is responsible for providing administrative and supervisory leadership; overseeing the production of the electronics product line; and implementing corporate goals, policies and directives.

Steve Smith has been appointed marketing manager of audiotape products for Ampex Magnetic Tape Division, Redwood City, CA. He is responsible for the development and implementation of all audiotape marketing programs. He also will oversee and coordinate the activities of all audio product managers.

Jeff Blackden and **Betsy Edwards** have been appointed to positions with Pinnacle Systems, Santa Clara, CA. Blackden is manufacturing manager and is responsible for materials requirements planning, purchasing, inventory control, vendor relations, quality control and factory service. Edwards is marketing communications manager. She is responsible for advertising, public relations, direct mail programs, collateral materials and trade shows.

Mary Zaller has joined Ultimatte, Reseda, CA, as sales manager. She will take over the sales and dealer liaison portion from Pat Smith, vice president, who is going into semi-retirement.

Jamal Hamdani has been appointed manager of systems engineering and international marketing for Moseley Associates, Santa Barbara, CA. He has been with the company for two years.

Daniel F. Maase has been appointed operations manager for commercial products at Varian Associates, Microwave Equipment Division, Santa Clara, CA. He is responsible for managing all commercial equipment operations, including engineering, manufacturing and program management.

Eugene O. Edwards, Greg Best, Jim Pickard and **George Reis** have been appointed to positions with Harris Broadcast Division, Quincy, IL. Edwards is vice president of sales and service. Best is engineering director, responsible for TV transmitter product development. Pickard is engineering director for sustaining engineering activities, including antenna design, manufacturing, testing and sales support, engineering records; and engineering equipment maintenance. He also is in charge of special equipment design for customers. Reis is engineering direc-

tor for radio product engineering.

Nigel W. Spratling, Debra Underwood and **Don Survilas** have accepted positions with Fortel, Norcross, GA. Spratling is the first European sales manager. Underwood is marketing support manager. Survilas is manufacturing manager.

Dean A. Miller, Ray G. Privette, William B. Rosenzweig and **Jett B. Logan III** have been appointed to positions with Nakamichi America, Torrance, CA, previously Nakamichi USA Corporation. Miller is executive vice president and general manager. He is responsible for home, mobile and professional audio equipment business in the United States. Privette is the vice president of operations. Rosenzweig is president of marketing. Logan is vice president of sales.

William C. Benison has been named president and chief executive officer of Modulation Associates, Mountain View, CA.

John McClimont has been appointed sales manager for broadcasting industry products at Conrac, Covina, CA. He is responsible for all sales and product planning activities for studio monitors and other broadcast video display products, and will work with the major TV network offices in New York and Los Angeles.

Gary L. Hudson has been appointed marketing and sales manager at Meyer Sound Laboratories, Berkeley, CA.

Charles J. Gaydos has been appointed national sales manager for Panasonic Broadcast Systems Company, Secaucus, NJ. Gaydos is responsible for organizing and managing the national sales group in the sales of M-II equipment to the broadcast and post-production markets. He also is in charge of sales for the education and industrial areas through Panasonic representatives.

Aaron Z. Snyder has been named northeastern district sales manager at Magni Systems, Portland, OR. He is responsible for all sales in the northeastern United States.

John McPherson, Jerry E. Smith, Carlo Severo and **George Kuchmas** have been appointed to positions with Sony, New York. McPherson and Severo have joined the Sony Communications Products Company. McPherson is vice president of marketing and will be re-

sponsible for marketing professional industrial TV production and distribution equipment and will head a 9-member national marketing group. Severo is vice president of customer service and will direct all service operations for the professional audio, video, broadcast and information systems products. He also will plan and control service and administrative policies. Smith is division vice president at Sony Professional Audio, with responsibility for sales and marketing to the recording studio and film and video production markets. Kuchmas is general manager of manufacturing for Sony Professional Products Company.

A.J. Menozzi has been promoted to president and general manager of dbx North America. He joined the company in October 1986 as vice president of marketing and sales.

Simon G. Shaw and **Richard Sirinsky** have been appointed to positions with CMX, Santa Ana, CA. Shaw has been appointed manager, Euroservice. He is responsible for sales and marketing functions, including customer service for Europe, Africa and the Middle East. Sirinsky is vice president and director of sales. He is responsible for worldwide sales.

James S. Nichols has joined Garner Industries, Lincoln, NE, as national sales manager for the electronics division. He is responsible for the coordination of sales and distribution of all magnetic media degaussers.

Art Kramer has been appointed president of Miller Fluid Heads, Burbank, CA. He recently opened a sales and distribution office in the United States.



“Tube Be... Or Not Tube Be..”

*That is the question
only VDC can answer.*

SPECIALIZATION

VDC sells only CRTs, and has the most knowledgeable sales force in the industry. Supplying drop in replacements for any manufacturer's tube type is our specialty.

QUALITY

VDC stocks CRTs featuring the latest dark glass, direct etch options in colors ranging from Black and White to European Amber. VDC replacement tubes are often of higher quality than the original tubes.

INVENTORY

With over 70,000 units in stock, representing 3,000 tube types, VDC ships most orders the same day they are received.

PRICING

No one sells the same high quality tubes for less. Not the OEMs, not other tube manufacturers, no one.

1-800-241-5005

VDC VIDEO DISPLAY
CORPORATION

Stone Mountain, Georgia 30086
(404) 938-2080 or Your local VDC distributor

Circle (119) on Reply Card

Tough as Sony.



What we wanted.

One word sums up everything we tried to achieve in the production of VI-K videotape: durability.

Why? Because for us, and you, it's not enough for a videotape to deliver the prettiest picture. It has to be able to do it over and over and over again.

Because the real world for professional videotape is constant jogging, shuttling, still frame editing... and deadlines. So rugged dependability counts every bit as much as dazzling picture quality.

How we got it.

Sony VI-K one-inch videotape was built to be uniquely durable, from the base film up. We developed a truly tough cross-linked binder system and coupled it with the strongest adhesive base film available.

This durable foundation protects an ultra-fine Vivax™ magnetic particle formulation, which delivers astonishing picture quality, higher stability and optimum S/N ratio.

The finishing touch is our carbon black anti-static back coating, which dramatically minimizes dropouts.

**Pound for pound,
Sony videotape
is the toughest
you can buy.**

What you gained.

Amazingly enough, despite being so durable, VI-K has the lowest headwear rate of any major one-inch tape you can buy.

It also has smoother runability and better winding properties. And, oh yes, it delivers an extraordinary picture, too.

What else got better.

Our efforts to provide you with the most durable videotape have also benefitted BCT Betacam® and BRK U-matic® videocassettes. They both provide you with trouble-free still frame editing, totally reliable repeated playback and worry-free long-term storage.

We made the cassette shells and components tough, too, through precision engineering to quality control standards as tough as our tape.

Treat it like a Sony.

Sony professional videotape has the same properties as any Sony: standard-setting video and audio with a "tough as nails" reputation. That's why it's the only videotape you can treat like a Sony.

And we think that hits the nail right on the head.



SONY
THE ONE AND ONLY.

Ampex supplies paint system

Boston Post Production, Boston, has purchased an AVA-3 video graphics system with SpeedTrace and Perspective options, two CVR-40 Betacam studio recorder/player VTRs and an ADO 2000 digital effects system from *Ampex*, Redwood City, CA.

Fuji relocates Dallas office

Fuji's Dallas office has been moved into a new facility. The address is: Fuji Photo Film USA, 1628 West Crosby Road, Suite 100, Carrollton, TX 75006; telephone 214-466-9200 (800-527-0804 outside Texas; 800-441-0528 in Texas).

Colorado Video relocates headquarters

Colorado Video has moved into new facilities at 5490 Spine Road, Boulder, CO; telephone 303-530-9580. The company's mailing address will remain the same: P.O. Box 928, Boulder, CO 80306.

EFX Systems adds Sony consoles and recorders

Sony Professional Audio, Park Ridge, NJ, has announced the sale of two MXP-3036 recording consoles and ADS-3000 SMPTE-based hard-disk automation systems to EFX Systems, a post-production studio in Burbank, CA. EFX also has purchased two Sony PCM-3324 24-track digital recorders, along with two PCM-3202 2-track recorders.

Faroudja Labs delivers 100th encoder to NBC

Faroudja Laboratories, Palo Alto, CA, has delivered its 100th NTSC encoder to NBC-Burbank for use in its newly constructed graphics center, the Magic Room. The encoders employ bidimensional comb filtering to eliminate the NTSC effects of cross color and cross luminance.

Cubicomp offers training videotapes

Cubicomp, Hayward, CA, has developed a series of videotapes to complement its in-person training classes and tests for the PictureMaker 3-D computer graphics system. The tapes were conceived and developed by Steven Tainer, manager of training and documentation. The tapes are an example of the capabilities of the PictureMaker system. Graphics for the series were created on PictureMaker/30 systems. The training course is divided into 18 tapes categorized in three sections: theory, applications and configurations.

Tainer developed the training series in conjunction with The CPU Group, a partnership of three PictureMaker-based ani-

mation and graphics companies established in 1986 to produce the tapes. Members include Bill Hite and Rick Hite of Marshall Productions, Nashville, TN; Scott Grey of Solid Ideas, Dallas; and Jay Sullivan and Lou Giacalone of Advanced Entertainment Associates, San Francisco and New York City.

KPIX adds five CMX 3100 editors

CMX, Santa Clara, CA, has sold five 3100 computer-assisted videotape editing systems to KPIX, the Group W CBS outlet for the San Francisco Bay area. The editors are operating in the station's five post-production suites.

Cromemco becomes a Dynatech Company

Cromemco, Mountain View, CA, has been acquired by Dynatech Corporation, Burlington, MA. Cromemco will retain its name and continue to operate out of Mountain View. Company management will stay the same.

Barco Electronics opens U.S. office

Barco Electronics, Kortrijk, Belgium, has made a commitment to the U.S. market with the establishment of its first U.S. office. Located in Atlanta, this facility will allow the company to directly manage sales and service for its products in the United States. Barco's debut in the United States was marked by its participation in COMMTEX International in Atlanta, Feb. 26-28.

TV stations receive Bogner antennas

Bogner Broadcast Equipment, Westbury, NY, has shipped two high-power antennas to: KDOR-TV Channel 17, Bartlesville, OK, part of the Trinity Broadcasting Network; and WFLI-TV Channel 53, Chattanooga, TN. Both antennas are 32-bay Bogner series BUI. The Channel 17 antenna includes heavy null fill for coverage close to the tower site.

Bonneville announces Ku-band uplink

Bonneville Satellite Corporation, Los Angeles, has announced a full-service Ku-band satellite uplink in Los Angeles. The earth station, which became operational Nov. 1, is available for recurring, occasional-use and dedicated services. The 4-port, 6.1m Ku-band uplink/downlink is frequency-agile and features full-arc capability with redundant HPAs and 300W transmitters. It is located atop the Dollar Building at 6430 Sunset Boulevard.

KARK-TV acquires NEC CCD cameras

KARK-TV, Channel 4, the NBC affiliate in Little Rock, AR, has opted to standardize its news-gathering operation on SP-3A CCD cameras with electronic shutters, from *NEC America*, Wood Dale, IL. The station wanted to replace its equipment with cameras that would be compatible with all tape formats.

NBC also has entered a long-term agreement with NEC involving the purchase of the SP-3A CCD camera systems for use by NBC news and NBC's owned-and-operated stations, primarily with Panasonic's M-II VTR format.

Marconi ships telecines to Australia

Australian TV company, Channel 10, from Sydney, has purchased its second B3410 digital line array telecine from *Marconi*, Chelmsford, England, after working with its first system for six months. The order was placed with Marconi Communication Systems in conjunction with GEC Australia.

Strand Lighting expands in Italy

Strand Lighting, Rancho Dominguez, CA, has acquired Quartzcolor Janiro SpA, Rome, a manufacturer of TV and film studio lighting products. Strand has been the worldwide distributor of Quartzcolor Janiro products for several years, and this acquisition will ensure that Strand Lighting will continue to provide the studio lighting market with products and after sales service.

Ikegami opens West Coast facility

Ikegami, Maywood, NJ, has opened a West Coast, 60,000-square-foot regional facility in Torrance, CA. The facility will serve as a major distribution and warehousing center for the 12 western states. After-sales service, customer training and on-premise repairs, and a full stock of spare parts for the company's broadcast TV cameras, monitors and CCTV products will be handled at the facility.

Video Post installs graphics system

Video Post & Transfer, Dallas, has installed its second Dubner Texta advanced character generator and graphics system. The generator becomes the standard text and background graphics system in its post-production suite. With the addition of the generator there is compatibility between all of the post-production suites at Video Post.

Sachtler relocates

Sachtler has relocated its U.S. headquarters to 55 North Main St., Freeport, NY 11520; telephone 516-867-4900.

Rank Cintel sells telecines

Rank Cintel, West Nyack, NY, has sold two ADS 1 telecines to the Gaylord Broadcasting chain, which is implementing an automation upgrade at its Milwaukee and Cleveland stations. The telecines will transfer movies and syndicated programming to 1/2-inch Sony Betacart, which combines with the Connelly automation system for on-air transmission. The telecines will eliminate the station's need for film editors as well as the storage of 16mm films.

Bext opens office

Bext has opened its office at 739 5th Ave., San Diego, CA 92101. The telephone number is 619-239-8462.

Micro Communications sells combiner

Micro Communications, Manchester, NH, has designed, manufactured and installed a high-power, dual-channel combiner for UHF television on the Sears Tower in Chicago. The MCI model uses two waveguide bandpass filters and two constant-impedance hybrids. The combiner allows two high-power UHF-TV transmitters of 120kW power level, operating on different channels, to use a common feedline and antenna system without causing interference to each other.

Wavefront purchases software division

Wavefront Technologies, Santa Barbara, CA, and *Abel Image Research* have reached an agreement for Wavefront Technologies' purchase of Abel's AIR 3-D software division. Wavefront will continue to develop and market its multipurpose graphics software and will evaluate the Abel code with the goal of combining the best features of each into a new generation of graphics software. Abel Image Research will concentrate on producing high-end computer imagery and will pursue new markets in CD-ROM, CD-I and interactive laser disc productions. Abel also will continue to develop high-end, application-specific software that will not be competitive with Wavefront products. To foster the relationship, Abel will join the technical advisory board of Wavefront.

Nakamichi sells dupe system

Nakamichi, Torrance, CA, has supplied 50 MR-1 professional cassette decks to Mark Custom Recording Services, a divi-

sion of Mark Records, Clarence, NY. The installation, performed by VSM Leasing Corporation, represents the largest MR-1 real-time tape-duplication system to date. Mark is expanding a system of more than 50 Nakamichi LX-5s that have been in operation for three years.

SWA acquires Audio & Design

Straight Wire Audio, Arlington, VA, and *Audio & Design Recording* have an-

nounced a joint venture for the distribution and manufacture of Audio & Design products in the United States. Audio & Design has been acquired by SWA and will move into SWA's manufacturing premises in Arlington, VA. SWA will import and service the entire Audio & Design line. The companies are pursuing joint development of proprietary digital technology for broadcasting and recording production.

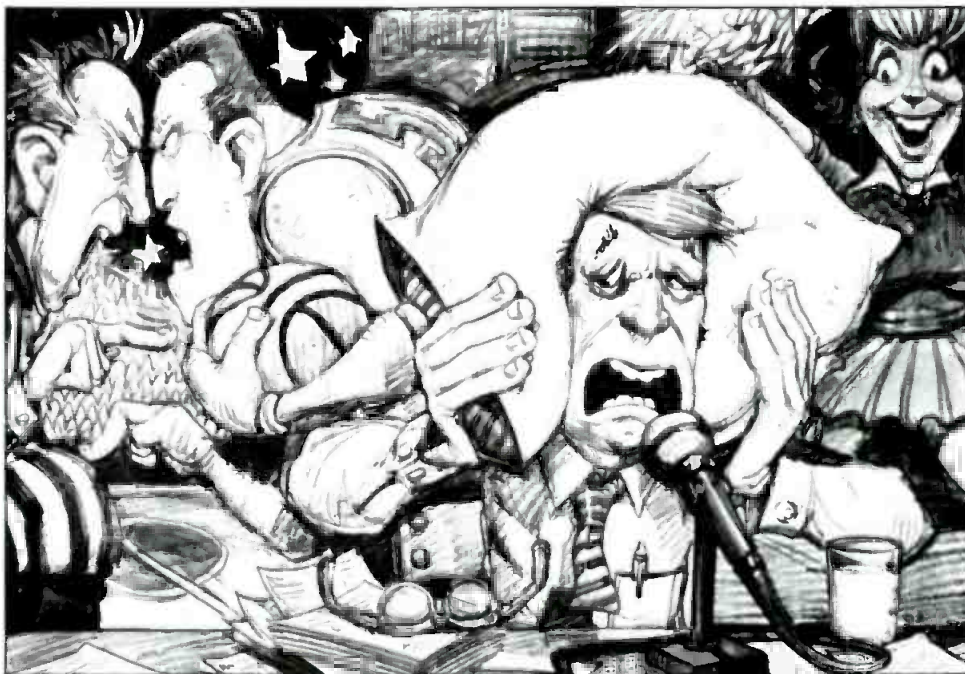

The alternative to our "double isolation" headsets.

The Shure SM1 and SM2 Headsets isolate you from sound in two exclusive ways.

First, these headsets use extra-large, pillow-soft ear pads for superior noise isolation and comfort. Second, they feature a noise-reducing mic, with a precision cardioid polar pattern, to leave background noises where they belong... in the background. The mic's tailored frequency response insures outstanding voice reproduction.

Other features include: an all-metal boom and double-braced, all-metal headband for greater durability and comfort; a patented boom mount for total mic position flexibility; detachable cable; and a stylish matte chrome and black finish that looks great "on camera".

The SM2 is a dual-ear headset, the SM1 — single. For complete information, write or call Shure Brothers Inc., 222 Hartrey Avenue, Evanston, IL 60202-3696. (312) 866-2553.



SHURE

Breaking Sound Barriers

Circle (121) on Reply Card



You can measure...

with the best monitor and the most accurate test set.

The FMM-2/FMS-2 series monitors provide an even greater degree of precision measurement than ever before... **You can measure** S/N below 90 dB, **You can measure** crosstalk below 85 dB, **You can measure** separations of better than 70 dB, **You can measure** frequency response to better than 0.25 dB, **You can measure** distortions to lower than 0.01%, and much more... Our uncluttered panels and autoranging voltmeters make these measurements a dream.

BELAR CALL ARNO MEYER (215) 687-5550
ELECTRONICS LABORATORY, INC.
 LANCASTER AVENUE AT DORSET, DEVON, PENNSYLVANIA 19333
 Call or write for more information on Belar AM, FM, Stereo, SCA and TV monitors.

Circle (123) on Reply Card

Harris and Allied announce agreement

Harris Corporation, Broadcast Division, Quincy, IL, and *Allied Broadcast Equipment*, Richmond, IN, have announced a sales and marketing arrangement. Under the arrangement, each company will retain its separate identity with no changes in ownership and will retain its own dedicated sales force. Allied also will assist Harris in the marketing of Harris radio transmission products, and has been designated as an exclusive authorized representative, permitting Allied sales personnel to present Harris' line of radio transmitters while Harris' direct sales force retains responsibility for the sale of the products. Allied also will be a distributor of selected Harris radio products, which the company will market, sell, install and service.

Allied Broadcast Equipment's Satellite Division, headquartered in Richmond, IN, also will be the 1987 exclusive distributor for the DART 384 digital receiver and its accessories from Fairchild Data Corporation, Phoenix, AZ.

Varian discusses broadcast unit purchase

Varian Associates, Palo Alto, CA, has concluded discussions with Philips Electronics concerning the purchase of Pye TVT Limited, Philips' broadcast transmission subsidiary in the United Kingdom. Pye TVT Limited, Cambridge, UK, designs and manufactures a wide range of broadcast transmission equipment and specializes in the supply of transmission equipment for TV frequencies.

Otari supplies recorders

Masterfonics Recording Studio, Nashville, TN, is the first studio in the United States to purchase the DTR-900 PD format, digital, multitrack recorder from *Otari*, Belmont, CA. The company chose the recorder for its remote-control features.

Mitsubishi delivers recorders

The Mitsubishi Pro Audio Group, San Fernando, CA, has announced several shipments of its digital multichannel tape recorders. Six X-850 32-channel digital recorders have been delivered to A&M Records, Gear Studios, Ivan Rene Moore Studios and Enterprise Studios, all in Los Angeles; Clinton Studios, New York; and Audio Media Studios, Nashville, TN. The first X-400/8 8-channel digital recorder has been shipped to the Burbank Studios in Southern California, for use at its film rerecording facilities.

We've taken apart half a million videocassettes and saved our customers 2 million dollars

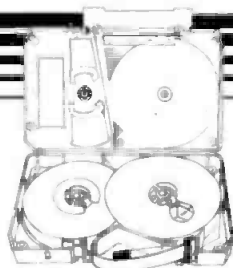

Before we'll reload a 3/4" u-matic videocassette we take it completely apart and rebuild it inside and out. We replace wiper flaps, friction pads, tape guides and leader — everything that's needed to make the cassette test as good as new. Only then will we reload it with new 3 M videotapes or other major brands. If we can't rebuild it we won't reload it.

Coarc also loads new cassettes with broadcast quality videotape for Betacart and 3/4" cart systems.

CoarcVideo™

Custom Loaded Videocassettes (518) 672-7202
 P.O. Box 2, Route 217, Mellenville, New York 12544

3/4" RELOADING □ PROFESSIONAL VHS & BETA □ 1/2" AND 3/4" CART CASSETTES

Circle (124) on Reply Card

Want more information on advertised products? Use the Reader Service Card.

1:7-)))

Limitless!

IKEGAMI'S NEW HK-323P IS THE IDEAL PORTABLE COMPANION FOR YOUR HK-323 FIELD/STUDIO CAMERA.

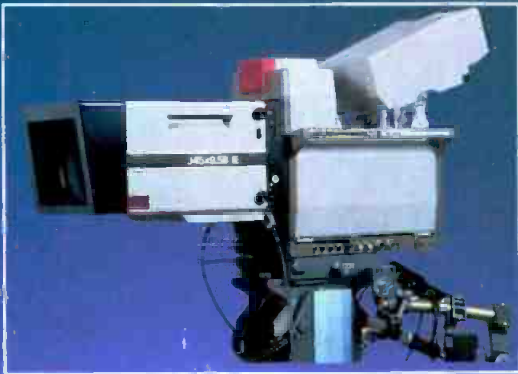

The HK-323 Field/Studio Camera

Ikegami's HK-323 1" and 2/3" field/studio cameras are big news...so is the smaller HK-323P companion camera. This lightweight hand-held model provides the user with limitless potential, flexibility and performance that meets and exceeds industry standards for excellence.

Featuring a built-in micro-processor for various software based control functions and fully automatic setup, the HK-323P operates from the same base station as the HK-323 and offers high performance prism optics, auto-knee circuitry to handle high contrast, scene files with extensive memory, for the sharpest picture quality regardless of scene color content or special color lighting. This, plus selectable gamma values; 0.45, 0.4, 0.35, two memorized servo filter wheels each with four positions, a back-up memory system and various adaptors for total system flexibility.

Go the limit with the HK-323 and HK-323P companion camera system.

For a complete demonstration of the Ikegami HK-323 and HK-323P, contact us or visit your local Ikegami dealer.



Ikegami

Circle (125) on Reply Card

Ikegami Electronics (U.S.A.), Inc. 37 Brook Avenue, Maywood, NJ 07607

East Coast: (201) 368-9171; West Coast: (213) 534-0050; Southeast: (813) 884-2046 Southwest: (214) 233-2844;
Midwest: (312) 834-9774; Hawaii: (808) 946-5955

www.americanradiohistory.com

Fluid heads and tripods

Miller Fluid Heads has introduced the following products:

- The Miller 20 for CCD camera payloads up to 20 pounds features sliding counterbalance plate, continuously variable fluid tension, 75mm claw-ball leveling and positive locks on pan and tilt.
- The Miller 30 for camera payloads up to 30 pounds features integrated variable counterbalancing, preset fluid tension settings in pan and tilt, quick-release plate and 100mm claw-ball leveling.
- The Miller 50 for camera payloads up to 50 pounds features integrated variable counterbalancing, preset fluid tension settings in pan and tilt, quick-release plate and 100mm claw-ball leveling.
- The Miller 80 for camera payloads up to 80 pounds features integrated adjustable counterbalancing and a sliding camera platform with quick-release plate, preset fluid tension settings in pan and tilt, a full positive-locking system with additional safety lock and 150mm claw-ball leveling.
- The Miller compact tripod is a lightweight, black-anodized tubular tripod with locks that feature overtightening protection and a raised spreader system.
- The Miller midi tripod is a midrange, 4-element tubular tripod, with black-anodized finish, locks and raised spreader system.
- The Miller maxi tripod has a heavy-duty, 4-element tubular construction, with black-anodized finish, raised spreader and locks.



Circle (350) on Reply Card

Audio mixer

Precision Design has introduced the ROAM-8, a remote on-location audio mixer. The unit is housed in a poly case and operates on ac or dc voltages. The mixer operates on dc through an internal extended-life battery pack. Input consists of eight mic or line channels with full low, mid and high EQ. Two independent headphone jacks with individual level adjust are provided along with a limiter, telephone logic and pink-noise generator. Output is sent via studio line feed or an internal telephone transmission network.

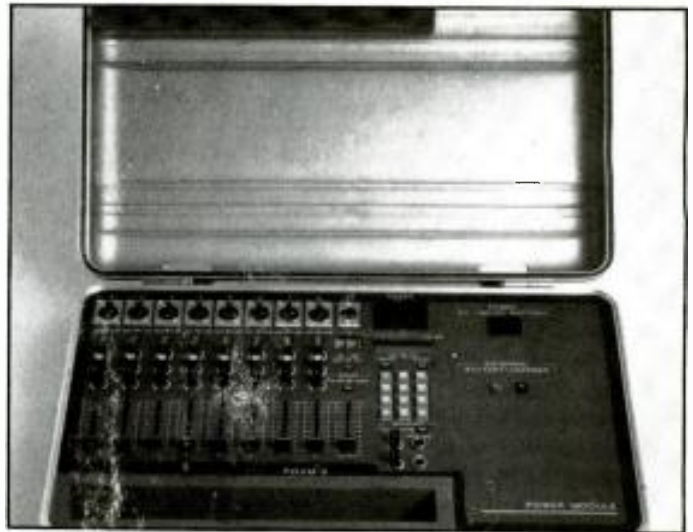

Circle (351) on Reply Card

Time-code generator/reader

For-A has introduced the TGR-3300 compact, self-contained time-code generator/reader. It generates and reads longitudinal time code (LTC) for high shuttle speeds and vertical interval time code (VITC) for slower speeds and pause. Both LTC and VITC can be selected either manually or automatically with line selection also possible for VITC. The system reads control track in the event of time-code loss. Other functions include EBU and SMPTE time code; slave-lock to correct or replace time code lost through tape deterioration; color frame lock to synchronize time code to color phase; drop-frame compensation; error bypass; and time-code display.

Circle (352) on Reply Card

Microphones

HM Electronics has introduced the following microphones:

- The HM58 unidirectional dynamic hand-held microphone with mic-mute switch comes with a 3-pin XLR cable, mic clamp and vinyl bag. It has a non-glare finish.
- The RM77 digital reverb unidirectional electret microphone has reverb built in. An adjustable control permits varying the amount of reverb and a 3-position switch provides the capability to mute or add echo. The mic also comes with a 3-pin XLR cable, mic clamp and vinyl bag. A built-in pop filter minimizes external interference.
- The EM43 omnidirectional electret lavalier microphone comes with mic clip, windscreen and case. It is designed to work in RF environments.

Circle (353) on Reply Card

Character generator add-on features

Laird Telemedia has introduced three add-on features for the model 1500 character generator:

- The model 1524 Data Tablet is used in conjunction with the Font Developer. It allows the user to edit and create new fonts and logos. The tablet provides a user-friendly, icon-driven menu. Fonts and logos can be drawn in freehand on the screen or traced on the tablet surface.
- The model 1526 Camera Entry is used in conjunction with the Font Developer, and allows the user to digitize any character, logo or picture and use it as a character in a font.
- The model 1528 Font Developer allows the user to create fonts and logos. Fonts the user already has may be resized to as small as six scans and as large as 256 tall. In single scan

FUJINON'S NEW A8.5x5.5ERM — THE WIDEST ZOOM IN THE WORLD



- **With extender — 9.3mm**
- **Without extender — 5.5mm**
- **Best maximum aperture of any wide angle lens**

The Fujinon advantage — deploying the 1.7X extender gives you a 9.3mm wide angle instead of 12mm.

You told us what you wanted in an ultra wide angle zoom. The added range and flexibility of an extender without settling for a wide angle any ENG can offer. You wanted a zoom that could cope with lower light level operation.



We've delivered. Designed and manufactured with your input, Fujinon's new A8.5x5.5ERM is the widest zoom made. Instead of a conventional 2X extender, it has a 1.7X extender. When it's in position, you still get an extra-wide 9.3mm. And, at the full tele positions (1X - 47mm, 1.7X - 80mm), it gives you a half F-stop speed advantage.

In fact, the F1.7 maximum aperture remains flat from 5.5mm out to 37mm and drops only to F1.9 at the full tele

position. Throughout its dual ranges, you get distortion-free zooms with all the brightness, contrast, and color accuracy that has made Fujinon famous. Naturally, the new A8.5x5.5ERM provides the high MTF and low longitudinal chromatic aberration you expect from Fujinon.

You also wanted absolute production control. To accommodate your needs, the lens accepts a full range of Fujinon studio conversion accessories including shot boxes that deliver push-button operation with accuracy to a single millimeter and zooms at the precise speed you want. It's even available with a built-in test pattern projector.

To learn more about all of Fujinon's wide angle zooms — the A3.5x6.5RM, A7x7RM, the new A8.5x5.5ERM, and the A18x8.5ERM — you'll get more information or a demonstration by calling the Fujinon location nearest you.

FUJINON INC. 10 High Point Drive, Wayne, NJ 07470 (201) 633-5600 Telex 6818115
SOUTH 2101 Midway, Suite 350, Carrollton, TX 75006 (214) 385-8902
MIDWEST 3 N. 125 Springvale, West Chicago, IL 60185 (312) 231-7888
WEST 118 Savarona Way, Carson, CA 90746 (213) 532-2861 Telex 194978



FUJINON

Circle (126) on Reply Card

steps this will provide the owner with 250 different sizes of any font. New font and logo creations can be done as well, using the character generator and entering in the new character manually. The Font Developer contains software to run both the Camera Entry and Data Tablet options.

Circle (354) on Reply Card

SMPTE time-code window generator



HORITA Company has introduced the WG-50 time-code window generator. The Micro-Window provides a means of making burned-in time-code window-dub copies of SMPTE time-coded videotapes. The generator reads play speed SMPTE time code and converts it into a digital clock type of display that is surrounded by a black mask. This time display is then inserted into the video signal for recording along with the picture. The generator also can be used to burn-in a time-

code window on an edit master tape when stripping it with black or color bars.

Circle (355) on Reply Card

Portable microwave spectrum analyzers

Hewlett-Packard has announced two portable, programmable microwave spectrum analyzers. The HP 8562A and 8562B analyzers meet MIL-T-28800C, Type III, Class 3, Style C requirements for ruggedness and feature 5-minute warmup time; synthesized tuning; AM/FM demodulators and speaker; and a continuously self-adjusting IF section. The 8562A has tracking preselection from 2.75GHz to 22GHz, while the 8562B is a non-preselected version for applications that don't require microwave preselection. Except for preselection, both versions are identical. A built-in frequency counter has 10Hz resolution and a delta-frequency mode that measures the frequency difference between a birdie and the recovery pilot. The analyzers also have a 1dB/division scale factor.

Circle (356) on Reply Card

Audio processor

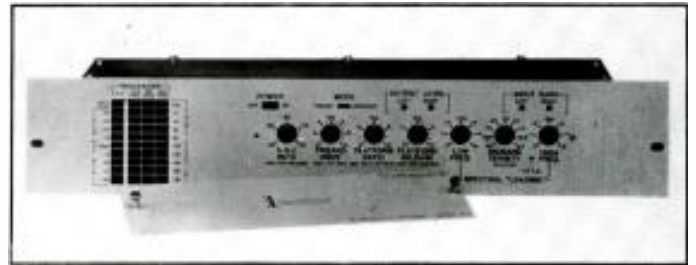

Inovonics has announced the model 255 stereo audio processor with Triband/PWM, which incorporates the triple function of gated, gain-riding AGC, 3-band dynamic compression and program peak limiting. Wide range control over subjective results is afforded by a variety of calibrated user-adjustments with emphasis on assignment of program spectral distribution and density. The unit uses pulse-width modulation in a system of soft-knee feedforward gain reduction. The upper crossover frequency is selectable to accommodate 50ms or 75ms or flat transmission characteristics.

Circle (357) on Reply Card

Tape analyzer system

Jasoni Electronics has introduced the TAS-1000 compact, self-contained tape analyzer. It plugs into audiotape equipment for checks and alignment of mono and stereo tape recorders and reproducers. Features include: noise generator for phase error alignment; sine oscillator; distortion less than 1%; frequency response of 1dB; built-in monitor speaker, switch selectable left, L+R, and right channels; stereo termination switch for 10kΩ and 600Ω sources; balanced inputs and outputs; and transformer powered.

Circle (358) on Reply Card

BTSC stereo generator

Leaning Industries has introduced the MTS-2 BTSC stereo generator. The unit encodes satellite or local programming into the BTSC (stereo television) format using dbx companding. Two pairs of left and right inputs may be selected by remote or local control and input switching can also be used for local ad insertion. The built-in stereo synthesizer may be used with mono services. A test-tone generator, separate video and 4.5MHz loop-throughs are provided.

Circle (359) on Reply Card

Electronic Post-Production for Film and Video

A USC/SMPTE sponsored national teleconference

Saturday, May 16, Los Angeles

Explore the latest trends and techniques in electronic post-production with experts from the film and TV industries. Speakers will discuss:

- Film-to-tape transfers
- Editing systems
- Special effects
- Standards conversion
- HDTV
- Future technology

For information on attending the seminar, contact the School of Cinema-Television, University of Southern California, at 213-743-7469 ext. 208.

Presented by USC and SMPTE
committee on education

DMM/storage oscilloscope

Leader Instruments has introduced the model LCD-5840 combination digital multimeter/storage oscilloscope. The oscilloscope section is equipped with a 200kHz bandwidth, 10mV sensitivity and an auto range mode that automatically sets the time base. An on-screen display of setting conditions includes sensitivity, time base, triggering, slope and sync. Other features include roll mode, pretrigger mode and a battery-backed memory that allows storage of three waveforms with their setting conditions. The DMM section offers automatic ranging, automatic polarity indicator, ac and dc measurement functions and a low-ohm mode.



Circle (360) on Reply Card

Lighting equipment

LTM Corporation of America has introduced a range of lighting equipment:

- A camera light features on-board dichroic and scrim and a focusing knob.
- The HMI Sun Gun uses the 270W HMI single-ended lamp. Input voltage is 24V or 30V.
- The Mark III 575W and 1,200W softlights are compact and can be operated in any position, vertical to horizontal, without restrictions.
- The HMI Multipar 8 uses eight Brite Beam 200W lamps offering a total of 1,600W with adjustable modular elements that can achieve a 180° spread. The lamp offers flat profile and can be ignited or cut off in pairs, and is focused by an individually rotatable set of four lenses offering different beam patterns.
- The microphone poles are made of carbon and fiber glass, and there is an access hole at the top of the pole if a wire needs to be run inside. The poles come in five sizes.

Circle (361) on Reply Card

Video test signal

Magni Systems has introduced the Dual Timing Pulse. It is a test signal that enables technicians to use existing NTSC monitors to test CAV equipment for delay timing and amplitude errors. For those applications where the CAV signals are encoded to NTSC format, the signal allows studios to use standard NTSC waveform monitors and vectorscopes to measure amplitude and delay errors between the CAV channels. The

- Audio Follow Video
- Balanced Stereo Audio
- Rack Mount 19" x 1-3/4"
- BNC Connectors - Video
- Multiple Edge-Board Audio Connector
- Centralab Switches - Interlocking
- Bifurcated Silver Contacts
- Legend Strip
- Unswitched Video Terminated - 75 OHMS
- Unswitched Audio Easily Terminated
- No Signal Loss
- No Signal Degradation
- Cross Talk Better Than -60db
- No Power Required
- Simple Construction - Long Life
- Light Weight - Under 5 lbs

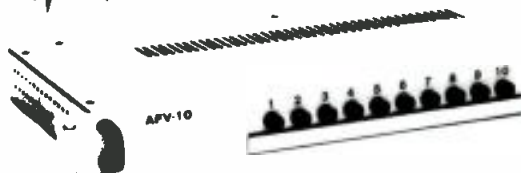

THE IDEAL WAY TO SWITCH MONITOR FEEDS
IN A PROBLEM-FREE, ECONOMICAL MANNER.

10 x 1 PASSIVE SWITCHER

LOW COST
\$295.00

Model AFV - 10

H.M. DYER Electronics, Inc.

48647 Twelve Mile Road Novi, Michigan 48050 (313) 349-7910

Circle (93) on Reply Card

FREE 32pg Catalog & 50 Audio/Video Applic.

PWR SUPP. EQ
PHONO, MIC
TRANS, ACM
TAPE, VIDEO,
LME, OSC

8-in/2-out, 12-in/4-out, 18-in/4-out

Video & Audio Out Amps, TV Audio & Recd Prod Consoles

OPAMP LABS INC (213) 934-3566
1033 N Sycamore Av LOS ANGELES CA, 90038

Circle (96) on Reply Card

PRECISION MAGNETIC TEST TAPES

STL

Standard Tape Laboratory, Inc.
26120 Eden Landing Road #5, Hayward, CA 94545
(415) 786-3546

Circle (97) on Reply Card

SAVE TIME

For fast, accurate service, please remove the peel off label used to address your magazine, and attach it to the Reader Service Card, the Address Change Card or to any correspondence you send us regarding your subscription.

Satellite TV Head End Equipment

Reliable CATV, TVRO and Head End equipment for the Broadcaster.



RECEIVERS • MODULATORS
DEMODULATORS • PROCESSORS

ISS INTERNATIONAL SATELLITE SYSTEMS
104 Constitution Drive, #4 Menlo Park CA 94025
West Coast (800) 227 6288
East Coast (800) 351 4477 (415) 853 0833

Circle (94) on Reply Card

Create with Your TBC



Your video production fantasies soar to new heights with ALTA's Cygnus. Our infinite window TBC/Synchronizer and its palette of special effects transform your video production dreams into reality.

With Cygnus' Digital Picture Freeze, strobos, variable posterizations, colorizations and variable mosaics, your creative limits vanish. And ALTA takes your video production dreams one step beyond with full 8-bit resolution, proc amp controls, 4 x 1 video/stereo audio switching and separate vertical and horizontal image enhancement controls. You master the entire spectrum with finger-tip ease.

Video fantasies materialize with Cygnus, ALTA's unbelievably economical creation for only \$4,990. Contact us for complete details.

Cygnus
ALTA
GROUP, INC

535 Race St. San Jose, CA 95126 408-297-2582

Circle (122) on Reply Card

signal is available on the model 1515 test signal generator.

A bowtie signal on the model 1515 generator also has been introduced, with 10ns increments between the timing marks generated with the signal. The bowtie signal is displayed on an oscilloscope or CAV waveform monitor to determine timing and amplitude errors between channels on CAV equipment. The generator displays both the 20ns bowtie and the 10ns bowtie simultaneously.

Circle (362) on Reply Card

Amplifier



McKenzie Acoustics has introduced the Q-MAX 600 stereo amplifier to complement its Q-MAX 7000 system PA loud-speaker enclosures. The amplifier is 300W per channel. The amp's input circuit eliminates hum loops without disconnecting the mains safety ground, and a relay-controlled delay banishes power surges and speaker thump during switch-on. A matte black design incorporates LED bar graph protection on the front panel. At the back of the amplifier, connection is offered via male and female sockets.

Circle (363) on Reply Card

Automation system

Rational Broadcast Systems has announced the total automation system. It provides real-time updates and ad hoc inquiry, with fingertip control of critical information. It integrates traffic, programming and billing, provides tape inventory with bar-code validation and writes reports. Existing PCs may be used as on-line terminals as well as for networking and file transfer. Total installation, documentation and training are all provided by Rational. The automation system is centered on a 32-bit minicomputer. Its database is self-reorganizing.

Circle (364) on Reply Card

Digital video effects system

Microtime has introduced the Genesis 1 Act 1 digital video effects system, which features continuous variable filtering and interpolation cards that result in compressed images with enhanced resolution and antialiased picture edges. The unit can operate with composite or component video. The filtering and interpolation cards are available to existing users as an upgrade.

Circle (365) on Reply Card

Uninterruptible power sources

Networx has introduced a line of uninterruptible power sources: the Networx Power Backers 330 and 450. They respond within 2ms and 4ms, respectively, furnishing uninterruptible power during blackouts, brownouts and power sags, and maintain power for up to 30 minutes. The power sources

also have fast-response circuitry that guards broadcast equipment, computers, computer data and other hardware against surges, spikes, RFI and EMI. The power sources are applicable to non-linear-type loads, operate from 120Vac, 60Hz single-phase input, and come with 6-foot, 3-wire power cords.

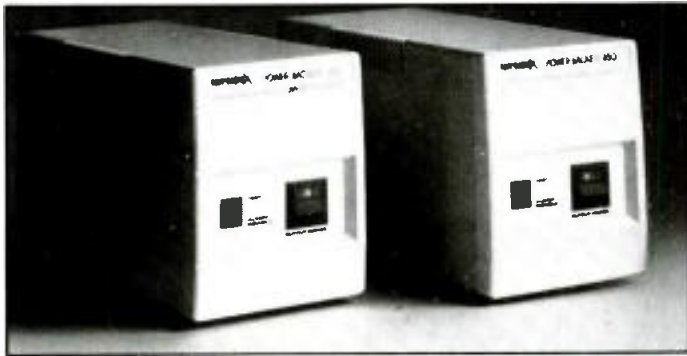

Circle (366) on Reply Card

Spatial image enlarger

Modulation Sciences has announced the Stereomaxx spatial image enlarger, which operates in the spatial domain. The unit is totally mono-compatible and is fully compatible with audio-processing gear. The unit is recommended as the next-to-last device in the audio chain, before the limiter.

Circle (367) on Reply Card

Solid-state 30kW UHF transmitter

NEC has introduced the PCU-930SSW high-power UHF 30kW transmitter that is 100% solid-state (both visual and aural). The transmitter is multichannel TV sound compatible, and can be used with any of the stereo generators without modification to the transmitter. The transmitter also features a solid-state, high-performance exciter with 30% fewer circuit components. Built-in remote-control/telemetry facilities allow unattended operation.

Circle (368) on Reply Card

Production cart

Nalpak Video Sales has introduced the TK-500 heavy-duty production cart featuring a 75-pound capacity; expandable/removable top shelf to accommodate monitor/recorders; and a large-capacity, adjustable bottom platform. The unit can be modified by lifting off the top shelf and adjusting the lower platform to create a 300-pound capacity luggage cart with mud guards, stair slides and a set of outrigger back wheels. The unit may be converted into a compact package that fits under an airline seat by flipping up the bottom shelf, folding in the back wheels and collapsing the handle.

Circle (369) on Reply Card

Static transfer switch

Powermark has announced microcomputer-controlled static transfer switches for providing 4ms bidirectional transfer between any primary and secondary power sources. When used in an off-line mode, the switches' microcomputer continually monitors the primary power source and transfers to an alternate source if power drops below a usable level. When primary power is restored the switch transfers the load back to the primary source. The switch also offers 4ms reverse transfer for on-line applications, switching to the ac line or other primary source if the secondary power fails. The switch is available in power ratings of 2.5kVA and 5kVA.

Other features include transfer and line-loss alarms and rack-mounting capability.

Circle (370) on Reply Card

Digital tape transfer console

Rupert Neve has introduced the DTC-I totally digital tape transfer console. It provides digital mixing and processing capabilities. All console parameters can be instantly reset under SMPTE time-code control. The console also permits the user to select or mix either of two stereo digital inputs and one stereo analog input with manual or auto crossfade from AES/EBU or 1610/1630 inputs to compatible outputs. Other features include: choice of signal path via EQ and DRC; motorized digital faders that provide left and right balance; stereo balance and stereo level—all on one fader for each input; capability to retain multiple stores of console settings on floppy disk; RS-232 printerport to provide a complete print-out of all console-stored settings; and separate analog and digital metering.

Circle (371) on Reply Card

Sine wave inverter



Nova Electric Manufacturing Company has announced the model 5060-12 sine wave inverter. It features transistorized circuitry in a pulse-width-modulated design, enabling the maintenance of close voltage regulation over a broad input voltage range. An LC filter at the output filters objectionable harmonics and results in a sine wave output with less than 5% total harmonic distortion. The output waveform enables the inverter to drive loads that are sensitive to deviations in the sine wave. The inverter will operate from automobile or truck alternators, from batteries and from power supplies producing any voltage between 11Vdc to 16Vdc and the output remains stable over the entire input voltage range.

Circle (373) on Reply Card

Positioner assembly

Precision Specialties has announced the Positioner Assembly model series P2000. The system is an elevation-over-azimuth axis positioner for 8- to 16-foot diameter reflectors, multi-antenna arrays, point-to-point communications, satellite communications, electronic news-gathering single antennas and other devices that require full hemispherical motion. The design geometry uses a linear actuator acting with a lever arm for elevation axis positioning and a close-coupled motor/gear box assembly for azimuth positioning.

Circle (374) on Reply Card

One SPIKE Can Cost DOWNTIME!

Overvoltage transients can bring the biggest installation down in a microsecond, or damage it cumulatively.

Surge-Master Heavy Duty Power Line Protectors give complete protection against all transients.

All audio and video transmission equipment is vulnerable to transients on AC power lines caused by heavy motors starting up (even elevators or testing your auxiliary power system), power company load adjustments—and of course, lightning. Even if your equipment operates from batteries charged by a UPS, you're not safe. If lightning knocked out your UPS, how long could you keep going?

The MCG Surge-Master offers two stage protection. The first reacts in nanoseconds to absorb lesser transients and the leading edges of major ones. The second stage absorbs the big ones, and has three modules on each line. So, in the unlikely event that one module should be knocked out, there are still two protecting you. And a system of indicator lights tells you not only when a fault has occurred, but exactly where it is. Modular construction (and the fact that Surge-Master is connected in parallel) makes replacement of damaged modules quick and easy. Initial installation requires minimal power interruption.

Available with capabilities from 100 to 5000 amps; for 120, 240 and 480 VAC; and for single, 3-phase, wye and delta power systems. MCG also manufactures smaller units for protecting individual pieces of equipment. To learn contact Bob Ivey at 516/586-5125 or at the address below.

Protecting industry since 1967

MCG

ELECTRONICS, INC.
12 BURT DRIVE
DEER PARK, N.Y. 11729



OPTIONAL
REMOTE UNIT DUPLICATES
FRONT PANEL



Circle (128) on Reply Card

Digital and analog audio recorders

Otari has announced the following products:

- The DTR-900 multichannel digital audio recorder. It is a 1-inch, 32-channel mastering recorder. The PD format assures the tapes made on a PD machine will record and play back on any other PD machine. The tape transport is based on the pinchrollerless transport, and will accept a wide range of external time base references including 50/60Hz, 59.94Hz, 9.6kHz, and composite video. The error-correction of the PD format allows mechanical razor-blade editing on digital tape and is capable of rerecording over a splice from a previously recorded tape.
- The MX-80 analog tape recorder is available in 2-inch, 32-channel, 24-channel and a 24-channel prewired for 32. It features a microprocessor-controlled, constant tension tape transport with dc-servoed reel motors. The machine is user-convertible between 30/15ips and 15/7.5ips speed pairs that allow the machine to adapt to both music production and TV sweetening/post-production. The recorder offers a built-in mini-autolocator, including three cue-point memories; repeat function; and return to zero. The memories are front-panel selectable and can be activated on-the-fly. Other features include tape speed referenced seamless punch-in/gapless punch-out; HX-Pro bias optimization; and a full-function remote-session controller.

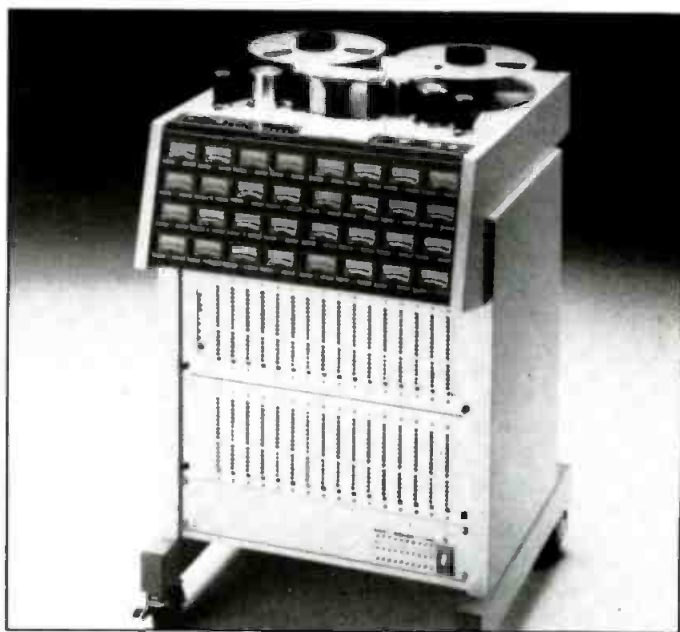

MX-80 analog tape recorder

Circle (375) on Reply Card

Lighting system

Lowel-Light Manufacturing has introduced the VIP system of lights.

- The V-light is a broad, 500W halogen source with a protective glass shield. It is small enough to fit in a large pocket.
- The i-light uses a 12V, 100W or 55W halogen lamp. Whether hand-held or camera-mounted, it can provide essential fill light, eye-light, highlight and contrast control, without overwhelming the available, natural light.
- The Pro-light uses various voltage lamps: 250W, 120V; 200W, 30V; 100W, 12V. It has interchangeable special-purpose reflectors, five swing-away accessories, plus a gel frame and brella.

Circle (376) on Reply Card

Rotary potentiometers

Penny & Giles has announced a line of precision rotary potentiometers. The units have twin precious-metal contact wipers and circular resistive elements of wire or hybrid conductive plastic. All models are supplied in heavy-duty sealed cases and are available with side or end terminals and flying leads. Wirewound track units are available in synchro sizes from 08 to 25, with resistance values from 30 Ω to 100k Ω . Rotational life exceeds 50 million cycles. Units can be built in multicup formats with up to 10 cups per shaft.

Hybrid track potentiometers, in synchro sizes from 05 to 18, have a standard resistance of 5k Ω with options for 2.95 Ω to 140.84 Ω per degree. Standard linearity is $\pm 0.15\%$. Resolution is infinite. Standard electrical angles are 340 $^\circ$ and 350 $^\circ$.

Circle (377) on Reply Card

Betacam cassette tape

RAKS Corporation has announced a 30-minute Betacam cassette tape. The tape's surface, with ultrafine, cobalt-treated oxides, gives high recording density and low chroma noise levels.



Circle (378) on Reply Card

Cable assemblies

C.A.E. is manufacturing and repairing cable assemblies for Ikegami, Hitachi, Sony, Panasonic and Sharp studio cameras and camera-to-VTR systems, as well as cable harnesses for video duplication systems. Special cable assemblies per customer requirements also are manufactured by the company or it can design cables to fit customers' systems.

Circle (379) on Reply Card

Production switcher

Ross Video has announced the 210A 10-input production switcher. Features include: wipe to a downstream key; a key learn button and variable-width drop shadow on a downstream keyer. The unit also has a function button that allows access to diagnostics and allows users to tailor several operating parameters of the switcher to their own needs.

Circle (380) on Reply Card

| : (-) |||

Perfect Timing

PROGRAMMABLE CLOCKS



750 E SERIES

One or Two Events,
Thumbwheel Programming
\$341-430

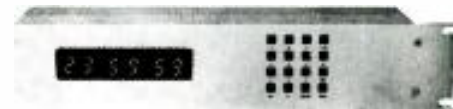

720 SERIES

10 Events,
Micro-Processor Based
\$845-1150



780 SERIES

Up to 96 Events Stored
in Random Access Memory
\$1313-1654



ES 790

1000 Events, Microprocessor-
Based, 32 Output Channels
\$2300



(213) 322-2136

142 Sierra St., El Segundo, CA 90245

Circle (129) on Reply Card

May 1987 *Broadcast Engineering* 163

News

Continued from page 4

NAB forms subsidiary to develop technologies

The National Association of Broadcasters has created NAB Technologies, a for-profit subsidiary. It will develop and bring to the market new production and transmission equipment to keep broadcasters in their traditional position of technological leadership.

Ted Snider, KARN/KKYK, Little Rock, AR, is NAB board chairman and chairman of the new subsidiary.

NAB Technologies will earn its profits from its share of royalties on products that it develops. Each newly elected NAB chairman will assume the chairmanship of the subsidiary. In addition to Snider, officers of NAB Technologies are: Edward O. Fritts, NAB president, as president; John Abel, NAB executive vice president/operations, as executive vice president; Henry L. Baumann, NAB senior vice president/general counsel, as general counsel; and Michael S. Harwood,

NAB executive vice president/chief financial officer, as secretary-treasurer.

NAB Technologies has announced that its first project will be to participate in the final development and marketing of FMX.

Completion of FMX development will be conducted by a new company—Broadcast Technology Partners. Holding a majority interest in the company is a group of Detroit-area investors led by John F.X. Browne, consulting engineer. Other owners are: NAB Technologies; CBS, which NAB previously has been associated with in developing FMX; and the two inventors of FMX, Thomas Keller, NAB senior vice president, and Emil Torick, former CBS Labs vice president, Audio Systems Research. Work on FMX will be conducted in a space provided by CBS Publications, Greenwich, CT.

IBC to feature exhibits and technical program

The next International Broadcasting Convention, IBC 88, will be held in Brighton Sept. 23 to 27, 1988.

As in 1986, the convention will be held

in the Metropole Conference and Exhibition Centre, the Grand Hotel and the Brighton Centre. The esplanade fronting that links the three locations will be used for outside exhibits.

As usual, there will be a technical program of papers by specialist authors, an exhibition of the latest broadcasting equipment and a social program that will include a special program for persons accompanying full-time convention delegates. The IBC Award also will be presented.

IBC is sponsored by the International Association of Broadcasting Manufacturers, Institution of Electrical Engineers, Institute of Electrical and Electronics Engineers, Institution of Electronic and Radio Engineers, Royal Television Society and the Society of Motion Picture and Television Engineers.

Further information can be obtained from the IBC Secretariat, Institution of Electrical Engineers, Savoy Place, London, United Kingdom, WC2R OBL. Telephone: 01-240 1871. Telex: 261176 IEE LDN G.

1:2=)))

NORTHSTAR

4030 148th Ave. N.E., Bldg. "N", Redmond, WA 98052 U.S.A.

UPLINK SCHEDULING (206) 885-4730



Northstar
Microwave
Systems
Inc.

- ★ Mobile Ku-band uplink service. Midwest S23
- ★ Video conferencing, sporting events, and SNG feeds
- ★ Special package quotes available
- ★ C band to Ku turnaround option

Division of Cam-Net Communications Network Inc.

Circle (130) on Reply Card



BROADCAST
engineering
CONFERENCE

Don't miss it:

**The second annual SBE National Convention
and
Broadcast Engineering Conference**

Plan now to attend the *working* engineer's convention. View the latest in broadcast equipment from leading manufacturers. Attend technical sessions designed to provide practical answers for the problems faced by broadcast engineers. Building on last year's outstanding success, the 1987 convention will provide more exclusive exhibit hours and an outstanding line-up of the industry's best technical experts.

The SBE National Convention and **Broadcast Engineering Conference** — the *must-attend* event for this fall.

**A.J. Cervantes Convention Center
St. Louis November 10,11,12**

Professional services

VIR JAMES P.C.
CONSULTING ENGINEERS
Applications and Field Engineering
Computerized Frequency Surveys
3137 W. Kentucky Ave. - 80219
(303) 937-1900
DENVER, COLORADO
Member AFCCE & NAB

 **Alpha Tower Design, Inc.**
901 Waterfall Way, Richardson, Texas 75080
214-783-2578
STRUCTURAL ENGINEERS SPECIALIZING IN TOWER DESIGN
REGISTERED TO PRACTICE IN 49 STATES THREE DIMENSIONAL COMPUTER ANALYSIS WITH LATEST DESIGN TECHNOLOGY INSPECTION & REVIEW TOWER MODIFICATIONS

EVANS ASSOCIATES
CONSULTING TELECOMMUNICATIONS ENGINEERS
AM-FM-TV-CATV-ITFS-LPTV SATELLITE
216 N. Green Bay Road
Thiensville, Wisconsin 53092
Phone: (414) 242-6000 Member AFCCE

FCC ON-LINE DATABASE
dataworld[®]
Allocation Terrain Studies
AM • FM • TV • LPTV • ITFS
P.O. Box 30730
Bethesda MD 20814
(301) 652-8822 1-800 368-5754

D. L. MARKLEY
& Associates, Inc.
CONSULTING ENGINEERS
2401 West Moss Ave.
Peoria, Illinois 61604
(309) 673-7511
Member AFCCE

CHIPS DAVIS
LEDE DESIGNS, INC.
Acoustics for Stereo
Facility Design
Consultation
(415) 459-2888

TEKNIMAX
TELECOMMUNICATIONS
DENNIS R. CIAPURA
PRESIDENT
11385 FORESTVIEW LN
SAN DIEGO, CA 92151 (619) 695-2429

SMITH and POWSTENKO
Broadcasting and Telecommunications
Consultants
2033 M Street N.W., Suite 600
Washington, D. C. 20036
(202) 293-7742

BLAIR BENSON
Engineering Consultant
TV Systems Design and Operation
23 Park Lane
Norwalk, CT 06854
203-838-9049

 **LAWRENCE L. MORTON ASSOCIATES**
21671 SUPERIOR LANE
LAKE FOREST, CALIFORNIA 92630
LAWRENCE L. MORTON, E.E.
AM • FM • TV
APPLICATIONS • FIELD ENGINEERING
ANTENNA BROADBANDING FOR AM STEREO
(714) 859-6015

JOHN H. BATTISON PE.
CONSULTING BROADCAST ENGINEER,
FCC APPLICATIONS AM, FM, TV, LPTV
Antenna Design, Proofs, Fieldwork
890 Clubview Blvd. North
Columbus, Ohio 43085
614/888-3364

Robert J. Nissen
THE NISSEN GROUP, INC.
Communications Technology Consultants
32 Ridge Drive • Port Washington, New York 11050
(516) 944-5477

BROADCASTING CONSULTANTS AND ENGINEERS
• FCC Applications and Field Engineering
• Frequency Searches and Coordination
• Tower Erection and Maintenance
• Facility Design and Construction
Contact:
KENNETH W. HOEHN
23400 Michigan Avenue
Dearborn, MI 48124
 (313) 562-6873

SELLMEYER & KRAMER, INC.
CONSULTING ENGINEERS
Steve Kramer, P.E. (214) 548-8244
Jack Sellmeyer, P.E. (214) 542-2056
AM FM TV MDS ITFS LPTV CATV
APPLICATIONS • FIELD ENGINEERING
P.O. Box 841 McKinney, TX 75069

ERIC NEIL ANGEVINE, P.E.
consultant in acoustics
specializing in broadcast studio acoustics
910 Lakeridge Drive Stillwater, OK 74075
405-624-6043 405-372-3949

ATT: CHIEF ENGINEERS
broadcast video maintenance
LUNAR VIDEO LTD
FAST TURNAROUND ON ENG. EFP. EDIT SYSTEMS, MONITORS, TEST EQUIP. SONY, JVC, PANASONIC, TEKTRONIX - UPS & AIR FREIGHT PUDEL DAILY
CALL COLLECT
138 E. 28th St, NYC (212) 686-4802

Consultation Services
Lightning • Power Conditioning • Grounding
Over 40 years experience work guaranteed
Roy Carpenter
President
Lightning Eliminators and Consultants
13007 Lakesland Rd. Santa Fe Springs, CA 90670
(213) 946-6886 TWX 910 586 1381

PATCHPRINTS Video Tie Lines
in 1 2 Aug 1 2 Mon A B
Custom Patch Bay Labeling for the Audio/Video industries
By
PATCH BAY DESIGNATION COMPANY
Div. of Glendale Rubber Stamp & Printing Co. Inc.
CHARLIE SCHUFER
P.O. Box 6278, Glendale, CA 91205
4742 San Fernando Road
Glendale, CA 91204 Telephone (818) 241-5585

ENG SERVICE Bill Nelson
V T R Chief Engineer
Associates, Inc.
Prompt TURNAROUND on
¾" editors, color ENG cameras.
3023 Holiday Drive, S.W. Phone
Huntsville, AL 35805 (205) 533-0571

UNUSED
CALL LETTERS
CALL
dataworld[®]
1-800-368-5754

TOWER DESIGN AND FABRICATION, INC.
TOWERS, ANTENNAS, STRUCTURES
New Tall Towers, Existing Towers
Studies, Analysis, Design Modifications, Inspections, Erection, Etc.
Rt. 1, Box 33AA,
Sturgeon, MO 65284 (314) 687-3932

R.J. GRANDMAISON, P.E.
CONSULTING ENGINEER
Applications and Rulemakings
11213 Split Rail Lane
Fairfax Station, VA 22039
(703) 764-0513
Member AFCCE

MAILING LABELS FROM YOUR COMPUTER!
We supply: AM/FM/TV broadcasters on computer diskettes.
Mailing labels.
Full direct-mail service.
STATIONBASE
Box 24092, Tempe, AZ 85282
(602) 437-3461

Why not run your business card here?
Only \$65 per insertion.
Frequency discounts available.
Call 913/888-4664

Professional services

EM

803.736-0540

Eureka Media Service

PAUL J. MASTORAKIS, CONSULTANT

TV—Systems Design—Installation—Repairs
Freelance Engineer

104 Charmont Drive, Columbia, SC 29223

Broadcast Rules Service

FCC Rules Parts 17, 73, 74

NPRMs Bimonthly updating Newsletter

\$75 for 1,800 page master volume plus

\$150 per year for updates

 Pike & Fischer, Inc. (301)654 6262

4550 Montgomery Ave. Bethesda, MD 20814

MICROWAVE SYSTEM LEASING

M/A COM 23VFM

LONG AND SHORT TERM LEASING

ALSO

CONSULTING—ENGINEERING

PURCHASING

PHONE—(212) 262-2880

L P L COMMUNICATIONS INC.

114 EAST 28 STREET, SUITE 601 N.Y., N.Y. 10016

Reconfirm your involvement in the broadcast industry!
Renew your subscription today.

Classified

Advertising rates in Classified Section are \$1.50 per word, each insertion, and must be accompanied by payment to insure publication.

Each initial or abbreviation counts a full word. Minimum classified charge, \$35.00.

For ads on which replies are sent to us for forwarding (blind ads), there is an additional charge of \$35.00 per insertion, to cover department number, processing of replies, and mailing costs.

Classified columns are not open to advertising of any products regularly produced by manufacturers unless used and no longer owned by the manufacturer or distributor.

TRAINING

ELECTRONICS DEGREE by correspondence. Earn Associate, then Bachelor's. NHSC accredited. Free catalog. Write Grantham College of Engineering, Dept. EE-5, 10570 Humbolt St., Los Alamitos, CA 90720. 8-82-tfn

FCC GENERAL RADIOTELEPHONE operators license through cassette recorded lessons at home plus one week seminar in Boston, Washington, Detroit or Philadelphia. Our twentieth year teaching FCC license courses. Bob Johnson Radio License Preparation, 1201 Ninth, Manhattan Beach, Calif. 90266, Telephone (213) 379-4461. 8-81-tfn

SERVICES

ONE STOP FOR ALL YOUR PROFESSIONAL AUDIO REQUIREMENTS. Bottom line oriented. F.T.C. Brewer Company, P.O. Box 8057, Pensacola, Florida 32506. 7-71-tf

3-D TELEVISION,—true stereographic NEW! LeaVision tm over/under (not red/blue). Viewers, consulting, lens rental. Info-SASE. DEMO (VHS/BETA)*photo* viewers-\$29.95 * \$2 S&H. TVLI-BE, CS3030 Lindenhurst, NY 11757 (516) 957-4393 (212) 245-6119. 9-86-tfn

TRANSMITTER TUBE REBUILDING SINCE 1941: 3CX2500, 4CX5000, 4CX15000 and many others. Write for details. FREELAND PRODUCTS CO., Rt. 7, Box 628, Covington, LA 70433. (504) 893-1243 or (800) 624-7626. 6-86-tfn

SQUEEZOOM FIELD SERVICE. Rebuild/Refurbish, Upgrade, or Repair your machine by Factory Trained Engineer. Retsyl Engineering, 515 Randwick Road, Dothan, Alabama 36301, (205) 794-7767. 5-87-2t

HELP WANTED

HELP WANTED TECHNICAL: Engineer for CBS affiliate FCC first/general licence or capability. Strong studio maintenance management and troubleshooting experience. Immediate opening in expanding progressive southwest. Contact Willie (619) 353-9990 or send resume to: 646 Main Street, El Centro, CA 92243. 5-87-3t

HELP WANTED (CONT.)

SALES

Due to growth, a major acquisition, and strong response to our expanded product lines at the recent NAB Show, long-range sales positions are available with a leading manufacturer of television broadcasting systems and studio systems.

Field Sales

Several growth opportunities exist in open territories for this solid broadcasting specialist firm. Prior field sales calling on television broadcasters preferred, but experience from technical side of station broadcasting could qualify the right individual. Our product base, TV broadcasting systems, has recently been augmented by acquisition of a leading producer of studio systems.

Inside Sales/Asst. to VP of Marketing

A technical knowledge of TV broadcasting will be required to handle inquiries for our complete line of transmitter and studio broadcasting equipment. Working closely with the VP of Marketing, this individual will handle inquiries, phone sales, and contact with our field sales and service staff. Requires both a capability to figure proposals and familiarity with methods/strategies of market planning.

Qualified applicants should contact VP of Marketing, Bob Anderman, at 413-568-9581.

Townsend Broadcast Systems Inc.
79 Mainline Drive
Westfield, MA 01085

MAINTENANCE ENGINEER: Come work in a fast growing Central Florida market. We're looking for a self-starter who can approach problems with a professional engineering attitude. Applicant should have prior experience in all areas of studio maintenance. Expert knowledge is needed in all tape machine formats as well as state of the art microprocessor based equipment. Salary commensurate with experience. E.O.E. Send resume to: Barry Edwards, WESH-TV, P.O. Box 7697, Orlando, FL 32854. 4-87-2t

HELP WANTED (CONT.)

Solid State Logic

is seeking an experienced

BROADCAST SALESPERSON

to join our growing West Coast operation

With the introduction of the SL5000M Series Audio Production System Solid State Logic requires an additional salesperson to cover the West Coast Broadcast Market.

This position involves direct sales and working with prospective broadcast clients to help translate their audio system requirements into specifications for production.

Applicants should have in-depth knowledge of broadcast audio practices and should have had technical or operational experience. Applicants with previous sales experience are preferred.

Please apply in writing, detailing your career experience to:

Andy Wild, Solid State Logic, 6255 Sunset Blvd., Los Angeles, CA 90028.

All enquiries will be handled confidentially.

SERVICE AND QC TECHNICIANS—Studer Revox seeks experienced Service and Quality Control Technicians for openings in both the Studer and Revox divisions. Thorough knowledge of recording systems is essential; experience with other audio components and microprocessor control systems preferred. Openings at Nashville headquarters. Excellent benefits, salary based on experience. Apply by written resume only to: Doug Beard, Director of Technical and Marketing Services, Studer Revox America, 1425 Elm Hill Pike, Nashville, TN 37210. EOE. 4-87-2t

Classified

HELP WANTED (CONT.)

HELP WANTED—TECHNICAL: ASSISTANT CHIEF ENGINEER—KRIV-TV, Fox Television, is seeking a qualified Assistant Chief Engineer. Must have minimum of 5 years television broadcast experience. Must have supervisory experience and be familiar with studio equipment, maintenance and UHF transmitter. Must also have good communication and budgeting skills. FCC license and SBE certificate required. Send resume to: KRIV-TV, P.O. Box 22810, Houston, Tx. 77227, Attn: Wendell Wyborny, VP/CE. 4-87-2t

CHIEF ENGINEER experienced in studio, transmitter, set-up and maintenance needed to fill opening in a progressive Christian TV group. Send resume to TCT, P.O. Box 1010, Marion, IL 62959. 5-87-1t

CHIEF ENGINEER: UHF Independent, WCGV-TV 24. At least 10 years experience in television. Totally familiar with UHF transmitters and studio operations. Good skills in personnel management, communications and budgeting. Appropriate FCC License. Salary commensurate with experience. WCGV-TV 24, is an Equal Opportunity Employer. Resumes to: Personnel Director, WCGV-TV24, 5445 North 27th St., Milwaukee, WI 53209. 5-87-1t

SALES MANAGER (for East and West Regions) Time Base Corrector manufacturer seeks Sales Managers. Must have technical background. TBC knowledge is helpful. Base of operation, Western will be in San Jose, Ca. and Eastern will be New York or nearby area. Please send resume to: HOTRONIC, INC., P.O. Box 26446, San Jose, CA 95159. 5-87-2t

MAINTENANCE ENGINEER—Top ten TV market. Immediate opening for strong maintenance background in ENG equipment, control room, cameras to videotape, microwave and transmitter equipment. First Phone required. Reply to Broadcast Engineering, P.O. Box 12901, Dept. 679, Overland Park, KS 66212. 5-87-1t

FOR SALE

RCA COLOR TELECINE SYSTEM, New/unused. To include: TK-66, color camera, TP-66, 16mm telecine projector, TP-7, 35mm slide projector, TP-55B, camera multiplexer. Write to: P.O. Box 23555-273, San Diego, CA 92123. 1-86-1fn

COPPER! For all your broadcast needs. #10 ground radials; 2, 4, 5, 8" strap, flyscreen, counter poise mesh. 317-962-8596. Ask for copper sales. 2-87-6t

CRYSTALS: Save a bundle on guaranteed T12A or BHM types in stock, tradeins taken. Also new crystals for oven holders for AM, FM and TV transmitters, 51 years in business! Eidson Electronic Co. (817) 773-3901. 5-87-1t

FOR SALE: TOWER DESIGN AND FABRICATION, INC., will custom design, fabricate and erect a tower structure to meet your requirements. 314-687-3932. 5-8-1t

FOR SALE: MIDWEST FM STATION, 35,000 watts. Only station in the county, 8 years old. Good investment property. 10 to 40 shares available. Send inquiries to Broadcast Engineering, Dept. 680, P.O. Box 12901, Overland Park, KS 66212. 5-87-1t

COMPUTER PROGRAMS inventory cables. IBM, TRS-80, and Apple computers. Basic \$45.00. Dbase III + \$65.00. TETRONICS CO., 8864F Town & Country Blvd., Ellicott City, Maryland 21043. 1-301-465-7352. PO's accepted. 5-87-3t

RCA TP-66 & TP-7 projectors sale reconditioned "like new" w/ latest mods, accessories also available. **SIMBER BROADCAST SERVICES, INC.**, (609) 435-1091. 5-87-1t

FOR SALE (CONT.)

SONY PVM-1220 MONITORS (2) \$900 ea. Tektronics 1420/528A 01 waveform/vectorscope W/RM \$2200. RTS TW-1222 intercom system expandable to 30 stations \$650 ESE hybrid telephone interface \$450. All like new! 716-342-4500. ROCHESTER, NEW YORK. 5-87-1t

SIX - 8 1/2" 75' OHM 90° MITER ELBOWS RCA -M1-27292-3 Marman clamp \$200.00 each. One -Microflect QK12 4 leg microwave tower with 2 antenna mounts \$500.00. Three - solid 12.2-13.2 GHz microwave antennas \$200.00 each. Pisces Corp. 617-378-3226. 5-87-1t

KAHN STR-84 AM stereo exciter and monitor. Offers. Rawlco Communications, Box 1300 Regina, Sask. Canada S4P3B9, (306-569-1300). 5-87-1t

CONTINENTAL VIDEO BROKERS: We sell and consign used Broadcast, Industrial Video and production equipment. Phone or write for monthly "WHAT'S FOR SALE" List. 177 Telegraph Rd., Suite 379, Bellingham, WA 98226. Phone (604) 858-8335. 5-87-1t

WANTED TO BUY

HIGHEST PRICES for 112 Phase Monitors, vacuum capacitors and clean, one kw or greater powered AM and FM Transmitters. All duty and transportation paid. Surplus Equipment Sales, 2 Throncliffe Park Dr., Unit 28, Toronto, Canada M4H 1H2, 416-421-5631. 3-86-1fn

WANTED: WW-II German and Japanese radio equipment. Unused US Navy and Signal Corps radio equipment before 1943. Pre-1923 radio equipment and tubes. August J. Link, Surcom Associates Inc., 305 Wisconsin Ave., Oceanside, CA 92054, (619) 722-6162. 7-86-1f

LENCO

A UNIQUE COMPANY WITH MUCH TO OFFER

Being a member of the Lenco Team means being a successful leader in one of seven Lenco divisions. Lenco means the beauty of the Black Forest of Southeast Missouri. Lenco means the German work ethic so prevalent in its personnel and so apparent in its products. Lenco means living in a clean, suburban-type university setting where hunting, fishing, hiking and water recreation are more the norm than the exception. Lenco means a slower pace of life that compliments the faster pace of business with a new, young, aggressive management team in a successful company that will celebrate its 40th anniversary in 1988. Yes, hi-tech in the Black Forest of Missouri is a reality. Surprised, not the Lenco Team!

NATIONAL SALES MANAGER ELECTRONICS DIVISION

We are now undergoing a search for the National Sales Manager of our Electronics Division.

REQUIREMENTS INCLUDE:

- 3-5 years of sales management in broadcast or computer graphics industries.
- A BSEE, marketing degree or strong business background.
- Superior interpersonal skills for intra-division, dealer and customer communications.

CONTACT: Paul Gerlach, General Manager, Lenco, Inc., Electronics Division, 300 North Maryland, Jackson, MO 63755, (314) 243-3147.

A WORLD OF INDUSTRY
UNDER ONE NAME



Want more information on
advertised products? Use the
Reader Service Card.

Advertising sales offices

CHICAGO, ILLINOIS
Tom Nilsen
Phone: (312) 887-0677
(312) 887-0684
15 Spinning Wheel Rd.
Ste. 430
Hinsdale, IL 60521

NEW YORK, NEW YORK
Diane Gottlieb-Klusner
Phone: (212) 702-3404
Josh Gordon
Phone: (212) 702-3405
866 Third Ave.
New York, NY 10022

SANTA MONICA, CALIFORNIA
Herbert A. Schiff
Phone (213) 393-9285
Jason Perlman
Phone (213) 458-9987
Chris Woodbury
Phone (213) 451-8695
Schiff & Associates
501 Santa Monica Blvd., Ste. 504
Santa Monica, CA 90401

NORWOOD, AUSTRALIA
Hastwell, Williamson, Rouse Pty. Ltd.
P.O. Box 419
Norwood 5067, Australia
Phone: 332-3322
Telex: AA87113

LONDON, ENGLAND
Nicholas McGeachin
Intertec Publishing Corp.
Roseleigh House
New Street
Deddington
Oxford OX5 4SP
England
Telephone: (0869) 38794
Telefax: (0869) 38040
Telex: 837469 BES G

TOKYO, JAPAN
Haruki Hirayama
EMS, Inc.
Sagami Bldg., 4-2-21, Shinjuku
Shinjuku-ku, Tokyo 160, Japan
(03) 350-5666
Cable: EMSINCPERIOD
Telex: 2322520 EMSINCJ



© 1987. All rights reserved.

Ad index

	Page Number	Reader Service Number	Advertiser Hotline		Page Number	Reader Service Number	Advertiser Hotline
Abekas Video Systems	75	57	415/571-1711	Miller, R.E. Pty. Ltd.	68	20	818/841-6262
ADC Telecommunications, Inc.	96-97	74	612/893-3010	Modular Audio Products	91,92		516/567-9620
Alpha Audio	120	100	804/358-3852	Mohawk Wire & Cable	112	89	800/422-9961
Alpha Electronics	118	87	800/221-5802	Nautel	48	32	902/823-2233
Alta Group Inc.	160	122	408/297-2582	NEC America Inc.	71	52	800/323-6656
Amber Electro Design Inc.	52	36	514/735-4105	New England Digital	117	92	212/977-4510
Ampex Corp. (AVSD)	53	27	415/367-2911	North Star Engineering	164	130	206/885-4730
Ampex Corp. (MTD)	27	16	415/367-2911	O'Connor Engineering	120	99	714/979-3993
Angenieux Corp. of America	119	98	305/595-1144	Opamp Labs Inc.	159	96	213/934-3566
Arrakis Systems, Inc.	21	14	303/224-2248	Orban Associates Inc.	7	118	800/227-4498
Audio Precision	147	109	800/231-7350	Orban Associates Inc.	17	12	800/227-4498
Audio Technologies Inc.	30	18	215/443-0330	Otari Corp.	15	11	415/592-8311
Audio-Technica U.S., Inc.	76-77	58	215/443-0330	Pacific Recorders & Engineering Corp.	125	146	619/438-3911
Audio-Video Engineering Co.	86	67	516/546-4239	Paco Electronics	82	51	213/747-6540
Auditronics, Inc.	55	39	901/362-1350	Panasonic Broadcast Systems Co.	59	42	201/348-7336
Belar Electronics Laboratory Inc.	154	123	215/687-5550	Panasonic Broadcast Systems Co.	61	44	201/348-7336
Bext Inc.	122	103	619/239-8462	Panasonic Broadcast Systems Co.	63	46	201/348-7336
Beyer Dynamic Inc.	85	66	516/935-8000	PCO, Inc.	107	82	818/700-1233
Broadcast Electronics Inc.	31	19	217/224-9600	Pesa Electronica S.A.	145	117	800/872-7372
Broadcast Supply West	102	78	800/426-8434	Polariod Corp.	109	85	800/225-1618
Broadcast Video Systems Ltd.	140	116	416/764-1584	Potomac Instruments	54	38	301/589-2662
BSM Broadcast Systems Inc.	70	62	509/448-0697	QEI	47	31	800/334-9154
C.O.A.R.C.	154	124	518/672-7202	Rank Cintel	105	81	312/297-7720
Cipher Digital Corp.	110	72	301/695-0200	Richardson Electronics Inc.	65	47	800/323-1770
Circuit Research Labs, Inc.	13	10	800/535-7648	RTS Systems, Inc.	72	53	818/843-7022
Clear-Com Intercom Systems	52	35	415/861-6666	Sachtler (USA)	79	59	516/867-4900
Comark	36-37	23	215/822-0777	Schneider Corporation	39	25	714/631-7430
Continental Electronics, Div. of Varian	130	108	214/381-7161	Selco Products Co.	118	86	800/257-3526
D.A.T.A., Inc.	91,92		800/854-7030	Sencore	135	112	800/843-3338
Datatek, Inc.	83	63	201/654-8100	Shintron Electronics	86	150	617/491-8700
Dictaphone Corp.	60	43	800/431-1708	Shively Labs	74	55	207/747-3327
Dynair Electronics Inc.	115	135	619/263-7711	Shure Brothers Inc.	11	9	312/866-2553
EEV, Inc.	87	69	914/592-6050	Shure Brothers Inc.	153	121	312/866-2553
Eastman Kodak Co.	123	104	212/930-7500	Sitler's Inc.	112	90	800/426-3938
Electro Impulse Lab.	38	24	201/741-0404	Sony Corp. of America (A/V & Pro Audio)	40-41	26	
ESE	163	129	914/592-6050	Sony Corp. of America (Broadcast)	24-25	15	201/833-5231
Fujinon Inc.	157	126	914/472-9800	Sony Corp. of America (Broadcast)	50-51	34	201/833-5231
Gentner Engineering Co., Inc.	80	60	801/268-1117	Sony Mag Tape	150-151	120	
Grass Valley Group, Inc.	9	8	916/273-8421	Spectrum Communications	74	56	215/631-1710
Gretag Ag, Regensburg	133	111		Stainless, Inc.	126	105	215/699-4871
H.M. Dyer Electronics, Inc.	159	93	313/349-7910	Standard Tape Laboratory, Inc.	159	97	415/786-3546
Harris Corp.	56-57	40	800/442-7747	Stanton Magnetics	132	110	212/445-0063
Harrison Systems	73	54	615/834-1184	Studer Revox America Inc.	35	22	615/254-5651
Hipotronics, Ind.	66	48	914/279-8091	Studer Revox America Inc.	127	137	615/254-5651
Hitachi Denshi America Ltd.	3	4	800/645-7510	Surcom Associates Inc.	88	71	619/722-6162
Howe Audio	104	80	800/525-7520	TASCAM Div. Teac Corp. of America	45	30	213/726-0303
Hughes & Phillips	84	65	818/768-4811	Tektronix Inc.	28-29	17	800/452-1877
IGM Communications	95	73	405/232-5808	Tektronix Inc.	99	76	800/452-1877
Ikegami Electronics Inc.	155	125	201/368-9171	Telex Communications, Inc.	43	28	612/887-5550
ISS International Satellite Systems	159	94	800/227-6288	Telex Communications, Inc.	139	114	612/887-5550
Intergroup Video Systems Inc.	121	101	800/874-7590	Test Probes Inc.	89-90		800/368-5719
JamPro Antennas Inc.	58	41	916/383-1177	Thomson-CSF/DTE	49	33	
Lake The Systems Company	IFC	7	617/244-6881	Total Spectrum Manufacturing, Inc.	19	13	914/358-8820
Leader Instruments Corp.	91,92		800/645-5104	Townsend Broadcast Systems	137	113	512/836-6011
Leader Instruments Corp.	5	5,6	800/645-5104	Trimm Inc.	67	49	312/362-3700
Lee International	100-101	79	212/691-1910	Trompeter Electronics, Inc.	89,90	140	818/707-2020
Leitch Video of America, Inc.	81	61	804/424-7290	Utah Scientific Inc.	131	136	800/453-8782
Lemo USA Inc.	89,90		707/578-8811	Varian	33	21	415/592-1221
Lenco Electronics	113	91	314/243-3147	Varian	69	50	415/592-1221
M C G Electronics, Inc.	162	128	516/586-5125	Video Display	149	119	800/241-5005
M/A-Com Mac Inc.	129	107	617/272-3100	Videotek, Inc.	140	115	602/997-7523
Magna-Tech Electronics Co., Inc.	111	88	212/586-7240	Ward-Beck Systems Ltd.	BC		416/438-6550
Matthews Studio Equipment	88	70	818/843-6715	Wheatstone Broadcast Group	IBC	2	203/393-0887
Matthews Studio Equipment	108	83	818/843-6715	Winsted Corp.	84	64	800/328-2962
McCurdy Radio Industries	44	140	416/751-6262				
MCL, Inc.	98	75	312/354-4350				
Micro Control, Inc.	62	45	817/295-0965				
Micro Phase	42	29	415/368-3869				
Micro Phase	108	84	415/368-3869				
Microdyne Corp.	103	79	904/687-4633				
Midwest Communications Corp.	1	3	800/543-1584				



A SUCCESS STORY

THE OBJECTIVE was no small task: design a radio console that would become the new standard.

THE METHOD involved listening to veteran broadcast engineers and installers. After all, they're the people who have seen and experienced all the ideas that came before. From this research we learned of the problems that had to be solved and the features that broadcasters required. We then added ten years of console building experience and innovation, and created the A-500a console.

THE RESULT: An unsurpassed console that exceeds prior broadcast standards. Its module/mainframe interface borrows from the computer industry, utilizing all-gold contact insulation displacement technology. The logic system is based on programming the module slot, allowing full module interchangeability. It also provides for separate programming of the module's "B" input selection, thus avoiding embarrassing false starts and mutes. Full console-to-machine control is supported without extensive use of interface boxes and cables. Three audio busses are provided to enhance talkshows and remote functions. There are separate processing loops for the speech and music paths, as well as individual channel insert points. A complete line of microphone and line inputs, remote selectors, and machine control modules is offered in virtually any combination, configuration or mainframe size you desire. The A-500a also features a full family of studio turret and turret components to ease facility design.

THE PERFORMANCE: Needless to say, it's a new age for audio, and the A-500a is a step ahead. While specifications don't say it all, ruler flat frequency response, .003% distortion, crisp square wave response and a noise spec that's unheard of deserve merit. Couple such performance, reliability and innovation together, and a new broadcast standard is set.

THE SUCCESS: WHEATSTONE broadcast consoles are installed in major markets all over the country, from frontline independents to national networks. They are in use right now at some of the world's largest institutions.

THE POSSIBILITIES: The possibilities are up to you.



Wheatstone Corporation

6720 V.I.P. Parkway, Syracuse, N.Y. 13211 (315) 455-7740

Circle (2) on Reply Card

Ward-Beck's Ubiquitous ST!

No matter what size the market - Chicago to Shreveport, New York to Seoul, Vancouver to Greenville - the versatility of Ward-Beck's ST Stereo Console is unsurpassed.

Flexible 24, 36 or 48 channel configurations can meet every need and fit every budget.

Available features... • 4-BAND EQ • INTEGRAL ROUTING SWITCHER • CENTRAL MICROPROCESSOR CONTROLLER • PROGRAMMING KEYBOARD • ALPHA-NUMERIC DISPLAYS • PEAK MONITOR/ANNUNCIATOR • AUDIO-FOLLOW-VIDEO INTERFACE.

Talk to us! Discover how affordable Super-Quality can be!



Ward-Beck Systems Ltd., 841 Progress Ave., Scarborough, Ontario, Canada M1H 2X1. Tel: 7416/438-5550 Tlx: 065-25399