

JULY, 1962

BROADCAST ENGINEERING



THE TECHNICAL JOURNAL OF THE BROADCAST INDUSTRY

TV AND COLOR TV HIGHLIGHTS

New Color Pickup Tube
and Details of Stereo
Color System

Conclusion:

TV Tape Fundamentals

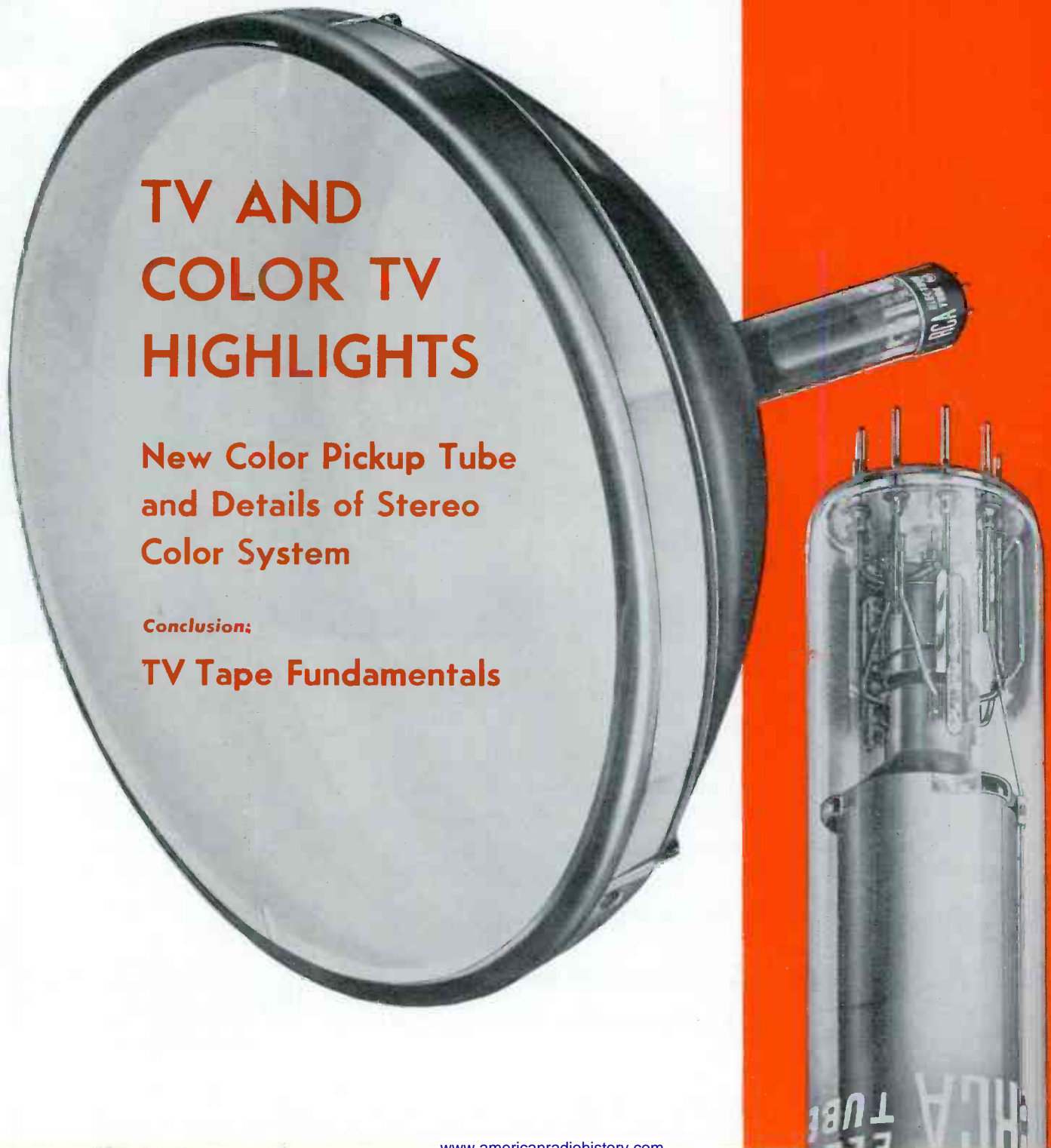



FIRST IN QUALITY BROADCAST EQUIPMENT

World's leading manufacturer of FM transmitters, ITA has earned an international reputation for creative broadcast engineering. Design concepts developed by ITA for use in its FM, AM, and TV transmitters and in studio equipment have established ITA as the "pace-setter" for the broadcast equipment industry. Now with EMI/US, manufacturers of TV cameras and accessories, ITA offers a full range of equipment from microphone to antenna systems for AM, FM, and TV.

ITA products are synonymous with dependability . . . *first* choice for quality and service.

ITA ELECTRONICS CORPORATION
BROADCAST DIVISION • LANSDOWNE, PENNSYLVANIA



ITA with EMI/US NOW SERVING BROADCASTING BEST

This VIS-75 Transistorized Switcher DOES MORE— IN LESS SPACE—Than Any Other Available



VIS-75

**New Sarkes
Tarzian Vertical
Interval Switcher
(VIS-75) goes
where you want
it to—does what
you want it to.**

Now, for the first time, you can get all the advantages of transistorized switching in a compact, low cost package. It's fully solid state—has amazing flexibility—is fully portable—only 19" deep, 17" wide, 3½" high.

Here are a few of the reasons the Tarzian VIS-75 made such a hit at the recent NAB show;

- No switching transients
- .1 microsecond switching
- 7 non-composite video inputs
- 5 composite video inputs
- Can feed special effects
- Can tape & program simultaneously
- Mounts in producer's table top, console, portable case
- Completely self-contained
- Exceeds color transmission requirements

We would be happy to arrange—at your convenience—a demonstration of the outstanding capabilities of the Sarkes Tarzian VIS-75.

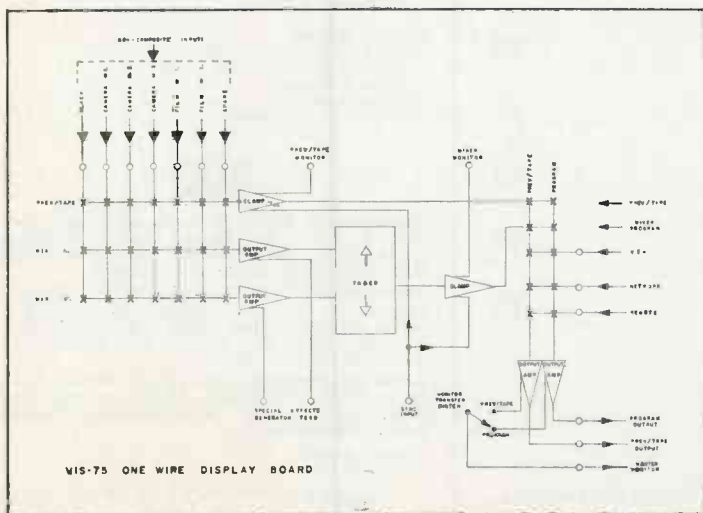

SPECIFICATIONS

- Inputs** Seven Noncomposite, Five Composite, including mixer & preview re-entry
- Outputs** One Preview Monitor;
One Line Monitor;
One Composite Program Line;
One Composite Preview/Tape Line;
One Noncomposite A Special Effects Feed;
One Noncomposite B Special Effects Feed;
Seven Camera Tally Control Contacts;
Seven Audio-follow-video Control Contacts
- Power Supply** Self-contained 105-125 V a-c Input
- Mounting** Standard 19" console or Portable Case
- Dimensions** 19" deep, 17" wide, 3½" high

call or write: broadcast equipment division



SARKES TARZIAN INC

east hillside drive • bloomington, indiana
edison 2-7251

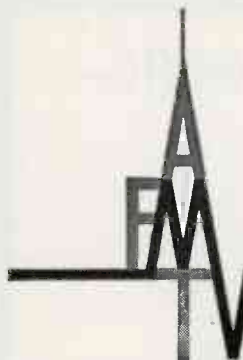

BROADCAST ENGINEERING

THE TECHNICAL JOURNAL OF THE BROADCAST INDUSTRY [®]

VOLUME 4

JULY, 1962

NUMBER 7

ROBERT E. HERTEL, Publisher

EDITORIAL

GEO. H. SEFEROVICH, Director
 JOHN BATTISON, Consulting Editor
 D. F. BOICOURT, Production Editor
 DUDLEY ROSE, Presentation Editor

ADVERTISING

E. P. LANGAN, Director
 R. J. HANCOCK, Manager
 S. F. WILSON, Production Manager

Great Neck, New York
 PAUL AND DON WEIL
 260 Northern Boulevard
 Telephone HN. 6-0212

Chicago 1, Illinois
 WILLIAM L. MILLER, JR.
 E. F. LUKENS
 307 N. Michigan Ave.
 Telephone FRanklin 2-5944

Cleveland 16, Ohio
 DAVID H. HERTEL
 3100 Wooster Road
 Telephone EDison 1-2370

Omaha 14, Nebraska
 BOB HOPKINS
 1705 Maenner Drive
 Telephone 393-1903

Southwest
 C. H. STOCKWELL CO.
 4916 W. 84th Street
 Mission, Kansas
 Telephone RAndolph 2-4417

Los Angeles 57, California
 MAURICE A. KIMBALL CO., INC.
 2550 Beverly Boulevard
 Telephone DUUnkirk 8-6178

San Francisco 4, California
 MAURICE A. KIMBALL CO., INC.
 580 Market Street
 Room 400
 Telephone EXbrook 2-3365

Paris 5, France
 JOHN ASHCRAFT
 9 Rue Lagrange
 ODeon 20-87.

London W. C. 2, England
 JOHN ASHCRAFT
 12 Bear Street
 Leicester Square
 WHitehall 0525

Tokyo, Japan
 INTERNATIONAL MEDIA
 REPRESENTATIVES, LTD.
 Kisha Kurabu
 14, 2-chome Marunouchi
 Telephone (502) 0656



Subscription Price: U. S. \$6, one year; Outside U. S. A., \$7. Single copies, 75 cents. Adjustments necessitated by subscription termination at single copy price.

BROADCAST ENGINEERING is published monthly by Technical Publications, Inc. Editorial, circulation and advertising headquarters: 1014 Wyandotte St., Kansas City 5, Missouri; telephone VICTOR 2-5955.

Corporate Personnel: Robert E. Hertel, President; Frank D. Smalley, Executive Vice-President; E. P. Langan, Vice-President; Kenneth Long, Vice-President.

Affiliated with

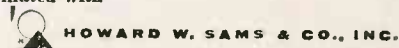

BROADCAST ENGINEERING

Contents

Stereo-Color Television 4

The Development of Image Orthicon Camera Tubes for Color Programming 8

New Emergency Generator 10

Audio Studio Maintenance 12

Television Tape Fundamentals 14

As Old As Radio 17

Ionization Research with Simple Tools 18

New Traffic Control System for Radio Spots 24

Departments

Engineer's Exchange 20

Book Reviews 26

Industry News 28

Product News 32

Index to Advertisers 40

Classified Ads 40

Professional Services 40

Cover

Pictures of color tubes are through the courtesy of Radio Corp. of America.

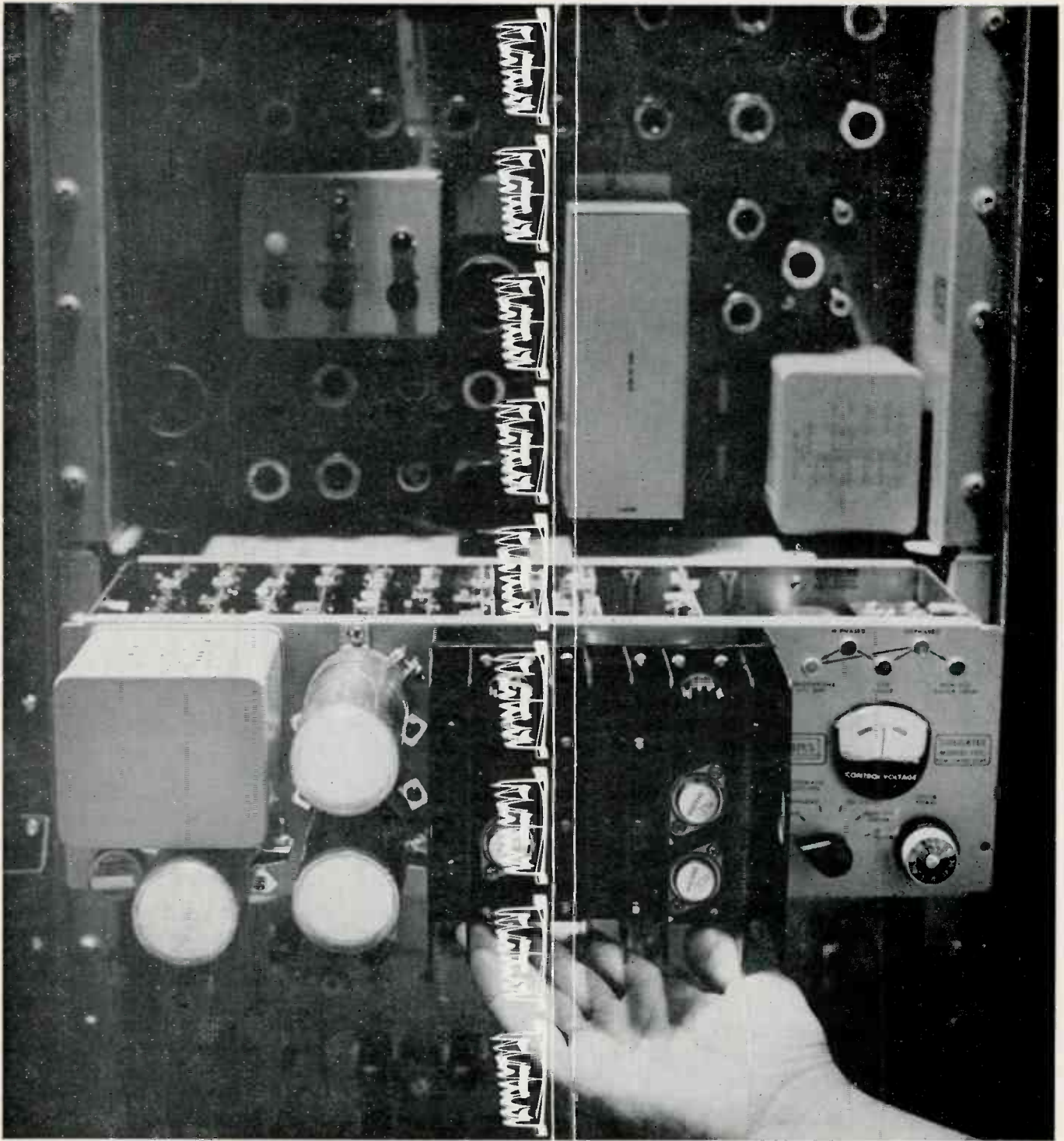

What color tape playback system takes up only 5¼" of rack space?

AMPEX Colortec.

Ampex Colortec* color adapter eliminates a complete extra rack of electronics: it fits into a 5¼" panel on your Videotape* recorder. It gives you color. Bright, beautiful color—with full bandwidth luminance and chrominance signals. Sharp black and white, too. And it's accurate to 3 parts per billion. The luminance and chroma are never separated but are processed together so that the picture is synchronous to 3.58 mc subcarrier to within ± 3 nano-seconds. Furthermore, it's the only



color recovery system that meets N.T.S.C. standards. Operation? Extremely simple with only two principal controls. What do these facts indicate? Simply this: even if you aren't contemplating color transmission yet, Colortec color tape playback system should figure in long-range plans. For details write the only company

providing recorders and tape for every application: Ampex Corporation, 934 Charter St., Redwood City, Calif. Sales, service engineers throughout the world.

*TM Ampex Corp.

STEREO-COLOR TELEVISION

Simple additions to optical system of television camera and receivers result in the addition of stereo-viewing, and, if desired, color rendition.

By James F. Butterfield
Stereotronics Corp.
Los Angeles, Calif.

A Stereo-Color Kit has recently been developed to convert black and white industrial television equipment to three dimensional pictures in full color. While the kit has certain limitations, it is a simple and economical method of color television, with many applications in the medical, industrial and military fields. The Stereo-Color Kit easily installs on any closed-circuit television using the Stereotronics System* of three dimensional television.

Operation of the Stereotronics System

To understand how the Stereo-Color Kit functions, one must first know the operation of the Stereotronics System. The latter consists of the optical components shown in Figure 1, which convert any industrial television to stereo pictures.

*Trademark of Stereotronics Corporation, Los Angeles, California.

Components

The components of the Stereotronics System are:

1. Stereo-Captor—an optical device which fits on the lens of the television camera.
2. Stereo-Screen—a transparent filter glass that replaces the implosion plate in the monitor (receiver).
3. Stereo-Hood—a housing hinged to the front of the monitor which supports an integral pair of optics before the viewer's eyes.
4. Stereo-Glasses—used in place of the Stereo-Hood for group viewing.

The Stereotronics System can be easily installed in minutes to convert a television picture to depth. A typical installation and application is shown in Figure 2. Here the technician is able to see in depth without wearing special glasses.

Theory

The technical operation of the Stereotronics System is shown in Figure 3. Two views of the subject are picked up by the Stereo-Captor from slightly different angles and optically relayed by mirror flats through the lens to be focused side-by-side on the face of the pick-up tube. The picture is transmitted electronically in the normal manner.

At the monitor, the two images appear side-by-side on the face of the cathode-ray tube. One image falls behind the right half of the Stereo-Screen which polarizes it at a 45° axis; the other image falls behind the left half of the Stereo-Screen, which polarizes it at a 135° axis. The picture is viewed through the optical elements of the Stereo-Hood, which consist of:

(1) Corresponding polarizers which permit one eye to see one



Stereo-Captor

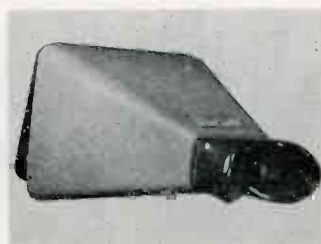

Stereo-Hood

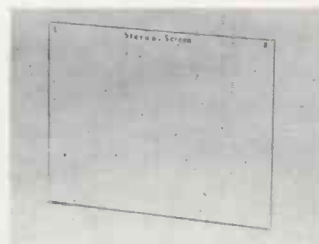

Stereo-Screen



Stereo-Glasses

Figure 1
Components of Stereotronics System.

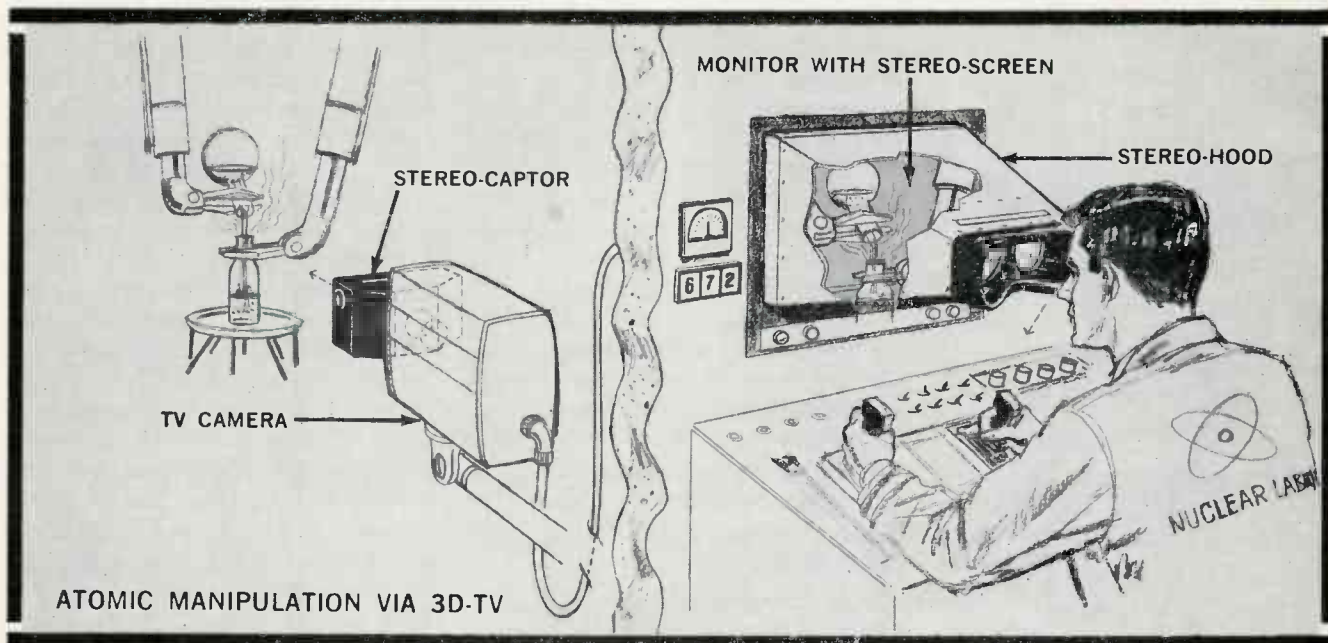

Figure 2
Typical Stereotronics System Installation.

image and the other eye to see the other image;

(2) Optical prism wedges which superimpose the images so that they appear in the same place in space.

Note that the pictures are interchanged at the camera by crossed mirrors. At the viewing end, the right eye sees the left image and the left eye sees the right image. In this manner, a channel is established from one point of observation at the left aperture of the Stereo-Captor to the left eye and from another point of observation at the right aperture of the Stereo-Captor to the right eye. This is achieved by optical devices at each end and by splitting the raster in half to accommodate the two images.

By mounting the Stereo-Captor on one lens of a turret camera, a manual or remote turret adjustment can change the picture from 2D to 3D and back again in a few seconds. The Stereo-Hood is then swung in place for 3D viewing and swung up, out of the way, for 2D viewing. If the Stereo-Captor is used on a non-turret camera, about 30 seconds are required to remove or install it.

Operation of Stereo-Color Kit

The two stereo channels can also be used for chromatic data transmission; that is, a two-channel color system can be achieved by utilizing a red-orange filter and blue-green filter at the transmitting end, and

at the viewing end. Two-channel color systems were used in early photographic processes for both still and motion pictures. They have now been supplanted by three-channel processes. The current NTSC system of home color television is a three-channel process and is capable of better color reproduction than a two-channel process. However, the latter will reproduce nearly the full spectrum range and is not limited to the two colors of the filters.

Components

The Stereo-Color Kit is shown in Figure 4. It consists of two sets of color filters and accessory items. The components are:

1. Bisected Color Filter. This is a ring holding a red-orange filter and a blue-green filter. It is positioned at "A" in the Stereo-Captor shown in Figure 3.

2. Daylight and Tungsten Color Temperature Filters. If the "K" temperature of the light source is greater than 3400 K, the Daylight Filter should be used to compensate for the excessive blueness of the light. If the "K" temperature is less than 3200 K, the Tungsten Filter should be used to compensate for excessive redness of the light. In these cases, the proper color temperature filter is placed behind the Bisected Color Filter. If the color

temperature is between 3200 and 3400 K, no color temperature filter is necessary.

3. Color Filter Slide. This is a metal slide holder in which are positioned a red-orange filter and a blue-green filter. It is inserted in a slot just behind the Stereo-Hood's optics, placing it at "B" in Figure 3.

4. Color Compensator. This device consists of two neutral density filters, one for each eye. These filters can be adjusted by knobs on the Color Compensator. It snaps into the eye port of the Stereo-Hood at "C" in Figure 3.

Theory

The technical explanation is simple. Each channel is filtered at the transmitting end to transmit half the color spectrum. The two images that are focused on the camera pickup tube and which appear on the cathode-ray tube are similar; however, they differ in the angles at which they are taken and they differ in gray scale.

Shades of gray form the method in which a black and white optical system transmits color. If the red-orange filter is placed over the camera lens, the whites and red-oranges will appear white or light gray on the reproducing screen. However, blacks and blue-greens will appear black or dark gray. The opposite occurs if a blue-green filter is placed

SCHEMATIC

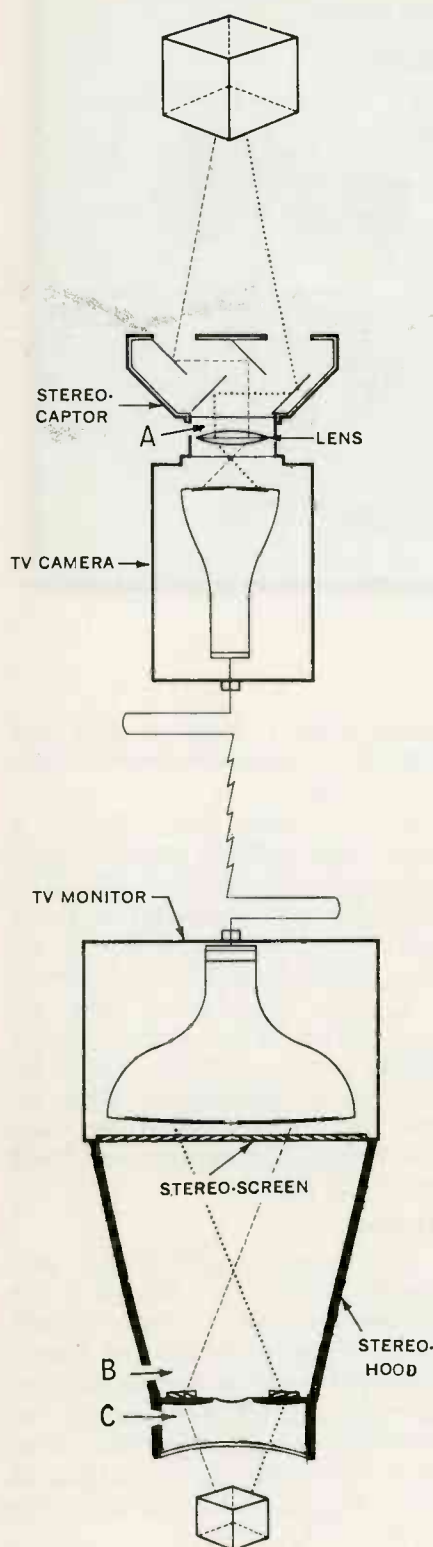

Figure 3

Schematic of Stereotronics System.

on the camera lens. In-between colors, such as browns, yellows and violets, will appear in varying shades of medium gray with either a red-orange or a blue-green filter. The gray of the image indicates the color of the subject. However, all

grays in the red-orange image will appear as different intensities of red-orange if viewed through a red-orange filter and the same occurs for the blue-green image. If the two images are viewed through their respective color filters and superimposed, then the various shades of red-orange and blue-green will blend to produce a rainbow of color.

The picture on the monitor is viewed through a Stereo-Hood which channels each image through the appropriate filter to the correct eye and makes the images apparently occupy the same place in space. The brain superimposes the images to appear as one in depth and blends them to full color.

Color Compensation

The foregoing occurs when the viewer's eyes are of equal strength; however, one eye or the other usually dominates. If the red-orange filter is on the right and the right eye dominates, the color picture will appear to have a red-orange cast. The opposite would occur if the blue-green eye dominated. To compensate for variations in visual acuity among individuals, the Color Compensator is employed. It consists of a polarizer placed in front of each eye with a small knob which permits rotation of the axis of polarization. This polarizer in combination with the polarizers in the Stereo-Hood form adjustable neutral density filters which can regulate the amount of light reaching the eye. When precise adjustment is made permitting the correct intensity of light to enter each eye, the picture suddenly appears in sharp bright color, providing a good reproduction of the original scene. The exact adjustment varies from individual to individual; however, once one makes the correct adjustment for his visual condition, no further setting is necessary. To find the correct adjustment requires a training period of a few minutes the first time. Later the adjustment can be made rapidly. Further color improvement can be obtained by varying the *brilliance* and *contrast* controls on the monitor.

The scene under observation requires at least twice the light intensity because the filters in the Stereo-Captor reduce the light about 60%. Flat lighting is desirable as shadows and partially lit areas of

the same color appear differently. The small areas that one eye sees and the other doesn't because of differences in the angle of view are reproduced in only one color. However, these are not significant or distracting. The stereo effect is usually heightened because the differentiation between the eyes is emphasized by the presence of color. In place of the Stereo-Hood, the Stereo-Glasses have been developed for group viewing of the three dimensional picture. It is possible to provide the glasses with the necessary color filters and a set of neutral density filters which can be snapped into place. The viewer then selects the proper neutral density filter for his eyes and snaps it into the glasses. This pair of glasses is then always adjusted for his eyes.

Disadvantages and Advantages

The disadvantages of the Stereo-Color Kit are that the picture is half size, optics are required between the viewer and the screen, and the range of color reproduction is somewhat limited. However, the Stereo-Color Kit has numerous advantages:

(1) *No Electronic Modification.* Existing black and white television equipment is used unchanged. System is entirely optical. There are no moving parts.

(2) *Perfect Registration.* The images can never be offset since the mind fuses them as one.

(3) *No Flicker.* The regulator frame is not changed.

(4) *Simplicity of Operation.* There are only two controls, which once set for the individual viewer need not be adjusted again.

(5) *Good Color Reproduction.* The two-channel system is so simple it gives good reproduction compared to three-channel systems, which lose much due to their electronic complexity.

(6) *Lightweight and Durable.* A minimum of equipment, weighing only a few pounds is added to the transmitting and receiving ends.

(7) *Picture Can Be Recorded.* Video tape, kinescope or Polaroid Camera recording can be made in the regular manner.

(8) *Compatible.* Viewer without receiving optics sees clear picture.

(9) *Rapid Installation and Conversion.* Installation takes one minute. Conversion from monochrome to color can be made in seconds.

YOUR TAPE HEAD KNOWS THE DIFFERENCE!

A triumph of RCA research in sound, RCA Red Seal magnetic tape will show you what your recording equipment is capable of!

Developed and produced to exacting standards, it's the superior tape used for recording the masters of RCA Victor phonograph records and RCA pre-recorded tapes. At the RCA Magnetic tape plant in Indianapolis, skilled engineers supervise every step of production, from the basic oxide formulation to the finished tape.

RCA Red Seal tape is quality control tested for frequency response, distortion, dropout, noise, and print-through; tested mechanically for coating thickness, layer-to-layer adhesion, cupping, slitting and anchorage. These precise controls give all RCA Red Seal tapes the required magnetic properties and recording-bias characteristic. As a result, every roll of RCA Red Seal tape is of the same high quality. For full details, fill in the coupon, now!



RCA VICTOR 
THE MOST TRUSTED NAME IN SOUND

MAGNETIC TAPE PRODUCTS MARKETING/RCA VICTOR RECORD DIVISION/155 EAST 24TH STREET/NEW YORK 10, NEW YORK

Please send me the brochure outlining essential physical and magnetic characteristics of RCA Red Seal Magnetic Tape.

NAME _____ TITLE _____

COMPANY _____

ADDRESS _____

CITY _____ ZONE _____ STATE _____

THE DEVELOPMENT OF IMAGE ORTHICON CAMERA TUBES FOR COLOR PROGRAMMING

In this article the author details the development of color image orthicons, and lists the specific functions for which each type is best suited.

By P. W. Kaseman
Radio Corp. of America
Electron Tube Div.
Lancaster, Pa.

THE INCREASING importance of color in television programming during the past few years has placed a great deal of emphasis on new camera tubes intended especially for color pickup. Improvements in the camera and other assorted optical and electronic equipment have continually demanded greater precision and sensitivity from the camera tube to achieve better image registration and picture quality under widely varying sets of studio and outdoor lighting conditions.

Type 6474

The 6474/1854 three-inch image orthicon announced in 1954 was the first tube designed especially for color pickup. It met all the basic requirements for a camera tube for simultaneous color pickup, although it met some requirements with greater ease than others. Lack of perfect geometry over the entire target area made perfect registration of three tubes out to the picture edges very difficult. The large amount of light required to reach the "knee" limited pickup to full daylight or a brightly lighted studio. Beam bending caused color edge effects and detracted from the picture quality. Even in these early years of color programming it became obvious that one type of image orthicon would not meet all the conditions encountered in color pickup. These problems led to the development of the Type 7513.

Type 7513

The 7513 three-inch image orthicon, which was commercially an-

nounced late in 1959, was designed primarily to overcome some of the shortcomings of the 6476 for studio color pickup. It has found a wide acceptance. The 7513 has greatly improved registration which results from three features: precision construction, the absence of magnetic parts in critical portions of the tube, and use of a field-mesh design.

Dynamic misregistration sometimes occurs in color cameras because the image charges on the target differ from one color channel to another. In tubes that do not use a field-mesh design, this target-charge differential is sufficient to pull the scanning beam away from its intended trajectory and to enlarge brightly illuminated areas (this effect is commonly called "beam bending"). An example of dynamic misregistration is the red hairline that sometimes appears around the face of a person on the screen. Because the face is lacking in blue and green light components, the image produced in the blue and green channels is smaller than that in the red channel. As a result, a red line appears between the face and the hair. The field-mesh design greatly reduces beam bending and eliminates this problem.

The field mesh also produces a flatter background signal, more uniform signal output (so that color values and brightness remain substantially unchanged over the entire television field), and significantly improved corner focus. All these improvements in the tube geometry and performance cannot be realized,

however, unless the tubes are operated in a camera system that incorporates precision deflecting and focusing coils, as well as an optical system which improves the corner focus of the optical image.

The 7513 was not intended to provide better sensitivity than the 6474. In fact, it requires approximately 25 per cent more light than the 6474 because its target capacitance is increased to provide the same signal-to-noise ratio as that of the 6474. This increase is necessary to compensate for degradation of the signal-to-noise ratio by the field mesh. The solutions to the light problems are found in two other types of image orthicons permit color pickup for color. These newer three-inch image orthicons permit color pickup at lighting levels previously considered sufficient only for black-and-white television and allow color telecasts of outdoor sporting events at night.

It should be noted that substantially less light is available to the image orthicon tube in a color camera than in a black-and-white camera. Specifically, the light level required to operate a tube in the blue channel of a color camera up to the knee of its transfer characteristic may be as much as 40 times that required to operate the same tube in the same manner in a black-and-white camera. This low blue efficiency is due to the large loss in the blue separation filter and the small amount of blue light available from the tungsten illuminating sources.

Type 4401

The 4401 was developed specifically to operate to the best advantage at low light levels. Table I lists the important characteristics of this and other image orthicons. The tube does not contain a field mesh in order that the signal-to-noise ratio may remain as high as possible at very low light levels. The 4401 can be operated with the highlights about one stop below the knee of the light-transfer characteristic. The light levels at outdoor night baseball games and football games are sufficient for such operation. The picture quality improves, however, as the light level is increased.

The signal-to-noise ratio shown in Table I is for operation at the knee, which requires approximately 150 foot-lamberts with an f/8 lens stop. A target capacitance of 100 micro-microfarads is used because the signal level from this capacitance provides an adequate signal-to-noise ratio for most color programming. With reduced target capacitance insufficient signal would be generated for a good signal-to-noise ratio, regardless of the light levels. An additional feature of the 4401 is a high-gain multiplier which produces a high signal level even when the tube is operated below the knee of the transfer characteristic.

Types 4415 and 4416

The newest image orthicons for color, the 4415 and 4416, are designed to combine the precision reg-

istration of the 7513 and some of the low-light-level characteristics of the 4401. These types permit operation of color cameras in studios equipped only for black-and-white lighting levels. The tubes have an efficiency sensitivity about 25 to 50 per cent higher than that of the 4401. They use precision construction and field-mesh design similar to that of the 7513 image orthicon, and have similar performance features. The 4416 incorporates a highly blue-sensitive photocathode to provide effective sensitivity for a trio of tubes in a camera that is substantially higher than that of similar tubes having the conventional panchromatic response. Because the optical efficiency of the blue channel of a color camera is normally lower than that of the other channels, the sensitivity of the camera is usually limited by the performance that can be obtained in the blue channel. The blue photocathode sensitivity of the 4416 in a color camera is nearly double that of a tube having panchromatic response. However, part of this increase in effective sensitivity is offset by the use of a slightly higher capacitance in the 4415 and 4416 tubes to compensate for the additional noise that results from the field-mesh design. As a result these tubes are slightly less acceptable for operation at light levels below the knee (for some outdoor night sporting events, for example, the 4401 will give superior performance).

Matching

Image orthicons intended for color pickup are supplied in matched sets of three. In the case of 4401 or 7513, the most sensitive tube in the set is designated for the blue channel, but may be used satisfactorily for other channels. Such is not the case for the 4415 and 4416 sets; the 4416 should be used only in the blue channel because of the lack of red response in its photosurface. The tubes in each set are matched by factory tests for similarity of background and signal variation over the scanned area.

Summary

The 7513 is the tube for use where the best in registry and signal-to-noise ratio is desired and sufficient light is available. The 4415 and 4416 sets will be most satisfactory when good registry and signal-to-noise ratio are desired but only black-and-white lighting levels are available. If light levels are not sufficient to operate either of these types, or if precision registry is not of prime importance, the 4401 will produce a satisfactory color picture at considerably lower light levels by operating below the knee. Comparative figures are shown in Table I. (In this table, the 5820A is included for reference only, not as a recommended tube for color operation. It should be noted, however, that the 7513 and 4401-V1 also have found wide application in black-and-white television.)

TABLE I

Type	Target—Mesh Spacing (Inches)	Target—Mesh Capacitance ($\mu\mu\text{f}$)	Operating Point* (lens stops relative to knee)	Faceplate Illumination for Operating Point (fc)	Amplitude Response at 400 TV Lines (per cent)	Signal-to-Noise Ratio for 4.5-Mc Band Width**
3" - DIAMETER IMAGE ORTHICONS						
5820-A	0.0022	100	(1) +1 to +2	0.020	50	40:1
7513	0.0007	300	(2) 0	0.030	45	
			(1) + $\frac{1}{2}$ to +1	0.045	50	55:1
4401 or 4401 V1	0.0022	100	(2) 0	0.007	50	
			(1) +1 to +2	0.014	50	40:1
4415	0.0018	120	(2) 0	0.010	40	37:1
Matched sets						
4416	0.0018	120	(2) 0	40	37:1

* (1) Indicates black-and-white; (2) color.
 ** Target set-up = 2 volts above cutoff.

NEW EMERGENCY GENERATOR

By Herbert Green,
Broadcast Consultant
Washington, D.C.

IT IS NOT very usual for consultants to write about a product; generally they write about installations they have built or designed, or else abstract ideas. However, in this case the subject is an item that is found in the equipment list of many radio stations—an emergency power generator. Such a piece of equipment is common in many installations both for portable and for fixed location work, but as the author knows from many hours of dragging a deadweight from truck to remote site and back again, they are far from light. Recently we came across a new model, and because it is so unusual permission was obtained from the maker to run one through a lot of rugged tests, and see just how much punishment it will take, in the way of overloads.

The unit in question is the Mite-E-Lite 2000. The power source is standard, and consists of a Briggs & Stratton 3.5-hp gas engine. This unit has the job of driving a generator (which is the part that concerns broadcast engineers), so it will suffice to say that this does its job in the usual excellent Briggs & Stratton manner.

Our interest is with the generator. Instead of the usual pounds of dead iron found in the standard self-excited ac alternator, this unit has only a revolving magnet and two coils of copper strap! Most readers will be familiar with the magneto used in aircraft and in the older

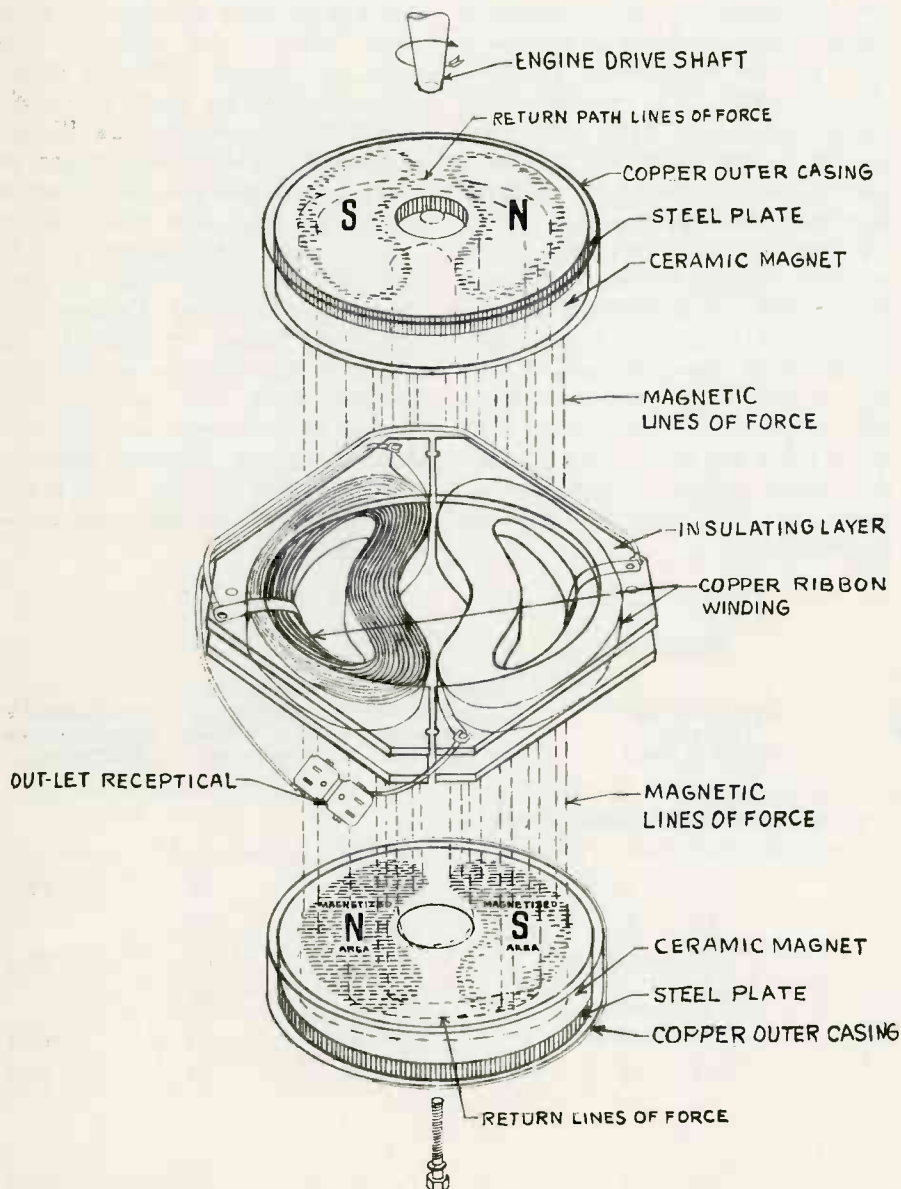

Figure 1. Line drawing showing the details of the magnetic circuits in the generator. Actual construction is very similar.

Details of a new form of construction for low weight emergency power unit show that there are new ways of applying well known principles in portable equipment.

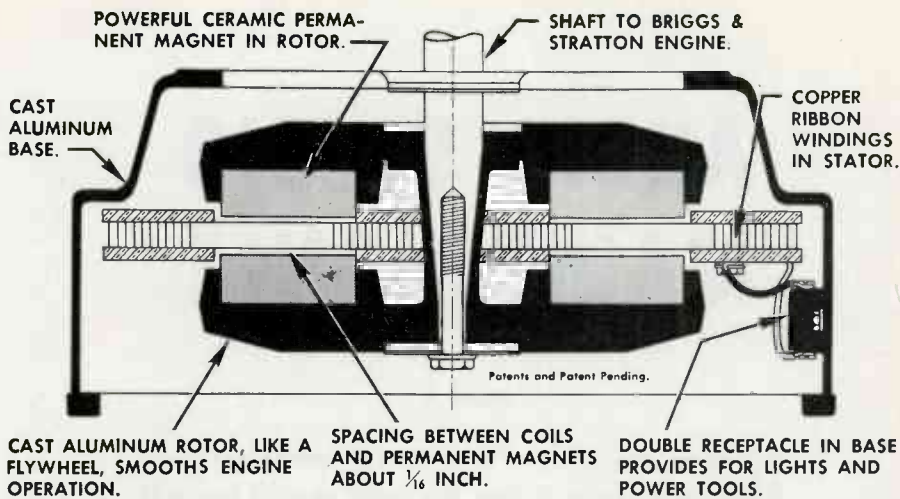

Figure 2. Simulated cut-away illustration of position of coils and magnets.

autos. In this device the field rotates and the armature is stationary—at least that is the effect obtained. In this generator the same principle is used, and Figure 1 shows how the magnets and coils are arranged.

Of particular interest to broadcast engineers is the fact that there are no brushes and no slip rings or commutators. Therefore there is no chance of static from a noisy brush, and no maintenance.

Theory of Operation

When a moving conductor cuts line of magnetism electricity is produced. In this case a moving field cuts a stationary conductor, but the same effect is obtained. The two magnets shown in Figure 1, above and below the coils (which are in series) rotate at crankshaft speed. This produces a rotating field in what is known as an *axial air gap*. At 3,600 rpm engine speed, alternating current with a frequency of 60 cps is produced.

The amount of current, or more importantly, the KVA available, depends on the size of the magnets, and the current carrying capacity of the coils. Naturally engine horsepower has to be sufficient to provide adequate drive, and overcome friction losses.

The unit that was tested was rated at 1.5 KVA, or 1,500 watts. This is just sufficient to drive an older 250-watt AM transmitter, which takes about 1,425 watts, plus a small console and enough speech

equipment for emergency use. Although the generator was not tested under heavy load conditions on the air, it was tested for power output with a dummy load consisting of 2,000 watts of light bulbs. With this load connected to it the voltage fell to 105 volts which is not far below that of many power lines that are faced in rural areas. At this point the engine was working pretty hard, but the frequency was 59 cps, well within the allowable tolerance for power lines.

The makers had stressed the point that the generator could be shorted without any ill effects. Needless to say such a remark is calculated to make a user "try for himself." With a heavy copper strap plugged into the outlet of the bed of the engine the generator was impossible to start. Either the rope puller didn't have enough muscle, or else didn't have the knack.

A heavy switch was then connected to the outlet with a copper strap across the other side. A clamp-on ammeter was positioned around the cables, and the engine started.

After allowing the engine to warm up and attain operating speed, the voltage was noted to be 125 V ac, 61 cps. A brave man then closed the switch and with a groan the generator stopped. This test was repeated many times, and each time the same thing happened. Then the generator was allowed to run at maximum load, under maximum

current conditions, and we obtained about 60 amperes before the unit finally stopped. The absence of dc field coils with their attendant heating under such conditions, and the extremely heavy copper strap used for the ac windings reduces heating effects, and enables the unit to perform under such conditions.

Noise

As with any four-cycle engine running at 3,600 rpm with only a small muffler, the noise output is relatively high, but with the addition of a suitable muffling unit this physical noise was reduced to better than tolerable levels for use on remotes when the generator has to be close to the microphone or even for use in a remote truck.

(Continued on page 40)



Figure 3. The electrical generating section is in the aluminum casting that forms the base of the generator.

AUDIO STUDIO MAINTENANCE

Part II

Although the proper measuring instruments are faster and easier to use, the small station can still make adequate measurements for maintenance purposes by using the equipment at hand, and following the instructions given in this article.

By Thomas R. Haskett
P. O. Box 41 - 31762
Michigan City, Indiana

MEASUREMENT of hum and noise requires only one operation, and can be done rapidly. Distortion measurements can be made at two or three frequencies (instead of the full range, as would be done in a complete proof), thus reducing testing. Frequency response is treated similarly. Comparison of these figures with previous complete data will usually reveal any less-than-optimum performance. This can invariably be traced to impending breakdown of a component (usually a tube). It is here that the mutual-conductance tube tester can be used to locate the faulty tube within an amplifier unit.

Hum

Measurement of the hum content of an amplifier points up a further test of tubes—that of their hum content. A tube tester is quite useless in this respect. Rejection of a tube on the basis of excessive hum is invariably made by using the equipment itself as the testing device, sometimes assisted by an external meter. The noise meter can be used to great advantage in this connection.

It is necessary to have a thorough understanding of amplifier differences in order to keep the hum low, and still get greatest use out of tubes. Excessive distortion is seldom a trouble in tubes functioning in

low-level preamp stages, but too much hum is a problem in such units. The reverse is usually true in high-level program or line amplifier stages. Here the signal level is high, well out of reach of hum, but this level frequently shows up excessive distortion.

On the basis of the foregoing, there is a further check for tube types employed in low-level stages, and that is the hum test. Input preamp stages require the most hum-free tubes. Attenuator busses cause a loss of level between preamps and program amps; the signal entering the program amplifier is low, so the input stage here must have a low residual hum too, although not necessarily as low as a preamp input stage.

The hum test will show up tubes which exhibit excessive hum. It will allow selection of the most hum-free tubes. In practice, the oscillator and noise meter are connected to the console (or other amplifier) and a hum and noise test conducted. Be sure to check the power supply for a hum-balancing pot. If there is one, the noise meter should be switched downrange until hum can be read on the meter. The hum pot should then be set for minimum hum as indicated on the meter.

The noise (or hum) reading obtained should be at least 45 db be-

low the console output level. If it is not, the figure should be written down and the preamp switched out of the circuit temporarily (to prevent transients from damaging the noise meter and the console volume indicator). A new tube should be installed in the preamp input socket. After warmup, the preamp should be switched back into the circuit and a new hum reading taken, and compared with the former.

It should be apparent by now that the spot proof technique is used as a rapid means of assurance that the amplifier either *is*, or *is not*, performing as it should. If it is, no further tests are necessary. If it is not, localizing methods can be used and the tube tester and direct substitution used to pinpoint the faulty stage or stages. Final approval of the remedial measures taken is made by the oscillator, and the distortion and noise meter.

Testing With Simple Equipment

If no oscillator and distortion meter are available, the procedures outlined may still be performed, although with some modifications. In place of an oscillator a "tone tape" must be made up. An oscillator must be borrowed and a tape recorded with about 15 minutes of 1000-cycle tone. The signal on the tape should be of constant amplitude, but this is the only important point. Hum, distortion, or even exact frequency, are not too important.

The tone tape furnishes a nearly-constant signal. The console VU meter can then be used as an indicating device, and a simple gain test made. Of course, the input level to the console must be known, and this can be accomplished by means of another VU meter, a VOM (on its db scale), or even by disconnecting the console VI and using it temporarily. Normally a pad will be used between the tape output and the console mike input—a resistive pad which attenuates and matches the two impedances. The level of the tape signal should be measured on the tape side of this pad. A record should be kept of both the input signal level at each preamp, and the attenuator settings necessary to bring the console VU meter to a reading of "0 VU." Measurement of gain made at intervals of three months will furnish a useful view of

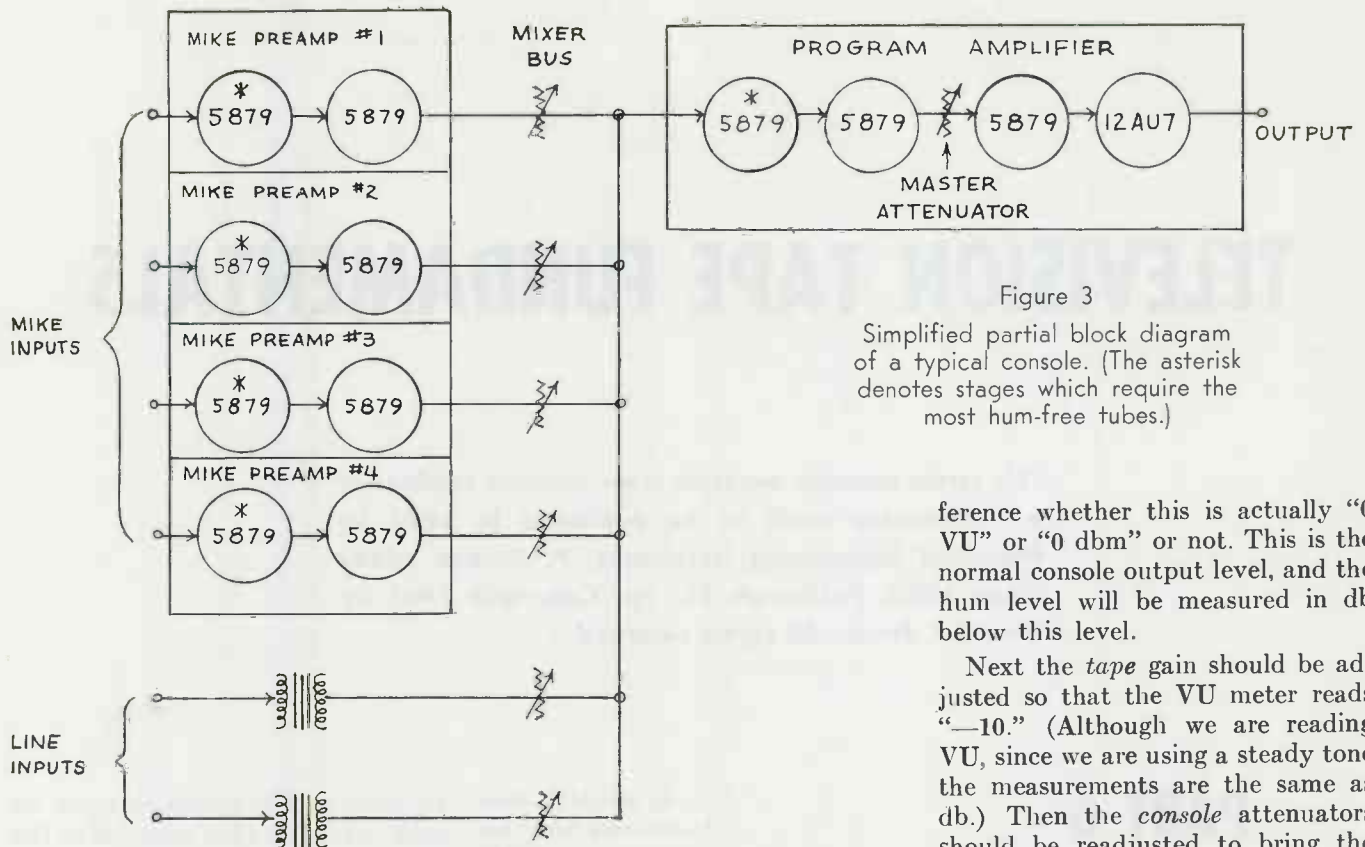

Figure 3
Simplified partial block diagram of a typical console. (The asterisk denotes stages which require the most hum-free tubes.)

ference whether this is actually "0 VU" or "0 dbm" or not. This is the normal console output level, and the hum level will be measured in db below this level.

Next the *tape* gain should be adjusted so that the VU meter reads "-10." (Although we are reading VU, since we are using a steady tone the measurements are the same as db.) Then the *console* attenuators should be readjusted to bring the needle back up to "0 VU." The range of the VU meter has been extended down 10 db. This means that the tone which now shows up as "0" on the meter is actually 10 db below the first tone.

After several readjustments of level (keeping track of the db on paper meanwhile) the tape should be stopped and the machine disconnected completely from the ac line. Any residual reading on the console VI is a hum reading. The meter reading should be added to all the previous 10 db steps to give the approximate level in db below the output level. If the meter reads "-4" on hum after 4 steps of 10 db each, the final hum level is "-44," or 44 db below the output level.

The considerations mentioned ear-

(Continued on page 27)

tube (or power supply) deterioration. It can be used to localize weak stages, with the tube tester brought into play to pinpoint specific tubes. Of course, the power supply can be rapidly checked by measuring its voltage output with a VOM and comparing the figure so obtained with the manufacturer's recommended value.

It might be supposed that a tape could be recorded with several frequencies and then used to check the frequency response of the console. This is feasible, but *not* using the VU meter as an indicating instrument. The frequency response of the standard VU meter is *not* linear. However, many VTVM's are flat throughout the audio range and can be used for this purpose. Of course,

the frequency-response technique is more desirable than the simple single-frequency gain method, as it gives a more complete picture of amplifier performance.

It is also possible to make *hum* tests without the benefit of a noise meter. Again, the tone tape and the console VU meter are used. Although this method does not have the accuracy of the noise meter, it will suffice, and will enable the engineer to keep the hum low, and get maximum service from all tubes.

The tape signal is fed to a mike input, as in the gain test. Attenuators are set at their normal operating positions on the console. Then the tape amplifier gain control is set to cause the console VU meter to indicate "0 VU." It makes no dif-

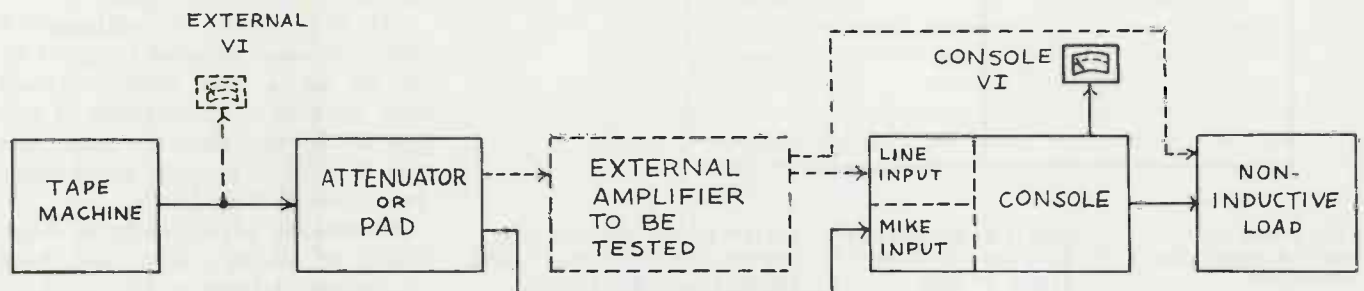

Figure 4
Equipment connections for spot proof. (When oscillator and distortion meter are not available.)

TELEVISION TAPE FUNDAMENTALS

This series contains excerpts from selected sections of a forthcoming book to be published in 1962 by Broadcast Engineering Notebooks, P. O. Box 10682 (Penn Hills), Pittsburgh 35, Pa. Copyright 1962 by Harold E. Ennes. All rights reserved.

PART 6 (Conclusion) Head Problems

Video Head Optimization

Obtaining the optimum amplitude of frequency-modulated input signal to the individual video heads is now fairly well standardized as follows:

1. While recording, the input amplitude to each head in turn is varied

over a considerable range, identifying each setting by a microphone input to the sound track.

2. In playback, the *rf* envelope at the switcher output is observed on the scope — noting the highest setting at which amplitude ceases

By Harold E. Ennes
Maintenance Supervisor
WTAE
Pittsburgh, Pa.

to increase. The recording input for each channel is then adjusted to this value.

The following precautions should be observed:

(a) The modulator video should be a composite "Window," "Stair-step," or keyed burst (with at least 5% white pulse) at standard input level.

(b) The modulator frequency and deviation adjustments should be critically set.

(c) The heads should be thoroughly clean, and free from residual magnetism.

(d) The vacuum guide must be previously set for the standard "tip projection." (Additional notes on this follow.)

(e) On playback, the switcher channel gain controls should be adjusted to a relatively *low* level (rather than higher in level) to avoid any possibility of an *rf* limiting factor in the switcher.

(f) This type of optimization should be done at more frequent intervals for a new head assembly than after 50 or more hours of use, due to the fact that the maximum rate of wear is greater, particularly during the first 20 hours.

Mechanical adjustments for elimination of scallop, skew, and head quadrature defects on the playback of an alignment tape is another facet of head optimization. This "stand-

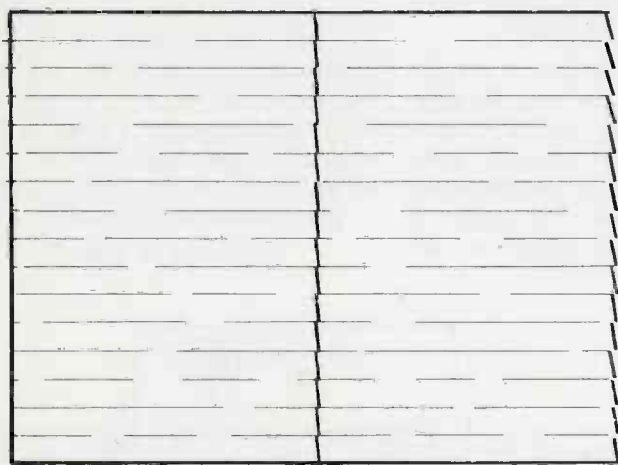

LEFT EDGE OF
RASTER PRACTICALLY
STRAIGHT

CENTER OF RASTER
BEGINS TO SHOW
TIME ERROR

RIGHT EDGE OF RASTER
SHOWS CONSIDERABLY MORE
ERROR THAN LEFT EDGE

Figure 26

Characteristic of line-to-line sync type of video monitor.

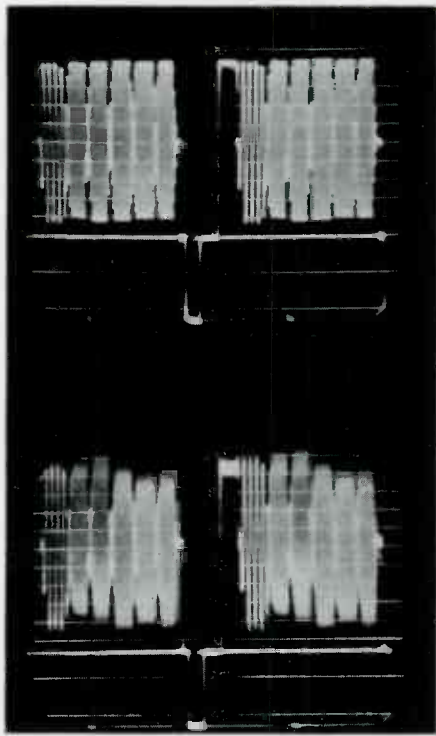

Figure 27

(a)
Input signal (amplitude
of bursts improperly
adjusted)

(b)
Playback signal

ardizes" the tip penetration and mechanical alignment to the manufacturer's standards. Some important notes to bear in mind:

(1) The mechanical adjustment on the horizontal (skew) position of the vacuum guide (which actually determines tip penetration) need normally be made only after initial installation of a new head assembly. After this, even though it is necessary to play back a non-standard tip projection without the use of the Automatic Compensator, ample range is provided on the electrical control to compensate any possible amount of recording error. When the *mechanical* adjustment is thrown out of standard, it is often impossible to remove the resulting scallop (height adjustment) due to interaction of these two adjustments on the concentricity of the guide-to-tape.

It should be recalled from previous articles that the wear on the pole tips is almost 100% complementary to the reduced tip velocity, and the mechanical readjustment for elimination of skew is *not* necessary, (in normal operating procedures).

(2) It is true that the mechanical height (scallop) adjustment will sometimes need to be readjusted to play back a non-standard tape with minimum scalloping. However, if the mechanical skew adjustment has

also been thrown off, it is sometimes a 10-minute job to return the head assembly to a standard position with the alignment tape, particularly for a relative newcomer. If *only* the height adjustment has been changed, a simple twist of the Allen head set-screw (about 5 seconds maximum) is all that is necessary.

(3) The degree of time-error displacements, and the distribution of the error horizontally across the raster, differ radically between two types of monitors normally used in the TV station. Fig. 12 in a previous issue illustrates the skew resulting with the guide too close to the head compared to the recorded time base, as it appears on a pulse-width (such as the synchroguide circuit) type of monitor sync. Cer-

tain types of master monitors, (for example the RCA TM-6), in order to meet the requirements of their particular applications, employ a synchronization which, for all practical purposes, results in a line-to-line sync, as compared to the averaging process of the pulse-width circuit.

The line-to-line sync tends to *start* each active line of picture information at the same spot following horizontal sync. (See Fig. 26.) By the time the beam has reached the end of the line, timing errors of the magnitude of an active line duration relative to the blanking duration begin to manifest themselves as spacing errors just prior to horizontal blanking. Thus the effect is *minimized*, but more so at the left of the raster than at the right. This can lead to an erroneous conclusion that the picture distortion exists only on the right side of the raster, which would be difficult to explain in theory!

Checking Frequency Response

The need for tube replacement or a complete video re-alignment of amplifiers is best and most conveniently checked by the keyed burst signal as was illustrated by Fig. 21 in the last installment.

Care should be taken to proportion the amplitudes of the single-frequency bursts as shown for the input signal of Fig. 21. The energy of frequency components in the normal picture is quite low above 1 mc. If sine waves are fed into the system with the higher frequencies at the same amplitude as the white pulse reference, considerable high frequency power exists which causes high frequency overload of the modulator due to the previously dis-

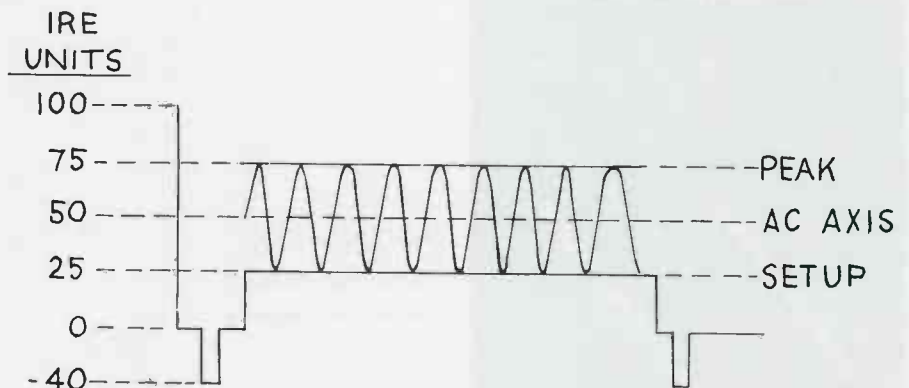

Figure 28

Proper signal proportion for keyed single frequency sine wave to check TV tape systems frequency-by-frequency.

cussed pre-emphasis. The same type of overloading occurs in the demodulation process due to natural limitations in high power, high frequency linearity. Fig. 27 shows the response obtained from such adjustment of the input signal, indicating some loss of higher frequencies as compared to the photo of Fig. 21. Note also that a shift in the ac axis occurs indicating selective frequency clipping. This type of input signal exceeds the normal limits of the modulation-demodulation process, and is of little value except as a "safety margin" check.

Fig. 28 shows the proper proportion of keyed, single frequency sine waves when this method is used for overall system video response checks. This will be recognized as that which is recommended by the FCC for single frequency runs on TV transmitters.

If a video sweep is used for FM circuit alignment, it should be remembered from Fig. 1 that the highest video frequency (4 mc) is represented by a carrier frequency of 1 mc (lowest carrier frequency). Thus peaking the carrier at the lower end increases the response at the higher video frequency.

When variable individual channel playback equalization is provided (as in the RCA TRT-1B), a recording of the keyed burst signal (as shown by Fig. 21) should be made after head optimization. Turn

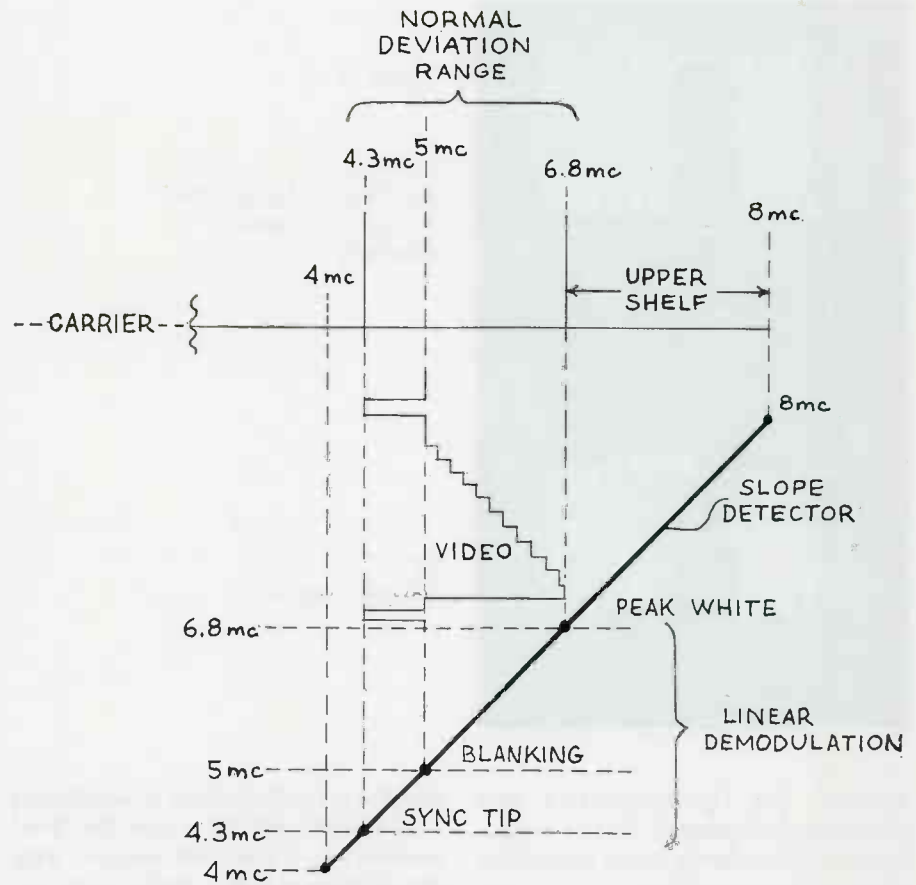
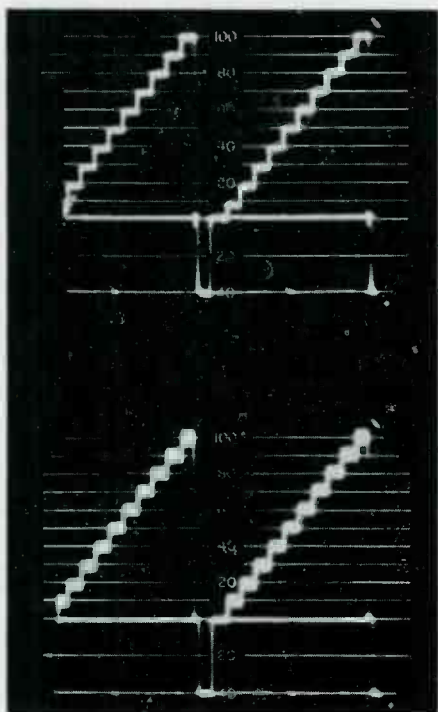

Figure 30
The demodulation slope should be essentially linear over a range greater than the normal deviation range of 4.3 mc to 6.8 mc.

all channel equalization controls to zero. Upon playback, bring one channel equalizer up to where the burst is relatively flat. (The external CRO indication at the line output will show this as a faint trace, since only

one channel is affected.) Then while observing the line output picture monitor, bring the other three equalizers up to match the first channel on the first two bursts (normally 0.5 mc and 1.0 mc). It will be observed that a very good match can be obtained on the lower frequency bursts while the higher frequency bursts will show some banding. But as pointed out in previous notes, most of the picture energy is in the lower frequency regions, and following this procedure will almost invariably result in optimum picture for normal programing, without banding.

Checking Amplitude Linearity

The "Stairstep" signal (Fig. 29) with ten steps should be adjusted at the system input so that each step is exactly 10 IRE units. The output at the line amplifier should be as shown by Fig. 29(b) if the modulation-demodulation process is linear. The slope detector in modern systems is normally capable of linear demodulation from 4 mc to 8 mc (Fig. 30). It is helpful for the maintenance engineer to determine

(Continued on page 25)

As Old As Radio

Gates Radio Co., an equipment pioneer, is this year celebrating its fortieth birthday and thus dates its beginning with radio broadcasting.

EDITOR'S NOTE: This year radio broadcasting is celebrating its fortieth anniversary. In recognition of this, we are publishing some vignettes of companies and mileposts along the way. This sketch of Gates is one in the series.

GATES RADIO CO. is celebrating its fortieth anniversary this year—having progressed from a one-room operation in 1922 to a relative giant in its specialized field today. Gates was founded in 1922 by Henry C. and Cora B. Gates, a partnership. The company was known at that time as the Gates Radio and Supply Co.

H. C. Gates was an alumnus of Purdue University with a background in industrial engineering. In the early 1920's while associated with the Jersey Cereal Food Co. at Irwin, Pa., Mr. Gates became interested in the construction of KDKA, which was about to be aired at East Pittsburgh by Westinghouse. Seeing the potential of the radio broadcasting industry even in those pioneering days, Mr. Gates established his company in Quincy, Ill.

The first products manufactured by the new firm were radio receivers and sound amplifying devices. In the mid-twenties, Gates began research on talking picture equipment, both for disc and film. This research program resulted in a non-synchronous machine for smaller theaters which at that time could not afford the more expensive equipment for talking pictures. From this non-synchronous machine developed the first form of present-day transcription turntables as used in commercial broadcasting stations. The first units were sold to such prominent stations as WEA, New York; WTAM, Cleveland; WLS, Chicago; and WLW in Cincinnati. Gates had established the reputation of sup-

plying the first commercial transcription turntables to the broadcasting industry.

From a partnership and a handful of employees in 1922, Gates has expanded in 40 years to five plants and headquarters in Quincy, with branch and sales offices in Houston, Los Angeles, Washington, D. C., and New York City. About 20 Gates sales engineers make up the field sales force, traveling all areas of the United States. Sales in Canada are handled by the Canadian Marconi Co. with headquarters in Montreal. Overseas sales are coordinated by the Gates export group—Rocke International Corp. in New York City. In 1957, Gates became a subsidiary of Harris-Intertype Corp., Cleveland, Ohio.

In the AM radio line, Gates offers transmitters ranging in power from 250 watts to 100,000 watts. For FM, Gates has a new line of transmitters ranging in power from 250 watts to 40,000 watts. Television transmitters are manufactured for 100 watts to 5,000 watts. Gates recently introduced its new Solid Statesman line of transistorized audio equipment, which includes three new audio control consoles and a complete line of transistor plug-in amplifiers.

Gates has reached the four-decade mark—40 years of service to an exciting and dynamic industry that boasts of the fact that there are more radios in use in American homes than bathtubs and refrigerators.



One of the first 33 1/3 rpm transcription turntables manufactured by Gates in the 1920's.



1930 Speech Input System manufactured by Gates.



Gates sound truck—before 1925.

Ionization Research With Simple Tools

THE STUDY of sudden ionization within the ionosphere such as that caused by meteors and objects entering the earth's atmosphere has become of vital importance. Although complex instrumentation is required to solve many of the problems associated with the full understanding of ionization, much useful information can be obtained with simple equipment. One such method is being pursued by making use of continuous signals in the VHF region at the E layer skip distance

and recording the reflected signals on an oscillograph.

During the war it was observed that VHF radio stations located at skip distances would burst through at random times. This phenomenon was finally correlated with visual sightings of meteors. Since the war attention has been given to the study by radio means of ionization due to these meteors, and has resulted in enhanced knowledge of the physics of the upper atmosphere. This has led to direct application in

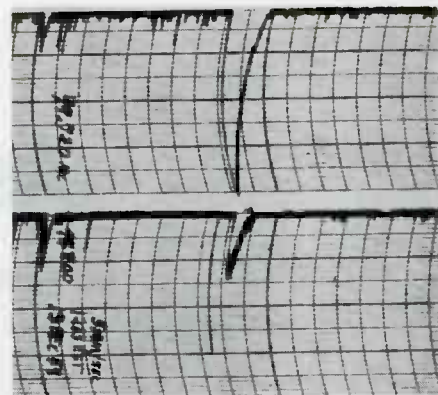

Figure 1. VHF signals from two transmitters located at Havana, Ill., received at Boston, reflected by an "under-dense" meteor trail. Recorder speed was 5 mm/sec.

By Melvin Wilson
Wayland, Mass.

Figure 2. Detailed analyses of signals by "over-dense" meteor trail. Signals recorded at a high chart speed (25 mm/sec).

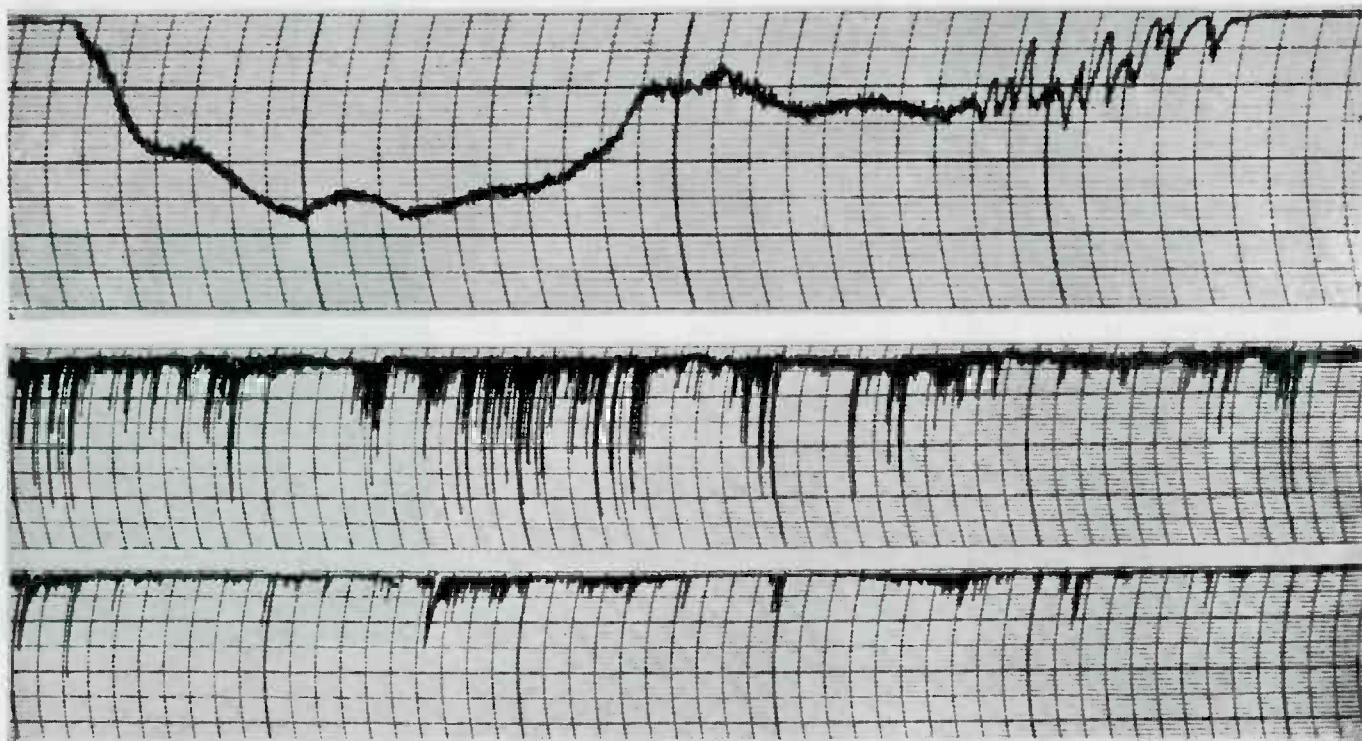
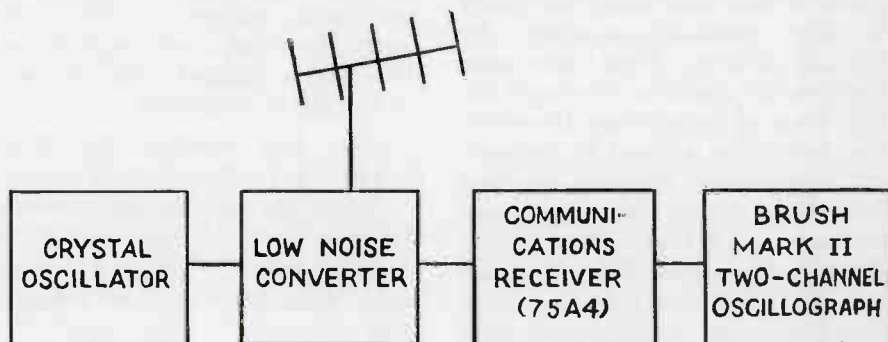

Figure 3. Simultaneous recording during Quadrantids meteor shower, January 3, 1960, of signals from two different Channel 2 television stations. Brush recorder chart speed 5 mm/sec.

Figure 4. Single channel receiving block diagram.



radio communications, and may have far reaching implications as man feels his way into space. Ground based surveys have been undertaken by means of oblique angle forward deflection due to meteor trails at E layer height (60 miles).

Such long distance transmission is made possible by ionization caused by the meteor's evaporation. This ionization in the form of a cylindrical column expands rapidly by diffusion in the rarified atmosphere. The ionization can be either "under-dense" or "over-dense" depending on the size of the meteor (whether larger or smaller than about .05 inch diameter). "Under-dense" reflections on VHF signals are specular (transmission path perpendicular to trail). "Over-dense" trails reflect over almost any angle. Although VHF signals for "under-dense" ionization last but a very short time, "over-dense" ionization has been observed to reflect signals up to 20 seconds.

Investigation with excellent results can be accomplished with relatively simple instrumentation. Requirements include a continuous signal transmitted for the skip distance, antenna, converter, receiver and direct writing recorder. The system must have excellent stability with controlled frequencies and an accurate time base for meaningful measurements. By use of National Bureau of Standards transmitters, stable converters and communications type receivers plus a dependable dual-channel recorder the worker has the necessary tools.

The recording means is of prime importance. Requirements for this recorder must include dependability, ease of operation, high sensitivity plus fast response, minimum overshoot, precision time base and permanent easily reproduced records. A Brush Recorder Mark II, with chart speeds of 1, 5, 25 and 125 mm/sec was used in these experiments.

The full meaning of these investigations still is not completely understood. Increased research in this field, together with exhaustive correlation of the recorded facts, is sure to lead to a better understanding of the nature of the upper atmosphere.

SAVE 3 WAYS

For dramatic, 3-way savings, specify PS4000C semi-conductor supplies for your TV operation. Transistorized unit increases overall efficiency.

with POWER SOURCES

transistorized
semi-conductor
power supply



CHECK YOUR 3-WAY SAVINGS

for the smallest — least expensive — best designed power supply available.

SPACE

Much-needed, costly rack space requirement is cut to a bare minimum. Unit, only 5 1/4" high, can be stacked in multi-

ples without dead-space between. Saves up to 85% of usual power supply space needs!

COST

Already priced below comparable vacuum tube units, VISUAL offers the Power Sources PS4000C at a new low price due to increased acceptance and quantity production.

BEST DESIGN FOR ECONOMY OPERATION

Proven semi-conductor design requires less maintenance time, less parts replacement, and reduces power costs up to 60%.

NEW LOW PRICE \$621⁰⁰

Due to industry acceptance and widespread use by networks and leading independents, VISUAL can now offer the Power Sources PS4000C at this new reduced price. Compare for 3-way savings.

For the best and most modern broadcast systems and supplies, look to VISUAL—your SOURCE for Superior Equipment from Specialist Manufacturers.

Write today for complete technical specifications.

VISUAL ELECTRONICS
CORPORATION

Keeps You in View!

356 west 40th street • new york 18, n. y. • pennsylvania 6-5840

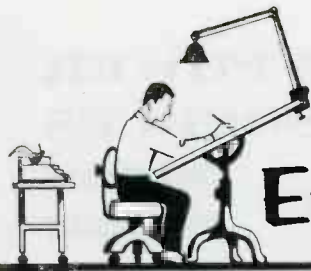

Engineer's Exchange

Quieting Control Room Relays

By Thomas R. Haskett
 P. O. Box 41--31762
 Michigan City, Ind.

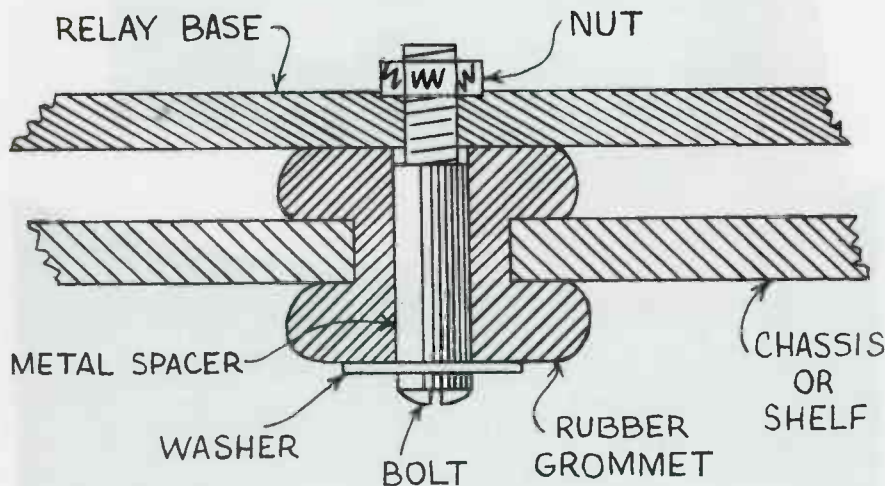

Figure 1

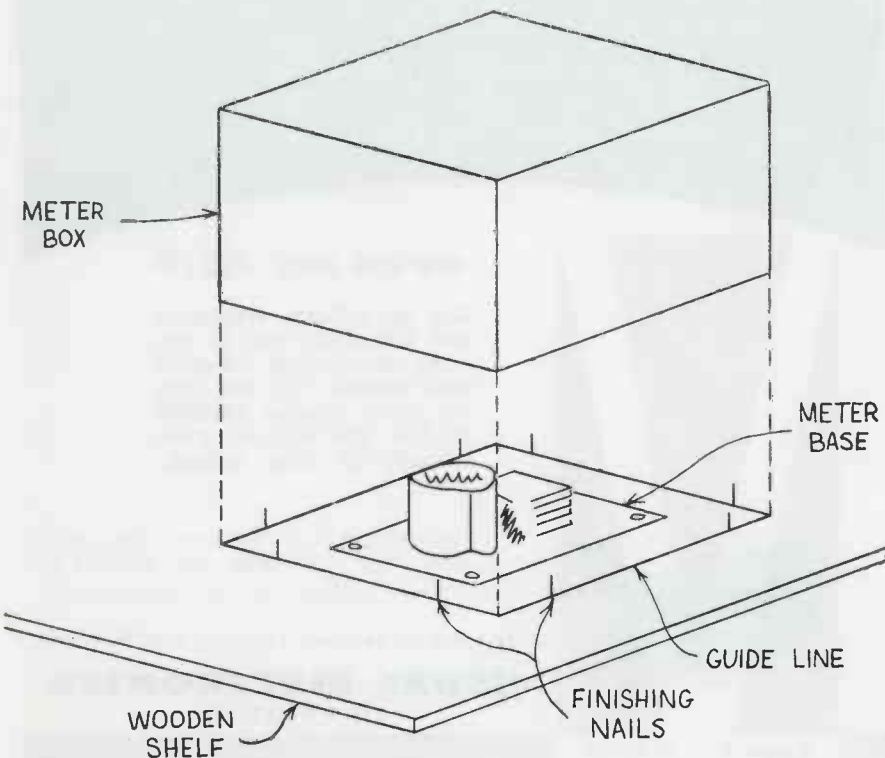

Figure 2

During modification of the studios of a radio station recently, the writer was faced with an unexpected problem. A new, deluxe model, two-channel console had been purchased, and it was desired to arrange four turntables, two tape machines, and some other equipment in the control room, so placed that a single announcer-operator could smoothly and efficiently utilize all of them. A "custom" wooden cabinet was therefore built, in the familiar horse-shoe shape, containing all of these units. To permit rapid, easy turntable starting, while reading copy, or being otherwise preoccupied, utility keyswitches on the console were used to trigger relays located immediately under each turntable assembly. The relays simply sat on shelves under the turntables, and produced the problem: the relay "thump" was amplified by the "sounding board" effect of the wooden frame, and picked up by the mike mounted above the console.

Figure 1 shows the mounting which was then employed for each relay. Many of the parts can be found in the junk box, the only determining factor being the grommet size. We used the most common type, that which requires a $\frac{3}{8}$ " mounting hole, and found No. 10 bolts, nuts and washers to match. Although the illustration is practically self-explanatory, one point should be made: The grommet must be under a slight compression for the cushioning action to be fully effective.

This practically silenced the relays, but, being in an experimental mood, we went a step further. Scraps of rock-wool insulation were glued inside a four-inch cardboard meter box, which was then up-ended over the relay. However, there was a possibility of the relay vibration causing the box to "walk" and the insulation interfere with the armature action. To prevent this a square guide line was drawn on the shelf around the relay base, spaced so that, when placed on this line, the box would be free of the relay. Then tiny finishing nails were driven part-way into the wood at eight points on the guide line, as shown in Figure 2. The nails, of course, held the carton securely in place.

Although metal or wooden cover

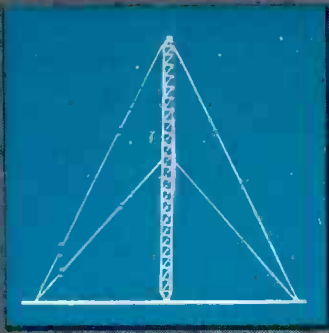
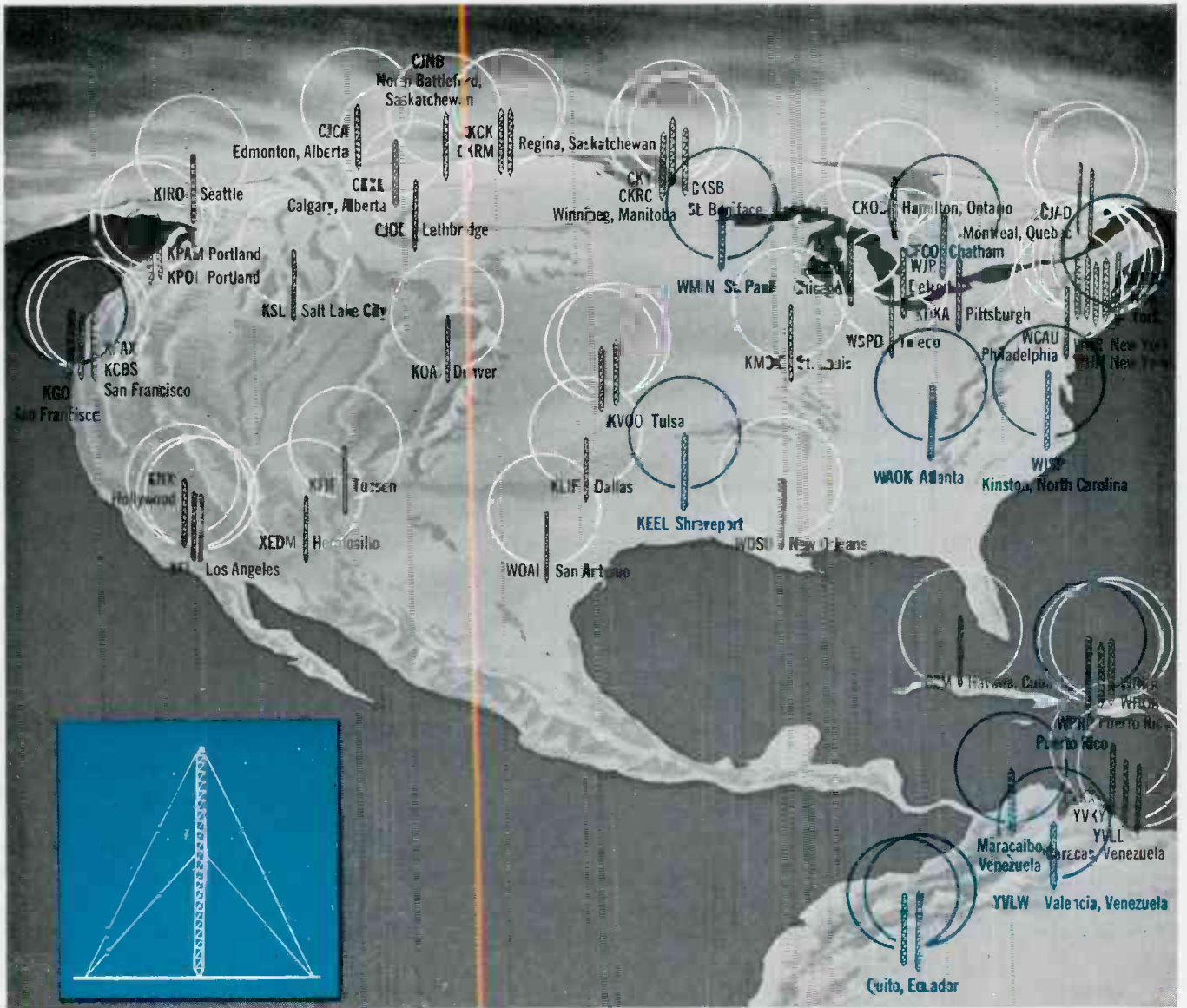

These NEW AM Radio Transmitters Speak with Continental Authority!

Here are preferential new installations made by discriminating major broadcasters. They indicate the proven quality, reliability and acceptance of Continental Electronics Transmitters.

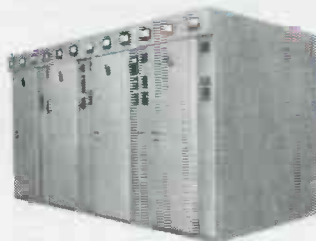

Type 317B 50kw AM transmitter



Type 314D 1kw AM transmitter



Type 315B/316B 5/10kw AM transmitter

Continental Electronics
MANUFACTURING COMPANY

Mailing Address: Box 17040, Dallas 17, Texas, 4212 S. Buckner Blvd., EV 1-7161 LTV Subsidiary of Ling-Temco-Vought, Inc.
Designers and Builders of the World's Most Powerful Radio Transmitters



boxes could have been used, the results obtained with the meter carts were so successful that we left them in position. With all relays shock-mounted and covered,

“thumps” were inaudible on the air, even with soft-voiced announcers, and in spite of the fact that the nearest relay was only three feet from the microphone diaphragm.

bolthead. Taking care not to upset anything inside the console drill a hole near the pot just behind “CUE.” Put the bolt through the hole, install another insulated spacer, attach a length of wire, put on nut and tighten.

Earphone Cue '62

By Lyell Gunderson
Chief Engineer
WATK, Antigo, Wis.

In radio stations today tight production is stressed just as much as any other phase of air work. Yet nearly all of us sometimes get caught pulling a net cut-in without looking at the clock, read a commercial only to glance down at an empty turntable—or perhaps turn off the air monitor when cueing a low level recording and forget it.

Here at WATK we have been sidetracking these embarrassing problems with the help of an automatic earphone cue switch. Our phone behaves normally until one of five pots, or one switch, is placed in the cue position, then the program is cut off and cue material is routed through them.

Our RCA board feeds a cue amplifier that has a six-hundred ohm out-

put which is loaded with a twelve-hundred ohm resistor at all times. However, when the cue amplifier is in use this resistor is shunted with our 1000-ohm phones for good quality and gain.

A double-pole double-throw relay, of the same voltage as your console relay supply, a few stove bolts, an old telephone switch and a tube of household glue are all that is needed to do this job. First disassemble the telephone switch for the parts needed to assemble the shorting switches. On a one-eighth inch stove bolt place a portion of the insulated sleeve about a quarter inch long, next a fiber spacer is placed on this and moved up to the bolt head where it is trimmed back as close as possible to the diameter of the

Moving now to the pot knob, take one of the fiber spacers cut in half the long way and point one end. This is glued to the back of the pot knob, pointing, as does the knob pointer, “smooth side” to contact blade. Now one of the contact blades is placed under the potentiometer mounting screw that is nearest the contact bolt and placed in a position to cover the contact bolt. Cut off the blade just below contact, take needle nose pliers and bend up so that it just clears the bolt.

Take an ohmmeter and connect to wire just installed and to console proper, replace knob and set so that when knob is turned to cue position the switch is closed. This is repeated for all pots with “cue.” Where the pot has no “cue” there may be spare contacts on the console switch. The wires are now connected to the relay which will be activated whenever cue is desired.

Once you have installed and used this unit you will never want to be without it.

Checking Tape Speed of Tape Recorders

By Robert E. Johnson, C.E.
WAXU Radio
Lexington, Ky.

Here is an idea which has proven very useful on several occasions in checking the tape speed of tape recorders, especially the home variety. Where a recorder is running slowly, there are frequently many adjustments to be tried, and this method quickly shows which ones are helping the situation. The method is to use a pre-recorded tape having a constant tone of several hundred cycle. Even a recorded telephone dial tone has proven effective. The idea behind this method is not to set the speed but to determine what will increase the speed. As the

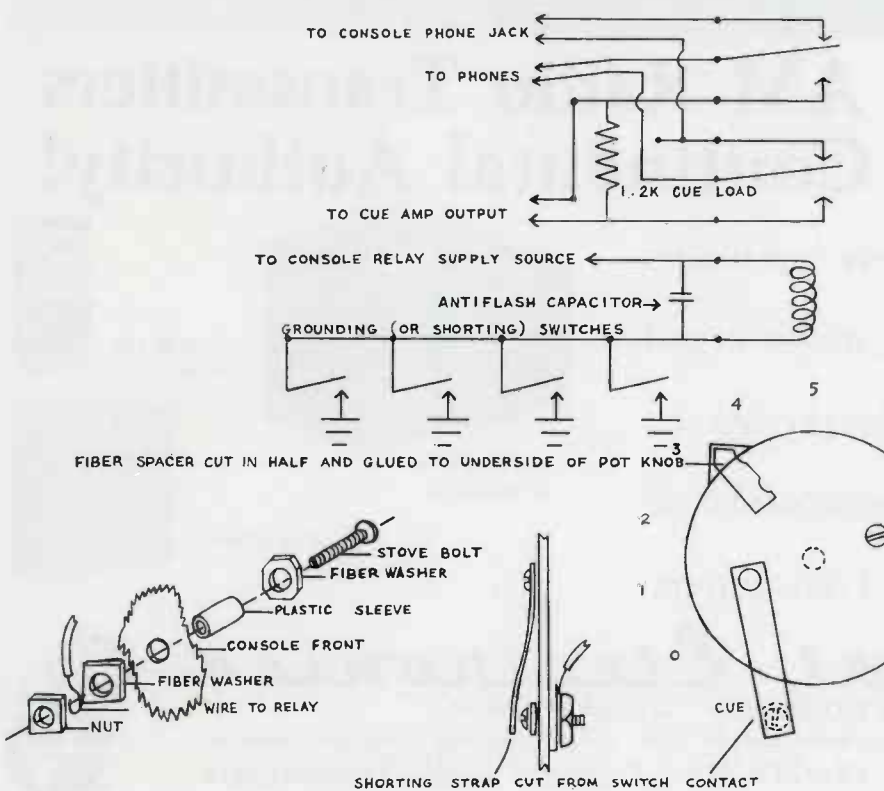

proper adjustments are made the pitch of the tone rises, and if improper adjustments are made the tone will lower. We located a mis-

aligned capstan bearing in five minutes using this method, after having spent over a year off and on looking for the difficulty in the instrument.

Remote Control Line Indication

By William Hoos
Chief Engineer WFBR
Baltimore, Md.

With remote control of a broadcast transmitter, the FCC requires that the control system be made fail-safe. This means, that in event of control line failure, or trouble in the control system, the plate circuits of the transmitter are automatically turned off. When our remote control system was being planned, we considered the question of the times

when the operator on duty would experience a failure of his transmitter. As the monitor goes dead, the immediate question is whether this is due to a failure in the transmitter itself, or a trouble in the control-telephone line system.

We found a very easy and inexpensive solution to this problem. The fail-safe circuit in our Rust sys-

tem puts a constant 2 ma. current on the control line to hold in the necessary relays. We simply opened one side of the control line, and inserted a 10 ma. meter. Now the operator has an instant answer to his question as to the area of trouble. With a failure, and the meter reading a normal 2 ma., he dials to turn on the auxiliary transmitter. If the meter reading is "off," get the phone company to restore the control line.

This meter offers other plus factors. One being that an indication of the condition of the control voltages in the unit can be constantly read. The "Lower" switching increases the current as read to 6 ma., and the "Raise" to 10 ma. Observation of the meter will indicate the condition of these functions.

Recently we noticed that after operating either "Raise" or "Lower," the meter did not return to 2 ma. Instead, erratic readings of 3 to 6 ma. were seen. This was due to a wet telephone cable which had developed a leak, both electrical and water. We were able to have this corrected before it became bad enough to cause complete failure.



INDESTRUCTIBLE?

Not quite. But you might think so if you saw our repair records! E-V professional microphones just seem to keep on going no matter what you do to them.

That's why we can afford to offer an unconditional two year guarantee against failure for any reason. (Just one exception . . . don't scratch the finish — we charge to fix that!)

Two years is a mighty long time, but E-V also offers a lifetime guarantee against defects in materials or workmanship. And our out-of-warranty repair charges are the most reasonable in the industry.

You profit every day from the dependability of E-V professional microphones. Isn't it time to follow the lead of major networks and leading Independent studios? Switch to Electro-Voice — dependably better!



ELECTRO-VOICE, INC., Commercial Products Division, Dept. 721V, Buchanan, Michigan

ElectroVoice®

New Traffic Control System For Radio Spots

RADIO Station KYA, San Francisco, has developed a traffic system which eliminates log typing and at the same time provides an immediate and accurate method of checking spot availabilities. Under the new system, the clerical time necessary to produce the log has been slashed from four hours a day to 15 minutes. Although this system means a reversal of normal station traffic procedures, the end result is a substantial improvement in KYA's operations. The TrafficCopy department can now serve as liaison between the sales department and the broadcasting department.

The heart of the new system consists of two pieces of equipment; an Acme visible traffic board, and a Verifax copier manufactured by Eastman Kodak Co. In operation typed sales orders are forwarded to the TrafficCopy department. The commercials are listed in a daily reminder diary to show what date they are scheduled to start and end. This provides a ready daily reference of changes to be made on the log.

The information on the sales orders is then typed on quarter-inch wide strips. These strips are posted

on an Acme Traffic Board visible reference. Information on the strips includes the name of the account, and various copy specifications: for instance, whether the announcement will be live, recorded or a combination of the two, and, if the announcement is recorded, which cut will be used.

Strips are placed in chronological sequence on the legal length (14 inches) frames of the visible traffic board, mounted on a vertical desk stand like pages in a book. Both sides of the frame are used. There is ample room on each for 40 or 50 line entries per page. One side of a frame represents an hour and a half of broadcasting time. Blank strips are used in between each type-written entry for spacing purposes. So that commercial availabilities may be checked at a glance, color strips are used to denote open time spots.

Frames are arranged in sequence by days, and cover one week's broadcasting time from Sunday to Saturday. Visible index markers pinpoint the days. To spot time availabilities for any one day, all that has to be done is flip the frames open at the proper spot and check the color strips. Future availabilities are designated by notations written

on the strips of existing commercials with non-reproducible colored pencil.

The visibly indexed frames, detached from their pivot post, are then inserted into the Kodak Verifax Signet Copier and reproduced as legal-sized documents. These pages form a new log—completely eliminating the necessity to type the log as was done previously.

The log for each day's broadcast is made up on the preceding day. KYA traffic manager simply removes the frames containing the schedule of commercial spots and announcements for the next day and places them, one by one, in the Verifax copier.

Working in ordinary room light, the secretary exposes the frame, with its copy information strips, to a light-sensitive matrix paper. In less than one minute, dry, white bond copies are ready to use. The matrix can be used to make as many as six additional copies of the schedule.

One important feature of the Verifax unit is that copy is reproduced on high-quality white bond paper. For KYA purposes, three copies of each log page are produced. When completed, the pages are collated and stapled together to make the daily log. The frames are returned to the visible index mechanism. The completed logs are checked against the sales orders to make sure that no terminated commercials have been left on, or no new commercials left off. Corrections, if any, are easily made in ink on the log pages. In addition, any last minute changes are easily inserted in the blank spaces between strips.

Completed logs are given to the program director. During the broadcasting period, the announcers write in the exact time that each commercial was put on the air, exactly as they did with the type-written log. These copies are then filed for three years, according to FCC regulations.

This system has produced numerous benefits. It has done away completely with the necessity of typing the log. The traffic manager can accomplish in 15 minutes what it formerly took her three or four hours to do. This has amounted to a time savings of approximately 25 hours a week.



The frames from the traffic board are inserted into a Kodak Verifax Signet Copier. Reproductions of the information on the frames is made by exposing the frames to a light-sensitive matrix paper.

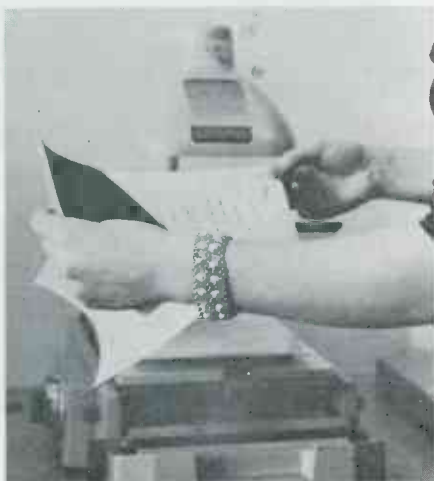

The schedule information is reproduced on dry, high-quality white bond paper, ready for use, less than one minute after exposure. Three copies of each page are reproduced; these are collated and stapled together to make the daily log. This eliminates the necessity of typing the log.

Television Tape

(Continued from page 16)

how far he can over-deviate the modulator without degrading the amplitude linearity. In this way, an indication of ageing tubes may be revealed before white, or sync, compression takes place under normal operations.

Servo Stability

The mark of a good clean servo system is immediate stabilization of the picture as the vacuum guide engages the tape with the rotating heads. Momentary instability immediately following this action is often caused by the velocity loop in the head servo, since this loop must function rapidly to obtain control tight enough for the phase loop to take over. Aside from "touchy" tubes (which generally may be located by lightly tapping with a pencil), the following points all have a bearing on general servo stability:

1. All tape transport tension adjustments; cleanliness of the head-wheel and capstan; control track head.

2. Condition of the tape, and number of splices. The latter is particularly important if the video heads have been worn to 1 mil or less of tip projection.

3. Centering of adjustments. Always ensure, in servo adjustments, that frequency controls are placed in the center of the rotation where frequency is lost. It is also good practice from a preventive maintenance standpoint to ascertain the minimum and maximum pulse widths obtainable from multivibrators, so that inability to obtain proper pulse widths, or a square wave, is anticipated before trouble occurs.

4. Become thoroughly familiar with the normal flow path of all control pulses so that the inputs and outputs of individual chassis, or circuitry, can be quickly traced.

5. Check power supplies and power supply regulation on a regular basis. Observe all gaseous voltage regulators for possible "blinking" or actual extinction under operation.

This concludes the series on tape fundamentals. The complete series is available in book form.

AVAILABLE FROM BLONDER-TONGUE

The new Benco T-6 VHF Translator Is Priced at \$845⁰⁰ (U. S. suggested list)

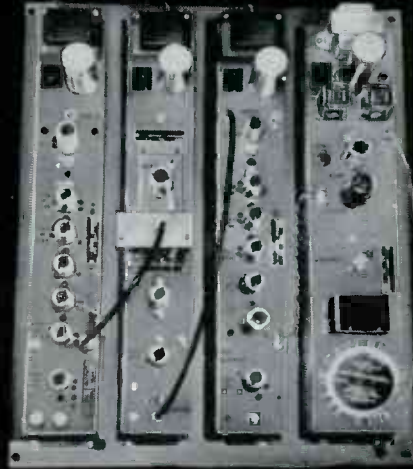

...It is
FCC Type Accepted, Rugged,
Available for Prompt Delivery

The Benco T-6 offers these advantages:

1. Meets all FCC specifications.
2. Provides constant output even in weak signal areas—preamp AGC activated by signals as low as 50 microvolts.
3. Automatic shutoff and identification.
4. Remote shutoff for any location up to 5 miles from the translator. (with RC-1).
5. Covers distances from 8 to 30 miles or more.
6. Prompt delivery to those who must have a low cost unit immediately to meet their 'on-the-air' time-schedule.

TECHNICAL SPECIFICATIONS

Primary Power Source117 v ± 10% 60 c/s
Power Consumption120 W
Temperature Ambient-30°C to + 50°C
Overall Noise Figure	
Low Band4 db ± 1 db
High Band6 db ± 1 db
Recommended Input50-4000 microvolts
Max. Permissible Power1 Watt (Peak Power)
Frequency Stability02%
Gain (maximum)105 db
Band Width6 Mc (3 db points)
Dimensions (metal base)18"x22½"
Weight27 lbs.

BENCO VHF AND UHF TRANSLATORS FOR EVERY TYPE OF INSTALLATION

MODEL T-1 VHF TRANSLATOR FCC type-accepted. 1 watt output for U. S. use • ideal for future expansion • meets all FCC specifications • noise-proof automatic shutoff • regulated power supply for stable operation • underrated output section for continuous service; weather-proof housing; quick easy coding of identification unit • built-in direct reading power meter.

MODEL T-14 VHF-TO-UHF TRANSLATOR. FCC type-accepted. 2.5 watts output. For U. S. use. Includes identification units with automatic "on/off," power indicator and voltage regulator. VHF input, channels 7-13.

MODEL T-13 VHF-TO-UHF. Same as T-14 except: VHF input, channels 2-6.

If you're planning a translator installation, contact Blonder-Tongue. Free layout service and field engineering assistance are available at nominal cost.

engineered and manufactured by

BLONDER-TONGUE

9 Alling St., Newark, N. J.

Canadian Div.: Benco Television Assoc., Tor., Ont. Export: Rocke Int'l Corp., N.Y. 16—Cables: ARLAB home TV accessories • UHF converters • master TV systems • closed circuit TV systems



FIRST
in Acceptance

FIDELIPAC[®]

**AUTOMATIC TAPE
CARTRIDGES by
CONLEY**

The cartridge that made station
automation possible



... Fidelipac Tape Cartridges by Conley. First and still best. Result! More successful broadcasters use Fidelipac Cartridges by Conley than any other.

Fidelipac assured dependability—its greater acceptance—result from these features.

- easily handled • easily stored
- easily reloaded • minimized tape breakage
- your present equipment was made to handle Fidelipac
- increased tape life • varying sizes permit programming from seconds to hours on a single cartridge
- automatically cued and ready for instant use
- technical perfection in every detail.

Be sure every time . . . put efficiency, economy, quality into your broadcast operations by putting Fidelipac Cartridges by Conley to work for you . . . for spot announcements, themes, station breaks, and delayed broadcasts.

Standard Lengths

In Three Cartridge Sizes:

Model 300 —with up to 300 feet of single coated tape

Model 600 —with up to 600 feet of single coated tape

Model 1200 —with up to 1200 feet of single coated tape

Ask for

FIDELIPAC "THE STANDARD OF THE INDUSTRY"
from your regular source of supply



**CONLEY ELECTRONICS
CORPORATION**

1527 Lyons Street • Evanston, Illinois

Book Reviews

FM Multiplexing for Stereo

Catalog No. FMS-1. Published by Howard W. Sams & Co., Inc., Indianapolis 6, Ind. 160 pages. Price: \$2.50.

"FM Multiplexing for Stereo," by Leonard Feldman (Director of Engineering, Crosby Teletronics Corp.) is the most up-to-date guide available on the principles of FM stereo multiplexing, the theory and operation of the various receiver circuits, and the alignment and servicing of these units. Profusely illustrated, the book is written on a level that will appeal to anyone with an interest in the subject, whether a layman, an audiophile, an engineer, or a technician.

Seven chapters include: Introduction to FM Stereo; Analysis of the Approved Stereo Signal; Converting to FM Stereo; Multiplex Decoder Circuits; Servicing Multiplex Circuits; FM Stereo Test Equipment and Multiplex Circuit Alignment; Latest Multiplex Circuits; and the Appendix.

Radio Electronic Transmission Fundamentals

Published by McGraw Hill Book Co., Inc., 330 W. 42nd St., New York 36, N. Y. Price: \$10.75.

This is a book that every technician, aspiring engineer, and even every engineer, in broadcasting, should have in his library. It covers very clearly and concisely all the important fundamentals of radio transmission theory. It is a book that this reviewer wishes he had had 20 years ago! Following a logical progression from power generation to radiation it goes into the whys and wherefores of transmission lines, antenna impedance, radiation, directional antennas, and every conceivable engineering point for the broadcast engineer.

Although it avoids math as much as possible, it does go a little way into calculus, and it provides a perfectly simple approach to a complex subject so that a reader who has little or no math training can still understand it. At the same time

it treats vectors and vector diagrams with a clarity that illustrates the important part that vectors play in engineering and the method of use.

Although the title uses the word "fundamentals" perhaps this is to avoid scaring the beginner reader. In fact, the material between the covers is far from fundamental, although it is treated in a very simple way so that it appears to be fundamental. The advanced engineer can find some very useful references in this book in connection with review work or for things he has plain forgotten! The blurb on the dust cover does not show any especial connection between the author and broadcast engineering; however, he has built a book that could only have been written by a man who knows what the average broadcast engineer *needs* to know! No radio engineer should be without a copy!

Transistor Substitution Handbook

Catalog No. SSH-3. Published by Howard W. Sams & Co., Inc., Indianapolis 6, Ind. 128 pages. Price: \$1.50.

The rapidly-increasing number of electronic devices which utilize transistors, and the growing number of transistor types, has necessitated an expanded third edition of the famous Howard W. Sams "Transistor Substitution Handbook."

This newly revised edition lists over 13,600 possible substitutions for more than 4,000 transistors—3,400 more than in the prior volume. Also contains a special section showing 1,514 replacements for 410 Japanese transistors. Also included in the book are references indicating the manufacturers from whom each type is available, polarity identifications, and a key number designating the basing diagram for each type.

A special semiconductor diode cross-reference directory, encompassing a color-code identification guide, lists over 760 substitutions. Explanations of why transistor substitution is possible, when it is appropriate, how to choose substitutes, and what precautions to observe when using substitute types are included to make this volume the most complete of its type available.

Audio Maintenance

(Continued from page 13)

lier in the section on hum testing with the oscillator and meter apply to testing with a tone tape and the console VI. This method also permits comparison of various input tubes, rejection of those whose hum is not at least 45 db below output level, and hum-testing of all newly-purchased tubes.

When using the console VI as an indicating device (in lieu of a noise meter), once the console itself has been tested and found to be operating properly, other studio amplifiers (or external preamps) may be tested *through* the console. To avoid the limitations of console preamps, the external amplifiers should be fed into the console by means of line, tape or turntable inputs (which usually includes isolation and matching transformers). Thus it is possible to use the tone tape and the console VU meter to test units other than the console itself.

Evaluation

There are *certain* tube functions which require testing and evaluation different from the methods outlined. Examples are: The bias oscillator in a tape recorder, the gain-controlling diode in an AGC-type amplifier, and all power-supply tubes. It must be remembered that tubes intended for these types of service must *first* be passed by the tube tester with respect to gross defects.

Evaluation of a bias oscillator is actually quite simple. Instructions regarding bias will be found in the technical manual supplied by the manufacturer. There is generally a bias adjustment, and a point at which a voltage may be read on a high-impedance VTVM which corresponds to the RF bias. If the adjustment will not produce the desired bias, a new tube should be installed. If several fresh tubes do not produce the desired results, another circuit component is usually at fault.

When a tube is used as a detector (a 6AL5, for example) in the function of gain-controlling diode in an AGC-type amplifier, a simple emission test by means of a tube tester

is the ideal test. Such a tube is built to carry much more current than it ever does in this service, so the only parameter of interest is cathode emission.

Diodes employed as rectifiers in power supplies, however, are subject to high current demands and the heat which that entails. Thus the ordinary tube tester will not accurately simulate their service conditions. The only criticism for a rectifier is its output power. It is therefore easy to test a power supply—simply measure the output

voltage under load and compare it with the manufacturer's information.

Gaseous voltage regulators are likewise single-purposed. Their sole test is their terminal voltage while in operation. This should be measured with a high-impedance VTVM. The VTVM may not be accurate, so try a fresh VR tube and compare its voltage with that of the one in use. Most regulators give ample indication of their demise anyway, as their colorful glow extinguishes when they stop regulating.

McMARTIN TBM 3000 FM MONITOR APPROVED BY FCC



- The newest and most up to date Monitor on the market today.
- Immediate delivery (after thorough checkout and alignment)
- Price: \$495
- For the very finest in reliability and performance, depend on McMARTIN FM and Multiplex Monitors

FEDERAL COMMUNICATIONS COMMISSION
WASHINGTON 25, D. C.

March 26, 1962

ADDRESS ALL COMMUNICATIONS
TO THE SECRETARY
IN REPLY REFER TO:
6179

McMartin Industries, Inc.
1612 California Street
Omaha, Nebraska

Attention: Mr. Ray B. McMartin
President

Gentlemen:

On the basis of the tests conducted at the Commission's Laboratory, type approval is hereby issued to you covering the equipment listed below for operation under Part 3 of the Commission's Rules:

Kind of Equipment: Frequency Monitor (FM Broadcast)
Make: McMARTIN Industries, Inc.
Model or Type: Type TBM-3000
Frequency Range: 88 to 108 megacycles
FCC Type Approval Number: 3-113

Originality by

McMartin Industries, Inc.

1612 California Street • Omaha, Nebraska

In Canada, Sold by: Canadian Marconi Company, Montreal 16, P. Q.

McMartin

Industry News

Change at Collins Radio

Howard L. Peters has assumed the post of director, central region sales succeeding Robert M. Winston, now director, commercial sales.

Mr. Peters joined Collins Radio Co. in 1959 as an avionics salesman and later represented Collins to airlines in the central region. During the past year he has served as central region assistant sales manager and directed field service activities in the region.

Before joining Collins, Mr. Peters was a salesman and assistant to the vice-president, sales, with an electronic firm within the General Precision Equipment Corp.

A college graduate with over 15 years' experience in the field of aviation and electronics, Mr. Peters has been an Air Force combat instructor and commercial pilot with

extensive experience in specialized sales and sales administration in electronics.

On-Air, Closed Circuit Educational TV System

An on-air, closed circuit educational TV system, designed to provide low-cost, multi-program instruction, was demonstrated recently for educators, industry leaders and government officials in Plainedge, N. Y. The demonstration was held to support proposed Federal Communications Commission rules which will open the 2,000 megacycle band for educational telecasting. The system which inter-connects all eight schools in the Plainedge school district was developed by Adler Electronics, Inc., New Rochelle, N. Y. Interest in the 2,000 megacycle band is based on the availability of

channels and low-cost equipment—both basic requirements for widespread development of educational television.

The system transmits the programs originated in the high school to seven other schools. At each school, a converter similar to that used for UHF TV converts the 2,000 megacycle signal to VHF and feeds it into the school's internal distribution system. The program can then be viewed on any standard TV receiver.

RCA Camera Tubes Used on New Experimental Camera

A 4½-inch diameter RCA camera tube, the 7295A, is the big eye of an experimental RCA camera which is said to produce color television pictures having richer hues and finer details than ever before attained in color studio cameras.

In the new camera, the 7295A picks up the black-and-white signal, while three 1-inch diameter vidicon tubes, RCA Dev. Types C74016, are used for the red, blue and green picture information. The imposition of a clean, precise, black-

Spotmaster



500R combination recorder-playback unit

Spotmaster

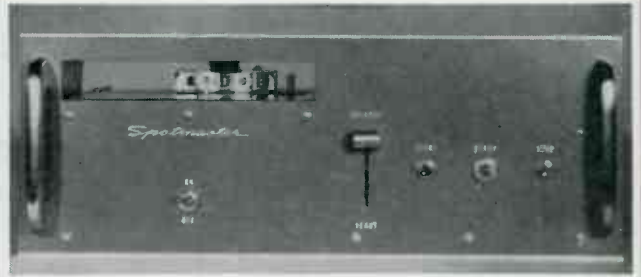

505R playback unit

NEW SPOTMASTER Rack Mount Cartridge Tape Equipment

Engineered for heavy-duty precision programming—as is all Spotmaster equipment—the 500R combination recorder-playback unit and the 505R playback unit are furnished complete with rack chassis slides ready to mount in your rack. Each unit slides in and out of the rack for ease of head and capstan cleaning, as well as other routine maintenance. All connections are made by use of convenient plugs in common use in all broadcast stations. Amplifiers and other components are conveniently placed for ease of servicing. The Model 500R is a complete recorder-playback unit and mounts in only 7" of rack space, as does the matching playback unit, Model 505R. Playback units may be mounted in multiple to provide complete facilities in one rack. Plug-in remote control and cue-trip amplifiers for automatic sequential switching available as optional extras on all playback units. Also available for immediate delivery, are the standard best selling 500 and 505 compact monophonic units. For information on our complete line of cartridge equipment contact:

BROADCAST ELECTRONICS 8800 BROOKVILLE RD., SILVER SPRING, MD. JU 8-4983

SOLD NATIONALLY BY: VISUAL ELECTRONICS CORP., 356 W. 40th St., N.Y., N.Y., Richard H. Ullman, Inc., 1271 Ave. of the Americas, N.Y., N.Y., CANADA—Northern Electric Co., Ltd., 250 Sidney St., Belleville, Ontario.

and-white signal from the one image orthicon tube onto the three primary color signals, a technique similar to that used in four-color printing, is designed to enrich picture hues and provide sharper definition. This composite signal also is said to provide superior black-and-white pictures on non-color TV sets.

Both types of TV camera tubes were designed by engineers of the RCA Electron Tube division at Lancaster, Pa.

McMartin Announces New Appointments

Ray B. McMartin, president, McMartin Industries, Inc., Omaha, Neb., has announced appointment of the following manufacturer's representatives who will serve territories indicated:

Art Cohen, serving Florida, Georgia, Alabama, Mississippi, Tennessee and Puerto Rico; H. H. Seay, covering the Ohio-West Virginia territory; and James M. Flora will serve the state of Michigan.

Radio Aids Takes Over Frequency Measuring Service

On May 8 the Illinois Bell Telephone-operated frequency measuring service at Lake Bluff, Ill., decided to terminate operations, and final measurements were made on May 14. No frequency measuring service is now performed at the facility except that necessary to maintain their own equipment.

Radio Aids, which has been in operation for nearly 14 years, with eight years of that time in a Lake Bluff location also, is now providing all the services that were dropped by IBT.

Announce Sale of Fleetwood Trademark

The Fleetwood trademark and all goodwill symbolized by that name has been sold to the Fleetwood Corp. of Canada, according to a recent announcement by W. J. Moreland, general manager, Conrac Div., Giannini Controls Corp., Glendora, Calif.

Sale of the U. S. registered trademark completes Conrac's planned withdrawal from the home television market, and points up the firm's concentration on the broadcast, industrial and educational fields, where the company's trademark Conrac will continue to be used.



OVER 1400 SIZES AND TYPES OF IERC HEAT-DISSIPATING ELECTRON TUBE SHIELDS

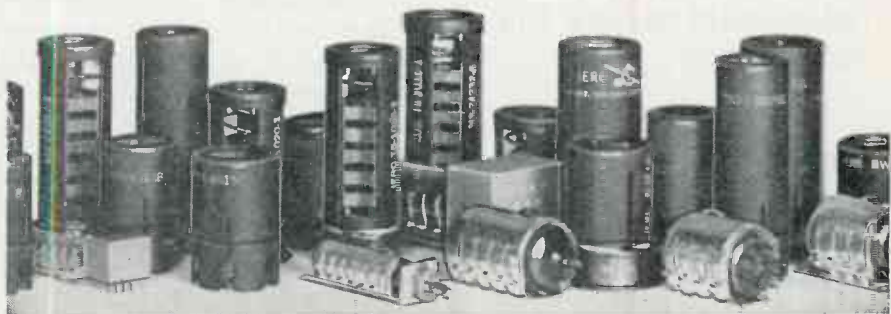

ARE EFFECTIVELY COOLING MILLIONS OF TUBES, EXTENDING LIFE AND RELIABILITY,



REDUCING DOWN-TIME AND MAINTENANCE COSTS IN THOUSANDS OF MILITARY AND



INDUSTRIAL ELECTRONIC EQUIPMENTS!

Write today for the facts on how you can improve equipment reliability with IERC Heat-Dissipating Tube Shields.

IERC  **DIVISION**

International Electronic Research Corporation
135 West Magnolia Boulevard, Burbank, California

Foreign Manufacturers: Europelec, Paris, France. Garrard Mfg. & Eng. Co., Ltd., Swindon, England

PROFESSIONAL STANDARD OF THE BROADCASTING INDUSTRY



... Proven by years of reliable service the world over.



728 STEREO
The professional standard. 7½ and 15 ips. Superior performance in all areas.



748 STEREO
The Olympian... champion of recorders. 3¾ and 7½ ips. 4-track play and record.



THE PT 6
The rugged, reliable "Workhorse" of the broadcast industry.



THE P 75
"The Editor"... includes all of the capabilities of the PT 6 plus extended performance and utility.

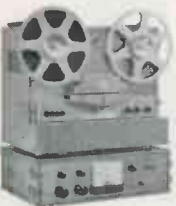

THE M 90
"Mighty" in all performance characteristics. Magnecord's finest tape instrument.

Magnecord sets the standard for Performance, Quality and Reliability in the professional sound and broadcast industry.

WRITE TODAY FOR MORE INFORMATION



MAGNECORD SALES DEPARTMENT
MIDWESTERN INSTRUMENTS
P. O. BOX 7509 • TULSA 35, OKLAHOMA

Industry News

Ampex Establishes New Advanced Research Facility

A new advanced research facility, known as the Alexander M. Poniatoff Laboratory, has been established by Ampex Corp. at the company headquarters in Redwood City, Calif.

The new laboratory will be under the personal direction of Alexander M. Poniatoff, founder and chairman of the board of directors of the corporation. It will be devoted to investigations of advanced and experimental techniques in magnetic recording, and will complement the activities of other research and development facilities of the firm. Initial staff members are Harold Lindsay, a staff assistant to Poniatoff, Alex R. Maxey and Alan Grace, video staff engineers.

South African Order Received by Gates

Gates Radio Co., subsidiary of Harris-Intertype Corp., Quincy, Ill., has received an order from the South African Broadcasting Corp. for 13 Gates FM transmitters, including five 10-kilowatt and eight 250-watt transmitters, each with a dual driver and single RF amplifier, and 25 cascade exciters.

The five 10-kilowatt FM transmitters will be used in a single installation in Bloemfontein, South Africa. Four of the 250-watt transmitters will be in Cape Town Minor with the other four installed together in Paarl, South Africa. The multiple installations at one site will permit broadcasts of identical program material in several different languages. The transmitters will be delivered to South Africa during the period of August through December, 1962.

Announce Sale of Gray Research & Development Co.

Gray Research & Development Co., Inc., Elmwood, Conn., the former broadcast and high-fidelity division of Gray Mfg. Co., has been sold to a group of its former managers and employees.

T. Gerald Dyar, manager of the Gray special products division, becomes president of the Gray Research & Development Co., which

will be completely independent under its new ownership. A new 7,500 sq. ft. plant has been erected, equipped and staffed on North Mountain Rd., Newington, Conn., and is already in production.

RCA Manager Post to Merrill A. Trainer

Radio Corp. of America, New York, N. Y., has appointed Merrill A. Trainer, an engineering and marketing executive in the broadcast equipment field for more than 30 years, to the new post of manager, international operations liaison, Broadcast & Communications Products Div.

Trainer will coordinate sales activity for division products in world-wide markets, and will continue to make his headquarters in the division offices at Camden, New Jersey.

N. S. Ponte Rejoins Continental Electronics

N. S. Ponte has rejoined Continental Electronics Mfg. Co., subsidiary of Ling-Temco-Vought, Inc., as head of the communication section of the firm's engineering department, Continental President J. O. Weldon announced.

Ponte, who was project engineer for BMEWS (Ballistic Missile Early Warning System) equipment before becoming station manager for American Committee for Liberation about a year ago, will be responsible for engineering commercial broadcast equipment, Weldon said.

Electronic Tube Demonstrated For Versatile TV System

A versatile television system designed to record or transmit images over long distances at low cost was demonstrated at the recent Institute of Radio Engineers' International Convention in New York City by the electronic tube division of Westinghouse Electric Corp., Elmira, N. Y. Heart of the system is the new slow-scan vidicon, type 7290, TV camera tube. With it, the TV camera produces one picture every eight seconds. The pictures can be stored on an ordinary tape recorder, sent over phone lines, or transmitted by radio such as a mobile two-way unit.

In operation, the slow-scan TV camera's lens focuses the live image on the vidicon's screen, and an elec-

trical camera shutter freezes the image. The camera circuit through an electron beam scans the vidicon's screen and converts the image into an audio signal which is then fed to a recorder, a phone line or a radio transmitter. An additional audio signal such as a human voice can also accompany the picture. At the receiving end, an electronic monitor converts the audio signal back to an image signal that is reproduced as a television picture. A stereo tape recorder can be used with the system to record material. Pictures go on one track of the stereo tape, and the sound goes on the alternate track.

FCC Type Approval For McMartin Monitor

The Federal Communications Commission has issued Type Approval covering the TBM-3000, FM broadcast frequency monitor, designed and developed by McMartin Industries, Inc., Omaha, Neb., and submitted Dec. 27, 1961, to the Commission's laboratory.

Certificate of Type approval was issued on the basis of extensive tests and evaluations conducted by the laboratory. The FCC assigned Type Approval No. 3-113.

Charles L. Range Appointed Regional Sales Manager

Altec Lansing Corp., a subsidiary of Ling-Temco-Vought, Inc., Anaheim, Calif., recently announced the appointment of Charles L. Range as regional sales manager for the company's product line in the mid-Atlantic states.

Ampex Magnetic Recording Head in Extended Use

Ampex Corp., Redwood City, Calif., reports that the longest known use of the firm's magnetic recording head—well over 50,000 hours without replacement or repair—has been called to its attention by Donald R. Cook, president, Fresno Mobile Radio, Inc., Fresno, Calif.

Cook stated that the heads of an Ampex model 350 audio recorder, used in a taped radio paging service for a variety of clients within a 20-mile radius of Fresno, have been in service more than 50,000 hours without special repairs and scant attention. Cook said, "The

recorder has not been out of service more than an hour or two at any one time since August, 1954. During the last four years the equipment has been in operation almost 24 hours a day and at no time less than 18 hours a day."

FEC Service Provided For PYE Radio Equipment

Installation and maintenance of mobile radio equipment manufactured by PYE Corp. of America is currently being provided by Federal Electric Corp., Paramus, N. J., the service associate of International Telephone & Telegraph Corp. The service will be provided by FEC's commercial division and the division's service centers in major metropolitan areas.

PYE Corp. of America is a subsidiary of PYE Telecommunications Ltd. of Cambridge, England.

Kilpatrick Joins Visual's Technical Sales Staff

Visual Electronics Corp., New York, N. Y., has announced that Leroy E. Kilpatrick has joined the company's technical sales staff, and will be supervising broadcast accounts in Alabama, Kentucky, Missouri and Tennessee.

GEL Appoints New Sales Representative

General Electronic Laboratories, Inc., Cambridge, Mass., has announced the appointment of Howard T. Dempsey as broadcast equipment sales representative. With headquarters in Denver, Dempsey's territory will cover Colorado, Wyoming, New Mexico, Arizona and Utah.

New Assignment for RCA Electron Tube Division

The distributor products department of the RCA Electron Tube Div., Harrison, N. J., has assumed complete product responsibility, including sales and distribution, for RCA citizens' band radio equipment, intercom systems and public address equipment, according to a recent announcement by Harold F. Bersche, manager, distributor products.

Use Broadcast Engineering's Classified Page

LEADING BROADCASTERS ENDORSE

Bauer Kit

1 Kw TRANSMITTER

- ★ "It is, without a doubt, the nicest looking transmitter on the market, and it has a most desirable arrangement of parts." —CONSULTANT
- ★ "Again I want to say that I think that our selection of the Bauer transmitter was a wise decision and already other people in the broadcasting industry in this area have shown an interest in the transmitter and we are glad and proud to show it to them."—KTOC, JONESBORO, La.
- ★ "It was a real pleasure for me to test out the Type 707 transmitter in Tacoma, and your organization is to be congratulated on the excellent design of this unit."—CONSULTANT
- ★ "56 spare time hours to build—45 minutes to check out—it's terrific!"—KXRK—San Jose, California
- ★ "The transmitter checked right out. We were all pleasantly surprised with the performance."—WDIG—DOTHAN, ALA.
- ★ AND MANY MORE.

They are all talking about the Bauer Model 707 1000/250 watt AM transmitter available either factory assembled or in KIT form.

WRITE FOR THE COMPLETE ENGINEERING STORY TODAY!



Bauer

ELECTRONICS CORPORATION

1663 Industrial Rd. • San Carlos, Calif.

PROFESSIONAL PRODUCTS IN KIT FORM

Product News

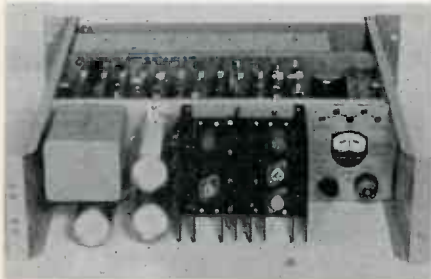

COLOR CONVERSION UNIT

Ampex Corp., 934 Charter St., Redwood City, Calif., has announced an improved and miniaturized Colortec color conversion unit for the company's Videotape TV recorder.

Improvements are said to permit greater versatility of operation and include completely automatic selection of operating modes for monochrome, standard color signals and non-standard color signals. The new unit is designed to employ full recovery of the original color burst information without alteration of amplitude or phase, and enable the burst signal to accompany the chroma signal. Additional features include expanded manual mode selection and novel circuitry design.

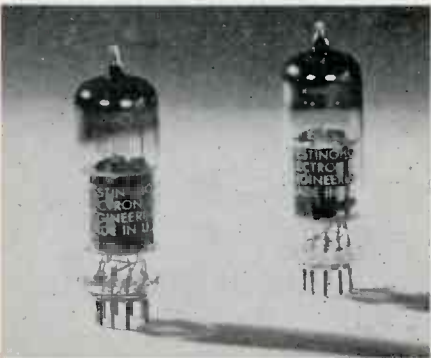

NEW TRIODE-TETRODE

A new nine-pin miniature triode-tetrode receiving tube, type 6/10JA8, is now available from Westinghouse Electronic Tube Div., P. O. Box 284, Elmira, N. Y. It is designed for dual purpose use as a low-voltage sync-separator and video-output tube. The tetrode section is rated at five watts maximum plate dissipation and 1.5 watts screen grid dissipation. The manufacturer states that up to 12,600 micromhos of transconductance can be obtained with 135 volts on the low-voltage plate and the screen grid. With this screen grid voltage and zero control grid voltage, the tube's plate characteristic curve has a knee at 30 volts and a plate current of 32 milliamperes. The triode section has a high amplification factor, making it particularly useful for

sync separation. This section is built for a maximum plate dissipation of one watt.

Two versions of the 6/10JA8 are available. One has a heater voltage rating of 6.3 volts and the other has 10.5 volts. The rated heater current of the 6.3-volt tube is 750 milliamperes, with a 450 milliamperes rating for the 10.5-volt tube. The latter version has controlled heater warm-up time.



PORTABLE TV TAPE RECORDER

Mach-Tronics, Inc., 185 Evelyn Ave., Mountain View, Calif., has introduced a portable television tape recorder which is said to have broad application in closed circuit instructional TV and broadcast studio use.

The MVR-10 uses 1-inch wide tape and is designed to record in excess of an hour's programming on a 10½-inch reel. Weighing less than 100 lb., the unit features solid state electronic circuitry and a uniquely-designed transport mechanism. It is completely self-contained, occupying 2.3 cu. ft. of space, including a built-in, 8-inch video monitor with integrated audio channel.

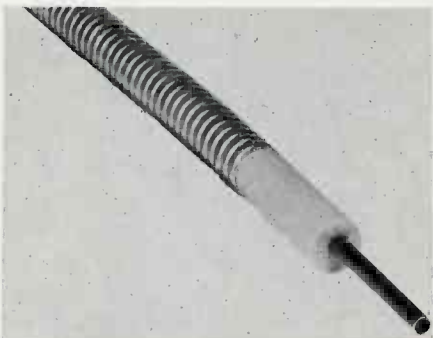

FOAM DIELECTRIC COAXIAL CABLE

Andrew Corp., P. O. Box 807, Chicago 42, Ill., has introduced the Foam Helix, a flexible, foam dielectric coaxial cable which is said to offer many desirable characteristics of air dielectric cable but requires no pressurization. The low density foam insulation, together with high conductivity of both copper conductors, is designed to result in minimum attenuation.

The cable is available in 50 ohm, ½-inch and ⅞-inch sizes in splice-free continuous lengths, with a selection of end fittings also available.

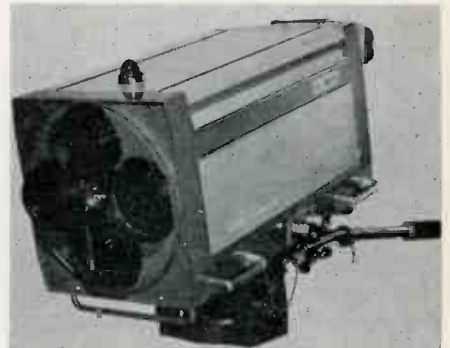

COLOR CAMERA FOR LIVE OR TELECINE USE

An improved, lightweight color television camera chain has been introduced by General Communications Div., EMI/US, 1750 N. Vine St., Los Angeles 28, Calif.

The model 204 offers simplified push-button signal selectors, controls centralized off-camera, and one-hand combined turret and focus operation. Also in the line is the high definition, rugged 203 image orthicon broadcast camera.

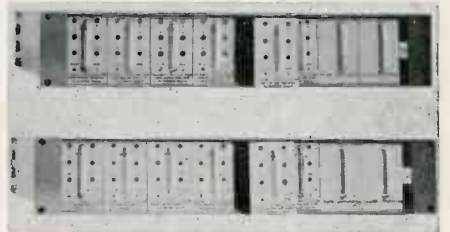

TELECHROME VIDEO AMPLIFIERS

Two new Telechrome video amplifiers, for use in both color and monochrome TV systems, have been announced by Telemet Co., 185 Dixon Ave., Amityville, Long Island, New York.

Model 3200-A1 is a video distribution amplifier, and model 3202-A1, a pulse distribution amplifier. Both are fully transistorized and are designed as self-contained, plug-in modules. Each has an individually regulated and fused power supply (operating from 117 vac) and is said to perform reliably at ambient temperatures to 60 deg. C. (140 deg. F.). When used in a mounting frame, eight amplifiers can provide a total of 32 outputs and eight inputs in 3½ inches of rack space. All input and output connections are made through standard UHF coaxial connectors, and all amplifiers plug in from the front of the frame, presenting a closed and flush appearance. Blank panels are available to maintain this appearance with less than eight amplifiers.

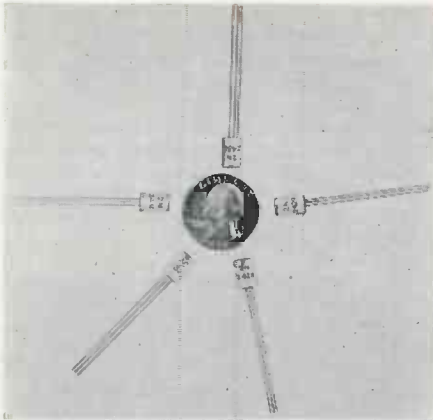

UNIVERSAL AUDIO TRANSISTORS

Amperex Electronic Corp., Semiconductor & Special Purpose Tube Dept., 230 Duffy Ave., Hicksville, Long Island, N. Y., has announced the first five of a line of universal audio frequency transistors. Manufactured by the uniform low frequency technique, the units are said to exhibit extremely flat beta characteristics, and uniformly high beta over the entire operating current range.

Type 2N2428 is a high gain PNP type with tight 2-to-1 beta range (80 to 170). The 2N2429 is similar to the 2N2428 but with higher beta (130 to 300). These types are for use as preamplifiers, drivers and low wattage output devices, and have maximum dissipation ratings of 165 mw and a 32-volt peak collector to emitter voltage rating.

The 2N2430 is an NPN device with a beta spread of 65 to 190, and is also available

as the AC127 in matched pairs with the AC132 for PNP-NPN complementary symmetrical class B 200 mw output applications. Type 2N2431 is a PNP medium power transistor capable of up to 2 watts power output per pair, and is designed for class A and B audio output stages. It features exceptionally linear input-output characteristics, high gain with a beta of 55 to 175, maximum dissipation of 550 mw and 32 volt collector to emitter voltage rating.

BURKE & JAMES ANNUAL CATALOG

The 65th annual catalog, featuring film equipment, has been announced by Burke & James, Inc., 321 S. Wabash, Chicago 4, Ill. The 148-page book includes camera and lens listings, the latest equipment, processing controls and time-savers. It is indexed for easy reference.



DYNAMIC BETA TRANSISTOR TESTER

The new Dynamic Beta transistor tester, model 1880, has been announced by RD Instruments Div., Hickok Electrical Instru-

ment Co., 10514 Dupont Ave., Cleveland 8, Ohio.

The instrument, suitable for testing either silicon or germanium transistors, measures ac beta, dc beta, leakage, and other transistor characteristics. A roll chart lists data for beta and leakage tests on more than 1,550 transistors. Transistor manufacturer's specification sheets are the basis of other tests.

NEW MONOCHROME VIDEO ALIGNMENT TAPE

Development of a new monochrome video alignment tape for use in evaluating the performance of quadruplex television tape recorders has been announced by Radio Corp. of America, Broadcast & Communications Products Div., Camden, N. J.

The tape is designed to enable broadcasters and other TV tape recorder users to determine accurate quadrature and vacuum guide alignment as the basis for the most effective operating conditions, maximum head life and the highest degree of tape interchangeability. It is wound on an 8-inch reel and contains five minutes of multi-purpose test signals.

NEW COMPACT COMPRESSOR

The new 663 compact compressor, a level compressor no bigger than a slide-type attenuator (1½x7x4 inches), is being offered by Fairchild Recording Equipment Corp., 10-40 45th Ave., Long Island City 1, N. Y.

The manufacturer states that with a device this size it is now possible to have level control on each microphone channel, and that it is no longer necessary to use the same compression on brass as on strings. Each group of instruments can be controlled in amount of compression and release time.

NEW PORTABLE EQUIPMENT FOR STATIONS ON THE MOVE

A-50 PORTABLE STUDIO



\$845.00

What is your need: Production Studio—Remote Facility—Main Studio? The unique Sparta A-50 handles all of these jobs well. The A-50 combines the many outstanding features of the A-10 Console. IT-12 turntables, viscose damped tone arms and other Sparta quality products. A rugged solidly built unit, the A-50 is designed for many years of continuous duty.

CP-5 CARTRIDGE PLAYBACK UNIT



\$145.00

An important new sales and production aid for all cartridge equipped stations. The CP-5 provides a modern method of auditioning commercials in the station or client's office. Full fidelity reproduction—convenient carrying handle. Durable finished in Sparta grey with handsome anodized front panel.

A-10 AUDIO CONSOLE

Compact in size—big in performance. The Sparta A-10 Console provides a total of eight high or low level inputs and other features normally found in only the most expensive equipment. Up to date solid state design plus plug-in modular construction make the A-10 a dependable top quality performer.



\$375.00

Call, Write or Wire Today

SPARTA ELECTRONIC CORPORATION

6430 FREEPORT BOULEVARD • SACRAMENTO 22, CALIFORNIA • GA 1-2070



Count down!



Parabam digital count-down clock tells time by the numbers...engineers and talent see how much time remains from any time segment. Unlimited remotes from split-second accurate master. Push-button resetting. Moderate price. Write now.

PARABAM

DIVISION OF **H** HOUSTON FEARLESS CORPORATION
12822 Yukon Ave., Hawthorne, Calif. / Osborne 9-3393

for your tower requirements check **ROHN SYSTEMS**

A complete tower erection service that has these special advantages:

- ✓ DEPENDABILITY
- ✓ RELIABILITY
- ✓ COMPLETE ENGINEERING
- ✓ COAST TO COAST SERVICE

Be sure to obtain price quotations and engineering assistance for your complete tower needs from America's foremost tower erection service.

ROHN SYSTEMS, INC.

6718 W. Plank Road

Peoria, Illinois

Product News



A-50 PORTABLE STUDIO

Sparta Electronic Corp., 6430 Freeport Blvd., Sacramento 22, Calif., has introduced the A-50 portable studio, designed to bridge the gap between permanent studio facilities and light duty remote equipment.

Features of the new unit include heavy-duty professional turntables; viscose-damped tone arms; cover serves as operator bench; fold-up work surface for copy and other needs; turntable cue system; monitor amplifier and speaker-screw-in legs allow quick, convenient set up; removable console; convenient carrying handles; and dove grey bonded plastic laminate finish. In addition to inputs for the two turntables and operator's microphone, three low-level inputs and two high-level inputs are provided.

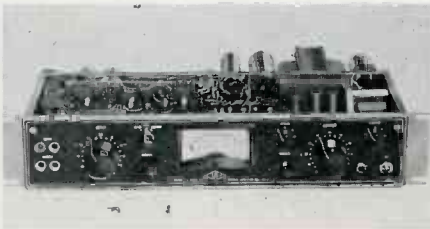

NEW LIMITING AMPLIFIER

The availability of a new, compact limiting amplifier has been announced by Universal Audio, Inc., 600 Sunset Blvd., Hollywood 28, Calif.

The model 175-B is a true peak limiting amplifier, designed to provide high-gain, low-distortion linear amplification at levels below the threshold of limiting, with excellent limiting characteristics and negligible increase in distortion at levels above. The new unit requires 3½ inches of rack space (mounted in standard 19-inch rack) and features a hinged front panel for easy accessibility to inner components.

The unit has a self-contained power supply, a switchable VU meter, and attenuators detented in 2 db steps. Input and output jacks are provided for interconnection with a system, and provision is also made for use with a remote VU meter.

AMPEREX TECHNICAL BOOKLET

A 10-page, detailed booklet on the type 6GB5, all-glass, beam power pentode with cavitrap plate for use in horizontal deflection stages in TV receivers, is being offered by Amperex Electronic Corp. Semiconductor

& Special Purpose Tube Div., 230 Duffy Ave., Hicksville, Long Island, N. Y.

The booklet features a detailed treatment with photographs, diagrams and graphs of the cavitrap plate which is the most outstanding structural feature of the tube and said to be largely responsible for the high plate to screen grid current ratio. Also included is a description and explanation of the advantages of the new, all-glass magnoval tube base.

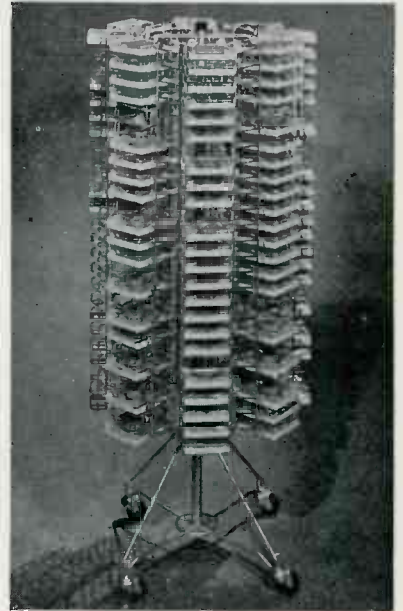

REVOLVING TAPE CARTRIDGE RACK

The new RS-200 Lazy Susan revolving tape cartridge rack has been announced by Broadcast Electronics, Inc., 8800 Brookville Rd., Silver Spring, Md.

The model holds eight removable rack sections providing storage for 200 cartridges. Each section holds 25 cartridges and may be removed from the rack to sub-control rooms or studios as desired. Extra rack sections, model RS-25, are available in single units and may be wall-mounted in multiple to provide unlimited cartridge storage space. The RS-200 is 51¼ inches high and 20½ inches in diameter, and features all-steel, zinc-plated construction with four heavy-duty casters for easy mobility.



STANTON UNIPOISE TONE ARM

Pickering & Co., Inc., Plainview, N. Y., has introduced the new Stanton Unipoise tone arm model 200 which is said to offer the stereo complement for one-half gram tracking of stereo records. According to the manufacturer, this is made possible through use of a single pivot bearing for friction-free motion in all planes and ultra lightweight construction for the lowest possible mass.

The unit features simplicity of design

incorporating a built-in arm rest. Arm balance in all planes is adjustable with a highly sensitive calibrated stylus force adjustment over the range of 1/2 to two grams. The entire moving assembly weighs 6 oz., and installation is said to be quick and easy. No soldering is necessary as signal cables plug into special receptacles which are an integral part of the mounting system.



CHANNEL-MATIC CONTROL SYSTEM

The Channel-Matic control system, said to be a new concept in multiple cartridge handling equipment, has been developed by Sound Corp. of America, 9162 Brookville Rd., Silver Spring, Md.

The standard unit holds eight continuous tape cartridges and offers instantaneous selection of 40 one-hour program channels of voice and music from local or remote positions. An automatic position is designed to provide continuous playback of 40 hours of programming.

Each cartridge may be started, stopped or removed independently, and any size cartridge can be accommodated. A transistorized preamplifier and tube power amplifier can accommodate up to 50 speaker or head phone stations. The unit is recommended for automatic announcing system, storecasting, background music and displays where alternate music and spoken programs are interspersed.

NEW VERTI-LYTIC CAPACITORS

A specially selected assortment of Verti-Lytic® capacitors for technicians who work on transistorized equipment has been announced by Sprague Products Co., North Adams, Mass. The EK-5 consists of 30 miniature single-ended electrolytic capacitors (two of the 15 most frequently used ratings) in an attractive blue case. Individually identified compartments keep each capacitor in place, permitting easy selection and removal.

The space-saving units, with their molded phenolic cases and moisture-resistant resin end seals, are said to have low leakage current and long shelf life. They are recommended for vertical mounting on printed wiring boards in crowded transistorized radios.

NEW FM ANTENNA CATALOG

A sales brochure describing in detail a new high gain series of FM antennas is available from Jampro Antenna Co., 7500-14th Ave., Sacramento, Calif. The series contains antennas from single to 20 bays, with gains up to 21 and power handling capacity of 50 KW, and were designed and developed especially to meet stringent requirements imposed by multiple stereo operation. Stereo crosstalk is minimized by extremely low VSWR characteristics in the antenna system. The booklet contains electrical and mechanical data on the firm's complete line of FM antennas.

Meet the Work Horse of all Tape Cartridge Systems

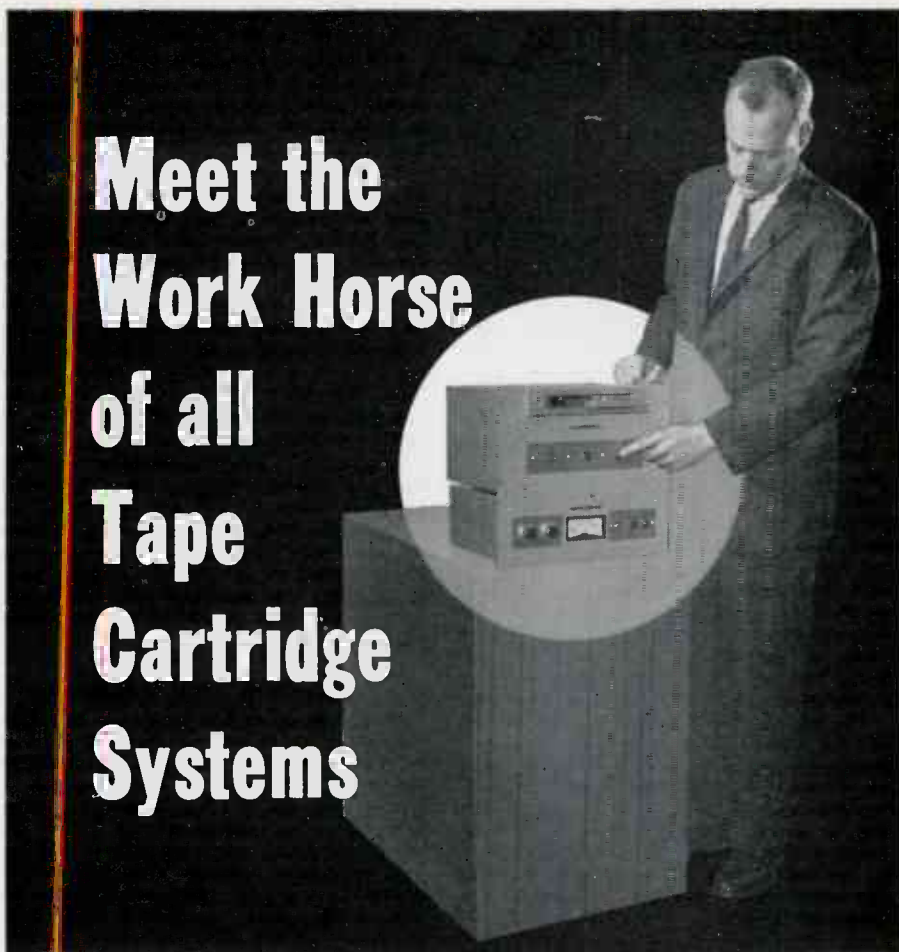

More than 6000 ATC Standard Units now in use in over 800 stations

Current industry figures indicate that almost 50% of the nation's broadcast stations are equipped with some type of tape cartridge equipment. Better than 55% of that equipment was supplied by Automatic Tape Control, Inc. In fact, more stations use ATC equipment than all other makes combined. ATC standard dual-tone recording amplifiers and playback units are still the broadcaster's best tape cartridge buy. The high fidelity of reproduction is firmly established. And the years of actual performance in stations all over the nation and Canada have proven beyond a doubt that ATC units are rugged and dependable. Frequency response is ± 2 db from 70 to 12,000 cps; ± 4 db from 50 to 15,000 cps; signal-to-noise ratio is 55 db; wow and flutter are under 0.2% RMS. For complete details write, wire or phone us collect.

Made by broadcasters for broadcasters

AUTOMATIC  TAPE CONTROL

209 E. Washington St. • Dept. 128 • Bloomington, Illinois

Marketed in Canada by Canadian General Electric, Toronto 4, Ontario

Product News

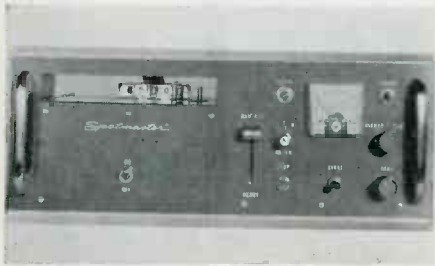

COMBINATION RECORDER-PLAYBACK UNIT

Broadcast Electronics, Inc., 8800 Brookville Rd., Silver Spring, Md., is offering the model 500R, a new combination recorder-playback unit. It is furnished complete with rack chassis slides ready for mounting in the rack. Each unit slides in and out of the rack for ease of head and capstan cleaning, as well as other routine maintenance. All connections are made by use of convenient plugs in common use in all broadcast stations. Amplifiers and other components are conveniently placed for ease in servicing.

The model 500R mounts in only 7 inches of rack space, as does the matching playback unit, model 505R. Playback units may be mounted in multiple to provide complete facilities in one rack. Plug-in remote control, as well as cue-trip amplifiers for automatic sequential switching, are available as optional extras on all playback units. The panel finish is metallic grey with raised aluminum lettering.

NEW FOUR-STATION HOME INTERCOM RADIO UNIT

Talk-A-Phone Co., 5013 N. Kedzie Ave., Chicago 25, Ill., has announced a new four-station home intercom radio unit designed to offer master station performance at the cost of a staff unit.

The new model, HI-4, is offered for either built-in or surface mounted installation, and may be operated in four, eight or 16-station Talk-A-Phone transistorized home intercom systems. Featuring simplicity of operation and installation, the new model requires a wall opening 4 1/8 inches wide, 6 1/2 inches high and 2 inches deep, and has a custom-designed stainless steel front panel measuring 4 13/16 inches wide and 7 3/16 inches high. Each HI-4 may be utilized for private conversation with any three other indoor or outdoor stations in the system.

According to the manufacturer, the system can combine various units to furnish complete intercom, as well as radio, all through the house. It can serve to listen-in on baby from any room, provide a means of identifying visitors without opening doors to strangers, and otherwise offer step-saving convenience and protection to the householder.

PROFESSIONAL TAPE TRANSPORTS

A new series of tape transports has been announced by Clark-Root, Inc., 211 Lambert St., Palo Alto, Calif. Designed to meet NAB broadcast standards, the C-R transport is said to play for 12 hours without repeating when a 14-inch reel is played at 3 3/4 ips, or for six hours when playing at 7 1/2 ips. The equipment handles two-track monophonic or four-track stereophonic tapes for AM or FM station use, and includes auto-

matic tape reversing and a safety system in the event of tape breakage.

Designated the No. 1100 series, individual transports are available for station application and are compatible with other broadcast equipment. Emphasis, however, is on using four Clark-Root transports as basic modules of a simplified, automated system, which can be expanded with more transports as the need arises. The control center is a punched-tape programmer designed to permit personalizing programs to any desired format, and is said to have the ability to select special types of programming at specific times. A new positive-action switching mechanism handles the switching pattern between the transports, and a safety standby system provides for unattended operation.

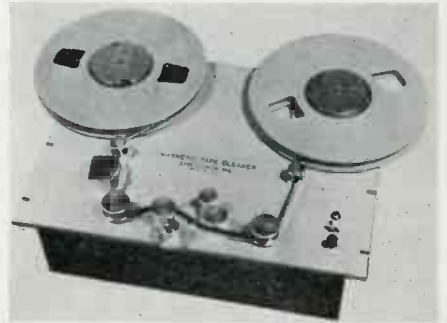

MAGNETIC-TAPE CLEANER

The model E magnetic-tape cleaner, designed for safe, rapid cleaning of both blank and recorded tapes, has been introduced by Cybronics, Inc., 132 Calvary St., Waltham, Mass.

According to the manufacturer, the unit removes lint, dirt, loose oxide or Mylar particles from both sides of the tape in a single pass. The cleaning process is entirely dry and does not affect the data stored on the tape, it was further stated. Features of the product include more uniform output levels on tapes used in instrumentation and telemetering; elimination of transient dropouts on data-processing tapes; removal of many of the persistent defects caused by imbedded foreign matter; and reduction of transport maintenance.

The unit, which will also function as a tape rewinder, measures 19 x 14 x 8 inches, and can be operated either rack-mounted or as a portable table model.

NEW! LOW ORIGINAL COST



STUDIO UNIT

ONLY ONE WIRE PAIR REQUIRED

REMOTE CONTROL SYSTEM

**10
or
25**

CHANNEL

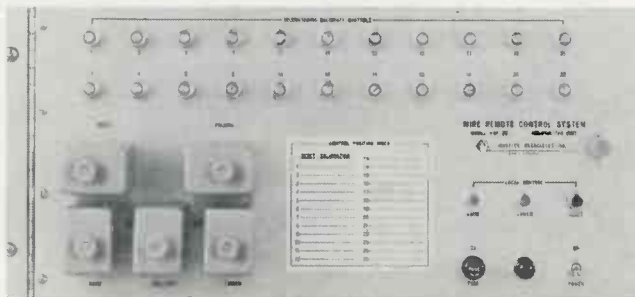

TRANSMITTER UNIT

Write For Descriptive Brochure



MOSELEY ASSOCIATES, Inc.

P. O. Box 3192 4416 Hollister
Telephone 976-1469
Santa Barbara, California

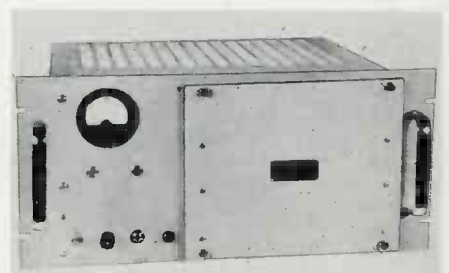

FM/SCA REBROADCAST RECEIVER

A new relay receiver for SCA multiplex and main channel rebroadcast applications has been introduced by General Electronic Laboratories, Inc., 195 Massachusetts Ave., Cambridge, Mass. The unit is used to pick up the broadcast signal and relay it without using tape recorders or SCA sub-channel generator.

The model FMR-1 feeds the signal to a station's transmitter multiplex exciter and, according to the manufacturer, the SCA signal is not demodulated but is injected at its sub-channel frequency (normally 67



Every day of life means hope

Every added day a leukemia victim lives means added hope that the cure might be found.

Temporary arresters have been found for this disease of the blood-forming tissues. And a vaccine has been discovered that will prevent leukemia in animals.

Strange, isn't it, that this most hopeless of all cancers might be the one that science will overcome first!

The American Cancer Society diverts one out of six of its research dollars to the support of further study of the cause and cure of leukemia. Surely this activity alone merits your support!

Fight cancer with a checkup and a check. Send your donation to **CANCER**, c/o your local post office.

**AMERICAN
CANCER SOCIETY**



kc). It is a superheterodyne-type receiver with a low-noise cascade amplifier. The first local oscillator is a crystal-controlled type. The RF portion of the receiver is followed by an IF strip with double-tuned transformers centered at 10.7 mc. The IF strip is followed by cascaded gated beam limiters. The discriminator which follows the limiter has been designed for wide band use with negligible distortion of both main channel and sub-channel signals. The receiver incorporates a wide band multiplex amplifier/cathode follower.

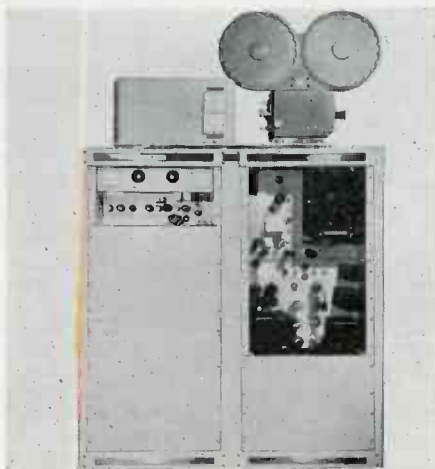

VIDEO FILM RECORDER

The RK 110, a video film recorder designed to operate with any broadcast or closed-circuit television system, is being offered by Vue-Tronics, Inc., 920 N. Citrus Ave., Los Angeles 38, Calif. Design features include maximum kinescope protection, and elimination of shutter edjstment, electronic shutters, camera phase generators, etc.

The recorder was designed to permit maximum flexibility to meet many specific customer requirements. Additional features include horizontal resolution to 600 lines and vertical to 450 lines on a 525 line, or 600 lines on a 735 system. Linearity is within one per cent of picture size with differential gain distortion less than five per cent. Composite of the video input signal is .3 to 2 volts peak-to-peak with drive pulses from .2 volts to 6 volts peak-to-peak, both to standard E.I.A. specifications. Video amplifier response is flat within 1 db from 20 cycles to 8 mc. Picture centering is accomplished through independent electrical adjustment of vertical and horizontal centering.

The unit weighs 350 lb. (less sound) and is housed in a two-bay, 48-inch rack. Panel space has been provided for audio recording or auxiliary equipment.

STEREO FILTER KIT

McMartin Industries, Inc., Omaha, Neb., has developed a stereo filter kit which can be added to all the company's multiplex receivers ever built.

The model MT-10 was designed to enable a commercial multiplex receiver to work better with FM-stereo. According to the manufacturer, the addition of such a filter will be necessary on all makes of receivers now in service.

CONDENSED SEMICONDUCTOR CATALOG

Amperex Electronic Corp., Advertising Dept., 230 Duffy Ave., Hicksville, Long Island, N. Y., has announced the publication of a new 15-page, condensed semiconductor catalog, which contains full listings and basic specifications of the company's complete line.

LOOKING FOR RACKS?

Turn to section 1400

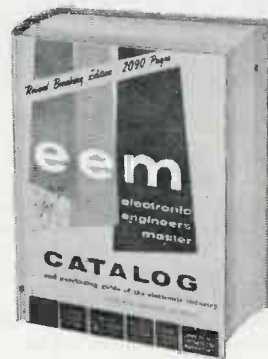

You'll find the catalog data
of these manufacturers:

Amco Engineering • American Aluminum
• Baltic Metal Prod. • Chassis-Trak •
Electro-Rack • Electronic Enclosures •
Falstrom • Flotron Indust. • Golding Mfg.
• Halliburton Enterprises • LMB (Heeger,
Inc.) • Leichner Mfg. • MM Electr.
Enclosures • Metex Electr. • Premier
Metal Prods. • Research Electr. • Rotary
Co. • South River Metal Prods. Co. •
Watson Mfg. Co. • Western Devices.

eem ELECTRONIC ENGINEERS MASTER
60 Madison Avenue • Hempstead, N. Y.

CROWN

Professional Tape Recorder

SUPRA PROFESSIONAL

Unexcelled for broadcast use

3 Heads
3 Speeds
3 Motors

Model BX801 — Full Track

Also available in half track monaural, two track and quarter track stereo.
All aluminum construction—10½" Reels

Crown gives more performance per dollar

FREQUENCY RESPONSE	IPS SPEED	FLUTTER & WOW	NOISE RATIO
± 2 db 30 to 28,000 CPS	15	.06%	60 db
± 2 db 30 to 16,000 CPS	7½	.09%	60 db
± 3 db 30 to 8,000 CPS	3¾	.18%	55 db

Write Dept. BE-762 or phone JA 3-4919
for catalog and price list.

CROWN INTERNATIONAL

Division of
INTERNATIONAL RADIO & ELECTRONICS CORP.
ELKHART, INDIANA

Product News



MODEL TDA2 VIDEO/PULSE DISTRIBUTION AMPLIFIER

Model TDA2, a completely transistorized amplifier, featuring space-saving compactness and high operating efficiency, is being offered by International Nuclear Corp., P. O. Box 6171, Nashville 12, Tenn.

The TDA2 has four separate outputs internally terminated at 75 ohms. Output terminals are type 83 coaxial connectors, to permit installation without altering existing cables.

The self-contained unit, with a regulated transistorized power supply, is 1 3/4 x 19 x 7 inches, and weighs less than 4 lb. Because of the transistorized circuitry, the TDA2 is said to produce very little heat. All transistors are socket-mounted and available at the front panel. The most important voltages and signals may be checked at the externally-mounted, color-coded test jacks.

Each unit is completely tested at the factory and is shipped with a manual containing individual measurements for volt-

Are Your Station Turntables Ready for Stereo Broadcasting?



THE ANSWER IS YES if you're using the new Fairchild 750 16" belt-driven playback turntable. The only turntable designed for stereo broadcasting! Write today for complete technical specifications on this remarkable new turntable. **Price: \$485.00**
Fairchild 752 Cabinet \$110.00

FAIRCHILD

RECORDING EQUIPMENT CORPORATION
10-40 45th Ave., Long Island City 1, N. Y.

ages, frequency response, noise level, gain, pulse output, and is ready for immediate operation, the manufacturer states.



NEW AMPEREX UHF TUBE

Amperex Electronic Corp., Power Tube Div., 230 Duffy Ave., Hicksville, Long Island, N. Y., is offering the model 8177, a metal-ceramic, coaxial, forced-air cooled power tetrode for frequencies up to 1,000 mc. The tube is especially designed for use as a power amplifier and frequency multiplier in TV transmitters, VHF-UHF communications and tropospheric scatter equipment.

According to the manufacturer, the 8177, with a high plate current capability of 0.95 amps, is able to provide a power output of 2,070 watts at 600 mc and 1,500 watts at 900 mc in class C telegraphy operation. The high plate current is said to enable the tube to work into a low impedance with high efficiency, making possible the high bandwidth. The unit is especially suited for 225-400 mc operation.

The tube is constructed with a helical thoriated tungsten filamentary cathode for extra long life, and the coaxial arrangement of the terminals is said to enable it to be used as a plug-in tube in coaxial circuits.

NEW 75-OHM COAXIAL CABLE FOR UHF-VHF

A 75-ohm version of Spir-O-foam coaxial cable for community and closed-circuit television services has been announced by Prodelin, Inc., Hightstown, N. J. Suited for trunking cable applications, the new version is a foamed polyethylene-insulated, aluminum-sheathed, semi-flexible cable especially designed for low-loss broadband performance, and fast and simple field installations. Cable features include unlimited operating life, RF shielding, clearly-marked sheaths for easy length measurements and cable identification.

Electrically matched to the new cable, Spir-O-lock connectors are said to be installed quickly and easily in the field, with no soldering operations or special flaring tools required. Spir-O-foam is supplied on non-returnable reels and is available in continuous lengths to 1,000 ft.

SOLID STATE AUDIO COMPRESSOR AMPLIFIER

A new, solid state audio compressor amplifier, designated QCN-1, has been announced by Quindar Electronics, Inc., 5 Lawrence St., Bldg. 9, Bloomfield, N. J.

The battery-powered, high-gain device can be furnished as a sub-assembly for mounting within existing equipment, or as a separate item. Outputs are 1/2-watt into a speaker, or 1 milliwatt into a 600-ohm load. The output is selected by a front-panel switch.

PHONO EQUALIZER-PREAMP

Collins Radio Co., Cedar Rapids, Iowa, has announced the development of model 356H-1 phono equalizer-preamp. Designed to equalize and amplify the output signal of a magnetic phono cartridge, the unit is used to replace passive equalizers and console or turntable preamplifiers.

The housing of the compact unit is constructed of steel for magnetic shielding, and components are packaged for inspection and maintenance. The escutcheon plate, for control identification outside the turntable cabinet, is made of brushed aluminum. The control shafts are 3 inches long and may be cut to proper length after mounting the unit in the cabinet.

The three-stage transistorized preamplifier provides a choice between two inputs and between four response curves (including RIAA/NAB), and a printed circuit board is used for maximum reliability. The first stage is a 2N1175A or equivalent germanium transistor featuring high input impedance and gain control to handle the range of various magnetic phono cartridge output impedances and levels. This stage is decoupled with an RC filter. The selector switch selects four response curves: (1) Flat, for test purposes, and mike preamp use; (2) Hi-Boost, which has a 4 db rise above normal at 15,000 cps; (3) Normal, which is the RIAA/NAB equalizing curve; (4) Hi-Cut, which has a 4 db drop below the normal curve at 15,000 cps.

The second and third stages provide an output of -10 dbm at 1,000 cps from a balanced output transformer of either 600 or 150 ohms. Voltage or current feedback provide stability with temperature changes and transistor aging or replacement. Input and output are terminated on a barrier terminal strip. The ac power supply is in a separate compartment. Two 1N1488 diodes, with an adequate filter, provide dc supply.

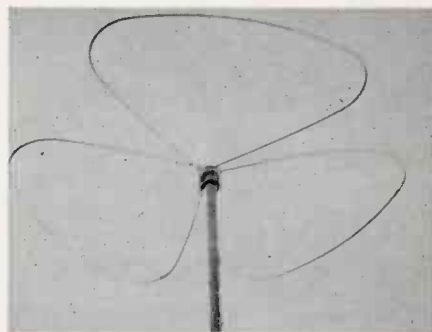

NEW VHF-UHF ANTENNA

Cush Craft, 621 Hayward St., Manchester, N. H., has introduced the Big Wheel, a new VHF-UHF clover leaf antenna. Omnidirectional, the unit is said to have horizontal polarization and extremely low Q, which results in improved band width, ease of matching and large capture area. Dual stacked, the Big Wheel gain figures (in all directions) compare favorably with seven element Yagi in its favored direction, the manufacturer states.

Performance specifications: Pattern—360 horizontal, variations of ±2 db or less. Band width—SWR 1:1.2 or less over 4 mc. Gain—single bay, approximately 5 db over Halo; two bay, approximately 5.5 db over single bay; four bay, approximately 7.5 db over single bay.

Mechanical specifications: Elements 1/4-inch—17T6 aluminum rod. Brackets—aluminum alloy. Insulation—polystyrene. Fasteners—stainless steel and plated steel. Mount—from 3/4-inch to 1 1/2-inch pipe. Packaged for shipment by parcel post.

RCA PORTABLE AUDIO CONSOLE

Radio Corp. of America, 30 Rockefeller Plaza, New York 20, N. Y., has introduced a new portable audio console, useful for remote originations, or as auxiliary studio equipment for advance preparation of taped shows. Fully transistorized and weighing approximately 65 lb., the console is built into a one-piece molded case with easily-removed legs.

The new unit includes three preamplifiers, two of which are equalized for use with its two built-in, three-speed turntables, and a remote line amplifier. Either turntable may be cued by a push-button switch below the turntable mixer. A selector switch is designed to enable the announcer/operator to select one of two microphone inputs or the remote line. Both output and turntable cues are monitored by plug-in earphones, and a master gain control handles volume for the mixed output.

As an additional feature, the console is equipped to feed a public address system through a separate volume control, making it a focal point for record shows, interviews and for other remote broadcasts attractive to onlookers.

MODEL DA-20B VIDEO AMPLIFIER

The model DA-20B video amplifier, completely solid state including regulated power supply, has been introduced by Dynair Electronics, Inc., 7564 Broadway, Lemon Grove, Calif.

The unit features a high impedance bridging input which may be looped or terminated with a 75-ohm termination plug; dual video outputs which are source-terminated in 75 ohms; and a continuously variable gain control designed to allow the amplifier to be operated at any gain setting from -10 db to +20 db.

The amplifier and power supply are enclosed in a weatherproof housing. Universal mounting brackets provide a convenient means of attaching the amplifier to a pole or building.

ELECTRONICS DATA HANDBOOK

A revised and enlarged edition of the Electronics Data Handbook, containing an up-to-date listing of most commonly used tables, formulas and reference material, has been published by Allied Radio Corp., 100 N. Western Ave., Chicago 80, Ill.

The third edition is a practical, informative guide for students, technicians, engineers and others in solving everyday radio and electronics problems. The TV picture tube interchangeability list has been updated, and the pilot-light data section now includes argon and neon pilot bulbs as well as standard filament types.

Here Is Your Advertising Medium To Sell Broadcast Equipment and Supplies . . .

Only BROADCAST ENGINEERING Offers These Advantages:

1. Blanket Coverage of Radio and TV Stations

Your advertising reaches the chief engineers, technicians, owners and managers at AM, FM and TV facilities throughout the U. S. and Canada. In addition, your sales message is delivered to all the industry's consulting engineers.

2. No Costly "Waste" Circulation

No longer do you need buy costly circulation among individuals in the general broadcast industry of no significance in station purchases. Other publications offer substantial coverage of programming personnel, advertising agencies, disc jockeys, account executives, sponsors and others of no importance to manufacturers of broadcast equipment.

3. Concentrated Station Buying Power

Now you are assured on-target coverage of all managerial and technical men responsible for purchases of all types of station equipment and operating supplies. Your sales message goes to the men who buy, specify or influence product selection. Never before has a single book provided such concentrated, integrated coverage of all the men who must be sold!

4. Powerful Editorial Impact

Broadcast Engineering is the industry's first and only technical journal. It covers all phases of the design, installation, operation and maintenance of AM, FM and TV facilities. Its editorial scope encompasses all engineering subjects of practical interest to operating personnel. Hundreds of paid subscriptions, requests for reprints, extra copies and letters of testimonial are evidence of high readership. Broadcast Engineering helps build buying interest in your products because it promotes the adoption of new and better broadcast techniques.

5. Better Advertising Results

Manufacturers of station equipment and supplies report excellent results from their programs in Broadcast Engineering. And more new advertisers come in each month. Plan now to promote your products through Broadcast Engineering . . . no other publication so completely captures the buying power of the industry!

NEW!

BATWING TV ANTENNAS CHANNELS 2-13

Write for Sales Catalog

JAMPRO ANTENNA CO.

7500 - 14th Avenue
Sacramento 20, California



Save 30% on 4-Track
Stereo Music on Tape!
Empty 3 in. Plastic Reels 7c ea.



BARGAIN PRICES! Send for our FREE Tape Recorder/Blank/Prerecorded Tape Catalog #B-3

SAXITONE RECORDING TAPE

* Oxide guaranteed not to rub off or squeak—or money back. Compare ours with other "Bargain" tape. You'll find it's more than just "price" when you deal with us. We are original pioneers in the tape recorder business and our reputation means everything to us.

600' Acetate (plastic), 5".....	.75
600' MYLAR 5" reel.....	.95
900' MYLAR (Polyester), 5".....	.99
1200' MYLAR, 1/2 mil. 5" reel.....	1.18
1200' Acetate (plastic), 7".....	1.19
1200' MYLAR, 1 1/2 mil. (Strong).....	1.58
1800' Acetate (plastic), 7".....	1.79
1800' MYLAR, 1 mil. thick, 7".....	1.99
2400' MYLAR, unensitized, 7".....	2.89
2400' MYLAR, tensitized, 7".....	2.99

Studios, Large Users Even Lower. PLUS POSTAGE.

NORELCO SPEAKER
Famous AD3800M, twin cone 8" (75-19,000 cycles) discontinued model, former list 16.00, usual net 9.90 going at 4.99 plus postage. (2 for 9.00). Other Norelco speaker sizes at bargain prices. Send for **SPEAKER SPECIFICATION SHEET.**

Also—Scotch, Irish, Audio, Reeves, Ampex and Sarks-Tarzan magnetic tapes, mikes, audiocass, needles, etc. We'll surprise you with our quotations!

SAXITONE TAPE SALES

(Division of Commissioned Electronics Company, Inc.)
1776 COLUMBIA ROAD WASHINGTON 9, D.C.

Emergency Generator

(Continued from page 11)

Electrical noise was absent, as was to be expected since there are no brushes or slip-rings. Listening on a sensitive high gain receiver the hum level appeared to be no worse than with a conventional source of power, and superior to some self-excited generators that have been encountered.

Just as a matter of interest the wave-form was examined on a 'scope. As anticipated the wave-shape was a pretty good sine wave, and far better than the "rounded square" waves that so often come out of a battery driven inverter.

Construction

The rotor magnets are made of barium ferrite which is a ceramic material possessing exceptionally strong magnetic properties. These magnets are cased in an outer copper band with a steel backing plate. The spacing between magnets and coils is not critical, and is of the order of 1/16 inches. The copper ribbons have no core, nor laminations, and are open wound in the form of a simple loop. The use of high flux permanent magnets might be considered risky due to the possibility of picking up pieces of iron in the field, which could jam the generator, or reduce the gap size; but there appears to be little trouble from this factor.

Although the Model 2,000 is rated at only 1,500 watts, or 1.5 KVA, it can be connected in parallel with any number of similar units and thus increase the power available by the arithmetic sum of the generator outputs. Due to the method operation, there is no difficulty in synchronizing such an assembly, and theoretically any desired output can be obtained. The flexibility of such a system is obvious—for example two units could be kept at the plant, and one in the remote truck. In the event of power failure at the plant the three could be connected in parallel providing 4.5 KVA. One feature the remote man will love is the low weight—60 pounds.

In all, this seems to be a most useful addition to the broadcast engineer's equipment line, and that of the manufacturer, Hearth Industries of Wellsville, N. Y.

Classified

Advertising rates in the Classified Section are ten cents per word. Minimum charge is \$2.00. Blind box number is 50 cents extra. Check or money order must be enclosed with ad.

The classified columns are not open to the advertising of any broadcast equipment or supplies regularly produced by manufacturers unless the equipment is used and no longer owned by the manufacturer. Display advertising must be purchased in such cases.

EQUIPMENT FOR SALE

Transmission line, styroflex, heliax, rigid with hardware and fittings. New at surplus prices. Write for stock list. Sierra Western Electric Cable Co., 1401 Middle Harbor Road, Oakland 20, California. 6-61 tf

Commercial Crystals and new or replacement crystals for RCA, Gates, W. E. Bliley and J-K holders; regrounding, repair, etc. BC-604 crystals. Also A. M. monitor service. Nationwide unsolicited testimonials praise our products and fast service. Eidson Electronic Company, Box 31, Temple, Texas. 9-61 tf

GOVERNMENT SURPLUS, NEW 10 CM. WEATHER RADAR SYSTEM—Raytheon, 275 KW peak output S band. Rotating yoke P.P.I. Weather Band 4, 20 and 80 mi. range. Price \$975 complete. Has picked up clouds at 50 mi. Wt. 488 lbs. Radio Research Inst. Co., 550 5th Ave., New York, New York. 5-62 8t

PHILCO MICROWAVE LINK, 7KMC System. Type CLR-6 also in stock: Repeaters, 12 and 24 channel multiplex. Large quantity. Exc. cond. Radio Research Inst. Co., 550 5th Ave., New York, N. Y. 5-62 8t

Surplus HF transmitter 2-20mc. Collins TCC Autotune. Clean. Complete. \$2,140 F.O.B. Tacoma area. Write KAYE, Fuyalup, Washington. 5-62 3t

Convert your 350 series Ampex to 14" reel capacity in one hour. Standard rack mounting. Special stainless steel base plate and complete instructions. \$95 F.O.B. Marston, Box 425, Bakersfield, Calif. 7-62 1t

BUY, SELL OR TRADE

Will buy or trade used tape and disc recording equipment — Ampex, Concertone, Magnecord, Presto, etc. Audio equipment for sale. Boynton Studio, 10 BE Pennsylvania, Tuckahoe, N. Y. 4-62 6t

MISCELLANEOUS

TV CAMERA—Low Cost—Easily Built—Complete schematics, instructions 50c. Denson Electronics, Rockville, Conn. 7-62 3t

A Classified Ad In BROADCAST ENGINEERING

Gets Results!

Send Yours Today!

Professional Services

VIR N. JAMES

Specialty

Directional Antennas

232 S. JASMINE DExter 3-5562
DENVER 22, COLORADO

Member AFCCE

JOHN H. BATTISON & ASSOCIATES
CONSULTING RADIO ENGINEERS

Specializing in AM-FM-TV Applications and measurements.

934-5 Munsey Building
1329 E. St., N.W. Washington 4, D. C.
DI 7-2330
Established 1954

Advertisers' Index

Ampex Corp.	3
Automatic Tape Control, Inc.	35
Bauer Electronics Corp.	31
Battison & Assoc., John H.	40
Blonder-Tongue Laboratories.	25
Broadcast Electronics, Inc.	28
Conley Electronics Corp.	26
Continental Electronics Mfg. Co.	21
Crown Intl.	37
Electro-Voice, Inc.	23
Electronic Engineers Master Catalog	37
Fairchild Recording Equip. Corp.	38
Houston Fearless Corp.	34
IERC Div., Intl. Electronic Research	29
ITA Electronics Corp.	IFC
James, Vir N.	40
Jampro Antenna Co.	39
McMartin Industries, Inc.	27
Magnecord Div., Midwestern Instruments	30
Moseley Associates	36
Radio Corp. of America Electron Tube Div.	BC
Radio Corp. of America, Victor Records Div.	7
Rohn Systems, Inc.	34
Sarkes Tarzian, Inc.	1
Saxitone Tape Sales Div.	39
Sparta Electronic Corp.	33
Stancil-Hoffman Corp.	40
Superscope, Inc.	IBC
Visual Electronics Corp.	19

all-transistorized New Sony Sterecorder 777

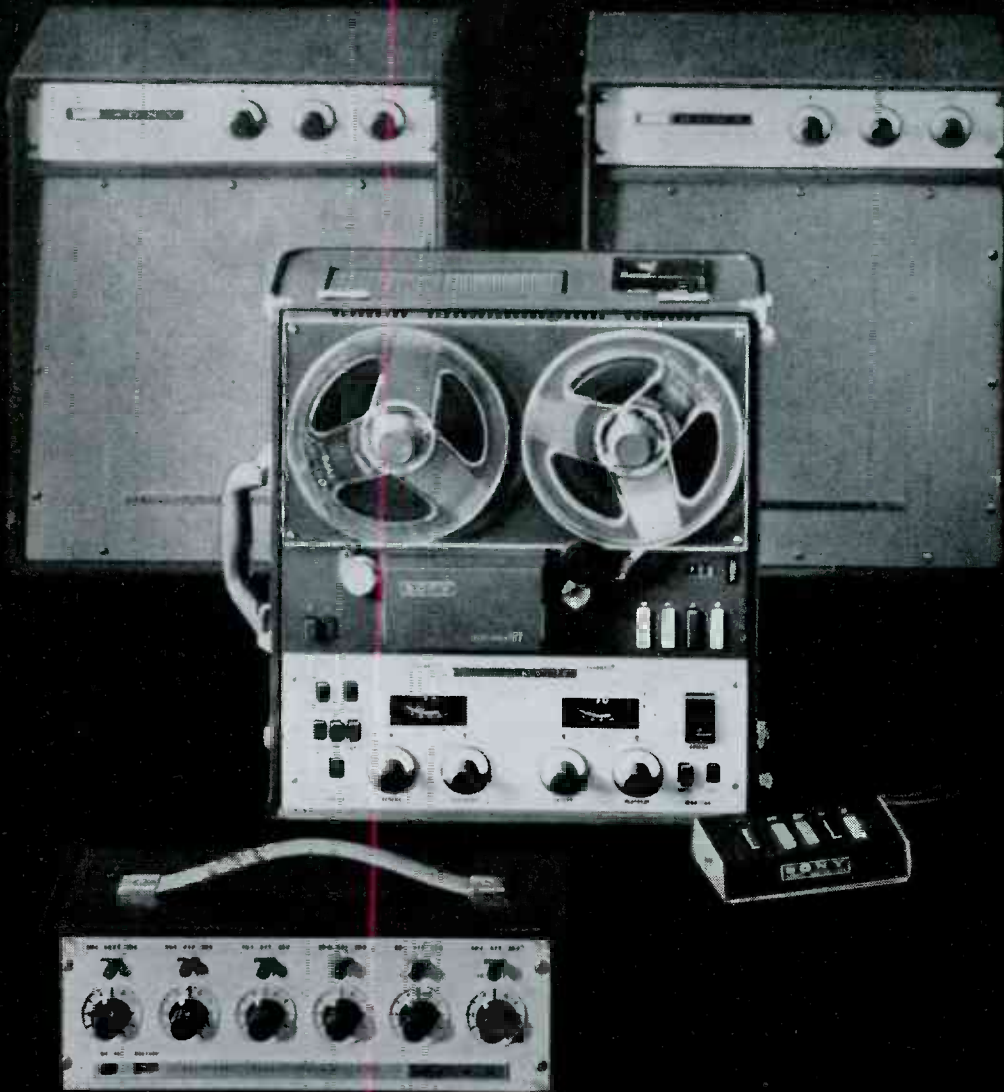

the first/complete/portable/all-transistorized/high fidelity PROFESSIONAL RECORDING & PLAYBACK SYSTEM

The most advanced achievement in recorder engineering to date, the superb new remote-controlled professional Sterecorder 777 series features the exclusive and patented Sony Electro Bi-Lateral 2 & 4 track playback Head, a revolutionary innovation that permits the playback of 2 track and 4 track stereophonic or monophonic tape without track width compromise—through the same head!

Included in an array of outstanding features are individual erase/record/playback heads, professional 3" VU meters, automatic shut-off, automatic tape lifters, an all-solenoid, feather-touch operated mechanism, electrical speed change, monitoring of either source or tape, sound on sound facilities, and an all-transistorized military plug-in type circuitry for simple maintenance. The three motors consist of one hysteresis synchronous drive motor and two hi-torque spooling motors.

Unquestionably the finest professional value on the market today, the 777 is available in two models, the S-2 (records 2 track stereo) and the S-4 (records 4 track stereo). Both models can reproduce 2 and 4 track tapes.* And, the Sterecorder 777 models will integrate into any existing component system. \$595 complete with portable case and remote control unit.

*Through the exclusive Sony Electro Bi-Lateral 2 and 4 track playback head.

Sony has also developed a complete portable all-transistorized 20 watt speaker/amplifier combination, featuring separate volume, treble and bass controls, mounted in a carrying case that matches the Sterecorder-777. \$175 each.

Also available is the MX-777, a six channel all-transistorized stereo/monophonic mixer that contains six matching transformers for balanced microphone inputs and recorder outputs, individual level controls and channel selector switches, Cannon XL type receptacles, a switch to permit bridging of center staging solo mike. \$175 complete with matching carrying case.

The first/complete/portable/all-transistorized/high fidelity/professional recording & playback system: \$1120 complete.

Sold only at Superscope franchised dealers. The better stores everywhere.

For additional literature and name of nearest franchised dealer write Superscope, Inc., Dept. B, Sun Valley, California.

All Sony Sterecorders
are Multiplex ready!

SUPERSCOPE

The Tapeway to Stereo

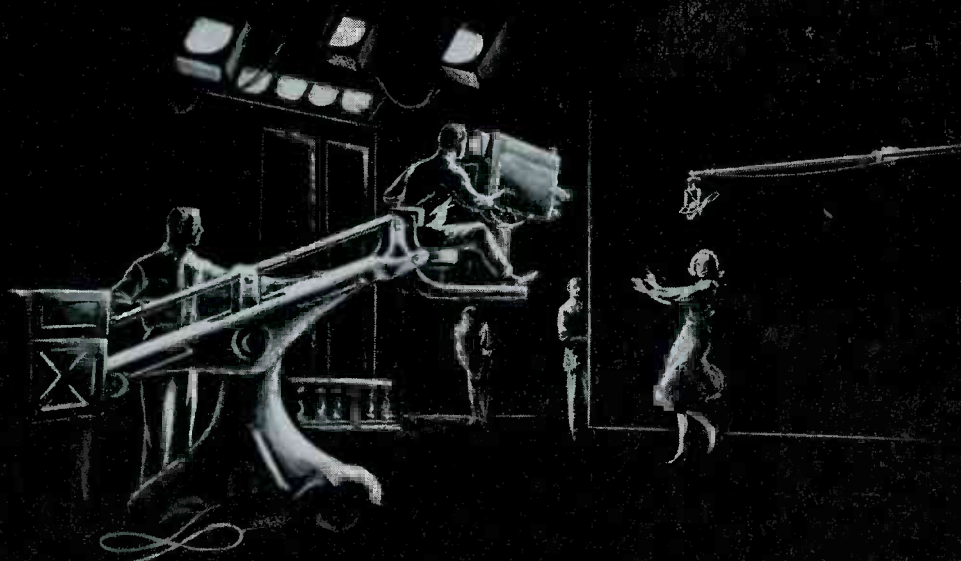

**WKRG-TV Selects
RCA-5820A
as "The best we've ever worked with"**



"We tried our first set of RCA-5820A's in April 1961. They are without a doubt the best camera tubes I have ever worked with," says Donald D. Patton, Chief Engineer, WKRG-TV, Mobile, Ala.

With RCA-5820A Image Orthicons, superior quality black-and-white TV is possible. WKRG-TV has confirmed this—after a search for the best camera tubes led them to the RCA-5820A. After more than 2,000 hours, the first set of

these I.O.'s was retired—and replaced with another set of RCA-5820A's, of course!

WKRG-TV's experience is typical. And because it is, the RCA-5820A is today's most popular Image Orthicon. More than 57,000 image orthicons have been produced by RCA over the past 15 years. For versatile black-and-white studio and outdoor operations, you can't beat them.

Your Distributor of Broadcast tubes can provide immediate delivery of RCA-5820A's, and other RCA tubes as well.

RCA Electron Tube Division, Harrison, N. J.



THE MOST TRUSTED NAME IN TELEVISION