

WPMY Cleveland's Rock Station

98.5	99.1	100.7	92.3	850	1100
------	------	-------	------	-----	------



Radio

THE RADIO TECHNOLOGY LEADER

Crowded Airwaves Require Station Cooperation

KCSN and KSBR get creative to solve interference issues



NOVEMBER 2017 | RADIOMAGONLINE.COM

NewBay

000004247

907-1-SOL

#BXBZFT *****AUTO**3-DIGIT 857
 #0010545 2# RDMA 0010545 E1702
 |||||
 BARRY MISHKIND
 CHIEF ENGINEER
 KOHN
 2033 S AUGUSTA PL
 TUCSON AZ 857 10-7905
 P0002

INO mini 636

NOAA Weather Receiver

KNOW WHICH WAY THE WIND BLOWS

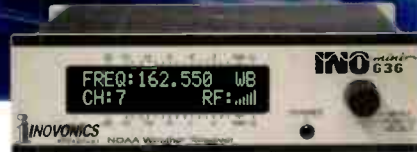

www.inovonicsbroadcast.com | sales@inovonicsbroadcast.com | 831-458-0552





Meet the Coupe We Never Built

Well worth the wait, DMX packs a ton of power into a small frame. For its engine, we chose a high-performance Wheatstone power plant that utilizes WheatNet-IP to give you options beyond anything we've done before.

Operation is smooth and construction is aircraft grade. It's the command surface that can be your standalone console or direct your entire network. Fast, flexible, formidable. V-8 or 16 input models, both surprisingly affordable.



DMX
ITS TIME HAS COME

for more information, please contact us: phone 1.252.638-7000 | pre.com | sales@pre.com



PACIFIC RESEARCH &
ENGINEERING

TABLE OF CONTENTS

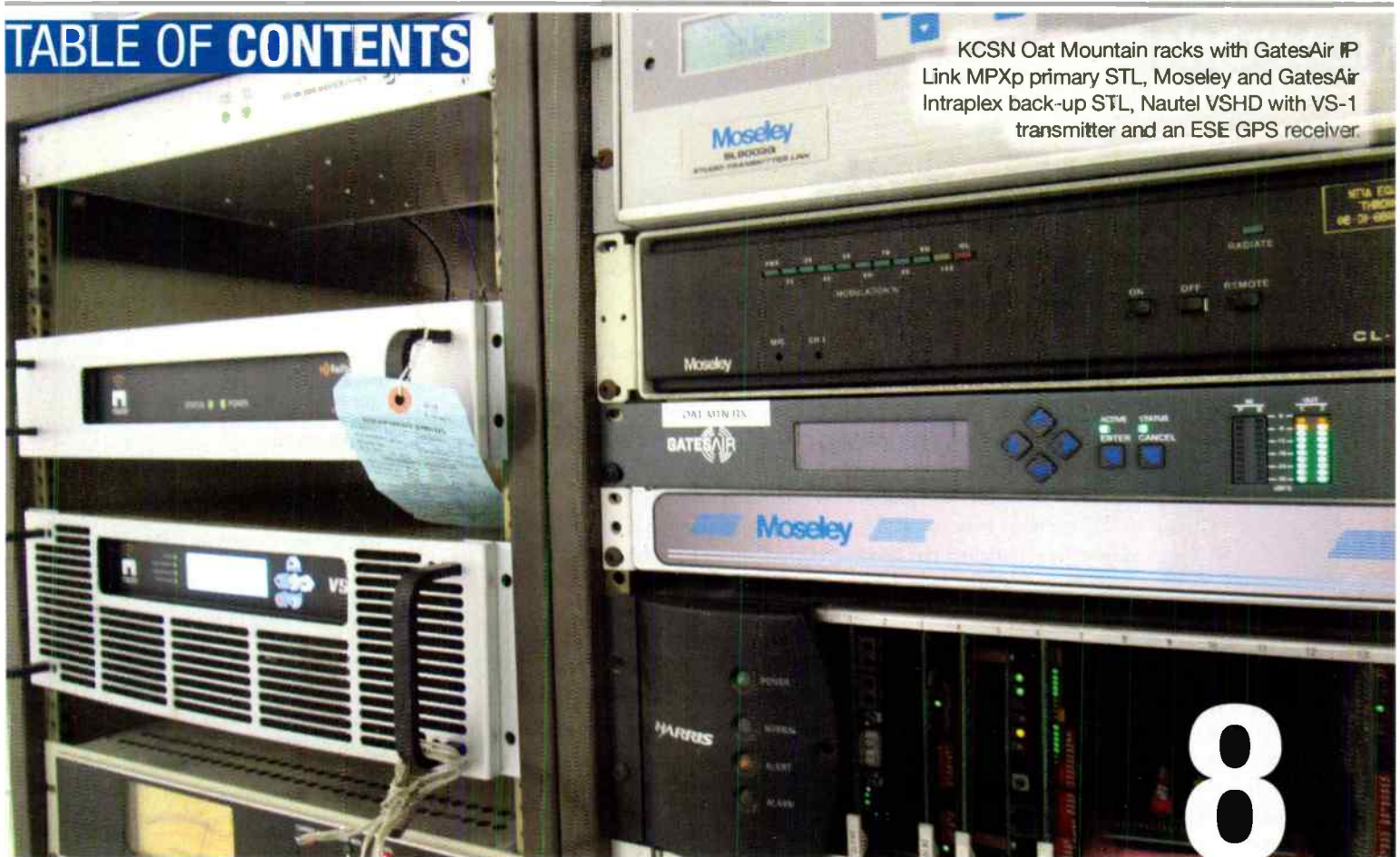

KCSN Oat Mountain racks with GatesAir IP Link MPXp primary STL, Moseley and GatesAir Intraplex back-up STL, Nautel VSHD with VS-1 transmitter and an ESE GPS receiver.

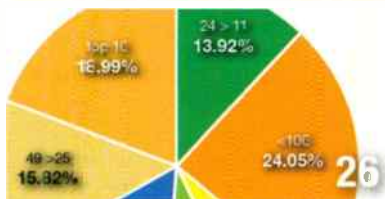

- | | |
|---|---|
| <p>4 Viewpoint
Managing Upwards
and Downwards</p> <p>6 FCC Update
No More Walls?</p> <p>8 Facility Showcase
The Stars Aligned for This
Three-Station SFN</p> <p>16 RF Engineering
AM Revitalization Efforts,
Part Three</p> | <p>20 Trends in Technology
Expand or Leverage
Your AM System</p> <p>26 Salary Survey
Don't Work for Free (Or for Cheap)</p> <p>29 New Products</p> <p>30 Tech Tips
Solving the Porsche Conundrum</p> <p>32 Gallery</p> <p>34 Sign Off
Broadcasting Is Intimate --
and Will Become Interactive</p> |
|---|---|

On the cover: KCSN's tower with antennas on Oat Mountain.



FIND THE MIC AND WIN!

Tell us where you think the mic icon is placed on this issue's cover and you could win a **UXA-110 TRACKLINK USB Interfac**. Send your entry to radio@RadioMagOnline.com by **Dec. 10**. Be sure to include your guess, name, job title, company name, mailing address and phone number. No purchase necessary. For complete rules, go to RadioMagOnline.com.

Managing Upwards and Downwards



Several months ago, I wrote about delegation and how to know if you can do it or not. This month, I'll tackle another responsibility of the department head: managing up and managing down.

When I say managing down, I'm referring to the instructions, tasks, projects and advice, of course; but there are also more personal elements. You must show gratitude. Be fair. Lead by example.

On the other hand, managing upward is something that wasn't obvious to me early on. Initially, I thought the relationship with my boss was unilateral. Aside from accomplishing the job, what else was there to do when trying to

keep the boss happy?

After some time managing people, I began to realize they were doing their utmost to keep me on an even keel. My full-time job is not easy. I learned those colleagues were indeed managing me (up), even as I managed them. They took the initiative when projects or problems came up. They did their best not to load me down with issues. They showed me appreciation as well. When I learned that, I started applying the same ideas in dealing with my boss.

Even if you are the smartest engineer, you also need to be a good employee in your boss's eyes. If not, expect to change jobs often.

We put together a great issue for you this month. The results of the 2017 Salary Survey are ready for your study. Our idea is to give you some material with which to evaluate whether your compensation is fair. If you didn't participate, please be on the lookout next year. We need your participation!

Lee Petro and Jeremy Ruck discuss the implications of rule changes, such as the elimination of the main studio rule and changes related to MoM proofs and certifications.

As a complement to the articles about rule changes and AM revitalization, this month's Trends in Technology takes a look at ways broadcasters can leverage their tower assets in ways other than just using them as radiators. We're not talking just talking about STL or RPU antennas either. Some good ideas here.

Dennis Sloatman has some advice on how to prevent odd and confusing issues related to RDS. (I hate it when car dealers get involved!)

In this month's Facility Showcase, LA 88.5 is an AAA-formatted station here in SoCal that has recently added another station to their single frequency network — for a total of three. How do they keep the mutual interference to a minimum over the greater Los Angeles basin? I'm not giving any clues. It's a great read.

And on our honored last page, the Wandering Engineer introduces the concept of CRM — customer relationship management. The thing is, there's nothing new about CRM. Radio's been doing it for years. What's old is new again (like Millennials discovering TV antennas). **0**

DOZENS of Transmitters **ONE** Common Control

The Award-Winning Advanced User Interface (AUI)

nautel.com/AUI **nautel**

Doug Irwin, CPBE AMD DRB | Technical Editor

FOLLOW RADIO MAGAZINE

Email | radio@RadioMagOnline.com
 Facebook | [RadioMagazine](https://www.facebook.com/RadioMagazine)
 Twitter | [@RadioMagazine](https://twitter.com/RadioMagazine)

EDITORIAL

Technical Editor: Doug Irwin, CPBE DRB AMD
 Managing Editor: Emily Reigart
 Web Editor: Michael Balderston

CONTRIBUTORS

Fred Baumgartner, Chris Cottingham, Dennis Sloatman, Jason Omellas, Lee Petro, Jeremy Ruck, The Wandering Engineer, Chris Wygal

CORPORATE

President and CEO: Steve Palm
 Chief Financial Officer: Paul Mastronardi
 Chief Content Officer: Joe Territo
 Controller: Rick Ng
 Vice President of Web Development: Robert Ames

VIDEO/BROADCAST GROUP

Executive Vice President: Carmel King
 Vice President of Sales/Group Publisher: Eric Trabb

ADMINISTRATION AND PRODUCTION

Publisher: John Casey
 Editorial Director: Paul J. McLane
 Production Manager: Lisa McIntosh
 Advertising Coordinator: Caroline Freeland

AUDIENCE DEVELOPMENT

Corporate Director, Audience Development: Meg Estevez
 Circulation Manager: Kwentin Keenan
 Circulation Coordinator: Michele Fonville

ADVERTISING SALES REPRESENTATIVES

U.S. Regional and Canada: John Casey
jcasey@nbmedia.com | 212-378-0400 x512

U.S. Regional: Michele Inderrieden
minderrieden@nbmedia.com | 212-378-0400 x523

International Sales Manager: Raffaella Calabrese
rcalabrese@nbmedia.com | +39 320 8911938

Japan: Eiji Yoshikawa
caliems@world.odn.ne.jp | +81 3 3327 5759

Asia-Pacific: Wengong Wang
wwg@imaschina.com | +86 755 83862930/40/50

Member: American Business Media

A NewBay Media Publication

NewBay Media, LLC
 28 East 28th Street, 12th floor
 New York, NY 10016

SUBSCRIPTIONS: Free and controlled circulation to qualified subscribers. Customer Service can be reached at: newbay@computerfulfillment.com or by calling 888-266-5828 (USA only) or 978-667-0352 (Outside US) or write us at Radio Magazine, P.O. Box 1884, Lowell, MA 01853, USA. Back issues are available by calling Customer Service.

LIST RENTAL: 914-386-1024
jganis@meritdirect.com

REPRINTS: For custom reprints and eprints please contact our reprints coordinator at Wright's Media 877-652-5295 or NewBay@wrightsmedia.com.

PHOTOCOPIES: Authorization to photocopy articles for internal corporate, personal or instructional use may be obtained from the Copyright Clearance Center (CCC) at 978-750-8400. Obtain further information at copyright.com.

Radio, Volume 23, Number 11, (ISSN 1542-0620) is published monthly by NewBay Media LLC, 28 East 28th Street, 12th floor, New York, NY 10016. Periodical postage paid at New York, NY and additional mailing offices. Postmaster: Send address changes to Radio, PO Box 1884, Lowell, MA 01853.

Copyright 2017, NewBay Media LLC. All Rights Reserved.

Let your talent focus on what they do best

“The ViA is a high-end codec that met all of our quality expectations. The Tieline team exceeded our expectations & helped us maximize the unit’s capabilities”

- Rob Brown, Sports information Director @ Roncalli High School



Power-up, tap “Connect” and go live!

Tieline’s ViA codec is so simple to configure and connect that your talent can focus on what’s most important - calling the game.

- Full duplex stereo program plus separate full duplex IFB communications
- 5 input digital mixer and configurable matrix router (3 x XLR inputs, plus stereo analog line in, or stereo digital in/out)
- Built-in dual band Wi-Fi with integrated web-browser
- Dual LAN & USB ports & optional ISDN, POTS or LTE modules
- Schedule, dial, manage & hangup connections automatically
- Adjustable input EQ & compression, plus AGC limiting
- 6.5 hours of power with one internal battery
- Restrict user access to settings with Admin & Basic modes



Join the #ViARevolution

(((ViA)))

Tieline 
The Codec Company

317-845-8000 | sales@tieline.com | tieline.com

World Radio History



by Lee Petro

No More Walls?

In a decision that eliminates any hope of WKRP in Cincinnati's Les Nesman getting his walls, the Federal Communications Commission adopted rules in October to eliminate the requirement that broadcasters maintain a main studio in or around a station's community of license. The rule necessarily also eliminates the requirement that broadcasters maintain at least two full-time employees. Although Les would have likely been chased out of WKRP's studio by now, the elimination of the main studio rule eliminated all doubt.

Earlier this year, the FCC issued a notice of proposed rulemaking seeking public comment on whether the main studio rule should remain in effect. Citing the online migration of all broadcast public inspection files by March 2018, along with the ability to remain in contact with the local community through email and social media, the commission proposed eliminating the main studio rule as a cost-saving mechanism.

After reviewing the public comments, the commission concluded that there have been sufficient technological developments to eliminate the need to a

have a fully-staffed, local main studio with the ability to produce programming. The commission noted comments asserting that it is rare for the public to visit main studios, with the majority of interested parties either calling on the telephone or sending a message through social media or email. With the migration of the public file to the FCC's online platform, the commission noted that a vast majority of public commenters supported the elimination of the rules.

The commission did attempt to address concerns that the elimination of the main studio rule will lead to a disconnect between broadcasters and the communities they are licensed to serve.

Both in the production of local news and the engagement with the local community, several commenters expressed concern that the elimination of the main studio rule would make it more difficult to ensure that broadcast stations respond to local emergencies quickly, and more generally, continue to serve in the public interest.

Ultimately, the commission rejected those concerns, noting the availability of social media and other forms of communications. The

commission also noted that the money saved from maintaining a local main studio

may encourage the construction of new radio stations in rural areas where the cost is higher, and the savings could be reinvested by the broadcasters in local news or other responsive programming.

The elimination of the main studio rule means that broadcasters will no longer be required to maintain a physical presence in its licensed community. It also means that broadcasters will no longer be required to maintain at least two full-time employees. Finally, the elimination of the rule removes the requirement that broadcasters have the ability to maintain local program origination equipment.

Broadcasters will still be required to maintain a local or toll-free telephone number for residents in the community license. Additionally, broadcasters that have not transitioned their public file to the online platform, and those that have chosen not to upload their existing political files to the online platform, will be required to maintain a local public inspection file accessible to the public during regular business hours.

The elimination of the main studio rule will become effective 30 days after publication of the Report and Order in the Federal Register. **0**

*Petro is of counsel at Drinker Biddle & Reath LLP.
Email: lee.petro@dbb.com.*

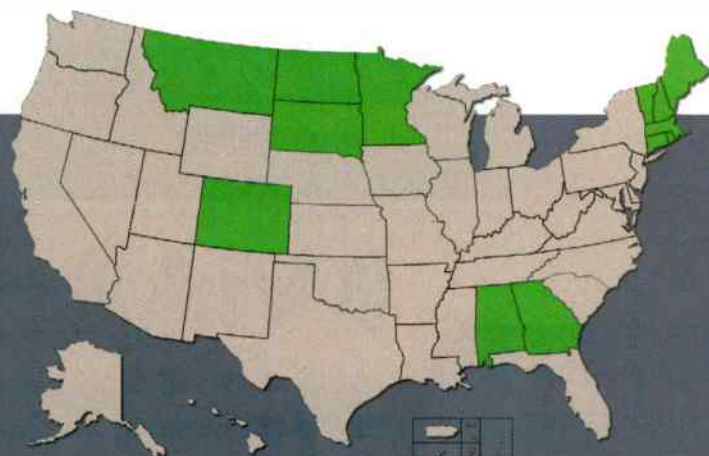

DATELINE

Dec. 1 — Stations with five or more full-time employees in Alabama, Colorado, Connecticut, Georgia, Maine, Massachusetts, Minnesota, Montana, New Hampshire, North Dakota, Rhode Island, South Dakota and Vermont place Annual EEO Public File Report in public inspection file.

Dec. 1 — Stations with 11 or more full-time employees in Connecticut, Maine, Massachusetts, New Hampshire, Rhode Island and Vermont file Broadcast Mid-Term Report (FCC Form 397) with FCC and place it in public inspection file.



Map indicates the extended range from Wheatstone's processor with multipath control.

Great Sound Is Subjective Increased Coverage is Measurable...

Scottie Rice, engineer for KSDS in San Diego, shared his experience in putting a Wheatstone processor on the air in place of another top-of-the-line audio processor. He was able to increase the distance of his listening area substantially.

To see/read Scottie tell the whole story, go to
wheatstone.com/multipath



It's Time You Tried a Different Processor

wheatstone.com/processors



phone 1.252.638-7000 | WorldRadio.com | sales@wheatstone.com





The Stars Aligned for This Three-Station SFN

by Mike Worrall

As many readers know, non-commercial FM stations are separated not by mileage (as is the rule in the commercial part of the FM band) but by predicted interfering contours. For example, in our co-channel situation, my predicted 54 dBu contour can't impinge on your predicted 40 dBu contour.

Unfortunately, due to the limitations of the prediction method, there are several situations similar to ours, namely: Two radio stations on the same frequency bordering a large metropolitan area, with both stations attempting to serve the metro — and both hampered by annoying mutual interference.

The above scenario is precisely what has historically confounded



The KCSN (highly directional) booster antenna.

Showing the severity of the historical problem; the green shading is a predicted signal level of 40–54 dBu. It's generally agreed that — absent interference — useable stereo reception can be had down to about 50 dBu, with useable mono down to about 35 dBu. Neither station had any hope beyond their 60 dBu, as the co-channel interference was too severe.

stations KCSN of Northridge, Calif. (on the northern end of the Los Angeles metro) and KSBR of Mission Viejo, Calif. (on the southern side), both broadcasting at 88.5 MHz. (SEE MAP)

Each station has adequately served their local areas for years with their own unique formats, but each has often complained to the other “I can hear your station in my station's parking lot!”

To make matters worse, the interference is often exacerbated by the “coastal coax” — tropospheric ducting phenomenon that often impacts FM reception in southern California.

The only available technical solution to this impasse was to create a single frequency network: two stations on the same frequency with identical programming.

Not wanting to jump into this without a complete understanding of the potential gains or pitfalls, we engaged engineering consultant John Kean to thoroughly analyze the RF landscape.

John's report was decisive and succinct: “The predicted results for the synchronous system are dramatic...adding first acceptable reception to millions of potential listeners located between the two stations.”

GO!

In June 2017, the stations entered into a joint programming agreement, whereby both would carry the successful AAA format devised by Program Director Sky Daniels, thus creating this single frequency network.

In fact, KCSN has operated a booster in west Los Angeles for many

Open the door to *your* possibilities!



ON THE AIR

Powerful, state-of-the-art automation with the flexibility to grow with you...

- The power of OPX in one stand-alone computer
- Easy to learn
- The power to handle the largest audio libraries
- Satellite and live programming
- Additional stations
- Remote voicetracking
- Remote control

OPX ONE



Call (888) 274-8721
(888) BSI-USA-1
or email us at sales@bsiusa.com

years. Hence, with the addition of KSBR, this has become a three-station SFN. (The original two-station SFN for KCSN was previously covered in Radio. Read it here: <http://tinyurl.com/ydb66dyt>.)

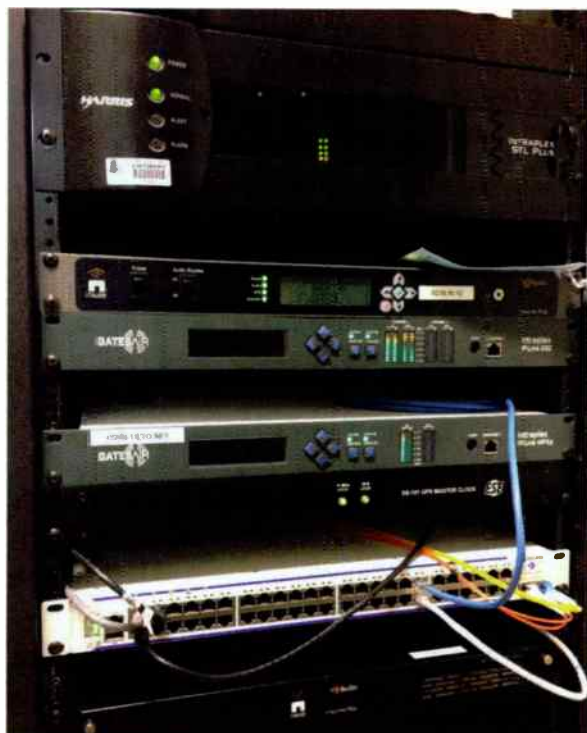

The bottom half of program distribution rack at KCSN, with Nautel HD Radio Exporter, GatesAir IP Link 200 (which receives content originated at KSBR and returns mix-minus to them), GatesAir IP Link MPXp primary STL, ESE ES-100 GPS receiver, Lucent switch and Nautel Importer.

Importantly, neither station was willing to consider changes to its existing antenna system or siting; the SFN needed to work “at the highest level that the state-of-the-art allows,” without any major changes to their existing antennas.

The technical travails of boosters and SFNs are well documented. Unless there is significant



terrain obstruction to act as a shield between transmitters, the reception suffers from noise and distortion as one travels between the transmitter sites as a result of differing modulation levels and/or timing offsets at the individual transmitters. In this particular case, there is no significant terrain shielding; we needed to make this work as best we could without any natural RF barriers.

As luck would have it, several products were unveiled at the 2017 NAB Show that looked very promising.

We knew that the modulation levels at all three transmitters needed to be identical, as differences of less than 0.25 dB have been shown to raise the received noise floor dramatically. (This effect is discussed in Nautel’s webinar on SFNs, which can be viewed on YouTube at <http://tinyurl.com/y98z6em2>.)

We reasoned that if we could create the composite FM baseband signal once and then distribute it as an MPX (composite) over AES (192 kHz sample rate) data stream to all three sites, we’d have a good chance of maintaining precise modulation level control.

We were happy to discover at the Orban booth that their new flagship 8700i processor, with includes (as a standard feature) a “DMPX” digital composite output as an AES data stream of either 192 or 384 kHz sample rate. Using the AES data stream (which I will now refer to as AES-192), we were able to create the entire FM baseband signal once, and then to replicate it for all three transmitters via the STL system as planned.

In addition, the 8700i includes a built-in RDS encoder and has provisions for incorporating external SCA generators into the digital composite output. Plus, the 8700i also features a “REF” input, enabling us to lock its sample rate to our GPS-delivered 10 MHz time base. We were also intrigued by its new “Multipath

Mitigator” phase correction scheme for reducing the effects of multipath distortion.

WITH ONE BOX TICKED

We now needed an STL system to transport the AES-192 stream to all three sites, with the special provision that it needed to be transparent to the AES-192 stream from Orban 8700i (no re-clocking or sample-rate conversion) and it needed to deliver its output signal at precisely the same time at all three sites.

We were familiar with the GatesAir Synchrocast system, having used it successfully to time-align booster systems using T1 architecture. However, the T1 payload isn’t large enough to handle the AES-192 stream.

At the GatesAir booth, we zoomed in on the new Intraplex IP Link MPXp, an IP-based audio codec that delivers a single, bi-directional FM MPX composite signal, and found it was



KCSN’s booster antenna from below.

available with the Synchrocast option, specifically designed for SFNs.

With Synchrocast, the IP Link MPXp will deliver its digital MPX output with 1 micro-second accuracy to all three sites, using both 1 PPS and 10 MHz signals from either an optional internal or external GPS receiver. The IP Link can be configured for “transparent AES,” such that the

ARRAKIS SYSTEMS

DIGILINK-XTREME 2.0 AUTOMATION

For a low \$100 per month you receive All software, Bridge hardware, support, and upgrades.
Always up to date, no yearly support contracts, plus next day Bridge replacement.
Just add a Windows PC and stir!



On Air Studio



Playlist Management



Production Studio



Network Recorder



Traffic Studio



Windows 8
compatible

On Air, Production, Traffic, News, Programming
complete

\$100 /month

call or go to our website today to learn more about Arrakis radio automation systems

www.arrakis-systems.com

970.461.0730

World Radio History

AES-192 stream presented to its input is passed through without sample rate conversion or level change. If bandwidth conservation is important, one can chose lesser sample rates and/or bitrates to reduce the data rate of the digital AES stream. Additionally, the IP Link MPXp simultaneously outputs both digital MPX stream (on an XLR-3 connector) and an analog composite signal (on a BNC connector) enabling connection to a back-up transmitter, for example.

SECOND BOX TICKED

Lastly, we needed three new HD-capable transmitters that would accommodate a digital MPX input.

In this way, the AES-192 FM baseband signal created at the studio would migrate through the system unmolested; with the IP LINK configured for transparent AES mode, the digital composite signal created at the studio in the Optimod 8700i is never changed in any way.

Though several transmitter manufacturers offered AES-192 capability, we felt that Nautel was most appropriate, largely because of their pioneering work in enabling HD Radio broadcasts in SFNs — important because our SFN is committed to HD Radio. The Nautel user interface allows one to enable a micro-second resolution delay offset, vital in SFN's for "moving" the inevitable interference area between transmitters.

Now, with three identical transmitters receiving identical AES composite signals, we were confident that we were as close to the "state-of-the-art" as we could get.

NOW WE SET OFF TO BUILD THE NEW SFN

Aiming to achieve T1 reliability while distributing the composite signal over IP, we specifically wanted to avoid the Internet.

After much head-scratching, we lighted on AT&T's switched Ethernet, a layer-2 based private



At KCSN Studios...

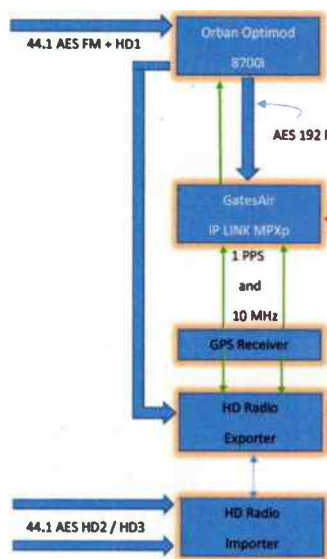

At XMTR Sites...

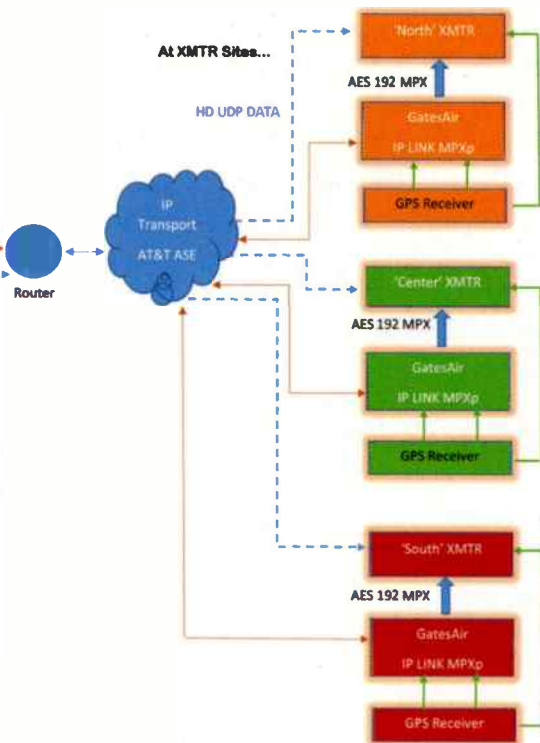

Simple one-line diagram of the 88.5 three-station SFN system.

Ethernet service with a service level agreement called Real Time. The Real Time SLA offers 5-millisecond one way latency, 3 ms jitter and a packet delivery rate of 99.995 percent. Not quite the "five nines" we enjoyed with T1 service, but pretty darn close, and the price was significantly less than a T1 (over the same distance).

The AT&T switched Ethernet is also convenient in that it allows us to put all of the IP codecs on the same layer-2 network. (Note: AT&T's lead time can be significant; in our case, it was more than 75 days. Note, too, that the IP Link MPXp is completely capable of using the Internet as a connection medium and can accommodate multiple streams from differing ISP via the optional Dynamic Stream Splicing feature).

All told, it seems to us that the stars aligned perfectly, dropping the next generation of SFN-capable hardware into our laps just when it was needed. 🍀



Top half of program distribution rack at KCSN, with Belar FMHD-1 monitor, Moseley 950 link to out-of-market translators, Orban Optimod 8700i and the former primary STL T1 frames.

Mike Worrall is Chief Engineer of KCSN, licensed to California State University, Northridge

IN STOCK!



Forge a Sound They Won't Forget

For a limited time **save \$2000** on Orban's OPTIMOD 8700i multi-band FM/HD processor. Grab more listeners with your bold, fresh signature sound. Only \$12,990.



On the Air at 88.5 KCSN/KSBR

MORE BACKGROUND

As part of the composition of this Facility Showcase, Radio magazine had a chance to ask Mike Worrall about the results of the SFN with the benefit of a little more time for analysis. Mike also described the methodology they intend to use to further align the system.

Radio: *The first thing we want to ask is what has been the result so far? How long has the system been operating? And what kind of feedback are you getting from listeners?*

Mike Worrall: Well let's see, we went on Sept. 12. We're talking on Oct. 6, so roughly three weeks. The results so far are pretty impressive, I think.

They're all rather anecdotal. We have not yet done any kind of scientific analysis. I'll put an asterisk on that and come back to it.

People are driving the freeways of southern California going "Wow, I can certainly hear you where I was never able to hear you before. Occasionally, it gets scratchy, but I'm able to ride through that, and get beyond the scratchy areas."

I think so far the results are encouraging.

RM: *You say there haven't been any scientific measurements as of yet, but do you have something in mind?*

MW: I do, and that is a result of a long conversation I had with John Kean — to whom I bow and genuflect to every time he's on the phone.

I said, "John, I don't have a lot of resources to make measurements, but I want to be more scientific about this than we've been able to sort of be so far."

He said "OK, look, here's what I do: Get yourself an HD Radio, and some sleep, and attack this at midnight on a Sunday night."

For example, "Find a stretch of highway that has been reported to be problematic, and with a radio, an audio recorder and a quarter wave antenna mag mounted to the roof of your vehicle, find a half mile section of road that you can come back to, and back to, and back to, and back to, and if you're able to log into your automation system, find a cut of music that you're comfortable with that's not wall-to-wall square waves, but has some dynamic range. Start that cut of music and start your vehicle and the recorder rolling with one transmitter on. Turn the other transmitter off.

"Come back, turn the other transmitter off, do the same stretch of highway with the same cut of music. Come back, turn both transmitters on. Do the same stretch of highway with the same cut of music."

Now you've got a baseline. Then you can begin to play with the delay from, for example KSBR's transmitter, incrementing the delay, say in 25-microsecond chunks. Go back to the starting point and do it again. Just get yourself some audio samples that are identical across that same stretch of freeway."

Now come back and analyze it. Say "OK, well from square one what does it sound like with only one transmitter on? What does it sound like with the other transmitter on? What does it sound like with both on? Now, begin to understand what making delay adjustments do over that stretch of road."

Now you've got an idea of where you are.

"Visit another stretch of road, and do the same thing. It's gonna be like whack-a-mole in some scenarios where changing it in one location is going to mess it up in another location so this is not going to be a process that's going to be consummated quickly and give you the end result in one stretch. You're gonna have to make some effort here and spend multiple nights trying to understand what all the iterations are. Then, once you get that figured out, add the booster to the equation."

I said, "John, I understand what you're saying. It's not going to be an easy fix, but I get the methodology that you're suggesting that I employ to try to figure out how all these things interact."

RM: *How does HD Radio enter into the picture?*

MW: Well, we are committed to HD, and we've been talking about this (meaning the two stations) for years. When we were talking to John Kean and Bert Goldman about it, they said — and this was earlier this year prior to the NAB Show — "Look, you pretty much want to forgo HD. It's not gonna work. The current generation-four architecture is such that there's no way to get the analog and the HD to work harmoniously. Until Xperi figures that out, you want to forgo HD."

Well, fast forward to NAB 2017, where we were talking Philipp Schmid about his experimentation with KUSC, and their booster in Santa Clarita, and how he overcame Xperi's gen-four architecture to enable HD to work in SFNs [Previously covered here: <http://tinyurl.com/yc4afmy>].

We said, "Hey, Philipp. We're down on our knees. We've got this SFN coming up. We really want to do HD. Are you comfortable allowing us to use Nautel's HD SFN system? Is it a final product? Is it a product that we can buy?"

He said, "No. It's not going to be ready until fourth quarter of this year."

We said, "Oh gosh, we really would like to do this coming out of the box, but can't wait until the fourth quarter. Will you allow us to use the beta version, or whatever version it is that you now have available here at the convention to come on with us as soon as we can?"

He said, "Yeah, sure."

He's just a good guy and was willing to help us out.

So to answer your question: yes. HD is a major part of this, and KCSN and its booster are on in HD at the moment, but KSBR found that they had antenna bandwidth issues, and they tried to turn on HD, and the transmitter immediately pulled it back. They're getting those antenna issues worked out, I think, as we speak. Tower crew was on site today, and hopefully by this time next week, the whole network will be up in HD. †



Mike Worrall



Try it for yourself: www.bwb.fm/v2demo

Monitor & control your transmitter, anywhere, anytime.

Advanced Remote Control - from any device!

All V2 Transmitters come with an Ethernet connection as standard, at no extra cost. There's no software to install and you can connect remotely from any web connected device such as a smartphone or tablet. Automatic email alerts instantly let you know of any faults - removing the need for regular site visits.

Amazing sound built-in! No need for a separate audio processor.

Sound great, right out of the box. One of the industry's cleanest exciters and ultra-low distortion modulator combine with 4-band audio processing and 14 presets to choose from.



Change parts in minutes and be back on the air!

If a lightning strike or power surge takes out your transmitter's power supply, you no longer need to remove it from the rack and spend hours disassembling it. You can simply slide in a replacement power supply in seconds.



www.bwbroadcast.com



by Jeremy Ruck, PE

AM Revitalization Efforts, Part Three

AM revitalization continues to move ahead. The First Report and Order is barely two years old, and now we find ourselves a couple months downstream from the release of the Third Report and Order.

The initial document was wide in its scope and caused some heartburn among broadcasters, as should have been expected. The recent release is notable for what it addressed — and for the cans kicked further down the road.

The commission notes this in the second footnote. Items still to be resolved are the most contentious of the original release. Namely, the proposal to change protections based on class; the rolling back of the nighttime RSS calculation methodology to that used before 1991; and the expanded band authorization surrender. These proposals may be addressed, and as the commission indicates, other items may be attached to the ongoing effort.

In 2001, the commission redefined what constituted a partial proof of performance. Prior to that time, all radials contained in the latest full proof of performances were considered. But the burden was reduced to require only the radials with a monitor point; and if a pattern has fewer than four monitor points, then the radials adjacent to the monitored radials required measurement.

The Third Report reduces the burden further by requiring only monitored radials to be measured. This change will certainly reduce the cost associated with a partial, but the lack of measurements in lobes, often not monitored, may allow array efficiency issues to go unnoticed. Thus, it is good practice to spot check these areas when field measurements are performed.

If your antenna system was proofed by MoM, then you should be familiar with the annual recertification process. Under the Third Report, that requirement disappears, unless changes to sampling system components are performed.

This change makes sense and should have been made years ago.

With the implementation of a MoM proof, reference field strength measurements are required. These field strength measurements essentially function as de facto monitor points, and as my friend of many years, Mike McCarthy, correctly pointed out, these measurements are crucial in diagnosing array health.

It used to be that monitor points, phase monitor readings and base current ratios were a three-way cross check on array health. With base current meters no longer required, the reference field strength measurements were the only way to identify an apparent problem as real world or sample system related. Just as locks keep honest people honest, the public availability of reference field strength measurements tends to make for good neighbors. Moving forward, only the initial set will be required.

One interesting change was the elimination of the survey requirements when converting an existing array to a MoM proof, if no modification of the tower quantity or geometry occurred.

The logic behind this was that it was an existing array, and so the towers are where they are supposed to be. Maybe they are — not only do we find tower coordinates to be incorrect in many cases, but I have also run across a couple of arrays where the towers were not at the correct spacing and orientation.

In one instance years ago, the owner used a compass and measuring tape to stake out the locations of the two towers. The resulting error in the tower azimuth and array spacing screwed up the null location, and necessitated a last minute CP modification. Field strength measurements played a large part in finding this problem.

Four additional items under MoM proofing were addressed, with results on adoption. A necessary clarification to the description of shunt capacitance in modeling the tower base region was made.

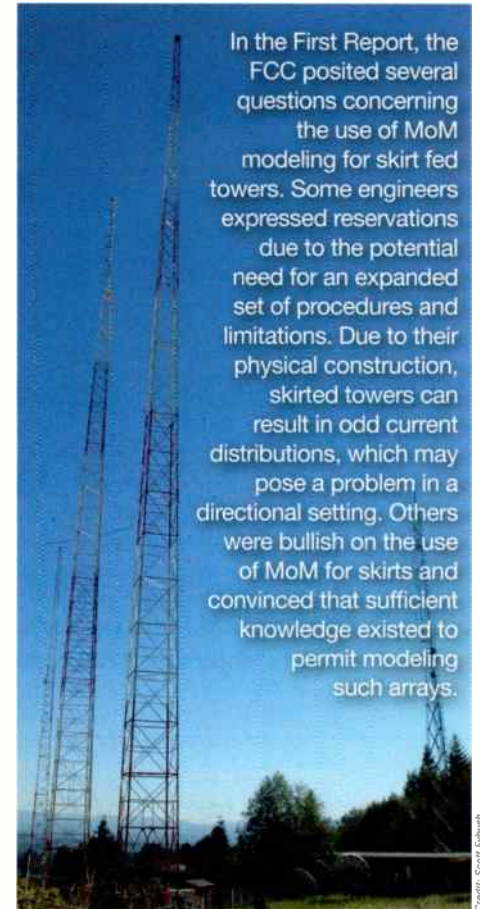

In the First Report, the FCC posited several questions concerning the use of MoM modeling for skirt fed towers. Some engineers expressed reservations due to the potential need for an expanded set of procedures and limitations. Due to their physical construction, skirted towers can result in odd current distributions, which may pose a problem in a directional setting. Others were bullish on the use of MoM for skirts and convinced that sufficient knowledge existed to permit modeling such arrays.

The adoption column contained changes to the MoM rules regarding re-proofing after antenna addition and elimination of current distribution measurements for certain configurations when MoM is used. In the case of the former, housekeeping tweaks were made so that changes that do not influence modeled values will not require re-proofing, while the latter eliminated current distribution measurements for top loaded systems. The proposal not adopted was the use of modeling for skirted towers.

In the First Report, the commission posited several questions concerning the use of modeling for skirt fed towers at paragraph 74. Specifically, the commission sought comments pertaining to constraints on skirt modeling, the use of specific software packages to model them, requirements for sampling and if any costs would arise from these proposals.

When a highly theoretical question is posed to a group of engineers, one should expect a collection of varying answers, which ultimately can be distilled down to one side or other of a central argument. That's exactly what happened.

Reservations were expressed about using MoM to model skirted towers due to the potential need for an expanded set of procedures and limitations. Additionally, due to their physical construction, skirted towers can result in odd current distributions, which may pose a problem in a directional setting, despite the potential workarounds. In the other camp, some were bullish about the use of MoM for skirts and convinced that sufficient knowledge exists to permit modeling such arrays. No doubt due to conflicting opinions between industry heavyweights, the commission elected to shove this issue aside.

The last item addressed in the Third Order pertains to the Main Studio Rule.

Two years ago under different leadership, the commission expressed reluctance to eliminate main studio requirements entirely due to concerns over ensuring compliance with local service obligations. While expressing this reluctance, it was also acknowledged in the First Report that the existence of a main studio for some AM stations especially in difficult economic climates, could represent a financial hardship. And so, at that time, comments were sought as to what extent the rules should be relaxed.

Now in late 2017, the commission has voted to eliminate main studio requirements, other than the maintenance of a local telephone number within the community of license, or alternatively, a toll-free number. This expected change is tied to a separate proceeding, which superseded the First Order proposal, and as a result, main studio rule changes have been dropped from AM revitalization as of the Third Order.

Certainly, the 2015 First Report was ambitious in scope and represented the first major changes to the AM-related rules, other than translators, in a quarter century. The latest report continues to chip away at the long list of proposals, but most of the items addressed this time around are mostly housekeeping in nature. I, for one, am pleased to see the commission taking an interest in AM, as the senior band is where broadcasting began.

While the number of points measured in a partial proof could have a minor economic impact to an AM station, how much revitalization

is really taking place?

Revitalization imbues something with new life, energy or activity. While the proposals so far appear to have a positive impact on the AM service, are the efforts bold enough?

Perhaps one of the forthcoming proposals

hinted at in the Third Report will be the long-awaited start of the transition to all-digital. That would be true AM revitalization. **0**

Ruck is the principal engineer of Jeremy Ruck and Associates, Canton, Ill.



Control Your Sonic Signature



NEW FEATURES

719 DAVID IV FM/HD BROADCAST PROCESSOR

- Streamlined 4th Generation DSP-based audio processor
- Precision FM Stereo generator with dual outputs, internal metering of your RDS/RDBS subcarrier
- 5 Bands of Dynamic Range Compression and "Graphic EQ"
- 25 factory presets and 20 customizable presets
- Network / remote controllable



5 Bands



Low Latency 3.9ms



Remote Network Interface





25 Presets



Award Winning

Better Radio Since 1972



ARRAKIS SYSTEMS INC.

All Arrakis consoles now have AoIP !

ARC-8
only \$849



ARC-10
from \$1,699



ARC-15
from \$3,799



MARC-15
from \$5,499

For more than 35 years, Arrakis Systems has led the way with ground breaking innovations in Radio. Now with SIMPLE-IP, all Arrakis consoles can be linked with the World Standard DANTE AoIP protocol for less than \$1,000 per studio.

Visit our website today !!!



Digilink-Xtreme

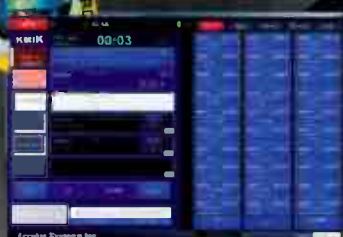

ACCENT furniture

Digilink-HD



SIMPLE-IP

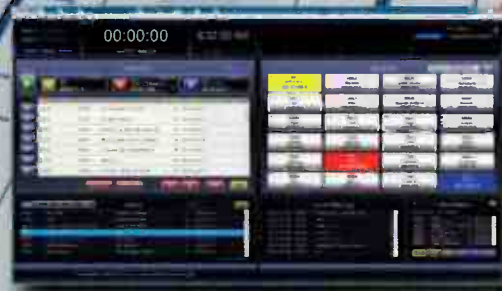

www.arrakis-systems.com

970.461.0730

World Radio History

'NEW'... talk studio consoles reinvented !!!

... available NAB

ARC-talk-Blue

5 Mic channels with dual Conferencing Bluetooth Phone interfaces

- Eight channels
- Stereo Program output
- 5 mic, 1 stereo line, 1 PC, & 2 Bluetooth inputs
- USB interface for play and record from a PC
- 2 Bluetooth interfaces for Two Cell Phone callers
- ...or... stream audio from any Bluetooth Audio device



NO Hybrids required

long life switches, conductive plastic faders, Socketed ICs for fast on site repair,



USB play & record



Fast, easy installation:

- RCA's for unbalanced I/O,
- Cat5's for balanced inputs,
- XLRs for mics & Program output

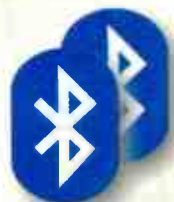

Dual Bluetooth Cell phone & Audio Streaming interfaces

Talk-remote studios Reinvented !!!

Powerful, compact, portable, and not needing a land line to take incoming calls, the 'ARC-talk-Blue' is ideal for talk studios or remotes that require a mic mixer with telephone caller interface. The revolutionary console features 5 high quality mic channels plus phantom power. Channels 6 & 7 on the console can be paired to any Bluetooth enabled audio device such as your Cell phone, MP3 player, MP3 recorder-editor, and more. Each 'Blue' channel features a button you push to connect an incoming caller and push again to disconnect from the caller. The channel One mic features 'Talk' buttons to talk to each Blue caller off line. No external hybrids are needed. OR... you can pair any Bluetooth enabled audio device such as an Ipad, Tablet device, or MP3 player and stream full bandwidth, high quality stereo (A2DP) audio into the console. The 'ARC-talk-Blue' also features a built in USB PC sound card on channel 8 so that you can play audio from your PC while recording the console Program output with your favorite software. Once again, Arrakis is 'The Leader' in Radio console evolution. Follow the Leader and visit our website today.



...the Bluetooth phone interfaces work with BOTH cell phones and Bluetooth headset enabled land lines.

list price **\$1,099**

www.arrakis-systems.com

870.461.0730

Expand or Leverage Your AM System

by Doug Irwin, CPBE AMD DRB

AM revitalization is an important industry topic, and in this article we're going to look at the various techniques used to either expand an existing AM system, or to otherwise leverage its presence.

TAKING ADVANTAGE OF A TOWER'S PRESENCE

When many AM transmitter sites were built, 50, 60 or more years ago, they were "way out of town" in locations that seemed, at the time, would never be encroached upon by housing tracts or strip malls. However, as time has gone on, that is exactly what happened with many sites. Now, ironically, many AM antennas are located in areas where it is difficult, if not impossible, to erect other new tower structures. Additionally, the presence of a developed site can be cost-effective for carriers and others seeking co-location. Using an AM site for additional communication services can be a very attractive option for the broadcaster, because of the benefit of this newfound revenue stream and if engineered properly, additions to the system will result in minimal headaches or problems for the existing AM operation.

The entire process can have its complications though. From an article Jeremy Ruck contributed to Radio magazine (<http://tinyurl.com/y86drtk8>), we have the following caveats: "...It is also important to remember that the addition of items to elements in a directional array bring in their own set of complexities.



The addition of antennas and line will require a partial proof or remodeling, if applicable. These additions will also affect the self-impedance of the tower, which will be different from the drive point impedance. Thus, any adjustments or apparatus used needs to take into account these differences, as well as differences that may occur between different patterns in the same array. Of course, before anything is added to an AM tower, a structural analysis should be performed. In many cases, AM towers were engineered to be essentially naked. As a result, many times there is no opportunity under current standards to add things to a tower and still comply with loading limits."

Talk to your AM consulting engineer prior to making any changes.

LOCATION OF VHF/UHF SERVICES ON AN AM TOWER

There are plenty of reasons to consider the addition of a VHF or UHF antenna to an AM tower, such as the construction of an auxiliary transmitter site for an FM operation or the addition of an FM translator antenna. It's not uncommon for stations to locate RPU antennas on top of AM towers, and quite often stations locate 950 MHz STL antennas on AM towers.

One way to accomplish this is an isocoupler, which, as the name suggests, allows you to couple energy (in this case VHF or UHF)

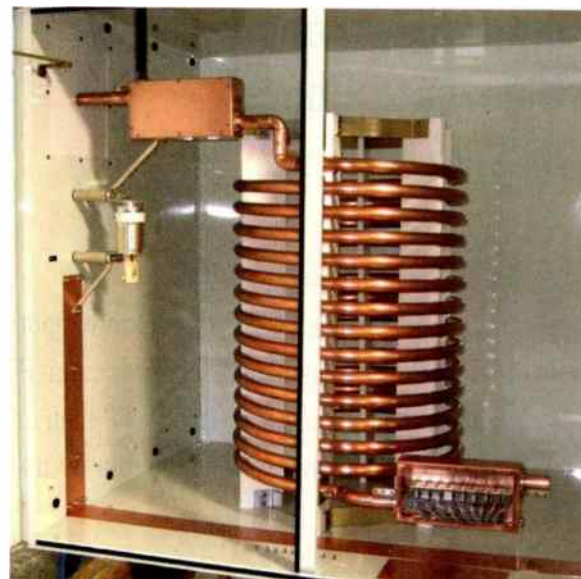

The Kintronic Labs ISO-RU-Cat5 provides a means by which Category 5 cables can be run up the tower while isolated from the AM RF.

while maintaining isolation from the native AM system.

LBA Technology's CAMI series of low, medium and high power broadband isolators allow for the addition of antennas on AM towers. CAMI systems are specifically designed to isolate single coaxial cable feeds for two-way, microwave and STL links, FM translators, FM, LPTV and television translators. Unlike tuned isocouplers, the same broadband CAMI model will fit all of these application frequencies without retuning.

The CAMI isocoupler family supports any combination of RF carriers from DC to 2700 MHz or more, and power levels up to 40,000 watts at FM. High Impedance AM isolation is achieved on any specified frequency between

Electrical Specifications	FMC-1.5	FMC-2.5	FMC-7.5	FMC-20	FMC-30
Nominal Power Rating	1.5 KW	2.5 KW	7.5 KW	20 KW	30 KW
Frequency within FM range	88 - 108 MHz				
Bandwidth (MHz)	6				
Insertion Loss at Fundamental Frequency	< 0.2 dB				

Basic specifications for Kintronic Labs' iso-coupler series for FM.

530–1710 kHz. Custom AM multi-frequency and high power systems are also available for special applications.

The CAMI provides a simple, cost-effective way to build an AM station's FM translator because the translator antenna can be mounted on the existing AM tower. CAMIs also pass AC or DC current to tower-top amplifiers and are resistant to weather and lightning.

Kintronic Labs offers the FMC line of isocouplers to facilitate the addition of FM antennas to AM towers. Power levels are from 1.5 kW to 30 kW of VHF power.

In addition to the FMC family, Kintronic also makes the LPTV isocoupler. (Many LPTV stations are being displaced in the TV repack

of STL receive or transmit antennas on series-fed towers.

ERI offers two different solutions for the use of FM or LPTV on AM towers: The Isolation Transformer models 404 and 425 series. The 404 is for low to medium power applications.

(See chart on page 22.)

The 425 series is for higher power applications (referring to both the AM power and VHF power). (See chart on page 22.)

If your station is bound and determined to use its AM radiator as a means of holding



3x3 LBA "CoLoCoil" installation, as seen from the "hot" side of an AM radiator.

process, so keep an eye out for potential new clients.) The LPTV isocoupler can handle up to 500 W; however, the ISO-74-LPTV Isocoil series from Kintronic has three separate devices: One to handle up to 6 kW, one for 3 kW and one for up to 1.75 kW.

Kintronic Labs offers their line of PCS isocouplers, for power levels from 100 W to 30 kW at frequencies between 150 MHz and 2.4 GHz, making them suitable for FM, VHF, UHF, cellular, high power paging, STL (studio-transmitter link), wireless internet and PCS applications.

Kintronic Labs also has a line of STL isocouplers. The FMC 0.1, the FMC0.2, and the STL band isocouplers at the 100, 200, and 300 W levels. They are used to facilitate the installation

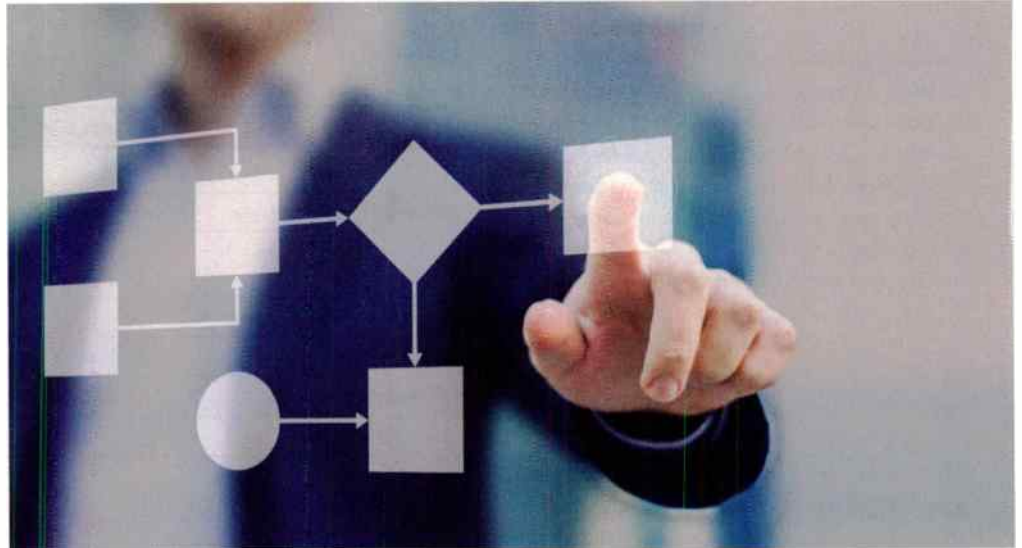

The station's off the air and you're out of pocket

No problem. Jet™ Active Flowcharts get you back on the air fast.

Sometimes you're just not available when a critical alarm occurs. That's when Jet Active Flowcharts take over.

Turn your transmitter site into an island of reliability with ARC Plus Touch and Jet Active Flowcharts from Burk Technology.

Call today for a free system configuration.

www.burk.com | sales@burk.com | 978-486-0086 x700

BURK
TECHNOLOGY

Call us to make your own deal!

Buy an ARC Plus Touch with RSI & AutoPilot® and get one Plus-X or PlusConnect I/O unit of your choice for free. Save up to \$1,595.

Offer valid through December 31, 2017.



BURK
TECHNOLOGY

www.burk.com | sales@burk.com | 978-486-0086 x700

up other antennas, you may want to consider changing it to a folded unipole.

In this case, instead of series feeding the tower, and having it sit above ground on an insulator (with high voltage between the tower and ground), the tower base is grounded and conductors are added, on brackets, so that they envelope the tower. These conductors then make up the radiator.

(Keep in mind that it's beyond the scope of this article to discuss the pros and cons of converting to a shunt feed from a series feed. We simply present it in the context of the subject. Speak to your AM consultant before opting to go this route.)

The Nott Ltd. folded unipole kit provides several other advantages, in addition to making your AM radiator a more friendly location for other RF services. According to Nott, it can potentially have greater bandwidth, improving the quality of the transmitted audio; and because the tower is now at ground potential, the need for transformers, base insulators, static drain chokes and arc gaps is eliminated. Lightning and static electricity problems are mitigated.

LBA offers the Tunipole, their version of the folded unipole system. Adding to the potential benefits of this type of antenna, LBA writes that it "provides extra bandwidth and efficiency; improves impedance match to reduce tuning unit loss and complexity; has identical radiation pattern to series fed; and, reduces tower height and ground system requirements." This type of antenna can be used in both directional and non-directional systems.



An ATU and filter combination for a diplexed system, manufactured by Kintronic Labs.

Operating Frequency Range:	88 MHz to 108 MHz (other frequencies available on application)
VSWR:	1.10:1, maximum
Power Rating (FM):	10 kW
Insertion Loss:	< 0.05 dB, maximum
AM Peak Voltage Rating:	7.5 kV
AM Shunt Capacity:	100 pF (approx.)

Specifications for the ERI model 404 isolation transformers.

	Model 425	Model 426	Model 427
Electrical Specifications			
Operating Frequency Range:	88 MHz to 108 MHz (factory tuned to specified frequency, other frequencies on application)		
VSWR:	< 1.05:1 at tuned operating frequency \pm 500 kHz < 1.10:1 at tuned operating frequency \pm 1 MHz		
Power Rating (FM):	25 kW	40 kW	50 kW
Insertion Loss:	< 0.05 dB, maximum	< 0.05 dB, maximum	< 0.05 dB, maximum
AM Peak Voltage Rating:	30 kV	30 kV	30 kV
AM Shunt Capacity:	60 to 70 pF (approx.)	60 to 70 pF (approx.)	60 to 70 pF (approx.)

Specifications for the ERI 425 series isolation transformers for higher power applications.

COMBINING MULTIPLE AM STATIONS INTO A SINGLE ANTENNA ARRAY

While some AM stations are able to take advantage of their tower site location for purposes other than originally intended, some are not, and have chosen to sell out the land that was, for years, an integral part of the antenna array. In some cases, the stations simply go dark; in other cases, engineering studies reveal the technical possibilities in diplexing, or even triplexing, with

another local AM array. Several firms are in the business of providing the gear necessary to facilitate such antenna arrays.

Omni-directional multiplexed antenna systems typically consist of a separate matching network and series trap filter to reject each of the other multiplexed frequencies for each of the multiplexed transmitters. These networks are located at the base of



Nine-tower phasor cabinet manufactured by Phasetek.



An ATU and filter combination manufactured by Phasetek.

the tower with each multiplexer input port fed by a separate transmission line from each corresponding transmitter. Directional multiplexed systems consist of the common point, phasing and power dividing networks (commonly known in toto as the phasor), the antenna tuning units, and the pattern and/or transmitter selection controller for each station. In a directional array each radiator will have a separate matching network and series trap filter to reject of the other multiplexed frequencies. This is installed between the ATU and the tower RF connection.

Kintronic Labs is a very well-known supplier of all of the necessary matching and passive RF filtering to get multiplexed omni-directional or directional stations on the air. (The company recommends the operating frequencies of multiplexed stations be separated by a minimum of 120 kHz for best audio bandwidth results for each station. Multiplexed stations with frequency separation between 70 kHz and 120 kHz additional filters will be required to achieve the desired isolation between the multiplexed transmitters.)

Leave Your Competitors in the Dust

Introducing VOLT, the VOLT radio processor from Omnia that gives you an unbeatable price and unbeatable performance. It's the only radio processor that offers the best performance in the industry with the most advanced Omnia products. The VOLT 1000 offers you the best performance in the industry with the most advanced Omnia products. The VOLT 1000 offers you the best performance in the industry with the most advanced Omnia products. The VOLT 1000 offers you the best performance in the industry with the most advanced Omnia products.

TECHNICAL SUPPORT: www.omnia.com/VOLT

INOVONICS
BROADCAST

For Challenging Reception Scenarios

AARON 650
FM REBROADCAST / TRANSLATOR RECEIVER

- Unique Software Defined Radio (SDR) front-end
- Unparalleled sensitivity, selectivity, and RF shielding
- Total control over bandwidth blend & multi-path mitigation with Manual Reception Processing
- Built-in Band Scanner™ and MPX, FFT
- No Dead Air—audio failover to SD Card or Web Stream
- Dynamic Web Interface for remote control & monitoring

Everything you need. **The iXm bundle.**
Get the iXm along with first class accessories. For an unbeatable price.

iXm Windscreens. Keep the noise away.

Get the ultimate protection for your iXm.

iXm Uplink. Transfer your interview via iPhone.

www.yellowtec.com

Cirrus® Radio Streaming - the Fastest Growing Streaming Provider

- Six Different Monetized Streaming Players to Use
- HTML5 Responsive Radio Streaming Players
- Free Custom Mobile Streaming Apps
- Free Sponsors to Generate Revenue
- No Hidden Fees, No Contracts, No Gimmicks
- 100% Customer Satisfaction
- 48+ Year Free Quote - Custom Streaming Plans Are Available

cirrus streaming

For more information, contact us at info@cirrusstreaming.com or [1-800-999-3214](tel:18009993214).

BGS

Broadcasters General Store
Family Owned & Operated Since 1979

Your source for broadcast equipment and services.

Contact us for a quote today!

352-622-7700 www.BGS.cc

Kintronic Labs utilizes "RF network synthesis techniques for the purpose of optimizing the input impedance bandwidth of each multiplexed antenna system port for an omni-directional tower or for common point bandwidth and pattern bandwidth optimization in the case of a multiplexed directional antenna system," according to the firm.

LBA Technology also offers custom-engineered diplexers, triplexers and multiplexers. Each system is designed for the specific frequencies, transmitter output powers and antenna base impedances and each is typically fabricated in a single, multi-compartment cabinet. The company also manufactures directional phasing equipment, in the range of 250 W to 250 kW, along with ATUs, rejection filters, and a wide range of radio frequency networks. Directional phasing equipment is normally designed to parameters provided by the broadcaster's consultant.

Phasetek is another veteran company in

the AM antenna business. In addition to their line of components for ATU cabinets and phasors (such as fixed and variable inductors and RF contactors) they also design and custom-build ATUs, phasors, diplexers, multiplexers (including the pass/reject filters) and de-tuning systems as well.

APPLICATIONS OUTSIDE OF BROADCAST

In this day and age, broadcast applications only account for a fraction of the potential antenna types that can be installed on AM towers.

Kintronic Labs offers several different means of adding other services to a series-fed tower, including the ISO-TEL Transmission Line Inductor and the ISO-RU-cat5. The former is literally low-loss coaxial cable wound as a coil, allowing for the installation of other antennas on the tower; the latter, a means by which services that need direct cat5 cables can be added to said tower. The category cables are run on the inside of a copper tubing inductor.

LBA Technology offers the CoLoCoil system, a variation of the iso-coupler idea, using parallel-resonant filters, composed of the outer conductor of the coax, and a parallel capacitor, to reject any RF energy from the tower itself, while allowing for installation of other RF services on a hot tower

According to LBA, the tuned circuits present a "lower capacitive footprint to the tower's lump base capacitance," while

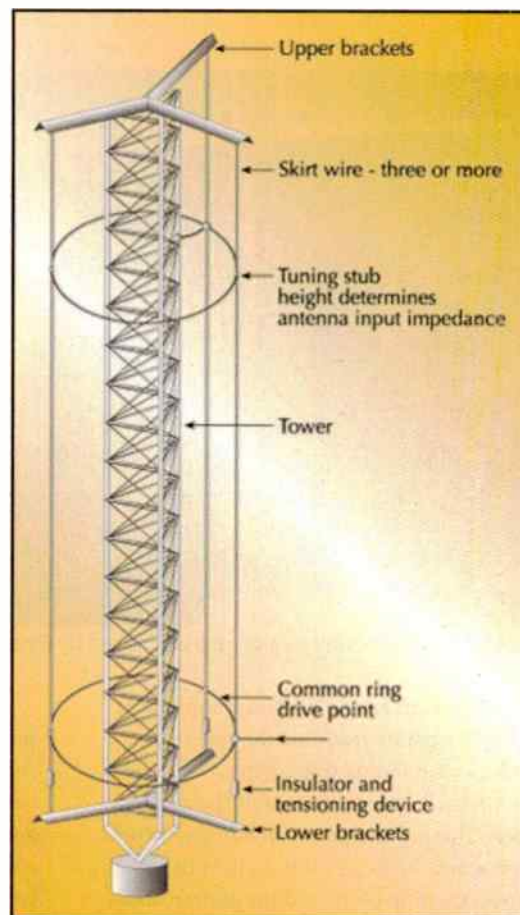

Basic drawing of a folded unipole (from Nott Ltd).

allowing the RF path for the cellular company, and a DC path for any control systems, or tower-mounted amplifier systems. The company also says they're ideal for AM directional arrays; will pass DC to 2700 MHz signals; and, they offer low insertion loss and low intermod distortion.

While AM antennas have always been used by the station in their quest for revenue generation, they are themselves now a means by which the station can generate extra revenue. We all know of cases where the land formerly occupied by the antenna became more valuable than the station itself. For stations that remain viable, the latest technology, described herein, can potentially improve the revenue outlook. **Q**

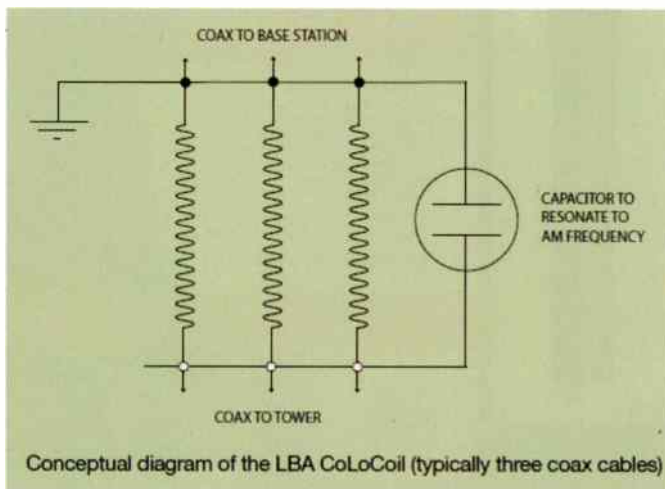

Welcome to **Bay Country**
BROADCAST EQUIPMENT

Your #1 Source For Quality Used Radio Broadcast Equipment

View our latest list of equipment on-line at:
www.baycountry.com

All equipment sold with a 15 day return gurantee

BUY...SELL...TRADE

7117 Olivia Rd.
Baltimore, MD 21220
Ph: 877-722-1031
www.baycountry.com
email: sales@baycountry.com

ARRAKIS SYSTEMS INC.

ARC-15BP ADVANCED RADIO CONSOLE

- analog & digital with USB sound card & Bluetooth
- Cat5 cabling for today's infrastructure
- Balanced & unbalanced outputs



Bluetooth
Cell phone & Audio
Streaming option

\$3,799
msrp



USB
play &
record



a NEXT
generation
analog console
that mixes analog
& digital with a PC USB
sound card built in. And, for
today's infrastructure the ARC-15
uses Cat5
cables

now with DANTE
AoIP options



SIMPLE-IP

- Fifteen channels
- Two Stereo Program outputs
- 1-5 mic, 8-12 stereo line, PC, & Phone in
- USB interface for play and record from a PC
- Mix minus in-out for an external Telephone hybrid
- Conductive plastic faders & multimillion operation switches
- Socketed ICs for ease of on site repair & LED lamps for long life



CAT 5
cables
included

visit our Website today for more information

www.arrakis-systems.com

World Radio History

Don't Work for Free (Or for Cheap)

by Doug Irwin, CPBE AMD DRB

Radio magazine is aimed at the community of radio engineers, of which you're a member. Towards that end, we want to present the most accurate salary and compensation information that we can for people in our community. How well we're able to do that depends upon the responses we get to the survey. For those of you who took it this year—our many thanks. To those of you who didn't—you can make up for it next year!

As we've seen in past surveys, there is a definite relationship between what you can earn from a station and the amount of money it makes, and that amount is likely to go up with market size. It's clear from the responses we got that you can add to your earning potential by moving up in market size. And, if you're someone who supplements your income with freelance work, you would do well to learn the going rates for local services. Survey results show many inconsistencies in the way clients are charged.

We'll start our analysis of this year's salary survey results by taking a quick look the respondents by market grouping.

In response to the question "At which market level do you normally work?" we have the following results:

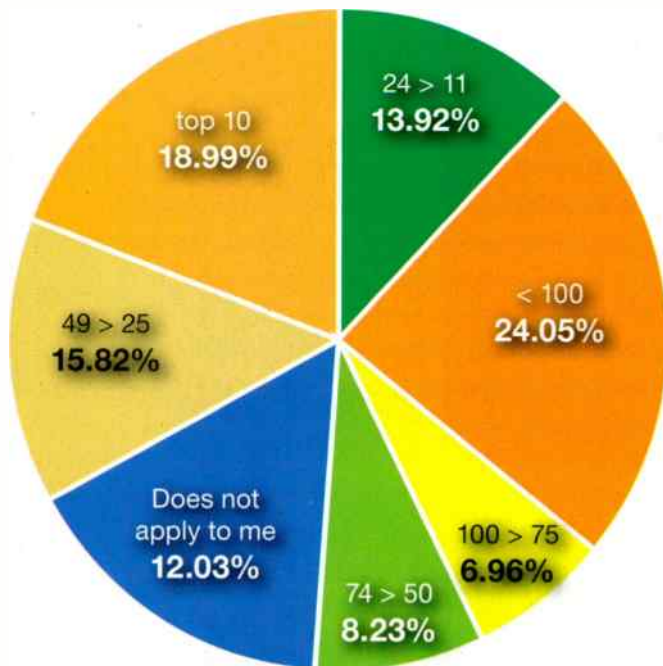

We're also interested in the job function of respondents. Those surveyed indicated they identify as:

Executive-level Engineering (corporate)	12.40%
Regional Director of Engineering (responsible for several markets)	7.44%
Station or Market Director of Engineering (responsible for station(s) in a single market)	38.84%
Staff Engineer/IT	22.31%
IT/IS Manager/Director	1.65%
Contractor	9.92%
Other engineering titles	7.44%

Next, we like to break down compensation by market size. (See top chart on page 27.)

It's unfortunate that we collected less than the ideal amount of responses from market groups 100 > 75, as well as 74 > 50; all we can do is share the information we got from those that did respond.

We haven't asked questions about compensation as related to job function. However, you can clearly see in markets 49 and above what the typical staff engineer receives in yearly pay. Going up the pay scale, you can see where the salaries of department heads stand, as well. It also appears that the difference in pay between the department head and staff members widens as you go up in market size, and we also note that the likelihood of a raise was much higher for engineers working in the top 10 markets.

THE UNIVERSE OF RESPONDENTS

As you have just seen, we break down some of the results by market size, and we also consider some of the information in the context of all markets. Let's take a look at those now.

Doing outside work. We won't call it "contracting" because the majority of the relationships between radio engineers and their clients are not governed by contracts.

Looking at results for all the market groups, we learn a few things about engineers who freelance. (See bottom chart on page 27.)

Half of radio engineers who responded do no outside work whatsoever; 2.78 percent only do contracting and are not otherwise employed; and 47 percent do a combination of contract and full-time work.

Contractor rates are all over the place. We find it hard to believe, but at least one respondent indicated they give away their time at the rate of \$11 per hour.

Most respondents charge more for emergency response; you can see the average hourly rate for that service is higher than what is charged for "normal" work.

Some charge clients for travel time (and not just the hourly mileage charge).

SALARY SURVEY

Yearly compensation	Markets greater than 100	Markets 100 > 75	Markets 74 > 50	Markets 49 > 25	Markets 24 > 11	Top 10
Less than \$20K	10.34%	0	0	0	0	0
\$20K to \$24.999K	0	0	12.50%	0	0	0
\$25K to \$29.999K	0	14.29%	0	0	0	9.52%
\$30K to \$34.999K	6.90%	0	12.50%	0	0	0
\$35K to \$39.999K	3.45%	0	0	0	0	0
\$40K to \$44.999K	3.45%	28.57%	0	0	5.56%	0
\$45K to \$49.999K	3.45%	0	12.50%	5.56%	5.56%	0
\$50K to \$54.999K	6.90%	14.29%	0	0	0	4.76%
\$55K to \$59.999K	0	14.29%	0	11.10%	5.56%	4.76%
\$60K to \$64.999K	24.14%	14.29%	0	11.10%	5.56%	9.52%
\$65K to \$69.999K	10.34%	0	0	11.10%	22.22%	4.76%
\$70K to \$74.999K	10.34%	14.29%	0	22.22%	16.67%	14.29%
\$75K to \$79.999K	6.90%	0	25%	5.56%	0	4.76%
\$80K to \$89.999K	0	0	0	16.67%	11.10%	9.52%
\$90K to \$99.999K	0	0	0	5.56%	5.56%	4.76%
\$100K to \$124.999K	3.45%	0	37.50%	5.56%	16.67%	19.05%
\$125K +	10.34%	0	0	5.56%	5.56%	14.29%
Did you get a raise last year?						
YES	44.83%	57.14%	37.50%	33.33%	44.44%	60%
NO	55.17%	42.86%	62.50%	66.67%	55.56%	40%

A number of respondents also make their clients pay a monthly retainer — although at least one respondent charges only \$35 per month for the right to call on him/her.

Setting rates can be difficult in any specific market. Ideally, one can learn what “the other guy” is charging before determining one’s hourly or monthly rates.

At a bare minimum, we suggest you do the following.

- **Study auto repair shop rates in the town where you reside.** Remember that car owners bring their vehicles to the shop. The repair guys don’t make house calls (unless they are charging way more).
- **How much do HVAC companies charge for techs to visit your transmitter site?** This is another good way to gauge the market rate. Surely your time fixing consoles/automation/transmitters is worth just as much as air-conditioner repair.

I do no outside work	50%
Contracting is all I do	2.78%
Employed but do outside work as well	47.22%

	high	low	average
Contractor hourly rates:	175	11	71.62
Do you charge premium rate for emergencies? If so, how much:	180	50	92.14
Do you charge for travel time?	120	35	61.14
Do you charge a monthly retainer?	750	35	308.46
	none	some	all
Do you have contracts with clients? (%)	61.67%	25%	13.30%

DB3011 Full Fidelity FM/HD Radio & IP Audio
Confidence Monitoring Receiver
Price: \$2100

DEVVA®
BROADCAST



Available in stock from Broadcast Depot, Call: 800-313-7592
www.devvabroadcast.com

Many respondents to this survey bemoaned the state of compensation in our industry. We suggest you do all you can, in terms of research, into how much your services are worth.

College degrees. While many respondents have a college degree (55.65 percent) only 41.77 percent of those have a degree in an engineering discipline, meaning just over 23 percent of all respondents have a degree in an engineering discipline.

Certifications. Specialized certifications are very prevalent in the broadcast engineering field:

Society of Broadcast Engineers (SBE)	46.49%
National Association of Radio Telecommunications Engineers (NARTE)	1.75%
Microsoft	7.02%
Cisco	4.39%
None of these	20.18%
FCC License	56.14%

Responses to “other” include amateur radio licenses, Amazon Web Services and RF safety certs.

Of those who indicated they have SBE certifications, the results were as follows:

Certified Audio Engineer (CEA)	3.85%
Certified Broadcast Networking Technologist (CBNT)	26.92%
Certified Broadcast Networking Engineer (CBNE)	9.62%
Certified Broadcast Technologist (CBT)	23.08%
Certified Broadcast Radio Engineer (CBRE)	28.85%
Certified Senior Radio Engineer (CSRE)	7.69%
Certified Professional Broadcast Engineer (CPBE)	30.77%
AM Directional Specialist (AMD)	5.77%
Digital Radio Broadcast Specialist (DRB)	5.77%
Certified Radio Operator (CRO)	1.92%

Professional organizations. Based on the results thus far, one would expect a high level of membership in the SBE, and that is indeed the case.

We find it interesting that, though 62 percent of respondents indicate that they are SBE members, only 46.5 percent actually hold certifications.

“Other” professional association memberships include the Western Association of Broadcast Engineers (<http://wabe.ca/>) a nonprofit organization, based in Canada, which has “the objectives to promote and advance the dissemination of engineering knowledge among its members, and to represent the interests of the majority of its members to duly appointed technical, educational and legislative institutions.”

Society of Broadcast Engineers	61.95%
Association of Public Radio Engineers	6.19%
Audio Engineering Society	3.54%
Institute of Electrical and Electronics Engineers	9.73%
National Association of Radio and Television Engineers	0.00%
American Radio Relay League	16.81%
None	30.09%
Other professional organizations	3.54%

Personal aspects. Anecdotal evidence indicates that broadcast engineers are predominantly “advanced” in age, and our survey results show largely confirm that idea.

24 or younger	2.65%
25-34	7.96%
35-44	15.93%
45-54	15.04%
55-64	41.59%
65-74	15.93%
74+	0.88%

This begs the question — what can we learn about the retirement plans for these respondents? The survey asked respondents in how many years do they anticipate their retirement?

1-2	16.35%
3-4	13.46%
5-6	8.65%
7+	61.54%

Another question related to the retirement issue asked: “On a scale of 0 to 100, how confident are you that you will finish your career in radio? 0 means you’re positive you’ll be doing something else; 100 means you are positive you will retire as a broadcaster.” The average of all responses was 78.

The survey results don’t appear to portend any mass exodus from the business. However, as the business evolves (as it always does, usually shifting toward fewer and fewer people), the chances are that the number of people remaining in the field will more or less match the number needed.

After all, though 57.52 of respondents are between the ages of 55 and 74 years old, 41.58 percent of the respondents are younger — many of whom are bound to keep at it.

Job satisfaction. Just how happy or unhappy are people working in the field of broadcast engineering?

Asked “if you could change one thing to improve your current job, what would it be?” many responded with similar answers. These

CONTINUED ON PAGE 29

NuVoodoo Snapchat Ads for Radio

NuVoodoo Media Services has added Snapchat Ads to its suite of digital marketing solutions for broadcast media clients.

NuVoodoo and Snapchat collaborated to develop tools specifically for radio and television media campaigns, enabling stations to reach their targets through Snapchat Ads.

"They fast-tracked specific capabilities for us that were on their development roadmap for months from now — such as zip code targeting — and sometimes within hours of our conversations with them," NuVoodoo Media Services Vice President of Product & Business Development PJ Kling.

NuVoodoo also recently released its latest Ratings Prospect Study, "which showed daily use of Snapchat among likely Nielsen respondents up a robust 28 percent since January," according to the announcement. And that number "was even stronger among those under the age of 35."

"While Facebook and YouTube remain the juggernaut social platforms, the next tier of Snapchat, Instagram and Twitter have grown significantly since our January study. While the numbers below reflect daily use among 14 to 54s likely to say 'yes' to Nielsen, for specific formats and narrow demographics, the penetration levels are nearly ubiquitous," said NuVoodoo Media Services Executive Vice President of Research Leigh Jacobs.

<https://www.nuvoodoo.com/> | (888) 986-6366

RadioKing StudioKing

RadioKing introduces a new live broadcasting software.

According to the release, the new software considers the needs of radio presenters/DJs, done with its ergonomics and aesthetics.

In addition to live broadcasts, the company says StudioKing offers Auto DJ and CrossFader for professional transitions, live metadata editing and samplers. Also, StudioKing enables users to choose broadcast quality and offers real-time display of connected listeners.

It's currently available in beta (Windows and Mac computers) for existing Radio Manager customers as a free download. Alternatively, prospective users can test it by creating a demo radio station.

A new version of this software is slated for the end of 2017, and the company says it will add the ability to record live shows as well as Skype integration, in addition to features suggested by beta users.

<https://www.radioking.com/> | +44 33-0684-5076



CONTINUED FROM PAGE 28

include: adding more staff (this is a big one); better compensation; better work/life balance.

This comment sums up many responses well: "Tired of working 60-70 hours a week with no pay raise, no bonus and increasing expectations from corporate. We need to be respected for our role in the operations."

Still the question: "On a scale of 0 to 100, how much do you like your job? 0 would mean you hate it; 100 would mean you love it." earned an average response of 78.

Radio is an industry that you either love or hate. Those who hate it find other things to do; those who love it stick with it, probably too readily and could benefit by knowing their professional worth.

Remember, there is a relationship between what you can earn from a station and the amount of money it makes; and that amount is likely to go up with market size as well. Therefore, it makes sense that you can add to your earning potential by moving up in market size.

And if you're someone who supplements your income with freelance work, you would do well to learn the going rates for local services. 0

AcousticsFirst.com
Materials to Control Sound & Eliminate Noise.™

Acoustic treatments as unique as you.

Toll-Free:
888-765-2900

Solving the Porsche Conundrum

by Dennis L. Sloatman

I perhaps like you, take RDS somewhat for granted here in the US.

In most cases, we connect a serial or Ethernet data stream from our playout system (by some means) to our RDS generator at the transmitter and observe title and artist/promotion information displayed on the receiver. At its root, it is a fairly straight forward system.

In Europe, the RDS system is utilized in a far more expanded scope — they mean business with RDS in Europe. It's actually a shame we often don't use its full capabilities here (although some do, for sure) but perhaps due in part to the sheer number of stations and the expanse of the US, it doesn't have the same applications here.

The other day, I received a phone call from a customer service manager at a local Porsche dealer, who wondered if I was having any unusual problems with two of my stations. I replied that, to the best of my knowledge, we were 100 percent. Within a few minutes, I learned some of the dealership's customers were complaining that there was a problem in the car receivers that resulted in seemingly random switching from one of my stations to another.

At first, my reaction was "huh!" But then I recalled that in Europe (where the Porsche is manufactured with Becker receivers installed) how big a deal RDS is, and this suggested a

connection.

I checked the RDS encoders on these two stations (one of which is a translator — more on that in a moment) and found, to my surprise, that the PI codes for both were at the



RDS has become standard fare for FM stations, especially over the last 10 years.

default PI code of "F000."

I know better than to leave these at default, but I recalled one of these encoders was recently updated with the latest firmware. While I am sure I entered the proper PI code, perhaps I didn't click the "update" button (who knows?). I really don't know why the translator RDS generator wasn't set — I never had occasion to look at it, and this was installed before I accepted the position.

In any case, it turns out that more advanced receivers (particularly those with advanced RDS capabilities) will sometimes change stations at "random" while the vehicle is in motion, if the same PI code is used by multiple stations. Doubtless, many customers have taken their cars back to the dealership, complaining of "faulty receivers" (as was the case with the local Porsche dealer) in areas with RDS PI code duplications.

Also, consider the scenario in which a station has a backup transmitter that sees only infrequent use but has the default PI code of F000

selected in that site's RDS encoder. When that site is in-use, and another station's encoder is set to default as well, this can lead to a confusing situation indeed. Once I discovered the issue, I corrected it from the comfort of my desk and all issues were resolved.

TRANSLATORS AND RDS

Now to the translator I referenced earlier: The proper PI code is somewhat "muddled" and can be a bit confusing. As you may know, the PI code is generated based upon a four-letter call sign using an on-line applet, one of which is available at <http://www.w9wi.com/articles/rdsreverse.htm>.

For example, WKHK will lead a PI code of 6FD0, but what to do about the translator call signs such as W291CL? This is not so much an issue for those stations

use the translator to "repeat" a parent station's programming, but what about when used as a translator for an HD2/HD3 format, which is likely unrelated in any fashion to the parent station's format?

I have researched the matter with several RDS experts and found some general guidelines (although no hard and fast rules).

Suggestions vary from "make something up which isn't already in-use" to change your station's call letters from a leading "W" to a "K" (or vice-versa). What I have chosen to do is to take the first four call letters of the translator (W291 in the example above — truncating the "CL") and generate a code. If someone has a better idea or has different information, please send an email to bdcastngr@gmail.com.

So check those PI codes at any site with an RDS generator and avoid your own "Porsche conundrum." 

Dennis Sloatman is the director of engineering and IT for Summit Media's Richmond, Va., stations.

**POWERFUL PRESETS
AUTOMATED AUDIO BACKUP**



The Award-Winning
Advanced User
Interface (AUI)

nautel.com/AUI 

NTi Audio Noise Monitoring Station

NTi Audio has debuted a Noise Monitoring Station that works for both short-term sound level measurements and long-term monitoring, and features remote control access.

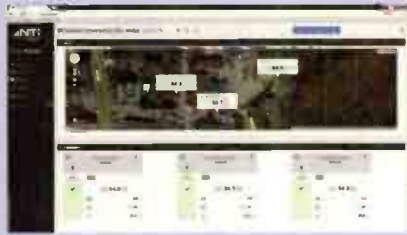

The core of the station is its XL2 Sound Level Meter, which also helps connect the station to the internet through a NetBox. The NetBox serves as an interface for the control of the XL2 and the remote access to the measured data. The monitoring station is connected to the internet via 3G, LAN or Wi-Fi. Operation of the Noise Monitoring Station can be done in either Gateway mode or Managed mode. In either mode, the analysis and post-processing of the measured data is done with the Data Explorer PC-software. It also features a M2230-WP weather-protected microphone designed for outdoor measurements.

NTi has also announced that the XL2 meter that is part of the Noise Monitoring Station is now calibrated according to IEC61672-3:2013. IEC61672-3 is an internationally recognized standard that deals with "procedures for periodic testing of time-weighting and integrating sound level meters." The current version describes both acoustic measurements and a variety of electrical tests. During the sound level meter calibration the detailed parameters of the XL2 are recorded and compared with the limits specified in the standard.

<http://www.nti-audio.com/> | (503) 684-7050

Studio Technologies Model 5401 Dante Master Clock

The Model 5401 Dante Master Clock is the latest release from Studio Technologies. Designed to provide precise timing signals for applications that use Dante Audio Audio-over-Ethernet media networking technology, Model 5401 implements a IEEE 1588 precision time protocol server compatible with the Dante implements and capable of simultaneously supporting the timing needs of up to hundreds of Dante devices.



Model 5401 provides PTP v1 compatibility for Dante and PTP v2 for AES67 applications. The unit can generate up to eight sine-wave audio tones on Dante transmit channels. A clock input connection allows for synchronization with a variety of timing reference signals.

Additional features of the Model 5401 unit include an internal oscillator; support for word clock; dual Gigabit Ethernet network interfaces; an integral web server; front panel indicators; LCD display; and pushbutton switches.

<http://www.studio-tech.com/> | (847) 676-9177

Precision | Innovation | Proven



RADIUS XP

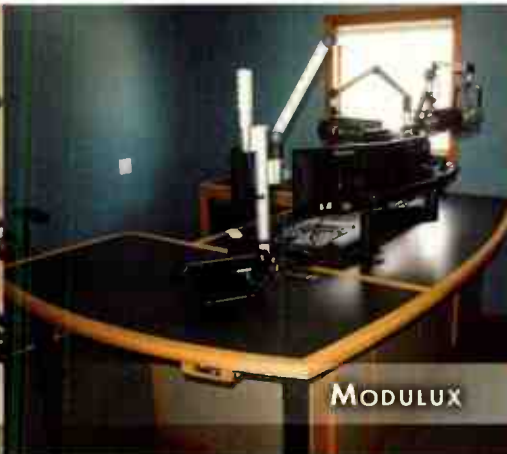

MODULUX



BIRCHLINE TALK TABLE

GRAHAM STUDIOS

Broadcast Furniture

866-481-6696 | www.graham-studios.com



815-222-3556

www.isupportradio.com

NEWPRODUCTS



Comrex Access NX

The latest IP audio codec from Comrex, the Access NX, is now available for shipping after its introduction at the 2017 NAB Show.

Access NX features Comrex's CrossLock reliability layer that enables error correction and network bonding. CrossLock monitors in real time and adjusts network usage based on performance. Additional features include an additional audio channel; a 5-inch capacitive touch screen; two USB jacks for 3G/4G and Wi-Fi connectivity, Ethernet Port and POTS modem compatibility; digital mixing and headphone busses; digital peak limiting; two stereo headphone outputs

with individual controls; and an optional four-channel mixer.

The codec is compatible with Access Rackmount and Bric-Link II from Comrex.

Comrex is offering the Access NX for \$4,000 as a remote unit and \$1,000 for the optional mixer.

<http://www.comrex.com/> | (800) 237-1776

FIND THE MIC SEPTEMBER WINNER

Congratulations to **April Chavez**

Broadcast Engineer
San Antonio, Texas

The mic was
on the structure in
the white under
the first catwalk.



She won a
**IBT-300 Bluetooth
Audio Receiver**



The winner is drawn from the correct entries for the issue two months prior. No purchase necessary. For complete rules, go to RadioMagOnline.com.

www.hosatech.com

GALLERY

GORMAN REDLICH DIGITAL ANTENNA MONITOR



MODEL CMF — Remote Controllable Digital Antenna Monitor — 2 Tower

Price \$3950

Additional Towers \$200 Each

The Model CMR is a state of the art instrument of unequalled accuracy and stability. With typical modulation, the CMR's true ratio readout is a factor of 10 more stable than instruments that measure normalized amplitude. With a 15kc IF for the measuring circuit, this monitor is ideal for diplexed arrays.

- True Ratio reading. Non-Reference and Reference amplitudes are separately measured and divided electronically to give an accurate digital reading.
- Stable, accurate phase reading with automatic phase sign.
- Amplitude or True Ratio may be selected for measurement with a front panel switch.
- Dual Surge Protection.

GORMAN REDLICH MANUFACTURING CO

257 W. Union Street Athens, Ohio 45701

Phone: 740-593-3150 jimg@gorman-redlich.com

www.gorman-redlich.com



MOORETRONIX
BROADCAST & INDUSTRIAL ELECTRONICS

Our 17th Year

Our client list continues to grow. Thank you for your confidence and equipment purchases.

We Re-Condition

Pacific Recorders BMX I-II-III, AMX, ABX and RMX, Stereo-Mixer and Mixer News-Mixer products.

Calibration Service & Refurbishment

Nems Clarke 120 and RCA WX-2 field intensity meters. Digital meter upgrade option available.

We Repair & Re-Crystal

STL Transmitters, STL Receivers, and RPU equipment.

See the "News-Update" page at our website.

Tel: 800-300-0733 Fax: 231-924-7812

WWW.MOORETRONIX.COM

E-Mail us at: rmoorejr@aol.com

Engineering Software

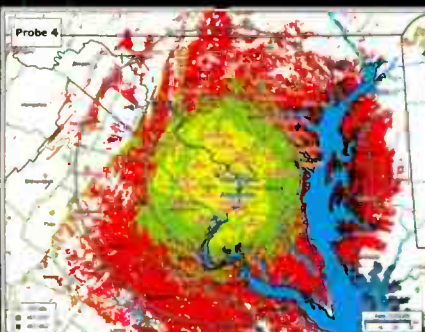

● Create "real-world" coverage maps, interference studies, and population reports with Probe 4™

● Find STL broadcast auxiliary and Part 101 microwave frequencies and generate PCN letters with Microwave Pro™

● AM Pro 2™, used daily by FCC engineers, performs skywave and groundwave allocation studies and AM coverage mapping.

● Map FM stations and discover upgrade possibilities using FCC minimum separations and contour-to-contour methods with FMCommander™

**The Leader In
Broadcast
Engineering
Software!**

V

Soft
COMMUNICATIONS®
R.F. Communications Software
and Engineering Consulting

www.V-Soft.com (800) 743-3684

MULTI-STATION CONTROL

for your Sage-Endec or DASDEC™



MSRA-RM (2U)

**with our
Multi-Station Relay Adapter**

- ★ Control up to 3 additional stations for a total of 4
- 100% Compatible with both the original Sage SE1822, the new Digital 3644 and now the Digital Alert Systems DASDEC™ when used in the analog audio mode
- ★ Both rack mount (MSRA-RM) and table top (MSRA) units available
- ★ Master & individual station recessed front panel multi-turn EAS audio gain controls
- ★ Individual left and right channel EAS activity LED indicators for each additional station
- ★ Test button for easy setup
- ★ Screw type pluggable Eurostyle connectors for positive and secure connections
- ★ Fail Safe gold clad relay contacts in case of a power failure, 2 relays for each station
MSRA-RM only \$599, MSRA only \$539.00

Also, our Multi-Station Relay Expander with relay contact output only for controlling digital switchers and routers



MSRE-RM (1U)

- ★ All of the same features above excluding the audio features and only 1U high (MSRE-RM)
- ★ 2 gold clad form "C" relay outputs for each station
MSRE-RM only \$339.00, MSRE only \$299.00

For details on these and other innovative products for the broadcaster, call or visit us on the web at:

www.dmengineering.com

2174 Chandler St. Camarillo, CA 93010
805-987-7881 800-249-0487

AcousticsFirst®

Materials to Control Sound & Eliminate Noise™



Toll-Free Number **888-765-2900**

AM Ground Systems Company

Complete AM Ground System Construction, Evaluation and Repair Services

www.amgroundsystems.com
866-22RADIO

GET YOUR OWN COPY!

Each month the *Radio Technology Leader* brings you the latest must-read information about radio broadcasting.

To start your own FREE subscription go to
www.myradiomag.com
and complete the online form TODAY!

ADVERTISER	PAGE	PHONE	WEBSITE	ADVERTISER	PAGE	PHONE	WEBSITE
Acoustics First	29	888-765-2900	www.acousticsfirst.com	Gorman Redlich	32	740-593-3150	www.gorman-redlich.com
Arrakis Systems	11,18-19,25,35	970-461-0730	www.arrakis-systems.com	Graham Studios	31	866-481-6696	www.graham-studios.com
Bay Country	24	877-722-1031	www.baycountry.com	Inovonics	1,17	800-733-0552	www.inovonicsbroadcast.com
BGS	23	352-622-7700	www.bgs.cc	Mooretronix	32	800-300-0733	www.mooretronix.com
Broadcast Software Int'l	9	888-BSI-USA-1	www.bsiusa.com	Nautel	4,10,12,20,30,34	902-823-5131	www.nautel.com
BW Broadcast	15	305-751-6129	www.bwbroadcast.com	Orban	13	480-403-8300	www.orban.com
Burk	21	800-255-8090	www.burk.com	Tieline	5	317-845-8000	www.tieline.com
Deva Broadcast	27	855-428-7272	www.devabroadcast.com	V-Soft Communications	33	800-743-3684	www.v-soft.com
DM Engineering	33	800 249 0487	www.dmengineering.com	Wheatstone	2,7 36	252 638 7000	www.wheatstone.com

This advertiser index is a service to readers. Every effort is made to ensure accuracy, but Radio magazine cannot assume responsibility for errors or omissions.

Broadcasting Is Intimate — and Will Become Interactive

by the Wandering Engineer

One of the twists of next-generation broadcasting is that it can, and often will, be interactive.

Radio was (and in many stations still is) all about customer (a.k.a. listener) relations.

My first stations made a point to get everyone who wouldn't die of mic fright on the air at least once every year. Everyone knew that we served the community first, but our sponsors paid the bills and we were there to serve them. As my markets got larger, the formulae never really changed. Community is community. Broadcasting is intimate.

When I want to know about an industry, I often seek out the trade magazines and subscribe. I read BE and Radio World magazine in high school, stretching my scant teenage qualifications to fill out that subscription bingo card.

The ads for DeVry showed me one way to that FCC First Class license that virtually guaranteed an overnight gig reading meters and playing tapes for \$1.60/hour.

It should come as no surprise that many of us read other industrial rags (that is what the people who produce them call these publications when they think we won't hear), and in one of them I learned about CRM, otherwise known as customer relations management.

It's now an industry and science of its own, with vendors of CRM systems and software as well as consultants and researchers.

I'd like to think that advertising works on everyone but me; I'd like to think that I'm immune to the huge CRM mechanism that seems so impersonal when what I really want is personal.

We all need personal connections, and we find it with the media of our life. My folks found it in radio. I found companionship in radio and TV. My kids find the same things in social media.

CUSTOMER SERVICE?

As I page through CRM magazine, I'm thinking about my last two customer experiences. I wrote a note to Ken the guy who does a local radio show called "In the Mood" that just tickled me. Now I have to listen late every Friday to see if my suggestion makes it to air.

Then I spent an hour on hold (they said the queue was six minutes) with a large electronics store on the other coast as I attempted to redeem a gift card I won at the NAB Show.

While there is indeed a space to enter the gift card data and instructions for how to do this on their website, the guy I barely understand on the phone is correct: If you use a magnifying loop to look at the fine print on the back of the card, it turns out that gift cards only work in the store.

Being disappointed by large electronics stores is not that big a deal, but they followed up the disappointment with many catch-up spams of the hard to unsubscribe variety.

PURPOSEFUL INTERACTIONS

Broadcasting will be more and more



electronically interactive as we mature. Seamless interactivity is social media on steroids for broadcasters. It drives digital ad insertion. It becomes rocket fuel for the marketing campaigns we sell that are so much more than the spots and the rate cards of decades past.

My mind can't get around what broadcasting will become without actually first experiencing it. That's going to have to wait until we build it, until the reception devices are out there, and until we program it. It's beyond my imagination — and I can imagine a lot of things.

Imagination isn't supposed to have limits. Maybe that is what art is — something beyond our imagination — and why we only know it when we experience it. Perhaps that explains why broadcasting is an art. **0**

The Wandering Engineer is an industry stalwart who has been in broadcasting since the days of Marconi and Tesla. He gives his thoughts on the current state of broadcast engineering and the broadcast engineer.

An advertisement for Nautel VS Series equipment. It features an image of a rack of electronic equipment. The text reads: "FREE Orban" in large letters, followed by "OR \$1,000 \$2,000 \$3,000" and "Discounts on all VS Series". At the bottom, it says "nautel.com/OrbanFree123" and the Nautel logo.

ARRAKIS SYSTEMS INC.

now with DANTE
AoIP options



SIMPLE-IP



USB
play &
record

Control room
and
Studio
monitors

MARC-15 MODULAR ANALOG CONSOLE

the MARC is a next generation analog console that mixes analog and digital technologies with USB PC sound card modules (on air software included). For today's cable infrastructure the MARC uses CAT5 cabling and RJ45 connectors (cables included). Three stereo buses plus dual conferencing phone hybrid mix minus buses handles the big jobs.

starts at
\$5,499

conductive plastic
faders and LED lighted
switches for reliability.
Socketed ICs for fast
on site repair.

very low
profile tabletop
design & fast access
to level adjustments and cabling



CAT 5 cables
for all
input/output

visit our Website today for more information

www.arrakis-systems.com



The Forever Console...Wheatstone LXE

Adapt to new technology, new techniques, and new workflows with LXE. Completely configure/reconfigure your console - every button, knob, and display on the surface is fully programmable using our intuitive ConsoleBuilder™ GUI/scripting interface.

With ScreenBuilder™ LXE, you can design dynamic custom touchscreen interfaces to augment LXE's extensive screen set. Beautiful to see and use.

Need more input faders? Enable up to four layers to double/triple/quadruple the number (up to 32) in the same footprint.

LXE is built to last in every way.

Learn more: wheatstone.com/lxe

