

THE BELL SYSTEM TECHNICAL JOURNAL

DEVOTED TO THE SCIENTIFIC AND ENGINEERING
ASPECTS OF ELECTRICAL COMMUNICATION

Volume 58

January 1979

Number 1

Copyright © 1979 American Telephone and Telegraph Company. Printed in U.S.A.

Advanced Mobile Phone Service: Introduction, Background, and Objectives

By W. R. YOUNG

(Manuscript received June 6, 1978)

This paper introduces a series of papers that describe in detail the Bell System's Advanced Mobile Phone Service (AMPS). It presents a brief history of mobile radio, highlighting the important events and legal decisions that preceded development of the AMPS system. The cellular system concept that has been embodied in AMPS makes large-scale mobile-radio service affordable to a sizable segment of the public. This concept calls for dividing transmission areas into "cells" to handle radio traffic, and, as traffic grows, subdividing those cells into smaller segments without increasing radio spectrum. This paper outlines AMPS objectives and sets the stage for more detailed articles on its evolution, its design and testing, and maintenance considerations.

I. INTRODUCTION

The potential for communicating with nonfixed points over the horizon without the use of wires was soon recognized following the invention of radio in the late 1800s and its development in the early 1900s. The first major use of this potential was to vessels at sea as an aid to navigation and safety. Since those early days, the use of mobile radio (as it is now called) has spread dramatically. Today it is used to communicate not only with ships at sea but with land vehicles, aircraft, and even with people using portable equipment.

The expanding need and concomitant growth have led to the development of the newest mobile system for common-carrier offering to the public, the Advanced Mobile Phone Service (AMPS),* the subject

* Known during developmental stages as High-Capacity Mobile Telecommunications System (HCMTS).

of this special issue of *The Bell System Technical Journal*. This system, in its mature configuration, will handle large quantities of mobile telephone traffic. High capacity will be achieved by dividing desired service areas into many small cells of radio coverage and, most important, by operating with the same radio spectrum utilized many times over within the service area.

This paper surveys the background and history of mobile radio, including governmental regulatory events, the development of systems used up to the present, and the emergence of new concepts and technology. The overview of AMPS introduces readers to the makeup, service objectives, and features of the new system.

II. BACKGROUND AND HISTORY

2.1 Early systems

In 1921 the Detroit police department made the earliest significant use of mobile radio in a vehicle.¹ That system operated at a frequency close to 2 MHz. The utility of this idea was so obvious that the channels in this low-frequency band were soon crowded.

New frequencies between 30 and 40 MHz were made available about 1940. A natural outgrowth of that development was the use of frequency modulation to improve reception in the presence of fading of the signal, electrical noise, and static. Opening the band encouraged a substantial buildup of police systems that started in the early 1940s and continues today.

Shortly thereafter, other users found a need for this form of communication. Private individuals, companies, and other public agencies purchased and operated their own mobile units and land (base) equipment. Over the years, the Federal Communications Commission (FCC) made available some 40 MHz of spectrum in bits and pieces between 30 and 500 MHz for various recognized and special uses. Today, approximately eight million licensed units enjoy this type of private service.* These systems are not generally connected directly to the telephone network.

In addition, the FCC has currently licensed over eight million citizens band radio units which are permitted to operate on 40 channels. An equal number of unlicensed units is also estimated to be operating on these channels. These figures graphically show that a great number of people want to communicate while on the move.

* In the early days, Bell System companies engineered, furnished, and maintained systems for private entities and public agencies such as police departments. This service was eliminated as a result of the 1956 consent decree: Final Judgment of January 24, 1956, in *U.S.A. vs Western Electric et al.*

2.2 Public correspondence systems

Immediately after World War II, the Bell System embarked on a program of supplying "public correspondence systems." The term means systems provided by a common carrier to permit communication among a variety of users that achieves large-scale economies by combining miscellaneous kinds of traffic into larger, more efficiently handled amounts. The FCC's official classification of this service is "Domestic Public Land Mobile Radio Service" (DPLMRS). (See Table I for a chronology of events in mobile radio history.)

The first of these public correspondence systems was inaugurated in 1946 to serve the city of St. Louis² with three channels near 150 MHz. The FCC had originally allocated six channels spaced 60 kHz apart, but the equipment was not sophisticated enough to prevent interference from adjacent channels being used in the same area. The St. Louis system was called an "urban" system.

In 1947, a "highway" system using frequencies in the 35- to 44-MHz band began operations along the highway between New York and Boston. These latter frequencies were thought to carry greater distances and, therefore, to be more useful in covering stretches of highway. However, these frequencies proved troublesome because of the skip-distance propagation phenomenon that carried unwanted conversations across the country. Today, the use of the 35- to 44-MHz band is declining.

Table I—History of mobile telecommunications related to common-carrier services

FCC Dockets		Service Offerings
	1946	First Bell System mobile service (150 MHz)
No. 8658, Bell System proposal for 40-MHz-bandwidth system	1947	Highway mobile service (35 MHz)
No. 8976, UHF TV, more detailed Bell System proposal for 40-MHz bandwidth system	1949	
	1956	First manual 450-MHz service
No. 11997, Bell System proposal for 75-MHz system at 800 MHz	1958	
	1964	First automatic 150-MHz service — MJ
	1969	First automatic 450-MHz service — MK
No. 18262, Allocation to common carriers		
— 75 MHz, tentative	1970	
— 40 MHz, firm	1974	
Open to "any" common carrier	1975	
Illinois Bell request for developmental authorization	1975	
Developmental authorization granted	1977	
	1978	AMPS Developmental System trial (850 MHz)

Both the urban and highway systems employed push-to-talk operation (somewhat unfamiliar to the ordinary telephone user) and were severely limited in the number of channels available. Nevertheless, more systems of both types were installed for cities and highways around the country. In many cases, the demand for service was such that the available channels could serve only a fraction of the demand for traffic and prospective customers had to be put on backlog lists.

Around 1955, the number of channels available at 150 MHz was expanded from 6 to 11 by the creation of new channels between old ones (i.e., channel spacing of 30 kHz). The year 1956 saw the addition of 12 channels near 450 MHz and the installation of the first system in this frequency range. All systems operated in the "manual" mode, with each call to or from a mobile unit handled by a special mobile operator. Mobile service still operates on a manual basis in some areas today.

In 1964, a new system, called the MJ, was developed and installed to improve efficiency, to reduce costs, and to achieve trunking advantage in cities having multiple channels. This system operated at 150 MHz, furnished automatic channel selection for each call, eliminated the need for push-to-talk, and allowed customers to do their own dialing. Most systems installed since 1964 are automatic, and many of the predecessor manual systems have been replaced.

In 1969 the automatic capability was extended to the 450-MHz channels with a system called the MK. The MJ and the MK were parts of the Improved Mobile Telephone System (IMTS),³ the current standard for mobile service. In some respects, especially in convenience of dialing, the service given to IMTS customers is commensurate with that obtained with land-line telephones.

Present-day mobile telephone service requires a single land transmitter station positioned at a high elevation so that received signal levels at mobile units are substantially above the ambient noise throughout most of the desired coverage area. For each channel, the output power of the land transmitter is typically 200 or 250 watts, and transmitting antenna gain is sometimes used to raise the effective radiated power to 500 watts. Such a system ensures coverage as far as 20 or 25 miles from the transmitter site. Although the signal level on a channel may be poor beyond 25 miles, it is still high enough to interfere significantly with other mobile communications on the same frequency within 60 to 100 miles of the land transmitter. Consequently, two land transmitters spaced more closely than this should not use the same mobile telephone channel frequency. If land transmitters on the same frequency are farther apart, each can serve mobile units within about 20 miles with only minor interference, because any mobile unit is much closer to the land transmitter serving it than to any interfering transmitter.

From its inception to the present, mobile service has remained a

scarce luxury. Each month, mobile telephone customers typically pay 10 to 20 times as much for mobile service as for residential telephone service. Despite the cost, many telephone companies can cite long lists of "held orders"—unfilled requests for service—from people who want to become mobile subscribers. Market studies⁴⁻⁷ have repeatedly uncovered a sizable demand at lower prices.

But even if the cost of mobile service could be reduced substantially, the primary factor that has hampered the spread of mobile service thus far has been the unavailability of spectrum. No new customers could be accommodated in many areas because only a few dozen channels are available for present-day service, and even these are fractured into several frequency bands and partitioned among different classes of service carriers.

Since 1949, common-carrier entities known as "Radio Common Carriers" (RCC), companies not providing public landline telephone service, have been given separate channels to furnish the same kind of mobile services as the wire-line common carriers (the Bell System and other telephone companies). With about the same number of channels available, they serve roughly the same number of customers. Table II shows the number of channels available for each type of carrier and the number of two-way mobile units served by each for the most recent year for which figures are available.

Compare the number (approximately 143,000) of RCC and wire-line common-carrier customers with the estimated 16 million or more private units not served by common carriers: the ratio is about 1:110.* There are many, both inside and outside the Bell System, who believe that this ratio reflects the number of available channels allocated to the different uses rather than the inherent demand for such services. The FCC has taken this into account in its most recent grant of 40 MHz of spectrum for use by common carriers.

2.3 Regulatory history

Since 1946, Bell System planners have been looking forward to the large-scale system they believed necessary to satisfy customer demands. Proposals for such a system were made from time to time, as described below. These generally were associated with FCC Dockets, as noted in the left-hand column of Table I.

In 1947, in connection with FCC Docket 8658, the Bell System asked for 12 more channels to use immediately in the same manner as the 6 already granted for urban service. Also requested was sufficient bandwidth for some 150 two-way channels from which large blocks of

* This is much smaller than the ratio of frequencies allocated (1:16) but is entirely consistent with the fact that the amount of traffic per mobile is much lower and channel loading is much higher in the private systems.

Table II—Channel allocations, number of mobile units, and number of systems

	Wireline Common Carriers			Radio Common Carriers	Total
	Bell	Independent	Total		
Number of two-way channels	23	23	23*	21†	54
MHz allocated	1.38	1.38	1.38	1.12	2.5
Number of mobile units (December 1977)	44,500	18,200	62,700	80,000‡	143,000 (approx.)
Number of systems (December 1977)	635	716	1,351	1,375	2,726

* Excludes 10 channels in the 35- to 40-MHz "highway" band, which are of limited and declining utility.

† Excludes the newest shared-with-TV channels in the 470- to 500-MHz band, since there has not been time for significant usage to build up.

‡ Projected forward from 1976 and earlier data.

channels could be assembled to achieve spectrum efficiency and capacity advantages. The planned 100-kHz spacing plus suitable guard bands (between mobile and land transmitters and between mobile and other services in adjacent bands) added up to approximately 40 MHz.

In 1949, a Bell System proposal representing a more mature plan for a broadband system was described in connection with FCC Docket 8976. This docket considered the disposition of UHF TV (470 to 890 MHz). The FCC decided at that time against providing a broadband mobile allocation in this band.

In 1958, the Bell System again made a broadband proposal, this time for a 75-MHz bandwidth (new estimated required spectrum) located at 800 MHz. This proposal was submitted as a response to an inquiry made by the FCC in its Docket 11997.

After considering the above proposal and the general pressure for more radio communications, in 1968 the FCC started Docket 18262, specifically addressed to the question of alleviating the large backlog of requests for frequencies for mobile use. Deliberating on requests for common-carrier service and for private-type service led the FCC to tentatively decide in 1970 to allocate 75 MHz for wire-line common-carrier use and 40 MHz to supplement private services. It proposed to do this by eliminating channels 70 through 83 in UHF TV and by using certain other pieces of spectrum from 806 to 947 MHz (a total of 115 MHz). The FCC invited industry to respond in 18 months with proposals for achieving communication objectives and demonstrating feasibility. In December 1971, the Bell System responded with a technical report which asserted feasibility by showing in considerable detail how a system might be composed.⁸

In 1974, the FCC made a firm allocation, different from the above: 40 MHz for wire-line common-carrier use and 30 MHz to supplement private services. The remainder of the 115 MHz was to be reserved pending further demonstrations of need. In doing this, the FCC strongly urged all suppliers to design their systems for greatest utility and spectrum efficiency.

Early in 1975, the FCC made some modifications in its 1974 decisions. One was to open the 40-MHz allocation for common-carrier service to "any qualified common carrier" rather than limit it to the wire-line carriers. In July 1975, the Illinois Bell Telephone Company filed a request to the FCC for authorization to install and test a developmental system in Chicago. This was granted in March 1977.

2.4 Emergence of key concepts

From our discussion thus far, it is obvious that the high-capacity system has been the result of planning and key concepts that have been emerging over a long period of time. Perhaps the first concept to be appreciated as necessary to an efficient, large-capacity operation was trunking, so much so that it was part of the proposal to the FCC in 1947. Trunking, as used here, is the ability to combine several channels into a single group so that a mobile can be connected to any unused channel in the group for either an incoming or outgoing call. This arrangement reduces blocking probability and greatly increases traffic-carrying efficiency relative to the situation in which a mobile unit can utilize only one fixed channel.*

One problem that bothered early planners was how to achieve full trunking advantage without requiring each mobile unit to be able to tune to every one of the channels in use for this service throughout the country. In those days, each new operating frequency required two quartz crystals and a position on the channel selector switch. The solution came when it became technologically feasible to construct a low-cost frequency synthesizer that could be set on any of a large number of frequencies but required only a small number of quartz crystals. While the basic idea is quite old, the circuit was made practical and economical only in the early 1970s. It is now taken for granted in ongoing planning.

The *cellular* concept and the realization that small cells with spectrum re-use could increase traffic capacity substantially seem to have materialized from nowhere, although both were verbalized in 1947 by D. H. Ring of Bell Laboratories in unpublished work. According to the

* The IMTS systems employ trunking to advantage, but the small number of channels in use in a given system (typically less than the 12 that could be assigned) limits trunking efficiency.

cellular concept, a desired service area is divided into regions called cells, each with its own land radio equipment for transmission to and from mobile units within the cell. It was further recognized that if the available channels were distributed among smaller cells the traffic capacity would be greater. Thus a system needing a relatively small capacity could use large cells, and, as necessary to achieve larger capacity, these cells could be divided into smaller ones. Each channel frequency can then be used for many independent conversations in many cells which are spaced far enough from each other to avoid undue interference.

From 1947 on, the teams planning the eventual system had faith that the means for administering and connecting to many small cells would evolve by the time they were needed. Those means did, in fact, become a reality with the advent of electronic switching technology.

Locating and *handoff* are concepts that come directly from the use of small cells. The act of transferring from one channel to another is called handoff. "Locating" is a process for determining whether it would be better from the point of view of signal quality and potential interference to transfer an active connection with a mobile unit to another land transmit/receive equipment, or perhaps to another land site.* The process entails sampling the signal from the mobile unit to determine if handoff from one voice channel to another is required. Since a mobile unit will sometimes move beyond the borders of one cell into another, it will be desirable to transfer the connection to an appropriate new cell.

The system, as presently planned, uses omnidirectional antennas when the cells are large. When smaller cells are created, directional antennas are used which divide each cell into three sectors, each served by an appropriate directional antenna at the cell site. This concept was introduced many years ago.† This advantageous arrangement reduces the amount of co-channel interference from surrounding cells and increases system capacity. It is covered further in Ref. 9.

The plan for increasing traffic capacity, as required, from a sparse system to a mature system in a given metropolitan service area, assumes the division of the large cells used at first into small cells as needed. The best method for achieving this is a growth plan developed in recent years (see Ref. 9).

III. OVERVIEW

This section gives an overview of the AMPS system, covering the objectives, the basic system, services and features, and additional problems and considerations.

* The prime purpose of this process is not to determine the geographic location of the mobile unit, although the geographical location is a statistical factor in performance.

† Described in Ref. 8.

3.1 Objectives

The major AMPS system objectives are discussed in the following paragraphs.

- (i) *Large subscriber capacity*: The capability of serving a large amount of traffic to many thousands of mobile users within a local service area, such as a greater metropolitan area, within a fixed allocation of several hundred channels is essential to AMPS.
- (ii) *Efficient use of spectrum*:* The scarcity of radio spectrum as a public resource demands that it will be used responsibly. AMPS will use it efficiently, for unless this is achieved, AMPS would lack the ability to take care of the large anticipated traffic within the allotted band.
- (iii) *Nationwide compatibility*: The FCC strongly urges nationwide compatibility. The objective means that mobile systems everywhere should provide the same basic service with the same standards of operation to be sure that a mobile station based in one place will achieve satisfactory service elsewhere.
- (iv) *Widespread availability*: Studies of existing services show that it is important to many users to be able to roam far from their normal home system and still receive service. Neither this characteristic nor nationwide compatibility necessarily implies universal coverage. Wide-area coverage will be achieved gradually as metropolitan systems extend their coverage into surrounding suburbs, and finally along the principal road and rail routes between metropolitan centers.
- (v) *Adaptability to traffic density*: Since the density will differ from one point in an area to another in a city and more remote points, and since all of this will change with time, an AMPS objective is to be adaptable to these variable needs.
- (vi) *Service to vehicles and to portables*: While AMPS is conceived primarily for use with vehicles, an important objective is to make it compatible with portables (hand-carried). This should be possible with little or no compromise in the design of the land-based network.
- (vii) *Regular telephone service and special services, including "dispatch"*: In addition to regular telephone service, AMPS should provide specialized services, such as dispatch or fleet operation, and special features, such as abbreviated dialing.
- (viii) *"Telephone" quality of service*: As for quality of service, the capability objective is essentially the same quality as ordinary

* A meaningful measure of spectrum efficiency is the number of simultaneous voice-communication paths that can be created per megahertz of spectrum and per square mile of area. This measure is useful where mobile terminals are statistically scattered throughout a service area.

nonradio telephone service. Since the types of impairments encountered are not always the same, it is sometimes difficult to ensure achieving identical quality. The goal is that the audio quality—faithful reproduction of voice and freedom from excessive noise and distortion—will not differ in overall effect as perceived by the user. It also means that service quality as measured by occasional blocking of the paths from customer to central office will not be noticeably greater than that encountered in the land network. This will be a very large improvement over current radio service, in which the pressure to accommodate many customers results in channel loading which frequently causes the probability of blocking to exceed 50 percent.

- (ix) *Affordability*: A goal is to make the service affordable by a substantial portion of the public and of businesses. Cost economies due to large production runs will tend to make this possible.

3.2 Basic system

Figure 1 shows the basic structure of the system as presently planned. The service area to be covered is divided into an appropriate number of cells. Each cell site has radio equipment and associated controls that can effect the connection to any mobile unit located in the cell. The cell sites are interconnected to and controlled by a central Mobile Telecommunications Switching Office (MTSO). The MTSO is basically a telephone switching office with substantial capabilities for software control. It connects to the telephone network and also provides the means to perform maintenance and testing and to record call information for billing purposes.*

All of the above make up the land-based part of the AMPS system. The mobile units complete the system.

The frequency layout (channel assignments) plan, the plan of operation for the system, and the way objectives cited earlier will be achieved are described in Ref. 9.

3.3 Services and features

The basic service is a telephone in a vehicle and is analagous to the individual telephone in the nationwide telephone network.

Beyond this, the intention is to offer mobile users features ordinarily available to telephone users, with emphasis on those of particular value in the mobile environment. One feature not generally available

* In this overview, the MTSO is portrayed as a compact monolithic entity. In future practice, however, there may be multiple MTSOs, as required for achieving greatest economy and sufficient capacity.

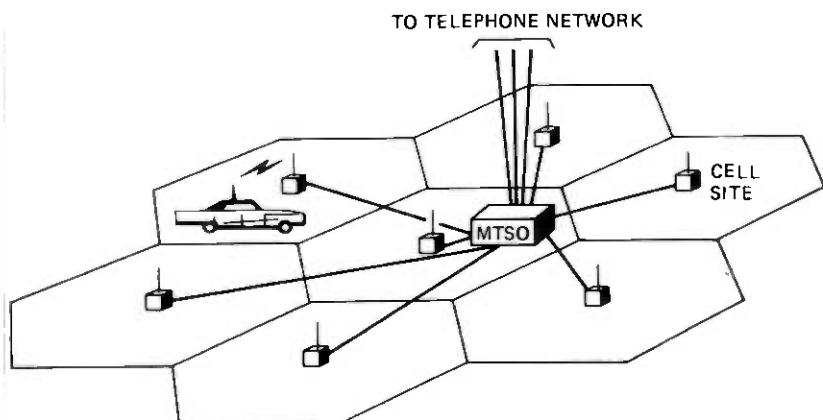

Fig. 1—The components and layout of the AMPS system.

in non-mobile phones, *pre-origination dialing*, will be included. This allows a customer to enter and store the called destination number before going off-hook. Then, when the user wishes to place the call, he begins the connection process by going off hook; the system uses this stored number to complete the connection. If the called line is busy or doesn't answer, the user may try again later without having to enter the same number again.

Eventually, the following vertical services, *Customer Calling Services*, furnished by ESS offices¹⁰ may be made available for mobile users:

- (i) "Three-Way Calling" permits a mobile user whose phone is already connected to another phone to originate a call to a third party, to switch back and forth between the connections, to bridge both connections as desired, or to connect the two other parties for continued conversation and then disconnect himself. With this feature, the mobile user can, for example, transfer a connection to another party.
- (ii) "Call Waiting" furnishes a signal to alert the mobile user to an incoming call while a conversation is already in progress. By making use of the three-way calling feature, the customer will be able to transfer, accept the new call, and hold or terminate the former connection in progress.
- (iii) "Speed Calling" permits a customer to originate a call to any of a few frequently called numbers by pushing one or two buttons. The connection is completed by the ESS in accordance with information stored there. This feature should be especially useful in a vehicle where a user cannot conveniently consult a directory or written notes. This feature will be implemented in the first working system.

In addition, it is expected that more features will be made available which can be implemented within the design of the mobile equipment. An example is "*Repertory Dialing*," which is similar to "Speed Calling" except that the mobile equipment stores the numbers and completes the calls. This feature is more useful than speed calling for vehicles that roam from system to system and, therefore, need to carry their own repertory.

3.4 Additional considerations

Other plans for mobile communications include numbering and dialing, the provision for roaming from system to system, the provision of operator service, and tariffs and billing.

3.4.1 Numbering and dialing

Each mobile unit is assigned a 10-digit number (including area code). The mobile user will dial seven or ten digits with a 0 or 1 prefix, where applicable, as if calling from a fixed telephone. The adopted numbering plan places no requirements on the overall nationwide numbering plan; for example, no special office or area codes need be set aside to separate mobile traffic from other telephone traffic.

3.4.2 Roaming

A strong need for serving vehicles that roam has been identified. This capability is needed not just within a greater metropolitan service area, but to other service areas and along the highways between. The roaming capability will not be demonstrated in the Chicago trial,* but a method of operation for systems beyond the trial has been planned. Wherever there is a system to serve it, a mobile unit will be able to obtain completely automatic service.

However, a call from a land telephone to a mobile unit which has roamed to another metropolitan area presents additional problems. While it would be logically possible for the system to determine automatically where the mobile unit is, and to connect it to the land party, there are two reasons for not doing so. First, the land customer will expect only a local charge if the mobile unit's number is a local one, and the mobile customer may not wish to pay the toll difference. Second, the mobile user may not want to have his whereabouts divulged through this system, automatically, without his permission. To respect the customer's wishes in this regard, the system will complete the connection only if the extra charge is agreed to, and only where it is possible without unauthorized disclosure of the service area to which the mobile unit has roamed.

* Identified in Section 3.5.

3.4.3 Operator services

Standard operator services will be available to mobile users. No special operators or operator services (except possibly for handling the roaming situation) will be required for the AMPS system.

3.4.4 Tariffs and billing

The MTSO will record connect and disconnect times, location information, and call-destination information as required for billing. The recorded information will be tailored to the needs of tariff and charging algorithms, when these have been determined.

3.5 System tests and trial

Tests to provide information for system planning, establishing feasibility, and implementing of AMPS have been conducted relevant to different aspects of the AMPS system. Most of these were directed at learning about radio propagation, radio noise and interference, antenna characteristics and performance, etc.

Currently there are two major "tests" of the AMPS system: (1) The Cellular Test Bed (CTB) in Newark, N.J., and (2) the Developmental System in Chicago, Ill. Since these are described fully in Refs. 11 and 12, respectively, in this issue, the discussion here is kept brief. Suffice it to say that the former is a system laid out geographically to simulate a mature cellular system and permit measurements of coverage and interference in an actual urban layout. It does not simulate the whole service involving mobile customers, but is a "laboratory in the field." The Developmental System is an initial installation of a system implemented to serve mobile users, and will demonstrate the service itself as well as its implementation. But since the Developmental System employs relatively few large cells, it is not intended to demonstrate operation of a fully mature, small-cell layout. These two major endeavors complement each other and, taken together, provide a demonstration of all the major features of AMPS.

As explained later, the trial of the Developmental System has two phases. The first, which started in July 1978, is called an "Equipment Test," has about 100 mobile units, and is intended to "shake-down" the system and demonstrate that the system operates satisfactorily. The second phase, following the Equipment Test, is called a "Service Test," involving approximately 2100 users, and will demonstrate the service aspects of the system.

IV. SUMMARY

This first paper of the series has provided a general introduction to and overview of AMPS. The papers that follow describe more com-

pletely the cellular concept, control architecture, voice and data transmission aspects, the Cellular Test Bed, and the Developmental System. Other papers describe the Mobile Telecommunications Switching Office, the subscriber set used in the equipment-test phase of the developmental system operation, the mobile telephone control unit used in the service test, the hardware used at cell sites, and laboratory test systems that were devised to obtain operational data during system tests.

REFERENCES

1. W. C. Jakes, ed., *Microwave Mobile Communications*, New York: John Wiley, 1974.
2. "Telephone Service for St. Louis Vehicles," Bell Laboratories Record, 24, No. 7 (July 1946), pp. 267-268.
3. H. W. Nyilund and R. M. Swanson, "Improved Mobile Dial Telephone System," IEEE Trans. Veh. Commun., 1 1963, pp. 32-36.
4. "Communications Tomorrow: Who? What? Which? Where? Why? and How Much?" Communications; Part I (October 1972), pp. 42-45; Part II (November 1972), pp. 20-23.
5. "World Mobile Telecommunications," Cambridge, Mass.: Arthur D. Little, 1974.
6. "A New Era in Mobile Communications," Raymond Kraus, Consulting Communications Engineers, Inc., 1976.
7. "The U.S. Mobile Equipment Market," Report No. 556, May 1978, Frost and Sullivan, Inc.
8. Bell Laboratories, "High-Capacity Mobile Telephone System—Technical Report," (December 1971), submitted to the FCC.
9. V. H. MacDonald, "AMPS: The Cellular Concept," B.S.T.J., this issue, pp. 15-41.
10. Bell Laboratories Record, 46, No. 6 (June 1965), page 210.
11. G. C. DiPiazza, A. Plitkins, and G. I. Zysman, "AMPS: The Cellular Test Bed," B.S.T.J., this issue, pp. 215-248.
12. D. L. Huff, "AMPS: The Developmental System," B.S.T.J., this issue, pp. 249-269.

Advanced Mobile Phone Service:

The Cellular Concept

By V. H. MAC DONALD

(Manuscript received July 17, 1978)

This paper shows how a cellular system operating within a limited block of frequency spectrum can meet the objectives of a large-scale mobile-telephone service designed with attention to cost restraint. It explores the key elements of the cellular concept—frequency reuse and cell splitting—and describes certain mathematical properties of hexagonal cellular geometry. A description of the basic structure and features of AMPS shows how the cellular concept can be put into practice.

I. INTRODUCTION

The preceding paper in this issue¹ noted that Bell System planners were already looking ahead to a more economical and widespread form of mobile-telephone service when early mobile telephone systems were being installed in the 1940s. Since then, system designers have recognized that a substantial block of radio-frequency spectrum, equivalent to hundreds of voice channels, is a prerequisite for a large-scale mobile service. This spectrum was provided by the FCC's reallocation of a portion of the former UHF television band for mobile service in Docket 18262. This paper cites the system objectives adopted over the years, explores the cellular concept which evolved in response to these objectives, and describes many aspects of a practical embodiment of the cellular concept—the Advanced Mobile Phone Service (AMPS) system.

II. OBJECTIVES FOR LARGE-SCALE MOBILE-TELEPHONE SERVICE

Over the years, system designers have set various objectives for large-scale mobile-telephone service, based on the interests of the

public, mobile-telephone customers, and mobile-telephone operating companies. The first paper in this issue¹ cited the following basic objectives:

- (i) Large subscriber capacity.
- (ii) Efficient use of spectrum.
- (iii) Nationwide compatibility.
- (iv) Widespread availability.
- (v) Adaptability to traffic density.
- (vi) Service to vehicles and portables.
- (vii) Regular telephone service and special services, including "dispatch."
- (viii) "Telephone" quality of service.
- (ix) Affordability.

Various systems might be devised to satisfy all the above objectives, except for the first two. The system must be capable of growing to serve many thousands of subscribers within a local service area, such as the environs of a single city, yet the provision of service must not be contingent on the continual enlargement of the allocated spectrum. The need to operate and grow indefinitely within an allocation of hundreds of channels has been the primary driving force behind the evolution of the cellular concept.

III. BASIC ELEMENTS OF THE CELLULAR CONCEPT

The two phrases *frequency reuse* and *cell splitting* summarize the essential features of the cellular concept.

3.1 Frequency reuse

Frequency reuse refers to the use of radio channels on the same carrier frequency to cover different areas which are separated from one another by sufficient distances so that co-channel interference is not objectionable. Frequency reuse is employed not only in present-day mobile-telephone service but also in entertainment broadcasting and most other radio services.

The idea of employing frequency reuse in mobile-telephone service on a shrunken geographical scale hints at the cellular concept. Instead of covering an entire local area from one land transmitter site with high power at a high elevation, the service provider can distribute transmitters of moderate power throughout the coverage area. Each site then primarily covers some nearby subarea, or zone, or "cell." A cell thus signifies the area in which a particular transmitter site is the site most likely to serve mobile-telephone calls. Figure 1 is a sketch of a cellular map or "layout." In principle, the spacing of transmitter sites does not need to be regular, and the cells need not have any particular shape. Cells labeled with different letters must be served by distinct sets of channel frequencies to avoid interference problems. A cell

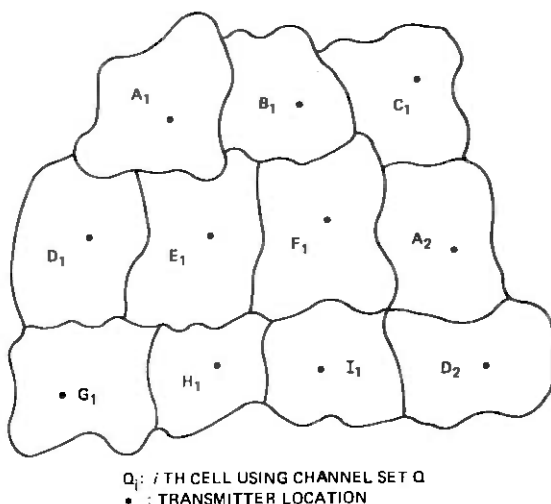

Fig. 1—Cellular layout illustrating frequency reuse.

therefore has the additional significance that it is the area in which a particular channel set is the most likely set to be used for mobile-telephone calls. Cells sufficiently far apart, such as those labeled A_1 and A_2 , may use the same channel set.

Through frequency reuse, a cellular mobile-telephone system in one coverage area can handle a number of simultaneous calls greatly exceeding the total number of allocated channel frequencies. The multiplier by which the system capacity in simultaneous calls exceeds the number of allocated channels depends on several factors, particularly on the total number of cells.

3.2 Cell splitting

If the total allocation of C channels is partitioned into N sets, then each set will contain nominally $S = C/N$ channels. If one channel set is used in each cell, eventually the telephone traffic demand in some cell will reach the capacity of that cell's S channels. Further growth in traffic within the cell will require a revision of cell boundaries so that the area formerly regarded as a single cell can now contain several cells and utilize all these cells' channel complements. The process called "cell splitting" fills this need.

Figure 2a illustrates an early stage of the cell-splitting process, in which the cell originally designated F_1 (in Fig. 1) has reached capacity. The area previously treated as cell F_1 now contains cells H_3 , I_3 , B_6 , and C_6 . If the demand in the area continues to grow, other larger cells will be split, and eventually, as in Fig. 2b, the entire region will be converted into smaller cells.

In practice, splitting a given cell may be less abrupt than our

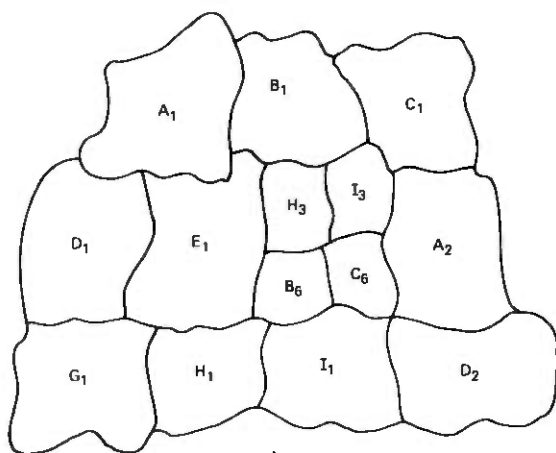

(a)

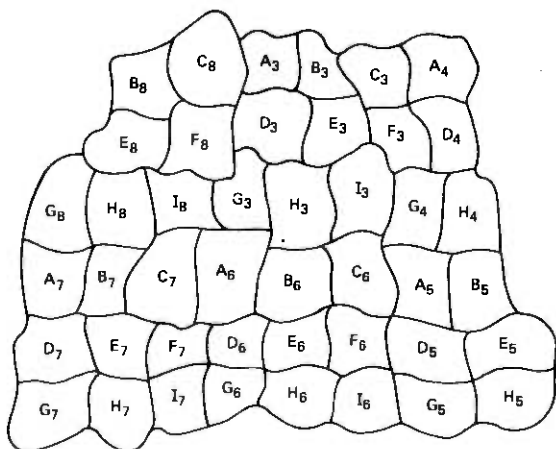

Q_i: i TH CELL USING CHANNEL SET Q

(b)

Fig. 2—Cellular layout illustrating cell splitting. (a) Early stage. (b) Later stage.

illustration implies. It is often sufficient initially to superimpose just one or two smaller cells onto a larger cell, so that the larger and smaller cells jointly serve the traffic within the area spanned by the smaller cell(s). The larger cell disappears at a later time, when all its territory becomes covered by smaller cells. We discuss this aspect of system growth in Section 7.3. In Figs. 1 and 2, for illustration the total allocation has been partitioned into nine distinct channel sets, labeled A through I. The figures show a progression from an initial stage (Fig. 1), in which each allocated channel is available once within the region spanned by cells A₁ through I₁, to a later stage (Fig. 2b), in which each channel is available in four different cells within that same region.

Successive stages of cell splitting would further multiply the number of "voicepaths," i.e., the total number of simultaneous mobile-telephone calls possible within the same region. By decreasing the area of each cell, cell splitting allows the system to adjust to a growing spatial traffic demand density (simultaneous calls per square mile) without any increase in the spectrum allocation.

The techniques of frequency reuse and cell splitting permit a cellular system to meet the important objectives of serving a very large number of customers in a single coverage area while using a relatively small spectrum allocation. Cell splitting also helps to meet the objective of matching the spatial density of available channels to the spatial density of demand for channels, since lower-demand areas can be served by larger cells at the same time that higher-demand areas are served by smaller cells.

IV. PROPERTIES OF CELLULAR GEOMETRY

The main purpose of defining cells in a mobile-telephone system is to delineate areas in which either specific channels or a specific cell site will be used at least preferentially, if not exclusively. A reasonable degree of geographical confinement of channel usage is necessary to prevent co-channel interference problems. Having defined a desired cellular pattern in concept, system planners achieve that pattern in the field through proper positioning of land transmitter sites, proper design of the azimuthal gain pattern of the sites' antennas, and proper selection during every call of a suitable site to serve the call.

The irregular land transmitter spacing and amorphous cell shapes shown in Figs. 1 and 2 might be acceptable in a system where the initial system configuration, including the selection of transmitter sites and the assignment of channels to cells, could be frozen indefinitely. In practice, however, the absence of an orderly geometrical structure in a cellular pattern would make adaptation to traffic growth more cumbersome than necessary. Inefficient use of spectrum and uneconomical deployment of equipment would be likely outcomes. A great deal of improvisation and custom engineering of radio, transmission, switching, and control facilities would be required repeatedly in the course of system growth.

Early in the evolution of the cellular concept, system designers recognized that visualizing all cells as having the same shape helps to systematize the design and layout of cellular systems. A cell was viewed as the coverage area of a particular land site. If, as with present-day mobile service, omnidirectional transmitting antennas were used, then each site's coverage area—bounded by a contour of constant signal level—would be roughly circular. Although propagation considerations recommend the circle as a cell shape, the circle is impractical

for design purposes, because an array of circular cells produces ambiguous areas which are contained either in no cell or in multiple cells. On the other hand, any regular polygon approximates the shape of a circle and three types, the equilateral triangle, the square, and the regular hexagon, can cover a plane with no gaps or overlaps (Fig. 3). A cellular system could be designed with square or equilateral triangular cells, but, for economic reasons, Bell Laboratories system designers adopted the regular hexagonal shape several years ago.

To understand the economic motivation for choosing the hexagon, let us focus our attention on the "worst-case" points in a cellular grid—the points farthest from the nearest land site. Assume a land site located at the center of each cell, the center being the unique point equidistant from the vertices. The vertices are in fact the worst-case points, since they lie at the greatest distance from the nearest land site. Restricting the distance between the cell center and any vertex to a certain maximum value helps to assure satisfactory transmission quality at the worst-case points. If an equilateral triangle, a square, and a regular hexagon all have the same center-to-vertex distance, the hexagon has a substantially larger area. Consequently, to serve a given total coverage area, a hexagonal layout requires fewer cells, hence fewer transmitter sites. A system based on hexagonal cells therefore costs less than one with triangular or square cells, all other factors being equal.

With our present understanding of cellular systems, we recognize that, because of propagation vagaries, it is not possible to precisely define a coverage area for a given cell site in the sense that the site never serves mobile units outside the area and always serves mobile units within the area. Nevertheless, the concept of a cell remains valid in the context of an area in which a certain land site is more likely to serve mobile-telephone calls than any other site.

A familiarity with some of the basic properties of hexagonal cellular geometry will give the reader additional perspective on subsequently

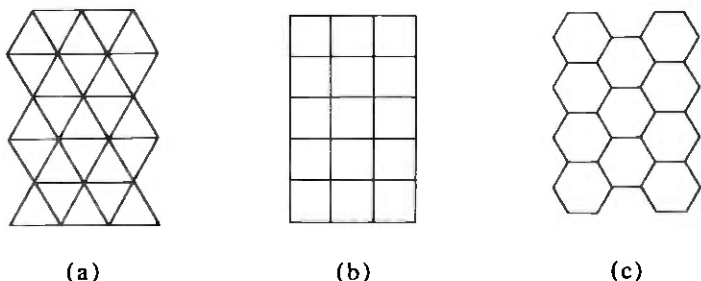

Fig. 3—Regular polygons as cells. (a) Equilateral triangles. (b) Squares. (c) Regular hexagons.

discussed details of radio-channel assignment in a cellular system. We now explain how cells using the same channel set are oriented with respect to one another and how cellular patterns and certain basic geometrical parameters are related to one another.

To lay out a cellular system in the sense of determining which channel set should be assigned to each cell, we begin with two integers i and j ($i \geq j$), called "shift parameters," which are predetermined in some manner. From the cellular pattern of Fig. 4, note that six "chains" of hexagons emanate from each hexagon, extending in different directions. Starting with any cell as a reference, we find the nearest "co-channel" cells, that is, those cells that should use the same channel set, as follows:

Move i cells along any chain of hexagons; turn counter-clockwise 60 degrees; move j cells along the chain that lies on this new heading.

The j th cell and the reference cell are co-channel cells. Now return to the reference cell and set forth along a different chain of hexagons using the same procedure.

Figure 4 illustrates the use of these directions for an example in which $i = 3$ and $j = 2$. A cell near the center of the figure is taken as a reference and labeled A. As each co-channel cell is located, it is also

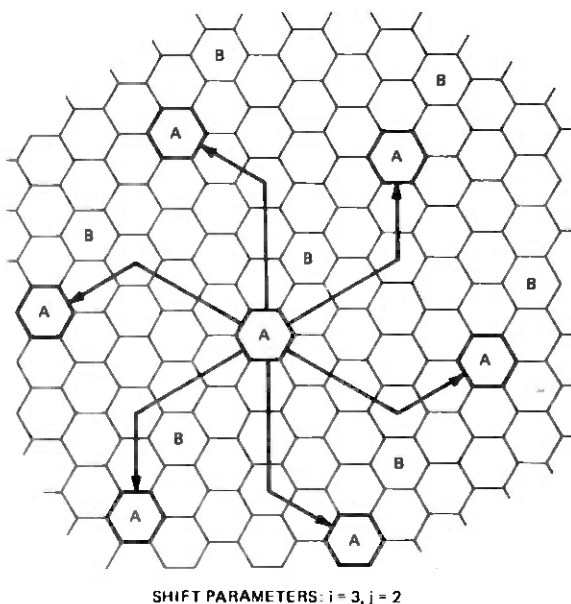

Fig. 4—Illustration of the determination of co-channel cells.

labeled *A*. To continue the cellular layout, one could choose another label, such as *B*, for a cell close to the reference cell and find this cell's nearest co-channel cells. However, once the position of all the cells labeled *A* is determined, it is not necessary to work through the procedure described above for subsequent labels. The pattern of cell labels built up around the reference *A* cell is simply replicated around all the other *A* cells by translation without rotation.

Co-channel cells could also be located by moving *j* cells before turning and *i* cells afterwards, rather than vice versa, or by turning 60 degrees clockwise instead of counterclockwise. There are four different ways of describing the procedure, and two different configurations can result. Each configuration is just the reflection of the other across an appropriate axis.

When a sufficient number of different labels has been used, all cells will be labeled, and the layout will be complete. The cells form natural blocks or clusters around the reference cell in the center and around each of its co-channel cells. The exact shape of a valid cluster is not unique; all that is required is that it contain exactly one cell with each label. The number of cells per cluster is a parameter of major interest, since in a practical system this number determines how many different channel sets must be formed out of the total allocated spectrum. The number of cells per cluster, *N*, turns out to be

$$N = i^2 + ij + j^2. \quad (1)$$

(The appendix to this paper derives this result and presents additional information on hexagonal cellular geometry.) The fact that *i* and *j* must be integers means that only certain values of the number of cells per cluster are geometrically realizable.

The ratio of *D*, the distance between the centers of nearest neighboring co-channel cells, to *R*, the cell radius, is sometimes called the "co-channel reuse ratio." This ratio is related to the number of cells per cluster, *N*, as follows:

$$D/R = \sqrt{3N}. \quad (2)$$

In a practical system, the choice of the number of cells per cluster is governed by co-channel-interference considerations. As the number of cells per cluster increases, the relative separation between co-channel cells obviously increases, and consequently poor signal-to-interference conditions become progressively less probable. Section 6.4 discusses a method for choosing the number of cells per cluster.

V. AMPS: A PRACTICAL REALIZATION OF THE CELLULAR CONCEPT

This section describes the physical structure of the AMPS system and provides a glimpse of its basic control algorithms to show how cellular operation can be effected in a working system.

The implementation of the cellular concept in a practical system requires the construction of an essentially regular array of land transmitter-receiver stations, called "cell sites" in AMPS. The design abstraction of an array of cells is embodied in the physical reality of the cell-site array. The dots in Fig. 5a symbolize an idealized AMPS cell-site array, consisting of a lattice of regularly spaced cell sites. For this idealized array of cell sites, an accompanying pattern of regular hexagonal cells can be visualized in at least two different ways: (i) cells whose centers fall on cell sites, "center-excited" cells (Fig. 5b), or (ii) cells half of whose vertices fall on cell sites, "corner-excited" cells (Fig. 5c).

Section 6.1 acknowledges the practical reality that it is seldom possible to position a cell site exactly at its geometrically ideal location and discusses the degree to which the actual location may deviate from the ideal.

Center-excited cells exemplify the previous practical definition of a cell as the area in which one particular cell site is more likely to be used on mobile-telephone calls than any other site. On any single call, neither the mobile unit's nor the system's actions would clearly delineate any cell boundaries, but a protracted study of system behavior would reveal the presence of center-excited cells satisfying the above pragmatic definition. Because of random propagation effects, any real cell only approximates the ideal hexagonal shape but, for purposes of design and discussion, it is appropriate to visualize cells as regular hexagons. The practical meaning of a corner-excited cell will be explained in conjunction with the ensuing discussion of directional cell sites.

5.1 Omnidirectional and directional cell-sites

The AMPS plan envisions that, at the inception of the system in any locality, the cell sites will use transmitter and receiver antennas whose patterns are omnidirectional in the horizontal plane.³ The use of omnidirectional antennas has traditionally been depicted by the cen-

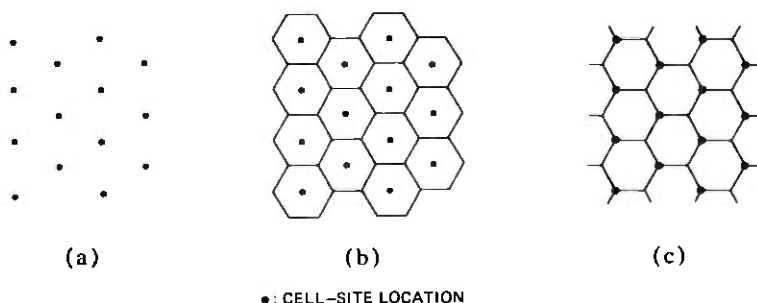

Fig. 5—Cellular geometry with and without cells. (a) Cell-site lattice. (b) "Center-excited" cells. (c) "Corner-excited" cells.

ter-excited cell pattern of Fig. 5b. The phrase "omnidirectional cell site" refers to a site equipped with omnidirectional voice-channel antennas.

In mature systems, cell sites will have three faces, that is, each voice channel in a cell site will be transmitted and received over one of three 120-degree sector antennas, rather than over an omnidirectional antenna. The antennas will be oriented as shown in Fig. 6, so that extensions of the edges of the antennas' front lobes form the sides of hexagonal cells as in Fig. 5c. These are the "corner-excited" cells that have customarily been employed to suggest the tri-directional coverage of AMPS cell sites in mature systems.

Cell sites are very expensive investments. The initial cost of a site, before installation of any voice-channel transceivers, is much greater than the incremental cost of each subsequently installed voice channel. At the inception of a system, the number of sites is governed strictly by the need to span the desired coverage area. At this stage, omnidirectional sites are used because the initial cost of an omnidirectional site is lower than that of a directional site. In mature systems, however, the potential, explained below, for cutting cost by reducing the total

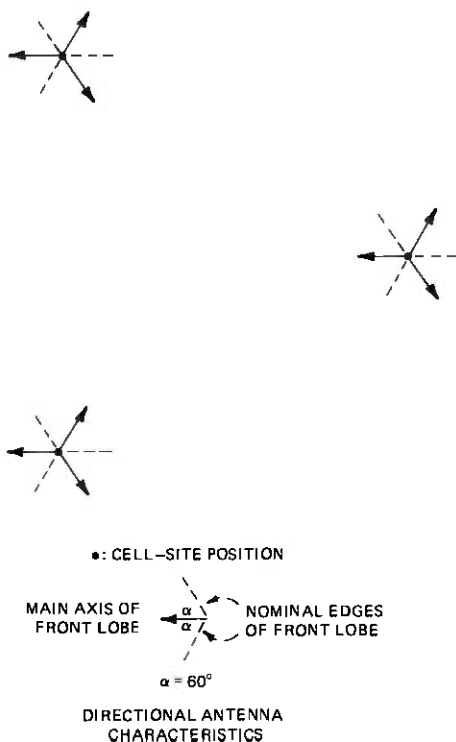

Fig. 6—Orientation of directional antennas at directional cell sites in AMPS.

number of cell sites needed to serve the existing telephone traffic load is the chief motivation for using directional cell sites.

In comparison with an omnidirectional land transmitting antenna, a directional antenna can deliver the same signal level in the region that it serves while causing substantially less interference within co-channel cells which lie outside the 120-degree wedge which the front lobe illuminates. Similarly, a directional land receiving antenna substantially attenuates interference received from mobile units at bearings not spanned by the front lobe. If omnidirectional systems and directional systems are to have comparable radio-frequency signal-to-interference statistics, the directional system can operate with a smaller co-channel reuse ratio, that is, a closer spacing between co-channel sites. By eq. (2), the smaller co-channel reuse ratio is equivalent to a smaller number of cells per cluster, or, more to the point, a smaller number of channel sets. Since the total number of channels is fixed, the smaller number of sets means more channels per set and per cell site. Each site can carry more traffic, thereby reducing the total number of sites needed for a given total load.

The use of three faces at each site with the orientation described above leads to certain convenient symmetries and relationships in the system design. A hexagonal cellular system could be designed, however, for a different azimuthal orientation of the directional antennas or for some other number of faces at each site.

5.2 Functional description of system operation

This section offers the reader a glimpse of the system control architecture, which is discussed in greater detail in Ref. 4. The main entities of an Advanced Mobile Phone Service system are the Mobile Telephone Switching Office (MTSO), the cell sites, and the mobile units. The central processor of the MTSO controls not only the switching equipment needed to interconnect mobile parties with the land telephone network, but also cell-site actions and even many of the actions of mobile units through commands relayed to them by the cell sites.

The MTSO is linked with each cell site by a group of voice trunks—one trunk for each radio channel installed in the site—and two or more data links, over which the MTSO and cell site exchange information necessary for processing calls. Every cell site contains one transceiver for each voice channel assigned to it and the transmitting and receiving antennas for these channels. The cell site also contains signal-level monitoring equipment and a "setup" radio, whose purpose is explained below.

The mobile equipment consists of a control unit, a transceiver, a logic unit, and two antennas. The control unit contains all the user interfaces, such as a handset, various pushbuttons, and indicator lights. The transceiver uses a frequency synthesizer to tune to any allocated

channel. The logic unit interprets customer actions and system commands and controls the transceiver and control units. A single antenna is used for transmission; two antennas together are used to provide space diversity for reception.

A few allocated radio channels serve as "setup" channels rather than voice channels; these channels are used primarily for the exchange of information needed to establish or set up calls. Applying the frequency-reuse concept to setup channels minimizes the number of channels withheld from voice use. Ordinarily, each site has one such channel. Whenever a mobile unit is turned on but the user is not engaged in a call, the mobile unit simply monitors a setup channel. The unit itself chooses which one of the various channels to monitor by sampling the signal strength on all members of a standard group of setup channels. The mobile unit then tunes to the channel which yields the strongest measurement, synchronizes with the data stream being transmitted by the system, and begins interpreting the data. Ordinarily, the mobile unit will remain on this channel; in some cases, the received data will indicate that the mobile unit should sample the signal strength on another set of channels before making a final choice. The mobile unit continues to monitor the chosen setup channel unless some condition, such as poor reception, requires that the choice of a channel be renewed. The setup-channel data words include the identification numbers of mobile units to which calls are currently being directed.

When a mobile unit detects that it is being called, it quickly samples the signal strength on all the system's setup channels so that it can respond through the cell site offering the strongest signal at the mobile unit's current position. The mobile unit seizes the newly chosen setup channel and transmits its page response. The system then transmits a voice-channel assignment addressed to the mobile unit, which, in turn, tunes to the assigned channel, where it receives a command to alert the mobile user. A similar sequence of actions takes place when the mobile user originates a call.

While a call is in progress, at intervals of a few seconds the system examines the signal being received at the serving cell site (the site that is handling the call). When necessary, the system looks for another site to serve the call. When it finds a suitable site, the system sends the mobile unit a command to retune to a channel associated with that site. While the mobile unit is changing channels, the MTSO reswitches the land party to the trunk associated with the new channel's transceiver. The periodic examination of a mobile unit's signal is known as "locating." The act of changing channels has come to be called "handoff."

The sole purpose of the locating function is to provide satisfactory transmission quality for calls.⁵ In this context, the term "locating" is

really a misnomer. The term was coined in the early stages of the evolution of the cellular concept, when system designers supposed that it would be necessary to know the physical position of the mobile unit accurately.

VI. SELECTION OF KEY SYSTEM PARAMETERS

This section discusses the current recommended values for some key system geometrical parameters and the methodologies which led to them. The most important objectives in the setting of parameters are cost restraints, good transmission quality, and a large ultimate customer capacity. In some contexts, conflicts appear among these objectives, and tradeoffs must be made so that no one objective is seriously undercut to benefit another.

6.1 Cell-site position tolerance

Previous sections have alluded to perfectly regular spacing of hexagonal cell sites. In practice, however, the procurement of space for cell sites may be one of the most difficult practical hurdles in engineering and installing cellular systems.

The current design permits a cell site to be positioned up to one-quarter of the nominal cell radius away from the ideal location. The site position tolerance has far more impact on transmission quality than on cost or capacity. Consequently, an analysis was made of the effect of the cell-site position tolerance on the overall probability distribution of the RF signal-to-interference ratio (S/I) on voice channels in mature systems. For simplicity and concreteness, the analysis focused on the value of RF S/I ratio which falls at the tenth percentile of the overall S/I distribution. This level decreased gradually as the cell-site position tolerance increased from 0 to about one-fourth of a cell radius, but it decreased rapidly beyond this break point. The tolerance was therefore set at a quarter radius to allow system administrators as much leeway as possible in positioning sites without significantly degrading the transmission quality.

6.2 Maximum cell radius

Setting the maximum cell radius, which is to be used in a system at its inception, is part of the general problem of achieving a satisfactory compromise between the objectives of low cost and good transmission quality. The maximum cell radius has only an indirect effect on the system objective of a large ultimate capacity.

Transmitter power is another important element in the overall reconciliation of low cost with high-quality transmission. In present-day mobile-telephone systems, the transmitter power of mobile units is smaller by an order of magnitude than that of the land stations. To

provide adequate reception of mobile transmissions emanating from any place where mobile units receive land transmissions, satellite receiver sites are deployed throughout the coverage area. A cellular system might be designed in this manner. However, the AMPS system designers consider a "balanced" system with comparable transmitter power in mobile units and cell sites to be a more economical design, because satellite receiver sites would represent a substantial fraction of the cost of full-fledged cell sites, yet possess far fewer capabilities.

When a system is first established, there is normally little frequency reuse. Since each initial cell is relatively large, the total number of cells needed to span the desired coverage area does not greatly exceed the number of channel sets into which the total allocation is partitioned. Even though two or more cell sites may be assigned the same channel set, mutually exclusive subsets can be used in the co-channel sites until a certain amount of growth in telephone traffic has occurred. For an initial period, therefore, the main channel impairment to contend with is ambient noise, both inevitable receiver thermal noise and man-made environmental noise.

In a startup system, an increase in land and mobile transmitter power, all other system parameters being held constant, would improve transmission quality by raising RF signal-to-noise (S/N) ratios, but it would also raise the system cost. From a broader perspective, however, increased transmitter power could be used to reduce system cost rather than to improve transmission quality. Increased power would permit the use of a larger initial cell radius for the same level of transmission quality, which in turn would allow fewer cell sites to cover the desired area. If an extra expenditure on transmitter power yields a greater cost saving in cell-site construction, the expenditure is desirable. At some level, however, additional transmitter power ceases to pay for itself. Not only does the incremental cost per decibel mount, but eventually practical considerations of feasibility and reliability also enter in. Furthermore, the relatively high level of transmitter power that is beneficial in the startup phases of cellular systems is largely superfluous in mature phases, since each stage of cell splitting essentially halves the mean distance between mobile units and their serving cell sites.

The chosen value of 10 watts delivered to the transmitting antennas is based on an evaluation of the cost, reliability, and power drain of present-day transmitters in the 800- to 900-MHz range. To supply approximately 10 watts of power at the antenna terminals, the system design requires 12 watts from mobile transmitters and 40 watts from cell-site transmitters to compensate for cable and combiner losses.

Cell-site antenna elevation and gain (in any vertical plane) influence the tradeoff between cost and transmission quality in much the same way as transmitter power. As with transmitter power, the selected

figures for antenna gain and elevation are the largest values normally achievable without excessive costs. The expected range of antenna gain is 6 to 8 dB relative to a dipole; the expected range of elevation above the ground, 100 to 200 feet.

Assuming that transmitter power and cell-site antenna gain and elevation are already established, the tradeoff between cost and quality in the early stages of AMPS growth is governed by the value chosen for the cell radius. Since increasing the radius both decreases cost and degrades transmission quality, the transmission-quality objective allows a controlled level of imperfection for the sake of economy.

The sound quality of AMPS calls is intended to be comparable in acceptability to the sound quality on calls over the land telephone network, but setting system parameters requires that this general guideline be reduced to more concrete terms.

The maximum cell radius depends on both subjective and statistical factors. To meet the sound-quality objective, designers required information both on customer opinions of mobile-telephone channels at 800 to 900 MHz and on the propagation of energy at these frequencies. In a subjective testing program,⁶ subjects rated the quality of simulated and actual mobile-telephone channels subjected to the rapid Rayleigh fading encountered in UHF mobile communications. The test results showed that at an RF S/N ratio of 18 dB, most listeners considered the channel to be good or excellent. The system designers concluded that the S/N ratio in a working system should exceed 18 dB with high probability. The AMPS transmission-quality objective was therefore quantified for design purposes as a requirement that this S/N value be exceeded in 90 percent of the area covered by any system.

Our knowledge of propagation is based largely on an extensive measurement program performed by Bell Laboratories in Philadelphia in the early 1970s and in Newark more recently.⁷ These measurement results corroborate studies performed in Tokyo,⁸ New York,⁹ and suburban areas of New Jersey.¹⁰ All these investigations and others¹¹ show that, for a given distance r between transmitter and receiver, the probability distribution of the path loss (attenuation) in decibels is approximately Gaussian. The mean of the distribution (in decibels) is approximated by a function of the form $k + 10n \log_{10} r$, in which k is a constant for a given transmitter-receiver pair and n is known as the path-loss exponent. The standard deviation amounts to several decibels. The bodies of data associated with different transmitter sites yield different numerical results for all these parameters, but the values which emerge from the total ensemble of Philadelphia and Newark measurements are a path-loss exponent n on the order of 4 and a standard deviation of roughly 8 dB.

At Bell Laboratories, a computer simulation was written to predict

many aspects of the behavior of a cellular system, including the overall statistics of received signal level. This simulation incorporates a propagation model based on the Philadelphia measurements, and it also models vehicle movements and the details of the locating algorithm.

The results of this simulation show that in an environment similar to Philadelphia a cell radius of 8 miles allows the system to meet the requirement that the S/N ratio be above 18 dB over 90 percent of the coverage area. Somewhat different values of maximum cell radius may be appropriate for situations in which any of the relevant parameters, such as the path-loss exponent, environmental noise, antenna gain, or antenna elevation, differ substantially from the assumed values.

6.3 Minimum cell radius

In the AMPS system, additional cell sites needed to relieve the telephone traffic demand on existing sites will be positioned midway between adjacent old sites. This simple procedure cuts the distance between adjacent sites in half and therefore cuts the cell radius by a factor of 2 and the cell area by a factor of 4.

The minimum cell radius, which is the cell radius after the final stage of cell splitting, has little effect on the system cost per customer or on transmission quality, but it plays a vital part in setting the ultimate system capacity. Each stage of cell splitting multiplies the number of cell sites in the desired coverage area by a factor of about 4. The system's total traffic-carrying capacity is also increased by essentially the same factor. In principle, the cell-splitting process could be repeated an indefinite number of times, but system designers cite a 1-mile cell radius as a practical minimum. If start-up cells have an 8-mile radius, three stages of cell splitting are possible. There is no insurmountable physical barrier to having smaller cells, but the greatest practical obstacles are the cell-site position tolerance and the burden of frequent handoffs. As previously stated, cell sites should be positioned within a quarter of a cell radius of their ideal locations. A tolerance of a quarter mile (corresponding to a 1-mile radius) is probably the most stringent requirement that can be contemplated. The mean distance traveled between handoffs is bound to decrease as the cell radius decreases. In a system composed of many cells with a radius of much less than one mile, handoffs would consume a significant fraction of the MTSO central processor's capacity.

6.4 Co-channel reuse ratio

The discussion of directional cell sites explained the economic incentive for minimizing the ratio of D , the distance between co-channel cell sites, to R , the cell radius. The co-channel reuse ratio (D/R) also has an impact on both the transmission quality and the ultimate customer capacity of the system. The influence on transmission quality

arises because the D/R ratio materially affects co-channel interference statistics. Since this ratio determines the number of channels per channel set, it sets a limit on each site's traffic-carrying capacity, which in turn limits the ultimate system capacity.

The allowable minimum value of D/R was set in much the same way as the maximum cell radius. Making D/R as small as possible serves the objectives of low cost and large capacity. On the other hand, making D/R as large as possible benefits transmission quality. As in the determination of the maximum cell radius, a compromise among objectives is achieved through the kind of transmission-quality objective described in the discussion of maximum radius.

The subjective testing program mentioned previously included an evaluation of the effect of co-channel interference on listeners' opinions. The results indicated that most of the subjects considered the transmission quality of a channel to be good or excellent at an S/I of 17 dB. To satisfy the AMPS quality objective, a system must provide an S/I of 17 dB or greater over 90 percent of its coverage area. The system simulation mentioned above shows that, in an environment similar to Philadelphia or Newark, a system meets the S/I requirement if the separation between co-channel sites is 4.6 cell radii when 120-degree directional antennas are used and 6.0 cell radii when omnidirectional antennas are used. These co-channel reuse ratios correspond, by eq. (2), to 7 cells per cluster (equivalently 7 disjoint channel sets) for directional sites and 12 cells per cluster for omnidirectional sites.

VII. DEFINITION AND DEPLOYMENT OF CHANNEL SETS

A complete description of a plan for deploying channels in a coverage area requires that some additional facts and procedures be specified. The degree of foresight with which channel sets are defined and used can materially affect the system's transmission quality, cost, and ease of adaptation to growth in telephone traffic.

7.1 *Reduction of adjacent-channel interference*

The design of a mobile-telephone system must include measures to limit not only co-channel interference but also adjacent-channel interference. Although the IF filters of both the cell-site and mobile-unit receivers significantly attenuate signals from the channels adjacent in frequency to the desired channel, it is advisable to avoid circumstances in which the received level of an adjacent channel greatly exceeds that of the desired channel.

This situation would arise at a cell site, for example, if one mobile unit were many times farther away from its serving cell site than another mobile unit being served by the same site on an adjacent channel. With a distance ratio of 10, for instance, the received level of the adjacent channel at the cell site could easily be 40 dB higher than

the level of the desired channel. In the presence of fading, severe adjacent-channel interference would result unless the receiver IF filter could greatly attenuate the adjacent channel. In general, a substantial spectral guard band would be required between channels to permit IF filters to reject the interference adequately.

Fortunately, in a cellular system, since only a fraction of the allocated channels belong to any one channel set, it is possible to avoid the use of adjacent channels in the same cell site, thereby keeping the probability of severe adjacent-channel interference low. Since stringent IF attenuation of adjacent channels is not essential, no guard band is needed.

AMPS voice channels have an FM peak deviation of 12 kHz and a spacing of 30 kHz.¹² With this spacing, 666 duplex channels can be created out of a 40-MHz spectrum allocation. The use of adjacent channels at the same site would require a larger channel spacing, and fewer channels would be available from the allocation. In the AMPS system, the largest possible frequency separation is maintained between adjacent members of the same channel set. Suppose that channels are numbered sequentially from 1 upward and that the frequency difference between channels is proportional to the algebraic difference of their channel numbers. If N disjoint channel sets are required, the n th set ($1 \leq n \leq N$) would contain channels $n, n + N, n + 2N$, etc. For example, if $N = 7$, set 4 would contain channels 4, 11, 18, etc.

In some cases, system designers can also prevent a secondary source of adjacent-channel interference by avoiding the use of adjacent channels in geographically adjacent cell sites. Figure 7 shows a cell-site pattern for 12 disjoint channel sets (12 cells per cluster). This pattern can be used in startup phases of AMPS, during which all sites will be equipped with omnidirectional voice-channel antennas. Only sets with adjacent set numbers (including 12 and 1) contain any adjacent channels. In the figure, each site is labeled with the number of its channel set. Center-excited cells are drawn in to aid in visualizing the nominal area in which each set is most likely to be used.

As previously discussed, when 120-degree directional cell-site antennas are employed in AMPS, transmission-quality considerations call for seven cells per cluster. In this case, it is impossible to avoid having adjacent channels at adjacent sites, because if there are only seven channel sets, any site plus its six neighbors constitute a complete cluster in which every channel may be assigned exactly once. With 120-degree directional antennas, however, it is possible to subdivide the seven channel sets and deploy the subsets geographically in such a way that the received adjacent-channel interference, at both the mobile units and cell sites, is usually attenuated by the front-to-back ratio of the cell-site directional antennas. (An example below illustrates this effect.) The AMPS plan subdivides each of the seven channel sets

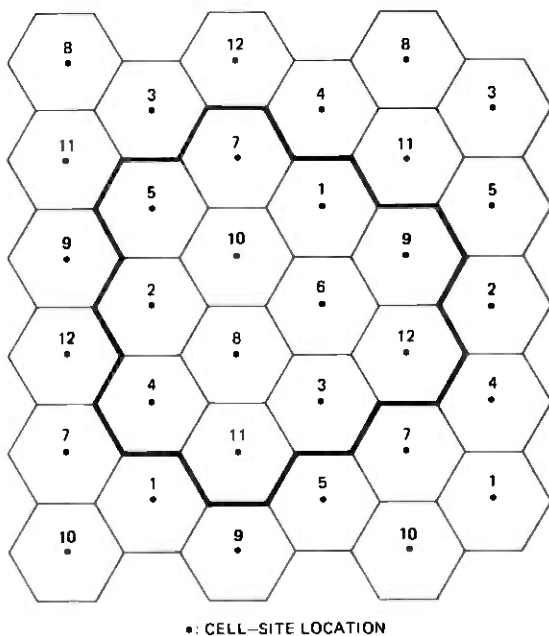

Fig. 7—Channel-set deployment pattern for 12 cells per cluster.

into three subsets. For example, set 4, containing channels 4, 11, 18, 25, 32, 39, 46, 53, 60, etc., subdivides into subset 4a with channels 4, 25, 46; subset 4b with channels 11, 32, 53, etc.; and set 4c with channels 18, 39, 60, etc. The notation is simplified if we simply number the channel subsets from 1 to 21, so that set n is subdivided into subsets n , $n + 7$, and $n + 14$.

Figure 8 shows one acceptable pattern for assigning channel subsets to cell-site faces. (The appendix to this paper describes a simple algorithm for assigning channel sets to cells; this algorithm would produce a differently labeled but equally acceptable pattern.) In Fig. 8, corner-excited cells are shown whose sides are projections of the edges of the antennas' 120-degree front lobes. Subsets with sequential subset numbers contain adjacent channels and are assigned to faces in such a way that they do not cover the same corner-excited cell, even though they may reside in adjacent sites. This procedure attenuates adjacent-channel interference by the cell-site antenna's front-to-back ratio in situations which otherwise would cause problems. For instance, in Fig. 8, suppose that a channel of subset 6 is serving the mobile unit at point M . The adjacent-channel interference that exists in both directions between the mobile unit and the cell site using subset 7 is attenuated by the front-to-back ratio of the directional antennas which transmit and receive subset 7.

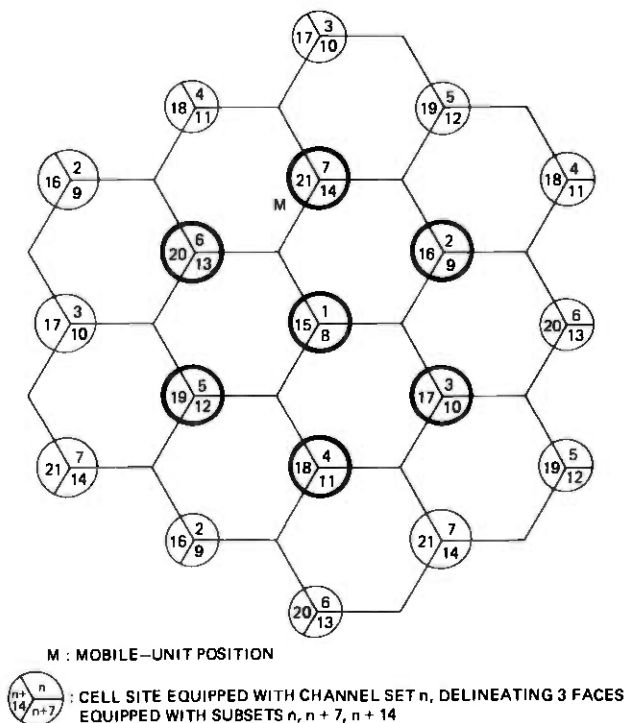
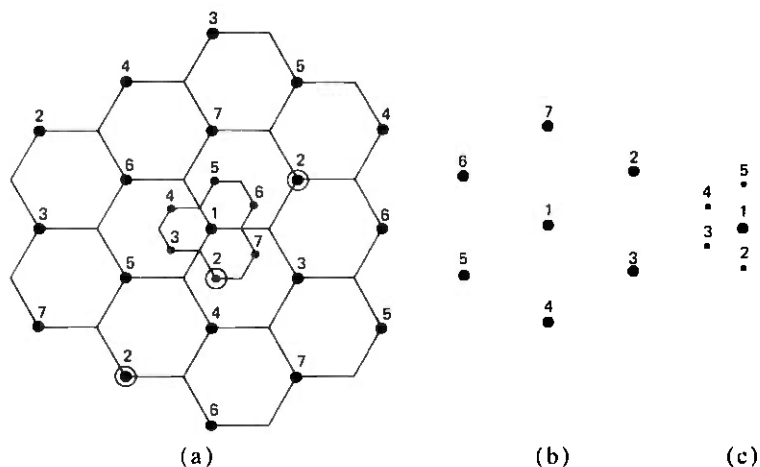

Fig. 8—Channel-subset deployment pattern for seven cells per cluster and three faces per cell site.

7.2 Cell splitting

The practical significance of cell splitting is that the distance between adjacent cell sites is cut in half, and through the action of the locating algorithm, the nominal coverage area of newly established cell sites is reduced to a quarter of the nominal area previously covered by existing sites. Conversely, wherever cell splitting occurs, it quadruples the cell-site density. The AMPS cell-splitting plan sets the ideal location for new sites at points midway between neighboring existing sites, although the actual position may be anywhere within a distance of one-quarter of a (smaller) cell radius. The previously existing cell sites together with the new ones form a hexagonal cellular lattice.

In the transition from a system based on 12 channel sets and omnidirectional cell-site antennas to one based on 21 channel subsets and directional antennas, a gradual alteration may be necessary in the assignment of channel frequencies to cell sites. Once directional operation is established, however, splitting does not cause any further alteration of existing channel assignments. Figure 9 shows an array of directional cell sites identified by single set numbers. In one area, six new cell sites have been established. The channel set assigned to any



● : PREVIOUSLY EXISTING OR "OLD" CELL SITE
 ■ : "NEW" CELL SITE INSTALLED DURING CELL SPLITTING

Fig. 9—Channel-set deployment pattern for seven cells per cluster, with multiple cell sizes. (a) Overall cell-site pattern. (b) Orientation of cluster of cell sites in larger-cell pattern. (c) Orientation of cluster of cell sites in smaller-cell pattern.

new site is determined by observing that the new site lies midway between two co-channel sites, each one situated a little more than one (larger) cell diameter away from the new site, both of which use the same channel set. This is the channel set which should be assigned to the new site. The sites labeled 2 in Fig. 9a are circled to illustrate this geometrical relationship. Figures 9b and 9c extract from Fig. 9a the channel-set patterns of the cell-site clusters at different stages of cell splitting. Successive stages of cell splitting preserve the internal geometrical relations within the cluster, but each stage causes the cluster to be rotated counterclockwise 120 degrees.

7.3 The overlaid-cell concept

In a coverage area where two or more sizes of cells exist simultaneously, special care must be taken to guarantee the correct minimum distance D between cell sites equipped with the same voice channels. As previously discussed, a certain co-channel reuse ratio D/R must be maintained, but when a system includes multiple cell sizes, the radius R has different values for different sites.

Figure 10 illustrates some unusual situations that arise whenever groups of cells of different sizes abut. Site A_1 lies within a group of larger cells. For a cellular pattern of seven cells per cluster, the nearest co-channel sites within the group of larger cells, such as sites A_2 and A_3 , should be separated from site A_1 by a distance of 4.6 larger-cell radii. Within the group of smaller cells, co-channel sites such as sites A_4 and A_5 are separated from each other by a distance of 4.6 smaller-

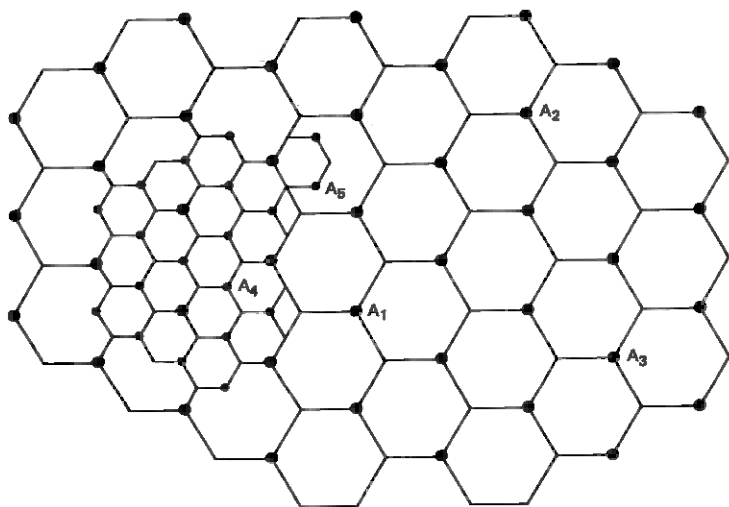

● : PREVIOUSLY EXISTING OR "OLD" CELL SITE
 ● : "NEW" CELL SITE INSTALLED DURING CELL SPLITTING

Fig. 10—Illustration of mixed cell sizes for discussion of overlaid-cell concept.

cell radii, or 2.3 larger-cell radii. Site A_1 is also in the correct position to be a nearest co-channel neighbor of sites A_4 and A_5 . The D/R ratio is satisfied for sites A_4 and A_5 because the appropriate value of R for these sites is the smaller-cell radius. Channels installed in site A_1 would cause no undue co-channel interference on calls served by sites A_4 and A_5 , because a mobile unit being served by one of these latter sites would tend to be within a range of about one smaller cell radius.

The troublesome questions pertain to calls served by site A_1 . If this site is to serve a larger-cell area, then it cannot use any of the same channels as sites A_4 and A_5 , because the co-channel reuse ratio (D/R) would not be satisfied for site A_1 if the larger-cell radius is taken as the appropriate value for R . This ratio would be satisfied if the smaller-cell radius could somehow be made applicable to site A_1 , but restricting site A_1 to serving only a smaller-cell area could mean inadequate coverage for some areas further removed from the site.

The dilemma affecting site A_1 is resolved by invoking the overlaid-cell concept. This concept recognizes that, when multiple cell sizes coexist, the cellular pattern is best viewed as the superposition of a fragmentary smaller-cell pattern on top of a complete larger cell pattern. The underlying larger-cell pattern does not disappear in a given region until the overlaid smaller-cell pattern is complete in that region.

Implementing the overlaid-cell concept requires that, in a region where cells of two sizes are present, the channel subset assigned to any cell-site face must be further subdivided into a larger-cell group and a

smaller-cell group. Each face of an older, previously existing site will use some of its channels to continue coverage of the same larger cellular area as before. The remainder of the channels assigned to the face will be restricted to covering a smaller area, corresponding to the smaller cell size. The subdivision of a subset into larger- and smaller-cell groups for an existing site is governed by the channel requirements of its new co-channel neighbors. For example, in Fig. 10, any channel installed in site A_4 or A_5 must be restricted to smaller-cell use in site A_1 . The way that a channel is restricted to smaller-cell use is simply to reassign the channel in software to a channel group which is treated as if it were serving a smaller cell. When appropriate, a call being served by a smaller-cell channel will be handed off to a neighboring new site if there is one, or otherwise to a channel belonging to the larger-cell group of the same face on which the call is already being served. As the telephone traffic loads grow in the new sites, reassignment of more and more channels in the old site to a smaller-cell group must follow, thereby reducing the capacity of the older site to serve the larger-cell area. For this reason, not only the local growth in telephone traffic around any older site but also the growth in traffic carried by that site's new co-channel neighbors can force cell splitting around the older site.

The various procedures described in this section for channel-set definition and deployment and for cell splitting allow the system to grow gradually and, on the whole, gracefully in response to a growing telephone traffic load. When an existing site reaches its traffic-carrying capacity, new sites are added around it one by one, only as needed, while the older site makes a gradual transition from larger-cell operation to smaller-cell operation.

VIII. SUMMARY

The FCC's allocation of a relatively large block of spectrum for public mobile communications has made a large-scale, economical mobile-telephone service feasible. The need for a method of serving many thousands of customers in a single local coverage area, while using a limited spectral allocation equivalent to several hundred voice channels, has spurred the evolution of the cellular concept. In practical terms, a cell is the area in which one particular group of channels is more likely to be used for mobile telephone calls than any other group. The essential elements of the cellular concept, frequency reuse and cell splitting, allow a cellular system to use spectrum efficiently, to grow gradually, and to supply service in response to a geographical pattern of demand.

In the AMPS system, the lattice of cell sites is designed to create a pattern of hexagonal cells. In the initial growth phase of a system in a given locality, cell-site voice-channel transmitters and receivers con-

nect to omnidirectional antennas. In later stages, cell sites have three faces, equipped with 120-degree directional antennas. The omnidirectional plan minimizes the startup costs for new systems, whereas the directional plan confines costs in mature systems by reducing the total number of sites required to serve a given offered load.

The key geometrical parameters of AMPS were chosen primarily to satisfy the objectives of moderate cost, good transmission quality, and a large ultimate customer capacity. In some cases, tradeoffs must be made among these joint objectives.

The ways in which channel sets are defined and distributed among cell sites in AMPS keep co-channel and adjacent-channel interference within acceptable bounds. The procedure for assigning channels to new cell sites introduced during cell splitting promotes graceful growth in response to increasing demand. As new sites are added, previously existing sites make a gradual transition from larger-cell operation to smaller-cell operation.

IX. ACKNOWLEDGMENTS

During three decades, many people have contributed to the definition of a mobile-telephone system structure capable of realizing the promises of the cellular concept. We shall mention just a few. W. R. Young and J. S. Engel helped to crystallize the overall system objectives. The cellular geometry of AMPS and the techniques for deploying and utilizing channel frequencies largely reflect the contributions of R. H. Frenkiel and P. T. Porter. In particular, the overlaid-cell concept, which governs system growth procedures, is the work of R. H. Frenkiel. M. A. Castellano also worked out many of the geometrical details of channel-set deployment. J. A. O'Brien and G. D. Ott contributed to the iterative process of proposing and evaluating the details of the locating algorithm.

APPENDIX

Fundamentals of Hexagonal Cellular Geometry

Certain intriguing mathematical relations emerge when one deals with hexagonal cellular geometry, yet there appears to be no published summary of all the basic relations with explanations of how they arise. This appendix is intended to fill the gap. We also present a novel algebraic method for using the coordinates of a cell's center to determine which channel set should serve the cell.

Figure 11 shows the most convenient set of coordinates for hexagonal geometry. The positive halves of the two axes intersect at a 60-degree angle, and the unit distance along either axis equals $\sqrt{3}$ times the cell radius, the radius being defined as the distance from the center of a cell to any of its vertices. With these coordinates, an array of cells can

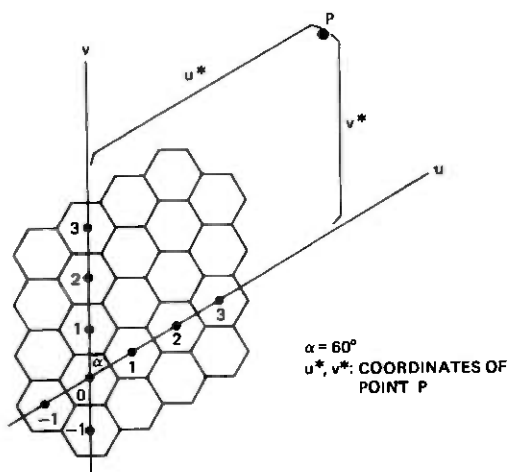

Fig. 11—A convenient set of coordinates for hexagonal cellular geometry.

be laid out so that the center of every cell falls on a point specified by a pair of integer coordinates.

The first useful fact to note is that, in this coordinate system, the distance d_{12} between two points with coordinates (u_1, v_1) and (u_2, v_2) , respectively, is

$$d_{12} = \sqrt{(u_2 - u_1)^2 + (u_2 - u_1)(v_2 - v_1) + (v_2 - v_1)^2}. \quad (3)$$

Using this formula we can verify that the distance between the centers of adjacent cells is unity and that the length of a cell radius R is

$$R = 1/\sqrt{3}. \quad (4)$$

We can calculate the number of cells per cluster, N , by some heuristic reasoning. The directions given in Section IV of this paper for locating co-channel cells result in a co-channel relationship between the reference cell with its center at the origin and the cell whose center lies at $(u, v) = (i, j)$, where i and j are the integer "shift parameters," with $i \geq j$. (See Fig. 4 for an illustration.) By eq. (3), the distance D between the centers of these or any other nearest neighboring co-channel cells is

$$D = \sqrt{i^2 + ij + j^2}. \quad (5)$$

Figure 4 illustrates the universal fact that any cell has exactly six equidistant nearest neighboring co-channel cells. Moreover, the vectors from the center of a cell to the centers of these co-channel cells are separated in angle from one another by multiples of 60 degrees. These same observations also hold for any arbitrary cell and the six cells immediately adjacent to it. The idea presents itself to visualize each

cluster as a large hexagon. In reality, the cluster, being composed of a group of contiguous hexagonal cells, cannot also be exactly hexagonal in shape, but it is nevertheless true that a properly visualized large hexagon can have the same area as a cluster. For proper visualization, refer to Fig. 12. The seven cells labeled *A* are reproduced from Fig. 4. The center of each *A* cell is also the center of a large hexagon representing a cluster of cells. Each *A* cell is imbedded in exactly one large hexagon, just as it is contained in exactly one cluster. All large hexagons have the same area, just as all clusters have the same area. The large hexagons cover the plane with no gaps and no overlaps, just as the clusters do. We therefore claim that the area of the large hexagon equals the area of any valid cluster. This area can be deduced from results already presented. We noted above that the distance between the centers of adjacent cells is unity. By eq. (5), the distance between centers of the large hexagons is $\sqrt{i^2 + ij + j^2}$.

Consequently, since the pattern of large hexagons is simply an enlarged replica of the original cellular pattern with a linear scale factor of $\sqrt{i^2 + ij + j^2}$, then *N*, the total number of cell areas contained

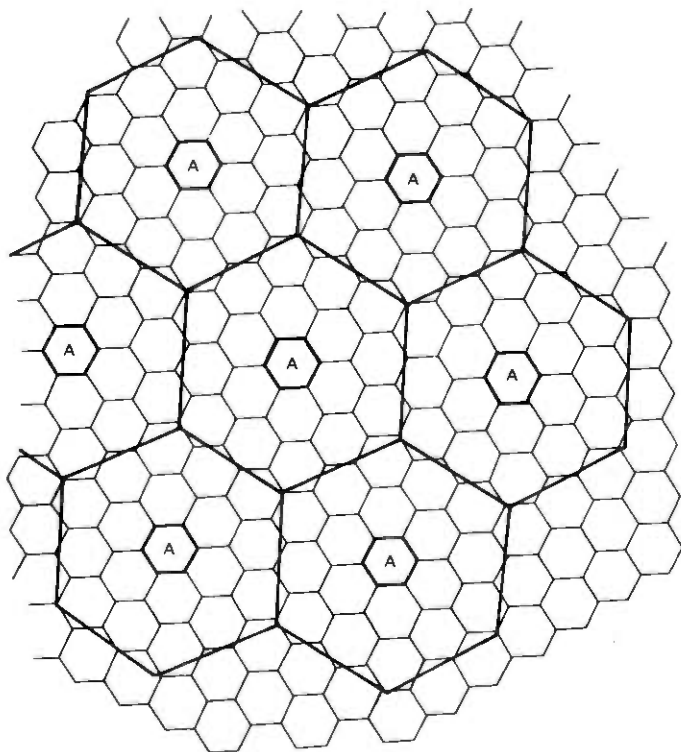

Fig. 12—Illustration for the heuristic determination of the number of cells per cluster.

in the area of the large hexagon, is the square of this factor, namely

$$N = i^2 + ij + j^2. \quad (6)$$

By combining eqs. (4), (5), and (6), we obtain the classical relationship between the co-channel reuse ratio D/R and the number of cells per cluster N :

$$D/R = \sqrt{3N}. \quad (7)$$

The rather cumbersome procedure described in the main body of this paper for performing a cellular layout can be replaced by a simple algebraic algorithm in certain cases of practical interest, namely those cases in which the smaller shift parameter j equals unity. (A pattern of 7 cells per cluster falls into this category.) For these cases, it is convenient to label the cells by the integers 0 through $N-1$. Then the correct label L for the cell whose center lies at (u, v) is given by

$$L = [(i + 1)u + v] \bmod N. \quad (8)$$

The application of this simple formula causes all cells which should use the same channel set to have the same numerical label.

REFERENCES

1. W. R. Young, "AMPS: Introduction, Background, and Objectives," B.S.T.J., this issue, pp. 1-14.
2. Richard H. Frenkiel, "A High-Capacity Mobile Radiotelephone System Model Using a Coordinated Small-Zone Approach," IEEE Trans. Veh. Technol., VT-19, No. 2 (May 1970), pp. 173-177.
3. Bell Laboratories, "High-Capacity Mobile Telephone System Technical Report" (December 1971), submitted to FCC.
4. Z. C. Fluhr and P. T. Porter, "AMPS: Control Architecture," B.S.T.J., this issue, pp. 43-69.
5. Gary D. Ott, "Vehicle Location in Cellular Mobile Radio Systems" IEEE Trans Veh. Technol., VT-26, No. 1 (February 1977), pp. 43-46.
6. V. H. MacDonald, "Subjective Voice-Circuit Quality Measurements in the Presence of Multipath Fading," Symposium on Microwave Mobile Communications, Boulder, Colo., 1972.
7. G. C. DiPiazza, A. Plitkins, and G. I. Zysman, "AMPS: The Cellular Test Bed," B.S.T.J., this issue, pp. 215-248.
8. Y. Okumura, E. Ohmori, T. Kawano, and K. Fukuda, "Field Strength and its Variability in VHF and UHF Land Mobile Service," Rev. Elec. Comm. Lab., 16 (September 1968), pp. 825-873.
9. W. Rae Young, Jr., "Comparison of Mobile Radio Transmission at 150, 450, 900, and 3700 MC," B.S.T.J., 31, No. 6 (November 1952), pp. 1068-1085.
10. D. C. Cox, "Time-and-Frequency Domain Characterizations of Multipath Propagation at 910 MHz in a Suburban Mobile-Radio Environment," Radio Sci., 7 (December 1972), pp. 1069-1077.
11. W. C. Jakes, Jr., ed., *Microwave Mobile Communications*, New York, John Wiley, 1974.
12. G. A. Arredondo, J. C. Feggler, and J. I. Smith, "AMPS: Voice and Data Transmission," B.S.T.J., this issue, pp. 97-122.

Advanced Mobile Phone Service:

Control Architecture

By Z. C. FLUHR and P. T. PORTER

(Manuscript received February 15, 1978)

The cellular concept used in the Advanced Mobile Phone Service (AMPS) system to achieve spectrum efficiency requires a complex and flexible distributed system control architecture. Three major subsystems serve as the control elements: the mobile unit, the cell site, and the switching office. System control functions are partitioned among these subsystems to handle the following AMPS control challenges: interfacing with the nationwide switched telephone network, dialing from mobile units, supervising calls from mobile subscribers in the presence of noise and co-channel interference, performing call setup functions including paging and access, and locating and handing off mobiles between cell sites. This paper explains the techniques used to achieve the control functions of the three major subsystems and the ways they in turn participate in control of the total AMPS system.

I. INTRODUCTION

The cellular concept, which achieves radio spectrum efficiency through the technique of frequency reuse, requires a grid of control elements (cell sites) distributed throughout a mobile coverage area to serve as the interface between the large numbers of moving customers and the nationwide switched telephone network. Meeting these requirements in a cost-effective manner and providing a framework for offering a variety of services to AMPS customers requires a complex yet flexible control architecture.

Before proceeding with our description of the system control architecture, which draws heavily on earlier investigations,¹⁻³ it will be helpful to look at some of the important system interfaces with the nationwide switched (wire-line) telephone network and with mobile users.

II. SYSTEM INTERFACES

2.1 Network interface

A single AMPS system is designed to serve customers within a given geographical area, known as a Mobile Service Area (MSA). This usually corresponds to a metropolitan area including a central city, its suburbs, and some portion of its rural fringe (see Fig. 1). However, it could encompass a portion of an extremely large metropolitan area or perhaps two or more cities located relatively close together.

Mobile customers are expected to subscribe to service in a specific MSA. While operating within its boundaries, a customer is termed a "home mobile." Outside this area, the customer is termed a "roamer." An objective of AMPS is to provide dial access between home mobiles and any other telephone (mobile or land-line) reached through the wire-line telephone network. Another objective is to provide access, as automatically as possible, to and from roamers. These goals are achieved by assigning each mobile customer a standard ten-digit telephone number composed of a three-digit area code plus a seven-digit directory number. This enables an AMPS system to interface with the wire-line telephone network using standard trunking methods (Fig. 2) and permits calls to be handled with standard telephone routing and signaling techniques.

2.2 User interface

AMPS radio links carry call control information in addition to voice communication. The customer's identification and the dialed digits (network address) are two call control items that must be supplied in a digital mode to the local system on every call from a mobile. Known as "preorigination dialing," the dialing sequence takes place before the mobile unit's first communication with the local system. A mobile customer dials the telephone number of the party being contacted into a register in the mobile unit, thus recording it in the unit's memory.

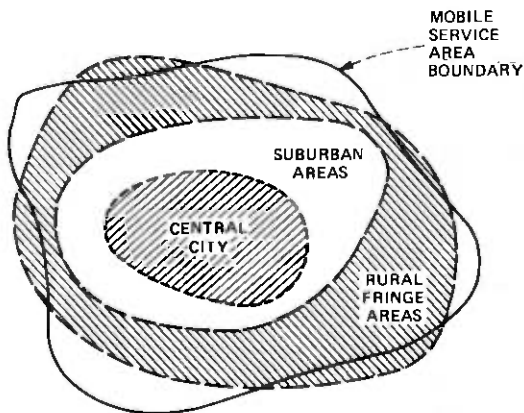
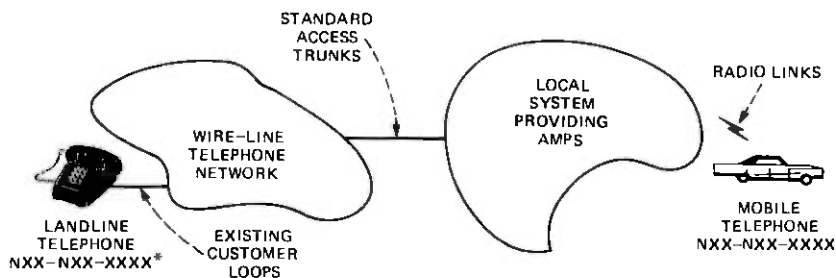

Fig. 1—Typical mobile service area.



* N = ANY DIGIT 2 THROUGH 9
 X = ANY DIGIT 0 THROUGH 9

Fig. 2—AMPS system interfaces.

The customer then initiates the communication with the land portion of the system according to procedures outlined in Ref. 4.

One major advantage of preorigination dialing is that a customer can dial at a slow rate without tying up a valuable radio channel. If a mistake is made, the customer can "erase" the dialed digits and redial the correct number. Only when the number is completely assembled and stored is the radio channel used, and then the number is sent as rapidly as possible in coded form along with other call-processing information.

The mobile telephone and the land portion of the system also exchange other information, such as the unit's supervisory state, the cell site being used, and the designated voice channel. These items are discussed in later sections.

III. SYSTEM CONTROL ELEMENTS

The three major system control elements are the mobile unit, the cell site, and the switching office.

3.1 The mobile unit

In addition to transmitting network address information, the mobile unit performs other control and signaling functions, which are discussed in Section IV. As noted in Ref. 5, the mobile unit is tunable on system command to any channel in the RF spectrum allocated to AMPS at any one of four power levels as pre-programmed. To perform these control and signaling functions, its design will most likely include a microprocessor.

3.2 The cell site

To achieve the grid of small coverage areas from which the cellular concept takes its name, land-based radios are located at cell sites throughout the mobile coverage area, as described in Ref. 5. Each cell site processes the signals to make them suitable for transmission

between the wire-line network and the radio network for all mobile telephones interfacing with it. This requires real-time control, which is accomplished with stored-program techniques. In addition, each cell site performs other control and signaling functions discussed below.

3.3 The Mobile Telecommunications Switching Office

The Mobile Telecommunications Switching Office (MTSO) serves as the central coordinator and controller for AMPS and as the interface between the mobile and the wire-line network. As described previously, all information exchanged over this interface employs standard telephone signaling. Hence, standard switching techniques are required within the MTSO. In addition, the MTSO must (i) administer radio channels allocated to AMPS, (ii) coordinate the grid of cell sites and moving subscribers, and (iii) maintain the integrity of the local AMPS system as a whole. These new switching functions require extensive use of stored-program technology within the MTSO.

3.4 Interconnection of subsystems

Interconnection of the three major control elements is shown in Fig. 3. The mobile telephone communicates with a nearby cell site over a radio channel assigned to that cell. The cell site, in turn, is connected by land-line facilities to the MTSO, which interfaces with the wire-line network. As Fig. 3 also indicates, a considerable amount of data is exchanged between pairs of AMPS control elements. For instance, call setup data are exchanged between the mobile telephone and the cell site over radio channels reserved for this purpose. The voice channels also carry data to control and to confirm various mobile telephone

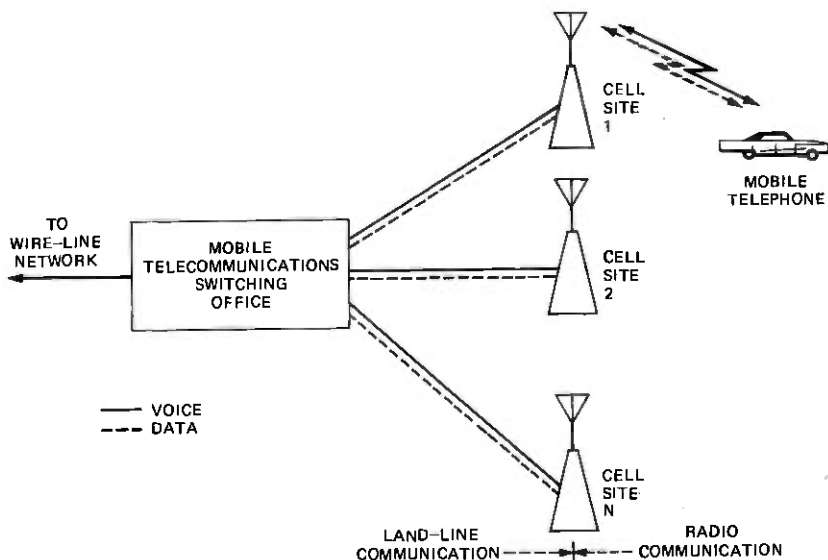

Fig. 3—AMPS system control elements.

actions. Between the cell site and the MTSO, separate facilities carry data to handle numerous call-processing and system integrity functions. All these functions are discussed below and in subsequent articles. In particular, Section VI of this paper presents scenarios of call setup sequences; we choose first to describe some of the general techniques and requirements of AMPS control.

IV. CONTROL TECHNIQUES

This section describes several important control techniques required by the cellular concept. These techniques relate to the functions of supervision, paging and access, and seizure collision* avoidance. Because of the distributed nature of the cellular plan, the important control function of ensuring system integrity (i.e., reliability and availability) is sufficiently broad in scope to require separate treatment (see Ref. 6).

4.1 Supervision

Classical land-line telephony defines supervision as the process of detecting changes in the switch-hook state caused by the customer. Mobile telephone supervision includes this process but has the additional task of ensuring that adequate RF signal strength is maintained during a call.

In a cellular system where intra-system interference is anticipated, the older mobile telephone technique of using a combination of RF carrier and a burst of tone cannot be used for supervision. As sketched in Fig. 4, some interfering signal will exceed typical values of the desired signal a significant fraction of the time. This is particularly bothersome at the end of a call when the desired mobile unit's transmitter must be turned off, and a burst of tone sent just prior to that time could be missed. Under these conditions, a false supervisory indication (caused by a co-channel interferer) would be created. The AMPS system uses a combination of a tone burst and a continuous out-of-band modulation for supervisory purposes. These are known respectively as signaling tone (ST) and supervisory audio tone (SAT).

4.1.1 Supervisory audio tone

Three SATs are set aside at 5970, 6000, and 6030 Hz. Only one of these is employed at a given cell site. The concept calls for using a SAT much as a land telephone uses dc current/voltage: A mobile unit receives a SAT from a cell site and transponds it back (i.e., closes the loop). The cell site looks for the specific SAT it sent to be returned; if some other SAT is returned, the cell site interprets the incoming RF

* Collision, as used here, means the loss of calls because of simultaneous arrival of two or more control messages.

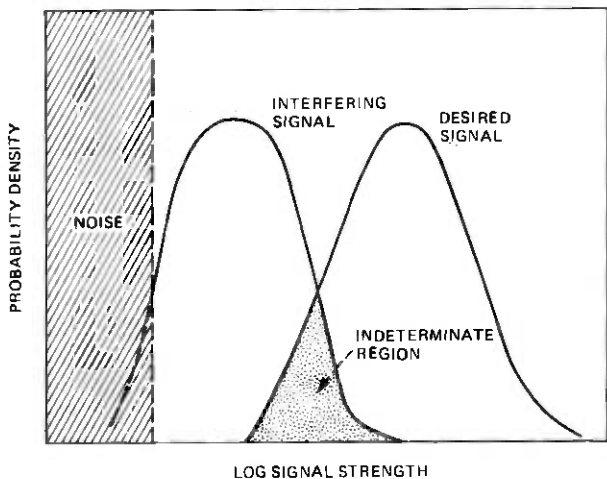

Fig. 4—Relative signal-strength distribution of desired and interfering signals.

power as being corrupted by interference, either in the land-to-mobile or in the mobile-to-land path (see Ref. 5).

In Fig. 5, we can see how the use of three SATs effectively multiplies the D/R (co-channel reuse) ratio for supervision by $\sqrt{3}$.^{*} For example, given a voice channel reuse factor of $N = 7$, a cell site with both the same RF channel set and the same SAT is as far away as if N were 21. This three-SAT scheme provides supervision reliability by reducing the probability of misinterpreted interference (same SAT and same RF channel).

The selected SAT frequencies are close together so that one phase-locked tracking filter can lock onto any of them. They are distant from the voice band by a factor of 2, so that filtering SAT from voice is relatively easy and so that intermodulation products are controllable. The FM deviation of the SAT is ± 2 kHz.

4.1.2 Signaling tone

Signaling tone (chosen to be 10 kHz) is present when the user is (i) being alerted, (ii) being handed off, (iii) disconnecting, or (iv) flashing for mid-call custom services (e.g., hold). Signaling tone is used only in the mobile-to-land direction. Figure 6 tabulates the various supervision states of the mobile when on the voice channel, as detected by the land portion of the system.

4.1.3 Locating

Another aspect of supervision with no counterpart in land line telephony is the function of locating. As discussed in Ref. 5, locating

^{*} It is shown in Ref. 5 that D/R is proportional to $N^{1/2}$; thus, if $N_2/N_1 = 21/7$, then $D_2/D_1 = \sqrt{3}$.

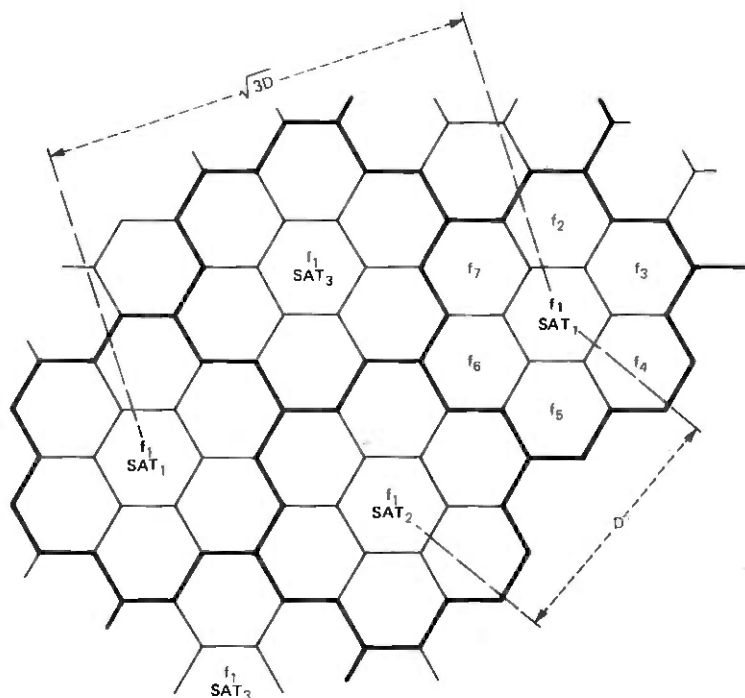

Fig. 5—SAT spatial allocation.

	SAT RECEIVED	SAT NOT RECEIVED
ST ON	MOBILE ON-HOOK*	MOBILE IN FADE OR MOBILE TRANSMITTER OFF
ST OFF	MOBILE OFF-HOOK	

SAT = SUPERVISORY AUDIO TONE
ST = SIGNALING TONE

* NOTE: RING CONFIRMATION REQUIRES THE MOBILE TO DELAY ST UNTIL THE RING ORDER IS RECEIVED.

Fig. 6—Supervision decisions made at cell site.

and handoff serve to keep the signal strength from a mobile unit at a high level during a call so that (i) the mobile's average S/I (signal-to-interference) ratio is adequate for its own good communication, and

(ii) other active mobiles do not experience high co-channel or adjacent-channel interference.

The methodology for locating requires two measurements. One is a measurement of the RF signal strength on appropriate channels, made using a tunable logarithmic receiver located at each cell site. The other is a measurement of gross range (based on round-trip delay of SAT), made on each active channel using the voice channel radios at the cell sites. Analysis of this information at the MTSO determines whether a change of channels and/or cell sites (handoff) is required. Additional details concerning locating are found in Ref. 7.

4.2 Paging and access (setup channel plan)

Seeking a called mobile unit that is at some unknown position in a service area is similar to the function performed vocally by persons called pages. Thus, the term "paging" is used in AMPS to describe the process of determining a mobile's availability to receive a given incoming call. The complementary function of beginning a call, performed by a mobile unit, is termed access. This involves (i) informing the system of the mobile's presence, (ii) supplying the system with the mobile's identification and the dialed digits, and (iii) waiting for a proper channel designation.

Two techniques are available to perform these paging and access tasks: (i) the special calling-channel method and (ii) the voice-channel method. The latter method, employed by older land mobile systems presently in service,⁸ uses an "idle tone" to indicate which of several functionally identical channels is available to serve a new call, first for signaling, then for voice; the special-channel method, which dedicates channels either to the paging and access function or to the voice function, is used in the maritime and the air-ground services.⁹ In a cellular system with many thousands of users and hundreds of channels and where the mobile unit can be made to scan the dedicated channels rapidly, the special calling-channel method is necessary because the information needed for the home/roam decision by the mobile cannot be handled by the single tone of the voice-channel method. Therefore, the AMPS control plan uses a set of special channels called setup channels for paging and access functions. These channels are distributed among the cell sites in an orderly way based on S/I considerations similar to those described in Ref. 5.

Plans for organizing use of the setup channel, based on the traffic assumptions reflected in Table I, take into account the differing demands placed on the system by paging and access. Paging information must be spread equally over the entire MSA. The information capacity requirements for paging will grow in proportion to the number of customers; however, splitting cells as described in Ref. 5 will not help to increase the capacity, since each point in the MSA needs all the paging information. The access requirements also increase with the

Table I—Traffic assumptions (based on a limited amount of early data from present-day service)

Calling rate	1 call/subscriber/busy-hour
Answer rate	Half of all attempts toward a mobile elicit a response
Traffic direction	60 percent mobile-originated 40 percent mobile-completed
Home/roam ratio	4:1
Mean rate of call arrival	1/second in densest cells

traffic, but access capacity increases with cell-splitting since each cell in the MSA needs the access information only for mobiles in that cell.

4.2.1 Access requirements

The following are the requirements on the access process:

(i) The capacity to handle access attempts must relate to the number of users. In areas saturated with access traffic, we expect this traffic to arrive randomly at about one arrival per second. This assumption should hold for cells of both the largest and the smallest radii. Furthermore, we expect each user to average 0.6 origination per hour, based on present-day usage statistics.

(ii) It must not place undue demands on the real-time processing capabilities of either the MTSO or the cell sites.

(iii) It must be accurate in the face of (a) co-channel interference from other cells and (b) collisions, already defined as the occasional arrival of two or more requests for service at the same time.

(iv) It must be stable (i.e., some rare overload situation must not cause the system to enter a state from which it cannot recover quickly).

Since the setup channels represent an expense both in capital and in channel resource (i.e., they subtract from the total reserve of channels), it is important to use these carefully and flexibly even though future traffic loads for paging and for access are not accurately known.*

4.2.2 Paging requirements

Current assumptions concerning future paging requirements are that the process must:

(i) Be able to handle 0.8 page per user per busy hour, of which half go unanswered. (This estimate is based on a sample of present-day users.)

(ii) Provide complete number flexibility to permit nationwide roaming and to accommodate any of the ten-digit telephone numbers possible today. (This assumption requires a 34-bit binary number for mobile identification.)

* Note, however, that signaling via "idle tone" would also represent an expense in that it adds channel holding time to calls in both directions.

(iii) Be capable of serving some unknown future demand (several hundred thousand users) while remaining economical in small cities with a user population of one thousand or less.

4.2.3 Setup channel plan

The plan that has evolved from these requirements allows paging and access functions, for the sake of economy, to be combined on the setup channels for the early years of growth when large cells with omnidirectional antennas are used. As the system grows, however, with cell splitting and the change to cell sites using directional antennas, more setup channels will be needed to handle the access function. The omnidirectional antennas would continue to handle the paging functions. Therefore, paging and access become separated when the first cell split occurs.

The paging messages themselves contain the binary equivalent of the mobile unit's directory number. Since a large amount of paging information has to be sent, efficient design suggests that the data be organized into a synchronous format (described later) of fixed-length words and synchronizing pulses. When paging is not needed, the cell site adds "filler text" in its place, merely to preserve the synchronous format.

Another type of message, called the "overhead word," is also sent periodically as part of the paging data stream to give the mobile certain descriptive information about the local system. The use of the overhead word permits flexibility in local system parameters (which are a function of local subscriber growth rates and traffic characteristics). These parameters can then be varied as actual field experience dictates. The overhead word includes:

(i) The MSA identification (called the Area Call Sign) to permit the automatic roaming feature.

(ii) The cell site's SAT identification.

(iii) A parameter (called N) which specifies the number of setup channels in the repeating set (the frequency reuse factor*). See item (ii) in Section 6.2.

(iv) A parameter (called CMAX) which specifies the number of setup channels to scan when a call is to be made.

(v) A parameter (called CPA) which tells the mobile units whether the paging and the access functions share the same setup channels.

Figure 7 depicts how the setup channels are assigned as systems grow through various sizes. The highest 21 channels are always used for setup purposes; these are the channels all mobile units are pre-programmed to recognize as those containing the necessary system identification (overhead word) information, no matter where the unit makes a call.

* This frequency reuse factor for setup channels may be different from that for voice channels.

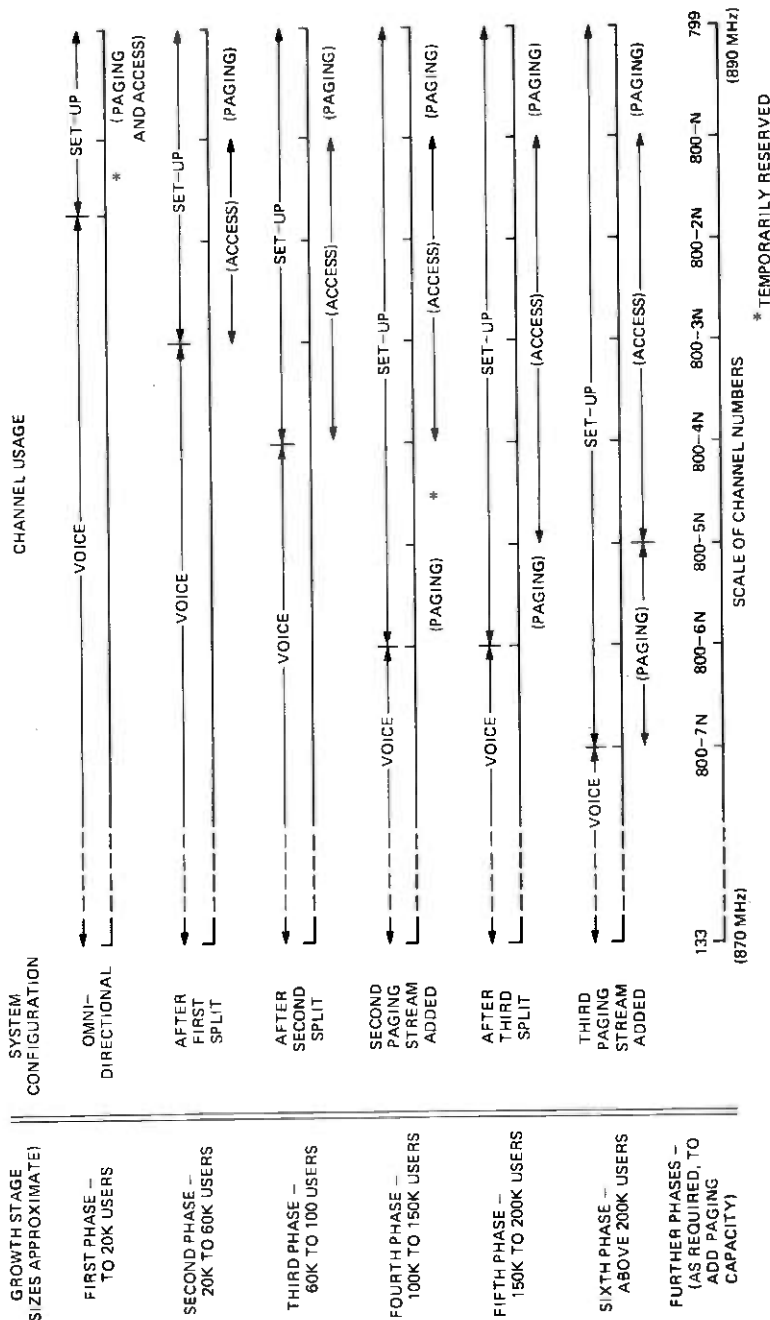

Fig. 7—Scenario for setup channel usage as users are added.

During the early period of growth (typically to about 20,000 users in a single MSA), paging and access can be combined on the setup channels. After that, cell splitting occurs and new access capability is needed. The paging capability from the original sites, with omnidirectional antennas using the original number of paging channels, remains adequate. A second cell split, at roughly 60,000 users, requires even more access capability but is expected to leave paging on the original setup channels from the original sites.

At some point, the paging capacity of the original setup channels becomes saturated. Since each channel is limited to the order of 10,000 bits/second (b/s), and since high redundancy is required to combat the fading problem in areas of low S/I, only 1200 b/s of real information can be sent. Some of this is overhead information. Thus, a practical limit is about 25 messages per second (90,000 per hour) at 100 percent loading. Actual service experience, of course, will dictate the resulting customer loading allowed (depending on how many ineffective attempts there are), but a ratio of 90,000 customers for each paging stream is probably an upper bound. Beyond that size, which should be exceeded in only a few cities by the end of the century, more setup channel sets for paging will be needed at the original omnidirectional cell sites. Logic designed into the mobile unit must anticipate the use of these additional setup channels. Mobiles will be assigned to a specific paging channel set—either the primary (highest N channels) or one of the additional sets—for use when at home, much as land telephones are assigned to central office codes within an exchange.

4.2.4 Setup channel use

Mobiles will use setup channels in the following sequence:

(i) When power is applied to a mobile unit, and about once a minute thereafter, it scans the top 21 channels and picks the strongest one on which to read an overhead message. This permits the mobile unit to determine if it is "home" and to retrieve the frequency reuse factor N . To receive its pages, it then rescans the appropriate* set of N channels to find the strongest channel. Since N can vary from city to city, it is read from the overhead message that is periodically being sent on all forward (cell site to mobile) setup channels.

(ii) When a call is to be either originated from or completed to a mobile unit, the unit must repeat the scanning process to self-locate itself to the best cell site (i.e., the strongest signal) for access. In this case, it scans CMAX channels.

(iii) The unit synchronizes to the word pattern on the chosen setup channel and determines if that channel is idle (discussed later). If so, it attempts an access by transmitting the necessary information to the cell site:

(a) If answering a page, its identification; or

* See Section 4.2.3.

(b) If originating a call, its identification and the dialed digits. The unit then turns its transmitter off but remains tuned and synchronized to the chosen setup channel.

(iv) After the land portion of the system has processed the access information, it sends a channel designation message to the mobile unit, much as a page would be sent, on the setup channel which the mobile unit had used previously. Upon receipt of this message, the mobile tunes to the designated channel, and the voice portion of the call can proceed.

4.3 Seizure collision avoidance

The initiation of a call by a mobile unit is a random event in both space and time, as the land portion of the system perceives it. Since all mobiles compete for the same setup channels, methods must be devised to minimize collisions and to prevent temporary system disruption if collisions do occur. Several techniques are used for this purpose.

First, the forward (toward the mobile) setup channels set aside every 11th bit as a "busy/idle" bit. As long as a cell site perceives legitimate seizure messages directed toward it, it sees that the "busy/idle" bit is set to "busy."

Second, the mobile sends in its seizure message a "precursor," which tells the land portion of the system with which cell site it is attempting to communicate. This is particularly necessary in systems with smaller cell sizes. For example, as explained in Ref. 5, in a system with 1-mile cells ($R = 1$ mile), co-channel interferers are less than five miles ($D = 4.7$ miles) from the serving cell site—well within the mobile's typical range of 5 to 10 miles. The information provided in the precursor is the digital-encoded equivalent of the SAT mentioned earlier; the mobile unit, having read this digital code message in the forward data stream of the setup channel being used, transmits it back to the cell site on the reverse half of the channel.

Third, before the mobile attempts to seize (access) a setup channel, it waits a random time. This cancels the periodicity introduced into the mobile seizures by the format of the setup channel messages.

Fourth, after a mobile unit sends its precursor, it opens a "window" in time in which it expects to see the channel become busy. If the idle-to-busy transition does not occur within the time window, the seizure attempt is instantly aborted.

Fifth, if the initial seizure is unsuccessful for any reason, the mobile unit will automatically try again and again at random intervals. However, to prevent continued collisions and hence system overload, a limit is placed on the number of automatic reattempts permitted.

V. DATA REQUIREMENT AND FORMATS

As a result of the control techniques described in the preceding section, considerable amounts of data are exchanged between pairs of AMPS control elements. The information requirements for the various

Table II—Requirements for information transfer

Channel	Type of Information	Number of Bits
Setup:		
Forward	Mobile page	24 or 34
	Channel designation	11
	Mobile power level	2
	Overhead (local parameters)	22 to 30
	System control	4
Reverse	Identification	56 or 66
	Dialed digits	64 (16 characters*)
	System control	4
Voice:		
Forward	Orders	5
	Channel designation	11
	Mobile power level	2
	System control	4
Reverse	Order confirmation	5
	Dialed digits (for custom-calling services)	64 (16 characters)
	System control	4

* Characters are defined as the digits 0-9, plus #, *, and other symbols reserved for future use.

channels are shown in Table II. The radio interface channels (mobile unit to cell site) differ from land channels (cell site to MTSO) not only in capacity requirements but also in the way they must be handled because of the differing nature of the noise impairments. This section describes the data requirements and formats* for the different AMPS interfaces: forward setup channel, reverse setup channel, voice channel, and land-line data link.

Before dealing with each of these interfaces in turn, we will describe common characteristics of the first three. One is the rapid fading experienced by signals as mobiles move through the complex RF interference pattern. To combat the burst errors caused by this fading, all data words are encoded and repeated several times at the source, and a bit-by-bit, 3-out-of-5 majority vote is taken at the receiver to determine the best-guess detected word to send to the decoder. The coding used on all radio channels is a shortened (63, 51) BCH† code [(40, 28) in the forward direction, and (48, 36) in the reverse direction]; this code has the capability of correcting one error while detecting at least two more, without unreasonable complexity. This type of coding scheme, along with the majority-voting technique, provides a good balance between a low miss rate (probability of not detecting a message when one is sent) and a low falsing rate (probability of detecting the wrong message).

Further description of the data channels is given in Ref. 10. In brief, however, the philosophy used is to send the data at the fastest bit rate possible over the RF channel, consistent with its bandwidth, thus filling

* For the sake of brevity, certain message details are omitted in this section.

† Bose-Chandhuri-Hocquenghem originated this linear block systematic error coding scheme; (63, 51) indicates that there are 63 bits transmitted, of which 51 are information and 12 are parity-check bits.

the channel as evenly as reasonably possible with energy. Channel capacity over and above the information needs is used up by redundancy, i.e., both by encoding and by repeating the message several times. Thus, a 10-kbs rate was chosen for the AMPS radio channels, to give a total maximum information throughput of 1200 b/s. Mobile unit cost is also an important consideration in the choice of formats.

Another characteristic which these radio channels have in common is the pair of error requirements for information transfer:

(i) The miss rate for messages should be in the range of 10^{-3} at $S/I = 15$ dB. Averaged over the entire service area, this implies a miss rate of about 10^{-4} . This miss rate is very small compared to the probability that a call will be missed because a mobile is unattended. Furthermore, it is consistent with the requirement placed on mishandled calls in the wire-line telephone network.

(ii) The falsing rate (incorrect data interpretation) should be less than 10^{-7} for a given message. This stringent requirement is necessary because, for example, in a system where 90,000 users are assigned to a given paging data stream, up to 45,000 mobile units might be listening to every page;* in this situation, the requirement implies that less than one transmitted page in 200 will elicit a false response (which the MTSS will be required to screen).

5.1 Forward setup channel

Data on this channel are transmitted continuously in a periodic format, so that idle mobile units can synchronize to the format to read a large volume of paging and local system information.

Details on the data format of the forward setup channel are shown in Fig. 8. The basic periodicity of the bit stream is 463 bits, summed as follows:

200 bits—Word A (40 bits, repeated 5 times)
200 bits—Word B (40 bits, repeated 5 times)
10 bits—Bit sync
11 bits—Word sync
<u>42 bits—Busy-idle bits</u>
463 bits

The five repeats of words *A* and *B* are interleaved to provide spacing in time, which in turn ensures partial decorrelation of bit errors between repeats of the same word. Note that a given mobile unit is not required to decode both of the two message streams; it chooses the *A* or *B* stream depending on whether its identification is even or odd.†

* This assumes that at least half the equipped mobiles are not energized at any given time.

† Determined by the last digit of its telephone number.

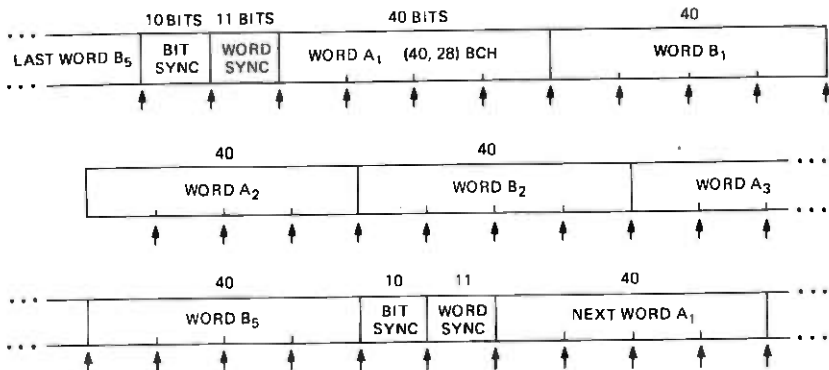

NOTES:

↑ = POINT OF BUSY-*idle* BIT INSERTION (AFTER EACH 10 MESSAGE BITS AND AFTER BIT AND WORD SYNC)

A_i = i^{th} OF FIVE REPEATS OF WORD FROM MESSAGE STREAM A

B_i = i^{th} OF FIVE REPEATS OF WORD FROM MESSAGE STREAM B

INFORMATION CONTENT OF WORDS

PAGES
CHANNEL DESIGNATIONS
OVERHEAD WORDS
FILLER TEXT

Fig. 8—Data format (forward setup channel).

5.2 Reverse setup channel

On this channel, the mobiles act in a random and competitive way to initiate calls. Both signals and interferences are turned on and off in an uncorrelated fashion.

Details on the data format of the reverse setup channel are shown in Fig. 9. A message is preceded by a 48-bit seizure precursor. Each message consists of 1 to 5 words of 48 bits each, repeated 5 times. The cell site performs a bit-by-bit, 3-out-of-5 vote to determine the 48-bit

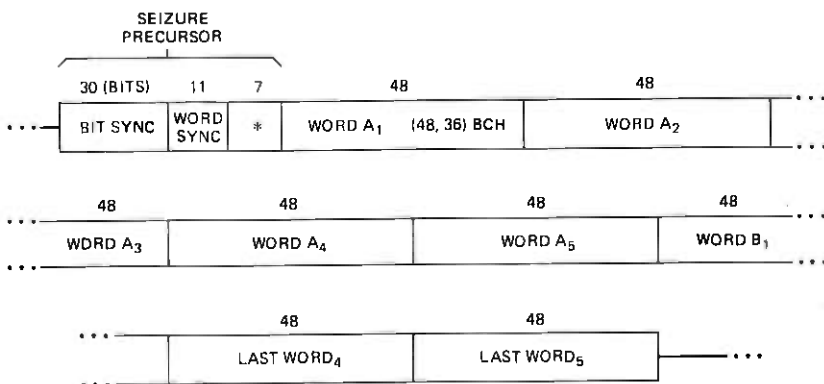

* ONE OF FOUR SEQUENCES TO IDENTIFY THE CELL SITE AT WHICH THE MESSAGE IS AIMED

Fig. 9—Data format (reverse setup channel).

encoded word; it then evokes a decoding algorithm to correct one error if necessary (or to reject the message as uncorrectable).

5.3 Voice channel

This channel is, of course, used primarily for conversation. However, data messages (primarily handoff) are also required on this channel. Unlike the reverse setup channel, a transmitted signal is always available to provide "capture" and thus suppress interfering data messages.

The technique used is "blank-and-burst": that is, the voice signal is blanked and the data are sent rapidly in a burst that uses a large part of the channel's bandwidth. The falsing rate requirement for this channel can be relaxed to 10^{-5} because the effect of falsing on this channel is similar to a mishandled call on the wire-line network (with which the 10^{-5} falsing rate is consistent).

Details on the data format of the voice channel are shown in Fig. 10. Note that messages are repeated 11 times in the forward direction but only 5 times in the reverse direction. The primary reason for this difference is that the handoff message, considered a critical function since false interpretation results in a mishandled call, is usually sent under atypically low S/I conditions.

5.4 Land-line data line

The capacity for information transfer between cell site and MTSO must be great enough to take care of a large number of functions and flexible enough to accommodate changes as the system matures. The choice of a 2400-b/s channel, with growth capability to two channels

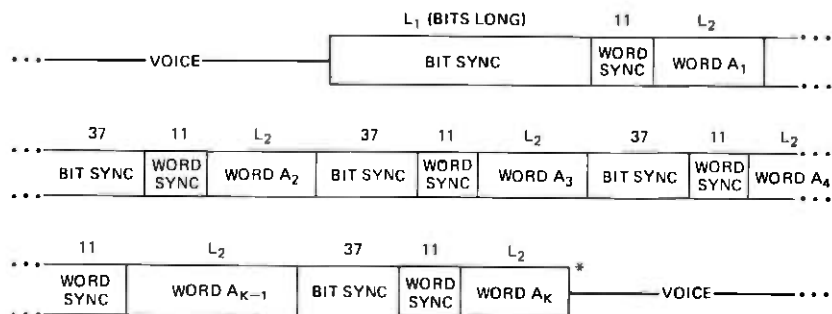

PARAMETER VALUE

	FORWARD	REVERSE
L_1 (BITS LONG)	100±	101
L_2 (BITS LONG)	40	48
K (REPEATS)	11	5

* NOTE:

ON THE REVERSE CHANNEL, A SECOND MESSAGE (B) MAY FOLLOW WORD A_K

Fig. 10—Data format (voice channel).

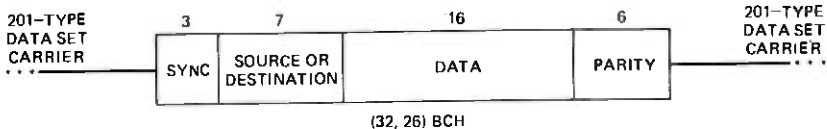

Fig. 11—Data format (land-land data channel).

in large systems and the use of the data format to be described, satisfy these qualitative requirements.

The coding scheme chosen is a (32, 26) BCH code, shortened from a basic (63, 57) BCH code. Synchronization is via a preamble embedded at the start of each message. Subtracting the 6-bit parity check and the 3-bit synchronization leaves 23 bits for information.

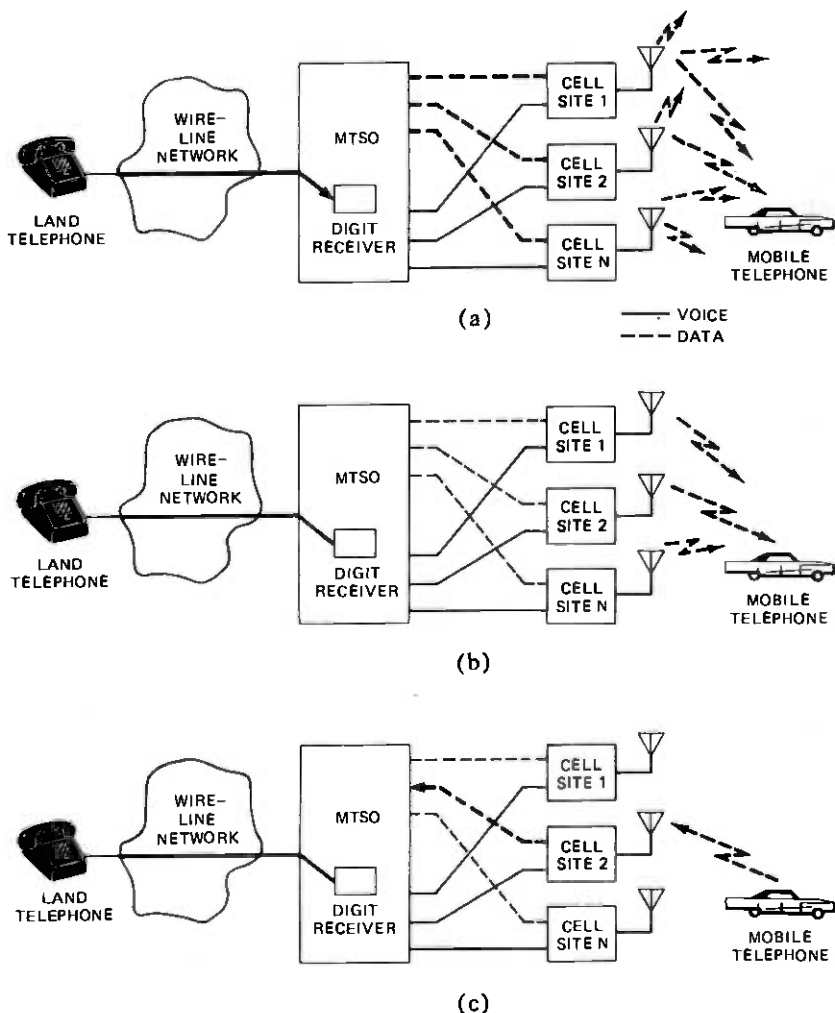

Fig. 12—Mobile-completed call sequence. (a) Paging. (b) Cell site selection. (c) Page reply. (d) Channel designation. (e) Alerting. (f) Talking.

Figure 11 is a sketch of the basic format. Each message has 16 bits for the actual data (specific commands, numbers to be transmitted, locating measurements, etc.) preceded by a 7-bit routing item, which generally takes one of three forms:

- (i) "Source" identification for messages sent from cell site to MTSO, (e.g., setup receiver, locating receiver, voice radio).
- (ii) "Destination" identification for messages sent from MTSO to cell site (e.g., setup transmitter, blank-and burst data unit).
- (iii) "AWC" (additional word coming) for multi-word messages in each direction.

VI. CONDENSED CALL SEQUENCES

Various control functions and the major control elements of the AMPS system have been described. The ways these elements work

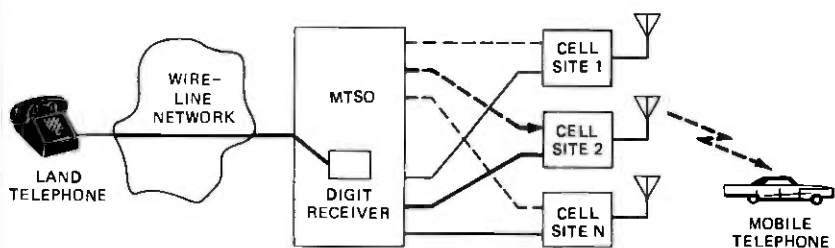

(d)

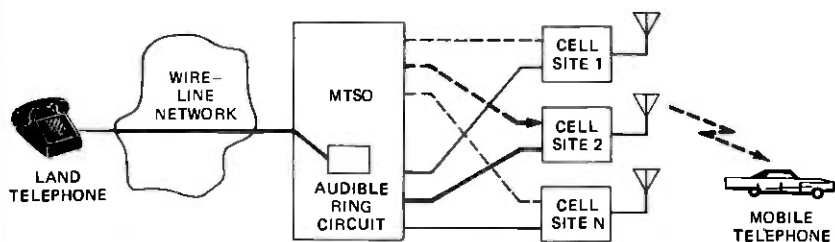

(e)

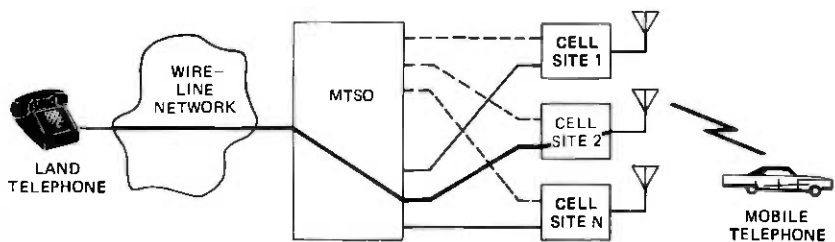

(f)

Fig. 12 (Cont.)

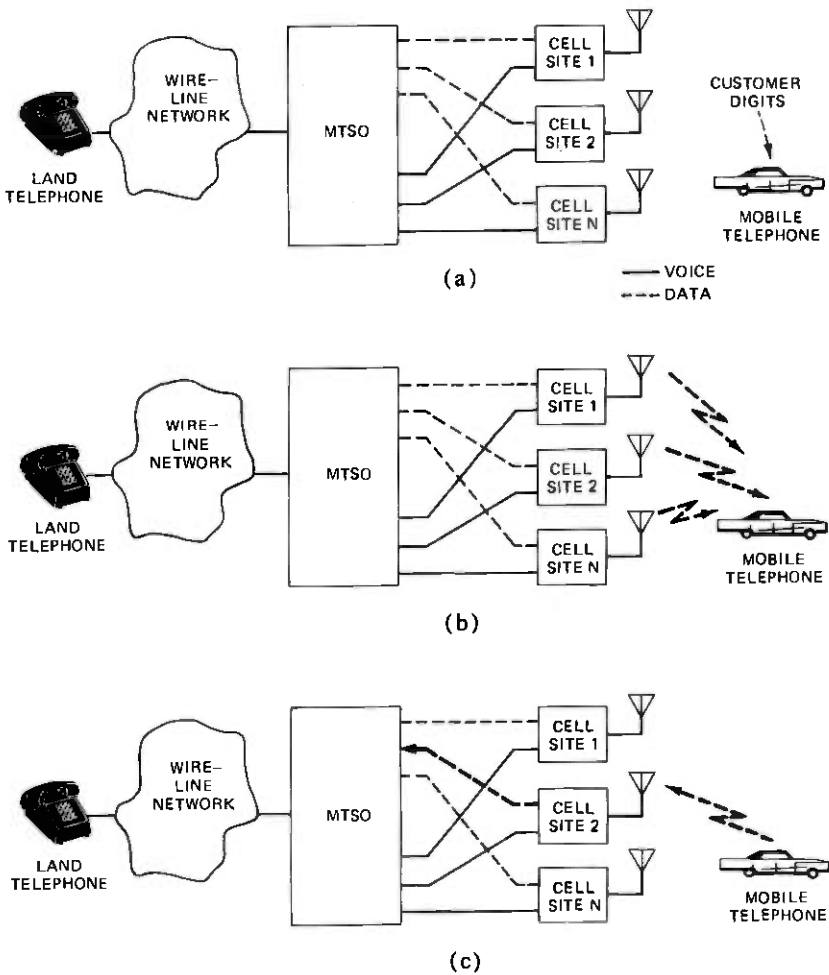
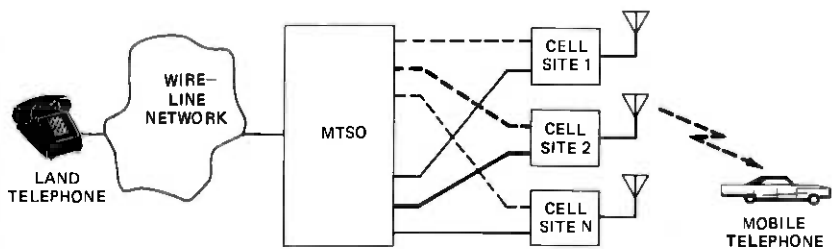

Fig. 13—Mobile-originated call sequence. (a) Preorigination. (b) Cell site selection. (c) Origination. (d) Channel designation. (e) Digit outpulsing. (f) Talking.

together to perform their control functions can be seen in perspective most effectively by describing rudimentary mobile call sequences. There are two basic types of mobile telephone calls—mobile-completed calls and mobile-originated calls. These are described next, in turn, to the point at which conversation occurs (talking state). Actions common to both call types are also discussed.

6.1 Initialization

When the mobile telephone is energized, it scans the setup channels according to a program in its memory (as described in Section 4.2.4) and selects the strongest one. This channel will normally be associated with a nearby paging cell site. The mobile telephone continues to monitor the selected forward setup channel for paging messages. It



(d)

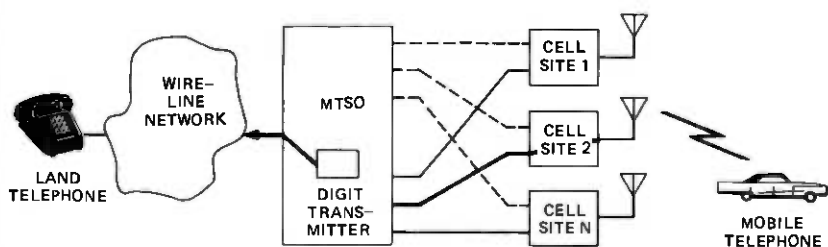

(e)

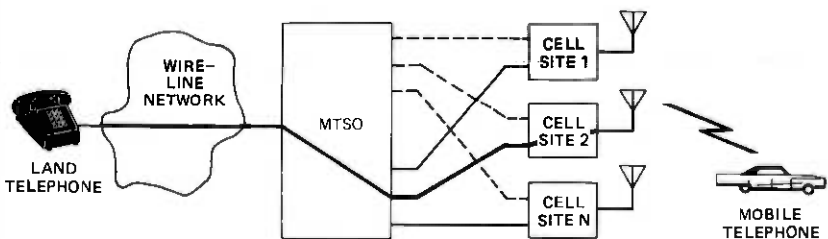

(f)

Fig. 13 (Cont.)

repeats the initialization process at regular intervals or when needed because of poor signal at the mobile, or until it is involved in a call.

6.2 Mobile-completed call

Figure 12 shows the actions required to process a mobile-completed call. There are:

(i) **Paging:** From the calling party's central office, the call is routed by standard wire-line network routing procedures to the home MTSO of the mobile. The MTSO collects the digits, converts them to the mobile's identification number, and instructs the cell sites containing paging channels to page the mobile over the forward setup channels. In this way, the paging signal is broadcast over the entire service area.

(ii) **Cell site selection:** The mobile unit, after recognizing its page, scans the setup channels used for access in the MSA, using parameters

derived from the overhead word, and selects the strongest one. The selected channel will probably be associated with a nearby cell site (usually the nearest cell site).

(iii) Page reply: The mobile responds to the cell site it selected over the reverse setup channel. The selected cell site then reports the page reply to the MTSO over its dedicated land-line data link.

(iv) Channel designation: The MTSO selects an idle voice channel (and associated land-line trunk) in the cell site that handled the page reply and informs the cell site of its choice over the appropriate data link. The serving cell site in turn informs the mobile of its channel designation over the forward setup channel. The mobile tunes to its channel designation and transponds the Supervisory Audio Tone (SAT) transmitted over the voice channel. On recognizing the transponded SAT, the cell site places the associated land-line trunk in an off-hook state, which the MTSO interprets as successful voice channel communication.

(v) Alerting: On command from the MTSO, the serving cell site transmits a data message over the voice channel to an alerting device in the mobile telephone which signals the customer that there is an incoming call. Signaling tone from the mobile causes the cell site to place an on-hook signal on the appropriate land-line trunk which confirms successful alerting to the MTSO. The MTSO, in turn, provides audible ringing to the calling party.

(vi) Talking: When the customer answers, the cell site recognizes removal of signaling tone by the mobile and restores the land-line trunk to an off-hook state. This is detected at the MTSO, which removes the audible ringing circuit and establishes the talking connection so that conversation can begin.

6.3 Mobile-originated call

Figure 13 depicts the various actions required to establish a mobile-originated call. These are:

(i) Preorigination: Using the preorigination dialing procedures described earlier (in Section 2.2), the customer enters the dialed digits into the mobile unit's memory.

(ii) Cell site selection: After the mobile unit is placed in an off-hook state, a process takes place similar to that described previously for the mobile-completed call (see item (ii) in Section 6.2).

(iii) Origination: The stored digits, along with the mobile's identification, are transmitted over the reverse setup channel selected by the mobile. The cell site associated with this setup channel receives this information and relays it to the MTSO over its land-line data link.

(iv) Channel designation: As for a mobile-completed call, the MTSO designates a voice channel and establishes voice communication with the mobile. The MTSO also determines routing and charging information at this time by analyzing the dialed digits.

(v) Digit outpulsing: The MTSO completes the call through the wire-line network using standard digit outpulsing techniques.

(vi) Talking: When outpulsing is completed, the MTSO establishes a talking connection. Communication between customers takes place when the called party answers.

6.4 Other common actions

6.4.1 Handoff

Figure 14 depicts the actions common to both mobile-originated and mobile-completed calls during the important process of handoff. These are:

(i) New channel preparation: Location information gathered by the cell site serving the mobile, as well as by surrounding cell sites, is

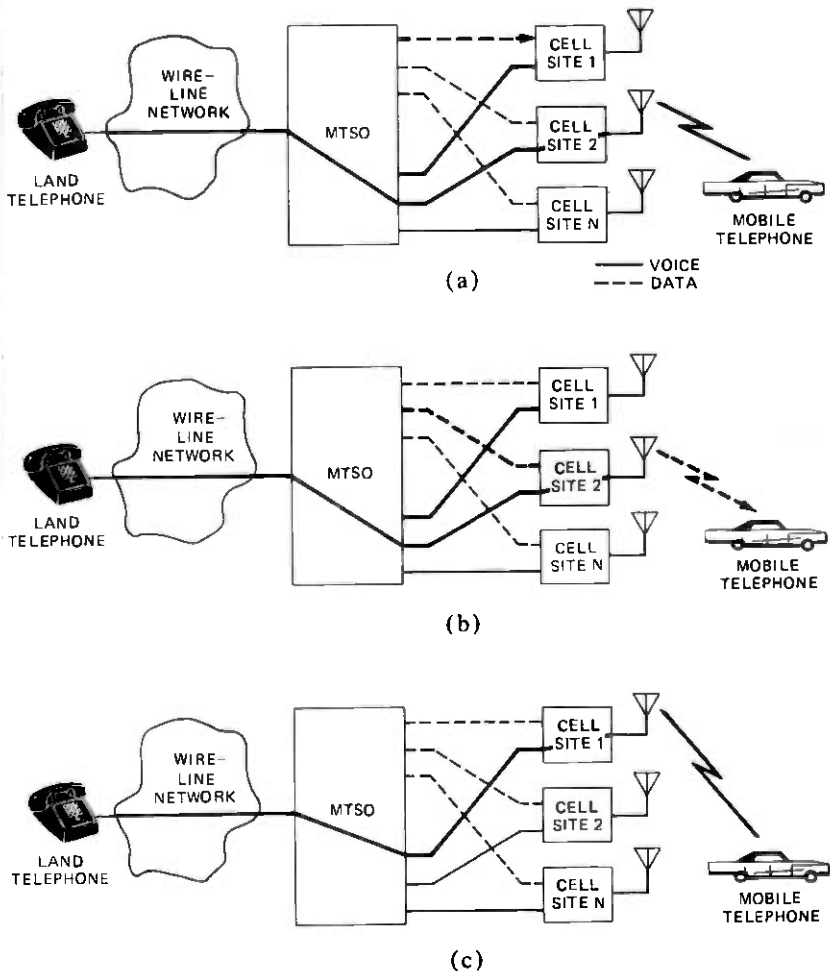

Fig. 14—Handoff sequence. (a) New channel preparation. (b) Mobile retune command. (c) Channel/path reconfiguration.

transmitted to the MTSO over the various cell site land-line data links. The data are analyzed by the MTSO, which decides that a handoff to a new cell site is to be attempted. The MTSO selects an idle voice channel (and an associated land-line trunk) at the receiving cell site and informs the new cell site to enable its radio. The receiving cell site turns on its radio and transmits SAT.

(ii) Mobile retune command: A message is sent to the current serving cell site informing it of the new channel and new SAT for the mobile in question. The serving cell site transmits this information to the mobile over the voice channel.

(iii) Channel/path reconfiguration: The mobile sends a brief burst of signaling tone and turns off its transmitter; it then retunes to its new channel and transponds the SAT found there. The old cell site,

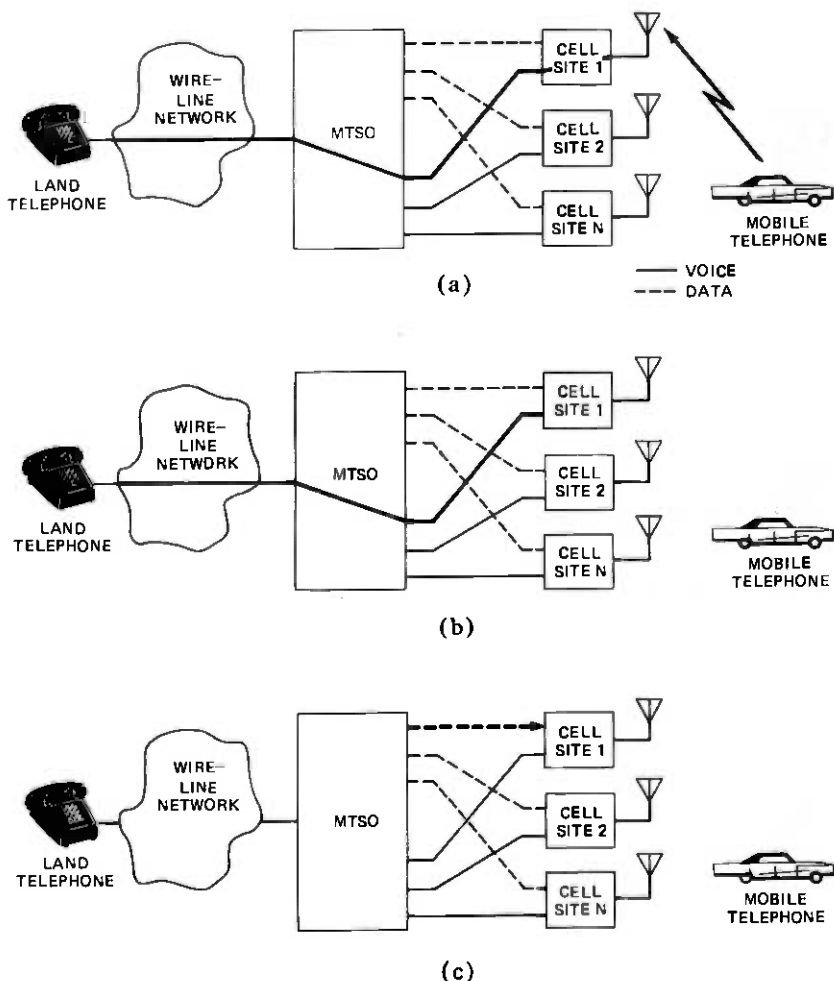

Fig. 15—Disconnect sequence (mobile-initiated). (a) Release. (b) Idle. (c) Transmitter shutdown.

having recognized the burst of signaling tone, places an on-hook signal on the trunk to the MTSO. The MTSO reconfigures its switching network, connecting the other party with the appropriate land-line trunk to the new serving cell site. The new serving cell site, on recognizing the transponded SAT on the new channel, places an off-hook signal on the associated land-line trunk. The MTSO interprets these two signals (off-hook on new trunk; on-hook on old trunk) as a successful handoff.

6.4.2 Disconnect

Figures 15 and 16 depict the actions common to both mobile-originated and mobile-completed calls during the call disconnect process. Disconnection can be initiated by either the mobile party or the land

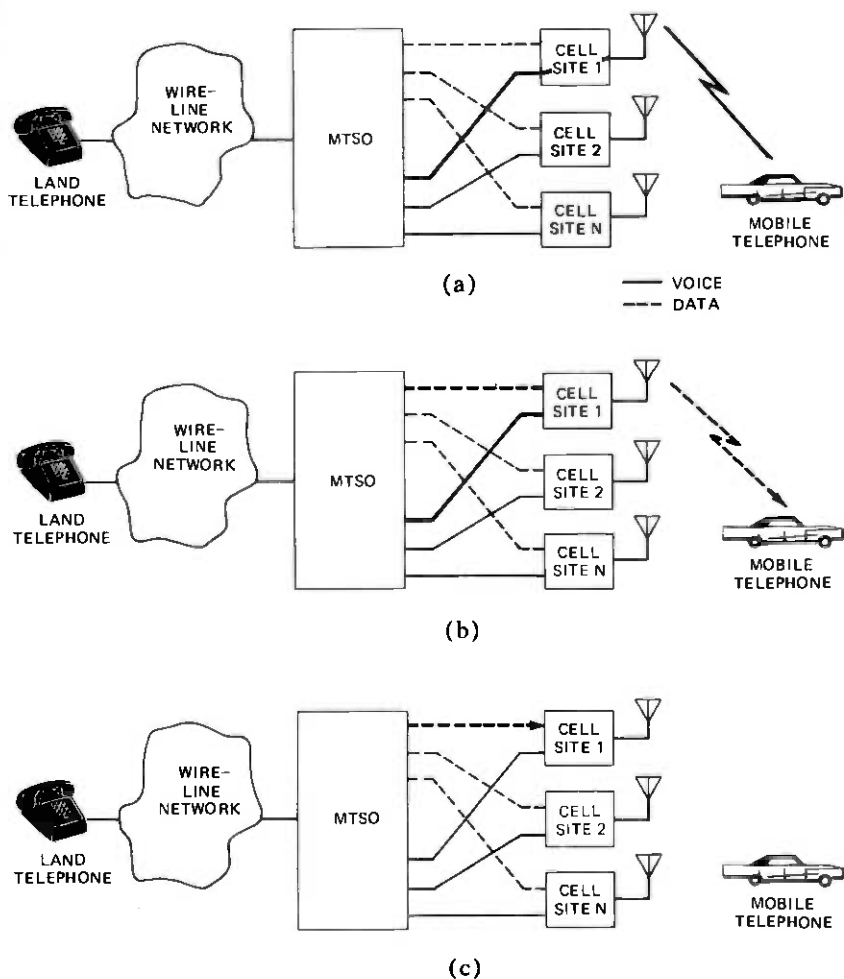

Fig. 16—Disconnect sequence (system-initiated). (a) Idle. (b) Ordered release. (c) Transmitter shutdown.

portion of the system (usually in response to an on-hook signal from a land party). The resulting actions differ somewhat.

Mobile-initiated disconnect: The actions occurring when the mobile party goes on-hook are:

(i) Release: The mobile unit transmits signaling tone and turns off its transmitter. The signaling tone is received by the cell site, which places an on-hook signal on the appropriate land-line trunk.

(ii) Idle: In response to the on-hook signal, the MTSO idles all switching office resources associated with the call and transmits any necessary disconnect signals through the wire-line network.

(iii) Transmitter shutdown: As the final action in the call, the MTSO commands the serving cell site over its land-line data link to shut down the cell site radio transmitter associated with the call. All equipment used on this call may now be used on subsequent calls.

System-initiated disconnect: The actions occurring when the land party goes on hook are:

(i) Idle: In response to the disconnect signal received from the wire-line network, the MTSO idles all switching office resources associated with the call.

(ii) Ordered release: The MTSO sends a release order data link message to the serving cell site. This cell site transmits this command to the mobile over the voice channel. The mobile confirms receipt of this message by invoking the same release sequence as with a mobile-initiated disconnect.

(iii) Transmitter shutdown: When the MTSO recognizes successful release by the mobile (via an on-hook signal on the appropriate land-line trunk), it commands the serving cell site to shut down the radio transmitter as described previously.

VII. SUMMARY

The Advanced Mobile Phone Service system achieves spectrum efficiency at the cost of control complexity. The control architecture resides in three widely distributed control elements: the mobile unit, the cell site, and the mobile telecommunications switching office. A typical large, mature system might have up to 100,000 mobile telephones, 50 cell sites, and a single mobile telecommunication switching office.

The three control elements work together to perform the system control functions. These include standard telephony control functions plus a set of functions resulting directly from either the cellular concept or the general radio environment. The control functions are partitioned among the control elements as shown in Fig. 17. This partitioning of functions is flexible. Because of the extensive use of stored-program technology in all the control elements, the control functions may be repartitioned to tune the system's performance as actual field service data become available in the future.

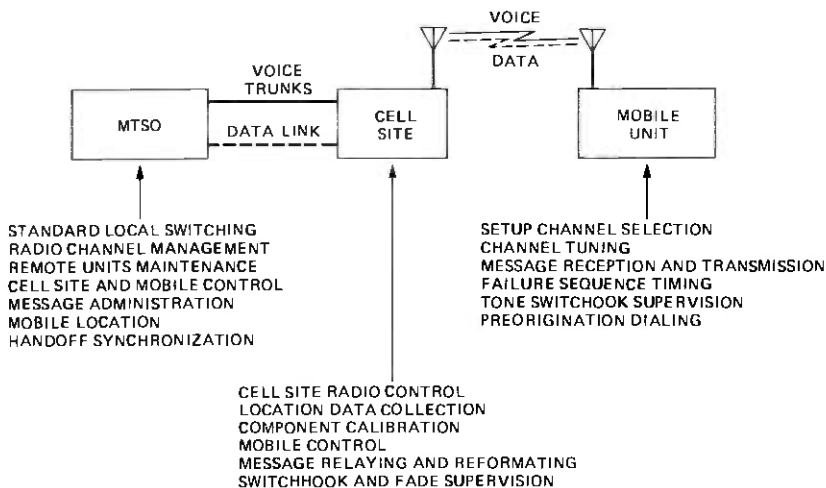

Fig. 17—Partitioning of control functions among AMPS control elements.

VIII. ACKNOWLEDGMENTS

Many people contributed to the control plan for the AMPS system. Aside from other authors in this issue, the following bear special mention: V. Hachenburg, B. D. Holm, G. D. Ott, R. J. Pennotti, S. A. Tartarone, and J. E. Wilkes.

REFERENCES

1. "No. 1 Electronic Switching System," *B.S.T.J.*, 43, No. 5 (September 1964).
2. P. T. Porter, "Supervision and Control Features of a Small Zone Radiotelephone System," *IEEE Trans. Veh. Tech.*, 20, No. 3 (1971), p. 75-79.
3. Z. C. Fluhr and E. Nussbaum, "Switching Plan for a Cellular Mobile Telephone System," *IEEE Trans. Comm.*, 21, No. 11 (1973), p. 1281-1286.
4. J. T. Walker, "AMPS: The Service Test Mobile Telephone Control Unit," *B.S.T.J.*, this issue, pp. 145-152.
5. V. H. MacDonald, "AMPS: The Cellular Concept," *B.S.T.J.*, this issue, pp. 15-41.
6. K. J. S. Chaddha, C. F. Hunnicutt, S. R. Peck, and J. Tebes, Jr., "AMPS: Mobile Telephone Switching Office," *B.S.T.J.*, this issue, pp. 71-95.
7. N. Ehrlich, R. E. Fisher, and T. K. Wingard, "AMPS: Cell-Site Hardware," *B.S.T.J.*, this issue, pp. 153-199.
8. H. W. Nyland, and R. M. Swanson, "Improved Mobile Dial Telephone Service," *Trans. Veh. Comm.*, 12, No. 1 (1963), p. 32-36.
9. FCC Rules and Regulations, Vol. VII, Part 21, Paragraph 21.521.
10. G. A. Arredondo, J. C. Feggeler, and J. I. Smith, "AMPS: Voice and Data Transmission," *B.S.T.J.*, this issue, pp. 97-122.

Advanced Mobile Phone Service:

Mobile Telephone Switching Office

By K. J. S. CHADHA, C. F. HUNNICUTT, S. R. PECK,
and J. TEBES, Jr.

(Manuscript received August 30, 1978)

The Mobile Telephone Switching Office provides centralized control of the Advanced Mobile Phone Service. Using a No. 1/1A Electronic Switching System, the Mobile Telephone Switching Office coordinates and controls the activities of the cell sites, interconnects the mobile telephones with the land telephone network, and maintains system integrity through automated maintenance. This paper gives an overview of the Mobile Telephone Switching Office and addresses the unique call processing and maintenance aspects of mobile telephony.

I. INTRODUCTION

The Advanced Mobile Phone Service (AMPS) provides high-capacity, high-quality mobile telephone service to a large number and variety of customers. The system blends two major communication disciplines: radio transmission and switching. The radio subsystem is based on cellular FM technology^{1,2} operating in the 850-MHz band. The switching subsystem is implemented on the No. 1/1A family of the Electronic Switching Systems (ESS).

As described in Ref. 3, the central coordinating element for AMPS is the Mobile Telephone Switching Office (MTSO). It controls the AMPS system and interfaces it with the land telephone network. The MTSO provides mobile customers with services that are similar to those available for land telephones. Basic mobile service includes direct dialed mobile-to-mobile, mobile-to-land, and land-to-mobile calling. An MTSO serves a large geographic coverage area, and all AMPS mobile calls are switched through it.

The AMPS radio equipment is located in remote cell sites.² Each cell site also contains duplicated stored program controllers, data link interface equipment, and auxiliary maintenance equipment. Cell sites

are connected to the MTSO via voice trunks (referred to as cell-site trunks) and data links.

A high degree of system reliability is attained through automated maintenance. The MTSO controls a number of automated hardware and software maintenance facilities that provide cell-site fault recognition, recovery, and diagnostic capabilities.

II. OVERVIEW OF NO. 1/1A ESS

The No. 1 ESS is described in detail in Ref. 4; the 1A Processor is described in Ref. 5. For completeness, however, an overview of the system is given here. A No. 1 and No. 1A ESS differ in the processor and memory complex.

A No. 1/1A ESS consists of processors, memory, switching network, trunk circuits, and miscellaneous service circuits. This is illustrated in Fig. 1. It is organized as a common control system. Programs that are stored in the switching system's memory provide the logic to control telephone calls. The processors and memory are duplicated for reliability.

The switching network provides a means of interconnecting the lines and trunks. It consists of a matrix of reed switches. Lines from local subscribers terminate on the switching network. Likewise, trunks interconnecting with other switching offices terminate on the network through trunk interface circuits. The reeds are switched under the control of the central processor to produce a metallic voice connection or path between them. The switching network is configured to connect

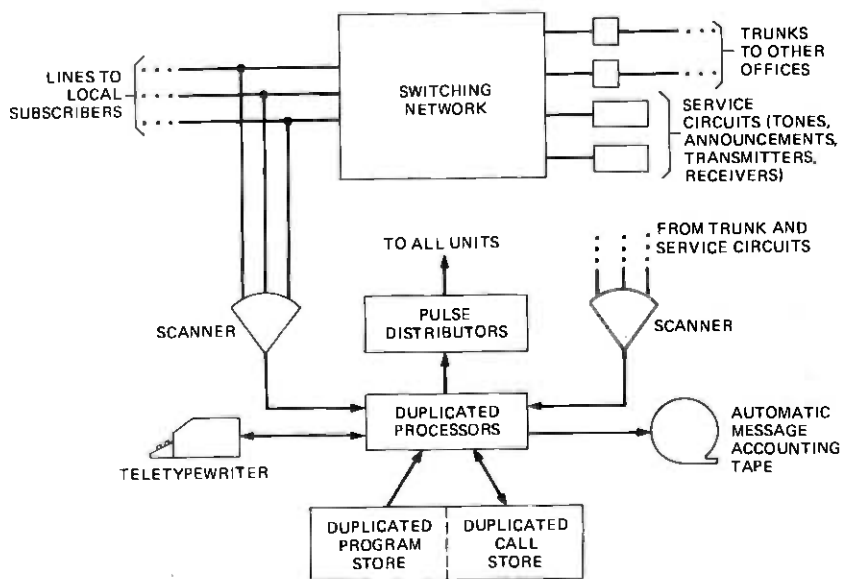

Fig. 1—No. 1/1A ESS block diagram.

any two lines and/or trunks together with an engineered probability of blocking.

As mentioned above, trunks interface to the switching network through trunk circuits which contain interface elements, sensing ferrets for call supervision, and relays to control trunk states for talking, signaling, and testing. A variety of trunk circuits are available, and each application is engineered to meet a particular need, e.g., trunk circuits connected to 2-wire or 4-wire transmission facilities.

The supervisory state of a call is indicated by the presence or absence of a direct-current flow. At least one, and often two, ferrets are employed in every connection (usually in the trunk circuit). Supervisory changes are detected by scanners which are read under the control of the central processor. Stored program control logic then interprets the scanner results. Scanners, then, are the real-time data input devices to the processor.

The central processor controls the switching network and trunk and service circuits by sending orders to them through pulse distributors. The pulse distributors perform an inverse function to the scanners.

Craftpeople interact with the processor through one or more teletypewriters. Through these, the processor prints its output messages and craftpeople input specific commands to the system. Another form of output is the Automatic Message Accounting (AMA) tapes that are used for charge recording data collection. These tape drives only record billing data.

The No. 1/1A ESS operates under the control of its stored program. Three types of programs are resident in the system: call processing, hardware maintenance, and administration. Call processing programs provide the logic that controls call setup and disconnect actions for the wide variety of call types. The maintenance programs provide the means of recognizing hardware failure conditions and reconfiguring the active/standby units to achieve a working system. The maintenance programs also provide diagnosis of suspected failed units to aid in the repair. Administrative programs provide mechanism for changing the system data base. The data base includes customer records, trunk records, billing data, and traffic counts.

An MTSO is built upon standard No. 1/1A ESS hardware. As explained in Section III, the switching operations are all trunk-to-trunk. The logic to control mobile telephone calls and to maintain the cell-site hardware is implemented as an addition to the ESS stored program.

III. MTSO INTERCONNECTION

3.1 MTSO to wire-line network

In the Chicago Equipment Test, the MTSO occupies a position in the switching hierarchy below a class 5, or local, office. This is illustrated in Fig. 2. The MTSO can be interconnected with one or more local offices over standard trunk facilities. Directory numbers for mobile

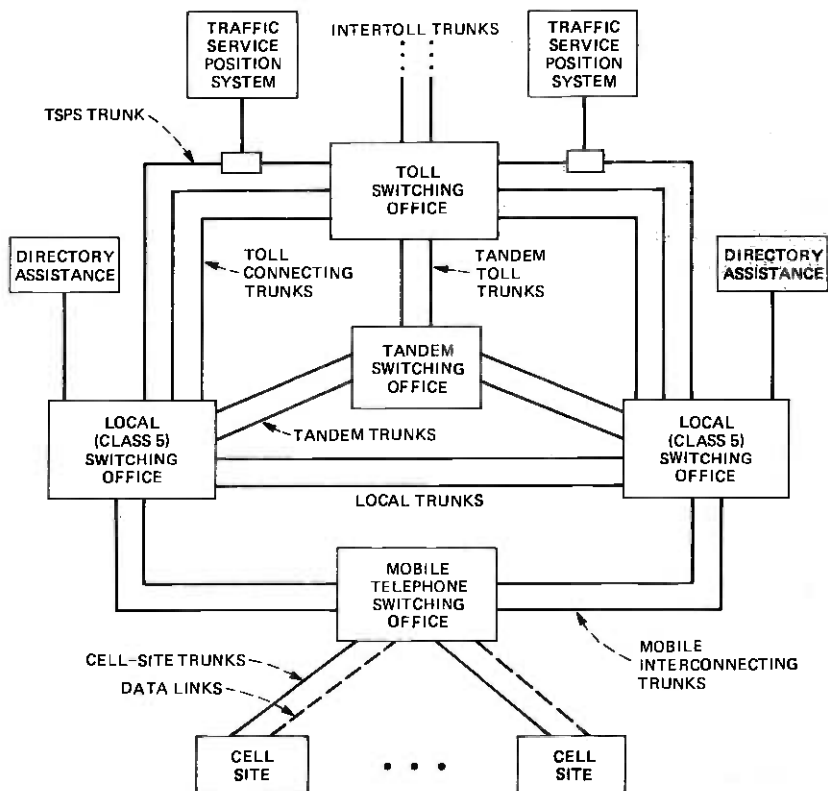

Fig. 2—Position in hierarchy.

telephones are assigned from within the local exchanges that are served by those interconnected offices. The MTSO interconnection arrangement is similar to that used with a Private Branch Exchange (PBX), and it makes use of existing capabilities in ESS local offices.

Mobile-originated calls into the land telephone network are outpulsed from the MTSO using *TOUCH-TONE** signaling. Dial-pulse signaling can also be used. The MTSO selects and seizes the outgoing trunk to the local office. It begins outpulsing the called digits after the local office sends a start pulsing, or wink, signal. The wink is a momentary battery reversal on the trunk. Answer and disconnect supervision signals are returned from the local office to the MTSO allowing charging records to be made.

On land-to-mobile calls, the local office outpulses the called mobile's telephone number to the MTSO using either multifrequency, dial pulse, or *TOUCH-TONE* signaling. The MTSO returns answer and disconnect supervision signals back to the local office.

The MTSO routes calls within the AMPS system and into the wire-line network. The simplest call routing is the mobile-to-mobile call. The

*Registered service mark of AT&T Co.

MTSO receives the dialed digits from the calling mobile, determines that the called number is another mobile, and completes the connection to that called mobile. None of the interconnected offices are involved. This case is illustrated in Fig. 3a.

On direct-dialed, mobile-to-land calls, the MTSO routes the call into the land telephone network through one of the local offices. Routing tables stored in the MTSO provide the association between the called number and the proper local office to be used. For standard calls, the directory number of the calling mobile does not influence the routing. Exceptions to this include operator assistance, emergency service, and repair service. The mobile-to-land connection is shown in Fig. 3b.

Land subscribers can directly dial calls to mobiles. Since mobile directory numbers are assigned from those available in local exchanges, there is a correspondence between each mobile and a particular local office. The land telephone network directs calls to the local office serving the exchange of the called number without knowing the call is to a mobile. Upon receiving such a call, the local office connects that call to a direct trunk to the MTSO which, in turn, completes the connection to the mobile. A land-to-mobile connection is identical to that shown in Fig. 3b.

Operator-assisted and service calls (e.g., repair service) can also be dialed from a mobile. The MTSO does not have direct trunks to operator or service bureau positions. Instead, it makes use of those services already available in the local offices. The MTSO routes these calls to a local office which connects the calls to operator and service position trunks. The call routing is shown in Fig. 3c.

3.2 MTSO to cell site

Figure 4 illustrates the interconnection of the MTSO to several cell sites. Two types of facilities are used. First, cell-site trunks provide a voice communication path. The number of trunks is engineered on the basis of traffic and desired blocking probability. Each trunk is physically connected to a cell-site voice radio. The type of trunk is dependent on the overall system transmission plan. This selection determines the appropriate ESS trunk circuit.

A cell site acts in the radio frequency domain as a traffic concentrator for the MTSO. Assuming an average busy-hour mobile unit occupancy of a few percent and a grade-of-service objective comparable with land service, an average busy-hour radio channel occupancy of at least 60 to 70 percent results for higher traffic cells.

The MTSO also connects with the cell sites through two 2400-baud data links operating in a full duplex mode. Figure 4 illustrates the connection of the data link equipment to the ESS and to the cell site. The data link hardware at the MTSO is not unique to AMPS; it is also used in No. 1 ESS Toll Common Channel Interoffice Signaling (CCIS). A Terminal Access Circuit (TAC) provides the interface between the internal ESS buses and the data link terminals (see Fig. 10). The TACS

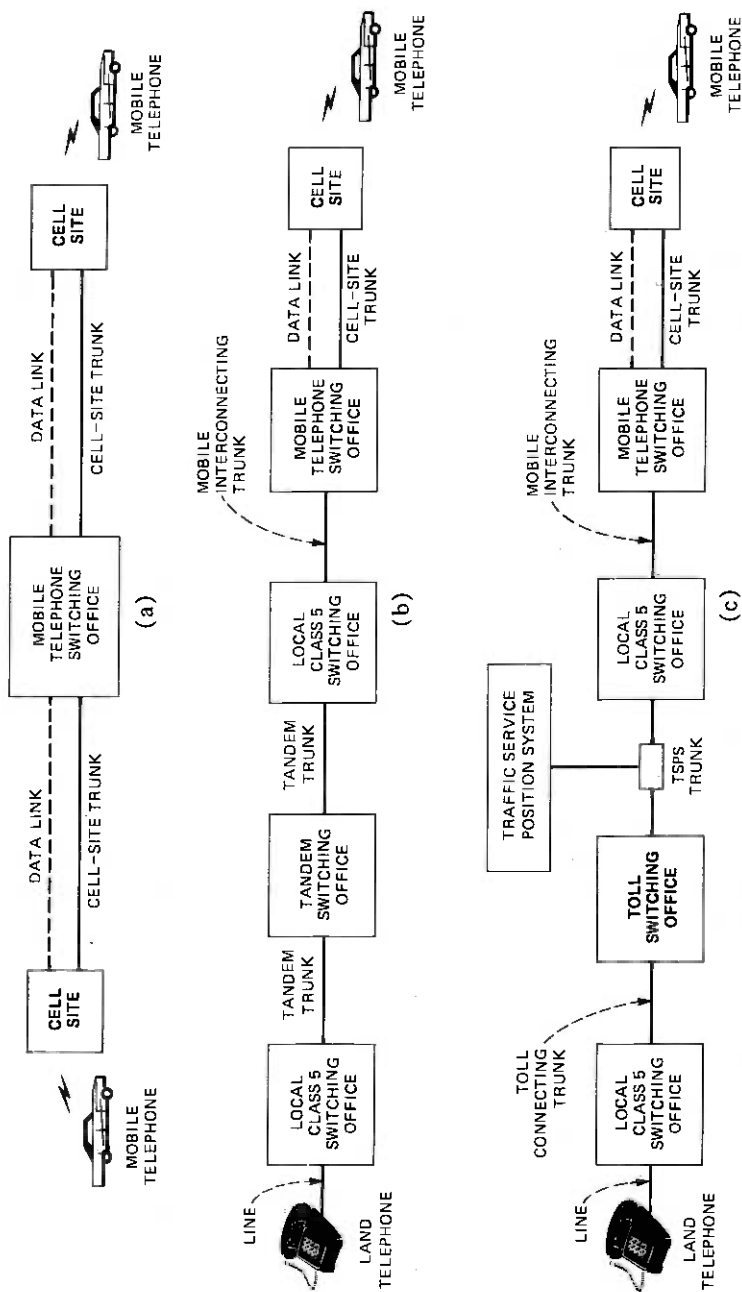

Fig. 3—(a) Mobile-to-mobile call. (b) Typical mobile-to-land call. (c) Typical mobile-originated, operator-assisted call.

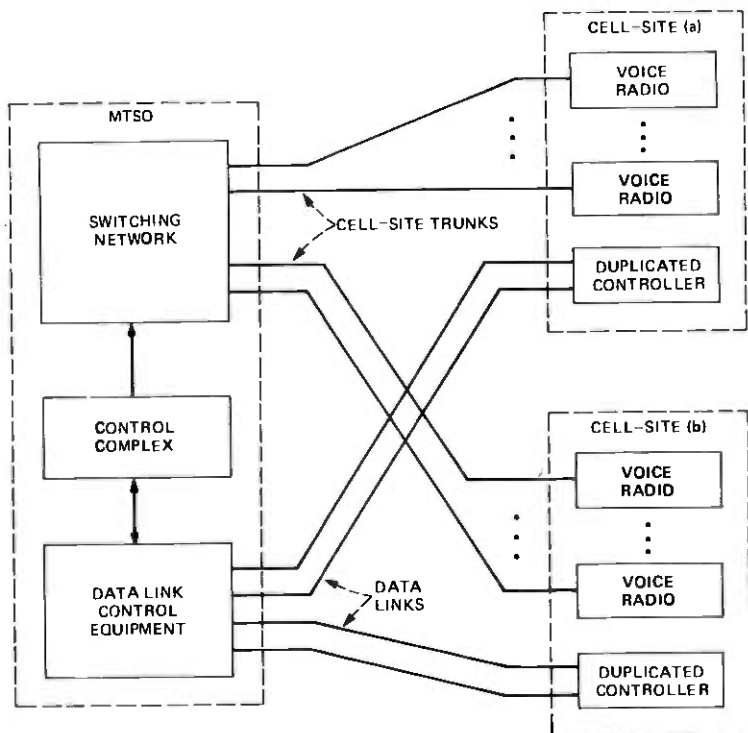

Fig. 4—MTSO—cell-site interconnection.

are duplicated for reliability. A duplicated pair of TACS controls 16 data link terminals, each of which drives two data modems. The data links to each of the cell sites are controlled by different terminals to provide high reliability. In the event of a data link failure, communication can continue between the MTSO and a cell site by reconfiguring either the TAC or terminal, as appropriate.

IV. MTSO CALL PROCESSING

The MTSO is the central controller for processing mobile telephone calls. Reference 3 describes the basic system plan and outlines some representative call sequences. In carrying out these sequences, the MTSO performs a number of functions that differ from a conventional wire-line switch either in the nature of the function itself or in the implementation. Table I illustrates these differences.

The following activities are representative of the MTSO call processing:

- (i) Providing switched interconnection with the land telephone network.
- (ii) Providing switched connections between mobile subscribers served by the MTSO.
- (iii) Administering the usage of the radio voice channels.

Table I—Land switching/mobile switching functional comparison

Function	Local ESS	MTSO
1. Connection	Space division network	Space and distributed frequency division network
2. Control	Central control	Path reconfiguration (handoffs) Central control Remote control (cell sites)
3. Attending (origination)	Scanners	Setup channel location/identification
4. Information receiving and transmitting	Dial pulse <i>TOUCH-TONE</i> ® Standard interoffice signaling	Preorigination digital dialing <i>TOUCH-TONE</i> interoffice signaling
5. Busy testing	Memory function	Memory function
6. Availability testing	Continuity tests	Paging
7. Alerting (ringing)	Subset ringing from CO (90 v, 20 Hz)	Activated in mobile by a digital message from MTSO
8. Supervising (call in progress)	Line scanners	Trunk scanners
9. Monitoring for transmission quality		Location function

(iv) Providing control over signaling with the mobile units.

(v) Providing control of the intercell location process and the resulting handoffs.

(vi) Recording charge information.

(vii) Providing custom services to mobile users.

The following examples illustrate the nature of mobile call processing within the MTSO.

4.1 Mobile-originated calls

The MTSO receives a request for a mobile-originated call as a data message from a cell site. Each origination message contains the calling mobile's identification, the complete called number as dialed, and the serving cell-site identification. The MTSO analyzes the called number. If the origination attempt is correct and allowed, the MTSO selects an outgoing trunk. The MTSO may deny an origination attempt from a restricted subscriber. If an attempt is incorrect or incomplete, the MTSO sends a reorder or intercept data message to the subscriber.

For the successful origination attempts, the MTSO selects an idle cell-site trunk (and associated voice radio). The MTSO sends a data message to the cell site serving the mobile, instructing the mobile to tune to the assigned voice frequency. The MTSO then scans the ferrod associated with the cell-site trunk for an on-hook to off-hook state transition which indicates that the mobile did indeed tune to the new channel. If a voice channel assignment confirmation is not received, the MTSO attempts a single retry. The call is terminated if the retry is not confirmed.

For those calls where the voice channel assignment is successful, the MTSO seizes an outgoing trunk to the local office as determined by digit

analysis. A transmitter is connected, and the called number is outpulsed. At the completion of outpulsing, the cell-site trunk is connected to the outgoing trunk, thereby establishing a talking path. Figure 5 illustrates the mobile-originated call setup switching process and associated signaling.

On each mobile-originated call, the MTSO makes an AMA entry for charging purposes. Section 5.1 elaborates on the contents of the data entry.

4.2 Mobile-completed calls

On a call to a mobile, the MTSO receives the completion attempt on an incoming trunk. It connects a digit receiver and collects the called digits. The MTSO analyzes the digits and identifies the called mobile if the dialed number is valid. Calls to invalid numbers are routed to an intercept announcement. The MTSO then initiates a paging process to locate the mobile within a particular cell. The MTSO does this by sending a data message to each active cell site. Only one cell site should respond, thereby identifying the called mobile's location. Three possible situations can occur. First, only one cell site responds and the call processing proceeds as described below. Second, no response is received. In this case, the MTSO retries the page process one time. A second no-response condition is taken to mean the mobile is not there,

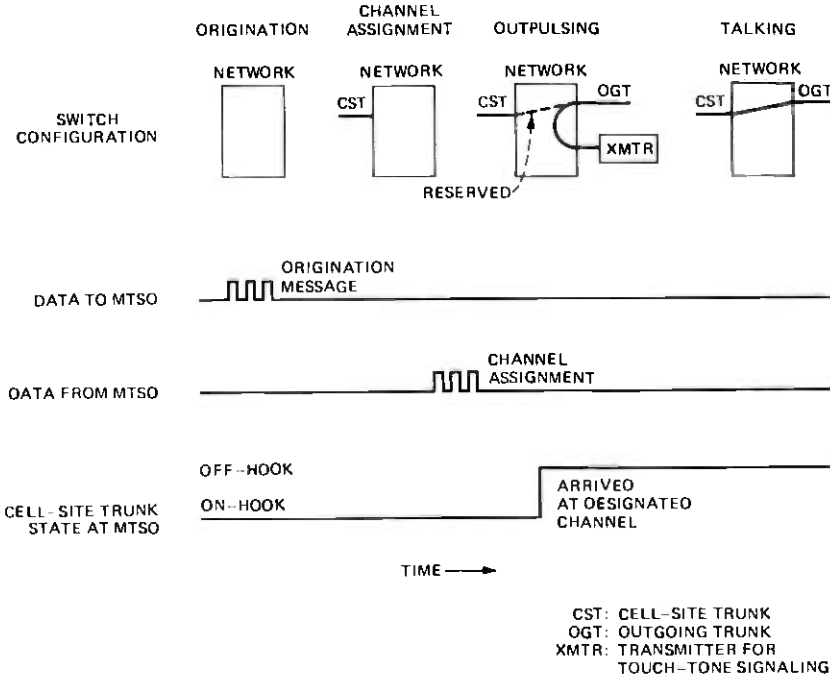

Fig. 5—Mobile-originated call.

and the MTSO connects the calling party to a recorded announcement. Third, more than one response may be received. This is an error condition, and the MTSO attempts to set up the call based on the first response. Subsequent responses are ignored.

For a successful page response, the MTSO directs the mobile to tune to a voice channel in the same manner as described in the previous section. Once the mobile has tuned successfully, the MTSO begins the alerting, or ringing, process. The MTSO alerts the mobile customer by sending a data message which activates an alert facility (ringer) in the mobile unit. The MTSO connects audible ringing tone to the calling party. Confirmation of the mobile's receiving the alert message is seen at the MTSO as an off-hook to on-hook state transition on the cell-site trunk. Next, the MTSO detects the mobile customer answer by scanning for an on-hook to off-hook transition on the cell-site trunk.

When an answer is received, the MTSO removes the audible ringing tone from the incoming trunk. It then connects the incoming trunk with the cell-site trunk, establishing the talking path between the two parties. Figure 6 illustrates the signaling and MTSO switching actions.

4.3 Locating and handoff

Calls in a talking state are supervised for adequate voice channel signal quality by the MTSO through a coordinated effort with the cell

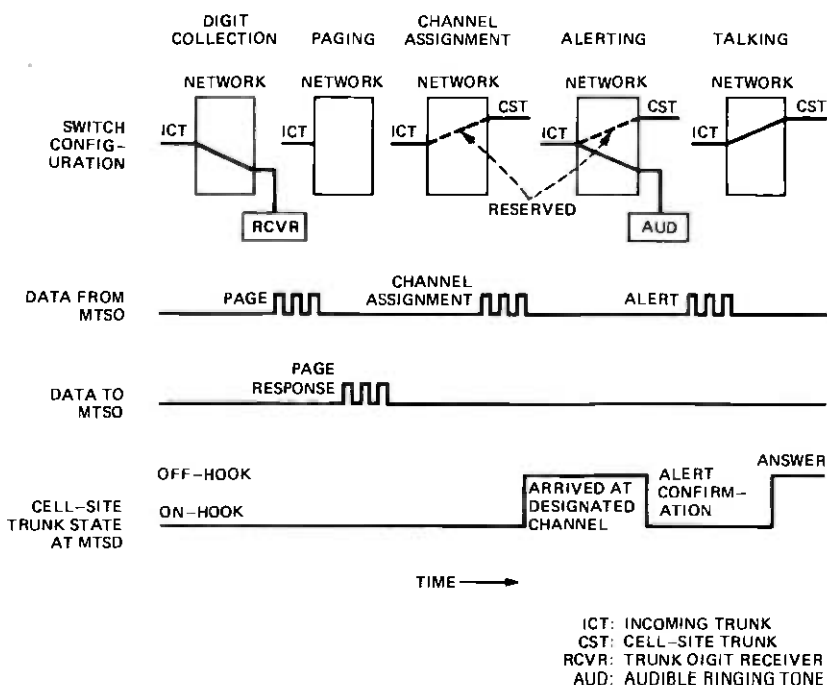

Fig. 6—Mobile-completed call.

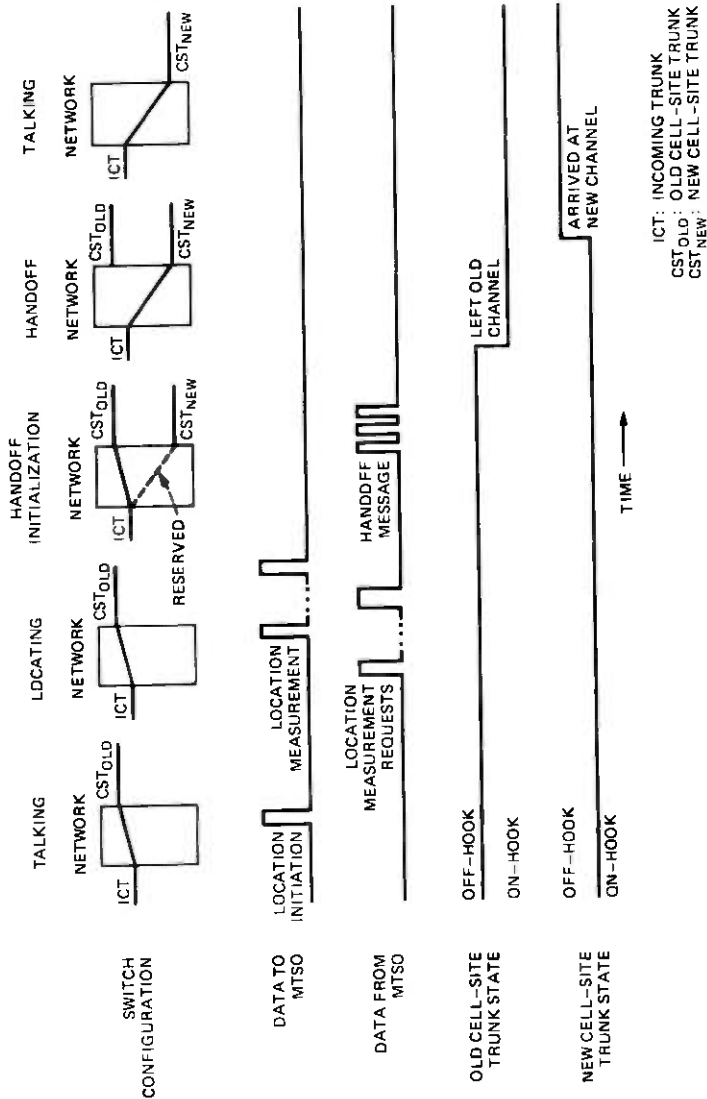

Fig. 7—Handoff.

sites. Under their internal program control, cell sites monitor the received mobile signal quality on all voice channels that are in use. The MTSO collects signal quality information from serving and adjacent cells and determines when a handoff process should be initiated. However, if no cell site can adequately serve the mobile, the MTSO leaves the call undisturbed on the original cell site.

The handoff process involves four operations:

- (i) Selecting a cell-site trunk to the new serving cell site.
- (ii) Instructing the mobile to tune from its present voice channel to the one corresponding to the new cell-site trunk.
- (iii) Setting up a talking path in the switching network from the new cell-site trunk to the incoming or outgoing trunk.
- (iv) Idling the talking path in the switching network between the old cell-site trunk and the incoming or outgoing trunk.

As shown in Fig. 7, the MTSO uses the states of the cell-site trunks to infer the state of the mobile. After the MTSO sends a data message instructing the mobile to tune, it scans the old cell-site trunk for an off-hook to on-hook transition as a confirmation that the mobile left the old voice channel. The MTSO also scans the new cell-site trunk for the opposite transition as a confirmation that the mobile arrived at the new channel. No AMA record is made for handoffs.

4.4 Disconnect

The MTSO is responsible for controlling the states of all equipment in a speech path. This equipment consists of an incoming or outgoing trunk, a switching network path, a cell-site trunk, a cell-site radio (transmitter-receiver pair), and a mobile unit transceiver. During both normal disconnect and failure actions, the MTSO deals with the radio components in addition to the switching network and trunks.

The MTSO turns on a cell-site transmitter when a voice path is set up and turns it off when a voice path is torn down. Thus, cell-site transmitters radiate power only while their associated channels are in use. The MTSO does this by sending data messages to the cell site.

During a normal disconnect where the land party goes on-hook first, the MTSO instructs the mobile via a data message to tune back to the setup channel. This clears the associated voice channel for the next call and puts the mobile in the correct state to initiate or receive its next call. If the mobile disconnects first, it autonomously retunes to the setup channel, and the MTSO turns off the associated cell-site transmitter by sending a data message.

Several ambiguous situations can occur during disconnect processing where the MTSO does not know the true state of the mobile. An example is when no carrier signal from a cell site is seen by a mobile. Here, the mobile autonomously times for several seconds and retunes to the setup channel. Thus, for some time, a mobile may be on a voice channel in an autonomous timing state during a possible disconnect. The MTSO holds the cell-site trunk associated with such a mobile for

a 5- to 6-second guard timing interval. This ensures that the trunk will not be reassigned to a new call before the old mobile leaves the channel.

In addition, mobiles exhibit another characteristic called fading. A mobile may be in a talking situation and drive into a radio path fade due to a poor propagation situation. The MTSO is notified of such an event by the cell site. If the length of a fade exceeds about 5 seconds, the cell site signals this to the MTSO by placing the associated trunk on-hook. The MTSO initiates normal disconnect processing, and it discovers that the disconnect was due to a fade when the cell-site voice transmitter is turned off. The cell site sends a message to the MTSO saying that the call was involved with fade timing. The MTSO records a fade indicator in the AMA record so that billing adjustments can be applied.

4.5 Unsuccessful calls

Calls may be unsuccessful for a variety of reasons including:

- (i) Dialing errors.
- (ii) Equipment malfunctions.
- (iii) Busy conditions.
- (iv) Traffic blocking.
- (v) Signaling errors.

The MTSO has a set of informative recorded announcements and tones which are used to provide indications about call failures to the originating party. For example, traffic-busy conditions are indicated by reorder tone.

Tones given to mobile users may come from either the MTSO tone sources or the mobile unit itself. The MTSO controls the application of the tones. For failures encountered after a mobile has successfully tuned to a voice channel, the MTSO connects the cell-site trunk to the appropriate tone source or announcement. If the failure occurs before voice channel assignment, the MTSO sends a data message instructing the mobile unit to activate an internal tone.

V. MTSO ADMINISTRATIVE PROCESSING

5.1 Billing

The MTSO records all charge-related data for the AMPS system on its AMA tape. In contrast to conventional wire-line switching offices, the MTSO records a billing entry for all calls to a mobile as well as those from a mobile. An entry is made on all calls that successfully tune to a radio voice channel.

For mobile-originated calls, the data that are recorded include the conventional called and calling numbers, answer time, and disconnect time. This portion of the record deals with the message unit and toll charges associated with the wire-line network. Also recorded in the AMA entry is the radio voice channel seizure and release times and the initial cell-site identification. These items pertain to the usage of the AMPS radio facilities.

For mobile-completed calls, the office in which the call originated creates a billing record covering the usage of the land telephone network. The MTSO records the radio usage data (the voice channel seizure and release times and initial cell site).

5.2 Service orders

The MTSO translation data base contains the records associated with each mobile customer. Typical data include:

- (i) Mobile directory number.
- (ii) Billing classification data.
- (iii) Custom services subscribed to.

Each time a customer is added or deleted or changes service options, the MTSO data base is updated accordingly. The records associated with this activity are called service orders.

Clerks receive written orders detailing service changes. They input these orders into the MTSO data base via a teletypewriter.

Messages changing the MTSO data base are called recent change messages. They are processed by an extensive set of MTSO programs which check them for format and data errors. Error conditions are flagged back to the clerk on the teletypewriter. Error-free messages cause the appropriate translation data records to be altered.

5.3 Trunk changes

The number of trunks interconnecting the MTSO with each local office and cell site is engineered based on the expected traffic. Given a traffic load and desired blocking probability, the required number of trunks can be determined. As a system grows, the number of trunks changes. Recent change messages are available in the MTSO to add or delete trunk records in the translation data base. Again, administrative programs process these messages for validity and update the data base accordingly.

One unique aspect of trunk changes in AMPS is a correspondence between a cell-site trunk and a radio voice frequency. The translation data in the MTSO memory associate a cell-site trunk with a specific frequency. When voice-channel frequencies are changed at a cell site, the corresponding trunk translations are altered with recent change messages.

5.4 Traffic measurements

As previously mentioned, the amount of traffic the system carries determines the amount of equipment in the MTSO. The MTSO collects traffic data on call attempts and equipment usage to aid office engineering. The traffic-engineered items include:

- (i) Number of trunks.
- (ii) Number of service circuits.
- (iii) Amount of memory.
- (iv) Amount of switching networks.

- (v) Number of data links.
- (vi) Number of cell sites.

Generally, three counts are maintained on each traffic-engineered component. These counts are total seizure attempts, total blocked attempts, and usage. Seizure attempts and blocked attempts are self-explanatory peg counts. Usage counts are taken at 10 or 100-second intervals. The usage counts indicate how many pieces of equipment in the group are busy at the sample time. The traffic measurements are summarized and printed on the MTSO teletypewriter at various times of the day.

VI. AMPS SYSTEM MAINTENANCE

6.1 System maintenance concepts

The measure of the success of a commercial venture is directly related to customer satisfaction and economic considerations. Telephone customers gauge their satisfaction by low-cost, continuous, accurate service with minimal service delay and/or interruption. System availability is defined as a measure of service continuity and accuracy, while maintainability can be defined as the ease with which failures can be detected, isolated, and corrected.⁴

Common measures of functional system reliability include the following measures, which are graphically illustrated in Fig. 8:

$$A = \text{Availability} = \frac{\text{MUT}}{\text{MTBF}} = \frac{\text{MEAN-UP-TIME}}{\text{MEAN-TIME-BETWEEN-FAILURES}}$$

$$A = 1 - \frac{\text{MEAN-RECOVERY-TIME (MRT)}}{\text{MTBF}}$$

$$DT = \text{Total Down Time Over System Life}(T) = (1 - A)T.$$

While the overall AMPS system objectives are comparable to those for the No. 1 ESS central office, the downtime objectives for a single cell site are somewhat less stringent. This is in part due to the geographic redundancy afforded by the cellular concept. Mobile coverage, albeit sometimes degraded, can be adequately provided by neighboring cells in the mature system.

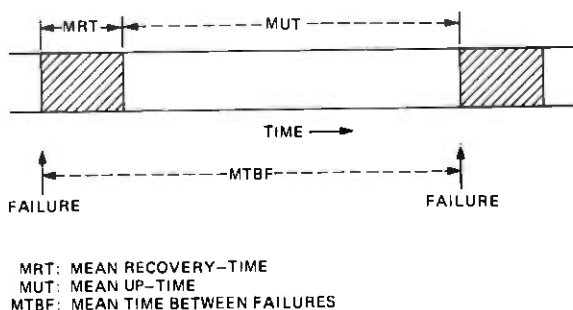

Fig. 8—Equipment availability.

To increase the MTBF of a system, the design must

- (i) Reduce component count.
- (ii) Increase component reliability.
- (iii) Make the system immune to human error.

However, in practice, the aforementioned items may be difficult to achieve. Equivalently, one can increase the availability of the system by reducing the overall system MRT. This can be accomplished by

- (i) Duplicating critical units.
- (ii) Providing good interconnection and automatic switching.
- (iii) Detecting faults rapidly.
- (iv) Providing automatic fault isolation.
- (v) Providing automatic fault location.

6.2 No. 1/1A ESS system maintenance

Maintenance of the 1/1A ESS system is described in Ref. 3. System maintenance emphasizes reductions in the MRT. This is accomplished by employing the following hardware techniques:

- (i) Duplication.
- (ii) Enabling codes and operation verification.
- (iii) Parity and bit corrections.
- (iv) Matched synchronized units.
- (v) Automatic quarantine.
- (vi) Hardcopy memory backup.
- (vii) Control access to stores and peripheral.
- (viii) Roving spares.

The maintenance program has three distinct functions:

- (i) Fault recognition and error recovery to restore the system to an operational state and isolate faulty hardware.
- (ii) Diagnose suspected faulty units and provide fault sectionalization and isolation.
- (iii) Routine exercises to supplement error recovery, fault sectionalization, and early detection of transient problems.

Many of the duplication and maintenance philosophies adopted in No. 1/1A ESS have been adapted to the AMPS cell maintenance software.

Figure 9 is a broad overview of the processing of fault condition within the No. 1/1A ESS.

6.3 Data link terminal access circuit and data terminal maintenance

The Data Terminal frame consists of two types of reconfigurable hardware units. These are the standard data terminal (DTRM) and the terminal access circuit (TAC). The DTRM is an autonomous controller for either one or two data links. Its primary function is to bidirectionally buffer and format data link messages. The DTRM contains a stored program controller which can be updated by the No. 1/1A Processor. The TAC interfaces the No. 1 ESS peripheral system with up to a

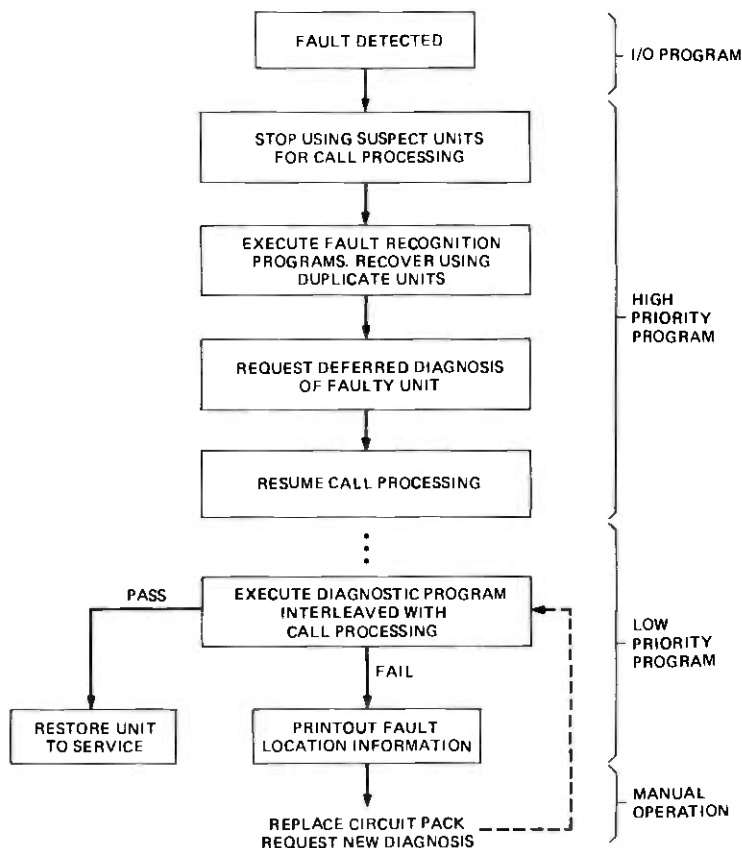

Fig. 9—Reaction to ESS trouble.

maximum of 16 DTRMs. The cell site interconnection is shown in Fig. 10.

When a No. 1/1A Processor executes a peripheral order, several self-checking circuits are activated as part of the I/O process. If one or more of these self-checks fail, an F-level interrupt is generated in the processor, and the F-level recovery programs are immediately given control. Since F-level interrupts are only generated during the execution of peripheral orders, the DTRM cannot always cause an interrupt when the fault occurs. Instead, trouble indicators are buffered in the TAC until a peripheral order is executed. Thus, certain interrupt inducing failures cannot be directly associated with the particular failing orders.

6.3.1 F-Level recovery programs

After a failure of a peripheral operation, the primary function of the F-level recovery programs is to configure a working peripheral system. Two basic techniques are used to isolate troubles in the peripheral

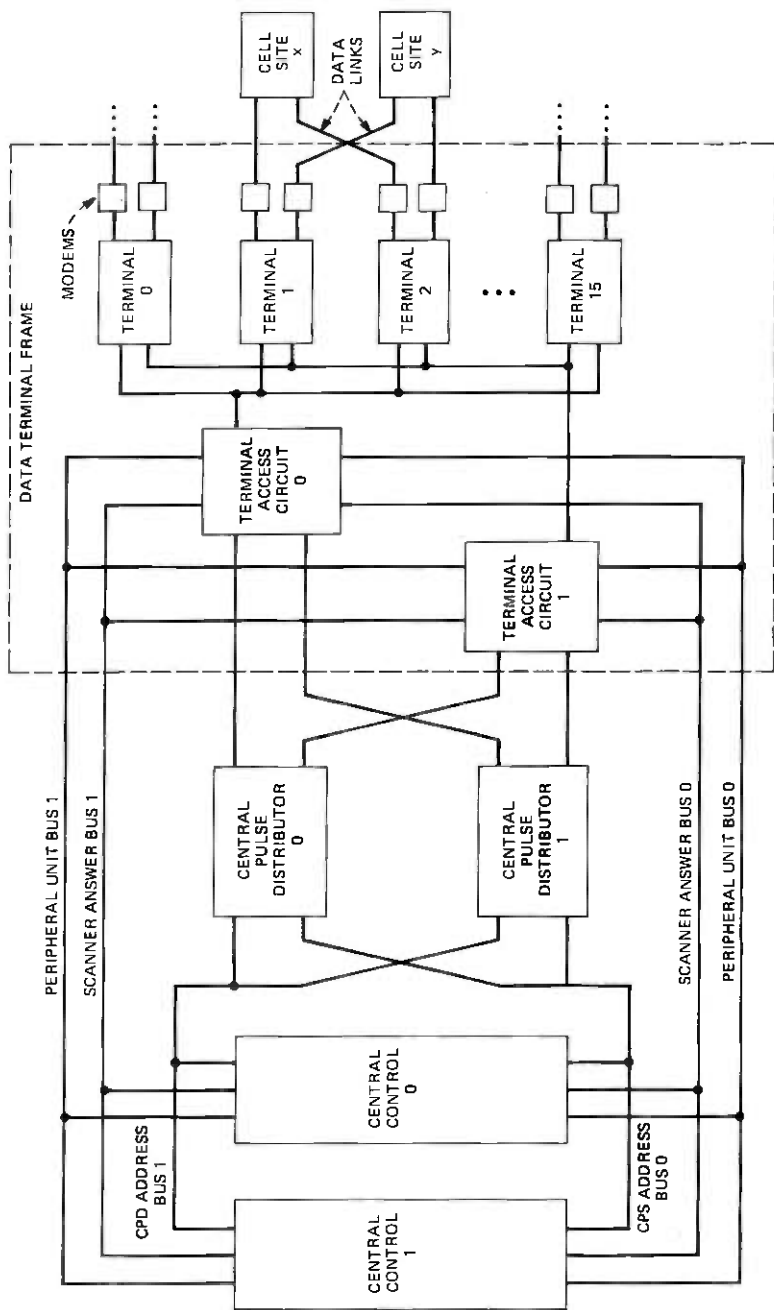

Fig. 10—Data terminal/cell site interconnection.

system: error strategy and fault strategy. The error strategy is utilized when the hardware failure cannot be reproduced (transient trouble). Isolation of the failing element is accomplished by error analysis of the peripheral configuration existing during previous F-level interrupts. The fault strategy is used when the F-level recovery program is able to reproduce the hardware failure indication. The fault can then be isolated by repeatedly reconfiguring the peripheral system and retrying the failing peripheral order until no hardware failure indications are received. After a working peripheral configuration has been determined, the duplicate of the failing element is established as part of the active peripheral configuration and diagnostic tests are requested on elements containing faults.

An inherent characteristic of the fault strategy is that a hardware self-check failure must be reproduced to indicate the fault. When the fault strategy encounters a peripheral configuration which causes no hardware self-check failures, it is assumed to be a working configuration. Because of the complexity of the data terminal frame peripheral elements, the precise environment and failure mode of a faulted element cannot be reproduced with high certainty.

By not attempting to reproduce the environment in the data terminal frame which induced the F-level interrupt, the fault recognition process cannot isolate the faulty element; rather, a peripheral configuration is established by selecting elements which are least likely to be faulty. Unlike the fault strategy, here, the fault is not isolated to a particular inactive element, although the fault is known to reside in some element that has been removed from service. Diagnostics in this case will determine which inactive element(s) are faulty.

A prerequisite for error analysis is statistics gathering. On every F-level interrupt involving a data terminal frame order, records of accumulated errors are updated for active peripheral system elements. These histories are used to establish the next configuration to be tried upon the detection of an error. The interrupt recovery procedure is illustrated in Fig. 11.

6.3.2 Non-Interrupt data terminal maintenance

The F-level recovery procedures are augmented by periodic reconfiguration and diagnostics. The standby data link and associated data terminal/modem are diagnosed immediately upon system initialization and at least once every several hours. Certain failures in the link diagnostic indicate that data terminal/modem problems may exist, in which case a data terminal diagnostic will be automatically invoked.

Since two cell sites share a data terminal/modem pair, the MTSO data link recovery programs must optimize the configuration of the terminals, cell controllers, and data links to maintain continuous communications to both cell sites. Since each cell controller can access all cell-site periphery, the data link configuration may ripple down and require a cell-site peripheral configuration.

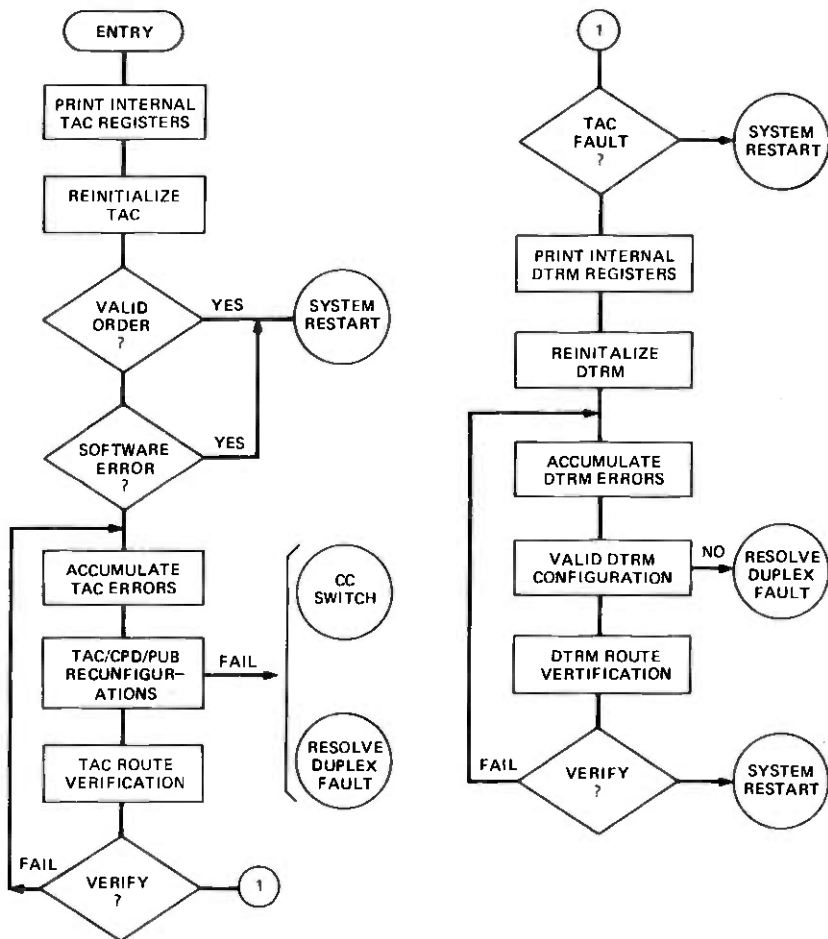

TAC: TERMINAL ACCESS CIRCUIT
 CC: CENTRAL CONTROL
 CPD: CENTRAL PULSE DISTRIBUTOR
 PUB: PERIPHERAL UNIT BUS

Fig. 11—Functional flowchart of data terminal frame, fault recognition.

6.4 Cell site maintenance

AMPS equipment differs from standard central office equipment in that a substantial portion of the common control hardware shared by all users is located remotely from the switching office. Since a remote cell site is an operational extension of the MTSO switching periphery, it requires the same high-quality maintenance considerations as if it were in the central office. AMPS uses a centralized maintenance scheme, with the majority of the cell site maintenance functions being controlled from the MTSO. The cell sites autonomously perform certain

error-detection, correction, and quarantine functions. However, all actions associated with hardware reconfiguration, recovery, transmission testing, and diagnostics are under direct control of the MTSO.

6.4.1 Semi-autonomous cell site maintenance activities

Each cell site is equipped with two independent controllers arranged in a dual-simplex configuration. The controller is a self-checking entity; its static data structures are periodically updated by the MTSO. There is no direct interconnection between the two controllers. Each controller does, however, monitor the condition of its mate.

The cell-site controllers operate as independent multiprocessors. They are software-configured with respect to their periphery. The MTSO provides each cell controller with a mask of allowed periphery. The controllers' masks are mutually exclusive. Each peripheral can receive control signals and data from either controller. The controllers will partially execute all orders received over the incoming data links from the MTSO. The orders will be completed only if that peripheral is allowed to the controller. The active controller is normally granted access to all active peripherals. The standby controller is assigned only to work with the standby data link so that it may report errors to the MTSO concerning the active controller's state. In addition, for some maintenance actions, the MTSO may grant the standby controller access to the off-line, redundant equipment during diagnostic sequences.

The cell-site controller also performs some autonomous error-checking functions to determine its own sanity. The cell-site controller's program audits its internal transient memory structures to ensure that they are logically consistent. To perform this audit, the program utilizes the configuration data for the peripheral provided by the MTSO. In this way, access to the peripherals is limited and the cell site can establish whether or not its peripheral buffers are in a legal state. A cell site will attempt to restore its data memory where possible, by invoking one or more recovery actions when an error is detected. Depending upon the severity of the detected errors, the cell-site controller will notify the MTSO and/or update internal error counters.

The cell-site controller program also provides autonomous recovery from peripheral errors. The program will resynchronize the data links with the MTSO when link errors are detected. Single-bit errors are corrected for data received on the radio data links, and peripheral operations must be restored on parity or read failures. The cell-site controller increments internal counters whenever an error is encountered. These counters are read periodically by the MTSO. These counts are trended based upon expected error rates and are utilized to uncover transient failures or degraded hardware.

If the cell-site controllers lose communication with the MTSO for an extended period of time, they will inhibit data link communication and quarantine themselves from their peripherals. When this happens, the MTSO must restart and/or reinitialize the cell site to regain call proc-

essing capabilities. Alternative, fail-safe mechanisms are also provided to ensure that cell-site transmitters can be turned off even though cell communications have ceased. These are implemented via carrier presence signaling and autonomous cell-site timers.

When a controller hardware error is detected, the controller will be reset to a fixed address and execute sanity checks of the processor complex. If the sanity check executes normally, the controller is restarted. In such a case, the MTSO is notified that an error was detected and a recovery sequence has been run. However, if the error is such that the controller cannot execute the sanity check, the controller takes itself off-line. The standby controller then notifies the MTSO that its mate has encountered an error from which it cannot recover. The resumption of call processing by the standby controller is done only at the direction of the MTSO. Periodically, the cell controllers execute a subset of the sanity checks. If these fail, the controller will take itself off-line and quarantine itself.

6.4.2 MTSO-directed cell site maintenance activities

The cell-site maintenance strategy in the MTSO is to use reliable error indicators coupled with extensive error analysis before invoking any reconfiguration actions. Periodic functional tests are used to exercise the on-line cell site hardware. These tests are run in each cell interleaved with normal call traffic. The periodic functional tests are the primary fault recognition mechanism. A broad overview of the maintenance structure is shown in Fig. 12. The uppermost level in the diagram illustrates the gathering of information that describes the general health of the system. This information includes:

- (i) Hardware faults from functional tests.
- (ii) Autonomous cell hardware error reports.
- (iii) Equipment alarms.
- (iv) Error counts.
- (v) Call failures.

Periodic functional tests are implemented by configuring the maintenance and test frame (MTF) in each cell site to simulate the functions of an operating mobile unit under automatic MTSO control. These tests consist of originating and terminating "calls" to the MTF, locating the MTF, performing handoff, and establishing audio continuity. The tests use the active cell-site equipment complement. These tests are interleaved with normal calls. During these tests, the maintenance and test frame is connected to the cell-site antenna system through the use of directional couplers so that the majority of the radio frequency equipment is included within the test loop. Failures or high-error rates in these tests are considered reliable indicators of cell site equipment problems. In addition, frequency and power tests are used as part of the periodic functional tests to aid in fault segmentation and to provide an early warning of degrading hardware modules. Another important periodic test is the frequency measurement of the cell-site system

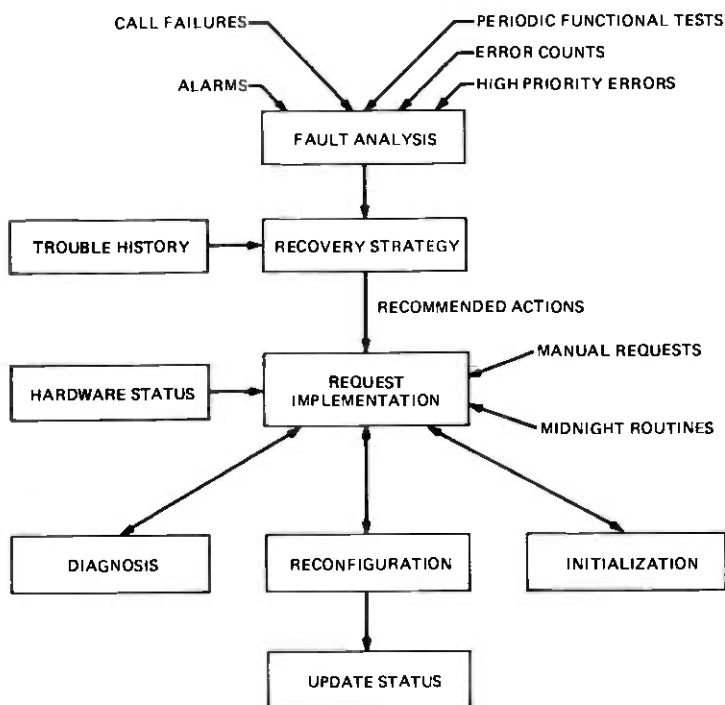

Fig. 12—Reaction to cell-site trouble.

clocks used to synthesize channels and radio carrier. The MTSO runs periodic diagnostic tests on the standby cell-site equipment to verify their readiness to assume active status if necessary. The MTSO will also attempt to diagnose each cell-site trunk at least once a day.

Failures detected during a call sequence are analyzed and logged by the maintenance system. This analysis detects abnormally high rates of failures and attempts to correlate hardware configurations with call failures and to identify malfunctioning equipment. Call failure error analysis is particularly aimed at trunks. If a unit is suspected to have malfunctioned, further tests may be scheduled. The combination of the above processes allows the maintenance system to detect failures reasonably free of the uncertainty due to radio frequency propagation and mobile unit failures.

The results of these tests are processed to determine a recovery action. If a particular unit appears faulty, it is placed out-of-service, and its duplicated mate, if applicable, is made active. The MTSO then initiates diagnostics on the suspected faulty unit. The diagnostics print results on the MTSO's teletypewriter indicating the action to be taken by the craft.

The next level of the cell-site maintenance structure implements the initial fault recognition and recovery strategy. Errors and fault indicators are mapped into a specific request for a maintenance action that

is most likely to eliminate the trouble. A history of previous error reports and device status is maintained. This history is used to determine the next action. Depending upon the source of a maintenance request, the status of the cell, and past activity, a maintenance strategy is automatically generated. The ultimate strategy is to completely reinitialize a cell site. Follow-up work is scheduled after a maintenance action has been taken. Examples include diagnostics or transmission tests on equipment that has been taken out of service and the reinitialization of data link and cell-site units being placed in service. Craft personnel may also initiate any reconfiguration and/or diagnostic tasks.

MTSO-controlled cell-site equipment diagnostics are functional in nature. Segmentation is limited to subfunctions rather than physical circuit boards. Diagnostic access points are limited to the standard peripheral input/output ports and directional antenna couplers. Signals may both be injected and extracted via these couplers. The direction of these samples may be either incident to the transceivers or the antennas. Typical radio tests include:

- (i) Baseband and radio frequency power.
- (ii) Antenna tests including RF standing wave ratio and antenna gain balance.
- (iii) FM deviation measurements.
- (iv) Transmission quality and RF quieting tests.
- (v) Frequency measurements.

In addition, the digital circuitry in the cell site is diagnosed. Typical digital equipment tests include:

- (i) Data bus verification.
- (ii) Parity generator/detector tests.
- (iii) Flip-flop and memory pattern tests.
- (iv) Logic sequencing and hardware lockout tests.

Loop-around facilities are provided on both the land data links and cell-site trunks. The diagnostics routines make extensive use of the looped facilities to perform both voice and data transmission quality tests. Many of the cell hardware components contain self-testing circuits. The diagnostics utilize the self-testing circuits primarily to aid in fault segmentation. Fixed voltage and frequency sources for meters and A to D converters are examples of the self-testing circuits in the cell site. Various self-checking circuits are also included in the cell-site hardware. The diagnostics periodically verify the operation of these circuits to ensure that these circuits will not incorrectly indicate a failed unit.

VII. SUMMARY

The Mobile Telephone Switching Office serves as the central coordinator for the Advanced Mobile Phone Service system. It provides the interface between the cellular mobile system and the land tele-

phone network. The MTSO has two primary responsibilities. First, it controls the mobile telephone calls; second, it controls the automated maintenance activities of the system. The MTSO is implemented on the No. 1/1A family of Electronic Switching Systems.

VIII. ACKNOWLEDGMENTS

Many people contributed to the design and implementation of the Mobile Telephone Switching Office. Several key contributors, in addition to the other B.S.T.J. authors, warrant special recognition. These are D. H. Carbaugh, J. J. Driscoll, R. P. Gornick, R. J. Hass, and B. D. Holm, R. L. Knipper, S. A. Tartarone, S. M. Theiler, and D. Vlack.

REFERENCES

1. R. E. Fisher, "AMPS: A Subscriber Set for the Equipment Test," B.S.T.J., this issue, pp. 123-143.
2. N. Ehrlich, R. E. Fisher, and T. K. Wingard, "AMPS: Cell-Site Hardware," B.S.T.J., this issue, pp. 153-199.
3. Z. C. Fluhr and P. T. Porter, "AMPS: Control Architecture," B.S.T.J., this issue, pp. 43-69.
4. "No. 1 Electronic Switching System," B.S.T.J., 43, No. 5 (Parts 1 and 2) (September 1964), pp. 1831-2609.
5. "1A Processor," B.S.T.J., 56, No. 2 (February 1977), pp. 119-327.

Advanced Mobile Phone Service:

Voice and Data Transmission

By G. A. ARREDONDO, J. C. FEGGELER, and J. I. SMITH

(Manuscript received July 28, 1978)

Use of the AMPS (Advanced Mobile Phone Service) microwave channel, operating in the 800- to 900-MHz band, creates unique problems in addition to those connected with conventional land communications. Because the channel characteristics are not fixed, they present design challenges and impairments that must be dealt with to protect mobile telephone users from experiencing excessive variabilities in voice transmission quality and in control and signaling reliability. This paper describes the radio transmission features of the AMPS system, emphasizing the processing and control techniques designed to deal with the dynamic nature of the mobile radio channel.

I. INTRODUCTION

Transmission of voice and digital control information over the AMPS microwave radio channel in the 800- to 900-MHz frequency range presents significantly different problems than those encountered in conventional land communication systems. Unlike wire-line systems, the channel characteristics are never fixed, but vary with movement of the vehicle and changes in its surroundings. These dynamics give rise to a formidable set of design challenges since the character of the radio channel can change dramatically during a single call as the vehicle moves through the service area and is "handed off" to successive cell sites. Although these channel variations will occur, the radio transmission parameters, and consequently the voice and data transmission functions, have been designed to prevent the user as much as possible from experiencing corresponding changes in voice quality and in control and signaling reliability.

This paper examines the relationship between the impairments produced by the channel and the characteristics of the transmitted waveform. In particular, a consideration of the constraints affecting

the performance of processors for voice and data transmission will provide the rationale for design selections in these areas. A feature of the system is the use of syllabic companding in the voice processor to control the modulation process in the presence of speech variability and also to enable the system to operate effectively in the presence of channel impairments. The technique chosen to transmit signaling data between the cell sites and the mobiles is described in detail. This technique incorporates a self-clocked modulating waveform and contains considerable redundancy to ensure reliable transmission over the mobile telephone channel.

Section II begins with a description of the radio channel. This channel is highly variable—no single set of rules covers all cases—and no attempt is made to qualify every statement with exceptions. However, the main features of the environment at 850 MHz that affect the design are presented, and impairments relevant to the cellular radio environment are outlined.

Baseband performance specifically related to mobile radio is discussed in Section III, along with the modulation methods and signal processing used in the system. Finally, Sections IV and V present an overview of the voice and data transmission methods chosen for AMPS.

II. THE AMPS MICROWAVE CHANNEL

2.1 *Multipath propagation*

Measurements¹⁻⁶ made by Bell Laboratories in Philadelphia, New York City, Whippany and Newark, N. J., and by others elsewhere confirm that a moving vehicle in an urban environment seldom has a direct line-of-sight path to the land transmitter. The propagation path contains many obstacles in the form of buildings and other structures, hills, and also other vehicles. Because there is no unique propagation path between transmitter and receiver, the instantaneous field strength at the mobile and base receivers exhibits a highly variable structure. The measurements show that the main propagation features in the radio environment are (i) multipath due to scatter or reflections from buildings and other obstructions most often within a few hundred feet of the vehicle, and (ii) shadowing of the direct line-of-sight path by intervening features of the terrain.

The received signal at the mobile is the net result of many waves that arrive via multiple paths formed by diffraction and scattering. The amplitude, phase, and angle of arrival of these waves are random, and the short-term statistics of the resultant signal envelope fluctuations over local geographic areas approximate a Rayleigh distribution.

Figure 1 shows a typical envelope of the received signal at a moving antenna measured along a short distance of travel. The so-called Rayleigh signal fades occur approximately one-half wavelength apart because of plane wave interference.² At carrier frequencies near 850

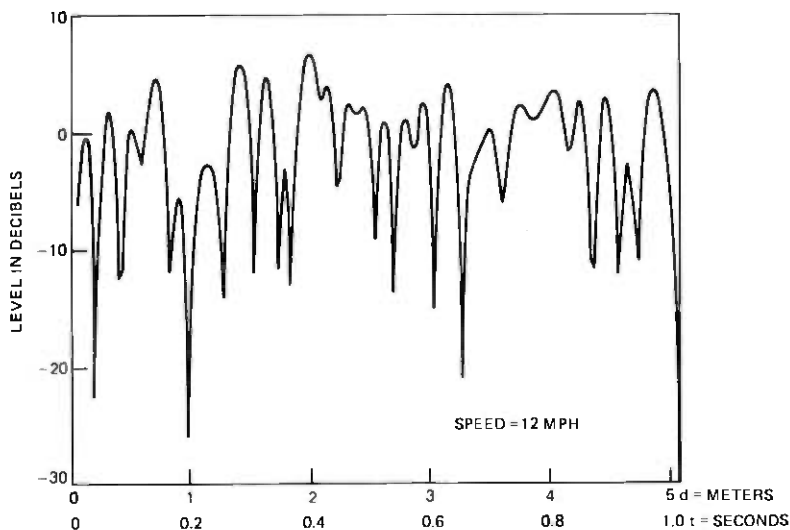

Fig. 1.—Sample of Rayleigh envelope (carrier frequency 850 MHz).

MHz, independent fades are about 7 inches apart. As the mobile receiver moves through the radio interference pattern, it is therefore subjected to frequent fades. By reciprocity, the base station receiver tuned to a different frequency experiences the same sort of fades, although not at exactly the same time. These Rayleigh fades place the most severe limits on the quality of voice and data transmission at UHF.

Signal envelope fades into noise and interference can cause severe degradation in voice and data transmission. Let us look in greater detail at the representation of the multipath fading pattern given in Fig. 1, starting with the amplitude distribution.

Figure 2 shows the probability distribution function of the received instantaneous signal power normalized to its mean value.² The statistics of the fades are such that 10 percent of the time the signal will be 10 dB below its local mean, 1 percent of the time 20 dB below the mean, etc., where mean is defined in the figure as the mean received signal power. The plot in Fig. 1 is in decibels below this mean. Since vehicle motion induces signal fades via the multipath interference pattern, both the fading rate and fade duration depend on vehicle velocity.^{2,7} Figure 3 is a plot, with velocity a parameter, of the rate of level crossing downward through a given level relative to the local mean. At 850 MHz, the rate of crossing a level 10 dB below the local mean happens to be numerically equal to the vehicle speed in miles per hour. Thus, at 20 mph, there will be a fade crossing the -10 dB level an average of 20 times per second. Related to the crossing rate is the average time the fading signal spends below a given level, i.e. the

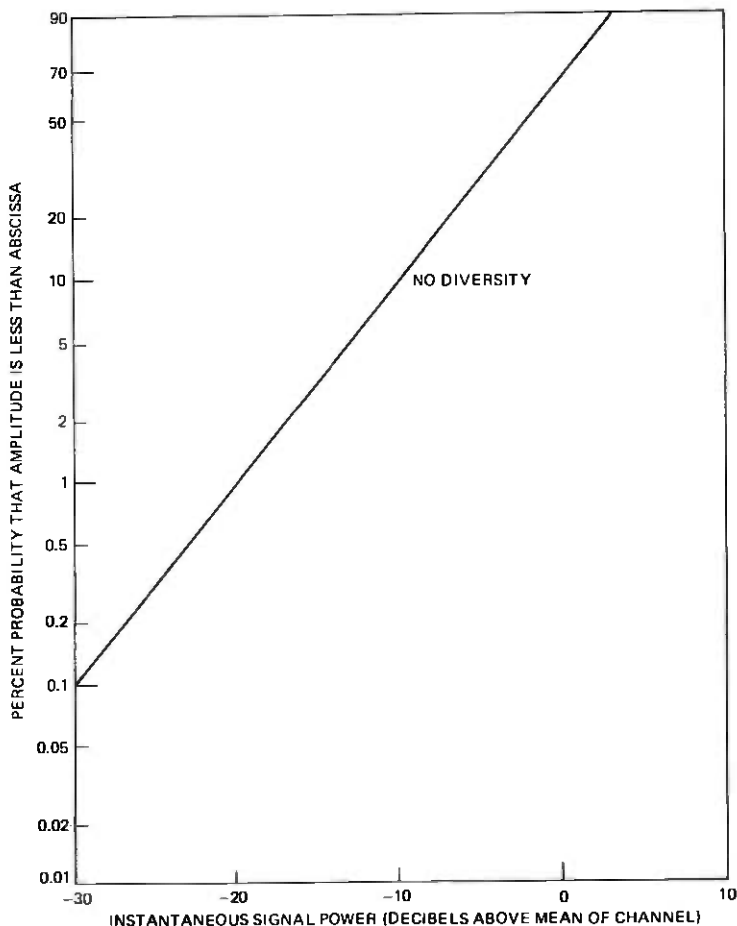

Fig. 2—Amplitude distribution function.

fade duration. The fade duration is inversely proportional to vehicle speed. At 20 mph, the average fade duration below -10 dB is 5 ms, as may be seen in Fig. 4.

In addition to the rapid Rayleigh fluctuations, there are also slower variations due to shadowing by local terrain features. Changes in the local mean-received signal power occur as the vehicle moves. The changes observed in local mean are slow only if compared to the Rayleigh fades, since 5-dB changes in mean signal level in less than 100 feet of vehicle travel are typical. A consistent result observed for these variations is that they have nearly a normal distribution for the received signal level measured in decibels—often referred to as a log-normal distribution. The variance of this log-normal distribution lies between 6 and 10 dB, with the larger variances generally found in heavily built-up urban areas.

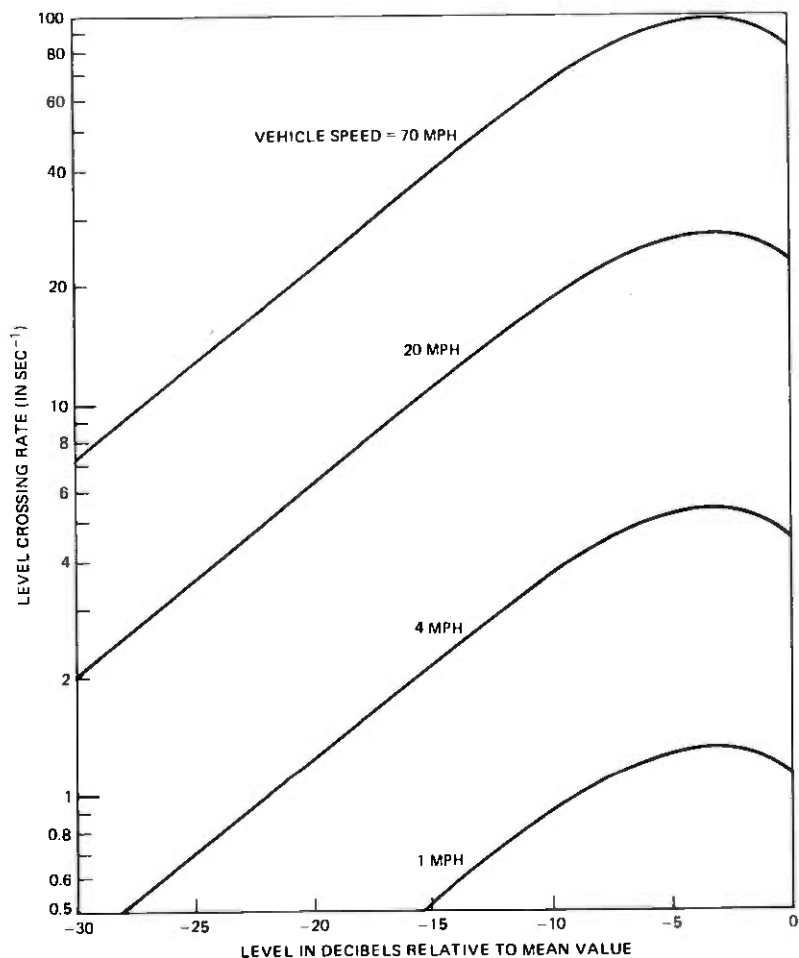

Fig. 3—Level crossing rate.

The delay distribution associated with multipath propagation has also been directly measured.^{4,8} Since the resultant received signal is the superposition of signals which arrive via many paths, a spread in channel delay is observed. Measurements have shown that the received signals have a spread in delay which can be of the order of 3.5 microseconds in urban areas. The delay distortion which can result from this phenomenon provides limitations on the maximum signal bandwidth that can be transmitted over the channel. The delay spread-related coherence bandwidth^{4,8,9} is defined as the bandwidth within which fading has a 0.9 or greater correlation. This bandwidth is usually >40 kHz in urban areas and >250 kHz in most suburban areas, so that frequency selective fading due to delay spread will not significantly

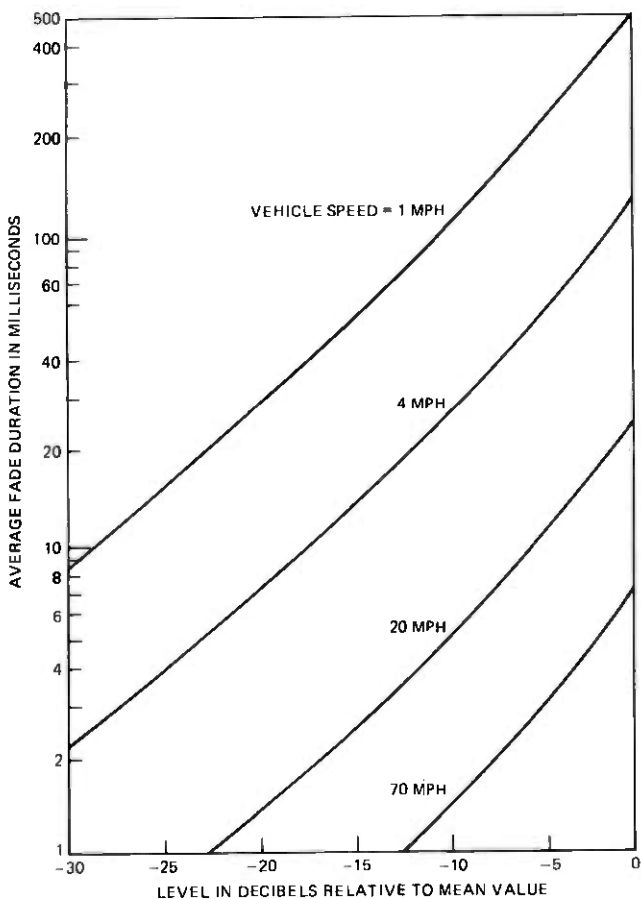

Fig. 4—Average fade duration.

impair transmission performance over the narrowband 30-kHz channels used in the AMPS system.

As the vehicle moves through the fading signal pattern, interruptions of voice modulation or losses of bits in data transmission occur when noise or interference captures the FM receiver during signal fades. The high rate of occurrence of deep fades, particularly those associated with multipath and shown in Fig. 1, provides the major source of transmission impairments in AMPS. While the use of linear modulation such as AM is conceptually possible, the rate of change and depth of fades that can occur at UHF have not permitted satisfactory transmission quality to be attained in this environment with those techniques. Frequency modulation—the approach used in AMPS—avoids the direct effect of these loss variations on information transmission. For this reason, frequency modulation has been selected for transmitting both

speech and the binary data associated with system control functions, and it is in the context of FM with discriminator detection that transmission impairments will be discussed.

2.2 Impairments

The fading signal described in the preceding section will be received in the presence of various sources of impairments including receiver Gaussian noise, random FM, system-generated interference, and man-made environmental noise.

At high carrier-to-receiver thermal noise ratios, the FM receiver is "captured" by the signal, and the conversion to baseband produces a noise component with approximately a Gaussian probability density for the instantaneous voltage and the usual parabolic power spectrum characteristic of discriminator detection.¹⁰ In addition to this "pseudo-Gaussian" noise is the so-called "click" noise¹⁰ that results from capture of the receiver by noise. This impairment occurs with high probability if the instantaneous noise level exceeds the IF signal amplitude, as it often does near the bottom of signal fades. During these intervals, the phase of the composite IF waveform can change by 2π radians in a time period commensurate with the reciprocal of the IF bandwidth. This change causes the discriminator to present an impulse to the baseband processor, with the result that the click noise power spectrum is approximately flat in the voice bandwidth after the FM discriminator. Clicks furnish a major baseband noise component, and arrive in bursts which are time-correlated with RF signal fades.

The same multipath phenomenon that produces Rayleigh fading creates another impairment, referred to as random FM.² Random FM results from vehicle motion, and is due to time variation in the composite phase angle of the multipath signal at the antenna terminals. It provides an additional error component in the discriminator response. The power spectrum at baseband of random FM is a monotonically decreasing function of frequency (Fig. 5). Because of the waveform parameters and processing used in AMPS, random FM represents primarily a lower bound on baseband impairments for voice transmission when other noise and interference sources are removed. It is not a significant factor in AMPS data transmission.

The co-channel interference that results from channels reused in a mature small-cell system creates additional impairments. As discussed in Ref. 11, the system employs frequency reuse. More than one user can share the same channel frequency if they are far enough apart, but since their separation distance is finite, channel reuse generates a form of co-channel interference. The level and distribution of this interference depend on the frequency reuse pattern, and this has been balanced against system cost and performance objectives. Other factors include the implementation specifics, such as antenna height, directiv-

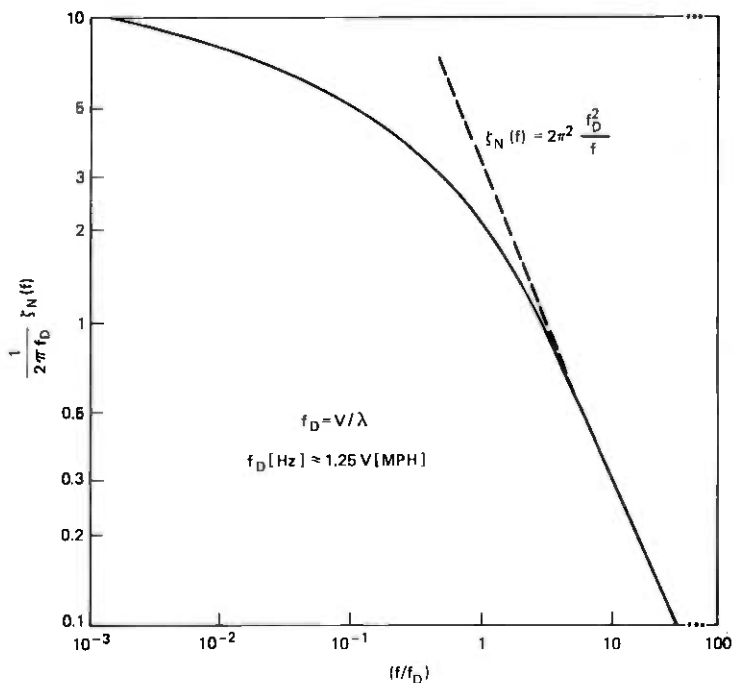

Fig. 5—Power spectrum of random FM.

ity, system handoff and control algorithms, siting requirements, and the channel assignment plan.

During the short-duration Rayleigh fades of the signal envelope caused by vehicle motion, the FM receiver can be captured by interference. The result is a burst of interfering voice modulation which is unintelligible because of the short duration of the fades (Fig. 4). In voice transmission, the relative amplitude of the baseband interference during the burst is dependent on the relative amplitudes of the instantaneous frequency deviation of the interfering and desired voice signals.

In addition, since the signal carrier and the co-channel-interferer carrier will usually be offset (because of oscillator tolerances) by a difference frequency that can fall within the receiver voice bandwidth, a detected difference frequency is sometimes audible as a "wobbling tone." For fading channels, this tone is audible at average carrier-to-interference ratios as high as 30 dB.

An associated side effect of co-channel interference, with offset-carriers, is the creation of additional click-line impairments that affect both voice and data transmission. The presence of a frequency offset increases the rate of occurrence of 2π phase steps due to carrier interference. The amplitude of the resulting interference clicks is generally less than those discussed earlier, since phase changes occur

more slowly than those produced by receiver noise. The rate of phase change for the interference clicks depends primarily on the carrier offset frequency rather than on the IF bandwidth.

Environmental noise provides another source of potential impairment to AMPS transmission. Automotive ignition systems are major noise sources in this category, but others include neon lights, electrical machinery, and arc welding systems. In contrast with receiver Gaussian noise, environmental noise is often nonstationary and impulsive. The intensity of environmental noise is a strong function of local traffic conditions, and can vary from insignificance (many rural and suburban areas) to levels which can completely dominate other sources of noise and interference (intense urban "rush-hour" traffic).

Data have been collected in the central cell region of the Cellular Test Bed¹² in Newark, N.J. to characterize the "impulse" noise environment in a typical urban area. For example, Fig. 6 gives the probability distribution function of the peak power level referred to the antenna terminals (using a 28-kHz predetection filter) produced by impulse-noise in urban Newark. Data for this figure were obtained by first screening the data base to determine the maximum impulse noise level in each half-second data record, and then using these largest values to form the "bounding" distribution function of Fig. 6.

In the AMPS frequency band, the time-density of the impulses is relatively low, so that the ratio of peak to average power is very large.

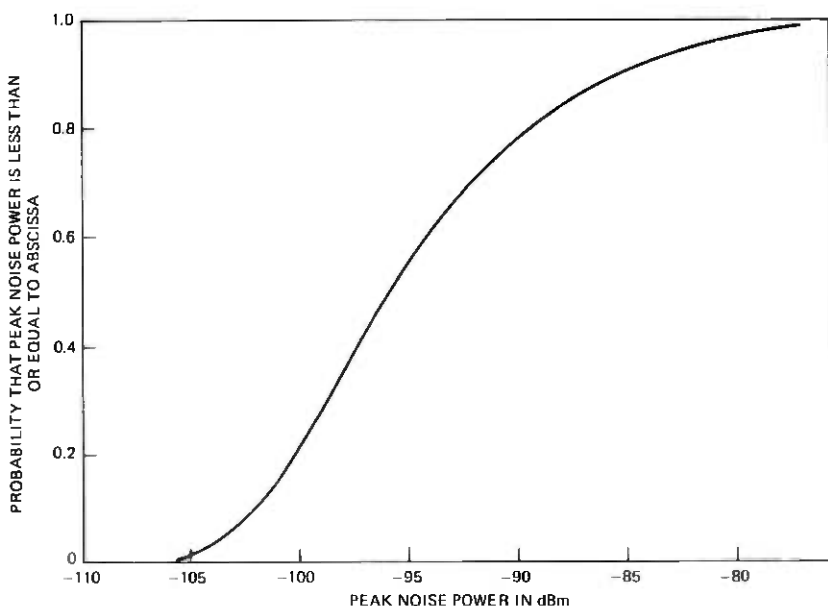

Fig. 6—Distribution function of impulse noise amplitude (848 MHz center frequency, 28 kHz bandwidth).

This is illustrated in Fig. 7, which contains two 1-second noise traces obtained from the Cellular Test Bed. The bottom trace contains post-IF filter noise data obtained by periodically sampling the composite receiver and impulse noise environment. The average noise power implied by this trace is about -120 dBm. The top trace contains only the largest value achieved by the composite noise process between successive points obtained for the bottom trace. For this example, the ratio of peak-to-average power is about 45 dB.

The non-Gaussian nature of this form of noise leads to baseband impairment characteristics different from those generated by receiver noise. The impairment tends to be a repetitive string of pulses, with pulse amplitude dependent on the relative amplitude of the "impulses" and RF signal, as well as the bandwidth and impulse response of the predetection filter. The baseband impairment power is proportional to the pulse rate. To place in perspective the relative importance of environmental noise and receiver Gaussian noise, current results indicate that environmental noise is primarily an urban consideration, and the impact on voice transmission will be more important than its effect on AMPS data transmission. The effect of environmental noise on signaling performance is low because the arrival rates of the noise impulses are low compared with the signaling data rates. Signaling is also aided in this respect by the redundancy used in data coding (Section V).

III. TRANSMISSION

In many FM systems, the capture of the receiver by the signal of interest at modest values (10 dB) of IF S/N or S/I ratio provides an important mechanism for enhancing baseband performance when RF impairments are present. The capture phenomenon is not as dramatic in suppressing impairments in the AMPS system as it is in broadcast nonvehicular FM systems because of the severity and rapidity of the signal fades on the mobile channel. These fades create transitory situations during which the RF signal no longer dominates noise or interference. The resulting loss of signal capture introduces impairments into the baseband response that can be orders of magnitude higher than those experienced with nonfading channels operating at the same average RF signal level. The severity of these impairments will not be uniform over the coverage region of AMPS, but will tend to follow the trends in signal and interference strength dictated by propagation considerations (path loss dependence and shadow fading).

The AMPS system employs both spatial diversity signal reception techniques and specialized designs for the voice and data transmission functions to prevent as much as possible the user from experiencing the effects of channel impairments.

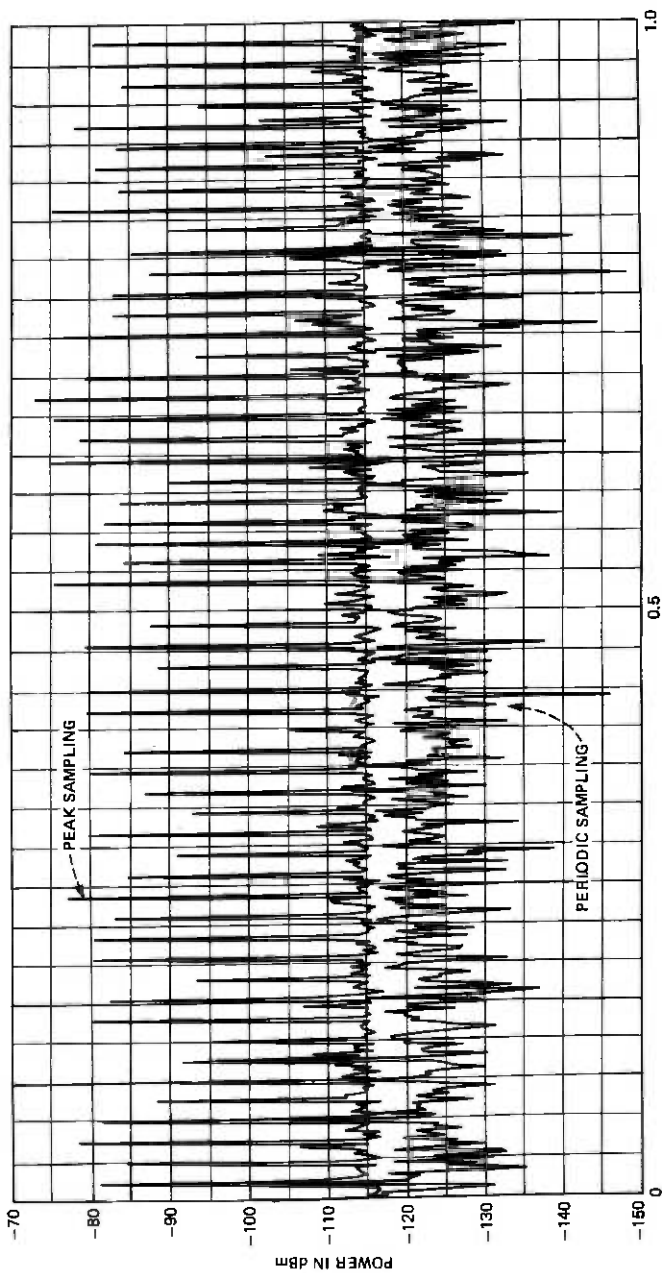

RF NOISE MEASUREMENTS FROM NEWARK - ONE SECOND OF ELAPSED TIME

Fig. 7—Environmental noise trace.

3.1 Channel spacing

In the AMPS system, RF transmission channels are spaced by 30 kHz. This spacing is achieved by limiting to 12 kHz the peak-frequency deviation generated by modulating voice signals, and by applying an RF frequency assignment plan that does not permit the use of adjacent channels in the same cell.¹¹

The frequency spacing of RF voice channels is an important system parameter, as it affects both performance and cost. The voice-channel spacing selected for AMPS reflects a consideration of each of these factors.

For practical reasons, the RF channels cannot be bandlimited prior to transmission from either the cell site or the mobile transmitter. Hence, the potential for transmission impairments that can result from adjacent channel interference is a major consideration.

The peak frequency deviation and baseband spectrum of the modulating signal determine the spectral occupancy of the radiated FM waveform. Adjacent channel interference resulting from "splatter" of this waveform into neighboring channels is influenced by the spacing of the RF channels, the adjacent channel response of the receiver predetection filter, and the geographic separation of adjacent voice channels.

Impairments resulting from adjacent channel interference can be reduced by increasing the frequency spacing of the voice channels. This approach, however, will also reduce the total number of RF channels available for use in the system. A reduction in the number of available channels increases the rate at which cell-splitting must occur in order that the user population be served without excessive facility-blocking. Thus, on the average, fewer users will be served by each cell-site, and an increase in costs will result.

The performance factors related to channel spacing have been investigated in the laboratory by using a Rayleigh Channel Simulator¹³ to test transmission in the various impairment environments. Laboratory data were used to quantify performance sensitivities and tradeoffs. The impairment environments included Gaussian receiver noise, man-made impulse noise, co-channel and adjacent channel interference, random FM, and frequency synthesizer noise. In addition, field data from the Cellular Test Bed have been used to corroborate the laboratory models and results obtained with them.

The results of these tests and also the results of cost-analysis studies were used to establish the channel spacing and waveform parameters that are used in AMPS.

3.2 Diversity

The high rate of occurrence of deep fades, particularly those associated with multipath and represented in Fig. 1, can be reduced by the

use of spatial diversity.² One class of systems using spatial diversity employs signals from two or more antennas that are co-phased and added prior to detection (equal-gain or "Granlund" diversity). Alternatively, the antenna which gives the highest S/N ratio could be selected for signal reception (selection diversity), or outputs of multiple antennas could be switched to a single receiver using a control algorithm that is driven by the detection of signal fades (switched diversity). Spatial diversity can significantly improve transmission performance because of the small probability that all antennas, if spaced a half wavelength or more apart, will simultaneously experience a signal fade. As an illustration, the distribution function for the composite envelope resulting from two-branch, equal-gain, diversity combining is compared with that of a single branch receiver in Fig. 8. With two branches,

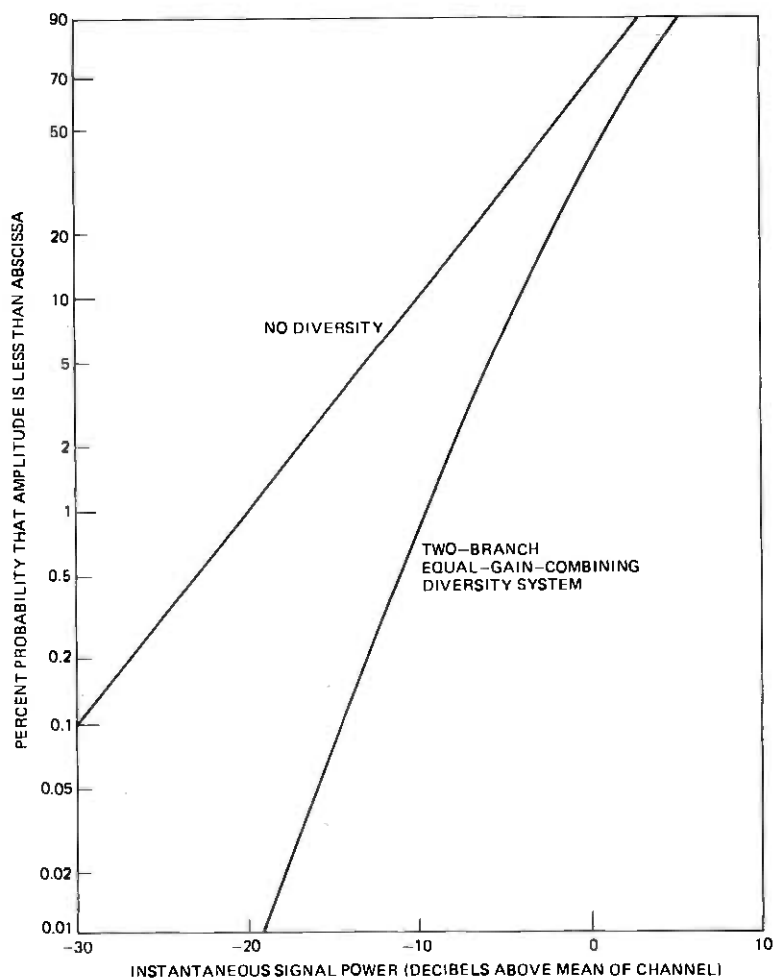

Fig. 8—Amplitude distribution functions.

the probability of fades 10 dB below the mean signal strength decreases to 0.8 percent from the 10-percent probability obtained without diversity. At 18-dB average carrier-to-receiver noise ratio, the resulting improvement in voiceband S/N ratio is about 12 dB.

This substantial improvement is not obtained without cost, however. Equal-gain and selection diversity each require simultaneous dual-channel reception for each diversity branch, including separate antennas and RF units, IF strips, etc., up to the point of the diversity combination. "Switched" diversity requires less duplication of equipment, so it costs less than the others, but it also does not work as well.² In AMPS, current plans are to use equal-gain or selection diversity at the cell sites, where the cost is shared by many users, and to use "switched" diversity in the mobile units.

IV. VOICE PROCESSING

4.1 Considerations

Control of the system RF characteristics, which affect the level of noise and interference impairments in the detected voiceband signal, involves considerations such as effective radiated power, cell radius, and the frequency reuse factor.¹¹ Since practical considerations restrict the flexibility of this type of control, other techniques, in addition to receiver diversity, have been investigated. In AMPS, speech signal processing has provided a relatively economical degree of freedom for substantially improving the quality of service.

In addition to RF considerations discussed earlier, studies¹⁴ have shown that considerable variability exists in talker volumes and in the corresponding amplitude of electrical signals generated by different talkers using telephone microphones. The average signal power at baseband in the FM receiver is proportional to the mean-squared frequency deviation, f_{rms}^2 , produced in the transmitter modulator. To maximize performance in the presence of impairments, it is important that f_{rms}^2 be controlled. In AMPS, the rms frequency deviation for the "nominal" talker is set at 2 kHz.

Previous studies¹⁴ suggest that, in the absence of some type of modulation control, talker and microphone variability will result in a log-normal distribution for f_{rms}^2 , with a standard deviation of about 5 dB. Speech from "weak" talkers will suffer a degradation in receiver-voiceband, signal-to-impairment ratio directly proportional to the reduction in f_{rms}^2 . This reduction directly affects perceived transmission quality, producing a commensurate reduction in the subjective rating of channel quality. At the opposite extreme, speech from "loud" talkers is impaired through excessive "clipping" distortion in the transmitter. (Amplitude clipping is used in the transmit processor to limit the peak-instantaneous frequency-deviation associated with the transmitted waveform so that adjacent-channel interference effects can be con-

trolled.) The baseband processing selected for AMPS provides a means of reducing the effect of variability in volume levels on impairment and distortion performance.

4.2 Description

Figure 9 is a block diagram of the voice processing circuitry. The use of filtering and amplitude limiting in the transmit processor, to control spectrum splatter into adjacent channels (and filtering in the receiver to control the effects of noise), follows typical design procedures for FM systems. The use of differentiator pre-emphasis and integrator de-emphasis to improve performance in the presence of channel impairments is also consistent with standard design approaches. A difference in this application is that, instead of suppressing noise relative to speech as in most FM systems (where the noise characteristics are different from those of the AMPS), de-emphasis here primarily shapes the spectrum of the major noise component (the "clicks") so that it is similar to, and generally subjectively masked by, the presence of speech.¹⁵

The compandor has been found to provide important improvements in AMPS voice transmission quality. It controls the effect of speech level variability on clipping distortion and frequency deviation generated by the modulator, and also improves the subjective quality of the channel when it is operating in the presence of impairments.

Compandors have been used in wire-line telephone circuits to improve performance over relatively noisy paths and also to reduce crosstalk problems. Their use in AM radio systems has been previously considered, but uncertainties in the path loss between transmitter and receiver for various links have forced the use of special channels dedicated to providing control information for the receiver. For analog FM transmission, however, path loss variation (or its equivalent) is far less of a problem than for AM transmission. Thus, use of the compandor in the AMPS system does not require complex special control channels.

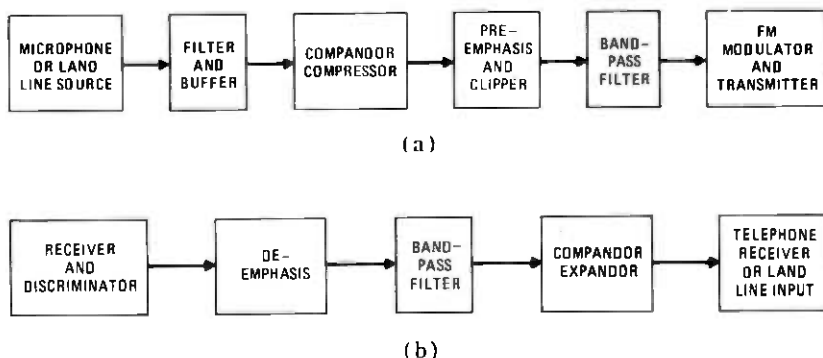

Fig. 9—AMPS audio processor. (a) Transmit processor. (b) Receive processor.

The syllabic compandor is made up of a matched compressor-expander pair with carefully controlled time constants. Both are variable gain devices, with gain control as illustrated in Fig. 10 and nominal input-output characteristics as shown in Fig. 11. The signal-dependent "gain" of the compressor is matched by a complementary signal-dependent "loss" of the expander so that speech may be transmitted without perceptible distortion and level changes. This matching is achieved by balancing and stabilizing the operating point of each of the devices, and insuring that each has the proper time constant for gain control.

The compandor in this application uses attack and recovery times^{16,17} of 3 and 13.5 ms, respectively, which are the CCITT-recommended nominal values. Achieving these values requires smoothing the output of a half-wave rectifier with a low-pass filter having a 20-ms R-C time constant. Although the selected values for the attack and recovery times reflect a compromise between low-frequency distortion and intersyllabic noise-quieting,¹⁷ they serve a dual purpose in mobile telephony. The compressor reduces, by the companding law, the variability in clipping distortion and rms frequency deviation associated with the distribution of speech volumes to which the system will be exposed. The most common companding law for wire-line systems is nominally 2:1, which provides a reduction in the output-level variation by a factor of 2 (in dB) over that of the compressor's input

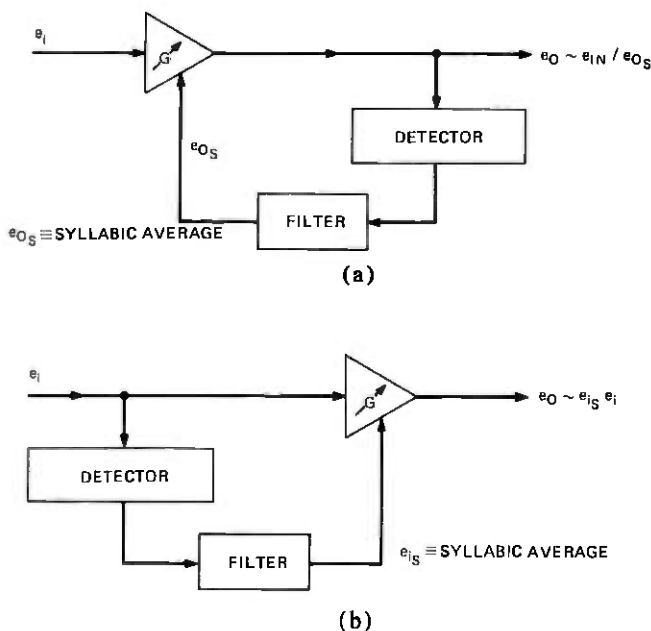

Fig. 10—Compandor operation. (a) 2:1 compressor. (b) 2:1 expander.

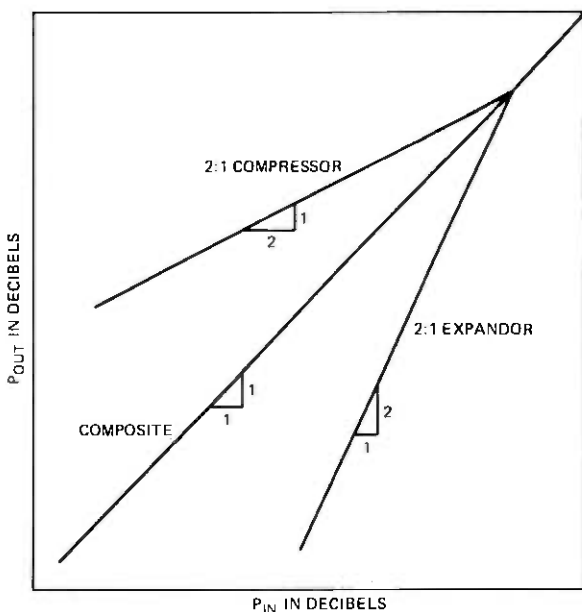

Fig. 11—Input/output characteristic of compandor.

waveform. The compressor's response time is sufficiently slow so that it does not respond to level changes that occur significantly faster than the 20-ms R-C time constant, but restricts primarily the slower syllabic variations. Hence, the compressor does not significantly affect the speech-crest factor and spectral content.

The bandpass filter which precedes the compressor serves to band-limit speech signals so that out-of-band speech energy does not influence the gain of the compressor or affect the inband loss of the amplitude limiter.

The receiver expander not only removes transmitter predistortion created by the compandor compressor, but also suppresses receiver noise and interference relative to speech signals, thereby quieting the receiver. For low-level impairments whose average level varies slowly with respect to the expander response time (such as random FM, Gaussian noise, and the co-channel carrier-offset "wobbling tone"), the expander output signal-to-impairment ratio (in decibels) is improved by a factor that approaches the companding law. This is the typical quieting mechanism for wire-line systems.

The second way in which the audio impairments of mobile radio are suppressed is through the finite response time of the expander. The expander is normally in a high-loss state in the absence of an applied audio signal. Thermal noise clicks present in the receiver-audio-filter response may be larger in amplitude than levels corresponding to

nominal talkers. However, individual clicks at the input to the audio receiver last only about 0.3 ms and lack sufficient energy in the loss control bandwidth to cause the expander to change from its high-loss state fast enough to respond to them.¹⁸ Since expander-loss control is achieved through integration of the received baseband signal by means of a low-pass filter with a time constant of 20 ms, the expander will not be fully driven from its high-loss state by burst of clicks or co-channel interference lasting less than about 20 ms. This inertia in the expander response results from the CCITT attack-time standard, which is made large enough to prevent excessive voice distortion at low frequencies due to compandor action. For mobile telephone operation, this specification serves a dual purpose by inhibiting the expander response to bursts of clicks and interference.

Because of the above attributes, the expander is a very effective suppressor of radio impairments at the receiver, especially in the absence of voice-signal modulation. The quieting is also subjectively evident between syllables and during natural pauses in speech. In addition, noise that is dominated by short-term speech power tends to be masked by speech. This, in conjunction with receiver quieting during the absence of speech, enables the 2:1 compandor/de-emphasis combination to provide a very effective subjective improvement in transmission quality in the presence of radio impairments. The nature and severity of the channel impairments, as discussed, create an acute need for such improvements.

The use of a higher companding law, such as 4:1, to magnify the transmission control and quieting performance of the 2:1 compandor planned for the AMPS system was also considered. Increasing the companding law beyond 2:1 can introduce additional voice transmission impairments¹⁵ because of the impact of the processing between the compressor and expander on the overall net loss of the compandor. Power removed from the speech signal by filtering and amplitude limiting (necessary functions for noise and RF spectrum control) can introduce commensurate syllabic-level variations in the speech signal leaving the receive-audio processor because of the multiplicative effect of the compandor. Limiting the companding law to 2:1 effectively eliminates this distortion mechanism, while still offering most of the subjective performance benefits of higher companding laws when channel impairments are present.

V. DATA TRANSMISSION

5.1 Purpose

Mobile units in the AMPS system respond to orders received from the cell sites, which are in turn controlled via data links from a Mobile Telecommunications Switching Office (MTSO).^{11,19} All phases of the

mobile call, including call setup, handoff between cell sites, and call disconnect require data signaling over the radio channel. On this channel, there are two categories²⁰ of signaling messages—those sent within a continuous stream of bits and those sent as discontinuous bursts. In the first category are mobile pages, system status reports, and various overhead function messages incorporated within a continuous digital stream transmitted over dedicated “paging” channels from the cell site to the mobiles. The second category includes call release and cell-site handoff orders sent to the mobile on the voice channel, and requests sent to the cell site on the appropriate “access” channel by the mobile for access to the system.

The paging message for a mobile consists principally of the mobile telephone number of the vehicle being paged plus some overhead bits as described elsewhere in this issue.²⁰ To the 28 message bits required for a page, 12 additional bits are appended for parity protection, and the encoded message is transmitted at a 10-kb/s rate. An active mobile tunes to the strongest paging channel in its assigned set and monitors the messages received while awaiting its own telephone number. From these messages the mobile can derive instruction pertaining to system access and eventual voice channel assignments.

The transmission rate for mobile access transmissions to the cell site and handoff commands from the cell site to mobile is also 10 kb/s, but these messages are not sent as part of a continuous data stream. To obtain synchronization of the discontinuous message transmission at the mobile or cell site receiver, these transmissions have a synchronization prefix attached that uses an alternating 1010... “dotting” sequence. This sequence, which is recognized as a 5-kHz tone, initializes the phase of a clock that is subsequently updated in a phase-locked loop. The message following the synchronization prefix consists of a burst of 10-kb/s data lasting approximately 100 ms. This message supplies the information necessary to accomplish the discontinuous signaling functions. For all data functions (continuous paging, discontinuous requests for service, handoff, and call disconnect), the messages are automatically repeated to provide five voting detections for each bit. The message repeats are stored and summed (majority voted) at the receiver.

5.2 Carrier modulation

All methods of digital transmission over radio channels are applicable to mobile radio. The method chosen for AMPS uses direct-binary frequency-shift-keying (FSK) of the carrier with discriminator detection. Binary data can be transmitted with FSK modulation up to a rate approximately equal to the IF bandwidth, but for any bit rate an optimum peak deviation exists that minimizes the bit error probability.

For AMPS, a biphas (Manchester), bit-encoding format was adopted. Each logic 1 is encoded as a 0, 1 and each logic 0 as a 1, 0, and the peak frequency deviation chosen to minimize the bit error probability on the fading channel is ± 8 kHz for an RF predetection bandwidth of approximately 30 kHz. The envelope of the Manchester-encoded base-band spectrum, and the resulting RF spectrum, are shown in Figs. 12 and 13. While this coding doubles the effective transmission rate, it does provide several advantages.

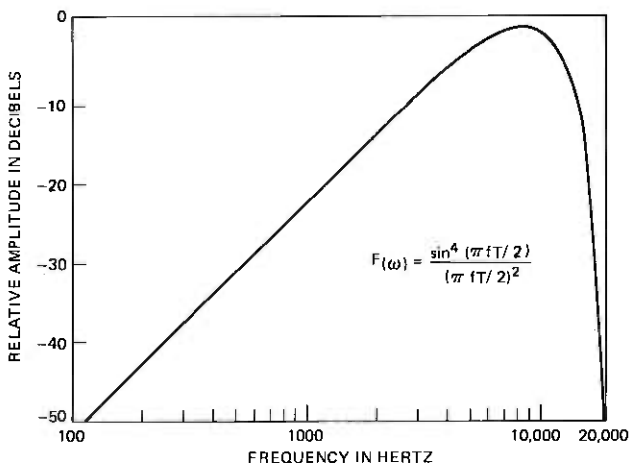

Fig. 12—Power spectrum of Manchester coded data (information rate = 10 kb/s).

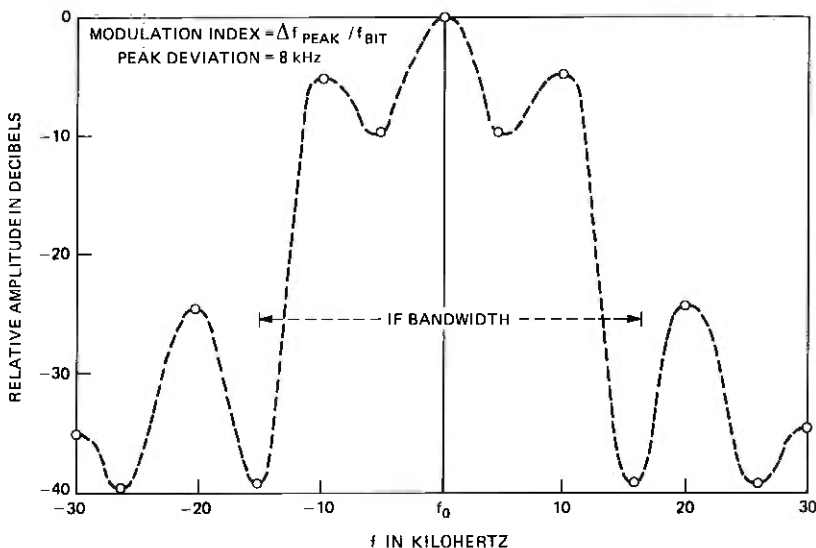

Fig. 13—RF spectrum of FSK signal.

Because of the biphasic coding of the 10-kb/s data stream, the peak of the power spectrum for data transmission is well above the voiceband. This separation is an advantage in a system transmitting both voice and signaling data on the same channel. Synchronization of the receiver to the data stream is also aided by the ever-present biphasic bit transitions which exist independently of the code transmission being sent. Furthermore, since the spectrum of biphasic coding has no zero frequency component, the desired binary FM waveform can be implemented with a phase modulator preceded by an integrator. The maximum modulator phase shift required is the shift over one bit interval (± 0.8 radian), which is within the capability of the phase modulator used for voice signals.

For data transmission as for voice, attention must be focused on the short-term signal-envelope variations (the Rayleigh fades), since for both modulation systems operating at carrier-to-noise or carrier-to-interference ratios of interest, the error performance is dominated by the fading character of the channel. The bit-error probability when the instantaneous carrier envelope is 15 dB above the noise level is, for noncoherent FSK, less than 10^{-7} . However, when the channel is subjected to Rayleigh fading at a 15-dB average carrier-to-noise ratio, the bit-error probability is approximately 3 percent. Thus, most errors occur during deep fades of the signal into noise or co-channel interference as the vehicle moves through the multipath interference pattern. These errors occur in dense bursts associated with the duration of individual signal fades. Furthermore, the bit-error probability is substantially independent of data rate until bit lengths approach the average fade duration. That is, integration over the bit interval cannot improve the error rate unless integration times are at least on the order of the average fade duration. Consequently, data rates should be either very low (200 Hz) or as high as the channel bandwidth allows. Time delay spread, which has no measurable effect on voice transmission, does affect the faster data modulation. The spread in time delay observed^{4,8} results in an irreducible bit error rate for digital transmission that is independent of the noise level. This rate, which is of the order of 10^{-2} or less, is due to FM distortions at baseband created by the delayed echoes at the receiver input. The effect of these echoes on message error rate is negligible because of the large amount of redundancy employed in the system to cope with the more severe effects of signal envelope fades into noise and interference.

The bit-error rate is essentially one-half during fades into noise or interference, and error-burst frequency and duration are related to the speed-dependent fade interval and fade-duration distributions. Figure 14 shows the frequency of error bursts of a given length for a 15-dB average carrier-to-receiver noise ratio. The data shown in this figure were obtained at 20 mph, where the average duration of a fade 15 dB below the mean signal level is approximately 25 bits for a transmission

rate of 10 kb/s. Error bursts of about 10 bits occur 10 times a second, a rate that is the average rate of occurrence of 15 dB fades at 20 mph. Note, however, that longer bursts of 50 bits or more occur every second. The reason for this is that fades below -15 dB have a high probability that they will be of long duration. That is, although the average fade duration of -15 dB fades is about 2.5 ms, durations five times this average are not at all unlikely. The error-burst distribution on a log plot (Fig. 14) is a straight line because the fade-width distribution (Fig. 15) follows an exponential law.

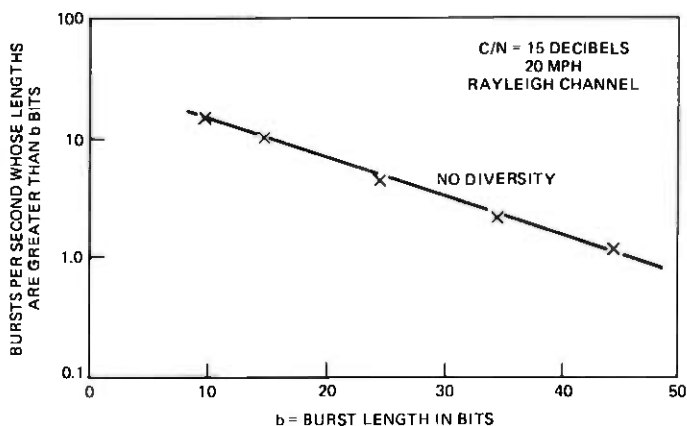

Fig. 14—Frequency of error bursts.

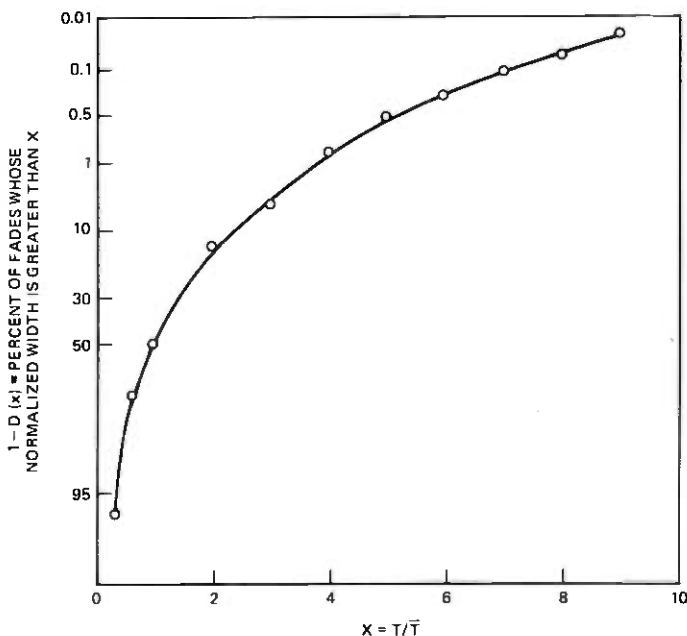

Fig. 15—Fade width distribution function.

5.3 Channel encoding

The virtual certainty that bits in long blocks will be lost for any practical mobile environment places constraints on the type of coding that can be used. Figure 16 illustrates why simple forward-error correction is not practical. To transmit 100 message bits in a fading channel with a message error rate of 2 percent at 15-dB average carrier-to-noise ratio requires a decoder capable of correcting 25 or more errors. One might consider massive interleaving of bits, which will reduce the number of message bits "trapped" by a given fade. Figure 17 shows the results of this on code detection performance. With a 50-bit spacing between each code bit (i.e., 50 words were interleaved to reduce error bursts), the error rate remaining after six error corrections in a 100-bit word is still approximately 5 percent. The effectiveness of bit interleaving in the mobile channel is limited by the high probability of long fades.

The radio channels do not lend themselves to a request for repeat and retransmission when an error is detected. Instead, each message is automatically repeated and the repeats summed to decrease the effective bit-error rate.

Each repetition is encoded with a cyclic redundancy check and the sum word is error-corrected. The usual trade-off is possible between the number of errors corrected and the number of errors detected. A single error correction on the summed message results in a performance comparable to the performance of land data links, and it has the advantage that implementation at the mobile is simple. For both the continuous paging function and the discontinuous functions of handoff on the land-to-mobile link, a 40-bit shortened BCH code (distance 5)

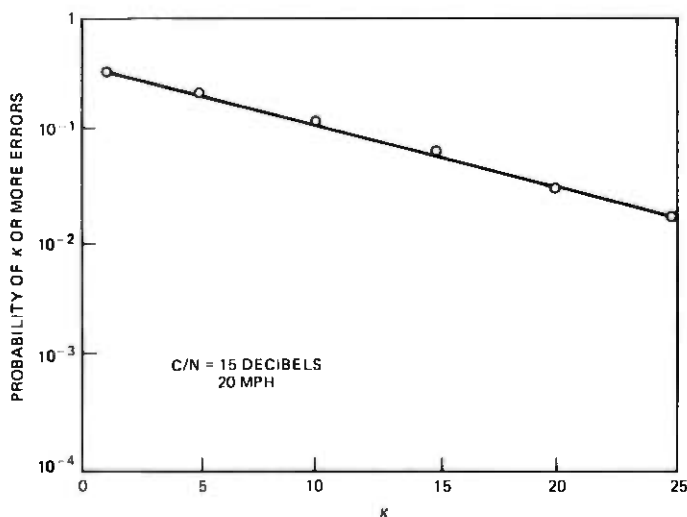

Fig. 16—Error rate distribution for single transmission of a 100-bit word.

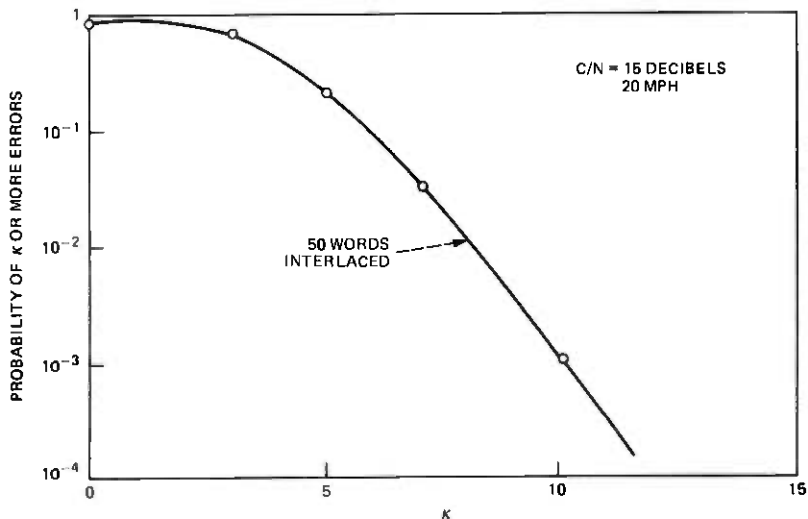

Fig. 17—Error rate distribution for a 100-bit word with bit interlace.

was chosen.²⁰ For the access and vertical services function on the mobile-to-land link, a 48-bit message using the same BCH code was chosen. Each message is given a total of five suitably spaced transmissions, and the five words are summed with bit-by-bit majority voting.* The one-error correction capability results in a word error rate of 2×10^{-3} at 15 dB. Because the probability is high that a given fade will create multiple errors, the spacing of the word-repeats is an important parameter related to the vehicle speed. For the data shown in Figs. 18 and 19, the spacing between corresponding bits in adjacent repetitions is 10 ms (or 100 bits), and is representative of the message formats of the AMPS system.

Message repetition with majority voting and single-error correction has proved to be a simple way to supply reliable signaling over the mobile telephone channel. The redundancy inherent in this approach and the self-clocking nature of the Manchester modulating waveform are the basis of the data transmission technique used to provide the signaling and control information essential to the operation of the system.

VI. CONCLUSION

The characteristics of the urban radio channel in the 800- to 900-MHz band have strongly influenced the design of the voice and data transmission systems in the AMPS system. The dynamic nature of the channel leads to extremely large fluctuations in the transmission

* The land-to-mobile discontinuous message is repeated 11 times, but only 5 of these repeats are loaded. The extra redundancy assures reception of the 5.

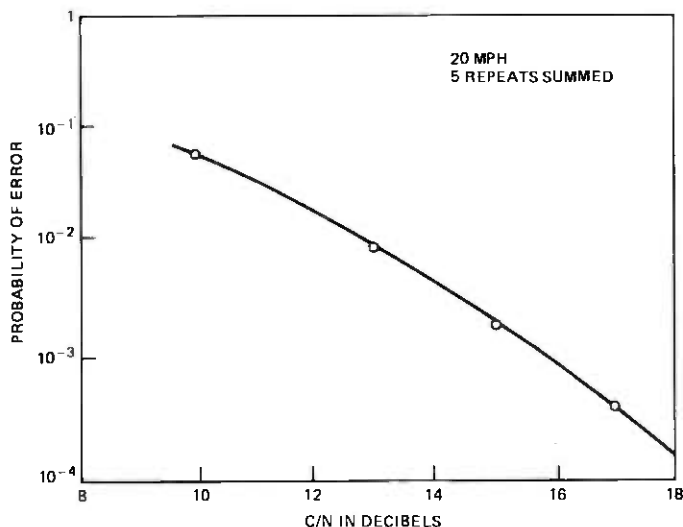

Fig. 18—Error rate for (40,28) code (carrier frequency 850 MHz).

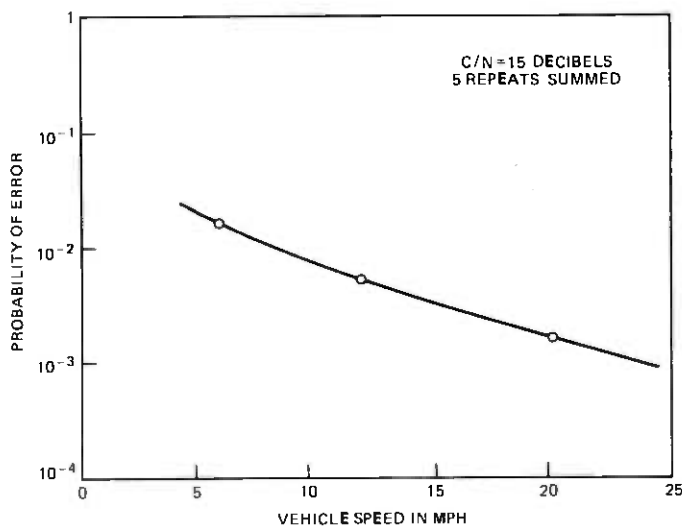

Fig. 19—Error rate vs vehicle speed for a (40,28) code.

environment not only from call to call, but also during individual calls. Since the potential impact of this variability is great, processing precautions have been taken in the AMPS system to prevent the user from experiencing corresponding variabilities in voice transmission quality and control reliability. The techniques themselves have undergone extensive testing, both in a controlled laboratory environment in which the radio channel is simulated and also in an experimental cell site at Whippany, N. J. Testing has also been carried out in the field as part of the Cellular Test Bed experiments in Newark, N. J. as

discussed in Ref. 12. These tests have not only given considerable insight to aid in selection of transmission models and objectives, but also supplied the means by which the design performance could be validated in the field environment.

REFERENCES

1. R. H. Clark, "A Statistical Theory of Mobile Radio Reception," *B.S.T.J.*, 37, No. 6 (July-August 1968), pp. 957-1000.
2. W. C. Jakes, ed., *Microwave Mobile Communications*, New York: John Wiley, 1974.
3. Y. Okumura, E. Ohmori, T. Kawano, and K. Fukuda, "Field Strength and its Variability in VHF and UHF Land-Mobile Radio Service," *Rev. Elec. Comm. Lab.*, 16 (September 1968), pp. 825-873.
4. D. C. Cox and R. P. Leck, "Distribution of Multipath Delay Spread and Average Excess Delay for the 900 MHz Urban Mobile Radio Path," *IEEE Trans. Anten. Prop.*, AP-23 (March 1975), pp. 206-213.
5. W. Rae Young, "Comparison of Mobile Radio Transmission at 150, 4500, 900, and 3700 MC," *B.S.T.J.*, 31, No. 6 (November 1952), pp. 1068-1085.
6. G. L. Turin et al., "A Statistical Model of Urban Multipath Propagation," *IEEE Trans. Veh. Tech.*, VT-21, No. 1 (February 1972), pp. 1-9.
7. G. A. Arredondo and J. I. Smith, "Voice and Data Transmission in a Mobile Radio Channel at 850 MHz," *IEEE Trans. Veh. Tech.*, VT-26, No. 1 (February 1977).
8. D. C. Cox and R. P. Leck, "Correlation Bandwidth and Delay Spread Multipath Propagation Statistics for 910 MHz Urban Mobile Radio Channels," *IEEE Trans. Commun.*, COM-23 (November 1975), pp. 1271-1280.
9. C. C. Bailey and J. C. Lindenlaub, "Further Results Concerning the Effect of Frequency-Selective Fading on Differentially Coherent Matched Filter Receivers," *IEEE Trans. Comm. Sys.*, COM-16 (October 1968), pp. 749-751.
10. S. O. Rice, "Noise in FM Receivers," *Proceeding of the Symposium of Time Series Analysis*, M. Rosenblatt, ed., New York: John Wiley, 1963, Ch 25.
11. V. H. MacDonald, "AMPS: The Cellular Concept," *B.S.T.J.*, this issue, pp. 15-41.
12. G. C. DiPiazza, A. Plitkins, G. I. Zysman, "AMPS: The Cellular Test Bed," *B.S.T.J.*, this issue, pp. 215-248.
13. G. A. Arredondo et al., "A Multipath Fading Simulator for Mobile Radio," *IEEE Trans. Veh. Tech.*, VT-22 (November 1973), pp. 241-244.
14. K. L. McAdoo, "Speech Volumes on Bell System Circuits—1960 Survey," *B.S.T.J.*, 42, No. 7 (September 1963), pp. 1999-2012.
15. G. A. Arredondo and J. C. Feggeler, "The Impact of the Unique Mobile Radio Channel on Information Transmission," 1977 NEC Conference Record, pp. 178-179.
16. R. O. Carter, "Theory of Syllabic Companders," *Proceedings of the IEEE*, 111, No. 3 (March 1964), pp. 503-515.
17. R. Toumani, U. S. Patent 3919654, issued November 11, 1975.
18. J. C. Feggeler, "Experiments with Companding in Mobile Telephony," 1976 ICC Conference Record, II, pp. 27-5 to 27-10.
19. V. Hackenburg, B. D. Holm, and J. I. Smith, "Data Signaling Functions for a Cellular Mobile Telephone System," *IEEE Trans. Veh. Tech.*, VT-26, No. 1 (February 1977).
20. Z. C. Fluhr and P. T. Porter, "AMPS: Control Architecture," *B.S.T.J.*, this issue, pp. 43-69.

Advanced Mobile Phone Service:

A Subscriber Set for the Equipment Test

By R. E. FISHER

(Manuscript received August 1, 1978)

The AMPS mobile telephone subscriber set, which is the mobile customer's link with the switched telephone network, consists of three basic elements: a control unit, a transceiver, and a logic unit. The control unit is the subscriber's primary contact with the AMPS system and is mounted in the passenger compartment of the automobile, within easy reach of the driver. The transceiver unit, generally mounted in the trunk compartment of the automobile, is attached to the control unit, logic unit, and antennas with appropriate interconnecting cables. The logic unit functions as a master controller for the mobile telephone equipment. A microprocessor-based design, using software implemented logic, governs the primary supervisory functions and furnishes operating flexibility.

I. INTRODUCTION

The AMPS mobile telephone subscriber set interfaces the mobile telephone customer with the switched telephone network via a two-way UHF radio path that connects the subscriber's automobile with a cell site. Voice signals, which are frequency-multiplexed with line supervision signals or time-multiplexed with 10-kb/s control signals, flow over this radio path.

The mobile telephone subscriber set consists of three basic elements: a control unit, a transceiver, and a logic unit.

The control unit is the subscriber's primary contact with the AMPS system and is mounted in the passenger compartment of the automobile, within easy reach of the driver and front seat passengers. It serves as the required physical interface between the customer and the telephone network via a handset for acoustical interface, a pushbutton keypad for entering commands into the telephone network, and signal lamps and/or acoustic tones for customer alerting.

The transceiver unit, generally mounted in the trunk compartment

of the automobile, is attached to the control unit and antennas with appropriate interconnecting cables. The transceiver is an all-solid state, full duplex, 850-MHz radio. It features 666 channel operation over the 825- to 845-MHz transmit band and the 870- to 890-MHz receive band, with 45-MHz duplex channel spacing. The transmitter provides 12 watts of output power at the antenna port, with phase-modulated audio or frequency-modulated 10 kb/s data. The receiver amplifies and demodulates selected signals from the diversity antennas and supplies voice output to the control unit and data output to the logic unit for decoding.

The logic unit functions as a master control for the mobile telephone equipment. It encodes and decodes 10 kb/s wideband digital information transmitted between the cell site and the mobile unit, performs transceiver control functions, and supplies user alerting information. A microprocessor-based design, using software-implemented logic, governs the required control functions and furnishes operating flexibility.

Two types of transceivers are being produced by outside manufacturers. The first transceiver uses a separate logic unit designed by Bell Laboratories. The second is a single, integrated transceiver/logic unit package.

The stand-alone transceiver with separate logic unit was installed in approximately 100 mobile units for the Equipment Test phase of a developmental system trial in Chicago¹ during mid-1978.

The integrated transceiver/logic unit package will be installed in approximately 2000 mobile units for the Service Test phase of the Chicago trial during 1979.

This paper describes the stand-alone transceiver, separate logic unit, Equipment Test subscriber unit, since only this unit was available at the time of this writing. However, it has essentially the same operating features as the Service Test unit.

II. CONTROL UNIT

A companion paper² describes the Service Test mobile control unit as well as general guidelines for design of an AMPS control unit based on human factor considerations. In this section, we consider the design of the Equipment Test control unit, which incorporates some of these guidelines.

Figure 1 is a photograph of the Equipment Test control unit which is composed of two sections: a handset and a cradle assembly interconnected to each other by a coiled plastic-covered cable. On the face-down side of the handset are the usual earphone and microphone.*

* In telephone parlance, the microphone is also known as a "transmitter," and the earphone as a "receiver."

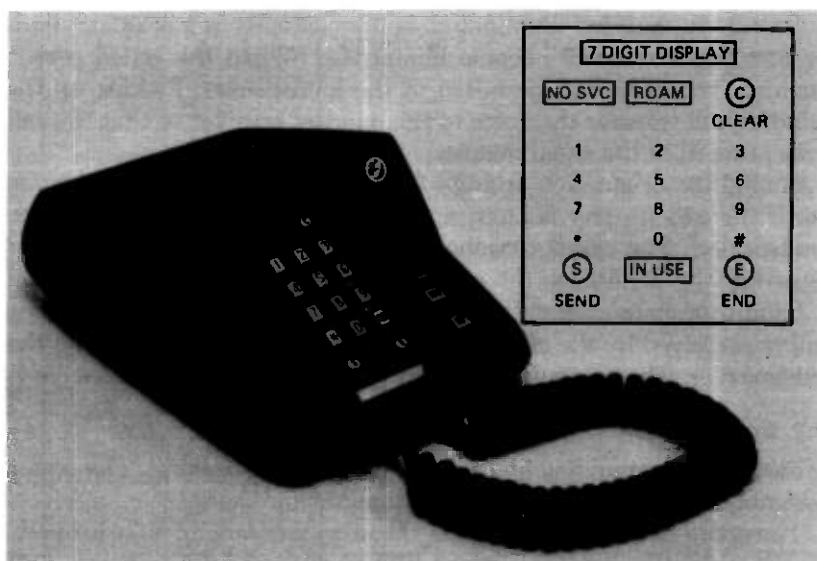

Fig. 1—Equipment test mobile control unit.

The earphone is similar in performance to the land telephone L3 unit, but a dynamic microphone replaces the carbon "transmitter."

The insert on Fig. 1 is a detailed sketch of the back (face-up) side of the handset which contains a dialed digit display, a pushbutton keypad, three call control keys labeled SEND, END, and CLEAR, and three back-illuminated indicator signs labeled NO SVC (no service), ROAM, and IN USE.

The cradle assembly contains a dc power key switch (in the upper right-hand corner), a loudspeaker with volume control, and two push-buttons labeled MW (message waiting) and HF (hands free).

2.1 Control unit operation

To originate a telephone call, the subscriber first turns on the dc power with the keyswitch. The subscriber performs preorigination dialing by depressing, in TOUCH-TONE® service fashion, the proper sequence of numbered pushbuttons. The "dialed" number will appear, moving from right to left, upon the 7-digit fluorescent display. If a 10- (or more) digit number is generated, only the last 7 digits will remain upon the display. If the customer makes a mistake, the CLEAR button should be depressed, which blanks the display so that a new origination attempt can be made.

When the customer is satisfied that the correct number has been entered into the display, call origination is started by depressing the SEND button. If the origination task proceeds successfully, the IN USE

indicator will become illuminated. If the customer is a roamer,* both **IN USE** and **ROAM** will become illuminated. When the called person answers, the voice will be heard in the loudspeaker. Picking up the handset will transfer the voice to the handset receiver so that the call may proceed in the usual manner.

Should the origination attempt fail, the **NO SVC** indicator will come on. If the called party is busy, a reorder tone will be heard from the loudspeaker. The call is terminated by depressing the **END** button or returning the handset to the cradle.

Land-to-mobile calls are processed in the usual way. An incoming call is perceived by the customer by an alerting tone coming from the loudspeaker. The customer responds by picking up the handset.

2.2 Control unit block diagram

Figure 2 is a simplified block diagram of the control unit. The cradle assembly contains two circuit boards: audio and digital.

The audio circuit board contains the necessary amplifiers to properly interface the handset microphone and earphone to the transceiver. It also contains the alerting oscillators, speaker amplifier, and associated volume controls.

The digital circuit board provides the digital interface between handset and logic unit.

The handset is connected to the cradle assembly with a 14-conductor handset cable. For this design, no attempt was made to multiplex the control/indicator functions. Thus, the **SEND**, **END**, **NO SVC**, **ROAM**, and **IN USE** functions are interconnected with the logic unit on essentially a one-wire-per-function basis.

When a numbered pushbutton is depressed during dialing, the decimal digit is first converted to a 4-bit binary number stored in a 64-bit recirculating shift register in the handset. The "dialed" digits, circulating around the shift register, drive the time-multiplexed, seven-segment, seven-digit fluorescent display. When the user depresses the **SEND** key to originate a call, the logic unit reads the recirculating shift register serially and stores the digits in the microprocessor random access memory (RAM).

III. TRANSCIVER UNIT

Figure 3 is a photograph of the Equipment Test transceiver unit, mounted on top of its companion logic unit. Because the mobile transceiver is basically a reversed† cell-site transmitter-receiver, many

* A "roamer" is a mobile customer obtaining service in a foreign (non-home) Mobile Service Area (MSA). Roaming services have been defined in Ref. 3.

† The transmit and receive bands are interchanged (reversed).

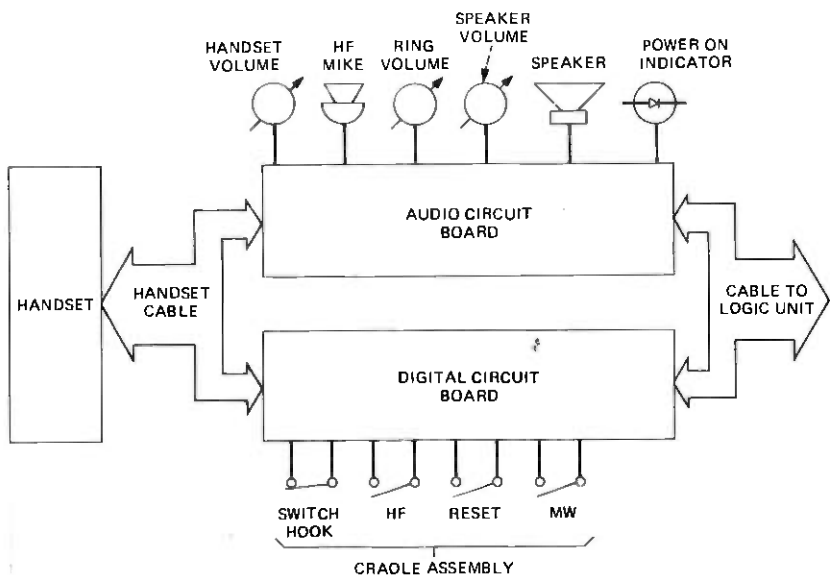

Fig. 2—Block diagram of control unit.

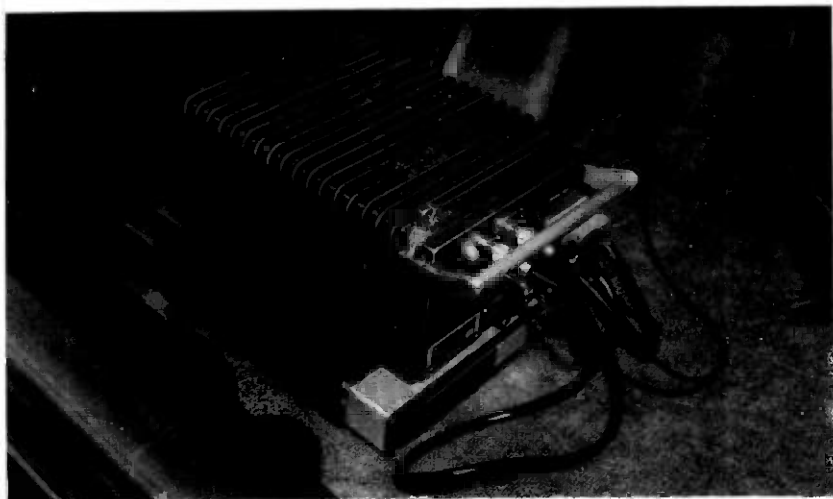

Fig. 3—Transceiver/logic unit.

transceiver subsections share a commonality with the cell-site radio described in Ref. 4. Thus, this section covers in depth only those transceiver subsections that differ substantially from any counterpart within the cell site.

The AMPS transceiver must have capabilities not found in present

mobile telephone systems. First, it must, upon command from the cell site, generate any one of several hundred RF channels. This new function requires a sophisticated frequency synthesizer. Second, the mobile unit must use space diversity to protect the RF channel against Rayleigh fading, thus allowing larger cells and closer frequency reuse. Third, new circuit technologies, such as high-level integration, must be used to reduce the mobile cost significantly.

The transceiver unit (see the block diagram in Fig. 4) is a sophisticated FM transmitter-receiver. It supplies duplex voice transmission and reception by dividing the RF band into two segments separated by the 45-MHz IF frequency, so that one frequency-generating system may serve as the source of both transmitter and local oscillator power.

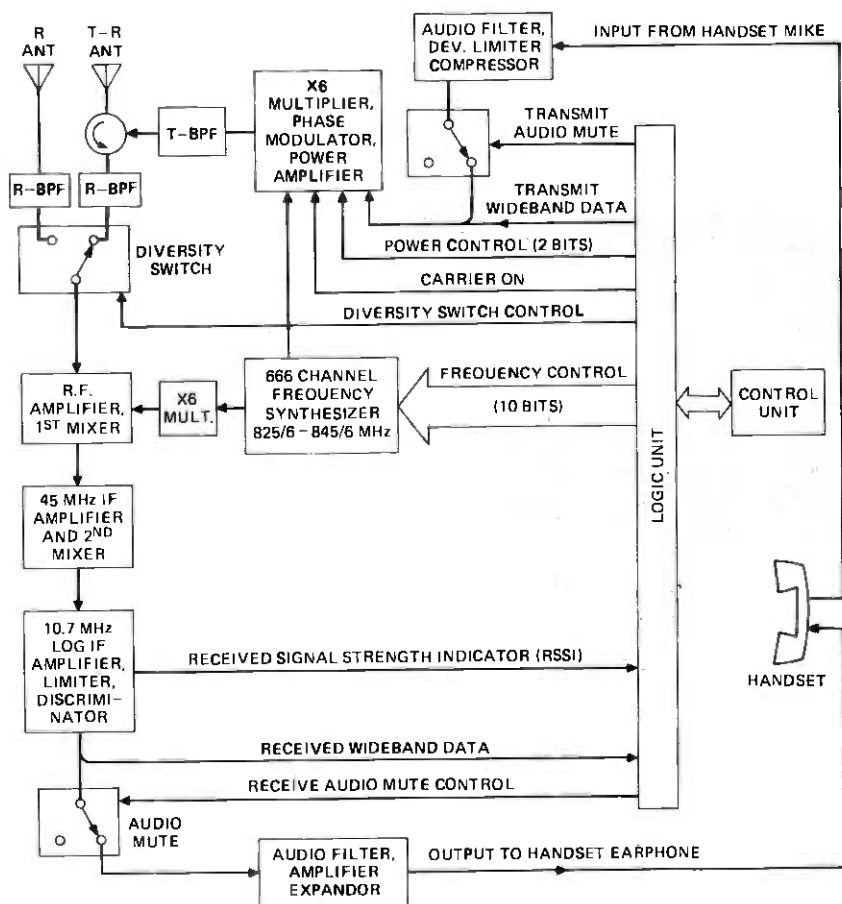

Fig. 4—Mobile transceiver block diagram.

The transceiver unit consists of several basic blocks operating together in the following manner: First, the frequency synthesizer generates any one of the 666 stable carriers upon digital command from the logic unit. Each milliwatt carrier is located in the 140-MHz region, which is $\frac{1}{6}$ of the final output frequency. A portion of the synthesizer power output is phase-modulated with audio from the telephone handset or frequency-modulated with wideband data from the logic unit. It is then multiplied in frequency six times and amplified in power to 12 watts by a transistorized modulator-multiplier-amplifier chain. The resulting signal, after being filtered for harmonic and spurious signals by a seven-stage 825- to 845-MHz transmit bandpass filter (T-BPF), is radiated by the vertically polarized transmit-receive (T-R) antenna.

Received signals entering the receive (R) and T-R antennas arrive at two identical seven-section, 870- to 890-MHz receive bandpass filters (R-BPF) that perform two functions: one ensures that the transmitter signal reflected by the T-R antenna (due to imperfect impedance match) will not overload the first mixer; the other protects the mixer from out-of-band signals such as nearby UHF TV transmitters.

The bandpass filter output signals enter the diversity switch, a PIN diode type actuated by a binary switching signal originating in the logic unit. The diversity switch output signal enters the radio frequency (RF) amplifier, then the first mixer where it is combined with a local oscillator (LO) derived from the frequency synthesizer and a low-power (10 mW) "times six" transistor frequency multiplier. Since the transmitter and LO are at the same frequency, the IF frequency is 45.0 MHz, the difference between the transmit and receive frequencies.

The mixer output at 45.0 MHz is amplified by a single-stage IF amplifier, and then down-converted by the second mixer to a second IF frequency of 10.7 MHz. The output is then filtered, limited, and finally demodulated by a frequency discriminator. The resulting audio or wideband data passes to the telephone handset receiver or to the logic unit, respectively.

3.1 Frequency synthesizer

The frequency synthesizer (Figure 5) generates any one of 666 stable carriers upon digital command from 10 parallel binary lines originating in the logic unit. Each milliwatt carrier, located in the 140-MHz region, is stable in frequency to within ± 2.5 parts per million over a -40° C to $+70^{\circ}$ C temperature range.

A relatively unstable voltage controlled oscillator (vco) generates the output carrier frequency f_0 . A portion of the output carrier power enters a mixer where it is heterodyned against the third harmonic of a master crystal oscillator operating at $f_{1/3} = 43.92$ MHz. The difference

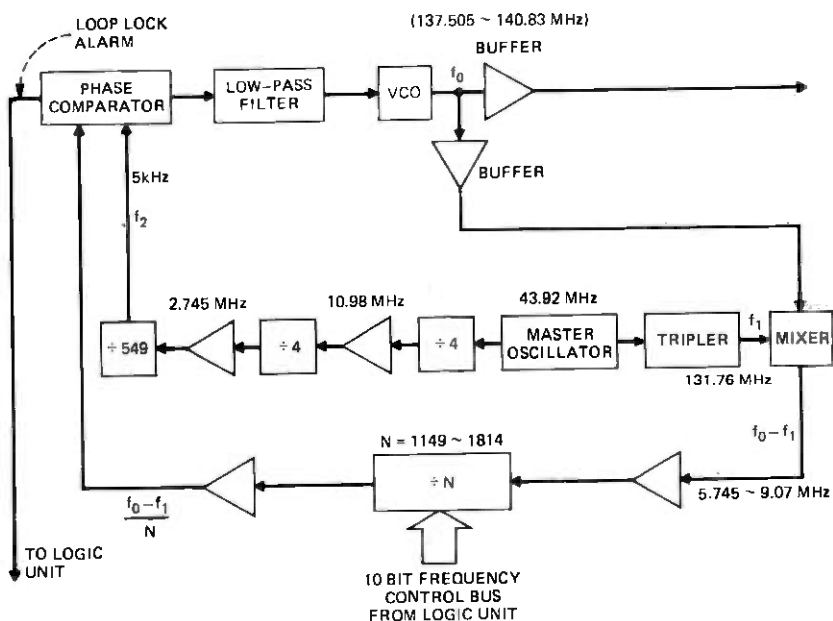

Fig. 5—Frequency synthesizer.

frequency, $f_0 - f_1$, which is in the 5.7- to 9.1-MHz region, is “divided down” by an integer N in a programmable digital frequency divider. The combination of binary dc voltages on the 10 binary program lines determines the division factor N . The divider output frequency, $(f_0 - f_1)/N$ nominally at 5 kHz, is compared with a stable 5.0-kHz reference frequency f_2 in the phase comparator. This reference is obtained by “dividing down” the 43.92-MHz master oscillator by a factor of 8784. Any phase error feeds back to the voltage-controlled oscillator, in the form of a dc control-voltage, thus keeping the total loop in phase lock. When in lock, the output frequency is given by $f_0 = f_1 + Nf_2$; therefore, f_0 will have the same long-term frequency stability as the 43.92-MHz master oscillator and yet can be varied in integer steps by assigning different numerical values to N .

The synthesizer output is quite pure; spurious frequencies are at least 90 dB down from the main carrier, noise that is 45 MHz removed from the carrier does not degrade the mixer noise figure, and phase noise associated with the carrier does not degrade a 30-dB audio output s/n ratio.

3.2 Phase modulator, multiplier, and power amplifier

The phase modulator, multiplier, and power amplifier chain are shown in Fig. 6. The phase modulator is a two-stage reflection type

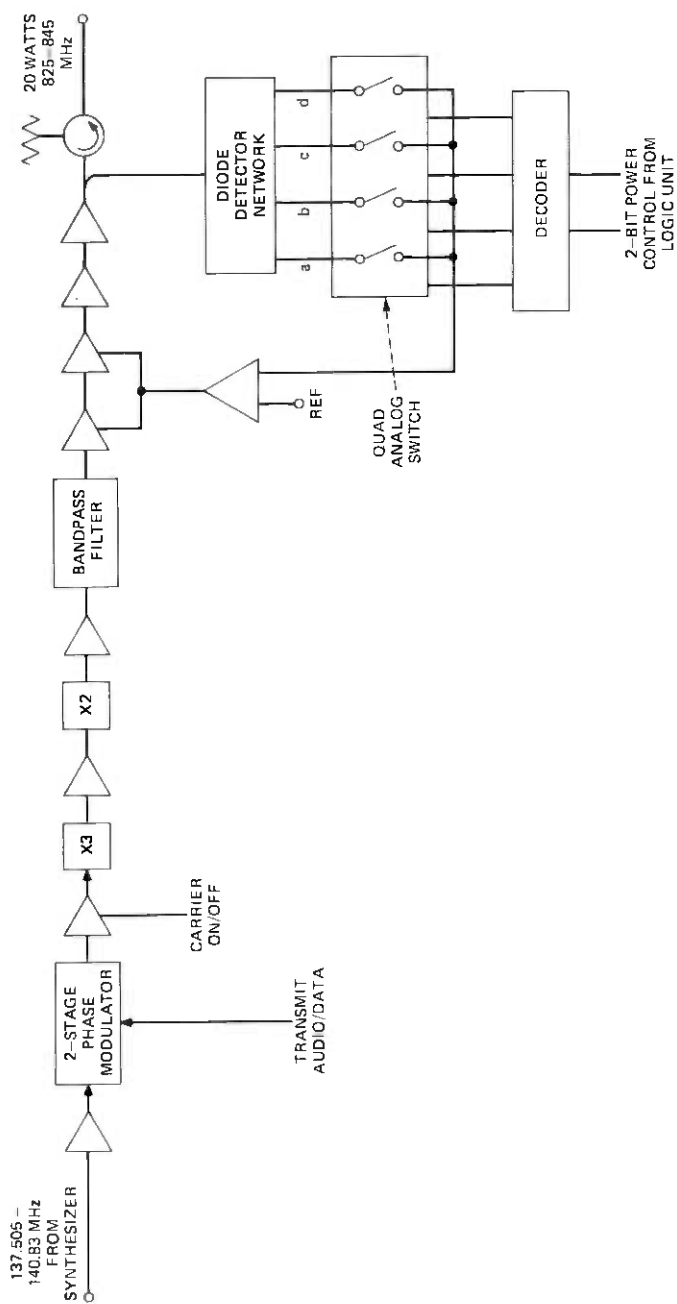

Fig. 6—Phase modulator, multiplier, and power amplifier.

employing varactor diodes driven by lumped element hybrids. The circuit provides a ± 2 -radian peak phase shift at $\frac{1}{6}$ the output frequency. This allows a peak modulation index of ± 12 radians after the frequency has been multiplied by a factor of 6 in the subsequent stages. Audio harmonics are at least 25 dB down at the maximum modulation index.

The multipliers and power amplifiers are all bipolar transistor Class-C amplifiers. Frequency multiplication is obtained, first by a factor of 3 and next by a factor of 2, by the classic method of tuning the collector stage of a transistor amplifier to the second or third harmonic of its input frequency.

Subsequent "straight-through" class-C amplifiers build up the milliwatt signals from the multipliers to about 20 watts output.

Power control is achieved by first detecting a sample of the output power by the diode detector network which has four different dc output voltages labeled *a*, *b*, *c*, and *d*. One of these four dc voltages is selected by the quad analog switch and delivered to a dc amplifier, which provides collector bias to two stages of the RF power amplifier. Thus, a servo network is formed that tightly regulates the RF power at one specified level. Should a different output level be desired, a new detector output voltage would be chosen by the analog switch which is driven by the 2-bit power control bus through a decoder. Thus, we obtain stable output power levels of 0, -6, -12, and -18 dB with respect to 12 watts (at the T-R antenna) by digital signals arriving from the logic unit.

A post transmitter bandpass filter (T-BPF in Fig. 4) reduces out-of-band noise and spurious signals to a level more than 55 dB below the 12-watt carrier. Noise at the receive channel, 45 MHz higher, is below -120 dBm. The output power does not vary more than ± 1 dB over the supply battery voltage range of 11 to 16 volts. The transmitter is designed to operate reliably and provide long life over a -40° C to $+70^{\circ}$ C temperature range.

3.3 Receiver chain

The receiver chain (see Fig. 7) follows the 870- to 890-MHz bandpass filter, and includes a two-stage RF amplifier, a first mixer, a 45-MHz IF amplifier, a second mixer, a filter, a limiter, and a discriminator. The receiver chain, like other portions of the mobile unit not subject to complete monolithic integration, achieves performance objectives at minimum cost.

The first unit in the receiver is a two-stage RF amplifier providing 15-dB gain with about a 3-dB noise figure. The composite receiver noise figure, measured at either of the two antenna ports, is about 6 dB.

Signals from the RF amplifier enter the first mixer where they are heterodyned against the 825- to 845-MHz local oscillator and converted

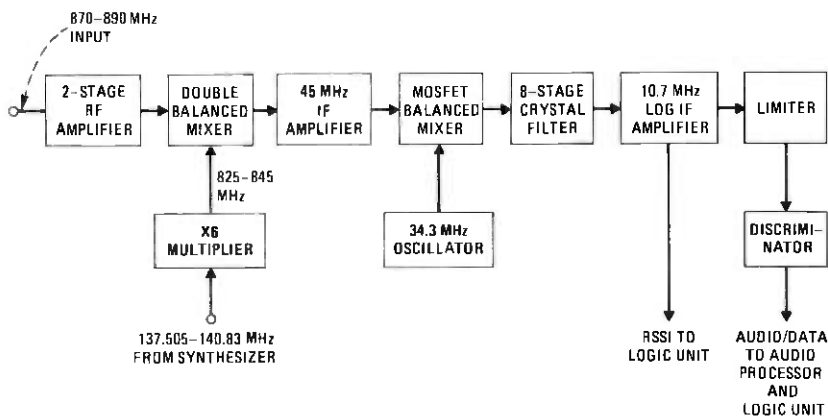

Fig. 7—Receiver.

to the 45.0-MHz first IF frequency. The mixer uses Schottky barrier diodes in a double balanced configuration. The conversion loss is about 6 dB.

The first IF amplifier employs a single common-source junction field-effect transistor (FET) yielding a gain of about 10 dB. Since the bandwidth of this stage is about 100 kHz, there is little channel filtering here. The second mixer consists of a single-balanced circuit built around two metal oxide semiconductor (MOS) FETs. Since essentially no channel filtering has yet been accomplished, this second mixer must be exceptionally resistant to the unwanted generation of cross modulation and intermodulation products.

A 34.3-MHz crystal-controlled oscillator provides injection to this second mixer. The resulting 10.7-MHz second IF signal then passes through an eight-resonator quartz crystal bandpass filter for the required channel filtering. This filter exhibits a 6-dB bandwidth of 28 kHz and 60 dB rejection of signals 60 kHz from the center of the passband.

The log IF amplifier^{5,6} consists of a cascade of progressively saturating differential amplifiers. Diode detectors are stationed at the output of each amplifier stage. The output currents from these detectors are summed in a network providing a log-amplifier output voltage called the received signal strength indicator (RSSI). This RSSI voltage rises smoothly and monotonically over an input signal range of -110 to -30 dBm measured at the antenna. The RSSI provides important signal strength information to the logic unit and switched diversity circuits. The limiter is designed to assure "hard" limiting over a dynamic range of at least 80 dB.

The subsequent discriminator operates at 10.7 MHz and has a "peak-to-peak" spacing of about 50 kHz. It consists of a quadrature detector

and a narrowband delay network primarily composed of a 10.7-MHz quartz crystal. Harmonic distortion is more than 32 dB below a reference 1000-Hz tone with ± 8 -kHz peak deviation.

3.4 Switched diversity

In a conventional nondiversity radio system, a single modulated RF carrier is propagated through space to the mobile receiver, where it is detected, amplified, and demodulated. For the two-branch diversity radio system described here, the RF carrier is fed to a single, vertically polarized, land-based antenna after modulation. This signal is then received by two vertically polarized antennas, separated by an appropriate distance, at the mobile receiver. If the antenna separation is sufficient (a few quarter-wavelengths), the two received signals are highly decorrelated; if one signal is in a deep fade, the other signal may be quite strong. The statistics of these Rayleigh fading signals have been thoroughly discussed by Jakes.⁷

A diversity receiving system can be quite expensive if it has multiple receivers. A method that employs a single receiver⁸ and yields low-cost diversity is shown in Fig. 8. Here, a conventional single-channel FM receiver connects to two antennas; R and T-R, via a single-pole, double-throw semiconductor diode switch. The switch commands, generated by a hard-wired logic controller, attempt to keep the receiver RF input always connected to that antenna with the stronger signal.

3.5 Detailed circuit operation

The specific switching algorithm used in the circuit was devised by Shortall.⁹ The function of the logic circuit is to generate a switch command whenever the instantaneous received carrier amplitude drops approximately 10 dB below its mean. As noted in Section 3.3, the log IF amplifier produces a dc voltage (RSSI) proportional to the log of the instantaneous carrier envelope.

Consider Fig. 8: The envelope output from the log IF (15) feeds through the highpass filter (1) that removes the dc component (i.e., the mean carrier amplitude) and allows only the fading information to pass. The filter cutoff frequency was chosen to be 0.5 Hz, which is high enough to block the slow variations in mean signal strength that occur when the vehicle is moving. The fading signal passes through a 2-kHz low-pass filter (2) to remove any high-frequency noise not related to fading. This filtered signal, with zero mean, is compared (see sketch A) with a negative dc reference corresponding to a 10-dB drop in signal power, in a comparator (3). If the signal drops below this reference, the comparator goes high and turns on a gated astable multivibrator (5), which generates switching pulses at a 2-kHz rate. At 35 mph, the average fade duration at the 10-dB level is 1 ms. The astable multivibrator switching pulses pass through the OR gate (6) and actuate the

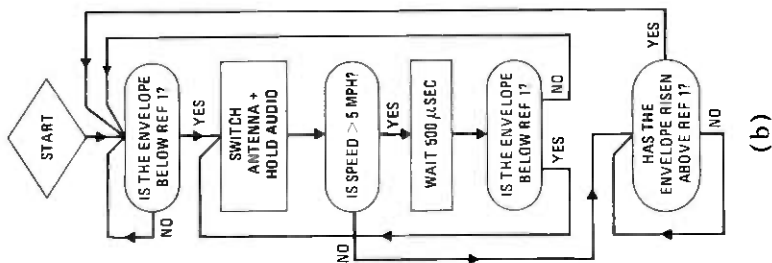

(b)

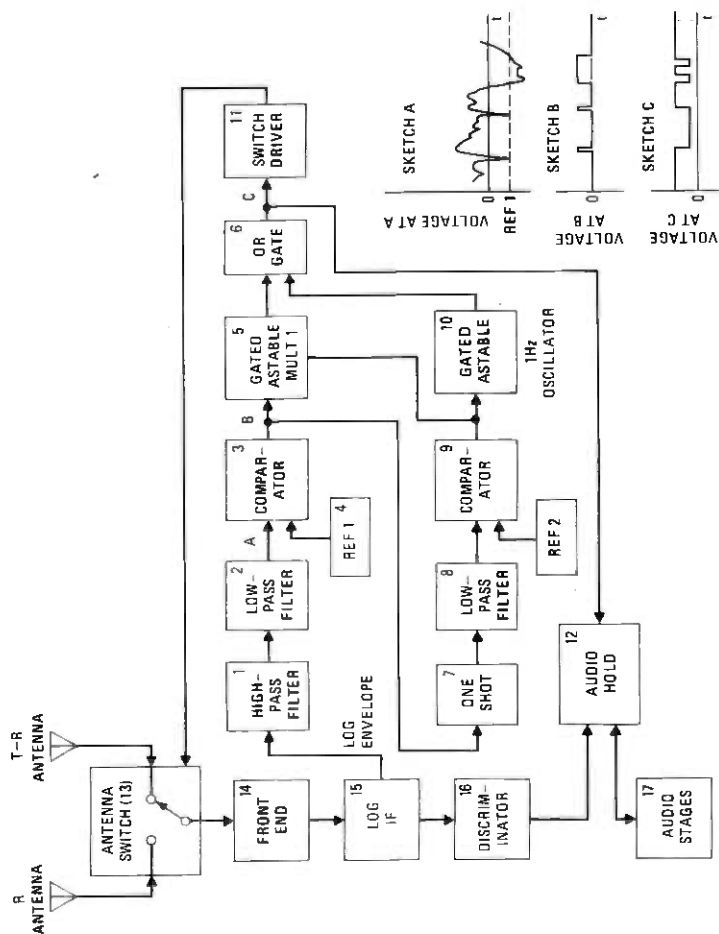

(a)

Fig. 8—Block diagram of switched diversity system and logic flow chart.

antenna switch (13) and the audio hold (12). When the signal falls below threshold, the first pulse from the astable multivibrator (5) causes a switch to the other antenna. If the signal is higher there, the comparator (3) turns the astable multivibrator (5) off before it can deliver another switch pulse. If the signal is lower at the other antenna, the astable multivibrator (5) continues to generate switch pulses until the signal at one of the antennas rises above threshold. If both of the signals should suddenly disappear, the circuit hunts for about 2 seconds, while the mean signal level stored in (1) goes to zero, and then stops.

Circuits 7 through 9 serve to count the number of fades produced over the last several seconds. Whenever the comparator (3) goes high, the one-shot multivibrator (7) delivers a pulse to the low-pass filter (8). The dc output of filter (8) is therefore proportional to the fade rate. It is compared in (9) with a reference adjusted so that the output is high whenever the fade rate is greater than 5 Hz, which corresponds to a vehicle speed of about 5 mph. When the vehicle speed falls below 5 mph, the comparator (9) is low, and the operation of unit (5) is changed from a gated astable multivibrator into a one-shot multivibrator. This change prevents the circuit from "hunting" during the long fades encountered when the vehicle is moving slowly.

Gated astable (10) is also turned on at low fading rates. It generates switch commands at a slow (1-Hz) rate to keep the receiver on the better antenna. Assume that the receiver is connected to antenna 1, and that the signal at antenna 2 is much weaker. The signal will drop suddenly when a switch is commanded by unit (10); but units (1), (2), (3), and (5) will interpret this as a fade and immediately bring the receiver back to the original antenna. Now, assume the receiver is connected to antenna 2 and that the signal at antenna 1 is much higher. The signal rises suddenly when the switch is made, and the mean signal strength stored in unit (1) rises as well. The next switching pulse causes the signal level to drop below the mean and, if the two signals differ by 10 dB, circuits (1), (2), (3), and (5) interpret this as a fade and switch back to antenna 1. Therefore, if the signal levels at the two antennas differ by more than 10 dB, the receiver is always connected to the better antenna. A logic flow chart for the system is shown in the lower part of Fig. 8.

The audio hold circuit is necessary to suppress audible switching transients produced by the sudden change in signal amplitude and phase during the antenna changeover which sets up ringing in the bandpass filters of the IF amplifier.

IV. LOGIC UNIT

The decision to use an outboard, Bell Laboratories-designed logic unit with the equipment test transceivers was made for two reasons.

First, contemporary radio manufacturers could readily supply a transceiver without logic. Thus, a contract for only the transceivers could be let well in advance of the equipment test without much risk. Second, the final decisions about the AMPS logic and control algorithms were made rather late in the development schedule. Thus, it was felt that the approach with the lowest risk was for Bell Laboratories to develop a logic unit which, if required, could be modified expeditiously.

Subsequent mobile units will have integrated transceiver/logic units with the logic unit designed by the radio manufacturer.

4.1 Logic unit sections

A mobile telephone logic unit can be conveniently divided into two sections: the digital section and the analog section.

The analog section performs analog (or quasi-analog) tasks such as:

- (i) 10-kb/s data reception and clock regeneration.
- (ii) Supervisory Audio Tone (SAT) detection, reconstitution, and transponding.
- (iii) Conversion of the analog received signal strength indicator signal into a binary number via an A/D converter.

The digital section performs all necessary logic operations required for AMPS call processing. The immense complexity of these call-processing functions has made the use of a stored-program controller all but mandatory. Thus, an 8-bit microprocessor was chosen to perform this task.

4.2 Digital section

4.2.1 Microprocessor

Figure 9 is a functional block diagram of the Bell Laboratories-designed logic unit. Its nucleus (1) consists of an INTEL 8080 one-chip microprocessor. This is an 8-bit parallel central processing unit (CPU) driven by a 2-MHz, two-phase clock (2).

The microprocessor has a 16-bit* address bus and an 8-bit bidirectional data bus, which it uses on a time-shared basis to communicate with memories and input/output (I/O) circuits. The microprocessor also provides periodically an eight-bit status word which is used by the CPU system controller (2) to develop signals for all the peripheral circuits.

The CPU has an interrupt control line which is held at logic 0 for normal program flow. A peripheral device can at any time request service from the CPU by simply applying a logic 1 on this control line, whereupon the CPU interrupts the main programs, sends an acknowledgment to the requesting peripheral, and executes instructions "jammed in" externally by the latter.

* Only 13 bits are used.

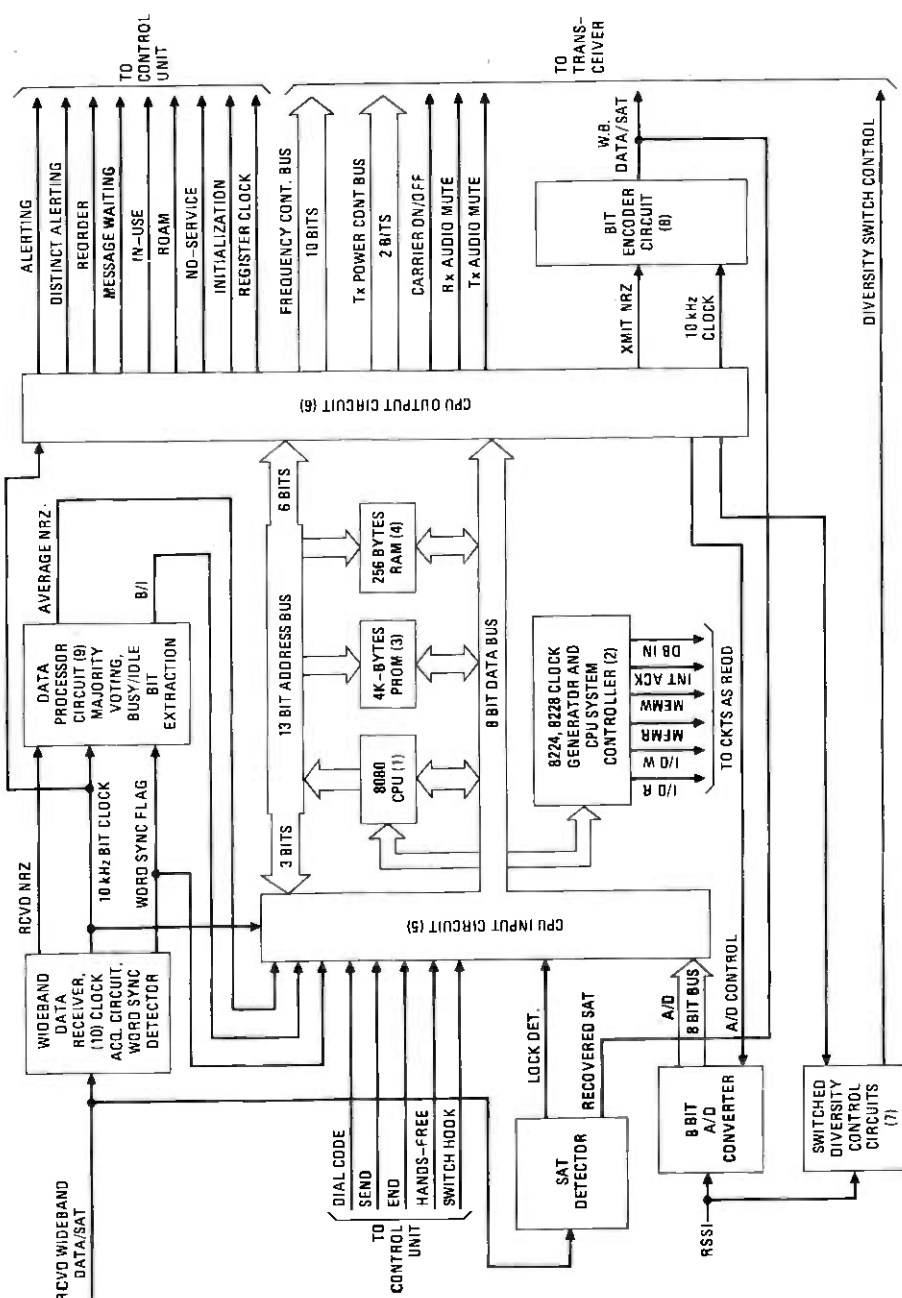

Fig. 9—Functional block diagram of Bell Laboratories-designed mobile logic unit.

The total memory is contained within a 4K-byte programmable read-only memory (PROM) (four 1K-byte ultraviolet erasable INTEL 2708s) (3) for main program storage and a 256-byte random access memory (RAM) (two 256×4 bit INTEL 5101s) (4) for temporary storage. Also, the NAM (number assignment module) is contained within the PROM.

The I/O circuitry (5) and (6) is the primary link through which external circuits interact with the CPU. The I/O circuits consist principally of an array of latches which store input stimuli or output commands directed to or from the CPU. When a specific latch must be accessed by the CPU, its address appears on the 13-bit address bus, and then an 8-bit data byte is directed to (or from) the addressed latch. Thus, all external peripherals are time-shared by the CPU.

4.2.2 Additional digital circuits

Several digital functions are performed by hard-wired logic circuits which are external to the CPU. Off-CPU logic is sometimes necessary because of speed/time constraints or programming complexity. Second-generation logic units are expected to perform most of the logic functions using software. These functions include (see Fig. 9):

- (i) The switched-diversity control circuits (7) already described in Section 3.4 and Fig. 8.
- (ii) The bit encoder circuit (8) which converts the NRZ* data originating in (6) into the Manchester-encoded 10-kbs wideband (WB) transmitted data stream.
- (iii) The data processor circuits (9) which perform the 3-out-of-5 majority voting and busy/idle bit extraction of the received 10-kb/s data stream.

4.3 Analog section and wideband data receiver

The basic function of the analog circuits in the logic unit is to convert noisy analog signals arriving from the receiver discriminator into clean, clocked TTL binary signals for the CPU. The WB data receiver, block (10) on Fig. 9, is required to perform the following functions:

- (i) It must distinguish when WB data are present on the discriminator output line, as opposed to the normal voice/SAT signal, to accomplish voice-channel data transmissions. The WB data receiver handles this function with a 5-kHz tone detector (a 5-kHz bandpass filter followed by a diode detector) since a dotting sequence (101010...), with a strong 5-kHz Fourier component, precedes every blank and burst message.

* Nonreturn to zero.

- (ii) It must reconstitute a relatively clean 10-kHz bit clock from the noisy WB data signal.
- (iii) It must, by a minimum error algorithm, convert the noisy received 20k-baud Manchester code into a 10-kb/s NRZ bit stream.
- (iv) It must detect Barker (word) sync pulses by a constant search for the 11-bit Barker word (11100010010).

We can best describe the implementation of functions (ii) and (iii) above by briefly reviewing the AMPS wideband data transmission and reception systems. The circuits have been described by Addeo.¹⁰⁻¹³

Figure 10 [a detailed drawing of block (8), Fig. 9] shows the wideband data transmission system and associated waveforms. The NRZ data sequence (A) is exclusive ORed* with the phase-coherent 10-kHz clock (B) to produce the Manchester (biphase) encoded bit stream (C). The clock phase is chosen so that an NRZ binary one becomes a zero-to-one transition in the middle of each NRZ bit cell. Correspondingly, an NRZ binary zero becomes a one-to-zero transition.

Some salient features of Manchester coding are discussed in Ref. 14. The advantages of the Manchester code can be summarized as:

- (i) The power spectrum (for a random code sequence) peaks at 10 kHz, well above the voice-band. Thus, a data receiver bridged across the FM receiver discriminator can easily distinguish between voice and data transmissions. This facilitates the use of blank and burst techniques so that a voice message is interrupted (blanked) for 200 ms to allow the reception of a data message burst.
- (ii) The ever-present code transitions, with zero dc component, permit binary FM to be achieved with a voice phase modulator preceded by an integrator.

In Fig. 10, the Manchester-encoded data (C) represent the instantaneous frequency of the desired binary FM waveform, where a binary one represents $f_0 + \Delta f$, and a binary zero represents $f_0 - \Delta f$

f_0 = carrier frequency (in the 825- to 845-MHz band). Δf = 8 kHz.

If a direct FM deviator were available,† it would be driven by waveform (C). Instead, the mobile transmitter described in Section III employs a phase modulator.

Since

$$\Delta f = \frac{1}{2\pi} \frac{d\theta}{dt}$$

where θ is the carrier phase, the Manchester waveform must be

* $A \oplus B$.

† At the present time, most equipment manufacturers prefer to use a phase modulator instead of a direct frequency deviator.

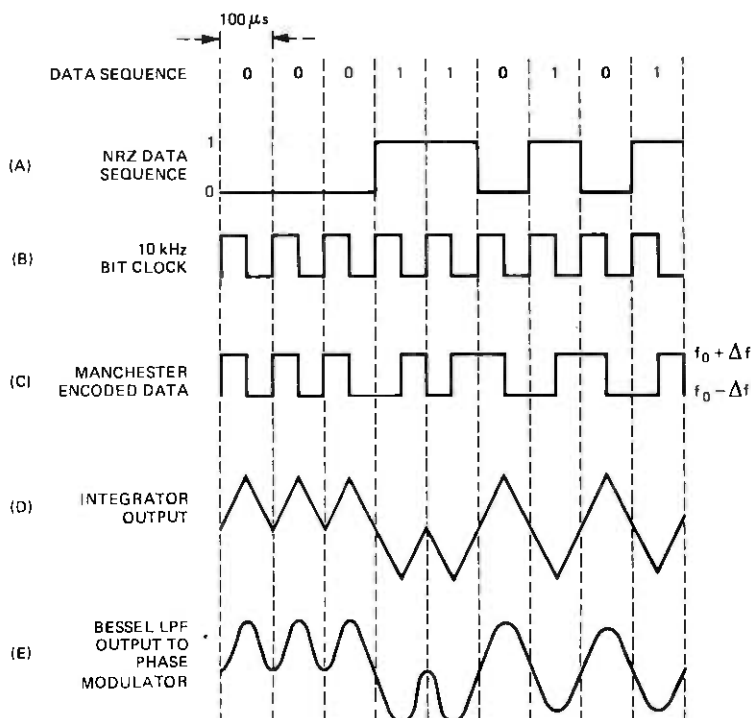
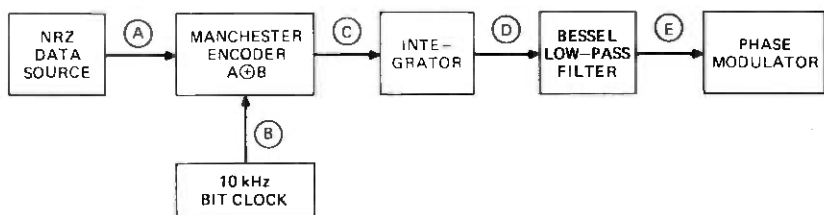

Fig. 10—Manchester bit encoder.

integrated before allowing it to drive the phase modulator. The integrator output is a triangular waveform (D), which is filtered by the Bessel (maximally linear phase) low-pass filter to become the phase modulator drive waveform (E).

Figure 11 (a partial drawing of block 10, Fig. 9) shows the wideband data reception system. Data from the FM receiver discriminator are sliced to become the noisy Manchester bit stream (A). The slicer removes amplitude noise, but the phase fluctuations remain. Thus, (A) is a noisy replica of the transmitted bit stream—waveform (C) of Fig. 10.

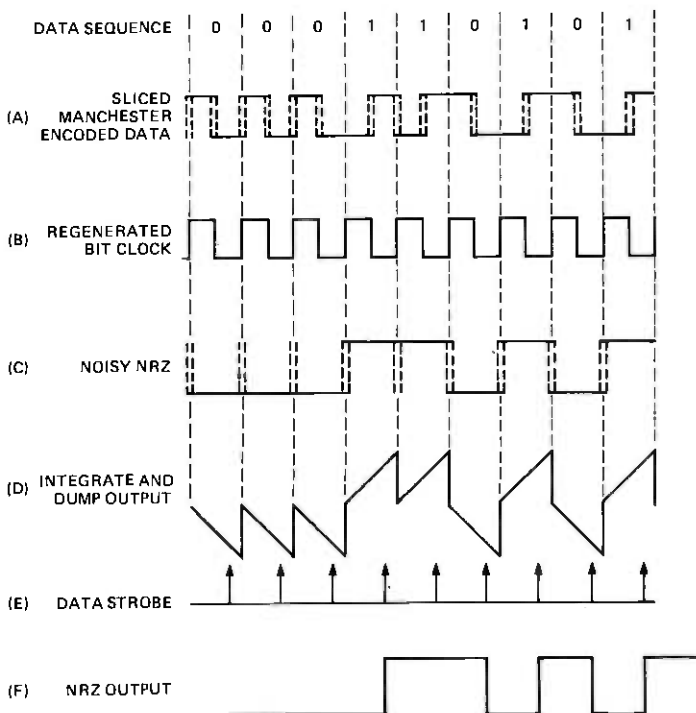
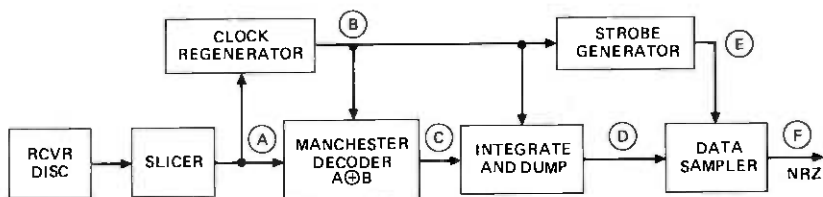

Fig. 11—Wideband data receiver.

A clock regenerator circuit extracts an almost noiseless 10-kHz phase-coherent, clock waveform (B). The regenerator employs a narrowband (10-Hz bandwidth) phase-locked loop to extract the 5-kHz Fourier component of the Manchester bit stream. This waveform is then frequency-doubled to obtain the desired 10-kHz bit clock. Certain code sequences—e.g., all ones or all zeros—lack this 5-kHz Fourier component. Thus, the bit clock must be able to “coast through” these sequences.

The Manchester data (A) are then “exclusive Ored” with the bit

clock (B) to produce the noisy NRZ bit stream (C). Note that the phase noise on (A) and/or phase error of the bit clock (B) produce unwanted spikes at the borders of each NRZ bit cell. The noisy NRZ bit stream enters the integrate-and-dump circuit, producing waveform (D), which is strobed before each dump by the data strobe (E). The data sampler retains the output from each strobed sample to produce the clean NRZ output (F). The integrate-and-dump circuit can be shown to be a matched filter, thus providing the best signal-to-noise enhancement.

V. ACKNOWLEDGMENTS

The Bell Laboratories logic unit was developed by E. J. Addeo and M. R. Karim. The control unit and transceiver were developed by Oki Electric Co., Tokyo, Japan.

REFERENCES

1. D. L. Huff, "AMPS: The Developmental System," B.S.T.J., this issue, 249-269.
2. J. T. Walker, "AMPS: The Service Test Mobile Telephone Control Unit," B.S.T.J., this issue, pp. 145-152.
3. W. R. Young, "AMPS: Introduction, Background, and Objectives," B.S.T.J., this issue, pp. 1-14.
4. N. Ehrlich, R. E. Fisher, and T. K. Wingard, "AMPS: Cell-Site Hardware," B.S.T.J., this issue, pp. 153-199.
5. T. H. Chambers and I. H. Page, "The High-Accuracy Logarithmic Receiver," Proc. IRE, August 1954, pp. 1307, 1317.
6. A. Woroncow and J. Croney, "A True IF Logarithmic Amplifier with Two-Gain Stages," Radio and Electronic Engineer, September 1966.
7. W. C. Jakes, Jr., *Microwave Mobile Communications*, New York: John Wiley, 1974.
8. A. J. Rustako, Y. S. Yeh, and R. R. Murray, "Performance of Feedback and Switch Space Diversity 900 MHz Mobile Radio Systems with Rayleigh Fading," IEEE Trans. Commun., *COH-21*, No. 11 (November 1973), pp. 1257-1268.
9. W. E. Shortall, "A Switched Diversity Receiving System for Mobile Radio," IEEE Trans. Commun., *COH-21*, No. 11 (November 1973).
10. E. J. Addeo, "Word Synchronization and Digital Signal Processing for a High Capacity Mobile Telecommunication System," 27th Annual Conference of the IEEE Vehicular Technology Group, March 16-18, 1977, Orlando, Fla., pp. 104-106.
11. E. J. Addeo, "An Approach to Digital Signal Processing for a High Capacity Mobile Telephone System," 26th Annual Conference of the IEEE Vehicular Technology Group, March 1976, pp. 52-57.
12. E. J. Addeo, "Digital Synchronizing Signal Recovery Circuits for a Data Receiver," U.S. Patent No. 4,029,900, June 14, 1977.
13. E. J. Addeo, "Method and Apparatus for Radio System Co-Channel Interference Suppression," U.S. Patent No. 4,025,853, May 24, 1977.
14. G. A. Arredondo, J. C. Feggeler, and J. I. Smith, "AMPS: Voice and Data Transmission," B.S.T.J., this issue, pp. 97-122.

Advanced Mobile Phone Service:

A Service Test Mobile Telephone Control Unit

By J. T. WALKER

(Manuscript received July 28, 1978)

Guidelines for the design of a mobile telephone control unit have been determined, based on considerations of driving behavior, customer preference, automobile environment, and calling procedure. This paper explains these guidelines and illustrates their application in the design of a service test control unit.

I. INTRODUCTION

The control unit in the Advanced Mobile Phone Service (AMPS) gives people in a moving vehicle access to mobile telecommunications service in much the way a telephone serves people in homes and offices. However, formulating control unit design guidelines for the AMPS involved meeting two challenges not encountered in land-line telephone experience. First, the vehicular nature of this telephone service requires that the control unit have negligible effect on driving behavior, satisfy the preferences of potential subscribers for small, unobtrusive units that are easy to use while driving, and conform to the automobile's environmental constraints.

Second, the AMPS signaling plan uses preorigination dialing to reduce the holding time for the radio channel. With preorigination dialing, call-setup functions normally performed in the switching office are incorporated in the mobile unit where they are controlled by the user.

Consequently, driving behavior, customer preference, automobile environment, and calling procedures were studied to establish design guidelines for control units for use during the developmental system trial¹ and beyond. This paper describes the principal findings from these studies and illustrates their application in the design of a control unit for the service test phase of the trial. The mobile subscriber set for the equipment test phase is described in Ref. 2.

II. DRIVING BEHAVIOR STUDIES

Behavior studies were conducted to investigate the effect of mobile telephone usage on driving. The studies began by looking at the additional activities that people commonly engage in while driving. Such activities include talking with passengers, adjusting the car's air conditioner or radio, and getting change to pay tolls. Although these activities cause some distraction, the studies show that drivers necessarily give priority to driving demands and adopt strategies to minimize the effects of secondary activities on driving behavior. For example, drivers delay in undertaking secondary activities until peak demands of the driving task, such as passing a car or turning a corner, are successfully completed. Drivers also interrupt the secondary activity when driving conditions demand attention, thereby performing the secondary activity at a slower pace.

The use of a mobile telephone is similar to the secondary activities described above. It is therefore reasonable to expect that drivers will employ strategies, such as pausing to review the driving environment after dialing every one or two digits, in order to minimize the effect of the telephone activities on driving behavior. The driving studies confirm this reasoning and show that drivers maintain the same level of driving control when performing mobile telephone activities, including call origination, as when performing other commonly accepted secondary activities such as adjusting a car radio to a specific station.

These studies also reveal that drivers can accommodate a wide range of control unit mounting positions. However, for ease of use they prefer controls that are mounted near the top of the instrument panel and to the right of the steering wheel.

III. CUSTOMER PREFERENCE

Potential AMPS subscribers view overall ease of use as an important consideration in choosing control units. The design direction provided by AT&T on the basis of research into customer preference shows that subscribers want units that are easy to use while driving and blend with the automobile environment. These preferences directly affect the mounting location and the design of the controls, primarily the dial and handset, for the control unit.

Subscribers feel more comfortable with control units that minimize the need to divert their eyes or alter their body positions in order to place or receive telephone calls. This suggests mounting the control unit near the top of the vehicle's instrument panel. Subscribers also desire relatively small, unobtrusive units that do not restrict access to vehicle controls or seating areas, nor affect the driver's view of the road ahead. Ideally, the control unit should be built into the instrument panel as are the car radio and air conditioning controls.

For overall ease of dialing, subscribers prefer a pushbutton dial with buttons having approximately the same size and spacing as those found on telephone sets equipped for *TOUCH-TONE*[®] calling.

Lightweight handsets that are comfortable to hold and easy to cradle on the shoulder are preferred. Full-size handsets (e.g., the Western Electric K-type) meet these needs especially well. Potential subscribers find short handsets and those with a flat cross section to be less desirable.

IV. AUTOMOBILE ENVIRONMENT

The automobile environment has mounting constraints as well as temperature, illumination, and noise levels not normally encountered in setting design objectives for telephone sets intended for use in office and residential environments.

4.1 Mounting constraints

While users would prefer that the control unit be built into the instrument panel, this is not now likely because tightly spaced controls, indicators, and optional devices such as radios and clocks cover most of the usable space within reach of the driver. Changes in the instrument panel which auto manufacturers introduce from year to year and the considerable variations existing between car models compound the problem. While no area close to the driver can be considered as reserved for the control unit, mounting locations are available which vary from car to car. A flexible, adaptive approach to mounting is required to position the control unit in locations acceptable to the driver.

4.2 Temperature levels

Control units mounted in front of or below the instrument panel should be designed to survive ambient temperatures as high as 85° Celsius.³ Traditional plastic housings and handsets normally used for telephone sets do not perform well at this temperature; thus, high temperature materials, such as polycarbonate plastic, should be used for the control unit. The top surface of the instrument panel is a desirable location for the control unit because it is easily seen and reached by the driver; however, temperatures at this location can reach 113° Celsius³ and, therefore, present a significant design challenge.

4.3 Illumination levels

The high illumination level of direct sunlight makes the use of light-emitting diode and incandescent indicators on the control unit especially difficult unless they are properly shielded. During night opera-

tion, on the other hand, the illumination level of the controls and visual indicators must not overwhelm the driver whose vision has adapted to night conditions.

4.4 Noise levels

Measurements made in the interior of intermediate-size automobiles show a surprisingly high ambient noise level, even when all windows are closed. At 55 mph on a smooth road, we observed ambient noise levels of about 70 dBA;* this is roughly the same level found in a busy secretarial office with telephones and typewriters in use. At 20 mph, the ambient noise level decreases to about 60 dBA. With the automobile parked in a quiet location and with the engine off, the interior noise level drops to about 40 dBA, the level observed in a quiet room. This wide variation in ambient noise level suggests that user-adjustable level controls are needed for the receive-audio signal, especially if a loudspeaker is used. The relatively high noise levels must also be considered in setting design objectives for the alerting signal level.

V. CALLING PROCEDURES

The AMPS signaling plan uses preorigination dialing to reduce the holding time for the radio channel. To place a call, the user dials a telephone number into a storage register within the mobile unit, where it is automatically held until the user presses a SEND function key. When this key is pressed, the mobile unit initiates the call attempt by sending a digital message, which includes the called telephone number, to the Mobile Telephone Switching Office. A telephone set with preorigination dialing must incorporate three functions normally performed at the switching office: (i) storing the dialed telephone number, (ii) clearing both prior numbers and dialing errors from the storage register, and (iii) forwarding the contents of the storage register to the network to initiate a call.

Human factors studies were conducted to develop calling procedures that are easy to learn and remember, that minimize the chance of making a serious error (e.g., losing a call), and that require only one-hand operation.

5.1 Storing dialed numbers

The studies show that users do not need a "dial tone" or other start-to-dial signal from the mobile unit. Indeed, it is better to permit drivers to initiate dialing at a convenient opportunity and pause after every one or two digits to review the driving environment. Therefore, the

* Acoustic sound pressure level measured in decibels relative to 0.00002 Pascal with A frequency weighting.

mobile unit should always be ready to accept numbers as they are dialed and enter them in its storage register. In addition, the user should receive a tone feedback signal from a loudspeaker in the control unit each time a dial button is pressed.

5.2 Clearing prior numbers

The studies indicate the user should not be required to clear the storage register of the last number called before dialing the next telephone number. Instead, the mobile unit should automatically clear the register when the first digit of the new number is dialed. However, if the user does not dial a new number, then the last number called should remain in the storage register. This permits placing calls to this last number as many times as desired merely by depressing the SEND key. In addition, the mobile unit should automatically clear the register when the first digit is dialed following (i) the initiation of a call to allow the user to enter a telephone number while conversing, and (ii) a time interval of two minutes or more after the previous digit was dialed to prevent the user from inadvertently entering two telephone numbers in the register. A power-off condition should also clear the storage register.

It was found unnecessary to incorporate a separate CLEAR function key, such as those found on pocket calculators, for clearing the register after a dialing error. It is simpler to combine this function with the call termination function in one END function key. Thus, a user would depress the END key to correct a dialing error, and then redial the number properly.

5.3 Initiating calls

In the AMPS system, the mobile unit stores the number dialed by the user; it does not interpret the digits in order to detect errors, determine when dialing has been completed, or perform other call processing functions. The end-of-dialing function has been delegated to the user, while error detection and other call processing functions continue to be performed at the switching office.

The human factors studies show that the user should perform the end-of-dialing function and thereby initiate a call attempt only by pressing the SEND key on the control unit. This procedure prevents the occurrence of unintended call attempts from users who instinctively reach for the handset before dialing. Removing the handset from its cradle should not initiate a call. After experience with the mobile telephone unit, users will learn that they need not pick up the handset until after dialing and pressing the SEND key. However, the mobile unit will operate properly even if users first pick up the handset, dial, and then press the SEND key.

5.4 Answering and terminating calls

Calls are answered by removing the handset from its cradle; they are terminated by returning the handset to the cradle. Calls are also terminated by pressing the END key, which saves returning the handset to its cradle before placing a new call.

5.5 Status Indicators

In land-line telephone service, the alerting signal is generated in the telephone set while the other call status signals (e.g., busy, reorder, intercept, and recorded announcements) are returned to the user from the telephone network. In the AMPS system, the reorder, intercept, and alerting call status signals must be generated within the mobile unit in response to commands from the Mobile Telephone Switching Office. The reorder signal sounds whenever a call attempt fails because of system conditions (e.g., all trunks busy); an intercept signal sounds in response to a user error.

The control unit has three visual status indicators to guide the user. These have been named IN USE, NO SERVICE, and ROAM. The IN USE indicator lights whenever a call is originated or answered, and goes off when the call is terminated. If the mobile unit is outside the radio coverage area of an AMPS system, then the NO SERVICE indicator informs the user. The ROAM indicator lights when the mobile unit roams into the service area of an AMPS system other than the one in which the subscriber is registered.

VI. SERVICE TEST CONTROL UNIT

The control unit for the AMPS service test is less than one-half the size of the control unit that the Bell System currently supplies its mobile telephone customers. The handset is placed on the side of the unit and behind the dial, and the base of the unit is shortened to the minimum length required to cradle the handset effectively (see Fig. 1).

This design includes a pushbutton dial having the same button size, spacing, and configuration found on telephone sets equipped for TOUCH-TONE calling. The handset, which is similar to the Western Electric K-type, is held recessed in its cradle by a hidden spring-retention latch. While the user can easily remove and replace the handset with a slight upward pressure against the spring, this same spring effectively restrains the handset against the longitudinal and lateral forces encountered in a moving automobile.

A loudspeaker built into the side of the unit supplies the reorder, intercept, and alerting call status signals, and allows the user to monitor call progress before picking up the handset. There are user-adjustable volume controls for the alerting signal and for both the speaker and handset received-audio signals.



Fig. 1—Control unit to be used in the service test.

6.1 Control layout

The controls and indicators are located on the unit's front surface, facing the driver. The two function keys (SEND and END) and the three mobile unit status indicators (IN USE, NO SERVICE, and ROAM) are grouped directly below the dial and above a "light island." The light island projects above the control surface and floods the controls with low-level illumination for night operation. The volume controls, a lock switch, and a telephone number card are located below the light island.

Recessed light-emitting diodes were chosen for the mobile unit status indicators; green for IN USE and yellow for both NO SERVICE and ROAM. Red is not specified because of its use as a hazard warning in the automobile.

6.2 Convenience features

In addition to the basic controls and indicators needed to place and receive calls, the control unit includes three convenience features. First, a pull-up card in a slot at the top of the unit serves as a minidirectory of frequently called numbers. Brief operating or calling instructions can also be listed as a reminder to the user. Second, placing the vehicle's ignition switch in either the "on" or "accessory" position automatically turns on the mobile unit and readies it for use. Turning the ignition switch off turns the mobile unit off, thereby preventing discharge of the car's battery. Third, a lock switch and associated visual indicator allow the user to deactivate and lock the mobile unit when leaving the car to prevent unauthorized use of the mobile telephone. The user unlocks the unit by dialing a 3-digit code preselected at the time the mobile unit is installed.

VII. ACKNOWLEDGMENTS

The development of the design guidelines and control unit model was the result of a team effort. In addition to the author, contributors included: C. E. Bronell, J. R. Everhart, B. L. Hanson, A. J. Kames, J. A. Meyerle, and R. R. Stokes, all of Bell Laboratories, and Henry Dreyfuss Associates of New York City.

REFERENCES

1. D. L. Huff, "AMPS: The Development System," B.S.T.J., this issue, pp. 249-269.
2. R. E. Fisher, "AMPS: A Subscriber Set for the Equipment Test," B.S.T.J., this issue, pp. 123-143.
3. "Preliminary Recommended Environmental Practices for Electronic Equipment Design," Environmental Standards and Test Methods Subcommittee of the Electronic Systems Committee, Society of Automotive Engineers, October, 1974.

Advanced Mobile Phone Service:

Cell-Site Hardware

By N. EHRLICH, R. E. FISHER, and T. K. WINGARD

(Manuscript received August 1, 1978)

The hardware facilities of the AMPS cell site connect the mobile radio customer to the land telephone network and perform actions necessary for RF radiation, reception, and distribution; voice and data communications and processing; equipment testing, control, and reconfiguration; and call setup, supervision, and termination. Cell-site operational control is achieved partially through wired logic and partially through programmable controllers. This paper describes the cell-site functional groups, their physical characteristics and design, and the ways they interface with the rest of the AMPS system.

I. INTRODUCTION

In the AMPS system, the interface between the land telephone network and the radio paths to the mobiles occurs at the cell sites. In addition to performing functions needed for trunk termination and for radio transmission and reception, the cell site handles many semiautonomous functions under the general direction of the Mobile Telephone Switching Office (MTSO). Figure 1 is a block diagram of the major AMPS subsystems.

Cell sites have facilities to:

- (i) Provide RF radiation, reception, and distribution.
- (ii) Provide data communications with the MTSO and mobiles.
- (iii) Locate mobiles.
- (iv) Perform remotely ordered equipment testing.
- (v) Perform equipment control and reconfiguration functions.
- (vi) Perform voice-processing functions.
- (vii) Perform call setup, call supervision, and call termination functions.

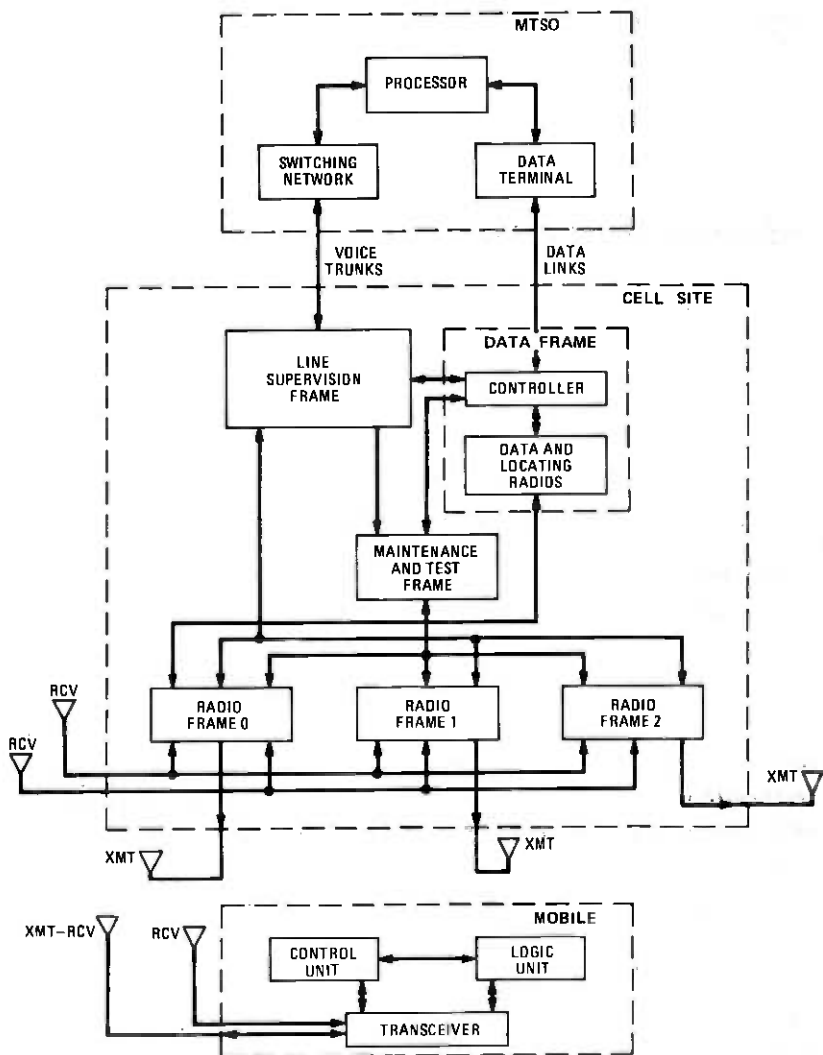

Fig. 1—AMPS major subsystems.

(viii) Handoff or receive from another cell site any mobile which has moved out of the normal service area of the cell site carrying the call.

Cell-site operations are controlled partially by wired logic and partially by programmable controllers. Control functions are redundant and can be reconfigured as needed to overcome a localized failure. A battery plant assures maintenance of service in case of commercial power outage. Facilities dependent upon traffic requirements in each cell coverage area are modular so that additional units may be installed as needed to match busy-hour traffic levels. This will ensure that plant investment can grow sensibly as a function of anticipated revenues.

Figure 2 is an isometric view of a typical cell site with a capacity of 48 voice channels. The precise number of frames at each site is a function of the voice channel requirements for that site. There are four frame codes, and the smallest size cell site requires one of each code. Each radio frame has a maximum capacity of 16 radios. When the number of voice radios grows beyond 16, another radio frame must be added. Each line supervision frame (LSF) can handle 48 voice channels and, when this number is exceeded, another LSF is added. A single data frame (DF) and a single maintenance test frame (MTF) are necessary regardless of the number of voice radios in the cell site. The maximum size of a cell site is 144 voice radios, which would require a total of 14 frames: nine radio frames, three line supervision frames, one data frame, and one maintenance test frame.* The discussion in this paper of the functional design of the cell site parallels the organization of these frames.

Section II describes the data frame, which serves as the master control center for the cell site. Section III describes the line supervision frame, which interfaces the four-wire voice trunks (originating at the MTSO) with the cell-site voice-radio transceivers. Section IV describes the radio frame, which is composed of two bays. Section V describes the maintenance and test frame, which gives the cell site the ability—through the use of another programmable controller—to test for troubles in the radio and audio equipment. Section VI describes the power system. Section VII describes the physical design of a cell site.

II. DATA FRAME

The data frame (see Figs. 3 and 4) contains the equipment for major cell-site control functions, which include communication with the MTSO, control of voice and data communication with mobiles, and communication with the controller in the maintenance test frame. Communication between controllers is necessary for requesting performance of specific tests and for receiving results. The DF contains both hardwired logic and programmable controllers. Only one set of hardwired logic and one controller is needed per cell site regardless of the number of voice radios. Because of the critical functions performed in the DF, redundancy of all subassemblies is provided to assure continuation of service in the presence of a failure. The DF can reconfigure itself under the direction of the MTSO, which maintains service by permitting any malfunctioning subassembly to be replaced with an off-line redundant unit.

The data frame (see Fig. 4) contains five major subsystems:

* In addition to these transmission and control frames, four additional WE 111A power system frames and an associated battery system are required for the maximum size cell site.

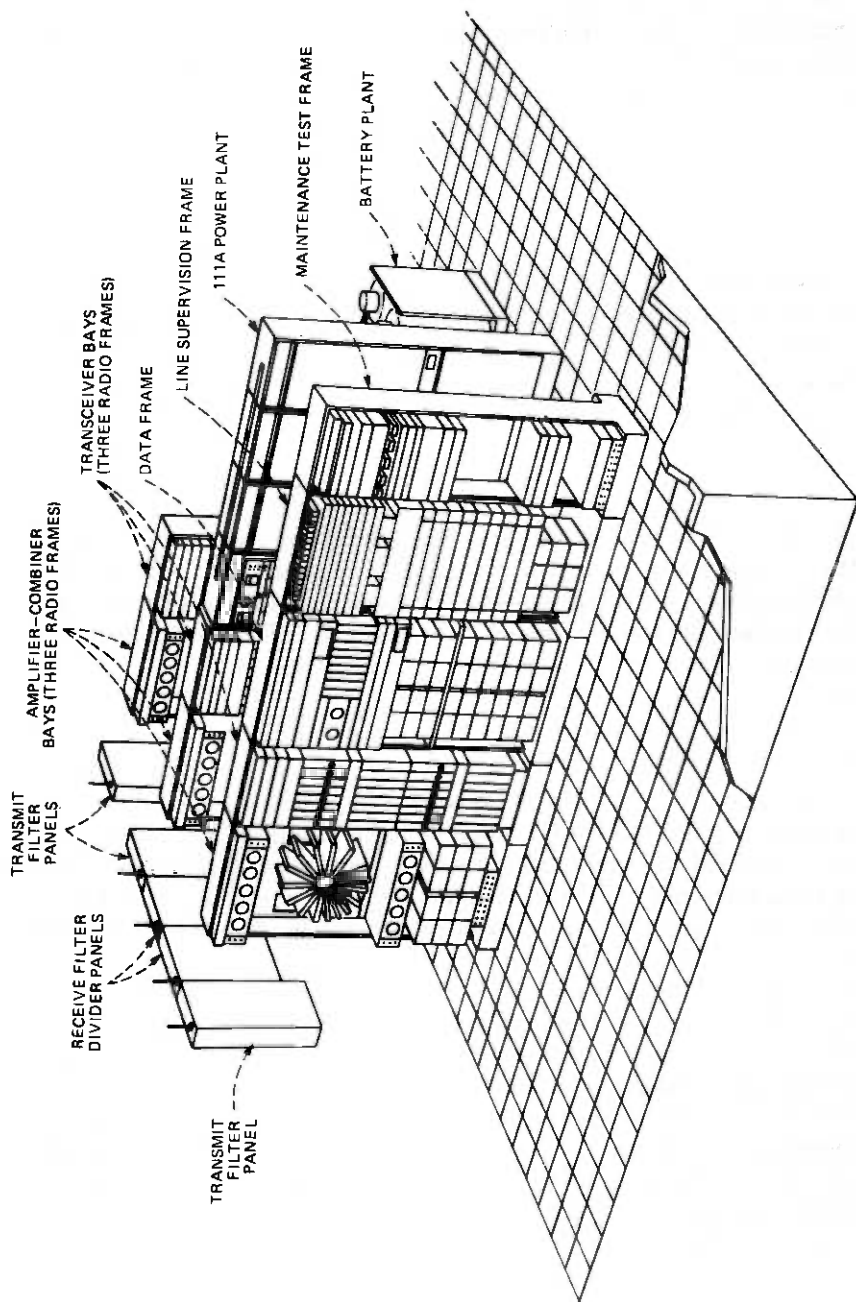

Fig. 2—Typical 48 channel cell-site.

- ① INTERCONNECTION PANEL
- ② COAXIAL INTERCON. PANEL
- ③ RF SWITCH UNIT
- ④ SYNTHESIZER PANEL
- ⑤ RADIO SHELF
- ⑥ DIVIDER SHELF
- ⑦ MAINTENANCE PANEL
- ⑧ PROCON PANEL
- ⑨ WRITABLE PROGRAM STORE PANEL
- ⑩ MAIN CONTROL UNIT
- ⑪ DATA SET PANEL
- ⑫ CONVERTER PANEL
- ⑬ FILTER PANEL

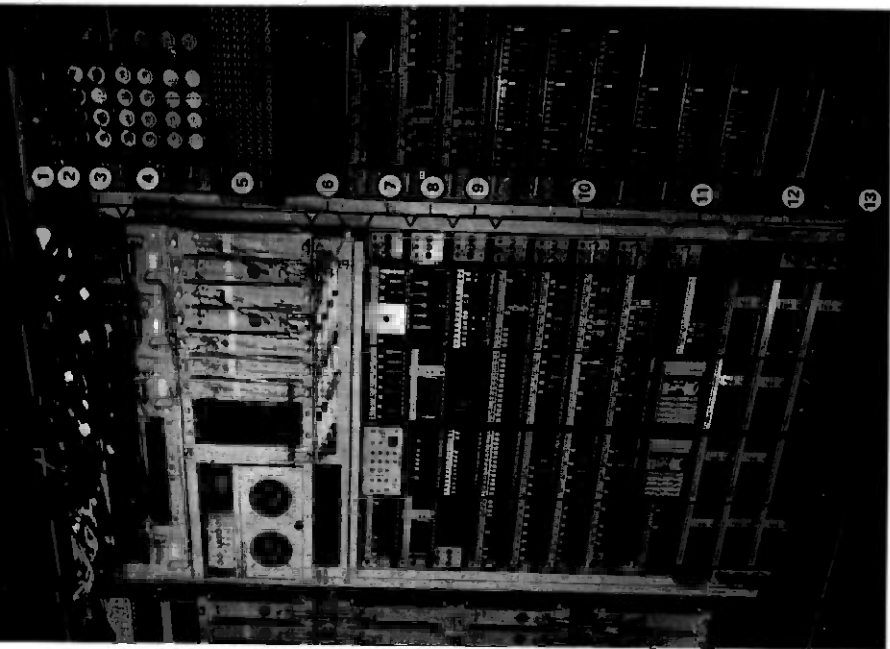

Fig. 3—Data frame.

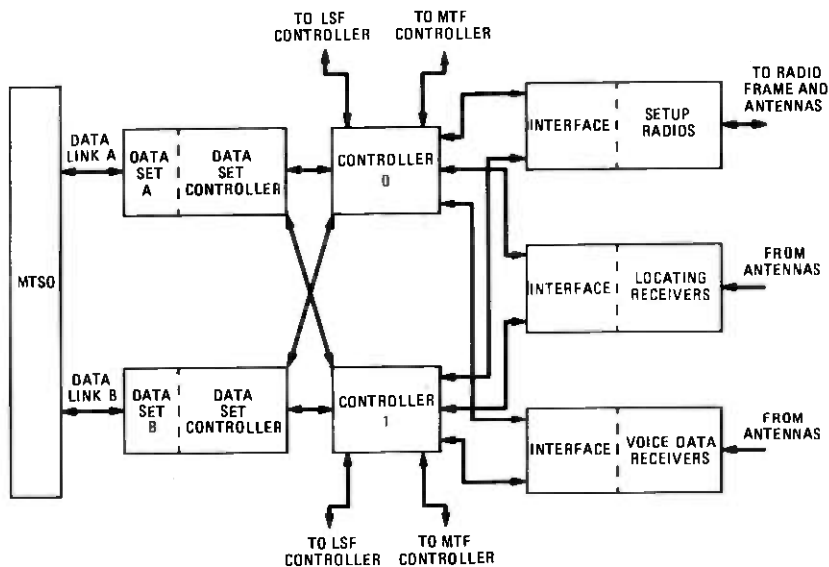

Fig. 4—Data frame block diagram.

- (i) Land data links, described in Section 2.1.
- (ii) Controllers described in Section 2.2.
- (iii) Setup radio communication, described in Section 2.3.
- (iv) Locating radios, described in Section 2.4.
- (v) Voice-channel data communications, described in Section 2.5.

2.1 Land data links

Data communication between the MTSO and each cell site takes place over two redundant data links connecting Western Electric 201D data sets at each termination. The 201D data set operates at a 2.4-kb/s rate and supplies TTL level outputs so that no buffering is required between it and the DF logic. The data set controller converts the 32-bit serial messages into 16-bit parallel words for transfer to the controllers. The 201D also can configure itself for loop-around testing under remote control of the MTSO. This feature is essential for maintenance because the cell sites will normally be unmanned. The data sets and the data set interfaces also operate in the reverse direction to take and transmit data from the controllers to the MTSO.

2.2 Controllers

The controller of the data frame (see Fig. 5) consists of a PROCON, a writable store unit (wsu), a parity generator and checker, and a data bus to connect the PROCON to the numerous peripherals with which it must communicate. All units are provided redundantly to assure continuation of service in the presence of failure.

The PROCON is a small general-purpose programmable controller,

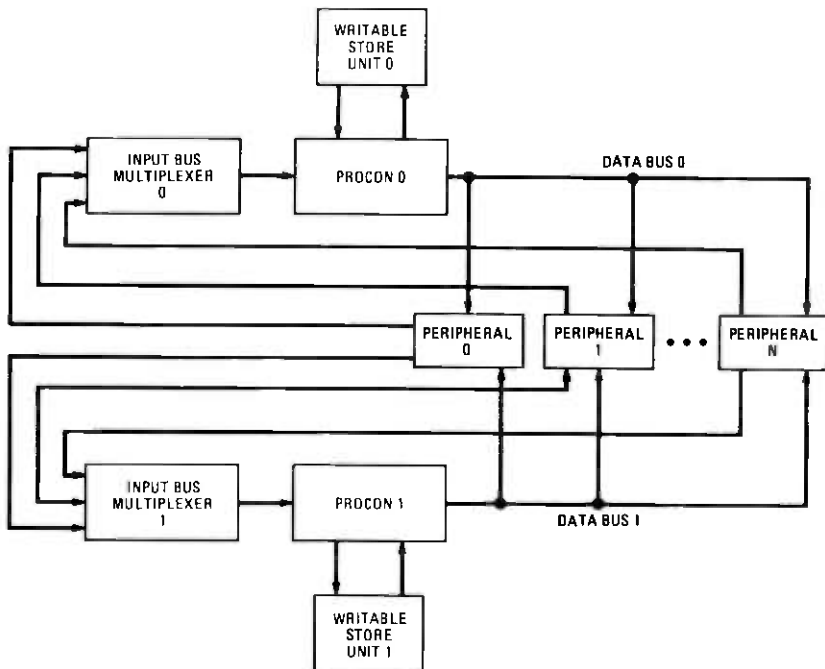

Fig. 5—Data frame controller.

developed at Bell Laboratories, designed to have sequencing and control functions with very high reliability. It is self-checking; an ASW (all seems well) signal indicates the presence or absence of a failure. The redundant PROCON recognizes this indication and reports failure to the MTSO. The MTSO will then use the properly functioning PROCON for further cell-site control and will print out in a maintenance center a request to dispatch a craftsman to the cell site to correct the problem.

PROCON processes 16-bit parallel data words but uses 24-bit words for program instructions. It contains data manipulation units (DMU), a control unit (CU-16), and program storage units (PSU). The DMU contains instruction decoders, internal registers, logical/arithmetic capability, and peripheral communication logic. The control unit contains program-addressing logic, clock distribution, and fault-detection circuits. Each PSU board contains 2048 (2K) 24-bit words of read-only memory (ROM). The PROCON contains 4000 words of ROM and accesses an additional 4000 24-bit words of random-access memory (RAM) in its associated wsu. This increases its effective program store capacity to 8000 words. The wsu also provides 2000 18-bit words of data memory (DM) for PROCON access. Sixteen bits of each DM word contain data, and the remaining two bits are used for parity.

The PROCON output is linked to a 16-bit data bus, which connects it to all peripherals, both within the DF and in other cell-site frames.

Separate control signals from the PROCON indicate the address of the peripheral to be connected to the data bus to receive a particular message. In a similar manner, peripherals are connected to the data bus to allow the controller to read information from a peripheral's output register when the peripheral is acting as a sensor. Parity is added at the source for all data messages placed on the bus and is checked by the unit receiving the message before it is used.

2.3 Setup radio communication

Setup radios, as described in Ref. 1, transmit only data, and are used in the initial phase of "setting up" the call prior to the establishment of a voice path for communication. They are for the general (shared) use of the cell site in communicating with all mobiles within its zone. In addition, the setup radios also transmit overhead messages to assure that idle mobiles within the cell coverage zone are ready and able to communicate should a call be initiated to or from the mobile.

In the forward direction (land to mobile), referred to as the forward setup channel, messages may be either one or two words in length. Each word consists of data bits transmitted serially at a rate of 10 kb/s and encoded before transmission to provide 28 message bits and 12 BCH error detection/correction bits for a total of 40 bits per word. In the reverse setup direction, the mobile transmits—at the same data rate—48-bit words, with 36 of these bits available for message information and 12 bits used for the error detection/correction code. The words in the reverse direction vary in number. The number of words needed is transmitted as part of the message information. In each direction, each word is repeated five times to allow a majority voting of the detected word to protect the integrity of the transmission against the effects of noise, multipath fading, and interference. To minimize the effects of noise that comes in bursts, the five repeats of each message in the forward direction are interleaved with similar messages addressed to another mobile. This group of two words, each transmitted five times, is preceded by 10 bits of dotting (alternate ones and zeros) for bit synchronization and 11 bits of Barker Code* for word synchronization (see Fig. 6). The bit-and-word synchronization permits the mobiles to frame the forward setup messages and determines when each word and each sequence of the five-word repeats begin and end. Each mobile will look at only one of the two interleaved sets of words in the message stream, depending on whether the last digit of the mobile's telephone number is odd or even.

An additional bit, called the busy-idle bit, is inserted immediately following the bit sync, the word sync, and every 10 bits of each message word. If the bit is a 1, the reverse setup channel of the particular cell

* Barker Code consists of a bit sequence that is highly unlikely to be reproduced by rhythmic or random noise. It is 11100010010.

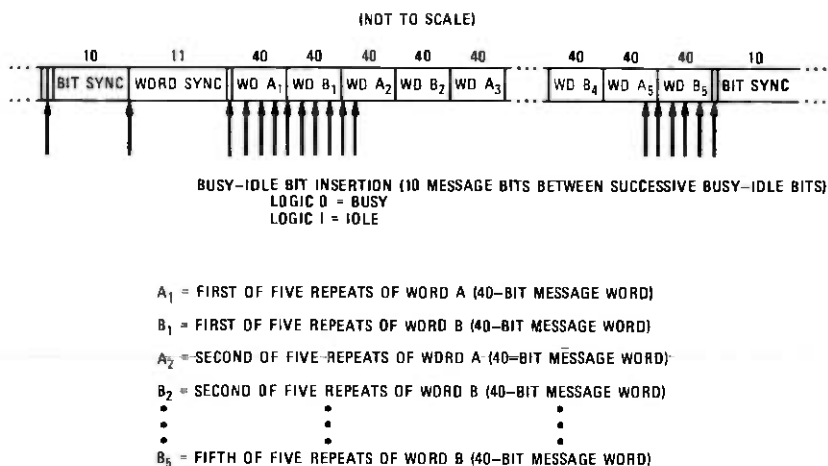

Fig. 6—Forward set-up channel message stream. A given logic unit reads only one of the two interleaved messages.

site transmitting the message stream is idle, and any mobile desiring to initiate a call or to respond to a page may transmit. If the bit is a 0, the reverse setup channel is being used by another mobile transmitting a call origination or a page response. A mobile wishing to transmit on that channel must wait a short time interval and monitor the channel again until idle bits are observed.

There is no essential difference between a voice radio and a setup radio, *per se*. In fact, the identical radio equipment codes may be used in either position. The differences in practice between the setup radio and the voice radio are the frequency channel to which each is assigned and the interface circuits that control the operation of the radio.

In the case of the setup radio transmitter, four circuit packs,* three designated as setup transmitter interface and one as setup transmitter controller, take the information from the controller and prepare it in a form appropriate to sending the data message over the setup channel. The three setup transmitter-interface packs behave as one functional unit. They latch and hold the data received from the controller, determine the appropriate time to load this word into a shift register, check the word for parity, inhibit the transmission of a word if parity does not check properly, shift the data out of the register one bit at a time to convert the word from parallel to serial form, and convert the data into Manchester coding.† The setup transmitter controller determines which of the setup radios will be used on line and which will be retained as the redundant spare. The setup transmitter controller has the capability of controlling up to five setup radio transmitters. In the Chicago developmental system, however, the anticipated traffic levels

* The physical design of these circuit packages is discussed in Section 7.2.

† See Ref. 2 for a discussion of Manchester coding.

during the equipment and service tests will not require more than one set-up transmitter and one spare.

2.4 Locating radios

To maintain signal strength sufficient for good-quality voice and data transmission, each mobile must communicate with an appropriately located cell site within the MSA. When a call is initially set up, locating the appropriate cell site is done by the mobile as it scans all setup channels and selects the one with the highest signal level for use in transmitting the reverse setup messages. After the call has been established, the mobile may move out of the area of sufficient signal strength. It then becomes necessary to route the call through another cell site whose location provides better signal quality to that mobile. Reference 1 describes how the system implements a handoff.

After the handoff event has been completed, the call continues until another handoff is required or until either party terminates the call.

To determine when and if a handoff is necessary, locating measurements are made once every few seconds on each active voice channel. Two techniques for locating are provided in the AMPS systems. The primary method is signal-strength measurement. The alternate method is called phase-ranging and is described in Section III.

Signal measurements for locating are performed by equipment consisting of a locating radio receiver (LRR), a tunable synthesizer, and a locating receiver interface (LRI). There are four LRRs with their associated synthesizers and interface circuit packs per cell site. Three sets are required to handle the busy-hour traffic load. The fourth is a spare to assure maintenance of service by reconfiguration should any of the on-line equipment become defective.

The cell-site controller (Section 2.2) keeps track of all calls which the cell is serving and makes a locating measurement on each call every few seconds. The controller sends, via the data bus to the LRI, a message containing a 10-bit binary number representing the channel code. The LRI then directs the associated synthesizer to tune its local oscillator to the frequency of the selected channel. The LRR develops an output voltage which is a function of the carrier signal quality. After a period of time to allow for settling, this voltage is held fixed by a track-and-hold circuit, while an analog-to-digital converter in the LRI converts the voltage representing an input signal range between -110 and -30 dBm into an 8-bit binary number and places it in the output register. Concurrently, a "Ready Output flag" is set to signal the controller that the measurement is available for readout. Because the controller has stored the channel number for which the measurement request was made, it is unnecessary to include any channel identification in the output word. Only the signal strength value is returned to the controller.

The MTSO considers voice channel signal quality information from the controllers in the serving cell and in adjacent cells. A handoff process is initiated to transfer the mobile as it moves between cells so that it will again be served by the cell site receiving the best signal quality. The process of executing the handoff is described in Ref. 1.

2.5 Voice channel data communications

After a call has been set up, it must be monitored to determine when it is necessary to send various orders to the mobile, such as an order to turn off the mobile's transmitter at the termination of the call, or an order following a user request for one of the optional vertical services. The method of monitoring the call (referred to as call supervision) is described in Section III for all features except locating, which has been discussed above. Orders and requests for vertical services must be transmitted so as not to interfere significantly with voice conversations. They are sent in the form of binary data messages over the voice channel by momentarily muting the voice and inserting a binary data sequence, then restoring the audio capability. The data sequence requires approximately a tenth of a second. This technique, called blank-and-burst, is discussed in more detail in Refs. 1 and 2. Below is a brief summary of the method of implementing this technique.

The data messages over the voice channel in the direction from the cell site to the mobile are referred to as forward blank-and-burst. Those from the mobile to the cell site are called reverse blank-and-burst. The forward blank-and-burst order is initiated by the MTSO, which sends an appropriate message over the data link to the controller in the cell site. The controller then sends the required message to the voice transmitter data interface (VTDI), a single function spread over three circuit packs; it also directs the LSF controller to set up the required connection in the LSF between the VTDI and the voice radio channel assigned to the addressed mobile. The VTDI accepts the order from the controller in three successive parallel 16-bit words and converts them into a single 40-bit serial word that is sent at a 10-kb/s rate to the voice radio transmitter via an electronically switched connection in the Line Supervision Frame (LSF). The message format is shown in Fig. 7. The VTDI also precedes the data word with the bit sync and the word sync and repeats this grouping of bit sync, word sync, and the 40-bit data word 11 times before the LSF restores the channel to the voice mode. The use of 11 repeats ensures that there will be a sufficient number of properly received words to permit accurate word decoding by the mobile's logic unit in the noisy or interference-limited environment of AMPS.

If the mobile customer has subscribed to vertical service features, his request for a specific vertical service (such as third-party add-on to a call) must be transmitted as a data word via the blank-and-burst

technique. The implementation of blank-and-burst in the reverse direction (mobile to cell site) is somewhat different from that of the forward direction.

The customer initiates his request for vertical service by entering a specific number sequence (including the telephone number of a third party, if applicable) via the *TOUCH-TONE*[®] calling pad into a register within the mobile logic unit. Then the customer depresses the SEND button* which is analogous to operating the switch-hook to obtain an operator's attention. The SEND button causes the signaling tone (ST)[†] to be transmitted over the voice channel for about 0.5 second. The LSF, recognizing that a signaling tone has been detected, operates a relay on the trunk switching unit to put the trunk into the on-hook state. When the MTSO, which monitors the on-hook, off-hook condition of each trunk, detects an on-hook condition of 0.5-second duration, it sends a message to the cell site telling the requesting voice channel to transmit data.

The voice receiver data (VRD) group in the data frame consists of a voice receiver data radio, a tunable frequency synthesizer, two interfacing circuit packs, and a data modem consisting of four circuit packs (clock initialization, clock acquisition system, Barker sequence detector and bit decoder, and majority voter). One VRD group is used for the entire cell site because traffic levels on it are expected to be low and the messages handled are not time-critical. It is backed up by a redundant spare. The working VRD must be tuned, therefore, to the frequency of the channel expecting a reverse blank-and-burst message. Upon receipt of the MTSO message indicating the channel number of a mobile that had "flashed," the PROCON orders the synthesizer associated with the data receiver to tune to the designated channel. When the PROCON detects the "in lock" flag (which indicates tuning is complete), it orders a forward blank-and-burst message to be sent to that mobile directing it to transmit a reverse blank-and-burst message. The mobile then transmits over the voice channel the data message corresponding to the request which the customer had initiated via the *TOUCH-TONE* calling pad and SEND button.

The reverse blank-and-burst message format is diagrammed in Fig. 7 and consists of 100 bits of "dotting" bit sync (alternate 1s and 0s), 11 bits of word sync (Barker code), and 48 bits of message data, of which 36 are information bits and 12 are error-detecting/correcting bits. This grouping of bit sync, word sync, and message is repeated four more times, for a total of five consecutive transmissions, except that in the last four the bit sync is limited to 37 bits of dotting rather than 100. The Barker sequence detection and bit decoder, the clock initialization,

* Other features of the SEND button are discussed in Ref. 3.

† The signaling tone is an out-of-voice-band 10-kHz tone detectable within the LSF. The function of the signaling tone and the operation of the LSF in detecting various states of the call are discussed in Section III.

and the clock acquisition system circuit packs detect the dotting and develop from it a clock signal synchronized with the clock in the mobile to facilitate detection of the Barker code and the data message.

The five transmissions of the message are each delayed within the majority voter shift registers long enough to cause them to enter the bit summing network (voter) in bit synchronism as shown in Fig. 8. As a result, a voted output occurs, one bit at a time, according to the detected value of each bit that occurred on at least three of the five

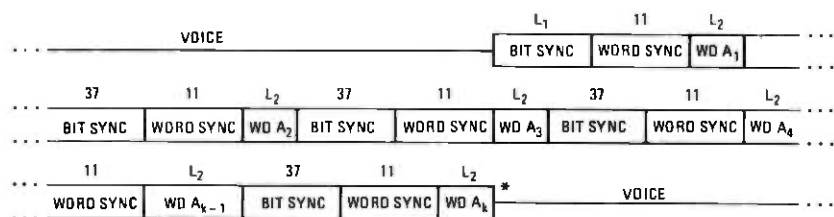

LEGEND

SYMBOL	FORWARD DIRECTION	REVERSE DIRECTION
K	11 REPEATS	5 REPEATS
L_1	100 BITS	101 BITS
L_2	40 BITS	48 BITS

* IN REVERSE DIRECTION A SECOND MESSAGE (B) MAY FOLLOW WD A_k.

† FORWARD DIRECTION IS FROM THE CELL SITE TO THE MOBILE.
REVERSE DIRECTION IS FROM THE MOBILE TO THE CELL SITE.

Fig. 7—Voice channel data message formats.

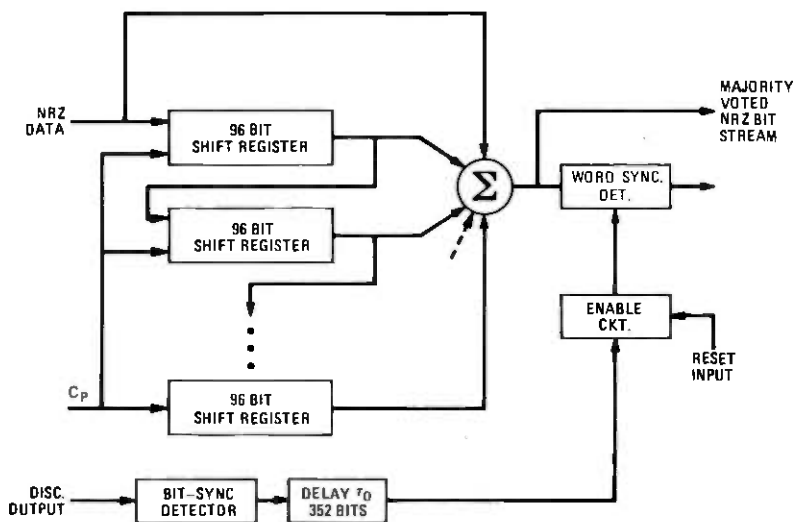

Fig. 8—Majority voting system.

transmissions. This word, made up of majority voted bits, is then converted in an interface circuit pack from a 48-bit serial word to three successive 16-bit parallel words and sent over the data bus to the PROCON. The PROCON tests the BCH error detection/correction coding, reformats the message, and sends the information over the data link to the MTSO. The MTSO performs the necessary actions to comply with the customer's request for a vertical service. The customer's request is received by the MTSO within a second after the "flash" message is received at the cell site.

III. LINE SUPERVISION FRAME

The line supervision frame (LSF), shown in Fig. 9, provides the perchannel audio-level speech-path interface between the MTSO-controlled telephone trunk network and the radio frame that transmits the radio frequency voice communication to and from the mobile unit. In addition to this principal function, the LSF also performs the following system functions:

- (i) Enables transmission of forward blank-and-burst data messages by connecting the VTDI circuits to the appropriate voice transmitter.
- (ii) Provides line supervision and control through monitoring of the supervisory audio tone (SAT) and the signaling tone.
- (iii) Turns transmitters and receivers on and off as requested by the MTSO via the DF according to the level of mobile telephone traffic.
- (iv) Provides range measurements on each mobile by measuring the phase delay of the received SAT.
- (v) Enables voice trunk maintenance tests to be performed by switching trunks into loop-back configurations.

The audio circuits in the LSF are supplied in modules. Thus, a single LSF can support from 1 to 48 separate voice channels. As many as three LSFs can be connected to a single DF, allowing the maximum capacity of a cell site to be 144 voice channels.

The LSF has two functional parts: the voice channel circuits and the frame controller. The voice channel circuits are modular; the quantity supplied varies according to the number of voice trunks terminating in the frame. This number depends on the traffic requirements for the cells, but it cannot exceed 48 in a single LSF. The controller is installed complete, with redundancy, independent of the number of trunks terminating in the frame.

Each voice channel circuit consists of a group of eight printed circuit boards and six jacks used for testing and monitoring the trunk/voice channel circuits and the voice channel circuits/voice radio interfaces.

- ① INTERCONNECTION PANEL
- ② TRUNK SWITCHING UNIT PANEL
- ③ JACK PANEL ASSEMBLY
- ④ SAT DISTRIBUTION PANEL
- ⑤ LSF DISPLAY UNIT
- ⑥ LSF CONTROL UNIT
- ⑦ VOICE CHANNEL CIRCUIT PANEL
- ⑧ CONVERTER PANEL

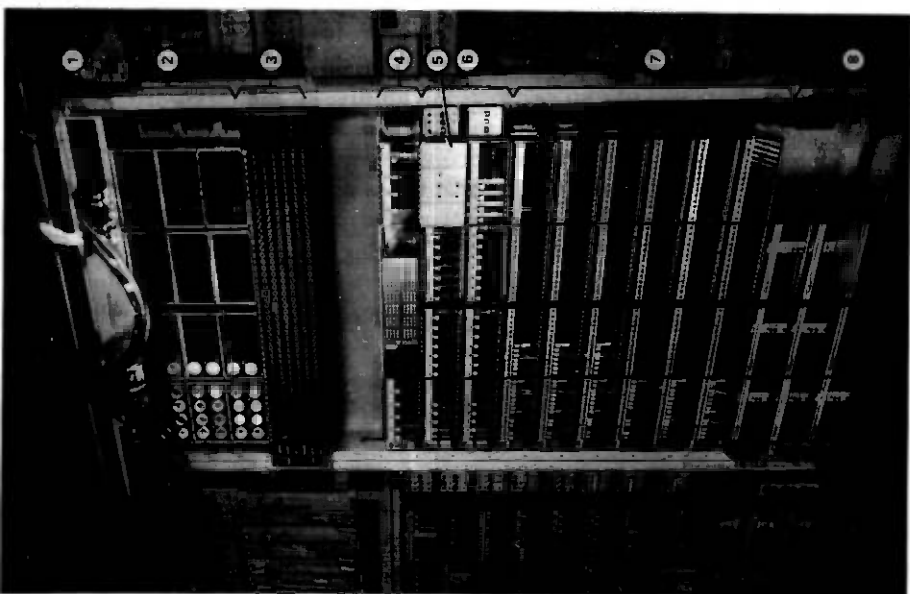

Fig. 9—Line supervision frame.

3.1 Voice channel circuits

The voice channel circuit performs all the baseband signal processing for a single voice radio. Before the transceiver baseband signals can interface with the telephone network, certain control signals must be added on the transmitter path, and other control signals must be removed from the receiver path. To obtain these control signals, each line circuit has access to several busses carrying both analog and digital information. Each line circuit is permanently wired to the 6-kHz supervisory audio tone (SAT) bus and to the 10-kHz clock bus. Access to the trunk-maintenance bus, serial-data bus, and phase-range bus is controlled by signals from the LSF controller. The state of each line circuit is indicated by a group of status signals that may be read by the LSF controller. The five status signals are: (i) transmitter power on/off, (ii) maintenance relay state (normal or loop-around), (iii) line control logic fade timing, (iv) line control logic timed out, and (v) off-hook. Each line circuit contains a logic circuit that controls dc line supervision on the MTSO-cell-site path and shuts off the cell-site transmitter if mobile-to-cell-site transmission is interrupted for more than 5.5 seconds.

The audio processing section serves to interface the four-wire, voice-grade, telephone trunks with the cell-site transceivers. A syllabic compandor reduces audio noise in the transmission system. The compandor is composed of two sections. A compressor at the transmitting end reduces variations in speech input power levels by a factor of 2 (in decibels). An expander at the receiving end performs the inverse operation. The loss of the expander must complement the gain of the compressor so that the end-to-end relative signal levels are unaffected. The overall effect of these circuits provides an improved signal-to-noise ratio for the received speech. Both the mobile and the cell-site audio circuits must contain similar speech compressors and expandors. (See Ref. 2 for a more complete discussion.)

Figure 10 is a block diagram of the audio processing circuits. The PC7 transmit-audio compressor circuit pack contains the compressor half of the compandor circuit. The audio from the voice trunk feeds into the compressor; the compressed audio output feeds into the audio filter. The PC1 transmit-audio filter contains a sharp 300- through 3000-Hz bandpass filter, which band-limits the audio from the compressor. One of the three possible cell-site SAT frequencies* is selected at the SAT cross-connect panel, added at the output of the low-pass filter, and combined with the audio signal in an operational amplifier summing circuit. The output is the composite audio and SAT signal, which is passed through the data/voice switch in the PC2 bit encoder

* 5970, 6000, or 6030 Hz.

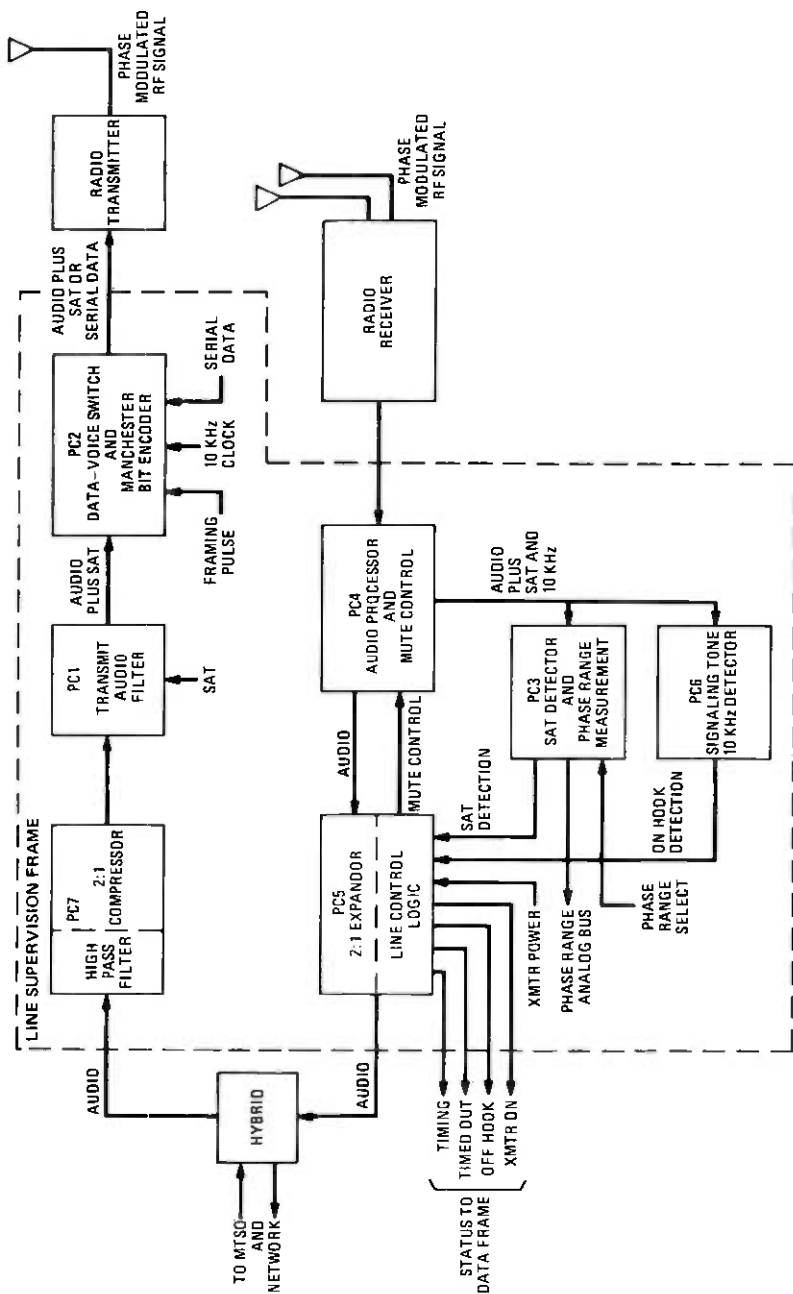

Fig. 10—Audio processing circuit.

and data-voice switch to the transmitter in the radio frame when the switch is in normal or voice position.

When the cell site must send short bursts of high-speed data (during the time the mobile is tuned to the voice channel), it uses the blank-and-burst mode. While data are being sent, a framing pulse switches the data-voice switch to the data mode. The framing pulse inhibits the audio, selects for use one of the two redundant data busses, disconnects the voice transmitter from the audio system, and connects it to the signaling system bit encoder. Serial data from the selected data bus are gated into the Manchester encoder. The data and the 10-kHz clock are exclusively NOR-gated to give a Manchester-encoded format. The data then pass through a Bessel shaping-filter, which removes the high-frequency components. The serial data message, Manchester-encoded, is then passed to the transmitter in the radio frame and transmitted to the mobile. See Ref. 5 for more details on data transmission.

Communications in the other direction—from the mobile—are received by the associated voice receiver in the radio frame. These signals contain audio plus the SAT and on occasion the 10-kHz signaling tone (ST). While data in the form of blank and burst messages are also sent from the mobile over the voice channel, those messages are not processed through the voice radios or the line supervision frame. Instead, they are received by the voice data radio receiver in the data frame and processed through its associated modem.

The output of the voice receiver's discriminator is sent to the PC4 receive audio processor, basically a combination bandpass filter and frequency modulation de-emphasis filter. The overall transfer characteristic is a 6-dB/octave slope in the voiceband and a sharp 24-dB/octave fall-off in the region outside the voiceband. The output is fed to the audio expander circuit. An output ahead of the filter, containing the SAT and the 10-kHz ST, is connected to the SAT and ST detectors, respectively. The audio expander circuit is mounted on the PC5 line control circuit card. The input to the expander is from the PC4 receive audio processor circuit pack and the output is connected to the operating company voice trunk.

In addition to the expander circuit, the PC5 line control circuit contains logic to detect the voice channel status, to control the on/off status of the voice transmitter and receiver, and to transmit status indications to the data frame controller. Voice channel status is developed from the transmitter power array in the LSF controller (see Section 3.3) and from the outputs of the SAT and ST detectors for the following status reports: timing, timed out, off-hook, and transmitter power on. The transmitter is turned off to prevent radiation of power on any channel not in use. Similarly, the receiver is disconnected from

the trunk to prevent receiver noise (which is maximum in the absence of a detected carrier) from entering the land line trunk when the channel is unoccupied. The muting circuits to disconnect the receiver from the trunk are located in PC4.

The SAT, which is added to the transmitter baseband signal at the output of the audio bandpass filter, is transponded at the mobile and detected in PC3 of the cell-site receiver signaling system. It monitors the continuity of the cell-site-to-mobile path and furnishes ranging information. The SAT detector output is at logic 1 as long as the correct SAT frequency is detected and the carrier-to-noise ratio is greater than 7 dB. If SAT is not detected, the line control goes into a timing condition. If recovery is not made in 5.5 seconds, the call is considered lost and the circuit will time out and shut off the cell-site transmitter.

A phase-locked loop detector performs an estimate of the distance between the cell site and the mobile by comparing the phase of the transmitted and received SAT signals. The mobile-to-cell-site distance is a linear function of this phase difference. The difference in phase is converted into a dc analog signal, which is connected via the phase-range switch and the phase-range bus to an analog-to-digital converter in the LSF controller.

The mobile may autonomously transmit a 10-kHz signaling tone as part of its disconnect sequence or as an acknowledgment of the receipt of certain orders. The PC6 contains a detector circuit, which is an active 10-kHz (ST) bandpass filter followed by a full-wave rectifier, low-pass filter, and level comparator. The ST output is a logic 1 when the tone is present. It is fed to the PC5 line control circuit. The line control circuit monitors both the SAT and ST logic outputs generated by the tone detectors in the signaling system and uses them to control the DC supervision current (off-hook signal) in the MTSO to cell-site trunk and the transmitter on-off status. When the mobile party disconnects, the mobile sends the 1.1-s, 10-kHz ST. The line control circuit, via control of the trunk switching unit, removes the off-hook signal from the land trunk. The MTSO detects the trunk on-hook transition and sends a blank and burst release order to the mobile to shut off its transmitter.

For maintenance aids, the voice trunks from the MTSO connect to a set of test jacks for each trunk. There are six jacks per trunk:

- (i) Transmitter network out: Disconnects the trunk and connects to trunk output.
- (ii) Transmitter compressor in: Disconnects the trunk and connects to the audio compressor input.
- (iii) Transmitter monitor: Monitors the transmit trunk.
- (iv) Receiver network in: Disconnects the trunk and connects to the trunk input.

- (v) Receiver out: Disconnects the trunk and connects to audio processor output.
- (vi) Receiver monitor: Monitors the receive trunk.

3.2 Trunk switching unit

The trunk switching unit (TSU) consists of the trunk maintenance switch and the loop signaling switch for one trunk. It contains two relays mounted on a printed circuit board. In the normal state, each trunk connects through its TSU to its associated audio processor. The maintenance relay signal from the LSF controller operates the maintenance relay to disconnect the trunk from the audio processors and connect it to the test trunk. A maintenance relay status signal is returned to the LSF controller to indicate that the relay has operated. The off-hook signal from the line control circuit operates the second relay to provide a closure for the loop signal current to operating company equipment.

3.3 Line supervision frame controller

The LSF controller receives data words from the DF cell-site controllers and examines each word to determine the voice circuit to be accessed and the function to be performed. The LSF controller consists entirely of wired logic and contains redundant circuitry, designated side A and side B. Each side may accept data words from either cell-site controller, the choice being determined by the load signal used. Both sides can access any of the voice circuits. A block diagram of one side of the LSF controller is shown in Fig. 11. To avoid complexity, this figure omits all interactions with the redundant side.

The transmitter power control circuit consists of two array access circuit packs, one for each side of the LSF controller, and two transmitter power array circuit packs, which are common to both sides of the controller. The array access circuit pack contains the control to set and reset the selected flip-flop in a 48-element array contained in the two transmitter power array circuit packs. The inputs consist of the radio address, the frame address, and the transmitter-on and transmitter-off signals. The output controls the on/off state of each voice transmitter and is sent to the transmitter via its associated PC5 line control circuit.

The maintenance selector circuit is similar to the power control circuit. It consists of two array access circuit packs, one on each side of the LSF controller, and two maintenance array circuit packs which are common to both sides of the controller. The maintenance array consists of 48 flip-flops that are set or reset by signals from the array access circuits. The outputs go to the 48-trunk switching units to operate the maintenance relays.

The data/voice selector consists of a demultiplexer circuit pack on each side of the LSF controller. Its purpose is to select the voice channel

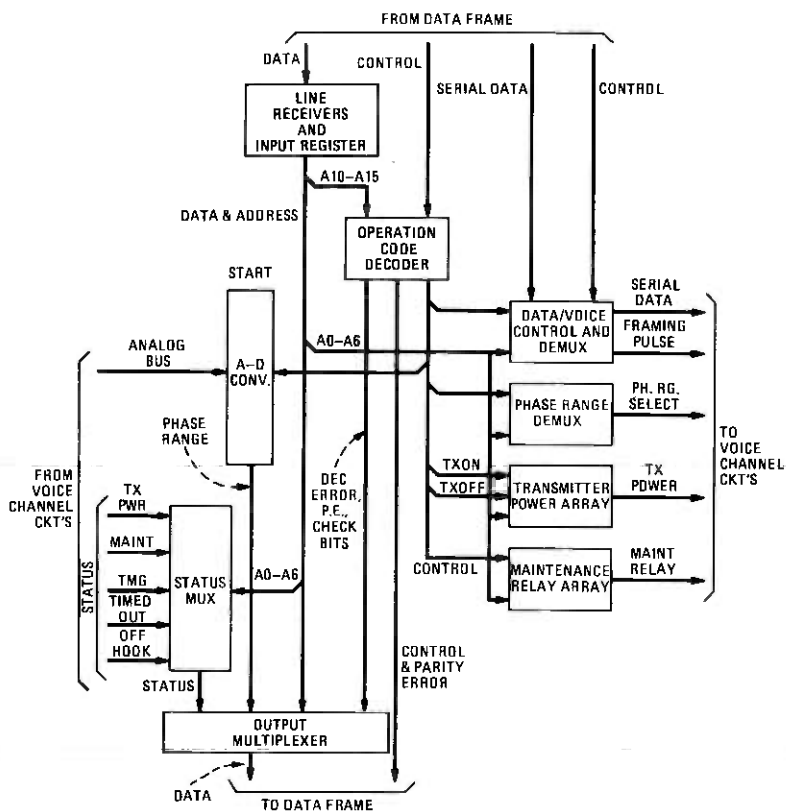

Fig. 11—Line supervision frame controller block diagram.

and control the flow of serial data for the forward blank-and-burst function. The data/voice selector contains an eight-bit register to store the radio address, the frame address, and the VTDI select bit. The VTDI select bit chooses the voice transmitter data interface it will use as the serial data and framing pulse source. The selected serial data are placed on a bus that drives all the bit encoder and data voice switches in the 48 voice circuits. The address output of the register is used to drive the data voice demultiplexer. It is a 1-out-of-48 decoder, which delivers the framing pulse to the selected bit encoder and data voice switch that receive the serial data.

The phase-range selector circuit consists of a phase-range demultiplexer circuit pack in each side of the LSF controller. The phase-range demultiplexer is a 1-out-of-48 decoder, which receives the radio and frame address from the input register and is enabled by the set phase-range switch signal from the operation code decoder. The analog-to-digital converters change the phase-range analog-voltage output of the phase-ranging circuit to an eight-bit binary code, which is transmitted to the cell-site controller.

AMPLIFIER COMBINER BAY

- | KEY | NAME |
|-----|---|
| ① | INTERCONNECTION PANEL |
| ② | POWER AMPLIFIER ASSEMBLY INCLUDES 8 POWER AMPLIFIER MODULES |
| ③ | CAVITY COMBINER (CHANNEL MULTIPLEXER) ASSEMBLY |
| ④ | POWER AMPLIFIER ASSEMBLY INCLUDES 8 POWER AMPLIFIER MODULES |
| ⑤ | POWER CONVERTER PANEL |
| ⑥ | FUSE MOUNTING PANEL |
| ⑦ | POWER FILTER PANEL |

TRANSCIVER BAY

- | KEY | NAME |
|-----|--|
| ⑧ | INTERCONNECTION PANEL |
| ⑨ | RF DIVIDER PANEL |
| ⑩ | JACK PANEL ASSEMBLY |
| ⑪ | RADIO CONTROL CIRCUIT PANEL |
| ⑫ | TRANSMITTER TRAY ASSEMBLY INCLUDES 8 CHANNEL TRANSMITTER MODULES |
| ⑬ | RF DISTRIBUTION PANEL |
| ⑭ | RECEIVER TRAY ASSEMBLY INCLUDES 8 RECEIVER MODULES |
| ⑮ | TRANSMITTER TRAY ASSEMBLY INCLUDES 8 CHANNEL TRANSMITTER MODULES |
| ⑯ | RF DISTRIBUTION PANEL |
| ⑰ | RECEIVER TRAY ASSEMBLY INCLUDES 8 RECEIVER MODULES |

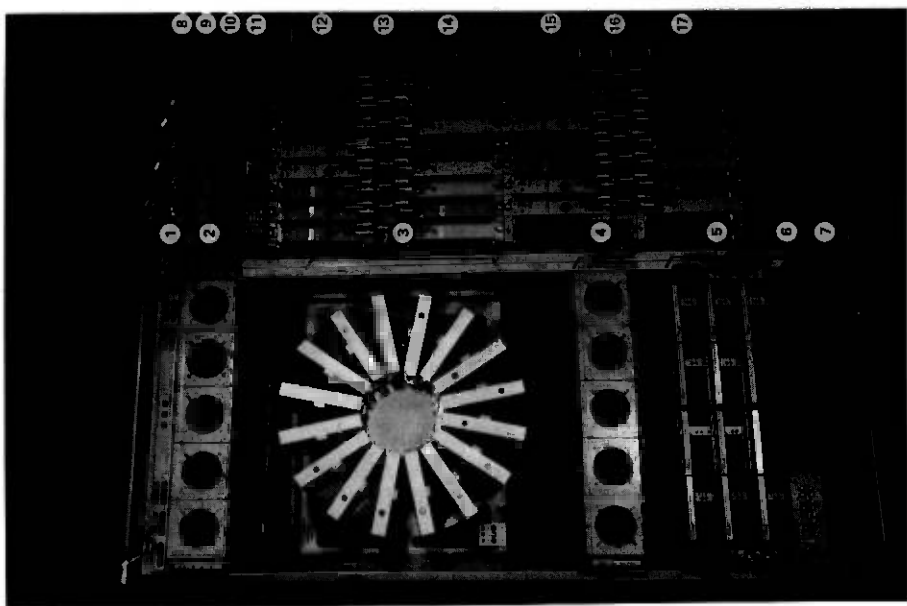

Fig. 12—Typical radio frame, equipped with 16 voice channels.

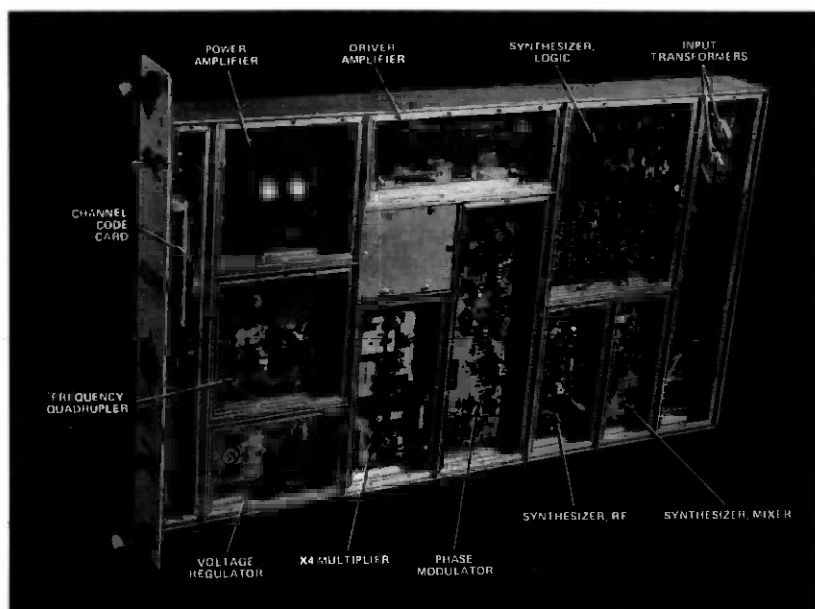

Fig. 13—Typical channel transmitter module unit with covers removed.

IV. RADIO FRAME

4.1 Overview

Figure 12 is a photograph of a 16-channel radio frame.*⁴ As stated earlier, each radio frame is composed of two bays. The transceiver (TR) bay contains 16 pairs of voice channel transmitters and receivers. A companion power amplifier/combiner (PA/C) bay amplifies and combines the outputs of the voice transmitters.

The radio frame interfaces with the radio transmission environment through three antennas: one for transmit, the others for two-branch space-diversity receive. When the cell site equipment is configured for omnidirectional coverage, these antennas are omnidirectional (in the azimuthal plane) with 10-dB gain. Alternatively, when the cell site functions in the directional mode, one radio frame services each face (direction) via three 120-degree directional antennas each with 10-dB gain.†

The radio frame interfaces with the LSF via 16 four-wire, balanced bidirectional trunks, one servicing each voice channel. "Transmitter-on" control signals originate within the LSF. Finally, dc power is supplied from the +24 V battery system as described in Section VI.

Each duplex voice channel (see Fig. 12) is served by a "radio" consisting of a set of four modules located within the radio frame.

* When more than 16 voice radio channels are required at a cell site, additional radio frames are added.

† Additional antenna gain, easily obtained in the directional mode, is not required.

- (i) A channel-transmitter module (see Fig. 13) produces a 1-watt carrier, which is phase-modulated by voice/SAT or frequency-modulated with 10 kb/s data provided by a transmit channel circuit within the LSF. A 666-channel frequency synthesizer, located within the transmitter module, generates the correct channel frequency, which is also the local oscillator for the companion receiver.
- (ii) A power-amplifier module (see Fig. 14) boosts the 1-watt angle modulated carrier, from the transmitter module, to 45 watts.
- (iii) The channel multiplexer combines the 16 45-watt carriers, from the power-amplifier modules, onto one coaxial transmission line, which goes to a transmit antenna.
- (iv) A channel-receiver module receives a two-branch diversity input derived from the two receiving antennas feeding an array of broadband amplifiers and hybrid power splitters. From these inputs and from a local oscillator signal, derived from the companion transmitter module, the receiver demodulates a baseband voice/SAT or data signal, which is delivered to a receive-channel circuit within the LSF.

A radio frame need not be fully loaded with modules; any number of sets, from 1 to 16, are used depending upon the required channel

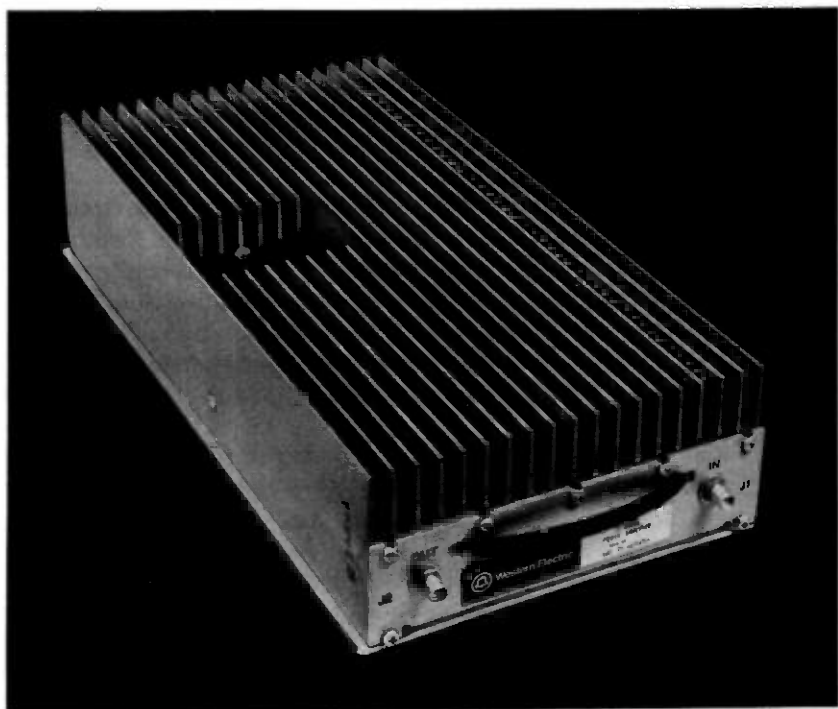

Fig. 14—Typical power amplifier module.

capacity. The channel multiplexer, as presently designed, must provide for all 16 channels; the unused inputs are terminated by 50-ohm loads. A brief design overview of each radio module follows.

4.2 Channel transmitters

Figure 15 is a block diagram of a 16-channel radio frame. The blocks marked $TRAN_0$ to $TRAN_{15}$ are 1-watt output, PM voice/SAT or FM data transmitter modules. The channel frequency for each transmitter, situated in the 870- to 890-MHz band, is generated within its self-contained frequency synthesizer. A digital program plug inserted into the front panel of each transmitter module selects the desired channel. Thus, each voice transmitter resides permanently on one selected radio channel.

Figure 16 is a block diagram of the frequency synthesizer, which uses the indirect frequency synthesis method to generate any one of 666 stable carriers upon digital command from 10 parallel binary program lines. Each carrier, at one-quarter the final output frequency, is stable to within ± 1 part per million over a 0°C to $+40^\circ\text{C}$ temperature range. A relatively unstable, varactor-tuned, voltage-controlled oscil-

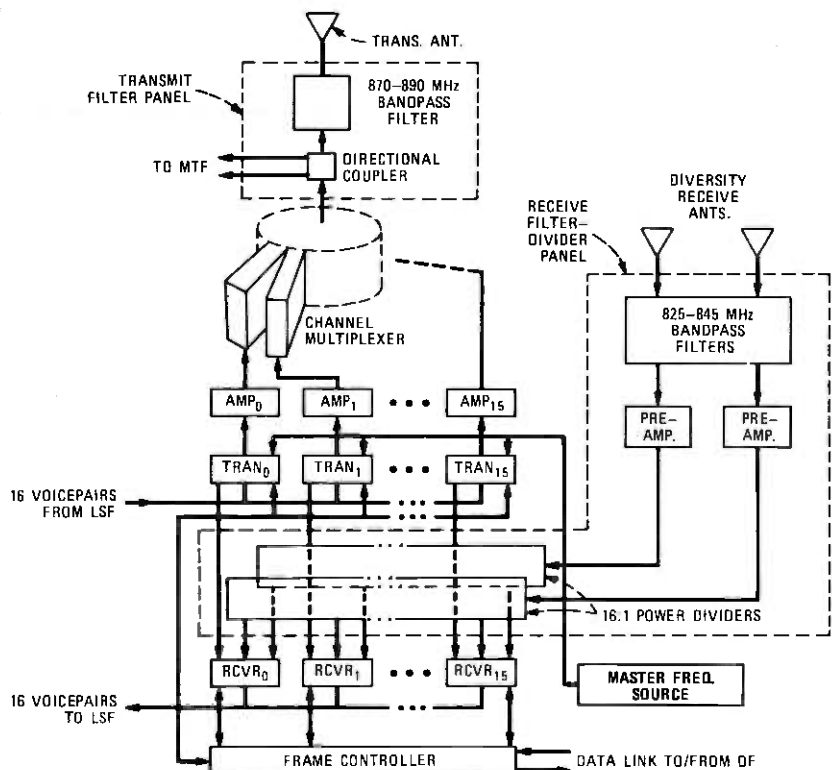

Fig. 15—Block diagram of 16-channel radio frame.

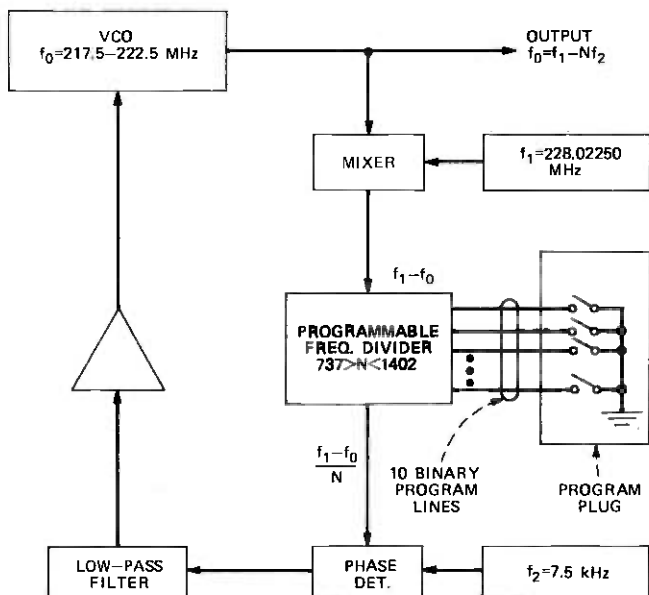

Fig. 16—AMPS cell-site frequency synthesizer.

lator (vco) generates the synthesizer output frequency f_0 . A portion of the vco output power enters a mixer, where it is heterodyned against $f_1 = 228.02250$ MHz, which is derived from a quartz crystal-controlled oscillator located within the MTF (see Section V). The output difference frequency $f_1 - f_0$ (between 5.5 and 10.5 MHz) is "divided down" by a selected integer N , in a programmable digital frequency divider. The specific combination of dc voltages on the 10 parallel binary program lines determines the division factor N , which can range between 737 and 1402. A stable 7.500-kHz reference oscillator (f_2) is compared with the divider output frequency $[(f_1 - f_0)/N]$, nominally near 7.5 kHz, in the phase detector. Any phase error is fed back to the vco in the form of a dc control voltage, keeping the total loop in phase-lock. When in lock, the output frequency is given by $f_0 = f_1 - Nf_2$. Therefore, f_0 will have the same long-term frequency stability as the two stable reference oscillators f_1 and f_2 , yet can be varied in integer steps of 7.5 kHz, by assigning different values to N . Since f_0 is in the 217.5- to 222.5-MHz band, which is one-quarter the output frequency, the 7.5-kHz frequency steps are multiplied to 30-kHz steps, the final channel spacing, in a subsequent $\times 4$ frequency multiplier.

As an example of this frequency synthesis process, suppose the transmitter is tuned to channel 134, which is centered at 870.030 MHz. Then

$$f_0 = \frac{870.030}{4} = 217.5075 \text{ MHz,}$$

and

$$f_1 - f_0 = 10.515 \text{ MHz.}$$

The division ratio is

$$N = \frac{f_1 - f_0}{f_2} = 1402;$$

thus, the frequency divider must be programmed to generate this integer.

The synthesizer output is quite pure. When the output frequency is quadrupled, the resulting audio noise in a 0.3- to 3.0-kHz band (after FM detection, deemphasis, and C-message weighting) is 40-dB below a reference 1-kHz tone with ± 8 -kHz peak frequency deviation.

Figure 17 shows the transmitter circuits following the frequency synthesizer. Power entering at a specified frequency in the 217.5- to 222.5-MHz band (from the frequency synthesizer) is first split, one portion going to a low-power-transistor frequency quadrupler which generates the 870- to 890-MHz local oscillator (LO) for the companion receiver. Since the LO equals the transmit frequency, the duplex-receive frequency will be 45 MHz lower (or higher) if the first intermediate frequency (IF) of the receiver is 45 MHz. For example, if a

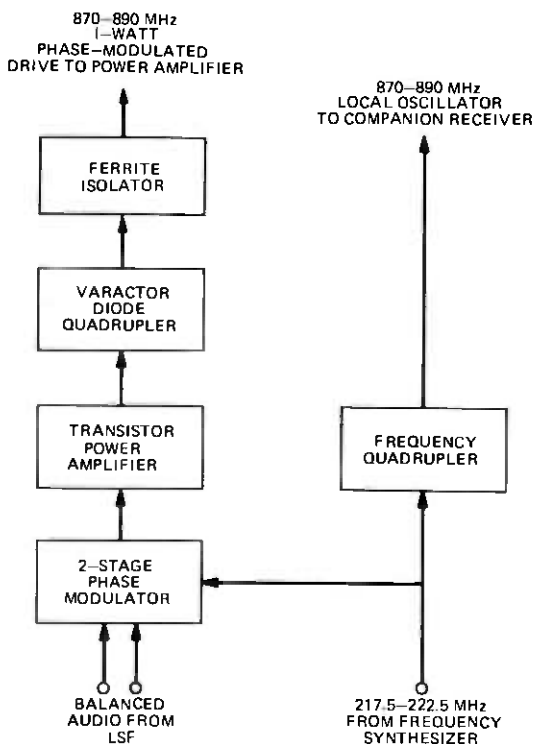

Fig. 17—AMPS cell site transmitter modulator and multiplier.

specific transmitter is programmed to transmit on channel 134, which is centered at 870.030 MHz, then its companion receiver will receive the duplex channel, located 45 MHz lower at 825.030 MHz.

The other portion of the output power (from the frequency synthesizer) enters the phase modulator, which is a two-stage, varactor-diode, reflection-type circuit. Balanced audio (or data) originating within the LSF modulates the dc bias on the varactor diodes. The modulator provides a peak phase deviation of ± 12 radians (after subsequent $\times 4$ multiplication) with less than 5-percent audio distortion.

The resultant phase-modulated carrier enters a four-stage transistor amplifier, where it is boosted to about 3 watts. This power drives a varactor-diode frequency quadrupler. After passing through a ferrite isolator, the quadrupler output appears as a 1-watt phase-modulated carrier in the 870- to 890-MHz transmit band. This output power is delivered to a companion 45-watt power amplifier located in the adjacent power amplifier/combiner frame.

4.3 Power amplifier

In Fig. 15, the blocks marked AMP₀ to AMP₁₅ are Class C power amplifier modules, which boost the 1-watt input from a companion transmitter to approximately 45 watts output. The power amplifiers, which consume most of the dc power in a cell site, are designed to be powered directly from the "raw" 24-V battery supply whose voltage can vary between +21 and +28 V, depending upon the battery's state of charge. Thus, a significant cost savings is achieved by avoiding a requirement for voltage regulation of these major loads. All other equipment within the radio frame is powered from regulated (dc-to-dc converter) voltage sources.

4.4 Channel multiplexer

The 45-watt output signal from each power amplifier module is delivered into a channel multiplexer,^{5,6} which is an array of 16 cavity resonators each functioning as a narrowband filter feeding a common load, the transmit antenna. The multiplexer combines these 16 signals with a maximum of 3 dB loss per channel. The minimum channel-to-channel isolation is 18 dB. Figure 18 is a photograph of the cavity multiplexer. Note that the cavities are arranged in a radial array about a 16-branch stripline feeder assembly contained within the center section. Power enters each cavity from a coaxial connector (and coupling loop) attached to the back of the cavity. The combined power exits the multiplexer by a coaxial connector connected to a "load point" at the back of the assembly. The coupling to each cavity is determined by an acceptable compromise between transmission loss and off-channel isolation. The length of each stripline to each cavity feedpoint, from the common load point, is approximately $\frac{3}{4}$ wavelength. To meet the 3-dB loss per channel, the channels are spaced

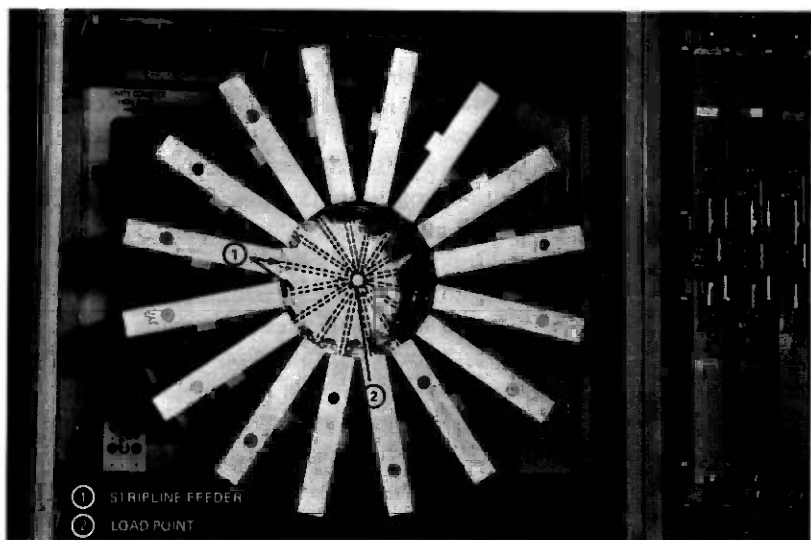

Fig. 18—Sixteen channel multiplexer.

630 kHz, or 21 channel frequencies, apart. Intermodulation is controlled by ferrite isolators, providing 30-dB reverse loss, contained within the output section of each 45-watt power amplifier. With three channels excited, the measured intermodulation products are at least 55 dB down from the desired signals.

4.5 Directional coupler post-transmit filter

The combined 16-channel group leaving the multiplexer (see Figs. 2 and 15) enters a transmit filter panel attached to the wall of the cell-site building. Here the channel group first passes through a dual directional coupler where samples (30 dB down) of the forward and reflected wave are taken. This sampled power feeds via two coaxial cables to the maintenance and test frame (Section V), where appropriate transmitter tests are made and analyzed.

Finally, the channel group passes through a low-loss, 870- to 890-MHz, bandpass filter, where out-of-band harmonics and spurious signals are removed. This interdigital filter is an eight-resonator structure that exhibits an inband loss of about 0.5 dB. The channel group reaches the antenna via a run of 1-⁵/₈ inch o.d. coaxial cable having a loss of about 0.66 dB/100 ft.

The transmitter system is designed to provide a power of at least 10 watts per channel at the transmit antenna.

4.6 Receiver filter/preamplifier/divider

The receive signals from each of the antennas first enter the receive filter-divider panel (see Figs. 2 and 15). The arrangement of radio hardware and signal distribution on both transmit and receive ends

was conceived with a basic modularity of 16 in mind. The transmitter channel multiplexer, though providing low loss, is relatively expensive. Thus, in the receive chain, the 1-to-16 demultiplexer was chosen to be a 16-way broadband hybrid-power splitter which is low in cost but unfortunately inserts a $10 \log 16 = 12$ -dB loss into each receive path. To recover this loss, a low-noise preamplifier (see Fig. 15) is stationed ahead of the power divider. Composed of two commercially available 25-dB gain low-noise amplifiers "parallel-coupled" via two 3-dB quadrature hybrids,⁷ this preamplifier provides redundancy and also reduces by 9 dB the generation of intermodulation spurious signals. The noise figure of this amplifier-hybrid combination is 2.5 dB, and the third-order intermodulation products at the output are greater than 65 dB down from two RF signals which are -35 dBm at the input.

This UHF preamplifier is preceded by an interdigital bandpass filter giving at least 55-dB rejection to signals arriving from the 870- to 890-MHz transmit band. The total system noise figure, measured at the antenna, should not exceed 10-dB.

4.7 Receiver

Following the receive-filter preamplifier and 16:1 divider (see Fig. 15) are 16 two-branch diversity receivers labeled RCVR₀ to RCVR₁₅.

Figure 19 shows a detailed block diagram of the receiver module. The RF receive band is 825 to 845 MHz. The transmit and receive frequencies are separated by 45 MHz, and the frequency synthesized for each transmit channel is used as the first conversion local oscillator frequency in the receiver. The voice receiver noise figure is about 11-dB. A two-resonator 825- to 845-MHz bandpass filter in the feed to each voice-receiver module prevents leakage of LO out of each module into other modules and helps suppress the "half-IF" response in Mixer A. The half-IF response results from the second harmonic of an incoming signal beating against the second harmonic of the mixer's local oscillator signal. For such a response to fall at the IF frequency, the incoming signal must be displaced, in frequency, one-half the IF frequency away from the local oscillator frequency.

In the voice-receiver module, the channel to be detected is first mixed down to 45 MHz in Mixer A, which is a Schottky-diode, single-balanced mixer. The conversion loss is about 6 dB. A PIN diode attenuator, ahead of Mixer A, is driven by an automatic gain control (AGC) bus and provides up to 40-dB of attenuation. This reduces the dynamic range of the signals entering the diversity combiner. A one-stage, 12-dB gain, 45-MHz IF amplifier with a two-resonator, 30-kHz bandwidth, quartz-crystal filter at both its input and output performs preliminary channel filtering.

The 45-MHz first IF is next down-converted to a 1.8-MHz second IF by Mixer B, a balanced FET type, which is driven by a 43.2-MHz

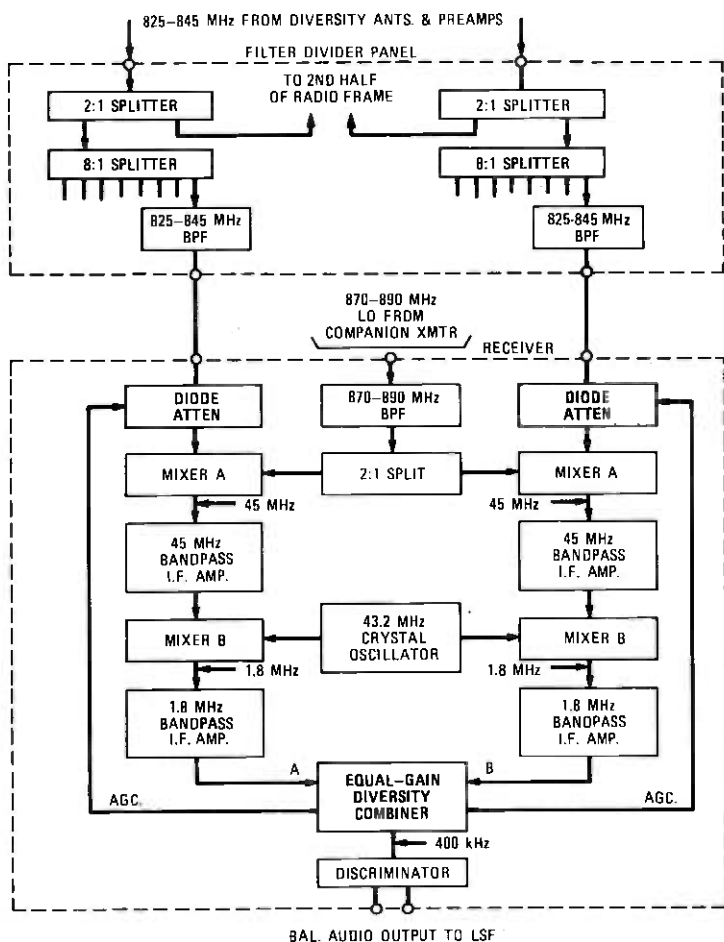

Fig. 19—AMPS cell-site voice receiver block diagram.

crystal-controlled second local oscillator. A 1.8-MHz IF amplifier with a two-resonator, 30-kHz bandwidth, L-C (inductor-capacitor) filter at both input and output performs final channel filtering. The combined gain of the second mixer and 1.8-MHz IF amplifier is about 43 dB, which is adjustable. The overall frequency response of the voice receiver is essentially eight-pole* (eight-resonator), with four poles resulting from the 45-MHz quartz-crystal filters and four poles from the L-C double-tuned circuits in the 1.8-MHz section of the IF amplifier.

The second IF frequency was made as low as the first IF image rejection would permit to simplify the design of the diversity combiner.

The two-branch, equal-gain diversity combiner uses a technique

* Eight poles appear in the low-pass prototype of this eight-resonator filter.

originally proposed by Granlund.⁸ The complete theory of operation of this system has been described by Halpern⁹ and Jakes¹⁰; a simplified explanation is presented in the appendix to this paper.

The practical limitations in the combiner design have resulted in its having a dynamic range of 50 dB. The gain and AGC in the mixer/IF were determined to suit these limitations.

The 400-kHz output signal from the diversity combiner enters a conventional limiter and a "quadrature coil" discriminator, both contained in one integrated-circuit package. The resulting baseband audio/SAT or data are then delivered over a balanced line to a receiver voice channel circuit in the LSF.

V. MAINTENANCE AND TEST FRAME

The MTF (see Fig. 20) contains the oscillators and frequency dividers to generate the master clock signals and the SAT for other equipment in the cell site. It also permits testing of the cell-site radios, the associated RF transmission circuits, and the voice trunks connecting the cell site to the MTSO.

The frame is digitally controlled by the maintenance test frame controller (MTFC), which is operated as a peripheral unit to the cell-site controller located on the DF. The MTFC's main function is to interface the cell-site controller with the various circuits and test instruments on the MTF. There is also a manual capability of loading commands into the MTFC locally, independently of the cell-site controller.

The MTF makes it possible to monitor the functioning of the cell site under the overall direction of the MTSO. When a local failure occurs, the MTF furnishes the information necessary to "maintenance busy" a faulty voice channel, or to reconfigure active and redundant circuits for maintaining service while a craftsperson goes to the cell site to replace the faulty unit.

5.1 Oscillator section

The master oscillator set generates a high-frequency reference (228.02250 MHz) and a low-frequency reference (7.500 kHz) for all the frequency synthesizers in the cell site (see Section 4.2). The 228-MHz oscillator is crystal-controlled and enclosed in a temperature-controlled oven. It has a frequency stability of ± 1 part per million per year. The frequency is distributed via coaxial cable to all radios in the radio frames and in the DF, and to the test synthesizer within the MTF. Thus, individual precise frequency sources for each of the radios are not required.

The 7.5-kHz clock signal is derived from a separate oven-controlled, 10-MHz oscillator, whose frequency is first divided by 4000 to 2.5 kHz

- ① INTERCONNECTION PANEL
- ② RF PATCH PANEL
- ③ 228-MHz REFERENCE PANEL
- ④ REFERENCE CLOCK GENERATOR PANEL
- ⑤ SUPERVISORY AUDIBLE TONE GENERATOR PANEL
- ⑥ CIRCUIT BREAKER PANEL
- ⑦ VOLTMETER PANEL
- ⑧ FREQUENCY COUNTER PANEL
- ⑧ LAMP AND DISPLAY PANEL
- ⑩ WORK SHELF ASSEMBLY
- ⑪ MILLIWATT REFERENCE GENERATOR
- ⑫ RF TEST UNIT
- ⑬ FRAME CONTROLLER
- ⑭ POWER CONVERTER PANEL
- ⑮ FUSE PANEL
- ⑮ POWER FEEDER PANEL



Fig. 20—Maintenance and test frame.

and then multiplied by 3. The signal is then distributed to the radios in a way similar to the 228-MHz clock signal distribution. The divider chain is tapped at 1 MHz for the PROCON clock and at 10 kHz for the serial data clock. A redundant master oscillator set will also be switched into operation automatically in the event of a lost output signal or a gross frequency change.

Three SAT frequencies—available at 5.97, 6.00, and 6.03 kHz—are each derived from a separate oscillator and distributed to the audio-processing circuits in the LSF. The 22-Hz (nominal) clock is generated by dividing the 10-kHz data clock by 456 to obtain 21.93 Hz and then sent to the LSF for use in fade time-out measurements. All clocks are redundant and can be tested by the counter within the MTF.

5.2 Test equipment

The MTF radio test equipment consists of a test receiver tunable to any transmitter channel and a test generator tunable to any receiver channel. A test frequency synthesizer for channel tuning and a test audio processor, in conjunction with the test radios, furnish controlled simulation of a mobile transceiver. There are also a digital voltmeter and a counter, both remotely controllable, and a standard 1-milliwatt, 1000-Hz reference oscillator. These units can isolate a trouble condition in the cell site, via remote control from the MTSO, to a single radio transmitting or receiving channel (or group of channels). The channel can then be shut down and a craftsman sent to replace or repair any faulty unit of the channel.

The test receiver measures the appropriate signals to compute the following parameters of each transmitter channel for comparison against specified maintenance limits:

- (i) Incident power to the antenna.
- (ii) Reflected power from the antenna.
- (iii) Transmitter frequency.
- (iv) Transmitter deviation.
- (v) Modulation quality (SINAD*).

The test generator injects known signals to allow measurement of the following parameters for each dual-diversity receiving channel:

- (i) Sensitivity (noise quieting with a low-level RF input).
- (ii) Audio output quality at an RF input above threshold.

5.3 Maintenance and test frame controller

Much of the equipment in the MTF is used to facilitate remote testing of the cell-site radios, the master oscillator equipment, and the interconnecting trunks. The MTFC serves as the digital control interface

*SINAD = $\frac{\text{signal} + \text{noise} + \text{distortion}}{\text{noise} + \text{distortion}}$

between the cell-site controller and the MTF oscillators and test equipment. It also serves as a data interface to the various instruments on the MTF. Since most of these instruments require several seconds to complete their measurements, the MTF does the waiting and raises a flag when a sequence of measurements is completed. This saves tying up the cell-site controller in a long-wait loop.

The MTFC consists of a PROCON and a writable store unit, similar to those in the DF, and a group of logic and modem cards. The PROCON controls the operation of the test equipment in the MTF and formats and transmits the responses to each requested test measurement. It operates under the direct control of the PROCON in the DF which, in turn, is commanded by the MTSO. The logic cards provide the necessary interface buffering, while the modem, test receiver, test generator, and SAT transponder simulate the action of a mobile to permit measurements of (i) the data messages transmitted or received by any radio and (ii) the performance of the SAT detection and phase-range measurement circuits.

A lamp and display panel provides a manual capability to load commands into the MTFC and to observe its bit-and-flag status. This panel can manually reset the MTFC for manual error recovery and system testing.

5.4 Typical test operation

All tests are controlled by the MTSO, which also has to operate on some of the data to arrive at the desired measurement. The following sequences show the test procedures but do not necessarily correspond to specific MTSO test algorithms.

5.4.1 Transmission power and frequency tests

To measure transmitted power, the power from the forward-power coupling ports of the directional couplers is summed and routed via a switch to the mixer input of the test receiver. Power from the reflected-power coupling ports of the directional coupler is summed and connected through a second position of the switch to the mixer input. After determining that the channel frequency to be tested is not in use on any of the antennas, the MTSO uses the test synthesizer to tune the test receiver to the desired frequency and energizes the appropriate transmitter. Transmitter forward or reflected power, depending on the position of the switch, is read by means of a calibrated voltmeter and transmitted to the MTSO. The application of appropriate scale factors permits calculating the power into the antenna, and return loss. These numbers are then compared against stored limits to determine whether performance is satisfactory or faulty.

With the system configured as for the power measurement, the frequency transmitted on the channel under test may also be deter-

mined. A frequency counter is connected via a switch to measure a subharmonic of the test-receiver local oscillator (LO/4) and the IF frequency from the test receiver. The counter display may be read locally or transmitted to the MTSO. The transmitter frequency may be calculated as $4 \times (\text{LO}/4) + \text{IF}$.

Maintenance of the clock systems also requires measurements of the master oscillator distribution bus frequency (228 MHz), the low-frequency group of clocks, and the SAT frequencies. Any such frequency may be individually measured on command from the MTSO.

5.4.2 Other radio measurements

To measure phase deviation, the SAT that is continuously modulating the transmitter channel is measured. The modulated discriminator output of the test receiver is measured locally using the MTF voltmeter. The voltmeter measurements are returned to the MTSO and compared to fixed, predetermined tolerance numbers.

To test whether the receiver sensitivity is within limits, the MTSO, after ascertaining that the channel frequency to be tested is not in use, uses the synthesizer to tune the test generator to the desired receiver frequency. The output of the test generator passes through a variable attenuator and a switch to the directional coupler of either diversity input of the receiver under test. The MTF switches the attenuator to its higher attenuation position. Noise-quieting of the receiver under test is verified at the MTSO. The output of the test generator is then switched to the other diversity input and the noise-quieting verified again. The two measurements are compared against a stored limit as a go/no-go test for each diversity section of the receiver.

To measure the audio output quality of the receiver, the MTSO applies a standard test tone to modulate the test generator over the voice trunk. The attenuator is switched to its lower attenuation state. The audio output from the receiver under test is verified for presence at the MTSO.

5.4.3 Data radio interface measurements

The test receiver and generator can receive and transmit serial high-speed data. This capability allows simple tests to be performed on the setup radio interfaces and voice radio data interfaces. To check the forward setup channel interface, a special 200-bit serial data message is transmitted via the setup transmitter and its interfaces to the test receiver. The test receiver sends the received data to the MTF, where it is stored in temporary memory. The controller then does a bit-by-bit comparison of the message with an identical message stored in its program memory and generates an "all-seems-well" message if the two messages check. The reverse setup channel is tested in the same manner except that the roles are changed—i.e., the test generator

transmits a message to the setup receiver and its interfaces where it is received, reformatted, and sent via the controller and the data link to the MTSO for checking. The voice radio data interfaces are checked in a similar fashion.

VI. POWER SYSTEM

In the Chicago developmental trial, the primary power system for each cell site is the Western Electric type 111A. The input to this system is commercial three-phase, four-wire, 208-volt, 60-Hz power. Its output is a nominal +24 volts with a capacity of up to 800 amperes. A J87123 battery plant floats across the rectifier outputs and provides an emergency power source in case of loss of commercial power.

The electronic equipment operates mainly from dc voltages at the levels of +5, ± 15 , and +24 volts. Commercial 60-Hz ac power is used for cooling fans in the radio and data frames and for the commercial voltmeter and counter in the MTF. An inverter can develop the necessary 110-volt, 60-Hz power from the battery plant during commercial power failure so that system operation and test can continue.

The +24-volt battery supply is distributed to all cell-site frames. The +24-volt loads are powered directly from the nominal +24-volt* battery busses. The +5- and ± 15 -volt loads derive their power from dc-to-dc converters. The total 24-volt load amounts to 300 amperes for a system with only one radio frame, 430 amperes with two radio frames, and 560 amperes with three radio frames. In all cases, another 100-ampere capacity has been included in the power plant for battery charging. Where the radio frames are not fully loaded with radios, or when all radio transmitters are not operating, these loads will, of course, be less.

VII. PHYSICAL DESIGN

The AMPS cell site is functionally and physically divided into frames of radio control and transmission equipment, a power system, antenna interface equipment connecting the radios to the outside antennas, antennas, cables, and supporting mast and structure. The cell site equipment must be capable of being located in a variety of places. The Chicago developmental system† includes (i) small self-contained buildings with a dedicated antenna mast, (ii) small self-contained buildings adjacent to an existing microwave tower to make maximum use of tower facilities, and (iii) a portion of the top floor of a large downtown central office building.

Rented building space of many types may be necessary for future growth. In addition, designs must consider the visual appearance of

* Which can vary between 21 and 28 volts, depending on the battery's state of charge.

† The developmental system layout is described in Ref. 11.

buildings; the antenna mast assembly, because of its height, will be especially visible and may draw the attention of local zoning boards.

Since the AMPS is a new service using largely new equipment, there was little to guide design decisions. Thus, there is a need to learn how the equipment will function and how people will use the service. Production will be low in volume for the early years, relative to other telephone equipment. For these reasons, the physical design concept chosen for the Chicago trial equipment sought to fill several objectives. The design had to be flexible to accommodate many anticipated early changes and to make maximum use of existing general-purpose hardware to avoid the expense, time, and tooling necessary to generate a customized equipment technology. The equipment was partitioned into smaller units than will be ultimately optimum so that the system would be more flexible and responsive to changes. This section contains a general physical description of the equipment designed to accommodate these considerations.

The cell-site equipment may be housed either in a dedicated building or in an appropriately located existing building. The approximate floor area required for the trial equipment is 22 by 23 ft with a vacant wall or ceiling required for the placement of antenna interface equipment such as the filter divider panels. The cell sites should take advantage of existing facilities where possible to meet operational and economic objectives.

The outside equipment consists initially of omnidirectional, vertically polarized transmit and receive antennas mounted on a free-standing mast, or other tower. These antennas must be located and installed with particular attention to height and diversity spacing requirements. As the system grows into a directional configuration, the antenna array will also require directional transmit and receive antennas. The antennas are connected to their respective filter panels within the building via coaxial cable feedlines that pass into the building through a cable hatch plate. An effective grounding system is required to minimize voltage potentials generated by lightning. The building and mast must be surrounded by an external ring ground, and the interior of the building must contain another ring ground with all equipment frames and metal cabinets connected to it.

A typical interior equipment layout is shown in Fig. 2. The antenna interface equipment is supported by a wall and located as near as possible to the hatch plate. The radio control and transmission equipment is housed in standard Bell System Electronic Switching System (ESS) frames, 7 ft high, 2 ft, 2 in. or 3 ft, 3 in. wide, and 18 in. deep. The end guards selected are 24 in. deep to protect the equipment wiring. The ESS cable trays on top of the equipment bays are used for frame interconnection paths, and most of the interbay cables are equipped with connectors. The frames are sufficiently modular in design so that

different channel capacity requirements of the various cell sites can be easily accommodated.

The remaining equipment, which may be considered as support equipment, consists of the power plant, battery stand and batteries, inverter, fuse panel, and air pressurization equipment.

7.1 Technologies

7.1.1 Components

Circuits for the AMPS cell-site equipment use both conventional discrete components (transistors, diodes, capacitors) and silicon integrated circuits (ICs). Analog and digital ICs with 5-volt and 15-volt power are used. Western Electric, commercial, and KS specification dual-in-line packages are employed, with most ICs having 16 pins. For ongoing designs beyond the trial hardware, additional emphasis is expected to be placed on using the highest-reliability devices available at acceptable costs. Many of the radio devices for use in the 900-MHz radio band are technologically new, and the technology is rapidly changing due in part to the considerable interest in this band generated by several new radio services, including AMPS.

7.1.2 Circuit boards

In addition to the conventional printed wiring board design, boards with wire-wrap interconnected socket pins on $\frac{1}{10}$ -in. centers are used in many of the plug-in logic circuit packages to give maximum flexibility for changes introduced during the trial. These will be replaced by double-sided or multilayer epoxy-glass printed boards on subsequent production of additional systems. Where circuits are replicated many times or high confidence existed that no changes would be made, conventional double-sided printed-wiring boards were chosen to save space and reduce cost.

7.1.3 Backplane wiring

The next level of interconnection is between circuit packs to merge them into panels or groups of panels. The logic boards are connected through the WE 947 backplane connector with an array of wire-wrap pins of $\frac{1}{8}$ -in. centers. Most of the power wiring is printed on the backplane. Where possible, a ground plane is also printed on the backplane to minimize noise. Most of the panel-level signal wiring for these panels is 30-gauge and is wrapped with an automatic wiring machine. Connections that require twisted pair or twisted-shielded pair for noise or impedance-matching considerations are manually installed after machine wrapping is completed. Figure 21 is a photograph of some of the backplane wiring.

The boards in the analog circuit sections of the frames generally use a lower-density connector, and the wiring between connectors is man-

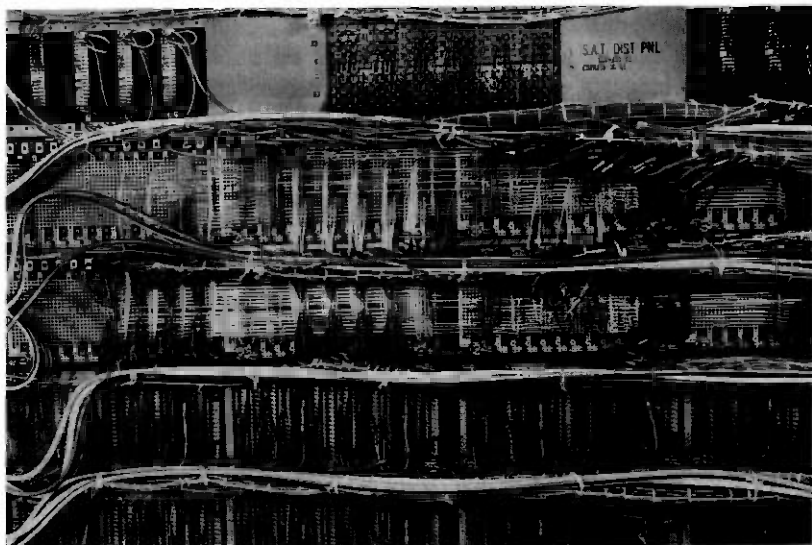

Fig. 21—Backplane wiring showing both local wiring and interpanel cabling.

ually wrapped. RF signals within a frame are routed using 0.141-in. semirigid coaxial cable terminated in SMA or type-N connectors. The semirigid cable minimizes spurious radiation and pickup and provides low signal loss in constrained space.

7.1.4 Frame wiring

The next level of wiring is between panels, or between the top of the frame and panels. For logic and audio signals, this wiring is generally twisted pair or twisted-shielded pair, depending on the sensitivity of the signal and the length of the run. Power wiring from the power modules uses large-gauge wire or laminated bus bars where the amount of current is large and space is limited. Semirigid coaxial cables are used for radio frequency signals.

7.1.5 Interframe cabling

Most wiring between equipment frames is via connectorized cable between interconnection panels at the top of the frames. Standard twisted pair cable is normally used, with twisted-shielded pair being used where extra shielding is required. The RF signals between frames, and between filter panels and frames, are routed on RG-214 coaxial cables fitted with type-N connectors. The filter panels are connected to the antennas with 1-5/8-in. semirigid coaxial cable between the transmitter filter panel and the transmit antennas and 7/8-in. semirigid coaxial cable between the receiver filter panel and the receive antennas.

7.2 Equipment and apparatus mechanical design

7.2.1 Circuit package mechanical design

The individual circuit packages for the cell-site equipment are all apparatus-coded and are of three general types. The most used are F-coded (a temporary manufacturing code for use during a trial period) packages that use either printed or wire-wrap boards for component interconnection and are fitted to the 946A circuit pack connector (see Fig. 22). These cards are mounted into 80A apparatus housings and connected to 947C backplane connectors. The F-coded circuit packages are used primarily for logic and control circuitry in the data frame and in the controllers of the line supervision and maintenance and test frames. They also contain some analog circuitry associated with the controllers. The main audio and signaling data circuits that are required on an individual channel basis are implemented on seven PC codes. These codes are also mounted in 80A apparatus housings but use gold fingers on 0.060-inch-thick, printed double-sided, epoxy-glass boards fitted directly into a backplane connector to reduce cost relative to the F-code boards (see Fig. 23). The third type of board used primarily for analog circuits is an A-code board also on epoxy glass but

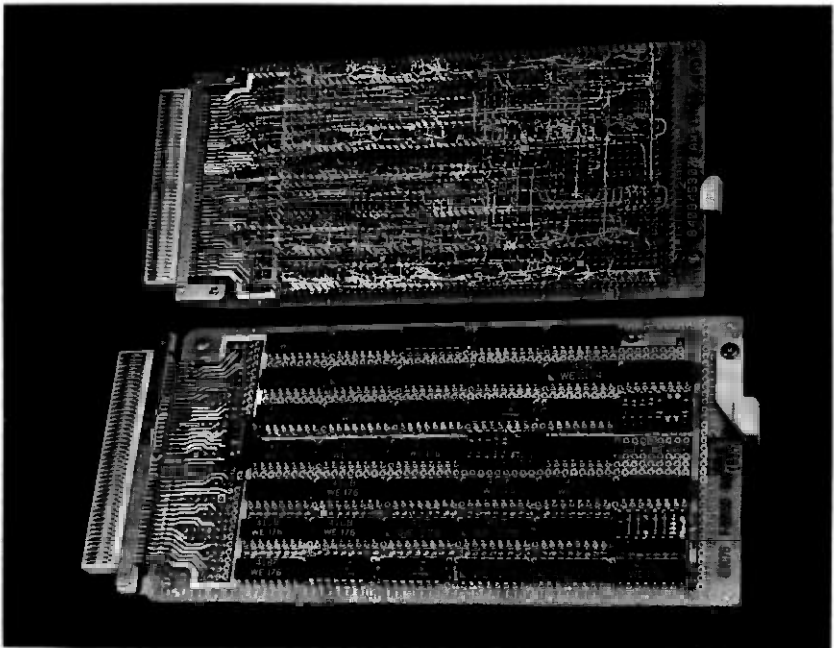

Fig. 22—F code circuit package.

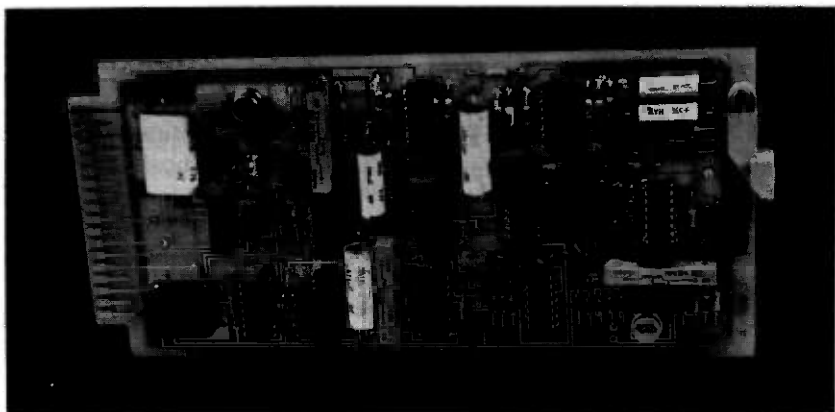

Fig. 23—PC code circuit package.

0.090-inch thick, with gold fingers that fit into a 36B apparatus housing containing 905B type connectors (see Fig. 24).

7.2.2 Mechanical design of the radio modules

Radio modules in the data frame perform setup, locating, and signaling functions. Other radio modules in the radio frame perform voice channel functions, a capability which can be increased on a module-per-voice-channel basis. Test radio modules are also housed in the maintenance and test frame, along with the reference frequency equipment. The transmitters, receivers, and synthesizers were designed by Bell Laboratories and manufactured under KS specifications. To maximize early design flexibility and to minimize early tooling costs, a flexible packaging technique using three special extrusions was developed. The radio subassemblies could be developed individually and later packaged together with a minimum of circuit interaction. Figure 13 shows the voice/data transmitter with its covers removed to illustrate the packaging technique. This same general design approach was used for the voice/data transmitters and receivers, the frequency synthesizers, the test radio modules, and the reference frequency leveler amplifiers.

The other major radio module is the power amplifier unit. It is used on an individual radio channel basis and was manufactured to a KS specification (Fig. 14). The heat sink for the power amplifier was specified to be compatible with a forced-air cooling system that is part of the radio frames. Power dissipation requirements and long-life considerations indicated forced-air cooling as the best way to get a cost-effective design for the 900-MHz output-power device.

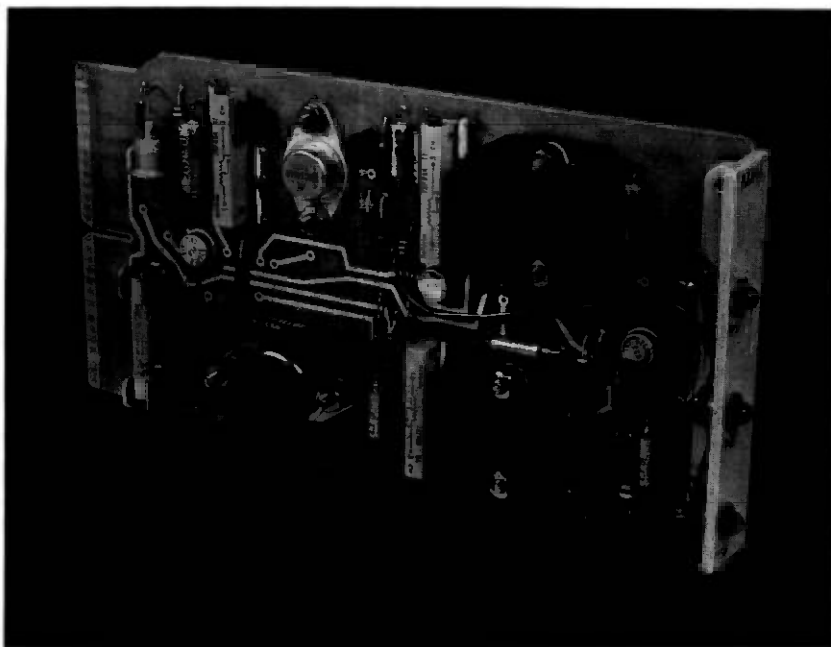

Fig. 24—A code circuit package.

7.2.3 Channel multiplexer

The channel multiplexer (see Fig. 18) is a 16-to-1 RF multiplexer, which uses individually tuned high Q cavities to combine efficiently the RF power from 16 transmitters into a single transmit antenna. The individual cavities must remain physically stable over a wide range of ambient temperature and varying power dissipation. To accomplish this, the cavities are made of invar, a steel formulation with a very small coefficient of thermal expansion. The cavities are plated with at least one-half mil of copper to provide good electrical conduction in the skin region at RF. A final thin layer of gold plate on the copper maintains good conduction at the material joints and ensures a good interface to the cavity interior. A fan cools the combiner, aids its temperature stability, and stabilizes the characteristics of the combiner stripline.

7.2.4 Power units

The primary power for the cell-site equipment is a +24-volt dc reserve power system, described in more detail in Section VI. The 24-volt direct current is distributed to each frame and either is used directly, in the case of RF power amplifiers, or is converted to the correct, regulated power needed by each frame. This conversion re-

quires the use of various quantities and combinations of four plug-in codes of dc-to-dc converters. One unit, coded 121A, is of the nominal 50-watt type which occupies only one-half of an apparatus housing, and has an output capacity of 2.3 amperes at -14.7 volts. The other three units—coded 122D, E, and F—are of the nominal 150-watt type, occupy a full apparatus housing, and have outputs of 7 amperes at $+14.7$ volts, 7 amperes at -14.7 volts, and 17.5 amperes at $+5.3$ volts, respectively. Although each of these codes was specified to unique AMPS requirements, they are part of a larger standard family of Bell System power converters. The converters of each code within a frame are connected to a common bus. Moreover, at least one extra power unit is provided for redundancy on each bus. In general, the loss of any single power unit will result in an alarm but no loss of service to customers.

7.2.5 Antennas and mast

Transmit and receive antennas for the trial system are high-gain, omnidirectional, and vertically polarized. They are end-supported but are electrically center-fed to minimize antenna-pattern squint-angle change over the frequency band. Two receive antennas per cell site provide diversity and there is one transmit antenna per radio frame (16 radio channels). The antennas are approximately 13 feet long, including the mounting, and are placed in a 2- $\frac{1}{2}$ -in. diameter fiberglass housing. When the system requires directional capability, the omnidirectional antennas will be augmented by directional transmit and receive antennas.

The omnidirectional antennas are typically mounted at the corners of a triangular platform (about 10 feet on a side) at the top of a 150-foot free-standing steel mast, as shown in Fig. 25. Later, the directional antennas will be mounted behind the contoured dielectric covers. There will be two receive antennas (for diversity) and one or two transmit antennas per face. Where an existing structure such as a microwave tower or downtown central office building is used, special mounting arrangements must be engineered for each site. As the system grows and cells are subdivided, the antenna height may be reduced to about 100 feet.

Since the vertical pattern has a half-power beamwidth of about 7 degrees, the omnidirectional antenna has the disadvantage of being susceptible to relatively small angular deflections from vertical. The antenna mast and platform were designed to minimize deflection and cost. The two major sources of deflections are the wind and uneven solar heating of the steel mast. In general, the antenna hardware was designed to meet two wind criteria; (i) system operation within specifications for normally encountered wind conditions, and (ii) survival under extreme but rare conditions such as winds up to 100 mph.¹²

The RF transmission line to the antennas uses semirigid air-filled

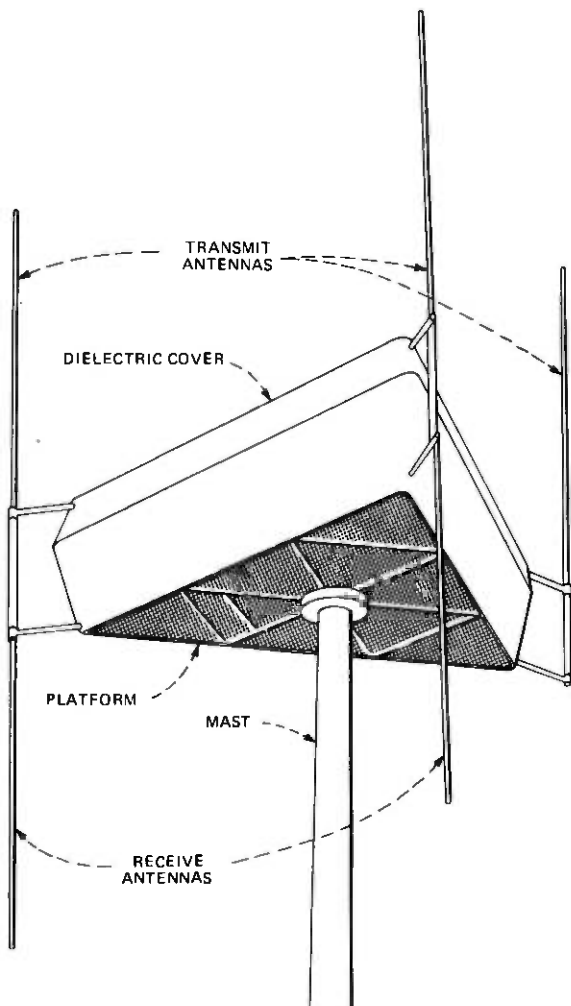

Fig. 25—Mast-mounted antennas.

coaxial cables to keep the RF losses low. The cables are routed inside the mast through a suspended conduit cluster. The conduit allows for cable system growth and ease of replacement if required. The interior mounting provides protection to the cables and significantly improves the visual appearance. An air pressurization system keeps the cables pressurized and dry internally.

APPENDIX

Operating Theory of the Two Branch, Equal Gain, Diversity Combiner

In Figs. 19 and 26, consider the two 1.8-MHz input signals, A and B, which arrive from the two 1.8-mHz IF amplifiers.

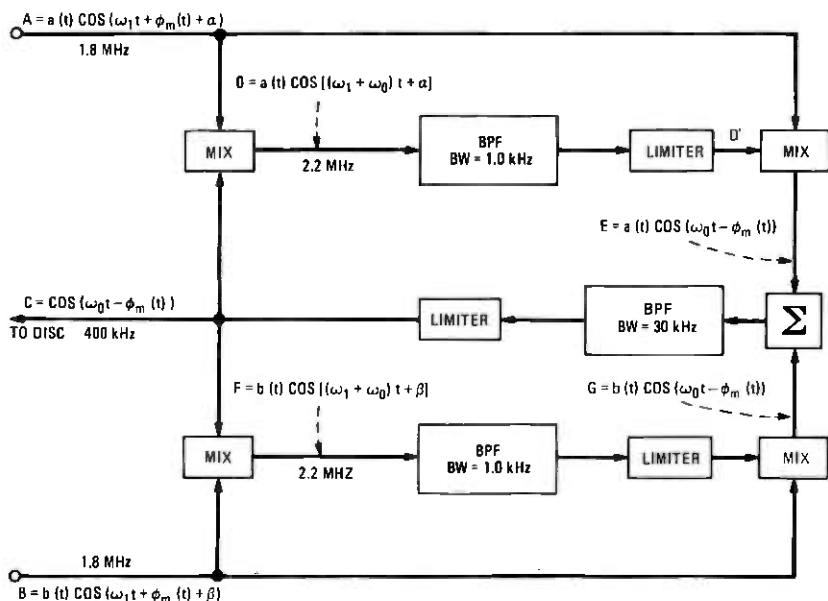

Fig. 26—Two-branch equal-gain diversity combiner.

$$A = a(t) \cos(\omega_1 t + \phi_m(t) + \alpha),$$

$$B = b(t) \cos(\omega_1 t + \phi_m(t) + \beta),$$

where

$a(t)$, $b(t)$ are slowly varying uncorrelated Rayleigh amplitude functions,

$\omega_1 = 2\pi(1.8 \text{ MHz}) = \text{carrier frequency}$,

$\phi_m(t) = \text{the voice phase modulation}$, and

α , $\beta = \text{slowly varying, random, uncorrelated, carrier phases of channels } A \text{ and } B, \text{ respectively.}$

It is the function of the combiner to co-phase A and B (set $\alpha = \beta$), so that A and B can then be coherently added together. Assume that this regenerative loop is already in operation so that there exists the constant amplitude output signal

$$C = \cos(\omega_0 t - \phi_m(t)),$$

where

$$\omega_0 = 2\pi(400 \text{ kHz}) = \text{output signal.}$$

Note that α and β are absent.

The upper left mixer (modulator) takes the product A and C whose upper sideband is

$$D = a(t) \cos[(\omega_1 + \omega_0)t + \alpha].$$

Note that the voice modulation term $\phi_m(t)$ has been removed, but the random modulation α remains.

The signal D , which is a 2.2-MHz carrier with slowly varying phase modulation, passes through the narrowband filter and limiter, which removes the amplitude term $a(t)$. The subtleties associated with the choice of the filter bandwidth are thoroughly discussed by Halpern⁹. The resulting constant-amplitude signal,

$$D' = \cos [(\omega_1 + \omega_0) t + \alpha],$$

is product-modulated with A in the upper right-hand "mixer." The lower sideband is given by

$$E = a(t) \cos [\omega_0 t - \phi_m(t)].$$

Note that this second modulation process has removed the random phase term α .

By similar reasoning, the signal

$$G = b(t) \cos [\omega_0 t - \phi_m(t)]$$

is generated by the lower regenerative loop. E and G , being phase-coherent, can be summed in a hybrid. This sum passes through a third limiter where the amplitude function is removed, giving the constant amplitude output signal

$$C = \cos [\omega_0 t - \phi_m(t)].$$

REFERENCES

1. Z. C. Fluhr and P. T. Porter, "AMPS: Control Architecture," B.S.T.J., this issue, pp. 43-69.
2. G. A. Arredondo, J. C. Feggeler, and J. I. Smith, "AMPS: Voice and Data Transmission," B.S.T.J., this issue, pp. 97-122.
3. R. E. Fisher, "AMPS: A Subscriber Set for the Equipment Test," B.S.T.J., this issue, pp. 123-143.
4. A. K. Johnson and J. I. Smith, "Radio Frequency Design for a High-Capacity Mobile Telephone System," Nat. Telecommun. Conf. Record (Los Angeles, Cal., December 1977), 1, pp. 16:4-1,2.
5. A. K. Johnson, "Determination of Filter Requirements for a High Capacity Mobile Telephone System Base Station," Symp. Microwave Mobile Commun. Conf. Record (Boulder, Col., September 1974), paper V-4, p. 32.
6. A. K. Johnson, "Computer Simulation of High Capacity Mobile Telephone System 16 Channel Multiplexer," IEEE Veh. Tech. Conf. Record (Orlando, Fla., March 1, 1977), p. 109.
7. K. Kurokawa, "Design Theory of Balanced Transistor Amplifier," B.S.T.J., 44, No. 8 (October 1965), pp. 1675-1698.
8. J. Granlund, "Topic in The Design of Antennas for Scatter," Lincoln Laboratories, Massachusetts Institute of Technology, Technical Report 135, November 1956.
9. S. W. Halpern, "The Theory of Operation of an Equal-Gain Predetection Combiner with Rayleigh Fading Channels," IEEE Trans. Commun., COM-22, No. 8 (August 1974), pp. 1099-1106.
10. W. C. Jakes, Jr., ed., *Microwave Mobile Communications*, New York: John Wiley, 1974, Ch. 5.
11. D. L. Huff, "AMPS: The Developmental System," B.S.T.J., this issue, pp. 249-269.
12. D. L. Chandler, "Deflection Analysis of Supporting Structures for Antennas to be Used in a Mobile Telephone System", IEEE Trans. Veh. Tech., VT-26, No. 2 (May 1977).

Advanced Mobile Phone Service:

Development Support Systems

By S. H. TSIANG

(Manuscript received July 24, 1978)

The Advanced Mobile Phone Service system contains four major subsystems, each of which has its own processor and software. To support the development of such a complex system, several laboratory test systems have been developed. They are for simulation, software debugging, overall system testing, and performance monitoring. These test systems, briefly described in this article, have been invaluable tools to the AMPS development.

I. INTRODUCTION

The Advanced Mobile Phone Service (AMPS) system is composed of four major elements: the Electronic Switching System, the data link, the cell site, and the mobile unit. In the Chicago Developmental System, the switching functions are performed by a No. 1 Electronic Switching System (ESS)¹ in conjunction with a programmable controller (PROCON) residing in each of the cell sites. The data link equipment is an adjunct to ESS. It has its own processor and memory and runs autonomously. The mobile unit is controlled by a resident microprocessor. Thus, processing a mobile call involves four separate processors. Each of these must be tested individually and then as a system.

Several laboratory test systems have been built to support the AMPS development. This paper describes those that have been or are being used for simulation, software debugging, integration testing, and data gathering. They are:

- (i) A Mobile Office Simulated Environment System (MOSES) that simulates the cell sites and mobile units for testing the ESS and data link software.
- (ii) A Maintenance and Traffic Simulator (MATS) that simulates cell site peripherals, mobile units, and mobile telephone users

to support cell site load testing and cell site controller software development.

- (iii) A Mobile Call Generator (MCG) that produces mobile traffic and monitors results using real mobile units for overall end-to-end testing of the system.
- (iv) A cell site response generator (a utility software package) that simulates cell site responses for ESS software testing.
- (v) A Data Retrieval System (DRS) that collects data for monitoring performance in an operational switching system.

Figure 1 is a simplified block diagram of AMPS and the points at which each test system is connected physically or symbolically.

II. MOBILE OFFICE SIMULATED ENVIRONMENT SYSTEM

Planning for switching software testing started at the exploratory stage of the AMPS project. It was recognized then that the cell site hardware would not likely be available during the early stage of software testing. Therefore, as a part of the exploratory work, a simulator that would be able to simulate the external environment was designed; this was named the Mobile Office Simulated Environment System (MOSES).

MOSES can simulate any number of cell sites and mobile units and communicates with the Mobile Telephone Switching Office (MTSO) via data links and voice trunks. It assembles the messages it receives, analyzes them, generates appropriate responses, and sends them back to the MTSO.

2.1 Hardware

The MOSES controller consists of a minicomputer and a complement of general-purpose I/O devices. The computer system processes and simulates digital signals. For analog signal detection and simulation,

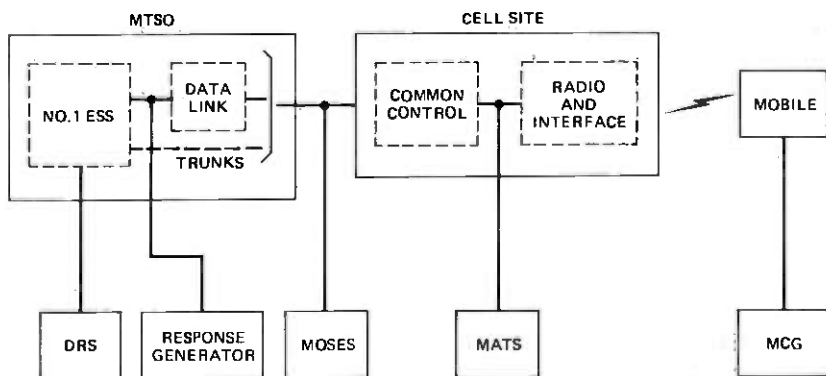

Fig. 1—Development support systems.

such as signaling on cell site voice trunks, standard ESS equipment is used.

2.2 Software

To make the simulator easier to use, MOSES is programmable in a high-level language, called ETSL (Extended Telephone Simulation Language). This greatly simplifies the design of users' test programs that specify a series of actions to be taken by MOSES; for example, "originate from a mobile and dial a certain number."

MOSES can process many independent test programs concurrently. It reads the users' inputs and converts them into execution blocks. Each block contains a word specifying the operation to be performed and a string of pointers that lead to the parameters necessary for performing the operation. The parameters are stored in a list built by MOSES. The word specifying the operation in each block identifies a function table. The function table contains pointers to routines that accomplish the required operation.

A MOSES run-time table-driven execution program performs sequential processing of execution blocks and their related tasks.

MOSES was fully implemented and used during initial software testing on the ESS test model. It was also employed extensively in debugging the software resident in the data link equipment. The first successful mobile call was placed through MOSES before the arrival of the cell site equipment in the test laboratory.

Because of the favorable experiences with MOSES, a second and expanded simulator, MATS (Maintenance And Traffic Simulator), was built for the Oak Park MTSO. The No. 1 ESS in that office was used, prior to the start of the Chicago Developmental System trial, as a major test facility for the AMPS software development. This included software residing in both ESS and the cell site controller.

III. THE MAINTENANCE AND TRAFFIC SIMULATOR

The MATS is a minicomputer-based system that simulates the actions of major cell site peripherals, mobile units, and mobile telephone users. It provides load testing and debugging support for the cell site controller (PROCON) software, and debugging support for cell site maintenance programs residing in the MTSO. MATS is capable of generating several thousand mobile calls per hour. It is intended to apply representative loads of various types to the system, including a load that approaches the design capacity of a single cell site. Since MATS is connected to the AMPS at input and output buses of a cell site controller, simulation is confined only to the cell site where the interface is made.

To provide the above functions and to simulate the cell site peripherals, MATS must:

- (i) Monitor the cell site controller output for orders being sent to peripherals.

- (ii) Simulate the actions caused by these orders, generate the appropriate response, and supply that response to the cell site controller at the proper time.
- (iii) Provide on-hook, off-hook, and voice path verification on test trunks.
- (iv) Accept user commands to control the actions of the simulated mobile units.

MATS employs the same high-level user input language as that used in the MOSES test system, ETSL. It has commands which allow the user to specify mobile unit actions (e.g., originate), check for mobile conditions (e.g., off-hook), and control program flow.

3.1 MATS hardware

The primary hardware components of the MATS hardware are the minicomputer and associated peripheral equipment, the cell site controller output bus monitor, the cell site controller input simulator, and the voice trunk control and monitoring equipment. These hardware components are shown in Fig. 2 and described in more detail in the following paragraphs.

3.1.1 Minicomputer

The minicomputer system consists of a processor with memory, a CRT display terminal, a magnetic tape unit, two cartridge disk drives, a card reader, and a high-speed printer.

3.1.2 Output monitor

The output bus monitor collects data being sent on the cell site controller output bus, as well as the peripheral address to which the data are being sent. It also monitors data being sent to the controller from a peripheral device and the sending device's address. The MATS software has the ability to selectively disable the monitoring of data to or from any peripheral. The information collected by the output monitor is buffered in a first-in/first-out memory and made available to the MATS software for analysis.

3.1.3 Input simulator

The input simulator allows MATS-generated data to be sent to the cell site controller as though they were coming from a real peripheral. Since MATS does not know at what time or in what order the cell site controller will read its peripherals, MATS software must be able to send the simulated data to the input simulator in advance and at any time. Therefore, an input simulation buffer memory is provided. Because the timing is critical between the read and the fetching of the simulated data, the speed of the buffer memory is a major consideration.

Simulated data may be sent to the cell site controller for any

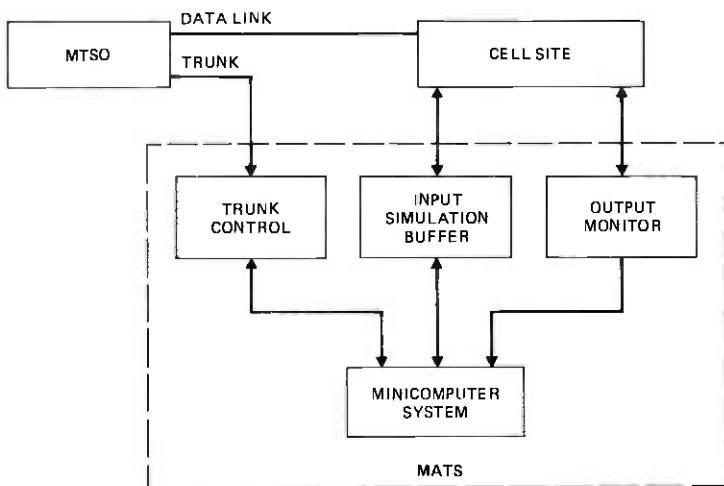

Fig. 2—Maintenance and traffic simulator.

peripheral device. A programmable bit mask selectively directs data from either the real device or from the input simulation memory to be sent to the cell site controller. As an example, this allows the data link to be specified as real, and to operate normally, while other peripherals are being simulated.

3.1.4 Trunk control

The trunk control hardware is used to terminate a set of test trunks from the MISO. Calls to and from simulated mobile units use these test trunks instead of the regular trunks to the cell site. The trunk control allows MATS to put the trunks off-hook and to selectively connect tone generators and detectors for voice path continuity verification.

3.2 MATS software

MATS is implemented on the MERT² (Multi-Environment Real-Time) operating system, which was developed at Bell Laboratories. The MATS software can be functionally divided into four modules: a process controller, user interface, cell site peripheral simulation, and ETSL program executor. These four modules have access to data structures in a common memory area. The primary data structures are process records and message buffers. A process in MATS is a functional package of software, which usually consists of a set of subroutines and associated data structures that simulate one cell site peripheral. The process record is used to store current information about each process. The message buffer is used to pass data between processes, and routines are provided for administering the message buffers.

3.2.1 Process controller

The primary functions of this module are task-scheduling and timing. To provide as exact an emulation of the cell site peripherals as possible, the peripheral's timing has to be closely duplicated. Also, because the amount of inputs from the system is large, MATS must be able to handle them with a minimum amount of overhead. For these reasons, MATS has its own suboperating system for task dispensing, intertask communication, and interaction with hardware. However, MATS still depends on the MERT operating system for hardware interrupt handling, file system control, and user interface support.

The process controller maintains two separate timing lists. The first, called a time-out list, contains those tasks that must wait until a certain time has elapsed before being executed. The second, called a deadline list, contains those tasks that must be executed by a certain time but may be completed before then. A scheduler routine searches these timing lists and starts the appropriate tasks at their appointed times.

3.2.2 User interface

The main function of the user interface module is to compile the ESTL program specified by the user. In addition, it contains a number of support routines that provide print, display, and record facilities for the various computer I/O devices. This module also initializes the MATS hardware and other MATS software modules.

All transactions between the cell site controller and the simulated peripherals, as well as the time they occurred, are recorded. A detailed analysis of these interactions is made available to the user at the end of a simulation session.

3.2.3 Peripheral simulation

The peripheral simulation module contains one program for each peripheral device type simulated. It also contains a call controller that simulates the actions of the mobile user and a scenario progress controller that acts as a command interpreter and directs the actions of the call controller. Each device simulation program consists of a set of action routines and a function table that specifies the order in which the action routines are to be executed.

3.2.4 ETSL executor

The MATS user specifies in his program, written in ETSL, the simulation scenarios, such as type and quantity of calls, and number of mobiles involved. ETSL allows the user to control and monitor all mobile unit actions as well as to verify talking connections on simulated calls.

The ETSL program executor performs the commands specified by

the user. It includes a table that contains the addresses of subroutines for each ETSL command implemented. Samples of ETSL commands are given in Table I.

IV. MOBILE CALL GENERATOR

The MCG provides an automated means for end-to-end testing of the entire Advanced Mobile Phone Service system. It employs a computer to generate calls and monitor the results on a small number of stationary mobile units. In essence, it emulates the mobile users. However, MCG, in addition, has the capability to monitor some of the internal behavior of the mobile unit and to force special events or abnormal mobile behavior to check potential trouble areas. Special events may include multiple seizures and critical interference, such as a fade, flash, or abandon, that occurs during call setup or while providing special service. Many of these events cannot be caused intentionally by a person because of lack of access to the internal actions of the mobile and because of the reaction times that are necessary. For testing purposes, it is desirable to be able to force abnormal mobile behavior to check for proper switching system and mobile reaction. This might be causing setup radio channel seizure or transmission failure, erroneous channel selection, or refusal of a mobile to release. The internal monitoring capability of MCG is used to gather data on internal mobile behavior, such as retry strategy.

In short, MCG is intended, in a step-by-step process, to verify that the system meets its requirements. It provides the desired monitor, control, and call-generating capabilities. It can supply all the customer's control stimuli and in addition can influence the internal behavior of the mobile. The test results consist of completion rates, specific errors, timing associated with calls, etc. The data are sufficiently detailed to allow further analysis and trouble identification.

4.1 Hardware

MCG is implemented on the same minicomputer as MATS. New hardware consists of a mobile unit interface for each mobile, and a

Table I—Samples of Extended Telephone Simulation Language (ETSL)

Command Name	Description
ORIG	Originate
CLEAR	Clear and reset mobile
MESG	Print message
ONHK	Go on hook
IF	Branch if equal
TALK	Verify talking path
PAGECHK	Check whether paging signal is received by mobile

multiplexer in the computer. Line drivers and receivers are provided both at the mobile and the computer ends (Fig. 3). The MCG hardware also includes a tone generator and detectors for each mobile for voice path verification. The interface at the mobile unit autonomously checks for status changes on those signal leads monitored by MCG and asynchronously reports these changes in serial form to the software in the computer. The commands from the computer to the mobile unit are also transmitted in serial bit streams. Therefore, between the computer and each controlled mobile, only two pairs of wires are needed, one for each direction.

The mobile unit consists of three functional units: a control unit, a transceiver, and a logic unit. The control unit, which includes the handset, controls, indicators, and associated tone circuit, is the interface between the user and the AMPS system. The transceiver provides duplex voice transmission and reception. The logic unit, which is built around a microprocessor, functions as the master control for the mobile unit, and encodes and decodes the digital signaling between the mobile and the cell site. The MCG hardware interfaces with the mobile units at the connector between the logic unit and the transceiver unit. Thus, no physical modification to the mobile units is required. A block diagram of the MCG hardware is shown in Fig. 3.

4.2 Software

MCG shares a significant portion of the MATS software, specifically the process controller and ETSL executor modules discussed in Sections 3.2.1 and 3.2.4. In addition, the MCG software contains three other modules: a hardware interface, a mobile monitor, and a mobile simulator.

The hardware interface module provides access to the MCG hardware. It includes an input and an output routine. The input routine receives mobile status change data through the multiplexer and passes them on to the mobile monitor. These input data include frequency change, carrier-on or-off, reorder, alerting, etc. The output routine enables the software to send orders (such as off-hook and dialed digits), to the mobile unit as if the orders were coming from the mobile's control unit.

The mobile monitor module receives status updates from the mobiles and maintains a status picture for each mobile. It also synthesizes multiple status changes on the monitored signal leads into a recognizable mobile order [such as Voice Channel Assignment (VCA) and release], which is then sent to the mobile simulator.

The mobile simulator module tracks the current state of the mobile. It also takes orders from the ETSL executor and translates them into the appropriate action instructions. These instructions then are sent

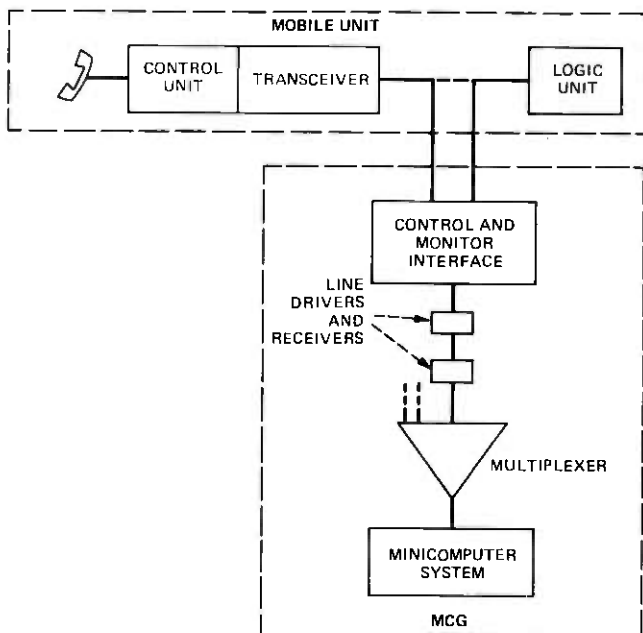

Fig. 3—Mobile call generator.

to the controlled mobile unit through the hardware interface output routine discussed earlier. For the status check orders, the mobile simulator sets the associated status check flags, so the mobile monitor will know which changes it is to report back.

V. CELL SITE RESPONSE GENERATION

In the AMPS project, the data link and the cell site hardware and ESS switching software were developed concurrently. Therefore, a way had to be found to facilitate initial program testing at the Oak Park MTSO independent of the data link and the cell site hardware. (The MOSES test system exists only at Bell Laboratories in Indian Hill and was not available at Oak Park.) To fulfill this need, a cell site response simulation program, known as the cell site response generator, was developed.

The response generator can provide most of the cell-site-to-MTSO messages: confirmation signals; and page, location, range, and signal strength replies. Thus, the response generator can be used to simulate mobile originating and terminating calls, and to test the locating and handoff software.

This simulation program is used in conjunction with the existing No. 1 ESS utility system. The utility system includes the AT function, with which the user can direct a utility function to be performed at a

specific program address where an AT flag is planted. It is with this facility that a program tester activates the response generator. Prior to a test run, the tester uses utility commands to specify the predefined response message type to be generated, the parameters to be used (e.g., the digits dialed in a mobile origination), the required time delay for the response message to arrive, and the AT flag program address. Upon detection of the AT flag, the response generator builds the appropriate response message and places it in an internal buffer. When the specified time has elapsed, the response generator scanning program removes the message from the buffer and passes it to a data link I/O program as if the message had come from an actual cell site. It should be noted that the response generator produces cell site responses as specified explicitly by the user whereas other test systems generate the simulated messages in response to request messages sent to the cell site.

While most cell site responses are transmitted via the data link, the confirmation signals (such as voice channel, or answer) are transmitted as on-hook or off-hook transitions on the cell site voice trunks.

The response generator provides the appropriate trunk status transitions through a relay wired to each cell site trunk used in simulation. These relays can be controlled via ESS by software. When a trunk confirmation signal is requested by the user, the response generator software places a special code in an internal buffer. When the specified time has elapsed, the response generator scanning program, upon detecting this special code, will control the special relay to cause the corresponding trunk to go on-hook or off-hook as required.

The response generator provides a means by which nearly all call processing software can be functionally tested without the data link and the cell site hardware. This has been a very valuable tool in the initial development of the call processing software at the Oak Park MTSO. It is also useful in segmenting the source of system trouble in ESS, in data link, or in cell site equipment.

VI. DATA RETRIEVAL SYSTEM

The Data Retrieval System (DRS) is a minicomputer-based data-gathering system. It is designed to help evaluate the AMPS performance. The system can monitor, on a continuing basis, events occurring in the switching system. In addition, it can, in effect, access any data memory location without affecting ESS operation. An event is defined as some action or collection of actions in the ESS that is identifiable by program or data memory addresses. For example, suppose the program that handles mobile origination were loaded in the ESS program memory starting at address AAA. It can be reasonably assumed that, when the

ESS is executing the instruction at location AAA, a mobile origination is being processed. The execution of the instruction at location AAA is considered to be an event. The events to be monitored can be changed easily.

The principal advantage of DRS is that it is noninterfering and transparent to the No. 1 ESS. Since it is connected to the ESS through already existing test connectors, it requires neither hardware nor software changes in the switching system.

One design objective was to make DRS a system that could be easily transported to a field site. The hardware, therefore, was kept to a minimum. A minicomputer was chosen as the main processor. The heart of the DRS is a specially-designed Interface-Matcher (IM), which serves as the link between the No. 1 ESS and the DRS processor. The matcher has the ability to monitor all registers in the ESS control processor (see Fig. 4). From these registers, the location of the program instruction being executed and the location of the data being interrogated or changed can be obtained. These addresses are used to determine when an event has occurred in the system.

The matcher appears to the DRS processor as if it were two storage areas, matcher address area and snapshot buffer area. The matcher address area stores the specified program memory and data memory addresses. Each time one of these addresses is encountered during program execution, the values of all ESS registers existing at that time will be loaded into the snapshot buffer area. The matcher address area is divided into program memory locations and data memory locations.

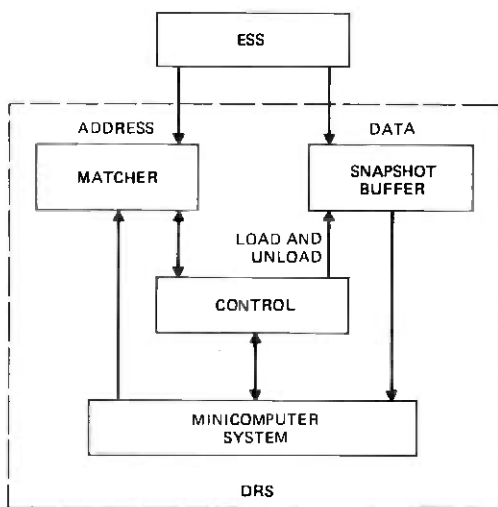

Fig. 4—Data retrieval systems.

Single addresses or pairs of addresses specifying address ranges can be used. The snapshot buffer area is a first-in/first-out buffer consisting of a fixed number of slots. Each slot is large enough to store values for all the ESS registers being monitored, plus additional information tags and time of day.

The main function of the matcher, therefore, is to provide snapshots of pertinent data whenever an address listed in the matcher address area is encountered. The data loaded in the snapshot buffer will remain there until processed.

All events to be monitored by DRS are defined prior to the actual data collection. Event definition consists of two parts, event attribute and event directive. Event attribute is used to identify a specific event, such as mobile origination or fade (loss of radio signal). It consists of an address or address range and, in the case of a data memory address, an optional action specification. The action specification allows the user to define an event as occurring during (i) a write into the location, or (ii) a read from the location, or (iii) either a read or a write. Event directive consists of a list of actions whenever the specified event is recognized. Generally, the actions are specifications of the data desired and the output medium to be used.

Because of its versatility and portability, DRS can also be an effective utility tool for troubleshooting subtle software problems in any working No. 1 ESS office in the field.

The DRS software is written in the high-level C programming language developed at Bell Laboratories. In addition to data-gathering functions, some of the more useful software debugging utility functions are also implemented.

VII. SUMMARY

The AMPS is a complex system. It contains several major subsystems, each of which has its own processor and software. The five laboratory test systems briefly described in this paper were designed to fulfill specific needs, either for the individual subsystems or for the entire system. The needs are simulation, software debugging, load test, performance monitoring, and overall system testing. These test systems have been invaluable tools to the AMPS development. They all share the common goal to ensure that AMPS meets its design requirements and provides a high quality of mobile service to the public.

VIII. ACKNOWLEDGMENTS

The development of the test support systems described in this article is the result of joint efforts of many people. F. W. Bowen and D. R. Fuller were responsible for the design of the MOSES system; L. D.

Mayfield and W. F. McMillan for the MATS and MCG systems; E. J. Fontenot for the Response Generator; and J. P. Lee and R. L. Lien for the Data Retrieval System. These people have made substantial contributions, and much credit is due to them.

REFERENCES

1. "No. 1 Electronic Switching System," B.S.T.J., 43, No. 5, Parts 1 and 2 (September 1964).
2. D. L. Bayer and H. Lycklama, "MERT—A Multi-Environment Real-Time Operating System," ACM, Operating System Review, 9, No. 5 (November 1975), pp. 33-42.

Advanced Mobile Phone Service:

The Cellular Test Bed

By G. C. DI PIAZZA, A. PLITKINS, and G. I. ZYSMAN

(Manuscript received August 1, 1978)

The Cellular Test Bed is a comprehensively instrumented field test laboratory supporting the development and evaluation of the Advanced Mobile Phone Service (AMPS). It consists of three main cell sites and six co-channel interferer sites configured in a small-cell hexagonal grid centered on the Newark, N.J. area. The sites interface with a central control and monitoring facility that incorporates a miniprocessor and related peripherals. A highly instrumented mobile laboratory performs fundamental data-gathering tasks and functions as the system mobile unit. A dedicated analysis facility is used to process and interpret the field-gathered data and simulate alternative operating system algorithms and their effect upon performance.

I. INTRODUCTION

Bell Laboratories is engaged in an ongoing field studies program to characterize the performance of UHF cellular mobile telecommunications systems. This program, designated the Cellular Test Bed (CTB) in its present phase, evolved from fundamental investigations of propagation-related phenomena. The initial thrust of the field studies program was to expand the work of previous investigators in order to generate a modeling of the influences of the environment on UHF signal propagation between a land site and mobile unit. To accomplish this modeling, a specially instrumented vehicle and land transmitting stations were developed and installed in the Whippany, N.J. and metropolitan Philadelphia, Pa. areas to provide UHF signal propagation data. The stations were located in a variety of propagation environments typical of suburban and urban communities so that conclusions drawn from the data are applicable to the broad deployment requirements of a practical cellular system.

Specifically, in the first phase of the field experiments, statistics were generated on UHF path loss as a function of range, propagation environment, and antenna elevation. The tests furnished data to characterize environmental noise and the correlation properties of signals received at the mobile unit from transmitting antennas at widely separated land sites. The results of these early experiments supplied the information necessary to specify system radio-plan parameters affecting radio coverage and frequency reuse.

A second phase of the field program emphasized the evaluation of specific antenna designs, equipment, and radio plan functions basic to the successful operation of high-capacity cellular systems. Field testing included data gathering on polarization and space diversity, vehicle location by signal strength and time delay, antenna gain and directivity, high-speed signaling, and voice transmission. These data have formed the basis for the development of cellular system control algorithms, particularly those related to vehicle location and handoff, and the performance specification of the radio transmission equipment.

The third and current phase of the program is structured to provide system-level evaluation of a broad class of cellular radio plan designs. The field configuration used for this effort, the CTB, consists of three main cell sites and six co-channel interferer sites installed in a small-cell hexagonal grid centered on the metropolitan Newark area. A primary objective of the CTB is the technical demonstration of small-cell interference-limited system operation.

The important features of the CTB test instrumentation and analysis facilities are:

- (i) The data base is generated in a field environment using all the essential features of a small-cell radio plan configuration.
- (ii) The instrumentation incorporates data-gathering facilities that permit the generation of a comprehensive, high-resolution data base, which can be used to design and evaluate system control algorithms.
- (iii) The analysis facilities provide for fast turn-around data validation and fully utilize the field instrumentation capability to develop performance results.

These features ensure that data gathered in the CTB are reliable, reproducible, and statistically consistent with the objectives of each test sequence.

II. CTB OBJECTIVES

Efficient spectrum management of cellular systems such as AMPS requires the effective application of many interrelated system control algorithms. These algorithms are used to process inputs such as received signal measurement data and, on the basis of assumed prop-

agation models, generate control decisions. The algorithm operation was developed and studies were performed using computer simulations that rely upon a statistical modeling of the propagation environment. The corresponding circuit functions were evaluated with hardware simulations of the radio transmission path. The CTB extends laboratory and computer simulation results by characterizing, in the field environment, basic operating sequences of the cellular radio plan and evaluating their influence on the quality of service.

The limited tests performed in the laboratory are extended in the CTB to incorporate hardware, software, and environmental interaction effects that are not well understood or anticipated. Consequently, final confirmation that circuit performance is predictable and proper comes from the live field environment. Similarly, the CTB provides a reference calibration for system-level performance simulations obtained by computer modeling. Computer-generated simulations are inherently well suited to evaluate effects of parameter perturbations and to extend simple system models to more complex configurations; the CTB provides a field reference to establish the validity of the basic models and enables proper interpretations of simulation results derived in modeling more sophisticated system configurations.

The CTB instrumentation, therefore, is designed to provide data on cellular system performance at two extremes of system complexity. The noise-limited system plan is studied in a three cell-site, omnidirectional antenna configuration; the small-cell interference-limited system plan is evaluated under the influence of a complete set of co-channel interferers in a directional antenna configuration. The latter arrangement stresses full frequency reuse, characteristic of the mature form of AMPS.

In both these equipment configurations, CTB data characterize system performance parameters, among which are the distributions of carrier-to-noise ratio (CNR) and carrier-to-interference ratio (CIR) over the cellular coverage region. Since these signal, noise, and interference relationships have a direct correspondence to voice quality and signaling reliability, they provide a first-order measurement of how closely system design objectives are being met.

Evaluations of signaling performance under dynamic field conditions are also of fundamental significance to the successful operation of AMPS. CTB-collected data relate transmission errors to the observed CNR and CIR distributions, to vehicle speed influences, to terrain characteristics, and to man-made noise effects.

Additional system functions tested in the CTB include vehicle-locating algorithms and voice channel handoff among cell sites. The frequency of handoffs, the location within the cell where handoffs occur most often, the improvement in CNR and CIR following handoffs, and the adequacy of locating decisions are all precisely characterized for

comparison with results achieved in simulations. Such comparisons provide a reference which serves to qualify and build confidence in system-simulation modeling.

The CTB must furnish performance evaluations which are easily interpreted and which, therefore, minimize the time needed for subsequent analysis at the system level. This capability has been incorporated through the minicomputer/microprocessor technology used to control tests, collect data, and perform preliminary processing. This technology makes it possible to simultaneously meet the seemingly contradictory objectives of rigorous performance characterization and timely engineering-level data interpretation.

III. CONFIGURATION

The Cellular Test Bed site configuration (Fig. 1) has three centrally located cell sites for radio coverage of the Newark, N.J. area, and six

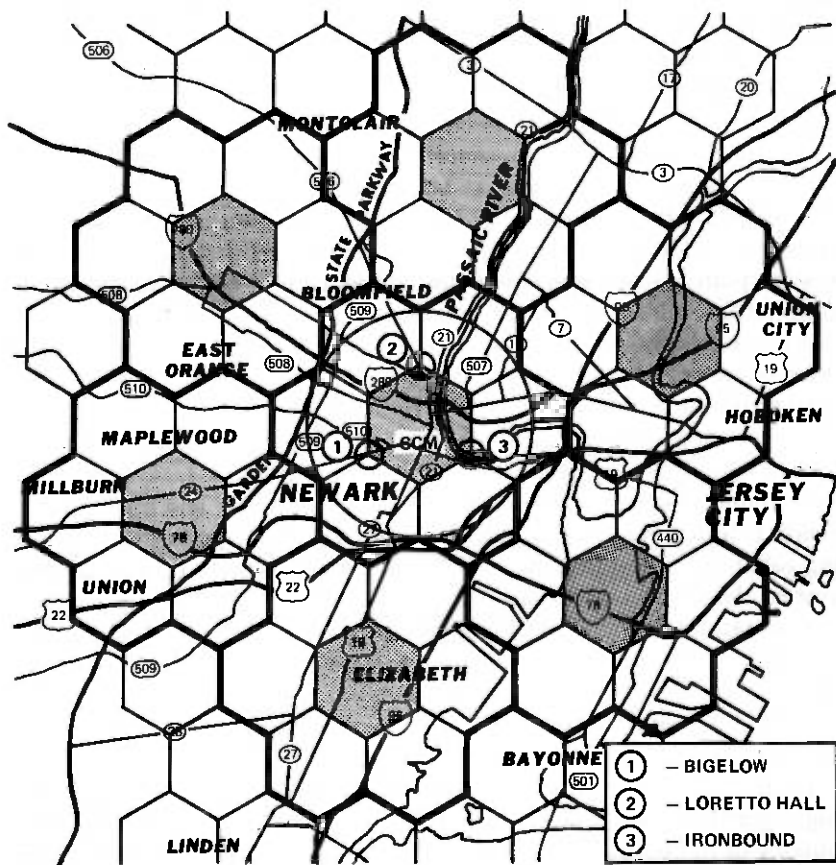

Fig. 1—Cellular Test Bed site configuration.

appropriately located remote transmitter sites for co-channel interference in the central coverage region. All sites are equipped with directional and omnidirectional antennas to permit the evaluation of both AMPS radio plan geometries. The sites can be power-controlled to simulate other radio plans. In the directional mode, the central sites provide corner-excited coverage of a single hexagonal cell, 1.4 miles in radius, and partial coverage of the six adjacent cells. In the omnidirectional mode, the same sites provide center excitation of three separate cells.

The six co-channel transmitter sites are located 4.6 cell radii from the central cell. Each CTB co-channel site simulates the interference generated by the three sites serving the particular co-channel cell by means of a power-control algorithm which accounts for antenna directivity and height, terrain, site location, and channel occupancy. The main and co-channel sites interface via voice and data land lines with a Central Control and Monitoring (CCM) facility located in central Newark. The CCM site emulates the algorithmic processing and radio plan control functions of an Electronic Switching System (ESS) in AMPS. It also contains the facilities necessary to acquire and record the collected data base.

The CTB "mobile" (Fig. 2) is a specially instrumented test vehicle designated the Mobile Communications Laboratory (MCL). It is equipped with the transceiver and control facilities necessary to perform the required operating and data-gathering tasks. Data acquired by the MCL are processed, formatted, and transmitted to a centrally



Fig. 2—Cellular Test Bed mobile—Mobile Communications Laboratory (MCL).

located telemetry site via radio link and then sent on to the CCM site via land lines. These radio and land links, in addition to the cell site links, permit essentially all measurement data, including the mobile data, to be acquired and stored on a common digital magnetic tape at the CCM. Additionally, audio generated at the CCM using specially calibrated analog recordings, is carried by land lines to the "serving" cell site where it is transmitted for recording at the MCL.

This CTB configuration is sufficiently flexible to test the radio plan and control algorithms for a number of system configurations that are of interest. By means of power control scaling, the CTB simulates various cell sizes and co-channel separation distances to permit evaluation of each stage of AMPS growth and study of other radio plan alternatives.

IV. DATA RECORDING

The design philosophy of the field instrumentation allows flexible use of the field components to emulate both noise and interference-limited system performance. Accordingly, the hardware and software are designed to accommodate the broad spectrum of operational algorithms proposed to control and manage a mature cellular system. To accomplish this, the field configuration incorporates data-gathering and performance-monitoring functions that offer the analyst all the data resolution necessary to quantify the performance of system-level control of each operational event. For example, it is expected that in AMPS a system control algorithm will sample the signal strength received from each off-hook mobile in the service area once every few seconds. So that the Cellular Test Bed can acquire the additional signal strength data necessary to evaluate the effectiveness of such periodic interrogations, capability is incorporated within the MCL and at each cell site to sample signal-strength information once every one-half second. The one-half second interval serves as the basic CTB data-acquisition frame for all data recording.

The cell site data-acquisition system sequentially samples, at a 512-Hz rate, the signal received from the mobile on all eight cell site receive antennas. These samples are averaged by the cell site processor to produce eight one-half second means of the signal strength, based on 64 samples each. Each mean value and the last instantaneous sample contributing to that mean are transferred to the CCM every data frame.

The MCL data acquisition system provides a more comprehensive RF data record since it performs more than 3300 measurements during the equivalent one-half second interval. On the basis of these measurements, the MCL establishes and transmits to the CCM the following radio transmission parameters for each data frame:

- (i) Mean received cell site setup channel carrier level from each of the three central cell sites.

- (ii) Mean received cell site voice channel carrier level from the serving cell site.
- (iii) Mean received interferer carrier level from each of the six interferers.
- (iv) Mean mobile-received noise.
- (v) Peak mobile-received noise histogram.

This microscopic data gathering and recording takes place concurrently with the execution of the system control operational algorithm under test. Similarly, all system status parameters, including those related to mobile-unit performance, are measured and recorded every one-half second. Such a data base enables system-control algorithm performance to be thoroughly evaluated and developed to maturity.

More specifically, the instrumentation data collected in CTB are grouped broadly into four categories which quantitatively characterize (i) radio frequency transmission, (ii) the performance of system control algorithms, (iii) the performance of specific system functions, and (iv) the performance of the data acquisition system; the latter data serve to qualify and aid the interpretation of the other three data categories. The data are further classified according to source: mobile or land-originated. Table I lists representative examples of each data category and identifies its source.

As described below, the data are collected from both instantaneously sampled and real-time processed events. The instrumentation data collected in the CTB include 30 instrumentation words from the MCL and 24 words of data from each cell site. To accomplish this, 102 words of instrumentation data are recorded during each one-half second of real time.

In addition, operational status, self-check results, and data from the

Table I—Representative examples of data categories and sources

Data Category	Source
1. Transmission Data:	
Carrier amplitude	Mobile and land
Average and impulsive noise	Mobile
Co-channel signals	Mobile
Locating signals	Land
2. Algorithm Data:	
Location estimates	Land
Handoff events	Land
Cell site/mobile traffic distribution	Land
3. System Function Data:	
Signaling performance	Mobile
Voice transmission	Mobile
Diversity	Mobile
4. Operational Data:	
Time references	Land and mobile
True vehicle position	Mobile
Control flags	Land
Bookkeeping data	Land and mobile

system control process are added to complete the data package. The full complement of data constitutes a 204-word record of information recorded every one-half second.

V. IMPLEMENTATION

The comprehensive data base described above is obtained from measurements using specially designed land site and mobile data acquisition facilities. Specific equipment designs for these facilities are described below.

5.1 Central cell sites

The radio coverage plans proposed for AMPS require the use of both omnidirectional and directional antennas. Consequently, each of the CTB central cell sites uses 12 antennas (three 6-dB* omnidirectional antennas and nine 8-dB directional antennas) to evaluate the coverage algorithms. An additional omnidirectional antenna is used at each site for test control. The composite antenna array, illustrated in Fig. 3, is

* Relative to one-half wavelength dipole reference antenna.

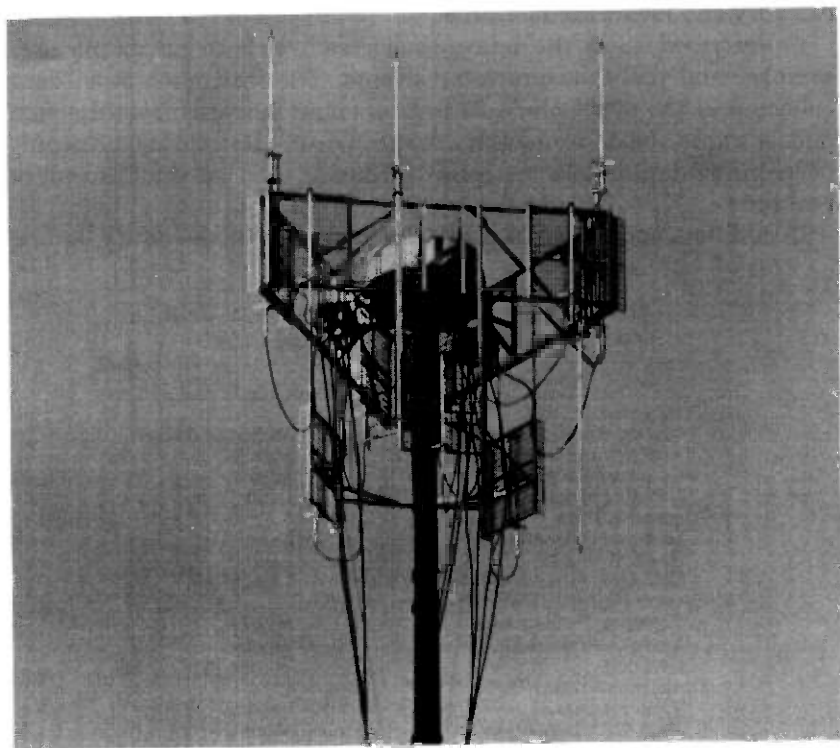

Fig. 3—Cell site antenna array.

supported approximately 100 feet above the local street surface by a free-standing Corten* steel mast at two of the cell sites and by a roof-mounted 50-ft mast at the third site. Each mast has a winch and an internal halyard assembly of three steel cables for raising and lowering the antenna frame from the ground to facilitate antenna and transmission cable servicing.

Two of the three omnidirectional antennas are appropriately spaced for diversity reception of the mobile unit transmission; the third is assigned for cell site transmission. Three directional antennas serve each of the three 120-degree sectors (or faces) surrounding the site. Two directional antennas, appropriately spaced, are used to achieve diversity reception for the face they serve; the third directional antenna is used for cell site transmissions. Figures 4 and 5 illustrate typical radiation patterns of the CTB antennas.

Each antenna in the array is coupled to the cell site equipment through a 150-ft, 5/8-in.-diameter, 50-ohm, semirigid cable having a

* Registered trademark of the U.S. Steel Company.

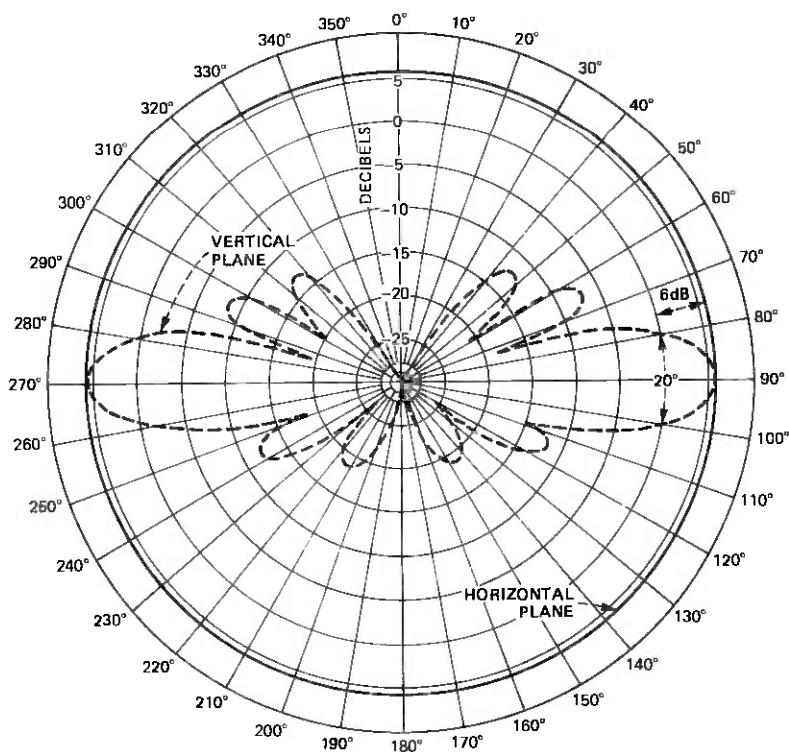

Fig. 4—Vertical pattern of 6-dB omnidirectional antenna.

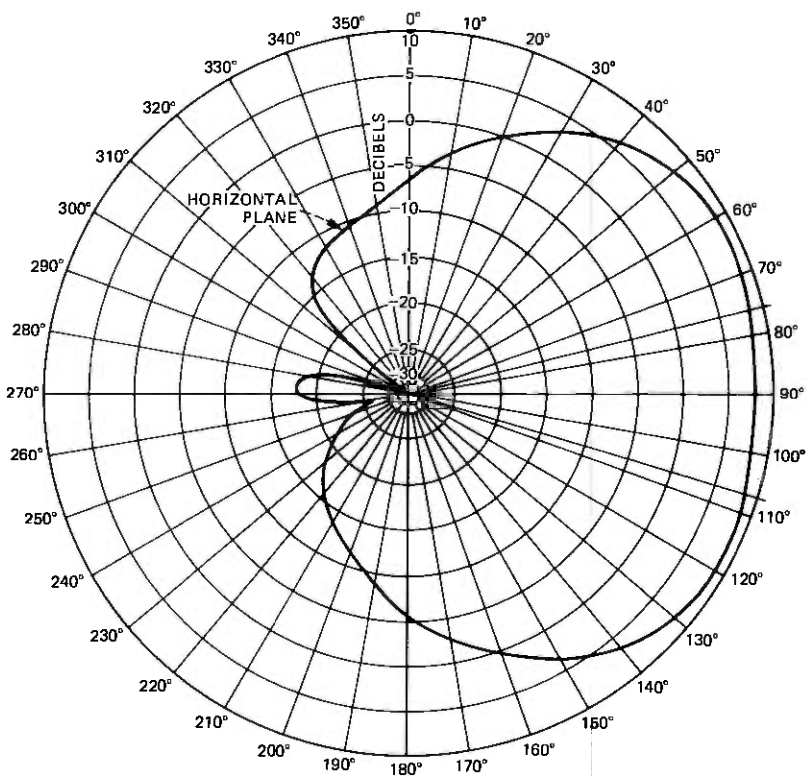

Fig. 5(a)—Azimuthal pattern of 8-dB directional antenna.

nominal RF transmission loss of 0.03 dB per foot at 850 MHz. The return-loss performance of the antenna, transmission line, and connector assembly is maintained at ≥ 15 dB.

The four transmit antennas are excited by the cell site configuration shown in Fig. 6. Two independent radios service omnidirectional operation; two additional independent radios service directional operation. Each transmit radio path includes a UHF variable-power amplifier, which can produce up to 10 watts at its corresponding antenna terminals, and the two radios servicing the directional antennas can transmit on any of the three cell site faces—A, B, or C.

The receiver configuration of the three central cell sites, shown in Fig. 7, is more complex. Two receive antennas are used to achieve diversity reception on each radio channel in service and, as in the transmit case, each radio serving the directional antennas can be switched to service any of the three cell site faces. Basic to the cell site operating and data-gathering architecture is the instrumentation receiver, which has been designed to satisfy, concurrently, the operating

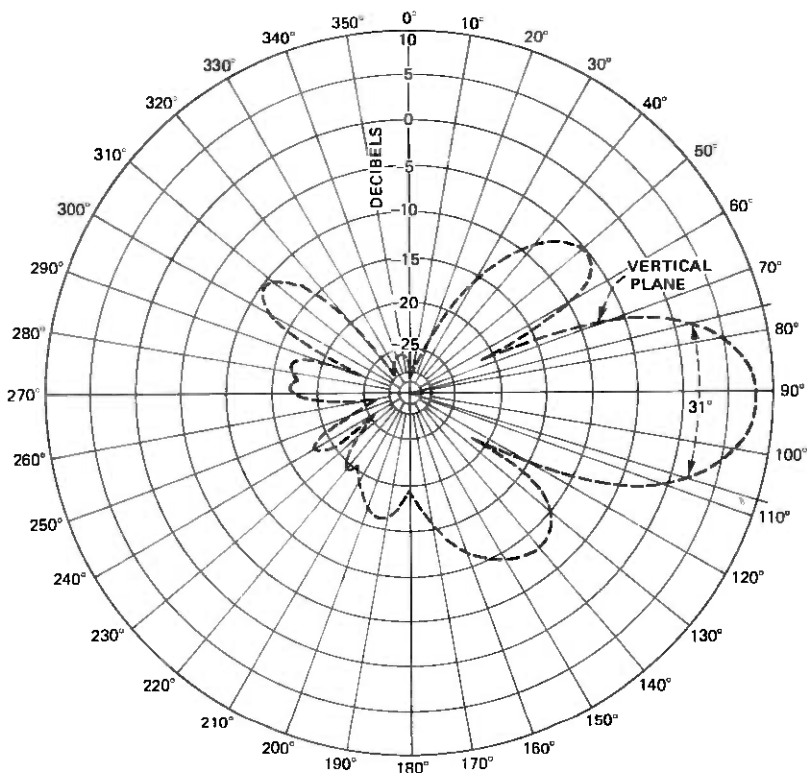
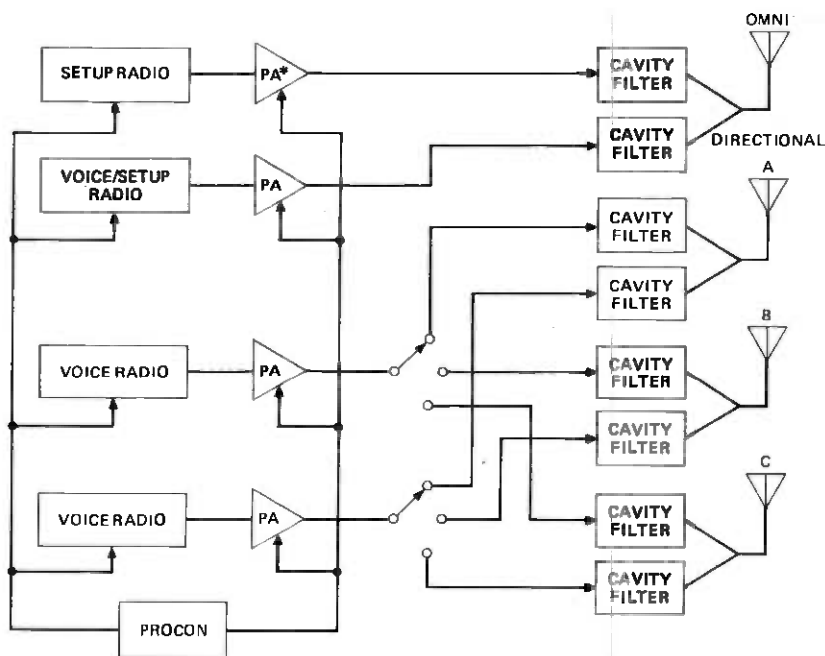

Fig. 5(b)—Vertical pattern of 8-dB directional antenna.

algorithm under test and the CTB's data-gathering requirements. At a 512-Hz rate, the receiver switch shown in Fig. 7 electronically sequences through all eight cell site receive antennas. The signal strength from each antenna is sampled to form a one-half second mean, which is calculated by the programmable controller (PROCON) and sent to the CCM site. The CCM requests, receives, and records such information from all three main cell sites every one-half second. All information recorded is tagged to identify the time of the measurements and the particular radio/antenna combination and cell site in use.

As mentioned above, a PROCON is embedded within the control architecture of each central cell site; it responds to command and interrogation messages sent by the CCM via conventional land lines and Western Electric 201 data set facilities. The cell site PROCON is interfaced to peripherals that enable it to perform data acquisition, data processing, and equipment calibration and surveillance functions consistent with cell site evaluation and data-gathering requirements.

To facilitate field modification of both the configuration and test



*PA - POWER AMPLIFIER

Fig. 6—Cell site transmitter configuration.

operations requirements, the PROCON at each site can be reprogrammed remotely from the CCM.

5.2 Co-channel sites

Since the co-channel sites need not perform system receive and data-acquisition functions, they have a much simpler transmission architecture than the central cell sites. Figure 8 shows that the interferer architecture includes two cell site radios with transmit functions only. These radios drive power amplifiers whose outputs are attenuated as required and are then hybrid-coupled to an omnidirectional antenna and a directional antenna. The radios can be modulated with either a voice signal originating at the CCM or a data signal supplied by a local signaling subsystem. The equipment control functions are administered by an eight-bit microprocessor that interfaces with the CCM via telephone data lines.

During field evaluation operations, both transmitters are active. One supplies the interference signal at the radio frequency used by the "serving" central cell site. The second transmitter generates a carrier signal at a frequency unique to the particular co-channel site. The MCL, therefore, acquires signal strength data on the composite inter-

ference generated by all six co-channel sites and the interference unique to each site.

5.3 Central control and monitoring site

Figure 9 illustrates the system design of the CCM, which is based on an HP 2100 miniprocessor data-acquisition system. Through software, it emulates radio plan control functions performed by an ESS, supervises data gathering and recording, and automatically calibrates and monitors the performance of all the Cellular Test Bed's land-based radio components. The CCM interrogates and instructs the mobile unit via telemetry link and the cell sites via specially conditioned land lines. Operator intervention, if needed, is also available. The cell site control message formats, as in the AMPS design, include seven parity bits to ensure high reliability of data transmission. The CCM software requests data retransmission whenever errors occur. The CCM also contains the calibrated audio facilities necessary to conduct voice quality tests.

5.4 Telemetry site

The telemetry site (TM) incorporates the radio transceiver facilities, which permit the CCM to reliably instruct and interrogate the MCL anywhere within the CTB test probe area. To meet the transmit/receive path reliability requirements of this important radio link, the TM site is centrally located within the probe area and uses a high-gain transmit and diversity-receive antenna system elevated 230 feet above the local street surface. The TM site also incorporates voice communication facilities to administer field test operations.

5.5 Mobile communications laboratory

The interior of the MCL (see Fig. 10) contains radio, logic, miniprocessor, and data-recording facilities. The RF/analog subsystem, which consists of five measurement channels driven by two electronically selectable RF preamplifiers fed from two receive antennas appropriately spaced for diversity reception, is illustrated in Fig. 11. The same antennas and preamplifiers also feed the AMPS mobile radio used to evaluate the performance of the voice and signaling subsystems.

The main measurement receiver uses a computer-controlled agile local oscillator, which mixes the RF signals down to three intermediate frequencies. Each of these frequencies feeds into two highly selective channels that use logarithmic detectors. Two channels (one high-gain, one low-gain) service each IF signal to achieve an instantaneous dynamic range that is linear from -150 to -30 dBm. The two channels are adjusted to maintain a 20-dB overlap centered at -90 dBm. The measurements for calculating real-time average values are selected using either the high-gain measurement or by accepting the low-gain

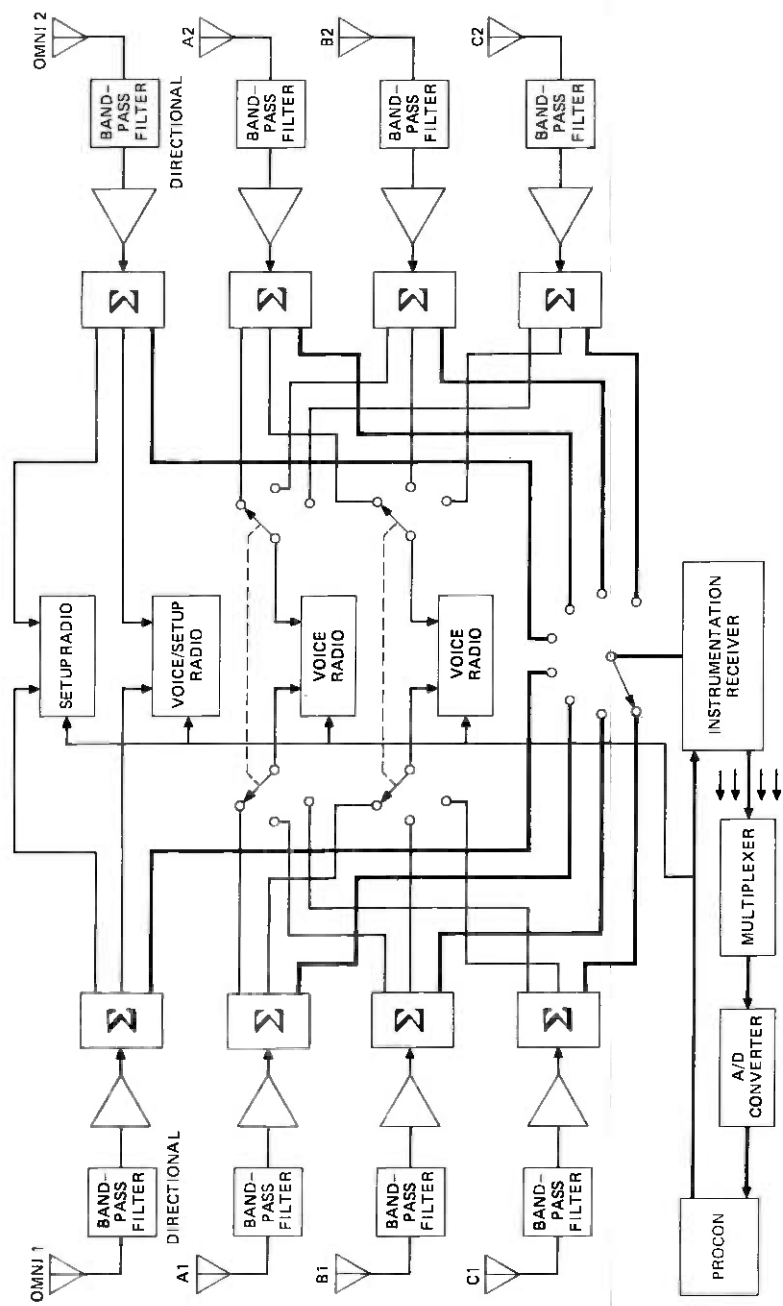

Fig. 7—Cell site receiver configuration.

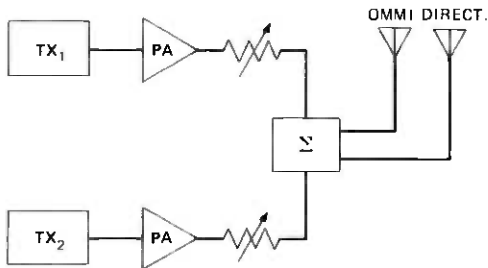

Fig. 8—Co-channel cell site transmitter configuration.

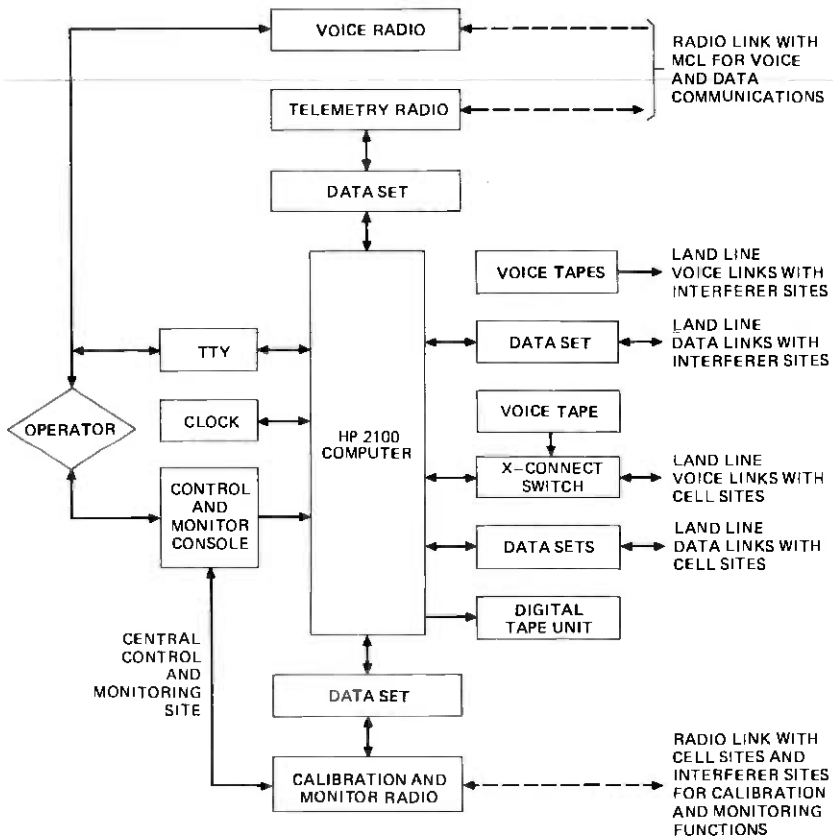

Fig. 9—Central control and monitoring facility.

result if it exceeds a threshold approximately in the middle of the overlap region.

Environmental noise is monitored on one antenna by a single logarithmic detector with a linear range from -150 to -70 dBm. The output of the diversity switch in the mobile radio is measured by an eighth logarithmic detector having a linear range from -120 to -40 dBm, with the useful range extending nearly 10 dB more at each end.



Fig. 10—Mobile Communications Laboratory interior.

Instantaneous data sampled from these receivers are processed to obtain a true incident power by a stored program reference tabulation. This processing translates the output from a 10-bit analog-to-digital converter to a number proportional to the corresponding instantaneous input signal power. The instantaneous signal power samples are summed over one-half second of real-time to calculate average values.

The MCL is also equipped with a gyroscopic-bearing and distance-tracking system so that all system status and measurement information recorded each one-half second are tagged with true vehicle position.

5.6 CTB calibration and performance monitoring

The calibration and performance-monitoring equipment in the CTB's hardware and software designs and the subsequent off-line statistical processing of the measurement data can precisely control and qualify the field experiments to obtain results comparable in resolution and reliability to those achieved in the laboratory. Examples of the calibration and performance monitoring subsystems incorporated within the central and interferer cell sites are shown in Figs. 12 and 13. The MCL uses a similar calibration and monitoring system.

The cell site transmit calibration and monitoring subsystem monitors, via precision coupler and temperature-compensated detection circuits, the RF power incident to and reflected from each antenna/cable assembly (see Fig. 12). The detected voltages, sampled and processed by the PROCON, are sent to the CCM, where they are monitored and recorded (on-line) to insure the integrity of the cell site transmit function.

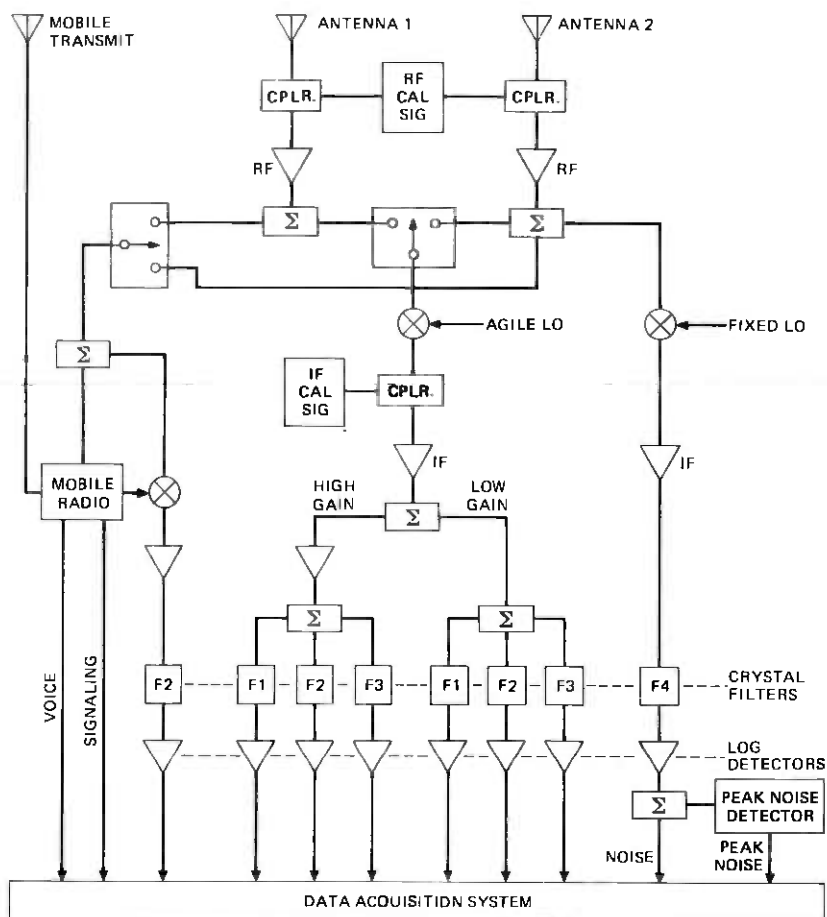

Fig. 11—MCL RF/analog subsystem configuration.

The type of calibration and monitoring subsystem used in the cell site receivers is illustrated in Fig. 13. In practice, the test generator is set, under CCM control, to a reference power level. The CCM then (via land lines and the PROCON) automatically steps a programmable, precision attenuator to supply the input reference signals necessary to calibrate the cell site instrumentation receiver over its entire 80-dB dynamic range. At each reference level, 1000 samples are taken and averaged to generate stored program reference tabulations which, during real-time data acquisition, are used to determine the true instantaneous signal strength incident at the terminals of the receive antenna. The test generator also furnishes a reference signal to each antenna and cable subsystem. The instrumentation receiver monitors the forward and reflected power to ensure that antenna system return-

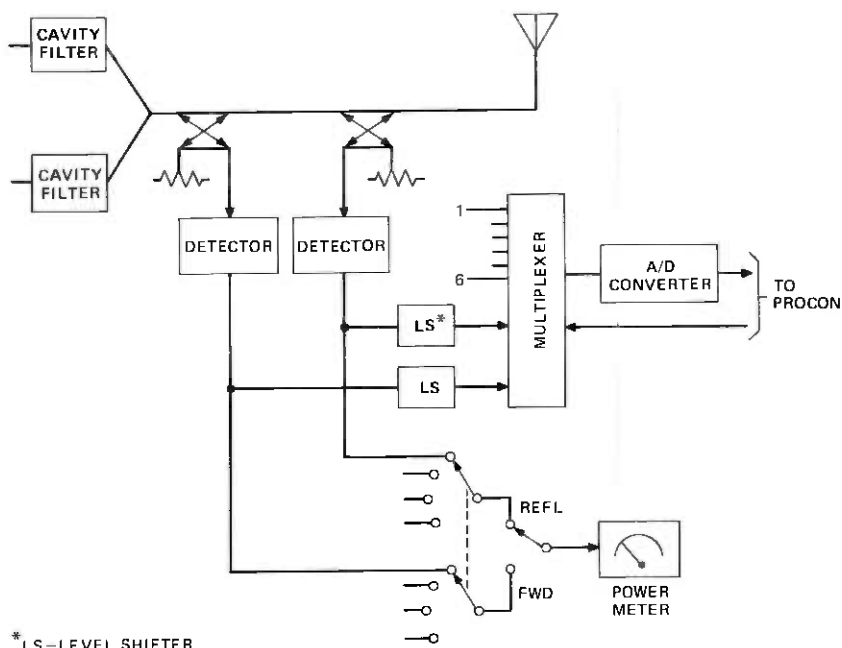

Fig. 12—Cell site transmitter calibration subsystem.

loss requirements are met. As shown, the test generator subsystem also furnishes the reference signals necessary to establish the FM quieting performance of the AMPS radios. Calibration of the CTB's transmit-and-receive subsystems is maintained within $\pm \frac{1}{2}$ dB during each field evaluation sequence. The calibrations are performed at least before and after each test sequence and are hardcopied as part of the data package.

VI. CONTROL/RECORDING ARCHITECTURE

This section describes the system control and data-recording structures of the CTB that perform the AMPS emulation and data-acquisition functions. As noted previously, an extensive data base of transmission parameters is established at the CCM every data frame. The algorithmic software module accesses the appropriate cell site transmission data at programmed intervals and makes system control decisions, which are communicated to the cell sites and implemented by the operating system. The following paragraphs discuss the communication, control, measurement, and data-recording aspects of CTB operation.

6.1 CTB data communication

As described earlier, the CTB field experiments are administered through the CCM, which is linked with cell sites by data lines and to

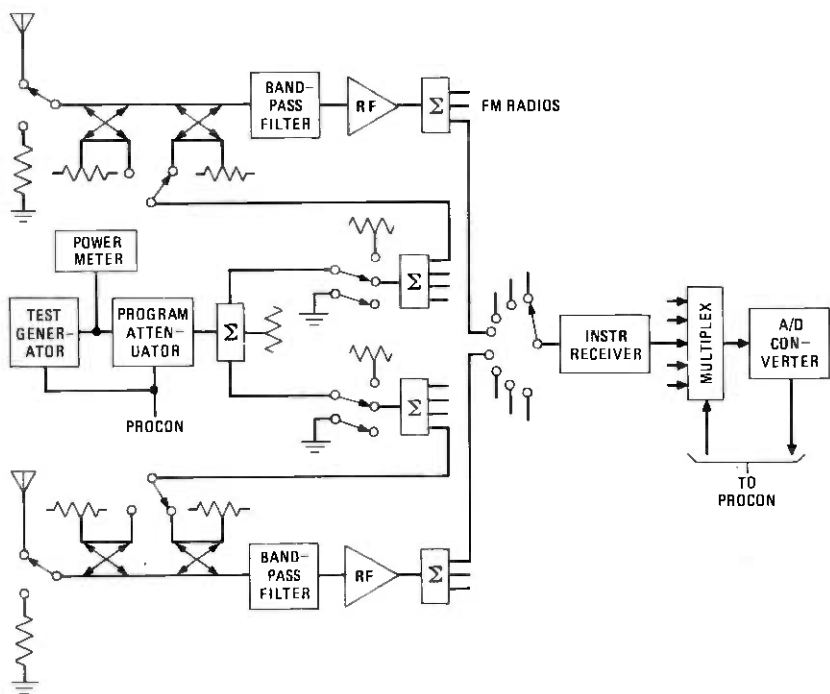

Fig. 13—Cell site receiver calibration subsystem.

the MCL by a full-duplex telemetry channel. These interconnections, together with powerful processing capability at each remote site, form a comprehensive data communications structure.

Basically, three types of messages are used for data communications within this field configuration: First, control messages, such as signaling requests to cell sites, permit the execution of system-level operations. Second, special data acquisition requests and data messages to and from cell sites and the MCL permit the acquisition of data at the CCM. Third, CTB operational-control messages permit the automatic calibration of cell sites, synchronize the data-acquisition frame at each cell site and the MCL, control interferer site power and frequency, and provide status information on the proper performance of the system. The last category of messages allows direct CCM instructions to the mobile logic unit via telemetry link and also permits the MCL and CCM operators to request test pauses.

The land-line messages are transmitted at a rate of 2400 b/s, while the MCL data transfer rate is 1800 b/s. All messages are formatted into 32-bit blocks with seven bits devoted to error control. The data are encoded in a shortened (127, 120) Bose-Chaudhuri-Hocquenghem (BCH) code, which is used in an error-detection mode with retransmission.

6.2 System control

The CTB configuration must be properly initialized to start data acquisition. First, the interferer transmitters and the main cell site instrumentation receivers must be tuned to the serving channel. Then the test can start by synchronizing the data-acquisition frames at each cell site and the MCL with the CCM system clock. From that point on, microscopic data measurements at the MCL and cell sites depend on their local clocks. The CCM data-collection subsystem initiates each frame with a "request-for-data" message to the cell sites and the MCL. The data received are checked and formatted by a CCM software module and placed in a buffer to the system-control algorithmic module. This module is coded so that it can access data available to the AMPS control algorithms only at the proper time intervals. The output of the module may request a system reconfiguration, which is accomplished by the CCM with appropriate data-link messages. All system decisions, requests for action, and actions are recorded with the underlying data for later analysis.

6.3 Measurement of RF transmission parameters

Radio transmission parameters are measured at each of the cell sites and at the MCL. Each cell site instrumentation receiver switches sequentially to each of eight RF channels (Fig. 7) for sampling the mobile carrier level as received on each of two omnidirectional and three pairs of directional antennas. The data-sampling rate is 512 Hz, enabling the acquisition system to make 64 measurements per channel each data frame. The samples are processed through a calibration stored-program reference tabulation to generate quantities proportional to the RF signal as received at the antenna terminals. The cell site programmable controller then forms eight averages from these samples every data frame. If we assume an underlying Rayleigh distribution, these averages estimate the local means within a 95-percent confidence interval of approximately 1 dB. These eight averages together with the final eight instantaneous samples form the RF parameter list, which is transmitted to the CCM every data frame and recorded on digital tape in the format shown in Table II.

6.4 MCL activities

The MCL is a highly sophisticated data acquisition facility. As discussed in Section V, its five basic measurement channels are alternately switched to two diversity-receiving antennas. Further, measurements are made on both the high- and low-gain IF channels with the MCL computer selecting the proper value in real-time. Measurements are made on setup, voice, interferer, and noise channels. In addition, the AMPS diversity signal and peak-noise distribution are measured.

Table II—CCM data tape format—frame record

Word	Description
1 to 10	CCM operational data
11 to 14	MCL operational data
	MCL measured data:
15	Serving channel diversity mean signal strength
16	Serving channel mean signal strength
17 to 22	Interferer 1 to 6 mean signal strength
23 to 25	Setup channel mean signal strength—3 cell sites
26	Noise mean
27 to 32	Peak noise histogram
33	Supervisory tone status
34	Serving channel
35	Mobile power status
36	Order
37	Standard deviation on serving channel signal strength
38 to 48	Signaling related data; voice and setup channels
	Cell site measured data:
49 to 65	Mean and instantaneous received signal strength—cell site 1
66 to 68	Reserved
69 to 77	Cell site 1 supervisory tone transmitted power and other status reports
78 to 93	Mean and instantaneous received signal strength—cell site 2
94 to 97	Reserved
98 to 106	Cell site 2 supervisory tone, transmitted power and other status reports
107 to 122	Mean and instantaneous received mobile signal strength—cell site 3
123 to 126	Reserved
127 to 135	Cell site 3 supervisory tone, transmitted power and other status reports
136 to 145	Algorithm requests
146 to 149	Algorithm calculations (e.g., angle-of-arrival data)
150 to 167	Interferer channel and frequency assignments
168 to 204	CCM status flags

Table III gives the fundamental MCL measurement sequence. As suggested, the sequence has 52 measurements with a data frame consisting of 64 repetitions of this sequence.

The MCL minicomputer processes the instantaneous data to obtain mean power estimates for every data frame. Each setup, voice, and interferer channel power estimate is based on 128 signal-strength samples since the contributions from both mobile diversity antennas are averaged together. Again, with a Rayleigh signal distribution, the averages estimate the mean power within a 95-percent confidence interval of approximately $\frac{3}{4}$ dB. Peak noise samples, which consist of 256 measurements per frame, are cast into a six-level histogram. The ranges are:

- 93 dBm < range 1
- 97 dBm < range 2 \leq - 93 dBm
- 101 dBm < range 3 \leq - 97 dBm
- 105 dBm < range 4 \leq -101 dBm
- 109 dBm < range 5 \leq -105 dBm
- 113 dBm < range 6 \leq -109 dBm.

The instantaneous measurements are recorded on the digital tape unit at the MCL, while the CCM receives processed data in histogram form.

Table III—MCL measurement sequence*

Measurement	Parameter
1 to 12†	Setup channel signal strength—3 cell sites
13	Serving channel signal strength—diversity
14	Noise
15	Peak noise
16 to 27†	Interferer 1-3 signal strength
28	Serving channel signal strength—diversity
29	Noise
30	Peak noise
31 to 34†	Serving channel signal strength
35	Serving channel signal strength—diversity
36	Noise
37	Peak noise
38 to 49†	Interferer 4 to 6 signal strength
50	Serving voice channel signal strength
51	Noise
52	Peak noise

* Sixty-four measurement sequences constitute a data frame.

† These samples constitute measurements on both mobile receive antennas and on both low and high gain channels. The proper subset of these samples is selected by software.

The signal-strength data transferred to the CCM and recorded there consist of:

- (i) Setup channels (three).
- (ii) Interferer channels (six).
- (iii) Voice channel.
- (iv) AMPS receiver.
- (v) Noise.
- (vi) Histogram (six levels).
- (vii) Standard deviation of voice channel signal power.

6.5 System function and algorithmic data

The MCL with its versatile mobile logic unit monitors the performance of the signaling system. It reports the results of the paging scan, supervisory tone outages, and correctable as well as incorrectable data errors on the voice channel. By reporting to the CCM the state of the AMPS mobile (such as its operating channel), the MCL gives a direct measure of the performance of the AMPS signaling system.

The MCL uses an analog tape recorder to record the voice as received on the AMPS serving channel. Timing and event markers are also recorded on the audio tape to synchronize it with the digital data. This provides a complete record of performance and objective information on the AMPS serving channel.

The cell sites monitor and report to the CCM the status of the supervisory tone present on the serving channel. Also, as described previously, the cell sites report to the CCM the final instantaneous received signal-level measurements on the serving channel.

The AMPS algorithmic-software module, embedded within the CCM

operating system, accesses the instantaneous data each locating interval. On the basis of these signal samples, it makes handoff decisions, which are then implemented by the CCM operating system. The operating system records on the digital tape algorithmic level calculations, decisions, assignments (such as channel number and mobile power), and the results of their implementation, while the system continues its data-gathering functions.

6.6 Operational data

The operational data recorded in the CTB provide timing and MCL position information. Both the CCM and the MCL are equipped with crystal-controlled clocks supplying timing data with 20- μ s resolution. The MCL timing data are transmitted to the CCM on the telemetry channel each data frame. The CCM-generated timing information is also recorded on digital tape. Using the calibrated position tracking system, the MCL's position is monitored each data frame and is known within tens of feet throughout a test.

Clearly, data acquired in the CTB must be reliable (or appropriately marked) to lead to valid performance evaluation. For this reason, on-line data on the state of the CTB are generated and recorded on the CCM digital tape. These data include trouble and status flags as described below.

If properly encoded data are not received at the CCM within the allotted time span (300 ms), a trouble flag is set to mark that event in the recorded data and a trouble report is issued on the CCM system console. An incomplete data package received at the CCM also causes a trouble flag and report. Once a complete error-free data transmission is received, the CCM validation routines examine the cell site signal-strength data for plausibility. If unreasonable measurement values are detected, the CCM sets a corresponding trouble flag.

Finally, the received signal-strength measurements are displayed in real-time on a graphics terminal. The test coordinator can request the display of any signal-strength measurement from each cell site. Unusual behavior in the displayed data is noted and may cause the test to be interrupted.

The AMPS locating-algorithmic program, which is resident within the CCM operating software, uses some of the cell site measured data to make required system handoff decisions. The algorithmic routine examines the aforementioned trouble flags and inhibits decisions when flags are set. If a handoff is deemed necessary, the algorithm requests new cell site and/or face and channel assignments from the operating system. This information is checked for plausibility and then stored and recorded on digital tape. Invalid algorithmic requests cause a trouble report to the system console and set a corresponding trouble

flag in the recorded data. Valid requests cause the operating system to issue the necessary instructions to the cell sites.

The MCL routinely sends the frequency of its AMPS operating channel to the CCM via telemetry. The CCM check routines, after accounting for response delays, compare the reported frequency of the MCL operating channel with that of the algorithm-assigned channel. In case of mismatch, a system reinitialization flag is set and recorded on tape, and a system-recovery process is initiated. The algorithm can also issue a system-restart request when a "lost mobile" condition occurs. This condition sets both the mobile status and the system reinitialization flags. On system reinitialization, the system software verifies the proper operational status of the cell site transmitters and measurement receivers. Improper operation is reported on the system console.

As part of the on-line monitoring system, the cell sites measure and report the RF output power of the transmitter to the CCM. This information is recorded on digital tape and is used on-line to alert the operator in case of a malfunction. The data are also collated and recorded within the 204-word block each data frame.

VII. DATA PROCESSING

The basic objective of the CTB data acquisition and processing tasks is to quantitatively evaluate system performance and to present results in a form suitable for system-level engineering evaluations that will help determine the final AMPS design. Fundamental to such performance evaluations is the capability of generating high-quality results in a form that is easy to interpret. CTB data processing achieves this capability through a combination of "quick-look" status-assessment programs, data-validation programs, various data-reduction routines, special data-collecting and data-organizing techniques, and highly interactive graphic procedures for displaying results.

The quick-look software enables a first-cut, fast-turnaround process for examining the field-collected data, prior to complete processing, to gauge how well the experimental data conform to pretest expectations. These cursory results are used to provide feedback to the data-collection activities, adjust the experimental setup as appropriate, and fine-tune the test configuration to collect data under conditions most suitable to the test objectives.

The data-validation and data-reduction routines convert the raw field data into a form suitable for input to the analysis programs. During this process, certain data are identified for removal from the data base, as necessitated by limitations in CTB field hardware or software. These routines, in combination, perform the translation of bulk-recorded field data into information suitable for the evaluation and evolution of algorithms in subsequent analyses. The analysis and

display software provides data organization specifically matched to final-performance interpretations. These programs are further enhanced by a capability to reproduce the field experiment in the laboratory. The system-control algorithms can be modified and evaluated in a real-time simulation, which uses the raw field data as its input and develops a new set of performance measures. This latter software has been designed to take full advantage of the high resolution in the instrumentation data collected in the CTB.

The majority of these data-processing functions are performed in a highly interactive, hands-on environment with a dedicated minicomputer. This arrangement permits the flexibility and control essential to the effective utilization of sophisticated programs and engineering judgment in processing the extensive CTB instrumentation data base.

The data recorded in the CTB accumulate at a rate of approximately 25,000 words per minute. The data-processing effort outlined above is necessary, therefore, to convert this serial field data into an effective and manageable data base. The listed processing techniques organize the data into a structured, easily interpreted form. The specific data structure selected for that purpose is based on a geographic grid, which easily accommodates graphic displays of results and aids the final engineering-level performance evaluations.

The data-processing tasks that precede and are basic to generating, managing, and analyzing the CTB data base are enumerated below.

7.1 Data validation

The first data-processing function, preliminary even to data validation, is performed in the field: Calibration references are generated for the instrumentation receivers, signal amplitude samples are real-time averaged, and true vehicle location data are recorded and merged with measurement results. The data are collected at the CCM and written on a common digital tape for further processing in the CTB minicomputer-based facility.

The minicomputer facility (Fig. 14) is used for many preliminary processing functions. First, each field tape is verified by self-checking/plotting routines. The verification process identifies and isolates equipment and operational software faults that occurred during data acquisition. The validated data are also inspected at this time to flag specific performance characteristics that may prove useful in analysis and interpretation.

Figure 15 shows a typical plot generated during the verification process. The figure includes six distinct types of recorded parameters, described below:

- (i) Average power. The data for average power are displayed as a time series, with each one-half-second average value individ-

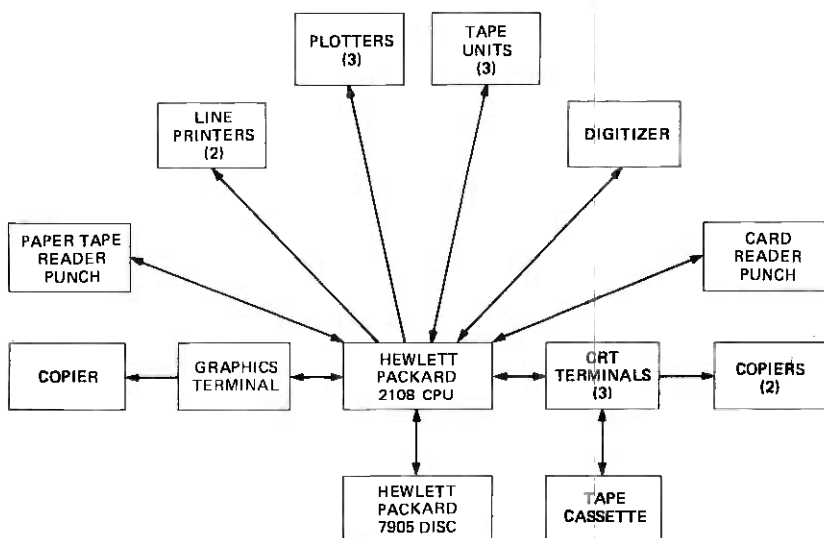

Fig. 14—Data Analysis Laboratory configuration.

ually plotted in dBm on a time axis scaled to 100 seconds per inch. (The abscissa is labeled in "record" numbers, where one record corresponds to a one-half-second data frame.) Traces 1 and 2 represent the averages for two of the three CTB cell site signals and trace 3 for the environmental noise data.

- (ii) Peak noise. The data for peak noise, plotted as trace 4, represent a weighted mean of the field-recorded threshold counts derived from a peak-detecting circuit. The equivalent average power of the noise peaks is plotted to the same scale as the other power data.
- (iii) Normalized signal variance. This variance, trace 5, characterizes the randomness of the transmission path. It is formed by calculating the one-half-second (256-sample) standard deviation for the power distribution and normalizing it to the mean value estimated over the same time period. A value of 1 corresponds to the Rayleigh distribution, while values in the range of 1 to 0 indicate Rician distributions with varying ratios of specular to random components.
- (iv) Trace 6 plots vehicle relative motion; its slope indicates speed. A 27.5-mph speed corresponds to a slope running on a diagonal across the page.
- (v) Location markers. The "major markers," which are inserted during data collection to provide coordinate references, appear as tick marks at the top of Fig. 15. Location marks and record numbers are used to isolate the data sections of operational faults and remove them from further processing.

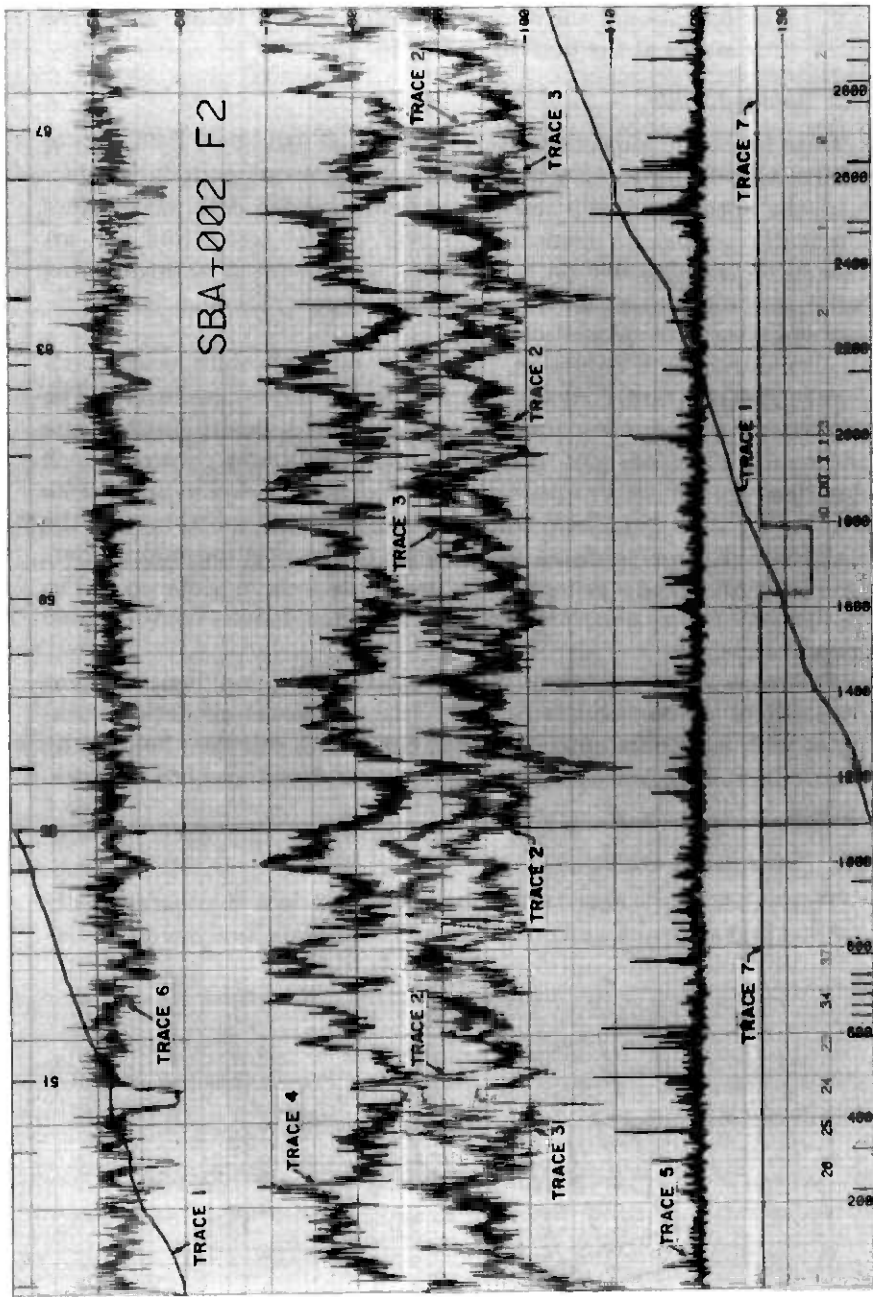

Fig. 15—Typical verification graph.

(vi) System trouble flags. The system flags, which are inserted by CTB operational software to identify system faults, appear as tick marks at the bottom of Fig. 15.

7.2 Data reduction

Data reduction indiscriminately converts all valid bulk field data to a form suitable for more complete selective processing. In data reduction, the normalized and compressed field-recorded data, which were efficiently packed for transmission over the telemetry link and arranged to expedite live data handling, are converted to engineering units and reformatted for more straightforward manipulation in subsequent statistical calculations.

Also, during data reduction, the field-entered absolute location reference markers are converted into true geodetic coordinates. The "digitized" coordinate data are also validated before further use through a microfilm plot, generated under computer control, which describes the vehicle's route. The microfilm is projected to produce an overlay on an original map trace which has been used to lay out the test route; it thus confirms the validity of the position information. One such route trace generated on the STARE system is shown in Fig. 16. The numbers alongside the marked route denote field-recorded major markers.

Following route validation, field-measured data and digitized coordinate data are consolidated to associate the proper geodetic coordinates with each data entry. The combined data can then be used by higher-level data-processing programs to yield performance interpretations.

7.3 Performance evaluation

The validated, reduced data are organized into a geographically defined grid structure and consolidated to facilitate analysis and inter-

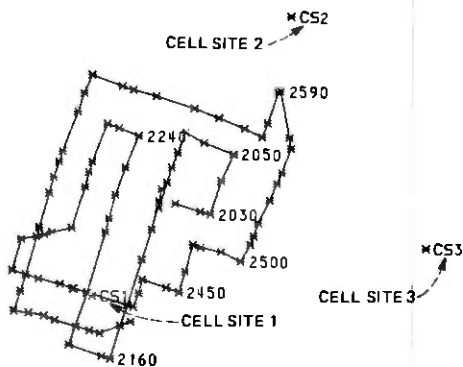

Fig. 16—Route trace on STARE system.

position. For this purpose, data collected in the measurement area of primary interest (a 28-square-mile circular region centered on the main cell) are subdivided into an array based on the MCL's position at the time the measurements were recorded. Such data organization is desirable because it lends itself to a straightforward evaluation of many significant system performance parameters. Handoff locations, signal amplitude distributions, and cell site service zones are typical performance parameters that are most directly described in a spatial representation. The location data supplied by the MCL accurately position the vehicle within tens of feet of its actual location and allow for such a data organization.

The principal area of interest in performance evaluations is circumscribed by the central cell's boundary. This area is subdivided into small square regions of approximately 300 feet on a side (about one city block). The outer area, extending for a distance of one radius beyond the main cell, is subdivided into regions of two different sizes, 300- and 600-ft squares, as shown in Fig. 17. This results in a data-base structure that geographically partitions the 28-square mile measurement area into about 4,500 regions. Each measurement result is identified according to the vehicle's true location at the time the data sample was collected and assigned to the appropriate small region.

The data maintained within the geographically based structure are arranged in a form to allow further processing without format conversions and time-consuming recalculations. These data are stored as accumulated running sums so that combining regions or merging data bases is accomplished by simple addition.

Table IV lists specific CTB data stored in this small-region form. Dividing the data base into 16-bit and 32-bit word formats minimizes the size of the data base while still retaining full data precision. The data in Table IV consist of system algorithm controlled events (entries 1 to 9, 16, 17, 24), propagation measurement results (entries 25 to 40), performance delineators (entries 10 to 15, 18, 19, 21 to 23), and a sum-distance-traveled entry (20). The symbols in the table are defined as follows:

- $\overline{S_s}$ = mean value of serving signal
- $\overline{S_m}$ = mean value of maximum signal
- \overline{N} = mean value of environmental noise
- \overline{I} = mean value of interfering signal
- $\overline{N_p}$ = mean value of weighted peak noise
- X, Y = preset threshold levels.

The "maximum signal" is the maximum of the three cell site signals received by the mobile; it represents the upper bound on system performance as determined by signal amplitude. This upper bound

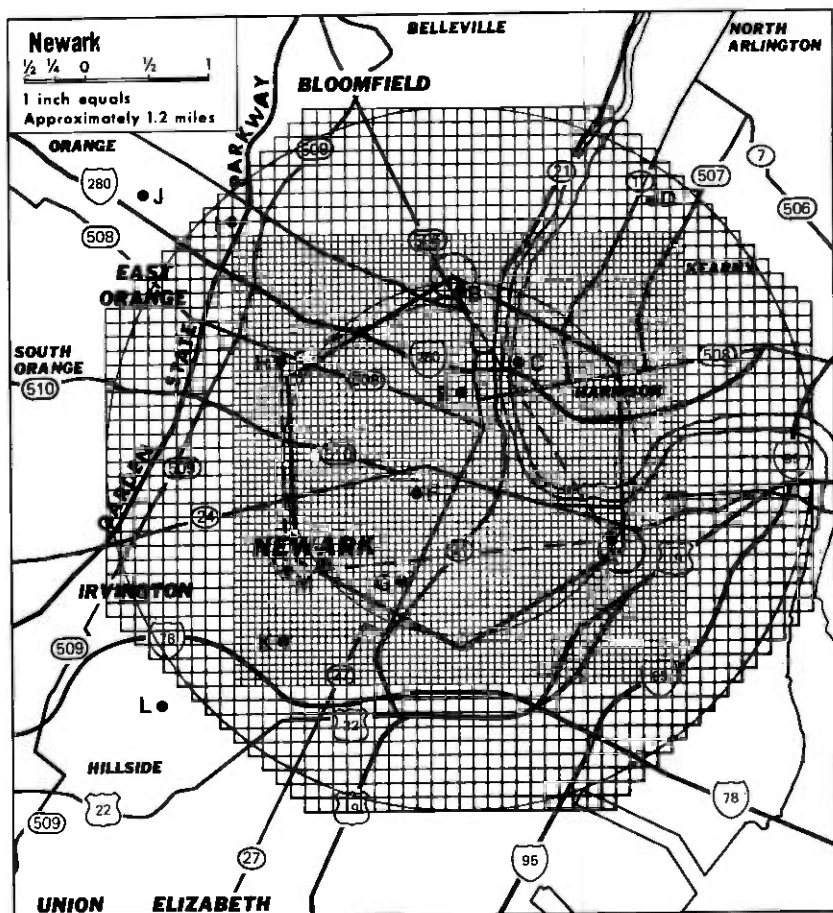

Fig. 17—Small grid binning structure.

Table IV—Information stored by region

16-Bit Words		32-Bit Words	
1 to 3	Number served by cell site	25	$\sum \bar{S}_i$
4 to 9	Number served by cell site face	26	$\sum (\bar{S}_i)^2$
10 to 12	Number $\bar{S}_i/\bar{N} < (X, X \pm 2)$ dB	27	$\sum \bar{N}$
13 to 15	Number $\bar{S}_i/\bar{I} + \bar{N} < (Y, Y \pm 2)$ dB	28	$\sum (\bar{N})^2$
16	Number of handoffs intercell	29	$\sum \bar{N}_p$
17	Number of handoffs intracell	30	$\sum (\bar{N}_p)^2$
18	Number $\bar{S}_m/\bar{N} < X$ dB	31	$\sum \bar{S}_m$
19	Number $\bar{S}_m/\bar{I} + \bar{N} < Y$ dB	32	$\sum (\bar{S}_m)^2$
20	\sum Distance	33	$\sum \bar{I}$
21 to 23	Number of signaling errors by cell site	34	$\sum (\bar{I})^2$
24	Number of nonstandard terminations	35	$\sum (\bar{S}_i \cdot \text{Distance})$
		36	$\sum (\bar{S}_i)^2 \cdot \text{Distance}$
		37	$\sum \bar{S}_m \cdot \text{Distance}$
		38	$\sum (\bar{S}_m)^2 \cdot \text{Distance}$
		39	$\sum \bar{I} \cdot \text{Distance}$
		40	$\sum (\bar{I})^2 \cdot \text{Distance}$

serves as a reference point for comparing the results of different algorithms.

Certain system performance evaluations have the greatest significance when displayed in a velocity-independent form. To obtain such results, the data collected while the mobile is stopped or moving slowly must be appropriately weighted. As an example, the one-half-second averaged signal amplitude is not a valid indicator of the mean local field strength at slow speeds. Velocity weighting (entries 35 to 40 of Table IV) preserves the distance dependence in the results while providing unbiased signal mean estimates.

Table V lists some of the results directly available from the data stored for each region. The data include statistical descriptors of signal strength and performance measures expressed as percentages of the total data collected within each region. Such data are available for each of the 4,500 small regions.

Further processing of the preliminary results develops outputs in a form suitable for specific performance evaluations. For these, graphic displays are most useful since they take advantage of the inherent ability of the human eye to sort quickly through large quantities of pattern data. Because of the geographic grid arrangement of data, it is a relatively straightforward task to develop graphic output in the form of "shade plots" of the desired information. In shade plots, the expected range of each variable is divided into a number of bands, each of which is represented by a unique shade of gray and plotted in an x - y grid.

A shade plot using the data generated from propagation rules developed from earlier field measurements is shown in Fig. 18. The algorithm that is used accounts for antenna height and gain (not all equal in this example) and calculates the signal level within each small region for each of the three cell sites with an assumed 10 watts of power delivered to the antenna terminals at each site. The maximum signal strength determined for each region is then plotted. Although this specific example produces a particularly symmetric result because of the idealized assumptions, the utility of this technique is apparent.

Figure 18 is an example of one general category of performance results. Conventional statistical data-processing techniques extend

Table V—Derived performance results

1. Mean and standard deviation S_s, N, S_m, I, N_p
2. $\bar{S}_s/\bar{N} < (X, X \pm 2)$ dB (percent)*
3. $\bar{S}_m/\bar{I} + \bar{N} < (Y, Y \pm 2)$ dB (percent)
4. $\bar{S}_m/\bar{N} < X$ dB (percent)
5. $\bar{S}_m/\bar{I} + \bar{N} < Y$ dB (percent)
6. Service by cell site (percent)
7. Service by face (percent)
8. Mean and standard deviation S'_s, S'_m, I' (prime denotes distance weighting)

* All percentages are normalized to total number of 1/2-second records within each region.

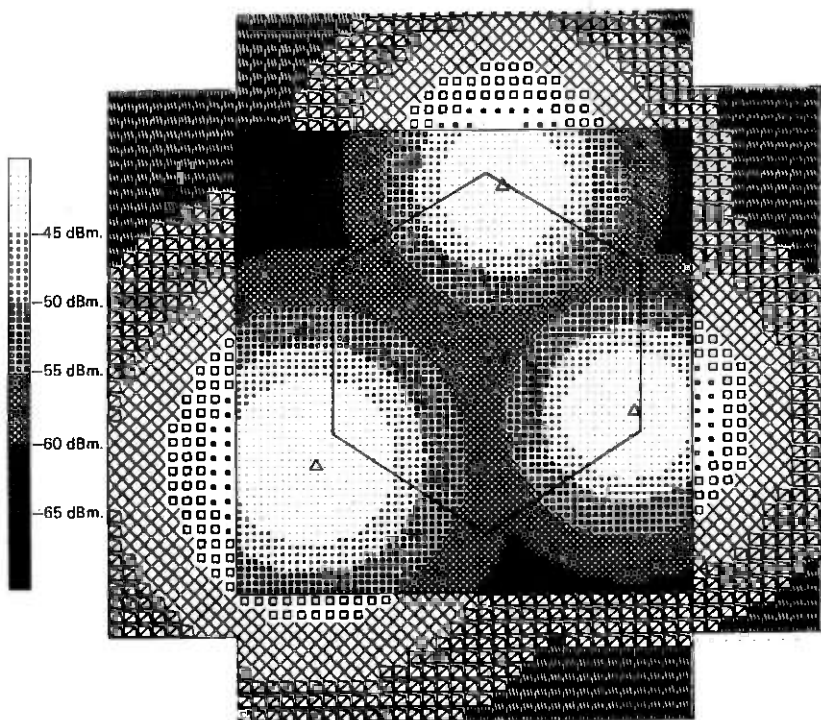

Fig. 18—Typical shade plot.

such shade plot characterizations to specific performance evaluations. In addition, a performance summary is calculated for each measurement run as the data are processed to the small-region form. The results (Table VI) provide a quick-look system-level overview, which can be compared with premeasurement expectations to gauge how the tests are progressing.

7.4 Real-time simulation

The real-time simulation software supplies a field-like operational capability in the data analysis laboratory. Because of the microscopic resolution with which the CTB signals and operations are monitored and recorded by the field instrumentation, field data can be reprocessed in the laboratory much the way they are processed by the system controller at the time of data collection.

In the simulations, the system operating algorithms can be modified easily to study the effects of proposed changes on the resulting system performance. The real-time simulations, operating on the identical instrumentation data used by the system controller in the field, generate outputs that can be used by the same analysis routines used to

process standard field data. In this manner, much of the time and cost penalties associated with field operations can be avoided as various alternative engineering solutions are explored. Once an apparently satisfactory modification is obtained, this result is confirmed through a final "live" evaluation of the new algorithm in the field.

In performing the simulations, the user can select for reprocessing specific data segments that represent spatial or time-based portions of the field-recorded data of particular interest. These data segments can be submitted to an array of algorithm and parameter modifications to test their influence on system performance while the initial system state (serving cell site, antenna, power, etc.) is user-specified or forced to duplicate the configuration that existed at the time the field data were observed. These techniques permit quick-turnaround iterations to isolate observed problems rapidly and to develop proven solutions.

Table VII lists examples of intermediate results that can be calculated and selected for display while the simulations are being performed. The data provide on-line feedback concerning the success of

Table VI—Tabulated performance results

Percent of area included in data base	
Total run time	
Total distance traveled	
Average velocity	
Total number of intercell handoffs	
Total number of intracell handoffs	
Probability of intercell handoff	
Probability of intracell handoff	
Total number of nonstandard terminations	
Total number of signaling errors by cell site	
Percent of time mobile was served by face and cell site	
Histograms	
\bar{S}_s/\bar{N}	5 to 30 dB
\bar{S}_m/\bar{N}	5 to 30 dB
$\bar{S}_s/\bar{I} + \bar{N}$	4 to 29 dB
$\bar{S}_m/\bar{I} + \bar{N}$	4 to 29 dB
$\Delta(\bar{S}_s/\bar{N})$	-30 to +30 dB
$\Delta(\bar{S}_s/\bar{I} + \bar{N})$	-30 to +30 dB
Time to first handoff	5 to 90 seconds
Time between subsequent handoffs	5 to 90 seconds

Table VII—Intermediate display options

Total time of run
Number of records processed
Total number of calls processed
Number of handoffs per call
Number of degraded calls
Number of locating data requests from serving and nonserving cell sites
Number of times locating signals are below secondary threshold while average serving signal is above degraded call level
Number of lost mobiles
Number of times trouble flag is set on requested data
Numbers and types of handoffs
Percent of time mobile is served by each cell site (and face)

the modifications and guide the choice of alternative solutions. The much more complete and laborious analysis processing is thus bypassed until viable solutions have been isolated. The combination of direct feedback during the simulations plus full analysis of final results assures a high success rate when the proposed solutions finally undergo field evaluation in the live system.

VIII. ACKNOWLEDGMENTS

Most major projects represent the efforts of many people. Such is the case with the Cellular Test Bed. The authors, in documenting the CTB, have merged the contributions of all members of the Mobile Telephone Field Studies Department. Their dedication and hard work are gratefully acknowledged.

Advanced Mobile Phone Service:

The Developmental System

By D. L. HUFF

(Manuscript received July 27, 1978)

A developmental AMPS system has been implemented in the urban and suburban areas of Chicago. A Mobile Telecommunications Switching Office at Oak Park, Illinois, controls the ten cell sites used in the system. An Equipment Test, serving approximately 100 mobile users, was initiated in mid-1978. A Service Test, involving approximately 2000 tariffed mobile units, will follow the Equipment Test. This paper describes the developmental system, the activities which were prerequisite to the major system test phases, and the status of the system as of July 1978.

I. INTRODUCTION

In March 1977, the Federal Communications Commission authorized Illinois Bell Telephone (IBT) to construct and operate a developmental AMPS system in the Chicago area. Configured as an AMPS start-up cellular system using large cells and omnidirectional antennas to minimize initial equipment needed, the system was laid out to cover approximately 2100 square miles in the urban and suburban areas of Chicago.

This developmental system has ten cell sites and 136 voice channels controlled by a Mobile Telecommunications Switching Office (MTSO) located at Oak Park, Illinois.

Technical and economic evaluations of the system are being carried out with a two-phase program: an Equipment Test phase, using approximately 100 mobile units assigned to Bell System personnel in the area, began in July 1978; a Service Test phase, with IBT authorized to furnish tariffed mobile service for up to 2500 mobile users, is scheduled to follow the Equipment Test.

Section II of this paper defines the basic objectives of the developmental system.

Section III describes the system that has been implemented, including the cell-site locations and the anticipated coverage area, buildings constructed at nine locations, and a mobile installation and maintenance facility.

Section IV discusses the major activities that were prerequisite to the start of the two evaluation phases. These activities included: the manufacture, installation, and testing of cell-site equipment; the development of various software programs; the construction of buildings to house equipment; the integration of cell sites with the MTSO; and the procurement and installation of mobiles. This section also discusses system test and operation activities.

Section V describes the early preliminary system test and evaluation activity using the MTSO at Oak Park, Illinois, interconnected to experimental cell sites and mobile units in the Oak Park laboratory and in Whippany, New Jersey. Successful tests of basic call processing, using early versions of software designs, have decreased the amount of testing that otherwise would have been necessary as the Chicago system was placed on line.

Section VI describes tools for collecting and processing data from the Chicago system, including the Data Retrieval System (DRS), and the Mobile Telephone Laboratory (MTL) used for radio propagation measurements and system trouble-shooting.

II. DEVELOPMENTAL SYSTEM—PURPOSES AND OBJECTIVES

Most of the principal Bell System objectives for the Chicago AMPS developmental system can be loosely grouped into two categories that relate to the system's two phases of test and evaluation:

- (i) Equipment Test objectives
- (ii) Service Test objectives.

2.1 Equipment Test objectives:

- (i) Complete all system shakedown and debugging activities necessary to assure a high-quality, reliable system during the Service Test period and in subsequent service.
- (ii) Test prototype designs of Bell System-supplied components and confirm the suitability of non-Bell System manufacturers' mobile units and cell-site radio equipment.
- (iii) Evaluate the basic engineering procedures used to lay out the system and apply experience gained to improve procedures for future systems.
- (iv) Verify achievement of objectives for radio serving signal quality, including acceptable location/handoff procedures.
- (v) Verify acceptability of system recovery procedures, call processing sequences, and the overall signaling plan.

- (vi) Demonstrate co-channel operation using two of the 10 cells spaced at the appropriate frequency reuse distance for start-up cellular systems.

2.2 Service Test objectives:

- (i) Verify quality of service anticipated and engineered for the Chicago developmental system, including voice circuit quality, low blocking rates, and overall technical performance.
- (ii) Confirm viability and worth of AMPS by demonstrating that the public's needs for mobile telephone communications can be met at a satisfactory cost.
- (iii) Collect data to support market study activities, including verifying various market research and sales prediction procedures currently being used to determine the future market for AMPS.
- (iv) Collect data for estimating the average traffic generated per mobile and the geographical distribution of mobile traffic.
- (v) Determine customer reactions and sensitivities to the basic service; mobile installation, operation, and maintenance procedures; and vertical services.

2.3 Overall developmental system objectives

During the overall test of the developmental cellular system, the objective will be to gain experience in:

- (i) Engineering and implementing an AMPS system.
- (ii) Selecting cell site locations.
- (iii) Installing and testing AMPS equipment.
- (iv) Operating and maintaining an AMPS system.
- (v) Interacting with mobile customers and equipment radio suppliers.

III. DEVELOPMENTAL SYSTEM DESCRIPTION

The AMPS developmental system in Chicago has been engineered to represent a typical start-up cellular system. Figure 1 shows the anticipated 2100-square-mile coverage area with the locations of the 10 cell sites indicated by crosses and three-letter codes (explained in Table I).

For the start-up AMPS system, cell-site locations were chosen, where possible, to take advantage of existing high-elevation structures for antenna placement, and to minimize site location deviations from the ideal grid. The use of existing structures reduced the initial system cost and the possibility of potential delays caused by zoning problems.

The compromise achieved with this layout required only three new antenna masts to be erected. The remaining seven cell sites have antennas on existing structures. In Fig. 2, the circles represent the

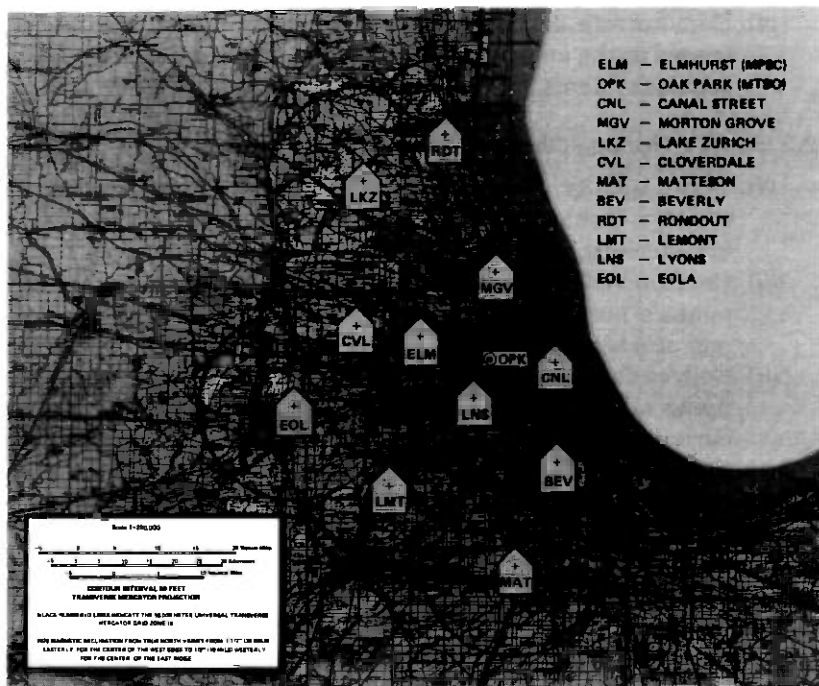

Fig. 1—Chicago service area.

Table I—Developmental system cell-site locations in Illinois and number of duplex voice channels assigned

Cell Site	Voice Channels	Antenna Height (ft)	Address
Beverly (BEV)	16	150	413 W. 105th Street Chicago
Canal Street (CNL)	26	550	10 South Canal Street Chicago
Cloverdale (CVL)	15	325	Schmale Road Cloverdale
Eola (EOL)	8	310	Drehl Road Eola
Lake Zurich (LKZ)	9	285	U.S. Highway 12 Lake Zurich
Lemont (LMT)	8	250	127th Street Lemont
Lyons (LNS)	16	150	8542 W. 44th Street Lyons
Matteson (MAT)	12	260	Vollmer Road Matteson
Morton Grove (MGV)	18	185	Narragansett Street Morton Grove
Rondout (RDT)	8	150	Bradley Road Libertyville Township
	136		

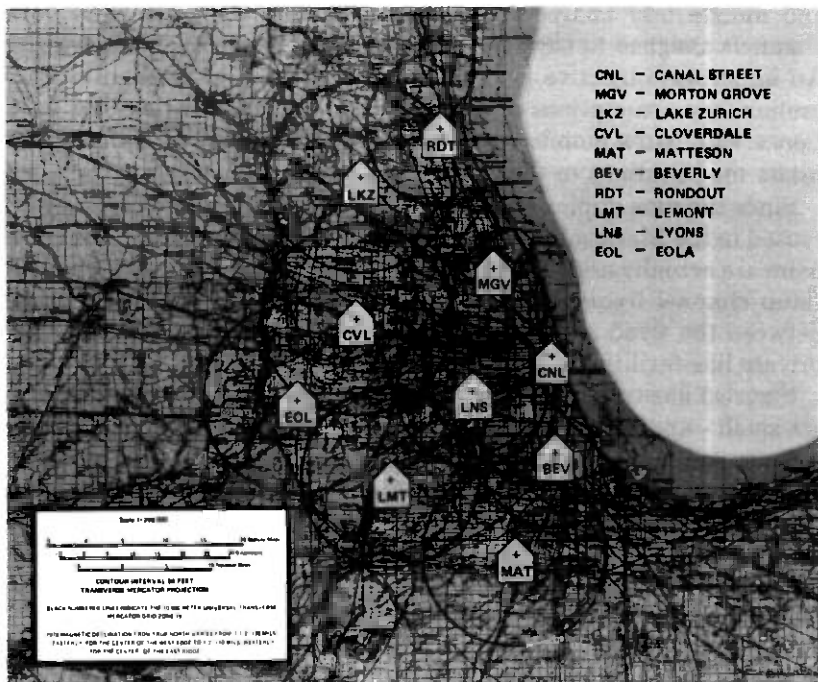

Fig. 2—Idealized coverage areas.

expected coverage area of each cell site. Variations in antenna heights and associated antenna cable losses lead to variations in the size of these circles. The circles represent the estimated ideal "36-dB μ contour"* that results from applying empirically derived 900-MHz path-loss and antenna-height advantage equations to the effective radiated power of each site. The idealized smooth contours will not be realized in practice, since propagation from each cell site will not be uniform in all directions.

For all cell sites except Canal Street, new buildings have been constructed to house cell-site equipment. Since the Canal Street location had available surplus floor space, it was the first to have cell-site equipment installed and made operational. The MTSO location at Oak Park, Ill., is indicated by a small circle in Fig. 1. AMPS software testing was carried out at this location, in addition to control of the developmental system as it came on line.

The system will serve approximately 2000 mobile units during the Service Test with an estimated 2-percent busy-hour blocking proba-

* On this contour, the approximate signal-to-noise ratio averages 18 dB. Studies have shown that this level of signal strength on the cell boundaries will provide the required overall quality of service for AMPS.

bility (based on certain assumptions about mobile traffic distributions and mobile user characteristics). Table I lists the number of voice channels assigned to each cell site using the current engineering rules. An important objective of the Service Test is an evaluation of these preliminary assumptions of traffic and user characteristics. The experience with AMPS mobile customers will serve as the basis for appropriate modifications to the engineering rules.

Since the nine duplex voice channels of the Lake Zurich cell site are reused in the Matteson cell, only 127 different voice channel frequency pairs are actually assigned to the developmental system, along with 10 setup channel frequency pairs. The required voice and data trunks between the MTSO and each of the cell sites is provided using tariffed private line facilities.

Figure 3 illustrates the floor plan of a typical cell site. The buildings are small—approximately 20 by 30 ft of floor space—with room for the cell-site equipment, power supply system, maintenance and test equipment, and maintenance personnel. Except during maintenance activities, the buildings are unattended. Figure 4 is a photograph of the Rondout cell site, showing the cell site building and the 150-ft monopole. Figure 5 shows the Cloverdale cell site, with the building at the foot of the 325-foot AT&T microwave tower and the antennas mounted on top of the tower.

One of the developmental system objectives discussed in the previous section involves determining customer reaction and sensitivity to installation and maintenance procedures. To avoid excessive customer inconvenience, a dedicated installation and repair facility in Elmhurst is being used in the Chicago developmental system. Termed the Mobile Phone Service Center (MPSC), it also serves as the base location for the Mobile Telephone Laboratory (MTL) and for the IBT craft force who maintain the ten cell sites. Spare parts and test equipment for the cell sites are housed at this location, as well as a small data-processing facility for rapid examination of MTL data. Figure 6 shows an external view of this building, while Fig. 7 is a floor plan showing the internal configuration. There are sufficient installation and repair bays at the center to handle the estimated numbers of customers per month during the Service Test. The size of the craft force and the amount of automated test equipment necessary to verify quickly the proper operation of an installed mobile have been determined based on processing Service Test customers efficiently and without undue inconvenience.

IV. MAJOR ACTIVITIES COMPLETED OR UNDER WAY

4.1 Cell-site equipment manufacture

Twelve complete sets of cell site equipment were assembled at the Western Electric factory in Burlington, North Carolina. Two sets of

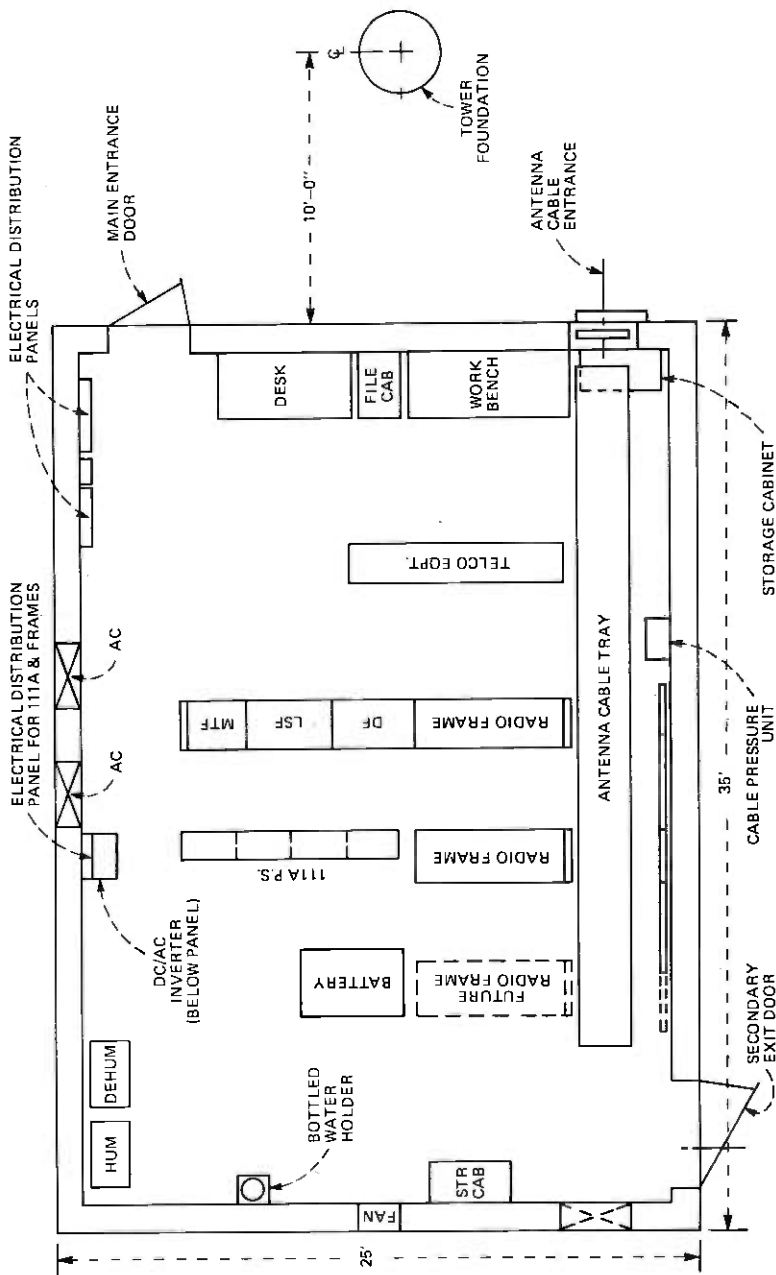

Fig. 3—Cell-site building layout.

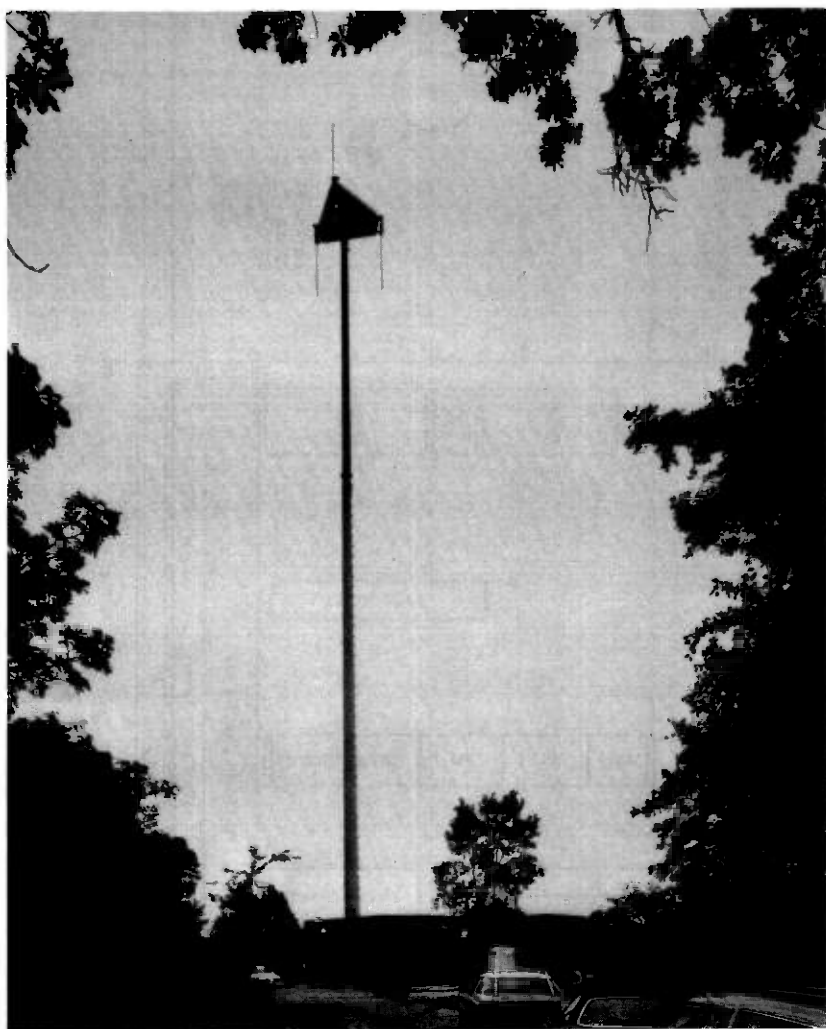

Fig. 4—Rondout cell-site building and mast.

equipment were used for early interface and software debug testing with the No. 1 ESS and mobile unit subsystems; one at the MTSO location at Oak Park, Illinois, and the other at the Bell Laboratories, Whippany, New Jersey, location where the cell site was designed. The remaining 10 sets of cell-site equipment were installed in the developmental system.

All cell sites were thoroughly factory tested before shipment. These tests included computer-driven wiring tests, manual tests, and tests with an HP-21MX minicomputer that thoroughly checked each cell-site

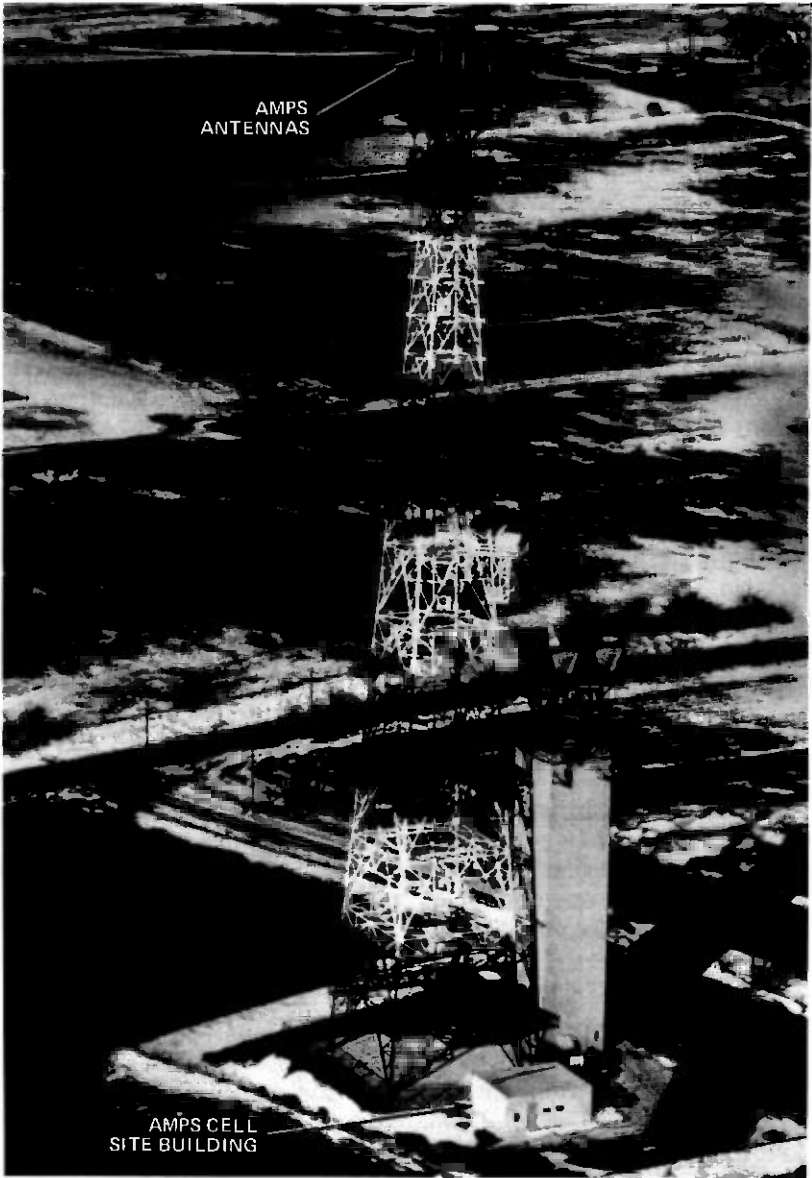

Fig. 5—Cloverdale cell site.

frame on a stand-alone basis. Tests of the interconnected frames (“string tests”) included manual adjustments and alignments of each site’s radio channels. Special software programs were loaded into the data frame programmable controller (PROCON), which executed and tested all the functional capabilities of the cell-site subsystem.



Fig. 6—The Mobile Phone Service Center in Elmhurst, Illinois.

4.2 Software development

The development of the software to be used in the No. 1 ESS MTSO for AMPS control and maintenance in the Chicago developmental system is basically complete.* As new capabilities were developed, they were incorporated into a new issue of the generic program, which was released for testing and debugging using the No. 1 ESS at the Oak Park laboratory. A cell site and four developmental mobiles, which were not part of the developmental system, were connected to the Oak Park No. 1 ESS to aid in the software testing and debugging effort. As each issue of the generic program stabilized, it was used to control the developmental system cell sites that were operational at the time.

Stored-program software has also been developed for the data terminal equipment, the maintenance and test frame equipment, and the data frame in the cell site.

Stored-program software for the logic unit of the Equipment Test mobiles also has been developed. The necessary capability was released incrementally via new programmable read-only memories installed in the logic units in use.

The three companies producing mobiles for the Service Test have developed the software required by their mobiles' designs.

4.3 Building construction

IBT contracted for the construction of the nine new cell site buildings required for the Chicago trial. All were completed by January 1978, except for the Rondout building, which was delayed because of a zoning problem. The mast foundation at the three sites using the 150-ft monopole mast required additional construction activity.

4.4 Cell-site installation, test, and integration

Installers of the Western Electric-Central Region (WE-CR) installed the 111A power plant and other peripheral hardware required for each

* It is anticipated that minor modifications will be made in the software based on experience gained during the Equipment Test.

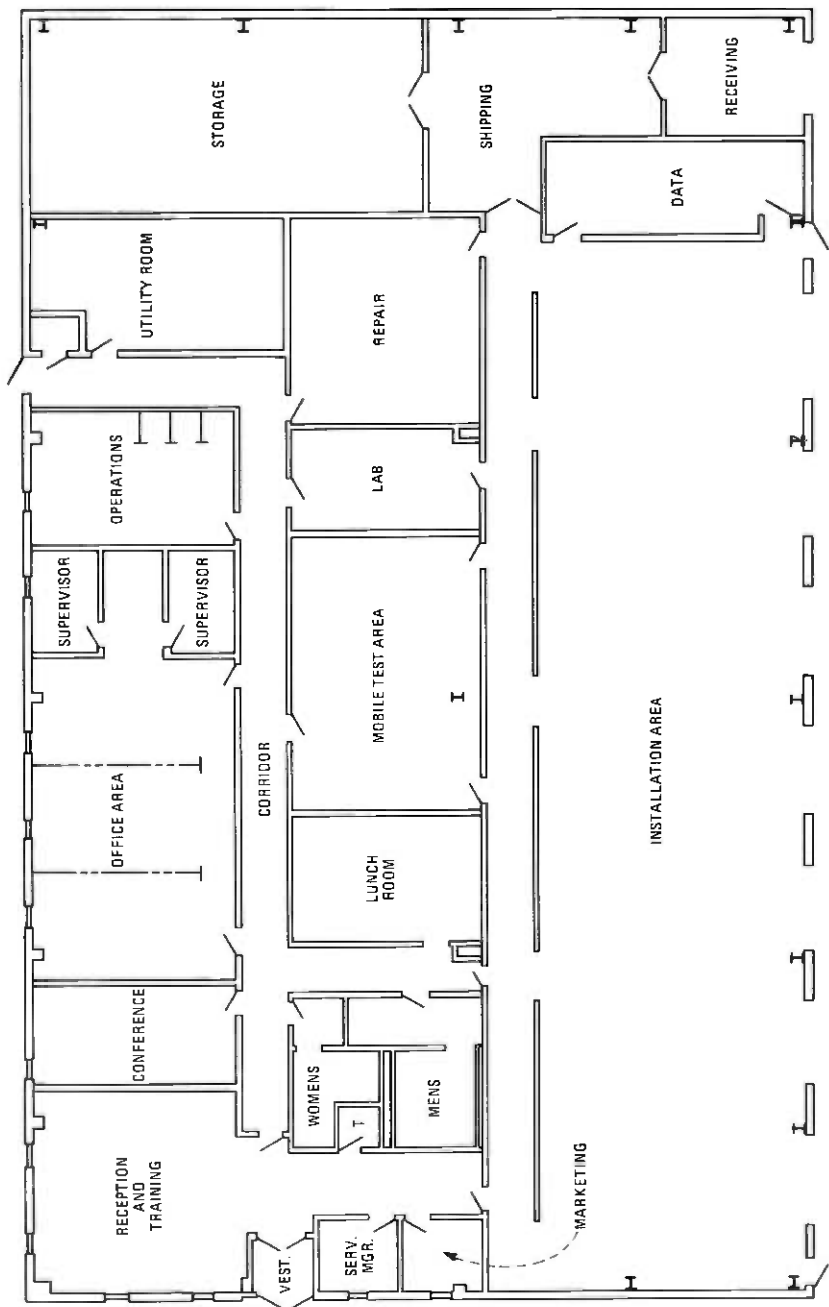

Fig. 7—Floor plan of Mobile Phone Service Center.

cell site, as soon as the building became available. IBT craftspeople installed the electronic equipment at each cell site except Canal Street, where WE-CR personnel did this work. IBT craftspeople, supported by Bell Laboratories and Western Electric-Merrimack Valley (WE-MV) installation engineers, also performed the installation testing of the cell sites using handbooks developed by WE-MV.

Installation test procedures included a large number of manual tests and final adjustments of equipment, followed by a rerun of the string test software programs used initially during factory testing. These tests involved 14 programs, each manually loaded into the data frame PROCON via a paper tape reader and a display, debug, and test (DDT) unit. Errors detected in the cell-site hardware were displayed as specific codes on a printer. Another program generated specific orders to, and received specific replies from, a single mobile unit, which was either the Mobile Telephone Laboratory (MTL) or an instrumented mobile-equipped automobile.

Another class of cell-site test used an HP-21MX minicomputer located at the Oak Park facility and patched into the voice and data trunks connecting the cell site to the MTSO. An autonomous cell-site-to-mobile test program was run, using either the MTL or a specially instrumented mobile-equipped automobile as the mobile. This program required the data frame operational software to be in use in the cell site and thus tested all hardware and software subsystems exclusive of the MTSO. All paging data transmission, voice transmission, supervisory, and fade and disconnect functions that take place between the cell site and mobile were tested.

The next step was to integrate the tested cell site and its operational software with the MTSO and its generic software; with the data terminal equipment and its resident software; and with the data- and voice-trunking facilities between the MTSO and the cell site. The integration commenced with the running of a cell-site initialization program called CLSI, part of the MTSO generic software program. This program initializes the data frame operational program and performs basic functional tests that ensure communication between the MTSO and the cell site. Basic simple call processing tests were then run on each voice channel of the cell site, including land-to-mobile and mobile-to-land calls. Finally, the resident cell-site diagnostic programs within the MTSO were employed to detect failed or suspect hardware and to confirm the system's ability to reconfigure cell site redundant equipment. With no major equipment problems apparent, integration of the cell site with the MTSO was considered complete, and it joined the previously integrated cell sites in participating in system operation and shakedown.

4.5 System test activity

As described in more detail in Section V, preliminary functional testing and debugging began in November 1976, with the No. 1 ESS

interconnected with an experimental cell site and fixed laboratory mobiles, all located in the Oak Park laboratory. Also tested was an experimental cell site at Whippany, New Jersey, controlled by an HP-21MX minicomputer simulating the MTSO control function. The tests at both locations led to the correction of numerous minor design problems that would not otherwise have been discovered until the developmental system testing was well under way.

System test planning was a continuing and evolving activity closely tied to the related activities of collection, processing, and evaluation of data. Planning included identifying required data, generating requirements for specific system tests to obtain the data, defining the data-collection technique, designing specific test plans, converting them to specific operating procedures, and planning the processing and analysis of the data.

System tests planned for the developmental system primarily address the confirmation of overall system performance of a commercially manufactured system, although some evaluation of specific technical functions are also being performed.

Specific tests not requiring the complete system were performed using the earliest available cell sites, while other tests requiring the complete system did not commence until May 1978.

A significant test activity, called partial week service, utilized the MTSO, all integrated cell sites, and all available mobiles operating as a system during weekends commencing in March 1978. This operational activity was very effective in discovering system problems in time for early correction.

Table II contains examples of other system-level tests currently being conducted.

4.6 Mobile procurement and installation activities

Two mobile designs are being used in the developmental system. OKI Electric Industry Company, Ltd., Tokyo, Japan, manufactured 135 mobile transceiver and control units for the Equipment Test phase of the program. In addition, OKI built 135 Bell Laboratories-designed logic units to control the transceivers. Early production models were subjected to exhaustive testing at Bell Laboratories, including environmental tests, and were placed into use in the experimental systems described in Section V. The production units underwent acceptance testing at the Mobile Phone Service Center in Elmhurst, Illinois.

Contracts for developing and producing approximately 2200 mobiles required for the Service Test were placed with OKI; with Motorola, Inc., Schaumburg, Illinois; and with E. F. Johnson, Waseca, Minnesota. These mobiles, to be leased to commercial customers during the Service Test, are manufactured to a specification requiring an integrated transceiver-logic unit and a standard interface between it and the control unit. Extensive testing of early production models of these

Table II—Examples of system-level tests being conducted

Facilities Used	Purpose	Procedures
<i>Service Area Coverage</i>		
MTL Cell Sites	Evaluate engineering coverage and service quality.	Measure signal strengths at selected locations in the 2100-square-mile system area.
<i>Voice Channel and Data Channel Signaling</i>		
HP-21 Minicomputer MTL Cell Sites	Validate forward blank and burst functions over the voice channel as tested and evaluated by the CTB. Evaluate data transmission over the forward setup channels.	HP-21 generates continuous stream of data messages from a cell site and MTL mobile measure data word error rates at various geographical locations having different propagation characteristics.
	Test and evaluate data transmission over the mobile-to-cell site reverse voice channel and the reverse setup channel.	Reverse setup channel and reverse voice data channel tests use MTL onboard mobiles to transmit large numbers of data messages to a particular cell site. HP-21 records errors that site encounters.
<i>Mobile Control Algorithm</i>		
MTSO MTL Cell Sites DRS	Determine the general performance of the location and handoff algorithms and the resulting ability to control mobile operating frequencies to permit an adequate serving signal and to prevent excessive co-channel interference.	MTL makes a record of the serving cell site and serving signal strength for onboard mobiles and the actual mobile geographic locations. DRS records location and handoff events.
<i>System Reconfiguration</i>		
MTSO Cell Site	Evaluate ability of generic MTSO diagnostic software to isolate and reconfigure any voice/data trunk group or other redundant equipment group within the data terminal equipment or cell sites.	Simulate equipment failure and note performance of MTSO system integrity programs.
<i>Cell Site Load Test</i>		
MTL MTSO Cell Site Mobiles	Evaluate ability of a cell site to respond to increasing traffic levels.	Computer-driven MTL mobiles plus vehicles equipped with Equipment Test mobiles place heavy traffic through a selected cell site.

mobiles was performed by Bell Laboratories. Delivery of these mobiles to Chicago commenced in November 1978.

A minicomputer-based automatic mobile test set was used for preinstallation testing of the Equipment Test mobiles and the testing of installed units in Bell System personnel's vehicles. Initially used in the mobile test laboratory in Whippany to evaluate early production units,

the test set was moved to the Mobile Phone Service Center described in Section III and used to perform acceptance tests of the Equipment Test mobiles. Operating instruction and maintenance handbooks were prepared for this test set, and IBT craftspeople were trained to operate the unit prior to the installation of the first significant quantities of Equipment Test mobiles. A similar test set was developed for use with the Service Test mobiles.

A Cooperative Mobile Supplier Program permits any qualified manufacturer of an AMPS mobile design to participate in the developmental system test. This program creates the potential for future additional competitive suppliers of commercial Bell System-owned or customer-owned mobiles. At present, eight manufacturers have expressed an interest in participating in this program.

4.7 Developmental system schedule

The fabrication and factory testing of cell-site hardware were complete at the end of 1977. Cell-site building construction was likewise complete by year's end, except for the tenth cell site which required relocation because of a zoning disapproval. Cell-site equipment installations, tests, and integrations with the MTSO were completed by late May 1978, with the exception of the last cell site. System shakedown and debugging started in April 1978 and continued throughout the Equipment Test, from July 1978, to the end of the year. The system tests outlined in an earlier section are under way. The Service Test phase will follow the Equipment Test phase. Software development and mobile procurement activities are on schedules that coincide with the support of the Equipment Test and Service Test phases.

V. EXPERIMENTAL SYSTEMS—TEST AND EVALUATION ACTIVITIES

Reference has been made to experimental systems established at the Oak Park and Whippany laboratories for early testing and debugging of an integration of all AMPS subsystems. Early versions of the MTSO generic software were developed and tested with a No. 1 ESS at Oak Park. The initial tests used a breadboard model of the cell site as the computer peripheral; from November 1976 to June 1978, a production cell site served as the MTSO peripheral. This cell site was connected to fixed nonradiating mobiles through a transmission simulator incorporating a Rayleigh fader. In May 1977, roof-mounted antennas were added at Oak Park to permit live radiation testing to mobile-equipped automobiles operating in the vicinity. A Bell Laboratories experimental FCC license was obtained for this purpose.

A production cell site installed at Whippany was connected to the Oak Park MTSO via leased voice and data trunks in February 1977.

Early system testing and debugging employed a fixed nonradiating mobile in the laboratory, connected to the cell site via a coaxial cable. Roof-mounted antennas were later added to provide a radiating capability, and testing continued under the control of an HP-21 minicomputer simulator of the MTSO, utilizing the Whippany cell site, and a mobile-equipped automobile.

The ability to investigate abnormal system performance caused by a hardware or software design problem at the responsible design location has greatly simplified the logistics of problem investigation and has accelerated problem correction.

The benefits derived from these experimental systems permitted:

- (i) Ongoing development and early functional integration of the hardware and software subsystems of AMPS.
- (ii) Development and refinement of procedures and techniques that were required to test and evaluate the developmental system.
- (iii) Development, validation, and evaluation of installation and test procedures that were used on cell-site and mobile equipment.
- (iv) Testing and debugging of the MTL system prior to assignment in the developmental system.
- (v) Early training of technical personnel responsible for operating, maintaining, and testing the developmental system.
- (vi) Early evaluation of operating, maintenance, and recovery procedures.
- (vii) Early experience with and refinement of equipment field change procedures, configuration control, and failed unit and spares logistics.

Test activities involving the experimental systems at Oak Park and Whippany diminished as developmental system equipment became more available. The use of these systems has resulted in shorter key activity intervals in the Chicago trial.

VI. DATA COLLECTION AND PROCESSING

6.1 Data collection tools

Three major data collection systems were developed for the Chicago trial: the Data Retrieval System (DRS), the Mobile Telephone Laboratory (MTL), and a telemetry capability in a selectable number of mobile units employed during the Service Test. In addition, a number of less-sophisticated tools were developed, such as specially instrumented mobiles in automobiles. Finally, specific functions of certain test units (such as the HP-21MX minicomputer for autonomous testing and trouble-shooting of cell sites) supply data from the developmental system.

6.1.1 Data Retrieval System

The DRS is a peripheral system that has been added to the No. 1 ESS MTSO to collect data for following the progress of a particular call and the operation of various facets of a given system algorithm, as well as to collect statistical data on many calls. The conversion of recorded DRS data to formats compatible with an HP-21 minicomputer is part of the overall data processing and analysis activity in the developmental system.

6.1.2 Mobile Telephone Laboratory

The second major data collection facility is the Mobile Telephone Laboratory, assigned to the Chicago area on December 1, 1977. The MTL tests and evaluates the system from the mobile's viewpoint and performs system trouble-shooting and system data collection functions. Because AMPS logic is distributed among the MTSO, the cell site's data frame PROCON, and the mobile logic unit, the monitoring and recording of logic activities within the mobile during various stages of a call is necessary to evaluate the performance of the overall system. The MTL performs this task by controlling and monitoring its instrumented on-board mobile units. The MTL is also a calibrated laboratory for measuring signal and noise environments at selected locations in the Chicago coverage area. It also performs testing of cell sites using the on-board minicomputer-controlled mobile units to originate calls automatically with specific time relationships at specific geographical locations.

Figure 8 is a simplified block diagram of the MTL. An onboard HP-21MX minicomputer subsystem controls all major equipment functions. A major subsystem collects signal and noise information from sources within the system using a well-calibrated instrumentation receiver with a wide dynamic range and low noise figure. This measurement receiver is rapidly tuned to the frequencies of interest using an agile local oscillator controlled by the on-board computer. Another subsystem contains four mobile units that can generate traffic under HP minicomputer control, and whose detailed operations can be precisely monitored and recorded for both real-time and off-line analysis.

Test transmitters and receivers on the vehicle provide an autonomous test and calibration capability to ensure that data being collected have not been invalidated by any malfunction of MTL equipment. Finally, a position and timing system permits associating collected data with time, vehicle speed, and vehicle position within the system.

Data-recording peripherals associated with the HP-21MX on-board computer include both magnetic tape and disk equipment and permit real-time on-board data examination using CRT displays, typewriter outputs, and printer outputs.

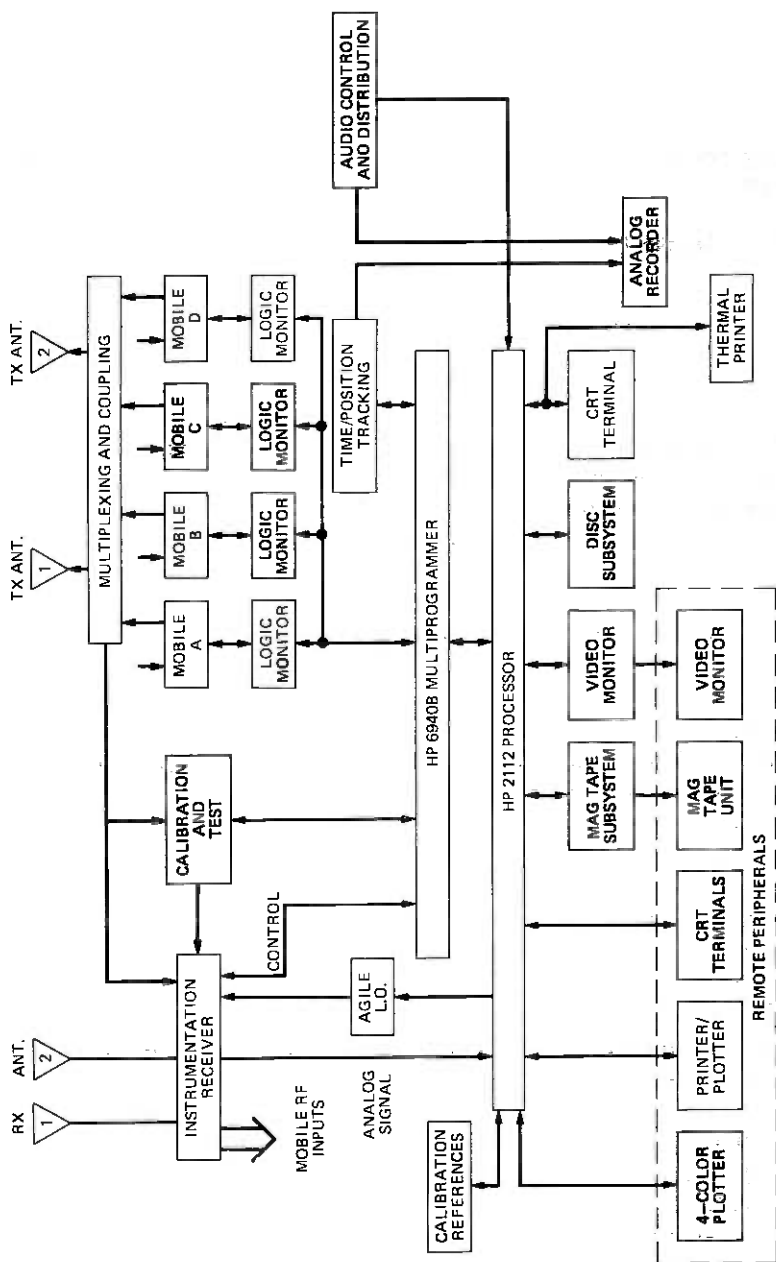

Fig. 8—Mobile Telephone Laboratory—block diagram.

6.1.3 Mobile unit telemetry

Certain data are desired on the performance of the mobile telephone equipment and, in particular, the interaction of the user with the system during the Service Test phase of the developmental system. For this purpose, a significant number of Service Test mobile units are designed to monitor many of their own actions and telemeter basic information about customer usage characteristics to the MTSO.

Control of the telemetry resides in the MTSO, which indicates to the mobiles whether or not telemetry is to be sent and the interval between transmissions. If telemetry is to be sent, the mobile autonomously initiates telemetry requests at the specified intervals. Upon receiving a request, the MTSO orders the mobile via the setup channel to send its accumulated telemetry information over the reverse setup channel. The DRS retrieves all telemetry data for subsequent analysis.

6.2 Mobile monitor and control units

Figure 9 is a photograph of mobile monitor and control units (MCU) housed in the glove compartment of a special test automobile. Each MCU is a unit of special test equipment electrically connected to the transceiver unit and the logic unit of an Equipment Test mobile telephone installed in the test automobile.

The two MCU units have the following features:

- (i) A continuous display of the channel number to which the mobile transceiver is tuned.



Fig. 9—Mobile monitor and control units.

- (ii) A continuous indication of the received (integrated) signal strength of the mobile unit.
- (iii) A provision for switching the mobile unit to a manual operation mode where the mobile is tuned continuously to a channel selected by the vehicle operator. This mode is used for establishing duplex voice communications in preparing for and controlling particular segments of a test involving the vehicle.
- (iv) A display of the mobile unit transmitter on-off state.
- (v) A continuous display indicating which of the two receive diversity antennas is being used.
- (vi) An ability to disconnect the diversity function and to select manually one or the other of the two antennas.

Three such specially equipped test automobiles have been used in the experimental systems at Whippany and at Oak Park and in the Chicago developmental system.

6.3 Data processing plans and facilities

The overall Chicago developmental system data processing program includes the following functional tasks: rapid (quick-look) verification that data were collected as intended; validation that the data truly represent actual system or subsystem performance; manipulation of data to produce outputs for analysis; further manipulation to add certain data to a larger data base; and manipulation of this larger data base to develop results of statistical significance as a function of some parameter, such as time or location.

The requirements for, and the uses of, Chicago developmental system data fall into two separate categories: system troubleshooting and system test and evaluation. System troubleshooting data requirements typically consist of specific test results, such as event listings, plots, and statistics compiled during a particular daily test over a period of time. System test and evaluation activities generally require larger amounts of data, typically collected over longer periods of time and in numerous geographical locations. Although both types of data are needed during the trial period, system troubleshooting is the predominant need for the early time frame, and initial data-processing efforts are concentrated here.

Two data facilities have been assembled for processing data collected in the developmental system. The first of these is a quick-look data-processing facility for MTL data located in the Mobile Phone Service Center building. It consists of additional computer peripherals in a room adjacent to the parked MTL and connected to the MTL computer via umbilical cables. This arrangement permits converting the MTL data collection equipment into a data-processing laboratory to allow preliminary validation of data and decisions on follow-up near-term activities to be based on observed test results. Software programs to

reduce and manipulate data for this quick-look function have been designed.

The other facility with a data-processing capability built around an HP-21MX minicomputer has been developed at Bell Laboratories, Whippany. Data reduction software processes DRS, HP-21MX, and MTL data collected and validated in Chicago. This system has the ability to merge DRS and MTL data for specific analysis tasks.

VII. CONCLUSION

A sophisticated developmental system for testing AMPS has been installed in Chicago. The investment of the Bell System in this trial is substantial in terms of design, development, and test activities completed and anticipated, and in terms of procurement costs for the MTSO, the cell sites, the mobiles, and the land and buildings required by the system. Successful completion of the Equipment Test and Service Test phases will add considerable technical information to the base of knowledge of cellular systems to be used in establishing standards for the service, as well as providing unique market-related information. The future of AMPS, and of the Chicago developmental system, will depend upon the results of the technical and market tests, as well as upon regulatory actions.

Contributors to This Issue

Gastón A. Arredondo, B.S., 1963, M.S., 1966, Ph.D., 1967, University of Iowa; Instructor in Electrical Engineering, University of Iowa, 1963-1967; Bell Laboratories, 1967-1977. Through 1969, Mr. Arredondo was involved in the analysis and design of phased array antennas for electronically steered radars. From 1970 to 1977, he was a member of the Mobile Communications Laboratory, where he worked on voice and data transmission requirements. He was appointed supervisor in 1975 with responsibilities which included transmission requirements and system standards for the Advanced Mobile Phone Service. Since 1977, he has been the general manager of the Empresa Nacional De Telecomunicaciones in LaPaz, Bolivia. Member, Sigma Xi, Tau Beta Pi, and Eta Kappa Nu.

Kanwar J. S. Chadha, B.E. (Honors), 1967, Punjabi University; M.A.Sc. (Control Systems), 1969, University of Toronto; Ph.D. (Systems Engineering), 1973, Case Western Reserve University; Bell Laboratories, 1973—. Mr. Chadha has worked on the development of system requirements for AMPS. He has worked on the design and implementation of the call processing software for AMPS in the mobile telephone switching office. He currently supervises the Remote Switching System Features Group, which is responsible for designing call processing features in No. 1/1A/2B ESS.

Gerald C. DiPiazza, B.S.E.E., 1960, Manhattan College; M.S.E.E., 1962, New York University; Bell Laboratories, 1960—. After microwave circuit and signal processing development activities on the Nike program, Mr. DiPiazza supervised propagation studies and field test simulations for the Advanced Mobile Phone Service. In 1977, he became head of a department engaged in the development and support of electronic power supplies and automated test systems. Member, IEEE, Eta Kappa Nu, Tau Beta Pi.

Nathan Ehrlich, B.S. New York University, 1944; B.E.E. Cornell University, 1949; Bell Laboratories, 1949—. Mr. Ehrlich's work has included development of moving target indicators, missile guidance systems, investigations of nuclear radiation effects on electronic equip-

ment, development of computer controlled display systems, and of command and control systems. Since 1975, he has been concerned with the design of logic and control equipment for the Advanced Mobile Phone Service. Member, National Society of Professional Engineers; Senior Member, IEEE.

John C. Feggeler, M.E., 1960, Stevens Institute of Technology; M.E.E., 1962, New York University; D.Sc. (E.E.), 1968, Stevens Institute of Technology; Bell Laboratories, 1960—. On joining Bell Laboratories, Mr. Feggeler became involved in a number of systems engineering projects related to the Safeguard system. Since 1974, he has been a member of the Mobile Systems Engineering Department, where his principal activities have been in the areas of radio transmission and signal processing. Member, IEEE, IEEE Communications Society, Sigma Xi, Tau Beta Pi, Eta Kappa Nu.

Reed E. Fisher, B.S.E.E., 1958, Penn State University; M.E.E., 1961, New York University; Bell Laboratories, 1958—. From 1958 through 1964, Mr. Fisher was engaged in the design and development of microwave filters, amplifiers, and diode switches. From 1964 to 1969, he studied high-speed microwave-carrier pulse techniques exploiting Gunn-effect devices. Since 1969, he has been supervisor of the AMPS Radio Design Group. Member, IEEE.

Zachary C. Fluhr, B.E.E., 1964, Cornell University, S.M.E.E., 1965, Massachusetts Institute of Technology; M.B.A., 1969, University of Chicago; Bell Laboratories, 1964-1977; Western Electric, 1977—. From 1965 to 1968, Mr. Fluhr worked on software development of the No. 1 ESS, concentrating on automatic maintenance of peripheral units and techniques for improving system capacity. In 1969 he became a supervisor and directed the development of support software tools for the 1A Processor, a high-speed high-throughput combination central control and storage for electronic switching use. In 1972 he became associated with the AMPS development, supervising various groups performing system and software design. He is currently a Product Manager at Western Electric responsible for planning activities associated with local switching products. Member, Tau Beta Pi, Eta Kappa Nu, Sigma Xi.

Duane L. Huff, B.S.E.E., 1959, University of Maine; M.E.E., 1961, New York University; Bell Laboratories, 1959—. Until 1976, Mr. Huff

was involved in the design, development, test, and evaluation of various radar systems associated with Bell Laboratories ballistic missile defense efforts. He is currently responsible for test planning and system evaluation activities under way in the trial of the Chicago developmental AMPS. Member, Tau Beta Pi.

Charles F. Hunnicutt, B.S.E.E., 1965, Worcester Polytechnic Institute; M.S.E.E., 1968, Rensselaer Polytechnic Institute; Bell Laboratories, 1968—. Mr. Hunnicutt initially worked on the system design and software architecture for an exploratory parallel processor known as PEPE for use in radar data processing. Since 1974, he has supervised the development of the AMPS call processing software. Currently, he is supervisor of the AMPS Call Processing and Systems Group. Member, Eta Kappa Nu, Sigma Xi, Tau Beta Pi.

Verne H. MacDonald, B.E., 1964, M.S., 1967, Ph.D., 1970, all electrical engineering, Yale University; one year's graduate study, Electrical Engineering Department, University of Edinburgh, Scotland; Bell Laboratories, 1966 (summer), 1970—. Since 1970, Mr. MacDonald has been engaged in AMPS system-design work, with an emphasis on radio-coverage and traffic-engineering problems. He is currently concerned with rules and standards for cellular systems. Member, Tau Beta Pi; New Jersey Professional Engineer's license.

Stephen R. Peck, B.S. (Science), 1969, Pennsylvania State University; M.S. (Computer Science), 1970, Pennsylvania State University; Bell Laboratories, 1970—. Mr. Peck initially worked on various aspects of the design, development, and testing of the SAFEGUARD multiprocessor operating system. Since 1974, he has been involved in AMPS system software and hardware development. Currently, he is a member of the AMPS Maintenance Design Group. Member, IEEE.

Andrew Plitkins, B.S.E.E., 1963, Washington State University; M.S.E.E., 1965, New York University; Bell Laboratories, 1963—. Mr. Plitkins has been engaged in RF circuit design for application in phased array radars, thin-film microwave circuit design and logic design. More recently, he has participated in RF propagation studies related to the utilization of the 800 to 900 MHz spectrum for mobile communications. He is presently supervisor of the Mobile Communications Laboratory's Test Planning and Analysis Group concerned with field modeling and evaluation of the Advanced Mobile Phone Service. Member, IEEE, Tau Beta Pi, Sigma Tau.

Philip T. Porter, B.A. (Physics), 1952, and M.A. (Physics), 1953, Vanderbilt University; Bell Laboratories, 1953—. Mr. Porter initially participated in early development planning for electronic station sets and *PICTUREPHONE*® visual telephone service; he also did systems engineering work on Autosevocom. In the mobile radio field, he has been involved in development of *BELLBOY*® paging, the Improved Mobile Telephone System, the Metroliner system, and others (including early planning studies leading to AMPS). From 1971 to 1977, he supervised a group involved in systems planning of network and mobile control logic for AMPS. He is currently responsible for studying other advanced system proposals. Member, Phi Beta Kappa.

John Ineson Smith, B.S. (electrical engineering), 1949, University of Michigan; M.S. (electrical engineering), 1954, Massachusetts Institute of Technology; Ph.D. (electrical engineering), 1963, Purdue University; Bell Laboratories, 1965—. As a supervisor in the Mobile Systems Development Department, Mr. Smith is currently involved in the development of radio frequency transmitters, amplifiers, and data systems for use in the Advanced Mobile Phone Service system now under test by the Bell System. He is active in the Microwave Theory and Techniques Group and Vehicular Technology Group of the IEEE. Member, Sigma Xi, Sigma Pi Sigma, Tau Beta Pi, Eta Kappa Nu, Phi Kappa Phi.

John Tebes, Jr., B.S., 1966, DePaul University; M.S., 1969, Ph.D., 1972, Purdue University; Bell Laboratories, 1972—. Mr. Tebes was initially engaged in systems engineering studies of private communications networks. Since 1975, he has been involved in the system design and call processing of AMPS. At present, he is concerned with ESS system program development. Member, Phi Eta Sigma, Sigma Xi.

S. H. Tsiang, B.S.E.E., 1947, University of Nanking, China; M.S.E.E., 1949, Carnegie Institute of Technology; Union Switch and Signal, 1949-1956; Bell Laboratories, 1956—. Mr. Tsiang's early work involved maintenance program design for the Morris experimental electronic switching system. He developed the dictionary technique to locate trouble in ESS. In 1961, he started working on No. 1 ESS. The work involved software design, test facility development, program administration, and field support. Since 1974, he has been engaged in Advanced Mobile Phone Service system development. Currently he is in charge of a group responsible for fault detection, recovery, and diagnostic program design of this system.

J. Thomas Walker, B.S.E.E., 1965, and M.S.E.E., 1966, Purdue University; AT&T, 1972-1974; Bell Laboratories 1966-1972, 1974-. Through 1972, Mr. Walker conducted systems engineering studies of PBX and key telephone systems. In 1972 he transferred to AT&T for a two-year assignment involving technical policy planning studies. In 1974, he returned to Bell Laboratories as a supervisor in the Mobile Communications Laboratory. Mr. Walker is currently supervising a group whose responsibility is to establish audio transmission and service quality requirements for cellular mobile telephone systems.

Theodore K. Wingard, B.S.M.E., 1958, Clemson University; M.S.M.E., 1964, North Carolina State University; Western Electric Company, 1958-1960; Bell Laboratories, 1960—. While at Western Electric and initially at Bell Laboratories, Mr. Wingard was involved in design activity for Nike Hercules. From 1963 to 1972, he worked on the airborne control system design for the Sprint missile. Since 1972, he has been supervisor of the Physical Design Group responsible for the physical design of the AMPS equipment. Member, Tau Beta Pi, Phi Kappa Phi, Sigma Xi.

W. Rae Young, B.S. (Electrical Engineering), 1937, University of Michigan; Bell Laboratories, 1937—. Mr. Young has held various assignments involving systems planning, studies, and generation of system requirements. The subjects include telegraph, data, telephone switching, military communications systems, and radio systems. In 1957 he became head of a department responsible for telegraph and data systems. Later assignments included the UNICOM project, toll switching studies, and government communications studies. Since 1970, he has been head of a mobile-radio systems department, concerned with planning improvements in *BELLBOY*® and IMTS systems, as well as with planning the AMPS system layout, architecture, and requirements. Member, Eta Kappa Nu, Sigma Xi, and Fellow, IEEE.

G. I. Zysman, B.E.E., 1959, Cooper Union; M.S.E.E., 1962, Ph.D. (Electrophysics), 1966, Polytechnic Institute of Brooklyn; Hazeltine Corp., N.Y., 1959-1960; Polytechnic Institute of Brooklyn, 1965-1966; Bell Laboratories, 1966—. Mr. Zysman's early work has been in the areas of microwave circuits and phased array antennas for radar applications. His more recent work has been in the area of mobile telephony, where he was responsible for the instrumentation of various UHF propagation experiments, the Cellular Test Bed control architecture, and data acquisition software for the Advanced Mobile Phone Service project. He is currently supervisor of the AMPS Cellular Test Bed Operations Group. Member, IEEE.

Papers by Bell Laboratories Authors

BIOLOGY

- Phosphate Metabolites in Lymphoid, Friend Erthroleukemic and HeLa Cells Observed by High Resolution ^{31}P Nuclear Magnetic Resonance.** G. Navon, R. G. Shulman, R. Navon, and T. Yamane, *Proc. Nat. Acad. Sci.*, 75 (1978), pp. 891-895.
- X-Ray Absorption Spectroscopy of Biological Molecules.** R. G. Shulman, P. Eisenberger, and B. M. Kincaid, *Ann. Rev. Biophys. Bioengineer.*, 7 (1978), pp. 559-578.

COMPUTING

- The Densest Hemisphere Problem.** D. S. Johnson and F. P. Preparata, *Theor. Comput. Sci.*, 6 (1978), pp. 93-107.
- A Portable Fortran Program to Find the Euclidean Norm of a Vector.** J. L. Blue, *Assn. Comput. Mach. Math Software*, 4 (March 1978), pp. 15-23.

ELECTRICAL AND ELECTRONIC ENGINEERING

- Adaptive Companding of Picture Signals in a Predictive Coder.** B. Prasada, A. N. Netravali, and A. Kobran, *IEEE Trans. Commun.*, 26, (No. 1) (January 1978), pp. 161-164.
- Bounds for Binary Codes of Length Less Than 25.** M. R. Best, A. E. Brouwer, F. J. MacWilliams, A. M. Odlyzko, and N. J. A. Sloane, *IEEE Trans. Information Theory*, 23 (1978), pp. 81-93.
- Coupler Equations for Tapered Beam-to-Film Couplers.** H. Kogelnik, *Archiv. fur Elektronik Ubertragungstechnik Electron. Commun.*, 32 (1978), pp. 191-194.
- On the Design of Quantizers for DPCM Coders: A Functional Relationship between Visibility, Probability and Masking.** J. O. Limb and C. B. Rubinstein, *IEEE Trans. Commun.*, 26 (May 1978), pp. 573-578.
- Electronic Structure and Excitonic Effects in $\text{Sm}_{1-x}\text{R}_x\text{S}$ Prior to Collapse.** G. K. Wertheim, I. Nowik, and M. Campagna, *Z. Phys. B.*, 29 (1978), pp. 193-197.
- A Low-Loss Diffraction Grating Frequency Multiplexer.** P. S. Henry and J. T. Ruscio, *IEEE Trans. Microw. Theory Tech.*, 26 (June 1978), pp. 428-433.
- A Microprocessor Controlled Interface for Digital Satellite Systems.** W. L. Aranguren and R. E. Langseth, *IEEE Trans. Commun.*, 26 (May 1978), pp. 631-638.
- A Microprocessor Log PCM/ADPCM Code Converter.** J. J. Dubnowski, *IEEE Trans. Commun.* 26 (May 1978), pp. 660-664.
- Optical Wavelength-Division Multiplexer for the 1-1.4 μm Spectral Region.** W. J. Tomlinson and C. Lin, *Electron. Lett.*, 14 (May 25, 1978), pp. 345-347.
- Some Effects of Phased Array Dispersion on Digital Error Rates.** R. E. Langseth, *IEEE Trans. Aeros. Electron. Syst.*, 14 (March 1978), pp. 334-343.

MATERIALS SCIENCE

- A Molecular Beam Apparatus for the Study of Gas-Surface Interactions.** M. J. Cardillo, C. S. Y. Ching, E. F. Greene, and G. E. Becker, *J. Vac. Sci. Technol.*, 15 (1978), pp. 423-428.
- Molecular Beam Epitaxial Writing of Patterned GaAs Epilayer Structures.** W. T. Tsang and A. Y. Cho, *Appl. Phys. Lett.*, 32 (April 1978), pp. 491-493.

PHYSICS

- Anomalous Absorption in Amorphous Solids at Low Temperature.** M. A. Bosch, *Phys. Rev. Lett.*, 40 (March 27, 1978), pp. 879-882.
- Anomalous Dimensionalities in the Spin Glass Problem.** P. W. Anderson and C. M. Pond, *Phys. Rev. Lett.*, 40, pp. 903.
- Computing Relative Redundancy to Measure Grammatical Constraint in Speech Recognition Tasks.** M. M. Sondhi and S. E. Levinson, *IEEE Int. Conf. Acoust. Speech Sig. Proc.* (April 1978), pp. 409-412.

On Creating Reference Templates for Speaker Independent Recognition of Isolated Words. L. R. Rabiner, IEEE Trans. Acoust. Speech Sig. Proc., ASSP-26 (February 1978), pp. 34-42.

The Direct Calculation of Wannier Functions SI Valence Bands. E. O. Kane and A. B. Kane, Phys. Rev., 17 (March 15, 1978), pp. 2691-2704.

Directory Assistance by Means of Automatic Recognition of Spoken Names. A. E. Rosenberg and C. E. Schmidt, Acoust. Speech Sig. Proc., (April 1978), pp. 718-721.

Far Infrared Absorption and Ionic Conductivity of Na, Ag, Rb, and K. β -Alumina. S. J. Allen, Jr., A. S. Cooper, F. DeRosa, J. P. Remeika, and S. K. Ulasi, Phys. Rev., 17 (May 15, 1978), pp. 4031-4042.

Hearing "Words" Without Words: Prosodic Cues for Word Perception. L. H. Nakatani and J. A. Schaffer, J. Acoust. Soc. Amer., 63 (1), (January 1978), pp. 234-245.

Heterostructure Lasers, Part A, Fundamental Principles, Part B, Materials and Operating Characteristics. M. B. Panish and H. C. Casey, Jr., New York: Academic Press (1978), pp. 1-72 (Part A), and pp. 1-330 (Part B).

Inversion of Articulatory-to-Acoustic Transformation in the Vocal Tract by a Computer-Sorting Technique. B. S. Atal, J. J. Chang, M. V. Mathews, and J. W. Tukey, J. Acoust. Soc. Amer., 63 (5) (May 1978), pp. 1535-1555.

Latent-Imaging Photopolymer Systems. E. A. Chandross, W. J. Tomlinson, and G. D. Aumiller, Appl. Opt., 17 (February 15, 1978), pp. 566-573.

A Method for Computing Motion in a Two-Dimensional Cochlear Model. M. M. Sondhi, J. Acoust. Soc. Amer. 63 (May 1978), pp. 1468-1477.

On Reducing the Buzz in LPC Synthesis. M. R. Sambur, A. E. Rosenberg, L. R. Rabiner, and C. A. McGonegal, J. Acoust. Soc. Amer., 63 (March 1978), pp. 918-924.

Room-Temperature Operation of Lattice-Matched InP/Ga_{0.47}In_{0.53}As/InP Double-Heterostructure Lasers Grown by MBE. B. I. Miller, J. H. McFee, R. J. Martin, and P. K. Tien, Appl. Phys. Lett., 33 (July 1978), pp. 44-47.

Self-Phase Modulation in Silica Optical Fibers. R. H. Stolen and C. Lin, Phys. Rev., 17 (April 1978), pp. 1448-1453.

Some Experiments with a Syntax Directed Speech Recognition System. S. E. Levinson and A. E. Rosenberg, IEEE Int. Conf. Acoust. Speech Sig. Proc. (April 1978), pp. 700-703.

Stable Room-Temperature Light Emission from Metal-Insulator-Metal Junctions. R. K. Jain, S. Wagner, and D. H. Olson, Appl. Phys. Lett., 32 (No. 1) (January 1, 1978), pp. 62-64.

A Study of Complexity and Quality of Speech Waveform Coders. J. M. Tribolet, P. Noll, B. J. McDermott, and R. E. Crochiere, IEEE Int. Conf. Acoust. Speech Sig. Proc. (April 1978), pp. 586-590.

Use of Oxygen-Doped Aluminum (x), Gallium (1-x), Arsenic for the Insulating Layer in MIS Structures. H. C. Casey, A. Y. Cho, and E. H. Nicollian, Appl. Phys. Lett., 32, (May 15, 1978), pp. 678-679.

Use of Vibrational Energy Transfer for Excited State Opto-Acoustic Spectroscopy of Molecules. C. K. N. Patel, Phys. Rev. Lett. 40 (February 27, 1978), pp. 535-538.

Valley-Valley Splitting in Inversion Layers on a High Index Surface of Silicon. L. J. Sham, S. J. Allen, Jr., A. Kamgar, and D. C. Tsui, Phys. Rev. Lett., 40 (Feb. 13, 1978), pp. 472-475.

SYSTEMS ENGINEERING AND OPERATIONS RESEARCH

Related Market Conditions and Interindustrial Mergers: Comment. Martin K. Perry, Amer. Econ. Rev., 68 (March 1978), pp. 221-224.

Some Applications of Digital Signal Processing in Telecommunications. S. L. Freeny, J. F. Kaiser, and H. S. McDonald, Applications of Digital Signal Processing (1978), pp. 1-28.