

# ELL LABORATORIES RECORD

AUGUST

1940

VOLUME XVIII

NUMBER XII

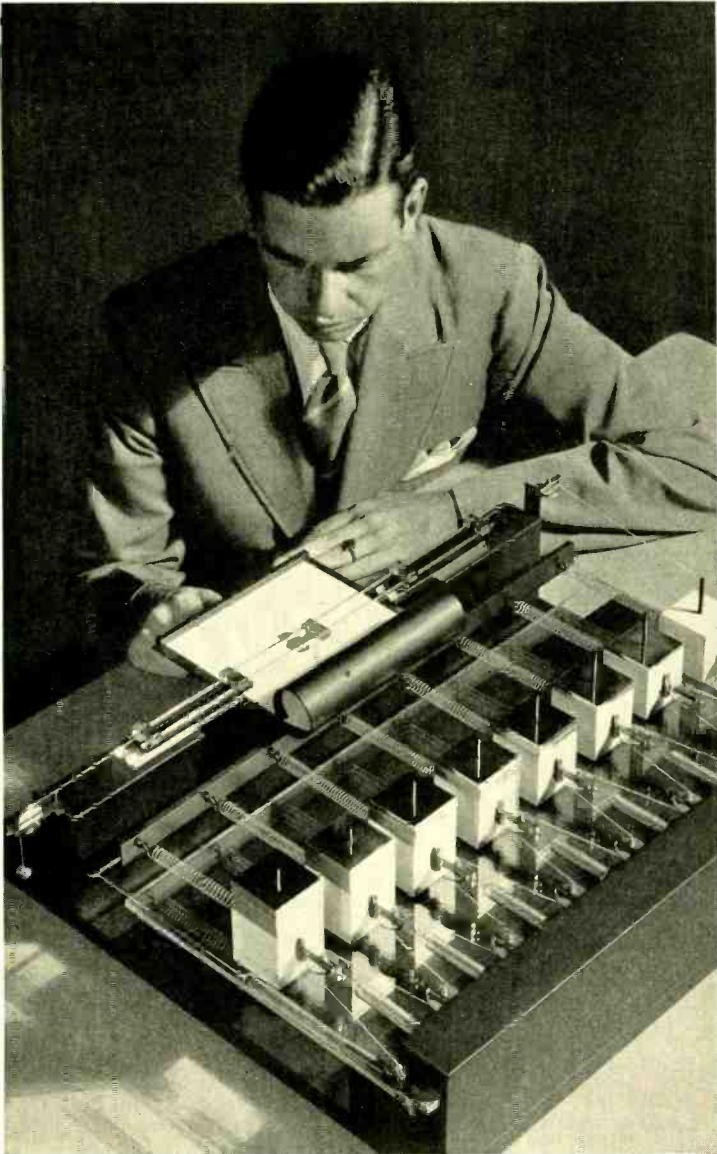

*Mechanical model for the  
study of hysteresis*



# The C<sub>5</sub> Carrier System

By L. R. MONTFORT  
*Toll Transmission Engineering*

THE first type-C carrier system was placed in service during 1924. It provided three voice channels in both directions in the frequency space above the usual voice band. Since then, improvements have been incorporated in successive models, designated C<sub>2</sub>, C<sub>3</sub> and C<sub>4</sub>. In the earlier systems, variations in transmission caused by changes in weather or by variations in circuit conditions were taken care of by manual adjustments, an alarm operated by a pilot channel serving to indicate when the adjustments should be made. Later, arrangements were included whereby these adjustments were made automatically under control of the pilot channel itself.

More recently many advances in carrier technique have been made, which it seemed desirable to apply to the type-C carrier system. As a result the C<sub>5</sub> carrier system was developed. Among the improvements incorporated are copper-oxide modulators and demodulators, new filter designs, negative-feedback amplifiers, improved equalization and higher gain, and a new type of automatic regulation. Most of the equipment has been completely redesigned, with the result not only of an improvement in performance but of a very substantial reduction in size and cost. While three and a half bays were required for the terminal that was used for the earlier system with an automatic regulator, less than one bay is needed for a complete terminal of the new system.

A complete system includes two terminals and, except for short systems, one or more repeaters. A block schematic showing one terminal and one repeater is given in Figure 1. The carrier channels are separated from the voice-frequency circuit at the terminals and at each repeater by line-filter sets, each consisting of a high-pass and low-pass filter. Two types of line-filter sets are used. One type is used when the voice circuit is an ordinary message circuit, requiring frequencies up to about 3 kc only, and the other, when it is a program circuit, requiring frequencies up to 5 kc.

The C<sub>5</sub> system occupies the frequency band from about 6.5 kc to a little over 28 kc—one direction of transmission using the range from 6.5 to about 15.5 kc and the other direction, the range from just under 18 to 28 kc. This use of different frequency bands for the two directions of transmission gives the advantages of four-wire transmission and minimizes near-end crosstalk. The earlier type-C systems employed three different frequency allocations for use when several systems were operated on the same pole line. The channels of the various allocations were staggered with respect to each other to reduce crosstalk between them. With the better transposition designs now available, and with methods of improving the crosstalk on the older lines, only two allocations have been provided for the C<sub>5</sub> system. These two allocations are alike for the low-

frequency bands, and the only difference in the high-frequency bands is that with one allocation the bands are inverted, the carrier appearing at the lower rather than the upper edges of the bands. These two allocations for the C5 system and the three used for the earlier C systems are shown in Figure 2.

The channels of the C5 system are terminated at the voice-frequency side as four-wire circuits. This permits them to be directly connected to other four-wire circuits, either voice-frequency or J or K carrier, without reduction to a two-wire basis. Four-wire terminating sets are added when the C5 circuits are to be carried to a two-wire circuit. The input and output voice-frequency levels are  $-13$  and  $+4$  db respectively.

Incoming voice frequencies pass directly to a modulator where they are converted to the higher frequencies used for transmission. The modulators are of the copper-oxide varistor type

and provide a high degree of balance, thereby eliminating the periodic maintenance required by the vacuum-tube modulators of the earlier systems to reduce carrier leak. The new modulators are also designed to limit the peaks of very loud talkers, which would otherwise overload the amplifiers. This reduction of peaks is accomplished without noticeable effect on the quality of the speech.

The output of each modulator contains two sidebands, and the associated channel band filter selects one and suppresses the other. A much flatter characteristic is attained in the pass-band of these filters than of the earlier types of filters, and because of this, four or five type-C channels can be operated in tandem without undue distortion. The overall characteristic of a channel of the new system is shown in Figure 3. A considerable reduction in the space required by the filters has been secured by using coils with magnetic core material of im-

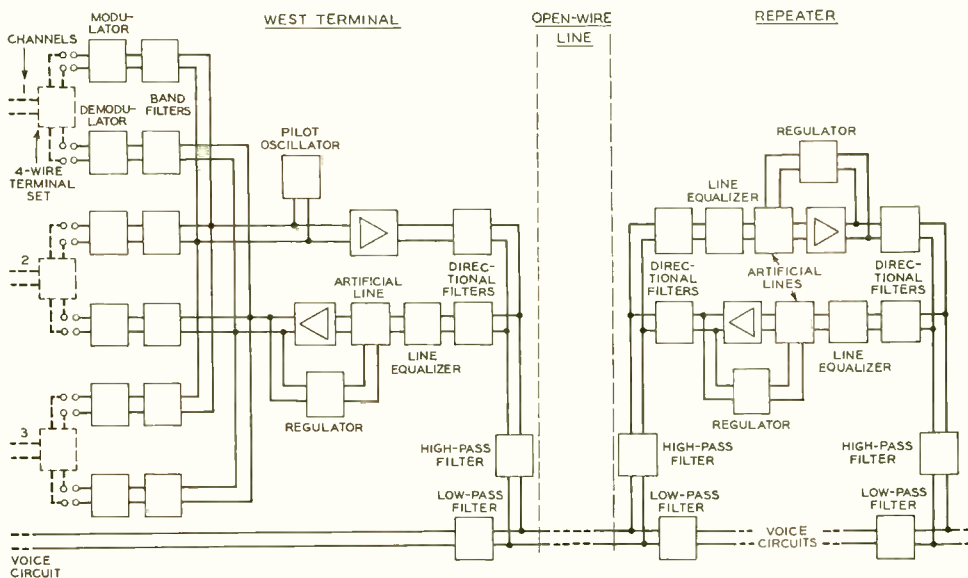

Fig. 1—Block schematic of a C5 terminal and a C1 repeater, which form the components of the new C5 carrier system

proved modulation performance instead of air-core coils.

Before being applied to the line, the outputs of the three transmitting band filters, together with that of the pilot oscillator are amplified in a common transmitting amplifier and put on the line at a level of +18 db. This amplifier is the same as that used in the receiving branch, and at repeaters. It uses only two tubes, and negative feedback gives satisfactory stability and low modulation. Amplifiers in the earlier system required 6 or 8 tubes, depending on the gain needed, and required periodic balancing of the output tubes to secure sufficiently low modulation. The directional filter between the amplifier and the line, and that in the receiving branch, separate the two directions of transmission and prevent the outgoing frequencies from entering the receiving circuit.

On the receiving side, the carrier currents—after passing through the directional filter—enter the equalizer. This provides additional loss at the lower frequencies where the line attenuation is smaller, so that at the input to the amplifier all frequencies are at approximately the same level. Between the equalizer and the ampli-

fier is a variable artificial line controlled by the regulator, whose action is governed by the level of the pilot signal picked off at the output of the amplifier. An increase in line attenuation causes the pilot level at the output of the amplifier to decrease, whereupon the regulator reduces the amount of artificial line and restores the pilot level to its normal value. The reverse takes place when a decrease in attenuation occurs, thus maintaining the input to the amplifier at constant level. On short non-repeated systems, a manually controlled potentiometer may be used in place of the automatic regulator.

The receiving band filters differ from those on the transmitting side only in their frequency band, and are identical with the transmitting filters used for the same channels at the distant terminal. The demodulators are similar to the modulators, using a varistor for modulation and a pentode to supply the carrier frequency. An amplifier tube is also provided to obtain an output level of +4 db, and the gain is adjustable over a small range to permit closer adjustment of the net loss of the individual channels.

Spaced on the average at intervals of 150 miles, the repeaters provide

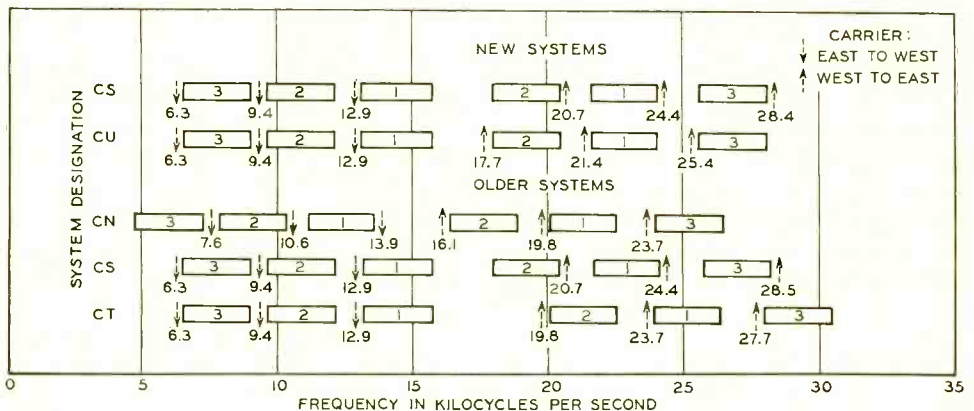

Fig. 2—Frequency allocations used for the old and new C-carrier systems

means of equalizing and amplifying each direction of transmission to restore the level of each channel to +18 db. The equipment for each direction of transmission through the repeater is similar to the common receiving circuit that is used at the terminal for the corresponding direction of transmission.

The 2B pilot channel used for regulating the C5 system automatically maintains the overall net loss of long systems to within  $\pm 2$  db over a wide variety of weather conditions. The pilot frequencies, derived from oscillators, are placed in the frequency space between channels, and are transmitted over the line with the sideband frequencies. The regulating system operates in much the same manner as that used for the J1-carrier system. When the pilot level departs by more than 0.5 db from its normal value, a control meter makes a contact that causes a motor to vary the amount of artificial line in the circuit as already described. By this means the output of each repeater or terminal is maintained at practically a constant level. The regulator corrects at the rate of 1 db per minute and has a range of about 20 db. In case of a sudden large change, such as would be caused by line failure, the regulator does not change the gain of the repeater, but instead turns in an alarm.

Thousand-cycle signalling is employed for ringing over the system. The usual office batteries of 24 and 130 volts are used for power supply,

with the addition of 110-volt a-c for operating the regulator motors. Where battery reserve is not warranted, the terminals and repeaters may be operated from an a-c source.

A complete terminal or repeater with automatic pilot channel equip-

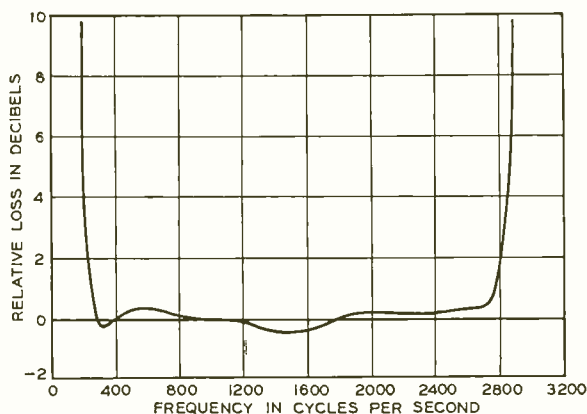

Fig. 3—Overall transmission-frequency characteristic of a C5 channel

ment is mounted in a single bay. Where bays 11 feet 6 inches high are used, there is sufficient space to permit the carrier-line filters and four-wire terminating sets to be included on the same bay. In the earlier models, three and one-half bays were required for a terminal and two bays for a repeater, when automatic regulation was included, and in addition it was necessary to place the line filters in a separate location. This very large saving in space is of considerable advantage since systems are often added in existing offices where space may be at a premium. As a result of all these improvements the field of application of these carrier systems has been greatly increased.



# New Hysteresis Model

By F. S. GOUCHER  
*Physical Research*

**M**ANY attempts have been made to represent, by mechanical models, the hysteresis effects obtained when solids are subjected to cyclic stresses, or when iron is subjected to alternating magnetic fields. A new model gives quantitative results for an important type of hysteresis. It is an outgrowth of a study of the straining of granular carbon in microphones, and it will draw curves very much like the

which exists in both mechanical and magnetic systems in addition to a basic elastic behavior. It may be described as a tendency for the material to persist in its state of strain or of magnetization; and it manifests itself in the well-known hysteresis loops obtained by plotting magnetization against magnetic force, when the latter is varied between two fixed limits. The tendency of the iron to persist in its state of magnetization is shown by the change of slope at the loop ends. The characteristic shape and area of these loops are independent of the rate at which the mechanical or magnetic force is varied.

In previous models the elastic component has been represented by springs and the hysteretic component has been introduced by sliding friction. The friction makes the system tend to persist in any given state of strain and furnishes a suitable means of producing equivalent effects under different rates of stressing, since sliding friction is to a first approximation independent of velocity. But the loop forms obtained with these models do not represent quantitatively the special type of hysteresis which we are considering here.

The loops obtained with iron in simple cyclic fields of low intensity, such as result from a single-frequency magnetizing current, have loop branches which are identical parabolas whose vertices are the loop ends. The vertex for the lower loop branch is at the point of minimum magnetic

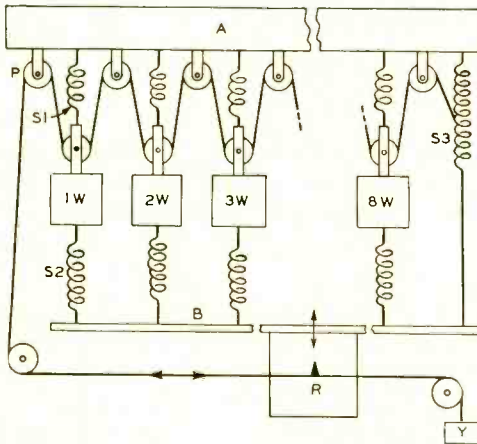

Fig. 1—Hysteresis is simulated mechanically by dragging wooden blocks 1w-8w, of increasing weight on a horizontal glass plate. Springs provide the elastic elements

magnetic curves of iron in low fields. Because mechanical and magnetic hysteresis are important in the field of communications, the model assumes a particular interest in telephone research.

Hysteresis may be considered as a special type of non-elastic behavior

force and that for the upper loop branch is at the point of maximum magnetic force. Even when the cyclic field is complex, as with currents of two frequencies combined in various ways, the loop branches are still identical parabolas with vertices at each maximum or minimum. The manner in which these loop branches combine has been previously described.\* The new hysteresis model quite accurately fulfills all of the essential characteristics of this complex type of hysteresis.

Eight wooden blocks of equal size are made to exert progressively increasing frictional resistance by the addition of metal weights each of which weighs the same as a block. The blocks rest on a horizontal glass plate as shown in Figure 1. They are attached to springs,  $s_1$  of relatively high stiffness attached to a fixed base, and  $s_2$  of relatively low stiffness attached to a bar B which is capable of motion in a direction to vary the tension on the springs.

The motion of the bar B measures the approximately equal forces applied to each block, since the motions of the blocks, when sliding, are relatively small. The slipping movements are integrated by a flexible thread which passes over the pulleys P as shown. One end is attached to a spring  $s_3$  which is stretched by B in a reversible manner since it has no frictional load. The thread kept at constant tension by weight Y moves a traveller of low friction in a direction at right angles to that of B. This traveller carries an electrically heated stylus which makes a trace on a piece of waxed paper attached to B and lying in the plane of its motion. In this way the integrated motion of the slipping blocks and the spring  $s_3$  is

automatically plotted as a function of the force applied to the blocks.

After the establishment of equilibrium, which occurs when the force has been carried through a few cycles, the first block to slip, after a maximum or a minimum, will be the block with the lowest friction. That is the block marked 1w, Figure 1. As the force de-

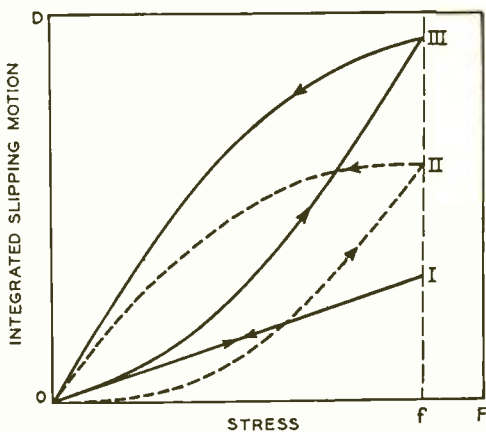

Fig. 2—The hysteresis loop III is the resultant of the elastic curve I, obtained from the stretching of spring  $s_3$ , Figure 1, when none of the blocks slips, and loop II made without the use of the spring  $s_3$

creases or increases block 2w follows, then 3w, and so on. Each block when started will continue to slip uniformly with equal increments of force until a new minimum or maximum has been reached. Also each block, once started, will slip the same amount with equal increments of force. This leads to an approximate parabolic relationship between the integrated motion of the blocks and the force, which becomes more exact the finer the grain of the model, i.e. the greater the number of blocks used.

The loop III, Figure 2, was made with the model as described. It is the resultant of two components, i.e. the elastic curve I which is obtained if

\*RECORD, July, 1935, p. 332.

none of the blocks is permitted to slip, and the loop II which results if the end of the thread attached to the spring  $s_3$  is held fixed. The relative magnitudes of I and II can be altered by changing the spring stiffnesses. Thus the loop may be long and thin

identical parabola with its vertex at the point of maximum force,  $f$ , its tangent at that point being a line parallel to the stress axis. Since curve I is a straight line, it follows that the lower and upper loop branches of III are also identical parabolas, with vertices at  $o$  and  $f$  respectively, and tangents parallel or coincident with curve I.

In Figure 3 are shown traces made with the model which illustrate the distinctive features of the hysteresis found in iron. In (A) are loops for equal magnitude of cyclic force but different mean values of the force. The loops are identical in shape and have been merely translated without rotation. In (B) is a family with the same minimum force for each loop, but a different maximum force. The lower branches which are coincident throughout their length are parabolic and identical in shape with the lower branch of curve III, Figure 1. In (c) the maximum force is the same for each loop; the upper branches are coincident and of the same parabolic form.

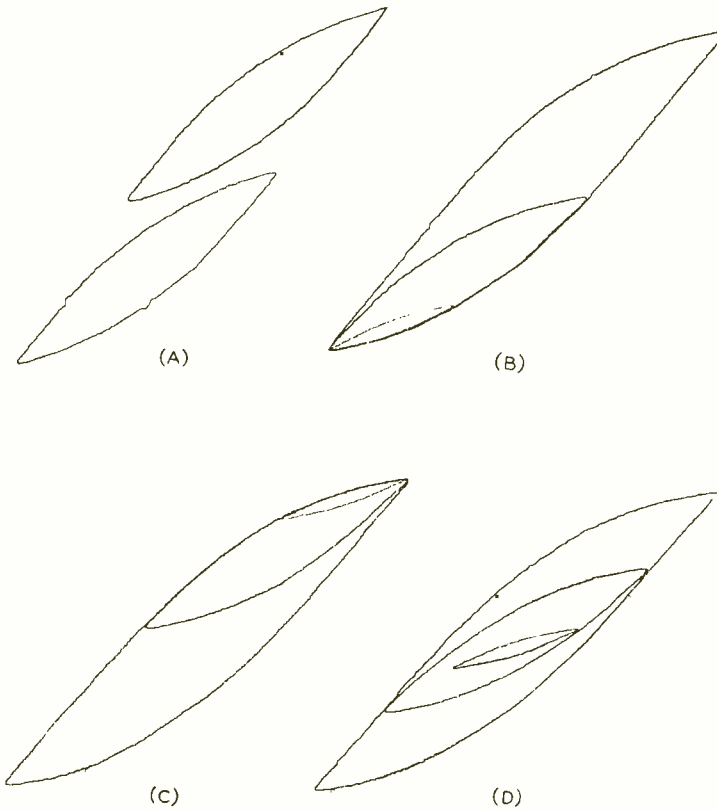

Fig. 3—Hysteresis loops made with the machine (stress horizontal and motion vertical): A, two loops with equal cyclic forces whose mean values are different; B, a family of loops with minimum forces equal; c, maximum forces equal; D, loop symmetrical about a point half way between the maximum and minimum force values

or as shown here for convenience, short and fat. The lower branch of loop II is substantially a parabola with its vertex at  $o$ , the tangent to it at that point being the stress axis  $o f$ . From the symmetry of the loop it is clear that the upper loop branch is an

identical parabola with its vertex at the point of maximum force,  $f$ , its tangent at that point being a line parallel to the stress axis. Since curve I is a straight line, it follows that the lower and upper loop branches of III are also identical parabolas, with vertices at  $o$  and  $f$  respectively, and tangents parallel or coincident with curve I.



largest loop. The effect is as though the smaller loops from (B) or (c) were translated without rotation to their position in (D).

The loops just described result from the application of simple cyclic forces for which there is only one maximum and one minimum in each cycle. The performance of the model when there are several maxima and minima within one complete cycle is shown in Figure 4. Trace (a) is obtained by reversing the forces at the numbered points on the force axis in the order given. Below is drawn the wave form from which reversal points were determined. It is the resultant of two frequencies in ratio 2 to 3 with equal amplitudes and a particular phase. Trace (b) corresponds to a wave form

obtained by combining two frequencies of widely different amplitudes. In (c) is the trace for two nearly equal frequencies of equal amplitude, i.e. a beat tone. Each loop branch is part of the same parabola with its vertex at the last maximum or minimum which has been traversed.

The similarity of the loop shapes obtained with this mechanical model and with a magnetic material indicates that a theory of magnetic hysteresis may be found which can be expressed in quantities analogous to those which represent the essential elements of the model. It has also led to the conclusion that slipping occurs under certain conditions, at or in the contact surfaces, when a granular aggregate is strained.

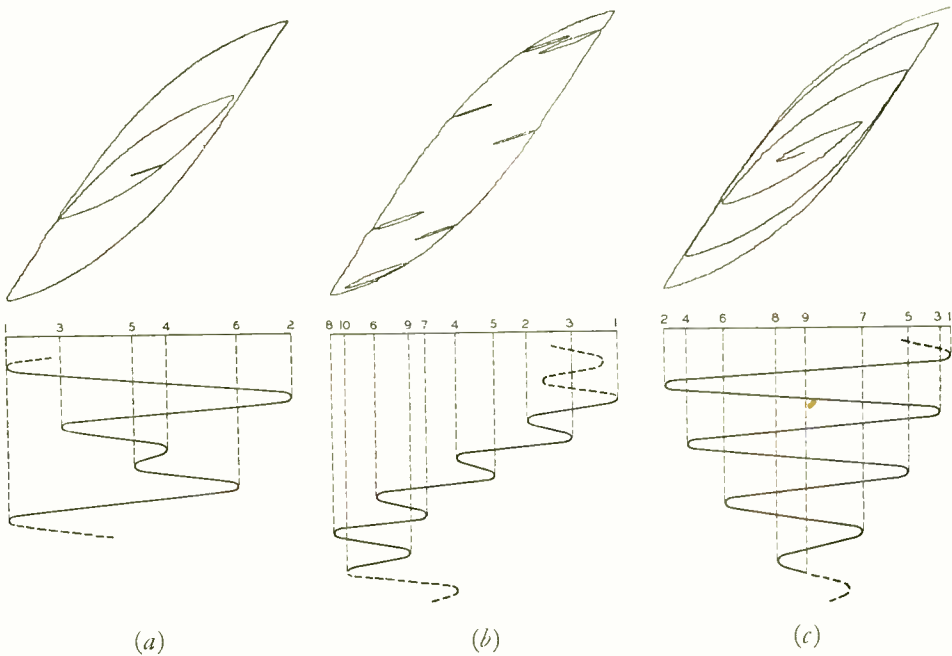
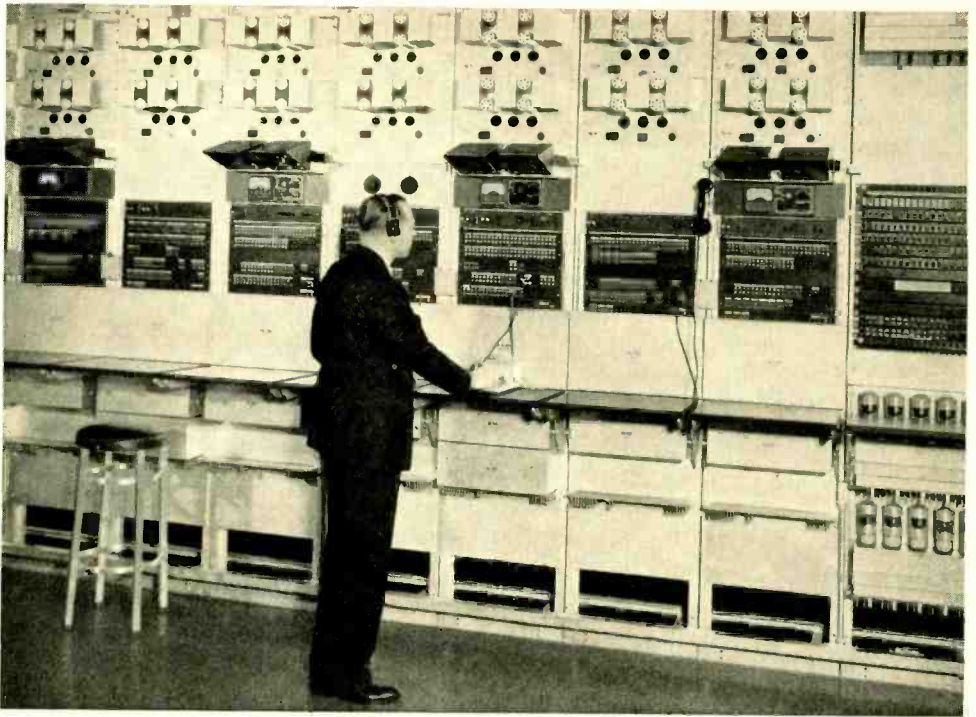

Fig. 4—Traces with several maxima and minima: a, force reversed at numbered points in the order given—this loop was made with two frequencies in the ratio 2:3 but of the same amplitude; b, wave form from two frequencies where the amplitude of one is several times that of the other; c, trace for a beat tone



## The 14C Program Amplifier

By S. T. MEYERS

*Voice-Frequency Repeater Development*

**I**N BROADCASTING networks there are usually points that serve as junctions for a number of program circuits. A nationwide network extending from New York to San Francisco, for example, might be branched at a considerable number of bridged points, consisting of branches to other cable and open-wire routes and connections to broadcast customers. The branching is accomplished through a bridging multiple, one arrangement of which is indicated in Figure 1. This arrangement has an amplifier in the incoming line, which acts as the line amplifier for the preceding section, and this amplifier feeds the bridging multiple either through resistances to make the

multiple impedance 600 ohms from that side, or through a transformer as shown, to obtain the proper impedance. Each output branch of this multiple has a resistance to increase the low impedance of the multiple to 600 ohms, and an amplifier to make up for the loss in the multiple.

These bridging multiples may have as many as eight or more outlets, and thus require as many amplifiers in addition to the incoming line amplifier. A considerable reduction in the equipment and space required, as well as a simplification in the circuit, could be secured if an amplifier were available with sufficient output capacity to make the individual amplifiers in each outgoing line unnecessary. With this

objective in view, the 14C amplifier—shown in the photograph at the head of this article—was developed. It has a low-impedance output and sufficient power-carrying capacity to supply four open-wire circuits at a volume of +14 vu each, or sixteen cable circuits at a volume of only +8 vu each. Since with these volumes one open-wire circuit may be used instead of four cable circuits, a bridging multiple when used with the 14C amplifier might be arranged as indicated in Figure 2, which shows a multiple feeding three open-wire circuits and four cable circuits. The cable circuits are supplied through an autotransformer, which reduces the voltage applied to them by one-half. Each branch has only balanced resistances, which serve both to build out the low impedance of the multiple and amplifier to the higher impedance of the line, and tend to prevent disturbances coming in over one branch from having a serious effect on the other branches of the circuit.

This new amplifier employs negative feedback to stabilize it against gain variations arising from variations in the tubes or power supply, and to reduce the non-linear distortion. The feedback also produces a

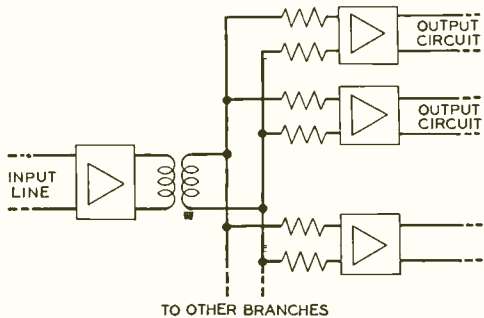

Fig. 1—A typical bridging multiple for program circuits which requires an amplifier in each branch in addition to the line amplifier on the incoming circuit

desirable flattening in the gain-frequency characteristic.

A calibrated and readily adjustable gain control is essential for an amplifier used on open-wire circuits to enable the gain to be changed quickly and accurately without the use of

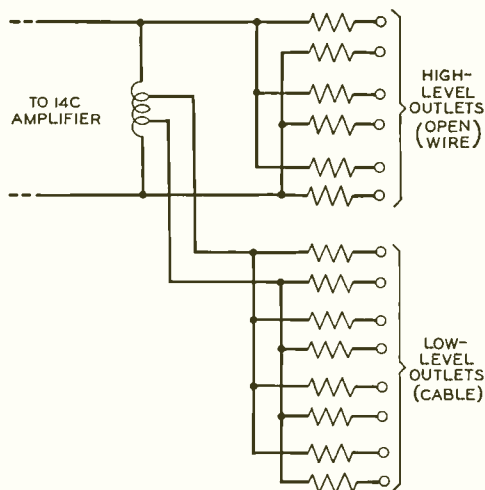

Fig. 2—When the 14C amplifier is used, the individual amplifiers in the branch circuits are omitted

measuring devices. One of the features of this new amplifier is the simple gain control through three rotary switches mounted on the front of the panel. These switches control the three potentiometers indicated in Figure 3. Two of the potentiometers are shunted across the feedback path, and give gain changes in 1 and 0.25-db steps. The 1-db control, shunted across the cathode resistance, has a range of 9 db, while the 0.25-db control, shunted across the middle of the feedback path, has a range of 1 db. The total range for these two controls is thus 10 db. A third control, associated with the input transformer, has three 10-db steps to provide an additional 30 db of control, thus making the total 40 db. The two slide resistances shown in the feedback path are for

calibration, and permit the gain indicated by the three switches on the front of the panel to be brought within at least  $\pm 0.15$  db of the true gain of the amplifier.

The amplifier is readily adaptable for application to program circuits at branching points, where a low output impedance is advantageous, or for use as a single line amplifier with a 600-ohm output impedance. Under this latter condition it is capable of supplying an output volume of +20 vu. Its frequency characteristics, either as a line or bridging amplifier, are flat to within 0.1 db from 30 to 8000 cycles. An equalizer shunted across the output provides adjustment for high frequencies. The amplifier is designed to allow the space current of

each tube to be measured by means of the 1R test set\* while the amplifier is in service.

Besides its use as a bridging amplifier as outlined above, the 14C amplifier will also be used as a non-bridging amplifier on open-wire and B-22 cable program circuits in the future. In this service it may be used in place of the 14B amplifier† on open-wire lines and the 12C amplifier‡ on cables, except at non-regulating points on B-22 cable circuits. The amplifier is particularly suited for use at junctions of cable and open wires, and, adapted by the association of a bridging multiple, to give proper levels.

\*RECORD, June, 1933, p. 315.

†RECORD, February, 1934, p. 162.

‡RECORD, January, 1931, p. 234.

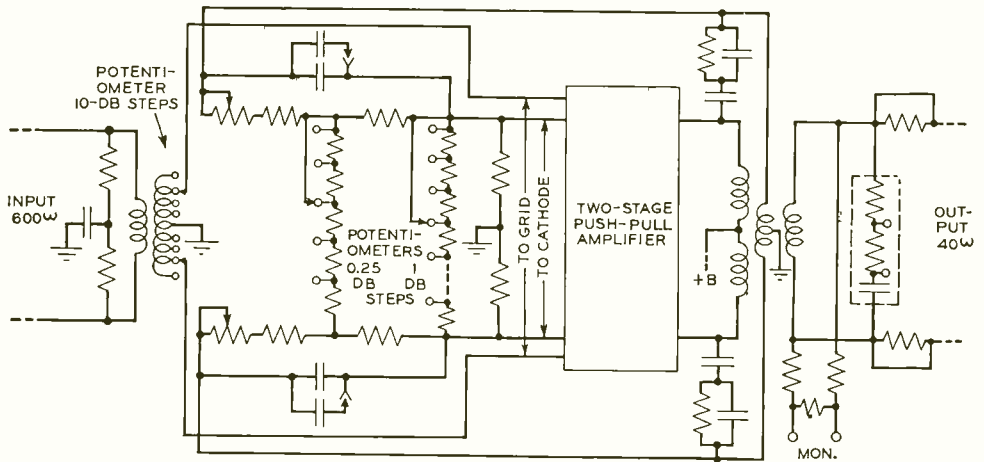

Fig. 3—Simplified schematic of the 14C amplifier

# Transmission Measuring Set for Outlying Telegraph Stations

By S. I. CORY

*Transmission Development*

FOR service at telegraph subscriber stations, maintenance men have carried until recently only a tool kit and an ammeter-voltmeter. These were sufficient where the subscriber was only a few miles from the central office and the connection was a simple loop. There has been need, however, for a portable testing arrangement to diagnose and remedy transmission troubles at outlying subscriber stations, which usually involve simplexed or composited open wire or cable. The recently developed 161A1 telegraph station test set fulfills this purpose. With it the several currents of importance in telegraph transmission can be checked conveniently and distortion and interference measurements made.

The set has a Wheatstone bridge type of circuit to measure the distortion of selected signals and another circuit for determining the amount and character of interference such as telegraph crossfire and power interference. A special plug is provided to connect the test set to the subscriber's teletypewriter. It is inserted in place of the sending or receiving relay and



in many cases saves the time and effort of opening soldered connections. When the special plug is used distortion and interference measurements as well as those of the line, bias and armature currents in the relay are made by merely operating keys. There is also a key to permit normal communication with the distant station while still set up for testing. The meter of the set can also be used as an accurate voltmeter or milliammeter during trouble investigations and installation work. A vacuum-tube half-wave rectifier, operated on 110-volt alternating or direct current, supplies current for measuring and relay-biasing circuits.

Distortion and interference measurements require special test signals and these measurements are made only during out-of-service periods. For distortion measurements, the teletypewriter characters known as

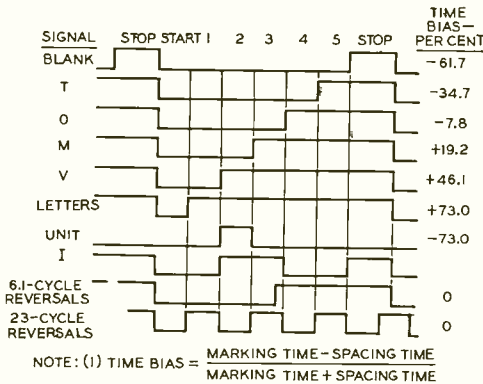

Fig. 1—Signals that are employed in the measurement of bias and characteristic distortion of telegraph circuits

Blank, T, O, M, V and Letters are measured in turn with forty to fifty repetitions of each of these characters. These and other signals used are shown in Figure 1. Interfering currents of given magnitude can be related to telegraph performance by measuring the steepness of the telegraph current wave as received from a distant station and the effect on telegraph operation can be approximated by adding together the components' effects.

The circuit used in measuring bias and characteristic distortion with the special test signals is shown in Figure 2. It is similar to a simple Wheatstone bridge and is balanced when the receiving relay of the set is operated with undistorted test signals. For example, if undistorted telegraph reversals are repeated by the

relay without distortion the marks and spaces are of equal duration and the meter will indicate zero, on the average, if the bridge potentiometer is set at its mid-point. For the "Blank" signal, the marking pulse lasts 1.42 units\* and the spacing pulse 6 units. The potentiometer arm is therefore set to give 6 units of current during the marking interval and 1.42 units during the spacing interval. Then the bridge is "balanced" and the meter indicates zero when receiving undistorted Blank characters. Distortion of the received signals produces unbalance of the bridge and causes the meter to indicate other than zero. The constants of the circuit are adjusted so that the meter indicates the distortion, directly in percentage of a .022-second dot. A high degree of damping is provided to prevent the meter from responding to the fundamental frequency of the teletypewriter characters which is only about 6 cycles per second for 60-speed signals.

Interference measurements are made with the circuit shown in Figure 3 by noting on the meter M the biasing current which just prevents the armature of the receiving relay from responding to the inter-

\*At a speed of sixty words per minute (60 speed) the duration of a unit pulse is .022 second.

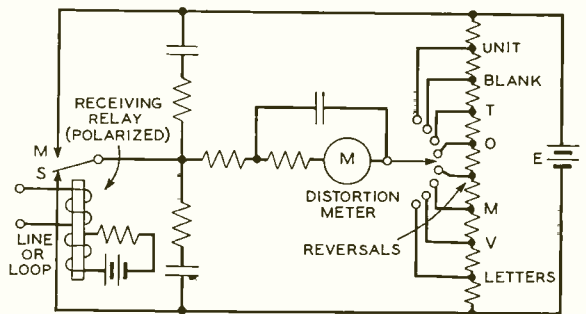

Fig. 2—A 161A test set has a Wheatstone bridge type of circuit for measuring distortion and bias in telegraph circuits

fering currents. Movement of the armature is indicated by a telephone receiver. The potentiometer P varies the biasing current.

The effect of a given interfering current can also be approximated with the circuit of Figure 3 by operating the switch to connect the meter M1 in the circuit as for the measurement of bias. The effect on bias of changing the biasing current by the amount of the interfering current can then be noted when receiving telegraph reversals or any of the selected teletypewriter characters.

Because of its convenience and accuracy for determining quickly in the

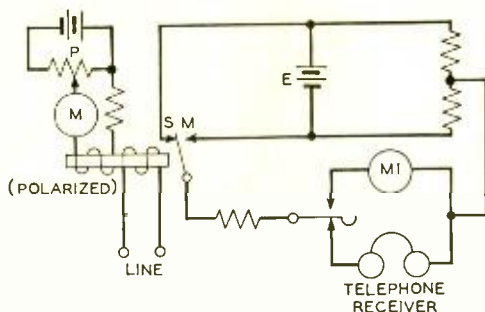

Fig. 3—Circuit for making interference measurements with the test set

field the causes of trouble in telegraph circuits this measuring set is a valuable addition to the growing list of transmission testing tools.

#### I.R.E. HONORS LLOYD ESPENSCHIED

*The Medal of Honor of the Institute of Radio Engineers has been awarded to Lloyd Espenschied "for his accomplishments as an engineer, as an inventor, as a pioneer in the development of radio telephony, and for his effective contributions to the progress of international radio coordination." Formal presentation of the medal to Mr. Espenschied was made at the Fifteenth Annual Banquet of the Institute held in Boston on June 28.*

*The medal, which was established in 1917, is the senior medal of the Institute and is awarded annually in recognition of noteworthy inventions and developments in electrical communication. Among those who have received this medal are Lee de Forest, M. I. Pupin, A. E. Kennelly, J. A. Fleming and G. A. Campbell.*

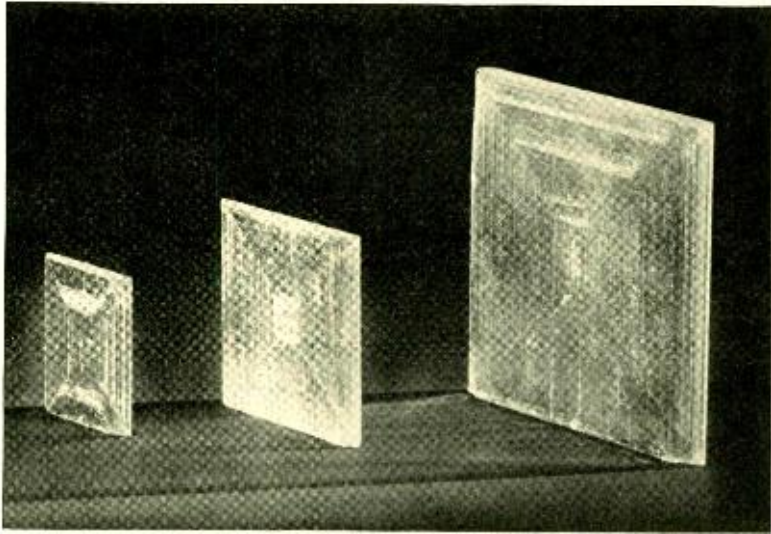

## Heavy-Water Rochelle-Salt Crystals

**T**HE piezo-electric effect in Rochelle salt has found practical application to some extent in microphones, receivers, phonograph pick-ups and electric filters. A limitation of its use, however, has been the rapid loss of the piezo-electric properties above temperatures of 75 degrees Fahrenheit. A. N. Holden of the Chemical Laboratories has recently found that Rochelle-salt crystals retain their piezo-electric properties to 95 degrees Fahrenheit if made with heavy water instead of ordinary water, as first suggested by S. O. Morgan.

Behavior of Rochelle salt proves to be in almost all respects the electrical analog of the magnetic behavior of iron and other ferromagnetic materials. Below a certain critical temperature a ferromagnetic material has been shown to consist of small domains, each spontaneously magnetized but with the directions of

magnetization of the many domains so distributed as to produce no net magnetization. A Rochelle-salt crystal similarly, in its anomalous temperature range, has been shown to consist of small domains polarized in two opposing directions. The process of charging the material in bulk, by an applied electric field, consists largely in reversing the direction of polarization of these domains.

The much higher internal damping and the variation with temperature of the natural frequency of vibration of bars of Rochelle salt make it very unlikely that the material could replace quartz, the other well-known and widely applied piezo-electric material. Extending the useful temperature range of Rochelle-salt crystals, however, will broaden their usefulness in fields where they are effective.

The crystal at the left above was made with heavy water, the other two are ordinary Rochelle-salt crystals.



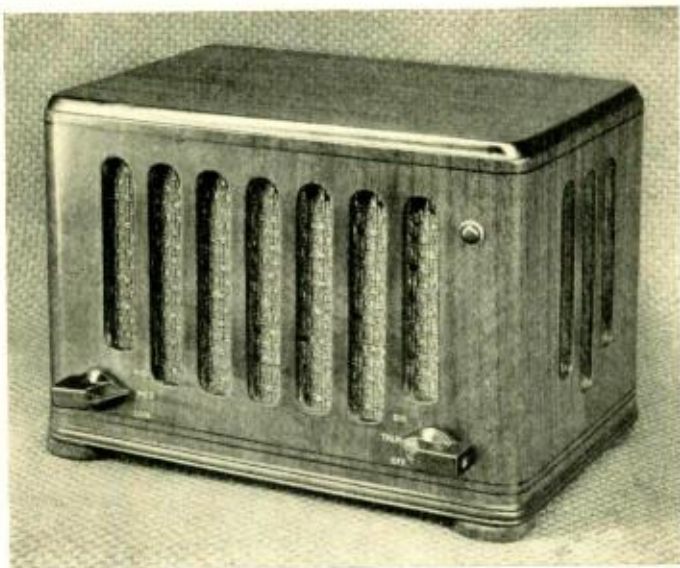

## A Loud-Speaking Telephone System

By ALFRED HERCKMANS

*Station Instrumentalities*

**T**HE 2-A Key Telephone System has been recently developed as an adjunct to regular telephone service to provide direct intercommunication by means of a loud speaker and distant talking telephone set at one end of the circuit and a regular handset at the other end. With this arrangement an executive, for example, may talk with his secretary as if she were across the desk from him.

The major part of the apparatus at the master station is housed in the small cabinet shown in the photograph at the head of this article. This is called the 321 telephone set. It is designed for setting on the desk at some convenient place in front of the user, and is operated by the three-position switch at the lower right. A similar switch at the lower left provides volume adjustment for the loud speaker,

but requires only occasional adjustment. Both loud speaker and microphone are behind the grill work. An amplifier is required in addition to this cabinet, and is arranged in a box that may be mounted beneath the desk or elsewhere as desired. A regular telephone, or one normally provided for main station or P.B.X. service, may be arranged for alternative use with the loud-speaker-microphone set, when for privacy reasons the loud-speaking feature is not wanted. The circuit arrangement of the system is shown in Figure 1.

The master station calls the secondary station by operating the control switch to the non-locking signal position, which sounds a buzzer at the secondary station. The switch returns to the talk position when released, and when the handset at the secondary station is lifted, relay G at the master

station is operated. This relay removes a short-circuit across the input to the amplifier, and as soon as the switch is turned to the talk position, connects battery to the microphone, a 638A transmitter, and lights the lamp. The secondary station calls by operating a key to sound a buzzer at the master station. The rest of the operation is the same as when the master station calls.

The provision of such a set has been difficult because of the inherent likelihood of "singing" in any arrangement of this sort. Whenever a microphone and receiver are closely associated, through being connected to the same circuit and having an acoustic coupling path between them, sustained oscillations called "singing" are apt

to be set up because of the inherent gain of the microphone. Any acoustic output from the receiver is picked up by the microphone, amplified, and returned to the receiver through the electrical coupling. Whenever the gain of the microphone is greater than the loss around this closed path, there is usually a rapid building up of the volume that makes the set inoperative. Such a singing condition is a potential possibility in any telephone set, but where a loud speaker with an additional amplifier is used, its avoidance is very difficult.

Such singing can be avoided by keeping the path to either the receiver or transmitter open at all times—the receiver being opened during transmission, and the transmitter during

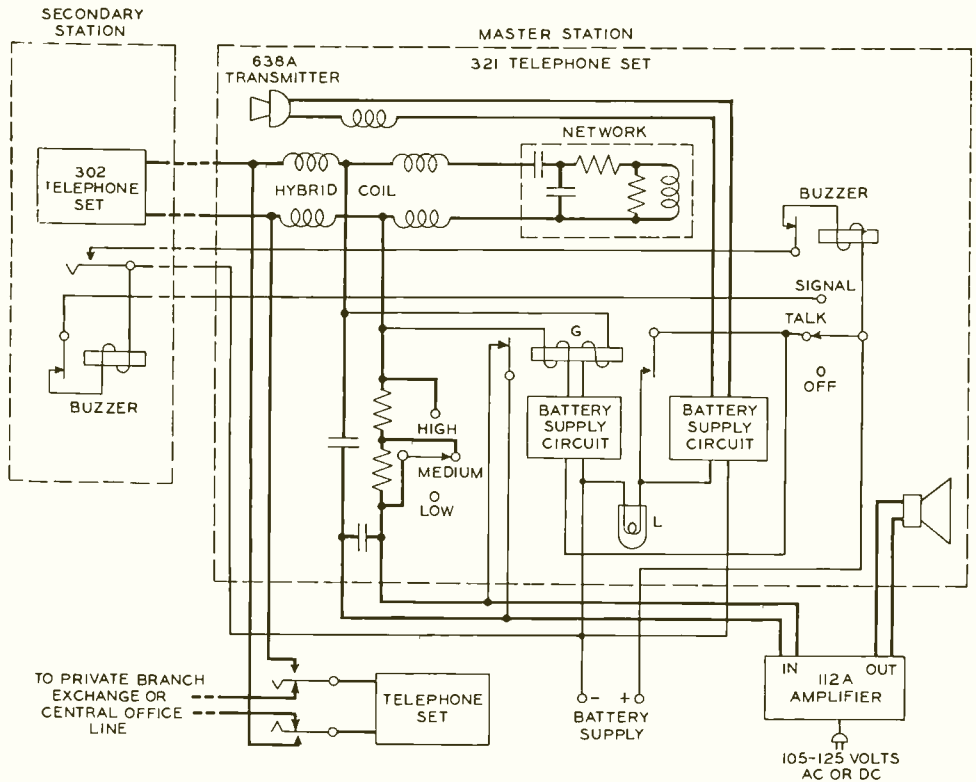

Fig. 1—Schematic of the 321 telephone set with associated amplifier and hand telephone set together with the telephone set and buzzer at the secondary station

reception. This may be done manually with a "press-to-talk" switch, or automatically with a voice-operated relay, and loud-speaking sets incorporating this feature have been developed and used. Such sets are spoken of as being of the "variable" type, transmission being in only one direction at a time, while the new 321 set is of the "invariable" type, requiring no switching operations during a connection. Its successful development has required very careful attention to a number of factors.

The important requirement of an "invariable" set is that there be a large loss around the local circuit from receiver to microphone and back to receiver that does not affect either the transmitting or receiving paths alone. This loss is secured to a considerable extent by the hybrid coil that electrically couples the microphone and receiver to the line. It is indicated in the upper left of Figure 1. Speech energy from the secondary station passes readily through the bridged connection to the amplifier, some of it reaching the coupled microphone circuit. Speech energy from the microphone, on the other hand, passes readily to the outgoing circuit through the coupling of the hybrid coil, but very little of it passes through the bridged connection to the amplifier and loud speaker.

Associated with the hybrid coil is a balancing network which should have an impedance the same as that of the line, and the effectiveness of the coil largely depends on the accuracy of this balance. Because the 321 tele-

phone set is designed for use with a very short line, the balancing network used simulates the impedance of a short line terminated in a subscriber set. A loss of about 17 db has been obtained across the hybrid coil from transmitter to receiver.

Since the user will ordinarily be about three feet from the loud

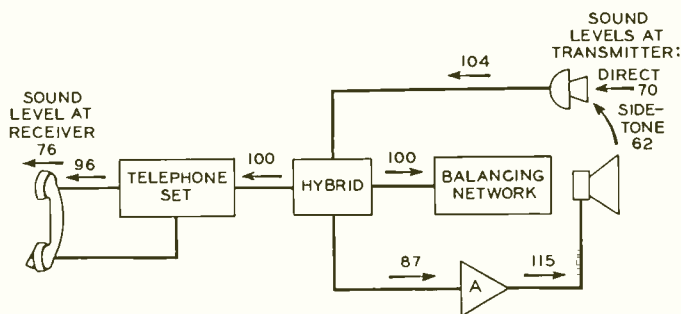

Fig. 2—Speech power distribution when master station is talking. Numbers over arrows indicate sound levels

speaker and microphone, the output of the loud speaker must be relatively large, while for the same reason the microphone must be sensitive enough to act on relatively small inputs. Since the loud speaker is physically very near the microphone, the likelihood of singing is greatly increased by this discrepancy in normal operating levels. A satisfactory solution can be obtained only by a careful correlation of the efficiencies and losses of every element that enters into the circuit, and by a careful arrangement of the relative positions of loud speaker and microphone.

The net gain around the local circuit is not the same at all frequencies, generally having pronounced peaks, and it is at these peak frequencies that singing occurs. It is this fact that makes careful positioning of the instruments important. The output of the loud speaker does not travel equally in all directions at all fre-

quencies. The higher frequencies are projected for the most part straight ahead, and only the low frequencies have sufficient energy at wide angles to produce singing. By facing the microphone and loud speaker in the same direction, therefore, the danger of the system singing at high frequencies can be considerably decreased.

speaker have been adjusted so that at the frequencies at which singing would be most likely to occur, the delay is such as to approach an out-of-phase condition at the loud speaker.

The acoustic and electrical levels at various points of the circuit when the master station is talking are indicated in Figure 2. The acoustic levels

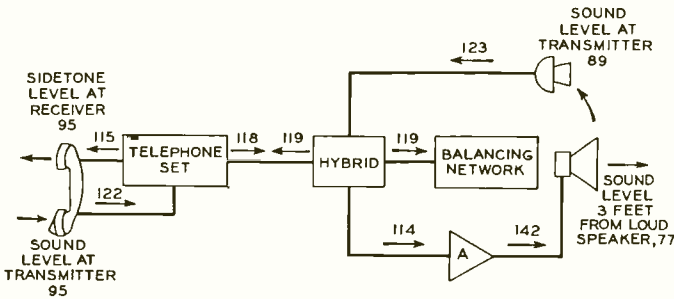

Fig. 3—Speech power distribution when secondary station is talking. Numbers over arrows indicate sound levels

Singing will occur, of course, only at a frequency at which the returned current is in phase with the directly transmitted current at the microphone. If the current returned by the microphone reaches the loud speaker terminals in phase opposition to the originating current at this point, for example, there will be a reduction rather than an increase in output volume at the particular frequency. This phase relation, of course, depends on the delay in the circulating path, which is partly electrical and partly due to the transit time of sound waves from loud speaker to microphone, which varies with the length of path. By moving the loud speaker, or microphone, inward or outward with respect to the front of the cabinet, the length of path may be changed. Advantage has been taken of this fact in the 321 set to greatly reduce the danger of singing. The positions of microphone and loud

are in terms of sound level in db above  $10^{-16}$  watts per square cm., and the electrical levels are in db above  $10^{-16}$  watts. The electrical level represents the total energy in the circuit, while the sound level represents the intensity of energy. It is assumed that with the speaker three feet from the microphone and

speech at ordinary conversational level, the sound level at the microphone will be 70 db. After passing through the microphone, this becomes 104 db in electrical units at the input to the hybrid coil. On the branch going to the line, there is a 4-db loss, giving 100 db on the line, and another 4 db through the coil at the secondary station, giving 96 db to the handset receiver. The equivalent sound level at the output of the receiver is 76 db, which is ample for good reception.

In the singing path across the hybrid coil to the loud-speaker branch, the loss of 17 db results in a level of 87 db. This is increased to 115 db by the amplifier, and, after passing through the loud speaker, results in an audible acoustic level at the ear of the speaker. Since he is talking at a considerably higher level, however, this is merely a hearing of his own voice at considerably reduced level and is impercep-

tible. Because of the control of the length of the path between loud speaker and microphone, and the directional characteristics of the loud speaker, the level at the microphone of this returned sound is 8 db below the directly received sound that produced it. Around this singing path there is thus an 8-db net loss instead of a gain, and singing will not occur.

An equivalent diagram giving the conditions when the secondary station is transmitting is shown in Figure 3. Because of the closeness of the mouth to the handset transmitter, the electrical level is 122. With 4-db loss through the hybrid coil of the secondary station, this becomes 118 db on the line, 18 db higher than for the other direction of transmission. A 4-db

loss through the hybrid coil of the 321 set gives 114 db to the amplifier, and the 28-db gain of the amplifier gives 142 db to the loud speaker. This results in 77-db acoustic level at the listener's ear.

With any such loud-speaking system, the signal-to-noise ratio is always less for the direction of transmission of Figure 2, than for the other direction, because of the greater distance of the mouth from the microphone, and thus the lower level of the speech at the microphone in relation to the entering noise. Under ordinary room noise conditions, however, the transmission from master to secondary is about equivalent to that obtained with the latest type telephone sets over a long telephone connection.

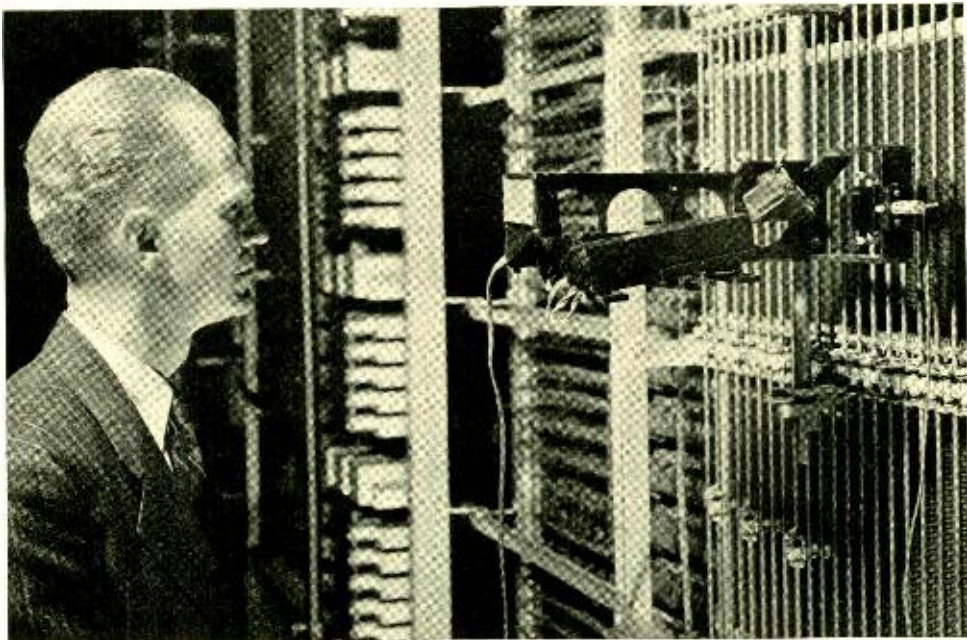

*T. F. Osmer, using a vibrometer, observes the effect of the operation of a nearby elevator rod on the relative motion between a brush on a stationary rod and its terminal. Simultaneously the noise generated by this relative motion is also measured*



# Crosstalk Balancing in the J-Carrier System

By H. B. NOYES

*Interference Prevention*

THE type-J carrier system is designed for open-wire lines, and line crosstalk is held to satisfactory values chiefly by transpositions.\* To bring the open-wire circuits into repeater and terminal stations, however, and for certain river crossings, cable is employed as

\*RECORD, January, 1940, p. 153.

with other open-wire circuits. The frequencies employed by the J system, running up to 143 kc, are much higher than such cables have been required to carry before. Twenty-eight kilocycles, the top frequency of the type-C carrier system, was the highest previous frequency except for the type-K cable system. Since far-end crosstalk

coupling increases almost directly with frequency, the coupling for the J system is over five times that for the C system. It was necessary, therefore, to take steps to reduce crosstalk on these incidental cables.

Three different types of incidental cables are employed. In many cases it is economical to use the existing voice-frequency cable. With such cable, the crosstalk at carrier frequencies is so high that special measures are required to reduce it. The other two types of cables used for new installations are of a special type. One is a cable containing large-gauge paper-insulated conductors with a shield between layers. Although the crosstalk in such a cable is less than for the usual toll-entrance cable, it is not low enough to be satisfactory at J-carrier frequencies without correction. The other employs a spiraled disc-insulated shielded-quad construction.

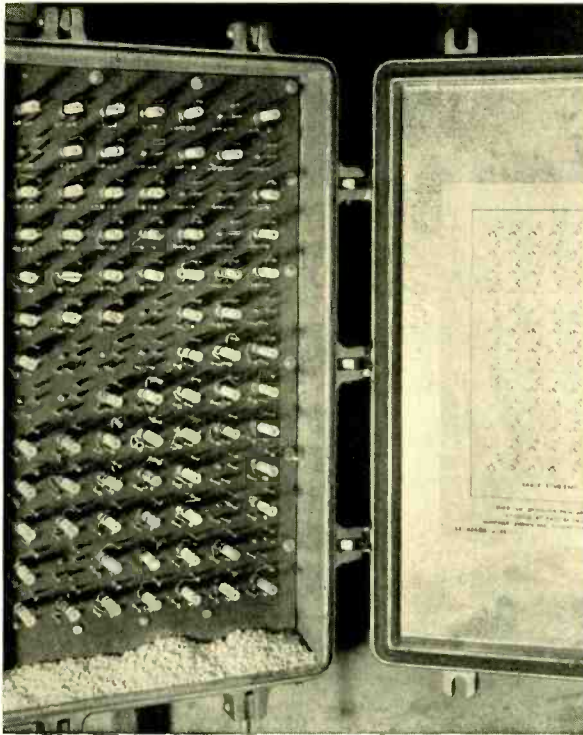

Fig. 1—Ninety-one balancing condensers are mounted together for balancing fourteen J-carrier pairs. The white powder in the bottom of the case is a desiccant used while balancing cable. After balancing has been completed, new desiccant is placed in cotton sleeving and hung in the cabinet

This gives negligible crosstalk between the shielded units under most conditions, but frequently it is necessary to obtain some further reduction in the crosstalk between the two sides of the same quad. For all of these cables, it appeared that the desired improvement could be obtained by the use of crosstalk balancing, which had been employed with considerable effectiveness in cables for the type-K system.\* There are differences between the requirements affecting these latter cables and the incidental cable used with the J system, however, that affect the type of balancing to be employed.

Crosstalk takes place through both the inductive and capacitive coupling between the pairs of the cable, and thus both a coil and condenser must be used for most effective balancing. Which form is the more effective when used alone will depend primarily on the ratio of inductive to capacitive coupling. With the cables used with the K system, more effective balancing can be obtained with a coil, and for this reason, coil-type balancing was employed. This would also be true of the types of existing cable that will be used for the J system, if the J pairs were selected at random.

For optimum results, inductive coupling must be balanced with a rather complicated mutual impedance whose design depends on the wire size, and thus a different design of coil is, in general, required for each wire size. The cable used with the type-K sys-

tem all has the same size of conductor, and thus one design of coil is sufficient while the conductors of existing incidental cables used with type-J system vary in size, and for each size of wire a different balancing coil would have to be developed in order to obtain optimum results, and this would add appreciably to the cost.

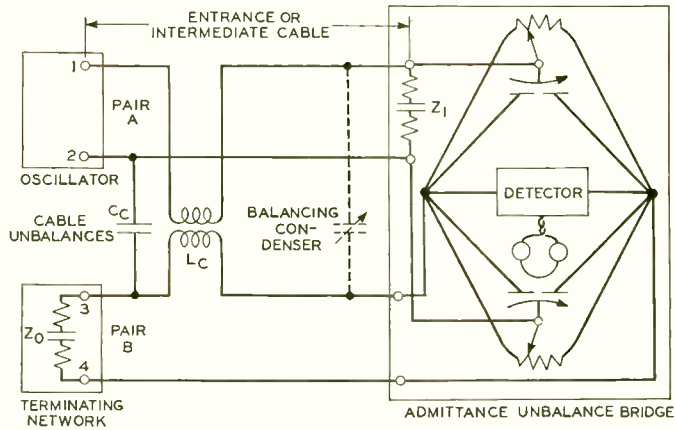

Fig. 2—Simplified schematic diagram showing method of measuring crosstalk

Capacitive coupling, on the other hand, can be balanced with a simple condenser, and since for J-system applications it is practicable to select a few pairs from a number of spare pairs for carrier operation, it seemed better to employ a simple condenser balancing, providing satisfactory results could be obtained.

Both the amount and type of coupling varies from pair to pair. To use condenser balancing alone, and obtain satisfactory results, it is necessary to measure the coupling between available spare pairs in the cable and to select those pairs with the lowest inductive coupling, that is those pairs that can be balanced best with a condenser. Since a simple condenser rather than a variety of mutual impedances depending on the wire size

\*RECORD, Feb., 1939, p. 185.

can be used for balancing, and since condenser balancing is inherently less expensive for the type-J system than the coil balancing, a twofold gain is realized as a result.

For these reasons, capacitance balancing was adopted for the incidental cables over which J systems are routed. The capacitance used is formed by winding a pair of wires on a small spool, and is adjusted by unwinding and cutting off wire until the desired amount of capacitance is secured. On many lines, not more than fourteen

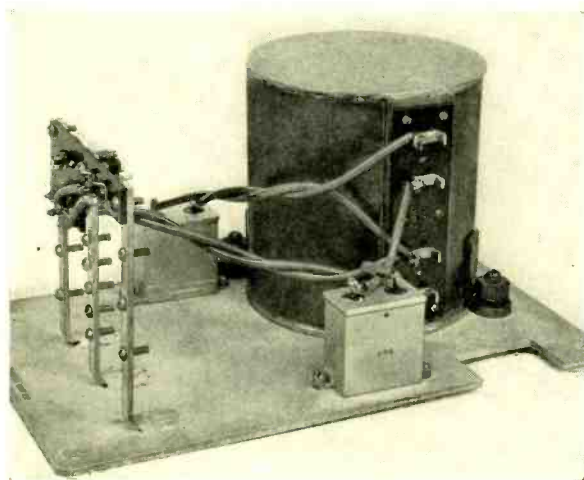

*Fig. 3—A terminal loading unit for disc-insulated cable showing balancing condenser mounted on upper part of the terminal plate*

pairs are expected to be used for J carrier, and 91 condensers are required to balance fourteen pairs if each must be balanced against all the others. These are mounted in a metal cabinet containing a desiccant as shown in Figure 1. Each of the spool-type condensers screws onto a threaded stud, and adjacent to each stud are two pairs of soldering lugs by which the condenser wires are connected to the various pairs.

The first step in balancing an existing cable is to measure the crosstalk

between available spare pairs so that the more suitable ones may be selected. This measurement is made with an admittance-unbalance bridge, shown in simplified form in Figure 2. At one end of the cable an oscillator is connected to one pair, A, which will be the disturbing pair, and a terminating network,  $Z_0$ , is connected to another pair, B, which will be the disturbed pair. At the other end of the cable these pairs are connected to the admittance-unbalance bridge—the disturbing pair to the input, and the

disturbed pair to the output. Crosstalk is induced in the disturbed pair through the inductive and capacitive unbalance coupling indicated by the coil L and the condenser C. The bridge is then adjusted until the voltage at the bridge, coming from pair A and attenuated by the bridge, is equal and opposite to the crosstalk voltage from pair B, as indicated by no tone in the detector. The terminating network  $Z_0$  on pair B, and an equivalent impedance,  $Z_1$  in parallel with the bridge, at the other end of pair A, terminate the lines in their characteristic impedances in order that no

reflections will occur.

The reading of the bridge settings after adjustment gives not only the amount of crosstalk, but the phase of the crosstalk, and thus indicates to what degree it may be reduced by a condenser. After all available pairs have been measured, the required number is selected from those having crosstalk that can be best corrected by condenser balancing. Two measurements are made on each combination, using pair A first as the disturbing pair and pair B as the dis-



turbed, then pair B as the disturbing and A as the disturbed. The two capacity readings may differ, and their average determines the capacity of the balancing condenser.

The actual balancing procedure is a slight modification of the measuring method. The selected pairs are first connected to the balancing cabinet. For any combination the desired value of the balancing condenser is determined as described above. This value is then subtracted from the setting of the capacitance arm of the bridge, and the bridge is set to this corrected value. A balancing unit is then connected across the pairs as shown by the dotted line of Figure 2, and is adjusted until zero tone is obtained in the

detector. After this, the ends of the wire are insulated and fastened, and the condenser is screwed onto its stud in the balancing cabinet and its ends soldered to the terminal lugs. On a few of the pairs, the crosstalk may be so low as not to require balancing, and this accounts for the empty positions in Figure 1. In general, however, pairs in existing cables need to be balanced, as do the pairs in the new paper-insulated shielded cables.

Because of the shielding provided for the disc-insulated spiral quad cable, no balancing between quads is required. If the pairs within each quad were always in their ideal positions, no balancing would be required for them either, because of their non-inductive arrangement. Occasionally,

however, slight unbalances exist between pairs within a quad, and balancing is required. Since the capacity required is small and must be accurately set, a small air condenser is used. For loaded intermediate cables these are

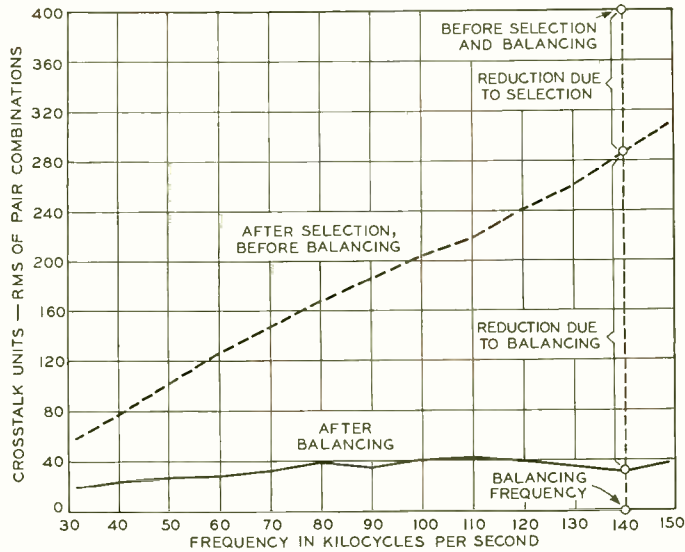

Fig. 4—Far-end crosstalk before and after selection and balancing on a typical cable

installed with the terminal loading units, as shown in the upper left of Figure 3. For lead-in or entrance cables, they are mounted on a small panel installed in the office.

Selecting and balancing on existing cables result in a crosstalk reduction of about 20 db at 140 kc. The results obtained on a particular cable are shown in Figure 4. The circle at 140 kc gives the root-mean-square value of crosstalk on ten available pairs before selection. The crosstalk on six selected pairs before balancing is indicated by the upper curve, and, after balancing, by the lower curve. In this case the selection and balancing were done at 140 kc, but the final crosstalk value is about the same over the entire range as it is at 140 kc.



# Determination of the Average Life of Vacuum Tubes

By D. K. GANNETT  
*Toll Transmission Engineer*

THE vacuum tubes used in the telephone plant are, on the average, very long-lived. However, with an individual vacuum tube as with a human being, the surest thing about life is that it will sometime end. Among a group of tubes which are made as nearly alike as possible and used under identical conditions, a few may die in infancy, many will live their normal span, and some will last to a ripe old age. Still, while the future of any individual tube may be unpredictable, there is a great deal more certainty about the probable average life of a large group of tubes.

The statistics of human life are studied by the life insurance actuary so that, knowing the "life expectancy" of people, he can determine the average annual cost of insuring their lives, and thus establish the proper insur-

ance premiums. Similarly, statistics regarding vacuum tube life are studied by the engineer, so that, knowing the "life expectancy" of the tubes, he can determine the average annual cost of replacing them when they fail. The engineer, however, has a broader interest than merely determining costs. He wants further to know whether a given type of tube is prone to fail suddenly in such a way as to affect service, or whether it usually fails gradually in such a way that it can be removed before it seriously affects service. He needs data which will enable him to prescribe testing routines that will make it possible systematically to remove tubes before they become service hazards. He wants to uncover troubles which may be corrected by improved methods or conditions of operation, or by changes in design or manufacturing technique.

The engineer is seldom in the fortunate position of the life insurance actuary of being able to obtain data from all of the individuals with which he is concerned. Therefore the engineer relies on field trials or studies of selected groups of tubes in the plant. In analyzing the results of such trials, he is faced with a further

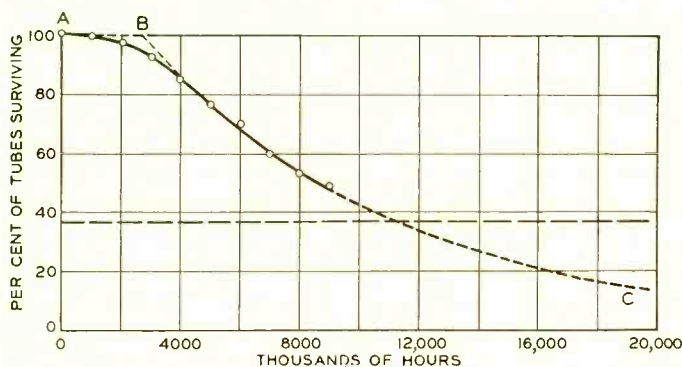

Fig. 1—Survival curve of vacuum tubes from trial at Southfields, N. Y., repeater station

complication. The tubes used in telephone plant have average lives which are measurable in terms of years so that a very long time would be required to obtain their complete history. When a new type of tube is developed, the engineer cannot afford to wait years to determine whether it is satisfactory for standard use. Methods of analysis of the field trial data are required, therefore, which will enable a reasonably accurate prediction of the average life of the tubes to be made in a comparatively short time, frequently much shorter than the average life.

Analysis of the data from many field trials in the past has indicated a certain pattern in the life statistics of vacuum tubes as now usually constructed. This pattern has been found to exist in every case in which sufficient data have been obtained to establish the facts. For such tubes, this gives a means, therefore, to predict from the early performance of a field trial the average life of the tubes being tested with reasonable assurance that the prediction will later be confirmed when all of the returns are in.

The pattern is merely that among a large group of tubes, after an initial period that varies with the type of tube, the rate of failure expressed in per cent of the tubes remaining in service tends to become constant just as though the tubes failed in random fashion. This is equivalent to saying that a curve showing the per cent of a group of tubes remaining in service plotted against the time after they are placed in service becomes approximately an exponential curve ( $y = A e^{-at}$ ) after the initial period has passed. An example of such a curve is shown in Figure 1, the data for which were obtained a few years ago from a

field trial of several hundred tubes at the Southfields, New York, repeater station. It will be seen that after three or four thousand hours, the experimental points fall quite accurately on the exponential curve that was drawn between b and c.

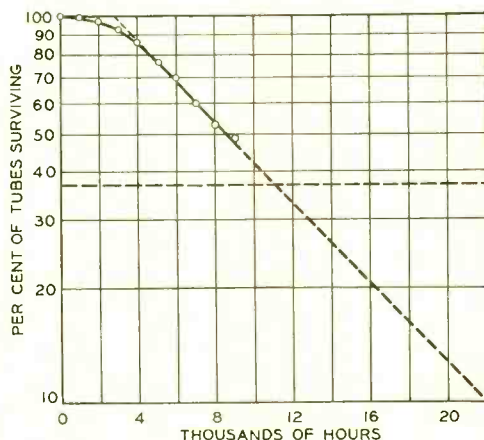

Fig. 2—A logarithmic plot of the data of Figure 1 becomes a straight line

The reason why tubes fail according to such a curve is complicated and not completely understood. The active material within a tube is sufficient to give a potential life many times that usually obtained. However, many things can occur within the tube to destroy its usefulness. Whatever the exact mechanism by which these effects occur, the result is an apparent gradual but random failure of the vacuum tubes.

To make practical use of this law of failure, advantage is taken of the fact that exponential curves become straight lines when plotted on semi-logarithmic coordinates. Figure 2 shows the data of Figure 1 plotted in this way. The simple procedure followed in analyzing trial data, then, is to plot the per cent remaining as ordinates against time as abscissas on semi-logarithmic coordinate paper.

As the trial proceeds, when several points have been obtained through which a straight line may be drawn, it is safe to assume that the exponential phase of the trial has been reached. The straight line may then be extrapolated into the future, as

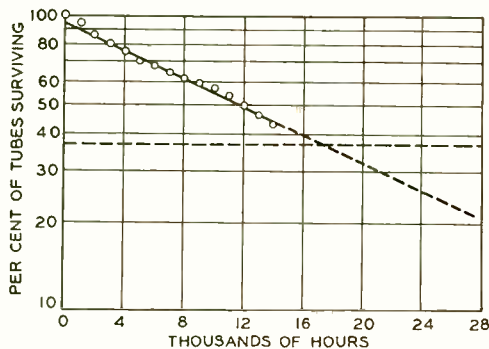

Fig. 3—Logarithmic plot of survival curve of vacuum tubes from trial that has been carried on at Morristown, N. J.

shown by the dotted line in Figure 2, with reasonable assurance that time will verify the line so drawn.

Figure 3 shows the similar treatment for data from another trial, at the Morristown, New Jersey, repeater station. In this case the initial rate of failure of the tubes was somewhat greater than normal, instead of somewhat less as in Figure 2. This type of curve is less common than that illustrated in Figures 1 and 2.

The average life of a group of tubes is the total number of tube-hours of service which they render divided by the number of tubes originally in the group. If the life curve is exactly exponential throughout, it can be shown that the average life corresponds to the time when about 37 per cent (100 per cent divided by  $e$ ) of the tubes remain in service. The extra life of the tubes which last longer than that compensates for the deficiency due to the tubes which failed earlier.

Even when the curves depart from the exponential in the initial period of the trial, as in the illustrations, this rule is still true with very slight error. When the exponential curve has been determined as just described, therefore, the average life may be estimated by noting on the curve the time at which 37 per cent of the tubes will remain in service. In Figure 2, the indicated average life is about 11,000 hours, while in Figure 3, it is about 17,500 hours.

When a considerable number of tubes are involved in a field trial, the points representing the experimental data usually tend to form a smooth curve, as in Figures 2 and 3, and there is little difficulty in drawing the straight line. In some cases, particularly when the number of tubes is smaller, the points are more erratic, and considerable judgment may be required in drawing the line. In these cases, the straight line may be drawn arbitrarily through the last experimental point and with such a slope that the area under it up to that point is the same as the area under a curve drawn through the actual experimental points. This results in establishing the exponential curve that would give the same number of tube-hours of service up to the time of the last experimental data, and the same number of tubes remaining in service at that time, as the actual experimental data. This is the best approximation that can be made with meager data to the curve that would have been obtained had more voluminous data from a larger number of tubes been available. Figure 4 represents a curve that has been drawn in this way, representing data from a trial of flashed 101F tubes.

For the data shown in Figures 2 and 3, there was an unusual oppor-

tunity to check the prediction of average life by statistics from the entire plant of the Long Lines department of the American Telephone and Telegraph Company. The trial at Southfields showed the results of operating 101F tubes at a filament current which was about six per cent lower than the then standard filament current. From the curve which was obtained (Figure 2) it was estimated, as noted above, that an average life of about 11,000 hours would be obtained at this lower filament current. Accordingly, the lower current was recommended to the plant in the fall of 1929, and shortly afterwards all of the filament circuits in the Long Lines plant were readjusted to that value. For a time, statistics were gathered from the 92,000 tubes then in the plant to note the effect of that change. When the change had become fully effective, the rate of failure became stable at 6.2 per cent per month. This corresponds to an average life of  $\frac{1}{.062}$  months, or 11,800 hours, thus verifying the prediction.

A little later, improvements were made in the 101F tubes, the effect of which was checked in the trial at Morristown whose results are shown in Figure 3. From the curve it was estimated that the average life would be increased to 17,500 hours. In 1932 when the improved tube had come into general use, the rate of failure among the 110,000 tubes in service dropped to an average of 4.02 per cent per month. This corresponded to an average life of  $\frac{1}{.0402}$  months, or 18,200 hours, again checking the prediction.

In field trials of vacuum tubes, the tubes that fail are classified according to the type of failure. Generally, the

principal cause of failure is decreasing filament activity. Other types of failure are: filament burnouts; failures due to the presence of gas in the tube resulting in loss of gain, grid current, etc.; mechanical failures, such as broken parts, short or open circuits, etc.; and noise and miscellaneous troubles. The reaction of these on service depends upon the type of equipment in which the tubes are used. If any of these types of failure occur in excessive numbers, and the operating conditions appear to be satisfactory, the problem is referred to the Electronics Research Department, which considers the possibility of reducing these failures by further development and improved design of

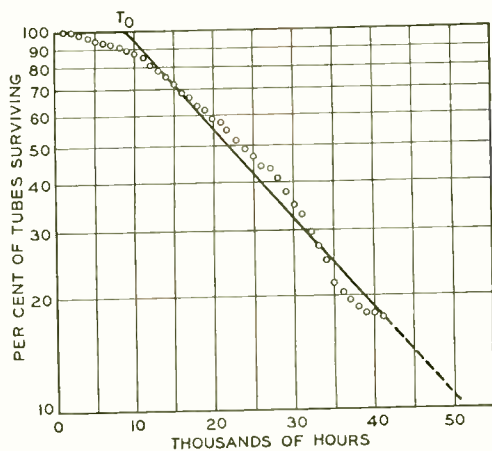

Fig. 4—Calculated survival curve to represent somewhat irregular experimental data

the tubes, or by improved control of the manufacturing process.

Most vacuum tubes in service are given regular tests, for the purpose of removing those tubes from service which have failed or are near failure. The nature of the tests varies with the kind of equipment in which the tubes are used. The endeavor, in these tests, is to insure removing tubes from service before they are likely to cause

difficulties or otherwise to affect service, while at the same time realizing as long a life as possible. The data from field trials are of considerable aid in determining the type of tests, the testing limits, and the interval between tests.

It is of interest in this connection, that it is a property of the exponential life curves described above, that the probable further life of a group of used tubes which are still good is the same as the probable life

of a group of new tubes, neglecting the effect of the initial period before the curves become truly exponential. For present tubes there would ordinarily be little advantage, therefore, to a system of tube maintenance in which all tubes are periodically replaced by new tubes. The short-lived tubes having already been weeded out, the tubes that remain are likely to last as long and give as good service as the new tubes with which they might be replaced.



*In making a life test of the door hinges of a telephone booth, the door is opened and closed repeatedly by a motor-driven mechanism until the hinges wear and the door fails to close completely. W. A. Krueger is shown inspecting a hinge for looseness*



## Contributors to this Issue

F. S. GOUCHER graduated from Acadia University in 1909 with the A.B. degree. The following two years he studied at Yale where he received the degrees of A.B. and M.A. Then he became research assistant to Professor Pupin at Columbia University and continued his graduate work there until 1917 when he received the Ph.D. degree from that institution. In 1934 he received the honorary degree of Sc.D. from Acadia. Dr. Goucher went overseas with the British Expeditionary Force. He remained in England after the war to carry on research work at University College, London, and at the General Electric Co., Ltd. In 1926 he joined the Laboratories and is now in charge of a group engaged in studies of contacts both with reference to their behavior in carbon microphones and in switching apparatus.

D. K. GANNETT at-

tended the University of Minnesota, receiving the degree of B.S. in Engineering in 1916 and the degree of E.E. in 1917. He joined the Engineering Department of the American Telephone and Telegraph Company in 1917, and was a member of the Department of Development and Research from 1919 to 1934 when it was consolidated with the Laboratories. Throughout this entire period he has been

concerned with transmission problems, for the most part the problems of toll telephone transmission but including some special problems such as submarine cable telegraph transmission and the wire transmission of facsimile signals. At present, as Toll Transmission Engineer, he is concerned with program transmission, toll signaling transmission, and vacuum tube applications in these and other systems.

S. I. CORY graduated from Ohio State Univer-



*F. S. Goucher*



*D. K. Gannett*



*S. I. Cory*



*H. B. Noyes*



*S. T. Meyers*



*Alfred Herckmans*



*L. R. Montfort*

sity in 1916 with the degree of B.E.E. He joined the American Telephone and Telegraph Company immediately and continued there in the Engineering and Development Departments until 1934 when he transferred to the Laboratories. Mr. Cory's work has been exclusively on transmission development problems, chiefly relating to telegraph systems and transmission measuring methods.

H. B. NOYES, after receiving the A.B. degree at Harvard in 1924, joined the Purchase Engineering Division of the Western Electric Company, where he made statistical and market analyses of commodities used by the Bell System. In 1927 he transferred to the Comptroller's Department of the American Telephone and Telegraph Company where he was engaged in mathematical development work in the Chief Statistician's Division. From there he transferred to the Department of Development and Research in 1928. In this department, and subsequently in the interference prevention group of the Laboratories, he has been engaged in investigations of crosstalk and noise problems important in the design of voice and carrier-frequency circuits.

S. T. MEYERS entered the Toll Systems Department of the Laboratories in 1927 after graduating from Stevens Institute of Technology with the degree of M.E. As a member of the carrier-telephone

group he assisted in the early work connected with the application of feedback to vacuum tube circuits. In 1931 he joined the voice-frequency repeater group, where he has since been engaged in the transmission design of voice-frequency and program equipment for toll circuits.

AFTER RECEIVING the A.B. degree from Columbia University in 1922, Alfred Herckmans spent two years in engineering study at the Massachusetts Institute of Technology, and then entered the Department of Development and Research of the American Telephone and Telegraph Company in 1925. His first work was on problems associated with the introduction of the handset for subscribers' use. Since transferring to the Laboratories in 1934 he has continued his work on design requirements, testing, and field trials of station apparatus.

L. R. MONTFORT graduated from the University of Virginia in 1926 with the degree of Electrical Engineer and at once joined the Development and Research Department of the A. T. & T. Associated with the transmission development group, he engaged in a variety of studies of open-wire problems—later working on open-wire carrier systems. Coming to the Bell Laboratories in the 1934 consolidation, he continued with carrier development, working on both the 2B regulating system and the C5 carrier system.



# Index to Authors, Volume XVIII

## A

ALLEN, L. H. . . . .	The IA Key Telephone System . . . . .	315
ASHWORTH, J. A. . . . .	Magnetic Materials Testing . . . . .	49

## B

BARCOCK, W. C. . . . .	Transpositions . . . . .	153
BARTHELD, L. P. . . . .	Equipment for the Demonstration Toll Call at New York World's Fair . . . . .	135
BEEKER, J. A. . . . .	Varistors: Their Characteristics and Uses . . . . .	322
BENNETT, W. . . . .	Weather by Telephone . . . . .	66
BISKEBORN, M. C. . . . .	Testing Shields for Carrier-Frequency Line Structures . . . . .	88
BRAND, S. . . . .	The "VU" and the New Volume Indicator . . . . .	310
BURROWS, C. R. . . . .	The Exponential Transmission Line . . . . .	174

## C

CHAFFEE, J. G. . . . .	Frequency Modulation . . . . .	177
CHASE, C. A. . . . .	Outside Plant Field Laboratory at Chester . . . . .	214
COLES, F. A. . . . .	Hearing-Test Machines at the World's Fairs . . . . .	290
CORY, S. I. . . . .	Transmission Measuring Set for Outlying Telegraph Stations . . . . .	365
CUSHMAN, R. A. . . . .	Audition Demonstration at the New York World's Fair . . . . .	273
CUSHMAN, R. A. . . . .	Weather-Announcing Tape Machine . . . . .	70

## D

DUDLEY, HOMER . . . . .	The Vocoder . . . . .	122
DUGUID, J. M. . . . .	Code Ringing Supply for Community Dial Offices . . . . .	243
DURKEE, A. L. . . . .	Spots on the Sun . . . . .	305

## E

ELLIOTT, A. M. . . . .	Operator-Training Facilities at Toll Switchboards . . . . .	119
------------------------	---	-----

## F

FARNSWORTH, D. W. . . . .	High-Speed Motion Pictures of the Human Vocal Cords . . . . .	203
FARNSWORTH, F. F. . . . .	Improvements in Drop Wire . . . . .	332
FLETCHER, HARVEY . . . . .	Stereophonic Reproduction from Film . . . . .	260

## G

GABRIEL, J. C. . . . .	Single-Sideband Short-Wave Receiver . . . . .	84
GAINES, W. L. . . . .	Automatic Cathode-Ray Oscillograph . . . . .	145
GANNETT, D. K. . . . .	Determination of the Average Life of Vacuum Tubes . . . . .	378
GOUCHER, F. S. . . . .	New Hysteresis Model . . . . .	358
GERMANTON, C. E. . . . .	Dialing Incomings . . . . .	15
GREENE, J. C. . . . .	The 3B Toll Switchboard . . . . .	104
GRISMORE, O. D. . . . .	Recording Transient Disturbances . . . . .	140

## H

HALLIGAN, C. W. . . . .	Telephone Facilities for Airport Traffic Control . . . . .	298
HARAZIM, S. J. . . . .	The 19 Type Oscillator for Measuring Program Transmission Lines . . . . .	108
HAWLEY, M. S. . . . .	Artificial Mastoid for Audiphone Measurements . . . . .	73
HAWLEY, M. S. . . . .	The 710-A Bone-Conduction Receiver . . . . .	12
HERCKMANS, A. . . . .	A Loud-Speaking Telephone System . . . . .	369
HERMANCE, H. W. . . . .	Printing Techniques in Analytical Chemistry . . . . .	269
HOPKINS, H. F. . . . .	Improved Loud-Speaking Telephone . . . . .	251
HUDACK, J. M. . . . .	The 13A Transmission Measuring Set for Program Transmission Lines . . . . .	108

## K

KING, A. P. . . . .	Metal Horns as Radiators of Electric Waves . . . . .	247
KORN, F. A. . . . .	Lockout Circuits . . . . .	21
KREISHER, C. . . . .	Cables for the J Carrier System . . . . .	328

## L

LACERTE, W. J. . . . .	Field Tests of the Crossbar System . . . . .	113
LECONTE, R. A. . . . .	Terminal Circuits for the J Carrier System . . . . .	292
LOVELL, C. A. . . . .	Crossbar Trunking Studies . . . . .	38

## M

MARRISON, W. A. . . . .	The Spark Chronograph . . . . .	54
MARRISON, W. A. . . . .	The "Telephone Clock" . . . . .	209
McKENNIE, C. B. . . . .	A Remotely Controlled Radio Receiver . . . . .	76
MERRILL, J. L. . . . .	Transmission Features of the Weather Announcement System . . . . .	283
MEYERS, S. T. . . . .	The 14C Program Amplifier . . . . .	362
MONTFORT, L. R. . . . .	The C5 Carrier System . . . . .	354
MONTGOMERY, H. C. . . . .	Analysis of World's Fairs' Hearing Tests . . . . .	98
MONTGOMERY, H. C. . . . .	Optical Curve Analysis . . . . .	28
MOORE, G. E. . . . .	Improved Repeater Tubes . . . . .	219
MOORE, H. R. . . . .	Broad-Band Carrier System for Open-Wire Lines . . . . .	226
MURPHY, E. J. . . . .	Dielectric Loss in Ice . . . . .	241

## N

NIELSEN, J. E. . . . .	Crosstalk Reference Standard . . . . .	232
NOYES, H. B. . . . .	Crosstalk Balancing in the J Carrier System . . . . .	374

## O

OSWALD, A. A. . . . .	The Manahawkin Musa . . . . .	130
-----------------------	-------------------------------	-----

## P

PAPE, N. R. . . . .	Continuous Breakdown Test for Enameled Wire . . . . .	58
PETERSON, E. . . . .	Gas-Tube Noise Generator for Circuit Testing . . . . .	81
PRUDEN, H. M. . . . .	Remote Control of Radio Systems . . . . .	91

## R

REICHLER, W. E. . . . .	Radio Compass for Small Vessels . . . . .	151
REIER, G. C. . . . .	Effect of Extended Signalling Range for Subscriber Loops . . . . .	182
REISE, H. A. . . . .	A One-Kilowatt Broadcast Transmitter . . . . .	17
ROSENE, V. E. . . . .	Alarm System for Auxiliary Repeater Stations . . . . .	345
RUNYON, B. F. . . . .	Contacts for Crossbar Apparatus . . . . .	278

## S

SCHUMACHER, E. E. . . . .	Wiping Solder with Improved Handling Characteristics . . . . .	303
SHEPPARD, H. A. . . . .	Signalling System for Intertoll Dialing . . . . .	337
SHETZLINE, R. A. . . . .	The Longitudinal Circuit . . . . .	2
SHOFFSTALL, H. F. . . . .	Circuit Features of the 3B Toll Board . . . . .	167
SKELLETT, A. M. . . . .	The Coronaviser . . . . .	162
SLADE, B. . . . .	Crosstalk Balancing Coils for the Type-K Carrier Tele- phone System . . . . .	199
SOFFEL, R. O. . . . .	Crossbar Call-Indicator Pulsing . . . . .	236
SOUTHWORTH, G. C. . . . .	Demonstration of Guided Waves . . . . .	194
STANSEL, F. R. . . . .	Beat Notes in High-Frequency Calibration . . . . .	116
STRYKER, N. R. . . . .	Sound Tests of Telephone Ringers and Dials . . . . .	343
SWAIN, R. R. . . . .	Intertoll Dialing with Step-by-Step Selectors . . . . .	266

## T

THORP, V. P. . . . .	Level Compensator for Carrier-Telegraph Systems . . . . .	46
TUFFNELL, W. L. . . . .	The Ortho-Technic Audiphone . . . . .	8

## V

VIETH, L. . . . .	Feedback Improves Electromechanical Recording . . . . .	171
VIOL, W. E. . . . .	Laboratory Tests of the Crossbar System . . . . .	186

## W

WEIS, JR., C. L. . . . .	Television Transmission Over Telephone Cables . . . . .	34
--------------------------	---	----

# Index to Subjects, Volume XVIII

(Roman Numerals Refer to Picture Sections)

## A

Acoustics (see Sound, Speech, Hearing and Acoustics)	
Aircraft (see Radio)	
Airport Traffic Control, Telephone Facilities for . . . . .	<i>Halligan</i> . . . . . 298
Alarm System for Auxiliary Repeater Stations . . . . .	<i>Rosene</i> . . . . . 345
Amplifiers, No. 14C Program . . . . .	<i>Meyers</i> . . . . . 362
Analysis, Optical Curve . . . . .	<i>Montgomery</i> . . . . . 28
Antennas	
Exponential Transmission Line . . . . .	<i>Burrows</i> . . . . . 174
Manahawkin Musa . . . . .	<i>Oswald</i> . . . . . 130
No. 33B Directive Antenna Control Unit (Picture) . . . . .	83
Audiphones	
Artificial Mastoid for Audiphone Measurements . . . . .	<i>Hawley</i> . . . . . 73
Beryllium Copper for Bone Conduction Receivers . . . . .	62
No. 710A Bone Conduction Receiver . . . . .	<i>Hawley</i> . . . . . 12
Ortho-Technic Audiphones . . . . .	<i>Tuffnell</i> . . . . . 8
Audition Demonstration at New York World's Fair . . . . .	<i>Cushman</i> . . . . . 273
Awards (see Prizes and Other Honors)	

## B

Beryllium Copper for Bone Conduction Receivers . . . . .	62
Biographies and Personalities	
Espenschied, Lloyd, Awarded I.R.E. Medal of Honor . . . . .	367
Meacham, L. A., Receives Eta Kappa Nu Award . . . . .	139
Scudder, F. J. and Reynolds, J. N. Receive A.I.E.E.	
Paper Award . . . . .	342
Williams, R. R., Awarded Elliott Cresson Medal . . . . .	272
Bone Conduction Receivers	
Artificial Mastoid for Audiphone Measurements . . . . .	<i>Hawley</i> . . . . . 73
No. 710A Bone Conduction Receiver . . . . .	<i>Hawley</i> . . . . . 12
Booths, Telephone	
Life Test of Hinges (Picture) . . . . .	382
Ventilating Fans (Picture) . . . . .	318
Bridge Oscillator . . . . .	Jan. I to IV

## C

Cables	
Cables for the J-Carrier System . . . . .	<i>Kreisher</i> . . . . . 328
Coaxial	
Crimping Tool for Coaxial Conductors . . . . .	152
Installing Crystal in Coaxial Filter (Picture) . . . . .	257
Stevens Point-Minneapolis, Section of Cable (Picture) . . . . .	65
Televising National Republican Convention . . . . .	336

## Cables (Continued)

Magnetic Strain Gauge for Aerial Cable Sheath . . . . .	181
Television Transmission Over Regular Cable Pairs . . . . .	<i>Weis</i> . . . . . 34
Testing Shields for Line Structures Operating at Carrier-Frequencies . . . . .	<i>Biskeborn</i> . . . . . 88
Wiping Solder with Improved Handling Characteristics . . . . .	<i>Schumacher</i> . . . . . 303
Carrier System and Equipment	
Alarm System for Auxiliary Repeater Stations . . . . .	<i>Rosene</i> . . . . . 345
C5 Carrier System . . . . .	<i>Montfort</i> . . . . . 354
Crosstalk Balancing Coils Designed for Type-K Carrier Telephone Systems . . . . .	
	<i>Slade</i> . . . . . 199
Crosstalk Reference Standard . . . . .	<i>Nielsen</i> . . . . . 232
Gas-Tube Noise Generator for Circuit Testing . . . . .	<i>Peterson</i> . . . . . 81
Installing Crystal in Coaxial Filter (Picture) . . . . .	257
J-Type Carrier Telephone System	
Broad-Band Carrier System for Open-Wire Lines . . . . .	<i>Moore</i> . . . . . 226
Cables for the J System . . . . .	<i>Kreisher</i> . . . . . 328
Crosstalk Balancing . . . . .	<i>Noyes</i> . . . . . 374
Terminal Circuits . . . . .	<i>Leconte</i> . . . . . 292
Measuring Lines for Program Transmission	
No. 19 Type Oscillator . . . . .	<i>Harazin</i> . . . . . 108
No. 13A Transmission Measuring Set . . . . .	<i>Hudack</i> . . . . . 108
Testing Shields for Line Structures Operating at Carrier-Frequencies . . . . .	<i>Biskeborn</i> . . . . . 88
Vacuum Tube for Coaxial Repeaters (Picture) . . . . .	222
Central Office Systems and Equipment	
Circuit Features of 3B Toll Boards . . . . .	<i>Shoffstall</i> . . . . . 167
Cleaning Contacts . . . . .	309
Coils for Operators' Telephone Sets . . . . .	185
Code-Ringing Supply for Community Dial Offices . . . . .	<i>Duguid</i> . . . . . 243
Crossbar System	
Contacts for Crossbar Apparatus . . . . .	<i>Rumson</i> . . . . . 278
Call-Indicator Pulsing . . . . .	<i>Soffel</i> . . . . . 236
Field Tests . . . . .	<i>Lacerte</i> . . . . . 113
Laboratory Tests . . . . .	<i>Viol</i> . . . . . 186
Lockout Circuits . . . . .	<i>Korn</i> . . . . . 21
Trunking Studies . . . . .	<i>Lovell</i> . . . . . 38
Dialing Incomings . . . . .	<i>Germanton</i> . . . . . 15
Effect of Extended Signalling Range for Subscriber Loops . . . . .	<i>Reier</i> . . . . . 182
Intertoll Dialing with Step-by-Step Selector . . . . .	<i>Swain</i> . . . . . 266
Motor-Driven Switchboard Clock . . . . .	235
Paper Shield for Switches to Prevent Dust (Picture) . . . . .	27
Weather Announcing System	
General Description . . . . .	<i>Bennett</i> . . . . . 66
Tape Machines, The . . . . .	<i>Cushman</i> . . . . . 70
Transmission Features . . . . .	<i>Merrill</i> . . . . . 283
Vibrometer for Measuring Relative Motion of Equipment in Panel Offices (Picture) . . . . .	373

## Chemical Laboratories

Continuous Breakdown Test for Enameled Wire . . . . .	<i>Pope</i> . . . . .	58
Dielectric Loss in Ice . . . . .	<i>Murphy</i> . . . . .	241
Electrographic Printing . . . . .	May—I to IV	
Heavy Water Rochelle-Salt Crystals . . . . .		368
Printing Techniques in Analytical Chemistry . . . . .	<i>Hermance</i> . . . . .	269
Wiping Solder with Improved Handling Characteristics . . . . .	<i>Schumacher</i> . . . . .	303
Chester, New Jersey		
Outside Plant Field Laboratory . . . . .	<i>Chase</i> . . . . .	214
Circuits		
Lockout Circuits . . . . .	<i>Korn</i> . . . . .	21
The Longitudinal Circuit . . . . .	<i>Shetzline</i> . . . . .	2
Clocks		
Motor-Driven Switchboard Clock . . . . .		235
Spark Chronograph, The . . . . .	<i>Marrison</i> . . . . .	54
Telephone Window Display of the A.T.&T. . . . .	<i>Marrison</i> . . . . .	209
Compass, Radio, for Small Vessels (No. 50A) . . . . .	<i>Reichle</i> . . . . .	151
Compensator, Level, for Carrier-Telegraph Systems . . . . .	<i>Thorp</i> . . . . .	46
Contacts		
Cleaning Contacts . . . . .		309
For Crossbar Apparatus . . . . .	<i>Runyon</i> . . . . .	278
Copper, Beryllium, for Bone Conduction Receivers . . . . .		62
Coronavisor, The . . . . .	<i>Skellett</i> . . . . .	162
Crossbar (see Central Office Systems & Equipment)		
Crosstalk		
Balancing Coils for K-Carrier System . . . . .	<i>Slade</i> . . . . .	199
Balancing in the J-Carrier System . . . . .	<i>Noyes</i> . . . . .	374
Measuring Set (Picture) . . . . .		225
Reference Standard . . . . .	<i>Nielsen</i> . . . . .	232
Crystals		
Apparatus for Demonstrating Piezo-Electric Effect (Picture). . . . .		208
Bridge Oscillator with Crystal Control (Picture) . . . . .	Jan.—I to IV	
Heavy Water Rochelle-Salt Crystals . . . . .		368
Installing Crystal in Coaxial Filter (Picture) . . . . .		257
Spark Chronograph, The . . . . .	<i>Marrison</i> . . . . .	54
"Telephone Clock" Window Display of A.T.&T. . . . .	<i>Marrison</i> . . . . .	209

## D

Dials, Sound Test of . . . . .	<i>Stryker</i> . . . . .	343
Dialing Incomings . . . . .	<i>Germanton</i> . . . . .	15
Dielectric Loss in Ice . . . . .	<i>Murphy</i> . . . . .	241
Drop Wire, Improvements in . . . . .	<i>Farnsworth</i> . . . . .	332

## E

Electrographic Printing		
Examples of . . . . .	May—I to IV	
Printing Techniques in Analytical Chemistry . . . . .	<i>Hermance</i> . . . . .	269
Electron Diffraction Patterns of Silica and Aluminum Hydrate . . . . .		240
Electron Multiplier (Picture) . . . . .		193

## F

Fans, Telephone Booth Ventilating . . . . .	318
Filters, Installing Crystal in Coaxial (Picture) . . . . .	257
Frequency Modulation . . . . . <i>Chaffee</i> . . . . .	177

## G

Gauge, Magnetic Strain, for Aerial Cable Sheath . . . . .	181
Guided Waves	
Demonstration of Guided Waves . . . . . <i>Southworth</i> . . . . .	194
Metal Horns as Radiators of Electric Waves . . . . . <i>King</i> . . . . .	247

## H

Handsets (see Subscriber Station Equipment)	
Hearing Tests, Analysis of World's Fairs' . . . . . <i>Montgomery</i> . . . . .	98
Hinges, Life Test of Telephone Booth (Picture) . . . . .	382
Hysteresis Model, New . . . . . <i>Goucher</i> . . . . .	358

## I

Ice, Dielectric Loss in . . . . . <i>Murphy</i> . . . . .	241
Insulation	
Continuous Breakdown Test for Enameled Wire . . . . . <i>Pope</i> . . . . .	58

## K

Key Telephone Systems	
No. 1A . . . . . <i>Herckmans</i> . . . . .	369
No. 2A . . . . . <i>Allen</i> . . . . .	315

## L

Lockout Circuits . . . . . <i>Korn</i> . . . . .	21
Loud Speakers, Nos. 750A and 751A . . . . . <i>Hopkins</i> . . . . .	251

## M

Magnetic Strain Gauge for Aerial Cable Sheath . . . . .	181
Magnetic Tape Machine for Weather Announcing	
Description of System . . . . . <i>Bennett</i> . . . . .	66
Tape Machine, The . . . . . <i>Cushman</i> . . . . .	70
Magnetization	
Hysteresis Model, New . . . . . <i>Goucher</i> . . . . .	358
Magnetic Materials Testing . . . . . <i>Ashworth</i> . . . . .	49
Manahawkin, New Jersey	
Musa System for London Service . . . . . <i>Oswald</i> . . . . .	130
Measurements and Testing	
Artificial Mastoid for Audiphone Measurements . . . . . <i>Hawley</i> . . . . .	73
Beat Notes in High-Frequency Calibration . . . . . <i>Stansel</i> . . . . .	116
Cathode Ray Oscillograph, Automatic . . . . . <i>Gaines</i> . . . . .	145
Crossbar System	
Field Tests . . . . . <i>Lacerte</i> . . . . .	113
Laboratory Tests . . . . . <i>Viol</i> . . . . .	186
Crosstalk	
Measuring Set (Picture) . . . . .	225
Reference Standard . . . . . <i>Nielsen</i> . . . . .	232

Measurements and Testing (Continued)

Enameled Wire, Continuous Breakdown for . . . . .	<i>Pope</i> . . . . .	58
Gas-Tube Noise Generator for Circuit Testing . . . . .	<i>Peterson</i> . . . . .	81
Magnetic Materials Testing . . . . .	<i>Ashworth</i> . . . . .	49
Program Transmission, Measuring Lines for		
No. 13A Transmission Measuring Set . . . . .	<i>Hudack</i> . . . . .	108
No. 19 Type Oscillator . . . . .	<i>Harizim</i> . . . . .	108
Optical Curve Analysis . . . . .	<i>Montgomery</i> . . . . .	28
Relay Chatter Meter . . . . .		254
Shields for Testing Carrier-Frequency Line Structures . . . . .	<i>Biskeborn</i> . . . . .	88
Strain Gauge, Magnetic, for Aerial Cable Sheath . . . . .		181
Switchboard Plug Testing (Picture) . . . . .		327
Ringers and Dials, Sound Tests of . . . . .	<i>Stryker</i> . . . . .	343
Telegraph Circuits, No. 161A Test Set for . . . . .	<i>Cory</i> . . . . .	365
Telephone Booth Door Hinges, Life Test of (Picture) . . . . .		382
Transient Disturbances, Recording of . . . . .	<i>Grismore</i> . . . . .	140
Vacuum Tubes, Determination of the Average Life of . . . . .	<i>Gannett</i> . . . . .	378
Vibrometer for Measuring Relative Motion (Picture) . . . . .		373
"VU" and the New Volume Indicator . . . . .	<i>Brand</i> . . . . .	310
<b>Metals</b>		
Beryllium Copper for Bone Conduction Receiver . . . . .		62
<b>Microphones</b>		
No. 637 Type for Ortho-Technic Audiphone . . . . .	<i>Tuffnell</i> . . . . .	8
Motion Pictures, High-Speed, of the Human Vocal Cords . . . . .	<i>Farnsworth</i> . . . . .	203
<b>Noise Studies</b>		
<b>N</b>		
The Longitudinal Circuit . . . . .	<i>Shetzline</i> . . . . .	2
New York World's Fair (see World's Fairs)		
<b>O</b>		
Operator Training Facilities at Toll Switchboards . . . . .	<i>Elliott</i> . . . . .	119
Operators' Telephone Sets, Coils for . . . . .		185
Optical Curve Analysis . . . . .	<i>Montgomery</i> . . . . .	28
<b>Oscillographs</b>		
Automatic Cathode-Ray Oscillograph . . . . .	<i>Gaines</i> . . . . .	145
For Recording Transient Disturbances . . . . .	<i>Grismore</i> . . . . .	140
<b>Oscillators</b>		
Bridge Oscillator (Picture Section) . . . . .		Jan.—I to IV
Calibrating Oscillators by Beat-Note Method . . . . .	<i>Stansel</i> . . . . .	116
No. 19 Type . . . . .	<i>Harazim</i> . . . . .	108
Ultra-High-Frequency Oscillator (Picture) . . . . .		121
<b>Outside Plant</b>		
Cables for the J-Carrier System . . . . .	<i>Kreisher</i> . . . . .	328
Crimping Tool for Coaxial Conductors . . . . .		152
Dielectric Loss in Ice . . . . .	<i>Murphy</i> . . . . .	241
Field Laboratory at Chester, New Jersey . . . . .	<i>Chase</i> . . . . .	214
Improvements in Drop Wire . . . . .	<i>Farnsworth</i> . . . . .	332
Testing Shields for Carrier-Frequency Line Structures . . . . .	<i>Biskeborn</i> . . . . .	88



**P**

Permeability Measurements of Magnetic Materials . . . . .	<i>Ashworth</i>	49
Physical Research		
Analysis of World's Fairs' Hearing Tests . . . . .	<i>Montgomery</i>	98
Crossbar Trunking Studies . . . . .	<i>Lovell</i>	38
Diffraction Patterns of Silica and Aluminum Hydrate . . . . .		240
High-Speed Motion-Pictures of the Human Vocal Cords . . . . .	<i>Farnsworth</i>	203
Hysteresis Model . . . . .	<i>Goucher</i>	358
Magnetic Materials Testing . . . . .	<i>Ashworth</i>	49
Optical Curve Analysis . . . . .	<i>Montgomery</i>	28
Stereophonic Reproduction from Film . . . . .	<i>Fletcher</i>	260
Varistors: Their Characteristics and Uses . . . . .	<i>Becker</i>	332
Plugs, Testing Switchboard (Picture) . . . . .		327
Power Plants		
Code Ringing Supply for Community Dial Offices . . . . .	<i>Duguid</i>	243
Printing		
Electrographic Printing . . . . .		May-I to IV
Printing Techniques in Analytical Chemistry . . . . .	<i>Hermanne</i>	269
Private Branch Exchanges		
No. 1A Key Telephone System . . . . .	<i>Allen</i>	315
No. 2A Key Telephone System . . . . .	<i>Herckmans</i>	369
Telephone Facilities for Airport Traffic Control . . . . .	<i>Halligan</i>	298
Prizes and Other Honors		
A.I.E.E. Paper Award to F. J. Scudder and N. J. Reynolds . . . . .		342
Elliott Cresson Medal to R. R. Williams . . . . .		272
Eta Kappa Nu Award to L. A. Meacham . . . . .		139
I.R.E. Medal of Honor Awarded to Lloyd Espenschied . . . . .		367
Probability Studies of Crossbar Trunking . . . . .	<i>Lovell</i>	38
Protection		
Automatic Cathode-Ray Oscillograph . . . . .	<i>Gaines</i>	145
Recording Transient Disturbances . . . . .	<i>Grismore</i>	140
Public Address Systems		
Audition Demonstration at New York World's Fair . . . . .	<i>Gushman</i>	273
Nos. 750A and 751A Loud Speaking Telephones . . . . .	<i>Hopkins</i>	251
Stereophonic Recording and Reproducing		
Carnegie Hall Demonstration . . . . .		258
Description of System . . . . .	<i>Fletcher</i>	260
Editorial Comment in New York World-Telegram . . . . .		277

Quartz Crystals (see Crystals) **Q**

Radio **R**

Aircraft		
Telephone Facilities for Airport Traffic Control . . . . .	<i>Halligan</i>	298
Antennas		
Manahawkin Musa, The . . . . .	<i>Oswald</i>	130
No. 33B Directive Antenna Control Unit (Picture) . . . . .		83

Radio (Continued)

Broadcast	
No. 14C Program Amplifier . . . . .	<i>Meyers</i> . . . . . 362
"VU" and the New Volume Indicator (745B) . . . . .	<i>Brand</i> . . . . . 310
Compass, No. 50A . . . . .	<i>Reichle</i> . . . . . 151
Frequency Modulation . . . . .	<i>Chaffee</i> . . . . . 177
General	
Bell System's Radio Services, April 1, 1940 . . . . .	302
Coronavisor, The . . . . .	<i>Skellett</i> . . . . . 162
Exponential Transmission Line, The . . . . .	<i>Burrows</i> . . . . . 174
Guided Waves, Demonstration of . . . . .	<i>Southworth</i> . . . . . 194
Metal Horns as Radiators of Electric Waves . . . . .	<i>King</i> . . . . . 247
Spots on the Sun . . . . .	<i>Durkee</i> . . . . . 305
Ultra-High-Frequency Oscillator (Picture) . . . . .	121
Receivers	
No. 23AB Remotely Controlled . . . . .	<i>McKennie</i> . . . . . 76
Single-Sideband Short-Wave Receiver . . . . .	<i>Gabriel</i> . . . . . 84
Transmitters, No. 443-A-1 Broadcast . . . . .	<i>Reise</i> . . . . . 17
Transoceanic	
Manahawkin Musa, The . . . . .	<i>Oswald</i> . . . . . 130
Single-Sideband Short-Wave Receiver . . . . .	<i>Gabriel</i> . . . . . 84
No. 23AB Remotely Controlled Radio Receiver . . . . .	<i>McKennie</i> . . . . . 76
Ship-to-Shore, Remote Control of Radio Systems . . . . .	<i>Pruden</i> . . . . . 91
Receiver, No. 710A Bone-Conduction . . . . .	<i>Hawley</i> . . . . . 12
Recording, Feedback Improves Electromechanical . . . . .	<i>Vieth</i> . . . . . 171
Rectifiers	
Varistors: Their Characteristics and Uses . . . . .	<i>Becker</i> . . . . . 322
Relays	
Chatter Meter . . . . .	254
Cleaning Contacts . . . . .	309
Contacts for Crossbar Apparatus . . . . .	<i>Runyon</i> . . . . . 278
Reproducing Machines for Hearing Tests at the World's Fairs	<i>Coles</i> . . . . . 290
Republican Convention at Philadelphia	
Coaxial Cable Used for Television Transmission . . . . .	336
Ringers, Sound Test of . . . . .	<i>Stryker</i> . . . . . 343
Ringing (see Signalling)	
Rochelle-Salt Crystals, Heavy Water . . . . .	368

S

Signalling	
Alarm System for Auxiliary Repeater Stations . . . . .	<i>Rosene</i> . . . . . 345
Code Ringing Supply for Community Dial Offices . . . . .	<i>Duguid</i> . . . . . 243
Crossbar Call-Indicator Pulsing . . . . .	<i>Soffel</i> . . . . . 236
Effect of Extended Signalling Range for Subscriber Loops . . . . .	<i>Reier</i> . . . . . 182
Intertoll Dialing with Step-by-Step Selectors . . . . .	<i>Swain</i> . . . . . 266
Signalling System for Intertoll Dialing . . . . .	<i>Sheppard</i> . . . . . 337
Silicosis—Electron Diffraction Patterns of Silica and Aluminum Hydrate . . . . .	
	240

Solder, Improved Handling Characteristics of Wiping . . . . .	<i>Schumacher</i>	303
Sound Recording Improved by Feedback . . . . .	<i>Vieth</i>	171
Sound, Speech, Hearing and Acoustics		
Analysis of World's Fairs' Hearing Tests . . . . .	<i>Montgomery</i>	98
Hearing Test Machines at the World's Fairs . . . . .	<i>Coles</i>	290
Optical Curve Analysis . . . . .	<i>Montgomery</i>	28
Sound Tests of Telephone Ringers and Dials . . . . .	<i>Stryker</i>	343
Stereophonic Recording and Reproduction		
Carnegie Hall Demonstration . . . . .		258
Description of System . . . . .	<i>Fletcher</i>	260
Editorial Comment in New York World Telegram . . . . .		277
Vocal Cords, High-Speed Motion Pictures of the Human . . . . .	<i>Farnsworth</i>	203
Vocoder, The . . . . .	<i>Dudley</i>	122
Subscribers Station Equipment		
Lucite Handset Exhibited at World's Fair (Picture) . . . . .		97
No. 1A Key Telephone Systems . . . . .	<i>Allen</i>	315
No. 2A Key Telephone Systems . . . . .	<i>Herckmans</i>	369
Sound Tests of Telephone Ringers and Dials . . . . .	<i>Stryker</i>	343
Telephone Facilities for Airport Traffic Control . . . . .	<i>Halligan</i>	298
Sunspots		
Coronavisor, The . . . . .	<i>Skellett</i>	162
Spots on the Sun . . . . .	<i>Durkee</i>	305
Switchboards (see Central Office Systems & Equipment)		
Switches—Paper Shield to Prevent Dust (Picture) . . . . .		27

## T

Telegraph Systems and Equipment		
Chatter Meter for Telegraph Relays . . . . .		254
Level Compensator for Carrier-Telegraph Systems . . . . .	<i>Thorp</i>	46
No. 161A Test Set for Transmission Tests . . . . .	<i>Cory</i>	365
Telephone Booths		
Life Test of Hinges (Picture) . . . . .		382
Ventilating Fans (Picture) . . . . .		318
Television		
National Republican Convention . . . . .		336
Television Transmission over Telephone Cables . . . . .	<i>Weis</i>	34
Testing (see Measurements and Testing)		
Toll Systems and Equipment		
Alarm System for Auxiliary Repeater Stations . . . . .	<i>Rosene</i>	345
Broad-Band Carrier System for Open-Wire Lines (Type J) . . . . .	<i>Moore</i>	226
C5 Carrier System . . . . .	<i>Montfort</i>	354
Cables for the J-Carrier System . . . . .	<i>Kreisher</i>	328
Circuit Features of the 3B Toll Board . . . . .	<i>Shoffstall</i>	167
Crosstalk		
Balancing Coils for Type-K Carrier System . . . . .	<i>Slade</i>	199
Balancing in the Type-J Carrier System . . . . .	<i>Noyes</i>	374
Measuring Set (Picture) . . . . .		225
Reference Standard . . . . .	<i>Nielsen</i>	232

Toll Systems and Equipment (Continued)		
Intertoll Dialing with Step-by-Step Selectors . . . . .	<i>Swain</i>	266
No. 3B Toll Switchboard . . . . .	<i>Greene</i>	104
Operator Training Facilities at Toll Switchboards . . . . .	<i>Elliott</i>	119
Signalling System for Intertoll Dialing . . . . .	<i>Sheppard</i>	337
Terminal Circuits for the J-Carrier System . . . . .	<i>Leconte</i>	292
Toll-Call Demonstration at the New York World's Fair . . . . .	<i>Bartheld</i>	135
Transpositions . . . . .	<i>Babcock</i>	153
Tools, Crimping, for Coaxial Conductors . . . . .		152
Training Facilities for Toll-Switchboard Operators . . . . .	<i>Elliott</i>	119
Transient Disturbances, Recording		
Automatic Cathode-Ray Oscillograph for . . . . .	<i>Gaines</i>	145
General Description of System . . . . .	<i>Grismore</i>	140
Transmission-Measuring Set, No. 13A . . . . .	<i>Hudack</i>	108
Transmitters, 637-Type, for Ortho-Technic Audiphone . . . . .	<i>Tuffnell</i>	8
Transpositions		
Longitudinal Circuit, The . . . . .	<i>Shetzline</i>	2
Methods of Transpositions . . . . .	<i>Babcock</i>	153
Trunking Studies for Crossbar System . . . . .	<i>Lowell</i>	38

## V

### Vacuum Tubes

Coaxial Repeater Tube (Picture) . . . . .		222
Determination of the Average Life of Vacuum Tubes . . . . .	<i>Gannett</i>	378
Electron Multiplier (Picture) . . . . .		193
Gas-Tube Noise Generator for Circuit Testing . . . . .	<i>Peterson</i>	81
Repeater Tubes, Improved . . . . .	<i>Moore</i>	219
No. 357A Vacuum Tube		
Photograph of Installed Tube . . . . .		1
X-Ray Photograph . . . . .		129
Varistors: Their Characteristics and Uses . . . . .	<i>Becker</i>	322
Ventilating Fans for Telephone Booths . . . . .		318
Vibrometer for Measuring Relative Motion (Picture) . . . . .		373
Vocal Cords, High-Speed Motion Pictures of the Human . . . . .	<i>Farnsworth</i>	203
Vocoder, The . . . . .	<i>Dudley</i>	122
"VU" and the New Volume Indicator (No 745B) . . . . .	<i>Brand</i>	310

## W

### Wave Guides

Demonstration of Guided Waves . . . . .	<i>Southworth</i>	194
Metal Horns as Radiators of Electric Waves . . . . .	<i>King</i>	247
Weather by Telephone		
General Description of System . . . . .	<i>Bennett</i>	66
Tape Machine, The . . . . .	<i>Cushman</i>	70
Transmission Features of System . . . . .	<i>Merrill</i>	283

### Wires

Continuous Breakdown Test for Enameled Wires . . . . .	<i>Pope</i>	58
Improvements in Drop Wire . . . . .	<i>Farnsworth</i>	332
Twisting a Pair for Experimental Purposes (Picture) . . . . .		Oct.-I

World's Fairs

Analysis of World's Fairs Hearing Tests . . . . .	<i>Montgomery</i> . . . . .	98
Audition Demonstration of the New York World's Fair . . . . .	<i>Cushman</i> . . . . .	273
Equipment for Demonstration Toll Call . . . . .	<i>Bartheld</i> . . . . .	135
Hearing Test Machines at the World's Fairs . . . . .	<i>Coles</i> . . . . .	290

X

X-Ray of No. 357A Power Tube (Picture) . . . . .		129
--	--	-----