

# BELL LABORATORIES RECORD



QUIET TUBES  
FOR AMPLIFICATION  
G. L. PEARSON

HETERODYNE  
OSCILLATOR  
T. SLONCZEWSKI

NON-DIRECTIONAL  
MICROPHONE  
R. N. MARSHALL

OCTOBER 1935 Vol. XIV No. 2

# BELL LABORATORIES RECORD

---

*Published Monthly by BELL TELEPHONE LABORATORIES, INC.*

PAUL B. FINDLEY, *Managing Editor*      PHILIP C. JONES, *Associate Editor*

*Board of Editorial Advisors*

C. S. DEMAREST      W. FONDILLER      H. A. FREDERICK      O. M. GLUNT  
H. H. LOWRY      W. H. MARTIN      W. H. MATTHIES      JOHN MILLS  
D. A. QUARLES      J. G. ROBERTS      G. B. THOMAS      R. R. WILLIAMS

---

SINGLE COPIES \$0.25; subscriptions are accepted at \$2.00 per year; foreign postage \$0.60 extra per year. Subscriptions should be addressed to Bell Laboratories Record, 463 West Street, New York City

---

## *In this Issue*

A Non-Directional Microphone . . . . .	34
<i>R. N. Marshall</i>	
Hysteretic Modulation . . . . .	39
<i>Robert M. Kalb—William R. Bennett</i>	
Telegraph Testing Facilities . . . . .	45
<i>A. J. Wier</i>	
A Speech Amplifier for Police Radio . . . . .	50
<i>J. E. Tarr</i>	
Centrifugal Type Voltage Regulators . . . . .	53
<i>J. H. Sole</i>	
Quiet Amplifier Tubes . . . . .	56
<i>G. L. Pearson</i>	
Carrier Frequency Heterodyne Oscillator . . . . .	60
<i>T. Slonczewski</i>	
Soldering Lead Cable Electrically . . . . .	65
An Ultra-High-Frequency Radio Receiver for Police Use. . . . .	66
<i>G. N. Thayer</i>	

*Volume 14—Number 2—October, 1935*

CLARKSON COLLEGE OF TECHNOLOGY  
ELECTRICAL ENGINEERING DEPT.

# BELL LABORATORIES RECORD

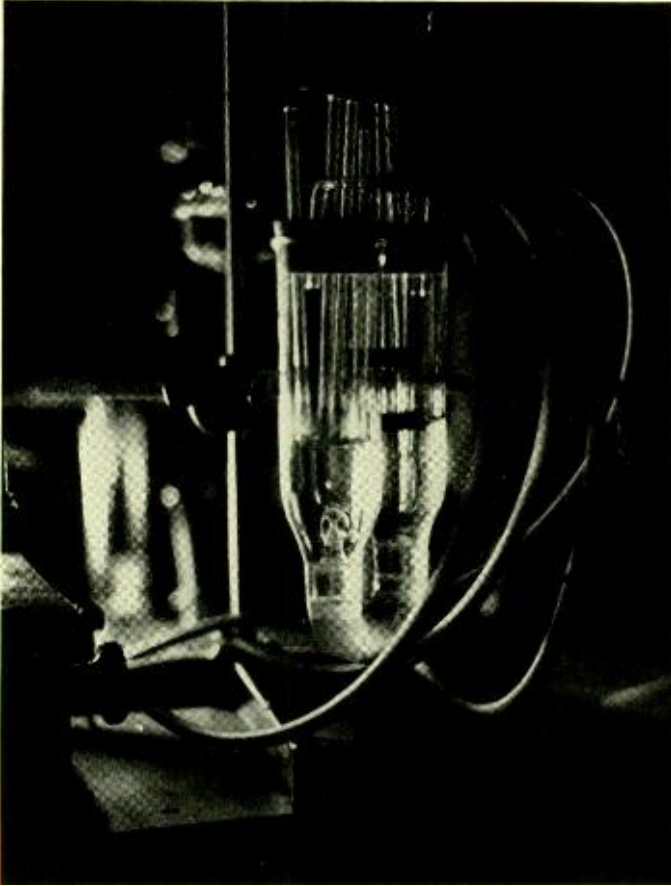

*Electrometric apparatus for measuring the relative strengths of weak acids*

VOLUME FOURTEEN—NUMBER TWO

*for*

OCTOBER

1935



## A Non-Directional Microphone

By R. N. MARSHALL

*Transmission Instruments Engineering*

SINCE its introduction in 1931, the Western Electric moving coil microphone has solved many of the difficulties encountered in broadcasting, sound recording, and public address service. While this microphone was a decided advance over apparatus existing at the time of its introduction, extensive field experience during the past four or five years and continued development studies have now made possible the production of a distinctly better instrument. While retaining all the good features of the previous, or 618A, type the new microphone has the added advantages of a more uniform frequency characteristic from 40 to 10,000 cycles, a considerably wider range than the 618A, and is essentially non-directional in its response. At the same time the microphone is smaller and lighter than the old, and thus of increased portability and convenience. It differs

radically from previous microphones in appearance, consisting of a two and one-half inch spherical housing with a two and one-half inch acoustic screen held a fraction of an inch off the surface. This microphone, known as the 630A, is shown above in the position in which it is normally used.

To build a microphone that will respond uniformly to sound pressures at its face is quite a different thing—and much simpler—than designing it to respond equally to sound coming from any direction. In general a sound field is disturbed by the presence of the microphone, and as a result the pressure at the face of the microphone will not be the same as it was before the microphone was placed in position. This change in pressure caused by the presence of the microphone is largely an effect of diffraction. It is limited to the higher frequencies, varies with the frequency, and is a function of the

size and shape of the microphone and the direction from which the sound waves approach the microphone. Because of this, previous microphones have shown a marked directional effect, which not only varied with the angle of sound incidence, but for any particular angle varied greatly with frequency.

This varying in response with direction and frequency results in a distortion of the output. In many cases—such as when used as a pick-up for large orchestras or choruses, or in sound picture studios—the sound reaching the microphone directly is only a small part of the total. The major part of the sound reaches the diaphragm only after one or more reflections from the walls of the room. As a result most of the sound arrives at the microphone from directions other than the normal one. If the response in these various directions differs, the output of the microphone will not truly represent the sound at the point of pick-up—and this, of course, is distortion. In the new microphone this directional distortion is so slight as to be imperceptible.

The directional effect for the 618A

microphone is shown in Figure 1 for five angles. At 10,000 cycles the difference in response between certain angles is 20 db, and at 5,000 cycles may be over 15 db. In the new microphone this variation has been greatly reduced, as shown in Figure 2. At 10,000 cycles the maximum difference in response for any two directions is only about 5 db, which is imperceptible to the ear. Moreover the new microphone is designed to be mounted so that its diaphragm is horizontal, and thus its response is perfectly uniform for all horizontal angles. The very slight residual directional effect exists only in the vertical plane. When it is used for picking-up addresses or other sounds arriving only in the horizontal plane, there is no directional distortion whatever.

This great improvement has been made possible by extensive study of the causes of the directional effect and the possible means of avoiding it. The directional effect is largely a function of the size of the microphone relative to the wavelength of sound. It might be avoided, therefore, if the microphone could be made small enough, but calculations showed that

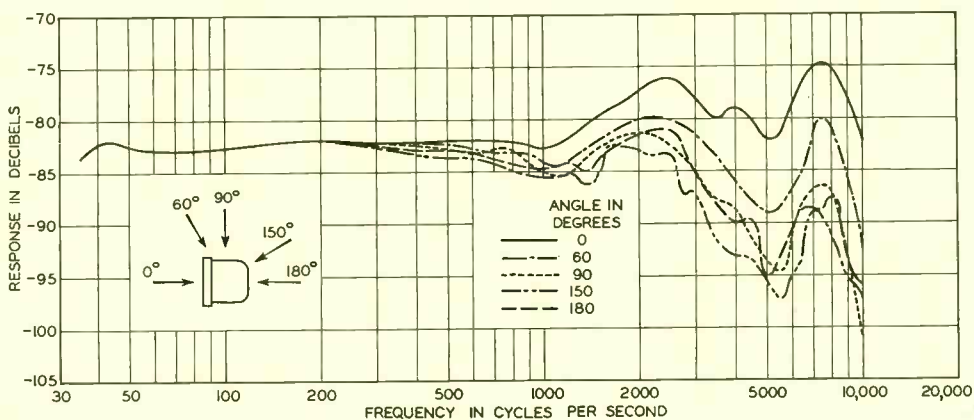

Fig. 1—Field response of 618A microphone over the frequency range from 40 to 10,000 cycles for five angles of incidence

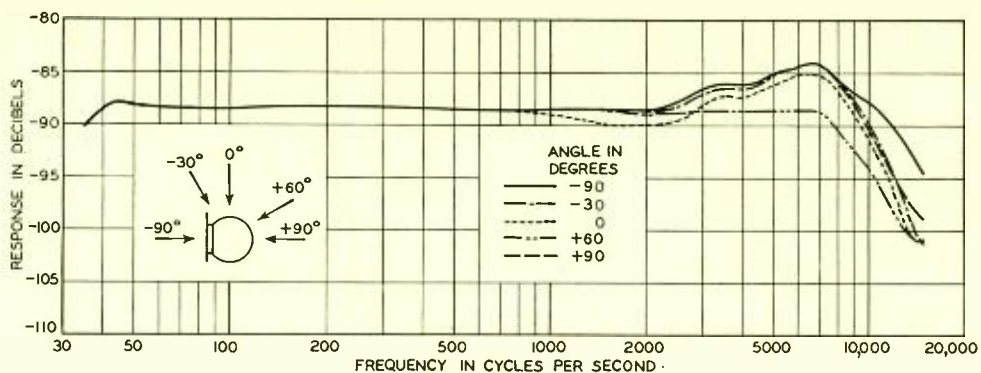

Fig. 2—Field response of new 630A moving-coil microphone for the same five angles of incidence and for the same frequencies

to make the effect negligible at 10,000 cycles, the instrument would have to be approximately  $\frac{1}{2}$ " in diameter. While a microphone of this size could have been built, its output would be considerably less than for the larger instruments, which is objectionable in a microphone designed for general broadcasting and sound picture use. The size of the new microphone was reduced, therefore, only to the point where a satisfactory output could still be obtained, and the remaining tendency to directional distortion was overcome in the design chiefly by employing a spherical shape and by using the acoustic screen mounted just in front of the diaphragm.

Studies made in these laboratories clearly brought out the effect of the shape of the microphone on the directional response. This is indicated in Figure 3, which shows the computed response at a point at the center of three different shaped objects of equal diameter with variation in frequency and direction of arrival. The abscissas are given as the ratio of the diameter of the object to the wavelength of the sound, but the table at the bottom indicates the corresponding frequencies for diameters of 1, 2, and 4 inches. It will be noticed that both the cylin-

der and cube result in a marked directional effect, made more serious by the wavy character of the response, while the variation in response for the sphere is much less and the waviness has practically disappeared.

With a spherical microphone mounted with the diaphragm horizontal, there would be a tendency for the response to be too high for high-frequency sounds coming down from above, that is directly toward the diaphragm, and too low for similar frequencies coming from angles very much below the horizontal. These effects have been almost completely avoided in the new microphone, and an essentially uniform response obtained from sound coming from all directions, by mounting an acoustic screen in front of the diaphragm. This screen was developed by F. F. Romanow, and is designed to produce a loss in sound passing through it, and to reflect back to the diaphragm sound coming from behind the microphone. It thus compensates for the unequal diffractive effects and makes the instrument non-directional in its response characteristics.

Besides these changes designed primarily to reduce the directional effects, extensive changes were made

in the internal construction and arrangement of the microphone to even out the response curve and to extend its range. The general construction is shown in Figure 4. In many of the earlier types of microphones, the cavity in front of the diaphragm introduced an undesirable resonance. In the new microphone this resonance is controlled by the design of the protective grid, which is that part of the outer shell directly in front of the diaphragm. Instead of being the source of undesirable distortion, the grid and cavity have become a valuable aid in improving the response of the instrument at very high frequencies. This grid also incorporates a screen to prevent dust and magnetic particles from collecting on the diaphragm.

The inherent loss due to the reduction in size is partially offset by making the diaphragm light in weight and of very low stiffness. It is very important that the diaphragm should vibrate as a simple piston throughout the entire range. To secure such action over a wide range of frequencies has proved in the past to be a very difficult problem. This problem has been solved quite satisfactorily in connection with the new microphone. No evidence of vibrating in other modes is shown by the diaphragm below 15,000 cycles.

The size and shape of the housing was selected with particular reference to the requirements that had to be met. The size is such that the housing fits closely over the diaphragm and thus produces little more diffractive effects than would the diaphragm itself, and the spherical form allows the maximum amount of air space behind the diaphragm, which is essential to minimize the impedance to vibration. To prevent resonance within the case, an acoustic-resistance baffle is provided to divide the space into two parts. A tube, with its outlet at the back of the housing, serves the double purpose of equalizing the in-

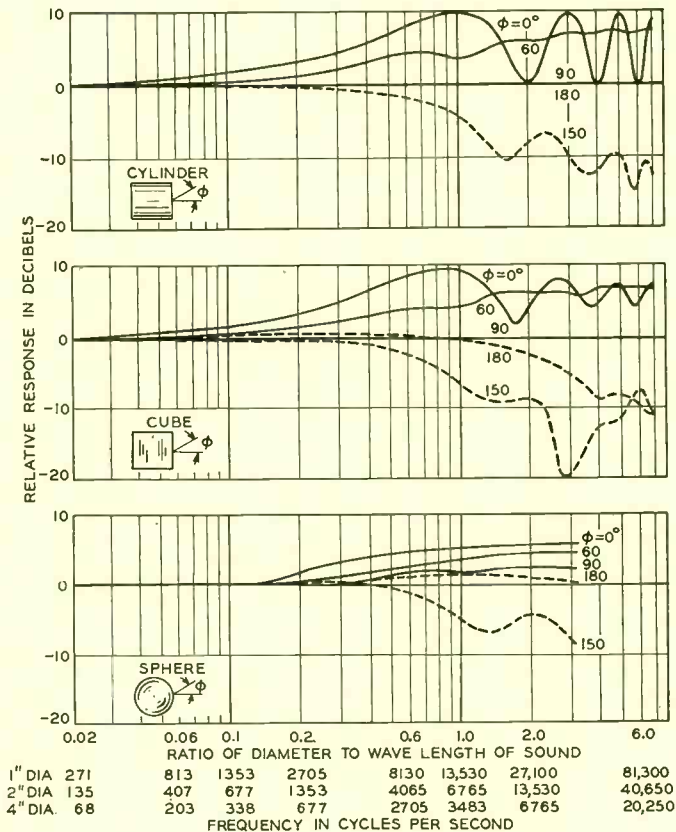

Fig. 3—Difference of response at the center of the end form of a cylinder, cube, and cylinder for sounds coming from different directions and at different frequencies

side and atmospheric pressures, and of increasing the response of the instrument at low frequencies.

The acoustic screen that compensates for the directional effects is mounted over the grid in front of the diaphragm, and is thus an additional protection for the diaphragm. This places it in a vulnerable position, however, but it is designed to withstand considerable shock and the acoustic screen itself is a separate unit and easily replaceable. The terminals of the microphone are provided in the form of a plug recessed in the housing behind the microphone unit. This ar-

range provides protection for the terminals and serves to conceal the connecting jack.

Thoroughgoing research and development studies have thus not only made it possible to provide a microphone that is smaller, more easily handled, and more attractive in appearance than previous types, but have extended the frequency range and reduced the directional effects to a point where they are imperceptible. Its convenient form and desirable characteristics make the new microphone suitable for practically any type of service.

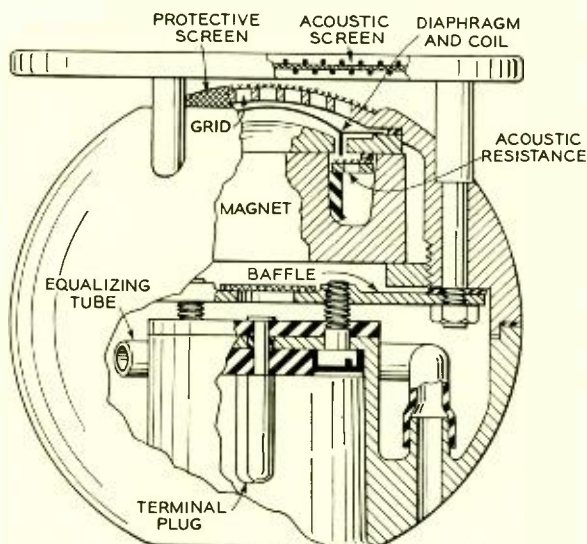

*Fig. 4—Simplified cross-sectional view of the non-directional microphone*



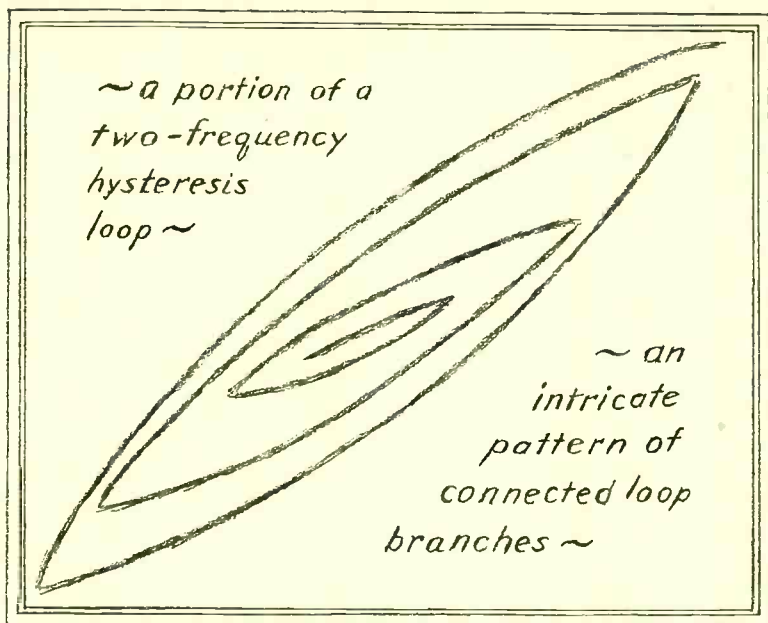

## Hysteretic Modulation

I—By ROBERT M. KALB, II—By WILLIAM R. BENNETT

*Wire Transmission Research*

### I. HISTORY AND BEHAVIOR

**O**FTEN it is stated that iron has a memory because it governs its actions in a way that depends upon changes it has undergone in the past. The mentality this credit implies must be a perverse one, for the essential feature of the hysteresis exhibited is contrariness. An attempt to produce a change of state, in other words, is opposed through some intrinsic property of the metal and this opposition is manifested by a lag of the response behind the actuating force. Furthermore, when this force first alternates between two points, the iron does not respond in exactly the same manner each time, but sufficiently chastened after a few repetitions, finally settles into a cyclic condition. When more complicated changes of the force are

made, the performance is of a truly complex character in which all the past history of the iron may play an appreciable part.

Iron is not uniquely imbued with hysteretic properties. Several metals and alloys, known collectively as ferromagnetic, exhibit the same behavior. Dielectrics likewise often show a similar dependence of the charge upon the voltage, and in mechanical systems, displacements which lag behind the force in a hysteretic manner are all too common.

Perhaps because of its obviousness, magnetic hysteresis has a long historical background. J. A. Ewing coined the name in 1881 from the Greek verb *ὑστερέω*, to lag behind. He made a thorough investigation of it and attempted simple explanations which have been largely substantiated

rather than outmoded during half a century. In the realm of weak fields, Lord Rayleigh was a pioneer. His researches extended over the low magnetizing forces which were destined to wide application throughout the communication industry.

One of Rayleigh's contributions was the analysis of hysteresis loops into harmonic components. We are immediately concerned, since the magnitudes of these components will tell us the distortion of a sine wave to be expected in an iron core coil or a loaded submarine cable—to name two examples.

Rayleigh found by experiment a parabolic relationship between the flux and the magnetizing force producing it, and deduced that in hysteresis loops of different sizes all the upper branches are one and the same curve displaced with respect to one another, and so likewise are the lower branches. In other words, when the force changes in the reverse direction and a new branch of the hysteresis loop is started, it has the same shape regardless of where it has been or where it comes from.

The exposition of hysteretic performance at weak magnetizations was made complete when E. Madelung formulated in concise statements the effects of the past history. He pointed out that it is iron's idiosyncrasy to forget first recent events and remember longest the earliest ones. His study disclosed that, when being carried through complicated changes, the first time the iron returns to a magnetization which has previously been either a maximum or a minimum, it instantly and irrevocably forgets all that has intervened. It attains magnetizations beyond, not by a continuation of the latest parabola, but along the extension of that by which

it arrived before. In its actions it is one hundred per cent behavioristic.

Now it turns out that Rayleigh's findings together with some of Ewing's ideas predicate this performance exactly. However, the latter's measurements, confirmed since, do not accord strictly with the perfect picture painted. Slight departures, possibly explainable in the light of recent generalizations of Rayleigh's theory, are observed. These prove to be quite small, so they can be ignored practically and Madelung's propositions can be used unchanged to predict the performance of iron under the influence of complex forces.

Since the waves produced by speech are themselves very complicated and hence the corresponding hysteresis loop patterns still more intricate, it might seem at first thought to be a hopeless task to attempt a theoretical study of the effects of hysteresis on telephone transmission. It would certainly appear to be advisable to start with something simpler than an actual speech wave. Since much of our telephone transmission theory is based on sinusoidal oscillations, it was natural to begin by studying the response to a single-frequency sinusoidal wave in the hope that the results might be of some use in predicting the behavior of the system when more complicated signals are transmitted. The theory of single-frequency hysteresis loops and of the resulting distortion and impedance change, in a form which comprehends Rayleigh's analysis, was given by E. Peterson in the *Bell System Technical Journal* for October, 1928. It was found possible to establish a useful correlation between this single-frequency theory and the performance of magnetic materials in circuits.

Restriction to a single-frequency

solution, however, excluded adequate treatment of certain phenomena which are of great importance. For example, the distortion of a wave consisting of a single frequency "f" normally results in the production of harmonics only, which are of frequencies 2f, 3f, 4f, 5f, etc.\* In transmitting over a multi-channel carrier system, we are thus able with a single-frequency theory to estimate only the interference which one channel causes in those higher frequency channels which include multiples of the frequency considered. Actually, we know that when two or more frequencies, say  $f_1$  and  $f_2$ , are simultaneously present in the system, the side frequencies or combination tones  $2f_1 + f_2$ ,  $2f_1 - f_2$ ,  $2f_2 + f_1$ ,  $2f_2 - f_1$ , etc., are generated, resulting in a much wider variety of inter-channel interference in both higher and lower frequency channels. It was desirable therefore to extend hysteresis loop theory to include at least two superimposed frequencies. It might indeed

seem necessary to solve the case of three, four, or any greater number of superimposed frequencies. It turns out, however, that little or no addi-

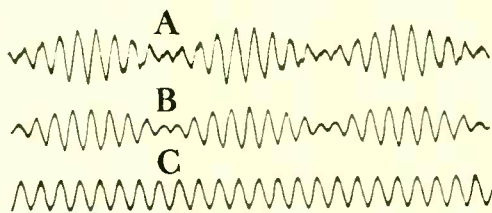

Fig. 2—The distorted voltage wave (a) appears across an iron core coil magnetized by the two-frequency current (b). One component of this current is shown by (c)

tional information of value is obtained by considering more than two frequencies unless the speech wave itself can be simulated and this is not possible with any reasonably small number of frequencies.

## II. CALCULATION AND MEASUREMENT

WITH regard to the actual mechanism of solving a hysteresis problem, we note that if the family of hysteresis loops for the magnetic

\*In the case of iron with no biasing magnetizing force, the hysteresis loops are symmetrical and only the odd harmonics 3f, 5f, etc., are produced.

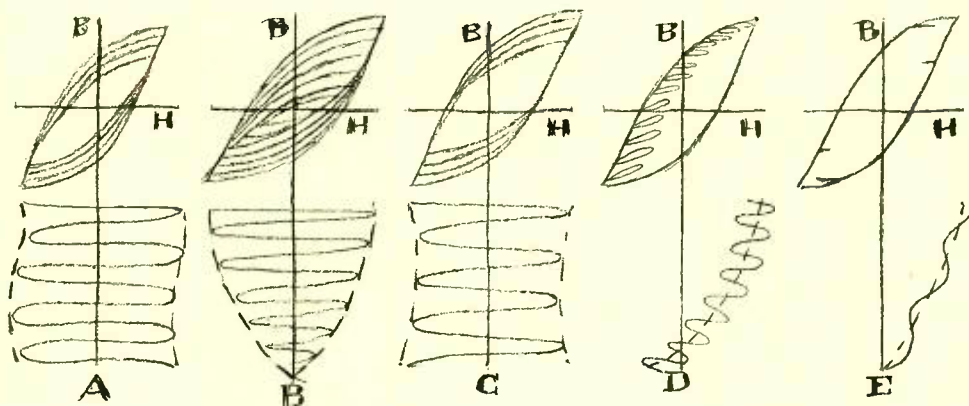

Fig. 1—How hysteresis loops vary when two waves of different frequencies and amplitudes interact in ferromagnetic device. In (a), (b) and (c), the frequencies are nearly the same; in (b) the amplitudes are identical; in (a) the high frequency has the larger amplitude, and in (c) it has the smaller amplitude. In (d) and (e) one frequency is much higher than the other; in (d) the high frequency has a larger amplitude than in (e)

specimen is known, the amount of induction in the iron at any time can be calculated in the single-frequency case provided three things are known.

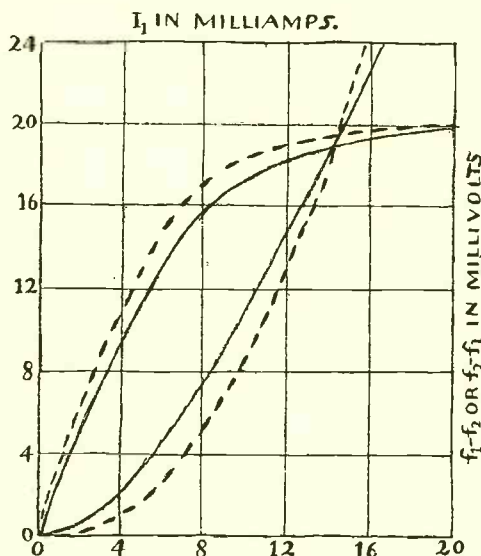

Fig. 3—With two currents exciting a coil, a change in one of these currents brings about dissimilar changes in the magnitudes of the two most important components of the distortion

First, we require the maximum value of magnetizing force reached during each cycle. This enables us to select the proper loop from the family. Next, we must know whether the magnetizing force is increasing or decreasing at the instant in question, so that we may select the proper one of the two loop branches. Finally, we require the actual instantaneous value of magnetizing force. With two applied frequencies the situation is much more complicated, as is illustrated by the sketch\* at the head of this article, which

\*Made from a photograph taken by F. E. Haworth with the hysteresigraph described in the RECORD for December, 1930.

shows a portion of a two-frequency hysteresis loop. Instead of a family of detached loops we now have an intricate pattern of connected loop branches. However, a sort of analogy exists. Corresponding roughly to the maximum amplitude, we have the envelope of the two-frequency wave, which is an approximate guide to the upper and lower limits of the loop branch we are traversing. The envelope of a two-frequency wave is a complicated function of time in contrast to the amplitude of a single-frequency wave, which is simply a constant. Likewise the question as to whether we are on an ascending or descending loop branch is more difficult in the two-frequency case. In the single-frequency case, we have simply two branches each cycle, while in the two-frequency case the duration of a branch varies widely with time. A mathematical method of representing a "branch-changing function" for a two-frequency wave was one of the many details that had to be supplied before the problem could be solved.

The loops resulting from two frequencies have subsidiary loops in a

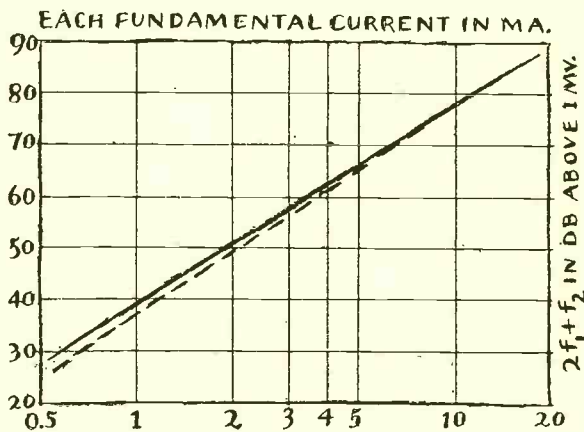

Fig. 4—When the two magnetizing forces have the same amplitude, the distortion voltages vary with its square. A typical component is shown here

variety of patterns within a main loop. These subsidiary loops range from tiny, slender ones to some almost the size and shape of the major loop. Unless the frequencies are rational multiples of each other no loop is ever exactly retraced, and depending upon the ratios of the amplitudes and of the frequencies, something of the sort depicted in Figure 1 continues interminably. Large loops may seem to shift slightly cycle after cycle; the trace may spiral inward and back again alternately; or an endless procession of little loops may seem to move around within a big one. It is from an analysis of this behavior that the distortion of a two-frequency wave must be described.

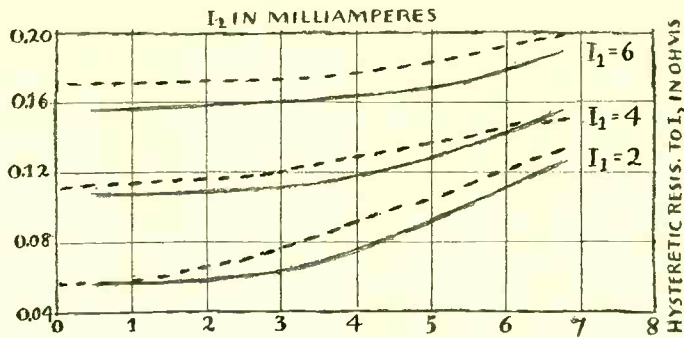

Fig. 5—Because of hysteresis, the resistance to one of two currents increases with either of them

monics and that the lower side frequencies of a pair differ in intensity from the upper ones. The amplitudes of all products follow a square law as functions of fundamental amplitudes. In other words, any component of the distortion is proportional either to the product of these amplitudes or to the square of one of them. Changes in the impedance to either frequency increase with either amplitude.

The phenomenon of hysteresis suppression whereby one frequency absorbs a part of the hysteresis loss which would normally be taken by the other, is found not to occur at the weak fields to which this treatment is limited. In addition to the initial permeability, only one parameter set by the intrinsic properties of the iron is needed to define both the modulation and the impedance variations caused by hysteresis. It is thus possible to express

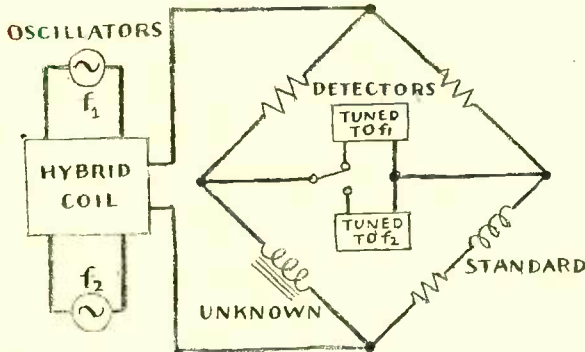

Fig. 6—In this bridge a balance at one frequency with others present is obtained by tuning the detector

Passing over the formal processes involved in the solution, which is given in a paper\* in the *Bell System Technical Journal* for April, 1935, we come to the results. It is found that the side frequencies  $2f_1 \pm f_2$ ,  $2f_2 \pm f_1$ , are in general stronger than the har-

press all two-frequency effects in terms of single-frequency impedance data so that the necessary constants can be easily determined from bridge measurements. The theoretical formulas for impedance change and generated modulation products have been checked by laboratory measurements

\*By Robert M. Kalb and William R. Bennett.

and have been found in agreement.

A novel bridge circuit, shown in Figure 6, was employed to measure the hysteretic impedances. Unlike the flutter bridge,\* which balances one of the currents out of every part of the bridge except the coils being measured, the arrangement shown here allows both currents to enter all arms of the

\*Described in the RECORD for September, 1930.

bridge, but admits only one of them to the tuned detector. To facilitate measurements at either frequency with no retuning, two detectors—one tuned to each frequency—are provided and the desired one can be selected by a switch. Thus measurements can be made on a single coil and the necessity of obtaining specimens in balanced pairs is obviated.

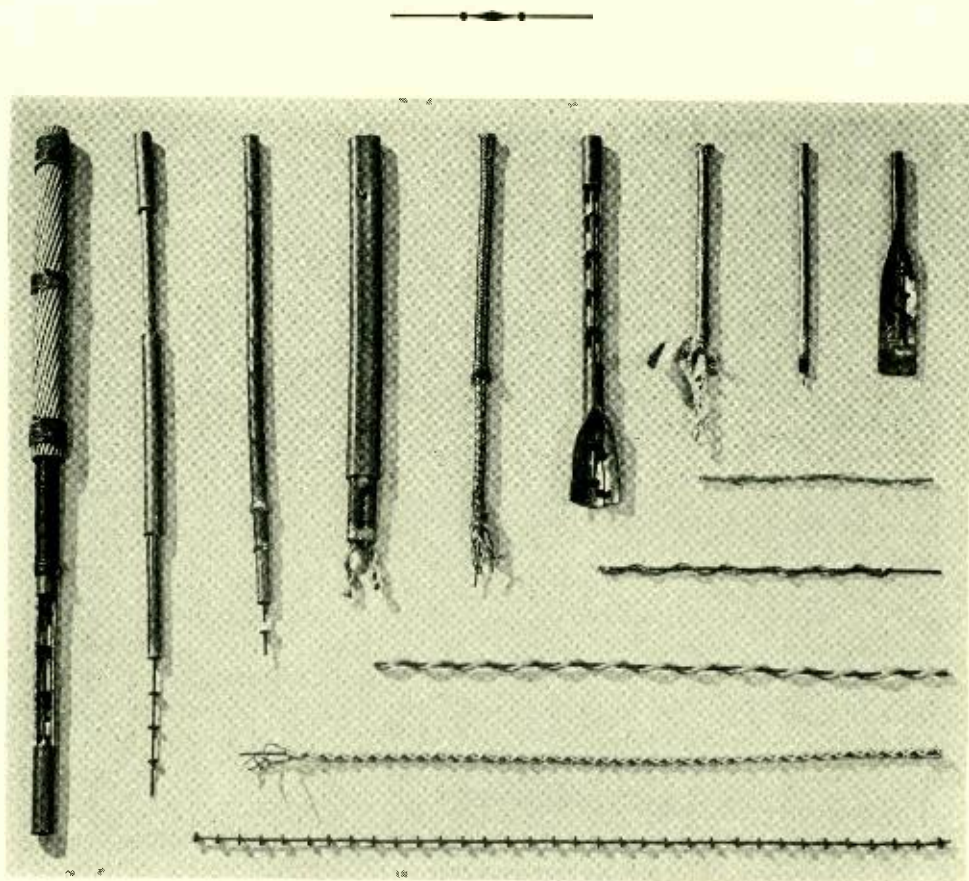

*Experimental Coaxial Structures*

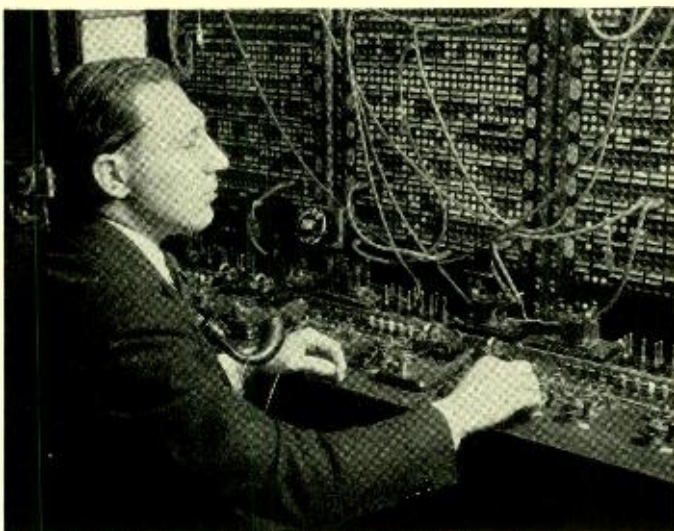

## Telegraph Testing Facilities

By A. J. WIER  
*Equipment Development*

**A**LTHOUGH the public is familiar with the many ramifications of the telephone system, and has some knowledge of the general types of switching operations that must be performed, it is not acquainted nearly so well with the facilities provided for handling leased-wire telegraph service which the Bell System offers. The widespread network of cables and open wire lines of the Bell System makes it a fairly simple matter to furnish lines for telegraph purposes. Another important factor in making telegraph facilities available is the ability to transmit telegraph messages over the same conductors that carry telephone conversations without affecting the transmission of telephone messages. By means of composite sets\* each wire of a telephone circuit can carry a telegraph message in both directions, and practically all of the long open wire

lines are equipped for this type of service. Cable circuits are also employed for telegraph service, but in cables the two wires of a pair are used, thus providing a metallic circuit. Both open wire and cable circuits are also employed for carrier telegraphy, which has come into increasing use in recent years.

Leased-wire telegraph facilities are employed by banking and brokerage houses, news services, and many industrial concerns in varying degrees and for a multiplicity of purposes. They may use the facilities continuously or only for certain hours of the day, and the number of stations connected to a single line also may vary from hour to hour. Provisions must be made, therefore, for making the large number of changes in connection as they are required, and for testing the facilities and maintaining them in good working condition at all times.

\*RECORD, Dec., 1928, p. 140.

The general plan employed is to connect the lines, subscriber's loop, repeaters, battery connections, and testing apparatus to jacks at a common point. Then by means of patching cords—short lengths of cord with a plug at each end—these various elements may be inter-connected as desired. The maintenance facilities employed provide for the most part

for testing only the telegraph equipment; the line conductors themselves are tested and maintained at a toll test board, which is usually separate from the telegraph equipment.

In the very early days of the telephone industry, when telegraph circuits were few, they were terminated for patching purposes in simple jack boxes which were usually mounted on

the wall. Each was made to accommodate the needs of the particular installation, and a very simple arrangement sufficed to care for the limited inter-connection and testing required. As the country grew industrially, and the demands for leased-wire service increased, this simple arrangement became inadequate, and toll test board No. 2 was developed, which was followed by Toll Test Board No. 3. These boards included facilities for all toll testing as well as for telegraph testing, but—like the jack boxes—they were built on a "job" basis: that is, each one was built to meet the specifications for a particular installation.

About the end of the first decade of this century, the telegraph testing equipment, particularly in the larger cities, had reached considerable proportions, and two new boards—Toll Test Board No. 4

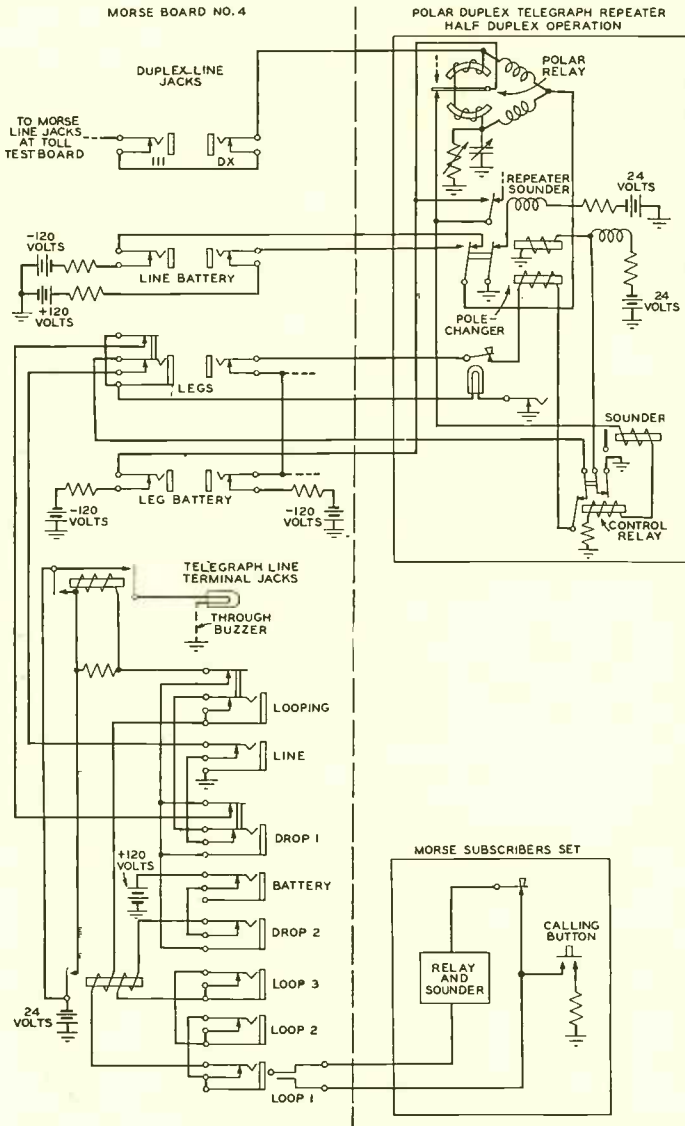

Fig. 1—Simplified schematic of the No. 4 Morse Board



and Morse Board No. 4—were developed to meet the more complex requirements. In these boards the first real attempt was made at standardization. A design was adopted which made it possible to stock the boards, and to supply them on order, with a considerably reduced amount of individual engineering. As a result the boards could be produced on a quantity basis, which allowed improved testing facilities to be provided at a reduced cost.

These new units were of the switchboard type, and consisted of a single-position four-panel or a two-position eight-panel section. Where only a few telegraph circuits were required, the telegraph testing facilities were incorporated in the toll test board, but for all other installations a separate Morse board was supplied. In this board subscriber's loops and the testing equipment were connected to cords and plugs in the key shelf. Each panel of the face equipment was equipped with jacks, which were arranged in an upper and a lower group. To the jacks of the upper group—called duplex jacks for reasons which now have little significance—are connected the lines, positive and negative battery, repeaters, and connections running to jacks of the lower group. The jacks

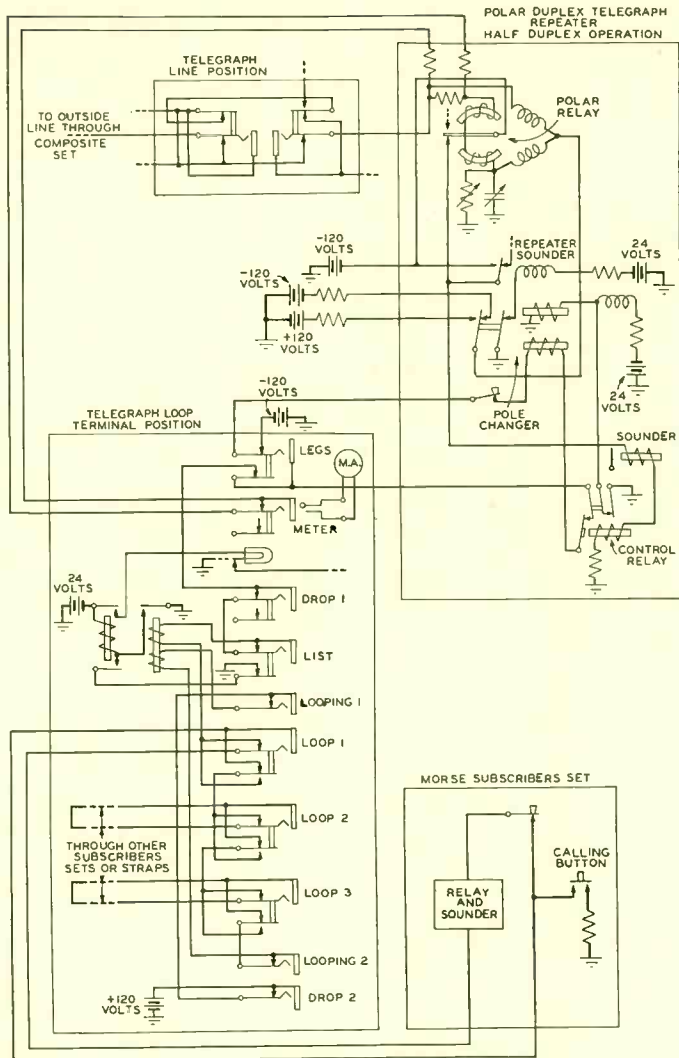
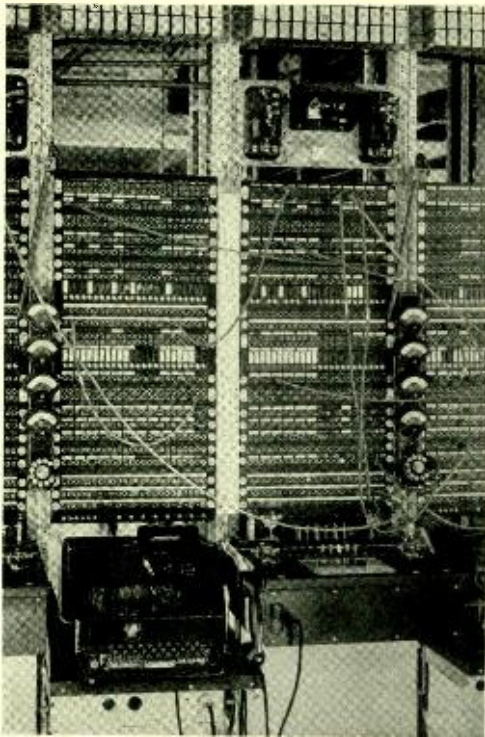

Fig. 2—Simplified schematic of the No. 9 telegraph test board

of the upper group are arranged in pairs, as shown in Figure 1, and double-ended patching cords were employed to set up the required connections. In the lower group are jacks, called telegraph line terminal jacks, into which the subscriber's loops and the testing equipment are plugged as required. These are so arranged that a number of subscribers can be connected into the same circuit or the test board attendant can connect his telegraph equipment into a line or

of the upper group are arranged in pairs, as shown in Figure 1, and double-ended patching cords were employed to set up the required connections. In the lower group are jacks, called telegraph line terminal jacks, into which the subscriber's loops and the testing equipment are plugged as required. These are so arranged that a number of subscribers can be connected into the same circuit or the test board attendant can connect his telegraph equipment into a line or



*Fig. 3—An installation of the No. 9 board in Kansas City*

loop to make the required tests, or to send or receive.

This board was standard for many years and is still furnishing satisfactory service in some offices. Being of the switchboard type, however, it incorporated a lot of expensive woodwork, and—in addition—required more space than was desirable under the crowded post-war conditions. Studies were made to determine what was possible toward reducing cost and space, and as a result of them, Toll Test Board No. 5 was developed. It incorporated both toll and telegraph testing facilities.

The telegraph positions of the new board, shown in the photograph at the head of this article, differed from those of the No. 4 Board in being arranged to mount on standard relay

racks, thus entirely eliminating the woodwork of the switchboard construction. In addition, the equipment was arranged in smaller upper and lower units, which permitted less expensive units without curtailing later expansion. The fundamental difference in circuit was that the subscriber's loops were connected directly to the loop jacks of the lower group instead of being connected to cords as they were in the No. 4 board. With this arrangement dummy plugs were employed to disconnect a subscriber, and double-ended patching cords were used to interconnect them as desired. A shelf, attached to the relay rack, carried the attendant's telegraph and telephone facilities and the testing equipment.

Although Toll Test Board No. 5 is still standard, its telegraph positions were superseded a few years ago by Telegraph Test Board No. 9, which differs from the No. 5 board only in circuit arrangements. The large growth in leased-wire telegraph service made it economical for operating reasons to split the board into two separate and distinct types of positions, Telegraph Line Positions and Telegraph Loop Terminal Positions. This arrangement allowed all the line testing and patching to be done at one board, and all the subscriber loop patching and testing to be carried on at another board. This segregation of operating functions made it possible to concentrate more circuits before each attendant and at the same time to simplify their operating functions. The line jack positions, see Figure 2, are equipped with jack circuits comparable to the Duplex Line Jack circuit, Figure 1, but they are wired so that they can be used with open wire, cable, or carrier telegraph facilities as desired. The loop jack po-

sitions are equipped with jack circuits which include the remaining jacks shown on Figure 1 except the battery jacks, which are no longer required because of the use of alarm type heat coils in all telegraph battery taps. In addition, meter jacks are provided for making current measurements on telegraph repeaters.

The testing equipment used in both the line and loop positions of the No. 9 board is practically the same as that used in the former board. It terminates on plugs and consists of a telephone set for use with trunks and teletypewriter subscribers; telegraph testing circuits for sending, receiving, or monitoring on Morse or teletypewriter circuits; volt-milliammeter cir-

cuits for making voltage and current measurements on line and loop circuits; meter circuits for making current measurements on repeaters, and a telegraph order wire circuit for communicating with distant offices.

A simplified schematic for the two types of positions of the No. 9 board is shown in Figure 2, where the differences between it and the No. 4 board of Figure 1 may be seen. The appearance of the new board is shown in Figure 3 and may be compared with the No. 5 board shown at the head of this article. Although both the No. 4 and No. 5 boards are still in service, the No. 9 board is being supplied exclusively for additions and new installations.

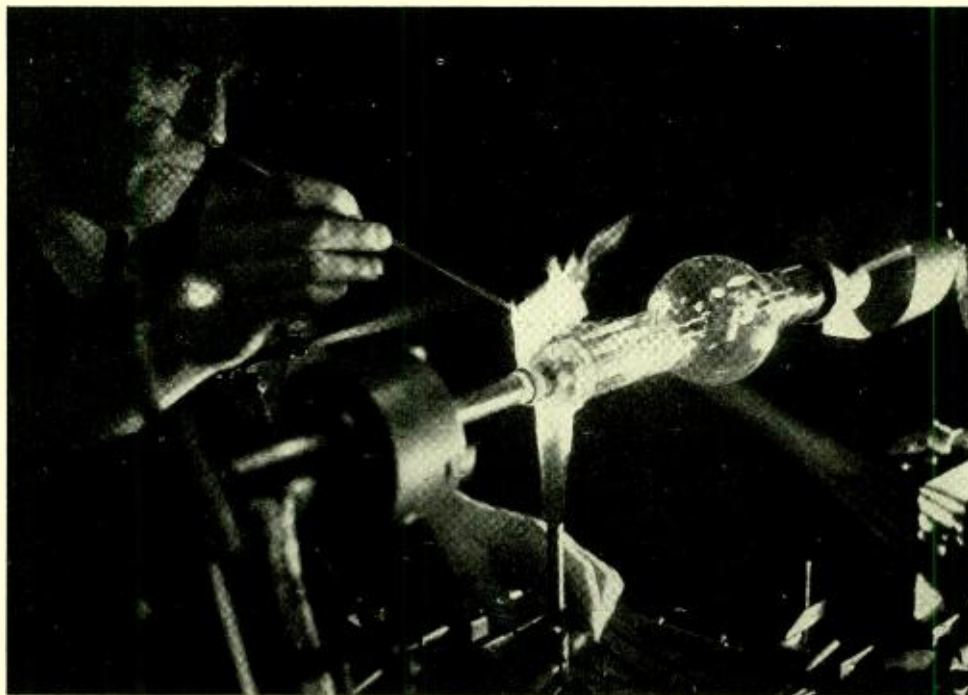

*Sealing-in an experimental vacuum tube*



## A Speech Amplifier for Police Radio

By J. E. TARR

*Radio Development Department*

**R**ADIO dispatching systems, which have come into wide use in recent years, are fundamentally broadcasting systems. In general they consist of a microphone, a speech amplifier, and a radio transmitter. Because of the variety in the type of service desired by various police departments, however, there has been considerable diversity in the auxiliary equipment employed. With a view to standardizing the functional units and making the system more simple, the Laboratories has recently developed a new speech amplifier, designed expressly for police service, which incorporates in a single unit a variety of functions that have heretofore required several different pieces of apparatus. This new amplifier, known as the 89A, is shown in the photograph at the head of this article. In a single small unit is a three-stage am-

plifier with gain control, a volume indicator, a signalling oscillator, two switching keys, and a vacuum tube rectifier circuit that permits the entire unit to be operated from a commercial alternating-current supply. The level indicator, prominent on the front of the unit, indicates the output level, and the knob at the right permits this level to be readily adjusted to the optimum value. The left-hand key below the level indicator sends an attention tone when depressed, and connects the amplifier for announcements when raised. The right-hand key is employed primarily when the amplifier is used with a microphone at the transmitter while most of the announcing is done from a remote point over a telephone line. Under these conditions the key at the transmitter station would normally be depressed, which connects the ampli-

fier to the incoming telephone line. Raising this key disconnects the line and connects the local microphone for emergency announcements.

The input switching key is provided with auxiliary contacts which may be connected to power relays associated with the radio transmitter. When this switch on the speech amplifier at either the dispatching or transmitting position is moved to the microphone position, the radio transmitter will automatically go "on the air." When a radio receiver is used at a dispatching position for monitoring, its control terminals may also be connected to these contacts, so that its loud speaker will be silenced whenever the local microphone is connected, thus preventing the possibility of acoustic feedback or singing.

The signalling key, when up, connects the amplifier for normal operation, but when down supplies a 400-cycle tone, a pitch of about G above middle C, to the radio transmitter. No separate oscillator tube is required; when the key is in the signalling position, the second-stage tube of the speech amplifier is connected to the oscillator circuit, which in turn is connected to the input of the third, or final stage, of the amplifier. The power level of the signalling tone can be controlled by an auxiliary potentiometer which is adjusted by means of a screwdriver inserted in a hole in the front panel of the amplifier.

The 89A speech amplifier is designed for operation with the Western Electric 600A transmitter, which is a standard double-button carbon microphone. This microphone was selected because its output is the highest, and its cost the lowest of available good-quality microphones. Exciting current for the microphone is supplied by the amplifier unit, which also incorporates the center-tapped coupling transformer required. The normal output volume of the amplifier is equivalent to about six milliwatts of single frequency power, but volumes 10 db higher may be used if desired. The zero level point of the volume indicator corresponds to the normal output volume but the multiplier resistance may be changed if it is desired to operate the amplifier at higher volumes. The maximum gain is approximately 65 db, which is sufficient for use with the 600A transmitter even for the maximum output.

As shown in Figure 1, the gain-frequency characteristic of the new amplifier for maximum gain is flat to within 2 db from 100 to 6000 cycles, which is a wide enough frequency range to transmit speech with very good intelligibility. With a gain of 10 db less than maximum, the characteristic is flat within the same limits up to 8000 cycles. When the amplifier is operated at the normal output level of six milliwatts the harmonic distortion is less than one per cent,

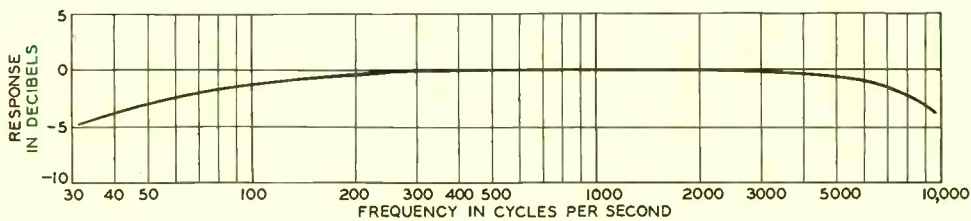

Fig. 1—The gain-frequency characteristic of the 89A amplifier is flat to within 2 db from 100 to 6000 cycles

while even at levels 10 db higher the distortion is less than five per cent. Power noise in the amplifier output is near the threshold of audibility under all operating conditions.

In appearance and general mechanical design the 89A amplifier resembles the radio receiver used at announcing and transmitter stations of police radio systems. As shown in Figure 2 the apparatus is mounted on a metal chassis which may be withdrawn from the cabinet after turning the two locking knobs on the front. All external connections to the amplifier are made through plugs and jacks located at the rear of the chassis, which greatly facilitates the removal of the unit for inspection and servicing.

This new unit provides not only a speech amplifier suitable for uni-



*Fig. 2—Apparatus for the 89A amplifier is mounted on a metal chassis which may be readily removed from the cabinet*

versal application to police radio-dispatching systems, but also such auxiliaries as a volume indicator, a signalling oscillator, current supply for the microphone, and the necessary switching facilities. Heretofore these have required the use of supplementary apparatus. Their consolidation in a single unit simplifies the arrangement of a police dispatching system.



## Centrifugal Type Voltage Regulators

By J. H. SOLE

*Equipment Development*

**B**ATTERIES have invariably been used in the telephone plant to insure the availability at all times of the power required for talking and signalling. It is desirable, moreover, that the voltage of the battery be maintained within close limits at all times, so that the design of the telephone apparatus may be simplified, the life of the battery increased, and maintenance reduced.

This can be accomplished by adjusting the voltage of the charging generator to a value slightly above the normal battery voltage, and by keeping the generator permanently connected across the battery terminals. This method is known as floating. Under normal conditions the generator carries the load and in addition provides a small trickle current to the battery, which maintains it fully charged at all times. Under these conditions the battery is always ready to take over the entire load in case of failure of the outside power supply. Much longer life and less maintenance may be obtained for the battery by this method of operation, since it is the alternate charging and discharging that gradually wear it out.

Successful floating, however, requires that the generator voltage be maintained close to 2.15 volts per cell of the battery. To secure this regulation economically on the smaller machines, the centrifugal type regulator shown in Figure 1 was developed. It consists of a separately excited d-c. motor with a centrifugal type vibrat-

ing switch mounted on one end of the shaft. The armature of the motor is connected across the terminals of the generator to be regulated, and since the motor operates under no-load conditions, its speed is proportional to the voltage across its armature as long as its excitation does not change. To maintain a constant excitation the field is operated at saturation and supplied from a constant source—usually the battery—through a ballast lamp.

The centrifugal switch, shown diagrammatically in Figure 2, consists of a rotating contact and a stationary contact which may be moved toward or away from the rotating contact by a dial while the regulator is either operating or at rest. The rotating contact is fastened to a flat spring secured at its two ends to a collar on the rotating shaft. Weights, riveted to the

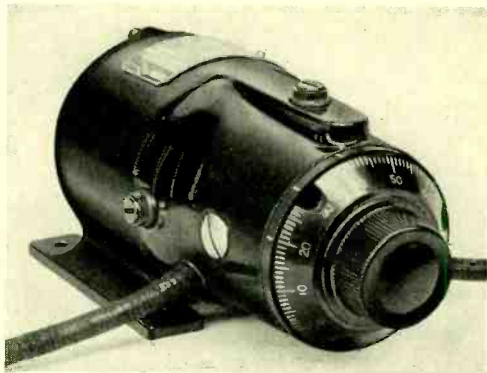

*Fig. 1—The centrifugal type voltage regulator consists of a small direct-current motor with a centrifugal contactor mounted at one end of the shaft*

spring, tend to deflect the rotating contact away from the stationary one as the shaft rotates. The regulating contact is connected across part of the field rheostat of the generator to be regulated. When the contact is closed the resulting generator field current is great enough to produce a voltage considerably higher than desired, and when it is open, the voltage is considerably less than desired. When the generator voltage increases, the governor motor speeds up proportionally and the centrifugal switch opens, thus decreasing the generator field and voltage. A decreased voltage, however, results in a lower speed of the governor motor and the centrifugal switch closes. In actual operation the contact opens and closes in rapid succession and maintains a generator voltage which may be adjusted to the desired value by moving the stationary contact toward or away from the

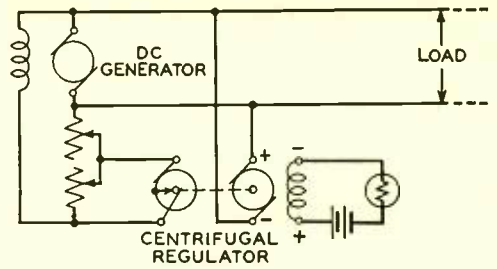

Fig. 3—Simplified schematic of circuit connections employed for centrifugal type voltage regulator

rotating one. The circuit connections for the voltage regulator are shown in Figure 3.

The vibrating contacts close several hundred times a second but the field current, due to the inductance of the field winding, does not follow the rapid increase and decrease in field resistance resulting from the movement of the contacts; instead, it maintains an average value that is constant as long as the governor motor speed is constant. Changes in speed, however, are very rapidly corrected. Even when full load is suddenly applied to an unloaded generator, the voltage remains constant except for a slight oscillation lasting only a small fraction of a second.

The very satisfactory operation of this regulator suggested that its advantages might be extended to apply to the twenty-cycle ringing supply generator. It was felt that maintenance on ringers in subsets could be reduced if the ringing supply voltage could be held more

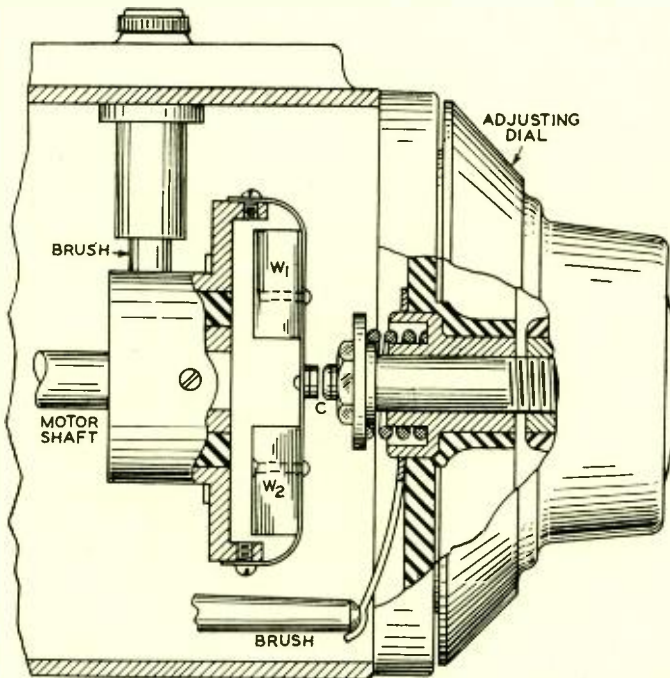

Fig. 2—Diagrammatic representation of rotating switch used with centrifugal type voltage regulator



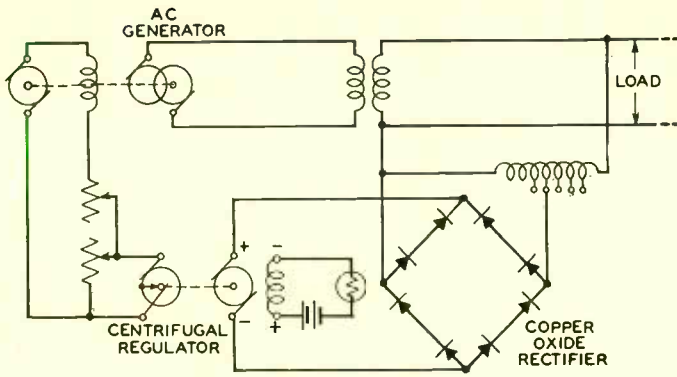

Fig. 4—Application of the centrifugal type voltage regulator to ringing supply generators

nearly constant. The regulator developed for d-c. generators was made applicable to a-c. generators merely by the addition of an auto-transformer and a copper-oxide rectifier. The auto-transformer takes care of the difference in voltage of the ringing and battery-charging generators and the rectifier converts the alternating current to direct current to supply the armature of the regulating motor, as shown in Figure 4. Since the copper-

oxide rectifier is independent of frequency, the regulator may be applied to any generator of suitable capacity with frequency from 20 to 5000 cycles by the use of a suitable auto-transformer. The regulators have found wide application. The d-c. regulator is used with charging generators up to 400 amperes at 33 volts, 200 amperes at 65 volts, or 150 amperes at 175 volts, and also with generators for teletypewriter power supply. An installation for toll development laboratories is shown in Figure 5. A switching arrangement permits either of the regulators to be used with either of the generators. The a-c. regulator has been applied to one-half ampere ringing machines where the earlier regulators would have consumed the full load output of the machine.

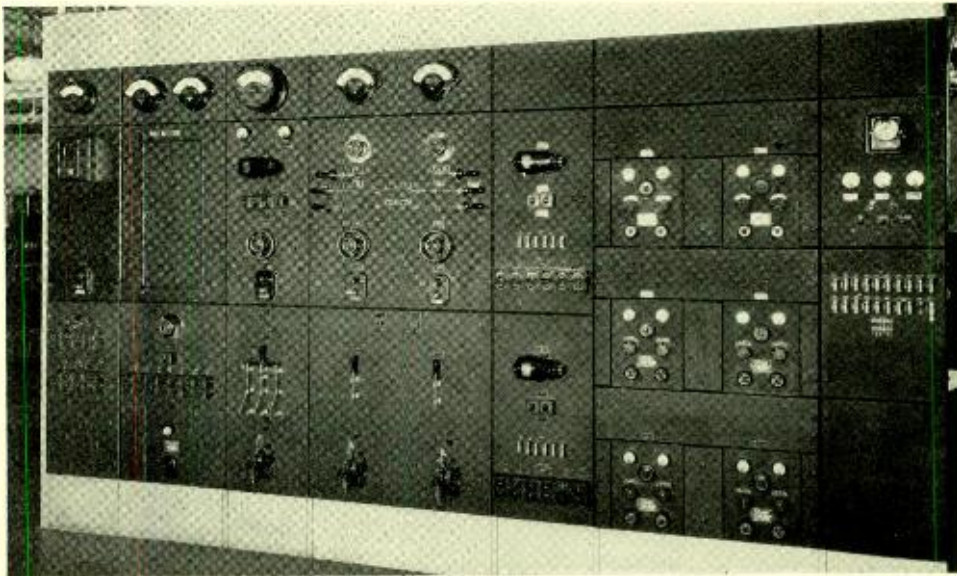
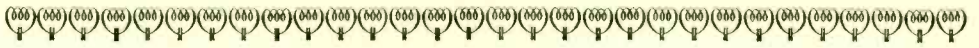

Fig. 5—Centrifugal type voltage regulators as employed in the toll laboratories



## Quiet Amplifier Tubes

By G. L. PEARSON

*Physical Research*

A SMALL electrical signal can be amplified by vacuum tubes to any desired amount provided the input voltage to the amplifiers is large enough to override the noises in the input circuit. Some of these disturbances can be eliminated, such as fluctuations of battery voltage, induction, microphonic effects and poor insulation, but others are inherent and it is these latter which determine the limit beyond which amplification cannot be advantageously increased. The fundamental limiting sources of noise are two, namely,

thermal agitation of electricity in the external circuits and the voltage fluctuations within the vacuum tubes themselves.

The impedance of the input circuit of high-gain amplifiers is often high or may effectively be made so by the use of a transformer. In this case the contribution of noise from the vacuum tube is small compared with the noise arising from thermal agitation in the input circuit. This is a desirable condition since it furnishes the largest ratio of signal to noise for a given input power. Sometimes, however, the input impedance is perforce so small that the tube noise may be comparable with or greater than thermal agitation noise. Such conditions may arise, for example, in amplifiers where the frequency dealt with is high or the frequency range is wide, in which cases bridged capacities reduce the impedance. It is, therefore, desirable to know the noise level to be expected from different types of tubes that may be used in the first stage of high-gain amplifiers as well as to be able to calculate the thermal noise level of the input circuit.

The noise of thermal agitation, first discovered by J. B. Johnson\*, arises from the fact that the electric charge in a conductor shares the thermal agitation of the molecules of the substance so that minute variations of potential difference are produced between the terminals of the conductor.

\*RECORD, February, 1927, p. 185.



Fig. 1—The noise level of vacuum tubes is tested by carefully shielding them from electrical disturbances and mounting them on a spring suspension to eliminate vibration

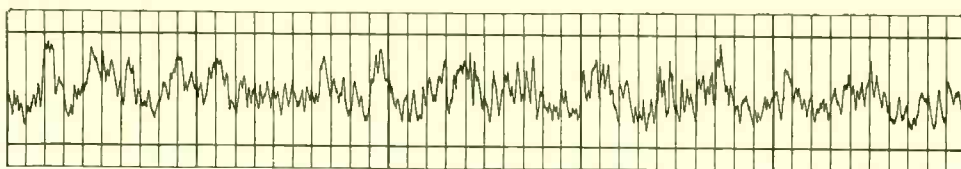

Fig. 2—Noise voltage fluctuations in the plate circuit of a 259B vacuum tube as shown by the rapid-record oscillograph

The mean square thermal noise voltage at the terminals of an open circuit resistance  $R$  is

$$\overline{V^2} = 4 k T R F$$

where  $k$  is Boltzmann's gas constant,  $T$  is the temperature in degrees Kelvin, and  $F$  is the frequency band width in cycles per second. At room temperature  $4kT$  has the value  $1.6 \times 10^{-20}$  when  $V$  is expressed in volts and  $R$  in ohms.

The noise in a thermionic vacuum tube arises from the fact that the space current is not a smooth flow of electricity but is subject to rapid and irregular fluctuations in magnitude. These are made manifest by voltage fluctuations across the external load impedance of the tube. Although the magnitude of this effect is small, it may be heard as a roar at the output of a high-gain amplifier. Figure 2 shows voltage fluctuations in a Western Electric 259B vacuum tube as recorded by the rapid-record oscillograph. While thermal noise in the circuit is accurately predictable, the noise originating in the vacuum tube is not completely understood and cannot be calculated accurately.

It is known, however, that the noise arises from a number of different causes. Chief among these are: (1) thermal agitation in the internal plate resistance of the tube, (2) shot effect from the space current in the presence of space charge,

and (3) space charge fluctuations due to positive ions.

Just as voltage fluctuations are produced by thermal agitation in the external circuits, so the internal plate resistance of the vacuum tube is a source of thermal noise. It has been deduced that this resistance produces thermal noise as if it were at the temperature of the cathode. This is the most fundamental source of noise in vacuum tubes and should set the limit in the ideal low noise tube.

The shot effect arises from the fact that the electrons are emitted from the cathode in a random manner, thus producing statistical fluctuations in the magnitude of the space current. When the cathode is relatively cool so that the emission is limited by temperature, the shot noise is proportional to the average value of the space current, but when the emission is increased so that a space charge is formed, as is the case in amplifying tubes, the fluctuations in space current are decreased and the shot noise becomes less prominent. If complete temperature saturation of the space current could be obtained, the shot

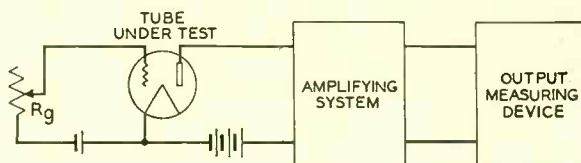
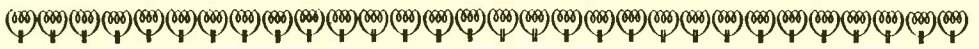

Fig. 3—Schematic amplifier circuit for measuring noise in vacuum tubes



# Carrier Frequency Heterodyne Oscillator

By T. SLONCZEWSKI  
*Apparatus Development*

THE measurement of frequency response is an important step in many problems associated with the development of communication equipment. In the majority of

times open to the objection that measurements made in this manner may miss entirely sudden changes which are confined to a narrow frequency band and it is often impractical to make arrangements at a sufficiently large number of frequencies to insure that all important values are included. Under these circumstances sweep measurements are usually made in which the frequency is changed continuously over the entire range while the effect which is being studied is observed on an indicator or recorded automatically.

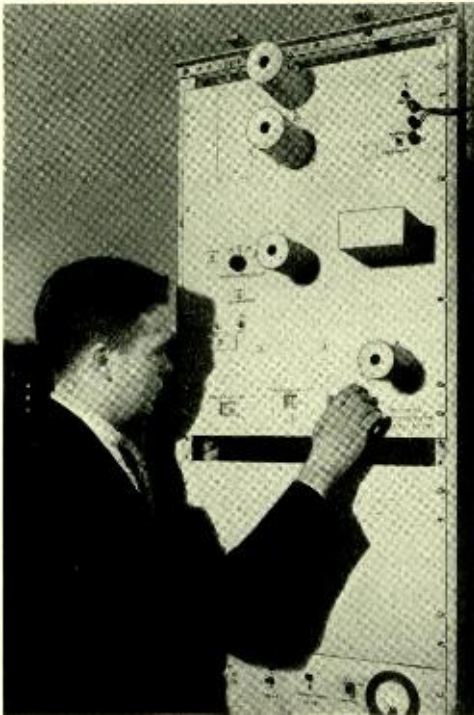

*Fig. 1—The carrier frequency heterodyne oscillator, which was designed for use in testing carrier frequency mechanical filters, shown in use by Mr. R. J. Morris*

A special type of oscillator has been developed for this purpose in which the output frequency is obtained by heterodyning two high frequencies, one of which is kept constant while the other is varied. A beat tone is thereby produced whose frequency is the difference of these two higher frequencies. This difference tone can be segregated from the heterodyned tones by filters and if these heterodyned tones are properly chosen the output frequency can be made to vary over the desired range. A number of oscillators of this type have been designed by the Laboratories\*, of which the 13A is probably the most widely known. The one here described differs from previous ones in that it covers a much higher frequency range—1 to 100 kilocycles per second. It was built for use in connection with the development of carrier-frequency mechanical filters. The frequency

instances the information sought is some type of frequency characteristic which is usually found by making measurements at a number of discrete frequencies on the device under investigation. This procedure is some-

\*RECORD, January, 1933, p. 137.

range is obtained by beating a 400-kilocycle tone from one oscillator against a frequency from a second oscillator which can be varied from 399 to 300 kilocycles.

In all sweep circuit measurements it is necessary that the power applied to the equipment tested remain constant as the frequency is changed, otherwise it would be impossible to distinguish between variations of power in the source and variations of response in the apparatus under test. It is also essential that no currents other than that of the desired test frequency be present, since if such spurious currents should exist in appreciable amount a false indication would result.

The percentage variation in the frequency of the variable oscillator here described is less than 25 per cent (300-400 kilocycles). It is therefore not difficult to arrange this part of the circuit so that its output is constant; but variations in the output of a heterodyne oscillator may be due to other sources, among the most important of which is the modulator. Modulation of the type used here takes place in the plate circuit of the tube, and the higher the input-frequency voltage across the internal plate impedance of the tube, the greater will be the modulated output. Any voltage drop through the external plate circuit decreases the voltage

across the internal plate impedance and reduces the modulation efficiency and therefore the output. In other words, the external plate impedance may be considered as introducing a series insertion loss in the circuit and it therefore should be low relative to the plate impedance and remain constant to prevent the voltage drop across the tube, and consequently the modulator output, from varying with frequency. On the other hand, it must not be forgotten that the modulator is also a generator of frequencies which in this case vary from 1 to 100 kilocycles. The condition for high-voltage output of a generator is that the external load impedance must not be low in comparison with its internal impedance.

These somewhat conflicting requirements were met in the carrier frequency oscillator by coupling the modulator to the amplifier through a shunt-terminated filter which transmits the highest modulator output, 100 kilocycles, without loss, and at the same time is approximately a short circuit for the input frequency range of from 300 to 399 kilocycles. The amplifier following the modulator was designed by conventional methods to prevent introducing appreciable variations of its output with frequency. As finally assembled the output of the new oscillator is constant throughout its frequency range to within 0.4 db.

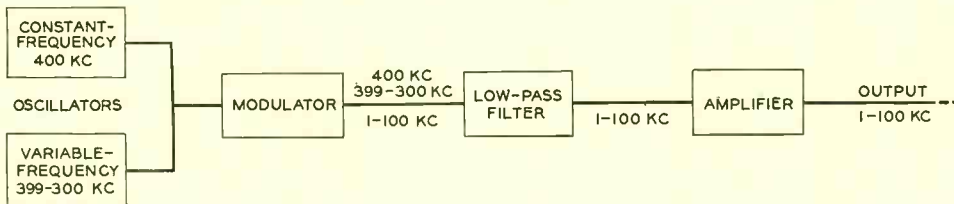

Fig. 2—By beating a constant frequency of 400 kc. against a frequency which is varied from 399 to 300 kc. an output from 1 to 100 kc. is obtained with this heterodyne oscillator circuit

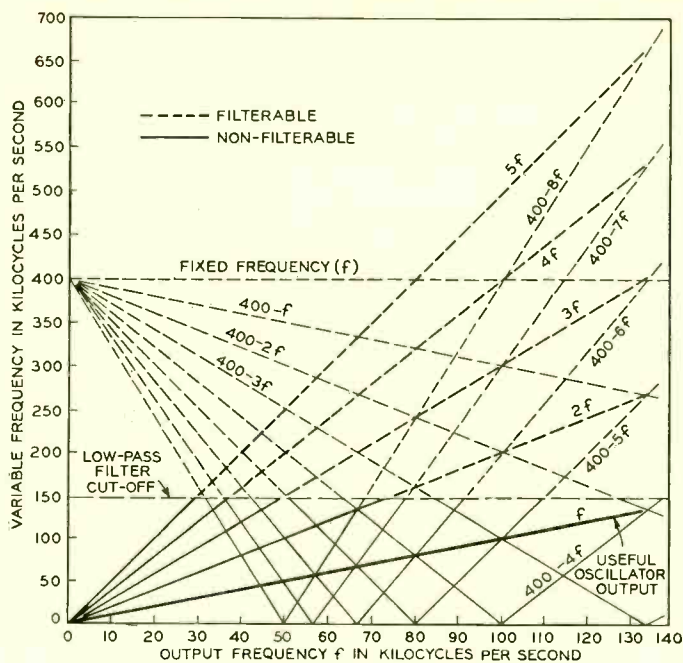

Fig. 3—The output of the heterodyne oscillator contains not only harmonics of the form  $nf$  but also other frequencies of the form  $400-nf$  which are called “birdies.” Only the lowest order harmonics and birdies are shown in the figure

Unfortunately the beat frequency is not the only product to appear at the modulator output. There are also the original heterodyne frequencies and in addition currents representing the sum as well as the difference of the original frequencies, also currents due to the sum and difference frequencies of integral multiples of these frequencies. Some of the more important undesired products generated are shown in Figure 3 where they are plotted as a function of the output frequency of the oscillator. The lines diverging from the origin indicate frequencies which are exact multiples of the output frequency of the oscillator, that is, its harmonics. These are always present in greater or less amount in any type of oscillator. The lines originating at 400 kilocycles and reflected from the axis of abscissas are not simply re-

lated to the output frequency. They are peculiar to the heterodyne type of oscillator and in laboratory parlance are called “birdies.” The origin of this term can be made clear by considering the frequency of the oscillator to have been set at 50 kilocycles, the middle of the scale. This frequency is not audible but the difference frequency  $400-8f$  can be heard as the control passes through the 50-kilocycle point. It will at first drop rapidly to zero and then rise again, producing a sound resembling a bird’s song. These “birdies”, if strong enough, may be just as objectionable as

harmonics, but they are usually made low in level as explained later and though sometimes still detectable by ear are negligible in intensity. Other groups of unwanted frequencies which would be represented in Figure 3 by lines diverging from 800 kc., 1200 kc. and higher frequencies are also produced, but these frequencies are either very high, in which case they are filtered out, or their order of modulation is high and their energy low. In either case their effect is negligible.

All harmonics above the highest output frequency can be removed by a filter following the modulator, but those within the frequency range cannot be filtered out and must be eliminated by other means. How this is accomplished may be understood by referring to Figure 4 where the output level of the modulator is plotted

against the input level. The modulation product decreases as the input level is lowered, the rate being faster the higher the order of modulation. For example, if the level of the heterodyne frequencies is decreased 10 db the modulator output level will drop 20 db, but the fourth order product which is an unfiltered second harmonic will drop 40 db, leaving a margin of 20 db by which the undesired product is lowered relative to the wanted output. Similarly the fifth order component, which is the lowest order unfiltered "birdie", will be dropped 30 db. By lowering the modulator input sufficiently the undesired distortion products can be reduced in this manner below any desired amount which, however, is limited in practice by the fact that a corresponding increase in amplification is required to bring the oscillator output to the desired level. Another limitation is that more filtering is necessary at frequencies from 300 to 400 kc. as the 1 to 100-kc. output is lowered. Some of the undesirable products can be still further reduced by the use of a balanced circuit since they will then appear in the two halves of the circuit in opposite phase and are therefore balanced out. In commercial circuits this gives an additional attenuation of about 26 db. By these combined methods the useful product in the new carrier frequency oscillator is maintained at least 50 db above those not wanted.

In all heterodyne oscillators it is important to adjust the frequency of the local oscillators very accurately when the output frequency of the oscillator is low, since a very small percentage variation in heterodyned frequencies will produce a large per cent variation in the small difference between these high frequencies. For this reason all heterodyne oscillators

are equipped with a low-frequency checking device so that they may be checked at a single low frequency, thus assuring that all of the low frequencies, which are the only ones appreciably affected, are correct. In the 100-kc. oscillator the check is made very simply and conveniently. The frequency control of the oscillator is set for a 60-cycle output and a filament transformer is connected by a switch in series with the oscillator output across a switchboard lamp. When the output frequency of the oscillator is nearly, but not quite, 60 cycles, say 61 cycles, the current from the oscillator will be in phase with the power supply current once per second and the light intensity will be high once every second. Half a second later the

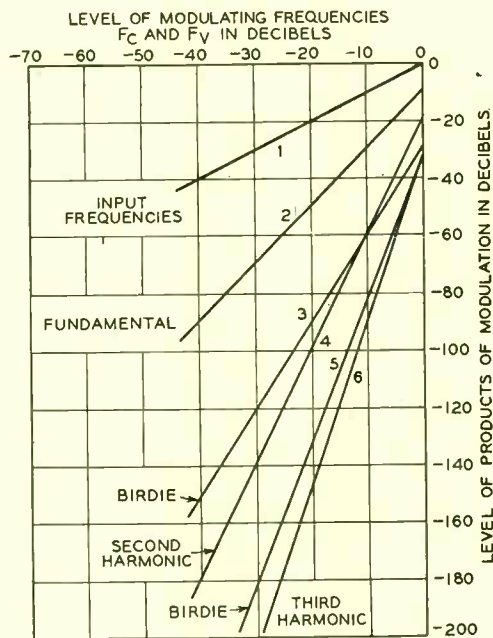

Fig. 4—Objectionable modulation products can be made negligible because these products drop much faster than the useful products as the levels of both are simultaneously reduced. This is shown in the figure where the order of the product is indicated by numbering the lines

two currents will be opposite in phase and the light intensity will decrease. The flicker is readily noticeable and permits a convenient and rapid adjustment to give perfect synchronism.

A special method of reading the frequency scale of the 100-kilocycle oscillator had to be devised to give the required accuracy over the wide range covered. It was desired to be able to set the frequency to within 35 cycles on the average. This means a scale 200 inches long, since 500 cycles per inch is the smallest scale spread which will allow settings of this accuracy to be made conveniently. A dial five feet in diameter would be needed to accommodate this length of scale which would be of unmanageable size and a worm drive with a micrometer drum was considered objectionable because it would require a calibration chart. The difficulty was solved by laying the scale out on

motion picture film which is moved by a sprocket in synchronism with the precision worm drive condenser used to control the frequency. The film is rolled on two spools, one of which is provided with a spring to take up the slack. In this manner the whole mechanism was made to occupy a space 3 by 4 by 5 inches. The scale was made by drawing lines in ink on a piece of black fixed film and printing a positive from it in the usual way.

The heterodyne oscillator has proven useful in a wide variety of experimental work. It is simple to manage since it is a-c operated and requires only two control dials, one for the frequency and the other for the output level. Oscillators of this type can be used not only to sweep quickly and accurately over a wide frequency range, but are also more convenient than other types where single constant frequencies are required.



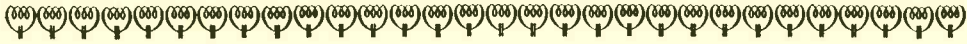

## Soldering Lead Cable Electrically

**A**N improved method of repairing ring cuts and similar sheath defects in aerial cable has been devised which uses electric current to melt and flow solder into the defect instead of the former procedure of wiping a solder joint over the affected spot.\* The new method has been found to be reliable and is much faster than that previously used. The outfit consists of a carbon electrode, an automobile type storage battery, and insulated wire conductors.

The electrode is a copper plated carbon rod beveled at one end at an angle of  $45^\circ$  and supported in a hollow wooden handle. This electrode is

\*The Telephone News, Bell Telephone Company of Pennsylvania, September, 1934.

connected by one of the conductors to one terminal of the six-volt battery which is located on the service truck or on the ground below the workman. The other battery terminal is connected by the second conductor to the cable sheath by means of a clamp.

After the defective spot in the sheath has been scraped clean the end of a piece of wire solder is held against it and touched with the beveled end of the electrode, thus completing the circuit. A current of approximately one hundred amperes flows and melts the solder which is then manipulated with the electrode until the solder is metallically united with the sheath. By continuing this procedure the entire cut is filled.





## An Ultra-High-Frequency Radio Receiver for Police Use

By G. N. THAYER  
*Radio Development*

**T**HE use of police radio has increased to such an extent in the last few years that the available frequency band, covering the region from 1.5 to 3.0 megacycles, has become overcrowded. As a consequence, the Federal Communications Commission has assigned a number of channels in the band from 30 to 42 megacycles for police use. While at first there was some doubt as to the practical value of this ultra-high-frequency band, the Western Electric police radio equipment\*, installed in Newark at the beginning of this year, has shown conclusively its great value for short-range radio telephone communication.

In general, two types of receivers are required for police work: one for use in patrol cars, which may be operated entirely from a six-volt

\*RECORD, June, 1935, p. 290.

battery, and the other for stationary locations where it is more convenient to operate off the commercial lighting supply. By providing two arrangements for controlling the car receiver, the Laboratories has actually made available three receivers, although all are alike in their essential circuit details. The car receiver is known as the 18 type, with letters A and B to differentiate the two types of control, while the station receiver is the 19 type. These are compact, superheterodyne receivers designed to stand up under the severe service they inevitably meet in police work, and to require a minimum of attention either in control or maintenance.

Experimental work preceding the design of these receivers disclosed several rather unusual and stringent requirements which are more or less peculiar to the ultra-high-frequency

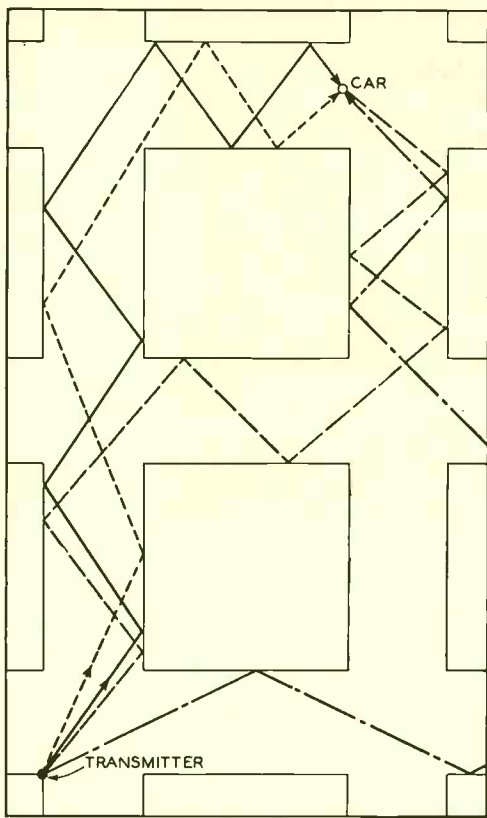

Fig. 1—A few of the many possible paths by which ultra-short waves may reach a police car receiver

band. These very high frequencies travel an essentially optical path, and suffer reflection to a greater or less extent by every object they encounter. As a result the waves reaching a patrol car in the street have not come in a straight line from the transmitting antenna but have been reflected back and forth by building walls and other structures, and thus reach the antenna only after a number of reflections. In general, there is more than one path by which the waves may reach the car antenna. This is indicated in a simplified way in Figure 1 which shows an idealized plan of a number of city blocks and indicates four possible paths for the

radio waves between transmitting station and car. This is a two-dimensional picture and in an actual three-dimensional city the possible paths are more numerous and complex.

Whenever waves reach a point by several paths, standing waves will result. There will be places where the waves arriving over different paths tend to reënforce each other and other places where they tend to cancel out. As a car moves along the street it will pass successively through these areas of reënforcement and cancellation with the result that the signal varies in intensity in a proportional manner. It has been found that with a car going 60 miles an hour these fluctuations have a period of the order of a fraction of a second. These rapid fluctuations in level require that the receivers be equipped with a very fast acting automatic volume control, so that the output of the loud speaker will remain constant at all times. The volume control circuit incorporated in these new receivers successfully maintains the audio output constant to within less than 3 db over a 100 db range in the received signal.

The transmitters are designed to radiate power only when an announcement is being made, and as a result the carrier is off the air for an appreciable part of the time. With the carrier and signal off the air, the effect of the automatic volume control would be to amplify the ignition noise up to the full output of the loud speaker, and the noise produced would be very objectionable. This condition is avoided by incorporating a device called a *codan* in these ultra-short-wave police receivers. The purpose of this device is to greatly reduce the audio output when no carrier is being received.

The word "codan" comes from the

initial letters of the phrase "carrier operated device, anti-noise." Various forms of "codan" have been used in other radio services. In this case a very simple type is used consisting of a small neon tube associated in a circuit with a vacuum tube. When the voltage across the neon tube exceeds a certain critical value the tube discharges, and its impedance drops to very low values, while below this critical value its impedance is essentially infinite to audio frequencies. This characteristic is utilized to block the audio output when the received signal drops below an average value of about 5 microvolts, which is below the minimum useful carrier level. The noise signal may be considerably above this in peak value, but the impulses are of such short duration that the average value is far lower. The effect of the automatic volume control and codan

is to give an input-output characteristic as shown in Figure 2. Below 5 microvolts of average signal there is no audio output, due to the action of the codan, and above 5 microvolts the audio output is essentially constant

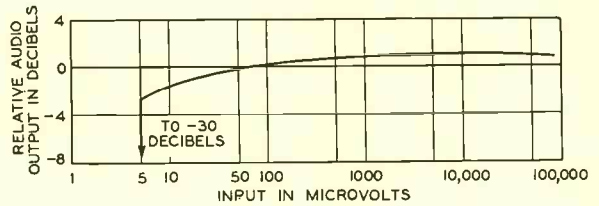

Fig. 2—Output level of 18 and 19 type radio receivers showing effect of codan and automatic volume control

for all magnitudes of received signal. The arrangement of the receiver electrically is indicated by the simplified schematic of Figure 3. There is a stage of tuned radio frequency amplification, a modulator, a beating oscillator, a two-stage intermediate-frequency amplifier, a detector, an auto-

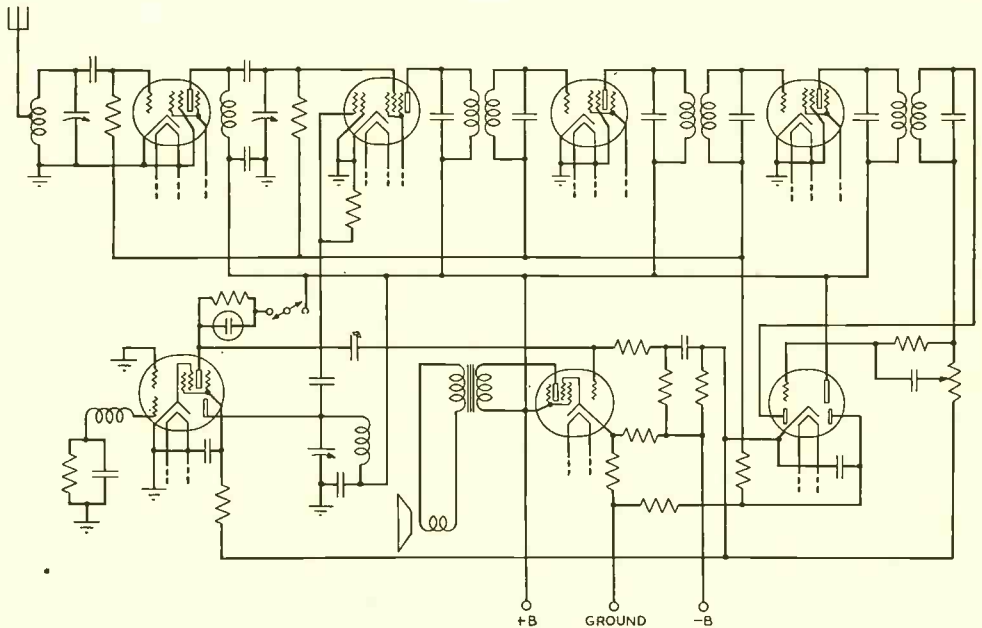
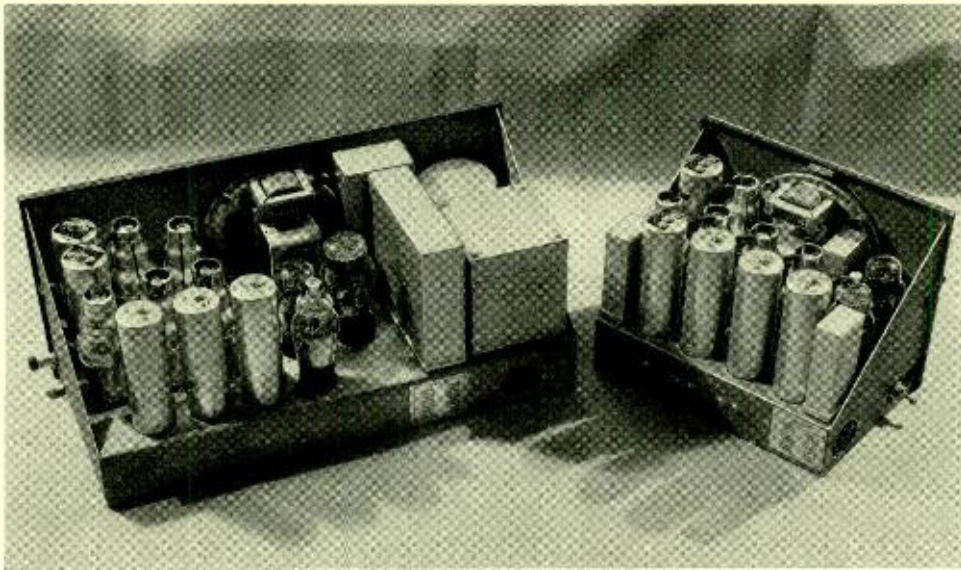

Fig. 3—Simplified schematic of 18 type radio receiver



*Fig. 4—19 type, left, and 18 type radio receivers removed from their cases*

matic volume control, a two-stage audio amplifier, and the codan. While there are thus nine functional stages, there are only seven vacuum tubes plus the small neon tube, several of the tubes performing more than one function. Thus the lower half of tube 7 serves as a beating oscillator while the upper half of the same tube is associated with the codan circuit. Tube 5 acts in a triple capacity. The left part of the lower half acts as a detector, the right part of the lower half as an automatic volume control, and the upper half as part of the audio amplifier. This circuit is identical for all three of the ultra-short-wave receivers, but the 19 type has in addition a full-wave rectifier tube for the high-voltage supply. For the 18 type receivers a dynamotor, operated off the car battery, supplies the necessary high voltages.

Physically the three receivers are quite similar except for size. The 18 type has outside dimensions of about seven by six by nine inches, while the 19 type receiver is seven and one-half

by seven and one-half by sixteen inches. Their external appearance is shown in the photograph at the head of this article. For both types of receiver the apparatus is mounted on a rigid chassis which carries a front panel on which are mounted the loud speaker and the controls. This chassis slides into an inclosing case as shown in the accompanying illustrations. The loud speaker is mounted in the front panel but a separate loud speaker may be employed if desired. Two types of shock-proof mountings are provided for the 18 type receiver: one for use when the receiver is to be mounted under the instrument panel of the car, and the other when it is mounted behind the seat of a coupe.

The only controls are an on-off switch, a volume adjustment, and a tuning control. The receivers are so stable, however, that tuning is rarely required. These controls are mounted on the front panel of the 18B and 19 type receivers, but for the 18A receiver are extended to a control unit on the steering wheel.

The selectivity characteristic of the receiver provides a flat pass band about 50 kc. wide, with an attenuation of 60 db at 100 kc. each side of the mid-band frequency. This gives a pass band of the order of 0.2 per cent of the carrier frequencies. In the broadcast band this would correspond to a band width of only about 2000 cycles, which will be recognized as extremely "sharp" tuning. As with most receivers for this type of work no

effort is made to reproduce a wide audio-frequency band; to do so would not appreciably improve the intelligibility and would considerably increase the noise admitted. The average acoustic fidelity characteristic is flat to within 6 db from about 70 to 3000 cycles. The general satisfactoriness of the receivers has been well demonstrated in the Newark installation, which has now been in successful operation for over eight months.

## Contributors to This Issue

---

R. N. MARSHALL received a B.S. degree from Princeton in 1930, and at once joined the Technical Staff of the Laboratories, where he assisted in the development of the 618A moving coil microphone. He later engaged in acoustic studies relating to microphones, which were for the most part carried on at Whippany to secure sufficiently quiet surroundings. More recently he worked on the development of the new non-directional microphone which is described in this issue of the RECORD.

ROBERT M. KALB received the degree of B.E.E. from Ohio State University in 1927, and spent the following year there as a graduate assistant. Coming to the Laboratories in 1928, he entered the Research Department, where he engaged in general transmission studies. His work has dealt principally with alternating-current magnetization and similar non-linear phenomena, and has included distortion in transmitters, repeaters, loaded lines, and submarine telephone cables.

W. R. BENNETT received the degree of B.S. in Electrical Engineering from Oregon State College in 1925, and the degree of A.M. in Physics from Columbia University in 1928. He became a member of the Technical Staff of the Laboratories after graduation from Oregon State, and was at first engaged in research on wire

telegraphy. Later he worked on the design of circuits for picture transmission and television, and took part in the development of terminal equipment for submarine telephone cables. His present work deals mainly with modulation and non-linear systems.

T. SLONCZEWSKI has been a member of the Laboratories technical staff since he received the degree of B.S. in E.E. from the Cooper Union Institute in 1926. He was at first engaged in the development of alternating circuit bridges but has recently devoted his attention to the study of oscillator circuits. This led to the design of the 100 kilocycle oscillator which was made to provide testing facilities in connection with the development of high frequency mechanical filters. His experience with measurements where sweep methods were used dates back to 1928 when he participated in the development of such a circuit for measuring the reflection coefficient of filters and coils. He has also done graduate work at Columbia University since his association with the Laboratories.

BEFORE COMPLETING a course in Mechanical Engineering at Stevens Institute of Technology, G. N. Thayer worked during the summer of 1929 in the Department of Development and Research of the A. T. and T. Company investigating



*R. N. Marshall*



*R. M. Kalb*



*W. R. Bennett*

the breakdown characteristics of projectors. In 1930 he joined the Technical Staff of the Laboratories. Here with the Radio Development group he first engaged in the development of aircraft receivers for both beacon and two-way communication service. More recently he has been engaged in the design of ultra-high-frequency receivers for police, marine, and point-to-point service.

J. H. SOLE received a B.S. degree in Electrical Engineering from the University of Michigan in 1916, and after a year with the Allis-Chalmers Company, joined the Army air service. Following three years in this branch and three with the air mail, he joined the Western Electric

Company at Hawthorne and engaged in general installation engineering. In the following year he transferred to the Technical Staff of the Laboratories where, with the Power Equipment group, he has been chiefly concerned with studies in voltage regulation.

A. J. WIER joined the Western Electric Company Installation Department, in 1912. Two years later he transferred to the New York Telephone Company at Buffalo, New York, where he engaged in central office maintenance work. After a year with the Pierce-Arrow Motor Car Company, he returned to the New York Telephone Company, where he did toll maintenance work until 1917, when he



*T. Slonczewski*



*G. N. Thayer*



*J. H. Sole*



*A. J. Wier*



*G. L. Pearson*



*J. E. Tarr*

joined the United States Army. Upon his return from France in 1919, Mr. Wier resumed his previous work with the Telephone Company, but in July of that year he transferred to the Equipment Engineering Department of the Western Electric Company at Hawthorne and later at Kearny, N. J. In 1923 he was given charge of the Western-Zone Analyzing Department and later he took charge of the Toll Practice Department. In 1928, he was transferred to the Toll Equipment group of Bell Laboratories, where he is still occupied with toll equipment development problems. He completed a two-year evening pre-legal college course some time ago, and recently, after completing a three-year law course at New Jersey Law School, Newark, he was granted an LL.B. degree.

G. L. PEARSON received the degree of A.B. from Willamette University in 1926 and A.M. from Stanford University in 1929. He came to the Laboratories that

year where he has since been engaged in studies of spontaneous electrical disturbances in circuits. The significance of such disturbances is evident when it is realized that the limit beyond which amplification cannot be effectively increased is determined by the noise level of the vacuum tubes and the other elements of the circuit. His work on low noise vacuum tubes followed as a natural development of these experiments.

AFTER RECEIVING his B.S. degree in Electrical Engineering from the University of Maine in 1927, J. E. Tarr took the introductory training course of the New York Telephone Company, and then transferred to these Laboratories. With the Systems Development Department, he first worked on the analysis and testing of local central-office equipment. In 1928 he transferred to the Radio Development Department where he has since been engaged in the development of speech-input equipment for radio systems.