

# BELL LABORATORIES RECORD

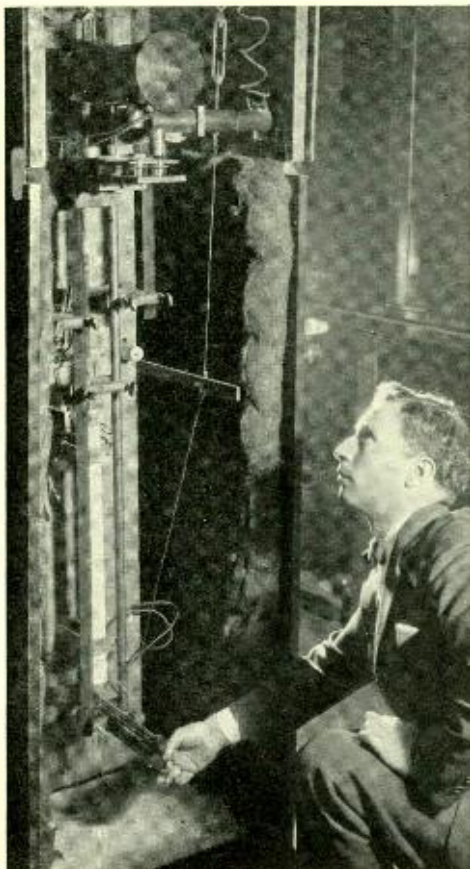

*P. P. Cioffi operating device, sensitive to four parts in a billion, for determining changes in length of magnetic materials with magnetization*

VOLUME NINE—NUMBER FOUR

*for*

DECEMBER

1930



## A New "B" Board for Panel Offices

By R. E. HERSEY

*Local Systems Development*

**I**N manual exchange areas with more than one central office, two types of switchboards are required for completing calls. At one, the "A" board, an operator answers the calling line and connects it to an idle trunk to the office called. At the other, the "B" board, an operator receives the number wanted from the "A" operator and connects the incoming trunk to that line. In dial offices, on the other hand, local calls between two subscribers are completed mechanically—without the aid of an operator. When both types of offices exist in the same area, therefore, provision must be made for transferring calls from one type of office to the other. Two additional types of switchboard positions are required. There must be means for completing to a manual office calls that originated in a dial office, and—the reverse situation

—of completing to a dial office calls that originated in a manual office.

Call indicators, already described in the RECORD\*, perform the first function. Mounted in the key shelf of the "B" board at a manual office, they flash to the operator the number that is wanted. To complete to a dial telephone calls coming from a manual office, a dial or key set is required at the "A" board, or a special "B" board with mechanical apparatus which enables the "B" operator to direct the connection to the number given by an "A" operator in a manual office.

In the earlier type of panel "B" board, shown in Figure 1, each position was equipped to answer incoming calls on any of sixty trunks. Each trunk was represented by two push-button keys and two lamps. The lamps

\* BELL LABORATORIES RECORD, Dec., 1929, p. 171. July, 1930, p. 515.

were mounted in two rows of thirty trunks each on the upright portion of the board. On the horizontal part of the board, each position had a key set of forty buttons, ten for each of the four digits, on which the "B" operator could "write up" the desired number.

This number would be passed to her by an "A" operator over a special trunk known as a call-circuit. On receiving the number, she would assign a trunk for the call, depress the corresponding assignment key, and then write up the number on her key set. When the assignment key was depressed, a guard lamp would light and remain lighted during the period of the call. When the call terminated, the disconnect lamp lighted, and the operation of the disconnect key released the connection.

With the advent of straightforward trunking\*, the method of operation changed. The "A" operator selected the idle trunk, and at the "B" board a guard lamp above the trunk keys would light to indicate the arrival of the call. The "B" operator would then depress the assignment key, receive the number over the trunk, and complete the call by means of her key set as before. Disconnection at the termination of the call was arranged to take place automatically instead of manually as in the previous systems.

Equipment for this type of "B" board con-

sisted of a group of six links per position of which five were equipped. Each link had two panel-type selectors, one for connecting the "B" operator to the trunks, and one for connecting her to an idle sender. Because of the comparatively small number of trunks accessible to an operator, there are times when no calls are arriving at her position and when she will of necessity be idle, and other times when calls are arriving faster than they can be handled. The efficiency of operation is a function of the number of trunks accessible to an operator. If, for example, two operators could have equal access to 120 trunks, or three operators to 180 trunks, the probability of a "no-call" period would be very small since the heavy call periods would not usually come at the same time for each of the sixty-trunk groups and the efficiency would be higher.

To secure this higher operating efficiency, to decrease the amount of equipment required, and to obtain cer-

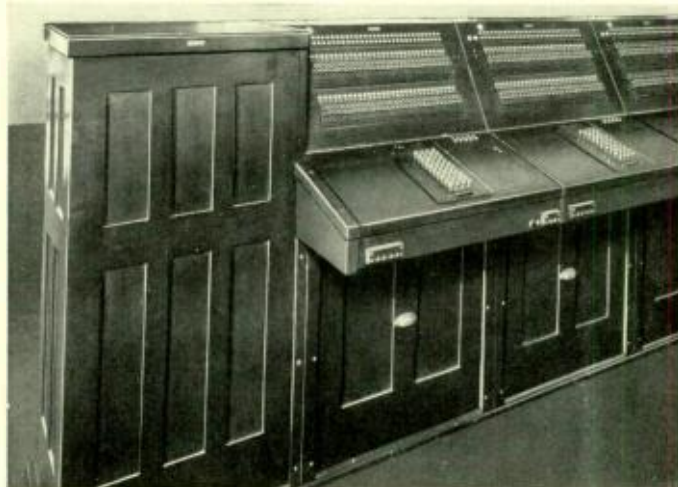

*Fig. 1—Each position of the older type of "B" board is equipped with keys and lamps for sixty trunks, and a key set of forty keys for "writing up" the number called*

\* BELL LABORATORIES RECORD, April, 1929.

tain other advantages, a new "B" board has recently been developed. One of the major economies built into the new board is a conversion feature which allows the incoming selector circuits used with it to be employed, with minor circuit changes when the originating office is ultimately changed to dial operation. Figure 2 and the headpiece show the simplicity of the new "B" position as compared to the earlier type (Figure 1). Call distribution is provided and therefore no trunk keys or lamps are required; and in addition the key set of forty buttons has been replaced by one of ten.

The equipment needed and its arrangement is indicated by Figure 3. The circuit is somewhat similar to that of the earlier arrangement except that each link, of which there are a maximum of fourteen in a group, has access to 120 instead of only sixty trunks. Each link, in addition to its trunk finder and sender selector, has also a 20-point position selector with which it locates an idle operator. As twenty positions are usually sufficient for an average-size dial office, all of the incoming trunks have access to each operator, and thus the operating efficiency is high.

A typical link frame is shown in Figure 4. At the top are the two 60-point trunk banks. To reduce trunk-hunting time as much as possible each link group is divided into two sub-groups and the trunks are divided between two banks. In each bank the multiple is transposed so that for one sub-group of links the trunks run up from 0 to 59 in

each bank and for the other sub-group the sequence is reversed being from 59 to 0, as the elevator goes up. Calls are automatically routed to the sub-group of links for which their terminals appear in the lower half of the banks and the choice of upper or lower banks is made by tripping the proper brush. The average hunting distance is thus approximately fifteen terminals instead of the sixty it would be were there no grouping arrangement.

The sender banks — two are required because connection to the sender is made over six leads and each bank includes only three—are beneath the trunk banks. One group of senders serves all the links in an average office, and the first idle one is siezed



*Fig. 2—Three sections of call-distributing "B" board*

by a sender selector on each call. About fifty senders suffice for an office requiring twenty operators. The senders are of the all-relay type and two are mounted as a single unit. The position selectors, of the 206 rotary type, are mounted at the top of the sequence switch and relay bays. In Figure 4 they are only partially visible.

In some areas, such as the downtown sections of New York, the traffic is very heavy during certain periods of the day and very light at others. Here forty or fifty positions of the "B" board are sometimes required during the busy periods, especially when serving several units in the same building. In such installations all the links are given access to the number of positions required to handle the traffic during the light-load periods.

The other positions are divided into as many groups as can be multiplied to the remaining terminals of the position selectors, and the links are divided into corresponding groups. Thus one group of links might have access to fifteen positions, and another group to another fifteen positions while both groups of links would serve an additional five positions which are able to handle all the traffic during periods of light load.

When a call comes in to this new type of "B" switchboard, the trunk-finder of an idle link at once starts hunting for the trunk, and at the same time the position finder rotates to reach an idle position. When both are found a connection is made from the "B" operator to the trunk, and an order tone returned to the "A" operator to signal her to pass the number

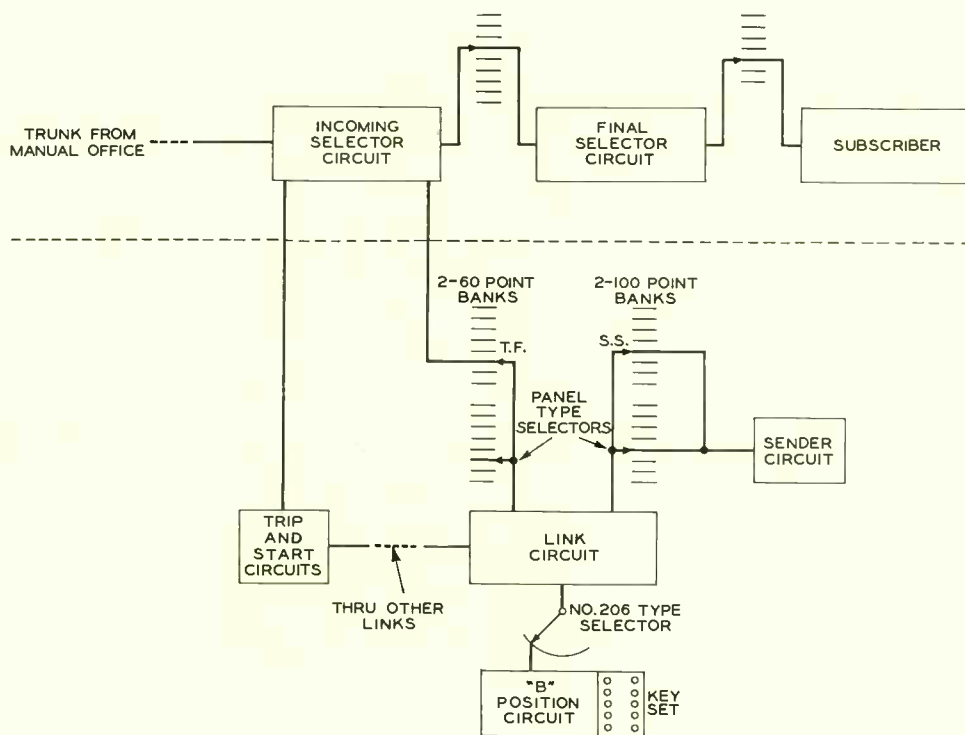
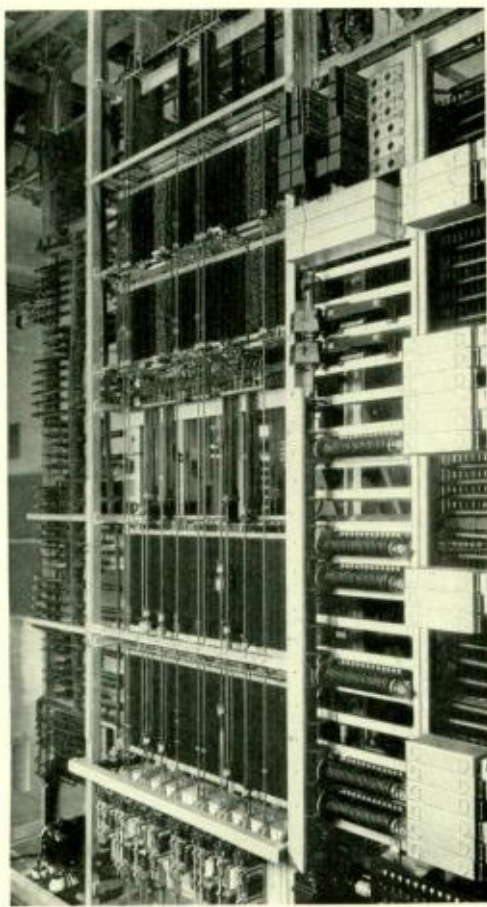

Fig. 3—Schematic diagram for call-distributing "B" board



*Fig. 4—A link frame includes two 100-point sender banks and—mounted above—two 60-point trunk banks*

wanted. At the same time the sender selector starts hunting, and by the time the "B" operator has received the number, a sender will generally have been found which will be indicated by a guard lamp. The operator

on receiving the number writes it up on her key set and after the last digit has been recorded, the link dismisses the "B" position, and establishes another path between sender and incoming selector to control the completion of the call. After the called line has been reached the link and sender also are dismissed.

Many novel features have been incorporated in this new board. If an operator removes her telephone plug—as was done when the headpiece was taken—her position will not be selected by the link circuit. If all the operators should remove their plugs at the same time, the position selectors will not hunt on the arrival of a call but an alarm will be sounded until an operator inserts her plug, whereupon the position finder will at once locate her position, and the link will then proceed in the usual manner. Also the position selectors do not hunt when all positions are busy but wait for an operator to become idle. Should there be more than four calls waiting at one time a calls-waiting alarm is given as an indication to the supervisors that four or more calls have been waiting for a predetermined interval. On the cable-turning section of the board is a meter which indicates the number of calls that are awaiting attention at any moment. These various features all tend to simplify the operation, or improve the service to the subscriber.

# A Magnetization-Curve Tracer

By F. E. HAWORTH  
*Physical Research*

**I**N the study of magnetic materials it is constantly necessary to employ magnetization curves and hysteresis loops, which are plots of the magnetic flux density in the sample against the exciting field strength. To obtain such curves it has been customary to wind two coils on the specimen; one carrying an exciting current supplied by a battery and the other, connected to a ballistic galvanometer, carrying the momentary induced current which is proportional to the change in magnetic flux. The exciting current is changed in small steps, and the induced current momentarily swings the galvanometer to a deflection proportional to the change in flux. Field strength may be calculated from the exciting current, and change in flux from the galvanometer deflection, so that by taking a large number of readings a curve may be plotted over any desired magnetic cycle. Such a method is necessarily slow and the resulting curve approaches accuracy over its entire range only as the steps are made very small. To avoid these two disadvantages a new apparatus has been developed which rapidly draws a continuous curve of high accuracy.

To obtain a continuous curve rather than a series of disconnected points it is necessary for the galvanometer to be made to remain at each de-

flection reached rather than to return to zero. This objective was approached by employing a fluxmeter instead of a ballistic galvanometer. The restoring torque of the fluxmeter is much less than of the galvanometer so that although deflecting quickly it returns very slowly. To prevent even the slow return caused by the small restoring torque, the arrangement shown as Figure 1 was provided.

A long, sensitive, photoelectric cell is mounted behind a V-shaped opening placed so that light reflected from the mirror of the fluxmeter will fall on it. The point of the V is located where the light falls when the fluxmeter is undeflected. The photoelectric cell, in series with a battery, is connected to the fluxmeter in parallel with the secondary winding on the specimen, and so poled that current flowing tends to deflect the meter. Current flowing

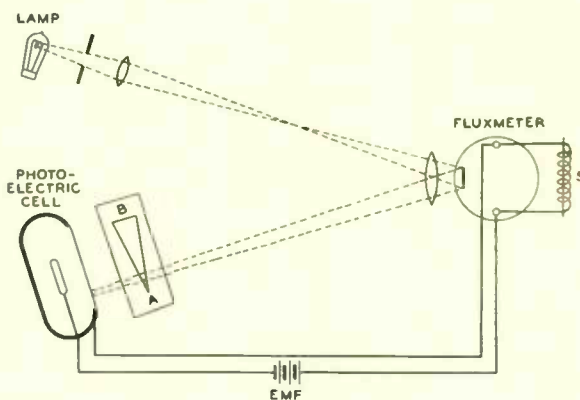

Fig 1—A photoelectric cell with wedge-shaped opening permits complete neutralization of the restoring torque of a fluxmeter

in this circuit is proportional to the amount of light falling on the cell, which in turn—because of the wedge-shaped opening—is proportional to the deflection of the fluxmeter. The battery voltage is so adjusted that the current flowing at any one position of the fluxmeter is just sufficient to offset the restoring torque. Since the restoring torque and the amount of current flowing are both proportional to the deflection, the restoring torque is just neutralized for all deflections.

As a result of this arrangement the deflection of the fluxmeter is always proportional to the flux in the specimen. An ordinary magnetization curve or hysteresis loop is drawn with flux as the ordinate scale and field intensity as the abscissas. The ordinate readings have already been provided for by the method just described, and by allowing light from a second lamp to fall on the flux meter mirror at a different angle of incidence from that of the lamp actuating the photoelectric cell, a point of light may be thrown on a sheet of sensitized paper which will be above or below a zero axis by an amount proportional to the flux. To move the chart so that the location of this point of light along the scale of abscissas is proportional

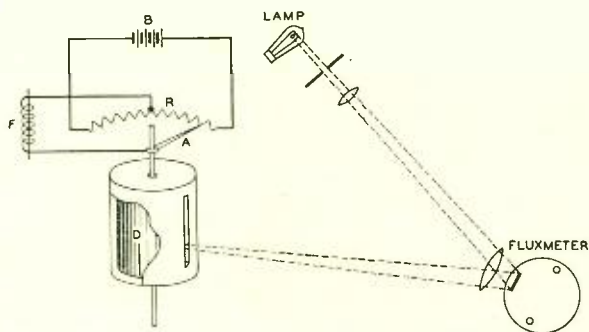

Fig. 2—The graph is made on a sheet of sensitized paper fastened to a drum, the rotation of which varies the exciting field of the specimen

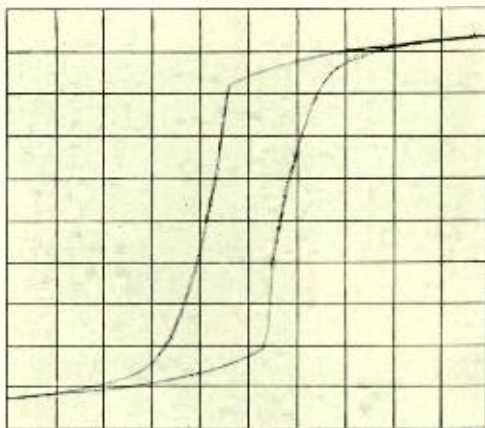

Fig. 3—Hysteresis loop of permalloy containing 78.1% nickel made on the new apparatus

to the field intensity the arrangement shown in Figure 2 is used.

A sheet of sensitized paper is mounted on a drum rotated, through gearing connected to one end of the shaft, by an adjustable speed motor. On the other end of the shaft is an arm carrying a brush that slides over a resistance arranged on an arc as shown. Because of the drop wire arrangement of the resistance and battery, the potential applied to the exciting winding of the specimen is proportional to the amount of rotation of the drum. At one position, selected as the axis of zero field, there will be no potential applied and at either side of this point the field will be in one direction or the other, and of an intensity proportional to the displacement of the drum from the zero position.

Turning the drum from a position where the arm A lies at some position to the left of the middle part of the resistance until it is the same distance to the right of the middle, changes the field in-



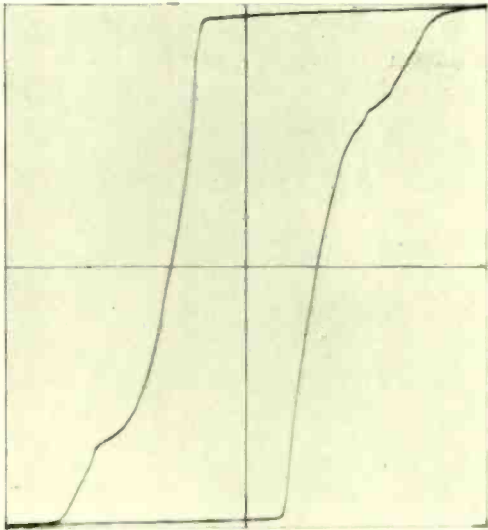

Fig. 4—Irregularities in a hysteresis loop are plainly indicated by the new method

tensity from a given intensity in one direction to the same intensity in the other. At the same time the flux has changed, and the light from the fluxmeter has moved across the drum by a proportional amount. This rotation thus causes a curve to be traced on the sensitized paper, and by reversing the rotation of the drum and turning it back to the starting position a complete hysteresis loop is drawn as shown on Figure 3.

This new development not only allows curves to be drawn very rapidly but gives results which are highly accurate over the entire range. No small irregularities are missed as they are very likely to be by the slower point-by-point method. Some or all of the irregularities on the hysteresis loop of Figure 4, for example would undoubtedly have been overlooked had

the point-by-point system been used.

The method also lends itself to rapidly drawing, on the same graph, a series of hysteresis loops for different amounts of magnetization, as shown by Figure 5. To produce such a set of curves it is necessary only to move the drum back and forth over successively increasing arcs until the maximum field desired is reached. Also any portion of a magnetization curve or hysteresis loop may be plotted by starting and finishing the drum's rotation at the desired positions. This is illustrated by Figure 6, which shows the initial magnetization curve of the specimen more fully plotted in Figure 3. For this graph the specimen was first demagnetized and rotation started when the arm A was at the middle of the resistance, and carried in one direction only. The straight line on this graph was drawn in to aid in calculating the initial permeability.

Combining both accuracy and speed

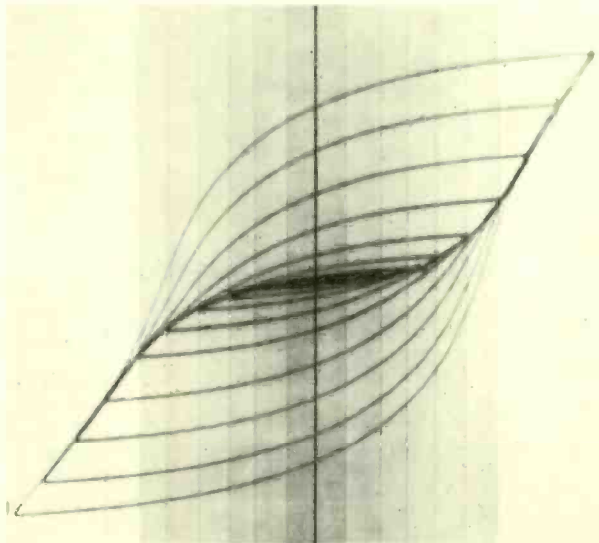

Fig. 5—A set of hysteresis loops for different field intensities is readily drawn by rotating the drum back and forth over successively widening arcs

with simplicity of apparatus, this new development is highly satisfactory for laboratory use and is finding increasing applications. Magnetic properties of specimens may be speedily

determined with a precision that permits the results to be used quantitatively which is not generally possible with the existing rapid methods of measuring magnetization.

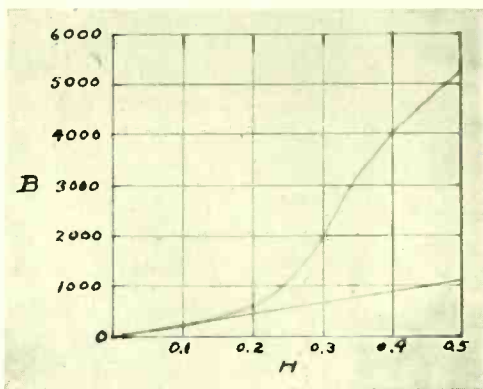
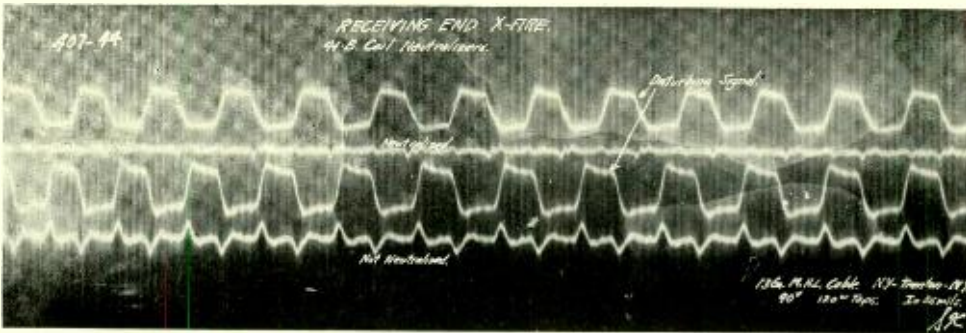

Fig. 6—Any portion of a magnetization curve may readily be drawn as shown in this illustration



### “Mohawk”

The last name to be added for probably many years to the roster of nearly 200 telephone central office names in New York City will be “Mohawk”, which will be introduced in Manhattan before the close of the year. In the future, as additional central offices are needed, new names will seldom be required. This is because under the modified designation plan to be introduced on December 16, each existing office will be designated by the present name and a numeral. As additional offices are established in the same general neighborhood they can be given the same name, but with a different office numeral.



## Cross-Fire Neutralization of Telegraph Circuits

By J. H. BELL  
*Telegraph Engineer*

**B**Y the method of compositing, already described in the RECORD,\* two grounded telegraph circuits may be obtained from any pair of conductors comprising a telephone channel. Practically all of the grounded telegraph circuits in the Bell System are obtained in this manner. Since the two circuits so derived, however, are connected through condensers and coils in the composite set, a certain amount of mutual interference is produced between them. Where entrance cables are used to continue open lines from the outskirts of cities to the metropolitan offices, and with cable circuits between offices, the conductors are generally grouped in quads, and through mutual electro-static capacitance, particularly with cable circuits and open wire circuits having entrance cable of considerable length, interference may arise between four telegraph circuits of a quad. Still another source of interference is the inductive coupling

through loading coils and line filters. The need for minimizing the effects of such interference, generally known as cross-fire, has been increased by the use of high speed telephone-typewriters which to a large extent have replaced the lower speed hand-sending methods.

Two differential duplex telegraph circuits, derived from a single metallic telephone channel, are indicated in schematic form in Figure 1. The fundamental characteristic of such telegraph circuits is the division of the outgoing current into two paths of equal impedance, one of the two balanced windings of a polarized relay being connected into each. The impedance of the line side is determined by the composite set, the line itself, and the terminal equipment at the distant end. To balance this there is a composite balancing set and, for the line, a duplex balancing network. For lines of any appreciable length this duplex network must include both resistances, to balance the line resistance, and condensers—connected through

\* BELL LABORATORIES RECORD, *December, 1928*, p. 140.

timing resistances—to balance the capacitance of the line to ground.

By this method the impedances of the line and composite set are balanced, and the outgoing current through the two coils of the polarized relay is also balanced. There is, however, an additional effect due to the coupling between the two circuits which has not been taken care of as yet. This coupling is represented by the capacitances between the two composite sets and between the two line conductors, represented by  $MC_0$ ,  $MC_1$ ,  $MC_2$ , and  $MC_3$ , on the sketch. Because of this coupling, current impulses sent over the circuit from Station A to Station C, indicated by the heavy arrows, produce short impulses in the B-D circuit which flow in both directions, to the near end at B and to the far end at D, as shown by the dotted arrows. Since the current that flows through a capacitance is proportional to the rate of change of voltage impressed across it, these induced impulses are short and correspond to the rising and falling sides of

the wave of the generating impulse.

These induced impulses are not balanced in the relay and their effect is much more severe at B than at D. The wave front is steeper at the sending

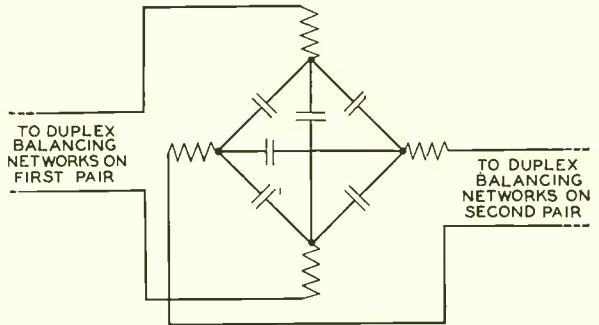

Fig. 2—The compensating network to neutralize sending-end crossfire makes connection to all four conductors of a quad

end and thus greater current passes through the capacitance near this end. As the initial impulse travels toward C more and more of the induced current will move toward D but because of the decreasing steepness of the wave front, the induction through  $MC_2$  and  $MC_3$  is smaller and the resultant effect is much less at D than it is at B.

To neutralize or balance out this

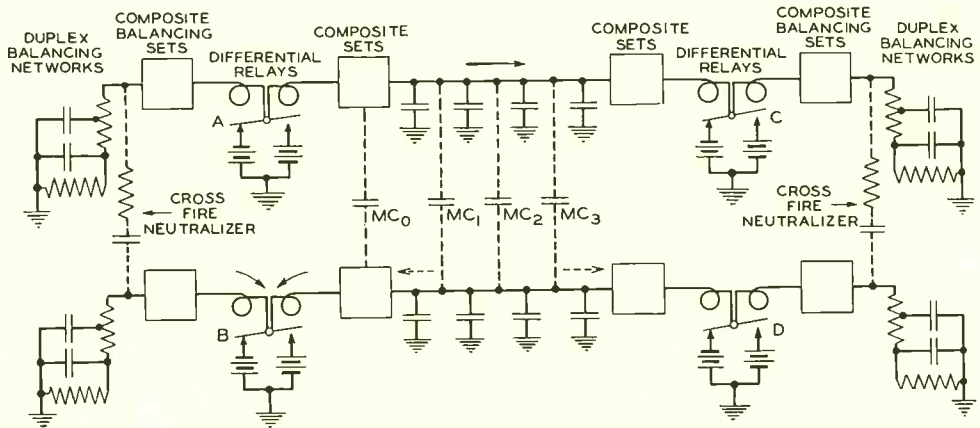

Fig. 1—Telegraph circuits formed from the two sides of the talking channel, showing the various capacitances and balancing networks

sending-end cross-fire, the balancing networks of the two circuits are connected together through a condenser and resistance in series as shown in dotted lines on the diagram. The impulse induced through this connection also divides, part flowing through the duplex balancing network and part through the composite balancing set and one coil of the relay. The neutralizing connection is so proportioned that this latter part just balances the induced impulse that comes in from the line.

A similar condition, although less pronounced, exists between the two telegraph circuits under consideration and the other two conductors which complete the quadded line circuit. Consequently it is advantageous to connect the duplex balancing networks of all four circuits through resistances and condensers, by the method shown in Figure 2.

Because of the decreasing effect of this type of cross-fire toward the distant end, practically all of the far-, or receiving-end, cross-fire arises through the inductive coupling of the

conductors in loading coils. This is indicated in Figure 3. The transmission of a current wave in line AC induces impulses in line BD which travel toward the distant end, as shown by the arrows, and may distort the signals at D. This interference is mutual, of course; impulses in BD affect line AC as those in the latter do BD. Although generally not so detrimental in its effect as sending-end cross-fire, it may be sufficiently troublesome at times to warrant provisions for overcoming it. This is achieved by connecting repeating coils,  $R_1$  and  $R_2$  of Figure 3, into the circuit. Their windings are poled opposite to the loading coils so that the inductive cross-fire is neutralized without affecting the received signals at the transmitting end.

Because of the different characteristics of various telegraph circuits, due to unequal distances and amount of entrance cable, the values of capacitance, resistance, and inductance coupling differ for each circuit. To facilitate the determination of suitable values for the parameters of the neutralizing circuits, a portable test-

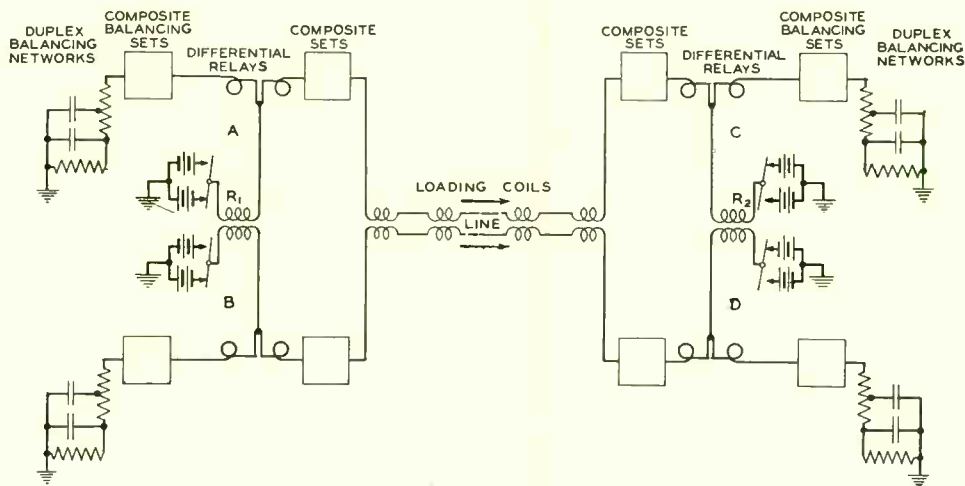
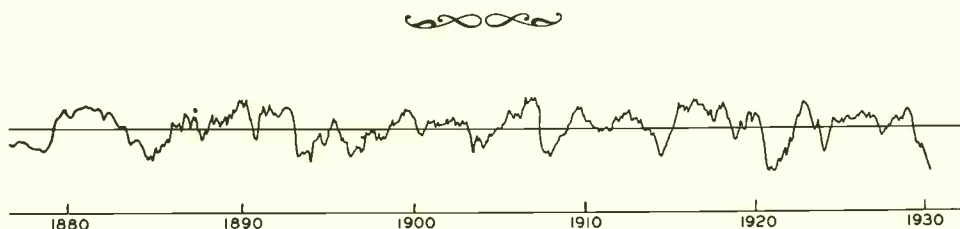

Fig. 3—Coupling between conductors through the loading coils is the cause of the greater part of the receiving-end crossfire

ing set was developed by the Laboratories. It is packed in a trunk for easy transportation. Based on tests with this set, fixed condensers, resistances and coils are permanently wired and associated with each group of conductors requiring neutralization. Connections from cross-fire neutralizing equipment to the telegraph operating sets, which may occasionally be changed, are made through jacks at the Morse board.

The nature of the cross-fire effect, both before and after neutralization, is shown by the oscillogram used as a headpiece. The bottom graph shows the unneutralized effect. The short cross-fire impulses in line with the rising and falling sides of each impulse in the disturbing circuit are plainly evident. With the neutralizing connections made, this disturbance is almost completely wiped out, as is indicated by the second graph from the top.



### *The Business Basis for Progress*

*The possibility of leveling the periodic cycles of boom and depression is an event of vast importance. . . . And with the widening acceptance of the idea that such control is possible, there is developing a sense of responsibility by business to make that possibility into an actuality. . . .*

*Business is still business, but it is also a good deal more than that. It is the chief agency in this country for giving all our people a safe, continuous and ever-improving economic basis on which to base their social and cultural progress. In other words, it is the agency of a democratic prosperity, just as our Government provided political democracy and our school system educational opportunity. . . .*

*The test of a civilization is the well-being and advancement of a population. It will take time to make business management a science that can begin the control of the cycles of business and to make it a profession that recognizes its full obligation to make industry serve society.*

—Walter S. Gifford, in "Saturday Evening Post,"  
November 8, 1930.

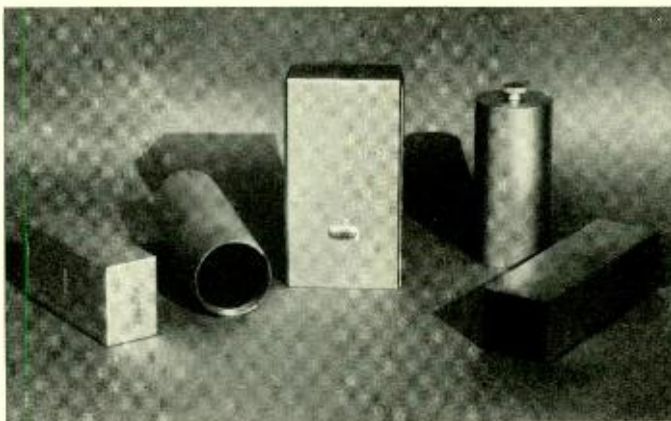

## Finishes on the Metal Parts of Telephone Apparatus

By H. G. ARLT

*Telephone Apparatus Development*

**F**INISHES are applied to metallic parts of telephone apparatus to obtain a uniform and pleasing appearance, and to protect against corrosion. These are the principal reasons, but finishes are also applied for specific purposes such as electrical insulation; heat or light reflection, or absorption; and to prevent sticking of parts.

At the present time some hundred standard metal finishes are being used on telephone apparatus parts. Paints, varnishes, enamels, baking japans, nitrocellulose lacquers and shellac solutions come within the grouping of organic coatings. The inorganic finishes consist of metallic coatings applied by various plating and dipping processes; and also several inert coatings such as the Bower-Barff and phosphate process finishes.

Paints are not used very extensively on metal parts owing to their softness. Paints consist of oxidizing oils, such

as linseed oil, combined with suitable pigments and dryers, and employ turpentine or mineral spirits as thinners. Because of the slow oxidation of the linseed oil, paint films remain soft for a period so relatively long as to render them unsuitable for apparatus to be assembled within a short time after the finish is applied.

Clear air-drying varnishes made from bodied oils, dryers, gums, resins and thinners are used in metal finishes principally as vehicles for aluminum bronzing powder. A bright, light-colored finish for structural framework is produced in this way, which gives a pleasant appearance and due to its light color and reflecting power adds considerable to the effectiveness of central office illumination.\* Clear baking varnishes are also used as vehicles for aluminum bronzing powder, the

\* For information on light-colored finishes for central offices see BELL LABORATORIES RECORD, Vol. IV, June, 1927, pp. 353-358; 358-362.

finishes in this case being applied mainly to apparatus parts and covers subject to much handling. The baked aluminum finishes have a much higher resistance to wear and impact than the air-dried finishes.

Baking varnishes pigmented with aluminum powder offer the only means of obtaining a highly-baked finish of light color, as all other light-colored pigments darken with baking, the darkening becoming deeper as the baking temperature is raised. Baked aluminum finishes have replaced black Japan finishes on central office apparatus and have been in use for the past two years. They have given satisfactory service and in addition have materially brightened up the interior of central offices.

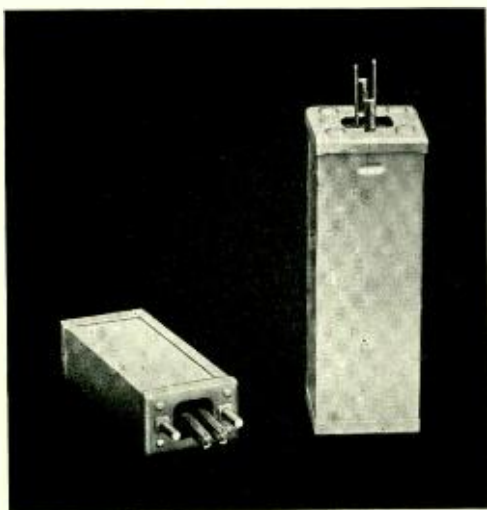

Fig. 1—Condensers finished with aluminum lacquer

Baking japans have been used on telephone apparatus for many years. Black is the usual color although some green and brown japans are being applied to telephone parts at the present time. The use of japans other than black leads to difficulties because of

color differences resulting from variations in baking temperatures which occur in commercial practice. Their use therefore is discouraged. The japan used at the present time produces a semi-dull black finish having the appearance of a machined and polished piece of hard rubber from which it derives its name. The name—"rubber finish japan"—is somewhat misleading, however, in that the japan contains no rubber. This material, which is manufactured at the Hawthorne plant of the Western Electric Company is the result of several years cooperative effort of the Western Electric Company's and the Laboratories' engineers to develop a material suited to the specific needs of the Bell System. It produces a hard, though elastic, finish which has the strongest resistance to mechanical wear and impact of any of the numerous organic finishes tested up to the present time in the Laboratories. This japan also offers excellent resistance to deterioration from perspiration which was one of the most important considerations leading to its adoption. The asphaltic base japans used in the past on some telephone apparatus have been almost entirely replaced by the rubber finish japan in view of the superior mechanical characteristics and more pleasing appearance of the latter material.

The use of nitro-cellulose lacquers on telephone apparatus undoubtedly will become more and more extensive in the future as their development proceeds. Polished, brushed and grained nonferrous metals such as brass and copper are usually given a coat of transparent lacquer to retard tarnishing. Pigmented lacquers, commonly known as lacquer enamels, are used for producing finishes in color. These materials produce films



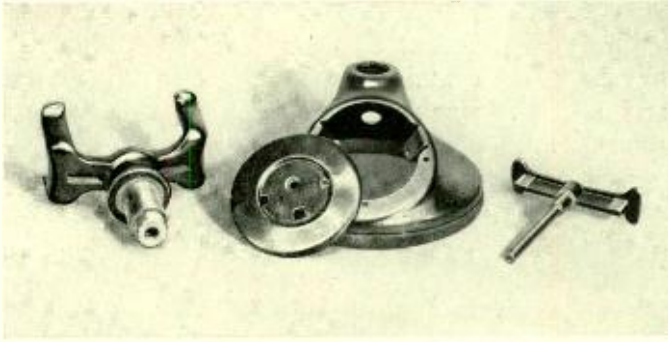

*Fig. 2—Parts of B1-type handset mounting finished with two coats of rubber finish japan. Base and apparatus blank are of steel and have been phosphate-processed previous to japanning. The japan has been applied directly to the sand-blasted surfaces of the cradle and plunger, both die-cast of aluminum-base alloys*

having the next best mechanical characteristics to baking japans.

Shellac solutions, which are used extensively for finishing wood, are seldom used on metal parts. Their only use on telephone metal work is for insulation on transformer laminations. Asphaltum paints and coal tar pitch also have insulation uses. The asphalt solutions applied as finishes produce soft electrical-insulating films and the coal tar pitch serves as an insulating corrosion preventive on loading coil cases which, when placed underground, are subject to considerable electrolytic corrosion due to stray ground currents. Rubber mixtures cured by heat alone are used to a limited extent to build up heavy electrical insulating coatings on irregular parts.

The organic finishes described above are applied principally by atomized spray, al-

though some are applied by dipping, brushing and flow-coating.

Of the inorganic coatings applied to metal telephone parts, the metallic platings are by far the most important. Zinc, applied by electroplating, is the most widely used and has proved to be the most effective of all platings in providing corrosion protection at reasonable cost for ferrous apparatus parts sub-

ject to normal indoor exposure. Nickel platings and composite finishes consisting of combinations of nickel and copper platings are used as rust preventives on parts on which the use of zinc is not advisable. Nickel is also applied for appearance reasons on non-ferrous parts subject to much handling. Electroplated tin is used primarily on parts which are to be soldered. Copper plating on telephone parts is not used very ex-

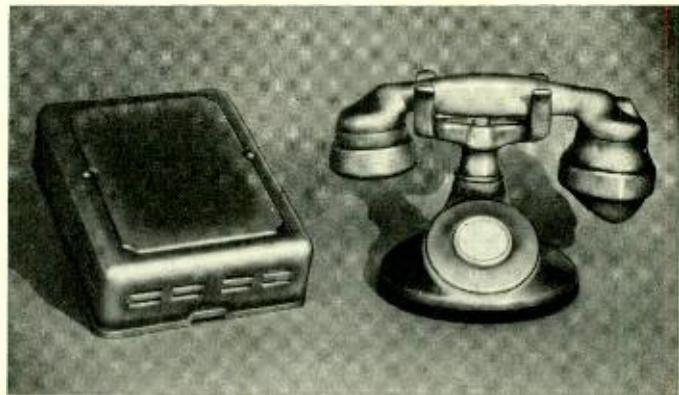

*Fig. 3—Subscriber equipment finished in two-tone colors. Oxidized silver parts are shown which have a silver-base color over which a black shading has been applied*

tensively at the present time. Gold is applied electrolytically on diaphragms and electrodes of transmitters to produce surfaces having low and uniform contact resistance. Chromium plating is used in several instances on small

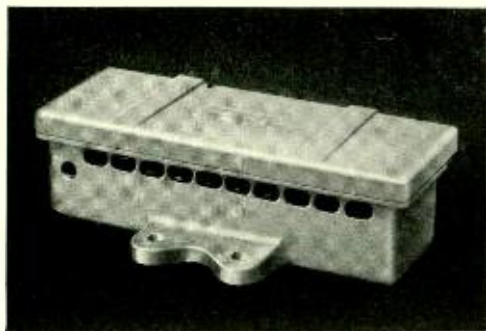

*Fig. 4—83-type protector mounting finished with hot-dipped galvanizing*

parts because of its wear resistance. As it also has prominent non-tarnishing qualities and extreme hardness, wider uses of chromium plating are being considered by the Laboratories at the present time.

Several metals, principally zinc, tin and solder, are applied to metallic telephone parts by hot dipping. To provide corrosion protection for ferrous parts exposed outdoors, hot galvanizing is employed. Tin finishes applied by hot dipping are particularly suitable in preventing season cracking of brass parts that are subject to outdoor exposure. These tin-dipped finishes constitute the first step in the production of the tin-coated sheet iron and steel which are extensively used in making sheet metal covers and containers for apparatus.

In addition to being applied by electroplating and hot dipping, zinc is applied to a large number of ferrous parts by the sherardizing process. In this process the parts are heated to

approximately 850° F. for a suitable period of time in a closed rotating container partly filled with metallic zinc dust. The resulting finish consists of a closely cemented and even coating of zinc-iron alloys high in zinc content. This finish is particularly suitable where a zinc coating is desired on deeply recessed parts which cannot be evenly electroplated.

Several so-called oxide coatings are used for decorative purposes on copper, brass and bronze. Most of these coatings are relieved by scratchbrushing or buffing in spots and are then protected from further changes in color by transparent lacquer coatings.

A chemical scale finish which has been used widely on telephone set parts is the magnetic oxide of iron produced by the Bower-Barff process. By this process the oxide is produced

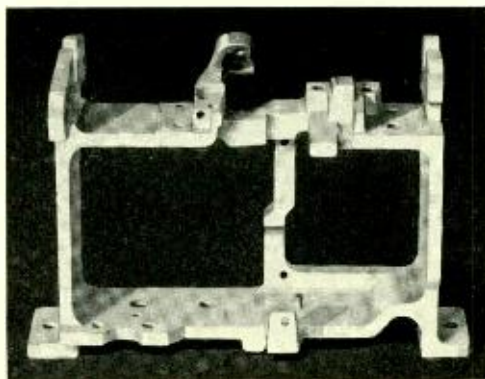

*Fig. 5—Frame of step-by-step switch with sherardized finish*

from the iron in the part itself by heating it to approximately 1400° F. in the presence of steam and a small amount of oil. This finish is then darkened by an application of linseed oil. Bower-Barffing produces a very hard, closely adherent finish having excellent corrosion resistant properties and pleasant dark gray appear-

ance but its use is limited somewhat due to its brittleness.

Another chemical scale finish, known as the phosphate process, is used extensively as an undercoating on ferrous parts to which a subsequent organic coating is to be applied. The process consists essentially of immersing the parts in a hot solution of phosphoric acid which results in a coating of iron phosphate being formed on the surface of the ferrous parts in the bath. The phosphate coating is a closely adherent crystalline deposit and has a slightly rough texture. It has given excellent results as a primer for organic coatings as its rough texture

promotes very good adherence of the organic material to the phosphate crystals. In addition the excellent adherence of the phosphate to the base metal retards lifting of the organic coating after pin hole corrosion has started.

This brief summary of the metal finishes gives only a birds' eye view of one field of endeavor toward improved appearance and better functioning of telephone apparatus. New materials and methods of application are constantly being investigated and as a result the finishes in use are constantly undergoing revision and improvement.

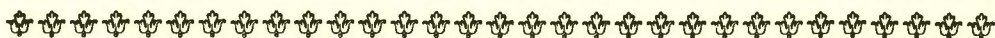

## Power for Magneto Offices

By R. D. de KAY  
*Equipment Development*

**P**ECULIAR to sparsely settled communities is the "magneto telephone office," a phrase which brings primarily to mind a central office having no storage battery. In these local battery systems Edison primary cells supply the talking currents at the switchboard, and dry cells at each subscriber's premises. The ringing currents are supplied at the subscribers' stations by local magneto generators, hand operated (from which the term "magneto office" derives its name); and, at the switchboard, usually by a vibrating pole-

It is in conjunction with several other changes in the equipment of magneto offices that the change from dry cells to storage batteries is being made. To improve articulation and reduce sidetone, the transmitter, receiver, and induction coil formerly used in these offices have been replaced by newer types. Because of its greater resistance, the new transmitter will operate efficiently only on a power supply providing a potential difference of at least eight volts. Moreover in the new operator's telephone circuit the operation of the talking key would introduce undesirable clicks in the operator's receiver unless a continuous current passed through the transmitter.

To fill both these requirements reliably and economically, it was decided that a small power plant of storage batteries, trickle-charged from the local supply of 115-volt alternating current, should be provided. The battery would have sufficient reserve capacity to fill the office requirements for at least twenty-four hours if the commercial power service failed. From the samples submitted by several manufacturers a unit was selected which, with slight changes, would meet all the requirements satisfactorily at a minimum price.

This unit consists of a pressed steel case divided into two compartments, one of which contains a four-cell battery and the other a dry-type trickle charger. A considerable saving in



*Fig. 1—The eight-volt power unit is compact and convenient for mounting*

changer operated by primary cells, with a hand magneto in reserve, or by a motor-driven magneto. It is for the first-mentioned purpose, to supply talking current at the switchboard, that storage batteries are now going to be introduced.

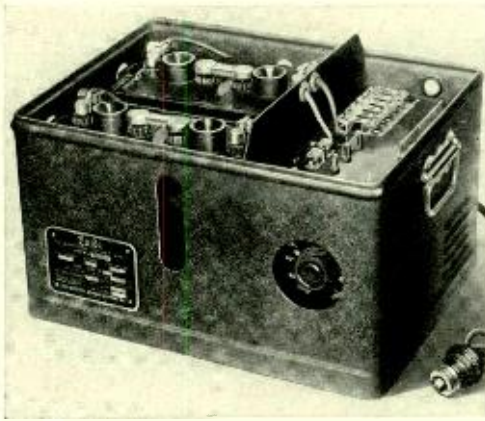

*Fig. 2—Removing the cover reveals the two compartments of the power unit*

price was obtained by using the manufacturer's standard case already developed for radio "A" and "B" battery eliminators, with a few minor changes in the openings. This case has a removable cover and is of such dimensions (fifteen by twelve by ten inches) that it can be mounted on a standard relay rack shelf, on top of the cabinet of dry cells for the ringing interrupter, or in any other convenient location.

The two two-cell batteries are enclosed in glass jars, and give a total of approximately eight volts. The jars bear high and low electrolyte level marks, and one cell of each pair is equipped with a three-ball electrolyte gravity indicator, in which all three balls float on the surface of the electrolyte at full charge, the blue ball sinks to the bottom at about five percent discharge, the white ball at about one-third and the red at about two-thirds. The life of these cells is guaranteed by the manufacturer for five years, but a longer life is expected

when used on this type of service.

The batteries are available in two capacities: one of twenty ampere hours at a half-ampere rate for the one- and two-position magneto boards, and the other of forty ampere hours at a one-ampere rate for boards up to five positions. In the few cases where more than five positions are installed, two units can be used if necessary. The cells are set in rubber buckets of sufficient capacity to hold the electrolyte in case a cell is accidentally broken. Handles are provided for lifting the unit, which weighs about thirty pounds with the small battery and sixteen pounds more with the larger battery. Batteries of the two types are interchangeable in the case, except for the rubber buckets which are individual to the batteries, and for this reason the price difference between the units with different capacities is very small.

The other compartment in the case contains a dry-disc rectifier, such as has been used in radio work quite ex-

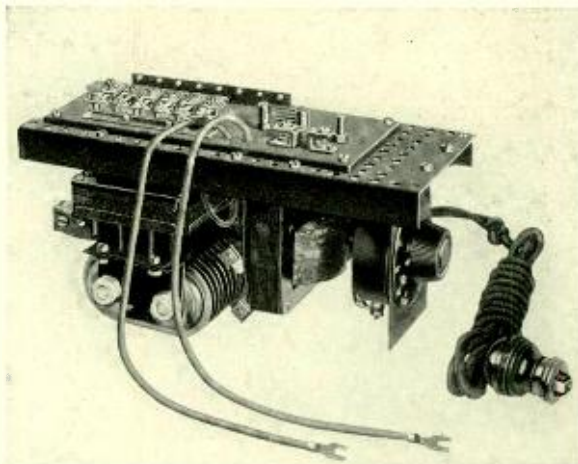

*Fig. 3—The link permitting charging at an increased rate is a clip movable to either pair of the terminal posts shown at the right-hand end of the mounting plate*

tensively, and the control equipment. The rectifier consists of a number of copper oxide rectifying discs, clamped, together with heat-radiating discs, to two rods mounted on the frame of a step-down transformer. The discs are arranged in series-parallel to give full-wave rectification of the low-voltage alternating current from the secondary of the transformer.

The control consists of a fifty-ohm rheostat in the secondary circuit of the transformer, which is capable of varying the charging rate from a tenth to a half ampere. A retardation coil for quieting the output and a fixed resistance for factory adjustments are also in this compartment. Across the top and attached to the metal framework on which this equipment is mounted is an insulating panel carrying fuse mountings, and a ground strip connected to the positive side of the battery. The panel carries as well a movable-link device permitting the rheostat to be entirely cut out and a higher voltage transformer tap cut in when it is desired to overcharge the battery or to charge it at a higher rate, as would be the case when the battery had become discharged after a prolonged power failure. When the

link is in the high-charge position, a charging current of about one ampere will be delivered by the rectifier, and a one-and-one-third ampere fuse is connected between the transformer secondary and the rectifying discs.

A flexible cord and plug connects the unit to any available electrical outlet for 115-volt alternating current. Connection to the battery can be made at any one of the six fuse mountings and the ground strip, a convenient hole in the case admitting leads for this purpose.

Estimates indicate that cost savings will accrue by using the power unit instead of primary cells with practically all magneto switchboards of more than two positions, even without using the improved operator's telephone circuit. When the power unit is also used to provide a constant current for this circuit the savings will be greater and will be obtained with the two-position as well as with the larger board. As there are about 3500 magneto switchboards now in use, the improvement in transmission made possible by the use of this new eight-volt power unit and the new operator's telephone circuit will be of much benefit to the Bell System.

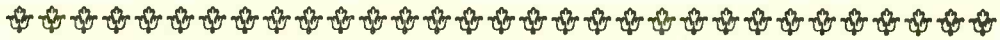

# Common Frequency Broadcasting Development

By G. D. GILLETT

*Radio Development*

**A**N unusually interesting step in radio broadcasting was taken on June 9, 1930, with the inauguration of regular commercial programs transmitted simultaneously on a single frequency from stations WHO, Des Moines, and WOC, Davenport, Iowa.

The congestion in the broadcasting frequency range had naturally led to a consideration of the possibilities of operating a group of stations on a single frequency.\* The possible usefulness of such a system had resulted in a number of previous attempts to secure the additional coverage offered by the simultaneous operation of two or more stations on a common frequency. "Matched crystals," and other means of independent frequency control had been tried but the frequency stability of the best equipment available in the past fell far short of that required for success.

Last winter the Central Broadcasting Co. of Iowa found themselves the possessors of a concrete example of the need for the simultaneous operation of two stations in that their stations WHO and WOC were compelled to divide time equally on 1000 KC so that the Davenport and Des Moines areas each received service from their local station but half the

time. These stations are 153 miles apart and either could be depended upon to render high-grade service only within a radius of about 50 miles of the station. It was felt that with the simultaneous operation of both stations, the Des Moines and Davenport areas would each receive full time service from its local station.

As these stations were equipped with Western Electric apparatus, the Central Broadcasting Company made arrangements with Western Electric for Bell Telephone Laboratories to undertake the development of equipment capable of maintaining the carriers of these two stations within the limits of synchronism required for their simultaneous operation. Extensive field tests and laboratory work had already been completed by the Laboratories to determine the degree of synchronism required for the satisfactory operation of stations on a common frequency and work was then well under way on the development of systems for the simultaneous operation of large groups of stations in synchronism. The successful operation of any system for the broadcasting of a single program on a common frequency requires that the carriers of the stations be maintained in almost exact synchronism, as any appreciable departure from synchronism will cause an objectionable flutter in the program received by a portion of the

\* *Some Possibilities and Limitations in Common Frequency Broadcasting*, DeLoss K. Martin, Glenn D. Gillett and Isabel S. Bennis, *Jour., Inst. Radio Eng.*, March, 1927.



*Fig. 1—In the group, from left to right, G. D. Gillett, Bell Telephone Laboratories engineer; Dr. C. B. Jolliffe, chief engineer, Federal Radio Commission; Paul A. Loyet, chief engineer, and Dr. Frank W. Elliott, vice-president, Central Broadcasting Company. The test car is equipped with an outside antenna*

listeners. Recent tests had shown that a newly developed crystal controlled oscillator unit designated as the D-90684 Oscillator-Amplifier possessed a frequency stability of a new order of magnitude for commercial equipment and that minor modifications would give it the exceptional stability required for the simultaneous operation of a small group of stations on a common frequency.

As a result of these tests a plan was evolved based on the use of one of these units at each station to replace the existing crystal control equipment, supplemented by a monitoring receiver located midway between the transmitters.

The D-90684 oscillator-amplifier is a relay rack mounted assembly consisting of a removable shielded unit

containing a constant temperature oven and a crystal oscillator, an amplifier having a maximum power output of thirty watts, and the necessary power control equipment. The amplifier tubes, meters and controls are mounted on the front of the panels and all other apparatus is mounted in the back and enclosed by a metal locker. The door of the locker is fitted, in accordance with our usual practice, with safety switches which automatically disconnect all high voltages from the equipment before the door can be opened. It was a simple matter to install one of these compact self contained units adjacent to each transmitter as is shown in Figure 2 to replace the existing crystal control equipment as the source of the carrier frequency.



The extraordinary frequency stability of these units has not been obtained through any radical change in design but has come rather as a result of the refinement of all the component elements to form a coordinated unit. A clamped crystal has been used in an improved type of holder, designed to maintain a constant pressure on the crystal and at the same time to prevent any lateral movement of the crystal which would cause a change in the crystal frequency. The crystal and its holder are mounted in an oven fitted with an improved thermostat capable of maintaining the temperature of the crystal constant within extremely narrow limits. This constant temperature oven is built as an integral part of the oscillator which has been designed to work the crystal under the conditions of optimum stability.

The oscillator and crystal are carefully shielded and isolated from the output stage by several buffer stages in order to prevent any change in the load conditions from being reflected back to the oscillator and thereby changing its frequency. Careful tests in the laboratory have shown that the output power could be varied from zero to full load without affecting the frequency within the limits of observation, which were about one part in a hundred million. It is relatively insensitive to changes in filament current, though this is maintained constant within narrow limits by a ballast lamp. Since a change of 1 per cent in the plate volt-

age causes an immediate change in the frequency of about one part in fifteen million and an ultimate change of about one part in two million, the oscillator is now being operated from batteries.

Since even with these oscillators absolute synchronism cannot be maintained indefinitely without readjustment, WHO was chosen as the reference frequency station and WOC was provided with means for the readjustment of its carrier frequency to exact synchronism with that of WHO. In order that the operator of WOC could easily determine the degree of



*Fig. 2—A corner of the operating room at station WOC, showing a part of the radio transmitter at the extreme right with the D-90684 Oscillator-Amplifier mounted adjacent to it. G. D. Gillett is holding the crystal oscillator and constant temperature oven, and over his head to the left is the loudspeaker on which the program for the monitoring station is received*

synchronism, a monitoring receiver was set up at a point mid-way between the stations and the program received there was transmitted back to station WOC by wire line. A departure of the two stations from synchronism is shown by a slow variation in the level of the program received and the necessary readjustment made by the operator to restore them to synchronism. The nicety of this adjustment can best be appreciated by the fact that a complete revolution of the control dial varies the carrier frequency at WOC by but one part in a million. With this equipment in commercial operation, a checking of the frequency every 15 minutes in connection with the regular routine inspection of the transmitter has been sufficient to maintain the carriers within an average of 1 cycle per minute of absolute synchronism. Departures from synchronism of this order of magnitude are not detectable within the normal service area of either station.

While with an installation of this type one is primarily concerned with frequency stability rather than permanence of calibration, the Laboratories have measured the frequency of these stations periodically. It was found at the time of the installation, after the disassembly and shipment of the equipment from New York, that the frequency was about two cycles difference from that measured before shipment. Measurements since that time have shown that the frequency varies over a period of time between seven cycles above the assigned frequency and seventeen cycles below it. Such a performance is dependent not only upon the proper design of the equipment but also on its maintenance and operation at WHO and WOC

by a technical staff of unusual ability and responsibility.

Before approval was sought from the Federal Radio Commission for the full time synchronized operation of these stations, careful surveys of the areas served were made by the engineers of the Federal Radio Commission, the Department of Commerce, the Central Broadcasting Company and the Bell Telephone Laboratories during their simultaneous operation on an experimental basis during the early morning hours in order to determine the nature of the service being rendered. Nearly three thousand miles were covered by the radio test cars during these tests. Upon completion of these surveys the Federal Radio Commission immediately granted permission for the simultaneous operation of WHO and WOC during regular broadcasting hours.

The surveys showed that the service rendered by the simultaneous operation of these two stations was substantially twice as great as the service given on a shared time basis. The normal service area of each station was increased and the night time reception at points over a hundred miles distant from either station improved by the practical elimination of rapid and selective fading as well as by an increase in the average field strength received.

In a small area midway between the stations, which received but a mediocre service originally since it lay outside the normal service area of either station, the reception with simultaneous operation was somewhat further impaired. However, tests in this area showed that the use of a simple directive antenna capable of discriminating against the weaker of the two stations at the point in question was

sufficient to render the reception at least equal to that from either station alone. A loop antenna grounded at one side instead of the center was found to be very effective.

Population studies made in connection with the field surveys show quite clearly how marked is the improvement in the service rendered by these stations under simultaneous operation as compared with operation on a shared time basis. On a shared time basis a population of approximately 1,000,000 received adequate service from these stations half the time, the value of which was greatly impaired by its intermittent character. With simultaneous operation the service area of each station receives full time service. No accurate estimate can be made of the number of people in the middle area, and outside the normal service range of either station alone, whose reception has been further impaired by simultaneous operation. The

importance of this effect can, however, be estimated from the fact that but 60 complaints of impaired reception were received by these stations in the first 35 days of simultaneous operation during the regular hours.

The marked increase in the service rendered by these stations through simultaneous operation is an indication of the possibilities of the improved service that can be made available to urban areas by the use of synchronized transmitters for the broadcasting of a common program. Although it is probable that the high powered station on a cleared channel will remain the best means of affording a high grade service to a metropolitan area while also rendering an acceptable service to large rural areas, common frequency broadcasting now appears to offer a definitely useful means by which to provide an improved coverage to a number of non-contiguous communities.

# Ringing Conditions on PBX Trunks and Tie Lines

By M. E. KROM  
*Local Systems Development*

**R**INGING requirements on a subscriber's line equipped with the usual sub-station set are principally concerned with operation of the ringer, but when a private branch exchange is involved the requirements are considerably more complicated. In most private branch exchanges the ringing current sent over the line operates relays and causes a lamp to be lighted in front of the operator. To accomplish this has required a series of developments involving several interesting problems, and since as many as 90 percent of the lines from some of the central offices located in business districts terminate in private branch exchanges, the importance of the development is evident.

The lamp in front of the PBX op-

erator is lighted from a direct current supply and not directly by the ringing current from the central office. It should light when ringing starts and remain lighted until the operator plugs into the jack. As the alternating current used for ringing is interrupted instead of being continuous, relays must be provided which will operate during the first interval of the ringing current and remain operated until the operator answers. One of the simplest circuits to accomplish this, shown in Figure 1, uses two relays (L and SL), the former of which has a double winding. One winding is connected across the line in series with the condenser R, and operates the relay when ringing current flows. Operation of the relay connects the secondary winding to battery through

one of its own contacts, and direct current flowing in this winding holds the relay operated. Another contact on the relay connects battery to the trunk lamp through a back contact on the SL relay. When the operator inserts a plug into the jack the SL relay is operated, thereby opening the lamp circuit, and releasing the L relay.

With this arrange-

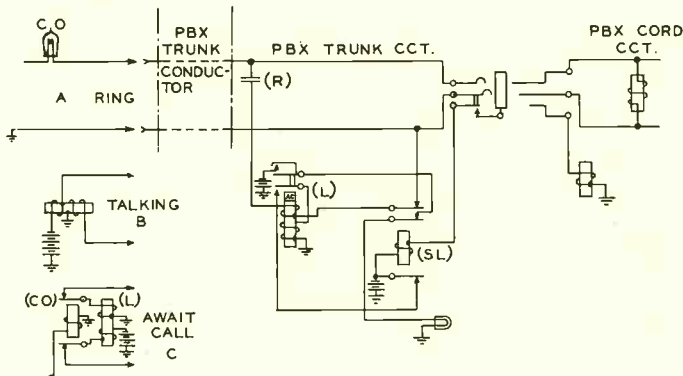
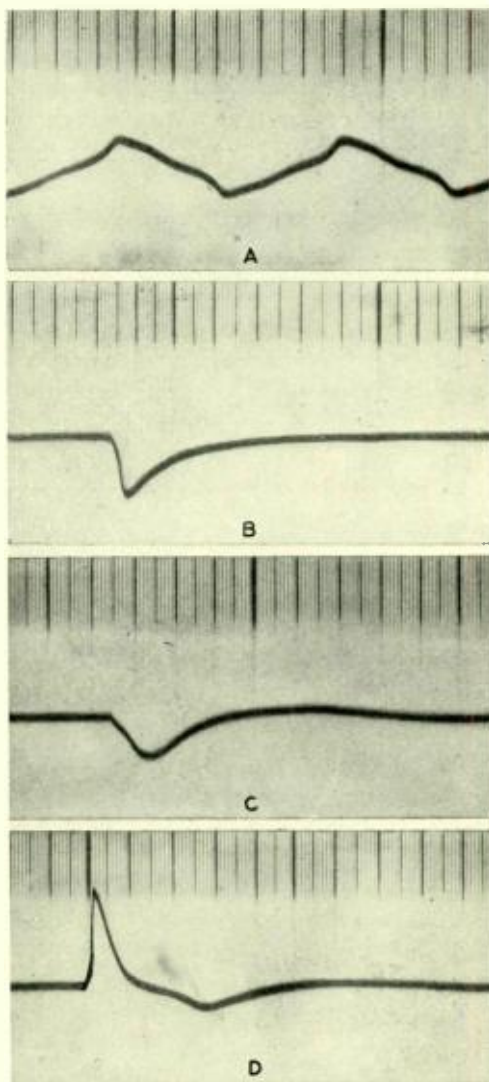

Fig. 1—Circuit connections at the central office are shown at A—for ringing, at B—for talking, and at C—for await call

ment several things must be considered in designing the circuit so that the lamp will operate only as required. Since the L relay locks on direct current, the flux produced by the locking winding will be unidirectional whereas that produced by the operating winding will alternate with the ringing current. With every other half cycle of ringing current, therefore, the relay would release unless the flux produced by the current in the locking windings were sufficient not only to counteract that produced by the current in the operating winding but to hold the relay operated as well. The relay must be sensitive enough to operate from minimum alternating ringing potential over the longest loop encountered, and must have sufficient direct current in the holding winding to prevent releasing or chattering when maximum alternating ringing potential is applied to the shortest possible loop.

One of the most severe conditions imposed, occurs immediately after the PBX operator pulls down the cord on disconnection. When the cord is removed, the relay L—in series with the condenser—is bridged across the trunk preparatory to giving a signal on the next incoming call. If at this time the connection has not been taken down at the central office, battery remains connected across the line as shown at "B" in Figure 1, so that a momentary current may flow through the L relay to charge the condenser R. This surge would be of considerable magnitude if the condenser had been disconnected from the line when it was charged in a direction to assist the talking battery. Under these conditions the current might be large enough to operate the relay, thus again locking it in and giving a false



*Fig. 2—A—Ringing current. B—Surge on condenser discharge. C—Surge caused by battery reversal at the central office. D—Surge caused by inductive discharge of battery feed relay*

signal to the operator if such a possibility were not avoided by careful design.

This surge, occurring when the plug is removed at the PBX, is often increased by the inductive discharge of the battery feed relay. While the plug is still in the jack a direct current

is flowing through the battery feed relay and the line. When the circuit is opened by the removal of the plug, a high potential is generated which increases the charge or discharge current of the condenser.

Another surge may be caused when disconnection takes place at a dial central office. This operation leaves the line connected as at C in Figure 1. In this case the battery connection to the line is reversed so that a current will flow to charge the condenser to the opposite polarity. The magnitude and durations of these surges relative

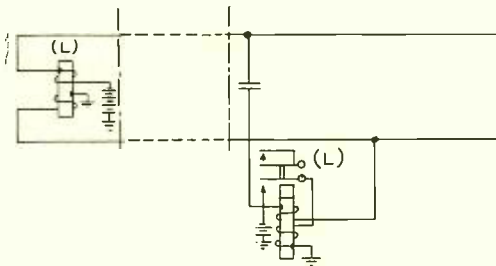

Fig. 3—By changing the polarity of the locking winding with respect to the operating winding the effects of the various surges may be reduced. Inner ends of windings are indicated by a semi-circular dot

to the ringing current, are shown on Figure 2. It will be noticed in this oscillogram that although the pulses are of the same order of magnitude, they are of shorter duration than

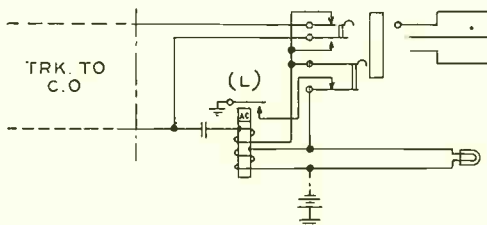

Fig. 4—Short-circuiting the condenser when the call is answered removes any charge that may have been left on it and reduces the momentary current that may flow when the plug is removed

even a single cycle of ringing current.

Various means are used to delay the locking of the ringing relay under these conditions. Perhaps the sim-

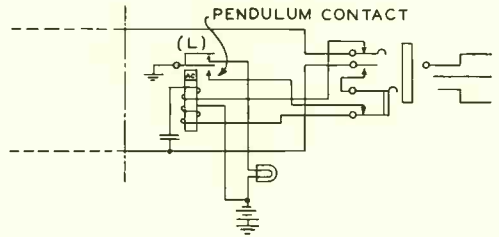

Fig. 5—Use of the pendulum J relay brings in a time element which avoids false locking of the L relay

plest is to "pole" the relay—that is connect the relay in the circuit so that the flux produced by the current in the locking winding is opposite to that produced by the momentary surge of current in the operating winding. This principle is illustrated in Figure 3. A study of this circuit will reveal that the condenser charging current flows through the relay in the opposite direction to the current in the locking winding. Likewise, the magnetomotive forces will be in opposition and will prevent the relay from locking as readily as it otherwise would if these forces were additive.

In many circuits, where reversed battery is used for supervision, it is possible for the surge current to flow through the relay in either direction, and in such cases additional methods to insure correct operation are employed. One of these is to short-circuit the condenser in series with the relay each time a call is answered. The purpose of this is to remove any charge that may have been left on the condenser by ringing current, because it is this charge that increases the amount of surge current when the cord is pulled down. The method of

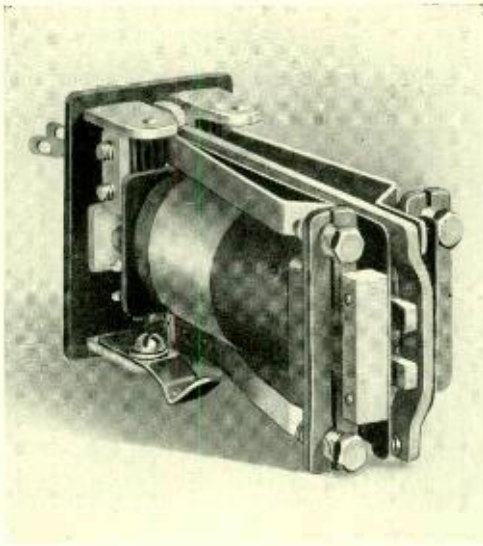

Fig. 6—The weight attached to the contact arm of the pendulum J relay is clearly evident in the photograph

discharging the condenser is illustrated in Figure 4. Insertion of the plug actuates the tip spring and closes a discharging circuit through the primary winding of the "L" relay. The winding of the relay is included in the circuit to limit the magnitude of the discharging current so as to prevent injuring the contacts of the jack.

A more recent method of securing correct signaling is by means of a specially designed relay used in the circuit arrangement shown in Figure 5. This relay, known as the pendulum "J" type, has a special pendulum contact arrangement consisting of a swinging contact arm, with a balancing weight affixed, which makes contact with the lower side of the relay armature. The impact of armature with this contact, when the relay first operates, causes the pen-

dulum contact to vibrate and thus delays closure of the locking circuit through it until vibration ceases, by which time the surge has expended itself and the relay will release instead of locking falsely. The construction of this relay is shown in the accompanying photograph.

Another ringing condition requiring careful design occurs on tie lines interconnecting two PBX's. Such tie lines often necessitate exceptional consideration because of the long distance over which ringing must be done. The ringing relays in these circuits must be very sensitive to respond to feeble ringing currents sent over long loops, and yet must be capable of withstanding extremely large transient currents which might introduce false signals. In these circuits a chain of three slow acting relays, operating from the contacts of the ringing relay, is required to delay incoming signals and insure correct operation of the signals on disconnection. On an incoming call the R, R<sub>1</sub>, R<sub>B</sub>, and R<sub>A</sub> relays, shown on Figure 7, must operate in the sequence designated. Operation of the R<sub>A</sub> relay, the last of this train, opens the operating circuit of the R<sub>B</sub> relay, and permits it to release and close a circuit to operate the L<sub>1</sub> relay. This locks in and causes a signal to appear before the operator. The delay introduced by

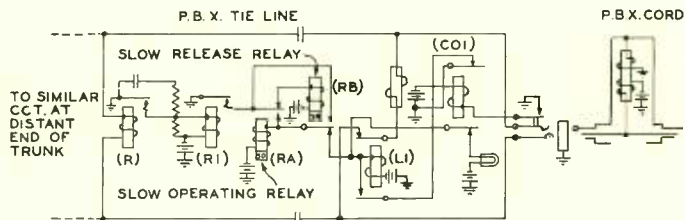

Fig. 7—A circuit that prevents transient surges from lighting the operator's line lamp uses a train of four relays, one of which is slow operating and one, slow release

the slow-operate RA relay and the slow-release RB relay is sufficient to give satisfactory operation and is yet not long enough to prevent operation of the LI relay during the ringing interval.

The surges appearing in this circuit are introduced by the inductive discharges of the retardation coil in the tie-line circuit when the cord is removed. This coil is used as a DC bridge to provide signalling in the cord circuit, and current is flowing in it while the plug is in the jack. When the cord is removed the circuit is

opened and as a result a high potential is generated in the retardation coil. This potential causes current to flow through and operate the "R" relay, and would cause false operation of the signal relay LI if no delay were introduced by the slow acting relays.

These are some of the more important conditions which make requirements for PBX ringing so difficult to meet. Successful ringing at Private Branch Exchanges is obtained, as are so many things, only by attention to seemingly small details.





NEWS AND PICTURES  
*of the*  
MONTH



*At the Hotel Stevens, in Chicago, S. P. Grace and R. M. Pease give a demonstration of toll-line dialing*



## General News Notes

---

### MOTION PICTURE ENGINEERS MAKE LABORATORIES VISIT

THE SOCIETY of Motion Picture Engineers, meeting in New York, October 20-23, devoted the last day of their convention to a program held in our Auditorium. A number of papers were presented, and at the close of the meeting luncheon in the restaurant was served. During the afternoon hours an inspection tour of the building and the Sound Picture Laboratory was made and various aspects of our work were shown to the visitors. Concurrently with the morning program and the inspection tour, a two-way television demonstration was given permitting each of the members to converse over the circuit between the building and 195 Broadway.

At the morning meeting T. E. Shea read a paper which touched on various construction details in the Bank Street Sound Picture Laboratory which were designed specifically for various problems encountered in the study of sound pictures. The delegates also listened with much attention to a description by F. F. Lucas of the ultraviolet microscope which has been responsible for his notable findings in biological research. In previous meetings on the three-day program papers also were read by W. C. Jones of the Transmission Instruments group, who discussed carbon and condenser microphones, and by G. Puller of the Special Products Department who described a new sound picture theatre reproducing system. At a night meet-

ing at the Roof Garden of the Hotel Pennsylvania following the Laboratories visit Dr. Fletcher spoke of the system devised for the aid of deafened persons in sound picture theatres and predicted installations in all of the large metropolitan motion picture houses within a short time.

Members of the Laboratories who acted as guides in escorting the visitors through the various Laboratories departments included, F. Hardy, I. H. Parsons, C. J. Beck, W. A. MacNair, C. H. Rumpel, J. R. Power, L. A. Elmer, E. W. Gent, R. V. Terry, J. F. D. Hoge, and C. A. Clarke.

### NEW FAIRCHILD PLANE

DELIVERY HAS been made of the new 71-A Fairchild monoplane recently purchased by the Laboratories to be used with the Ford tri-motor plane in carrying out tests in aircraft communication. The plane, powered with a 420-horsepower Pratt and Whitney, series C, Wasp motor, will supplant the Fairchild craft which has been employed for nearly three years in airplane radio-telephone development. The new Fairchild has a sweep-back wing and a wingspread of 50 feet 8 inches.

The plane has been equipped with a 9-A and 9-B Radio Receiver, 8-A Radio Transmitter, 4-A Tuning Unit and associated apparatus, which were installed at the Fairchild factory in Farmingdale by J. W. Greig assisted by W. A. Funda. The 9-A Receiver, for long-wave reception, will be used



*Aircraft radio development goes on. Fairchild 71-A monoplane acquired by the Laboratories to replace the original Fairchild plane used in aircraft radio work*

for landing information from local airport transmitters, as well as weather forecasts and beacon signals regularly transmitted from stations of the Department of Commerce.

The 8-A Short-wave Transmitter and 9-B Short-wave Receiver will provide two-way communication between the plane and ground station. Power is supplied by a dynamotor used in conjunction with a storage battery.

The original Fairchild cabin plane, equipped also with a Wasp motor, made 613 flights in the two years and five months that it was in the Laboratories' service and was flown nearly 60,000 miles. It was exclusively used in the plane-to-ground tests of the aircraft radio-development program until the acquisition of the Ford plane a year ago.

#### EDISON VISITS LABORATORIES

THOMAS A. EDISON was a visitor to the Acoustical Research Labora-

tories on October 28. He was received by H. D. Arnold, H. A. Frederick and Harvey Fletcher and was escorted through the Acoustical Research Department where he observed several examples of the work carried on. On his visit he was accompanied by Mr. and Mrs. H. K. Hitchcock, and Mr. and Mrs. Theodore Edison. Mrs. Hitchcock is a sister of the inventor, and Mr. Theodore Edison, his son.

The familiar figure of Mr. Edison, walking with a firm step despite his four score years, was instantly recognized and word of his visit spread to many sections of the building. In the Acoustical Laboratories the method employed in making audiometric measurements was described to him and his own audiogram was charted by Dr. Fletcher.

Several records demonstrating acoustical phenomena were also played for him, following which the visitors were taken to the auditorium where

a demonstration of television was given. Mr. Edison spoke over the television system with Mrs. Hitchcock and Mrs. Edison who had been escorted by G. F. Fowler to the 195 Broadway terminal of the system. Mr. Edison was aided in hearing by special amplification in the television booth. He revealed marked interest in the details of the television system and reported he saw and heard very well.

#### SITES CHOSEN FOR SERVICE TO HAWAII

SITES for radio stations for telephone service across the Pacific Ocean have been purchased by the Transpacific Communication Company, Ltd., a subsidiary of the American Telephone and Telegraph Company. Erection of the stations will begin early next year and service between the United States and Hawaii is scheduled for January, 1932.

This is the first step in the move of the Bell System to connect its United States network with Far Eastern countries in or bordering on the Pacific. The project contemplates eventual establishment of services to Japan, Australia, the Philippines and Alaska, as well as to ships at sea.

The transmitting station will be located at Dixon, near Sacramento, California. The 15-kilowatt transmitter to be installed there, which will be similar to those used in the transatlantic telephone service, will operate on wave lengths between 14 and 44 meters. The antennas will have marked directional characteristics. Other transmitters will be installed as new channels are opened.

The receiving station will be located at Point Reyes, on the coast northwest of San Francisco. Its antennas also have directional characteristics.

The equipment for both stations is now being built in the Laboratories and by the Western Electric Company. The radio transmitting equipment was designed under the general direction of A. A. Oswald. M. E. Fultz and N. F. Schlaack have charge of the transmitter design and F. F. Merriam, the antenna design. F. A. Polkinghorn is in charge of both the receiver and receiving antenna design. In the Systems Development Department the wire-line connecting equipment was developed under the supervision of J. A. Coy and the circuits were laid out by E. Vroom. Power equipment was designed by J. L. Lawew's group. The preparation of the manufacturing information and supervision of installation was in charge of W. H. Bendernagel.

The radio channels set up by these stations initially will connect with the telephone system of the Mutual Telephone Company of Hawaii. This consists of wire networks on several of the islands, to be linked to each other by a low-power short wave radio telephone system that is being extended to cover the entire archipelago.

#### COLLOQUIUM

THE COLLOQUIUM embarked on its program for the 1930-1931 season on October 20 when K. K. Darrow spoke on the subject of atomic disintegration by alpha particles. In his address Dr. Darrow brought out the controversy which has existed for some time between two schools, that of Rutherford and his collaborators on the one hand, and of the University of Vienna on the other. The main topic for discussion, however, was a recent paper by Pose which promises to reconcile the differences between the two groups.

On October 27, S. O. Morgan delivered a paper on *The Debye Theory of Dielectrics*. Outlining the idea of the permanent dipole introduced by Debye, a theory which led to an explanation of the dielectric properties of liquids and gases, the speaker then discussed the application of the Debye theory to the problem of determining the structure of organic compounds.

## ADMINISTRATION

ON THE morning of October 20 Dr. Jewett addressed the Assembly of California Institute of Technology at Pasadena and spoke at noon before a joint meeting of the Electric Club and the Los Angeles Section of the A.I.E.E. on *Some Present Day Problems in Electrical Communication*. That evening he addressed a dinner meeting of the University Club, Pasadena, on recent developments.

On November 21st, Dr. Jewett spoke at a combined meeting of civic organizations at Summit, New Jersey.

Preceding the meeting, he was entertained at dinner at the Canoe Brook Country Club by Vice-president Wiley of the New York Telephone Company.

RECENT ADVANCES in communication were described by S. P. Grace in talks in Providence and Boston during the latter part of October and early November. In Infantry Hall at Providence Mr. Grace spoke on October 29 under the auspices of the Providence Engineering Society before an audience of 2200 persons. He repeated the discourse on the night following before 1800 employees of the New England Telephone and Telegraph Company and their friends. On the afternoon of October 29 Mr. Grace and R. M. Pease were luncheon guests of the Lions Club. Mr. Pease

gave a talk on sound recording for motion pictures at the luncheon.

Mr. Grace's Boston appearance took place at Tremont Temple on November 5 before an audience of 3200. The meeting was sponsored by the Metropolitan Electrical League and Associated Engineering Societies. In Boston, also, the talk and demonstration were repeated on the following night for the local telephone employees. At each of these New England appearances Mr. Grace was accorded an enthusiastic reception.

An interesting sidelight on the Boston talk is contained in the following comment taken from the Boston News Bureau's description of Mr. Grace's address:

"Thinking it would be diverting to ascertain what the inverted or scrambled name was of his friend, Robert F. Estabrook, operating vice-president of the New England Telephone Co., Mr. Grace had previously experimented in this direction. The result was surprising. Holding the transmitter before him, he spoke these words into it—'That's the gink'—and sharply and clearly from the loud speaker came the name, 'Estabrook!' Truly, science is marvelous."

WILTON L. RICHARDS, until recently Consulting Historian of the Laboratories, died at his home in Brooklyn on November 7. Entering the Bell System in 1878, Mr. Richards was at first one of the workers in the shop where the telephone was born. Among his later contributions to the art were the first practicable head-receiver; the bi-polar hand receiver, ancestor of the type still used with the desk-stand; the balanced circuit by which a two-way channel is split into two one-way channels.

In 1915 Mr. Richards was in charge of the transmission features of the Bell System exhibit at San Francisco.

At about the same time he was placed in charge of our Historical Museum. Marking his completion of a half century of service, the RECORD pub-

lished in October 1928 an account of his distinguished career in telephone engineering, in which work he is mourned by a host of friends.

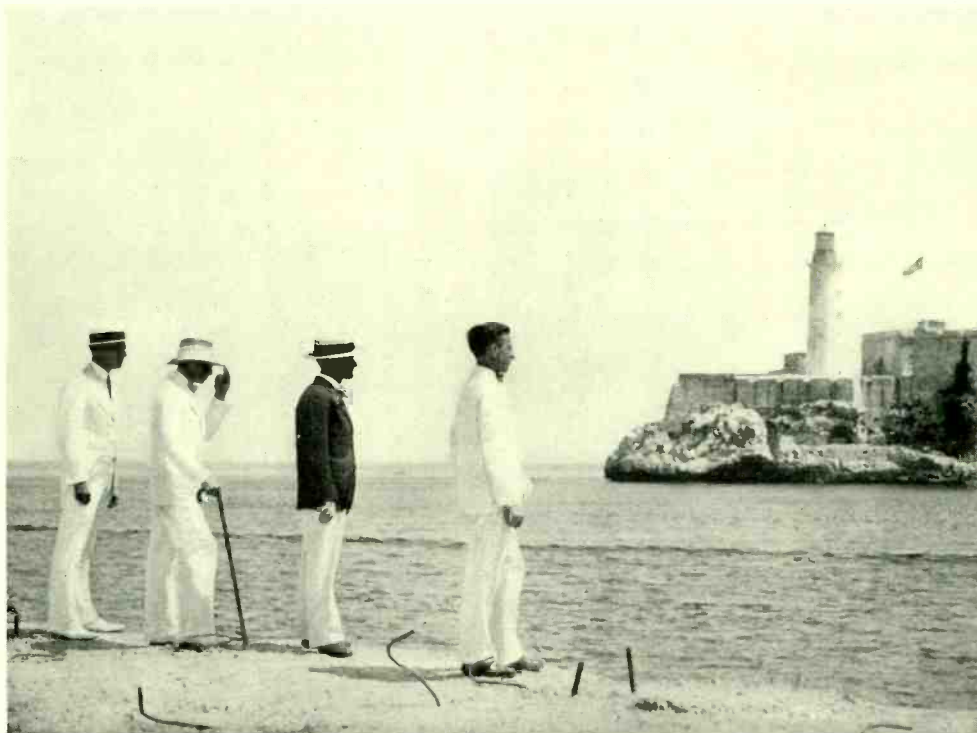

*Bell System engineers, supervising the installation of the Key West-Havana cable-terminal equipment, on a Sunday afternoon stroll view Morro Castle from across the harbor. W. F. Malone, B.T.L. at the right, and at his left are H. Flack, E. L. Johnson, J. Crockett of the Western Electric Company. Final tests of the terminal equipment are being made by W. F. Kannenberg and A. B. Ellicock of Toll Development*

## Departmental News

### PATENT

DURING THE period from October 5, to November 3, 1930, the following members of the Patent Department visited Washington in connection with the prosecution of patents: F. H. Crews, P. C. Smith and H. A. Flammer.

A. G. KINGMAN attended the Annual Convention of the Telephone Pioneers of America at Los Angeles on October 17 and 18.

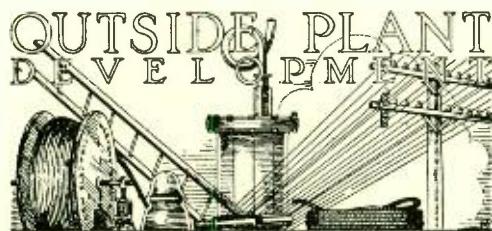

A TRIP to Hempstead, Long Island, was made by L. S. Ford, R. C. Jones and W. C. Redding to inspect the laying of a trial order of 1212-pair pulp-insulated cable.

F. B. LIVINGSTON visited Allentown to observe the splicing of 1818-pair 26-gauge pulp-insulated cable.

AT THE Chester field laboratory G. A. Anderegg, W. C. Redding and J. G. Brearley inspected a small trial installation of aerial cables which have been set up preliminary to an extensive experimental installation to be made for comparison of sheaths of different types and thicknesses under extreme conditions of exposure. Mr. Brearley was at Hawthorne during October to observe the manufacturing operations by which these sheaths are applied on the cables.

S. C. MILLER visited manufacturers in Pittsburgh and Chicago in connection with plant apparatus.

L. W. KELSAY was in Boston and Chicago on work pertaining to a field trial of building terminals.

L. H. BURNS was at the Bethlehem steel plant at Lebanon to supervise the inspection of steel insulator pins for use in Western States. W. T. Jervey was in Montana, Utah, Colorado and Missouri in connection with this installation of open-wire line insulators on these pins.



ON OCTOBER 27 L. E. Gaige became Field Engineer in the Detroit Territory, replacing R. C. Kamphausen who is returning to New York for special assignment work. In company with Mr. Kamphausen, Mr. Gaige recently made an introductory trip to Indianapolis, Port Huron, Holland, Grand Rapids and Saginaw.

J. A. ST. CLAIR made a trip to Detroit and Indianapolis for the purpose of introducing Mr. Gaige to the Michigan Bell, Indiana Bell and Western Electric Company people in the Detroit Territory. Mr. St. Clair also visited E. J. Bonnesen, Field Engineer at St. Louis, before returning.

INVESTIGATION WORK called W. E. Whitworth, Field Engineer at Cleve-

land, to Akron, Cincinnati, Castalia and Columbus during October.

R. C. KOERNIG, Field Engineer at Omaha, spent a few days in Des Moines, North Platte, Minnesota, Sioux City and Denver to attend regular review conferences.

A. J. BOESCH, Field Engineer in the Philadelphia Territory, visited Washington, Charleston, Richmond, Baltimore, and Pittsburgh during October in connection with general inspection matters.

E. J. BONNESEN, Field Engineer at St. Louis, visited Tulsa and Stroud, Oklahoma, in connection with Inspection Engineering matters. During the same month H. K. Farrar was in Albany and T. L. Oliver was in Boston and New Haven on similar work.

IN CONNECTION with a quality survey on panel equipment, R. O. Hagenbuck spent two days at the Hawthorne plant of the Western Electric Company. During the latter part of the month P. S. Olmstead spent several days at Hawthorne on a quality survey on handset transmitters.



#### TRANSMISSION INSTRUMENTS

W. ORVIS was at Hazelton, Pennsylvania, for two days inspecting coal mines in connection with granular carbon work.

R. CALAME completed twenty years of service on November 4.

QUESTIONS ON the handset job required A. W. Hayes' presence at Hawthorne early in the month.

#### ELECTRO-OPTICAL RESEARCH

H. E. IVES delivered talks on various aspects of television before the Optical Society meeting at Charlottesville, Virginia. He also discussed the production of pictures in relief.

#### ACOUSTICAL RESEARCH

A PAPER entitled *Miscellaneous Noise Measurements* was presented by J. C. Steinberg at the Middle Eastern District Meeting of the American Institute of Electrical Engineers in Philadelphia. Dr. Fletcher also attended this meeting.

H. M. OWENDOFF was at the Washington League for the Hard of Hearing supervising the installation of a public address system with head receivers for the use of deafened people.

#### RADIO RESEARCH

F. B. LLEWELLYN read a paper entitled *A Rapid Method for Measuring the Signal-to-Noise Ratio in a High Gain Receiver* before the Boston section of the Institute of Radio Engineers.

AN ADDRESS *Modern Physics* was given by J. A. Becker before a joint meeting of the Physics Club of New York and The Chemistry Teachers Club at the Stuyvesant High School, New York City. His talk emphasized recent developments common to both physics and chemistry.

#### CHEMICAL RESEARCH

B. L. CLARKE and L. A. Wooten have collaborated in an article appearing in the current Analytical Edition of *Industrial and Engineering Chemistry*. The title is *A Null-point Method of Potentiometric Titration for Determining Acid or Alkali in Paper*.



A PAPER *Dielectric Polarization of Some Organic Compounds in the Dissolved, Liquid and Solid States* by S. O. Morgan and H. H. Lowry is published in the November number of the *Journal of Physical Chemistry*.

#### SUBMARINE CABLE

W. M. BISHOP sailed on October 30 on the *S.S. Karlsruhe* for Germany to join the group of Laboratories men at Nordenham on work connected with the transatlantic telephone cable.

#### LABORATORY ENGINEERING

C. A. KOTTERMAN was in Washington to examine the exhibit maintained by the Laboratories at the National Academy of Sciences Building.

#### TUBE SHOP

WILLIAM WHITE, in charge of the operation of the high-power equip-



*William White*

ment in the Tube Shop, completed twenty-five years of service on November 11. His work with the Western Electric Company and later the Laboratories has been in electrical maintenance, as motor tender, power-room attendant, power-switchboard operator and electrician. For several years

he was in charge of the maintenance of the power room supplying the Physical, Chemical and Research Laboratories.

When the water-cooled tube, which made possible high-powered radio transmission, was developed a number of years ago, he supplied the voltage when the first tests were made. In 1925 he was transferred to the Tube Shop power room which provides the voltage on tests for both water-cooled and air-cooled tubes.



#### LOCAL SYSTEMS

A QUARTER of a century of service with the Western Electric Company and Laboratories was completed by L. B. Stark on November 13. Starting his career in the present building on equipment drafting work, Mr.



*L. B. Stark*

Stark in 1907 transferred to Hawthorne where he was made supervisor of power and circuit drafting. In

1912 he was called back to New York to handle the circuit drafting work on the semi-mechanical system. He supervised the laying out of the circuits of the first semi-mechanical equipment, the Newark installation which was put into service in 1915. Since 1916 he has been with the former Engineering Department and the Laboratories on circuit work. His work at the present time is on circuit development for panel systems.

H. E. POWELL is in Philadelphia on work of a committee which is studying ringers and associated substation central office ringing equipment to bring about improvements in service.

#### TOLL CIRCUIT DEVELOPMENT

J. MESZAR is at Minneapolis to observe the installation of a new No. 3 toll switchboard. With K. H. Muller, Mr. Meszar was in Chicago to assist in the toll-line dialing demonstrated by S. P. Grace in his Hotel Stevens talk. Later, at Providence, Mr. Muller and B. McKim assisted Mr. Grace in lining up the circuits for the call announcer demonstration.

A. F. GRESELL conducted tests on the voice-frequency equipment at the ship-to-shore radio transmitting station at Ocean Gate.

CHARLES WHITE completed twenty years of service on November 14.

#### CARRIER AND REPEATER DEVELOPMENT

DURING THE remainder of the year A. L. Bonner, B. A. Fairweather and A. H. Shuper will be testing the 44-B repeaters and associated circuits which have been installed at sixteen repeater stations between New York and Greenville, South Carolina. These circuits will be used for the experimental trial of the 4000-mile cable circuit which

is to start about the first of next year. H. I. Romnes of the Toll Circuit group is at Norlina, North Carolina assisting Messrs. Bonner and Fairweather in tests on the circuits and equipment.

#### MANUAL AND TOLL EQUIPMENT

WITH ENGINEERS of the American Telephone and Telegraph Company, D. C. Meyer visited Atlanta to be present at the cut-in on Nov. 2 of the new toll installation. This is one of the largest open-wire toll terminal installations in the country, as well as one of the largest carrier installations. It is also the first to use the No. 8 test and control board on open-wire lines.

J. A. MAHONEY went to Montreal to discuss engineering matters with the Northern Electric Company in connection with extension circuits for the transatlantic telephone cable.

#### SPECIAL EQUIPMENT DEVELOPMENT

W. H. BENDERNAGEL completed twenty years of service in November.

A talk on transatlantic telephony was given by Mr. Bendernagel before the Pratt Institute Alumni Association at the Fraternity Clubs Building, New York City, on November 11.

#### POWER DEVELOPMENT

V. T. CALLAHAN participated in tests of engines using furnace oil instead of gasoline at the engine manufacturer's factory in Buffalo.

F. T. FORSTER visited the Electric Storage Battery Company's plant at Philadelphia to witness tests of counter emf cells. In addition he discussed various storage battery matters.

H. M. SPICER inspected the power transfer switch equipment at the Washington - Cleveland combined panel and toll office in Buffalo.

VARIOUS POWER plant questions in connection with the new toll office in Atlanta were discussed by J. L. Larew with Southern Bell Telephone Company engineers in that city.

M. A. FROBERG observed installation work at eight offices in the East and Middlewest on studies of field problems affecting noise tests on power equipment.

#### DIAL EQUIPMENT DEVELOPMENT

THE CUTOVER of the dial equipment installed for the Jamestown Telephone Company at Jamestown, New York, by the Automatic Electric Company was attended by E. J. Kane.

F. W. TREPTOW participated in a meeting of an equipment survey committee at Hawthorne.

COMMON SYSTEMS developments were discussed by H. E. Marting in a recent visit to Hawthorne. With E. K. Eberhart he also inspected a trial installation of a new type of fuse pot at Scarsdale, New York.

AFTER THIRTY-TWO years of service in the Bell System Reinhold Petersen retired on October 24. With the exception of a short period in 1899, Mr. Petersen was in the service of the Western Electric Company and the Bell Telephone Laboratories continuously from the time of his graduation from Stevens Institute of Technology in 1898.

Entering the employ of the Western Electric Company in New York in July, 1898, as a switchboard-cabling draftsman, he was in 1907 transferred to Hawthorne and worked on equipment drafting work. At the start of the dial program in 1912, he returned to New York. During the subsequent three years he was actively engaged in the circuit development for the semi-mechanical system which was

first put into commercial operation at Newark in 1915. Still engaged in equipment drafting work, in 1920 he was placed in charge of the Equipment Drafting Department, which position he held until January 1927,



*Reinhold Petersen*

when he joined one of the groups in the Systems Department engaged in design work.

On his final day with the Laboratories a number of Mr. Petersen's friends, practically all of whom had been associated with him throughout the greater part of his service, gave a luncheon in his honor. Several short addresses were given in tribute to his marked sincerity, kindness and helpfulness during his years of service. Among the speakers were A. F. Dixon, H. H. Lowry, who presided at the gathering, A. Thomas of the Kearny Plant and John Harper from Hawthorne. Many interesting and amusing anecdotes relating to incidents in the growth of the Equipment Drafting Department during Mr. Petersen's period of service were recalled by the speakers.

#### STAFF DEPARTMENT

EDWARD J. GROWNEY, operator of elevator "C" until it was temporarily

discontinued two months ago and now a doorman at Washington Street, completed thirty years of service with the Western Electric Company and the Laboratories on November 9.

Few men in the building are better known than Ed Growney. Obliging



*E. J. Growney*

and courteous, he was at hand in old elevator "C" morning after morning to take care of the overflow crowd from the front elevators at 463 West Street. In three decades elevator "C" has gone through many vicissitudes — he has seen the old wooden elevator supplanted by the steel freight and passenger elevator which, in turn, is now being replaced by a more modern elevator — but Ed Growney remains firm and not much changed. With the exception of a short period when he worked as porter, he has been operating elevators all during his association with the Western Electric Company and Laboratories.

Almost thirty years in elevator operation — one often wonders how far a man has travelled during this time. Ed Growney will admit it is quite far. But not being of a statistical trend of mind he ventures no estimate.

PHILIP CURRAN completed twenty years of service on November 2.

THIRTY YEARS of service with the Western Electric Company and the Laboratories were completed on November 2 by William J. Cuddy, who is in charge of price files and records in the Accounting Department.

After working in various capacities in the accounting department of the Western Electric Company Mr. Cuddy in 1907 was transferred to the Factory Engineering Department, forerunner of the present Plant Department. He was in charge of the clerical work of this department until 1919 when he returned to the Accounting Department in charge of



*W. J. Cuddy*

special plant studies. Two years later he was transferred to statistical work on special reports of company activities. Called back to the Accounting Department in 1923, he took charge of plant accounting on building, permanent fixtures, machinery and furniture. From this work he was transferred to voucher accounting and placed in charge of price files and records two years ago.

E. J. SANTRY and J. S. HARTNETT attended a conference of the American Management Association in Chicago during the latter part of October.

J. S. HARTNETT has been named

as a member of the Unemployment Relief Committee of the New York Junior Board of Trade.

WITH PROFOUND regret the Laboratories has learned of the death of



*James A. Joblin*

James A. Joblin, attorney in charge of Workmen's Compensation, Labor Laws and Taxes, which occurred on November 4 in the Samaritan Hospital, Brooklyn, following an operation. He was thirty years old.

Mr. Joblin was a graduate of Albany Law School in 1924 and became a member of the Laboratories in 1926. His helpfulness and good fellowship had won him many friends.

### PUBLICATION

Three of the Laboratories' publications, designed by A. R. Thompson, were shown in the American Institute of Graphic Arts' annual exhibition of commercial printing. This exhibition, after a month's stay at the Art Center in New York, travels in duplicate to the principal cities of the country.

### PERSONNEL

G. B. THOMAS attended the conference at Lehigh University on the relation between Industries and Tech-

nical Schools held in connection with the dedication of the James Ward Packard Laboratory of Electrical and Mechanical Engineering.

J. S. EDWARDS recently attended the First Aid Instructors' Conference of the Eastern Division of the New York Telephone Company at Albany.

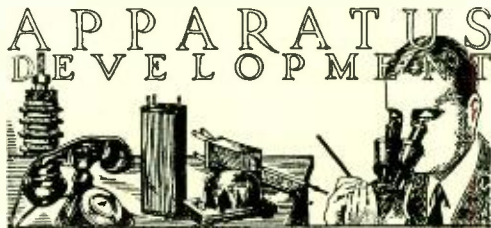

### TELEPHONE APPARATUS

W. J. SHACKELTON, at Washington, attended meetings of the National Research Council, and the Electrical Definitions and Electrical Insulation Committees of the American Institute of Electrical Engineers.

E. B. WHEELER and J. H. Bower were at Washington to discuss flashlight battery tests with other large users of batteries, battery manufacturers, and the Bureau of Standards. After the conference Mr. Wheeler went to Baltimore in regard to the manufacture of distributing-frame wire.

A. C. WALKER has been made a member of the National Research Council.

IN CONNECTION with the filters to be used in antenna modulation measurements on the experimental long-wave transatlantic radio E. B. Payne was at Bangor, Maine.

C. R. YOUNG and K. F. Rodgers attended the recent district meeting of the American Institute of Electrical Engineers at Philadelphia. While there they inspected, in company with L. E. Abbott of the Materials Devel-

opment group, the General Electric and Westinghouse electro-welding plants and observed the application of welding to manufacturing operations.

AT PHILADELPHIA also, L. E. Herborn visited the Leeds & Northrup Company in connection with the manufacture of a portable impedance bridge for antenna measurements.

#### MATERIALS DEVELOPMENT

C. H. GREENALL and V. P. Triolo spent the month of October at Hawthorne in connection with the manufacture of lead cable sheath.

C. E. NELSON was in Harrisburg and Stamford for two weeks on contact noise studies. On these same problems L. E. Dickinson was in Stamford, Trenton and Atlantic City.

A JOINT committee meeting of the Western Electric Company and Laboratories engineers on gauges was attended by J. R. Townsend at Kearny. He later visited the Chester field laboratory to observe the installation of several lead sheathed cables for test purposes. During the month he was also at the New Jersey Zinc Company at Palmerton, Pennsylvania where he discussed a new zinc alloy.

#### MANUAL APPARATUS

M. N. SMALLEY visited the plant of the Teletype Corporation at Chicago in connection with work on printing telegraph apparatus.

#### DIAL APPARATUS

G. W. FOLKNER attended the recent convention of Telephone Pioneers at Los Angeles.

A VISIT to Hawthorne was made by J. R. Fry to discuss new relay developments.

J. D. TEBO was in Seneca Falls, New York, in connection with new de-

velopments on short-circuiting relay protectors.

MATTERS CONCERNING the new small ringer for the combined handset required D. H. Gleason's attention at Hawthorne.

H. M. KNAPP visited the Western Electric Distributing House Shop at New Haven in connection with dial contact investigations.

ON THE trial of new gain control relays in pilot-wire regulators B. F. Runyon was in Allentown, Bedford and Pittsburgh.

#### SPECIAL PRODUCTS

C. F. EYRING is author of the article *Conditions Under Which Residual Sound in Reverberant Rooms May Have More Than One Rate of Decay* which was published in the October issue of the Journal of the Society of Motion Picture Engineers. In the same issue R. L. Hanson presents a paper *One Type of Acoustic Distortion in Sound Picture Sets* and F. L. Hunt described the production aspects of the sound picture recently made of a lecture by Dr. Fletcher, which illustrates acoustic principals of sound recording.

R. D. GIBSON is in Hollywood working on sound-picture recording.

W. R. GOEHNER spent a week at Hawthorne during the past month observing the manufacture and testing of light-valve ribbon for use in sound-picture recording.

AT THE recent convention of the Society of Motion Picture Engineers in New York, J. Crabtree presented the report of the committee studying the adaptation of color to films. E. O. Scriven acted as chairman of the Papers Committee in the absence of J. W. Coffman. He was assisted by C. A. Clarke and M. E. King.

H. M. STOLLER is in Hollywood to supervise the trial installation of a new high-power recording system at the Paramount Studios. Fifty motors will be used to operate cameras and recording machines instead of the fifteen motors used with the present system. Mr. Stoller previously visited the General Electric Company at Fort Wayne, Indiana to discuss questions arising on projector motors.

H. PFANNENSTIEHL is in Hollywood on matters pertaining to the recording of sound pictures with the West Coast Branch of ERPI and various producers.

R. V. TERRY visited Hawthorne to discuss various questions in the manufacture of re-recording equipment and also to look over the work in connection with portable sound picture reproducers. M. C. Gauthier also spent some time in Hawthorne on the re-recording apparatus.

ON NOVEMBER 6, J. C. Field, in charge of Train Dispatching Apparatus, rounded out twenty-five years of service in the Bell System. After receiving a C.E. degree at Princeton in 1903 and the degree of S.B. from M. I. T. in 1905, Mr. Field joined the Western Electric Company. Following a student course, he worked in the shop on switchboard assembly and testing, and in equipment engineering on preparation of specifications for switchboards and associated equipment. Transferring to laboratory, he engaged in general circuit work and in the development of semi-automatic switching of the panel type. In the old "physical laboratory" he worked on the development of equipment for train dispatching with which he has been associated most of the time since.

During the war period, Mr. Field was employed on deep-sea submarine

detection both in New York and at the naval laboratory at Nahant, Massachusetts. He also worked on methods of selective control of mine systems for the Coast Artillery.

Thirty-eight patents have been credited to him in his twenty-five years of work on Laboratories problems.



*J. C. Field*

He was the father of the ideas which resulted in the so-called A-C System of Train Dispatching. This includes the 60-A Selector and its associated apparatus and constitutes the Western Electric Train Dispatching System which has been standardized by the principal railroads throughout the world. He was also active in the development of remote control of power equipment and the protection system for bank vaults.

In honor of Mr. Field's twenty-fifth anniversary Mr. Glunt gave a luncheon in his office on November 11. In addition to Mr. Field and Mr. Glunt, J. J. Kuhn, T. E. Shea and E. O. Scriven were present.

#### RADIO DEVELOPMENT

F. W. CUNNINGHAM was at Washington to testify before the Federal Radio Commission as an expert wit-



*Interior of Fairchild plane showing radio-telephone control equipment*

ness concerning the application of the *Chicago Daily News* for permission to erect a 50 kw broadcasting station.

F. M. RYAN visited Washington to attend the second meeting of the committee on Aeronautic Radio Research on which he is serving as the representative of the Institute of Radio Engineers. The purpose of this committee is to make surveys of research work now in progress and to determine what steps, if any, need be taken to insure the most effective application of such research to the needs of aeronautics.

A SURVEY for the

installation of a 50 kw radio-telephone broadcasting equipment for Carter Publications, Inc., of Fort Worth, Texas, was made by J. C. Herber. He also visited Providence to inspect station WJAR owned by The Outlet Company.

J. W. GREIG and H. B. FISCHER visited the Bureau of Standards and the Bureau of Lighthouses in Washington to obtain information on the radio beacon systems used by these departments. They also inspected the Western Electric 400 watt radio-telephone equipment recently installed by the government at Silver Hill, Maryland.

H. E. J. SMITH supervised the installation of a Western Electric 400 watt radio-telephone equipment for the police Department of Toledo.

THE INSTALLATION of a 1 kw radio transmitter and associated speech input equipment for the Uhalt Radio Company, New Orleans, was directed

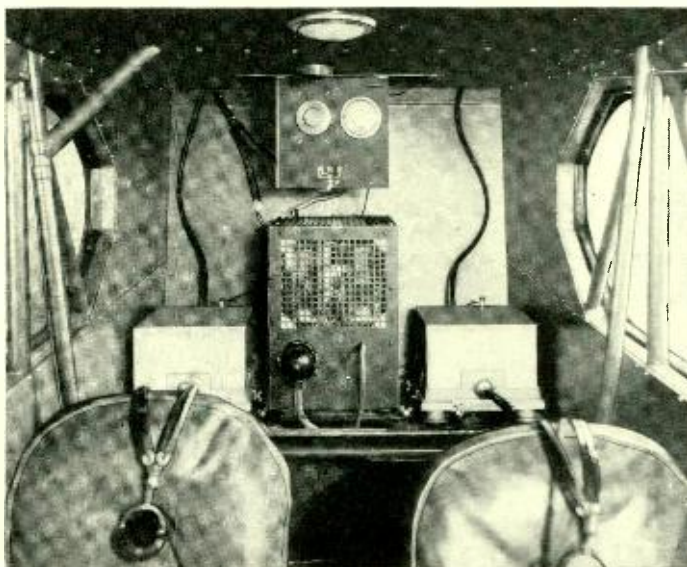

*Receivers, Transmitter, and above, 4-A Tuning Unit, installed in new Fairchild plane for air-to-ground radio-telephone communication*



by F. H. McIntosh. While in New Orleans, Mr. McIntosh also conducted a survey of the proposed location for a similar equipment for Saenger Theatres.

J. F. MORRISON and J. C. HERBER visited St. Louis to inspect and adjust the 5 kw radio telephone broadcasting equipment owned by the Greater St. Louis Broadcasting Corporation.

A. B. BAILEY inspected station WSB, owned by the Atlanta Journal.

THE INSTALLATION of a 1 kw radio-telephone broadcasting equipment and associated speech-input equipment for the Coffeyville Journal at Coffeyville, Kansas, was supervised by O. W. Towner. He also made a survey of the proposed sites for a 1 kw radio transmitter for the Inter-mountain Broadcasting Corporation of Salt Lake City and later went to San Diego to convert to crystal control the 1 kw radio transmitter owned by the Airfan Radio Corporation.

R. E. POOLE visited Bradley, Maine, to inspect the 24 kw radio transmitter recently installed for the American Telephone and Telegraph Company for use in making antenna studies.

W. L. BLACK visited the station of Gimbel Brothers, WCAE, at Pittsburgh.

S. E. ANDERSON recently returned from Cheyenne, Wyoming, and Oakland, California, where he assisted the Boeing Air Transport in the adoption of newly-developed circuit arrangements which materially increase the operating range of their Western Electric aircraft radio-telephone sys-

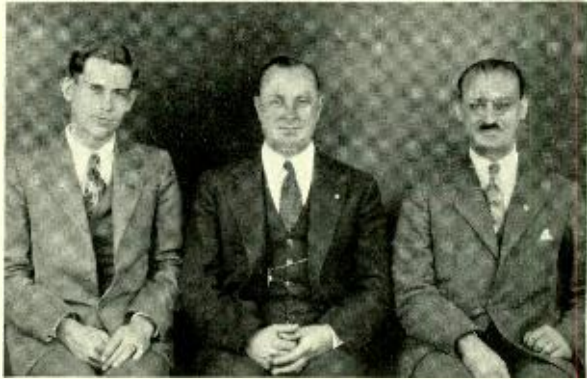

*Executive Committee of the Bell Laboratories Club Orchestra. V. C. Applewhite, Business Manager; L. E. Melhuish, Conductor; and R. J. Podeyn, Librarian*

tem. On his return trip Mr. Anderson visited Oklahoma City to inspect the Western Electric radio transmitter which is being used by the Gulf Oil Company in connection with its geophysical survey work.

THE LABORATORIES Ford airplane was flown from Hadley Field to Cleveland on tests of a vibrating reed instrument as a course indicator. Signals from the range transmitter recently installed at Bellefonte, Pennsylvania, by the Department of Commerce were used for this purpose. Concurrent with this investigation, transmission tests were conducted with the Laboratories ground station at Whippany, New Jersey. Captain A. R. Brooks and D. K. Martin, P. D. Lucas, R. J. Zilch and D. B. McKey made the trip. Two-way communication was maintained with the Whippany ground station throughout the entire flight.

A RECENT passenger in the Laboratories' new Fairchild airplane was Prince Edmundo Ruspoli of Italy, communication officer for the seaplane line operating between Rome and Constantinople via Brindisi.

Prince Ruspoli commented very favorably on the design and performance of the Western Electric airplane telephone system which was demonstrated to him by D. B. McKey and J. M. Henry during the flight. P. D. Lucas piloted the Fairchild.

DURING October, similar demonstrations were given for Captain Thomas C. Reeves in charge of the Signal Corps Aircraft Radio Laboratory, Wright Field, Dayton; D. W. Foote of the Northwestern Airways; and Mr. Seeley of the National Park Airways. These demonstrations were conducted by A. R. Brooks, P. D. Lucas, D. B. McKey, F. C. Ward, J. M. Henry and J. P. Dolbear.

THE FORD tri-motor plane, after a year of service, was flown to Detroit last month for general inspection at the factory. Within this period 240 flights were made, with a total mileage of 29,980 miles in 296 flying hours. All during the flight two-way communication was maintained with the ground station at Whippany. Above Detroit, 480 miles from Whippany, clear and strong signals were

received. The plane was piloted by Captain A. R. Brooks, with J. W. Greig, C. T. Garner, and R. J. Zilch in charge of the radio equipment.

## CLUB

A PROGRAM of Christmas music will be given in the auditorium during luncheon hour on December 22 and 23 by the Laboratories orchestra. A medley of Christmas carols as well as music appropriate to the Christmas season by famous masters will be played. The orchestra has been rehearsing industriously under the capable leadership of L. E. Melhuish and the special Christmas music promises to be an occasion of much delight and entertainment, as well as an innovation in the annual program of the Bell Laboratories Club activities.

Admission will be by ticket only which may be obtained from D. D. Haggerty, Room 164. Owing to the limited seating capacity of the auditorium but 700 persons can be accommodated at each concert. Laboratories members planning to attend are urged to apply for tickets early.





*R. D. de Kay*



*G. D. Gillett*



*M. E. Krom*

the war as commanding officer. In 1922 he left the navy and joined the power development group of the Laboratories, where he is now in charge of rectifier and machine development.

AFTER GRADUATION by Harvard with the degrees of A.B. (1919) and S.B. in E.E. (1921), Glenn D. Gillett began his engineering work in the power field. Entering the Bell System in the Department of Development and Research in 1922, he was engaged for several years in studies of radio field strength distribution. For graphic representation of the results, he developed the field strength contour map. Since transferring to our Radio Development group in 1929, Mr. Gillett has been concerned with problems of common frequency broadcasting.

M. E. KROM spent the summer vacation following his junior year in college with the Michigan State Telephone Company, and on receiving his

B.S. degree from Purdue in 1923 at once joined the Laboratories. With the Laboratory Group of the Local Systems Department he was at first engaged in testing panel circuits, and later was occupied with relay design and fundamental studies. In the spring of this year he transferred to the Fundamental Development Group and at the present time is engaged in radio-interference studies at Mendham.



*J. H. Bell*

J. H. BELL was in South Africa with the Signal Corps of the British army during the Boer war and in 1902 went with the Engineering Department of the British Post-Office. He left to join the Western Electric Company at West Street in 1911. Since that time he has been with the Laboratories continuously, engaged in telegraph development work and such allied systems as picture transmission. At the present time he is in charge of telegraph development.