

BELL LABORATORIES RECORD



A receiving-antenna structure of the ship-to-shore radio system, at Forked River



VOLUME EIGHT—NUMBER SEVEN

for

MARCH

1930



The Prior Art

By E. W. ADAMS

Assistant General Patent Attorney

NO discussion of patents proceeds very far without some reference to the "prior art" and as the term is not defined in the usual dictionaries, some consideration of what it is, where it is to be found, and its effect on the patenting of inventions should be of interest to inventors and potential inventors.

Unfortunately, the term is not capable of short and accurate definition. Broadly speaking, the prior art is the sum total of human knowledge prior to the present moment. With reference to the patenting of inventions, it is limited to that portion of human knowledge which embraces what has been invented or constructed, or what has been made available to the public by use, patents, or printed publications. It has been designated by a recent commentator as "an indefinite multitude of inventions which were once new but have already become old."

This multitude of inventions, publications, patents, and things which have been constructed or used is widely distributed and is not readily accessible. To find the prior art with reference to a given invention it is necessary to have recourse to certain available sources of information, which may be divided into the patented art, the published art, and the common knowledge and usage of professions or trades.

The patented art is usually a part of the published art although not

necessarily so, because patents of some countries are not published. There is no publication of patents in such important countries as Belgium and Italy, for example, and there was a period when there was no publication of patents in France. It is useful, however, to consider the patented art in a separate classification because, quite apart from the publication of patents, the granting of a patent has by statute a very definite effect upon subsequent patents for inventions. A determination of whether an invention is in the patented art involves a search but fortunately the patents in the major countries are classified.

In the United States, the patents are quite finely divided into classes in accordance with the subject matter claimed. In Great Britain, a comprehensive digest of the patents is published in classified form. The German Patent Office classifies according to subject matter each of its patents as issued; this classification, however, is somewhat different from that used in the United States. In France, the patents are classified along broader lines. In other countries, in general, some attempt is made at a classified index but as most of the important inventions are patented in one of the major countries, a search through the classified files of these countries will give a very comprehensive knowledge of the patented art.

The published art includes the entire field of printed publications.

The most fertile part of this field is to be found in the technical and trade journals and the proceedings of the various scientific societies. There are a number of indexes published and useful for this purpose which are familiar to most engineers. These indexes, of course, do not take the investigator to all of the published art but they are very useful in locating the more important publications. Such sources of information as doctors' theses and publications of local societies can only be found by following some definite clue.

The common knowledge and usage of a profession or trade is reflected in the technical articles, but useful material along this line is also to be found in trade catalogs, bulletins, instructions accompanying apparatus sold, and in correspondence between members of the trade or profession. About the only way to run down this sort of information is to consult with men who have had experience in the particular profession or trade under investigation.

An apparatus, system, or process which has been made and used or sold is presumed to be a part of public knowledge and hence a part of the prior art, although actual knowledge of such manufacture and use or sale may not be nearly as widely distributed as a printed publication. In fact, a single use or sale establishes the existence of the device or process as of the date of such use or sale. In some countries, France for example, prior use or sale anywhere and at any time before the filing of an application for patent is within the prior art. In others, the use or sale must be within the country.

The effect of the prior art on the patent is always one of limitation. In

general, the prior art may be considered as the environment of an invention and the extent to which an invention differs from that environment determines the scope, or, as it is often put, the place of the invention in the art. This generalization is, however, of little value unless it is kept in mind that the material embraced in the prior art differs for each invention and its effect is different with respect to the same invention in different countries. It is for this reason that in speaking of the date of an invention as the boundary line between invention and the prior art, consideration must be given to a particular invention and a particular country.

In determining the prior art with reference to a particular invention, we are concerned not merely with the date upon which the invention was conceived or first took definite form in the mind of the inventor but with the effective date, which is a very different thing. In some countries this effective date is the date upon which the application is filed, and publication of any kind or public use of the invention anywhere prior to this date is considered as prior art. In others, the publication or use must have been within the country to be prior art. In the United States, the effective date is the date upon which the invention is completed. Although the granting of a valid patent may be barred by statute because of publications, patents, public use, or sale subsequent to the date upon which the invention was completed, if an application is not filed within two years, these are statutory bars, and it is erroneous to call them part of the prior art as is often done.

In an effort to remove, in a measure, the hardship placed on an inventor by the material variations in the

patent statutes of various countries, an international agreement, known shortly as the "Patent Convention," has been entered into by most of the important countries of the world. It provides that an application for patent filed in one of the contracting countries within a year of the first filed foreign application is granted an effective filing date corresponding to the actual filing date of the first application. An application filed January 2, 1928, in the United States, for example, entitles the inventor or his assignee to an effective filing date in France also of January 2, 1928, provided the actual filing in France is effected prior to January 2, 1929. Thus publication or use within the "Convention" year prior to the actual filing date in France, is excluded from the prior art by operation of the Convention.

Space does not permit a discussion of the provisions of the patent laws of the various signatory countries making the Convention effective or of the legislation enacted to extend Convention priority over the period of

the World War. Under special conditions, such extensions have the effect of excluding much from the prior art which otherwise would be included.

Sufficient has been said of the more striking differences of the patent statutes in the more important countries to indicate that to obtain complete patent protection on an invention, certain precautions should be observed with reference to publication, public use, or sale. Unless these precautions are observed it may well happen that in one or more countries the invention will be prematurely added to the prior art.

The safe procedure, if world wide patent protection is contemplated, is to make sure that applications for patent are filed in all countries where protection is desired before the invention is either patented, published, used, or sold in any country. If circumstances do not permit following this preferred procedure, the first filed application should precede publication, use, or sale, and the remaining applications should be filed within the Convention year.



Prevention of Crosstalk in Phantom Loading Units

By J. R. WEEKS, JR.
Telephone Apparatus Development

WHEN two telephone circuits are close together, conversations taking place in one would be heard in the other, although at considerably reduced intensity, if special precautions were not taken. This form of magnetic and electrostatic induction is called crosstalk and its elimination has always been an important matter to the telephone industry. Methods of elimination vary with the type of circuit and apparatus. Those used with phantom loading units are typical for certain classes of apparatus and indicate the extreme care that is sometimes required.

A phantom circuit is an additional talking channel which may be obtained by suitable arrangements from each pair of metallic circuits. The general scheme is indicated in Figure 1. They are used chiefly with long circuits where the cost of additional channels becomes a matter of considerable importance. The two metallic circuits, which serve as the foundation for the phantom, are called side circuits, and careful balance between them and in the phantom repeating coils is required to avoid crosstalk. This care in balancing must be extended in even greater degree to the loading coils which are required for the phantom as well as for the two side circuits.

The purpose and method of loading has already been discussed in the RECORD.* To accomplish it the two sides of the line are connected to separate windings on the core of each side-circuit loading coil (Figure 2) in such a manner (series-aiding) that both windings produce flux through the core in the same direction. In the phantom circuit, the instantaneous current is, as indicated in Figure 2, in the same direction through the two line windings instead of in opposite directions. To the phantom current, therefore, the windings of the side-circuit coils are parallel-opposing and produce no appreciable loading effect.

Because of this a separate loading coil is used for the phantom circuit as shown in Figure 3, and the combination of one phantom and two side circuit coils is called a loading unit. Here is an arrangement that could very

* BELL LABORATORIES RECORD, September, 1927.

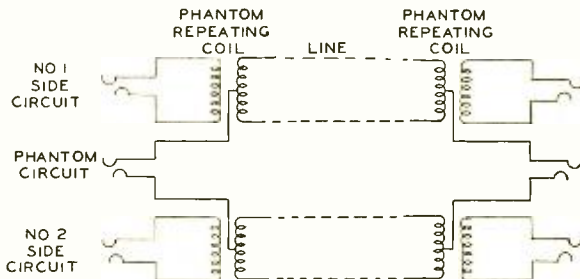

Fig. 1—Phantom circuits, by providing an additional talking circuit for every two pairs of wires, increase the number of circuits of a cable by fifty per cent

readily produce crosstalk if every possible precaution were not taken. If, for example, one wire of one of the side circuits has a greater inductance, resistance, or capacitance than the

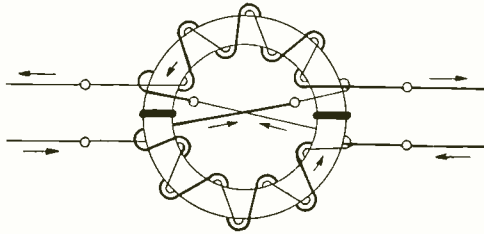

Fig. 2—The direction of the instantaneous currents and fluxes in a side circuit and loading coil are indicated by the arrows

other wire of the same circuit, an unbalance will exist which will cause crosstalk.

The most effective method found for reducing crosstalk in phantom loading units is to remove the causes; that is, the small unbalances which produce it. Accordingly, extreme care is taken in designing and building the component coils to keep them physically and electrically symmetrical. All the coils are toroidal in shape. A semi-automatic winding machine is utilized to put exactly the same number of turns on each winding and to distribute them uniformly. Since the

winding builds up faster on the inside of the core, it is necessary to build up the outside artificially. This is accomplished by using paper or muslin, one layer between layers of wire. The insulation over the core, and between the windings, is carefully placed to insure that the capacitances between windings, or between winding and core, will be well balanced.

In the case of the side-circuit coil, the space on the core is divided exactly in half by separating washers, and on each half are wound two windings. The outer winding on one side of the core is cross-connected to the inner on the other side to form one line winding (Figure 2). The four windings are connected so that when each pair of windings is put in one wire of the cable pair they are series-aiding around the circuit to the side-circuit current. This construction of putting half of each line winding on each section of the core is used to obtain a high degree of coupling between windings. This also tends to prevent any dissymmetrical currents in the wires of a pair—due to accidental causes such as grounds—from magnetizing one part of the core more than the other and thereby producing unbalance. This form of unbalance would accentuate the effects of volt-

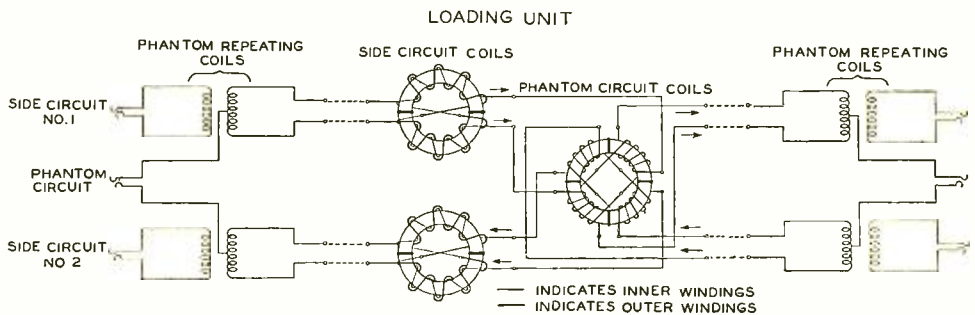

Fig. 3—On this diagram of a phantom group of circuits the instantaneous current directions indicated are for the phantom-circuit current only

ages induced by nearby power circuits.

In the case of the phantom coil it is even more important to preserve symmetry since all four wires of the phantom group pass through it. It is wound in eight sections, two on each quarter of the core. These are so connected that they are parallel-aiding to the phantom circuit, thereby adding inductance, and series-opposing to the side circuit to which, consequently, they do not add any appreciable inductance. They are cross-connected with the inner winding on one quadrant connected to the outer on the opposite quadrant.

The phantom coil, wound in this manner, is assembled on a wooden dowel beneath two side circuit coils, and the three coils are connected to form a loading unit. Iron washers are placed between adjacent coils to reduce the coil-to-coil coupling. The units are assembled one on top of the other until the required number, which varies from one to seven in the present standard cases, are on the dowel. Each unit is connected to a short length of cable, called a spindle cable, which reaches to the top of the dowel with sufficient extra length to permit splicing to the cable stub.

In the final adjustment, crosstalk from one side circuit to the other is balanced out by rotating the three coils with respect to each other so that their small stray magnetic fields neutralize each other. The coils are then clamped rigidly by wooden nuts on the top and bottom of the dowels.

This balancing does not reduce the crosstalk between the side circuits and the phantom circuit, which must, therefore, be compensated for in another operation. After the whole dowel assembly has been carefully dried and impregnated under vacuum and potted in a sheet iron container, the units are connected in a crosstalk

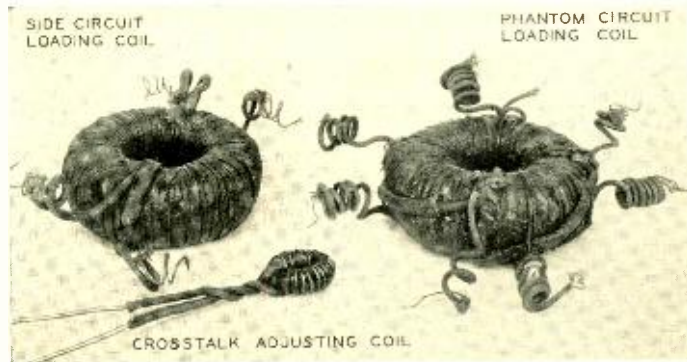

Fig. 4—A phantom coil, two side-circuit coils, and not more than two adjusting coils are required to make up a phantom loading unit

measuring circuit having the proper impedances to simulate an actual loaded cable. An adjustable inductance in connection with this circuit is used to determine what additional inductance must be added to the windings to bring the crosstalk to a minimum. In general the residual phantom-to-side crosstalk in phantom loading units is principally due to inductance unbalance. In those instances where the unbalance of capacitance is the greater, the inductance adjustment can still be used, with certain limitations, to correct for it also, since crosstalk from capacitance unbalance tends to be either in the same or the opposite phase to crosstalk from inductance unbalance. At the present time no corrections are required for resistance unbalance.

The addition of only a few micro-

henrys of inductance will be required if all previous operations have been made properly. A series of small coils varying from 3 to 150 microhenrys has been provided to make these ad-

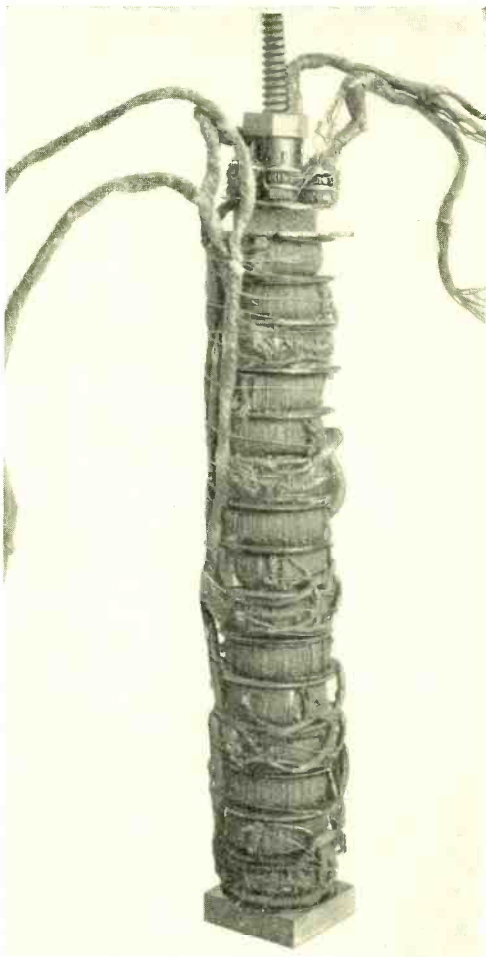

Fig. 5—A dowel assembly of five loading units showing spindle cable and crosstalk adjusting coils

justments. A total of about 850,000 of the coils were made last year for use with loading units. Since it is important to keep the resistance unbalance of the loading units as small as practicable, the adjusting coils are wound to have low resistance values, a few turns of heavy gauge wire being

used on toroidal cores not much larger than an old-fashioned wedding ring. Their size relative to the side and phantom coils appears in Figure 4.

After the proper coil has been selected by the above test, it is mounted on a fibre plate on the dowel and spliced into the proper wire of the spindle cable (Figure 5). The final manufacturing operations of potting the sheet iron containers in the big cast iron or welded steel cases, and of connecting the cable stub are carried out as carefully as possible so as not to disturb the balance obtained. As a final check each unit is measured at the end of the cable stub just before shipment. It is generally found that the crosstalk is increased by only one or two crosstalk units, each such unit representing an induced current of only one millionth of the value of the current producing it.

In a typical loading unit, one microhenry of inductance unbalance (corresponding to about .005%) will produce about two crosstalk units and one micromicrofarad of capacitance unbalance will produce about one unit. It can therefore readily be seen to what pains it is necessary to go in order to keep the average of the shop output of these loading coils to fifteen crosstalk units. The loading coils with permalloy dust cores, due to their smaller size, have materially helped in this direction—especially in keeping the capacitance-unbalance crosstalk down to a minimum. Capacitance crosstalk is neutralized partially by adding the small inductance coils during the final adjustment, as mentioned.

Such use of inductance adjustments for capacitance-unbalance crosstalk has directional effects, because inductance-unbalance crosstalk flows around the two ends of the disturbed circuit in

, whereas capacitance-unbalance crosstalk divides and flows around the two ends of the circuit in parallel. Consequently, when capacitance-unbalance and inductance-unbalance crosstalk are in phase at one end of the circuit, they will tend to be in phase opposition at the other end of the circuit. The inductance-crosstalk adjustments are made to obtain the maximum benefit from the phase opposition at the particular end of the circuit where the reduction is the more important.

During the past few years a number of improvements have been made in design and manufacturing methods.

Noteworthy among these are improved insulation between windings and between windings and core, vacuum drying processes, and better winding machines. The introduction of humidity-controlled conditions in the entire loading-coal section of the plant and the potting of the units while still under vacuum in sheet iron cylinders have, in addition, almost entirely eliminated the seasonal variations in the average crosstalk of the shop output. The result has been the reduction of the average phantom-to-side crosstalk of the loading-coil output of the Western Electric Company until it is now only about fifteen crosstalk units.

The Answer to Poor Talkies

“ . . . We find that most of the complaints we have heard against the talkies have come from people in small communities. This point is important, because the future of the talkies depends upon the success with which they can be shown in rural theatres, and if excellent sound recording becomes a jumble of unintelligible noises when shown in a small-town theatre, the talkies will never be successful.

To investigate this situation, we visited several movie houses on a recent trip to Florida, and in a town of less than fifteen thousand inhabitants we found the answer. There are two theatres in this town. The pictures on display during our visit had recently been shown in New York, and the critics had been unanimous in declaring the recording good in both films. In the first theatre the dialogue and sound effects were reproduced as clearly and effectively as we have heard in any New York house, but in the second theatre the reproduction was not at all satisfactory. The machines used in the two houses were similar types (sound-on-disc, in which phonographic records are used) but they differed greatly in one respect—namely, the manufacturer. The first house was equipped with standard Western Electric sound apparatus . . . the second with one of those cheap, unproven makes of reproducing outfits that have been appearing on the market by the dozens recently. In a desire to save a few hundred dollars, theatre owners in small towns (and some of the larger ones) are installing these cheap make-shift machines, and consequently losing thousands of dollars in patronage, as well as giving the talkies a bad name.

The remedy is simple. The theatre owners should do more intensive thinking and manufacturers of standard talkie equipment should do more intensive selling.”

. . . Harry Evans in “Life,” February 7, 1930.

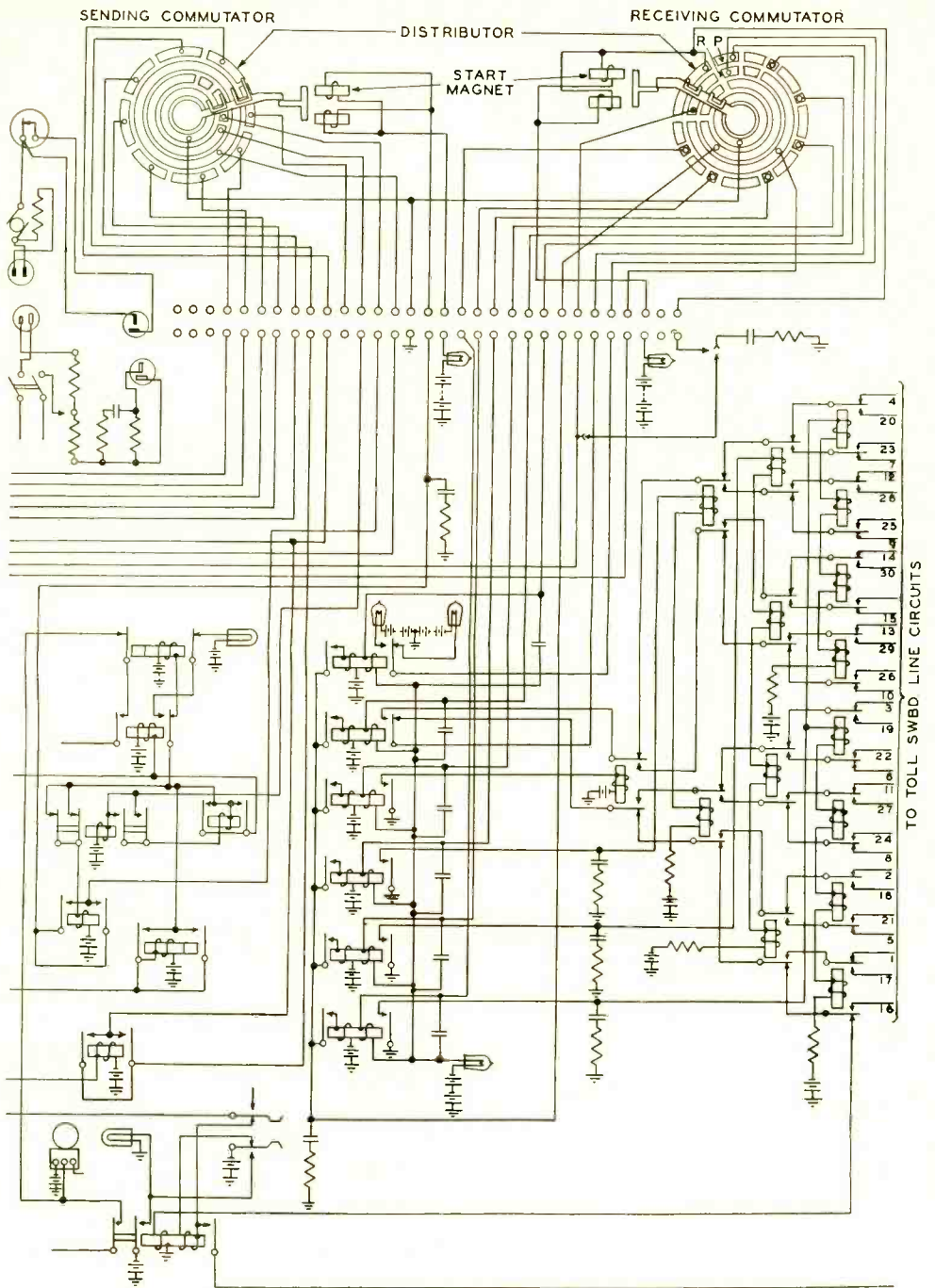

Fig. 1—Distributor signalling circuit

Function of the Toll Circuit Laboratory

By K. M. FETZER
Toll Systems Development

WORK in a circuit development laboratory generally falls into one of two classes. The first is the study by actual operation tests of circuit arrangements whose performance can, for the most part, be predicted by analysis. In this class fall those circuits whose successful operation depends mainly upon the functioning of relays and other switching devices in the proper sequence. The second class is the study of circuit arrangements whose exact performance cannot readily be predicted because many variable or only partly known factors are involved.

Circuits of the first class may be further divided into two sub-groups. One group requires performance tests in the laboratory because the sequence of operation and the release of relays or other switching devices may be too close to permit dependence on analysis alone. In such cases the best guarantee of successful performance in the plant is a laboratory test with all variable factors adjusted unfavorably. The other sub-group includes those circuits that involve switching operations so complex as to require performance tests in the laboratory, even though no close operating sequences

are in question. The chief reason for testing such circuits is that the human mind is not infallible; that in so great a complexity the chances of error in an analysis alone are too great to be overlooked.

Consider, for example, the distributor signalling circuit illustrated in Figure 1. This circuit is part of a system for transmitting over a single two-way, or two one-way, telegraph circuits, supervisory signals for a group of thirty toll lines operating on straightforward traffic. The system enables a toll operator, building up a call over one of these lines, to receive the same switchhook signals from the subscriber in the distant city that she would from a subscriber in the same exchange area.

The distributor sends a chain of pulses over the circuit which causes the brush arm of the receiving commutator to make one revolution and

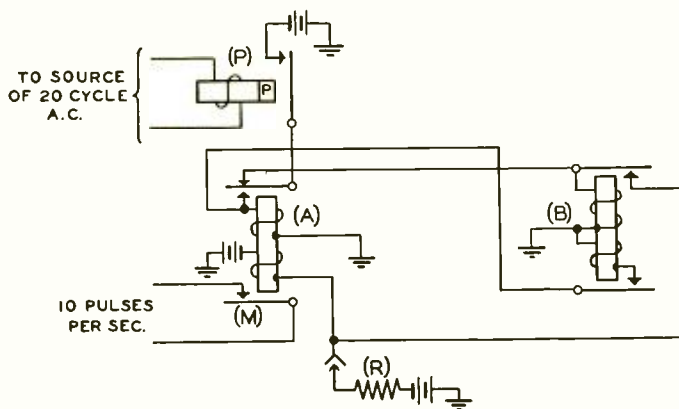

Fig. 2—When relay P operates 20 times per second, relay M will operate 10 times per second

to operate certain of the "pyramid" relays shown on the lower right side of the sketch. These connect one of the thirty leads to the toll switchboard circuits through the "P" and "R" segments of the receiving commutator to either positive or negative battery through the contacts of one of the relays in the middle of the diagram. One revolution of the commutator arm, corresponding to the transmission of one signal, thus selects one of thirty circuits and connects to it a momentary pulse of either positive or negative battery. The particular line selected, and the polarity of the pulse, depend upon the make-up or combination of the train of pulses sent over the telegraph circuit, of which

there are thirty variations. If it is negative, a relay is operated which lights the operator's supervisory lamp. If it is positive, this relay releases, and the lamp is extinguished.

The operation of this circuit depends on nothing more formidable than the proper functioning of relays and the commutator arms in the proper sequence. Yet, these relays must operate, lock up, transmit the pulses to the switchboard line circuit, and release in the time consumed by one revolution of the commutator arm, which is about one-fourth second. The complication is such that no one would suggest passing such a circuit on to the field without a very careful laboratory test.

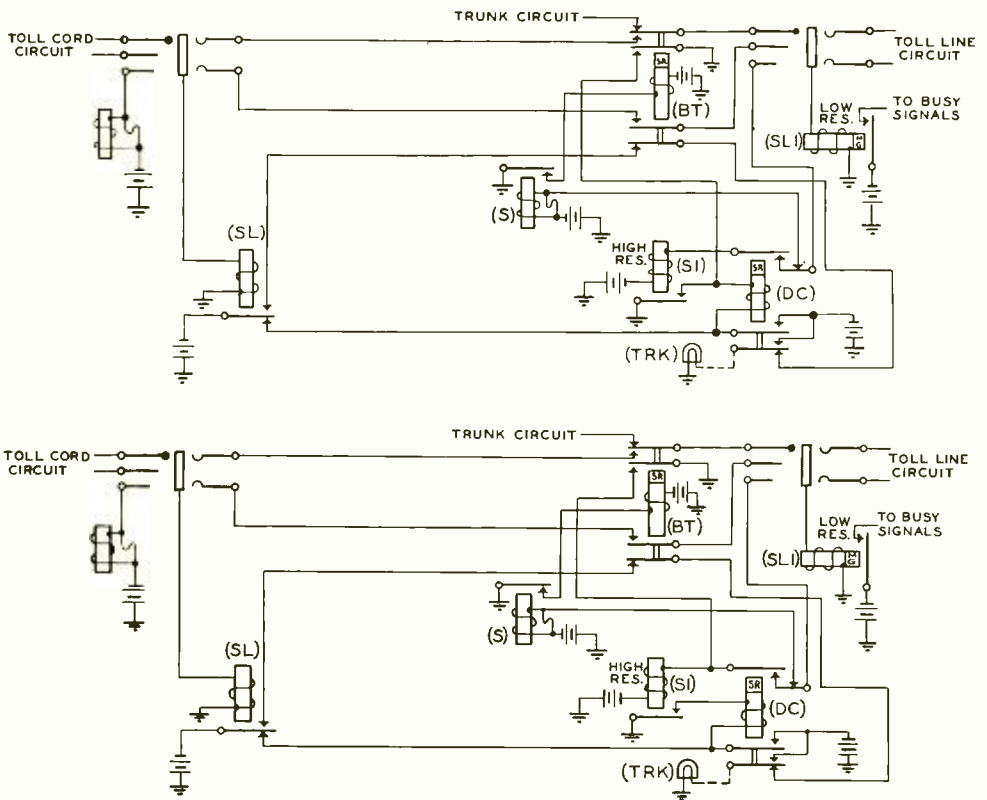

Fig. 3 (above)—Inter-position trunk circuit as originally conceived. Fig. 4 (below)
The same circuit as modified

Many circuits, however, not nearly so complicated as the one just described, need laboratory testing to insure satisfactory operation of the relays because of certain operating sequences. The simple circuit shown in Figure 2, for example, is intended to produce opens and closures of contact "M" on relay "A" ten times per second, or just half the rate at which relay "P" operates.

Since relay P is polarized, its contact closes twenty times per second when operated from a source of twenty-cycle alternating current. On the first half-cycle, relay B is operated on its upper winding. This connects the upper winding of B in series with the lower winding of A to battery and ground, and the windings were designed to allow the resulting current flow to hold B operated and to operate A. It was expected therefore that at the end of the first half-cycle relay B would hold and that relay A would operate.

When the contacts of relay P closed again at the beginning of the first half of the second cycle, it was further expected that relay A would be held operated by its upper winding whereas relay B would release because the direction of current flowing through its lower winding is opposite to that through its upper winding. On the release of P for the second time, relay A also would release and thus complete the cycle of operation.

When the circuit was tried in the laboratory all went as expected except that the current through the lower winding of A and the upper winding of B did not build up rapidly enough to hold B operated, although the final or steady state current was ample. This slow building up of the current was due to the self-inductance of the lower winding of A, and the trouble

was remedied by shunting this winding with a non-inductive resistance shown at R in Figure 2. This resistance provides a path through which the holding current for relay B can build up quickly, and is made high

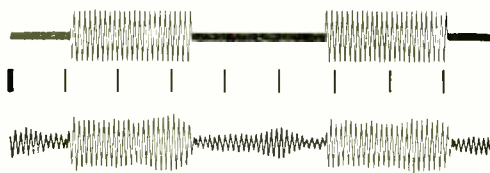

Fig. 5 (above)—Oscillogram of outgoing line current for 1000 cycle signalling.
Fig. 6 (below)—Oscillogram showing echoes filling up gaps between spurts of thousand cycle signalling

enough so that it does not, by its shunting action, prevent relay A from operating.

Another example which illustrates how even rather careful circuit analysis may not show up a fault which will be caught in a laboratory test is shown in Figure 3. This sketch illustrates part of an inter-position trunk circuit, the features not important to this discussion being omitted.

Correct operation requires that when relay SL releases—relays S and BT being operated at the time—DC should operate through a contact on BT, and in doing so release S and operate S₁. The release of S releases BT but the release of BT should not release DC which should be held in through the contact of S₁. Both BT and DC are "slow release" relays, to make the proper sequence of action more certain.

The critical sequence is that S₁ must operate and hold in DC through one circuit before S, BT, and DC have released. The operating margins seemed ample on analysis, as the operating time of S₁ should be much less than the combined release time of

fast release relay, S, and the two slow release relays, BT and DC.

In spite of this apparently safe margin, laboratory tests showed that the DC relay sometimes failed to hold

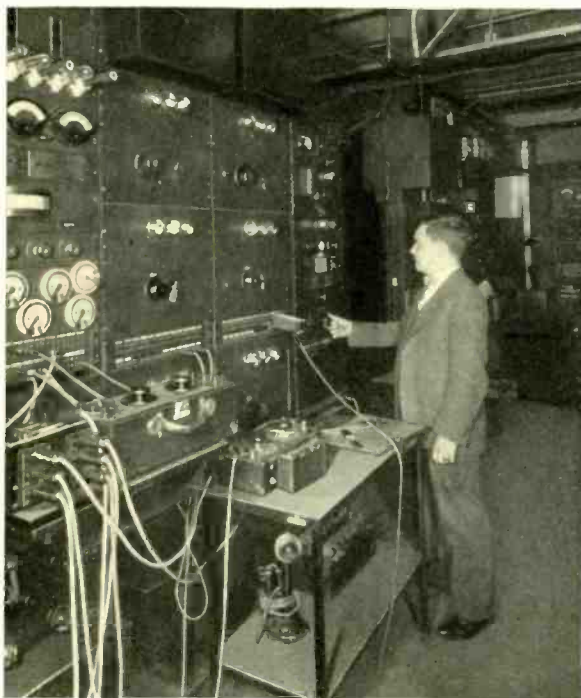

Fig. 7—Equipment used in the toll circuit laboratory for testing a multi-channel carrier system

up. This was found to be due to chatter of the contacts of the S1 relay on first closing. This is a bad habit that certain relays have. Although the chatter lasts only a few one-hundredths of a second, it is long enough at times to permit the DC relay to release. The trouble was remedied by a very slight change in the circuit allowing the S1 relay to be operated when the connection was first established, and then having it held operated in series with SL1 through a contact on DC. This arrangement is shown in Figure 4.

It is, however, in the study of cir-

cuit arrangements whose exact performance cannot readily be predicted—forming the second class of laboratory work—that some of the most interesting studies are made. Con-

sider, for example, a voice-operated echo suppressor, which on long telephone circuits* suppresses the transmission of echoes in one direction while speech is being transmitted in the other. One chain of relays must operate when voice currents are in one direction and another chain when they are in the other. The energy required to operate the necessary relays is far greater than that of the voice currents so that amplifier circuits are necessary, and since the relays must be operated by direct currents, whereas the voice currents are alternating, rectifier circuits are also required. The relays must operate on any voice currents that are strong enough to cause objectionable echo currents, yet must not operate on line noises. The sensitivity

of the amplifier must thus be closely regulated and must be greater for tones of the voice than for the somewhat lower tones of line noise. In one type of echo-suppressor circuit, the relay chain must operate within about 0.006 second after the voice current comes on; and must hold up for about 0.120 second after the voice current dies out.

With such requirements, it is evident that an echo-suppressor circuit cannot be designed in full detail without experimental work in the labora-

* BELL LABORATORIES RECORD, November, 1927, p. 80.

tory, and that such experimental work is not only exceedingly interesting but highly educational as well. Although the laboratory work may be efficiently performed by engineers other than those who lay out the fundamental scheme of design, the closest contact and cooperation is required between the laboratory and the circuit-design engineers since the detailed design of such a circuit is likely to grow a step at a time, with frequent optional arrangements from which to choose. The time and effort that might be wasted in proposals and counter-proposals without such cooperation can readily be imagined.

Perhaps no circuit development of recent years has uncovered more interesting and surprising situations than that of 1000-cycle signalling over toll lines.* The circuit that receives the signals must be connected to the toll line at all times during the call and must be responsive to signalling currents much weaker than the voice currents to which it must not respond. To obtain this discrimination the signalling currents are sent in little spurts of 1000-cycle tone, each spurt $1/40$ second long and with $1/40$ second of silence separating the spurts, as shown in Figure 5. The signalling circuit must be made to respond to this code but not to the voice currents although the voice currents themselves contain large elements of 1000-cycle tone. The design of the signal receiving circuit to obtain this discrimination required much laboratory work, supplemented by field tests in

which the proposed circuits were connected for observation to lines carrying actual commercial calls.

When the signal-receiving circuits, or ringers as they are called, were installed commercially in the plant, it was found that on certain open-wire toll lines, notably those between Cleveland and New York, they failed to respond to signalling currents on some days and responded properly on others. The surprising element was that the failure to respond occurred during unusually dry weather when the insulation resistance of the line was good and the shunt or leakage loss less than usual. Tests showed that when the ringers failed, they could be made to operate by connecting resistances or other circuits in parallel with them to shunt away some of the current that they would normally receive. It was also found that if the

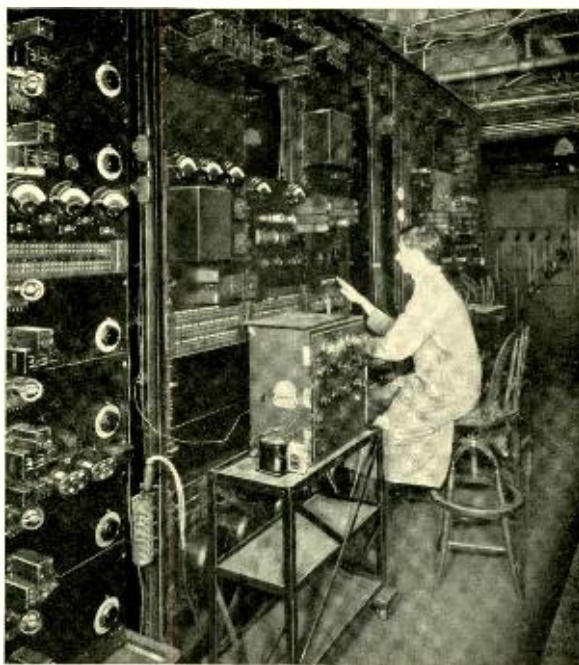

Fig. 8—Testing equipment for voice-frequency repeaters

* BELL LABORATORIES RECORD, June, 1929, p. 391.

toll line circuits were arranged for single direction transmission, the ringers would always respond properly to signal currents in that direction. Oscillograms of the currents

the failures were caused by echo, or reflection currents. In the talking condition no echoes were noticeable so that the toll circuits were not equipped with echo suppressors. When the circuits were in the signalling condition, however, they were not terminated as they were in the talking condition, and reflection of the signalling currents was taking place. The echo currents thus formed were partially filling up the gaps in the signal currents, which were necessary for the proper operation of the ringers. On wet days, however, the reflected currents drained off by the relatively poor insulation resistance to such an extent that they did no damage. The echo currents had to make two trips over the line to be harmful whereas the useful currents made only one, and thus the poor insulation had only half the effect on the useful currents. The remedy was to properly terminate the line circuits at both ends under all conditions.



Fig. 9—In this part of the toll circuit laboratory, repeaters for a three-channel carrier system are tested

received by the ringers on the days when they failed to operate showed the failures were caused by echo, or that the gaps between the little spurts of tone were being partially filled up by currents of a very similar character but of somewhat lower amplitude, as illustrated in Figure 6.

From this data it was deduced that

These incidents serve to show the importance of carefully testing new circuits. Due to complexity of the arrangement of the closely timed operating sequences, analysis alone is not sufficient. The young engineer or engineer-to-be can find few, if any, better fields than the circuit laboratory in which to gain valuable experience.



Telephone Line Insulators

By C. D. HOCKER
Outside Plant Development

THE telephone plant requires of an insulator much more than merely that it hold the line wire up off the crossarm. Many of these requirements are common to all insulators. But precisely what is required of any one in particular varies to some extent with the circuit served and the plant associated. An insulator well adapted to one job may be far less so to another. Properties important to its function belong not only to constituent materials, but to design and method of mounting. Thus the development* of insulators must concern itself with the improvement of their general and basic properties and with their refined adaptation to special purposes.

Preeminently an insulator is asked to insulate. In service it should occasion no more loss in signalling power than is warranted in the circuit it serves. In the case of direct current, and low-frequency alternating current signalling circuits, the sum of all the transmission losses occurring in the insulators, pins, and crossarms is small compared with the losses due to the resistance of the line wires themselves. An insulator used in such a circuit has chiefly to obviate undue losses of power by leakage over its surface, through the mounting pin and

crossarm and thus to the insulator paired with it. This surface leakage is kept small, by proper choice of both the design and material of the insulators. The most important design feature is the provision of a suitable petticoat which will preserve a well protected dry path. The petticoat may be a double one when a particularly long dry path is needed. The choice of material for making the insulators is important in maintaining low surface leakage. A transparent material is best for telephone line insulators because the ingress of light discourages insects from building, under the insulator petticoat, nests which increase the conductivity of the dry path. Thus porcelain insulators, which may be very good when new, deteriorate in service much more rapidly than glass, because of this bothersome habit of the insects.

To meet the needs of the telephone plant for insulators on non-carrier-current circuits, the insulators which are chiefly used are: exchange insulators, employed on subscribers' loops and other non-toll circuits; toll line insulators, used on the shorter toll lines; and DP (double petticoat) insulators, used principally on the longer toll lines. All of these are made of ordinary soda-lime glass.

The insulators required for carrier-current circuits need to have special electrical properties to keep down power losses in the circuits they serve. In these circuits, now bearing currents

*The science of insulator materials and designs discussed in this article has been developed over a period of many years. Engineers of the American Telephone and Telegraph Company have been responsible for much of the advance in the field of carrier-current insulators.

of frequencies up to about 30,000 cycles per second, there is a substantial power loss at the insulators due to absorption by the glass as well as to the leakage over the surfaces. In fact, where ordinary soda-lime glass insulators are used on high-frequency

erties. It is highly resistant to surface etching on prolonged exposure to the weather, and it has the favorable electrical characteristics of a low dielectric constant and a low dielectric absorption. Like all glasses, this special product is a fused non-crystal-



Above, carrier-current insulators, of "low-loss" glass; left to right: CS, CW, CM. Below, non-carrier-current insulators, of soda-lime glass; left to right: Toll line, DP, Exchange

line combination of acidic constituents, primarily silica, and of alkaline ingredients, but particular choices of these two constituents and their proportions are necessary to produce glass having the desired properties. Specifically, the glass is of the borosilicate type, a type so called because the acidic ingredients are a combination of boron oxide and silicon oxide (silica). In this respect it differs from the ordinary lead, soda-lime, and soda-lead glasses, which employ silica as the only important acidic

carrier-current circuits, the losses in the insulators form a large part of the total losses, particularly in wet weather. Accordingly, carrier-current insulators made of a special "low loss" glass are used as extensively as possible. These insulators are styled by double initials, such as CS, CW, or CM. The initial "C" denotes carrier-current application; "S" denotes their intended use on steel pins, "W" on wooden pins, and "M" in mid-span installations.

Special "low loss" glass is desirable for use in making carrier-current insulators chiefly because of two prop-

erties. It is highly resistant to surface etching on prolonged exposure to the weather, and it has the favorable electrical characteristics of a low dielectric constant and a low dielectric absorption. Like all glasses, this special product is a fused non-crystal-

line combination of acidic constituents, primarily silica, and of alkaline ingredients, but particular choices of these two constituents and their proportions are necessary to produce glass having the desired properties. Specifically, the glass is of the borosilicate type, a type so called because the acidic ingredients are a combination of boron oxide and silicon oxide (silica). In this respect it differs from the ordinary lead, soda-lime, and soda-lead glasses, which employ silica as the only important acidic element and are distinguished by the alkali used—lead oxides, or combinations among lead oxide, soda and lime. Ordinary green glass is a soda-lime glass, owing its green color to accidental impurities of iron in the sand (silica) used in its manufacture.

dielectric constant and relatively low dielectric absorption. A low dielectric constant in glass is fairly closely associated with a high silica or acidic content. The phase-angle characteristics of glasses, which taken together with the dielectric constant measure the dielectric absorption, are less clearly predictable from the composition of the glass. Compositions of glass have been experimentally made, however, which are almost as favorable as fused silica in dielectric absorption and dielectric constant. These special compositions cannot be used advantageously at present in the manufacture of telephone insulators because of their greater cost or lesser adaptability to molding.

Several design features contribute materially to the realization of low power losses in carrier-current insulators. Enlarging the wire-groove diameter in relation to the pin diameter decreases the capacity of the insulator and thus reduces its dielectric absorption. Similarly the losses are reduced by permitting no thin spots in the glass and providing an air gap between the top of the insulator pin and the crown. It would even be desirable to have the outside of the carrier-current insulator metal-covered if this could be done without encouraging insects to nest beneath the darkened petticoats. This is because some of the capacity-currents entering the dielectric must first traverse an insulator surface and in so doing dissipate power if the surface has a high resistance.

In spite of careful selection of materials and design of insulators, some power is lost by an alternating current passing from one wire to the other of a pair through the path formed by the insulators, pins and

crossarms. This path may be regarded as made up of three condensers: two good ones in which the glass of the insulators constitutes the dielectric, and a third one which is poor because its dielectric is the wood of the crossarm. The power losses in the insulators are low because the glass has been chosen for its good dielectric properties, but there is no available way to make the wood crossarm a good dielectric. Consequently, this poor crossarm condenser is deprived of its power-absorbing effect by shunting it with a conductor interconnecting the insulator pins of a pair. In the case of the CS insulators, the steel pins on which they are mounted are directly connected by a conductor. CW insulators, intended for use on pole lines already equipped with wooden pins, are bonded by conductors which are attached to copper thimbles placed over the pins before the insulators are installed.

Insulators of all types must be shaped to insure reasonable strength, adaptability to manufacture, and the firm securing of line wires without slipping. The design of insulators to achieve strength is guided by a great deal of experience gained with insulators of different shapes and thicknesses of glass. Manufacturing experience has indicated the types of shape which are adaptable to automatic molding, and the precautions which the manufacturer must take to obviate introducing strains in the glass during fabrication. To secure firm retention of line wires in the annular side grooves, various shapes of groove have been tried; the present shape in the newer insulators approximates as nearly to rectangular indentation as manufacturing facility permits.

Other mechanical considerations

are also involved in determining methods of mounting. If the pin is too high, it is difficult to design with the required resistance to bending. The insulator must, however, be sufficiently elevated above the crossarm to obviate excessive wetting of the insulator under its petticoat by splashing from the crossarm during a rain. For types of service in which insulators are subjected to unusual stress, the threads of a steel pin must first be cushioned by a soft metal, such as lead, to prevent the insulator from breaking.

Trials, educated guesses, and more trials have been the instruments for advancing the development of insulators. The trials have for the most part concerned the performance of experimental insulators installed on outdoor test lines. For several years the American Telephone and Telegraph Company has maintained a station near Phoenixville, Pennsylvania, where experimental insulators are tested. A small wooden building shelters electrical measuring equipment with which a resident engineer measures the power losses occasioned by different insulators in all kinds of weather and keeps a record of their performance over long periods.

It is disheartening to wait upon the caprices of the weather several months or a year before learning whether a simple insulator modification has merit. Observations on insulators in service have made possible the generalization that rain and dust accumulation are the chief agencies that cause deterioration. In accordance with these findings, attention is now being given to the development of accelerated weathering methods and

equipment for producing in a relatively short time effects comparable to those of long outdoor exposures.

The economic advantages of good line-insulation are found in the numerous savings it makes possible in plant investment. It may maintain a high level of signal strength, or reduce the requisite number of repeater stations. In general, the longer the telephone line, the greater the amount which can profitably be spent for insulators. But expense above a certain limit becomes unreasonable. Thus, in the present state of the art of silica manufacture, transparent fused silica could not economically be used for making insulators. Although a splendid insulator material, its cost for a long carrier-current system would be greater than that of some alternative method for securing equivalent transmission efficiency, such as using cheaper insulators and more repeater stations.

The great progress in working out and standardizing CS, CW, and other insulators for carrier-current systems has not yet closed the book on insulator material and design. As the science of insulators advances, quite different types may replace those now conventional. A carrier-current insulator, for example, which would mount directly on wooden pins, and which would not require the accessory copper shells and their bonding, would have a wide field of use. An ideal material for insulators would be a metal with low dielectric constant and low dielectric absorption. Such an insulating metal, cheap, tough, difficultly etched, and transparent, would receive a warm welcome from outside-plant engineers, if they survived the surprise of its discovery.

Excellence in Auditoriums

By W. A. MACNAIR
Special Products Development

ON basis, our judgments of the acoustics of auditoriums appear at first thought to be qualitative and diverse rather than quantitative and similar. But we get an indication that this may not be altogether so when we find that there is some approach to unanimity of opinion regarding what auditoriums are "good" and what "bad." When several observers listen to sounds in an auditorium whose acoustic properties are changed from time to time, they will concur to a significant degree upon one acoustical arrangement as "best." Their agreement leads us to look, among the various physical parameters whereby acoustic properties are measurable, for some quantitative index corresponding to their aesthetic judgment. Were such an index discovered, auditoriums could with its help be confidently engineered by physical procedures to meet aesthetic criteria.

The first parameter so used was "reverberation time"—the time required for a sound in a room to decay sixty decibels in power level. Several investigators have reported the optimum reverberation times for auditoriums of various sizes; the plots of their results are shown in Figure 1. All find that the optimum time increases with the size of the auditorium, extending from about one second for a few thousand

cubic feet to two seconds for a million cubic feet.

For a true physical criterion of "bestness," however, some quantitative acoustic feature of an auditorium should be used which has the same value for all auditoriums in their best acoustical arrangement. Only then could it be supposed that the physical quantity underlying the aesthetic judgment had been found. A further step toward such a quantity can be made by choosing, instead of the reverberation time, the time taken by the sound from a standard 1000-cycle

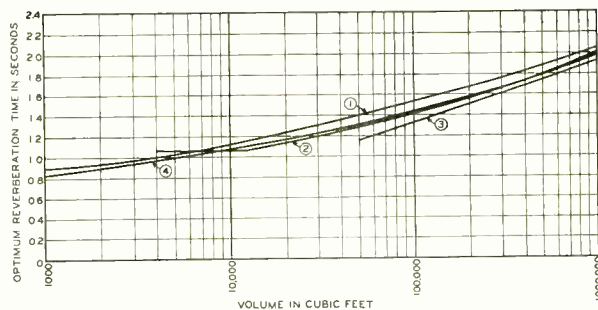

Fig. 1—The optimum reverberation time of a room varies with its volume, as shown (for 512 cycles) by the experimental work of (1) Watson, (2) Lifshitz, and (3) P. E. Sabine, and by (4) a theoretical calculation

source to decay to the threshold of audibility after the source is cut off. In the range of auditorium volumes in which optimum reverberation time varies from one to two, the optimum value of the new parameter only varies from 1.0 to 1.6, effecting considerable progress toward constancy.

Recently, however, it has been

shown that one-half the product of this time and the "loudness"* set up by the standard source constitutes a parameter which has a fixed value for all auditoriums acoustically best, whatever their sizes. More exactly, this parameter is the integral of instantaneous loudnesses caused by the standard source, taken over the period between the time the source is cut off and the time the sound becomes inaudible. Its optimum value is 32.6 for a 1000-cycle tone.

The meaning to be attached to this discovery is that, when a sound is cut off, it is the combination of its loudness and the time of its audibility that is sensed. Since the quantitative combination of these two factors has the same value for all ideal auditoriums, the aesthetic sense concerned must resemble a ballistic instrument, atten-

an important practical application of it. Staccato notes of equivalent intensity can be heard better in acoustically "live" than in acoustically "dead" rooms. Indeed a stream of speech or music can be made to sound considerably louder, without augmenting its peak amplitudes, by merely "livening" the auditorium. Up to a certain point, persistence can be made to take the place of intensity in improving the audibility of sounds, but if they are too much prolonged, successive sounds will incoherently overlap and apparent loudness will be gained at a too great expense of articulation. It is the ideal balance of loudness and persistence that is specified by equating the new parameter to its optimum constant. In recording sound pictures, therefore, it will be possible to attain apparent loudness, without overload-

ing the vacuum tubes and vibrating parts of the recording system, by livening the recording stage.

With the aid of the new parameter, the curve of optimum reverberation times for 1000 cycles in rooms of various volumes can be derived by purely mathematico-physical methods. That the values thus computed agree closely with those experimentally determined is shown in Figure 1.

Among other results which the parameter has assisted to secure is the curve of optimum reverberation times for tones of different frequencies in a room of any particular size.

Since the parameter is specified in terms of loudness and its time of decay, and the reverberation time in terms of power level and its time of decay, the key to this problem is the relation between the rates of decay of loudness and of power level. This

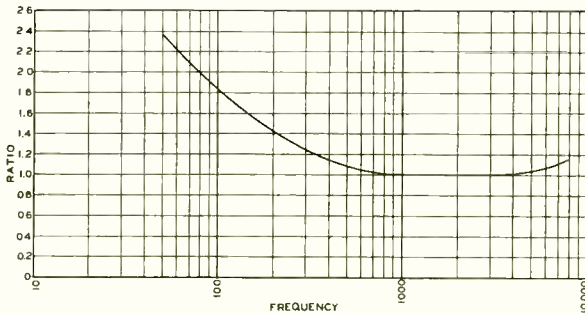

Fig. 2.—The ratio of rates of decay of loudness and of power varies with the frequency

tive only to the value of the parameter and indifferent to how the factors combine to attain that value, whether by a loud tone decaying rapidly or a faint tone slowly.

Common experience bears out this theory in a direct way, and points to

* The sensation level of a sound is defined as its power level in decibels above its power level at the threshold of audibility. The loudness of a sound is defined as its sensation level, for tones of 1000 cycles; and, for tones of other frequencies, as the sensation level of a 1000-cycle tone which is judged equally loud.

relation had been worked out in these Laboratories for different loudnesses and frequencies by Dr. Fletcher and his associates. At 1000 cycles, and indeed in the range between 700 and 4000 cycles, the two are identical; at lower and higher frequencies the loudness decays more rapidly than the power level. If it is specified that the calculation shall apply to tones of equivalent loudness, whatever their frequency, equating the new parameter to its optimum constant is the same as asserting that the loudnesses of these tones should all decay at the same rate under the best conditions. Thence from Dr. Fletcher's work the most desirable rates of decay of power, and thus the most desirable reverberation times, can be calculated for all frequencies (Figure 2).

The well-known formula of W. C. Sabine indicates that the reverberation time is inversely proportional to the number of absorption units in the room. If this formula is accepted, the optimum absorption-frequency characteristic for an auditorium of any volume can be readily figured from the curve of optimum reverberation times against frequencies for that volume. If the room is to be panelled predominantly with a single material, the absorption-frequency characteristic of the best material for the purpose can thus be determined, to guide the search for the proper substance. In Figure 3 appear the optimum absorptions at all frequencies, relative to that at 1000 cycles.

The calculation of these absorp-

tions affords an opportunity for a further check, rough but interesting, of the validity of the theory that the new parameter should have a certain constant value under ideal acoustic conditions. This check arises from

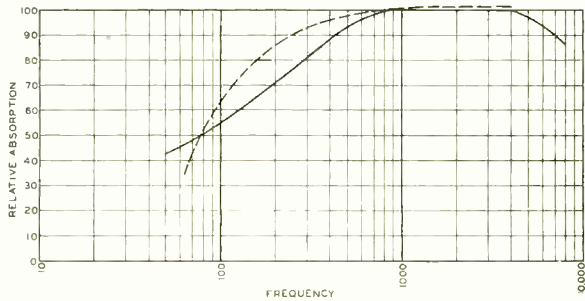

Fig. 3—The ideal absorption-frequency characteristic of an auditorium approximates the characteristic (broken line) of an audience as calculated by W. C. Sabine

the observation, often made, that an auditorium which when empty has an excessive reverberation time frequently obtains excellent acoustic properties when filled with an audience. Since under these conditions the audience is the major absorbant, its absorption-frequency characteristic should approximate the optimum. The characteristic of the average audience has been figured by W. C. Sabine; to its plot in Figure 3, the optimum calculated from the new theory shows an encouragingly close correspondnce.

Supported by the confidence in it which these experimental checks give, the theory is being applied to the solution of other important problems in acoustic engineering. With its assistance, the construction and treatment of auditoriums may be placed on a more exact basis.

Improved Equipment for Information Service

By J. F. DAHL
Local Systems Development

TO enable a telephone user to obtain a subscriber's number when it is not available through a directory, information desks and groups of operators are maintained by all operating companies. Although it costs millions of dollars annually and produces no direct revenue in compensation, this service is constantly being bettered for the benefit of telephone users in accordance with Bell System policy.

A great improvement to this ser-

vice was the adoption some years ago of the Centralized Information Bureau for use in the larger urban areas. In many of the larger cities, such as New York and Philadelphia, it has been found more practical and economical to provide several central bureaus while in smaller cities, one of them is sufficient. Although a large number of cable conductors between the central offices and the bureau are required for this method of operation, their cost is usually offset by the gains

obtained. Among other things, the concentration of the operators into one place (brought about by the centralized bureaus) reduces the cost of operation, and speeds up the service by making a larger group of operators available for answering calls.

The present standard information desks are known as the No. 1 and the No. 2. The latter, which has already been described in the RECORD*, uses rotary files for subscriber's records. The No. 1 desk, employed in areas where the directory listings exceed

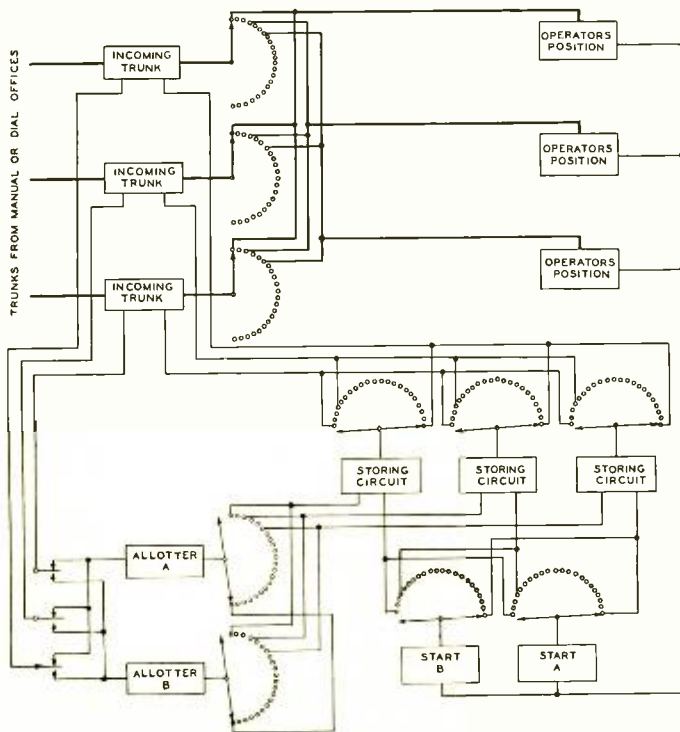

Fig. 1—A simplified diagram of the main switching steps in the operation of the No. 3 Information Desk

* BELL LABORATORIES RECORD, May, 1928, page 294.

the capacity of the rotary files, provides space for the necessary number of records in book form.

The operator's position equipment for both of these desks consists in the main of key and lamp equipment for connection to incoming trunks. The No. 1 desk has facilities for connecting thirty incoming trunks into a position, while the No. 2 desk permits a maximum of fifty-three. Where the number of incoming trunks exceeds the capacity of one position these limits make it necessary to divide the incoming trunk groups into subgroups, and the operator's positions into teams. Each subgroup of trunks is cross-connected into each position of the associated team. A call appearing on an incoming trunk lights the associated lamp signal on every position and can be answered by any of the team.

Increasing the number of operators' positions in a team will, in general, tend to reduce the number of slow answers and to improve the overall operating efficiency. This is particularly true of information operators because their work time per call is longer than that of ordinary operators. As the number of positions in the team increases, however, the increment of improvement in operating conditions becomes correspondingly smaller. This is especially true where, with present arrangements, all of the trunk signals appearing on positions of the team are available to all the operators in

the team, which makes it possible for more than one operator to attempt to answer the same call. Furthermore, the present equipment limits the number of positions possible in a team to a rather small figure.

During peak traffic loads, all oper-



Fig. 2—Directly in front of the operator is the key panel and all around her are the various directories to which she may refer by merely turning slightly in her chair

ators of a team are frequently busy at once and calls are waiting to be answered. Those delayed are attended to as operators become idle. While every reasonable effort is made to handle delayed calls in the order in which they appeared, it often happens that they are answered out of turn. Operating efficiency is not always at its maximum during these peak load periods, due to the small size of the various operators' teams.

To avoid some of the limitations of these earlier desks and to improve in general the service rendered to telephone users, a new system has been developed entirely different from anything used at the present time. It involves new circuits, equipment, and desk units which combined are known commercially as "Information Desk



Fig. 3—A group of information positions arranged as a connected whole

No. 3." The circuits are arranged for call distribution to idle operators and for sequence answer of delayed calls. The new system allows a team of operators to serve a maximum of 120 incoming trunks and permits a much larger team of operators, numbering from 35 to 40. This arrangement is expected to make possible some increase in operating efficiency, and also to reduce materially the number of slow answers experienced during peak loads with the present system.

Call distribution is accomplished by equipping each incoming trunk with a rotary type selector whose bank terminals connect to a maximum of forty-four paths connecting to positions. These selectors hunt over their bank terminals and connect to the first idle operator. The hunting proceeds automatically but the time of starting is controlled by the start circuit.

Sequence answering is obtained by the use of an allotter circuit, a common group of storing circuits, and a

start circuit. All the incoming trunks of a group are connected to one or the other of two allotters—each consisting of a rotary type selector and associated relays. Two allotters are employed to prevent a trouble occurring on one of them from interfering with the operation of the entire group of trunks. Only one call, however, is allotted a storing circuit at a time. The twenty bank terminals of the allotters are connected to twenty storing circuits each of which includes two rotary type selectors having access to 60 trunks. After an allotter has chosen a storing circuit, the proper selector hunts for the incoming trunk on which a call has appeared. If one or more of the operators is idle, the start circuit sends a signal through the storing circuit to the selector connected to this trunk, which at once begins to hunt the idle information position. Had all the operators been busy, the start circuit would not have acted, and other incoming calls would

have been assigned successive storing circuits where they would be held until an operator became idle. As this occurs, the start circuits—of which there are also two, corresponding in function and operation to the allotters—send signals through the storing circuits to start the trunk selectors hunting for idle operators in the order in which the calls came in.

The general scheme of operation is suggested by Figure 1 which shows a small part only of the entire system. For each 120 trunks there are twenty storing circuits so that any number of calls up to that number may be held to await the attention of an operator. A special arrangement for trunks from toll offices, which gives calls appearing on them preference, is also provided.

The comparatively small amount of equipment required for the operator's position has facilitated the design of a new desk section, which permits a maximum of four looseleaf directory binders for local listings to be placed in an open position before each operator. Space for the necessary toll and miscellaneous directories is also provided. Each operator's position is provided with an offset swivel chair which allows her to reach any of the various books and records at her position without changing focal distance or position of her body. The appearance of a single position is shown in Figure 2 and of a group of positions in Figure 3.

Among the many features of this system is the provision of calls-waiting lamps in each position to indicate unanswered calls; and the provision of storing-circuit-busy lamps at the chief operator's or supervisor's position to indicate the number of calls that are waiting. The calls-waiting

signal lamps at the operators' positions are of value in promoting general operating efficiency, while the storing-circuit-busy lamps assist the chief operator or supervisor in determining the proper operating force requirements throughout the day.

Outgoing trunk and tie lines are provided to permit an operator to reach a distant bureau or office when necessary. To establish such a connection, the operator merely depresses an out trunk key shown at the right of Figure 4. This automatically assigns an idle trunk and causes its associated selector to rotate in search of the operator's position originating the call. A lighted lamp-signal indicates when the connection is established.

Provision is made also so that an incoming call may be referred to the

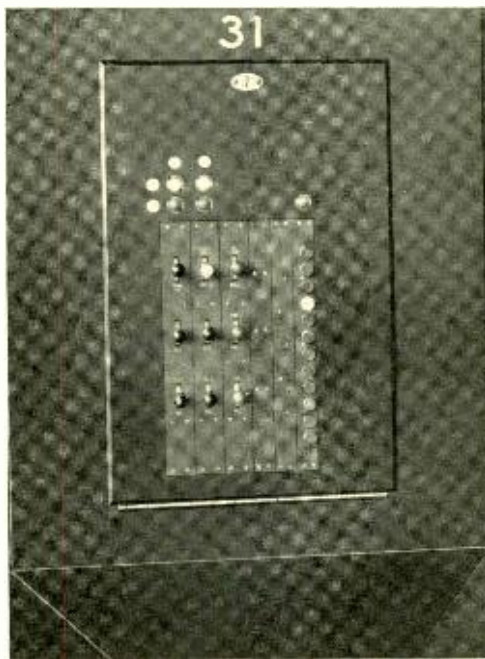

Fig. 4—The key panel is simple in arrangement and equipment. Keys for the two paths are at the left and above them lamps to indicate that the trunk is in use and also that calls are waiting attention

supervisor's position. To permit the operator to continue her duties under this condition a second incoming trunk path, used in common with other operators' positions, may be provided. As there are only forty-four bank terminals on the incoming trunk selectors, the number of operators' positions must be less than this number when both paths of a position are used. With forty terminals, for example, connecting into the individual paths to forty different positions, there remain four which may be used as second paths common to the forty positions.

An automatic timing feature is provided to determine when either al-

lotter is not properly performing its functions. If all calls do not clear within a specified time, their associated allotter is automatically removed from service. All trunks in a group then function through the remaining allotter. Timing equipment is also furnished with each start circuit to automatically remove either when failure occurs. Visual and audible alarm signals are given for both the allotter and start circuits to indicate when a circuit failure has occurred. Means are provided in addition to permit the maintenance man to remove an allotter or start circuit from service for routine testing of the circuits without interruption of service.

How Investment Income Pays Insurance Premiums

"When I reached my 28th birthday I had saved \$1,000. At 5½% this paid me \$55 a year. I took out a \$3,000 life insurance policy on which the yearly premium deposit was \$56.70. The income from my investment was reserved to pay for the insurance. Thus I immediately increased my estate from \$1,000 to \$4,000.

"Then I established a fixed policy of saving a reasonable portion of my earned income each month and at the end of the year invested it in securities. I did not put my savings in speculative securities, but was influenced entirely by safety considerations. On an average my investments have returned 5½% income and from year to year I have taken out as much additional life insurance as that investment income would pay for.

In the beginning my salary was \$3,000, of which I saved and invested \$500. Each year I got a moderate salary increase. Up to age 35 I managed to save about 16% of my earned income. From then on, when my salary was \$5,000 a year or higher, I saved and invested a little over 20% of it. Up to my last birthday, when I was 40 years of age I had saved \$12,450 out of earned income. My series of life insurance policies now total \$29,500. So the present value of my estate is \$41,950.

Income from \$12,450 at 5½% amounts to \$684.75; the total amount of my life insurance premium deposits, at the rates at which I took out the several policies, is \$680.61. So the one almost exactly offsets the other."

. . . as "Craig Wright" tells it to Wallace Ames, Financial Editor of Popular Science Monthly.



A New Timing Disc for the Oscillograph

By ALBERT SCHREIBER
Telephone Apparatus Development

IN the study of moving parts of dial apparatus, small intervals of time must be accurately measured. The means most commonly used in the Laboratories is the vibrating-mirror oscillograph, modified to use bromide paper instead of film. A motor-driven disc allows a beam of light to fall on the paper every hundredth of a second to form timing lines as already described in the RECORD.* An oscillogram of this type is shown in Figure 1.

The unit most commonly employed in making time studies, however, is not the hundredth but the thousandth of a second, so that it is commonly necessary to divide the distance between the hundredth-second time lines into ten parts. Originally these sub-divisions were estimated by eye but it has been found that different observers estimate them differently when reading the same oscillogram. Ordinarily the discrepancies are of the order of .001 second but, as the observers tire from an excessive amount of such reading, the deviations may go as high as .002 or even .003 seconds. To reduce these personal errors, dividers, scales, and film micrometers have been used.

Even when personal errors are neglected, it is doubtful whether readings from an oscillogram with hundredth-second timing lines can be depended on to better than .001 second because

of instrumental errors arising from two sources. The largest errors are due to momentary changes in the speed of the paper, or in a lesser degree to unequal shrinkage during development which gives a somewhat

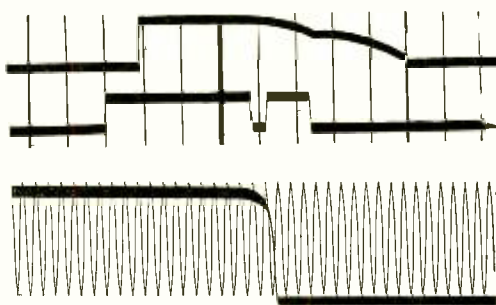

Fig. 1 (above)—Until recently the most commonly used oscillogram had timing lines every .01 second. Fig. 2 (below)—For precision work the trace of a thousand cycle wave has been used

comparable result. Constituting the second source of instrumental errors are changes in speed of the timing disc. These may be caused either by small variations in the period of the tuning fork, which controls the speed of the motor driving the disc, or by "hunting" of the motor itself, causing it to swing slightly ahead of or behind the fork. Cases have been observed in which the first two-thirds of the distance between lines actually represented one-half of the time and the remaining third the other half.

For precision work, therefore, it has been common practice to use for reference lines an accurate 1000 cycle

* BELL LABORATORIES RECORD, April, 1929, p. 327.

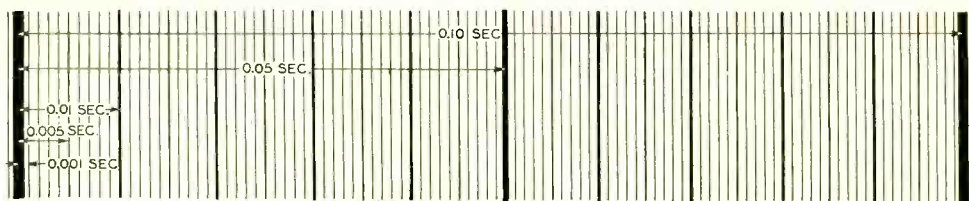

Fig. 3—Timing lines are thrown by the new disc every thousandth of a second with a different thickness of line for the tenths, twentieths, hundredths, and two-hundredths seconds

wave traced on the paper by one of the elements of the oscillograph. An oscillogram of this type is shown in Figure 2. By speeding up the paper to 940 feet per minute, so that there is about three sixteenths of an inch between peaks, it is possible to determine times up to one second with a probable accuracy of .0002 seconds. This method, although yielding dependable results, is laborious because each peak of the time wave must be counted and recounted since there is always the possibility of a peak having been missed or of adding one extra.

To obtain the advantage of the thousand-cycle timing wave while avoiding its disadvantages, W. W. Scibert suggested that a timing disc be designed to throw thousandth-second timing lines on the paper. After some experimenting it was found possible to proportion the apertures of the disc so that a different width of

line would be thrown on the paper for tenths, twentieths, hundredths, two-hundredths, and thousandths of a second. An oscillogram marked in this manner is shown in Figure 3.

With paper speeds of only 90 feet per minute it is possible to obtain an accuracy of .001 second with the new timing disc. For ordinary work a speed of 160 feet per minute, giving about one thirty-second of an inch between the thousandth-second lines, has been found convenient, and with it readings can be made to the nearest half-thousandth of a second. For greater accuracies the paper must be run at higher speeds, and 940 feet per minute, giving about three sixteenths of an inch per thousandth of a second, has been successfully used.

Even at high speeds, however, the thousand-cycle wave gives slightly greater accuracy than the new disc because of the small variations in the

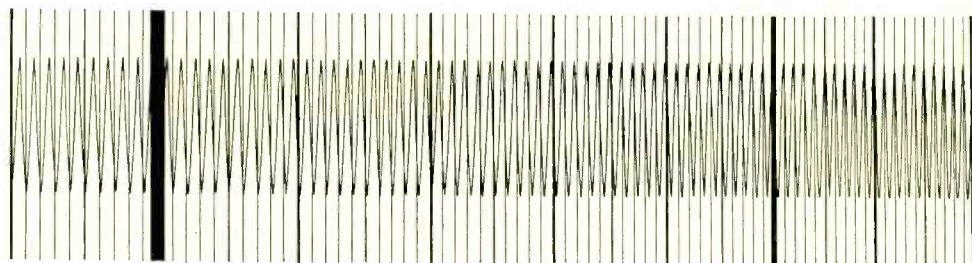

Fig. 4—Slight variations in speed of the timing disc sometimes occur as shown by the deviation of the thousandth-second lines from the peaks of the thousand-cycle wave

speed of the disc already mentioned. An oscillogram illustrating this is given as Figure 4. Notwithstanding this slight superiority of the thousand-cycle wave, time may be read, with the new timing disc operating at high speed, to an accuracy of .0003 seconds for intervals up to .020 seconds, and to an accuracy of .0006 second for intervals up to .100 second. The thousandth-second time lines are thus a considerable improvement over the hundredth-second lines and make it possible to read the oscillograms much more easily and rapidly as well as with greater accuracy.



Royal Address Carried by Transatlantic Circuits

Radio channels and land networks of the Bell System offered the means whereby the words of King George V opening the London Conference were conveyed to millions of American listeners in the early morning hours of January 21. The King's address, delivered before the assembled delegates in the historic Royal Gallery, was transmitted over the most far-reaching radio and wire system ever to be employed in broadcasting history.

The address was directed over the telephone circuits of the British Post Office to Rugby from whence it was transmitted overseas to the A. T. & T. receiving stations at Houlton and Netcong. It was also broadcast across the Atlantic over the experimental short-wave channel of the British Broadcasting Company from Chelmsford, England. In this country and Canada a total of 121 stations were linked by the facilities of the Long Lines Department of the A. T. & T. Co. over both the Columbia and National Broadcasting Company chains.

At the Long Lines office at Walker Street, four channels were monitored from time to time while the long and short wave voice-currents were being alternately picked up from Houlton and Netcong. Because of the varying strength of the signals in the early morning hours these recurrent shifts to long and short waves were employed to obtain the most effective reception. Despite the difficulties that transmission at early dawn offered, His Majesty's words were heard with remarkable clarity on this side of the Atlantic



Bell System Contributors to the Encyclopaedia

By HELEN M. CRAIG

Technical Library

THE fourteenth edition of the Encyclopaedia Britannica has recently come from the press and in twenty-four volumes is now in place on our library shelves. As is to be expected in any current work of reference, the field of science and engineering receives much attention. In this field the Bell System and our Laboratories are variously represented. Dr. Jewett served as a member of the editorial Advisory Board. In a comprehensive article on the telephone Mr. Gifford traces its history in the United States and other countries, describes modern equipment and apparatus, and concludes with statistical data of much interest. In his capacity of President, Mr. Gifford also gives in Volume I a brief account of the American Telephone and Telegraph Company.

Other Bell System contributors include H. E. Ives and R. V. L. Hartley of our Laboratories. Dr. Ives' article on television is illustrated by pictures of familiar scenes and faces. Technical features of the apparatus are set forth in some detail and mention is made of the historic demonstration held in April 1927 between New York and Washington. Mr. Hartley writes on amplifiers, outlining the various stages of their development. From the Department of Development and Research, Ralph Bown contributes an article on broadcasting. He describes the American system, gives a short

history of its development and discusses broadcasting as a business. Reference is also made to radio legislation. Under the heading "Phonograph" is an article by J. P. Maxfield, formerly of our Laboratories.

Of the many articles on subjects of interest to scientists and research workers, it is possible here to mention only a few. There is an article on the electron by R. A. Millikan, on the velocity of light by A. A. Michelson and on radioactivity by Sir Ernest Rutherford. Sir Oliver Lodge writes on physics and Sir Richard Glazebrook on research. Compton treats of the Compton Effect and O. W. Richardson of thermionics. Industrial chemistry is discussed by Harrison F. Howe. The article on sound is by A. B. Wood of the Admiralty Research Laboratory while that on acoustics of buildings is contributed by A. H. Davis of the National Research Laboratory. Corrosion and rusting are dealt with by G. B. Bengough. On engineering education we have Charles F. Scott writing from the American viewpoint and from the British, Sir Robert Hadfield. . . . The list could be extended indefinitely; it would become a "who's who" in the world of science.

Alexander Pope must have dreamed of just such a work. It was he who remarked, "Index learning turns no student pale, yet holds the eel of science by the tail."



NEWS AND PICTURES
of the
MONTH

*including Club Activities and
Biographical Notes*

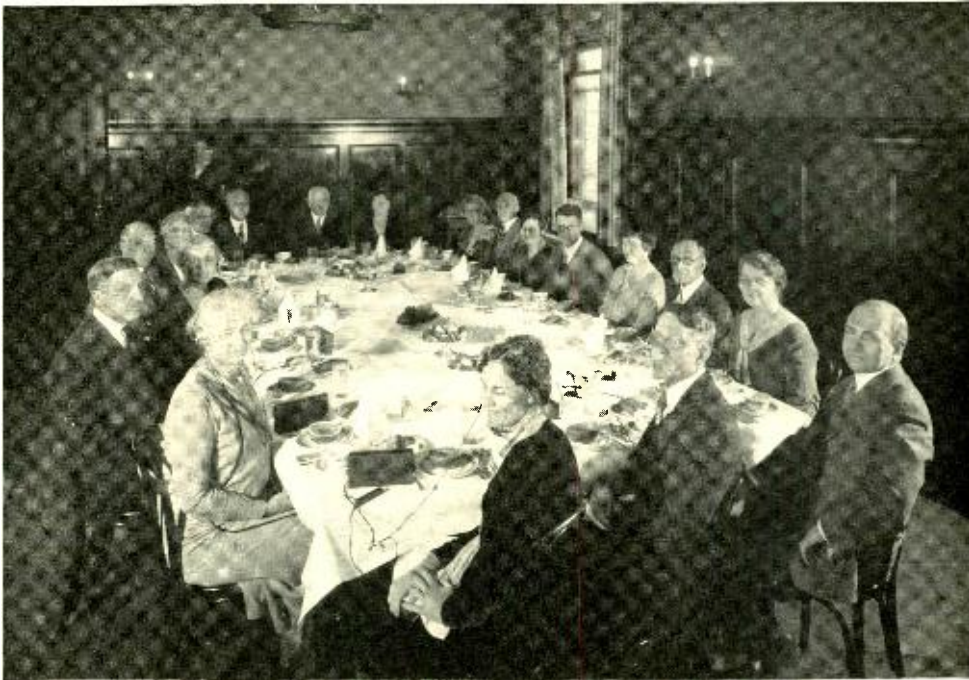

Board of Managers of the American Federation of Organizations for the Hard of Hearing entertained at luncheon in the Laboratories by H. P. Charlesworth, H. D. Arnold, and Harvey Fletcher



News of the Month

ON February 14, Dr. Jewett gave one of the Aldred Lectures at Massachusetts Institute of Technology, his subject being *What Industry Expects of the Graduate*. On February 20 he spoke at Swarthmore College on *Electrical Communication*.

As an aftermath of his recent trip Dr. Jewett again gave informal talks on Japan. He spoke before the D&R and O&E engineers and later detailed some of his experiences and observations before a group of women members of the A. T. & T. and Western Electric Companies at 195 Broadway.

* * * *

H. P. CHARLESWORTH has been appointed a delegate to represent the Board of Trustees of Engineering Foundation, Inc. at the celebration of the fiftieth anniversary of the founding of the American Society of Mechanical Engineers to be held in April.

* * * *

THE PROGRAM of the mid-winter convention of the American Institute of Electrical Engineers held in New York, January 27-31, included an inspection tour of the Laboratories on the afternoon of January 29. The visitors were greeted in behalf of the Laboratories by John Mills. A short talk on television was given by Herbert E. Ives followed by demonstrations of color television. The delegation, numbering about 200, was conducted through the building in two groups. Specially appointed members of the technical staff served as guides.

MEMBERS of the Physics Club of New York and New Jersey State Science Teachers' Association were guests of the Laboratories on January 18. The visitors were entertained in the auditorium by demonstrations on phonograph records of inverted speech, heart beats, phase distortions and pitch of tones. In addition a demonstration of the call announcer was given by R. F. Massonneau and the functioning of the artificial larynx described by R. R. Riesz.

* * * *

THE BOARD of Managers of the American Federation of Organizations for the Hard of Hearing held its winter meeting at the Laboratories, January 17, upon the invitation of Harvey Fletcher, president of the body. The visitors were entertained by H. P. Charlesworth, H. D. Arnold and Dr. Fletcher at luncheon and were later conducted through the Historical Museum. The Federation is a national organization undertaking work of social, educational and economical nature on behalf of deafened persons. It is particularly concerned with the prevention and alleviation of deafness among children.

* * * *

ONE of the most enthusiastic receptions given to his talks on recent developments in communication was accorded to S. P. Grace on the afternoon of January 31 at the Michigan Engineering Conference at Ann Arbor. Mr. Grace's talk, entitled *The Field of the Engineer in Com-*

munication and listed on a two-days' program of engineering activities, was attended by an audience of 3,000 which included President Ruthven of the University of Michigan; practically all of the members of the Engineering school, both faculty members and undergraduates; numerous students and teachers from other departments of the University; and about 1,000 representative engineers and business men from all parts of the state who were attending the conference. Mr. Grace included with his talk a demonstration of the call announcer and other recently developed apparatus. In the evening the guests were addressed by President Hoover over the radio at the conference banquet.

As in the past demonstrations, the dial pulses actuating the call announcer were transmitted over long distance circuits to the Laboratories, and the spoken numbers were transmitted to Ann Arbor for projection to the audience. E. R. Smith and J. B. Shiel of the Systems Development department assisted in arranging circuits. R. M. Pease aided in the demonstrations.

On January 24, Mr. Grace spoke on communication developments at Louisville under the auspices of engineering societies of Louisville and vicinity.

* * * *

PROFESSOR G. P. THOMSON of the University of Aberdeen addressed the Colloquium on *Electrons and Waves*. The greater part of his talk was devoted to describing some of his own experiments on the diffraction of electron waves by passage through very thin sheets of metal.

OUTSIDE PLANT

C. D. HOCKER and F. F. FARNSWORTH were at Philadelphia to confer

on motor vehicle paints with members of the E. I. DuPont de Nemours Company. While on the trip they visited the paint research laboratories of the DuPont Company.

C. H. AMADON and J. G. SEGELKEN were at Brunswick, Georgia, making an investigation of the commercial production of southern yellow pine poles treated by the eight-pound empty cell process. Mr. Segelken made a similar investigation at Spartanburg, South Carolina.

W. E. MOUGEY of Kearny was in Iowa City in regard to investigations on tape armored cable.

L. V. LODGE visited Nashua, New Hampshire, to make a study of northern white cedar poles in that locality.

W. J. LALLY visited the Indiana Steel and Wire Company at Muncie in connection with the manufacture of steel strand and steel line wire, and continued his trip to Hawthorne in connection with the manufacture and testing of line wire. Mr. Lally also made a trip to New Haven with representatives of the American Telephone and Telegraph and Southern New England Telephone Companies to observe field trials of drop wire clamps.

S. C. CAWTHON of Kearny visited Oklahoma City in connection with the development of tape armored cable.

C. KREISHER of Hawthorne was at Kearny for a week and then went to Point Breeze, also on tape armored cable work.

PUBLICATION

DURING 1929 one hundred and three different papers written by Bell System men and published in the scientific and technical journals both here and abroad were made available in reprint form to public libraries,

colleges and universities, governmental departments, and the associated companies by the Bureau of Publication. In all, over 190,000 reprints were distributed. Foremost on this list from the standpoint of copies distributed were the papers *Some Universal Principles of Communication* by John Mills, *Interruptions on Telephone Conversations* by K. W. Waterson of the A. T. & T. Co., and a series of articles reprinted from the Bell Laboratories Record and bound within one cover, entitled *Short-Wave Transatlantic Radio-Telephony*. About 25,500 copies of the Mills reprint, 19,000 copies of the Waterson reprint, and 12,700 copies of the Transatlantic Radio-Telephony pamphlet were distributed, mostly to the associated companies.

One of the largest instruction bulletins yet prepared, the bulletin for the 7-A Radio Telephone Broadcasting Transmitter, was included among the thirty-one instruction bulletins clearing through the Bureau of Publication during 1929 and forwarded to the Western Electric Company for printing and distribution. The bulletin, 128 pages in length and containing 106 illustrations, outlined the 50 kw transmitting equipment in operation at the Crosley station WLW in Cincinnati and proposed for station WABC of the Columbia Broadcasting Company. The material was organized and written by A. W. Kishpaugh's group and the work of editing and preparation of illustrations was carried on under the supervision of C. D. Hanscom.

THE MONTREAL section of the Engineering Institute of Canada was addressed on January 30 on sound pictures and their research origins, by Paul B. Findley. The next day he addressed, on the same subjects, the

semi-monthly assembly of the headquarters staff, Bell Telephone Company of Canada, at Montreal. Both talks were illustrated by sound pictures shown by courtesy of the Northern Electric Company.

ON FEBRUARY 14, P. C. Jones gave a lecture and demonstration on sound pictures before the Columbia University Engineering Societies. He was assisted in the demonstrations by W. C. F. Farnell.



H. W. FLANDREAU went to Manhasset, Long Island, to apply new adjustments to 114-EA (trip) relays on trial there.

J. W. GOODERHAM visited Philadelphia in connection with a field investigation of radio interference.

A. P. GOETZE made a trip to Philadelphia in reference to studies of the life of precious metal contacts.

F. J. SCUDDER and S. F. BUTLER attended the cutover of the first battery cut-off and new call distributing cordless office at the Churchill-Penhurst office at Pittsburgh.

E. W. HANCOCK spent several days at Detroit, Philadelphia and Pittsburgh making investigations of central office equipment.

W. J. LACERTE visited the trial installation of message rate trunks at Stamford.

L. H. JOHNSON went to Hartford on work in connection with improved coin collectors.

MESSERS. J. Meszar, F. M. Wiese and D. R. Fenlon were at Kalamazoo

in Jackson, Michigan, installing and testing a trial installation of toll line dialing.

F. B. ANDERSON and W. Q. OGDEN were at Norlina, North Carolina, and McKenney, Virginia, where they tested and observed the operation of a trial installation of apparatus providing improved methods for detecting and locating faults in toll cables.

MESSRS. F. S. Entz, H. I. Romnes, R. A. Brader and A. L. Bonner were at Kingston, New York, to observe the operation of pilot wire regulating equipment.

J. O. SMETHURST visited Tufts College in connection with college recruiting work.

W. W. RINDLAUB was in Chicago to supervise the installation of a bay of equipment associated with a trial of improved voice-frequency carrier telegraph equipment.

W. R. KRUEGER was in Syracuse to discuss the trial installation of the out-trunk preselector equipment with the Western Electric representatives.

E. J. JOHNSON made a trip to the Carolinas, Georgia and Alabama in connection with college recruiting work.

C. BORGMANN and R. G. KOONTZ visited Detroit, Jackson and Kalamazoo to observe several new equipments involving new developments.

R. L. LUNSFORD and H. T. LANGABEER visited Syracuse for the cut-over of Office 9 which has been provided with an improved power plant.

J. H. SOLE spent several days at Durham, North Carolina, in connection with the trial of centrifugal voltage regulators.

R. P. JUTSON went to Greensboro and Durham, North Carolina, to inspect several trial installations of power apparatus.

D. H. WETHERELL spent a week at Hawthorne in connection with the introduction of zone and overtime registration equipment required for panel offices.

E. J. KANE visited Wilkes-Barre in connection with frame cabling problems in dial offices.

C. E. BOMAN inspected the first installation of low type superstructure on No. 11 equipments at Stroudsburg. He also visited Wilkes-Barre and Kingston, Pennsylvania, in connection with studies being made on fusing of relay rack equipments.

C. H. ACHIENBACH attended the meeting of the switchboard and equipment cost reduction committee at Hawthorne.



D. S. BENDER, field engineer in the New York No. 1 territory, and E. F. Helbing, of the Apparatus Inspection Department, visited Wayne, New Jersey, in connection with a special investigation on ringing machines. Mr. Bender later made a trip to the Providence Toll Office and conferred with Telephone Company engineers on apparatus matters.

H. K. FARRAR, field engineer in the New York No. 2 territory, attended a field review conference held at Albany, January 23.

I. W. WHITESIDE, field engineer in the Philadelphia territory, visited New York to discuss field engineering matters with members of the Inspection Engineering Department.

G. GARBACZ, field engineer in the

Cleveland territory, made a trip to Cincinnati in connection with field studies on call indicator equipment now being installed there.

R. C. KAMPHAUSEN, field engineer in the Detroit territory, visited Flint, Pontiac and Jackson, in connection with a special investigation on step-by-step power plants.

C. A. JOHNSON, field engineer in the Chicago territory, made a trip to Decatur to conduct a special investigation on step-by-step apparatus and equipment. Mr. Johnson also visited Effingham, (Ill.), Champaign and Milwaukee in connection with engineering complaint matters.

E. J. BONNESEN spent several days in Kansas City to discuss various engineering complaint matters with the Southwestern Bell Telephone Company people.

W. E. WHITWORTH, field engineer in the Omaha territory made an investigation on tape armored lead covered cable in Iowa City. Mr. Whitworth also visited Sioux City, Minneapolis, Fargo and Denver, in connection with general engineering complaint matters.

H. C. CUNNINGHAM attended a survey conference on raw materials held at Kearny.

C. J. HENDRICKSON visited Hawthorne in connection with a survey conference on dials.

E. G. D. PATERSON and W. H. STRACENER attended a survey conference on cable terminals held at Hawthorne.

P. S. OLMSTEAD attended a survey conference on 555 type receivers used with talking motion picture apparatus.

W. A. BOYD visited the Chicago *Daily News* broadcasting station, WMAQ, at Elmhurst, Illinois, to investigate matters concerned with

various noises on the carrier wave.

H. M. CRAIG, who has been assisting C. A. Johnson, field engineer in the Chicago territory, has returned to New York. S. C. Bates, who recently completed several weeks field training together with F. H. Knapp at the new step-by-step office in New Haven, has replaced Mr. Craig at Chicago.

J. H. SHEPARD, JR., made a trip to Providence to discuss Inspection Engineering work with student engineers of Brown University.

S. H. ANDERSON and A. F. GILSON visited the General Electric works at West Lynn to discuss engineering complaint matters.

G. D. EDWARDS, who is now making a trip covering the eight field engineering headquarters of the Inspection Engineering Department and principal cities of the various operating areas, was in Los Angeles January 25-29. Mr. Edwards was joined by J. A. St. Clair, field engineer of the San Francisco territory, and H. W. Nylund, who replaced Mr. St. Clair February 17 as field engineer in that territory. Later in the week they proceeded to San Francisco.

W. A. SHEWHART took a prominent part at the joint A.S.M.E.-A.S.T.M. meeting in the discussion of the application of statistics to engineering. He stated that the engineer must follow the footsteps of physicists in turning to statistics. He spoke of the absurdity of the term "constant" as applied in many of the quantities in which the engineer deals. The engineer looks up the tensile strength of steel or of southern pine in his handbook and seems to assume that this is the strength of the material, when it is certain that any actual specimen will either be stronger or weaker. The amount and distribution

of this possible excess or shortage is fully as important as the so-called "mean value." The remedy, he said, is to present, not "constants," but a statement of the distribution of values.



DURING THE PERIOD from January 5, to February 4, 1930, members of the Patent Department visited the following cities in connection with the prosecution of patents: Washington, F. H. Crews and P. C. Smith; Cambridge, Mass., G. M. Campbell.



F. M. RYAN has been named on a committee on *Aeronautic Radio Research* organized by the Department of Commerce under the chairmanship of Harry H. Blee, Director of Aeronautic Development. The committee will concentrate its activities on radio research work pertaining to aeronautics as part of program of the Department of Commerce in seeking to overcome obstacles standing in the way of the maximum of safety and reliability in air transportation. Mr. Ryan has been designated as the representative of the Institute of Radio Engineers on the committee.

On February 2, at the National Aeronautic meeting of the Society of Automotive Engineers at St. Louis

he presented a paper *Provision of Radio Facilities for Aircraft Communication*, written in collaboration with E. L. Nelson.

J. M. WILSON and W. W. WERLING attended an A.S.T.M. subcommittee meeting on insulating materials held on January 28 in the Engineering Societies building at New York.

H. A. ANDERSON has been temporarily transferred to the Hawthorne works of the Western Electric Company, effective March 1, to direct certain of their metallurgical activities.

J. ABBOTT spent a week in Hawthorne to attend conferences on dials.

J. R. IRWIN visited the Baring and Nebraska exchanges in Philadelphia to investigate contact conditions on sender apparatus.

G. B. BAKER visited the Philadelphia Instrument Shop in connection with adjustment problems on relays used in aircraft radio equipment.

V. F. MILLER visited Trenton in connection with new step-by-step equipment installed there.

C. G. MCCORMICK spent a month at Hawthorne to study manufacturing methods.

H. L. KITTS spent several weeks at Hawthorne on matters concerned with sound reproduction equipment.

A. C. WALKER went to the Leeds and Northrup Company at Philadelphia to discuss matters regarding special recording apparatus.

E. L. NELSON attended a conference of Radio Engineers at Washington called by the Federal Radio Commission.

F. W. CUNNINGHAM made a survey of the projected site of a 50 kw broadcasting equipment for the Stromberg-Carlson Company at Rochester.

B. R. COLE supervised the installation of a 5 kw broadcasting and speech input equipment for the Atlanta *Journal*.

A. B. BAILEY directed the installation of a 6-B Radio Transmitter for station WKRC of Cincinnati.

J. C. HERBER supervised the rebuilding of a 1 kw transmitter for the Hotel Lassen, Wichita, Kansas. He later inspected stations WMAQ, Chicago *Daily News*, and WCAE, the Pittsburg station of Gimbel Brothers.

MESSRS. A. B. Bailey, S. A. Magness, J. F. Morrison and E. Babcock made a field strength survey on a tentative site for the location of a 50 kw broadcasting equipment for the Columbia Broadcasting system at Jones Beach, L. I.

O. W. TOWNER inspected stations KVI of the Puget Sound Broadcasting Company at Kent, Washington; KHQ of Louis Wasmer, Inc., at Spokane; and KPO of Hale Brothers at San Francisco. He later made a survey for a 50 kw broadcasting equipment for station KNX, owned by the Western Broadcasting Company of Los Angeles.

RESEARCH

A. F. BENNETT again visited Hawthorne on his work on new high quality deskstand transmitters.

N. BLOUNT was at Hawthorne in regard to improvements in deskstand receivers.

R. M. BURNS and D. C. SMITH visited Harrisburg to make tests on the sulphur and dust contents of central office air.

R. E. DRAKE and H. F. HOPKINS attended a survey committee meeting at Hawthorne on the No. 555 receiver.

A. W. HAYES visited Hawthorne in connection with special development tests on station handset transmitters.

E. W. KERN visited Baltimore to inspect measurement apparatus.

J. H. INGMANSON was at Hawthorne in connection with the development of rubber covered wire.

H. H. LOWRY visited the Jeddo-Highland Coal Company at Jeddo, Pennsylvania, in connection with his work on carbon in telephone transmitters.

A TALK ON *Industrial Research as a Career for a Physicist* was given by Herbert E. Ives before the student body at Haverford on January 14.

ON FEBRUARY 6 Harvey Fletcher again spoke over the radio on *How Noise is Measured and Why*. The address was given over station WNYC in connection with the work of the Noise Abatement Commission.

R. A. HEISING was chosen as one of the three new managers named by the board of direction of the Institute of Radio Engineers to serve for the ensuing year.

A. A. OSWALD contributed a paper to the symposium on *Transoceanic Communication* given at the mid-winter convention of the American Institute of Electrical Engineers at New York on January 27 to 31. His subject was *Technical Features of the New Short-Wave Radio Station of the Bell System*.

E. B. FERRELL, speaking at the Oakhurst Community Club of Ocean Township, New Jersey, explained the radio transmitting operations at Deal Beach and pointed out that the maximum wave-length used is 73 meters, well out of the range of ordinary broadcasting frequencies.

BELL LABORATORIES CLUB

A GOLF TOURNAMENT, January 29, indoors of course; sixty-four starters. Tom Rice again took the low-score prize in the qualifying round with 82 for thirty-six holes. Lacerte took second from Bill Clarkson after a tie. Prize-winners in the finals:

GROUP I

Class A: Bill Burger defeated W. J. Lacerte 4
up

Class B: Bill Harvey defeated O. Willifrod 2
up

Class C: J. Kennelty defeated G. Brodley 5 up

Class D: R. H. Sampson defeated H. K. Baker
2 up

GROUP II

Class A: G. Kellogg defeated H. L. Downing
6 up

Class B: H. W. Wood defeated E. Peterson 5

up
Class C: W. Gallup defeated D. H. King 4 up

Class D: I. A. McCorkendale defeated D. Angus
6 up

THE WOMENS' HEALTH COURSE, which opens March 6, was outlined by Dr. Adele Streeseman (A. T. & T.) at a noon-hour meeting in the auditorium February 14. Instructors, the Misses M. S. Harold, M. E. Ball, G. Kellogg, E. E. Dittmar, L. Feil, L. M. McMahan, and C. Matrice, have themselves been instructed by our Personnel Department under the leadership of Miss Crawford, with lectures by Drs. Streeseman and Bristol and Mr. Schaefer of A. T. & T. and Dr. McLeod of Columbia.



Contributors to this Issue

FOLLOWING his graduation from Armour Institute of Technology in 1908 with the degree of B.S.E.E., E. W. ADAMS studied law at the National University Law School and obtained his LL.B. two years later. Continuing his studies, he received the degree of M.P.L. from George Washington University the next year. For the four years following his graduation from Armour he was an Assistant Examiner in the United States Patent Office and during this period was admitted to the bar in the District of Columbia and later in the state of New York. In 1912 he entered the Patent Department of the Western Electric Company, and from 1913 to 1916 was in Antwerp and London for the International Western Electric Company. On his return from Europe he again joined the Laboratories where he remained until another foreign assignment took him to London and

the continent in 1925 and 1926. At the present time he is Assistant General Patent Attorney for the Laboratories.

* * * *

JOHN R. WEEKS, JR., graduated from Sheffield Scientific School of Yale University in 1914 with the degree of Ph.B. He entered the student course of the Western Electric Company in Chicago immediately after, and after completing it, he transferred to the Research Department where he was engaged in vacuum tube development. He was in the U. S. Signal Corps for a short period and received a commission just after the armistice. From 1920 to 1925, with the Apparatus Development Department, he was occupied with insulation studies—principally of rubber for submarine cables. For part of the time he was supervisor of the group. From 1925 to 1929 he was engaged in the design of filter and



E. W. Adams



J. R. Weeks



K. M. Fetzer



C. D. Hocker



J. F. Dahl



W. A. MacNair

loading coils, again serving as supervisor. At the present time he is supervising a group developing condensers.

* * * *

AFTER graduation by North Carolina State College in 1914 and six years' experience in railway signalling, KARL M. FETZER entered the Toll Systems Development group of the Laboratories. His early work was in toll line signalling including methods for "straightforward" operation. In 1923 he was given charge of the toll circuit laboratory, whose operation he describes in this issue of the Record. In May, 1929, he was transferred to supervision of a design group concerned with terminal and signalling circuits.

* * * *

C. D. HOCKER received the A. B. degree from Wabash College in 1912 and three years later the Ph.D. degree from the University of Michigan. Entering the Chemical Research Department that autumn, he participated in investigations of vacuum-tube filaments, enameled wire, metal finishes, and corrosion and its testing; and supervised at various times groups engaged in metallurgy, chem-

ical analysis, research on transmitter carbon, and current engineering activities. In 1927 he transferred to the Outside Plant Development Department where, as Ceramics Apparatus Engineer, he has charge of groups investigating conduits and their construction, ceramic insulators, paints and miscellaneous products, and cable joining and maintenance.

* * * *

RECEIVING the B.S. degree from Colgate in 1920, W. A. MACNAIR spent a year as assistant physicist with the Bureau of Standards, interesting himself with aeronautical instruments, and a year as instructor in mathematics and physics at the Michigan College of Mines. Two years of further study at Johns Hopkins University brought him the M.S. and Ph.D. degrees in physics and a National Research Council Fellowship. Returning to the staff of the Bureau of Standards in 1927, he worked for a year on atomic structure as associate physicist, then went to the research division of the Victor Talking Machine Company. Last spring he joined the staff of the new Sound Picture Laboratory.

J. F. DAHL started with the Chicago Telephone Company in 1907 while still attending school. During the following ten years his work covered practically every branch of the telephone system. During the war he was in government service and left in 1919, as a commissioned officer, to join the Laboratories. Here he has been engaged for the last ten years in circuit design in the Systems Development Department.

* * * *

ALBERT SCHREIBER entered the Engineering Department of the Western Electric Company in New York City in 1913 and spent the following four years on design work with the Machine Switching Apparatus Department. From 1917 to 1919 he served in France with the 11th U. S. Engineers. After the war he returned to the Laboratories, to take up dial apparatus development.

* * * *

AFTER graduation from St. Lawrence University and Pratt Institute

School of Library Science, HELEN M. CRAIG joined the staff of the Engineering Societies Library as reference librarian. For two years she was with the H. W. Wilson Company as indexer for the Industrial Arts Index.

In 1918 she came to the Technical Library of the Laboratories, where she is now engaged on special problems in searching and collecting technical information.

* * * *

HARRY EVANS, motion-picture editor of "Life," in granting permission to use the italic filler on page 313 of this issue says, "providing you definitely state that the article was written of my own free will as a

statement of fact, and not in any sense as propaganda. . . . I am glad if the article has been a source of satisfaction to your company as it was written from the heart. Lord knows something should be done about the talkie equipment that is being sold to the unsuspecting owners of theatres in small towns."



A. Schreiber