

July 1989

Preventive maintenance

IT INSTALLER TECHNICIAN

The training and educational magazine for cable television technical personnel.

***** 3-DIGIT 565
 000075903 805 10 03
 FRED MCCORMACK
 DESIGN ENG
 HASTAD ENG
 305 E 5TH ST
 HALSTAD MN 56548

JV
FM
file



Special pull-out poster inside

SATE

**When They Are Relying On You
To Get The Job Done . . .**

**Track down
tough to find
CATV, MATV
and RF
Distribution
Troubles in less
than half the
time you now
spend . . .**

**With The FS74 CHANNELIZER SR.™
TV-RF Signal Analyzer
\$3495 Patented**

When your customers are relying on you to get the job done, you need reliable and accurate test results . . . without having to worry about calculations that can add errors and time to your system tests.

The FS74 CHANNELIZER SR. eliminates errors and saves you time with 100% automatic and exclusive tests you can trust.

- All Channel DIGITAL tuner (5-890 MHz) covers all Sub-band, VHF, UHF, FM Cable Channels.
- Exclusive Frequency offset readout alerts you to carrier shifts.
- Integrated Wide-band monitor lets you see the system problems your customer sees that regular TVs don't.
- 5 μ V sensitivity (-46dB) with autoranged attenuators make CLI tests a snap.
- Automatic S/N and Hum tests on any IN-USE channel.
- Built-in DVM tests AC/DC Voltage and resistance.



The FS74 CHANNELIZER SR. gives you one integrated CATV and MATV troubleshooting and performance testing system that you can rely on to get the job done . . . fast.

Reader Service Number 1.

**Call 1-800-843-3338 or write
for a 10 Day Video Preview
on the FS74!
(In Canada, call 1-800-851-8866)**

SENCORE

3200 Sencore Drive Sioux Falls, South Dakota 57107

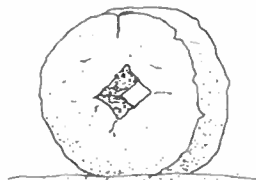

THE WHEEL, 2000 B.C. (BEFORE CABLE)

EVERY FEW THOUSAND YEARS ANOTHER UNEXPECTED IDEA COMES ALONG.

The New Antronix® CAM-Port™ Is Now Being
Incorporated Into the Antronix Series of Multi-taps.

The "Connector Activated Mechanism" (CAM)

The Antronix® CAM-Port™, a revolutionary leap forward in port design, is now available in our entire series of multi-taps.

For years, we've been setting industry standards with our taps and here's why we're about to do it once again with our new Antronix CAM-Port.

New CAM Action.

The new CAM mechanism will automatically grip any size center conductor with the exact contact pressure to insure a reliable, intermittent-free connection.

New Contact Design.

The key to a proper mechanical and electrical con-



nection is the contact area. Present design, by its own nature has to have a marginal contact area. In the CAM-Port, the whole contact is the contact area.

Normally Open Contact.

This normally open contact design allows perfect plating over the entire contact area.

The Incredible Result:

Exact contact pressure.
No insertion wear on the contact. Perfect contact plating.
No more loose connections.
No more port failures.

The new CAM-Port will soon be standard equipment on all Antronix cable products.

Antronix is now connect-

ing the world of communications better than ever. And, suddenly, every other cable port is obsolete.

Make your perfect connection today. Call Antronix at 201-446-2626.

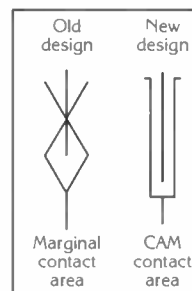

ANTRONIX

Connecting the World of Communications.

CAM-Port™ is Patent Pending
Copyright Antronix®, 1989

Reader Service Number 2.

Contents

Departments

From the Editor 6

News 8

You and the SCTE 11

The Society launches its Installer Certification Program and recognizes members at Expo '89.

Safety on the Job 46

Dana Eggert of Performance Plus details basic safety practices for installers.

Installer's Tech Book 49

Classifieds 53

Products 56

Installer Input 58

Cardinal Communications' Gregg Nydegger discusses the importance of installs, upgrades, downgrades and service calls.

Out of Focus 64

Ad Index 64

Calendar 65

From the NCTI 66

Tom Brooksher gives an update on Triangle Tech's Cable Television Lineman/Installer program.

Cover

Keep your finger on the pulse of your system with preventive maintenance. Art by Geri Saye.

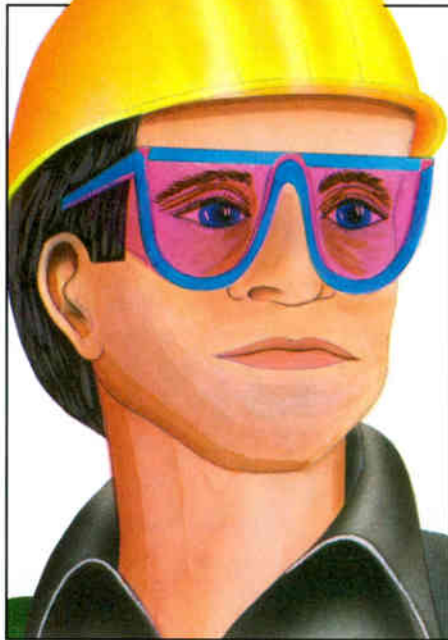

Installer/tech poster 27

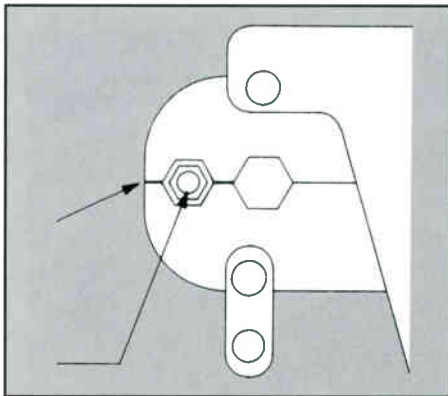

Hex crimp tools 25



Out of Focus 64

Features

PM and power 16

Jerry Schultz of Power Guard describes how to make sure your system's standby power stays at peak performance level.

F connector revisited 18

The F connector's impact on signal leakage is examined by Alan Babcock of Warner Cable Communications.

CLI compliance 20

NaCom's John Mulhearn addresses the positive impact that a good leakage program can have on your operation.

PM and FO 22

Special considerations for fiber-optic maintenance are highlighted by John Holobinko of American Lightwave Systems.

Hex crimp tools 25

The installer's role in assuring a good connector-to-cable interface is explained by TCI's Barry Smith and ATC's Dave Franklin.

Basic electronics 26

Ken Deschler of Cable Correspondence Courses focuses on power supplies.

Is this you? 27

A special pull-out poster of the well-equipped installer/technician.

Instructional Techniques 43

This month's edition includes "Are you organized?" by Tailgater.

IT-Installer/Technician © 1989 by Communications Technology Publications Corp. All rights reserved. Installer/Technician (ISSN 104-1253) is published monthly by Communications Technology Publications Corp., 12200 E. Briarwood Ave., Suite 250, Englewood, Colo. 80112—or—P.O. Box 3208, Englewood, Colo. 80155, (303) 792-0023. July 1989, Volume 2, Number 3. Office of publication is 12200 E. Briarwood Ave., Suite 250, Englewood, Colo. 80112. Second-class postage paid at Englewood, Colo., and additional mailing offices. POSTMASTER: Please send address changes to Installer/Technician, Box 3208, Englewood, Colo. 80155.

Perhaps our most important contribution to CATV powering is restoring meaning to the word reliability.

In the past fifteen years we've made some very significant contributions to the CATV industry. We've developed the most efficient standby power concepts. We've developed the powering technology that delivers the cable signal with unprecedented reliability.

In fact, every major standby power innovation has come from Alpha, including complete status monitoring, automatic performance monitoring, uninterrupted power output, and more. But what makes us proudest is to hear people in the industry say we've brought respectability to the standby power business.

Standby power systems were introduced to make CATV signal delivery more reliable.

Ironically, many of the standby systems were notoriously unreliable. They gave the entire industry a black eye.

We've worked very hard to design and build products that keep working under the most demanding environmental conditions. The fact that we're continuing to grow at an increasing pace while others have faded or disappeared shows that our concern for quality is right. And when our customers tell us we've restored confidence in standby power systems, that's the payoff.



Alpha Technologies. We're here to back you up.



3767 Alpha Way, Bellingham, WA 98226-8302
TELEPHONE 206-647-2360 FAX 206-671-4936

5700 Sidley St., Burnaby, B.C. V5J 5E5
TELEPHONE 604-430-1476 FAX 604-430-8908

Reader Service Number 3.

From the Editor

IT INSTALLER TECHNICIAN

Paul R. Levine
President/Publisher

Martin L. Laven
VP of Sales and Marketing

Toni I. Barnett
VP of Editorial

Patricia A. Willbourn
National Sales Manager

Wayne H. Lasley
Editor in Chief

Lu Ann Curtis
Account Executive

Rikki T. Lee
Associate Editor

Nell Anderson
Account Executive

Shelley Bolin
Assistant Editor

Cindy Cole
Marketing Director

Chuck Grossman
Editorial Assistant

Barbara Bellomo
Classified Ad Manager

Sharon F. Lasley
Art Director

Marie T. Beert
Marketing Administrative Asst.

Brad Hamilton
Asst. Art Director

Maria Sullivan
Production Coordinator

Mary L. Sharkey
Circulation Manager

Jim Watts
Asst. Production Coordinator

Kathleen Jackson
Circulation Clerk

Kenny Edwards
Controller

Nancy Parkin
Assistant to Controller

Advisory Boards

Alan Babcock
Warner Cable Communications Inc.

Wendell Bailey
National Cable Television Association

Richard Covell
Society of Cable Television Engineers

Dana Eggert
dB Associates

Joseph Girard
Cooke Cablevision Inc.

Roland Hieb
National Cable Television Institute

Ron Hranac
Jones Intercable Inc.

Patrick K. McDonough
United Cable Television Corp.

Larry R. Linhart
NaCom

Celeste Rule Nelson
Television Publications Inc.

David Pangrac
American Television and Communications Corp.

Dan Pike
Prime Cable

Rex Porter
Midwest CATV

Jon Ridley
Jerrold Division / General Instrument Corp.

William Riker
Society of Cable Television Engineers

Barry Smith
Tele-Communications Inc.

Sunny side of the street

It was a hot time in the city. And I mean that literally. Orlando, Fla., was the site for this year's Cable-Tec Expo, sponsored by the Society of Cable Television Engineers. As temperatures hovered in the 80s, individuals and companies from the cable community's technical arena gathered for four days of sessions, workshops and exhibits.

Things warmed up on Thursday with the Annual Engineering Conference, held at the Stouffer Orlando Resort, with sessions on high definition television, digital video, cable vs. telco and fiber-optic technology. During the membership luncheon in the afternoon, SCTE honored several of its members and announced the new slate of officers. They are President Jack Trower, WEHCO Video; Western Vice President Richard Covell, General Instrument/Jerrold; Eastern Vice President Victor Gates, Metrovision; Secretary Wendell Woody, Anixter Cable TV; and Treasurer Pete Petrovich, Petrovich & Associates.

The first Service in Technology Award from our sister magazine, *Communications Technology*, was given to Bill and Anna Riker. Also, Austin Coryell presented a check from Texscan's Bert Henscheid on behalf of the SCTE Scholarship Committee, and Tom Hall (secretary of the U.K. SCTE) and Glenn Jones (CEO of Jones Intercable) both received Special Recognition Awards. (For more on the membership meeting, see "You and the SCTE," page 11.)

In the course of the next three days the action was really hot (and I mean that figuratively), with workshops on the SCTE's Installer Certification Program, installing fiber-optic cable, signal leakage, signal level meter basics and more. These workshops all ran concurrently to allow conventioners to pick and choose those they were most interested in.

An Exhibitor Training Center was created to allow companies exhibiting at this year's Expo to offer formal presentations of their products and related technologies. Technical demonstrations included "Bench sweeps" by Kalun, "Leakage testing" by Trilithic, "Fiber optics" by Anixter, "Time domain reflectometers" by Riser-Bond, "XLF drop connectors" by Cable Connector Corp., "RFI shielding and sealant" by Loctite Corp. and

"Leakage Evaluation System" by Long Systems. Also held in the Training Center was the "Painless technical writing" course, conducted by Jones Intercable's Ron Hranac and our own Rikki Lee.

Activity went from a boil to a simmer in the evenings, with parties hosted by Wavetek, Jerrold, Anixter, Raychem, AT&T, the SCTE Florida Chapter, the Florida Cable Television Association and Scientific-Atlanta, and of course Expo Evening at Sea World. So if you were unable to make it to this year's expo, try to make it to Nashville next year and see what's cooking. Whatever it is, I'm sure it will be hot!

On your marks, get set...

Go! To the first annual Cable Games that is. Sponsored by the SCTE Rocky Mountain Chapter, CT Publications, the Colorado Cable TV Association and the National Cable Television Institute, the games are being held at the CCTA convention July 19-21 at Marriott's Mark Resort in Vail, Colo.

Whoops!

Yes, it's true. Even the best of us make mistakes. Last month we ran an article by Les Read of Sammons Communications titled "Don't take 'de feet' lightly." At the top of the second page a paragraph was deleted that read as follows:

"Another option is the sole. The one most used is a Vibram #430 or equivalent, with good gripping power and relative ease of cleaning. A second sole option is often the Vibram #100 sole that could be described as snow treads on your feet. This has excellent gripping power, which is great for pulling a lasher on uneven surfaces. It has two disadvantages: It is difficult to clean when muddy and it can mark floors. If one is routinely entering customers' houses it is not the best choice (unless you carry plastic covers for your boots!) Also if you wear it in a yard where dogs are penned, you must learn to be extremely careful where you step. It should be noted there is a difference in oil resistance between these two soles, but that is not a factor affecting most of us."

We regret any confusion caused by this oversight.

Toni I. Barnett

on tap at **Toner**



XMT SERIES
2-Way, 4-Way, 8-Way
5-550 MHz Multi-Taps

- Plated Solid Brass F Connectors
- Baked Acrylic Corrosion Coating
- Stainless Steel Mesh RFI Gasket
- Neoprene Weather Gasket
- Stainless Steel Hardware
- Sealed F Ports
- Plastic Cover Over PC Board

toner
cable equipment, inc.

800-523-5947

IN PA 800-492-2512
FAX 215-675-7543
969 Horsham Road
Horsham, Pennsylvania 19044

Reader Service Number 4.

Summit Media acquires CT Publications Corp.

GOLDEN, Colo.—Summit Media International, publisher of *Media Business*, *Media Business Review* and *Newspapers & Technology*, recently acquired CT Publications Corp. (CTPC) of Englewood, Colo. CTPC publishes *Communications Technology*, *Installer/Technician* and *Cable Strategies*.

This acquisition will reunite Summit Media President Paul Maxwell and CTPC President/Publisher Paul Levine. Under the agreement, Levine will become president and chief operating officer of Summit Media's newly formed cable TV division and will oversee day-to-day operations of that group.

Holland forms new company

LOS ANGELES—Holland Electronics Corp., a distributor of CATV, SMATV and LAN products is now open for business. According to Michael Holland, founder of the company and former president of Pico Macom Inc., Holland Electronics will focus on introducing new technologies and innovative products to the industry utilizing a highly-trained technical sales team. In addition to a complete line of headend equipment, the company is fea-

turing an extensive line of RF connectors and accessories. Holland Electronics Corp. is located at 5308 Derry Ave., Suite W, Agoura Hills, Calif. 91301; (800) 628-6688, (818) 597-0015, (818) 597-0206 (FAX).

National Cable Museum names Riker director

UNIVERSITY PARK, Pa.—William Riker, executive vice president of the Society of Cable Television Engineers, was recently appointed to the board of directors of the National Cable Television Center and Museum (NCTCM). He was also named to the NCTCM Education Committee.

The NCTCM, located on the campus of Penn State University, was established in 1986 to provide educational and training opportunities about CATV and its services to the public; establish a comprehensive national archive of the history and development of CATV and to take oral histories of its founders and of leaders from the private sector and government; maintain a repository for the documents, programming and artifacts to preserve them for research and scholarly activity; and monitor the development of cable and allied broadband communications services as they relate to subscriber services and to actively pursue their future development for the public good.

RMT employee wired for sting operation

REDONDO BEACH, Calif.—It was not a normal Wednesday for Chuck Blanchard, regional sales director at RMT Engineering's Southern California office. He received a call from the company's home office in Sunnyvale, Calif., that someone in Blanchard's area wanted to sell test equipment.

Blanchard made arrangements to meet with the dealer the next day. After discussing prices, the dealer told Blanchard that there was other equipment available and only cash was acceptable. The dealer went to his car and returned with a field strength meter, which he agreed to sell for \$500. Blanchard made a mental note of the serial number and arranged the transaction for the following day.

RMT's computer produced a record of having repaired the meter two years ago; the meter belonged to Century Cable of Redondo Beach. A phone call to the system revealed that this particular meter had indeed been stolen in 1987 (at least the thief had waited for it to be repaired). At this point the local authorities were contacted. According to the police, the only way to catch the thief and retrieve the meter was to wire someone with a hidden microphone, meet the dealer and get him to admit the meter had been stolen. Since Blanchard had made the initial contact, he was the logical choice.

The next day, he met with the Undercover Division of the Redondo Beach Police Department. At the station, he was briefed on the sting operation and was fitted with a hidden microphone and a light armor vest. Soon, Blanchard and the detectives met near the arranged location, the Miami Spice restaurant. By the time Blanchard entered, the Los Angeles Sheriff's surveillance team was in the parking lot and the undercover team in the restaurant, all in place.

As expected, the suspect was there. Blanchard talked with him about the meter and other items for sale. After getting the suspect to admit to the theft, the booth was surrounded by detectives and the perpetrator was handcuffed. In the trunk of his Mercedes he had stashed several converters, meters and a commercial grade camera. So the police arrested the thief, Century Cable received the stolen meter and Blanchard saved the day.

THE LOOK OF QUALITY

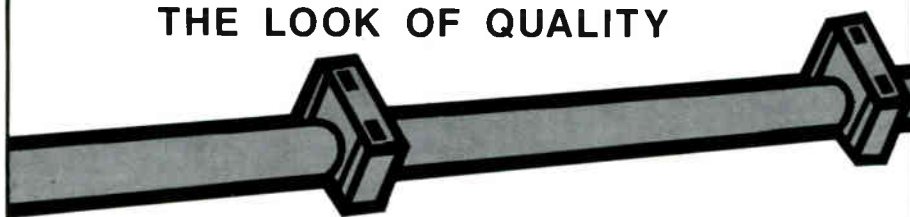

With RB-2 Cable Clips, your drop cable will be installed absolutely positively correctly every time.

The RB-2 Clip Gun System eliminates any chance of damaging the cable and it lasts the life of the drop. No signal degradation. No trouble calls. Just a quality installation delivering a quality signal.

For information call 800-548-7243.



Telecrafter Products

Products creatively designed for the cable industry

Reader Service Number 5.

IT

INSTALLER TECHNICIAN

IT INSTALLER TECHNICIAN

Installer/Technician magazine is distributed FREE each month to qualified cable TV personnel. Before you can qualify you MUST fill out this form completely. Incomplete forms will not be processed.

- 1) I wish to receive *Installer/Technician* FREE
 Yes No

Name _____
(please print or type)

Title _____

Company Name _____

Address _____

City _____ State _____ ZIP _____

Signature _____ Date _____

- 2) Please check the category that best describes your firm's primary business (check only one).
- Independent Cable Operator
 - MSO (two or more cable TV systems)
 - Independent Contractor
 - Microwave or Telephone Company
 - SMATV or DBS Operator
 - MDS, STV or LPTV Operator
 - Government Agency
 - Educational TV Station, School or Library
 - Other _____
(please describe)

- 3) In the performance of my job I authorize, specify or recommend products and/or services for purchase.
 Yes No

- 4) Primarily my responsibilities involve:
- Inside Plant (working within one specific office)
 - Outside Plant (working outside of your company's office environment, i.e., in a mobile unit, at various locations on a daily basis)

IT 7/89

Place
Stamp
Here

CT

PUBLICATIONS CORP.

P.O. Box 3208
Englewood, CO 80155-3208

IT

**INSTALLER
TECHNICIAN**

You and the SCTE

SCTE launches Installer Certification Program

The Society of Cable Television Engineers' (SCTE) new Installer Certification Program was officially launched at Cable-Tec Expo '89, held June 15-18 in Orlando, Fla. The program, which tests and certifies the skills of cable system installers through written and practical examinations, was introduced in a workshop presented June 16 and 17 by Installer Certification Committee Program Chairman Richard Covell and Director of Chapter Development and Training Ralph Haimowitz. Examinations in the program were administered for the first time on the final day of the Expo.

The program will be administered through the Society's local chapters and meeting groups, from training to testing, under the auspices of the national organization. Modeled after the Society's highly

successful Broadband Communications Technician/Engineer (BCT/E) Certification Program, the Installer Program was developed, according to Covell, "...to establish a standardized level of both technical and practical expertise for drop installations (and) certify that an individual has acquired this expertise and can accomplish a satisfactory installation, whether it be aerial or underground, or at a single home or multiple dwelling unit.

"The cable television industry desires to maintain a highly qualified base of CATV installers," Covell said. "Installers desire a career path in their field, a way to be recognized for their knowledge and ability, and a way to increase their worth and their income."

The workshop provided an overview of the program and offered attendees the opportunity to examine advance editions of the program manual, an in-depth guide to the various facets of installation that candidates for certification in the program will be tested on. The manual will be provided to those who join the Society at the Installer Level of SCTE membership, and also will be available for purchase to all interested parties. "Ultimately," Covell concluded, "we hope the completion of this program will help installers attain a more rewarding career!"

SCTE presents awards at membership meeting

The Society of Cable Television Engineers held its annual membership meeting June 15, the opening day of Cable-Tec Expo '89 at the Stouffer Orlando Resort

SCTE presents awards at membership meeting

The Society of Cable Television Engineers held its annual membership meeting June 15, the opening day of Cable-Tec Expo '89 at the Stouffer Orlando Resort

New Product

RISER-BOND

INSTRUMENTS

Model 1210

TIME DOMAIN REFLECTOMETER
CABLE FAULT LOCATOR

- SUPERTWIST LIQUID CRYSTAL DISPLAY
- AUTOMATIC DISTANCE CALCULATION
- WAVEFORM/DATA PRINTER STANDARD
- RECHARGEABLE NICAD BATTERIES STANDARD
- TESTS ALL TYPES OF METALLIC PAIRED CABLE
- LIGHTWEIGHT, COMPACT AND RUGGED PACKAGING
- EASY TO OPERATE

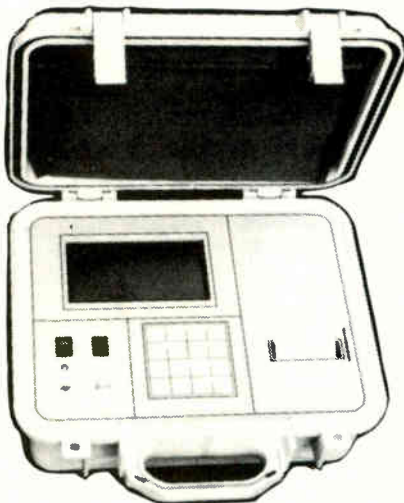

\$4,395
Complete

For more information or to place an order call or write:

RISER-BOND
INSTRUMENTS
402-694-5201

Reader Service Number 6.
505 16TH ST.
BOX 188
AURORA, NE 68818

YOU TOLD US...

"I waste too much time looking for misplaced parts/supplies on my truck."

So we invented the **TAILGATER LIDSYSTEM.**

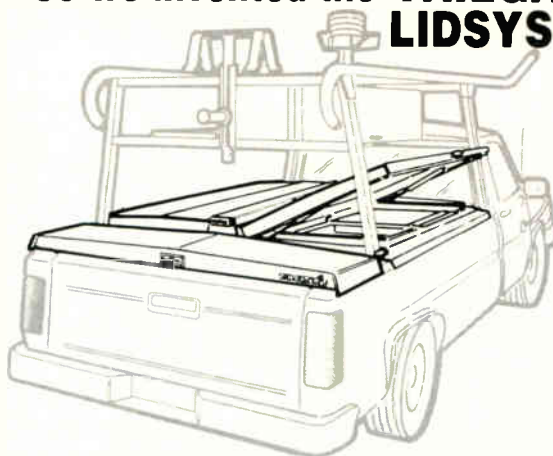

With the TAILGATER LIDSYSTEM, tools and supplies can easily be organized in specialized compartments. All within view at a glance. The TAILGATER

LIDSYSTEM helps you find what you want, when you want it. So you'll spend more time working, and less time worrying. Find out how.

Call 408/424-7710



Reader Service Number 7.

Versatile Truck Bed Systems
TAILGATER
561 Brunken Ave., Ste. H
Salinas, CA 93901

in Orlando, Fla. The following members were recognized at the meeting:

- Outgoing members of the SCTE board of directors were Mike Aloisi and Gary Selwitz.

- Coordinators of technical programs of state/regional cable shows for the Society were Texas Show—Ron Boyer, Dan Pike and Les Read; Atlantic Show—Bill Riker; Great Lakes Show—Vic Gates and Ralph Haimowitz; Eastern Show—Mike Aloisi; and Western Show—Pete Petrovich and Dave Large.

- Richard Kirn received an award for

his service to the Society as expo program chairman for 1989. Expo Program Committee members Mike Aloisi, Paul Levine, Bill Riker, Wayne Sheldon, John Walsh and Scott Weber also received awards.

- Eight SCTE members were elevated to senior member status: Richard Amell, Metrovision; Tom Elliot, Tele-Communications Inc.; Mark Harrigan; Herman Holland, Lawton Cablevision; James Lollar, Trans-Am Communications Co.; Pete Petrovich, Petrovich and Associates; and John Wong, FCC.

- Glenn Jones of Jones Intercable received a Special Recognition Award for his donation of a copy of the Jones Dictionary of Cable Television Terminology to each of the Society's members.

- Paul Beeman of Viacom Networks was the 1989 recipient of the Society's Member of the Year Award in recognition of his tireless dedication to the Society through over 23 BCT/E Certification Program technical seminars at local and national SCTE events during the past three years.

The National Cable Television Institute (NCTI) was the recipient of the 1989 President's Award in recognition for its service to the industry through technical correspondence courses. Five SCTE meeting groups were elevated to full chapter status in the Society: Inland Empire Chapter—Spokane, Wash.; Michiana Chapter—South Bend, Ind.; Mount Rainier Chapter—Seattle, Wash.; Southern California Chapter—Santa Corita, Calif.; and Upstate New York Chapter—Rochester, N.Y.

TOTAL LEAKAGE PROTECTION



INTRODUCING SNIFFER III™

From signal leakage detection to easy CLI certification, the SNIFFER III now adds the power of microvolt display to the industry standard SNIFFER Leakage Detection System. The new microvolt display joins a host of other SNIFFER III features that will put you in total control of your signal leakage



COMSONICS, INC.

An Employee Owned Corporation
1350 Port Republic Road, P.O. Box 1106, Harrisonburg, VA 22801
Toll Free (800) 336-9681, In VA (703) 434-5965

Reader Service Number 8.

SCTE chapters and meeting groups

As a service to SCTE members, the following is an up-to-date listing of the Society chapters and meeting groups, with each group's contact person and phone number. Members should take this opportunity to join a local group.

For more information on becoming a member, contact Pat Zelenka at the SCTE national headquarters, (215) 363-6888.

Appalachian Mid-Atlantic Chapter

Contact: Richard Ginter, (814) 672-5393

Cactus Chapter

Contact: Harold Mackey, (602) 866-0072

Caribbean Area Chapter

Contact: Jerry Fitz, (809) 766-0909

Cascade Range Chapter

Contact: Norrie Bush, (206) 254-3228

Central Illinois Chapter

Contact: Tony Lasher, (217) 784-5518

Central Indiana Chapter

Contact: Joe Shanks, (317) 649-0407

Chattahoochee Chapter

Contact: Jack Connolly, (912) 741-5068

Chesapeake Chapter

Contact: Thomas Gorman, (301) 252-1012

Delaware Valley Chapter

Contact: Diana Riley, (717) 764-1436

Florida Chapter

Contact: Rick Scheller, (305) 753-0100

Gateway Chapter

Contact: Darrell Diel, (314) 576-4446

Golden Gate Chapter

Contact: John Parker, (408) 437-7600

Great Lakes Chapter

Contact: Daniel Leith, (313) 549-8288

Ever Wonder Where Engineering Professionals Look For The Latest Developments In CATV Technology?

While engineers in some industries exhaust extensive time culling through many sources for the latest information, you have to move a lot faster in this business. Which is why so many cable TV system engineers are turning to the intelligent source:

Communications Technology.

As the official trade journal of the SCTE, **Communications Technology** serves the engineering community with an editorial content that is unsurpassed. Written by industry experts and leaders, **Communications Technology** provides monthly information and features on construction techniques, preventive maintenance, product and industry news, training tips, new technologies, testing and regulations, SCTE programs, events and a whole lot more.

COMMUNICATIONS TECHNOLOGY

Official trade journal of the Society of Cable Television Engineers

Cable's number one choice!

**For your free subscription, complete and return the subscription form below to:
CT Publications, P.O. Box 3208, Englewood, Colo. 80155-3208.**

COMMUNICATIONS TECHNOLOGY

Official trade journal of the Society of Cable Television Engineers

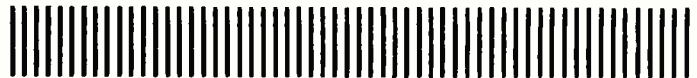

I wish to receive/continue to receive *Communications Technology*.

Yes No

Name _____
(please print/type)

Title _____
(please be specific)

Company Name _____

Address _____

City _____ State _____ ZIP _____

Signature _____ Date _____

1. Are you a member of the SCTE
(Society of Cable Television Engineers)?
Yes No

2. In the performance of my job, I authorize,
specify or purchase products and/or services.
Yes No

3. Please check the category that best describes your
firm's primary business (please check only one).

- 1. Cable TV Systems Operations
 - a. Independent Cable TV Systems
 - b. MSO (two or more Cable TV Systems)
- 2. Cable TV Contractor
- 3. Cable TV Program Network
- 4. SMATV or DBS Operator
- 5. MDS, STV or LPTV Operator
- 6. Microwave or Telephone Company
- 7. Commercial Television Broadcaster
- 8. Cable TV Component Manufacturer
- 9. Cable TV Investor
- 10. Financial Institution, Broker, Consultant
- 11. Law Firm or Government Agency
- 12. Program Producer or Distributor
- 13. Advertising Agency
- 14. Educational TV Station, School or Library
- 15. Other _____

(please describe)



OUTSTANDING

IN STRENGTH AND PERFORMANCE

Cable Prep's RTH-4500 Ratchet T Handle for ease of operation

- Easy to install on any coring or stripping/coring tool with a 3/8" shaft with 3 flats.
- Can be purchased separately or at a discounted price with a new CABLE PREP SCT or DCT tool.
- Self contained unit - maintenance free.
- Fully backed by Cable Prep.
- Competitively priced. • Made in the U.S.A.
- Service-oriented manufacturer.

Copyright 1989 Ben Hughes Communication Products Co

So user friendly it can be used with our competitor's tools!



cable prep

BEN HUGHES COMMUNICATION PRODUCTS CO
207 Middlesex Avenue, P.O. Box 373
Chester, Connecticut 06412-0373
(203) 526-4337 FAX. (203) 526-2291

We make your job easier!

Greater Chicago Chapter

Contact: Joe Thomas, (312) 362-6110

Heart of America Chapter

Contact: Nathan Brewster, (816) 795-1100

Hudson Valley Chapter

Contact: Wayne Davis, (518) 587-7993;
or Bob Price, (518) 382-8000

Inland Empire Chapter

Contact: Michael Lajko, (208) 263-4070

Iowa Heartland Chapter

Contact: Dan Passick, (515) 266-2979

Michiana Chapter

Contact: Thomas White, (219) 259-8015

Miss/Lou Chapter

Contact: Rick Jubeck, (601) 992-3377

Mt. Rainier Chapter

Contact: Sally Kinsman, (206) 867-1433

New England Chapter

Contact: Bill Riley, (617) 472-1231

North Central Texas Chapter

Contact: Vern Kahler, (817) 265-7766

North Country Chapter

Contact: Doug Ceballos, (612) 522-5200

North Jersey Chapter

Contact: Art Muschler, (201) 672-1397

Ohio Valley Chapter

Contact: Robert Heim, (419) 627-0800

Oklahoma Chapter

Contact: Gary Beikman, (405) 842-2405

Old Dominion Chapter

Contact: Margaret Harvey, (703) 238-3400

Piedmont Chapter

Contact: Rick Hollowell, (919) 968-4661

Razorback Chapter

Contact: Jim Dickerson, (501) 777-4684

Rocky Mountain Chapter

Contact: Rikki Lee, (303) 792-0023

Southern California Chapter

Contact: Tom Colegrove, (805) 251-8054

Tennessee Chapter

Contact: Larry Warren, (901) 352-7650

Tip-O-Tex Chapter

Contact: Arnold Cisneros, (512) 425-7880

Upstate New York Chapter

Contact: Ed Pickett, (716) 325-1111

Big Sky Meeting Group

Contact: Marla DeShaw, (406) 632-4200

Bonneville Meeting Group

Contact: Roger Peterson, (801) 486-3036

Central California Meeting Group

Contact: Andrew Valles, (209) 453-7791

Chaparral Meeting Group

Contact: Bill Simons, (505) 988-9841

Dairyland Meeting Group

Contact: Jeff Spence, (414) 738-3180

Dakota Territories Meeting Group

Contact: A.J. VandeKamp, (605) 339-3339

Dixie Meeting Group

Contact: Greg Harden, (205) 582-6333

Great Plains Meeting Group

Contact: Jennifer Hays, (402) 333-6484

Hawaiian Island Meeting Group

Contact: Howard Feig, (808) 242-7257

Midlands Cable Training Association

Contact: John Page, (712) 323-0420

New York City Meeting Group

Contact: Andrew Skop, (201) 328-0980

Palmetto Meeting Group

Contact: Rick Barnett, (803) 747-1403

Snake River Meeting Group

Contact: Jerry Ransbottom, (208) 232-1879

Southeast Texas Meeting Group

Contact: Harold Null Jr., (713) 947-7114

Wheat State Meeting Group

Contact: Mark Wilson, (316) 262-4270

Wyoming Meeting Group

Contact: Matt Forgas, (307) 324-7137

You Deserve Quality!

Your quality CAD system design maps come from Cable Link, Inc.



- strand mapping
- system design
- drafting services
- as-built mapping
- walkout
- make ready

Reader Service Number 11.

(614) 221-3131

Cable Link, Inc. Buys, Sells, Repairs, converters, line amps, line extenders, headend, traps, parts

CABLE'S HOTTEST TICKET

1989 Eastern Show

ATLANTA
August 27-28-29

Atlanta Merchandise Mart

Be Sure You Receive
ALL The Information On The
1989 Eastern Show.
SEND COUPON TODAY!

SPONSORED BY
SOUTHERN CABLE
TELEVISION ASSOCIATION

Reader Service Number 12.

Your ticket to ease, convenience and economy...the most flexible registration package for a major show...suit your budget, suit your schedule...your ticket is not only hot...it's a great value.

Your ticket to a top performance...a complete display of goods and services from the industry's leading suppliers...a firsthand look at the products that make the difference for today's cable professional...a hot ticket for performers.

Your ticket for big impact, wide reach and bottom line results...from legal and regulatory matters to the benefits and applications of new technologies, the industry's brightest and best will provide answers and solutions that make a difference. CATA Open Forum, hard hitting management sessions and SCTE Technical Sessions combine for your hottest ticket to results!

Your ticket to the front row...spice your show with excitement and southern hospitality, from the spectacular welcoming reception to the gala banquet featuring the nation's top entertainers...be sure you're holding cable's hottest ticket for fun!

ES 200

CLIP AND MAIL TO:
THE 1989 EASTERN SHOW
c/o Convention & Show Management
6175 Barfield Road, Suite 220
Atlanta, GA 30328

NAME _____

COMPANY NAME _____

ADDRESS _____

CITY, STATE, ZIP _____

BUSINESS TELEPHONE _____

IT 7/89

Preventive maintenance on CATV power supplies

By Jerry Schultz

President, Power Guard Inc.

All CATV systems must use a number of power supplies, either the normal ferroresonant or standby type. Although power supplies of either type usually are considered to be simple as compared to the other electronic components used in the system, they none the less can present the cable operator with major problems. This is due in part to the large area one supply normally covers. More importantly, this is the point at which the system must interface with the electric utility's power line.

Since the cable operator has no control over what is on these lines, it can be assumed that all manner of damaging spikes and surges will attempt to enter the cable system through the power supply at this point. Therefore, it is very important that the power supply and the associated surge protection devices are maintained at their peak performance level.

Ferroresonant supplies

Power supplies with no standby capability may be found in some non-critical areas served by only one utility power grid. In this situation some type of ferroresonant supply may be used to power the system. Modern ferroresonant supplies are of simple design and contain only a transformer and one self-healing long-life capacitor, plus whatever surge protection

devices are used.

Since this design is very reliable, with the exception of surge protection devices, these supplies can be expected to give years of trouble-free service with little or no maintenance. Although a pending failure of this type of supply is difficult to predict, a visual inspection for damaged or loose connections when working in the area of a supply is advisable. Under normal conditions no periodic maintenance should be required on the supplies themselves.

Most power supplies, whether standby or ferroresonant, contain some type of surge protection on the input, output or both. These devices are your first line of defense against surges that can cause damage throughout the system. As a result, they must be kept in top working condition at all times. Checking surge protection components may not be as simple as it seems, since many such devices are not in very accessible locations. Even if visible, a defective unit may not exhibit physical signs of damage.

Most input surge protection devices are of a type known as metal oxide varistors (MOV). The MOV is a soft limiting device, which means that as the surge voltage applied to the device increases, the limiting voltage also increases. The construction of the MOV junction is such that it can not dissipate heat effectively and as a result several surges in rapid order can cause the device to overheat. Since the resistance of an MOV decreases with heat, it will eventually short out and fail. If the MOV is placed before the line circuit breaker or the device rating is low enough, the unit may be completely vaporized leaving only the leads remaining.

Testing of MOVs in the field is difficult at best and as a result you are usually limited to a visual check for overheating or other physical damage. MOVs used for input protection have a voltage rating of 130 to 150 VAC for a 115 VAC line and power ratings of 40 to 250 joules or more. Some MOVs currently on the market are fused and have a light to indicate their condition. It is strongly recommended that this type of device be used whenever possible. This allows positive identification of a defective unit as well as easy replacement since these are usually plug-in devices.

The normal output surge protection device is a specially configured series of zener diodes. Since the zener diode is a DC device, the zener units must be formulated in a back-to-back manner to accommodate the AC output voltage. Unlike the input MOVs, the zener diode is a hard limiting device. As a result, when the rated output voltage is reached the zener conducts and attempts to maintain the clamping voltage at that point. The zener diode junction, unlike the MOV, does conduct heat away from the junction and takes repeated surges within its ratings without damage due to overheating.

The usual failure mode of a zener type surge device is a short circuit that usually causes obvious damage to the unit. Since the output of a ferroresonant supply is current limited, a failure of this device frequently causes a short that puts the power supply out of service. As with input surge devices, output surge devices should be checked as often as practical.

Another device that helps in the fight to keep surges out of the system is the time delay relay. Although not a surge protector in the true sense, this device keeps all power off the system for

Wideband Noise

On Lower Off-Air Channel?



Before



After



2903
Interference
Eliminator

Hundreds in use by CATV systems. Full details in free catalog C/87 - the industry's most complete selection of filters and traps for CATV, Private Cable, Institutional TV and Local Area Networks.



C/87

Microwave Filter Co., Inc. 6743 Kinne St., E. Syracuse NY 13057
Toll Free: 1-800-448-1666 • Collect: 315-437-3953 • Telex: 249-613 • Fax: 315-463-1467

Reader Service Number 13.

a period of time (usually about 10 seconds) whenever power is first returned to the supply. A properly designed time delay relay has the distinct advantage of being able to prevent power surge damage to the system without itself being exposed to the surge. A time delay relay can be tested by removing and again applying power to the power supply. However, if the system has power the time delay unit should be fine. Time delay relays are found only in the non-standby supplies and should not require special preventive maintenance.

Standby power supplies

Standby power supplies can be broadly classified into two groups: the single supply where the same transformer is used for both normal and standby operations, and the split supply that uses two transformers and has separate supplies for normal and standby operation. The split supply group can also be broken down into two types: the driven inverter and the saturating inverter. Since operating parameters of the saturating inverter are primarily determined by transformer design, no inverter controls are present.

Field inverter control adjustments of all other types of supplies should be avoided unless specified by the manufacturer. This leaves the battery charger voltage as the only field adjustment that should normally be attempted. This adjustment should only be made if required due to a change in battery type. Any adjustment of charger voltage requires a quality digital voltmeter and must be set according to the particular manufacturer's instructions.

This brings us to the number one problem facing the cable technician—batteries, batteries, batteries. No matter what kind of standby power supply you have, batteries will almost certainly be your biggest problem. For the purpose of this article all batteries will be lumped into two groups: the standard or refillable stationary lead acid battery (automotive batteries should not be used) and the sealed "maintenance-free" lead acid battery. *Important: Proper safety equipment including safety glasses and gloves must be worn when servicing batteries.* A quality digital voltmeter must be used in all battery voltage tests. For best results the batteries should be at or near full charge.

Before DC testing of the standby supply, a visual inspection for loose, corroding or broken terminals and wires should be made. At every opportunity, an assessment of the general condition of the entire supply, a check for discolored or low water levels in lead acid-type battery cells and the presence of some type of protective coating (as specified by the battery manufacturer) on the battery terminals should be made.

After correcting any problems that have been found, a check of the battery string voltage should be made. Battery voltage should be in the range of 12 to 14 volts per battery, depending on battery condition and type. With the voltmeter still attached, switch the standby into DC operation by switching the AC circuit breaker to the "off" position. The battery string voltage will drop rapidly for a minute or two and then stabilize. With the supply still in standby mode, use the voltmeter to check and note the voltage of each battery in the string. Reapply power to the supply by switching the input circuit breaker to the "on" position. After the specified delay (usually about 10 seconds) the unit should switch back to normal power.

Now compare the voltage readings of each battery. All batteries should be within 0.5 volts of each other. If any battery in the string is 0.5 to 1 volt lower than any other battery in the string, the battery string should be discharged by running in standby for at least 15 minutes. The batteries should then be charged for at least four hours and retested. After retesting, any battery



that is more than 1 volt below the others should be replaced.

If a defective battery is found in a string of batteries over one year old, all batteries in the string should be replaced. If it is cost prohibitive to replace all batteries in the string, a replacement battery of a similar age should be used. This will prevent the premature failure of a new battery in an old string.

If the supply fails to go into the standby mode when AC input power is switched off and bad batteries are suspected, further tests are required to determine battery condition. The charger should be disconnected from the string and each battery tested individually with a "load" type battery tester similar to the Viewsonics VSBATT. Defective batteries should be replaced as specified before.

In closing, the most important thing to remember is that periodic maintenance is required on all types of standby supplies. A good rule of thumb is to visit them at least every three months, more often in warm climates or as often as necessary. These maintenance suggestions are intended only as a guide and do not necessarily include all tests that some manufacturers or cable companies may require. ■

The author wishes to thank David Cushman and Todd Schultz for their help in proofreading and suggestions that made this article possible.

The F connector revisited

By Alan Babcock
Technical Training Manager
Warner Cable Communications

F connectors are the subject of much discussion in the cable industry today. Historically, little emphasis was placed on this small, inexpensive device. With renewed interest in signal leakage and the F connector's role in causing leakage, cable television engineers have started looking at the impact of the F connector. Many people also are looking at the repair costs incurred in fixing customer reception problems caused by F connector failures.

One of the first tasks technical employees learn when they get a job in the cable television industry is "cutting on an F connector." Many companies train and retrain their employees on proper methods of putting F connectors on drop cables. Statistics and experience, however, show that hundreds of thousands of connectors are installed incorrectly each year. Twenty-five percent of service calls are caused by poor craftsmanship. This suggests that even with all the training,

people still aren't putting connectors on correctly.

In 1988 the cable television industry purchased 69.4 million F connectors. If all of these connectors were laid end to end they would stretch for a distance of 832 miles. Why did the industry purchase all of these connectors? The majority of these connectors weren't used on new installs. As all service techs are aware, a lot of connectors are replaced to correct customer reception and signal leakage problems. The reception and leakage problems are mostly caused by water damage and/or poor craftsmanship. If there is so much training and retraining occurring why are the service techs continuing to change so many connectors?

So what's the problem?

Part of the problem is the connector itself. Connector manufacturers have made attempts to improve the F connector. At least two manufacturers have introduced crimpless connectors in an attempt to improve the ease of connector installation while at the same time improving reliability. The Society of Cable Television Engineers and the National Cable Television Association's Engineering Committee both have groups working on improvements for the F connector.

A problem experienced by technicians and installers is selection of the correct connector for the type of cable being used. Connector sizes are selected for specific braid densities (40 percent, 60 percent, quad shield, etc.) and if the wrong connector is used, a failure will occur. Determining the proper connector is difficult because the sizes all look the same to the naked eye.

Installers and technicians must rely on the standard crimp-type F connector for most of the connections they make in the course of their jobs. Because most of the 69.4 million connectors purchased in 1988 were crimp-type, this article will review what is needed to install this type of connector correctly.

Proper tools

Tools used include a prep tool (strip back tool), a hex crimper and a 7/16-inch wrench. The prep tool is used to prepare the end of the cable for the connector installation. Most installers and technicians use the pocket knife for a prep tool. As long as they are careful in the use of the pocket knife there isn't a problem. The



most frequent damage done to a connector when using a knife is the scoring of the center conductor. It also is difficult when using a knife to prepare the cable the same way each time. When using the knife, be careful not to damage the end of the cable or your fingers. When Raychem introduced its crimpless connector a few years ago, a prep tool was introduced with it. This prep tool should only be used with the Raychem connectors. Don't use it to prepare a cable for installation of a crimp-type connector.

For a crimp-type connector, about 3/8-inch of braid should be folded back over the cable jacket. The amount of braid is critical. If too much braid is folded over and sticks out of the end of the installed connector water will wick into the connector. If not enough braid is folded over there won't be enough mechanical gripping force when the crimp is made and the connector will pull off or cause signal leakage. The size of the crimp sleeve on the connector is designed for a specific amount of braid. Without the right amount of braid, the connector will fail. Tools designed to prepare the cable end correctly are manufactured by several companies.

Crimpers should be checked periodically to verify that they are making a full crimp on the connector. Those sold in the last few years have adjustments that can be made to improve the crimp action. Older crimpers may need to be replaced if they don't make a satisfactory crimp. This tool is not to be used for a hammer or wrench. If you notice the sides of the connector have collapsed in on the cable or the crimps rings are distorted after the connector is crimped, adjust or replace the crimper. Replaceable crimp jaws are available for some crimp tools to make repair more economical. If the cable shape is changed during the connector installation, an impedance mismatch may occur causing picture degradation, water ingress and/or signal leakage.



Lemco

the
tools
of the
trade

Call for your free
catalogue.

(800) 233-8713

Reader Service Number 14.



Maybe the most important tool to be used in F connector installation is the 7/16-inch wrench. A connector must be wrench tightened to help prevent signal leakage problems. Warner Cable recommends the use of a torque wrench for tightening connectors. A soon-to-be-introduced recommendation for the industry is a tightness of 20 to 22-inch pounds of torque on an F connector. Finger tight is less than half that, at about 8-inch pounds. A finger tightened connector on a tap at a pole is already starting to work loose by the time the installer or technician who installed it has climbed down the pole or ladder. These loose connectors cause signal leakage, water ingress and customer reception problems.

A perfect fit?

How do technicians and installers know if the connector they are installing is "perfect"? Physical inspection is the best way to tell if a connector is installed properly. Warner uses a service provided by Production Products Company (PPC). A PPC representative instructs the installers and technicians in a system on proper connector installation, then each individual installs one connector on a piece of drop cable. The individual's connector sample is numbered to make it traceable. The samples are taken to the PPC facilities where they are inspected and pull-tested. Feedback is then provided to the individual about recommended tool replacement or technique improvements. This has proven to be an effective method of improving the reliability of connectors used by Warner.

A connector can only be as good as the technique used to install it. Inspect your tools and check your technique. Make quality control checks on each F connector and take the time to properly install each one. Proper installation of F connectors is essential if reductions in signal leakage are to be realized. ■

**BLOCK AID™
RFI SHIELD AND SEALANT**

**We Can Help You Prepare
for the July 1990
Signal Leakage Deadline
and Reduce Service Costs.
For more information call:
(203) 278-1280
Ask for Technical Service**



Loctite Corporation
Newington, Connecticut

**IT INSTALLER
TECHNICIAN**

Upcoming editorial focus

August (Eastern Show)
Safety and Equipment Use

September (Great Lakes Show)
Construction Practices

October (Atlantic Show, Mid-America Show)
Troubleshooting the Cable System

For editorial information, contact:
Toni Barnett, Vice President of Editorial
Shelley Bolin, Assistant Editor
(303) 792-0023

For advertising information, contact:
Martin Laven, VP-Sales & Marketing
Patti Willbourn, National Sales Manager
(303) 792-0023

CLI compliance: A new incentive for preventive maintenance

By John Mulhearn
Senior Engineer, NaCom

There have been numerous articles written concerning signal leakage and CLI (cumulative leakage index) compliance, most addressing what a system must do to meet the requirements. The purpose of this article is to address the positive impact that a good signal leakage program can have on your operation.

Overcoming obstacles

For most systems struggling to start a signal leakage program, the major obstacles are manpower, personnel education and, in some cases, poorly constructed or old plant. In researching system operators' response to signal leakage and CLI compliance it became apparent that the current emphasis on this subject not only creates a great opportunity for education, but also provides additional justification for rebuilding and rewiring old plant.

Everyone I spoke with, from system operators to vendors, was more than willing to share their experiences. The consensus was that now is the time to educate both technical and non-technical personnel about the hows, whys, benefits and costs of a good signal leakage program.

Whether you have a program already in place or are still scrambling to develop one, you should be aware that there are



many resources currently available to help you make more effective, efficient decisions, such as:

- 1) CLI software packages
- 2) More reliable, simplified test equipment
- 3) Contractors who can perform detection, correction, training and yearly maintenance

In addition, these knowledgeable resources will assist you in justifying the increased start-up costs to replace damaged spans and poorly shielded SMATV wiring and/or add technicians to your work force.

Familiar problems

At first glance, signal leakage detection and correction appears to be another burden on already overstrained resources. However, a quick review shows that some of the major causes of signal leakage are familiar problems to both service and maintenance technicians:

- radial cracks
- illegal outlets
- broken tap ports
- unterminated cables
- loose connectors
- warped and/or partially open housings
- damaged or corroded passives

Not only are these the same problems found during trouble calls and when sweeping the plant, but most will begin as minor leaks and gradually become major service problems. Several result in annoying intermittent problems that can be expensive to find. Locating and correcting these types of problems on an ongoing basis will reduce the time and resources needed for other technical operations (sweeping, monthly tests, etc.) and eventually will lower the number of trouble calls. Therefore, integrating CLI as part of a preventive maintenance program will result in improved customer service.

The installers' normal routine should include signal leakage detection and correction. They also should participate in regular CLI maintenance so they can understand the importance of tightening connectors, reporting plant problems and disconnecting illegals. This will not only improve the quality of the install, but will improve its chances of remaining problem free, allowing technicians and installers more time to concentrate on plant maintenance and training.

You can decrease the additional resources needed for signal leakage by changing the priority of your preventive maintenance procedures. In this sense your signal leakage program can be considered another preventive maintenance tool to help improve the quality of your service—not just an attempt to keep the FCC happy.

Don't let rainy days get your cable service down.



Reduce Signal Leakage and Protect your Drop Cable Connections Against Rainy Weather. Use our Insulation Sleeves and Endcaps.

- Prepackaged
- Quick and easy to install
- Automatically shrinks
- Fits snugly and uniformly
- No torch required
- Reduces installation costs
- Custom sizes and shapes available

Insulation Systems

461 Nelo Street, Santa Clara, CA 95054
[408] 986-8444 • FAX [408] 986-8447

Reader Service Number 16.

Due to overwhelming demand, SCTE is reprinting its publication entitled "FCC Advisory Committee: Signal Leakage" (1980 edition - stock #TR-2)

"This work is extremely comprehensive...a must-read for anyone who wants to understand the issue of leakage."
-Ted Hartson,
Post-Newsweek Cable

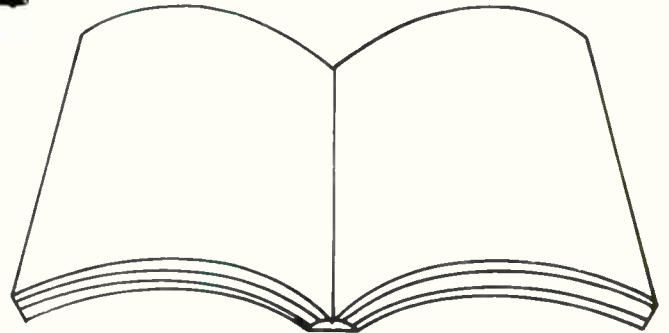

SCTE member cost - \$18.00
Non-member price - \$25.00

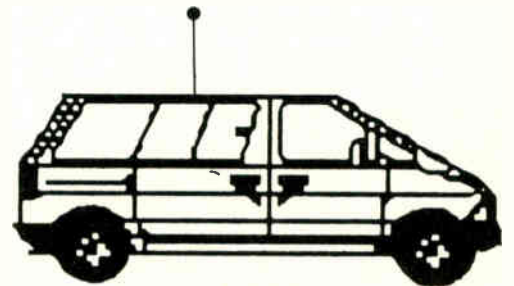

**Now available from
the Society of Cable Television Engineers!**

TO ORDER: All orders must be prepaid. Shipping and handling costs are included in the Continental U.S. All prices are in U.S. dollars. SCTE accepts MasterCard and Visa. To qualify for SCTE member prices, a valid SCTE Identification Number is required, or a complete membership application with dues payment must be included with this order.



**Send orders to:
SCTE
669 Exton Commons
Exton, PA 19341**

Maintaining fiber-optic systems

By John Holobinko

Vice President of Marketing and Sales
American Lightwave Systems

Lightwave video transmission systems eliminate many of the maintenance problems associated with standard coaxial and microwave-based systems. However, as with any technology, fiber introduces its own particular set of maintenance considerations. Fiber-optic system maintenance can be broken down into two basic areas: the fiber plant and the electronics.

Fiber plant maintenance

As with a well-run coaxial-based system, superior maintenance and operation of a lightwave system starts with thorough planning and documentation during design and initial system installation. Fiber-optic systems have a maximum transmission distance based on each particular system's optical budget. At system design time, the difference between the output power of the transmitter minus the minimum power sensitivity of the receiver (related to the signal-to-noise ratio and number of channels) is calculated. This is called the "link optical budget." Against this budget, the design engineer subtracts the loss of the fiber, fusion splices, connectors, optical splitters and any other sources of optical loss (see accompanying figure).

In a well-designed system, there will be at least 2 dB (preferably 3 dB) of optical margin left over after all of these link losses are added together. This gives the engineer an additional factor that can be applied against future fiber cable breaks, aging of the system and unforeseen sources of future system degradation. If 2-3 dB sounds like a large number for a safety margin, remember that a fiber plant has a lifetime conceivably longer than 40 years. For example, there are CATV systems in the field that are 10 years old and show very little, if any, aging of the fiber. Consider that today's single-mode fibers are many magnitudes better than the best fiber installed 10 years ago and you see

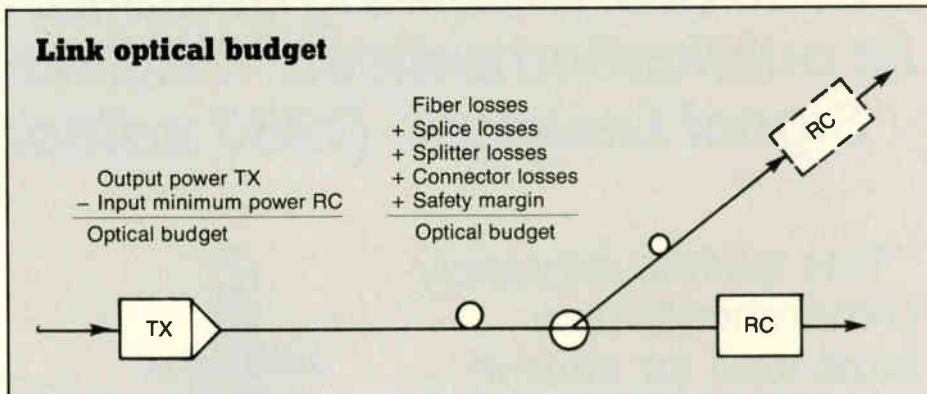

that to be short-sighted relative to initial design is truly a tragic and wasteful mistake.

Since fiber does not emit nor is susceptible to electromagnetic/radio frequency interference (EMI/RFI), use of sweeping techniques and sniffers plus fear of FCC interference rules can be forgotten! The biggest concerns in the fiber plant relate to changes in optical attenuation and optical return loss. One cause of increased optical attenuation in the fiber is incorrect installation of the cable, in which case a strain or sharp bend on the cable causes fiber microbending. This can occur sometime after the initial installation as strain builds up with cable expansion and contraction. If attenuation increases beyond the allowable optical margin and past the safety margin, loss of signal quality will result.

A normal and very desirable procedure when the optical system is installed is to record the attenuation of each fiber link, the output power of each transmitter and input power at each optical receiver. Additionally, pertinent RF level information relative to the specified modulation equipment chosen also is recorded in a logbook for each equipment location.

Fiber cable damage

Much has been written on the subject of emergency restoration of fiber systems. An optical time domain reflectometer (OTDR) will help establish the source of the break within a few meters. More often

than not, the location of the break will be known since it will be caused by an auto accident, fallen tree or, in the case of underground plant, via the proverbial "backhoe fade" phenomenon. Two solutions exist in the form of emergency restoration kits that are available from a number of manufacturers and 24-hour emergency repair service from independent companies whose service availability and cost vary by area. Each approach has its benefits. However, clearly the best solution is to design the fiber system as a counter rotating ring network. Although explaining this in detail is outside the realm of this article, a counter rotating ring design ensures that a cut anywhere on the system path does not cause any loss of service. This means that the link can be repaired in an orderly fashion using the best materials available without worrying about any loss of customer service during the time it takes to repair the damaged cable.

The expectations for reliability and signal quality continue to grow in the CATV environment. As the overall plant (fiber optic and coaxial) evolves toward a network instead of a series of interconnected systems, a maintenance philosophy of "problem detection and correction before outages" is required vs. a philosophy of "wait for the customer to pinpoint the source of the outage." In this newer environment no customer loss of service is treated as a fact of life. A fiber-optic maintenance plan can be designed easily that provides long-term system benefits. A summary of considerations for system design and maintenance can be found in Table 1.

Electronics maintenance

Electronics maintenance entails detection of potential problems before they occur and correcting unanticipated problems on a timely basis. Preventive main-

Table 1: Variables affecting fiber-optic system reliability

System architecture	Operating practices
Modular system architecture	Adequate initial safety margin
Remote status monitoring	Proper construction
Test points, fiber connections	Initial testing, proof of performance
Shared power supplies	Adequately updated system logbooks
Counter rotating rings	Periodic preventive maintenance
Hot standby switching	

tenance entails both the optical signal levels as well as the RF levels at various points throughout the fiber-optic transmission system.

Adequate optical power at the receiver is the keystone to maintaining high signal quality. Therefore, changes (negative) of optical power need to be detected quickly. Detecting changes in optical attenuation can be accomplished by a number of techniques. The worst case is that on many systems the optical link must be disconnected at the optical receiver, and an optical power meter connected to measure incoming power. This value is compared to the initial logbook and any changes noted. Further, an OTDR can be used in the same way with the link disconnected to measure the actual attenuation and detect a location where a discontinuity occurred in the fiber. In addition to measuring attenuation, this allows detection of a high reflection point in the fiber, which is of critical concern to AM over fiber systems. Front-mounted optical connectors on both AM and FM transmitters are a critical requirement. These allow optical measurements to be made as desired by one person with easy access to the fiber demarcation points, without the need for additional personnel or optical demarcation panels that add attenuation to the link.

The disadvantage to both the optical power meter and the OTDR is that the optical link must be disconnected in order to make any optical measurements. This is especially undesirable with AM systems, where the practice of fusion splicing (or other hard splicing of the transmitter and receiver to the fiber) has been required by many manufacturers in lieu of optical connectors in order to achieve acceptable AM system performance.

One solution that allows transmitters and receivers to be easily connected and disconnected from the fiber plant is via standard front-mounting optical connectors. This eliminates the need to break the fiber in an AM system when access to the fiber or the optical transmission equipment is required. Some manufacturers of FM optical receivers provide this feature by allowing the operator to measure incoming optical power via a test point on the front of the optical receiver with a digital voltmeter while the system is operating and without disconnecting the fiber.

Remote monitoring of operational levels can be very beneficial and should allow for transmitters, receivers and video modulators to be monitored and the data remotely related to a central office, eliminating the need for visiting the site in

Table 2: Fiber-optic test equipment

Equipment	Purpose
Digital voltmeter	Track operating levels; adjust, restore levels
Spectrum analyzer	Measure carriers, flatness of spectrum
Optical power meter	Measure optical power at transmitter, receiver
True RMS voltmeter	Measure signal-to-noise at baseband
NTSC waveform generator	Generate baseband video signals for performance measurements (installation)
Vectorscope	Measure differential phase, differential gain, etc. (installation)
Waveform monitor	Measure other video parameters (installation)
OTDR	Measure fiber attenuation, reflections; determine location of fiber breaks
Remote status monitoring	Measure system performance in real time
Automated digital tester	Measure relative changes in system operating levels

order to conduct preventive maintenance measurements. This eliminates the need for truck rolls in order to conduct periodic maintenance and provides a ready log of operating levels on a periodic basis. If a hard error occurs, it is pinpointed to the module level and the technician can be dispatched with the appropriate spare in hand, thereby minimizing the mean time to system restore.

Of course, a change of attenuation is only one source of a change in optical power. The other two sources are changes in the transmitter output power or change in the optical receiver performance. Comparing front panel mounted test point voltages or remote status monitoring information for each module to the initial system log is a critical determinant in pinpointing the cause of optical power loss. In a system with a well-designed optical automatic gain control (AGC), any change of optical power that is not catastrophic will have no effect on the signal performance. The AGC maintains the RF output level independent of optical received power. Some systems use a pilot carrier vs. average RF signal level to control AGC. This is a very desirable feature, especially for systems with multiple links or that have data carriers in addition to video. However, a preventive maintenance program will show that changes in the link have occurred so that problems are detected before actual signal degradation or system outage has a chance to occur in the future.

The most critical factor in fiber-optic system performance relates to RF levels. For example, an unanticipated increase in the RF level of one carrier going into an optical transmitter can have the effect of overmodulating the laser, resulting in increased harmonics and distortion, thereby affecting all of the other channels on the fiber. Therefore, signal levels must be monitored on a channel-to-channel basis, not simply average RF levels into and out of the system.

An ideal system will have both auto-

matic frequency control (AFC) and AGC on each one of the modulators/multiplexers and demultiplexers/demodulators associated with the system so that RF levels are automatically maintained at each point on an individual channel basis. Preventive maintenance involves testing these levels and comparing to prerecorded levels from the system log, utilizing a spectrum analyzer. At the input to the transmitter the flatness of the combined channel stream also should be monitored. Ideally, a BNC test jack with adequate isolation (e.g., -24 dB) will be available on the front of every module, so that performance can be monitored without affecting performance due to the RF loading of the spectrum analyzer.

The most reliable way to measure weighted signal-to-noise ratio calls for an RMS voltmeter and measures the base noise, then the signal-to-noise. Only a proper weighting network is required in addition to the RMS voltmeter. The disadvantage is that signal must be removed from the channel in question. Other signal parameters are usually tested at the time of system installation as part of performance testing. Only normal CATV type equipment is required for these tests. (See Table 2.)

Using automated test equipment

Currently, a number of automated digital test sets are available that perform the multiple functions of a spectrum analyzer, vectorscope, waveform monitor and RMS voltmeter. The advantage of these systems is their speed and ability to perform many of the measurements without disabling the operational link. Their main advantage is their absolute accuracy relative to the analog test gear they replace. However, as trend analysis tools they are very valuable. Properly used, they can effectively predict problems by comparing changes in the measurements they per-

(Continued on page 66)

From Headend to Drop

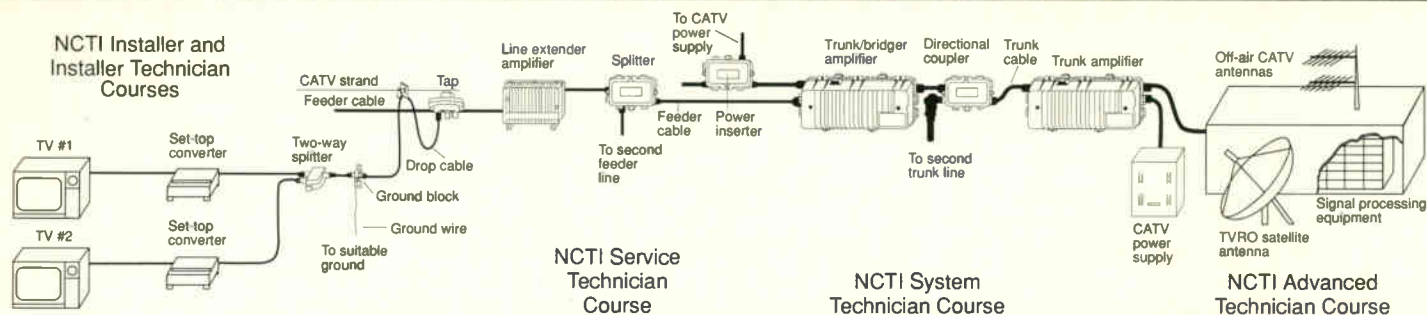

NCTI is the industry's technical training source

Where is your technical training need?

At the installer level? Continuing education for your Chief Tech? Technical insight for your Customer Service Reps? No matter what level of technical training your operation needs, NCTI has courses to offer.

For more than 21 years NCTI has been providing the technical training cable industry professionals need to ensure engineering excellence. Why has NCTI become the industry's technical training source?

Technical Excellence

NCTI lessons are authored by experts and reviewed by a Board of Technical Advisors which includes some of the industry's most experienced engineers and technicians.

Up To Date

NCTI lessons have been undergoing an intensive updating process. Material is carefully screened and changed to reflect the rapid advancement in technology and techniques.

Comprehensive

From F-connectors to satellite receivers, from modulators to set-top converters, NCTI covers the full range of cable industry technical issues.

Self Paced

NCTI's courses are designed to allow students to progress at their own pace, and to study when and where they are most comfortable. As a result, NCTI students complete a far greater proportion of courses than most like training programs.

Easy To Administer

NCTI takes the pain out of your technical training. We make it simple to enroll students and monitor their progress. Each time a student submits an exam, a grade report is promptly returned. And, each quarter management receives a Progress Report showing the status of each student in their system.

Our goal is to provide the industry's best training materials and to produce qualified technicians and engineers equipped to construct and operate first class cable television systems.

To learn how you can put NCTI training to work in your system, or how to enroll, call us at (303) 761-8554, or return the coupon.

Do it today!

Send For Your FREE Training Kit Today!

Name _____

Title _____

Company _____

MSO affiliation _____

Address _____

City _____ State _____ Zip _____

Phone _____



Mail this form to:

NATIONAL CABLE TELEVISION INSTITUTE

P.O. Box 27277, Denver, CO 80227
(303) 761-8554

IT 7/89

The F fitting interface and the hex crimp tool

By Barry Smith

Technician, Tele-Communications Inc.

And Dave Franklin

Project Engineer, American Television & Communications Corp.

There are many aspects of the F connector-to-cable interface that affect its reliability. Many parameters, such as connector crimp ring sizes, cable diameters, braid coverage and the like, are determined by the system's purchasing agent as directed by the chief technician and are beyond the control of the average installer or technician. They usually must take what they are given and have little or no opportunity to decide such compatibility issues.

There is one area, however, that allows for individual responsibility and initiative in attempting to provide the best possible interface—the proper alignment, fit and maintenance of the hex crimp tool. We alone are responsible for ensuring 1) that it is kept in good working order, 2) that it is properly sized for the connectors we have, and 3) that it is properly utilized for its designed purpose and only for that purpose.

Quality work begins with quality tools. We must recognize that a hex crimp tool is a precision instrument that deserves and demands just as much care and upkeep as a pair of climbers, our safety belt or even our signal level meter. If we are negligent with any of these devices our performance will be adversely affected, possibly to the point of being unacceptable.

There are several specific areas of concern regarding the proper use and care of the crimp tool. First, we must realize that the use of the crimp tool in a task for which it was not designed, such as using it in place of a hammer or pliers, will be harmful to the tool's ability to perform its intended function. Second, using a tool too small for a connector's crimp ring will damage its capacity for use with properly sized connectors (not to mention the poor interface of cable to connector, which will automatically arise). Third, we must be aware of the problems that can be caused by an improperly sized or poorly maintained crimp tool.

The problems caused by misuse of a crimp tool, as briefly stated before, are obvious. The effects of neglect, as stated in the third warning, may not be so readily discerned. Additionally, the means of correcting the first two practices is clear—don't do them! Ever! The corrective action in the third instance is not as well known, nor is it as easy to accomplish. This article is written to 1) help you understand the problems caused by an improperly sized hex crimp tool and 2) instruct you in the proper means of checking and adjusting the crimp tool.

Retention capability vs. crimp hex (nominal hex size = 0.324 inch)

	Before adjustment	After adjustment
Tool jaw gap	0.012 inch	0.001 inch
Average measured hex size	0.331 inch	0.326 inch
Average pull-off (53 percent braid)	45 pounds	66 pounds
Average pull-off (67 percent braid)	60 pounds	91 pounds

Checking crimp tool adjustment

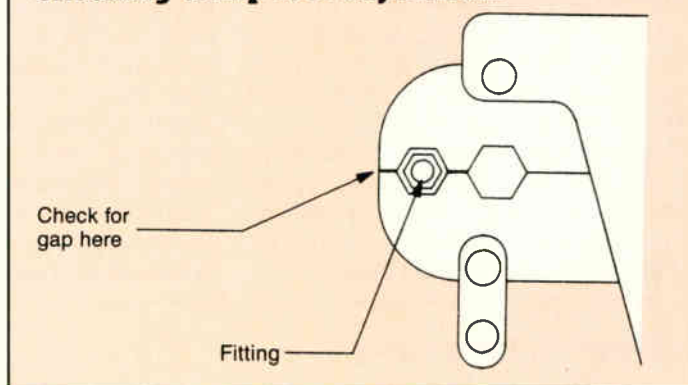

Differences in performance

Before we detail the procedures for checking and adjusting crimp tools let's look at the difference that can be achieved by such measures. We began with a standard crimp tool that had been used for some time without any special care. Using this tool, we prepared several samples of cable/connector assemblies and measured their retention capability. We measured the gap between the crimp tool jaws while crimping the assemblies, then measured the outside diameter (OD) of crimped connector samples. We then repeated this procedure with a correctly adjusted tool. The accompanying table details the results obtained for the small diameter (0.324 inch) hex of our crimp tool. Similar results were achieved on the large hex (0.360 inch) on the same tool at the same time.

The difference in performance is significant. After simple adjustments of the crimp tool the retention capability increased by 20 to 30 pounds, taking the assemblies from marginal/failing performance to superior performance. Which assemblies would you rather have in your systems? When's the last time you checked the settings of your crimp tool?

Checking/adjusting the crimp tool

There are two different levels of crimp tool checks that may be performed. The first one is intended as a quick and easy field check that will give a high degree of confidence in the tool's ability to perform adequately. Begin with the front hex cavity of the two-cavity tools. Insert a connector of the proper dimensions, without any cable, into the proper hex cavity of the crimp tool. Crimp the connector while holding a dollar bill between the flat area at the nose of the tool. When the crimp tool is fully compressed the dollar bill should be held firmly. If not, the crimp tool should be adjusted or rebuilt.

A more precise method of checking the crimp tool adjustment requires a thickness gauge. Again, fully compress the jaws of the tool with an empty fitting in the foremost hex cavity. With the tool's handles secured (by hand, with tape or some other means), use the thickness gauge to measure the gap between the jaws at the nose of the tool. If the gap is greater than 0.004 inches the tool must be adjusted.

To adjust the crimp tool remove the "adjustment cam keeper" and turn the cam one notch at a time. Consult the instruction

(Continued on page 64)

Basic electronics theory

This is Part XV of a series about basic electrical and electronic principles.

By Kenneth T. Deschler

Cable Correspondence Courses

This month we will look at a collection of circuits that change an alternating current (AC) input voltage to a direct current (DC) output voltage.

Power supplies are used to provide all of the voltages necessary for the operation of devices such as CATV amplifiers, TV receivers and the equipment contained in the headend of a cable system.

Parts of a power supply

Figure 1 shows a block diagram of a power supply containing four main sections: the *transformer* that is used to either step up or step down the input voltage, the *rectifiers* that are used to change AC voltages to pulsating DC voltages, the *filter* that is used to smooth out the pulsating voltage from the rectifiers and provide a nearly constant value of DC voltage, and the *regulator* that is used to maintain a constant voltage from the power supply despite changes in the input voltage level or output current demands.

Regulation of a power supply will be discussed in a later installment.

In previous lessons we covered the principles of operation of both the transformer and filter circuits. Rectifiers are devices that allow current to flow in only one direction. Any current wishing to flow in the opposite direction is blocked. In Figure 2, we see a rectifier (D_1) across an AC input. Also shown are the input and output voltage waveforms. A series dropping resistor (R_1) has been added to prevent excess current flow that would cause the rectifier to burn up. As shown in the figure, current flow is against the arrow. Power supplies are classified as being either full or half wave.

Figure 1: Power supply

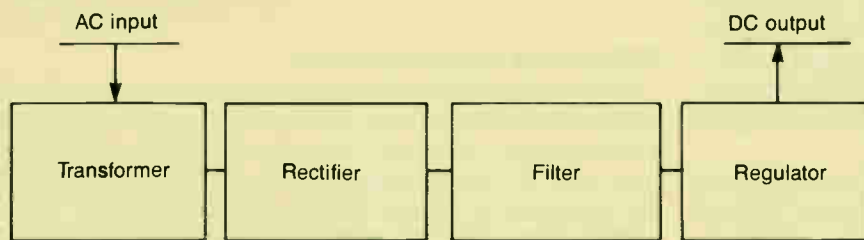

Figure 2: Rectifier across an AC input

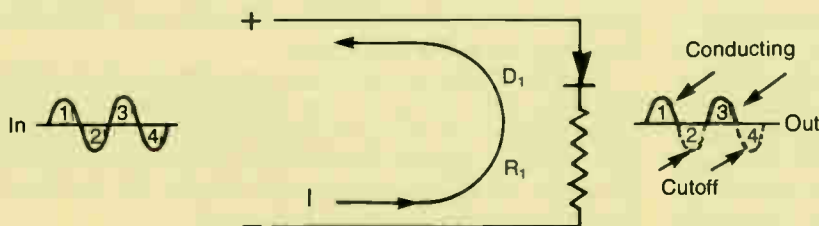

Figure 3: Full wave power supply

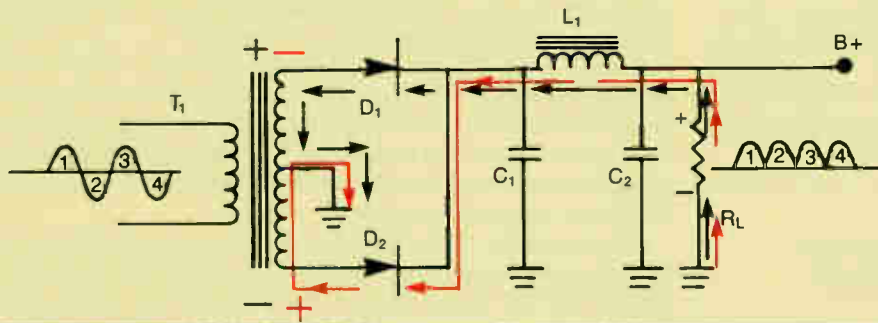
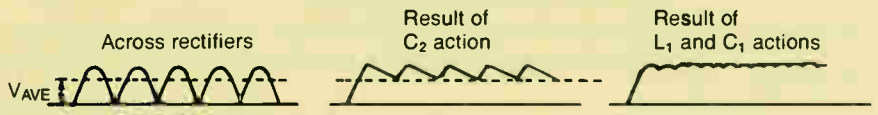

Figure 4: Waveforms across rectifiers



Full wave power supply

Figure 3 is a schematic diagram of a full wave power supply containing a power transformer, two rectifiers and a capacitive input (pi type) filter network. Alternating current enters the primary of transformer (T_1) and is stepped up in the secondary. Assuming that the top of the transformer is positive, current flows from ground, up through the load resistor (R_L) giving it the polarity shown and across the top of C_2 , charging it to a value equal to half the voltage across the secondary. It then flows through the inductor L_1 (filter choke), across the top of C_1 charging it, through the rectifier D_1 and back to ground through the center tap on the secondary of the power transformer.

On the next alternation the bottom of the transformer secondary is positive, causing current to flow up through the load resistor, across the capacitors and through the filter choke, down and through D_2 , and up to the center tap to ground. Sometimes, for the sake of economy, the filter choke is replaced by a resistor. The output waveform shows the pulsating voltage across the rectifiers as current flows alternately through one and then the other. Current never goes negative, therefore the output is a pulsating direct current whose value goes from zero to a maximum value back to zero.

Figure 4 shows the waveforms across the rectifiers, the result of the action of C_2 and the results of the actions of L_1 and C_1 . While current is flowing, the capacitors charge to the maximum value of voltage, then begin to discharge as the voltage value changes. Because of the time constant involved, these discharges tend to fill in the space between pulses, thereby raising the average DC value of the output voltage ($B+$). The small fluctuation

(Continued on page 57)

July 1989

IT INSTRUCTIONAL TECHNIQUES

The special advertorial supplement to Installer/Technician magazine

Tallgater

2

July 1989

IT INSTALLER TECHNICIAN

The training and educational magazine for cable television technical personnel.



Special pull-out poster inside

Are you organized?

(If not, it could cost you time)

By Dick Renard

Marketing Manager, Tailgater Inc.

Are you frustrated going to your next call knowing you will be rummaging around in the back of the truck for the components needed to complete the upcoming installation? Is your time wasted working out of storage boxes or modified milk containers? How much time would be saved by lifting a lid or opening a door and seeing just what's needed in its own compartment? Wouldn't it be easier when restocking your truck to have specific slots for each item?

The solution to these problems is Tailgater's Versatile TruckBed System. Tailgater Inc., located in Salinas, Calif., has been providing lid systems to the cable industry since 1984. Recognized primarily for their organizational capabilities and sizable payload capacity, Tailgater products present outstanding value to the cable

company by outfitting their installers for maximum service efficiency.

Management at your cable company wants you to finish as many jobs as possible in a day and that puts the pressure on you to perform. However, additional pressure is created when a better job could be accomplished if you weren't wasting time looking for improperly stored items.

Tailgater, through the use of lightweight all-aluminum lids, revamps the bed of a pickup truck into a large lockable storage compartment. Accessible from all sides, various options allow you to organize components and tools to fit your work style.

Just under the lids are the rolling parts trays. These trays move longitudinally on casters and carry two Lewis bins. Lewis bins, made of plastic, measure 11 x 16 x 2½, 3½ or 5 inches in depth. Dividers are available allowing compartments down to one-inch square. A closed-cell seal on

the outboard side of the tray prevents its movement while the truck is underway. Removable rolling parts trays easily handle small items, such as connectors, grounding straps, anchors, etc.

Under the rolling parts trays you can install fender trays. Five feet in length, each fender tray will hold three Lewis bins. By mounting the trays to the sides of the pickup bed, a large storage area is opened up in the center of the truck for short ladders, spools of cable, shovels, etc. Mounting two trays together in the center of the bed allows for the storage of a cargo drawer, without affecting the bin capacity of the fender trays.

Tailgater's CargoDrawer, also aluminum, measures five feet long by 21½ inches wide. Rolling on four six-inch wheels, the drawer will hold large components as well as up to 15 Lewis bins. Utilized as a "wheelbarrow," the drawer can be pushed to your MDU job site. Even if your truck cannot be positioned by your work area, you can organize the CargoDrawer so all the components needed are at your fingertips. Completing the option list under the lids is a cable caddie. This mobile cart carries two RG-6 spools or you



Tailgater TruckBed System, outfitted as an installer truck, showing the work deck, upper cabinet, ladder lock and beacon bracket, water jug, rolling parts tray and cable caddie.

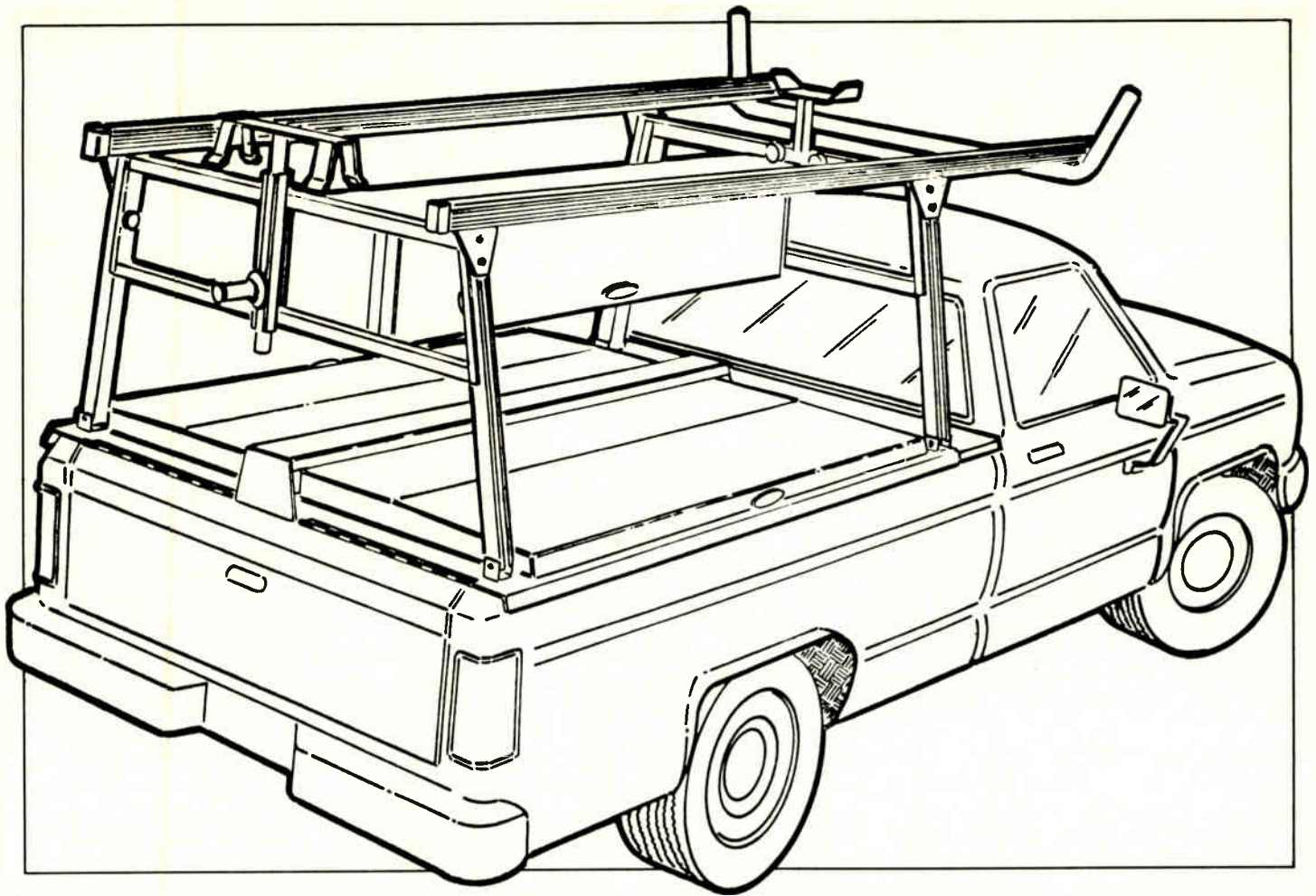

New lid system configuration and all-aluminum rack, which debuted at Cable '89. The Tailgater Basic Lid System now starts as low as \$1,295.

can adapt it to carry up to eight smaller spools.

Above the lid system is the ladder rack, constructed of extruded channel aluminum. This modular system is able to carry two long or two short ladders, and is designed to allow one man to remove a 20-foot ladder without assistance. Tailgater's unique ladder lock will secure the ladders to the rack and, with the addition of a padlock, secure the ladder from the public. An upper cabinet provides additional lockable storage for items like reference books, decoders or more Lewis bins. If needed, two cabinets may be mounted to the rack. To carry sticks, conduit or grounding rods, a four-inch

diameter PVC tube container is available. Its 10-foot length allows you to carry standard lengths, thereby cutting down shop time modifying material to fit into your truck or van. If you have elected to mount the upper cabinet and PVC tube to the rack, your rearward visibility will not be diminished as these options are positioned just at the upper edge of the rear window.

The Tailgater TruckBed System easily transfers from truck to truck. When you go to resell your vehicle, just switch Tailgater to the new truck instead of trying to sell it off as you would other systems like utility or service bodies. Depending on how often you replace trucks, the Tailgater TruckBed System will last three to

four trucks.

Your time is precious, both to you and to your employer. Tailgater provides a system that maximizes efficiency and organization. It is durable and long lasting because its aluminum construction resists rust and corrosion. Perhaps even more important than organizational efficiency is the professional image a truck equipped with a Tailgater TruckBed System presents to the community. When pulling into a neighborhood, customers will take notice that you are in a clean and organized service vehicle. Remember, cable TV and all that surrounds it have to spell service. Tailgater's TruckBed System helps you to demonstrate service in very practical ways.

Versatile Truck Bed Systems

TAILGATER
INCORPORATED



561 Brunken Ave., Suite H
Salinas, Calif. 93901
(408) 424-7710

Looking over your shoulder

By Dana Eggert

President, Performance Plus

Typically, new installers receive most of their job training by riding shotgun with an experienced installer. While this method proves valuable in providing real-time experience, the relatively short training period, usually two to three weeks, necessitates focusing on the many technical aspects of the job and potential variations to the standard drop process. As a result, emphasis on learning to do every job safely tends to get little emphasis during this on-the-job training process. Instead, safety training is often left for the new installer to pick up on his own, or in a more formal training environment.

Safety is an attitude

While the cable company should, indeed, be responsible for ensuring that each installer has a copy of the company safety manual and has the opportunity,

formal or on-the-job, to practice and demonstrate an understanding of those procedures, it is ultimately each installer's responsibility to make safety an ongoing part of day-to-day activities, to take safety along on every job and to make safety an attitude.

A safe attitude means being constantly aware of your surroundings, focusing on the job you are doing and watching carefully for hazards that may potentially affect the job you are performing. A safe attitude means taking the time to do it right the first time. It means climbing down the pole to get the right tool for the job, rather than trying to make do with what you have. It means climbing down the ladder and moving it over, rather than trying to stretch out just a little more. It means using a tool pouch to raise and lower tools to the man on the pole, rather than tossing them up or down. It means assuming the strand is always "hot," rather than boldly grabbing

it without testing it. It means wearing a hard hat every time you climb a pole, rather than rationalizing it as "just a quick trip up and down." It means checking and sharpening your gaffs on a regular basis, rather than thinking "they'll make it through a few more days." And so forth, and so on.

Often, new installers erroneously think that safe practices take more time, and cutting a few corners can save time. In fact, it is just the opposite. By practicing safe procedures throughout the drop process, you work smarter and more efficiently because you are carefully focusing on each step of the job you are doing. Chances are good that an installer whose ladder isn't over far enough will spend a good amount of time trying to reach out to the tap, only to finally climb down the ladder and move it anyway. Why waste the time and take the chance of falling off when you don't have to?

Accidents hurt

Burning a pole hurts! Not to mention the inconvenience to the subscriber for not being able to finish the drop. I don't know about you, but hitting my thumb with a hammer still brings tears to my eyes. I hate it when that happens. But I know why it happens—when I am not paying full attention to what I am doing; when I think, "I've got this stuff down good"—whammo, right on the old thumb. Accidents always hurt someone! Focusing on your job carefully helps protect you and others around you.

The following safety practices are taken from the *Performance Plus Installer Manual*. They are intended as very basic safety information to introduce new installers to the situations encountered every day on the job that require a positive safety awareness.

A major way of preventing accidents, fires and property damage is to keep all company buildings, yards, trucks and vehicles, and each job whether on company premises, public roadways, or private premises in clean, neat and orderly condition. Good housekeeping is the responsibility of each installer and is essential at all times.

All jobs should be performed in a neat

Figure 1: Ladder placement

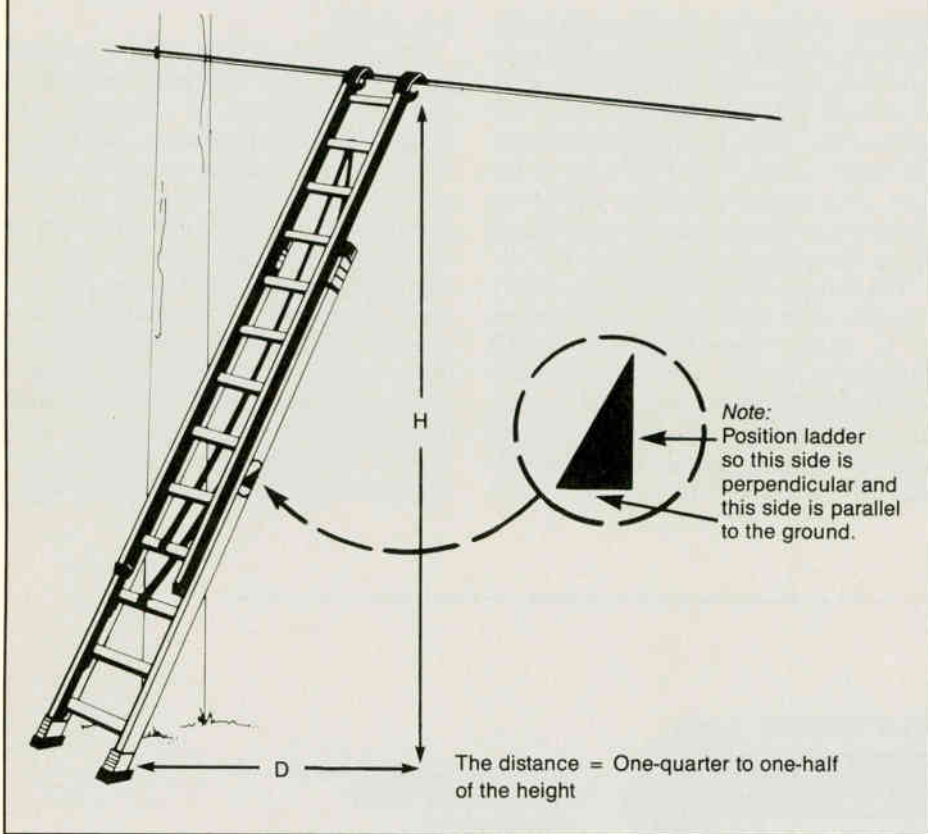

and orderly manner with tools, scraps, parts, equipment and materials neatly placed or stored out of the way of work or traffic. All trucks and vehicles should be kept in orderly condition with tools, parts, materials and equipment properly stored and secured when necessary. Dispose of trash properly.

Climbing

Before climbing poles, ladders, scaffolds or any other elevated structures, always personally assure yourself that the structure or device is strong enough to safely sustain your weight. Observe the soundness and guying of the pole. Particular care must be taken to see that the soil has not been graded away from the base of the pole so as to reduce the normal depth of setting. Check for unsafe surface conditions such as ice, moss, vines, cracks, pressure-treated poles (such as CRC), erosion from multiple holes from climbing hooks, soft or crumbly wood texture, etc. If such conditions exist, a ladder may be the safest means of reaching the desired height.

Prior to mounting the pole or climbing a ladder, always check the climbing space for potential electrical hazards, objects that could cause head injuries or other hazardous situations. Identify all foreign conductors near the working zone. The following should always be treated as energized equipment at the same voltage as the energized line: cases of transformers, boosters, regulators, oil switches, or line reclosers; cross arm braces; ungrounded pole hardware; ungrounded portions of switch rods, handles and mechanisms; all strand and down guys; primary metering equipment; all wires that are down; all wires in proximity of tree-trimming that are not grounded. If it isn't grounded, it isn't dead.

Always address the pole or ladder before climbing. To address the pole, stand at arm's length so that both hands are on either side of the pole or ladder. Look up to determine your climbing path. Then begin your climb.

Stop all work on poles or work involving contact with open wires and strand immediately whenever there are indications of an approaching electrical storm. Do not resume work until the storm has passed.

Pole climbing: If the pole has been determined safe, climb the safest route within the normal climbing space. The two methods of climbing are "free climbing" and "hitchhiking." To free climb, address the pole, then alternate opposite hands and hooks up the pole hand-over-hand style. When you reach the desired loca-

Channelization guidelines			
Urban and residential streets (Posted speeds not to exceed 40 mph)			
Posted speed limit	Taper distance	Cone separation	Number of cones
0 - 25 mph	85 feet	25 feet	4
26 - 35 mph	165 feet	35 feet	5
36 - 40 mph	215 feet	40 feet	6
Freeways, expressways and major roadways			
Posted speed limit	Taper distance	Cone separation	Number of cones
0 - 25 mph	125 feet	25 feet	6
26 - 35 mph	250 feet	35 feet	8
36 - 50 mph	600 feet	50 feet	13
Over 50 mph	660 feet	55 feet	13

tion on the pole, set your hooks, then secure your safety strap around the pole and snapped into the D ring. Then lean back. Hitchhiking is the preferred method of climbing on Class One poles. Consult your supervisor for practical pole climbing instruction before ever attempting to climb a pole. Only one worker should ascend or descend a pole at a time.

Wear body belts and safety straps when working on a pole. Body belts and safety straps should be inspected frequently for cuts and breaks, and should not be used if their condition is doubtful. Always fasten safety straps to solid objects. Place straps around the pole.

After circling the pole with the strap, make sure the snap hook is properly engaged in the D ring, that there is no twist in the strap and the snap hook opening is upward on both ends before leaning back. Never rely on the "click" as an indication that the fastening is secure.

No belt attachments such as plier holsters, pouches or other equipment should obstruct or conflict with the D ring or be attached closer than four inches to the D ring. Do not attach wire or cable to the body belt or its rings. The approved method is to attach the cable to an approved hand line and attach the hand line to the proper belt ring. When climbing, never use pins, braces, conduits, strand or guys as handles.

Climbing equipment should be worn only when climbing is required and must not be worn while driving or riding in a vehicle; setting or handling poles; climbing ladders; working on the ground, floors or roofs; or when inside the customer's home. OSHA (Occupational Safety and Health Administration) rules require climbers be removed beyond three feet of the pole.

Descend the pole in the same manner

as you ascended the pole. Before descending with the free climbing method, set your hooks again, then unhook your safety strap. Release one hook from the pole, straighten your leg and drop down until it hooks back into the pole. Repeat this process the rest of the way down the pole.

Ladder climbing: Only portable wood or fiberglass ladders, straight ladders and extension ladders should be used. Portable metallic ladders should *never* be used.

Remove the ladder from the vehicle by sliding it off the back of the ladder rack or by lifting it sideways off the rack and sliding it down the side of the vehicle, being careful not to scrape the ladder against the vehicle. Replace the ladder in a similar manner. Before climbing any ladder, make sure it is safe, noting any cracks, or missing or worn parts. Do not use boxes, benches, tables or any makeshift substitute for ladders.

Place single or extension ladders at an angle so that the horizontal distance from the top support to the base of the ladder is not less than one-quarter nor more than one-half the length of the ladder (Figure 1). Where this is not possible, call your supervisor. (Note: There is usually a guide decal on the side railing of all recently approved ladders to aid in achieving proper slope.)

Face the ladder when ascending or descending, and use both hands. Raise and lower materials and tools, in addition to what is normally carried in the tool pouch, by hand line. When used on slippery surfaces, additional precautions must be taken to prevent the ladder from slipping.

Keep your hands on the side rails when extending or lowering extension ladders, never the rungs. On a two section ladder, allow a minimum overlap of three feet for

Figure 2: Safety equipment

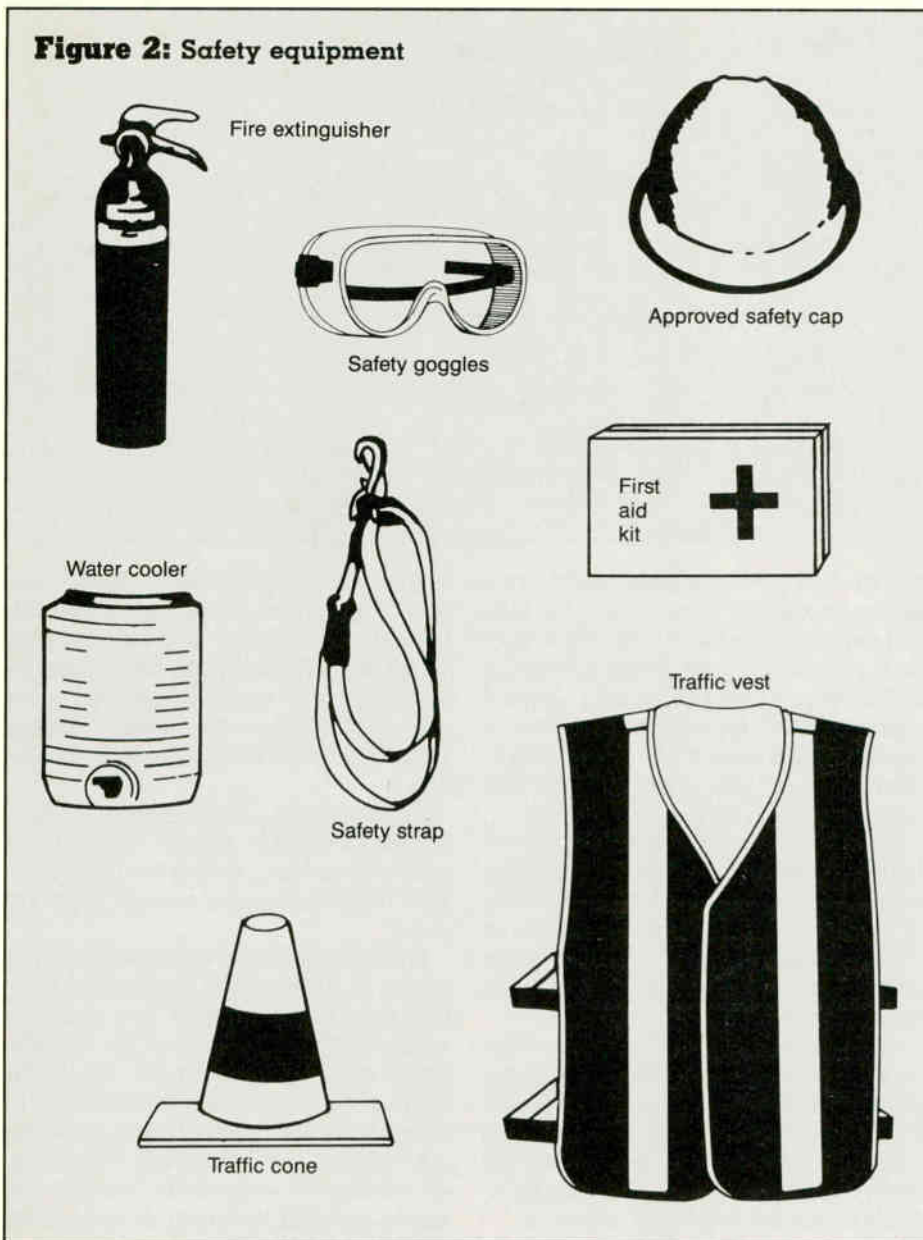

ladders up to 26 feet long, allow a minimum of four feet for ladders from 26 to 48 feet and for ladders 48 to 60 feet, allow a minimum overlap of five feet.

When working from ladders that are more than 20 feet long, secure the ladder at the top or have another employee hold it at the bottom. Only one worker should work on the ladder at a time unless the ladder is designed for two-man operation.

When working from ladders, avoid leaning over or reaching out farther than arm's length unless the ladder is tied or otherwise secured at the top. Do not stand on the top rung of a ladder or on the top two steps of a step ladder.

Ladders placed near doors or in passageways should be protected against being struck by the door or by traffic through the passageway by suitable barriers and warning signs, or by another

worker holding the ladder.

Do not move a ladder while another employee is on it. Always wear a safety strap and belt. Secure to the strand and ladder when working from an extension ladder. Tie or otherwise secure ladders in heavy wind conditions.

Motor vehicle operation

Work vehicles should be driven and parked in a manner that creates a favorable impression on the public, with extra courtesy and consideration for other drivers and pedestrians. The preferred method of parking your vehicle is at the curb in front of the installation site. All parked vehicles should have a cone placed approximately two feet in back of the vehicle on the active traffic side.

Most vehicle accidents occur when backing up the vehicle after it has been

parked for a period of time. Avoid parking on private property such as driveways where backing up will be necessary to leave. If parking on private property is unavoidable, the safest approach is to back onto the property, checking carefully for children, toys, pets, etc. Place a safety cone in front of the vehicle immediately after parking. Upon completion of the installation, the vehicle will be pointed so that direct entry into traffic is possible. When retrieving the safety cone, *check again* for children, toys and pets *before* putting the vehicle in gear.

All doors, end gate enclosures and detachable equipment must be made secure before driving. When driving or riding in a company vehicle equipped with seat belts, the belt must be worn by the driver and front seat passengers at all times during operation.

Safety equipment

The following OSHA-defined safety equipment is recommended to be carried on the installer's vehicle:

- 1) Two traffic cones
- 2) Fire extinguisher (ABC type, 2½ pounds recommended)
- 3) A first aid kit
- 4) Safety cap, gauntlet gloves, eye protection, body belt and safety strap, lanyard, rubber gloves
- 5) Flags and reflectors

If the installation process interferes in any way with the natural flow of traffic, warning signs and/or channelizing devices must be used. Check with local and state codes for traffic control procedures.

Each service vehicle required to set up at a pole or manhole location that will affect the normal flow of traffic must carry approved warning signs. OSHA requires a "men working" sign to be used in conjunction with minor maintenance for protection of the workers in or near the roadway. An "advance flagger" sign is required in advance of any point at which a flagger has been stationed to control traffic through a construction or maintenance project that has obstructed the normal traffic flow. A high level warning device, or "high boy" may be required in some states on roads with speed limits of 45 mph or greater.

The function of safety cones is to warn and alert drivers of hazards created by construction or maintenance activities in or near the travelled way, and to guide and direct drivers safely past the hazards. Channelization is the setting up of safety cones into a taper. The minimum desirable taper distance, cone separation, and number of cones are shown in the accompanying table. ■

Installer's Tech Book

Converting dBmV to $\mu\text{V/m}$

By Ron Hranac
Senior Staff Engineer, Jones Intercable Inc.

Channel 14 or A (121.2625 MHz)

dBmV	$\mu\text{V/m}$	dBmV	$\mu\text{V/m}$	dBmV	$\mu\text{V/m}$	dBmV	$\mu\text{V/m}$
-60	2.55	-35	45.28	-10	805.28	16	16067.41
-59	2.86	-34.14	50	-9	903.54	17	18027.93
-58	3.21	-34	50.81	-8	1013.78	18	20227.67
-57	3.60	-33	57.01	-7	1137.49	19	22695.82
-56	4.04	-32	63.97	-6	1276.28	20	25465.13
-55	4.53	-31	71.77	-5	1432.01	21	28572.34
-54	5.08	-30	80.53	-4	1606.74	22	32058.69
-53	5.70	-29	90.35	-3	1802.79	23	35970.45
-52	6.40	-28	101.38	-2	2022.77	24	40359.50
-51	7.18	-27	113.75	-1	2269.58	25	45284.11
-50	8.05	-26	127.63	0	2546.51	26	50809.60
-49	9.04	-25	143.20	1	2857.23	27	57009.31
-48	10.14	-24	160.67	2	3205.87	28	63965.50
-47	11.37	-23	180.28	3	3597.04	29	71770.47
-46	12.76	-22	202.28	4	4035.95	30	80527.80
-45	14.32	-21	226.96	5	4528.41	31	90353.67
-44	16.07	-20	254.65	6	5080.96	32	101378.49
-43	18.03	-19	285.72	7	5700.93	33	113748.54
-42.10	20	-18	320.59	8	6396.55	34	127627.96
-42	20.23	-17	359.70	9	7177.05	35	143200.92
-41	22.70	-16	403.60	10	8052.78	36	160674.08
-40	25.47	-15	452.84	11	9035.37	37	180279.28
-39	28.57	-14	508.10	12	10137.85	38	202276.68
-38	32.06	-13	570.09	13	11374.85	39	226958.17
-37	35.97	-12	639.66	14	12762.80	40	254651.25
-36	40.36	-11	717.70	15	14320.09		

Channel 15 or B (127.2625 MHz)

dBmV	$\mu\text{V/m}$	dBmV	$\mu\text{V/m}$	dBmV	$\mu\text{V/m}$	dBmV	$\mu\text{V/m}$
-60	2.67	-35	47.52	-10	845.12	16	16862.41
-59	3.00	-34.56	50	-9	948.24	17	18919.94
-58	3.36	-34	53.32	-8	1063.95	18	21228.52
-57	3.78	-33	59.83	-7	1193.77	19	23818.79
-56	4.24	-32	67.13	-6	1339.43	20	26725.13
-55	4.75	-31	75.32	-5	1502.86	21	29986.08
-54	5.33	-30	84.51	-4	1686.24	22	33644.94
-53	5.98	-29	94.82	-3	1891.99	23	37750.24
-52	6.71	-28	106.39	-2	2122.85	24	42356.47
-51	7.53	-27	119.38	-1	2381.88	25	47524.74
-50	8.45	-26	133.94	0	2672.51	26	53323.63
-49	9.48	-25	150.29	1	2998.61	27	59830.10
-48	10.64	-24	168.62	2	3364.49	28	67130.48
-47	11.94	-23	189.20	3	3775.02	29	75321.64
-46	13.39	-22	212.29	4	4235.65	30	84512.27
-45	15.03	-21	238.19	5	4752.47	31	94824.32
-44	16.86	-20	267.25	6	5332.36	32	106394.64
-43	18.92	-19	299.86	7	5983.01	33	119376.75
-42.52	20	-18	336.45	8	6713.05	34	133942.91
-42	21.23	-17	377.50	9	7532.16	35	150286.42
-41	23.82	-16	423.56	10	8451.23	36	168624.14
-40	26.73	-15	475.25	11	9482.43	37	189199.40
-39	29.99	-14	533.24	12	10639.46	38	212285.21
-38	33.64	-13	598.30	13	11937.67	39	238187.93
-37	37.75	-12	671.30	14	13394.29	40	267251.25
-36	42.36	-11	753.22	15	15028.64		

Channel 16 or C (133.2625 MHz)

dBmV	$\mu\text{V/m}$	dBmV	$\mu\text{V/m}$	dBmV	$\mu\text{V/m}$	dBmV	$\mu\text{V/m}$
-60	2.80	-35	49.77	-10	884.97	16	17657.42
-59	3.14	-34.96	50	-9	992.95	17	19811.95
-58	3.52	-34	55.84	-8	1114.11	18	22229.37
-57	3.95	-33	62.65	-7	1250.05	19	24941.77
-56	4.44	-32	70.30	-6	1402.58	20	27985.13
-55	4.98	-31	78.87	-5	1573.72	21	31399.83
-54	5.58	-30	88.50	-4	1765.74	22	35231.19
-53	6.27	-29	99.29	-3	1981.20	23	39530.04
-52	7.03	-28	111.41	-2	2222.94	24	44353.43
-51	7.89	-27	125.00	-1	2494.18	25	49765.37
-50	8.85	-26	140.26	0	2798.51	26	55837.67
-49	9.93	-25	157.37	1	3139.98	27	62650.89
-48	11.14	-24	176.57	2	3523.12	28	70295.46
-47	12.50	-23	198.12	3	3953.00	29	78872.80
-46	14.03	-22	222.29	4	4435.34	30	88496.74
-45	15.74	-21	249.42	5	4976.54	31	99294.97
-44	17.66	-20	279.85	6	5583.77	32	111410.79
-43	19.81	-19	314.00	7	6265.09	33	125004.96
-42.92	20	-18	352.31	8	7029.55	34	140257.87
-42	22.23	-17	395.30	9	7887.28	35	157371.92
-41	24.94	-16	443.53	10	8849.67	36	176574.20
-40	27.99	-15	497.65	11	9929.50	37	198119.51
-39	31.40	-14	558.38	12	11141.08	38	222293.75
-38	35.23	-13	626.51	13	12500.50	39	249417.69
-37	39.53	-12	702.95	14	14025.79	40	279851.25
-36	44.35	-11	788.73	15	15737.19		

Channel 17 or D (139.25 MHz)

dBmV	$\mu\text{V/m}$	dBmV	$\mu\text{V/m}$	dBmV	$\mu\text{V/m}$	dBmV	$\mu\text{V/m}$
-60	2.92	-35.34	50	-10	924.73	16	18450.77
-59	3.28	-35	52.00	-9	1037.56	17	20702.10
-58	3.68	-34	58.35	-8	1164.16	18	23228.14
-57	4.13	-33	65.47	-7	1306.21	19	26062.41
-56	4.63	-32	73.45	-6	1465.60	20	29242.50
-55	5.20	-31	82.42	-5	1644.43	21	32810.62
-54	5.83	-30	92.47	-4	1845.08	22	36814.13
-53	6.55	-29	103.76	-3	2070.21	23	41306.13
-52	7.35	-28	116.42	-2	2322.81	24	46346.24
-51	8.24	-27	130.62	-1	2606.24	25	52001.34
-50	9.25	-26	146.56	0	2924.25	26	58346.46
-49	10.38	-25	164.44	1	3281.06	27	65465.80
-48	11.64	-24	184.51	2	3681.41	28	73453.84
-47	13.06	-23	207.02	3	4130.61	29	82416.56
-46	14.66	-22	232.28	4	4634.62	30	92472.90
-45	16.44	-21	260.62	5	5200.13	31	103756.31
-44	18.45	-20	292.43	6	5834.65	32	116416.49
-43.30	20	-19	328.11	7	6546.58	33	130621.45
-43	20.70	-18	368.14	8	7345.38	34	146559.68
-42	23.23	-17	413.06	9	8241.66	35	164442.66
-41	26.06	-16	463.46	10	9247.29	36	184507.70
-40	29.24	-15	520.01	11	10375.63	37	207021.05
-39	32.81	-14	583.46	12	11641.65	38	232281.43
-38	36.81	-13	654.66	13	13062.14	39	260624.06
-37	41.31	-12	734.54	14	14655.97	40	292425.00
-36	46.35	-11	824.17	15	16444.27		



Cable Exchange

Technically certified equipment
Largest database of equipment available

The following is a partial listing available
for immediate shipment to qualified buyers.

Call: 1-(800)-422-2567 to place your order.

In Colorado, call 1-(303)-694-6789

Mention this ad
for special pricing!

BENCO
BPF-B, BAND PASS FILTER, CH 8
BLONDER-TONGUE
BPF, CH SINGLE
ESM-TVRO, MODULATOR
MCA-B, CH PROCESSOR AGC
MCA-BTVB, CH PROCESSOR AGC
MCX-V, XTAL CONTROL CONV
BRAIN
MD-43, DECODER DTMF 5FUN
CASCADE
CEPS-3, POWER SUPPLY
CCOR
CSA-300-3, EQUALIZER T4XX
DISP-3, DISTRIBUTION SPLITTER 3-3
EQA-1A, EQUALIZER T4XX
EQA-220-2, EQUALIZER T4XX
EQA-220-4, EQUALIZER T4XX
EQA-220-6, EQUALIZER T4XX
EQS-186-4, EQUALIZER LAN
T-421-002, TRUNK AMP
CENTURY 3
3122H, AMP MODULE
COMPUVID
CDD-5, WEATHER COMPUTER
CDD-51, COMPUTER INTERFACE
CKB-1, KEYBOARD
PS-209-1, BAROMETER
EAGLE
NE-E, TRAP
NE-F, TRAP
JERROLD
AO-36, SURGE SUPPRESSOR, 30V
AO-6, SURGE SUPPRESSOR, 60V
C2-CAR-AGC, COM II
C2-CHASSIS, COM II
C2-CH/IF-07, COM II
C2-CH/IF-11, COM II
C2-IFA-2, COM II
C2-IF/CH-04, COM II
C2-IF/CH-10, COM II
C2-PSC-2, COM II
CFM-5, COM FM CHASSIS
CFM-5FM, COM FM FM MOD
CFM-5PS, COM FM POWER SUPPLY
COM-MC-13, COMM II SIGNAL PROCESSOR
FFT4-17, FEED FORWARD TAP
FFT4-20, FEED FORWARD TAP
FFT4-23, FEED FORWARD TAP
FFT4-26, FEED FORWARD TAP
FFT4-29, FEED FORWARD TAP
FM-1, FEEDER MAKER
FM-2, FEEDER MAKER
FM-3, FEEDER MAKER
FM-4, FEEDER MAKER
JRX3102, CONVERTER
JSM2, CONVERTER
JSM2DIC, CONVERTER
JSM3, CONVERTER
JSM3DIC, CONVERTER
LFP1S, PASSIVE FILTER
RCG-115N, RETURN CARRIER GENERATOR
SEP-225H, EQUALIZER-ADJ.
SEP-250H, EQUALIZER-ADJ.
SEP-255H, EQUALIZER-ADJ.
SEP-260H, EQUALIZER-ADJ.
SEP-260J, EQUALIZER-ADJ.
SEP-260L, EQUALIZER-ADJ.
SEP-274H, EQUALIZER-ADJ.
SEP-274L, EQUALIZER-ADJ.
SEP-274ST, EQUALIZER-ADJ.
SEP-274TL, EQUALIZER-ADJ.
TRA-108A, RETURN AMP
MACOM
DCW-06DB, MINITAP
DCW-09DB, MINITAP
DCW-12DB, MINITAP
DCW-16DB, MINITAP
DCW-20DB, MINITAP
DCW-24DB, MINITAP
DCW-30DB, MINITAP
DSV-3, SPLITTER, 3-WAY, 5.5DB
MAGNAVOX
3800-30, SPLITTER
MISC
4-WAY, 4-WAY SPLITTER
40-00532, MAST CLAMP
OAK
MARK-III, SCRAMBLER
PECA
1SD1212
PHASECOM
2105-10, MODULATOR, TV, 10 IN, IF OUT
2105-13, MODULATOR, TV, 13 IN, IF OUT
2106-10, MODULATOR, TV SAW, CH 10
2106-IF, MODULATOR, TV, IF/OUT
2175-E, MODULATOR, COHERENT, CH E
2176-10, MODULATOR, COHERENT, CH E
2206-E, MODULATOR, TV, CH E
7060, CHASSIS FOR DRAWER
7060-00, CHASSIS FOR DRAWER
7060-03, CHASSIS FOR DRAWER
7060-RACK, RACK FOR 7060 CHASSIS
7120-02, MODULATOR, PHASE LOCKED, CH 2
7161-05, MODULATOR, HRC CH 5
7161-06, MODULATOR, HRC CH 6
7161-09, MODULATOR, HRC CH 9
7161-10, MODULATOR, HRC CH 10
7161-11, MODULATOR, HRC CH 11
7161-12, MODULATOR, HRC CH 12
7161-168, MODULATOR, HRC CH 168
7161-F, MODULATOR, HRC CH F
7161-G, MODULATOR, HRC CH 10
7161-PCG072, PILOT CARRIER, HRC, CH 72
7161-PCG120, PILOT CARRIER, HRC, CH 120
7161-PCG168, PILOT CARRIER, HRC, CH 168
7170-03, MODULATOR COHERENT, CH 3
7170-04, MODULATOR, COHERENT, CH 4

Cable Exchange

PHASECOM

7170-05, MODULATOR, COHERENT, CH 5
7170-06, MODULATOR, COHERENT, CH 6
7170-07, MODULATOR, COHERENT, CH 7
7170-08, MODULATOR, COHERENT, CH 8
7170-09, MODULATOR, COHERENT, CH 9
7170-10, MODULATOR, COHERENT, CH 10
7170-11, MODULATOR, COHERENT, CH 11
7170-12, MODULATOR, COHERENT, CH 12
7170-13, MODULATOR, COHERENT, CH 13
7260-06, DEMODULATOR, TV, CH 6
7360-02, PROCESSOR, HETRODYNE, CH 2
7360-03, PROCESSOR, HETRODYNE, CH 3
7360-04, PROCESSOR, HETRODYNE, CH 4
7360-05, PROCESSOR, HETRODYNE, CH 5
7360-06, PROCESSOR, HETRODYNE, CH 6
7360-07, PROCESSOR, HETRODYNE, CH 7
7360-08, PROCESSOR, HETRODYNE, CH 8
7360-10, PROCESSOR, HETRODYNE, CH 10
7360-11, PROCESSOR, HETRODYNE, CH 11
7360-12, PROCESSOR, HETRODYNE, CH 12
7360-13, PROCESSOR, HETRODYNE, CH 13
7360-F, PROCESSOR, HETRODYNE, CH F
7500-02, INPUT CONVERTER, CH 2
7760-02, INPUT CONVERTER, CH 2
7760-03, INPUT CONVERTER, CH 3
7760-04, INPUT CONVERTER, CH 4
7760-06, INPUT CONVERTER, CH 6
7760-07, INPUT CONVERTER, CH 7
7760-08, INPUT CONVERTER, CH 8
7760-10, INPUT CONVERTER, CH 10
7760-11, INPUT CONVERTER, CH 11
7760-13, INPUT CONVERTER, CH 13
7780-11, INPUT CONVERTER, CH 11
7780-12, INPUT CONVERTER, CH 12
7780-22, INPUT CONVERTER, CH 22
7780-24, INPUT CONVERTER, CH 24
7780-29, INPUT CONVERTER, CH 29
7780-35, INPUT CONVERTER, CH 35

PICO

XUV-H, XTAL CONTROL CONV

PIONEER

BC2001, CONVERTER
BC3300, CONVERTER

RAYCHEM

TF-500-C, THERMOCRIMP CONNECTOR
TP-500-C, THERMOCRIMP CONNECTOR
TP-750-C, THERMOCRIMP CONNECTOR
TP-875-C, THERMOCRIMP CONNECTOR
TS-500-C, THERMOCRIMP CONNECTOR
TS-750-C, THERMOCRIMP CONNECTOR
TX-750-C, THERMOCRIMP CONNECTOR

SCIENTIFIC ATLANTA

C230250, SPECTRUM INVERTER FOR 6350

STANDARD COMPONENTS

CS PLUS-2, CONVERTER

STURGEON BAY

CC-1005, ROKA CLIP
CC-1010, ROKA CLIP
CC-1020, ROKA CLIP

TEXSCAN

EQ-08/250, EQUALIZER, 250MHZ/8DB
EQ-08/300, EQUALIZER, 300MHZ/8DB
EQ-12/300, EQUALIZER, 300MHZ/12DB
KCMG, MANUAL GAIN BRIDGER
PCAB-1, TRUNK BRIDGER AGC
PCAD-1D, TRUNK BRIDGER AGC
PCAD-1H, HOUSING FOR PCAD-1D
PCMD-2, TRUNK BRIDGER
PCMB-2H, HOUSING FOR PCMB-2

PCM-4, TRUNK AMP

PCM-4H, HOUSING FOR PCM-4
PCRA, RETURN AMP
PCSPL-1, SPLITTER
PCSPL-2, SPLITTER
PCSPL-3, SPLITTER
PCSPL-4, SPLITTER
PCTB-6, TRUNK TERMINATING BRIDGER
PD-0, PAD
PD-3, PAD
PD-6, PAD
PD-9, PAD
PH, HOUSING — P SERIES
PPLUG, POWER PLUG
T3LE, LINE EXTENDER
T4BDC-8, PAD
T4BDL-12, PAD
T4CM, CONTINUITY MODULE
T4SPL, PAD
TFAV, TRUNK AMP AGC
TFM, TRUNK AMP MGC
TFPS, POWER SUPPLY
TH, HOUSING FOR T SERIES
VEQ-12/250, EQUALIZER
VEQ-12/300, EQUALIZER
VEQ-8/300, EQUALIZER
XH, HOUSING FOR X SERIES
XR2A, FORWARD MOD AGC
XR2B, BRIDGER MOD INTERMEDIATE
XR2B-2, BRIDGER 2 OUTPUT
XR2B-4, BRIDGER 4 OUTPUT
XR2DA, DIST AMP HYBRID AGC
XR2DM, DIST AMP HYBRID MGC
XR2F-1, INPUT MOD
XR2F-13, INPUT MOD
XR2F-14, OUTPUT MOD
XR2F-19, OUTPUT MOD
XR2F-3/110, INPUT MOD
XR2F-4, INPUT MOD
XR2F-5, OUTPUT MOD
XR2F-7/110, OUTPUT MOD
XRF-8, OUTPUT MOD
XR2HA, LINE AMP HYBRID HRC
XR2HM, LINE AMP HYBRID HRC
XR2LAF-1, POWER INPUT MOD
XR2LAF-2, POWER INPUT MOD
XR2LAF-3, POWER OUTPUT MOD
XR2LAF-4, POWER OUTPUT MOD
XR2LARA, REVERSE AMP MOD
XR2LA-PS, POWER SUPPLY
XR2LS-3, LINE EXT
XR2M, FORWARD MGC MOD
XR2PS, POWER SUPPLY
XR2RHA110, REVERSE AGC MOD
XR2SPH, HOUSING FOR XR2PS
XR2-13, TAP, 4 WAY
XRBI, INTERMEDIATE BRIDGER
XRCE-3, LINE EXT
XRCE-6, LINE EXT
XRDC-16, LINE EXT
XRDC-8, LINE EXT
XRLA, LINE AMP
XRLS-2, LINE EXT
XRLS-3, LINE EXT
XRPG-3, PILOT CARRIER GENERATOR
XRPR, POWER SUPPLY
XRRP, LINE EXT
XRSP, LINE EXT
TIMES FIBER
T6875, CABLE, .875 BARE/NEW/2600' PER REEL

Call: 1-(800)-422-2567 to place your order.

In Colorado, call 1-(303)-694-6789

Classifieds / Directory

Help Wanted

TECHNICIANS

- Service
- Leakage
- Preventive Maintenance

Cable TV Montgomery is seeking experienced CATV Technicians. Good driving record required. Excellent salary & benefits package offered. If qualified, please call or send resume to:

CABLE TV MONTGOMERY

Human Resources Department
250 Hungerford Dr., Rockville, MD 20850
(301) 294-7667

E.O.E.

Palmer CableVision

Construction Technicians Maintenance Technicians

Fast growing Palm Springs area Cable Company has full time openings. Challenging position, advancements, and good benefits. Must have a valid drivers license and good driving record.

Send resume to or call:

**Palmer CableVision
Personnel
41-725 Cook Street
Palm Desert, CA 92260
(619) 340-1312**

Leader in the placement of Cable Television Professionals
Call Toll Free 800-433-2160; In Texas, call 817-599-7623; FAX 817-599-4483

TECH MANAGEMENT

CH TCH, N, 30K
CH TCH, MW, 30K
CONST MGR, NE, 40K
CH TCH, SE, 26K
CH TCH, SE, 30K
HDEND ENG, SE, 35K
STF ENG, SE, 32K
STF ENG, NE, 40K
CH TCH, W, 32K
TCH MGR, MW, 30K

TECHNICIANS

LN TCH, N, 10/HR
LD TCH, MW, 23K
SW TCH, E, 13/HR
SER TCH, S, 9/HR
LEAK TCH, NE, 12/HR
LN TCH, W, 12/HR
HDEND TCH, SE, 23K
Designer, SE, 25K
LN TCH, N, 11/HR
LN TCH, SW, 10/HR

TECHNICIANS

SER TCH, E, 11/HR
LN TCH, MW, 9/HR
LN TCH, E, 12/HR
LN TCH, MW, 9/HR
LD TCH, SE, 10/HR
LEAK TCH, E, 11/HR
LN TCH, S, 10/HR
SW TCH, NE, 13/HR
MICRO, NE, 32K
VIDEO TCH, E, 30K



JIM YOUNG & ASSOCIATES

One Young Plaza 1235 Ranger Highway Weatherford, TX 76087

Call for information about these and many other opportunities nationwide.

SERVICE TECHNICIANS

Do you have:

- A valid CT driver's license?
- An electronics background?
(preferred, but not necessary)
- The ability to deal well with people?

If you answered yes to the above, then Cablevision, the leader in the Cable TV industry, may have an immediate opening for you as a Service Technician.

We offer competitive salaries, excellent benefits & realistic advancement opportunities. Call Carol - (203) 846-4700, x213.

CABLEVISION

28 Cross St., Norwalk, CT
Equal Oppty. Employer M/F

**To Place A Classified Ad
Call Barbara Bellomo
at 1-303-792-0023**

Experienced Professional Installation and Supervisory Personnel needed for full service contractor.

New York Office 518-783-5425
Florida Office 813-334-8776

Summit Cable Contractors, Inc.
a national contractor needs experienced linemen, splicers and technicians in addition to fully equipped residential and MDU subcontractors.

817-277-6995
EOE

NEEDED

Experienced aerial & underground forepersons, line persons, supervisors and subcontractors.

PERRY COMMUNICATIONS, INC.
215-941-6808
216-964-2829

Service Technicians

Friendship Cable, a subsidiary of Buford Television, Inc. has openings for Service Technicians in Texas, Arkansas, Georgia and North and South Carolina. Applicants must have at least 2 years cable television experience, a valid driver's license, and a good driving record. Employees will be required to live within the system, therefore, relocation may be necessary.

We offer a competitive salary and a generous benefits package. Please send resume or call for an application to:

Buford Television, Inc.
P.O. Box 9090
Tyler, Texas 75711
214-561-4411
EOE/M/F

Now Hiring Underground Contractors

Work available immediately!
Need equipment to cut streets.
Short-term work and top dollar paid.

TCS CABLE
Steve Vespa
(301) 646-0025

Equipment For Sale

MCI

Midwest Cable Inc.

Constantly Buying and Selling
New and Used Converters,
Line Gear, Test Equipment,
Head End Equipment

Converter Rebuild

(402)592-0322

Tim or Ron

To Place A Classified Ad
Call Barbara Bellomo
at 1-303-792-0023

Anthony's ANTHONY'S
MANUFACTURING SERVICE

PLOW BLADES
Irrigation/Wire/Combination
For Any Machine—For Any Application

(800) 383-PLOW P.O. Box 17701
Colorado Springs, CO 80935



FOR SALE

200 used RCA 36 channel converters.
Model # M 153.
Good condition.
Guaranteed to work.

817-731-3077
Ask for Kent

AERIAL BUCKET TRUCKS

Large selection geared for CATV
**STANDARD TRUCK &
EQUIPMENT CO.**
1155 Hill St. S.E.
Atlanta, GA 30315
Phone: 1-800-241-9357



Equipment Repair

"The Cable Equipment Repair People"

- Line Amplifiers Repaired
All Makes And Models
- Signal Level Meters Repaired and Calibrated
- Flat Rate Labor Plus Parts

For reliable, guaranteed repair, please
send your cable equipment to ACS.

ADVANCED CABLE SERVICES
2045 S. Valentia St., Suite 4

Denver, CO 80231
FAX: (303) 337-3084
Call (303) 337-4811

ACS

We Market Used Equipment

Equipment Wanted

WANTED
SURPLUS EQUIPMENT
Oak N-12, Jerrold DRX-3DIC &
DRX-3105.

WE ALSO BUY & SELL
ALL TYPES OF CATV EQUIPMENT.
CALL

CABLE LINE
415-337-8301

AMCI

**TELECOMMUNICATIONS
CORP.**

- Door to door sales
- Audits
- Drop Rebuilds
- Trapping
- Drop Installation
- Pre/Post Wire

2 N. Sandusky Street • PO. Box 690 • Delaware, Ohio 43015
(614) 363-3645 • (800) 937-AMCI • FAX (614) 363-1451

"Cable Television - Second Edition"

By Bill Grant

A complete text on basic CATV technology
for self-study or reference including

Hard cover - 400 pages - 140 illustrations
Complete index - 10 page Glossary of Terms

\$32 per copy includes mailing inside USA
(add \$5 for shipment outside USA)

Send check or money order to:

GWG Associates, PO Box 473
Richmondville, N.Y. 12149
Phone (518) 868-2246

FIBER
CONNECTION

**The Fiber School
And Construction Company, Inc.**

Call: 1-800-937-3423 1-800-YES FIBER

The Fiber Connection, Inc.
PO Box 245
Stafford Springs, CT 06076

CHARLES O' REILLY
C.E.O.

Home Phone: (203) 871 6750

CABLE CONSTRUCTORS, INC.

IRON MOUNTAIN, MICHIGAN
COAX - FIBER

QUALITY SERVICE PERFORMED ON A TIMELY BASIS
- SINCE 1957 -

MAPPING - DESIGN - CONSTRUCTION - ENGINEERING
CABLE CONSTRUCTORS, INC.

1-800-338-9292

KLUNGNESS ELECTRONIC SUPPLY (KES)

1-800-338-9299

ESCOE GREEN ENGINEERS

Specializing in design of analog, audio video, and data transmission on coaxial or fiber networks.

- AutoCad
- Intergraph
- Magic
- Linex
- Design
- Strand Mapping
- Construction
- Drafting Services

Daryl Rosenberger

5569-3 Bowden Rd., Jacksonville, FL
(904) 636-0244 • FAX (904) 636-0277

EMPLOYMENT OPPORTUNITIES AVAILABLE

D & D CABLE CONTRACTORS



Aerial/Underground Installs
Prewire - Postwire
Drop Replacements
Auditing Services
Underground Construction

Dwayne Witt
414-738-9041

4 Seneca Court
Appleton, WI 54911



CONTRACT INSTALLERS, INC.

UHF Radio Equipped Trucks • Uniformed Installers

HOUSE INSTALLATIONS

Aerial Underground Prewire

APARTMENT INSTALLATIONS

Post wire Prewire Commercial Building

Tap Audits

*Install or Remove Traps and/or Converters
Drop change over for System Rebuilds*

LENNY FISCHER
(414) 582-7087

P.O. Box 1564
Appleton, Wisconsin 54913-1564

TSB, Inc.



- DESIGN, STRAND MAP, AS-BUILTS
- CAD DRAFTING SERVICE
- HEADEND RACKING AND RENOVATIONS
- CLI
- TAP AUDITS
- ONSIGHT TECHNICAL TRAINING
- STRUCTURAL ANALYSIS OF TOWERS

P.O. Box 244
(605) 665-1393

Yankton, SD
57078

White Sands

Jumper Cables

Custom connectors and cables for all aspects of CATV

Gilbert AHS

PPC

LRC and others

All types of cable from

Belden

Comm Scope

Times

Quick delivery on all colors and lengths.

Write or call: (602) 581-0331

P.O. Box 43437, Phoenix, AZ 85080-3437

CATV DESIGN

ASSOCIATES, INC.

- Design
- Strand Mapping
- As-Built Mapping
- System Analysis
- AutoCad Drafting
- LinexCad Drafting
- Cad Training/Setup
- Drafting Services

3100 S. LAMAR, SUITE 101, AUSTIN, TX 78704

STEVE WILLIAMS (512) 444-2461 President
DOUG BURNS Vice President

Quality Reconditioned Test and Measurement Instruments

Signal Level Meters

Spectrum Analyzers

Network Analyzers

Sweep Generators

Microwave/Waveguide Components

hp Tektronix Riser Bond Texscan Wavetek

Calibration and Repair Service

EMS Instruments

800-234-7434



PUBLICATIONS CORP.

Barbara Allen Bellomo

Classified Ad Manager

COMMUNICATIONS TECHNOLOGY • CABLE STRATEGIES
INSTALLER/TECHNICIAN

12200 E. Briarwood Ave. • Suite 250 • Englewood, Colo. 80112 • (303) 792-0023

Mailing Address: P.O. Box 3208 • Englewood, Colo. 80155

TELEFAX (303) 792-3320

Products

System analyzer

Wavetek RF Products introduced the Model 1882A Sweepless Sweep system analyzer for measurement of critical system parameters of signal level, carrier-to-noise, cross-modulation and second/third-order composite distortion. The 1882A's leakage detection function provides a means of patrolling for leaks between amplifier test stations. In addition, it provides a non-interfering, normalized system frequency response test capability.

For further details, contact Wavetek RF Products, 5808 Churchman Bypass, Indianapolis, Ind. 46203-6109, (317) 788-5965; or circle #120 on the reader service card.

Leakage detector

Texscan Instruments recently announced the availability of its Searcher Plus+ hand-held leakage detector. The product is designed to speed identification and repair of signal leaks in any broadband

transmission system. An audio alarm increases in pitch as the received signal gets stronger. It is calibrated in microvolts per meter and can be set to hold peak readings for five seconds.

The detector's mounting bracket connects the external whip antenna and DC power from the truck; when unplugged from the bracket, it switches to an internal battery. According to the company, there is no need to add special frequencies since the detector is tuned to a mid-band channel carrier. A fixed tuned dipole antenna is available as an option to perform quantitative CLI measurements.

For more details, contact Texscan Instruments, 3169 N. Shadeland Ave., Indianapolis, Ind. 46226, (317) 545-4196; or circle #132 on the reader service card.



For further information, contact Metrotech Corp., 670 National Ave., Mountain View, Calif. 94043, (415) 940-4900; or circle #126 on the reader service card.



Fault locator

Now available from Clic Instruments Ltd., the CCR-2 high-resolution cable fault locator is designed to simplify the location and identification of line impairments on communications cable with typically 5-inch resolution. The CCR-2 utilizes microcomputer technology to implement time domain reflectometry (TDR) methodology. According to Clic, the on-line help menus make the CCR-2 usable by field personnel with no advanced technical knowledge. Packaged in a 6 x 9 x 10-inch aluminum case, the portable unit comes with a rechargeable internal gel-cell power pack and an AC adaptor charging unit.

For additional information, contact Clic Instruments Ltd., 6230A Lancaster Rd., Ottawa, Ontario, Canada K1B 5L8, (613) 731-9030; or circle #122 on the reader service card.

Lubricants

A line of anti-seize lubricating compounds that prevent seizure, galling and rust of metal parts, fittings and connectors is available from Klein Tools. The compounds speed assembly and disassembly of metal items by "plating" surfaces with an exclusive formulation of microflake nickel or copper particles and premium flake graphite suspended in a non-volatile

INSTALLERS

If you think you are
GOOD ENOUGH
we have an opening for you.

Upgrade Your Technical Skills
Improve Your Marketability
Climb the Ladder to Technical
SUCCESS!!

WE OFFER TECHNICAL TRAINING IN:
Signal Reception • System Design
Headend Engineering • Service
Test Equipment • System Activation
FCC Proof • CLI • Satellite/TVRO
and much more.

Offering CATV Technical training
since 1974. Enroll for one course
or the entire two year program...

BUT DO IT NOW!
New classes begin Sept. 5, 1989.

For information, call or write:

Cable Television Technician
Dakota County Technical College
1300 145th St. E.
Rosemount, MN 55068
800-548-5502, Ext. 350

Reader Service Number 20.

FO cable locator

Metrotech Corp. introduced an updated version of its system for locating underground fiber-optic cable. The Focal II fiber-optic locating system features a permanent 50 watt transmitter that generates two customer-selected frequencies within the 150 Hz to 9.999 kHz range. Frequency setting can be made at the factory or in the field.

The Focal II transmitter microprocessor automatically monitors and controls the output, impedance and current, tripping an alarm system when necessary. The LCD alternately displays the line voltage, current, frequency, impedance, time of day and time remaining until automatic shutoff.

Two receivers are available. The Model 650F passive/active receiver can receive two active frequencies—9.82 kHz and 153 Hz are standard (optional adjustment to two frequencies between 150 Hz and 9.999 kHz is available) and two passive frequencies—50/60 Hz and 14-22 kHz. The Model 850 receiver, which receives 9.82 kHz, features a patented visual and audible left/right guidance system that directs the user toward the cable, automatic gain control and LCD display of field strength and pushbutton cable depth measurement.

carrier. The compounds are said to help reduce downtime, costly maintenance and replacement of metal parts as well as helping to prevent heat seizure, corrosion, galvanic pitting and electrolysis.

For more information, contact Klein Tools Inc., 7200 McCormick Blvd., Chicago, Ill. 60645, (312) 667-9500; or circle #129 on the reader service card.

Rod pusher

The Ditch Witch P40 and P80 directional rod pushers, manufactured by The Charles Machine Works Inc., are designed for trenchless, long-range pipe and cable installations. The P40 and P80 rod pushers are compact and lightweight, producing equal force either pushing or pulling. The P80, with 81,350 pounds of thrust, can push rod distances of up to 500



feet or more through compactible soils in normal conditions. The P40 delivers 39,150 pounds of thrust, and is capable of boring lengths of 200 feet or more. Hand-held Ditch Witch electronic locators are used to monitor bore depth and direction with signals sent from a radio transmitter inside the rod pusher boring head.

For more information, contact The Charles Machine Works Inc., P.O. Box 66, Perry, Okla. 73077-0066; (800) 654-6481; or circle #121 on the reader service card.

Bandpass filter

Microwave Filter's Model 6297 band-pass filter is designed to isolate data channels at the headend. Passband is 100 to 120 MHz and loss is 2 dB maximum. Rejection at 95.25 MHz is 30 dB minimum and 50 dB minimum at 133.25 MHz. Return loss is 15 dB minimum. The unit comes mounted on a 19 x 1.75-inch aluminum rack panel. Connectors are type F and impedance is 75 ohms.

For more information, contact Microwave Filter Co., 6743 Kinne St., East Syracuse, N.Y. 13057, (315) 437-3953; or circle #128 on the reader service card.

Basic electronics

(Continued from page 26)

seen in the output is referred to as *ripple voltage*.

Another form of full wave power supply

is the bridge rectifier circuit shown in Figure 5. In this circuit, four rectifiers are used. The main advantage of this circuit is that for a given transformer, the bridge rectifier circuit will provide almost twice the output voltage of the conventional full wave power supply circuit.

Half wave power supply

Shown in Figure 6 is a half wave power supply circuit. Besides having only one rectifier, the main difference between a full and a half wave power supply circuit is that the half wave circuit has more ripple. In operation, current flows from ground, through the load resistor, across both capacitors and the choke, through the rectifier and down the secondary to ground.

Test your knowledge

- 1) What is a power supply?
- 2) Name the four parts of a power supply.
- 3) Define ripple.
- 4) What are the two differences between full and half wave power supplies?
- 5) Name three uses of power supplies in the cable TV industry. ■

Figure 5: Bridge rectifier circuit

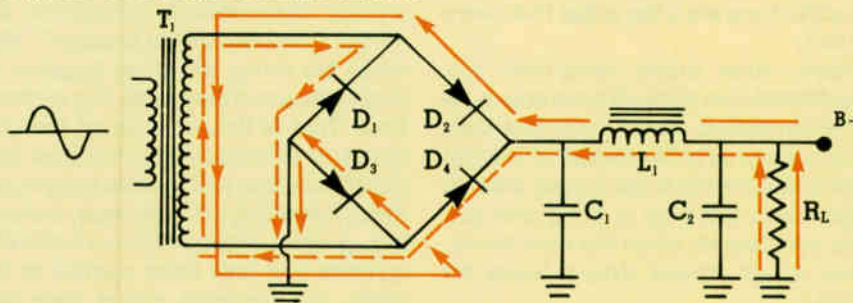
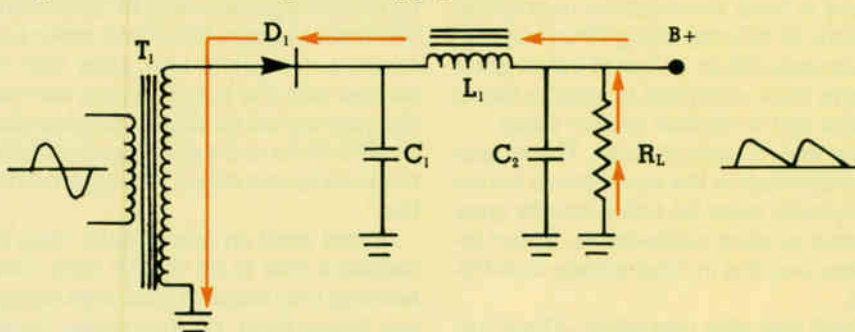

Figure 6: Half wave power supply circuit



- Answers**
- 1) A collection of circuits that change AC to DC.
 - 2) Transformer, rectifier, filter and regulator circuits.
 - 3) The small fluctuation in the output DC value of a power supply.
 - 4) The half wave circuit uses only one rectifier and has a larger value of ripple voltage.
 - 5) They are used to provide operating voltages for amplifiers, TV receivers and headend equipment.

How an installer saved my cable system

By Gregg A. Nydegger

Regional Engineer, Cardinal Communications

Installs, upgrades, downgrades and service calls—these are basics of cable life. Done well, they pay the bills. Done poorly, they eventually do in any cable system.

These four tasks are the ideal starting point in every maintenance and preventive maintenance program. What follows are proven suggestions on using these basic activities to keep systems running well.

Across the country today, cable TV trucks will roll down the roads. Many new droplines will be installed, many pay units added (a few disconnected) and many service calls will be solved. And many causes and signs of future service calls will go unheeded or unnoticed.

Why? Sometimes it is a lack of training. If installers do not know what they are looking for, they certainly will not find it. Often it is a lack of concern. "Job security for the technicians," or "Let somebody else do it," are heard many times. Sometimes it is simply time pressure. "I know something should be done, but I'm already 45 minutes late for my next install."

All the reasons add up to one thing: money. It costs plenty to send a truck back to the same address several times. It costs more if some of these are overtime trips after hours by the on-call technician. It costs when downgrades or total disconnects result from poor or frequently interrupted service.

Obviously then, getting the job done right originally, maintenance and preventive maintenance are not things to be taken lightly. They always have had and always will have an impact on the bottom line. Here are some suggestions to help ensure this impact is positive by taking full advantage of installs, upgrades, downgrades and service calls.

New installs

One of the most crucial times in the life of a cable system has to be when a new install is performed. The distance be-

tween tap and television, whether 50 or 250 feet, and the manner in which the dropwire traverses it, have a direct bearing on future troubles and maintenance.

The old adage, "Why not do it right the first time?" should be every installer's motto (and every other cable employee's motto for that matter). Taking the easy way out does not pay off in most businesses and it certainly does not in cable.

Foresight is a key word in installs. Installers should consider how well their work will hold up (as far as physical appearances go) and perform technically five, 10 or more years from now. Many installs would have been done differently if only the installers had realized they might be technicians someday and have to maintain and service their old work. Many installs would have been done differently if only the managers and chief technicians knew how much trouble and expense would be involved in maintaining and servicing them.

Foresight should apply to many aspects of installs. Here are a few areas that come to mind:

Trees—How many droplines are thoughtlessly run through trees only to be torn down during windstorms? Granted, some houses sit in the middle of a forest and it is impossible to get a clear shot. In those cases the drop is hung and you cross your fingers when the wind blows. (Then again, these drops could be buried.)

Houses like that, however, are the exception. Usually there is only one tree to contend with. What then? Mid-span around it! Sure, the installers may spend an extra 15 minutes doing it that way and use an extra 30 or 40 feet of cable, but it is more than worth that to avoid a future service call to replace broken cable.

One last thought on trees. Those cute little sapplings in the yard when a house is originally wired for cable usually grow to become giant cable-eaters. Smart installers keep this in mind as they route the drop.

Street and alley clearance—There are huge creatures that lurk in the dark (and

even the daytime) that seemingly exist only to tear down drop cables. Garbage trucks, moving vans, cement trucks, dump trucks, etc. will play havoc with low-hanging droplines. Often it appears like an installer will run wire to the lowest point on the house so he can work everything from a step ladder.

Once again a little extra time spent on the install pays off. It takes more wire, stapling and time to attach at the peak of the house (or at least someplace higher than the lowest point), but it keeps the phones from ringing every time the garbage trucks hit the streets.

Clearance may seem like such an elementary and simple thing. Yet I know of systems where the technicians complain that certain drops are torn down every two or three months. Do they ever raise them? Heck no! They just put them back up. That is not only lack of foresight, but also lack of common sense.

Common sense and clear thinking play a big role in installs. Installers should be asking themselves questions like, "What's the best splitter location?" Many times the wiring will come together in a crawl space and the splitter lays on the dirt floor. That is fine as long as the crawl space is constantly dry. But how many are? Countless splitters are lying in puddles, pretending to be sponges, and soaking up water. Presto! Service calls! If the splitters had only been stapled to floor joists, the outcome would have been different.

"Should this drop be RG-59 or RG-6?" If all drops were 75 feet long, this would be a moot question. But, for those drops 125 feet or longer, RG-6 can make a difference. Murphy's Law says that the houses with the longest drops will have the most outlets on cable. Many installers run RG-59 for miles and then complain to the technicians about "the taps running low."

A final word on new installs: Give the installers time to do the job right. Overbooking only leads to frustrated workers and poorly done, sloppy installs. Quality work takes time. →

Coming in August...



The Magazine for Cable System Operations

Subscribe to MSO today— the best cable has to offer.

MSO—from experienced cable journalists and the founders of *Multichannel News*, *CableVision*, *Communications Technology* and *Installer/Technician!*

MSO—the first hands-on operations magazine for cable television system managers.

MSO—helps system operators and cable system department managers do their jobs better and more efficiently by example. **MSO**, with the most experienced team in the business, gets behind the hype and covers the how and why. **MSO** explains the stories behind the news and shows what to do about it.

MSO—the cable tool for managers with regular departments covering the business of actually operating a cable system...from management techniques to marketing that works to technical benefits (in layman's language) to finance to cable programming to customer service to local ad sales.

MSO—the indispensable monthly cable magazine.

Complete the subscription information below and mail to Circulation Manager, MSO, P.O. Box 3208, Englewood, CO 80155



MSO is distributed FREE of charge to qualified cable professionals. Before you can qualify, however, you must complete a subscription form. **INCOMPLETE FORMS WILL NOT BE PROCESSED.**

I wish to receive/continue to receive **MSO**

Yes No

3. Please check the category that best describes your firm's primary business (please check only one).

- 1. Cable TV Systems Operations
- a. Independent Cable TV Systems
- b. MSO (two or more Cable TV Systems)
- 2. Cable TV Contractor
- 3. Cable TV Program Network
- 4. SMATV or DBS Operator
- 5. MDS, STV, or LPTV Operator
- 6. Microwave or Telephone Company
- 7. Commercial Television Broadcaster
- 8. Cable TV Component Manufacturer
- 9. Cable TV Investor
- 10. Financial Institution, Broker, Consultant
- 11. Law Firm or Government Agency
- 12. Program Producer or Distributor
- 13. Advertising Agency
- 14. Educational TV Station, School or Library
- 15. Other _____

(please describe)

Name _____
(please print/type)

Title _____
(please be specific)

Company Name _____

Address _____

City _____ State _____ ZIP _____

Signature _____ Date _____

1. Primarily, my responsibilities include:

- Corporate Marketing
- Corporate Operations
- System Marketing
- System Operations
- Other (please specify) _____

2. In the performance of my job, I authorize, specify or purchase products and/or services.

Yes No

Wire-in installs, service level changes and service calls

These three activities lie at the heart of a good maintenance and preventive maintenance program. Why? They put cable employees in contact with a lot of miles of existing drop cable. (I use the term drop meaning the wire from the tap to where it attaches at the back of the television. If just that part of the drop from tap to ground block is well cared for, then that part from ground block to television will be a system's downfall.)

Too many systems equate maintenance only with caring for the trunklines and feederlines. Often systems even over-emphasize trunklines to the detriment of feederlines. A proper maintenance program, however, must put the right focus and attention on all three types of lines: trunk, feeder and drop. It makes no difference what wonderful shape two of the three are in if the other one is allowed to degrade into an unsatisfactory condition.

To use these activities wisely, make sure you are not wearing blinders. I wonder how often a scene like the following is repeated daily: The installer gets out of the truck, walks to the house (as he does this his eyes are busy scanning the work order) and is met at the door by the subscriber. The installer goes directly to the television, wires up the converter quickly and heads out to the pole. Once there he locates the drop he wants, hooks it up or changes traps, etc., and hurries back to the house to see if everything is working okay. Then he is off to the next job.

On the surface this sounds okay. The job was completed and all was well. Or was it? The employee never really paid attention to anything other than the limited things he was there for. He had on "blinders."

An employee need not be like the Greek's mythical creature Argus and have a head with 100 eyes. Two eyes are all it takes if they are used wisely. What should employees be looking for and what kinds of questions should they be asking themselves?

Was the install done right the first time? Do not prolong the agony of a poorly done install. If time permits, redo it. If it does not, at least get a time schedule so someone can get the install done properly.

Does the drop look like it has been well maintained? Have past service calls been done correctly? There are countless drops that are simply spliced to death. I have seen drops of 100 to 125 feet that have over 10 splices in them. Sure, somebody had come to these houses in the

"Installers should consider how well their work will hold up...and perform technically five, 10 or more years from now."

past and "fixed" the cable, but he sure did not do it right!

Someone once said that putting a splice in a drop is like scheduling your next service call for that address. There is a lot of truth in that. Many times the most cost-effective (in the long run) and technically sound choice is to change out the drop instead of splicing it. Make sure that service calls are not really a disservice to the cable.

More questions to ask include: Are there limbs hanging heavily on the cable? Are the staples or siding clips loose, causing the cable to hang low and look ugly? Is the P-hook fastened to the house securely? Do the ground block and wire look okay? These sound like a lot of time-consuming questions, but actually just walking out the drop on the outside of the house (which should only take two or three minutes) will answer them quickly.

Now, for some questions for inside the house. If the cable comes into a basement, does the wire look okay? Is the stapling holding up? Is the wire routed too close to furnace ducts or hot water pipes? Here is a big question: Has the subscriber cut into the cable to hook up illegal outlets? Time and time again a close check of the inside wiring will turn up all sorts of extra connections radiating signal in all directions and costing the cable company money in lost revenues.

How about the transformer on the back of the set? Is it on the right terminals? Is it a new, modern kind? If not, change it. For approximately 50 cents or less, you will get better balance ratios, better isolation, etc.

By far one of the most important questions should be: How do the fittings look? Many systems are filled with the old, two-piece varieties. These were great in their time, but the hex crimp, one-piece fittings do a superior job. Good advice would be to change out all old fittings at the tap, at the ground block, behind the set, on the converter jumper, etc. I am convinced this alone will save countless service calls and cut down significantly on signal leakage.

In short, when cable employees are at

a residence doing upgrades, downgrades, service calls or whatever, they should be looking for anything that could affect the future performance of that install.

Signal meters

Signal meters have to be one of the best maintenance and preventive maintenance tools in the industry. Unfortunately, many meters seldom leave the comfort of their trucks. If the pictures look good after an install or upgrade, that is satisfactory for a lot of installers. "If the picture's good, that means the signal's good, right?"

Wrong! Good pictures can still hide many things. Here again an employee should be asking questions *and* using the meter. Are the signals flat across the band? Are there suckouts or peaks? Are signals excessively tilted? Are they too low? Just borderline? Too high? These could be indications of amplifiers at the wrong levels, damaged cables, wrong tap values, etc.

Signal readings should be written down if at all possible for every work order and attention called to them if anything abnormal appears. Often signal readings will catch developing feederline or trunkline problems before they become catastrophic. Problems are just like tooth cavities. The best time to find them is while they are small if you cannot prevent them altogether.

Even if employees are at a residence to install only a pay service, they should still look through all other channels. Installers and technicians are literally the eyes and ears of a cable system. If they are trained to know what to look for, they often will spot trouble long before the subscribers do.

What should they be looking or listening for? Beats, distortion, electrical noise, fundamental pickup, hum bars, buzzing in the sound, etc. Once again, anything abnormal or degrading to picture quality should be reported at once. What look to be minor problems can suddenly blossom into major problems. Nip them in the bud!

Installs, upgrades, downgrades and service calls will always consume the major portion of cable employees' time. However, if employees will but stop, look and listen while going about these tasks, cable systems will benefit greatly. *And on-call technicians will sleep at night.* ■

Reprinted with permission of the National Cable Television Association from its 1985 "NCTA Technical Papers."

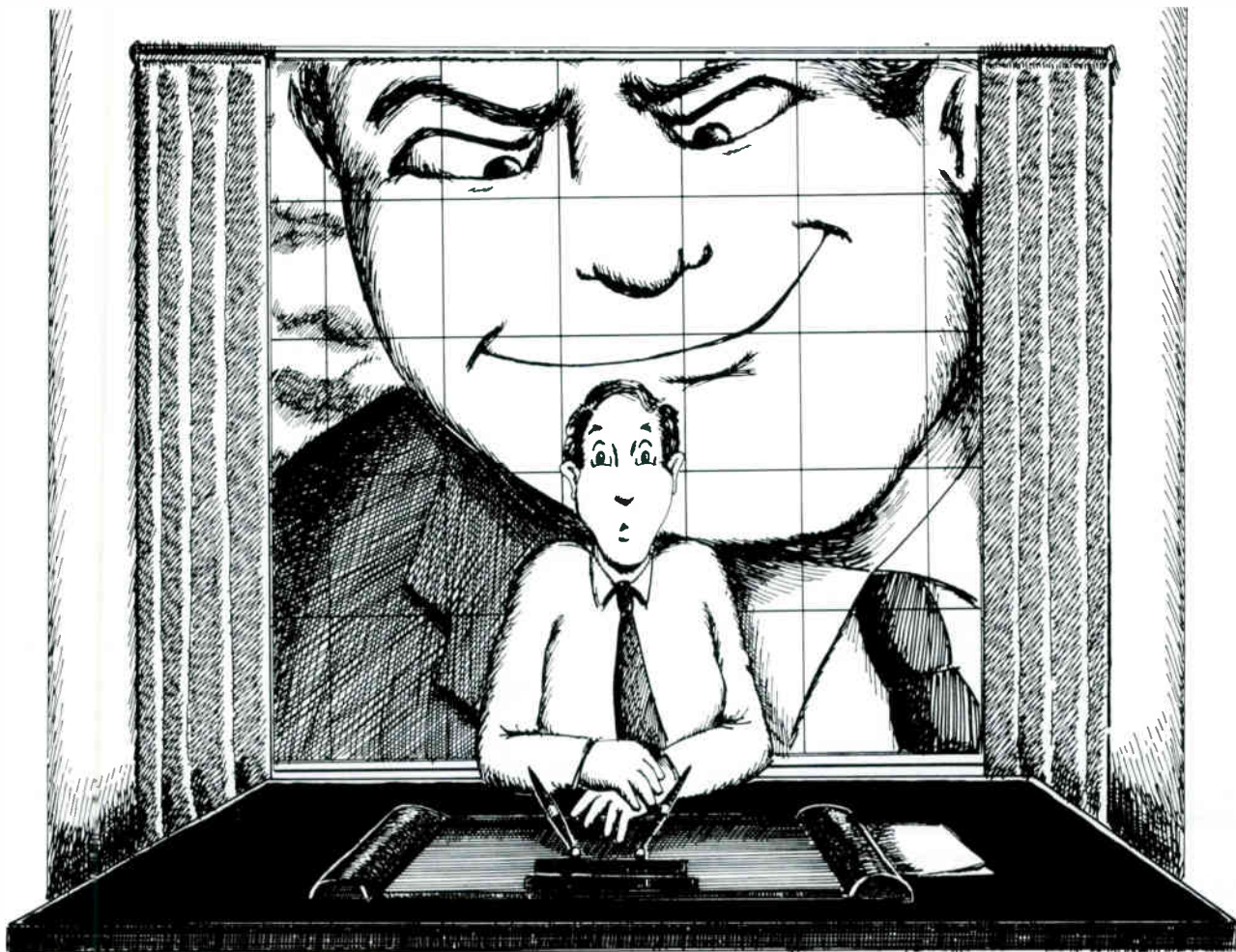

Guess which one is buying the other one's business

Sixty hour weeks... Years with little or no vacation... Labor problems... Cash flow problems. You worked mighty hard building your business. But "some day" you figured on cashing in your chips and enjoying the good life.

Then "some day" finally arrives and you're back where you started. A kid all

over again. Wet behind the ears. Lost in a sea of sharks.

Because in all those years of *building* a business, you never learned beans about *selling* a business.

You're not alone. Each year thousands of successful American companies get sold for lots less than they're worth. Why? Because their owners didn't turn to S.J. Haupt.

At S.J. Haupt we serve only one purpose: *To get the owners of private companies top dollar for their life's work.*

We achieve this by identifying the largest pool of interested *cash buyers* and then bidding the price up among them. The more interested parties there are, the more you get for your company. Simple? Yes. Easy? No.

Because we don't just go to your nearest competitor, or the company across town. We search for interested, suitable, solvent buyers across the United States, Europe and the Far East.

We then make sure you walk away with the best deal at the best terms. Only after that do we get paid for our services.

If your company does \$5-50 million in annual sales, and you're thinking of selling it sometime during the next three years, call S.J. Haupt & Company today.

And see all those years of hard work pay off.

S.J. Haupt & Co.

527 Madison Avenue
New York, NY 10022
(212) 750-7800

Reader Service Number 21.

*"Our Business is Selling
Your Business"*

Out of Focus



Zach Beasley gets a head start on his career in cable with a little "hands-on" training. (Submitted by Steve Kerrigan, Rancho Santa Margarita Cablevision.)

Hex crimp

(Continued from page 25)

sheet that came with the crimp tool to properly identify the parts. If no instruction sheet exists contact the tool's manufacturer to acquire one. Typically, the cam will tighten when turned in a counterclockwise direction. It is possible to overtighten the crimp tool. Such overtightening can damage the tool, which may necessitate rebuilding the tool. Continue the adjustment process, turning the tension cam one notch at a time, until the jaws' gap is less than 0.003 inches. If this tolerance cannot be achieved the tool should be rebuilt or replaced.

Once the crimp tool jaws have been properly set, crimp another empty connector. Using a micrometer or a dial caliper, measure and record the diameter across the three pairs of parallel flats. No single measurement should be more than 0.005 inches greater than the nominal hex value, nor should the average of the three measurements be more than 0.003 inches above nominal. Repeat these measurements for all hex cavities contained in the tool. If any of the measurements are outside the specified range and cannot be adjusted into the tolerances, the tool should be rebuilt or replaced.

With the emphasis on system reliability and plant longevity the foregoing procedures seem to be an easy yet effective means of improving both. An initial training program coupled with an ongoing maintenance policy and periodic inspections will provide a greater level of total system performance. The benefits in customer satisfaction and employee productivity, not to mention the potential reduction in signal leakage problems, will more than offset any loss of time or money incurred in implementing these simple procedures. ■

Ad Index

Alpha Technologies	5
Antronix	3
Ben Hughes/Cable Prep	14, 68
Cable Exchange	51, 52
Cable Link	14
ComSonics	12
Dakota County Votech Institute	56
Insulation Systems	20
JGL Electronics	65
Jones International	65
Lemco Tool	18
Loctite	19
Microwave Filter	16
NCTI	24
Pico Macom	13
Power Guard	67
Riser-Bond	11
SCTE	21
Sencore	2
Southern Cable Television Association	15
Steve Haupt & Co.	63
Tailgater	11
Telecrafter Products	8
Toner Cable	7

Installer Technician Poster

Ben Hughes/Cable Prep	Jensen Tools
Diamond Communications	Lemco Tool
Drop Shop	Mega Hertz Sales
Interstate Cable Enterprises	Multilink
Interstate Dropline Installers	Riser-Bond
Jackson Tools	Sachs Communications

Calendar

July

July 14: SCTE Mount Rainier Chapter technical seminar on data. Contact Sally Kinsman, (206) 867-1433.

July 15: SCTE Cactus Chapter technical seminar. Contact Harold Mackey Jr., (602) 866-0072.

July 15: SCTE Chaparral Meeting Group technical seminar. Contact Bob Baker, (505) 763-4411.

July 16: SCTE Old Dominion Chapter technical seminar. Contact Margaret Harvey, (703) 248-3400.

July 17-19: New England Cable Television Association annual convention and exhibition, Marriott Hotel, Newport, R.I. Contact Bill Durand, (617) 843-3418.

July 18-20: Florida Cable Television Association annual convention, The Registry

Resort, Naples, Fla. Contact (904) 681-1990.

July 19: SCTE Razorback Chapter technical seminar, Days Inn, Little Rock, Ark. Contact Jim Dickerson, (501) 777-4684.

July 19: SCTE Dairyland Meeting Group technical seminar on signal security and theft, Royale Hotel, West Bend, Wis. Contact Jeff Spence, (414) 738-3180.

July 19: SCTE Great Plains Meeting Group technical seminar on headend maintenance, satellite technology and off-air signals. Contact Jennifer Hays, (402) 333-6484.

July 19-21: Colorado Cable Television Association annual convention, Marriott's Mark Resort, Vail, Colo. Contact (303) 863-0084.

July 20: SCTE Rocky Mountain Chapter's "Cable

Upcoming

Aug. 27-29: Eastern Show, Atlanta Merchandise Mart, Atlanta.

Sept. 20-22: Great Lakes Expo, Convention Center, Columbus, Ohio.

Oct. 3-5: Atlantic Show, Convention Center, Atlantic City, N.J.

Oct. 17-19: Mid-America Show, Hilton Plaza Inn, Kansas City, Mo.

Dec. 13-15: Western Show, Convention Center, Anaheim, Calif.

fiber optics, Italian Gardens, San Jose, Calif. Contact John Parker, (408) 437-7600.

July 21: SCTE Heart of America Chapter technical seminar, American Cablevision, Kansas City, Mo. Contact Wayne Hall, (816) 942-3715.

July 25: SCTE Satellite Tele-Seminar Program, "High definition television technology (Part I)," 12-1 p.m. ET on Transponder 7 of Satcom F3R. Contact (215) 363-6888.

July 25-29: Rocky Mountain Cable Television Association convention and **Wyoming Cable Television Association** meeting. Contact Bob Carnahan, (307) 265-3130.

July 26: SCTE Piedmont Chapter technical seminar. Contact Rick Hollowell, (919) 968-4631.

games" and technical seminar on CLI, Marriott's Mark Resort, Vail, Colo. Contact Rikki Lee, (303) 792-0023.
July 20: SCTE Golden Gate Chapter technical seminar on

JONES INTERNATIONAL PROUDLY PRESENTS NEW PRODUCTS AND PROGRAMMING SERVICES

WE HAVE SOMETHING FOR LITERALLY EVERYONE!



MIND EXTENSION™ UNIVERSITY!

A FREE basic cable programming service allowing subscribers to earn college credits from major universities through quality telecourses.

GALACTIC RADIO!

Enhance your basic cable with our FM stereo service including six stereo music formats, three sports/news/talk superstations, plus In-Touch, a reading service for the visually impaired.

JONES BUSINESS LEARNING GROUP!

Interactive video and video tape training products for CSR's/Techs and in-house personnel.

THE JONES DICTIONARY!

The resource of cable terminology.

FOR MORE INFORMATION, CALL TOLL-FREE
1-800-525-7002

Reader Service Number 22.

Cable Test Equipment Specialists



"Look"

\$25 off

coupon in upcoming card deck.

**Prompt, Professional Services
at Reasonable Prices!**



JGL ELECTRONICS, INC.

4425 BLACKSTONE DRIVE
INDIANAPOLIS, IN 46237

**1-317-783-6130
1-800-888-6130**

Reader Service Number 23.

A program for success

By Tom Brooksher

Marketing Director, National Cable Television Institute

A year ago in this column we told you about a unique program we had just started in partnership with Triangle Tech in Pittsburgh, Pa. to help meet the industry's need for trained installers. It is a vocational training program that is designed to produce qualified, well-trained, entry-level technical personnel for the industry. At that time, the National Cable Television Institute (NCTI) had trained, tested and certified Triangle Tech's instructors, and the program had just graduated its first class of 11 installers who completed the NCTI-based curriculum, passed NCTI-administered tests and had received NCTI certification.

With another year under our belts we thought it was time to give you an update on the progress of the program. We asked Richard Wirth at Triangle Tech to provide us with a state-of-the-program report from the perspective of the school, the students and the cable industry companies that have hired program graduates.

Triangle Tech report

The Cable Television Lineman/Installer program at Triangle Tech is heading into its second year and the results are impressive. Five classes completed the program at four different sites across southwestern Pennsylvania and another class is just graduating. All 52 of the program's graduates are NCTI-certified and 36 are already working with cable systems and contractors throughout Maryland and Pennsylvania. Nearly 88 percent of the graduates have received at least one job offer.

Cable TV Montgomery hired 18 graduates. Mark Barber, director of field operations for the rapidly growing Rockville, Md. system says the grads can meet the challenges of a complex system. "We need versatile installers who can handle a variety of different situations," he said. "We're involved in new building, rebuilding and over-building. I've found Triangle Tech's grads have the background necessary for us to shape the installers that we need."

PM for FO

(Continued from page 23)

form, rather than using them to perform absolute measurements. In this regard, their only disadvantage is that they must be transported from location to location in order to perform the required measurements. Clearly, an integrated remote status monitoring system with measurement capabilities is still the optimum solution, but the automated tester may be programmed for a wide variety of manufacturer independent parameters and will be useful for the non-fiber equipment as well.

At the time of system purchase, adequate spare equipment should be ordered so that any module that fails can be replaced. Ideally, all major system components including transmitters, receivers and power supplies should be front slide-in modules so that replacement is fast and does not require two people. The replacement module should be calibrated using only a digital voltmeter according to the values recorded in the system logbook to restore service. Ideally, optics should be

separate from power supplies so that a loss of power does not require disruption of the optical path for disconnection of an optical transmitter or receiver.

Selection of spare equipment quantities is determined by the rate of failure of the particular manufacturer's equipment. If a FITS analysis (failures per 10^9 hours) is not available, then the system designer must rely on the manufacturer for a recommended spares quantity for the various system components. After system installation, it is a good idea to keep all spares operating as an additional channel and/or link where possible. In this way, there will be no question as to the functionality of the spare equipment if and when a system failure occurs.

The most effective part of fiber-optic system maintenance is the combination of thorough link design and installation coupled with periodic performance monitoring. Detecting and correction of problems before system outages in a non-critical timeframe is clearly advantageous to the approach of reacting to hard outages and trying to restore the system after service outages have occurred. ■

Harry Angles, president and owner of H.S. Angles Cable Services in Latrobe, Pa., hired five grads and is considering hiring more. His company provides line/pole construction services to several cable systems in western Pennsylvania. "I think the school does a good job, especially in climbing," he said. "The climbing skills are excellent and that's 75 percent of the job in our work."

Triangle Tech's program serves a two-fold mission. It supplies cable operators and contractors with skilled personnel and also gives employment opportunities to those in need. The majority of the program's students are unemployed or underemployed who receive federal and state retraining funds.

The program, which stems from NCTI's agreement with the school to provide entry-level training designed to help meet demands at cable systems and related industries, has drawn favorable reviews from job training officials. "I'm very pleased with the results and attitudes of our participants," stated David Suski, director of the Washington/Greene County Job Training Agency. "I am very pleased that Triangle Tech is now involved in training within the cable industry. It is also gratifying that NCTI is putting their stamp of approval on the graduates."

Triangle Tech plans to expand the program with more classes and has proposed a cable training project for Pennsylvania Department of Labor and Industry funding.

A little background

Triangle Tech has been in operation since 1944 and is accredited by the National Association of Trade and Technical Schools and approved by the state of Pennsylvania. Historically, its specialty has been education in the drafting fields, offering an associate's degree in specialized technology in architectural and mechanical computer-aided drafting and design. In addition, programs have been added to include refrigeration, heating, ventilation and air conditioning technology.

If there is an institution in your area that you would like to recommend for such a program, or if you would like any further information on the NCTI/Triangle Tech program call Jerry Neese or Tom Brooksher at (303) 761-8554. Or write to us at P.O. Box 27277, Denver, Colo. 80227. ■

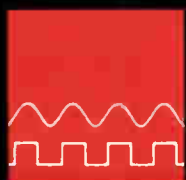

POWER GUARD POWER SUPPLIES

EXPERIENCE

Power Guard's founder, Jerry Schultz, has been manufacturing standby power supplies since 1974.

EFFICIENCY

Power Guard started the move to high efficiency in 1985 when we shipped our first 90% efficient power supply.

MODULARITY

Power Guard products are completely modular and entirely field serviceable.



VALUE

Power Guard delivers highly efficient, top quality products at competitive prices.

WARRANTY

Reliability and experience are the reasons Power Guard's 5 year warranty is the industry's longest warranty.*

COMMITMENT

Power Guard is 100% committed to being number one in standby power supplies!

CALL 1-800-288-1507 FOR PRICING AND INFORMATION.



POWER GUARD

801 Fox Trail • P.O. Box 2796
Opelika, Alabama 36801
1-800-288-1507 • (205) 742-0055

*This is a limited warranty.

Distributed by Midwest CATV

Reader Service Number 24.

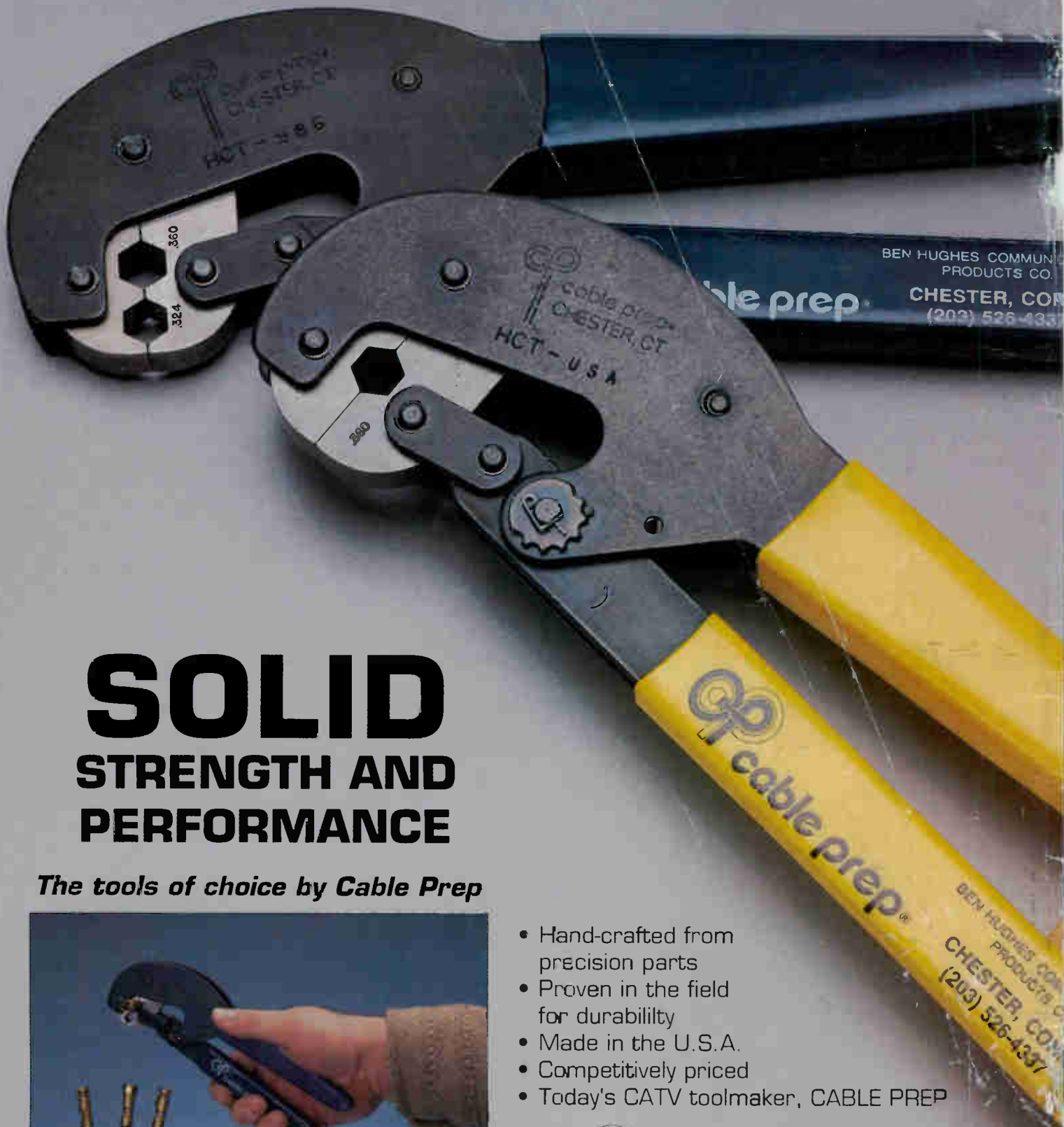

SOLID STRENGTH AND PERFORMANCE

The tools of choice by Cable Prep



- HCT-986 – hex sizes presently recommended by SCTE for standardization
- HCT-USA – one hex .360 for Gilbert Engineering's Universal "F" Connector System

- Hand-crafted from precision parts
- Proven in the field for durability
- Made in the U.S.A.
- Competitively priced
- Today's CATV toolmaker, CABLE PREP



cable prep

BEN HUGHES COMMUNICATION PRODUCTS CO

207 Middlesex Avenue, P.O. Box 373
Chester, Connecticut 06412-0373
(203) 526-4337 FAX: (203) 526-2291

We make your job easier!

Copyright 1989 Ben Hughes Communication Products Co

Reader Service Number 25.