

# Radio Guide

Radio's Technology Magazine

July 1990  
Vol 3 Issue 7



511 18th Street SE  
Rochester, MN 55904

Address Correction Requested

Chief Engineer  
KBNB AM/FM  
5710 TROWBRIDGE DR  
EL PASO TX 79925-3341

Bulk Rate  
U.S. Postage  
**PAID**  
Minneapolis, MN  
Permit 4632

# CHAIRMEN of the BOARDS

*"It's amazing that you can offer a console of that quality for the low price tag that was on it."*

*"I would recommend the XL SERIES audio consoles to anyone with a small budget who is looking for 'big quality'."*

*"Congratulations! We believe you've built the most perfect audio console available to broadcast stations."*

*"We have found that noise and distortion are lower --much lower, in fact-- than audio consoles selling at three to four times the price of the RAMKO XL Series!"*

## JUST PART OF THE STORY:

- STEREO, SINGLE & DUAL CHANNEL
- HUGE, INDIVIDUAL, MULTI-COLOR "VU" METERS
- LONG LIFE SWITCHES. Silent, illuminated, 5 million operation input/output switches
- DISTORTIONLESS, SOLID STATE SWITCHING & VCA audio control.
- EASE OF INSTALLATION. 2 screw drivers & a wire stripper. All other functions switch & jumper programmable.
- TOTAL RF PROOFING. Of the hundreds installed absolutely no RF reported.
- FREE 2 WEEK TRIAL & 2 year parts & labor warranty.
- SUPER 20TH ANNIVERSARY BONUS! For a limited time, take 10% off all published prices.
- ROTARY & OPTIONAL NOISELESS, LONG LIFE LINEAR FADERS (exclusive, non-moving contact design!).
- EXTRAORDINARILY LOW PRICES. Check the competition!
- 4, 6, 8, & 12 MIXER, 15 to 31 inputs.
- 9 INPUT MIX/MINUS BUSS & programmable start/stop controls
- AND A WHOLE LOT MORE.

EXAMPLE WITH ANNIVERSARY DISCOUNT:  
 8 mixer, single channel.....\$2,606 !!!  
 12 mixer, dual channel.....\$3,735 !!!

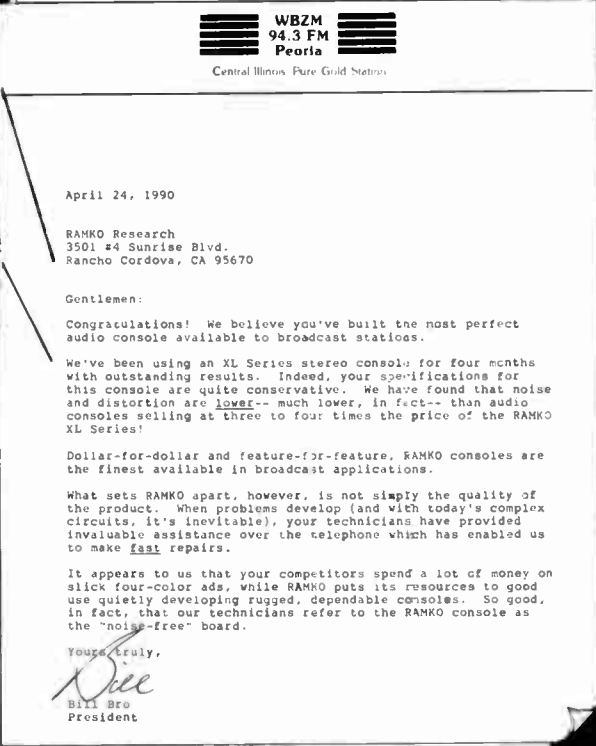
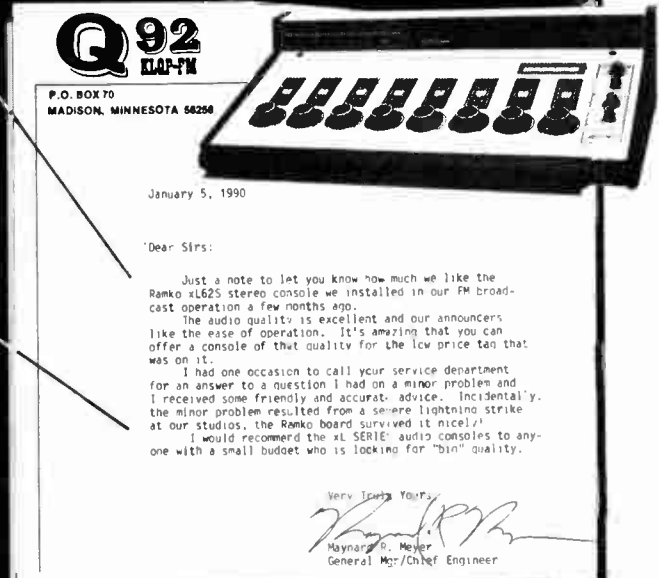

FOR THE REST OF THE STORY CALL:

TOLL FREE (800) 678-1357 or FAX: (916) 635-0907

3501-4 SUNRISE BLVD.  
 RANCHO CORDOVA, CA 95742

**RAMKO** RESEARCH

**Radio Guide**  
**- Contents -**  
 July-1990  
 Volume 3 Issue 7

- 4 Editorial Comments
- 7 SBE National News
- 8 PCL-606 Capacitor Fix
- 9 Radio Guide Forum
- 10-13 Tube Topics
- 14 Marti TSL System Retrofit
- 15 The Thin Green Line
- 16-18 Folded Unipole Antenna
- 19 Laws for Engineers
- 20-23 State of the Art 50 kW AM
- 24 Servicing ITC 99B Cart
- 25 BE Console Bleed Fix
- 26-28 TX Site You Can Live With
- 29 Contract Engineer Guide
- 30-31 Product Guide
- 32-33 Tips From The Field
- 34-43 Classified Ads
- 46 Broadcast Computer BBS's

Cover Photo Courtesy of  
 Allied Broadcast Equipment

**We Need  
 Your Pictures**

*Send a color photo of  
 your studios or transmitter  
 site to Radio Guide.*

*We'll select one each  
 month and print it on the  
 cover. Let's see what you've  
 done at your station.*

*. . . Editor*

**SPOIL YOUR LISTENERS.... Not Your Audio**  
 Pure Sonic Integrity-99.997% Distortion Free



**FX 50 Exciter**

No matter what your format is . . . no matter which processing you run; your entire system is no better than your exciter. So why limit the potential of your signal? Join the hundreds of broadcasters that have already realized what a difference the FX 50 can make. Call BE now at 217-224-9600.



**BE**® **BROADCAST ELECTRONICS INC.**

4100 N. 24th ST., P.O. BOX 3606, QUINCY, IL 62305, (217) 224-9600, TELEX: 250142, FAX: (217) 224-9607

**CCA**

**Evolution**

CCA has delivered more than 3,000 Broadcast Transmitters over the past 25 years. For 25 years our designs have been refined and improved. The result is the Evolution of the world's most perfected, most tested, most reliable, Radio Transmitter

- Grounded Grid Triode**
- Longest Tube Life**
- Auto Power Control**
- VSWR Power Foldback**
- Single Phase Optional**

**CCA Electronics**  
 P.O. Box 426  
 Fairburn, GA 30213  
 (404) 964-3530 Fax (404) 964-2222

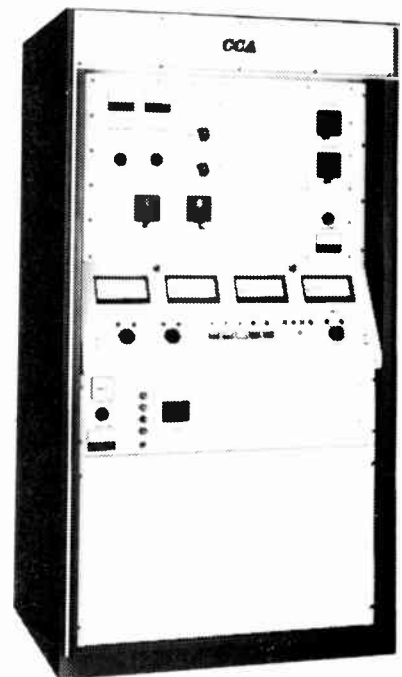



# More After This!

## Is Your Job Safe? Have You Done All You Can?

There comes a time, when you've gotten all the station equipment in shape and there's no new construction going on, that everything is pretty much a matter of routine maintenance. That's the time when, if it's ever going to happen, you may be faced with "corporate downsizing." Of course, we know what that means -- your job may be eliminated!

Your position is not something that you should take lightly or take for granted. You must always provide the GM with a reason to justify the engineering department expenses. And, as we all know, the biggest item (although it may not seem like it) is your salary.

Are you conscientiously doing all that you can, on a daily basis, to justify the costs of keeping you on staff? Or do you feel that, just because you're a great engineer and can fix anything with nothing, this ensures you a permanent position at the station. It's kind of like driving -- we all think we're great. It would be a mistake to adopt that philosophy toward your engineering position.

It's simple -- it's not how intelligent you are, but how fast and how well you can fix a problem. To just sit back and wait for something to break, just doesn't make much sense at all. You should adopt an aggressive routine maintenance program for your technical plant. I'm sure you've run into those that say, "If it isn't broke, don't mess with it." I'm also sure that you'll probably find most of those people out on the street.

Try using that maintenance method at a hospital, computer facility -- or aircraft hangar. Why should it be any different at a radio station? Literally everything and everyone at your radio station depends upon the proper operation of the technical plant. If it goes away, then what else matters?

*Radio Guide July-1990 Page-4*

The real problem with routine maintenance is that, if it's done well, no one really notices. That's why it is essential that you provide the GM with weekly reports of the status and operation of all equipment. Included in these reports, should be the amount of down-time, the reason for it and what can be done in the future to prepare for a similar situation. Just as important, should be a listing of the up-time. You should provide, in simple short form, the potential down-time that you estimate your preventive maintenance program has eliminated.

Let's say you've found a sticky phase protection relay at your transmitter site. You corrected the problem and, of course, no one was the wiser. What if you had not found that relay in the course of your preventive maintenance program? The transmitter blower motor could have overheated with the loss of a phase, burned out, and you would have been off the air until you found a replacement! How much would that motor have cost the station, and how much would the off air time have cost? Let the GM know. You know what the cost of a motor is. You know what your average spot load is. Figure it out. In this way, you will be able to let management know that you are doing your job, even though "nothing ever breaks around here."

Don't just put your reports in the GM's mailbox. Set up a weekly face-to-face meeting. Sales and programming do it -- why shouldn't the most important department at the station do the same thing! By meeting on a regular basis, you will develop an ongoing personal relationship with your GM. When it does come time to request additional funding for the engineering department, you will find it easier to be able to discuss those needs if you've had a chance get to know each other

and found a common ground to discuss the needs of the station.

When a catastrophe does occur, don't be afraid to call the manufacturer, or a nearby engineer -- or even a contract or consulting engineer. Chances are, they may have the answer to your problem or at least may be able to steer you in the right direction. If you let your ego get in the way, you're not going to do your best work.

... Editor

### Next Month

*A way to make engineering become a profit center instead of an "expense."*

### Radio Guide

Volume 3 Issue 7 July 1990  
Publisher: Ray Topp

#### SALES

Dale Tucker  
865 Hawthorne Dr.  
Walnut Creek, CA 94518  
(415) 935-1470

#### EDITORIAL

Ray Topp  
511 18th St. SE  
Rochester, MN 55904  
(507) 280-9668  
Fax (507) 280-9143

Radio Guide is published monthly by Rochester Radio Publishing. Copyright 1990, all rights reserved.

Free subscriptions are available to all people involved in radio broadcasting and allied fields. Send name and address or any changes to Radio Guide at the above address.

All letters and copy submitted to Radio Guide are assumed to be for publication, unless notified otherwise.

# Used Equipment Extravaganza!

All items available three ways (unless otherwise noted):

**STRICTLY AS-IS**

**GUARANTEED WORKING CONDITION**

**COMPLETELY REMANUFACTURED**

If you don't see what you need, call. Chances are we have it or know where to get it!

\* means item is not available remanufactured. All shipping FOB Dallas, Texas.

All items except AS-IS carry 10 day money-back guarantee.

## Automation:

Cetec 7000 Level 1: \$1000-\$4500  
Cetec 7000 Level 2: \$1500-\$5500  
Cetec I/O Cards: \$150-\$350  
Gates RA-5: \$100-\$350  
Gates SC-48: \$50-\$200\*  
Harris System 90: \$500-\$4000  
Harris Source I/O Cards: \$50-\$250  
Schafer 902.5: \$1000-\$3250  
Schafer 903: \$1200-\$4000  
Schafer 903E: \$1500-\$5000  
Schafer I/O Cards: \$50-\$250  
Schafer I/O Cables: \$25-\$75  
SMC RAC-50: \$300  
SMC RP1000: \$500-\$2000  
SMC 3060: \$500-\$2000  
SMC DP1: \$200 (for parts only)

## Multi-Cart:

IGM Go-Cart(78): \$1200-\$3000  
IGM Instacart(48): \$2500-\$7500  
ITC DELTA III (3) Mono: \$2600  
Schafer Audiofile I (48): \$1250-\$4200  
Spare Module: \$300-\$1200  
Schafer Audiofile II/A: \$1500-\$4800  
Spare Module: \$500-\$1500  
Support Module: \$500-\$1000  
SMC 581(Dual): \$50-\$400  
SMC 721 (Dual): \$200-\$900  
250 Carousel (24): \$500-\$1850  
350 Carousel (24): \$750-\$2150

## Single Cart Decks:

Audi-Cord Stereo R/P: \$550-\$1100  
Audi-Cord A Mono Play: \$150-\$600  
Harris Criterion R/P Mono \$250-\$750  
ITC WP Mono: \$850  
ITC RP Stereo: \$1600  
SMC 790 Mono Record: \$350-\$850

## Reel-To-Reels:

Ampex 352-2: ~~Sold~~  
ITC 750: \$300-\$850  
ITC 750 R/P Mono: \$400-\$1100  
MetroTech 523: \$100-\$300\*  
Revox A-77: \$100-\$850  
Schafer-Teac: \$50-\$300\*  
Scully 270: \$100-\$850  
Scully 255: ~~\$250~~  
Scully 280B: \$350-\$1200

## Logging:

Computer List & Load for Schafer  
903: \$400-\$1200  
Logging Printers (see Printers)  
Schafer/Cetec Encoder: \$300-\$1200  
Schafer/Cetec VEL Cards: \$200-\$600

## Remote Controls:

Cetec 7000: \$125-\$300  
Schafer 900 Series: \$50-\$250

## Printers:

Anadex: \$50-\$300  
Axion: \$50-\$400  
Extel AF/AH-11R: \$100-\$400  
Extel Paper Winder: \$50  
TI Silent 700: \$50-\$400

## CRT Terminals:

Beehive: \$50-\$300  
Lear Siegler: \$50-\$300  
Others: Call

## Miscellaneous:

CRL SPP-800: \$250-\$1000  
DAP 610: Call  
Equipment Racks: \$50-\$400  
IGM 25 Hz Sensors: \$50-\$200  
Ramsa WR-500 Console: \$500  
Satcue 400: \$595  
Schafer Time Gates: \$200-\$750  
SMC TS-25 Tone Sensor: \$100-\$300  
TFT 760 EBS System: ~~\$350~~ \$300  
TT Preamps: \$50

**bai**  
Broadcast Automation, Inc

The Only Name in Broadcast Automation You Need To Know...

**Call Toll Free (800) 336-8004 or FAX (214) 380-0823**

4125 Keller Springs Suite 122 Dallas, Texas 75244 (214) 380-6800

# WHY YOU SHOULD PAY MORE FOR LESS.

**New Name-  
Same Great Cart!**  
The ITC Cart II Cartridge, formerly ScotchCart® II

*Less phase jitter caused by poorly tracking tape, because the naturally lubricated concave guides gently position the tape and allow the cartridge machine to perform critical guidance.*

*Less tape noise and signal loss with our 100% laser-inspected, high output, low noise tape which delivers better frequency response and keeps signal-to-noise ratio high, harmonic distortion low.*

*Less wow and flutter or stop cue overshoot, because there's no rotating hub to wear out, warp or rattle.*

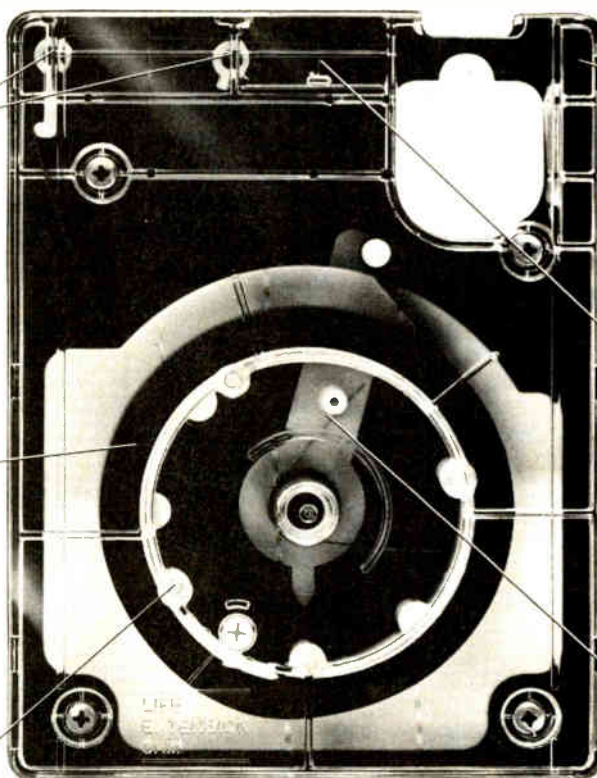

The ITC Cart II Cartridge, formerly ScotchCart® II

*Less chance of the cartridge cracking or breaking, because the tough polycarbonate cover withstands repeated use and abuse.*

*Less head wear, tape steering and modulation noise, because there aren't any pressure pads to add friction.*

*Less chance of tape destruction, because our patented dynamic tension control system ensures proper tape-to-head contact, and provides constant tension to control looping and prevent twisting.*

With broadcast cartridges, like everything else, you get what you pay for. With ITC Cart II cartridges, you get a revolutionary design that delivers trouble-free operation, superb sound quality and a life expectancy that's second to none.

We have renamed the cartridge due to trademark considerations, but only the name has changed, the cartridge and tape are the

same. New name, same great cartridge and performance.

For a complete listing of ITC Cart II dealers, call ITC toll-free at 800-447-0414 (in Illinois, call collect 309-828-1381.) Or write to ITC at P.O. Box 241, Bloomington, IL 61702-0241.

Because a cheaper cartridge may be more trouble than you can afford.



# SBE National News

## SBE Seeks Licensing Relief

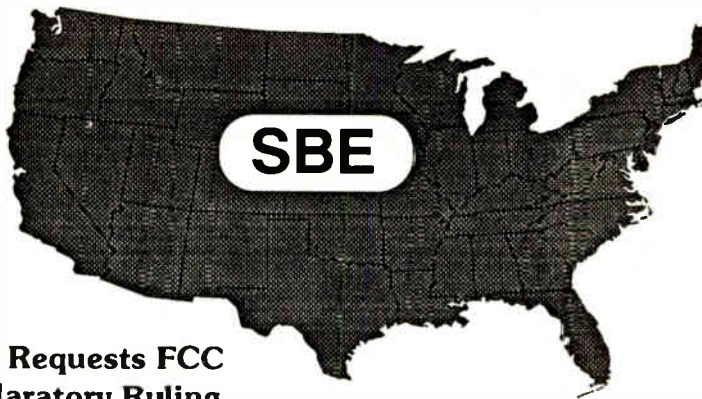

### SBE Requests FCC Declaratory Ruling Seeking Relief From State Licensing Regulation of Broadcast Engineers

The SBE filed, on June 19, 1990, a request for a declaratory ruling with the FCC asking for the establishment of a policy of limited Federal preemption of state and local regulation of technical operators of broadcast stations. In the filing, the SBE asked the FCC to prevent states and local authorities from licensing technical operators of broadcast and other FCC-regulated communications facilities.

The filing was prepared as a result of many months of study by the SBE. During that time, some instances of state attempts to establish their authority of broadcast engineers became evident. In one case, the Texas Attorney General indicated that radio operators may in fact be subject to registration and other requirements or restrictions under the Texas Engineering Practice Act.

In order to protect the job interests of SBE members and other broadcast engineers, the Society strongly opposes such state regulations. President Brad Dick noted that the imposition of such local and state statutes posed a threat to the members' employment.

In addition, the possibility of regulation by individual states' regulatory boards could further hurt the station employees by limiting their employability outside any state in which they might be registered. They could even be required to pass examinations by the state, which often do not include material applicable to the broadcast field. The engineer could even be subject to fines and to other alleged unauthorized practice of engineering. In at least one case, the person could be

fined up to \$10,000 or imprisoned for as long as one year.

"Clearly such regulations are out of touch with reality," said Dick. "SBE is prepared to go to whatever lengths possible to protect the interests of our members."

**October 1, 1990  
Annual SBE Election**

# MARTI RPU's

## In Stock 3 Day Delivery!



**CARTWRIGHT**  
COMMUNICATIONS COMPANY

7812 Red Sky Drive  
Cincinnati, Ohio 45249

**800-543-8614**

# PCL-606 Capacitor Replacement

**Don Mussell - Broadcast Engineering Services**  
**Mouth of Wilson, Virginia (606) 633-5466**

If you are responsible for the care of any Moseley PCL-606 STL systems, that are over four years old, take note. The power supply in the transmitter has a 7200 mFd, 25 volt capacitor that can fail without warning and make you scratch your head trying to figure out what went wrong.

The symptoms: No power output, all LED indicator LEDs are lit green, and PA current half of normal.

The cause: The electrolytic has opened up in the variable DC supply to

the 5 watt power amp., dropping the voltage to 4.5 volts -- and power output to zero. Replace this capacitor, and the others in both the transmitter and receiver, at four-year intervals, and you will save yourself an embarrassing failure during drive time on Friday.

This solution reminded me of the fact that I have replaced somewhere around 500 capacitors in the last year at various stations, in various equipment. Most of the equipment is anywhere from new to ten years old, and

the electrolytics are by far the only failures I have experienced lately.

I was visiting a friend's two-way repair shop back in January and casually looked at one of the radios on the bench. I half-jokingly told him the problem was probably the big filter capacitor on the top. He checked it (after spending two hours looking everywhere else for the problem) and found the capacitor shorted. Problem solved!

## Just What the Doctor Ordered...

You've got a bright, contemporary sound that's the envy of your competitors — but your playlist includes a lot of material from a different era — a time when things sounded great but, well, "dull." On top of that, those old disks and carts are noisier than your new equipment, and they aren't getting any quieter!

### Not a "generic" prescription

The Orban 290 $\mathcal{R}$  continuously analyzes your audio and adds just the correct amount of sparkle and space for *each* tune or spot. Used in transfers, it gives your library the contemporary sound you need while its **Open Sound**<sup>™</sup> single-ended noise reduction cleans up hiss and surface noise.



**orban**

**LISTEN TO THE DIFFERENCE**

a division of AKG Acoustics, Inc.

1525 Alvarado Street

San Leandro, California 94577 USA

Tel 415/351-3500 FAX 415/351-0500

### Strong Medicine

The Orban 290 $\mathcal{R}$  — three unique processing functions in two independent channels of audio problem solving power. Don't let tired audio undermine your 90's sound. Call your favorite equipment supplier today and try out a 290 $\mathcal{R}$ . You'll be feeling fine in the morning!





# Radio Guide Forum

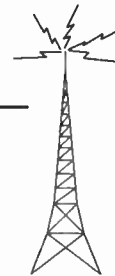

## Letters and Questions From Radio Guide Readers

### Editor:

The FCC in the New York City and Philadelphia areas seem to be serious about AM-NRSC compliance. They are visiting every AM station to insure they are meeting the NRSC standards. They also are asking to see a copy of the last proof (harmonic measurements for mono stations).

*Stu Engelke, CE  
WWDJ  
Hackensack, New Jersey*

### Editor:

In reference to the engineer in Cochran, Georgia with the CD's that skip, I have found something else that helps the sound of scratched CD's. Try "Armorall" (yes, the stuff you put on car tires to shine them up).

Spray the Armorall directly on the bottom of the CD (where the music is embedded), then wipe gently with a circular motion with a lint-free cloth. I have found that simple procedure saves CD's that I thought would need to be discarded.

It also seems to increase the dynamic range of the audio. I would be interested in others who have tried this and agree. Or maybe a manufacturer that has documented this and agrees or disagrees.

*Glen Dingley, CE  
KHSB  
Alvin, Texas*

**If you have questions  
on equipment problems,  
send them to Radio Guide.**

### Editor:

I need specification on equipment and software for a low cost automation system built around a PC computer, cart decks, cassette decks, CD's, and reel decks.

*Tim Lavender  
WHAY-FM  
P.O. Box 69  
Court Square  
Whitely City, KY 42653  
(606) 376-2218*

### Editor:

Sony does not supply replacement NICAD batteries for the Sony TCM-5000 cassette recorder anymore. If you have a TCM-5000 and need new NICAD batteries, return the dead battery (they need the old case) to:

**Jeff Martin  
Alexander Batteries  
4410 West Elm  
P.O. Box 365  
McHenry, IL 60050  
(800) 323-3813**

Alexander will re-pack your case with 1000 mAh cells for \$20.00 plus handling.

*Marvin Fiedler, CE  
KCOR  
San Antonio, Texas*

### Editor:

I need a schematic and/or technical manual for Western Electric model 451-A1 250 watt AM transmitter.

*Lewis Downey  
KRCL  
208 West 800 South  
Salt Lake City, Utah 84101  
(801) 363-1818*

### Editor:

Just a note to say that the tip, AM Transmitter Tilt Remedy, which appeared in the May 1990 issue of Radio Guide will work as "advertised," except that it could cause problems meeting the NRSC standards in place now. The technique described is known as high-level clipping and was used with high level modulated transmitters years ago.

The difficulty is that the circuit generates harmonics of the audio signals, thereby broadening the bandwidth of the transmitter. The FCC now requires NRSC filtering after audio processing. This circuit will generate frequencies above 10 kHz, which were so carefully filtered out by the NRSC box. The circuit will operate better than a transmitter driven into overmodulation, but not within the range which will avoid second channel interference.

*Edward Schober  
Radiotechniques  
Haddon Heights, New Jersey*

### Editor:

I need a Collins 20-V-3 transmitter technical manual or handbook. This is for a Mexican radio station. Please answer by mail to this address:

*Lucia Lastra  
XETR  
Apdo. Postal #160  
Cd. Valles  
S. L.P., Mexico 79000*

**Get it off your chest.  
Get it in the  
Radio Guide Forum!**

# Tube Topics

## The Care & Use Of Power Tubes From The Publication *Tube Topics* - by Econco

The complete pamphlet "Tube Topics" may be ordered free of charge from Econco. Call (800) 532-6626.

### Tube Installation

Prior to installing a tube, it is wise to inspect the socket to determine if there are any broken pieces of finger stock. Broken pieces of finger stock can fall into the equipment causing shorts and therefore damage. They should be located and removed prior to installation of the tube. Individual finger contacts can break off, on occasion, and as long they are located and removed, the socket ring does not require replacement. If more than 20% of finger stock are broken off, the contact ring should be replaced. Consecutive gaps around the tube can cause improper tuning, instability and lead to premature failure.

Repair kits are available for most sockets from manufacturers. This method is far cheaper than replacing the entire socket. Econco is happy to advise a tube user as to where specific socket replacement parts may be obtained.

### Socket Problems

Loose contact on a tube socket will always lead to problems. Some socket designs have a wire wound spring encircling the outside circumference of the finger stock to increase individual finger contact pressure. These should be replaced if they break or loose tension. Adequate contact pressure is vital for proper operation and long life. Some socket have stops which are set so that the tube has the grid contacts in the middle of the contact area when the tube is fully inserted. This positioning can be checked by inserting and then removing a new tube. The scratch marks

*Radio Guide July-1990 Page-10*

on the grid contacts will show the position of the tube relative to the socket contacts.

### Tube Insertion

Gently rock, and slightly rotate, the tube as it is being inserted into the socket. This helps avoid bending and breaking of finger stock. Be sure to apply sufficient force to seat the tube all the way into the socket. Never use a

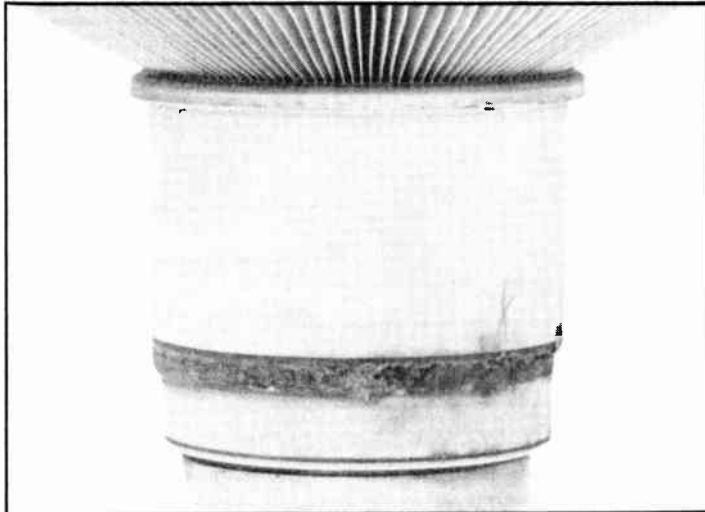

*Burned and melted grid ring on an industrial triode. Failure was caused by poor contact between grid ring and socket.*

lever or hammer on the tube to set it into the socket. Manual pressure should be adequate. An intermediate point is reached when the grid contact finger-stock slides up the tube sides and first contacts the contact areas. It is important to be sure the tube is fully inserted in the socket beyond this initial point of resistance.

### Tube Without Sockets

Many industrial tubes and tubes used in AM radio are not socketed but are installed into the equipment by bolted or clamped connections. Clamped anode connections made of stainless steel should have some method

of strain relief to avoid excess pressure collapsing the anode of the tube, as it heats up in operation. Stainless steel has a much lower coefficient of thermal expansion than copper. All bolted or screwed connections should be tight. It is important to see that the clamps are snug providing good electrical contact around the entire circumference of the contact area.

Due to the radio frequency fields present, all clamps and bolts should be made from non-magnetic materials. Copper, brass or non-magnetic Series 300 stainless steel fasteners are preferred. stainless steel is not a good conductor of electricity and, while used for clamping, it should not be part of the current path.

### Maintenance

#### Heat

With the single exception of the temperature necessary to obtain proper filament electron emission, heat is the enemy of vacuum tubes.

#### Air Cooled Tubes

Air cooled power tubes generally do not require maintenance throughout their normal operating life, provided that the socket is in good condition and the filter on the cooling fan is cleaned or replaced periodically. Most transmitter air cooling is done with squirrel cage blowers. It is extremely important to check the impeller blades on these blowers. The blades can fill with dirt, drastically reducing their efficiency and therefore airflow through the tube. The blades should be scraped with either a screwdriver blade or knife to remove caked on dirt.

## Tube Topics . . . (continued)

In conditions where dirt, bugs and dust are present, the cooling fins on the anode should be checked for dirt. If they are plugged, remove the tube and use an air hose to blow the dirt from the fins. Blow the cleaning air in the reverse direction of normal air flow through the tube. Particular attention should be paid to the area of the tube where the cooling fin is attached to the anode. The greatest blockage occurs at the point where the cooling air first hits the fins. This is also the point of maximum temperature and therefore maximum heat transfer to the airflow.

Air cooled tubes require greater air flow when operated at higher altitudes due to the decreased density of the cooling air. The tube data sheets give correction information for high altitude operation. External arcing at altitude may also require a lowering of plate and screen voltages due to the lower insulating value of air at altitude.

Air cooled tubes should have an air interlock switch on the cooling fan to prevent application of any voltages to the tube unless cooling air is flowing. The switch should be checked for proper operation. The heat generated by the filament alone can destroy a tube without cooling air flow.

AM and FM transmitters should never have air duct work fastened directly to their tops. Ducting increases back-pressure, restricting airflow which can result in excess tube temperature. Some exhaust ducting has fans to help move exhaust air. If not properly designed, they can actually reduce airflow. If this fan fails, it will definitely reduce cooling air flow. In situations where it is felt necessary to install ducting to remove exhaust air, it is advisable to construct a hood over the transmitter with a six-inch open air gap between the transmitter and the duct-work.

### Liquid Cooled Tubes

Water and vapor cooled tubes should be supplied with clean, filtered, low conductivity water -- ideally from a closed system. A strainer should be installed on the tube input side. A screen mesh of 36x36 per inch should provide adequate filtering. The system should be free of solid materials, such as Teflon pipe tape and rust, to prevent blockage of small cooling passages and subsequent tube overheating. A flow interlock switch should be installed on the tube outlet line.

Certain liquid cooled tubes are sensitive to the direction of water flow. The direction of water flow may be a function of whether the tube is mounted

with its anode up or down. Adequate water flow is critical in water cooled tubes to prevent localized boiling and destruction of the tube. Check the tube data sheet for information on direction of flow and cooling water volume requirements.

Vapor cooled tubes require the correct water level be maintained. Scale build-up on the anode should be checked every six months, as scale can destructively reduce the heat transfer from the anode to the cooling water. Water condition is very important in vapor cooled installations. Steam is very active chemically and will react with the materials in the system to form contaminants. **(cont. on page-12)**

# ***ECONCO***

*Now in our 20th year  
providing quality rebuilt tubes.*

**These are a few of  
the tubes we rebuild:**

**3CX2500F3**

**3CX3000A7**

**3CX3000F7**

**4CX5000A**

**4CX15,000A**

**4CX3000A**

**WE BUY DUDS.**

**WE ALSO REBUILD REFLEX KLYSTRONS.**



**ECONCO**  
1318 COMMERCE AVENUE  
WOODLAND, CA 95695  
Phone 916-662-7553

**OUTSIDE CA 800-532-6626 EXT. 30**  
**FROM CANADA 800-848-8841**  
**TELEX 176756**  
**Fax 916-666-7760**



# Tube Topics . . . (continued)

## Tuning

Each equipment manufacturer provides instruction or guides for proper tuning and operation of their equipment. They should be followed closely when adjusting the equipment. The power tubes in the equipment should be operated at their rated filament voltage whenever tuning or adjusting the equipment, and not at reduced levels. This assures adequate emission levels from the tube making performance levels which should be achieved by proper tuning and adjustment. After all adjustments are complete, the filament voltage may be set as described in the "Normal Tube Operation" portion of this booklet, to achieve maximum tube life.

## Normal Operation

Whenever a tube is received from the supplier, it is a good idea to inspect the package and check the tube for physical damage as soon as possible. Tubes are very fragile and subject to shipping damage despite the care taken in packaging. Open the box and remove the tube. A check with a VOM can make a quick evaluation for broken filaments. Lay the tube on its side and check for continuity (a very low resistance) between the two filament contacts. The filament contacts should indicate a "short" as the filament circuit is of very low resistance when cold. Also check to see that there is no continuity (open) between either filament connection and the other tube elements. The only continuity should

be between the filament contacts, with all other elements being electrically isolated from the filament and each other. If the tube shows a short, contact the supplier. Do not attempt to install it.

## Filament Voltage

The proper adjustment and regulation of filament voltage is the single

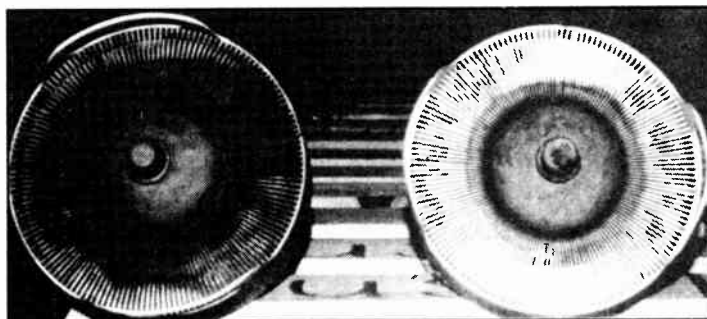

*Comparison of normal heat dissipation on anode on the right versus indication of excessive dissipation on the anode on the left. Cause is either restricted cooling air flow or improper loading.*

most significant area where tube users can affect the life and performance of their tubes.

## Metering

The metering of filament voltage, on the majority of equipment, is not accurate. Often, the metering is a multimeter which is switched to read various operating parameters. To be useful for filament metering, the meter must be calibrated to read voltage at the tube socket and must be capable of being read accurately to one-tenth of a volt. Often the filament voltage is measured at the input to the filament transformer. In high current circuits, such as the filament, the voltage drops in the wires going to the tubes can be significant.

All filament meters should be calibrated with an accurate iron vane or RMS reading digital meter.

The object is to determine the heating value of the power being supplied to the filament. The calibration voltage should be taken at the tube socket, or connection, with the filament operating. This will compensate for any line drop losses. In locations where the line voltages fluctuate more than 5%, the supply to the filament transformer should be equipped with a constant voltage transformer (such as Sola Transformer). The diagram is a filament supply circuit capable of precise adjustment over the most beneficial range. It assumes a 240 volt supply to the circuit.

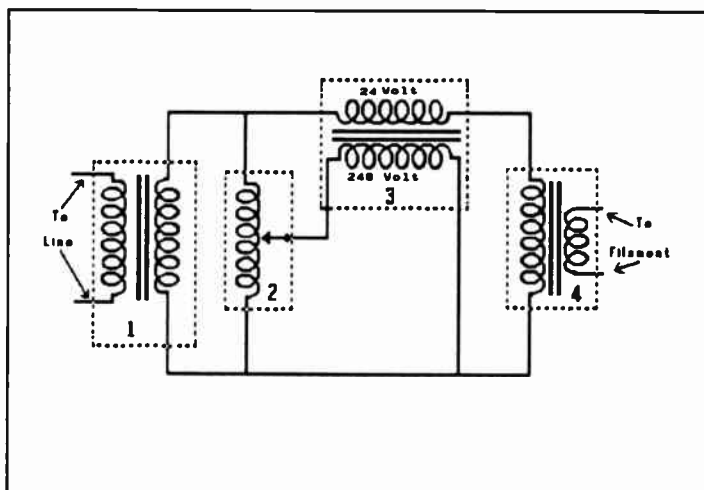

**Schematic diagram for an optimum filament voltage supply circuit.**

1. "Sola" constant voltage transformer connected to supply. Sized for KVA rating of filament.
2. "Variac" variable auto transformer controlling a "Buck/Boost" transformer. KVA rating equal to 10% of filament KVA.
3. 240 to 24 volt secondary fixed transformer. KVA rating => 10% of filament KVA.
4. Existing filament transformer.

The variable transformer should be mounted such that it is adjustable from the control panel of the equipment. This will allow adjustment of the filament voltage, while the equipment is operating, for proper tube operation and as an aid in trou-

## Tube Topics . . . (continued)

bleshooting. Unfortunately, many transmitters (and most industrial equipment) are built with a filament transformer which has, at the most, taps located inside the equipment, for the adjustment of filament voltage. We recommend that, if the equipment is operated for long periods, the filament circuit should be modified as shown.

### Filament Operation

The thoriated tungsten filament used in vacuum tubes depends upon sufficient filament temperature to provide adequate electron emission for normal operation. Power tubes should not be operated in the emission limited mode! The use of filament voltage to control output power is not the correct method of operation. It will destroy a tube quicker than operation at over-voltage.

The operator, by adjusting the filament voltage, can control the operating temperature. Each tube is unique; while one tube may make full operating power at a filament voltage of 7.3 volts, its replacement may require 7.4 volts to attain the same power. It is for this reason, we recommended that all tuning be done at the rated filament voltage. After tuning is complete, then the filament voltage can be reduced to provide extended life.

Though cathodic type tubes can be damaged by operation of the heater at reduced filament voltage, we have never seen a case where operation, at proper reduced voltage after tuning, is anything but beneficial to directly heated filamentary tubes. It is important to operate the tube at rated voltage for the first 100 to 200 hours before reducing it as described in the next section.

### Initial Operation and Tuning

Upon initial installation, the filament should be run for a period of 100 to 200 hours at its rated filament voltage. This initial operation allows the getters (materials which absorb and hold residual gas) to finish the vacuum of the tube in its actual operating envi-

ronment. After this initial run-in time, it is excellent practice to operate the filament at reduced voltage, provided that proper operating parameters can be obtained at the reduced voltage.

First, tune and run the equipment to normal operation with the filament at rated voltage. Then, without changing any other adjustments, reduce the filament voltage until the tube deviates from normal operating conditions. This point is the beginning of emission limited operation. Continued operation at this point can be destructive to the tube. Raise the voltage to one-tenth or two-tenths of a volt above the lowest voltage where the tube worked properly. This should maximize tube life at no reduction in performance. The one-tenth to two-tenths setting above the emission-limited voltage, allows for minor line fluctuations and requires less frequent adjustment as the tube ages.

A power tube operated in this manner will generally yield life 50% greater than a tube run continuously at rated filament voltage. If the tube is removed and then replaced, it is not necessary to run it at rated voltage beyond the time necessary to tune the equipment.

FILAMENT LIFE versus PEAK FILAMENT EMISSION  
Typical 4CX5000A

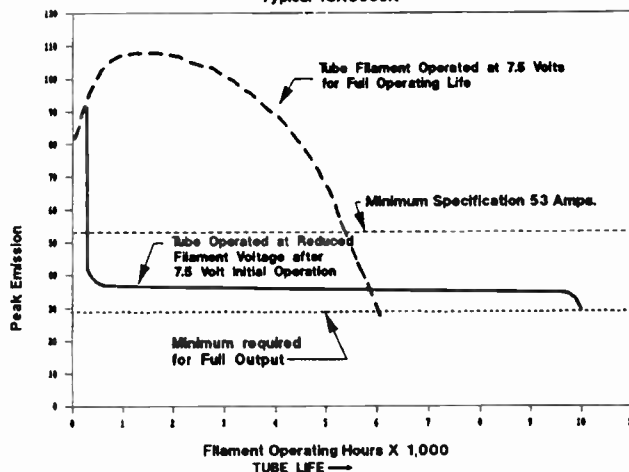

The "Write" Stuff  
Send Your Tech-Tips  
To Radio Guide  
or Fax Them to  
(507) 280-9143

## POWER-side™

### PROBLEMS

- Adjacent Channel Interference
- Antenna Null Distortion
- Co-Channel Interference
- Power-line Re-Radiation
- Building Re-Radiation
- Receiver Tuning
- Low Fidelity Home Radios
- Co-Channel Beat
- Selective Fading

### SOLUTION!

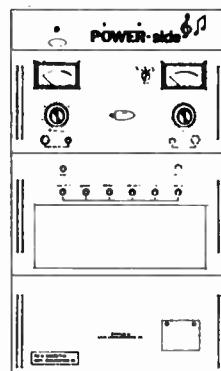

### POWER-side™

The solution to many of AM radio's most serious technical problems

From the developers of the AM STEREO system that isn't afraid of the dark  
and will let you drive right past FM Stereo

425 MERRICK AVENUE, WESTBURY, NY 11590 • (516) 222-2221



# Marti TSL System Retrofit

## 8 kHz Filters Reduce TSL Interference

By William Collindres - Marti Electronics  
Cleburne, Texas (817) 645-9163

An FCC Rule Part 74 TSL, transmitter/studio link, is a valuable tool for the broadcaster. It allows him to bring back remote control data or voice quality audio from the transmitter without using the valuable main channel sub-carriers. Also, if the main transmitter goes off, you still can have control over the remote control when using a TSL return link.

The major problem with a Part 74 TSL, or "P Channel," is that there are only 8 channels available for use in the US for all 10,000+ radio stations and 1100+ TV stations. That means that there is a lot of overcrowding in that band in most medium to large

markets. The over use of the "P Channels" can cause some problems when several stations are crowded in together, geographically.

Many times a TSL receiver will work great for years until someone turns on an adjacent channel transmitter. The adjacent channel could then cause interference with the existing channel and corrupt the returned remote control data.

Marti Electronics has been supplying Part 74 "P Channel" TSL systems for quite sometime and has encountered the interference problem more than once. Although there is no cure for someone being on your exact

channel, other than cross polarization of antennas and the hope that they are aiming their transmit antenna away from you, we can help with adjacent channel problems.

Normally we ship our TSL systems with 25Khz filters in the receivers. This allows for maximum deviation on the P Channels and is an easier system for the average engineer to maintain.

If you have a Marti TSL system and are getting adjacent channel interference and since you are an above average engineer (you are reading Radio Guide after all),

there is a cure for the interference.

You can retrofit your existing system with 8kHz filters that will only hear your channel and reject adjacent P Channel interference. The 8kHz filter will reject a channel just 10kHz away and properly clean up any adjacent channel interference.

The procedure will require retuning the TSL transmitter to its exact frequency, cutting the deviation slightly and re-tweaking the distortion in the receiver.

The cost of the 8kHz filter is based on a 1/2 price exchange of the filter for your particular receiver. If you want to have us do the work, it will be the 1/2 price exchange and a \$35.00 service charge.

**For more information call**  
**Marti Electronics**  
**(817) 645-9163**

## IT'S METAL!

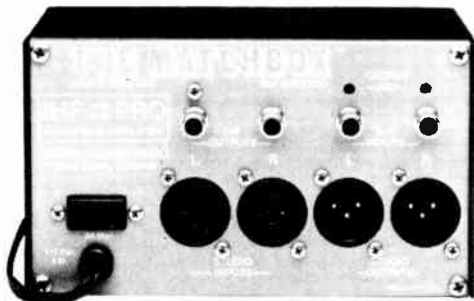

### THE MATCHBOX IS IMPROVED!

The industry's most used level and impedance converter has been updated, with an all-metal chassis, gold-plated RCA connectors, and new XLR's. The metal box keeps out hum, noise, and RF. The new connectors keep the audio clean. The only thing we didn't "improve" was the price!

**HENRY ENGINEERING**  
**(818) 355-3656**

**We Build Solutions**

## Are You a Writer?

Radio Guide  
is looking for  
monthly columnists.

We need writers  
in these areas:

RF Transmission  
FM Antennas  
AM Antennas  
AM DA Arrays  
AM Transmitters  
FM Transmitters  
STL/TSL Remote Ctrl.  
Transmitter Audio



# The Thin Green Line

By Art Reese, CE - Satellite Music Network

Mokena, Illinois (708) 479-1717

For those who've spent the last year in the Sahara, several people who consider themselves real audiophiles (including a couple of SMN staffers) actually swear by the idea of putting a green permanent marker line around the inside and outside edges (only) of the compact disc. *not* on the flat surfaces, just on the edges -- the thin plane.

Does it work? It does seem to clean up the sound enough for the virgin ear crowd (including some of your listeners?) to notice on their high-priced stereo systems.

Why does it work? Well, think of it as a form of optical multipath, with an assist from the principles of fiber optics. In the case of the compact disc, not only does the laser light go through the disc and bounce off the aluminum back to be retrieved by the sensor, it also propagates through the disc and bounces off the inner and outer edges of the disc, also to be picked up by the sensor.

There are two ways of eliminating the problem. The first is to round off the corners on the edges of the disc, a practice not recommended for consumers, but already done by some recording companies in their disc construction. The second is the green line on the edges. The red-end spectrum absorption powers of the green marker almost eliminates the propagation of stray laser light back to the sensor, and that's all it takes.

Listening tests were conducted on two identical compact discs, one treated with this "green line" method and one without, by Stardust Manager Dave Allison at the SMN studios. The results have been convincing.



## CRL SPOTLIGHT

### Upgrade your FM Stereo Generator with the CRL SG-800A



Your stereo generator is an important part of your overall on the air quality. Older generators can often color your audio because they can not handle dynamically processed audio very well. The digitally synthesized CRL SG-800A produces a flawless composite baseband signal. Our unique low distortion pulse amplitude modulator ensures maximum stereo separation (60 dB typical). The SG-800A is also available with two low-pass filter options, including the new CRL DSP-1 digital low-pass filter. The price of the SG-800A starts at \$1795. Our two week trial program will let the SG-800A prove itself to you. Call or write us for details.



#### Circuit Research Labs, Inc.

2522 West Geneva Drive  
Tempe, Arizona 85282-3192 U.S.A.  
(800) 535-7648 (602) 438-0888 FAX (602) 438-8227  
Bulletin Board System (602) 438-0459

**If This Issue Isn't Yours**

**Call Radio Guide at (507) 280-9668 to get your own subscription**

# The Folded Unipole Antenna for AM Broadcasting

## A Broadband Alternative to the Series-Fed AM Antenna

By Ron Nott - Nott Limited  
Farmington, New Mexico (505) 327-5646

As the technology of electronics and broadcasting continues to improve, it allows the AM broadcaster to increase transmitter modulation and process the audio to try to cover the greatest area and attract the greatest listenership. Improvements in transmitters and audio equipment have given us much more capacity to do these things, but the end result must still be fed into the RF system to disseminate the signal through space to the listeners. If the RF system, which includes antenna, tuning unit, transmission line and transmitter output network, does not have broad, symmetrical bandwidth and good impedance matching, all ones efforts and new equipment may be wasted. As electronic equipment continues to improve, development continues in the RF system, as well.

### The Antenna

In the past, it has been traditional to just build a tower, measure the impedance and adjust the antenna tuning unit to present the proper impedance to the transmission line at the carrier frequency. Sometimes the results are very good; and sometimes they are not good at all. The impedance and bandwidth of a conventional series-fed tower cannot be adjusted. The impedance can be estimated by the height of the tower and the bandwidth can be improved by building a large cross section tower. Sometimes there are constraints that limit the height of the tower. And a thin tower is much less costly than one of large cross section, so it may be necessary to have a thin and/or short tower that does not provide optimum performance.

Radio Guide July-1990 Page-16

The resistance decreases rapidly when a tower is less than a quarter wavelength in height. This can cause an inefficient, narrow band RF system that is very poor in performance. There may also be instances when a tower could be utilized as an AM antenna, except that it is too tall (more than  $5/8$  wavelength), and if it has FM, TV or other antennas on it, it does not have a base insulator. Even if it has a base insulator, the VHF and UHF antennas must be fed through expensive isocouplers.

What is needed is an AM antenna that is on a grounded tower and has adjustable input impedance and broad bandwidth. It should also have the capacity to be easily sectionalized for tall tower applications.

### Enter the Folded Unipole

The folded unipole has all these features, is easily installed and tuned and may be employed at a very reasonable cost. The first of many advantages is that the tower is grounded. In lightning areas this allows immediate drainage of static electricity. If the tower is struck, most of the lightning pulse goes directly to ground. The cost of the base insulator is eliminated. Isocouplers may be eliminated if VHF or UHF antennas are on the tower.

The next important advantage is the inherent broad bandwidth of the unipole. Because the skirt causes the effective antenna diameter to be large, the height to diameter (H/D) ratio is much reduced over a thin tower. This relatively low ratio contributes to a naturally broad bandwidth for the antenna.

An additional benefit is that the velocity of propagation within the antenna is reduced, allowing an antenna to perform as if it were about 90 degrees tall. This is not a lot, but it can be important if you are required to reduce antenna height near an airport. When the unipole is combined with a capacitive hat, a short tower can become a good antenna.

### The Unipole is Tunable

Another important advantage of the folded unipole is the adjustable input impedance. A series antenna has an impedance fixed mainly by its height, but the unipole is adjustable throughout a wide range. The height of the upper commoning ring and its tap may be adjusted up or down to get the desired results. The two most popular methods are:

1. Adjust the height of the commoning ring to present 50 ohms resistance at the feed point. Depending on the antenna height and geometry, the reactance will usually fall within the range of 200 to 350 ohms positive. This means all that is required is a series capacitor (preferably adjustable) of equal reactance. The input to the capacitor will then present an impedance of 50 ohms plus zero reactance, a good match to most coaxial cable. Note that an antenna tuning unit is optional, depending on what you choose to do.

2. Adjust the height of the ring upward until zero reactance is found. the resistance will usually fall into the range of 110 to 125 ohms which is matched with an antenna tuning unit (ATU), preferably broadbanded. This may not be possible with electrically

short towers (less than about 75 degrees). This principle is part of the Howard method, developed by Mr. George Howard, engineer, Sarasota, Florida. Combining the Howard method with a broad band ATU may well be the ultimate method for broad, symmetrical bandwidth.

It should be noted that most stations that have installed the folded unipole have an immediate improvement in their over-the-air sound quality. The sound is rich, fuller and seems to have a penetrating quality which improves the effective range of the station. This has been noted, whether the station is directional or non-directional. It should be mentioned that the unipole performs very well in directional antenna systems because, when properly designed and applied, it is a very broadband, stable element.

### Transmitter Site Consolidate

Consolidation of AM and FM transmitter sites is becoming popular, and the folded unipole antenna services very well in this service. If a station has built a tall FM tower, with traditional methods it would not be suitable for an AM radiator as is. However, a folded unipole would allow it to be utilized for the AM transmitting facility. If, for example, the FM tower is  $3/4$  wavelength at the AM frequency, the unipole is easily sectionalized by inserting fiberglass insulators in the skirt wires. The lower portion then becomes the AM antenna. The upper portion is detuned to make it "disappear". That is, it may be de-resonated to eliminate AM current from it. For instance, if the lower portion had been sectionalized at  $3/8$  wavelength, the facility would perform as if it were a  $3/8$  wavelength antenna while the upper portion of the tower, being detuned, would contribute nothing to the AM field.

While this may sound like a complicated process, it is not. Sectionalizing an AM tower is an expensive and difficult procedure, but sectionalizing a folded unipole is simply a matter of inserting the fiberglass insulators into the pre-cut skirt wires furnished in the kit. The lower portion is tuned as a

conventional unipole while the upper portion is detuned with its own reactance in a weatherproof housing on the tower near the insulators. It may also be tuned conjugately through a length of coaxial cable, the reactance then being placed in the ATU housing or in the transmitter building

An FM tower has been used as an example. A TV broadcast tower or a communications tower could be used just as well. Any tall structure can be tuned to become an antenna with a unipole and conversely, any tall structure may be detuned with a unipole type detuning skirt.

(continued on page-18)



# CRL SPOTLIGHT

## Upgrading your FM Processing?



The CRL FM1G audio processing system is the perfect answer for those of you with a small budget, but a large budget need for FM processing. With the FM1G you get the market's cleanest limiter, the SMP-850, followed by the SG-800A digitally synthesized stereo generator. The SMP-850 features a powerful input compressor, followed by our exclusive variable transfer function pre-emphasis limiter. Image widening stereo sound field enhance circuitry is standard equipment. The SG-800A's digital pulse amplitude modulator produces a flawless baseband stereo signal. Find out what the FM1G can do for you. We have a two week trial program available. Call or write us for details.



**Circuit Research Labs, Inc.**  
 2522 West Geneva Drive  
 Tempe, Arizona 85282-3192 U.S.A.  
 (800) 535-7648 (602) 438-0888 FAX (602) 438-8227  
 Bulletin Board System (602) 438-0459



## Folded Unipole . . . (continued)

### The Detuning Skirt

If your AM station suffers from problems of re-radiation from objects in its near field such as power line poles or towers, water tanks, bridges, etc.,

any of them may be de-tuned with a de-tuning unipole skirt to return your antenna pattern to normal. The folded unipole is a very versatile device, capable of solving many problems for the AM broadcaster. The unipole is a tunable antenna and the only difference between its use as an antenna and as a detuning skirt is the way it is tuned. It has successfully been used to detune

an FM tower located in the middle of an AM directional array.

### More Advantages

If a tower is required to have obstruction lighting on it, the folded unipole allows the elimination of lighting chokes or transformers as well as horn or ball gaps. Getting rid of the base insulator eliminates the need for all of these devices in addition to eliminating isocouplers. If an existing series fed tower is converted to a unipole, the base insulator is bypassed with lengths of copper strap supplied with the kit.

Although the unipole may not be well known, it has been in service in AM broadcasting for more than 40 years. Its advantage of broad bandwidth was not appreciated until competition for FM became serious. AM radio has the capacity to sound almost as good as FM, provided that its RF system is of broad bandwidth and the AM receivers are equally broad in their reception.

Its hard to control the quality of receivers, but a broadcaster can improve the quality of his transmission with good audio equipment, a broad-band transmitter and a quality broad-band RF system. All the components must be viewed as a system. Installing a new audio processor is like putting a patch on an old blanket. It may help, but if the processed audio cannot get through a narrow band RF system, the full value of the new processor will not be realized.

Converting an existing AM antenna to a folded unipole is a minor change as far as the FCC is concerned, but in light of the AM freeze you should contact your consultant if you're considering the change. Moving an AM antenna to an FM site would be a different situation. Again, call your consultant.

Look at your entire RF system and test it. If you think there may be weak links in the chain, contact Nott, Ltd. They can provide assistance in improving your facility to the point where you can be assured you are broadcasting excellent audio quality as well as getting maximum range.

## CRL SPOTLIGHT

Audio Noise Problems?  
...Your solution is  
a **dynafex®**  
noise reduction system.



Ever wished for a simple, yet effective way to remove audio noise? Our **dynafex®** system is a unique combination of downward expansion and dynamic audio filtering providing up to 30 dB of noise reduction. To use, set the threshold that you want **dynafex®** to start working at—then listen to how quiet things get. Plus, because **dynafex®** is a single ended system, it will remove noise from sources that compounded systems cannot. Thought of some noisy applications?

We offer two models: Our DX-1 (mono) is for mic. or line level sources, and features extended threshold range. Our DX-2 (stereo/2 channel) is for line level applications. Find out how much noise **dynafex®** will make you miss. Call or write for more information. Our units are also available on a two week trial.

dynafex® is a registered trademark of CRL, Inc.



**Circuit Research Labs, Inc.**  
2522 West Geneva Drive  
Tempe, Arizona 85282-3192 U.S.A.  
(800) 535-7648 (602) 438-0888 FAX (602) 438-8227  
Bulletin Board System (602) 438-0459

# Laws for Broadcast Engineers

*By Mel Crosby - Sequoia Electronics*

1. If anything can go wrong, it will. Everything goes wrong at once. If there is a possibility of several things going wrong, the one that will cause the most damage will be the one to go wrong first.
2. Whenever you set out to do something, something else absolutely must be done first!
3. It is impossible to make anything foolproof, because fools are so ingenious.
4. There is always an easier way to do anything. When looking directly at the easier way, especially for long periods, you will not see it.
5. Anytime things appear to be going better, you have overlooked something. If you explain so clearly that nobody can possibly misunderstand, somebody will.
6. If you do something you are sure will meet everyone's approval, someone surely won't like it.
7. In case of doubt, make it sound convincing. When forced to choose among alternative courses of action, most people will, unflinchingly, choose the worst one possible.
8. A wire cut to length will be too short. A fail-safe circuit destroys others. Interchangeable parts won't.
9. Every device protected by a fast-acting fuse will protect the fuse by blowing first.
10. After a unit has been re-assembled, extra components will be found on the bench.
11. You will always find lost things in the last place you look. Things always fall at right angles.
12. Any device requiring service or adjustment will be least accessible.
13. If you keep anything long enough, you can throw it away.
14. If you throw anything away, you will need it as soon as it is no longer available.
15. You get the most of what you need least. If you want to get along, go along.
16. Once you have exhausted all possibilities and fail, there will be one solution, simple and obvious, and highly visible to everyone else.
17. Put away a tool you are certain you are done with, and you will need it again, instantly.
18. If it jams, force it. If it breaks, it needed replacement anyway. If you mess with a thing long enough, it will break. Don't force it: get a larger hammer.
19. There is never time to do it right, but there is always time to do it over.
20. All great discoveries are made by mistake. An ounce of image is worth a pound of performance.
21. No matter how much you do, you will never do enough. What you don't do is more important than what you do do.
22. The man who can smile when things go wrong has thought of someone else he can blame it on.
23. Nothing gets built on schedule, or within budget, but it always works better if you plug it in.
24. Any tool, when dropped, will roll into the least accessible corner of the shop.

# Constructing A State-of-the-Art 50 kW Stereo AM Station

By Frank Berry - WQYK-AM  
Tampa, Florida (813) 576-6055

On November 23, 1987 at 2:45 p.m., Infinity Broadcasting Corp. became the owner of WCBF, Tampa. My first official duty as Director of Technical Operations was to voluntarily take the station off the air as it would remain pending a total technical renovation. Our sign-on target date was April first-ish. This is a diary of the renovation.

## Inspection of Facilities

From a purely technical standpoint, and in my opinion, the station was unsafe and illegal. The studio facilities consisted of a very old RCA console, Ampex 351 and Tascam tape machines, two Technics turntables two Technics cassette machines and three BE cart playback decks. Not a single machine operated properly. The console was putting out 120Hz power supply hum at a level roughly 15dB below the program output level and would occasionally begin to motorboat, pegging the VU meters.

The transmitter plant was equipped with a Continental 317C and a Harris BC-5H transmitter operating into an antenna phasing system that could best be described as "wanting," (and that is a charitable assessment), to borrow a phrase from our consulting firm, Jules Cohen and Associates. The phasing equipment was not shielded, RF lines terminated outside the phasor cabinet and the input matching network was mounted on top of the 50 kW phasor. There were no interlocks to prevent access during normal operation.

The transmission lines were a mixture of rigid 3-1/8", rigid 1-5/8", 3" Heliac, 1-5/8" Heliac, 1/2" Heliac and a short piece of 4" Heliac, all tied together to somehow get the signal from the phasor to the towers. Some were

above ground and some were buried just under the surface. All lines leaked at a rate of slightly more than one tank of nitrogen per day! The dehydrator was not functioning, possibly due to being over-worked.

The antenna turning units were of standard design but were undersized for the power levels at which the towers operated. Daytime ATU's were located inside small block buildings at the base of the towers while nighttime ATU's were located in plywood huts, attached to the outside walls of the daytime ATU buildings.

RF wiring between daytime and nighttime ATU's was run in such a manner as to require that the operator reach across a live conductor to take base current meter readings!

The station towers were far undersize for their heights and in bad physical condition. Replacement was obvious. Fences around the towers were 4' in height and located in such close proximity to the towers and ATU buildings as to allow you to reach across the fences and touch the RF lines feeding the towers.

The ground system appeared to be in repairable condition though it was not connected to the transmission system except at the ATU's. There was no copper strap running from the tower bases into the transmitter building.

The station was not making licensed pattern even though the pattern had recently been augmented by as much as 100% in certain directions!

Thorough inspection revealed some severe problems with the transmitters. It was my decision to rebuild them and hope that the repair costs wouldn't exceed their replacement costs. Everything else in the station was thrown out, sold, traded or put into storage.

## Repairs to the Transmitters

The Continental transmitter was the first repair job we tackled.

I must take a moment to say "thanks" to Juan, Mike and Gary from the parts department at Continental Electronics. They were able to supply me with some transmitter parts that have not been used in fifteen years. For the first few weeks of the repair project, each time I called for parts and told them that I had a 317C transmitter, they asked whether it was a 317C-1 or a 317C-2. I told them it was a 317C period. I gather that there are not many of these transmitters left in operation and I appreciate their help in chasing down parts.

We began by stripping the transmitter cabinets of most parts, being sure that all coil taps were carefully marked! We were able to obtain 10 gallons of the strongest industrial cleaner I have ever seen. Its use required that we wore rubber gloves but it certainly did clean up the grime and accumulated crud. All silverplated coils, vacuum capacitors and mounting hardware were cleaned and then polished with commercial grade silver polish.

Diode stacks, resistors and other components (except transformers and chokes) were dipped in a bath of commercial cleaner and water, scrubbed down using brushes and then hosed with pure water and air dried for a minimum of two weeks before being re-installed in the transmitter. Transformers and inductors were cleaned with compressed air and then sprayed with a clear plastic coat to help prevent moisture from damaging them until the transmitter was ready to be powered back up.

A total of perhaps \$85,000 was spent on replacement parts for the 50



kW transmitter. Some of these parts included a new HV plate transformer, new tubes and all around new sockets for the 4CX35000 PA tubes, hundreds of new resistors, RF chokes, capacitors, diodes, insulators and lots of missing hardware.

The Harris BC-5H transmitter was less costly to repair but was actually a bigger headache because it was never properly tuned to operate at this frequency. As originally shipped, the transmitter operated on 620 kHz. On it's present frequency of 1010 kHz, many frequency determining parts were the wrong value. This required a complete re-tune before we could reasonably expect the transmitter to perform as it was intended.

It was at that point we discovered some major transmitter problems. There was no PA bias; the supply had been disconnected to reduce hum and noise caused by bad filter capacitors in the power supply. The modulation reactor had a few shorted turns which caused some modulation spikes in the negative direction. Transmitter carrier shift was in excess of 7% due to a bad 3rd harmonic resonator in the plate circuit and a PA plate suppressor that tended to resonate at some harmonic of 1010 kHz. The resonator was replaced and the suppressor was removed and replaced with a smaller coil value. The transmitter was completely re-tubed.

### Tower Replacement

Prior to taking the three towers down, I hired a firm to survey the tower spacing, orientation and plumb. They reported that the towers were located in their correct positions, but the two end towers were leaning -- in different directions. Perhaps this was why the pattern was out. I placed an order for new Allied towers. I required towers of solid galvanized steel construction with 24" faces and required that one tower be able to support two 6" grid dishes and a single 450 mHz Yagi for the TRL. I further required that the tower holding the extra antennas be star guyed at the antenna level and that all guys be Phillystran. At the advice of Allied, we measured the dimensions of the existing tower foundations and anchor points and determined that while the foundations were adequate to support the additional weight of the towers, the anchors were not. All anchor points were replaced with foundations 100% over the size necessary to provide safe guying.

### Security Fences

Following a conference with WQYK GM, Charlie Ochs, it was decided that we would construct a 6" chain link fence around the entire property and provide a single, locked 12" gate for entrance. It was also decided that this fence should have links

(continued on page-22)



## Recycle Carts

to reduce audio tape and cartridge costs

Improved Tapecaster® X-100 cart loader with single lever control enables error-free loading to one-second tolerance. Long-life, heavy-duty synchronous motors and rugged all-steel chassis and top deck make X-100 the only loader you'll ever need. Among its features are:

- Adjustable tape tension
- Precision electronic timer with automatic reset
- Editall splicing block

For complete information call or write.

**TAPECASTER®**

a division of



**Auditronics, Inc.**

3750 Old Getwell Road • Memphis, TN 38118  
Phone: 901-362-1350 • FAX: 901-365-8629

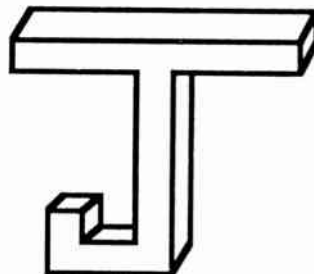

**SQUARED** →  
TECHNICAL SERVICE

543 West 100 North  
West Bountiful, Utah 84010

801-298-8515

### Equipment Repair and Calibration

*We service most AM/FM broadcast monitors, remote control systems, excitors, STL's, TSL's RPU's, Etc.*

**Give Us A Call  
Check Our Rates  
STL Loaner Program**

## 50 kW AM . . . (continued)

welded together at the top and bottom to insure good electrical connection between links and that the fence should be bonded along the bottom to the station ground system using copper straps. These measures would, hopefully, reduce arcing between links and, therefore, reduce the radiation of harmonics.

The task of constructing 4500' of chain link fence is not a small one. The task of welding all links together, galvanizing the welds and then brazing the

fence to the ground system made the job far more difficult and grossly more expensive.

### Phasing and Termination

Alan Gearing of Jules Cohen and Associates designed the antenna phasing and termination equipment for us. The system was designed for AM stereo and was, therefore, very wideband with symmetrical sidebands. It was designed to handle two daytime transmitters and two nighttime transmitters any one of which can be switched into the day pattern. The night pattern, non-directional into tower #2 with towers #1 and #3 detuned or non-directional

into tower #3 with towers #1 and #2 detuned, can be driven only by the nighttime (5kW) transmitter inputs. The design also provides the switching to put any transmitter into the dummy load. Kintronics constructed the phasing and termination equipment as per Alan's specs. I'm sure Tom King of Kintronics got plenty of gray hair over the control ladder for this system. Thank you, Tom.

### Transmission Lines

At the advice of Bernie Segal of Jules Cohen and Associates, I ordered Andrews 2-1/4" Heliac transmission lines. Since these lines were to be buried, we chose Heliac rather than rigid transmission lines. At 50 kW, the center tower carries slightly over 33 kW of power. Bernie felt that the 2-1/4" lines were large enough to handle the voltage and current, but I felt it was necessary to pressurize the lines with sulphur hexafluoride rather than nitrogen. Sulphur hexafluoride increases the voltage flashover point by roughly 500% and, even at a cost of \$1400 per tank, as compared to \$13 per tank for nitrogen, the cost is far less than the cost of replacing a 650-foot transmission line. At the time of this writing, no transmission line failures have occurred.

### Building Renovations

We began the building renovations by disconnecting all transmitting equipment and removing all equipment that would not be re-installed. We then removed all electrical service to the transmitter portion of the building. The existing transmitter room was, in my opinion, too small to comfortably hold the equipment that we would be installing. All rooms adjoining the transmitter were stripped and all interior walls were removed, giving us a transmitter room that measured 35 x 25 feet.

In the original 1959 installation, the transmitter room was designed to house a water cooled 50 kW transmitter. This transmitter required the inclusion of a small basement to house the pumps, pipes and various plumbing devices necessary for water cool-

## Audible Improvement!

### FM

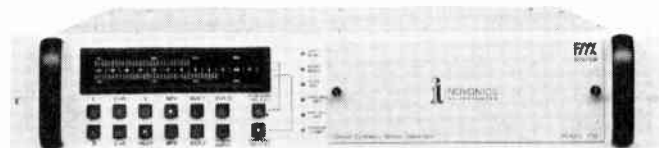

Our 706 FM Stereo Generator maintains 16kHz response and 75dB separation through *digital synthesis* of pilot and subcarrier. This assures **full modulation** with an *inherent* low residual above 54kHz, though an adjustable pre-pilot composite clipper is included.

The 706 also features internal combining and metering of up to 3 SCA/RDS channels, and has two independent composite outputs. It is 100% - compatible with *your choice* of audio processing, and the FMX™ System is a plug-in option.

### AM



Inovonics' 222 is the simple, effective and affordable path to NRSC compliance. Its built-in peak control, adaptive preemphasis and no-overshoot 10kHz filter make you *sound better* too!

## Inovonics Inc.

1305 Fair Ave., Santa Cruz, CA 95060

CALL: 1-800-733-0552 – FAX: (408) 458-0554



ing. Upon inspection of the flooring, I nearly fell through the floor into the basement. The existing lumber was dry-rotted. We replaced the existing 2 x 8 wood support beams and 3/4" plywood flooring with a new 2 x 12 pressure treated beams over-which we laid 3/4" marine plywood flooring. This provided the support necessary for the 50 kW transmitter, the 5 kW transmitter and the phasing cabinets, and allowed us to route all cabling through the basement.

Room size permitted the installation of all transmitters and phasing equipment in a single line in the center of the room, over the basement. An insulated, soundproof wall was constructed just behind the front edge of the transmitters and phasor. The 50 kW power supply cabinet and Continental dummy load were located behind the transmitters over floor trenches running to the basement for power and control wiring.

Three equipment racks were installed in front of the transmitters and phasor. These racks were located directly in front of the phasing cabinets to permit easy monitoring of the system parameters as the phasor was adjusted. All power, control and metering RF and audio wires enter and exit the racks through a trench into the basement. All RF transmission lines enter the building through a trench into the basement and then up through the bottom of the phasor. Sampling lines enter the building with the RF transmission lines, run through the basement and enter the racks by way of the trench.

### RF Tuneup

My hat again goes off to Al Gearing. He was able to achieve the licensed daytime pattern in three tries! While this pattern is not critical, it has some very tight nulls. He obtained the licensed nighttime pattern in only four tries. All during the construction process, I was worried that everything would fall apart when we tried to tune up the pattern. This simply did not happen. Thank you Al!

### AM Stereo Conversion

When management decided to operate this plant in stereo, I had some misgivings about how the old transmitters would perform. I was mostly concerned with the IPM figures we would likely see from the Continental 317C transmitter and how they would compare to the performance of the simple plate modulated Harris. It was for that reason, and the possibility that some mods would have to be made to the stereo exciter for the 50 kWw Continental, I decided to purchase two C-QUAM exciters, one for the 50 kW and one for the 5 kW.

I chose to use Delta exciters because of my good experiences with Delta equipment. When the exciters were connected to the transmitters, I was impressed. The Harris transmitter took right off and performed beautifully with just minor tweaking of the exciter equalizers. The Continental exhibited excessive IPM in the form of a strangely crooked L+R baseline when viewed on our phasescope. The transmitter didn't sound too bad (in fact it sounded good), but the IPM looked bad. We were finally able to trace the problem to a capacitor missing from the carrier grid of the transmitter. The purpose of this capacitor is to keep modulation off the carrier control grid while allowing the peak grid to modulate slightly, improving the modulation linearity.

The Continental 317C is now performing quite well with just a touch of IPM (actually less than the Harris BC-5H). Oh yes -- we did make deadline. At exactly 12:00 noon, April 1, 1988, WQYK-AM signed on with a dedication ceremony transmitted live from that AM transmitter plant on both WQYK-AM and WQYK-FM.

Do You Know Someone  
Who Can Use  
Radio Guide?

Send Us Their Name  
We'll Get Them on The List



# Puts your signal in it's place!

If you need a quality antenna, you need:  
**JAMPRO ANTENNAS, INC.**  
The really experienced one for over 30 years.

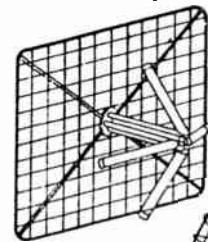

JAHDCP  
Arrowhead  
Screen Dipole

JSDP CP Spiral  
Broadband Antenna

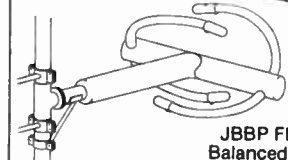
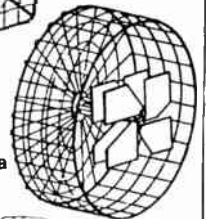

JBBP FM Antenna  
Balanced Excitation

**JAMPRO** is the world leader in custom-designed, directional, CP antennas.

- With over 1600 of our penetrators delivered, more stations have penetrated their market.
  - Our custom-made directional antennas are operating world wide.
  - Full-scale antenna measurements on **JAMPRO's** all-year, all-weather test range.
  - We custom-make tower structures to duplicate your's, for optimum results.
  - Ask about **JAMPRO's** low-power educational packages.
- Give us your requirements and see how fast we produce.

**JAMPRO Antennas, Inc.**

6939 Power Inn Road  
Sacramento, CA 95828  
(916) 383-1177 • Telex: 377321  
FAX (916) 383-1182



# Servicing Aging ITC 99B Cart Machines

By Art Reese, CE - Satellite Music Network  
Mokena, Illinois (708) 479-1717

As the ITC 99B cartridge machine heads into its 15th year of production, we are beginning to discover some of the weaknesses to which age subjects them. Since our particular units here at Satellite Music Network are presently pushing 8 and 9 years of pretty much dependable and continuous service, we are encountering anomalies which we have not seen before, and for which there is not (nor could there be) mentions in the service manual.

**1. Solenoid residual magnetism:** We've discovered two versions of this malady. In the first, the solenoid plunger becomes magnetized, which manifests itself in an inability of the pinch roller to retract completely at the end of play. In the second instance, the entire solenoid becomes magnetized. In our case,

it was causing the pinch roller to intermittently lose full contact with the capstan, causing a lot of tape "wowing" and time stretching on the air! We discovered the problem with a magnetometer (available from Lauderdale Electronics Labs) although a non-magnetic, steel screwdriver would have done the same thing. In any event, a good healthy treatment with a bulk eraser (we used Garner 105 for such assignments) solved the problems of magnetized solenoids quite handily.

**2. Solenoid resistance:** It is a good idea to include the measurement of solenoid resistance in your quarterly or six-month PM of your 99B. Replace the solenoid if the resistance approaches 55 ohms, since, at that point, the solenoid will no longer draw the proper current and solenoid operation may become unreliable.

**3. Deck Plates:** If you start getting unreliable solenoid action no matter what you do to make it better, then it may be time to replace the deck plate. The reason is that the cross-shaft bearings wear out and replacing them in the field is almost impossible. Besides, if the machine has had that much use, the deck plate itself has already had grooves worn in it by the many thousands of carts which have been inserted and removed from the cart machine.

When you order the deck plates from ITC, be sure to specify if the deck

plate is for a playback only, A-type record, or B-type record unit. The prices vary widely, since there is a difference in what needs to be added to bring the machine up to current specs.

A nice side-effect is that you will find that phase error from cart to cart is reduced with a new deck plate, since all carts will then rest on a true perpendicular surface with respect to the head.

**4. False cue-up:** The cart stops in mid-operation, or goes into fast forward. The source of this problem can be a number of things. One of the biggies is head noise. A pole piece can develop a noisy internal connection, the result of which then makes the microprocessor think that it's receiving a cue tone of any sort from the tape. The check for this is to monitor the cue output amp on the 50-pin control plug. We've found that anything worse than -40 dB output with a blank cart is cause for replacement. Typical noise levels are in the -47 to -49 dB range. The cure is either to turn the head over and swap it for the left channel pole-piece (only in a pinch, until a new head can come along) or get a new head.

The second biggest source of false cueing is usually the head leads. Replacing them is the cure, of course. In a pinch, soldering the wire-to-pin connection (which is not done at the factory!) will usually end that problem -- at the cost of the shrinkage of the vinyl insulation.

Surprisingly, the rest of the audio path (the audio and control cards) are the parts of the system least likely to cause problems. (All bets are off however, if there have been lightning problems with a machine in the recent past).

The wise 99B owner usually has a spare microprocessor on hand for such contingencies. However, replace the TL072 cue amp IC on the audio card first, then the filter IC's on the control card before replacing that expensive microprocessor, just in case.

## How do you interface a thingumajig to a whatchamacallit?

We don't know, but the *UNI-200* Universal Interface card from Broadcast Devices could help! The *UNI-200* gives you a neat and reliable way to interface remotely controlled devices ranging from antenna switches at the transmitter site to CD players in your production studio. The *UNI-200* is a compact (2.5 x 3.5) circuit card with four opto-isolated inputs. It provides on and off control of a relay (momentary or latching) and two open collector status outputs with lamp flashing capability. The various modes of the card are dip switch programmable and have adjustable flash and momentary hold rates.

Try one — you may even come up with a way to interface that old whatchamacallit!

Contact Broadcast Devices or your local broadcast distributor today for more details.

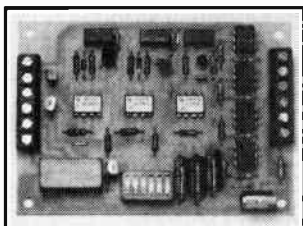

The *UNI-200* Universal Interface Card



Broadcast Devices, Inc.

5 Crestview Avenue  
Peekskill, NY 10566  
(914) 737-5032

# Console Bleed

By Tim McCartney (218) 751-1680

I have found Broadcast Electronics consoles to be quite popular, probably due to their good quality, reasonable price, and strong customer support. Thus, I have had occasion to work on a few.

An intermittent problem has occurred on two A150 series consoles. Since BE uses the same input and line amplifier boards on most of its models, this advice may be pertinent to other consoles as well, such as the S350 series.

The problem is that unwanted audio leaks into one of the two program lines, even though its input channel is not switched to program. Sometimes this bleed-through can be attenuated by moving to another source, the delegation switch controlling the unwanted audio. Of course, this is not an appropriate solution.

BE's customer service department suggests several simple procedures to resolve such a problem.

## Input Channels: Bad FETs

First, one input channel circuit board at a time is pulled. If the problem is cured, then the trouble is unique to that board, with a bad output FET the most suspicious component (Q6, Q7, Q13, Q14).

Another indication of defective FETs is a large VU meter "pop" when switching between program and audition on an input channel.

If just one FET is bad, it can affect all of the console input channels. Thus, the culprit component could well be on any input board, not necessarily the one through which the unwanted audio is routed.

## Line Amps: Bad Cap

If the bleed-through does not appear to be related to any one input channel, the next place to look is in the program mixer-line driver amplifiers. Or, it may be better to try this step first, because just two such boards are used.

If the problem is limited to one program channel, a simple swap of the

amps demonstrates whether or not the bleed-through follows. If so, the suspect component is the 1 uFd capacitor (C8) on the driver input. The part can be changed, or an oscilloscope can establish if any DC is present at the capacitor and/or console output.

## DC - Daylight

The worst problem with intermittents, is that the bleed-through may not occur at the selected moment of attempted repair. Thus, it's possible that a final resolution will take from DC 'til daylight.

GET THE BEST OF *BOTH* WORLDS

WITH

BARRETT ASSOCIATES, INC.



OR

CHOOSE FROM 240  
LINES OF NEW EQUIPMENT

CHOOSE FROM OUR  
RECONDITIONED AND  
GUARANTEED PRODUCTS



barrett associates, inc.

BROADCAST EQUIPMENT

CALL 1-800-748-5553

FOR MORE INFORMATION

# LPTV

## Sideband Suppression Notch Filters & Video Aural Combiners

Reduce sideband radiated power & meet FCC transmitter standards.

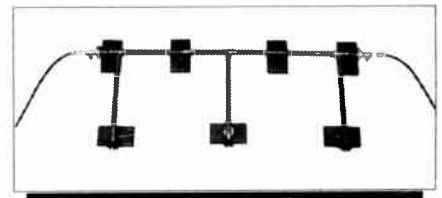

Full Details In Bulletin #15  
Ask For Our FREE Catalogs!

Request BTV/87 which describes  
TV/FM/MMDS Broadcast Filters and  
Combiners for service radio bands

Catalog BTV/87

Need A Special Filter? Call Us Today!

**"We Make Filters In A Hurry For Customers In Trouble!"**

Microwave Filter Co., Inc. • 6743 Kinne St. • E. Syracuse, NY 13057

Toll Free (US/Can.): 1-800-448-1666 • Collect (NY/AK/HI): 315-437-3953

FAX: 315-463-1467 • Telex: 249-613

# Transmitter Site You Can Live With

## Doing It Right The First Time

By George Mimbs, CE - WIKS  
New Bern, North Carolina (919) 633-1500

Okay, it's finally here! The mailman finally brought your new upgrade construction permit, and visions of "new toys" dance before your glazed eyes. It's time to find those old notes and hand drawn prints of your "dream site." Blow the dust off them and see how much of your dream will survive the budget process. With most ownership and management, you'll have a hard time getting your dream site equipped with all the bells & whistles your greedy little heart desires, but you'll never know until you put them down on paper and show them to the boss.

Have you thought of everything? That word covers a lot of territory, but let's start with the basics -- namely, "how big a building can I get away with?" Your scribbled notes say 20 x 20. Is this big enough for you (and your heirs of a technical type) to live with? Figure what you need, and double it! Five years down the road, you may be able to get that auxiliary transmitter, or that dummy load, or even that rack that's been pushed over against the wall in your office for ten years or so. In the future, the only thing that's certain is change -- so there could even be five

possible, give this area it's own outside entrance, so that their service people go nowhere but "their" space. Another nice thing about possibly partitioning the building is that it will give you a "quiet area" in which to work, loaf, consult or whatever.

Pre-wired modular jacks in this area will give renters the chance to bring their own phones & pay for their outside lines, or have a second line installed (when the time comes) and bill for monthly service per client or just divvy up the phone line charges into their monthly rental amount. While we're on the subject of telephones, why is it that the transmitter site phone never works? If you've got problems, the blower noise from the transmitter makes you go outside (hopefully you've got a long cord) to talk to the manufacturer's parts/service people, or the genius at the other station you always talk to for advice.

Now, while you've got the chance, put a modular jack everywhere at the site you may ever need to stand -- even outside. If your budget is tight, do it yourself! This will probably be the kindest thing you'll ever do for yourself. Once your jacks are in place, pick telephones you're comfortable with. The one piece phones will work well, but how about a cordless phone? For clarity's sake, maybe an operator headset with a noise cancelling microphone and headset amplifier will make troubleshooting and talking much quicker -- plus the factory guy (or local genius) will understand you when you ask, "Why did it do that?"

Another point for "liveability" at the site is the availability of power when/where you need it. Sure, there's three phase power in the high voltage supply and 115 VAC over there in the rack --

or six firms renting space on your tower, or leasing your 67 or 92 kHz subcarriers. Where are you going to put them, when each renter will need power, signal connections, rack space, and air conditioning?

If you can manage it, make room for the future! Literally! Try to get a partition in the building so that you can set aside an area for people who (hopefully) will jump at the chance to hang their stuff on your new stick. Make sure your master site key gives you access to this room, but that their keys do not give them access to your transmitter area. If

## Don't Retire that Old Executive ... Retrofit!

With Broadcast Devices' field proven 10-minute retrofits you can make your old sturdy Harris Executive console perform like today's top of the line. These affordable retrofit electronics are modern plug-in replacements for the old technology mic preamps and line amps. They eliminate the cost and time it takes for a complete studio redesign and still give you 1990's specs! The reliability of our retrofits eliminate the maintenance headaches that cause embarrassing downtime.

Contact Broadcast Devices or your local broadcast distributor today for more details.

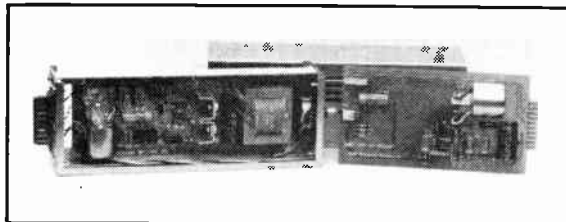

BDI HLR-100 Line Amp and HPR-100 Retrofit Preamp

These modules will also retrofit other Harris consoles including the Diplomat, President and Ambassador series.



Broadcast Devices, Inc.

5 Crestview Avenue  
Peekskill, NY 10566  
(914) 737-5032



but what about your soldering gun, or your 'scope, or your portable radio with the dead batteries? Have power *everywhere!* This should be done by a licensed electrician at the time of construction, but if you're careful to meet your local electrical code, put your own duplex receptacles everywhere you can envision ever needing them. Look overhead at the ceiling of your dream site. How would you like a couple of floodlight fixtures installed and aimed into the rear of your transmitter cabinet and high voltage cabinet? How about another flood fixture aimed into the rack? A "shop light" fixture over your workbench?

What workbench? That's one great reason to oversize the building as much as you can!

How about some battery powered emergency lights mounted on the wall? Then, if you don't have a generator, you'll still be able to see your problems after you discover the flashlight's batteries are dead. All this lighting will be surprisingly cheap, if it's part of the initial construction, or it's a great way to upgrade your less-than-perfect site for comparatively small change.

Here are a few other places you may not have thought about lighting. You'll probably put a "yard light" outside the building, but would you appreciate a couple of floods over the transmission bridge/tower base? Assuming you're able to talk the boss into a generator, if the generator's outside the building, put a flood light over it. When the generator won't crank after dark, you'll be able to see why! Don't forget a few weatherproof AC receptacles on an exterior wall if you ever plan any power tool/weed-whacker usage.

Security is very important at the site, both for RF/electrical dangers (idiots who like to parasail off towers) and your own personal safety at three in the morning. Don't cheap the installation out by using the building as part of the perimeter fencing. If you can, put a tall fence and razor-ribbon around the site, at

least ten feet away from the building and tower. NAB RF warning signs should be posted by each gate. For gates, you will need a wide, vehicular size gate for refueling your generator or tower work. You may think that ten foot fencing with razor-ribbon is overkill for security, but I, personally, have had a site where idiots tried parasailing from about 800 feet up the tower! If it's your transmitter site, make damn sure that only authorized people gain entry. If you use the building as part of the perime-

ter, they use their car or truck to get onto the roof and then just jump down inside, or slip down onto the transmission bridge. Bingo, they're in! There are people in this world who think you put that tower there just to give them a platform to try their deer hunting rifle scopes from!

(continued on page-28)

## **FM** Harmonic Low Pass Filters 500 - 50,000 Watts

**Delivery: 30 Days (Faster For Your Emergencies)**

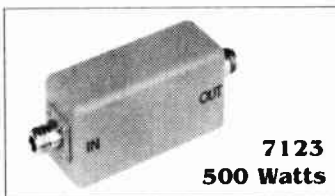

**7123**  
500 Watts

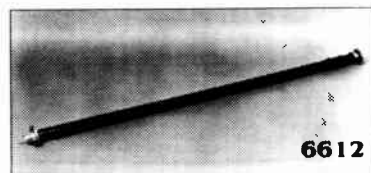

**6612**

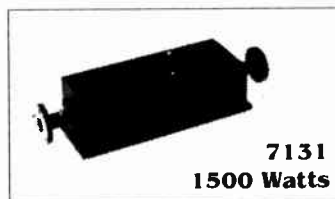

**7131**  
1500 Watts

Model #	Watts
6612	6,000
6516	15,000
7772	30,000
7455	50,000

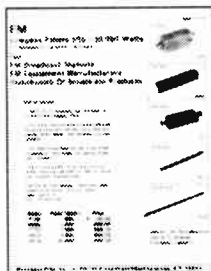

**Bulletin #14**

### **Full Details In Bulletin #14!**

Also, request BTV/87 which describes TV/FM/MMDS Broadcast Filters & Combiners for service radio bands.

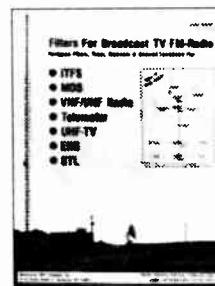

**Catalog BTV/87**

**Need A Special Filter? Call Us Today!**

**"We make Filters In A Hurry For Customers In Trouble!"**

**Microwave Filter Company, Inc.**

**6743 Kinne St. • E. Syracuse, NY 13057**

Toll Free(US/Can.): 1-800-448-1666 • Collect(NY/AK/HI): 315-437-3953  
FAX: 315-463-1467 • Telex: 249-613

## Transmitter Site . . . (continued)

Does it snow where you are? If so, put ice shields on everything and beef up the roof. A couple of years ago, I lost four strobe flash-heads, my building roof had eight holes in it, and my air conditioning compressor wound up about six inches high, following an ice-storm. If you're going to have a generator outside, put some kind of shield or deflector above it. If ice takes out the generator, you're dead in the water (or dead on the ice)!

When the power lines are installed, contact the local power company about making an underground run from the last power pole to the building. If ice takes above-ground lines down around the building, you could be risking your life to go into the site - especially if the lines fall across your fence! Your leases for tower space should state that everybody must install ice shields on anything that gets hung on your tower! If you do this right to begin with, you'll be on the air and sounding great when the other guys are patching their roofs and buying new generators,

air conditioners, STL dishes or tower light photocells.

Use some method of getting the transmitter exhaust outside. There are many ways to do this, and it could save your expensive equipment should the air conditioner fail. Transmitters and other gear are not really intended to work at 150 degrees ambient temperature.

You've given a lot of thought to the equipment's happiness, now what about yours? Now's your chance to be the envy of all your fellow engineers. See how much extra it would cost to install a sink and toilet! During rain, snow, darkness, routine and emergency maintenance -- nature will call!

You've read this and are probably thinking, "I'll never be able to get all this past the boss!" Think again. Compared to the cost of your new plant, all these items will only increase the price marginally -- and every one of these ideas, along with your own improvements, will possibly keep you on the air, or at the least, minimize your down time. Strobe repairs are not cheap, and new roofs or air conditioners are not cheap!

Temperature related failures of remote controls, or other gear, can cost money. Tell the boss that money spent now will save later. Now's your chance to "do it right" -- this is going to be *your* site! If you ever leave the station, you don't want your replacement sticking needles into a small image of you! This site could stand as a testimonial to your foresight and common sense -- which would you prefer?

# 125 REASONS TO CALL RADIO RESOURCES

**...plus one we can't mention.\***

At Radio Resources, we're home to over 125 manufacturers of high quality equipment, supplies, accessories, and rental items. ■ For over 20 years, we've earned the business of thousands of broadcasters like yourself by providing exceptional service and competitive prices -- all delivered with a friendly touch.

**\* And that other little reason...** it's our ever-changing monthly special. Too outrageous to advertise -- you'll have to call each month for details. ■ So pick up the phone -- it's on our nickel!

**WE'LL EARN YOUR BUSINESS**

**RADIO  
RESOURCES**

7483 Candlewood Road  
Hanover, Maryland 21076

1-800-54-RADIO  
in Maryland: (301) 859-1500  
24-Hour Fax: (301) 859-3042

**GM's & PD's**

*You Can Have Yours*

**Call (507) 280-9668  
For Your Own Copy of  
Radio Guide**

# Contract Guide

Contract Engineering Services  
For The Broadcast Industry

## Harnack Engineering

Kirk Harnack  
1385 Lamar  
Suite 5  
Memphis, TN 38104  
(901) 278-1306  
(800) 366-7618  
*Studio Design & Construction*  
*Maintenance*  
*STL Engineering*  
*RF Plant Design & Const.*

## Electro-Labs

James Chase  
RFD #3 Box 124  
Angola, IN 46703  
(219) 665-6427  
*Contract Engineering Service*  
*Field intensity measurements*  
*for AM, FM, TV (UHF & VHF).*

## Boyd Broadcast Technical Services

21818 SW Columbia Circle  
Tualatin, OR 97062  
(503) 692-6074

## South Jersey Broadcast

Dan Garafolo  
Box 63 North Main St.  
Williamstown, NJ 08094  
(609) 875-9728

## Phoenix Broadcast Engineering

David Dickson  
851-A East Coshise Dr.  
Phoenix, AZ 85020  
(602) 371-0991  
*12 years experience in recording*  
*studio and broadcast engineering*

Look for this  
name on the  
cart...▶

Audiopak's new molded-in logo and Quality Assurance Seal are your guarantee of genuine Audiopak performance—the consistent reliable performance that's made Audiopak the #1 choice of demanding broadcasters worldwide. They count on the proven performance of original-design Audiopak casings and the longevity and quality of Audiopak tape. For every application and every cart machine made Audiopak carts are "true blue" dependable, cart after cart after cart—accept no substitutes.

**audiopak**  
BROADCAST CARTRIDGES

The cart  
the world  
counts on,  
cart after cart after cart.



**PA S**  
PROFESSIONAL AUDIO SUPPLY

**Professional Audio Supply**  
5700 E. Loop 820 South  
Fort Worth, TX 76119  
817-483-7474  
800-433-7668

...Look for this  
name on the  
carton.◀

There's no substitute for good value, friendly service and fast delivery, either. We give you all three, plus the genuine Audiopak carts you need—workhorse" A-2s, "stereo" AA-3s and "CD-ready" AA-4s. So be sure to order "the carts the world counts on" from a source you can count on:  
**Professional Audio Supply**

**If You Are A Contract Engineer,  
Call Radio Guide To Be Listed Here  
(507) 280-9668**



# Product Guide

## ***New Products and Services For Your Radio Station***

**Call These Manufacturers and Suppliers for Information  
on These Latest Products and Services**

### **Somich Engineering PL-1 Pilot-Lock**

The new **Pilot-Lok** is a computer-designed phase-linear filter that restores stereo integrity to the most heavily clipped composite signal, by protecting the 19 kHz pilot. It works with any composite processor, and is guaranteed to improve the stereo coverage of any FM station.

The **PL-1** totally eliminates the tendency of stereo receivers to blend to mono in the presence of heavy composite processing. Full stereo separation is now possible without sacrificing Dial Dominance. The **PL-1** lists for \$395 and is available from your favorite dealer.



**Contact: Jim Somich, Somich Engineering  
1208 Stoney Run Trail, Broadview Heights, OH 44147 (216) 526-4561**

# Product Guide

## Environmental Technology Announces New Dehydrator

Environmental Technology Inc, South Bend Indiana, announces their new **ADH-2** automatic dehydrator for pressurizing waveguide, air-dielectric coaxial cable, feed horns, and similar applications, with dry air.

The **ADH-2** dehydrator features rack mounting (outdoor mounting optional) and automatic regeneration, which eliminates the need for manual reactivation or replacement of the desiccant.

An LED display provides parameter, functional and error code data. Unique **ADH-2** features include built-in test and fault diagnostic capability along with an alarm relay and indicator for critical problems. Additional indicators provide **POWER**, **WARNING**, and **ALARM** status information.



The new, patent pending, **ADH-2** employs micro-controller technology. All **ADH-2**'s operate from 120 VAC and 208/240 VAC at 50Hz/60Hz. Units compensate for powerline and voltage fluctuations. The **ADH-2** size is 5-1/4" x 19" x 19" (HxWxD) with a weight of approximately 25 pounds.

**Contact: Steve Leykauf, Environmental Technology**  
**1302 High Street, South Bend, Indiana 46618 (219) 233-1202**

# Tips From The Field

## Solid State FM Transmitters and Blocking Capacitors

By Craig Miller  
Honolulu, Hawaii

A few years ago, I had a problem where my solid state QEI 500 watt backup transmitter. It would work fine into the dummy load, but would die when it was switched into the antenna.

KHPR uses a Comark FM antenna on which the center conductor comes out on a strap to one of the arms of the CP antenna bay. This effectively puts a DC short between the inner and outer conductors of the antenna and, hence, the feed line.

The problem with my QEI was that one of the blocker capacitors on one of the four output transistors was shorted. This put the 50 volt collector supply right onto the center conductor of the feedline.

When the QEI was on the dummy load, the collector would see 50 ohms to ground, through the shorted capacitor, and it would have enough juice to handle that extra load. But when the QEI was switched onto the antenna, the collector supply would see a dead short to ground, and that would bag out the supply -- and the TX would appear to be dead.

After replacing the shorted blocking capacitor, the QEI worked fine on both the dummy load and the antenna. When working with solid state transmitters, remember that there isn't enough voltage to cause serious arcing, but you still have to keep DC off the inner conductor.

## Mothballs and Ants

By Ben Downs - KISX  
Tyler, Texas (214) 593-4444

Here's a low-tech solution to a problem all of us face during the summertime. Mothballs seem to provide the "set-and-forget" solution to ants inside ATU's, I've always needed.

I just roll a few mothballs into each corner of the ATU and everything stays away. Likewise, since my transmitter shed is up on blocks, I throw a handful or two under the shed, put four or five mothballs into each corner, and place a few under the transmitter and power supply. The mothballs evaporate within a month or three but, in the meantime, I stay ant and bug free.

**Send Your Tech-Tips  
To Radio Guide  
Fax (507) 280-9143**

Radio Guide July-1990 Page-32

# Let the CIA listen to your competition and playback the commercials for you.



## Spying was never so easy!

Hook up the RUSSCO CIA-1 to a radio & a cassette recorder. It records only the speech, filters out the music. The sales manager's job just got a lot easier. The CIA-1 practically pays for itself at just \$299.



## A little sports-remote mixer so smart it never needs batteries!

This feature-filled little 3 channel handfull works off your phoneline & makes remote work simple. Let us tell you more. You'll love RUSSCO's TELEMOTE 321!



ELECTRONICS INCORPORATED

5690 E. Shields Ave., Fresno, CA 93727

Call us (209) 291-5591



# Tips From The Field

Technical Tips From  
Radio Guide Readers

## Ampex 350 Caps

By Joe Schloss - KICD  
Spencer, Iowa (712) 262-1240

There is an old workhorse that lives in broadcast stations, and it's called the Ampex 350 Series tape transport. Have you noticed that the tar-filled capacitors always get warm and, in time, the tar leaks out.

Here are two means of fixing them. If you still have the metal caps, drill three holes, spaced every 120 degrees, add screws, and the cap won't pop off anymore. Or, if you don't have the cap, you can use a 16 oz., plastic Pepsi bottle.

Cut the bottle about one and a half inches from the bottom.

Put the piece over the capacitor and shrink it down with a heat gun. Don't use a Coke bottle, they don't shrink enough. This works well, and you are recycling empty soft drink bottles to boot. Be careful, the capacitors may have PCB's in them, so look before you leap.

**We Need Tech-Tips**

## TFT 724A Monitor Click Fix

By Frank Zeller - WBJC-FM  
Baltimore, Maryland

I read Bruce MacMillan's article, in the January, 1990 issue of Radio Guide, since WBJC has a pair of TFT-724's of the same age. It is an amazing coincidence that several days after reading the article, one of our monitors developed the same problem of audible clicks and flutter in the left meter.

The addition of a 1K resistor between C-21 and CR-2, as was suggested, eliminated the flutter in the left meter and the audible clicks. I was not convinced that altering the design of the monitor that had worked so well, for so many years, was the solution.

The resistor was removed and the circuit around Z-5 was checked with a 'scope while the left meter was fluttering. Glitches were observed on pin-4 of Z-5 (the 12 volt buss). The glitches appeared on the buss only when the left meter was near 100%. Filter capacitor C-25 (15uF 25V) was defective. Replacement of the capacitor corrected the problem.

## Automation Head Cleaning Tool

By Earl Hocker, CE - KTAN  
Sierra Vista, Arizona

KFFN has an SMC Automation system, including several SMC Carousels (models 352/452). Since the playback heads of these Carousels are recessed about eight inches from the front, it was difficult to access these heads for cleaning.

Our solution was to cut a piece of 1/4" doweling about 10" in length. Small holes were drilled into each end of the dowel. A common household double-ended cotton swab was cut in half and a these half pieces were inserted into the holes on the ends of the dowels. This provided a simple inexpensive method of cleaning the hard to reach heads.

## Brass Rod Source

By Jim Swift - WSNX  
Muskegon, IL (616) 733-2126

If you're ever in a spot for some brass rod (such as used for tuning and loading controls), make a trip to the local hardware store. I have found that toilet-ball rods work great.

# JNS

## CD Quality Audio Switchers

Two families of audio routing switchers - 8300 & 9000

- ALL with CD level performance
- from 1 x 10 to 60 x 60
- with level metering
- All with relay crosspoints
- optional machine control
- from LED indicator switches through PC/computer control

**8310**  
10 stereo in 1 stereo out  
**\$895.00**

**J.N.S. Electronics, Inc.**

408/729-3838 FAX 408/926-1003 P.O. Box 32550, San Jose, CA 95152



# Equipment For Sale

**RF meters, used and tested**  
Sangamo mica transmitting capacitors,  
assorted sizes, large variety

**Dan's Discount Radio Parts**  
Cavendish, VT  
802-226-7582

---

**Wilkinson SG-1E** Solid state stereo generator.

**Collins AW-810** tube type FM exciter.  
**Harris/Gates model TE-3** FM exciter  
tuned to 104.1 mHz.

**TFT remote control.** Wireless model 8610,  
needs work.

**TFT remote control.** Wireless model 8600,  
2nd unit, needs work.

**Moseley PCL/303/composite** STL on  
950.00 mHz.

**Moseley PCL/505/composite** STL on  
951.00 mHz.

2) **Russco Studio-Pro** turntables. No  
tone arms.

**Energy-Onix 25 kW** FM transmitter. Only  
two years old, heavy duty, grounded grid  
PA.

**Joseph Bahr**  
154 Guajataca St.  
Crown Hills, Rio Padres  
Puerto Rico 00926  
809-756-5914

---

4) **RCA solid state 25W** base stations on  
161 mHz band (700 series). Tunes to  
your channel - \$160, un-tuned - \$115. All  
have mike, but without antennae.

**General Electric** custom all solid state  
25W mobile 2-way tuned on 161/70 mHz.  
Mike included, but without antenna. \$255.  
Matching 115 VAC power supply, fully  
regulated. \$55

2) **Bliley vacuum crystals** for Collins  
830-310Z on 93.5, 97.7, 99.7, 100.3, 104.5.  
\$45 each.

**Vacuum low frequency crystal** for Wil-  
kinson type phase modulated FM exciter  
X-864 for 94.7 and 101.7. \$60

**Bill Fulgham**  
KBRA FM-96  
Freer, TX 78357  
512-394-6896

**250 feet LDF-5-50** Helix  
**3-bay antenna system** with de-icers.  
**250 feet HJ7-50A 1-5/8"** Helix

**John Carroll Jr.**  
WKJC-FM  
523 Meadow Rd.  
Taurus City, MI 48764  
517-362-3417

---

**CRL PMC-3000A** peak modulation con-  
troller. Works great. \$500 or best offer.

**John C. Davis**  
KSRM/WHQ  
HC2 Box 852  
Juelbatna, AK 99669  
907-283-5811

---

**All equipment as-is at "GIVE AWAY"**  
prices. Make offer!

4) **Ampro 2-channel** audio mixing con-  
soles (2 are 6-position and 2 are 8-posi-  
tion). Solid state, heavy duty pots with  
keys, monitor amp.

6) **Ampex 351 decks.** Mono heads, Lang  
solid state electronics.

4) **RCA folding mike booms.** 10-foot ex-  
tended.

**EMT broadcast** audio equalizer.

2) **RCA remote mixers** (4 position plus  
master).

**Gates model M5701** monitor amps,  
M5700 program amps, M54702 power  
supply with shelves.

**B&W model 400** distortion meter.

**B&W model 300** frequency meter.

**B&W single sideband** receiver adapter  
model 370.

**Sprague "transimulator"** (simulates re-  
sistor and capacitor values).

**Marconi Labs** Universal Bridge.

**Heathkit model SB-310** receiver.

**Heathkit lab** frequency generator. 100  
kHz to 30 mHz.

**Heathkit variable** voltage power supply.

**Heathkit model IM-30** transistor tester.

---

**Al Arkus**  
Radio Free Europe/Radio Liberty  
1775 Broadway  
New York, NY 10019  
212-397-5309

**Moseley RPU** transmitter/receiver. On  
161.67 and 166.25.

**CBS FM stereo level control** (slim-line).  
**Ampex 440** mono reel deck.

2) **Sennheiser 421's** in boxes.

**Martl microphone** with on/off switch.

**Microtrac 6444B** mixer board (new).

**Andrew 1-5/8" 87R's**, grounding and  
splice kits, 7/8" L44N, 75AN, 75ECT, 7/8"  
hangar kits and round member adapters.  
All items new.

**Bird Wattmeter.** 100 watt load w/2 slugs.

2) **Optimods.** 8000 and 8100A.

**ESE 301AE** timer.

**BE 150A** 8-channel mono console. New.

**Ramsa WR-130** portable mixer. Best of-  
fer.

**Spotmaster 505** playback cart machine.  
\$250

**MCI digital remote control.** 1/2 price.

**MCI 450** mHz, 10 watt, TSL. Return link.

**Heathkit** microphone mixer. \$40

**Sparta delay** cart machine. \$100

**SMC** random access. \$250

6) **Repeat coils.** Offer.

**ERI 2-bay** (current style) antenna on 92.1  
mHz. Offer.

**3-line speakerphone** with coupler. \$100

**McKay AM** base and head. \$100

**CRL QC400.** Almost new. 1/2 price.

**Gates Criterion.** As-is. \$75

2) **BE 2000 RP** cart machines. \$750 ea.

**CBS Audiomax + Volumax + Record-**  
ing Volumax.

**Misc RF relays.**

**ITC stereo RP** Premium. \$1750

**ITC mono RP** Premium. Needs work.  
\$550

**ITC SP.** High-speed cue. \$500

**CBS 5500A** NTSC color corrector.

**CBS 7000** chroma keyer.

**CBS 8000** MKII Image Enhancer.

**CBS 5500** Sensor.

**Jim Phillips - WZOM**  
408-1/2 Clinton  
Defiance, Ohio 43512  
419-782-8591  
419-782-FAXX

**Equipment Guide**

**Remember:**

**There's no charge**  
**There's no word limit**



4) Otari ARS-1000 with 25Hz decoders. \$1000  
IGM Go-Cart 24. \$2500  
SMC RP-1000 brain with DS-20 switcher and clock, with TAC-1 time announce. \$2700  
2) SMC 250 carousels. One with elec. random select, and one with Schaffer random access. \$350  
SMC 721 dual cart PB in drawer. \$500  
SMC 710 single cart PB in drawer. \$250  
ITC RP, with 3 tones. \$700  
Revox A77. \$350  
250) 10-1/2" reels of easy-listening music with no dupes. All in very good condition with play sheets. \$10 each.

Jim Wenstrom  
Wynne Broadcasting  
503-882-4656

---

Stationmaster PD-455 antenna. New in box. \$465 or best offer.  
2) Conex AS101. 10 x 1 routing switchers. \$590 or best offer.  
6) Conex AS401 remotes. \$99  
Shure M267 mixer. \$390 or best offer.  
Gentner EFT9000 transciever. \$640  
Symetrix T-101 telephone interface. \$318  
Henry turntable controller UTC. \$145  
Conex DS25B dual 25Hz sensor. \$350 or best offer.

Dick Eressy  
WFCC  
1457 Main St.  
West Chatham, MA 02669  
508-945-4855

---

Audio & Design 769X-R vocal stressor. \$750  
4) Scully 270 tape players. \$200 each.  
2) Conex 25Hz dual detectors. \$200 ea.  
Moseley TRC15AW remote control for phone lines. \$800  
UMC mono cart recorder. \$800  
2) UMC mono cart players. \$500 each.  
Sparta stereo generator. \$350

Scott Dean  
Dean Engineering  
P.O. Box 25085  
Fresno, CA 93729  
209-434-2358

---

Gorman-Redlich model CEB EBS encoder/decoder. In service only one year, excellent condition, rack mount. Suppliers charge \$525 for new one. Only \$400

Denny Ainsworth  
Kangaroo Productions  
333 Trotters Ridge  
Lawrenceville, GA 30243  
404-963-4634

---

Automation system. Complete with unlimited walk-away time. SMC RP-1000 brain, DS-20 switcher, PDC-3A clock, power supply, TS-25 tone sensors.  
4) Otari ARS-1000DC reels.  
4) BE auto rewind units.  
4) SMC 352-RSB Carousels.  
3) SMC racks with doors.  
Remoter system for RAC-21.  
Manuals and spare parts included.  
\$14,000 (negotiable).

Eric Nichols  
KMCR-FM  
P.O. Box 189  
405 East Norman  
Montgomery, MO 63361  
314-564-2275

---

Collins model 830-D FM transmitter. 1000 watts with Collins exciter and stereo generator. Like new condition.  
CBS model 411 stereo Volumax. Like new.  
Extel AH/P11R teleprinter. Like new.

James D. Anderson  
WKCU/WXRZ  
2192 Highway 72 East  
Corinth, MS 38834  
601-286-8451

---

CCA 10 kW AM transmitter. Good condition, on the air now on 1210 kHz. Make offer.

Jim Stanford  
WYLD  
2228 Gravier  
New Orleans, LA 70119  
504-822-1945

---

6-bay Dielectric 1-5/8" line FM antenna tuned to 93.5 mHz.  
10 kW 1-5/8" line iso-coupler.  
300 feet 1-5/8" Heliac transmission line.

---

Moseley RPL-2 RPU receiver tuned to 161.7 & 161.76 mHz.  
Scala CL-FM Yagi antenna for translator. Tunes to 93.5 mHz. (new)  
Kay Industries T-12000A rotary phase converter (2 hours use).  
4) Inovonics model 375 Ampex reel-to-reel electronics.  
Inovonics model 370 Ampex reel-to-reel electronics.  
Sparta A-15 5-pot news console.  
SMC 570 cart playback unit.  
Okidata 192 printer.  
3) Ampex 350 reel transports.  
Ampex 354 reel transport.  
2) Teac R720 reel transports.  
CBS 4450A Stereo Audimax.  
CCA 20 kW 3-1/8" line FM harmonic filter.  
40 feet Andrew LDF-50A coax line.  
30 feet Andrew LDF-50A coax line.  
RCA WO-91B oscilloscope.  
Hickock 600A tube tester.  
Shafer 901-902 automation system with, (6) Teac/Schaferdeck reel-to-reels + I/O cards, (6) cart I/O cards, (3) rack cabinets.

Ernie Nearman  
KUMU AM/FM  
441 North Nimitz Hwy.  
Honolulu, HI 96817  
808-531-4511

---

2) Shure SM-7 microphones. Used only 5 months! Will sell together or separately. \$275 each.

Brian Rowland  
WQHI Radio  
904-422-2100

---

Scully 280 reel deck. 2-track record/play, works good. \$700  
Neuman U87 mike. Works good. \$700.  
IGM model 382A time machine for automation. Offer.  
Extel AH11R printer for parts. \$40  
#91-318 Phillips Dodge hangars for 3-1/8" rigid line.  
Parts off a damaged Jampro JSCP 6-bay antenna tunes to 106.7 mHz. Will sell all or parts. Offer.  
Hygain Scanner. Works good. \$50

Tony Wortman - WJAG Radio  
309 Branch Ave.  
Norfolk, NE 68701  
402-371-0780

---

## AUTOMATION:

IGM Instacarts, (1) mono and (1) stereo, both 48 trays. \$3000 for both.

**Shafer 8000 automation controller.** Mini-computer with CRT terminal, loggers, 3 rack cabinets, complete extra system for backup. \$1500 for both systems plus spares parts galore.

4) **SMC Carousels** if purchased with Schafer 8000. \$500 each.

**Harris 9002 automation system.** (2) CRT terminals, racks, (4) Otari ARS-1000 reel decks, (2) IGM GO-CART 24, Spare parts, fully loaded, super clean. \$7500

**Otari ARS-1000 reel to reel reproducer.** Near mint condition, with 25Hz sensor. \$1000

**Schafer blue equipment rack.** \$100

**IGM 12-tray Instacart.** \$750

**IGM GO-CART 24.** \$1500

**ITC RP cart recorder.** \$850

**ITC cart machine racks mounts.** Will work with Premium series cart machines such as RP, WP, etc. \$20

**Ampex 440 deck** with Schafer stereo solid state playback electronics. \$250

**Teac/Tascam Model 2 mixer.** Slide pot, 6-channel. \$150

**Autogram AC-6 console.** With timer, extra outboard phono preamp chassis, super clean. \$2800

4) **Teac/Tascam model 32-2 reel deck.** 2-track stereo, dual capstan, factory rack mounts, virtual new condition. \$750 each.

**McMartin audio processor** and **McMartin stereo generator.** \$250 each or \$400 for both.

3) **6-foot military spec.** standard rack cabinets (19"). \$75 for all.

**Harris MS-15 Exciter.** \$2500

**TTC model X exciter.** New. \$4500

**TTC FM-300J solid state 300 watt FM transmitter.** New. \$7500

**Sintronic 10 watt solid state FM exciter.** \$850

**Gary Gaskey**

**KWHO**

**261 Main St. #6**

**Weed, CA 96094**

**916-938-3828**

4) **Scully 285 reproduce decks.**

**Ampex 354FT stereo rec/play deck.**

**Spotmaster distribution amp.**

**Martl PGM-20 line amp.**

**M.W. Persons 25Hz tone decoder.**

**Ampex 350 with Inovonics 370 R/P electronics.**

# PETER DAHL CO.

## Save \$\$

Heavy Duty Replacement Transformers, DC Filter chokes and capacitors for AM & FM transmitters manufactured by:

AEL, CCA, CSI, COLLINS, CONTEL, CONTINENTAL, BAUER, GATES, HARRIS, SINGER, McMARTIN, GE, RAYTHEON, RCA, SINTRONIX, ITA, WILKINSON.

Many other models also available.

*FAST Delivery and FREE Technical Support*

5869 WAYCROSS AVENUE  
EL PASO, TEXAS 79924  
(915) 751-2300  
TELEX: 76-3861 PWDCO  
FAX: (915) 751-0768



1 pair) **Inovonics 370 R/P electronics.**

**Apt Holman preamp/control center.**

**LPB Citation C-10 stereo console.**

2) **ITC SP mono cart players.**

2) **Equipment racks.**

**MCI JH-110B.** 14" reels.

3) **Abco 500-cart floor stand wire cart racks.**

**Phil Wells**

**KJQY Radio**

**625 Broadway #1200**

**San Diego, CA 92101**

**619-238-1037**

**Harris STX-1B AM stereo generator.**

**Harris STM-1B AM stereo monitor.**

Both set up for C-Quam. \$7500 or best offer.

**Bill Bailey - KJEF**

**P.O. Box 1248**

**122 North Market St.**

**Jennings, LA 70546**

**318-824-2934**

**ERI FMC-11 antenna.** 6.2783 power gain on 96.9 mHz. Best offer.

**Mark P-9A72GN STL antenna.** 890-960 mHz, like new. Best offer.

**Scala PR-450/U STL antenna.** 940-960 mHz, like new. Best offer.

**Ramsa WR-T820B 8-group output recording console.** Like new, best offer.

**500 feet Andrew HJ8-50B Heliac on reel.** Best offer.

**Taylor Fast**

**KKOW AM/FM**

**Route 5 Box 45**

**Pittsburgh, KS 66762**

**316-231-7200**

**SMC Automation System:**

**ESP-2**

4) **Carousels**

9) **Otari reel decks with 25Hz sensors**

2) **Cart playback units**

2) **Amdek video screens**

**(continued on page-38)**

**Studio remote unit**

Two years old, includes 6 racks and is currently on air. Valued at \$48,000. Will sell for \$30,000. Let's talk.

**Lyman James**

**KWKL**  
P.O. Box 650  
Wichita, KS 67201  
316-265-1065

---

**Scientific Atlanta** dual 15kHz audio channel card for Satcom 1R Digital Satellite receiving system. Excellent condition. \$600

**Michael Brown**

**Radio Broadcast Consultant**  
3740 SW Comus St.  
Portland, OR 97219  
503-245-4889

---

**Sparta 3310** dual mono audio console. 10 rotary mixers, program, audition and cue outputs. 5-watt cue amp, 12-watt monitor amp, large VU meters. Good condition, recently removed from TV audio production room. \$1000

**Rich Bierle**

**KFYR-TV**  
200 N. 4th St.  
Bismark, ND 58501  
701-255-5757

---

**Gates BC1-G** AM transmitter. 1kW on 1430 kHz. Excellent condition, taken out of service because of power increase. \$2500 or best offer.

**Gene Kirchner**

**WRDN**  
P.O. Box 208  
200 3rd Ave. West  
Durand, WI 54736  
715-672-8989

---

**Orban 9000A1** with NRSC. \$1650 or best offer.

**50 kW water cooled** dummy load. New, never used. Best offer.

**5-element heavy duty** Phelps Dodge SPC-5 antenna. New, for 92.3 mHz, in original boxes. Best offer.

**48-cart Shafer** Audiofile. Mint condition.

**All Anderson**

**KBMR**  
3500 East Rosser Ave.  
Bismark, ND 58501  
701-255-1234

---

**Modulation transformer** for Gates BC-5, in factory box. Will consider delivery along I-5. Make and offer.

**Marvin G. Pangburn**

**KAJO Radio**  
P.O. Box 230  
600 Roguelea Ln.  
Grants Pass, OR 97526  
503-476-6608

---

2) **Dale SPA-200** power arrester SPA-200 for 3-phase wiring systems. Lightning damage and surge protector. Brand new, never been installed. Best offer.

**Charles E. Phillips**

**WXVO-FM**  
P.O. Box 987  
Clinton, TN  
615-457-2697  
615-435-0987

---

**ERI FMXL-2E** 2-bay FM antenna in excellent condition. Used only 18 months. Replaced due to frequency change. Mounting brackets not included. Tuned to 101.1 mHz. Make and offer.

**David L. Winegardner**

**KBTN**  
P.O. Box K  
216 W. Spring  
Neosho, MO 64850  
417-451-1420

---

**1976 Harris FM2.5-H3** 2500 watt FM transmitter with TE-3 exciter. Includes stereo generator, spare driver tube (new), and two final tubes (each make 100% power). Tunes to 102.3 mHz. Available immediately. \$8000 firm. Located in Peoria, Illinois area.

**Richard Parker**

**WTAZ-FM**  
332 Detroit Ave.  
Morton, IL 61550  
309-263-0102

---

2) **McMartin RPU** transmitters. 30 watt, 50F3, 450/450.35. \$1600

**McMartin RPU** receiver. 450/455.35. \$800

**Joe Mauk**

365 W. Menlo Ave.  
Fresno, CA  
209-266-5800

---

**Orban 8000A**. Mint. \$1600

**CBS Volumax**. Mint. \$150

**CBS Audimax III**. Mint. \$150

**DAP-310 tri-band**. Excellent. \$250

2) **Harris/Gates 944** Solidstatesman limiters. Excellent pair. \$300

**Harris 6550** satellite receiver chassis with power supply and down-converter. No demod cards, mint. \$400

**BE model 8M20** mono 8-channel console. Good condition. \$600

2) **Satcue 400** switchers for Unistar formats. Mint. \$500 each.

2) **Magnecord 1022** stereo reel transports for parts. Electronics OK.

2) **Magnecord 1021** mono reel transports for parts. Electronics OK.

**Magnecord 1021** mono reel deck in portable case. Good condition.

**Ampex AG-600** mono reel deck in portable case. Good condition.

4) **Scully 270's** for parts.

Make offer on any items.

**Hal Widsten**

**KGNB**  
1540 Loop 337 N.  
New Braunfels, TX 78130  
512-625-7311

---

**Fairchild DART 384** satellite receiver. 2 years old, with 15 kHz card. \$4200 or assume 29 lease payments @ \$156 monthly.

**ERI 2-bay antenna** on 98.3 mHz. 2 years old. Available September.

**J. Alex Bowab**

**WDLT-FM**  
2402 Wolf Ridge  
Mobile, AL 36618  
205-344-3698

---

**Gatesway-80** mono console. Mint condition. \$795

**Gates** mono Yard console. \$200

**Harris/Gates Diplomat** console. \$900

**CBS Volumax**. \$100



2) Sparta model D12-4 turntables. \$95 each.  
Sparta remote console and turntables. \$795  
Bird 1 kW dummy antenna. \$395  
Bogen RTP-1 remote amp. \$50  
Harris Criterion-90 stereo play cart deck. \$885

Paul Willey  
WNAW Radio  
466 Curran Highway  
North Adams, MA 01247  
413-663-3419

4) Otari ARS-1000 reel to reel decks with 25Hz detectors. Excellent condition. \$750 each.  
Harris System 90 "Brain" with D-J controller keyboard. Make an offer. Working when removed from service.

Terry Jordan  
WGNI-FM  
211 N. 2nd St.  
P.O. Box 2027  
Wilmington, NC 28401  
919-763-6511

75 feet Cablewave HCC-158, 1-5/8" Air coax with no connectors. \$8.00 per foot.

Rich Biver - KDOM  
P.O. Box 218  
1450 N. Highway 60  
Windom, MN 56101  
507-831-3908

Screenstar video projector. 6-foot screen with optional stand. Excellent for sales training of technical training video cassette classes. \$750

Frank Kavenik  
WNVF-AM  
Suite 331  
126 E. Wing St.  
Arlington Heights, IL 60004  
708-394-9995

Phelps Dodge 3-bay circular polarized antenna. Tuned to 92.7 MHz.  
Moseley WRC-10T remote control.

# FM BROADCASTERS!!

## We can meet all your FM transmitter needs!!

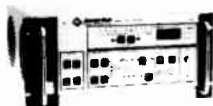

### SOLID STATE - LOW POWER

Amplifiers and transmitters are available at the popular levels of 30W, 100W, 300W, 500W, and 1KW. All units are solid state, broadband, and designed for both local and remote operation.



### ONE AND TWO TUBE HIGH POWER

Medium transmitters with broadband solid state drivers and one zero bias grounded grid triode in their PA are available at 1.5KW, 3.5KW, 5.5KW, 7.5KW, and 12KW. Higher power transmitter utilizing two grounded grid triodes (one as a driver) are available at standard outputs of 15KW, 22KW, 25KW, 30KW, 40KW, and 50KW.



## Energy-Onix

752 Warren Street Hudson, New York 12534  
(518) 828-1690 FAX (518) 828-8476

*A Wise Enterprise*

Glynn Hayes  
KWJM  
113 North Main  
Farmerville, LA 71241  
318-368-3094

Weather radar by Bendix. Out of Boeing 737. Complete with antenna. \$1500  
Gateway II console. 8-channel, solid state. \$450  
180 foot tower. 36" face, fresh paint. \$2650

Clark Ratliffe - WADE  
#1 Radio St.  
Wadesboro, NC 28170  
704-694-2175

RCA BTF-3B 3 kW FM transmitter on 98.5 MHz. 1 & 1/2 units available for parts. Best offer.

Daryl Hancock  
WYCR-FM  
P.O. Box 234  
Hanover, PA 17331  
717-637-3831

Vacuum Capacitors:  
Variable UCX-500, 15kV, 75A  
VC6-32, 32kV  
VC-250, 20kV  
VC-250, 32kV  
JCS-1000, 7.5kV  
JCSL-2000, 3.0kV

(continued on page-40)

**Mica Transmitting Capacitors:**  
Faradon .0002 mfd, 20kV, 6A  
Faradon 2000 mmfd, 12kV, 20A  
Faradon .002 mfd, 12kV, 20A  
Sangamo .00015 mfd, 10kV  
Sangamo .0039 mfd, 25kV, 25.5A

Large assortment of 200 watt resistors from very low to high resistance. Also a few 50 and 100 watt units.

**Gates 26-VC-2144** variable large inductors from 5/10 kW transmitters.

**Modulation transformer** for 10 kW high-level modulation. New unit, used only to check it out.

**Filter chokes** from high voltage transmitter power supply.

**Sola constant voltage transformer.** Primary 190/380v to 260/520v @ 1000 VA. Secondary 188v at 8.46 amps, 236v at 4.23 amps.

**Harris/Gates Solidstatesman AGC** model 994-66229-004

**Harris/Gates Solidstaesman** limiter model 994-6543-001

**R. Elm**  
**WWJC**  
1120 E. McCuen St.  
Duluth, MN 55808  
218-626-2738

**Studiomaster 16x8x2** console in Anvil Road Case. Very low hours, excellent condition. \$1600

**Teac 80-8 recorder.** 1/2", 8-track with DX-8 noise reduction. With PB64 patch pay, excellent condition. \$1600

Will deliver within 200 mile radius at no charge.

**Bill Busetti**  
**Lizard Studio**  
1124 W. 2nd  
Florence, CO 81226  
719-784-3540

2) **SMC 352-RS** Carousels. \$1200 each.  
**SMC RSC-100** random selector for Carousels. \$200

**SMC Mini-Pro-1** programmer. \$500

6) **Otari/SMC ARS-1000 DC** reel decks. \$1200 each.

**Conex 25Hz** generator. \$100

**Revox PR-99** reel deck. \$100

**dBx-900 series** with all modules (942 series). \$1800

**Harris satellite** receiver frame. \$800

*Radio Guide July-1990 Page-40*

**Orban 111B** dual reverb. \$300  
2) **Technics SL-1015** turntables. \$500 each.

**Randy Thomas - WEGZ**  
101 West Omaha St.  
Washburn, WI 54891  
715-373-5151  
Fax 715-373-5153

**RCA MI-27330 3-1/8"** motorized coaxial switch. \$650

**Modulation Sciences CP-803** composite audio processor. \$750

**Orban Optimod 8000A** with manual and test specs. \$1200

**Bill Hughes**  
**Textech Inc.**  
Tyler, TX  
214-534-8537

**CRL PMC300A** peak modulation controller. Excellent condition. \$495

2) **Telex Magnecord 1422** tape decks with amps. Good condition. \$100 each.

**Commodore 64** computer keyboard with monitor and encoder. \$80

**CBS Labs Audiomax 4440A.** Very good condition. \$50

**CBS Labs Volumax 4111.** Very good condition. \$50

**Control Design CO25G 25Hz** tone generator for making your own music tapes. Very good condition. \$100

2) **QRK Custom-2** turntables with tone arms. \$250 each.

**John C. Davis**  
**KSRM/KWHQ**  
HC-2 Box 852  
Soldotna, AK 99669  
907-283-5811  
Fax 907-283-9177

The following equipment is available for sale as individual pieces or as a package. All equipment has been professionally maintained and is in excellent working order. This studio is in operation at this time. All equipment is sold as Used Equipment, AS-IS, with no warranty expressed or implied. Shipping not included.

2) **Teac 1B** audio consoles. 4 years old, excellent. \$58.50 each.

**Sony custom MX-16** audio console. 10 years old, excellent. \$857.50

**Custom cabinetry.** Black, oak trim, 6 years old, excellent. \$650

2) **NAD 5200** CD players. 3 years old, excellent. \$312.75 each.

3) **Luxo 16001** mike arms. 4 years old, like new. \$34.98 each.

3) **Shure** mike shock mounts. 4 years old, like new. \$22.50 each.

3) **Shure SM5B** mikes. 4 years old, like new. \$83.70 each.

**NAD 4150 AM-FM** stereo monitor. 3 years old, like new. \$188

**NAD 3150** monitor amp. 50W/channel, 3 years old, like new. \$158

2) **Auratone 5** monitor speakers. 5 years old, good condition. \$116 each.

2) **Teac V5RX**, 2-channel cassette recorders. 4 years old, excellent. \$197.55 each.

**Tascam 234**, 4-channel cassette recorder. 3 years old, excellent. \$453.25

2) **Tascam 22-2**, 2-channel reel recorders. 3 years old, excellent. \$439.60 each.

2) **Teac 3440**, 4-channel reel recorders. 5 years old, excellent. \$718 each.

2) **Teac EQ-10** signal processor/equalizer. 3 years old, excellent. \$80.55 each.

2) **Gates** signal processor/limiter. 10 years old, very good. \$298.75 each.

**Radio Shack TQ2** phone. 3 years old, excellent. \$23.70

**DAC-1 ATS** telco interface. 3 years old, excellent. \$90

2) **Radio Shack turntable** pre-amp. 5 years old, excellent. \$20 each.

2) **QRK 12C**, 3-speed turntables. 5 years old, excellent. \$247.50 each.

2) **Microtrak 501** tone arms. 5 years old, excellent. \$67.05 each.

Package Price - - \$7,100

**Darrell Williams**  
**Dakota American Communications**  
1210 Taft St. North  
Suite 510  
Arlington, VA 22201  
703-276-9245

**CCA FM 10DS** stereo generator. Working when removed from service March-89. \$300

**Gates Criterion-80** mono cart machine. Record/play, very good condition, 2 cue tones, new pinch roller and lamps. Total mechanical and electrical alignments completed. With desktop cabinet. \$650

(continued on page-41)

Gate Criterion-80 mono cart machine. Playback only, very good condition, ready to go in desktop cabinet. \$450

J. Stack  
WMPO Radio  
614-992-64865

**ESP-1 Automation System:**

- 5) SMC 350 series Carousels
- 2) SMC 721 dual play cart decks.
- 4) Revox A77 reel decks.

Extel printer

AL-1 cassette memory loader

PDC-4A Superclock

PSB-3 power supply

DS-20A Audio switcher

ESP-1 programmer

RAC-31 remote control

- 4) Equipment racks
- 2) TS-25 tone sensor units

Was operational when removed from service in March-90.

\$11,000 plus shipping.

**WCLT Radio**

674 Jacksontown Rd. SE  
Newark, OH 43055  
614-345-4004  
Fax 614-345-5775

ITC Premium R/P mono cart deck. Rack mount, good condition, 3-tone. \$1150

4) ITC Premium SP mono cart decks. Rack mount, less than 5 years old with low hours, 3-tone. \$800 each.

ITC Premium 3D triple deck mono cart deck. Rack mount, good condition. \$1000  
Arrakis routing switcher. 16 stereo in X 8 stereo out. Rack mount, includes power supply and connectors, 5 years old. \$600.

Fon-Box telephone interface or talk shows, etc. Good condition. \$100

Otarl ARS-1000 stereo reel playback decks with 25Hz tone sensor. Low hours in excellent condition. \$1000 each.

Automation system. SMC MSP full feature, 200 event, for satellite format, tape service or live assists. Includes remote control, 4 years old, like new condition. \$3200

D. Doelitzsch  
WDDD  
1 Broadcast Center  
Marion, IL 62959  
618-997-8123

# TRANSCOM CORP.

Fine used AM & FM Transmitters  
and also New Equipment

For the best deals on Celwave products  
Andrew cable,  
Shively & Comark antennas.

1981	CSI T3F	3 kW FM
1981	McMartin BA5K	5 kW AM
1976	RCA BTF-20E1	20 kW FM
1978	Collins 828E1	5 kW AM
1984	McMartin 3.5K	3.5kW FM
1976	CCA AM-50,000D	50 kW AM
1974	RCA BTA-5L	5kW AM
1972	Harris BC10-H	10Kw AM
1986	Harris FM 2.5K	2.5 kW FM

201 Old York Rd.  
York Plaza Suite 207  
Jenkintown, PA 19046

215-884-0888 or 800-441-8454

Fax No. 215-884-0738

SMC ESP-1 automation system with (4) random select Carousels, controller, clock, dual cart player. In excellent condition. \$6000

iso-coupler on 99.3 mHz.  
160 feet 1-7/8" Heliac.

Jack Jensen  
KLVJ  
P.O. Box 704  
Mountain Home, ID 83647  
208-587-8424

4CX3000A tube. Brand new in the box. \$800

2) Shure M67 mixers. Both in good condition. \$125 each or \$225 for both.

Filament transformer for 4-500 tubes. All four outputs good. \$100

Ken Carver  
PLS Technologies  
1418 Amber Rd.  
Killeen, TX 76543  
817-699-1530

RCA BTA-10H, 10,000 watt AM transmitter. \$9,000  
RCA-50H, 50,000 watt transmitter. \$15,000

V.C. Stone  
804-685-3128

Send Your  
Tech-tips  
to Radio Guide



# Equipment Wanted

**Wanted: Orban 8000As and 8100s.  
ITC Cart decks of all types.**

**Hall Electronics  
John Hall  
1712 Allied Street  
Charlottesville, VA 22901  
804-977-1100**

---

**Wanted: Dead or alive. Pultec EQs; Fairchild & Teletronix limiters; Neumann, Telefunken, AKG, RCA, and Scheps microphones. Tube Macintosh or Marantz amps and pre-amps. Sontec, ITI, and Lang EQs. Neve or API equipment. Boxes of old tubes. UREI, Orban, United audio, dBx, and other outboard gear. Ampex ATR-102 or 104. Parts for MCI JH-110/114 recorders. Altec 604s/crossovers/Tannoy speakers. JBL 2231; Altec 288-H driver; misc. equipment of all types.**

**Please call Dan Alexander  
2944 San Pablo Ave.  
Berkley, CA 94702  
415-644-2363  
Fax 415-644-1848**

---

**Wanted: Professional disc cutting equipment and blank discs to make 78 and 45 RPM records. Prefer stereo set-up from mid-60's. I also buy 50's records in quantity, as well as old Coke machines and jukeboxes.**

**Kim Gutzke  
7134 15th Ave. S.  
Minneapolis, MN 55423  
612-866-6183**

---

**Wanted: To buy an old tube-type Mari RPU transmitter in the 161 mHz band.**

**George Shurden  
WCLD  
Highway 61 South  
Cleveland, MS 38732  
601-843-4091**

---

**Wanted: Pair of ITC R/P cart machines. Must be in stereo and in excellent condition. Must be willing to sell cheap.**

**Paul Lotsof  
KAVV-FM  
Box 42977  
Tucson, AZ 85733  
602-889-9797 between noon and mid-night, MST, seven days a week.**

---

**Wanted: SMC 350RS Carousels. Stereo preferred, working or not.  
Audicord stereo cart machines. "E" series preferred.  
SMC full size racks.  
AM 1 kW solid state transmitters. Nautel or Continental preferred.  
FM 3.5 or 25-35kW transmitters. Harris or BE, others considered.  
Optimod 8100A and 9100B processors.**

**Paul Buck  
Northern Lites Radio Network  
1402 Ashum St.  
Sault St. Marie, MI 49783  
906-632-7375**

---

**Wanted: Remote sports broadcasting equipment. Need headset (prefer Sennheisser or Astrolite), board (prefer Maxtel but not too picky), wireless mike. Also more than one single-line Comrex (or other brand) systems. Need Shure mixer.**

**Russell Scott  
Texas Sports Productions  
478 E. Magnolia  
San Antonio, TX 78212  
512-735-1067**

---

**Wanted: Harris MW-1 or MW-1A transmitter.**

**Frank Kavenik - WNVR-AM  
Suite 331 126 East Wing St.  
Arlington Heights, IL 60004  
708-394-9995**

---

**Wanted: 2-bay circularly polarized FM antenna. Tuned to 91.1 mHz or close.**

**Warren Wilson  
KJTY  
2519 NW Topeka Blvd.  
Topeka, KS 66617  
913-357-8888**

---

**Wanted: Two high-power FM antennas. One on 96.5 mHz and one on 107.5 mHz. 6 or more bays.  
3" Coax switch.**

**J. Boyd Ingram  
WBLE  
P.O. Box 73  
Batesville, MS 38601  
601-563-4664  
Fax 601-563-9002**

---

**Wanted: STL dish. 6 foot or larger.**

**J. Alex Bowab  
WDLT-FM  
2402 Wolf Ridge  
Mobile, AL 36618  
205-344-3698**

---

**Wanted: ITC 3D cart machine.  
Inexpensive reel to reel for production room spare.**

**Eric Nichols  
KMCR-FM  
P.O. Box 189  
405 East Norman  
Montgomery City, MO 63361  
314-564-2275**

---

**Wanted: Moseley Model 6020 STL receiver.  
Collins/Continental 310-Z-2 FM exciter.  
2) 6-foot STL dishes.**

**(continued on page-43)**

**Wanted: Burk or Marti wireless remote control.**

**100-200 watt or 1 kW TV transmitter.**

**Audio/video TV STL.**

**Revox PR-99 automation playback deck (stereo).**

**Belar FM-M1 modulation monitor.**

**Joseph Barr**

**154 Guajataca St.**

**Crown Hills, Rio Piedras**

**Puerto Rico 00926**

**809-756-5914**

---

**Wanted: Harris System 90 (that uses Tec screens) for parts.**

**Tony Wortman**

**WJAG/KEXL**

**309 Braasch Ave.**

**Norfolk, NE 68701**

**402-371-0708**

---

**Wanted: Used FIM-41 field strength meter.**

**Used audio limiters for SCA use.**

**Al Anderson**

**KBMR**

**3500 East Rosser Ave.**

**Bismarck, ND 58501**

**701-255-1234**

---

**Wanted: 4) Otari ARS-1000 reproducers or four Revox PR-99's.**

**Cart machines in good condition.**

**1kW FM transmitter.**

**3 to 5 bay FM antenna, tuned to 98.7 or near.**

**Console, turntables, mod monitor (FM), etc.**

**Howard McDonald**

**KKMT/KKMT-FM**

**P.O. Box 710**

**Ennis, MT 59729**

**406-682-7171**

# Studer DYAXIS

## Digital Editing System

With 760 megabyte hard drive providing 1 hour of stereo recording at 44.1 kHz. DSP Accelerator card included. System complete with Macintosh II-cx computer with 2 megabytes of memory, Apple extended keyboard and mouse with Radius Pivot monitor and Radius card. System has been used less than 50 hours.

**Tom Jones**

**KNXR**

**220 South Broadway**

**Rochester, MN 55904**

**(507) 288-7700**

---

**Wanted: Altec 438 or 436 (A,B, or C) compressor amplifiers.**

**James Gangwer**

**942 32nd St.**

**Richmond, CA 94804**

**415-236-2721**

---

**Wanted: Used production studio equipment. College station looking to improve facilities.**

**Mike Snelgrove**

**WIDR-FM**

**1511 Faunce**

**Western Michigan University**

**Kalamazoo, MI 49008**

**616-387-6305**

---

**Wanted: Tower CPU case. 6 bays with or without power supply.**

**Trade broadcast engineering shareware programs. Write for a list and send yours.**

**Michael Shannon**

**WZZP-FM**

**P.O. Box 644**

**100 Center**

**Mishawaka, IN 46544**

**219-256-1836**

**Wanted: EMI FMI antenna bays. Tuned to 92.1 or +2 channels.**

**Jim Fellows**

**KCMA**

**2021 S. Lewis #760**

**Tulsa, OK 74104**

**918-747-9999**

**Fax 918-747-7345**

## *Are You a Writer?*

**Radio Guide  
is looking for  
monthly columnists.**

***We need writers  
in these areas:***

**RF Transmission**

**FM Antennas**

**AM Antennas**

**AM DA Arrays**

**AM Transmitters**

**FM Transmitters**

**STL/TSL Remote Ctrl.**

**Transmitter Audio**

# Business Guide

Broadcast Services  
and Consultants

## **GOODRICH** enterprises, Inc.

Parts and technical service for all  
**McMartin** - Transmitters, Consoles, Exciters  
*Modulation Monitors Calibrated*  
*Transmitter Tubes - New and Re-Built*

11435 Manderson St.  
Omaha, NE 68164  
Phone (402) 493-1886  
Fax (402) 331-0638  
Telex 940103 WU PUB TLX BSN

## **NORTHERN** MAGNETICS

CERTIFIED TAPE HEAD SERVICES

Northern Magnetics is an industry leader in the supply and service of tape heads and tape head products.

P.O. Box 16409  
Minneapolis, MN 55416  
Phone: (612) 333-3071  
Telex: 1561238 MPS UT  
FAA Repair Station # C14-57

## **Test Equipment**

*Why Buy When You Can Rent?*

### **POTOMAC - DELTA - BIRD**

Other Equipment Available

*Call for Rates and Availability*

### **Radio Resources**

1-800-54-RADIO (1-800-547-2346)  
(301) 859-1500

## **BRENTLINGER** **BROADCAST** **ENGINEERING, INC.**

*Charles Jayson Brentlinger*  
President

COMPUTERIZED REPORTS / ALLOCATION STUDIES  
AM • FM • AM DIRECTIONALS • AUDIO • STL • SATELLITE COMMUNICATIONS  
4338 East Acoma Drive • Phoenix, Arizona 85032 • (602) 867-0181

## **Consulting Communications Engineers**

- FCC Data Bases
- FCC Applications and Field Engineering
- Frequency Searches and Coordination
- AM-FM-CATV-ITFS-LPTV

### **OWL ENGINEERING, INC.**

1306 W. County Road. F,  
St. Paul, MN 55112  
(612) 631-1338 "Member AFCCE"

**Place Your Business Card Here**

**Reach All Broadcast Engineers**

**With Your Message**

**Call Radio Guide at (507) 280-9668**

**For Information on Your Space**





(802) 226-7582  
FAX: 802-226-7738

### COMMERCIAL RADIO COMPANY

Transmitter Parts for: RCA, Gates, Collins  
Non-PCB Filter and Mica Transmitting Capacitors

DANIEL W. CHURCHILL  
DUTTONSVILLE SCHOOL DRIVE  
CAVENDISH, VT. 05142

## Tube Rebuilding Freeland Products

- We Buy Duds -

Since 1940  
Save About 50%



800-624-7626  
504-893-1243  
Fax 504-892-7323

Including for TV  
RCA Cermolox and UHF Klystrons

FCC's Engineering  
AM, FM and TV Data Bases  
On floppy (or) 9-track tape

Call today to request a free sample

Communication Data Inc.

6105 E. Arlington Blvd.  
Falls Church, VA 22044  
703-534-0034

# SBE

## STANLEY BROADCAST ENGINEERING

James S. Stanley

P.O. Box 24601  
Tempe, AZ 85282

(602) 264-8752

**DISSIPATION ARRAY® SYSTEM  
SPLINE BALL IONIZER™**  
SURGE TRANSIENT PREVENTION  
CONSULTING & ENGINEERING DESIGN SERVICE



**Lightning Eliminators  
& Consultants, Inc.**

6687 Arapahoe Road, Boulder, Colorado 80303  
(303) 447-2828 FAX (303) 447-8122

# LIGHTNING PREVENTION SYSTEMS

LIGHTNING PROTECTION AND PREVENTION SYSTEMS  
FOR COMMUNICATIONS TOWER SITES.

204B Cross Keys Road, Berlin, NJ 08009  
FAX 609-767-7547 • (609) 767-7209

**Don't Wait Until It's Too Late!**

# HE HALL

## Electronics

THE BEST DEALS ON QUALITY  
REBUILT & BRAND NEW  
BROADCAST EQUIPMENT

We BUY & TRADE equipment too!  
Please phone or send for our latest flyer.

10:00AM-6:00PM EST

804-974-6466  
FAX 804-974-6450

1305-F Semnole Trail  
Charlottesville, VA 22901

# Broadcast Computer BBS's

## **Second opinion BBS**

24-hours  
300/1200/2400/9600 baud - 8/N/1  
SBE Chapter 28 news and files  
414-771-3032

## **The Communications Exchange**

24-hours  
300/1200/2400/9600 baud  
SBE Chapter 24 news and files  
608-274-7776

## **Allied/RW Broadcast BBS**

300/1200/2400/ baud - 8/N/1  
Basic programs and ASCII files  
317-935-0531

## **AV-Sync**

24-hours  
1200/2400/9600 baud - 8/N/1  
Broadcast, recording, engineering files  
404-320-6202

## **Broadcasting Computer Database**

24-hours  
300/1200/2400/9600  
19,200 Baud Hayes/HST  
Broadcast, Engineering, Ham radio,  
MediaNET, On line database  
713-937-9097

## **Network Communication System Broadcast BBS**

300/1200 baud  
Technical tips and schematic graphics  
601-373-0160

## **Flamethrower Broadcast Resource**

24-hours  
300/1200/2400/ baud - 8/N/1  
Broadcast engineering and Ham radio  
804-550-3338

## **ICEWEB**

24-hours  
300/1200 baud  
CATV and engineering files and  
message base  
608-274-8601

## **Broadcasters BBS**

24-hours  
1200/2400 baud  
Broadcast/media files and msg.base  
602-872-9148

## **Western Washington Freq.Coord**

24-hours  
300/1200/2400 baud  
FCC coordination pgm. and data files  
206-443-6170

*Radio Guide July-1990 Page-46*

## **Broadcasters Link**

24-hours  
Announcer/programming orientation  
919-739-6150

## **SBE Chapter 22 (Central New York)**

24-hours  
300/1200/2400 baud  
315-474-5070

## **Radio Daze**

24-hours  
300/1200/2400 baud  
Engineering and programming  
219-256-2255

## **KTOL Radio Point**

24-hours  
300/1200/2400 baud (also 14,400 HST)  
206-459-4689

## **The Rock Board**

24-hours  
300/1200 baud  
Music orientation  
201-857-8880

## **Olympia Broadcasting Networks**

24-hours  
1200/2400 baud - 8/N/1  
Fro Olympia affiliates  
314-361-6688

## **DFW Frequency Coordination**

24-hours  
300/1200/2400/9600 HST  
SBE Chapter 67 frequency coordina-  
tion and general broadcast engineering  
214-647-0670

## **Colorado Broadcasters**

24-hours  
Denver SBE Chapter materials and  
Colorado frequency coordination  
303-341-0129

## **Northern California FCC**

24-hours  
300/1200/2400 baud  
San Francisco area frequency coordi-  
nation  
FidoNet 1:125/777  
415-391-2657

## **Broadcasters BBS**

24-hours  
300/1200/2400 baud  
Wide ranging broadcast topics  
602-872-9148

## **Trillion**

24-hours  
300/1200/2400 baud  
Broadcast engineering topics  
616-530-0821

## **Videopro**

24-hours  
300/1200/2400 baud  
Production concerns  
703-455-1873

## **Chapter 75 SBE**

24-hours  
300/1200/2400 baud  
Little Rock Chapter  
501-753-6536

## **Visions Infoline**

General media  
201-769-1779

## **Gannett HelpScreen**

USA Today  
201-525-3982

## **Rock and Roll Party**

Broadcasters  
404-982-0960

## **Broadcasters Forum**

Broadcast info  
602-395-9978

## **So. California Media Line**

Broadcast  
619-289-4027

## **Programmers Retreat**

209-526-9987

## **Colorado Springs Broadcast BBS**

New BBS on line  
719-634-5661

## **Black Hole BBS**

9600 Baud (HST)  
419-228-7236  
Fidonet 1:234/16  
Amateur radio, Radio & TV engineering.

## **CRL Customer Service BBS**

602-438-0459

## **Air Studio**

Broadcast - Broadcasting - Amateur  
Radio  
313-546-7045

# Get ready for Fall sports with **MARTI !**

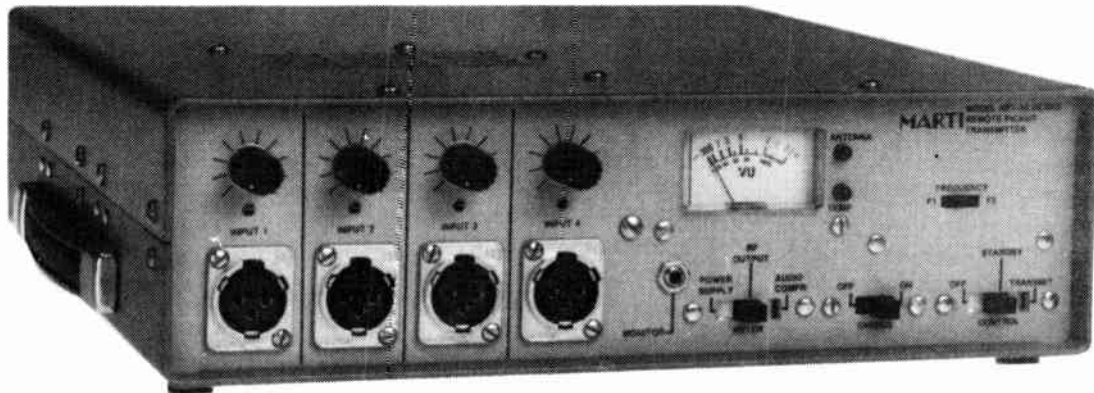

RPT-30 Single-frequency \$1695.00, Dual-frequency \$1725.00

Don't miss valuable Fall sports revenue by not having a Marti.

Marti has been bringing back live sports remote-broadcasts for over 30 years. Put Marti's proven reliability to work for you.

Marti has RPT-30 and CR-10 systems in stock and ready to ship. Contact your broadcast products dealer or Marti for more details.

**MARTI** *The Performance-value leader in Broadcast Equipment*

Marti Electronics, Inc., P. O. Box 661, Cleburne, Texas 76033-0661  
(817) 645-9163 Telex #794835 "Marti CLBN" FAX (817) 641-3869



# RADIOMIXER.<sup>®</sup> For everyone who thought a PR&E console was out of reach.

**Y**ou've tried, but your console budget just can't accommodate a Pacific Recorders BMX—not this time. So you're probably thinking about settling for a copy, even though it won't have the standard-setting features, performance and long-term reliability that have made our BMX consoles so successful.

Fortunately, you don't have to settle. Radiomixer is genuine PR&E. All the way from its high quality components to its efficient BMX-style layout, comprehensive telephone mix system and unique Off Line Mix Matrix. Yet its manufacturer-direct price is no higher than the "clones."

How did the PR&E engineering team build a less expensive console without lowering our standards? Let's start with what we didn't do:

We didn't compromise on quality. Radiomixer uses the highest caliber components throughout, including our standard professional-spec meters, faders, and switches. Plus the best-sounding VCA technology in the industry. To keep Radiomixer's cost down, we've limited the number of different module types and mainframe sizes, and simplified the construction of the card frame, mainframe and modules.

The final result? In less than a year, Radiomixer has quietly become one of our most popular consoles. In fact, it's now one of the best-selling boards in broadcasting. Our color brochure will tell you more of the reasons why, and help you configure a Radiomixer for your particular application. To get your copy, call PR&E direct at 619-438-3911.



**PACIFIC RECORDERS & ENGINEERING CORPORATION**  
2070 Las Palmas Drive • Carlsbad, CA 92009 • Tel 619-438-3911 • Fax 619-438-9277

