

# RADIO GUIDE

Attention: CHIEF ENGINEER  
KLTO  
4180 N MESA ST  
EL PASO TX 79902-1420

BULK RATE  
U.S. POSTAGE  
**PAID**  
ROCHESTER, MN  
PERMIT 445

Address Correction Requested

A Forum for Radio Engineers  
Ray Topp Editor/Publisher (507) 280-9668

September 1989

Volume 2 - Issue 9

Copyright 1989 - Rochester Radio

511 18th Street SE

Rochester, MN 55904

## Computer BBS Call

On page 18, of this issue, we have started a permanent listing of all broadcast related computer bulletin boards. Numbers and information listed were gleaned from my own files and information supplied by others. I would like to expand this listing to include the specific services & files that each BBS has to offer. Any Sysops out there -- please give me a call, and we'll get your specific information listed in the next issue of Radio Guide.

There are quite a few good BBS systems out there, but in my opinion, most engineers don't know about them. Well, here's your chance to let the engineering community know you exist.

Speaking of BBS systems, I know I've said that Radio Guide has been working on a national technical BBS. Well, we're still working on it, and we're almost there. Believe me, it's worth the wait.

## The Bare FAX

Why is it that, ever since the advent of the FAX machines everyone uses all these ridiculous expressions? The "bare FAX," or "just the FAX please." And would the one station that has not obtained its FAX machine via a trade-out, please call me.

On page 20, of this issue, we've included a FAX transmittal sheet with the names and numbers of Radio Guide Advertisers. You can copy or cut out this 8½ X 11 sheet, and send it to an advertiser, should you wish more information regarding their products and services.

At the same time, you may want to let them know what you think about the Radio Guide and thank them for their advertising support. It's important to let them know that you read the Radio Guide each month.



**You receive an important extra with every quality TTC transmitter...**

*We're there with Total Support if you need us. Our 24-hour Total Support Hot Line lets you call for technical, engineering, or maintenance support at any time. All our transmitters and translators are made with strict attention to quality control.*

*Get to know TTC and our full line of AM and FM Transmitters, made in the U.S.A.—FM from 10 Watts to 40,000 Watts, AM from 500 Watts to 50,000 Watts. For more information, call TTC: Television Technology Corporation (303) 665-8000 • FAX: (303) 673-9900*

**The Quality is TTC**

**TTC TOTAL SUPPORT**

## And You Thought I Was Done

I could be wrong, but are some of you not writing articles for Radio Guide because you don't want to see your name in print? It's possible. There are probably some of you who have technical information to share, but just don't have the courage to tack your name to it. We've all been there. "Was it skill, or just dumb luck, that allowed me to fix that problem?" "Is it really fixed; have I covered all possibilities?" "I'm probably the only one who doesn't know this!" Those fears are not groundless, but don't let them prevent you from writing your technical information down and sending it to Radio Guide for publication. We are all in various stages of professional development, and none of us -- NONE OF US -- are at the point that we can say we are an expert in all areas of broadcast technology.

I'm sure you have known someone in broadcasting who seems to be a "guru." Yet, when you actually get to know them, it's not surprising to find that, although they really do have expertise in certain areas, in many others you are, at least, their equal -- if not more experienced. What actually sets them apart from the engineering community is that they have taken the time to write and share their knowledge with others. This is all I'm asking you to do.

## In This Issue . . .

- Page 2      Corrections - Info - Help
- Page 3      Effects of Cable Capacitance
- Page 4      Battery Operated Signal Tracer  
Capstan Plunger Tales
- Page 6      Listener Information Line  
IGM Automation Tip
- Page 7      Old Tapecasters Never Die
- Page 8      Otari Falsing Fix  
Moseley ITC-3D Parts Tips
- Page 9      RCA BTF-20E Pointers
- Page 10     CD Interface
- Page 11     Open Delta Alert
- Page 12     Gentner MRC-1000 Meter System
- Page 13     RPU Range Increase  
Technics SP-15 Tips
- Page 14     Harris FM TX Tips  
Sparta 602-A TX Fix
- Page 15     Collins 8316 Socket Problems
- Page 16     Three-Phase Transformer Configurations

## Corrections - Info & Help

### Satcom 1R Crystal Info

From Bill Monroe - WEEO  
Wayneboro, Pennsylvania

Bill called with information regarding Satcom 1R digital receiving gear. It seems a short time ago, Satcom 1R, transponder 19, went down. It also seems that many stations did not have a crystal for the backup transponder. Bill says that International Crystal is aware of the specs, and has data on file for the crystals for Scientific Atlanta as well as Fairchild gear. All you have to do is let them know what unit you've got and what transponder number.

The crystals cost only \$15.00 plus shipping. They can cost up to \$60.00 from other "normal" sources. You may want to give them a call or write to them:

International Crystal  
P.O. Box 26330  
701 W. Sheriden  
Oklahoma City, OK 73126  
(800) 426-9825

Thanks for the tip - - editor

### AEL Help Wanted

Jack Parker, of WVBE-FM, needs a technical manual, or a copy of same, for an AEL FM2.5KD transmitter. Give him a call at (513) 621-6960, if you have any information on this transmitter. He can also be reached at home at (606) 371-2231 - - editor

### Alternative Control Ladder Test

From K. Scott Johnson, CE - WINA/WQMZ  
Charlottesville, Virginia

In the June issue of Radio Guide, Bob Howe of WGBL suggested a way of troubleshooting series-wired interlock switches in a transmitter. His circuit involved a latching relay, and could conceivably require several trips to isolate the switch that's causing the trip. There's one easier method; one that I've used successfully several times in such situations.

My solution was simply to mount a small fuse (rated at less than 50% of the holding current of the high-voltage or control relay) across each overload relay contact or interlock switch contact. Then, when the transmitter trips, the fuse across the open switch or relay contact blows. Find the blown fuse, and you've found the offending switch/contacts. Of course, you need to have the transmitter's low-voltage supply off, until all doors are closed and interlocks engaged, or you'll blow the fuses before they have a chance to tell their tale.

### So How Come You Never Write?

If you have any short tech-tips, send them in. Remember, it doesn't do anyone any good if you keep that information to yourself. Don't assume that everyone knows about your special technical tip - - so send them in!  
Editor

## CRL SPOTLIGHT



### Upgrading Your FM Processing?



The CRL FMIG audio processing system is the perfect answer for those of you with a small budget, but a large budget need for FM processing. With the FMIG you get the market's cleanest limiter the SMP-850, followed by the SG-800A digitally synthesized stereo generator. The SMP-850 features a powerful input compressor, followed by our exclusive variable transfer function pre-emphasis limiter. Image widening stereo sound field enhance circuitry is standard equipment. The SG-800A's digital pulse amplitude modulator produces a flawless baseband stereo signal. Find out what the FMIG can do for you. We have a two week trial program available. Call or write us for details.



**CRL Systems**  
2522 West Geneva Drive  
Tempe, Arizona 85282 U.S.A.  
(800) 535-7648 (602) 438-0888  
TELEX: 350464

### Is Everything OK?

If we're doing alright, let us know. If we're not serving your needs, let us know that too - - and at the same time be sure and tell us what you think needs correction, modification or expansion.

Remember, Radio Guide depends upon your suggestions for its content, direction and its very existence. You've said you've wanted it, so here it is. Please, help to create a useful technical publication.

### NRSC-2 Dilemma? No Problem.

We deliver the simple, effective, and inexpensive solution to your compliance with the mandatory NRSC specification.

Easily installed in only minutes, our product utilizes digital techniques for full asymmetrical peak control, self-regulating pre-emphasis and no-overshoot lowpass filtering. It works with any existing processing, or can even stand alone as the only processor you really need!

INOVONICS' MODEL 222 - \$590

**Inovonics Inc.**

CALL: 1-800-733-0552  
FAX: (408) 458-0554



### ZH-1 Dual Transmitter Peak Processor

ONLY \$460.00



- ★ Separate peak control for main and auxiliary transmitters
- ★ Permits running main AM processor at the studio
- ★ Exclusive, low Second Harmonic Clipper, outputs low pass filtered for NRSC protection

**hnat hinder inc**

42 Elaine Street • R.R. 1 • Thompson, Connecticut 06277  
(203) 935-9066 • (203) 935-9242

# Effects of Cable Capacitance

By Greg Hahn - WRKA  
Louisville, Kentucky  
(502) 423-9752

You're probably familiar with the effects of RC networks in pre-emphasis and de-emphasis circuits. They cause intentional changes in the frequency response.

The same thing can happen in the interconnection of any two pieces of audio equipment when the capacitance of the cable starts adding up on long runs.

The Belden catalog says 8451 cable has a capacitance of 34 pF per foot. Most cable that I have found, is in the ballpark so I will use a nice round 30 pF per foot for my calculations.

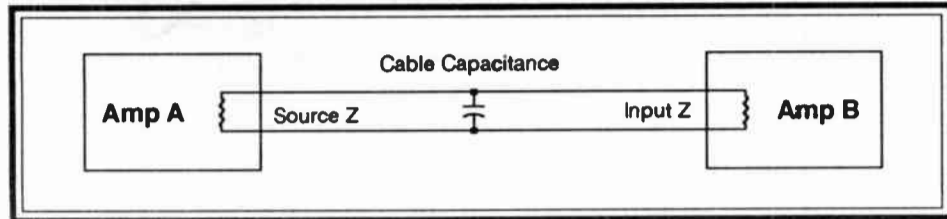

The diagram shows two amplifiers connected together with 1000 feet of our 30 pF per foot cable. This gives us the equivalent of a 0.03 uF capacitor. The total resistance of the circuit is the output impedance of amplifier A in parallel with the input impedance of amplifier B.

The cut-off frequency,  $F_c$ , is the point that the high frequency rolloff reaches -3 dB. It can be determined by the following formula:

$$F_c = \frac{1}{6.28 (RC)}$$

Where R is total resistance of circuit in ohms, and C is total capacitance of cable in farads

If the output Z of amplifier A is 600 ohms and the input Z of amplifier B is 10k ohms, our total R is 566 ohms. Plugging those into the formula above, we get:

$$\frac{1}{6.28 \times 566 \times 0.00000003} = 9378 \text{ Hz}$$

If this is the program feed to our FM transmitter, we have a problem. Since the capacitance of the cable cannot be easily changed, we'll have to change the resistance of the circuit.

If we terminate the end of the cable at the input of amplifier B with a 620 ohm resistor, that will make the load Z 584 ohms. This, paralleled with the 600 ohm source Z, gives us 296 ohms for circuit R. We now have:

$$\frac{1}{6.28 \times 296 \times 0.00000003} = 17,932 \text{ Hz}$$

This is a much better situation, but due to the gentle rolloff characteristics of the RC network, it's still not good enough for top notch audio. We need a cutoff frequency of 30 kHz or better. At a 30 kHz cutoff, you will be down approximately 1 dB at 15 kHz. You'll be down 0.5 dB at 15 kHz, with a cutoff frequency of 40 kHz.

The best way to lower the resistance of the circuit is to use an amplifier with a very low output impedance to drive the line. Many of the active balanced outputs on the newer equipment have output impedances of 100 ohms or so. With an arrangement like this, you wouldn't even need that 620 ohm terminating resistor and your cutoff would still be over 50 kHz.

Another way would be to use a transformer to lower the source impedance to 150 ohms. Use another transformer at the other end to convert back to 600 ohms and step up the voltage to your original level. (the second transformer should be terminated with 600 ohm load)

Don't trust the manufacturer to give you the true output Z. The figure they give may be the proper load for their equipment. The true output Z can be found by running a 1 kHz tone through the amplifier under test. With no load connected to the output terminals, measure the output level. Then find the resistance value, when placed across the output, required to drop that level by 6 dB. This resistance is equal to the true output Z of the amplifier.

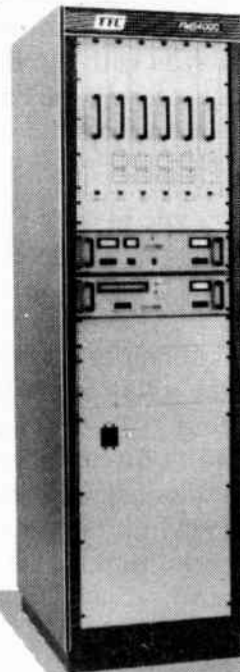

## WORLD STANDARD IN SOLID STATE FM TRANSMITTERS

**Solid state quality and efficiency.** TTC's new FMS-Series FM Transmitters are available in 1kW, 2kW, 4kW and 8kW models. Broadband, efficient power amplifiers are transparent to the high-spec TTC Exciter.

**Redundant systems for high reliability.** Individual 1000 Watt plug-in amplifiers provide extremely easy service and maintenance. These transmitters remain on the air automatically—even in the unlikely event of a power amplifier failure. Exclusive "fail-on" control circuits keep the transmitter operating should a control circuit fail.

**World-acclaimed TTC Model X Exciter.** The Model X provides truly outstanding performance, with all distortions measuring .01% or less and FM composite signal-to-noise ratio an amazing 90dB down. Frequency response is .05dB from 20Hz to 100kHz for unparalleled loudness and clarity.

Made in U.S.A. For details on our full line of AM and FM transmitters and translators, call TTC: Television Technology Corporation, Phone: (303) 665-8000 FAX: (303) 673-9900

**The Quality is TTC**

- 100% solid state
- Very high efficiency
- Fully automated control
- Superlative specifications
- Integral lightning protection
- Redundant power amplifiers
- Broadband—no tuning required

## The NEW, SX-87-MUX has the low price and digital performance you've waited for!



**ONLY \$495.00**

### Why pay thousands more . . .

The SX-87-MUX combines the isolation afforded by its unique Bi-Directional amplifier with a high speed feed and return path multiplexing scheme to provide constant nulls approaching 40dB in actual usage.

- No elaborate auto nulling schemes
- No fancy echo canceling digital algorithms
- No wallet shrinking price tag

The only thing elaborate about the SX-87-MUX is its performance!

Before you mortgage your next hybrid, consider buying one of ours. The only real difference is the price!

**NOTE: Direct replacement SX-87-MUX logic boards are now available for all existing SX-87's. Upgrade your's today. Only \$148.00 FOB.**

**hnat hinders inc**

42 Elaine Street • R.R. 1 • Thompson, Connecticut 06277  
(203) 935-9066 • (203) 935-9242

# Battery Operated Audio Tracer

By John A. Bredesen, P.E. - KLCC-FM  
Eugene, Oregon

Anyone who has worked around audio systems knows that it's necessary at times to be able to go to any point in the path to trace a signal, when troubleshooting. A traditional way is with a pair of headphones. This works (after a fashion), but it loads the circuit and, given the relatively low level of the typical line, can be difficult to hear, if the location isn't quiet.

A solution to the problem is to use some type of amplification. You can drag out an amplifier and a speaker, look for an "unused" power outlet near the project, and hope that a ground loop doesn't interfere with the feed. A simpler solution is to get a small battery powered amplifier/speaker combination, and consider it another piece of test equipment. Radio Shack has such a device (Catalog #32-2031) for around \$18. It's powered by four "C" cells and has the bonus of a mike level input. It's quality won't threaten JBL or Bose, but it's good enough to tell if the signal has bad distortion or hum. It comes with 3.5 mm mini-jacks for both inputs, but these can be changed to whatever pleases you. I think there would even be room for an XLR type connector for the mike input, which would allow you to do quick mike checks.

One problem with any battery powered equipment is that of leaving it turned on when you're finished with it. Radio Shack also has a solution to that problem! For about two bucks, you can get an LED with a built in flasher. It's the same size as a standard LED and can be mounted on the front panel through an appropriately sized hole. I did this with the amplifier/speaker here at KLCC. One word of caution -- be careful with the supply voltage. It is rated up to 5 volts (without a dropping resistor) because of internal circuitry. In the case of the amplifier/speaker, the four batteries provide 6 volts. A series resistor won't work because, when the internal CMOS chip has the LED turned off, there is no significant current to cause a drop across the resistor. This results in the full supply voltage being applied to the LED flasher. The simple solution is to place a regular LED in series instead of a resistor. This provides a second flashing source which can enhance the visual alert. More diodes can be placed in series for higher voltages. Of course you can always use a voltage divider, but this has the disadvantage of increasing current draw from the battery.

## Capstan Plunger Tales

By John Gaboury, CE - KAWC Radio  
Yuma, Arizona

It was a dark and stormy night. The reel to reel playbacks leered menacingly at me. I knew what the problem was -- but I didn't know what to do about it. The capstan roller wouldn't keep constant pressure when the machine was activated by the sequencer and . . . wow, wow!

The capstan solenoid pushes a flexible rod, instead of pulling like a sensible solenoid. As a result of that, and poor geometry, the solenoid plunger was galled, and the ridges would allow varying degrees of engagement. The machine and the company were out of production, and no spare parts were available. I had one spare solenoid which I could install, and wait a week until the "wow" started again.

I thought of the hammer on my Colt .45, put the spare plunger in my pocket, and the next day went to the friendly local gunsmith. He said, yes, he could case-harden the plunger. He took the plunger, put it in a pie tin with a raised center, and poured the tin full of a case-hardening powder (Kasnit). He heated the plunger cherry red, then tipped it over into the powder. After it cooled, he took a file to the plunger, and it turned the file! I now had a plunger which was extremely hard on the outside, soft inside, and retained all of its magnetic properties.

Case hardening is a process which causes malleable iron or mild steel to absorb carbon to a depth of several thousandths of an inch. This gives a very hard and durable surface. Other processes such as nitriding and cyaniding can produce the same results, but are far too dangerous for any but the expert. The deck kept proper capstan pressure throughout the rest of its life.



**EMERGENCY**

**THINK MLW-1**

**AUTOMATIC**

- SWITCH TO SECONDARY OR TERTIARY STEREO INPUTS ON PRIMARY LOSS OF CHANNEL
- SWITCH TO SECONDARY OR TERTIARY STEREO INPUTS ON PRIMARY LOSS OF AUDIO
- LOSS OF CHANNEL CORRECTION
- AUDIO POLARITY CORRECTION
- User programmed sequence and time delays
- On-line audio monitoring and stereo audio switching
- Microprocessor based
- Audio error alarms and level matching

**AND MORE... CALL OR WRITE FOR COMPLETE DETAILS**

**TITUS TECHNOLOGICAL LABORATORIES**  
77 Kreiger Lane, Glastonbury, CT 06033  
(203) 633-5472

# Simple...Higher MODULATION



ModMinder will allow you to increase your overall loudness with no processing artifacts. There's no trade-off. If your goal is to run loud and clean, ModMinder will give your signal even more prominence. How? Call us and we'll tell you.

**ALLIED**  
BROADCAST EQUIPMENT  
A HARRIS COMPANY  
**800-622-0022**

# 4, 6 & 8 MIXER, SINGLE AND DUAL CHANNEL STEREO, ..... \$1395 TO \$2950!!

**NOW AVAILABLE!!**  
PROGRAMMABLE, MIX/MINUS BUSS WITH BALANCED OUT.

The incredible, new **xL SERIES** audio consoles.



xL82S shown

## FIELD PROVEN

The new xL SERIES consoles utilize much of the same high performance technology that has made our audio switchers, DA's, preamps & mixers famous the world over. And, as you are reading this, these new consoles are proving themselves in numerous installations across the country. "No RF problems of any kind"... "Our sound has noticeably improved since installing your boards"... "Our people really enjoy the ease of operation"... "Would recommend your consoles to anyone that asks"... Your console actually tested out better than your spec's".

## NEW TECHNOLOGY LOWERS COSTS

Dramatic new developments in IC technology have enabled us to design these consoles with fewer components and naturally less labor. The end results are not only a significant price reduction and higher performance than previously possible but, in addition, higher reliability.

## MORE BANG FOR THE BUCK

Huge expanded scale, -40dB to +3dB, multi-colored LED VU meters (4" & readable in bright light across the room); Four individual meters on dual channel units; Switch programmable muting on each mixer and input; Nine input selects on the last channel; Mono sum output; Plug-in modules for ease of service; Optional switch programmable remote control start/stop; Remote start/stops use front panel input and output selects or input select and pot up start/ pot down stop; Double shielding for total RFI protection...and as you'll see in the rest of this ad ...much, much more.

## FOR THE SKEPTICS

Anyone can write an ad touting the virtues of their product. Well, we have always felt that we haven't passed muster until you say so. That's why all RAMKO products are shipped on a two week trial basis. You're the final judge. No ifs, ands, or buts! Simply put, if at any time within two weeks of receiving your equipment you are not entirely satisfied, or have just changed your mind, return it in like new condition. Upon verification of condition an immediate refund (less shipping charges) will be issued, for prepayment or C.O.D.s, or your account will be credited if purchased open account. What more could anyone ask? Pricing that will save you hundreds of dollars...Unsurpassed quality & performance...A no risk opportunity to prove to yourself that you get exactly what you want and everything we claim is true. And, everything we manufacture is backed by a 2 year warranty.

## DON'T DELAY

Call RAMKO RESEARCH direct or your RAMKO dealer for further information or to place your order. You have nothing to lose except perhaps some preconceived notions about how much quality *really* costs.

TOLL FREE (800)678-1357

FAX (916)635-0907

# RAMKO RESEARCH

3501 #4 SUNRISE BLVD.  
RANCHO CORDOVA, CA 95742  
(916)635-3600

## FEATURES OVERVIEW:

1. EXPANDED SCALE VU METERS (-40dB to +3dB) multi-colored LED.
2. PLUG-IN SHIELDED INPUT MODULES.
3. MIC/LINE SELECT JUMPERS ON EACH CHANNEL.
4. MONO/STEREO FEED SELECT ON EACH CHANNEL.
5. GAIN SELECT PATCH PANEL ON EACH INPUT.
6. PROGRAMMABLE MUTING SWITCHES ON EACH INPUT.
7. NINE INPUTS ON LAST CHANNEL.
8. 2 WATT CUE AMP.
9. ROCK SOLID, SHORT CIRCUIT PROOF SUPPLY WITH LED INDICATORS.
10. MONITOR SELECT/GAIN CONTROL. Prog 1/Prog 2/External.
11. PHONES SELECT/GAIN CONTROL. Prog 1/Prog 2/External/Cue.
12. INTERNAL CUE SPEAKER.
13. VCA CONTROLLED MIXERS.
14. PADDED ARM REST.
15. MONO SUM OUTPUT.
16. PLUG-IN IC'S THROUGHOUT.
17. FOUR INDIVIDUAL PWR. SUPPLIES. Meters, Cue amp., Power amp., Main audio.
18. INSTANT ACCESS. Two,

quarter turn fasteners.

19. ILLUMINATED 5 MILLION OPERATION IN/OUT SELECT SWITCHES.

20. HIGH VOLTAGE SOLID STATE AUDIO SWITCHES. Cannot be overdriven nor damaged by overvoltage.

21. EXTERNAL 20 WATT POWER AMP.

22. ON AIR LIGHTS RELAY.

23. REMOTE START/STOP OPTION. Programmable for operation from in/out select switches or mixer pot-up start & mixer pot-down stop.

24. COMPLETE INTERNAL LABELING. All labeling for in's & out's, gain adjusts, programming, levels, etc., is provided internally for easy installation.

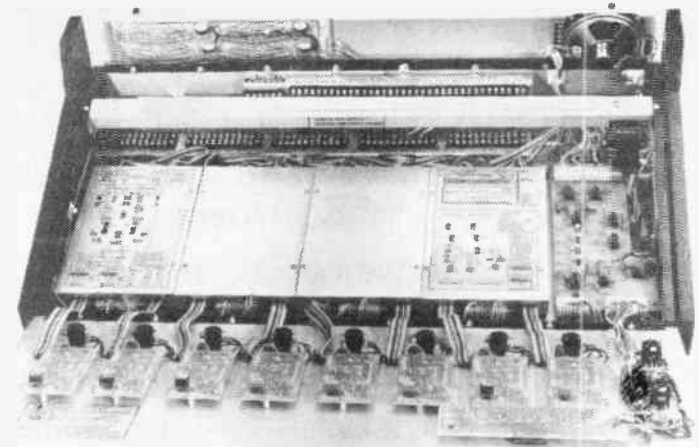

## PARTIAL SPECIFICATIONS

INPUTS: Two per channel except the last channel which has nine. Balanced bridging 1k ohms in mic mode & 150k ohms high level. Input #1 of each channel programmable mic thru high level. Input #1 of each channel may be strapped for mono or stereo feed.  
OUTPUTS: Balanced low impedance, +25dBm max into 600 ohms. May be used balanced or unbalanced. Stereo sum balanced out. Program outputs factory set for +8dBm but may be recalibrated for

any other level.

METERING: Expanded scale, 4" solid state tri-color with VU ballistics. 2 each on single channel units & 4 each on dual channel models.

MONITOR: Stereo, muted monitor outputs @ +4dBm. External 20 watt stereo amp included. Three position selector for PRO1, PROG2 & EXTERNAL in.

CUE: Mono-sum to 2 watt internal amp & speaker and phones. Switch programmable speaker muting.

S/N: Mic level in @ -50dBm & +8dBm

out; -68db. High level @ 0dBm in & +8dBm out; -75dB (typically -78dB).  
DIST: Below noise floor. Typically .009%.

RESP: 10Hz-20kHz; ±1dB  
CROSSTALK: PROG1 to PROG2; -70DB.

SIZE: xL4..19"W x 8.5"H x 17"D.  
xL6..25"W x 8.5"H x 17"D  
xL8..30"W x 8.5"H x 17"D

POWER: 115VAC, 50/60HZ, 40W.  
230VAC available at additional charge.

FINISH: Polyurethane Carbide black, Linear white, Ramko Grey.

## MODELS & LIST PRICES:

xL41S .....\$1395  
4 mixer single channel stereo  
xL42S .....\$1650  
4 mixer dual channel stereo  
xL 61S .....\$1975  
6 mixer single channel stereo  
xL62S .....\$2375  
6 mixer dual channel stereo

xL81S .....\$2650  
8 mixer single channel stereo  
xL82S .....\$2950  
8 mixer dual channel stereo  
RSS4 .....\$225  
Remote start/stop (xL4)  
RSS6/8 .....\$325  
Remote start/stop (xL6 & xL8)

LF6 .....Contact factory  
Linear faders; Available 6/89  
LF8 .....Contact factory  
Linear faders; Available 6/89  
PS230B .....\$50  
230VAC power source

# Listener Information Line

By Jay White - KASH/KKSD

Anchorage, Alaska

(907) 522-1515

It seems, more and more, that if I'm not coming up with new ways to do things, or looking for the perfect way to save time or money, my job just isn't exciting anymore. I must admit, when the GM told me we were going to start a sports scores call-in line, I considered two things: the old answering machine that the announcers have such a hard time putting messages on, and the \$200 magic box that answers the line and plays a cart. This isn't saving time or money.

Here's a circuit that I came up with to solve the problem:

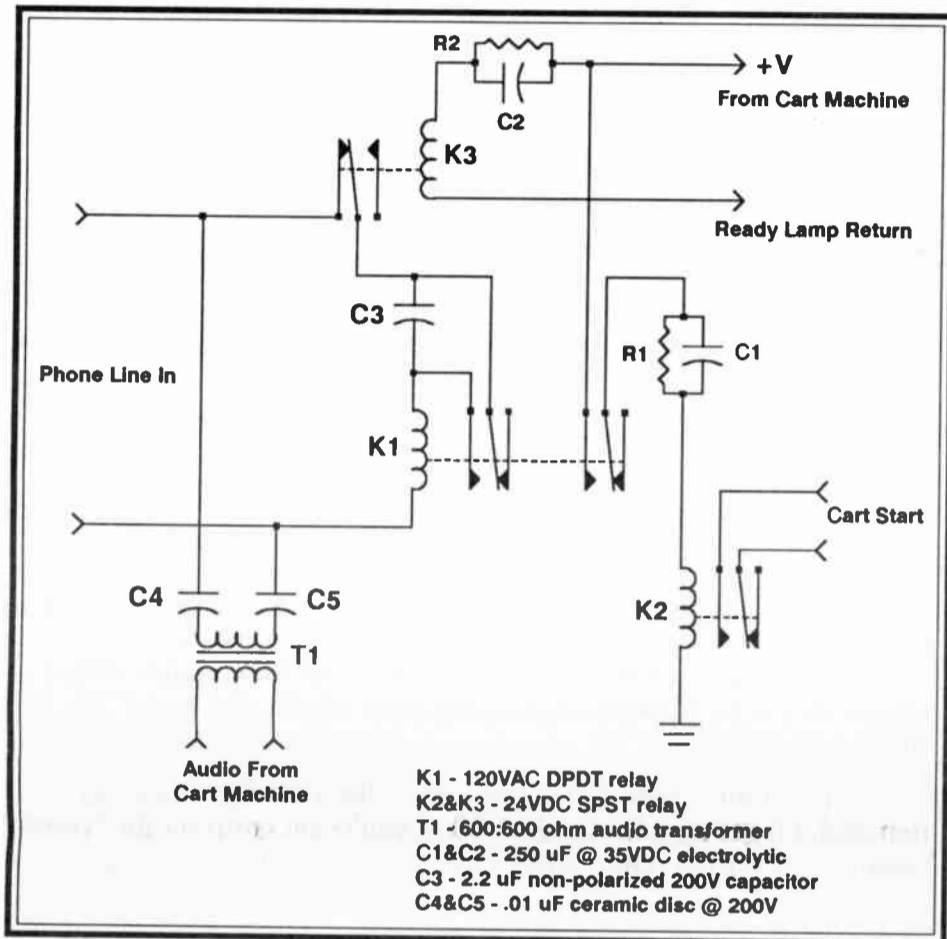

As the ringing voltage reaches K1 (120 VAC relay), through C3, it is latched on, by bypassing C3. The second set of contacts on K1 delivers +VDC from the cart machine to the RC network of R1 and C1, providing a momentary voltage to K2 to start the cart machine. Cart audio is fed through T1, C4 and C5, back to the caller.

The line is "hung up" by using the remote ready lamp voltage to open the normally closed contacts of K3. Firing the relay through R2 and C2, provides the momentary function to unlatch the K1 relay, thus disconnecting the line when the cart cues up.

This is a pretty generic circuit that will work with most cart machines, with minor modifications.

## IGM Automation Tip

By Dave Bickford - WMKS  
Springfield, Vermont

Attention IGM EC automation users. Be sure the only files on your EC software disk are AUTOEXEC.BAT, CONTROL.EXE, FILE.TDY, and COMMAND.COM (or any that IGM may have added recently). We had the extremely annoying problem of the switcher starting two sources at the same time. We'd end up with a spot over music or two spots at the same time.

We checked out every possible cause, from noise on the cue tracks of carts, to possible interference from fluorescent lights. Finally, after numerous phone calls to IGM, they had me check the files on my disk. Somehow certain files that were on my DOS disk ended up on the disk I was using for the EC system! After re-formatting that disk and copying the correct files from a new disk supplied from IGM, the problem went away. Our EC has been working perfectly ever since. Many thanks to IGM's Rick Sawyer for his infinite patience.

This is one reason  
we sell more  
cart machines  
than anyone else.

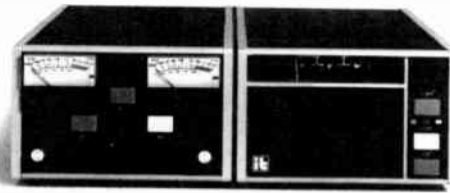

The 99B series Master Recorder features a patented erase splice-locate and azimuth-adjust system (ELSA)

And here are three more.

Allied Broadcast  
Equipment  
800/622-0022

Our Authorized 3M Dealers

Broadcast  
Services Company  
919/934-6869

Broadcast  
Supply West  
800/426-8434

3M International Tapetronics - The World Leader in Cart Machines

© 1989 3M Company

3M



## CRL SPOTLIGHT

Create Personality Instantly  
... Just Add Voice!



CRL's IPP-100 Instant Personality (mic) Processor is just what your station needs to enhance its personality. The IPP-100 is a fully integrated broadcast microphone processor with 18 preset memory positions. A powerful two band, parametric equalizer drives a two band compressor with adjustable band splitting. Mic or line level input and outputs, key lock security system, LED status system, and easy to use analog controls make the IPP-100 simple for anyone to use. Plus the IPP-100 features an external audio loop for special effects processors, and full remote control capability. Best yet, get all this digitally controlled power for only \$1295.

CRL  
SYSTEMS

CRL Systems  
2522 West Geneva Drive  
Tempe, Arizona 85282 U.S.A.  
(800) 535-7648 (602) 438-0888  
TELEX: 350464

# Old Tapecasters Never Die

By David M. Raley, PE  
Laurel Hill, North Carolina  
(919) 462-2292

If your station is one of those that can afford to dispose of its cart machines as soon as they are scratched, just turn the page; nothing here will be of any use to you. This is written for the technician who has to maintain, with spit and bailing wire, a barn full of junk that should have a log chain thrown around it and be pulled into the river.

Understand from the beginning that I mean no denigration of Tapecaster. The old style manual lever Tapecasters are, if anything, too rugged. At a time when all the good little "state-of-the-art" machines have had the decency to melt through the cracks in the floor, that old "topless wonder" still puts in a day's work. But...

From time to time, after the heads are worn through to the mounting stud, they will miss a cue. Somebody once told me that if the heads were so worn that cues were missed, the audio quality would have suffered so much that any sane person would replace them. The missed cues were a feature, like the "cry strips" on a car's brake shoes, to let you know that it was time for a change. Well, we're talking radio here; that leaves out the sanity part. Besides that, some heads do wear unevenly.

Now, 101 station managers out of 50 will tolerate bassy sounding spots 1,000 times longer than they will abide a cart running through. I once had to put the old heads back in; they sounded better to a person who shall remain nameless. And (sorry Tapecaster), sometimes they run through just for the exercise.

When, a few years back, I told a certain station manager that he couldn't turn up the cue gain because there was no control for that, he had me install a pot for that purpose and was astonished that it didn't help. If you are associated with such a person, or if you just want to save yourself some grief, read on. The solution is at hand.

What we have here is a straight forward two stage audio amplifier with variable gain in the first stage, built around an LM1458 dual OpAmp. It replaces the three transistor pre-amp of the Series

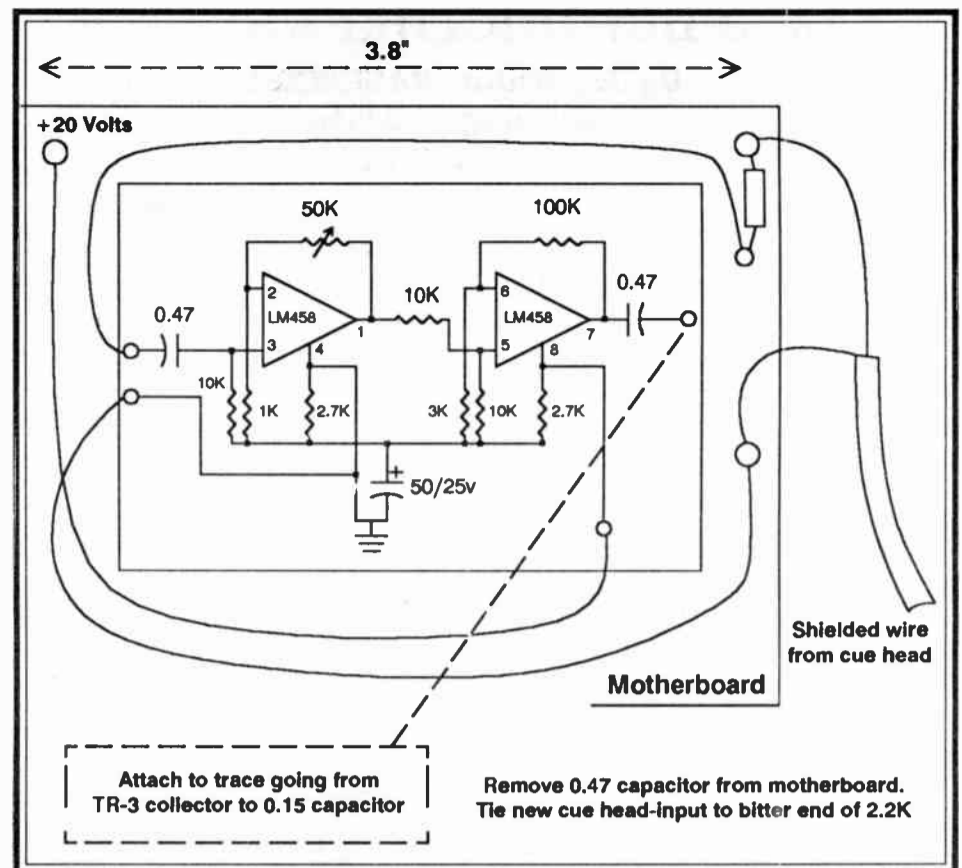

700, and will doubtless work in many other similar machines. The gain of our circuit, at full throttle, is 20 dB higher than the original circuit. You may have to adjust it down to eliminate false cues. The layout isn't critical. It is better to build it on a small piece of perf-board and attach the in/out and power to the mother-board, rather than drilling on the mother-board itself.

Remove the three input transistors that it will replace and any other un-needed parts that are in the way of a flat fit. Keep the attaching wires reasonably short. Separate the two boards with a couple of pieces of weatherstripping such as you use under the pinch roller rod.

Parts should cost \$10.00 or less. If there is a great outcry of demand, I'll get up a kit for \$15.00. If you're on contract for "routine repairs," be sure to charge the station extra for this field change.

# Little Noisemaker.



This little gray box is about to have a big effect on the way you test your audio equipment.

No longer will you have to bother with individual tones to set proper audio levels. With Delta's SNG-1 Stereo Noise Generator you can make a variety of tests with *true* stereo noise, all at the flip of a switch.

You'll get a much more realistic view of what your equipment is doing. Whether you prefer white, pink, or USASI noise spectra, the SNG-1 provides it, in both continuous and pulsed output modes.

Say goodbye to hit or miss processor adjustments using varying program material. The award-winning SNG-1 spans the entire frequency range, so you'll cover the highs, the lows, and everything in between.

The external gate input permits an infinite variety of pulse shapes and durations so you can test your equipment to the absolute

fullest. For standalone convenience simply switch to the internal pulse mode.

With the SNG-1 you'll always get an accurate and repeatable standard to base your measurements on. And for only \$495, there's no bigger value.

To discover how the Little Noisemaker can help you in a big way, call or write today. And be sure to ask for your free copy of Delta's Noise Primer, "Employ Some Noise." Delta Electronics, Inc., 5730 General Washington Drive, P.O. Box 11268, Alexandria, VA 22312. Phone: (703) 354-3350, FAX: (703) 354-0216, Telex: 90-1963.

The Above Standard  
Industry Standard.

DELTA ELECTRONICS



©1989 Delta Electronics, Inc.

# Otari Falsing Fix

By Mark W. Croom - Broadcast Technical Services  
Pequot Lakes, Minnesota  
(218) 568-5369

When I came to KTIG as an announcer about five years ago, I was warned that "certain programs are not to be played on the live-assist system." It uses four Otari ARS-1000 reproducers with a Persons 3A programmer. The reason given was that some of these syndicated, high speed duplicated program reels would cause false stops (and false advances) at unpredictable times. It was a problem we had lived with ever since the system was installed. After I took some technical training, I decided to attack the problem and see if anything could be done about it.

What I found was that the 25 Hz detectors had no delay time built into them, so they would respond to 25 Hz tones only milliseconds in length. Many of the programs we air here are recorded sermons and the like, and if a speaker would crowd his mike and create a "pop," it would cue the detectors, even though it was not a true cue tone. Other types of low frequency noise would also cause false cues and their attendant disruptions in programming.

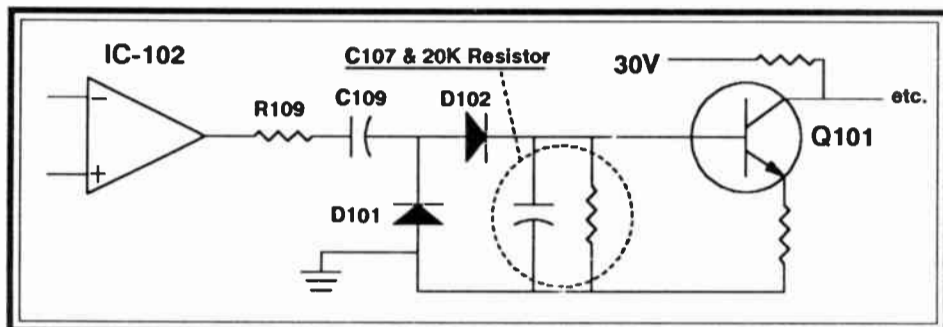

After some experimentation, I came up with the following solution, which has worked well in our machines: (1) Increase the value of electrolytic capacitor C107 from 10 uF to 47 uF. This increases the charging time so the machine is less sensitive to brief bursts of noise in the 25 Hz range. (2) Add a 20K (or so) resistor in parallel with C107 to provide a "bleeder" resistance. This makes the detector less sensitive to brief but repetitive noises which might cause false cueing. It seemed easiest to me to add this resistor underneath the board on the solder side. You may want to insulate the leads with heat-shrink or something similar. If you have experienced this problem, I hope this will help you to a more trouble-free automation experience.

## More ITC-3D Parts Tips

By Vince Edward - WBGW  
Tallahassee, Florida  
(904) 385-1156

In the June issue of Radio Guide, Larry Fiebig gave out a great tip, on 3Ds that wouldn't run when the start button was pushed, or would chatter the start relay. C206 is the first part I replace when my decks show these symptoms; it works every time.

Here are three more tips, for 3Ds that drive you nuts:

1. Audio "pop" when a cart re-cues. Pull the cue board on the deck that pops and swap it with another deck card. If the audio pop disappears, replace C27 on the offending board.

2. Audio "pop" on one or more decks (swapping cards makes no difference). Flip the machine over and replace C13 (a,b,c) on the utility card. If you're careful, you can do it without removing the card.

3. Cart runs and runs . . . and runs, without re-cueing. You get a complaint that a deck won't re-cue. So, you pull the lid and jack up the cue sensitivity a bit. A couple of days later, the same complaint; again, you use the same cure. This cycle continues until, oh-oh, no more adjustment on the pot! You pull the cue card and check every part. Didn't find anything wrong did ya. Thought so.

Change C205, C207, and C210. These caps, over a period of time, will dry out. Although they may check good on your meter, they are unable to pass audio. 4.7 uF can be used in place of the 5 uF caps, and it works every time.

# ECONCO

Now in our 20th year  
providing quality rebuilt tubes.

These are a few of  
the tubes we rebuild:

3CX2500F3

3CX3000A7

3CX3000F7

4CX5000A

4CX15.000A

4CX3000A

WE BUY DUDS.

WE ALSO REBUILD REFLEX KLYSTRONS.



ECONCO  
1318 COMMERCE AVENUE  
WOODLAND, CA 95695  
TELEPHONE 916-666-7553

OUTSIDE CA 800-532-6626 EXT. 30  
FROM CANADA 800-848-8841  
TELEX 176756  
FAX 916-666-7760

## Havin' A Heat Wave?



The Informer calibrated thermometers come in two models ideal for every radio station. The Informer II has a large LCD readout, high and low memories with reset, and range from -40 to +120 degrees. An AA battery powers the unit for up to one year, and the 50 foot probe line and triple sealed sensor mean you stay cozy while giving the forecast.

To measure temperature in transmitter buildings, Bradley has designed the Informer TX just for you. The unit provides an output of 10 millivolts per degree (100°F equals one volt) and is perfect to interface with your remote control. Users need to supply 5 to 12 volts for operation.

Informer II \$54.95

Informer TX \$48.95

Special: Now through the end of the year, mention this ad when you place your order for any two Informers and save \$10.00!



**BRADLEY  
BROADCAST  
SALES**

8101 Cessna Avenue  
Gaithersburg, Maryland 20879-4177

800-732-7665 / 301-948-0650  
Fax: 301-330-7198

Where Service and Engineering Make The Difference



# RCA BTF-20E Pointers

By Meryl Valnes, CE - KVOX AM/FM  
Moorhead, Minnesota  
218-233-1522

In February of this year, I was sitting at home trying to recuperate from a long night's work, when the phone rang. The operator on duty said the FM transmitter was off the air. Our station broadcasts at 99.9 MHz with an RCA BTF-20E transmitter.

When I got to the station, I tried turning the transmitter on. I got plate volts and plate current, but no RF output. Upon opening up the transmitter, I found what was left of the center conductor of the feed line going out of the transmitter and the finger-stock of the loading control, lying on the tube shelf -- and five nice holes in the outer conductor of the feed line.

After the parts arrived, I put the transmitter back together and found that the transmitter would not load up properly. I could only get 13 kW of power output (our normal power is 18.5 kW). I should point out my transmitter has always been hard to load up properly, and would just barely make 105% of operating power.

After spending several nights trying in vain to find the problem, I telephoned Jim Droege in Beatrice, Nebraska. He suggested trying to re-tune the driver for a better match to the final, since I had low PA grid current and high PA screen current.

Before I could try this, however, I burned up the same parts again, plus about 6 feet of feed line connecting with the harmonic filter, contaminating the harmonic filter. Once again, I ordered the parts for the transmitter, plus 6 feet of 3 1/8" feed line, and a 90 degree elbow. I called Jim and had him come up to give me a hand.

We took the harmonic filter down and found black soot throughout the entire filter. Using the RCA manual and the harmonic filter information book as guides, we thoroughly cleaned the filter. A drawing in the literature showed the filter should be installed 24 inches from the top of the transmitter cabinet. Ours had been installed 7 feet from the transmitter. As long as we had the harmonic filter and all the feed line down, we decided to install the filter by the book's specifications.

## Loafing Along

After we had everything put back together, we determined the driver was tuned up properly, re-neutralized the transmitter, and tuned it up. When we had everything ready to go back on the air, we checked the tuning and loading controls. They were within an inch of being where the book said they should be. Now I am able to get about 21 kW out of the transmitter, and it loafes along at 18.5 kW. I don't know for sure that moving the harmonic filter fixed my loading problem, but it was the ONLY thing that was changed.

What knocked us off the air in February? I was missing one or two of the fingers on the finger stock for the loading control of the transmitter. As I was having problems with the exhaust fan in the transmitter room, I can only guess that the heat built up inside the transmitter, causing continued deterioration of the finger stock for the loading control.

The second time this happened, I know what caused it. When my transmitter was installed, the modulation monitor tap was on the 90 degree elbow of the feed line. The exhaust fan had gone out again, and the center conductor of the "N" connector fell, and shorted out the feed line.

My suggestions to keep this from happening to you are: 1) Keep a close eye on the finger stock for the tuning and loading controls. When they show signs of wear, replace them. They cost about \$120 per control. 2) If you have your modulation monitor tap in the feed line, REMOVE IT. On my transmitter, J4 on the top of the transmitter was not being used. I am now using it for my modulation monitor. If something should happen to it, it will fall on the Teflon shelf, with very little harm. If I had done this before, I would have saved myself \$9600!

I should point out that last fall I had put a new 4CX15000 into my transmitter and replaced the tube socket. I am currently using the same tube that went through all the problems and am expecting to get another year or so of life out of it.

# POWER-side™

## PROBLEMS

Adjacent Channel Interference
Antenna Null Distortion
Co-Channel Interference
Power-line Re-Radiation
Building Re-Radiation
Receiver Tuning
Low Fidelity Home Radios
Co-Channel Beat
Selective Fading

## SOLUTION!

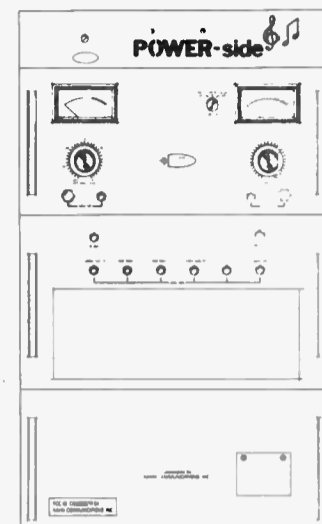

**POWER-side™**  
The solution to many of AM radio's most serious technical problems

From the developers of the AM STEREO system that isn't afraid of the dark and will let you drive right past FM Stereo

425 MERRICK AVENUE, WESTBURY, NY 11590 • (516) 222-2221

# Audio Interfacing Solutions

Whether you need consumer to pro interfacing, line amplifiers or distribution amplifiers, the Series-200 Utility Amplifier System is the solution. Up to 11 input or output modules can be arranged in one 3.5-inch rack chassis to provide the interface you need. We offer a wide variety of standard stock configurations at affordable prices. They include a 1 x 10 stereo DA, two 1 x four stereo DAs, five stereo line amps and 11 consumer-to-pro interfaces. Because each output has individual active balanced amplifiers you get separate gain controls for each. Levels can be easily matched to your exact requirements -- a feature only found on very costly distribution systems. Rear panel connections to the Series 200 are via simple screw clamp connectors for all balanced connections and standard phono jacks for unbalanced consumer interfacing. Contact your local distributor or Broadcast Devices today for more details.

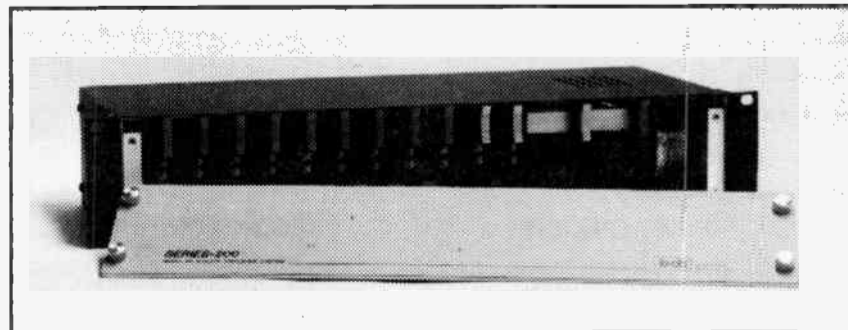

Complete systems start at under \$1400.  
Custom configurations are also available.

Affordable solutions for the broadcaster ...  
5 Crestview Avenue Peekskill, NY 10566 (914) 737-5032

**bdi** Broadcast Devices, Inc.

# CD Interface

By Ted Fuller - WRNA  
China Grove, North Carolina

I chose opto-isolators over relays for my consumer CD player-to-broadcast interface needs. Relay contacts sometimes have trouble with very low currents and may eventually develop intermittents. I was also concerned about using relays in a matrixed keyboard circuit, which is directly connected to a very sensitive micro-processor. Optos are low-current, low noise drivers with high isolation. The entire remote interface had to be located inside the CD player, and it had to be small.

I mounted all the components on a small PC board, and placed it directly behind the CD keyboard. A single shielded cable ran from the board through a small hole in the CD, and on to the console. Three inches of wire connected each opto-isolator directly to the terminals of the PLAY and STOP switches. Short, isolated wires at this point will help prevent static damage.

10 mA though the opto-diode will provide sufficient conductivity through the opto-transistor to act as a closed switch (for General Electric HA23A1 and HA1SA1 opto-isolators). Opto-transistor polarity is important here, and the keyboard pulses must not be distorted. Diodes may be found in the CD circuit between the keyboard and the micro-processor, and may help determine polarities. A schematic of the CD may help speed connections.

The interface was powered by 10 volts un-regulated as found inside the CD. Avoid connections to regulated portions of the CD supply, as regulator overloading and erratic operation of the CD may result. Looking at the schematic, S1 was a relay contact on the console control board. Some consoles may have logic capable of driving the opto-circuit directly, without any mechanical switches.

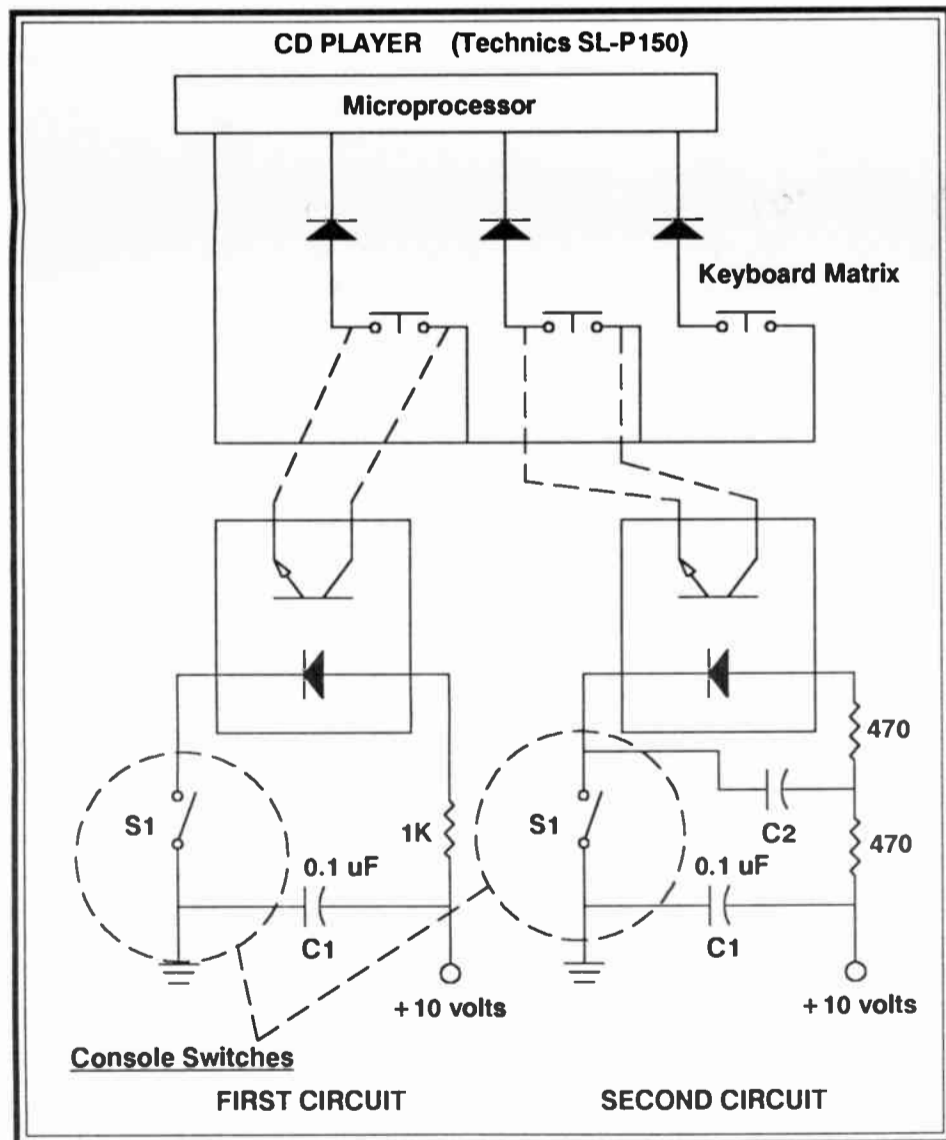

The first circuit was the one I used, since there was no need to eliminate contact bounce. C1 helps to prevent RF and unwanted pulses from entering the CD power supply, since some electrolytics in some supplies may pose a high impedance at RF.

The second circuit will help with contact bounce. Care must be taken in the circuit placement of C2, to avoid false triggering and too much C2 discharge through the opto-diode. Use a small value of C2 so that the opto-transistor will change states quickly. In the worst case, add a Schmitt Trigger.

Non-Ionizing Radiation Protection  
(Electric & Magnetic Fields)

## MEASURED RESULTS.

**Frequency Response**  
E-field: 0.5 MHz to 6 GHz  $\pm$  2 dB  
H-field: 5 MHz to 300 MHz  $\pm$  2 dB

**Power Range**  
E-field: .02 to 2653 mw/cm<sup>2</sup>  
H-field: .37 to 3770 mw/cm<sup>2</sup>

Protecting your employees from non-ionizing radiation is only one reason to check out the Holaday HI-3000 Series Family of Broadband Field Strength Meters. Protecting your company from costly citations and lawsuits are two more good reasons. Holaday Meters are OSHA approved, and satisfy both existing and proposed ANSI safety standards. Holaday field strength meters automatically reset to zero, even while operating. Each has a Peak Hold Memory Switch. Units include E-field and H-field probes; batteries, headset, and carrying case. For more information, call or write:

**HOLADAY INDUSTRIES, INC.**  
MEMBER OF THE BOWTHORPE GROUP  
14825 Martin Drive, Eden Prairie, MN 55344  
Telephone: (612) 934-4920 Telex: 29-0922 FAX: 934-3604

## Silence is Golden and less work with telcom c4 for RADIO and TV.

### The NR system you just set and forget.

- A product of ANT Telecommunications, Inc.
- No overshooting.
- No pre or post echo.
- No wasting time with lining up — not even for tape exchanges.
- Applications: Cartridge machines, STL, RPU, Reel-to-reels, Cassettes
- Up to 118dB dynamic range — the widest dynamic range available in any noise reduction system today.
- Over 15,000 channels in use worldwide.
- No breathing or pumping.

**telcom c4**  
Silence by Design

Distributed by:  
**RAM BROADCAST SYSTEMS INC.**  
346 W. Colfax Street, Palatine, IL. 60067  
New York (516) 832-8080 Chicago (312) 358-3330 Tennessee (615) 689-3030

# Open Delta Alert

From R.V. (Bud) Stuart - Sturadco  
Susanville, California

I dug out this information from an RCA Bulletin dated 1977. This might keep some of the younger techs, just making their first three phase installation, from having problems -- by always insisting on CLOSED DELTA connections for their transmitter installations.

Always check voltages before making any connections on three phase power, and beware the "wild leg" for 120 volt equipment.

## RCA Technical Bulletin (GTB-1)

### Three Phase Power Input to Broadcast Transmitters

The purpose of this bulletin is to recommend the conventional CLOSED DELTA three phase power connection for your transmitter. DELTA connection is preferred for transmitter operation because it offers superior phase-to-phase regulation and stability. Refer to Figure-1 for conventional DELTA three phase analysis. Caution must be exercised when connection 120 volt equipment, when utilizing the DELTA connection, for most equipment will not survive "high leg" (208 volt) connection

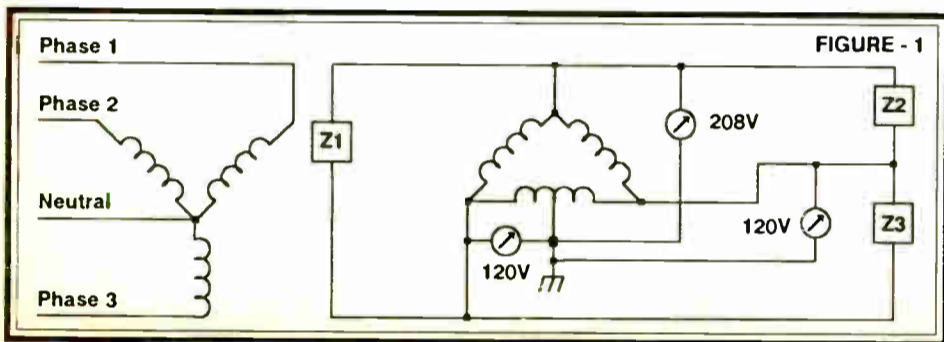

The conventional WYE connection also offers good phase-to-phase regulation and stability. It is often utilized for transmitter reduced power output. Refer to Figure-3 for the conventional WYE connection.

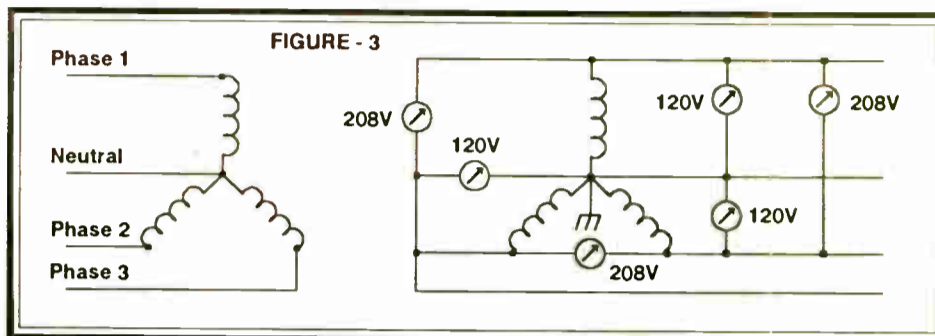
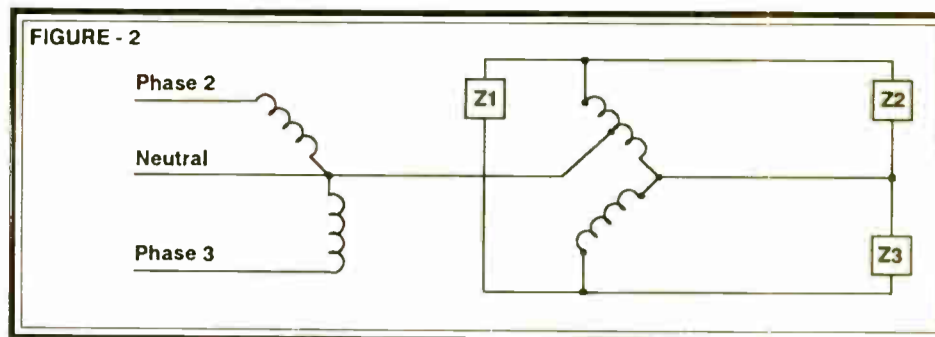

To be expressly avoided, is the OPEN DELTA three phase connection, sometimes referred to as the "SCOTT" connection, "Phanton Three Phase" connection, or "V-V" connection. A two transformer connection on a three phase line is very likely an OPEN DELTA system. Due to the inherent susceptibility to third harmonic distortion, phase shift, and line transient disturbances, OPEN DELTA power connection is undesirable for radio broadcast stations or similar installations. Because of this lack of stability, ratings of rectifiers and filter capacitors may be exceeded, resulting in frequent component failure. Refer to Figure-2 for a diagram of the OPEN DELTA connection, which is to be avoided.

## PUT YOUR PC ON LINE WITH THE NEW PC ACCESSIBLE MRC 1620 REMOTE CONTROL SYSTEM

As a broadcast engineer, you want to utilize the newest PC technology that will work intelligently and make your job as easy as possible. The Moseley MRC 1620 is the first intelligent, PC-accessible, integrated package that will do just that. This cost-effective system consists of a stand alone Remote Terminal that allows an optional Control Terminal or IBM PC with TaskMaster20 software to monitor and control remote facilities from dedicated and/or dial-up control points.

### The MRC 1620

- Operates as a stand alone dial-up Remote Terminal or with standard studio Control Terminal.
- Dual communication ports at Control and Remote Terminal allow direct and dial-up access at either terminal.
- Comes standard with 32 relay isolated commands, 16 telemetry and 16 status channels with filtered terminal blocks.
- Front panel LEDs provide visual indicators of input channel and system status. Digital meter displays telemetry, channel value, calibration and limits.



**Make the Intelligent Choice!**  
**The MRC 1620 Remote Control System**



### The TaskMaster20 Software

- The easy to use software automatically adjusts out of parameter conditions according to user defined control strategy.
- Current alarm conditions are displayed on an "alarm" page. Up to 20 of the latest alarms and hourly log data from the last 30 hours (stored in battery backed RAM of the MRC 1620) can be reviewed at your convenience.
- Monitors up to 63 sites.
- Remote set-up attributes and calibration may be downloaded from the remote terminal and stored to disk for editing and future uploading.
- Three levels of password security.

**For your free TaskMaster20 software demo disk, contact Moseley Marketing at 805-968-9621.**

# Moseley

Moseley Associates Incorporated  
111 Castilian Drive  
Santa Barbara, CA 93117-3093  
a Flow General Company  
Phone 805 968 9621  
Telex 658448  
FAX 805 685 9638

# Gentner VRC-1000/2000 Metering System Failure

By Don Colbert - KLSE/KZSE  
Rochester, Minnesota

Broadcasters who use the Gentner VRC-1000 or VRC-2000 remote control systems, may be surprised to learn of at least one additional error message which cannot be programmed and which is not sufficiently documented to be easily understood. It is called "metering system failure." It can occur whenever one of at least three conditions exist. These include:

1. A DC analog input voltage which exceeds the range of the analog to digital (A/D) conversion system (i.e. -5 to +5 volts DC or 0 to +10 volts DC).
2. A DC analog input voltage which is within the range of the A/D conversion system, but contains noise signals which peak outside the range.
3. A faulty multiplexer and/or A/D converter. This problem is mentioned as a possible cause of metering system failure in the Gentner manual, trouble-shooting section. However, no mention is made of this problem causing an error message.

When a metering system failure occurs, all disable functions are locked out, including the manual disable on the command module. Since the A/D converter is continuously sampling the metering lines, error messages keep on accumulating. As soon as an alarm message is erased, either by entering the (#) or (010) codes, another is instantly generated. Therefore, the Gentner will continue calling the telephone numbers on the call list. These latter statements apply if the fail-safe has been disabled to allow the transmitter(s) to stay on.

Here are some suggestion for isolating the cause of the problem:

1. Remove the metering input cable connector from the back of the Gentner. If the Gentner alarms can now be cleared, the problem is most likely to be in the voltages coming from the transmitter(s). If the alarm condition still is present, the trouble is probably in the Gentner.

2. Assuming that disconnecting the metering inputs cured the problem, reconnect the metering cable to the Gentner (so the metering lines are properly loaded) and check the voltages on each line with a digital voltmeter and/or DC-connected oscilloscope. Any lines whose voltages (DC or DC plus noise) exceed the 10 volt range of the Gentner, should be removed from the punch block. The trouble should disappear as soon as the offending voltage(s) is/are removed.

**WARNING:** An excessive voltage on any of the metering inputs may cause spurious pulses to appear on the other input lines. It has not, as yet, been determined if this phenomenon is caused by A/D fold-over or internal breakdown of components, which allow multiplexer and/or A/D pulses to feed back into the input lines. If these spurious pulses disappear when the Gentner is shut off or the metering cable connector is removed, they are being caused by an overdriven input line.

AT KLSE/KZSE, a faulty power meter calibration potentiometer, on a Gates FM-1C transmitter, produced a DC potential of 13 volts. The plate current and plate voltage sampling inputs were within the normal range. In addition, plate voltage, plate current and power were being sampled from a Harris FM-25K transmitter. The overvoltage on the Gates power metering line caused 3 volt pulses, with a repetition rate of 16 Hz., to appear on top of the DC analog voltages coming from the three Harris sampling lines. There were no pulses on any of the Gates sampling lines. Removing the metering input cable connector caused the Gentner to settle down. With the connector block back in place, power was removed from the Gentner and the pulses disappeared.

Suspecting some weird relationship between the Gentner and the Harris analog board, the board was exchanged with a new spare. No luck. Finally, a DC check of the individual metering input lines on the punch block revealed the overvoltage on the Gates FM-1C power circuit. The line was removed from the punch block and the Gentner was restored to normal operation. Until a replacement potentiometer can be installed in the Gates power metering circuit, power is being calculated using the Gentner's indirect method.



**We remember our customers even after the sale is complete.**

**b** **(619) 433-5600**  
**barrett associates, inc.**  
BROADCAST • AUDIO EQUIPMENT

**It's hard to stop.**



**W**hat is it about the Signature III that keeps so many leading station groups and consulting engineers coming back for another, and another, and...? Is it this console's unparalleled record of reliability and longevity? The LPB Signature III's easily maintained modular electronics? Its excellent RFI immunity? Or is it designed-for-radio features like the following:

- 3 inputs per channel
- Identical Program 1 and Program 2 output busses
- Remote starts on all channels (except channel 1)
- Mono/stereo input switch (on stereo consoles)
- Components and connections clearly labeled for painless installation and easy maintenance

Chances are, it's all of the above. But whatever the reasons, leading stations and engineers across the country demand Signature III's "unstoppable" performance. In fact, they've made it one of the most popular consoles ever built. If you've been spending too much time inside your console lately, contact your broadcast equipment dealer or call LPB for full information and specifications at (215) 644-1123.

LPB Signature III audio consoles are available in 6,8,10 and 12 channel stereo and 6,8 and 10 channel mono configurations.

**LPB**<sup>®</sup>  
28 Bacton Hill Road • Frazer, Pennsylvania 19355  
Tel: 215-644-1123 • Fax: 215-644-8651

# RPU Range Increase

By Patrick Keogh - WNFL/WWKFX  
Green Bay, Wisconsin  
(414) 468-5445

Here at WNFL we had a need to increase the range of our RPU system into an adjacent market. Our system consisted of a standard Marti RPU on 450 mHz. We use RPT-25 transmitters with 5-element yagi antennas at the remote site, and use a BR-10 Marti receiver with a colinear vertical (6dB gain) antenna with 7/8" Helix at 240 feet, on one of our AM towers. The usable range with this system was 10-15 miles.

The adjacent market of Appleton, some 15-25 miles to the South, was of interest to our sales department, from the time that we absorbed an FM station in that market and moved our studios up to Green Bay. Our ability to do remote broadcasts some distance past our known Marti range, became a reality when the following scheme was implemented.

Since you can't tamper with the power output of remote transmitters (legally), or very well have sales people perched on rooftops with 42-element long-john beams, I decided that we'd do something to the receiver. I came across a company known as Advanced Receiver Research, in a ham magazine, and looked them up. They offer a line of compact, high quality, receiver pre-amplifiers for the communications industry. They can be reached at Box 1242, Burlington, CT, 06013, or phone (203) 582-9409. The prices of their products are very much within the budget of most broadcasters.

I selected a Model P432VDG, which has 16 dB of gain. This unit is designed for service in the 430-450 mHz Amateur Band. It has bandwidth usable for our RPU, which is at 450.450 mHz. The pre-amp is enclosed in a small box the size of two match boxes, and has BNC connectors for input and output. The design of the pre-amp uses low-noise GaAsFETs for better rejection of overloading and intermod.

The pre-amp was inserted between the output of a duplexer and the receiver. We use a duplexer with our base transmitter/receiver in place of a T/R relay, to achieve so degree of intermod rejection in the receiver. Our studio site is within a couple of miles of a well occupied hill, where most two-way services for the community are located. Our duplexer, or the use of a bandpass cavity, is recommended by Advanced Receiver Research to keep the pre-amp from possible overload by out-of-band signals. Without the use of the cavity, the benefits of the pre-amp might be completely wiped out from the crud coming into it and wiping out your RPU signal.

A cheap Radio Shack AC adapter was pressed into service to power the pre-amp. This system expanded our useful range 5-10 miles beyond our previous coverage. We can now get a usable signal into Green Bay from the Appleton area, which opened possibilities to the sales department.

The pre-amp has proved very reliable in our application and has been in use for three years now, with no problems from lightning. Also, remote locations that were noisy or hit-and-miss, were cleaned up with now usable signals. The price of the P432VDG pre-amp was \$79.95. A bandpass cavity can be had for about \$150-\$180. Of course, since we had a duplexer, our outlay was for only the pre-amp. I would suggest this project for any station that needs more RPU range, or one that just wants to clean up scratchy spots. Although not a cure-all, it sure helped us.

## Technics SP-15 Tip

By Bill Tilton, CE - KELA/KMNT  
Centralia, Washington

I have had several of these turntables fail, apparently because C4 (100 uF 250 V) on the Power Circuit Board is a little underrated. The symptoms include failure to start reliably. A dead spot develops every 90° rotation. Replacement of C4 solves the problem.

I have also noticed that the speed increment switches develop mechanical problems due to dust or grime collecting around the push-buttons. A thorough cleaning improves operation. This also applies to the start, stop and speed lock controls.

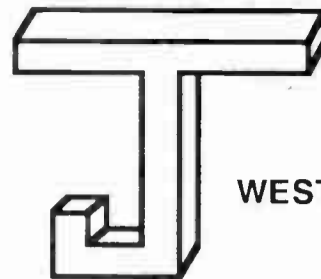

SQUARED  
TECHNICAL SERVICE

543 WEST 100 NORTH  
WEST BOUNTIFUL, UTAH 84010

801-298-8515

### EQUIPMENT REPAIR AND CALIBRATION SERVICE

WE SERVICE MOST AM/FM BROADCAST MONITORS,  
REMOTE CONTROL SYSTEMS, EXCITERS, STL's, TSL's,  
RPU's, ETC.

#### GIVE US A CALL

- CHECK OUR RATES-
- TURNAROUND TIME-
- STL LOANER PROGRAM-

## Blank Cassettes... Perfect for Demo Spots

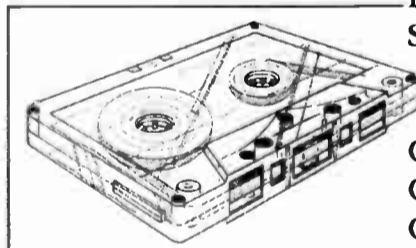

BASF Pure Chrome  
Shape Precision see-thru shell  
in quantities of:  
50 100  
C-5's \$.63 ea. \$.55 ea.  
C-10's \$.69 ea. \$.60 ea.  
C-15's \$.74 ea. \$.65 ea.

Custom lengths are also available

BASF LHD Normal Bias  
Michelex German made shells  
in quantities of:

50 100  
C-5's \$.49 ea. \$.42 ea.  
C-10's \$.53 ea. \$.46 ea.  
C-15's \$.58 ea. \$.50 ea.



PHONE: (507) 288-7711

FAX: (507) 288-4531

Tom Jones Recording Studios  
220 South Broadway  
Rochester, Minnesota 55904

# Harris FM TX Tips

By Kyle Magrill - Daytona Group  
Ormond Beach, Florida  
(904) 672-2304

Here are a couple of technical tips for the Harris FM-series of transmitters. Unfortunately, I do not have the schematics at hand, so I cannot give the exact part numbers.

The recommendations are as follows:

1. On FM-20, 20H, and 20K series, make sure that the hose clamp, which secures the anode strap, is placed evenly around the tube. Improper alignment may result in poor contact between the tube and strap, which almost invariably leads to arcing that can destroy the straps. It is not a bad idea to use two clamps for this purpose. The FM-25K, although using a different cavity, also exhibits similar problems, and benefits from a second clamp.

2. With respect to the FM-25K, the area above the cavity where the high voltage feed-through is routed, is very inaccessible due to the need to remove a large number of screws on the back cover plate. Never-the-less, it is important that this area be cleaned occasionally to prevent catastrophic arcing of the high voltage components and wiring present in this area.

3. A low efficiency (less than 80%) problem with a 25K revealed no obvious signs of failure and the 8990 tube tested good. Close inspection of the tube socket revealed that several very small wires, all designated as part of L8, were missing. L8 connects the cathode to ground. Apparently one or more of these small wires had broken free and several more appeared to have burned up. Replacing them with resistor leads solved the problem.

4. It is fairly common for the bias bridge to fail in the older FM series of transmitters. If this occurs, the transmitters will continue to operate in a grid-leak fashion. They will exhibit unusual tuning characteristics and most importantly, if the drive falls below a minimum point, the tube will become a diode, and "super-conduct." If that happens, you will get a current overload. This symptom may happen while the operator is adjusting the tuning or loading of any stage. Usually, the final will be reacting more or less normally when, suddenly, the PA current meter will jump up simultaneously with an overload trip-out. Use the test points provided inside the front access door to test output of the bias supply. I have seen this problem in the 20H, 20K and 2.5H, but since the supplies are all the same, it could happen to any one of the series.

## Sparta 602-A TX Fix

By Michael Martindale, DE - KVON/KVYN  
Napa, California  
(707) 252-1440

Here is something that engineers with an older Sparta Model 602-A FM transmitter should know.

I received a call one morning, telling me we were off the air. Ironically, was the same morning of the 30-second silence campaign. I arrived at the site and discovered smoke in the transmitter building. After the smoke cleared (about 2 hours), I was finally able to enter the building. I assumed a short and that the breakers had tripped. What I did find, was a short in the screen supply, and that the breakers HAD NOT tripped. The systems was still hot, meaning the machine was cooking itself.

I lost a cap, choke, rectifiers, various other parts, and yes -- the transformer. The insertion of HV fuses on the AC side of the rectifier stack can prevent this from happening. There is a mod kit available that is easy to install and will save you a lot of headaches and money.

# More Samples And Bits For The Buck.



## CD Player Excellence From Technics

The SL-P999 CD Player from Technics is truly a marvel of audio excellence. 20-Bit signal processing and 8 Times oversampling assure outstanding signal fidelity. 4-Digital to Analog Converters (2 per channel) help achieve exceptional sonic clarity. Specially selected parts such as fast-recovery diodes and high capacity electrolytic capacitors help minimize distortion.

For the broadcaster, the SL-P999 incorporates the cue-to-music feature. Simply select the cut you desire and the SL-P999 will automatically cue to the first sign of audio. In addition, a cue wheel is provided for manual cueing/search in 0.2 second increments.

For under \$500.00 you can own this outstanding CD Player. Call us toll free to order yours.

# BSW<sup>®</sup>

BROADCAST SUPPLY WEST

America's Full-Time Broadcast Supplier

**1-800-426-8434**

ORDERS • INFORMATION • SPECIFICATIONS  
BSW • 7012 27th Street W • Tacoma, WA 98466 • FAX 206-565-8114

## Equipment Guide

The Yellow Pages of Broadcasting

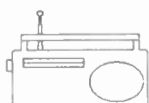

Use the Equipment Guide to buy or sell your used gear.

# Collins 831G Socket Problems

By Paul Easter  
D&E Broadcast Services  
Corpus Christi, Texas

A Collins 831G transmitter, I maintain, had burned up a driver plate transformer in January of 1989, and then another one in early June of 1989. When the first one failed, we checked the transmitter completely, especially the overload circuits. We could find no reason for the failure. The transformer looked like it had slowly overheated over a long period of time, then shorted, primary to secondary, feeding 220 VAC into the driver plate supply rectifier and filters.

The driver plate transformer was the only expensive spare part the station had, leading us to believe that the transformer had failed in the past. When the transformer failed the second time, we were even more suspicious. (A few months later, while we were cleaning out the storage building at the transmitter site, we found a third driver plate transformer.)

We coupled our 'scope to the output of the transmitter (at the line section for the wattmeter), and started looking. If you tuned the driver plate tuning capacitor just right, the carrier would start to "pinch off", that is, heavily AM modulate. This was also the point where the grid current would peak on the PA tube (the next stage). For a few micro-seconds at a time, the carrier would go away. I wouldn't have believed it, if I hadn't seen it for myself.

We examined the transmitter and socket again, hi-potted everything twice, and found nothing. We were getting very tired, so we decided to call it a night, and tuned the transmitter so that it wouldn't exhibit AM modulation.

The next night, we found a few small burn marks on the screen ring of the tube itself. The socket looked fine, so we cleaned everything carefully and re-inserted the tube and tried it again. The problem persisted. We then removed the "chimney" (also called an air guide), and re-inserted the tube. We examined the socket very carefully with an inspection mirror. The screen collet seemed to be out of alignment in the back left area of the tube.

We found that both the screen collet and the stand-offs in the tube socket were threaded. If the collet is taken apart and re-assembled improperly, there is a gap between the screen ring on the tube and the screen collet. Further examination proved this to be the case. The tube socket had been replaced some time ago (the old one was on the spare parts shelf). After removal of the collet and re-assembly, the problem was gone. The fingers of the collet were at the very top of the screen ring of the tube, though. We felt that this was a little too close for comfort.

We removed the tube, and inserted a brass washer under each of the stand-offs. The fingers of the collet now touch the screen ring right in the middle. The tube socket alignment, in this transmitter, is very critical. Since the amplifier is grounded-screen, the screen collet alignment is especially critical. Of course, whenever any work is done on the socket, especially the screen collet, the neutralization should be checked.

Any time a socket is re-assembled (in any transmitter), a few minutes with an inspection mirror and a good light is time well spent. Mechanical drawings of the critical assemblies in transmitters would be helpful, when problems like this occur.

## Use Your Fax Machine

See Page 20 for the Radio Guide FAX-GRAM

Copy or cut out this form and use it to contact  
Radio Guide advertisers for more information  
on their products and services.

Save time by using the Radio Guide FAX-GRAM

## IT'S OUR 15TH BIRTHDAY

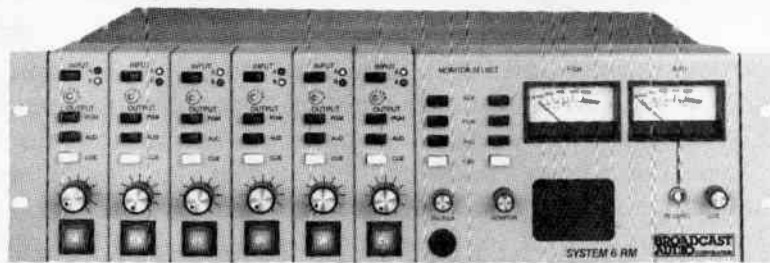

## BUT YOU GET THE PRESENT!

That's right — with the purchase of any SERIES IV, SERIES VI, or SYSTEM 6RM audio console, we'll give you a present of additional mixers, accessories, or upgrades, equal to 15% of the console base price. Select your gifts from our November, 1988 price list. Save even more with generous cash discounts!

Hurry - Our **15TH BIRTHDAY CELEBRATION** expires September 30, 1989. Big Savings and Great Sound from **BROADCAST AUDIO**. Plus, we'll still be here next year!

**BROADCAST  
AUDIO CORPORATION**

11306 SUNCO DR.,  
RANCHO CORDOVA, CA 95742  
(916) 635-1048

## CARTING CD's?



**YOU NEED SYNCHROSTART!** Synchronostart will synchronize you CD player and cart recorder to make carting a one-button operation. Eliminate those annoying "clipped intros" that often happen because you CD player starts quicker than the cart recorder. Whether you dubs are done by the PD or by the "nighttime college kid," they'll all be tight and consistent. Synchronostart makes CD dubbing fast, accurate, and one-button easy!

**HENRY ENGINEERING**  
**(818) 355-3656**  
**We Build Solutions**

# 3-Phase Xfmr Configurations

By Michael Hendrickson  
Hedberg Broadcasting Group  
Blue Earth, Minnesota

An article in the June 1989 issue of Radio Guide, brought to mind that there are many younger technical people in the field who may not be familiar with three phase power. Many stations do not require three phase power because they operate at a lower power level. This article is intended to give some brief information on three phase power transformer configurations as supplied by the power utility.

Normally the radio station is only concerned with the secondary connection of the power transformers. These connections supply the power to the station. There are two types of connection configurations, the WYE configuration and the DELTA configuration. The DELTA configuration can come in two variations, the CLOSED DELTA and the OPEN DELTA.

The WYE configuration (figure 1) is a 120/208 volt secondary. The voltage from each phase to the neutral is 120 volts. The voltage from phase to phase is 208 volts.

The CLOSED DELTA (figure 2) and OPEN DELTA (figure 3) each supply a 120/240 volt secondary. The voltage from Phase A or Phase B to neutral is 120 volts. The voltage from Phase C to neutral is 208 volts. The voltage from phase to phase is 240 volts. Phase C is normally referred to as the "wild leg." The National Electrical Code specifies that Phase C is NOT to be used for any load connected from Phase C to neutral. Phase C is to be used only for phase-to-phase loads.

There is no problem with having a CLOSED DELTA configuration supplying power. The problem with a DELTA configuration arises when the power utility supplies you with an OPEN DELTA (figure 3). The power utility likes the OPEN DELTA configuration simply because it requires only two transformers instead of three. Each of the voltages specified for the CLOSED DELTA apply to the OPEN DELTA. The problem with the OPEN DELTA is that the phase relationship of each leg can vary as well as the voltages, depending upon the load. Harris Corporation has an excellent paper describing the problems with the OPEN DELTA configuration.

I have found, over the years, that if you specify to the power utility that you need three phase power, the utility will normally supply you with a 120/240 OPEN DELTA configuration. I have met with considerable resistance when I told them I wanted a CLOSED DELTA. In a couple of cases I was told there would be a special charge for the third transformer. However, when I told the same utilities that I wanted 120/208 three phase, there was no problem, even through the WYE requires three transformers. I now automatically specify 120/208 three phase when I need three phase power.

If you are in the situation where you have service with an OPEN DELTA configuration, the fix is simple. Request that the power utility supply the third transformer, and close the DELTA. There will be no change in the secondary voltages in the electrical service. If you request the utility to change the configuration to a WYE, you have to remember that the secondary voltages will be 120/208 and NOT 120/240.

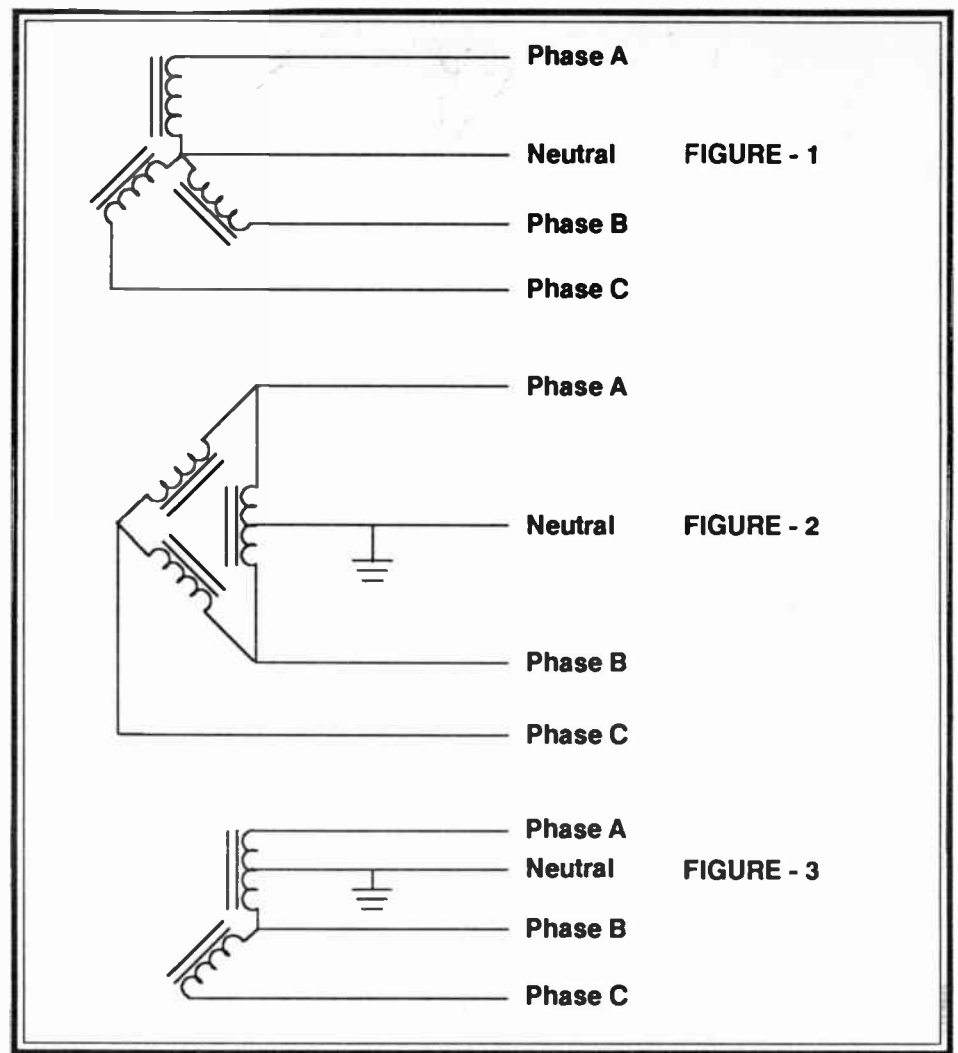

For more information on the OPEN DELTA problems, see the paper published by Harris Corporation: Susceptibility of the Open-Delta Connection to Third Harmonic and Transient Disturbances. The paper was issued in 1967, and revised in 1969.

## MIC-MAZE Comprehensive Support Processor



### Applications: Microphones...plus

The Mic-Maze is also a multifunction device that is ideal for FM processing, SCA, STL, TV, satellite up-link, and production. Standard options include pre-emphasis, de-emphasis, clippers, and asymmetry control, all dip switch selectable.

**hnat hinders inc**

42 Elaine Street • R.R. 1 • Thompson, Connecticut 06277  
(203) 935-9066 • (203) 935-9242

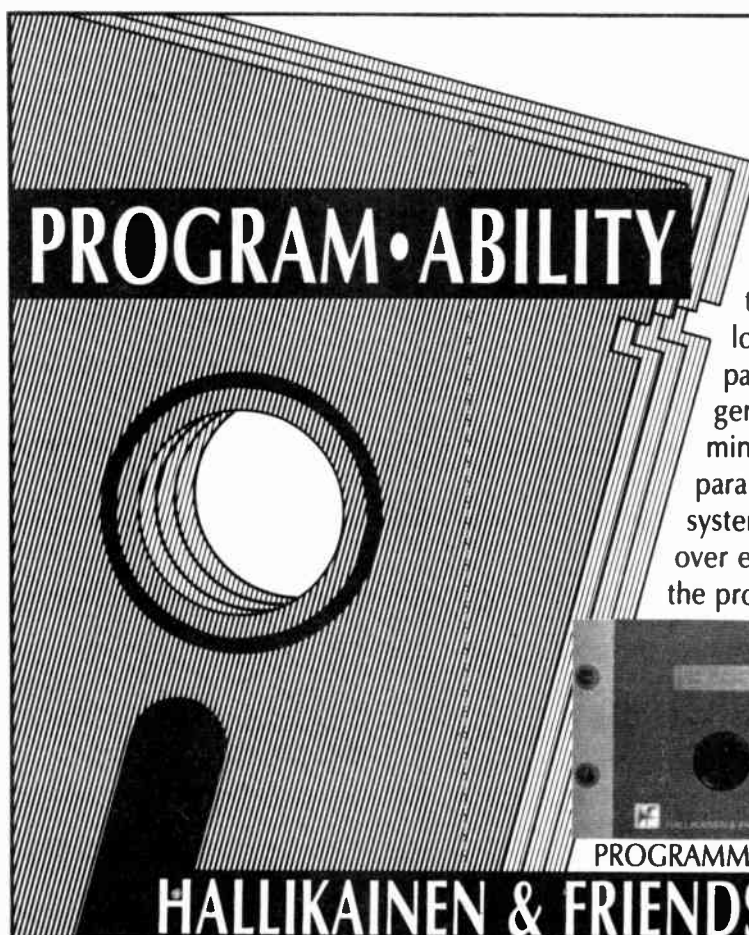

## PROGRAMMABLE DIGITAL REMOTE CONTROL.

What others promise, Hallikainen & Friends delivers to your exact specs with the DRC 190. With its extended BASIC language, the DRC 190 can control, alarm, display and log measured and calculated system parameters. Typical installations also generate a daily report showing the minimum, maximum and average of each parameter, simplifying oversight of the system. For true flexibility of user control over evolving equipment demands, get with the program, get the DRC 190.

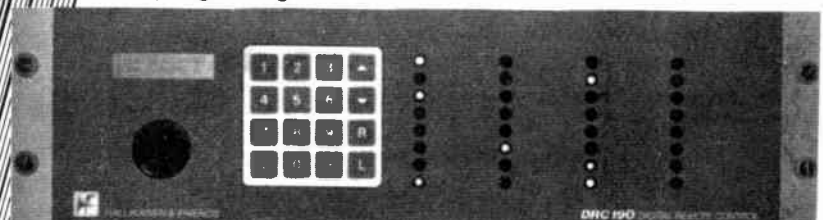

PROGRAMMABLE EXPANDABLE AFFORDABLE DRC 190

**HALLIKAINEN & FRIENDS** 141 SUBURBAN E4 805 / 541-0200  
SAN LUIS OBISPO, CA 93401-7590 USA



35th Annual  
University of Wisconsin/Extension

# BROADCASTER'S CLINIC

October 16-19, 1989  
Madison, Wisconsin

Supported in part by  
*Radio World and TV Technology*

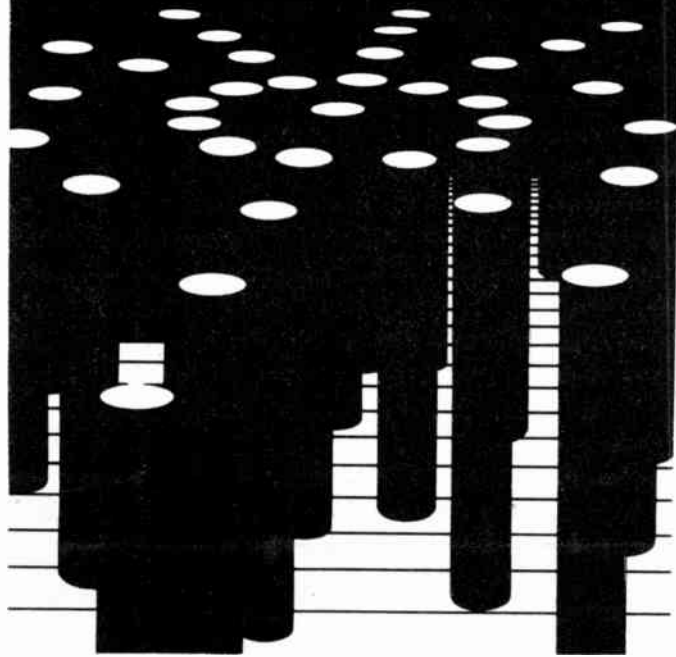

## GENERAL CONFERENCE INFORMATION

### DATES

Monday through Thursday, October 16 through 19, 1989

### LOCATION

All sessions of the **Broadcasters' Clinic 1989** will be held at the Holiday Inn Southeast, Highway 12 and 18 at I-90, Madison, Wisconsin, 53704. Phone: (608) 222-9121.

### FEE

\$100 - Any two days  
\$135 - Any three days  
\$160 - All four days

Fee covers program materials, continental breakfasts and luncheons as indicated, refreshment breaks, the Pizza-Engineering forum, and two evening receptions with hot hors d'oeuvres (cash bar).

You are entitled to an 80% refund if cancellations are received prior to October 9, 1989. Enrollees who do not cancel are obligated for the full fee. Substitutions may be made at any time.

### ACCOMMODATIONS

Please make your own room reservations with the Holiday Inn Southeast, Highway 12 and 18 at I-90, Madison, Wisconsin, 53704. Phone: (608) 222-9121. We suggest that you make your reservations before September 25, 1989, while discounted rooms are being held for the Seminar. Please specify that you are attending the **Broadcasters' Clinic 1989**.

### CREDIT

Conference enrollees can earn up to 2.8 Continuing Education Units (CEUs) from the University of Wisconsin.

### INFORMATION

For further conference or exhibitor information, contact Don Borchert, Director of Engineering, WHA Radio and Television, 821 University Avenue, Madison, Wisconsin 53706. Phone: (608) 263-2157.

This program is offered by UW-Madison in cooperation with UW-Extension.

## MONDAY, OCTOBER 16

- 7:45 am Registration and Continental Breakfast
- 9:15 **General Broadcast Engineering Sessions**  
The Educated Technologist Citizen  
*Mark Durenberger, Director of Network Development  
WCCO Sports Networks, Minneapolis, MN*  
A Practical Approach to Getting the Greatest Benefits from NRSC  
*William Ammons, CRL Systems, Tempe, AZ*  
FMX™: Consumer and Professional Applications  
*Thomas Keller, Broadcast Technology Partner, Springfield, IL*
- 12:15 pm Luncheon
- 1:30 - 4:30 **Concurrent Workshops**  
Antenna Systems for Radio  
*Don Markley, D.L. Markley & Associates  
Ralph Evans III, Ralph Evans & Associates  
John Saddler, Federal Communications Commission*  
Technical Management  
*John Commuta, President, Market-Line*  
FX 50: The FM Exciter with Audio Performance that  
Rivals CD Specifications  
*Ed Anthonie, Design Engineer, Broadcast Electronics*
- 7:30 Our Famous Pizza-Engineering Forum  
*Mark Durenberger*

## TUESDAY, OCTOBER 17

- 7:45 am Registration and Continental Breakfast
- 9:00 **Engineering Sessions: Radio**  
Where Are You? Use the Global Positioning System  
*Garrett Lysiak, President, Owl Engineering, St. Paul, MN*  
Off-Premises Monitoring and Remote Control Via Satellite  
*Peter Burk, President, Burk Technology, Teppell, MA*  
Do Folded Di-Poles Really Work? (discussion based on experience)  
*Lawrence Behr, President, L.B.A. Group, Greenville, NC*  
950 MHz Aural STL/TSL Systems (including alternatives in  
congested areas)  
*Jeff Nordstrom, Allied Satellite*
- 12:15 Luncheon
- 1:30 **Engineering Sessions: Radio**  
I S D N: Its Impact on the Broadcast Engineer  
*A presentation by AMERITECH*  
Satellite Communications for Broadcast: A Ku Band Update  
*John Brimrose  
Mark Durenberger  
Ray Conover  
RCA/GE Americom*  
*And More . . .*
- 4:30 **Equipment Exhibits Open**  
Reception and Cash Bar

## WEDNESDAY, OCTOBER 18

- 7:45 am Registration and Continental Breakfast
- 9:00 **Engineering Sessions: Radio and Television**  
Integrating Leading Edge Technology in Current Audio Production  
*Bill Mullin, Operations Manager, Pyramid Audio*  
Compact Disc: Theory and Maintenance  
*Denon America, Parsippany, NJ*  
Utilizing CAD for Broadcast Applications  
*Kahn, Phillips & Associates, Oak Park, IL*  
PC-Controllable Automated Video Measurements  
*Mel Infanzon, TEKTRONIX*  
*And More . . .*
- Noon **Equipment Exhibits Open**
- 6:30 **Engineering Forum**  
*Moderator: Ken Dixon, WHA Television*

## THURSDAY, OCTOBER 19

- 7:45 Registration and Continental Breakfast
- 9:00 **Engineering Sessions: Television**  
Television Station Automation  
*David Bird, Broadcast Television Systems*  
How Expansion and Contraction Can Cause Problems in Rigid  
Coaxial Transmission Line (discussion of solutions)  
*Andrew Corporation*  
Multi-Channel UHF Antenna Systems  
*Ernest Mayberry, LDL Communications, Laurel, MD*  
The D2 Format: Field Reports  
*William Carpenter, AMPEX Corporation*
- 12:15 Luncheon
- ??? Adjournment . . . See you next year!

## Broadcast and Media Related Computer Bulletin Boards

Call (507) 280-9668 to have your BBS listed here.

If you have any additional information  
regarding the content of these and/or any other BBS systems  
let us know that too.

Visions Infoline 201-769-1779 (General Media)

Gannett HelpScreen 202-525-3982 (USA Today)

Colorado Broadcasters 303-572-6256 (Engineering)

AV-Sync 404-320-6206 (Technical & Engineering)

Rock & Roll Party 404-982-0960 (Broadcasters)

Broadcasters Forum 602-395-9978 (Broadcasters Info.)

Trillion 616-530-0821 (SBE and Ampex Information)

So. California Media Line 619-454-1629 (Broadcasting)

Broadcast Computer Database 713-937-9097 (Engineering)

Flamethrower 804-730-1291 (Engineering - Ham Radio)

## SCR Gate Drives

Used on Continental FM Transmitters

VPH1109D & PTR1332

- \$85.<sup>00</sup> to repair your SCR Gate Driver
- 1 Year Warranty

*With a warranty like this - why buy new?*

Quick Turnaround - Next Day Available  
Over 10 yrs Experience

We also repair - Power Monitor PCBs  
Control Circuit PCBs

**(813) 932-7722**

## PowerCon Electronics

Industrial Electronic Services  
9420 Lazy Lane Bldg. E-3

Tampa, FL 33614

**(813) 932-7722**



## Puts your signal in it's place!

If you need a quality  
antenna, you need:  
**JAMPRO ANTENNAS, INC.**  
The really experienced one  
for over 30 years.

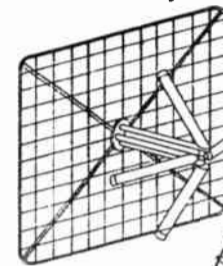

JAHD CP  
Arrowhead  
Screen Dipole

JSDP CP Spiral  
Broadband Antenna

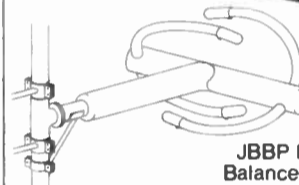
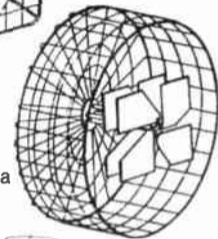

JBBP FM Antenna  
Balanced Excitation

**JAMPRO** is the world leader in  
custom-designed, directional,  
CP antennas.

- With over 1600 of our penetrators delivered, more stations have penetrated their market.
  - Our custom-made directional antennas are operating world wide.
  - Full-scale antenna measurements on **JAMPRO's** all-year, all-weather test range.
  - We custom-make tower structures to duplicate your's, for optimum results.
  - Ask about **JAMPRO's** low-power educational packages.
- Give us your requirements and see how fast we produce.

**JAMPRO Antennas, Inc.**

6939 Power Inn Road  
Sacramento, CA 95828  
(916) 383-1177 • Telex: 377321  
FAX (916) 383-1182

### What is This Device?

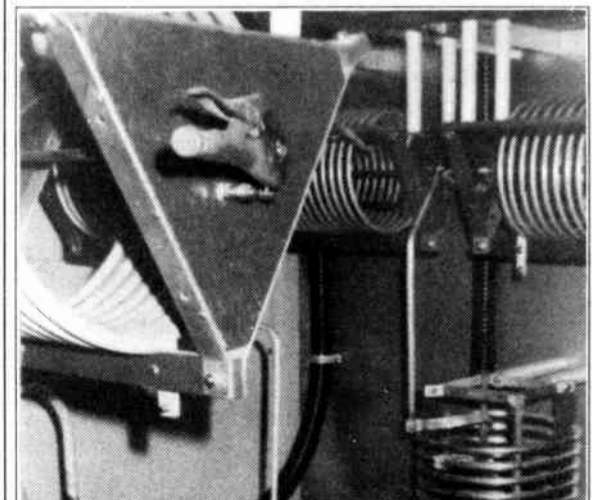

- A. Torque Amplifier
- B. Radial Off-Set Phase Adjustment
- C. Hand-Held Power-Meter

**Ron Radio Communications, Inc.**  
P.O. Box 201 Brightwaters, NY 11718  
"Simply the Best for Less..."  
**NRSC Compliance:**

---

Energy Onix Add On NRSC Processor (Includes Mod Monitor roll-off filter) Ideal for Multi unit processing \$ 520

---

Inovonics Add On NRSC Processor (Installs after present AM Processor) \$ 520

---

Hnat Hinds NRSC Tri-Maze (Replaces your present AM Processing with the BEST AM Processing system on the Market \$ 1,695

---

8 0 0 - 6 6 6 - 3 5 2 5



(802) 226-7582  
FAX: 802-226-7738

**COMMERCIAL RADIO COMPANY**  
Transmitter Parts for: RCA, Gates, Collins  
Non-PCB Filter and Mica Transmitting Capacitors

DUTTONSVILLE SCHOOL DRIVE  
DANIEL W. CHURCHILL CAVENDISH, VT. 05142

**SEARCHFM - SOFTWARE**  
Professional MSDOS Broadcast Software.  
SEARCHFM, QCHANNEL, EDFM, SEARCHTV  
With monthly FCC database pool service.

Doug Vernier, Broadcast Consultant  
1600 Picturesque Dr.  
Cedar Falls, IA 50613  
319 266-7435

**Kidd Communications**  
**Equipment - Prices - Knowledge**  
to help you with all your broadcast needs

*Call us today!*

**Kidd Communications**  
4096 Bridge Street Suite 4  
Fair Oaks, CA 95628  
916-961-5433

**STAGOR**  
**BROADCAST**  
**SYSTEMS**

**Stephen Gordoni**

702 Lakeside Circle Drive  
Wheeling, Illinois 60090

(312) 870-1463

**Broadcast Equipment**  
**Systems and Assistance**



**K.E.I.** Phone 305-771-2947  
201 N.E. 57th Street  
Fort Lauderdale, FL 33334

**M.C.I. Tape Machine - Circuit Board Repair**  
*Fast Turnaround*

**FCC's Engineering**  
**AM, FM and TV Data Bases**  
On floppy (or) 9-track tape

**Call today to request a free sample**

**Communication Data Inc.**  
6105 E. Arlington Blvd.  
Falls Church, VA 22044  
703-534-0034

**SBE** **STANLEY BROADCAST**  
**ENGINEERING**

**James S. Stanley**  
Engineering Consultant

P.O. Box 24601  
Tempe, AZ 85282 (602) 264-8752

**NORTHERN**  
**MAGNETICS**  
CERTIFIED TAPE HEAD SERVICES

Northern Magnetics is an industry leader in the supply and service of tape heads and tape head products.

Phone: (612) 333-3071  
Telex: 1561238 MPS UT  
FAA Repair Station # C14-57

P.O. Box 16409  
Minneapolis, MN 55416

**BRENTLINGER**  
**BROADCAST**  
**ENGINEERING, INC.**

**Charles Jayson Brentlinger**  
President

COMPUTERIZED ENGINEERING REPORTS / ALLOCATION STUDIES  
AM-FM-AM DIRECTIONALS-AUDIO-STI-SATELLITE COMMUNICATIONS

4338 East Acoma Drive • Phoenix, Arizona 85032 • (602)867-0181

**Tube Rebuilding**  
**Freeland Products**

- We Buy Duds - *Since 1940*  
*Save About 50%*



800-624-7626  
504-893-1243  
Fax 504-892-7323

Including for TV  
RCA Cermolox and UHF Klystrons

**Consulting Communications**  
**Engineers**

- FCC Data Bases
- FCC Applications and Field Engineering
- Frequency Searches and Coordination
- AM-FM-CATV-ITFS-LPTV

**OWL ENGINEERING, INC.**

1306 W. County Road. F,  
St. Paul, MN 55112  
(612)631-1338 "Member AFCCE"

# The Radio Guide FAX-GRAM

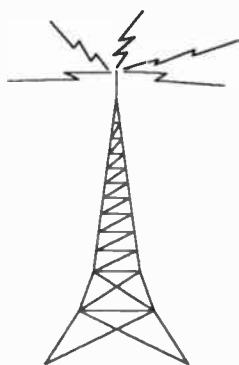

Use This FAX Transmittal Sheet to Contact Advertisers  
for More Information on Their Products and Services.

Tell Them the Radio Guide is Working for You.

Let Them Know You Appreciate Their Support.

Advertisers FAX Numbers are Listed Below

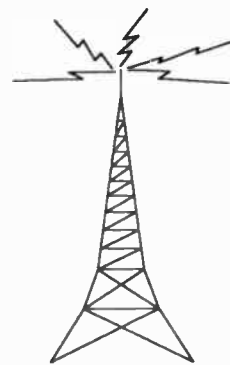

## Radio Guide Fax-Gram

Volume 2

Issue 9

September 1989

A Service of Rochester Radio Publications

### This Message For:

Company: \_\_\_\_\_ Fax No. \_\_\_\_\_

Date: \_\_\_\_\_

Total Pages, Including This Page: \_\_\_\_\_

Bradey Broadcast 301-330-7198  
Broadcast Audio 916-638-0512  
Broadcast Supply West 206-565-8114  
CRL Systems 602-438-8227  
Delta Electronics 703-354-0216  
Econco 916-666-7760  
Hallikainen & Friends 805-544-6715  
Henry Engineering 818-355-0077

Holaday Industries 612-934-3604  
Inovonics 408-458-0554  
Jampro Antennas 916-383-1182  
LPB 215-644-8651  
Moseley Associates 805-685-9638  
RAM Broadcast 312-358-3577  
Ramko Research 916-635-0907  
Tom Jones Recording 507-288-4531  
TTC 303-673-9900

### This Message From:

Name: \_\_\_\_\_ Station: \_\_\_\_\_

Address: \_\_\_\_\_

City: \_\_\_\_\_ State: \_\_\_\_\_ Zip: \_\_\_\_\_

Phone: \_\_\_\_\_ Fax: \_\_\_\_\_

Message: \_\_\_\_\_

\_\_\_\_\_  
\_\_\_\_\_  
\_\_\_\_\_