

VOLUME 6 — NUMBER 6

DECEMBER 1975

\$1.50

# R

ecording  
engineer  
producer

1002 2<sup>ND</sup> AVE ROYDO  
DOUG POMEROY  
COLUMBIA RECORDS  
49 E 52<sup>ND</sup> ST  
NEW YORK

NY 10022

INCLUDING: CONCERT SOUND REINFORCEMENT

Anatomy of a groove . . .  
'THE LACQUER' . . .

page 17

# EVERYTHING AUDIO

designers/builders of turnkey facilities

Studios  
with a  
difference



SUPERSCOPE TAPE DUPLICATORS,  
San Fernando, California

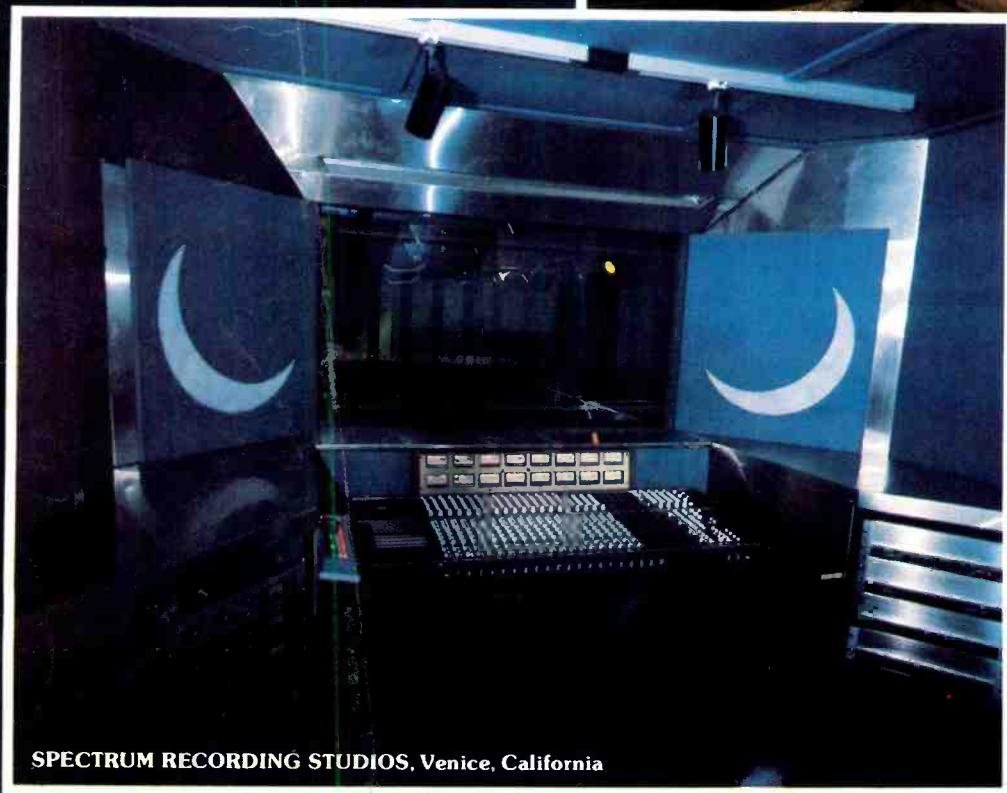

SPECTRUM RECORDING STUDIOS, Venice, California

you can  
hear.

Accept our invitation to contact us and discuss your studio needs.  
14045 Sherman Way, Van Nuys, California 91405/(213) 873-4447



## There's no place like home.

To get it together, and down on tape. Recording at home, working out ideas in private, at your own pace, gives you the freedom and control to help you get the music right. Your way.

With the TEAC 3340S 4-track multichannel recorder with Simul-sync, the Model 2 super flexible 6-in, 4-out mixer with pan and multiple patch points, the A-3300S2T half-track mastering recorder, the ME-Series of electret condenser mics, plus associated accessories...you have all the essential gear you need, at affordable prices, to set up your own multi-track recording rig.

It's more than a system...it's your access to the technology of music...it's the vehicle to make your inner musical perceptions audible reality. It works. And you can make it work for you.

Simply call (800) 447-4700\* toll free for the name of your nearest TEAC retailer.

\*In Illinois, call (800) 322-4400.

# TEAC

The leader. Always has been.

TEAC CORPORATION OF AMERICA: 7733 Telegraph Road, Montebello, California 90640



# crown audio equipment

## Tested... by ear...

Test instruments and specifications provide many little bits of information about audio equipment performance. Crown equipment always shows up well on this spec-by-spec comparison.

But there is only one instrument that can evaluate total sound performance. That's your ears!

And your ears deserve, indeed must have, the very best equipment in your studio to record, playback and amplify sound. We think you deserve Crown.

For over twenty-five years, Crown has manufactured audio equipment for recording and broadcast studios. Crown reliability, low distortion and ruggedness is well-known. But most users like Crown simply because it sounds good. They've tested it — by ear.

But, judge for yourself. Only *your* ears can really tell you how good Crown equipment is.

**Amplifiers** for studio monitors, headphones, paging systems. Designed for dependable service. Circuits designed for protection against shorts or mismatches. 1M distortion less than .05% over the entire bandwidth. 19" rack mount. 3-year warranty on parts, labor and round-trip shipping.



### D-150A Stereo Amplifier

80 watts RMS per channel into 8 ohms, 1 Hz to 20 kHz. 5 1/4 inches high. 25 pounds. Rear-mounted switch converts to mono mode (160 watts).



### DC-300A Stereo Amplifier

155 watts per channel into 8 ohms, 1 Hz to 20 kHz. 7 inches high. 48 pounds. Simple wiring change converts to mono mode (310 watts).

### VFX-2 Crossover for bi-amping monitors



### D-60 Stereo Amplifier

The ideal headphone amp. 30 watts per channel into 8 ohms. 1 3/4 inches high. 10 pounds, 60 watts mono.



### M-600 Single- Channel Amplifier

The latest addition to the Crown family of amplifiers. 600 watts into 8 ohms, 1 Hz-20 kHz 92 pounds. Built-in cooling. Peak-catching meter and threshold lights for convenient monitoring.

**Transports** for 1/4" tape handling. Professional design for day-in, day-out use. Rugged, heavy front panel (19" rack mount) for stable, trouble-free alignment. Three-motor design. One-piece fly-wheel and capstan. Electro-magnetic braking. Heads available for 4, 2 or 1 channels; 1/2, 1/4 or full track.



### 800 series

Computer-logic controls allow any command sequence, prevent tape breakage. Feather-touch push buttons. Photo-cell sensing for automatic shut-off in all modes. Remotely controllable. Suitable for automatic operation.



### 700 series

Mechanical interlock. Push-button mode controls. Play and stop modes remotely controllable. Automatic shutoff in play mode.

**Recorder electronics** for versatile off-the-shelf design. Four different electronic packages, which can be combined with either transport for just the capabilities you need. 19" rack mount. Headphone output jack on all models.



### CX series

Two channel record/playback • Plug-in modules for all functions • Built-in remote record (CX-800's) for no thumps on tape at beginning or end of record mode • Available with 600 or 250 ohm balanced XLR cannon inputs and outputs as an accessory.



### SX series

Two channel record/playback • All circuit functions on four permanently mounted printed circuit cards • Rear panel bias adjust • 2 HI-Z unbalanced mics per channel.



### SX mono series

Single channel record/playback • SX construction • Balanced and unbalanced line outputs •

### SP Player

Two channel playback only • Three-speed equalization • 600 ohm balanced output.

Call us today at 219/294-5571,  
or write for complete specs.

When listening  
becomes an art



# crown

Box 1000, Elkhart, Indiana 46514

# WHEN THE TOUR'S OVER, YOU WON'T HATE IT.

After a couple thousand bone-shaking miles, a few dozen one-nighters in towns way out in the boondocks, and a million cheeseburgers, you're not going to put up with anything less than a perfect mixer.

The Yamaha Sound Mixers were designed to put reliability where it belongs. Between the good music and the receptive audience.

To tell the truth, Yamaha Mixers sound like

they aren't there. They add no coloration to the sound, only control.

And since we know how things get knocked around on the road, we've made them rugged enough to take it. (One's been accidentally dropped off a truck and still made the gig without any repair.)

On the road, it's got to be right the first time.

And when a Yamaha Mixer is right every time, you learn to trust it.

And in a while, to love it.



P.O. Box 6600, Buena Park, California 90620

# NUMBER ONE



## SON AND GRANDSONS



**SON** 52 inputs  
26 mixing positions



**GRANDSON** 36 Inputs  
18 mixing positions



**GRANDSON II** 48 inputs  
24 mixing positions

For years, the Auditronics family of consoles has produced sound leaders. From New York to Bangkok.

Our Son and Grandsons deliver faultless performances night after night. In front of the most hardened authorities.

Yet our success is no mystery. In both recording and the broadcast industry, Auditronics has become a standard for craftsmanship and technology. A reputation won on the firing line.

Think about it. And don't make a sound without calling us first.  
Leasing/Financing Plans Available.

INTERNATIONAL DEALERS: J-Mar Electronics, Ltd., Toronto, Canada/Studio Equipment, Paris, France/  
Syntec Electronic Distributors, Sydney, Australia.

 **auditronics, inc.**  
P.O. Box 12637 • Memphis, Tenn. 38104 • 901/276-6338

- the magazine to exclusively serve the recording studio market . . . all those whose work involves the recording of commercially marketable sound.
- the magazine produced to relate . . . RECORDING ART to RECORDING SCIENCE . . . to RECORDING EQUIPMENT.



Editor/Publisher .... MARTIN GALLAY  
Managing Editor ..... WAYNE YENTIS

Business Manager ..... V.L. GAFFNEY  
Circulation Manager LARRY DOUGLAS  
Reader Service  
Manager ..... DEBRA LYNNE  
Assistant Editor .. MARGE ANDERSON



'RECORDING engineer/producer' is published bi-monthly (six times a year) by RECORDING & BROADCASTING PUBLICATIONS, 1850 No. Whitley Avenue, Suite 220, Hollywood, CA 90028, and is sent to qualified recipients in the United States. Subscriptions for other than qualified individuals or companies may be purchased at \$7.50 per year (6 issues). All foreign subscriptions Surface Mail - \$8.50, Air Mail - \$15.00.



RECORDING engineer/producer is not responsible for any claim made by any person based upon the publication by RECORDING engineer/producer of material submitted for publication.



Material appearing in R-e/p may not be reproduced without written permission of the publisher.



Controlled Circulation postage paid at Los Angeles, California.

Address all correspondence to:  
RECORDING engineer/producer  
P.O. Box 2449  
Hollywood, CA 90028  
(213) 467-1111

'THE LACQUER' by Wayne Yentis . . . 17

Magnetic Tape . . .  
UNDERSTANDING THE PRINT THROUGH  
PHENOMENON by Marty Eggers . . . 27

An Alien View of  
MULTI TRACK TAPE MACHINE  
ALIGNMENT by Peter Butt . . . 31

The UNIVERSAL (AMPHITHEATER)  
SOUND SYSTEM by Gary Davis . . . 45

letters & late news - 10  
book review - 43  
new products - 55  
classified - 66

cover photo:

'Anatomy Of A Groove' . . .  
Brian Ingoldsby, MCA Recording  
Studios, Universal City, California

THIS ISSUE SPONSORED BY THE FOLLOWING ADVERTISERS

A & R RCRD MFG . . . . .	65	JBL . . . . .	26
AKG . . . . .	15	MAGNETIC RESEARCH LABS . . . . .	28
ALLISON RESEARCH . . . . .	44	MINCOM DIV. 3M . . . . .	54-55
AMBER . . . . .	59	MODULAR AUDIO . . . . .	29
AUDIO CONCEPTS (KELSEY). . . . .	14	NASHVILLE STUDIO SYSTEMS . . . . .	24
AUDIO INDUSTRIES . . . . .	51	ORBAN/PARASOUND . . . . .	11
AUDIO TECHNIQUES. . . . .	13	PANDORA . . . . .	69
AUDITRONICS. . . . .	4	PEAVEY ELECTRONICS. . . . .	30
AURATONE . . . . .	48	QUANTUM AUDIO . . . . .	53
AUTOMATED PROCESSES (API) . . . . .	21	SCIENTIFIC AUDIO. . . . .	47
CALIFORNIA SWITCH & SIGNAL . . . . .	66	SCULLY METROTECH . . . . .	57
CAPITOL MAGNETICS . . . . .	33	SHURE BROTHERS. . . . .	CVR 4
COLLEGE OF RCRDG ARTS . . . . .	70	SPECTRA SONICS. . . . .	18, 60
COMMUNICATIONS CO . . . . .	69	TABER. . . . .	58
CROWN INTERNATIONAL . . . . .	8	TEAC. . . . .	21
DBX . . . . .	56	TELEX. . . . .	3, 60
ELECTRO-VOICE . . . . .	16	UNI-SYNCH. . . . .	49
EL-TECH . . . . .	62	UREI. . . . .	10, 66
EVERYTHING AUDIO . . . . .	CVR 2	WESTLAKE AUDIO . . . . .	35-38
HARRISON (STUDIO SUPPLY) . . . . .	CVR 3	WHITE INSTRUMENTS. . . . .	12
INFONICS. . . . .	25	WINDT AUDIO. . . . .	70
INOVONICS. . . . .	63	YAMAHA INTERNATIONAL . . . . .	9
INTERFACE ELECTRONICS . . . . .	61		

# Get 27 Handles on Your EQ Problems

27 precise vertical equalizer controls on the Model 527-A front panel show graphically the 40 Hz to 16 kHz equalization you introduce to create the sound you want. Each of the 527-A's precision equalizers is centered on a standard ISO 1/3 octave frequency, providing the engineer/producer with a creative tool which gives him total command of the entire audio spectrum for contouring or correction. The versatile 527-A also doubles as a "room equalizer" for correcting deficiencies in monitor or sound system response, using the controls as attenuators for system peaks.

Whether your interest is live performance amplification, live recording, re-recording, mastering, or broadcast production, the 527-A is an indispensable creative tool.

So, get a handle on your EQ problems. Get a 527-A from your UREI dealer.

**UREI**  
QUALITY  
OF COURSE

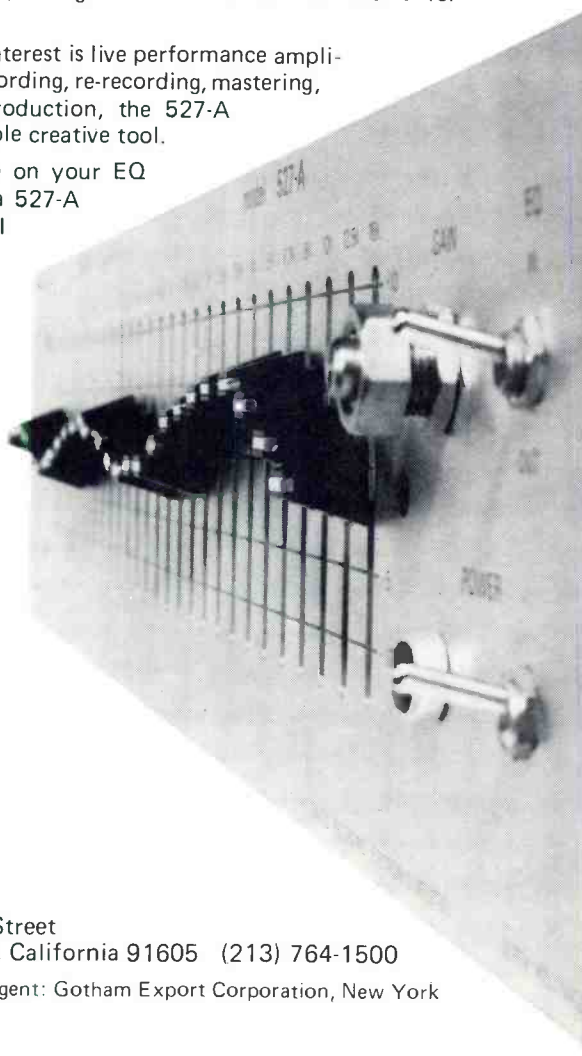

11922 Valerio Street  
No. Hollywood, California 91605 (213) 764-1500  
Exclusive export agent: Gotham Export Corporation, New York

## Letters & Late News

FROM: Don Davis, President  
Synergetic Audio Concepts  
Tustin, CA 92680  
(714) 838-2288

*Really outstanding. "The Electrical Part of the Recording Studio, Part 1: Understanding the Neutral" by Jerry Simon is invaluable.*

*"Spectrum Analysis in the Recording Studio" by Wayne Jones (Amber Electro-dynamics) is accurate and thorough — and badly needed. Real time analyzers are vital to both the recording engineer and the sound reinforcement engineer.*

*You may remember that R-e/p carried my article on real time analyzers in 1971. Jones' article is the first good article that I have seen since then.*

ED: According to tabulation of the most useful articles in the previous issue, as noted on returned Reader Service Cards, many many readers echo Mr. Davis' welcome comments. UNDERSTANDING THE NEUTRAL and SPECTRUM ANALYSIS ran virtually neck-and-neck as the most useful articles in the October issue . . .

### BASF PRESENTS WORLD'S FIRST MAGNETIC TAPE TO SMITHSONIAN

A piece of the world's first magnetic recording tape was recently presented to the Smithsonian Institution. Dieter H. Ambros, President of BASF Wyandotte Corporation, made the presentation to S. Dillon Ripley, Secretary of the Smithsonian, at a concert, "Music From the Age of Jefferson," held in the Smithsonian's Baird Auditorium.

The concert was devoted entirely to selections from the time of Thomas Jefferson, who, besides his other talents, was a devoted amateur musician. The Smithsonian has recorded the concert and is making either records or cassettes available to the public in a package with explanatory notes. Following the premiere, the concert will be taken on a tour of major American cities. Both recording and live performances were made possible by a gift from BASF Wyandotte Corporation.

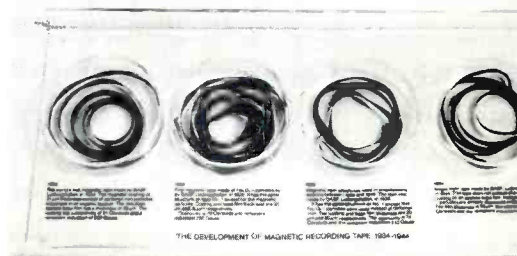





Ambros

Ripley

BASF developed magnetic tape in Germany in 1932. Until that time, magnetic recording depended primarily on steel wire and, in the U.S., steel was used until the mid-forties. Magnetic tape was not only lighter than steel, but it could also be cut and spliced, thereby allowing it to be edited.

Commercial production of magnetic recording tape began in July, 1934, at BASF's plant in Ludwigshafen, Germany, and led a year later to AEG's Magneto-phon, the first magnetic recorder to resemble equipment in use today. The 1934 tape was made of cellulose acetate, coated with carbonyl iron powder. It could be played on one side only and was further limited by a playing speed of one meter per second.

The presentation to the Smithsonian also included three other tape samples, representing product improvements through 1944, just before introduction of the medium in the U.S.

The first concert ever to be recorded on tape took place in Ludwigshafen on November 19, 1936, when BASF tape was used to record the London Philharmonic under Sir Thomas Beecham. From this point of departure, BASF went on to become a world leader in tape sales. BASF Systems, a division of BASF Wyandotte Corporation, manufactures quality audio tape for the American market.

#### CLAUDE HILL OPENS AUDIO CONSULTANTS, INC., IN NASHVILLE; TO BE EXCLUSIVE 'MCI' REPRESENTATIVE IN SOUTHEAST

With showrooms and offices at 7 Music Circle, North in Nashville the new firm, according to founder Claude Hill, "has been established to serve the professional audio market in the southeast with every possible service, from a single microphone or patch cable to a complete turnkey studio project from design through construction."

In addition to the exclusive representation the complete line of MCI consoles and recorders, Audio Consultants will also handle other prominent pro-audio lines, some of which are AKG, DBX,

Dolby, Elpa, Eventide, Neumann, MRI, Multi-Synch, Orban/P and others. The new company will build a stock of fine re-conditioned equipment.

Audio Consultants' Claude Hill has had successes in both the recording studio, and in the equipment design and manufacturing fields. Says Hill, "I hope my experience on both sides of the fence will be a valuable part of the service we can render to all levels of customer."

AUDIO CONSULTANTS' mailing address is: P.O. BOX 12403, NASHVILLE, TN 37212. Telephone (615) 256-6900.

#### TEAC LICENSES DBX NOISE REDUCTION

dbx noise reduction will be offered in Teac tape recorders under a license agreement just completed according to David Blackmer, president of dbx, Incorporated. The license permits Teac to incorporate dbx noise reduction in its machines in all three tape formats.

The system used will be the same 2:1 double ended compression/expansion system presently sold as an outboard accessory by dbx, and will be compatible with dbx noise reduction systems now in use.

dbx noise reduction improves the effective signal to noise ratio of the tape recorder by approximately 30 dB, which

# The Sensual Equalizer.

Whether on record or in live performance, today's most commercially successful music is more visceral, immediate, and sensual than ever before. This impact has been achieved through advances in the musician's art, and through a quantum jump in the control available in audio processing.

The Orban/Parasound Parametric Equalizer, Model 621, has received outstanding acceptance since its introduction because it combines economy (\$340/channel) with extraordinary control. Each of its four non-interacting bands permits continuous, stepless adjustment of bandwidth, equalization, and center frequency. Each band can be tuned over a 20:1 frequency range with no change in curve shape (unlike some competitors), and peak gain remains constant as the bandwidth is varied. The unique "constant-Q" equalization characteristic is more musical than the usual reciprocal curves, and lets the equalizer create infinite-depth dips to remove hum, whistles and ring modes—making it ideal for cinema and sound reinforcement as well as recording studio and

broadcast applications. Other outstandingly useful features include a front-panel gain control and a peak-stretching overload lamp which indicates clipping anywhere in the equalizer circuitry.

While our spec sheet (available from the address below) gives the details in cold black-and-white, it cannot describe the sensual interaction between man and machine which occurs when the frustrating limitations of conventional equalizers are finally overcome, and the user is given the power to create sound that feels really right. Our ability to deliver this power at an affordable price is the true reason for the O/P Parametric's success. But don't take our word for it—discover the Sensual Equalizer for yourself, soon.

For further information, contact

**orban/parasound**

680 Beach St.  
San Francisco Ca. 94109  
Or contact your local  
Orban/Parasound distributor



...machines, EMT, ... sound ... also ... need

machines to produce ... with a dynamic ... that achieved by pro ... ment. The dbx sys ... some 10 dB extra ... vents tape overload ... of the major advan ... system is that level ... during recording and playback are ... not critical.

dbx, INCORPORATED, 296 NEWTON ST., WALTHAM, MASS. 02154.

**HOW TO MEASURE PARAMETERS OF AUDIO PRODUCTS APPLICATION NOTE AVAILABLE FROM HEWLETT PACKARD**

How to use low-frequency wave and spectrum analyzers to measure distortion, frequency response, wow and flutter, signal-to-noise ratio and cross talk of high-quality audio products is detailed in a new application note from Hewlett-Packard. This 16-page brochure discusses various types of distortion that occur in audio amplifiers, tape recorders, equalizers and loudspeakers. Methods of measurement are shown. Frequency response measurements of these products are explained in detail.

An analysis of harmonics in musical instruments illustrates the use of the spectrum analyzer in synthesizing voices

of various instruments. Sections are devoted to acoustic response of rooms, signal-to-noise ratio and cross talk.

Application Note 192, 'Using a Narrow Band Analyzer for Characterizing Audio Products' is available free of charge from Hewlett-Packard.

**INQUIRIES MANAGER, HEWLETT-PACKARD CO., 1501 PAGE MILL RD., PALO ALTO, CA 94304.**

**GEORGE ALEXANDROVICH NEW STANTON VICE PRESIDENT, PROFESSIONAL PRODUCTS MANAGER**

Walter O. Stanton, President of Stanton Magnetics, Inc., announces the appointment of George Alexandrovich as Vice President, Field Engineering and Professional Products Manager for the company.

For the past 13 years, Mr. Alexandrovich served as Vice President and General Manager at Fairchild Sound Equipment Corp.

Mr. Alexandrovich, who has already commenced his new position at Stanton, will also serve as Chief Field engineer for Pickering and Co., Inc.

**ROBERT D. PABST NEW ELECTRO-VOICE GENERAL MANAGER**

Robert D. Pabst has been appointed executive vice president and general man-

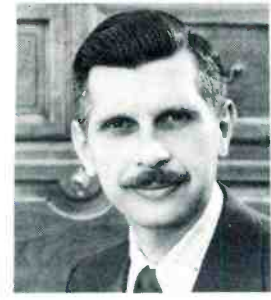

Alexandrovich



Pabst

ager of Electro-Voice, Inc., a subsidiary of Gulton Industries Inc. The announcement was made by Philip Garnick, E-V president who stated that Mr. Pabst will be in full charge of all Electro-Voice operations. While Mr. Garnick remains as president, this appointment will enable him to devote more time to his responsibilities as group vice president of Gulton Industries. As general manager, Mr. Pabst's duties will also include those of former E-V executive vice president-operations, James E. Cobb who resigned August 31, to join Advent Corp., Cambridge, Massachusetts.

**AUDIO CONCEPTS/DAVE KELSEY SOUND OPENS NEW LOS ANGELES HEADQUARTERS/SHOWROOM**

On January 5, 1976, Audio Concepts (better known as Dave Kelsey Sound) will open, what is thought to be, the largest pro audio showroom in the West. The new 9,000 square foot facility will feature a complete 16 track room to demonstrate the firm's acoustical design service, as well as their new high level studio monitors. The new facility will also house fully equipped studio displays for both 4 and 8 track recording; a complete broadcast production facility; a live performance stage area for full concert sound reinforcement; and, the first disco showroom in the West - with a 20' by 20' dance floor and a full display of disco lighting equipment.

The new location will be at:  
7138 SANTA MONICA BOULEVARD, HOLLYWOOD 90046. (213) 851-7172.

**WESTINGHOUSE UNIT TO SELL PREFERRED SOUNDS**

PSI Industries, a new corporation owned principally by S.A. Nastro, announces the recent purchase of Preferred Sounds, Inc. from Longine-Wittnauer, a unit of Westinghouse Electric, Corp.

Preferred Sounds, Inc. produces audio tape recordings and coordinated print-and-film materials for use in education, training, and medical communications, and duplicates recordings of classical and popular music.

Mr. Jerry H. McPherson has been elected president of Preferred Sounds. Mr. McPherson has been with the company since its inception in 1969.

Vice-President of marketing is Mr. John W. Berry, who recently joined PSI after six years with Infodex Cassette Corp., as National Sales Manager. Mr.

# NEW AUDIO SPECTRUM MONITOR!

## 1/3 OCTAVE REAL TIME ANALYSIS MODEL 142

**FEATURES**

- PEAK READING • TWO MEMORIES: CUMULATIVE OR SAMPLE • VARIABLE TIME CONSTANTS (0.1 - 2 SEC.) • CALIBRATED IN DBM • 10-20-30 DB DISPLAY RANGE • 40 HZ to 16 KHZ ON 1/3 OCTAVE ISO CENTERS • 11 x 28 LED ARRAY • BUILT-IN PINK NOISE SOURCE • 3 1/2" x 8" DEEP RACK MOUNT.

**USES**

- PROGRAM MATERIAL MONITORING • RECORDING AND MIX-DOWN ANALYSIS • PORTABLE SYSTEM ADJUSTMENT • TAPE EQUALIZATION AND CALIBRATION • TRANSMISSION LINE EQUALIZATION • BEFORE-AFTER COMPARISONS • FREQUENCY RESPONSE TESTING



Suggested List Price \$3200

ALSO: Active and passive equalizers • Other real time analyzers  
Dealer inquiries invited

White

Call or write today: WHITE INSTRUMENTS, INC.  
P.O. BOX 698 512/892-0752 Austin, Texas 78767

Berry will be responsible for overall sales development and the company's direct sales force.

PSI will continue their eight-track, cassette, and reel to reel music duplication. New services will be multi-media audio duplication with coordinated print and film materials for use in education, training and medical communications.

Mr. McPherson also announced that the company will invest substantial sums of money into nationwide radio and TV broadcast sales. The company has underway a package due to hit the market place in November, through its Westchester music Company affiliation.

Manufacturing and corporate head-

quarters will remain located in the modern 30,000 square foot facility in Rye, New York.

#### NASHVILLE STUDIO SYSTEMS COMPANY FORMED

Located in the heart of Nashville's Music Row, the new company has been established to meet the needs of both professionals and semi-professionals, and will offer complete studio design, equipment service as well as sales.

The company's new offices have been constructed around a working control room, where the latest in studio equipment will be available to customers for hands-on experience.

According to the firm's manager, Emil Handke, "This is a fresh new approach for a sales/service organization in this area . . . we think it's going to offer the customer a chance to evaluate new gear in a typically relaxed control room atmosphere."

**NASHVILLE STUDIO SYSTEMS, 16 MUSIC CIRCLE, SO., NASHVILLE, TN 37203 (615) 256-1650.**

#### DOLBY OFFICE AND LABORATORY OPENING IN CALIFORNIA

A new head office and laboratory will be opened by Dolby Laboratories Inc. in San Francisco, California. The office will

*continued on page 70 . . .*



# Our system is hard to beat

The all time favorite monitor system in U. S. recording studios is the Altec 604. Add our Mastering Lab frequency divider with its improved mid-range, distortion-free crossover and extended bass and you have a system that is truly hard to beat.

We have packaged 604s and M/L dividers in a bass reflex enclosure and named them Big Reds. For super bass response and increased sound pressure level, we add an extra 15" woofer, plus a low frequency crossover and call them Super Reds.

Use our M/L dividers to perk up your present 604s or go all the way with either of our Red systems and join the list of studios that benefit from monitoring with the Mastering Lab system.

**audiotechniques, inc.**

142 Hamilton Avenue, Stamford, CT 06902 Telephone: 203 359 2312

#### MASTERING LAB CROSSOVER USERS

A & M Recording  
American Recording  
Applewood Studios  
A & R Recording  
Artists Recording Studio  
Atlantic Recording Studio  
Audio Arts  
Autumn Sound  
Randy Bachman  
Berklee College of Music  
Black Crack Studios  
Blue Rock Studios  
Caribou Ranch  
Catholic University  
Chariot Studio  
Cherokee Recording  
Conway Recording  
Dallasonic Recording  
Davlen Sound

Dawnbreaker Studio  
Disney World  
Dynamic Sounds  
Earth Audio  
Falcon Records  
Fanshawe College  
Good Times Studio  
Great Lakes Audio  
Hallmark Studios  
Wally Heider, Los Angeles  
House of Music  
Intercontinental Absurdities  
John Kay  
Kendun Recorders  
David Kershenbaum  
Mama Jo's  
Manta Sound  
Minot Sound  
MZH Studios

Graham Nash  
Nimbus Nine Productions  
Ochoa Recording Studio  
ODO Recording  
Original Sound  
P & P Recording  
Richard Perry  
Pinellas Music  
Producer's Workshop  
RCA, N.Y.C.  
RCA, Los Angeles  
Roade West Recording  
Rockland Recording  
Salty Dog Studio  
Sigma Sound  
Sound Exchange  
Sound Factory  
Sound Ideas  
Sound Labs

Springfield Sound  
Sundance Recording  
Sunset Sound  
Sunswept Studio  
Howard Schwartz Recording  
Synchron Studios  
TDF, Florida  
The Guess Who  
Toronto Sound  
United Artists Studios  
University of Mass, Boston  
Valentine Recording  
Vantone Studios  
Venture Sound  
Village Recorder  
Western Recording  
Whitney Recording



***“Best Wishes for the Holiday Season”*** and a very special ***“Thank You”*** for helping us to become one of the largest pro audio dealers on the west coast. On January 5th, we’ll be moving to our new 9,000 sq. ft. facility, and we look forward to serving you even better in the coming year. We’ll be stocking more lines; adding additional sales, service, and engineering people; and staying open evenings and Saturdays. We’ll be featuring the largest and most complete pro audio showroom in the West. Stop by and see us.

**AUDIO CONCEPTS/DAVE KELSEY SOUND**  
7138 Santa Monica Boulevard • Hollywood • California 90046 • (213) 851-7172  
***“The Professional Sound People”***

RECORDING • BROADCAST • DISCO • SOUND REINFORCEMENT

Professionals throughout the world are using the unique Torsional Transmission Line Principle in our big Studio Standard BX-20E. It duplicates and enhances natural reverberation with a control and predictability not possible with natural "vibes."

Now the Torsional Transmission Principle is available in the first truly *portable* reverb. Our two-channel, studio quality BX-10E.

It lets you adjust independent decay time of 1.5, 2.5, or 3.5 seconds. There's also separate high frequency and low frequency equalization for each channel. A reverb/dry signal mix for each channel as well. Input sensitivity selection of +12, +6, -6, and -22dBm. And a stereo/mono switch.

The BX-10E uses motional feedback circuitry, so instant variation of decay time is possible during recording. You can make

dynamic adjustments to a score while it is being recorded. The BX-10E features an ingenious two point pendulum suspension within an insulated case with a foam lining. You can use the BX-10E near monitors without fear of acoustic feedback or structure-borne sound and vibrations.

Despite all it has going for it, the BX-10E is only 17 x 12 x 19 inches small and weighs only 55 pounds. Visit your AKG professional dealer for a personal introduction. Or write to us.

**AKG MICROPHONES • HEADPHONES**

distributed by

PHILIPS AUDIO VIDEO SYSTEMS CORP.,

AUDIO DIVISION

91 McKee Drive, Mahwah, New Jersey 07430

A North American Philips Company



## **AKG reverbs go beyond natural reverberation. Naturally.**

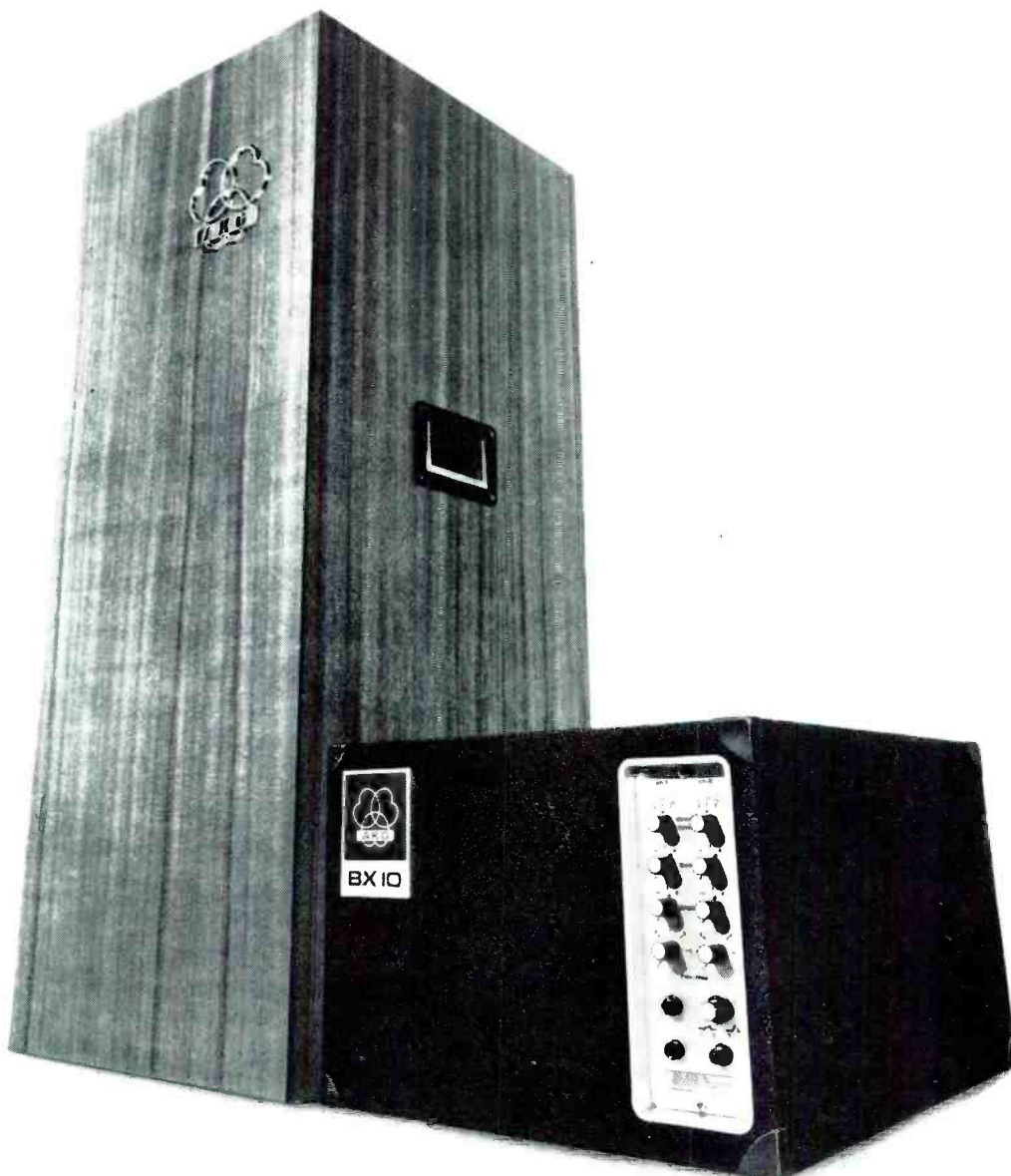

# Please don't dance on your tape recorder!

We've seriously gone about the business of designing the best possible loudspeaker for monitor use. With computers, and anechoic chambers, and all the rest. And, having gained a monster new insight into bass speaker performance, we've come up with what looks like a winner. The Sentry III.

We've run all the curves that prove, in a most scientific, sober fashion, that the system is really quite good. We've got polar graphs, and frequency response curves, distortion measurements, total power output curves, power handling test results, and SPL data galore.

But what happens when we demonstrate the Sentry III? Leading engineers (whose names we hesitate to divulge—but you know them) leap about in their control rooms DANCING for heaven's sake! Snapping their fingers and feeling the sound, and reveling in the sensory pleasure of a clean first octave. And last octave too, for that matter.

And they run from one side of the studio to the other trying to find holes in the distribution of the highs . . . and they can't . . . and they LAUGH! It's very unseemly (but secretly quite gratifying). So we try to thrust our good numbers and graphs at these

serious engineers, but they'd rather listen and compare and switch speakers. And make rude remarks about their old monitors.

Who will stand still long enough to heed our technical story? Perhaps you're the serious-minded, sober-sided engineer we're looking for. If so, by all means write us. We've got quite a stack of strait-laced, objective literature describing the Sentry III monitor loudspeaker just waiting to be seen and appreciated.

And after you've read our story, perhaps we can arrange a demonstration of this speaker for you. The Sentry III. Bring your tap shoes.



**SENTRY III**  
Monitor Loudspeaker

a **gulton**  
company

**Electro-Voice**®  
INC

SENTRY III Frequency Response 40-18,000 Hz  $\pm$  3 dB; Sound Pressure on Axis at 4' with 50 watt input 113 dB; Dispersion 120° horizontal, 60° vertical; Size 28½" W x 20¼" D x 36" H, Weight 156 lbs. \$650 suggested professional net (slightly higher in Western States), SEQ active equalizer extends response to 28 Hz, \$60.00.

ELECTRO-VOICE, INC., Dept. 1151RP, 674 Cecil St., Buchanan, Michigan 49107

# The Lacquer Roundup

by Wayne Yentis

The lacquer master disc figures in the manufacture of 100% of the phonograph records made in the world today. It is an essential part of the record industry and there is no current alternative. That so large an industry could depend on a single element implies that the lacquer process provides a completely satisfactory link in the chain of record production processes. It has served for 40 years in essentially the same form for every mechanical recording format since the 78 RPM disc.

"In the beginning," say the old-timers, "there was wax." The lore of early recording processes is rich with stories of crusty stoves and steaming vats, and rubber-gloved recording engineers blending their special wax formulas or crouching for hours at a wax shaving machine. The logistics of making recordings on that unwieldy and fragile medium were complex and required manual coordination of many elements that today are simply and conveniently automated. And the end result was a 40 pound breakable record that was ruined if you played it. Despite its cumbersome aspects, the recording industry was growing healthily, based substantially on wax's ability to do the job.

Then, somewhere in France in the early '30s, someone found he could make a reasonable recording on a metal disc coated with a French produced fire-proof lacquer called *Pyrolac*. The recording could be played many times, the disc was light weight and much less fragile than wax. A true invention from the press of necessity. Because it allowed instant replay it was called the "Instantaneous."

Just who first tried *Pyrolac* on a disc was not definitely determined, but some say he was an American named Bill Speed who was working in France with the French film industry. At any rate, the French firm *Pyral* was formed to produce the lacquer discs (*Pyral* from the original *Pyrolac*, and *al* from aluminum) and Bill

Speed was granted license to produce lacquer masters in the US, which he did under the name Audio Devices.

Of course the majority of recording operations were up to their elbows in wax equipment and it took them some time to notice the convenience of lacquers, but in 5 or 6 years most had seen the light and closed their kitchens.

Soon other companies appeared with lacquer disc products, made by their own processes which were hoped to be competitive. Some were for awhile, some were not, and the scale of the industry remained too small to be interesting to larger companies.

In the late forties, spurred perhaps by the onslaught of competition, Audio Devices branched into the manufacture of magnetic recording tape. Later the *Pyral* people decided to make tape also and released Audio Devices from the licensing agreement in exchange for tape making technology.

Since then the process of lacquer blank production has been developing more or less independently in the confines of the individual plants. Several people felt they had a "better idea" how to make blanks, went into the business and developed their techniques, then later sold out to other lacquer companies. In this way the technologies have spread, but the remaining producers of blanks still maintain strict security around certain processes.

In 1973 Audio Devices was acquired by Capitol Magnetic Products and as of this writing there are only two other lacquer manufacturing companies in the US, *Transco* and *Allied*. The bulk of the US market belongs to *Capitol* and *Transco* both of whom do a brisk business abroad as well. In Europe *Pyral* is still the principal supplier. *EMI* in England has been producing blanks under license from *Pyral* since 1947.

The early manufacturers of blanks worked out their own lacquer formulations and metal processing techniques, but for a long time *ALCOA* has been the sole supplier of aluminum blanks. Most lacquer raw materials are now furnished by one supplier here in the US.

All the domestic manufacturers of blanks display righteous discomfiture at the aluminum situation. The lacquer industry is not big enough to entice other aluminum producers to make "aluminum circles." Admittedly the aluminum circles have to be very good ones, and the pains involved in producing them just don't justify the returns in terms of business for Mr. Aluminum.

"During the War," the old-timers continue, "you couldn't get aluminum." So they coated lacquers on glass. The results were usable, and in fact most of the old timers will say they recorded better than aluminum discs. But the breakage problems recalled the days of wax and everyone was relieved when aluminum

# DISCO POWER

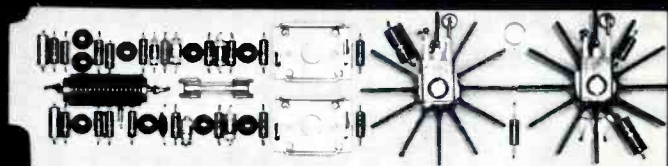
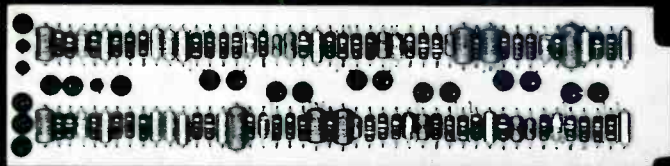

Model 505 Electronic Filter: 18dB/octave filter; integral power regulation, two complete crossovers for Bi-amplification or as a three-way filter for Tri-amplification; imperceptible transition; standard frequencies; S/N better than 100dB below +4dB output, 20Hz to 20kHz, unweighted.

Model 700 Power Amplifier: 60 watts continuous (120 watts, bridged configuration); unmeasurable THD; S/N better than 100dB below full output, 20Hz to 20kHz, unweighted.

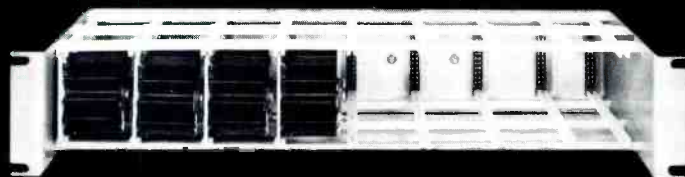
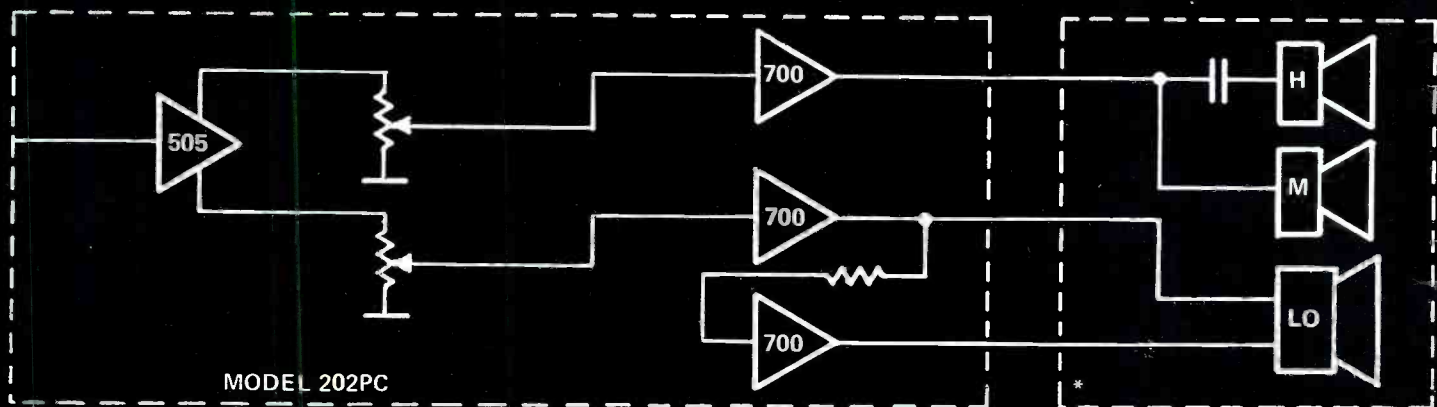

Model 202PC Card Holder: designed to accept Model 505 and Model 700 for an efficient, compact, integrated system to provide unequalled sound power.

\*Speaker systems by SPECTRA SONICS are matched to system configuration.

SPECTRA SONICS Models 505 and 700 are a powerful combination for the truest sound reinforcement. These SPECTRA SONICS audio components may be arrayed for bi/tri/quad amplification to produce kilowatts of power at pre-inflation prices! Data on a sound reinforcement system, GUARANTEED to produce outstanding performance, to meet your specific requirements, may be obtained by contacting SPECTRA SONICS at:

770 Wall Avenue  
Ogden, Utah 84404  
(801) 392-7531

6430 Sunset Blvd., Suite 1117  
Hollywood, California 90028  
(213) 461-4321

## SPECTRA SONICS

LEADER IN ADVANCED TECHNOLOGY





appeared again.

Pyral has recently made an arrangement with Gotham Audio Corporation to explore the US market potential for the Pyral disc. Their manufacturing processes have been evolving separately from those in this country, and they have announced recent technological improvements which should make their product interesting to our domestic cutters. Also, they produce their own raw lacquer materials and have access to an aluminum other than ALCOA.

Both Transco and Capitol also continue to refine their processes. Most visibly, Capitol has executed a completely fresh start in a new lacquer plant in Winchester, Virginia. The knowledge and expertise gained from 37 years of producing lacquer blanks in a well seasoned, if not rustic, plant in Glenbrook, Connecticut has moved to a brand new air conditioned laboratory/factory, just around the corner from Capitol's new giant plating and pressing plant and tape duplication facility.

The close liaison between the lacquer plant and the plating and pressing plant can't help but be handy in the control of lacquer plating problems.

A major feature of the new plant is the installation of two drying tunnels. Drying the freshly coated discs is one of the most critical processes in their manufacture. Establishing a stable drying cycle can require days of preparation and down time. To risk the drying environment to a run of experimental materials could mean an extended interruption of the regular production if only one tunnel is available. The second tunnel, then, will be useful in development projects as well as serving as a part time back-up for the production tunnel.

## HOW ARE LACQUERS BUILT?

The simplicity of the lacquer mastering disc calls attention to the most minute flaw. Because it consists of the combining of only two physical components; the coating and the substrate, the combining process as well as the components themselves must be as flawless as possible.

As mentioned earlier ALCOA is the sole supplier of aluminum disk blanks in this country, so both Capitol and Transco start with the same material. It arrives as calendered aluminum discs, very smooth and polished as per the requirements of the lacquer industry. Each company has their own ways of treating the aluminum to optimize its characteristics above and beyond its condition when received.

Capitol has invested in some whopping big lapping machines to grind off the original surface of the aluminum blanks as they come from ALCOA. The lapping also makes sure the disc is flat. The result is an even flatter and essentially smoother surface with favorable crystal-

line structure and absolute control of surface contaminants.

Pyral, on the other hand, treats their aluminum discs in a way that chemically alters the surface for better lacquer adhesion. Transco, too, has its own process of aluminum treatment.

The lacquer raw materials are the same for all makes of blanks, the basic ingredient being cellulose nitrate, which exists in several forms including an explosive form known as gun cotton. The pure stuff can be formed into a tough and durable coating. But by itself it is hard and brittle, it decomposes readily (and rapidly) and is just not suitable for scribing with a stylus. The cellulose nitrate as prepared for use in lacquer blanks has been treated for just the softness, texture, tensile strength, melting point, flow characteristics, drying qualities, and surface flatness to make it a good recording material. However it still has some of the qualities of its explosive cousins, a thought to keep in mind in handling the chip from the cutting stylus.

It is the selection of additives and the blending procedures that recall the waxen

days of yore with the secret recipes and slow cooking pots in the back room. Forty years of experimentation and development are now being augmented by newly developed agents used to stabilize and soften the raw material.

There are 4 categories of conditioning agents added to the raw nitrocellulose: *Plasticizers*, which provides controllable softness; flexibility and elasticity of the coating; *Resins*, which improve coating smoothness, improve the adhesion to the substrate, and add solid material which aids coating and drying properties; *Pigments*, which make the coating opaque, or nearly so, aiding visual inspection of the coating; *Solvents*, which are the fluids which melt everything together into a smooth homogeneous coatable mass.

Capitol, upon moving to the Winchester plant, adopted a continuous blending process which replaces their previous methods of batch blending. This is intended to reduce the variations and shifting tolerances encountered in batch processing, producing a more consistent high quality product. It also reduces the opportunity for the user to sort out

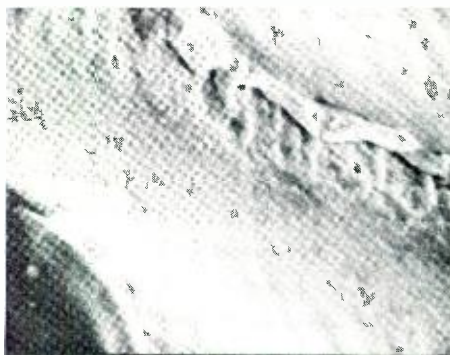
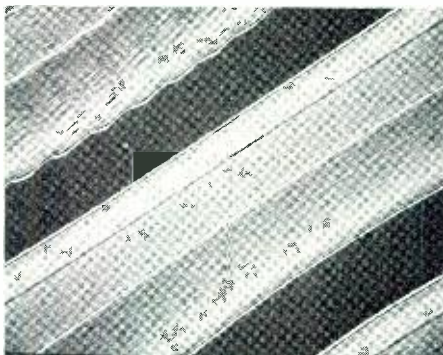

*These remarkable scanning electron photo micrographs were taken by Mr. Csaba Hunyar, Technical Director of United Artists Records in Los Angeles. Because of its increased depth of field, higher magnification potential, and ability to view the specimen from oblique angles, the scanning electron microscope provides a much clearer and more readable image of the groove than the conventional scope found on a cutting lathe.*

*The first photo, at the upper left, was made perpendicular to the surface of the lacquer, yielding the same view as a lathe mounted microscope. It shows an unmodulated groove and unmodulated CD-4 carrier in the adjacent groove to the upper left. Notice the sharpness and detail from the top surface all the way down to the bottom of the groove. Magnification, 1000X.*

*The three additional photos show portions of the same groove as photographed with varying degrees of magnification. The angle view is 30 degrees from the perpendicular. The modulated grooves show signs of "ripping," where the lacquer fails to cut smoothly during periods of heavy high frequency modulation. A small ridge can also be seen on either edge of the groove, which is a phenomenon known as "horning."*

*Magnification of the photo at the upper right, 400X. Magnification of the photo at the lower left, 2000X. Magnification of the photo at the lower right, 7000X.*

# Remix Automation comes of age with a NEW PROGRAMMER by AUTOMATED PROCESSES... World leader in console automation.

Created in answer to industry need and available now, this extremely reliable programmer, the Model 1024, has been designed to accommodate every known console requirement. With over 1000 control channels, it provides functional capability for future growth as well . . . and at a reasonable price!

Unlike previous programmers, the Model 1024 uses a digital data cartridge to store programming information. During playback, data is recalled from the cartridge in sync with the program tape or other timing source . . . without accumulation of delay at each pass since timing data is included in the data on the cartridge. New data is recorded at each updating pass and previous data is formatted as part of the new data. But because previous data is retained in the cartridge, it is always possible to return to the former mix . . . and up to ten final mixes may be stored for later recall.

The system is normally referenced to an internally generated MagLink timing code recorded on one track of the multi-track tape, but the timing reference may be the output of any time code generator, or from a tape timer (thereby requiring no tracks of the multi-track tape). Since no data is recorded on the multi-track tape during remix, crosstalk problems are eliminated. The timing code track can also serve to control the audio tape machine and to synchronize

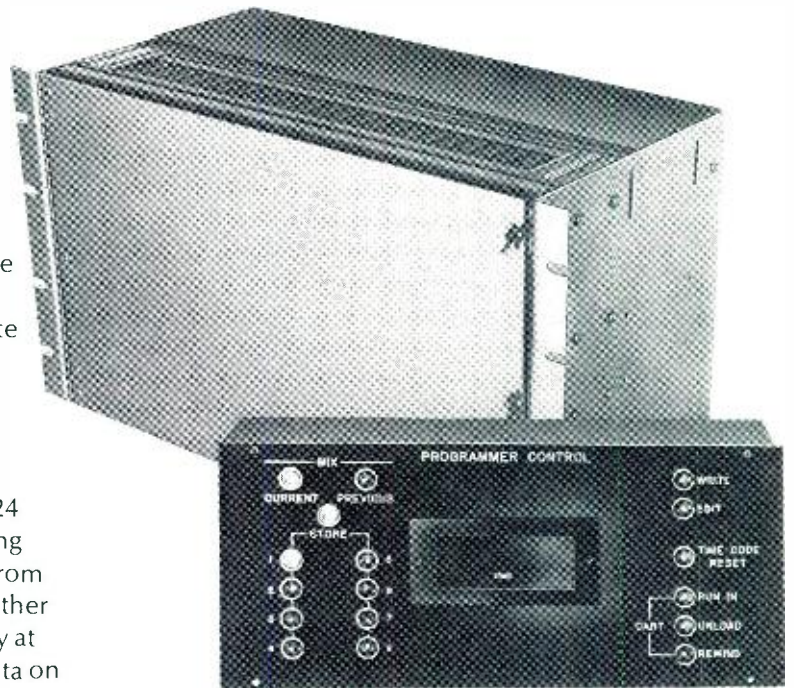

additional tape machines by means of a MagLink or Minimag Synchronizer.

Program tapes made with the Model 1024 are totally compatible from studio to studio whether the automation system used is simple or complex. What's more, this new programmer is compatible with existing consoles and can easily be retro-fitted into current installations.

If you would like to find out why audio professionals continue to prefer Automated Processes consoles and components, write or call today.



**AUTOMATED PROCESSES, INC.**  
789 PARK AVENUE, HUNTINGTON, NEW YORK 11743 - 516-427-6024

Circle No. 114

"good" batches of discs from bad ones.

## COATING and DRYING

The methods used to put the nitrocellulose, or lacquer, on the aluminum blank are again guarded by the makers. If it isn't sprayed, brushed, poured, spun, dipped, or wiped on, what's left? Capitol hints at extruding the material onto the disc like a sheet, as well as mentioning spreading it on with a knife coater. Whatever the means employed it is certain that the coating process is very sophisticated and carefully conceived and executed.

After the discs are coated they immediately start to dry and cure. The drying operation is perhaps the most critical single process in the entire procedure. Even with optimum materials and coating processes, the final quality of the disc isn't determined until the solvents have evaporated and the disc is dry.

The parameters to be most closely controlled are the rate and temperature of solvent evaporation. Many surface defects are attributed to excessive excursions of these parameters. Pinholes are usually a result of too fast an evaporation rate, which can also cause a cooling and lowering of dewpoint resulting in a water precipitate blush, or haze, on the surface. Orange peel is also caused by a rate-temperature phenomenon, and can be accompanied with a clumping of pigment particles, which show up as noise in the recorded groove.

Blisters, bubbles, mottle, pimples, pits, dimples, voids, porosities, etc. are known by name, and the factors which cause them are at least being studied, even if they sometimes elude control. The drying environment is equipped with controls for every aspect of air temperature, humidity, pressure, velocity, and cleanliness.

## INSPECTION

After the discs are coated and dried they are 100% visually inspected. The inspectors grade the discs into the three quality grades commercially available. Presumably the inspectors have eyes at least as keen as an average cutting engineer, who is known as a type who carefully examines small items, at short range. Master quality discs are to be flawless on at least one side. The 100% visual inspection so far is the most efficient means to select and grade the discs, but it does not result in 100% certainty that every disc is what it is labeled to be.

## PACKAGING

After inspection and grading the center holes are punched and the discs are packaged for shipment.

Nearly 40 years of experience in the handling and shipping of blanks has not

produced the fool proof shipping container. It is common knowledge among the consumers of lacquer blanks that the outermost discs in the package will probably be damaged. From time to time a new packaging technique will be tried aimed at reducing shipping damage without increasing shipping cost. So far, they're still working on it.

## CUTTING THE LACQUERS

All mastering studios stock both Audiodisc and Transco blanks and for the most part use them without preference of one above the other. Lacquer blanks are not commonly known to have the subjective sound qualities that are often attributed to different brands of magnetic tape. The cutting engineer is usually the one who selects which brand to put on the turntable, and he selects it usually on the basis of rotating his inventory of blanks. The stream of supply from either manufacturer is not absolutely steady, depending on their individual production problems, and occasionally both manufacturers face difficulties from their common suppliers. For this reason mastering studios must keep a close control over their inventory of blanks. Accounts are usually kept open with both suppliers in the event one of them runs into problems.

The desire to stock up heavily is offset by the premium price of blanks these days, which is around \$6 for a 14 inch master blank used for cutting a 12 inch LP side. But all studios which have been operating more than a year or two have felt the pinch of a scarcity of blanks. Without exception they feel lucky to be able to buy them when they can.

Considering the 100% inspections at the factory, and the supreme efforts to assure a safe delivery of blank discs to the user, a rather high percentage of blanks are never used. They are rejected by the cutter for one reason or another and returned to the factory for credit. Many cutting engineers are ruthless in selecting a disc for an important master, rejecting the disc for the most miniscule flaw, even if it may have no effect on the quality of the final product.

Should any problem arise with the final pressings, or with the making of the metal parts, the cutting engineer will probably become involved with the problem, whether or not the fault lies with either him or with the lacquer. As the pressures and purses get bigger in the big time, the willingness to settle for less than perfection dwindles. Today's top mastering studios are demanding top quality blanks. The practice is so widespread the lacquer manufacturers are obliged to go along with it, and in fact all have a liberal return-for-credit reject plan. This plan has evolved through the years, especially actively when the demand for disc quality increased with the advent of microgroove

and stereo recording in the late 40's and 50's. Earlier, since the requirements were less stringent, there were fewer rejects from the user and returns were not significant. All the manufacturers at one time would reclaim the metal disc from suitable returns and recoat them as lower grade discs. In fact they offered a recoating service, so that studios could recycle their cutting goofs. That service no longer exists, but all suppliers extend the 100% replacement warrantee for rejects.

The reject rate is a prime cause for the rise in price of blanks. It costs the manufacturer to absorb the returns so of course they endeavor to minimize the returns by increased inspection and internal rejection. Discs rejected during manufacture can be reclaimed and reused, as their history of contamination is known. Discs returned from the field are considered no longer reliably clean or straight and thus the materials cannot be reclaimed.

Increased inspection, however, calls for increased handling of the discs, which in itself is a major contributor to damage.

The cost of rejects is paid in part by the user too, in the handling and paper work involved in repacking and shipping back the duds. Nobody likes rejects, although the manufacturers wonder sometimes when they examine rejects from certain customers and can find nothing wrong with them. But such is the nature of the recording industry at the present time.

*The aluminum substrate discs, supplied by ALCOA to all three US manufacturers of lacquer blanks, are extremely flat and smooth as delivered. Capitol further refines the flatness and smoothness with this specially designed lapping machine, which removes the tiny surface irregularities and impurities which may remain in the untreated blanks. Microscopic flaws in the substrate surface can give rise to visibly noticeable flaws in the finished lacquer surface.*

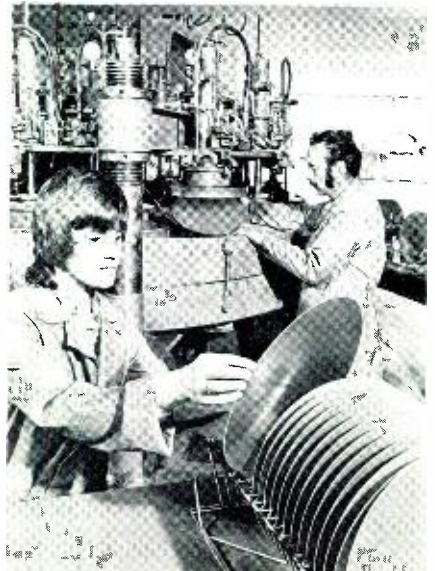

## RECENT APPLICATIONS

Lacquer proved itself more than adequate for the requirements imposed by microgroove and stereo recording. And it has proven adequate to handle the requirements of more recent mechanical recording processes: four channel sound and color video recording.

The companies that are developing these processes are determined to make them work and the results to date are technical marvels. They really do work. But development is continuous and one area of concern is the examination of the effect of lacquer as the recording medium for these processes.

CD-4 for instance, has a very special blend of recording requirements. The principle feature is that the 4 channel positions are encoded by means of a modulated 30kHz carrier tone recorded in the groove. As modern cutter heads cannot record frequencies as high as 30kHz, half speed cutting techniques must be used, which effectively doubles the bandwidth of the cutter head.

Developing a playback stylus and cartridge capable of tracking the groove in a vinyl pressing is another miracle pulled off by CD-4 designers; happily the same cartridges perform serviceably on the softer and more compliant lacquer masters and refs. If the springback and elasticity characteristics were more constricting than they are, it may have been necessary to have test pressings made in

order to audition test refs, a serious inconvenience.

A special diamond cutting head was designed and built to achieve a more defined and controlled short wavelength cut. The wavelength of the 30kHz tone is .00067 inch at an 11.5 inch diameter and .00032 inch at the inner diameter of 5.5 inches, for a 33.3 ipm disc.

Sharper angles and smaller radius cutting edges provide a smoother burnishing of the groove wall as well as the increased definition required by these short wavelengths.

The special cutting stylus also has unique operating characteristics when it dips into the surface of a lacquer blank. These characteristics are of course of interest to the lacquer manufacturer who wants to make sure his product is compatible with the CD-4 process.

The chip normally moves up and out of the way of a sharp and properly heated stylus, and neatly into the waiting inhalation of the chip pickup tube. The diamond stylus, however, produced different results, and the chip stubbornly avoided attempts to capture it.

Stan Ricker at the JVC Cutting Center in Los Angeles noticed that the chip behaved more favorably if the 30kHz carrier was activated before the stylus touched the lacquer. That coupled with bringing the chip tube opening nearer to the cutting stylus, and raising the stylus heater current to compensate for the increased airflow around the cutting area proved to minimize the problem. However, it seems

to have minimized it for blanks of some makes more than for others.

Other properties, such as noise level, which seem to be equivalent for most makes of blanks using conventional cutting techniques, are proving to be different when subjected to storing the information required by CD-4. One of the inherent drawbacks of CD-4 is its limited dynamic range, in the area of 33 – 37 dB as opposed to 68 to 70 dB for a well cut conventional lacquer. There is something in the process, possibly associated with the modified cutting stylus arrangement, that makes one brand of blanks consistently noisier than another, most noticeably at the smaller groove diameters. The difference is particularly noticeable with the application of an unmodulated carrier to the groove. This problem, like many the lacquer plants have encountered before, may be puzzling for awhile but in time can be solved.

The video disc also makes special demands on lacquer blanks. The resolution required is incredible, enough detail is required to accommodate a 4.5MHz bandwidth signal for color reproduction. Of course to achieve that high a response, playback speeds of up to 1800 rpm are required. That, in turn, places new requirements on groove pitch, or lines per inch, in order to get decent playing time on a disc. The lacquers of today are able to meet the requirements of mechanical video recording which suggests that their full potential for sound recording has not yet been approached.

*Every disc is individually inspected at several points in its manufacture. Only discs with visually perfect surfaces are passed on to center punching and packaging operations, where they are inspected again. With so many inspections it is curious how blemished discs can get through to the user. The answer may lie in the increased handling, which subjects the discs to increased risk of damage.*



*Controlled drying of the disc after coating is essential to the production of lacquer masters. All of the producers have taken great pains to assure a controlled drying environment. This drying tunnel at Capitol's plant is equipped with air handling equipment designed to control every aspect of temperature, humidity, pressure, and velocity, and maintains air purity to a class 100 standard (100 particles per cubic foot no larger than .5 microns in size).*

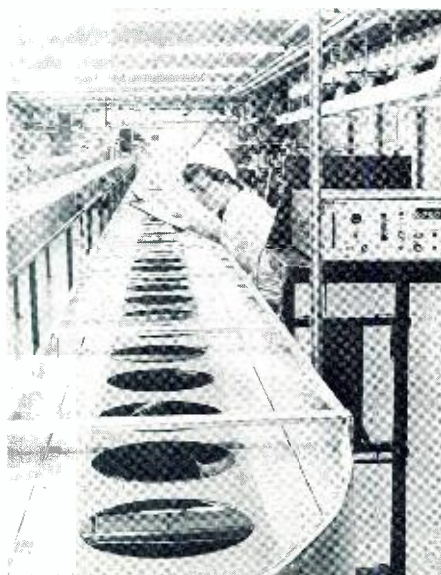

*Lacquers are periodically tested for cutting properties and noise under typical user conditions. Some of the lacquers are also sent through the plating process to determine metal forming characteristics. These continuous checks maintain product quality and provide research data for further improvement of the lacquer.*



# Old-New Reel Time Recorder

Telex/Magnecord series 1400 broadcast quality recorder/reproducer. An old name that spells reliability. A new design for today's state of the art.

- The Old. Telex/Magnecord products are still made in the USA so parts and service are always available. The series 1400 is still built on a solid die cast aluminum main frame for reliable operation around the clock. It's still available in full, half and

quarter track configurations, has fail safe differential brakes and accepts 8 1/4 inch reels. It also still comes with three motors—but then, that's touching on the new.

- The New. A brushless d.c. servo drive with a crystal oscillator control reference so accurate it virtually eliminates program timing errors. New, three speeds: 3 3/4 - 7 1/2 - 15 ips. New catenary head block for straight tape loading, the convenience of one hand cueing and the bi-level illumination of push button controls. New DTL logic controls eliminate EMI and provide fast, spill

proof tape handling gentle enough for half mil tape. And new electronics, clean to 60 dB S/N at all speeds.

- If you're looking for a real time, reel recorder with old name reliability but designed for today's demands, you'll find it in the Telex/Magnecord series 1400. For complete information please write:



PRODUCTS OF SOUND RESEARCH

## TELEX®

COMMUNICATIONS, INC.

3600 ALDRICH AVE. SO. • MINNEAPOLIS, MINN. 55420 U.S.A.

Europe: 22, rue de la Légion-d'Honneur, 93200 St. Denis, France

Canada: Telak Electronics, Ltd., Scarborough, Ontario

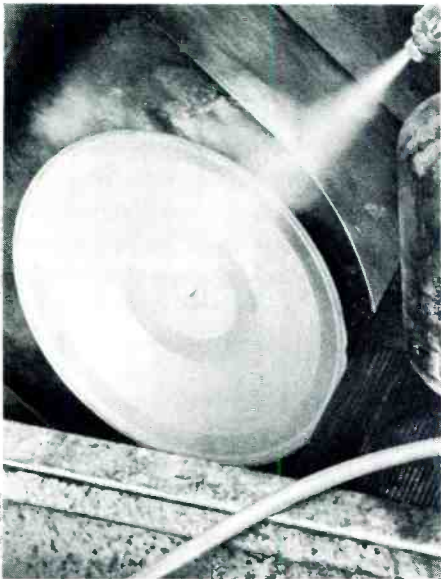

The cut lacquer master is treated and coated with a solution which precipitates metallic silver onto the lacquer surface. The purity and consistency of the lacquer formulation is critical to the proper adhesion of the silver to the lacquer; discontinuities and voids will appear as ticks and pops in the final pressings.



The silver coated masters are then immersed in a nickel plating bath where temperatures reach 130–140 degrees, F, not really scorchingly hot, but certainly warm enough to stress the lacquer coating and accelerate the evaporation of solvents, all of which combine to degrade the condition of the master.



After silvering and plating, the metal master is stripped away from the lacquer master. This is another hand operation and involves moderately rough handling of the lacquer master. Although the lacquer master itself can withstand repeated plating processes, the master is inevitably eventually damaged through processing and handling.

#### FAULTS

There is ultimately only one test that can be applied to a lacquer blank before cutting it, and that is simply a careful look at it in a well lit location.

Surface blemishes include pits, bubbles, pimples, imbedded particles, hazy surfaces, orange peel and discolorations. Scratches and abrasions also occur, and danger of them is always near. Some of these conditions do not render the disc unusable, such as minor imperfections under the label area or outside the cutting area, and certain kinds of visible pits with virtually no physical depth. These discs

may or may not be suitable for masters, but they are certainly useful for refs, certain kinds of dubs, and for lathe set up purposes.

Warped, or non-flat, discs are most apparent when they're mounted on the revolving lathe turntable. A patterned or strongly textured wall covering or curtain behind the lathe will expose a warped blank by undulations of the reflected background in the rotating disc surface. Many absolutely good, even perfect (!?) discs are rejected by misinterpreting a visual indication of a flaw. For example unless the *back side* of the disc and the

lathe turntable are absolutely dust and lint free, bumps and ripples can be seen in the top surface when the vacuum chuck pulls the disc snugly down on the debris. A human hair between the table and disc will show up as a serious ripple, and even very small soft particles can falsely indicate a warped or unserviceable disc. For this reason the surface of the turntable should be inspected and cleaned daily, and checked again when a warped disc is found. The problem is less severe on the cork surface of Scully lathes than with the metal Neumann turntables. Scullys are also more often equipped with ad-



# WHY ME?

Why carry low end gear for the semi-pro as well as larger professional studio equipment?

The answer is simple.

I want you to start right, with the right equipment for your needs, no matter how small.

The way I figure it, it won't be too long before you will outgrow your initial set-up and graduate to bigger gear. When that happens we'll be here to work and grow with you.

We're with you all the way — from portable 4 track mixers to full blown 16/16 turn key installations.

I'm Emil Handke and I'm ready when you are

**Because I Believe in you.**

Dealers for the El-Tech 16/16-25 recording console



**NASHVILLE  
STUDIO  
SYSTEMS**

16 Music Circle South Nashville, Tennessee 37203 (615) 256-1650  
Write or call for details today

vance ball cutter heads, which minimizes the adverse effects of slight ripples and waviness in the blank.

Surface imperfections in the lacquer, if they are severe enough can break a cutting stylus. Deep pits and imbedded particles are likely to cause catastrophic failure, unless a bad warp gets it first. This is not too common anymore, and can be avoided by looking closer at the disc before starting.

In any case the stylus is inevitably subject to wear as it carves out its precision groove from the lacquer coating. Stylus life can be optimized by frequent cleaning and careful use of stylus heat.

Unfortunately there are also defects which arise in lacquer discs that are invisible to the eye. The first time some of them become apparent is during the cutting process. The chip may not behave properly, breaking or sticking to the groove wall or to the stylus. The lacquer may be too fresh or "green," which causes a "gray" cut. Usually green discs are detected by their stronger odor of solvent before they are put on the lathe.

Advance ball systems sometimes cause problems with the lacquer blanks, by scoring the surface with the sapphire ball that tracks the surface flatness of the disc.

There may be any of several noises which will show up on playback. Once around swishes and squeals can be caused by temperature differentials across the disc, and are not necessarily defects in the disc itself. The lamp over the lathe turntable should be far enough from the disc to avoid uneven heating while the table is not turning.

There are faults which do not appear until the plating operations. Ticks and pops are commonly found in the metal "mother" when they didn't exist in the master lacquer. Sometimes it's the fault of the plating and sometimes the fault of the lacquer. Perhaps a microscopic globule of plasticizer remains intact in the coating. A groove cut into it or near it may allow it to ooze out into the groove, making plating difficult.

According to some users the lacquer master should be sent to the plating plant as soon as possible after it is cut. The cut lacquer has considerably more surface area than an uncut blank, and the process of drying is accelerated. Plating can be inhibited by excessively dry lacquer.

Finally, defects inevitably accumulate on the lacquer master disc in the course of handling. It is quite possible to plate the lacquer disc and strip it many times, making several "metal masters," from which, in turn, can be made many "mothers," and many more "stampers," etc.

It is rumored that the second or third metal master pulled from a lacquer is sometimes better, or mellower, than the first. But most cutting engineers and platers agree that the plating processes

only bring risk of deterioration to the lacquer master, at the very best the lacquer is unchanged. Fate will catch up with it eventually. Usually the first good metal master that is pulled from a lacquer retires it from further plating operations.

The active life of the lacquer master is brief, full of hazard, charged with responsibility, and ends with a toss in the trash bin, all the tender loving care that was lavished on it (or the lack of it) having been transferred to more durable metal parts.

That the technology of cutting lacquer masters has become an art is the result of the cutting industry's response to the gen-

eral record industry and its requirements. The manufacturers of the lacquer masters are obliged to serve the requirements of the only customers they have, the cutters, who have generally tightened their tolerances for defects. The result is continued efforts to refine the processes already developed over the past 40 years. Since lacquer has so far been unsurpassed in its ability to preserve the gymnastic twirlings of a well tuned cutting stylus, no one talks about what its replacement is going to be. As long as the cutting stylus is used as the recording instrument, the recorded medium will remain a lacquer coated disc for a long time to come.

# The duplicator !

We'll solve your tape duplicating problems . . . large or small . . . whatever your operating budget! A complete, professional line of tape and in/cassette duplicating gear . . . reel-to-reel, reel-to-cassette, cassette-to-cassette.

System 200 offers professional quality cassette tape duplicating. Reel and cassette masters and cassette slaves in many configurations . . . for large volume reproduction.

D-8 and RR-Series duplicators produce multiple reel-to-reel dubs for recording studios and commercial duplicating firms.

The Model 102 Cassette Copier . . . for the office or library. Produces two superb C-30 cassette duplicates in one minute!

Call Infonics Sales (219 879-3381) today . . . or write Infonics, P.O. Box 1111, 238 Hwy. 212, Michigan City, Indiana 46360

Export Representative:



BROADCAST/COMMUNICATIONS DIVISION  
**SINGER PRODUCTS**  
COMPANY INCORPORATED

ONE WORLD TRADE CENTER, SUITE 2365  
NEW YORK, N.Y. 10048, CABLE: EXREGNIS

D-8 RR.SERIES



**@ infonics**<sup>®</sup>  
A Subsidiary of PHOENIX ENTERPRISE

**SOUTHEAST REGIONAL SERVICE CENTER**  
Service - Repair - Overhaul - Rebuild  
Tape And Production Equipment Company  
Chamblee, (Atlanta) Ga. 30241  
Call (404) 458-8273

JBL MODEL 4315 STUDIO MONITOR



## JBL's new 4315. There's never been a wider range studio monitor. Of any size.

And, four more things:

It's a four way system. It has the most sophisticated cross-over network ever designed. It's compact, shallow, portable. Perfect for wall mounting, horizontally or vertically. It's yours for \$714.

There's more. Much more. Go hear the rest.



magnetic tape . . .

## Understanding The "PRINT-THROUGH" Phenomenon

by

MARTY W. EGGERS

3M Company

Nearly everyone associated with professional recording has at some time encountered the phenomenon of magnetic printing of adjacent layers of recording tape, more commonly referred to as "print-through." The phenomenon is not unique to any particular type of tape but occurs on *all* magnetic tapes.

Generally speaking, most high output/low noise studio mastering tapes used today for music recording in this country have been designed to achieve the highest possible signal-to-noise ratio, or dynamic range, while maintaining an acceptable signal-to-print ratio. Some of the more recent high output/low noise tapes, which tolerate exceptionally high recorded levels, have made the professional recording industry more sensitive to print-through.

Because these new tapes are so important in advancing the state of the art in professional recording, it is now more important than ever that industry professionals understand print-through, what causes it and how to minimize its effects. What follows is an attempt to aid in that understanding.

### MEASURING SIGNAL-TO-PRINT RATIO

The recording industry refers to print-through in terms of a signal-to-print ratio expressed in decibels (dB). There are several methods of measuring the signal-to-print ratio of a tape. One method that is commonly used is to record a tape with a 1 kilohertz signal (15 ips) at a specified reference flux level, say 320 nanowebers per meter. The recording is arranged in a non continuous manner so that when the tape is wound on a take-up reel, the layer immediately above and below the recorded portion are subjected to the bias signal but not the 1 kHz signal. The roll is usually stored at room conditions for 24 hours and then played back *without rewinding*, i.e. in the opposite direction that the recording was made. The signal-to-print ratio is measured as the difference in dB between the recorded signal and either the pre-printed or the post-printed signal, whichever gives the *smaller ratio*. This method determines that, under these conditions, the printed signal is "X" dB below the recorded signal.

The signal-to-print ratio of a tape is dependent on several things. These include the type of magnetic oxide, thickness of the backing material, and coating layer as well as tape speed and frequency of the recorded signal.

The wavelength ( $\lambda$ ) of a recorded signal is determined by the recording speed and frequency of the signal recorded and may be expressed by the formula.

$$\text{Wavelength (in mils)} = \lambda = \frac{\text{tape speed (ips)}}{\text{frequency (kHz)}}$$

The signal-to-print ratio is dependent upon the recorded wavelength and tape thickness. It can be shown that the highest level of print-through occurs when the relationship

$$\lambda = 2 \pi C$$

exists. Here  $\lambda$  is the most critical printing wavelength in mils

and C is the *total* tape caliper (in mils). For a typical tape caliper of about 2 mils then, the most critical wavelength is about 12 mils. This corresponds to a frequency of about 1200 Hertz when operating at 15 inches per second. A 1000 Hz signal is commonly used as a test signal for other purposes and since it is sufficiently close to the 1200 Hz value which is most critical for the average tape, it is commonly used for print tests.

The signal-to-print ratio of a tape, for practical purposes, is independent of the level of a recorded signal. That is, one can record a tape at standard operating level or 3 dB above standard level or 6 dB above standard level and obtain the same *signal-to-print* ratio at all three record levels.

### CONSIDERING PRINT-TO-NOISE RATIO

In the practical analysis of the audibility of a printed signal one should also consider print-to-noise as well as signal-to-print. Tape noise or "bias noise" has a masking effect on print-through, because printed signals are usually no more than slightly above bias noise level. This noise level does not change when the *record* level is changed. However, the absolute level of printed signals will increase when the recorded signal level is increased and therefore, print-to-noise will increase. Keep in mind that the signal-to-print does not change as explained earlier. As the print-to-noise ratio increases, the printed signal becomes more detectable in the background. Figure 1 illustrates this principle.

This concept also explains why two tapes with identical signal-to-print ratios may not produce the same subjective "print" results. For example, Tape A has a signal-to-print of 55 dB and Tape B also has a 55 dB signal-to-print, but has a 3 dB higher noise level. The print-through on Tape B will be less audible because the higher noise level masks the printed signal to a greater degree than on Tape A. This is illustrated in Figure 2.

A similar subjective condition exists in multi-track recording. That is, although the print-to-noise may be audible in a

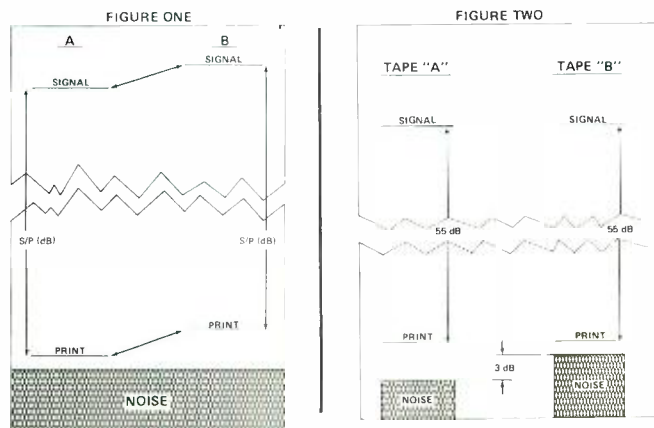
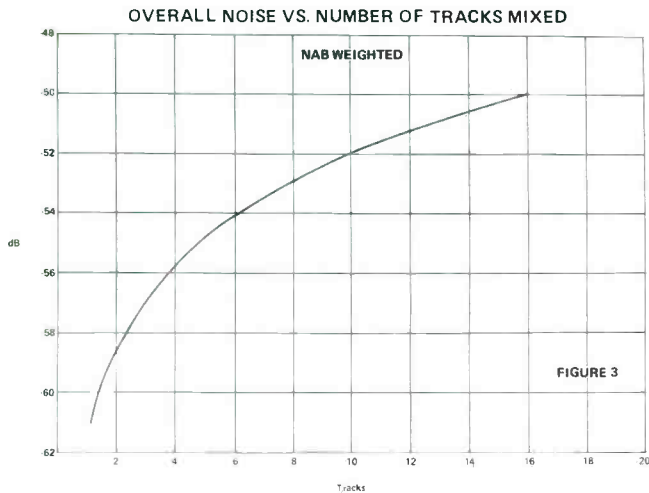

Figure 1: Signals recorded at different levels show that even though the signal-to-print ratio is the same, print-through is more audible in case 'B' because it is higher above the noise level.

Figure 2: Higher noise level of Tape 'B' more effectively masks print-through even though the signal-to-print ratio is the same.

single track recording, it will be less audible when mixing two or more tracks of program material. This is because the mixing operation causes an increase in noise level on all tracks. Figure 3 reveals the effect on the overall noise level of combining several individual tracks of tape noise.

This figure shows that a printed signal on an individual track may be audibly above the noise level when listening only to that track. However, mixing as few as four additional tracks to this signal increases overall noise approximately 6 dB, making the print-through much less audible. This masking effect is magnified as the number of channels mixed increases, as is the case in 16 and 24 track recording.



### MINIMIZING PRINT-THROUGH

To minimize print-through, it is well to understand the conditions that can affect its behavior. Most print-through occurs within a short time after initial layer-to-layer contact of the recorded tape. The levels of the printed signals will increase slightly over extended periods of storage but will eventually reach a maximum level. The print versus time is a logarithmic relation. Because the greatest amount of print does occur quite soon after recording, some degree of print-through will be detected if a tape is recorded, rewound and replayed immediately. But, as discussed earlier, print levels do increase

over extended periods of storage. Figure 4 illustrates how print-through increases with time (tests made at room temperature).

Environmental conditions, specifically temperature, also play a major role in influencing to what extent print-through occurs. All else being equal, higher temperatures produce higher print-through levels. It is good practice to record and store tapes where normal room temperatures of 70° to 80° Fahrenheit are maintained. Care should be taken so that excessive heat is not present on the tape transport during recording. Even excess heat from motors and erase heads can

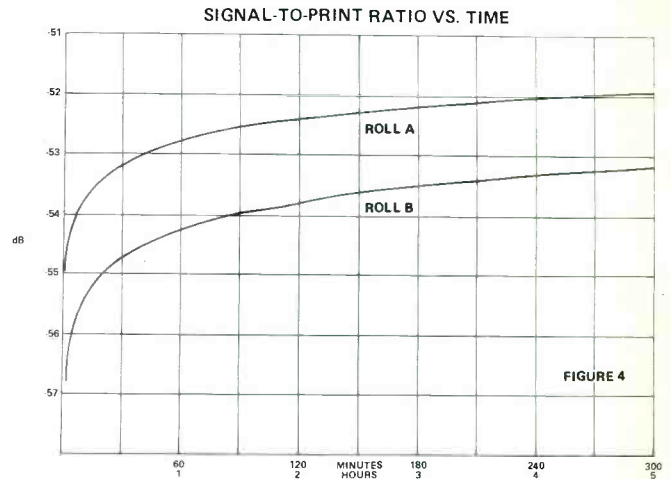

create sufficient heat on the tape to cause more print-through.

Another factor that can increase printing phenomenon is stray magnetic fields, either AC or DC. Such stray fields can cause print-through to increase by several dB. Stray magnetism can be encountered when the tape is being recorded and while it is in storage. Potential source of stray fields are magnetized heads, guides, and idlers on tape machines. These recorder components often become magnetized after extended periods of use and should, therefore, be checked and demagnetized regularly. One should also be sure that fields from motor and solenoid windings do not penetrate the top plate of the

## Magnetic Reference Laboratory

Whether you're using low noise or high output tape, with or without Dolby, from 1/4" to 2", 3 3/4 to 30 ips, you'll choose MRL . . . because only MRL guarantees every test tape they manufacture.

Their dependability and accuracy have made MRL the world wide choice of most major recorder manufacturers . . . and, after all, they would know what test tape is best for their recorders, they're the people who design and build them

For full information, contact:  
Magnetic Reference Laboratory, Inc.  
229 Polaris Ave., Suite 4  
Mountain View, CA 94043  
(415) 965-8187

Exclusive Export Agent: Gotham Export Corp., New York, N.Y.

transport and approach the tape path, because these, too, can be problem causing.

There are several methods of checking for magnetized transport components. One is by using a "magnetic viewer," a useful device that can actually "see" magnetic fields. These fields induce magnetism in a liquid magnetic dispersion, which can then be seen through the transparent side of the viewer (one such unit known as a Plastiform Magnetic Viewer, is manufactured by 3M Company). Magnetized heads or guides can sometimes be detected by making a splice in a section of magnetic tape and passing it through the transport. If undesirable magnetism is present, a



"pop" or "click" will be heard at the splice when the tape is replayed. A sensitive gauss meter or magnetometer can also be used to measure stray fields. *head "reads" out in bias? - Mb*

The degree of printing is also influenced by the waveform of both the bias and erase currents. For example, a nonsymmetrical bias waveform or one containing even order harmonics not only will increase print-through but will also introduce noise into the recording. Therefore, bias and erase waveforms should be checked periodically with an oscilloscope or wave analyzer to make certain these conditions do not exist.

Another factor that influences the amount of layer-to-layer transfer is the separation between layers. This is why a tape with thinner backing will print more readily than a tape with the same magnetic coating but a thicker backing. In addition, a "tight" wind will cause tape layers to be closer together, further increasing print-through potential. Excessively tight winds, in addition to increasing print-through potential, may also cause physical distortion to occur during storage. Therefore, very high take-up tension, generally the cause of tight winds, should be avoided.

One further good practice is to store rolls "tails out" and to rewind them before playing. This act of high speed winding has the effect of "erasing" print-through that may have occurred during storage. Several high speed winds can be even more effective in minimizing print.

While there has been much discussion of print-through and signal-to-print over the years, there has also been much misunderstanding of this phenomenon. This paper has been an attempt to lay bare some of the mysteries of print and correct some of the misconceptions that have surrounded the subject. In so doing it may help the user to understand the nature of print and optimize his procedures to minimize the adverse effect on the recording.

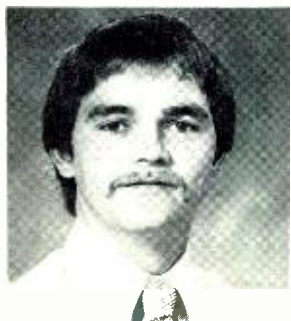

*The author:*

*MARTY EGGERS, 24, is a technical service engineer for the Magnetic Audio/Video Products Division of 3M Company in St. Paul, Minnesota.*

*A native of Council Bluffs, Iowa, Eggers earned his B.S. degree in Electrical Engineering from the Iowa State University. He joined 3M in June 1973.*

## Modular Audio Products

### VARIABLE PARAMETER EQUALIZER



■ Continuously variable center frequency—three independent, overlapping ranges; 50Hz to 500Hz, 300Hz to 3KHz and 1.5KHz to 15KHz.

■ Continuously variable bandwidth — variable from 6dB/octave to 15dB/octave.

■ Discretely variable boost and cut — twelve steps from -12dB to +15dB.

■ Equalization in-out switch with remote D.C. control and LED indicator — standard 5 volt logic levels.

■ High output capability — up to +27 dBm into 600Ω, TYP THD .05%.

■ Low noise — -85dBm unweighted 20Hz to 20KHz.

Actual Size

### Bandwidth / Frequency / Level

Modular Audio Products is an engineering oriented company providing a complete line of console and studio components. In addition to supplying the finest quality products, we also provide the technical and application backup to go with them.



Call or write us today for information on this and other state-of-the-art units.

**MAP MODULAR**  
AUDIO PRODUCTS, Inc.

A UNIT OF MODULAR DEVICES, INC.

1385 Lakeland Ave. ■ Airport International Plaza  
Bohemia, New York 11716 ■ 516-567-9620

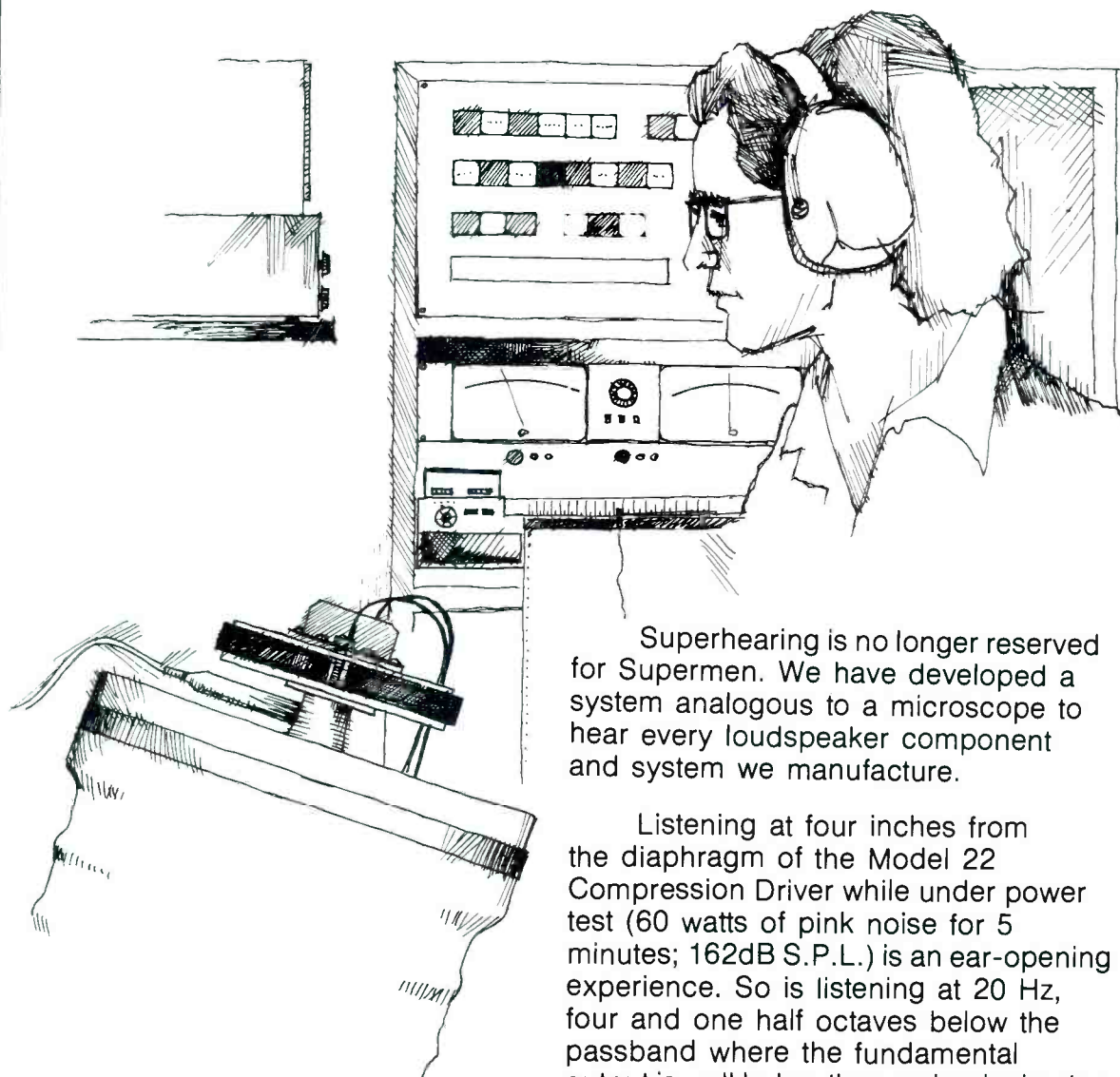

Superhearing is no longer reserved for Supermen. We have developed a system analogous to a microscope to hear every loudspeaker component and system we manufacture.

Listening at four inches from the diaphragm of the Model 22 Compression Driver while under power test (60 watts of pink noise for 5 minutes; 162dB S.P.L.) is an ear-opening experience. So is listening at 20 Hz, four and one half octaves below the passband where the fundamental output is well below the mechanical noise of the moving system.

We listen to each production unit in these and other ways to insure uniformity.

Superhearing was developed to assure that we would be an efficient, reliable transducer manufacturer. You can expect state-of-the-art performance at the lowest possible price from Spider/Peavey. Model 22, at \$85.00, is at your Peavey dealer now. The SP1, at \$450.00, will arrive soon.

What we make today sounds like what we made yesterday.

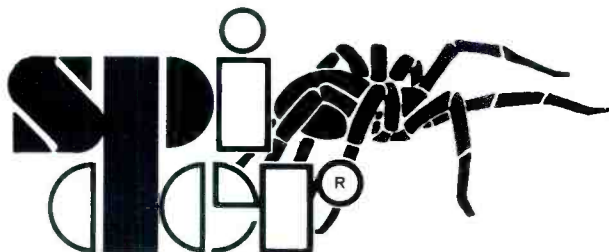

**SPIDER/PEAVEY** BOX 2898 / MERIDIAN, MS. 39301

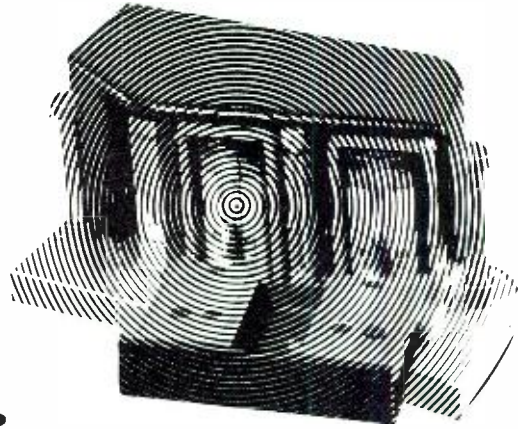

**an alien view of . . .**

# **Multi-Track Tape Machine Alignment**

**by Peter Butt**

I've spent a lot of time, over the past few years, aligning tape machines of various manufacture. I've also spent a lot of time spreading the gospel regarding that subject to anyone who would listen and to some who wouldn't. Even neglecting the merit of my bigotries and prejudices in that area, I can only state matter-of-factly that having a reputation for that sort of thing will not get one invited to parties.

In spite of the social implications of steadfast views on the theoretical factors of the magnetic recording art reduced to the level of screwdriver practice, I am prepared to attempt a summary discussion of the points I feel are worthy of attention. My effort is directed at the void of commentary or criticism on the subject from others. Like a seasoned babysitter, I tend to feel that too much silence is cause for some sort of remedial action.

In all fairness, the reader is entitled to know that I speak as an outsider concerning the studio end of the recording business. My background consists primarily of electronics troubleshooting. The last four years have been spent in the area of high-speed tape duplication of cassette, 8-track cartridge, and ¼-inch open reel format program material. Over this relatively short period of time I think I have been able to stretch the practical limits of the state of the magnetic recording art to the point where high-speed duplicated programs can be fairly compared to vinyl disc counterparts. I freely admit to never having observed a recording session or multi-track mix down. I expect that the pearls of heresy to follow will be of value if they only serve to stimulate correspondence on the subject. Having declared my lack of qualifications on this matter, we shall now proceed to the show-and-tell

portion of this article.

At first glance, it might appear that there aren't any really significant problems in the area of studio multitrack machine alignment. By just about any standard the recording media far exceeds the quality of 8-track cart or cassette tape stock. System bandwidths exceed 15 kHz by a comfortable margin. Record and reproduce characteristics are mild compared to the radical pre and post-emphasis used in consumer tape products. Wavelengths are generally greater than 0.001 inch and signal-to-noise ratios are running around 60 dB. Any tape duplicator engineer presented with that state of affairs would probably think he died and went to heaven.

Consider the case of loss of response due to simple azimuth error. Inspection of Table 1, showing azimuth loss at 0.001 and 0.002 inch wavelengths for three different track formats holds no surprises. At 15 and 30 ips, the error must be gross indeed to account for even 1 dB loss at a 0.001 inch wavelength.

Simple azimuth response loss is not the whole bag, unfortunately. As long as the program signals recorded are mono only, there's no problem at all. When there's a stereo spread such as drums, strings or voices, then it's a whole other story.

If the azimuthal alignment of the record and reproduce heads of the multi-track machine isn't very close to 90 degrees relative to the edge of the tape, some tracks are going to lead others in seeing any recorded signal common to more than one track, as in the case of a two or more channel stereo spread. Figure 1 shows this kind of situation. When any stereo program has one channel delayed slightly the panned or mono mix of that program is going to sound rather poor.

This sort of problem is quite a serious one in the case of stereo programs recorded at 7.5 ips on ¼-inch tape.<sup>1</sup> The time delay between channels carrying common information has the obvious effect of causing objectionable (or non-objectionable) phase cancellation and

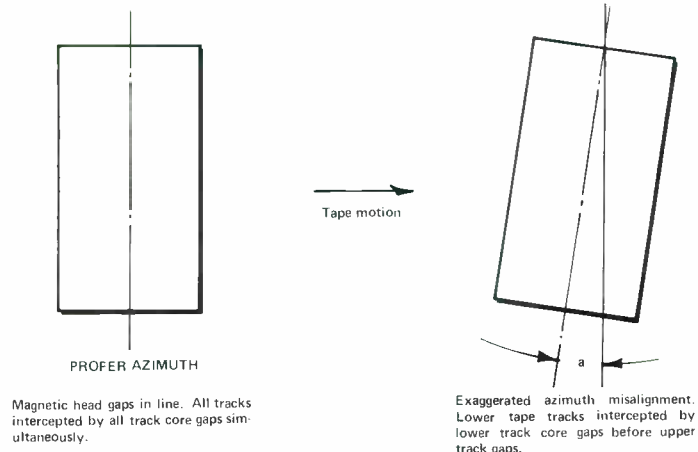

FIGURE 1

**Table 1 AZIMUTH ERROR VERSUS REPRODUCER HEAD RESPONSE LOSS FOR 1 AND 2 MIL WAVELENGTHS AZIMUTH ERROR IN DECIMAL DEGREES, LOSS IN DECIBELS**

AZIMUTH ERROR DEGREES	0.075 INCH TRACK WIDTH		0.070 INCH TRACK WIDTH		0.043 INCH TRACK WIDTH	
	$\lambda = 0.001$	$\lambda = 0.002$	$\lambda = 0.001$	$\lambda = 0.002$	$\lambda = 0.001$	$\lambda = 0.002$
	dB	dB	dB	dB	dB	dB
0.00	-0.00	-0.00	-0.00	-0.00	-0.00	-0.00
0.01	-0.00	-0.00	-0.00	-0.00	-0.00	-0.00
0.02	-0.01	-0.00	-0.01	-0.00	-0.00	-0.00
0.03	-0.02	-0.01	-0.02	-0.00	-0.01	-0.00
0.04	-0.04	-0.01	-0.03	-0.01	-0.01	-0.00
0.05	-0.06	-0.02	-0.05	-0.01	-0.02	-0.01
0.06	-0.09	-0.02	-0.08	-0.02	-0.03	-0.01
0.07	-0.12	-0.03	-0.10	-0.03	-0.04	-0.01
0.08	-0.16	-0.04	-0.14	-0.03	-0.05	-0.01
0.09	-0.20	-0.05	-0.17	-0.04	-0.07	-0.02
0.10	-0.25	-0.06	-0.21	-0.05	-0.08	-0.02
0.11	-0.30	-0.07	-0.26	-0.06	-0.10	-0.02
0.12	-0.36	-0.09	-0.31	-0.08	-0.12	-0.03
0.13	-0.42	-0.10	-0.36	-0.08	-0.14	-0.03
0.14	-0.49	-0.12	-0.42	-0.10	-0.16	-0.04
0.15	-0.56	-0.12	-0.49	-0.12	-0.18	-0.05
0.16	-0.64	-0.16	-0.55	-0.14	-0.21	-0.05
0.17	-0.72	-0.18	-0.63	-0.15	-0.23	-0.06
0.18	-0.81	-0.20	-0.70	-0.17	-0.26	-0.07
0.19	-0.90	-0.22	-0.78	-0.17	-0.29	-0.07
0.20	-1.00	-0.25	-0.87	-0.21	-0.32	-0.08

**Table 2 ELECTRICAL PHASE SHIFT VERSUS AZIMUTH ERROR FOR THREE TRACK FORMATS**

AZIMUTH ERROR DEGREES	0.075 INCH TWO TRACK		TRACK 1 REFERRED TO TRACK 8 0.070 INCH TRACK WIDTH		TRACK 1 REFERRED TO TRACK 12 0.043 INCH TRACK WIDTH	
	$\lambda = 0.001$	$\lambda = 0.002$	$\lambda = 0.001$	$\lambda = 0.002$	$\lambda = 0.001$	$\lambda = 0.002$
	°	°	°	°	°	°
0.00	0°	0°	0°	0°	0°	0°
0.01	9.8	4.9	56	28	58	29
0.02	19.6	9.8	112	56	116	58
0.03	29.4	14.7	168	84	175	87
0.04	39.2	19.6	224	112	233	116
0.05	49	25	280	140	291	145
0.06	59	29	336	168	344	175
0.07	69	34	392	196	407	204
0.08	78	39	448	224	465	233
0.09	88	44	504	252	524	262
0.10	98	49	560	280	582	291
0.11	108	54	616	308	640	320
0.12	118	59	672	336	698	349
0.13	127	64	728	364	756	378
0.14	137	69	784	392	815	407
0.15	147	74	840	420	873	436
0.16	157	78	896	448	931	465
0.17	167	83	952	476	989	495
0.18	176	88	1008	504	1047	524
0.19	186	93	1064	532	1105	553
0.20	196	98	1120	560	1164	582

modification of the stereo image.<sup>2</sup> The question is how can this problem be eliminated or at least minimized?

The object is to minimize electrical phase differences caused by geometrical record head and reproduce head azimuth errors. Perhaps the easiest way to do this in a studio situation is to combine a couple of fairly widely spaced tape track outputs on a console mix bus and adjust the repro head azimuth for a maximum indication on the board channel VU meter while playing the 15 kHz azimuth adjustment portion of the alignment tape. While doing this the final adjustment should be checked to see that all reproduce channel outputs will combine to a peak indication on the board VU meter. Rewind and replay the azimuth portion of the tape several times to verify the repeatability of the final adjustment and that there are no tape tracking irregularities of an intermittent nature.

Another way of checking for proper phase agreement between channels is to monitor pairs of track outputs with a phase scope. At 15 ips, it should be possible

to maintain phase errors between tracks to about 90 degrees or less. Perfection is kind of hard to achieve in this kind of adjustment because of the difficulty in manufacturing heads whose track gaps line up very precisely over the entire width of the tape path. Typical tolerances are ±100 micro-inches. That should be the worst case for this phenomenon, commonly known as *gap scatter*. If two tracks in a head are at the maximum limits of that tolerance, i.e., one at plus 100 and the other at minus 100 micro-inches, we should expect to see a phase error between tracks of about 72 degrees at 15 kHz at 15 ips. At 30 ips, we would logically expect to obtain a phase agreement of about 45 degrees or better between tracks at 15 kHz.

It's important to pay very close attention to all parts of the reproducer alignment procedure. The response and phase coherence of the entire recording process can be no better than the reproducer itself because the recording portion of the system must be aligned against the reproducer. Errors tend to grow like

pyramids because they depend upon previous steps. Inattention or error early in the alignment process can become unmanageable later on. This is as true for ¼-inch machines as it is for 4, 8, 16, and 24-track models. The prime difference being the time required to complete each step of the process since the same step or operation must be repeated or at least verified for each program channel.

In the case of 16 and 24-track machines, the reproducer frequency response adjustment can be particularly tricky if a full-track alignment tape is used. The reason for this, as most studio technicians know, is that evil demon, the fringing response phenomenon.<sup>3</sup> In the case of Ampex tapes having the guard bands between tracks erased to yield a remaining track format conforming to the one you're using, this consideration is unnecessary.

If you're using a full-track tape, failure to account for the effect of fringing can result in a 3 to 4 dB reduction in low-frequency reproducer response below specification.

**Table 3 MULTI TRACK REPRODUCER FRINGING RESPONSE CONTRIBUTION AT LONG WAVELENGTHS**

f(Hz)	15 IPS, MULTI-TRACK 38.1 CM/SEC 0.070" TRACK				30 IPS, MULTI-TRACK 76.20 CM/SEC 0.070" TRACK				15 IPS 2-TK, ¼"	30 IPS 2-TK, ¼"	15 IPS 0.043 TK	30 IPS 0.043 TK
	$\lambda$ (IN)		EDGE TK dB	INNER TK dB	$\lambda$ (IN)		EDGE TK dB	INNER TK dB				
	$\lambda$ (CM)	dB			$\lambda$ (CM)	dB						
30	0.500	1.27	2.77	3.42	1.00	2.54	2.89	3.59	2.24	2.33	3.15	3.23
31.5	0.476	1.21	2.76	3.41	0.952	2.42	2.88	3.58	2.24	2.32	3.14	3.23
40	0.375	0.953	2.70	3.32	0.750	1.91	2.85	3.53	2.19	2.30	3.10	3.20
50	0.300	0.762	2.62	3.21	0.600	1.52	2.81	3.48	2.14	2.27	3.04	3.18
63	0.238	0.605	2.54	3.09	0.476	1.21	2.76	3.41	2.08	2.24	2.98	3.14
100	0.150	0.380	2.30	2.76	0.300	0.762	2.62	3.21	1.91	2.14	2.80	3.04
125	0.120	0.305	2.17	2.57	0.240	0.610	2.54	3.09	1.81	2.08	2.68	2.98
250	0.0600	0.152	1.63	1.84	0.120	0.305	2.17	2.57	1.41	1.81	2.20	2.68
500	0.0300	0.0762	1.04	1.09	0.0600	0.152	1.63	1.84	0.93	1.41	1.55	2.20
700	0.0214	0.0544	0.79	0.81	0.0429	0.109	1.34	1.46	0.72	1.18	1.22	1.90
1000	0.0150	0.0381	0.57	0.57	0.0300	0.0762	1.04	1.09	0.53	0.93	0.90	1.55
2000	0.00750	0.0191	0.29	0.29	0.0150	0.0381	0.57	0.57	0.27	0.53	0.47	0.90
2500	0.00600	0.0152	0.23	0.23	0.0120	0.0305	0.46	0.46	0.22	0.43	0.38	0.74
4000	0.00375	0.00953	0.15	0.15	0.00750	0.0191	0.29	0.29	0.14	0.27	0.24	0.47
5000	0.00300	0.00762	0.12	0.12	0.00600	0.0152	0.23	0.23	0.11	0.22	0.19	0.38
6300	0.00238	0.00605	0.09	0.09	0.00476	0.0121	0.19	0.19	0.09	0.17	0.15	0.30
7500	0.00200	0.00508	0.08	0.08	0.00400	0.0102	0.16	0.16	0.07	0.15	0.13	0.25
8000	0.00188	0.00476	0.07	0.07	0.00375	0.00953	0.15	0.15	0.07	0.14	0.12	0.24

# Acoustical Guarantee

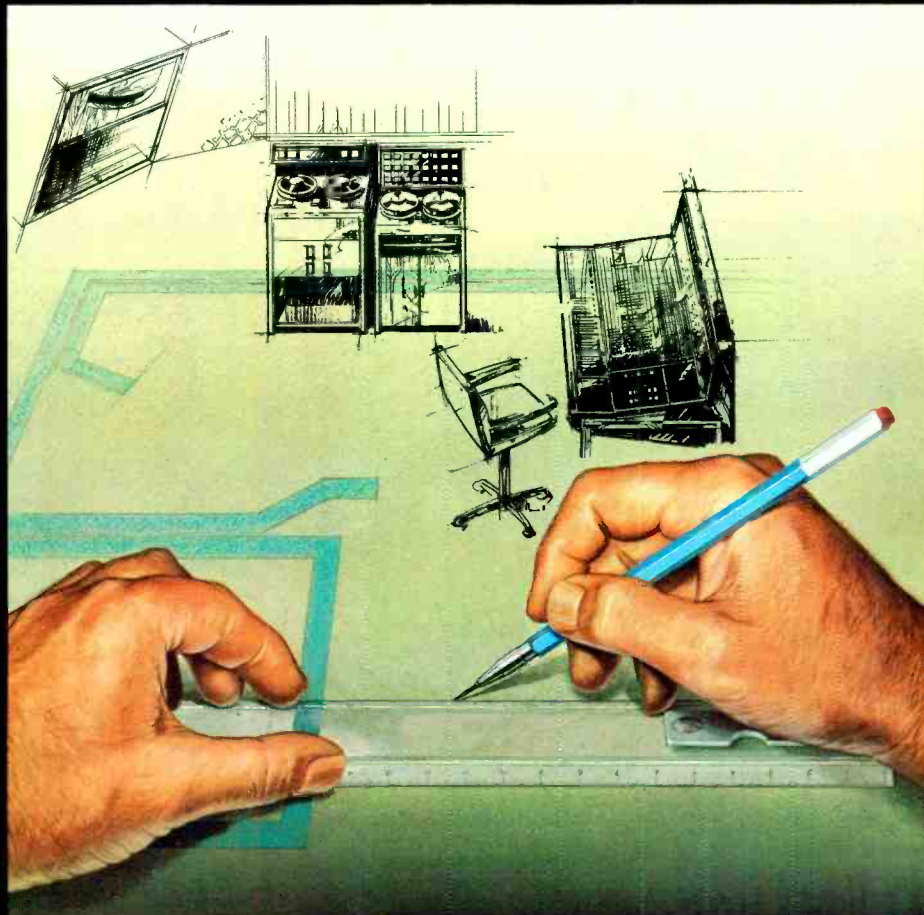

## Performance Specifications

from acoustic design.  
to down beat...

**Westlake  
Audio**

"The control room sounds good here but not over there. Stand up and you've lost your mix. Lean back in your chair and all the bass is gone. The monitor has to be loud to hear it. Turn your head and big changes occur. The stereo image moves."

"The drum leakage in this studio is terrible. The strings sound great but the bass is loose and muddy. This room is so dead the sound isn't happening and the musicians can't get into it."

These are subjective observations which producers and engineers have made and lived with for years in many studios. We at Westlake are prepared to talk to you about a guarantee *against* those things happening in your studio.

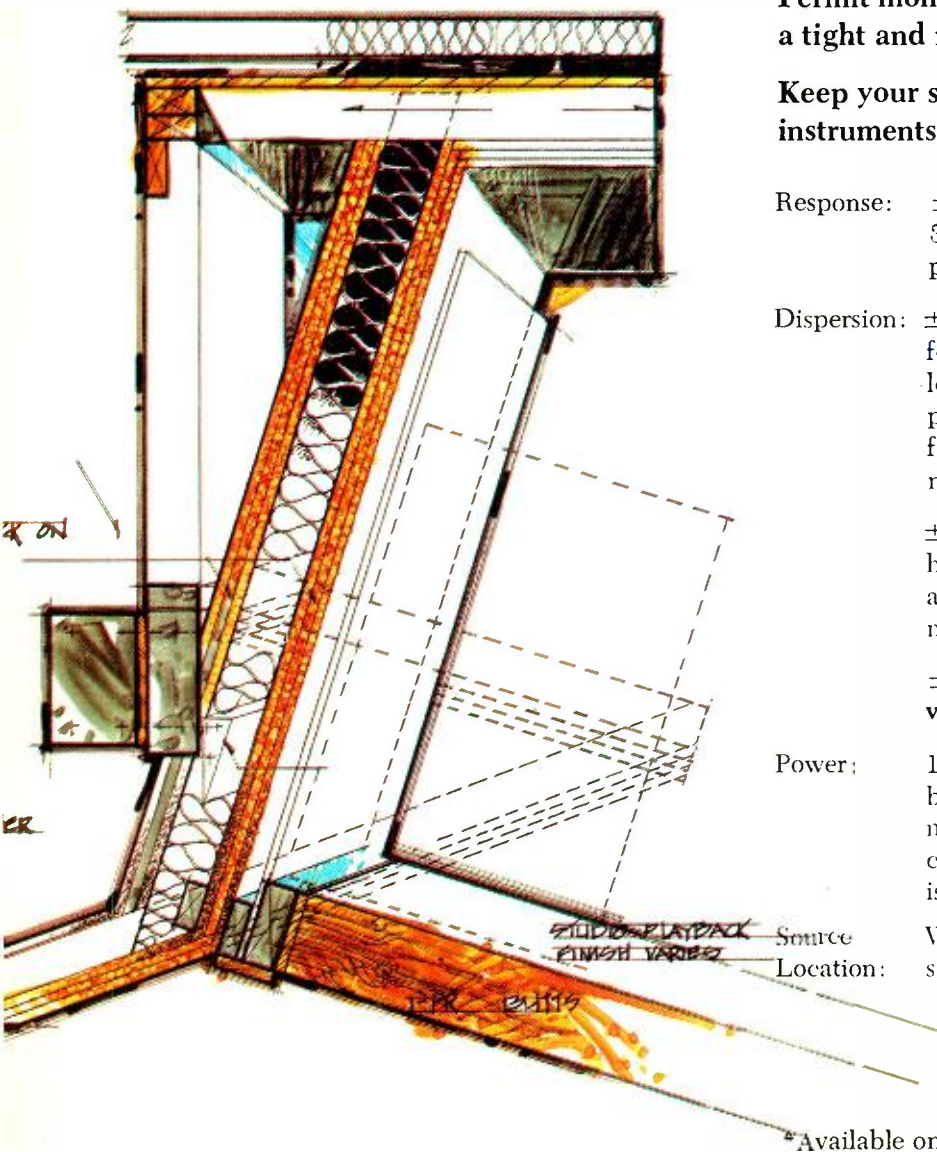

# Guarantee of Acoustics by Westlake Audio\*

## WE WILL GUARANTEE YOU A CONTROL ROOM WHICH WILL:

**Allow you to stand . . . sit . . . lean forward or back . . . move left or right and subjectively not change your mix.**

**Let you accurately pinpoint any musical instrument within a 360° quad listening environment.**

**Permit monitoring loud or soft while retaining a tight and musical sound.**

**Keep your stereo "locked center" on all instruments panned to the middle.**

Response:  $\pm 3$  dB upon speaker installation, 31 Hz-16 KHz measured with B & K  $\frac{1}{3}$  octave pink noise source. *Between speakers*,  $\pm 1$  dB.

Dispersion:  $\pm 2$  dB @ 10 KHz across a minimum 10 foot horizontal plane at the console (from left of the engineer to the right of the producer or vice versa) from any one of the four monitors, measured with pink noise source.

$\pm 2$  dB @ 10 KHz across a minimum 10 foot horizontal plane front to back in the mixing area from any one of the four monitors, measured with pink noise source.

$\pm 2$  dB @ 10 kHz from 6" above console vertically to 6" down from ceiling.

Power: 116 dB SPL minimum, linear scale, with broadband pink noise source from one monitor measured at the mixer's ear. The control room potential with four monitors is a minimum of 128 dB SPL.

Source: Within 2 dB of *total sum* from any two sources in the 360° quad circle environment.

\*Available on all new projects from Jan. 1975 on.



# al Performance Specifications

## WE WILL GUARANTEE YOU A STUDIO WHICH WILL:

Have a tight rhythm sound under all recording conditions yet allow the producer and engineer the option of changing the midrange character anywhere from “dead” to “very live” in less than sixty seconds. — *Any location in the room.* —

Provide drum cages which are live inside, something that the drummer can get into, allowing you to get a bright drum sound from an open drum cage.

Let you obtain a natural piano sound with excellent isolation from loud electronic instruments. — *With the piano in the room, lid open and not caged in.* —

Provide an echo chamber with low end “mud” removed by trapping in the chamber, resulting in a chamber that “sings.”

Room Character: The characteristic “room sound” which results from recording in a three dimensional area is eliminated by the utilization of an active ceiling. From 40 Hz up, this produces an infinite third dimension such as would be present in an amphitheater.

Separation: Active traps are built into the studio walls which allows “in-studio” vocals, eliminating the need for the usual vocal booth. 30 dB of isolation can be provided between the band and a vocalist only 10 feet away, resulting in 30 dB of isolation @ 40 Hz or tuned frequencies.

Traps: Drum cages, bass traps and broad band attenuators will provide in excess of 24 dB isolation @ 40 Hz. The piano can be recorded in the studio while still providing over 20 dB broadband rejection of unwanted sound to the piano mikes *with lid open!*

THE CONTROL ROOM AND THE STUDIO ARE YOUR TOOLS AND SHOULD WORK FOR YOU... NOT AGAINST YOU.

THAT'S WHAT AN ACOUSTICAL GUARANTEE IS ALL ABOUT!

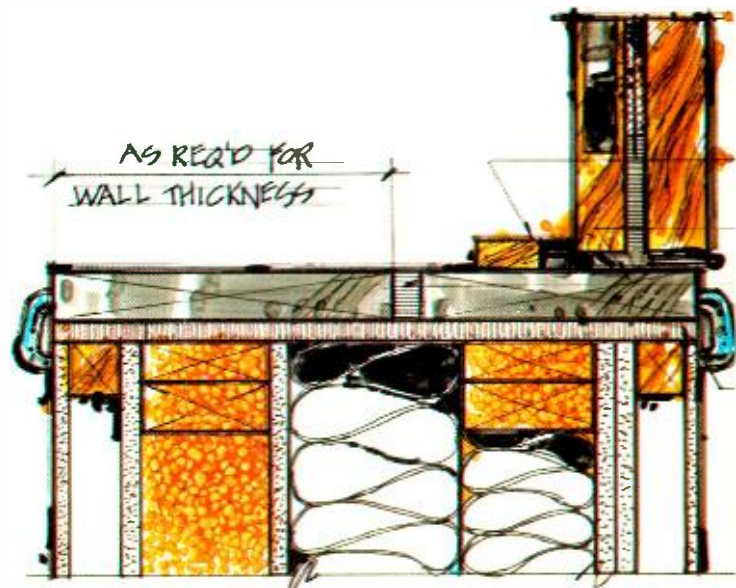

DOOR JAMB DETAIL

**Kent R. Duncan, President, Kendun Recorders, Burbank, California:**

*"The new room has been in operation for six months now and our success is as much a tribute to Westlake Audio and Tom Hidley as it is to our long hours and attention to detail (and possibly some good engineering). Our Westlake room made us a 2 studio operation but instead of just doubling our gross, we went from \$12,000 a month to \$60,000 a month. The incredibly accurate planning of our Westlake turnkey installation resulted in completion exactly on time, response precisely as promised, all equipment functioning within one day of installation, and all within budget! In the past six months we have mastered such acts as Stevie Wonder, Bob Dylan, America, Buddy Miles, Fleetwood Mac, Rick Nelson, Tower of Power, Livingston Taylor, Isley Bros., Rod McKuen, Nitty Gritty Dirt Band, Emmitt Rhodes, Richard Greene, El Chicano, Nana Mouskouri, Cleo Laine, Bola Sete, San Sebastian Strings, Jo Stafford, Maxayn, Pharoah Sanders, Archie Shepp, Ballin' Jack, Vickie Lawrence, Maureen McCormick & Chris Knight, Don McLean, Vikki Carr, Bill Medley and even Rodney Allen Rippy. Over half these acts were recorded on Westlake monitors in various studios around the country, attesting to the fact that truly, you are the professional."*

**Christopher Stone, President, Record Plant Recording Studios,**

**Los Angeles:** *"As you know, we have used Westlake Audio and yourself since the inception of the company for all of our studio design, construction, electrical interface and implementation. During the past four years you have designed and implemented eight studios for us in New York City, Los Angeles and Sausalito. Obviously we are known as a Westlake-designed operation. We have built our total reputation around your studio design and have always been happy with our decision to utilize you on an exclusive basis for all our acoustical requirements and equipment consultation. The success of your design speaks for itself in the form of our success as an independent studio operation."*

**John Sandlin, Vice President A & R, Capricorn Records, Macon, Georgia:** *"Words alone cannot express my appreciation for the friendly and courteous atmosphere I enjoyed while at Westlake mixing Bonnie's (Bonnie Bramlett) album.*

*It was really a pleasure to work with such extremely competent and dedicated people. Thank you for giving me an opportunity to experience the automated mixing facilities and to work around the type of people I love and can relate to.*

*Take care of Baker, he's incredible."*

**John Boylan, John Boylan, Inc., Hollywood, California:**

*"First of all, this is my third project in a row to be mixed on your monitors and once again it looks like we have a winner — a record that sounds as good at home as it did in the control room. From a producer's nontechnical viewpoint, this ability to trust a studio monitor and come out with even results is extremely satisfying. Secondly, the Westlake Monitor never seems to vary in any substantial way from studio to studio, in the control rooms that you've designed. So I have no worries about consistency in today's widely dispersed recording scene."*

*Complete, unedited photocopies of these and many other testimonial letters are available on request from Westlake Audio.*

*Phone or write direct to Tom Hidley, President.*

## WE PUT OUR MONEY WHERE OUR MOUTH IS!

Below are excerpts from a typical acoustical system acceptance from a client authorizing the release of the final portion of the construction monies from a trust account.

### SYSTEM PERFORMANCE ACCEPTANCE

In accordance with the terms set forth in that certain agreement contained within Westlake Audio's invoice number 3930 dated March 1, 1974 mutually accepted by Westlake Audio, Inc. and Sounds Interchange, the undersigned hereby:

1. Acknowledges receipt of and accepts a final sound measurement report from Westlake Audio, Inc.
2. Agrees that Westlake Audio has, as relates to the design and construction of the Sounds Interchange studio facility, Toronto, Canada, it met or exceeded all performance specifications as set forth in the Westlake Audio brochure entitled Acoustical Design The Key To The Success Of Your Studio as amended and signed by T. L. Hidley on February 8, 1974.
3. Acknowledges that all work has been completed in a satisfactory manner and that all materials have been delivered.
4. Acknowledges the fact that Westlake Audio, Inc. has complied with and fulfilled all the terms set forth in a certain Letter of Credit drawn in favor of Westlake Audio, Inc. and hereby instructs the advising bank — Bank of America, Westlake Boulevard, Westlake Village, California, U.S.A. to honor and pay at sight said Letter of Credit on or after December 6, 1974.

SOUNDS INTERCHANGE LTD.

By 

Dated DEC 6/74

**THAT'S WHAT AN ACCOUSTICAL  
GUARANTEE IS ALL ABOUT!**



from acoustic design  
to down beat...

**Westlake  
Audio**

6311 Wilshire Blvd.  
Los Angeles, California 90048  
(213) 655-0303

730 16th Ave. South  
Nashville, Tenn. 37203  
(615) 254-9998

that will permit reliable and stable head-to-tape contact and minimization of our old friend, the spacing loss discussed earlier.

When you run out of theory in a given situation it always helps to ask around a little. My investigations indicate that it also helps to avoid sharp changes in head contour even at places where the tape does not actually contact the head. Sharp corners are contributors to the magnitude of the acursed bumps.

Bound as it is to the reproducer head-to-tape geometry, there doesn't seem to be a whole lot the average maintenance guy can do to solve the problem in his situation. In the event magnetic heads are re-lapped<sup>11</sup>, it might be well to see if any sharp edges about the repro head face can

be rounded off and also that the new ramp angle on the re-lapped head surface recedes at least as rapidly as it did before relapping.

Since knowledge is reputed to be closely associated with power, there is yet another approach to minimization of the head bump problem. That is to define it and keep a record of it so that it will be familiar. Not as in the case of an old and esteemed friend, but as an adversary to be reckoned with. One way is to characterize the low-frequency response of the reproducer using the record electronics as the excitation mechanism. A sweep oscillator and strip-chart recorder is useful for this purpose but the pencil and graph paper method will sustain when all else fails. In addition, a check of the reproducer

response with a calibrated flux loop will also shed some light into the dark corners of the unknown.<sup>12</sup> I have found the flux loop of such enormous assistance in magnetic recording system fault evaluation that I am surprised that they aren't in wider use. I can't say that any groupies have been drawn to me by its magical powers, but building several of the little jewels has been a worthwhile effort.

Just a few more words concerning the role of equalization and phase considerations in the reproducing part of the process. I have been aware of, and have mentioned repeatedly a conviction that reproduce and record equalization characteristics that differ significantly from one program channel to another are a cause of electrical phase shift that contributes to the over-all phase errors arising from geometrical considerations. Strictly speaking, this is a true statement. The magnitude of this contribution may not be as great as I had expected.

A late analysis of the impact of excessive reproducer boost at 16 kHz for the case of the NAB 50 microsecond characteristic shows that the gross effect of a +6 dB excess boost at 16 kHz will result in a phasing loss of a little over 0.5 dB at around 2.5 kHz. The results of the analysis is shown by the curves of Figure 3.

Each of the curves of Figure 3 corresponds to a deviation from the specified 50 micro-second NAB reproducer post-emphasis characteristic. The straight line at the base of the family of humps represents the phase-shift of the precise 50 micro-second boost itself. Since the idea here is to compare the impact of misaligning one repro channel for boost at 16 kHz to compensate for problems elsewhere, (separation loss, head gap defects, electronics defects, etc.) against a properly aligned channel, it seems reasonable to show the ideal situation for comparison. For two properly adjusted, perfect repro channels, there would be zero phase-shift of one track, referred to the other.

If the 16 kHz boost is raised by 1 dB over spec, the additional phase-shift contribution, referred to the other reference channel is shown by the first hump above the straight line reference. A 2-dB boost is shown by the next line up, and so-on up to +6 dB boost for the top curve.

I only labor the point for the sheer joy of having found a factor in magnetic recording that's not as bad as I originally thought it was.

Pressing on with the reproducer alignment discussion, it is at times necessary to align a machine for a recording characteristic for which an alignment tape is not available. Specifically, tapes for the NAB 3180/50 microsecond and Ampex  $\infty/18$  microsecond may be available on an occasion when it is necessary to align to the IEC  $\infty/35$  microsecond response. This situation has

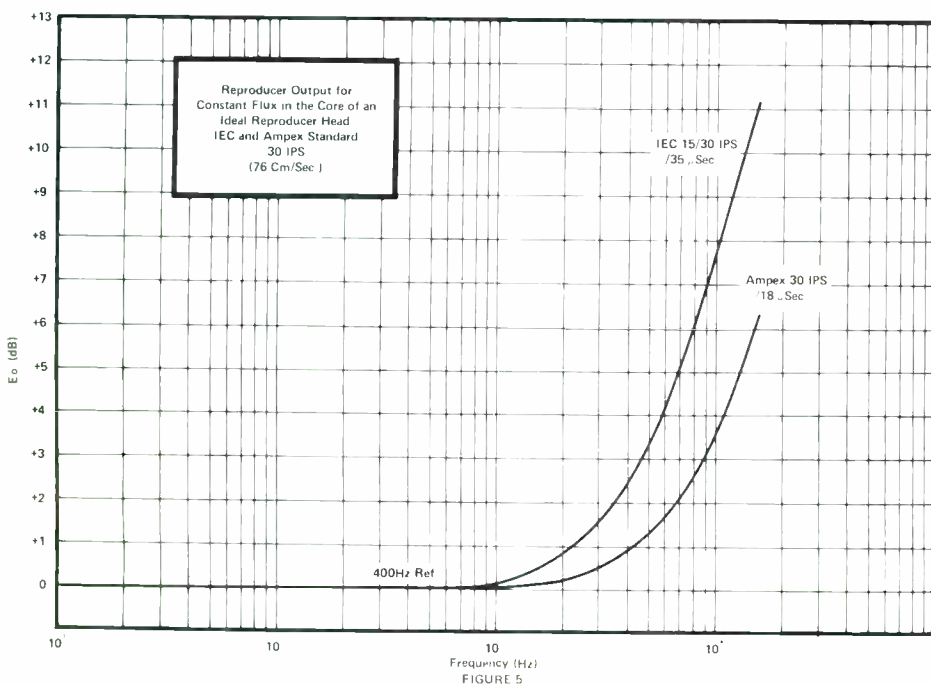
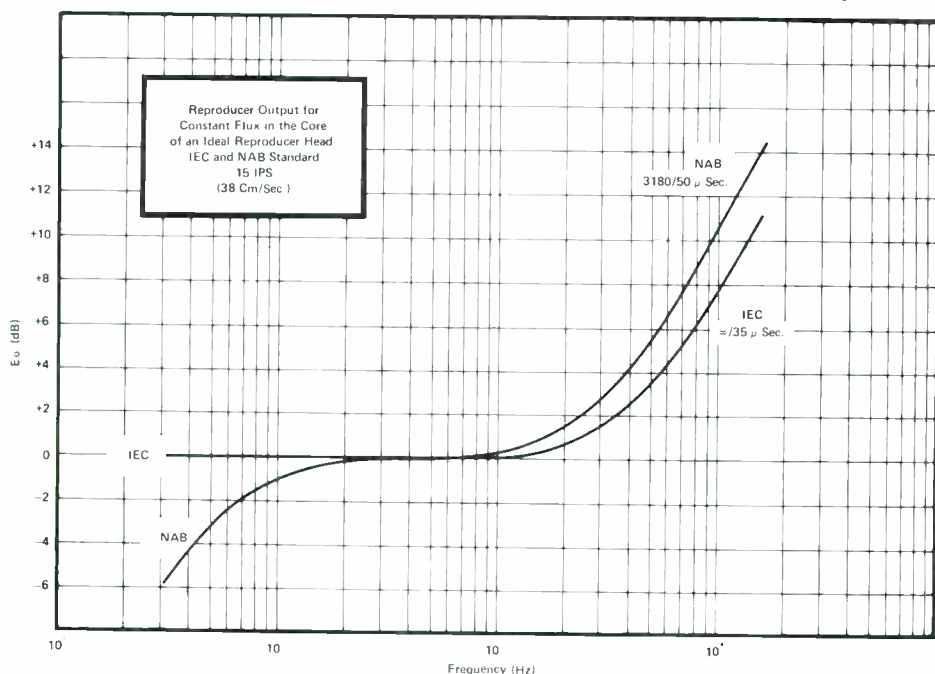

been considered in the literature earlier.<sup>12</sup> I thought so much of the idea that similar computations have been undertaken for the cases of the reproducer responses for 15 and 30 ips studio speeds that are prevalent in the United States and Europe.

The relative output of properly adjusted reproducers of different response specification to the traditional "constant flux in an ideal reproducing head" has been calculated and graphed. Figure 4 shows the 15 ips responses while Figure 5 shows the 30 ips responses. The proper reproducer output response when playing (International Electrotechnical Committee) an IEC 15 ips tape on an NAB 15 ips machine is shown as Curve 'A' in Figure 6. The inverse of that curve, for the case of playing a 15 ips NAB tape on an IEC 15 ips reproducer is shown in that same figure as Curve 'B'.

Similarly, Figure 7, Curve 'A' shows the response of an IEC 30 ips tape played on a properly adjusted Ampex 30 ips machine while Curve 'B', the inverse, shows the response of a properly adjusted IEC 30 ips machine playing an Ampex 30 ips tape. No fringing considerations have been made in determining the curves of Figures 4 through 7. Specific data used in generating the response curves is given in the appendix and elsewhere.<sup>13</sup>

I guess that about does it as far as the routine reproducer section alignment is concerned. If any of my audience are still awake after the preceding discussion, I encourage them to press further for an almost as exciting examination of the recording side of the process.

Proper alignment of the record section of the machine is dependant entirely upon the accuracy of the alignment of the reproducing section. All adjustments and judgments made about the recording system must be seen through the reproducer. Even if we've been careful and right, up to now, it will not ease our task to blow it all somewhere in the second part.

As a precaution against doing that, let's examine some of the factors that are significant in establishing a magnetic field on a strip of iron oxide. First, there is a mechanism for translating a current analogue of the program signal into a magnetic field. As an aid in increasing the efficiency of the transfer of the signal flux field to the tape, it has been found that it is useful to add a high amplitude, high frequency signal to the audio signal. The benefits of this are many; increased recording efficiency, reduced noise residual, reduced signal distortion, and improved high frequency response.<sup>14</sup>

Beyond these fairly well known and easily verifiable results, there are some other, more subtle effects that can be used in ways to make our project a little easier and our results a little tighter.

The bias current causes a high frequency magnetic field to exist about the vicinity of the recording head gap. To be

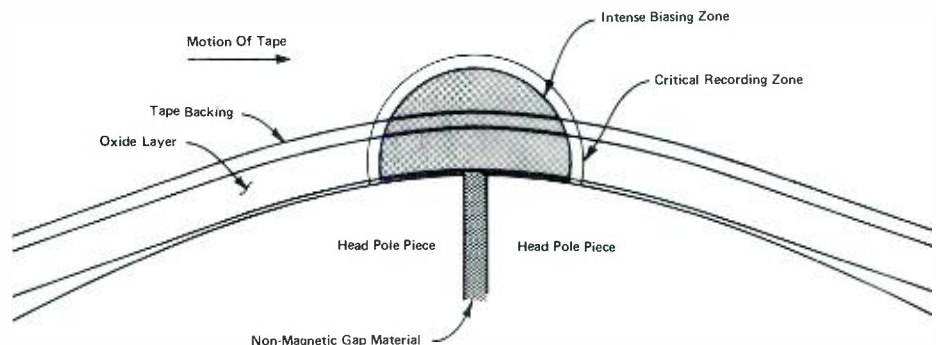
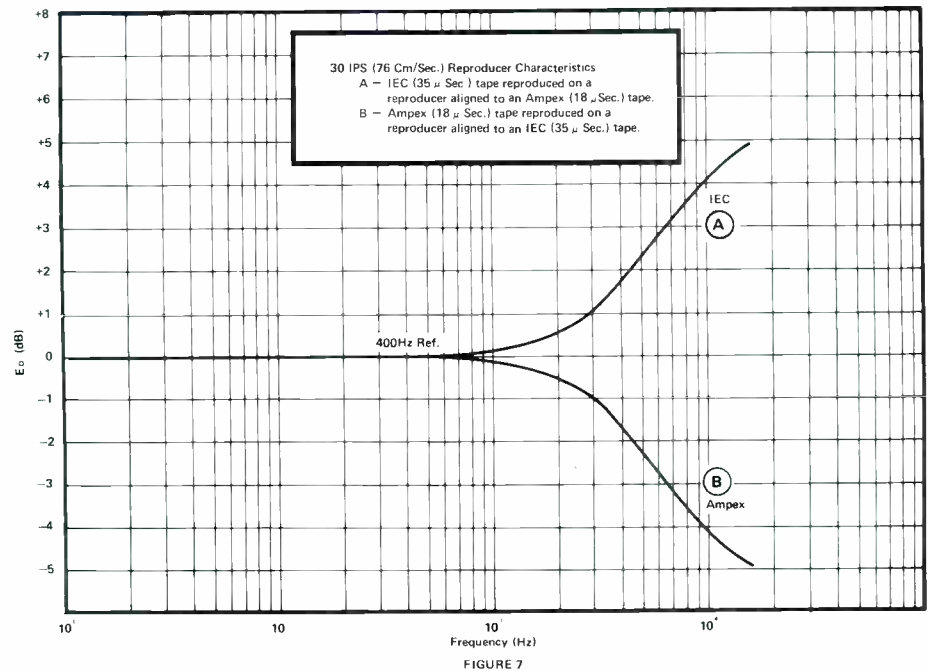
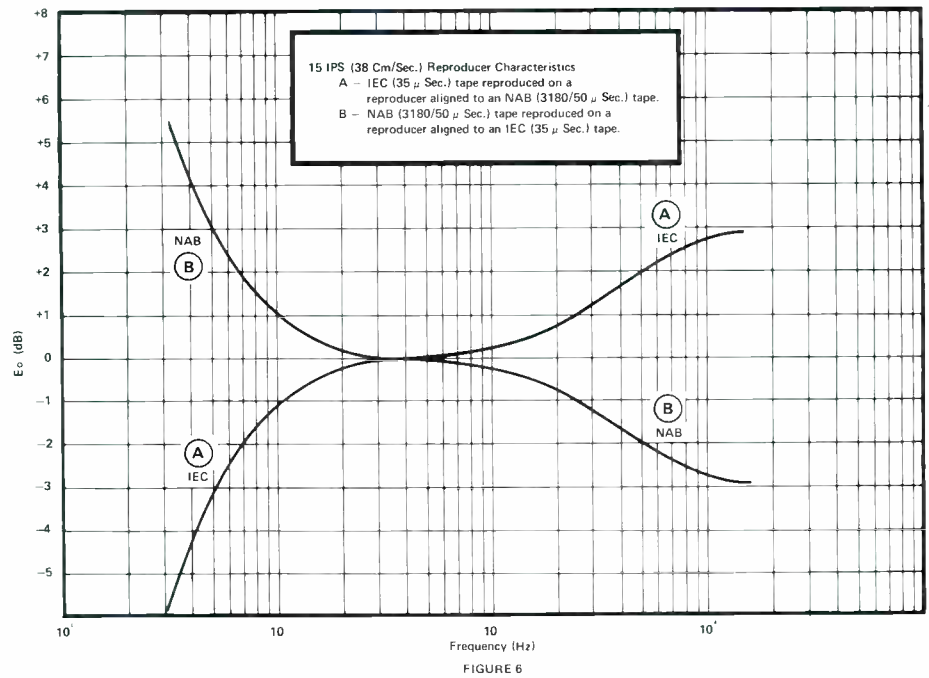

effective as an aid to the recording process, the bias field must be strong enough to magnetically saturate the oxide as it passes over the record head gap,<sup>15</sup> from left to right, as in Figure 8. As the tape enters the Intense Biasing Zone, it is alternately saturated in both directions by the bias field. The tape then passes through this region and into the Critical Recording Zone.

The Critical Recording Zone contains a field intensity below the tape saturation level corresponding to the linear magnetization characteristic of the tape oxide. Modulation signal magnetic fields that are present in this critical zone, and have a period long enough to have their recorded wavelength exceed the length of this Critical Recording Zone, will have their fields impressed on the oxide and will remain on the tape. Those modulation signal magnetic fields that have periods short enough to undergo one or more transitions within the critical zone will tend to be lost or impressed on the tape much less strongly.

The point of all this is that the point at which the recording process occurs is not precisely at the record head gap itself, but at some point after the trailing edge of the gap. Further, the nature of the field in the vicinity of the gap is such that position of the Critical Recording Zone is dependant upon the intensity of the biasing field, and the length of the recording head gap. It turns out that the physical width of the Critical Zone is also proportional to the intensity of the biasing field.

Experimental work has shown that there is some basis in observed performance for the brief recording process model, presented above, to be generally credible<sup>16,17</sup> for most purposes.

Because the record gap trailing edge may not closely coincide with the actual Critical Recording Zone, where the recording actually occurs, difficulties may arise if our goal is to align the record head for optimum azimuth for recording and then decide to use the synchronization feature of the machine for ping-ponging of tracks. The geometry of the record head may be correct for recording a signal that is then subsequently reproduced on the reproducer head and system we have so carefully aligned earlier. It may be considerably less than optimum for reproducing a recorded signal itself.

By the same argument, attempts to align the record head azimuth to an alignment tape in sync mode may tend to optimize the reproduce characteristics of the head at the expense of its recording performance. After the record head is biased, its effective recording azimuth and gap-scatter characteristics may be considerably different from what they might otherwise be supposed.

The effect of the bias level on the physical location of the Critical Recording Zone may be demonstrated by

recording coherent 1 kHz signal on 2 or more tracks of the tape at peak sensitivity bias. If the bias level of one track is varied while the phase of the reproducer playback of the recorded signals is monitored with a phase indicator, a change in the phase relationship of the variable-biased track with the fixed-bias track will become evident.

This phenomenon has been used, at times, to attempt to minimize the recording phase errors due to gap scatter with respect to the phase and gap scatter characteristics of the reproducer portion of the machine.

It should be clear that attempts to adjust a recording system in this way could be extremely difficult without a phase indicating device that gives an indication of phase error polarity, and also knowledge of the leading and trailing gaps in both the record and playback head stacks.

The idea of doing this does seem to be attractive at first. If the leading-most record gap were over-biased sufficiently to shift its Critical Recording Zone into close agreement with the trailing-most record gap Critical Zone, the difference in bias level between the two worst-case gaps could possibly be only 3 or 4 dB of bias current (not sensitivity). The high-frequency sensitivity of the most heavily biased track could be made up with additional record pre-emphasis. By the illustration of Figure 3, above, the contribution to electrical phase shift of the heavily biased and pre-emphasized signal by the excess HF boost would likely be even less than for the same increment in reproduce post-emphasis. This is because the amount of record pre-emphasis needed for generation of the proper flux-frequency characteristic is most generally less than required for the reproduce response.<sup>17</sup>

The moral of these descriptions is intended to be that alignment of a recording/synchronization system for optimization of one set of performance features can often cause significant degradation of performance in other respects. It's a good idea to know what your options and priorities are before undertaking to choose one of them.

I think highly of a recording set-up procedure of setting all record channels to a very similar bias drive setting, relative to peak sensitivity at a medium wavelength. Following this, adjusting the record head azimuth for minimal phase — error-spread as observed by the reproducer head ought to be the simplest method of record channel bias and azimuth set-up. In adjusting final bias setting, it may be a good idea to find a correlation between the drop in over-biased sensitivity and the ratio of bias level relative to maximum sensitivity peak. For example, suppose the amount of over-bias you use corresponds to, say

½ a dB over peak sensitivity in *actual bias current*. It may save set-up time to adjust all tracks for maximum sensitivity, then switch the VU's over to read bias current, and adjust the bias cal's to -0.5 dB and then adjust all the bias drives up to 0 dB. This method has the advantage of allowing thermal effects to stabilize before final bias setting.

As far as over-biasing is concerned, the high frequency effects of over-biasing are far less severe at 15 and 30 ips than at lower tape speeds. This is because the over-bias effects are actually most effective as short wavelength effects. ( $\lambda \leq 0.0002$  inches.) The wavelengths at 15 and 30 ips are a good deal longer than they are at 1-7/8 ips, so the bias won't tend to kill the high frequency sensitivity to the extent that it does at low speeds. By the same token, small drifts in bias current will be less likely to have the drastic effect on recording flux-frequency response than they do at lower speeds and very short wavelengths. Also, on the subject of biasing. The heat dissipated by the power of the bias in the record head windings may make the bias current-level-time-dependent due to changes in the head winding resistance, and in the permeability of the core material. Taking time to be sure that the bias setting you have selected is really where you want to be is really time well spent.

Record pre-emphasis should be set-up last. Sweep your input signal up to 15 kHz and adjust for optimal flatness against the repro VU reading. Check your inter-track phase once again, while you are at it. Finally, sweep down to below 30 Hz and check out your low-end repro response one more last time.

Adherence to an alignment procedure tailored to your specific needs is an important part of quality recording, no matter how wide your tape is or how fast it runs. The only way anyone can arrive at a procedure that suits his needs and will yield the best performance from his equipment is to be aware of the many factors affecting the recording and reproduction process so that the best approach to optimizing his system can be chosen. When this attitude is retained by the maintenance engineer, he can manage the performance of his recording systems so that he won't be compromising one aspect of his machine's capability without realizing what's happening.

I hope my experiences in the high speed duplicating game will be of benefit to my colleagues in the real-time world. I sometimes feel that real-time recording should be so easy compared to 32-times-speed cassettes, that I tend to lose sight of the problems studio engineers do have. In any event, I expect that maybe some others, beside myself, may be moved to conclude that, in high-quality recording of any kind, *everything really does matter*.

... appendix overleaf

# APPENDIX

## Where The Numbers Came From

### AZIMUTH ERROR LOSS CALCULATIONS:

$$L = 20 \text{ Log}_{10} \left[ \left( \frac{\lambda}{\pi \omega \tan \Theta} \right) \sin \left( \frac{\pi \omega \tan \Theta}{\lambda} \right) \right]$$

WHERE: L = signal loss in dB  
 $\lambda$  = recorded wavelength  
 $\omega$  = reproducer head core width  
 $\Theta$  = angle of record/reproducer gap azimuth disagreement

### REFERENCE:

E. Daniel, P. Axon "The Reproduction of Signals Recorded on Magnetic Tape". Journal of the Institution of Electrical Engineers 1953, Part III, Page 162.

### ELECTRICAL PHASE-SHIFT VERSUS AZIMUTH ERROR CALCULATIONS:

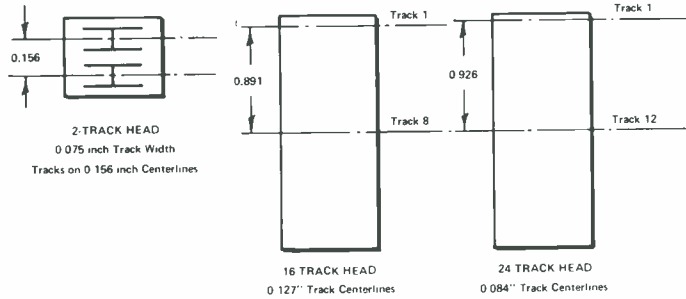

### RELATIVE POSITIONS OF REFERENCE TRACK CENTER-LINES FOR TWO, 16, AND 24-TRACK FORMATS.

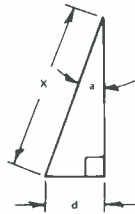

X = 0.156 for 2-track  
 X = 0.891 for 16-track  
 X = 0.926 for 24-track  
  
 $d = X \sin \alpha$   
 $d(360) = \Theta$  in degrees

### GEOMETRY FOR CALCULATIONS:

d = relative gap displacement  
 $\alpha$  = azimuth error (deviation from true 90° relative to tape edge)  
 $\lambda$  = recorded wavelength  
 $\Theta$  = electrical phase difference between tracks in degrees.

NOTE: Gaps assumed to be precisely co-linear.

### FRINGING RESPONSE CALCULATIONS:

$$F(k) = 20 \text{ Log}_{10} \left[ 1 + \left\{ \frac{2 - \exp \frac{-2\pi fd_1}{s} - \exp \frac{-2\pi fd_2}{s}}{2\pi f \frac{W}{s}} \right\} \right]$$

WHERE: f = recorded frequency in Hz at speed s  
 $d_1$  = distance from one core edge to that track edge  
 $d_2$  = distance from other core edge to other track edge  
 W = reproducing head core width  
 F(k) = fringing contribution in dB

### GEOMETRICAL ASSUMPTIONS:

- (a) 70-MIL Track Geometry Assumptions:  
 0.010 inch tape edge guard band  
 0.057 inch inter-track guard band  
 0.020 inch shield core symmetrically centered between reproducing cores  
 Edge Track Constants:  $d_1 = 0.010$ ,  $d_2 = 0.019$ ,  $W = 0.070$   
 Center Track Constants:  $d_1 = 0.019$ ,  $d_2 = 0.019$ ,  $W = 0.070$
- (b) 75-MIL, ¼-inch Track Geometry Assumptions:  
 0.008 inch edge guard band  
 0.081 inch center guard band  
 0.050 inch shield core symmetrically centered between reproducing cores  
 Track Constants:  $d_1 = 0.008$ ,  $d_2 = 0.015$ ,  $W = 0.070$
- (c) 43-MIL Track Geometry Assumptions:  
 0.010 inch edge guard band  
 0.041 inch inter-track guard band  
 0.020 inch shield core symmetrically centered between reproducing cores  
 Edge Track Constants:  $d_1 = 0.010$ ,  $d_2 = 0.010$ ,  $W = 0.043$   
 Center Track Constants:  $d_1 = 0.010$ ,  $d_2 = 0.010$ ,  $W = 0.043$   
 Center track constants differ from edge track constants by less than 0.001 inch. Their

effect is only slightly different from the edge track and therefore separate computation was neglected.

The width of the shield cores have been assumed and will vary with reproducer heads of different manufacture.

### REFERENCE:

J.G. McKnight, "The Fringing Response of Magnetic Reproducers at Long Wavelengths." March, 1972. J.A.E.S. Vol. 20 No. 2, P 100.

### DIFFERENTIAL PHASE-SHIFT VERSUS REPRODUCER EQUALIZATION POST-EMPHASIS HIGH-FREQUENCY BOOST CALCULATIONS:

The reproducer post-emphasis network responsible for its high-frequency response characteristic is a single-pole R-C network having a time constant specified as determining the frequency characteristic. The response of the reproducer system may be described by the expression:

$$E = 10 \text{ Log}_{10} \left[ \frac{1 + \left( \frac{f}{f_h} \right)^2}{1 + \left( \frac{f_l}{f} \right)^2} \right]$$

WHERE: E = reproducer output in dB  
 f = the recorded frequency being reproduced  
 $f_h$  = the high-frequency characteristic corner frequency given by:

$$f_h = \frac{1}{2\pi T_h} \quad \text{where } T_h \text{ is}$$

the network RC time-constant in seconds.

$f_l$  = the low-frequency characteristic corner frequency given by:

$$f_l = \frac{1}{2\pi T_l} \quad \text{where } T_l \text{ is}$$

the network RC time-constant in seconds.

### REFERENCE:

J. McKnight, "Flux and Flux-Frequency Measurements and Standardization in Magnetic Recording" JSMPTF June, 1969, Vol. 78, P 465.

The above expression is the inverse of that given in the cited reference which states it as the expression for the short-circuit flux-frequency response recorded on the tape itself. The inverse of that function is taken to govern the frequency-response of a given reproducer.

For the purposes of determination of the electrical phase-shift due to the changing reactance portion of the high-frequency post-emphasis network of the reproducer, the expression used to generate the curves showing relative phase shift is:

$$E = 10 \text{ Log}_{10} \left[ 1 + \left( \frac{f}{f_h} \right)^2 \right]$$

The low-frequency roll-off term in the denominator degenerates to unity if the value of  $f_l$  is zero. This was done to eliminate the difficulty of calculation of the effects of two turn-over frequency points rather than only one. Because the frequency of interest, 16 kHz lies fairly far from the influence of the low-frequency roll-off network, negligible error will be encountered.

The approach for calculation of the phase shift due to comparison of reproduced signals from two channels adjusted to different relative boosts at 16 kHz recorded frequency. The 50 micro-sec. N.A.B. high-frequency characteristic was chosen as a worst-case example.

The reproducer boost at 16 kHz for a properly adjusted 50 micro-second post-emphasis is 14.19 dB. Additional boosts in 1 dB increments were arrived at by adjusting the value of  $f_h$  to yield boosts of 15.19, 16.19, 17.19, 18.19, 19.19, and 20.19 dB and solving for the RC constant yielding that corner frequency:

$$T_h = \frac{1}{2\pi f_h}$$

Having determined the time-constants necessary to yield the required boosts, the phase-shift due to differences in channel post-emphasis can be calculated.

$$\Theta = \tan^{-1} \frac{X}{R}$$

gives the phase-shift of a simple network consisting of a resistance and reactance.

The familiar relation for capacitive reactance,

$$X_c = \frac{1}{2\pi f C}$$

Substituting:

$$\Theta = \tan^{-1} \left( \frac{1}{2\pi f C R} \right) \quad \Theta = \tan^{-1} \left( \frac{1}{2\pi f RC} \right)$$

Letting:  $RC = T_h$

We have:  $\Theta = \tan^{-1} \frac{1}{2\pi f T_h}$

The relative phase shift between two channels of differing post-emphasis is then:

$$D = \left[ \tan^{-1} \left( \frac{1}{2\pi f T_2} \right) - \tan^{-1} \left( \frac{1}{2\pi f T_1} \right) \right]$$

WHERE: D = phase difference angle  
 f = the reproduced frequency  
 T<sub>1</sub> = the H.F. time-constant of the reference channel  
 T<sub>2</sub> = the H.F. time-constant of the second channel

Two sinusoids of the same frequency will add in proportion to the cosine of the phase angle between their vectors.

A and B, with phase difference  $\theta$

If A = a sin (wt), and B = b sin (wt +  $\theta$ ) then

$$A + B = \left[ (a + b) \sin (wt) \right] \cos \theta$$

For equal values of the amplitudes a and b, the level loss due to the phase difference  $\theta$ , the sum in dB's is simply:

$$L = 20 \log_{10} (\cos \theta) \quad \pi/2 \leq \theta \leq \pi/2$$

#### CONSTANT FLUX REPRODUCER OUTPUT CALCULATIONS:

The general expression for the output of a properly adjusted reproducer to a constant flux in the core of an ideal reproducer head is given by:

$$E = 10 \log_{10} \left[ \frac{1 + \left( \frac{f}{f_h} \right)^2}{1 + \left( \frac{f}{f_l} \right)^2} \right]$$

E = output in dB  
 f = the frequency of interest  
 f<sub>h</sub> = the high frequency network corner frequency  
 f<sub>l</sub> = the low-frequency network corner frequency

A reference frequency of 400 Hz was arbitrarily chosen for the curves shown. Inclusion of the 400 Hz correction is as follows:

$$E = 10 \log_{10} \left[ \frac{1 + \left( \frac{f}{f_h} \right)^2}{1 + \left( \frac{f}{f_l} \right)^2} \cdot \frac{1 + \left( \frac{400}{f_h} \right)^2}{1 + \left( \frac{400}{f_l} \right)^2} \right]$$

The curves for reproducer output for an I.E.C. reproducer playing an Ampex tape and vice-versa were generated using the same basic expression:

$$L = I_T - I_T$$

WHERE: I<sub>T</sub> is the response characteristic of the reproducer of interest  
 I<sub>T</sub> is the reproducer response characteristic that would yield flat response when excited by the test tape  
 I is the observed response of the reproducer to the test tape.

Constants for determination of reproducer responses in addition to the 15 and 30 ips characteristics plotted above are tabulated below:

TAPE SPEED		TRANSITION FREQUENCIES		EQUIVALENT TIME CONSTANTS		STANDARDIZING ORGANIZATION
CM/SEC	IPS	f <sub>l</sub> , Hz	f <sub>h</sub> , Hz	T <sub>l</sub> , μSEC	T <sub>h</sub> , μSEC	
76.20	30	0	9095	∞	17.5	AMPEX
		0	4547	∞	35	
38.10	15	50	3183	3180	50	NAB, EIA
		0	4547	∞	35	
19.05	7.5	50	3183	3180	50	NAB, EIA
		0	1592	∞	100	
		0	2274	∞	70	
9.53	3.75	50	1768	3180	90	NAB, RIAA
4.76	1.87	50	796	3180	200	AMPEX
		100	1326	1590	120	
		50	2274	3180	70	

#### REFERENCES

- P. Butt, "Stereo Tape Machine Alignment for Mono Compatibility" Broadcast Programming and Production, P 13 - 19, July-August 1975 Vol. 1, No. 2.
- R. Factor "Phasing and Flanging" Recording Engineer/Producer Aug. 1975, P 11 - 15 Vol. 6, No. 4.
- J. McKnight, "The Fringing Response of Magnetic Reproducers at Long Wavelengths" J.A.E.S. March, 1972 P 100 Vol. 20, No. 2.
- W. Wallace, Jr. "The Reproduction of Magnetically Recorded Signals" Bell System Technical J. Vol. 30 Oct. 1951, P 1145.
- W. Grimwood, F. Kolb, Jr., D. Carr "Standardized Audio Response from Magnetically Striped Motion-Picture Films" J.S.M.P.T.E. Vol. 78, June, 1969 P 435.
- J. McKnight, "The Fringing Response of Magnetic Reproducers at Long Wavelengths." J.A.E.S. March, 1972, Vol. 20, No. 2 P 100
- S. Katz, "Where Superior Recordings Begin: Alignment." Recording Engineer/Producer, Feb. 1975 Vol. 6, No. 1 P 19.
- J. G. McKnight, "Tape Reproducer Response Measurements with a Reproducer Test Tape." J.A.E.S. April, 1967, P 7 - 11.
- S. Duinker, J. Geurst. "Long Wavelength Response of Magnetic Reproducing Heads with Rounded Outer Edges" Philips Repts. 19, Feb. 1964, P 1 - 28.
- S. Duinker "Short Wave-length Response of Magnetic Reproducing Heads with Rounded Gap Edges" Philips Res. Repts. 16, P 307-322, 1961.
- R. Kinzie "Relapping Your Own Magnetic Recorder Heads" Recording Engineer/Producer Aug. 1975, Vol. 6, No. 4, P. 47.
- P. Butt "Mundane Applications of the Flux Loop" Recording Engineer/Producer August 1974, P 41 - 47, Vol. 5, No. 4.
- J. McKnight, "Measuring a Tape Reproducer with IEC-Response, Using An N.A.B.-Response Test Tape" J.A.E.S. 1964, Vol. 17, No. 5, P 572.
- J. McKnight "Flux and Flux-Frequency Measurements and Standardization in Magnetic Recording" J.S.M.P.T.E. June 1969, Vol. 78, P 457.
- C. Lowman "Magnetic Recording" P 71 - 74, McGraw-Hill, 1972.
- M. Camras "An X-Field Micro-Gap Head for High Density Magnetic Recording" IEEE Trans. on Broadcast & Television Receivers, Vol. BTR-10, P 93 (May 1964).
- J. McKnight "The Effect of Bias Amplitude on Output at Very Short Wavelengths" J.A.E.S. April 1961, Vol. 9, P 98.
- J. McKnight "Absolute Flux and Frequency Response Characteristics in Magnetic Recording: Measurements, Definitions, and Standardization" J.A.E.S. July 1967, Vol. 35 No. 3 P 261, 262.

The author:

PETER BUTT has been a frequent contributor to the pages of R-e/p. He has been involved in electronics in the divergent areas of nucleonics, broadcasting and military communications, satellite communications, and test instrumentation.

He has turned his attention to the reproduction of sound for the past four years. A resident of the Los Angeles area, he now serves as a consultant specializing in magnetic recording problems pertaining to studio and high-speed duplication applications.



#### BOOK REVIEW

### SOUND SYSTEM ENGINEERING by Don and Carolyn Davis

SOUND SYSTEM ENGINEERING by Don and Carolyn Davis. In their preface, the authors state that "the gifted professional knows and respects the best of the past and skillfully integrates it into the future." Because this new, completely up-to-date book discussed audio systems as a whole, the authors briefly review the most significant persons and events that brought audio systems to their present high level of technology. Also, the bibliography in Appendix II of this book lists many of the audio pioneers and their original papers.

Chapter 1 is devoted to audio systems and covers such subjects as types of sound systems, system elements, and the function of the sound system.

The decibel notation system, loudspeaker directivity and

continued on page 70 . . .

# 1976 PROMISES TO BE...

THE YEAR OF THE PROGRAMMABLE AUDIO REVOLUTION. ALLISON RESEARCH PROMISES THE INDUSTRY STANDARD SYSTEM. MOST AUDIO MANUFACTURERS AGREE. HERE'S OUR STARTING LINE UP.

## THE GREAT EQUALIZER

- Fully addressable/programmable
- 24 equalizing frequencies
- 14 frequency 18dB/octave cutoffs
- Preset-able, gang-able
- Real time display of E. Q. curves
- Superior audio specs

## THE FABULOUS FADER

- Look ma, no knobs!
- $\frac{1}{4}$  dB precision tracking
- Fully addressable/programmable
- Noiseless, unlimited life
- Electronically settable — no nulling

## ON TAP

- Fully programmable patching, limiting expanding, compressing, etc.

## THE NEW 65K PROGRAMMER

- 65,000 Bits of capacity
- 3.2 millisecond access time
- No nonsense data storage on master or synchronized tape
- Self testing circuitry
- Proposed standard by most console manufacturers

## THE MEMORY PLUS SYSTEM

- Plug in retro-fit to any console
- Programmable level, group masters assignments, solos & mutes
- Visual monitors on all parameters
- Expandable to E. Q., Panning & Echo
- Total concept human engineering

## PANNER PERFECT

- Fully addressable/programmable
- Visual quad pan field monitor
- Knobless control — electronically settable
- Superior audio specs

AFTER ALL,  
WE DID START THE WHOLE THING!



allison research inc  
nashville, tennessee  
[615] 385-1760



# The Universal (Amphitheater) Sound System

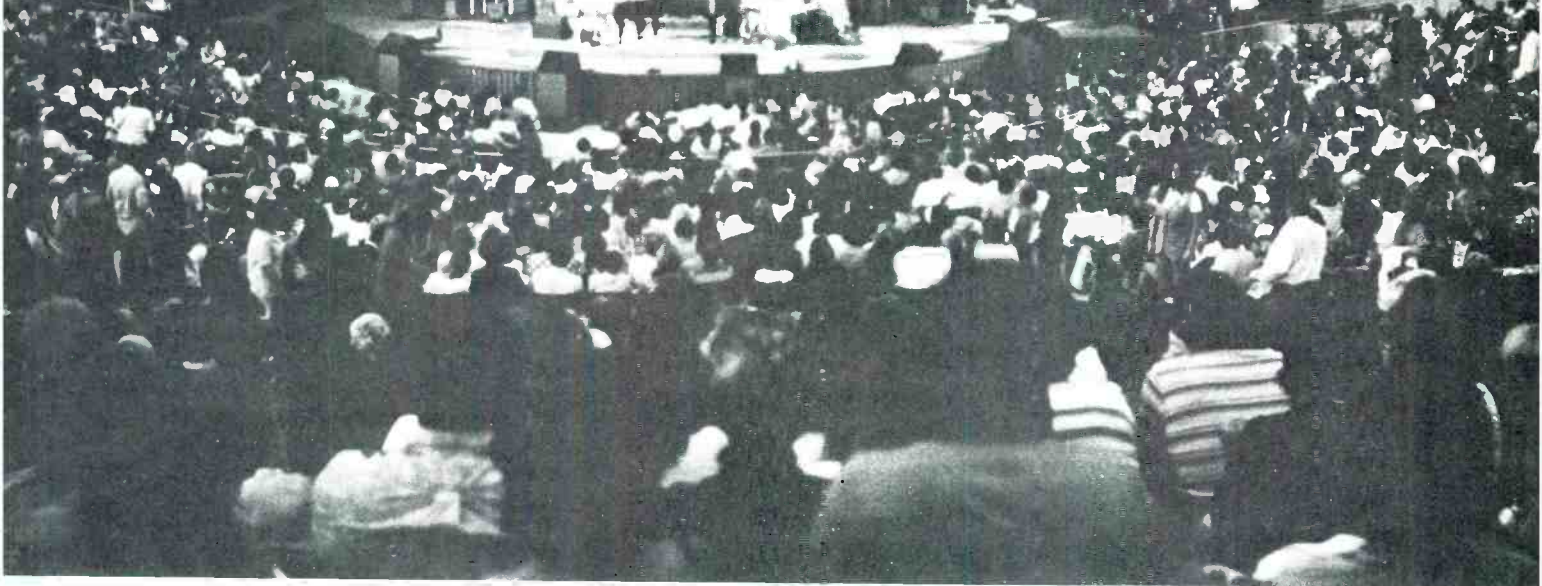

by GARY D. DAVIS

Located in the studio complex known as Universal City, the Universal Amphitheatre has unobstructed seating that spans a 170-degree arc, with about 140 feet from stage center to the last row, which is elevated about 30 feet above the first row. The acts that play the Amphitheatre during its summer season span a broad spectrum of musical tastes, from country to rock and from solo vocalist to large group and orchestra. Although the stage and seating area is completely surrounded by high walls; there is no ceiling; performances are done under the stars.

As might be expected, creating a viable sound reinforcement system for the Amphitheatre was no easy job. The variety of acts made necessary a full-capability system, one with a substantial number of input channels and with plenty of stage monitoring, so performers could hear themselves and one another. Despite the walls, wind noise had to be overcome, and without adversely affecting the frequency response of the system. There had to be adequate acoustic power and coverage to give every listener a solid-

sounding show, without blasting the front rows or generating feedback. What's more, the system had to serve more than one act per show, with fast and reliable scene changes. Most important, the coordination of the sound reinforcement hardware with the lighting and stage crews, and with the individual performers and their people, had to be smoothly and efficiently handled.

As originally conceived when the Amphitheatre first opened, performers were expected to supply their own audio systems, thus the absence of a house system. This situation soon proved unworkable for a number of reasons, both financial and practical (it is practically impossible to learn the acoustic requirements of a house as complex as the Amphitheatre, critically adjust the system, and do a polished mixing job with only a day of preparation time . . . typically the time available for rehearsal).

To make a long story somewhat shorter, Stanal Sound came to the Amphi-

*continued . . .*

*... Stanal Sound's STAN MILLER in the Universal Amphitheater audio booth*



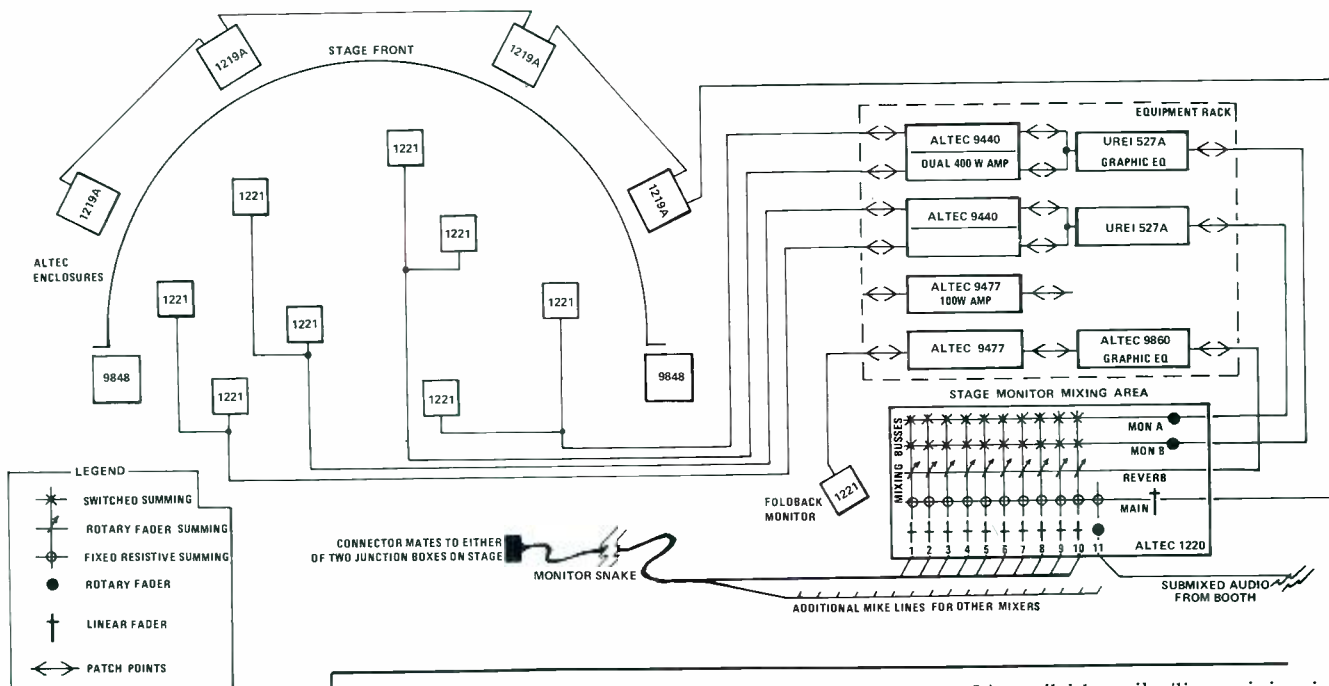

theatre with one of its first scheduled acts, John Denver. Stanal, headed by Stan Miller, is an independent sound contracting business with headquarters in Kearney, Nebraska. Stanal's expertise, substantial stock of equipment, and rapport with the artist all impressed Universal's management. What began as a two-week engagement solely for John Denver became an

entire season for Stanal, and ultimately a regular contract. Apparently, Stan Miller was the right person with the right facilities in the right place at the right time.

The Amphitheatre has grown considerably in its brief history. The stage has been expanded, extra seats have been installed, and the walls around the seats were added. Also, the wall behind the stage was made higher. With this growth, there have been some problems, and Stanal has worked closely with Universal to keep on top of the situation. In an evolutionary sense the first-year touring sound system gave way to a semi-permanent system that is stocked with equipment from one of Stanal's four 40-foot tractor-trailer rigs. Before going into too much detail on the growth and problem solving, a brief description of the current sound reinforcement system would seem to be of value.

The Sound Reinforcement System at the Amphitheatre

On stage there are 54 separate input channels brought to a pair of junction boxes that *mult* each input, allowing two mikes to be connected to one channel or one mike to feed more than one mixer. A multi-channel snake carries all 54 inputs to the audio booth in the rear of the seating area, via underground conduit. Another group of cables in the same conduit carries the mixed audio back down to the stage area, where it feeds each of two towers that provide the main house reinforcement. Stage monitor mixing is done immediately adjacent to the stage from a platform installed on one of the towers. The monitor mix can be derived either from the first 27 mike channels, or the last 27, depending on the junction box to which the monitor snake is connected.

In terms of actual equipment, there

are 64 available mike/line mixing input channels in the audio booth, with an additional 20 mike inputs and 2 line inputs at the stage monitor mixing area (the stage monitor mixing can be expanded or cut down, as needed). There are 16 custom speaker enclosures for the house reinforcement, each a tri-amplified unit.

The stage monitor speakers are basically of two varieties, self-powered bi-amplified, or remote-powered with built in high-level crossover network. A total of 12 stage monitors are frequently used, with an extra few monitors in reserve. Extensive intercom facilities permit the audio booth to stay in constant contact with the stage monitor area, the lighting crews, and backstage. There are even a couple of intercom headsets on stage, so the stage manager and performers can speak with the soundman . . . during a show, when necessary.

How The System Is Used

Smaller acts generally won't need all 54 inputs, but it is surprising how many of the inputs are needed and used. Very often, a performer who normally works with a small group will hire additional musicians and/or vocalists to enhance the Universal Amphitheatre show. After all, the "Hollywood" audience is a genuine showcase, and is considered worth the extra effort and expense involved.

The larger *Las Vegas* type acts and orchestras often do need 54 mikes . . . or more. When this is necessary the task is accomplished by connecting two mikes to one input channel (only matched mikes are used in those channels which are doubled).

The many inputs really become valuable in making a smooth transition from one act to the next. Many of the on-stage mikes and instruments are placed on risers, platforms of varying area and

THE MOST ACCURATE PROFESSIONAL PICKUP IN THE WORLD!



FOR GUITAR, PIANO, BASS . . . ANY ACOUSTIC INSTRUMENT.

FOR INFORMATION WRITE OR CALL:

**FRAP**

FLAT RESPONSE AUDIO PICKUP  
A DIVISION OF STEREOSONIC, INC.  
Box 40097, San Francisco 94140 • (415) 824 2223

Circle No. 125

**Sphere**  
ELECTRONICS

THE CONSOLE COMPANY

Los Angeles (213) 349-4747  
(213) 845-9661  
Nashville (615) 794-0155

Circle No. 126

# The \$750 alternative.

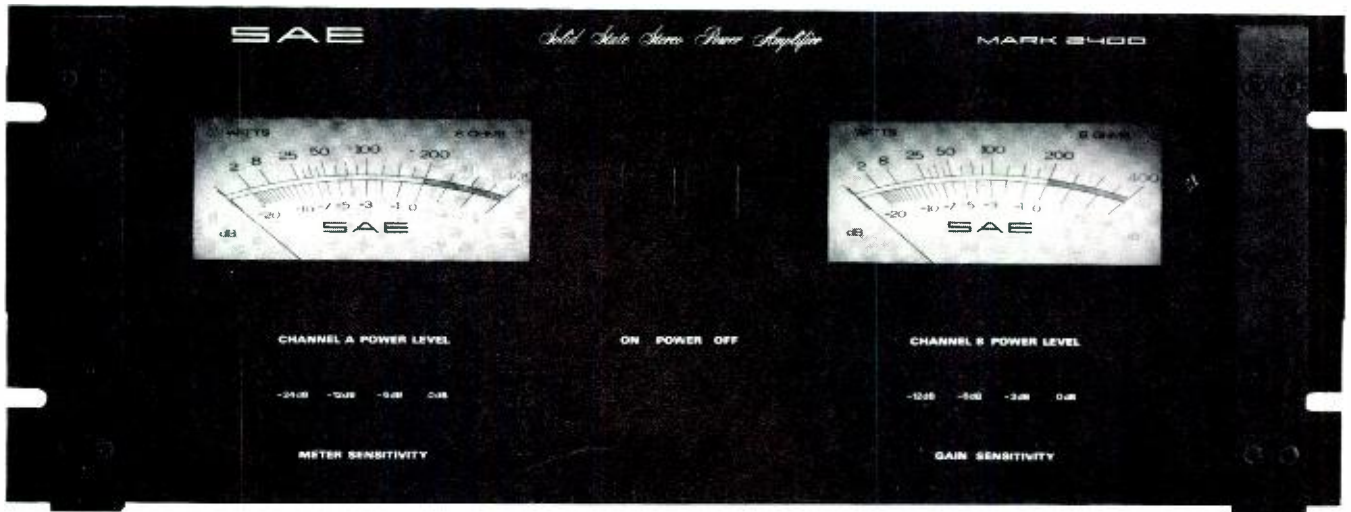

SAE 2400 Professional Dual-Channel Power Amplifier

The 2400 Professional amplifier—SAE's \$750 alternative. We give you maximum power, performance, reliability, and versatility for your dollar.

**POWER**—200 watts RMS, per channel, both channels driven into 4 or 8 Ohms from 20Hz to 20kHz at no more than 0.05% Total Harmonic Distortion.

**PERFORMANCE**—The 2400 is built to typical SAE specifications which include extremely low IM Distortion and low noise, as shown by the following graphs and specifications:

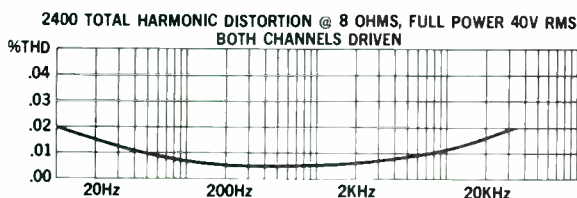
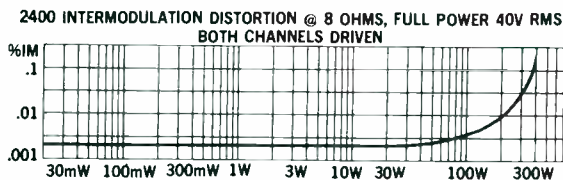

## Other Specifications:

IM Distortion from 200mW to rated power at 4 or 8 Ohms with any 2 mixed frequencies between 20Hz and 20kHz at 4/1 voltage ratio..... 0.05 % Max.  
 Input Sensitivity ..... 1.5 volts, RMS  
 Frequency Response at rated power..... ±0.25dB, 20Hz to 20kHz  
 Noise ..... Greater than -100dB below rated power  
 Transient Response of any Square Wave ..... 2.5 μ sec. rise and fall time  
 Slew Rate ..... 40 V/μ sec.  
 Dimensions ..... Front panel: 19"Wx7"H, Chassis: 11"D  
 (excluding handles, controls and connections)

Specifications comply with FTC requirements for power amplifiers.

**RELIABILITY**—Series-Output circuitry assures high current capability without loss of wide power bandwidth, low leakage current or super high slew rate. High demand reliability is built in through the use of 8 triple diffused output transistors.

**VERSATILITY**—The 2400 is a very efficient power package, weighing less than 42 lbs. and having a depth of only 11". Available in black rack mount (as shown) or our traditional satin gold and black.

**OTHER FEATURES**—Dual relay disconnect circuits, plug-in board modules, feedback level control, direct power reading VU meters and forced air cooling—features normally associated with power amplifiers costing considerably more than the SAE 2400.

**COMMENT**—You'd have to look a long time to find a power amplifier that delivers so much value. Superb power, superior performance and total reliability makes the SAE 2400 truly the \$750 alternative.

## Components for the connoisseur.



Scientific Audio Electronics, Inc.  
 P.O. Box 60271  
 Terminal Annex  
 Los Angeles, California 90060

Please send me the reasons (including available literature) why the SAE 2400 Professional Amplifier is the "\$750 Alternative."

NAME \_\_\_\_\_

ADDRESS \_\_\_\_\_

CITY \_\_\_\_\_ STATE \_\_\_\_\_ ZIP \_\_\_\_\_

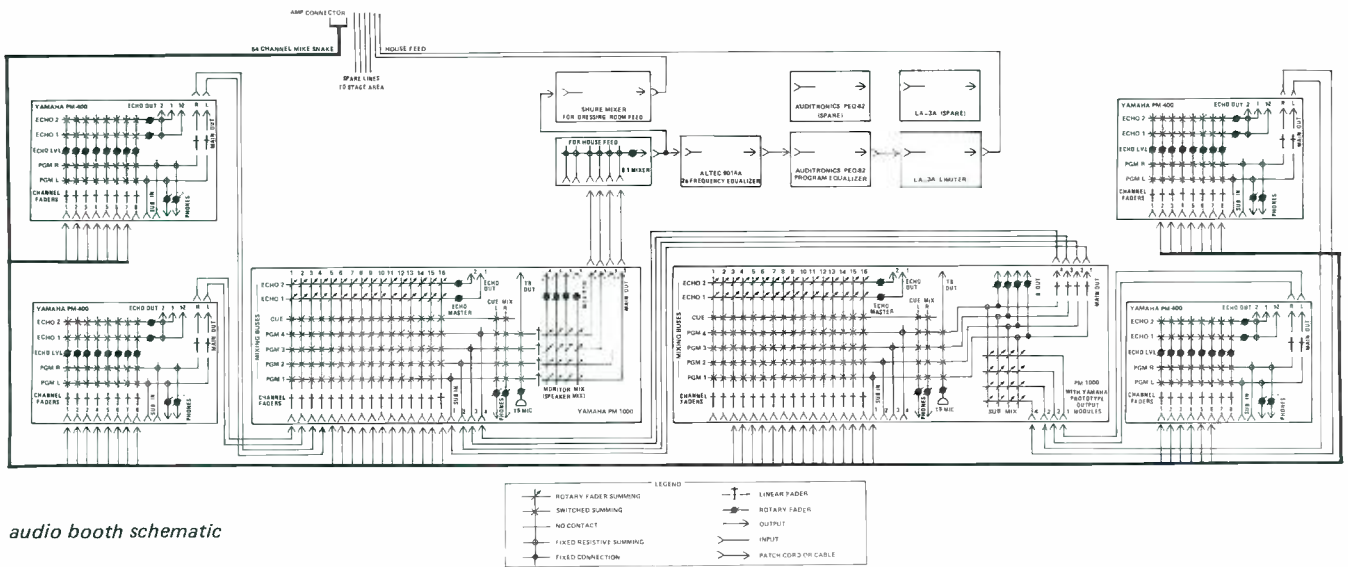

audio booth schematic

height. The miking on each riser remains plugged in, even when the riser is pushed off the main stage area and out of view. When the acts change, the stage crews need only to move the appropriate risers into place. This can be accomplished easily during the intermission, since few last-minute mike set-ups and almost no patching need be done.

The audio booth is set up with numerous sub groups, adjacent input channels that are associated with one or another riser. Each group is controlled with only

one Master fader. Thus, when risers are exchanged, the appropriate mikes can be made live and others killed, by moving only a few faders. A related advantage is that once established, a mix need not be lost from one night to the next.

Sub-grouping of input channels may also be done for another reason. For example, all drum mikes may be routed through one Master fader. Vocal mikes may be routed through another. Brass mikes may be routed through still another Master fader, and so on. Thus, if there is

too much vocal in the overall house mix, only one fader need be moved, the *Vocal Master*. In this way, touch up of the house mix can be done without re-structuring the entire vocal mix, (or whatever portion of the program is in question).

The various Master faders, and their associated console output channels, are not fully combined within the console. Neither is the reinforcement a multi-channel system. Instead, several output channels are mixed down to a monaural program in an external combining amplifier, which ultimately feeds the main reinforcement speakers.

**HOLDS UP ON THE ROAD**

**TYPE 85 FET DIRECT BOX**

AMP. INST. PICKUP

INPUT SPEAKER

**COUNTRYMAN ASSOCIATES**  
424 UNIVERSITY AVE. - PALO ALTO, CA. - 94301 - PHONE 415-326-6980

### Single vs Multi-Channel Reinforcement

Both Stanal Sound and Universal feel that every seat in the house ought to have the best possible opportunity to enjoy the show. Due to the very wide seating arc, a multi-channel reinforcement system would primarily benefit only that portion of the audience in the central seating area. Therefore, single-channel reinforcement is used; the same mix is fed to both sound towers. The speaker dispersion is such that the horizontal coverage is exceptionally even, and there is only about 6dB variation in level between the front and rear of the house.

### A Closer Look At The Audio Booth Mixing

In the booth there are two Yamaha PM-1000 consoles, each with 16 input channels and four main mixing buses. The consoles have built-in phantom power which comes in handy for many of the condenser mikes used on stage. The two consoles are linked by routing the four Master outputs of one board into the four Sub inputs of the next. This is a neat way to obtain the equivalent of a 32-input by 4-output console. Although the house mix is single-channel, the mixdown is not done in the console, as previously explained. Instead, each Master fader controls one sub group of input sources. The combining amplifier accepts up to six of these sub mixed sources and blends them

equally to create the mono house feed. The combining amp, built by Stanal, is really a 6:1 mixer without level controls that isolates each input from the others and is 600-ohms in and out.

To augment the two PM-1000's, four Yamaha PM-400 mixers are used. Each of these units is an 8-input by 2-mixing bus board. Depending on the requirements of the show, the PM-400's can be "chained" by connecting the main output of one into the submixer input of the next, or they can be connected to the PM-1000's. When connected to the PM-1000's, the PM-400 outputs can be brought through regular input channels, or they may be applied directly to the four mixing buses via the console's Sub Input facilities. (Since the external combining amplifier does have 6 inputs, two channels of mixed audio from a PM-400 can be mixed down to mono without passing through either PM-1000.)

As a practical and convenient measure, several mikes are assigned to one PM-400 or another, forming sub groups. One riser's mikes may appear on one PM-400, and another riser on another PM-400. Thus, when the acts change, the soundman can physically bring the active input channels closer, moving the unused channels aside. With 54 mike lines and 64 mixing inputs, and with so many ways to combine the output channels, the system's flexibility is phenomenal.

Although they are not often needed for the particular system at the Amphitheatre, there are several *spare* inputs and outputs in the audio booth. Both PM-1000 consoles have two echo mixing buses that could be used to build stage monitor mixes. The PM-400 mixers also have two echo mixing buses each, as well as auxiliary input and output circuits with independent level controls. If needed, sub mixes can be done in the audio booth, then sent down to the stage monitor mixer (via spare cables in the conduit), where it is incorporated in the stage monitor mix. Thus, precious stage monitor mixing inputs are *stretched* by taking advantage of mixing capability in the main audio booth. The PM-1000's have playback inputs that can be used to feed recorded music during intermissions. The PM-1000's also have built-in talkback capability, which is handy for making announcements. (Stanal prefers a 2-channel Clear-Com unit for their extensive intercom requirements.)

#### Equalization

Stanal considers proper equalization absolutely essential. However, EQ should be done only after correct miking and system set-up have been established. In Stan Miller's own words, "you can't make a bad sound system good by equalizing it . . . it must be good to begin with." There are several points in the sound system where equalization can be applied, and each point is used for a particular effect.

# Touper III

THE FIRST TRULY EXPANDABLE/CONTRACTABLE  
LIVE MUSIC MIXING SYSTEM

28 INPUTS  
\$6600.00

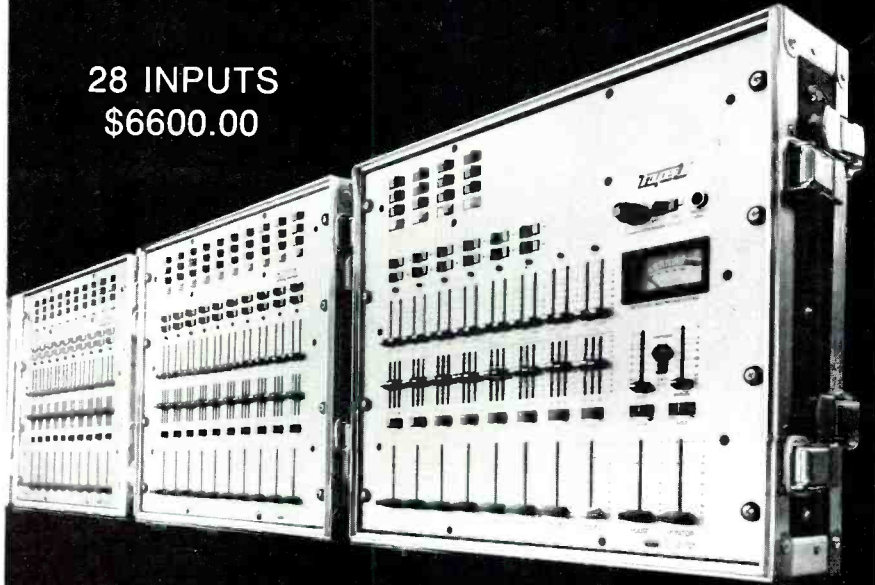

SUPER QUIET • LIGHTWEIGHT • VERSATILE

Each input contains the following: mix level control, solo switch, 3-band graphic equalizer, monitor and echo send, LED peak indicator, mic pads and group assign switches. Output control module features include: subgroup level controls, with solo switch and equalizers; house, echo receive, and monitor level controls. Additional features on the output module are: VU meter and peak indicator switchable to any input or output through the solo system, headphone jack, headphone level control, and preview selector switch for listening pre or post fader; announce level controls for monitor and house, two auxiliary receive controls for line inputs. Back panel features: XLR-type connectors for balanced inputs and outputs, on/off switch for built-in phantom power supply for condenser microphones, optional multi-pin connector for snake to replace mic and line inputs, external equipment jacks, echo send and receive jack, subgroup outputs, and subgroup defeat switch that inactivates the subgroup system for mono operation. Write or circle number for literature and specifications.

Manufactured by



AUDIO SYSTEMS DIVISION  
5559 CAHUENGA BLVD.  
NO. HOLLYWOOD, CA 91601

DEALER AND REPRESENTATIVE INQUIRIES

CALL (213) 985-9501

# Sportscaster Headset... Color, Action, Hands-free Mobility

Combine the finest omnidirectional dynamic boom mike with an equally high performance binaural headphone and you have the superior Sportscaster headset...the Telex CS-90. For live broadcasts, from the station or on remotes, with cue and program monitoring and hands-free convenience. The audience hears every word, clearly, crisply, with crowd noise for background color and atmosphere. Circumaural ear cushions screen out noise in the immediate area so that special acoustic facilities are unnecessary. Supplied with convenient in-line, mike-muting "push-to-cough" switch. The Sportscaster headset. Color, action and hands-free mobility. For complete information please write:

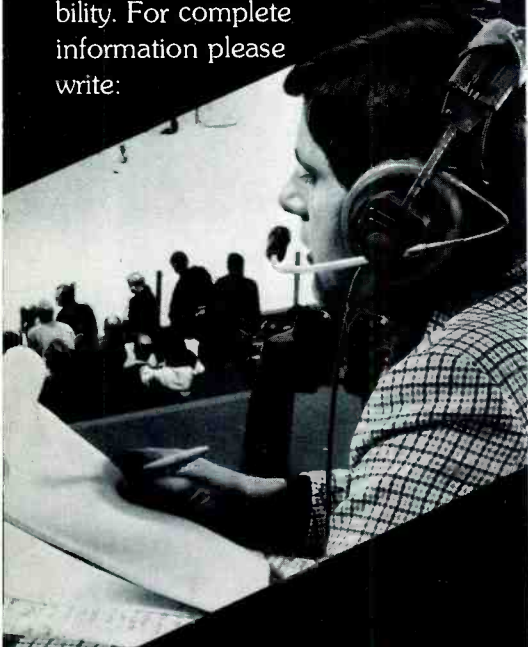

PRODUCTS OF SOUND RESEARCH

**TELEX**  
COMMUNICATIONS, INC.

9600 ALDRICH AVENUE SOUTH  
MINNEAPOLIS, MINN. 55420 U.S.A.

Europe: 22, rue de la Légion - d'Honneur,  
93200 St. Denis, France  
Canada: Telex Electronics, Ltd., Scarborough, Ontario

Each PM-400 input is equipped with 2-knob equalization;  $\pm 15$ dB of shelving at 100Hz (BASS) and at 10kHz (TREBLE). Each PM-1000 input is equipped with 3-knob equalization;  $\pm 15$ dB of shelving at 100Hz (BASS) and at 10kHz (TREBLE), and  $\pm 15$ dB of peaking at any of 3 switchable frequencies, 1kHz, 2kHz or 4kHz (MIDDLE). Thus, the soundman can individually trim each input source for the exact frequency response characteristic he feels is needed. There is also equalization on the four master output channels of one PM-1000 (the same 3-knob system as on the inputs).

Further equalization is provided by an Altec 9014A "Acousta Voice" equalizer that is placed in the mono house feed, just after the combining amplifier. The house has been tuned with this 1/3-octave unit, a real-time analyzer and pink noise to give the most even frequency response from seat to seat and to reduce any peaks in the response, thereby increasing the maximum available gain before feedback. Since a considerable amount of time was spent tuning the house the 9014A equalizer is not generally used for touch up EQ of the house mix.

For overall house mix equalization adjustments, the individual channel equalizers need not be readjusted. An Audiotronics PEQ-82 program equalizer has been installed following the Altec EQ. When, for instance, more bottom or extra presence is desired, the PEQ-82 can be used.

The speaker system is a valid point where frequency response can be altered. The three outputs of the electronic crossover feed separate power amplifiers for each section of the speaker enclosures, and these levels may be individually balanced. While not the most convenient place to make an equalization change, the electronic crossovers are sometimes re-adjusted.

### Filtering

The PM-1000 inputs all have high pass filter switches that can be set to roll off response below 40 or 80Hz. The PM-400 mixers have similar filters on each output channel, only with roll off below 80Hz or 160Hz. The 80Hz filters are often used to lessen wind noise, vocal P-pops, and stage-coupled rumble, and low-end leakage. The 40Hz filters are not needed because the electronic crossovers in the sound towers contain built-in 40Hz filters.

A roll off below 40Hz is desirable for several reasons. For one thing, it protects low frequency drivers from cone damage in the event a microphone is dropped. Since there is virtually no program material below this frequency anyway, little difference, if any, is heard. In fact, the sound will often be improved by the roll off because the power amplifiers will have more reserve power available for transient peaks in the mid and upper bass regions where the ear is more sensitive. Another reason why the 40Hz roll off is

desirable is that low frequency information can cause *boominess*, excessive reverberance, which will tend to degrade the sound in the seating area. Finally, the low frequency sections of the speaker enclosures at the Amphitheatre have a bottom end cut-off near 40Hz, so the filter eliminates potential loudspeaker distortion.

### Mix Level

The mix level and power amplifiers are adjusted for an average rear-seat listening level of about 94dB SPL. Universal management, anxious to comply with local ordinances and to maintain good relations with neighboring communities, has found that 94dB is a reasonably solid level that is, at the same time, "safe." To absolutely prevent any excesses, an SPL meter in the audio booth is calibrated nightly and carefully monitored.

A Teletronix (UREI) LA-3A limiter is placed in the house feed, just after the PEQ-82 equalizer, even though limiting is seldom used. (Mix levels are such that, except on occasional peaks, the limiter would not be riding gain.) Even when the limiter is switched on, its effect is minimal and natural sound is maintained.

It is worth noting that Stanal has found it advantageous to both the audience and the performers when on-stage instrument amplifiers are kept at reasonable levels. Guitar and instrument amps tend to flood the near-stage audience, as well as the audio booth, with disproportionate sound. Since vocals are *overlaid* on the instruments, this tends to cause them to be mixed at the top of the system's dynamic range. If this happens, the seats at the extreme sides of the stage, where instrument amps don't provide much coverage, will hear too much vocal. Therefore, a better balanced mix, one with more even house coverage and more *space* in which the soundman can work, is achieved by turning down the stage amps just a bit. The resulting increase in available house mix levels more than makes up the difference on stage.

### The Sound Towers

The two towers are assembled with rigid tubular steel, are well-braced, and are anchored in concrete to avoid resonances. Although the primary purpose of the towers is to support the speaker enclosures at the requisite height and angles, many theatrical lights are also mounted on them. A large rack in each tower contains twelve power amplifiers and an electronic crossover network. As illustrated, the 3-band output of each crossover is routed through patch points so that, if one crossover should fail, both amplifier tracks may be driven by the remaining crossover. This type of extra-safe redundancy is typical of Stanal's approach (which is to anticipate a problem before it happens and to be ready to patch around and fix it quickly).

The crossover is built by Stanal, using

circuit cards that are fabricated to their specifications by DeCoursey Engineering Labs, in Los Angeles. The racks housing the crossovers and amplifiers are completely steel-enclosed to minimize RF

interference. This is a tricky problem with SCR dimmers in the lighting system and a multitude of security guards carrying walkie-talkies. Enclosing the racks cause a lot of heat build-up, and Stanal was initially unable to locate a fan that could both move the necessary volume of air to keep the racks cool, and do so without generating too much noise. Necessity is the mother of invention, to borrow an old phrase, and Stan Miller tells us the racks are now cooled by converted furnace blowers.

The speaker enclosures are built by Stanal, with assistance from Altec. Their sensitivity is constant throughout the usable frequency range of 40Hz to 22kHz. Dispersion is about 40-degrees vertical by 90-degrees horizontal. The low frequency section consists of a modified 816 reflex horn and a 421-8H 15-inch loudspeaker. The mid frequency section consists of a modified 511 horn (the throat cut off to enlarge the diameter) and a 291-16A driver. The high frequency section consists of an 811B horn and an 802-8D driver. The crossover frequencies are at 800Hz and 6kHz.

The 8 enclosures on each tower are somewhat coupled acoustically, thereby increasing effective bass output. They are they are covered at the top of the tower by acoustic "clouds," baffles that have been installed to limit the escape of

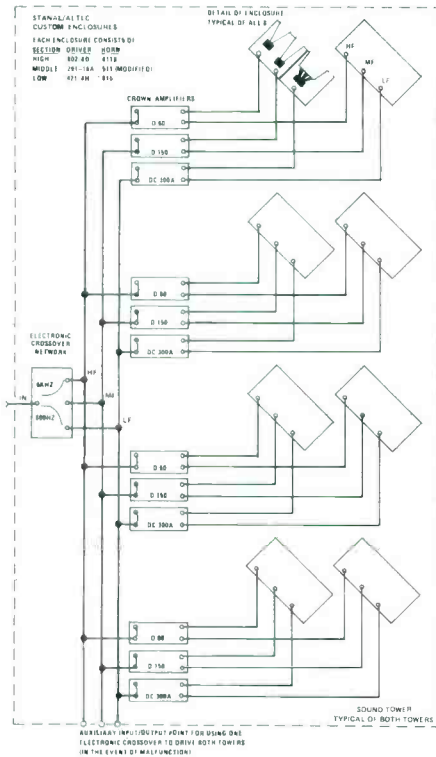

view of one of the towers showing speaker placement . . .

sound from the Amphitheatre, a measure which has been proven effective.

#### The Stage Monitors

The stage monitor mixing is usually done with an Altec 1220 console, having 10 mike inputs and one auxiliary (line) input. There is one Main Output channel that has 2-knob equalization;  $\pm 16$ dB of

# Multi-Track Recorders just don't get any better\*... than

**MCI** ... from **AUDIO INDUSTRIES CORPORATION**

**a|c** ... **EXCLUSIVE** sales and service

**MCI** ... **factory trained technicians**

\*... did you know that all MCI recorders are first assembled, calibrated, QC'd and test-run at the factory before shipment... then re-assembled, re-calibrated, re-QC'd and test-run again by AIC prior to customer delivery...

MCI / AIC ... twice the value!

## audio industries corporation

1419 N. LA BREA AVENUE • HOLLYWOOD, CALIF. 90028 • TELEX 67-7363

**Just One Call Does It! (213) 851-4111**

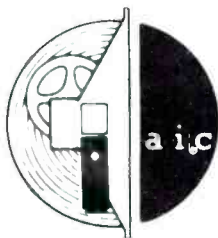
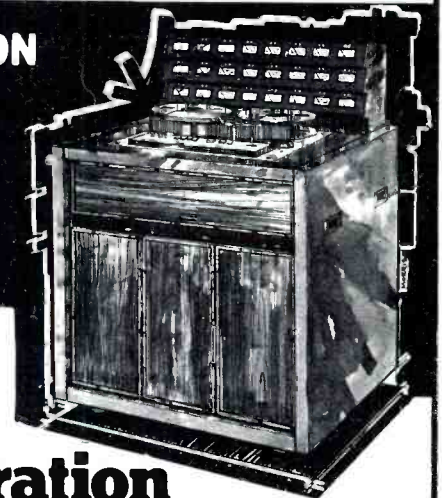

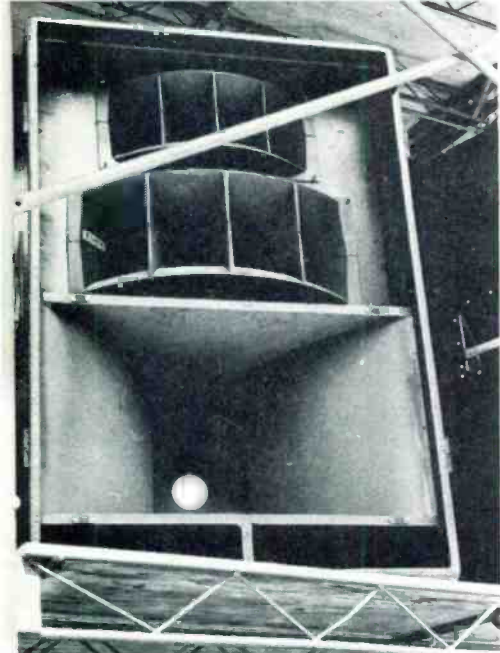

... close-up of one of the speaker enclosures

shelving at 100Hz (BASS) and at 10kHz (TREBLE). In addition, there are two unequalized Monitor Output channels. All three outputs are used to feed various monitor speakers around the stage. There is also a Reverb Output, which is used by the console operator for his foldback monitor. The 1220's input channels are each equipped with 2-knob equalization that is similar to its main output channels.

When needed, an additional Altec 1220 console is available. Sometimes, one of the PM-400 mixers is not needed in the main audio booth, and is brought down to augment the stage monitor mix. On at least one occasion, one of the PM-1000 consoles was moved to the tower to do stage monitor mixing. The reinforcement system is versatile, allowing the monitor mixing facilities to be tailored to meet the needs of each act.

There are three graphic equalizers available for stage monitor feeds, two UREI 527A's and one Altec 9860. These units are used more as line driver amplifiers than as graphic equalizers, although some touch up equalization may be done with

them. The graphic equalizers are especially important when used for a sub mix that is fed from the audio booth, and that is derived from the PM-1000 echo buses (which are pre-fade and post-EQ), since house EQ may not meet the needs of the stage monitor mix.

Two types of stage monitor speakers are in use, Altec 1219A's and Altec 1221's. The 1219A's are semi-permanently mounted on four pedestals that are spaced around the front edge of the stage. These speakers are bi-amplified with built-in power modules. The 1221's have built-in high-level crossover networks and are driven by power amplifiers in a rack next to the stage monitor mixer. There are two 9477 100-watt amps and two 9440 400-watt per channel 2-channel amps (operated at 40% of full power). The 1221's are arranged on stage as needed . . . up to 8 of them, and another is used by the soundman to listen to his foldback mix. While not often used, a pair of Altec 9848 studio monitor speakers are also available.

Due to the distance between the main reinforcement speakers and the stage, and due to the coverage of the speakers, not much sound reaches the stage directly from the house system. This helps avoid feedback and protects the performers' eardrums. The stage monitor system is designed to place speakers close enough to the performers for them to easily hear themselves, yet in such a way that the monitors do not create visual clutter for the audience.

#### Grounding and AC Power Isolation

The first season, with Stanal's touring equipment, there were a number of grounding problems. Some of the difficulty was due to a poorly designed cable harness that had been installed underground between the audio booth and the stage when the Amphitheatre was new. Both ends of that harness were joined to mult boxes with screw-type terminals, and the box at the stage was located at floor level. Problems developed because fire hoses were used to wash down the floor after each show, and the water seeped into the box and corroded

the terminals. If that wasn't enough of a headache, the stage itself had been expanded several times, so the grounding between stage sections was unreliable. The uncertain grounding really became evident when the SCR dimmers, located directly beneath the amplifier racks in the towers, were operated. During a show, one or another combination of dimmer settings would suddenly create hum or buzzing that wasn't evident in the rehearsals. Ultimately, there was only one thing to do . . . rewire the audio and AC conduits throughout the stage and audio booth.

At considerable expense to Universal, all the original audio cables were excavated, and new conduit was installed. A single, uninterrupted length of cable was run from the mixing consoles all the way down to the stage, and up to a point where the water would not reach the cable end. AMP locking connectors were installed at either end of the mike snake. These are large plastic-encased, computer-type connectors with replaceable gold-plated contact pins and a quick-release locking lever. They have proved to be very reliable.

For AC mains, 3 Topaz "Ultra-Isolation" transformers were purchased . . . also at considerable expense to Universal. These units were the only sure way to eliminate RFI and switching spikes. One transformer feeds each sound tower, and a third transformer powers the audio booth and the stage (instrument amplifiers and electric instruments). A carefully designed grounding scheme avoids ground loops: all instrument and stage equipment grounds are "lifted" and carried to a single (mechanical) earth ground via the audio booth consoles. Filter capacitors are incorporated in the equipment, so full inductive and capacitive isolation is attained. With its steel racks, isolation transformers, and fully-shielded low-impedance lines, the present system is more carefully grounded than the typical touring sound reinforcement system. However, the extra effort and expense are worthwhile; this season there have been very few grounding problems.

It is worth noting that virtually all audio lines are balanced or floating, and are low impedance (150-600 ohms). The Yamaha consoles and mixers, and the Altec consoles have balanced low-Z outputs, and all microphones are low impedance. This provides extra protection against differences in ground potential, with optimum common-mode rejection of any spurious fields that might otherwise induce noise in the line.

#### The Human Element

As nice as the sound system is, it would be of little value without the right people behind it. Stanal Sound has a full-time soundman, Steve Wooley, who maintains the equipment, sees to it that each act is provided with the miking and monitoring they require, and does the

... typical stage set-up showing monitor placement





mixing. When an act has their own soundman, the Stanal crew does their best to acquaint the visitor with the capabilities (and limitations) of the sound system, and then allows as much freedom as possible. One tip that Steve shares with soundmen who have been primarily studio engineers is to maintain as much headroom as possible in the mix . . . instead of mixing with the meters pegged. During a performance, if one requires additional level on a specific input channel which is already near maximum, Steve does not increase that channel's level any further. Instead, he reduces the level of all other input channels, and then brings up the gain of the master fader. This technique keeps distortion down and increases the available dynamics, thereby heightening the impact of the performance. Unfortunately, too many people have either become used to the distortion and compression of poor sound systems, or to the substantially compressed dynamics made necessary by the recording medium. Steve feels strongly that a soundman, as well as the performers and audience, should not settle for inferior dynamics or for distortion.

Since Stanal does a good deal of touring with many groups, there is a thorough understanding of and empathy for the visiting soundman.\* This helps to establish an immediate rapport and an atmosphere where a good deal can be accomplished in minimal time . . . a solid asset where only one or two rehearsals can be scheduled before opening night.

Stanal tries to have enough of a variety in equipment that almost any requirements can be met. However, if an act wants to use their own console, they are able to do so. The Stanal/Universal system is provided at no cost to the performers. So common sense and economics strongly favor using the house system.

Having good equipment is only part of the battle for good sound. The equipment must be maintained properly, when problems do develop, they must be quickly remedied. Stanal's crew works closely with several of the union crews at Universal, assuming a supervisory role in order to maintain much of the sound system. Stan Miller encourages his people to stop for a moment and think when a problem occurs, and to then act to bypass and/or correct it. The Stanal people are all aware of the signal flow, and a system block diagram is available as an aid to locating any failures. Sufficient spare channels and spare equipment is on hand to cover most bases, and for extra speed there are numerous patchpoints to bypass any problems. The Yamaha PM-1000 consoles are equipped with Cue buttons that allow the soundman to listen to any input channel during the show and to find a bad mike . . . without interrupting the program feed; the problem channel alone can be killed until the mike is replaced.

If you have the opportunity to visit

the Universal Amphitheatre, you can judge for yourself the quality of the sound system. In Stan Miller's words: "Everyone's interested in making a profit out of this whole thing, that's why we're all here . . . So we've done everything we can to have everyone who comes in here have faith in us . . . and we do anything we can for them . . . in fact, it's their show. I understand how the artists feel, better probably than anyone could ever imagine, because I'm out with these people all the time. We can offer the best of two worlds to the artist. We tell them to come in and mix their own thing . . . to

do what they want to do the way they want to do it. We merely ask them to tell us, up front, what they want and we'll try to give it to them."

\*Some of Stanal's regular clients include: The Captain and Tenille, Johnny Cash, Mac Davis, John Denver, Neil Diamond, The Fifth Dimension, Isaac Hayes, Engelbert Humperdink, Olivia Newton John, Tom Jones, Charlie Rich and Stevie Wonder. Although the firm's headquarters are in Nebraska, they work all across the U.S., as well as in numerous foreign countries.

## Check Out Quantum Audio Labs' QA-3000

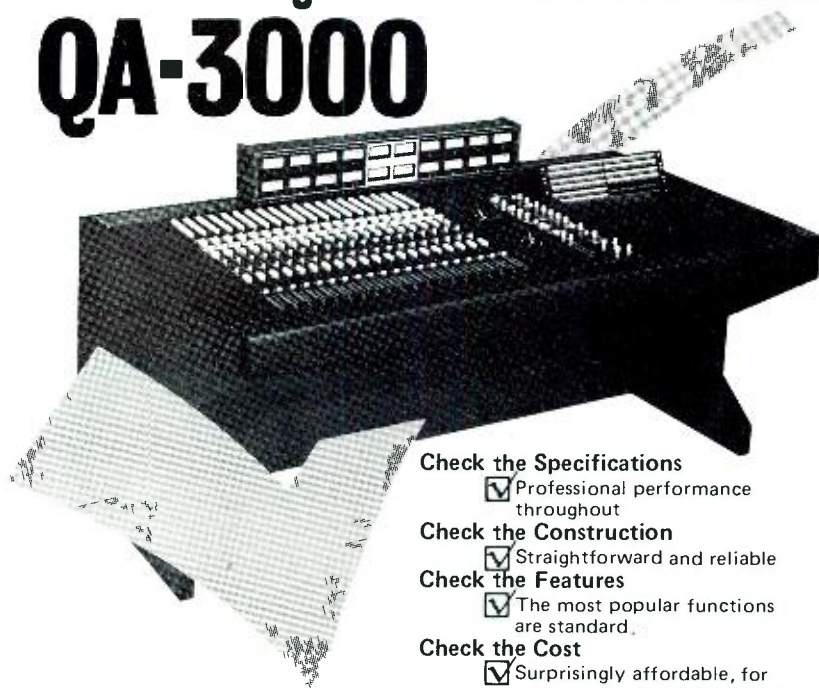

### Check the Specifications

- Professional performance throughout

### Check the Construction

- Straightforward and reliable

### Check the Features

- The most popular functions are standard.

### Check the Cost

- Surprisingly affordable, for example: 20 in x 16 out with quad mixdown \$15,000.\*

The QA-3000 PROFESSIONAL RECORDING CONSOLE is a modular system that can be outfitted to meet exactly your requirements, and can be expanded later to meet your growing needs. From 8x8 to 40x16, every console includes:

- 4 Echo Busses
- Cue & Solo
- 8-Freq/4-Knob EQ
- Quad Mix w/Panning
- Talkback
- High & Low Cutoff Filters
- Monitor Mixing
- Phantom Power
- Mic Pad & Level Trim

Currently available options include: Joystick quad panners, combination patch bay/producer's desk, double housing to accommodate extra inputs and/or patch bay, and mounting pedestals for single or double housings.

\*Mounting pedestal not included.

For full technical specifications and the name of your nearest dealer, write or phone (213) 841-0970. Ask about our QM-8A, too.

 **QUANTUM**  
AUDIO LABS, INC.

1905 Riverside Dr., Glendale, CA 91201

Quantum Audio Labs is an independent manufacturer and is not affiliated with any retail stores, although companies bearing a similar name may appear on Q.A.L.'s authorized dealer list.

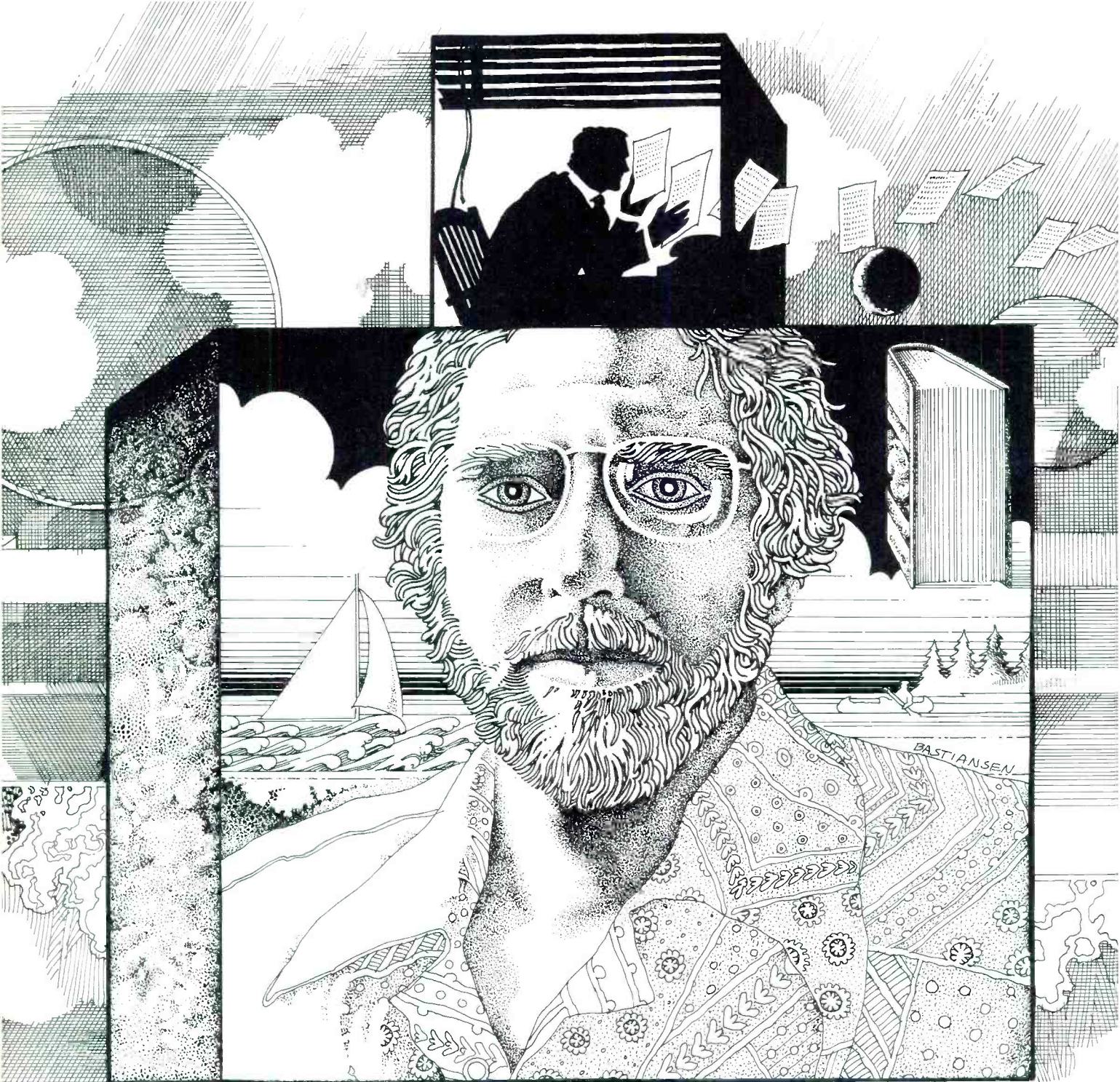

**This ad is addressed to the hard-headed businessman within you.**

You're probably a very creative guy when it comes to making recordings. But you're probably also a very businesslike guy when it comes to buying recording equipment.

And it's only right. Because you're putting a lot of money into that equipment. And how it performs ultimately affects your most valuable asset: Your reputation.

So we think it's a real

compliment when top professionals like the ones listed to the right recommend 3M pro audio gear. Ask them why they recommend it and here's what they'll tell you:

**Mechanical and signal capabilities.** Check the specifications. And check out things like punch-in, punch-out flexibility due to our exclusive isoloop drive.

**Reliability and dependability.** This has been demonstrated by 3M installations in vans and studios all over the world, where 3M machines are performing day in and day out under the most demanding circumstances.

**Exceptional resale value.** This is a very important consideration when you want to trade in or trade up.

**A superb service organization.** We have offices in New York City, Memphis, Washington, D.C., Detroit, Chicago, San Francisco, Los Angeles, Atlanta, Pittsburgh, Providence, and Grand Prairie, Texas. Plus our flying squad of troubleshooters that operates out of our St. Paul headquarters.

So next time you're in the market for pro audio equipment, think of 3M.

Because the gear that makes the most sense to you as a creative person, also makes the most sense to you as a businessman.

PROFESSIONAL AUDIO PRODUCTS  
**Mincom Division** **3M** COMPANY  
 3M CENTER · SAINT PAUL, MINNESOTA 55101

Circle No. 133

## You want an expert opinion on 3M pro audio gear?

### Ask an expert.

If you know the recording industry, you know at least one of the men listed below. And you know you can count on getting straight answers from them.

So give one of them a call. He'll be glad to give you the whole story.

### 3M PRO AUDIO DEALERS

#### Recording Studios

Ron Newdoll  
Accurate Sound Corp.  
114 5th Avenue  
Redwood City, CA 94063  
Tel. (415) 365-2843

Welton Jetton  
Auditratics Systems Division  
207 Summit Street  
Memphis, TN 38124  
Tel. (901) 272-9641

Dave Harrison  
Studio Supply Company, Inc.  
1918 Division Street  
Nashville, TN 37202  
Tel. (615) 327-3075

Bill Wilson  
LaSalle Audio  
740 N. Rush  
Chicago, IL 60611  
Tel. (312) 266-7500

Rick Maze  
The Maze Corporation  
514 Alton Road  
Birmingham, AL 35210  
Tel. (205) 591-4800

Tom Hidley  
Westlake Audio  
6311 Wilshire Blvd.  
Los Angeles, CA 90048  
Tel. (213) 655-0303

#### GSA Contracts

Lee Deane  
Fidelity Sound Co., Inc.  
1200 18th St., N.W.  
Washington, D.C. 20036  
Tel. (202) 296-9110

#### Television Applications

Byron Fincher  
RCA Broadcast Systems  
Camden, NJ 08102  
Tel. (609) 963-8000

# New Products



QUANTUM AUDIO LABS, INC

## QA-3000

PROFESSIONAL RECORDING CONSOLE

### QUANTUM AUDIO QA-3000 FLEXI CONSOLE LINE

Quantum Audio Labs' QA-3000 is a full-capability, fully professional recording console designed for maximum flexibility at a reasonable cost. Modular, all solid-state construction assures reliability and ease of maintenance. The system may be outfitted with as few as 8 input and 8 output busses, or up to 40 in by 16 out, with quad mixdown.

All consoles are equipped with 4 echo

busses, quad mix w/pan, monitor mixing, cue & solo, talkback, phantom power, 8-freq/4-knob EQ, high and low cutoff filters, mic pad & level trim, true VU meters, and conductive plastic faders.

Currently available options include: Joystic quad panners, combination patch bay/producers' desk, double-sized housing, and mounting pedestals.

QUANTUM AUDIO LABS, INC. 1905 RIVERSIDE DR., GLENDALE, CA 91201 (213) 841-0970.

Circle No. 134

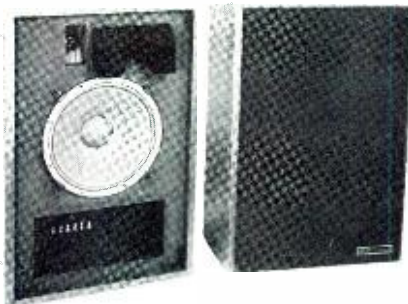

### NEW SPECTRA SONICS MODEL 3000 MONITOR SYSTEM

Spectra Sonics announces a new, tri-amplified, monitor, loudspeaker system. This system is designed for external crossover networks and for separate power amplifiers for each of the low, mid-range, and high frequency transducers. Superb American craftsmanship is distinctly apparent in the cabinet construction. The enclosure is sturdily constructed of one inch plywood and is covered in gunstock walnut formica for strength and appearance. The grill cover is removable for easy access to the speakers and a centrally located termination panel at the rear per-

mits simple installation.

The Model 3000 is available now, competitively priced at \$846.00.

SPECTRA SONICS, 770 WALL AVE., OGDEN, UTAH 84404 (801) 392-7531.

Circle No. 135

### FIRST SIX POSITION-MICROPHONE ATTENUATOR INTRODUCED BY SESCOM

Designated Model IL-18, the new in-line attenuator features a six-position balanced "O" pad, giving the user a signal loss range of 10dB, 15dB, 20dB, 25dB, 30dB, or the direct position. This versatility offers both better economy and convenience as it can replace all other kinds of fixed pads for field use.



Construction features include: rugged die cast housing with an epoxy finish, a CTS rotary switch with a durable aluminum knob, and 1% non-inductive precision resistors for accuracy.

Priced at \$25.50 per unit, the Model IL-18 is immediately available and can be ordered from one of Sescom's distributors or directly from the factory.

**SESCOM, INC., P.O. BOX 590, GARDENA, CA 90247. (213) 770-3510.**

Circle No. 136

**FURMAN SOUND PARAMETRIC EQUALIZER/PREAMP**

The Furman Sound Parametric Equalizer/Preamp is a versatile equalizer which may, if desired, be used as an instrument preamp, to directly drive a high-quality power amp, or as an equalizer alone for use with conventional instrument amps.

The advantage of the parametric lies in its ability to tune to exactly that frequency which offers the optimum improvement in tone quality. The equalizer is a three-band type, meaning that three frequencies may be tuned and controlled simultaneously. The three bands cover bass, midrange, and treble in broadly overlapping ranges. Once frequencies have been selected, the exact amount of boost or cut required at each may be set with the "Equalization" control, allowing over 20 dB boost or cut. Further, each



band has a "Bandwidth" control, which allows the user to determine the extent to which frequencies adjacent to the selected frequency are affected by the equalization control — a band as narrow as 1/3 octave or as wide as 5 octaves may be selected.

A preamp gain control and bypass switch with LED indicator are also included. Inputs and outputs are via phone jacks. The unit is AC powered and mounts in standard 19" equipment racks. It is also suitable for general equalization use in recording studios, and is excellent for notching out feedback in PA systems.

Price \$250.

**FURMAN SOUND SERVICE, 60 BRADY ST., SAN FRANCISCO, CA 94103 (415) 863-0097.**

Circle No. 137

**REVOX 3500 DYNAMIC UNIDIRECTIONAL MICROPHONE**

This microphone features wide, flat frequency range, high output and true cardioid characteristics and has been de-

signed for the most exacting use. Its outstanding performance in relation to its small size has been achieved by the development of a specially constructed pressure gradient transducer. Despite the small size of the diaphragm, sensitivity is maintained at a high level by means of a highly efficient magnetic circuit.

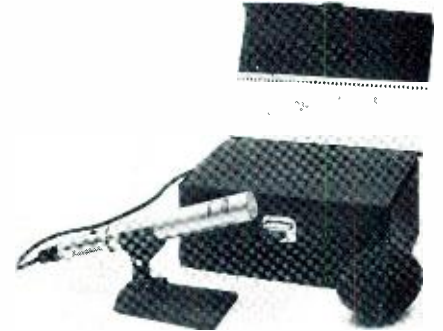

According to the manufacturer the unique construction of the 3500 housing reduces handling noise to a minimum and the microphone may be used either stand mounted or handheld.

The 3500 comes complete with colored windshield, clamp, table stand and presentation case; termination is cannon XLR type; impedance: 600 ohms. Overall dimensions are 6.3" long by 0.945" diameter.

Each microphone comes with its own frequency response curve. Frequency response: 40-18000 Hz.

Price: \$165.00.

**REVOX CORP., 155 MICHAEL DR., SYOSSET, NY 11791. (516) 364-1900.**

Circle No. 139

**MODEL 2400 DUAL-CHANNEL POWER AMPLIFIER DEBUTS AT SAE**

The SAE (Scientific Audio Electronics) Model 2400 professional dual-channel power amplifier is a 19-inch rack mounted unit with handles and anodized black face plate designed for professional installation.



According to Marketing Manager Michael Joseph, "This amplifier delivers 200 watts RMS, per channel, both channels driven into four or eight Ohms from 20Hz to 20kHz with no more than 0.5% Total Harmonic Distortion. It is ideal for clubs, discotheques, or in the home where

dbx eliminates tape noise when connected to any reel-to-reel recorder. You can make original recordings with no audible hiss or background noise, which even the most expensive studio recorders cannot achieve using conventional noise reduction systems.

dbx 157 is a two-channel simultaneous tape noise elimination system which permits monitoring off tape while recording.

It is fully compatible with all dbx professional studio systems and costs \$600.00 from professional audio dealers. Switchable (record or play) 150 series noise elimination systems start as low as \$187.50 per channel.

For complete product information and a list of dealers serving your area, circle reader service number or contact: **dbx, Incorporated, 296 Newton Street, Waltham, Massachusetts 02154, (617) 899-8090.**

**dbx eliminates tape noise**



# It's all in the family



**The new Scully 284B-8:**  
1-inch 8 channel master  
recorder with DC Servo  
and 14" reels.

**The new Scully 284B:**  
1/4" or 1/2" recorder with  
1-4 channels and 14" reels.

**The new multi-purpose  
Scully 280B:**  
up to 11.5" reels with AC motors  
or DC Servo capstan drive.

Scully's new 280B family of innovative audio tape recorders has a list of improvements and features that won't quit. As a result, Scully can handle any recording assignment you have. Just take a look.

- Optional DC capstan servo
- Speeds to 30 in/sec.
- Transports up to 14" reels
- New direction sensing control logic
- Functionally illuminated controls
- 1/4" full-track to 1-inch 8-track recorders
- Innovative low-noise electronics
- Common components for interchangeability

- 14" reels for 30 in/sec. mix-downs
- Variable Speed accessory with L.E.D. exact speed read-out

Scully makes it easy for you, including sales and service which is available from over 200 distributors throughout the world. For all the facts, write, Telex or phone.

▶ **Scully | Metrotech**

Division of Dictaphone

475 Ellis Street  
Mountain View, California 94043  
(415) 968-8389 TLX 34-5524

Scully and Metrotech are trade marks of Dictaphone Corporation, Rye, New York.

better-than-average power requirements are necessary to adequately drive a sound system."

The 2400 is said to have excellent performance specifications including maximum Harmonic and Intermodulation Distortion levels of 0.05%; an input sensitivity of 1.5 Volts, RMS;  $\pm 0.25$ dB frequency response (20Hz to 20kHz) at rated power; and a greater than -100dB noise level below rated power.

The unit is designed for maximum reliability and features Series-Output circuitry and triple diffused output transistors plus forced-air cooling, direct power reading VU meters, feedback level control, plug-in board modules and dual-relay disconnect circuits. Weight: less than 42 pounds and retail at \$750.00.

SAE (SCIENTIFIC AUDIO ELECTRONICS, INC.) P.O. BOX 60271, TERMINAL ANNEX, LOS ANGELES, CA

Circle No. 141



#### EL-TECH 16 BY 16 CONSOLE

The El-Tech Model 1616-25 recording console was designed for the budget minded 8 or 16 track studio operator. 16 inputs and 16 outputs with 16 track monitor and cue busses provide the user with a full 16 track capability with no compromise in either quality or convenience, according to the manufacturer.

All inputs are assignable to the first 8

output busses with the remaining 8 outputs coming direct from inputs 9 through 16. Relay switching allows seeing track outputs 1 through 8, or 9 through 16 on the VU meters. A 96 point patch bay allows access to all the track inputs and outputs as well as the stereo, echo, and tie line inputs and outputs.

Two cue busses are available with relay switching from track inputs and

outputs. The stereo monitor busses are also relay switchable from track input to track output. Each input features mike gain, line gain, solo, echo send, and 5 band - 15 frequency equalization. Other features include master cue, solo and echo send controls as well as two echo busses with returns for each. Optional balanced line level input and output transformers are available as well as optional plug in amplifiers to raise -10 dB level recorders to +4 dB levels.

Price: \$9775.

EL-TECH, 112 17 STREET, KNOXVILLE, TN 37916. (615)

Circle No. 143

## Change Sound to Silence with a **TABERASER**



This rugged, heavy duty bulk tape eraser wipes sound from all magnetic tapes, cartridges, cassettes and magnetic film stock; handling up to 2".

It erases with minimum residual noise because the field automatically diminishes at the end of each 30-second cycle.

A thermal control and blower keeps the unit below 71° C.

Available for 60Hz or 50Hz operation.

For the distributor in your area—Call or write:

**TABER** Manufacturing & Engineering Company  
2081 Edison Ave. • San Leandro, Ca. 94577 • (415) 635-3831

#### RSE LIVE PERFORMANCE MIXER

RSE announces its new 15 microphone channel live performance mixer. This 15 channel mixer (can be supplied in 10 or 20 microphone channel configuration) provides treatments for left and right PA and stage monitor; there are also two auxiliary outputs for treatments such as echo or reverberation and two more for tape recording. There are four auxiliary inputs for the return signals from the treatments in the tape recorder.

Input channels: Each input channel has tone controls for bass lift or cut, treble lift or cut and middle lift. The fourth tone control governs the frequency of maximum/minimum lift and is continuously variable. The bass cut switch provides correction for close microphone effects. There is a continuously variable sensitivity control, switched input attenuator and a peak reading meter. Two channels in each group of five have additional line inputs for direct injection from instrument amplifiers. The channel signal is sent to the PA output via a linear movement fader and a rotary panpot. A control that sends the channel signal to the monitor operates independently of the channel fader and the controls for the two treatment outputs can be



switched to 'before' or 'after' the channel fader. The channel mute switch disconnects the channel signal from all outputs.

**PA outputs:** The signals from the channel panpots are sent to the left and right PA via a pair of linear motion faders. Each PA output channel has bass and treble controls for peak reading meter.

**Monitor output:** Monitor output

channel which derives a signal from the monitor controls on all the input channels has a linear movement fader and bass and treble controls.

**Treatment channels:** The two treatment-send channels have rotary faders and bass and treble controls. The two return channels have sensitivity, bass and treble controls. The treatment returns can be sent to the PA via linear motion

faders and panpots. they can also be sent to the monitor. If the treatment facilities are not being used in the normal way, they can be used instead as extra monitor channels or as sub group channels.

**Tape recorder channels:** The PA signals can be sent to a two track tape recorder via independent level controls.

Returns from the tape recorder can be sent back to the PA left to left and right to right. They can also be sent to the monitor. Thus, the PA signals can be recorded or alternatively a pre-recorded tape can be played into the stage monitor and simultaneously mixed with live signals into the PA. The tape recorder facilities can be used in rehearsal and for making demonstration tapes.

**Listen facilities:** On every input channel and every other input and output there is a listen switch. When this is pressed, the corresponding signal is fed into a pair of phones which plug in near the front of the mixer. If no listen switches are pressed, the phones are automatically connected to the stereo PA output. The PA can be disconnected from the normal main signals and connected instead to the listen channel. This allows individual input channels to be fed to the PA and is useful in setting up.

**Talk facilities:** By means of a local microphone, the mixer operator can talk to the monitor for communication with



## Why does Pye Recording Studios use the Amber Audio Spectrum Display?

Amber model 4550  
\$1,800 US List

Noel Jesudian, Chief Technical Engineer of Pye Recording Studios in London's West End, originally bought the Amber 4550 as an analytical instrument for use in his electronics laboratory.

"We have found however that the unit has an additional role within our newly equipped cutting suites. It has substantially reduced the amount of blank lacquer wastage and increased our productivity. In addition, when clients are present during disc mastering sessions, the unit helps them to relate specific musical activity to potential problem areas."

The Amber 4550 Audio Spectrum Display is being successfully used in more and more studios, disc and cassette mastering facilities and radio and TV stations around the world. Find out why. Contact Amber or your dealer today for a demonstration.

AMBER ELECTRO DESIGN LTD  
1064 chemin du Golf  
MONTREAL QUEBEC CANADA  
H3E 1H4  
(514) 769 2779

**amber**

the stage or to the tape for recording program notes on the tape. When the 'talk to monitor' switch is pressed, the normal monitor signal is reduced in level to allow the talk to come over.

**Auxiliary meters:** In addition to the meters on the input channels and the PA output, there are two other peak reading meters that can be switched to any of the other inputs or outputs of the mixer.

**Construction:** Five input channels are built as a single module and the output and auxiliary channels are built as another module of the same size. All circuits are on fibreglass PC boards and all internal connections are soldered. The mixer has a low flat profile with input channels arranged from the left and the outputs and auxiliary channels on the right. The meters are on the back on a raised angled strip and all are in line with their corresponding channels. All connections except listen headphones are at the back via XLR (cannon type) connectors. The wooden carrying case is covered with heavy carpet and can be converted to a table which holds the mixer at a convenient angle. Power supplies are contained in a separate carpet covered box. Dimensions (15 channel): mixer packed for transport; 52" w x 33" d x 9" h; weight; 180 lbs: power supply: 15" w x 14" d x 9" h; weight; 35 lbs.

Price upon request.  
**LAMB LABORATORIES INC., 155  
 MICHAEL DRIVE, SYOSSET, NY  
 11791. PHONE: (516) 364-1900.**

Circle No. 145

### AUDIO TRANSPORT SYSTEMS MIC SNAKES

ATS MIC SNAKES are engineered and constructed for greatest reliability under constant use conditions by sound engineers and traveling musicians. Special

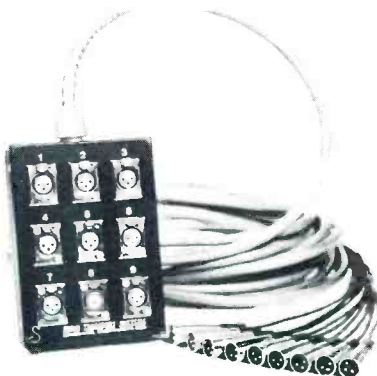

attention has been given to the common problems associated with portable multi-conductor cabling systems in an attempt to develop a unit capable of providing years of trouble free service on the road.

**SPECIFICATIONS:** Cable: Tinned

copper conductors, color-coded polypropylene insulation, cabled in pairs, each pair and its drain wire under aluminum foil/polyester shield, PVC jacket overall.. No. 22 (7/30) wire. All exposed cable pairs are protected by thick wall shrink tubing.

**Connectors:** Switchcraft A3M and D3F (with epoxied insert set-screw). **Terminating Box:** Black anodized connector top. Black wrinkle finished steel body. **Strain Relief:** Concentric wire mesh strain relief with rubber clamp down collar to eliminate cable failure due to crimping or twisting. **Shield:** Shield (drain wire) integrity is maintained throughout as well as foil shield continuation to within 1 inch of terminating connector. **Inside terminating box** each drain wire is tied to both pin 1 and the body ground lug of its respective connector. **Steel body** provides electrostatic as well as electromagnetic shield protection. **Line Identification:** Terminating box: one quarter inch screened numerals. White ink per MIL SPEC. **Male connector:** One quarter inch numerals cold stamped into connector barrel between insert set-screw and strain clamp set-screw.

**Dimensions:** 6 or 9 line = 5"x7"x2". 12 or 15 line = 7"x9"x2". 19 or 27 line = 11"x17"x2".

**AUDIO TRANSPORT SYSTEMS, 985 PLEASANT ST., BRIDGEWATER, MA 02324. (617) 697-6000.**

Circle No. 147

### DOKORDER INTRODUCES UP-GRADED MODEL 1140 FOUR TRACK RECORDER

Dokorder's Model 1140 4-Channel tape recorder, announced earlier this year, is now being delivered after an extensive redesign to incorporate some unique features and functions.



Among these new additions is an automatic multi-sync feature. Through the use of sophisticated logic circuitry, the 1140 removes the burden of getting in and out of Sync and in and out of Source by performing these functions automatically.

Other elements of the 1140 designed

# COMPLIMITER™

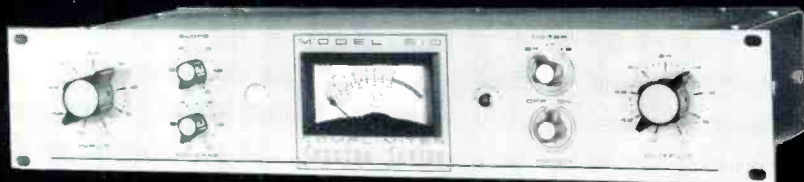

MODEL 610

Used in recording studios; disc mastering studios; sound reinforcement systems; TV, AM, FM broadcast stations to maintain a *sustained average signal at a level significantly higher* than that possible in conventional limiters, and with performance that is seldom attained by most *linear amplifiers*. Rack mounted, solid state, functional styling, the Model 610 is in stock for immediate shipment.

Specifications are available from:

## SPECTRA SONICS

770 WALL AVENUE, OGDEN, UTAH 84404  
 (801) 392-7531





for convenience and ease of operation include Program Memory, which automatically rewinds a tape to a selected point and either stops or replays the material; built-in bias with bias controls up front on the transport and a 200kHz bias frequency for greater noise reduction; logic controlled touch-buttons for transport functions and motion-sensing circuitry for anti-spill tape handling; peak level indicators; and one of the few erase heads available capable of erasing the exotic new tapes now being introduced.

The four-channel 1140 with 10½" reels has a suggested retail price of \$1,199.95. An optional, floor-standing console is available for \$39.95.

**DOKORDER, INC., P.O. BOX 8, LAWDALE, CA**

Circle No. 148

### ESS PROFESSIONAL 'BLUE OX' SOUND REINFORCEMENT SYSTEM

Mr. Victor Comerchero, President of ESS, INC., 9613 Oates Drive, California 95827, today announced the introduction of a new professional sound reinforcement system called the Blue Ox.

"In expanding our product categories into the professional market, we have carried with us our concepts of high fidelity sound reproduction and married these with the very special requirements of professional sound.



'Blue Ox' is a high power handling capacity sound reinforcement loud-speaker system designed to provide not only exceptionally high sound pressure levels, but to do so, according to the company, while maintaining very low distortion and the all important transparent high resolution in the middle and upper ranges that is so vital to preserving the delicate and precise nuances of live performances.

Power rated at 50 Watts continuous power, at one watt, it produces 104 dB sound pressure level at four feet. The system has been subjected to power tests using music as a source where the Blue Ox system has handled program material with musical peaks of greater than 375 watts for periods of eight hours and more.

The low frequency system by itself is capable of handling well over 150 watts RMS per driver.

For the mid and high frequencies, the Blue Ox utilizes a HEIL Air-Motion Transformer consisting of four 2.75 lb. Alnico V magnets with a flux density of 10,500 gauss in a .140" gap, said Mr. Comerchero.

The Blue Ox is available with two versions of the HEIL Air-Motion Transformer. The standard version utilizes a 1 mil. Teflon diaphragm with a frequency response of 1.5 to 25 kHz.

For lesser power handling and greater high fidelity requirements, a 1/2 mil. Teflon diaphragm is also provided which has a frequency range of 800 Hz to 25 kHz.

The Blue Ox system has a suggested retail of \$995.00.

**ESS, INC., 9613 OATES DRIVE, SACRAMENTO, CA 95827.**

Circle No. 149

### NEW PRO SOUND I.D. COLLARS PROTECT AUDIO CABLES AGAINST THEFT

Audio cables are protected against theft, color coded for length and quickly identified when equipped with low cost I.D. collars now available from Pro Sound.

Pro Sound imprints owner's name, address or identifying mark. Collar slips

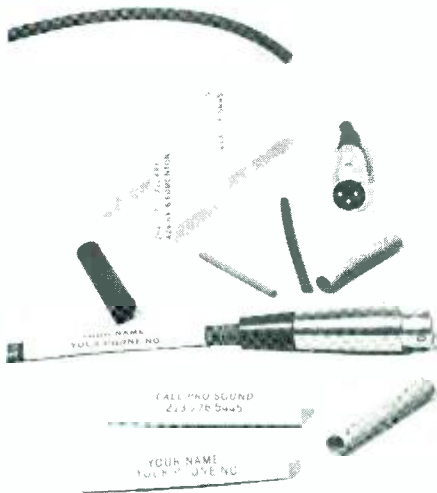

over cable end. Heat is applied to shrink collar up snugly around cable.

Available in five colors (blue, red, yellow, white and black) and in two sizes (3/8" and 1/4"). Permits color coding of cables according to length. Prevents confusion with other property. Discourages theft. Advertises owner's business or group.

Price: \$.30 ea for 50 pieces, \$.25 ea for 100 pieces, \$.20 ea for 250 pieces (price includes imprinting of two lines of copy). Availability: stock to one week.

**PRO SOUND, P.O. BOX 91798, LOS ANGELES, CA 90009. (213) 776-5445.**

Circle No. 150

### New Interface Electronic Crossover

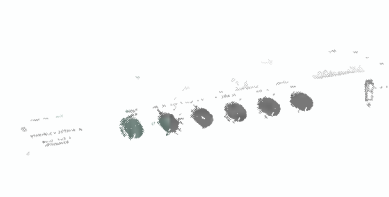

Three-way tuneable crossover has crossover points fixed at 3db. down. It is tuneable 130-1700 and 110-14000 Hz, with all outputs in phase at all frequencies. No null crossover and 12 db/octave Butterworth response. It has 600-ohm transformer outputs at 8 volts rms maximum. Voltage gain is 2 maximum. Distortion under 0.1%. Rack mounted panel measures 1¾". Price \$295.00.

### Stage Monitors

Model 24X4-24L Stage Monitor Mixer provides eight completely independent monitor mixes of 24 inputs with three frequency equalizing and slider channel master on each input. Options include 16 X 4 mainframe, balanced 600 ohm + 8dbm outputs, and foam lined trunks. Combination module Model 100K for both stage monitoring and master recording.

### Series 300 Mixers

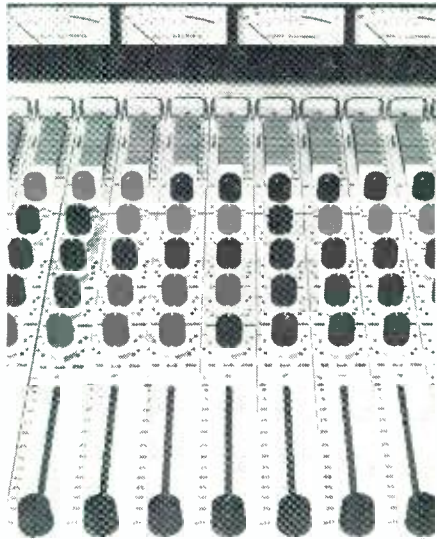

Designed primarily for recording studios, Interface Electronics mixers are also now increasingly being used in sound systems because of their flexibility, ruggedness, reliability and portability. Track masters are used as submasters (up to eight with the Series 300) and the mixdowns provide for feeding each submaster to right or left or any shading between, with mixdown masters used for right and left sound system masters.

Now in fully wired mainframes with input and output connectors and integral-lighted four inch VU meters, the Models 16X8, 24X8 and 30X8 can be supplied with Talk-Slate module for recording studio use or in a foam-lined trunk for portable use. Price of the complete 24X8 is \$10,340.00

### INTERFACE ELECTRONICS, INC.

3810 Westheimer/Houston. Texas 77027/(713) 626-1190

#### Partial List of Dealers:

**Calif:** Tri-Tronics, North Hollywood, (213) 985-6616; Bob Cohen Sound, San Francisco (415) 989-1130  
**Ill.:** Milam Audio, South Pekin (309) 348-3112; Gill Custom, Chicago (312) 598-2400  
**Iowa:** Advanced Audio, Iowa City (319) 354-3104  
**Mass.:** Terry Hanley Audio, Cambridge (617) 661-1520  
**N.Y.:** Boynton Studio, Morris (607) 263-5695; Unistage, Buffalo (716) 853-6500; Harvey Radio, New York (212) 832-8675; Martin Audio, New York (212) 541-5900; Sunset Sound, Columbus (614) 239-6945  
**Ohio:** Sunset Sound, Columbus (614) 239-6945  
**Penn.:** Short Sound Systems, Pittsburgh (412) 761-2724  
**Tenn.:** Carlo Sound, Nashville (615) 356-0202  
**Texas:** Interface Electronics, Houston (713) 626-1190; United Audio, San Antonio (512) 684-4000

Dealerships still open in some areas.



### WHITE INSTRUMENTS MODEL 4004 PASSIVE EQUALIZER

The Model 4004 Passive Equalizer is a full range one-third octave equalizer designed for professional sound reinforcement applications. High reliability components are used throughout. As a passive device, no noise is introduced. All filter sections are designed for low distortion and there is no hard clipping at high level.

There are twenty-four double-tuned constant-K notch filters on I.S.O. one-third octave centers from 63 Hz to 12.5 kHz. Each filter section provides from 0

to -15 dB of attenuation by a calibrated front panel control. The responses of two adjacent sections add smoothly without response curve ripple.

To control the ends of the spectrum, there are finishing filters which give varying degrees of roll-off. A low-cut filter with a cut-off rate of at least 15 dB/octave is adjustable from FLAT to 40 Hz through 160 Hz. A high-cut filter provides 18 dB/octave of roll-off and is adjustable from FLAT to 16 kHz through 10 kHz.

The Model 4004 is designed to be in-

serted into a 600 ohm link circuit and has less than 1 dB of insertion loss with all controls in the flat position. There is an accessory socket on the rear of the unit for plugging in a low level crossover network for bi-amping. Both 12 dB/octave and 18 dB/octave networks are available at any crossover frequency desired.

The Model 4004 Passive Equalizer has a black anodized brushed aluminum finish. It mounts in a standard 3½ inch rack space and requires 9 inches behind the panel. A front mounting security cover is furnished as standard.

The Model 4004 has a suggested list price of \$760.

WHITE INSTRUMENTS, INC., P.O. BOX 698, AUSTIN, TX 78767.

Circle No. 152

### TOP-OF-THE-LINE SOUND REINFORCEMENT FROM SUNN

Known as the Model 15, these units feature two 15" special design speakers in a front loading exponential horn for uniform bass projection, a Sunn/Magna high frequency compression driver coupled to a unique wooden radial horn for mid-range reinforcement, plus a pair of high frequency piezoelectric tweeters to insure extended treble response.

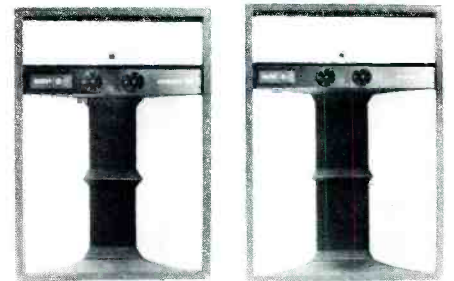

The enclosure is said to offer minimum distortion through all audio frequencies at excessive sound pressure levels with uniform dispersion and high power handling capacity (200 watts continuous).

The Sunn Model 15 is highly recommended for keyboard reinforcement, among other applications.

SUNN MUSICAL EQUIPMENT CO.,  
AMBURN INDUSTRIAL PARK,  
TUALATIN, OREGON 97062.

Circle No. 154

### THE ALEMBOIC F-2B STEREO PRE-AMPLIFIER

A two channel high quality tube-type preamp suitable for use with electric guitars, basses or any low level musical instrument pickups. Each channel features volume, bass, middle, and treble controls, and two input jacks. Inputs No. 1, when used alone, give direct access to the grids of the first stage of amplification. This feature, it is stated by the manufacturer, is the result of a special design which switches out the series resistance for the No. 1 jacks, resulting in substantially less noise than comparable

# 16:16 BIG

**Basic Features**

- 16 Input Channels
- 16 Monitor Cue Channels
- 2 Cue Busses
- 2 Echo Busses
- 8 Mixing Busses & 8 Direct Outputs
- 96 Point Patch Bay
- 5 Band-15 Frequency Equalization
- Pro or Industrial Grade Construction
- Phantom Power
- Optional Balanced Inputs or Outputs
- Optional Input Amplifiers for low level inputs

\$9775. small

There is simply not enough room to amply describe the virtues and specifications of the el-tech 1616-25 recording console in the limited space of this advertisement.

Suffice to say we believe this console to be the most outstanding value, feature for feature, in the 16 track market today.

Write or call for information and specifications today.

Distributed through

Nashville Studio Systems  
16 Music Circle South  
Nashville, Tennessee 37203

112 17th Street  
Knoxville, Tenn. 37916  
(615) 546-5509



designs incorporating series resistance. Inputs No. 2 provide 6 dB pads. Both inputs No. 1 and No. 2 on a channel may be used simultaneously, too. In this case both signals are resistively mixed in equal proportions.

Both outputs are on the rear panel, as is a third, mono, output. Also on the rear panel are the on-off switch and fuse post. The top cover is easily removable with a Phillips screwdriver for tube replacement and adjustment of the hum balance control (preset at factory).

The tone control characteristics are of a type which experience has shown to be of particular usefulness to musicians. There is no absolutely flat position.

For those musicians interested in deliberately increasing distortion, it is suggested that the two channels be cascaded (i.e., the output of one plugged into the input of the other). This may be done without risk of damage to the unit. Overall volume may then be controlled with the volume control on the power amplifier.

The F-2B Stereo Preamp may be used with any power amplifier having a line level input. The unit may be rack mounted in standard 19" racks.

Specifications: Input Sensitivity (Voltage required for line level output, using input No. 1, 1 kHz, Volume and Tone controls at Maximum); 8mV RMS. Output Level - Nominal: Line level (1 V RMS). Maximum Voltage Swing; 150 V peak-to-peak. Input Impedance: Inputs No. 1; 1 megohm; Inputs No. 2, 136 K ohm. Output Impedance: Stereo outs; 40k; Mono outs, 90 k. Tube complement: Two 7025. Fuse: 1/2 Ampere 3AG. Power Requirements: 10 Watts. Size: 1 3/4" H, 19" W, 8" D.

DISTRIBUTED BY THE LD HEATER COMPANY, BEAVERTON, OREGON

Circle No. 155

STABLE AC SOURCE COMPENSATES FOR SUPPLY VOLTAGE VARIATIONS

Frequency Technology's TDC Division, announces the Series OC1 STABLE



AC SOURCES, which provide regulated AC outputs from variable input voltage, feed stabilized voltage to critical electrical equipment. The units handle a  $\pm 15\%$  input voltage variation, reduce this input range to a modest  $\pm 3\%$  variation for subsequent loads.

The STABLE AC SOURCES are passive capacitor-transformer combinations, which use no semiconductor circuits for their compensation capability, and are offered either as separate components for Original Equipment Manufacturers (OEM), or as fully assembled units with metal case, circuit breaker protection, and input-output cables. This photo shows the OEM components; the accompanying photo illustrates the assembled unit.

Prices for the open-construction (OEM) versions rated at 2 KVA and 3 KVA are \$309 and \$438, respectively. Metal enclosed units sell for \$376 and \$479, respectively. Delivery is approxi-

mately 3 weeks after receipt of order. The STABLE AC SOURCES are available for a wide range of input and output voltages, covering all conventional utility voltage levels, as well as non-standard voltage ranges. Besides simply stabilizing a nominal supply voltage, the units may combine step-up or step-down functions as well, enabling them to match electrical equipment to supply voltages outside the design range.

FREQUENCY TECHNOLOGY, INC.,  
BOX 365, WHITCOMB AVE.,  
LITTLETON, MA 01460(617)456-3374.

Circle No. 156

### CETEC MODEL 4000 COMPRESSION DRIVER

Designed to be incorporated in new or existing loudspeaker systems where power handling capability is a must, the Gauss Model 4000 is said to appeal to both professional user and serious audiophile.

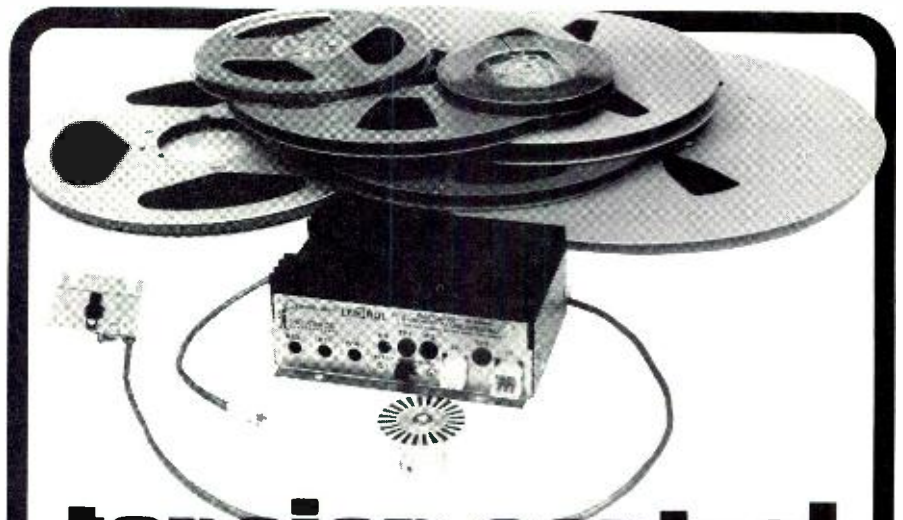

## tension control

**ATTENTION AMPEX OWNERS:** TENTROL provides constant tape tension from beginning to end of any size tape reel by controlling the torque of the supply-reel motor  Ends pitch change with reels as large as 14 inches  Extends head life  Improves high-frequency performance  Kit is easily installed in the field on nearly all Ampex professional studio recorders and tape duplicators  \$270 for Ampex AG-440C kit; \$300 for all others.

**i** INOVONICS  
INCORPORATED

1630 Dell Avenue, Campbell,  
CA 95008 (408) 374-8300

Circle No. 157

R-e/p 65

# Quincy Jones... demands quality



Photographed at RECORD PLANT, Los Angeles, CA  
 "...I mix with AURATONE® 5C Super-Sound-Cubes® the little powerhouse speakers. They tell me exactly what will be in the grooves. You hear it all with AURATONE®!"

Join "Q" and other seasoned music world pros, top record company executives, engineers, producers, and artists who lay it on the line with AURATONE®.



Durability, flat full-range response, amazing power handling, and portability have made AURATONE® 5C's the Record Industry's favorite "mixdown monitors,"...for comparison and final mixes, auditioning, remotes, and reference standard speakers.



See your Dealer or order Factory Direct (30-day return privilege, one year guarantee), \$49.95 pr. (CA add tax); Shipping/ Handling: \$3.00 pr. U.S., \$5.00 pr. outside Cont. U.S.

Mail to: AURATONE PRODUCTS  
 P.O. Box 580-C1, Del Mar, Ca. 92014  
 Ship \_\_\_\_\_ pair 5 C's. Amount Enclosed \$ \_\_\_\_\_

Name (Please print) \_\_\_\_\_ Job Title \_\_\_\_\_ Date \_\_\_\_\_

Shipping Address \_\_\_\_\_

City \_\_\_\_\_ State \_\_\_\_\_ Zip \_\_\_\_\_

Please send additional information.

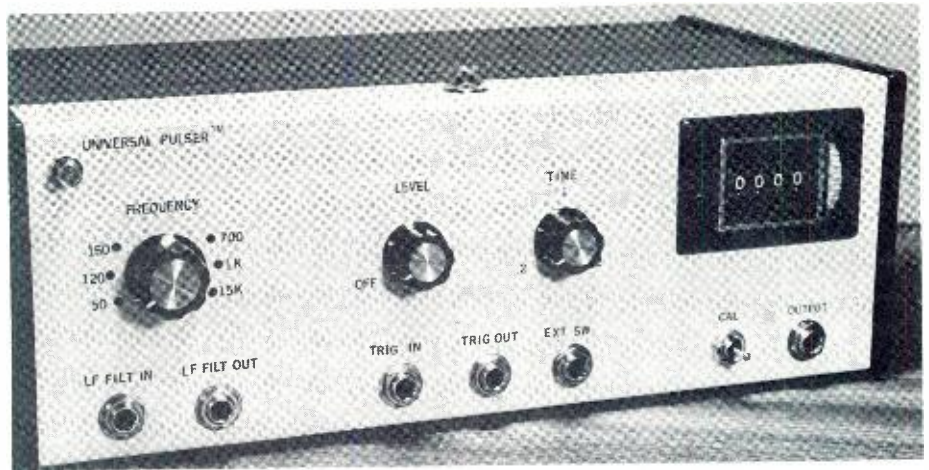

Crafted to the same rigid quality standards as other Gauss loudspeakers, specifications include a throat diameter of 2", 16 ohms nominal impedance, a usable frequency range of 500 to 12,500Hz, and flux density of 20,500 Gauss. Net weight is 29 pounds. CETEC AUDIO, 13035 SATICOY ST., NO. HOLLYWOOD, CA 91605. (213) 875-1900.

Circle No. 158

## UNIVERSAL PULSER™ A-V PROGRAMMER FROM TAPEHEADS

The Universal Pulser is an extremely versatile audio-visual programmer whose unique features make it an invaluable tool for recording studios, producers and others involved in film/slide production. It functions as a low distortion sine wave signal generator, audio-visual programmer, pulse control circuit, pulse counter, and low frequency filter.

The unit is compatible with all single-pulse film/slide show formats, including audible systems (700 Hz, 1 kHz), inaudible systems (50 Hz, 120 Hz), and systems which require a 150 Hz stop pulse. In addition, an internal trigger circuit automatically transposes pulse frequencies from one tape machine to another - provided the original chimes or pulses are recorded on a separate track. When triggered from a pulsed tape recording, the control circuit may be used to cycle a second pulser, projectors, or any other electronic equipment.

Other features include: Filter for suppressing low frequencies in music or voice tracks which might otherwise cause misfiring of projectors utilizing the 50 Hz pulsing format. Fully adjustable pulse length (0.2 to 2.0 seconds). 15 kHz test tone and calibration switch to facilitate tape machine and equipment alignment. Automatic four digit pulse counter which accumulates either internally or externally generated pulses.

Specifications: Integrated circuitry with calibrated notch filters. Output amplitude remains within 1 dB across the frequency range. No warm-up time required. Sine wave harmonic distortion

is less than .5%. Output level is 0-4 volts PP. Output impedance is 600 Ohms, unbalanced. Timer: R-C relay circuit, adjustable .2 - 2 seconds. Trig-out: contacts rated 125 volts, 3 amps. Trig-in: high impedance 50 Hz - 20 kHz, .75 volts minimum. High pass filter: -30 dB @ 50 Hz, high impedance.

The Universal Pulser is delivered with a two year warranty. Dimensions: 4" x 12" x 6". Weight: 3 lbs. Price: \$399.95. TAPEHEADS, 4020 BEECHER ST., N. W., WASHINGTON, D.C. 20007 (202) 338-6610.

Circle No. 159

## BEYER DYNAMIC SOUND TO-INFRA-RED-TO SOUND TRANSMISSION COMPONENTS

Revox Corporation announces the release of a number of Beyer Dynamic components for sound to-infrared-to sound transmission technique.

This transmission method uses invisible light radiation and, therefore, the usual problems of RF pick up, etc. experienced with inductive loop and normal carrier wave systems are non-existent.

### Infrared transmitter IS76

This year, a number of German television manufacturers have shown television sets with built-in infrared transmitters. For televisions and other devices not so equipped, Beyer Dynamic offer an elegantly styled transmitter which contains (visible on the front plate) ten transmitter diodes in line, specially equipped with back reflectors.

With the aid of a special output control unit, the transmitter can be adapted to a variety of output characteristics from hi fi systems to radios and even a high impedance microphone; an LED being used as a peak indicator.

### Infrared receiver IE76

This receiver has been developed for use with existing headphones. The IE76 receiver is a small pocket size device that can either be worn, using the attached neck cord or pocket clip or can simply be placed by the listener's chair. The receiver includes a headphone socket, on/off switch and volume control and is

fitted with two diodes with special lenses to accept the light waves from the transmitter together with indirect (reflected) light waves which are then transmitted to the demodulator circuitry. The IE76 can be used with the Beyer transmitter IS76 or with infrared transmitters of other manufacture.

The IS76 transmitter, in fact, allows for the 'cascading' of various auxiliary transmitters so that even, for example, large film studios can be covered with infrared rays with none of the interference problems that can be experienced with conventional inductive loop and radio systems. Infrared transmission opens the door to many new and exciting possibilities.



**Technical data:**

Carrier frequency: 95 kHz  
 Modulation mode: FM  
 Maximum deviation: 30 kHz at 30mV/  
 100 Kohms

Frequency range: At least 40-10000 Hz  
 Distortion: Better than 1.5%

Infrared receiving headphone DT444

This new headphone features a built-in receiver similar to the Beyer Dynamic IE76. The receiver is powered by a nine volt rechargeable battery.

Professional net Prices:

Infrared transmitter IS76: \$92.50  
 Infrared receiver IE76: \$76.00  
 Infrared receiving headphone DT444:  
 \$119.50

Charging unit for IE76 and DT444  
 (LSG3): \$12.50

REVOX CORP., 155 MICHAEL DR.,  
 SYOSSET, NY 11791 (516)364-1900.

Circle No. 161

**Classified**

**CLASSIFIED ADVERTISING  
 RATES**

Prepaid\* with submitted copy:

One column inch (1" X 2 1/4") . . . \$35.00

1/2 column inch (1/2" x 2 1/4") . . . 20.00

\* (If billing is required add 20%)

**SERVICES:**

**AVAILABLE SERVICES:** Milam Audio Co. specializes in every phase of professional studio wiring. From complete systems to individual pre-wired parts and components. Available from stock; Patch Bays; Custom Mike Panels; Multi Paired Cabling and Harnesses; etc.

**MILAM AUDIO CO.**  
 1504 N. Eighth Street  
 Pekin, Illinois 61554  
 (309) 346-3161

**CASSETTE DUPLICATION** —  
 any quantity, any length,  
 mono or stereo.  
**CANTOR PRODUCTIONS**  
 26 W. Nottingham Road  
 Dayton, Ohio 45405  
 (513) 277-6571

**CUSTOM CASSETTE LABELS**  
 1,000 Labels Alike, \$36.50. 1,000  
 Labels split 500 per side, \$54.50. Maxi-  
 mum 50 words per side. Black/blue ink.  
 Two week delivery. Shipping 10%.  
**TARZAC**  
 638 Muskogee Avenue  
 Norfolk, Virginia 23509

**FOR RENT**

**RENT YOUR EXTRA AUDIO**

- 16 Track Machines
- Consoles
- Outboard Equipment
- Remote Facilities

**R S C**  
 (213) 461-9722

**EQUIPMENT**

**ONE STOP FOR ALL YOUR PROFESSIONAL  
 AUDIO REQUIREMENTS  
 BOTTOM LINE ORIENTED  
 F. T. C. BREWER COMPANY**  
 P. O. Box 8057, Pensacola, Florida. 32505

**SPLICE TAPE FASTER, BETTER, BY  
 SHEARING.** Experts recommend NAGY  
 SPLICERS. Quality, long-lasting instru-  
 ments. Reasonably priced. Details:  
**NRPR / Box 289**  
**McLean, VA 22101**

**HANDBOOK OF MULTICHANNEL  
 RECORDING**

by F. Alton Everest

320 pages 201 illustrations

The book that covers it all . . . a comprehensive guide to all facets of multi-track recording . . . acoustics . . . construction . . . studio design . . . equipment . . . techniques . . . and much, much more.

**Hardbound \$10.95 Paperback \$7.95**  
 send check or money order to:

**R-e/p BOOKS**  
 P.O. BOX 2449  
 HOLLYWOOD, CA 90028

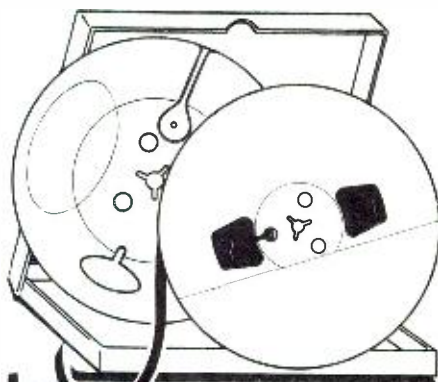

**complete  
 supplies for  
 reel to reel  
 audio recording**

**TAPE** **AMPEX** and **Scotch**  
 all professional grades  
 on reels or on hubs

**EMPTY REELS** all sizes, widths  
 and hub types

**BOXES** for all reels, in various colors

**LEADER-,TIMING-& SPLICING TAPES**

Top Quality Competitive Pricing  
 Immediate Shipment  
 Call or Write for our Catalog

**recording supply corp.**  
 1291 RAND RD -DES PLAINES, IL 60016  
 312/297-0955

Circle No. 163

**send for  
 FREE CATALOG  
 audio accessories**

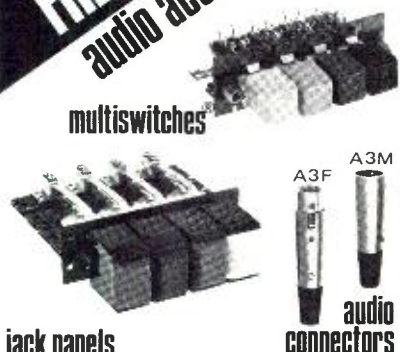

**CALIFORNIA SWITCH & SIGNAL**  
 A complete line of audio accessories  
 OEM Prices • Immediate Delivery  
 1009 W. Arbor Vitae, Inglewood,  
 California 90301 (213) 776-3554

Circle No. 164

# The Great Gain Getter!

The Universal Audio Model 560 Feedback Suppressor is a low-cost sound reinforcement tool for increasing gain before "howlback" in sound systems. Ideal for use in meeting rooms, schools and churches. Microphone or line-level input and output permits insertion between mike and amplifier or in line-level circuits. By centering the 560's four 1/6 octave notch filters on the system's most prominent resonant frequencies, gain can be increased up to 12 dB and intelligibility significantly improved. Each filter is tunable, 60 Hz to 6000 Hz in two ranges. Notch depth is adjustable to -20 dB.

The 560 can also improve broadband and/or 1/3 octave equalization methods by providing final "tweaking" of microphone proximity effects and troublesome residual resonances. UREI quality, of course.



11922 Valerio Street, No. Hollywood, California 91605  
(213) 764-1500

Exclusive export agent: Gotham Export Corporation, New York

Circle No. 165

## EQUIPMENT (continued)

### FREE CATALOG & AUDIO APPLICATIONS



CONSOLES  
KITS & WIRED  
AMPLIFIERS  
MIC, EQ, ACN,  
LINE, TAPE, DISC,  
POWER  
OSCILLATORS  
AUDIO  
TAPE BIAS  
POWER SUPPLIES

**OPAMP LABS, INC.**  
1033 N STAMFORD AVE  
LOS ANGELES, CALIF 90038  
(213) 934-3560

Circle No. 167

### AUDIO PRO CLEANER

The sensational new cleaner that eats up studio grime, makes your equipment look like new, cleans heads, tape guides, capstans . . . and everything else in the studio! Send \$11.95 for one gallon plus 8 oz. sprayer post paid to:

**AUDIOTECHNIQUES, INC.**  
142 HAMILTON AVE.  
STAMFORD, CONN. 06902  
(203) 359-2312

Small Studio/Road Package — AKAI GX400DSS 4 chan. sync, 15 hrs. old. Revox A77 1102HS 2 chan. master. Gately Pro II 6x2 pan mixer & Gately SM6-mixer, EK6-Echo, EQ6-EQ. \$3000.

**EAPCO, BOX 83**  
GLOVERSVILLE, NY 12078

FOR SALE: Spectra Sonics 1020-8/16 Console 16 track monitoring; 15 frequency select (Lo, Mid, Hi) stage E.Q. \$18,000.00.

Total Experience Recording Studios  
6226 Yucca Street  
Hollywood, CA 90028  
462-6585

### MCI . . . DOLBY

Two Great Names!

Two Great Products!

For Authorized Factory Representation in the Progressive Midwest, Contact:

**JERRY MILAM**  
MILAM AUDIO CO.  
700 W. Main Street  
So. Pekin, IL 61564  
(309) 348-3112 / 348-9605

MCI . . . Now the best selling multi-track recorder!

MCI . . . only from Audiotechniques, Inc. in the great northeast!

Tape recorders from one track to 24 track

Recording consoles up to 40 input

MCI sales-service  
factory trained technicians  
Studio design and  
construction service

**AUDIOTECHNIQUES, INC.**  
142 Hamilton Avenue  
Stamford, Conn. 06902  
(203) 359-2312

## MULTI-TRACK

- ★ SERIES "B" MIXING CONSOLE
- ★ VARI-BAND 5 SECTION PARAMETERIC EQUALIZER
- ★ DUAL EQUALIZED REVERB
- ★ LONG & SHORT THROW SLIDE FADERS
- ★ HIGH BALLISTIC VU METER

P.O. BOX 3187  
HOLLYWOOD, CA 90028  
(213) 467-7890

Circle No. 169

High Intensity tuned sound reinforcement systems, including narrow band (5Hz) feedback suppression, detailed regenerative response room equalization  $\pm 1$ dB, <15% articulation loss of consonants. 1000's of customized professional products, all shipped prepaid/insured.

**Music & Sound Ltd.,** 11½ Old York Rd., Willow Grove, PA 19090  
(215) 659-9251  
Inventors / Engineers

FOR SALE: PROFESSIONAL CUSTOM CONSOLE for small quality four track studio. 12 in 5 out. Complete cue system. Matrix monitoring, talk back, Pan, 4 echo, 4 speaker monitoring system. All above in beautiful walnut console . . . Gately components, 6 large API meters. Low price. Photograph sent on request. 2 yrs. old. Mint condition.

**RBY RECORDING**  
190 Chestnut Dr., Roslyn, NY  
(516) 621-8211

### FOR SALE OR LEASE:

Complete professional recording studio, good voice & music clientele, mid Manhattan. 4 track w/8 track additions (Scully machines). Includes musical instruments. WRITE:

BOX 235  
SCARBOROUGH, NY 10510

### FOR SALE

**SPECTRA SONICS 1020 CONSOLE**  
20x8+4, 2 cue systems, on connectors ready to plug in, \$12,500. Stantron racks, remote cables, power supplies, amps; best offer.

**LARRABEE SOUND STUDIOS**  
8811 Santa Monica Blvd.  
Los Angeles, CA 90069 (213) 657-6750

FOR SALE: MCI JH-416 18 in/out Console, latest model with large producer area — No. 18,600. Replacing with new MCI 528 Automated Console. 604E's with electronic crossovers, amplifiers & enclosures. \$400 ea., complete. New list \$850 ea.

**SOUND 80, INC.**  
2709 E. 25th Street  
Minneapolis, MN 55406  
612/721-6341

## Snakes & Cables



Professional  
Quality  
& Construction

Factory  
Direct Prices

(example: 100 foot XL-type cable — Belden 8412 with Switchcraft A3 connectors \$34.95 prepaid)

Orders processed same day  
COD's accepted

Write for free catalog and price list, with full information on other assorted goodies in little black boxes.



**Windt Audio Engineering**  
13026 Saticoy St., No. 4  
N. Hollywood, CA 91605  
(213) 768-0100

Circle No. 166

**ATTENTION**

MCI 8, 16, 24 track owners

**MCI SPARE PARTS KIT**

A specially assembled kit to provide parts support for the MCI JH-16 recorder in 8, 16, or 24 track configurations. Audiotechniques, Inc. has packaged this kit in a handy rigid plastic compartment case with parts index and re-order form. A regular \$385 value, we'll ship it anywhere in the U.S. prepaid for \$325. C.O.D. or check in advance only.

**AUDIOTECHNIQUES, INC.**  
142 Hamilton Avenue  
Stamford, Conn. 06902  
(203) 359-2312

16 x 16 Custom Console Spectrasonic components, \$12,500. Four Shure M67s, four M63s, one M68, and one M688 Stereo Mixer with four pan pots, assembled as four track console, \$800.

**FIFTH FLOOR STUDIOS**  
517 W. Third  
Cincinnati, O. 45202  
(513) 651-1871

Community Light & Sound Professional fibreglas sound reinforcement products.

**BRANDY BROOK AUDIO**  
P.O. Box 165  
Seymour, CN  
(203) 888-7702

**CONSOLE:** Spectrasonics Custom Console . . . 24 input, 16 buss, 24 track monitor, 6 echo returns, 2 ques. 16 light beam VU meters, total of 80 slide attenuators, many gold records, looks & operates like new, original written S/S bid: \$59,080.00; sell for \$17,750.00. Photo enclosed. Financing available. Contact:

**BRIAN**  
Paramount Recording Studios  
L.A. (213) 461-3717

Used set of heads for 16 track Scully M-100 (Erase, Rec-Play) (channel 3 may not play back). . . . . 800.00  
Used Capstan motor for Scully M-100 16 track . . . . . 225.00  
Pinch roller for Scully M-100 16 track (like new) . . . . . 50.00  
Neuman Es59 Disc Cutter Head (3) like new . . . . . 200.00  
Presto Disc Recording Amp . . . . . 85.00  
Cinema equaliser 4031B . . . . . 130.00  
Shure M67 mixers. . . . . ea. 110.00  
Sony C37A mic . . . . . 190.00  
Berlant Concertone 2 track in portable cases like new . . . . . 250.00  
RCA 44BX. . . . . 100.00  
RCA 44BX style (Military) model PB90A2 Serial No. 2107. . . . . 70.00  
McIntosh audio compensater (2) Model C-4 . . . . . ea. 35.00  
Telex rec-play electronics RP84. . . . . 85.00  
Leslie combo pre amp model 020875 . . . . . 85.00  
Pioneer Reverb Sr202 . . . . . 70.00  
(513) 522-9336

**FOR SALE:**

2 MCI 416 consoles 24 in/out. Input modules modified to include latest improvements for increased headroom and lower noise distortion. EQ modified for mid range boost/cut function. Matching custom producers desk and connecting right angle rack for outboard gear included. Very impressive package.  
. . . . . \$19,000.00 ea.

Scully mono lathe. Westrex 2B mono head. Fairchild 660. Fairchild 600 Hi-frequency Pultec EQP-1A. Pultec MEQ-5 mid range. Haeco monitor & Cutter electronics. Custom monitor panel. . . . . \$5,000.00

Westrex 3D II A stereo cutter head and RA-1700/3D II AH Amplifier. Haeco low frequency crossover and custom monitor panel. . . . . \$7,500.00

**CHEROKEE RECORDING STUDIOS**  
751 N. Fairfax Avenue  
Los Angeles, CA 90046  
(213) 653-3412

**MAXELL RECORDING TAPE. ALL WIDTHS.** Best prices. Write NOW, and SAVE.

**N.A.B. AUDIO**  
P.O. Box 7, Ottawa, IL 61350

**For Sale:** Ampex PR-10-2 portable; Ampex 351 R/P electronics; or trade complete 351 mono and the PR-10 for a large 2 trk. Also Electrocomp EML 500 synthesizer (modf'd for use with external modules, sequencers...).  
Call: Tim (214) 368-8530 or 368-6846

**JBL CROSSOVER NETWORKS,** Model 3110, New, Original box, close out price \$48.00 each.  
**IPEC, 1032 N. Orange Drive**  
Hollywood, CA 90038  
(213) 462-2376

**One Way Noise Reduction (10-14dB)** for cutting rooms / tape copies; + monitor equalizers at \$75/channel; + free room equalization with purchase of 1/3 octave filters; + 1000's of state of the art studio products, customized - aligned - calibrated - biased, etc. **Music & Sound Ltd.,** 11 1/2 Old York Rd., Willow Grove, PA 19090. (215) 659-9251.  
**All Shipped Prepaid/Insured**

**AUTOMATED QUAD PANNING**  
THE UNIQUE AQC SYSTEM (PAT. APPLIED FOR)  
CAN DO WHAT HANDS CANNOT  
4, 8, 16 & 24 INPUTS  
**VIDEO & AUDIO ARTISTRY CORP.**  
p.o. box 4571, boulder, colorado 80302  
(303) 499-2001

**FOR SALE:** New 14" NAB Ampex aluminum flanges have never been removed from original box. Package of 10 - \$8.00 prepaid. **SOUND INVESTMENT CO.,** POB 338, DUNWOODY, GA. 30338.

**Your oscilloscope can be a Real Time Audio Analyser. Add ARA-412.**



**ARA-412 Acoustic Response Analyser.**

Now you can perform Real Time Audio Analysis with just three things — (1) your dc oscilloscope, (2) a "pink noise" source, and (3) the new ARA-412. This unique, easy-to-use instrument permits you to test microphones . . . isolate cross talk . . . balance crossovers . . . check loudspeaker deficiencies . . . test tone controls . . . adjust equalization . . . and much more. The ARA-412 is priced at **\$1,450**

For additional applications, write for the free ARA-412 data sheet: (FOB San Diego)

**COMMUNICATIONS COMPANY inc.**

3490 Noell Street  
San Diego, CA 92110  
Telephone (714) 297-3261

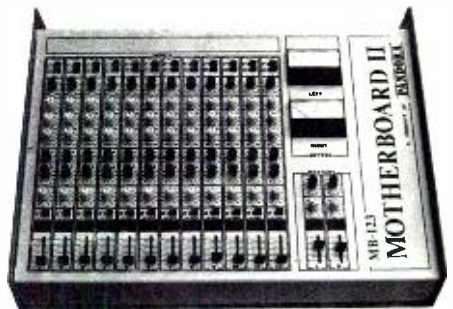

by request **ANOTHER MOTHER**

This new P.A. Mixer is equipped with low Z mike inputs, switchable line inputs, LED Overload indicators, switchable 20 dB mike pads, channel on switch, 3 range reciprocal EQ, two send systems, full panning, mike trims, stage monitor feeds, echo returns, and state of the art signal processing.

Put them all together they spell Mother

**MOTHERBOARD II**

**PANDORA SYSTEMS INCORPORATED**  
P.O. BOX 964 • NASHVILLE, TENNESSEE 37202 • (615) 320-0623

Circle No. 170

Circle No. 171

**TRAIN FOR CAREERS AS**

- Recording Engineer
- Record Co. Executive
- Producer

**WE TEACH**

- Audio Engineering
- Recording Techniques
- Music for Producers & Engineers
- Music & Copyright Law
- Record Business and Finance
- Synthesizer and Disc Mastering

LEARN FROM PROFESSIONALS IN A COMMERCIAL 16-TRACK STUDIO.

**APPLY NOW**  
NEW SEMESTER STARTING FEBRUARY 10

**COLLEGE FOR RECORDING ARTS**

(Licensed by California State Board of Education, Approved by the National Academy of Recording Arts & Sciences Institute.)

665 Harrison St., San Francisco 94107  
(415) 781-6306

**PROKITS** — Your best value in low cost mixing equipment.

**MICROMIXER** — Up to 16 inputs, EQ, separate monitor mix, mic pad, mute, etc. PA and Stereo versions.

**GATELY ELECTRONICS**  
57 W. Hillcrest Avenue  
Havertown, PA 19083  
(215) 449-6400

**WANTED: Studer Model A-80.**  
Paramount Recording Studios  
(213) 461-3717 L.A.

**MAJOR US SOUND SERVICE**

Annual Inventory Turnover  
**\$300,000.00**

Inventory Available for Immediate Delivery  
Write for Detailed Listing of Industrial and Musical Sound Equipment  
**STANAL SOUND LTD.**

816 East 25th, P.O. Box 396  
Kearney, Nebr. 68847  
308-237-2207

**EMPLOYMENT**

Experienced mixer/engineer, formerly with Wally Heider Recording and top Nashville studios, seeking to relocate, preferably in a smaller city. Strong musical background and managerial experience.

Call (916) 362-2863

**MAJOR N.Y. STUDIO ADDING EXPERIENCED MUSIC MIXERS.**

Send Resume to:  
RECORDING-engineer/producer  
Box 2449, Dept. N  
Hollywood, CA 90028

**WANTED: AUDIO ENGINEER**

Experienced, mature, audio editor with following for busy mid-town NY A/V and radio production studio. Do your own thing and handle overflow from our main facility. Will consider percentage and/or HR./MO. deal.

Write: **RECORDING-engineer/producer**  
P.O.Box 2449, Dept. SH  
Hollywood, CA 90028

*continued from page 13...*

combine some of the activities now carried out in London with those of the present Dolby office in New York, which will be closed shortly after the San Francisco office opens in January 1976, at 731 Samsome Street (415/391-8892). The new office will have the functions of research and development, new market development, licensing, and U.S. sales of dolby professional noise reduction equipment manufactured in London. The company's policy of specialization in noise reduction technology will remain unchanged.

San Francisco executives will comprise Dr. Ray Dolby, President; David Robinson, Vice President Engineering; Ioan Allen, Vice President Marketing; Ian Hardcastle, Vice President Licensing; and John Gladysiewicz, Vice President Finance and Administration. Morley Kahn, who has been Vice President, Manager of U.S. Operations at the New York office for the past four years, is leaving the company at the end of January.

The Dolby factory and offices in London will be responsible for manufacturing and international sales of the company's professional noise reduction products. London executives will be: Gary Holt, General Manager; Bob Tallon, Production Manager; Elmar Stetter, International Sales Manager; and John Lewis-Crosby, Controller of Finance and Administration.

Sales and service of professional Dolby products in the New York area will continue through the company's distributors, Audio-Techniques and Martin Audio. For special Dolby projects on the East Coast, George Schowerer, a member of the present New York office, will remain in the New York area. In Los Angeles, Steve Katz will be joined by Phil boole from London to strengthen the company's efforts in the film industry.

*continued from page 43...*

**BOOK REVIEW  
SOUND SYSTEM ENGINEERING**

coverage, the acoustic environment, designing for acoustic gain and interfacing the electrical and acoustical systems are topics discussed in the succeeding chapters.

Chapter 7 covers installing the sound system. Circuit levels, grounding and shielding, serving cable, useful wiring concepts, impedance matching, fundamentals of time delay, and proofing the installed system are explained in depth.

Next the authors discuss equalizing the sound system, instrumentation, sample design application, and specifications. The many appendices give symbols and abbreviations, recommended installation practices, priority systems, definitions of terms, test questions and answers, and other useful reference information.

To supplement the text material, this complete guide to sound system engineering is filled with drawings, photographs, charts, graphs and tables.

**SOUND SYSTEM ENGINEERING**, No. 21156 (ISBN: 0-672-21156-4). Size: 296 pages; 8½ x 11, hardbound. Price: \$19.95pp.

**SOUND SYSTEM ENGINEERING** is available from R-e/p Books. Send check or money order for \$19.95 (US) to: R-e/p Books, Box 2449, Hollywood, CA 90028

Send for...

DISC McGROOVE'S...



NOW THAT YOU'RE READY TO GO TO PRESS...

Top quality... from MASTERING... to the PACKAGED DISC... at an all inclusive affordable price.

**a+r record manufacturing corporation**

902 NO. INDUSTRIAL BL.  
DALLAS, TX 75207 (214) 741-2027



# Meticulous Attention to Detail

## It speaks for itself

### HARRISON 3232 MASTER RECORDING CONSOLE TYPICAL PERFORMANCE CHARACTERISTICS

Measurements quoted are typical of a 24 input console and are the average of 10 input modules measured in serial #001. In no case were any individual distortion figures 50% more. All noise measurements were within 1 db and all crosstalk was within 2 db of the average. Unless otherwise stated, all measurements were taken with VCA set for unity gain and mike trim adjusted so that a -50 dbm input at 1 KHZ produced a +4 dbm output signal. Inputs not driven were terminated with a 150 ohm resistor. All measurements were taken with all VCA's, transformers, etc. in place.

Mike Preamp Equivalent Input Noise  
(20 KHZ Bandwidth) -127.5 dbm

Output Signal to Noise (20 KHZ Bandwidth)  
(-50dbm Input Set For +4 Out) 77.5db

IM Distortion of Mike Preamp with +2dbm Input  
(equivalent to Sine Wave + 4)  
Set to Produce +24 Out .008%

IM Distortion Total Channel  
(-50dbm in, +4dbm output .05%)  
(-30dbm in, +24dbm output .15%)

Crosstalk with all inputs assigned  
to their respective outputs;  
inputs on either side of measured output driven  
(10KHZ -82db) (1KHZ -85db) (100HZ -85db)

Crosstalk with adjacent input modules  
assigned to each other  
(10KHZ -78db) (1KHZ -83db) (100HZ -84)

Frequency Response (20HZ to 20KHZ)  
Ref 1KHZ (+0 -1db)

Head Room (output set below threshold  
of clipping or triangulation)

10K Load (20HZ +28.5dbm)  
(1KHZ +28.5dbm)  
(20KHZ +28dbm)

600 Ohm Load (20HZ +25.5dbm)  
(1 KHZ +25.5dbm)  
(20KH +25dbm)

Source Resistance of Line Outputs  
(all frequencies 20HZ to 20KHZ) 60 ohm

Level Change at Output  
(600 ohm Term to 10K Term) .85db

Specifications  
subject to change without notice.

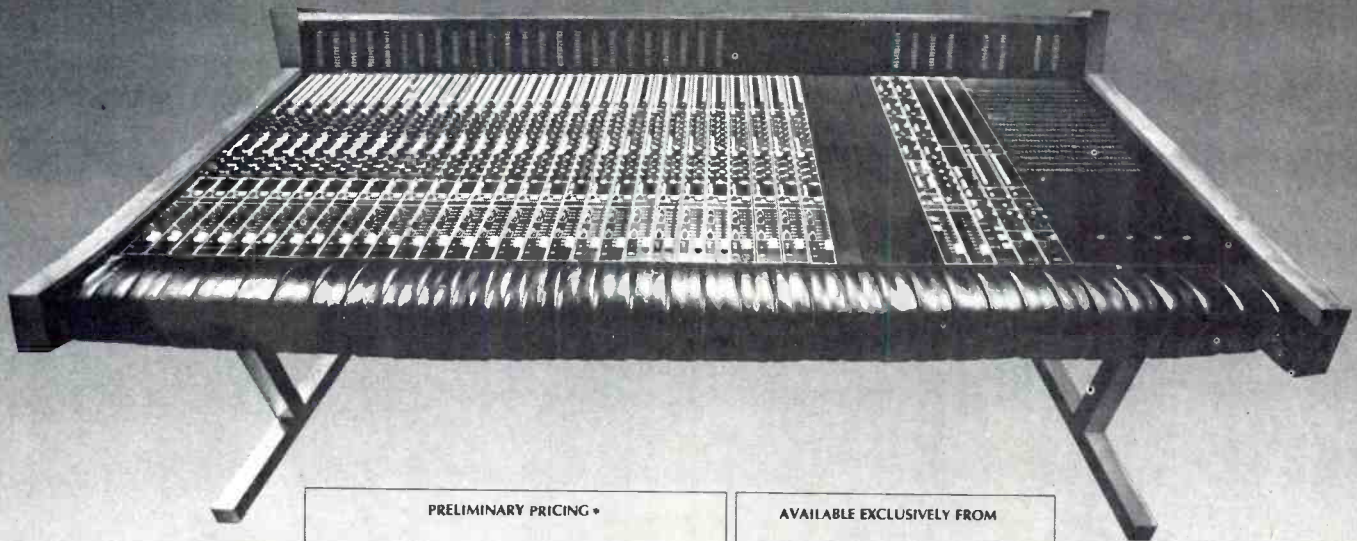

#### PRELIMINARY PRICING\*

16 in 16 out	\$40,432.00
24 in 24 out	53,000.00
32 in 32 out	65,680.00
Extra I/O modules	1,435.00
Extra light meters	150.00
Custom signal flow	Individually quoted
Automation (allison)	Individually quoted

\*All prices, FOB Nashville, include installation into a prepared facility within the continental U.S., subject to change without notice.

#### AVAILABLE EXCLUSIVELY FROM

Studio Supply Co—(615) 327-3075  
Box 280—Nashville, TN 37202  
Westlake Audio—(213) 655-0303  
6311 Wilshire Blvd. Los Angeles, Cal. 90048  
Scenic Sounds—London  
3M—France—Paris  
Continental Far East—Tokyo

Call today for details

## NO COMPROMISE

# Harrison

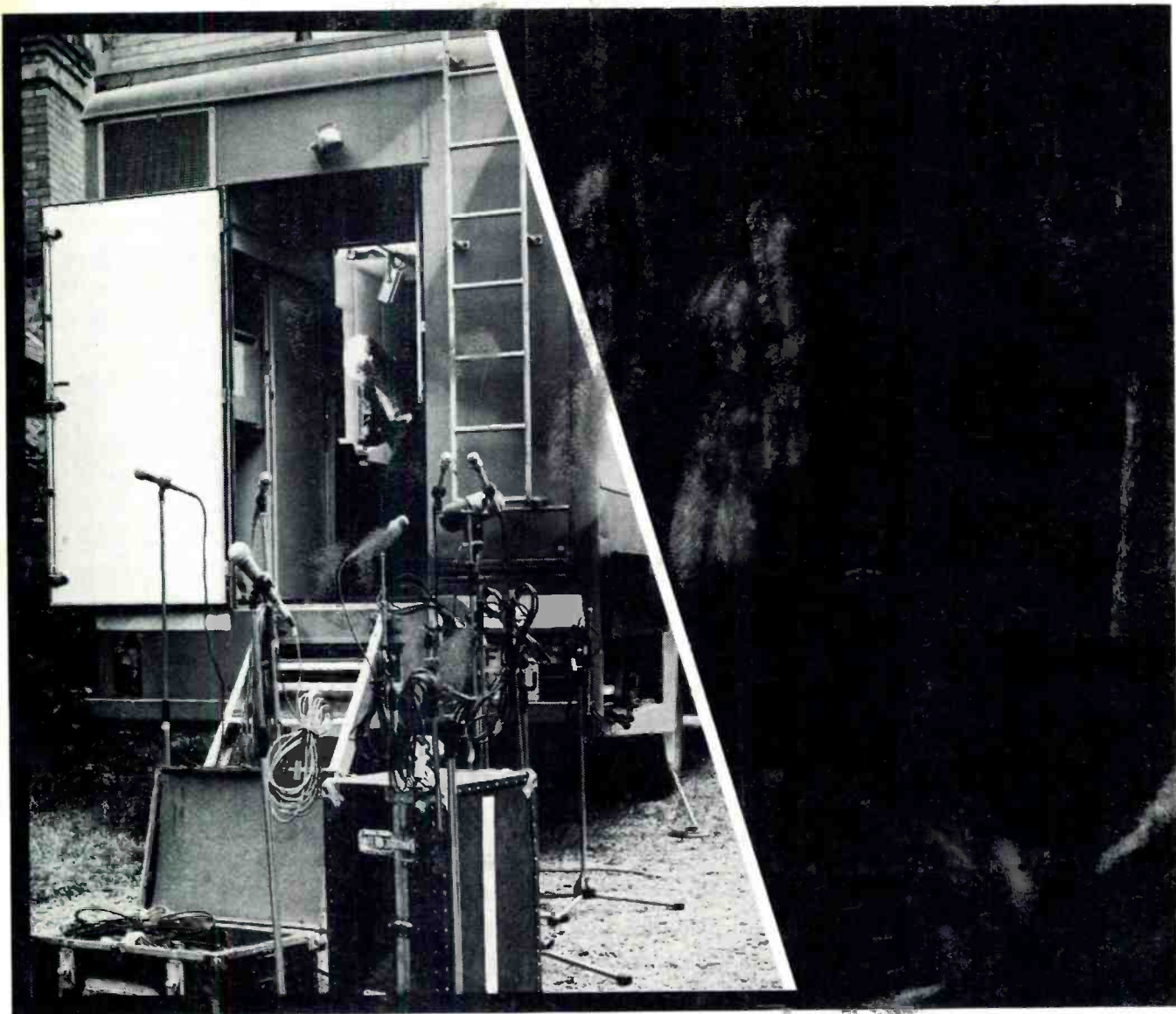

## Stones' Rolling Studio.



A complete recording studio in a van? For Mick Jagger, it's almost a necessity. Mick and the Stones can be inspired to produce their next hit anytime; but when they're on tour or vacationing, the best recording studios aren't always around the corner. For these moments of midnight inspiration, the Stones rely on their Shure-equipped mobile studio for the unmatched recording perfection they insist upon. Whether in a recording session or on stage, the Stones' Shure SM53, SM58, SM5C, SM33, and SM54 microphones are their assurance of consistent quality and natural sound.

Shure Brothers Inc.  
222 Hartrey Ave., Evanston, IL 60204  
In Canada: A. C. Simmonds & Sons Limited



Manufacturers of high fidelity components, microphones, sound systems and related circuitry.

Circle No. 175