

JOURNAL OF THE A. I. E. E.

MARCH *1925* 1925



PUBLISHED MONTHLY BY THE
AMERICAN INSTITUTE OF ELECTRICAL ENGINEERS
33 WEST 39TH ST.
NEW YORK CITY

American Institute of Electrical Engineers

COMING MEETINGS

Spring Convention, St. Louis, April 13-17

Annual Convention, Saratoga Springs, June 22-26

Pacific Coast Convention, Seattle, Wash., September 15-17

Regional Convention District No. 1, Swampscott, Mass., May 7-9

MEETINGS OF OTHER SOCIETIES

The American Physical Society, Pasadena, March 7

Illinois State Electric Association, Hotel Sherman, Chicago, March 18-19

Southwestern Div. N. E. L. A., Eastman Hotel, Hot Springs, Ark., April 21-24:
Middle West Div. Omaha, May 20-22

American Electrochemical Society, Niagara Falls, N. Y., April 23-25

American Association of Engineers, Orlando, Fla., June 2-5

National Electric Light Association, San Francisco, June 15-19

JOURNAL

OF THE

American Institute of Electrical Engineers

PUBLISHED MONTHLY BY THE AMERICAN INSTITUTE OF ELECTRICAL ENGINEERS
33 West 39th Street, New York

Subscription. \$10.00 per year to United States, Mexico, Cuba, Porto Rico, Hawaii and the Phillipines, \$10.50 to Canada and \$11.00 to all other Countries. Single copies \$1.00.

Entered as matter of the second class at the Post Office, New York, N. Y., May 10, 1905, under the Act of Congress, March 3, 1879. Acceptance for mailing at special rate of postage provided for in Section 1103, Act of October 3, 1917, authorized on August 3, 1918.

Vol. XLIV

MARCH, 1925

Number 3

TABLE OF CONTENTS

Papers, Discussions, Reports, Etc.

<p>Notes and Announcements..... 211</p> <p>Voice-Frequency Carrier Telegraph System for Cables, by B. P. Hamilton, H. Nyquist, M. B. Long and W. A. Phelps..... 213</p> <p>Broadcasting Progress in Europe..... 218</p> <p>Corona in Oil, by A. C. Crago and J. K. Hodnette..... 219</p> <p>First Installation "Director" Telephone Equipment..... 222</p> <p>Polarized Telegraph Relays, by J. R. Fry and L. A. Gardner..... 223</p> <p>Revisions in National Code..... 228</p> <p>Power System Transients, by V. Bush and R. D. Booth..... 229</p> <p>Decreasing Cost of Electricity..... 240</p> <p>Temperature Errors in Induction Watthour Meters, by I. F. Kinnard and H. T. Faus..... 241</p> <p>Historical Review of Electrical Applications on Shipboard, by H. L. Hibbard and Wm. Hetherington, Jr..... 249</p> <p>Discussion at Annual Convention</p> <p style="padding-left: 20px;">Papers on Automatic Stations (Bany, Wallau, Butcher, Wyatt, Wensley, Place)..... 263</p> <p style="padding-left: 20px;">Papers on Current-Limiting Reactors (Oesterreicher, Stephens and Kierstead, Dann, Boyajian, Blake)..... 270</p> <p style="padding-left: 20px;">A 35,000-kw. Induction Frequency Converter (Shirley)..... 276</p> <p style="padding-left: 20px;">The Inertaire Transformer (Dann and Kellogg)..... 278</p> <p style="padding-left: 20px;">Theory and Calculation of the Squirrel-Cage Repulsion Motor (West)..... 280</p> <p style="padding-left: 20px;">The Transmission Unit and Telephone Transmission Reference Systems (Martin)..... 282</p> <p style="padding-left: 20px;">The Transient Visualizer (Turner)..... 283</p>	<p style="padding-left: 20px;">Temperature Rise of Stationary Electrical Apparatus As Influenced by Radiation, Convection and Altitude (Montsinger and Cooney)..... 283</p> <p style="padding-left: 20px;">Effect of Altitude on Temperature Rise (Doherty and Carter)..... 283</p> <p style="padding-left: 20px;">Underground Alternating-Current Network Distribution for Central Station Systems (Kehoe)..... 288</p> <p style="padding-left: 20px;">General Light and Power Supply of Chicago (Armhurst and Jackson)..... 288</p> <p style="padding-left: 20px;">A Study of Underground Distribution Systems for the City of New Orleans (Bullard)..... 288</p> <p style="padding-left: 20px;">Equivalent Single-Phase Networks for Calculating Short-Circuit Currents Due to Grounds on Three-Phase Star Grounded Systems (Shetzline)..... 293</p> <p style="padding-left: 20px;">Standardization in Construction and Operation as Applied to Light and Power Companies (Sindeband)..... 295</p> <p style="padding-left: 20px;">Dielectric Field in an Electric Power Cable—II (Atkinson)..... 295</p> <p style="padding-left: 20px;">Potential Gradient and Flux Density (Douglas and Kane)..... 295</p> <p style="padding-left: 20px;">Some Notes on Street Lighting (Millar)..... 296</p> <p style="padding-left: 20px;">Selective Circuits and Static Interference (Carson)..... 297</p> <p style="padding-left: 20px;">The Direct Method of Calculation of Capacitance on Conductors (Dwight)..... 299</p> <p style="padding-left: 20px;">Insulator Test Specifications..... 300</p> <p style="padding-left: 20px;">Illumination Items</p> <p style="padding-left: 40px;">Daylight Reflection Facts..... 204</p> <p style="padding-left: 40px;">Sitting in a Draft and Facing Glaring Light Sources..... 204</p>
--	--

Institute and Related Activities

<p>Program for the Spring Convention..... 305</p> <p>Cleveland Regional Meeting Postponed..... 307</p> <p>One-Day Convention for Students to be held in Philadelphia..... 307</p> <p>Future Sections Meetings..... 307</p> <p>A. I. E. E. Midwinter Convention..... 308</p> <p>The Edison Medal Presented to John White Howell..... 309</p> <p>District No. 1 will Hold Another Regional Meeting..... 311</p>	<p>Open House for Engineers at Oklahoma University March 17..... 311</p> <p>A. I. E. E. Directors' Meeting..... 312</p> <p>Niagara Frontier Section is Formed..... 312</p> <p>Nebraska Section Organized..... 312</p> <p>Comments Requested on Preliminary Drafts of Standards..... 312</p> <p>On the Design for a Bifilar of Non-Reactive Type Resistance Coil..... 312</p> <p>Scholarship in Electrical Engineering at Columbia University..... 312</p>
---	---

(Continued on next page)

A REQUEST FOR CHANGE OF ADDRESS must be received at Institute headquarters at least ten days before the date of issue with which it is to take effect. Duplicate copies cannot be sent without charge to replace those issues undelivered through failure to send such advance notice. With your new address be sure to mention the old one, indicating also any change in business connections.

Copyright 1925. By A. I. E. E.

Printed in U. S. A.

Permission is given to reprint any article after its date of publication, provided proper credit is given.

Institute and Related Activities—Continued.

Ellwell Fellowship in Electrical Engineering	313	Oliver Heaviside	316
American Engineering Standards Committee		Obituary	317
Recommendations for Future Standards	313	Engineering Societies Library	
The Standardization of Dry Cells	313	Book Notices	317
Telephone Poles are also to be Standardized	314	Past Section and Branch Meetings	320
American Engineering Council		Engineering Societies Employment Service	
National Board for Jurisdictional Awards	314	Positions Open	324
Engineering Foundation		Men Available	324
Carnot Centenary	314	Membership	325
United Engineering Society		Officers of A. I. E. E.	334
Extracts from President's Report	315	Local Honorary Secretaries	334
Personal Mention	316	A. I. E. E. Sections and Branches	335
		Digest of Current Electrical News	336

Current Electrical Articles Published by Other Societies

Journal of Franklin Institute, January 1925

Notes on Dr. Louis Cohen's paper on Alternating Current Cable Telegraphy,
by L. A. MacColl

Journal of the Western Society of Engineers, December 1924

High Voltage Phenomena, by G. Faccioli

National Electric Light Asso. Bulletin, January 1925

Development in the Generation and Distribution of Electric Energy during
1924, by H. W. Cope

Physical Review, January 1925

On the Influence of Temperature Upon the Photo-Electric Effect, by J. Rud
Nielsen

A Universal Calibration Curve for Ballistic Galvanometers, by D. P. Randall

Electronic Bombardment of Metal Surfaces, by H. E. Farnsworth

On Some Properties of Neon Tubes, by B. N. Ghose

Determination of Elementary Charge e From Measurements of Shot Effect,
by A. W. Hull and N. H. Williams

Diffusion of Electrons Against an Electric Field in the non-Oscillatory Ab-
normal Low Voltage Arc, by J. T. Compton and C. Eckart

On Method of Varying and Sensitiveness of Ballistic Galvanometers, by M.
Masius

Proceedings of the Institute of Radio Engineers, February 1925

Discussion on a Method of Measuring Very Short Radio Wave Lengths and
Their Use in Frequency Standardization. F. W. Dunmore and F. H.
Engel

Recent Investigations on the Propagation of Electromagnetic Waves, by
M. Baeumler

Journal of the A. I. E. E.

Devoted to the advancement of the theory and practise of electrical engineering and the allied arts and sciences

Vol. XLIV

MARCH, 1925

Number 3

Our Midwinter Convention

That the Midwinter Convention was a success in every way is now a matter of Institute history and it may not be unwise to analyze the apparent reasons.

It is customary to have the midwinter convention the most serious event, from a technical standpoint, of the Institute year and a glance at the program indicates that the Meetings and Papers Committee wasted no waking hours in the delivery of technical papers of which there were some twenty in all. The balance of the program of papers was remarkable, covering fields of such diversified interests as to bring about a registration of more than fourteen hundred. The individual papers were original and told of things particularly interesting to men in the line of work covered by them.

The presentation of all the papers was most excellently done by the authors in a clear and concise way in the least possible time. At most of the sessions all the papers had been presented within the first hour or within a few minutes of that time, leaving the rest of the period for discussion which is so essential in order that the best may be gotten from them. Anyone may read a paper and get much out of it, but when the author and his questioners can meet, with plenty of time for constructive discussion, then is the greatest benefit derived.

The filling up of a program with many technical papers does not necessarily spell success for a convention, but a sufficient and diversified list with plenty of time for a full discussion as was the case at this convention, brings a gratifying result to all concerned.

To the Convention Committee, the Meetings and Papers Committee, to the chairmen of the various committees under whose auspices the papers were prepared, and to the authors of the papers, the President desires to express his sincere thanks for the careful, unselfish and considerable work in the preparation of the convention.

FARLEY OSGOOD

Our Standards

How naturally and with what confidence do we pick up our book of "Standards" when some subject included therein is under discussion. We are fully justified in doing so in the knowledge that this work is the result of hundreds of the best minds in the many branches of our industry, and dating back to the days when standardization was just coming into being.

When it is realized that over two-hundred well informed, thinking men of our Institute are constantly working toward the developing and classifying of these most essential bases of our work, it is right for us to have confidence in the results of such effort.

The membership of the various committees carrying on this great work is so balanced in the experience of its individuals as to bring as far as possible all points of view to the focal center of every standard undertaken. The methods of procedure brings together the latest knowledge from research, the best technique of theory and the fullest knowledge of practical application.

The A. I. E. E. Standards as is their scope, are strictly on engineering, yet as manufacturing, commercial and all applications are based on or governed by engineering rules, the wording of the same must be such as to define definitely the subject, clearly describe its technique, have no ambiguity toward correct interpretation, in order that the widest and most practicable use for all concerned will be the result.

FARLEY OSGOOD

Three New A. I. E. E. Standards Adopted

On January 21, 1925, the Board of Directors adopted three additional sections of the revised A. I. E. E. Standards, as follows: No. 38, "Standards for Electric Arc Welding Apparatus," No. 8, "Standards for Synchronous Converters," and No. 14, "Standards for Instrument Transformers." These revised sections of the A. I. E. E. Standards now available in pamphlet form at a cost of 25 cents per pamphlet, are part of the series of sections, each dealing with a specific subject, to be issued from time to time as completed, in the course of the revision of the entire A. I. E. E. Standards now in progress. A section on "Standards for Industrial Control Apparatus" was adopted May 16, 1924, and is also available at the same price.

The "Standards for Electric Arc Welding Apparatus" include the following types of apparatus applied to arc-welding work: D-C. Generators; Motor-Generator Sets (including dynamometers), A-C. Transformers; Resistors. The apparatus is dealt with under the following heads: scope, service conditions, definitions, rating, heating, efficiency, dielectric test, standard values for current and voltage, markings on rating plates.

The "Standards for Synchronous Converters" also apply to Field Control Converters, Synchronous Booster

Converters and Cascade Converters. Frequency Converters and Rotary Phase Converters will be included in another section.

The "Standards for Instrument Transformers" apply to transformers designed for use with measuring or control devices.

Some Leaders of The A. I. E. E.

Arthur Edwin Kennelly, the twelfth president of the Institute, was born in Bombay, India, December 17, 1861. His early education was gained in private schools in England and Scotland, and at University College, London.

At fifteen years of age he entered the British telegraph service as an operator, five years later being appointed assistant electrician of a cable repair steamer. In 1886 he was advanced to the position of senior ship electrician for the Eastern Telegraph Company. In 1887 he came to the United States and engaged as principal assistant in the electrical laboratory of Thomas A. Edison, where he remained seven years. In 1894 he became associated with Dr. Houston as consulting engineer. In 1902 he was appointed professor of electrical engineering at Harvard University, where he has continued until the present time, also as director of electrical research at Massachusetts Institute of Technology. In 1921-22 he was American exchange professor in applied science to French universities from a group of seven American universities.

In 1895 Professor Kennelly was given the honorary degree D. Sc. by the University of Pittsburgh, and the same by the University of Toulouse, France, in 1923. In 1906 the M. A. degree was given him by Harvard University.

Dr. Kennelly received the Institution and Fahie premiums from the British Institution of Electrical Engineers, the Howard Potts Gold Medal and Edward Longstreth Silver Medal from the Franklin Institute, for electrical research. During the World War he was civilian liaison officer for the United States Signal Corps, A. E. F. He is a Chevalier of the Legion d'Honneur of France.

Dr. Kennelly is the author of a large number of electrical books and technical papers, published during the past twenty-four years, and is a Member and Honorary Member of many American and foreign scientific societies and associations.

He was president of the A. I. E. E. throughout the years 1898-1900.

The Symposium—A Stimulator for Technical Meetings

Engineering is an exact science, but nevertheless some of its applications involve certain compromises which are more or less matters of personal opinion. In such matters, the symposium form of treatment has in the past met with such success that it is indeed worthy of more universal adoption. Consisting of a

series of short articles on a common topic, by several authors and accompanied by oral discussions, a symposium then, quite naturally brings forth an interchange of ideas which is mutually beneficial to all concerned, for the opinions of all the individuals are interwoven into a unified whole of considerable value.

Nearly two years ago the Papers Committee of the Illuminating Engineering Society decided that a discussion on Street Lighting would be appropriate for their Annual Convention. In looking over a list of possible authors for a paper on this subject, the committee found a number of engineers who were specialists in this field, any one of whom could be called upon to write such a paper. The Symposium form of discussion seemed to lend itself very readily to this condition and accordingly a problem in the form of a questionnaire was sent to representative specialists in this field throughout the country. Each specialist was requested to make his specific recommendation for the lighting of a definitely described street. The solutions to this problem were received by the Papers Committee, sometime in advance of the meeting at which they were to be presented and the results were coordinated slightly so that each solution was in the same general form.

Following the presentation of these solutions a very comprehensive discussion took place. The variety of the opinions portrayed in the various problems brought forth many comments from the listeners as well as from the authors themselves. From such results as these the symposium proved itself worthy of commendation even from those who had previously been the most skeptical of it.

The symposium idea was liked so well that it was later used at the New York district meeting of the Society, at which time the many phases of office lighting were thoroughly discussed. It is also quite possible that future meetings will employ this novel method of increasing the interest in discussions of similar nature.

Such a discussion brings into the limelight the practical as well as the theoretical aspects of a problem, for costs as well as spacing distances, foot-candle intensities, and desirable types of lighting units must necessarily be quite fully discussed since the opinions of the participants will naturally vary somewhat on these various points. The consolidation of ideas obtained in this manner creates a better understanding among engineers, which is beneficial to an engineer's clients as well as to himself for unless there is a reasonable degree of agreement among the engineers who may be called upon to solve the problems of a client, how is the latter to know which of the several designs or opinions are best suited to his needs?

It is to be hoped that the intelligent use of the symposium in the future will aid in raising the standards of the profession as a whole for there are indeed many possibilities in this form of discussion, not alone in the field of illumination but in the other divisions of the electrical industry as well.

Voice-Frequency Carrier Telegraph System for Cables

BY B. P. HAMILTON,¹
Associate, A. I. E. E.

H. NYQUIST,¹
Member, A. I. E. E.

M. B. LONG,²
Associat , A. I. E. E.

and W. A. PHELPS²
Associate, A. I. E. E.

Synopsis.—Carrier telegraph systems using frequencies above the voice range have been in use for a number of years on open-wire lines. These systems, however, are not suitable for long toll cable operation because cable circuits greatly attenuate currents of high frequencies. The system described in this paper uses frequencies in the voice range and is specially adapted for operation on long

four-wire cable circuits, ten or more telegraph circuits being obtainable from one four-wire circuit. The same carrier frequencies are used in both directions and are spaced 170 cycles apart. The carrier currents are supplied at each terminal station by means of a single multi-frequency generator.

* * * * *

A TELEGRAPH system has recently been developed which utilizes the range of frequencies ordinarily confined to telephonic communication. It represents a special application of the carrier method of multiplexing telephone and telegraph circuits, which has already been described.³

The new system has been designed particularly for application to four-wire telephone circuits. Installations have been made at New York and Pittsburgh, by means of which ten telegraph circuits are derived from one four-wire telephone circuit extending between these cities. Additional installations are planned and under way in which it is expected that a greater number of telegraph circuits will be obtained from each four-wire telephone circuit.

Experience in commercial service extending over a considerable period has fully demonstrated the effectiveness of this system.

GENERAL FEATURES

In a general way, the voice-frequency system resembles the high-frequency carrier system for open-wire lines, which has been described in the paper referred to above. The most important differences are that the voice-frequency system uses (1) a four-wire cable circuit instead of a two-wire open-wire circuit, (2) the same frequencies for transmission in both directions, (3) frequencies of the voice range rather than the higher frequencies used in open-wire carrier telegraph systems, (4) a multi-frequency generator instead of vacuum tube oscillators to supply the carrier currents and (5) fixed band pass filters instead of adjustable tuned circuits for segregating the several telegraph circuits.

Fig. 2 shows in a simplified manner the essentials of the telegraph system under discussion. Reference to Fig. 1, which shows a four-wire telephone circuit,⁴ will

make clear how the line portion of the telegraph system is derived from such a telephone circuit. As indicated in Fig. 1, the four-wire cable circuit uses two pairs of wires, one pair for transmission in each direction. When a voice-frequency telegraph system is applied to a telephone circuit the four-wire terminating sets, which normally terminate the circuit when used for telephone purposes, are removed and voice-frequency carrier telegraph equipment is substituted.

Signal Traced Through System. A general layout of the system is shown in Fig. 3 and, in describing the operation, reference is made to this figure. The path of a signal from the sending operator to the receiving

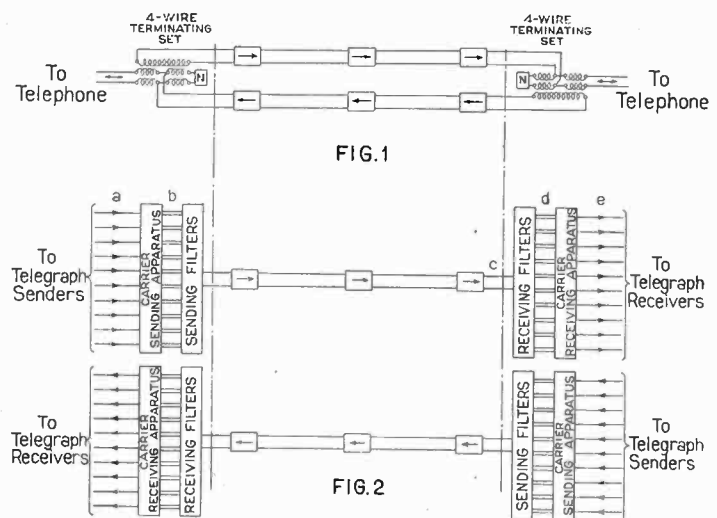

FIGS. 1 AND 2

operator, on one of the ten two-way circuits will be considered. To produce a spacing signal the sender opens his key (shown at the left of the figure) which causes the sending relay to operate so as to short-circuit the source of alternating current. To produce a marking signal the key is closed, which causes the sending relay to operate and to remove the short circuit. This permits the alternating current from the generator to flow freely into the filter. This sending filter is so constructed as to permit relatively free passage of current of frequency near the particular carrier frequency for which it is designed. For other frequencies the filter practically shuts off the current.

1. American Telephone & Telegraph Co., New York, N. Y.

2. Bell Telephone Laboratories, Inc., New York, N. Y.

3. *Carrier-Current Telephony and Telegraphy*, E. H. Colpitts and O. B. Blackwell, TRANSACTIONS, A.I.E.E., 1921, page 205.

4. *Telephone Transmission Over Long Cable Circuits*, A. B. Clark, TRANSACTIONS, A.I.E.E., Vol. XLII, 1923, page 86.

Presented at the Midwinter Convention of the A. I. E. E., New York, N. Y., February 9-12, 1925.

After passing through the filter, the current mingles with currents from other channels and all are transmitted over the line as a resultant composite current. After flowing through the line in this mixed-up condition, the currents encounter the receiving filters which resemble the sending filters in that each transmits a relatively narrow range of frequencies in the neighborhood of the carrier frequency for which it is designed,

channels by the receiving filter and (e) their final form in the receiving sounder circuit. The points where the oscillograms were taken are shown in Fig. 2 at *a*, *b*, *c*, *d*, and *e*, the cases being correspondingly denoted on the oscillograms.

Carrier Frequencies. The carrier frequencies are so chosen as to be odd multiples of a basic frequency of 85 cycles per second. The lowest frequency used is

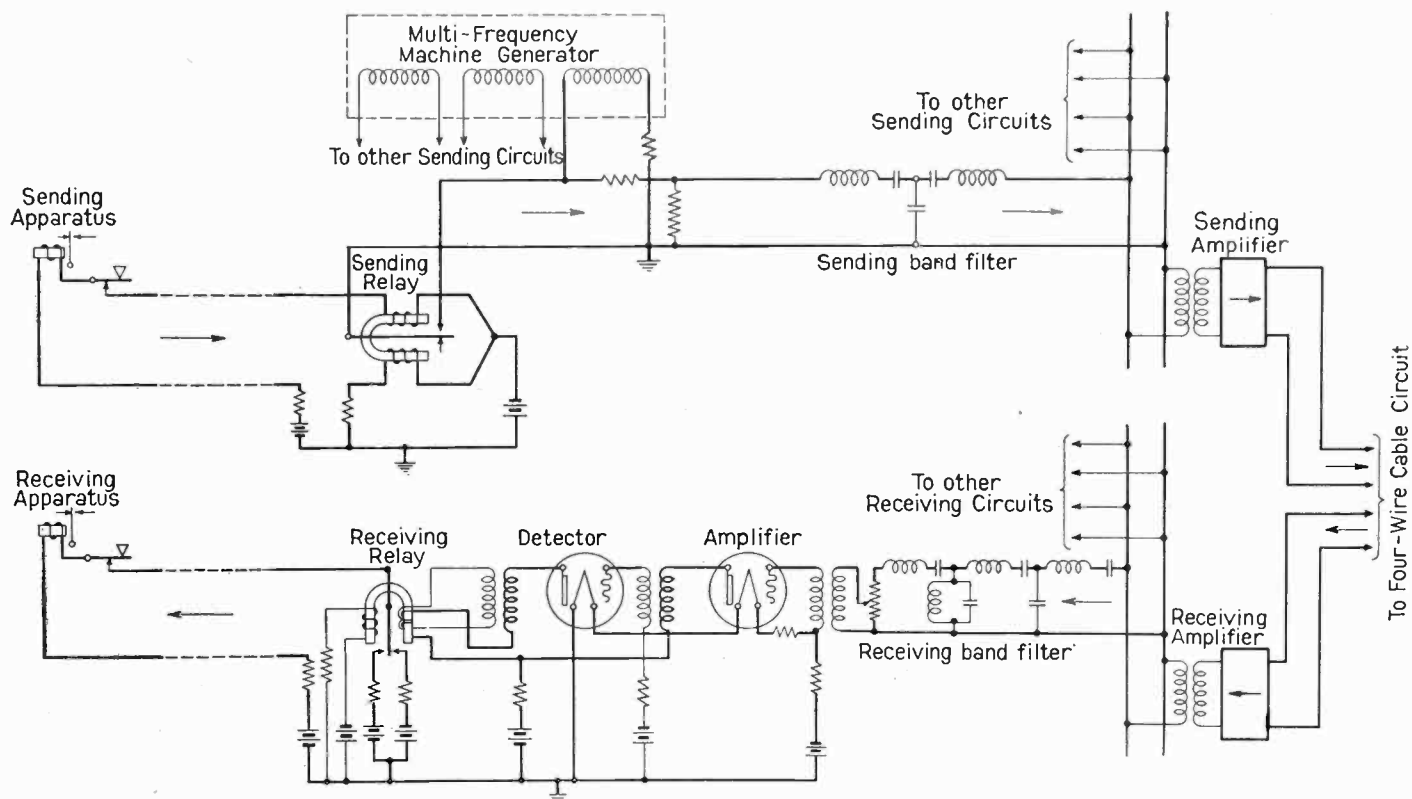

FIG. 3

and in that it acts substantially as an open circuit to other frequencies. By means of these receiving filters the currents are separated and each flows freely into its own channel. After passing through the receiving filter the current enters the detector whose function is to convert the alternating current signals into direct-current signals which are capable of actuating the receiving relay. The receiving relay in turn transmits direct-current signals to the receiving operator's sounder or local relay.

This sequence of events is illustrated in the series of oscillograms of Fig. 4, which shows the different forms of a group of telegraph signals in the 425-cycle channel from the time, when as d-c. impulses, they flow through the sending relay windings, to the time when again, as d-c. impulses, they flow through the receiving relay and sounder circuit. It shows (a) their form in the sending relay and telegraph key circuit, (b) their translation into alternating current prior to passing into the sending filter, (c) their mingling with other similar impulses of different carrier frequencies after passing through the sending filter and on to the line as a single resulting wave flowing through the four-wire circuit, (d) their form after separation from the other

the fifth multiple of 85 cycles, that is, 425 cycles per second. Starting with this frequency, the carriers are spaced at 170-cycle intervals from their nearest neighbors, so that in the ten-channel system the uppermost

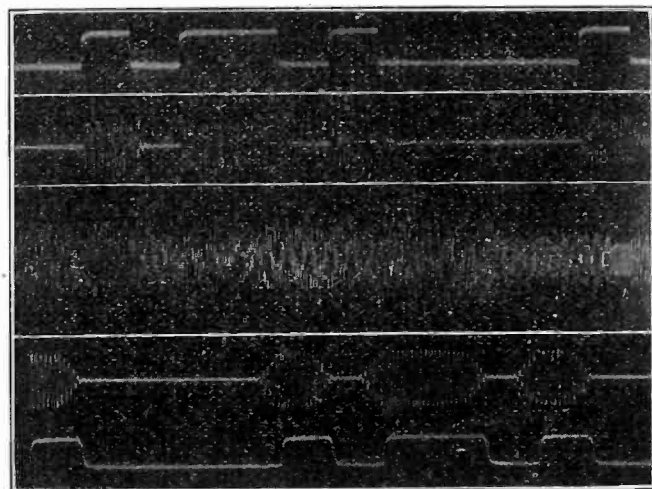

FIG. 4

frequency is 1955 cycles per second. Each channel has assigned to it a range of frequencies 85 cycles above and below its own frequency. For example, the chan-

nel using a carrier frequency of 1105 cycles has assigned to it the range between 1020 to 1190 cycles. Choosing the carrier frequencies in this manner and placing each carrier midway in the band of frequencies assigned to it, has the effect of giving maximum discrimination against interfering frequencies generated in the various vacuum tube repeaters. As is well known, when a number of frequencies are transmitted simultaneously through a vacuum tube, currents which cause interference are generated due to small departures from linearity on the part of the tube characteristic. Some of the most important of these currents have frequencies equal to the sum and difference of the frequencies of the transmitted currents taken in pairs. Since the carrier frequencies are all odd multiples of the common frequency, 85 cycles, it follows that the sum and difference of the frequencies are even multiples of 85 cycles and therefore are located midway between the carrier frequencies. This permits obtaining the maximum discrimination against these interfering frequencies by means of the filters, of which the characteristics are set forth below.

The number of carrier telegraph circuits which can be derived from a single four-wire cable circuit depends on the type of loading and, to a less extent, on the length of the circuit. It has been mentioned above that at the present time ten two-way carrier telegraph circuits are operated simultaneously over a four-wire circuit between New York and Pittsburgh, a distance of about 400 miles (644 km.). This is not, however, the maximum possible number of telegraph circuits which can be derived from the type of circuit used with this installation. Four-wire circuits which are loaded with coils of small inductance transmit a wider range of frequencies and are already in use for telephone purposes. If such circuits were used instead of the type employed with the present installation, at least fifteen two-way carrier telegraph circuits could be obtained.

DESCRIPTION OF APPARATUS

Carrier Current Generator. Vacuum-tube oscillators are the source of the carrier current in carrier systems previously developed. In this system, however, all the carrier currents for the ten channels are obtained from a compact multi-frequency generator driven by a motor built into the same housing with the generator.

The generator is an inductor-alternator designed to generate currents of ten different frequencies in ten different magnetic circuits electrically independent of each other. The machine has two field coils common to all the stators. The exciting current for these two windings is supplied by a storage battery. On the pole arc of each stator opposite each of the narrow disk-like rotors, mounted in a row on the shaft, are cut a number of slots, the number per unit length depending on the frequency to be generated. The stator windings for each circuit are placed in these slots. The rotor belonging with each stator has a corresponding

group of slots cut in it but no windings are placed in these rotor slots. The result is equivalent to ten separate alternators except that the field excitation is common to all. The flux in any stator tooth is greatest when a rotor tooth is opposite it and least when a rotor slot is opposite it. This variation in flux in the stator teeth as the rotor moves induces the voltage in the windings on these teeth. All the windings of a given stator are connected in series, so the total voltage generated in each stator is the sum of these separate voltages in the several windings.

A comparatively small generator is able to supply carrier currents to several ten-channel systems because, by using terminal repeaters or amplifiers (Fig. 3) the amount of energy required to operate each telegraph channel is very small, and no channel produces any noticeable interference in another drawing current from the same stator winding. The terminal voltage

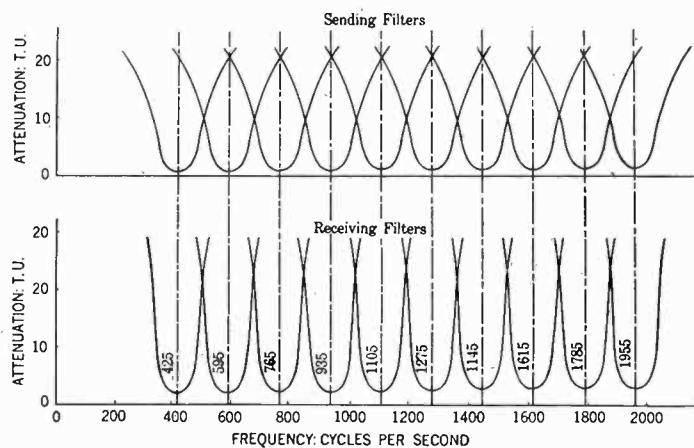

FIG. 5—CHARACTERISTICS OF FILTERS

of each stator is 0.7 volt and a current of 40 mils may be drawn from it without producing change a in terminal voltage sufficient to cause interference in any telegraph circuit drawing current from the same set of windings.

The driving motor is a small shunt-wound machine which receives its energy from a 24-volt storage battery. The speed of the motor is maintained accurately at 1700 rev. per min. by means of a centrifugal type of governor which controls the amount of current flowing through the shunt field winding. As the stability of the carrier frequencies depends on the constancy of the motor speed, it is necessary that the governor control the speed within narrow limits.

As a means of checking the speed of the generator an electrical frequency indicator is provided. This device is connected to and indicates the frequency of one of the generator circuits. As the frequency of an alternator is directly proportional to the speed it gives an indication of the correctness of the speed and also of all frequencies produced by the generator.

Filters. Fig. 5 shows the transmission characteristics of the transmitting and receiving filters. These filters are designed to transmit as wide a range in the neighborhood of the carrier frequencies as is necessary

to secure the desired quality of transmission and at the same time exclude interfering currents, whether they be caused by foreign interference, direct transmission from other channels, or distortion in the repeater tubes. The principal interfering currents due to the latter are located 85 cycles on either side of the carrier frequencies. The receiving filters have been designed to reduce these interfering currents to about 10 per cent of their original value.

In addition to screening out any undesired frequencies produced in the generator windings, the sending filters have the following more important functions. Each sending filter presents a high and comparatively non-dissipative impedance to the currents issuing from the other sending filters and also "rounds off" the impulses of the modulated carrier wave passing through it. The modulation of the carrier current by the sender's key produces what is called a "square" wave, that is, a wave containing not only the carrier plus and minus the frequency at which the key is operated but also the carrier plus and minus a large number of multiples of the frequency. Some of the component frequencies of this transmitted wave not only are found unnecessary in reproducing the transmitted signal at the receiving end but also lie within the range of adjacent channels and produce interference in them unless screened out by the sending filter in the channel in question.

The effect of the sending and receiving filters in "rounding off" the modulated carrier wave, that is, in screening out the objectionable components of the signal wave, is shown by the oscillograms of Fig. 4. The combined effect of the two filters on the shape of the modulated carrier may be seen by comparing oscillograms (b) and (d) of this figure, which show respectively the appearance of the modulated wave before it enters the sending filter and after passing through the sending filter, over the line and through the receiving filter. Another interesting point in connection with these oscillograms is the time lag due to the circuit which is shown by the relative differences in position of the two waves referred to above. Owing to the limitations imposed by the ordinary oscillograph all of the traces shown in Fig. 4 were not taken simultaneously. This accounts for minor inconsistencies which are revealed by a careful inspection.

Detector. The detector receives alternating current signals from the line after the signals belonging to that particular channel have been selected by the receiving filter. It consists of two vacuum tubes in tandem, the first tube (Fig. 3) amplifying the received signals, and the second converting them into direct-current pulses which operate the receiving relay. The receiving relay then repeats these telegraph signals into the receiving direct-current circuit which contains the receiving sounder.

To improve the operation of the receiving relay a device called an accelerating circuit or "kick" circuit,

such as is used in open-wire carrier-telegraph systems, is interposed between the detector tube and the receiving relay. This circuit is obtained by introducing a transformer whose high-voltage side is connected in series with the detector tube and a winding of the receiving relay and whose low-voltage side is connected to another winding of the relay. When the current in the high-voltage side is constant, there is no current in the low-voltage side, but if the former current suddenly changes, as at the beginning or end of a marking signal, there is a sudden rush of current in the low-voltage circuit which has the effect of causing the relay to operate promptly and positively.

Relays. As shown in Fig. 3, the sending and receiving relays are of the polar type. These relays are identical and interchangeable with those used in the metallic and open-wire carrier-telegraph systems. They are described in the paper on telegraph relays which has been prepared for presentation at this meeting.

Power and Testing Equipment. In the development of the voice-frequency carrier telegraph system, the central thought was the desirability of designing a system which would fit into the existing cable telephone and telegraph plant. It has been possible to use the standard voltages obtainable from the storage batteries in such plants without exception.

In line with the policy of simplifying this new system as far as possible, the amount of auxiliary testing apparatus was reduced to a minimum. This policy has been assisted by the stability of the cable circuits and the use of a multi-frequency generator as a source of carrier currents. Only two pieces of special testing apparatus are used at each station, namely, the frequency indicator, and a thermocouple voltmeter for checking the alternating voltage in each generator circuit.

LINE AND REPEATERS

As has been pointed out elsewhere in this paper, the voice-frequency carrier telegraph system was designed primarily for use on small-gage, four-wire cable circuits. These circuits are loaded and provided with vacuum tube repeaters at 50 to 100-mile (80.5 to 161 km.) intervals, depending on the weight of loading used. The repeaters used in long toll circuits are similar to those described at an earlier date.⁵ The characteristics of the long cable circuits used in voice-frequency carrier telegraph transmission have also been described in a more recent paper.⁶

EQUIPMENT FEATURES AND ARRANGEMENTS FOR GIVING SERVICE

The apparatus which is associated with each of the ten two-way circuits in this system has been segregated according to function and each group of apparatus per-

5. *Telephone Repeaters*, by Bancroft Gherardi and Frank B. Jewett, TRANSACTIONS, A.I.E.E., 1919, page 1287.

6. Clark, *Loc. cit.*

forming the same function, such as the detector, has been mounted on a separate steel panel. Each one of these panels forms a unit in itself. This type of construction allows the substitution of new apparatus performing some particular function in the system without an expensive redesign. Thus, it is possible to

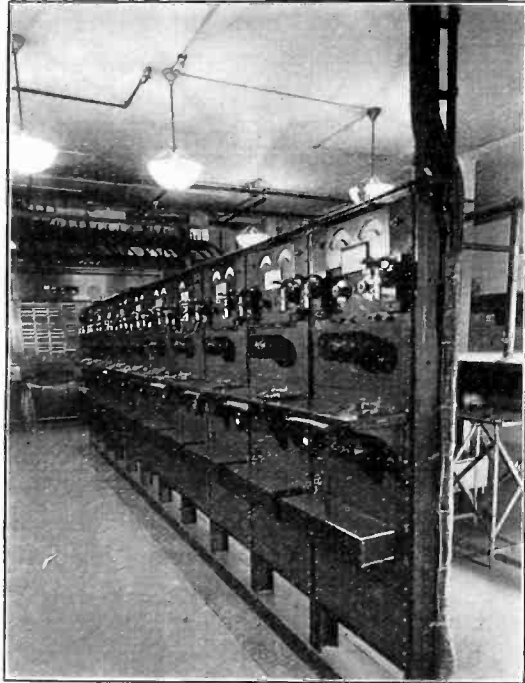

FIG. 6

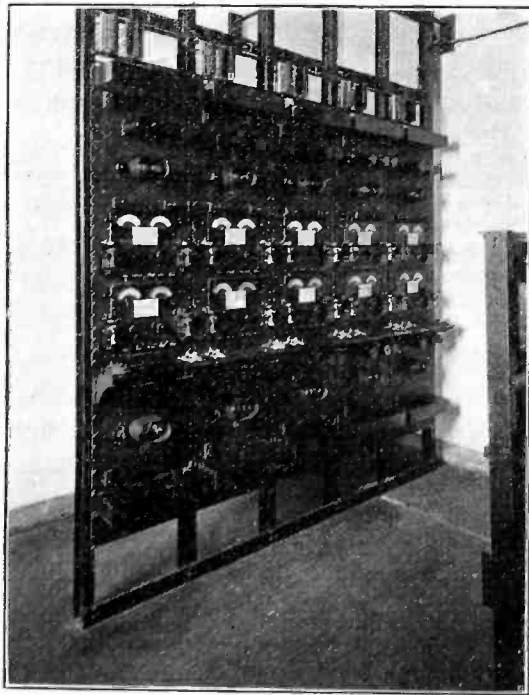

FIG. 7

install future improvements in the several circuits of the system in an economical manner.

These unit panels are mounted on pairs of vertical I-beams and the combination is termed a "bay." The bays are of different heights, depending on the requirements of the office in which they are installed. Fig. 6 shows a line-up of so-called low-type bays (about five

feet high) in the Pittsburgh office. Each bay in this line-up contains sufficient equipment to provide for the transmission and reception of signals at the Pittsburgh terminal of one of the ten two-way telegraph circuits. Fig. 7 shows a line-up of similar equipment in the New York office, this layout differing from the one in Pittsburgh in that it uses high instead of low-bays. Each bay in this line-up contains sufficient terminal equipment for two of the ten two-way telegraph circuits.

In addition to the bays described above there are three bays, carrying auxiliary equipment. This auxiliary equipment consists primarily of control and testing apparatus for batteries and carrier supply. Two of these bays, namely, the generator and carrier supply bays are shown in Fig. 8. This figure shows two of the multi-frequency generators (one a spare machine) described

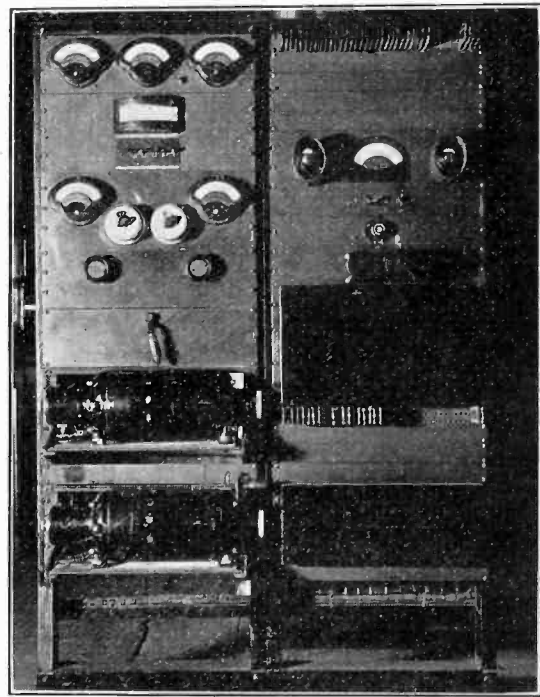

FIG. 8

above, and the carrier testing equipment. The control equipment associated with these machines is mounted on the panels above the generator and the frequency indicator is mounted on the panel to the right of this control apparatus.

SWITCHING AND MONITORING ARRANGEMENTS

The monitoring arrangements, which enable the attendant to check the quality of signals passing over a circuit or to trace trouble quickly and easily, are similar to those now in use in the open-wire carrier and metallic telegraph systems. These arrangements are described in the paper on the metallic telegraph system which has been prepared for presentation at this meeting and, therefore, will not be given in detail here. In a general way it may be said that switches and meters are provided to connect the telegraph batteries to local

apparatus, to provide either one-way or two-way service and to facilitate repeating to other telegraph systems.

CAPABILITIES OF SYSTEM

Field tests over the New York-Pittsburgh system have shown that each telegraph circuit derived therefrom is of high grade, allowing signal speeds of 35 to 40 cycles per second. That is, with machine sending, it is possible to transmit 140 to 160 words per minute (five letters and a space per word) each way over each telegraph circuit. Considerably higher speeds may of course be obtained by widening the frequency range assigned to each telegraph circuit.

The New York-Pittsburgh system may be used in connection with a multiplex printing telegraph system and three printer messages may then be sent simultaneously in either direction on each carrier circuit. Assuming 50 words per minute as the working speed for each of the three printers a total of 1500 words per minute could be transmitted simultaneously in either direction over the ten circuits.

A simple numerical example will indicate what is technically possible by the application of this type of telegraph system to toll cables. A toll cable $2\frac{5}{8}$ inches (6.7 cm.) in diameter contains about 300 pairs of No. 19 B. & S. gage (0.91 mm.) conductors. Utilizing the phantom circuits this gives a total of 225 four-wire circuits. Counting 30 messages in each direction per four-wire circuit it is evident that it is technically possible to transmit 6750 messages in each direction simultaneously.

The "break" feature of this system is satisfactory. It functions in a manner similar to that used with the metallic telegraph system. It takes about 0.1 second to transmit a "break" signal over a 1000-mile (1610 km.) circuit.

FIELDS OF APPLICATION

It will be evident that while the foregoing description assumes that this system is applied to four-wire circuits, it could be readily applied to two-wire circuits by transmitting half of the carrier frequencies in one direction and the other half in the opposite direction. Furthermore, if the impedance characteristic of the line could be reproduced with sufficient accuracy in networks to balance the line at the repeaters, the same frequencies could be transmitted in both directions and as many of them could be so transmitted as the natural "cut-off" of the line would permit.

While the voice-frequency carrier telegraph system has been designed primarily for use on an ordinary telephone circuit, the system may be applied to carrier telephone or radio telephone channels without involving radical changes in either the telegraph system or the telephone circuit to which it is applied.

BROADCASTING PROGRESS IN EUROPE

Installation of radio receiving sets is at present illegal throughout most of continental Europe, yet the freedom with which governmental regulations are being ignored forecasts acceptance of broadcasting on a systematic plan.

The reluctance of different nations to modify their radio laws has been due to several causes, one of them being the expected interference between broadcasting stations in the several countries. Another important factor has been concern lest removal of restrictions should cause an excessive importation of foreign made receiving sets.

Czecho-Slovakia the central nation of Europe sees in radio the means of building up Prague as one of the outstanding musical and cultural centers of the world. As the center of national opera which will probably be broadcast, Prague will also play a new part in the national spirit and advancement of the country on cultural lines. The government will control broadcasting and plans to erect stations for operation on a rental basis by a broadcasting company.

In England alone is broadcasting well organized at present on a scale comparable to that in the United States, and some other countries have come forward with radio programs.

For instance, one of the first broadcasting stations on the continent was installed at Kristiania, Norway. Tests were made with this station and complimentary reports were heard from many countries, even as far as Ireland and France. A broadcasting company has now been formed and Norway is one of the leaders in application of the art in Europe.

Sweden has enjoyed broadcasting for two years. The Telegraph Administration has plans for a comprehensive system of stations interlinked by telephone lines. Owners of receiving sets are licensed on the basis of a low annual fee, loud speakers being assessed at a considerably higher rate because they are considered more or less in the class of luxuries.

Great progress in broadcasting has been made in Germany during the last year. Plans are under way to organize a power carrier broadcasting service, the idea being to superimpose a high frequency carrier current on power circuits at various low-tension centers. The power companies would render the broadcasting service and supply subscribers with receiving sets on a rental basis, but the general supervision and organization of the service would be taken care of by a broadcasting company. The success of this system would rest upon the low rental which would make it possible for everyone to subscribe, and the elimination of elaborate receiving sets and aerials.

Several stations are planned for Austria but at present this country has only one station, operated by a broadcasting company. The service is not organized.

Corona in Oil

BY A. C. CRAGO*
Non-member

and

J. K. HODNETTE*
Non-member

Synopsis.—Experiments were made to determine certain effects of high local voltage stresses in transformer oil. The resistivity of the oil was measured by a special method immediately following a period of voltage stress. The results were

1. A greatly reduced resistivity when the stressing voltage was greater than that producing visible corona.
2. A gradual increase in resistivity following removal of stress.

The "rapidly applied" breakdown voltage was found for samples of oil which had been previously subjected to high voltage stresses. The dielectric strength varied in a manner similar to the resistivity, but showed an actual improvement in dielectric strength when the oil was given a rest period of 15 minutes.

Definite conclusions are given at the end of the paper.

* * * * *

THE recent increasing investigation of the mechanism of conduction and breakdown in dielectrics makes any additional data bearing on this subject worth while¹. This paper discusses certain effects on electrical, physical and chemical properties of transformer oil when subjected to high local voltage stresses, dealing chiefly with certain temporary changes in conductivity and dielectric strength resulting from this treatment.

In the latter part of 1923, Professor H. B. Smith of Worcester Polytechnic Institute raised the question of the possibility of the temporary lowering of dielectric

It was decided to try the resistivity of the oil as an indicator of its quality. It seemed probable that any reduction in the dielectric strength of oil would be accompanied by a reduced resistivity. Various methods of measurement were tried in an effort to find one suitable. A microammeter with a sensitivity of 10^{-7} amperes per scale division was placed in the circuit in series with the high voltage line (see Fig. 1) and properly protected, the 60-cycle alternating current passing through a condenser to ground and the direct-current passing through a high inductance and the meter. A direct-current bias of 1000 volts was used, and the direct-current across the needle gap measured. The sensitivity of the meter was not enough for quantitative results, but deflections were found and increased with the voltage. No effect was noted at potentials lower than that producing visible corona.

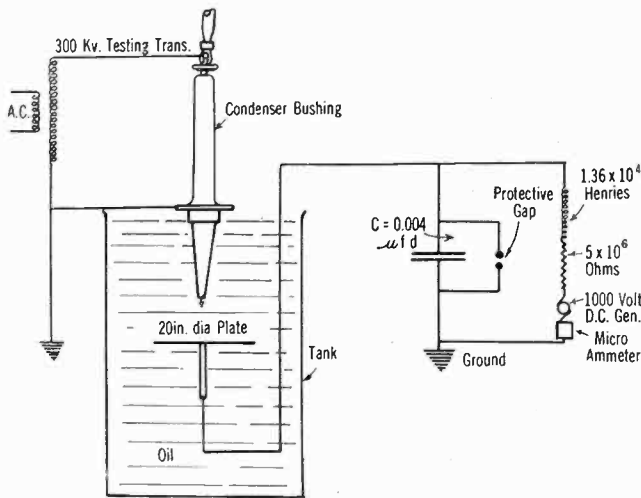

FIG. 1—APPARATUS FOR PRODUCING CORONA AND MEASURING SERIES CONDUCTIVITY

strength of oil due to high local voltage stresses, such as might occur at sharp corners in a transformer, although visible corona might not be present. Investigations were undertaken to determine this effect at potentials both below and above corona voltage.

RESISTANCE MEASUREMENTS

A needle gap was used as a source of the high-voltage gradients. This gap consisted of a sharpened 0.05 in. brass rod spaced 12 in. from a ground plate. It gave visible corona at 55 kv., r. m. s.

* Both of Westinghouse Electric & Mfg. Co., East Pittsburgh, Pa.

1. See Bibliography.

Presented at the Midwinter Convention of the A. I. E. E., New York, N. Y., February 9-12, 1925.

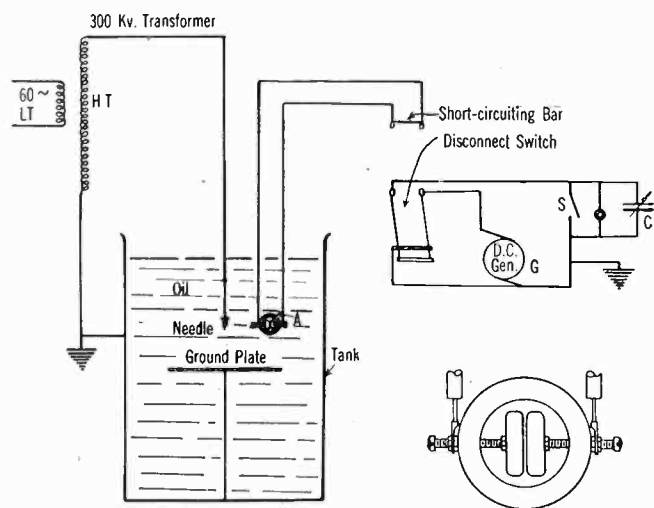

FIG. 2—GLOW-TUBE METHOD OF MEASURING OIL CONDUCTIVITY

Fig. 2A is a detailed sketch of the electrodes used in measuring conductivity

Attempts to measure conductivity between a pair of electrodes (Fig. 2) were more successful. These electrodes were brass disks with rounded corners. They were $1\frac{1}{2}$ in. in diameter, and $\frac{3}{8}$ in. thick, spaced 0.10 in. apart. The supporting ring was made of hard rubber, as were the tubes carrying the conductors to the electrodes. The assembled gap was suspended in the oil near the needle with the faces of the electrodes

in the same vertical plane with it, and at approximately the same level as its point.

The conductivity of the oil was found by measuring the current flowing when 1000 volts d-c. was applied across the gap. This current was too small to be measured by available galvanometers. A novel type of meter was suggested by Doctor J. Slepian. This proved to be satisfactory for the service required. The circuit for it is shown in Fig. 2. It consists of a condenser C in series with a 1000 volt generator G and the measuring gap. This condenser is shunted by a neon glow tube and a switch S .

When switch D is closed and the generator is running, a small current passes across the gap, through the shunting switch and to ground. To measure this current, the switch S is opened, and the time required for the condenser to charge up to the glow voltage of the tube is measured with a stopwatch. The tube glows momentarily. The elapsed time is recorded. This operation is repeated as often as desired.

The approximate conductivity is found as follows: The generator was excited to give 1165 volts at the terminals. The glow voltage of the tube is 325 volts. The exact equation for the resistance, assuming it constant is:

$$r = \frac{t}{c} \cdot \frac{1}{\log_e \left(\frac{E_0}{E_0 - E_t} \right)}$$

where

E_0 is the generator voltage

E_t is the glow voltage of the tube

r is the resistance of the oil across the gap

C is the capacity of condenser C in farads

t is elapsed time in seconds.

As a first approximation, when E_t is small compared to E_0 , the current equation is,

$$\text{Average current} = \frac{\text{final condenser volts} \times \text{capacity}}{\text{time}}$$

$$i = E_t \frac{C}{t} \text{ and}$$

$$r = \frac{\text{average gap voltage}}{\text{average current}}$$

$$r = \frac{E_0 - 1/2 E_t}{i} = \frac{E_0 - 1/2 E_t}{E_t} \cdot \frac{t}{C}$$

but $E_0 - 1/2 E_t = 1165 - 162.5 = 1002.5$ volts.

Using 1000 volts the resistance is,

$$\frac{1000}{325} \cdot \frac{t}{C}$$

This differs from the exact equation results by 1.1 per cent. For a capacity of 0.000115 microfarads and a time of one second, the resistance would be approxi-

mately 2.67×10^{10} ohms. Converting this to resistivity with the assumption that Ohm's law holds, the resistivity per inch cube with the above conditions would be,

$$\frac{(1.5)^2}{4 \times 0.1} \pi \times 2.67 \times 10^{10} = 4.73 \times 10^{11} \text{ ohms.}$$

This is resistance measured in one second. Sixty seconds seemed to be about the limit of time for good results. This corresponds to a resistivity of 2.8×10^{10} ohms per inch cube. This method was simple and rugged, and gave the required degree of accuracy.

In operation, the disconnect switch (Fig. 2) was opened. The desired stressing voltage was impressed on the needle-gap for a period of time. Immediately after removing this voltage, switch D was closed, and measurements of resistivity taken as indicated above.

DIELECTRIC TESTS

The actual dielectric strength of oil subjected to high local stresses was tested with a Westinghouse standard test-cup (sharp-cornered disk electrodes, one inch in diameter, spaced 0.10 inches apart.)

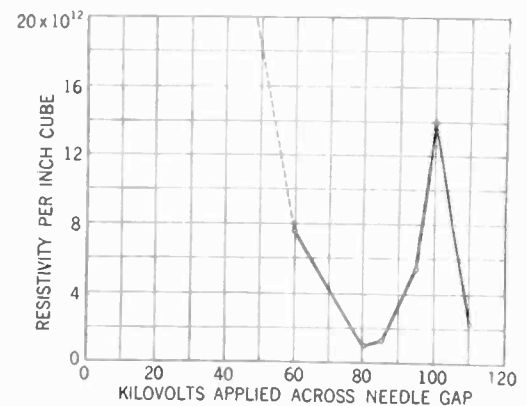

FIG. 3—VARIATION OF RESISTIVITY WITH STRESSING VOLTAGE
Resistivity measured with 1000 volts across 1/10 inch gap

A sample of oil was drawn from the vicinity of the needle immediately after the stressing voltage was removed, and tested for breakdown, an average of five or more breakdowns being used.

EXPERIMENTAL RESULTS

A series of tests was made on Wemco A transformer oil. This oil had been used for miscellaneous testing purposes previous to these tests, but still had a dielectric strength of about 33-kv -r. m. s., which is an indication of good oil.

Fig. 3 shows the variation of resistivity with the stressing voltage, the voltage being applied for 15 min. Note the dip at 80 kv. and the lack of effects below 55 kv., the corona potential.

Fig. 4 indicates the way in which the resistance varies with time after the stressing voltage is removed. The shapes of these curves vary considerably with individual tests. However, they all show: 1. That the low resistance is only temporary: 2. that a resistance meas-

ured about a minute after stressing voltage is removed, is about as accurate as a resistance measured during stressing, since in general, the time-resistance curve approaches the zero-time axis nearly at right angles to it.

Fig. 5 shows the extent of the affected region around the needle. The curve shows that the effect of corona is very decided to a distance of one foot under the conditions of test. Since the effects observed last over

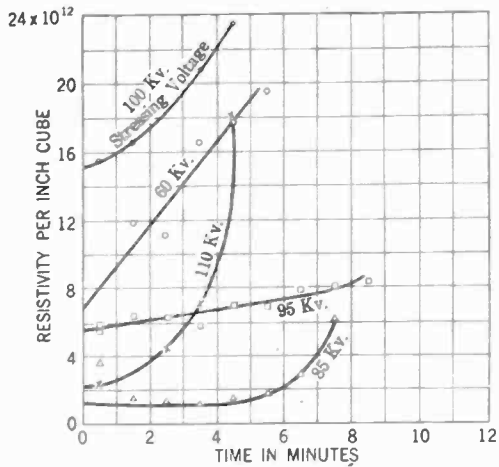

FIG. 4—VARIATION OF RESISTIVITY WITH TIME AFTER STRESSING VOLTAGE IS DISCONNECTED

a period of minutes, it would be very unlikely for them to be highly localized, as there would be a spreading due to diffusion.

Fig. 6 indicates the effect of time of application of the high gradient on the dielectric strength of the oil, showing that most of the lowering of the dielectric strength occurs very quickly.

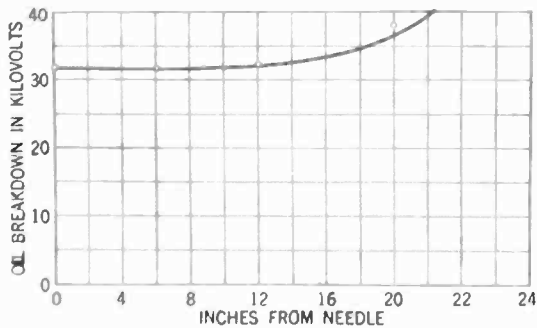

FIG. 5—EXTENT OF THE AFFECTED REGION IN THE TANK

The variation of dielectric strength with stressing voltage is shown in Fig. 7. The effects are not noticeable at voltages which do not produce visible corona, but become pronounced at higher voltages. The hump in the curve at 100 kv. is discussed later.

The following table brings out very emphatically the temporary nature of the corona effects. For each of the three tests, the strength of a sample was measured in the test cup. Then a stressing voltage was applied to the needle gap for the indicated time. Two samples were then taken from the region near the needle. One was given a dielectric test immediately. The other was tested after 15 min. In each test, the lowering of

the dielectric strength disappears entirely, and an actual improvement occurs.

Initial breakdown	Stressing kv. r. m. s.	Time applied	Resulting breakdown	Breakdown after 15 min.
32.8	120	15 min.	29.4	39.6
29.6	100	15 min.	26.4	30.8
29.6	100	1 hr.	25.0	30.2

Attempts to find permanent effects on the oil due to the stressing voltage were unsuccessful. The conductivity of samples taken before and after stressing, was measured accurately several days afterwards.

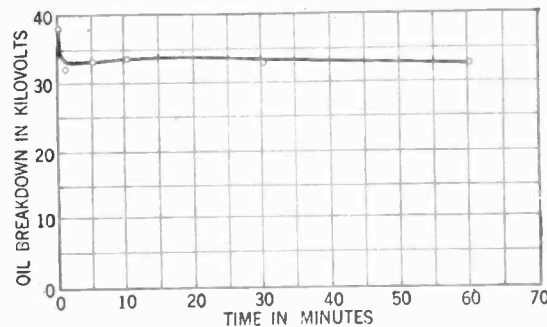

FIG. 6—THE EFFECT OF DURATION OF STRESS ON THE DIELECTRIC STRENGTH OF TRANSFORMER OIL
100 kv. applied on needle

The percentage of unsaturates was also determined. The only variations in these quantities were such as could be accounted for by ordinary experimental error. The water content seemed to gradually decrease as the tests progressed, but varied with the number of tests rather than as any function of the stressing voltage.

ACCURACY OF RESULTS

It is not the desire of the writers to give an impression of great accuracy in the quantitative results obtained. As in most tests with dielectrics, the variations were wide. To a certain extent, tests used in producing the

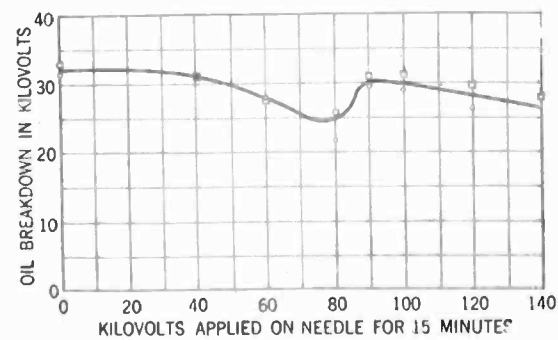

FIG. 7—THE EFFECT OF HIGH LOCAL VOLTAGE STRESSES ON THE DIELECTRIC STRENGTH OF TRANSFORMER OIL

curves are selected tests. However, the tendencies and shapes of the curves are definite and are found in practically all of the tests made. It is this rather than the quantitative results which should be emphasized.

DISCUSSION

Certain parallels may be drawn between the effects of corona in oil and the phenomena of ionization in air.

The conductivity in both cases must result from the presence of charges capable of moving. The normal conductivity in air is due to a very few ionized particles which are always present. The normal conductivity of oil might be due either to the transfer of electrons from one metal electrode to the other across conducting particles, or to the presence of positively and negatively charged ions in the oil or of the oil, migrating due to the electric field. As the voltage stress becomes very great, molecules may be torn apart into plus and minus ions. Due to the relatively high viscosity, and the high molecular weights, the diffusion rate, and consequently the rate of re-combination of the charged particles and their rate of migration in an electric field, is very slow. This would account for the persistence over a period of minutes of the effects noted.

As to the effects on the dielectric strength: In air, the dielectric strength is hardly affected unless the ionization is intense enough to produce space charge and disturb the voltage gradient. In oil, the ionization necessary to produce a space charge will be much less since the mobility of the ions is so low. No attempt has been made up to the present to determine mathematically the possibility of space charge with the degree of ionization found in the experimental results. It should be possible to do this, and it will be attempted.

The "hump" mentioned in the curves of kv. vs. resistivity and kv. vs. dielectric strength (Fig 3 and Fig 7) was unexpected. When the first curve of the dielectric strength was determined, a smooth curve was drawn with a downward curvature, assuming the 100-kv. value as high and the 80-kv. value as low. However, when the run was repeated several days later, a curve identical to the previous one was obtained. The same hump was later found to exist in the resistance values.

One plausible explanation of this hump, and one which is presented because no better one appears, follows.

Tests made with oil of low water content did not show the decided dip at 80-kv. It is possible that the size of water particles are such that they migrate rather rapidly at the 80-kv. value, so that they exist in the concentrated electric field in rather large numbers, thus affecting the breakdown. At the 100-kv. point, the migration may be so rapid near the needle that the water content is reduced. Unfortunately, the water content was not determined for the tests referred to, and the oil was later destroyed.

CONCLUSIONS

The above tests allow certain definite conclusions to be drawn:

1. That, with the type of needle gap used, no appreciable effect on the electrical characteristics of the oil occurs below the point where visible corona starts.
2. That above this potential, a phenomenon similar in some respects to ionization in air, occurs with oil.

3. That with the sample of oil used, the resistivity and breakdown do not continually decrease as the stressing voltage is increased.

4. That the effects noted are produced in a very few minutes and are temporary in nature.

5. That, since the effects described in this paper all occur only at voltage stresses which produce visible corona, they do not exist in properly designed commercial apparatus.

Bibliography

- K. W. Wagner, TRANSACTIONS A. I. E. E., Vol. 41, Pg. 281.
 Rogowski, *Archiv. f. Elektrot.* Vol. 13, part 2 pg. 123.
 "The Conductivity and Dielectric Strength of Transformer Oils K. Draeger. *Archiv. f. Elektrot.*, Vol. 13, part 5, pg. 366-291.

FIRST INSTALLATION

"DIRECTOR" TELEPHONE EQUIPMENT

The first public central office telephone installation using the "director" type of automatic switching equipment was successfully completed November fifteenth, at Havana, Cuba. The equipment was manufactured by the Automatic Electric Company of Chicago, and installed by them in co-operation with the engineers of the International Telephone and Telegraph Corporation, New York.

The "director," installed as an adjunct to the Strowger system, permits the dissociation of the numbering scheme from the trunking plan, and thus affords all of the advantages of tandem trunking without consideration of limitations sometimes imposed by directory numbers. In this and certain other respects it serves a purpose similar to that of the "sender" equipment used in connection with the Western Electric Company's panel type machine switching system.

While the advantages to be derived from the use of the director are fully demonstrated only in the conversion of large networks from manual to automatic operation, frequently substantial economies in trunking are afforded by its adaption to certain offices or certain parts of existing automatic networks. This was the case in connection with the Havana project, in that the installation of "directors" in two suburban offices serving adjacent areas permitted the routing of traffic to or from the city network over a common group of trunks, and at the same time permitted the establishment of a universal numbering scheme—*Committee on Communication*.

Recent statistics indicate that the sale of tungsten filament lamps (exclusive of miniature lamps) in the United States during 1924, aggregated 252,000,000 lamps. This indicates a gain of about 2½ per cent over the sales of 1923.

The sale of carbon lamps on the other hand has decreased to about 1,000,000. This is less than one half of one per cent of the total sales of large lamps during 1924.

Polarized Telegraph Relays

BY J. R. FRY¹
Non-member

and

L. A. GARDNER²
Associate, A. I. E. E.

Synopsis.—This paper is to discuss two forms of polarized telegraph relays which have been developed by the Bell System and applied originally to the metallic telegraph system. One of these relays was designed primarily for operation under severe and exacting circuit conditions and the other for application generally. Both relays are of the same general construction except that the former is more sensitive than the latter and is furnished with an auxiliary accelerating winding. Furthermore, this relay has in-

corporated in it certain refinements in construction and materials, which cause it to be extremely sensitive and to give reliable service for a comparatively long period without attention. The construction is of special interest in that the polarizing force of the permanent magnet is neutralized by the mechanical restraining force of the armature. A magnetic material having characteristics well suited to relay design and a new contact material are employed, which greatly improve the operating characteristics of the relay.

INTRODUCTION

THE development of new types of sensitive polarized relays, for use in the Bell System, was undertaken as a result of a demand which arose in connection with the development of the metallic polar-duplex telegraph system. A paper on this system is being presented at this session.³ Later these relays were applied to the carrier telegraph systems,⁴ one of which is being described in a paper at this meeting.

A number of polarized relays, manufactured in this country and abroad, were experimented with and found inadequate, in certain respects, for application to these systems without extensive modifications. For satisfactory performance, it was found that the relay should meet the following general requirements: 1. Have a high degree of sensitivity, 2. Retain adjustment for a long period, 3. Faithfully and accurately repeat signals with a small amount of maintenance.

From the standpoint of sensitivity, the relay is required to operate on reversals of line current of a minimum of one milliampere and at the same time obtain proper impedance characteristics without exceeding practical limits in the dimensions of the windings. Over small-gage cable conductors having large mutual capacity and high resistance, the wave-shape of the received current is badly distorted. This wave-shape, in addition to the magnitude of the current available, makes more drastic the requirements for sensitivity. It is interesting to note that, under average conditions, the ratio of power controlled by the contacts in the local circuit to that required by the line windings, is about five thousand to one.

In the case of main-line telegraph relays, it is essential that no considerable changes in length of signals take place as such effects are generally cumulative over long

circuits, where several relays are employed in repeating signals. As contrasted with relays used for circuit-switching purposes, telegraph relays are called upon to function continuously under severe conditions, and to perform successively hundreds of thousands of times in a few hours.

In order to furnish a good quality of telegraph service, it is essential that very few relay failures occur during service periods. If this is not accomplished, considerable valuable circuit-time is lost and the relay maintenance expense becomes an excessive factor in the cost of giving service.

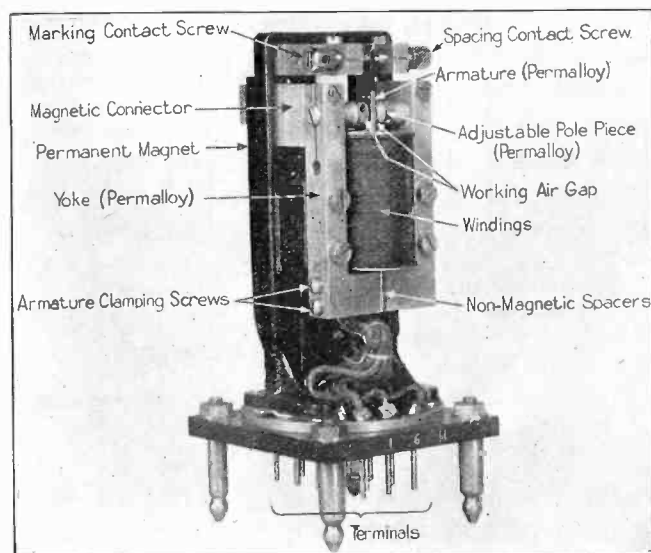

FIG. 1—No. 209-FA POLARIZED RELAY (COVER REMOVED)

DESIGN FEATURES

The relay which has been designed to meet the foregoing requirements is shown in Fig. 1 and is known as the 209-FA relay.

A polarized relay is fundamentally different in its operation from the ordinary neutral relay, in that it is selective to the polarity of the operating current and is more sensitive in its operation. A type of magnetic circuit was chosen which, it was felt, would best lend itself to obtaining a relay which would meet, as completely as possible, all of the requirements above outlined.

1. Bell Telephone Laboratories, Incorporated, New York, N. Y.
2. American Telephone and Telegraph Company, New York, N. Y.
3. Metallic Polar-Duplex Telegraph System for Long Small-Gage cables. J. H. Bell, R. B. Shanck and D. E. Branson.
4. "Carrier Current Telephony and Telegraphy" by E. H. Colpitts and O. B. Blackwell, TRANSACTIONS of the A. I. E. E., 1921, page 205.

Presented at the Midwinter Convention of the A. I. E. E., New York, N. Y., Feb. 9-12, 1925.

Fig. 2 shows the magnetic circuit and the arrangement of the relay elements. It is seen to consist of a Wheatstone-bridge type of magnetic circuit in which the four equivalent air-gaps, two upper and two lower, may be considered as the four arms of the bridge with the permanent magnet placed across two opposite corners of the bridge and the armature and windings in the position customarily occupied by the galvanometer. The operating windings are placed over the armature in the form of a single stationary spool, sufficient clearance being provided to allow the armature to move within the spool. The paths of the polarizing and operating fluxes are shown by the solid and dash lines, respectively, for the armature in its midway or neutral position. When the armature is in the midway position there is no polarizing flux through it, since it connects two points of the circuit of equal magnetic potential; as it moves toward the left pole-piece, the

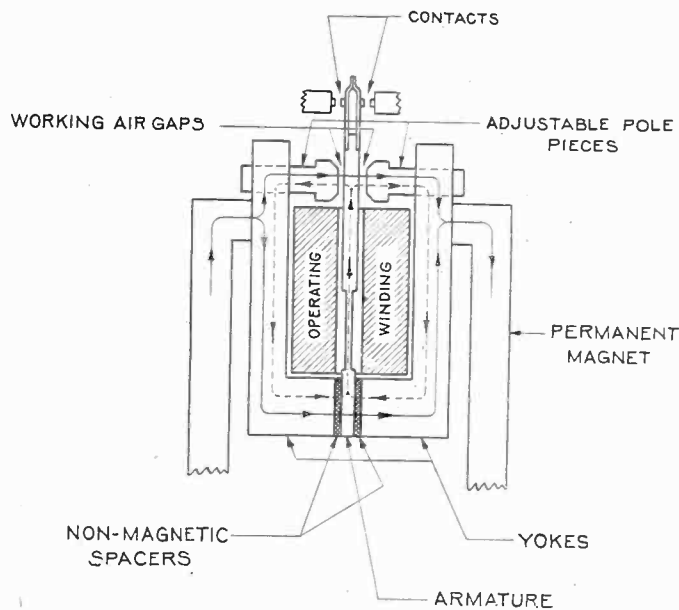

FIG. 2—DIAGRAM SHOWING MAGNETIC CIRCUIT AND ARRANGEMENT OF RELAY ELEMENTS

polarizing flux flows through it in a direction assumed to be positive and when it moves toward the right pole-piece, the polarizing flux flows in the opposite or negative direction. The operating flux, in addition to the two return paths shown through the yokes, has a third path through the permanent magnet, but, substantially, none of this flux returns by this path due to the high reluctance of the permanent magnet as compared to that of the yokes. It is seen that these fluxes aid and oppose each other in the four gaps in such a manner as to produce a torque on the armature about a point midway between the upper and lower sets of air-gaps. With the direction of fluxes shown, the armature would tend to move in a clockwise direction. The forces established in all four of the gaps can be utilized in moving the armature only when the armature is movably supported at a point midway between the upper and lower gaps. In the design of this relay, the armature is not supported at this point, but is firmly

clamped and supported at the lower gaps between the yokes, non-magnetic spacers forming proper reluctances to prevent short-circuiting the permanent magnet. This method of suspension, of course, prevents the forces established in the lower gaps from doing useful work upon the armature, but the overall advantages gained by this arrangement more than compensate for the apparent loss in sensitivity. This method of armature support permits of a more simple design of the relay; it eliminates the use of pivots; it permits the use of a single-spool construction instead of a two-spool arrangement; it allows a more practicable adjustment of the relay and more stable operation, and it affords a simple arrangement whereby the stiffness of the armature can be utilized to neutralize the polarizing force acting on the armature, thereby increasing the sensitivity of the relay as will be explained later in greater detail.

The pull acting between the pole-piece and the armature in each gap is expressed, according to Maxwell's law, by the equation:

$$P = \frac{(\phi_p + \phi_i)^2}{8\pi S} = \frac{1}{8\pi S} (\phi_p^2 + 2\phi_p\phi_i + \phi_i^2)$$

where P is the force in dynes, ϕ_p is the polarizing flux in the air-gap set up by the permanent magnet, ϕ_i is the operating flux generated in the air-gap by the winding (both expressed in maxwells), and S is the effective area of the air-gap in sq. cm.

This shows that the pull acting on the armature in each air-gap is made up of three components: The first term is the pull due to the permanent magnet and is the force acting on the armature with no current on the relay and is commonly spoken of as the polarizing force. The second is the important component, as it is the force which operates the relay; it is this component which makes the relay selective to the polarity of the operating current because its direction is dependent upon the sign of ϕ_i . Since its magnitude is proportional to the product of the polarizing flux and the flux generated by the operating current it shows why a high polarizing intensity is effective in obtaining a highly sensitive relay. The third term is a pull on the armature which would be the only one to appear if the relay were not polarized and is of twice the frequency of the second term.

As explained above there are two magnetic air gaps in which forces are effective to produce motion of the armature, and it is the resultant of these component forces in the two air-gaps that controls the relay. In Fig. 3 is shown how the resultant of the polarizing components of force in the two air-gaps varies as the armature is displaced in the air-gap. In the midway or neutral position of the armature the resultant polarizing force on the armature is zero, but as the armature is displaced in either direction the force is one of attraction of increasing intensity between the armature and pole-piece toward which the armature is displaced as

shown by the solid line. The armature, being supported in cantilever beam fashion, will be resistant to displacement from its midway position in the air-gaps due to its natural stiffness. This force of restitution of the armature is opposite in direction or opposing to the polarizing force as the armature is displaced from the midway position and is proportional to the displacement. If the armature is designed so that its force of restitution is approximately equal to the polarizing force acting on it for all positions of the armature

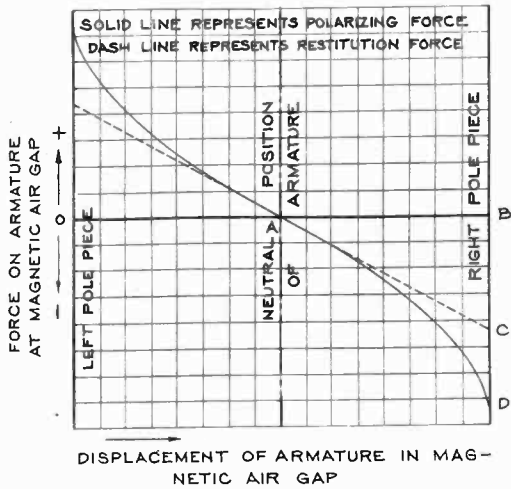

FIG. 3—DIAGRAM SHOWING HOW POLARIZING AND RESTITUTION FORCES VARY WITH POSITION OF ARMATURE

the sensitivity of the relay will be greatly increased. Thus, in Fig. 3, if the polarizing force on the armature were not in some manner neutralized, the work required to move the armature across the air-gap would be represented by the area *ABD*. By balancing the force of restitution of the armature against the polarizing force on the armature in the manner described, the work necessary to move the armature across the air-gap is reduced to the area represented by *ACD*. In actual practice, the motion of the armature is limited by the contacts rather than by the pole-pieces, and the displacement of the armature between the contacts is made small in comparison with the length of the magnetic air-gaps. Hence, the working range of the armature displacement in the magnetic gaps is limited to a short distance on either side of the neutral position shown in Fig. 3, where a very close balance between the polarizing force and restitution force of the armature, can be realized. The armature is practically in a floating condition and can be controlled by the application of a small force. The advantage of neutralizing the polarizing force on the armature by an external force and thus increasing the sensitivity of the relay was pointed out by Mr. D. D. Miller of the Bell Telephone Laboratories, Incorporated.

Fig. 4 shows how the resultant of the operating forces, or the component represented by the second term of the above discussed equation varies in the two gaps as the armature is displaced in the air-gap. The condition of constant strength and direction of current through the

relay winding is assumed. It is minimum when the armature is in the midway position and increases as the armature moves toward either pole-piece. Its direction may be either to aid or oppose the direction of the polarizing component shown in Fig. 3, since it is dependent upon the direction of the operating current. It is this component of force which controls the operation of the relay under influence of the operating current and it can be of small magnitude since it need be only of sufficient value to upset the equilibrium of forces shown in Fig. 3. The third component of force, acting on the armature represented by ϕ^2 is of small magnitude compared to the first two terms, but its effect is to decrease the sensitivity of the relay and increase the distortion and residual characteristics, since its direction opposes the operating component when the armature moves toward the neutral position and aids it when the armature moves away from the neutral position.

Thus it is seen that when the relay operates under the influence of reversals of current through the relay winding, both the operating and polarizing fluxes reverse in direction through the armature, which causes the relay to be highly sensitive to the magnetic properties of the armature. The parts entering into the magnetic circuit of this relay, except—the permanent magnet—are made of an improved magnetic material known as permalloy⁵ recently developed in the laboratories of the Bell System. This material has a very low coercive force compared to customary magnetic materials used in relays, resulting in almost complete collapse of the operating flux when the magnetizing force is removed. As a result, distortion of the re-

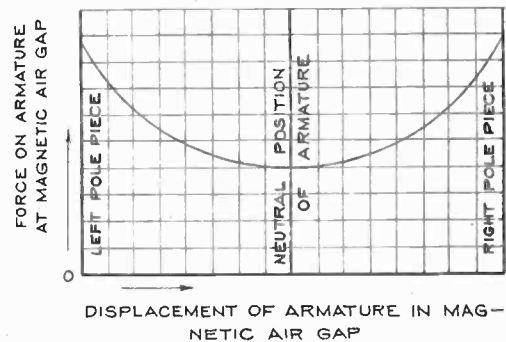

FIG. 4—DIAGRAM SHOWING HOW OPERATING FORCE VARIES WITH POSITION OF ARMATURE

peated signal is less, since the relay is less affected by the previous state of magnetization to which it may have been subjected by the preceding signal. On account of the higher permeability and the smaller residual effects of the material, the sensitivity of the relay is increased. It is evident from Fig. 3 that if the relay retains an appreciable amount of residual mag-

5. "Permalloy, a New Magnetic Material of Very High Permeability" H. D. Arnold and G. W. Elmen. The Bell System Technical Journal for July 1923. Page 101. "Electrical Communication", April 1924.

netism after the subsidence of the signal current, it will cause the armature to become biased by upsetting the balance between the polarizing and restitution force and decrease the sensitivity of the relay on the succeeding signal. Thus the use of this material results in marked improvements in the operating characteristics of the relay.

The relay is provided with six separate windings; four are employed as line windings, and two as auxiliary windings connected in a local circuit. The requirements of the metallic polar-duplex telegraph system are such that the four-line windings should be mutually balanced to a high degree both with respect to their impedance characteristics and their operating effects upon the relay. In order to meet these requirements it is necessary that each of the four windings have the same number of turns and resistances and be symmetrically located with respect to the armature and working air-gaps of the relay. This is obtained in practice by spirally twisting four well-insulated copper wires together and then winding as a single conductor on the relay spool in the usual manner. On top of and concentric with the line windings are two conductors wound in parallel. In the metallic telegraph system, these two windings are used in a circuit to form what is known as the *vibrating* or *accelerating* circuit, and this circuit is controlled from the contacts of the same relay. This feature serves to reduce distortion of signals by causing the relay to operate under the influence of the current in a local circuit before the operating current from the line at the time of reversal becomes sufficient to move the armature. It also reduces the armature travel-time and chatter and tends to make the relay more sensitive in its operation.

The relay contacts are required to make and break fairly large currents in circuits having large values of inductance and capacity. On relays used in terminal

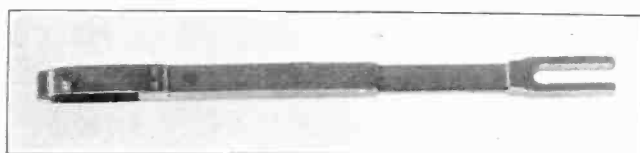

FIG. 5—ARMATURE OF NO. 209-FA RELAY

type repeaters, the voltage between one stationary contact and the corresponding armature contact is 240 volts. Due to the feeble currents which operate the relay, the contact-gap must necessarily be small, which, in practice, is adjusted to about 0.004 in. (0.10 mm.). The work of obtaining an adjustment of this gap is aided by marks on the capstan head of the contact screws. It is highly desirable to have a relay the contacts of which do not rebound or chatter as the armature breaks and makes contact. By eliminating contact-chatter the relay will be capable of transmitting signals at greater speeds and with less distortion, and the life of the contacts will be increased. An extended

study of the dynamic action of the armature at the contacts was made with a view of diminishing or eliminating contact rebound. This is an old problem of telegraph relay design and many efforts have been made during the past to solve this problem satisfactorily, but most solutions proposed resulted in devices or designs which were complicated and not adapted for commercial use.

A practical design of armature was developed, which is easy to manufacture and is effective in eliminating contact rebound. This design is shown schematically in Fig. 2 and by a photograph in Fig. 5. The magnetic part of the armature extends through the relay coil and is



FIG. 6—OSCILLOGRAM SHOWING CURRENT FROM ARMATURE CONTACTS

Upper curve—Armature of ordinary design
Lower curve—Armature of standard design

just long enough to reach through the working air-gaps. The armature is extended to the stationary contact screws of the relay by riveting on to it two nickel-silver springs carrying the armature contacts. These two springs are bent at the free end and tensioned so that they touch and rest upon one another with a fixed pressure between them. By this construction the mass of the moving end of the armature is kept as small as possible so that at the moment of impact the tendency to rebound is thereby reduced. When the armature contact strikes the fixed contact one armature contact spring is displaced with respect to the other spring causing the ends of the springs to slide upon each other. This rubbing action tends to damp out the rebound as the energy of impact is absorbed by friction between the two springs. Other advantages gained by keeping the effective mass of the armature small, are reduction in the travel time of the armature and quicker time of response. In order to prevent the armature from adhering to either pole-piece, small nickel-silver disks are welded to each side of the armature directly opposite to the pole-pieces. Fig. 6 shows oscillograms of the current from the armature contacts with the relay in a terminal type metallic telegraph repeater, operating full duplex. The top wave shows the current from the armature contacts with the relay equipped with an armature of ordinary design, that is, having the contacts mounted directly on the magnetic material which extends the entire length of the armature. The lower wave shows the same relay operating under identical conditions as

above except that it is equipped with the standard design armature shown in Fig. 5. The improvement in the repeated signal of the relay is apparent both with respect to contact chatter and travel-time of the relay.

On account of the high voltage, the energy content of the circuits which the relay controls, the small contact-gaps and the feeble forces available to operate the relay, it was found that contacts made of material usually found on telegraph apparatus would not with-

stand the large number of operations daily required without excessive maintenance. This problem was studied with reference to the contact requirements of relays operating under the conditions imposed by the various repeaters, and an alloy was developed which is a decided improvement. The use of this improved

relay from the circuit. This feature is illustrated in Fig. 8, which shows the relay with its cover attached to a mounting plate and connecting block. The square phenol-fibre base of the relay is provided with four guide pins which definitely locate the relay with respect to the mounting plate and the connecting block, and is also furnished with 15 terminals on which electrical connections to the windings and contacts of the relay are terminated as shown in detail in Fig. 1. The connecting block is the medium by which electrical connection is established between the circuit and the relay. It is fastened to the rear of the mounting plate, has the same number of terminals as the relay, and the circuit is permanently wired to these terminals. When the relay is inserted into position on the mounting plate, electrical contact between the relay and connecting

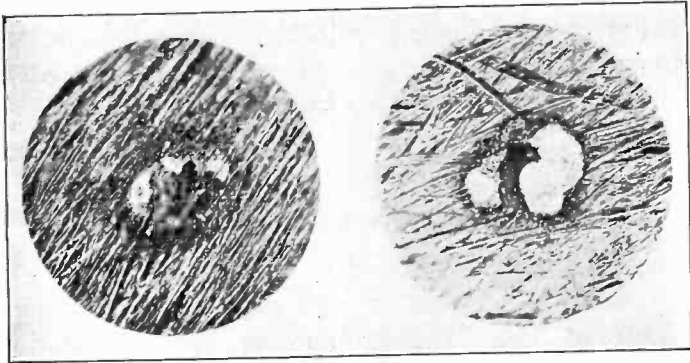

FIG. 7—PHOTO-MICROGRAPHS OF NO. 209-FA RELAY ARMATURE CONTACTS
Right—Marking contact
Left—Spacing contact

stand the large number of operations daily required without excessive maintenance. This problem was studied with reference to the contact requirements of relays operating under the conditions imposed by the various repeaters, and an alloy was developed which is a decided improvement. The use of this improved

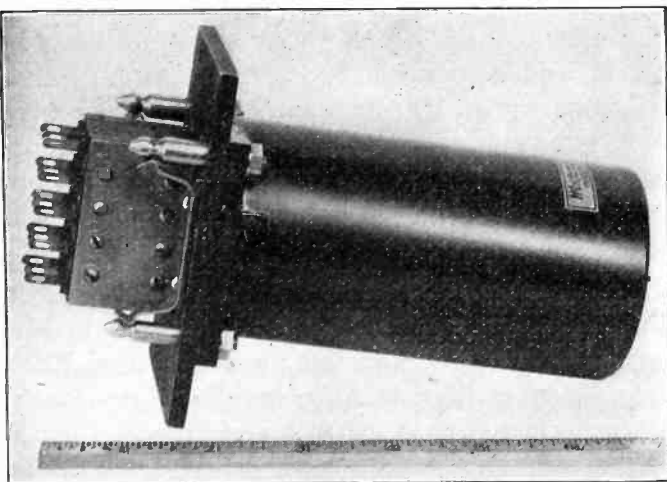

FIG. 8—NO. 209-FA RELAY WITH MOUNTING PLATE AND ASSOCIATED CONNECTING BLOCK

contact material extends the service period of the relay, without contact failure, to approximately thirty times over that with alloys previously used. Fig. 7 shows photo-micrographs of armature contacts of a relay which had been in service for 8½ months without being removed from service. This amount of service is equivalent to each contact making and breaking the circuit approximately 45,000,000 times.

One of the design features of this relay is the arrangement which permits of the ready removal of the

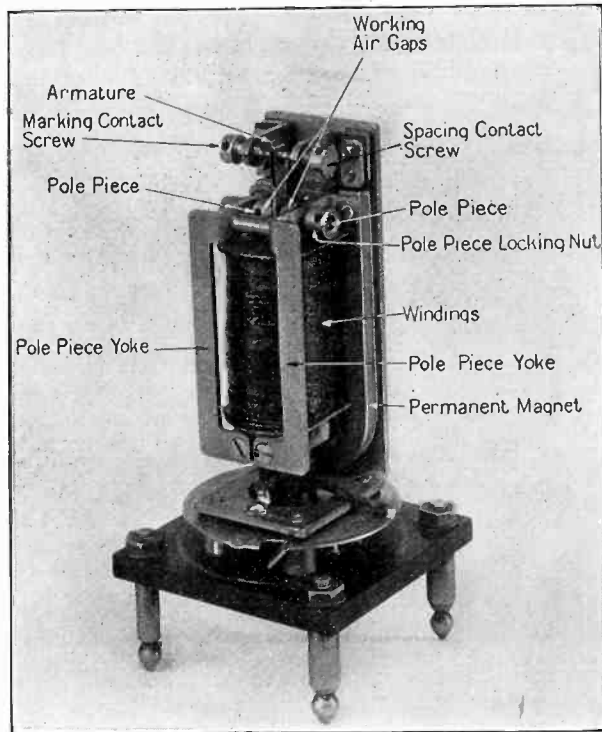

FIG. 9—NO. 215-A POLARIZED RELAY (COVER REMOVED)

block terminals is automatically established. Resilient members fastened on the rear of the mounting plate, engage into recesses in the four guide-pins and hold the relay rigidly in position on the mounting plate. In case of relay trouble, the relay may be quickly removed and a spare relay inserted, thus keeping the time of circuit interruptions to a minimum.

There are a number of places in these systems where polarized relays are required, but which do not have to operate under as exacting conditions as the relay just described. For this purpose, a cheaper relay has been developed known as the 215-A relay, and this is shown in Fig. 9. It employs the same type of magnetic circuit as the 209-F A relay, and the same design features of mounting and chatterless armature springs are also incorporated. It does not have as refined adjusting features, nor will it operate on as small currents. It is provided with two balanced line windings.

APPLICATION AND MAINTENANCE

At the present time there are in operation about 2500 of the 209-type relays. Of this number, about 2000 are operating in the metallic telegraph system and the remainder in the carrier telegraph systems. These carrier telegraph systems make use of about 1000 relays of the 215-type and in the metallic telegraph system, about 2400 relays of this type are used.

As a result of field experience, it has been found that the maintenance schedules for these relays can be arranged to cover long periods with practically no interruptions occurring in service. In terminal-type repeaters and through-type metallic repeaters, this period is for satisfactory relay operation, approximately three months and six months, respectively.

Means are specially provided whereby these relays may be checked or adjusted quickly and accurately external to the telegraph repeaters; that is, the relays



FIG. 10—RELAY TEST TABLE

are adjusted to the best operating condition without consideration of the telegraph circuit to which they are to be applied. This arrangement, known as a relay-test table, is shown in Fig. 10. These tests consist of obtaining an inspection and adjustment for sensitivity, differentiability, and freedom from bias. A local vibrating circuit is also provided for testing the 209-type relay so that it will function properly under the influence of the vibrating circuit in the telegraph repeaters.

The essential steps in adjusting a relay consist in withdrawing the contact screws sufficiently to permit inspection and cleaning. The pole-pieces are then withdrawn so that the effect of the permanent magnet upon the armature is made small, thus permitting the armature to stand in its neutral position. Any foreign material may be readily removed from the work-

ing air-gaps. Each contact-screw is then adjusted independently so as to have a separation of 0.002 in. (0.05 mm.) from the corresponding armature contact, and this results in a contact travel of 0.004 in. (0.10 mm.). Following this, the pole-pieces are adjusted so that the relay will respond without bias to 20-cycle a-c. ringing current of a magnitude about equal to that available in the telegraph repeaters. In order to have a margin of operation in the repeater, a d-c. sensitivity test is given with less current than above. In addition to the above a vibrating-circuit test on the 209-type is made. In general, the time required to adjust and test a relay is about six minutes.

REVISIONS IN NATIONAL CODE

The Signaling Committee of the National Fire Protection Association is now engaged in a general revision of the "Regulations for the Installation, Maintenance and Use of Municipal Fire Alarm Systems," and the resulting revised Regulations are to be submitted to the N. F. P. A. annual convention in May, 1925, for approval. This committee held a meeting late in January, and have called a public hearing on the changes proposed, to be held March 17, at the rooms of the New England Insurance Exchange, 18 Oliver Street, Boston. All interested are invited to present their views. Copies of the present and proposed rules may be obtained from the National Fire Protection Association, 40 Central Street, Boston.

The last general revision was made in 1920, and was finally adopted in 1922. Introduction of improved methods and apparatus for current supply, circuit protection, signal transmission and the handling of alarms, have made it desirable to consider the adoption of revisions in general classifications of fire alarm systems and the provision of detailed requirements which are both more comprehensive and specific.

The Signaling Committee is also considering amendments to the "Regulations for the Installation, Maintenance and Use of Signaling Systems, used for the Transmission of Signals Affecting the Fire Hazard," which were last revised in 1919, and amended in 1923. These include all privately owned fire alarm systems, watch services, sprinkler supervisory systems, etc.

Mr. C. E. Beach, Consulting Engineer, Security Mutual Building, Binghamton, N. Y., is the Chairman of the Sub-committee on Municipal Fire Alarm Systems. Mr. G. S. Lawler, Chief Engineer, Associated Factory Mutual Insurance Cos., 184 High Street, Boston, Mass., is the Chairman of the Sub-committee on Signaling Systems. Suggestions for revisions in the respective Regulations should be addressed to these gentlemen. Many members of the A. I. E. E. will be interested in one or the other of these Regulations.—*Committee on Communication.*

Power System Transients

BY V. BUSH¹
Fellow, A. I. E. E.

and

R. D. BOOTH¹
Associate, A. I. E. E.

Synopsis.—The steady state load limits of a power network may be examined by familiar methods of analysis. However, the instability of a system with one or more elements working close to these limits sets lower values of power at which the system can be expected to give satisfactory operation under the sudden changes in load or connections which it must successfully sustain in operation. This paper presents methods for the analysis of power systems under transient conditions.

A qualitative discussion of the problem is given, followed by an outline of a point-by-point scheme of analysis which takes into account the inertia of machines, field transients, etc. The value of

this scheme depends upon having available rapid methods of analysis applicable to conditions prevailing at a given instant during the transient. Therefore, there is also included a description of the methods which have been found advantageous, notable among which is a superposition method of solving systems by means of charts. This is a powerful means of attacking complicated systems. The method of point-to-point analysis is applied to specific types of networks as examples. There is also given an extension of approximate methods of analysis presented previously.

The paper is confined to the exposition of the methods of analysis which we have found convenient and powerful.

INTRODUCTION

WITH electrically long transmission lines, the ultimate carrying capacity of the line and the economic loading are of the same order of magnitude. Hence it becomes imperative to examine carefully and in detail the maximum power limit of such lines from technical considerations.

The problem is far from simple. If there were no system disturbances to be considered, no voltage fluctuations, no load variations, and so on, then a steady state analysis, using, of course, long line formulas, would readily give the load limits. It is when we attempt to consider disturbances that matters become complicated. Yet analysis is necessary, for while the margin to be allowed between operating load and ultimate steady-state load limit will always be a matter of judgment, there must be available definite facts in regard to the behavior of typical systems under the application of definite assumed disturbances on which such judgment can be based.

There are only three ways in which the knowledge necessary for a proper judgment can be gained:

1. Mathematical analysis.
2. Test of laboratory models.
3. Experience.

We shall not, for some time, accumulate sufficient experience with long lines operating close to their theoretical power limits to enable proper engineering margins of safety to be determined. So we must rely upon analysis and test.

Each of these should be made as nearly a complete treatment of the actual problem as possible, but neither can absolutely reproduce the conditions of the actual network. Test is limited because small machines cannot have the same relations between their electrical and mechanical constants as do large machines. Analysis is limited by the complexity of the problem. As in the analysis of all physical problems, something must be

approximated or assumed to make a solution possible. Yet each mode of attack should be pushed as far as possible in completeness. The economic importance of the problem warrants taking great pains to omit nothing from consideration that may be important. Analysis and test are complementary. The final check of theory is by test, and the final attack on the actual problems of system design must be by analysis.

In general the problem before us is this: Given a system of power stations connected by transmission lines, and operating close to the steady state power limits of some of its elements, how susceptible is such a system to disturbances of the sort which it will encounter and which it should sustain without rupture? In other words, what is the degree of stability of such a network when subjected to disturbances of the types likely to be encountered in practice? This problem is best solved at present by showing in detail how the system will react to certain definite assumed disturbances of a nature like those to be encountered in practice. For example, how will the system perform if a certain section of line is suddenly tripped out, or if a generating unit is suddenly dropped off? The answer to such questions is the definite guide needed to compare different system designs, and give the basis of judgment as to whether a given layout is satisfactory for the service for which it is intended.

The factors entering the problem are very numerous. The electrical constants of lines and machines are involved as in a steady state solution. In addition, during disturbances, the behavior of exciters, governors, and regulators comes into play, and the mechanical constants of machines as well as their electrical behavior must be considered. In other words, we are concerned not only with the distribution and time variation of voltage and current in the network, but also with the time variation of the air gap flux of machines, and their mechanical phase relations.

¹ Both of Jackson & Moreland, Engineers, Boston, Mass.

Abridgement of paper presented at the Midwinter Convention of the A. I. E. E., New York, N. Y., February 3-12, 1925. Complete copies available upon application to Institute headquarters.

BASIS OF ANALYSIS

During a power-system transient we have a succession of instantaneous states which occur in sequence,

APPLICATION AND MAINTENANCE

At the present time there are in operation about 2500 of the 209-type relays. Of this number, about 2000 are operating in the metallic telegraph system and the remainder in the carrier telegraph systems. These carrier telegraph systems make use of about 1000 relays of the 215-type and in the metallic telegraph system, about 2400 relays of this type are used.

As a result of field experience, it has been found that the maintenance schedules for these relays can be arranged to cover long periods with practically no interruptions occurring in service. In terminal-type repeaters and through-type metallic repeaters, this period is for satisfactory relay operation, approximately three months and six months, respectively.

Means are specially provided whereby these relays may be checked or adjusted quickly and accurately external to the telegraph repeaters; that is, the relays



FIG. 10—RELAY TEST TABLE

are adjusted to the best operating condition without consideration of the telegraph circuit to which they are to be applied. This arrangement, known as a relay-test table, is shown in Fig. 10. These tests consist of obtaining an inspection and adjustment for sensitivity, differentiability, and freedom from bias. A local vibrating circuit is also provided for testing the 209-type relay so that it will function properly under the influence of the vibrating circuit in the telegraph repeaters.

The essential steps in adjusting a relay consist in withdrawing the contact screws sufficiently to permit inspection and cleaning. The pole-pieces are then withdrawn so that the effect of the permanent magnet upon the armature is made small, thus permitting the armature to stand in its neutral position. Any foreign material may be readily removed from the work-

ing air-gaps. Each contact-screw is then adjusted independently so as to have a separation of 0.002 in. (0.05 mm.) from the corresponding armature contact, and this results in a contact travel of 0.004 in. (0.10 mm.). Following this, the pole-pieces are adjusted so that the relay will respond without bias to 20-cycle a-c. ringing current of a magnitude about equal to that available in the telegraph repeaters. In order to have a margin of operation in the repeater, a d-c. sensitivity test is given with less current than above. In addition to the above a vibrating-circuit test on the 209-type is made. In general, the time required to adjust and test a relay is about six minutes.

REVISIONS IN NATIONAL CODE

The Signaling Committee of the National Fire Protection Association is now engaged in a general revision of the "Regulations for the Installation, Maintenance and Use of Municipal Fire Alarm Systems," and the resulting revised Regulations are to be submitted to the N. F. P. A. annual convention in May, 1925, for approval. This committee held a meeting late in January, and have called a public hearing on the changes proposed, to be held March 17, at the rooms of the New England Insurance Exchange, 18 Oliver Street, Boston. All interested are invited to present their views. Copies of the present and proposed rules may be obtained from the National Fire Protection Association, 40 Central Street, Boston.

The last general revision was made in 1920, and was finally adopted in 1922. Introduction of improved methods and apparatus for current supply, circuit protection, signal transmission and the handling of alarms, have made it desirable to consider the adoption of revisions in general classifications of fire alarm systems and the provision of detailed requirements which are both more comprehensive and specific.

The Signaling Committee is also considering amendments to the "Regulations for the Installation, Maintenance and Use of Signaling Systems, used for the Transmission of Signals Affecting the Fire Hazard," which were last revised in 1919, and amended in 1923. These include all privately owned fire alarm systems, watch services, sprinkler supervisory systems, etc.

Mr. C. E. Beach, Consulting Engineer, Security Mutual Building, Binghamton, N. Y., is the Chairman of the Sub-committee on Municipal Fire Alarm Systems. Mr. G. S. Lawler, Chief Engineer, Associated Factory Mutual Insurance Cos., 184 High Street, Boston, Mass., is the Chairman of the Sub-committee on Signaling Systems. Suggestions for revisions in the respective Regulations should be addressed to these gentlemen. Many members of the A. I. E. E. will be interested in one or the other of these Regulations.—*Committee on Communication.*

Power System Transients

BY V. BUSH¹
Fellow, A. I. E. E.

and

R. D. BOOTH¹
Associate, A. I. E. E.

Synopsis.—The steady state load limits of a power network may be examined by familiar methods of analysis. However, the instability of a system with one or more elements working close to these limits sets lower values of power at which the system can be expected to give satisfactory operation under the sudden changes in load or connections which it must successfully sustain in operation. This paper presents methods for the analysis of power systems under transient conditions.

A qualitative discussion of the problem is given, followed by an outline of a point-by-point scheme of analysis which takes into account the inertia of machines, field transients, etc. The value of

this scheme depends upon having available rapid methods of analysis applicable to conditions prevailing at a given instant during the transient. Therefore, there is also included a description of the methods which have been found advantageous, notable among which is a superposition method of solving systems by means of charts. This is a powerful means of attacking complicated systems. The method of point-to-point analysis is applied to specific types of networks as examples. There is also given an extension of approximate methods of analysis presented previously.

The paper is confined to the exposition of the methods of analysis which we have found convenient and powerful.

INTRODUCTION

WITH electrically long transmission lines, the ultimate carrying capacity of the line and the economic loading are of the same order of magnitude. Hence it becomes imperative to examine carefully and in detail the maximum power limit of such lines from technical considerations.

The problem is far from simple. If there were no system disturbances to be considered, no voltage fluctuations, no load variations, and so on, then a steady state analysis, using, of course, long line formulas, would readily give the load limits. It is when we attempt to consider disturbances that matters become complicated. Yet analysis is necessary, for while the margin to be allowed between operating load and ultimate steady-state load limit will always be a matter of judgment, there must be available definite facts in regard to the behavior of typical systems under the application of definite assumed disturbances on which such judgment can be based.

There are only three ways in which the knowledge necessary for a proper judgment can be gained:

1. Mathematical analysis.
2. Test of laboratory models.
3. Experience.

We shall not, for some time, accumulate sufficient experience with long lines operating close to their theoretical power limits to enable proper engineering margins of safety to be determined. So we must rely upon analysis and test.

Each of these should be made as nearly a complete treatment of the actual problem as possible, but neither can absolutely reproduce the conditions of the actual network. Test is limited because small machines cannot have the same relations between their electrical and mechanical constants as do large machines. Analysis is limited by the complexity of the problem. As in the analysis of all physical problems, something must be

approximated or assumed to make a solution possible. Yet each mode of attack should be pushed as far as possible in completeness. The economic importance of the problem warrants taking great pains to omit nothing from consideration that may be important. Analysis and test are complementary. The final check of theory is by test, and the final attack on the actual problems of system design must be by analysis.

In general the problem before us is this: Given a system of power stations connected by transmission lines, and operating close to the steady state power limits of some of its elements, how susceptible is such a system to disturbances of the sort which it will encounter and which it should sustain without rupture? In other words, what is the degree of stability of such a network when subjected to disturbances of the types likely to be encountered in practice? This problem is best solved at present by showing in detail how the system will react to certain definite assumed disturbances of a nature like those to be encountered in practice. For example, how will the system perform if a certain section of line is suddenly tripped out, or if a generating unit is suddenly dropped off? The answer to such questions is the definite guide needed to compare different system designs, and give the basis of judgment as to whether a given layout is satisfactory for the service for which it is intended.

The factors entering the problem are very numerous. The electrical constants of lines and machines are involved as in a steady state solution. In addition, during disturbances, the behavior of exciters, governors, and regulators comes into play, and the mechanical constants of machines as well as their electrical behavior must be considered. In other words, we are concerned not only with the distribution and time variation of voltage and current in the network, but also with the time variation of the air gap flux of machines, and their mechanical phase relations.

BASIS OF ANALYSIS

During a power-system transient we have a succession of instantaneous states which occur in sequence,

¹ Both of Jackson & Moreland, Engineers, Boston, Mass.

Abridgement of paper presented at the Midwinter Convention of the A. I. E. E., New York, N. Y., February 3-12, 1925. Complete copies available upon application to Institute headquarters.

each of which changes into that which follows. Actually there are an infinite number of such states and the transition is entirely gradual. However, as done in many mathematical devices, we may consider only a finite number of such states occurring at finite intervals of time. If the time interval is short, we may approach the actual process in this manner as closely as is necessary for accuracy. We practically choose a time interval sufficiently short to avoid undue error, and as long as is consistent with this condition, in order to shorten the necessary computation. Hence analysis of the transient behavior involves, first, the solution of the network under the conditions prevailing at each of these chosen instants, and second, a computation of the manner in which the conditions determining these instantaneous solutions vary with the elapsed time.

When a system passes from one instantaneous state to another, the transition, so far as the transmission lines are concerned, is accomplished by means of traveling waves. These die out within a cycle or two. If the chosen time intervals are large compared with the time constant of the traveling waves, then the conditions prevailing at each instant for given terminal conditions on the line will be substantially the same as though these terminal conditions were sustained. In other words, the instantaneous solution for the transmission line will be given by formulas applying to the steady performance of the line as represented most conveniently in circle diagrams.

In machines the case is somewhat different. When the terminal voltage on a synchronous machine is suddenly altered in phase or magnitude, there is an armature transient which lasts a few cycles only. This armature transient may be neglected since it lasts for a brief interval, and its effect, if taken into consideration, would amount only to a minor correction to be applied to the field current. After this has died out, conditions in the machine are those given by curves giving the machine performance for steady conditions, provided they are entered with the actual values of field current and angle which prevail at the instant under consideration. The field current and angle change slowly, due to the large time constant of the field circuit, and the inertia of the machine; and, as we pass from one instantaneous state to another these slow changes must be computed and allowed for.

Therefore, if for any given instant we state the connections and electrical constants of any network, the flux of any connected synchronous machines, the relative phase angles between them, the characteristics of any connected load, and the voltage and current distribution in phase and magnitude, we specify to a sufficient degree of accuracy, the condition of the system at that instant. If sufficient of these data are given for a certain instant, we can solve the remainder from the circle diagrams of lines and connected machines, using these latter at the values of field current and angle actually existing at the instant considered.

OUTLINE OF METHOD OF ANALYSIS

Before going into the detail of computation of the complete solution, let us consider qualitatively what happens to a typical system during sudden load changes.

Consider a system consisting of a load supplied in parallel from a local steam station and a hydro station transmitting power over a long line which has synchronous condensers at the receiver end. When a load is suddenly applied at the receiver end of such a system, the increment is shared in the first instant between (1) the steam stations, (2) the synchronous condensers, and (3) the line and hydro station. Each begins to drop back in phase at a rate depending upon the load increment applied and the moment of inertia of its rotor. The field fluxes remain substantially unchanged during the first instant, and then start to alter at a rate depending upon the constants of the field windings and upon the rate at which armature currents are simultaneously changing. After an interval the regulators act and the variations of field current are, thereafter, influenced by this new factor. The governors on the various units also come into action after an interval, and the rate of phase change of each machine is thereafter correspondingly influenced by the increment shaft torque applied by the prime mover as the throttle is changed in position.

Preliminary consideration of the sequence of these events show that at first all of the rotating equipment on the system will start to change speed, and that the apparatus which supplies the larger increment of load in proportion to its kinetic energy of rotation, probably the synchronous equipment nearest to the load, will slow down most rapidly. In slowing down this equipment so changes the phase position of its field structure with respect to the terminal voltage that it delivers a smaller and smaller load increment which eventually passes through zero. It then takes power until the excess changes the direction of swing. Meanwhile the other machines must deliver the deficit in power created by the swing of the first machine, thus in turn carrying a load which makes their rate of phase change greater, so that they follow the first machine through a similar cycle. In this manner synchronous apparatus on the system oscillates about some power point. The condensers of course oscillate about the zero power axis and the generators tend to oscillate about their respective governor characteristic curves plotted against the time.

While this discussion relates primarily to sudden load application, there is a similar sequence of events when a generating unit is dropped at the receiver end of the line, or when a transmission circuit is suddenly tripped out. The methods of analysis presented are applicable to any of these cases, or to three phase short circuits in any part of the system considered.

Given a power system operating under known steady conditions, and given a disturbance such as a change of load or connections suddenly impressed on this system,

it is desired to compute in detail the time variations of all factors in the system in which we are interested.

There is an immediate change, first to be computed, which follows directly after the start of the disturbance and after the lapse of a very small interval of time. This small time interval, a cycle or two, is sufficient for the subsidence of traveling waves, and for the armature transients in machines to have disappeared; but it is insufficient for appreciable change in the relative mechanical phase angles of machines, or appreciable change in the magnitude of the flux in machines.

This immediate change can hence be computed by a solution based on the characteristics of lines and machines in which the given quantities are all the mechanical phase angles and values of flux. These are sufficient to fix the system, and a solution then gives the phase and magnitude of voltage and current everywhere, and hence the new values of power and reactive volt amperes in each machine. We will assume for the present that this solution is made, and later we will return to specific examples, and show how such a solution can be obtained in a manner conveniently adapted for the transient analysis.

We now have the solution for the first instant after the beginning of the disturbance, and hence the values of power which appear immediately after the disturbance in each machine involved. The difference between these values and the initial values of power give the power increments, plus or minus, on each machine. In the first instant these increments are applied entirely to produce positive or negative acceleration of the rotors, and these accelerations may be computed, when the speeds and moments of inertia of machines are known, by well known formulas.

If now this power increment remained constant, that is if the flux in the machine and its terminal voltage suffered no further change in either phase or magnitude, and if there were no additional power supply to the unit from governor action, we could compute its position for subsequent times from

$$\theta = \frac{\alpha t^2}{2}$$

Where α is the acceleration and θ is the mechanical change in angle. In making this computation, we may, as noted below, make as a refinement a correction for the power consumed by damper windings. Of course, quantities do not remain constant in the manner indicated above, yet, if we choose a sufficiently small time interval, the error in assuming them constant may be made as small as we please. In fact, even although a small variation in the factors involved occurs during the time interval, we may estimate the variation and allow for it. The accuracy in the estimate could be checked presently, and in case of serious discrepancy, corrected by a recomputation. It is possible though to avoid the cut and try process involved in this estimate of power increment and this is in fact necessary if the

analysis is not to become unduly laborious. The superposition methods of analysis which are described below enable this to be done by a correction applied to a characteristic curve.

In the first instant after the occurrence of a disturbance, each machine will also have an increment of armature current. Due to the fact that the magnetic linkages with the field winding cannot be changed instantly the field current will also undergo a sudden change. The amount of this change can be obtained from the increment of armature reaction, since the total magnetomotive force on the magnetic circuit of the field remains constant. In this computation allowance is, of course, made for the incompleteness of coupling between armature and field circuits. It is sufficient to use the increment of armature current in quadrature to the induced voltage.

We thus obtain the value of field current in each machine at the instant after the beginning of the disturbance. If there were no further change in armature current and in the absence of regulator action, we could then compute the field current, and hence the flux, in each machine for subsequent times. The field current would return exponentially to its original value, the decrement of the exponential being given by the time constant of the alternator field circuit. In the first short interval of time the regulators will not have acted, so we can compute in this manner the flux in each machine at the end of a chosen short time interval, except for one effect. This is the result of further armature current change during the interval. Such change produces a field current increment in exactly the same manner as the initial change. This may be termed for convenience the subsidiary field transient. It could be allowed for as follows: Estimate the terminal voltage at the end of the chosen interval, from the machine characteristic determine the corresponding armature current and armature reaction, and from this the subsidiary field transient. Apply to this the field decrement corresponding to half the time interval to allow for the fact that the effect is produced continuously throughout the interval at approximately constant rate, and add the result, with proper sign, to the field current obtained from the previous computation. Upon obtaining the next solution the estimate of voltage could be checked. While this method of allowing for subsidiary field transients would work, it is laborious in that it involves a cut and try method. Again the superposition method of obtaining instantaneous solutions which we use in this transient analysis enable us to allow for this subsidiary transient without using cut and try methods. This will appear in the examples which follow.

From the above we now have at the end of a chosen time interval the values of flux in all machines and their relative mechanical phase positions. It is hence possible, by just the same methods employed for the previous solution, to solve for the voltage and current

everywhere in the system at the end of this interval. We may then compute new power increments, and new values of field current.

We then proceed with a second time interval. The procedure is exactly as before with two exceptions. First in computing the angular space travel of machines in the second and subsequent intervals, we must not only compute as before that due to their angular accelerations in the interval, but must add the travel due to the velocity which existed at the beginning of the second interval with respect to a constant speed base. The angle for the second interval is given from

$$\theta = V_1 t + \frac{\alpha_2 t^2}{2}$$

where V_1 is the angular speed at the end of the first interval, obtained from

$$V_1 = \alpha_1 t_1$$

except for the effect of power increment during the interval, allowed for as before. Second, it is necessary in computing the field current change in the second interval, to apply the decrement for the interval to the total field current increment at the end of the first interval due to both initial and subsidiary field transients, and to add on the curves the effect of the subsidiary transient in the second interval.

Proceeding in this manner, we can compute the variation point by point with the time, of the voltages, currents, powers, and angles in the system. This is continued until sufficient data is obtained to make evident the behavior of the system subsequent to the beginning of the disturbance. During this process we will shortly arrive at a lapse of time sufficient for the voltage regulator to begin action. When this occurs we shall need to add a new term in our computation of field currents, namely the increment produced by the regulator action on the exciter. This is obtained from a curve of main field current against time after closing of regulator contacts, drawn for the particular exciter system involved. Mr. R. E. Doherty has developed the form of these exciter transients in much detail¹, and we have checked many of his derivations. It is accurate for small increments with shunt wound exciter and brushes on neutral to add the separate effects of field decrement and exciter action. In other words, the effect of exciter field built-up occurs, as far as small increments are concerned, as though the field current were otherwise stationary in value. The consideration of compounded exciters requires that the two effects be considered in combination by a cut and try process.

It may even occur in the course of the analysis that the terminal voltage of a machine will rise to a point where the regulator contacts will again open. This is taken into account by a curve very similar to the above, again allowing a definite interval of time after arriving

at the new voltage for the delay in opening of contacts due to time lag of the relays. This is one or two-tenths of a second, depending on the regulator design.

Another effect which occurs after an interval where prime movers are involved is governor action. This is readily taken into account, provided we know the governor characteristics, by including with the power increment used in calculations of angular swing a new increment, of the same or opposite sign, as the case may be, due to governor action. For this we need simply a curve for the governor giving additional power supply to the unit against the time. It is in fact best to construct this as we proceed, as the rate of response of a governor depends upon the increment in speed, or the total response depends upon the integral of the speed change. This again is a matter requiring detailed analysis of its own, and unfortunately complete information in regard to the behavior of all types of governors is not yet available in the form necessary. We have been assisted in arriving at reasonable curves for governor action by certain studies carried out by the General Electric Company. The action of steam governors is especially important. The lag of hydraulic governors is so much greater that the power transient is usually past its critical stage before they get into action.

From the above it is evident that point by point analysis of this sort depends principally upon a proper adaptation of methods of obtaining instantaneous solutions under the conditions set up by the transient analysis. Especially is it possible to proceed with facility when the charts are so modified that cut and try processes, both on power variation and on subsidiary field transients, are avoided. We will, therefore, devote much of this paper to the treatment of rapid solutions under the peculiar terminal conditions which obtain where such solutions are a part of a transient analysis. We will follow this by examples employing the methods developed.

Experimental methods of studying transients, using alternating current artificial lines, and small machines to represent the various generating and condenser stations, have been used by Evans and Bergvall to give a means of checking theory. This is a valuable procedure which will undoubtedly be extended. When it is attempted, however, to obtain from such an artificial system transient data which will apply directly to an actual system, we encounter a difficulty in that the relations between electrical and mechanical constants and the relation between armature and field constants cannot be made the same in a small machine as in a large one. One way of avoiding this difficulty is to replace the small rotating machines by stationary phase modifiers, and to then manually make the phase adjustments and generated voltage changes indicated by the point by point analysis. The artificial network then becomes simply a convenient means of arriving rapidly at the steady state solutions necessary for the complete analysis. This method of representing gener-

1. R. E. Doherty, TRANS. A. I. E. E., 1922.

ating stations in an artificial network has been developed by Messrs. H. H. Spencer and H. L. Hazen at the Massachusetts Institute of Technology, and they have written a paper to appear shortly describing the apparatus and its use, so that it need not be further discussed here. The advantage of the method, of course, is that the solutions for points in a transient analysis may be obtained more rapidly when complicated systems are considered.

The refinements to be introduced in the transient analysis are a matter of judgment, and experience with the method soon shows the relative importance of various factors. One point of this sort deserves particular mention. During the progress of a transient the speed of a machine will change slightly, and strictly its characteristic as used in the solutions for instantaneous points should then be altered so as to apply to its actual speed. We have found, however, that in cases in which the disturbance was such as to approximately produce loss of synchronism the speed change during the portion of the transient which must be computed in order to predict results was usually well below 1 per cent, so that we have not considered this particular refinement necessary when treating transients due to sudden disturbances.

DERIVED CURVES

For the solutions incident to this transient analysis, the primary tools, or reference charts, are the characteristics, preferably in the form of circle diagrams as shown above, of generators, connecting lines and transformers, condensers, and loads. From these are taken off as needed in the course of the study of a particular

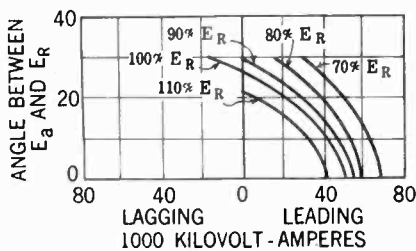

FIG. 2—DERIVED QUADRATURE KV-A.-CHART OF CONDENSER PERFORMANCE INPUT

transient problem, special curve sheets for rapid use in obtaining solutions for a given point of time. These are, for reasons which will appear below, most conveniently put in the form of plots of kilowatts or reactive kilovolt-amperes against electrical angle with respect to some base angle as reference, for lines, generators and condensers. The vector used as a base may be the terminal voltage at some chosen point for steady state normal load conditions. On each sheet is a nest of curves for various terminal voltages. For a machine it is also necessary to prepare a separate sheet for each value of field current. Curve sheets of this sort are

shown in Figs. 1 and 2 for a 20,000 kv-a. synchronous condenser. Similar charts for a line are shown in Figs. 3 and 4.

These curve sheets are used by superposition methods for obtaining solutions for a network where angles and flux values are the known parameters. It has been found desirable to put kilowatt and quadrature kilovolt-ampere relations on separate sheets, and treat them separately rather than to attempt to superpose circle diagrams themselves. The reason for this is that these

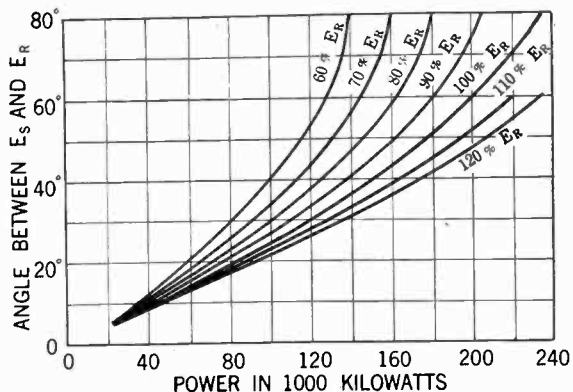

FIG. 3—DERIVED POWER CHART OF TRANSMISSION LINE PERFORMANCE

solutions are made as a part of a transient solution and because when done it is possible to avoid laborious cut and try processes by a single alteration in the curve sheets used in superposition. Upon superposing these curves a resultant diagram is obtained satisfying all power relations for the network, as well as a second diagram which satisfies all quadrature relations. A final superposition of these two gives a set of conditions which is common to both, and hence is a solution of the network under given conditions.

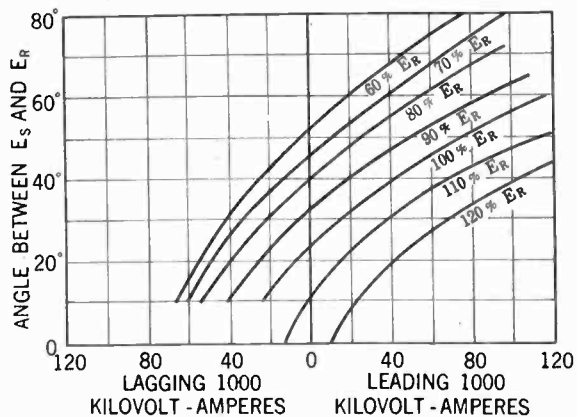

FIG. 4—DERIVED QUADRATURE KV-A.-CHART OF TRANSMISSION LINE PERFORMANCE

This, in brief, is the scheme of the superposition method. It is difficult to explain clearly in general terms, but specific examples will be presented in some detail, and in the course of this, it will appear why these particular superposition methods, avoiding the necessity of cut and try processes, have been adopted for the solutions incident to this transient analysis.

EXAMPLES

The underlying theory of this analysis has been presented in foregoing sections and it has been noted that characteristics of machinery, and lines are most readily introduced into the calculations in the form of kilowatt vs. angle charts and reactive kilovolt-amperes vs. angle charts. This modification of the ordinary solution has been found desirable for two main reasons: first, that the intersections obtained by use of the ordinary charts were obscure, and second, that refinements to introduce mechanical movement and subsidiary transients in the fields were readily appli-

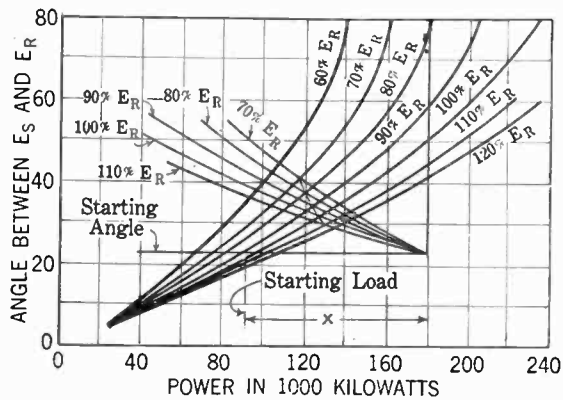

FIG. 5—SUPERPOSED CHARTS FOR DETERMINATION OF POWER CONDITION LOCUS

cable to the new charts in such a manner as to eliminate the cut and try processes otherwise incident to the consideration of these factors.

The method of using these new tools will be illustrated in examples. The first case will be very simple for the purpose of presenting the general method, and because of its simplicity will not involve all of the refinements necessary for solutions of more nearly representative systems. The other cases will consider more extensive systems and will, we hope, present the method and refinements in sufficient detail making the extension to more complex systems apparent.

Consider first a system consisting of a generating station of such dimensions that the high tension voltage at the sending end of a transmission line is substantially fixed in phase and magnitude, with a line transmitting power from this station to a receiver point where a condenser is operating to regulate voltage. Let us determine the operation of the system upon the sudden application of a block of load of constant kw. and kv-a. at the receiver end of the line.

The characteristics used for the solution of the first point are, Fig. 3, the receiver end power characteristic of the line plotted vs. angle between the sending and receiving end voltages, E_s and E_r , Fig. 4, the receiver end kv-a. characteristic plotted also vs. angle between E_s and E_r , Fig. 1, the power characteristic of the condenser for the known initial field excitation plotted against electrical angle between the voltage of the impressed field or the center line of field structure and the

terminal voltage E_r , and Fig. 2, the corresponding quadrature kv-a. characteristic for the condenser.

Locate upon Fig. 3 the operating point of the line before the application of the additional load x ; then place Fig. 1 upon Fig. 3 so that its 0° line coincides with this point of operation. If the zero power point of the condenser is also located at this point, the graph indicates steady state power conditions. However, since we are considering the application of an additional load of x kw., place the zero power line of the condenser on the load line equal to the total load as shown in Fig. 5. Initially, the power in the condenser is zero, so that the angle between terminal voltage and field structure is zero. Thus, the vertical distance between the displaced axes gives the angle between the voltage at the sending end of the line and the field structure of the condenser, which remains unchanged in the first instant after the application of additional load.

It is apparent from Fig. 5 that the power requirements of the system independent of the reactive kv-a. could be satisfied at any point on a locus indicated by the intersection of characteristics of the line and the condenser, for corresponding terminal voltages, shown on the dotted curve. This fixed superposition applies when the kw. of the load is independent of terminal voltage E_r . In case of a load characteristic showing a variation of kw. with E_r , it is sufficient to simply slide the two superposed curves horizontally with respect to one another, as the intersections are spotted in succession, keeping the total horizontal displacement equal to the power in the load corresponding to the particular voltage curves being considered. This same process

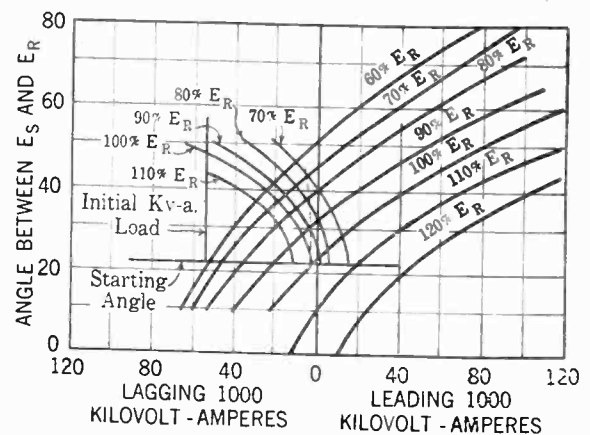

FIG. 6—SUPERPOSED CHARTS FOR DETERMINATION OF QUADRATURE KV-A.-CONDITION LOCUS FOR INITIAL CONDITIONS

applies to the consideration of quadrature kv-a. below.

We can, in very similar manner, satisfy the kv-a. requirements independent of the power. In Fig. 6, we have made a solution for kv-a. under the initial conditions.

The conditions obtaining upon the addition of a load of y kv-a. are as indicated in Fig. 7.

The dotted curve indicates the possible operating range without regard to power requirements. It now remains to simultaneously satisfy the power and kv-a.

relations. This we can do by superposition of the two resultant characteristics when plotted upon a common base. We have chosen condenser angle and E_r as the determining characteristics, but in this example line angle and E_r could be used equally conveniently.

When the two preceding loci are thus plotted, we obtain Fig. 8, the intersection indicating the operating point for the instant immediately following the application of load. Now knowing the receiver voltage and the angle of the condenser, we can readily determine line angle, line power and the other information desired.

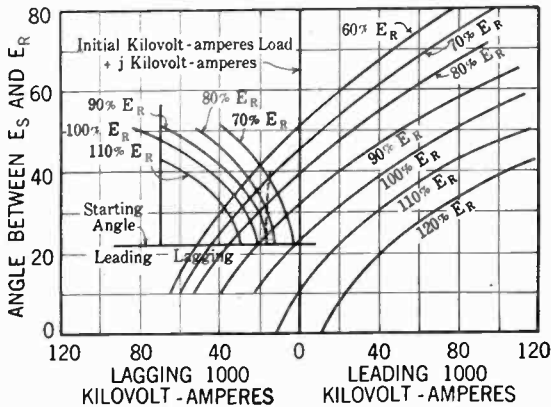

FIG. 7—SUPERPOSED CHARTS FOR DETERMINATION OF QUADRATURE KV-A.-CONDITION LOCUS FOR CONDITIONS AFTER ADDING LOAD

The above indicates the approach to the problem but certain factors have as yet been omitted from the solution. The first is the transient that occurs in the condenser field as the current in the condenser armature becomes altered. The condenser characteristic used above was made for a fixed value of field current. The field transient may be taken into account by showing this characteristic on a somewhat different basis. Let

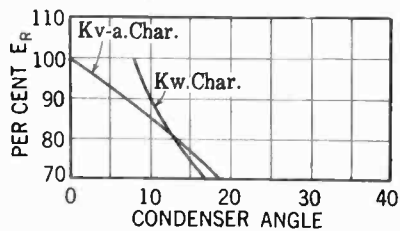

FIG. 8—SUPERPOSITION OF POWER AND KV-A.-LOCI TO OBTAIN COMMON POINT

us compute, in advance, the change in condenser field current due to transformer action per ampere change of each component of armature current. Now construct the condenser characteristic in such a manner that for a constant terminal voltage the curve is not drawn for constant field current, but at each point for the field current which would obtain, in accordance with the change of armature current in arriving at this point. Since this change of armature current for a given change in electrical angle is definite both in power and kilovolt-amperes for any particular terminal voltage, the resultant change in exciting current which would have obtained,

is likewise definite. When in computing later points, the conditions to be determined are for an instant at an interval of time after some preceding known conditions, the increment of field current is computed as a current generated equally throughout the interval considered and is then attenuated in a corresponding manner before being applied. For convenience the time interval chosen between computed points is taken equal, in order to facilitate the computations and make curves useful for more than one point. When the condenser curves are thus constructed the solution will automatically be corrected to allow for the field transient in the machine.

It may be noted that the above method of introducing the field transient involves the assumption of field currents in the condenser, which differ at each point of the chart and do not correspond on the two characteristics. However, since the operating point obtained as a solution is that point at which the condenser angle and terminal voltages are identical on the two characteristics, the field currents involved on each characteristic at the intersection will be identical and correct for the

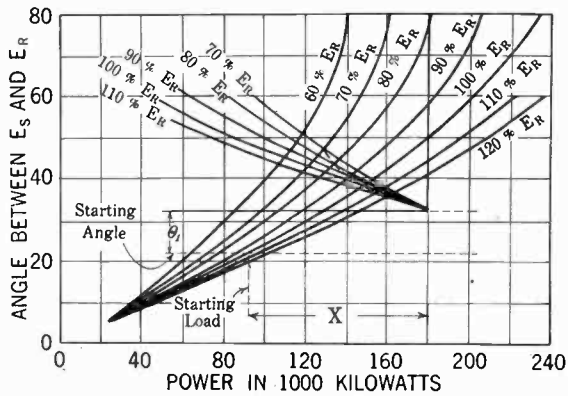

FIG. 9—SUPERPOSED CHARTS FOR POWER LOCUS SHOWING SHIFT FOR ANGULAR TRAVEL

conditions obtained as a solution. At no other points on the curves would this obtain.

Let us now determine the conditions obtaining after a short interval of time t . The rotor of the condenser has now made an angular movement of θ deg. given by,

$$\theta_1^\circ = \omega t + \frac{1}{2} \alpha_1 t^2$$

where α_1 is the acceleration due to power increment at the preceding point, and ω is the relative angular velocity at the beginning of the interval; zero in this case, but to be included for later points. Also the field current increment at the preceding point will have attenuated to a new value, even if the armature current has remained unchanged during this time t .

First construct condenser characteristics for the new attenuated value of field current, correcting the curves as before to the field current that would obtain at any point that involves an armature current other than found for the last-known condition of flux.

This curve will now be used in conjunction with the line characteristic in a manner similar to computations for the initial conditions; except that since the rotor has

been slowing down and has moved the distance θ behind synchronous speed position, the pole pieces of the condenser have now assumed an angle equal to the angle of the preceding point plus the angle of travel. This is shown in Fig. 9. It will be apparent that the condenser may be delivering or receiving power at the end of this interval different from that at the starting time, and that the movement due to this additional accelerating force during the interval considered, has not been incorporated in the calculations. This is done by moving each point of the characteristic curves by an angle θ_2 . Since the difference in power between that delivered at the preceding point and the new is variable during the time interval, we must consider a resultant acceleration. If we assume the variation of power to be linear with time during the short interval, we find that

$$\theta_2 = \frac{1}{6} \alpha_2 t^3$$

where α_2 is the maximum acceleration due to an additional power increment during the period, and corresponds to the difference in power delivered from the condenser at the successive time intervals. Hence, after choosing a given time interval, we can compute what additional movement the rotor would complete during the interval by considering the power at the preceding point as a base and computing the maximum acceleration which would obtain at any other power as that created by the difference between that power and the power at the preceding point. The additional movement due to this is then added to the electrical angle of the condenser for each point on the characteristic. This may be most readily done by merely rotating the axis of the power characteristics by the proper amount about the power point of the preceding interval, and then replottting the characteristic by measuring ordinates from this displaced axis. The same change in ordinate for each electrical angle of the condenser and terminal voltage is added to the kv-a. characteristic of the condenser.

Where damper winding effects are important they can be introduced into the calculations at this point. Since these effects are induction motor action which is a function of the difference between the angular velocities of the rotor and the impressed voltage, we have the data for computation of this action. This will be facilitated if we consider this action to be the resultant of a constant slip velocity equal to the velocity $\omega + \frac{1}{2} \alpha_1 t$, plus a variable velocity equal to $\frac{1}{4} \alpha_2 t^2$. Since this variable element can be expressed as a function of power at the end of the interval in a manner similar to space travel we can predict the damper winding effects that would obtain from operation at any point and add these effects to the characteristic of the synchronous machine in the manner indicated for power change in the interval. The field windings of the machine will give us similar effects, but in compu-

tations made for typical cases we have found these negligible.

Succeeding points are now computed in similar manner and the progress of the transient mapped out point by point. After sufficient time has elapsed for regulator action to begin, the field current increment due to this cause is also added in at each point, taken from a curve for the regulator used on the condenser. The process is continued until sufficient information is obtained to determine whether the system will or will not lose synchronism, and how much voltage fluctuation is involved.

From the above the method undoubtedly appears more laborious than it really is, although it is admittedly not simple, the problem being inherently complex. Yet in applying the superposition method, many short cuts will be seen; the necessary portion of characteristics only need be plotted, etc. For a system such as above considered, after the circle diagrams and first angle charts are prepared, two practised computers may readily determine the effect of a given disturbance in a day. Of course more complicated cases take much more time.

Let us now apply these tools to more complex systems. Consider the system shown in Fig. 10. For

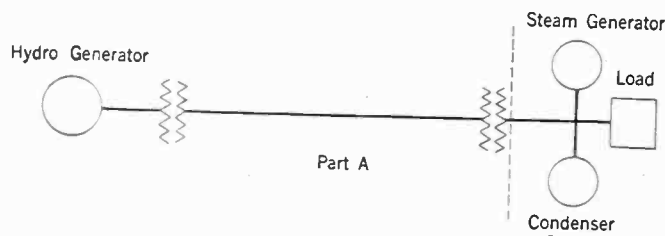

FIG. 10—SYSTEM LAYOUT FOR EXAMPLE

simplicity consider the system broken into two portions as indicated by parts A and B. We can prepare characteristics for the part indicated as A which will show independently the power and kv-a. characteristics of the line and generator at the receiver end vs. the angle between the voltage at the receiver end of this system and the voltage of the impressed field of the generators. This can be prepared quite easily in the manner outlined below for computations of the approximate analysis. These curves, in the form of constant field current characteristics, can readily be applied to any case by choosing points from curves of proper values of field current to make up the characteristics which include the subsidiary transients. These subsidiary effects of changing armature currents can be applied to the characteristics in a similar manner to that used for condensers in the previous example. It will be noted here that the curves are plotted in terms of receiver values whereas the factors which enter into the computation of the field changes are sending-end values. These sending-end values are quite easily obtained when the equation for sending-end current is noted.

$$I_s = C_o E_r + D_o I_r$$

For any characteristic at constant receiver voltage, we may compute the change in sending-end current by multiplying the change in receiver-end current by D_o . Hence the constant D_o may be incorporated with the transformation ratio of armature to field of the generator to make it a vector ratio of receiver-end current to

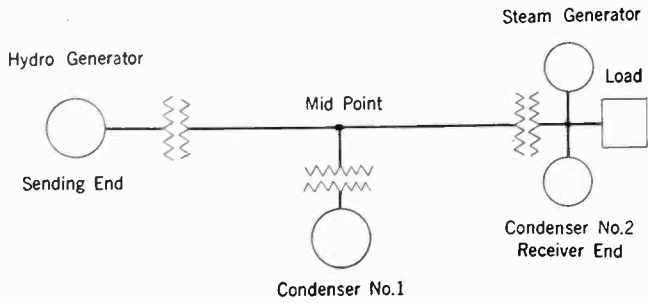

FIG. 11—SYSTEM WIRING DIAGRAM

field current. In this case we must compute and include the angular swing of the hydro generators as well as of the condensers. This is handled in the same manner for each, computing with respect to a constant speed base. With these modifications the portion of the

consideration. The rate of swing of condensers and generators will not be the same, so each is computed separately, and this shift changed accordingly at each point. In this example the movement of the rotor of the turbo generator due to governor action, must also be considered. The unbalanced force to produce acceleration is the difference between electric and mechanical shaft torques. The details of this computation of the variation of mechanical shaft torque need not be discussed further at this point.

With these slight modifications we have now reduced our data for this system to a form similar to that used in the first example and no difficulties of solution should be found.

Let us now consider a system that involves transmission lines sectionalized by condensers as indicated in Fig. 11. The treatment of this case, if modified slightly, will also apply when the mid condenser is replaced by a generator, or generator and load.

The method of attack on this problem is similar to that used for previous cases, but is more involved as the present example has one additional degree of complexity.

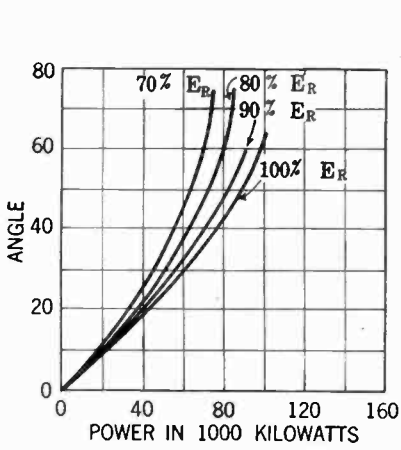

FIG. A

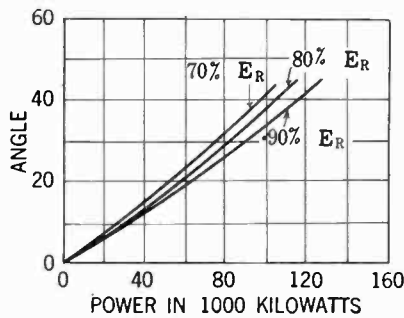

FIG. B

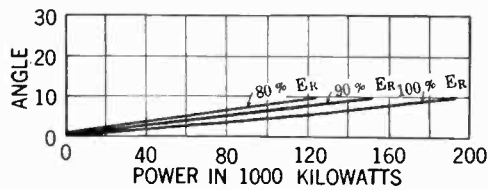

FIG. D

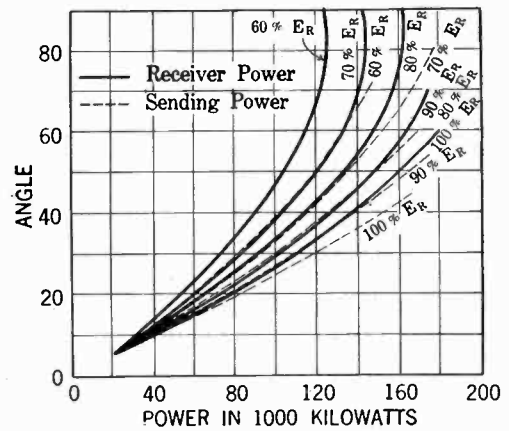

FIG. C

FIG. 12

- a. Receiver Power Characteristic of Generator and First Section of Line
- b. Power Characteristic of Condenser No. 1
- c. Power Characteristic of Second Section of Line
- d. Power Characteristic of Condenser No. 2 and Steam Generating Station

system shown in A can be readily handled in a manner similar to that of the preceding case.

The portion B of the system can be reduced to an equivalent single electric machine plus a load by adding together, as we compute each point, the characteristics of the steam generator and the condenser for equal angle displacements at the same terminal voltages. This is accomplished by superposing the individual characteristics with a shift in the direction of the axis of angles of an amount given by the angular displacement of the machines as computed for the instant under

The necessary tools for this solution are characteristics similar to those previously used. The power characteristics are shown in Fig. 12. It will be understood that these are to be modified as in previous cases, to take care of increment power and subsidiary field transients in the interval under consideration.

Fig. 12A is the receiver power characteristic of the hydro-generator and the first section plotted against angle between the voltage of the impressed field and the voltage at the mid point E_m . This is similar to one of the characteristics used in the preceding example.

Fig. 12B is the power characteristic of the condenser installation No. 1, plotted against the angle between the voltage of the impressed field and the terminal voltage E_m .

Fig. 12C is a plot of both the sending and receiving power characteristics of the second section of the line against angle between E_m and E_r . This figure, for simplicity, shows but one set of terminal voltage conditions.

Fig. 12D is a summary plot similar to 12B for both the condenser No. 2 and the steam generator.

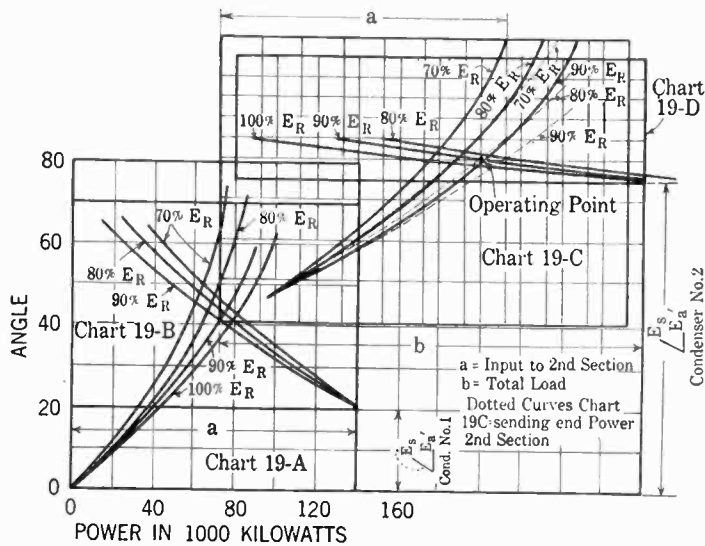

FIG. 13—SUPERPOSED CHARTS FOR DETERMINATION OF POWER LOCUS

When the various angles between the field structures of machines are known, it will be sufficient to show the manner of obtaining the solution at a given instant. From an examination of Fig. 13, it will be apparent that the power conditions will be everywhere satisfied for any set of terminal conditions given by an arrangement of the charts as shown. The kv-a. conditions could be similarly treated, but in order to obtain good intersections in this particular type of system it has been found advantageous to adopt a slightly different method than used in previous examples, although it will be apparent that a similar group of charts could have been set up for solutions for reactive kilovolt amperes.

The power charts are moved in position, keeping the relations shown in Fig. 13 always satisfied, and from each grouping of the power charts we record the power and angle of each of the component charts together with the terminal voltages assumed. We now tabulate with this material the kilovolt-ampere wattless component which would be required in each of the two condensers, as determined from line charts, in order to make conditions fixed by these power relations an actual operating condition. This then provides us with a tabulation of required wattless component of each of the condensers against terminal voltage. We also have a tabulation of terminal voltages, fluxes and internal angles of these same machines as specified by the power components of the condenser output. Since each of these sets of

data specify the condenser conditions, we now have a means of determining the operating point by finding the point at which the specifications of operating conditions from power and wattless components of load are identical. Since condensers one and two must simultaneously satisfy these requirements the solution may not be immediately apparent and will be briefly outlined.

Plot the required condenser actions as in Figs. 14A and 14B. Fig. 14A shows the required input to the mid point condenser for various receiver voltages E_r , plotted vs. E_m and 14B in a similar plot for the condenser at the receiver end. We have also shown on these plots the kv-a. characteristic of the corresponding condensers for various angles between the pole pieces and the terminal voltages. The above figures show graphically what condenser angle will be required at each station for various combinations of mid point and receiver voltages as specified by reactive kv-a.-relations. Since the power relations, first satisfied, have also specified the angles on the condensers for similar combinations of

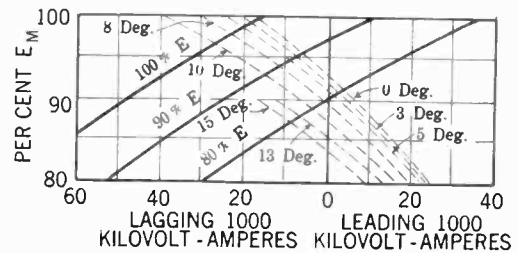

FIG. 14A—MID-CONDENSER REQUIREMENTS

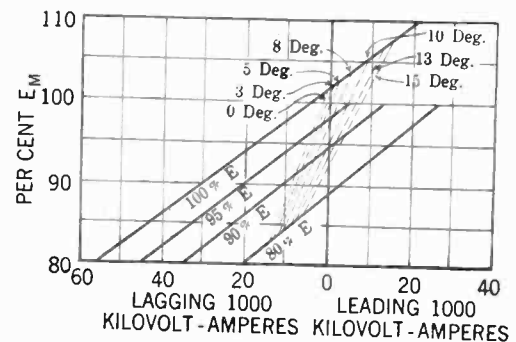

FIG. 14B—END-CONDENSER REQUIREMENTS

voltage, we can plot the requirements specified by each set of conditions and thus determine the operating point. From superficial consideration of the above, it might appear that a plot of requisite condenser angle at each point as determined from power and reactive requirements would be sufficient to determine independently each of the condenser angles. However, since we have an additional requirement that the power and kv-a.-relations for both condensers shall be satisfied simultaneously—i. e., when all other determining conditions of the circuit are identical—we find it desirable to

express the angle of each condenser in terms of some function common to both.

We find that the angle of the mid point condenser can be expressed in terms of the first section line angle, since the condenser field structure will maintain a posi-

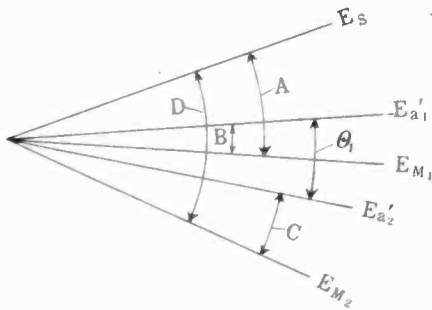

FIG. 15

- a. First Section Line Angle for Preceding Point
- b. Electrical Angle of Condenser for Preceding Point
- c. Electrical Angle of Condenser Plus Space Travel Due to Acceleration
- d. Total Angle of First Section of Line
- e. Travel Due to Velocity of the Rotor Plus Acceleration of Power of Preceding Point

tion with respect to the sending voltage in accordance with the computed angle θ , plus the angular movement due to acceleration during the interval which is later incorporated in the condenser characteristic. Where

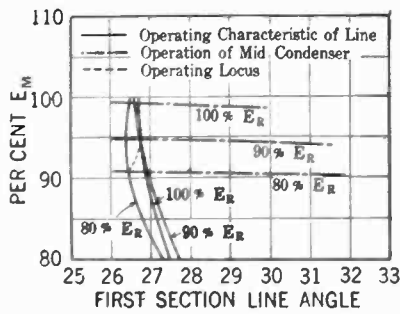

FIG. 16A—DETERMINATION OF OPERATING LOCUS OF MID-POINT CONDENSER

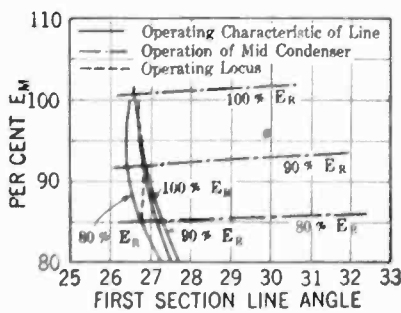

FIG. 16B—DETERMINATION OF OPERATING LOCUS OF RECEIVER APPARATUS

we have referred to the angle between the pole pieces of a machine and the terminal voltage, we mean the angle between the space position of the voltage of the impressed field at the start of the interval and the terminal voltage at the end of the interval. Hence we know that the line angle of the first section, at any time, must equal the line angle at the start of the interval, minus the electrical angle of the condenser at the start of the inter-

val, plus the angle θ , plus the angular movement of the rotor during the interval, plus the electrical angle of the condenser. This for computations for conditions at any given time reduces to a constant plus the angle of the condenser. These relations are shown in the vector diagram, Fig. 15.

In a similar manner we can express the action of the receiver end condenser in terms of the angle of the first section of the line by knowing the total angle of the system at the preceding point and deducting from this

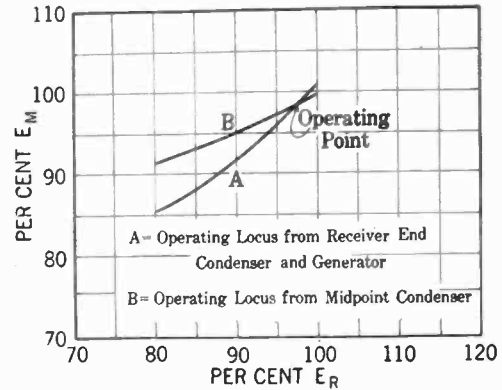

FIG. 17—SUPERPOSITION OF CONDENSER OPERATING LOCI

the angle necessary in the second section to transmit the reactive kv-a. specified for any condenser position with the values of E_m and E_r also specified, and adding the change in receiver end condenser angle shown on graphs. By this construction we obtain graphs which depict the requisite angle of the first section of line as specified by the mid point condenser and by the receiver-end condenser which we can superimpose on the line angle specified by the power relations as shown in Figs. 16A and 16B. These two charts give loci of

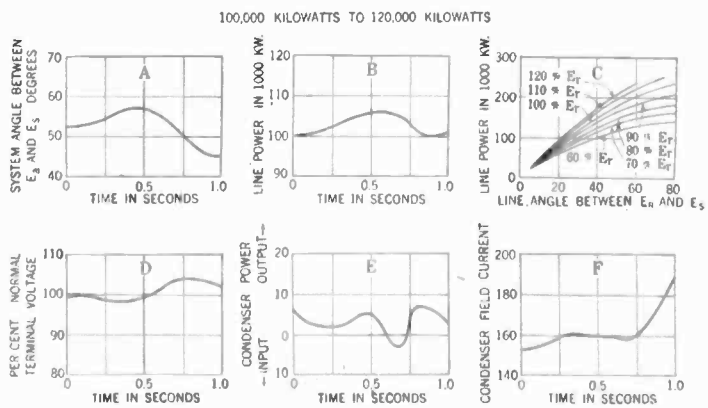

FIG. 18

operation which would be possible as specified by each of the condenser characteristics. Now, by superimposing these two loci as shown in Fig. 24, we obtain the operating point.

It may be remarked that the power characteristics shown in Figs. 16A and 16B are identical but the operating point determined from plotting both condenser characteristics on one chart is obscure. This results from attempting to determine the intersection of two lines in space, i. e. three dimensions—from one pro-

jection. However, by transferring the operating lines to the above Fig. 17, we obviate this difficulty.

We have found that the results of the foregoing analysis may most readily be presented in the form of plots similar to those in Fig. 18, which depict results of calculations for a system similar to that used in the second example. Fig. 18c, which is a plot of line power vs. line angle, is found especially useful. If the points are plotted upon this characteristic, it will be possible to predict whether the system will stay in synchronism or go out by the movement of the operating points. It can be demonstrated analytically than when the power over a section of line decreases as the angle increases, that element of the system has entered upon a cycle of cumulative instability. There are many interesting features indicated in these curves, but the space available is so limited that this discussion must be omitted.

CONCLUSION AND COMMENTS

We have outlined in this paper certain methods of analysis of the behavior of power systems during transient conditions. We have confined the paper to an exposition of methods. As a result of our experience in using these methods, we have several suggestions which we believe will assist others in their application to specific problems.

The stability of systems is greatly influenced by the characteristics of the connected machines. Hence it becomes desirable to obtain comparisons between machines of different designs from the standpoint of their relative effects in the maintenance of stability in a system. We find this can be most readily accomplished by analyzing their performance when connected to a typical simple system, using approximate analyses. However, the process should be checked by occasional complete analyses in order to make sure that the result of introducing approximations is to affect each machine studied to substantially the same extent. For example, the use of an exciter system of more rapid response will undoubtedly influence the comparison between alternators, and may even render a different approximation more nearly applicable. That is, it may become advisable to use the assumption of constant air-gap flux in the approximate methods of comparison when such an exciter system is used rather than the assumption of a complete subsidence of field transient such as appears to give more dependable results when the exciter system responds slowly. A complete analysis will determine the matter. It is also advisable to analyze the effect of the machine studied in different networks in order to be sure that the simple one adopted as a basis for comparison will give results which are not misleading.

It appears, from approximate analyses we have made of complicated networks, that a disturbance may often produce instability in a single element of the networks, and that when this occurs the network as a whole will

become unstable provided the element is of a magnitude comparable with the remainder of the system. Whether approximate analysis indicates correct conclusions in such a case can of course be determined by a point by point analysis. Even when the network is so complex that a complete analysis would be very laborious, the question may often be settled by the computation of two points only to give the direction in which operating characteristics begin to vary after the first instant. The approximate analysis based on transient reactance gives the solution for the first of those points applying to the instant after the application of the disturbance. The second point, if refinements are considered unnecessary may even be computed in the same manner after introducing computed angular differences.

We have found in examining the behavior during disturbances of a portion of a system, such as a trunk transmission line, that widely different results are obtained according to whether this element is treated as a separate unit or in connection with the network to which it connects. Hence, in examining the design of such an element of a system, it is advisable to make at least some complete analyses of the entire system. The influence of a connecting line depends not only upon its line constants but also upon those of any generating stations and load to which it ties the main transmission unit.

DECREASING COST OF ELECTRICITY

From a survey recently made in 32 cities, it is brought out that the cost of electricity has decreased very considerably in comparison to other living commodities. Since December, 1913, the cost of electricity has decreased 8.6 per cent while the cost of clothing has increased 74.2 per cent. Other necessities have increased rather than decreased; for instance, house furnishings have increased 116 per cent, housing 68 per cent, foodstuffs 42.4 per cent and miscellaneous necessities 69.1 per cent.

Like electricity, the cost of lamps has decreased. In the past two years prices have been reduced 37 per cent.

The time is ripe for the greater use of light than ever before. Without electric service and light, every activity in which we are engaged would suffer and yet there are many who hesitate to buy an additional portable lamp for their home or larger sizes of lamps for the factory or office for fear of a slight increase in the electric bill. With the added comforts and many advantages of more and better light, the present day low cost of light as shown by comparison to other commodities offers a most effective selling point in merchandising good lighting.

Night and day, a perpetual light will burn in memory of the men of New York City who perished in the World War. The light illumines a golden star atop a flagstaff, and is the gift of Rodman Wanamaker

Temperature Errors in Induction Watthour Meters

An Analysis and the Development of a Temperature-Sensitive Magnetic Material Suitable for Compensation

BY I. F. KINNARD¹
Associate, A. I. E. E.

and

H. T. FAUS¹
Associate, A. I. E. E.

Synopsis:—This paper is presented in two principal divisions, Part I and Part II. The first deals with the general problem of small errors due to temperature changes in watthour meters and describes methods of segregating the various components of these errors. It is shown that they may be divided into two principal groups, termed Class 1 and Class 2. Class 1 errors are operative at all power factors and are of the greater importance; Class 2 errors are important only at low power factors, and methods of eliminating these are pointed out. Both of these classes are further subdivided into their component parts.

In Part II of the paper is described a method of compensating for Class 1 errors by means of magnetic shunts made of thermalloy. The term "Thermalloy" is applied to a series of copper-nickel-iron alloys having a large negative temperature coefficient of permeability and other unusual properties. These alloys are discussed in some detail, their manner of preparation and application being considered original.

In the appendix, a novel magnetic thermometer utilizing thermalloy is described.

* * * * *

Part I

INTRODUCTION

AN electro-magnetic device, such as an induction watthour meter, the operation of which depends upon the exact magnitude and phase relation of the various fluxes, is more or less susceptible to changes due to variations in temperature. This is to be expected when it is considered that almost all of the properties of ordinary electrical and magnetic materials change to some extent with temperature and that in some of the essential materials in a watthour meter, such as copper and magnet steel, this change is very marked. It is true that this type of watthour meter is, to a large extent, inherently self-compensating and that the variation in speed of a well-designed meter, when a change in temperature occurs, has generally been considered too small to have any serious effect on accurate metering. In keeping with the constant tendency toward more precise measurement of power, however, it is expedient that this problem should be given careful consideration and steps taken to reduce the small effect of ambient temperature and self-heating.

There has been very little material published on the problem of temperature errors in induction meters, as far as the authors have been able to determine. Fawcett² has described a precision watthour meter in which he has used a manganin lag plate and a control magnet mounted upon a bi-metal support which moved in and out in such a manner as to effect a temperature compensation. There has been at least one other meter designed utilizing the bi-metal principle in an

endeavor to correct temperature errors by mounting the magnet adjustment-disk so that it is free to move closer to or farther from the magnet depending upon the ambient temperature. These schemes are dependent upon a mechanical motion about which there is always more or less uncertainty, and the magnitude of the compensation depends upon the position of the full load adjustment on the meters; so they are at best only approximations.

In order to arrive at a proper understanding of the nature of this problem, it will be well to review the causes of temperature errors in some detail.

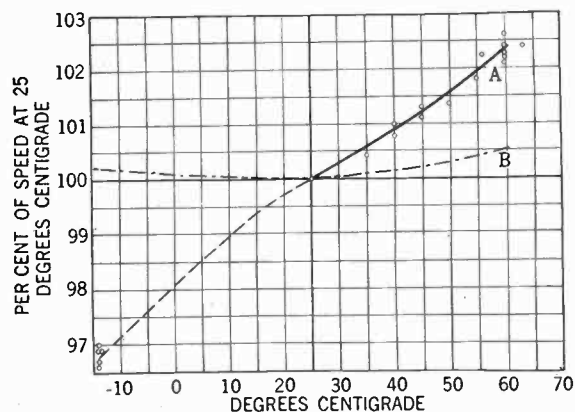

FIG. 1—TEMPERATURE-SPEED CURVES FOR INDUCTION WATTHOUR METERS
A—Power Factor = 1.0
B—Power Factor = 0.5

ANALYSIS OF TEMPERATURE ERRORS

It is generally known that induction-type watthour meters increase slightly in speed when a temperature rise occurs. Fig. 1 is typical of the relationship existing between percentage change in meter speed and temperature for common types of watthour meters at unity power factor and at 50 per cent power factor. It will be seen that a considerable difference in speed may be occasioned by a change from outside zero

1. Both of Engineering Department, West Lynn Works, General Electric Company.

2. New Precision Watthour Meter—*The Electrician*, March 7, 1924.

Abridgment of paper presented at the Midwinter Convention of the A. I. E. E., New York, N. Y., February 9-12, 1925. Complete copies available upon application, to Institute headquarters.

weather to a heated room, which is of course an extreme condition of use. The effect of temperature at low power factors, current lagging, is much less than at unity, which indicates a greater tendency toward self-compensation under the former conditions. Different makes of watt-hour meters exhibit considerable difference in temperature characteristics, and some have a greater speed increase with rising temperature than that shown in Fig. 1; but in general they all follow the same laws.

In order to analyze the phenomena of temperature errors, we adopted the experimental method of selecting one possible variable and by holding it constant while the temperature was changed noting the result on the meter's performance.

There are two main classes into which the various factors governing changes due to thermal effects may be divided:

1. Factors governing the magnitude of either potential or current fluxes, or both, or the magnitude of the damping flux.

2. Factors governing the phase relation between potential and current fluxes.

Due to the fact that the torque is proportional to the sine of the angle between the useful potential and current fluxes, and that in a properly adjusted meter these are exactly at right angles for unity power factor, it follows that any small variations in flux phase relations are not important at high power factors. For example, a shifting of three degrees at 100 per cent power factor changes the torque only 0.14 per cent, while the same change in angle if the meter were operating at 50 per cent. power factor causes a change in torque of nearly 9 per cent. It might, therefore, be stated that errors under Class 1, are equally operative at all power factors and that those under Class 2, while negligible at unity power factor, are increasingly operative as the power factor decreases.

It has long been suspected that the control magnets were responsible for a large share of the observed temperature coefficient falling under Class 1. Several writers³ have pointed out that permanent magnets have a decided temperature coefficient and that their strength decreases with an increase of temperature.

In order to ascertain to just what extent the magnet was responsible for the errors observed at unity power factor, it was necessary to devise some method whereby the braking torque could be held constant while the meter was raised to various temperatures. This was attempted in several ways, one of which was evidently quite successful as will be described below. Tests of this nature are inherently difficult and tedious, but great pains have been taken in obtaining the results herein described and it is believed that the information is reliable.

The method that we found to be most successful

3. The Effects of Changes of Temperature on Permanent Magnets—*Am. Jour. Sci.*, Vol. XV, No. 87, March, 1903.

for holding the damping flux constant was by the use of a soft iron magnet having the same shape as the standard type I-14, with which we were working. Magnetizing windings, having sufficient turns to provide the required damping flux by the use of a very small magnetizing current, were placed around each half of this magnet. In order to measure accurately just how much damping flux was cutting the disk, an exploring coil wound in the general form of the figure 8 and shaped to conform to the outline of the meter disk was wound on a celluloid form and placed in close proximity to the bottom of the disk. Substantially, all of the damping flux that cut the disk was linked with this exploring coil. By connecting the latter to a ballistic galvanometer and reversing the primary current in the electro-magnet, a means of measuring the total flux ballistically was provided. In order to get the required accuracy of one-tenth of one per cent which we desired in this

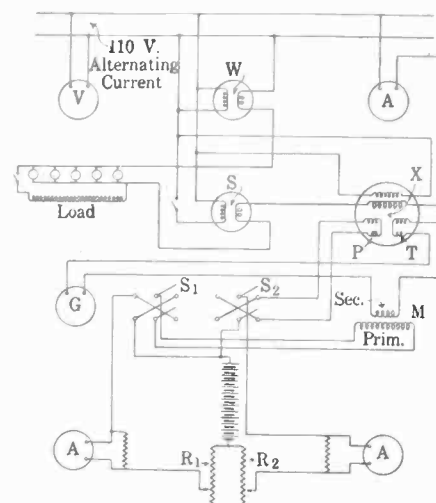

FIG. 2—DIAGRAM OF CONNECTIONS OF APPARATUS FOR DETERMINATION OF TEMPERATURE ERRORS DUE TO MAGNETS

P—Damping Magnet Winding
 X—Meter Under Test
 T—Exploring Coil
 W—Wattmeter
 G—Galvanometer
 V—Voltmeter
 A—Ammeters
 M—Mutual Inductance
 S—Standard Watthour Meter.

experimental work, a null method of measurement was adopted rather than a deflection method. This consists essentially of simultaneously reversing the currents in the primary of a standard mutual inductance and in the magnetizing coils on the magnets. The respective impulses in the secondaries were passed differentially through a ballistic galvanometer, and when the point of balance was obtained the value of the current in the mutual inductance was the measure of the total effective flux of the damping magnets.

A diagram of connections is shown in Fig. 2. The reversing switches S_1 and S_2 were connected together mechanically so that they could both be reversed at the same instant. The procedure in making the test was to adjust the current in the damping electro-magnet by means of the rheostat R_2 until the meter ran at the desired speed. The flux was then measured by adjusting the current in the primary of the mutual induct-

ance until the galvanometer gave no deflection when both switches were reversed. The value of the flux passing through the disk and exploring coil could be readily calculated from well-known magnetic formulas such as are used for ordinary ballistic testing and need not be given here. After the meter speed at room temperature had been measured, the temperature of the meter under test was raised to the desired value, the damping flux was adjusted to its original strength, and the speed was again determined by comparison with a standard test meter which was kept at room temperature.

This test was reasonably satisfactory and gave results which were quickly checked to within one-tenth of one per cent. One great advantage which it possessed was that the meters under test need not be changed in any other respect; and, therefore, the results obtained were directly applicable to a standard induction watt-hour meter. This apparatus was first useful to determine the relationship existing between meter speed and total flux in a magnet under constant load conditions. Fig. 3 shows one of the

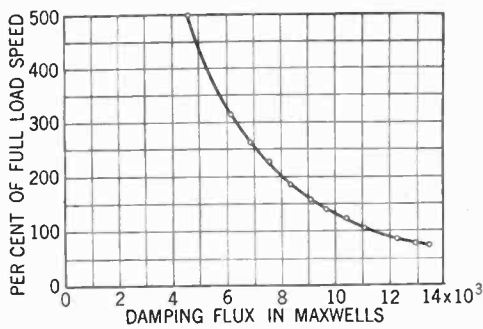

FIG. 3—RELATION OF DAMPING EFFORT TO TOTAL FLUX IN MAGNETS

Meter run under constant load conditions and damping flux varied.

curves obtained on a meter running at full load and unity power factor, the damping flux being varied in such a manner that the speed changed from approximately 75 to 500 per cent of full load speed.

If plotted on double logarithmic paper, the speed will be seen to vary inversely as the 1.8 power of the flux.

Meter speeds were next measured, at various temperatures, and constant damping torque at unity power factor and 50 per cent power factor both at full load and light load. Part of these tests were made with the lag plate completely removed from the meter, thus determining just what effect this had on the temperature coefficient. Complete curves were taken in each case, and sufficient points were obtained and check tests made to minimize observational or accidental errors.

The results of tests at 100 per cent power factor are shown by Curve A in Fig. 4. It will be seen that even with constant braking flux the meter speed still increases with increase in temperature. This must be due to an actual increase of driving flux cutting the

disk, as it cannot be explained by a change in phase relation of the flux as noted previously.

Referring further to Fig. 4, Curve B represents a temperature-speed curve taken with the retarding torque supplied by a standard control magnet. The

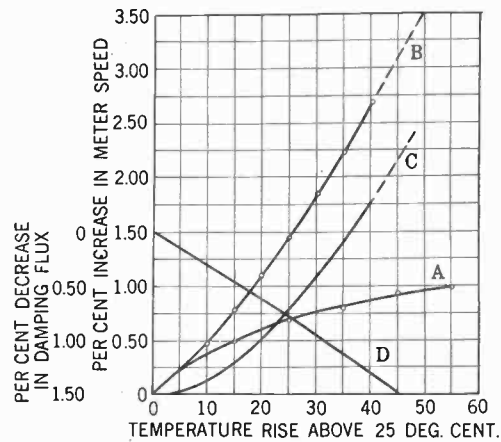

FIG. 4—SEGREGATION OF TEMPERATURE ERRORS IN INDUCTION WATT-HOUR METER AT UNITY POWER FACTOR

- A—Change in Speed with Constant Damping Flux
- B—Change in Speed with Standard Control Magnet
- C—Change in Speed Due to Standard Control Magnet
- D—Variation in Damping Flux of Standard Control Magnet

difference between these two curves is represented by Curve C and is the effect of the change in flux of the damping magnet on the meter speed. Curve C, then, is the actual change due to the temperature coefficient of one particular magnet; and, although we have

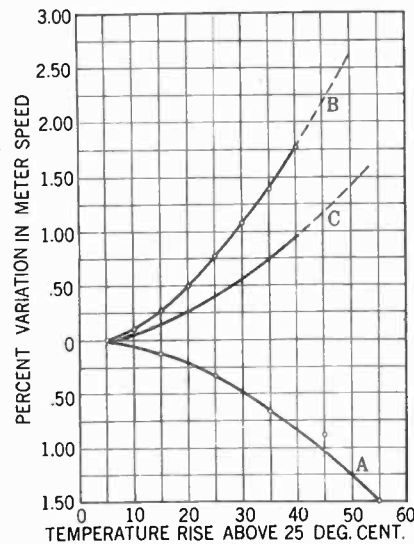

FIG. 5—SEGREGATION OF TEMPERATURE ERRORS IN INDUCTION WATT-HOUR METER AT 50 PER CENT POWER FACTOR

- A—Change in Speed with Constant Damping Flux
- B—Change in Speed Due to Standard Damping Magnet
- C—Change in Speed with Standard Damping Magnet

reason to believe that magnets vary somewhat in regard to the magnitude of this effect, this curve is fairly representative. The diagonal Curve D in Fig. 4 represents the actual change in total flux of the magnet corresponding to this change in meter speed as obtained from the flux-speed curve shown in Fig. 3. This shows

a nearly linear relation and indicates that the temperature coefficient of the magnet is approximately -0.0003 per deg. centigrade.

In Fig. 5 Curve A are shown the results of tests made with a constant damping flux at 50 per cent power factor. In this case, the meter slows down with in-

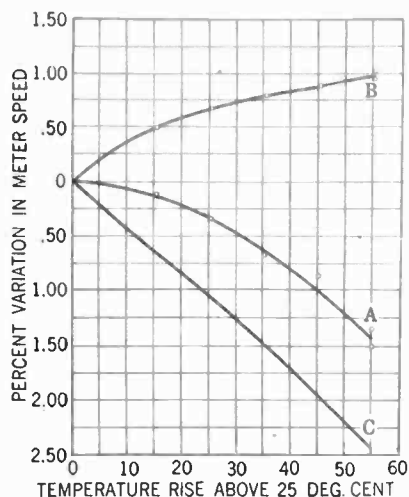

FIG. 6—SEGREGATION OF TOTAL CLASS II ERRORS AT 50 PER CENT POWER FACTOR

- A—Net Change in Speed with Constant Damping Flux
- B—Increase in Speed Due to Change in Driving Torque
- C—Total Change in Speed Due to Class II Errors

creasing temperature and this effect is undoubtedly due to the shifting of phase relations noted under Class 2 errors less the increased driving torque, as shown in Fig. 4 Curve A. By adding to the former curve, the change in speed due to the permanent magnet Fig. 4

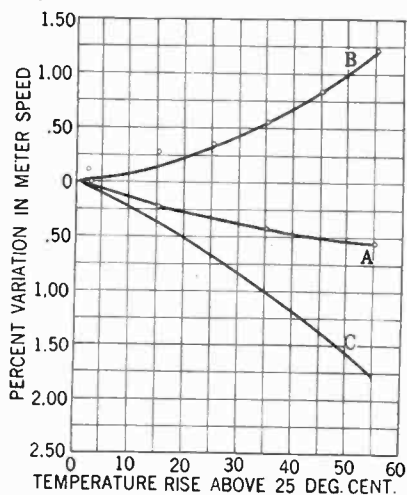

FIG. 7—SEGREGATION OF CLASS II ERRORS WITHOUT LAG PLATE

- A—Net Change in Speed with Constant Damping Flux
- B—Increase in Speed Due to Change in Driving Torque
- C—Total Change in Speed Due to Class II Errors Without Lag Plate

Curve C, we arrive at Curve C Fig. 5, which is the usual increase in speed noted with a standard meter at 50 per cent power factor.

Considering Fig. 6, Curve A is the same as shown in Fig. 5 and is the net negative error observed at 50 per cent power factor with damping flux held constant.

If we now subtract from this the error observed at 100 per cent power factor under the same conditions, which is constantly present in the opposite direction, we arrive at Curve C, the total change in driving torque due to a shift in phase angle with temperature. It will be noted that this is nearly a straight line, and the reason for it will be described later.

The lag plate was then removed and the 50 per cent power factor test repeated. The results are plotted in Fig. 7 Curve A. By subtracting from this the results of a similar test at unity power factor, we obtain the total

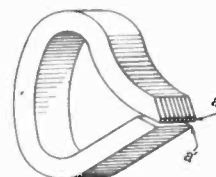

FIG. 8—STANDARD TYPE OF SINGLE WATTHOUR METER MAGNET

change due to shifting of phase angle, as shown by Curve C. By comparing these results with Fig. 6, it will be seen that the lag plate has a very decided part in the meter's temperature coefficient at low power factors.

In order to check these results, some direct tests (which it is hoped will be described in more detail in a later paper) were made on permanent magnets; and, insofar as horseshoe magnets of the general types found in Fig. 8 are concerned, it has been conclusively shown that the relation between strength and temperature is such as is illustrated by the curve in Fig. 9. In a properly treated magnet, there is a definite strength corresponding to a given temperature, and heating and cooling curves are substantially the same for temperatures under 100 deg. cent. providing the magnet is held at any one temperature for a sufficient length of time to reach equilibrium.

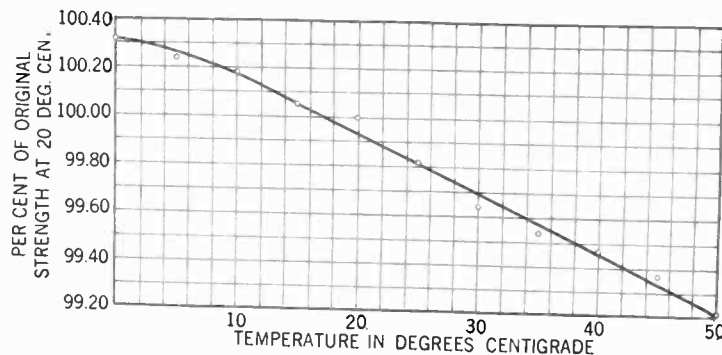

FIG. 9—RELATION BETWEEN MAGNET STRENGTH AND TEMPERATURE

It has been suggested by some of our colleagues that the jaws of the magnet at aa' , Fig. 8, might open slightly with a temperature rise, thus causing an increase in the length of air gap and a consequent diminution of flux. Thorough investigation has been made of this effect

and it has been found negligible in relation to the others; for although a very slight effect of this nature does exist, it amounts to only a small percentage of the total observable increase in meter speed with temperature. A very extended investigation of this phase of the problem was completed nearly two years ago by the author, and the method adopted for detecting changes in the gap with temperature was to insert a skeleton meter with magnet attached in an oil bath suitably controlled with heating and cooling coils. Any change in the gap was amplified by means of a scissors-arm arrangement and the motion was accurately measured with a cathetometer. In order to get the effect of changes in the length of gap on the meter speed, the magnets were forced apart by means of a special clamp and the actual change in gap measured with an optical device which reflected a beam of light on a scale at a distance. The principal conclusions derived from this work were as follows:

Class 1:

1. Internal changes in permanent magnet steel.
2. Change in length of air gap of magnets.
3. Change in permeability of magnetic circuits of the potential and current elements.
4. Small change in magnitude of potential flux, due to shifting in phase of the magnetizing current (see vector diagram in Fig. 10).

Class 2:

1. Change in resistance of potential windings.
2. Change in iron losses in potential element.
3. Change in resistance of lag plate.

DISCUSSION OF CLASS 2 ERRORS

From theoretical considerations, it may be shown that the predominant reason for Class 2 temperature errors in induction meters lies in the fact that the resistance of the potential windings causes a phase displacement between the applied, or line, voltage and the induced voltage and that the value of this resistance is dependent upon temperature.

Without reviewing the general theory, we may state that the torque is proportional to the product of the current and potential fluxes and the sine of the angle between them. We have already shown (page 12) that the lag plate accounts for about 30 per cent of the Class 2 temperature errors by virtue of its change in resistance; hence we shall now leave it out of the discussion. Since the power used to drive the disk is only about 0.1 per cent of the loss in the potential element, when discussing vector relations between the main fluxes and potential drops this small induced current may be entirely neglected.

Considering the potential element, then, we may represent it by the simple equivalent circuit as shown in Fig. 10A; the line voltage V is balanced by the induced voltage E_1 and the $I_0 r_1$ drop in the windings. The exciting current I_0 may be divided into the usual components E/g and E_1/jb representing the power and magnetizing portions respectively. If we now draw the vector diagram for this circuit as shown in Fig. 10B, using the actual measured values of the various constants of an induction watt-hour meter, the relative importance of iron losses and ohmic resistance as they affect the phase relations is seen at a glance. The torque T may be expressed by the following equation as noted above:

$$T \propto \phi_E \phi_I \sin \Delta;$$

or, since $\phi_E \propto E_1$ and $\phi_I \propto I$,

$$T \propto E_1 I \cos \Delta_1.$$

Now $\Delta_1 = \lambda + \psi$, where $\cos \lambda$ is the line power factor and ψ is the angle between the line voltage and the induced voltage. Therefore, to get a change in torque due to change in angle ψ , either r_1 or I_0 must change.

It is evident that the angle ψ is approximately directly proportional to the resistance r_1 , and therefore, at low line power factors any change in r_1 means an appreciable change in torque.

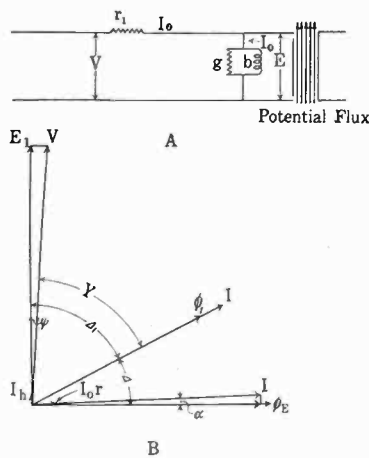

FIG. 10

A. Equivalent Circuit Diagram of Potential Element of Watt-hour Meter, Secondary Circuit Neglected.

B. Vector Diagram of Watt-hour Meter Omitting Secondary (Lag Plate and Disk) Currents

1. All magnets tested showed a definite tendency to open their gaps under temperature, so that the length of air gap was increased by amounts varying from 0.1 to 0.35 per cent for a 60 degree (Centigrade) rise. This expansion is undoubtedly due to the relieving of internal strains and is partly dependent on the exact heat treatment to which the magnets have been previously subjected.

2. The meter speed was affected by amounts ranging from 0.08 to 0.26 per cent by changes in the dimensions of the air gap due to 60 degrees (centigrade) rise in temperature. The maximum change noted accounts for less than 7 per cent of the total temperature error in the meter, and on the average the increase in the length of the air gap might be expected to account for approximately 5 per cent of this error.

As a result of this work, the factors causing temperature errors may be further subdivided as follows:

If, however, the iron losses are eliminated entirely, thus bringing I_0 in phase and equal to I_m , the magnitude of $I_0 r_1$ remains practically unchanged with no resulting change in torque. This is not strictly true, because the theory of the meter assumes E_1 to be proportional to V and a shifting of the angle of the vector $I_0 r_1$ with varying iron losses will result in a small variation in this proportionality. This variation affects Class 1 errors slightly and may be grouped with them.

From the above discussion, it will be seen that if the resistance r_1 be either held constant or reduced to a negligible value, the principal cause of Class 2 tempera-

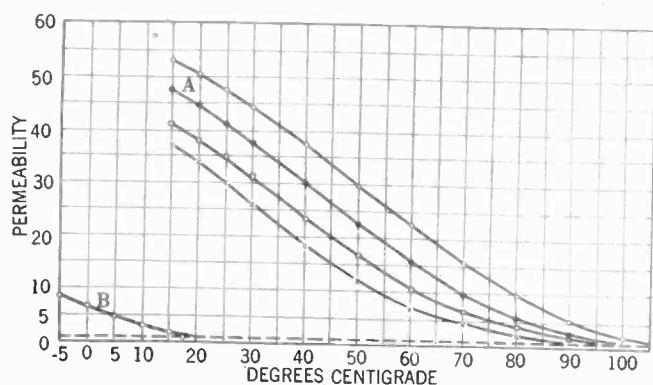

FIG. 11—TEMPERATURE-PERMEABILITY CURVES FOR FIVE SAMPLES OF THERMALLOY $H = 15$

ture errors will be removed. In precision meters it is preferable to reduce the ohmic resistance by enlarging the winding space available in the potential element.

In order to check the above analysis experimentally, an induction meter was tested without a lag plate at 50 per cent power factor. By starting with an additional resistance inserted in the potential circuit, it was possible to keep the total resistance constant as the meter was heated to 60 deg. cent. by gradually cutting out the former. It was found that the meter then had substantially the same characteristic speed-temperature curve as that shown in Fig. 1, thus indicating that change in resistance was entirely responsible for Class 2 errors.

DISCUSSION OF CLASS 1 ERRORS

These errors are operative at all power factors and are the most important to be considered. They arise from causes that, in general, cannot be removed and hence must be compensated for. In the great majority of cases, single phase meters are operated at power factors above 90 per cent; and, hence, if Class 1 errors can be eliminated, a substantial advance in the art of accurate metering has been effected.

A very satisfactory method of accomplishing this has been worked out and will be described in Part II.

Part II

THERMALLOY, A TEMPERATURE-SENSITIVE MAGNETIC MATERIAL

We have recently succeeded in developing a series of magnetic copper-nickel-iron alloys having low points of

magnetic transformation combined with a linear temperature-permeability relation. The particular series of alloys that have been found satisfactory for our purposes have been given the distinguishing name of "Thermalloy" and a letter is used to designate the exact composition in each case. At present chief use is made of two particular alloys belonging to this group which are designated as thermalloy A and thermalloy B. In Fig. 11 is shown a family of curves representing the relationship existing between permeability and temperature for samples of this material in a constant field of 15 gauss.

In order to test these alloys for uniformity, a simple device is made use of as illustrated in Fig. 12. A standard test piece, T , weighing five grams is suspended by a permanent magnet, A , in a water bath which can be gradually heated by the small heater B . When the test piece has reached the temperature at which the magnet can no longer retain it due to the fact that it has become practically non-magnetic, it falls into the retaining basket, C . The temperature of the bath is read by a thermometer and this gives a value that is proportional to the point of magnetic transformation of the material under test. Although this reading is somewhat below the true transformation point, when the test piece falls from the magnet its permeability is very low indeed and for most purposes can be considered non-magnetic at that particular temperature, which we shall term its release point.

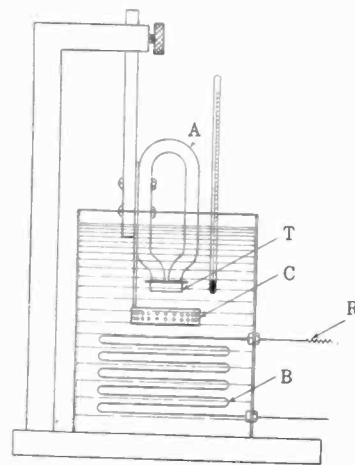

FIG. 12—DEVICE FOR CONTROL TESTS ON THERMALLOY

In obtaining release points we usually make use of a sample $5/32$ inch in thickness, and it has been found from experiment that there is practically no difference in results if samples varying from $1/16$ in. to $1/8$ in. are used. This simple test, therefore, gives a very ready means of comparing different melts of the same material and also of obtaining the relationship existing between apparent point of transformation and percentage composition of the alloy.

By referring to the permeability-temperature curves in Fig. 11 it will be noted that the permeability rapidly decreases at a nearly constant rate until it approaches that of air when its rate of decrease diminishes. It

might be noted at this time that the so-called "release point" as measured by our testing device agrees very well with the temperature at which these curves appear to reach the permeability of air. For example, Curve A is taken on a material that has a release point varying from 92 to 98 deg. cent., whereas the curve indicates approximately 100 deg. cent.

Fig. 13 shows release points plotted against per cent copper, and it is interesting to note that the relationship is practically linear. Small irregularities in the case of some of the samples are probably due to slight variations in the pouring temperatures and cool-

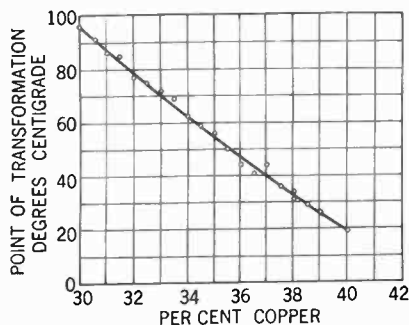

FIG. 13—CURVE SHOWING RELATION BETWEEN COPPER CONTENT AND APPARENT POINT OF MAGNETIC TRANSFORMATION OF THERMALLOY

ing rates. The samples were melted in an Ajax high frequency induction furnace, poured, and allowed to cool in sand moulds. Alloys of this nature vary markedly in magnetic properties with composition and heat treatment,⁴ hence conditions must be carefully controlled in order to produce uniform results. Gans and Fonseca⁵ have published an interesting article showing how the point of transformation from a ferromagnetic to para-magnetic state in pure copper-nickel alloys varies with the composition. The values of transformation points obtained by them check those shown in Fig. 13 very closely, although they worked with pure nickel. This close agreement is probably largely accidental, however, because methods of test differ widely and they do not specify heat treatment which is very important. These investigators found a linear relation which checks our results, but so far as we have been able to learn no one has investigated the character of permeability-temperature curves below the transformation point for these alloys.

Thermalloy A contains approximately:

- Cu 30.0 per cent
- Ni 66.5 per cent
- Fe 2.2 per cent
- Impurities 1.3 per cent

One effect of adding iron to the alloy is to raise the point of magnetic transformation. The addition of 2.3 per cent of iron to an alloy of 70 per cent pure nickel and 30 per cent electrolytic copper raised the

release point about 45 deg. cent. Since most commercial nickels contain some iron we simply add sufficient additional to bring the total percentage up to the desired value. Among other advantages it is possible to obtain the required results at a much lower cost in this manner.

Heat treatment of thermalloy has important effects on its magnetic properties. Grade A, for instance, gives an average reading of 95 deg. cent. as its release point in our test when cooled slowly in a sand mould; if it is cast in graphite moulds it is practically non-magnetic at 20 deg. cent. The same metal when cast in a mould of zirconium silicate released at 60 deg. cent. The castings in both of these cases were one-half inch square and seven inches in length. In the case of the bar having the 60 deg. release point heating for two hours at 700 deg. cent. and cooling in air raised this point to 98 deg. A sample having a release point of 95 degrees was heated to 900 deg. and quenched in cold water. This treatment lowered its release point to 75 deg. It will be seen, therefore, that in order to obtain uniformity in results it is necessary to carefully control the conditions under which the alloys are made.

The heating and cooling permeability-temperature curves are practically identical for thermalloy, providing it is held at any one temperature for a sufficient length of time to reach equilibrium. This is on account of the extremely small hysteresis loss in this material. In Fig. 14 are shown the points obtained on a hysteresis loop taken at a maximum magnetizing force of 100 H, which serves to bring it well past the knee of the normal induction curve. Within the limits of accuracy of the apparatus used in obtaining these data very little loss

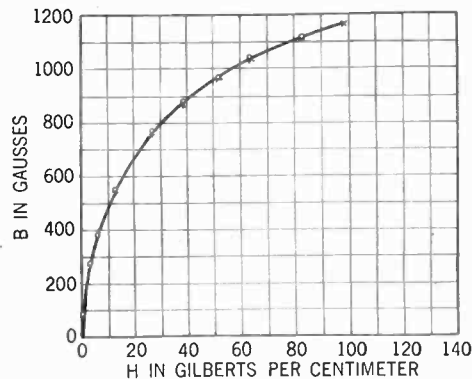

FIG. 14—HYSTERESIS LOOP FOR THERMALLOY A
Temperature = 29.5 deg. cent.

can be detected. Another unusual characteristic is that the retentivity is only about 8 per cent of the maximum induction so that with an air gap in the magnetic circuit the remanence should be inappreciable.

The Heusler alloys⁶ are similar from a metallurgical point of view to the alloys just discussed since both are solid solutions with copper as the solvent. Also the Heusler alloys have low points of magnetic trans-

4. Nickel and its Alloys—Bureau of Standards Circular, No. 100.

5. Die Magnetischen Eigenschaften von Nickel-Kupfer Legierungen—Ann. Physik, 61, p. 742.

6. Verhandlungen der Physikalischen Gessellschaft, 5, p. 219; 1903.

formation and increasing the copper content lowers this critical point. In general, they are more difficult to work with, both in regard to casting and machining, than the copper-nickel series.

From the foregoing it will be seen that we now have available an almost perfect means of compensating for variations in watt-hour meter speed with temperature. Fig. 17 shows a magnetic shunt made of thermalloy inserted between the damping magnets, of a watt-hour meter. In this arrangement two single magnets are paired together and the polarity is such that there is a small amount of flux circulating around the path *a, b, c, d*. We may think of this part of the flux as being shunted from the main path across the gaps and it is increased by the insertion of the small bridge, *S*, of thermalloy, which may be termed a magnetic shunt. With an increase of temperature the total flux of a magnet decreases as has previously been described, whereas in order to effect a compensation for Class 1 errors it is necessary that the total damping flux actually increase somewhat. In the device shown in Fig. 17, this condition does exist because as the temperature rises, the permeability of the magnetic shunt decreases linearly and a larger percentage of the total flux

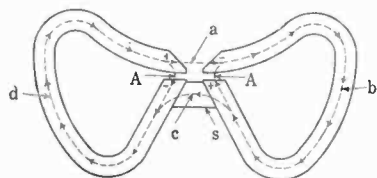

FIG. 17—SCHEMATIC DIAGRAM OF MAGNET COMPENSATION WITH THERMALLOY

crosses the air gaps *A. A*. By selecting a shunt of the correct dimensions this effect will exactly compensate for the overall temperature error of the meter.

An average speed-temperature curve for a watt-hour meter has been shown in Fig. 1. It will be seen that the rate of decrease of meter speed with temperature increases rather rapidly just below room temperature, whereas the rate of increase in permeability of thermalloy *A* below room temperature has a tendency to decrease. This would result in under-compensation at low temperatures, and in order to overcome this difficulty we have made use of a compound magnetic shunt; that is, we insert a piece of thermalloy *B* in parallel with the first. This has a release point of 15 deg. cent. and hence is non-magnetic at ordinary room temperatures. As the temperature falls, however, it serves to correct the under compensation as above noted due to its increasing permeability, thus giving results that are correct at very low temperatures. The cross sections of these two shunts are so adjusted that the meter runs at correct speed at -14 deg., $+25$ deg. and 55 deg. cent., and the compensation holds good over considerably larger ranges.

CONCLUSIONS

Temperature errors in induction watt-hour meters can be divided into two general classes,—1. Those

affecting the magnitude of the driving flux or damping torque, 2. Those affecting the phase relation between the line voltage and induced voltage in the potential element.

The permanent magnets used for damping are responsible for the greater portion of the errors under Class 1, and this being due to a natural characteristic of magnet steel cannot be eliminated.

Ordinarily, Class 2 errors are not of great importance, but they can be reduced by proper design of the potential element. They are caused almost entirely by changes in resistance of the potential windings and lag plate.

Class 1 errors may be neutralized by a single compensation, consisting of a device whereby a small portion of the flux is shunted through a special alloy—(thermalloy)—the permeability of which is very sensitive to temperature.

Induction watt-hour meters compensated with thermalloy magnetic shunts, even without any further modifications, are practically independent of temperature changes over very wide ranges providing the power factor is reasonably high. By suitable modifications, the compensation may be made independent of power factor.

The application of compensated magnets to meters on a production basis gives a reasonable degree of uniformity in results, and very rarely will errors as high as 0.013 per cent per deg. cent. rise be encountered.

This method of compensation has the distinct advantage of being independent of any necessary adjustment of the meter, and is extremely simple and positive in its action.

By preparing certain copper-nickel-iron alloys in the form of castings suitably heat treated, a linear relationship is obtained between permeability and temperature. By controlling the copper content the point of transformation of these alloys may be made to occur at almost any desired temperature below that of pure nickel.

The hysteresis loss of thermalloy is extremely low; hence the heating and cooling curves in a constant field are practically identical, although there is a small time lag before the metal reaches equilibrium at any one temperature.

It is believed that some of the characteristics of these alloys, such as perfectly reversible straight line permeability-temperature relationship, combined with negligible hysteresis, have escaped previous notice and that they are an important contribution to engineering materials.

It is probable that the linear temperature-permeability relationship of thermalloy is due to the non-homogeneous manner in which the copper is held in solution, which gives the effect of the summation of a large number of alloys, each having a different transformation point.

In addition to temperature compensation, thermalloy may be used for a variety of purposes one of which is a direct reading low temperature thermometer as described in the appendix.

Historical Review of Electrical Applications on Shipboard

BY H. L. HIBBARD¹
Fellow, A. I. E. E.

and

WM. HETHERINGTON, Jr.¹
Associate A. I. E. E.

Synopsis.—During the year 1919, the Chairman of the Marine Committee of the Institute appointed a sub-committee with a view to compiling and recording data relative to the development and growth of electricity on shipboard. The instructions to the sub-committee included the preparation of a report, or historical review, which was to form the basis for a continuing record of such matters in the files of the Institute.

After a careful investigation of the situation, the historical sub-committee found itself confronted with a task of no small proportions and one which would require, with the limited time available for such research work, probably several years to complete. An outline was prepared, however, of the ground which it was intended to cover and a preliminary report, submitted with the Marine Committee's report at the annual convention at White Sulphur Springs in 1920 and appears in the Institute's Transactions for that year.

Continuing with the work for several years, the Historical Committee in April, 1923, submitted its report to the Marine Committee of the work and investigations which had been then made to date. This report of April 27, 1923 with its "Foreword" is given complete as rendered with such minor changes and corrections as shown by

further investigations to be necessary. To this original report a brief section on "Electric Ship Propulsion" has been recently added. To complete this report to date, the sections on "Electrical Auxiliaries" and the appended list of references, are still to be added, although considerable work has already been done in connection therewith.

Although it is regretted that the report is not complete in all details, the Marine Committee has felt that owing to the rapidly increasing interest in shipboard electrical installations that the time is opportune for the presentation of this information as at present compiled and with a view to completing the report at as early a date as practical.

While we appreciate that this paper, owing to its volume, will be read in the abstract only by those casually interested, to those who are interested in the subject, we trust the information will prove of considerable value. As information of this character has its greatest value as a historical record, we trust the Institute may be able to take steps to preserve the same in a substantial and conveniently accessible form in its files.

* * * * *

FOREWORD

FOR the past four years during the existence of this sub-committee, investigation of this subject and collection of data has been carried on with varying results and against many discouragements. It has seemed particularly difficult to obtain information of this nature from the many sources and individuals from whom it has been sought.

Furthermore, the subject has seemed to expand with the work as it was carried on, until it has become a serious problem to determine what information, from the mass of data available, should be recorded, and what discarded as being of insufficient value to include in the review. In other words, to what extent should the scope and detail of the work be carried on in order to cover items of historical value without making the review of such volume as to injure its usefulness. After careful consideration, it was decided to make brief mention with dates, of many of the historical items which have come to the authors' attention, while with others, believed to be of considerable interest, more space and attention has been given.

It was also deemed desirable to divide the review in the order of development into several sections as follows, to assist in its preparation, its usefulness and future revision:

I. General growth and development in the marine field.

II. Lighting, wires and cables.

III. Interior Communication.

IV. Electrical Auxiliaries.

V. Electrical propulsion.

VI. Appended list of references.

These sections are, in some cases, divided into further sub-divisions, particularly in case of electrical auxiliaries, where the development of some of the more important is treated at some length. Throughout the subject matter, references are frequently made to sources of information and the appended list of references is given for the assistance of those who in the future, wish to pursue the study of this subject.

While the investigation and review, owing to the extent of the task and the limited time available for the work, has not been as complete and thorough as we would have liked, it is hoped that the information given will prove of interest and value to those interested in subject, and form the basis for further information and data, by additions and revisions as time goes on.

Acknowledgment is hereby made, for particular assistance in the line of information and references to Lieut. Commander A. M. Charlton, U. S. Navy, Lieut. A. G. Quinn, U. S. Navy, Mr. T. L. Gatchel of the Bureau of Engineering, Navy Department, Mr. Maxwell W. Day of the General Electric Company, Mr. G. A. Pierce of the Wm. Cramp & Sons Ship and Engine Building Company, Mr. I. H. Osborne of Federal Shipbuilding Corporation, Mr. A. E. Waller of the Ward Leonard Company, and to also express thanks to Mr. William Hetherington, Jr., Member of the Sub-

¹ Both of the Cutler-Hammer Mfg. Co., New York, N. Y. To be presented at the Spring Convention of the A. I. E. E., St. Louis, April 13-17, 1925.

committee for his assistance in the preparation of the Review.

H. L. HIBBARD

Chairman, Historical Subcommittee

GENERAL GROWTH AND DEVELOPMENT OF
ELECTRICITY IN THE MARINE FIELD

Although electricity has been used, both on merchant and naval vessels for more than forty years, its progress and development, particularly in the merchant marine, has been very slow as measured by land standards. Several very early lighting installations were made on merchant vessels, and this method of illumination later came into quite general use, but little further development occurred in this country in the merchant marine until about the beginning of the World War in 1914.

Even in the American Navy, by far the greatest user of electricity on shipboard,—although a few early lighting installations were effected after the first one installed on the *U. S. S. Trenton* and several miscellaneous experimental installations on auxiliaries were made—no great progress was noted until the complete electrical plants installed in 1898 to 1900 on the Battleships *Kearsage* and *Kentucky*.

Of the earliest electrical lighting plants on merchant vessels, we find very full mention made in a booklet entitled "Uses of Electricity on Shipboard" by J. W. Kellogg, consisting of a series of articles reprinted from Marine Engineering apparently about 1904 or 1905 and from these certain extracts are quoted below.

"The first electric plant that was ever put into operation in the hands of strangers was on the steamship *Columbia*, and was installed under directions from Mr. Edison. In a report dated February 24th, 1882, Mr. J. C. Henderson, who was at that time Advising Engineer of the Oregon Railway and Navigation Company, states that in the summer of 1879, while the *Columbia* was under construction, he wired the ship for electric lights; the plant was started on the 2nd of May, 1880. There were 110 lamps installed, and No. 11 wire was used for mains and No. 32 wire for the loops, insulated by double-paraffined cotton, and painted over all. The report states that the wires were run throughout the entire vessel, but lights were only placed in the passengers' rooms and the main saloon. The engineer of the vessel stated that 115 lamps were operated over four hundred hours without one lamp giving out. Two years after the plant was started it was reported that from the time of starting until that day the plant had operated to the entire satisfaction of the company under all circumstances.

"From 1880 to 1882 there was very little done in steamship work, but early in the latter year, the Edison Company installed a plant on the *Queen of the Pacific* constructed at Wm. Cramp & Sons Ship and Engine Building Company 1882, and on Mr. James Gordon Bennett's steam yacht *Namouna*. The former plant was installed as the result of the success of the one

on the *Columbia*. The next we hear is of electric light being used on the Russian Steamers plying the river Volga in the summer of 1882. There is a description of the *Queen of the Pacific* in one of the early bulletins of the Edison Company, showing 146 lamps to have been installed. The circuits were so run that any individual lamp could be controlled. Switches were placed under the direction of the steward, one switch controlling all lamps forward of the engine room, another, saloon, dome and shaft alley. The lamps were arranged to screw into a socket in the ceiling of each state room, and the wires were led in such a way as to be concealed. The last of July 1882, it was reported that the plant on the yacht *Namouna* operated without accident on a voyage across the Atlantic.

"During this summer, plants were also installed on the Long Island Sound Norwich Line Steamer *City of Worcester*, and on the steamer *Carolina*, of the Baltimore Bay Line. Later in the fall a plant was ordered for the steamer *Virginia* of the latter line and for the *Albatross* of the United States Fish Commission. Of 22,000 lights installed up to October 1882, 2000 of them had been placed on steamships.

"In December 1882, an order was given for a plant of 120 lights for the steamer *Kate Adams*, running on the Mississippi River. About the same time, the English Edison Company received an order for plants for two ocean steamships for the Ocean Steamship Company of New Zealand. The first one, the *Tarawera*, was thrown open to the public in December 1882. This was the first English vessel on which the Edison system had been applied. There were 150 lamps with an *L* type of machine, driven by three-cylinder Brotherhood engine. The captain stated that the electric plant on this vessel worked well throughout the voyage from Greenock, Scotland, to Melbourne, Australia.

"Early in 1883, a plant was ordered for the steamer *Carolina* of the Oceanic Steamship Company of San Francisco, running between San Francisco and the Sandwich Islands. In a report of the collision between this steamer and the *Riverdale*, the captain of the *Carolian* said (January 1883): 'We had a most satisfactory demonstration of the working of the Edison electric lights, which were only extinguished in the damaged part of the boat, thus removing all cause of fire, which would have been certain had any other method of lighting been employed'.

"The description of the plant on the steamer *Pilgrim*, of the Fall River Line, in April, 1883, shows that there were 910 lamps installed, the current for operating being generated by one *L* and two *K* dynamos, driven by two Armington & Simms engines belted direct to the dynamos. Steam was furnished from a special boiler at 80 lbs. pressure. Connections were also made with the ship's donkey and main boiler, to be used in cases of emergency. The dynamos were arranged to be used together or separately, and regulated by an Edison regulator. Current was taken from the dynamo room

to the main deck through Edison tubes; these ran vertically on the forward side and there divided to each side of the boat. Each branch ran aft to the center of the boat and from that point, vertically to the ceiling of the galley deck. It was the intention to provide a system that would prevent the lamps being extinguished by an accident, each section being independent of the other.

"In June, 1883, the London Edison Company installed a plant on the steamship *Oregon*, which was building at Glasgow for service between Liverpool and New York, and on the steamer *Rio Pardo*, for the Brazilian coasting trade. In the bulletin of May 31st, 1883, the Edison Company reported twenty-four plants on steamships, aggregating 4850 lights.

"In part, a report of the chief engineer of the *Albatross* is as follows: 'There are 139 eight-c. p. lamps placed in multiple and so distributed throughout the vessel as to illuminate every place where light is desired. There are four circuits, viz: a double circuit on each side of the ship for the forward lamps; and double circuit on each side of the ship for the after lamps; a single independent circuit for the outside lamps, with switch in the engine room; and an independent circuit for the engine room. The mains are not only double circuits, but each consist of two No. 10 wires. The advantage of this system of wiring is manifest, as, in the event of breaking a wire from collision or other cause, the remaining wires will be ample to carry the current. The mains, however, are brought together and soldered where they are attached to the binding posts of the dynamo.

"The wires are insulated with cotton cloth and white lead and when passing through damp places they are further protected by rubber tubing. On each main wire and near the dynamo, as well as near each group of lamps, is a cut-out plug which contains a short piece of fusible wire. The main office of this plug is two fold: it may be used as a switch to cut that wire out of the circuit at pleasure, also to prevent the heating of the wires beyond the fusing point of the metal (400 deg.) thus rendering the system harmless as to fire.

"In this same report, Chief Engineer Baird made very elaborate tests to determine the cost of operating and gives a comparison of the cost of the electric light with gas on the basis of price charge by the Washington company. He figured that the cost of gas would be a little over three times what the Edison incandescent lamp was costing on that ship. He omitted the cost of labor, as no additional men were required for running the dynamo and engine. He figured out the electric light as costing \$0.0135 per candle power per hour.

"In the first installations simply a paraffin-covered copper wire was used for carrying the current; now there is first a layer of pure para rubber; then vulcanized rubber with a large quantity of the best grade of rubber in the compound; then braid, and either a lead or steel tube for the outer covering. When the character of the work at that time is compared with

that of the present day, one cannot help being impressed with the durability of electrical plants. If, with such means as they had at their command in the early days, successful installation could be made, how much greater should be the results obtained at this time! Any well designed installation today should last as long as the hull of the ship. The liability to damage from fire is a minimum; there is freedom from dirty, ill-smelling lamps which render ventilation difficult, and there is practically no heat. Electric fixtures are easily adapted to ornamental designs and the lamps can be arranged to give the best lighting effect; and for power purposes, a matter of no small account is the freedom from leaky steam pipes through cargo spaces."

Charles Cory & Sons Company also claims to have effected one of the very first complete installations on merchant vessels, this being on the *Santa Rosa* about 1882.

EARLY NAVAL HISTORY

The first incandescent electric lighting plant in use in the navy was installed on the *U. S. S. Trenton* in the New York Navy Yard in 1883 and in the August (1921) number of the *Journal* of the American Society of Naval Engineers, an article, by Lieut.-Commander Charlton descriptive of the plant and results obtained therefrom, forms very interesting reading. The contract for this installation was awarded to the Edison Electric Lighting Company at a cost of \$5500.00 and called for the dynamo and engine, complete, to supply 238 lights of 10, 16 and 32 candle power. All the necessary conductors, switches and appliances were to be of the most approved pattern as used by the Edison Co. and the fixtures for the lights were to be furnished by the Navy Department. The dynamo was of the Edison type *L* shunt-wound bipolar with a terminal voltage of 110 and a capacity of 120 amperes.

The engine was a horizontal Armington & Simms, single cylinder, 9½ x 12 in. stroke, and made about 270 rev. per min. From its flywheel extended a 8½ in. belt to a 14 in. pulley on the armature shaft, which was driven at about 900 rev. per min.

The wiring system of the *Trenton* was run in pine moulding and, for the various mains, consisted of a single strand, tinned and covered with rubber insulation. For the branch leads, it was mostly untinned and covered with cotton insulation and paint. Although more trouble was experienced from defective wiring than from any other part of the plant, the results in general were sufficiently satisfactory to have proven the entire practicability of lighting naval vessels by electricity, and the plant in the *Trenton* continued in successful operation until she was lost in March 1899.

We also learn from an article by Lieut. Harry George, U. S. N. on *Electricity in the Navy*, presented May 26th, 1902, before the A. I. E. E., that

"The lighting of the *Trenton* proved a success and was in operation for a full three years' cruise, confirming the

committee for his assistance in the preparation of the Review.

H. L. HIBBARD

Chairman, Historical Subcommittee

GENERAL GROWTH AND DEVELOPMENT OF
ELECTRICITY IN THE MARINE FIELD

Although electricity has been used, both on merchant and naval vessels for more than forty years, its progress and development, particularly in the merchant marine, has been very slow as measured by land standards. Several very early lighting installations were made on merchant vessels, and this method of illumination later came into quite general use, but little further development occurred in this country in the merchant marine until about the beginning of the World War in 1914.

Even in the American Navy, by far the greatest user of electricity on shipboard,—although a few early lighting installations were effected after the first one installed on the *U. S. S. Trenton* and several miscellaneous experimental installations on auxiliaries were made—no great progress was noted until the complete electrical plants installed in 1898 to 1900 on the Battleships *Kearsage* and *Kentucky*.

Of the earliest electrical lighting plants on merchant vessels, we find very full mention made in a booklet entitled "Uses of Electricity on Shipboard" by J. W. Kellog, consisting of a series of articles reprinted from Marine Engineering apparently about 1904 or 1905 and from these certain extracts are quoted below.

"The first electric plant that was ever put into operation in the hands of strangers was on the steamship *Columbia*, and was installed under directions from Mr. Edison. In a report dated February 24th, 1882, Mr. J. C. Henderson, who was at that time Advising Engineer of the Oregon Railway and Navigation Company, states that in the summer of 1879, while the *Columbia* was under construction, he wired the ship for electric lights; the plant was started on the 2nd of May, 1880. There were 110 lamps installed, and No. 11 wire was used for mains and No. 32 wire for the loops, insulated by double-paraffined cotton, and painted over all. The report states that the wires were run throughout the entire vessel, but lights were only placed in the passengers' rooms and the main saloon. The engineer of the vessel stated that 115 lamps were operated over four hundred hours without one lamp giving out. Two years after the plant was started it was reported that from the time of starting until that day the plant had operated to the entire satisfaction of the company under all circumstances.

"From 1880 to 1882 there was very little done in steamship work, but early in the latter year, the Edison Company installed a plant on the *Queen of the Pacific* constructed at Wm. Cramp & Sons Ship and Engine Building Company 1882, and on Mr. James Gordon Bennett's steam yacht *Namouna*. The former plant was installed as the result of the success of the one

on the *Columbia*. The next we hear is of electric light being used on the Russian Steamers plying the river Volga in the summer of 1882. There is a description of the *Queen of the Pacific* in one of the early bulletins of the Edison Company, showing 146 lamps to have been installed. The circuits were so run that any individual lamp could be controlled. Switches were placed under the direction of the steward, one switch controlling all lamps forward of the engine room, another, saloon, dome and shaft alley. The lamps were arranged to screw into a socket in the ceiling of each state room, and the wires were led in such a way as to be concealed. The last of July 1882, it was reported that the plant on the yacht *Namouna* operated without accident on a voyage across the Atlantic.

"During this summer, plants were also installed on the Long Island Sound Norwich Line Steamer *City of Worcester*, and on the steamer *Carolina*, of the Baltimore Bay Line. Later in the fall a plant was ordered for the steamer *Virginia* of the latter line and for the *Albatross* of the United States Fish Commission. Of 22,000 lights installed up to October 1882, 2000 of them had been placed on steamships.

"In December 1882, an order was given for a plant of 120 lights for the steamer *Kate Adams*, running on the Mississippi River. About the same time, the English Edison Company received an order for plants for two ocean steamships for the Ocean Steamship Company of New Zealand. The first one, the *Tarawera*, was thrown open to the public in December 1882. This was the first English vessel on which the Edison system had been applied. There were 150 lamps with an *L* type of machine, driven by three-cylinder Brotherhood engine. The captain stated that the electric plant on this vessel worked well throughout the voyage from Greenock, Scotland, to Melbourne, Australia.

"Early in 1883, a plant was ordered for the steamer *Carolina* of the Oceanic Steamship Company of San Francisco, running between San Francisco and the Sandwich Islands. In a report of the collision between this steamer and the *Riverdale*, the captain of the *Carolian* said (January 1883): 'We had a most satisfactory demonstration of the working of the Edison electric lights, which were only extinguished in the damaged part of the boat, thus removing all cause of fire, which would have been certain had any other method of lighting been employed'.

"The description of the plant on the steamer *Pilgrim*, of the Fall River Line, in April, 1883, shows that there were 910 lamps installed, the current for operating being generated by one *L* and two *K* dynamos, driven by two Armington & Simms engines belted direct to the dynamos. Steam was furnished from a special boiler at 80 lbs. pressure. Connections were also made with the ship's donkey and main boiler, to be used in cases of emergency. The dynamos were arranged to be used together or separately, and regulated by an Edison regulator. Current was taken from the dynamo room

to the main deck through Edison tubes; these ran vertically on the forward side and there divided to each side of the boat. Each branch ran aft to the center of the boat and from that point, vertically to the ceiling of the galley deck. It was the intention to provide a system that would prevent the lamps being extinguished by an accident, each section being independent of the other.

"In June, 1883, the London Edison Company installed a plant on the steamship *Oregon*, which was building at Glasgow for service between Liverpool and New York, and on the steamer *Rio Pardo*, for the Brazilian coasting trade. In the bulletin of May 31st, 1883, the Edison Company reported twenty-four plants on steamships, aggregating 4850 lights.

"In part, a report of the chief engineer of the *Albatross* is as follows: 'There are 139 eight-c. p. lamps placed in multiple and so distributed throughout the vessel as to illuminate every place where light is desired. There are four circuits, viz: a double circuit on each side of the ship for the forward lamps; and double circuit on each side of the ship for the after lamps; a single independent circuit for the outside lamps, with switch in the engine room; and an independent circuit for the engine room. The mains are not only double circuits, but each consist of two No. 10 wires. The advantage of this system of wiring is manifest, as, in the event of breaking a wire from collision or other cause, the remaining wires will be ample to carry the current. The mains, however, are brought together and soldered where they are attached to the binding posts of the dynamo.

"The wires are insulated with cotton cloth and white lead and when passing through damp places they are further protected by rubber tubing. On each main wire and near the dynamo, as well as near each group of lamps, is a cut-out plug which contains a short piece of fusible wire. The main office of this plug is two fold: it may be used as a switch to cut that wire out of the circuit at pleasure, also to prevent the heating of the wires beyond the fusing point of the metal (400 deg.) thus rendering the system harmless as to fire.

"In this same report, Chief Engineer Baird made very elaborate tests to determine the cost of operating and gives a comparison of the cost of the electric light with gas on the basis of price charge by the Washington company. He figured that the cost of gas would be a little over three times what the Edison incandescent lamp was costing on that ship. He omitted the cost of labor, as no additional men were required for running the dynamo and engine. He figured out the electric light as costing \$0.0135 per candle power per hour.

"In the first installations simply a paraffin-covered copper wire was used for carrying the current; now there is first a layer of pure para rubber; then vulcanized rubber with a large quantity of the best grade of rubber in the compound; then braid, and either a lead or steel tube for the outer covering. When the character of the work at that time is compared with

that of the present day, one cannot help being impressed with the durability of electrical plants. If, with such means as they had at their command in the early days, successful installation could be made, how much greater should be the results obtained at this time! Any well designed installation today should last as long as the hull of the ship. The liability to damage from fire is a minimum; there is freedom from dirty, ill-smelling lamps which render ventilation difficult, and there is practically no heat. Electric fixtures are easily adapted to ornamental designs and the lamps can be arranged to give the best lighting effect; and for power purposes, a matter of no small account is the freedom from leaky steam pipes through cargo spaces."

Charles Cory & Sons Company also claims to have effected one of the very first complete installations on merchant vessels, this being on the *Santa Rosa* about 1882.

EARLY NAVAL HISTORY

The first incandescent electric lighting plant in use in the navy was installed on the *U. S. S. Trenton* in the New York Navy Yard in 1883 and in the August (1921) number of the *Journal* of the American Society of Naval Engineers, an article, by Lieut.-Commander Charlton descriptive of the plant and results obtained therefrom, forms very interesting reading. The contract for this installation was awarded to the Edison Electric Lighting Company at a cost of \$5500.00 and called for the dynamo and engine, complete, to supply 238 lights of 10, 16 and 32 candle power. All the necessary conductors, switches and appliances were to be of the most approved pattern as used by the Edison Co. and the fixtures for the lights were to be furnished by the Navy Department. The dynamo was of the Edison type *L* shunt-wound bipolar with a terminal voltage of 110 and a capacity of 120 amperes.

The engine was a horizontal Armington & Simms, single cylinder, 9½ x 12 in. stroke, and made about 270 rev. per min. From its flywheel extended a 8½ in. belt to a 14 in. pulley on the armature shaft, which was driven at about 900 rev. per min.

The wiring system of the *Trenton* was run in pine moulding and, for the various mains, consisted of a single strand, tinned and covered with rubber insulation. For the branch leads, it was mostly untinned and covered with cotton insulation and paint. Although more trouble was experienced from defective wiring than from any other part of the plant, the results in general were sufficiently satisfactory to have proven the entire practicability of lighting naval vessels by electricity, and the plant in the *Trenton* continued in successful operation until she was lost in March 1899.

We also learn from an article by Lieut. Harry George, U. S. N. on *Electricity in the Navy*, presented May 26th, 1902, before the A. I. E. E., that

"The lighting of the *Trenton* proved a success and was in operation for a full three years' cruise, confirming the

opinion that no modern vessel is complete without a plant for lighting by electricity."

"The proved efficiency of the *Trenton* installation, and the valuable experience gained in that vessel, led to the application of electricity for lighting other vessels. The ships authorized by Act of Congress in August 1882, namely the *Dolphin*, *Atlanta*, *Boston* and *Chicago* were so equipped and since then an electrical plant has been looked upon as an essential feature of all vessels of war, the scope having been extended to include both lighting and the electric drive of numerous auxiliaries hitherto controlled by steam or hydraulic power."

"The early ships were provided with one generator hence, in case of breakdown, it was necessary to have recourse to oil lamps."

"The specifications of the next vessel authorized by Act of Congress in 1885 and 1886, called for two complete plants each an exact duplicate of the other. This was not decided upon without some opposition. It was proposed originally to install two generators, one of large capacity to supply the night load and a smaller one to furnish current for lamps required during the day. This idea was finally abandoned because of the possible over-powering of the smaller dynamo by the larger one unless carefully watched, the decreased relative economy of the smaller generator, and the diminished number of spare parts necessary in a duplicate installation."

All the earlier lighting installations were, like the *Trenton*, provided with Edison bipolar generators, belt-driven to an Armington & Simms or other reciprocating type engine.

Voltmeters were not used until after the early 80's and field regulation was not indulged in until about the same time, all of the early installations simply having the pilot light on the generator for gaging voltage and candle power of the lamps.

Two other Naval lighting installations which followed soon after the *Trenton* and the others mentioned, were the *U. S. S. Charleston* whose plant and contract trials are described in Volume 1, 1889 of the *Journal of The American Society of Naval Engineers*, and the *Newark* the electric plant of which is described in Volume 3, 1891 of the same *Journal*.

While the earliest electric lighting plants have been described above as marking the first step towards modern installations in the Navy, electricity was used to some limited extent as far back as Civil war times. Lieut. Commander Charlton, in an article entitled "Electricity in the Old Navy" in the November issue 1920 of the *Journal of the American Society of Naval Engineers*, describes, in considerable detail, the apparatus and experimental equipment which was used in torpedo and gun firing, and the first efforts in arc lighting and searchlights on the *U. S. S. Nina*.

A most interesting and comprehensive article by Lieut. B. A. Fiske, entitled "Electricity in Naval Life" appeared in Volume 22, No. 2, 1896 of the *Proceedings*

of the U. S. Naval Institute, Annapolis, Md. This article, of more than 100 pages, by the now retired Rear Admiral Fiske, takes up, in a most interesting manner, practically every phase of the installation of electricity as it then existed in the Navy, including many hopes and predictions for future development. It may be noted with interest statements in this article that about ten years before, the writer had delivered a lecture before the Franklin Institute, when there were present a commodore and captain of the Navy; in a conversation after the lecture, these high Naval officers attempted to point out the impossibility of using the electric light on board ship, by reason of the impracticability of getting sufficient space for the dynamo. At the same time, the author points out that at the time of his article the electric light is now a sine qua non in modern warships. The author further mentions that a very important enemy of electrical appliances on shipboard has been the fatal facility with which bad electrical apparatus can be installed. Nevertheless he asserts that it is a fact that uses of electricity in the Navy are increasing, including the use of electric motors, for the training of turrets, the hoisting of ammunition, etc., and especially for ventilating.

In view of the present state of the art on naval vessels, it is interesting to note the anticipations of Lieut. Fiske when he said "Let us hope that we shall soon see a civilized modern ship in which there shall be a fine large dynamo room like those in the great New York hotels, where power will be generated for lighting the ship, making the signals, hoisting the ammunition, turning the turrets, hoisting the boats, ringing the bells, weighing the anchor, sounding the alarms, steering the ship, firing the guns, etc., etc. And why should we not have a neat electric galley, such as are frequent in New York, where the meals of all may be prepared in cleanliness and quiet with only a fraction of the fuss and confusion now attending the getting of food and coal and heating of water." In view of recent developments, particularly in radio, the final remarks of Lieut. Fiske are especially noteworthy when he said, with regard to "signaling at sea," "The electrician and the inventor recoil in despair before the difficulties which this problem presents. Yet there must be a way to signal across the water. The question is 'where is the way?' If we can talk with ease from New York to Chicago, if we can telegraph under all the oceans and send news to and from all quarters of the world, why—*why* can we not signal half a mile over the water from ship to ship."

Continuing with the general and later developments in the Navy, it is noted that a few power installations, mostly of an experimental nature, were effected,—such as the ammunition hoists on the Cruiser *New York* and the Battleships *Massachusetts*, *Indiana* and *Oregon*, turret turning equipments on the Cruiser *Brooklyn* and certain minor auxiliaries such as small ammunition hoists on the gunboats *Wilmington* and

Helena. The extensive use of electrical apparatus for lighting and power purposes as we have already mentioned, was not made however until the Battleships *Kearsage* and *Kentucky* were constructed in 1898 and 1900, these vessels having seven 50-kw. engine-driven, 80-volt generating sets, which were operated in series on the three-wire system to give 80 volts for lighting and two voltages, 80 volts and 160 volts for power motors. The larger portion of the auxiliaries on these battleships, including the winches, boat cranes, ventilating fans, broadside ammunition hoists and auxiliaries were electrically operated. The anchor windlass and steering gear, however, were steam driven.

Lieut. George's article also points out that the advances of electricity for naval purposes may be shown by a comparison between the electrical plant of the *Indiana*,—one of our best battleships completed and commissioned in 1895,—and that of the *Kearsage*, commissioned in 1900. The displacement of the *Indiana* is 10,200 tons and she is equipped with 24-kw. 80-volts generators for supplying current to 500 incandescent lamps, four 60-centimeter searchlights, two two-h. p. ventilating motors for dynamos, four ¼-h. p. portable ventilating sets with winches and ammunition hoists covering about 36-h. p. or a total of 67-kw., about seven watts per ton of displacement.

The *Kearsage*, with a displacement of 11,595 tons, was provided with seven 50-kw. generators of 80 volts, as we have already stated, and her total power and lighting requirements were 655,240 watts or approximately 57 watts per ton displacement.

For a complete description of the electric plants on the battleships *Kearsage* and *Kentucky*, we would refer those interested to a paper read by Naval Constr. J. J. Woodward, U. S. N. before the Society of Naval Architects and Marine Engineers, November 1899 and for the results of the tests of the electrical equipments on these vessels, to a paper read by the same officer before the same Society, November 1900.

After the *Kearsage* and *Kentucky*, some succeeding battleships retained the original plans for the use of steam drive for many of their auxiliaries, and the *Kearsage* and *Kentucky* are the only vessels in the Navy using the three-wire control. While after the *Kearsage* and *Kentucky* there was some consequent lack of progress in the electrical equipment of capitol ships, the use of electricity soon progressed rapidly, until now practically all auxiliaries on capitol ships are provided with electric drive and recent ships are equipped with electrical propulsion. Further and more elaborate details of these developments are referred to under the sections for auxiliary and electric propulsion.

SOME DEVELOPMENTS IN FOREIGN NAVIES

Marine Engineering of June 19th, 1896 has an article by Herr A. Dietrich, on German war vessels, which states: "All new German warships under construction have electricity as motive power, not only for ventila-

ting fans but also for turning gears of 15-mm. guns, turret ammunition hoists, boat hoists, coaling winches and such gear. Only one vessel in the German Navy, the nearly finished *Aegir* is experimentally fitted throughout with electrical apparatus, even for steering gear and windlasses. The result of this experimental installation will decide if, in the future, electricity can be used more extensively for motor power on board ship and if the heat sources can be dispensed with."

From Lieut. George's article, the following information as to practice current at the time in the German, Russian and French Navies, is taken:

German. Furst Bismarck—Battleship 10,650 tons displacement, with an electric generating plant of 325 kw. output supplying current to 900 incandescent lamps, 44 motors for ventilation, a drying room, ammunition hoist, gun-training gear, coaling winches, refrigerating plant and searchlights.

Kaiser Frederick III.—Armored cruiser 11,130 tons displacement. Five generators with output of 324 kw. supplying power as follows: Incandescent lighting 38,260 watts, searchlights, 55,500 watts, ventilation 28,340 watts, ammunition hoists, 17,440 watts, gun-training gears 8880 watts, coaling winches 7400 watts, refrigerating plant 4500 watts.

Russia. *Retvizan*—Battleship, built at Cramps shipyard, Philadelphia, Pa. (1900-1901) Electric installation three 132-kw., four 66-kw., and one 60-kw. generators with a maximum output of 588 kw. These generators supply current to 1167 incandescent lamps, six 30-in. projectors and the following auxiliaries:

- 4—turret-turning motors
- 4—elevating motors
- 4—rammer motors
- 4—turret ammunition hoists
- 12—60 in. blowers for forced draft system
- 18—motors for hull ventilation
- 6—pump motors
- 2—boat crane motors
- 1—capstan motor
- 8—ash-hoist motors
- 1—steering motor
- 30—ammunition hoist motors for battery
- 2—submerged torpedo motors
- 1—workshop motor
- 1—torpedo lathe motor
- 1—bread-mixing motor
- 1—laundry motor

Also a number of portable fans, helm indicators and other electrical signaling devices.

France. *Jena*—Battleship—displacement 12,052 tons, two generators of 98.4-kw. capacity, and two of 49.2 kw. capacity, total output 295.6 kw.

"Heretofore the dynamos have been located in the main portion of the vessel, the dynamo rooms forming sub-divisions of one general compartment between transverse watertight bulkheads. The rapid develop-

ment of the electric drive and its application to ammunition hoist and gun operation has made the question of dynamo rooms and their location one of the most important in ship design.

LATER DEVELOPMENTS IN THE MERCHANT MARINE

Returning to the development of electricity on merchant vessels, we find, as already stated, comparatively little progress made after the early lighting installations on the *Columbia* and the aforementioned other vessels, until practically the beginning of the World War, when a decided impetus seemed to be felt in the use of electricity on a broader scale, due apparently to the increasing adoption of Diesel engines for propulsion with electrical auxiliaries as a necessary sequence. In the meantime, we have a record of some lighting and power installations of relative importance which may be of interest:

In 1897 and 1898 *La Grande Duchesse* was constructed at Newport News Shipyard for the Plant Line and we are told that in the April, 1897 issue of *Marine Engineering* in a manner that is quite amusing today that "Electricity now is such a necessity aboard ship that every steam vessel designed has at least a lighting plant. As complete an installation as can be found on a merchant vessel is that with which the new Plant Liner *La Grande Duchesse* is equipped. In this steamship electricity is used for seven distinct and separate purposes. The plant is located in a separate compartment, aft of the engine room between the thrust bearings, and consists of two 20-kw. 110-volt machines." The vessel was evidently equipped with about 700 incandescent lights and a 12 in. projector, and a few motors for ventilation and other minor purposes.

The August 1897 number of *Marine Engineering* and also the *Journal* of American Society of Naval Engineers, describe what was apparently one of the first important power installations on merchant vessels consisting of 16 electric cranes installed on the Steamer *Bremen*. These cranes had rotating motors of 7 h. p. at 700 rev. per min., hoisting 25 h. p. at 900 rev. per min. worm gear drive being used. The controllers were of double type two feet high and equipped with magnetic blowouts.

Mr. William Henry Allen, in a paper read before the Institute of Electric Engineers and recorded in Volume 3, 1891, *Journal* of The American Society of Naval Engineers, says: "Ship's lighting dynamos are greatly improved of late, series-wound armature machine having been found to work satisfactorily"—the author recommends 60 volts for merchant ships as being suited for both glow lamps and projectors. He also expresses it as having been his experience that dynamos can be readily made with cooling surfaces and rate of development of heat so proportioned that neither the armature nor field magnet will rise more than 50 deg. cent. beyond the temperature of the surrounding air after running for six or seven hours.

In a folder issued about 1922 by the General Electric Co. on Motor and Controller Equipment on Merchant Vessels, the following statement appears:

"One of the first installations aboard a merchant ship was made on the *SS Prinz Heinrich* of the Norddeutscher Lloyds, now the *SS Porto*, managed by Portuguese interests, where six electric cargo winches were installed in 1894.

In the *Scientific American Supplement* of November 4th, 1899, appears a paper delivered by Alexander Siemens in Dover, England. This interesting article reviews the development of generators, wiring and auxiliary drives to date, and advocates further use of electricity on shipboard. Reference is also here made apparently for the first time, to the use of stalling resistances for winches.

Although, as we have already stated, small electric lighting plants on merchant vessels had come into general use, and, in a few instances, electricity had been used for power applications, comparatively little progress had been made as late as 1914. This was probably due in a large measure, to the conservatism of the Marine Engineer and sea-faring man in the adoption of new and untried apparatus. About this time, however, the advent of the fuel-oil engine-driven ship marked a great stepping stone to the adoption of electrical power, particularly for auxiliary purposes. In November 1917 the author presented a paper *Application of Electricity to Various Auxiliaries on Shipboard* before the Society of Naval Architects and Marine Engineers in New York, in which the development of electricity in the marine field was reviewed up to that time and the prediction was made that the time was rapidly approaching, if not already here, when the results obtained would justify the construction generally of vessels electrically equipped in all or many of their power applications.

One of the very first noticeable instances of this kind was the vessel *Christian X.* constructed by Burmeister & Wain Co., Copenhagen and its first voyage to this country in about 1912 created marked attention. Since that time, it is understood that a large number of vessels of this type have been constructed and projected by that company. (A total of 152 to beginning 1925.)

In 1916 or 1917 a number of merchant vessels were built in this country including tankers and cargo vessels employing electrical auxiliaries, among these being the Tanker *La Brea* with electrically operated pumps, and the Tanker *Solitaire*, (completed in 1920 by the Texas Co.,) with oil engine drive and electrical auxiliaries throughout including electric heating. A number of tank vessels were constructed in 1917-1918 by the Pennsylvania Shipbuilding Company, Gloucester, N. J. These were vessels of 7500 d. w. t. and were equipped with geared steam turbines and electric auxiliaries operated by a-c. motors. These a-c. equipments for various reasons proved disappointing.

During the War, the U. S. Shipping Board Emergency Fleet Corp. planned the construction of 50-100 oil engine driven cargo vessels with electrical auxiliaries. A number of the Diesel engines were contracted for and specifications and requisitions prepared for the purchase of the electrical equipment. The close of the War, however, coming soon after, prevented the carrying out of these plans. A few years later, in 1921, the Shipping Board reconditioned the cargo vessel *William Penn* and equipped it with oil engines by the Wm. Cramp & Sons Ship and Engine Building Company of the Burmeister & Wain make, and with electrical auxiliaries. The vessel has since made one or more trips around the world, and has reported excellent results from her equipment.

Very shortly after the construction of the *William Penn*, two electrically equipped motor ships, the *Californian* and *Missourian* were constructed for the American Hawaiian Steamship Company by the Merchants Shipbuilding Company with engine installed by the Cramps Company and have been in service about a year.

The cargo ore carrying boat *Cubore* with a Diesel engine drive and electrical auxiliaries was constructed by the Bethlehem Shipbuilding Corporation in 1920, and in 1921 three oil tankers similarly equipped were constructed on the Pacific Coast for the Standard Oil Company of California, these being the *Charlie Watson*, *Hillman* and *Harper*.

During this time, rapid strides also were being made by the European countries, in the adoption of the use of electricity on their merchant vessels particularly of the motor ship type, and England as well as Scandinavian countries was and is continuing to construct many vessels of this type.

One of the first notable English motor ships which visited New York on its maiden voyage in the Fall of 1920 was the *La Paz* constructed by Harland & Wolf of Glasgow, which company has since constructed additional motorships to a considerable number.

At the present time there are under construction in this country a considerable number of vessels employing either electrical propulsion, electrical auxiliaries, or both and among these some of the more important ones may be mentioned as follows:

Four War Department Hopper Dredges are under construction at the Sun Shipbuilding Company, Chester, Pa., provided with Diesel electric propulsion and electrical auxiliaries. These boats have two 1000-b. h. p. Diesel engines direct connected to two 700 kw. 150 rev. per min. 500-volt generators for propulsion purposes. Also a similar equipment for operating the main suction pump. There are two 225-b. h. p. Diesel engines operating two 150-kw. 275-rev. per min. 250-volt generators for auxiliary purposes, and one 150-kw. 580-250-volt motor generator set. In addition to the switchboard equipment, these vessels are provided with with a large number of electrically driven

auxiliaries, including pumps, deck machinery, etc.*

The Tanker *Standard Service* is being built for the Standard Oil Company of California at the Union plant of the Bethlehem Shipbuilding Corporation with Diesel electric drive consisting of two 400-b. h. p. engines, direct connected to two 245-kw. propulsion generators operating two 300-h. p. 130-rev. per min. propulsion motors.*

Ferry boats *Golden Gate* and *Golden West* are under construction at Robertson's Shipyard at Alameda, Cal. for the Golden Gate Ferry Co. of San Francisco. These vessels are to be Diesel electrically driven.

The City of New York is constructing at the Staten Island Shipbuilding Company, three ferry boats, steam turbine, electrically driven with several electrical auxiliaries, including steering gear, etc.*

Ferry boat *Poughkeepsie* was recently put in service across the Hudson with Diesel electric drive and some electrical auxiliaries, and reports on the electric apparatus appear to be very satisfactory.*

The Wm. Cramps & Sons Company is reconditioning a steam vessel, *Seekonk*, with direct Diesel drive and electrical auxiliaries.*

The New York Shipbuilding Company is reconditioning two steam vessels, the *Ashbee* and the *Jacksonville* with direct Diesel drive and electrical auxiliaries.*

The Submarine Boat Corporation at its Newark Bay Yard is constructing a 5000 ton vessel with direct Diesel drive and electrical auxiliaries.*

The Federal Shipbuilding Corporation at Kearney, N. J., is constructing for the Pittsburgh Steamship Company, two vessels for operation on the Great Lakes, which are to be direct Diesel driven and have a very full complement of electrical auxiliaries, including pumps, steering gear, anchor windlass, cargo cranes and mooring winches.*

LIGHTING, WIRES AND CABLES

The development of electric lighting in the U. S. Navy dates from the year 1883 when the *U. S. S. Trenton's* installation was made; in fact this vessel was the first man-of-war in the world to be so illuminated.

Generating Sets. From Lieut. George we learn that "belted sets were installed on several vessels up to the latter part of the eighties when direct connected sets first made their appearance. The early direct-connected sets had horizontal engines and by ingenious design were fairly compact and not excessive in weight.

"In 1889, horizontal engines were abandoned in favor of the vertical type. The first vertical engines were two-cylinder, non-condensing, designed for an initial steam pressure of 80 pounds, with cranks at 90 deg., but the pounding that resulted made necessary a spacing of 180 deg. between cranks in subsequent design.

*NOTE: At the present time (Jan. 1925) all of the above vessels under construction have been completed and have been in service from one to two years with very satisfactory results.

"The dynamos connected to these engines were four-pole machines with field coils on vertical and horizontal axes, bringing the lower field coil in a position where it was subject to oil and water, and much trouble was experienced with this coil in this arrangement of poles.

"Tandem compound engines have been used extensively and were first installed on the *U. S. S. Chicago*.

"In the proposed 16,000-ton battleships recently authorized by Congress, it is proposed to install the apparatus in two separate compartments, the dynamo rooms to be entirely independent of each other electrically, and to be situated in opposite ends of the vessel. Each dynamo room is to be supplied with four 100-kw. sets which will supply the output necessary to handle the battle load, lighting load and all auxiliaries. All forward circuits will be supplied by a distribution board located near the forward dynamo room but separate from it; all after circuits from the after distribution board to be similarly situated. By suitable transfer switches, both the distributing boards may be electrically connected and the entire load thrown into either dynamo room at will. This will increase the military efficiency of the installation, as in case of accident rendering either dynamo room uninhabitable, the battle load could be thrown on the remaining room."

The engines for generating sets in the Navy passed through the various development stages of single cylinder, vertical and horizontal, tandem and cross-compound, until the time of the *U. S. S. New Hampshire* built at the New York Shipbuilding Company's plant, on which two 200-kw. turbo-generators were installed. These were installed as a change, as the original contract required reciprocating engine sets, all of 100 kw. A somewhat similar change was soon followed on the *U. S. S. South Carolina* and *Michigan* where four 200-kw. turbo sets were installed in each vessel in place of reciprocating equipments.

For the next battleships, namely the *Delaware* and *North Dakota* four 300-kw., 125-volt generating sets were installed. The use of this size and number of sets was continued for a period of about six years, covering the installations in eleven battleships.

The *Arizona* was the first battleship in which different voltages for light and power were installed. This vessel was equipped with two 240-volt turbo-generators for power systems and two 120-240-volt generators with 120-volt balancers for light and power system.

With the introduction of electric drive for main propulsion use was made of the regular ship's generators as exciters and consequently the capacity of the sets was increased to six 300-kw. turbo-generating sets, and at the present time six 750-kw. turbo sets are contemplated for airplane carriers.

Ships' Voltage. In the earliest naval installations of electric lighting systems 110 volts potential was used. In 1888, however, a Naval Board was appointed to

decide on a single standard voltage, and 80 volts was selected. In 1901 the Navy Department deemed it advisable to consider changing the standard voltage, and as a result of considerable investigation and deliberation, 125 volts was then fixed as a standard.

Further experience on shipboard indicated the desirability of considering a change from this voltage of 125 to a higher potential, and beginning with the *U. S. S. Arizona* all capital ships were provided with two voltages as mentioned above, one of 120 volts for lighting and 230 volts for power applications. A very complete treatise on the reasons for the change in the Navy standard voltage from 80 to 125 is included in an article by Lieut. W. V. N. Powelson, U. S. N., presented at a meeting of the A. I. E. E., in New York on May 28th, 1902.

In Mr. Kellogg's article we are told that the original voltage used on merchant ships was in the neighborhood of 50 and that the Navy used at one time 65 which was later changed to 80. This information seems somewhat conflicting, however, as the *Trenton's* equipment was 110 volts as was apparently those on the vessels immediately succeeding.

In the merchant service after the early installations the use of simple generating sets for lighting was generally adopted. These equipments, in most cases, consisted of small standard lighting sets that were manufactured for the purpose by various builders, and in the majority of cases single cylinder, single acting, direct-connected to a 110-volt generating set, and in the majority of merchant vessels, particularly of the cargo type, such an equipment for lighting constituted practically all the electrical apparatus installed.

As we have previously pointed out, the growth and adoption of electricity became more rapid just before the World War and various ships were constructed utilizing electricity much more extensively, particularly in the case of the motor ships.

As an example of two quite extensive installations which were made about that time, we would cite the vessels *Northern Pacific* and *Great Northern*, constructed by the Cramps Company for the Great Northern S. S. Co. in 1914 and 1915. These vessels had four 35-kw., 110-volt generating sets operated by 3200-rev. per min. steam turbines using 200-lb. pressure.

In addition to a very complete lighting system including 1700 Mazda lamps and two 18-in. search lights, power applications were supplied for ventilating and exhaust fans, cargo elevators, galley and pantry motors, refrigerating machines, etc.

The wiring was on the two-wire system and the material used represented the latest marine construction including the use of the basket-weave, galvanized-iron, cable which was secured directly to the structure of the vessel, eliminating the customary conduits and moldings. This was probably one of the first instances of the use of this wire on merchant vessels in this country.

Wires and Cables. The *U. S. S. Trenton* was the

first vessel of the Navy to have electric cables installed for illumination purposes which work was done by the Edison Company of New York City during the construction of this vessel at Navy Yard, New York.

The history of the development of the electric cable in the U. S. Navy is an interesting one and we are indebted to Lieut. Allen G. Quynn, U. S. N. for the following description:

"The lighting system on the *Trenton* was divided into the following circuits, spar deck, gun deck, berth deck, orlop deck, ward room and Admiral's quarters, fire and engine rooms and hold. The wiring for these main circuits was of No. 12 or No. 14 single conductor cable about 6530 or 4107 circular mills. The cable was led about the ship in pine moldings, the molding containing two grooves for the wires and painted over for watertightness. In the branch circuits, a smaller cable of about 1624 circular mills was used and run in a smaller molding similar to that described above. Much trouble was experienced in this installation with salt water getting behind the molding and rotting the insulation."

"The cable used was rather primitive; for the mains, it consisted of a single strand of copper wire tinned and covered with a rubber insulation. The branch wire was generally untinned, covered with cotton insulation and painted. A small number of the branch leads, however, were tinned and insulated with what proved to be a very inferior quality of rubber. The mains were fitted with cutout boxes, each one supplying three or four lamps.

"In addition to the main lighting, portable deck lanterns and engine room portables formed a part of the *Trenton's* installation, twin-conductor cable was used for these lights, two fine flexible wires being surrounded by gutta-percha covered with jute braiding.

"In 1887 the *Trenton* was re-wired, particular attention being paid to the installation of the circuits and subsequently gave much better satisfaction. From the time of the first installation just described until 1887 there was but little development in the kind of cable used on Naval vessels, or in the method of running the cable. Trouble was still experienced from corrosion of insulation due to salt water. This often transformed the copper wire to a semi-conductor which became excessively heated and created danger of fire when surrounded by combustible material."

Wiring on the earliest vessels of the U. S. Navy was installed in wood moldings, the same as for the *U. S. S. Trenton* above described. Branches were, in most cases, spliced and the first junction branch boxes were used about 1885-1886. Fuses were used about the same time, usually an ordinary single fuse placed in the branch circuit on a small insulation base which was inserted in the molding.

Up to 1887 the *U. S. S. Omaha*, *New Hampshire*, *Dolphin*, *Atlanta* and *Boston* had been wired for electric lighting. The *U. S. S. Atlanta* was the first vessel in

which an attempt was made to introduce watertight junction boxes.

To Lieut. Quynn's description, we are also indebted for the following:

"The first recorded departure from the use of moldings for running cable aboard a naval ship was in 1898. At this time conduit was introduced and the specifications then in effect called for running cable in either conduit, flexible conduit or molding. Conduit was to be of seamless drawn iron or steel tubing of commercial iron pipe sizes and to have a continuous lining tube of approved insulating material. Conduit for magazines was to be made of seamless brass tubing with a lining of hard rubber. Flexible conduit was for use in locations subject to mechanical stress, as inside of steel masts or when flexibility was desired. The specifications merely called for flexible conduit of approved design and went no further into detail.

"Molding had by no means been replaced at this time, but modified somewhat, and was used in accordance with the following specifications: Molding will be in two pieces, that part containing the gutters for the wire and known as the molding proper, the other part as a flat piece called the backing strip. It will be made of well seasoned wood and when run over hard wood surfaces, it will be of same material as the surface." "Conduit came into more general use shortly after this being employed in all parts of the watertight system, that is, below deck and when necessary to run leads through watertight decks and bulkheads. Molding was still used in all cases where wires were led over woodwork. When running conduits through watertight decks, or bulkheads, standard stuffing tubes were used; in going through non-watertight decks and bulkheads, bushings of hard rubber were employed."

In the case of merchant ships, the *St. Paul* and *St. Louis*, built in 1895 by Wm. Cramp & Sons Ship and Engine Building Company, conduit was used throughout machinery spaces, on the sun deck and open decks for lighting and power.

Quite a complete description of wiring as used in the Navy from the earliest times to about 1902 is included by Lieut. H. George, U. S. N. in his article *Electricity in the Navy*, presented before the A. I. E. E., May 26th, 1902.

From Lieut. Quynn's article we further learn that from 1902 until the present time, there had been no radical changes in the methods of making up standard conductors, but the insulating and protective covering used have been modified considerably. The numbers of the strands used in making up stranded cable has been changed to supply the flexibility and conductivity desired for various kinds of cable.

The use of conduit and in a few special cases of molding, remained in effect until 1916. In that year these methods of running cable were superseded to a great extent by introduction of armored cable.

The first U. S. Naval installations employing armored

cable were made on the *U. S. S. Oklahoma* and *Nevada*. The cable used on these ships is of three types, 1. plain (external covering of plain cotton braid), 2. armored (external covering of galvanized steel armor), 3. leaded and armored (lead-sheath over-tape conductor and this covered with a galvanized steel armor). Plain conductors are used in turret center columns where protection is not necessary and in connections with portable fixtures. Armored conductors are used for leads to semi-portable fixtures, as boom and anchor lights. Leaded and armored conductors are used in permanent leads throughout the ship. All conductors are installed directly against decks and bulkheads by approved hangars, the metal surfaces under them having been previously red leaded and painted. Where conductors pass the watertight bulkheads, stuffing tubes are used; but when passing through beams and non-watertight bulkhead, a clearance hole is drilled and the edges rounded off. Conductors, after installation, are treated with a coat of shellac and painted to match the surroundings. When conductors are led up to decks where they are liable to mechanical injury, a protection conduit extending 18 in. above the deck is used, with a terminal tube at the top and suitable bushing at the bottom. In wiring installations aboard the latest naval vessels, cables of the three types described above are used for all purposes. Conduit and molding is now found only on the older vessels and is being replaced by armored cable wherever re-wiring becomes necessary.

This type of cable was developed in Europe and was introduced into the United States with the building of the Argentine battleships *Rivadavia* and *Moreno*. For further data relating to this type cable, refer to paper by H. A. Hornor at San Francisco, Sept. 16, 1915, A. I. E. E.

In connection with the earliest installations we have the following data from Wm. Cramp & Sons Ship and Engine Building Company regarding electric plant installed by them up to 1895.

Name.	Type.	Year
<i>S. S. Queen of the Pacific</i>	1 Engine, 2 Belted Generator, Edison System.	1882
<i>Mariposa</i> —Steamer	1 Generating Set, belted.	1883
<i>Alameda</i> — “	1 “ “ “	1883
<i>Atalanta</i> —Yacht	1 “ “ “	1883
<i>Olivette</i> —Steamer	1 No. 3 dynamo, 75 light, 16 CP belted. 1 No. 10 dynamo, 250 light, 16-c. p. belted. (Edison).	1887
<i>Philadelphia</i> —U. S. Cruiser	3 Hor Generating Sets	1890
<i>Caracas</i> —Steamer	1 Generating Set, belted.	1890
<i>Venezuela</i> — “	1 “ “ “	1889
<i>H. M. Whitney</i> “	1 “ “ “	1889
<i>Algonquin</i> — “	1 “ “ “	1889
<i>U. S. Cruiser New York</i>	1—200 ampere	} Direct Connected 1890
“ <i>Columbia</i>	2—400 ampere	
<i>U. S. S. Indiana</i>	2—400 “	1893
<i>U. S. S. Massachusetts</i>	3—24 Kw.	1893
<i>U. S. S. Massachusetts</i>	3—24 “	1893
<i>U. S. Cruiser Minneapolis</i>	3—24 “ Generating Sets	1894
<i>Columbia</i> —Yacht	1—Generating Set, Direct-connected.	1893
<i>U. S. S. Brooklyn</i> (Cruiser)	1—Double	1896
	3—Single	
<i>U. S. S. Iowa</i>	4—24-kw. generating sets	1896
<i>St. Louis</i> —Steamer	5—sets	1895
<i>St. Paul</i>	5—sets	1895

INTERIOR COMMUNICATION

While the first naval vessel in the U. S. Navy to be equipped with interior communication systems was the *U. S. S. Trenton*, in 1883, there is every reason to believe that electric bells were installed in naval vessels at least ten years prior to this time. Most of the appliances used were furnished by the Western Electric Company and Chas. Cory & Sons of New York City, who were pioneers in the development of marine electrical interior communication systems.

The first systems of interior communication devices to be installed in marine service were undoubtedly voice tubes and mouthpieces followed by mechanical telegraphs, gongs, gong-pulls and bells. The firm of Chas. Cory & Sons began the manufacture of voice tubes in 1845 and in about 1860 the manufacture of mechanical interior signaling devices mentioned above were undertaken.

The first telegraph to be patented in this country was that patented by Gisborne in 1862.

We are advised by Chas. Cory & Sons that in 1882 the manufacture of electrical devices such as watertight bells and buzzers, annunciators, fire alarm thermostats, etc., was undertaken by them and the first completed electrical installation to be made on a merchant ship was made by this firm on the *Santa Rosa* about this time, followed by the installation of similar equipment on the *U. S. S. Trenton*, above described.

We are also informed that the Western Electric Company took an active part in the early development and installation of interior communication devices in the early 90's and particularly developed watertight vibrating bells, and watertight telephones for the U. S. Navy. This company also supplied loud speaking telephones and a fire control system extensively used by the U. S. Navy.

Engine Room Signals. One of the first systems of interior communication to receive the serious attention of marine engineers was the signaling system between the engine rooms and points above deck for signaling the desired operation of the propeling machinery. In the *Proceedings* of the American Society of Naval Engineers, Vol. 3, chapter II, page 197, is a very interesting discussion by H. P. Norton U. S. N. dealing with this system as follows:

“One of the first methods was the system of shaft and gears. There was a pedestal on deck or on the bridge, fitted with horizontal dials and a pointer moving in a horizontal plane. The signals stop, stand-by, and the several intervals of speed, ahead and astern were engraved on the horizontal dial. In the engine room there was a vertical dial fitted with a pointer and the same signals were engraved on its face as on the dials on deck. In moving the lever at the deck dials until the pointer indicates the desire order, the pointer of the engine room dial was moved by the shafting and bevel gears to the same order and at that same instant a gong is struck.”

To indicate the point of view of some of the operating personnel at this period, regarding the application of electricity for use for interior communication signaling systems, it is interesting to note the following comment by Assistant Engineer W. F. Worthington, U. S. N. regarding the above system:

"I should strongly object to the use of electricity for signaling to the engine room or for showing in the chart house the state of the engine. The electric light and bells on board frequently fail to operate without giving any previous warning of their defective condition. The electrical apparatus for showing when the double bottoms contain water has never worked, although many of the compartments had, at times, large quantities of water in them. The electrical apparatus for signaling when a coal bunker is on fire has never worked but once, and on that occasion there was neither fire nor even anything combustible in the bunker. The fundamental difficulty with all such electrical apparatus is that it is impossible to tell, by inspection, whether it is certain to work or not."

At about this time it appears there had been developed several forms of electrical engine telegraph and, under the discussion of the article presented by H. P. Norton, U. S. N., the following may be quoted:

"To obviate objection to lead of wires in mechanical forms of telegraph, several forms of electrical engine telegraphs have been developed, the most successful of which is the electrical reply telegraph invented by J. B. Willis and Elliott Bros., London, England. While the cost of fitting an electrical telegraph into a vessel would be less than for a mechanical one, the first cost is much greater. It is also more expensive to keep in order and requires much more attention, etc. In spite of complications of parts, the committee ordered by British Admiralty in 1887, to report on the various systems of signaling on board ship, reported very favorably on the Willis system and February 1889, the system had been found so successful on the *Imperieuse*, that it was installed on the *Camperdown*, *Rodney* and *Aurora* and was to be installed on the *Magnificent*, *Marathon*, *Galatea*, *Medusa* and probably on the yacht destroyer *Albert*."

Fire Alarms. Fire alarm systems used in naval vessels at first consisted of an annunciator actuated by thermostats located in coal bunkers, magazines, store rooms, etc. On some of the earliest vessels such as *U. S. S. Maine* (original) and *U. S. S. Terror*, a form of mercurial thermostat developed by The Electric Heat Alarm Company of Boston, Mass., was used. This form was superseded by helical coil type. The thermostat consisted essentially of a helix of metal ribbon, the metal having a large expansive coefficient and a terminal block with an adjusting screw. This form of fire alarm was installed on all vessels of the Navy up to the *U. S. S. South Carolina* class when the form of thermostat was changed from the helical type to mercurial type which is still in use. The

mercurial type consists essentially of a thermometer with contacts adjustable to the various temperatures at which it is desired to have the thermostat operate depending upon their location in the vessel.

Telephones. About the year 1890, the first marine telephones were installed on the U. S. Cruiser *New York*, (the first New York). They were single direct circuits; that is, two telephones used in place of voice tubes. The instruments were of the "Bell" type and installed by Chas. Cory & Sons of New York City. The first loud-speaking marine telephones were designed by this firm and installed on the *Korea* and *Siberia* and the *U. S. S. Charleston* about 1895.

The first complete central energy switchboard telephone systems were installed on the *S. S. La Grande Duchesse* built at Newport News Shipbuilding & Dry Dock Co., about 1897 or 1898.

We are indebted to the Holtzer Cabot Electric Co. of Boston, Mass., for the following description of telephones in the U. S. Navy as prepared by Mr. Vernon Durbin which deals largely with the development of fire control telephones.

"Telephones in the United States Navy have been developed along two distinct lines. One is for general intercommunication between the various offices, state-rooms and compartments of the ship, commonly called "Ship Service System." The other is to provide communication, under battle conditions, between various points such as central station and guns tops, torpedo rooms, etc., and is commonly called "Fire Control Telephone System." There have been some systems installed for other purposes, such as maneuvering when a ship is being docked, but the same apparatus and circuits have been used as for the other systems.

"The use of telephones for fire control systems dates back to 1905. The Navy Department at that time authorized each battleship of the Atlantic Fleet to expend a certain amount of money to secure and install telephones for fire control purposes. A number of the ships secured telephones of the type used by the Signal Corps for Coast Artillery fire control work, consisting of heavy metal construction, having a transmitter located on the side of the head over one ear and a receiver over the other ear. Others of the ships secured commercial head receivers and transmitters and mounted them on improvised breast plates and connected them up in groups as best served their purposes.

"As a result of these preliminary installations, it was decided by the Navy to make a permanent installation of fire control telephones on board the battleships of the fleet. This was in 1906 and just prior to the departure of the fleet on its memorable cruise around the world.

"One of the systems which had been installed the previous year by the ship's crew and which gave satisfactory results was that of the *U. S. S. Illinois*. It was the work of Elec. Gunner F. P. Adams and Arthur Cobb, of Boston, and consisted of a double-head receiver of commercial type such as used by operators of telephone

switchboards, and a breast transmitter made up of a heavy leather breast plate supported on the chest by a metal frame work and carrying a commercial transmitter on a short bracket which was riveted to the leather. A single wire was used for each circuit, the frame of the ship serving as a common return for all circuits.

"Each circuit was provided with a separate primary battery of about a half dozen cells. Each circuit terminated in a jack at a central point, and enabled an operator to plug in on any circuit and interconnect if necessary.

"When the Bureau of Steam Engineering, in 1906, decided to make a permanent installation of fire control telephones, certain modifications to the system of Adams and Cobb were decided upon. The circuits were made full metallic. A single storage battery for all circuits was provided with impedance coils for each circuit. The transmitters and receivers of the telephones were connected in series and as many as fifteen telephones were connected in multiple on each circuit. Provision was made to cut out the transmitter when not desired. Motor generators were provided for charging the storage batteries. The generators were of the "Noiseless" type and provided with load coils, choke coils and condensers so that the battery could be charged while being used on the telephone circuits without introducing noise into the telephones; or the battery could be dispensed with and the telephone operated direct from the motor generator.

"The material for the systems was furnished to the ships just prior to their departure and was installed by the ships crews while the fleet was making the voyage around South America to the West Coast. The wiring consisted of rubber insulated wire, laid up in cables. The conductors were not made up into twisted pairs, however, and some cross-talk was experienced from this source.

"The telephones furnished were of two types: One was provided with a heavy leather covering with cushions around the ears for use at guns and in exposed locations; the other was for use in the central station and other protected locations and consisted of commercial head bands and receivers. On both types of telephones the transmitter was supported by wire framework from the head set, the breast plate being dispensed with. This system was the first to be designed and installed by the Navy Department. It met with varying success, some ships getting good results and others poor.

"Various modifications were tried out in the following years. One of the systems installed was of the so-called "loud speaking type" consisting of a low-resistance sensitive transmitter and receiver in series for each circuit, that is, if it was desired to talk from the central station to a number of outlying stations there was a separate circuit to each of the outlying stations and a separate transmitter for each circuit, a multiple

mouthpiece being used so that all the transmitters could be talked into at one time. Receivers were large and were mounted on the chest with flexible metallic tubes and rubber ear cushions carrying the sound to the ears. This type of system was soon discarded and the original type adhered to, the modifications being in the nature of improvement to overcome weaknesses that developed in service.

"One of the first modifications consisted of making all parts of metal and all parts watertight with stuffing tubes for the wires and rubber ear cushions to make the sets more comfortable and exclude external noises. Each telephone that was equipped with a transmitter had it in circuit continuously, which reduced the efficiency of the circuit considerably and also introduced noise into the circuit. The transmitter efficiency was rather low on account of the watertight feature. Later modifications consisted of equipping the telephones with push-buttons so that only the telephone from which talking was taking place had its transmitter in circuit. A condenser was also provided to prevent direct current from flowing through the receivers, which reduced the voltage drop and prevented depolarizing the permanent magnets of the receivers.

"It was also found satisfactory to make sets of aluminum instead of brass, so as to reduce the weight. The first sets employed were designated as type *F* and *G*. There then followed types *R*, *C*, *C S*, and *C n*. The type of set which was developed just prior to the World War, known as the *Utah* type, consisted of two watertight receivers mounted on a head gear made of webbing and provided with a steel spring going around the back of the head and attached to the receivers by a ball and socket joint so arranged that the receivers were held against the ears with a certain amount of pressure. The transmitter was mounted on an aluminum breast plate by means of arms which permitted the transmitter to be swung upward towards the mount or down out of the way. The transmitter was of a commercial type except mounted in a heavy aluminum case and provided with a large flaring mouthpiece. The breast plate also carried a small cast box with a gasketed cover which contained terminals, condenser and a push-button for cutting the transmitter in and out of circuit.

"The telephones were connected to permanent wiring of the ship by means of a special jack and plug of extremely heavy construction. The opening into the jack was at the bottom and, under normal conditions, was covered by a cap with a gasket. When the plug was inserted into the jack, a clamping ring secured it in place. This type of set operated quite satisfactorily and there were many thousands of them used during the war. They were installed on transports and auxiliary craft of various kinds as well as on battleships.

"The wiring for all of these systems consisted of a pair of wires running from the central station to all of the telephones which were normally connected to a

given circuit. Various arrangements of switches were provided for grouping these circuits in various ways and for transferring telephones from one group connection to another.

"There was also developed and used a type of system wherein each individual telephone was provided with a pair of wires to the central station and a switchboard so arranged that any telephone could be connected to any one of a number of groups by means of keys and without the use of cords and plugs. Direct-current receivers were used:—that is, receivers without permanent magnets or transmitters, were developed which were less sensitive to extraneous noises. These gave better transmission than had previously been obtained.

Present Systems. Systems of interior communication in the U. S. Navy have made very material advances in design, efficiency, and operation. Today there are probably at least fifty different systems of interior communication and signaling.

To cover the scope of ship control by interior communication systems, on modern battleships is without the province of this review, but for those interested, reference can be made to a very complete article by Lieut.-Commander Alexander M. Charlton, U. S. N., entitled "Ship Control on Modern Battleships" appearing in March 1922 issue of *Marine Engineering and Shipping Age*."

ELECTRIC PROPULSION

The history of electricity as applied to the propulsion of ships may be divided into three distinct periods, each period differing with respect to the fundamental method and type of application.

The first period, consisting of the use of electromagnetic motors which received their current from primary batteries, dates back to 1838, when Emperor Nicholas of Russia contributed the necessary expenses towards the experiments of Prof. M. H. Jacobi, a distinguished electrician of that time.

Later experiments on the same principle were carried out by Robert Hunt of England in the early fifties, by G. E. Dering in 1856, and in France, by Count De Moulins in 1866.

The results of these early experiments demonstrated the possibility of driving boats electrically, but not its commercial feasibility by the methods used.

The second period closely follows the advent of dynamo electric machines and storage batteries. The first known marine application in which the propelling motor was operated from storage batteries was that in the launch named *Electricity* and built by the Electric Power Storage Company of London in the year 1882.

Between the years 1882 and 1896, the development of the electric launch had reached its peak. The number of installations of this type being so numerous it is needless to refer to all the applications, but in a broad way we may say that the system proved entirely

successful, when facilities for charging the storage batteries were readily available.

The application of electricity generated on board ship for propulsion purposes marks the third and present period.

The first application of electric drive considered in this new sense was a Diesel electric-driven boat built in 1904. How far we have advanced in the art of Diesel electric drive may be gleaned from the fact that this first boat had direct connected exciters, the Ward Leonard system of control, electric auxiliaries throughout, including the steering gear and deck auxiliaries and bridge control.

This boat was named the *Vandal* and was built in Nishni Novgorod for Nobel Bros. of St. Petersburg, Russia, for the transportation of oil between Rebinsk on the Volga and St. Petersburg, a distance of 700 miles.

This boat was 245 ft. long, 32 ft. beam and had a loaded displacement of 1100 tons. Her machinery consisted of three Diesel engines of the vertical, three cylinder, single acting, four cycle type of approximately 120 horse power each and were built by the Diesel Motor Company of Stockholm, Sweden.

The complete electrical equipment was furnished by the Allmanna Svenska Elektriska Aktiebolaget of Westeras, Sweden. (The General Electric Company of Sweden.)

A second vessel named the *Sarmat*, having a displacement of 1150 tons, was built for this same company in 1905 having two Diesel engines directly connected to generators and having an aggregate horse power output of 360. This vessel was fitted with a magnetic clutch between the motor and generator allowing the equipment to be operated on a direct connected basis for straight ahead running.

These two vessels and a small pleasure boat named the *Venoga*, which was put in service on Lake Geneva in 1905, mark the beginning of the development of "Electric Drive" as the term is now generally understood.

The first electric drive installation, using the turbine as a prime mover, was in the *S. S. Graeme Stewart*, a fire boat owned by the City of Chicago. This boat was followed in the same year by a sister ship the *Joseph Medill*.

These vessels were built by the Manitowac Dry Dock Company of Manitowac, Wisconsin, and entered service in 1908. The propulsion machinery of each boat consists of two two-stage, 660-horse power, 1500-rev. per min., Curtis turbines, each direct connected to a 250-volt d-c. generator, which supplies current to two 500-s. h. p., 200-rev. per min., twin-screw propulsion motors. The centrifugal pumps, which supply water to the nozzles, are mounted on extensions of the generator bases. Pilot house control is used.

The first application of alternating current for ship propulsion was made in a small way in a vessel named

the *Electric Arc*. The prime mover in this case being a four-cylinder Crossley gas engine of 45 b. h. p. This original and successful application, which was made by the late Mr. Henry A. Mavor, led him to experiment on a larger scale and the result was that, in 1912, the *Tynemount* was put on trial for service on the Great Lakes, due apparently to no fault of the electrical apparatus, direct drive was substituted before the vessel went into service.

The prime mover consisted of two six-cylinder, 250-b. h. p. Diesel oil engines, each coupled to a three-phase a-c. generator rated at 500 volts. Special features included in this installation consisted of the generators being wound for different frequencies and the induction motor having two independent stator windings, one of 30 poles and the other 40.

In this study of the progress of electric drive up to the year 1913, we have little more than a list of small, and more or less experimental, installations catalogued in chronological order.

It may, therefore, be well to pause at this point and retrospect the entire field and see if the historical background furnishes us with the necessary scientific facts established by experiment to form even the slightest foundation for that which is to follow.

Two experiments had been made with alternating current; one in which the prime mover was a gas engine, and the other, a Diesel engine.

Two successful installations had been made with turbines as the prime movers, using d-c. propelling machinery.

After these installations had been effected, the situation changes and turbines are used as the prime movers with alternating current and on a scale and in powers not indicated by the early state of the art.

In the year 1913, the turbine-electric-driven collier, the *U. S. S. Jupiter* was launched, a vessel of 20,000-ton displacement and 5400 s. h. p. The wonderful and pronounced success of this vessel was the real reason for the adoption of electric drive in the capital ships of the U. S. Navy.

The engineering field is a most suitable one for the application of a well founded and proved science in a new field. It seems most probable, therefore, that the real historical background of these later installations lies not in the direction of the former marine applications, but in the natural application of principles involved and proved in central station practice on land modified to suit shipboard conditions.

The father of this new application and the man who strongly advocated its adoption against all opponents was Mr. W. L. R. Emmet, of the General Electric Company, and particular credit should be given him for his pioneer work in this field.

The years following 1913 are rich in examples of new applications, and the field has broadened until it embraces practically all types of vessels.

The United States Navy ranks first in the sponsoring

of electric drive on a large scale, and has aided greatly in the pioneer work and development.

The first battleship installation was on the *U. S. S. New Mexico*, placed in service in 1920. The equipment on this vessel consists of two main turbine generating sets and four propelling motors. The *U. S. S. Tennessee* was placed in service in the same year and in 1921 the Battleships *California* and *Maryland*, in 1922 the *West Virginia* and in 1923 the *Colorado*. All of the above vessels are rated 28,000 s. h. p., and have propelling motors of the induction type.

Two airplane carriers rated at 180,000 s. h. p. each, are now in course of construction. The equipment for each of these vessels consists of four turbine generators and eight propelling motors, two motors being placed on each propeller shaft.

The propelling motors on the above vessels have the pole-changing feature and the battleships may be operated with one or two generators; the airplane carriers with from one to four, according to the speed and power required.

The Imperial Japanese Navy also made a start similar to the U. S. Navy by trying their first experiment on a fuel ship. *H. I. J. M. S. Kamoi*, a vessel of 20,000 tons loaded displacement, was placed in service in 1922. The equipment consists of one main turbine generating set and two propelling motors of the synchronous type; also an auxiliary turbine generating set capable of driving the ship at reduced speed. The power rating of this vessel is 8000 s. h. p.

The advancement of electric drive has been equally as rapid in the merchant marine although much more diversified in character.

For clarity, the types of vessels will be classified under two broad divisions, "Merchant Vessels" and "Special Types" and the specific type of installation under the two headings "Turbine Electric Drive" and "Diesel Electric Drive."

Merchant Vessels—Turbine Electric. Among the foremost of this type of vessel may be mentioned the *S. S. Eclipse*, placed in service in 1920,—a cargo vessel of 15,900 tons displacement,—and the sister ships, *Invincible*, *Archer*, *Independence* and *Victorious*. The propelling equipment of these vessels consists of one turbine generator and an induction-type propelling motor rated at 3000 s. h. p.

The *S. S. Cuba*, a combined passenger and cargo vessel, was placed in service in 1920 and the *S. S. San Benito* in 1921. These two vessels are equipped with propelling motors of the synchronous type, rated at 3000 s. h. p.

Merchant Vessels—Diesel Electric. The Diesel electric form of drive has been applied to two combined passenger and cargo vessels, the *M. S. La Playa* and *M. S. La Marea*. The equipment on each vessel consists of four Diesel-engine-driven generating sets which may be operated in series for the driving of the

propelling motor and in any number to suit the load conditions.

Special Types—Turbine Electric. Ferry Boats: During the years 1923 and 1924 the following boats were placed in service: *S. S. Hayward*, *S. S. San Leandro*, *S. S. W. R. Hearst*, *S. S. Rodman Wanamaker* and *S. S. Geo. W. Loft*.

Coast Guard Cutters: The *U. S. S. Tampa*, *U. S. S. Haida*, *U. S. S. Mojave* and *U. S. S. Modoc*, placed in service in 1921, are equipped with turbine electric drive and synchronous type of propelling motors.

Great Lakes Ore Carrier, self unloading type: Machinery is now under construction for the above type of vessel and will be placed in service this year. The propelling equipment is turbine electric drive with induction type of propelling motor.

Special Types—Diesel Electric. Tankers: During

the year 1923 the *M. S. Standard Service* and *M. S. Alaska Standard* went into service and in 1924 the *M. S. Anahanc* and *J. H. Senior*, all Diesel electric drive.

Ferry Boats: During the year 1922 the ferry boats *M. S. Golden West* and *Poughkeepsie* and in 1923 the *M. S. Golden Gate* were placed in service.

Tow Boats: Diesel electric drive has also been applied to tow boats and during 1924 four vessels of this type were placed in service the *P. R. R.* No. 16 and the *Van Dyke* No. 1, 2 and 3.

Other types: Diesel electric drive has also found ready application in other types of which may be mentioned the Army dredges, *A. Mackenzie*, *W. L. Marshall*, *Dan C. Klingman* and *Wm. T. Russel*, the canal boats, *Twin Cities* and *Twin Ports*, the fishing trawler *Mariner*, the stern wheel tow boat *J. B. Battle* and also numerous yachts of from 90-to 550-h.p. rating.

Discussion at Annual Convention

PAPERS ON AUTOMATIC STATIONS

(BANY¹, WALLAU², BUTCHER³, WYATT⁴, WENSLEY⁵, PLACE⁶)
CHICAGO, ILL., JUNE 25, 1924

R. H. Earle: In the development of the hydraulic division of automatic control systems for hydro electric units, it has been the experience of the writer that the major problem is to obtain the desired action of the turbine gates during the periods of starting and stopping the machine. In response to electrical signals the turbine gates must be opened or closed and the gate opening must be controlled in such a manner as to prevent violent speed changes and to prevent unnecessary shocks to the machine itself, the water conduits, and the power system. As stated by Mr. Wensley this action is secured by modifying the usual governor system, by using motor-operated gates, or by using a special electrically controlled service motor to move the gates.

The operations of starting and stopping may be accomplished with varying degrees of refinement depending upon how much disturbance is allowable in the particular installation. In general the limiting feature is the amount of disturbance which the electrical power system or the penstocks can withstand, as the machine is sufficiently rugged to withstand any shocks which are likely to occur. It follows therefore, that when a small low-head machine is connected into a large power system, a comparatively crude type of control may be used satisfactorily, and as the machine becomes larger in comparison with the remainder of the power system, or where long penstocks are encountered, more precise methods of starting and stopping must be used.

Besides the main problem of starting and stopping, there is the question of holding the turbine gates closed when the machine is shut down and a number of protective features which fall in the hydraulic section of the control system.

If a governor is used means should be provided to close the gates in case of breakage of the governor belt or failure of power for the flyball motor.

In the governor oil-pressure system a pressure-operated switch is arranged to stop the turbine in case the pressure falls below a certain value. In some of the more elaborate systems

the oil level is automatically maintained at the correct height in the pressure tank. Oil pressure is conserved in the pressure tank when the machine is shut down by an automatic valve in the pipe line between the pressure tank and governor. This valve closes automatically when the machine is stopped and thus prevents oil leakage. In addition it is desirable that the oil pump be motor driven, the motor being controlled by a pressure regulator in such a manner as to maintain normal oil pressure in the pressure tank.

Except for bearing protection, explained by Mr. Wensley, the protective features just mentioned include all which are usually necessary.

It is interesting to observe the growing tendency to apply remote and automatic methods to large turbines in stations where there are operators in order to centralize the control at the switchboard and to obtain increased safety of the machinery.

One of the most common examples is an automatic stopping system which is being included as a safety feature on nearly all the large installations. By the opening of a single switch the switchboard operator is enabled to close the turbine gates quickly, disconnect the generator from the line and apply the brakes, all without the assistance of the second or third operator. Any number of such switches may be used, located as desired throughout the station.

These features will be recognized as the emergency stopping means found in the automatic station, in which case the opening of the control circuit is accomplished by the bearing-temperature relays or other protective devices.

This system is being adopted rapidly on the largest machines not only because it affords means for stopping the unit in the minimum possible time, but because in case the operator becomes confused, he has to do but one thing to stop the machine. This system has prevented at least one disastrous accident to a large unit in the knowledge of the writer.

The most common remote-control features used in manually controlled stations are the switchboard control of the speed-setting and load-setting adjustments of the governor, together with an indication at the switchboard of the gate opening at which the machine is running. This equipment is designed to be used with large units where it is especially desirable to have the machine under the direct control of the switchboard operator. With this equipment the switchboard operator can start and stop the machine with no assistance from the second operator instead

1. A. I. E. E. JOURNAL, Vol. XLIII, December, p. 1145.

2. A. I. E. E. JOURNAL, Vol. XLIII, June, p. 555.

3. A. I. E. E. JOURNAL, Vol. XLIII, July, p. 622.

4. A. I. E. E. JOURNAL, Vol. XLIII, December, p. 1148.

5. A. I. E. E. JOURNAL, Vol. XLIII, June, p. 508.

6. A. I. E. E. JOURNAL, Vol. XLIII, July, p. 634.

of the usual custom of having the second operator start the machine and bring it up to speed by hand.

We have explained these applications to manually controlled stations to show how the developments in automatic control are not only influencing the smallest water power developments but are being adopted on the largest units just as fast as they prove to be as dependable as the human operator.

We would like to bring out the relation between the Types C and D control mentioned in Mr. Wensley's paper, Type C being the remote control of the distant station by pilot wire and Type D being supervisory control over the telephone circuit. The latter is, of course, only a special case of the Type C and is the method used by one manufacturer. The general form of the pilot wire control includes a few wires between the master and automatic stations together with suitable selectors by which these wires may be connected into various local circuits at the two stations. In this way various functions can be accomplished without having separate pilot wires for each. Different manufacturers accomplish these results by various forms of selectors.

As to general hydraulic practise, we received the impression from Mr. Wensley's statements regarding Francis and Nagler type runners that the efficiency of the runner alone should govern the choice between the two and that the Nagler type should be adopted with some caution.

We wish to point out that it is not the runner efficiency but the over-all plant efficiency which determines the choice between the two types of runners. At the very lowest heads especially for very large units, the Francis wheel will not allow commercial speeds so that the Nagler type is practically the only solution. At a considerably higher range of heads and for smaller capacities the Nagler wheel is less suited because the gain from speed is insufficient to neutralize the lesser part gate efficiency and the Francis type should be used down to the limit of prohibitive clogging. Between these extremes is a region in which either type is practical. In making the choice here the following points should be considered in addition to the first cost.

The efficiencies of the Nagler and Francis runners will usually be about the same at the normal load, but the Francis type may be better at fractional loads.

The speed of the Nagler wheel will be higher allowing a more efficient generator.

The Nagler runner will maintain its original efficiency and power whereas the passage of trash may clog the smaller passages of the Francis runner, reducing the efficiency and power if not necessitating a complete shut-down of the machine for cleaning.

The ability of the Nagler runner to pass large objects without clogging allows a wide spacing of the trash racks with a consequent smaller loss of head through the racks.

The resultant of all these conditions favors the Nagler type of wheel more and more as the head becomes less, particularly if the generator is connected into a large power system or in case there are several units in the station so that the turbine can run continuously at the most efficient load.

Considering motor-driven flyballs, we believe that this type is not superseding the older type to the extent that Mr. Wensley states: Belt-driven or direct-connected flyballs have certain inherent advantages over the motor-driven types as built at present in that they register the speed of the machine at all times independently of the electrical conditions of the generator. The older types are often preferred for this reason.

The advantage of the motor drive is, of course, that it is very flexible in its location, is neat and simple in appearance, and may be somewhat cheaper than the belt drive.

Mr. Wensley suggests a reduction in the WR^2 required in a hydroelectric unit, and states that the purpose of the flywheel effect is to stabilize the generator during changes of load while the governor is moving the gates. We wish to add that the

purpose of the WR^2 is not only to smooth out load changes, but even more important to absorb changes in torque. Contrary to popular understanding a hydraulic turbine is not a constant-torque machine particularly under low heads which includes most of the automatic stations. In low-head machines the water velocities are high compared with the head and a large part of the total head is draft head. As a result the water flows at high velocities and low pressure and flow conditions are disturbed. The resulting torque on the wheel is not only variable but is likely to have sudden pulsations which must be ironed out by the flywheel.

A unit having too small a WR^2 is not only difficult to govern during synchronizing but does not deliver a constant amount of power. Even though the latter is not objectionable in itself, the varying output causes a continuous re-adjusting of the gates by the governor with consequent wear on the regulating machinery. Although machines having too small a WR^2 are rare they occur often enough to establish quite definitely what is the minimum flywheel effect required.

As for the necessity of brakes, the writer knows of some machines which have been in operation for a period of years which do not come to a dead stop but drift very slowly without damage to the thrust bearing. The real advantage of brakes appears when it is desired to stop quickly in emergency and we favor their use in automatic stations when the cost is not prohibitive.

H. A. S. Howarth (by letter): Abundant operating and test data show that Kingsbury thrust bearings do not require brakes for their protection. Enforced running at very low speed actually improves the bearing surfaces. (See *Transactions A. S. M. E.* 1919, Slow-Speed and Other Tests of Kingsbury Thrust Gearings). As a hydroelectric unit slows down complete separation of the bearing surfaces is maintained almost to the point of stopping. The better the fit of the surfaces the slower the bearing will rub before metallic contact is noticeable. From about one rev. per min. to rest the friction coefficient rises markedly and assists in bringing the unit to rest. When the unit is kept turning slowly by water leakage, no harm will result to the thrust bearings, but a brake will be required for stopping the wheel.

W. H. Millan: In connection with Mr. Bany's paper, it appears that the synchronous motor field is excited from the terminals of the generator. This is wrong because we would expect the set to stay on the line irrespective of the generator voltage. A situation may arise where it is necessary for this machine to operate possibly an hour at a voltage in the neighborhood of twenty-five or fifty and I do not believe that the motor would stay on the line as an induction motor (with the field open) without locking out on temperature. Also I do not quite understand how the set is held on the d-c. bus as a d-c. motor when a-c. power has disappeared (waiting for power return) when the d-c. reverse-power relay is set to take the machine off at a reverse value less than the running-light current of the set.

In connection with storage-battery trickle charge, we had quite a discussion in our sub-committee which brought out the fact installing a storage battery in an automatic station and charging it continuously at 0.2 or 0.3 ampere did not satisfy conditions. Some of us have had experiences with pasted-plate batteries where 0.3 ampere applied continuously disintegrated the grids and at the end of a year and a half we suddenly found ourselves without a battery in an important automatic station.

Referring to the emergency lockout relay which Mr. Wallau mentions in connection with his a-c. reclosing feeder equipment which prevents a feeder reclosing if the short circuit has been in excess of 900 amperes, I believe this an excellent idea but feel that on heavy or important circuits this limit should be increased. I have seen circuits burned clear only after three reclosures when the behavior of the switch gear indicated a short-circuit current many times this limit.

J. L. Woodbridge: I think the statement in this paper that "the 6-minute rating is the maximum current that can safely be taken from the batteries without serious injury to the plates" may be misleading. A battery may discharge at any rate that the cells can give for the length of time they can give that discharge, without injury to the battery. I call this point to attention because the paper as it now stands might be construed to mean that there is some high rate of discharge that is injurious to battery plates and this is not true.

There is, of course, a practical limit to the useful output of the battery both from the standpoint of voltage drop and from the standpoint of duration and the 6-minute rate of the battery is approaching this practical limit. In other words, at higher rates than the 6-minute rate, the voltage drop becomes excessive and the output of the battery is less useful on that account. Furthermore, the time limit is so short at higher rates that in many cases it would not cover the duration of the interruption. The 6-minute rate is, therefore, usually considered the practical limit in determining the size of the battery for a given service, although in special cases higher rates have been provided for. It should be carefully noted, however, that any limit thus fixed has nothing to do with any possible injury to the plates.

V. E. Thelin: We have developed a simplified type of substation in Chicago which is fully automatic, being operated in response to time. This station, which has been in operation for approximately five years, is just completing three years of operation without any maintenance or inspection being given and in

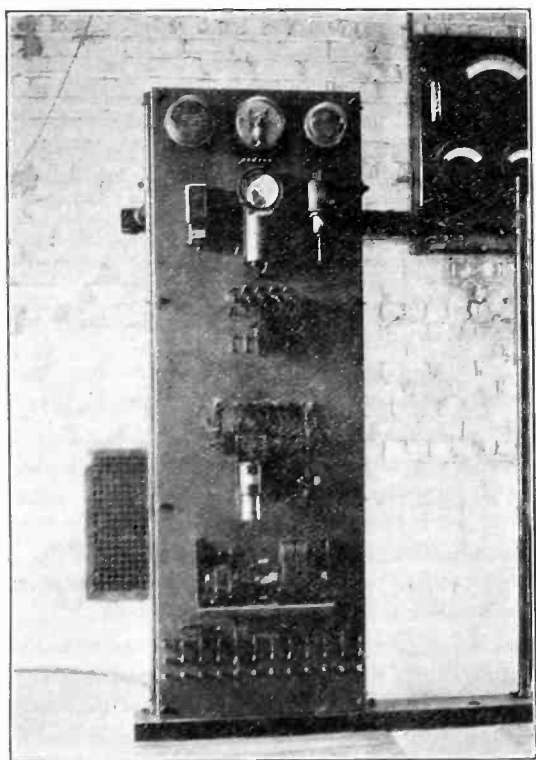

FIG. 1—AUTOMATIC FEEDER OR RAILWAY SWITCHBOARD

that time we have had two interruptions. One was due to a finger on a relay being bent out of shape and the other due to the clock stopping on account of dirt which was cleaned out with gasoline and is running satisfactorily to date.

We are using Bullock compound-wound rotaries, which have the series field short-circuited and are, therefore, operating as shunt-wound rotaries. We have great confidence in the shunt-wound rotary due to the fact that on extreme overloads the voltage drops, thus transferring the load to surrounding substations.

We are using automatic reclosing circuit breakers on the feeders, without any resistance whatsoever in series with them,

and if a feeder becomes short-circuited, it is cut off and the breaker closes again automatically when trouble is cleared.

The perfect operation of this equipment is due to its simplicity, the entire control panel being approximately 20 in. wide and 70 in. high. A brief description of the operation of this equipment is as follows:

Time clock No. 1 in the upper portion of the slide closes the master relay No. 2 which in turn closes the half-tap contactor No. 3 which connects the rotary to the half-voltage taps on the transformer. The converter then starts up to synchronous speed with the field excited from the substation bus and the rotary, therefore, comes up with correct polarity. In case it should come up incorrect, the polarized relay will shut the station down, and after a definite time, it will start again, slip a pole and thus correct the polarity. Assuming that it comes

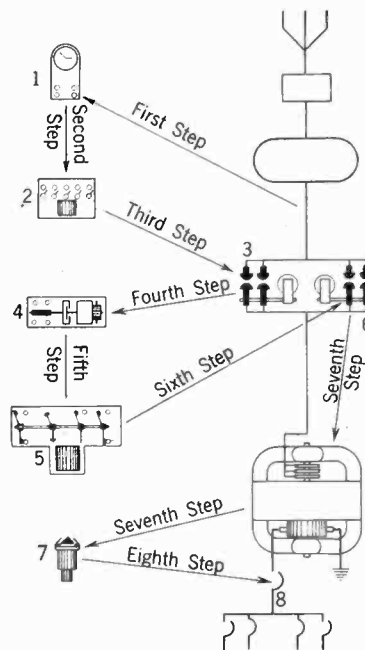

FIG. 2—DIAGRAM SHOWING SEQUENCE OF STARTING OPERATIONS

up correctly, the polarized relay No. 4 then operates and closes the combination changeover switch No. 5 which opens the half-tap contactor No. 3, closes the full-tap contactor No. 6, changes the connection to the shunt-field windings from the bus to its own self excitation, after which relay No. 7 operates, closing the automatic reclosing circuit breaker No. 8 which picks up the station load.

Further details of the operation of this station can be found in the A. I. E. E. PROCEEDINGS for December 1922.

David K. Blake: The practise of applying small automatic substations to d-c. networks approaches a-c. distribution. As I see it, there are three factors which have hindered the use of alternating current in this territory. The first has been the battery, the second the elevator and the third the customer's equipment. The improved reliability of supply to substations has eliminated the necessity of the battery, at least it has for most companies. A-c. elevator equipment is now available to meet most requirements. The remaining factor is the customer's equipment which is by no means a small factor.

The practise of supplying small automatic a-c. substations in the surrounding territory approaches the higher voltage distribution with a consequent increase in distribution economy and improvement in voltage regulation. Other advantages of this practise are that "all of the eggs are not in one basket" and the short-circuit currents on the distribution circuits are considerably reduced. This reduction in short-circuit currents has numerous advantages, such as the reduction in duty on oil circuit breakers and other substation equipment as well as the duty of the primary cutouts located on the distribution feeders.

G. I. Wright: While there has been a very rapid development in the automatic substation field, the methods of overload and short-circuit protection and arrangement of switching apparatus are far from standardized and substations made up of two 2000-kw. 1500-volt conversion sets, as described by Mr. Butcher, are about the largest so far and these are still under construction. When it is realized that a large suburban 1500-volt electrification will necessitate substations of 10,000 or 12,000 kw., which means either four, five, or six units, depending upon the size used, it is doubtful if full automatic operation is advisable. Partial automatic operation for such stations, such as the use of automatic feeder reclosing equipments, and push button control of starting the machines, is thought to be very advantageous.

The systems of supervisory control which have recently been developed, give an excellent means of controlling circuit breakers at switching and tie stations from a remote point and thus isolating the affected portions of the distribution system in case of trouble.

The author, in general, states that with 60-cycle supply for 1500-volt service, the motor-generator is superior to the converter in reliability, maintenance cost, and the amount of installed capacity necessary to carry short time overloads. Where the machines are protected against injurious flashovers by modern high-speed circuit breaker, it is not thought that the maintenance of a two-unit synchronous converter should be any greater than that of a three-unit motor-generator set. There is considerable difference in opinion as to the amount of installed capacity necessary for a given load in this class of service. The author states that where the capacity of the substation is determined by the short-time or commutating capacity of the machines, it is necessary to install 50 per cent more converter capacity than if motor generators were used. The substations which fall in this classification are those in the outlying sections of a suburban system where the maximum loads are those caused by simultaneously starting of long trains during the rush-hour periods, and which do not occur more than a very few times each day. Due to the infrequency of these loads, the ability of the stations to shift overloads to adjoining stations and the fact that it is considered desirable to install a complete spare unit in each station, which could be operated for these short periods if necessary, it is not thought that it is necessary to install appreciably more capacity if converters rather than motor-generators are used.

Even if the maintenance of the converters is decreased by not loading them up to their rated capacity, the investments in extra capacity to reduce this maintenance would be out of all proportion to the savings which could be expected. This can be appreciated when it is realized that one 2000-kw. unit installed complete represents an investment of possibly \$80,000.

In regard to the relative efficiency of conversion of the two types of apparatus, all-day efficiencies were carefully calculated for a large suburban steam-railroad electrification, using 2000-kw. 1500-volt conversion sets, and a difference of $3\frac{3}{4}$ per cent in efficiency was found in favor of the synchronous converter.

A. M. Garrett: Mr. Butcher's paper deals principally with future installations, because the first installation of such capacity in this country is yet on paper. In comparing the efficiencies of the converter and the motor generator, I agree with Mr. Wright in his deductions that there is a pronounced difference in the amount of efficiency when the study is made in economies in regard to 24-hour load. It is gratifying to the operating companies whenever a railway company decides to make its traction system 1500 volts direct-current as this is in line with the operating company's policy of one frequency in generation. It will give greater flexibility to the operating company and therefore better service to the customer.

The paper shows the manufacturers are apparently alive to the design and the problems that will come up with the 1500-volt

direct-current service. They are designing machines of a size that will apply to steam-road electrification where the substations will have capacities of 8000, 12,000, possibly 16,000 kw. They are not only providing machines to take care of the higher current and voltage, but they are providing the necessary application for automatic operation.

In the case of automatic operation with either a converter or motor generator, the necessary protection should be taken to prevent certain lockout features from coming into action with every abnormal condition. A flashover on a commutator by no means indicates the unit is disabled or even requires inspection, and precautions should be taken to prevent under such circumstances the withdrawal of the machine from service until inspected.

A. C. Grayson: The Public Service Electric Company of New Jersey has recently placed in operation three noiseproof automatic substations, which are known as the Miller Street, Norfolk Street and Race Street Substations. The Miller and Norfolk Street Substations are located in Newark, N. J., within a mile radius of the center of the city, and the Race Street Substation is located in Bloomfield, N. J., about 4 miles from Newark.

The Miller Street Substation is probably one of the largest combined commercial and railway automatic substations in the country. The present capacity consists of two 13,200-volt supply feeders, one bank of three 1000-kv-a. one-phase transformers; one bank of three 2000 kv-a. one-phase transformers, two 1500-kw., 600-volt d-c. synchronous motor-generator sets, and three 4150-volt, three-phase feeders. The ultimate capacity will consist of five 13,200-volt feeders, two banks of transformers having a capacity of 10,000 kv-a. each, two 1500-kw motor-generator sets and twelve 4150-volt, three-phase feeders. The entire equipment is fully automatic with the exception of the 13200-volt supply feeders, which are manually controlled and equipped with reverse-power relay protection.

The transformer banks have automatic control so arranged that they are connected or disconnected from the bus depending upon the amount of load carried. In addition to this they are equipped with the usual protective features such as overload, differential and temperature relays.

The commercial 4150-volt, three-phase feeders are automatic d c. controlled, with three reclosures on overload before lock-out.

Either of the two motor-generator sets (depending upon which one is leading), starts up automatically on low voltage and the second machine cuts in when the load exceeds the capacity of the first. Shutdown is of course accomplished in the inverse order. Starting voltage is supplied from 30 per cent starting taps on the power transformers, thus eliminating the use of starting compensators.

A double railway bus is provided, one operating at 550 and the other at 600 volts, direct-current. By means of double-throw switches the railway feeders may be connected to either of the two buses. Usually the local heavy feeders operate at 550 volts and the long feeders at 600 volts. The two buses are connected by a bus tie breaker which is closed when only one machine is in operation, the bus voltage being 550 volts. When the first machine is overloaded the second machine cuts in at 550 volts; the bus tie breaker then opens and the second machine builds up its voltage to 600. Each railway feeder is protected by a high-speed circuit breaker which cuts in a load indicating resistance when the breaker opens on short circuit. There is a spare equipment connected to a transfer bus so that it can replace any equipment taken out of service for inspection or repairs.

The substation building is 60 ft. x 100 ft. x 30 ft. high of two story construction. It is divided into four separate rooms for the high-tension equipment, transformers, commercial equipment and motor generators.

On account of the location and the noisy operation of motor-

generator sets, soundproof construction was used throughout with special soundproofing in the motor-generator room.

Forced ventilation is supplied to the motor generator by means of two 20,000 cu. ft. per min. blowers, one for each unit. Air is taken at the top of the rear of the building, and is drawn through a series of baffles to the blowers in the basement which discharge the air to the pits under each machine. Each blower is started and stopped automatically with its machine. After the air leaves the machines it escapes through another series of baffles to the outside. The baffles are so arranged as to give alternate contraction and expansion of the air without causing an appreciable drop in static pressure.

The walls and ceiling of the motor-generator room are covered with a one-half inch thickness of flaxilinum with a one inch air space between the flaxilinum and the brick wall. The flaxilinum is then covered with plaster to give a finished appearance. As a precaution against transmission of vibrations, the motor-generator foundations are completely isolated from the building. The foundation block is cast separately and rests on what is known as "anti-vibro" block. The vertical spaces between the foundation and the floor are filled with a plastic compound. There is only one door leading from the motor-generator room to the outside and this is a double refrigerator type.

With both machines running the noise cannot be detected when standing on the outside of the building, and for all practicable purposes it is a 100 per cent noise-proof installation.

No soundproofing is used in the other rooms of the substation except that which is afforded by the solid brick walls.

The substation has been operating automatic about four months and has proved very satisfactory.

The Norfolk St. substation is of the same design as Miller St. except that the present installed capacity consists of two 13200-volt feeder equipments, three 2000-kv-a. transformers, two 4150-volt three-phase feeders and one 1500-kw. synchronous motor-generator set. On account of its location, the architecture is not quite as elaborate as Miller Street but the same methods of soundproofing were used. This substation has been operating satisfactorily for about three months.

The Race Street Substation is a single unit, automatic railway substation with one 100-kw. rotary converter. The building is of soundproof construction with solid brick walls, but no soundproofing is used on the inside of the walls. This precaution was not thought necessary because of its location, and the fact that the converter is less noisy than a motor generator.

No forced ventilation is used, the converter drawing the air from the outside of the building and discharging it through the roof.

This substation has also been in satisfactory operation for about three months.

The Public Service Electric Company have now in the process of design or construction, fourteen new automatic substations. These are divided into three classes: (1) Commercial (4150 Volt, a-c.); (2) Railway; (3) Combined commercial and railway.

In addition to these, a number of the older substations are being changed over from 2400 volts, two-phase, to 4150 volts, three-phase and the new three-phase feeders will be made automatic reclosing even though an operator is required for the remaining apparatus in the substation. It is thought that the satisfactory operation resulting from automatic reclosing feeders justifies the slight increase in expense as compared to the manually operated.

A study is now being made on the use of supervisory control and it is very probable that it will be adopted for these substations in the near future.

H. T. Porter: An important advantage of automatic operation of hydroelectric plants is the increased amount of kilowatt hours obtainable as compared with manually operated plants. The average operator knows little and cares less about efficient

utilization of water, and in the latter type of station he is to a large extent in control of the manner in which water is used. In the automatic type proper consideration by the engineers of the best way to operate the plant first determines the type of control to be adopted and secondly the method of operation. Many variable factors are eliminated from operation and the plant may be so designed as to shut down under unfavorable conditions and await more favorable conditions of load, or water, provided of course, that some storage, or pondage, is available and the station is tied into a fairly large system. This point is brought out because it has proved an important factor in several recent cases in the decision to install automatic equipment.

Mr. Wensley's paper clearly explains the methods of operation, but does not state how the turbine gates are held closed. In practically all types of automatic control the governor is provided with a solenoid-operated oil-cylinder brake which holds the turbine gates closed when the unit is not in operation. Further, along the line of governor, a good practise is to provide for starting the oil-pressure pump when oil pressure is admitted to governor. Coincident with these occurrences the brake on the turbine-gate shaft is released and the turbine swing gates partially open allowing the unit to come up to synchronizing speed and under governor control. Proper design of the turbine gates prevents their swinging fully open, except under governor control and upon a heavy demand for load, since they are generally designed to balance at from 1/4 to 3/4 of full open position. This prevents the unit from ever obtaining full runaway speed, and also precludes possibility of the gates slamming shut or opening violently. The gates can, of course, be designed to balance at any predetermined opening.

The motor-driven governor fly ball has thoroughly demonstrated its superiority over the mechanically belt-driven element. Its use eliminates belts, pulleys, belt tighteners and attendance, and replaces a heretofore source of weakness, especially in the automatic plant.

Where automatic stations are a part of, and subordinate to, a comparatively large system and main stations, their generator fly-wheel effect may be considerably reduced. In other words, if the system is previously provided with sufficient inertia to hold the system frequency to satisfactory limits the automatic plant need as a minimum require only enough inertia to allow of synchronizing and placing the unit on the line. As a rule, however, the generator fly-wheel effect should be such as to give

a constant of at least 2,500,000 in the formula $C \frac{W^2 \times R.P.M.^2 R.}{B H P}$

In instances where a plant is required to do considerable regulating, this value should be in the neighborhood of 5,000,000 and in the case of a plant designed to take care of regulation of the major part of a system this value may be as high as 10,000,000.

Engineers usually specify $W R^2$ as computed from the formula

$W R^2 = \frac{810,000 \times h. p. \times T}{(R P M)^2 \times d}$. Where h. p. is load applied, T is

time of governor action, and d is percentage of speed rise. As a matter of convenience full-load conditions are generally assumed. This application should always be made with a view towards what will occur when load changes smaller than 1/2 load occur, since full and very large load changes are infrequent and of little consequence. Under approximately open-water conditions the governor should ordinarily be set to operate the gates through their full stroke in not less than 1 1/2 seconds and through a stroke corresponding to about 1/10 load change in 3/4 to 1 second. Very large units require longer time of governor action to avoid racking the operating mechanism. For practical purposes proportional load changes may be assumed to require a directly proportional time of governor action. Further, a 1/10-load change should not cause a speed variation of more than 2 1/2 per cent from normal and a good value is 1 1/2 per cent.

This may be applied to the above formula to determine proper $W R^2$. This load change is commercial and the engineer must use his judgment and knowledge of the system to determine permissible speed or frequency variation. Also it should be kept in mind that the above formula is for a water-rhoostat load and does not take into account the effect of the rest of the electrical system in steadying the frequency. If closed conduits supply water to the unit the governor time element must be such as to limit pressure variations to safe values and the $W R^2$ must be increased. Pressure variations in themselves affect regulation approximately in direct proportion to the $3/2$ power of the momentary increase or decrease in effective head. Regulation is dependent to a large extent upon local conditions and it is almost impossible to set forth any definite methods for determination of $W R^2$ required which will be applicable to all cases.

Automatically oil-operated brakes in the speaker's opinion should not usually be required. They introduce an extra item of control with attendant complications and cost. Oil is usually taken from the governor system for their operation and the piping is liable to develop leaks. When the turbine gates are closed conditions can be made and should be such that the unit will stop. Hand-operated mechanical brakes should be provided to stop the wheel if the gates should get clogged and to hold the unit when under inspection, etc. When the turbine-gate mechanism becomes so worn that the wheel continues to rotate, adjustments or repairs as found necessary should be made.

The lubrication of turbine bearings is more or less difficult because water under pressure containing foreign matter is always introduced and it is a question of lubricating each bearing individually. The grease cup is practically a thing of the past, since it is hard to put grease under sufficient pressure, to lubricate properly some bearings without having grease squeeze out through the threads. Pressure fittings of various types such as the "alemite" have been used with good success. The grease compressor may be of the portable type for small plants or the stationary type for large plants with a flexible hose connection. This lubrication need only be periodic and can be taken care of by the visiting attendant. If the grease compressor is portable it should have sufficient capacity to grease all of the turbine bearings with one filling. The main turbine bearing is always of the water-lubricating lignum-vitae type, or oil-lubricated bab-bitted type. The latter is gaining some favor for large vertical units. Its principal disadvantages are inaccessibility on vertical units and possibility of mixture of water and oil. A motor-driven oil pump and auxiliary belt-driven oil pump should be supplied so that one pump will always be available. Thermostat protection is usually provided for this type. With the lignum-vitae type an electrical alarm attachment should be provided to indicate failure of lubricating water supply to bearing. Water-supply piping should be suitably lagged to prevent danger of water freezing in winter in an unheated automatic plant.

There are some plants being installed from which governor has been omitted and a mechanical hand and electrically operated control supplied. The only reason is to effect a saving in first cost, and this saving is small if properly designed equipment is supplied. Usually a governor is justified since it allows greater flexibility of operation and makes the unit more independent of the rest of the system in case of trouble.

F. R. George: Mr. Wensley issued somewhat of a challenge to the operating man. The operating man in California deals with the steam plant as a standby, and, therefore, his hydro becomes the base load of his system and requires more attention than the steam plants. However, the efficiencies in the steam plant, as Mr. Wensley stated, are more carefully looked after. The hydro plants are not looked after in the same manner, I think perhaps because of a lack of satisfactory unit of efficiency comparable to so many kilowatts per barrel of oil.

We have a great deal of difficulty in keeping ahead of the demand, and, therefore, when it comes to a question of going to our

boards of directors and asking them for appropriations to put in an automatic plant or to revamp an old plant to automatic operation, the first question asked us is: "About how many kilowatts shall we get out of the plant? Naturally the automatic plant lends itself only (I say so advisedly) to small capacities. When we have our plans all worked up and find that it is practical and perfectly possible to convert an old plant and we reach the point where we are asked the amount of kilowatt hours we are going to get from that plant, and it is a comparably insignificant amount, the Board of Directors say: "No, we must devote our time and money at present to the development of new power in order to keep abreast of the demand" and, therefore, the installation of the automatic control device is again delayed or postponed.

The California situation at the present time lends itself very well to the thought and to the entertainment of the application of automatic devices. We are now facing one of the driest seasons in our history, meaning that our operating costs are going to be quite excessive due to the necessity for reversing our operation and placing dependence upon our steam generating equipment to offset the shortage in the hydro-power plants due to the drought, and therefore any economies which we could effect in the operation of our hydro plants would help in a measure to offset the unusual high operating costs which will maintain due to the drought.

E. E. Woodward: There seems to be a great deal of misunderstanding in regard to the synchronous-motor governor drive. Our company was probably the pioneer in using it to any extent, and we have been using it for about three years, and we have no complaints so far.

While called a synchronous-motor drive, the motor is not synchronous at all but is squirrel-cage induction three-or two-phase motor. This motor will start at 25 per cent of full voltage, and while it is not synchronous at this voltage it is very nearly so at 50 per cent voltage, and at full voltage the lag is so small that it cannot easily be detected.

Mr. Porter brought out the matter of brakes being needed to hold the gates closed on an automatic plant. That was one of the first things we discovered, and we have a very simple brake on the governor which is operated by oil pressure. It is really operated by a spring. We have an automatic throttle valve which is closed so as to keep the pressure in the tank during the period of rest. By this means we are able to hold the pressure for two or three weeks, if necessary, and have enough to start with. When the oil pressure is shut off from the governor, the spring sets the brake and the gates are locked closed. As soon as the oil pressure is thrown into the governor, the brake is released.

In the matter of generator brakes, we don't undertake to say whether they should be used or not, but if they are and if they use oil from the governor, we want that oil pressure to be shut off after the wheel is stopped, otherwise we might lose much oil through the brake cylinders and leakage elsewhere. We are now developing a brake valve that will apply the brakes and release them after an interval of five, ten or fifteen minutes, as may be desired.

L. F. Harza: I am not fully in accord with Mr. Wensley's belief that automatic operation will result in dividing up an available head into several smaller heads for reduction in flowage damages and saving in the cost of dams. The saving in cost of dams is doubtful when we consider the resulting multiplication of cofferdams, control gates and machinery. The storage obtained usually justifies the higher dam. Likewise the higher dam is not crippled in time of flood while the several substitute low head projects might cease entirely to operate under flood conditions. However, this is a question which can be settled only for each individual river.

It is our belief that many of the features developed for the automatic plant can well be applied to a manual station of any

size, regardless of how well its size may justify the expense of operators. We are all familiar with mistakes made by operators in emergencies. Cool headed action by a human operator can be least expected when most needed. Protective relays may at times fail to function but should be more reliable under emergencies than human operators.

We are also of the opinion that self synchronizing either by damper windings or synchronous motors and mechanical differential will ultimately replace manual synchronizing even in manual stations. It would eliminate the human element in one more operation where a mistake might be disastrous. All the operator would then need to do would be to close a master switch which would start the cycle of operation necessary to put a unit into service.

We have developed several automatic stations, equipped with hand brakes only. I regret to advise that the units do not all stop rotating when tripped out of service, even though the heads are low, in two cases as low as 8.5 ft. No harm has resulted as yet from failure to stop but the slow speed of rotation suggests the danger of failure of the oil film and injury to the bearing. Moreover, if tripped out by the bearing thermostats failure to stop rotating would defeat the purpose of these thermostats. I shall be inclined for future installations to favor automatic brakes. Automatic brakes can be operated from the governor tank by air as well if not better than by oil as far as interfering with the normal functions of the governor is concerned. Connection to the governor tank should be closed automatically as soon as the unit stops, to prevent continued loss of air or oil. Most units when once stopped will not start again after releasing the brakes.

I am not convinced that engineers usually waste money on fly-wheel effect. Where an installation is a small part of the generating capacity of a system operating in parallel with a system of steam turbo-generators, a small fly-wheel effect can be used and the mistake of over-weight of rotor may at times be made. More often however, the case is that the manufacturer has a standard line of patterns which he tries to adapt to vertical or horizontal machines, water wheel or engine-driven by the least possible adjustments. The manufacturer should have a vertical line of machines developed for water-wheel service.

The writer is convinced by experience with the development of several automatic stations that they have a great future. Automatic means are now available for meeting almost any operating condition or emergency with a degree of success and reliability, dependent chiefly upon the relays. Different manufacturers, to avoid patent infringement, accomplish the same purpose with relays often operating upon widely different principles and sometimes with widely different degrees of success. It behooves the purchaser to examine carefully into the relays offered with any installation, as to the extent of their previous application and success.

F. C. Hanker: There are one or two points I would like to bring out in connection with the automatic generator station. Mr. Harza has mentioned the effect of the method of starting on the system operation. If you take the small, low-speed machines, the current they will draw when thrown on the line at full voltage will not exceed three times the rating of the unit. But when you consider the larger, high-speed machines, that current becomes more of a factor in the system operation and must be recognized in the method of operation or the method of control that is selected.

The experience in manual operation with the starting of large synchronous condensers shows conclusively that those machines can be started on a system of comparatively small size without disturbance by using proper precautions in the starting. But when you come to a high-speed large-capacity unit relative to the size of the system, then it is necessary to take the starting current into account. That is one place where the automatic synchronizer is quite important.

Another phase of the problem involves manually operated stations. In the Northwest, and I presume in other systems, there has been trouble experienced following an interruption to service in getting the stations back on the line and restoring service in a minimum of time. In some cases recent failures have shown that the time to restore units to service is about fifteen minutes. A good deal of that time is spent by the operators in getting the various water wheels and hydraulic elements stabilized, so that if they had automatic synchronizers, those automatic synchronizers could be applied to the main units and the operators could devote their entire time to the operation of the hydraulic parts, governors and water wheels, and get those stabilized.

The automatic control equipment of itself has been well developed in the synchronous-converter, motor-generator and the synchronous-generator application. No equipment is perfect, but the experience we have had makes us very hopeful that this equipment can be developed to a point where its efficiency and reliability will more than equal the hand-operated station.

S. E. Bettes (by letter): Where automatic substations are located in building basements a special ventilation system is required to insure an adequate supply of clean air to keep the

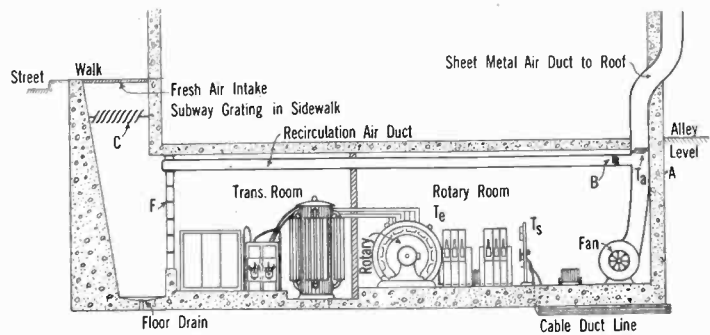

- T_a (Thermostat) Closes A and C } When Temperature falls below 85 deg. Fahr.
- T_e " Opens B } Prevents fan running when temperature is lower than 70 deg. Fahr.
- T_s " Turns steam into radiators when temperature is below 80 deg. Fahr.
- F Dry type filter

operating temperature below the danger point. This system must adopt itself to all the requirements of the automatic station operation and as in the case of the station itself change its own operation to suit the conditions existing.

The following outline of operation is used in our automatic rotary-converter substations and is proving very satisfactory. The accompanying sketch shows the ventilation schematically.

All air entering the station is drawn through the sidewalk grating and through the dampers C. After passing through the dry-type air filters which remove the dirt the clean air goes through the transformer and high-tension switch room into the rotary-converter room. Self-closing fire doors are provided in this wall to prevent fire from one room to the other.

The fans in the rear of the station draw the hot air out of the station and force it up the duct to the discharge which is above the roof of the building. There are two fans, each capable of supplying sufficient air to cool the station.

The automatic features provided are:

The fans are automatically started when the rotary is put on the line unless the temperature is lower than 70 deg. Fahr. When the air coming from the rotary is warmer than 70 deg. the thermostat T_e closes the automatic starter and the fan starts. If the air passing the thermostat T_a is above 85 deg. Fahr. all the air goes up the duct to the exhaust. If the air is just less than 85 deg. Fahr. the dampers at A and C start to

close and the damper *B* starts to open. This allows part of the air to return to the intake end of the station and tempers the cold air coming in. A further reduction in temperature of the air passing thermostat *T* causes *A* and *C* to close entirely and all the air goes back through the station.

To provide a source of heat when no machines are operating, steam radiators are placed so as to warm parts likely to be damaged by cold. The thermostat *T* turns on the steam if the temperature goes below 60 deg. Fahr.

The failure of the damper control will cause the *A* and *C* damper to open and the *B* damper to close so that the machines will get the maximum amount of cooling air.

Any draft action caused by warm air up the exhaust duct after the machines are shut down will remove warm air from the station until the temperature reaches 85 deg. when the thermostats will close *C* and *A* and prevent further cooling. This is important during the winter months.

Rain coming through the sidewalk grating cannot enter the station and is disposed of through the drains.

H. Bany: In answer to Mr. Millan's question regarding whether the generator is disconnected from the d-c. bus upon reverse power, nothing further occurs than the three operations mentioned under operating features on the fifth page of the paper. The d-c. line breakers do not open and the set merely runs idle from the d-c. end. If any other operations do occur they must be caused by some other abnormal condition, such as, a-c. undervoltage or a-c. power failure.

It does not seem that there is any sacrifice being made by having the motor field excited directly from the generator as Mr. Millan questions, instead of from the exciter. Since normal excitation on the motor gives about 0.8 leading power factor at full load, if the load and excitation are both reduced proportionally, the motor will not pull out of step at the lower d-c. bus voltages. If the a-c. voltage should be low so that the motor does pull out of step, the time delay of 40 seconds mentioned in the first paragraph of the second column, sixth page, will shut down the set and a restart will not be allowed until the a-c. line voltage is again 80 per cent. of normal or above.

C. A. Butcher: With reference to remarks by Messrs. Wright and Garrett, concerning comparative efficiencies of converters and motor-generators, the difference in all-day efficiency is less in favor of converters, if it is established that smaller motor generators may be used to supply the peak loads incident to infrequently scheduled heavy trains, or in other words, if the substation capacity is based on commutating capacity, rather than the continuous rating of the machines. Mr. Wright states that this may apply to the outlying substations; however, it would seem that during periods of light traffic, such as is the case during the off-peak load, the same applies to all stations.

The largest 1500-volt automatic railway substation soon to be placed in operation has a total capacity of 8000 kw., made up of four 2000-kw. converter sets.

R. J. Wensley: It is my feeling that the purpose of this paper has been accomplished. It was intentionally written in such a manner as to bring out in discussion some of the disputed points in the operation of Automatic Hydro-Electric Generating Equipments. The discussions by Mr. R. H. Earle and Mr. H. T. Porter are both distinct contributions to the general subject. The discussion of the desirable amount of fly-wheel effect as given by Mr. Porter is of especial value.

C. W. Place: I wish to point out that the method of operation as outlined by the previous speaker, is not the one that will most nearly meet conditions in the middle western territory. The most economical operation will be that of using the steam plants as base-load plants and the hydroelectric stations for carrying peaks. The introduction of more and more interconnection of systems and the building of base-load steam plants, makes this use of hydroelectric stations particularly valuable.

PAPERS ON CURRENT-LIMITING REACTORS

(OSTERHEIMER¹, STEPHENS AND KIERSTEAD², DANN³, BOYAJIAN⁴, BLAKE⁵)

CHICAGO, ILL., JUNE 26, 1924

N. L. Pollard: There are only a few points which I wish to emphasize. One is the question of thermal capacity which has been causing the committee considerable worry during the last two years.

If reactors having two small thermal capacity are used, it is possible for them to fail thermally in case the relays on the circuit do not function properly. On the other hand, if reactors having a long-time thermal capacity are purchased, the cost is excessive. In order to get some idea of the increase in cost I secured a quotation from one manufacturer for a reactor having a thermal capacity of 13 seconds and an alternate price on another reactor of the same capacity having a thermal capacity of 22 seconds. The price of the 22-second thermal capacity reactor, if I recall correctly, was approximately 35 per cent greater. The price increases very rapidly as the thermal capacity goes up.

Some operating men are of the opinion that if a reactor has a thermal capacity slightly in excess of that of the cable, it will be sufficient.

Mr. Dann brought out in his paper this morning that there were two extreme points of view. One was that the reactor might act as a fuse and be the first to fail in the circuit, the other, that the reactor should have enough thermal capacity so that it will be the last thing in the circuit to fail. The reactor is supposed to be a protective device and cuts down the amount of the short circuit so that the oil circuit breaker can safely rupture it. If it should fail the oil circuit breaker might not be able to rupture the increased current and what was originally a feeder short circuit becomes a bus short circuit. This, as we all know, is a very serious matter in a large generating system.

From what information the committee has been able to obtain, the failures this last year have been fewer, although there have been several serious failures which only demonstrates the fact that the reactor is not yet a perfect piece of apparatus and that improvements can be made that will make it even better than it is at present. During the last few months several serious failures have been called to my attention.

R. S. Schurig (by letter): I wish to discuss the paper by Messrs. Kierstead and Stephens and wish particularly to refer to the mechanical stresses occurring in the insulators during short circuits. The test data submitted by the authors in Fig. 10 show clearly that the observed peak stress on the braces is slightly in excess of the peak electromagnetic force. The authors thus reach the important conclusion that the peak stress on the braces is likely to exceed not only the average electromagnetic force but also the peak electromagnetic force.

The peak stress will, of course, be a maximum in the immediate vicinity of resonance.⁶ Since the peak stress varies materially from a relatively low value in some cases to a relatively high value at resonance, it is desirable to know—

1. how to predict roughly whether a reactor is resonant or not and
2. how to estimate the peak stress at resonance.

These two items will be discussed in the following.

1. In order to predict whether a reactor is resonant, one must determine its natural frequency, which may roughly be calculated from the following approximate formula:

1. A. I. E. E. JOURNAL, Vol. XLIII, December, p. 1141.
2. A. I. E. E. JOURNAL, Vol. XLIII, December, p. 1142.
3. A. I. E. E. JOURNAL, Vol. XLIII, November, p. 1050.
4. A. I. E. E. JOURNAL, Vol. XLIII, October, p. 958.
5. A. I. E. E. JOURNAL, Vol. XLIII, July, p. 604.
6. Resonance occurs when an electromagnetic force having a frequency equal to the natural frequency of the reactor is applied, the natural frequency being the frequency of free vibrations, such as would occur, for instance, if a heavy direct-current were suddenly applied to a pair of adjacent reactors.

$$f = 3.13 \sqrt{\frac{S}{W + \frac{I_0}{r^2}}} \text{ cycles per sec.} \quad (1)$$

where

S is the stiffness of the reactor unit in pounds per inch, the stiffness being the force (applied at the center of gravity of the reactor and acting in the direction of the displacement) to give unit deflection. In the set-up of Fig. 8, for instance, the stiffness would be measured in a horizontal direction.

W is the weight of the reactor in pounds.

r is the distance from the base of the foot insulators to the center of gravity, assuming that the reactor when displaced rocks about an axis in the plane of the base of the foot insulators. The minimum value of r for a rigid reactor is the distance from the base to the center of gravity, not including the height of the base insulators.

I_0 is the moment of inertia of the reactor about an axis perpendicular to the vertical axis of the reactor and passing through the center of gravity. If the reactor is considered as a hollow cylinder having outer and inner radii R_1 and R_2 , and a height h , measured without insulators, all in inches, I_0 is

$$I_0 = \frac{W}{4} \left(R_1^2 + R_2^2 + \frac{h^2}{3} \right) \text{ lb. - in.}^2 \quad (2)$$

The above formula for natural frequency is based on the following assumptions:

(1) that the reactor displacement is one of translation and rotation combined. In the total absence of rotation the natural frequency becomes simply:

$$f = 3.13 \sqrt{\frac{S}{W}} \text{ cyc. per sec.} \quad (3)$$

(2) that the displacement is elastic. Insulators are, of course, not perfectly elastic, but tests of busbar insulators, for instance, have shown that their behavior, in vibration, may be closely approximated by assuming them elastic.

(3) that the damping is small.

(4) that, for the derivation of the moment of inertia I_0 as expressed in (2), the center of gravity of the reactor is at the geometrical center of the unit and that the mass is uniformly distributed within the volume of a hollow cylinder.

(5) that the reactor base insulators are bolted to a rigid, massive foundation.

Example 1. Reactor without Braces

Estimate the natural frequency, when the constants are:

- $W = 1550$ lb.
- $R_1 = 16$ in.
- $R_2 = 6$ in.
- $h = 30$ in.
- $r = 15$ in.

$S = \frac{1000}{32} = 32,000$ lb. per in. assuming that a horizontal steady force of 1000 lb. applied at the center of gravity of the reactor displaces the center 1/32 in. horizontally.

Solving first for I_0 :

$$I_0 = \frac{1550}{4} \left(256 + 36 + \frac{900}{3} \right) = 230,000 \text{ lb. in.}^2$$

Then

$$\frac{I_0}{r^2} = \frac{230,000}{225} = 1020 \text{ lb.}$$

It is seen that the effect of the rotation due to rocking is equivalent to adding more than 1000 lb. to the weight of the reactor. Hence the natural frequency is from (1)

$$f = 3.13 \sqrt{\frac{32,000}{1550 + 1020}}$$

or $f = 11$ cycles per sec. approximately.

If no rocking occurred, *i. e.* if the motion were pure translation, the frequency would approximately:

$$f = 3.13 \sqrt{\frac{32,000}{1550}}$$

or $f = 14$ cycles per sec.

Example 2.

Reactor similar to that of example 1, but *equipped with braces*, such that a steady horizontal compression force of 20,000 lb. applied to two adjacent reactors at the level of their centers of gravity shortens the distance between the centers by 0.01 inch. Hence

$$S = \frac{20,000}{0.005} = 4,000,000 \text{ lb. per in.}$$

If the other constants are as above, the natural frequency is roughly, from (1)

$$f = 3.13 \sqrt{\frac{4,000,000}{1550 + 1020}}$$

or $f = 123$ cycles per sec.

If total absence of rotation were assumed here, the natural frequency would be

$$f = 159 \text{ cycle per sec.}$$

It is seen then that, for a reactor of a given size, the stiffness of the base supports and braces is the chief factor determining whether or not mechanical resonance can occur. Thus a reactor which is not resonant when set up without braces, may become resonant or near resonant when braces are used.

(2) *The resonant peak stresses* may be calculated⁷ by assuming elastic supports and braces, if the following items are known:

- initial value of average electromagnetic force, (defined as the electromagnetic force due to the r. m. s. initial short-circuit current).
- natural frequency of reactor
- mechanical damping of reactor unit
- decrement of short-circuit current.

If the current decrements given by Hewlett, Mahoney and Burnham,⁸ for heavy short circuits (*i. e.*, system reactance up to 30 per cent) are used, and the free-vibration decrements due to the mechanical damping of the reactor insulators are assumed to be the same as those for busbar insulators,⁹ the calculated peak stresses, expressed in terms of the initial value of average electromagnetic force, are approximately as follows for 60-cycle short-circuits:

If the natural frequency is one tenth the current frequency or lower, the maximum stress is 1.0 times the initial average magnetic force.

If the natural frequency is half the current frequency, the maximum stress is 2.2 times the initial average magnetic force.

7. The theory of the calculations is that employed in the paper by Doherty and Kierstead "Short-Circuit Forces on Reactor Supports"; A. I. E. E. JOURNAL, August 1923.

8. "Rating and Selection of Oil Circuit Breakers," A. I. E. E. TRANS. 1918, p. 123.

9. The amplitude of free vibrations of bus insulators was found by tests to diminish as $e^{-0.5 \frac{q}{n} t}$ diminishes with time, where q is 2π times the natural frequency of the insulator and n , the sharpness of resonance, is a constant averaging about 5. for a variety of tests of porcelain bus supports. Thus for a 20-cycle support, the decay of the free vibrations is expressed by

$$\frac{e^{-0.5 \frac{q}{n} t}}{e^{-12.6 t}}$$

It is quite likely that the reactor insulators and busbar insulators have similar rates of decrement at corresponding natural frequencies, because in both cases the stress is absorbed by insulator units consisting of porcelain members held in metal supports.

If the natural frequency is equal to the current frequency, the maximum stress is 4.5 times the initial average magnetic force.

If the natural frequency is twice the current frequency, the maximum stress is 3.2 times the initial average magnetic force.

If the natural frequency is four times the current frequency, or larger, the maximum stress is 2.5 times the initial average magnetic force.

For 25-cycle short-circuits, the peak stresses are somewhat reduced being as much as 25 per cent lower.

The above data indicate that the highest stress is due to resonance at current frequency, while the stress due to resonance at twice the current frequency is less. The high resonant stress at current frequency is due to the d-c. component of short-circuit current.

It follows from the above figures, that a low natural frequency, well below half the current frequency, gives lower stresses than any high natural frequency whether resonant or not.

A further point to which attention is to be called is the occurrence of *tension stresses in the braces*. Although the reactors are connected so that the average stress on the braces is compression, resonance, or near-resonance, will bring about heavy tension stresses of the order of twice the initial average electromagnetic force.

R. A. Hentz: That a reactor is a protective device pure and simple has been pointed out and this fact should be kept prominently in mind. In large metropolitan systems the reactor is second only to the oil circuit breakers in protecting the system. Furthermore, it aids the circuit breakers in performing their duty by keeping the tremendous concentrations of energy occurring at times of short circuit within safe limits.

Unlike the oil-circuit breaker, some part of the cost of which may be charged to the normal operation of the system, the current-limiting reactor must function entirely as a protective device and the entire cost is chargeable as a premium on the insurance obtained from such protection. This premium is very high, consisting as it does not only of the operating losses in the reactors but also of very considerable capital charges. These capital charges include not only the reactors themselves but also, what is a very sizeable item, the extra cost of building and compartments to house them and the leads and insulators to reach them. Obviously with such a heavy charge for protection, operating engineers want to be sure that they are actually obtaining the insurance being paid for. With this before us, it hardly seems that the matter of reliability could be stressed too emphatically and by reliability is meant not only that of the reactors themselves for which the manufacturers are responsible, but also that of the design and installation made by the operating companies.

The thermal capacity of reactors has been touched upon and this is a most important consideration affecting their reliability. Certainly, any protective device, which due to insufficient capacity, would burn up just at the time it was to justify its installation should not be considered. The total cost including building, compartments, etc., is so large that the little extra investment for increased copper cross section to obtain a device adequate for all conditions to which it may be subjected, is well worth while. Indeed when considering the total investment the difference between reactors with scant copper and ones built upon safe design is a very small percentage, and this is partially returned through decreased operating losses. It would seem that a copper cross section with a thermal capacity above that of the underground cable it protects is advisable.

Reference was made in Messrs. Kierstead and Stephens' paper to shunting resistors. The effectiveness of these devices is something about which definite information is much to be desired. Some of the early troubles with the reactors, thought at first to be over-voltage but later determined to be insufficient mechanical strength, and referred to at the bottom of Page 3, second column, of this paper, occurred on The Philadelphia Electric system, and

a large number of resistors were added. Of a total of some 378 feeder coils supplying mainly underground cables, about one-third of these have shunting resistors. Uniformly good service has been obtained from coils with and without resistors.

A number of uses of reactors have been brought out in the several papers this morning, but one to which I personally am somewhat partial has not been touched upon, namely, their use for starting large 2300-volt motors driving generating-station auxiliaries. It is now generally considered that the best way of starting these motors is on full voltage, but in certain cases, particularly with some high-speed motors, this is not advisable, and in such cases reactor starting is a very satisfactory method. It possesses an additional advantage where differential relay protection is used, as the currents in the line and in the motor neutrals are always equal. We have several motors driving air and condensate pumps so equipped, and they start with entire satisfaction.

W. B. Kirke: In the paper by Messrs. Kierstead and Stephens on Current-Limiting Reactors, the authors make a general statement that in three-phase reactors the mechanical forces between coils will be repulsive if symmetrically connected, and attractive if the middle phase is reversed. This statement is true only if one is considering the average force throughout a cycle after the transients of the short-circuit currents have died out. If one is considering peak forces during the transient periods there are times when repulsive forces of very great magnitude can be built up between an outside coil and the other two of a three-phase reactor, even with the middle phase reversed. This condition is shown in the accompanying diagram where the instantaneous value of the current is near the maximum in an outside coil and returns in the other two.

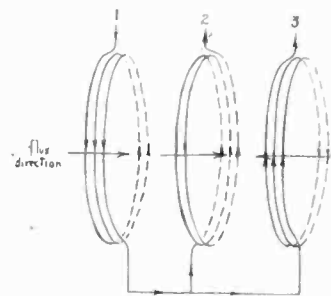
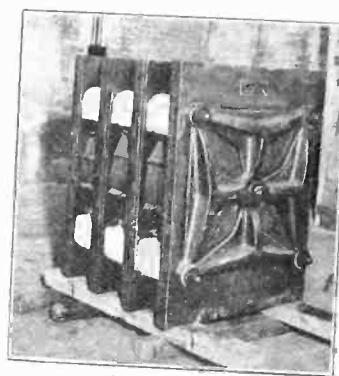

THREE-PHASE CURRENT-LIMITING REACTOR

Due to the very great space limitations in the galleries of the two Waterside stations of The New York Edison Company, we were compelled to install reactors of minimum dimensions. Three-phase insulated-winding type of coils offered the only practical possibility. In these reactors there are developed under the worst possible conditions with a short circuit at the terminals of the reactors, with full 11,000-volt connected capacity and with the short circuit occurring at a certain point on the voltage wave, repulsive forces whose values are in the neighborhood of 100 times the weight of the reactors. To withstand such forces, the reactors are equipped with non-magnetic manganese-steel headers which are designed to withstand a breaking load of 400,000 lb. They are held together by four chrome-nickel steel bolts and one center bolt of Tobin bronze. The headers are designed to eliminate, as much as is consistent with mechanical strength, circulating currents induced in the headers. This is accomplished by placing the metal in four Y sections which gives the minimum volume of metal in the positions where the currents circulate.

Joseph Slepian: The matter of resistor-shunted reactors has received considerable discussion in the past, and Messrs. Kierstead and Stephens mention this briefly in their paper. It is not often that we get in such a brief account a clear statement as to two rather distinct actions that such a resistor may have. First

of all, it may convert energy into heat, and also being a conductive shunt, it may by-pass energy. Messrs. Kierstead and Stephens point out that there will be dissipation of energy in the case of surges from the outside of the system coming into a protected station. On the other hand, they point out that the resistors will permit energy to pass out from any disturbance that occurs within a station on the line. It is clear that these actions do take place, but the action of passing energy may take place equally well when the disturbance occurs outside on the system and the resistor will permit some of this energy to pass by the reactor and into the protected station.

It is on this ground, I believe, that a good deal of theoretical opposition to shunting resistors has been based. It is evidently a quantitative matter. It is the relation between the value of the resistor and the values of the circuit constants that is going to determine what effect is predominant, and a general qualitative statement cannot, I believe, be made. The question to be determined is whether the constants that arises in practise and the resistance values that may be used are of such values as to make one action or the other predominant.

Mr. Boyajian's paper has been of very great interest to me, and on one point I believe I differ a little. In the curve for the d-c. excited reactor under variable a-c. excitation, Mr. Boyajian, as I understand it, correlates or identifies the first bend with the small inflection that one gets in the magnetization curve on direct current. It seems to me that is not at all an essential element here and that one would get the same effects that Mr. Boyajian speaks of if this inflection were not there. One must consider a complete curve for positive and negative excitations (Fig. 1 herewith). The little inflection at the origin is then hardly apparent. With zero d-c. excitation, if one super-imposes an alternating magnetomotive force the ampere turns vary between two equally spaced limits on either side, and the flux variation are determined by the curve above and below the axis. If one gives, however, a d-c. excitation that brings one to a point as in Fig. 2, then superimposes alternating magnetomotive force, the extremes of magnetomotive force then occupy points in the curve that are not symmetrical with respect to the origin. One may get only a small change of flux with one direction of current and a large change of flux with the other direction of the alternating current. It is evident that we may interpret the application of direct current as a shifting of the origin on the excitation curve, so that with direct current imposed the curve may be shifted up as in Fig. 1A, or with large enough direct current it may be shifted so that the lower saturation is shifted through the origin and the curve becomes displaced as in Fig. 1B.

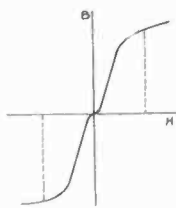

FIG. 1

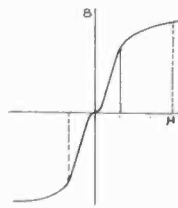

FIG. 2

When we have two cores, with opposite d-c. excitations, and add the two fluxes together the resultant curve will be as in Figs. 3 and 4. With the alternating current applied, for small alternating current, the extremes of current give only small changes of flux, but with large alternating currents the extremes of flux begin to be large. Thus I identify the lower bend in Mr. Boyajian's curves with the saturation and not with the inflection that one gets for small magnetizations, in the usual virgin magnetization curve.

Another point of considerable interest to me is the relation that Mr. Boyajian gives between the kv-a. of controlling frequency in such apparatus as Alexanderson's modulator, and the

controlled frequency. Sometime ago I carried on an analytical investigation as to what relations necessarily exist between powers, which may be exchanged between frequencies in an iron reactor, and for simplicity and shortness of time I will just state the nature of the results for a simple inductance. When an inductance has iron in it, instead of there being a straight-line relation between flux and ampere-turns, it is curved and we may express the inductance of a coil as a power series in terms of the current. That is $L = L_0 + L_1 i + L_2 i^2 + \dots$. The constant terms would correspond to ordinary inductance, and we

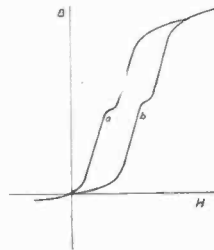

FIG. 3

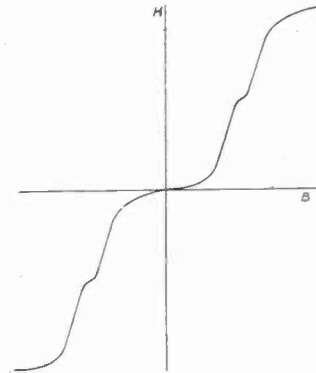

FIG. 4

are all familiar with its effects. It is the higher terms that tie the frequencies together. If we consider the second term alone by itself, we find that it operates to tie frequencies together in groups of threes and exchange power between these frequencies. A group of three frequencies which this ties together will necessarily be related in such a way that the sum of the frequencies with properly chosen signs will equal zero.

Then there is a further very interesting relation between the powers that are exchanged between these three frequencies. If power P_1 of frequency F_1 , power P_2 of frequency F_2 and power P_3 of frequency F_3 , are tied together by the term L_1 in a power exchange, then these powers are all proportional to their respective frequencies, and the sum of the powers with the properly chosen signs must necessarily be zero.

Just as an example to make this clear, we may take the case of the Alexanderson modulator or amplifier. We may have normal radio frequency of 50,000 cycles, and a controlling frequency of 1000 cycles. Then as the result of the interaction in the iron core, some energy from the 50,000 cycles may be converted into 51,000 cycles. The first relation which I mentioned is satisfied because $50,000 + 1000 - 51,000 = 0$. Furthermore the powers corresponding to the three frequencies are proportional to the frequencies themselves, so as Mr. Boyajian points out, if you have a controlling frequency of 1000 cycles and a controlled frequency of 50,000 cycles the power of the 1000-cycle frequency is to the power of the 50,000 frequency input as one is to fifty.

V. Karapetoff: Designers of reactors would benefit by a wider use of the concept of permeance, both in testing and in computing reactors. Generally speaking, the inductance of a coil can be written in the form

$$L = n_c^2 P_c + \sum n_p^2 \Delta P_p \tag{1}$$

where n is the number of turns, P is a permeance, the subscript c stands for "complete" and the subscript P for "partial."¹⁰ The two terms on the right-hand side can be combined into one, using the so called equivalent permeance, so that eq. (1) becomes

$$L = n_c^2 P_{eq}$$

This formula will be found useful in predetermination of the inductance of a coil from test data. Let a coil of dimensions a, b, c , and whose number of turns is N , have an inductance L ,

10. See V. Karapetoff, "The Magnetic Circuit," Chap. X.

determined by an actual test. The equivalent permeance of the coil is

$$P_{eq} = L/N^2 \quad (3)$$

Let it be required to design a reactor of the same proportions but for a different inductance L_1 . Let the dimensions of the new reactor be ma , mb , mc , and the number of turns N_1 . The permeance of similar magnetic circuits varies as their linear dimensions (as is also the case with the conductance of similar electric circuits). Thus, the permeance of the new circuit is $m P_{eq}$, and its inductance is

$$L_1 = B_1^2 P_{eq} m \quad (4)$$

Knowing L_1 and P_{eq} , the designer can choose m and N_1 to satisfy this equation. Out of an infinite number of solutions he can select one which gives a minimum cost, or a minimum loss, or standard dimensions, etc.

The foregoing formulas are also useful in judging about the best proportions of a coil. It will be seen from eq. (1) that for a maximum inductance the permeance must be as great as possible, and moreover as many linkages as possible must be complete rather than partial. This means short magnetic paths of large cross-section and avoiding turns which link only with a small fraction of the total magnetic flux.

The concept of permeance is also useful in the determination of electromagnetic forces acting upon a reactor (*ibid.*, the last chapter). The derivative of the permeance in a given direction is proportional to the component of the mechanical force acting in that direction. Therefore, these forces can be estimated on the principle of virtual displacements. Moreover, mechanical forces become zero when the inductance reaches its maximum, because then its derivative becomes equal to zero. This shows the advantage of choosing coil proportions corresponding as nearly as possible to maximum inductance. Mechanical stresses are then smaller and can be more readily controlled.

So far the shape of protective reactors has been largely determined by manufacturing considerations and by space economy. It would be of interest to ascertain, both experimentally and mathematically, nature's own shapes of maximum inductance. The following experiment is suggested. Let an extremely flexible coiled conductor of a definite length be immersed in transparent insulating oil, and supported at several points say by means of floating corks, to be in an indefinite mechanical equilibrium. Let a strong d-c. current be passed through the conductor. The conductor will then tend to assume the shape of a coil of maximum inductance, and useful conclusion may be drawn from its final shape. Guides and obstacles may be placed in the tank to limit the motion in certain directions, and in this way practical shapes may be obtained, perhaps unknown at present.

In Fig. 5 of the paper by Kierstead and Stephens the mechanical forces are shown to be of the nature of compression, indicating that the reactor tends to increase its permeance to a maximum by shortening the magnetic paths and increasing their cross-section. On the other hand, in Mr. Oesterreicher's Fig. 20 some of the arrowheads seem to indicate a repulsion between the turns. While it is possible to connect turns or layers for mutual repulsion, such an arrangement would correspond to a non-inductive winding and therefore would not be suitable for a protective reactor. The sketches in these two papers should be reconciled.

Mr. Oesterreicher's Tables I and II are not clear. If a summation over half a cycle is desired, the readings corresponding to 180 deg. should be omitted because they belong to the beginning of the second half cycle.

S. I. Oesterreicher: The two paramount requirements of every reactor are thermal capacity and mechanical strength. From the standpoint of the design, these two requirements go hand in hand. Large thermal capacity during short circuits demands large conductor volumes, which automatically gives the reactor mechanical strength. The limitations imposed upon these conditions are mostly economic and partly space require-

ments. Both are within the sole control of the operating engineer.

Regarding the conductor stranding of which Mr. Dann speaks, I believe it is well to use as large individual wires in a stranded cable as consistent with a conservative design. The advantage of large individual wires is a natural stiffness of the stranded cable. During short-circuit stresses, this cable stiffness gives the reactor additional mechanical strength.

To limit the eddy currents to reasonable values in a coarse cable stranding, our firm uses enameled wires in stranded cables. The eddy-current losses in such enameled-wire cables are equal to or less than, those in the fine stranding.

Among the many interesting points of the Kierstead and Stephens paper I find a number in which I readily agree. To a few however I wish to make some comments. One of the statements—that reactors must be made of fire-proof materials only—needs additional qualification.

It so happens that we manufacture reactors made of fire-proof materials as well as some with fibrous materials. Our experience with the fibrous-type coils is as good as with the fire-proof reactors. The limiting feature in both cases is the thermal capacity. If these limits are greatly exceeded, both types suffer equally. While I am greatly interested in the test which the authors cite about a fire-proof reactor which has been driven up to 725 deg., what I would like to ask is do the authors still consider this reactor safe for central-station operation after the test.

At 725 deg. cent. the copper loses almost 75 per cent of its original tensile strength and will rupture readily when subjected to mechanical vibrations caused by the magnetic fields surrounding the conductor.

I have data of several reactor conductor ruptures caused by what I believe is nothing else than excessive heating of the copper.

The authors also mention some flashover test made upon certain types of reactors, which showed dielectric strength up to 100,000 volts. If such is the case I can see no reason for installing auxiliary devices within the reactor to protect against over voltages. If a 13,200-volt system is subjected to over voltages anywhere near the 100,000-volt mark, such system will break down at dozens of places before the critical breakdown voltage of the reactor is reached.

The expression given by Prof. Karapetoff for the permeance factor is a great help to the reactor designer. This factor is also known as the inductance or shape factor of the winding.

I believe, Prof. Morgan Brooks in University of Illinois Bulletin No. 10 as well as the late Dr. Rosa in the Bureau of Standards Bulletin calls attention to a similar permeance or inductance factor of solenoids.

In regard to Figs. 20a and 20c of my paper, which show the winding turns in repulsion toward each other, I wish to call Prof. Karapetoff's attention to my statement, "whether the forces are attractive or repulsive, depends upon the interconnection between turns or layers and upon the current distribution throughout the winding."

In multilayer windings all layers or turns cannot be placed in the same magnetic planes, thus it must be evident that their inductances and mutual inductances cannot be the same. If this is true, it cannot be claimed that all turns are always trying to locate themselves in the common magnetic center of the solenoid. From my experience, as far as the end layers and turns of a solenoid are concerned I saw a number of windings, distorted in a general direction as indicated by the arrows.

It seems that Prof. Karapetoff, himself, thinks that the experiment which he suggests if carried out, will lead to some unknown shapes in solenoid design, which I believe, can be caused only by the uneven self and mutual inductances between layers and turns. The discrepancy in the summation of Tables 1 and 2 is due to the step-by-step method used and should not be expected to be analytically exact.

F. H. Kierstead: In his book entitled "The Magnetic Circuit," Professor Karapetoff has presented a very rational method of calculating magnetic forces, which we have used and found to be of very great value not only in predetermining the exact value of a magnetic force and its direction, but also in predetermining how changes in the circuit conditions will affect the force.

In regard to the direction of the force on a particular turn of a reactor, I wish to say that it is our conception that the turn tries to move in a direction such that the inductance of the circuit will be increased. Now if a turn of a reactor moves away from the rest of the turns, the inductance will be decreased but if it moves toward the rest of the turns the inductance will be increased. Therefore, the forces on the turns of a reactor are in such a direction as to try to cause them to move together. An exception to this is conceivable in the case where the conductor of a reactor consists of several strands in parallel and the paralleling of these strands is so poorly done that the current in one of the strands is actually reversed in direction to that in the other strands. In this case, the former strand would be repelled by the latter strands. That would mean tremendous losses in the reactor, and I don't think it occurs in any modern reactor.

In answer to Dr. Slepian's discussion in which he points out that some energy is by-passed by the resistor into the protected station. I wish to state that it is our practise to make the resistance of the resistor well above the surge impedance of the circuits to which it is connected so that the energy which it by-passes is of very much reduced voltage.

We have in our paper stated that the resistors permit a portion of the high-voltage energy of a disturbance that occurs within a station to pass out into the lines. Dr. Slepian has stated in his discussion of our paper that the resistors will equally well permit a portion of the high-voltage energy of a disturbance which occurs on the lines to pass into the station. Dr. Slepian is correct in the case where there is only one feeder connected to the bus but where there are several feeders equipped with reactors and resistors a disturbance originating within the station has several paths of escape out into the lines while a disturbance originating out on one of the lines has only one path into the station. Therefore, since there is usually more than one feeder connected to a bus, the resistor will in general by-pass considerably more high-voltage energy from a station into the lines than from the lines into the station.

In regard to whether resistors are required or not, I wish to state it is not a question of protecting a reactor from over-voltages, but rather it is a question of whether a central station company wishes to obtain the advantages of the absorption of high-voltage energy which will take place in the resistor, and thus reduce the value of over-voltages which may arise on the system.

Mr. Kirke in his discussion of our paper has pointed out that in the case of a three-phase set of reactors placed co-axially and connected with the middle phase reversed, there are some conditions under which the force for a portion of the cycle will be repulsive although the average force over a cycle will be attractive. This is true but the peak value of such repulsive forces in the most favorable case is only $\frac{1}{3}$ the peak value of the attractive force under the most favorable conditions and the average force over a cycle under the conditions which gives the highest instantaneous repulsive force is zero. It has been our experience that in general, the distance between adjacent phases of co-axially placed reactors has been so large that the repulsive forces were not large if the middle phase was reversed.

The value of Mr. Schurig's discussion of our paper lies chiefly in the fact that it gives a method of determining the stresses on reactors. The constants he has taken necessarily are only typical of one rating of reactors, and, therefore, cannot represent the great range of reactors which are liable to be encountered.

W. M. Dann: The discussion we have had brings out that not all engineers are in full sympathy with the shunted reactor because the inductance of the reactor is a real barrier to high-fre-

quency disturbances and it seems like folly to add something which might by-pass some of those disturbances into the circuits that are to be protected and in that way detract from the effectiveness of the barrier which is intended to keep those disturbances on the side of the reactor where they originate.

Mr. Osterreicher referred to the Cos Cob iron-core reactors. It really was a sort of bold stroke to design those reactors and put them in the circuits. I remember that at the time all of us looked with more or less awe on those big iron-core reactors.

I think that my remarks about finely stranded cable may have given Mr. Osterreicher a wrong impression because of course the strands in the cable are large enough to give it mechanical strength. There have been no cases of trouble that I know of where the cable itself has not had sufficient mechanical strength to withstand the mechanical stresses.

A. Boyajian: As mentioned in my paper, Messrs. W. B. Kirke and F. Dubsy co-operated with the writer in this investigation at one time, and I was very much pleased that Mr. Kirke was here and discussed the subject. I agree with him in the discussion which he has offered.

I am pleased that Dr. Slepian has verified by profound mathematics the conclusion at which I arrive from a simple physical consideration relative to the ratio of controlling and controlled kilovolt-amperes being equal to that of respective frequencies.

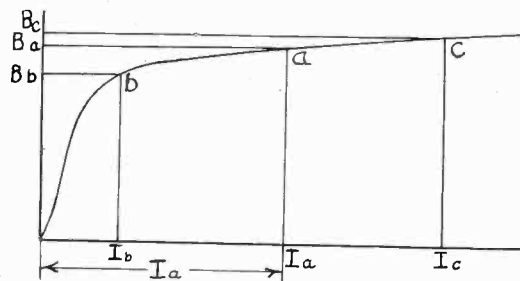

FIG. 1—D-C. MAGNETIZATION CURVE

As to the shape and interpretation of the volt-ampere curve, on which subject Dr. Slepian feels that he differs a little from me, I doubt if there is any essential difference. In my paper I have first stated the fact that each one of the three representative magnetization curves (*viz.*, I—the simple d-c. *B-H* curve, II—the simple a-c. volt-ampere curve, and III—the a-c. volt-ampere curve with superposed d-c. excitation) have two bends. This is a fact regardless of our interpretations, and is a satisfying parallelism to know. The bends of case III are shifted to the right as compared with those of case II, the more so the larger the d-c. excitation. The existence and position of the two bends in the case of combined d-c-a-c. excitation, I have interpreted as follows.

Referring to the accompanying Fig. 1, let the d-c. excitation correspond to the point *a* of the magnetization curve. Superposition of alternating current will vary the flux in the directions of *b* and *c*. In the range between *b* and *c* the alternating-current reactance will be very low and practically constant,—very low on account of the saturated condition of the core, and practically constant on account of the fact that the magnetization graph is a straight line in this zone. It follows, therefore, that for values of alternating current up to $(I_a - I_b)$, the volt-ampere curve will be straight and of small slope like the initial solid portion of Curve III (Fig. 2).

For large values of alternating current, the presence of direct current will exert only a small influence on reactance, so that Curve III must finally approach Curve II, (Fig. 2), asymptotically, never crossing it. Having the initial and final portions of Curve III, we can draw in its intermediate portion as shown dotted. At the initial part, *i. e.*, up to the first bend, wave shape is fairly free from harmonics. At the final part, that is,

above the second bend, wave shape is more and more that of simple a-c. excitation without d-c. Between the two bends, *i. e.*, in the part shown dotted, wave-shape has a very prominent second harmonic. The substance of this detailed explanation will be found in the text of my paper. Whether the point of view of "the shifting of the origin" offered by Dr. Slepian is any more illuminating or satisfying than the point of view of "the shifting of the two bends" (which latter, by the way, is a statement of fact) is a matter to be decided by every person for himself. In either case, recourse has to be taken to the d-c. magnetization curve for a detailed explanation and here the two explanations coincide.

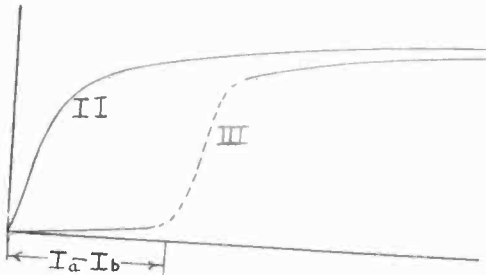

FIG. 2—II. A-C. VOLT-AMPERE CURVE WITHOUT D-C.
III. A-C. VOLT-AMPERE CURVE, D-C. SUPERPOSED

I have learned from Prof. Bush that tests at M. I. T. gave smaller losses than those obtained by us, and it is hinted that the difference is due to second harmonic copper losses in the d-c. circuit. The oscillograms given in my paper indicate an entirely negligible second harmonic current in the d-c. circuit, this being accomplished by proper balanced design. The correct explanation of the differences seems to be in stray losses. Since the writing of this paper, our units were tested with and without tank, with and without steel clamps, and considerable changes in losses were observed. Although stray losses are more or less unavoidable phenomena with large units, especially with saturated cores, it appears that the determination of their exact location and magnitude may lead to considerable improvements in losses by suitable design to reduce them to a minimum.

A 35,000-KW. INDUCTION FREQUENCY CONVERTER¹ (SHIRLEY)

CHICAGO, ILL., JUNE 27, 1924

F. C. Hanker: There is some question as to the application of the machine described that I want to discuss, particularly on the basis of considerations that Mr. Shirley has outlined. He has given in his paper three considerations. If you will analyze them, you will find the first is applicable to either the synchronous unit or the type described. In the second, in the amount of inductive kv-a. returned to the system appears to be questionable whether the type described is as effective as the straight synchronous, because the induction machine must of necessity receive its magnetization from either the 25-cycle or the 60-cycle system, depending on the voltage condition. That means that you have to compensate for that excitation or magnetization from the line either through other apparatus connected to, say, the 25-cycle system, or an additional machine that would be supplied with the set. If you take existing conditions, it would not be very serious or very harmful to supply the magnetization from the 25-cycle systems but in other cases where the power factor of the 25-cycle load is much lower, then it is a handicap to the machine.

If you take the third consideration he has given I fully agree with him as to the desirability of maintaining voltage in connecting the two systems, but it is a question in my mind whether

the reactance of the magnitude, that you obtain with the special machine, is going to be particularly effective and whether it is going to be of sufficient advantage to overcome the disadvantage of cost both in reduction in efficiency and in the complication of the machine.

If you take a similar machine which fortunately is available for comparison, the efficiency as given by Mr. Shirley shows losses of some 2000 kw. at full load. On the Brooklyn system they have a straight synchronous machine of practically the same rating, with about 500 kw. lower losses. In other words, the efficiency of the two sets inherently penalizes the special induction outfit. As the 500 kw. are largely constant losses, they are present all the time the machine is in operation. At 7000 hours a year they represent three and a half million kilowatt hours, which represents a considerable investment if capitalized, and would indicate the disadvantage to which this special outfit would be subjected.

From the other standpoint of the voltage, it is undoubtedly true that low reactance between stations of the same capacity is of considerable advantage, but it is also true that the tie must be of sufficient magnitude and low enough reactance in order to be effective in maintaining the voltage on the two systems. In the present instance that reactance is given as about twenty per cent, which represents a very appreciable drop, particularly when you consider the relative sizes of the two systems.

Here is a machine of some 35,000 kw. between systems of, 200,000 kw., or that order, of one frequency and at least 100,000 kw. of a different frequency, which means that the tie between those two systems is of comparatively high reactance. If you take the synchronous converters, only a small difference in voltage between the two supply circuits will cause reversal on one, which is the particular point that Mr. Shirley is endeavoring to overcome.

It would be interesting to ask if there has been any operating result that substantiates the advantages claimed for the induction type, and whether there has been any improvement observed in operation under abnormal conditions. It is only under those conditions that any difficulty may be expected from the reversal of synchronous commutating machines. The slight advantage if any is secured at a considerable expense, and the question of application should be very carefully considered before any of the special outfits are utilized.

It does involve complications and does involve both losses and increase in the magnetizing which every power company is endeavoring to keep down just as much as possible.

E. B. Shand (by letter): Mr. Shirley has described a type of frequency converter which has had a very limited application, therefore it is quite justifiable to discuss it from a comparative standpoint with respect to the type of machine ordinarily used in similar applications, that is, the frequency converter set composed of two synchronous machines. This discussion intends to follow this above idea, using the data presented by Mr. Shirley to represent the induction or cascade type of machine.

Attention may be called to the three considerations enumerated by Mr. Shirley as determining the selection of the cascade type of machine for tying together the particular systems referred to. The first of these, that of reversibility of operation, allowing the set to be considered a spare unit for either system, applies equally well to synchronous sets, and is rather a consideration for the installation of a frequency converter, regardless of type. The two remaining considerations deal with the ability of the cascade machine to transfer reactive kv-a. as well as power between the two interconnected systems. This is the main differentiation between the abilities of the two types of apparatus considered. In the synchronous set, the interconnection between the two electrical systems being through the common shaft is purely mechanical, so that power alone may be interchanged. In the cascade set, the interconnection is partly through the common

1. A. I. E. E. JOURNAL Vol. XLIII, December, p. 1147.

shaft, and partly through the air-gap flux of the induction machine, this magnetic link allowing the interchange of the reactive kv-a. If my memory serves me rightly, this characteristic has given to the induction-type frequency converter the name "general transformer" for it serves approximately to connect systems of different voltage and frequency as the transformer does systems of the same frequency.

It may be noted that with the induction-type converter the synchronous machine plays no direct part in the interchange of magnetization, so that for the purpose of a simple analysis it may be assumed non-existent or disconnected. The frequency converter then becomes a wound-rotor induction motor with the stator windings connected to the 60-cycle system, and the rotor windings, through a suitable transformer, to the 25-cycle system. This combination is capable of interchanging magnetization, but is completely incapable of interchanging power. By analogy, therefore, this apparatus might be designated "the general synchronous condenser." The rotor will rotate at 25/60 of the synchronous speed at 60 cycles, and the air-gap flux interlinking both windings will generate voltages in the stator and rotor windings in the ratio of 60:25, on the basis of an equal number of turns in each winding. If the voltage ratio of the two systems varies from that determined from the design of the converter, the reactive kv-a. will flow until the reactive drop in the machine has equalled the voltage difference. The magnetizing current is supplied from the system with the relatively higher voltage. This is all similar to the flow of reactive kv-a. in a transformer, except that the frequency and the voltage per turn is not the same in the two windings. It thus happens that for every 60 kv-a. drawn from the 60-cycle system only 25 kv-a. is supplied to the 25-cycle system; and, conversely, 25 kv-a. drawn from the 25-cycle system becomes 60 kv-a. when taken from the stator terminals.

In the above mentioned arrangement of the "general synchronous condenser" there is no definite frequency ratio between the two circuits; this depends entirely on the frequencies as determined by the governors of the two systems thus interconnected. When the synchronous machine is connected to the same shaft, and electrically connected to the rotor of the induction machine, the frequency ratio becomes as definitely fixed as in the case of the two synchronous machines mechanically connected together. The induction set, therefore, locks in synchronism the two systems which it interconnects. The relative phase displacement of the two systems will determine the load on the set, and if the phase displacement becomes too great, the set will drop out of step. The overload at which this will occur depends upon the design of the two machines, making up the set. The extreme overload capacity of such a set is of the same order as in the case of the synchronous type of set. With this in mind, it is believed that some of the statements in the second paragraph of Mr. Shirley's paper will be seen to give a deceptive idea of the relative limitations of the two types of sets with respect to pulling out.

Returning to the subject of the interchange of reactive kv-a. it will be seen that the ordinary transformer diagram may be used to determine the relative values of this interchange. Utilizing Mr. Shirley's data, the following impedances may be set down.

Stator reactance	6.6%
Rotor reactance	5.4%
Transformer reactance	4.5%
Magnetizing current	36.5%
External reactance (60-cyc. system)	3%

It is assumed, in addition, that the synchronous generator is excited to furnish the magnetizing current, that is, that the set will operate at unity power factor at no-load. The results of these conditions will be as follows:—If the 25-cycle voltage drops so that the stator input is 37,000 kv-a. at 60 cycles, the output from the secondary alone will be 10,000 kv-a.; assuming,

however, that the magnetizing kv-a. from the generator is added to this, the total 25-cycle output will be 15,000 kv-a., while the voltage drop in the set will be 17 per cent. Assuming now that the 60-cycle voltage drops until the stator output is 37,000 kv-a. the rotor input will be 21,000 kv-a., of which 5500 kv-a. will be supplied from the generator so that the net set input will be 15,500 kv-a. The corresponding voltage drop in the set will be 23 per cent. The above calculations check roughly with Fig. 13 of Mr. Shirley's paper.

It is considered that the logical conclusion from these figures is that the average interchange of reactive kv-a. should be

$$\frac{37000 + 15400}{2} \text{ or } 26,300 \text{ kv-a. with an average drop of}$$

20 per cent. The set reactance based on its rating of 37,000 kv-a. would then be about 28 per cent from the standpoint of voltage regulation of the two systems. If the installed capacity of frequency changers of this type were considered to be from 20 per cent to 25 per cent of the capacity of smaller system, a figure which is not generally exceeded, it will be seen that the reactance of the tie between the two systems will be of a magnitude of between 110 per cent and 140 per cent, as compared with the smaller of the systems. With a tie of this value of reactance, it is evident that the effect of the induction frequency converter in equalizing the voltages of the two systems must be very limited in fact, in considering a transformer tie of this nature, the regulating effect on voltage would ordinarily be disregarded.

The third consideration enumerated in the paper is closely connected with the above discussion; it regards the possibility of paralleling synchronous converters fed from the systems of both frequencies because of the tie formed by the induction frequency converter. The load distribution between two converters paralleled on the direct-current side depends upon the relation between their supply voltages. Under full-load conditions, one machine will reverse its power flow and the other carry double load when the supply voltage on one machine drops more than 10 per cent with respect to the other. The fact that the induction frequency changer set will allow double this voltage variation to carry full load reactive kv-a. signifies that the adoption of this type of machine will not be a deciding factor in determining whether or not converters may be paralleled under the conditions referred to above.

From the analysis as developed above, the writer's conclusion is that as a voltage tie between systems the capabilities of the induction type of frequency converter are negligible so far as any practical results are concerned, and that this characteristic of the induction converter should have no particular influence on the choice of sets.

O. E. Shirley: The discussions of this paper by Mr. Hanker and Mr. Shand both point out that the first point given for the selection of the induction frequency converter for the New York systems is applicable to the synchronous set as well. This, of course, is quite evident, and it was not intended to convey the idea that this characteristic was the exclusive property of the induction set, but simply to present, as completely as possible, the considerations that led to the choice of the induction frequency converter.

With regard to the question of magnetization of the induction machine it should be noted that under normal load conditions the magnetizing current for the induction machine is supplied by the synchronous unit and, therefore, the power factor on both sides, as it affects the systems, is unity. It is, therefore, evident that the additional machine suggested by Mr. Hanker is not necessary.

The comparison of the efficiency, presented by Mr. Hanker, shows a difference of about 1.4 per cent at full load. Part of this difference is accounted for by the assumption of a round number of 2000 kw. for the losses of the induction set. This value is somewhat high and, when used as a basis for calculating the

difference of efficiency, it introduces an error of considerable magnitude. A comparison of efficiency of sets designed for the same characteristics as to insulation, break-out torque, and temperature rise shows that the difference is more nearly $\frac{3}{4}$ per cent than the value given above.

The break-out torque, which is mentioned in Mr. Shand's discussion, in the case of the induction frequency converter is largely dependent on the torque of the synchronous unit, since the torque of the induction machine with voltage maintained on the two systems is considerably above that of the usual synchronous machines. The maximum torque of this frequency converter with voltage maintained on both systems is over 200 per cent of normal, being very appreciably in excess of the 150 per cent torque of the usual design of unity-power-factor synchronous machines with a short-circuit ratio only slightly over unity. (Note that by short-circuit ratio is meant ratio of field amperes for no-load normal voltage to the field amperes for rated current on short circuit.)

The behavior of synchronous converters, operating in parallel on the d-c. buses with a-c. supply from systems of different frequency, is affected by a number of factors which have not been taken in account in either of the discussions, nor the original paper, but which must be considered in judging the operating characteristics of the converters in this way. These synchronous converters are usually located in sub-stations, and the drop in the line and transformers will have a very decided practical effect in limiting the current taken by them during disturbances. The induction frequency converter being located at the central station and close to the bus will transmit a very considerable amount of reactive kv-a. balancing the voltages to a marked degree, and then the additional drop between the main buses and the synchronous converters should limit the current sufficiently to prevent injury to the converters under many conditions which would cause serious trouble if the induction frequency converter were not used.

The calculations by Mr. Shand from which he concludes that the effect of the induction set is negligible in causing a drop in voltage on one system, when a disturbance takes place on the other system, can best be answered by data taken from recording charts showing the results of a severe disturbance on the 25-cycle system under actual operating conditions. The connected capacity on the 60-cycle system was 35,000 kw. at Hell-Gate, 14,000 kw. at Waterside, and 108,000 kw. at Sherman Creek. The voltage on the 25-cycle system dropped to 62 per cent of normal and on the 60-cycle to the following values:

Hell-Gate	71 per cent
Sherman Creek	81 per cent
Waterside	76 per cent
East 188 Street Sub-Station	76 per cent

These values of voltage drop do not bear out Mr. Shand's statement that "the regulating effect on voltage would ordinarily be disregarded."

A similar problem in parallel operation of synchronous converters from different stations of the same frequency had been encountered on the New York systems and this was worked out by tie lines between the stations. The size and characteristic of the induction frequency converter was based on experience with these tie lines, and since the tested values of reactances agreed very closely with the calculated values, there is no reason to believe that the operation with the frequency converter tie should not be as successful as with the ordinary tie lines.

The induction frequency converter has not been used to secure parallel operation of synchronous converters as outlined above, since the operating conditions of the two systems have not yet been such as to make this method of operation desirable. A second converter, however, is being built for parallel operation with the first and there is every reason to believe that the equalization of the voltages of the two systems will be successful

whenever this method of operation is required, as the use of the two sets will take care of increased capacities which will be available and may be used later.

THE INERTAIRE TRANSFORMER¹

(DANN AND KELLOGG)

CHICAGO, ILL., JUNE 27, 1924

A. H. Mauder Transformer oil, in common with most liquids dissolves the gases of the atmosphere to some slight extent. Though the quantity of oxygen which can be held in solution by transformer oil is very slight when expressed in weight units and insufficient to produce any appreciable quantity of oxidation products, it would nevertheless, be sufficient to destroy the effectiveness of the inert atmosphere of the Inertiaire transformer should any large part of it diffuse from the oil into this atmosphere. It is well known that any gas thus held in solution will readily diffuse out into an atmosphere of some other gas until a certain equilibrium depending on the partial pressures and solubilities of the gases present is reached.

The above facts being indisputable it became necessary in the course of the development of the Inertiaire transformer to go pretty thoroughly into this matter and determine some solubility constants not heretofore published and work out methods to analyze oil for these gases which will be published in a future paper. However, the solubility of the gases of the atmosphere in "Wemco A" oil can now be stated as follows:

	Gas temp. Deg. Cent.	Coeff. of ab- sorption cc. of gas per cc. of solvent.	Solubility grms of gas per gm of solvent
Nitrogen	25	.0925	.000127
Oxygen	25	.1705	.000266

From these figures by the application of the law of partial pressures it follows that this oil when in equilibrium with air will contain per cc. the following in solution:

Nitrogen0734 cc.
Oxygen0353 cc.

Total

1087 cc.

Now if this oil has stood in contact with air so long as to reach an equilibrium with it and is then used in an Inertiaire transformer it will, as soon as the air above the oil has been swept out by the inert gas, commence to liberate the oxygen it holds in solution.

Another factor of importance in this discussion is the chemical combination which is known to go on between oxygen and transformer oil and possibly goes on with structural materials of the transformer as well.

To find out what influence these factors, *i. e.*, physical solution and chemical combination, will have on the Inertiaire transformer atmosphere it seems desirable to answer, at any rate approximately, the following questions.

1. How much oxygen will, in this way, be introduced into the inert atmosphere?
2. Will this oxygen be chemically reabsorbed and, if so, how quickly?
3. How quickly will oil exposed to air dissolve oxygen?
4. How much oxygen does transformer oil customarily carry in solution?

From the experimental data available it may be said that, if air-saturated oil be charged into an Inertiaire transformer in which a gas space of the usual proportions is used, between 7 and 8 per cent of oxygen may be expected in the atmosphere one or two days after all air has been swept out, this quantity of oxygen having diffused out of the oil in which it had been held in physical solution. The oxygen will after this be slowly reabsorbed by chemical combination with the oil, but would take many weeks to be eliminated.

1. A. I. E. E. JOURNAL, Vol. XLIII, December, p. 1144.

These difficulties can be overcome by using oil free from dissolved oxygen. The oil could be freed from this either by treatment under vacuum, by bubbling nitrogen through it or use the atmosphere can be cleared of oxygen on 2 or 3 successive days as has been heretofore done in the installation of the inertaire transformer. Otherwise, the nitrogen used initially to displace the air in the transformer can be bubbled through the oil thus displacing oxygen in solution as well as the oxygen in the atmosphere.

With regard to the rate at which oil will take up a gas by solution, this seems to be considerable and leaves no doubt that oil left exposed to the atmosphere or handled with pumps drawing in air around glands or pistons will contain some considerable quantity of oxygen in solution.

It was experimentally determined that 10 sq. cm. of tranquil oil surface with a large depth of gas-free oil beneath it will absorb 1 cc. of gas in 7 minutes.

The following results were obtained by analyzing various samples of "Wemco A" oil for dissolved gases:

	Per cent by Volume of Gas.			
	N ₂	O ₂	CO ₂	Total
Oil from sealed can.....	6.1	.2	.0	6.3
Oil from pump from storage tank (No. 1).....	6.0	2.5	.2	8.7
Oil from pump from storage tank (No. 2).....	9.1	3.3	.2	12.6
Oil from transformer with air atmosphere.....	7.0	2.2	.2	9.4

These figures point to the conclusion that oil except it comes from a sealed can must be expected to contain oxygen in solution and precautions must be taken in some one of the above ways of preventing this oxygen from contaminating and reducing the effectiveness of the inertaire gas cushion as a preventative of explosion and as a preserver of the oil.

L. H. Hill: It was my privilege to supervise the installation of the first Inertaire transformers, seven 8333 kv-a., 66000 volt units at the Grand Tower Station of the Middle West Power Company.

One of the interesting things noted in connection with this installation was that the oxygen content in the gas space before any nitrogen was blown or drawn in was only about 17 per cent, instead of 20.7 per cent, which is the oxygen content of the atmosphere. These transformers had been set up and the gas space closed some two or three months before these analyses were made and no breathing is believed to have taken place in that time. The reduction in oxygen content is largely due to slow oxidation of the oil. Oxygen is also somewhat more soluble in oil than nitrogen, which would also make for a reduction in oxygen content in the gas space.

This question of absorbed gases in the oil appears in another connection. The oxygen was initially removed from the gas space of the Middle West Transformers by blowing in nitrogen from a cylinder. The oxygen was reduced to less than 1 per cent by this method. After the transformer had stood over night it was found that the oxygen had come up to 3 or 4 per cent. After blowing down again to less than 1 per cent, the oxygen came up to about 2 per cent the next day and remained around this figure.

Tests previously made have shown that practically perfect mixing of the gases is obtained during the blowing-in process, so it is logical to assume that the increase is due to the oxygen coming out of the oil.

During the first week that the transformers were in operation the load curve showed about one-third to one-half full load for eight hours during the day, with no load during the remainder of the time. The breathing regulators prevented breathing entirely during this period, which shows the value of using a breathing regulator with the inertaire transformer.

D. R. Dalzell: I think we will all agree that there are two distinct types of explosions that have occurred in transformers, namely, the rapid generation of gas due to decomposition of the oil by internal arcing, or, as it is termed by Messrs. Dann and Kellogg, a primary explosion; and also an explosion of secondary nature, due to the ignition of a gaseous mixture above the oil level in the tank. In the first case, the rate of increase of pressure is a function of the energy liberated at the fault, and occasionally may be so great as to produce effects much the same as those following a secondary explosion.

In the case of the ordinary "open" type of transformers not having their tanks completely filled with oil, a few secondary explosions have been experienced. These usually resulted in the cracking or breaking of the cover and sometimes the tank, and in a few cases burning oil was thrown about, with serious damage to the station. The usual cause of these explosions was arcing or static discharge on the exposed portion of the leads above the oil level, igniting a mixture of air and gases due to internal arcing in the oil.

The primary explosions, having a less sudden increase in pressure, usually blew off the manhole cover, and were not generally attended by burning oil above the surface. These were caused an internal failure in the windings.

It was realized that although explosions had occurred on only a very small percentage of transformers, yet their seriousness warranted all possible study to determine means of preventing them and minimizing their consequences.

Of the study made on this subject, beginning as early as 1913, it will be of interest to relate briefly those tests illustrating that a relief diaphragm would not protect the tank from secondary explosions.

Tests were made to determine whether an explosive mixture of gas and air could be produced above the oil level by arcing under oil, and also whether a diaphragm covering the manhole opening would break and prevent damage to the tank in case of a secondary explosion. A large transformer tank was nearly filled with oil, and arcs passed between electrodes under the oil, thereby generating gas which mixed with the air. Horn fibre diaphragms of thickness ranging from 5 to 10 mils. were placed over the manhole opening. A spark gap was located above the oil to explode the gas.

Preliminary tests were made to determine the most explosive mixtures of gas and air, and when this value, about 40 per cent gas, was obtained, the gas exploded, resulting in the breaking of cover bolts, breaking and lifting of the cover, and scattering of burning oil. The diaphragm was destroyed, but failed to protect the cover.

Similar tests were made using an oil seal between the cover and tank. In this case, the tank was nearly filled with water, then oil added up to the normal oil level. Gas was introduced to the air space and the mixture ignited. Again the cover was blown into the air, proving that the seal was of no value.

One of the earliest steps (about 1910) taken to prevent the ignition of gas above the oil, was to place a metal shield around the lead, extending from the cover to a point below oil level, and grounded to the cover. This ground shield of course prevented arcing between leads or any static discharges, and has since been generally adopted as a standard construction in terminal bushings.

The next scheme tried was that of filling the space in the tank above the oil with a gas chemically inert, using a gasometer with which to maintain slight constant outward pressure and a tube of gas from which the gasometer was replenished when necessary. Patent No. 1,326,019 covering this combination, was issued to Mr. F. C. Green, a General Electric Field Engineer, (now deceased). The first test, using carbon dioxide gas, was on some 750-kv-a. transformers at the Remington Arms Plant at Ilion, N. Y., in March, 1916. In May of the same year, a 5000-kv-a. transformer of this type was installed at the Narragansett

Electric Co., Providence, R. I. Considerable difficulty was experienced in reducing the outward leakage of gas to a reasonable amount, since the sealed cover construction, as we now know it, had not yet been completely developed. While this scheme no doubt would have been effective, yet it was at best an inconvenience to the operator to maintain.

In the meantime, the conservator was being developed by the General Electric Co., the first installation being made at Laurinsburg, N. C., later in 1916. This construction, with its completely oil-filled main tank, absolutely prevented any further secondary explosions. A pressure relief, consisting of a thin metal diaphragm mounted above the oil level in the end of a large pipe on the cover, was provided to take care of any increase in pressure due to generation of gas from internal failures.

In addition to this function, the conservator also prevented moisture from entering the main transformer tank and prevented air from coming in contact with hot oil, together with the resulting possibility of sludging. Therefore, since we believed that the conservator provided all the advantages of inert gas, without requiring any attention from the operator, and that the possibility of damage to the tank from primary explosions was so remote, no further experiments of this nature were made.

Our subsequent experience with this type of transformer has been that to date, with about 1600 units in service having a total rating of over 8,000,000 kv-a., so far as we know there have occurred explosions in only 15 units, all of these being of the primary type of explosion previously mentioned. In only 5 has any damage resulted to the tank or cover, the diaphragm in all other cases relieving the pressure. Where tank damage resulted, it was in the earlier types using a metal diaphragm, which was found bulged, but did not break quickly enough to prevent the manhole cover from being blown off or the cover from cracking. Of course, as the diaphragm bulged, it automatically increased its strength against bursting.

These cases emphasized the necessity of using a diaphragm having a definite breaking point, independent of the suddenness of the applied pressure. With this in view, thin glass was adopted several years ago, and in no case has this failed to function properly.

The service record of the conservator units just outlined indicates that the standard construction of conservator with pressure relief will dissipate any except extraordinary pressures without damage to a reasonably strong tank.

In the application of an inert gas as a further precaution against harmful pressures, we have favored the maintenance of the gas pressure by an auxiliary supply tank rather than by an automatic breather, primarily because of the uncertainty of the latter type and secondarily because of its demand on operating attention. It should not be overlooked that if a slight leak develops in any of the joints above the oil level when an automatic breather is used, there is no very convenient means of detecting the presence of oxygen and moisture which may be drawn in through such leaks, whereas with a slight pressure maintained at all times by an auxiliary tank, we have an easy and positive method of discovering leaks in the same manner as oil leaks are discovered in a conservator transformer.

Any inert gas may be applied to the conservator transformer by extending the pipe from the auxiliary oil tank down into the main tank far enough to form a pocket for the gas which may be introduced from commercial containers. Any outward leakage of gas would be indicated by a gradual dropping of the oil in the oil gage on the conservator. Expansion and contraction of the oil takes place in the usual way in the conservator, and the gas-cushion remains undisturbed. Such a pocket may also be formed by inverted chambers located at any convenient place in the tank directly under the cover, and when so located, there is retained the advantage, inherent in the conservator construction, of having any leak made visible by oil. This construction also obviates the necessity for periodic changing of the deoxidiz-

ing chemicals in the breather of the "Inertaire" construction.

C. F. Scott: The authors of the paper have set out the desirable results to be obtained in the handling of transformer oil and then have shown how, by a very simple means, these results are accomplished. The simplicity of the results is sometimes an indication of the difficult path and the many problems which have occurred in the solution of the problem. The result in this case seems to be a very happy one as the effective prevention of oxidation is secured by means which can be added in a simple way to present transformers provided their cases are tight.

The operation of electrical apparatus meets various limitations. Temperature is one of the most serious and in general the reason why temperature is serious is because it causes deterioration of materials. I remember the story of a discussion between Mr. Westinghouse and a theoretical engineer who was quibbling about rise of temperature and insisting upon some very low figures. Mr. Westinghouse suddenly asked him why not operate the machine red hot if it did not damage the insulation? The present paper does show that when oxygen is not present the oil maintains its integrity at a very much higher temperature, hence the temperature limitations usually applied to transformers can be very considerably raised in so far as the oil itself is concerned. If other materials are found which can be used as solid insulating material in transformers which are durable at higher temperatures than at present, then the way is open for operating them at present temperatures with higher factors of safety. Under emergency conditions of extreme overload, Inertaire transformers should be found serviceable and safe.

This transformer, therefore, appears to me to meet satisfactorily some of the present difficulties and limitations in transformer operation by preserving the oil, and it also indicates a way of making safe the operation of the transformer at higher loads and higher temperatures.

W. M. Dann: The discussion on this paper seems to bring out the fact that it is agreed that an inert gas is a very desirable thing to use in a transformer. A point that ought not to be overlooked is that while the freedom from the dangers of both primary and secondary explosions which the Inertaire transformer gives is a decided advantage from the insurance point of view, it is by no means the prime consideration in advocating its use. The elimination of the injurious effects of oxygen on the oil is a feature which, apart from the insurance against explosions, makes the use of the Inertaire transformer economically well worth while.

I think that Mr. Dalzell's feeling that the automatic breathes of the Inertaire transformer involves uncertainty is wrong and is probably due to his not having actual experience with its operation in service. It is very simple and is very much freer from uncertainty than the auxiliary supply tank with its reducing valve which must be depended upon to protect automatically the transformer from the high pressure of the auxiliary tank.

THEORY AND CALCULATION OF THE SQUIRREL-CAGE REPULSION MOTOR¹

(WEST)

CHICAGO, ILL., JUNE 27, 1924

H. C. Specht (by letter): The calculation method shown by Mr. West will, without doubt, interest all motor designers. The way of demonstrating the different fluxes gives a very clear picture which can be easily understood. On the other hand, such a method of calculation without the use of diagrams and saturation curves seems to me rather complicated for routine design work, in spite of the fact that the effect of short-circuit current under the brushes and iron losses have been neglected. It is also assumed that all m. m. f. and fluxes are sinusoidal, which does not often correspond to the type of winding usually employed in a commercial motor. Another assumption is that of constant

reluctance, whereas this will vary inversely with the saturation, which will have a very marked effect on the characteristics of the motor at overloads and when starting.

Possibly the neglect of these items is responsible for a discrepancy in the calculated curves shown in Fig. 6. Curve No. 4, as drawn, indicates that the starting torque of a repulsion motor will be increased by the addition of a squirrel-cage winding. This cannot possibly be the case, and Curve No. 4 should cross Curve No. 1 somewhere below synchronous speed, and show a starting torque considerably larger than that shown by Curve No. 1 representing the combined windings.

Using diagrams, in connection with the saturation curve for magnetizing voltage and flux, simplifies the calculation method, particularly when the motor is first calculated as the straight repulsion type and thereafter corrections are made for the effect of the squirrel-cage winding, short circuit current under the brushes, iron loss, etc. This method also gives a clear picture of the effect of the different items and any errors in calculation may be more easily noticed.

P. L. Alger (by letter): The element in design of the squirrel-cage repulsion motor that is all-important is the choice of the constants of the squirrel cage, and this is the point in which the new motor described by Mr. Bergman differs most from all previous motors of the same class.

Theory shows that insofar as starting is concerned, the squirrel cage should have the highest possible impedance, together with the lowest possible ratio of resistance to reactance. The ratio of resistance to reactance must be low in order to hold the axis of the squirrel-cage current as far away from the axis of the cross-field flux as possible, since this will give the least possible reduction of cross-field flux for a given squirrel-cage current. During normal operation, the squirrel cage should have the lowest possible impedance and a fairly definite, but rather low, ratio of resistance to reactance. This is true because maximum power factor at normal load is secured with a particular value of squirrel-cage reactance and because suitable values of pull-in torque and of losses are obtained with a particular value of resistance. Finally, insofar as commutation is concerned, the squirrel cage should have the lowest possible impedance, and a high ratio of resistance to reactance, since in this way the energy of commutation is most readily and completely dissipated without sparking.

Consideration of methods of securing these diverse values of the squirrel-cage impedance shows that it is very important to have no saturation in the reactance flux paths for the squirrel cage, since any such saturation would reduce the ratio of starting reactance to running reactance, which ratio should be made as large as possible. Also, the squirrel cage should have a low d-c. resistance, with eddy currents of such a magnitude as to be inappreciable up to double line frequency, but considerable at commutation frequency. As the eddy currents give the effect of a reduction of reactance as well as an increase of the effective resistance, they are altogether objectionable at starting and altogether desirable for commutation.

In the new motor, these requirements have been met in a way which seems theoretically the best possible. The squirrel-cage leakage flux path has an air gap in it calculated to be of such a magnitude as to avoid all saturation at starting, and this air gap is filled with a metal wedge of such a resistivity as to give eddy currents that are inappreciable at operating frequencies, but are considerable at commutation frequency.

K. L. Hansen (by letter): Although Mr. West has made use of certain simplifying assumptions with reference to the angle of hysteresis advance and the effect of eddy currents in the shielding commutating strips, it must be conceded that the agreement between the tested and calculated values is sufficiently close to justify these assumptions, especially when the complexity of the calculations is taken into consideration. It is rather unfortunate, however, that neither design constants nor dimensions are given

in the paper, thus making it impossible to compare the results with those obtained by a method differing somewhat from that of the author.

It is clearly set forth in the paper that the ratio between the constants of the squirrel cage and the constants of the commutated winding must be held between close limits, otherwise the no-load losses become excessive or the starting torque per ampere will be too low. The fact that at no load the motor develops two torque components neutralizing each other instead of just sufficient torque to overcome the friction losses, as is usually the case, tends to make the no-load losses high. The no-load losses of the particular machine discussed in the paper appear to be approximately 25 per cent of the full-load output. That may not be excessive in a 3 h.p. motor, but the same percentage losses in a larger machine would be excessive, and it would be of interest to learn what results have been obtained on motors of say 10- or 15-h.p. capacity.

The analysis of the squirrel-cage repulsion motor may be approached from a different viewpoint from that which Mr. West has chosen as his starting point. About thirty years ago Professor Ferraris suggested that single-phase induction-motor operation could be explained by considering the single-phase alternating field as made up of two components revolving in opposite directions. It seems that this method has not been looked upon with favor as a starting point for quantitative analysis, but I have found it exceedingly useful in the solution of just such problems as that discussed by Mr. West.

Analysis of the squirrel-cage repulsion motor from this viewpoint also leads to four equations with four unknowns, so the numerical calculations may not be much simplified, if any, but the forming of the equations from physical considerations is made more simple and direct by this method. It is not necessary to resolve the primary winding into two components at right angles to each other, nor to consider the transformer and rotational voltages separately. Equally, there is no need of considering the squirrel-cage as the equivalent to a commutating winding with the brushes short-circuited in two rectangular axes. From the viewpoint of two oppositely rotating fields the squirrel cage is considered as a polyphase circuit with two current components flowing in it of frequencies proportional to s and $(2-s)$, where s = slip. These current components are physical realities and are plainly shown on the oscillogram in Mr. West's paper. The reactances which these current component components meet are likewise proportional to s and $(2-s)$.

I have not derived the formulas of the squirrel-cage repulsion motor from the viewpoint of two rotating fields, mainly because the constants are not given in the paper so that results can not be compared anyway. Another reason is that I have applied this method in considerable detail to a number of similar problems in a paper entitled "The Rotating Magnetic Field Theory of Alternating-Current Motors," which will be published in the *JOURNAL* at some future time.

I am indebted to Mr. Specht for calling attention to a point which should perhaps have been explained more fully in the paper. It is natural to believe that Fig. 6 of my paper is wrong as has been claimed by Mr. Specht, because at first thought it would seem that the addition of a squirrel-cage to a repulsion motor must necessarily reduce the starting torque. Paradoxical as it may seem, however, this is not true, and it is a fact that if the squirrel cage is removed from a properly designed squirrel-cage repulsion motor, the starting torque will be materially reduced unless the brush position is changed.

The explanation is that although the ampere turns of the squirrel cage partially neutralize the field ampere turns of the stator winding, and thus reduce the field flux per ampere of line current, the starting impedance is much reduced so that the starting current is greater. The starting torque is roughly proportional to the product of the starting current times the field flux, and therefore may or may not be decreased by the

addition of a squirrel cage, depending on the relative design constants of the motor and squirrel cage, and the angle of brush setting.

The curves of Fig. 1 give in a general way a comparison between the starting torques of a repulsion motor and of a squirrel-cage repulsion motor for different brush positions. It will be noted that for brush positions close to the low-impedance neutral, the plain repulsion motor has the higher starting torque, but as the brushes are shifted farther from neutral a point is reached beyond which the squirrel-cage repulsion motor has the higher starting torque.

It is of course true that the maximum torque obtainable is less for a squirrel-cage repulsion motor than for the corresponding plain repulsion motor. It should also be noted that the starting torque of the squirrel-cage repulsion motor is less sensitive to slight changes in brush position than is the plain repulsion motor.

The omission of certain minor factors in the derivation of the equations is, in my opinion, fully justified. If all factors that affect the motor operation were taken into consideration, assuming that it were possible to do so, the results would differ from those obtained by the method given in the paper by percentages in comparably smaller than the percentage difference between the starting torque values of curves 1 and 4 of Fig. 6 which Mr. Specht referred to. In calculating starting torque, it is

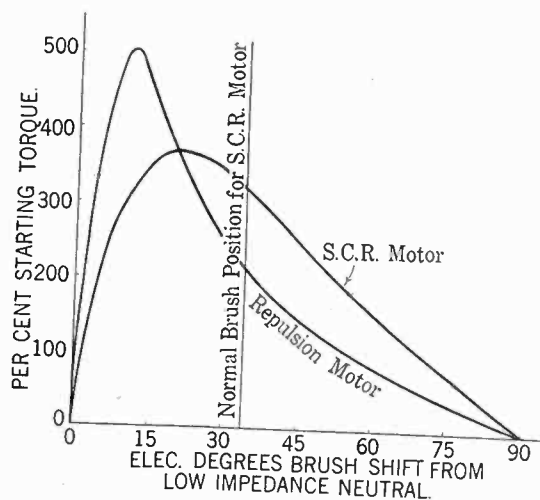

FIG. 1—CURVE OF COMPARISON BETWEEN STARTING TORQUES OF A REPULSION MOTOR AND A SQUIRREL-CAGE MOTOR FOR DIFFERENT BRUSH POSITIONS

sometimes necessary to make certain allowances, such as those for saturation and the effects of the currents in the short-circuited coils. The calculation of starting torque is so very much easier and shorter than the general calculation that the necessary allowances can easily be made.

I feel safe in saying that it is impossible to make a reliable quantitative predetermination of the performance of a squirrel-cage repulsion motor by first calculating the performance of a plain repulsion motor and then making allowances for the effect of a squirrel-cage unless experimental or other accurate data for motors of somewhat similar design characteristics are available. For example, I do not believe that the design of a 2-pole, 25-cycle motor could be most advantageously worked out on that basis if experimental or other reliable data were available for 4-pole, 60-cycle motors only. The conclusion which Mr. Specht arrived at concerning the curves of Fig. 6 might be said to be characteristic of the results that might be expected from the use of that method, for as I tried to show by the curves of Fig. 6, the action of each rotor winding is altogether different from that which it would have if the other winding were removed.

The method of calculation which I have outlined in the paper is too complicated for general routine design work, but, in my

opinion, the design of a motor of which many thousands will be built, is of sufficient importance to justify the carrying out of a number of complete calculations so as to determine the most economical use of materials, to get a better idea of the best proportions of the design constants, and to learn how the operating characteristics of a motor will be affected by a change in any one of the design constants.

I am in complete agreement with Mr. Alger except in regard to the way in which squirrel-cage resistance affects the starting torque. At standstill, the current in the squirrel cage is almost all in the field axis, since the commutated winding effectively shields the squirrel cage in the transformer axis. The effect of the squirrel-cage resistance is to cause the field flux to lag the line current in time phase, thus making it less effective in producing torque.

In reply to Mr. Hansen's question about the no-load losses, it may be said that the no-load losses need never be objectionable. The larger the motor, the lower the percentage no-load losses may be made. For a 10-h. p. motor, the no-load losses are approximately 11 per cent of the full-load input.

I am glad that Mr. Hansen has succeeded in working out the theory of single-phase commutator motors by the revolving-field method, for it seems that it is necessary to use the revolving-field method in order to allow properly for the effects of eddy currents in the squirrel-cage bars.

The revolving-field method and the cross-field method both have their advantages, and in my opinion neither method should be used to the exclusion of the other. The revolving-field theory allows for the variation of inductance and resistance with frequency variations in the rotor conductors and would give the slip-frequency and double-frequency components of the rotor current directly. On the other hand, the cross-flux theory is, in my opinion, easier to work with, especially for commutator motors, and in the case of the squirrel-cage repulsion motor gives a clearer picture of the effect of the squirrel-cage currents on the power factor than would be obtained from the revolving-field point of view. The "current in the transformer axis of the squirrel cage" and the "current in the field axis of the squirrel cage," which are given directly by the cross-field method, have definite and very useful physical meanings.

I regret that Mr. Hansen has not completely worked out the equations for the squirrel-cage repulsion motor following the revolving-field method. I believe that the equations which he would obtain by that method, starting with the same assumptions, would be identical in form with mine. At least it should be possible to transform the equations obtained by one method into those obtained by the other. Possibly his final equations would appear in a form that would give an easier method of calculation than mine. A direct comparison of equations would be more convincing and probably easier than a comparison of calculated data.

THE TRANSMISSION UNIT AND TELEPHONE TRANSMISSION REFERENCE SYSTEMS¹ (MARTIN)

CHICAGO, ILL., JUNE 25, 1924

A. M. Wilson: Of course the application of preferred numbers offers a very reasonable solution for a number of problems that are arising more and more with different sizes of equipment and materials; but the use of the distortionless circuit should be of service in connection with problems in inductive interference.

I should like to know if there is any possibility of using this type of circuit in investigations of inductive interference, instead of, or in conjunction with, the telephone interference factor meter.

The type of meter is connected to a power circuit, for the purpose of indicating what may be going on in a neighboring telephone circuit. It would seem more logical, and very desirable, to have an instrument connected directly in the telephone circuit, to indicate the effects produced in the telephone circuit.

1. A. I. E. E. JOURNAL, Vol. XLIII, June, p. 504.

W. H. Martin: Referring to Mr. Wilson's question, a distortionless circuit of the type referred to has been used in a fundamental investigation in the laboratory of the effects of loudness, distortion and the presence of noise on the intelligibility of reproduced speech sounds. For this purpose, the circuit was arranged so that all three of these factors could be varied, either separately or in combination. In this way, the circuit is of service in connection with the consideration of the noise produced in telephone circuits by induction from electrical power systems.

The telephone-interference-factor meter was designed to provide a ready and portable means for rating the wave shapes of power systems and apparatus from the standpoint of producing interference to telephone circuits. As described in the paper by H. S. Osborne in the 1919 TRANSACTIONS of the A. I. E. E., it is based on the interfering effects of extraneous single-frequency currents in a commercial telephone receiver on the intelligibility of speech sounds given out by the receiver and also on the general relation that the current induced in telephone circuits by a given voltage or current in a power circuit is approximately proportional to the frequency. It, therefore, takes into account both the inductive effect between the power and telephone circuits and the interfering effect of the currents in the telephone circuit. The distortionless circuit which has been described in the paper on the transmission unit does not provide a means for measuring interference which can be used instead of, or in conjunction with, the telephone-interference-factor meter.

THE TRANSIENT VISUALIZER¹ (TURNER)

CHICAGO, ILL., JUNE 25, 1924

J. R. Craighead: This device serves the purpose of repeating a transient so that it can be properly studied by the eye or where there is any question of suitable illumination can be better photographed because of repetition. This should lend itself to the use of higher velocities and consequently larger and more easily readable records on the oscillograph than have been obtained. The possible limit of speed on the oscillograph in the direction of the motion of the film is chiefly the photographic effect. This device should enable the photographic effect to be much improved, provided the nature of the switch is such that duplication can be assured in the transient at excessively high speeds. Can Mr. Palmer furnish any statement regarding the practicable limits?

Another point which enters into the successful duplication of a transient is the effect of varying contact in a switch. In attempting to get single transients at definite points in the e. m. f. wave, I have had occasion to work with somewhat larger currents and the results have not been successful. That is, it is possible to construct a switch for small currents or for potentials which carry practically no current at which duplication can be made quite accurately.

When we get to apparatus the size of ordinary oil switches and large circuits, this kind of duplication is not practicable because although the actual duplicating relay can be made to operate accurately, the oil switch itself has a sufficient variation in time so that it is not practicable to secure a duplication of the particular point on the wave that is desired.

In regard to the separation of components of wave forms, as mentioned on page 5, the method of separation is not very clearly stated. I understand it to be the use of the transient visualizer to maintain a constant zero, and alteration of the circuit connections is necessary to obtain the oscillogram in each particular case. I should like to ask Mr. Palmer whether this solution is that which is intended.

H. M. Turner: Mr. Craighead raised the question regarding duplication at high film speed. I can say that we have experienced no difficulty with retracing when operating at a

film speed of 1200 ft. per min. Usually, however, we are operating at 600 ft. per min. and the retracing is practically perfect. It should be pointed out that a small constant friction load on the photographic drum shaft is necessary to prevent oscillations.

So far as current-carrying capacity is concerned there is no reason why it cannot be greatly increased by using wider brushes. In demonstrating fundamental principles there is no particular advantage in using large currents. In general it is convenient to use currents of 15 amperes or less. However, when studying the performance of particular pieces of equipment where several hundred amperes, or in extreme cases, probably several thousand are involved a special design would be required. In the case of alternating current advantage may be taken of the fact that the circuit may be opened when the current is at or near the zero value.

With reference to the method of separating the components, the transient visualizer makes it possible to start all components from the same point on the film. First, the transient current is taken by closing the circuit at the desired point at the electromotive force wave. Second, the transient visualizer is short-circuited and the permanent component is taken. Third, with the permanent component flowing through the oscillograph element in the reversed direction the line is short circuited by means of the transient visualizer and the transient component is taken in proper relation. In order to avoid tripping the circuit breaker two identical circuits are connected in series and the short circuit is applied to one of them.

TEMPERATURE RISE OF STATIONARY ELECTRICAL APPARATUS AS INFLUENCED BY RADIATION, CONVECTION AND ALTITUDE¹

(MONTSINGER AND COONEY)

EFFECT OF ALTITUDE ON TEMPERATURE RISE²

(DOHERTY AND CARTER)

CHICAGO, ILLINOIS, JUNE 25, 1924

W. J. Foster: For a great many years I have been a party to the effort to obtain correction factors for rotating machinery from data collected at high altitudes and at sea level, thus deriving empirical formula, but I must confess that it seems a hopeless task.

I think Messrs. Doherty and Carter have pursued the only feasible method, that is, establish the conditions of air density by exhausting the air in something similar to the drum they have used. After all this is done, there remains the difficulty of classifying rotating apparatus. There is the wide open machine where no attempt whatever is made to give direction to the movement of air which is the cooling medium, and on the other hand, the totally inclosed machine where practically all the heat is carried off by the air passing through. Between those two we have all kinds of partially inclosed machines, and the effect on temperature rise is often very accidental. That is why it is so difficult to determine the proper correction even though you use a large number of cases between machines that have been tested at approximately sea level and after installation at high altitudes.

One can understand this statement if he is familiar with what often happens on the testing floor of the manufacturer. If for any reason a machine is changed in its position during test (I am now speaking of a machine that is largely open or only partially inclosed) the resultant temperatures with the same conditions of load will vary a few degrees, due to the movement of the air, to the amount of air passing through and to the other machines that happen to be running in the vicinity.

I have seen the same thing in machines installed outside, *e. g.*, in the case of a 5000 kw. direct-connected steam-engine-driven generator at low speed, where temperatures were known at certain times to be considerably higher than at other times.

1. A. I. E. E. JOURNAL, Vol. XLIII, September, p. 803.

2. A. I. E. E. JOURNAL, Vol. XLIII, December, p. 1143.

1. A. I. E. E. JOURNAL, Vol. XLIII, December, p. 1148.

After careful examination it was found due to the accident of the direction of the wind outside the building when the machine was started up.

I have watched Mr. Montsinger with considerable interest during the last ten years in his efforts to obtain proper correction factors for stationary apparatus. I think he has the problem quite well solved, and Mr. Doherty I think has attacked the problem in the correct manner.

When I first studied heat many years ago in the secondary schools, we had the dissipation of heat as due to radiation, conduction and convection. I still like to think of the conduction

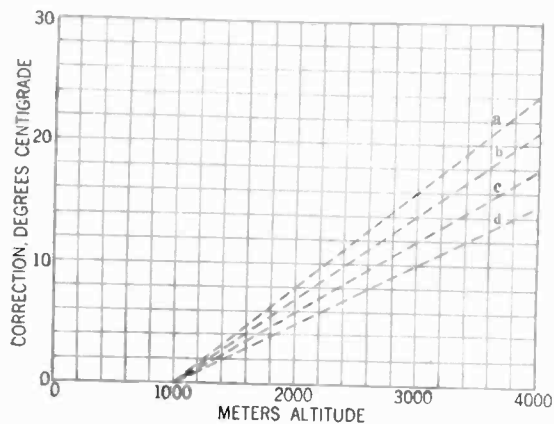

FIG. 1—PRESENT A. I. E. E. RECOMMENDATION FOR TEMPERATURE-RISE CORRECTION

This covers machines intended to operate at altitudes above 1000 meters. The curves (a) (b) (c) and (d) show the value of the correction in degrees centigrade, which amounts to 10 per cent of the standard temperature rise, applied to machines having:

- (a) Class B insulation, 80 deg. standard rise by embedded detector.
- (b) " B " 70 " " " " thermometer.
- (c) " A " 60 " " " " embedded detector.
- (d) " A " 50 " " " " " thermometer.

factor and in a totally inclosed machine of the cooling medium, the air which passes through as a carrier quite similar to what we would have if we used water or some liquid which would have greater capacity for heat than the air; I think that makes the problem simpler in totally inclosed machines.

When it comes to a matter of establishing standards, I hope to see this whole subject put on the basis of sea level and the formula for convection applied from sea level. It seems to me that is the only scientific way for a body of engineers to proceed in standardization.

E. B. Paxton: The present A. I. E. E. Standards Rule (Paragraph 2215) recommends that the temperature rise of electrical machinery intended for operation at high altitudes shall be reduced at the rate of 10 per cent for each 1000 meters by which the altitude exceeds 1000 meters. A comparison of the values given in the first column of Table I of the paper by Messrs. Doherty and Carter shows this value to be in close agreement with the results given there for rotating machinery, namely, the values: 9 per cent, 10.7 per cent and 11 per cent.

The present A. I. E. E. rule makes no distinction between methods of temperature measurement when applying the altitude correction, whereas strictly speaking a lesser percentage should be employed when correcting for temperature rise measured by embedded temperature detectors than when correcting for temperature rise measured by thermometer on the surface due to the increased percentage base. A graphical interpretation of the present A. I. E. E. rule applied to the limiting temperature rises allowed for Class A and B insulation, which shows the correction in degrees instead of per cent, is given in Fig. 1.

Following this rule it is evident that a machine with Class A insulation specially rated for operation at 3000 meters will be given a rating occasioned by

(1) 50 deg. $- (10\% \times 2 \times 50) = 40$ deg. rise, at sea level if the temperature is measured by surface thermometer; or

(2) 60 deg. $- (10\% \times 2 \times 60) = 48$ deg. rise at sea level if the temperature is measured by embedded temperature detector.

The correction is 10 deg. in the first case and 12 deg. in the second case. Obviously for a given load the drop from the copper to the surface is the same regardless of the altitude so that the number of degrees correction should be the same in either case. The method of expressing the correction in per cent based on a single percentage base is incorrect to this extent.

Mr. Doherty has recognized this fact in his paper by establishing a lower percentage correction when internal temperature is considered as shown by the second column of values in Table I. Had the corrections been expressed in degrees correction rather than in percentage of rise correction, one set of values would replace the two sets of percentages given for internal and surface measurements for any one class of insulation. For example the percentage established for Turbine Generator fields with

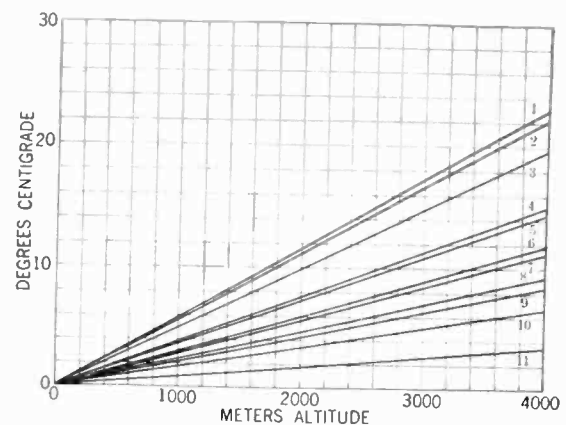

FIG. 2—INCREASE IN TEMPERATURE RISE OF VARIOUS MACHINES WITH ALTITUDE

The increase is given in degrees C. The values are computed from the values in the Doherty and Carter paper.

- (1) Turbine generator fields (rotors), enclosed ventilation, 11 per cent of 52-deg. surface rise or 7.15 per cent of 80-deg. internal rise.
 - (2) Air-blast transformers, 11 per cent of 50-deg. rise, surface or internal.
 - (3) Generator and motor bare-copper-strip fields, open type, 9 per cent of 55 deg. rise.
 - (4) Turbo-generator armatures, enclosed ventilation, and generators and motors, enclosed type, 10.7 per cent of 35-deg. surface rise or 6.25 per cent of 60-deg. internal rise.
 - (5) Generators and motors with insulated fields and armatures, open type, 9 per cent of 40-deg. surface rise or 6.5 per cent of 55-deg. internal rise.
 - (6) Totally enclosed motors, 5.35 per cent of 55-deg. rise.
 - (7) Reactors and bus bars, 4.7 per cent of 60-deg. rise.
 - (8) Natural-draft transformers, 4.6 per cent of 50-deg. rise.
 - (9) Rheostats, meters and miscellaneous stationary apparatus, 4.2 per cent of 50-deg. surface rise.
 - (10) Oil-insulated self-cooled corrugated-tank transformers, 4.2 per cent of 40-deg. surface rise or 3.06 per cent of 55-deg. internal rise.
 - (11) Oil-insulated self-cooled, plain-tank transformers, 2.2 per cent of 40-deg. surface rise or 1.6 per cent of 55-deg. internal rise.
- Based on 10 per cent and 4 per cent of A. I. E. E. Standard temperature rise.

enclosed ventilation is 11 per cent of 52 deg. surface temperature rise or 7.15 per cent of 80 deg. internal temperature rise = approximately 6 deg. correction per 1000 meters.

Fig. 2 shows the values given by Mr. Doherty expressed in degrees instead of percentages. He arrived at these values by selecting typical cases of temperature rise for a given type of machine and applying the percentage correction. Consideration of the first column of percentages in Table I of the paper or of Fig. 2 shows that all apparatus falls roughly into one of two groups to which the correction percentages of 10 per cent and

4 per cent per 1000 meters for surface temperature may be fairly definitely applied. These two groups are as follows:

- | | |
|--|-------|
| Rotating Machines (Except Totally Enclosed Motors) | } 10% |
| Air Blast Transformers | |
| Transformers (Except Air-Blast Transformers) | } 4% |
| Reactors and Busbars | |
| Rheostats, Meters, Relays and Miscellaneous Stationary apparatus | |
| Totally Enclosed Motors | |

The dotted lines in Fig. 3 show the degrees correction obtained by applying the above percentages to the standard A. I. E. E. temperature rises for Class A and Class B insulation.

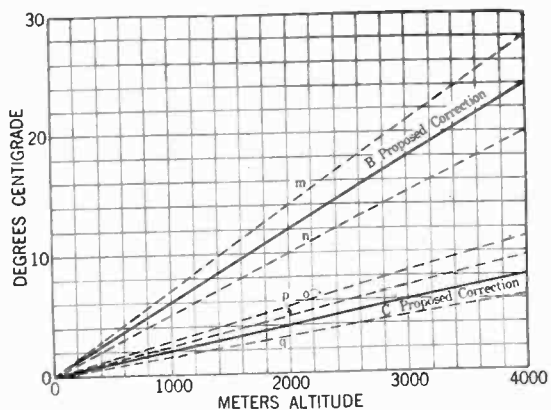

FIG. 3—INCREASE IN DEGREES TEMPERATURE RISE WITH ALTITUDE

Curve	Per Cent	Surface Rise
(m)	10	70
(n)	10	50
(o)	4	70
(p)	4	60
(q)	4	40

The proposed corrections are shown by curves (B) and (C). (B) is 10 per cent of 60-deg. surface rise. (C) is 4 per cent of 50-deg. surface rise.

The solid lines show a compromise between the dotted lines which should be sufficiently accurate for standardization purposes.

Fig. 4 shows a superposition of the curves in Fig. 1, Fig. 2 and Fig. 3, namely:

The preceding part of this discussion has served to correlate the data at hand and enables a proposition for the numerical values of a standard correction to be made. The remaining problem is one of application in the A. I. E. E. Standards.

The present A. I. E. E. Rule, par. 2215 reads as follows:

"2215 **Altitude.**—Increased altitude has the effect of increasing the temperature rise of some types of machinery. In the absence of information in regard to the height above sea level at which a machine is intended to work in ordinary service, this height is assumed not to exceed 1000 meters (3300 ft.). For machinery operating at an altitude of 1000 meters or less, a test at any altitude less than 1000 meters is satisfactory, and no correction shall be applied to the observed temperatures. Machines intended for operation at higher altitudes shall be regarded as special. It is recommended that when a machine is intended for service at altitudes above 1000 meters (3300 ft.) the permissible temperature rise at sea level, shall be reduced by 1 per cent for each 100 meters (330 ft.) by which the altitude exceeds 1000 meters."

There are two objections to the rule as stated:

(1) The rule is loose in that a machine tested anywhere under 1000 meters is considered suitable for operation anywhere under 1000 meters. This may lead to a difference in temperature rise of about 6 degrees, thus causing the temperature of a machine to exceed the allowable temperature limit by that amount when operating at 1000 meters in a 40 deg. ambient temperature, if it is tested near sea level at the limiting standard temperature rise, as many machines now are.

(2) The rule states that all machines for operation above 1000 meters shall be regarded as special.

In the interests of economy it is advisable to reduce insofar as possible the special applications of machines. Fundamentally there is no more reason why there should be a multiplicity of ratings for different altitudes than for different temperatures of the air in which a machine must work due to different climatic conditions. The effect of increased temperature, due to increase in temperature rise, of a machine operating at abnormal altitudes is of no more consequence than the same effect, due to an average correspondingly great difference in ambient air temperatures, existing in different localities. Yet in the former instance it has been considered necessary to give the machine a rating based on an entirely different temperature rise. Weather Bureau reports show a difference of 11 deg. cent. for the month of July between the normal surface temperatures of the northern and southern portions of the United States, a difference in temperature which corresponds to the extreme correction necessary for an increase in altitude of 2000 meters, namely that for turbine-generator fields. For this difference of 11 deg., which occurs in innumerable more instances than a similar difference for altitude, there is no provision made in the A. I. E. E. Standards—nor should there be. The mean daily maximum temperature for the month of July for same regions differ by about 17 deg. cent. which corresponds to the extreme correction for an increase in altitude of nearly 3000 meters.

There is also probably the less reason for these different ratings for different altitudes because generally the effect of increased altitudes is offset by lower ambient temperature conditions. A report published by the weather bureau of the United States makes the statement that:

"The observed decrease in temperature with elevation is, on the average about 1 degree Fahrenheit for 330 ft. (5.5 deg. cent. per 1000 meters): it is more rapid in summer than in winter."

If credence can be attached to the above statement there will be only a very occasional occurrence of such unusual conditions

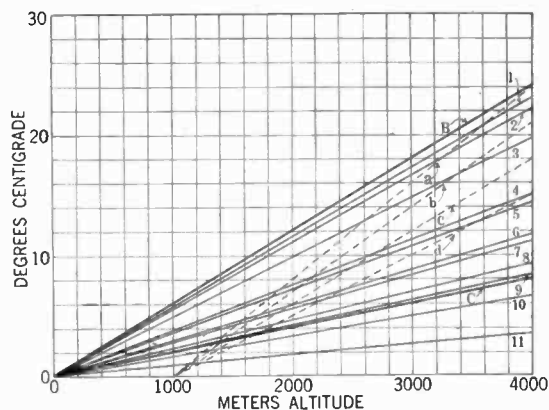

FIG. 4—HOW PROPOSED CORRECTIONS COMPARE NUMERICALLY WITH PRESENT A. I. E. E. RECOMMENDATION AND EXPERIMENTAL DATA

This chart is a combination of Figs. 1, 2 and 3. Curves (1) to (11) are calculated from experimental data on various machines as listed under Fig. 1. Curves (a), (b), (c) and (d) are the present A. I. E. E. recommendations as shown in Fig. 2. Curve (B) is the proposed temperature correction for the kinds of apparatus shown by curves (1) to (5). Curve (C) is the proposed correction for kinds of machines shown by Curves (6) to (11). These two curves are shown also in Fig. 3.

of service as to warrant special consideration. It should be borne in mind, however, that in many instances machines are operated in buildings the inside temperatures of which may not correspond closely to the outside temperatures.

The matter of application of machines for high altitudes could be greatly simplified by considering altitude as one of the service conditions that affect the heating of electrical machinery in operation. The correction could be made most simply and

effectively by considering it in connection with the limiting ambient temperature in which a machine may safely carry its rated load.

Fig. 5 shows the limiting ambient temperature at various altitudes in which a standard apparatus, rated on a basis of sea level, may be expected to carry its rated load without exceeding the maximum limiting temperature established by the A. I. E. E. Standards. It will be clearly seen that these curves have been arrived at by subtracting from a 40-deg. ambient the resultant correction given in Fig. 3.

Expressed in words the proposed guide would be:—Rotating machines (except totally enclosed motors) and air-blast transformers.

These types of apparatus shall be suitable for carrying their rated load provided the ambient temperature does not exceed a value of 40 deg., less 6 deg. for each 1000 meters by which the altitude exceeds sea level.

Transformers (except air-blast transformers)

Reactors and bus bars

Rheostats, meters, relays and

Miscellaneous stationary apparatus

Totally enclosed motors.

These types of apparatus shall be suitable for carrying their rated load provided the ambient temperature does not exceed a value of 40 deg., less 2 deg. for each 1000 meters by which the altitude exceeds sea level.

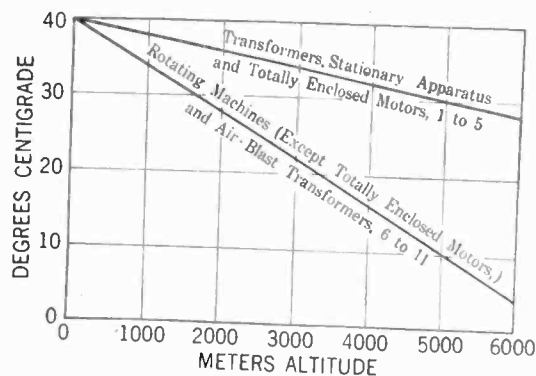

FIG. 5—PROPOSED RULE LIMITING COOLING-AIR TEMPERATURE AT HIGH ALTITUDES

This chart illustrates the proposed rule which designates the limiting ambient temperature in which standard apparatus rated on a basis of sea level may be expected to carry rated load without exceeding the maximum limiting temperature.

The effect of the proposed method of applying the rule is to make the correction definite over all altitudes including altitudes less than 1000 meters. But it should be noted as important that a standard apparatus rated on a basis of sea level would be on the proposed basis suitable for operation up to at least 1000 meters under usual conditions of service and that the size or rating of machines applied under these conditions will not be changed. Furthermore, the effect is to regard the application of apparatus at higher altitudes as special either by de-rating or using a larger machine, only when the higher altitude is coupled with unfavorable values of ambient temperatures, as given by the proposed rule.

L. B. Cherry: I wish to ask Messrs. Montsinger and Doherty if, in their research, due consideration was given to the possible effects that varying degrees of humidity might have on the rise of temperature. It is readily seen, that even at high altitudes, equipment might be installed in basements or even under-ground enclosures where, with contributing sources of moisture, and under conditions of poor ventilation, sea-level conditions of humidity might prevail, and thus effect heat radiation. Do varying degrees of humidity seriously effect radiation?

H. M. Hobart: I want to speak in favor of Mr. Paxton's proposition. This is a subject on which we have been working in the Standards Committee for a good many years but we have had to wait for Mr. Paxton to show us the simple and satisfactory way to deal with it.

I don't think that from Mr. Paxton's brief presentation we would all be sufficiently impressed with its merits and I hope that it will be given the most careful study.

There is one little matter that ought to be taken into account in actually working out the way in which Mr. Paxton's plan should be assimilated into the standardization scheme, if it meets with the approval with which I hope it will meet, and that is that all these little refinements when we are able to figure them out to a nicety result in showing people how to work closer to the so-called approved limit. It comes within the ability of the operating engineers to load their machines for a larger part of the time up to those values that have been described as "approved" limits. Now when these limits were established, they were associated with conditions which practically ensured that the average temperature reached was 10, 15 or more degrees below the established limit. But when people are encouraged to take up this very interesting practise of adjusting the load, putting on more and more load until a limiting value is reached or approached, the deterioration of insulation is bound to be more rapid. The deterioration may still be quite slow, the machine may have a satisfactorily long life, but even though the life may be satisfactory, it is bound to be shorter than if it were running at a lower temperature. Maybe 105 deg. is too conservative or maybe it is just right, but whichever it is, the machine will have a shorter life with this new knowledge that we are getting, tempting us to approach limits, than when we kept further away from those limits, regarding them as sorts of danger signals. I don't say there is any danger in approaching and staying at those limits; that is a point to be investigated but certainly it is a new and comparatively untried thing to operate machines in accordance with this new conception of the limiting values and it is bound to shorten their life. The life may still be entirely satisfactory but it can't help being shorter as far as relates to insulation deterioration. I don't believe insulation deterioration is often a factor determining the life of a machine. Other factors enter in determining when a machine should be thrown out and a new machine put in. Nevertheless, it is a fact if you have a scheme of things that makes you run 5 or 10 deg. higher temperature than you used to run, as far as the insulation is concerned, the life of the machine will be shorter, and that ought to be taken into account in working this scheme into the plan of things. If 105 deg. is the right limit with the old ideas, it ought to be reduced to 100; if 105 is already too conservative on the old ideas, it will probably be about right for the new basis.

J. R. Craighead: I want to put in one little plea for simplicity in this rule. The feature I think that has been most satisfactory in the previous rules has been the fact that virtually there was no rule up to 1000 meters. That allowance was made as representing the general conditions under which apparatus satisfactory at sea level would work reasonably well.

Now Mr. Paxton's rule as shown in Fig. 5 would require that for every foot advanced from sea level there is a definite change in the condition under which a customer can operate his apparatus. I think that is really impracticable. Whether the rules are made this way or not it will be necessary for the operator, and to some extent the manufacturer, to base their work on the idea that there is a flat step at the start of the curve, a rise over which apparatus for sea level can be used without special investigation or separate temperature limit. And it would seem to me a very desirable thing that the Institute rules should be so worded or arranged that this flat step is taken care of in the rules. At the present time this is up to 1000 meters; possibly that is not the correct value for it, but some flat first step should be assumed.

E. B. Paxton: I would like to say in regard to the point Mr. Craighead made, that the correction up to 1000 meters would generally be so small it might be regarded as negligible in operating the machine, that is, no one who operates the machine is going to worry about whether ambient temperature is 36 deg. or 40 deg.

What I am proposing is that this correction be applied as a matter of operating, as one of the service conditions which will affect the way the machine may be operated rather than to make it apply to the rating of the machine.

There is one further point I would like to make in that same connection and that is that there is a natural tendency for the temperature of the cooling air to be less at the higher altitudes. The weather bureau made the report that the temperature would probably decrease $5\frac{1}{2}$ deg. for every 1000 meters of altitude. Now just how much credence should be given to that for the reason that machines are often operated inside, is a question, but I think very likely the inside temperature drop may be of a corresponding degree.

N. S. Diamant (by letter): In Doherty and Carter's paper the statement appears that the heat transmission by convection was practically unchanged when the surface was painted with aluminum. It would appear as if they imply free convection. So, their results and their theory would seem to be in contradiction to the tests submitted several years ago by the late John R. Allen of the University of Michigan to the Society of Heating and Ventilating Engineers. Allen found that with aluminum paint the heat transmission by free convection of ordinary house radiators was reduced from 100 per cent for a bare unpainted cast-iron radiator to 75 per cent. The effect of other paints seemed to be on the same side, namely, there was a decrease in free convection for most paints that were tried.

Tests I have made several years ago on the effect of paint on forced convection agrees with that of the authors, namely, that the paint has no effect on forced convection.

In connection with this subject it may be added that it has been found by Allen and other investigators that it is the last coat of paint that effects heat transmission by free convection.

With reference to the effect of altitude on the cooling of dynamo electric machines of the rotating type or machines cooled by forced convection, some very interesting material will be found in the excellent work done by the Bureau of Standards on the cooling of airplane engines when flying in various altitudes.

F. D. Newbury: I desire to discuss these two papers from the standpoint of their relation to the A. I. E. E. Standards. I have had the privilege of reading Mr. Paxton's valuable discussion, and wish to endorse his suggestion that the altitude correction in the Standards apply to the limiting value of cooling-air temperature rather than to temperature rise. The adoption of this suggestion would completely avoid the necessity for special machines designed for special temperature rises and places this question of altitude correction among service conditions where it properly belongs.

The present Institute Standards, paragraph 2215, provide that no correction for altitude shall be made for altitudes of 1000 meters and less. The data presented by Messrs. Doherty and Carter indicate that for rotating machines the correction at 1000 meters would be in the neighborhood of 6 deg. with proportionately smaller corrections for lower altitudes. In spite of this maximum difference of about 6 deg. I believe the present provision that no correction for altitude be made except for altitudes above 1000 meters should be retained. This suggestion is made in the interest of simplicity, and because this rule has been well-established, not only in this country, but in practically all of the important manufacturing countries. The I. E. C. Rules for Electrical Machinery contain the following paragraph:

"Altitude.—In the absence of any information in regard to the height above sea level at which the machines is intended to work in ordinary service, this height is assumed not to exceed

1000 meters. If the machine is intended to work at an altitude above 1000 meters, a correction to the temperature rise should be applied. The value for this correction has not yet been fixed by the I. E. C."

As an example of British practice, the British Standard Specification for Electrical Performance of Industrial Motors and Generators (No. 168 of 1923) maybe quoted:—

"The Standard Ratings provided in this Specification are suitable for machines operating at altitudes not exceeding 3300 ft. above sea level. Machines for use at higher altitudes are dealt with in Clause 44. Machines intended for service at altitudes above 10,000 ft. are not considered standard."

(Clause 44.) "When a machine intended for service at high altitudes is tested near sea level, the limits of temperature rise given in Table I shall be reduced $1\frac{1}{2}$ per cent for each 1000 ft. above sea level at which the machine is intended to work in service. The correction shall not be applied for altitudes below 3300 ft."

The German Rules (V. D. E. of 1923) apply to "Generators operating at an altitude of 1000 meters or less. Special agreement is necessary for higher altitudes."

As an example of French practice, the French Standards for Electrical Machinery produced, by the heavy-machinery manufacturers and approved by l'Union des Syndicats de l'Electricite, July 22, 1920, contain a paragraph to the same effect as paragraph 2215 of the A. I. E. E. Standards.

It will be observed that the rule providing for no correction up to and including 1000 meters has been adopted by the I. E. C. and by four of the most important manufacturing countries. Any change of the A. I. E. E. Standards in this particular would undoubtedly be difficult to establish internationally, and we should differ from established international standards only when the importance of the matter is very great.

From the standpoint of our every-day work, I believe the present rule providing for a correction only above 1000 meters should be retained. The great bulk of electrical apparatus is operated in locations having an altitude less than 2000 ft. (600 meters). All of the eastern half of the United States (east of 100 deg. longitude, passing through Texas, Oklahoma, Kansas, Nebraska, and the Dakotas), is less than 2000 ft. altitude, except for the higher ridges of the eastern mountains. The experimental data furnished by these two papers show that the correction for 1000 meters amounts to a reduction of 4 deg. to 6 deg. for various parts and types of rotating machines, applied either to the guaranteed temperature rise, or, as proposed by Mr. Paxton, applied to the 40 deg. cooling-air temperature. Probably more than 95 per cent of the rotating machinery built in the United States is installed in locations having altitudes less than 2000 ft., for which the permissible cooling-air temperature would be reduced, according to the papers under discussion, only 2 or 3 deg. For transformers, the reduction in permissible air temperature for altitudes less than 1000 meters would be less than 1 deg. If the proposal for a correction starting at sea-level were adopted, I am confident it would be a dead letter for the great majority of electrical apparatus tested.

The data presented in these papers indicate that some change in the present correction should be made for altitudes sufficiently high to make the correction worth while. As I have indicated, I believe we should retain the present plan of no correction until 1000 meters is exceeded. I believe also that we should adopt Mr. Paxton's suggestion, and apply the altitude correction to the permissible cooling-air temperature, instead of to the guaranteed temperature rise, as now provided for in the A. I. E. E. Standards. In order to retain the present rule of no correction until 1000 meters is exceeded, and at the same time make the corrections for higher altitudes agree with the experimental data that has been presented, and further, to avoid odd and fractional values of limiting air temperatures, I suggest that the Standards contain a table of definite limiting cooling-air temperatures for various altitudes, instead of a general rule expressed either by a formula or by a curve.

effectively by considering it in connection with the limiting ambient temperature in which a machine may safely carry its rated load.

Fig. 5 shows the limiting ambient temperature at various altitudes in which a standard apparatus, rated on a basis of sea level, may be expected to carry its rated load without exceeding the maximum limiting temperature established by the A. I. E. E. Standards. It will be clearly seen that these curves have been arrived at by subtracting from a 40-deg. ambient the resultant correction given in Fig. 3.

Expressed in words the proposed guide would be:— Rotating machines (except totally enclosed motors) and air-blast transformers.

These types of apparatus shall be suitable for carrying their rated load provided the ambient temperature does not exceed a value of 40 deg., less 6 deg. for each 1000 meters by which the altitude exceeds sea level.

Transformers (except air-blast transformers)

Reactors and bus bars

Rheostats, meters, relays and

Miscellaneous stationary apparatus

Totally enclosed motors.

These types of apparatus shall be suitable for carrying their rated load provided the ambient temperature does not exceed a value of 40 deg., less 2 deg. for each 1000 meters by which the altitude exceeds sea level.

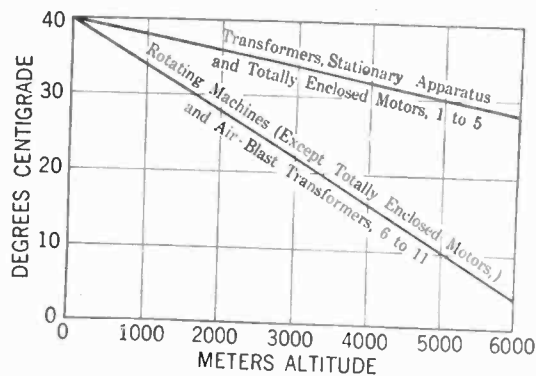

FIG. 5—PROPOSED RULE LIMITING COOLING-AIR TEMPERATURE AT HIGH ALTITUDES

This chart illustrates the proposed rule which designates the limiting ambient temperature in which standard apparatus rated on a basis of sea level may be expected to carry rated load without exceeding the maximum limiting temperature.

The effect of the proposed method of applying the rule is to make the correction definite over all altitudes including altitudes less than 1000 meters. But it should be noted as important that a standard apparatus rated on a basis of sea level would be on the proposed basis suitable for operation up to at least 1000 meters under usual conditions of service and that the size or rating of machines applied under these conditions will not be changed. Furthermore, the effect is to regard the application of apparatus at higher altitudes as special either by de-rating or using a larger machine, only when the higher altitude is coupled with unfavorable values of ambient temperatures, as given by the proposed rule.

L. B. Cherry: I wish to ask Messrs. Montsinger and Doherty if, in their research, due consideration was given to the possible effects that varying degrees of humidity might have on the rise of temperature. It is readily seen, that even at high altitudes, equipment might be installed in basements or even under-ground enclosures where, with contributing sources of moisture, and under conditions of poor ventilation, sea-level conditions of humidity might prevail, and thus effect heat radiation. Do varying degrees of humidity seriously effect radiation?

H. M. Hobart: I want to speak in favor of Mr. Paxton's proposition. This is a subject on which we have been working in the Standards Committee for a good many years but we have had to wait for Mr. Paxton to show us the simple and satisfactory way to deal with it.

I don't think that from Mr. Paxton's brief presentation we would all be sufficiently impressed with its merits and I hope that it will be given the most careful study.

There is one little matter that ought to be taken into account in actually working out the way in which Mr. Paxton's plan should be assimilated into the standardization scheme, if it meets with the approval with which I hope it will meet, and that is that all these little refinements when we are able to figure them out to a nicety result in showing people how to work closer to the so-called approved limit. It comes within the ability of the operating engineers to load their machines for a larger part of the time up to those values that have been described as "approved" limits. Now when these limits were established, they were associated with conditions which practically ensured that the average temperature reached was 10, 15 or more degrees below the established limit. But when people are encouraged to take up this very interesting practise of adjusting the load, putting on more and more load until a limiting value is reached or approached, the deterioration of insulation is bound to be more rapid. The deterioration may still be quite slow, the machine may have a satisfactorily long life, but even though the life may be satisfactory, it is bound to be shorter than if it were running at a lower temperature. Maybe 105 deg. is too conservative or maybe it is just right, but whichever it is, the machine will have a shorter life with this new knowledge that we are getting, tempting us to approach limits, than when we kept further away from those limits, regarding them as sorts of danger signals. I don't say there is any danger in approaching and staying at those limits; that is a point to be investigated but certainly it is a new and comparatively untried thing to operate machines in accordance with this new conception of the limiting values and it is bound to shorten their life. The life may still be entirely satisfactory but it can't help being shorter as far as relates to insulation deterioration. I don't believe insulation deterioration is often a factor determining the life of a machine. Other factors enter in determining when a machine should be thrown out and a new machine put in. Nevertheless, it is a fact if you have a scheme of things that makes you run 5 or 10 deg. higher temperature than you used to run, as far as the insulation is concerned, the life of the machine will be shorter, and that ought to be taken into account in working this scheme into the plan of things. If 105 deg. is the right limit with the old ideas, it ought to be reduced to 100; if 105 is already too conservative on the old ideas, it will probably be about right for the new basis.

J. R. Craighead: I want to put in one little plea for simplicity in this rule. The feature I think that has been most satisfactory in the previous rules has been the fact that virtually there was no rule up to 1000 meters. That allowance was made as representing the general conditions under which apparatus satisfactory at sea level would work reasonably well.

Now Mr. Paxton's rule as shown in Fig. 5 would require that for every foot advanced from sea level there is a definite change in the condition under which a customer can operate his apparatus. I think that is really impracticable. Whether the rules are made this way or not it will be necessary for the operator, and to some extent the manufacturer, to base their work on the idea that there is a flat step at the start of the curve, a rise over which apparatus for sea level can be used without special investigation or separate temperature limit. And it would seem to me a very desirable thing that the Institute rules should be so worded or arranged that this flat step is taken care of in the rules. At the present time this is up to 1000 meters; possibly that is not the correct value for it, but some flat first step should be assumed.

March 1925

E. B. Paxton: I would like to say in regard to the point Mr. Craighead made, that the correction up to 1000 meters would generally be so small it might be regarded as negligible in operating the machine, that is, no one who operates the machine is going to worry about whether ambient temperature is 36 deg. or 40 deg.

What I am proposing is that this correction be applied as a matter of operating, as one of the service conditions which will affect the way the machine may be operated rather than to make it apply to the rating of the machine.

There is one further point I would like to make in that same connection and that is that there is a natural tendency for the temperature of the cooling air to be less at the higher altitudes. The weather bureau made the report that the temperature would probably decrease $5\frac{1}{2}$ deg. for every 1000 meters of altitude. Now just how much credence should be given to that for the reason that machines are often operated inside, is a question, but I think very likely the inside temperature drop may be of a corresponding degree.

N. S. Diamant (by letter): In Doherty and Carter's paper the statement appears that the heat transmission by convection was practically unchanged when the surface was painted with aluminum. It would appear as if they imply free convection. If so, their results and their theory would seem to be in contradiction to the tests submitted several years ago by the late John R. Allen of the University of Michigan to the Society of Heating and Ventilating Engineers. Allen found that with aluminum paint the heat transmission by free convection of ordinary house radiators was reduced from 100 per cent for a bare unpainted cast-iron radiator to 75 per cent. The effect of other paints seemed to be on the same side, namely, there was a decrease in free convection for most paints that were tried.

Tests I have made several years ago on the effect of paint on forced convection agrees with that of the authors, namely, that the paint has no effect on forced convection.

In connection with this subject it may be added that it has been found by Allen and other investigators that it is the last coat of paint that effects heat transmission by free convection.

With reference to the effect of altitude on the cooling of dynamo electric machines of the rotating type or machines cooled by forced convection, some very interesting material will be found in the excellent work done by the Bureau of Standards on the cooling of airplane engines when flying in various altitudes.

F. D. Newbury: I desire to discuss these two papers from the stand-point of their relation to the A. I. E. E. Standards. I have had the privilege of reading Mr. Paxton's valuable discussion, and wish to endorse his suggestion that the altitude correction in the Standards apply to the limiting value of cooling-air temperature rather than to temperature rise. The adoption of this suggestion would completely avoid the necessity for special machines designed for special temperature rises and places this question of altitude correction among service conditions where it properly belongs.

The present Institute Standards, paragraph 2215, provide that no correction for altitude shall be made for altitudes of 1000 meters and less. The data presented by Messrs. Doherty and Carter indicate that for rotating machines the correction at 1000 meters would be in the neighborhood of 6 deg. with proportionately smaller corrections for lower altitudes. In spite of this maximum difference of about 6 deg. I believe the present provision that no correction for altitude be made except for altitudes above 1000 meters should be retained. This suggestion is made in the interest of simplicity, and because this rule has been well-established, not only in this country, but in practically all of the important manufacturing countries. The I. E. C. Rules for Electrical Machinery contain the following paragraph:

"Altitude.—In the absence of any information in regard to the height above sea level at which the machines is intended to work in ordinary service, this height is assumed not to exceed

1000 meters. If the machine is intended to work at an altitude above 1000 meters, a correction to the temperature rise should be applied. The value for this correction has not yet been fixed by the I. E. C."

As an example of British practice, the British Standard Specification for Electrical Performance of Industrial Motors and Generators (No. 168 of 1923) maybe quoted:—

"The Standard Ratings provided in this Specification are suitable for machines operating at altitudes not exceeding 3300 ft. above sea level. Machines for use at higher altitudes are dealt with in Clause 44. Machines intended for service at altitudes above 10,000 ft. are not considered standard."

(Clause 44.) "When a machine intended for service at high altitudes is tested near sea level, the limits of temperature rise given in Table I shall be reduced $1\frac{1}{2}$ per cent for each 1000 ft. above sea level at which the machine is intended to work in service. The correction shall not be applied for altitudes below 3300 ft."

The German Rules (V. D. E. of 1923) apply to "Generators operating at an altitude of 1000 meters or less. Special agreement is necessary for higher altitudes."

As an example of French practice, the French Standards for Electrical Machinery produced, by the heavy-machinery manufacturers and approved by l'Union des Syndicats de l'Electricite, July 22, 1920, contain a paragraph to the same effect as paragraph 2215 of the A. I. E. E. Standards.

It will be observed that the rule providing for no correction up to and including 1000 meters has been adopted by the I. E. C. and by four of the most important manufacturing countries. Any change of the A. I. E. E. Standards in this particular would undoubtedly be difficult to establish internationally, and we should differ from established international standards only when the importance of the matter is very great.

From the standpoint of our every-day work, I believe the present rule providing for a correction only above 1000 meters should be retained. The great bulk of electrical apparatus is operated in locations having an altitude less than 2000 ft. (600 meters). All of the eastern half of the United States (east of 100 deg. longitude, passing through Texas, Oklahoma, Kansas, Nebraska, and the Dakotas), is less than 2000 ft. altitude, except for the higher ridges of the eastern mountains. The experimental data furnished by these two papers show that the correction for 1000 meters amounts to a reduction of 4 deg. to 6 deg. for various parts and types of rotating machines, applied either to the guaranteed temperature rise, or, as proposed by Mr. Paxton, applied to the 40 deg. cooling-air temperature. Probably more than 95 per cent of the rotating machinery built in the United States is installed in locations having altitudes less than 2000 ft., for which the permissible cooling-air temperature would be reduced, according to the papers under discussion, only 2 or 3 deg. For transformers, the reduction in permissible air temperature for altitudes less than 1000 meters would be less than 1 deg. If the proposal for a correction starting at sea-level were adopted, I am confident it would be a dead letter for the great majority of electrical apparatus tested.

The data presented in these papers indicate that some change in the present correction should be made for altitudes sufficiently high to make the correction worth while. As I have indicated, I believe we should retain the present plan of no correction until 1000 meters is exceeded. I believe also that we should adopt Mr. Paxton's suggestion, and apply the altitude correction to the permissible cooling-air temperature, instead of to the guaranteed temperature rise, as now provided for in the A. I. E. E. Standards. In order to retain the present rule of no correction until 1000 meters is exceeded, and at the same time make the corrections for higher altitudes agree with the experimental data that has been presented, and further, to avoid odd and fractional values of limiting air temperatures, I suggest that the Standards contain a table of definite limiting cooling-air temperatures for various altitudes, instead of a general rule expressed either by a formula or by a curve.

The following statement is suggested:

SERVICE CONDITIONS

Usual Service Conditions.

Temperature and Altitude.—Machines conforming with these standards shall be suitable for carrying their rated load, when the temperature of the cooling air does not exceed the values, at the corresponding altitudes, given below:

Up to and including 1000 meters (3300 ft.)	40 deg. cent.
Above 1000 meters to and including 1500 meters (5000 ft.)	35 deg. cent.
Above 1500 meters to and including 2000 meters (6600 ft.)	30 deg. cent.
Above 2000 meters to and including 3000 meters (10,000 ft.)	25 deg. cent.
Above 3000 meters	20 deg. cent.

The corresponding values for self-cooled transformers would be:

Up to and including 1000 meters (3300 ft.)	40 deg. cent.
Above 1000 meters to and including 3000 meters (10,000 ft.)	35 deg. cent.
Above 3000 meters	30 deg. cent.

V. M. Montsinger: From the nature of these discussions it is not necessary to comment on the various methods proposed for incorporating the altitude correction in the Standards. This must be considered at some future meeting of the Standards Committee.

In reference to Mr. Cherry's question about the effect of humidity on the temperature rise, the following are the approximate facts.

Humidity of course does not affect the loss of heat by radiation. The loss of heat by free convection is practically unaffected by the moisture unless the air is fog laden. The amount of water ordinarily in the air is so small even though the humidity is high that the effect is in the order of one per cent or less. The question of humidity has been considered but the conclusion was that for practical purposes it can be neglected.

R. E. Doherty: The authors are gratified that the results outlined in their paper may prove useful as a basis for the revision of the A. I. E. E. Rules relating to the subject.

The principle on which Mr. Paxton's plan is based is fundamentally sound, and the details of his plan are, in our opinion, the most promising that have been proposed.

Mr. Montsinger has answered Mr. Cherry's inquiry about humidity.

UNDERGROUND ALTERNATING-CURRENT NETWORK DISTRIBUTION FOR CENTRAL STATION SYSTEMS¹

(KEHOE)

GENERAL LIGHT AND POWER SUPPLY OF CHICAGO²

(ARMBRUST AND JACKSON)

A STUDY OF UNDERGROUND DISTRIBUTION SYSTEMS FOR THE CITY OF NEW ORLEANS³

(BULLARD)

CHICAGO, ILL., JUNE 26, 1924

E. R. Thomas: I would like to discuss a few things on the flicker problem which came up in Mr. Kehoe's paper. In Fig. 6 of his paper, there is a plot of some data that were collected on the flicker of incandescent lamps. This subject of lamp flicker dates back to the old problem of 25 versus 60 cycles, or what minimum frequency can be used for lighting. In the study of that subject we are indebted primarily, I believe, to Messrs. Kennelly and Whiting for their thorough research on critical frequency, which was made with a specially arranged Bunsen photometer.⁴

Fig. 1 herewith shows the results of their data and was primar-

1. A. I. E. E. JOURNAL, Vol. XLIII, June, p. 545.
 2. A. I. E. E. JOURNAL, Vol. XLIII, July, p. 608.
 3. A. I. E. E. JOURNAL, Vol. XLIII, November, p. 1058.
 4. The Frequency of Flicker at which Variation of Illumination Vanish, Kennelly and Whiting, *Trans. N. E. L. A.*, 1907, pp. 327.

ily intended as discussion of frequency in regard to flicker. Now, we are probably more interested in the so-called dip or wink, that is if we are going to put both power and light on the same set of mains, what will the increments of starting currents do to our light?

In connection with this, Messrs. Kennelly and Whiting have obtained some data of various ranges of flicker and plotted this

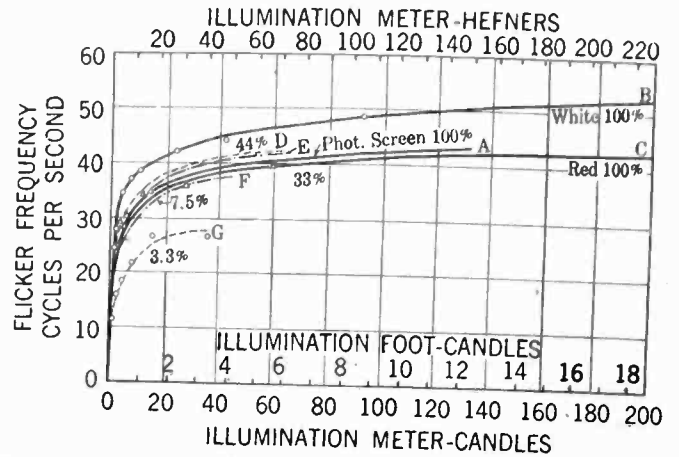

FIG. 1—CURVE OF FREQUENCIES AT WHICH FLICKERING IN DIFFERENT INTENSITIES OF ILLUMINATION, APPEARED TO VANISH

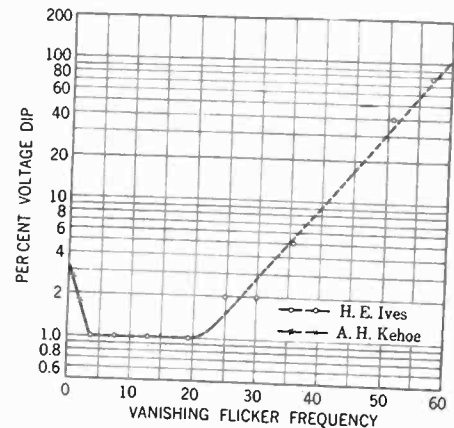

FIG. 2—VOLTAGE VARIATION WHICH CAUSES FLICKER PHENOMENA 25 WATT TUNGSTEN LAMP

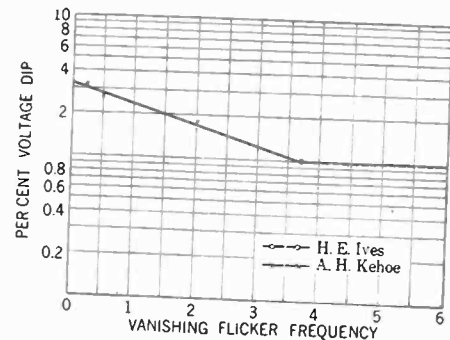

FIG. 3—VOLTAGE VARIATIONS WHICH CAUSE FLICKER PHENOMENA 25 WATT TUNGSTEN LAMP

against light intensities. These are shown by the curves, D, E, F, and G, that is 44, 33, 7.5 and 3.5 per cent flicker in light intensities.

Dr. H. E. Ives at the Bureau of Standards obtained some interesting data on flicker.⁵ He used a rather unique method in studying voltage dip. This consisted in employing an alternator whose voltage and frequency could be varied, and superimposing

5. Allowable Amplitudes and Frequencies of Voltage Fluctuation in Incandescent Lamp Works. H. E. Ives. *Trans. Illumination Engineering Society*, 1909, pp. 709.

March 1925

this a-c. voltage on a d-c. voltage. The proportion of a-c. voltage to d-c. voltage was varied to give a range from pure d-c. voltage to pure a-c. voltage.

Figure 2 is a replot on semi-log coordinates of Dr. Ives' data on 25-watt tungsten lamps. You will notice that it gives a rather straight-line plot through the points. To this I have added a plot of the data collected by Mr. Kehoe, which appears in the lower left-hand corner. I believe that the reversal of these curves may probably be explained as depending on the physical reactions on the pupil of the eye attempting to adapt itself to a varying intensity of light.

Figure 3 is merely a repetition of Fig. 2 showing some of Mr.

Messrs. Kennelly and Whiting have stated that this flicker frequency ceases to be objectionable at less than 7.5 per cent. Their figures are all given in terms of illumination, while ours are in per cent of voltage fluctuation. The 7.5 per cent change in illumination corresponds to about 2.4 per cent voltage variation on an ordinary Mazda lamp, thus checking our research fairly closely.

J. E. B. Stuart, Jr.: The remarks I want to make concern a continuation of some of the arcing data taken in connection with Mr. Kehoe's paper.

All of the data presented in the paper were taken with the idea of establishing a critical-point curve, or something like that, but

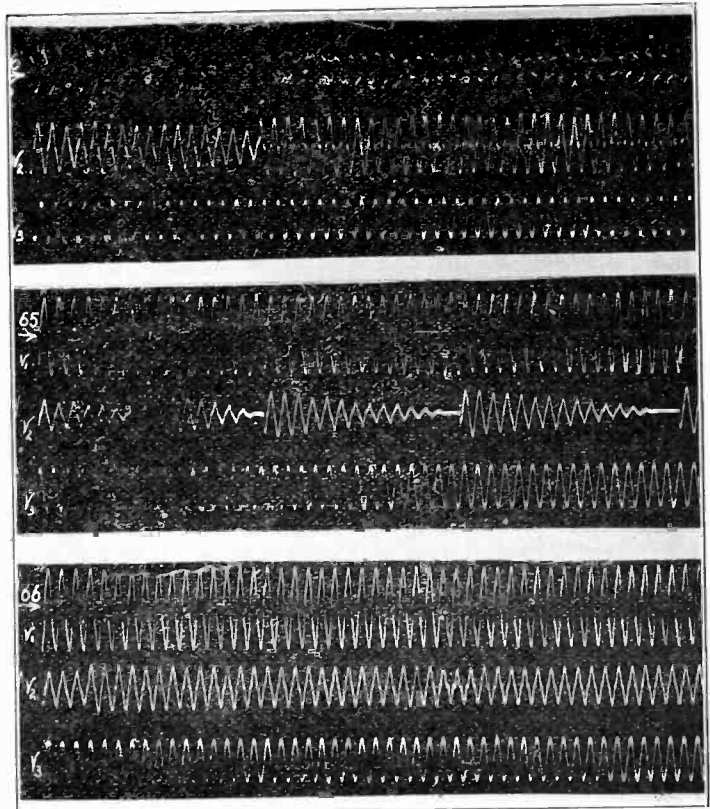
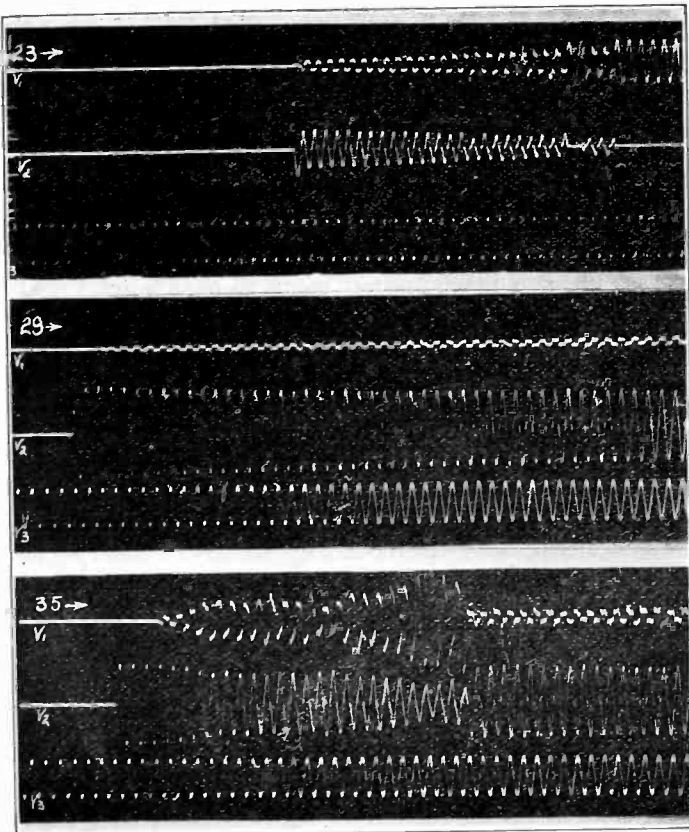

ARCING TESTS ON LEAD-COVERED CABLE

These oscillograms show the voltage and current in arcs from sheath to copper of single-conductor cables. The conductor and the sheath were short-circuited by copper wire (or, in case of Film No. 23, by a nail driven through the sheath). Sixty-cycle Voltage was then applied between sheath and conductor. The voltage across the arc is shown by V_1 . The current through the arc is shown by V_2 . V_3 shows the 60-cycle timing voltage. Further details on the respective tests are given in the following:

Film No. 23—4/0 cable, 6/32 in. rubber. Nail driven in the center of cable. Voltage (440 volts) applied at one end of copper and sheath. Maximum current, 11,000 amperes. Voltage wave increases gradually and current wave decreases gradually until the arc breaks.

Film No. 29—4/0 cable, 6/32 in. rubber. Arc started at center with three strands of No. 18 copper. Voltage (1600 volts) applied at both ends. Maximum current 555 amperes. The arc held twelve seconds. The duration of the arc at this voltage is not consistent. In this test the dying out of current and the consequential building up of voltage are clearly shown.

Film No. 35—500,000 cir. mil conductor, 20/32 in. paper. Arc started with two strands of No. 32 copper at one end. Voltage (2750 volts) applied at other end. Maximum current, 294 amperes. A rather unstable condition, which is characteristic of a number of the arcs, is shown, but this arc held for twelve seconds.

Films Nos. 6, 65, and 66—Three stages of an arc on 4/0, 6/32 in. rubber cable. The arc was started with two strands of No. 32 copper, at one end. Voltage (2750 volts) was applied at the other end. Maximum current, 635 amperes. The arc held until the switch was opened at the end of two and one-half minutes. Film No. 6 shows the sputtering effect which is characteristic of sheath to copper arcs. They go out sometimes, remain out a few cycles and then reappear. Film No. 65 was taken a minute after the start of the arc. The arc appears to go out but then revives again. Film No. 66 was taken two minutes after the start and the arc is still persisting strongly.

Kehoe's data plotted to a larger scale which bears out the same fundamental laws laid down by Messrs. Kennelly and Whiting. Some of the points brought out were:

The smallest range of flicker which could be recognized with certainty was about 1.4 per cent variation in illumination. This would correspond to about 0.5 per cent variation in voltage, on an ordinary Mazda lamp, and is somewhat lower than any point which we were able to observe.

Another point of interest from their data is that the most sensitive flicker frequency for small ranges of flicker is in the neighborhood of $2\frac{1}{2}$ cycles. Our data shows this occurring at about $3\frac{1}{2}$ cycles.

we soon decided that the results were too inconsistent for plotting curves of any accuracy, so after the paper was handed in we did a lot of test work, where it was known that the arc would persist. We didn't try to fix the persisting point accurately but just ran through a number of tests where we were either sure of getting a good arc or none at all, and thus obtained roughly upper and lower limits. I may say that as far as our results showed, the plot of the voltage and current seems to be a hyperbolic function, but we have not done enough work to make sure of it.

All of the tests taken in the beginning were made with the arc from conductor to sheath, which is the condition usually met,

especially where a single-conductor cable is used. We noticed a very peculiar action after a while. The lead sheath burned back much faster than either the conductor or the insulation and eventually this action tended to extinguish the arc, so we tried a few tests with copper-to-copper arcs. I won't describe the hook-up. It showed plainly that it is a much more persistent effect and much more dangerous when an arc is once started. The burning back is uniform. The arc is very uniform. The oscillograms show it too.

In all we tested about two-hundred samples, and took over seventy oscillograms. I have picked out several of them as they are rather interesting and they are reproduced in the accompanying illustration.

F. C. Hanker: Mr. Kehoe's paper presented some interesting data on distribution systems, and it has been very reassuring as to the reliability of the network. There is one point in connection with the so-called universal system described, particularly in the voltages that may be selected. There has been considerable work on standardization of utilization voltages, as it is called, in which the voltage at the lamp or utilization device has been standardized at 115 volts with recognized departures at 110 and 120. That standardization was satisfactory under past conditions as affecting motors and control as higher voltages were even multiples of the lamp voltage.

With the three-phase, four-wire system, which is apparently the one most generally considered on the network, we have a factor which causes trouble on the motor and the control voltage in case the two lower voltages of the utilization device on single-phase is adopted. If you take the 110-volt standard the three-phase potential will be 190 volts, which is considerably less than the tolerance allowable on standard motors at say 220 volts or the control of the same voltage range or multiple. The 115-volt standard corresponds to 198 volts and the 120-volt to 208 volts, which is more nearly the standard of the control and motor devices.

The other difficulty is in connection with the single-phase utilization devices. In case you adopt 220 volts or slightly higher, it would be necessary to go to at least 125 volts, line to neutral to secure 220 volts on the delta.

Any development or system that is adopted should take into consideration the total cost to the industry, because if you take an odd voltage, such as would result in the using of 110 volts or 115 volts in a number of cases, there will be the additional expense of development and the possibility of trouble with existing devices. There probably would not be that difficulty where you come to systems that have conditions like New York, or some of the larger systems, where it is necessary that they maintain very close voltage regulation. If the system is generally used that condition would not always exist and we will have voltage drops that will bring us much below the guaranteed satisfactory operating condition on the standard equipment.

Before there is a too general use of the new system, if it is generally adopted, there should be some agreement as to the voltages to be adopted in order to minimize as much as possible the additional expense that may be involved in the development of the new equipment for the different conditions.

There are a great number of utilization devices in service now, and a great deal of difficulty caused in shifting from one town to another, or, in a number of cases, from one part of the city to another, in that the utilization devices are not generally applicable to the wide voltage range. Some devices, such as the toaster stove and that class, are designed so that they have quite a wide voltage variation and still are satisfactory. Others, like the electric iron, waffle iron, and devices of that general type require rather a close voltage regulation, and at the present time it is necessary that we have two standards to meet the range that we encounter in different parts of the country.

The lamp situation prior to the present standardization, I think, is sufficient warning to see the necessity for careful stand-

ardization and careful study of the voltages that will be used on the network system. Undoubtedly there is no question as to the economy from the distribution system itself. But when you take into consideration the other factors, it is quite necessary that considerable thought be given to voltage standardization.

A. H. Sweetnam: In connection with Mr. Kehoe's paper there has been considerable comment outside the meeting regarding the relative current demand of a standard three-phase motor wound for, we will say 220 volts, when operated at 220 volts and at some lower voltage, such as 208 or 199 volts, supplied by a low-tension network.

It follows, naturally, that a motor wound for 220 volts and operated at a lower voltage, other conditions being the same, will draw less excitation and greater load current. Tests which I have had made on several small three-phase squirrel-cage motors indicate an appreciable improvement in power factor when operated below rated voltage, but at the expense of lowered efficiency from approximately one-fourth to full load. I do not know that this condition will prevail with motors having characteristics differing from those tested, but it would appear to me that this question should be very carefully determined before giving consideration to the adoption of such a network scheme. The commercial aspect seems to have a great deal of bearing since, under the conditions stated, customers supplied from a network would be paying a premium by reason of the lowered efficiency of the equipment.

R. A. Paine: I think Mr. Kehoe has taken a big step in advance in enabling central-station companies who have been burdened with a rather expensive d-c. system in order to maintain the highest reliability of service, to decrease this expense, and I want to agree with one of the comments that Mr. Bullard made, *i. e.*, if you leave out the storage battery, I think we have a fair promise of getting as reliable service from the a-c. system as from the d-c. system.

In connection with the arcing tests made by Mr. Kehoe, I think they are fundamentally sound and in agreement with theory. I think this is due to two reasons. One is that in the a-c. system, of course, the voltage goes through a zero point, and the other is that if you take a circuit and use d-c. on that circuit and then also use a-c. on the same circuit, you have, in addition to the resistance when you use a-c., reactance which will tend to lower the voltage across the gap and, therefore, tend to extinguish the arc. One of the serious questions that has confronted most distribution engineers is: Is the a-c. 220-volt system going to be self-clearing as our d-c. systems always have been?

With radial a-c. systems at the present time we have something less than 0.1 per cent interruptions, and any device which will take care of that 0.1 per cent interruption must be very rugged. I do not believe that we have as yet had enough experience to tell what devices will be suitable from manhole use, as I believe all of Mr. Kehoe's installations are made in vaults inside of buildings and from that point supply the outside underground system.

As to the matter of the operation of 220-volt motors on say 200 volts or 208 volts, I believe that the gain in power factor of operating these 220-volt motors at somewhat reduced voltage will in a large degree offset any loss of efficiency, as most motor installations are considerably overmotored.

There is one thing, though, that must be done. We must *maintain* at the customer's service the somewhat reduced voltage. We can not have any long shoestring secondary.

Mr. Kehoe discussed the question of high-reactance transformers. It is absolutely essential in a network, using different sized transformers, that the reactance of the present distribution transformer be increased over its present 3 or 4 per cent, and it would seem somewhere between 7 and 10 per cent is the proper figure.

However, if any company wishes to try an experimental network, we have recently made some studies which would

indicate that if you use an identical size of transformer throughout your network system, let us say you adopt a 50, 75 or 100 kv-a. as your standard, using all of one size, you can operate a network satisfactorily. Of course, that would be only a transient condition, because you can not operate continually a growing network with only one size of transformer.

E. P. Peck: Mr. Kehoe's paper, I think, brings out the first solution of what now appears to be the coming method of supplying a-c. underground load. The handicap that the a-c. system had for years was that it could not stand on the same footing with the d-c. system in reliability.

The United Company was, to my best knowledge, the first to put the a-c. subway system on a very reliable basis. The system that they described, as well as the systems described in the next two papers, appealed to me very much, because they have done a thing which has been done time and time again in history in a number of lines. They have simplified the mechanism. Almost any development starts out with a complicated mechanism, which gets more complicated by adding devices to take care of different troubles that come up. Finally some one comes out with a very simple thing that either does not have all the troubles or else takes care of them in a very simple way. This applies, I think, particularly to the system described by Mr. Bullard for New Orleans.

One of the questions that occurred to me in connection with the New Orleans system particularly, although it applies also to the system proposed for Chicago if I understand it correctly, in which you have high-voltage feeders, 11,000, 12,000, or 13,200 volts supplying high-reactance transformers directly and from there into a network, is: What will the regulation be all over that network? This applies also to Mr. Kehoe's paper where the voltage is lower. The 10 per cent reactance transformer has quite a high drop, particularly where it carries motor load. The primary voltage will undoubtedly be well sustained, but how will the secondary voltage behave under all conditions of starting motors and other load variations?

The self-protection feature which is referred to in Mr. Kehoe's paper is, as far as I can recall, the first analysis of a thing that a good many have recognized in a general way. Personally, I will have to admit that I was very much surprised to find that arcs were self-extinguishing on voltages as high as this paper shows, particularly with quite high currents. However, there is still a question as to just what will happen in case of the high concentrations of energy that will occur on these large systems, also a question as to what will happen in terminal boxes, at lugs and things of that kind.

H. W. Smith: These papers contain a valuable contribution to the art of electrical distribution. During the past five or ten years, there has been intensive development in the field of large generating stations, high-voltage transmission, and the use of automatic switching equipment for substations. The best talent in the industry has been employed on these problems with the result that tremendous strides have been made. There is, however, a growing realization of the fact that the total investment in the distribution system is greater than in generating and substations, and that great economies can be obtained by applying the same grade of engineering talent to study the problems of distribution.

In many large cities, the Edison three-wire system has been the accepted standard for distribution in the underground section. The Edison system, backed up as it generally is with large storage-battery reserve, has proved extremely reliable. However, the cost of distribution is much greater than for alternating current, and there is a general tendency in most cities towards the restriction of the Edison d-c. load, and in some cases studies have been made towards replacement of the Edison d-c. by an a-c. system.

In studying the a-c. distribution system with a view to making it more reliable, a very valuable contribution has been made by

Mr. Kehoe, and his paper clearly indicates the lines under which he has been working.

In considering this subject, I wish to call attention to some available papers which have been written on this subject. At the 14th Convention of the Association of Edison Illuminating Companies in October 1922, Mr. W. C. Eglin, Vice President and Chief Engineer of the Philadelphia Electric Company, presented a paper on the "Future Development of Distribution Systems." This paper deals with the general economics of the distribution problem, and recommends a three-phase, four-wire, secondary distribution system. It is pointed out that the ideal system for general distribution at lighting voltage must comply with several requirements:

- (1) It must be polyphase to permit the operation of motors.
- (2) It must be a symmetrical polyphase system.
- (3) The voltages available must be suitable for both light and power requirements.
- (4) One conductor must be a neutral which can be grounded in such a way as to limit the voltage of all other conductors to ground to a value below 150 volts.

A three-phase, four-wire system is recommended, the only drawback being its adaptation to the present normal voltages of lighting and power apparatus.

In studying the general system, the economics of the whole industry should be considered, and any system which covers special apparatus should, if possible, be restricted. If it is necessary to carry two lines of motors or appliances, it will place a burden on the industry as a whole.

The use of a three-phase, four-wire secondary system with grounded neutral will require changes in standard control equipment as three overload relays will be necessary to give complete protection. Also in the case of low voltages, certain changes may be necessary in the design of holding coils of contactors.

The distribution system should be laid out so that the standard squirrel-cage motors can be used as far as possible with standard control equipment.

The automatic network switch mentioned in these two papers will be built in the following sizes—250, 500, 800 and 1200 amperes.

It will be of great advantage to the industry if in the development of the a-c. network, the requirements can be met with as standard apparatus as possible. In other parts of the world, there are three-phase, four-wire systems, 200-350, 220-380 and 240-415 volts, and it is to be hoped that this condition will not obtain here.

Another contribution to this subject was made in a paper by Mr. M. T. Crawford, entitled "Alternating Current Underground Distribution" presented at the 41st Convention of the Association of Edison Illuminating Companies, 1922. This system which is used in Seattle, parallels all distribution transformers on the secondary mains with primary connections on alternate feeders and with oil circuit breakers installed in the secondary of each transformer, which are equipped with power directional relays operative on a reversal of power flow equal to or greater than 150 per cent of the transformer capacity. These switches are not automatically reclosing.

H. A. Stanley: I want to speak more particularly about Mr. Bullard's paper. He has a fine paper and is starting out to accomplish a very desirable end, but I would like to indicate two or three points where I think he may perhaps get into trouble; two or three difficulties, perhaps, inherent in the proposed system.

If you distribute lighting and power from the same set of mains, you must provide regulating capacity for the total power load as well as the lighting load, which introduces somewhat of an economic waste. I think I foresee possible difficulties in rate making. Rates are ordinarily differentiated in regard to investment, but you have here the same investment for both power and lighting and you have only the load factor differential left

to take into account in making a power rate below the lighting schedule.

Mr. Sweetnam has noted a point in reference to power-factor—improved power factor of the motor load benefiting the central station but the customer paying for it. Speaking from the viewpoint of a smaller company, and this perhaps would not apply to a large company; it seems to me the lower voltage on the motors is going to lead to a further difficulty. It would be difficult for the smaller company to maintain (already too low) constant voltage. Two hundred volts at no load leaves no leeway for voltage fluctuations with load. The comment of the motor manufacturers on this point should be of interest. If you are starting from zero and building a new company and your customer has not become accustomed to good voltage, that is one thing, but the customer who has become accustomed to it will not take readily to the lower voltage.

It seems to me the system lends itself somewhat to the theft of current and more than ordinary precautions will have to be taken in metering.

Now, there may be a few possible difficulties in apparatus details. It strikes me that the network protective device does not lend itself readily to manhole installation, at least in the present state of the art; there are some major difficulties to be overcome in perfecting the device for that purpose.

Another point I think is important if I correctly interpret Mr. Bullard's paper. To work on a 13,000-volt feeder, it obviously must be dead. The theory appears to be to operate the feeder switch at the substation and the automatic devices will function at the far end of the feeder. On a feeder of this size there will be from ten to twenty-five network switches. How are you going to protect the cable splicer? On the usual theory of disconnecting switches it would be necessary to have two breaks in series at each possible point where the cable could be energized. I should hardly suppose you could depend on the network switch for protection of human life. Are disconnecting switches in the program and will you send a man around to open them at twenty or thirty-points before doing maintenance work?

W. L. Abbott: I remember conventions thirty years ago where the lion and the lamb of a-c. and d-c. did not concert so harmoniously as they have in this meeting. It was conceded as a great victory for the a-c. school when d-c. systems were fed from a-c. generators in transmission lines.

With that combination of the two, it was thought the ideal system had been evolved, but now take a glance at the situation here in the Loop in Chicago, where Mr. Armbrust pointed out we have now a load of 75,000 kw. per square mile, and are contemplating a load of 200,000 kw. within twenty years, and, of course, it won't stop at the end of twenty years.

How are we going to distribute that load? In fact, how are we going to transform it? Substations are not altogether desirable, and space for substations is not readily available, and it is a growing problem to find locations where these substations may be placed sufficiently near together in such a congested territory as the Chicago Loop district.

Then, there is the other problem of distributing this power through the streets. If you could see a cross-section of the downtown streets of Chicago, you would wonder where the next main is going to get in at all. The street is full from the surface ten feet down. True, more space could be made available if all of these underground structures could be taken out and rearranged, but they are crisscrossed and with huge manholes and sewer openings which have just about reached the limit of capacity. Then, again, the heat evolved by these d-c. distribution lines is very considerable, and any greater congestion of those lines is going to be a serious matter.

We will have to get more power and have more power distributed in the Loop than we have now. It can not be done much longer by adding more copper in our distribution. It

will have to be done at higher voltage, and the last transformation must be made in the building which is to be served.

That is the problem which is approaching.

R. B. Mateer (by letter): In many of our cities accepted primary distribution voltages are 2400 and 4000, while transmission potentials over cables linking generating and distributing substation range from 6000 to 13,200 volts, and any step forward which will limit the investment in or eliminate the use of distributing substation is commendable.

It is suggested, however, that in all inter-connected network the transformers should be of a uniform or standard size and as far as possible evenly spaced. Such practice will not only be a step forward in our efforts at standardization, but will materially assist in uniform loading of the step-down equipment.

A. H. Kehoe: The discussions have indicated the importance of keeping standard equipment throughout the entire electrical supply system, including the utilization devices. The adoption of three-phase, four-wire combined light and power services having a reduced voltage for motor operation, is sometimes considered as making it necessary to adopt an additional line of motors having a lower voltage rating than is at present the standard. On a large number of electrical supply systems, motors are operating at reduced voltage due to the low power factor current supplied through small sizes of isolated transformers. The adoption of a three-phase, four-wire supply is for the purpose of supplying lighting service from combined mains, and there is no reason to use this system, except at locations where satisfactory lighting service can be obtained. Therefore polyphase voltage when used for motors will not be below the amount now regularly found in practice.

I doubt if for typical motors the average loading condition makes for lower efficiency. Generally there is an improvement in efficiency due to the reduced voltage, up to about three-quarters load on the motor, which is probably above the average loading of motors. Because of the large number of motors now operating at reduced voltage I doubt if the efficiency will be changed by the adoption of three-phase, four-wire systems.

Regulation due to transformer reactance is accomplished with automatic regulators in each supply feeder. The division of current is so nearly uniform that the regulation between any two points in the network depends upon the drop in the secondary mains, as the automatic regulating equipment will maintain a constant voltage at the low-voltage supply points to the mains.

It is important in designing a reliable network to omit any type of equipment in which faults may develop which will not clear themselves. The concentration of current at any point where trouble can occur is usually well below the values indicated in my paper, and there should be no necessity of exceeding these to meet any conditions which are likely to arise in the next few years.

In presenting distribution-system designs, uniform and standard connections of network cables and locations for distribution transformers are assumed. In actual service however, it is inevitable in many locations to have concentrated loads which are as large as the entire remaining load in the immediate vicinity. In such cases the center of distribution of the particular district is not at the existing intersections of the mains, but is at the particular concentrated load. The economical design will then not allow the adoption of a single size of distribution transformer and a standard transformer location throughout the entire system. This condition results in the network of street mains being of smaller capacity than would otherwise be the case to supply load. There results a lack of uniformity and standardization of equipment which however does not make it any more difficult to obtain uniform loading of distribution transformers, if indicated design is used.

Concerning protection of cable splicers, in many districts one non-automatic break is considered sufficient, and two breaks in series have been used with one—an automatic oil circuit breaker.

With these network units open, and the high-voltage supply grounded, it is impossible to have the switch function automatically as its closing energy is obtained from the supply side of the switch. If one of these switches is closed manually with the high-voltage cable grounded in the immediate vicinity of workmen, the condition will be similar to closing a knife disconnecting switch on a grounded feeder, except that the fuse protection at the network switch will clear the backfeed.

W. R. Bullard: The question of the selection of service voltage of the three-phase four-wire system, so as to satisfy as nearly as possible existing voltage standards, is one that has received a lot of attention by various engineers. One of the schemes which was given some consideration for use in New Orleans would utilize 400 volts as the delta voltage giving 230 volts between each line and neutral. In this case autotransformers would be connected between line and neutral at lighting services in order to obtain a neutral for the usual three-wire 115/230-volt system. Existing motors, which are connected delta, could be reconnected Y and operated without further change on the 400-volt system. This proposal has the advantage of a saving in copper of the low-voltage mains due to the higher voltage. However, in this case it was found that the cost of the autotransformers and losses therein would more than offset any saving in losses and cost of the secondary mains.

In this connection I would refer to a point which was brought out in my paper; namely, that once the size of the secondary mains and the corresponding capacity of distribution transformer installations is established, these secondary mains will continue to serve the load indefinitely with practically the same copper losses, regardless of what the growth of load may be. Low-voltage mains therefore continue in a more or less fixed physical state after they are once installed. On the other hand the connected capacity of autotransformers in a 400-volt system would continue to grow with the growth of load and their cost would some day out-strip the cost of the low-voltage mains, regardless of any economy which might be secured by the use of a higher voltage system at the start. Furthermore, I believe it has been brought out in Mr. Kehoe's paper that the 400-volt system would not be able to burn off short circuits with the same facility that the 200-volt system will.

It is somewhat unfortunate for the three-phase four-wire system that the present standards for lighting and power voltage are just what they are, but in selecting the voltages to use on this system it would seem that an out-and-out compromise effecting both types of service would have some serious disadvantages. The use of 120 volts for lighting, for instance, would give a somewhat higher voltage for power than the use of 115 volts, but the resulting voltage would still be non-standard for motors and the lighting voltage in this case would not be the preferred standard. Time alone will tell just what the trend of standardization will be. However, in the meantime we have selected what seemed to us to be the most desirable arrangement in view of the present standards.

I might also mention that while we expect to supply the customers at the start with 115/200 volts, we are buying transformers rated at 120 volts. This will reduce the duty on regulators at heavy loads and will enable a change to 120 volts to be made without difficulty if it is ever found to be desirable.

In regard to Mr. Stanley's point concerning the difficulty of adjusting rates of power and lighting service to meet the combined power and lighting system, I feel that the rates should be treated as secondary to the economics of the problem rather than modify the economics by using a more costly system in order to satisfy existing rates. Furthermore, common facilities for the power and lighting loads are usually provided in the generating station and are also provided from that point at least to some point in the substation. It is therefore rather difficult to see why the same principle should not be extended to the remainder of the distribution system as far as rates are concerned.

Referring to Mr. Stanley's point concerning the additional cost of regulator capacity to regulate the power load I feel that the case must be an exceptional one indeed where it can be shown to be more economical to provide separate facilities and regulate only the lighting load. If the reference is to station regulators this type of equipment represents a small part of the cost of the whole system, and any saving of regulator capacity will, I believe, at least for New Orleans be much more than offset by the additional cost for duplicate primary cables which would be necessary to serve unregulated power loads.

I failed to mention in my paper the method of protection to workmen which we expect to use in case work is to be done on primary cables or on transformers. The procedure in this case will be first,—to kill the primary feeder by opening the switch at the generating station and

Second,—to ground and short circuit the primary cables in the generating station and also at one or two points external to the station, points being selected for this purpose which will offer most effective protection, and permanent facilities for grounding and short circuiting being provided at these points.

EQUIVALENT SINGLE-PHASE NETWORKS FOR CALCULATING SHORT-CIRCUIT CURRENTS DUE TO GROUNDS ON THREE-PHASE STAR GROUNDED SYSTEMS¹

(SHETZLINE)

CHICAGO, ILL., JUNE 26, 1924

H. M. Trueblood: The question of the degree of precision worth while in estimating short-circuit currents in power networks presents itself as of immediate importance as soon as consideration of the problem of the inductive effects of these currents in exposed communication circuits is undertaken; for it is necessary only to glance over a single-line diagram of a large modern power system to realize that an exact calculation of the distribution of residual current due to an arbitrarily located fault to ground will be a lengthy, difficult and expensive proceeding.

Certain factors tend toward the conclusion that a comparatively low order of precision is all that can be justified. Among these are the matter of the impedance of the fault itself, and the uncertainty introduced into the calculated induction due to lack of knowledge of the distribution of current in the earth. As to the first of these, it is usually essential to know what maximum effects may be expected. From this point of view, the impedance of the fault may be neglected, because on practically any system faults to ground can occur having impedances negligible compared to the other impedances involved.

Regarding the distribution of current in the earth, it is known from tests that this is very different in different localities. Where there is no information on this point, a large uncertainty is introduced into the calculated induction for parallels of moderate or wide separations, although the uncertainty regarding the magnitude of the short-circuit current itself due to this cause is of a much smaller order, probably never over 15 per cent. However, I do not think this uncertainty is of much importance as an argument for limiting an otherwise desirable precision in estimates of short-circuit current. In important cases, the effect of the distribution of the earth current can always be determined by tests, and it is reasonable to expect that as time goes on, general information regarding this important factor in different localities will be collected. Cases occur, of course, in which estimates of induction of a rather rough character suffice, as when it is known that the induced voltages will be small. However, in cases in which the induced voltages will be large, even where they are well beyond tolerable magnitudes, fairly precise estimates are usually necessary, since it is generally desirable to determine what reductions in the magnitude of the

¹ A. I. E. E. JOURNAL, Vol. XLIII, November, p. 1014.

residual current might be effected by possible changes in the power system.

From such considerations as these, it has seemed desirable to some of us who have been studying the problem of low-frequency induction in telephone circuits, to have a method of estimating power-system short-circuit currents, accurate, let us say, to 10 or 15 per cent., and capable of application to fairly complicated networks. Fortunately for us, the problem is one of so much importance in the operation of power systems that it has received a great deal of attention from power engineers, and our work upon it has benefited greatly from a study of the valuable and ingenious methods of attack which have been devised by these engineers and which are referred to in Mr. Shetzline's paper.

While the time and labor for a rigorous solution are greatly reduced by the methods suggested by Mr. Shetzline (he has stated, for instance, that only about 10 hours' work was necessary to obtain the solution of the illustrative example given in his paper), the amount of computation necessary would, nevertheless, in some cases still be excessive. Two general possibilities for bringing the labor involved in such cases within bounds have received attention. The first of these involves a judicious simplification of the network, and this usually means also a combination of the method of the paper and the "equivalent single-phase" method, an eye being kept throughout the work

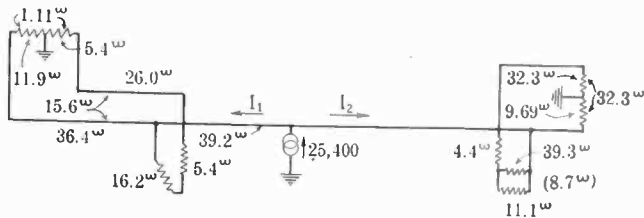

FIG. 1

on the matter of what short circuit locations are important, what currents it is necessary to know accurately and what currents are unimportant. These questions, of course, are directly related to the location of exposures.

In the accompanying diagrams and in the tabulated numerical results, Mr. Shetzline's illustrative example is carried further, in order to illustrate the application of this process of simplification. It is assumed that only two currents are desired—those to the right (I_2) and the left (I_1) of the fault. Fig. 1 herewith is the simplified network, derived from Fig. 9 of Mr. Shetzline's paper by consolidating the 6.5-ohm generating station and the 4.6-ohm line to the right of it into the single 11.1-ohm impedance shown

	I_1	I_2
Exact Method.....	350	602
Method of Fig. 1.....	355	575
Method of Fig. 2.....	290	203

at the right in Fig. 1, and by suppressing certain branches of the network completely. In a process of this sort, one is guided by a consideration of the relative magnitudes of the self and mutual impedances, and their positions in the network with reference to the branch carrying the desired current. Fig. 2 illustrates the "equivalent single-phase method." As the table shows, the simplified method gives results within 4 or 5 per cent of the correct values, whereas the single-phase method gives one result which is only about one-third of the correct value. The work involved in applying the method of Fig. 1 is only a little greater than that of the single-phase method.

The solution just discussed is satisfactory for the purpose of determining the currents I_1 and I_2 , which alone we have supposed to be of interest in this case. It would not, however, be adequate to the demands of an engineer whose job it is to determine relay settings for the system. This brings me to the second possibility, which is that of reproducing in miniature the equiva-

lent network of the system worked out according to Mr. Shetzline's paper, and obtaining a desired current distribution by direct readings on ammeters. This scheme, of course, suggests itself at once to any one acquainted with the use of calculating tables by power companies and with the papers by power engineers on this subject. The difficulties in setting up a miniature network, using direct current (and thus assuming a common phase angle for all impedances), are encountered in connection with the mutual impedances which it is necessary to use at certain places in Mr. Shetzline's equivalent networks. Aside from this, the network is, of course, simpler than the three-wire network, since it has only two wires. I am not prepared to say that in all cases it will be found possible to represent the

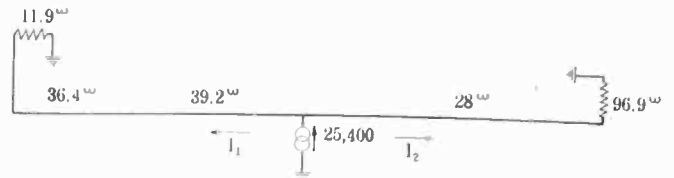

FIG. 2

mutual impedances correctly, although so far in our consideration of the question, we have found no cases in which it could not be done.

The adjoining Figs. 3 and 4 illustrate arrangements for representing the mutual impedance M of Fig. 7 of Mr. Shetzline's paper. The transformer ratio is taken as unity, for simplicity. The resistance R and R' in Fig. 3 are adjusted until the two currents marked I are equal, and until the two currents marked

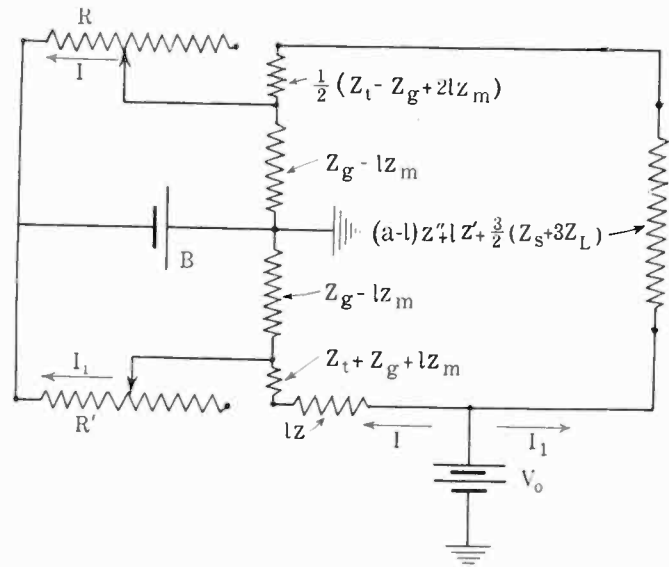

FIG. 3

I_1 are equal. The battery B may have any suitable voltage. When this adjustment has been made, and the other impedances have the indicated values, the d-c. miniature network correctly reproduces the network of Mr. Shetzline's Figures 2 and 3, of course under the assumption that all impedances have a common phase angle. This may be verified by calculating the voltage drops around the two paths from the network terminal of the battery V_0 to the ground common to the two impedances $Z_0 - lz_m$. It will be found that the results are the same as in Mr. Shetzline's equations (4) and (5).

Fig. 4 is merely to show how to proceed in case the impedances (resistances) $Z_0 - lz_m$ of Fig. 3 should be negative. lz_m being greater than Z_0 , it will be seen that by proper choice of the factor N (the ratio of the currents in the resistances R' and R to the

currents to the right and left of the fault, respectively), the remaining resistances may be made positive. The correctness of the construction may be verified as in the other case.

R. D. Evans (by letter): Mr. Shetzline in his paper has presented an ingenious solution of a complicated problem and without doubt his solution is essentially correct.

In reviewing the paper I do not find that different effective impedances of machines when carrying single-phase loads and when carrying the balanced polyphase loads have been assumed. However, the method presented in the paper is a general one and may readily be modified to meet this condition, it being necessary only to determine new values for machine impedances.

There appears to be a typographical error in connection with the illustrative example. One would expect that the 13,500-kv-a. transformer at Station B would supply a relatively large residual current. For this reason it would appear that the residual current flowing from Station B to Station A should be considerably less than the value of 350 amperes given in the last table.

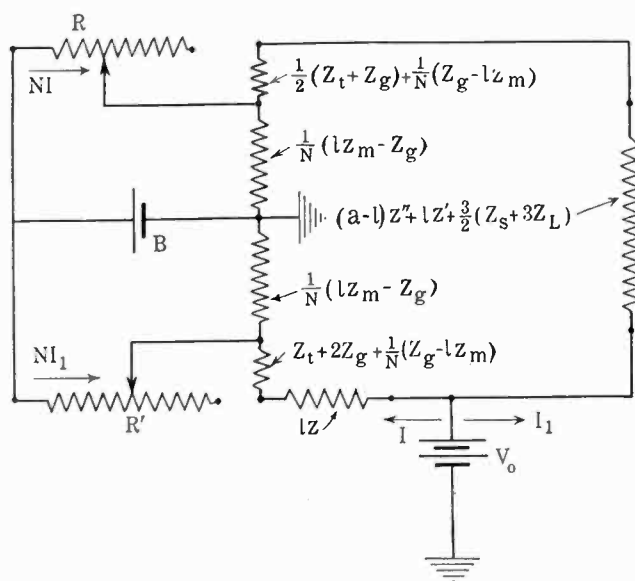

FIG. 4

It has been our practice to solve single-phase short-circuit problems by the use of "phase-sequence quantities." Our method is an application of the general method developed by C. L. Fortescue² for the solution of unbalanced-polyphase-circuit problems. This method has been developed particularly for the solution of the various power-circuit problems and possesses a number of advantages, some of which will be mentioned. The phase-sequence method of calculation may be arranged so that steps used in the solution of line-to-ground short circuits may also be used to solve the other types of short circuits, namely, the three-phase short circuit and the single-phase line-to-line short circuit. A further advantage of this method is in the ease of application to calculating boards, because the complications of inductive coupling between branches, mentioned during the discussion, are avoided. It is my intention to publish, in the near future, an article describing this method and when this has been done, the relative merits of the two methods for the calculation of the various problems may be determined. In closing, I wish to emphasize the great advantage which, in my opinion, resides in the phase-sequence method from the analytical point of view in giving adequate conceptions of unbalanced-circuit conditions.

R. A. Shetzline: Mr. Evans has correctly pointed out that the impedances designated Z_g and Z_L should be those for the

proper current distribution in the machines, and also that this matter may be taken care of without difficulty and without impairment of the generality of the method.

Mr. Evans' reference to a typographical error is probably due to a misunderstanding regarding the line to which the 13,500-kv-a. transformers at station B are connected. From his statements, I presume that he believes them to be directly connected to the 44-kv. line. However, the transformers are metal-lically separated from the 44-kv. line by the 27,000-kv-a. bank of delta-delta transformers. Accordingly, the residual current in the section fault to station B will also be that in the section station B to station A.

Mr. Evans has stated that the phase-sequence method of calculation may be used to determine three-phase short-circuit and single-phase line-to-line short-circuit currents, in addition to single-phase line-to-ground short-circuit currents. Three-phase short-circuit currents are readily determined on a single-phase basis by well known methods and present no difficulties. As regards the calculation of single-phase line-to-line short-circuit currents, I wish to state that the substitution of equivalent networks and of a single fictitious generator is applicable to this case also, with corresponding results as regards simplicity of solution.

STANDARDIZATION IN CONSTRUCTION AND OPERATION AS APPLIED TO LIGHT AND POWER COMPANIES¹

(SINDEBAND)

CHICAGO, ILL., JUNE 26, 1924

E. P. Peck: In connection with Mr. Sindeband's paper, the plan, as a whole, is unquestionably right. The details will vary as time goes on. The main thing in a plan of that kind is to be sure that your standards are workable and that there are no unworkable theoretical ideas that some one happens to have put into them. I foresee that he is going to have a good deal of trouble with specialty salesmen. As soon as you standardize and decide to use one man's equipment, every manufacturer of specialties in the country will concentrate on you to have you change over and use his specialty.

DIELECTRIC FIELD IN AN ELECTRIC POWER CABLE—II²

(ATKINSON)

POTENTIAL GRADIENT AND FLUX DENSITY³

(DOUGLAS AND KANE)

D. M. Simons: The paper by Messrs. Douglas and Kane is of great interest and I think their method can be applied to cable work advantageously.

They have possibly been more interested in the method than in the results of their test, and have so stated. One of their results in regard to cables might cause a slight confusion. Referring to Fig. 3, they mention in the text that they have discovered that the point of maximum stress in their three-conductor cable model was at the surface of the conductor and at the point nearest to the outer sheath, while most observers have found it toward the center of the cable. Mr. Atkinson has pointed out in his previous paper that the stress toward the sheath depends not only on the conductor insulation but also on the belt insulation and that if the thickness of the belt is reduced, the maximum stress swings around from the center or axis of the cable to the direction of the sheath. As far as I can tell from rough measurements of Fig. 2, the authors have apparently dealt with a cable which had all the insulation on the conductors, and no belt insulation. Their experimental results are therefore correct, but they do not disprove, and I am sure do not intend to disprove, the general statement that in practice cables normally

2. "The Method of Symmetrical Coordinates Applied to the Solution of Polyphase Networks" by C. L. Fortescue, *TRANS. A. I. E. E.*, Vol. XXXVII.

1. *A. I. E. E. JOURNAL*, Vol. XLIII, December, p. 1147.
 2. *A. I. E. E. JOURNAL*, Vol. XLIII, December, p. 1146.
 3. *A. I. E. E. JOURNAL*, Vol. XLIII, December, p. 1148.

having an appreciable thickness of belt, the maximum stress is toward the center or axis of the cable.

H. Halperin: In regard to Mr. Atkinson's paper, it has been our experience in test and service failures that a large percentage of the failures in three-conductor, 33-kv., sector cables were at the outer corners of the sectors. According to the author, the maximum dielectric stress is at these corners.

E. W. Kane: In regard to Mr. Simons' remarks in relation to Fig. 2, he is correct in stating that in our particular test we made no belt insulation, and we agree with his conclusion, and referring to Fig. 3 we may note that the part of the curve will be lower at the right-hand side when the belt insulation is used.

In regard to Mr. Atkinson's paper on the gradient in three-phase cables, it is perhaps ungracious to attack the accuracy of his results on the basis of a single test; however, a theoretical point of some importance is involved. The electrostatic field in any three-phase cable is, in certain places a pulsating field, but in other places it is a rotating electrostatic field.

In Fig. 1 at the left, is shown the field at an instant when the charge on the conductor 1 is a maximum, the field shown at the right is ninety degrees time phase later, when the charge on conductor 1 is zero.

Consider the field at the point P at the instant of time shown in the left-hand figure, the field is upward, to the left and rather small. At the instant of time phase shown in the right-hand

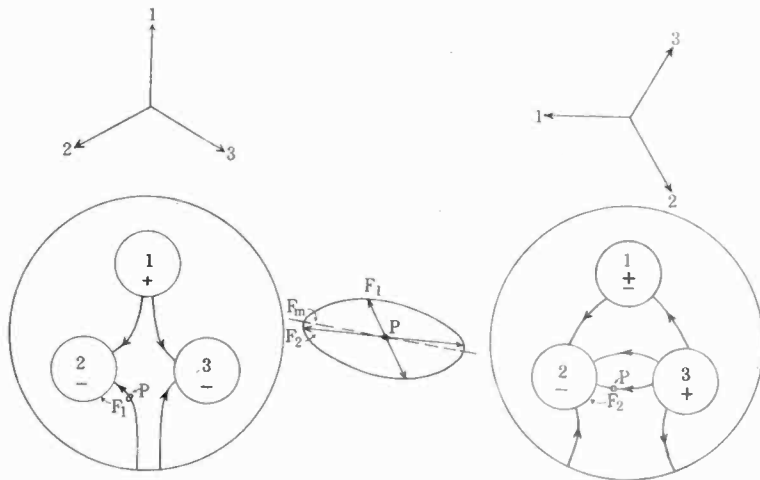

figure, the field is nearly horizontal and much larger. At other instants of time these components are present in different degrees. The ellipse in the center shows the locus of the force F at the point P at various intervals of time. It is a rotating electrostatic field.

The electrodes measuring maximum gradient should be oriented along the axis of maximum F , that is F_m and not radially to the conductor. At the surface of the conductor the field is always radial and there is no criticism of Mr. Atkinson's results here. We contend merely that our method has advantages in the line of speed for these conditions.

A three-phase field can be split up in two single-phase fields which can be combined geometrically at all points and algebraically where they are in the same direction, as at the conductor surface.

R. W. Atkinson: I am going to refer to the paper of Messrs. Douglas and Kane wherein they refer to some of my work. They speak of the fact that the field is not radial at all points. Just in a word, the point that they make does not affect the accuracy of the data which has been given. It is possible for stress to be greater in some other direction. The stress, though, has all been given in either radial stress at the surface of the conductor which is correct as given, or it has been given as stress at some other part of the insulation and in a certain direction. Usually the radial stress approaches very nearly the maximum stress that can exist at a point in any direction.

SOME NOTES ON STREET LIGHTING¹

(MILLAR)

CHICAGO, ILL., JUNE 27, 1924

L. A. S. Wood: Mr. Millar has preached the gospel of moderation, and, while I subscribe to that doctrine, it is rather difficult to determine just where moderation ends and intemperance begins.

I hope that Mr. Millar's remarks regarding low intensities with diversified illumination will not be taken as his recommendations for modern street-lighting practice. In another part of his paper he refers to the desirability of high intensities with uniform illumination, provided such can be obtained without undue glare, and this, in my opinion, is the best kind of illumination suitable for modern traffic conditions.

The tables on the last page showing the tendency of modern street-lighting practice toward higher intensities are very interesting, and it is gratifying to note that the standards set by the City of St. Louis are so very much higher than the standards prevalent in 1916. I feel, however, that there is still a very wide margin for increased intensities of illumination before we get out of the range of moderation.

Mr. Millar refers to the control of light by prismatic refractors and the possibilities of directing the light flux in such a manner as to build up the illumination between units to higher intensities than could be obtained without such control. In this connection, I would like to refer to a prismatic refractor which was presented at the Illuminating Engineering Society last fall. This refractor bends part of the light flux from the direction of the property line and adds it to the light flux in the directions "up and down" the street producing unsymmetrical or what is sometimes called "asymmetrical distribution." I believe that the tendency from now on will be the direction of asymmetrical distribution as compared to symmetrical distribution for street illumination.

F. C. Caldwell: I would particularly emphasize the difficulty experienced in laying down practicable specifications for good street lighting. This is, of course, especially true where, with high-intensity lighting, the elements of aesthetic effect and of making the street a pleasant place in which to walk or ride are important factors. Probably an adequate illumination of the building fronts as well as of the pavement should be included in such specifications and perhaps information on the foot-candle intensities needed for this purpose may become available. Indeed I hope we may make a small beginning along this line in connection with the Columbus demonstrations.

Apropos of this type of lighting, I am not quite so sure as Mr. Millar seems to be, about the place of the refractor. With him I would question whether any refractor now available is suited to this case, but might not one be made that would give just the illumination desired. While a rather uneven or spotted illumination on the pavement is not objectionable, should not the illumination on the buildings be as uniform as practicable. Would it not be in order then to design a refractor which would redirect that part of the light, perhaps 30 to 40 per cent, which now falls upon the adjacent buildings, on the same side of the street. This makes a bright spot opposite the light and is otherwise ineffectively used because of the small angle at which it strikes the walls. Again there is all the flux that escapes to the sky from a diffusing globe.

If without attempting to increase the illumination on the pavement or to make it more uniform, most of the light in these two zones, that is the flux which does not fall upon the sidewalks, the pavement or the opposite buildings, could be redirected by a refractor and thrown across the street onto the building fronts, a refractor might well justify itself even in high-intensity and ornamental lighting.

It is almost useless however to throw light onto dark-faced buildings. If the illumination of the walls as well as the floor

1. A. I. E. E. JOURNAL, Vol. XLIII, June, p. 495.

of the street is accepted as important and the city is to spend money to accomplish it, an organized effort, probably by education rather than ordinance, should be made to get owners to use light-colored building material and to keep it clean. Once such a practice becomes general a builder would hesitate to place his building at the disadvantage of being invisible at night.

From another point of view asymmetric refractors may become important in the high intensity of business streets. The movement to eliminate poles will, if carried to its logical conclusion, result in the support of the trolley wires from the fronts of the buildings and the mounting of street lights on large brackets. A downtown street without an obstruction from end to end, is a pleasant thing to think upon. Here refractors would be almost necessary.

At another point the public should take an interest in conditions accessory to street lighting. Hitherto illumination has had to take second place to the trees on the street. With changing conditions it appears to be time for this order to be reversed. I know a street where the trees are kept, for the most part, back to the line of the house-fronts. The effect of openness and breadth is very pleasing. Perhaps however, such an arrangement of the trees as a general policy would be too much to hope for. It is not at all unreasonable however to locate the trees on the lot line instead of at the curb and this is a requirement well within the rights of the public, for safety, if for no other reason. Again, regulations for the trimming up of trees may well be made and enforced, on the same grounds.

The testing of the Columbus demonstration will be completed next week. While for the most part the results are not yet worked out, a few points seem to have been rather clearly established. One is that four 15,000-lumen lights on a 500-ft. block give more satisfactory results than ten 6000-lumen lamps, which is the spacing hitherto used. Again our experience indicates that 150 lumens per linear foot gives very satisfactory lighting for ordinary business streets and that 300 lumens makes fine "whiteway" illumination. Also 25 to 50 lumens per foot covers very nicely the usual range of residence streets and boulevards.

The important questions of incandescent versus magnetite-arc lamps and of diffusing globes vs. refractors, symmetrical and unsymmetrical, have not had final consideration, but we hope to throw some light upon them before we are through.

Mr. Millar has spoken of character in standards. There are few expenditures involving so much money that we made with more inadequate judgment than in the purchase of lamp standards. Their selection is generally left to someone who, in other matters of art, would certainly not claim to be a qualified critic. Probably it is usually the salesman, rather than the standard which decides the matter.

The increasing emphasis which is being put upon the aesthetic aspects of city planning indicates the reference of such a selection to the best practicable commission of architects and artists. In the case of large orders, a standard specially designed by a competent artist should be used and if it can embody some feature characteristic of the city so much the better.

Finally, let me advise anyone who would conduct an extended series of tests of street lighting to arrange to close up his other affairs for the time being. Our efforts in Columbus have convinced me that the most practicable place to test street illumination is anywhere else but on the street.

G. H. Stickney: We all realize that the new thing, which is creating the need for better street lighting and more light, is the automobile. Ten or fifteen years ago the principal traffic on city streets was moving about six miles per hour. Now it has attained a speed of twenty or more miles per hour.

It is therefore necessary to see more clearly and further if accidents are to be avoided. Street lighting, in general, has not adapted itself to this demand which the automobile has created,

and greater progress in this direction is essential to the preservation of life, limb, and property.

The question of symmetrical and asymmetrical distribution of light from street-lighting units is a very live one at the present time. It is not merely a comparison of two systems, since there are many possible characteristics of asymmetrical distributions. There are several schools of thought on the subject, and more experience is necessary before the best conclusions can be expected.

Past experience has indicated, that when such new possibilities are opened up there is a tendency to go to extremes. Having made such mistakes, I am inclined to expect the best practice to be found nearer a medial point rather than at an extreme. I believe asymmetrical distribution is here to stay, but not to the exclusion of symmetrical distribution. Nor do I think it probable that the best forms of asymmetrical distribution have yet been secured.

We should expect to find ways of utilizing light more effectively, but this one feature should not be over emphasized to the exclusion of other considerations.

There seems to be a natural tendency to think that it is desirable to put as large a portion of the light on the pavement and provide uniform illumination over this entire area. However, practically all of the tests and demonstrations have indicated that when the amount of light is limited, as is usual in street lighting, better visibility is secured where sections near the unit receive more illumination than the more distant areas, provided, of course, this is not carried too far. Such illumination often appears uniform to the eye, and seems to give better results than a similar amount of light distributed as to give measured uniformity.

This is undoubtedly one of the factors which is bringing about the tendency toward the use of higher power units, even with incandescent lamps, in spite of availability of small sizes. It is, of course, promoted also by the superior economy of the larger lamps.

D. K. Blake (by letter): Mr. Millar, in his paper on page 5 mentions three important factors in the development of street-lighting systems which should be of considerable interest to the distribution engineers. They are first, the development of remote-control systems; second, the practice of connecting multiple incandescent lamps to the commercial service mains and, third, the increase in municipal expenditures per capita for street lighting. Because of the expenditures involved and because of the relation of the street-lighting system to the distribution system these factors are additional reasons for an intensive and extensive economic study of the distribution system as a whole.

It seems to me that the highway-lighting units mentioned on page 8 should be of considerable help in solving the problem of rural electrification. Because the highway-lighting unit increases the rural load and consequently reduces the cost of central station service to the farmer, its use should be justified on the highways where otherwise it would not be advisable to spend the money for the installation of these units.

SELECTIVE CIRCUITS AND STATIC INTERFERENCE¹

(CARSON)

CHICAGO, ILL., JUNE 25, 1924

L. W. W. Morrow: I would just like to ask the question if we are faced with the proposition of always suffering from static interference and is there no remedy?

J. R. Carson: The question of static interference is the same problem we come across in telephone transmission, that is, when the signal comes so weak that the interference energy level

1. A. I. E. E. JOURNAL, Vol. XLIII, December, p. 1145.

becomes comparable with the signal, we have got to either face interference or we have got to raise our power.

To my mind, the attempt to actually eliminate static by any form of selective circuit would be comparable with the attempt to find a perpetual motion machine. It is there and we have got to receive certainly a frequency range for signaling and from the very nature of the thing we must receive the interference in that range. We have all recognized that principle more or less in telephone engineering: in engineering long lines we must put in repeaters at intervals, depending upon the amount of interference or the interference energy level.

J. D. Robinson: Mr. Carson modifies his statement in a manner which possibly might be a little bit indeterminate for most of us. He says that he has no hopes for the selective circuit. Now that bears out an unknown number of things. Just why that modification?

J. R. Carson: There are, of course, possibilities other than frequency selection. For example, we all know that the wave antenna has been successful to a certain extent in eliminating interference, and I don't wish to imply that that form will not be successful in reducing it by a substantial amount, but that is a different basis, that is not frequency discrimination, that is discrimination with respect to direction in which the signal interference comes. That is, the interference comes in from all directions, the signal from one direction. We have here, therefore, a means of excluding part of the interference, and in some cases a very large part without any frequency discrimination whatsoever. Here again, however, we encounter an irreducible minimum of interference, namely the interference arriving from substantially the same direction as the signal.

L. J. Peters: About a year ago I carried on some studies, some of those carried on by Mr. Carson, using about the same methods, although not quite so elaborate.

On the second basis, that is the basis of average power over a period of time or the average grouping square current, I arrived at about the same conclusions, but my own dissatisfaction with the method of average power was that I wasn't quite certain as to whether you could compute the actual interference by using average power, that is, over a period of time, and I would like to know Mr. Carson's idea on that subject. You might have a condition that would produce considerable noise in your receiver, and yet the average power that you got from that might figure out to be fairly low. I was hoping that I could arrive at some means by which you could actually estimate the maximum amount of noise you might get in your receivers.

Mr. Carson: The question, as I understand it, really comes down to how close a measure of interference the mean square current furnishes. I mentioned in the paper that that is a question that can't be answered, exactly, except by experiment.

On the other hand, suppose we have two circuits and they absorb the same amount of power. In the first place since we don't know what the individual form of disturbance is, the only basis which we can define our circuit to is as shown in the paper. On the other hand it is reasonably certain that they will be substantially the same in the long run though at any particular instant and for some particular type of interference, one circuit might be superior to the other and vice-versa. In the case of random disturbances, however, it is impossible to attempt to deal with the particular wave form of the instantaneous interference.

I have also examined the question as to whether, for example, a wave-filter of a large number of sections as compared with the wave-filter of a small number of sections, having practically the same mean current, might reduce the peak, and found that it would depend upon the relative frequency and form of the individual disturbances. In one case you might find that in a long wave-filter the peak would actually be larger than in the short wave-filter, but owing to the absolute random character of the interference, nothing in the way of design can be done on

that basis, and as regards the actual effect in reducing intelligibility, that would have to be subject to experiment. That is, if we have two filters which absorb the same mean interference, it is purely a question for experiment as to whether we can distinguish in the two circuits any difference in the effects of the interference on the intelligibility of the signal, which is what we are primarily concerned with.

J. Slepian (by letter): Every observer of radio progress must be bewildered by the great variety of circuits, most plausibly and ingeniously contrived for eliminating the great bugbear of radio, static interference. Now Mr. Carson sheds a great light on this subject by showing that practically all these various schemes are inherently alike; that when properly designed they are capable of reducing the static signal ratio just so far, and no farther. This is a very great achievement, and if it could be popularized, and made widely known, it would save a tremendous amount of useless work on the part of not only amateurs, but many professional men. Also, much of this effort might be diverted into paths which are beyond the assumptions of Mr. Carson's analysis, and may therefore have a chance of success. It is with this last in mind, that I would like to ask some questions, with the hope of specifying more precisely the types of circuit or apparatus to which Mr. Carson's analysis applies.

Apparently, the selective circuits of Mr. Carson's paper exercise only a frequency discrimination. That is, they have impedances which depend only on the frequency, when steady state is reached with a sinusoidal input. Circuits made up only of elements with linear characteristics will always have this property.

Now, frequency is not an instantaneous property of a voltage or current. A voltage or current must be watched for a finite length of time before periodicity can be noted, and a frequency assigned to it. Thus determining a frequency or a component frequency, must involve a remembering or integrating process, by which the past is tied up with the present. It is only natural therefore to find that Mr. Carson's analysis is based on the properties of certain integrals. Mr. Carson finds that the integrating processes, which determine the response of the selective circuits, when applied to random disturbances such as static, give residues, which can not be reduced below a certain figure.

Now the question I wish to raise, is whether the introduction of elements with non-linear characteristics does not get outside the limitations which Mr. Carson shows inherently exist for linear elements. The response of such elements cannot be described only in terms of frequency, but such instantaneous quantities as amplitude must be considered. For example, I am told, that considerable improvement in static ratio may be obtained by limiting devices, which prevent response to inputs which exceed a certain amplitude. Such a device has no selectivity whatsoever, being independent of frequency, and the formulae of Mr. Carson, if blindly applied would indicate that it would be entirely ineffective; yet the device does actually reduce static.

I had an opportunity to mention these points to Mr. Carson, and he told me he thought it possible to take into account non-linear elements by considering relations between combination frequencies. I would be very pleased if he would outline how this might be done. When dealing with elements which depend on instantaneous quantities such as amplitude, will it not be necessary to consider the whole infinite series of combination frequencies?

J. R. Carson: Dr. Slepian, in his interesting discussion has very properly called attention to the fact that the selective circuits dealt with in my paper are linear networks and function solely by frequency discrimination. He has also raised the important question as to what can be done in the way of eliminating static interference by non-linear devices which function on the base of amplitude discrimination. This is a very complicated question, quite outside the scope of the paper itself.—I am rather

afraid that in our conversation referred to by Dr. Slepian, I gave him a too optimistic impression. At any rate, while I have given the problem considerable study, I am not prepared as yet, to make any extensive discussion of it, certainly not an analytical one. There are, however, a few features of the problem which are of interest, and which indicate that a great deal more experimental data regarding the physical and psychological phenomena of audition must be accumulated before anything like a satisfactory handling of the problem is possible.

If the receiving circuit includes a non-linear circuit element, then when interference and signal are simultaneously present, the signal is modulated by the interference. If the non-linear characteristic is given analytically, it is possible to calculate the form of the modulated or distorted signal, but it is not, as yet, possible to predict the effect of such modulation in the intelligibility of the received signal. That, however, this effect and the possible benefits to be expected from the non-linear device must be dependent on the intensity and frequency of the interfering disturbances can be inferred from the following ideal limiting case of the non-linear device.

Suppose that we have an ideal device which automatically destroys both signal and interference during the intervals of time when the interference exceeds a specified tolerable limit, but does not affect the signal except during these intervals. It will be clear, I think, that such a device may prove either beneficial or injurious depending on the duration and frequency of these intervals and the relative intensity of the interference. For occasional bursts of intense interference of short duration its effect ought to be beneficial. For frequent bursts of interference or large duration, it would probably completely kill the intelligibility. Consideration of this ideal case does not permit us to make any general inferences; it does, however, I think, show how the whole problem is bound up with the phenomena of audition, and that it depends strictly on the character of the interference. In other words no such general statements can be made regarding non-linear devices for reducing static interference, as can be made in the case of frequency selection.

THE DIRECT METHOD OF CALCULATION OF CAPACITANCE OF CONDUCTORS¹

(DWIGHT)

CHICAGO, ILL., JUNE 27, 1924

D. M. Simons: I would like to emphasize Mr. Dwight's statement that while his solution is in terms of capacity, insofar as the geometric relationships are concerned, his work is immediately applicable to the calculation of thermal resistance, electrical resistance, dielectric loss, etc. His paper is especially valuable inasmuch as it makes it possible to make a rigid calculation of thermal resistance between conductors and sheath, which calculation is believed to be the most usual calculation where the geometric relationship between the three conductors as one electrode and the sheath as the other electrode are involved.

I would like to point out also that Mr. Dwight's formula is really merely a guide to a long and difficult mathematical process. It will be found that its application is by no means similar to the use of a simple formula involving one or two slide-rule operations, but that it is really a laborious computation. It is to be hoped that someone will have an opportunity of making a large series of such computations so as to make the exact data available throughout the range of the usual proportions of three-conductor cables.

Vladimir Karapetoff: Mr. Dwight's paper is certainly a bold attempt to treat the problem in a somewhat novel manner, and I hope that the method outlined is not only correct but is the simplest method possible for this particular problem. I mean that while we cannot solve this problem by the so-called method of inversion, yet there is another method which gives

splendid results for two spheres.² This latter method would be of no use if it were not for two facts: first, that all the fictitious charges are concentrated between the center of each sphere and its periphery on the center line; and, secondly, that all consecutive charges decrease in magnitude. Therefore, by putting an infinite number of charges along both center lines, you create a new electrical system such that for that system both spheres are equi-potential surfaces. According to a general theory of electrostatics, if you have found a possible distribution of electricity in equilibrium, then this is the only possible distribution. Thus, having found a solution, we know that it is the solution.

It seems to me that Mr. Dwight goes to an unnecessary complication by not limiting himself to linear charges but taking charges distributed upon cylinders, and I wish to suggest that he try the same method as is used with spheres.

S. E. Pero: (by letter): The final results in Mr. Dwight's paper seem to admit of simplification by a continuation of the analysis. At least in the case of the single-phase overhead-line formula which is the one I have examined particularly, the solution of the series equation by the method of successive substitutions will reduce the formula to the usual form by which Mr. Dwight checked his result numerically. This method of solution was applied by Mr. John R. Carson in his paper "Wave Propagation over Parallel Wires: The Proximity Effect," *Phil. Mag.* April, 1921, and in allied investigations. In fact, in 1920, we obtained a solution for the capacity in the case of two wires enclosed in a sheath, of which the single-phase circuit was treated as a special case.

Mr. Dwight's analysis of the latter problem may be continued in the following way. Denoting by λ , the ratio a/s where a is the radius of the conductors and s the interaxial separation, the capacity c between the wires of a single-phase overhead line, is, by formulae (13), (15), (17), (19) and (21) of the paper

$$\frac{1}{C} = 4 \left[\log \frac{1}{\lambda} - \lambda L_1 - \frac{\lambda^2}{2} L_2 - \dots - \frac{\lambda^n}{n} L_n - \dots \right] \quad (1)$$

where

$$L_n = A_n + B_n + C_n + \dots \quad (2)$$

$$A_n = \lambda^n$$

$$B_n = \lambda^n \left[\frac{n}{1!} \lambda A_1 + \frac{n(n+1)}{2!} \lambda^2 A_2 + \dots \right] \quad (3)$$

$$C_n = \lambda^n \left[\frac{n}{1!} \lambda B_1 + \frac{n(n+1)}{2!} \lambda^2 B_2 + \dots \right]$$

Consequently, by equations (2) and (3),

$$L_n = \lambda^n \left[1 + \sum \frac{k}{1} \frac{(n+k-1)!}{(n-1)! k!} \lambda^k L_k \right] \quad (4)$$

$$= \lambda^n l_n \quad (5)$$

where

$$l_n = 1 + n \lambda^2 l_1 + \frac{n(n+1)}{2!} \lambda^4 l_2 + \dots \quad (6)$$

Equation (6) is identical in form with equation (35) of Mr. Carson's paper on proximity effect. The solution may be obtained as explained in that paper, or may be derived by successive substitutions. By the latter method, the solution of the set of equations (6) is given by the limit of the sequence $l_n^{(0)}, l_n^{(1)}, \dots, l_n^{(n)}$ where

$$l_n^{(0)} = 1$$

$$l_n^{(1)} = \left(\frac{1}{1 - \lambda^2} \right)^n$$

1. A. I. E. E. JOURNAL, Vol. XLIII, November, p. 1034.

2. A. Russell, "Alt. Currents," Vol. I, Chap. 8

$$t_n^{(7)} = \left(\frac{1}{1 - \frac{\lambda^2}{1 - \lambda^2}} \right)^n$$

or, finally, t_1 is given by the continued fraction

$$t_1 = \frac{1}{1 - \frac{\lambda^2}{1 - \frac{\lambda^2}{1 - \lambda^2}}}$$

$$= t = 2 \frac{1 - \sqrt{1 - (2\lambda)^2}}{(2\lambda)^2} \quad (7)$$

and $t_n = t^n \quad (8)$

From equations (5) and (8), $\lambda^n L_n = \lambda^{2n} t^n \quad (9)$

and substituting this, (1) becomes

$$\frac{1}{C} = 4 \left[\log \frac{1}{\lambda} + \log (1 - \lambda^2 t) \right]$$

$$= 4 \log \frac{1 + \sqrt{1 - 4\lambda^2}}{2\lambda}$$

$$= 4 \log \frac{s + \sqrt{s^2 - 4a^2}}{2a} \quad (10)$$

which is formula (22) of the paper, the usual expression for the capacity in this case.

While the succeeding formulas are considerably more complicated it is possible that the foregoing method is applicable to them also.

Formulas (10) and (11) are credited to Mr. Curtis. As a matter of fact, these formulas are very old and they, or their equivalents, are found in such standard works as Hobson "Plane Trigonometry" 2nd. ed. p. 261, Bromwich "Theory of Infinite Series" pp. 158-159 and Webster "The Dynamics of Particles and of Rigid, Elastic and Fluid Bodies," p. 391.

H. B. Dwight: The mathematical derivation by Mr. Pero of the standard formula for capacitance of two overhead wires, from series (21) of my paper, is a very interesting and useful result. The simplification obtained in this way in the expression for capacitance is considerable, and if, as he suggests, a similar simplification can be made in the three-conductor formula (52), it would be a great advantage.

A check on the use of inverse surfaces or image surfaces for calculation of capacitance, as employed in my paper, can be made by using this method to calculate the capacitance of a sheathed cable with one eccentric conductor. The result is exactly the same algebraical expression as given by Alexander Russell, in "Treatise on the Theory of Alternating Currents," Edition of 1914, page 165, although his result was obtained without using images.

The fact that the three discussions of this paper suggest that it would be desirable that a mathematical investigation of considerable length be undertaken, shows that in electrical engineering, the same as in the science of physics, research cannot be carried on entirely by laboratory experiments, but a definite place must be given to research by calculation.

The JOURNAL of the A. I. E. E., by publishing papers which give the results of electrical engineering research by calculation, has done a great deal to make this type of research possible. This support should be continued. In spite of the demand which is sometimes expressed that all papers published should be interesting reading, research papers should be judged according to the criterion of whether they constitute a step in the solution of a problem in electrical engineering.

Mr. Simons is quite right about the length of the calcu-

lation in the paper which I presented. In fact, I would have hesitated to have written this up as a paper and sent it in if the cable people had not assured me (this applies particularly to the three-conductor calculation, which is extra long) that in spite of the length they wanted to use it.

There are very large opportunities, especially in this calculation of shortening the work for the people using the calculations. That is a long, tedious work but is quite worth while.

The indirect method suggested by Prof. Karapetoff of using a large number of concentrated charges instead of this rather new method of charges spread over surfaces will not avoid the troublesome use of angles of direction, so far as I can see. There would be three rows of concentrated charges in three directions at 120 degrees apart. However, the only test is to solve the problem the new way, if possible, and then see if it really saves work. It certainly has a good chance because the method presented is so very long.

I am not in the cable business but I shall do what I can to continue this problem as the prospects of getting results for the work invested look encouraging to me.

Prof. Karapetoff suggested that I try an alternative method involving concentrated charges. That would take about 100 hours of work.

INSULATOR TEST SPECIFICATIONS

The proposed Insulator Test Specifications Standards which are published herewith are the result of some three years' work on the part of a Subcommittee of the Standards Committee of the Institute.

This Subcommittee or Working Committee is one of number engaged in the complete revision of the Standards Rules. In its organization, as in that of all the other Working Committees, the personnel is picked to represent as well as possible the various interests involved, in this case in the production and use of line insulators.

Difficulty has been experienced in the past in selecting insulators for given purposes on the basis of published performance data and also in comparing results of tests made by different people at different times. Those who frequently purchase insulators have realized that there has been great variation in the methods of making insulator tests so that results are not always comparable. Different purchasers have also required variations in tests which in some cases have handicapped production without securing an increase in the reliability of the product and it has been generally recognized that a very considerable gain would be realized for everyone concerned if methods of making insulator tests could be made uniform.

It has been the practise of insulator manufacturers to catalog insulators on the basis of a more or less arbitrary voltage rating corresponding to line voltage. It is well recognized, however, that very many users install insulators of considerably higher voltage than the catalog rating for a given purpose. It has seemed logical, therefore, to rate the insulator at its actual performance as determined by test and then leave it to the user to secure for his particular purpose the insulator which he considers best adapted to it.

The National Electrical Safety Code in its revised form will contain certain recommendations concerning

the proper insulator for use under various conditions and the Institute Subcommittee believes that it is not within its province to attempt to solve this part of the problem and has confined its activities merely to defining the methods of making the tests which are most generally used in the selection of insulators. It is hoped that everyone interested will carefully consider these proposed specifications.

The Chairman of the Subcommittee, Mr. R. E. Argersinger, 147 Milk Street, Boston, Mass., will greatly appreciate any criticisms of these specifications and they should be sent in promptly so that the Insulator Subcommittee may have an opportunity to consider them and submit their recommendations to the Standards Committee in time for final action by that Committee at its May meeting.

REPORT ON INSULATOR TEST SPECIFICATION STANDARDS

I. SCOPE AND PURPOSE

These specifications are not to be interpreted as forming complete insulator specifications but rather as defining the methods of making the various tests described when they are required.

II. DEFINITIONS

1. Pin Insulator. A pin insulator is a complete insulator consisting of one insulating member or an assembly of such members without tie wires, clamps, thimbles or other accessories, the whole being of such construction that when mounted on an insulator pin, with suitable fittings, it will afford insulation and mechanical support to a conductor.

2. Shell. A shell is a single insulating member without cement or other connecting devices.

3. Suspension Insulator. A suspension insulator unit is a shell assembled with its necessary attaching members.

4. String. A string consists of two or more suspension insulator units flexibly connected in series.

5. Dry Flashover Voltage. Dry flashover voltage is the voltage at which the air surrounding a clean dry insulator or shell breaks down between electrodes, with the formation of a sustained arc, the test being made as described under "Dry Flashover Test."

6. Wet Flashover Voltage. Wet flashover voltage is the voltage at which the air surrounding a clean wet insulator or shell breaks down between electrodes with the formation of a sustained arc, the test being made as described under "Wet Flashover Test."

7. Puncture Voltage. Puncture voltage is the voltage at which an insulator or shell is electrically punctured when subjected to a gradually increasing voltage, the test being made as described under "Puncture Voltage Test."

8. Combined Mechanical and Electrical Strength. The combined mechanical and electrical strength of an insulator is the load in pounds at which the insulator fails either electrically or mechanically, voltage and mechanical stress being applied simultaneously as described under "Combined Mechanical and Electrical Strength Test."

9. Rating. The rating of an insulator shall be its dry flashover and wet flashover voltages expressed in kilovolts.

Under standard test conditions the average of the dry flashover voltages of six units shall be within 5 per cent and the average of the wet flashover voltages of six units shall be within 10 per cent of the corresponding rating voltages.

These allowances are made to provide for variables which are difficult to control.

III. PAYMENT FOR MATERIAL TESTED

As far as practicable, tests shall be made upon units which have some defect and are not salable but are otherwise acceptable to the inspector for the test in question. In addition, purchaser shall be allowed to test commercial insulators to destruction up to $\frac{1}{2}$ of a per cent of the total number ordered. If additional units are desired for such tests they shall be paid for by the purchaser.

IV. DESIGN TESTS, PIN INSULATORS

1. Dry Flashover Test. Dry flashover test shall be performed with the pin insulator mounted in a vertical position on a steel pin of circular section 1 in. (2.54 cm.) in diameter mounted on a cross-arm and of such length that the ratio of the shortest distance from the outer edge of the head around the insulator to the cross-arm, to the shortest distance from the edge of the head around the insulator to the pin shall be 1.25. The cross-arm shall be a grounded metallic tube not less than 3 in. (7.63 cm.) and not more than 5 in. (12.7 cm.) in outside diameter and shall extend at least 3 ft. (0.914 m.) on either side of the center line of the insulator pin. No other grounded structure shall be nearer than 3 ft. (0.914 m.) to any part of the insulator or conductor. The head of the insulator shall be fitted with a straight smooth metallic rod or tube not less than $\frac{1}{2}$ in. (1.26 cm.) in outside diameter extending in a direction at right angles to the cross-arm and at least 2 ft. (0.609 m.) in either direction from the center line of the insulator head. This rod shall be secured in the upper groove by means of at least one turn of wire not smaller than No. 8 A. W. G. placed in the side tie wire groove.

The character of the testing equipment and method of measuring voltage shall conform to the Standards of the A. I. E. E.

The test shall be performed by applying voltage between the rod fastened to the head and the steel pin, and raising it at a rate of approximately 10,000 volts every fifteen seconds to a value at which dry flashover occurs. The initial applied voltage shall be approximately 80 per cent of dry flashover voltage.

Records shall be made of barometric pressure, air temperature and humidity.

2. Wet Flashover Test. The testing arrangement shall be the same as in the dry flashover test with the addition of equipment to provide a finely divided and reasonably uniform spray at an angle of 45 deg. from the vertical and at a rate of 0.2 in. (5.07 mm.) per minute. The water shall have a resistance of from 6000 to 8000 ohms per in. cube (15,200 to 20,300 ohms per cm. cube) and shall be delivered to the spray nozzle at a pressure of not less than 35 and not more than 50 pounds per sq. in. (2.46 to 3.51 kg. per sq. cm.) measured at the nozzle. The vertical and horizontal dimensions of the vertical area sprayed shall be measured in a plane through the vertical axis of the insulator and shall be at least 1.75 times the corresponding over-all projected dimensions of the insulator. The precipitation shall be determined by measurements taken, with the insulator removed at the location of the top, center and bottom of the vertical axis of the insulator when in its test position. The water shall be collected in a vessel having a top diameter of six inches. Individual measurements shall show a variation of not more than 25 per cent from the mean of the three measurements.

Methods of applying and measuring voltage and of recording data shall be the same as for the "Dry Flashover Test" except that the insulator shall be sprayed one minute before voltage is applied and that the initial applied voltage shall be approximately 80 per cent of the wet flashover voltage.

3. Corona Formation Voltage. The testing arrangement shall be the same as for the dry flashover test using a darkened room. A voltage well above the corona point shall be applied and slowly lowered until all brush discharges disappear from the insulator. The point of disappearance shall be the corona voltage.

Methods of measuring voltage and of recording data shall be the same as in the "Dry Flashover Test."

4. Puncture Voltage Test. In making this test the insulator shall be inverted and immersed in oil with the line and tie wire grooves served with a single conductor not smaller than No. 8 A. W. G. The pin hole shall be provided with a cemented thimble in which shall be inserted a close fitting metal pin. Voltage shall be applied between the pin and the conductor in the tie wire groove.

Methods of applying and measuring voltage and of recording data shall be the same as in the "Dry Flashover Test," except that the initial applied voltage shall be approximately the dry flashover voltage and the voltage shall be increased at a rate of approximately 1000 volts per second until puncture occurs.

V. DESIGN TESTS, SUSPENSION INSULATORS

1. Dry Flashover Test. Dry flashover test shall be performed with the insulator, unit, or string, suspended vertically by the maker's standard cross-arm suspension hardware carried at the end of a grounded wire or suitable conductor suspended so that the vertical distance from the uppermost point of the insulator hardware to the supporting structure shall not be less than 3 ft. No other grounded structure shall be nearer than 3 ft. or one and one-half times the string length to any part of the unit or string. The insulator pin, or corresponding fitting, shall carry an inverted pipe tee made of smooth 3/4 in. pipe standard iron pipe size the head of the tee being not less than 6 ft. long, the stem of the tee being coupled at the middle point of the head and having such a length that the distance from the upper surface of the horizontal head of the tee to the lowest edge of the porcelain shall not exceed 0.7 of the diameter of the lowest unit.

Potential shall be applied between the stem of the pipe tee and the grounded suspension by raising the voltage at the rate of approximately 10,000 volts every fifteen seconds to a value at which dry flashover occurs. The initial applied voltage shall be approximately 80 per cent of dry flashover voltage. Records shall be made of barometric pressure, air temperature and humidity.

The character of the testing equipment and method of measuring voltage shall conform to the Standards of the A. I. E. E.

2. Wet Flashover Test. The wet flashover test shall be performed using the same general arrangement as in the dry flashover test with the addition of equipment to provide a finely divided and reasonably uniform spray at an angle of 45 deg. from the vertical and at the rate of 0.2 in. (5.07 mm.) per minute. The water shall have a resistance of from 6000 to 8000 ohms per inch cube (15,200 to 20,300 ohms per cm. cube) and shall be delivered to the spray nozzle at a pressure of not less than 35 and not more than 50 pounds per sq. in. (2.46 to 3.51 kg. per sq. cm.) measured at the nozzle. The vertical and horizontal dimensions of the vertical area sprayed shall be measured in a plane through the vertical axis of the unit or string and shall be at least 1.75 times the corresponding overall projected dimensions of the unit or string. Precipitation shall be determined by measurements, taken with the unit or string removed at the location of the top, center, and bottom of the vertical axis of the unit or string when in its test position. The water shall be collected in a vessel having a top diameter of six inches. Individual measurements shall show a variation of not more than 25 per cent from the mean of the three measurements.

Methods of applying and measuring voltage and of recording data shall be the same as for the dry flashover test except that the unit or string shall be sprayed one minute before voltage is applied and that the initial applied voltage shall be approximately 80 per cent of the wet flashover voltage.

3. Corona Formation Voltage. The testing arrangement shall be the same as for the dry flashover test using a darkened room. A voltage well above the corona point shall be applied and slowly lowered until all brush discharges disappear from the insulator. The point of disappearance shall be the corona voltage.

Methods of measuring voltage and of recording data shall be the same as in the "Dry Flashover Test."

4. Puncture Voltage Test. Puncture test shall be performed with the insulator unit inverted and immersed in oil, voltage being applied between the cap and stud or corresponding metal fittings.

Methods of applying and measuring voltage and of recording data shall be the same as in the "Dry Flashover Test," except that the initial applied voltage shall be approximately the dry flashover voltage and the voltage shall be increased at a rate of approximately 1000 volts per second until puncture occurs.

5. Combined Mechanical and Electrical Strength Test. This test shall be performed with the insulator unit mounted so that mechanical tension can be gradually applied simultaneously with a potential 25 per cent below the rated dry flashover voltage and having a frequency not greater than 60 cycles. Tension and potential shall be applied between the cap and pin or corresponding fittings of the insulator.

The mechanical tension shall be brought up rapidly to a value approximately 75 per cent of the probable tension at puncture after which it shall be increased at the rate of 2000 lb. (907.2 kg.) per minute until puncture takes place.

Methods of measuring voltage and of recording data shall be the same as in the "Dry Flashover Test."

VI. ROUTINE TESTS, PIN INSULATORS

1. Preliminary Test. Before assembly, all shells shall be subjected to vigorous dry flashover potential at normal frequency 25 to 60 cycles for 3 minutes. If more than 5 per cent fail, the lot* may be retested. If on reset more than 3 per cent fail, the lot* shall be rejected.

2. Test after Assembly. After assembly the insulators shall be subjected to a vigorous dry flashover test for two minutes. Insulators failing under this test shall be rejected.

3. Puncture Test. Puncture test shall be made on units which have passed the final routine flashover test. Rejection of units for puncture shall be based on the "Average Variation" in puncture voltage determined as follows:

DETERMINATION OF "PER CENT AVERAGE VARIATION" IN PUNCTURE UNDER OIL TEST

Purchaser will select from units offered for final inspection not more than 1/2 of one (1) per cent of the total quantity and not less than three (3) units.

Let $V_1 V_2 V_3 \dots V_n$ = individual puncture values
 V = average puncture voltage
 $V = (V_1 + V_2 + V_3 \dots + V_n)/n$

Let $a_1 = V - V_1 \quad a_2 = V - V_2 \quad a_3 = V - V_3 \quad a_n = V - V_n$
 Consider all the values of a as positive, that is, neglect the signs.

Let a = average variation
 A = per cent average variation

Then $a = (a_1 + a_2 + a_3 \dots + a_n)/n$
 $A = 100 a / V$

Example:
 Five insulators punctured at: 150, 135, 145, 138, 142 kv., respectively.

$$V = (150 + 135 + 145 + 138 + 142)/5 = 142$$

$$a = (8 + 7 + 3 + 4 + 0)/5 = 4.4$$

$$A = 100 \times 4.4/142 = 3.09 \text{ per cent}$$

If "Per Cent Average Variation," A , exceeds 10 per cent, the entire quantity shall be rejected, or at the manufacturer's option and expense an additional 2 per cent or a minimum of 10 units may be tested. If the "Per Cent Average Variation" A ,

*In all cases where the term "lot" is used, it should be defined as including only the number of units on the testing pan at one time.

obtained from this second test only exceeds 10 per cent, the entire lot shall be rejected. Further, if the Average Puncture Voltage V is less than 130 per cent of rated Dry Flashover Voltage, the entire lot shall be rejected.

VII. OPTIONAL TESTS—PIN INSULATORS

1. **Thermal Test—Preliminary.** After the routine "Preliminary Test," a number of representative shells of each type used shall be subjected to a "Thermal Test." The number tested shall not exceed 1/10 of 1 per cent of the order and shall not be less than five (5) shells. This test shall consist of ten (10) immersion cycles. Each cycle shall be made by immersing the shell in a bath of water maintained at a temperature of approximately 205 deg. fahr., or 96 deg. cent. The shell shall remain in this bath ten (10) minutes and then shall be immediately immersed in a bath of water maintained at a temperature of approximately 39 deg. fahr., or 4 deg. cent., in which it shall remain for ten (10) minutes and after which the next cycle shall immediately follow. The transfer period between immersions should not exceed five (5) seconds in length. During this time the shell shall be tapped with a hammer to detect cracks which may have occurred. After the fifth and tenth cycle and following the cold bath, the unit shall be given a momentary "Dry Flashover Test."

If more than 20 per cent of the shells subjected to this test fail, the entire quantity represented shall be rejected.

2. **Thermal Test—Final.** After the "Test After Assembly" a number of representative assembled insulators shall be subjected to a "Thermal Test." Specifications for this test shall be the same as the specifications for the "Thermal Test" on pin insulator shells except that each insulator shall be mounted on a pin of the type to be used with it, that the temperature of the hot bath shall be approximately 150 deg. fahr., or 66 deg. cent., and the word "insulator" shall be substituted for the word "shell."

VIII. ROUTINE TESTS, SUSPENSION INSULATORS

1. **Preliminary Test.** Before assembly, all shells shall be subjected to vigorous dry flashover potential at normal frequency 25 to 60 cycles for 5 minutes.

If any shell fails during the fourth or fifth minute of the test, the test shall be continued until no shell fails during the last two minutes of test. The excess time is based on the testing of quantities up to 100 at one time. For quantities greater than 100, the excess time after the last failure may be less than two minutes by agreement between manufacturer and purchaser. If more than 5 per cent fails the lot* may be retested. If on retesting more than 3 per cent fails the lot* shall be rejected.

2. **Mechanical Test.** All assembled units shall withstand for three seconds without sign of distress a mechanical pull in line with the axis of the insulator amounting to approximately 40 per cent of the rated ultimate strength. This test shall be given before the final electrical test, and in the case of cemented units shall be made not more than 7 days after cementing.

3. **Test after Assembly.** One of the three following tests shall be made as outlined under a, b, or c:

(a) *High Frequency Test*

For this test the manufacturer may at his option be governed by either of the following specifications:

1. After assembly, each suspension insulator unit shall be subjected to a damped high frequency or impact test for from three (3) to five (5) seconds in which the insulator shall be tested at a voltage approximately 15% above the normal frequency flashover value. The frequency shall be of the order of 200,000 cycles per second in damped trains, the source of energy being a circuit having a frequency of 25 to 60 cycles. All units failing shall be rejected.

*In all cases where the term "lot" is used, it should be defined as including only the number of units on the testing pan at one time.

2. After assembly, each suspension insulator unit shall be subjected to a high frequency discharge from a 60-cycle transformer adjusted for a no load voltage of not less than 115% of the 60-cycle dry flashover of the unit, this test to be continued for a period of not less than three seconds. The high frequency superimposed upon the 60-cycle voltage shall not be less than 100,000 cycles per second. All units failing shall be rejected.

(b) *Normal Frequency Test*

After assembly each suspension insulator unit shall be subjected to a vigorous dry flashover test at normal frequency 25 to 60 cycles for three minutes. All units failing shall be rejected.

(c) *Overvoltage Test*

After assembly each suspension insulator unit shall be lowered in an upright position into a bath of insulating oil, slightly immersing the tips of the lowest parts and the rim to a depth sufficient to prevent flashover. Air shall cover the bottom of the shell to conduct the charging current to the shell. One hundred twenty per cent of Dry Flashover Voltage to a frequency not greater than 60 cycles shall then be applied between the terminals of the unit for two minutes, with one minute after the last puncture. All units failing shall be rejected.

4. **Puncture Test.** Puncture Test shall be made on units which have passed the final "Test After Assembly." Rejection of units for puncture shall be based on the "Average Variation" in puncture voltage determined, as follows:

DETERMINATION OF "PER CENT AVERAGE VARIATION" IN PUNCTURE UNDER OIL TEST

Purchaser will select from units offered for final inspection not more than 1/2 of one (1) per cent of the total quantity and not less than three (3) units.

Let
 $V_1 V_2 V_3 \dots V_n$ = individual puncture values
 V = average puncture voltage
 $V = (V_1 + V_2 + V_3 \dots V_n)/n$

Let
 $a_1 = V - V_1 \quad a_2 = V - V_2 \quad a_3 = V - V_3 \quad a_n = V - V_n$

Consider all the values of a as positive, that is, neglect the signs.

Let
 a = average variation
 A = per cent average variation

Then
 $a = (a_1 + a_2 + a_3 \dots + a_n)/n$
 $A = 100 a/V$

Example:

Five insulators punctured at: 150, 135, 145, 138, 142 kv. respectively.

$$V = (150 + 135 + 145 + 138 + 142)/5 = 142$$

$$a = (8 + 7 + 3 + 4 + 0)/5 = 4.4$$

$$A = 100 \times 4.4/142 = 3.09 \text{ per cent.}$$

If "Per Cent Average Variation" A exceeds 10 per cent the entire quantity shall be rejected, or at the manufacturer's option and expense an additional 2 per cent, or a minimum of 10 units may be tested. If the "Per Cent Average Variation" A , obtained from this second test only exceeds 10 per cent the entire lot shall be rejected. Further, if the Average Puncture Voltage V is less than 130 per cent of Dry Flashover Voltage, the entire lot shall be rejected.

5. **Ultimate Mechanical Strength.** Ten units shall be selected for this test from each 1000 ordered. If any fail at less than 85 per cent of the manufacturer's rated ultimate strength, an additional 20 units shall be tested at the manufacturer's expense. If none fail at 85 per cent of manufacturer's rating the lot shall be accepted and if any fail, rejected.

In the case of cemented units the test shall be made not more than 7 days after cementing.

ILLUMINATION ITEMS

By the Lighting and Illumination Committee

DAYLIGHT REFLECTION FACTS

All of us are familiar with the panoramic view most store windows present on a bright, cloudless day. A steady stream of passing vehicles, street cars and pedestrians, seen against a background of distorted buildings, usually meets the gaze of the interested passerby and the value of the window display itself is lost merely because it cannot be clearly seen without conscious effort on the part of the observer.

In order to determine more accurately the factors which are concerned in the elimination of these troublesome reflections a careful study has recently been made of the reflected images from sixty-five typical store windows. It was first necessary, of course, to determine which of the various bright objects in the street caused the most objectionable reflections from the plate glass windows. It was found that light colored sidewalks were the most serious from the standpoint of harmful reflections due to the high illumination on the horizontal surface. Street cars, and light colored buildings on the opposite side of the street were also the cause of pronounced reflections; light colored streets, passing vehicles and pedestrians were next in order of importance.

LIGHT BACKGROUNDS ARE PREFERABLE

It was also important to know how conditions inside of the windows affected the visibility of the display. With this end in view various kinds of backgrounds in typical windows were studied. It was soon seen that the character of the background has considerable influence on the effectiveness of the window. While it is not of major importance to have a light background in windows where the displays are light, yet such a condition is desirable in that the general illumination on the display is increased due to the reflection of the background and a large surrounding dark surface against which distracting images are seen is eliminated. Light colored backgrounds in windows having dark trims have a very definite value, in that the displays can at least be seen by silhouette. Many display windows in practise have backgrounds of dark wood finishes which add to the richness of the display and form a pleasing contrast with light colored trims. This effect is lost however, if the background is too dark.

With these facts in mind, the next step for the engineers was to find ways and means of overcoming the bothersome reflected images. By actual measurement of the illumination in several windows and the brightness of the display, the fact was soon established that the display must be illuminated so that its brightness is at least equal to the brightness of the reflections themselves, if the veiling effect of the images, reflected from the window glass, is to be entirely overcome.

A table was compiled from these data enabling one to determine easily the foot-candles necessary on any display to eliminate objectionable reflections. By

measuring the daylight illumination in any given win-

TABLE I
Foot-Candles Required to Satisfactorily Illuminate Windows Having Displays with Various Reflection Factors When Images of Objects in Bright Sunlight Are Present

Objects in sunlight causing	Color tone of display material usually employed in windows				
	Very Dark 5%	Dark 20%	Medium 35%	Fairly Light 50%	Very Light 65%
Light-Colored Building	1,200	300	170	150	150
Dark-Colored Building	400	150	150	150	150
Dark-Colored Pavement	1,200	300	170	150	150
Light-Colored Sidewalk	1,800	450	260	180	150
Light-Colored Street Cars	1,400	350	200	150	150
Dark Automobiles	200	150	150	150	150
Clouds	4,000	1,000	570	400	300
Sky	1,700	425	250	170	150

dow and subtracting the value from the corresponding foot-candle value in the table, the required foot-candles of artificial illumination which must be supplied is determined.

Recent improvements in lighting equipment have made it possible to meet these requirements very easily. Flood lighting the entire display or spot-lighting the principal objects in the display offers an effective means of raising the illumination to the required level. The auxiliary lighting equipment should be installed on separate circuits so that higher levels of illumination can be obtained as desired at different hours of the day or at different seasons of the year.

By eliminating daylight reflections, the attractiveness of the window display and its value as an advertising medium are greatly increased.—*Light*, January, 1925.

SITTING IN A DRAFT AND FACING GLARING LIGHT SOURCES

When one finds himself sitting in a draft in somebody's office or in a friend's home, he does not hesitate to protect himself from this exposure. He may change his seat or may even ask that the draft be reduced or eliminated. This is a privilege which is recognized by both host and visitor and no offense is involved. Why should not the same principle be applied to lighting? How often one finds himself facing a glaring light source. Does he feel as free to mention this annoyance? Even those who recognize the harmful influence of glaring light seldom find it easy to suggest that it be shaded or extinguished. It is felt that the host might be offended, and, doubtless, there is ground for the fear. The effect of exposure to a draft is so easy to trace to its cause that every one recognizes the danger and hosts would not suffer guests to be unnecessarily exposed.

This illustrates very well the need for educational work in lighting—for a continual campaign against glare. The millennium in lighting will not have arrived until every one feels as free to complain against glare as against drafts. To bring this about is no small task, but constant, tactful agitation whenever a proper opportunity presents itself will eventually change the attitude of the public mind.—*Electrical World*, Dec. 27.

JOURNAL OF THE American Institute of Electrical Engineers

PUBLISHED MONTHLY BY THE A. I. E. E.
33 West 39th Street, New York
Under the Direction of the Publication Committee

FARLEY OSGOOD, *President*
GEORGE A. HAMILTON, *Treasurer* F. L. HUTCHINSON, *Secretary*

PUBLICATION COMMITTEE
DONALD McNICOL, *Chairman*

L. W. W. MORROW E. B. MEYER
F. L. HUTCHINSON L. F. MOREHOUSE

GEORGE R. METCALFE, *Editor*

Subscription. \$10.00 per year to United States, Mexico, Cuba, Porto Rico, Hawaii and the Philippines; \$10.50 to Canada and \$11.00 to all other countries. Single copies \$1.00. Volumes begin with the January issue.

Changes of advertising copy should reach this office by the 15th of the month for the issue of the following month.

The Institute is not responsible for the statements and opinions given in the papers and discussions published herein. These are the views of individuals to whom they are credited and are not binding on the membership as a whole.

Program for the Spring Convention

The coming convention in St. Louis, April 13-17, promises to set a record for Spring meetings. Technical sessions of unusual quality, delightful social features, including a specially attractive program for the ladies, and an excellent hotel and location will all contribute to the success of this convention. A very competent and enthusiastic committee, drawn from practically all the electrical interests in St. Louis, has made complete arrangements for the enjoyment of all who attend.

THE TECHNICAL SESSIONS

Power plants and systems, industrial, marine and mine applications, machine design and communication will constitute the major topics of the technical papers. Five of the most modern power plants will be discussed in one session and another session will cover the use of frequency changers, reactors, automatic substations and cable crossings. Four machinery papers will cover short-circuit currents, two-speed synchronous motors and self-excited synchronous motors. In the general topic of communication papers will be given on loud speakers, railroad communication, echo suppressors and frequency multipliers. Under the heading of industrial topics there will be papers on marine applications of electricity, mining applications, industrial heating, induction furnaces, babbitt pots, rubber-mill drive and glass manufacture. Automobile lighting will be covered in another paper. The accompanying list explains the technical sessions in more detail.

EXCELLENT HOTEL AND LOCATION

The Hotel Chase, which will be convention headquarters is ideal for an Institute meeting. It is comfortable, commodious

and up-to-date and is situated in beautiful surroundings. Furthermore St. Louis is most attractive at the season when the meeting will be held. Directly across from the hotel is Forest Park and surrounding it are impressive residential districts. Within Forest Park are to be found the Art Museum, the Jefferson Memorial, the Zoological Gardens, the Municipal Theater and the home of the Missouri Historical Society. Tennis, golf and horseback riding are available.

The hotel is within 15 minutes ride of the central business district of St. Louis and motor buses and trolley cars pass the door.

Dancing is a regular evening feature in the Palm Room and guests in the Lounge may enjoy a musical program without charge from 7:00 P. M. to 1:00 A. M. every evening.

The room rates are \$3.50 to \$6.00 per day for single rooms and \$6.00 to \$8.00 for double rooms, all rooms having private baths. Very reasonably priced club meals are served three times a day.

ENTERTAINMENT

Among the events of a lighter nature scheduled for the meeting are an informal reception and dance for Monday evening, April 13, a smoker and also a ladies theater party Wednesday evening, and a banquet and dance Thursday evening. For the dances a number of schemes have been laid to promote an informal atmosphere so that all may become acquainted. At the smoker there will be entertainment in cabaret style by the Municipal Opera chorus and others and a buffet supper will be served.

The banquet on Thursday evening will be another delightful function. The plans are to make this occasion lively and free from solemnity. There will be short talks by two or three very prominent speakers including Past-President F. B. Jewett, vice-president, Western Electric Company. Entertainment specialties and music will be enjoyed during the evening and at 10:30 dancing will start. Square and round dances, favors, confetti, etc., will help to make a gala night.

GOLF AND TENNIS

Every day golf and tennis may be played on the country-club and municipal links and courts which are nearby. Automobiles will be furnished free morning and afternoon to those who wish to play. There will be tournaments for both ladies and men.

INSPECTION TRIPS

The great number of the industries of St. Louis offers a wide variety of things to be seen. Power plants and systems, many industrial establishments, telephone systems, etc., offers a wide diversity.

The Cahokia plant of the Union Electric Light and Power Company will of course be of great interest. A special trip will be made to this plant, probably Wednesday afternoon. A number of other trips also will be arranged.

A sightseeing trip for ladies and gentlemen will be made Wednesday afternoon through some beautiful sections of the city.

DELIGHTFUL PLANS FOR THE LADIES

Many special attractions have been arranged for the ladies and it is expected that many of them will attend. A committee composed of a group of St. Louis ladies will see that everything possible is done for the enjoyment of the guests and plans have been made to interest them at all times. The ladies, particularly, will enjoy the comforts of the excellent Chase Hotel and its surroundings.

LADIES' OUTINGS AND THEATER PARTY

A ladies outing to the Midland Valley County Club is scheduled for Tuesday. Bridge will be played and prizes given by local electrical concerns will be awarded. Golf may be played if desired. Thursday an outing to the Riverview Club is planned with a ladies putting contest as the feature. On both of these outings there will be no expense to the ladies for luncheon, automobiles or greens fees.

Another sightseeing tour for both ladies and men is arranged

for Wednesday afternoon. The route will touch Washington University, Art Museum, the Municipal Theater, Shaws Garden and fine residential districts.

The theater party for the ladies on Wednesday evening will be held while the men are at the Smoker. For this also there will be no charge for tickets or transportation.

SPORTS FOR THE LADIES

Ladies may play golf every day on several courses which are located near the hotel. Tennis also may be played by those who prefer. Automobiles will be furnished.

Of course the ladies will be present at the dance on the opening evening but furthermore there will be dancing every evening in the hotel. The banquet on Thursday evening also will be well attended by the ladies. The committee promises only a few short speeches, some good entertainment and a lively dance to close the evening.

The general committee of arrangements for this convention as appointed by President Osgood, consists of Messrs. B. D. Hull (Chairman), Edward Bennett, H. E. Bussey, J. M. Chandlee, H. W. Eales, J. Harrison, Chris. H. Kraft, L. W. W. Morrow, C. P. Potter, W. L. Rose, Herbert S. Sands. Subcommittees have been appointed, the chairmen of which are as follows: Entertainment, W. L. Rose, Finance, G. A. Waters; Publicity, C. L. Matthews; Registration and Hotel, J. M. Chandlee; Special Feature, C. H. Kraft; Technical Inspection, C. C. Robinson; Technical Meetings, C. P. Potter, and Transportation, J. L. Buchanan.

TENTATIVE TECHNICAL PROGRAM FOR SPRING CONVENTION, ST. LOUIS

MONDAY, APRIL 13
2:00 P. M.

POWER PLANTS SESSION

Under auspices of Committee on Power Generation,
VERN E. ALDEN, Chairman

1. *Trenton Channel Station*, C. F. Hirshfeld, Detroit Edison Co.
Data and engineering reasoning leading to the design chosen for the Trenton Channel Plant. The plant will have an ultimate capacity of 300,000 kw. with 50,000-kw. units. Powdered fuel is employed.
2. Informal discussion on the electrical and mechanical features of the following stations—
Philo Station of the Ohio Power Company, by E. H. McFarland, Beech Bottom Power Company.
Weymouth Station of the Edison Electric Illuminating Company of Boston, by I. E. Moulthrop.
Cahokia Station of the Union Electric Light and Power Co., by H. W. Eales.

TUESDAY, 9:30 A. M.

POWER SYSTEMS SESSION

Under auspices of Committee on Power Generation,
VERN E. ALDEN, Chairman

3. *Interconnection of Systems with Frequency Changers*, H. R. Woodrow, Brooklyn Edison Co.
A discussion of the 35,000-kv-a. synchronous-synchronous frequency changer which ties together the 60-cycle and 25-cycle systems of the Brooklyn Edison Company.
4. *Eight Years' Experience with Protective Reactors*, James Lyman, L. L. Perry and A. M. Rossman, all of Sargent & Lundy.
Results of eight years' experience with reactors in operation in three large power stations. The action of the reactors in a number of cases of actual trouble is analyzed.
5. *Mississippi River Crossing of Crystal City Transmission Line*, by H. W. Eales and E. Ettlinger, both of Union Electric Light & Power Co.
Description of two long, 132-kv., river-crossing spans designed for heavy ice loading. Calculations for sags and tensions used.

6. *Application of Automatic Control to Substation Apparatus*, W. H. Millan, Union Electric Light & Power Co.

This paper contains suggestions for eliminating some of the troubles which may develop in the automatic operation of substation equipment. It applies particularly to alternating-current distributing substations and direct-current substations feeding heavy Edison networks.

TUESDAY, 2:00 P. M.

MACHINERY SESSION

Under auspices of Committee on Electrical Machinery,
H. M. HOBART, Chairman

7. *Initial and Sustained Short Circuits in Synchronous Machines*, V. Karapetoff, Cornell University.
Analytical and graphical treatment of general cases of armature windings displaced by arbitrary angles, with applications to one-, two- and three-phase machines.
8. *Short-Circuit Currents of Synchronous Machines*, R. F. Franklin, General Electric Co.
The application to a number of practical cases of the general formulas for short-circuit currents as given in the companion paper by V. Karapetoff.
9. *A Two-Speed Salient-Pole Synchronous Motor*, R. W. Wieseman, General Electric Co.
A specially shaped pole is used to obtain two speeds at high efficiency.
10. *Self-Excited Synchronous Motors*, J. K. Kostko, Palo Alto, Cal.
Analysis of design possibilities of the self-starting high-power-factor synchronous motor.

WEDNESDAY, 9:30 A. M.

COMMUNICATION SESSION

Under auspices of Committee on Communication,
O. B. BLACKWELL, Chairman

11. *A New Hornless Type of Loud Speaker*, C. W. Rice and E. W. Kellogg, both of General Electric Co.
Description of a series of tests directed to the evolution of a loud speaker free from resonance and the development of a practical speaker which gives an output approximately proportional to the actuating force, and independent of frequency.
12. *Communication in Railroad Operation*, I. C. Forshee, Pennsylvania Railroad System.
A description of the use on railroad systems of the telegraph, telephone, telautograph, telegraph printer and radio.
13. *Echo Suppressors for Long Telephone Circuits*, A. B. Clark, American Telephone & Telegraph Co., and R. C. Mathes, Bell Telephone Laboratories, Inc.
An account of a device for suppressing echo effects sometimes encountered in very long telephone circuits. The possibilities and limitations of the device are discussed.
14. *Frequency Multiplication*, N. Lindenblad, Radio Corporation of America, and W. W. Brown, General Electric Co.
The paper presents in a condensed form physical conceptions of the operation of iron-cored frequency multipliers and some results of an investigation to determine the possibilities of increasing the usefulness of large high-frequency alternators through use of frequency multipliers.

THURSDAY, 9:30 A. M.

MARINE SESSION

Under auspices of Committee on Applications to Marine Work,
L. C. BROOKS, Chairman

15. *Historical Review of Electrical Applications on Shipboard*, H. L. Hibbard and Wm. Hetherington, Jr., both of Cutler-Hammer Mfg. Co.
A review of the progress in electrical installations on vessels from the time of the first electric lighting system to the present day.
16. *The Electrical Engineer in the Merchant Marine*, G. A. Pierce, William Cramp & Sons.
An exposition of the responsibilities of the electrical engineer in the merchant marine and a plea for creation of an official rank for him compatible with his responsibilities and duties.

17. *Electrical Ship Propulsion*, H. F. Harvey, Newport News Shipbuilding & Dry Dock Co. and W. E. Thau, Westinghouse Electric & Mfg. Co.

Study of main drive, control, auxiliaries, etc., used on various types of vessels.

FRIDAY, 9:30 A. M.

MINING SESSION

Under auspices of Committee on Applications to Mining Work,

F. L. STONE, Chairman

18. *Cool-Mine Electrification*, W. C. Adams of Allen & Garcia Co.
A discussion of some of the most vital problems of coal-mine electrification and descriptions of some concrete installations.

19. *Application of Motors to Line Locomotives*, W. C. Clark, Westinghouse Elec. & Mfg. Co.

An analysis of the basic design data necessary for applying electric motors to mine locomotives.

20. *Automobile Lighting*, J. H. Hunt, General Motors Research Corporation.

A study of the problem of head lights, particularly with reference to plans for eliminating dangerous glare.

21. *A Vibration Recorder for Pathological Analyses*, by C. I. Hall, General Electric Co.

The design characteristics of an instrument to be used by physicians for recording the tremors of a patient, and to resolve the motions into their vertical and horizontal components.

FRIDAY, 2:00 P. M.

INDUSTRIAL SESSION

Under auspices of Committee on General Power Applications,

A. E. WALLER, Chairman

22. *Load-Building Possibilities of Industrial Heating*, C. L. Ipsen, General Electric Co.

A survey of the use of electric heating for steel treating, copper and brass annealing, vitreous enameling, glass annealing, baking ovens, and impregnating tanks.

23. *A High-Frequency Induction Furnace Plant for the Manufacture of Special Alloys*, P. H. Brace, Westinghouse Elec. & Mfg. Co.

Description of production on a commercial scale of very pure special alloys by means of a high-frequency induction furnace. Complete data are given on the furnace and its operation, the high-frequency power plant and the electrolytic iron refinery used in conjunction with the furnace.

24. *Electrically Heated Lead, Solder and Babbitt Pots*, J. C. Woodson, Westinghouse Elec. & Mfg. Co.

Discussion of design and theory of electrically heated pots with much detailed data useful to both designer and user.

25. *Synchronous-Motor Drive for Rubber Mills*, C. W. Drake, Westinghouse Elec. & Mfg. Co.

A study largely applying to the use of dynamic braking of synchronous motors.

26. *Use of Purchased Power in Glass Manufacture*, A. L. Harrington, Pittsburgh Plate Glass Co.

Deals largely with the installation of electrical equipment in a large plate-glass factory. Unusual conditions in some places call for special design and construction.

One-Day Convention For Students to be Held in Philadelphia

A one-day meeting, especially for enrolled Students of the Institute, will be held in Philadelphia, Monday, March 9th, under the guidance of the Philadelphia Section. This meeting will be patterned after a regular Institute Convention with a technical session, inspection trips and an evening meeting. Electrical engineering students will attend from at least nine colleges located in or near Philadelphia.

The meetings will be held in the Engineering Building, University of Pennsylvania, with the Moore School of Electrical Engineering as host. The technical session will start at 10:30 a. m. and will include papers by students from several colleges. The Moore School will also be host at the midday luncheon; at 2-30 p. m. inspection trips will be made to several points of interest. The dinner at 6:30 p. m. will be combined with the regular Philadelphia Section Dinner.

At the evening meeting, starting at 8:15 p. m., President Farley Osgood will speak on, "What a College Man Goes up Against and How to Meet It." After the address there will be entertainment by Moore School students. The regular Philadelphia Section meeting will be combined with this meeting.

Future Section Meetings

Baltimore

The Pallophotophone, by Dr. C. A. Hoxie, General Electric Co. March 20, 8:15 P. M., Johns Hopkins University.

Power from Waste Fuel, by Messrs. Coulter and Schnure, Bethlehem Steel Co. April 17, 8:15 P. M., Sparrows Point, Md.

Erie

Patents and Inventions, by A. A. Buck, General Electric Co. March 17.

Automatic Substation. April 21.

Fort Wayne

Talk relative to Traction Work by R. M. Feustal, President, Indiana Service Corporation. Moving pictures. To be held at G. E. Club Rooms, Building 16-2, 8:00 P. M. March 19.

Inspection trip to the new automatic telephone exchange, corner Barr and Berry Streets. Mr. E. L. Gaines will have charge of the meeting. April 23, 8:00 P. M.

Lynn

The Origin of Life, by Dr. Harlow Shapley, Astronomer, Dr. G. H. Parker, Biologist, and Dr. Kerstog Lake, Theologian. Annual Dinner. March 28, New Ocean House, Swampscott.

New York

The Engineer as an Executive. A joint meeting of the New York Sections of the A. S. C. E., A. S. M. E., A. I. M. E. and the A. I. E. E. and also the New York Electrical Society. Each organization will provide a speaker to cover the subject from the viewpoint of their particular field. Final details are not yet available. Meeting will be held in Auditorium, Engineering Societies Bldg., 33 West 39th St., New York, on Wednesday evening, March 18, 1925.

St. Louis

Electrical Transmission of Pictures. March 25.

National Spring Convention. April 13-17.

Seattle

Broadcasting by Radio and Long Lines, by J. W. Greig and J. R. Tolmie. March 18.

Economics of Transmission-Line Design, by E. A. Loew. April 15, Tacoma.

Vancouver

Main-Line Railway Electrification, by R. Beeuwkes. March 6.

Power-Factor Correction, by R. L. Hall. April 3.

Cleveland Regional Meeting Postponed

The regional meeting announced for May 22-23 in Cleveland has been postponed. As the Spring Convention will be held in St. Louis, April 13-17, and this will be followed shortly by the Annual Convention, June 23-27, it was thought inadvisable to hold the Cleveland meeting at the time originally chosen.

A. I. E. E. Midwinter Convention

The Midwinter Convention of the Institute, which was held in New York, February 9-12, was an outstanding success both in regard to the character of the papers presented and the large attendance. Nearly fifteen hundred members and guests registered for the Convention, which places it among the largest gatherings the Institute has ever held.

It has become a tradition that the Midwinter Conventions of the Institute are the most highly technical of any of its meetings, and entertainment features of all kinds are subordinate to the work of presenting and discussing papers reflecting the most recent and important developments or problems in the electrical field.

In this respect, the last Midwinter Convention came thoroughly up to this tradition, as the papers generally were of very high standard and the discussions gave evidence of a detailed study and digestion of the papers in advance; in fact, more than half of the discussers presented carefully prepared written discussion. It was also noticeable that the attendance at the technical sessions was unusually good. The auditorium was comfortably filled during most of the sessions, some of which were extended far beyond their scheduled time of adjournment.

COMMITTEE MEETINGS

During Convention week, there was unusual activity among the Committees, and numerous meetings were held, including the following: Constitution Revision; Meetings and Papers; Publications; Standards; General Power Appliances, Power Generation, Power Transmission and Distribution; Protective Devices; and the Coordinating and Executive Committees of Geographical District No. 1 (Northeastern).

ENTERTAINMENT AND TRIPS

The entertainment features of the meeting were well attended and were thoroughly enjoyed. On Monday evening, the New York Section proved to be a most cordial host at the smoker which it gave to all members. Specialties of this occasion were a mystifying magician, the singing of "Happiness Boys" and a news picture just released. The largest attendance (591) recorded at a New York Midwinter dinner-dance, was present on Thursday evening at the Hotel Astor.

Many of those at the meeting took advantage of the opportunity to make inspection trips. The two special trips,—namely, to the Hudson Avenue Plant of the Brooklyn Edison Company and to the Bell Telephone Laboratories, Inc.,—were well patronized. In addition, there were many other trips made by individuals and small groups.

The General Convention Committee and the Meetings and Papers Committee deserve the hearty congratulations of the membership for the successful manner in which both the technical and social features of the Convention were carried out.

TECHNICAL SESSIONS

MONDAY, 2:30 P. M.

The first technical session was called to order at 2:30 o'clock Monday afternoon by President Osgood, who spoke briefly with regard to the advisability of holding the Midwinter Convention every other year in New York City and in the alternating years, having the meetings convene in one of the Atlantic Coast cities not far from New York.

He also spoke of the Regional Meeting, of which there will be several this year, and pointed out that, due to the growth of the Institute, there was neither time nor room at the National Convention to present all of the information on electrical engineering matters that should be given consideration at that time. It was therefore proposed to raise the Regional Meetings up to the standard of National Conventions, so that much of the advance in the art might be promulgated through the Regional Meetings, thereby relieving the load now resting on the National Conventions. He also mentioned the enthusiastic meetings which he had attended in the West following the Pacific Coast

Convention, and in closing, referred to the Engineering Foundation and the desirability of increasing its endowment to an extent which will yield a million dollars a year for research work, to be carried on under the auspices of the four Founder Societies or the National Research Council.

President Osgood then called upon the authors of the papers scheduled for the first session, to abstract them as briefly as possible, following which the discussion on any or all of the papers would be taken up together. Papers were abstracted as follows: *A New A-C. General-Purpose Motor*, by H. Weichsel; *The Single-Phase Induction Motor*, by L. W. Perkins; *The Effect of Full-Voltage Starting on Induction Motors*, by J. L. Rylander; *Another Form of Self-Excited Synchronous Induction Motor*, by Val. A. Fynn. These were followed by a very full discussion, presented by the following: Chas. F. Scott, W. L. Upson, R. E. Ferris, V. Karapetoff, L. W. Perkins, W. C. Kalb, H. L. Wills, F. G. Baum, R. E. Dougherty, A. M. MacCutecheon, K. L. Hansen, (read by C. N. Johnson), W. B. Hall, C. H. Sonntag, P. H. Thomas, George S. Smith, F. C. Hanker and H. Weichsel,—followed by the closures of the authors.

MONDAY, 8:00 P. M.

The Smoker and entertainment given under the auspices of the New York Section, was held at the Hotel Astor. Mention of this has already been made elsewhere.

The entertainment was thoroughly enjoyed and the Belvedere Room of the Hotel was filled to capacity.

TUESDAY, 10:00 A. M.

The Session was called to order by President Osgood, who was assisted by P. H. Thomas, Chairman of the Committee on Transmission and Distribution, under whose auspices the Session was held. The following papers were presented in abstract: *The Artificial Representation of Power Systems*, by H. H. Spencer and H. L. Hazen, *Power-System Transients*, by V. Bush and R. D. Booth, *Testing Impregnated-Paper Insulated Lead-Covered Cables*, by Everett S. Lee, *Predicting Central-Station Demands and Outputs*, by F. C. Ralston. The paper on *The Thermal Time Constants of Electrical Machines*, by A. E. Kennelly was scheduled to be presented at the Tuesday afternoon Session, but by general consent this was transferred to the closing portion of the morning Session in view of Professor Kennelly's inability to attend the afternoon Session. An enthusiastic discussion of these papers followed by Messrs. E. L. Moreland, V. Karapetoff, F. C. Hanker, C. L. Fortescue, F. G. Baum, D. W. Roper, F. W. Davidson, J. B. Whitehead, R. W. Atkinson and W. A. Del Mar.

TUESDAY, 2:30 P. M.

This Session was held under the auspices of the Committee on Electrical Machinery: H. H. Hobart, Chairman, was prevented from attending due to illness, and the meeting was called to order by President Osgood, who requested the presentation of the following papers: *Squirrel-Cage Induction Motor Losses*, by T. Spooner, *Complete Synchronous-Motor Characteristics*, by J. F. H. Douglas, E. D. Engeset and R. H. Jones, and *Factors Affecting the Design of D-C. Motors for Locomotives*, by R. E. Ferris. An unusually thorough and protracted discussion of these papers followed, in which the following members took part: Messrs. W. E. Davis, C. L. Dawes, C. F. Hansen, J. A. Duncan, H. Halperin, C. F. Wagner, R. C. Bergvall, E. J. Rosch, I. M. Stein, V. Karapetoff, V. M. Montsinger, W. B. Kouwenhoven, C. M. Laffoon, G. E. Luke, E. B. Paxton, P. L. Alger, O. E. Shirley, A. M. MacCutecheon, H. Weichsel and Q. Graham.

TUESDAY, 4:30 P. M.

The Board of Directors of the Institute held its regular monthly meeting at this time, a resumé of which is given in another column.

WEDNESDAY, 10:00 A. M.

This Session was presided over by President Osgood, assisted by J. H. Morecroft, Chairman of the Electrophysics Committee,

under whose auspices this Session was held. The following papers were presented in abstract: *Study of Direct-Current Corona in Various Gases*, by F. W. Lee and B. Kurrelmeyer, *Effect of Repeated Voltage Application on Fibrous Insulation*, by F. M. Clark, *Corona in Oils*, by A. C. Crago and J. K. Hodnette, *Stresses in Bus Supports During Short Circuits*, by O. R. Schurig and M. F. Sayre. Discussion of these followed by Messrs. J. B. Whitehead, F. W. Lee, B. Kurrelmeyer, H. W. Fisher, M. F. Skinner, Jos. Slepian, G. E. Luke, D. Bratt, A. C. Crago, J. A. Duncan, H. Halperin, Everett Lee, R. W. Atkinson, F. W. Peek, Jr., D. W. Roper.

WEDNESDAY, 8:15 P. M.

One of the most enjoyable features of the Convention was the presentation of the Edison Medal to John White Howell, "for his contributions to the development of the Incandescent lamps."

This was followed by an address by Major-General Patrick, head of the United States Air Service, who first showed a reel of motion pictures illustrating the various uses made of the aircraft in warfare, after which he explained the features presented by the picture in greater detail. A more detailed account of the Edison Medal Award will be found elsewhere in this issue.

THURSDAY, 10:00 A. M.

This Session was under the auspices of the Committee on Instruments and Measurements, of which Professor A. E. Knowlton is Chairman. He assisted President Osgood in presiding, and the following papers were presented: *Electrical Measurements of Physical Values*, by Perry A. Borden, *Use of the Oscillograph to Measure Mechanical Phenomena*, by Harvey L. Curtis, *Temperature Errors in Induction Watthour Meters*, by I. F. Kinnard and H. T. Faus, *Storage-Battery Electrolytes*, by G. W. Vinal and G. M. Schramm. Discussion followed by: H. B. Brooks, J. R. Craighead, F. V. Magalhaes, Alexander Nyman, Everett S. Lee, C. E. Skinner, J. W. Legg, C. H. Sharp and J. L. Woodbridge.

THURSDAY EVENING

The closing feature of the Convention was the dinner-dance at the Hotel Astor on Thursday evening. This was attended by over 500 members and guests. It has grown to be a traditional event of the Midwinter Convention, and, as usual, proved a most delightful and successful affair.

The personnel of the Convention Committee, to whose efforts the success of this convention arrangement is attributable, comprised the following: Messrs. L. F. Morehouse, H. H. Barnes, Jr., W. S. Gorsuch, E. M. Meyer, L. W. W. Morrow, H. S. Sheppard, H. A. Kidder, F. M. Feiker, J. C. Parker, J. B. Bassett, A. F. Dixon, E. E. Dorting, C. R. Jones, F. A. Muschenheim, R. A. Paine, Jr., G. W. Alder, H. E. Farrer, S. P. Grace, C. B. Keyes, R. L. Shepherd, C. E. Stevens, A. E. Waller, T. S. Bacon, C. M. Gilt, G. E. Hall, H. Y. Hall, C. M. Schaeffer, W. K. Vanderpoel, R. H. Tapscott, D. L. Galusha and H. R. Woodrow.

The Edison Medal Presented to John White Howell

One of the most pleasant and impressive features of the Midwinter Convention was the presentation of the Edison Medal to John White Howell on Wednesday evening, February 11th.

President Osgood presided, opening the meeting, by stating that the time was very fitting, on the 78th birthday of Thomas A. Edison, for the members of the Institute to assemble to honor a gentleman through a Foundation bearing the name of Thomas A. Edison. He then called upon Secretary Hutchinson to explain the significance of the Edison Medal.

Mr. Hutchinson, in a few brief remarks, explained that the Edison Medal was founded by a group of friends of Thomas A. Edison, who desired to commemorate the achievements of a quarter of a century with the art of electric lighting, with which the name of Edison had been so conspicuously identified. It was

decided that the most effective means of accomplishing this object was by the establishing of a gold medal which might serve as an honorable incentive to scientists and engineers to maintain, by their work, the highest standard of accomplishment as set by Edison. The American Institute was chosen to make the awards from year to year, and the Edison Medal Committee of twenty-four members was organized. The first award was made in 1909 to Elihu Thomson and other awards have subsequently been made to Frank Julian Sprague, George Westinghouse, William Stanley, Charles F. Brush, Alexander Graham Bell, Nikola Tesla, John J. Carty, Benjamin G. Lamme, W. L. R. Emmet, Michael I. Pupin, Cummings C. Chesney, Robert A. Millikan and John W. Lieb.

President Osgood then introduced Past-President of the Institute, John W. Lieb, who briefly delineated Mr. Howell's work and achievement in the development of the incandescent lamp. His remarks were, in part, as follows:

We have an inadequate appreciation of how meagre was then our knowledge of the laws of the phenomena and manifestations we encountered in our daily tasks in making practical applications of the new discoveries.

We fail to appreciate how imperfect or utterly lacking were the tools and instruments required for our measurements and tests, and as for any guiding text books or literature, they simply did not exist and they only appeared from the press as difficulties were gradually overcome and solutions were found for the perplexing problems encountered.

It is important that we should direct a retrospective glance at those early days of the Electrical Industries, whose beginnings have passed into history, for such a backward look is necessary to properly appreciate and evaluate some of the early achievements.

We should be prepared to recognize the ready response that was made to the new conditions of progress and development as they arose, as exemplified to a notable degree in the career of the distinguished engineer whom we are to honor in the presentation this evening of the Edison Medal.

A native of New Jersey, born in 1857, John White Howell came of a family in which inventive capacity and mechanical ability were already manifest in several previous generations.

He enjoyed the benefits of a college education, attending both Rutgers College and Stevens Institute of Technology, and while he did not graduate from either, Stevens awarded him the honorary degree of Electrical Engineer in 1898.

Early in 1881, he became particularly interested in the work Mr. Edison was doing in Menlo Park in preparation for the commercial production of the Incandescent Lamp and the development of the apparatus and equipment for the system of electrical generation and distribution which bears Mr. Edison's name.

As early as 1881, Howell wrote a thesis on the "Economy of Electric Lighting by Incandescence," giving data on the efficiency of dynamos and lamps, carrying capacity of conductors, drop in house wiring, etc., which appeared in 1882 as a booklet entitled "Incandescent Electric Lights"; one of the earliest publications containing authoritative data in the new field.

His active association with the work at Menlo Park began in July, 1881, first in connection with the equipment of the lamp factory for the photometric measurement and testing of incandescent lamps then emerging from the experimental and laboratory processes, and developing methods and procedure for their manufacture on a commercial scale.

No direct reading instruments, voltmeters or ammeters, were available at this time—watt-meters were then not even thought of, the International unit of power the watt not having been recognized until 1889—and the science of photometry has as its major instrument the Bunsen bar photometer with sperm candles as the primary standards of light.

It will then be appreciated that the passage from intensive and necessarily hasty researches and investigations to production on a commercial scale, with definite and accurately reproducible standards, required the devising of a whole series of suitable apparatus and equipment that put to the test the ingenuity and inventive faculty of the pioneers in the new field.

While these efforts to place the measurements required by the new industry on a scientific bases were proceeding, under Mr. Howell's direction, he also devoted his energies to improvement in the many phases of the lamp manufacturing problem and for each detail he devised new apparatus, improved existing devices and methods and left a permanent impress on the art in many directions.

The experimental apparatus and time-consuming methods available for obtaining high vacua were not at all adapted to the exhausting of the globes for incandescent lamps and improvements in this apparatus early occupied his attention.

The old Sprengel mercury pumps of the laboratory were modified, so that more perfect vacua were obtained, reducing to a small fraction the time required, all of which contributed to making practicable an efficient and commercial lamp and incidentally reducing production costs.

Many of these processes continued in use until the supersession of the mercury pump by mechanical methods of exhaust, supplemented later by chemical methods.

The latter, like many other fundamental inventions in this field, originally introduced from abroad, required adaptation to American manufacturing methods and Howell made the necessary improvements and modifications in the process, some of them the subject of letters patent.

He also developed methods of clamping filaments to the leading-in-wires, clamp paste for joining filaments to clamps, the perfection of a seal between the glass and leading-in-wires, automatic filament treating machines, machines and apparatus for seating in the lamps, stem-making machines, etc.

While many of these inventions and improvements represented advances in manufacturing methods, effecting large economies in the utilization of labor, they were also fundamentally contributory to the continued advance in the efficiency of the lamp, the securing of uniformity of the product and improvement in the life of the lamps, and they were generally valuable in making the incandescent electric lamp the high quality product which is its conspicuous characteristic, adding enormously to the convenience and economy of electric lighting.

In the introduction of the "flashing" processes for obtaining filaments of uniform cross section and uniform illumination, in the production of squirted cellulose filaments, in the introduction of the so-called "Gem" filaments and in the application of the pasted and wire-drawn Tungsten filaments; while he was not the original inventor of these important improvements, his wide knowledge of every detail, mechanical, electrical and chemical, and of the art of producing an efficient lamp of high quality, was of incalculable advantage in securing the practical application of the new developments, and his contributions to the advancement of the state of the art are of fundamental importance and have served to keep the lamp in the forefront of the rapid progress being made in all electrical applications.

He conducted a series of investigations on the phenomena that take place in the vacua of exhausted lamps, the effect of the degree of exhaustion on the blackening of lamps and the filling of globes with foreign gases.

The effects of irregularity of pressure on the life of lamps connected to distribution systems are well known and in the endeavor to ensure a proper lamp life, his attention was early directed toward improving existing methods of regulating feeder pressure and providing reliable pressure indications.

In the early 80's there being no reliable direct reading voltmeters available, Mr. Howell developed a type of instrument for use by central stations which supplied the urgent need for a reliable pressure indicator, which was known under his name and became the standard for central station switchboards until the improved Weston instruments came into the market.

The Howell voltmeters were also constructed for portable use and other types based on a similar principle were designed to indicate relative pressure at feeder ends, thus securing the comparative indications for ready control of the voltage supplied to the lamps on the system.

In his exhaustive tests of lamp life and its relation to the applied voltage, he discovered in 1888 an exponential relation of initial candle power to lamp life which he reported in an important paper before the American Institute of Electrical Engineers in that year.

These early investigations, resulting in the determination of the exponential ratio of 3.65 for the relation of initial candle power to hours of lamp life, are the basis of a law which has been found to be substantially accurate for a wide variety of incandescent lamp filaments.

Beginning with his thesis on "Economy of Electric Lighting by Incandescents" in 1881, Mr. Howell has contributed extensively to the technical journals, to the PROCEEDINGS of the American Institute of Electrical Engineers and the Association of Edison Illuminating Companies.

No appraisal of Mr. Howell's achievements in the Electrical industry would be complete without an allusion to the unusual position of confidence and esteem to which he has attained through many years of contact with leaders in the industry, in which his sterling character, retiring modesty, good judgment and sense of fairness have won for him the confidence of his own immediate business associates, as well as of those with whom he has had less direct relations.

Mr. Howell has made notable contributions to progress in every detail of the art of making incandescent lamps, enabling the production of lamps of increased efficiency, longer life, more uniform quality and better adaptability to commercial requirements, thus greatly extending the use of electric lighting and aiding in placing service from central stations within the reach of millions of our people.

At the conclusion of Mr. Lieb's address, President Osgood read several messages of congratulation from friends of the medallist who were unable to be present, including Gano Dun, Chairman of the Edison Medal Committee, Doctor Elihu Thomson, Frank J. Sprague and others. President Osgood then presented the medal to Mr. Howell, who, in receiving it, spoke as follows:

As a man gets along in years his mind often turns back and thinks of the past and some of my pleasantest thoughts are remembrances of pieces of work which have been well done. Work well done makes a man's life of value to his fellow men. And now to have this Committee tell me that I have done good work by awarding this medal is a very great comfort to me and it will sweeten the rest of my life.

As I came from my home in Newark to this meeting to-night I noticed

the lights and I believe every light I saw from the largest to the smallest; from large street lights to small automobile lights was an incandescent filament. And yet when I was 21 years old Mr. Edison had not yet invented the Incandescent Electric Lamp, and we knew only gas, oil and candles and an occasional electric arc light. When I worked at Menlo Park I often went home at night on the P. R. R. and the conductors carried lanterns on their arms to enable them to read the tickets.

The Edison Lamp works was started in Menlo Park in the Fall of 1880, so 1881 was the first complete year of their operation. In 1881 they made 35,000 lamps. Now the G. E. Co. makes 1000 lamps every minute of every working day and the G. E. Co. together with other lamp manufacturers all over the world, who work under the patents of the G. E. Co. make over 3000 lamps per minute every day.

During these years two great developments have taken place, one affecting the quality of the lamp, and one affecting the cost and manufacturing facility. Improvements in quality have been made by changes in the filament, vacuum and other details inside the lamp. I will consider this quality development in three periods.

1. The period of the carbon filament.
2. The short period in which the metallized filament and the tantalum filament held the field, and
3. The period of the tungsten filament.

The carbon filament was alone in the field from 1880 to 1905. During this time a great advance was made. The treated filament was developed to its full value, the squirted cellulose filament was introduced, and so was the phosphorus exhaust. These and other minor developments improve the quality of the lamp greatly. Any improvement in lamp quality may be utilized in two ways: the life of the lamp may be kept the same and its efficiency increased; or the efficiency may be kept the same and the life increased.

It has been the policy from the beginning to keep the life constant and utilize all the improvements in increasing the efficiency. So during the carbon filament period the efficiency increased from 1.68 lumens per watt to 3.4 lumens per watt. In order to compare the relative quality of two lamps we may compare the seventh power of the two efficiency figures, or we can compare the lives of the two lamps at the same efficiency. If we do this we will find that the 1905 carbon filament lamp if tested at the efficiency of the 1881 lamp will have a life 139 times as long as the life of the 1881 lamp, so we say the value of the 1905 lamp was 139 times the value of the 1881 lamp.

The metallized carbon filament invented by Dr. Whitney of the Research Lab. of G. E. Company was introduced in 1905 and the result was a lamp which had a value 4.77 times the value of the 1905 carbon filament lamp. A year or so later the tantalum filament lamp invented by Von Bolton was introduced with the result that there became available a lamp having a value 2.71 times that of the metallized carbon filament lamp.

Both the metallized carbon filament and the tantalum filament lamp promptly gave way and were displaced as a result of the remarkable improvement brought about by the introduction of the tungsten filament lamp in 1907. This is the lamp which reigns supreme today. Like all other forms of the incandescent lamp it has been improved and its efficiency increased by the engineering and development work which has been spent upon it, but it is still the tungsten filament lamp, and owes its efficiency and value to the use of tungsten as the filament. Since 1907 the filament has been changed from a squirted filament to the drawn tungsten wire invented by Dr. Coolidge of the Research Laboratory; the exhaust process has been developed and improved; and tungsten filaments of different crystalline structure have been developed for use in different types of lamps. This work and development includes a number of improvements which are inventions in themselves. The efficiency of the 40 watt tantalum filament vacuum lamp of 1906 was 4.9 lumens per watt. The efficiency of the tungsten filament vacuum lamp today is 1.03 lumens per watt. Compared on the basis of lives at the same efficiency the tungsten filament lamp of 1925 has 180 times the value of the tantalum filament lamp of 1906.

During the 44 years of the history of the incandescent lamp its efficiency has improved from the 1.68 lumens per watt of the original carbon filament lamp of Edison to the 10.3 lumens per watt of the modern vacuum tungsten filament lamp of today. In other words, the value of the tungsten filament vacuum lamp of 1925, when compared with the carbon filament lamp of 1881 is 325,000 times as great.

So far I have considered only the vacuum lamp. The gas filled lamp of Dr. Langmuir's made an enormous improvement especially in large lamps. During the year in which the gas filled lamp was introduced we made 500 watt tungsten filament lamps of both kinds—vacuum and gas filled. The vacuum lamps gave 8.17 lumens per watt and the gas filled lamps gave 14.44 lumens per watt. The gas filled lamp would last 54 times as long as the vacuum lamp at the same efficiency.

The gas filled lamp completed the triumphs of the incandescent lamp, it has enabled the incandescent lamp to enter the field of very large lamps and special lamps; it has practically driven the arc lamp out of the market, and made street lighting better and cheaper than ever before. Its use is being extended constantly and will continue to be still more extended.

The problem of lamp exhaustion has been with us from the beginning. The chief difficulty in exhausting a lamp is taking care of the moisture which adheres to the surface of the glass. The amount of this moisture is very considerable and can be liberated by heating the glass. As the glass is heated hotter and hotter, even up to the softening temperature

f the glass, more and more moisture is liberated, so during or immediately before exhaustion the lamp must be heated to a temperature considerably higher than it will attain under any condition of use. In practise we heat the lamp as hot as practicable and to at least 300 deg. cent. After the moisture is driven from the glass, the problem is to get rid of it. During the first 15 years of the history of the lamp the exhausting was done on mercury pumps which would not pump out this water vapor, so it was absorbed by phosphoric anhydride in a glass cup placed to bring the dryer as close as possible to the lamp, but even then the absorbing action took place through the exhaust tube which was of small diameter and about 1/2 inches long. This absorption took considerable time and exhausting an ordinary lamp in this way took a half an hour. The modern way of getting rid of this water vapor and other residual gases is by chemicals. An Italian engineer—Malignani, discovered that phosphorus vaporized in the lamp under proper conditions precipitated all water vapor and all other gases remaining in small quantities in a lamp after it had been exhausted to a vacuum less than one millimeter pressure. He painted the inside of the exhaust tube with red phosphorus and exhausted the lamp on a fast mechanical pump. When the vacuum was under one millimeter the lamp was lighted to high incandescence and a blue glow appeared all through the bulb. The connection with the pump was then closed and the phosphorus heated, driving a lot of phosphorus vapor into the bulb while the blue glow filled the bulb. The blue glow instantly disappeared and a good vacuum resulted. The exhaust tube was then sealed off from the bulb. By this method lamps were exhausted in about one minute, the lamps being thoroughly heated before they were put on the pump. In the present day practise the phosphorus is applied as a coating on the filament—the lamp is exhausted on a highly developed rotary vacuum pump to a pressure less than one tenth of a millimeter of mercury. The lamps are well heated beforehand, but are not lighted up during exhaustion. After the lamps have been sealed off and based they are lighted up bright—a blue glow appears in the lamp which immediately disappears leaving a good vacuum of less than one thousandth of a millimeter pressure of mercury. While we have used this phosphorus exhaust for 30 years we do not yet fully understand its action. We believe its action is not entirely chemical, because other materials will condense or clean up water vapor, oxygen, hydrogen, nitrogen, CO or CO₂. We believe that a chemical action takes place with oxygen and water vapor and that the products of these combinations are carried to the surface of the glass and held there. We also know that under the condition of ionization indicated by the blue glow, gases which do not combine chemically with phosphorus are carried to the glass and held there permanently. These gases may be liberated in the lamp in their original condition if the glass be heated again hot enough to vaporize the phosphorus.

We believe that phosphorus has a continuing action during the life of the lamp in case any oxygen or water vapor is liberated in the lamp.

We believe that the phosphorus acts solely to get and keep the vacuum. It acts on gases only. Phosphorus used in this way is called a "getter"—it gets the vacuum—it is used in all vacuum lamps.

The difficulty in understanding this action of phosphorus is realized when we know that other materials which are chemically inactive under ordinary conditions have the same action as phosphorus which is active chemically. With these other materials it seems that the action must be mechanical in its nature.

There is another kind of getter also used in all vacuum lamps, the action of which is to reduce the blackening of the lamp. This getter is usually a halogen compound, such as a fluoride, and it is applied to the filament as a coating. In practise it is mixed with the phosphorus and the mixture is put on the filament. When the lamp is flashed after exhaustion the getter vaporizes and condenses on the bulb where it remains. During the life of the lamp atoms of tungsten fly from the hot filament to the bulb and slowly blacken the bulb. This getter reduces this blackening very much.

The action of this fluoride getter to reduce blackening is shown by putting inside a lamp a thin piece of glass about the size of a dime. After the filament has been flashed and the getter vaporized this small piece of glass is moved away from the place it occupied when the getter was vaporized. The lamp is then burned on life test and the spot which was covered by the glass blackens very much more rapidly than the rest of the bulb.

Developments affecting the cost and manufacturing facilities have been going on during the entire history of the lamp. In 1881 no glass working machinery existed. All glass work was done by skilled glass workers. Today no skilled glass workers are employed in the factory. In the beginning bulbs were blown from glass tubing by skilled labor. Later they were blown directly from the glass furnace by skilled labor. Now they are made by an entirely automatic machine. A large frame or turn table which carries a good many separate bulb blowing units, rotates in front of the open mouth of the furnace full of molten glass. An arm of a bulb blowing unit reaches into the furnace and picks up a measured amount of glass which is shaped, placed on the end of a blow pipe, and then a mold closes about it while air pressure through the blow pipe blows it into a bulb just the size and shape of the mold. The mold opens and the bulb is delivered automatically to another machine which cuts off the surplus glass, leaving the bulb all ready for use. One of these machines will make over 50,000 bulbs in 24 hours and three of these machines take glass from one big tank of molten glass.

The inside part or stem is also made on an automatic machine. The three glass pieces which compose it are automatically fed to the machine, held in

their proper relative positions, and sealed together. In this sealing the inner end of the exhaust tube, which is the small tube projecting out of the flare end of the stem tube, is sealed into the flat glass which forms the wire seal, then a jet of air blows into the outer end of the exhaust tube and blows an opening from the exhaust tube through the soft mass of glass, and this opening makes the connection between the exhaust tube and the inside space of the lamp. It is through this tube that the lamp is exhausted. This construction puts the tip made by sealing off the tube inside the base of the lamp, removing it from the round end of the bulb where it has always been regarded as an objectionable feature of the lamp.

The stem is then put on another automatic machine which inserts the filament supports, after which the filament, which is a very strong tungsten wire, is draped on the supports by hand. Then the two parts, the bulb and the mount, are put in their proper relative positions on the sealing-in machine and the flared end of the stem is sealed in the open neck of the bulb, thus completing the structure of the lamp.

While on the sealing machine the glass bulb and stem are heated very hot and they are placed on the exhaust machine in this hot condition. The exhaust machine connects the lamp to four pumps, one after another, and these pumps produce a vacuum in the lamp of about one tenth of a millimeter of mercury. The filament is not lighted during exhaustion. The lamp is automatically sealed off and delivered to the basing machine. After basing the lamp is lighted to high incandescence, the blue glow comes and goes and the lamp is finished.

As a result of these improvements briefly referred to, the number of lamps produced per operator per hour is now 150 times the number produced per operator per hour in 1881.

At the close of Mr. Howell's remarks, he was tendered a rising vote of congratulation, which concluded the presentation ceremony.

The remainder of the evening was devoted to the lecture by Major-General Patrick of the United States Air Service, on the subject of military air-craft and their uses, to which allusion has been made elsewhere in this issue.

District No. 1 Will Hold Another Regional Meeting

Geographical District No. 1 is planning to hold its second regional meeting on May 7, 8 and 9 at Swampscott, Mass. A three-day meeting is planned for Thursday, Friday and Saturday, and there will be an excellent program. Two of the major technical subjects covered will be cables and live changing of transformer ratios. There will also be papers on generator testing, needle gaps, education and other topics.

Entertainment and inspections have been well planned and a good meeting is assured.

District No. 1 was the pioneer in inaugurating the first regional meeting, the one held in Worcester last year, and the coming meeting is being watched with great interest by Institute members.

Open House for Engineers at Oklahoma University March 17

A St. Patrick's Day celebration known as the Engineering Open House will be held on March 17 by the engineering departments of the University of Oklahoma. Everyone in the University and in the State is invited to the affair. All electrical displays will be in charge of the A. I. E. E. Branch while other demonstrations will be in charge of the other engineering departments. The new \$100,000 Engineering Building will be the scene of the celebration.

The engineering open house is an annual affair at the University. It is held on March 17 on account of the tradition of the school which holds that St. Patrick is the patron saint of engineers. Its purpose is to acquaint the public with the accomplishments of the Engineering Departments.

In addition to the engineering displays there will be a continuous moving-picture show or other entertainment. Also the "St. Pat's Dance" and the engineers' banquet are held during the same week.

A. I. E. E. Directors' Meeting

A meeting of the Board of Directors of the American Institute of Electrical Engineers was held at Institute headquarters, New York, on Tuesday, February 10, 1925, during the Midwinter Convention.

There were present: President Farley Osgood, Newark, N. J.; Past President Frank B. Jewett, New York; Vice-Presidents J. E. Macdonald, Los Angeles; S. E. M. Henderson, Toronto; H. E. Bussey, Atlanta; Edward Bennett, Madison, Wis.; Harold B. Smith, Worcester, Mass.; L. F. Morehouse, New York; H. W. Eales, St. Louis; Managers R. B. Williamson, Milwaukee; A. G. Pierce, Cleveland; Harlan A. Pratt, Hoboken, N. J.; W. K. Vanderpoel, Newark, N. J.; H. P. Charlesworth, New York; H. M. Hobart, Schenectady; G. L. Knight, Brooklyn, N. Y.; John B. Whitehead, Baltimore; J. M. Bryant, Austin, Tex.; E. B. Merriam, Schenectady; Treasurer George A. Hamilton, Elizabeth, N. J.; Secretary F. L. Hutchinson, New York.

A report was presented of a meeting of the Board of Examiners held February 5, and the actions taken at that meeting were approved. Upon the recommendation of the Board of Examiners, the following actions were taken upon pending applications: 154 Students were ordered enrolled; 464 applicants were elected to the grade of Associate; 4 applicants were elected to the grade of Member; 8 applicants were transferred to the grade of Member; 3 applicants were transferred to the grade of Fellow.

The Board approved the appointment by the President of the following Committee of Tellers to canvass, count, and report upon the nomination and election ballots received in connection with the 1925 election of Institute officers, and the ballots on the constitutional amendments: Messrs. R. R. Kime (Chairman), W. G. Freeman, A. F. Hamdi, Elwood A. Merwin, J. W. Nostrand.

Upon the recommendation of the Chairman of the Sections Committee, the Board granted a request to organize a Section of the Institute at Buffalo, N. Y., to be known as the "Niagara Frontier Section."

Upon the recommendation of the Standards Committee, it was voted to authorize the Standards Committee to submit to the American Engineering Standards Committee for adoption as American Standards, the A. I. E. E. Standards approved by the Board of Directors on January 21, namely, the Standards for Synchronous Converters, Instrument Transformers, and Electric Arc Welding Apparatus.

Other matters of importance were discussed, reference to which may be found in this and future issues of the JOURNAL.

Niagara Frontier Section Is Formed

The Niagara Frontier Section is a new Section organized on February 2 by members located in and near Buffalo and Niagara Falls. The election of officers were as follows: Chairman—J. Allen Johnson, Electrical Engineer, Niagara Falls Power Company; Vice-Chairman—H. B. Alverson, Electrical Engineer, Buffalo General Electric Company; Secretary and Treasurer—A. W. Underhill, Jr., Electrical Engineer, Niagara, Lockport and Ontario Power Company; Chairman Membership Committee—C. C. McCarthy, Westinghouse Electric & Mfg. Co.; Chairman Program Committee—G. H. Jump, General Electric Company, and Chairman Constitution Committee—L. C. Nicholson, Chief Engineer, Niagara, Lockport and Ontario Power Company.

Nebraska Section Organized

A new Section of the Institute, to be known as the Nebraska Section, was formed on February 3 at a meeting held in Omaha. Officers were elected as follows: Chairman, P. M. McCullough, Division Plant Engineer of the Northwestern Bell Telephone Company; Vice-Chairman, O. J. Ferguson, Dean of the Engineering College, University of Nebraska, and, Secretary-Treasurer, C. W. Minard, Assistant Engineer of the Nebraska

Power Company. At this meeting a motion was unanimously carried that P. H. Patton and C. A. Robinson be extended a vote of thanks for their work in connection with organizing the Section.

The formation of this Section and the Niagara Frontier Section mentioned in this issue brings the total number of Institute Sections up to forty-nine.

Comments Requested on Preliminary Drafts of Standards

In the progress of the work of the revision of the A. I. E. E. Standards, four more sections of the Standards have been brought by the working committees to a point where the comments of the general Institute membership are desired prior to their presentation for adoption as Institute Standards. These sections are as follows:

No. 5—Direct Current Generators and Motors.

No. 7—Alternators, Synchronous Motors and Synchronous Machines in General.

No. 16—Railway and Mine Locomotive Control Apparatus.

No. 39—Resistance Welding Apparatus.

These drafts of standards have been prepared by working committees in whose appointment every effort has been made to select the men from all branches of the art most competent to contribute directly to the development of an accurate and generally acceptable set of standards. Before their adoption as Institute Standards, however, the procedure is being followed of submitting each section to the Institute membership for comment and criticism. Copies of each of the four reports noted above are now available, without charge, and all who are interested are requested to apply for copies to Institute Headquarters.

In order that these reports may be revised and adopted as Institute Standards this Spring, it would be necessary for all comments to be in within a period of one or two months.

On the Design for a Bifilar Type of Non-Reactive Resistance Coil

By PROFESSOR H. NUKIYAMA AND MR. Y. SHOJI OF JAPAN.

The above paper has been communicated to the Institute and is printed in separate pamphlet form.

The authors show that when a bifilar resistance is made up of fine insulated manganin wire, the distribution capacitance between the going and returning conductors may give rise to a very appreciable error, when the resistance is used in alternating-current measurements. The amount of this capacitance error was measured over a range of telephonic frequencies, in a particular bifilar resistance, and was found to conform to computation, by considering the bifilar resistance as a twin-wire cable, using the ordinary hyperbolic-function formulas.

It is shown that by winding the bifilar resistance on a bobbin and dividing it into sections, error can be made negligibly small. Thus, a bifilar winding of 100,000 ohms can be made to have a phase-angle error of less than five deg. at 5000 cycles per sec., by winding its coil in thirty different sections, or about 3300 ohms per section.

Copies of the paper in complete pamphlet form may be obtained, free to members of the Institute, on application to the office of the Secretary.

Scholarship in Electrical Engineering at Columbia University

The governing bodies of Columbia University have placed at the disposal of the American Institute of Electrical Engineers each year a scholarship in Electrical Engineering in the Schools of Mines, Engineering and Chemistry of Columbia University. The scholarship pays \$350 toward the annual tuition fees which vary from \$340 to \$360, according to the details of the course selected. Reappointment of the student to the scholarship for

the completion of his course is conditioned upon the maintenance of a good standing in his work.

To be eligible for the scholarship, the candidate recommended will have to meet the regular admission requirements, in regard to which full information will be sent without charge upon application to the Secretary of the University or to the Secretary of the Institute.

In a letter addressed to the Secretary of the Institute, an applicant for this scholarship should set forth his qualifications (age, place of birth, education, reference to any other activities, such as athletics or working way through college, references and photograph). A committee composed of Messrs. Francis Blossom, H. C. Carpenter and W. I. Slichter will consider the applications and will notify the authorities of Columbia University of their selection of a candidate. The last day for filing applications for the year 1925-26 will be June 1, 1925.

The course at the Columbia School of Mines, Engineering and Chemistry is three years, and is on a graduate basis. A candidate for admission must have had something of a general education, including considerable work in mathematics, physics and chemistry. Three years of preparatory work in a good college or scientific school should be sufficient if special attention has been given to the three preparatory subjects mentioned. A college graduate, with a Bachelor of Science degree in engineering, can generally qualify to advantage. The candidate is

admitted on the basis of his previous collegiate record, and without undergoing special examinations. Other qualifications being equal, members of Student Branches of the A. I. E. E. will be given preference.

The purpose of this advanced course is to produce a high type of engineer, trained in the humanities as well as in the fundamentals of his profession. It is hoped that members will show a keen interest in this scholarship, so insuring the choice of a candidate of the highest qualifications.

Ellwell Fellowship in Electrical Engineering

Through the generous gift of Cyril F. Ellwell, Stanford A. B. '07 and E. E. '08, there has been created the Ellwell Fellowship, available for the year 1925-26 in the Electrical Engineering Department of Stanford University.

This fellowship carries with it a stipend of \$500, and its purpose is to assist those of limited means in professional ambitions along electrical lines, thus affording a fair degree of comfortable support during the University session without the necessity of doing remunerative work to add to actual income.

To be eligible, the applicant must have at least gained the degree of Bachelor of Science in Electrical Engineering or a substantial equivalent.

A year's work normally leads to a degree in Electrical Engineering.

American Engineering Standards Committee

RECOMMENDATIONS FOR FUTURE STANDARDS

The American Society for Testing Materials has been designated by the A. E. S. C. to sponsor a sectional committee on specifications for hard drawn copper wire and medium hard drawn copper wire and specifications have been submitted and approved, subject to revision through the regular sectional committee before acceptance as American Standards. The Society's specifications for tinned, soft or annealed copper wire and rubber insulation have been submitted to the sectional committee on insulated wires and cables.

Following considerable discussion, the special committee acting on railway and highway bridge work at its January 7th meeting, voted the following recommendation:

1. That work on highway bridges should be allowed to develop further before attempting national standardization through a sectional committee.

2. That the unification of railway bridge specifications should be undertaken under a thoroughly representative sectional committee, and that the American Railway Engineering Association and the American Society of Civil Engineers should be invited by the A. E. S. C. to act as joint sponsors for the sectional committee.

Work is also under way through the organization of five technical working committees for the standardization of radio receiving apparatus, with a sub-committee on; Transmitting and Receiving Sets and Installation. Arthur Van Dyck, of the Radio Corporation of America, is Chairman; on Component Parts and Wiring, L. G. Paent, of the Radio Club of America Chairman; on Vacuum Tubes, Their Mechanical and Electrical Characteristics, C. B. Joliffe, Bureau of Standards, Chairman; on Electro-Acoustic Devices, Lloyd Espenschied, Am. Tel. and Tel. Co., Chairman; on Power Supply and Outside Plant, for the protection of Radio equipment against Lightning and Power lines; radiation from power lines and inductive disturbances from electrical devices and current supply from dry batteries and rectifying devices,—L. W. Chubb, Radio Apparatus Section, Associated Manufacturers of Electrical Supplies, Chairman.

The sectional committee contains official representatives

from twenty national organizations. Professor John H. Morecroft of Columbia University, is chairman and Doctor Alfred N. Goldsmith, Chief Broadcast Engineer of the Institute of Radio Engineers and secretary of the Institute of Radio Engineers, is Secretary. The Institute of Radio Engineers and the American Institute of Electrical Engineers are taking formal leadership in the sectional committee work.

Mining Codes are also under consideration, and four codes have already been formulated by the committee in charge, among them 3. Safety in Mine Transportation, sponsored by the American Mining Congress and 4. Mine Illumination, sponsored by the Bureau of Mines. One of the main functions of this committee is the coordination of the work on the various mining standards being promulgated by the A. E. S. C. and in addition to these interests are the Electric Mine Lamps, Permissible Portable, Safety Rules for Installing and Using Electrical Equipment in Coal Mines, Storage Battery Locomotives for Use in Gaseous Mines, Specifications for the Testing and Use of Explosives, Screening of Ores, Drainage of Coal Mines, Underground Transportation in Coal Mines, Ventilation of Coal Mines, Ventilation of Metal Mines.

THE STANDARDIZATION OF DRY CELLS IS ALSO UNDER CONSIDERATION

Since 1890, when dry cells first appeared in this country, the industry has grown very rapidly, especially within the last few years, when the annual production amounted to several hundred million cells.

Much preliminary work has been done by the Bureau of Standards in respect to the standardization of sizes and the revision of specifications for dry cells, resulting in the elimination of the many unpopular sizes and bringing about considerable saving of productions.

A meeting of the committee appointed by the Bureau of Standards to devise standard designations for the various types and sizes of batteries was held in New York on June 12, 1924, and suggestion made to broaden the work, with a view to establishing American Standards for dry cells. The matter was

further discussed by members of the Associated Manufacturers of Electrical Supplies and put before the American Engineering Standards Committee for formal procedure.

Upon recommendation of a special committee, under the chairmanship of F. L. Rhodes, the Bureau of Standards was invited and agreed to act as sponsor for a representative sectional committee for the work, scope of which will be as follows: "Standardization of dry cells and batteries with respect to types, sizes, assemblies, designating system, terminal arrangements, markings, methods of test and possibly required minimum performance, including dry cells and batteries for telephone, ignition, flash light, radio and other uses."

TELEPHONE POLES ARE ALSO TO BE STANDARDIZED

An interesting instance of the organized use of experts in the wood using industries to reduce the serious waste of our forest products, referred to by President Coolidge in his address to the National Conference on the Utilization of Forest Products, is the organization of a large committee of technical experts to develop national specifications for wood poles. The U. S. Forest Service considers that standardization of forest products is basically important as a means to economy in timber utilization.

These are the poles commonly used for telephone and telegraph lines, and produced to the extent of something over three million during 1923 for the use of steam and electric railways, electric light and power companies. The sponsors for this project under the procedure of the American Engineering Standards Committee, are the United States Independent Telephone Association and the Bell Telephone System, both of which have an important interest in developing specifications that will assure quality and economy in the utilization of wood poles for line construction. This project grew out of a recommendation of the American Electric Railway Association to the A. E. S. C. that a national system of such specifications should be developed, so as to make available to all interests the great economies possible under nationally uniform specifications.

At the first meeting of the sectional committee recently held in New York, twenty-three members were present, representing seventeen of the twenty-three associations on the committee. The Chairman of the committee is Mr. R. F. Hosford, of the Department of Development and Research of the American Telephone and Telegraph Company; and the Secretary is Mr. A. B. Campbell, of the engineering staff of the National Electric Light Association.

A conference on the unification of overhead line materials was held at the Engineering Societies Building, on January 13, representatives of nineteen interested organizations being present.

The conference recommended by unanimous action that an extensive program on the unification of overhead line materials go forward, under the procedure of the American Engineering Standards Committee. It was decided that the work should include cross arms, pins, pole steps, brackets and moulding; pole line hardware, including such items as anchor rods, bolts and lag screws brackets, cross arm braces, guy fittings, pins and strand for suspension and guying; and strain insulators, spools, knobs, etc.

There was an extended discussion as to whether work on insulations should be limited to low voltage material, or whether the other important types of insulators should be included. This led to the appointment of a small committee to formulate definite recommendations. This committee reported the following recommendations, which were unanimously approved:

"Certain classes of insulators have reached a stage of development which seems to warrant standardization; others can be standardized as to certain important dimensions; still others are in a development stage which makes attempted standardization, other than along the broadest of lines, of questionable wisdom. It is recommended that standardization in this general field be undertaken to such an extent as the facts developed by a sub-

committee, or such other agency assigned to this work, may seem to warrant. Of the other types, strain insulators for low potentials, spools, knobs, etc., which are used in common by the several branches, standardization is recommended." The conference agreed that the work should include nomenclature, material specifications, and dimensional data.

The following committee, advisory to the A. E. S. C. in the organization of the work, was appointed:

R. F. Hosford, Chairman, American Telephone and Telegraph Co., Alexander Maxwell, National Electric Light Association, G. C. Hecker, American Electric Railway Association, C. C. Beck, Associated Mfrs. of Electrical Supplies, J. C. Johnson, Telephone Section, George Eisenhauer, Electrical Section, American Railway Association.

An important part of this committee's work will be a recommendation on the question of sponsorship. All interested groups will participate in the work through representation of one or more sectional committees which will be set up for the work.

Mr. C. E. Skinner, the Chairman of the A. E. S. C., acted as Chairman of the conference.

AMERICAN ENGINEERING COUNCIL

NATIONAL BOARD FOR JURISDICTIONAL AWARDS

A special investigating committee of the American Engineering Council have proven the worth to labor of the National Board for Jurisdictional Award in the Building Industry after its five years' trial activity. The Council will continue its affiliation with the Board through the reappointment of Rudolph P. Miller, former superintendent of buildings in Manhattan, as its representative.

Mr. W. E. Bryan, representing the Associated Engineering Societies of St. Louis, asserts that the Board, in its five years' of existence, has "performed a valuable service not only to labor, the contractor and owner, but to the public at large." The work of the Board, according to the committee, has been of definite advantage to that large branch of engineering profession engaged in the design and construction of building projects, actually dictating the conditions under which men may or may not operate. The committee believes that engineers and architects are fitted both by training and nature to exercise judicial function in such matters since they occupy an impartial position linked with knowledge of correct technical procedure and effective execution. "And the fact that the labor unions have almost universally accepted the decision of the Board indicates their faith in the engineering profession. The committee feels that the American Engineering Council cannot afford to overlook this evidence of good faith as it indicates a capacity to render public service which is too important to disregard."

Other members of the investigation committee of the American Engineering Council are Dean Dexter S. Kimball, of Cornell University, Dean Perley F. Walker, of the University of Kansas and W. B. Powell, of Buffalo.

The next meeting of the National Board of Jurisdictional Awards has been called for March 9, 1925, at Washington, D. C., Mr. Miller to serve as chairman.

ENGINEERING FOUNDATION

CARNOT CENTENARY

The Founder Engineering Societies, the American Physical Society, the American Chemical Society and several universities and engineering colleges joined in celebrating on December 4, 1924 the centenary of the publication by Nicolas Leonard Sadi Carnot of his great principle of thermodynamics. The ceremonies were in Engineering Societies Building, New York, under auspices of Engineering Foundation. The interesting addresses

by Dr. W. F. Durand, President of American Society of Mechanical Engineers, who presided, and by Prof. M. I. Pupin, of Columbia University, and Dr. W. L. R. Emmet, Consulting Engineer of General Electric Company, have just been printed in a booklet along with a copy of a portrait of Carnot made in 1817. The pamphlet may be obtained by request to Engineering Foundation, at 29 West 39th Street.

United Engineering Society

EXTRACTS FROM THE PRESIDENT'S REPORT FOR YEAR 1924

During the year 1924, care of trust funds has received a major share of attention. Through the advice of the Finance Committee the Board has adopted the policy for restricting all future investments for trusts to securities legal in New York for guardians, executors, trustees and savings banks.

The Engineering Societies Building has been maintained in excellent condition and has been fully occupied. Several requests for offices have been declined,—one for nearly a whole floor.

Memberships of the Founder Societies at the end of 1924 totaled 53,007 and of the Associate Societies 27,328, an aggregate of 80,335 engineers having headquarters in the building.

On February 18, 1924, Dr. Joseph Struthers, Treasurer since February 24, 1910, died after a long illness. Jacob S. Langthorn, Am. Soc. C. E., was elected Treasurer at the meeting April 24 and began his duties on that date.

All departments of the United Engineering Society closed the year with credit balances. The assets for which the Society is responsible (real estate at cost, trust funds at book value, and Library as appraised) total about \$3,100,000.

EXTRACT OF REPORT OF TREASURER FOR YEAR 1924

CASH STATEMENT, YEAR 1924

RECEIPTS			
Cash in bank January 1, 1924.....		\$ 12,765.05	
Petty Cash, January 1, 1924.....		250.00	
From Founders and Associates (Including Library Appropriations).....	\$133,107.29		
From Societies not in building.....	15,083.45		
" Various Accounts.....	27,123.36		
" Library Service Bureau.....	19,213.07		
" Sale of Securities.....	73,946.68	268,473.85	
			\$281,488.90
PAYMENTS			
For Operating Payroll.....	\$ 49,072.01		
" Expenses.....	38,977.80		
" Equipment, Repairs & Alterations.....	8,042.13		
" Miscellaneous, Including Taxes.....	4,570.48		
" Purchase of Securities.....	39,628.63		
" Library Payroll and Expenses.....	57,682.67		
From Depreciation and Renewal Fund.....	10,368.11	208,341.83	
Cash on hand January 1, 1925.....			\$ 73,147.07
Distribution of Cash on Hand:			
Operating Cash.....		\$ 10,254.59	
Petty Cash.....		250.00	
Depreciation and Renewal Fund Uninvested Principal.....	\$ 5,832.09		
Engineering Foundation Fund Uninvested Principal.....	49,734.83		
Library Endowment Fund Uninvested Principal.....	136.50		
General Reserve Fund Uninvested Principal.....	2,500.00		
John Fritz Medal Fund Uninvested Cash.....	439.06		
Reserve for Depreciation of Capital of Library.....	4,000.00	62,042.48	
Total.....			\$ 73,147.07
In addition, United Engineering Society recorded on its books:			
Net Income paid to Engineering Foundation Board.....			\$ 26,366.79

Paid to banks for collection, custody and advice.....	367.25	
Paid to U. E. S. for Amortization of Premium.....	282.25	649.50
Engineering Foundation Fund Gross Income.....		\$ 27,016.29
Interest from Invested Income of Engineering Foundation.....		1,654.41
Interest Purchased.....	285.94	
Paid to bank for collection, custody and advice.....	24.65	310.59
Total Interest.....		\$ 1,965.00

BALANCE SHEET

ASSETS

Real Estate:			
Land.....	\$ 540,000.00		
Building.....	1,369,398.28		
Equipment.....	33,171.16		
Founders' Preliminary Expenses.....	24,000.00	\$1,966,569.44(a)	
Investments and Cash Uninvested:			
Depreciation & Renewal Fund.....	\$ 175,269.29		
Engineering Foundation Fund.....	477,720.05		
Library Endowment Fund.....	96,047.00		
General Reserve Fund.....	10,000.00		
Reserve for Depreciation of Library Capital.....	4,000.00		
Operating Cash and Petty Cash.....	10,504.59		
Accounts Receivable.....	2,141.97		
			\$2,742,252.34

LIABILITIES

Founders' Equity in Property.....	\$1,966,569.44
Depreciation and Renewal Fund.....	175,269.29
Engineering Foundation Fund.....	477,720.05
Library Endowment Fund.....	96,047.00
General Reserve Fund.....	10,000.00
Reserve for Depreciation of Capital of Library.....	4,000.00
Deposits on Account Hall Rentals.....	647.00
Credit Balance in Accounts Receivable.....	96.88
Deferred Credit-Miscellaneous Contributions to Library.....	5,699.92
Credit Balance in Activity Accounts.....	6,202.76
	\$2,742,252.34

PERSONAL MENTION

E. D. ARNTZEN has left his position with the West Penn Power Company and is now connected with the Commonwealth Edison Company, 2452 N. Kedzie Boulevard, Chicago.

CLARENCE G. JOHNSON has changed position from the Union Utilities Company, Chicago, and his new affiliation is with the United Power and Light Corporation, Abilene, Kansas.

ELMER C. JUHNKE has left the U. G. I. Contracting Company, Philadelphia, to accept a position in the control department of the Westinghouse Electric and Manufacturing Company, Philadelphia.

A. V. DEBEECH has resigned his position as Assistant Electrical Engineer in the Motive Power Department of the Interborough Rapid Transit Company, to go with the Canadian General and Finance Company, Toronto, Canada.

ELMER D. JOHNSON has accepted a temporary appointment as Junior Examiner in the United States Patent Office at Washington. Mr. Johnson was previously engaged in sales service for the Apex Electrical Distributing Company in Chicago.

W. W. SIMONS has resigned his position with the Telephone Supply Sales Department of the Western Electric Company and is now in the engineering department of the David Grimes Radio & Cameo Record Corporation, Jersey City, N. J.

EBERT W. HENDERSON, who has been with the Canadian Crocker-Wheeler Company since 1908, Ontario, Canada, has now returned to the States and his new work will be with the Reliance Electric and Engineering Company, Cleveland, Ohio.

HERBERT V. VARNEY, formerly employed as assistant system operator of the Toledo Edison Company, Toledo, Ohio, has re-

deal with the usual analyses required in working load, copper, tin, antimony, arsenic, aluminium, the precious metals and the iron-alloys, and are specifically intended for referee analyses in disputes, where great accuracy is essential.

CIRCUIT TROUBLES AND TESTING.

By Terrell Croft. N. Y., McGraw-Hill Book Co., 1924. 224 pp., illus., diags., 8 x 6 in., cloth. \$2.50.

A practical manual for wiremen, troublemen, etc., dealing with the causes of troubles in power and lighting circuits and with methods for locating and correcting them. The information is largely given by illustrations, with as little text as possible. The book covers aerial, underground and interior circuits.

CONNECTING INDUCTION MOTORS.

By A. M. Dudley. 2d edition. N. Y., McGraw-Hill Book Co., 1925. 361 pp., illus., diags., 9 x 6 in., cloth. \$3.00.

A practical book by an experienced worker, dealing with the winding characteristics of induction motors and intended for operators and repair men. Five chapters have been added to this edition and minor alterations and corrections made in the older portion of the book.

CUGLE'S PRACTICAL NAVIGATION.

By Charles H. Cugle. N. Y., E. P. Dutton & Co., 1924. 351 pp., tables, 9 x 6 in., cloth. \$6.00.

This book purports to give the student all the rules and problems in navigation used in everyday work at sea, together with short definitions of the theory of navigation and other information needed by young officers. The problems are accompanied by full solutions. The book is based on the 1925 Nautical Almanac and thus takes into account the changes from Greenwich Mean Time, adopted this year by the principal governments.

DIE DAMPFLOKOMOTIVE.

By J. Jahn. Berlin, Julius Springer, 1924. 356 pp., illus., 9 x 6 in., boards. 18.-gm.

Beginning with Stephenson's "Rocket" and continuing the story to the present day, Professor Jahn gives an account of the way in which the modern locomotive has developed. Each change in design is illustrated by a cut of an actual locomotive and the novelty in the design is pointed out. The material is classified on the basis of wheel arrangement, so that the volume is convenient for reference use, as well as for study. It is intended for readers familiar with current designs and should prove useful to engineers and designers.

DESIGN OF RAILWAY LOCATION.

By Clement C. Williams. 2nd edition. N. Y., John Wiley & Sons, 1924. 517 pp., illus., diags., maps, tables, 9 x 6 in., cloth. \$4.00.

This book is intended as a text-book, rather than a treatise, and therefore is rather an outline than an exhaustive treatise. The explanation and development of underlying principles, rather than the description of current practice is the aim of the author. Considerable space is given to the principles of railroad economics. The book has been prepared with a view chiefly to the extensive revision and relocation of railroads now in process in the United States, but attention is also given to the projection of new location.

ELASTIZITÄT UND FESTIGKEIT.

By C. Bach and R. Baumann. 9th edition. Berlin, Julius Springer, 1924. 687 pp., illus., diags., 9 x 6 in., boards. \$5.75.

This treatise has become so well-known to engineers, during the thirty-five years since its first appearance, that it is scarcely necessary to do more than announce the appearance of a new enlarged edition. The reader will find a thorough discussion of the theoretical principles, accompanied by a wealth of numerical data obtained by experiment, and an interesting collection of photographs of test-pieces, showing the results after undergoing tests of various kinds.

ELECTRIC CABLES; Their Design, Manufacture and Use.

By William A. Del Mar. N. Y., McGraw-Hill Book Co., 1924. 208 pp., diags., tables, 9 x 6 in., cloth. \$2.50.

The general interest aroused by the author's lecture at the University of Pennsylvania and the lack of a modern book on wires and cables have induced him to publish the notes prepared for this course. The book deals with the methods of manufacturing bare and insulated wires and cables, methods of testing and of locating faults, cable design, resistance, losses, inductance, electrolysis, etc. Specifications and standards are given, and there is a good bibliography.

ELECTRICAL ENGINEERING.

By L. A. Hazeltine. N. Y., Macmillan Co., 1924. (Engineering Science Series.) 625 pp., diags., tables, 9 x 6 in., cloth. \$6.50.

Contents: Fundamental physical relations.—Electric conduction.—Electrostatics.—Electromagnetism.—Alternating Currents.—Transient currents and electric waves.—Conduction in gases and electrolytes.—Electrical measuring instruments.—Electrical measurements.—Direct-current machines.—Synchronous machines.—Induction machines.—Transformers.—Transmission and distribution.—Electrical communication.

Professors Hazeltine's book presents in a single volume the essential elements of electrical science and of its applications to the various branches of electrical engineering. It is too concise for effective home study but is rather intended for use as a college text or as a reference book. It is based on the course given by the author at the Stevens Institute of Technology.

The book aims to give an accurate presentation of the fundamentals of each branch from all appropriate aspects. There is the author believes, considerable novelty in the methods of treatment throughout.

THE ELECTRON.

By Robert Andrews Millikan. 2d edition. Chicago, University of Chicago Press, 1924. (University of Chicago Science Series.) 293 pp., illus., diags., charts, tables, 8 x 5 in., cloth. \$1.75.

Dr. Millikan's book is intended to present the evidence for the atomic structure of electricity, to describe some of the most significant properties of the electron and to discuss the bearing of these properties on the structure of the atom and the nature of electromagnetic radiation. His account deals mostly with the researches that have been carried on under his own supervision, but the preceding work from which these grew and parallel work by others is reviewed also. The book is intended not only for physicists but also for readers with less technical training. The new edition has been brought up to date.

FERROUS METALS. By M. S. Birkett. 165 pp.

NON-FERROUS METALS AND OTHER MINERALS.

By N. M. Penzer. 264 pp. Lond., Ernest Benn, Ltd., 1924. 2 v., 10 x 8 in., cloth. 21 s. each.

In these two volumes is presented a concise, authoritative review of the metal resources of the entire British Empire. The information is selected and presented with an eye to the needs of the business man rather than the specialist. It includes a general description of its metal, its properties and uses, information on the localities where it is found, and statistics on production, consumption, exports and imports. The volume on ferrous metals contains considerable historical information on the various products of iron and steel. The non-ferrous volume has an excellent selected bibliography on the metals considered.

GRUNDBEGRIFFE DER MECHANISCHEN TECHNOLOGIE DER METALLE.

By Georg Sachs. Leipzig, Akademische Verlagsgesellschaft M. B. H., 1925. 319 pp., illus., diags., tables, 10 x 6 in., paper. \$3.15.

This book is intended to give a survey of the great mass of information available on the mechanical properties of the metals used in construction, with its frequent apparent contradictions. The author's first object has been to group the results of the various researches with close regard to the conditions of the research; this has frequently been sufficient to reconcile apparent discrepancies.

The book is chiefly confined to the basic, simple processes of treating metals. The mechanical properties of molten and solid metals are discussed, as are the effect of crystallization and the properties of crystalline aggregates, the effects of cold working and annealing, and the mechanical properties of pure metals and alloys. A valuable list of references to the sources of the data used is included. The book is a useful collection of the information most needed by builders of machinery.

HANDBOOK TO THE EXHIBITION OF PURE SCIENCE.

British Empire Exhibition, 1924. Arranged by the Royal Society. 228 pp., 8 x 5 in., paper. (Gift of Macmillan Co., N. Y.)

This handbook, prepared for use in connection with the exhibition of pure science arranged by the Royal Society for the British Empire Exhibition, consists of two parts. The first contains twenty-two brief essays by prominent British scientists, reviewing in non-technical language our present knowledge on various important questions. Sir Joseph Thomson writes on the

Electron; Dr. W. F. Aston on Atoms and Isotopes; Sir Richard Glazebrook on the Origins of Wireless; Mr. J. E. Sears on the Principals of Fine Measurement.

The second part is a catalog of the exhibits, with notes describing their methods of functioning and their purposes.

LECONS SUR LA COMPOSITION ET LES FONCTIONS PERMUTABLES.

By Vito Volterra and Joseph Peres. Paris, Gauthier-Villars et cie., 1924. 183 pp., 10 x 6 in., paper. 20 fr.

Professor Volterra has already outlined the theories here developed in two previous books on integral equations and integro-differential equations and on the functions of lines. In those books, however, the concepts now presented, which have as their common origin the method given by him for solving integral equations, appear only indirectly and in application to the solution of certain problems in analysis and mathematical physics. In the present work the theory has been disengaged from the researches to which it was an auxiliary and is presented independently in more systematic and complete form.

LEHRBUCH DER METALLOGRAPHIE.

By Gustav Tammann. 3rd edition. Leipzig, Leopold Voss, 1923. 450 pp., illus., diags., tables, 9 x 6 in., paper. \$3.40.

In this book, the Director of the Göttingen Institute for Physical Chemistry offers a text on the theoretical aspects of the science of metals, adapted for the use of mature students. The basis of the volume is in general his own extensive researches and the arrangement of the material, which differs from the usual one, is intended to present the information so that it will emphasize the points of theoretical importance.

This edition has been enlarged by the inclusion of the results of recent investigations in metallography.

PROBLEMES D'ELECTROTECHNIQUE.

By Adr. Curchod. Paris, Albert Blanchard, 1925. 594 pp., diags., 10 x 6 in., paper. 48 fr.

A collection of practical problems in electrical engineering, with complete detailed solutions. These problems are of commonly recurring types, dealing with the fundamental laws and with the design of alternating and direct current dynamos and motors, transformers, etc. The book is intended to supplement college textbooks by providing additional problems and to aid engineers by refreshing their memories of methods.

PROTEINS AND THE THEORY OF COLLOIDAL BEHAVIOR.

By Jacques Loeb. 2nd edition. N. Y., McGraw-Hill Book Co., 1924. (International Chemical Series.) 380 pp., diags., tables, 8 x 6 in., cloth. \$3.50.

The first part of Dr. Loeb's book discusses the behavior of proteins. A great number of experiments are presented which show that the proteins follow the ordinary laws of chemical combination and that there is no chemistry of colloids differing from that of crystalloids.

The second half is devoted to the theory of the colloidal behavior of proteins. A new mathematical and quantitative theory is developed on the basis of Donnan's theory of membrane equilibria, which is believed to be applicable to all colloids.

The new edition includes the results of Dr. Loeb's later experiments.

RADIOACTIVITY AND THE SURFACE HISTORY OF THE EARTH; being the Halley Lecture, May 1924.

By John Joly. Lond., Oxford University Press, 1924. 40 pp., diags., maps, 9 x 6 in., paper. \$1.35. (Gift of Oxford University Press, American Branch.)

In this interesting lecture, Dr. Joly presents clearly and concisely the modern view of the surface activities of the earth and discusses the nature and source of the energy that causes these activities.

RARE EARTHS, their Occurrence, Chemistry and Technology.

By S. I. Levy. 2d edition. N. Y., Longmans, Green & Co., Lond., Edward Arnold & Co., 1924. 362 pp., 9 x 6 in., cloth. \$6.00.

This book is intended to supply a complete, coherent account of our present knowledge of the rare earths, which is not overloaded with detailed accounts of large numbers of chemically similar compounds. The new edition takes account of the literature up to June 1924.

SCIENTIFIC RESEARCH AND HUMAN WELFARE.

By Franklin Stewart Harris and Newbern J. Butt. N. Y., Macmillan Co., 1924. 406 pp., 8 x 5 in., cloth. \$2.50.

An account of some of the inventions and discoveries that make up the civilization of today, intended for general readers

and written in popular style. Sections are devoted to health, communication, transportation, illumination, agriculture, engineering and mining, manufacturing and the home. In each section the great advances are recorded, with an account of the steps by which they were evolved. The ultimate purpose of the book is to call attention to the value of research in various lines and to plead for greater support of investigations.

SCREW PROPELLERS AND ESTIMATION OF POWER FOR PROPULSION OF SHIPS ALSO AIRSHIPS PROPELLERS.

By Charles W. Dyson. N. Y., Simmons-Boardman Pub. Co., 1924. 2 v., diags., tables; v. 1, 9 x 6 in.; v. 2, 16 x 10 in., cloth. \$15.00.

The third edition of this work differs materially from the preceding one. All the design curves given there have been discarded and new curves developed from equations derived from well-authenticated observations. This has resulted in new curves for basic apparent slip, based upon the hull of the ship and the ratio of the length of after body to draft. More attention has been given also to variations in hull form. This edition, Rear-Admiral Dyson states, is the last which he will prepare.

STATICS, including Hydrostatics and the Elements of the Theory of Elasticity.

By Horace Lamb. 2d edition. Cambridge, England, University Press, 1924. 357 pp., diags., 9 x 6 in., cloth. \$5.75. (Gift of Macmillan Co., N. Y.)

This textbook contains the substance of lectures given at the University of Cambridge for a number of years to students with some knowledge of elementary mechanics and ability to apply the methods of the calculus. Prominence is given to geometrical methods, particularly those of graphical statics. In this new edition, considerable additions have been made to the chapters on elasticity.

SUR L'ELECTRODYNAMIQUE DES CORPS EN MOUVEMENT.

By Albert Einstein. Paris, Gauthier-Villars et Cie, [1925]. 56 pp., port., 7 x 5 in., paper. 6 fr.

The memoir here republished in convenient form appeared first in 1905, in the *Annalen der Physik*. It is here that Einstein first explained his celebrated theory of restricted relativity. The volume forms one of a series of reproductions of great scientific papers.

SWITCHGEAR FOR ELECTRIC POWER CONTROL.

By E. Basil Wedmore and Henry Trencham. Lond., Humphrey Milford, Oxford Univ. Press, 1924. 335 pp., illus., diags., tables, 9 x 6 in., cloth. \$8.35. (Gift of Oxford University Press, American Branch.)

This book discusses the various types of fuses, circuit breakers, reactors, etc.; the methods of protecting lines from leakage, excess current, etc.; switchboard equipment and arrangement and other devices and methods used in the control of electric power. The authors state that the book should assist the designer, for it contains much about design, from the point of view of the user, which the designer finds it difficult to learn. Users of switchgear, on the other hand, will find in the book things about use, from the viewpoint of the designer, which it is to their advantage to understand.

TECHNICAL MECHANICS, STATICS, KINEMATICS, KINETICS.

By Edward R. Maurer and Raymond J. Roark. 5th edition. N. Y., John Wiley & Sons, 1925. 364 pp., diags., tables, 9 x 6 in., cloth. \$3.50.

This may be fairly described, the authors say, as a theoretical mechanics for students of engineering. It is not comparable to books commonly called *Theoretical Mechanics*, generally intended for students of mathematics or physics, nor to those commonly titled *Applied Mechanics*, which include the strength of materials, hydraulics, etc. The title of *Technical Mechanics* has been chosen to indicate this differentiation.

This edition is rewritten, with improvements in the presentation, changes in subject matter and arrangement, and many new problems.

DIE ZUSTANDSGLEICHUNG VON GASSEN UND FLUSSIGKEITEN . . .

By J. J. Van Laar. Leipzig, Leopold Voss, 1924. 368 pp., 10 x 6 in., paper. \$3.45.

For over thirty years Dr. van Laar has been an active investigator of the phenomena accompanying the change from the liquid to the gaseous state, and of the equation of state. The

results of his work, scattered through many periodicals, are now presented as an organic whole in the present volume, which should be of considerable interest to students of thermodynamics and physical chemistry. The book deals particularly with the variability of the constants of Van der Waal's equation, with critical conditions, vapor pressure phenomena and coexisting vapor and liquid phases.

STANDARD ELECTRICAL DICTIONARY.

By T. O'Connor Sloane. N. Y., Norman W. Henley Pub. Co., 1924. 790 pp., illus., 7 x 5 in., cloth. \$5.00.

To this edition a third part, comprising twenty-two pages, has been added, devoted to new terms introduced by radio engineering.

Past Section and Branch Meetings

SECTION MEETINGS

Akron

Adjustable-Speed A-C. Commutator Motors, by H. C. Uhl, General Electric Co. Illustrated with slides. Joint meeting with A. S. M. E. Luncheon was served. January 23. Attendance 70.

Atlanta

A talk was given by Mr. Farley Osgood, National President. In his address Mr. Osgood explained the duties and functions of the Institute, its object, its problems, its endeavors, its service to the engineering field and to its individual members, and the power possessed by electrical engineers through the Institute. January 2. Attendance 90.

Boston

Sound; Its Electrical Analysis, Amplification, and Control, by Dr. Harvey Fletcher, Western Electric Co. Those taking part in the discussion which followed the talk were: Professors Eugene A. Crockett, Frederick A. Saunders, Charles A. White and F. S. Dellenbaugh, Jr. The meeting was held under the auspices of the American Laryngological, Rhinological and Otolological Society and the A. I. E. E. and was participated in by many other societies. January 24. Attendance 800.

Bureau of Standards Methods, by E. C. Crittenden, Bureau of Standards. Illustrated with slides. Discussion was participated in by Dr. A. E. Kennelly, Professor Drisko and Professor W. L. Smith. Joint meeting with Illuminating Engineering Society. January 30. Attendance 55.

Cincinnati

Research and Industrial Progress, by Dean H. Schneider, University of Cincinnati. Joint meeting with Cincinnati Engineers Club. January 15. Attendance 130.

Columbus

Super Power Interconnection in Ohio, by R. R. Krammes, Ohio Power Co. The talk was followed by a film entitled "Electrifying Ohio." October 24. Attendance 17.

Methods of Automatic Train Control, by B. J. Schwendt, N. Y. C. R. R. This talk was followed by a film entitled "The Man at the Throttle." November 21. Attendance 18.

Modern Methods of Lamp Manufacture, by A. W. Janowitz, General Electric Co. The talk was accompanied by a film; and

Radio, by F. R. Price. January 30. Attendance 24.

Connecticut

Transmission of Photographs by Radio, by C. F. Jenkins, Jenkins Laboratories. The speaker outlined the cylinder scheme employed in the recently announced method of transmitting photographs by radio and pointed out that the method which he had developed substantially reduced the time of transmission. January 13. Attendance 500.

Illumination, by Walter Sturrock, General Electric Co. A demonstration was given of the effects of various kinds and colors of lighting as pertains to factory illumination, exterior lighting and show-window lighting. Refreshments were served. January 20. Attendance 75.

Supervisory Control, by P. B. Garrett, Westinghouse Electric & Mfg. Co. The speaker demonstrated equipment for controlling isolated stations from a central point. Mr. Garrett also exhibited the Klydonograph, an instrument for recording surges on high-tension circuits. January 6. Attendance 76.

The Historical Development and Future of the Electrical Industry, by R. M. Davis, Electrical World. The lecture was illustrated with slides. A dinner preceded the meeting, which was held jointly with the Electrical Cooperative League. January 23. Attendance 44.

Detroit-Ann Arbor

Automatic Substations, by James W. Bishop, Detroit Edison Co. The speaker reviewed the history of the automatic substation outlining some obstacles met and methods devised for correcting them. Chester Lichtenberg and R. J. Wensley, Westinghouse Electric & Mfg. Co., gave short talks outlining the manufacturer's viewpoints. Slides and moving pictures were shown. January 13. Attendance 250.

Erie

The Properties of Speech, Music and Noise and Their Relation to Electrical Communications, by Dr. Harvey Fletcher, Western Electric Co. Joint meeting with the Erie Technical Federation. January 19. Attendance 600.

Indianapolis-Lafayette

A picture, entitled "Temperature and Motor Endurance," was shown, after which W. A. Black led in a discussion of the film. January 23. Attendance 25.

Lehigh Valley

Transportation, by W. B. Potter, General Electric Co. January 22. Attendance 103.

Los Angeles

Electrical Distribution in, and Illumination of, an Office Building, by Carl A. Sanborn, Homes and Sanborn. The talk was illustrated by slides; and

Evolution of the Building Industry, by Paul W. Penland, Blue Diamond Material Co. A dinner preceded the meeting. January 13. Attendance 119.

Lynn

Mr. T. H. Soren, Vice-President of the Hartford Electric Light and Power Co. gave a talk on the engineering work and power development of his company and described the first installation of a commercial mercury turbine. A discussion followed regarding coal-oil fuel, life of fire brick, storage of coal and other economies. November 25. Attendance 120.

With Mac Millan in the Arctic, by Ralph P. Robinson. The lecture was illustrated by slides. Ladies night. December 18. Attendance 610.

Automatic Substation Control Equipment, by Chester Lichtenberg, General Electric Co. Illustrated with slides. A moving picture of a typical railroad installation was shown. January 7. Attendance 200.

The Application and Description of the Art of Oxy-Acetylene Welding, by Hugh H. Griffith, Linde Air Products Co. Motion pictures were shown. Joint meeting with the Thompson Club. January 16. Attendance 72.

Milwaukee

Recent Progress in Radio Communication, by Professor E. M. Terry, University of Wisconsin. The lecture was accompanied by slides and moving pictures. January 21. Attendance 200.

Minnesota

Local Progress in the Electrical Industry. This was a symposium, participated in by Messrs. D. W. Flowers, S. B. Hood, V. A. Wolcott, E. Marshall, C. E. Kenning and H. E. McWethy. November 17. Attendance 79.

Total Eclipses of the Sun, by Professor F. P. Leavenworth. December 8. Attendance 20.

Nebraska

Organization Meeting. February 3. Attendance 17.

Philadelphia

Fractional-Horsepower Motors, by E. B. George, General Electric Co. A moving picture showed the assembling of these motors. January 12. Attendance 112.

Pittsburgh

Radio Progress, by S. M. Kintner, Westinghouse Electric & Mfg. Co. January 13. Attendance 152.

Pittsfield

Solar Eclipse, January 24, 1925, by Dr. Harlan T. Stetson. The speaker described various phenomena of an eclipse. (On January 24 the Section ran a special train to New Milford, Connecticut, to witness the eclipse. 650 made the trip.) January 22. Attendance 450.

High-Voltage Practise in Europe, by B. Nikiforoff. The lecture was illustrated with slides, showing various types of foreign installations. February 3. Attendance 125.

Portland

The Electrical Power Installation of the Long Bell Lumber Company at Longview, by L. D. Beach. The talk was illustrated by slides. January 14. Attendance 75.

Providence

The Total Eclipse of the Sun, by Professor C. H. Currier. January 13. Attendance 55.

Rochester

Putting the Gyro to Work, by Robert A. Lea, Sperry Gyroscope Co. The speaker also gave a description of the high-intensity searchlight recently invented by Mr. Sperry. January 16. Attendance 52.

San Francisco

The No. 3 Development of the Pit River Project, Pacific Gas & Electric Co., by E. A. Crellin and O. W. Peterson. Illustrated by slides of the work in progress. A dinner preceded the meeting. December 12. Attendance 150.

Recent Progress in Illumination, by J. R. Cravath. The speaker illustrated his talk with specimens of illuminating fixtures and displayed slides of spectacular illumination of large office buildings. Joint meeting with Illuminating Engineering Society. January 30. Attendance 85.

Schenectady

Transportation by Electricity, by W. B. Potter, General Electric Co. January 29. Attendance 400.

Seattle

Mr. L. D. Beach, Long Bell Lumber Company, outlined in detail the various features of the installation of the electrical generating equipment, the switching equipment and the logging machinery. Illustrated with slides. December 17. Attendance 37.

Southern Virginia

The Virginia Water Power and Development Commission, by J. R. Horsley, A. W. Giles and A. W. Drinkard, Jr.,

The James River Development, by A. J. Saville,

Hampton Roads as a World Port, LeRoy Hodges and

Principles of Port Development, Elihu Church. The four addresses named were given at afternoon and evening sessions of a meeting held jointly with the A. S. C. E., A. S. M. E. and A. A. E. January 16. Attendance 100.

Spokane

Progress in the Art of Illumination, by W. R. Matthews, Washington Water Power Co. The talk was illustrated with model lights, shades and color lighting, followed by a moving picture of the life of Thomas A. Edison, showing his first attempts in making an electric light. January 30. Attendance 23.

Springfield

Measuring Instruments for Switchboard and Testing Service, by F. H. Bowman, General Electric Co. January 16. Attendance 48.

Syracuse

High-Frequency Phenomena and the Lightning Generator, by F. W. Peek, Jr. The talk was illustrated with slides. November 17. Attendance 100.

The Guiding Wire in Electromagnetic Transmission, by O. B. Blackwell, American Telephone and Telegraph Co. December 1. Attendance 150.

Mr. Farley Osgood, National President, spoke on Institute affairs, engineering education, the place of the engineer in the community and other phases of the engineer's life. January 12. Attendance 45.

The History of Communication, by Wm. C. Dariet, Postal Telegraph Co. The talk was illustrated with moving pictures. January 26. Attendance 145.

Toledo

Radio Broadcasting Stations,—Past, Present and Future, by J. W. B. Foley. January 22. Attendance 32.

Toronto

Electrical Measurement of Physical Values, by Perry A. Borden. January 9. Attendance 98.

Traffic Control, by C. A. B. Halvorson, Jr., General Electric Co. The speaker described and illustrated with slides several signal systems, their operation and application. Joint meeting with the Illuminating Engineering Society. January 23. Attendance 75.

A New High-Voltage Insulator, by Professor Harold B. Smith, Worcester Polytechnic Institute, Mr. A. C. Stevens, Secretary-Treasurer, District No. 1, A. I. E. E., also addressed the meeting regarding the activities of the District. January 29. Attendance 44.

Utah

Sources of Radio Interference and Some Preventative Measures, by K. V. Laird, Capital Electric Co. January 28. Attendance 57.

Vancouver

The Theory of Light According to Modern Ideas, by J. G. Lister. The address was accompanied by spectroscopic experiments and illustrated by slides. January 9. Attendance 32.

Electrical Equipment of the Consolidated Mining and Smelting Company's Zinc Plant, by R. H. Lockyer. The paper was illustrated by slides. February 6. Attendance 18.

Washington, D. C.

Construction of City Electric Railways with Underground Trolley Systems, by R. H. Dagleish, Capitol Traction Co. The talk was illustrated with slides. Refreshments were served and a dinner preceded the meeting. January 13. Attendance 67.

Worcester

Power-Factor Correction in Industrial Plants, by C. W. Drake, Westinghouse Electric & Mfg. Co. January 15. Attendance 60.

A Survey of Current Progress in Radio Engineering, by Dr. J. A. Dellinger, Bureau of Standards. January 29. Attendance 75.

BRANCH MEETINGS**Alabama Polytechnic Institute**

A talk was given by George A. Wright on the opportunities offered to engineering graduates by the Westinghouse Company. January 7. Attendance 38.

A-C. Generators, by Albert E. Duran. The lecture was accompanied by slides. January 28. Attendance 30.

Business Meeting. February 4. Attendance 16.

An informal talk was given by Mr. Boring, General Electric Co. February 11. Attendance 37.

University of Arkansas

Engineering Achievements in 1924, by Ben Avery, student, *Ramsay Turbo-Electric Locomotive*, by Raymond Buchanan, student, and

What Happens When the Exciter Switch is Opened in a Large Power House? by Sam Dill, student. January 20. Attendance 26.

Armour Institute of Technology

Chicago's Traction Problem, by Major Kelker. November 13. Attendance 40.

Smoker. November 21.

History of Electricity, by C. R. Bishop, student. November 27. Attendance 30.

A talk was given by A. R. Brunner, Liquid Carbonic Company, who gave the students some idea of what will be expected of them when they seek employment after graduation. January 15.

Commercial Survey of a Large City, by E. Thurston, Illinois Bell Telephone Co. January 29. Attendance 40.

California Institute of Technology

Recent Developments in Electric Motors, by H. C. Hill, General Electric Co.

Control Apparatus, by H. K. Winterer, General Electric Co. January 14. Attendance 27.

Case School of Applied Science

Municipal vs. Private Ownership and Operation of Electric Central Stations, by F. O. Fountain, Ohio Public Service Co. December 5. Attendance 39.

Catholic University of America

Effect of Electricity on Modern Civilization, by Mr. Ripley, General Electric Co. Refreshments and "smokes" were served. December 16. Attendance 28.

Clarkson College of Technology

Business Meeting. The following officers were elected: President, F. H. Porter; Secretary, F. S. McGowan, and Treasurer, W. Augustine. September 19. Attendance 27.

Talk was given by Professor A. R. Powers. October 14. Attendance 22.

Hull Design, by Professor Ross. October 28. Attendance 25.

Comparison of Engineering in China with That in America, by James Chi Chu. November 18. Attendance 30.

Comparison of Education in 1880 with the Education of the Present Time, by Dr. Brooks. January 13. Attendance 26.

Clemson Agricultural College

Hydroelectric Practise in the South, by G. C. Wise, and

The History of Radio, by L. R. W. Jacobi. February 4. Attendance 13.

University of Colorado

Mr. P. B. Garrett, Westinghouse Electric & Mfg. Co., described and demonstrated a complete supervisory-control set. He also described and demonstrated the Klydonograph. Mr. Wm. Trudgion, Denver Westinghouse Office, made a few remarks. January 8. Attendance 80.

University of Denver

Inspection trip through the Lacombe Station of the Public Service Company of Colorado. January 23. Attendance 16.

Drexel Institute

Talk was given by Mr. Lange, E. E. Department. November 7. Attendance 23.

The Construction of the New Delaware Station, by Mr. Hopping, Philadelphia Electric Co. In his talk Mr. Hopping told of the boiler and turbine installations and the water supply of the Station. Mr. Bailey, of the same company, described the electrical installations in the plant. Joint meeting with the A. S. M. E. and A. S. C. E. December 19. Attendance 75.

Testing of Oil Used as an Insulator, by Dr. J. E. Schraeder. The speaker illustrated his talk with slides and showed diagrams of various equipment he developed to make these tests. January 23. Attendance 28.

Georgia School of Technology

Automatic Controls, by Mr. Fishback. The lecture was illustrated with slides. February 5. Attendance 47.

University of Idaho

The General Electric Works at Schenectady, N. Y., and the Company's Ideas on Engineering Graduates, by M. M. Boring. January 14. Attendance 24.

Kansas State College

A Few Points from Einstein's Theory, by Dale Nichols. December 8. Attendance 75.

Mr. R. M. Kerchner outlined the plans for an electrical show to be given on Engineers Day. February 5, of Farm & Home Week, February 2-7. January 12. Attendance 77.

University of Kansas

Transformers, by Carl A. Degering, General Electric Co. The lecture was illustrated. February 5. Attendance 35.

University of Kentucky

Political and Industrial Invasions Are Responsible for the Advancement of Civilization, by Professor Jones, College of Arts and Sciences. December 18. Attendance 22.

Lafayette College

Transformers and Their Place in Superpower Distribution, by H. O. Stevens, General Electric Co. November 8. Attendance 19.

Supplementary Radio Communication with the Pennsylvania Power and Light Co., by George G. Mercer. November 15. Attendance 11.

Speed Control of Electric Motors, by the Electric Control and Manufacturing Co. December 6. Attendance 19.

Transformer Design, by A. B. Foster, Packard Electric Co. The lecture was illustrated. January 14. Attendance 19.

University of Maine

Relation of the Maine Public Utilities Commission to the Electrical Utilities of the State, by Harold D. Coffin. January 15. Attendance 22.

Marquette University

Transformer Construction and Testing, by Messrs. A. S. Hill and Greensward, students. A demonstration followed the presentation of the paper. November 13. Attendance 25.

Developments in Motor Control, by C. T. Evans, Cutler-Hammer Mfg. Co. In the discussion which followed, Professor Douglas made a few remarks. January 29. Attendance 35.

Massachusetts Institute of Technology

Lightning, by F. W. Peek, General Electric Co. The author discussed his deductions from observations of natural lightning and gave an account of the operation of an artificial lightning generator capable of producing a potential of 2,000,000 volts. After the talk slides and motion pictures were shown of the high-voltage generator in operation. February 5. Attendance 124.

Mr. A. H. Lavers, Superintendent of Buildings and Grounds, gave a general discussion of the new a-c. system on the campus. M. J. Miller, the college electrical engineer, gave a detailed description of the apparatus used in, and the construction of the new system. January 27. Attendance 21.

University of Michigan

Two films, entitled respectively "Queen of the Waves" and "The Panama Canal," were shown. January 21. Attendance 230.

School of Engineering of Milwaukee

Superpower Projects, by Bruce Douglas, Cahill and Douglas. January 23. Attendance 25.

University of Missouri

The Introduction of the Machine Switching System in St. Louis, by W. O. Pennell, Southwest Bell Telephone Co. December 3. Attendance 50.

Montana State College

Electrical Furnaces, by J. C. Dow, Montana Power Co. December 16. Attendance 128.

A lecture, accompanied by motion pictures, was given by B. L. Snoddy, General Electric Co. January 13. Attendance 108.

University of Nevada

Protective Apparatus, by Wm. Malarkey, General Electric Co. Two moving pictures, entitled respectively "Operation of Automatic Railroad Substation and Its Apparatus" and "Supervisory Relays," were shown. January 14. Attendance 25.

Mr. Boring, General Electric Company, gave an informal talk upon the work done by the students at the General Electric Company factory and the benefits derived from their course. January 28. Attendance 36.

University of North Carolina

Evolution of the Modern Electric Light, by Chas. E. Ray, *Proper Office Lighting*, by P. M. Rutherford, and *Glare and Its Prevention*, by B. C. Cooper. November 20. Attendance 20.

Evolution of Meters and Electrical Measuring Instruments, by C. L. Jones,

The Watthour Meter, by Mr. Geddy, and *Kv-a. or Power and Demand Meter*, by H. C. Klingenschmitt. January 15. Attendance 21.

University of North Dakota

The Cahokia Power Station in St. Louis, by Vernon Cox, and *Submarine Cables*, by L. J. Lunas. January 19. Attendance 19.

Ohio Northern University

Electricity in the Steel Plant, by Nathan Clarkin, and *Modulation in a Radio Transmitter*, by Emerson Smith. January 14. Attendance 23.

Motor Control, by Mr. Fishback. The lecture was illustrated. January 22. Attendance 40.

Electric Lighting, by P. V. Funk; and *The X-Ray*, by G. E. Thompson. January 29. Attendance 27.

Ohio State University

Radio Transmitting Equipment, by S. C. Aikenhead, Willard Storage Battery Co. A detailed account of experiments in connection with the broadcasting station at Cleveland. January 16. Attendance 40.

Several films on "The Manufacture of Wire and Cable" were shown. January 30. Attendance 25.

Oklahoma Agricultural & Mechanical College

Business Meeting. The following officers were elected: President, Brent Wrigley; Vice-President, Carl Box, and Secretary-Treasurer, Kenneth Woodyard. January 20. Attendance 7.

Student Benefits from A. I. E. E., by Ivan Knight, and *A. I. E. E. and Progress*, by Professor R. B. George. February 3. Attendance 16.

University of Oklahoma

Business Meeting. Plans were discussed for the electrical display at the Annual Engineers Open House. January 8. Attendance 20.

Business Meeting. January 15. Attendance 29.

Pennsylvania State College

Super Power, by Mr. Lippman, student, and *Telephone Work*, by Mr. Lehman, student. January 14. Attendance 30.

Lecture by E. B. Tuttle, Bell Telephone Co. His talk embraced all of the parts of the telephone system as it is now used, and was illustrated by appropriate moving pictures and slides. January 20. Attendance 185.

University of Pennsylvania

Smoker. January 9. Attendance 80.

Business Meeting. The banquet to be held on February 11 was discussed. January 20. Attendance 95.

Purdue University

An Aeroplane Trip Through Europe, by C. M. Ripley, General Electric Co. The relation of the use of power and machinery to the standards of living was well brought out. February 5. Attendance 297.

Rhode Island State College

Two motion pictures were shown. One was entitled "Some Practical Uses of Compressed Air," and the other one showed one phase of Thomas Edison's life. December 18. Attendance 45.

Traffic Control Systems, by C. S. Rogers, General Electric Co. January 8. Attendance 30.

Rutgers University

History of the Electric Light, by W. E. Dunn. November 3. Attendance 15.

Some Phases of the Electrification of Steam Railways, by W. A. Miller, student. A few remarks were added by Professor Creager. November 17. Attendance 16.

Pole-Line Construction, by H. Crowley, student and

Customer Ownership of Public Utilities, by L. E. Post, student. December 15. Attendance 6.

University of South Dakota

Power Development in 1924, by Mr. Slotsky. Another talk was given by Dr. Brackett. January 17. Attendance 6.

University of Southern California

Talks by H. A. McCarter and Bob. Cockfield on a trip to the General Electric's Plant. Refreshments were served. April 3.

The Purposes and Objects of the E. E. Department, by Professor Clark and Nye. Refreshments were served. May 6.

Talk by Dean Waugh. A supper preceded the meeting. After the meeting an inspection trip to the Radio Station, KHJ, was taken. November 6.

A film, entitled "Production of the 8-Cylinder Cadillac," was shown. November 27.

The Development of Power and the Reason for the First Shortage of Energy, by Mr. Lowery, Southern California Edison Company. A moving picture was shown which presented the aviation program of the U. S. and the various types of planes used and now in construction. Joint meeting with A. A. E. December 18.

Business Meeting. January 8.

Stanford University

Talk by D. C. Bertrand, student, on the course as given by the Westinghouse Company. January 13. Attendance 25.

Obstacles Met by the Young Engineer and How to Overcome Them, by Mr. Bosch, Pacific Gas and Electric Co. Professors Marx and Ryan gave short talks on the work of the Student Branches of the A. S. M. E. and A. I. E. E., respectively. Joint meeting with the A. S. M. E. in the form of a smoker. January 27. Attendance 120.

Swarthmore College

The Vocational School Man in Engineering, by John J. Matthews, Pennsylvania State Supervisor of Industrial Education. Joint meeting with A. S. M. E. and Swarthmore College Engineers Club. January 12. Attendance 58.

University of Texas

Business Meeting. The following officers were elected: President, A. A. Brown; Vice-President, A. M. Baker; Secretary-Treasurer, Jim. B. Coltharp; Critic, W. H. Hollingsworth, and Reporter, J. Schwab. January 8. Attendance 15.

Business Meeting. January 22. Attendance 12.

University of Utah

Business Meeting. The following officers were elected: Chairman, S. W. Pixton; Vice-Chairman, C. F. Coombs; and Secretary-Treasurer, H. H. Tracy. October 29. Attendance 12.

Virginia Polytechnic Institute

Laying of Oceanic Cables, by F. E. Rotenberry, *Motor-Generator Type of Locomotive*, by H. E. Coston, *A-c. Power Transmission Versus D-c.*, by G. W. Bolton; and *Electrical Conductors, Especially Copper and Aluminum*, by J. H. Chiles. January 16. Attendance 25.

The General Electric Company's Test Course, by C. W. Hoilman, and

Rural Electrification, by D. C. Heitshu. January 22. Attendance 34.

University of Virginia

Queenstown-Chippawa Power Development, by J. E. Glick, student,

Scientific Work of Joseph Henry, by H. H. Long, student, and *Misuse of the Word Engineer*, by L. R. Montfort, student. February 3. Attendance 15.

State College of Washington

Business Meeting. December 15. Attendance 22.

Business Meeting. The following officers were elected: President, Tom Hunt; Vice-President, R. Fish; Secretary, C. Backus; Treasurer, E. Phillipi; Reporter, R. Fridlund; Executive Council, C. Calbick and A. Sorenson. January 27. Attendance 18.

University of Washington

World Power Conference, by C. E. Magnusson, University of Washington. The main feature of Dr. Magnusson's talk was the hydroelectric development in Norway and Sweden. John Norhadl was elected Chairman of the Branch. December 9. Attendance 13.

The Student Engineer and His Work in the General Electric Company's Shops, by M. M. Boring, General Electric Co. January 16. Attendance 44.

Addresses Wanted

A list of names of members whose mail has been returned by the Postal Authorities is given below, together with the addresses as they now appear on the Institute records. Any member knowing the present address of any of these members is requested to communicate with the Secretary at 33 West 39th St., New York, N. Y.

All members are urged to notify the Institute headquarters promptly of any change in mailing or business address, thus relieving the member of needless annoyance and also assuring the prompt delivery of Institute mail, the accuracy of our mailing records, and the elimination of unnecessary expense for postage and clerical work.

1.—Cyril St. C. Boland, 413 N. Jackson St., Atlanta, Ga.

2.—Edward F. Bradley, c/o So. Calif. Edison Co., Camp 62 Big Creek Calif.

3.—W. T. Chappell 3708 5th Ave., Pittsburgh, Pa.

- 4.—J. E. Contesti, 368 West 117th St., New York, N. Y.
- 5.—W. C. Finely, 211 John St., Oakland, Calif.
- 6.—P. G. Fossatti, 3426 S. Michigan Blvd., Chicago, Ill.
- 7.—Harry N. Gilbert, 379 Cottage Ave., Glen Ellyn, Ill.
- 8.—F. Leon Grajales, 710 No. Medina St., San Antonio, Texas.
- 9.—A. Fred Hansen, 462 West 37th St., Los Angeles, Calif.
- 10.—G. Hizawa Mitsubishi Shoji Kaisha 5 1 Chome Urakueho, Tokyo, Japan.
- 11.—E. V. Karlson, c/o Cons. Coppermines Corp. Kimberly, Nev.
- 12.—I. J. Larson, 71 Roseville Ave., Newark, N. J.
- 13.—Wm. Shiel Norton, 10 Grove St., New York, N. Y.
- 14.—David M. Oseroff, 505 12th St., Brooklyn, N. Y.
- 15.—H. J. Phillip, 1617 So. Burlington St., Los Angeles, Calif.
- 16.—W. B. Pradhan, L. E. E., Gamdevi Kennedy Bridge, Bombay No. 7, India.
- 17.—Harry J. Rice, 58 Van Reypen St., Jersey City, N. J.
- 18.—A. Shohan, Lombard, Ill.
- 29.—Wm. G. Shull, St. George Hotel, 60th & Blackstone Ave., Chicago, Ill.
- 20.—Gilbert H. Strand, Western States Gas & Elec. Co., Camp R, Placerville, Calif.
- 21.—O. B. Wooten, Texas A. & M. College, College Station, Texas.

Engineering Societies Employment Service

Under joint management of the national societies of Civil, Mining, Mechanical and Electrical Engineers as a cooperative bureau available only to their membership, and maintained by contributions from the societies and their individual members who are directly benefited.

MEN AVAILABLE.—Brief announcements will be published without charge and will not be repeated, except upon requests received after an interval of one month. Names and records will remain in the active files of the bureau for a period of three months and are renewable upon request. Notices for this Department should be addressed to **EMPLOYMENT SERVICE, 33 West 39th Street, New York City**, and should be received prior to the 15th of the month.

OPPORTUNITIES.—A Bulletin of engineering positions available is published weekly and is available to members of the Societies concerned at a subscription rate of \$3 per quarter, or \$10 per annum, payable in advance. Positions not filled promptly as a result of publication in the Bulletin may be announced herein, as formerly.

VOLUNTARY CONTRIBUTIONS.—Members obtaining positions through the medium of this service are invited to cooperate with the Societies in the financing of the work by nominal contributions made within thirty days after placement, on the basis of \$10 for all positions paying a salary of \$2000 or less per annum; \$10 plus one per cent of all amounts in excess of \$2000 per annum; temporary positions (of one month or less) three per cent of total salary received. The income contributed by the members, together with the finances appropriated by the four societies named above, will it is hoped, be sufficient not only to maintain, but to increase and extend the service.

REPLIES TO ANNOUNCEMENTS.—Replies to announcements published herein or in the Bulletin, should be addressed to the key number indicated in each case and with a two cent stamp attached for reforwarding, and forwarded to the Employment Service as above. Replies received by the bureau after the positions to which they refer have been filled will not be forwarded.

POSITIONS OPEN

CHIEF TELEPHONE ENGINEER, well up in British P. O. circuits, manual boards and instruments for large firm of telephone manufacturers in England who are developing this side of their business. State age, salary required and when free. Headquarters. London. R-5124.

ENGINEER, with excellent technical training and interested in engineering work with insulation and processes. Some chemical training desirable. Young man preferred though previous experience will be of value. Apply by letter stating training, age and salary expected. R-5595.

MEN AVAILABLE

TECHNICAL GRADUATE of electrical engineering course from reputable college. Experience on General Electric Company Test Course. Age 23, single. Employed at present. Southern location preferred with reputable concern. Available after July 1, 1925. B-9308.

RESEARCH ENGINEER, electrical and mechanical, age 36. Twelve years' experience. Important accomplishments. B-208.

GRADUATE ELECTRICAL AND MECHANICAL ENGINEER, age 33, married. Protestant. Broad experience of twelve years, comprising five years steel mill production and maintenance, two years U. S. Navy, two years anthracite coal industry, two years power plant construction, one year valuation of public utilities. Desires permanent position assuring permanent residence with steel mill or public utility. B-8935.

ASSISTANT PROFESSOR OF ELECTRICAL ENGINEERING in prominent middle western university desires opportunity for more responsible duties. Twelve years' teaching experience and three years' practical experience to form good foundation in both theory and practice. Will consider teaching position where high standards of scholarship are maintained, or engineering position dealing with electrical problems. B-9318.

ELECTRICAL-MECHANICAL ENGINEER, wide experience in the design, installation and rehabilitation of industrial plants, seeks a suitable connection as chief engineer, superintendent of plants, chief electrician, master mechanic, on actual work or in a consulting capacity. Could devote entire or part of his time. Will take financial interest if desirable. B-8327.

ELECTRICAL ENGINEER, technical graduate, age 26, desires responsible position with growing electrical concern, production, installation or radio development. Experienced in motor work, installation, wiring storage batteries. One with opportunities for advancement desired. Available middle of April 1925. Location, New York City or New Jersey. B-9353.

GRADUATE E. E., with about four years testing, design of power plants, substations, industrial buildings, and switchboard engineering experience. Desires transfer with the object of bettering and advancing in the field. Available on reasonable notice. Location, preferably New York or vicinity. B-8852.

GRADUATE ENGINEER, B. S. E. E., 27, wishes position with public utility corporation in middlewest. Two years' experience as field engineer in distribution engineering department of large western public utility corporation, and over a year's experience as engineer for the construction department of the same organization. Can furnish best of references. Available on a week's notice. B-9354.

ELECTRICAL ENGINEER, college graduate, 30, ten years' experience light and power utilities, design of electrical apparatus and salesmanship, two years G. E. test. Speaks English, Spanish and French fluently, knows continental business methods and American practices, is seeking position as salesman with available electrical firm for Central and South America. B-9367.

ASSISTANT TO CHIEF EXECUTIVE of a large electric utility company desires change. Capable of assuming responsibilities and getting results in engineering and operating problems. Graduate E. E. with eleven years' experience in consulting and utility work. Age 34, married, excellent health, minimum salary \$5000. B-754.

ILLUMINATING ENGINEER, technical graduate, five years' experience in commercial and industrial lighting practice and design. Thoroughly familiar with the latest developments in illumination. More than one year's experience in sales promotion. Desires connection with a public service corporation or well established firm. Available on reasonable notice. Middle-west or Northwest preferred. B-9377.

CHIEF ELECTRICIAN AND ELECTRICAL SUPERINTENDENT, desires a position with industrial concern or public utility. Age 26, married, technical education. Three years General Electric test, foreman of a testing department, three years electrical superintendent and resident engineer of a large paper mill supervising hydro-electric operation, maintenance and construction. Available at once. Eastern states preferred. Salary \$2400. B-9390.

GRADUATE ELECTRICAL ENGINEER with two years' experience in design and research with large engineering corporation, one year teaching in technical school and knowledge of three foreign languages and one foreign country. Desires position with manufacturing concern engaged in either domestic or foreign trade. Available on short notice. B-7830.

INDUSTRIAL AND MECHANICAL ENGINEER, experienced in factory layout, processing, maintenance, costs, organization, development of new products, research engineering and industrial relations. Desires new permanent connection where energy and ability count, in either industrial or educational field.

Age 41, married. Available two weeks or less. B-4137.

ELECTRICAL ENGINEER, technical graduate, experienced in mechanical and electrical design of single-phase, polyphase and direct current motors, desires position with firm manufacturing motors. Broad experience in experimental and development work. Available on reasonable notice. Age 35, married B-9395 V. P. Sparks).

MECHANICAL OR INDUSTRIAL ENGINEER, 41, married, two years factory layout, equipment, maintenance; one, engineering research and development new products. Two years industrial relations. Head mechanical engineering state university, also head department another prominent institution. Organizational and administrative experience in industry. Available in one week. Location, preferably East. B-4137.

DISTRIBUTION AND TRANSMISSION ENGINEER, graduate E. E., age 25, four years design, calculation and construction of high and low voltage lines. Desires connection in the East. B-9401.

ELECTRICAL CONSTRUCTION FOREMAN, ten years' experience, age 38, married, desires position with public utility or construction company. Experience in power plants, transformer stations, substations and Westinghouse test floor. B-7514.

GRADUATE ENGINEER, five years' experience in the estimating, construction and maintenance of transmission and distribution systems of a public utility. Desires a position with a company offering opportunities for advancement. Present position, assistant field engineer. Location immaterial. Available fifteen days' notice. B-9408.

ELECTRICAL ENGINEER, fourteen years' experience design, construction and operation; valuation and rates; last five years with public utility company as manager and engineer, desires to change. Speaks German fluently. Age 39, married. Location preferred, West or Middlewest. B-9409.

GRADUATE ELECTRICAL AND MECHANICAL ENGINEER, age 32, married, ten years of experience in design and manufacture of electrical apparatus and specialties. Good theoretical and practical knowledge of high tension electrical engineering. Executive and administrative ability, desires to connect with a concern located in New York or New England states. B-9406.

ELECTRICAL ENGINEER, M. I. T. 1924, age 22, single. Desires position in the electrical engineering field with prospects of experience and advancement. Location dependent upon opportunity. Varied experience in railway, substation, construction and meter work. Available on two weeks' notice. B-8503.

INSTRUCTOR IN PHYSICS, single, 26, B. S. E. E., seven years' experience teaching college physics prominent Eastern schools. Capable organizing, planning, managing courses

involving lecture, laboratory, quiz. Have done considerable graduate study, some research. M. A. June. Wish instructorship large school offering good opportunity for advanced research leading to Ph. D. Available September. Location not material. B-7644.

ELECTRICAL ENGINEER, married, 29, B. S. in Eng. 1921. Experienced power house construction and maintenance, high tension substation construction and maintenance, mine electrical installations and inspections. Present employed as division distribution engineer by large public utility. Desires position distribution engineer with public utility or consulting engineers. Would also consider construction work. B-7047.

ELECTRICAL ENGINEER, university graduate, age 35, married, no children. Broad experience in installation, operation and maintenance of electrical and mechanical equipment in coal and metal mining and industrial plants, also experienced in power houses, high voltage transmission, substations and distribution. Desires responsible position in charge of such work. Would consider position abroad. B-9113.

ASSISTANT EXECUTIVE technical graduate, 33, married, desires connection with progressive company in commercial capacity, or industrial engineering firm. Work has covered manufacturing, time studies, plant layout, distribution systems, costs, sales, advertising and statistical studies of expenses, revenues and other administrative problems. Location, New York, New England. Available reasonable notice. B-9122.

MANUFACTURING EXECUTIVE, 35, married graduate of M. I. T. in chemical engineering. Has wide experience in manufacturing development and financial work. Familiar with acid, alkali, coal tar, dyestuff and typographical industries. Experienced in operation, production and research work and modern accounting and control systems. Prefers New York City or New Jersey. B-9421.

ELECTRICIAN, six years' experience in electrical construction and maintenance. Technical education. At present an electrical contractor, but desires change. Location, Chicago. B-7513.

ELECTRICAL ENGINEERING GRADUATE, age 27, having had experience in testing, electrical transmission, distribution and maintenance. At present connected with large public utility in middlewest. Desires responsible position with public utility or manufacturing company. Available on ten days' notice. B-9414.

ELECTRICAL ENGINEER, experienced in design, manufacture, and testing of rubber, paper and varnished cambric transmission and distribution cable. Desires a position with either a cable manufacturer or firm of high standing consulting engineers. Available on two weeks' notice. Locate anywhere. B-9120.

ELECTRICAL ENGINEER, seven years' experience on generating and substation design, desires connection with public utility, engineering

or construction company. Age 27, married; available one week, salary \$3000. B-9423.

ELECTRICAL ENGINEER, 38, graduate Northwestern college, B. S. and E. E. degrees. Broad experience testing, design, installation, layout, specification; supervision buildings, industrial installations for light, power and signal systems. Five years present executive position paying \$4500 large Detroit firm. Desires electrical position with responsible firm in Northwest. Available thirty days' notice. B-9422.

MECHANICAL AND ELECTRICAL ENGINEER with twenty years' experience in the design, erection and operation of the mechanical and electrical equipments used about coal mines. A good executive, can handle men and can cooperate with others. Excellent experience in power plant management. B-5088.

DESIGNING ENGINEER, B. S. E. E. 1923, experienced in electrical contracting, estimating and designing of electrical work for light and power in large buildings. Location immaterial. Minimum salary \$2400 in the United States, \$3600 foreign. B-9433.

ELECTRICAL ENGINEER, B. S. M. E. and E. E. 1916, 29, excellent physique. Nine years' experience in design and application electric generating plant and substation machines, also auxiliaries. Desires position with consulting engineer, construction company, power company, where there is need for man with engineering and executive ability. Present salary \$3600. Available reasonable notice. B-9432.

ENGINEER-EXECUTIVE, electrical, industrial or constructional; B. S. degree E. E. 1915, 32, married. Experience; two years' graduate apprentice work Westinghouse Electric and Manufacturing Company, two years officer U. S. Army, five years plant engineer covering time study, rate setting, efficiency and production work, one year substation construction work. Employed, available reasonable notice. B-9436.

RECENT GRADUATE in electrical engineering from a well known university, desires a position abroad in either India, Cuba, West Indies or South America. Age 24, single. Would prefer a position either in operation or transmission. B-9434.

ASSISTANT ENGINEER, 32, married, engineering graduate of Eastern university. Eight years' experience as electrical inspector, draftsman, chief electrical draftsman, junior engineer and assistant consulting engineer. Prefers permanent position as assistant engineer along consulting lines or in a medium sized plant. Available at once. Location, East or Middlewest. B 6552.

RESEARCH ENGINEER, 44, married, electrical electrochemical engineer, competent carry on research design patent work. Wide recent experience along these lines. Accustomed control working staff. Also power plant and transmission line design, college and extensive practical experience over period of years. Available at short notice. Location, Canada or United States. B-9279.

MEMBERSHIP — Applications, Elections, Transfers, Etc.

ASSOCIATES ELECTED FEBRUARY 10, 1925

- *ADAMS, CARLTON FITCH, Student, University of Washington, 3714 University Way, Seattle, Wash.
- *ALBACH, HENRY JOHN, Night Chief Operator, Western Union Telegraph Co., Butte, Mont.
- ALBAUGH, ARTHUR, Technical Assistant to Electrical Engineer, Consolidated Gas, Electric Light & Power Co., Baltimore; res., Hamilton, Md.
- *ALGER, PRENTISS B., Construction Inspector, Boston Edison Laboratory, Mass. Ave., Boston; res., Brookline, Mass.

- *AMES, WALTER C., Jr., Asst., Dept. of Elec. Engg. Massachusetts Institute of Technology, Cambridge, Mass.; for mail, Smithfield, Va.
- *ANDERSON, DAN, Electrical Engineer, H. S. Taylor, 285 Beaver Hall Hill, Montreal, Que., Can.
- *ANDRICH, JOHN, Surveyor, United States Reclamation Service, Pilot, Wyo.
- *APPLEBY, HARRY ADDISON, Chief Draftsman, Signal Engineer's Office, Atchison, Topeka & Santa Fe Ry., La Junta, Colo.

- *ATTERLING, KARL GUSTAF, Draftsman, Trans. Dept., Westinghouse Elec. & Mfg. Co., East Pittsburgh; res., Willinsburg, Pa.
- AVERY, SIDNEY HYDE, Railway Commercial Dept., General Electric Co., Schenectady, N. Y.
- BACH, LOUIS, Draftsman, 312 E. 8th St., New York, N. Y.
- *BAIR, RALPH SHERMAN, Electrical Engineer, Western Electric Co., Inc., 463 West St., New York, N. Y.
- BAKER, IRVIN T., Electrical Designer, Consolidated Gas, Electric Light & Power Co., Baltimore, Md.

- *BALDWIN, MORRIS JUDSON, Testing Dept., General Electric Co., Schenectady, N. Y.; for mail, Pittsfield, Mass.
- BARDSLEY, CHARLES E., Electrical Contractor, Bardsley-Riley Electric Co., Newport, R. I.
- *BARRELL, ROBERT WEBB, JR., Mine Locomotive Engg. Dept., General Electric Co., Erie, Pa.
- BARROWS, KENNETH CAMPBELL, New Business Manager, Midwest Power Co., Devils Lake, N. D.
- BARTELS, DUDLEY, District Engineer, Canadian General Electric Co., 1065 Pender St., Vancouver, B. C., Can.
- BAUER, JOHN A., Planning & Estimating Engineer, Western Electric Co., Inc., 268 W. 36th St., New York, N. Y.
- BECKERT, ELMER HENRY, Asst. Designing Engineer, Switchboard Dept., General Electric Co., Schenectady, N. Y.
- *BELFREY, RALPH SHERMAN, Instructor on Relays & Switches, Northern Electric Co., Ltd., 131 Simcoe St., Toronto, Ont., Can.
- BELLINGER, FRED WARNER, Electrical Superintendent, Butte, Anaconda & Pacific Ry. Co., Anaconda, Mont.
- *BEMENT, DAVID LESLIE, Asst. Superintendent, Northern Indiana Gas & Electric Co., 571 Hohman St., Hammond, Ind.
- *BENNETT, LORNE McDOUGAL, Cost Engineer, The Cleveland Railway Co., 700 Hanna Bldg., Cleveland; res., Lakewood, Ohio.
- *BENSON, WILFRED RAYMOND, Field Engineer, Bell Telephone Co. of Canada, Toronto, Ont., Can.
- BENTLEY, WILLIAM HEATHCOTE, Asst. Engineer, Dept. of Telephones, Regina, Sask., Can.
- BERGSTRASER, ELMER JEROME, Asst. Electrical Engineer, Murrie & Co., New York; res., Jamaica, N. Y.
- *BETTS, PHILANDER HAMMER, Engineer, Western Electric Co., Inc., 463 West St., New York, N. Y.
- *BJORNSSON, BJORN GUTMUNDSSON, Asst. Engineer, Western Electric Co., Inc., 463 West St., New York; res., Brooklyn, N. Y.
- *BLONQUIST, HAROLD ROBERT, Electrical Designer, Stone & Webster, Inc., 147 Milk St., Boston, Mass.
- *BOORUJY, GEORGE, Electrical Contractor, 10 Lafayette Ave., Summit, N. J.
- *BOROKHOVICH, JOHN A., Elec. Construction Inspector, Brooklyn Edison Co., Pearl & Willoughby Sts., Brooklyn; res., New Brighton, S. I., N. Y.
- *BOSSERT, JOHN L., Electrical Designer, Stevens & Wood, 120 Broadway, New York; res., Brooklyn, N. Y.
- BOUNCE, PAUL REVERE, Electrical Designing Engineer, Westinghouse Elec. & Mfg. Co., Sharon, Pa.
- *BOWKER, EDGAR I., Milwaukee Electric Railway & Light Co., 210 Public Service Bldg., Milwaukee, Wis.
- BRIEFS, CURT, Designing Engineer, Electric Bond & Share Co., 71 Broadway, New York, N. Y.; res., Jersey City, N. J.
- BRONSON, GEORGE ALLEN, Electrician, General Electric Co., Erie, Pa.
- BROWN, BERNT NICOLAI, Electric Testing, Electrical Testing Laboratories, 540 E. 80th St., New York; res., Brooklyn, N. Y.
- BROWN, HENRY JAMES, Head of Section, Testing Dept., General Electric Co., Schenectady, N. Y.
- BROWN, HERBERT DUNHAM, Electrical Engineer, General Electric Co., Schenectady, N. Y.
- BROWN, RAYMOND LESTER, Sales Engineer, The New Departure Mfg. Co., Bristol, Conn.
- *BROWN, ROY JAMES, Demonstrator in Electrical Engineering, University of Toronto, Elec. Bldg., Toronto; for mail, Acton, Ont., Can.
- *BROWNELL, HAROLD SPENCER, Elec. Estimate Man, Engg. Dept., Birmingham Electric Co., 2100 North 1st Ave., Birmingham, Ala.
- BRUN, OSCAR, JR., Motor Testing, Century Electric Mfg. Co., St. Louis, Mo.
- *BRUNS, WILLIAM H., Asst. to Test Engineer, Otis Elevator Co., Yonkers; res., New York, N. Y.
- BUECHE, HARRY STEPHEN, Station Tester, Brooklyn Edison Co., 14 Rockwell Place, Brooklyn, N. Y.
- *BURLINGAME, ROBERT ELMORE, Student, Elec. Engg. Dept., University of Minnesota, Minneapolis, Minn.
- *BUTTERWORTH, PERCY TAYLOR, Trouble Dispatcher, Edison Electric Illuminating Co. of Boston, 39 Boylston St., Boston, Mass.
- CAMPKIN, WILBERT LEE, Head Switchman, Regina Auto. Exchange Saskatchewan Government Telephones, Cor. Lorne & 12th, Regina, Sask., Can.
- CAREY, EDWARD F., Electrical Construction Foreman, Dwight P. Robinson Co., Inc., 3722 Fifth Ave., Pittsburgh, Pa.
- CAREY, JASON C., Engineer, Distribution Dept., Southern California Edison Co., 306 W. 3rd St., Los Angeles, Calif.
- *CARL, WELLINGTON C., Electrical Engineer, Westinghouse Elec. & Mfg. Co., East Pittsburgh; res., Wilkesburg, Pa.
- CASKEY, JOSEPH FORREST, Supt. of Telegraph, Lehigh Valley Railroad, Bethlehem, Pa.
- *CAVERLEY, LOYST CERYL, Asst. in Elec. Engg., Massachusetts Institute of Technology, Cambridge, Mass.
- *CHATHAM, CLYDE LARZELERE, Engineer, Public Service Electric & Gas Co., Prospect & Van Houten Sts., Paterson, N. J.
- *CHILBERG, ELMER N., Switchboard Engg. Dept., General Electric Co., Schenectady, N. Y.
- *CHOLICK, JOHN GEORGE, Student, Oregon Institute of Technology, Portland, Ore.
- CHRISTOPHER, PERCY CHARLES, Shop Foreman, General Electric Co. Service Shop, 1508 4th Ave., So., Seattle, Wash.
- *CLARK, LEMORE WILDER, General Engineer, Westinghouse Elec. & Mfg. Co., East Pittsburgh; res., Pittsburgh, Pa.
- CLARKE, RICHARD JOSEPH, Electrical Engineer & Contractor, 17 Gt. Brunswick St., Dublin, Ireland.
- *CLEARY, JOHN VINCENT, Substation Operator, Third Avenue Railway Co. of New York, 175th St. & Southern Blvd., Bronx, New York, N. Y.
- *CLEMENT, NEAL F., Draftsman, Cleveland Union Terminals Co., Ulmer Bldg., Cleveland, Ohio.
- *CLEVELAND, HARRY ROLAND, JR., Student, Danville, Que., Can.
- *CODY, MARTIN F., JR., Asst. Electrical Engineer, Board of Education, Flatbush Ave. & Concord St., Brooklyn; res., Elmhurst, N. Y.
- *COE, SIMEON M., JR., Manager, Emergency Engineering Co., Sterling, Ill.
- *COLEMAN, JOHN B., Engineer in Charge, Radio Station WBZ, Springfield, Mass.
- *COLYER, HOLLIS J., Engineer, Michigan Bell Telephone Co., 1365 Cass Ave., Detroit, Mich.
- *CONE, JAMES HOLWAY, Field Engineer, Distribution Engg. Dept., West Penn Power Co., 18 Wood St., Pittsburgh; res., Wilkesburg, Pa.
- CONWAY, CHARLES WESLEY, Student, Purdue University, West Lafayette, Ind.
- *CONNER, GEORGE W., JR., Salesman, Pomeroy's Inc., Reading, Pa.
- *CONNON, WILLIAM DEWEY, Engineering Assistant, Bell Telephone Co. of Penna., 261 N. Broad St., Philadelphia, Pa.
- COOK, JOHN E., Asst. Switchboard Operator, Northeast Power House, Kansas City Power & Light Co., Kansas City; res., Independence, Mo.
- *CORRADO, ANTHONY, 5613 Church Court, Chicago, Ill.
- *COSTENOBLE, ERICH H., Substation Operator, Philadelphia Electric Co., Germantown & Moreland Aves., Philadelphia, Pa.
- *COX, JOSEPH HERBERT, Engineer, P. I. & T. Engg. Dept., Westinghouse Elec. & Mfg. Co., East Pittsburgh, Pa.
- COX, WALTER RONALD, Senior Switchgear Draughtsman, General Electric Co., Ltd., Witton, Birmingham; for mail, London, W. C. 2, England.
- *CRAGO, ALAN C., Research Engineer, Westinghouse Elec. & Mfg. Co., East Pittsburgh; res., Wilkesburg, Pa.
- *CRAVENS, RUSSELL C., Test Engineer, Indiana Service Corp., Spy Run Power Plant, Fort Wayne, Ind.
- *CRIVY, ALFRED, Electrical Draftsman, City of New York, Municipal Bldg., New York, N. Y.
- CROFUT, WILLIAM, Inspector, Elec. Engg. Dept., Brooklyn Edison Co., 561 Grand Ave., Brooklyn, N. Y.
- *DAHL, HAROLD WILLIAM, Electrical Engineer, Electric Machine Mfg. Co., 14th & Tyler St., N. E., Minneapolis, Minn.
- DANI, ANTHONY, Asst. Engineer, American Tel. & Tel. Co., 24 Walker St., New York, N. Y.
- DANIA, GEORGE, Draftsman, Electrical Dept., New York Central Railroad, 466 Lexington Ave., New York, N. Y.
- DAVENPORT, THOMAS LELAND, Foreman, Elec. Construction Dept., Union Gas & Electric Co., 1107 Plum St., Cincinnati, Ohio.
- *DAVIDSON, JOSEPH, Junior Asst. Engineer with State Engineer, Albany; res., Hoosick Falls, N. Y.
- DAVOLIO, UMBERTO, Electrical Draftsman & Estimator, Thompson-Starrett Co., New York, N. Y.
- *DAY, HOWARD BLOODGOOD, Engineer, Sales Dept., The Holtzer-Cabot Electric Co., 101 Park Ave., New York, N. Y.; res., Westfield, N. J.
- DENNIS, OLIVER HENRY, Central Office Installer, Southwestern Bell Telephone Co., Kinloch Bldg., 10th & Locust Sts., St. Louis, Mo.
- DETLOR, WILLIAM KENNETH, Telephone Engineer, Bell Telephone Co. of Canada, 118 Notre Dame St., West, Montreal, Que., Can.
- *DE TURK, ELI R. S., Test Work, Westinghouse Elec. & Mfg. Co., 818 South Ave., East Pittsburgh; res., Wilkesburg, Pa.
- DEVLIN, ROBERT VINCENT, Engineer, Mine Locomotive Dept., General Electric Co., Erie, Pa.
- DHIR, RUP CHAND, Student, University of Wisconsin, 25 S. Randall St., Madison, Wis.
- *DIEFENBACH, LOWELL TOMAN, Testing Engineer, Commonwealth Edison Co., 28 N. Market St., Chicago, Ill.
- *DIEHM, CHARLES, Substation Battery Construction, Electric Storage Battery Co., 19th & Allegheny Ave., Philadelphia, Pa.
- *DOMINGUES, LOUIS, Student Engineer, General Electric Co., Schenectady, N. Y.; res., Pittsfield, Mass.
- *DORMER, WILLIAM JOHN SMYLLIE, Engineer, Bell Telephone Co. of Canada, 47 Ontario St., W., Montreal; for mail, Verdun, Que., Can.
- *DRAZEN, ALEAZAR MICHAEL, 5123 Raymond Ave., St. Louis, Mo.
- DUNHAM, FRANCIS EDWARD, Electrical Engineer, Central Station Engg. Dept., General Electric Co., Schenectady, N. Y.
- *DUTTON, WATSON POTTER, Student Radio Engineer, General Electric Co., Radio Test, Schenectady, N. Y.

- *EACKER, EARL H., Asst. Superintendent, Charlestown Gas & Electric Co., 27 Main St., Charlestown; res., Brookline, Mass.
- ECKEL, CARL H., Student Engineer, Testing Dept., General Electric Co., Schenectady, N. Y.
- *EDE, FRANK CEEYIN, Experimental Tester, Standardizing Laboratory, General Electric Co., West Lynn; for mail, Boston, Mass.
- EINHART, HARVEY, Turbine Testing Dept., General Electric Co., Schenectady, N. Y.
- *EITMAN, JOSEPH FREDERICK, Designing Engineer, Transformer Engg. Dept., General Electric Co., Fort Wayne, Ind.
- *ELDER, CLAYTON THOMAS, Illuminating Engineer, Cleveland Electric Illuminating Co., Illuminating Bldg., Cleveland, Ohio.
- ELLIS, F. C., Research Engineer, 420 Wrigley Bldg., Chicago, Ill.
- *ELLIS, WALTER RAYMOND, Engineer, Westinghouse Elec. & Mfg. Co., East Pittsburgh; res., Wilkensburg, Pa.
- *ELMORE, PITTS, Student, Elec. Engg. Dept., Oregon Agricultural College, 427 S. 5th St., Corvallis, Ore.
- *ENNIS, FREDERICK JOHN, Sales Correspondent, A. J. Reed, 2401 Chestnut St., Philadelphia, Pa.; res., Palmyra, N. J.
- FAIKE, JOHN A., Electrical Engineer, Westinghouse Elec. & Mfg. Co., 3rd & Elm Sts., Cincinnati; res., Norwood, Ohio.
- *FALLON, GLOVER PATTERSON, Technical Assistant Engineer, Consolidated Gas, Electric Light & Power Co., Monument & Constitution Sts., Baltimore; res., Roland Park, Md.
- *FELLER, JOHN EDWARD, Tester, New York Edison Co., 667, 1st Ave., New York, N. Y.; res., Springfield, Ohio.
- *FIELD, RUSSELL MORSE, Engineer, Elec. Engg. Dept., Worcester Polytechnic Institute, Worcester, Mass.
- *FINDLEY, RUSSELL LYND, Designing Engineer, Power Engg. Dept., Westinghouse Elec. & Mfg. Co., East Pittsburgh; res., Wilkensburg, Pa.
- FISHER, LEANDER WINSOR, Draftsman, Engg. Dept., Public Service Co. of Northern Illinois, Evanston, Ill.
- FLEMING, HENRY F., Designer, Philadelphia Electric Co., 1000 Chestnut St., Philadelphia, Pa.
- *FLETCHER, LOUIS DUBOIS, JR., Asst. Examiner, United States Patent Office, Div. 2, Washington, D. C.
- *FORNEY, CHARLES DAVID, Tester, United Electric Light & Power Co., 514 W. 147th St., New York, N. Y.
- *FOSTER, DUDLEY EDWARDS, Electrical Engineer, Electrical Alloy Co., Morristown, N. J.
- FOSTER, HUBERT F., District Engineer, Consumers Power Co., 129-131 Pearl St., Grand Rapids, Mich.
- *FRAZIER, RICHARD HENRY, Electrical Engineer, Railway & Industrial Engineering Co., Greensburg, Pa.
- *FREEMAN, AARON, Plant Instructor, Chesapeake & Potomac Telephone Co., 3913 Kate Ave., Baltimore, Md.
- FREEMAN, CARL E., Superintendent, Power House, York Haven Water & Power Co., York Haven, Pa.
- *FRENCH, GEORGE BRADLEY, Salesman, Landers, Frary & Clark of New Britain, 266 Pearl St., Hartford, Conn.
- FREERICKS, BERNARD, JR., Supervisor, Freed-Eiseman Radio Corp., Sperry Bldg., Brooklyn; res., New York, N. Y.
- *FREY, ARTHUR PAGE, Automatic Substation Inspector, United Railways & Electric Co., 908 Continental Bldg., Baltimore, Md.
- FRIEDMANN, LOUIS, Electrical Engineer, The New York Edison Co., Waterside Station, 1st Ave. & 40th St., New York, N. Y.
- FUDGE, LAWRENCE, Engg. Dept., General Electric Co., 609 Colman Bldg., Seattle, Wash.
- *FULLER, HUBER E., Tester, Duquesne Light Co., 2101 Beaver Ave., Pittsburgh; res., Bellevue, Pa.
- *GAFFORD, BURNS NEWMAN, Instructor, Elec. Engg. Dept., University of Texas, Austin, Texas.
- *GAJE, RALPH ELLIOT, Designer, Idaho Power Co., Boise, Idaho.
- *GALLAGER, JACOB BOON, Engineer in training, Philadelphia Electric Co., Chester; res., Glenolden, Pa.
- *GARRETT, RUSSELL A., Hydraulic Maintenance Engineer, Consumers Power Co., 244 W. Michigan Ave., Jackson, Mich.
- *GARVER, HARRY LEE, Requisition Engineer, General Electric Co., 211 Seward Place, Schenectady, N. Y.
- *GATES, HENRY STILLMAN, Electrical Engineer, Westinghouse Elec. & Mfg. Co., Sharon, Pa.
- GEGOU, PAUL HENRY, Cable Electrician, New York Station, French Cable Co., 25 Broad St., New York, N. Y.
- *GEIGER, DOUGLAS GEORGE, Telephone Electric Engineer, Bell Telephone Co. of Canada, 118 Notre Dame St., W., Montreal, Que., Can.
- GERATY, GEORGE C., JR., Electrical Engineer, Electrical Contracting Co., 844 Rush St., Chicago, Ill.
- GILBERT, RALPH HALLETT, Asst. Engineer, New York Telephone Co., 104 Broad St., New York, N. Y.
- *GILKESON, CHARLES L., Technical Assistant, Trans. & Distr. Dept., The Philadelphia Electric Co., 2301 Market St., Philadelphia, Pa.
- GILMARTIN, THOMAS V., First Grade Tester, New York & Queens Elec. Lt. & Pr. Co., Lawrence & Amity Sts., Flushing; res., Elmhurst, N. Y.
- *GOLDSMITH, HARRY WOLFE, Quotation Division, General Electric Co., 1321 Walnut St., Philadelphia, Pa.
- *GOODENOW, REGINALD MARTIN, Electrical Designer, Stackpole Carbon Co., St. Marys, Pa.
- *GOUGHNOUR, WARD CABLE, Field Engineer, General Electric Co., Pittsfield, Mass.
- *GRANDY, LEWIS STEPHEN, Instructor, Elec. Engg. Dept., Dunham Laboratory, Yale University, New Haven, Conn.
- GRANT, ARTHUR GORDON, Wire Chief, Moose Jaw Exchange, Dept. of Telephones, Moose Jaw, Sask., Can.
- *GRAVES, HERBERT PATRICK, Engineer, Bell Telephone Co. of Penna., 416 7th Ave., Pittsburgh, Pa.
- *GRAY, PAUL MILTON, Instructor, Elec. Engg. Dept., University of North Carolina, Chapel Hill, N. C.
- *GREENE, HARRY ASHLAND, JR., Consulting Radio Engineer, 313 Lighthouse Ave., Monterey, Calif.
- GRIESEMER, OLIN ALFRED, Electrical Engineer, Lehigh Portland Cement Co., Coplay, Ormrod, Pa.
- *GRIMSHAW, HERBERT REGINALD, Operating Engineer, Tennessee Electric Power Co., Cleveland, Tenn.
- *GROEGER, ROSCOE CHARLES, Electrical Engineer, Northwestern Electric Co., 408 S. Hoyne Ave., Chicago, Ill.
- *GROSSER, GEORGE ELWOOD, Switchboard Engineer, Automatic Sec., Westinghouse Elec. & Mfg. Co., East Pittsburgh; res., Wilkensburg, Pa.
- GUIDA, THOS. JOHN, Asst. Electrical Engineer, Union Carbide & Carbon Research Laboratory, Thompson Ave. & Manley St., Long Island City; res., Corona, N. Y.
- HAEDLER, HANS, Chief Engineer, Best Foods Inc., 1900 Bryant St., San Francisco, Calif.
- *HAGGERTY, JOHN J., Contractor, 634 N. Lincoln Ave., Scranton, Pa.
- HAMILL, JOHN WALTER, Construction Engineer, The Dingle Clark Co., 435 Engineers Bldg., Cleveland, Ohio.
- HANSON, FREDERICK E., Methods Engineer, Western Electric Co., Inc., 268 W. 36th St., New York; res., Brooklyn, N. Y.
- *HARDCASTLE, EDWARD, Engineer's Assistant, United Electric Light & Power Co., New York, N. Y.
- HARDSOG, HARRY NEWTON, Student, School of Electrical Engineering, Purdue University, West Lafayette, Ind.
- *HARRIS, LEO KERN, Testing Dept., General Electric Co., Schenectady, N. Y.
- *HARTMAN, HOWARD WILLIAM, Apparatus Layout, Research Lab., General Electric Co., Schenectady, N. Y.
- *HAWKINS, RALPH MEREDITH, Student in Electrical Engineering, University of Toronto, Toronto, Ont., Can.
- HEALY, WILLIAM LEWIS, Electrical Engineer, H. L. Cooper & Co., U. S. Engineer Office, Wilson Dam, Florence, Ala.
- HEATH, EDWARD BEAUMONT, Test Man, General Electric Co., Schenectady; res., Scotia, N. Y.
- HEFLIN, NEAL MINTER, Statistician, Monongahela West Penn Public Service Co., 503 Bethlehem Bldg., Fairmont, W. Va.
- HERLIHY, JOHN A., Asst. Superintendent, Supply Dept., Edison Electric Illuminating Co. of Boston, 39 Boylston St., Boston, Mass.
- HESS, WILLIAM TALMAN, Engineer, Underground Dist., New Orleans Public Service, Inc., 1804 Tchoupitoulas St., New Orleans, La.
- *HICKERNELL, LATIMER FARRINGTON, Asst. Investigation Engineer, Elec. Engg. Dept., Commonwealth Power Corp., Jackson, Mich.
- *HIRSCHEL, LESLIE, Electrical Tester, Williamsburg Power Plant Corp., 500 Kent Ave., Brooklyn; res., Woodhaven, N. Y.
- *HOFF, CARL JOHAN REINHARDT, Draftsman, Edison Illuminating Co. of Boston, 39 Boylston St., Boston, Mass.
- *HOMAN, CHARLES WILLIAM, Electrical Inspector, Brooklyn Edison Co., Inc., 561 Grand Ave., Brooklyn, N. Y.
- HOOPER, ROSCOE, Supt. of Telegraph, The Kansas City Southern Railway Co., 11th & Wyandotte Sts., Kansas City, Mo.
- HORNE, JAMES, Electrician, Construction Dept., New York Edison Co., Irving Place & 15th St., New York, N. Y.
- *HOUGH, EUGENE LAWRENCE, Designing Engineer, Switchboard Dept., General Electric Co., Schenectady, N. Y.
- *HOUSER, KENNETH O., Transformer Sales Engineer, General Electric Co., Pittsfield, Mass.
- *HOWE, GLENN ELLIOTT, Testing Dept., Southern California Edison Co., Alhambra; res., Los Angeles, Calif.
- HOWES, FREDERICK STANLEY, Junior Demonstrator, Elec. Laboratory, McGill University, Engg. Bldg., Montreal, Que., Can.
- *HUBBARD, FRANK AARON, Radio Research Engineer, Western Electric Co., Inc., 463 West St., New York, N. Y.
- *HUDACK, JOHN MARTIN, Electrical Engineer, Western Electric Co., Inc., 463 West St., New York, N. Y.
- HUDSON, HUBERT LESLIE, Chief Clerk, Service Shop, General Electric Co., 1508, 4th Ave., South, Seattle, Wash.
- *HUGHES, EDGAR TEMPLE, Material Engineer, Phoenix Utility Co., Hazleton, Pa.
- *HUNT, ORVILLE DON, Instructor, Elec. Engg. Dept., Kansas State Agricultural College, Manhattan, Kans.
- *ILGENFRTZ, PAUL, Draftsman, Southern California Edison Co., 2nd & Boylston Sts., Los Angeles; for mail, Pomona, Calif.

- *IMBURGIA, CHARLES, Asst. Elec. Engineer, American Gas & Electric Co., 30 Church St., New York; res., Brooklyn, N. Y.
- *ISRAEL, DORMAN D., Radio Engineer, Clearstone Radio Co., McMillan Ave. & Essex Place, Cincinnati, Ohio.
- *JACKSON, RUSSELL R., Traffic Engineer, Ohio Bell Telephone Co., 76 South High St., Akron, Ohio.
- *JARVIS, KENNETH WARNER, Radio Engineer, Crosley Radio Corp., Cincinnati, Ohio.
- *JOHNS, FRANCIS J., Westinghouse Elec. & Mfg. Co., East Pittsburgh; res., Wilkesburg, Pa.
- JOHNSON, ALBERT L., General Manager Mineralac Electric Co., 1045 Washington Blvd., Chicago, Ill.
- JOHNSON, ERLAND, Draftsman, Allis-Chalmers Mfg. Co., West Allis; res., Milwaukee, Wis.
- *JOHNSON, GEORGE HERBERT, Engineer, The Pacific Tel. & Tel. Co., 421 Sheldon Bldg., San Francisco; for mail, Berkeley, Calif.
- *JOHNSTON, ANDREW MOREY, Draftsman, The Steel Co. of Canada, Ltd., Hamilton, Ont., Can.
- *JONES, EVAN R., Instructor in Engineering Physics, University of Colorado, Boulder; res., Englewood, Colo.
- JONES, J. W., Manufacturers Agent, Weston Electrical Instrument Co., 611 Granite Bldg., St. Louis, Mo.
- JONES, TOM B., Sales Engineer, Century Electric Co., 1827 Pine St., St. Louis, Mo.
- JOY, JOHN M., Test Engineer, Connecticut Light & Power Co., 111 W. Main St., Waterbury, Conn.
- JUERGENS, WALTER A., Salesman, Reliance Electric & Engineering Co., 622 Union Central Bldg., Cincinnati, Ohio.
- *KAHN, FRANK, Research & Investigation, Philadelphia Electric Co., 2301 Market St., Philadelphia, Pa.
- KALEM, JOHN CHRYSOSTOM, Appraisal Engineer, Murrie Co., Inc., 45 E. 17th St., New York, N. Y.
- *KAMM, J. LLOYD, Engineering Dept., National Lamp Works of General Electric Co., Nela Park, Cleveland; res., East Cleveland, Ohio.
- *KATZMAN, JACOB, Electrical Testing, Dubilier Condenser & Radio Corp., 48 W. 4th St., New York, N. Y.
- *KEELY, CLIFFORD D., Sales & Service Representative, Westinghouse Union Battery Co., 109 W. 64th St., North Bergen, N. J.
- *KEENE, ELMER L., Asst. Foreman, Transformer Test, Westinghouse Elec. & Mfg. Co., East Pittsburgh; res., Wilkesburg, Pa.
- *KEENER, JACOB, Electrical Contractor, Elsdon Electric Co., 5608 S. Sawyer Ave., Chicago, Ill.
- *KEITH, WAYNE EVARTS, Engineering Assistant, New England Tel. & Tel. Co., 50 Oliver St., Boston; res., Campello, Mass.
- KENNARD, GEORGE ARTHUR, Maintenance Electrician, Kansas City Power & Light Co., Northeast Station, Kansas City, Mo.
- KENNER, ARTHUR, Telephone Systems Engineering, Western Electric Co., Inc., 468 West St., New York, N. Y.
- *KENRICK, GLEASON WILLIS, Instructor, Elec. Engg. Dept., Massachusetts Institute of Technology, Cambridge; res., Brockton, Mass.
- *KENT, HARRY EDMUND, Research Associate, Headquarters Engg. Staff, National Electric Light Association, 29 W. 39th St., New York; res., Providence, R. I.
- *KERCHNER, RUSSELL M., Instructor, Elec. Engg. Dept., Kansas State Agricultural College, Manhattan, Kans.
- KINDAHL, HENRY SIGFRID, Electrical Draftsman, Thomas E. Murray, Inc., 55 Duane St., New York; res., Brooklyn, N. Y.
- *KING, GEORGE W., Electrical Engineering Dept., Commonwealth Power Corp., Jackson, Mich.
- *KINNEY, ERNEST ALLEN, Electrical Engineer, Spooner & Merrill, 425 Power Theater Bldg., Grand Rapids, Mich.
- KIRKWOOD, RALPH VAN SWEARINGEN, Electrical Engineer, Construction Service, Quartermaster Corps, U. S. A., 2245 Munitions Bldg., Washington, D. C.
- KISSEL, FREDERICK TEMPLETON MANHEIM, Acting Chief Electrical Engineer, Public Works Dept., Wellington, New Zealand.
- *KOHLER, HARRY WILLIAM, Electrical Engineer, The Milwaukee Electric Railway & Light Co., Public Service Bldg., Milwaukee Wis.
- *KRESSLER, CHARLES HORNER, Cadet Engineer, Operating Dept., Penna. Power & Light Co., Allentown, Pa.
- *KUBIAK, HENRY JOSEPH, Designing Engineer, Westinghouse Elec. & Mfg. Co., 3180 Salmon St., Philadelphia, Pa.
- *LAMB, JAMES J., Manager, Radio Dept., Lamb Bros., Michigan, N. D.
- LANCASTER, ELON FLOYD, Fan Motor Dept., General Electric Co., 100 Woodlawn Ave., Pittsfield, Mass.
- *LANE, RALPH BELFORD, Student Engineer, General Electric Co., Schenectady, N. Y.
- *LANG, GERALD F., Student Engineer, Engg. Dept., Public Service Co. of Colorado, Boulder, Colo.
- LARSEN, THORSTEIN, Brooklyn Edison Co., Brooklyn, N. Y.
- LARTER, WILLIAM DAVID, Dist. Superintendent, Saskatchewan Gov't. Telephones, Lorne St., Regina, Sask., Can.
- LAWRENCE, FRANKLIN P., Plant Supt. Southwestern Bell Telephone Co., 357 Boatmen's Bank Bldg., St. Louis, Mo.
- *LAWTON, FREDERIC LEWIS, Electrical Engineer, General Engg. Lab., General Electric Co., Schenectady, N. Y.
- LEACH, THOMAS, Wire Chief, Saskatchewan Gov't. Telephones, Lorne & 12th, Regina, Sask., Can.
- *LEAR, WILLIAM HARRISON, Equipment & Transmission Tester, American Tel. & Tel. Co., 40 Rector St., New York, N. Y.
- LEARNED, EVERETT D., Power Sales Engineer, Worcester Electric Light Co., 11 Foster St., Worcester, Mass.
- *LEE, JOHN ADAM, Power Plant Foreman, United States Reclamation Service, Pavilion, Wyo.
- LEESON, JAMES HERBERT, Dist. Plant Chief, Dept. of Govt. Telephones, Regina, Sask., Can.
- *LEGGETT, JOHN ALEXANDER, Service Engineer, Westinghouse Elec. & Mfg. Co., 12 Farnsworth St., Boston; res., Lowell, Mass.
- LERCH, RUSH T., 216 Burke St., Easton, Pa.
- *LIEBERMAN, HENRY, Transmission & Interference Inspector, Tri-State Tel. & Tel. Co., 369 Cedar St., St. Paul; for mail, Stillwater, Minn.
- *LINDLEY, JAMES RALPH, Sales Engineer, C. F. Pease Co., 813 N. Franklin, Chicago, Ill.
- *LISTMANN, C. WERNER, Junior Electrical Engineer, Bureau of Power & Light, City of Los Angeles, 120 E. 4th St., Los Angeles; res., Glendale, Calif.
- *LONGLEY, FRANK ROGERS, Student Engineer, General Electric Co., Schenectady, N. Y.
- LORIA, DAVID JERROLD, Electrical Designer, Public Service Production Co., 54 Park Place, Newark, N. J.
- *LOUGHERY, GEORGE BACON, JR., Engineering Assistant, Bell Telephone Co. of Penna., 1230 Arch St., Philadelphia, Pa.
- *LOUKIANOFF, GREGORY M., Designing Engineer, General Electric Co., Pittsfield, Mass.
- LOVE, NELSON ROOSEVELT, Chief Engineer for E. Stenger, 807 Tramway Bldg., Denver, Colo.
- *LUECKE, THEODORE EDWARD, Engg. Assistant to Manager, Monongahela West Penn Public Service Co., Union Trust Bldg., Parkersburg, W. Va.
- *LYMAN, WALTER JORDAN, Apprentice Engineer, Duquesne Light Co., 308 Philadelphia Bldg., Pittsburgh, Pa.
- *LYNCH, CHARLES BYRNE, Engineer, General Electric Co., Schenectady, N. Y.
- *MACDONALD, RALPH ALEXANDER, Transitman, Salt River Valley Water Users Association, S. R. V. W. U. Ass'n. Bldg., Phoenix, Ariz.
- MACLEAN, KIRBY DONALD, Field Superintendent, Day & Zimmerman, Inc., 1600 Walnut St., Philadelphia, Pa.
- MAIER, OTTO THEODORE, Asst. Commercial Engineer, New Orleans Public Service, Inc., 201 Baronne St., New Orleans, La.
- MALECKAR, WILLIAM RICHARD, Salesman, Aluminum Co. of America, 528 McKnight Bldg., Minneapolis, Minn.
- *MALTBY, CLARENCE LAUREN, Requisition Engineer, Public Service Co. of No. Illinois, 72 W. Adams St., Chicago; res., Evanston, Ill.
- MANION, WILLIAM J., Plant Engineer, Southwestern Bell Telephone Co., Boatmen's Bank Bldg., St. Louis, Mo.
- *MANNING, JAMES B., Meter Man, Puget Sound Power & Light Co., 504 S. 2nd St., Kelso, Wash.
- MANSFIELD, CARROLL GOLDEN, Engineering Assistant, High Voltage Bushing Engg. Dept., General Electric Co., Pittsfield, Mass.
- MARCELLUS, FREDRICK STEADWELL, Electrical Engineer, General Electric Co., Schenectady, N. Y.
- *MARCHESE, VINCENT JAMES, Neutralizer of Neutrodyne Radio Receivers, Fred-Eiseman Radio Corp., Manhattan Bridge Plaza, Brooklyn, N. Y.
- MARLOW, VERNON H., Instructor, National Electrical School, 4006 Figueroa St., Los Angeles, Calif.
- MARSH, EDGAR S., Tester, Westinghouse Elec. & Mfg. Co., Sharon, Pa.
- *MARTHENS, ARTHUR S., Railway Equipment Engineer, Westinghouse Elec. & Mfg. Co., East Pittsburgh, Pa.; for mail, New Rochelle, N. Y.
- MARZAN, MELECIO MINA, Agoo, La Union, Philippine Islands.
- *MASLIN, ALBERT J., Transformer Engineer, Westinghouse Elec. & Mfg. Co., East Pittsburgh, Pa.
- *MASON, ALBERT F., Interference Engineer, Northwestern Bell Telephone Co., Telephone Bldg., Omaha; for mail, Fremont, Nebr.
- MASON, EARL CLIFTON, Electrical Draftsman, Puget Sound Navy Yard, Bremerton; for mail, Seattle, Wash.
- *MATLIN, ISRAEL, Inspector, Safety Insulated Wire & Cable Co., Bayonne, N. J.
- *MATSUO, KENZO, Student, Worcester Polytechnic Institute, Worcester, Mass.
- *MAUST, CHARLES ISRAEL, Electrical Draftsman, United Gas Improvement Contracting Co., Broad & Arch Sts., Philadelphia, Pa.
- McAULEY, PATRICK HAROLD, Transmission Engineer, P. I. & T. Engg. Dept., Westinghouse Elec. & Mfg. Co., East Pittsburgh, Pa.
- *McCOY, ROBERT LESLIE, Asst. to Chief Engineer, Locke Insulator Corp., Maryland Trust Bldg., Baltimore, Md.
- *McCRACKEN, WILLIS FLOWERS, Student, The Pacific Tel. & Tel. Co., 1200 Third Ave., Seattle, Wash.
- *McCULLOUGH, ROBERT THOMAS, Electrical Engineer, Long Island Lighting Co., Bay Shore, N. Y.

- *MCDONALD, JOHN WOOD, Engineer, Office & Field Duty, Commonwealth Power Corp., Jackson, Mich.
- McKAY, JOHN WILLIAM, Acting Foreman, Northern Electric Co., 131 Simcoe St., Toronto, Ont., Can.
- *MCLEAN, GORDON E., Switchboard Diagram Engineer, Westinghouse Elec. & Mfg. Co., East Pittsburgh; res., Wilksburg, Pa.
- *MENZEL, ARTHUR FREDRICK, Test Engineer, Freed-Eisemann Radio Corp., Sperry Bldg., Brooklyn, N. Y.
- *METZGER, WALTER EARNEST, Salesman, Westinghouse Elec. & Mfg. Co., Interurban Terminal Bldg., Columbus, Ohio.
- *MEYER, HAROLD FREDERICK, Assistant Engineer, Vacuum Oil Co., Bayonne; res., Woodcliff, N. J.
- MIER, C. WALKER, Transmission Engineer, Southwestern Bell Telephone Co., 1150 Boatmen's Bank Bldg., St. Louis, Mo.
- *MILBURN, JOHN BLAIR, Switchboard "B" Operator, Duquesne Light Co., Cheswick, Pa.
- *MILLER, HAROLD EDWARD, Junior Electrical Engineer, National Advisory Commission for Aeronautics, Langley Field; res., Hampton, Va.
- MILLER, JOSEPH I., Wireman, Switchboard Division, St. Paul Gas Light Co., St. Paul, Minn.
- *MINNIUM, BYRON BIDDLE, Engineer, Walbert Mfg. Co., 925 Wrightwood Ave., Chicago, Ill.
- MISENER, EARLE CHELSEA, Student, Polytechnic College of Engineering, Madison & 13th St., Oakland, Calif.
- MONTAGUE, ROY GIVENS, Switchboard Repair Man, The Pacific Tel. & Tel. Co., Santa Cruz, Calif.
- *MONTEITH, ALEXANDER CRAWFORD, General Engineer, Westinghouse Elec. & Mfg. Co., East Pittsburgh, Pa.
- *MOOR, HARVARD EDGAR, Assistant Engineer, Bangor Railway & Electric Co., 84 Harlow St., Bangor, Me.
- MOORE, LESLIE STEPHENS, Ultimate Cost Comparison Engineer, Bell Telephone Co. of Canada, Montreal, Que., Can.
- MOORE, WILLIAM CHARLES, District Superintendent, Dept. of Govt. Telephones, Moose Jaw, Sask., Can.
- *MORENO, GERARDO, Electrical Draftsman, Pacific Gas & Electric Co., 567 Sutter St., San Francisco; res., Berkeley, Calif.
- *MORGAN, GODFREY, JR., Senior, Elec. Engg., Cornell University; Asst., Mech. Lab., Sibley College, Ithaca, N. Y.
- MORSS, PHILIP REIED, Factory Staff, Simplex Wire & Cable Co., Cambridge A, Mass.
- MOWRY, REGINALD IRVING, Testman, General Electric Co., Schenectady, N. Y.
- *MUCHA, THEODORE, D. C. Watthour Meter Demand Tester and Repairman, Duquesne Light Co., 725 North Ave., Wilksburg, Pa.
- *MUIR, ANDREW CHARLES, Testing Dept., General Electric Co., Schenectady, N. Y.
- *MULLEN, JOSEPH NORMAN, Superintendent, Cap Magdalen Pulp & Lumber Co., Ltd., Riviere Madeleine, Gaspé Co., Que., Can.
- *MURPHY, JAMES KEITHLEY, Asst. Maintainer, Signal & Electrical Dept., Southern Railway System, Orange, Va.
- *NAEGELI, FREDERICK ALBERT, Draftsman, Interborough Rapid Transit Co., 600 W. 59th St., New York; res., Astoria, N. Y.
- *NASH, HAROLD R., Asst. Cable Trouble Engineer, Elec. Engg. Dept., Detroit Edison Co., 2000 2nd Ave., Detroit, Mich.
- *NATTRESS, DAVID IRVING, Meter Dept. Assistant, Hydro-Electric Power Comm. of Ontario; c/o Ontario Power Co., Niagara Falls, Ont., Can.
- NELSON, FRED SPERRY, Telephone Engineer, Atchison, Topeka & Santa Fe Ry., Topeka, Kans.
- *NEUMAN, LEONARD JOSEPH, Instructor, Physics Dept., University of Oregon, Eugene, Ore.
- *NORTON, EDWARD LAWRY, Telephone Engineer, Western Electric Co., Inc., 463 West St., New York, N. Y.
- *NOTTINGHAM, FRANK OLIVER, JR., Testing Dept., General Electric Co., Schenectady, N. Y.
- NOWELL, FREDERIC GEORGE, Student, New York Electrical School, New York, N. Y.
- *NYE, JOHN FREMONT, Engg. Dept., Westerly Light & Power Co., 2 Canal St., Westerly, R. I.
- *O'DAIR, EDWARD F., Electrical Engineer, Railway Engg. Dept., General Electric Co., 120 Broadway, New York, N. Y.
- *OLDS, RICHARD NORTHCOTTE, Electrical Engineer, Commonwealth Power Co., Wildwood, Ave., Jackson, Mich.
- *OLIN, HENRY A., Engineer, Elec. Dept., Phoenix Utility Co., Minn. Pr. & Lt. Co. Bldg., Duluth, Minn.
- *O'NEIL, HORACE THEODORE, Electrical Engineer, Western Electric Co., Inc., 463 West St., New York, N. Y.
- *O'NEILL, OWEN, Asst. Engineer, Planning Div., T. & D. Dept., United Electric Light & Power Co., 56 Cooper Sq., New York; res., Brooklyn, N. Y.
- PABST, WILLIAM, Teacher, Dept. of Applied Electricity, Brooklyn Technical High School, Flatbush Ave. Ext. & Concord St., Brooklyn; res., Richmond Hill, N. Y.
- PANNABAKER, JOHN JOSEPH, Chief Operator, Vanadium Corp. of America, Bridgeville; for mail, Pittsburgh, Pa.
- *PAPAZIAN, NERSES, Electrical Designer, Western Electric Co., Inc., 25 Spruce St., New York, N. Y.
- PARKER, SIDNEY R., Construction Foreman, S. Edw. Eaton & Co., 591 Hudson St., New York; res., Brooklyn, N. Y.
- *PARRACK, VASCO ROOSEVELT, Field Engineer, West Penn Power Co., Pittsburgh; res., Wilksburg, Pa.
- *PATISTEAS, MICHAEL JOHN N., Div. of Design & Drafting, Stone & Webster, Inc., 147 Milk St., Boston, Mass.
- *PAXSON, HOUSTON RANDOLPH, Electrical Designer, Philadelphia Electric Co., 1000 Chestnut St., Philadelphia, Pa.
- *PEARLMUTTER, HARRY JOCOB, Electrical Draftsman, French & Hubbard, 210 South St., Boston, Mass.
- PEIRSON, DAVID HARPER, Senior Operator, Substation, Philadelphia Electric Co., 106 N. 11th St., Philadelphia, Pa.
- *PETTENGILL, JOHN BRADLEY, Tester, New York Edison Co., 92 Vandam St., New York; res., Brooklyn, N. Y.
- PEW, RICHARD K., Asst. Radio Laboratory Instructor & Student, Dodge's Institute of Technology, Valparaiso, Ind.
- *PHELPS, GEORGE OSBORN, Standardizing Laboratory, General Electric Co., West Lynn; res., Lynn, Mass.
- *POWELL, ALBERT PERRY, 530 Cambridge St., Allston, Boston, Mass.
- POWERS, LAWRENCE WAYNE, Operating Dept., United Electric Light & Power Co., E. 134th St. & Locust Ave., New York, N. Y.
- PRETZ, JOHN C., Electrical Draftsman, Lehigh Portland Cement Co., Young Bldg., Allentown, Pa.
- PRICE, JOSEPH PRESSLY, Student, Stanford University, 340 Warwick St., Oakland, Calif.
- PRITCHETT, EDWARD CRAWFORD, Engineer, Westinghouse Elec. & Mfg. Co., East Pittsburgh; res., Wilksburg, Pa.
- *RABKE, RAYMOND FRANKLIN, Laboratory Assistant, Westinghouse Elec. & Mfg. Co., East Pittsburgh; res., Wilksburg, Pa.
- *RAMSDEN, CLAYTON WAYNE, Asst. Engineer, Safety Insulated Wire & Cable Co., First St., Bayonne, N. J.
- *RAYMOND, HUBERT NELSON, Central Station Sales, General Electric Co., 1016 Continental Bank Bldg., Salt Lake City, Utah.
- REDPATH, ARLINGTON JOHN, Turbine Engineering Dept., General Electric Co., Erie, Pa.
- *REED, RUSSELL OAKLEY, Relief Operator, Portland Electric Power Co., Portland; res., Estacada, Ore.
- REINHARDT, JOHN P., Electrical Contractor, 27 Chestnut Ave., Rosebank, S. I., N. Y.
- RENNER, LESTER N., Engineering Inspector, Northern Ohio Traction & Light Co., Terminal Bldg., Akron, Ohio.
- *RETTENMEYER, F. X., Telephone Engineer, Western Electric Co., Inc., 463 West St., New York, N. Y.
- RHINE, FRED PREYER, Elec. Engg. Dept., Detroit Edison Co., 2000 2nd St., Detroit, Mich.
- *RICH, WILLIAM CRANE, Cost Investigator, Philadelphia Electric Co., 2301 Market St., Philadelphia, Pa.
- RIDER, LORENZO NELVIN, Manager, Western Electric Co., Inc., 6215 Carnegie Ave., Cleveland, Ohio.
- RILEY, CECIL F., Planning Engineer, Western Electric Co., Inc., 268 W. 36th St., New York; res., Tuckahoe, N. Y.
- RIVERA, MANUEL M., Student Employee, International General Electric Co., Schenectady, N. Y.
- ROBINSON, HENRY BURTON, Engineering Assistant, Brooklyn, Edison Co., Pearl & Willoughby Sts., Brooklyn, N. Y.
- RODNITE, JOHN JOSEPH, Valuation Engineer, Murrie & Co., 52 Broadway, New York; res., Brooklyn, N. Y.
- *ROESCH, ROBERT EVANS, Engineer, In charge of Substation Construction, Phoenix Utility Co., Cienfuegos, Cuba.
- *ROGAL, EDWARD, Morgan's Inc., 33 Simmons St., Roxbury; res., Brookline, Mass.
- *ROHRDANZ, EDWIN C., Richmond Safety Gate Co., 160 N. Wells St., Chicago; res., Blue Island, Ill.
- RONNINGEN, ANDERS, Maintenance Laboratory, Western Electric Co., Inc., Chicago; for mail, Cicero, Ill.
- ROSE, ELMER BARTON, Inspector, Northern Ohio Traction & Light Co., Line Dept., Akron, Ohio.
- *ROSENBERG, BENJAMIN, Engineer, The Pacific Tel. & Tel. Co., 835 Howard St., San Francisco, Calif.
- *ROSS, GEORGE OSCAR, Instructor Industrial Education, Perry High School, Perry, N. Y.
- *ROSS, MALCOLM VAUGHN, Asst. Electrical Engineer, Brown Corp., La Tuque, P. Q., Can.
- ROSSI, ALBERT F., Electrical Instructor, Jefferson Vocational School, 903 Washington St., St. Louis, Mo.
- *RUE, EDWARD CHARLES, Chief Trouble Dispatcher, The Edison Electric Illuminating Co. of Boston, 39 Boylston St., Boston, Mass.
- RUSS, CHARLES N., General Foreman, Electrical Repair Shop, Bureau of Power & Light, 211 East Power St., Los Angeles, Calif.
- RUFF, JOHN WITHERS, Industrial Power Engineer, Charleston Consolidated Rwy. & Lgt. Co., 141 Meeting St., Charleston, S. C.
- *RUFVOLD, ARNOLD SOFUS, General Engg. Dept., Westinghouse Elec. & Mfg. Co., East Pittsburgh; res., Pittsburgh, Pa.
- RYDER, FRANK, Chief Electrician, Canadian Co-operative Wheat Producers, Ltd., Fort William, Ont., Can.
- *SALNEU, GEORGE C., Electrical Engineer, Philadelphia Electric Co., 2301 Market St., Philadelphia, Pa.

- SANDE, NICHOLAS CHARLES**, Asst. Operator, Chester Station, Philadelphia Electric Co., 10 E. 5th St., Chester, Pa.
- ***SCHAEFFER, J. PHILIP**, Assistant to Asst. Manager, Patent Dept., General Electric Co., Schenectady, N. Y.
- ***SCHAEFFER, ELMER RAYMOND**, Head, Research Dept., Johns-Manville, Inc., 292 Madison Ave., New York, N. Y.
- SCHER, ISAK**, Engineer, Dwight P. Robinson & Co., 3708 Fifth Ave., Pittsburgh, Pa.
- ***SCHMITZ, RICHARD OEOIL**, Designing Engineer, General Electric Co., Pittsfield, Mass.
- ***SCHONBORN, ROBERT JOHN**, Elec. Service Inspector, City of Los Angeles, Bureau of Power & Light, 120 E. Fourth St., Los Angeles; res., Pasadena, Calif.
- ***SCHOTTLE, GEORGE JESSE**, Junior Patent Examiner, U. S. Patent Office, Washington, D. C.
- ***SCHUCH, LELAND STANFORD**, Engineer, Westinghouse Elec. & Mfg. Co., 1909 Blake St., Denver, Colo.
- SCHUMACHER, HENRY A.**, Test Dept., New York Edison Co., 92 Vandam St., New York, N. Y.
- SCHUMP, RICHARD RITTER**, Street Engineer, Commonwealth Edison Co., 72 W. Adams St., Chicago, Ill.
- ***SCOTT, JOHN ALEXANDER**, Research Assistant, Massachusetts Institute of Technology, Cambridge; res., Arlington, Mass.
- SCOTT, WILLIAM MOUNTS**, Electrician, Construction Dept., New York Edison Co., Brooklyn, N. Y.
- ***SEALEY, WILLIAM CURTIS**, Engineer, Transformer Engg. Dept., Westinghouse Elec. & Mfg. Co., East Pittsburgh, Pa.
- ***SEE, WOON HOWE**, Testing Dept., General Electric Co., Schenectady, N. Y.
- SEITZ, VALENTINE**, Chief of Engg. Dept., Cleveland Clinic, Euclid Ave. & 93rd St., Cleveland, Ohio.
- ***SELLECK, HAROLD GEORGE**, Maintenance Engineer, The Connecticut Power Co., Middletown, Conn.
- SELQUIST, ROLF**, Engineer, Copperweld Steel Co., 30 Church St., New York, N. Y.
- SESSIONS, ALMA PRESTON**, Asst. Engineer, Substations, Southern California Edison Co., Edison Bldg., Los Angeles, Calif.
- SHARP, CLIFFORD S.**, 9 Seymour Ave., Jamestown, N. Y.
- ***SHARP, HUBERT**, Asst. Electrical Engineer, Mountain States Tel. & Tel. Co., Denver, Colo.
- SHAW, FRANK MARTIN**, Electrician, 348 White Plains Road, New York, N. Y.
- ***SHEA, H. GREGORY**, Salesman, Puget Sound Power & Light Co., Electric Bldg., Seattle, Wash.
- ***SHERMAN, RUSSELL E.**, Electrician, Public Service Electric Co., 71-77 Murray St., Elizabeth, N. J.
- ***SHERMER, FRANK CHARLES**, Engineer, Electric Plant Dept., Philadelphia Suburban Gas & Electric Co., Wyncote; res., Philadelphia, Pa.
- ***SHEW, EDWARD BARRETT**, Estimator, Philadelphia Electric Co., 1000 Chestnut St., Philadelphia, Pa.; res., Haddon Heights, N. J.
- ***SHIELDS, STANLEY**, Test Man, Canadian General Electric Co., 541 Gilmore St., Peterboro, Ont., Can.
- ***SHOCKLEY, HENRY MAURICE**, Junior Asst. Switchboard Engineer, Canadian General Electric Co., Peterboro, Ont., Can.
- SHOREY, GEORGE HEYSMAN, JR.**, Test Dept., General Electric Co., Schenectady, N. Y.
- SINGLETON, BRENNAND**, Contract Engineer, Canadian General Electric Co., Ltd., 212 King St., W., Toronto, Ont., Can.
- ***SINIAPRIN, NICHOLAS M.**, Mechanical Draftsman, State Dept. of Architecture, Albany, N. Y.
- SIPLEY, LOUIS WALTON**, District Manager, Crescent Truck Co., 10 S. 18th St., Philadelphia, Pa.
- SKAROLID, CHARLES THOMAS**, Interference Engg. Dept., Northwestern Bell Telephone Co., 420 3rd Ave. S., Minneapolis, Minn.
- ***SKLAR, LOUIS B.**, Electrical Draftsman, United Gas Improvement Contracting Co., 13th & Cherry Sts., Philadelphia, Pa.
- SMITH, FRANK**, Inspector, Elec. Engg. Dept., Brooklyn Edison Co., 360 Pearl St., Brooklyn, N. Y.
- ***SMITH, GUERDON WILLARD**, District Superintendent, Vulcan Power Co., Newburg, N. J.
- SMITH, HOWARD ELMER**, Testing Dept., General Electric Co., Schenectady, N. Y.
- SMITH, SIDNEY BERTRAM**, Research Engineer, Marconi Wireless Telegraph Co., Marconi House, Strand, London; for mail, Chelmsford, Essex, England.
- SMITH, WALTER EDWARD**, Production Department, Ward Leonard Electric Co., Mount Vernon, N. Y.
- ***SNOW, WILLIAM BORING**, Engineering Student, Stanford University, Stanford University, Calif.
- ***SPAFFORD, PERRY PARKER**, Electrical Engineer, Texas Power & Light Co., Inter-urban Bldg., Dallas, Texas.
- ***SPECTOR, MORRIS**, Examiner, Division 26, U. S. Patent Office, Washington, D. C.
- ***SPETHMANN, GLENN EDWIN**, Acting Resident Engineer, Northwestern Bell Telephone Co., Sioux Falls, S. D.
- ***STEBBINS, FREDERICK OSBORNE**, Consulting Engg. Dept., General Electric Co., Schenectady, N. Y.
- STEINMETZ, ALFRED A.**, Draughtsman, The Western Union Telegraph Co., 195 Broadway, New York, N. Y.
- ***STOLL, ALVIN**, Student, School of Engineering of Milwaukee, Milwaukee, Wis.
- SUSSDORFF, ROBERT ROY**, Test Engineer, Sperry Groscope Co., Sperry Bldg., Manhattan Bridge Plaza, Brooklyn, N. Y.
- ***SWEET, EVERETT LEPRILETE**, Trans. & Distr. Dept., The Philadelphia Electric Co., 2301 Market St., Philadelphia, Pa.
- SYKES, ERNEST AUGUSTUS**, Operator (Hydro), Montreal Light, Heat & Power Cons., "Club House" Cedars, Que., Can.
- TANAKA, KIN-EMON**, Electrical Engineer, Mitsubishi Electrical Engineering Co., Kobe, Japan.
- TAYLOR, DANIEL JAMES**, Asst. to Electrical Engineer, 88 Broad St., Boston; res., West Somerville, Mass.
- TAYLOR, J. D.**, Division Transmission Engineer, Northwestern Bell Telephone Co., 420 3rd Ave. So., Minneapolis, Minn.
- ***TAYLOR, MERTON LINDON**, Electrical Inspector, Brooklyn Edison Co., Brooklyn, N. Y.
- ***TAYLOR, RICHARD V.**, Engineers' Training Course, Westinghouse Elec. & Mfg. Co., 211 East End Ave., Pittsburgh, Pa.
- ***TAYLOR, WILLIAM TREAT**, Engineer, Traffic Dept., Southern California Telephone Co., 740 So. Olive St., Los Angeles, Calif.
- ***TENNANT, GEORGE EARL**, Cadet Engineer, Syracuse Lighting Co., 431 Fulton St., Syracuse; res., Nedrow, N. Y.
- TEW, MARIAN MURIEL**, Draftsman, Bureau of Power & Light, 207 S. Broadway, Los Angeles, Calif.
- THAYER, C. J.**, Order Clerk & Correspondent, Westinghouse Elec. & Mfg. Co., Supply Sales Dept., East Pittsburgh; res., Edgewood, Pa.
- ***THOMAS, EARL ROGER**, Asst. Engineer, United Electric Light & Power Co., 130 E. 15th St., New York, N. Y.; res., Palisades Park, N. J.
- ***THOMPSON, GEORGE WASHINGTON**, College of Electrical Engineering of Milwaukee, 185 Biddle St., Milwaukee, Wis.
- ***THOMPSON, JOHN HURLBURT**, Student Engineer, New England Tel. & Tel. Co., 50 Oliver St., Boston; res., Brookline, Mass.
- TIERNEY, WILLIAM HENRY**, Superintending Service Shop, General Electric Co., 1508, 4th Ave., South, Seattle, Wash.
- ***TIMBERLAKE, PHIL SAMUEL**, Testing Course, General Electric Co., Schenectady, N. Y.
- TOMLINSON, HENRY RITTER**, Elec. Engg. Dept., Fall River Electric Light Co., 85 N. Main St., Fall River, Mass.
- ***TOPANELIAN, EDWARD JR.**, Research Assistant to Prof. H. B. Smith, Worcester Polytechnic Institute, Worcester, Mass.
- ***TORRENS, THEODORE MABIN**, Supervisor, New York Telephone Co., 104 Broad St., New York, res., Brooklyn, N. Y.
- TOWNSEND, GEORGE RICHARD**, Asst. Engineer on Design, General Electric Co., 1 River Road, Schenectady, N. Y.
- ***TRANZEN, KARL**, Operating Engineer (Stationary), Marshall Field & Co., 121 N. State St., Chicago, Ill.
- ***TROOP, CHARLES RAWLINS**, Material & Supply Inspector, New York Central Railroad, 466 Lexington Ave., New York, N. Y.; res., Jersey City, N. J.
- ***TROSTER, MATHEW**, Asst. to Test Engineer, Otis Elevator Co., 1 Woodworth Ave., Yonkers; res., Bronx, New York, N. Y.
- ***TROW, LUTHER SMITH**, Engineer, Worcester City Hospital, Worcester, Mass.
- ***TSUI, JOHN H. H.**, Tester, Westinghouse Elec. & Mfg. Co., East Pittsburgh; res., Wilkensburg, Pa.
- ***TUNELL, ROBERT HENRY**, Engineer in Systems Development, Western Electric Co., Inc., 463 West St., New York, N. Y.
- TURK, PAUL COLUMBUS**, Oil Circuit Breaker Design Section, General Electric Co., Schenectady, N. Y.
- TURNER, JOHN WALTON**, Local Manager, Regina Exchange, Dept. of Govt. Telephones, Regina, Sask., Can.
- TURNER, ROBERT HAWTHORN**, Draftsman, Dwight P. Robinson & Co., 116 Dorrence St., Providence, R. I.
- TUTTLE, EDWARD LEROY**, Methods Engineer, Western Electric Co., Inc., 309 W. Washington St., Chicago, Ill.
- TYRRELL, RAYMOND FREDERICK**, Inspector, Brooklyn Edison Co., 561 Grand Ave., Brooklyn, N. Y.
- ***VALENTINE, HADDON P.**, Station Operator, Puget Sound Power & Light Co., Bothell; res., Seattle, Wash.
- ***VAN PELT, EUGENE VAN BUREN**, Supervisor of Foreign Wire Relations, Chesapeake & Potomac Telephone Co. of W. Va., 406 Morrison Bldg., Charleston, W. Va.
- ***VASCONDELOS, JOAQUIN MARQUEZ**, Instrument Tester, The Milwaukee Electric Railway & Light Co., 3721 Hillside Lane, Milwaukee, Wis.
- ***VILETT, EVERETT WALTER**, Cadet Engineer, Public Service Production Co., 80 Park Place, Newark, N. J.
- VORONOVSKY, THEODORE GREGORY**, Draftsman, Construction Engg. Dept., General Electric Co., Schenectady, N. Y.
- ***VOUCH, STEPHEN J.**, Railway Equipment Engg. Dept., General Electric Co., 209 Seward Place, Schenectady, N. Y.
- ***WAGNER, BERZ STEPHEN**, Transmission Engineer, The Cincinnati & Suburban Bell Telephone Co., 225 E. 9th St., Cincinnati, Ohio; res., Covington Ky.
- ***WALTHER, HENRY**, Transmitter Development, Western Electric Co., Inc., 463 West St., New York, N. Y.
- WATTS, HALBERT ORREN**, Foreman, Electrical Construction, The Sierras Power Co., Riverside, Calif.

- *WATTS, THOMAS RAYMOND, Engineer, Power Sales Dept., Union Gas & Electric Co., 25 W. 4th St., Cincinnati, Ohio.
- *WEAR, ERNEST GEORGE, Asst. System Operator, Public Service Co. of Northern Illinois, 310 Van Buren St., Joliet, Ill.
- WEIR, ALEX, Engineering Draftsman, New York Central Railroad, 466 Lexington Ave., New York; for mail, Albany, N. Y.
- *WELLS, BEN F., Publicity Engineer, Westinghouse Elec. & Mfg. Co., East Pittsburgh; res., Wilkingsburg, Pa.
- *WERLY, BERLYN MCINTYRE, Asst. Electrical Engineer, Eastman Kodak Co., Kodak Park, Rochester, N. Y.
- *WEST, FREDERICK POWER, Electrical Engineer, United Electric Light & Power Co., 130 E. 15th St., New York, N. Y.
- *WETTON, NORMAN HENRY, Electrician, Toronto Hydro-Electric System, Toronto, Ont., Can.
- WHITE, HAZEL MARGUERITE, Asst. Engineer, Saskatchewan Gov't. Telephones, Regina, Sask., Can.
- *WILKINSON, HENRY BERNARD, Overhead Engineer, Adirondack Power & Light Corp., Schenectady, N. Y.
- *WILLIAMS, ARTHUR, Electrician, Lord Electric Co., 105 West 40th St., New York, N. Y.
- WILLIAMS, JOHN C., Electrical Engineer, Service Engg. Dept., Western Electric Co., Inc., 346 Claremont Ave., Jersey City, N. J.
- WILLIAMSON, THOMAS A., Central Station Switchboard Operator, Waukegan, Ill.
- WOLFF, SAMUEL, Asst. Engineer, Roth Bros. & Co., 1400 W. Adams St., Chicago, Ill.
- *WOODLING, GEORGE VICTOR, Train Control Supervisor, Pittsburgh & Lake Erie R R., 141 Insurance St., Beaver; for mail, Pittsburgh, Pa.
- WRIGHT, SUMNER BISBEE, Telephone Engineer, Dept. of Development & Research, American Tel. & Tel. Co., 195 Broadway, New York, N. Y.
- *WYRTZEN, CURTIS C., Foreman, Claude Neon Lights, Inc., 318 E. 32nd St., New York, N. Y.; res., Bloomfield, N. J.
- YONEZAWA, MASAJIRO, Resident Representative in U. S. A.; Asst. Engr., Elec. Dept., Japanese Gov't. Railways, 1 Madison Ave., New York, N. Y.
- *YOUNGLOVE, GEORGE WILSON, Lighting Research Laboratory, National Lamp Works, General Electric Co., Nela Park, Cleveland, Ohio.
- *ZIMMERSCHIED, CLARENCE R., Test Floor & Engg. Dept., Electric Machinery Mfg. Co., 1331 Tyler St., N. E., Minneapolis, Minn.

- KELLER, MAX LEO, Electrical Engineer, 2100 Lincoln Park West, Chicago, Ill.
- LYON, FRED D., General Superintendent, Cahokia Power Plant, St. Louis, Mo.

**TRANSFERRED TO GRADE OF FELLOW
FEBRUARY 10, 1925**

- MORROW, L. W. W., Associate Editor, *Electrical World*, New York, N. Y.
- ROBINSON, LLOYD N., Electrical Engineer, Stone & Webster Inc., Seattle, Wash.
- PEEK, FRANK W., JR., Consulting Engineer, General Electric Co., Pittsfield, Mass.

**TRANSFERRED TO GRADE OF MEMBER
FEBRUARY 10, 1925**

- BAUM, HARRY, Asst. Professor of Electrical Engineering, College of the City of New York, New York, N. Y.
- CHATFIELD, CLARENCE E., Sales Engineer, W. D. Hamer Co., Indianapolis, Ind.
- CLEMENT, MILLARD F., Manager, Orange County Public Service Co., Inc., Middletown, N. Y.
- ELLIOTT, HAROLD F., Consulting Engineer, Federal Telegraph Co. of Delaware, San Francisco, Calif.
- FREED, JOSEPH, D. R., President and Chief Engineer, Freed-Eisemann Radio Corp., New York, N. Y.
- MERTENS, B. de M., Assistant Electrical Superintendent, B. C. Electric Railway Co., Vancouver, B. C. Can.
- NIESSE, JOHN L., Tel. & Tel. Engineer, New York Central Lines, New York, N. Y.
- OESTERREICH, EDMUND W., Superintendent, Underground Lines, Duquesne Light Co., Pittsburgh, Pa.

RECOMMENDED FOR TRANSFER

The Board of Examiners, at its meeting held January 12 and February 5, 1925, recommended the following members for transfer to the grade of membership indicated. Any objection to these transfers should be filed at once with the Secretary.

- To Grade of Member**
- BAKER, GEORGE C., Assistant Engineer in charge of Planning Division, Brooklyn Edison Co., Brooklyn, N. Y.
 - ISAACSON, CHARLES B., Electrical Engineer, All American Cables, Inc., New York, N. Y.
 - LOFTUS, PETER F., Consulting Electrical Engineer, Timblin, Pa.
 - MEIN, WILLIAM C., Vice-President and Chief Engineer, Seivickley Electric Manufacturing Co., Sewickley, Pa.
 - OWEN, HARRY, Superintendent, Electrical Department, Truxillo Railroad Co., Puerto Castilla, Honduras, C. A.

APPLICATIONS FOR ELECTION

Applications have been received by the Secretary from the following candidates for election to membership in the Institute. Unless otherwise indicated, the applicant has applied for admission as an Associate. If the applicant has applied for direct admission to a higher grade than Associate, the grade follows immediately after the name. Any member objecting to the election of any of these candidates should so inform the Secretary before March 31, 1925.

- Ahlstrom, W., Commonwealth Edison Co., Chicago, Ill. (Applicant for re-election.)
- Anderson, T., Rogers Pyatt Shellac Co., Jersey City, N. J.
- Andress, J. M., 318 West 57th St., New York, N. Y.
- Andrews, J. K., General Electric Co., Pittsfield, Mass. (Applicant for re-election.)
- Argo, J. P., Memphis Power & Light Co., Memphis, Tenn.
- Austin, C. F., Commonwealth Edison Co., Chicago, Ill.

- Baker, F. C., United Electric Light & Power Co., New York, N. Y.
- Baker, K. G., Century Electric Co., St. Louis, Mo.
- Baldwin, E. M., Baldwin-Stewart Electric Co., Hartford, Conn.
- Balfour, R., Western Electric Co., Inc., New York, N. Y.
- Baring, J. W., Commonwealth Edison Co., Chicago, Ill. (Applicant for re-election.)
- Bateman, G. R., Toronto Hydro-Electric System, Toronto, Ont., Can.
- Beach, A. B., Commonwealth Edison Co., Chicago, Ill.
- Beck, W., Montgomery Elevator Co., Moline, Ill.
- Beck, W. W., Michigan Bell Tel. Co., Detroit Mich.
- Belasco, P. D., The Ohio Bell Telephone Co., Cleveland, Ohio.
- Betzer, C. E., Commonwealth Edison Co., Chicago, Ill.
- Bihler, G., Utah Power & Light Co., Bingham Canyon, Utah.
- Bohner, C. W., New York Edison Co., New York, N. Y.
- Booth, R. B., Alabama Power Co., Birmingham, Ala.
- Bowman, P. F., Commonwealth Edison Co., Chicago, Ill.
- Brockington, H. G., Schiefer Electric Co., Buffalo, N. Y.
- Brooks, J. A., Brooklyn Edison Co., Inc., Brooklyn, N. Y.
- Brown, G. E., General Electric Co., Boston, Mass.
- Brown, N. W., General Electric Co., Pittsfield, Mass.
- Brownlee, A. L., Commonwealth Edison Co., Chicago, Ill.
- Burnham, C. M., Jr., Commonwealth Edison Co., Chicago, Ill.
- Cantilina, N., Paterson Vocation School, Paterson, N. J.
- Capocéfalo, J. A., Westinghouse Elec. & Mfg. Co., Bridgeport, Conn.
- Carlson, P., St. Paul Gas Light Co., St. Paul, Minn.
- Carlson, R. J., Public Service Corp., Newark, N. J.
- Carpenter, J. F., Northern States Power Co., Minneapolis, Minn.
- Castle, C. V., Delaware & Atlantic Tel. & Tel. Co., Camden, N. J.
- Cavagnaro, A. E., Union Gas & Electric Co., Cincinnati, Ohio.
- Chapman, A. A., Partner, Peer-Chapman Electrical Co., Yorkton, Sask., Can.
- Chrisman, D. E., Commonwealth Edison Co., Chicago, Ill.
- Chulstrom, J., Western Union Tel. Co., New York, N. Y.
- Clancy, E. D., Westinghouse Elec. & Mfg. Co., Bridgeport, Conn.
- Clarkson, C. N., Pacific Gas & Electric Co., Modesto, Calif.
- Clement, A. W., University of Washington, Seattle, Wash.
- Colson, L. G., Commonwealth Edison Co., Chicago, Ill.
- Compton, K. R., Commonwealth Edison Co., Chicago, Ill.
- Connors, J. J., Interborough Rapid Transit Co., New York, N. Y.
- Conrad, A. B., Northern Ohio Traction & Light Co., Akron, Ohio.
- Cooper, R. L., Baldwin-Stewart Electric Co., Hartford, Conn.
- Croclann, A., Eastern Steel Casting Co., Newark, N. J. (Applicant for re-election.)
- Cronin, D. F., Cherry River Paper Co., Richwood, W. Va.
- Cryder, J. W., Pittsburgh Transformer Co., Philadelphia, Pa.
- Davls, U., Commonwealth Edison Co., Chicago, Ill.
- Dehls, F., All America Cables, Inc., New York, N. Y.

Total 460
*Formerly Enrolled Students

**ASSOCIATES REELECTED
FEBRUARY 10, 1925**

- CONVERSE, CLOVIS MILLER, Manager, Power Apparatus Dept., St. Paul Electric Co., 145 E. 5th St., St. Paul, Minn.
- INNES, FRANK R., Electrical Engineer, Sessions Engineering Co., 208 La Salle St., Chicago, Ill.
- KELLER, COSTANTINE CHARLES, Clergyman, Temple, Texas.
- SANFORD, DUDLEY, Assistant Treasurer, Union Electric Light & Power Co., Webster Groves, Mo.

- MEMBERS ELECTED
FEBRUARY 10, 1925**
- HEDRICK, EARLE RAYMOND, Professor of Mathematics, Southern Branch, University of California, Los Angeles, Calif.
 - JONES, BRUCE LEE, Div. Superintendent of Construction, Alabama Power Co., Ledger Bldg., Birmingham, Ala.

- Dobbs, H. O., Puget Sound Power & Light Co., Portland, Ore.
- Donaldson, R. J., Commonwealth Edison Co., Chicago, Ill.
- Doty, A. P., Westinghouse Elec. & Mfg. Co., Bridgeport, Conn.
- Doughty, G. F., Simplex Wire & Cable Co., New York, N. Y.
- Downing, L. H., Century Electric Co., Philadelphia, Pa.
- Duncan, J. A., Brooklyn Edison Co., Brooklyn, N. Y.
- Dunlevy, J. N., Commonwealth Edison Co., Chicago, Ill.
- Elliott, R. K., Commonwealth Edison Co., Chicago, Ill.
- Emmons, H. A., Western Union Telegraph Co., New York, N. Y.
- Evans, H. R., Pratt Institute, Brooklyn, N. Y.
- Everitt, W. L., University of Michigan, Ann Arbor, Mich.
- Faley, W. F., Tri-State Tel. & Tel. Co., St. Paul, Minn.
- Falk, K. K., Commonwealth Edison Co., Chicago, Ill.
- Farmer, R. A., Northern States Power Co., Minneapolis, Minn.
- Farnell, W. C. F., Bell Telephone Laboratories, Inc., New York, N. Y.
(Applicant for re-election.)
- Fetsch, J. T., Jr., General Electric Co., Schenectady, N. Y.
- Fitch, J. C., Commonwealth Edison Co., Chicago, Ill.
- Fix, F. W., Jr., Public Service Co. of No. Illinois, Chicago, Ill.
- Flynn, T. F., Engineer, Albany, N. Y.
- Fox, E. C., (Member), Richardson-Wayland Electrical Corp., Roanoke, Va.
- Freile, O., McGraw-Hill Co., New York, N. Y.
- Gager, E. H., (Member), Commonwealth Edison Co., Chicago, Ill.
- Gailun, B., U. S. S. Arizona, c/o Postmaster, San Francisco, Calif.
- Giroux, C. H., (Member), U. S. Engineer Dept., Washington, D. C.
- Glick, J. E., University of Virginia, University, Va.
- Goldberg, H. J., Toronto Hydro-Electric System, Toronto, Ont., Can.
- Grimm, W. F., Commonwealth Edison Co., Chicago, Ill.
- Grindel, O. V., Commonwealth Edison Co., Chicago, Ill.
- Grondorf, H., Pacific Gas & Electric Co., San Francisco, Calif.
- Gropp, G. J., Electrical Inspector, 561 Grand Ave., Brooklyn, N. Y.
- Gustafson, O. A., General Electric Co., Schenectady, N. Y.
- Hajos, E., Radio Corp of America, New York, N. Y.
- Hall, O. T., The Packard Electric Co., Warren, Ohio.
(Applicant for re-election.)
- Hall, R. E., General Electric Co., Schenectady, N. Y.
- Hamilton, G., Jr., Erie Railroad Co., Jersey City, N. J.
- Harlan, K. G., Electrical Engineer, Seattle, Wash.
- Harris, H. V., Bureau of Power & Light, Los Angeles, Calif.
- Hartenheim, M., The Electric Generator Corp., Pittsburgh, Pa.
- Hatch, A. R., Commonwealth Edison Co., Chicago, Ill.
- Hatzimihail, M. R., Pennsylvania Railroad Co., Long Island City, N. Y.
- Hau, L. J., Commonwealth Edison Co., Chicago, Ill.
- Hauck, C. F., Commonwealth Edison Co., Chicago, Ill.
- Hawkins, H. C., Northwestern Bell Tel. Co., Minneapolis, Minn.
- Hervey, W. K., Commonwealth Edison Co., Chicago, Ill.
- Hieronimus, R. E., General Electric Co., Schenectady, N. Y.
- Hillard, M. C., So. California Edison Co., Los Angeles, Calif.
- Rinckley, R. M., Dwight P. Robinson & Co., Inc., Pittsburgh, Pa.
- Hodnetto, J. K., Westinghouse Elec. & Mfg. Co., East Pittsburgh, Pa.
- Hoffhaus, H. B., Des Moines Electric Co., Des Moines, Iowa.
- Hoffman, L. B., 28 Gates Ave., Montclair, N. J.
- Holley, B. D., Commonwealth Edison Co., Chicago, Ill.
- Houychurch, A. W., Brooklyn Edison Co., Brooklyn, N. Y.
- Horgan, F. J., 239 Broadway, Newport, R. I.
- Howell, M. T., Municipal Power & Light Dept., Los Angeles, Calif.
- Howes, E. T., 337 N. Mathers St., Los Angeles, Calif.
- Hoynek, L. A., Bemis Bros. Bag Co., St. Louis, Mo.
- Hunt, W. T., Northern Electric Co., Ltd., Regina, Sask., Can.
- Inouye G., Hayakawa Denryoku K. K., Tokyo, Japan; c/o Mitsui & Co., New York, N. Y.
- Iwafuchi, Y., Toho Electric Power Co., Tokyo, Japan; c/o Mitsui & Co., New York, N. Y.
- Jaques, C. A., Commonwealth Edison Co., Chicago, Ill.
- Jasper, C., Commonwealth Edison Co., Chicago, Ill.
- Johnson, F. B., Commonwealth Edison Co., Chicago, Ill.
(Applicant for re-election.)
- Johnson, F. D., Westinghouse Elec. & Mfg. Co., East Pittsburgh, Pa.
- Johnson, H. J., Commonwealth Edison Co., Chicago, Ill.
- Johnston, F. E., Radio Corp of America, Riverhead, N. Y.
- Jones, A. O., Commonwealth Edison Co., Chicago, Ill.
- Kaim, A. V., Commonwealth Edison Co., Chicago, Ill.
- Kane, E. D., Detroit Edison Co., Detroit, Mich.
- Kapple, F. R., Northwestern Bell Telephone Co., Minneapolis, Minn.
- Kates, W., Day & Zimmerman, Inc., Philadelphia, Pa.
- Keene, C. L., Commonwealth Edison Co., Chicago, Ill.
- Kellerman, W. C., Commonwealth Edison Co., Chicago, Ill.
- Kelly, C. B., Commonwealth Edison Co., Chicago, Ill.
- Kennedy, A., Trans. Radio Operator, Radio WHN, Loews State Theatre, New York, N. Y.
- Kennedy, R. B., Commonwealth Edison Co., Chicago, Ill.
- Kenyon, H. H., General Electric Co., Pittsfield, Mass.
- Kille, L. A., Bell Telephone Laboratories, Inc., New York, N. Y.
- King, R. P., Stromberg-Carlson Tel. Co., Rochester, N. Y.
- Kirkland, J. S., Commonwealth Edison Co., Chicago, Ill.
- Kjellgren, E., General Electric Co., Pittsfield, Mass.
- Kleene, W. F., Commonwealth Edison Co., Chicago, Ill.
(Applicant for re-election.)
- Kuder, B., Consolidated Gas Elec. Lt. & Pr. Co., Baltimore, Md.
- Kunkel, W. R., Commonwealth Edison Co., Chicago, Ill.
- Kvist, A. E. K., General Electric Co., Pittsfield, Mass.
- La Moree, C. D., Clapp & La Moree, Los Angeles, Calif.
(Applicant for re-election.)
- Krause, C. E., Okla. A. & M. College, Stillwater, Okla.
- Latham, I. J., Commonwealth Edison Co., Chicago, Ill.
- Lawrence, J. D., Jr., Ky. & W. Va. Power Co., Sprigg, W. Va.
- Leavitt, R. B., Claude Neon Lights, New York, N. Y.
- Luhman, T. G., Westinghouse Elec. & Mfg. Co., East Pittsburgh, Pa.
- Lewis, E. H., Edison Elec. Ill. Co. of Boston, Boston, Mass.
- Loftis, I. C., Electrical contractor, Brevard, N. C.
- Lyon, E. D., Commonwealth Edison Co., Chicago, Ill.
- Macha, A., Electric Controller & Mfg. Co., Cleveland, Ohio.
- Mackoff, P. M., Electrical Testing Laboratories, New York, N. Y.
- Marley, G. W., Commonwealth Edison Co., Chicago, Ill.
(Applicant for re-election.)
- Martin, P. S., New England Power Co., Worcester, Mass.
- McBroom, H. R., Hydro-Electric System, Toronto, Ont., Can.
- McCabe, J. V., (Member), U. S. Navy Supply Depot, Brooklyn, N. Y.
- McCallum, V. E., Commonwealth Edison Co., Chicago, Ill.
- McNary, J. C., Asst., U. S. Radio Inspector, Dept. of Commerce, Detroit, Mich.
- Meister, J. B., Commonwealth Edison Co., Chicago, Ill.
- Melcher, H. R., University of Wisconsin, Madison, Wis.
- Merritt, M. S., Alabama Power Co., Birmingham, Ala.
- Meyer, W. P., Salesman & Installation, Radio Sets, Murdock, Neb.
- Mills, L. S., 71 E. Elm St., Chicago, Ill.
- Moffatt, P. K., Memphis Power & Light Co., Memphis, Tenn.
- Montgomery, T. B., Westinghouse Elec. & Mfg. Co., Chicago, Ill.
- Mooney, R. H., Commonwealth Power Corp., Jackson, Mich.
- Moore, W. G., Commonwealth Edison Co., Chicago, Ill.
- Morill, W. J., General Electric Co., Fort Wayne, Ind.
- Mueller, F. G., Commonwealth Edison Co., Chicago, Ill.
- Mylre, C. B., Westinghouse Elec. & Mfg. Co., Edgewood, Pa.
- Myles, J. A., Commonwealth Edison Co., Chicago, Ill.
- Neal, C. T., Patent Lawyer, C. D. Tuska, Springfield, Mass.
- Norden, M., (Fellow), Norden Co., Inc., New York, N. Y.
- Noren, H. E., Public Service Co. of No. Illinois, Evanston, Ill.
- Norton, H. M., General Electric Co., Pittsfield, Mass.
- O'Donoghue, A. S., The Cleveland Union Terminals Co., Cleveland, Ohio.
- Parr, J. F., Stevens & Wood, Platte City, Mo.
- Pates, A. J., Chesapeake & Potomac Tel. Co., Washington, D. C.
- Peirce, C. L., Jr., (Member), Hubbard & Co., Pittsburgh, Pa.
- Perry, L. P., Central Hudson Gas & Electric Co., Poughkeepsie, N. Y.
(Applicant for re-election.)
- Pfau, A., Jr., American Resistor Co., Milwaukee, Wis.
- Pickells, C. W., Jr., N. Y. & Queens Elec. Lt. & Pr. Co., Flushing, N. Y.
- Planas, E. J., New York Electrical School, New York, N. Y.
- Platis, C. S., 61 W. 3rd St., Salt Lake City, Utah.
- Podlasky, B., Bureau of Pr. & Lt., City of Los Angeles, Los Angeles, Calif.
- Poss, J., Jr., Brooklyn Edison Co., Brooklyn, N. Y.
- Prusman, C. A., Commonwealth Edison Co., Chicago, Ill.
- Rafuse, I. S., Bell Telephone Laboratories, Inc., New York, N. Y.
- Rahr, F. A., Jr., Hoberg Paper & Fibre Co., Green Bay, Wis.

- Ratcliffe, H. H., Jr., Westinghouse Elec. & Mfg. Co., East Pittsburgh, Pa.
- Reid, W. J. W., Otis Fensom Elevator Co., Hamilton, Ont., Can.
- Rhoades, M., 1st Lieut. Cavalry, U. S. A., Fort Bliss, Texas.
- Rinehart, J. R., Commonwealth Edison Co., Chicago, Ill.
- Ringdahl, H. O., F. A. D. Andrea, Inc., New York, N. Y.
- Romig, F. W., Brooklyn Edison Co., Brooklyn, N. Y.
- Ross, R. V., Westinghouse Elec. & Mfg. Co., Wilkesburg, Pa.
- Rosset, M. J., Brooklyn Edison Co., Brooklyn, N. Y.
- Rothen, E. M., Russell & Stoll Co., New York, N. Y.
- Rush, I. L., Commonwealth Edison Co., Chicago, Ill.
- Ryan, E. A., Commonwealth Edison Co., Chicago, Ill.
- Salle, W. H., Commonwealth Edison Co., Chicago, Ill.
- Samson, J. J., Commonwealth Edison Co., Chicago, Ill.
- Sanderson, G. L., City Building Dept., Akron, Ohio.
- Schlasman, W. H., American Tel. & Tel. Co., New York, N. Y.
- Schrank, W. H., Brooklyn Edison Co., Brooklyn, N. Y.
- Schultz, E. B. E., Power House No. 1, Big Creek, Calif.
- Schwab, C. B., Erner Electric Co., Cleveland, Ohio.
- Schwartz, L., Elec. & Mech. Contractor, Bronx, New York, N. Y.
- Scott, D., J. G. White Engg. Corp., New York, N. Y.
- Seibert, R. H., Ohio Bell Tel. Co., Cleveland, Ohio.
- Shea, E. C., The Interstate Utilities Co., Spokane, Wash.
- Sheehan, T., E. J. Murphy Co., Springfield, Mass.
- Sherwood, B. C., Commonwealth Edison Co., Chicago, Ill.
- Silvers, R. C., American Tel. & Tel. Co., New York, N. Y.
- Simmons, F. C., Southeastern Underwriters Association, Atlanta, Ga.
- Simpson, H. W., Bell Telephone Co. of Canada, Toronto, Ont., Can.
- Singh, S., Duquesne Light Co., Pittsburgh, Pa.
- Smith, H. E., Commonwealth Edison Co., Chicago, Ill.
- Smith, K. M., Commonwealth Edison Co., Chicago, Ill.
- Smith, T. L., 79 S. Main St., South Norwalk, Conn.
- Sorab, R., 354 10th Street, Brooklyn, N. Y.
- Spoehrer, H. F., McClellan & Junkersfeld, Cahokia Power Plant, Cahokia, Ill., for mail, St., Louis, Mo.
- Stearns, K. R., Worcester Polytechnic Institute, Worcester, Mass.
- Steele, T., Yorkton Municipal Power Plant, Yorkton, Sask., Can.
- Stelzer, J. G., Commonwealth Edison Co., Chicago, Ill.
- Stocking, S. I., Commonwealth Edison Co., Chicago, Ill.
- Stohlquist, G. A., Northern Ohio Traction & Light Co., Akron, Ohio.
- Tracy, C. R., The Penna-Ohio Power & Light Co., Youngstown, Ohio.
- Van de Water, J. W., Western Electric Co., New York, N. Y.
- Van Lear, G. M., United Electric Lt. & Pr. Co., New York, N. Y.
- Wagner, C. P., Northern States Power Co., Minneapolis, Minn.
- Wahlquist, H. W., Northern States Power Co., Minneapolis, Minn.
- Walsho, J. M., Fort Qu' Appelle, Saskatchewan, Can.
- Warner, J. H., Commonwealth Edison Co., Chicago, Ill.
- Warren, R. D., All America Cables, New York, N. Y.
- White, E. S., California Telephone Co., Los Angeles, Calif.
- Williams, R. D., Michigan Bell Telephone Co., Detroit, Mich.
- Winans, J. D., Public Service Production Co., Newark, N. J.
- Woodbury, P. D., Westinghouse Electric & Mfg. Co., New York, N. Y.
- Woodmancy, W. T., Crecelius & Phillips, Cleveland, Ohio.
- Wyatt, E. A., Commonwealth Edison Co., Chicago, Ill.
- Wylie, W. L., Commonwealth Edison Co., Chicago, Ill.
- Zinder, H., Commonwealth Edison Co., Chicago, Ill.
- (Total 233)
- Foreign**
- Alijan, H., G. I. P. Railway, Parel, Bombay, India.
- Bapooji, E. J., The Shahabad Cement Co. Ltd., Shahabad, India.
- Das, A. C., The Rajkot State Electric Supply Co., Rajkot, Kathiawar, India.
- Davenport, A. E., Public Works Dept., Hamilton, N. Z.
- Kamensky, M. D., (Fellow), Direction of United Gov. El. Stations, Leningrad, Russia.
- Hart, W. C., Electrical Contractor, "The Shrubbery," Collymore Rock, St. Michael, Barbadoes, B. W. I.
- Knight, R., Dannevirke Electric Power Board, Dannevirke, N. Z.
- Mehta, S. M., The Invicta Electrical Equipment Co., Fort Bombay, India.
- Mooney, V. S., Electric Power Board, Dannevirke, N. Z.
- Moore, J. W., (Member), Tela Railroad Co., Tela, Rep. Honduras, C. A.
- Pallonji, D., Marine Elec. Engg. Works, Bombay, India.
- Seaviour, C. H., The Marconi International Marine Communication Co., London, W. C., 2. Eng. for mail, Portuguese, E. Africa.
- Storarr, J. H., Rees Roturbo Mfg. Co., Wolverhampton, Eng.
- Witty, G. F., Electric Power Board, Wellington, N. Z.
- Yun, G. C., Yu-Foong Cotton Mill, Chengchow, Honan, China.
- Total 15
- STUDENTS ENROLLED
FEBRUARY 6, 1925**
- Adkins, Preston L., Oregon Agricultural College
- Aldrich, Stephen P., Colorado State Agricultural College
- Amburgh, Sydney M., University of Colorado
- Armstrong, Cole A., Colorado State Agricultural College
- Arnold, Albert, Rhode Island State College
- Austin, Kirby B., Oregon Agricultural College
- Baier, Jacob J., Lafayette College
- Bailey, Floyd J., Bucknell University
- Barker, Dale, University of Wyoming
- Barlow, Paul L., Clarkson College of Technology
- Bennett, Stanton A., University of Michigan
- Benson, Harold E., University of Colorado
- Blevins, Edward, Texas A. & M. College
- Blum Herman, Brooklyn Polytechnic Institute
- Blunt, Allyn W., California Institute of Technology
- Bodine, Frank E., Colorado State Agricultural College
- Botten, Alfred R., University of North Dakota
- Brainard, Maurice, Rensselaer Polytechnic Institute
- Browne, William H., Bucknell University
- Buchanan, Graham C., Texas A. & M. College
- Buchan, Thomas A., Virginia Polytechnic Institute
- Burgwin, Stephen L., University of Michigan
- Burrell, Randolph W., Rensselaer Polytechnic Institute
- Campbell, Hewitt, University of Missouri
- Catlett, William A., Virginia Polytechnic Institute
- Chu, James C., Clarkson College of Technology
- Clark, Kenneth B., University of Kansas
- Combs, Zenas P., Colorado State Agricultural College
- Compton, Kenneth G., State College of Washington
- Conkel, Lloyd J., Michigan Agricultural College
- Cooke, James W., Virginia Polytechnic Institute
- Cox, Vernon L., University of North Dakota
- Crawford, Gavin M., Kansas State Agricultural College
- Culbreth, Harry W., Virginia Polytechnic Institute
- Cumming, Marlin L., State College of Washington
- Dake, Cecil B., Clarkson College of Technology
- Dana, Laurence E., Chicago Technical College
- Dance, William F., Jr., Virginia Polytechnic Institute
- DeMaio, Nicholas, Clarkson College of Technology
- Dewey, Leland K., Michigan Agricultural College
- Edwards, William G., Jr., University of Colorado
- Evans, Hayward W., Virginia Polytechnic Institute
- Evjen, R. W., University of British Columbia
- Faner, Carl G., Pennsylvania State College
- Fogle, Howard D., Oregon Agricultural College
- Foster, Calvin E., University of Missouri
- Fox, Robert S., Drexel Institute
- Gard, John D., Alabama Polytechnic Institute
- Gluckman, Manuel, Rhode Island State College
- Goff, Othel G., Oregon Agricultural College
- Granger, Wayne E., California Institute of Technology
- Grant, Vernon H., University of Washington
- Graves, Francis C., Virginia Polytechnic Institute
- Greenberg, Roy, University of Wyoming
- Gutshall, Randolph W., University of Colorado
- Harkins, Stanley F., Pennsylvania State College
- Harrison, William N., Clarkson College of Technology
- Hawkins, James B., Virginia Polytechnic Institute
- Hein, Ralph W., State College of Washington
- Heiser, Edwin S., Bucknell University
- Henkle, Claire V., Oregon Agricultural College
- Hennessey, William, Clarkson College of Technology
- Hoddy, George W., Ohio State University
- Hogan, James E., Pennsylvania State College
- Holub, Edward, University of Wisconsin
- Hopkins, J. Wallace, Carnegie Institute of Technology
- Hopkins, William A., Jr., Virginia Military Institute
- Johns, William T., Jr., Virginia Polytechnic Institute
- Jones, Vivan B., O'Neil, State College of Washington
- Keck, Theodore A., Jr., Virginia Polytechnic Institute
- Kellar, Kendall H., Virginia Polytechnic Institute
- Kirwen, Maurice S., Ohio State University
- Knox, Alvin C., University of Southern California
- Knudstrup, Aksel J. C., Michigan Agricultural College
- Lacy, Joel W., Jr., Virginia Polytechnic Institute
- Lamoreau, Paul D., University of Maine
- Little, Elliott M., University of Toronto
- McCormick, Charles E., Colorado State Agricultural College
- McDonald, Malcolm, University of British Columbia
- McMullan, James J., Brooklyn Polytechnic Institute
- Melroy, Paul P., Pennsylvania State College
- Melton, Edward M., Virginia Polytechnic Institute
- Mohler, Francis, Virginia Polytechnic Institute
- Moody, Douglass N., Virginia Polytechnic Institute
- Moran, Joseph H., Virginia Polytechnic Institute
- Murphy, John J., Virginia Polytechnic Institute
- Murton, Chandler R., Clarkson College of Technology

Nagamino, Kimikata, Mass. Institute of Technology	Roso, Clarence J., University of Colorado	Thomas, Hunley E., University of Colorado
Nagloy, Dorcy D., State College of Washington	Rosencrans, Charles A., Bucknell University	Thompson, Bennet R., University of Missouri
Osborne, A. Francis, Virginia Polytechnic Institute	Rotenberry, F. E., Virginia Polytechnic Institute	Thompson, Kenneth A., Virginia Polytechnic Institute
Park, Chauncey M., Michigan Agricultural College	Rudser, Karl L., University of North Dakota	Thompson, Thomas M., University of Missouri
Perkins, Chester W., Case School of Applied Science	Scholldt, Jacob E., University of Colorado	Town, George R., Rensselaer Polytechnic Institute
Phillips, George O., Virginia Polytechnic Institute	Scott, Frank F., University of Michigan	Tucker, Guy O., University of Utah
Picatti, George G., State College of Washington	Scott, Percival T. W., California Institute of Technology	Turner, Alfred H., University of Delaware
Pla, Isidoro L., Drexel Institute	Scull, Herbert M., Columbia University	Turner, Carlyle R., Virginia Polytechnic Institute
Ploof, Julius L., Clarkson College of Technology	Shideler, James H., University of Southern California	Van Ollinda, Frederick, Rensselaer Polytechnic Institute
Pond, Lee C. D., Virginia Polytechnic Institute	Shook, Earley M., Texas A. & M. College	Voyack, Joseph, Cooper Union
Porter, Frank H., Clarkson College of Technology	Sincock, Charles B., Colorado State Agricultural College	Waldhorst, Frank, University of North Carolina
Pote, Alfred J., Mass. Institute of Technology	Slinger, Robert N., Oregon Agricultural College	Walther, George J., Syracuse University
Pound, John C., Oregon Agricultural College	Smith, Edwin D., Jr., Columbia University	Webber, Harlan M., University of Colorado
Pritchard, Samuel R., Jr., Virginia Polytechnic Institute	Smith, Junius R., Clemson Agricultural College	West, T. Hume, Stanford University
Pyles, William T., Virginia Polytechnic Institute	Smith Marshall E., University of Michigan	White, George T., Virginia Polytechnic Institute
Reinhard, William N., University of Detroit	Smith, Neal D., California Institute of Technology	Wibaut, Pierre, Mass. Institute of Technology
Rice, George A., University of Wyoming	Smith, Uel L., University of Missouri	Widener, B. M., Virginia Polytechnic Institute
Ridings, Garvice H., Virginia Polytechnic Institute	Smyth, Ellison A., IV, Virginia Polytechnic Institute	Wiegel Howard B., State College of Washington
Ridley, Frank E., University of Southern California	Sohon, Harry, Cornell University	Wilkinson, William H. H., Syracuse University
Risher, John C., Jr., Colorado State Agricultural College	Soupos, Basil, Columbia University	Woody, William H., Virginia Polytechnic Institute
	Spears, Meade G., Clarkson College of Technology	Young, Gerald C., Virginia Polytechnic Institute
	Staley, Marcus R., Virginia Polytechnic Institute	Zappe, Oscar O., Texas A. & M. College
	Steede, John H., University of British Columbia	Zvorist, Herbert, University of North Dakota
	Sudlow, William H., Clemson Agricultural College	Total

OFFICERS OF A. I. E. E. 1924-1925

President	
FARLEY OSGOOD	
Junior Past Presidents	
HARRIS J. RYAN	FRANK B. JEWETT
Vice-Presidents	
J. E. MACDONALD	EDWARD BENNETT
HERBERT S. SANDS	JOHN HARISBERGER
S. E. M. HENDERSON	HAROLD B. SMITH
H. E. BUSSEY	L. F. MOREHOUSE
WILLIAM F. JAMES	H. W. EALES
Managers	
R. B. WILLIAMSON	H. M. HOBART
A. G. PIERCE	ERNEST LUNN
HARLAN A. PRATT	G. L. KNIGHT
WILLIAM M. MCCONAHEY	JOHN B. WHITEHEAD
W. K. VANDERPOEL	J. M. BRYANT
H. P. CHARLESWORTH	E. B. MERRIAM
Treasurer	
GEORGE A. HAMILTON	
Secretary	
F. L. HUTCHINSON	
Honorary Secretary	
RALPH W. POPE	

LOCAL HONORARY SECRETARIES

T. J. Fleming, Calle B. Mitre 519, Buenos Aires, Argentina
Carroll M. Mauseau, Caixa Postal No. 571, Rio de Janeiro, Brazil
Charles le Maistre, 28 Victoria St., London, S. W., 1, England
A. S. Garfield, 45 Bd. Beausejour, Paris 16 E, France
H. P. Gibbs, Tata Sons, Ltd., Navsari Building, Fort Bombay, India
Guido Semenza, 39 Via Monte Napoleone, Milan, Italy
Eiji Aoyagi, Kyoto Imperial University, Kyoto, Japan
Lawrence Birks, Public Works Department, Wellington, New Zealand
Axel F. Enstrom, 24 A Grefteuregatan, Stockholm, Sweden
W. Elsdon-Dew, P. O. Box 4563, Johannesburg, Transvaal, Africa

A. I. E. E. COMMITTEES

(A list of the personnel of Institute committees may be found in the January issue of the JOURNAL.)

GENERAL STANDING COMMITTEES AND CHAIRMEN

EXECUTIVE, Farley Osgood
FINANCE, G. L. KNIGHT
MEETINGS AND PAPERS, L. W. W. MORROW
PUBLICATION, Donald McNicol

COORDINATION OF INSTITUTE ACTIVITIES, Frank B. Jewett
BRD OF EXAMINERS, H. H. Norris
SECTIONS, Harold B. Smith
STUDENT BRANCHES, C. E. Magnusson
MEMBERSHIP, E. E. Dorting
HEADQUARTERS, E. B. Craft
LAW, L. F. Morehouse
PUBLIC POLICY, H. W. Buck
CODE OF PRINCIPLES OF PROFESSIONAL CONDUCT, John W. Lieb
SAFETY CODES, Paul Spencer
STANDARDS, H. S. Osborne
EDISON MEDAL, Gano Dunn
COLUMBIA UNIVERSITY SCHOLARSHIP, Francis Blossom
AWARD OF INSTITUTE PRIZES, L. W. W. Morrow

TECHNICAL COMMITTEES AND CHAIRMEN

COMMUNICATION, O. B. Blackwell
EDUCATION, Harold Pender
ELECTRICAL MACHINERY, H. M. Hobart
ELECTROCHEMISTRY AND ELECTROMETALLURGY, George W. Vinal
ELECTROPHYSICS, J. H. Morecroft
INSTRUMENTS AND MEASUREMENTS, A. E. Knowlton
APPLICATIONS TO IRON AND STEEL PRODUCTION, F. B. Crosby
PRODUCTION AND APPLICATION OF LIGHT, G. H. Stickney
APPLICATIONS TO MARINE WORK, L. C. Brooks
APPLICATIONS TO MINING WORK, F. L. Stone
GENERAL POWER APPLICATIONS, A. E. Waller
POWER GENERATION, Vern E. Alden
POWER TRANSMISSION AND DISTRIBUTION, Percy H. Thomas
PROTECTIVE DEVICES, H. R. Woodrow
RESEARCH, John B. Whitehead

A. I. E. E. REPRESENTATION

(The Institute is represented on the following bodies; the names of the representatives may be found in the January issue of the JOURNAL.)
AMERICAN ASSOCIATION FOR THE ADVANCEMENT OF SCIENCE, COUNCIL
AMERICAN BUREAU OF WELDING
AMERICAN COMMITTEE ON ELECTROLYSIS
AMERICAN ENGINEERING COUNCIL
AMERICAN ENGINEERING STANDARDS COMMITTEE
AMERICAN MARINE STANDARDS COMMITTEE
APPARATUS MAKERS AND USERS COMMITTEE
BOARD OF TRUSTEES, UNITED ENGINEERING SOCIETY
CHARLES A. COFFIN FELLOWSHIP AND RESEARCH FUND COMMITTEE
ENGINEERING FOUNDATION BOARD
JOHN FRITZ MEDAL BOARD OF AWARD
JOINT CONFERENCE COMMITTEE OF FOUR FOUNDER SOCIETIES
LIBRARY BOARD, UNITED ENGINEERING SOCIETY
NATIONAL FIRE PROTECTION ASSOCIATION, ELECTRICAL COMMITTEE
NATIONAL FIRE WASTE COUNCIL
NATIONAL RESEARCH COUNCIL, ENGINEERING DIVISION
SOCIETY FOR THE PROMOTION OF ENGINEERING EDUCATION, BOARD OF INVESTIGATION AND COORDINATION
U. S. NATIONAL COMMITTEE OF THE INTERNATIONAL ELECTROTECHNICAL COMMISSION
U. S. NATIONAL COMMITTEE OF THE INTERNATIONAL ILLUMINATION COMMISSION
WASHINGTON AWARD, COMMISSION OF
WORLD'S CONGRESS OF ENGINEERS—1926, BOARD OF MANAGEMENT

LIST OF SECTIONS

Name	Chairman	Secretary
Akron	J. T. Walther	F. L. Haushalter, B. F. Goodrich Co., Akron, Ohio
Atlanta	W. R. Collier	H. N. Pye, Box 1743, Atlanta, Ga.
Baltimore	W. B. Kouwenhoven	R. T. Greer, Lexington Building, Baltimore, Md.
Boston	F. S. Dellenbaugh	W. H. Colburn, 39 Boylston St., Boston, Mass.
Chicago	G. H. Jones	K. A. Auty, Room 1000, Edison Bldg., Chicago, Ill.
Cincinnati	O. Shepard	E. S. Fields, Union Gas & Electric Co., Cincinnati, O.
Cleveland	C. P. Cooper	R. A. Carle, 1771 Caryon Road, East Cleveland, O.
Columbus	F. R. Price	O. A. Robins, 1517 Franklin Ave., Columbus, O.
Connecticut	Wm. A. Moore	A. E. Knowlton, Dunham Laboratory, Yale University, New Haven, Conn.
Denver	W. C. Du Vall	R. B. Bonney, Telephone Building, P. O. Box 960, Denver, Colo.
Detroit-Ann Arbor	F. L. Snyder	G. B. McCabe, Detroit Edison Co., Detroit, Mich.
Erie	B. L. Delack	L. H. Curtis, General Electric Co., Erie, Pa.
Fort Wayne	A. B. Campbell	J. L. Moon, General Electric Co., Ft. Wayne, Ind.
Indianapolis-Lafayette	W. A. Black	Victor T. Mavity, 539 N. Capitol Ave., Indianapolis, Ind.
Ithaca	J. G. Pertsch, Jr.	Geo. F. Bason, Cornell University, Ithaca, N. Y.
Kansas City	D. D. Clarke	G. E. Meredith, Kansas City Pr. & Lt. Co., Kansas City, Mo.
Lehigh Valley	J. L. Beaver	G. W. Brooks, Penna. Power & Light Co., Allentown, Pa.
Los Angeles	C. A. Heinze	R. A. Hopkins, 420 S. San Pedro St., Los Angeles, Calif.
Lynn	B. W. St. Clair	H. S. Twisden, General Electric Co., Lynn, Mass.
Madison	R. G. Walter	Leo J. Peters, Elec. Laboratory, University of Wisconsin, Madison, Wis.
Mexico	D. K. Lewis	E. F. Lopez, Fresno No. 111, Mexico, D. F., Mexico
Milwaukee	C. T. Evans	F. K. Brainard, Allis-Chalmers Mfg. Co., West Allis, Wis.
Minnesota	E. H. Scofield	A. G. Dewars, St. Paul Gas Light Co., St. Paul, Minn.
Nebraska	P. M. McCullough	C. W. Minard, 509 Electric Building, Omaha, Neb.
New York	H. H. Barnes, Jr.	R. H. Tapscott, 124 E. 15th St., New York, N. Y.
Niagara Frontier	J. Allen Johnson	A. W. Underhill, Jr., 605 Lafayette Building, Buffalo, N. Y.
Oklahoma	T. M. Fariss	A. D. Stoddard, Box 382, Bartlesville, Okla.
Panama	F. B. Coyle	M. P. Benninger, Box 174, Balboa Heights, C. Z.
Philadelphia	C. D. Fawcett	R. H. Silbert, Philadelphia Elec. Co., 2301 Market St., Philadelphia, Pa.
Pittsburgh	M. E. Skinner	G. S. Humphrey, West Penn Power Co., 14 Wood St., Pittsburgh, Pa.
Pittsfield	N. F. Hanley	J. R. Rue, General Electric Co., Pittsfield, Mass.
Portland, Ore.	H. P. Cramer	Lindsay W. Ross, Pacific Telephone and Telegraph Co., Park and Burnside, Portland, Ore.
Providence	W. B. Lewis	F. N. Tompkins, Brown University, Providence, R. I.
Rochester	F. T. Byrne	E. A. Reinke, Stromberg-Carlson Tel. Mfg. Co., Rochester, N. Y.
St. Louis	B. D. Hull	Chris. H. Kraft, 315 N. 12th St., St. Louis, Mo.
San Francisco	F. R. George	A. G. Jones, 807 Rialto Building, San Francisco, Calif.
Schenectady	J. R. Craighead	W. E. Saupe, Test Dept., General Electric Co., Schenectady, N. Y.
Seattle	J. Hellenthal	C. E. Mong, 505 Telephone Bldg., Seattle, Wash.
Southern Virginia	H. B. Hawkins	E. W. Trafford, Dept. of Publ. Utilities, Richmond, Va.
Spokane	J. S. McNair	Joseph Wimmer, Home Tel. & Tel. Co., 165 S. Howard St., Spokane, Wash.
Springfield, Mass.	G. W. Atkinson	J. Frank Murray, United Elec. Lt. Co., Springfield, Mass.
Syracuse	W. C. Pearce	L. N. Street, College of Applied Science, Syracuse University, Syracuse, N. Y.
Toledo	P. R. Knapp	Max Neuber, 1257 Fernwood Ave., Toledo, O.
Toronto	H. C. Don Carlos	W. L. Amos, Hydro Elec. Power Commission, 190 University Ave., Toronto, Ont.
Urbana	Chas. T. Knipp	Charles A. Keener, 308 Electrical Laboratory, University of Illinois, Urbana, Ill.
Utah	H. W. Clark	John Salberg, W. E. & M. Co., Salt Lake Terminal Bldg., Salt Lake City, Utah
Vancouver	C. N. Beebe	A. Vilstrup, B. C. Electric Railway Co., 425 Carroll St., Vancouver, B. C.
Washington, D. C.	J. H. Ferry	Frank R. Mueller, Bliss Electrical School, Washington, D. C.
Worcester	S. M. Anson	Fred B. Crosby, 15 Belmont St., Worcester, Mass.
Total 49		

LIST OF BRANCHES

Name and Location	Chairman	Secretary
Alabama Poly Inst., Auburn, Ala.	R. A. Betts	A. E. Duran
Alabama, Univ. of, University, Ala.	C. M. Lang	S. E. Dawson
Arizona, Univ. of, Tucson, Ariz.	Edward Moyle	James A. Wilson
Arkansas, Univ. of, Fayetteville, Ark.	Hugh McCain	R. T. Purdy
Armour Inst. of Tech., Chicago, Ill.	A. L. Steamwedel	W. H. Sothen
Brooklyn Poly Inst., Brooklyn, N. Y.	W. A. Ock	G. C. Moog
Bucknell Univ., Lewisburg, Pa.	W. A. Stevens	R. J. Clingerman
California Inst. of Tech., Pasadena	W. A. Lewis	A. E. Schueler
California, Univ. of, Berkeley, Calif.	R. A. Hurley	J. M. Edwards
Carnegie Inst. of Tech., Pittsburgh, Pa.	P. M. Hissom	D. Beecher
Case School of Applied Science, Cleveland, O.	F. B. Schramm	G. J. Goudreau
Catholic Univ. of America, Washington, D. C.	K. T. Williamson	G. B. Mangam
Cincinnati, Univ. of, Cincinnati, O.	R. T. Congleton	W. C. Osterbrook
Clarkson Coll. of Tech., Potsdam, N. Y.	F. H. Porter	F. S. McGowan
Clemson Agri. College, Clemson College, S. C.	R. W. Pugh	O. A. Roberts
Colorado State Agri. Coll., Ft. Collins	S. Aldrich	F. E. Bodine
Colorado, Univ. of, Boulder, Colo.	G. Cartwright	W. T. Crossman
Cooper Union, New York	E. J. Kennedy	A. W. Carlson
Denver, Univ. of, Denver, Colo.	C. C. Herskind	T. R. Cuykendall
Drexel Institute, Philadelphia, Pa.	J. P. Carr	W. P. Turner
Florida, Univ. of, Gainesville, Fla.	J. Weil	C. Washburn, Jr.
Georgia School of Tech., Atlanta, Ga.	R. A. Goodburn	J. A. Minor
Idaho, University of, Moscow, Idaho	H. Armstrong	R. C. Beam
Iowa State College, Ames, Iowa	V. Womeldorf	G. G. Thomas
Iowa, Univ. of, Iowa City, Iowa	G. C. K. Johnson	C. A. Von Hoene
Kansas State College, Manhattan	R. B. McIlvain	G. J. McKimms
Kansas, Univ. of, Lawrence, Kans.	C. H. Freese	G. R. Vernon
Kentucky, Univ. of, Lexington, Ky.	R. K. Giovannoli	R. M. Willis
Lafayette College, Easton, Pa.	J. B. Powell	P. O. Farnham
Lehigh Univ., S. Bethlehem, Pa.	E. W. Baker	D. C. Luce
Lewis Institute, Chicago, Ill.	E. Millison	C. P. Meek
Maine, Univ. of, Orono, Me.	R. N. Haskell	S. B. Coleman
Marquette Univ., Milwaukee, Wis.	W. J. Hebard	C. Legler
Massachusetts Inst. of Tech., Cambridge, Mass.	Stuart John	H. W. Geyer
Michigan Agri. Coll., East Lansing	C. M. Park	O. D. Dausman
Michigan, Univ. of, Ann Arbor, Mich.	F. J. Goellner	M. H. Lloyd
Milwaukee, Engg. School of, Milwaukee, Wis.	L. C. Eddy	E. L. Ruth
Minnesota, Univ. of, Minneapolis	R. W. Kellar	H. R. Reed
Missouri, Univ. of, Columbia, Mo.	M. P. Weinbach	U. Smith
Montana State Coll., Bozeman, Mont.	W. A. Boyer	J. A. Thaler
Nebraska, Univ. of, Lincoln, Neb.	H. Edgerton	R. R. Mülle
Nevada, Univ. of, Reno, Nev.	C. Hicks	G. Fairbrother
New York Univ., New York, N. Y.	D. Wright	J. P. Della Corte
North Carolina State College, Raleigh, N. C.	H. Seaman	J. W. Lewis
North Carolina, Univ. of, Chapel Hill	T. B. Smiley	H. L. Coe
North Dakota, Univ. of, University	Leo Frank	D. Donaldson
Northeastern Univ., Boston, Mass.	E. H. Barker	C. M. McCoombe
Notre Dame, Univ. of, Notre Dame, Ind.	M. A. Brule	J. A. Kelley, Jr.
Ohio Northern Univ., Ada, Ohio	Mr. Cotner	J. K. Fulks
Ohio State Univ., Columbus, O.	T. A. McCann	R. E. Madden
Oklahoma A. & M. Coll., Stillwater	B. Wrigley	K. Woodyard
Oklahoma, Univ. of, Norman, Okla.	R. E. Thornton	F. O. Bond
Oregon Agri. Coll., Corvallis, Ore.	F. C. Mueller	W. D. Bridges
Pennsylvania State College, State College, Pa.	C. MacGuffie	J. H. Schmidt
Pennsylvania, Univ. of, Philadelphia	H. W. Steinhoff	J. W. Emling
Pittsburgh, Univ. of, Pittsburgh, Pa.	E. A. Casey	J. E. Lange
Purdue Univ., Lafayette, Ind.	S. B. Mills	M. G. Seim
Rensselaer Poly. Inst., Troy, N. Y.	F. M. Sebast	C. E. Daniels
Rhode Island State Coll. Kingston, R. I.	C. S. North	D. Brown
Rose Poly. Inst., Terre Haute, Ind.	P. Wilkens	R. A. Reddie
Rutgers University, New Brunswick, N. J.	W. S. Dunn	H. Crowley
South Dakota, Univ. of, Vermillion, S. D.	C. Barret	H. Babb
Southern California, Univ. of, Los Angeles, Calif.	C. B. Little	J. Shideler
Stanford Univ., Stanford University, Calif.	M. L. Wiedmann	F. E. Crever
Swarthmore Coll., Swarthmore, Pa.	C. J. Wenzinger	J. S. Donal, Jr.
Syracuse Univ., Syracuse, N. Y.	W. D. Johnson	W. E. Phillips
Tennessee, Univ. of, Knoxville, Tenn.	S. R. Woods	F. J. Guice
Texas A. & M. Coll., College Station	A. A. Ward	L. H. Cardwell
Texas, Univ. of, Austin, Tex.	A. A. Bown	J. B. Coltharp
Utah, Univ. of, Salt Lake City, Utah	S. W. Pixton	H. H. Tracy
Virginia Military Inst., Lexington	H. P. Watson	J. P. Black
Virginia Poly. Inst., Blacksburg, Va.	E. M. Melton	M. R. Staley
Virginia, Univ. of, University, Va.	W. A. Whitaker	H. H. Long
Washington, State Coll. of, Pullman	Tom Hunt	C. H. Backus
Washington Univ., St. Louis, Mo.	E. Zimmerman	S. E. Newhouse, Jr.
Washington, Univ. of, Seattle, Wash.	J. Nordani	J. W. Lewis
West Virginia Univ., Morgantown	W. W. Mountain	J. U. Neill
Wisconsin, Univ. of, Madison, Wis.	R. R. Benedict	H. E. Reinhold
Yale Univ., New Haven, Conn.	E. H. Eames	F. P. Tomaino
Total 79.		

Nagamino, Kinukata, Mass. Institute of Technology	Rose, Clarence J., University of Colorado	Thomas, Hunley E., University of Colorado
Nagley, Dorcy D., State College of Washington	Rosencranz, Charles A., Bucknell University	Thompson, Bennet R., University of Missouri
Osborne, A. Francis, Virginia Polytechnic Institute	Rosenberry, F. E., Virginia Polytechnic Institute	Thompson, Kenneth A., Virginia Polytechnic Institute
Park, Chauncey M., Michigan Agricultural College	Rudser, Karl L., University of North Dakota	Thompson, Thomas M., University of Missouri
Perkins, Chester W., Case School of Applied Science	Schofield, Jacob E., University of Colorado	Town, George R., Rensselaer Polytechnic Institute
Phillips, George C., Virginia Polytechnic Institute	Scott, Frank F., University of Michigan	Tucker, Guy C., University of Utah
Picatti, George G., State College of Washington	Scott, Percival T. W., California Institute of Technology	Turner, Alfred H., University of Delaware
Pla, Isidoro L., Drexel Institute	Scull, Herbert M., Columbia University	Turner, Carlyle R., Virginia Polytechnic Institute
Ploof, Julius L., Clarkson College of Technology	Shideler, James H., University of Southern California	Van Ollinda, Frederick, Rensselaer Polytechnic Institute
Pond, Lee C. D., Virginia Polytechnic Institute	Shook, Earley M., Texas A. & M. College	Voyack, Joseph, Cooper Union
Porter, Frank H., Clarkson College of Technology	Sincock, Charles B., Colorado State Agricultural College	Waldhorst, Frank, University of North Carolina
Pote, Alfred J., Mass. Institute of Technology	Slinger, Robert N., Oregon Agricultural College	Walther, George J., Syracuse University
Pound, John C., Oregon Agricultural College	Smith, Edwin D., Jr., Columbia University	Webber, Harlan M., University of Colorado
Pritchard, Samuel R., Jr., Virginia Polytechnic Institute	Smith, Junius R., Clemson Agricultural College	West, T. Hume, Stanford University
Pyles, William T., Virginia Polytechnic Institute	Smith Marshall E., University of Michigan	White, George T., Virginia Polytechnic Institute
Reinhard, William N., University of Detroit	Smith, Neal D., California Institute of Technology	Wibaut, Pierre, Mass. Institute of Technology
Rice, George A., University of Wyoming	Smith, Uel L., University of Missouri	Widener, B. M., Virginia Polytechnic Institute
Ridings, Garvice H., Virginia Polytechnic Institute	Smyth, Ellison A., IV, Virginia Polytechnic Institute	Wiegel Howard B., State College of Washington
Ridley, Frank E., University of Southern California	Sohn, Harry, Cornell University	Wilkinson, William H. H., Syracuse University
Risher, John C., Jr., Colorado State Agricultural College	Soupos, Basil, Columbia University	Woody, William H., Virginia Polytechnic Institute
	Spears, Meade G., Clarkson College of Technology	Young, Gerald C., Virginia Polytechnic Institute
	Staley, Marcus R., Virginia Polytechnic Institute	Zappe, Oscar O., Texas A. & M. College
	Steede, John H., University of British Columbia	Zvorist, Herbert, University of North Dakota
	Sudlow, William H., Clemson Agricultural College	Total

OFFICERS OF A. I. E. E. 1924-1925

President	
FARLEY OSGOOD	
Junior Past Presidents	
HARRIS J. RYAN	FRANK B. JEWETT
Vice-Presidents	
J. E. MACDONALD	EDWARD BENNETT
HERBERT S. SANDS	JOHN HARISBERGER
S. E. M. HENDERSON	HAROLD B. SMITH
H. E. BUSSEY	L. F. MOREHOUSE
WILLIAM F. JAMES	H. W. EALES
Managers	
R. B. WILLIAMSON	H. M. HOBART
A. G. PIERCE	ERNEST LUNN
HARLAN A. PRATT	G. L. KNIGHT
WILLIAM M. MCCONAHEY	JOHN B. WHITEHEAD
W. K. VANDERPOEL	J. M. BRYANT
H. P. CHARLESWORTH	E. B. MERRIAM
Treasurer	
GEORGE A. HAMILTON	
Secretary	
F. L. HUTCHINSON	
Honorary Secretary	
RALPH W. POPE	

LOCAL HONORARY SECRETARIES

T. J. Fleming, Calle B. Mitre 519, Buenos Aires, Argentina
Carroll M. Mauseau, Caixa Postal No. 571, Rio de Janeiro, Brazil
Charles le Maistre, 28 Victoria St., London, S. W., 1, England
A. S. Garfield, 45 Bd. Beausejour, Paris 16 E, France
H. P. Gibbs, Tata Sons, Ltd., Navsari Building, Fort Bombay, India
Guido Semenza, 39 Via Monte Napoleone, Milan, Italy
Eiji Aoyagi, Kyoto Imperial University, Kyoto, Japan
Lawrence Birks, Public Works Department, Wellington, New Zealand
Axel F. Enstrom, 24 A Greftevegatan, Stockholm, Sweden
W. Elsdon-Dew, P. O. Box 4563, Johannesburg, Transvaal, Africa

A. I. E. E. COMMITTEES

(A list of the personnel of Institute committees may be found in the January issue of the JOURNAL.)

GENERAL STANDING COMMITTEES AND CHAIRMEN

EXECUTIVE, Farley Osgood
FINANCE, G. L. KNIGHT
MEETINGS AND PAPERS, L. W. W. MORROW
PUBLICATION, Donald McNicol

COORDINATION OF INSTITUTE ACTIVITIES, Frank B. Jewett
BRD OF EXAMINERS, H. H. Norris
SECTIONS, Harold B. Smith
STUDENT BRANCHES, C. E. Magnusson
MEMBERSHIP, E. E. Dorting
HEADQUARTERS, E. B. Craft
LAW, L. F. Morehouse
PUBLIC POLICY, H. W. Buck
CODE OF PRINCIPLES OF PROFESSIONAL CONDUCT, John W. Lieb
SAFETY CODES, Paul Spencer
STANDARDS, H. S. Osborne
EDISON MEDAL, Gano Dunn
COLUMBIA UNIVERSITY SCHOLARSHIP, Francis Blossom
AWARD OF INSTITUTE PRIZES, L. W. W. Morrow

TECHNICAL COMMITTEES AND CHAIRMEN

COMMUNICATION, O. B. Blackwell
EDUCATION, Harold Pender
ELECTRICAL MACHINERY, H. M. Hobart
ELECTROCHEMISTRY AND ELECTROMETALLURGY, George W. Vinal
ELECTROPHYSICS, J. H. Morecroft
INSTRUMENTS AND MEASUREMENTS, A. E. Knowlton
APPLICATIONS TO IRON AND STEEL PRODUCTION, F. B. Crosby
PRODUCTION AND APPLICATION OF LIGHT, G. H. Stickney
APPLICATIONS TO MARINE WORK, L. C. Brooks
APPLICATIONS TO MINING WORK, F. L. Stone
GENERAL POWER APPLICATIONS, A. E. Waller
POWER GENERATION, Vern E. Alden
POWER TRANSMISSION AND DISTRIBUTION, Percy H. Thomas
PROTECTIVE DEVICES, H. R. Woodrow
RESEARCH, John B. Whitehead

A. I. E. E. REPRESENTATION

(The Institute is represented on the following bodies; the names of the representatives may be found in the January issue of the JOURNAL.)
AMERICAN ASSOCIATION FOR THE ADVANCEMENT OF SCIENCE, COUNCIL
AMERICAN BUREAU OF WELDING
AMERICAN COMMITTEE ON ELECTROLYSIS
AMERICAN ENGINEERING COUNCIL
AMERICAN ENGINEERING STANDARDS COMMITTEE
AMERICAN MARINE STANDARDS COMMITTEE
APPARATUS MAKERS AND USERS COMMITTEE
BOARD OF TRUSTEES, UNITED ENGINEERING SOCIETY
CHARLES A. COFFIN FELLOWSHIP AND RESEARCH FUND COMMITTEE
ENGINEERING FOUNDATION BOARD
JOHN FRITZ MEDAL BOARD OF AWARD
JOINT CONFERENCE COMMITTEE OF FOUR FOUNDER SOCIETIES
LIBRARY BOARD, UNITED ENGINEERING SOCIETY
NATIONAL FIRE PROTECTION ASSOCIATION, ELECTRICAL COMMITTEE
NATIONAL FIRE WASTE COUNCIL
NATIONAL RESEARCH COUNCIL, ENGINEERING DIVISION
SOCIETY FOR THE PROMOTION OF ENGINEERING EDUCATION, BOARD OF INVESTIGATION AND COORDINATION
U. S. NATIONAL COMMITTEE OF THE INTERNATIONAL ELECTROTECHNICAL COMMISSION
U. S. NATIONAL COMMITTEE OF THE INTERNATIONAL ILLUMINATION COMMISSION
WASHINGTON AWARD, COMMISSION OF
WORLD'S CONGRESS OF ENGINEERS—1926, BOARD OF MANAGEMENT

LIST OF SECTIONS

Name	Chairman	Secretary
Akron	J. T. Walther	F. L. Haushalter, B. F. Goodrich Co., Akron, Ohio
Atlanta	W. R. Collier	H. N. Pye, Box 1743, Atlanta, Ga.
Baltimore	W.B.Kouwenhoven	R. T. Greer, Lexington Building, Baltimore, Md.
Boston	F. S. Dellenbaugh	W. H. Colburn, 39 Boylston St., Boston, Mass.
Chicago	G. H. Jones	K. A. Auty, Room 1000, Edison Bldg., Chicago, Ill.
Cincinnati	O. Shepard	E. S. Fields, Union Gas & Electric Co., Cincinnati, O.
Cleveland	C. P. Cooper	R. A. Carle, 1771 Caryon Road, East Cleveland, O.
Columbus	F. R. Price	O. A. Robins, 1517 Franklin Ave., Columbus, O.
Connecticut	Wm. A. Moore	A. E. Knowlton, Dunham Laboratory, Yale University, New Haven, Conn.
Denver	W. C. Du Vall	R. B. Bonney, Telephone Building, P. O. Box 960, Denver, Colo.
Detroit-Ann Arbor	F. L. Snyder	G. B. McCabe, Detroit Edison Co., Detroit, Mich.
Erie	B. L. Delack	L. H. Curtis, General Electric Co., Erie, Pa.
Fort Wayne	A. B. Campbell	J. L. Moon, General Electric Co., Ft. Wayne, Ind.
Indianapolis-Lafayette	W. A. Black	Victor T. Mavity, 539 N. Capitol Ave., Indianapolis, Ind.
Ithaca	J. G. Pertsch, Jr.	Geo. F. Bason, Cornell University, Ithaca, N. Y.
Kansas City	D. D. Clarke	G. E. Meredith, Kansas City Pr. & Lt. Co., Kansas City, Mo.
Lehigh Valley	J. L. Beaver	G. W. Brooks, Penna. Power & Light Co., Allentown, Pa.
Los Angeles	C. A. Heinze	R. A. Hopkins, 420 S. San Pedro St., Los Angeles, Calif.
Lynn	B. W. St. Clair	H. S. Twisden, General Electric Co., Lynn, Mass.
Madison	R. G. Walter	Leo J. Peters, Elec. Laboratory, University of Wisconsin, Madison, Wis.
Mexico	D. K. Lewis	E. F. Lopez, Fresno No. 111, Mexico, D. F., Mexico
Milwaukee	C. T. Evans	F. K. Brainard, Allis-Chalmers Mfg. Co., West Allis, Wis.
Minnesota	E. H. Scofield	A. G. Dewars, St. Paul Gas Light Co., St. Paul, Minn.
Nebraska	P. M. McCullough	C. W. Minard, 509 Electric Building, Omaha, Neb.
New York	H. H. Barnes, Jr.	R. H. Tapscott, 124 E. 15th St., New York, N. Y.
Niagara Frontier	J. Allen Johnson	A. W. Underhill, Jr., 605 Lafayette Building, Buffalo, N. Y.
Oklahoma	T. M. Fariss	A. D. Stoddard, Box 382, Bartlesville, Okla.
Panama	F. B. Coyle	M. P. Benninger, Box 174, Balboa Heights, C. Z.
Philadelphia	C. D. Fawcett	R. H. Silbert, Philadelphia Elec. Co., 2301 Market St., Philadelphia, Pa.
Pittsburgh	M. E. Skinner	G. S. Humphrey, West Penn Power Co., 14 Wood St., Pittsburgh, Pa.
Pittsfield	N. F. Hanley	J. R. Rue, General Electric Co., Pittsfield, Mass.
Portland, Ore.	H. P. Cramer	Lindsay W. Ross, Pacific Telephone and Telegraph Co., Park and Burnside, Portland, Ore.
Providence	W. B. Lewis	F. N. Tompkins, Brown University, Providence, R. I.
Rochester	F. T. Byrne	E. A. Reinke, Stromberg-Carlson Tel. Mfg. Co., Rochester, N. Y.
St. Louis	B. D. Hull	Chris. H. Kraft, 315 N. 12th St., St. Louis, Mo.
San Francisco	F. R. George	A. G. Jones, 807 Rialto Building, San Francisco, Calif.
Schenectady	J. R. Craighead	W. E. Saupe, Test Dept., General Electric Co., Schenectady, N. Y.
Seattle	J. Hellenthal	C. E. Mong, 505 Telephone Bldg., Seattle, Wash.
Southern Virginia	H. B. Hawkins	E. W. Trafford, Dept. of Publ. Utilities, Richmond, Va.
Spokane	J. S. McNair	Joseph Wimmer, Home Tel. & Tel. Co., 165 S. Howard St., Spokane, Wash.
Springfield, Mass.	G. W. Atkinson	J. Frank Murray, United Elec. Lt. Co., Springfield, Mass.
Syracuse	W. C. Pearce	L. N. Street, College of Applied Science, Syracuse University, Syracuse, N. Y.
Toledo	P. R. Knapp	Max Neuber, 1257 Fernwood Ave., Toledo, O.
Toronto	H. C. Don Carlos	W. L. Amos, Hydro Elec. Power Commission, 190 University Ave., Toronto, Ont.
Urbana	Chas. T. Knipp	Charles A. Keener, 308 Electrical Laboratory, University of Illinois, Urbana, Ill.
Utah	H. W. Clark	John Salberg, W. E. & M. Co., Salt Lake Terminal Bldg., Salt Lake City, Utah
Vancouver	C. N. Beebe	A. Vilstrup, B. C. Electric Railway Co., 425 Carroll St., Vancouver, B. C.
Washington, D. C.	J. H. Ferry	Frank R. Mueller, Bliss Electrical School, Washington, D. C.
Worcester	S. M. Anson	Fred B. Crosby, 15 Belmont St., Worcester, Mass.
Total 49		

LIST OF BRANCHES

Name and Location	Chairman	Secretary
Alabama Poly Inst., Auburn, Ala.	R. A. Betts	A. E. Duran
Alabama, Univ. of, University, Ala.	C. M. Lang	S. E. Dawson
Arizona, Univ. of, Tucson, Ariz.	Edward Moyle	James A. Wilson
Arkansas, Univ. of, Fayetteville, Ark.	Hugh McCain	R. T. Purdy
Armour Inst. of Tech., Chicago, Ill.	A. L. Steamwedel	W. H. Sothen
Brooklyn Poly Inst., Brooklyn, N. Y.	W. A. Ock	G. C. Moog
Bucknell Univ., Lewisburg, Pa.	W. A. Stevens	R. J. Clingerman
California Inst. of Tech., Pasadena	W. A. Lewis	A. E. Schueler
California, Univ. of, Berkeley, Calif.	R. A. Hurley	J. M. Edwards
Carnegie Inst. of Tech., Pittsburgh, Pa.	P. M. Hissom	D. Beecher
Case School of Applied Science, Cleveland, O.	F. B. Schramm	G. J. Goudreau
Catholic Univ. of America, Washington, D. C.	K. T. Williamson	G. B. Mangam
Cincinnati, Univ. of, Cincinnati, O.	R. T. Congleton	W. C. Osterbrook
Clarkson Coll. of Tech., Potsdam, N. Y.	F. H. Porter	F. S. McGowan
Clemson Agri. College, Clemson College, S. C.	R. W. Pugh	O. A. Roberts
Colorado State Agri. Coll., Ft. Collins	S. Aldrich	F. E. Bodine
Colorado, Univ. of, Boulder, Colo.	G. Cartwright	W. T. Crossman
Cooper Union, New York	E. J. Kennedy	A. W. Carlson
Denver, Univ. of, Denver, Colo.	C. C. Herskind	T. R. Cuykendall
Drexel Institute, Philadelphia, Pa.	J. P. Carr	W. P. Turner
Florida, Univ. of, Gainesville, Fla.	J. Weil	C. Washburn, Jr.
Georgia School of Tech., Atlanta, Ga.	R. A. Goodburn	J. A. Minor
Idaho, University of, Moscow, Idaho	H. Armstrong	R. C. Beam
Iowa State College, Ames, Iowa	V. Womeldorf	G. G. Thomas
Iowa, Univ. of, Iowa City, Iowa	G. C. K. Johnson	C. A. Von Hoene
Kansas State College, Manhattan	R. B. McIlvain	G. J. McKimms
Kansas, Univ. of, Lawrence, Kans.	C. H. Freese	G. R. Vernon
Kentucky, Univ. of, Lexington, Ky.	R. K. Giovannoli	R. M. Willis
Lafayette College, Easton, Pa.	J. B. Powell	P. O. Farnham
Lehigh Univ., S. Bethlehem, Pa.	E. W. Baker	D. C. Luce
Lewis Institute, Chicago, Ill.	E. Millison	C. P. Meek
Maine, Univ. of, Orono, Me.	R. N. Haskell	S. B. Coleman
Marquette Univ., Milwaukee, Wis.	W. J. Hebard	C. Legler
Massachusetts Inst. of Tech., Cambridge, Mass.	Stuart John	H. W. Geyer
Michigan Agri. Coll., East Lansing	C. M. Park	O. D. Dausman
Michigan, Univ. of, Ann Arbor, Mich.	F. J. Goellner	M. H. Lloyd
Milwaukee, Engg. School of, Milwaukee, Wis.	L. C. Eddy	E. L. Ruth
Minnesota, Univ. of, Minneapolis	R. W. Kellar	H. R. Reed
Missouri, Univ. of, Columbia, Mo.	M. P. Weinbach	U. Smith
Montana State Coll., Bozeman, Mont.	W. A. Boyer	J. A. Thaler
Nebraska, Univ. of, Lincoln, Neb.	H. Edgerton	R. R. Mülle
Nevada, Univ. of, Reno, Nev.	C. Hicks	G. Fairbrother
New York Univ., New York, N. Y.	D. Wright	J. P. Della Corte
North Carolina State College, Raleigh, N. C.	H. Seaman	J. W. Lewis
North Carolina, Univ. of, Chapel Hill	T. B. Smiley	H. L. Coe
North Dakota, Univ. of, University	Leo Frank	D. Donaldson
Northeastern Univ., Boston, Mass.	E. H. Barker	C. M. McCoombe
Notre Dame, Univ. of, Notre Dame, Ind.	M. A. Brule	J. A. Kelley, Jr.
Ohio Northern Univ., Ada, Ohio	Mr. Cotner	J. K. Fulks
Ohio State Univ., Columbus, O.	T. A. McCann	R. E. Madden
Oklahoma A. & M. Coll., Stillwater	B. Wrigley	K. Woodyard
Oklahoma, Univ. of, Norman, Okla.	R. E. Thornton	F. O. Bond
Oregon Agri. Coll., Corvallis, Ore.	F. C. Mueller	W. D. Bridges
Pennsylvania State College, State College, Pa.	C. MacGuffie	J. H. Schmidt
Pennsylvania, Univ. of, Philadelphia	H. W. Steinhoff	J. W. Emling
Pittsburgh, Univ. of, Pittsburgh, Pa.	E. A. Casey	J. E. Lange
Purdue Univ., Lafayette, Ind.	S. B. Mills	M. G. Seim
Rensselaer Poly. Inst., Troy, N. Y.	P. M. Sebast	C. E. Daniels
Rhode Island State Coll. Kingston, R. I.	C. S. North	D. Brown
Rose Poly. Inst., Terre Haute, Ind.	P. Wilkens	R. A. Reddie
Rutgers University, New Brunswick, N. J.	W. S. Dunn	H. Crowley
South Dakota, Univ. of, Vermillion, S. D.	C. Barret	H. Babb
Southern California, Univ. of, Los Angeles, Calif.	C. B. Little	J. Shideley
Stanford Univ., Stanford University, Calif.	M. L. Wiedmann	F. E. Crever
Swarthmore Coll., Swarthmore, Pa.	C. J. Wenzinger	J. S. Donal, Jr.
Syracuse Univ., Syracuse, N. Y.	W. D. Johnson	W. E. Phillips
Tennessee, Univ. of, Knoxville, Tenn.	S. R. Woods	F. J. Guice
Texas A. & M. Coll., College Station	A. A. Ward	L. H. Cardwell
Texas, Univ. of, Austin, Tex.	A. A. Bown	J. B. Coltharp
Utah, Univ. of, Salt Lake City, Utah	S. W. Pixton	H. H. Tracy
Virginia Military Inst., Lexington	H. F. Watson	J. P. Black
Virginia Poly. Inst., Blacksburg, Va.	E. M. Melton	M. R. Staley
Virginia, Univ. of, University, Va.	W. A. Whitaker	H. H. Long
Washington, State Coll. of, Pullman	Tom Hunt	C. H. Backus
Washington Univ., St. Louis, Mo.	E. Zimmerman	S. E. Newhouse, Jr.
Washington, Univ. of, Seattle, Wash.	J. Nordahl	J. W. Lewis
West Virginia Univ., Morgantown	W. W. Mountain	J. U. Neill
Wisconsin, Univ. of, Madison, Wis.	R. R. Benedict	H. E. Reinhold
Yale Univ., New Haven, Conn.	E. H. Eames	F. F. Tomaino
Total 79.		

DIGEST OF CURRENT INDUSTRIAL NEWS

NEW CATALOGUES AND OTHER PUBLICATIONS

Mailed to interested readers by issuing companies.

Ground Rods.—Revised engineering data and tests, 6 pp., on "Copperweld" ground rods. Copperweld Steel Company, Rankin, Pa.

Megohmers.—Bulletin 135, 8 pp. Describes Standco "2 in 1" megohmers for measuring insulation resistance. Herman H. Sticht & Company, 15 Park Row, New York.

Ball Bearing Motors.—Bulletins H-280, 16 pp., and H-287, 32 pp. Describe Fairbanks-Morse ball bearing motors. Fairbanks, Morse & Co., Indianapolis, Ind.

Oil-Electric Locomotive.—Bulletin 44103.1, 8 pp. Describes the sixty-ton, oil-electric locomotive developed by the General Electric, American Locomotive and Ingersoll-Rand companies. General Electric Company, Schenectady, N. Y.

Portable Electric Tools.—Catalog 8, 32 pp. Describes Black & Decker portable electric tools and shop equipment, including drills, grinders, tappers, screw drivers, etc., and bench equipment. The Black & Decker Mfg. Company, Towson, Maryland.

Vreeland Oscillator.—Bulletin 984, 8 pp. Describes the Vreeland oscillator and other devices for producing high frequency alternating currents necessary to measure inductance, capacity and resistance. Leeds & Northrup Company, 4901 Stenton Avenue, Philadelphia, Pa.

Weldless Steel Poles.—Bulletin 12, 4 pp. Describes Mannesmann one-piece, seamless, tubular steel poles for trolley, telephone, telegraph or transmission lines. Greater strength with less weight than welded poles, among other advantages, are claimed for this product. Viele, Blackwell & Buck, U. S. Representatives, 49 Wall Street, New York.

Relays.—Bulletin 47640.2, 16 pp., devoted to induction, time, over-current relays, types IA-201, IA-202, IA-205 and IA-206. Details of construction, lists of available ratings and principles of operation are covered, together with other general information. General Electric Company, Schenectady, N. Y.

Switch Houses.—Bulletin 458, 2 pp. Describes a new line of Condit switch houses for indoor and outdoor service. These houses are used to provide protection for switching equipment where the power required is too small to justify the erection of a more expensive substation. Condit Electrical Manufacturing Co., South Boston, Mass.

Transformers.—Bulletins 2039 and 2040, each 4 pp. Describe Pittsburgh polyphase power transformers, including five-legged design. The bulletins contain illustrations of the design of various sizes of such transformers, and compare their performances with three single-phase transformers. Bulletin 2038, 4 pp., describes the new Pittsburgh self-cooled radiator type transformer. Pittsburgh Transformer Co., Columbus & Preble Aves., Pittsburgh, Pa.

Insulation Testing Equipment.—Catalog 1075, 52 pp. Describes Megger and Bridge Megger testing sets for testing electrical insulation and all types of electrical apparatus. Illustrated with charts, diagrams and photographs and contains a chapter on "Insulation and the Measurement of its Resistance," which goes into the causes of breakdown, effects of temperature, surface leaks, etc. James G. Biddle, 1211 Arch Street, Philadelphia, Pa.

Burrows Permeameter-Epstein Core Loss Apparatus.—Bulletin 533, 8 pp. Describes Burrows permeameter designed for testing bar samples, which is considered the most accurate known arrangement for obtaining normal induction, residual induction and coercive force data on straight samples of maximum permeability not exceeding 10,000. The Epstein core loss apparatus, also described in the bulletin, is designed for measuring core losses in accordance with A. S. T. M. testing specifications. Leeds & Northrup Company, 4901 Stenton Avenue, Philadelphia, Pa.

Oil Switches and Circuit Breakers.—Bulletin 423-3, 4 pp. Describes the type "Y" line of Condit oil switches and circuit breakers, manual and electrical remote control, automatic or non-automatic. Bulletin 456-2, 4 pp., describes electrically operated mechanism for the automatic closing and reclosing of oil switches and circuit breakers, (indoor or outdoor) by direct or alternating current. Condit Electrical Manufacturing Co., South Boston, Mass.

Centrifugal Pumps for Handling Oil.—Bulletin 126, 28 pp. Comprises the result of an investigation of the performance of centrifugal pumps when pumping oils, made for the Goulds Manufacturing Co., by Robert L. Daugherty, Professor of Mechanical and Hydraulic Engineering, California Institute of Technology. The various charts show the performance of centrifugal pumps when handling oils varying widely in viscosity, as compared with the performance when pumping water, and will be of assistance in determining the performance of centrifugal pumps when handling viscous liquids of any kind. The Goulds Manufacturing Co., Seneca Falls, N. Y.

NOTES OF THE INDUSTRY

Dust Seals for Hanger Boxes.—The Fafnir Bearing Company, New Britain, Conn., has placed on the market a new extra dust seal furnished with its hanger boxes and pillow blocks, and for use under conditions where there is an unusually large amount of dust, such as exists in cement mills, grinding rooms, mines, etc.

The American Resistor Company, Milwaukee, Wis., manufacturer of "Globar" a non-metallic electric heating element, has opened branch offices at 46 Dey Street, New York; 917 Packard Bldg., Philadelphia; 802 Title Insurance Bldg., Los Angeles. The British Resistor Company, Aintree, Liverpool, England, and Kummler & Matter, Aarau, Switzerland, have been appointed representatives.

Thin Lead Colored Pencil.—To meet the growing demand among draftsmen, engineers, editors, artists, etc., for a colored pencil with the same diameter lead as an ordinary drawing pencil, a new line of "Unique" pencils with thin leads, has been developed by the American Lead Pencil Company. The new product, made in red, blue, green and yellow, is said to possess many advantages over the soft and flaky leads found in ordinary thick colored pencils. Samples will be forwarded upon request to the American Lead Pencil Company, 204 Fifth Avenue, New York.

The Sangamo Electric Company, Springfield, Ill., has developed a maximum-demand attachment for use on its horizontal polyphase watthour meters. As this meter gives power-factor indications on balanced circuits in addition to energy measurements, the use of a maximum-demand attachment permits energy, kilowatt-demand and power-factor readings to be taken on the same meter. This demand attachment as well as the maximum-demand attachments for Sangamo single-phase and vertical polyphase watthour meters can now be supplied with a contact device which will ring a bell, or give some other suitable signal, when the demand during any time interval reaches a certain predetermined value.

Charles M. Young, chief engineer of the Jeffrey-DeWitt Insulator Company, Kenova, W. Va., died on January 31, of blood poisoning. Mr. Young was only thirty years of age, but was responsible for many improvements in the manufacture of high tension insulators. He designed most of the automatic machinery for forming Jeffrey-DeWitt insulators, made improvements in their mechanical strength, designed a combined tensile and electrical testing machine for final tests, and made many other valuable and permanent contributions to the success of this product.

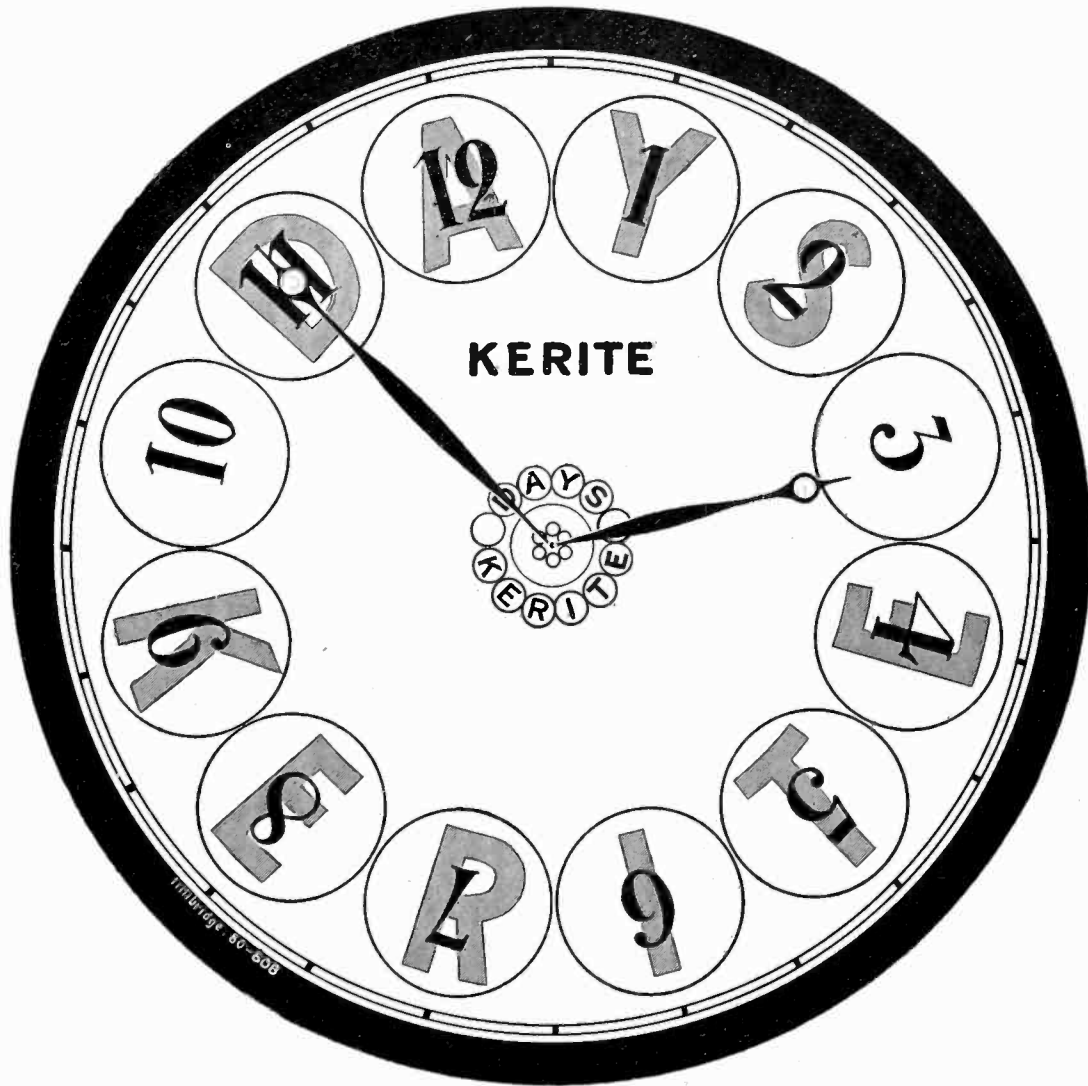

*Time is the great test.
The most efficient and
permanent insulation
known is*

KERITE

THE KERITE INSULATED WIRE & CABLE COMPANY INC
NEW YORK CHICAGO

HOFFMANN PRECISION ROLLER BEARINGS

Make Good Heavy-Duty Motors Better

These heavy-duty bearings, manufactured to unequalled standards of precision, afford the maximum of serviceability under the severe conditions which motor service imposes—conditions often involving heavy loads, hard service, temporary overloads, shock, jar and vibration. They have all the speed qualities of the best ball bearing, with a far greater steady load capacity than any ball bearing and a large overload capacity. They make possible true anti-friction economies in the field of heavy-duty motors.

Our engineers will welcome an opportunity to work with yours, in applying these heavy-duty high-precision bearings to your motor equipment, with a view to longer life, lower maintenance and improved performance.

**NORMA-HOFFMANN
BEARINGS CORPORATION**
Stamford — Connecticut
PRECISION BALL, ROLLER AND THRUST BEARINGS

For Motors

SUBJECT TO

**Heavy Loads,
Overloads,
Load Changes,
Hard Service,
Shock, Jar,
Vibration**

**All Speeds
and Powers**

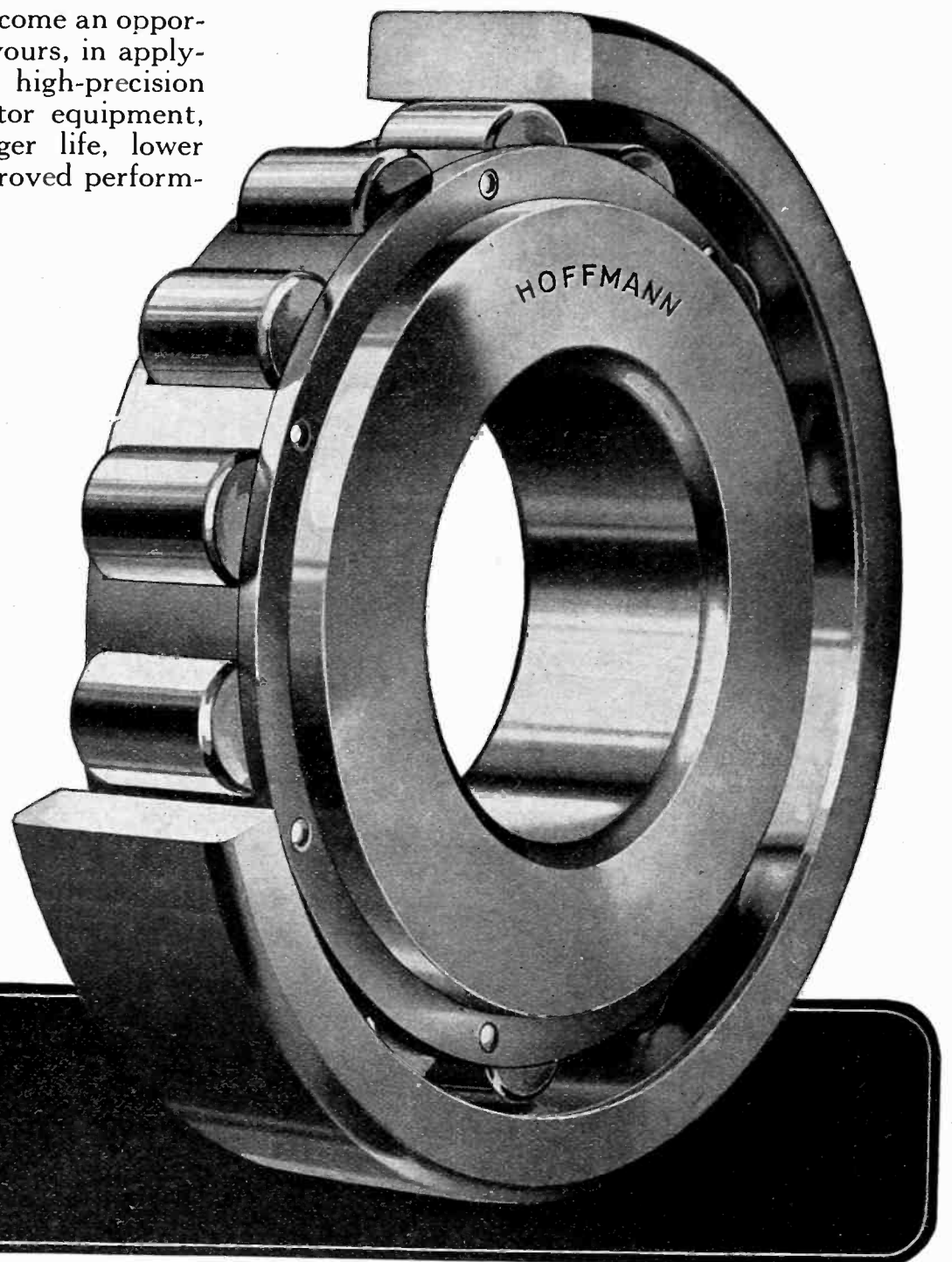

Please mention the JOURNAL of the A. I. E. E. when writing to advertisers.



New Departure Ball Bearings

952

PERSISTENCE in the pursuit of quality has brought an unexampled demand for New Departure Ball Bearings from the leaders in American industry. Growth has brought greatly enhanced responsibility for the maintenance of the highest standards as well as unusual facilities for research and continued improvement.

The New Departure Ball Bearing is more than a mere mechanical device. It is a product built about an ideal and a service co-extensive with the life of the mechanism in which it is installed.

Every part, including the balls, is made in the New Departure plants—excepting only the hot rolled steel.

The New Departure Manufacturing Company
 Detroit Bristol, Conn. Chicago
 56 Victoria St., London, S. W. 1, England

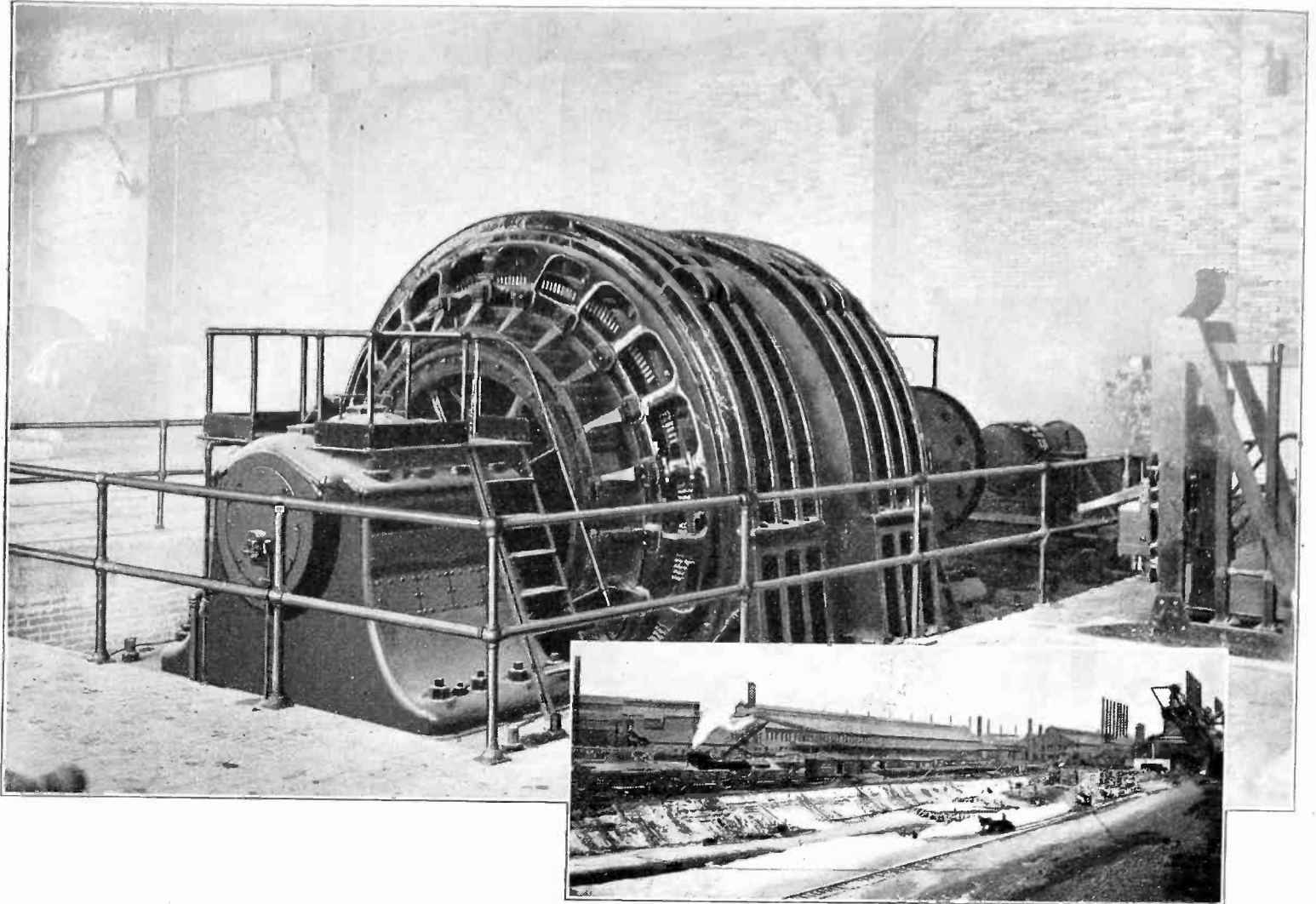

On the largest blooming mill motor in the country

NATIONAL Pyramid Brushes are the choice of the engineers responsible for the performance of the largest blooming mill motor in the United States. This motor has two commutators in series, 900 volts DC on each, total 1800 volts, current 9000 amperes. Starting from rest, the motor is capable of accelerating to 120 RPM in one direction, then reversing to 120 RPM in the opposite direction in six seconds. Momentarily, the motor will develop 22,000 HP at 50 RPM.

National Pyramid Brushes give sparkless commutation on this giant machine. The commutators are in excellent shape, and the brushes have a long life. They were selected as standard after other brushes had failed.

The ability of National Pyramid Brushes to perform perfectly under the most severe conditions is complete proof of their capacity to do equally well in average installations.

Our Sales Engineers are at your service.

National Pyramid Brushes

Manufactured and guaranteed by
NATIONAL CARBON COMPANY, INC.
Cleveland, Ohio Carbon Sales Division San Francisco, Cal.

Canadian National Carbon Co., Limited, Toronto, Ontario

Emergency Service Plants

CHICAGO, ILL.: 551 West Monroe St.
Phone: STate 6092

PITTSBURGH, PA.:
7th Floor, Arrott Power Bldg. No. 3, Barker Place
Phone: ATLantic 3570

NEW YORK, N. Y.: 237 East 41st St.
Phone: VANderbilt 0425

Please mention the JOURNAL of the A. I. E. E. when writing to advertisers.

Advantages of Ball Bearings for Electric Motors

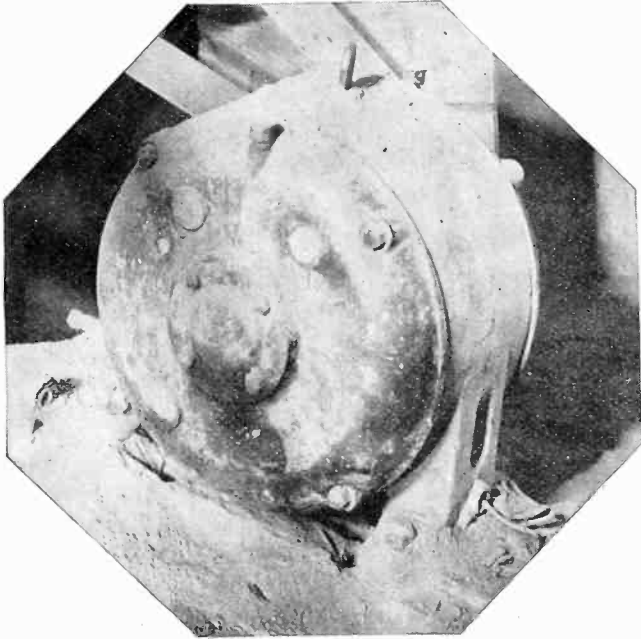

Louis Allis motor with Fafnir Ball Bearings under bad conditions in a clay products company. This motor has been in service continually for 5 years; the only expense connected with it has been greasing once a month and cleaning once a year.

III. Clean Bearings.

There is hardly a place in any shop or any industry where electric motors are not subject to conditions of dirt or dust. At their best industrial plants are pretty dirty places—at their worst we have the conditions of the cement mill, woodworking plant, grinding room, steel mill and coal mine.

Under these inevitably dirty conditions plain bearings absorb an astonishing amount of dirt. Their open housings make it easy for dirt to be drawn in as the shaft revolves. This dirt collecting inside the bronze bearing acts as an abrasive, making both shaft and bearing wear rapidly. The result is a dropping of the armature, a short circuit, time out for rebabbiting and possibly a new armature shaft. When this is happening regularly to all the motors in a plant, it means money.

The end-bells of ball bearings are dirt-proof. Even under conditions like those in the photograph the bearings are *always* running clean. This means: 1.—Longer motor life. 2.—No costly repairs. 3.—No time out for repairs.

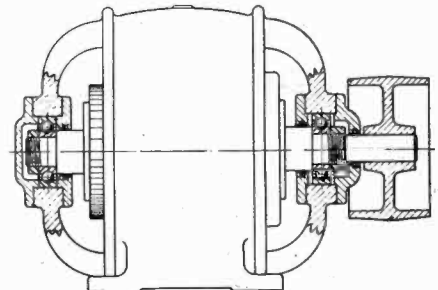

Typical ball bearing motor mounting. Note the sealed end-bells which absolutely prevent dirt from getting into the bearing.

The Fafnir Bearing Company

Detroit

New Britain, Conn.

Chicago

Makers of high grade ball bearings—the most complete line of types and sizes in America.

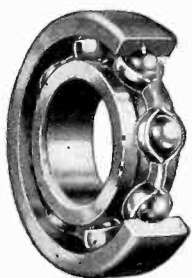

FAFNIR

BALL BEARINGS

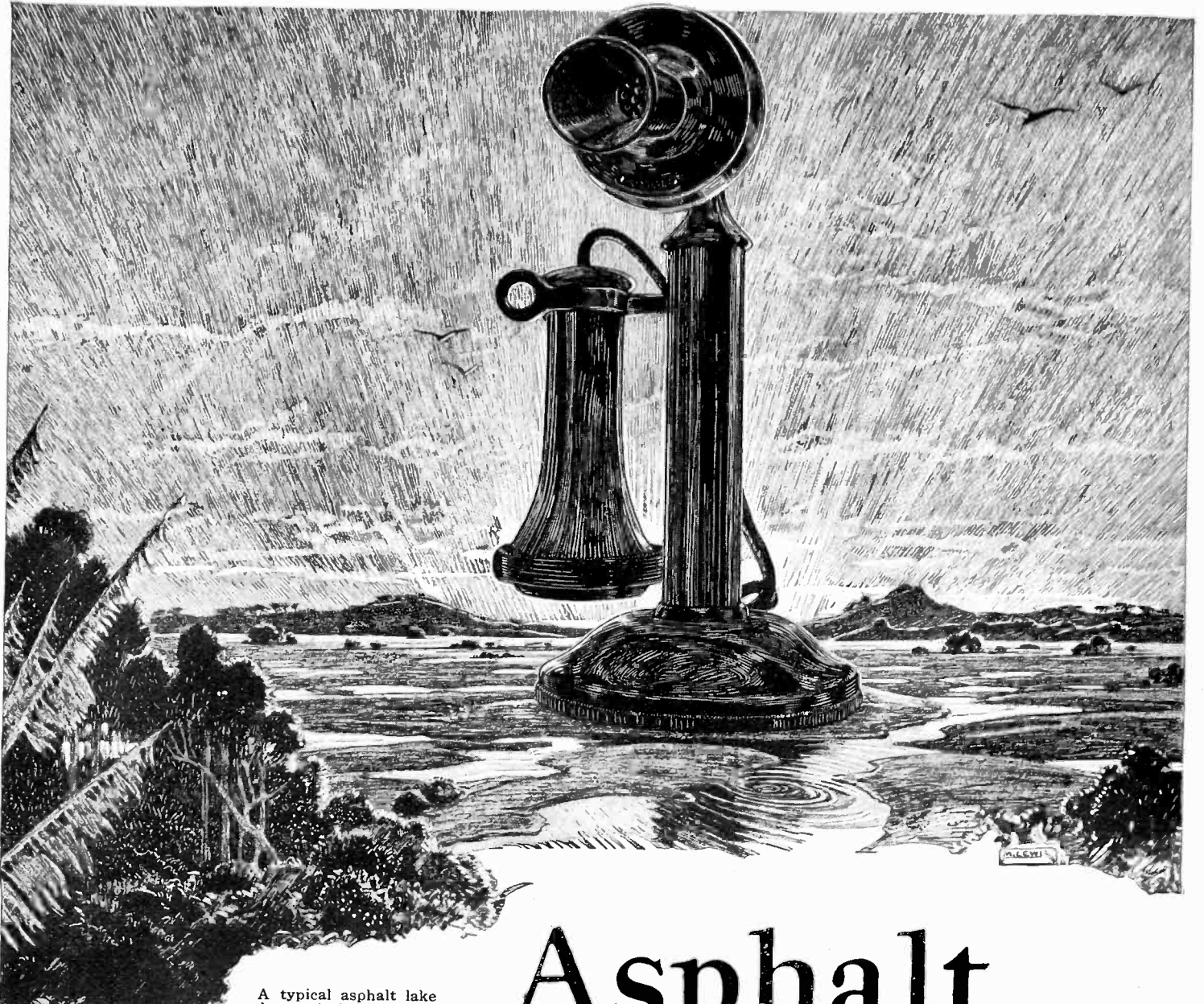

A typical asphalt lake under tropical skies where asphalt oozes up from the depths of the earth. In the United States asphalt is produced in the refining of petroleum.



The test. This rubbing instrument imitates the pressure of your hand on the coated transmitter stand. Applied steadily for days, it gives an equivalent of several years' actual service.

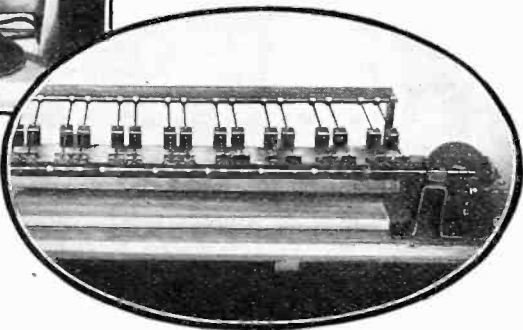

Asphalt

— in your telephone*

It is a fact! Asphalt, like that with which your streets are paved, is used to help coat the telephone on your desk—a protection against the perspiration and pressure of your hand.

Why asphalt? is a natural question. The answer is the same as to why gold? Why silk? Why coal?—or any of the other surprising materials in a telephone. *It is the best for the requirement.*

Search for these "bests" has led Western Electric all over the world. Your telephone is the product of six continents, but of one guiding purpose—to produce an instrument that will work right, look right and last long.

*No. 10 of a series on raw materials.

Western Electric

SINCE 1869 MAKERS OF ELECTRICAL EQUIPMENT

Please mention the JOURNAL of the A. I. E. E. when writing to advertisers.

Now, Mr. Dealer— It Costs You Nothing to Give PULLEY SERVICE

HOW to give service on motor pulleys, without tying up too much money in stock has been a problem with many dealers in the past.

A small stock of pulleys always fell short of being adequate to cover the range of sizes called for. And a big stock with its slow turn-over, made service cost too much.

But now—you can give pulley service without tying up one cent in stock. And you can make just as good profit. The stock Rockwood Paper Pulleys—and the distribution plan behind them—makes this possible.

We now carry 2194 sizes of Rockwood Paper Pulleys in 16 industrial centers. And other distributing points are being established. These stock sizes of

Rockwood Paper Pulleys are from 1½" to 14" diameters—in a complete range of face widths and shaft sizes. 2194 different sizes in all—each a finished pulley, ready for immediate demand.

2194 pulley sizes represent too much money for dealers to tie up in a slow moving item like pulleys. Yet, we know after years of experience that it takes all these sizes to give *real pulley service*, without resorting to boring or turning down, which only increase the cost of the pulley and adds nothing to its value.

We have placed a stock of the standardized sizes of Rockwood Paper Pulleys near you. This is *your stock*. Use it—and you can give the pulley service you have always wanted to give.

Listed below are the Rockwood Paper Pulley warehouses established to date. Order from the warehouse nearest you giving the diameter of pulley wanted, width of belt to be used, shaft size and dimensions of keyway in shaft. Ask for booklet, (form 546).

- | | |
|---|-----------------------------|
| BOSTON, MASS., ROCKWOOD PAPER PULLEY STORES, Inc., Olmsted-Flint Company, Cambridge | All Sizes 2 to 14 in. dia. |
| CHICAGO, ILL., ROCKWOOD PAPER PULLEY STORES, Inc., Chicago Electric Company, 740 W. Van Buren St. | All Sizes 2 to 14 in. dia. |
| CINCINNATI, O., ROCKWOOD PAPER PULLEY STORES, Inc., The Doermann-Roehrer Co., 450-456 East Pearl St. | All Sizes 2 to 10 in. dia. |
| CLEVELAND, O., ROCKWOOD PAPER PULLEY STORES, Inc., The Strong, Carlisle & Hammond Co., 1394 W. Third St. | All Sizes 2 to 14 in. dia. |
| DENVER, COLO., ROCKWOOD PAPER PULLEY STORES, Inc., The Hendrie & Bolthoff Mfg. & Sup. Co., 1635 17th St. | All Sizes 2 to 8 in. dia. |
| DETROIT, MICH., ROCKWOOD PAPER PULLEY STORE, Inc., Spaulding Electric Company, 1344-1346 Michigan Ave. | All Sizes 2 to 14 in. dia. |
| INDIANAPOLIS, IND., ROCKWOOD PAPER PULLEY STORES, Inc., 1801 English Avenue | All Sizes 2 to 14 in. dia. |
| KANSAS CITY, MO., ROCKWOOD PAPER PULLEY STORES, Inc., Webb Belting Company, 1501 West Twelfth St. | All Sizes 2 to 10 in. dia. |
| LOS ANGELES, CAL., ROCKWOOD PAPER PULLEY STORES, Inc., Illinois Electric Company, 313 S. San Pedro St. | All Sizes 2 to 20 in. dia. |
| NEW YORK CITY, ROCKWOOD PAPER PULLEY STORES, Inc., W. A. Jones Fdy & Machine Co., Church and Murray Sts. | All Sizes 2 to 14 in. dia. |
| PHILADELPHIA, PENN., ROCKWOOD PAPER PULLEY STORES, Inc., Charles Bond Company, 617 Arch St. | All Sizes 2 to 14 in. dia. |
| PITTSBURGH, PENN., ROCKWOOD PAPER PULLEY STORES, Inc., Transmission & Belting Co., 325 Second Ave. | All Sizes 2 to 12 in. dia. |
| SALT LAKE CITY, UTAH, ROCKWOOD PAPER PULLEY STORES, Inc., Capital Electric Co., 310-314 W. Second South St. | All Sizes 2 to 8 in. dia. |
| SAN FRANCISCO, CALIFORNIA, BUZZELL ELECTRIC WORKS, 532 Sansome St. | Most Sizes 2 to 18 in. dia. |
| SEATTLE, WASH., ROCKWOOD PAPER PULLEY STORES, Inc., Seattle Hardware Co., 501 First Ave. South | All Sizes 2 to 14 in. dia. |
| ST. LOUIS, MISSOURI, ROCKWOOD PAPER PULLEY STORES, Inc. 801 North Second Street | All Sizes 2 to 14 in. dia. |

2194
STOCK SIZES
ROCKWOOD PAPER PULLEYS
(1½ to 14-inch Diameters)

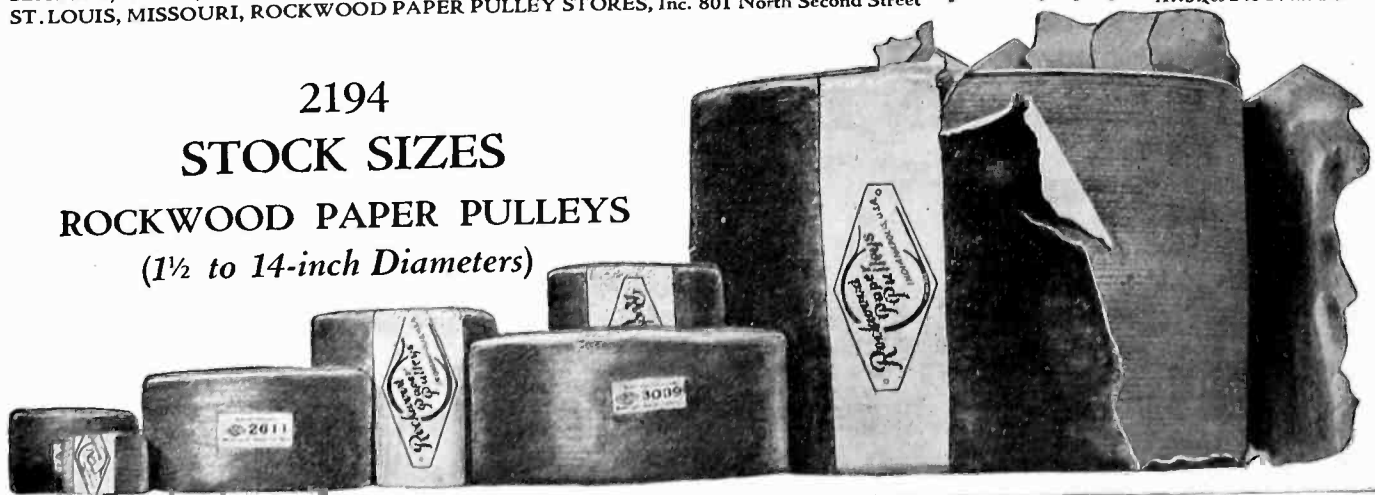

THE ROCKWOOD MANUFACTURING CO Indianapolis, Ind.

Please mention the JOURNAL of the A. I. E. E. when writing to advertisers.

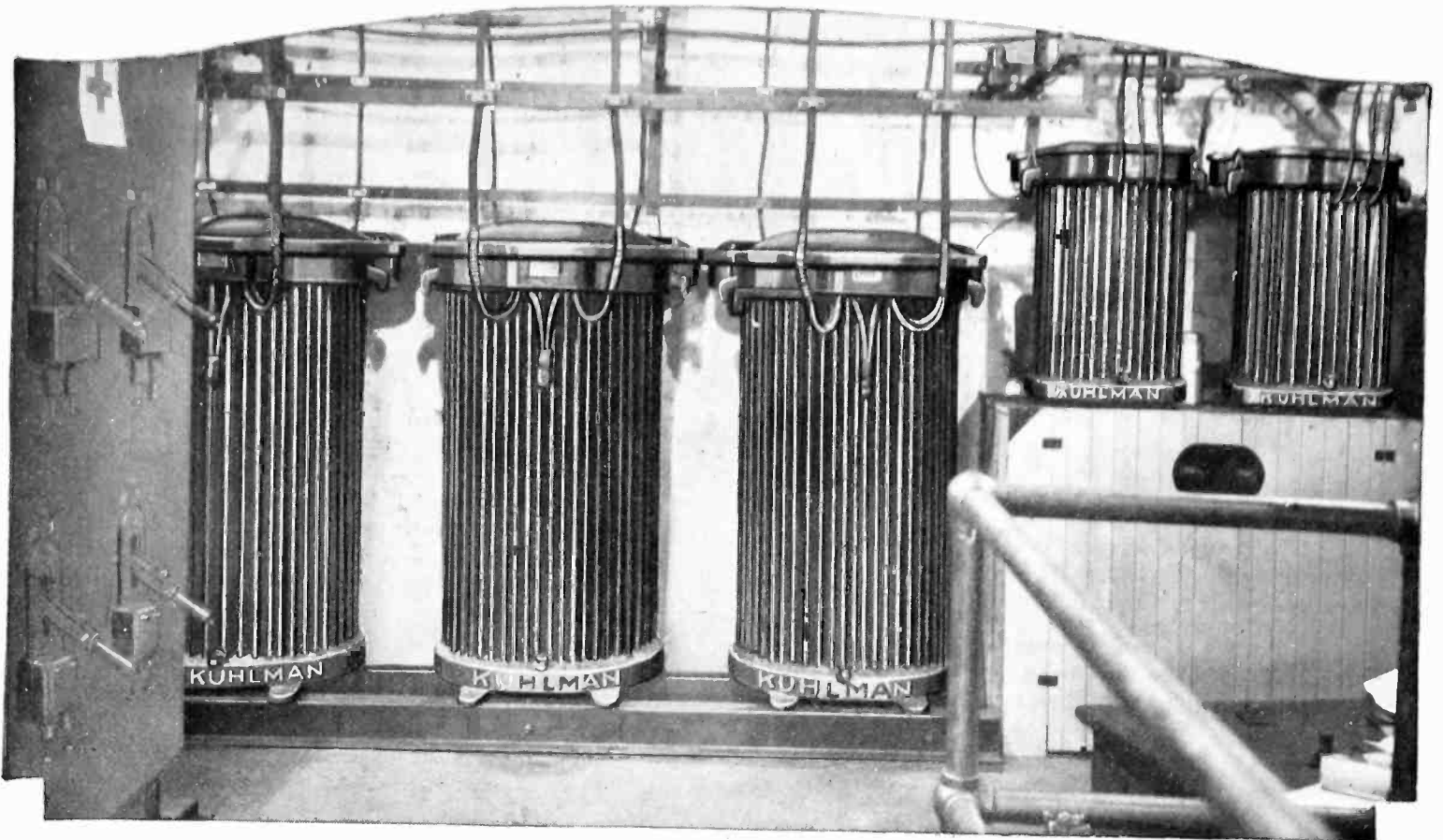

Kuhlman Transformers

for prompt shipment

When you need a power or distribution transformer in a hurry, wire us your needs.

We make a specialty of giving as quick service as is consistent with high efficiency.

On the other hand please let us know your problems as far in advance as possible.

But if you need quick help try us.

ASK FOR BULLETIN 210

KUHLMAN ELECTRIC COMPANY

Manufacturers of Power, Power Distribution and Street Lighting Transformers

BAY CITY

MICHIGAN

KUHLMAN TRANSFORMERS

Please mention the JOURNAL of the A. I. E. E. when writing to advertisers.

DOSSERTS

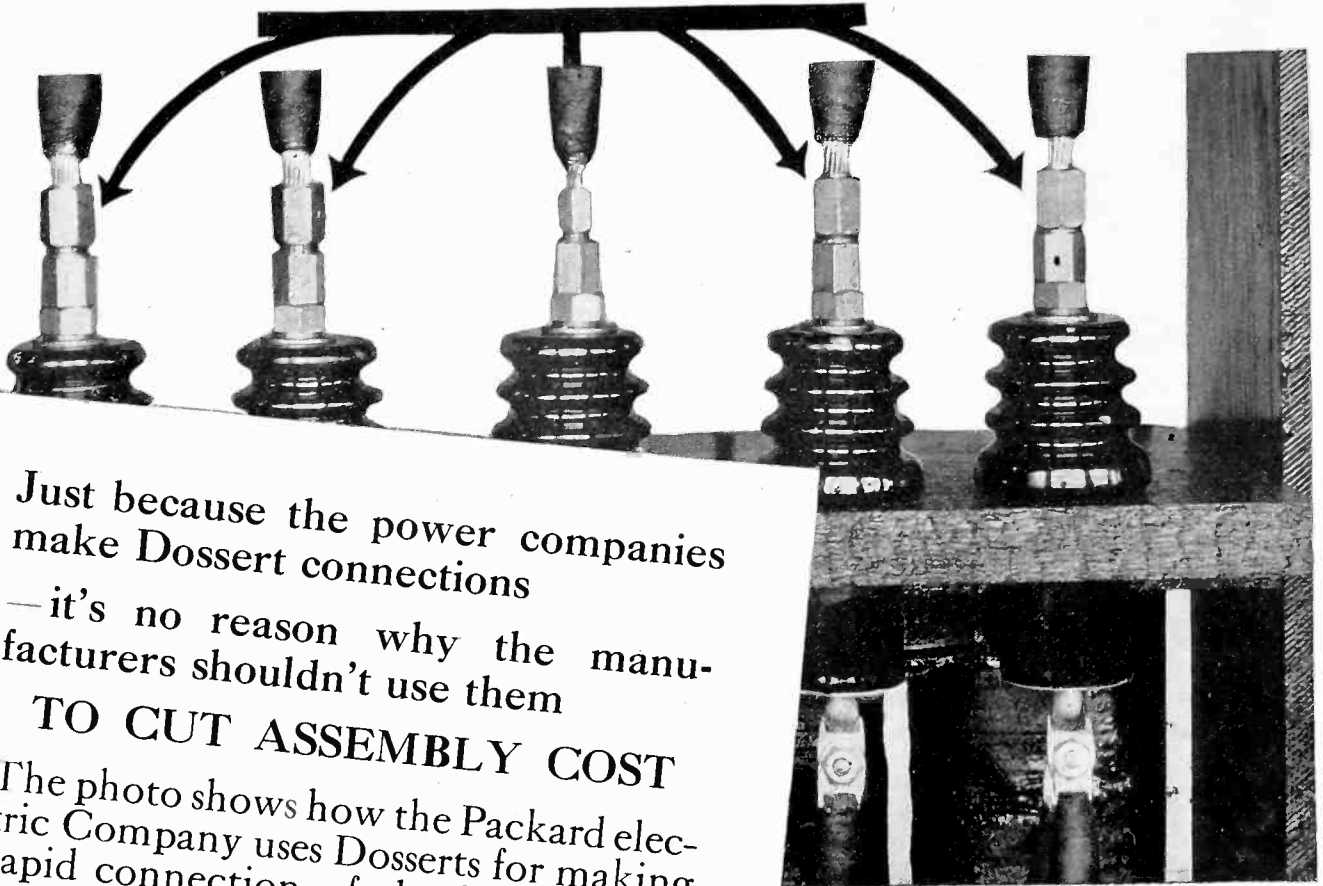

Just because the power companies
make Dossert connections

—it's no reason why the manu-
facturers shouldn't use them

TO CUT ASSEMBLY COST

The photo shows how the Packard elec-
tric Company uses Dosserts for making
rapid connection of the high voltage
leads to the external circuit in their
Metering Transformer.

The Dosserts are mounted on the
porcelain bushings.

The power companies know Dosserts
—so when you give them Dosserts in
your equipment—they know how to
value them.

The Dossert Tapered Sleeve principle
of connection gives you a means
toward efficient joints—at a saving in
time and labor.

The Dossert Book shows the many
varieties of joints obtainable with
Dosserts.

Many time-saving
kinks toward better
connections in this
**DOSSERT
BOOK**



Write to
DOSSERT & CO.

H. B. Logan, President

242 West 41st St., New York

FREE

Please mention the JOURNAL of the A. I. E. E. when writing to advertisers.

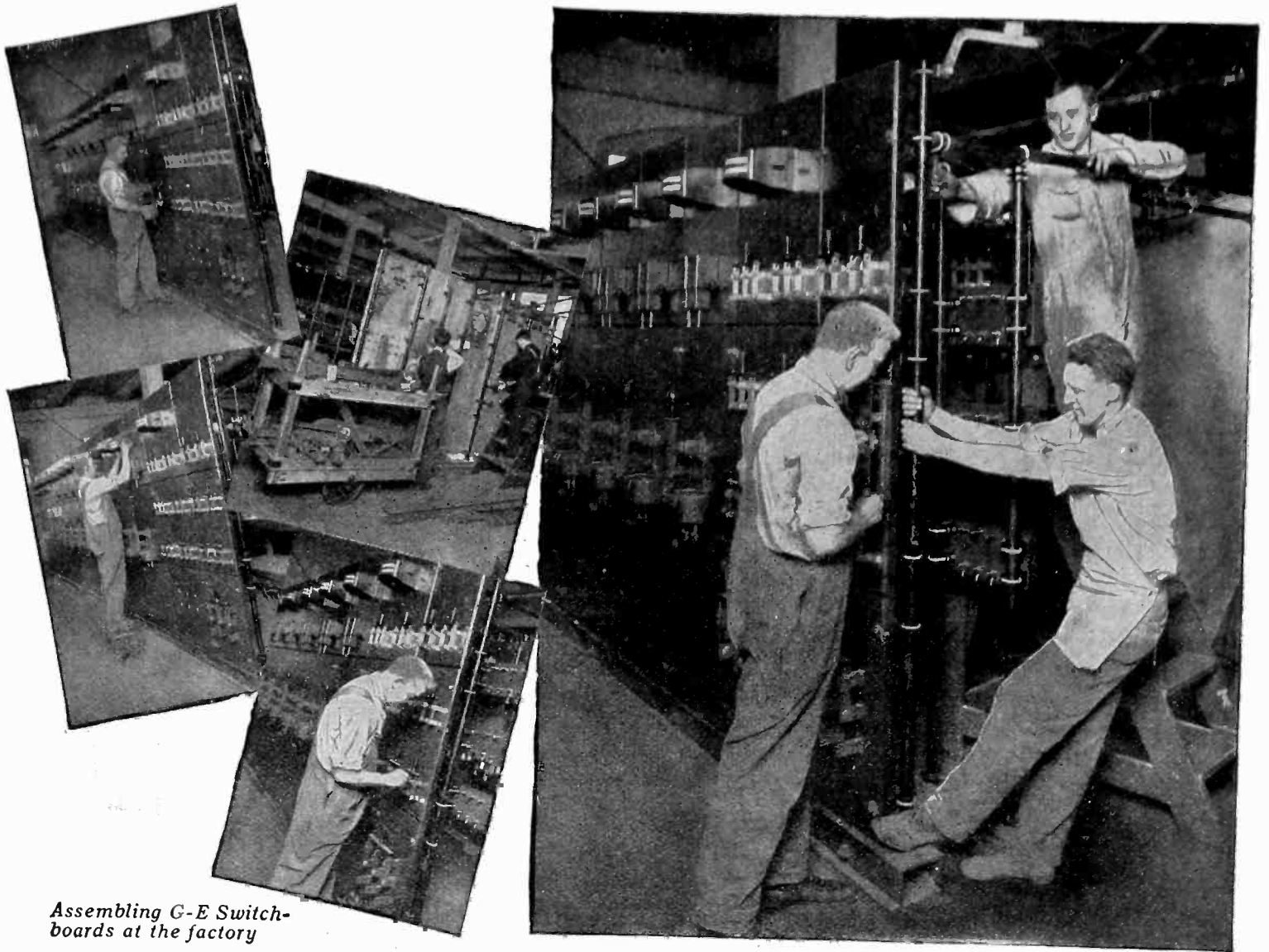

Assembling G-E Switchboards at the factory

Apply the *responsibility* test to your switchboards

Look *beyond* your switchboard.

Look into the character of each device to be sure it is worthy of trust. Will each switch and circuit breaker meet every operating condition imposed? Is the construction back of the panels accessible, neat and dependable? Have the proper relays been selected? Will all the instruments perform accurately, and under the test of time?

These are factors you must consider. They are assured in G-E Switchboards because—



G-E responsibility is undivided. By coordination of design, manufacture and assembly, the size, strength and appearance are consistent with the duty, and your switchboard is adequate for the service.

GENERAL ELECTRIC

GENERAL ELECTRIC COMPANY, SCHENECTADY, N. Y., SALES OFFICES IN ALL LARGE CITIES

Please mention the JOURNAL of the A. I. E. E. when writing to advertisers.



**There Is
No Substitute**

**Specify
Champions**

The principle of interchangeability developed by Champion and so heartily appreciated by power and transmission companies, runs through the entire line of Champion outdoor bus supports.

Thanks to the design of the interchangeable hardware, you eliminate the necessity for carrying a large reserve stock. With Champion it is not needed. You can make quick changes for repairs or minor extensions from a few standardized parts and supplies. Also because of this standardization the factory can make immediate shipments and there is no delay in deliveries.

You also profit by Champion's superior ruggedness and a higher degree of dependability than was ever before available. For in Champion bus supports the insulators are one-piece, solid and thick, and of cementless construction—manifestly a great step forward. Unique methods of attaching the interchangeable hardware prevent overstress by temperature, impact or expansion and increase their ruggedness.

Still further superiorities made possible by Champion design are higher puncture strength, greater ability to withstand shocks, stones and power arcs.

Specify Champion.

Champion one-piece porcelain interchangeable insulators for all types of outdoor bus supports and switches are made in four different sizes: 7,500 volts; 15,000-25,000 volts; 35,000 volts; 44,000 volts. Write for Bulletin D containing complete information.

THE CHAMPION SWITCH COMPANY—550 ABBOTT ROAD—Post Office Box 816—Buffalo, N. Y.

SALES REPRESENTATIVES

Garland Affolter Engineering Company
Rialto Building San Francisco, California
Garland Affolter Engineering Company
I. W. Hellman Building Los Angeles, California
Garland Affolter Engineering Company
Alaska Building Seattle, Washington

Champion Switch Company
Rooms 510-512 2 Rector St. New York City
A. H. Savage & Company
914 Pioneer Building St. Paul, Minnesota
T. W. McKay
Manitoba Power Co., Ltd., Winnipeg, Can.

Ralph D. Ernest
702 Kresge Building Detroit, Michigan
Champion Switch Company
412-413 Glenn Building Atlanta, Georgia
Champion Switch Company
924 Marquette Building Chicago, Illinois

The CHAMPION SWITCH COMPANY

Please mention the JOURNAL of the A. I. E. E. when writing to advertisers.

**TYPE
9140**



The New **LOCKE HEWLETT**

A NEW design of the Hewlett Insulator — one which is fully equal in strength to the cemented type.

Combining all of the inherent advantages of the Hewlett design, this new design is an improvement in every way over the original Hewlett Insulator which has enjoyed wide popularity for many years. The increased strength of the Hewlett, which, for the first time, places it on a par with cemented types, is made possible by a new method of fabrication which permits of rectangular holes for the connecting links and gives a larger

bearing surface; resulting in a higher total, but lower unit stress, on the porcelain.

The contour has been changed providing for more effective washing and improving its electrical characteristics — all combining to give a more pleasing appearance.

These and many other advantages have only been made possible by the employment of dense porcelain — the same porcelain which is used in the manufacture of all Locke Insulators.

This new Hewlett is offered for any and all service where a suspension type insulator is required. General specifications and complete information, including latest data on electrical and mechanical characteristics, will be furnished upon request.

LOCKE INSULATOR CORPORATION

BALTIMORE, MD.

Factories: Victor, N. Y., and Baltimore, Md.

LOCKE
PORCELAIN

Please mention the JOURNAL of the A. I. E. E. when writing to advertisers.

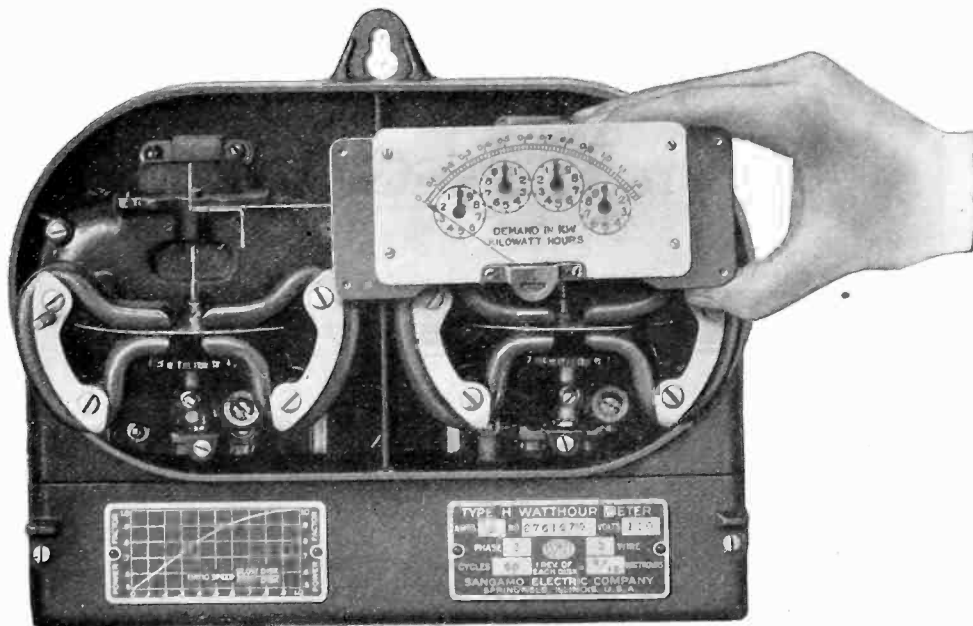

NOW—polyphase maximum demand in addition to energy and power-factor

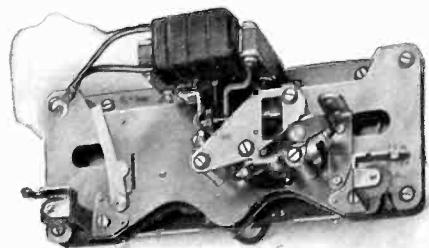

Maximum-demand attachment for the Sangamo Horizontal Polyphase Meter. All Sangamo Maximum-demand Attachments can now be supplied with a contact device which will ring a bell, or give some other suitable signal, when the demand during any time interval reaches a certain predetermined value.

THE development of a maximum-demand attachment for the Sangamo Horizontal Polyphase Meter enables kilowatt-demand readings, in addition to energy and power-factor readings, to be taken on the same meter.

The maximum-demand attachment gives on a single dial the energy consumption and the maximum kilowatt demand that has occurred since the last meter reading and resetting. It can be furnished on any horizontal polyphase meter in place of the standard recording train. The timing motor, escapement, resetting device and other principal parts are the same as used in the single-phase and vertical polyphase demand attachments which have given universal satisfaction.

Power-factor readings are obtained with the horizontal polyphase meter on balanced circuits by observing the relative speeds of the two disks and referring to a conversion graph located on the cover.

With all three factors which enter into most rate schedules so readily and accurately determined, you owe it to yourself and to your customers to determine actual load conditions.

SANGAMO ELECTRIC COMPANY
Springfield, Illinois

New York Boston Chicago Birmingham San Francisco Los Angeles

1013-2

SANGAMO METERS

FOR EVERY ELECTRICAL NEED

Please mention the JOURNAL of the A. I. E. E. when writing to advertisers.

Allis-Chalmers

Steam Turbo-Generators

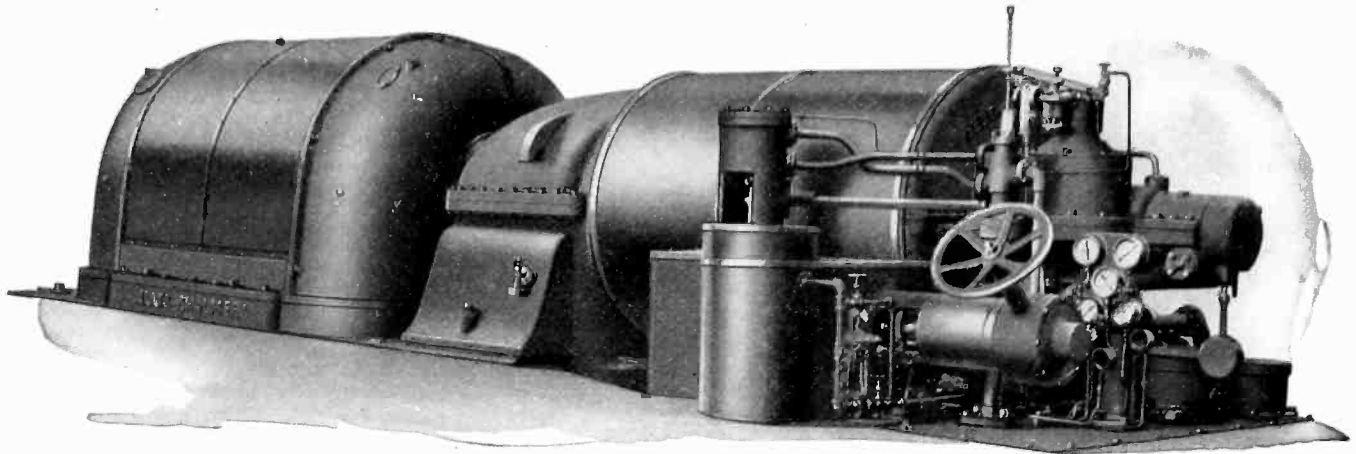

The above cut shows an Allis-Chalmers 5000 K. W. steam turbine and generator unit of the most modern design built for the Municipal Power Plant of the City of Ashtabula, Ohio. The Municipal Power Plant Station of the City of Cleveland, Ohio and the Lake Union Power Station of the City of Seattle, Washington, are the largest Municipal Power Plants in the United States and are equipped exclusively with Allis-Chalmers steam turbines and generators.

The exacting requirements of Municipal Power Plant service embodying perfect regulation, continuous uninterrupted operation, highest economy and freedom from repairs or adjustments can only be met by the highest type of prime mover. The Allis-Chalmers Manufacturing Company has installed steam turbine power generating equipment in a very large number of Municipal Power Plants in the United States many of which are exclusively equipped with Allis machines.

The fact that Allis-Chalmers turbines meet the requirements of service mentioned above makes these machines ideal for all manufacturing establishments and especially for those where the processes of manufacture require continuous operation.



PRODUCTS

Steam Turbines
 Electrical Machinery
 Steam Engines
 Condensers
 Oil Engines
 Gas Engines
 Hydraulic Turbines
 Pumping Engines
 Centrifugal Pumps
 Mining Machinery
 Metallurgical Machinery
 Crushing Machinery
 Cement Machinery
 Flour Mill Machinery
 Saw Mill Machinery
 Air Compressors
 Air Brakes
 Steam and Electric Hoists
 Farm Tractors
 Power Transmission Machinery

ALLIS-CHALMERS

MILWAUKEE, WIS. U. S. A.

Please mention the JOURNAL of the A. I. E. E. when writing to advertisers.

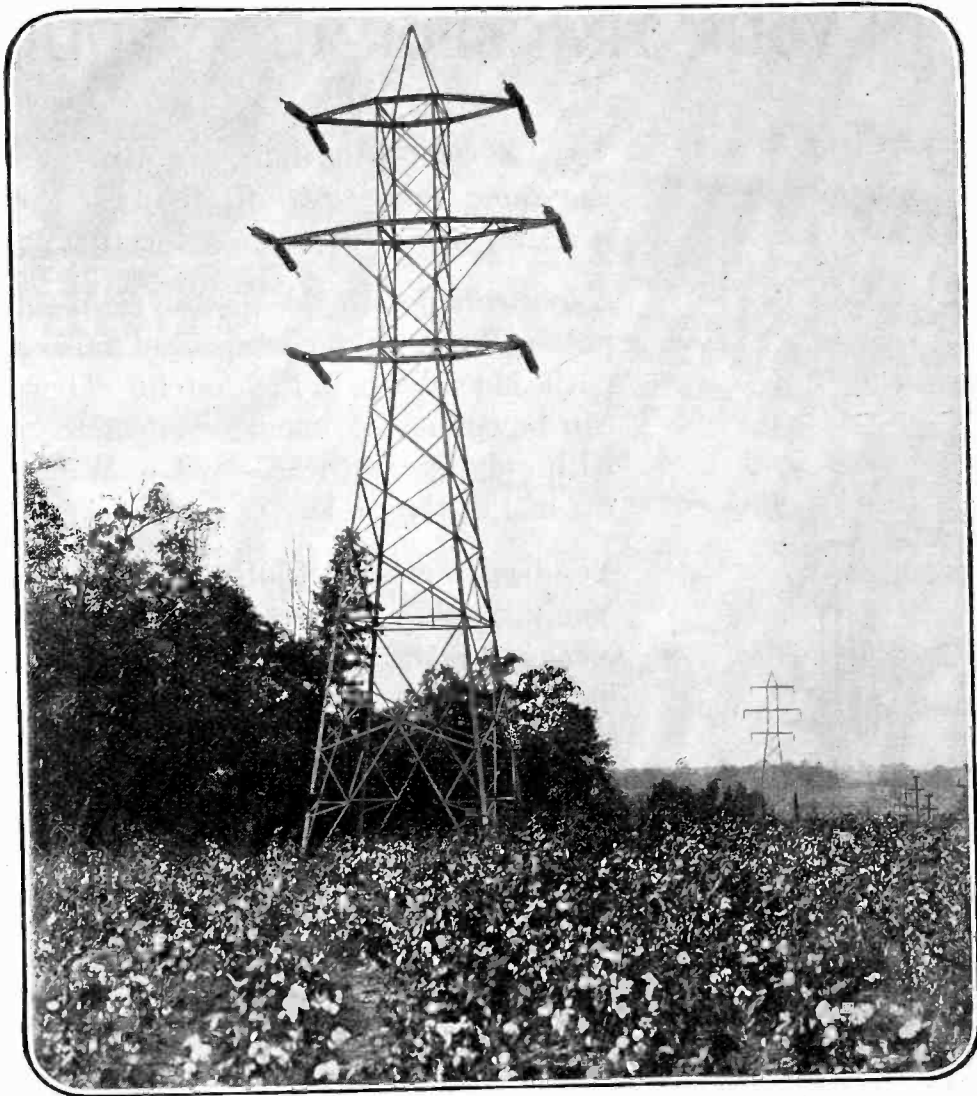

J-D Wins Recognition In New Industrial South

This is one of the arteries of power in the new industrial south. The scene is near Charlotte, N. C., on the lines of the Southern Power Co. Many thousands of J-D thick porcelain, cementless insula-

tors have recently been placed in service in this thriving section of the U. S. A.

Here as elsewhere the merit of these permanent, reliable insulators has won recognition.

Jeffery-Dewitt Insulator Company

Kenova, W. Va., U. S. A.

Agents:

Sydney, Wellington, N. Z.,
Bombay, Paris, Milan, Tokio.

District Offices:

New York, 2 Rector St.
Chicago, 924 Marquette Bldg.
Atlanta, 413 Glenn Bldg.

Agents:

St. Paul, Seattle, San Francisco, Los
Angeles, Spokane, Montreal, Canada.



Please mention the JOURNAL of the A. I. E. E. when writing to advertisers.

SIMPLIFY the FLEXIBILITY IN YOUR TRANSFORMER VAULT

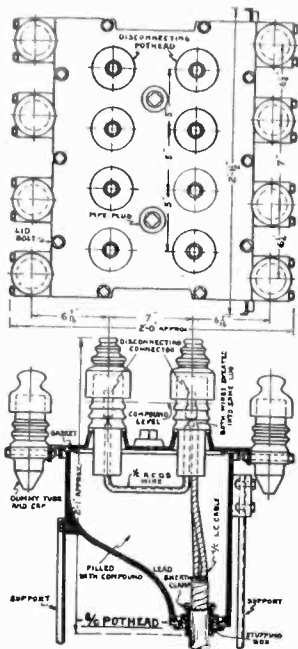

**EIGHT CONDUCTOR
POTHEAD**

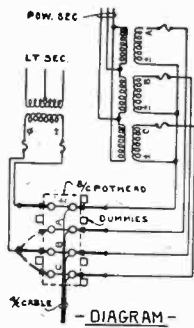

Two different loads independently operated from the same cable—real flexibility. You can do it neatly with G & W disconnecting potheads.

A four conductor cable uses an eight tube G & W pothead. Parallel each pair of tubes inside the pothead as shown in the sketch. Then each load can be connected independent of the other and with only one pothead—a G & W pothead—on the end of the cable.

You have a clean-cut job. You have simplicity. You need have no lead wipes and no special bus arrangement. You can disconnect at the pothead in case of trouble on one load while the other still functions. This is flexibility.

In the same way you can use a six tube pothead on a three conductor cable and a four tube pothead for a two conductor. G & W potheads and boxes are great solvers of distribution problems. Let us help you. Get our catalog.

Simplicity, flexibility and safety are incorporated in your system when you use G & W specialties.

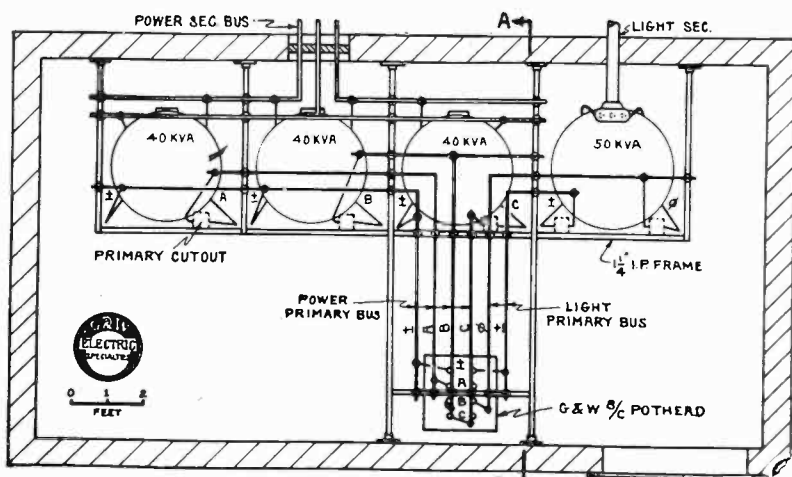

PLAN

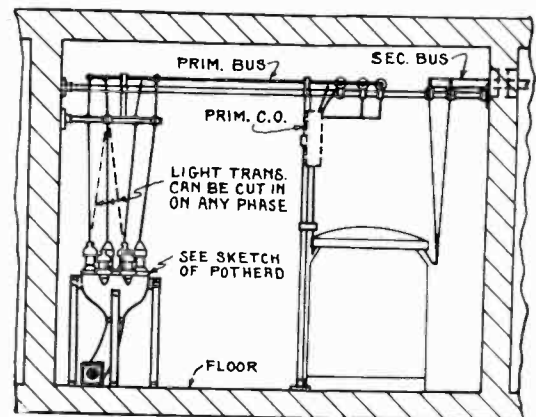

SECTION A-A

SALES REPRESENTATIVES IN THE LARGER CITIES



CATALOGS, BULLETINS, BLUEPRINTS AND PRICES ON REQUEST



**SHARPLES
SUPER CENTRIFUGAL
FORCE**

Announcing

A very important service for Switch and Transformer Oil Purification



THE SHARPLES SUPER CENTRIFUGE

The Westinghouse Electric and Manufacturing Company, internationally known as one of the world's leading electrical institutions, has, as of January 2, 1925, been appointed the exclusive agent for the sale and distribution of the Sharples Super Centrifuge, when used for purifying and reclaiming insulating oils, particularly in combination with the Sharples process for reconditioning switch oils.

This important manufacturing and sales combination of the two leaders in their respective lines of transformer and oil switch design and centrifugal treatment of oil, should result in an unusually effective and dependable service to those who have valuable investments in oil switches and transformers.

The new Sharples process, when used with the Sharples Super Centrifuge, reclaims broken down switch oil, resulting in an oil of high dielectric strength, free from moisture and other impurities, and approaching new oil in its anti-moisture absorbing qualities. In fact, it results in an oil equivalent to new oil in all its essential characteristics.

THE SHARPLES SPECIALTY COMPANY
2300-2324 Westmoreland Street, Philadelphia

Mail
Coupon
Today 

The Sharples Specialty Company,
2300-2324 Westmoreland Street, Philadelphia

Gentlemen:

Please send me Descriptive Leaflet No. 20242 giving full information about the *New Sharples Switch and Transformer Oil Process*.

Name.....

Address.....

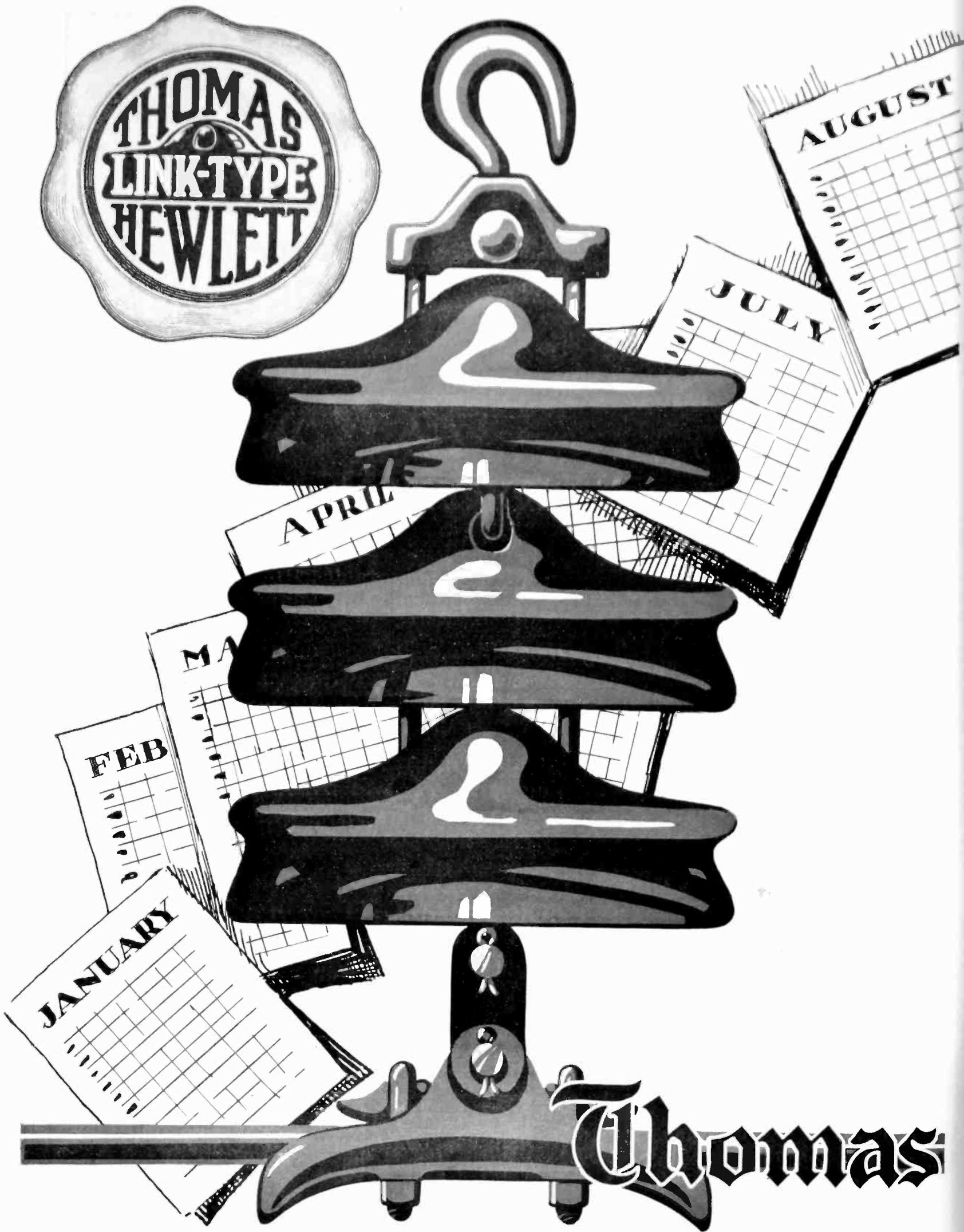

Please mention the JOURNAL of the A. I. E. E. when writing to advertisers.



Do You Want Perfect Records?

Here is a Logical Way of Insuring a "Clean Slate"
Month After Month and Year Upon Year, Insofar
As Insulators Are Concerned.

WHEN the monthly report cards continue to come in year after year showing *No Insulator Failures, No Losses From Any Cause*, that's when you'll be glad that you selected Thomas LINK-TYPE Hewletts for your lines. It's the one cementless unit with a long term record. It represents the original Hewlett design, tested in every clime and for practically every known type of service. It will last indefinitely. No replacements necessary.

Ask Any User

THE R. THOMAS & SONS CO.

East Liverpool, Ohio, U. S. A.

New York

Boston

Chicago

London

Western Electric Co., Inc.
on the Pacific Coast

Northern Electric Co., Ltd.
in Canada

LINK-TYPE Hewlett

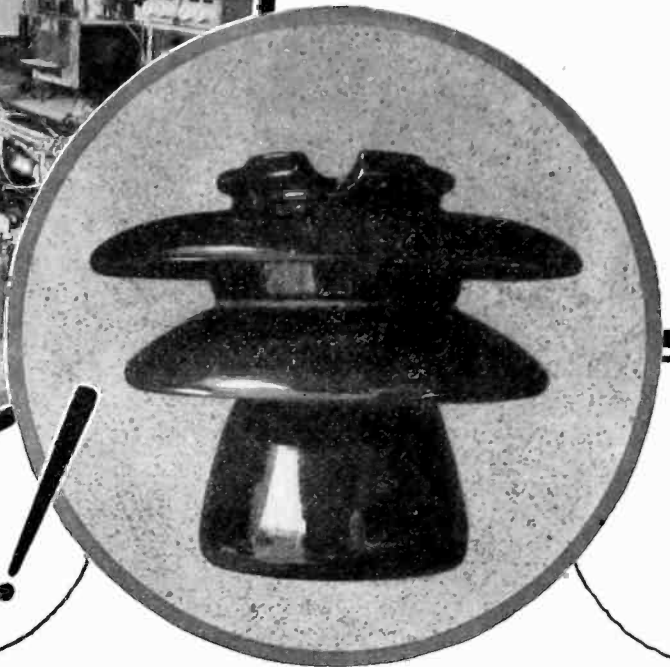

MUD—the right kind!

THERE is a popular misconception that the material which is baked to form porcelain insulators, is just plain mud.

In Westinghouse porcelain insulators, the mud consists of three carefully-selected ingredients: clay, flint and feldspar. The proper proportions, to produce the highest mechanical and electrical strength, have been determined only after exhaustive tests in our Ceramic Research Laboratory, and these proportions are rigidly adhered to thereafter in manufacturing.

Three samples taken from our pug mills at intervals of one month, from entirely different lots, when analyzed gave contents as shown at the right. These values illustrate how carefully the standards, when once set, are maintained—another reason why Westinghouse porcelain insulators are best.

Westinghouse Electric & Manufacturing Company
 Agent for Westinghouse High-Voltage Insulator Co.
 General Office: Derry, Pa.
 Works: Derry, Pa., Emeryville, Calif.

	First Month	Second Month	Third Month
Water at 60° C.	22.40	23.00	23.10
Further Heating			
120° C.20	.40	.40
Combined Water	6.20	6.60	5.80
SiO ₂	66.20	66.50	66.30
Al ₂ O ₃	23.40	23.10	23.30
CaO35	.15	.15
MgO42	.36	.50
SO ₃35	.20	.27
* { Na ₂ O } { K ₂ O }	2.80	2.60	3.20

*Variation caused by cumulative error due to taking weights by the difference method.

Another Reason Why

Westinghouse

X 78481

Please mention the JOURNAL of the A. I. E. E. when writing to advertisers.

Years From Now

YEARS from now, today's performance will be history, serving to point the way for the new engineers.

The coming generation will profit by your experience, just as you profit by the experience of your predecessors.

Records always have been, and always will be, the sure guide for the engineer. If a family of manufactured products has a consistent record for good service, it is a safe conclusion that those products are made under correct principles and can be depended on for quality.

O-B Insulators have an enviable service record today and will be maintaining that record many years from now.

The Ohio Brass Company
Mansfield, Ohio, U. S. A.

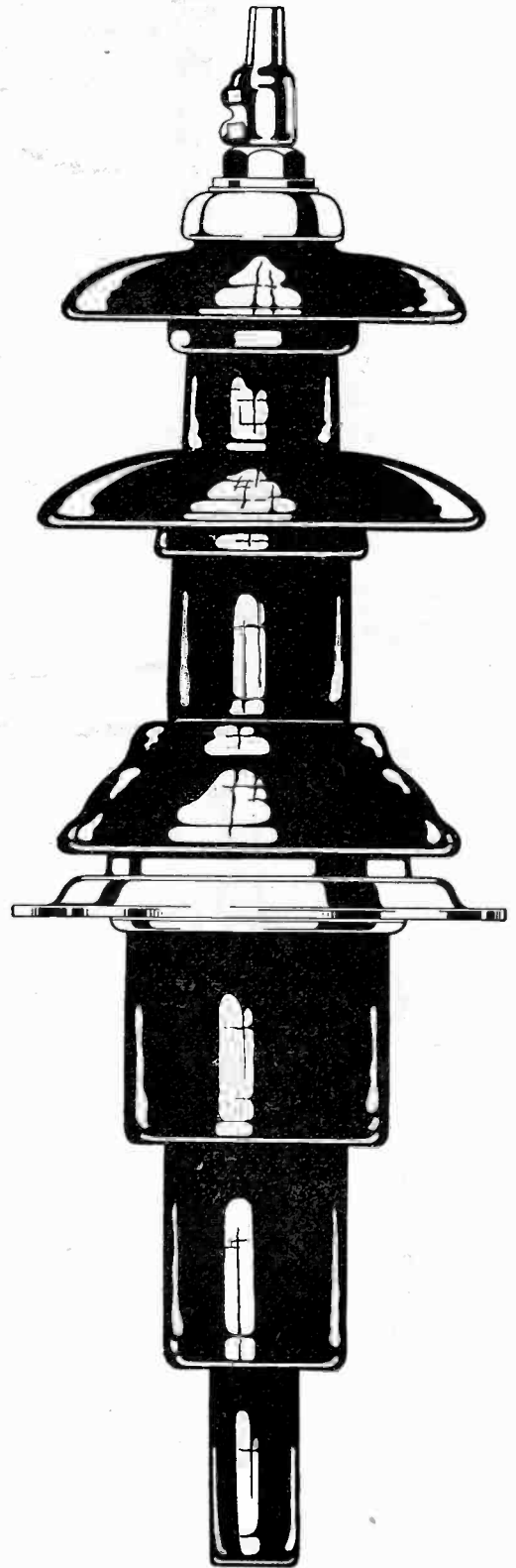

B
INSULATORS
TIME IS THE TEST

Prevention

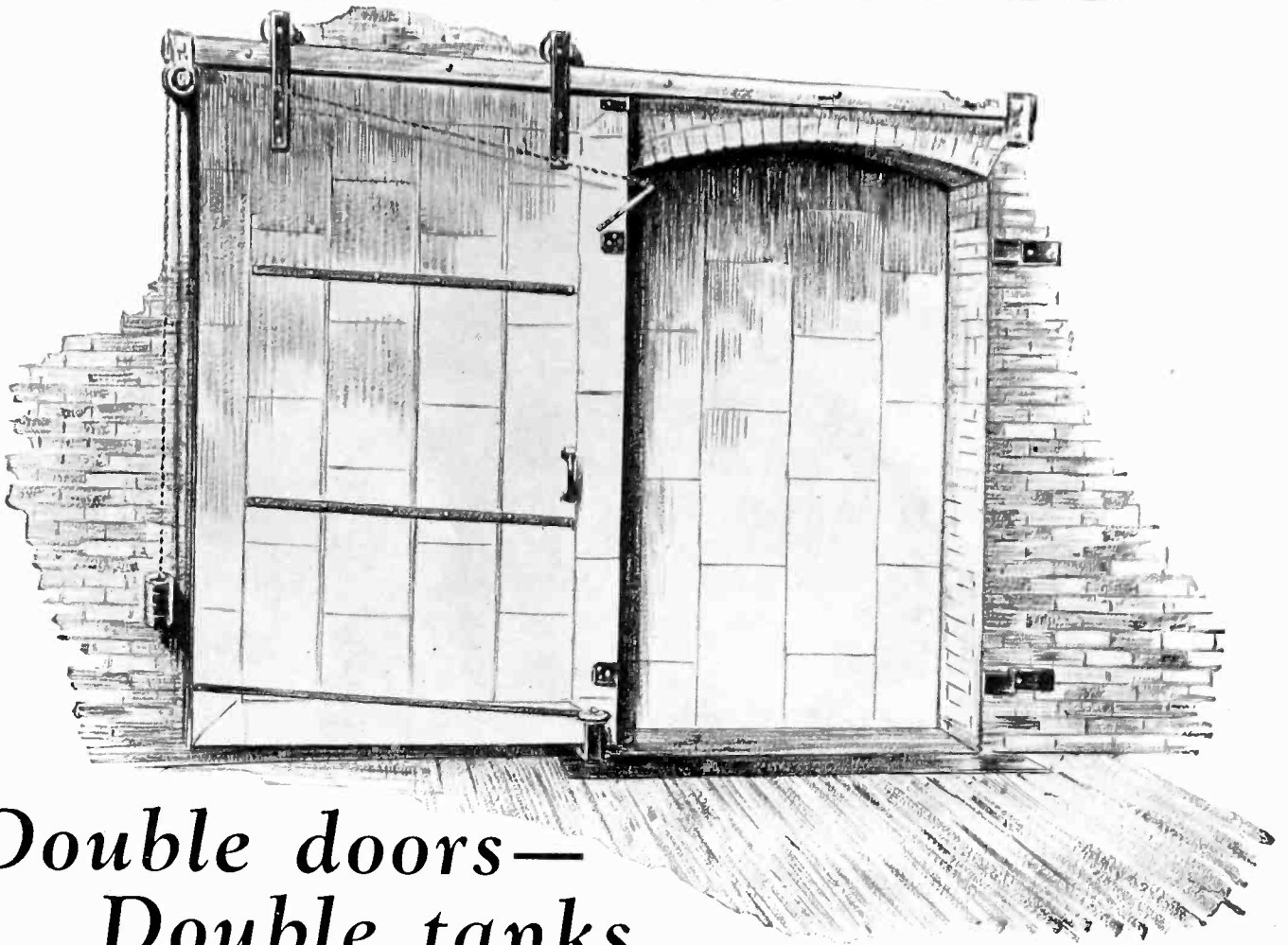

Double doors— Double tanks Confine the flames

Double fire doors are considered essential for factory fire protection.

The double tank construction of the Condit Type D-21 Oil Circuit Breaker provides a two-fold barrier—affords prevention of cell fires, curbs flame throwing, cools and condenses gases and oil vapors. Like double doors, double tanks reduce fire hazard to a minimum.

For safety, insist on double tank construction.

“*Get in touch with Condit*”

CONDIT ELECTRICAL MFG. CO.

*Manufacturers of Electrical Protective Devices,
South Boston, Mass.*

*Northern Electric Company
LIMITED*

Sole Distributor for the Dominion of Canada

Specifications:—Standard sizes 1200 amperes or less, 15,000 volts or less. Interrupting capacity 4600 amperes at 15,000 volts.

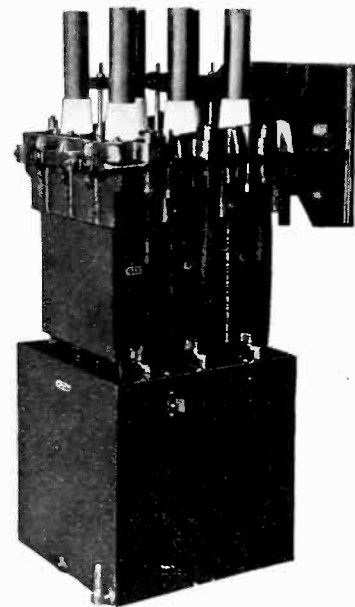

Type D-21

The Type D-21 is a common frame breaker similar in construction to the Type D-17.

CONDIT

7657

Please mention the JOURNAL of the A. I. E. E. when writing to advertisers.

QUICK DELIVERY on Special Bushings



THE manufacture and rapid delivery of bushings made to special or standard design is an important phase of our business. We are doing this for central station companies as well as manufacturers. Many companies of both groups are availing themselves of this service. Even though we specialize on this prompt delivery, the same high quality is maintained as in our pin and suspension types of line insulators.

Our large modern factory located at Macomb, Illinois, lies nearly in the center of the United States, so no matter in what section our products are desired we can give rapid delivery at low cost.

Send for our complete new catalogue of Illinois High Tension Insulators and Bushings.

ILLINOIS ELECTRIC PORCELAIN Co.
MACOMB, ILLINOIS

ILLINOIS

HIGH
TENSION

INSULATORS

A QUICK BREAK!

THE severity of the duty on an oil circuit-breaker, opening under short-circuit conditions, is proportional to the length of time the arc persists in the tank. Reducing this time means better service from the breaker. The high-speed arcing contacts on Westinghouse high-powered, high-tension breakers decrease this time greatly, thereby reducing the stresses in the breaker to a minimum. This feature reduces maintenance and inspection.

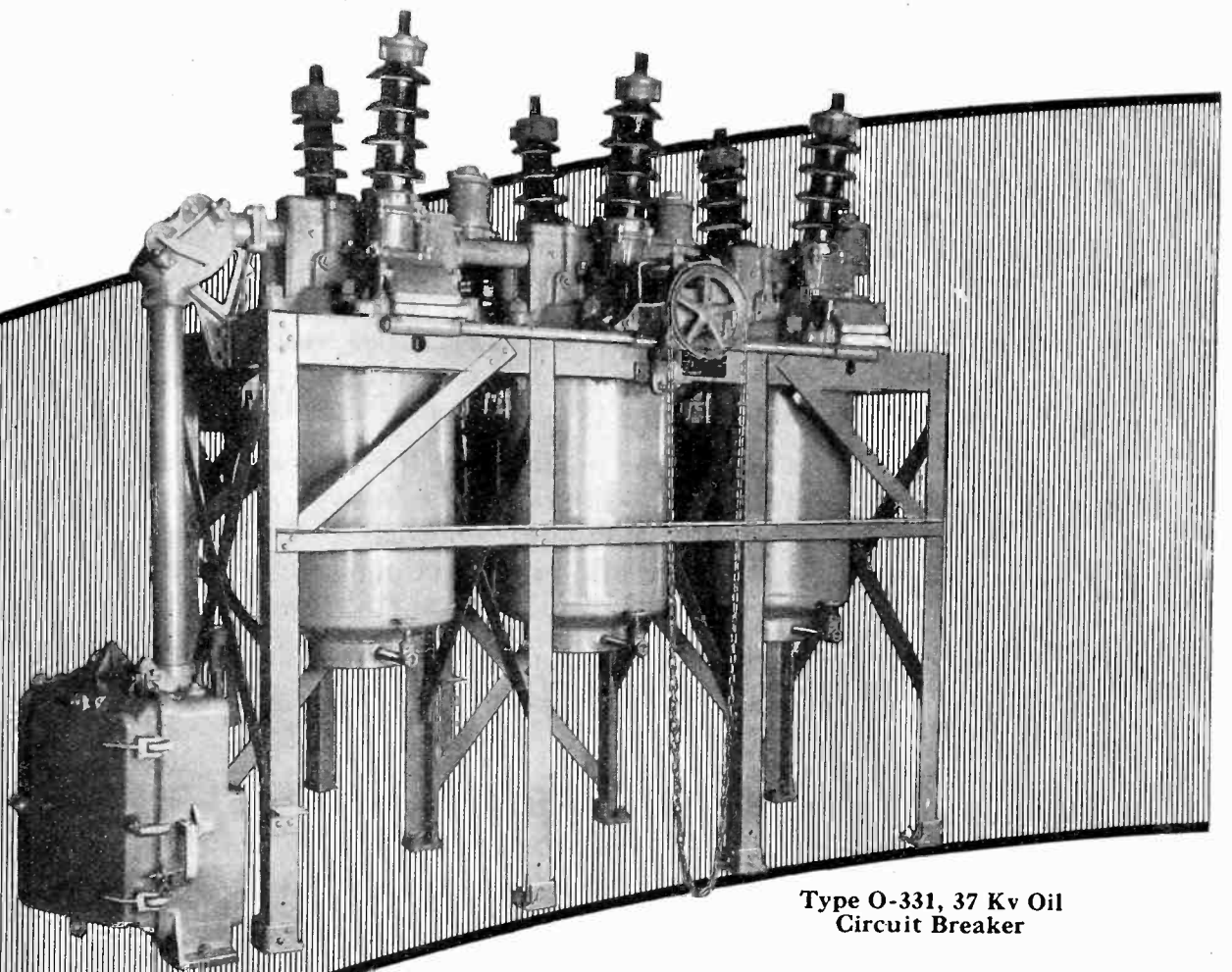

Type O-331, 37 Kv Oil
Circuit Breaker

Westinghouse

X79710

Please mention the JOURNAL of the A. I. E. E. when writing to advertisers.

THESE curves show the times for both plain-break contacts and high-speed contacts on a 37 kv. type O-331 Oil Circuit-Breaker to open various distances. On a breaker of this rating, the arcing contacts will separate, on the average, six inches before the destructive arc is broken. The high-speed contacts travel this distance in less than one-third the time required for the plain-break contacts, thus lessening the duty on the breaker structure.

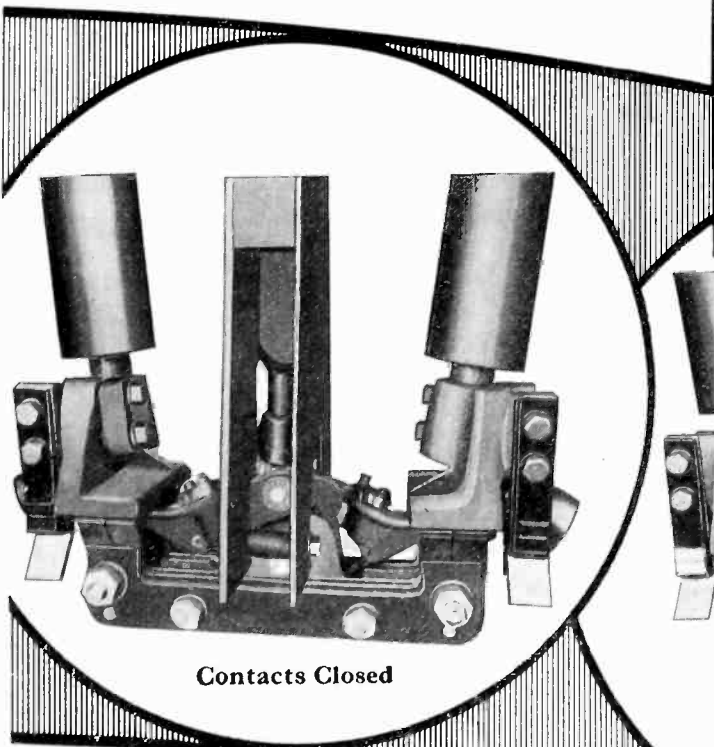
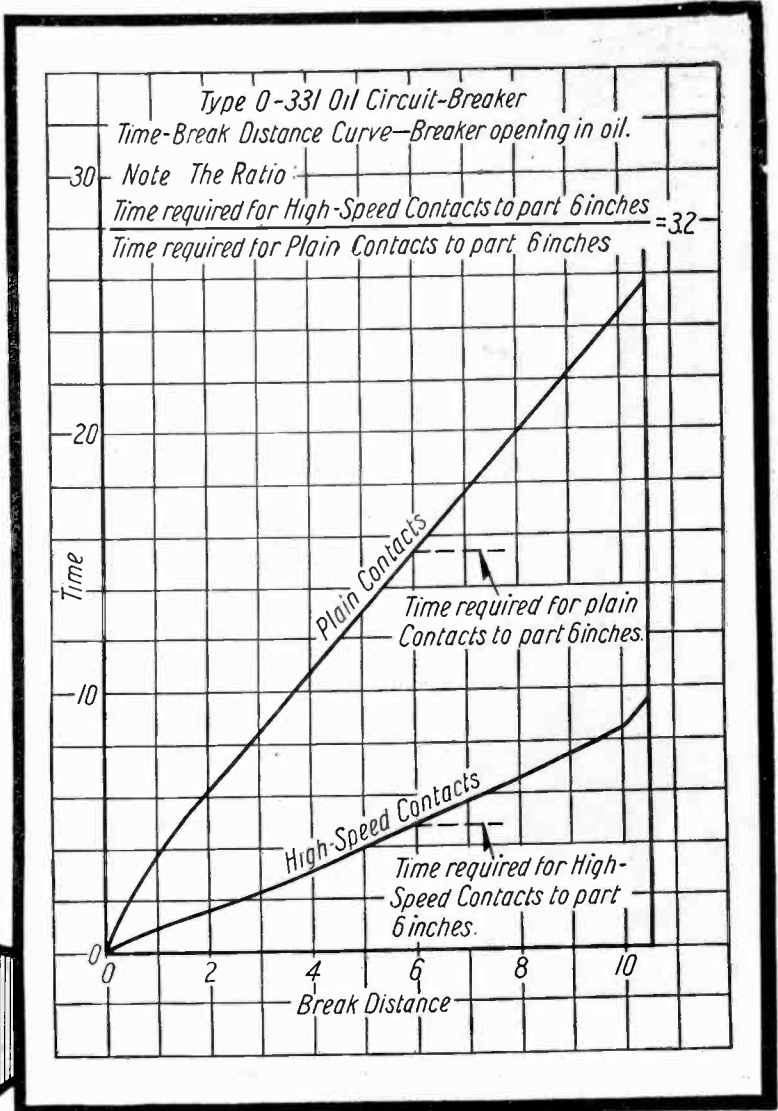

Contacts Closed

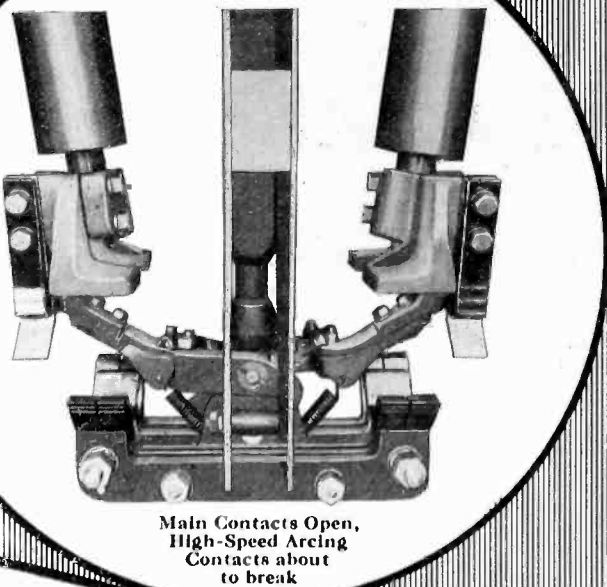

Main Contacts Open, High-Speed Arcing Contacts about to break

Westinghouse Electric & Manufacturing Company
 East Pittsburgh Pennsylvania
 Sales Offices in All Principal Cities of the
 United States and Foreign Countries

Westinghouse

X79711

Please mention the JOURNAL of the A. I. E. E. when writing to advertisers.

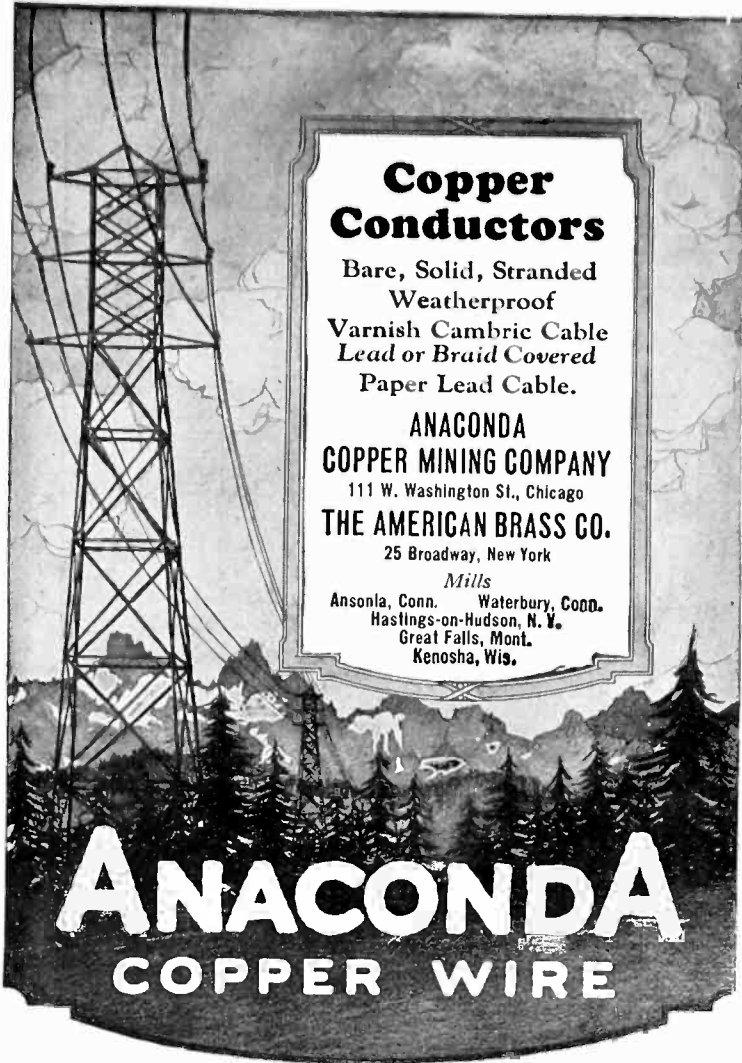

Copper Conductors

Bare, Solid, Stranded
Weatherproof
Varnish Cambric Cable
Lead or Braid Covered
Paper Lead Cable.

**ANACONDA
COPPER MINING COMPANY**
111 W. Washington St., Chicago

THE AMERICAN BRASS CO.
25 Broadway, New York

Mills
Ansonia, Conn. Waterbury, Conn.
Hastings-on-Hudson, N. Y.
Great Falls, Mont.
Kenosha, Wis.

ANACONDA

COPPER WIRE

Filling the Pothead



Properly filling the pothead with compound is one of the most important points in its installation. The compound should be thoroughly heated to a point which gives free flowing and eliminates any lumps or bubbles such as will be found when the compound is approaching, but not quite up to pouring condition. The pothead and cable should be warmed, as pouring compound into a cold pothead may cause voids, due to the sudden chilling of the compound, causing it to bridge over small spaces instead of flowing into them.

**Minerallac Insulating Compound
No. 78**
is recommended for this work

MINERALLAC ELECTRIC COMPANY
1045 Washington Blvd., Chicago



**Lapp Insulators
do not fail!**

LAPP INSULATOR CO., Inc.
LE ROY, N. Y.

Sales Representatives

BIRMINGHAM, ALA., Industrial Supply Co., 714 Brown-Marx Bldg.
CHARLOTTE, N. C., J. W. Fraser & Co., Commercial Bank Bldg.
CHICAGO, Transelectric Co., Inc., 360 No. Michigan Ave.
CLEVELAND, O., Engineering Merchandising Syndicate, 608 Rockefeller Bldg.
COLUMBUS, O., Engineering Merchandising Syndicate, 600 Joyce Realty Bldg.
DALLAS, TEX., Jack D. Milburn, 304 Interurban Bldg.
DENVER, The O. H. Davidson Equip. Co., 1633 Tremont St.
INDIANAPOLIS, W. D. Hamer Co., 518 Trac. Terminal Bldg.
KANSAS CITY Mo., Power Machinery Co., 301 Dwight Bldg.
MINNEAPOLIS, J. E. Sumpter Co., 940 Security Bldg.
NEW YORK CITY, Shield Electric Co., 149 Broadway.
PHILADELPHIA, Rumsey Electric Co., 1007 Arch St.
PITTSBURGH, Henry N. Muller Co., 812 Westinghouse Bldg.
PORTLAND, O., S. Herbert Lanyon, 1120 Board Trade Bldg.
SAN FRANCISCO, S. Herbert Lanyon, 509 New Cal Bldg.
SYDNEY, AUSTRALIA, Chas. M. Terry.
WELLINGTON, NEW ZEALAND, Jas. J. Niven & Co.

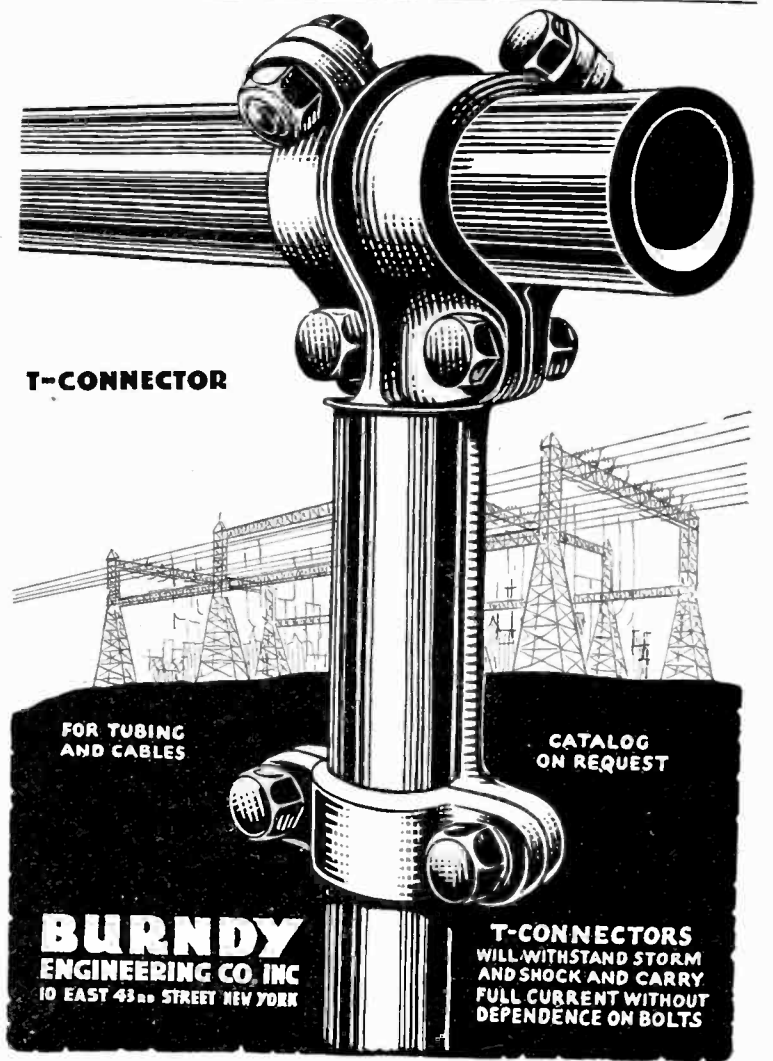

T-CONNECTOR

FOR TUBING AND CABLES

CATALOG ON REQUEST

**BURNDY
ENGINEERING CO. INC**
10 EAST 43rd STREET NEW YORK

**T-CONNECTORS
WILL WITHSTAND STORM
AND SHOCK AND CARRY
FULL CURRENT WITHOUT
DEPENDENCE ON BOLTS**

Please mention the JOURNAL of the A. I. E. E. when writing to advertisers.

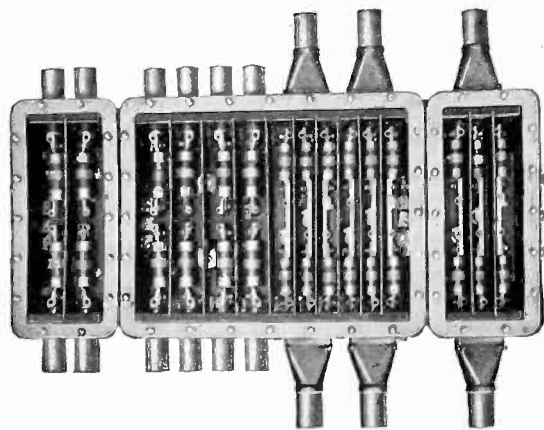

LARGE MULTI-UNIT TYPE DISTRIBUTING JUNCTION BOX

STANDARD Cable Junction Boxes insure maximum economy, convenience and flexibility in the installation and operation of underground electric cable systems. Their special bimetallic connecting nipples provide, among other advantages, positive protection to the cable insulation from moisture and reduction in the risk and cost of jointing cables to the box.

If you are interested in effective devices of this kind write our nearest office for further information.

Standard Underground Cable Co.

BOSTON PHILADELPHIA ATLANTA CHICAGO ST. LOUIS LOS ANGELES
 NEW YORK WASHINGTON PITTSBURGH DETROIT SEATTLE SAN FRANCISCO
 FOR CANADA: STANDARD UNDERGROUND CABLE CO. OF CANADA, LIMITED, HAMILTON, ONT.

Hazard

RUBBER INSULATED
WIRES & CABLES

HAZARD POWER CABLE for boreholes or mine shafts.

The heavy layers of tough and elastic rubber insulation are absolute insurance against current leakage.

A lead sheath, two layers of asphalted jute, galvanized steel armor wires (submarine cable type) and two layers of asphalted jute over all, afford complete protection against mechanical injury, and provide strength for suspension in borehole or mine shaft.



Sample and full information on request,

“Made for Users Who Want the Best”

HAZARD MFG CO WILKES-BARRE PA
 NEW YORK, CHICAGO, PITTSBURGH, DENVER, BIRMINGHAM

Please mention the JOURNAL of the A. I. E. E. when writing to advertisers.

"AMERICAN BRAND"

Weatherproof Copper Wire and Cables

COST



TRADE MARK

"AMERICAN BRAND" WEATHERPROOF WIRE AND CABLES HAS NO EQUAL

You can buy weatherproof wire cheap, but is it worth what it costs?

"American Brand" gives you more mileage per dollars with a longer life on the line.

Get a sample and satisfy yourself.

American Insulated Wire & Cable Co.
954 West 21st Street, Chicago

ELECTRICAL WIRES and CABLES

FOR EVERY ELECTRICAL PURPOSE

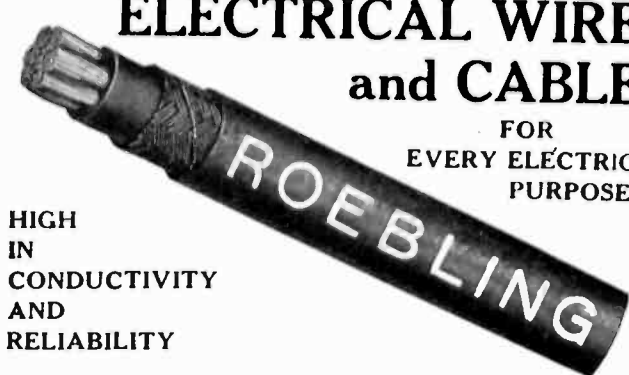

ROEBLING

HIGH IN CONDUCTIVITY AND RELIABILITY

JOHN A. ROEBLING'S SONS CO.
TRENTON, NEW JERSEY



ACME WIRE

PRODUCTS

"Cottonite"—Uniform cotton covering over high grade enamel—A high-dielectric space-saving magnet wire.

ACME MAGNET WIRE

"Enamelite"—Plain enameled copper wire
"Cottonite"—Cotton-covered "Enamelite"
"Silkenite"—Silk-covered "Enamelite"
Magnet Wire—Cotton or silk, single or double

ACME COIL WINDINGS

Field Coils, Meter Coils, Ignition Coils, Windings for Audio and Radio Frequency Transformers.

ACME VARNISHED INSULATIONS

Varnished Cambrics—Black and yellow
Varnished Silks and Tapes—For every requirement
Varnished Papers—Black and yellow
Varnished Tubing—"Spaghetti", all sizes, 5 colors
"Celatsite" Wire—Tinned, spaghetti-covered wire for radio sets: 5 colors
Insulating Varnishes

Catalog sent Engineers and Executives

THE ACME WIRE COMPANY
Main Office and Plant, New Haven, Conn.
New York Cleveland Chicago
52 Vanderbilt Ave. Guardian Building 53 W. Jackson Blvd.

THE ELEMENTS OF OUR BUSINESS

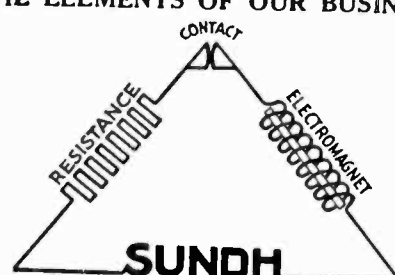

SUNDH

TRADE-MARK

Automatic Starters
Circuit Breakers
Float Switches
Hand Starters
Magnet Switches

Pressure Regulators
Remote Switches
Speed Regulators
Transfer Switches
Valve Control

WRITE FOR CATALOG

Sundh Electric Company, Newark, N. J.
Branch Offices or Sales Representatives in Principal Cities



Specify
Thomas Quality Insulators
for
Permanently Dependable
SERVICE

THE R. THOMAS & SONS CO.
East Liverpool, Ohio
New York Boston Chicago London



DUDLO



Magnet Wire & Windings

have established an enviable reputation among the electrical manufacturers for giving satisfaction wherever used in the production of electrical equipment necessitating use of material of unquestionable high quality.

We solicit the wire and coil problems of all electrical manufacturers and we guarantee them satisfaction from all angles.

DUDLO MANUFACTURING CORPORATION,
FORT WAYNE, INDIANA, U.S.A.

Please mention the JOURNAL of the A. I. E. E. when writing to advertisers.

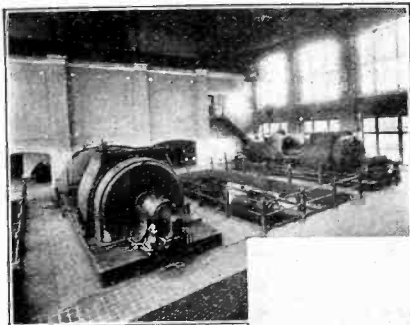

Wired With **SIMPLEX**

Penn. Central Power Co.
Saxton Substation

Day & Zimmermann, Inc., Engrs.

Simplex Wires and Cables are rendering satisfactory service in many of the larger power stations of the country. Insulated with rubber, paper or varnished cambric and covered with braid, lead or steel armor, they are made for the particular conditions under which they are installed.

Why not submit your specifications to us?

CHICAGO
SAN FRANCISCO
NEW YORK

SIMPLEX WIRE & CABLE CO

MANUFACTURERS

201 DEVONSHIRE ST., BOSTON 9

FACTORY
AND MAIN OFFICE
AT BOSTON

WIRE PRODUCTS For Varied Applications

We manufacture many types of wires, cords and cables for specific uses. Among them are:

Rubber Covered Wire—Solid Conductor, Stranded Conductor, Flexible Conductor, Extra Flexible Conductor. Lamp Cords, Reinforced Cords, Heater Cord, Brewery Cord, Canvasite Cord, Packinghouse Cord, Deck Cable, Stage Cable, Border Light Cable, Flexible Armored Cable, Elevator Lighting Cable, Elevator Operating Cable, Elevator Annunciator Cable. Switchboard Cables, Telephone Wire, Flameproof Wires and Cables, Railway Signal Wires, High Voltage Wires and Cables. Automobile Ignition Cables, Automobile Lighting Cables, Automobile Starting Cables, Automobile Charging Cables. Moving Picture Machine Cable.

Boston Insulated Wire & Cable Co.

Main Office and Factory:
Dorchester District Boston, Mass.
Canadian Branch, Office and Factory, Hamilton, Ont.



ATLANTIC INSULATED WIRES

DOLPHIN Insulated Wire

A code wire of high quality known for its great dielectric strength and resiliency, and used for its dependability and maximum service. Built on the same lines as the widely known and used "Triton"—Intermediate Grade 25%; and "Neptune"—30% para.

ATLANTIC Insulated Wire & Cable COMPANY
Rome, N. Y.

"COPPERWELD"

GROUND RODS DO NOT RUST

LONG LIFE—Protection from rusting because of welded-on copper.

NO FITTINGS—One piece and pointed. Easy to solder grounding wire to pure copper surface of rod.

EASY TO DRIVE—Steel core gives rigidity.

LOW INSTALLATION COST—Little time and field labor is required to install Copperweld Rods.

PLAY SAFE—Why rely on a high resistance or rusted-off ground, which fails to function when required most?

SAFETY FIRST—Use Copperweld Ground Rods and maintain a permanent low resistance ground for all time.

Copperweld Steel Company

FORNELY WELDED COPPER CLAD STEEL COMPANY
MAIN OFFICE & MILLS: BRADDOCK P. O. RANKIN, PA.
30 CHURCH ST., NEW YORK. 129 S. JEFFERSON ST., CHICAGO
403 RIALTO BLDG. SAN FRANCISCO

COPPERWELD IS MADE BY THE MOLTEN WELDING PROCESS

Please mention the JOURNAL of the A. I. E. E. when writing to advertisers.

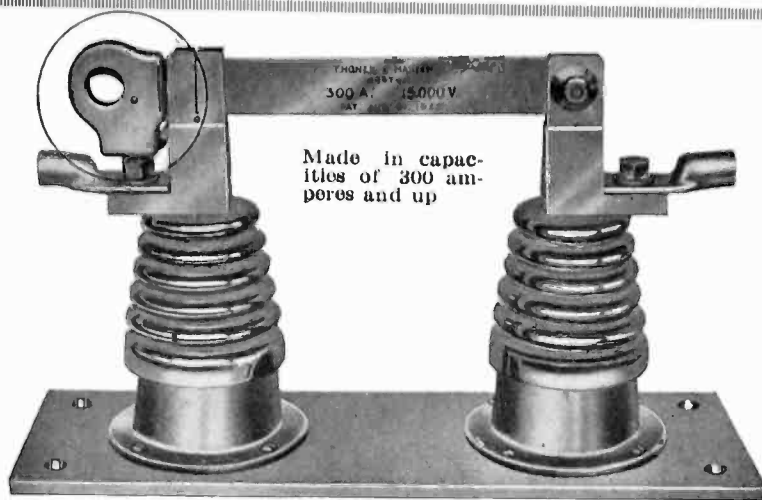

T & M SWITCHES

are specified regularly by the largest power companies and leading engineering organizations.

They are abreast of modern engineering design and requirements. An example is the disconnecting switch here illustrated, an exclusive feature of which is the bolt type lock. Extremely simple and accessible, the locking mechanism will safely withstand the heaviest short-circuits to which such apparatus is subjected in service.

Let us know your needs on any heavy duty a-c. or d-c. switch problem. We shall be glad to submit drawings and quote prices.

THONER & MARTENS

463 Commercial St.,

BOSTON, MASS.

RESEARCH EQUIPMENT

The General Radio Company is prepared to supply to order apparatus within our field for Research and Thesis work.

ARTIFICIAL LINES A SPECIALTY

For communication and power work. The smooth lines used in the recent important researches at the Massachusetts Institute of Technology and described in the December, 1923, Journal were made in our factory.

GENERAL RADIO COMPANY

Massachusetts Ave. and Windsor Street
CAMBRIDGE, MASS.

Manufacturers of Electrical and Radio Laboratory apparatus for a decade

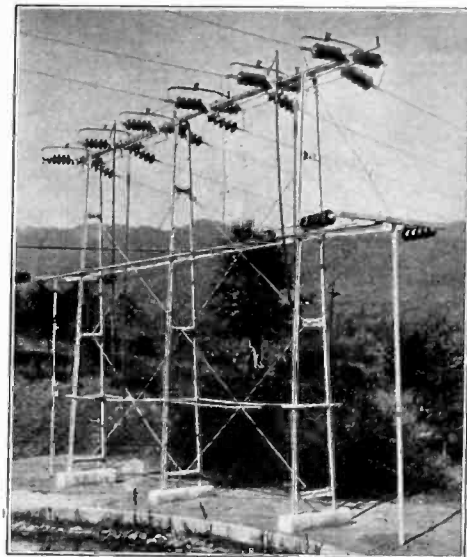

**Simpler—
Stronger—
Better—**

Installation K-P-F
60 KV. Switches,
San Joaquin Lt. &
Pwr. Corpn., Calif.

K-P-F POLE TOP SWITCHES consist of fewer parts, are more rugged and require less labor and material for installation than any other.

Each pole becomes a self-contained unit. Switches are shipped ready to bolt on to cross-arm in place of line insulator.

One crossarm supports it. Contacts are far removed from insulators and a unique device prevents sticking or freezing.

Send for bulletin K105 containing full details.

K-P-F ELECTRIC CO.

855-859 Howard St.

San Francisco

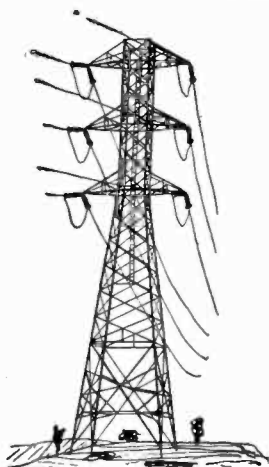

Transmission Line Structures

Built of High Elastic Limit Steel

Refined — Rolled — Fabricated —

Galvanized in Our Own Plants

PACIFIC COAST STEEL COMPANY

MANUFACTURERS OF

OPEN HEARTH STEEL

STRUCTURAL SHAPES MERCHANT AND REINFORCING BARS

TRANSMISSION TOWERS AND STRUCTURES

Gen'l Office: Rialto Bldg., San Francisco

Plants: San Francisco, Portland, Seattle

Please mention the JOURNAL of the A. I. E. E. when writing to advertisers.

Economize

Dubilier Condensers

for

Remote Control Systems

Condensers should be used in remote control systems as a measure of economy.

A Dubilier condenser—used to absorb spark energy at the opening and closing of contacts, lengthens the life of the contacts.

A Dubilier condenser—placed across the coils of a relay magnet—increases its power factor—brings about snap action!

Their permanent and unvarying capacity—their low loss quality — and their absolute dependability make Dubilier condensers the safest and surest for your use.

For information relative to Electro Static Condensers for any voltage at any capacity, address 43 West 4th St., New York, N. Y.

Dubilier

CONDENSER AND RADIO CORPORATION

De Laval Oil Purifier

protects Seattle's transformers

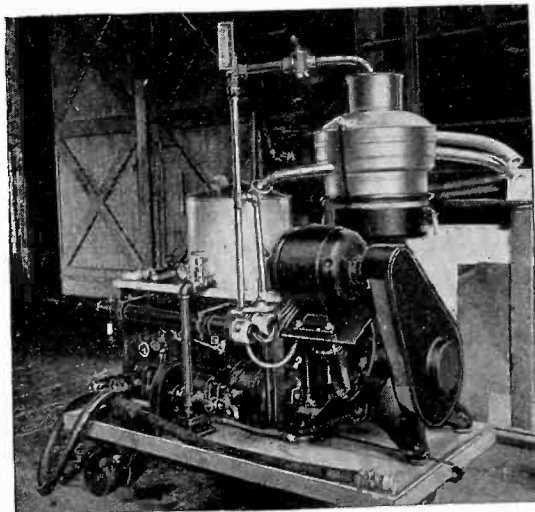

THE De Laval Oil Purifier shown above is maintaining the dielectric strength of the oil used in the transformers and switches of the City Lighting Department of Seattle, Washington.

Four of the five largest utility companies in America and hundreds of smaller ones in all parts of the world now use these machines to maintain the dielectric strength of transformer oil or to keep turbine oil clean, or both.

These companies, like the Seattle Lighting Department, have proved to their own satisfaction that De Laval centrifugal purification is the better way of maintaining the efficiency of turbine or Diesel lubricating oil and that the dielectric strength of transformer oil, switch oil and other insulating oils can be maintained at less expense by centrifugal dehydration.

Mail the coupon for full details.

The De Laval Separator Company

New York
165 Broadway

Chicago
29 East Madison Street

De Laval Pacific Company
61 Beale St., San Francisco

Please send Bulletin containing further information regarding the De Laval Oil Purifier as checked below:

- Purification of turbine lubricating oil.
- Purification of Diesel lubricating and fuel oil.
- Dehydration of transformer oil.

Name.....

Company.....

Address.....

JAT-618T

No Generator or Feeder Panel is complete



Recording Ammeter for Wall or Switchboard

without
TRADE MARK
BRISTOL'S
REG. U. S. PAT. OFFICE

Recording Electrical Instruments

The facts are there—permanently recorded on 24-hour charts that show the voltage, current, frequency, kilowatts, as they existed during every minute of the day.

An important part of our service lies in our abilities and facilities for investigating conditions and recommending equipment suitable for each particular case. Perhaps the experience of others may interest you. We have much data that is of interest.

Write us today.

Every electrical man should write us now for Catalog 1501-BC

The Bristol Company
Waterbury, Conn.

Branch Offices:

Boston New York Philadelphia Detroit Pittsburgh
 Chicago San Francisco



JEWELL PORTABLE NO. 2

Whether for switchboard mounting or for laboratory or portable testing, Jewell instruments have gained the recognition of Electrical Engineers throughout the country.

We shall be glad to submit instruments for competitive tests and comparisons.

Jewell Electrical Instrument Co.
 1650 Walnut St. - Chicago



DUNCAN MODEL E

The ideal direct current watt-hour meter. A pioneer in the service with a record for unstinted accuracy, and a reputation for dependability under all conditions that naturally recommends it to fastidious engineers who demand the best in the art.

DUNCAN ELECTRIC MFG. CO.
 Lafayette, Ind.

PUMPS

INDUSTRIAL-AGRICULTURAL-MUNICIPAL-RESIDENTIAL

A TYPE FOR EVERY SERVICE

Bulletins on Request

THE GOULDS MANUFACTURING COMPANY

Seneca Falls, N. Y.

Agencies in all principal cities

GOULDS

Pittsburgh Transformer Company

Largest Manufacturers of Transformers exclusively
 in the United States

Pittsburgh, Pennsylvania

AMERICAN TRANSFORMERS

FOR ELECTRIC FURNACES Complete Transformer and Control Unit

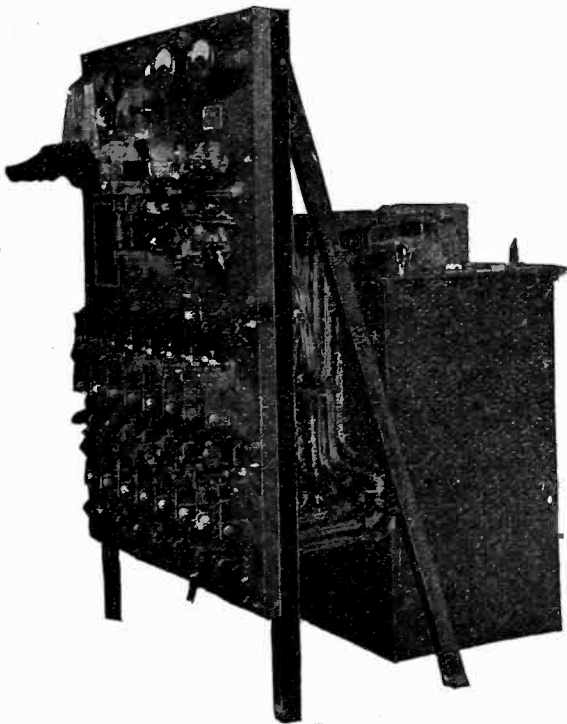

HERE is a 50 KVA, 60-cycle, 220-volts primary; 3 to 240-volts secondary transformer in 3-volt steps, complete with control board, protective circuit breaker, meters and pilot lamp. Voltage control is obtained by means of series parallel coils and tapped auto transformers. Knife blade switches are used. This is only one of the types of furnace transformers which we build. American Transformers are the result of over 20 years' experience in designing and constructing transformers for almost every purpose.

The consistent and growing demand for them in America's large industrial plants is evidence of the reliable service which they render.



American Transformer Company
176 Emmet Street
Newark, New Jersey



Send for Bulletin No. 1030 Descriptive of Industrial Transformers for almost every purpose.

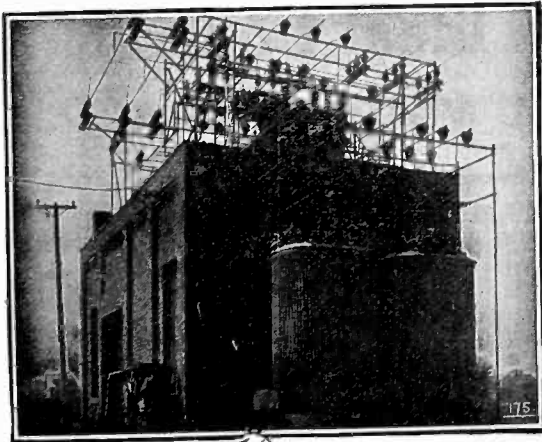

Fine engineering, high class workmanship and excellent materials make more consistent performers out of—

Moloney Transformers

Low densities in iron and copper, large cooling surfaces, liberal insulation and great mechanical strength are well known features which have made them so thoroughly satisfactory in the field.

Moloney Electric Company
Main Office and Factories:
St. Louis, Mo.
Sales Offices in Principal Cities

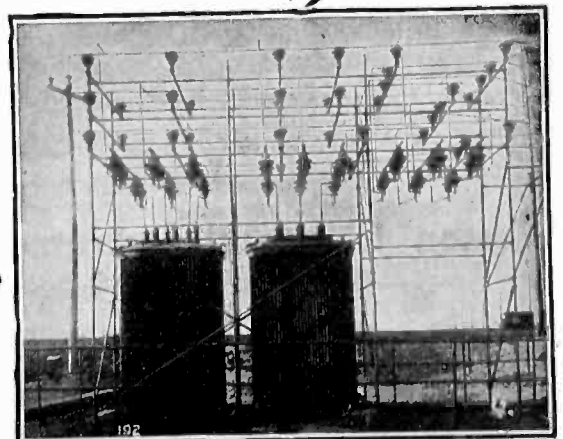

Please mention the JOURNAL of the A. I. E. E. when writing to advertisers.

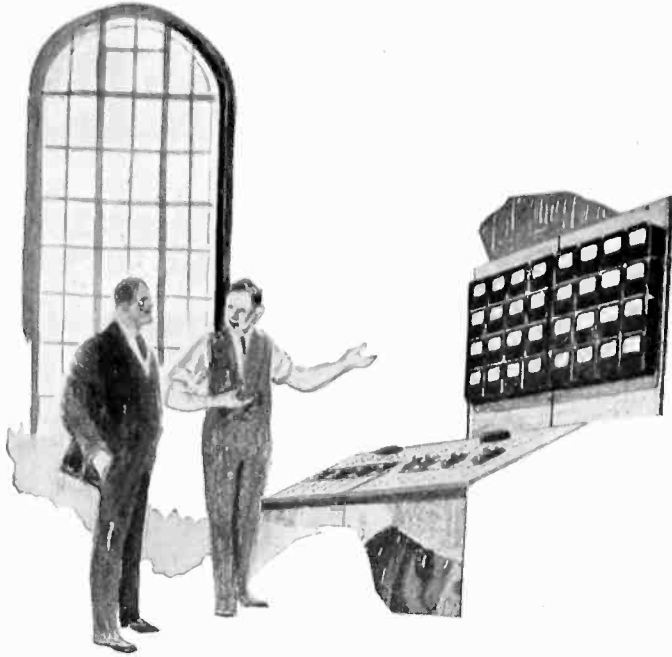

*The Best Power Plant Instrument
Investment We Ever Made*

**Weston Rectangular Instruments
Make Ideal Feeder Panel Ammeters**

THESE rectangular instruments are ideal for station feeder panels.

They are small in size, compact and handsome in appearance. Their wide open scales drawn with bold types of arcs and figures make for great legibility and scale illumination.

Regardless of what the operating conditions are—whether the switchboard is small or exceptionally large these rectangular instruments are admirably suited for feeder panel use.

As many as thirty can be accommodated on a 24-in. panel 30 in. high and because of their compact arrangement and simplicity of case design they present to the station operator practically an unbroken field of legible easy reading scales, and the readings of the entire bank can be visualized at a glance.

The new size $5\frac{3}{4}$ in. wide x 6 in. high x $4\frac{1}{2}$ in. deep with a scale length of $5\frac{1}{8}$ in. embodying Weston dependability and accuracy has received commendation everywhere.

Smaller instruments, easier readings, better illumination, these are only three of the reasons why Weston Rectangular Instruments have gained instant recognition.

Write for Bulletin 1504 giving full details.

Weston Electrical Instrument Corp.
48 Weston Ave., Newark, N. J.

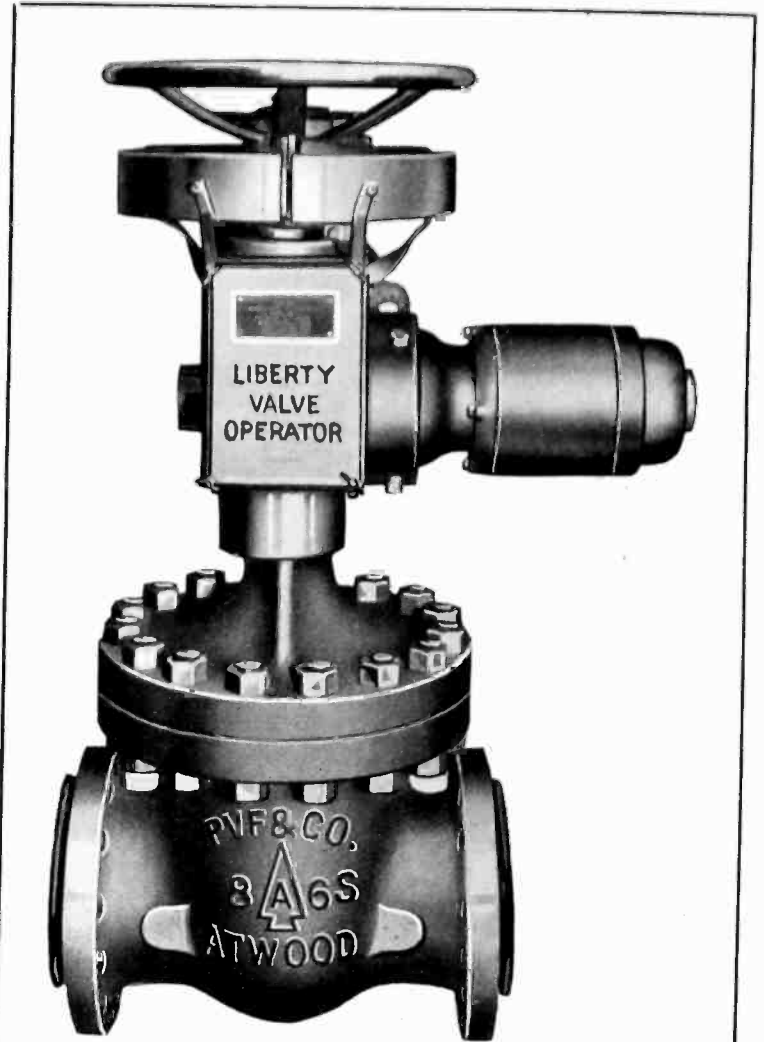

**The Ideal Control
for your valves**

Be sure that every important gate valve in your high or low pressure steam, water, oil or gas lines is under your complete control from conveniently located stations or central panel board by equipping them with the

**LIBERTY
Valve Operator**

Absolutely dependable in operation. Limit switch and safety clutch prevent overtravel and jamming under any condition. The motor is disengaged when idle. Steam, dust and waterproof.

Unexcelled flexibility in application. Either push button control through relays or manually operated switches can be provided.

Investigate this greatly improved control.

A necessity for safety.

Let us advise you in full on your valve control problems. Write for circular J-3.



Liberty Electric Corporation
Stamford, Conn.



An Ideal Small Portable A.C. Instrument Suitable for Every Testing Purpose

Roller-Smith Type HA

Small portable, A. C. Ammeters, Milliammeters, Voltmeters, and Wattmeters will cut your testing costs. HA instruments are invaluable for making all general tests of A. C. motor and generator circuits, light and power circuits, household electrical appliances, etc. Also useful to electrical contractors, plant electricians, students and to schools and colleges.

These ROLLER-SMITH HA instruments are light weight, compact portable instruments, accurately calibrated and built of the best materials. They give excellent service. Bulletin No. AE-150 which describes HA instruments, will be sent on request.



ROLLER-SMITH COMPANY

Electrical Measuring and Protective Apparatus

Main Office: 12 Park Place, NEW YORK
Works: Bethlehem, Penna.

Baltimore	Dallas	New Orleans	Seattle
Bethlehem	Denver	New York	St. Louis
Birmingham	Detroit	Philadelphia	St. Paul
Boston	Los Angeles	Pittsburgh	Toronto
Buffalo	Memphis	Salt Lake City	Washington
Chicago	Montreal	San Francisco	Havana,
Cleveland			Cuba

New!

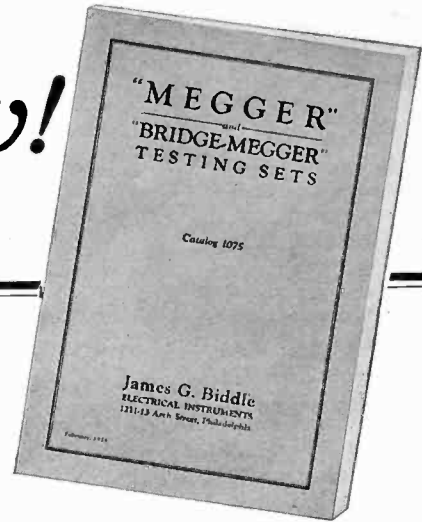

We cordially invite you to avail yourself of the information contained in this **NEW CATALOG**

The subject dealt with is Electrical Insulation and the "Megger-method" of testing it.

The book is more than just a catalog—it contains 52 pages of valuable information, illustrated with charts, diagrams and photographs. There is a carefully written chapter on "Insulation and the Measurement of its Resistance", which goes into the causes of breakdown, effects of temperature, surface leaks, etc. The description of "Megger" and "Bridge-Megger" Testing Sets shows how absolutely unique and well made these instruments are, and is followed by thirteen articles containing directions for testing *all* types of electrical apparatus.

The experience of engineers throughout the United States engaged in all branches of electrical work has been drawn upon for this book, and the subject is presented to you in a simple, concise and readable form.

If you are an electrical engineer, a plant manager or superintendent, or in any way vitally connected with the manufacture, installation or up-keep of electrical equipment, Catalog 1075 will be of value to you and you ought to have a copy. Write us to-day. No charge.

James G. Biddle

1211-13 Arch Street

Philadelphia

Chandeysson

Built to last

Also

A. C. Motors
Slip Ring and Squirrel Cage

Motor Generator Sets

Electroplating
Generators and
MG Sets

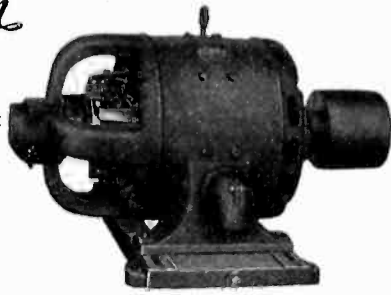

Direct Current Motors
1 to 125 H. P.

Bulletins on Request

CHANDEYSSON ELECTRIC COMPANY
Mo. Pac. Ry. and Bingham Ave. St. Louis, Mo.

Sturtevant Electric Motors

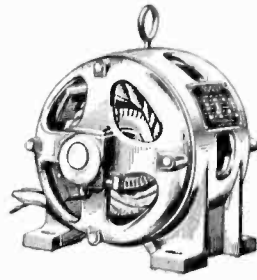

—A. C. and D. C.; single and polyphase—built in sizes from small fractional to 250 horse-power—designed to operate under a constant full load where uninterrupted service is demanded.

B. F. STURTEVANT COMPANY
HYDE PARK, BOSTON, MASS.

Trade "ESCO" Mark

ELECTRIC SPECIALTY CO.

Engineers and Manufacturers

DESIGN — DEVELOP — PRODUCE

Small Motors, Generators, Dynamotors,
Motor Generators, Rotary Converters, Etc.

FOR SPECIAL PURPOSES

Send Us Your Problems

222 South Street STAMFORD, CONN., U.S.A.

Star Ball Bearing Motors

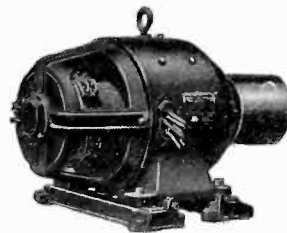

For
Hard
Usage



A. C.
and
D. C.

Complete line of standard motors and generators,
all sizes up to 75 h.p. and 50 kw. respectively.
Our Engineering Department at your service for all special applications

STAR ELECTRIC MOTOR CO.
NEWARK, NEW JERSEY

THE NEW "MARTIN" A.C. to D.C.

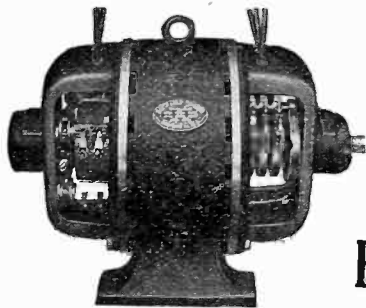

Rotary Converter and
Synchronous Motor

A self-starting and most efficient machine, that cuts conversion losses to a minimum. Designed to operate on 110, 220, 440 volts; 25, 30 and 60 cycles. Delivers D. C. of any desired voltage up to 250. Made in capacities from 100 Watts up to 100 Kw.

FOR MOTION PICTURES
ARC WELDING
BATTERY CHARGING

Bulletins on request.

NORTHWESTERN ELECTRIC COMPANY

Also Mfrs. of "AK" Variable Speed A. C. Motors
409 So. Hoyne Avenue, Chicago, Ill.
Minneapolis—8 N. Sixth St. Kansas City, Mo.—1924 Grand Ave.
Toronto, Can.—308 Tyrell Bldg., 95 King St., F.

"IRVINGTON" PRODUCTS

Black and Yellow

Varnished Cambric Varnished Paper
Varnished Silk
Flexible Varnished Tubing
Insulating Varnishes and Compounds
"Cellulak" Tubes and Sheets

IRVINGTON VARNISH & INSULATOR CO.
Irvington, New Jersey.

Sales Representatives in all principal cities

ELECTRICAL TESTING LABORATORIES

80th Street and East End Ave.
NEW YORK

Inspections — Tests — Research

Tests may be used by the purchaser for the following purposes:

- (1) To determine the quality of competing samples. This enables the purchase of the best quality for the money.
- (2) To make sure that shipments comply with specifications. This makes possible the assurance to the customer that shipments match buying samples.
- (3) To furnish an impartial decision in case of disputes between purchaser and manufacturer.

Testing places the whole buying problem on a sound basis.



Is your
name on our
mailing list
for bulletins
and catalog?

Morganite Brushes

Morganite
Brush Co., Inc.
519 W. 38th St.
New York

Please mention the JOURNAL of the A. I. E. E. when writing to advertisers.

They Keep a-Running

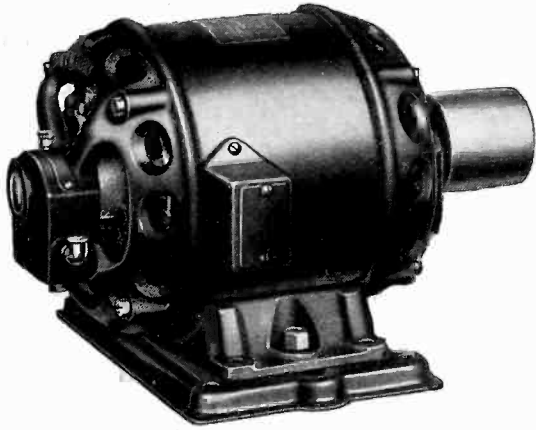

Bearings of Highest Grade Cast Phosphor Bronze

The bearings in Century Repulsion Start Induction Motors are made from the highest grade cast phosphor bronze bearing metal that can be obtained. They are cast from metal heated in electric furnaces in the Century plant—the composition of each individual heat being exactly determined. They are then accurately machined on all dimensions and provided with machine cut figure-8 oil grooves, which insure a thorough distribution of oil throughout the entire length of the bearing. Lateral shifting is prevented by a heavy shoulder on one end of the bearing—built with liberal dimensions, they withstand the pounding of gear drive and pressures from unintentionally heavy belt tension.

These are just a few of the reasons why many Century Motor owners report continuous service for 20 years without a single bearing replacement.

Built in all standard sizes from 1/8 to 40 h. p.—temperature rise not more than 40° Centigrade.

Send for Bulletin No. 29

Bulletin No. 29 outlines all the superior features of Century Repulsion Start Induction Single Phase Motors—send for your copy today.

CENTURY ELECTRIC COMPANY
1827 Pine St. St. Louis, Mo.

29 Stock Points in the United States and
More Than 50 Outside Thereof



1/8 to 40 H.P.

1/8 to 40 H.P.

CROCKER-WHEELER

PIONEER
MOTOR
MANUFACTURERS
Established 1888

Government
Printing Office
Washington, D. C.

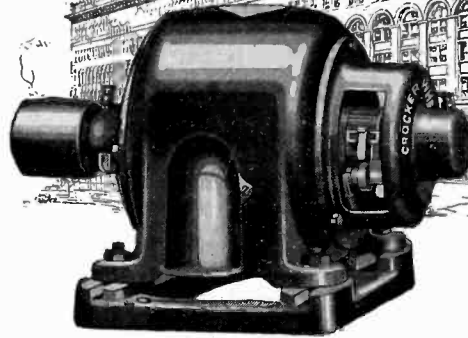

In the largest printing plant in the world!

*Crocker-Wheeler Motors drive
practically every machine*

At 6:30 P. M. the manuscript of the famous report on the blowing up of the Maine reached the Government Printing Office. At 10 A. M. next morning the printed report—298 pages of text, 24 full page engravings and one lithograph in colors—lay on every desk in the Senate and House.

To turn out on time the almost endless stream of bills, resolutions, pamphlets and periodicals, to print "The Congressional Record," with its daily circulation of many thousands, to meet the exacting and often sudden demands of Congress, Uncle Sam's great printing plant must have power equipment which is unfailingly dependable.

From the beginning the Government Printing Office has practically standardized on Crocker-Wheeler Motors and Generators. Today its power equipment includes 1500 Crocker-Wheeler Motors. All four main generators are Crocker-Wheeler, too.

CROCKER - WHEELER COMPANY
AMPERE NEW JERSEY

BALTIMORE
BIRMINGHAM
BOSTON
BUFFALO

CHICAGO
CLEVELAND
DETROIT
NEW HAVEN

NEW YORK
PHILADELPHIA
PITTSBURGH
SAN FRANCISCO

Foreign Distributor: International Western Electric Co.



MOTORS & GENERATORS

Please mention the JOURNAL of the A. I. E. E. when writing to advertisers.

“To say that we are well pleased is putting it mildly”

OF course, we expected that the tremendous advantages of the FYNN-WEICHSEL MOTOR as a power-factor corrective would create a sensation. A motor capable of correcting power-factor while operating as a power motor would naturally open the way to tremendous economies.

We knew, too, that the FYNN-WEICHSEL MOTOR, while correcting the power-factor of the circuit in which it was connected, would, through its high starting torque, synchronous speed and overload capacity, prove of immense value as an industrial motor. But the enthusiasm with which users praise this motor for its power drive characteristics has far exceeded our expectations.

Here for instance, is an extract from a letter written us by an official of the Federal Machine & Welder Company of Warren, Ohio, one of the first firms to install a FYNN-WEICHSEL MOTOR:

“We were much surprised to find that this one motor corrected the power-factor running from 50 to 60, up to 85, which eliminated the penalty clause on our power contract. Since that time we have put in another to put ourselves on the safe side and to say that we are well pleased is putting it mildly. We have not had one minute’s trouble with the motors in question and they have been in continuous service 9 hours a day every working day since installed . . .

“This type of motor has served us in two purposes; giving us a more efficient power drive and eliminating our defective power-factor.”

We, too, can say that “to say that we are well pleased is putting it mildly.” And if you want the finest motor in existence for constant-speed power drive, combined with efficient power-factor correction, we can make it possible for you to say the same.



CI20-6

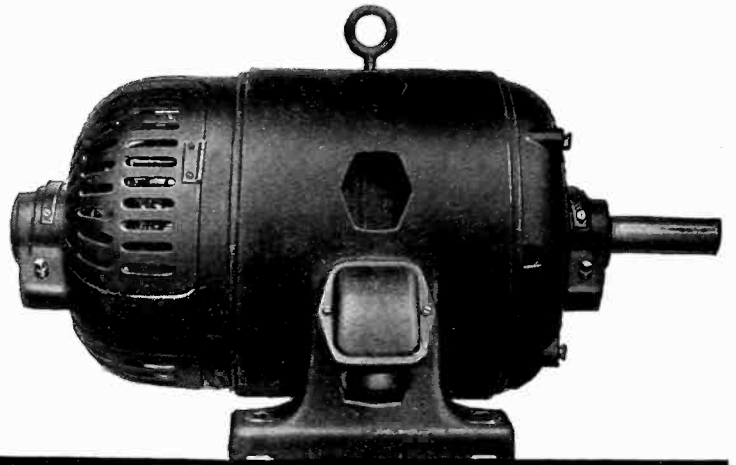

Fynn-Weichsel

The motor that corrects power-factor

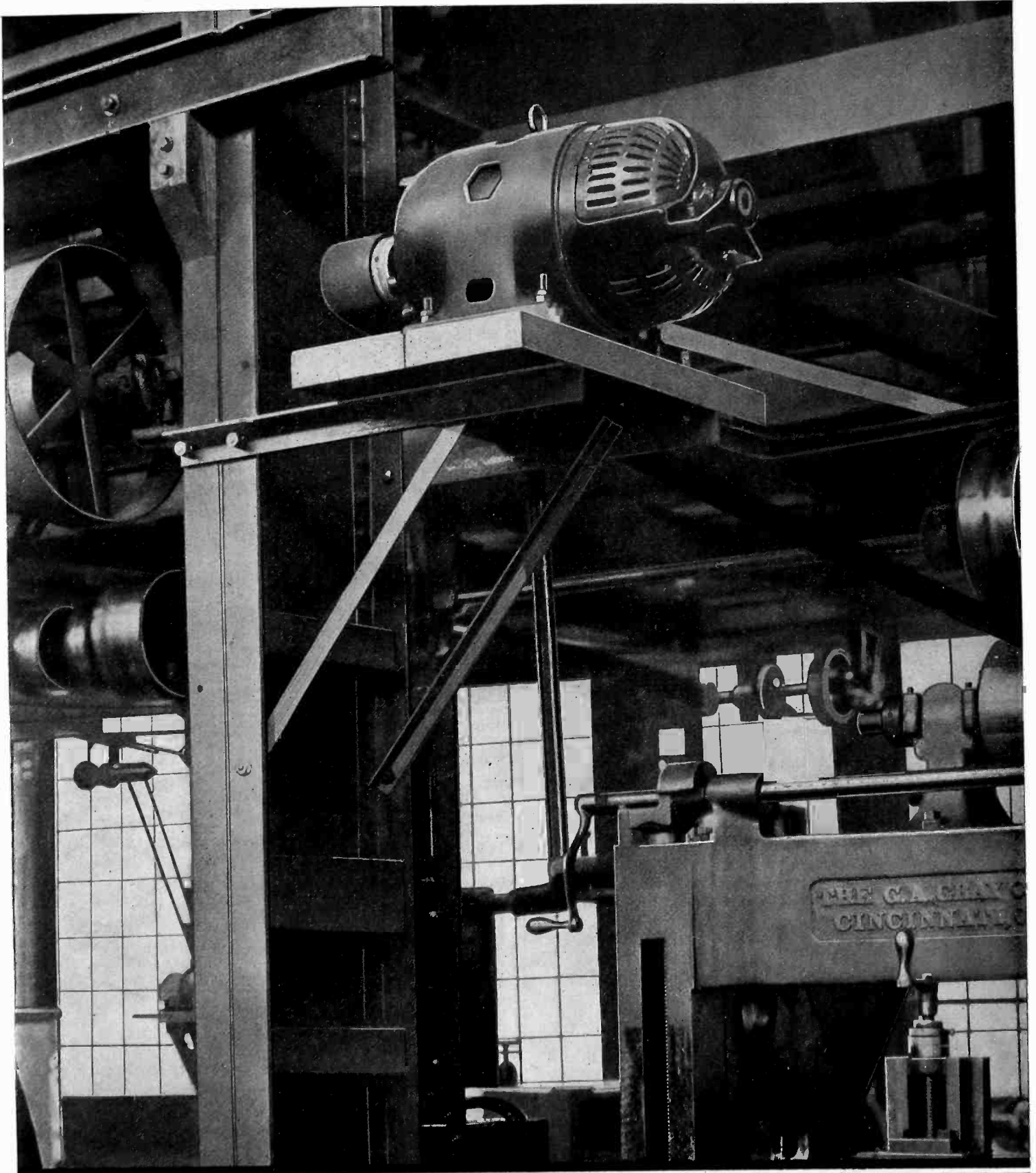

WAGNER ELECTRIC CORPORATION
SAINT LOUIS

WAGNER ELECTRIC CORPORATION

You may send me—without obligation on my part—a copy of your bulletin No. 134, describing THE FYNN-WEICHEL MOTOR.

NAME

COMPANY

STREET

CITY

STATE

Please mention the JOURNAL of the A. I. E. E. when writing to advertisers.

Write Department F1

For your copy of pamphlet describing
MIDWEST AIR FILTERS
New Model Type U2

The latest development in modern equipment for providing CLEAN AIR for turbo-generators, air compressors, diesel engines, mill motors and similar machines.

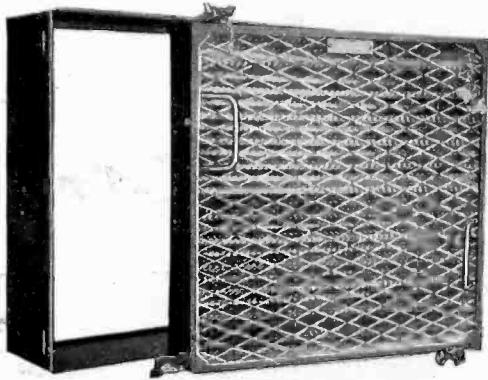

New Model Type U2.

MIDWEST AIR FILTERS

MIDWEST CANADA LIMITED
83 Craig Street, W.
MONTREAL CANADA

INCORPORATED
100 EAST 45TH STREET
NEW YORK CITY

MIDWEST AIR FILTERS PACIFIC, INC.
955 MONADNOCK BUILDING
SAN FRANCISCO, CAL.

MORSE SILENT CHAIN DRIVES

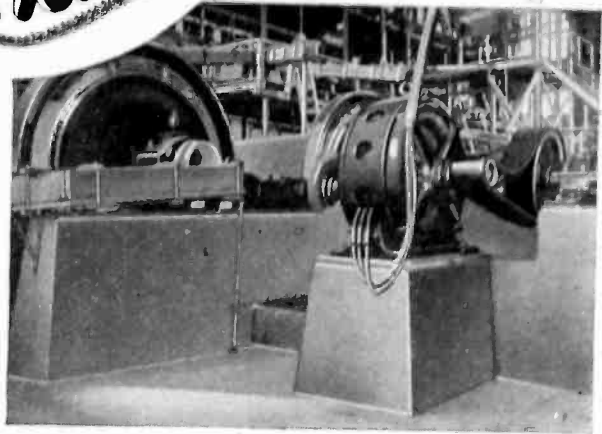

100 H. P. Morse Silent Chain driving tube-mill unit in mill of Tonopah-Belmont Development Co., Tonopah, Nev.

As shown by the illustration, each unit of two tube mills at Tonopah is driven by a 100 H. P. motor, running at 570 R. P. M., the power being transmitted by Morse Silent Chains.

Morse Silent Chains are the kind of power drives that industrial plants can install with confidence. They are 98.6% efficient, and give dependable service year after year. For complete information get in touch with the nearest Morse Engineer.

MORSE CHAIN COMPANY, ITHACA, N. Y.

There is a Morse Engineer near you

2172-30

Atlanta, Ga.	Chicago, Ill.	New York City	San Francisco, Cal.
Baltimore, Md.	Cleveland, Ohio	Minneapolis, Minn.	St. Louis, Mo.
Boston, Mass.	Denver, Colo.	Philadelphia, Pa.	Toronto, Ont., Can.
Charlotte, N. C.	Detroit, Mich.	Pittsburgh, Pa.	Winnipeg, Man., Can.

THE ROWAN A.C. STARTING SWITCH

PUSH BUTTON OPERATED
OIL IMMERSED



FOR
STARTING AND STOPPING SMALL SQUIRREL CAGE
MOTORS THAT CAN BE THROWN ACROSS
THE LINE

ROWAN CONTROL

THE ROWAN CONTROLLER CO., BALTIMORE, MD.

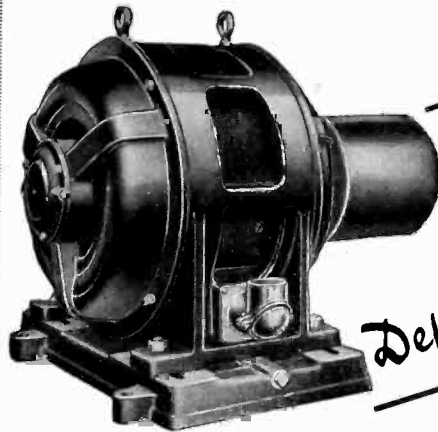

*Built
for
Dependability*

WHEN the Electro Dynamic Polyphase Induction motor was first conceived, it was our determination to produce a motor as dependable as human ingenuity and practical limitations would permit. A motor so well designed, electrically and mechanically, of such sturdy construction, of such expert workmanship, that it would be practically trouble-free and fool-proof.

Our engineers will be glad to explain to you the many distinctive features that mean absolute dependability and true economy.

ELECTRO DYNAMIC COMPANY

(Est. 1880)

BAYONNE, N. J.

Manufacturers of A. C. and D. C. Motors and Generators.
1/2 to 1000 H.P.

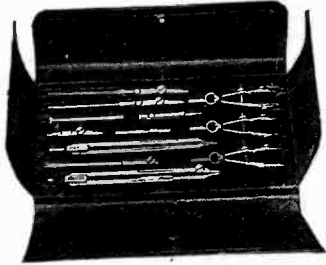

No. 1487 E
Extra Fine Three Bow Set
Price, \$4.95

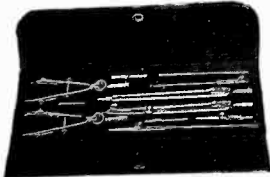

No. 1548 E
Two Bow Set
Price, \$2.60

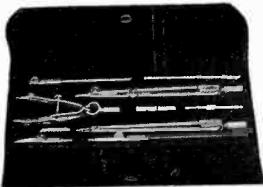

No. 1547 E
One Bow Set
Price, \$2.30

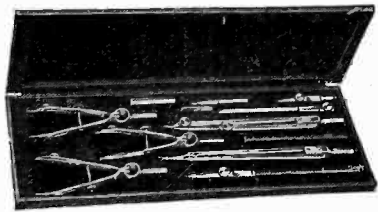

No. 1550 E
Three Bow Set
Special Price, \$2.75

SAVE 50%

We must reduce our stock of these fine imported instruments so we have made prices that will do it.

The prices shown are at least 50% less than the regular retail price—however you are to be the judge—if not satisfied your money will be cheerfully refunded.

PAY THE POSTMAN

New York Blue Print Paper Co.,
102 Reade Street,
New York, N. Y.

MARINE RULES



Recommended Practise for Electrical Installations on Shipboard

THE Marine Rules have been drawn up to serve as a guide for the equipment of merchant ships with electrical apparatus for lighting, signaling, communication and power, but not including propulsion. They indicate what is considered the best engineering practise with reference to safety of the personnel and of the ship itself, as well as reliability and durability of the apparatus. These rules are intended to supplement the STANDARDS of the A. I. E. E., which should be followed wherever applicable.

Linon covered, 97 pp., price, \$1.00 per copy, with discount of 25% to members of the A. I. E. E., dealers, and purchasers of ten or more copies.

AMERICAN INSTITUTE OF ELECTRICAL ENGINEERS

33 West 39th Street, New York



17 Black Degrees
3 Copying

The largest selling Quality pencil in the world

VENUS PENCILS

FOR light masses, dark masses, shadows and accents—fine lines, coarse lines, sketches, and the most detailed finished drawings, the famous VENUS Pencil is unequalled.

17 Black Degrees
6B Softest to 9H Hardest
also 3 Copying

Plain Ends,— per doz. . . . \$1.00
Rubber Ends,—per doz. . . . 1.20

At stationers, drafting supply dealers and stores throughout the world

American Lead Pencil Co.
204 Fifth Ave., New York
and London, Eng.

VENUS ERASERS
are perfect.



Made in 12 sizes.

MAIL COUPON FOR FREE SAMPLE
Send samples VENUS degrees checked—and a VENUS ERASER.
For bold, heavy lines 6B-5B-4B-3B
For general writing and sketching 2B-B-HB-F-H
For clean, fine lines 2H-3H-4H-5H
For delicate, thin lines 7H-8H-9H

Name _____
Address _____
Profession _____

PROFESSIONAL ENGINEERING DIRECTORY

For Consultants In the Fields of Engineering, and Related Arts and Sciences

Established 1857
ALEXANDER & DOWELL
 Attorneys at Law
 PATENT, TRADEMARK AND
 COPYRIGHT CASES
 902 F Street, N. W. Washington, D. C.

EDWARD E. CLEMENT
 Fellow A. I. E. E.
 Attorney and Expert
 in Patent Causes
 Soliciting, Consultation, Reports,
 Opinions
 McLachlen Bldg. Washington, D. C.
 700 10th St., N. W.

FREYN ENGINEERING COMPANY
 Formerly Freyn, Brassart & Company
 Engineers
 London CHICAGO Philadelphia
 Steam, Gas & Oil Power Plants
 Fuel, Oil, Tar, Gas Combustion Engineering
 Electrification of Rolling Mills
 Design and Construction of Electric Furnace
 Installations

AMBURSEN DAMS
 Hydroelectric Developments
 Water Supply and Irrigation Dams
 DAMS ON DIFFICULT FOUNDATIONS
 AMBURSEN CONSTRUCTION CO.
 Incorporated
 Grand Central Terminal, New York
 Kansas City, Mo. Atlanta, Ga.

HAROLD A. DANNE
 LIGHT AND POWER
 41 PARK ROW NEW YORK

VAL. A. FLYNN
 Consulting Engineer
 Specializing in designing, solving manufac-
 turing difficulties, appraising value of inven-
 tions, developing novel ideas, advising on
 all patent matters.
 Service to Manufacturers, Patent Attorneys
 and Capitalists.
 Boatmen's Bank Bldg. ST. LOUIS, MO.

THE AMERICAN APPRAISAL CO.
 Valuations and Reports
 of
 Public utility, industrial
 and all other properties
 Rate Cases Condemnation Suits
 Reorganizations Liquidations
 NEW YORK MILWAUKEE
 1896 And Principal Cities 1922

DAY & ZIMMERMAN, Inc.
 Engineers
 Power Plants, Sub-Stations,
 Transmission Lines, Industrial Plants
 Examinations and Reports, Valuations,
 Management of Public Utilities
 1600 WALNUT ST., PHILADELPHIA
 New York Chicago

FORD W. HARRIS
 Fellow A. I. E. E., Member A. S. M. E.
 Member bar of Supreme Court
 PATENTS
 Soliciting, Reports and Litigation
 HIGGINS BUILDING LOS ANGELES

W. S. BARSTOW & COMPANY
 Incorporated
 Financial and Operating
 Managers of
 Public Utilities
 50 Pine Street New York

ROBERT E. DENIKE, Inc.
 Electrical Engineers
 and Constructors
 NEW YORK CITY

L. F. HARZA
 HYDRO-ELECTRIC ENGINEER
 Monadnock Bldg. Chicago

BATTEY & KIPP
 Incorporated
 ENGINEERS
 Complete Industrial Plants
 Power Plants & Electrical Installations
 Engineering Reports, Analyses & Appraisals
 123 W. Madison Street CHICAGO

Fellow A. I. E. E. Member A. S. M. E.
W. N. DICKINSON
 Consulting Analyst
 BUSINESS AND ENGINEERING
 PROJECTS ANALYZED
 Aeolian Hall, 33 W. 42nd St., New York City

WILLIAM S. HIGBIE
 Electrical Engineer
 ENGINEERING AND PURCHASING
 SERVICE
 Design—Manufacture—Construction
 Own Shops
 Own Yard for Handling
 114 LIBERTY ST. NEW YORK CITY

BLACK & VEATCH
 Consulting Engineers
 Water, Steam and Electric Power Investiga-
 tions, Design, Supervision of Construction,
 Valuation and Tests.
 Mutual Building KANSAS CITY, MO.

DAVID V. FENNESSY
 Consulting Power Engineer
 MILLS BUILDING EL PASO, TEXAS

ELECTRIC HEATING ENGINEERS
 Electricity applied for heating air, water,
 oils, chemicals, compounds, ovens,
 dryers, and industrial processes.
 High voltage and large capacity work a
 specialty. Utilization of surplus and off peak
 power. Temperature and remote control.
 Consulting—Manufacturing—Erecting
 Hynes & Cox Electric Corporation
 36 State Street, Albany, N. Y.

WALTER G. CLARK
 Consulting Engineer
 Electrical, Mining and Industrial
 Reports
 Supervision of Organization and Arrange-
 ments for Financing
 LOS ANGELES NEW YORK
 1211 Insurance Exch. Bldg. 40 Wall St.

FORD, BACON & DAVIS
 Incorporated
 ENGINEERS
 115 Broadway, New York
 Philadelphia Chicago San Francisco

Dugald C. Jackson
 Edward L. Moreland
JACKSON & MORELAND
 CONSULTING ENGINEERS
 31 St. James Ave. Boston, Mass.

Make your specialized
 service known to the
 electrical industry
 through a card in the
ENGINEERING DIRECTORY

FRANK F. FOWLE & CO.
 Electrical and Mechanical
 Engineers
 MONADNOCK BUILDING CHICAGO

E. S. LINCOLN
 Consulting Electrical Engineer
 Designs Investigations Reports
 Electrical Research Laboratory
 534 Congress St. PORTLAND, MAINE

PROFESSIONAL ENGINEERING DIRECTORY

For Consultants in the Fields of Engineering, and Related Arts and Sciences

J. N. MAHONEY
Consulting Engineer
Fellow A. I. E. E. Mem. Am. Soc. M. E.
Design, Supervision, Specifications, Reports
Specialist in Electrical Power Switching and
Protective Equipment, Industrial and
Railway Control and Brake
Equipment
615-77th STREET BROOKLYN, N. Y.

**DWIGHT P. ROBINSON
& COMPANY**
Incorporated
Design and Construction of
Power Developments, Electric
Railways, Industrial Plants
125 East 46th Street, New York
Chicago Atlanta Youngstown Philadelphia
Los Angeles Montreal Rio de Janiero

STONE & WEBSTER
Incorporated
Examinations Reports Appraisals
on
Industrial and Public Service
Properties
NEW YORK BOSTON CHICAGO

MCCLELLAN & JUNKERSFELD
Incorporated
Engineering and Construction
Power Developments—Industrial Plants
Examinations—Reports—Management
NEW YORK
68 Trinity Place
Chicago Philadelphia St. Louis

SANDERSON & PORTER
Engineers
Reports Designs
Construction Management
Hydroelectric Developments
Railway, Light and Power Properties
Chicago New York San Francisco

PERCY H. THOMAS
Consulting Engineer
ELECTRIC POWER
Generation - Transmission
Applications
120 BROADWAY NEW YORK

W. E. MOORE & CO.
Engineers
Plans and Specifications for
Hydroelectric and Steam Power Plants
Industrial Plants and Electric Furnaces
Union Bank Building Pittsburgh, Pa.

SARGENT & LUNDY
Incorporated
Mechanical and Electrical
Engineers
1412 Edison Bldg., 72 West Adams Street
CHICAGO ILLINOIS

**UNITED GAS & ELECTRIC
ENGINEERING CORPORATION**
Engineers Management
Construction Appraisals
Reports, Estimates and Specifications
Now supervising the Engineering
and Operation of 32 Public Utility
Properties located in 12 states
111 BROADWAY NEW YORK CITY

N. J. NEALL
Consulting Engineer
for
Electrical and Industrial Properties
12 PEARL STREET BOSTON, MASS.

SCOFIELD ENGINEERING CO.
Consulting Engineers
Power Stations Gas Works
Hydraulic Developments Electric Railways
Examinations & Reports Valuations
Philadelphia

THE U. G. I. CONTRACTING CO.
Engineers & Constructors
Power Developments, Industrial Plants, Gas
Plants, Transmission Systems, Appraisals
Broad & Arch Sts., PHILA., PA.
421 Peoples Gas Bldg., Chicago, Ill. 928 Union Trust
Bldg., Pittsburgh, Pa.

NEILER, RICH & CO.
Electrical and Mechanical
Engineers
Consulting, Designing and
Supervising
Manhattan Building - - - Chicago

**SESSIONS ENGINEERING
CO., INC.**
ENGINEERS AND CONSTRUCTORS
Steam, Electric, Hydro and Industrial Plants
Appraisals, Surveys and Reports
208 SOUTH LASALLE ST., CHICAGO
Western District Office—Portland, Ore.

VIELE, BLACKWELL & BUCK
Engineers
Designs and Construction
Hydroelectric and Steam Power Plants
Transmission Systems Industrial Plants
Reports Appraisals
49 WALL STREET NEW YORK

OPHULS & HILL, Inc.
Formerly Ophuls, Hill & McCreery, Inc.
CONSULTING ENGINEERS
112-114 WEST 42nd ST., NEW YORK CITY
Ice Making and Refrigeration
Investigations and Reports

JOHN A. STEVENS
CONSULTING POWER ENGINEER
8 Merrimack Street
LOWELL MASSACHUSETTS

**THE J. G. WHITE
ENGINEERING CORPORATION**
Engineers—Constructors
Oil Refineries and Pipe Lines,
Steam and Water Power Plants,
Transmission Systems, Hotels, Apartments,
Office and Industrial Buildings, Railroads
48 EXCHANGE PLACE NEW YORK

**PUBLIC SERVICE
PRODUCTION COMPANY**
Engineers and Constructors
Design and Construction of Power Plants,
Substations and Industrial Plants
Examinations and Reports, Valuation and
Management of Public Utilities
80 PARK PLACE NEWARK, N. J.

STEVENS & WOOD, INC.
Design Finance Construct
Power Plants, Transmission Systems, Hotels
Apartments, Office and Industrial Buildings
Railroad Electrification
Management of Public Utilities
Mahoning Bank Bdg. 120 Broadway
YOUNGSTOWN, O. NEW YORK CITY

GARDNER S. WILLIAMS
Mem. Am. Inst. Cons. Eng. Mem. Am. S. C. E.
Consulting Engineer
Hydroelectric Developments
Investigations and Reports
Cornwell Bldg. ANN ARBOR, MICH.

*To be printed in the following
issue, copy for cards must be
received by the 20th of the month.*

William M. Stockbridge Victor D. Borst
STOCKBRIDGE & BORST
Patent Lawyers
41 PARK ROW NEW YORK CITY

J. G. WRAY & CO.
Engineers
J. G. Wray, Fellow A. I. E. E. Cyrus G. Hill
Utilities and Industrial Properties
Appraisals Construction Rate Surveys
Plans Organization Estimates
Financial Investigations Management
1217 First National Bank Bldg., Chicago

Classified Advertiser's Index for Buyers

Manufacturers and agents for machinery and supplies used in the electrical and allied industries.

Note: For reference to the advertisements see the Alphabetical List of Advertisers on page 46.

- AIR COMPRESSORS**
Allis-Chalmers Mfg. Co., Milwaukee
General Electric Co., Schenectady
Western Electric Co., All Principal Cities
- AIR COMPRESSOR FILTERS**
Midwest Air Filters, Inc., New York
- AIR FILTERS, COOLING**
Midwest Air Filters, Inc., New York
- AIR WASHERS**
Sturtevant Company, B. F., Boston
- ALARMS, TEMPERATURE, PRESSURE**
Cory & Son, Inc., Chas., New York
- AMMETER COMPENSATING COILS**
Minerallac Electric Co., Chicago
- AMMETERS, VOLTMETERS**
(See INSTRUMENTS, ELECTRICAL)
- ANNUNCIATORS, AUDIO-VISIBLE**
Cory & Son, Inc., Chas., New York
- BATTERY CHARGING APPARATUS**
Electric Specialty Co., Stamford, Conn.
General Electric Co., Schenectady
Western Electric Co., All Principal Cities
Westinghouse Elec. & Mfg. Co., E. Pitts-
burgh
- BEARINGS, BALL**
Fafnir Bearing Co., New Britain, Conn.
New Departure Mfg. Co., The, Bristol, Conn.
Norma-Hoffmann Bearings Corp., Stamford,
Conn.
Standard Steel & Bearings, Inc., Plainville,
Conn.
Strom Ball Bearing Mfg. Co., Chicago
- BOXES, FUSE**
General Electric Co., Schenectady
Metropolitan Device Corp., Brooklyn, N. Y.
Western Electric Co., All Principal Cities
Westinghouse Elec. & Mfg. Co., E. Pitts-
burgh
- BOXES, JUNCTION**
G & W Elec. Specialty Co., Chicago
Metropolitan Device Corp., Brooklyn, N. Y.
Standard Underground Cable Co., Pittsburgh
- BRUSHES, COMMUTATOR**
Carbon
Morganite Brush Co., Inc., New York
National Carbon Co., Inc., Cleveland
Westinghouse Elec. & Mfg. Co., E. Pitts-
burgh
Copper Graphite
Morganite Brush Co., Inc., New York
National Carbon Co., Inc., Cleveland
Westinghouse Elec. & Mfg. Co., E. Pitts-
burgh
- BUS BAR FITTINGS**
Burndy, Engineering Co., New York
Champion Switch Co., Buffalo
General Electric Co., Schenectady
Westinghouse Elec. & Mfg. Co., E. Pitts-
burgh
- CABLE ACCESSORIES**
Dossert & Co., New York
G & W Electric Specialty Co., Chicago
General Electric Co., Schenectady
Minerallac Electric Co., Chicago
Standard Underground Cable Co., Pittsburgh
Western Electric Co., All Principal Cities
- CABLES**
(See WIRES AND CABLES)
- CABLEWAYS**
Roebling's Sons Co., John A., Trenton, N. J.
- CAMBRIC, VARNISHED**
Belden Mfg. Co., Chicago
Irvington Varnish & Ins. Co., Irvington, N. J.
- CHAINS, POWER TRANSMISSION**
Morse Chain Co., Ithaca, N. Y.
- CIRCUIT BREAKERS**
Air-Enclosed
Cutter Co., The, Philadelphia
Roller-Smith Co., New York
Sundh Electric Co., Newark, N. J.
Western Electric Co., All Principal Cities
Oil
Condit Electrical Mfg. Co., S. Boston
General Electric Co., Schenectady
Westinghouse Elec. & Mfg. Co., E. Pitts-
burgh
- COILS, CHOKE**
Champion Switch Co., Buffalo
General Electric Co., Schenectady
Railway & Ind. Eng. Co., Greensburg, Pa.
Westinghouse Elec. & Mfg. Co., E. Pitts-
burgh
- COILS, MAGNET**
Acme Wire Co., New Haven, Conn.
Belden Mfg. Co., Chicago
Dudlo Mfg. Co., Ft. Wayne, Ind.
General Electric Co., Schenectady
Westinghouse Elec. & Mfg. Co., E. Pitts-
burgh
- CONDENSATION PRODUCTS**
Bakelite Corporation, New York
Condensite Co. of America, Bloomfield, N. J.
General Bakelite Co., New York
Redmanol Chemical Products Co., Chicago
- CONDENSERS**
Steam
Allis-Chalmers Mfg. Co., Milwaukee
General Electric Co., Schenectady
Westinghouse Elec. & Mfg. Co., E. Pitts-
burgh
Radio
Dubilier Condenser & Radio Corp., New
York
General Radio Co., Cambridge, Mass.
- CONDUIT, UNDERGROUND FIBRE**
Western Electric Co., All Principal Cities
- CONNECTORS, SOLDERLESS**
Dossert & Co., New York
Western Electric Co., All Principal Cities
Westinghouse Elec. & Mfg. Co., E. Pitts-
burgh
- CONNECTORS AND TERMINALS**
Belden Mfg. Co., Chicago
Dossert & Co., New York
G & W Electric Specialty Co., Chicago
Western Electric Co., All Principal Cities
Westinghouse Elec. & Mfg. Co., E. Pitts-
burgh
- CONTACTS, TUNGSTEN**
Fansteel Products Co., Inc., North Chicago
General Electric Co., Schenectady
- CONTROLLERS**
General Electric Co., Schenectady
Rowan Controller Co., Baltimore
Sundh Electric Co., Newark, N. J.
Western Electric Co., All Principal Cities
Westinghouse Elec. & Mfg. Co., E. Pitts-
burgh
- CONVERTERS—SYNCHRONOUS**
Allis-Chalmers Mfg. Co., Milwaukee
Electric Specialty Co., Stamford, Conn.
Northwestern Electric Co., Chicago
Westinghouse Elec. & Mfg. Co., E. Pitts-
burgh
- COPPER CLAD WIRE**
Belden Mfg. Co., Chicago
Copperweld Steel Co., Rankin, Pa.
Standard Underground Cable Co., Pittsburgh
Western Electric Co., All Principal Cities
- CUT-OUTS**
Condit Electrical Mfg. Co., S. Boston
General Electric Co., Schenectady
G & W Electric Specialty Co., Chicago
Metropolitan Device Corp., Brooklyn, N. Y.
Western Electric Co., All Principal Cities
Westinghouse Elec. & Mfg. Co., E. Pitts-
burgh
- DRAWING MATERIALS**
Keuffel & Esser Company, Hoboken, N. J.
N. Y. Blue Print Paper Co., New York
- DYNAMOS**
(See GENERATORS AND MOTORS)
- DYNAMOTORS**
Electric Specialty Co., Stamford, Conn.
- ELECTRIFICATION SUPPLIES, STEAM
ROAD**
General Electric Co., Schenectady
Ohio Brass Co., Mansfield, Ohio
Westinghouse Elec. & Mfg. Co., E. Pitts-
burgh
- ENGINEERS, CONSULTING AND CON-
TRACTING**
(See PROFESSIONAL ENGINEERING
DIRECTORY)
- ENGINES**
Gas & Gasoline
Allis-Chalmers Mfg. Co., Milwaukee
Sturtevant Company, B. F., Boston
Oil
Allis-Chalmers Mfg. Co., Milwaukee
Sturtevant Company, B. F., Boston
Steam
Allis-Chalmers Mfg. Co., Milwaukee
Sturtevant Company, B. F., Boston
- FANS, MOTOR**
Century Electric Co., St. Louis
General Electric Co., Schenectady
Star Electric Motor Co., Newark, N. J.
Sturtevant Company, B. F., Boston
Western Electric Co., All Principal Cities
Westinghouse Elec. & Mfg. Co., E. Pitts-
burgh
- FARM LIGHTING GENERATORS**
Western Electric Co., All Principal Cities
Westinghouse Elec. & Mfg. Co., E. Pitts-
burgh
- FIBRE**
Belden Mfg. Co., Chicago
National Vulcanized Fibre Co., Wilmington,
Del.
- FLOW METERS**
Cory & Son, Inc., Chas., New York
General Electric Co., Schenectady
- FURNANCES, ELECTRIC**
General Electric Co., Schenectady
Westinghouse Elec. & Mfg. Co., E. Pitts-
burgh
- FUSES**
Enclosed Refillable
General Electric Co., Schenectady
Western Electric Co., All Principal Cities
Westinghouse Elec. & Mfg. Co., E. Pitts-
burgh
Enclosed Non-Refillable
General Electric Co., Schenectady
Western Electric Co., All Principal Cities
Open Link
General Electric Co., Schenectady
Metropolitan Device Corp., Brooklyn, N. Y.
Western Electric Co., All Principal Cities
High Tension
Metropolitan Device Corp., Brooklyn, N. Y.
Western Electric Co., All Principal Cities
- GEARS, FIBRE**
General Electric Co., Schenectady
National Vulcanized Fibre Co., Wilmington,
Del.
- GENERATORS AND MOTORS**
Allis-Chalmers Mfg. Co., Milwaukee
Century Electric Co., St. Louis
Chandeysson Electric Co., St. Louis
Crocker-Wheeler Co., Ampere, N. J.
Electric Specialty Co., Stamford, Conn.
Electro-Dynamic Co., Bayonne, N. J.
General Electric Co., Schenectady
Northwestern Electric Co., Chicago
Star Electric Motor Co., Newark, N. J.
Sturtevant Company, B. F., Boston
Western Electric Co., All Principal Cities
Westinghouse Elec. & Mfg. Co., E. Pitts-
burgh
- GENERATING STATION EQUIPMENT**
Allis-Chalmers Mfg. Co., Milwaukee
Crocker-Wheeler Co., Ampere, N. J.
General Electric Co., Schenectady
Western Electric Co., All Principal Cities
Westinghouse Elec. & Mfg. Co., E. Pitts-
burgh
- GROUND RODS**
Copperweld Steel Co., Rankin, Pa.
Western Electric Co., All Principal Cities
- HEADLIGHTS**
Ohio Brass Co., Mansfield, O.
- HEATERS, INDUSTRIAL**
General Electric Co., Schenectady
Western Electric Co., All Principal Cities
Westinghouse Elec. & Mfg. Co., E. Pitts-
burgh
- INDICATORS, LOAD**
Cory & Son, Inc., Chas., New York
- INDICATORS, SPEED**
Biddle, James G., Philadelphia
Roller-Smith Co., New York
- INDICATORS, WATER LEVEL**
Cory & Son, Inc., Chas., New York
- INSTRUMENTS, ELECTRICAL**
Graphic
Biddle, James G., Philadelphia
Bristol Co., The, Waterbury, Conn.
Ferranti, Ltd., London Eng.
Ferranti Meter & Transformer Mfg. Co.,
Ltd., Toronto, Ont.
General Electric Co., Schenectady
Westinghouse Elec. & Mfg. Co., E. Pitts-
burgh
Indicating
Ferranti, Ltd., London, Eng.
Ferranti Meter & Transformer Mfg. Co.,
Ltd., Toronto, Ont.
General Electric Co., Schenectady
Jewell Elec. Instrument Co., Chicago
Roller-Smith Co., New York
Westinghouse Elec. & Mfg. Co., E. Pitts-
burgh
Weston Elec. Inst. Corp., Newark, N. J.
Integrating
Biddle, James G., Philadelphia
Duncan Elec. Mfg. Co., Lafayette, Ind.
Ferranti, Ltd., London, Eng.
Ferranti Meter & Transformer Mfg. Co.,
Ltd., Toronto, Ont.
General Electric Co., Schenectady
Roller-Smith Co., New York
Sangamo Elec. Co., Springfield, Ill.
Western Electric Co., All Principal Cities
Westinghouse Elec. & Mfg. Co., E. Pitts-
burgh
Radio
General Radio Co., Cambridge, Mass.
Jewell Elec. Instrument Co., Chicago
Repairing and Testing
Electrical Testing Laboratories, New York
Jewell Elec. Instrument Co., Chicago
Scientific, Laboratory, Testing
Biddle, James G., Philadelphia
General Electric Co., Schenectady
Jewell Elec. Instrument Co., Chicago
Metropolitan Device Corp., Schenectady
Roller-Smith Co., New York
Western Electric Co., All Principal Cities
Westinghouse Elec. & Mfg. Co., E. Pitts-
burgh
Weston Elec. Inst. Corp., Newark, N. J.
Telegraph
Western Electric Co., All Principal Cities

Please mention the JOURNAL of the A. I. E. E. when writing to advertisers.

Made by Westinghouse



THE spirit of George Westinghouse has again manifested itself, in the OB Watthour Meter, as built by his old associates. It is the product of MEN and their ART, a contribution surely worthy of its birthright.

As usual, Westinghouse engineering has contributed heavily toward the success of the OB Meter. The value of research is particularly apparent in the success achieved through the development of the drawn steel base and frame.

Without the special cold rolled steel made to the specifications of the Westinghouse Research Laboratories, the task would have been a more difficult one. Each shipment of steel is carefully tested by the experts at East Pittsburgh before it is put into production. Uniformity is the result.

The Westinghouse Company has unexcelled manufacturing facilities to assure not only the highest grade product, but also adequate quantity production and stocks which assure prompt service.

The OB Watthour Meter is the result of 36 years of specialized experience.

Worthy of Its Birthright

AS in '88, when Shallenberger invented the first practical induction-type meter, Westinghouse again, in 1924, makes the greatest advance in the art. For 36 years, Westinghouse engineers and tool makers have been pioneering the way, introducing new watthour meters, each one built upon this foundation of experience—and each was the accepted standard of its day.

The OB Meter goes further in this direction than any meter ever marketed. It is a departure in many ways—in size, weight, materials of construction, accessibility and in *greater accuracy* it stands alone.

You understand *better* why it was possible for Westinghouse to develop this new meter, if you have ever visited the Newark Works. There you can find everything that *modern* manufacture stands for, as well as many tried-and-true methods which, with Westinghouse, are a tradition.

WESTINGHOUSE ELECTRIC & MANUFACTURING COMPANY
NEWARK WORKS: NEWARK, N. J.

Please mention the JOURNAL of the A. I. E. E. when writing to advertisers.

Classified Advertiser's Index for Buyers—Continued

INSULATING MATERIALS

Board
West Va. Pulp & Paper Co., New York

Cloth
Acme Wire Co., New Haven, Conn.
Irvington Varnish & Ins. Co., Irvington, N. J.
Minerallac Electric Co., Chicago
Westinghouse Elec. & Mfg. Co., E. Pittsburgh

Composition
American Lava Corp., Chattanooga
Bakelite Corporation, New York
Belden Mfg. Co., Chicago
Condensite Co. of America, Bloomfield, N. J.
General Bakelite Co., New York
Redmanol Chemical Products Co., Chicago
Westinghouse Elec. & Mfg. Co., E. Pittsburgh

Compounds
Minerallac Electric Co., Chicago
Standard Underground Cable Co., Pittsburgh
Western Electric Co., All Principal Cities

Fibre
National Vulcanized Fibre Co., Wilmington, Del.
West Va. Pulp & Paper Co., New York

Lava
American Lava Corp., Chattanooga, Tenn.

Mica
Acme Wire Co., New Haven, Conn.
New England Mica Co., Waltham, Mass.

Paper
Acme Wire Co., New Haven, Conn.
Irvington Varnish & Ins. Co., Irvington, N. J.

Silk
Acme Wire Co., New Haven, Conn.
Irvington Varnish & Ins. Co., Irvington, N. J.

Tape
Belden Mfg. Co., Chicago
Minerallac Electric Co., Chicago
Okonite Co., The, New York
Western Electric Co., All Principal Cities
Westinghouse Elec. & Mfg. Co., E. Pittsburgh

Varnishes
General Electric Co., Schenectady
Irvington Varnish & Ins. Co., Irvington, N. J.
Minerallac Electric Co., Chicago

INSULATORS, HIGH TENSION
Composition
General Electric Co., Schenectady
Glass
Hemingray Glass Co., Muncie, Ind.
Porcelain
General Electric Co., Schenectady
Jeffry-Dewitt Insulator Co., Kenova, W. Va.
Lapp Insulator Co., Inc., LeRoy, N. Y.
Locke Insulator Corp., Baltimore
Ohio Brass Co., Mansfield, O.
Thomas & Sons Co., R., East Liverpool, O.
Western Electric Co., All Principal Cities
Westinghouse Elec. & Mfg. Co., E. Pittsburgh

INSULATORS, TELEPHONE & TELEGRAPH
Hemingray Glass Co., Muncie, Ind.
Western Electric Co., All Principal Cities

LAMP GUARDS
Western Electric Co., All Principal Cities

LAVA
American Lava Corp., Chattanooga

LIGHTING FIXTURES
Cory & Son, Inc., Chas., New York

LIGHTNING ARRESTERS
General Electric Co., Schenectady
Western Electric Co., All Principal Cities
Westinghouse Elec. & Mfg. Co., E. Pittsburgh

LOCOMOTIVES, ELECTRIC
General Electric Co., Schenectady
Westinghouse Elec. & Mfg. Co., E. Pittsburgh

METERS, ELECTRICAL
(See INSTRUMENTS, ELECTRICAL)

MICA
New England Mica Co., Waltham, Mass.

MOLDED INSULATION
Bakelite Corporation, New York
Belden Mfg. Co., Chicago
Condensite Co. of America, Bloomfield, N. J.
General Bakelite Co., New York
Redmanol Chemical Products Co., Chicago
Westinghouse Elec. & Mfg. Co., E. Pittsburgh

MOLYBDENUM
Fansteel Products Co., Inc., North Chicago

MOTORS
(See GENERATORS AND MOTORS)

OHMMETERS
Cory & Son, Inc., Chas., New York
Jewell Elec. Instrument Co., Chicago
Roston-Smith Co., New York
Weller Elec. Instr. Corp., Newark, N. J.

OIL SEPARATORS & PURIFIERS
DeLaval Separator Co., The, New York
Sharples Specialty Co., The, Philadelphia

PANEL BOARDS
(See SWITCHBOARDS)

PATENT ATTORNEYS (See PROFESSIONAL ENGINEERING DIRECTORY)

PLUGS
General Electric Co., Schenectady
Western Electric Co., All Principal Cities
Westinghouse Elec. & Mfg. Co., E. Pittsburgh

POLES, STEEL
Pacific Coast Steel Co., San Francisco
Western Electric Co., All Principal Cities

POLES—TIERS, WOOD
Western Electric Co., All Principal Cities

POTHEADS
G & W Electric Specialty Co., Chicago
Standard Underground Cable Co., Pittsburgh
Western Electric Co., All Principal Cities

PROTECTIVE DEVICES
Metropolitan Device Corp., Brooklyn, N. Y.
Western Electric Co., All Principal Cities

PULLEYS, PAPER
Rockwood Mfg. Co., The, Indianapolis

PUMPS
Allis-Chalmers Mfg. Co., Milwaukee
Goulds Mfg. Co., Seneca Falls, N. Y.

PUMPS, SPIRAL
Cramp & Sons Ship & Engine Bldg. Co.,
The Wm., Philadelphia

RADIO LABORATORY APPARATUS
General Radio Co., Cambridge, Mass.
Westinghouse Elec. & Mfg. Co., E. Pittsburgh

RAILWAY SUPPLIES, ELECTRIC
General Electric Co., Schenectady
Ohio Brass Co., Mansfield, O.
Western Electric Co., All Principal Cities
Westinghouse Elec. & Mfg. Co., E. Pittsburgh

REACTORS
Metropolitan Device Corp., Brooklyn, N. Y.

RECTIFIERS
General Electric Co., Schenectady
Wagner Electric Corp., St. Louis
Western Electric Co., All Principal Cities
Westinghouse Elec. & Mfg. Co., E. Pittsburgh

REGULATORS, VOLTAGE
General Electric Co., Schenectady
Western Electric Co., All Principal Cities
Westinghouse Elec. & Mfg. Co., E. Pittsburgh

RELAYS
Cory & Son, Inc., Chas., New York
Westinghouse Elec. & Mfg. Co., E. Pittsburgh

RESISTANCE ELEMENTS
General Electric Co., Schenectady

RHEOSTATS
Biddle, James G., Philadelphia, Pa.
General Electric Co., Schenectady
Sundh Electric Co., Newark, N. J.
Western Electric Co., All Principal Cities
Westinghouse Elec. & Mfg. Co., E. Pittsburgh

ROPE, WIRE
Roebing's Sons Co., John A., Trenton, N. J.

SEARCHLIGHTS
General Electric Co., Schenectady
Westinghouse Elec. & Mfg. Co., E. Pittsburgh

SOCKETS AND RECEPTACLES
General Electric Co., Schenectady
Western Electric Co., All Principal Cities
Westinghouse Elec. & Mfg. Co., E. Pittsburgh

SOLENOIDS
Acme Wire Co., New Haven, Conn.
Belden Mfg. Co., Chicago
Dudlo Mfg. Co., Ft. Wayne, Ind.
General Electric Co., Schenectady
Sundh Electric Co., Newark, N. J.
Westinghouse Elec. & Mfg. Co., E. Pittsburgh

STARTERS, MOTOR
Condit Electrical Mfg. Co., So. Boston
General Electric Co., Schenectady
Rowan Controller Co., Baltimore, Md.
Sundh Electric Co., Newark, N. J.
Westinghouse Elec. & Mfg. Co., E. Pittsburgh

STOKERS, MECHANICAL
Sturtevant Company, B. F., Boston
Westinghouse Elec. & Mfg. Co., E. Pittsburgh

SUB-STATIONS
General Electric Co., Schenectady
Westinghouse Elec. & Mfg. Co., E. Pittsburgh

SWITCHBOARDS
Allis-Chalmers Mfg. Co., Milwaukee
Condit Electrical Mfg. Co., So. Boston
General Electric Co., Schenectady
Metropolitan Device Corp., Brooklyn, N. Y.
Western Electric Co., All Principal Cities
Westinghouse Elec. & Mfg. Co., E. Pittsburgh

SWITCHES

Automatic Time
Ferranti, Ltd., London, Eng.
Ferranti Meter & Transformer Mfg. Co.,
Ltd., Toronto, Ont.
General Electric Co., Schenectady
Minerallac Electric Co., Chicago
Sundh Electric Co., Newark, N. J.
Westinghouse Elec. & Mfg. Co., E. Pittsburgh

Disconnecting
Champion Switch Co., Buffalo, N. Y.
Condit Electrical Mfg. Co., So. Boston
General Electric Co., Schenectady
K-P-F Electric Co., San Francisco
Thoner & Martens, Boston

Fuse
General Electric Co., Schenectady
Metropolitan Device Corp., Brooklyn, N. Y.
Thoner & Martens, Boston

Knife
Condit Electrical Mfg. Co., So. Boston
General Electric Co., Schenectady
Western Electric Co., All Principal Cities
Westinghouse Elec. & Mfg. Co., E. Pittsburgh

Oil
Condit Electrical Mfg. Co., So. Boston
General Electric Co., Schenectady
Western Electric Co., All Principal Cities
Westinghouse Elec. & Mfg. Co., E. Pittsburgh

Remote Control
Condit Electrical Mfg. Co., So. Boston
General Electric Co., Schenectady
Rowan Controller Co., Baltimore
Sundh Electric Co., Newark, N. J.
Western Electric Co., All Principal Cities
Westinghouse Elec. & Mfg. Co., E. Pittsburgh

TACHOMETERS
Biddle, James G., Philadelphia

TANTALUM
Fansteel Products Co., Inc., North Chicago

TELEGRAPH APPARATUS
Western Electric Co., All Principal Cities

TELEPHONE EQUIPMENT
Cory & Son, Inc., Chas., New York
Western Electric Co., All Principal Cities

TESTING LABORATORIES
Electrical Testing Labs., New York

TOWERS, TRANSMISSION
Pacific Coast Steel Co., San Francisco
Western Electric Co., All Principal Cities

TRANSFORMERS
Allis-Chalmers Mfg. Co., Milwaukee
American Transformer Co., Newark, N. J.
Duncan Elec. Mfg. Co., Lafayette, Ind.
Ferranti, Ltd., London, Eng.
Ferranti Meter & Transformer Mfg. Co.,
Ltd., Toronto, Ont.
General Electric Co., Schenectady
Kuhlman Electric Co., Bay City, Mich.
Moloney Electric Co., St. Louis
Pittsburgh Transformer Co., Pittsburgh
Wagner Electric Corp., St. Louis
Western Electric Co., All Principal Cities
Westinghouse Elec. & Mfg. Co., E. Pittsburgh

Factory
American Transformer Co., Newark, N. J.
Kuhlman Electric Co., Bay City, Mich.
Moloney Electric Co., St. Louis
Pittsburgh Transformer Co., Pittsburgh
Wagner Electric Corp., St. Louis
Western Electric Co., All Principal Cities

Furnace
Allis-Chalmers Mfg. Co., Milwaukee
American Transformer Co., Newark, N. J.
Moloney Electric Co., St. Louis
Pittsburgh Transformer Co., Pittsburgh

Metering
American Transformer Co., Newark, N. J.
Ferranti, Ltd., London, Eng.
Ferranti Meter & Transformer Mfg. Co.,
Ltd., Toronto, Ont.
Pittsburgh Transformer Co., Pittsburgh

Mill Type
Pittsburgh Transformer Co., Pittsburgh

Radio
American Transformer Co., Newark, N. J.

Street Lighting
Kuhlman Electric Co., Bay City, Mich.
Western Electric Co., All Principal Cities

TROLLEY LINE MATERIALS
General Electric Co., Schenectady
Ohio Brass Co., Mansfield, O.
Western Electric Co., All Principal Cities
Westinghouse Elec. & Mfg. Co., E. Pittsburgh

Please mention the JOURNAL of the A. I. E. E. when writing to advertisers.

THERE is probably no material in all the world that has the same scope of adaptability as National Vulcanized Fibre. It has found its way into every industry—electrical, automotive, textile, radio, railroad construction, transportation, luggage, sporting goods and whatnot. And even now, after it has been a vital part of industry for more than thirty years, nearly every day finds a new use for National Vulcanized Fibre. We illustrate a few of the more common uses:



Because of its toughness, National Vulcanized Fibre is one of the best materials for silent gears.

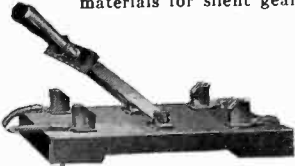

Because of its high dielectric strength, National Vulcanized Fibre is first choice for every sort of electrical insulation.

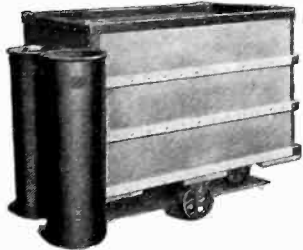

Because of its strength and resiliency, the world's finest trucks and roving cans are made of National Vulcanized Fibre.



VUL-COT—the strongest waste basket ever built, and the lightest—is made of National Vulcanized Fibre.



And the world's finest trunks are made with "Keystone Trunk Fibre"—a National Vulcanized Fibre product.

Whatever it is—put it up to National Vulcanized Fibre. We maintain an organization of chemists devoted solely to service with customers and prospective customers.

The National Vulcanized Fibre Company operates six great plants and maintains sales and service offices at New York, Boston, Philadelphia, Pittsburgh, Cleveland, Chicago, San Francisco, Detroit, Rochester, Birmingham, Denver, Toronto, Greenville, St. Louis and Baltimore. Main office, Wilmington, Delaware.

NATIONAL VULCANIZED FIBRE

"—the material with a million uses"
SHEETS : RODS : TUBES : SPECIAL SHAPES

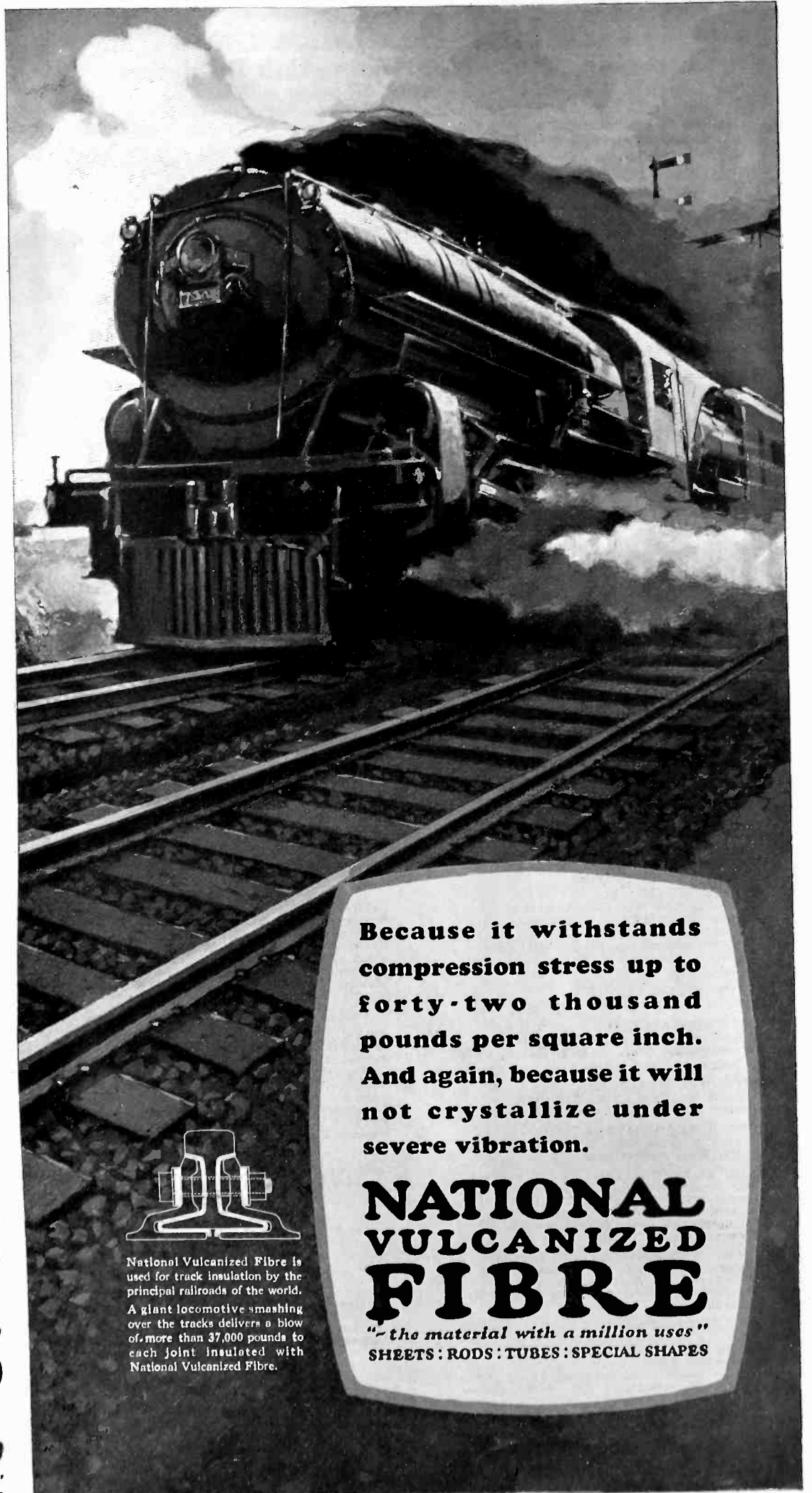

Because it withstands compression stress up to forty-two thousand pounds per square inch. And again, because it will not crystallize under severe vibration.

NATIONAL VULCANIZED FIBRE

"—the material with a million uses"
SHEETS : RODS : TUBES : SPECIAL SHAPES

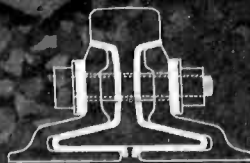

National Vulcanized Fibre is used for track insulation by the principal railroads of the world. A giant locomotive smashing over the tracks delivers a blow of more than 37,000 pounds to each joint insulated with National Vulcanized Fibre.

Please mention the JOURNAL of the A. I. E. E. when writing to advertisers.

Y-26 High-Heat Mica Plate

Especially Adapted for Heating Unit Insulation

Not only does Y-26 possess the advantages of natural sheet mica for insulating purposes—but it is more economical, as comparison of prices will prove. Leading manufacturers of heating appliances have given it their enthusiastic approval and specify it regularly for their products.

Y-26 can be cut or punched to any form, or supplied in sheets 24 in. by 42 in., ten mils thick or over.

We welcome your tests on Y-26. Ask us for samples and prices; if desired also, an analysis of your heating unit problem.



NEW ENGLAND MICA CO., Waltham 54, Mass.

New York Office - 220 Broadway

PEARLESS STANDARDIZED MICA INSULATION
 India Moulding Plate Flexible Mica Sheets Commutator Rings
 India Segment Plate Mica and Paper Sheets Commutator Segments
 Amber Segment Plate Mica Cloth (sheets or Washers, etc.
 Amber Small Segment Plate (rolls) Y-26 High-Heat Mica
 High-Heat Plate (Volatile Plate
 Blinder for heat units) Mica and Paper Tape Mica Lamp Shade Plate
 Tubes, Bushings, etc.

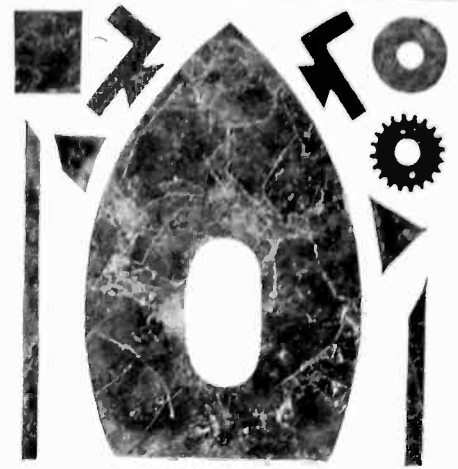

Y-26 BLANKED FORMS

HAVE you read the stories of American Glass? Of Bakelite and Velox? Of titanium? How was manganese steel discovered? What did a Serbian herdsman contribute to telephony? How was radio activity found? What did teredos suggest to engineers about tunnels?

Popular Research Narratives

contains 50 interesting 5-minute stories by scientists and engineers in a book of 160 pages, attractively bound in blue cloth, for 50 cents.

Send your order today to

Engineering Foundation, 29 West 39th Street, New York

Classified Advertiser's Index for Buyers—Continued

TURBINES, HYDRAULIC

Allis-Chalmers Mfg. Co., Milwaukee
 Cramp & Sons Ship & Engine Bldg. Co.,
 The, Wm., Philadelphia

TURBINES, STEAM

Allis-Chalmers Mfg. Co., Milwaukee
 General Electric Co., Schenectady
 Sturtevant Company, B. F., Boston
 Western Electric Co., All Principal Cities
 Westinghouse Elec. & Mfg. Co., E. Pitts-
 burgh

TURBINE SIGNAL SYSTEMS

Cory & Son, Inc., Chas., New York

TURBO-GENERATORS

Allis-Chalmers Mfg. Co., Milwaukee
 Westinghouse Elec. & Mfg. Co., E. Pitts-
 burgh

VALVE CONTROL, ELECTRIC

Cory & Son, Inc., Chas., New York
 Liberty Electric Corp., Stamford, Conn.

VALVES, JOHNSON HYDRAULIC

Cramp & Sons Ship & Engine Bldg. Co.,
 The Wm., Philadelphia

VARNISHES, INSULATING

General Electric Co., Schenectady
 Irvington Varnish & Ins. Co., Irvington, N. J.
 Minerallac Electric Co., Chicago
 Westinghouse Elec. & Mfg. Co., E. Pitts-
 burgh

WELDING EQUIPMENT, ELECTRICAL

General Electric Co., Schenectady
 Ohio Brass Co., Mansfield, O.
 Westinghouse Elec. & Mfg. Co., E. Pitts-
 burgh

WIRES AND CABLES

Armored Cable
 Belden Mfg. Co., Chicago
 Boston Ins. Wire & Cable Co., Boston
 General Electric Co., Schenectady
 Hazard Manufacturing Co., Wilkes-Barre,
 Pa.
 Kerite Ins. Wire & Cable Co., New York
 Okonite Company, The, Passaic, N. J.
 Roebling's Sons Co., John A., Trenton, N. J.
 Simplex Wire & Cable Co., Boston
 Standard Underground Cable Co., Pittsburgh
 Western Electric Co., All Principal Cities

Asbestos Covered

Belden Mfg. Co., Chicago
 General Electric Co., Schenectady

Automotive

Belden Mfg. Co., Chicago
 Boston Ins. Wire & Cable Co., Boston
 General Electric Co., Schenectady
 Kerite Ins. Wire & Cable Co., New York
 Roebling's Sons Co., John A., Trenton, N. J.
 Simplex Wire & Cable Co., Boston
 Standard Underground Cable Co., Pittsburgh
 Western Electric Co., All Principal Cities

Bare Copper

American Ins. Wire & Cable Co., Chicago
 Anaconda Copper Mining Co., Chicago
 Belden Mfg. Co., Chicago
 Copperweld Steel Co., Rankin, Pa.
 Hazard Manufacturing Co., Wilkes-Barre,
 Pa.
 Roebling's Sons Co., John A., Trenton, N. J.
 Standard Underground Cable Co., Pittsburgh
 Western Electric Co., All Principal Cities

Copper Clad

Copperweld Steel Co., Rankin, Pa.
 Standard Underground Cable Co., Pittsburgh
 Western Electric Co., All Principal Cities

Flexible Cord

Belden Mfg. Co., Chicago
 Boston Ins. Wire & Cable Co., Boston
 General Electric Co., Schenectady
 Hazard Manufacturing Co., Wilkes-Barre,
 Pa.
 Okonite Company, The, Passaic, N. J.
 Roebling's Sons Co., John A., Trenton, N. J.
 Simplex Wire & Cable Co., Boston
 Standard Underground Cable Co., Pittsburgh
 Western Electric Co., All Principal Cities

Fuse

General Electric Co., Schenectady
 Roebling's Sons Co., John A., Trenton, N. J.
 Western Electric Co., All Principal Cities

*Lead Covered (Paper and Varnished cambric
 insulated)*

Anaconda Copper Mining Co., Chicago
 Atlantic Ins. Wire & Cable Co., Rome, N. Y.
 General Electric Co., Schenectady

Hazard Manufacturing Co., Wilkes-Barre,
 Pa.

Kerite Ins. Wire & Cable Co., New York
 Okonite Company, The, Passaic, N. J.
 Roebling's Sons Co., John A., Trenton, N. J.
 Simplex Wire & Cable Co., Boston
 Standard Underground Cable Co., Pittsburgh
 Western Electric Co., All Principal Cities

Magnet

Acme Wire Co., New Haven, Conn.
 Belden Mfg. Co., Chicago
 Dudlo Mfg. Co., Fort Wayne, Ind.
 General Electric Co., Schenectady
 Roebling's Sons Co., John A., Trenton, N. J.
 Standard Underground Cable Co., Pittsburgh
 Western Electric Co., All Principal Cities

Rubber Insulated

Atlantic Ins. Wire & Cable Co., Rome, N. Y.
 Belden Mfg. Co., Chicago
 Boston Ins. Wire & Cable Co., Boston
 General Electric Co., Schenectady
 Hazard Manufacturing Co., Wilkes-Barre,
 Pa.
 Kerite Ins. Wire & Cable Co., New York
 Okonite Company, The, Passaic, N. J.
 Roebling's Sons Co., John A., Trenton, N. J.
 Simplex Wire & Cable Co., Boston
 Standard Underground Cable Co., Pittsburgh
 Western Electric Co., All Principal Cities

Trolley

Anaconda Copper Mining Co., Chicago
 Copperweld Steel Co., Rankin, Pa.
 Roebling's Sons Co., John A., Trenton, N. J.
 Standard Underground Cable Co., Pittsburgh
 Western Electric Co., All Principal Cities

Weatherproof

American Ins. Wire & Cable Co., Chicago
 Anaconda Copper Mining Co., Chicago
 Copperweld Steel Co., Rankin, Pa.
 General Electric Co., Schenectady
 Kerite Ins. Wire & Cable Co., New York
 Okonite Company, The, Passaic, N. J.
 Roebling's Sons Co., John A., Trenton, N. J.
 Simplex Wire & Cable Co., Boston
 Standard Underground Cable Co., Pittsburgh
 Western Electric Co., All Principal Cities

Please mention the JOURNAL of the A. I. E. E. when writing to advertisers.

Fansteel Products Company specializes in the manufacture of rare metals.

Fansteel Products Company manufactures tantalum in sheets, wires and rods. Other metals manufactured by the same company which may help solve electrical difficulties are molybdenum in sheets, wires and special shapes or tungsten contact points.

Fansteel tungsten electrical contacts are universally used and are accepted as standard throughout the electrical trade.

FANSTEEL PRODUCTS COMPANY, INC.
North Chicago Illinois

A Great Engineering Library

THE Engineering Societies Library, 33 West 39th St., New York, is a reference library for engineers, directed by the National Engineering Societies. It contains 150,000 volumes and receives 1500 periodicals relating to civil, mining, mechanical and electrical engineering, metallurgy and industrial chemistry.

A staff of experienced investigators is available to make searches upon engineering subjects, prepare lists of references and translate engineering publications from foreign languages.

The Library can also supply photoprint copies of any articles appearing in engineering journals, old or recent. Prices for any services will be quoted on application.

The new plan of lending books should particularly commend itself to those who can seldom visit the Library. A good collection of modern American works on engineering, including most of those recently published, is now available and these books may be borrowed by members of the A. I. E. E. and other Founder Societies, located in any part of North America.

At Your Service

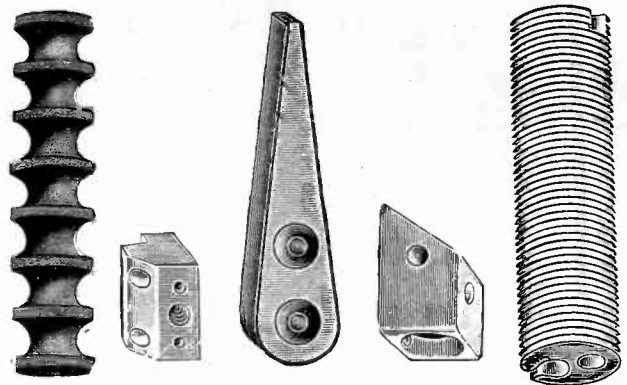

INSULATORS

made of

LAVA

Do you use insulators?

Do you want parts made to special design?

Do you want a material that is non-corrosive and heat resistant?

Lava is specified by manufacturers of electrical appliances.

Write us for specific information.

AMERICAN LAVA CORPORATION
27-67 Williamson St.

Chattanooga Tennessee
Manufacturers of Heat Resistant Insulators

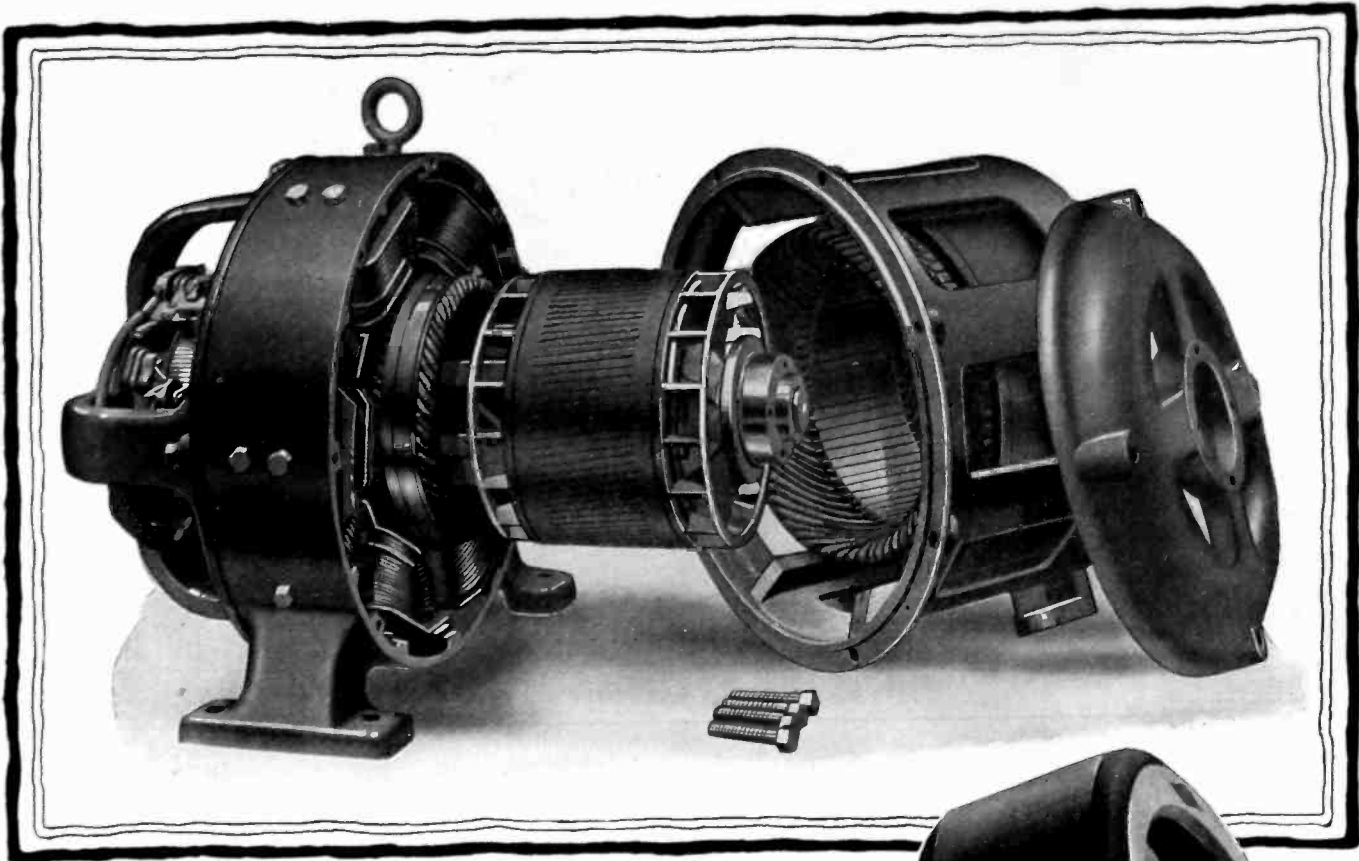

SRB Bearings Standard Equipment in Continental Electric Motors

The most accepted improvement in general purpose motors is the adoption of proper sized ball bearings. Their use has long since passed the experimental stage for SRB experience in this field goes back as far as 1904.

It is significant, therefore, that ball bearings and the SRB type in particular are standard equipment in motors manufactured by the Continental Electric Co., Inc., of Newark, N. J. Effective lubrication, elimination of starting friction, reduction in maintenance cost and assurance of continuous operation are a few of their numerous points in favor of their use.

The Continental Motor is one of many to which SRB Bearings are promoting smoother, quieter, longer life. They are particularly adapted to the severe service requirements of this field because of their great carrying capacity and endurance qualities. This sturdiness is due to fundamentally correct designs and manufacturing methods developed through twenty-five years experience in the production of anti-friction bearings.

Write for Technical Bulletin E-1 entitled "Selection of SRB Bearing Sizes for Horizontal Electric Motors"



Standard Steel and Bearings, Incorporated

PLAINVILLE

"The Standard Ball Bearing"

CONNECTICUT

Please mention the JOURNAL of the A. I. E. E. when writing to advertisers.



Independence Hall



Airplane View of a Section of Philadelphia

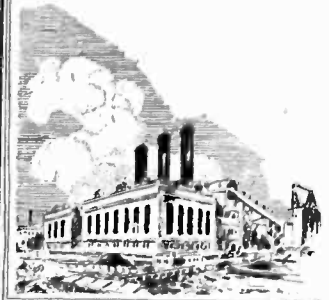

Delaware Station

To minimize that now frequent call

“The Lights are Out”

**you should also approve
Metropolitan AA Rotary Meter Switches**

**Metropolitan
Rotary**



Open Position

The purpose of this meter switch in addition to its protection against tampering is the fact that your customers can, in a 100% safe operation, renew fuses without breaking the cover seal—all to your benefit in the reduction of service calls.

**Classification AA is the highest Underwriters' rating,—
to quote:**

“Enclosed switches coming under this classification must

necessarily be so designed that the fuse terminals are disconnected from both line and load terminals when the switch is open and the fuse exposed for inspection or replacement.”

In the interest of economy, safety and the building of Public Good Will, you should also approve it. Write for full data and miniature working model.

METROPOLITAN DEVICE CORPORATION
1250 Atlantic Avenue, Brooklyn, N. Y.

Gentlemen: Please send full information with miniature model of the Metropolitan AA Rotary Meter Switch.

Name..... Company.....

Please mention the JOURNAL of the A. I. E. E. when writing to advertisers.

THE OKONITE COMPANY
and
THE OKONITE-CALLENDER CABLE COMPANY, Inc.

WISH TO ANNOUNCE
that on

FEBRUARY 1, 1925

they established their own
sales offices and warehouse in
Chicago and offices at St. Louis.
Chicago address — 310 South
Michigan Boulevard, corner
Jackson Boulevard.



THE OKONITE COMPANY
INCORPORATED 1884

THE OKONITE-CALLENDER CABLE COMPANY, Inc.
PASSAIC, NEW JERSEY

Sales Offices: New York - Chicago - Pittsburgh - St. Louis
Atlanta - Birmingham - San Francisco

F. D. Lawrence Electric Co., Cincinnati, O. Novelty Electric Co., Philadelphia, Pa.
Pettingell-Andrews Co., Boston, Mass.

Canadian Representatives: Engineering Materials Limited, Montreal

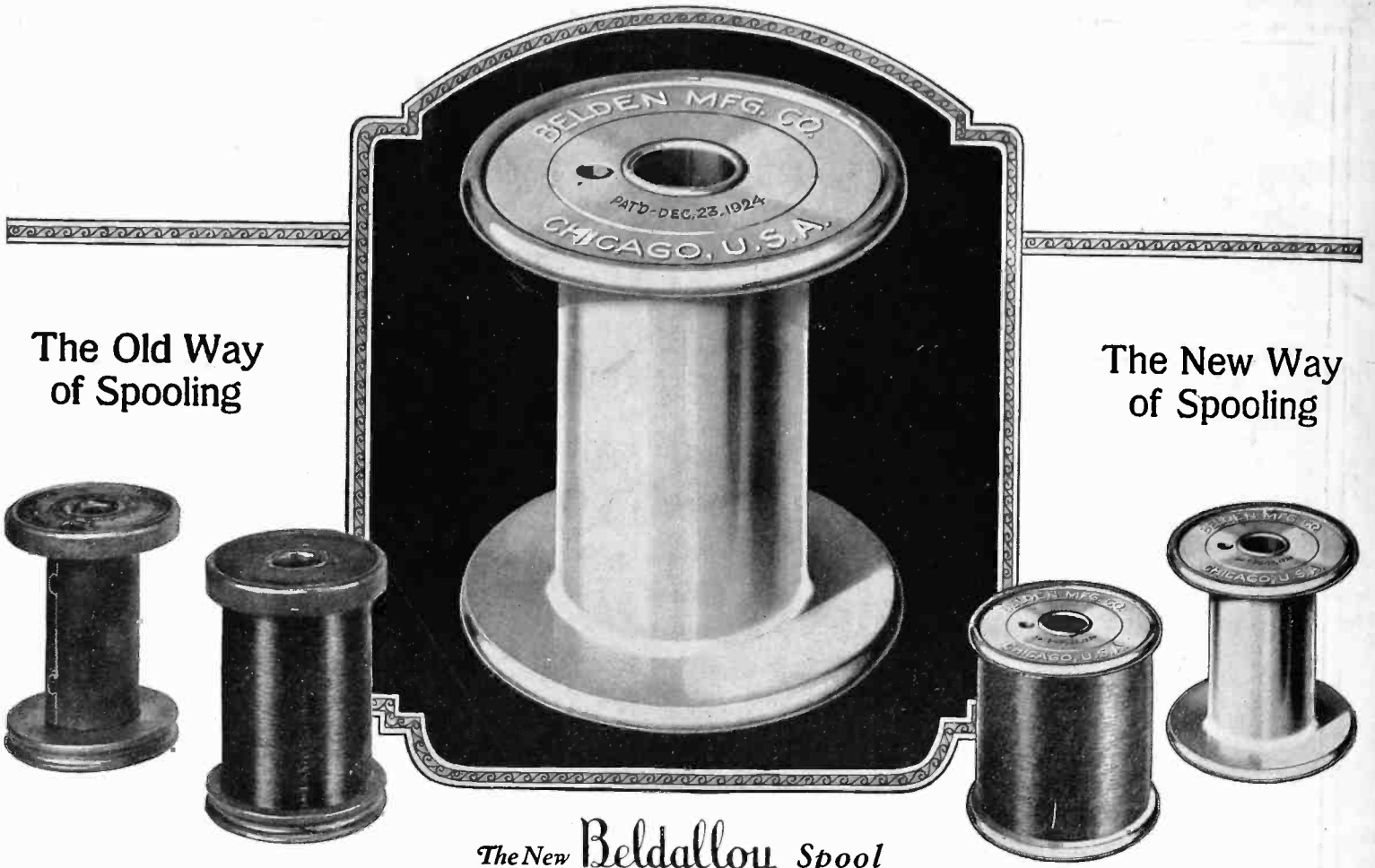

The Old Way
of Spooling

The New Way
of Spooling

The New Beldalloy Spool

An Outstanding Achievement

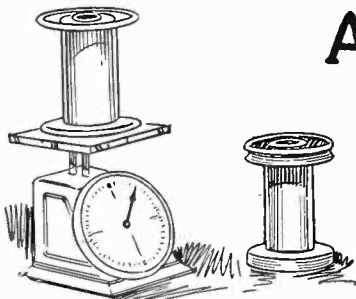

Freight or express less per pound of wire. Return charges on spools are correspondingly less



Spool investment less, due to increased weight of wire per spool. Economy of storage space due to fewer spools.

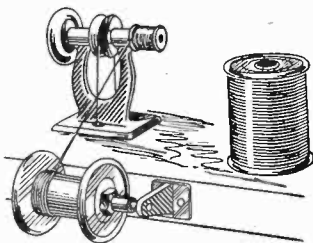

Less spool changes, less splicing, and less tangling on your winding machines with the Beldalloy spools.

For more than four years, Belden research engineers have been engaged in an intensive effort to devise a better method of spooling magnet wire, especially the finer sizes.

The outcome is the new Beldalloy Spool, a cast, all-metal spool of light weight, perfect balance and great mechanical strength. The ends of the seamless brass tube, which forms the sleeve or bore of the spool, are rolled to uniformly accurate dimensions making the tube absolutely concentric to the barrel of the spool. Therefore, perfect spooling is always obtained.

The rigid flanges cannot warp or loosen in transit to interfere with the removal of the wire by the user. The new spool also suffers less deterioration in handling, assuring the user of a larger credit for "returned spools."

The investment in spools is less per pound of wire, because the new spool has greater capacity. In winding coils, there is less "dead-end" waste and fewer splices and spool changes than with the older types of spools.

In addition, the Beldalloy spool is so accurately balanced that the winding speed of coil winding machines can be materially increased without danger of stretching or otherwise damaging the wire, resulting in increased output of better coils.

Belden Magnet Wire of the smaller sizes is being supplied on the new spools as rapidly as conditions will permit. Eventually, the entire output of fine sizes will be offered on the new spools. It will pay you to investigate the advantages of the new Beldalloy Spool. It means greater production and more profits.

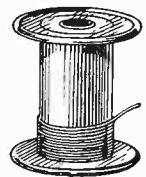

Less "dead-end" waste in your coil winding with the new spool, due to its greater capacity.

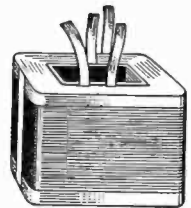

Output increased and more uniform as to resistance and turns, due to better spooling.

Specify
Belden

Belden Manufacturing Company

4631 W. Van Buren St.

CHICAGO

Manufacturers of Electrical Wire Products Since 1902

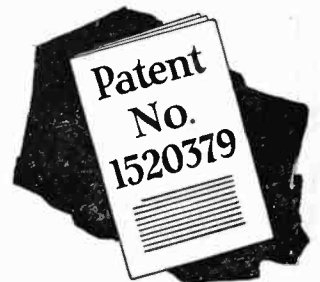

The Beldalloy spool is covered by a broad patent. It is distinctly a Belden product.