

AUSTRALIA'S DYNAMIC ELECTRONICS MONTHLY!

\$2.75\*  
NZ \$3.50

# Electronics Today



MAY 1985

## HI-FI SPECIAL - NEW TECHNOLOGIES & BEST BUYS

Registered by Australia Post. Publication No. NBP0407.



**GREAT \$99 MODEM  
TO BUILD!**



**STARWARS: WILL IT REALLY WORK?  
NEW VARIABLE BIAS AMP - REVIEW  
WE REVIEW LOW COST CD PLAYER  
BUDGET BURGLAR ALARM TO BUILD  
PRACTICAL FORTH COMPUTER PROJECT**

# The one you can't afford not to own!

# AQUARIUS™

The REAL computer that starts from under \$100! You'd love to learn about computers? But thought all you could buy for your money were a few boring games. Now, we are the EXCLUSIVE Australian distributors of the new Aquarius. Not the "Claytons" computer but the perfect beginner's computer which gives you the opportunity to see what a real computer does.

Learn how to RUN YOUR OWN PROGRAMS in the Basic language! PLAY GAMES! Organise your HOUSEHOLD FILES! And much much more!

Simply connect the Aquarius to any colour TV and it's ready to teach and entertain the whole family. There's something for everyone. And what's more, you won't outgrow the Aquarius! As you need to

learn more, the Aquarius offers a huge range of add-ons that will take you into the world of electronic wizardry once offered only by the BIG ones.

With a full moving-key keyboard Aquarius is truly EASY to USE. Microsoft BASIC computer language is built right in! The easy-to-read manual and simplified instruction cards make learning a snap.

CREATE your own VISUAL EFFECTS with 16 colours and 256 built-in characters or design your own sound effects! Once you start to expand your Aquarius with the huge software and hardware range you'll find endless uses and possibilities for your system. With its own mini expander, data recorder, memory expansion cartridges and thermal printer you'll soon wonder what the Great

Computer Secret was all about!

## FANTASTIC SOFTWARE RANGE

With more than two dozen fantastic games and educational programs available now and many being developed to add to the range shortly, there's just no end to the versatility of Aquarius. Software cartridges just plug into your Aquarius and you're ready for work or play. All software programs are available separately so you can purchase only those which interest you.

AQUARIUS with built in 2K memory (expandable to 34K) and its long list of expansion units and software is the REAL computer for the price of a TOY!

### 1. MINI EXPANDER

Adds versatility to your AQUARIUS. Game playing is easier and more exciting with 2 detachable hand controllers and additional sound channels. Also has 2 cartridge ports so you can plug in your expanded memory cartridge into one even while you're using software in the other.

Cat X-6005 ..... \$69

### 2. DATA RECORDER

Save your own program or utilise one of the many great software programs available on cassette with this great value unit.

Cat X-6010..... \$49

### 3. MEMORY EXPANSION CARTRIDGES

16K or 32K memory cartridges give you far greater flexibility by giving your computer a much larger memory. For more advanced programming.

16K Cartridge Cat X-6015..... \$69

32K Cartridge Cat X-6020 ..... \$129

### 4. THERMAL PRINTER

Ideal for documenting programs, keeping records or printing charts and records. You'll probably never again see one at this price!

Cat X-6025 ..... \$129

Paper roll to suit. Cat X-6026 ..... \$350

### Aquarius Colour Computer

Cat X-6000

Fantastic Value ONLY

**\$99**



Dick Smith Electronics Pty Ltd

COMPUTERSTOP



Your one stop computer shop at your nearest Dick Smith Electronics centre.

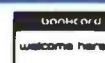

A-923

# Electronics Today

INTERNATIONAL

**EDITOR**  
David Kelly

**EDITORIAL STAFF**  
Mary Rennie  
Jon Fairall B.A.  
Geoff Nicholls B.Sc./B.E.  
Robert Irwin B.E.  
S. K. Hul B.Sc. (Hons)

**ADVERTISING PRODUCTION**  
Danny Hooper

**ADVERTISING SALES**  
Arthur Whall  
Kate Stuart

**ART DIRECTOR**  
Vicki Jones

**ART STAFF**  
Sharon Hill

**READER SERVICES**  
Elizabeth Barnett  
Felicity Skinner

**ACOUSTICAL CONSULTANTS**  
Louis Challis and Associates

**MANAGING EDITOR**  
Jamleson Rowe

**PUBLISHER**  
Michael Hannan

**HEAD OFFICE**  
140 Joynton Avenue, (PO Box 227)  
Waterloo, NSW 2017.  
Phone: (02) 663-9999 Sydney.  
Telex: 74488, FEDPUB.

**ADVERTISING OFFICES  
AND AGENTS:**

**Victoria and Tasmania:** Virginia Salmon  
The Federal Publishing Company, 23rd  
Floor, 150 Lonsdale Street, Melbourne, Vic.  
3000. Phone: (03) 662-1222 Melbourne.  
Telex: 34340, FEDPUB.

**South Australia and Northern Territory:**  
The Admedia Group, 24 Kensington Road,  
Rose Park, SA 5067. Phone: (08) 332-8144  
Adelaide. Telex: 82182, ADMEDIA.

**Queensland:** Geoff Horne, C/- The Federal  
Publishing Company, 25 Balaclava Street,  
Woolloongabba, Qld. 4102. Phone: (07)  
391-4041, (07) 391-8003. Telex: AA145520.

**Western Australia:** Cliff R. Thomas, Adrep  
Advertising Representative, 62 Wickham  
Street, East Perth, WA 6000. Phone: (09)  
325-6395 Perth.

**New Zealand:** Chris Horsley, 4A Symonds  
Court, Symonds Street, Auckland. Telex:  
NZ60753, TEXTURE. Phone: 39-6096.  
Auckland.

**Britain:** Peter Holloway, John Fairfax and  
Sons (Australia) Ltd, Associated Press  
House, 12 Norwich Street, London EC4A  
1BH. Phone: (01) 353-9321 London. Telex:  
262836, SMHLDN.

**Japan:** Genzo Uchida, Bancho Media  
Services, 5th Floor, Dai-ichi Nisawa  
Building, 3-1 Kanda Tacho 2-chome,  
Chiyoda-ku, Tokyo 101. Phone: (03)  
252-2721 Tokyo. Telex: 25472, BMSINC.



**ELECTRONICS TODAY INTERNATIONAL**  
is published monthly by the Electronics  
Division of the Federal Publishing Company  
Pty Limited, 140 Joynton Avenue, Waterloo,  
NSW 2017. Typeset and printed by  
ESN-The Litho Centre, Sydney. Distributed  
by Gordon and Gotch Limited, Sydney.  
Cover price \$2.75 (maximum and  
recommended Australian retail price only;  
recommended New Zealand price, \$3.50).  
Registered by Australia Post. Publication No  
NBP0407. ISSN No 0013-5216.

COPYRIGHT © 1985, THE FEDERAL  
PUBLISHING COMPANY

## FEATURES

<b>Hi-fi in 1985 — a revival</b>	12
Wending your way through what's new and what's value	
<b>CD players: new developments</b>	18
Where are the leading Japanese manufacturers going?	
<b>Forth a computer language for hackers</b>	90
A no nonsense language — until Tom Moffat!	
<b>VZ200 Video hardware interrupt</b>	99
Operations and applications	
<b>The strategic defence initiative</b>	114
Starwars is possible but how practical?	

## PROJECTS

<b>ETI-699: 300 Baud Direct Connect Modem</b>	54
<b>ETI-1527: Home Burglar Alarm Module Part 1</b>	64
<b>ETI-694: Forth Development System</b>	72

## REVIEWS

<b>Good listening Technics SU-V6X integrated amplifier</b>	25
A variable "class A" amp	
<b>The main movement by the Marantz CD44</b>	32
From strength to strength with each new CD player	
<b>Sharp PC-1401 advanced maths package</b>	94
A challenging new package from Portacom	

## OFFERS

Subscriptions offer	47
Nashua offer	106
Burglar alarm competition	71
GFS Talkman & Philips VCR competition results	109
ETI mail order books	78 & 79, 88 & 89

## DEPARTMENTS

News Digest	6	Ideas for Experimenters	82
Sight & Sound News	30	Idea of the Month	82
New Components	42	MicroBee Column	104
New Equipment	48	Shoparound	70
Computing News	84	MiniMart	120
Communications News	110	Perspective	121
Letters	9	Dregs	122

**COVER:** The photograph of the interior of Hi-Fi Junction, 324 Oxford St., Bondi Junction, NSW, was taken by Robert Charter. The photograph of the modem was taken by Greg McBean.

# FROM HOBBYIST TO PROFESSIONAL - FLUKE MUST BE YOUR FIRST MULTIMETER CHOICE FOR FEATURES, QUALITY AND VALUE



**FLUKE MULTIMETERS  
CARRY A ONE YEAR  
MINIMUM WARRANTY\*  
AND ARE BACKED BY  
COMPREHENSIVE SPARE  
PARTS, CALIBRATION  
AND SERVICE**

## 1 8050A

- 4½ digit bench portable • 0.03% basic accuracy • 10uV, 10nA, 10mohm sensitivity
- True RMS to 50kHz • dB with 16 reference impedances • Relative reference for comparing values • Mains/Battery option

## 8010A 8012A (similar to 8050A)

- 8010A has 10A range and true RMS • 8012A has low ohms (0.001ohm resolution) • Both have conductance • Mains/Battery option

## 2 8020B

- 3½ digit • 0.1% basic accuracy • Eight functions including conductance
- Continuity beeper

## 3 8021B 8022B

- 3½ digit • 0.25% basic accuracy • Diode test • Continuity beeper (8021B only)

## 4 8024B

- 3½ digit • 0.1% basic accuracy
- 11 functions including temperature with K type thermocouples • Peak hold on voltage and current • Logic detection and continuity testing • Audible and visible indicators

## 5 8026B

- 3½ digit • 0.1% basic accuracy • True RMS to 10kHz • Conductance to 10,000Mohm
- Diode test and continuity beeper

## 6 8062A

- 4½ digit • 0.05% basic accuracy • Similar to 8060A without counter and dB • Relative reference • True RMS to 30kHz

## 7 8060A

- 4½ digit • 0.05% basic accuracy • True RMS to 100kHz • Frequency counter to 200kHz • dB and relative dB • Microprocessor self diagnostics • Relative reference for comparing values • Direct resistance to 300Mohm

**LOW COST 70 SERIES  
WITH ANALOG & DIGITAL  
DISPLAY**

**3 YEAR  
WARRANTY**

## 8 73

- 3200 count display • 32 segment bar graph
- 18 ranges • Automatic power down
- 10A current range • Autorange • 0.7% basic accuracy • 2000 hour battery life

## 75

- All the features of the 73 plus:
- Audible continuity tester • Autorange/Range hold • 0.5% basic accuracy • Low mA range

## 77

- All the features of the 75 plus:
- Touch Hold function • 0.3% basic accuracy
- Multipurpose protective holster

**ACCESSORIES INCREASE  
THE VERSATILITY OF  
YOUR FLUKE  
MULTIMETER**

An extremely wide range of accessories is available for your Fluke multimeter.

SOLD & SERVICED IN AUSTRALIA BY

**ELMEASCO**

*Instruments Pty. Ltd.*

Elmeasco Instruments Pty Ltd - incorporated in N.S.W.

**NEW SOUTH WALES**

15 Macdonald Street,  
MORTLAKE  
P.O. Box 30, CONCORD  
NSW 2137  
Tel: (02) 736 2888  
Telex: AA25887

**VICTORIA**

12 Maroondah Highway,  
RINGWOOD  
P.O. Box 623, RINGWOOD  
VIC.3134  
Tel: (03) 879 2322  
Telex: AA36206 ELMVIC

**QUEENSLAND**

243 Milton Road,  
MILTON  
P.O. Box 2360, BRISBANE  
QLD 4001  
Tel: (07) 369 8688  
Telex: AA44062

**SOUTH AUSTRALIA**

99 King William Street,  
UNLEY  
P.O. Box 1240, ADELAIDE  
SA 5001  
Tel: (08) 271 1839  
Telex: AA88160

**WESTERN AUSTRALIA**

20 Barcomb Way,  
GOSNELLS  
P.O. Box 95, GOSNELLS  
WA 6110  
Tel: (09) 398 3362

**ADVERTISERS' INDEX**

Active Electronics .....	86,87
Allen Bradley .....	96
Altronics .....	62,63
Applied Technnology .....	95,102
Audio Engineers .....	35
Daneva Australia .....	103
Delsound Pty Ltd .....	43
Dick Smith Electronics .....	2,22,23 36,51, 98
Disco World .....	77
Electronic World .....	37
Elmeasco .....	4
Energy Control .....	24
ETI Books .....	37, 78,79,88,89
ETI Offers .....	47,71,106
Express Alarm Supplies .....	70
Falk Electrosonnd .....	24,37
Ferguson Transformers .....	97
GFS .....	77
GRM .....	69
Hale & Rogers .....	28
Hewlett Packard .....	113
Icom Australia Pty Ltd .....	120
IEI .....	107
Jaycar Electronics .....	40,41,80,81
Leisure Imports .....	96
Philips .....	10
Pioneer .....	21
Prepak Electronics .....	107
Pulsar .....	96
Rod Irving Electronics .....	16,45,52 53,118,119
Rose Music Pty Ltd .....	11
Scan Audio Pty Ltd .....	28
Scientific Devices .....	97
Scope .....	IBC
Siemens Ltd .....	108,OBC
Soanar Electronics .....	83
Sony Australia .....	17
Westinghouse .....	109
Zap Electronics .....	71

This index is provided as an additional service. The publisher does not assume any liability for errors or omissions.

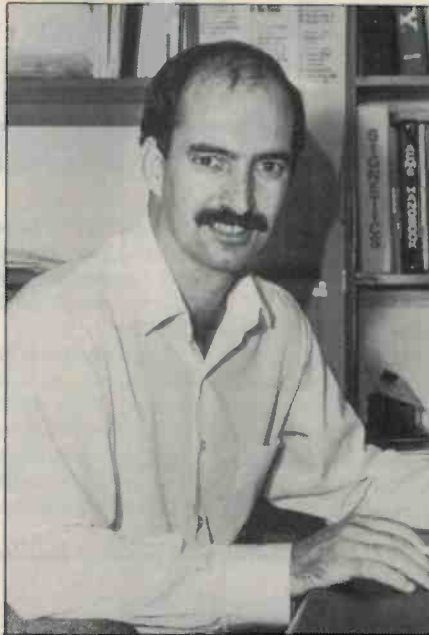

**THIS ISSUE WE DECIDED** to have a close look at hi-fi because of the intense activity in the industry at the moment — manufacturers seem to have doubled their usual output of new products.

We have seen compact disc players come down to almost a third of their introductory prices, with hardly any noticeable reduction in quality.

There is little doubt that the CD player is the most significant thing that just about anyone can buy to upgrade their hi-fi equipment, cheap CD player or not. Now that players are becoming much more affordable, buyers are discovering a renewed interest in fidelity that is being reflected in their purchases of high power amplifiers and better quality speakers.

There are many reasons for the seemingly endless range of hi-fi products that have or will be released this year, but most come back to the fact that manufacturers have predicted that the market would turn its attention away from video towards audio.

The only thing that is likely to slow down sales of hi-fi in Australia is the fact that

virtually all equipment is imported. The fall in the value of the Australian dollar has meant that most hi-fi prices have gone up.

But, be careful. We have had at least one retailer claim a price rise of around 40% because of the devaluation of the Australian dollar over the last six months.

While it is true the dollar has fallen in value, the fall has been nothing like 40%. Anyone who cares to check will find our dollar has fallen against most currencies over the last six months by just under 20% and against the Japanese yen by 15%.

That means that price rises as a result of devaluation for products from most countries should be less than 20% and for products from Japan 15%.

☆ ☆ ☆

Also of special interest in this issue is the ETI-699 300 baud modem. Designed by Geoff Nicholls around a new chip from AMI, this project promises to be one of the most successful for some time. You will be hard pressed to find a kit supplier that won't be carrying it.

**David Kelly**  
Editor

**SERVICES**

**TECHNICAL INQUIRIES:** Technical inquiries by mail must be accompanied by a stamped self-addressed envelope. There is no charge, but we reserve the right to publish the inquiry and the reply in *Electronics Today* or any of its associated publications. We can only answer queries relating to projects and articles as published. We cannot advise on modifications, other than errata or addenda. Difficult questions may take some time to answer.

**GENERAL INQUIRIES:** For all inquiries about back issues, subscriptions, photocopies of articles, artwork or submitting articles, call (02) 663-9999 or write to: ETI Reader Services, 140 Joynton Avenue (PO Box 227), Waterloo, NSW 2017.

**CONTRIBUTIONS:** Submissions must be accompanied by a stamped, self-addressed envelope. The publisher accepts no responsibility for unsolicited material.

**COPYRIGHT:** The contents of *Electronics Today International* and associated publications is fully protected by the Commonwealth Copyright Act (1968). Copyright extends to all written material, photographs, drawings, circuit diagrams and printed-circuit boards. Although any form of reproduction is a breach of copyright, we are not concerned about individuals construct-

ing projects for their own private use, nor by bands (for example) constructing one or more items for use in connection with their performances. Commercial organisations should note that no project or part project described in *Electronics Today International* or associated publications may be offered for sale, or sold in substantially or fully assembled form, unless a licence has been specifically obtained so to do from the publisher, The Federal Publishing Company, or from the copyright holders.

**LIABILITY:** Comments and test results on equipment reviewed refer to the particular item submitted for review and may not necessarily pertain to other units of the same make or model number. Whilst every effort has been made to ensure that all constructional projects referred to in this edition will operate as indicated efficiently and properly and that all necessary components to manufacture the same will be available, no responsibility is accepted in respect of the failure for any reason at all of the project to operate effectively or at all whether due to any fault in design or otherwise and no responsibility is accepted for the failure to obtain any component parts in respect of any such project. Further, no responsibility is accepted in respect of any injury or damage caused by any fault in the design of any such project as aforesaid.

# Printronics builds China pc board factories

Printronics, the Sydney based printed circuit board manufacturer, has just announced a contract with the People's Republic of China to set up \$47m worth of factories.

Negotiations began with the Chinese government in March 1984, with stiff competition from overseas based companies. General manager Michael Brinsden attributed the company's success to its good track record in this area of manufacture. This in-

cludes 14 years worth of experience at two factories, one in Sydney and the other in Melbourne.

Under the terms of the agreement, Printronics will set up five complete factories in China. Detailed planning has been completed for the introduction of the

first factory in Schezuan. Negotiations are now underway for the construction of the second factory, which will be located in Beijing.

Each plant will be able to handle single and double sided boards. They will be capable of generating multiple layer boards with up to fourteen layers. Chinese and Australian staff have been swapped to ensure rapid

technological transfer to the Chinese. Six Printronics staff have been in China, while five Chinese spent time at the Melbourne plant.

Printronics expects that the sale will lead to further work offshore. The company is currently chasing orders throughout SE Asia. Brinsden said that Australia's market was just too small to guarantee a fruitful existence.



## A new face at ETI

Sau Kong Hui (Jerry to his friends) has joined ETI after a stint at the Uni of New South Wales where he was working on the design of a cattle tracking chip (and you think you're weird). He was born into a big family in Hong Kong. A misspent youth singin', dancin' and playin' tennis ended at the tender age of 18 when he was second sourced to some particularly nasty professorial types at the University of Warrick in England. After buying his freedom from the poms he came to Australia in 1983 to do a masters degree.

His interests still include singing and playing guitar (it pays better than engineering) and table tennis. He was a finalist in the New Territories Table Tennis Competition in 1976. Now he plays for fun. His greatest claim to fame: he can carry five dishes in each hand.

## We ask world to follow us on BMAC

The Department of Communications (DOC) is gearing up for the November meeting of the CCIR, the international standards setting authority for radio and broadcast communications. Having taken the plunge to go it alone with the BMAC transmission standard for satellite TV transmission (see ETI March 1985), DOC is anxious to see the standard adopted internationally.

It is almost a certainty that one of the MAC (multiplexed analogue components) systems will be chosen as the favoured standard. MAC offers far superior transmission quality to any conventional TV standard. The real race will be between the five different MAC standards. They differ only in the way

they handle the sound component of the signal.

Front runners are the B and C versions. Both systems time multiplex audio data, the B version at baseband and the C on an rf carrier. B can carry 6 audio channels and fit into cable constrained bandwidths. C gives higher quality sound, but requires a higher bandwidth and is far more complex technically.

BMAC was developed by the British, refined by the Canadians, bought by the Americans and sold to the Australians. Thus it has a solid international following. It is the system favoured over North America and will probably be used by Mexico when its satellite broadcasting begins soon.

CMAC was also designed in

Europe, but has remained a home grown product. It is the favoured system over most of the continent, especially with the highly nationalistic French.

CCIR does not have the power to force countries to use a particular system. However endorsement carries considerable international weight. If the conference selects BMAC it is likely we will soon be joined by many other nations in BMAC transmission. When that happens considerable economies of scale should become apparent as overseas markets open up; making earth stations much cheaper.

If CCIR goes CMAC the process will be longer and a lot slower and Australian consumers will suffer.

## SA Technology Park — bigger all the time

South Australia's Technology Park has scored another coup. The aerospace company, British Aerospace Australia (BAeA) has decided to set up a \$4.3 m facility in the park.

BAeA is working on a num-

ber of contracts for the Australian defence forces, including work on the FA 18 contract for the RAAF. There is also offset work involving the Orion aircraft for the Navy and the army's SAM, the Rapier. All this

work is leading to export orders.

BAeA has also been involved in the Starlab project. The company is looking for a close involvement in the future of space science in this country.

## New far-infrared laser

Physicists at UCLA in Santa Barbara in the US have announced the world's first tunable powerful laser to operate in the far-infrared.

The result of a five year \$US5m research effort, it will allow scientists to probe molecular systems that are sensitive

to a wide range of far-infrared waves. By tuning to specific frequencies they can identify the precise frequency at which responses occur. Understanding these is the key to understanding the motions of molecules in a wide variety of physical interactions.

## Queensland Electronic Show

The Electronics industry in Queensland is gearing up for the biggest trade show of the year in Brisbane. It's the Queensland Electronics Show, and it's being held at the Crest Hotel from May 9-12, 1985.

The show is an opportunity for retailers to show off their latest offerings. According to

the show organizer, Mr Rob Woodland, the Electronics Show will see a convergence of Queenslanders as they come from all over to see the exhibits.

Companies represented will include National, Sony and Toshiba. They will exhibit CD players, MSX microcomputers and much more.

## Starlab is dead, long live Starlab

Australia's most prestigious space project, Starlab (See ETI May 1982) died quietly in December, after receiving the death of a million cuts. Far from being depressed, however, scientists at Mt Stromlo observatory were hustling the Federal government for \$50m to fund a project being dubbed "Son of Starlab".

Originally conceived as a joint project between the US, Canada and Australia to build an ultraviolet space telescope, Starlab was continually plagued by money problems. The Federal government was initially reluctant to put money into it, and the Canadians had an on-going problem dividing scarce dollars between their various space interests.

The death knell was sounded by the Canadians who withdrew last year, conserving their money for experiments on Spacelab, the European Space Agency's orbiting laboratory, and their own space program.

After endless talks with anyone who would listen, Mt

Stromlo director Dr Donald Mathieson was able to sell Australian expertise to the Europeans and Americans in the form of detection systems for a new far-ultraviolet telescope set to fly in 1992.

The new telescope will operate in the range 200-1200 Angstrom. This will complement NASA's space telescope, which gets going at around 1200.

The exact division of labour on the new telescope remains to be worked out. It seems likely that the Australian effort will include the electronics and instrumentation. According to Mathieson, Australian technology in the field of light detection is at least two years ahead of comparable work overseas.

Australian industry will be a major beneficiary of the new project. Hawker DeHavilland, the Commonwealth Aircraft Factory and James Optics have all been involved in the development of the system, together with overseas companies like British Aerospace and Matra.

## NEW IE Aust President

Mr Bob Davies has just been appointed President of the Institute of Engineers. In his acceptance speech he said that Australia's economic future depended on the government finding carrots for local industry, rather than using sticks to defend them against foreign competition.

## TI sells AI

TI has introduced its Explorer system into the country. The Explorer is being advertised as the first affordable artificial intelligence machine on the market here. AI is distinguished by its use of logical symbolism rather than numerical processes in solving problems. The explorer uses LISP as its programming language.

## AWA satellite on target

AWA has announced that its subcontract work for Hughes aerospace on the Aussat project is proceeding as planned. This involves the communications system monitor and the station management subsystem, contracts worth about \$5m.

## More papers

The Institute of Radio and Electronic Engineers has issued a final call for papers for IREECON 85, the annual convention of the institute. This year's gabfest will be held in Melbourne between September 30 and October 4. Subjects covered include virtually every subject of interest to electronic engineers. For more details get in touch with IREE.

## Perth Electronics Show

Manager Chris Gulland is already talking up the Perth Electronics Show to be held August 1 to 4, 1985. Over 100 exhibitors are expected for this year's show from all sections of the industry. Organisers are expecting to be able to charter a jet to fly industry people from the eastern states out west.

## Chip copywrite

Intel registered the first integrated circuit under the US Chip Protection Act during a ceremony in Washington DC. The chip was a CMOS EPROM, an Intel 27C256. The Chip Protection Act makes it illegal to copy the topographical features of a chip for 10 years after it is registered. There is no similar law in Australia.

## Sydney apricots look good

The British BBC Acorn computers are to be manufactured at North Ryde in Sydney, according to an agreement signed by Barson Computers and Acorn.

Barson, distributors of both the Apricot and Acorn, already has plans to produce the Apricot at the factory so the expansion

makes good sense.

The Apricot has been awarded a contract with TAFE and the Department of Agriculture, and the deal is part of an offset program. It is understood that Australian content in the new computers will be twenty per cent right from the start of the contract.

## Viatel banking

The Commonwealth Bank is to be the first bank in Australia to set up a remote banking service.

According to John Koch, the retail manager of the Commonwealth, it is now possible to obtain a range of services by wire.

Access to Viatel is via either a personal computer or a dedi-

cated terminal. The manager of Telecom's Viatel services, Lindsay Cunningham, says that personal computer owners will need to add a modem and autodialler to their systems to receive the services.

Meanwhile information providers continue to queue up for space on Viatel, with sixty already signed up. This is twice

Telecom's target for the start of services.

Telecom is also looking at the possibility of launching electronic yellow pages. Currently only two systems operate; one in the Netherlands and the other in Sweden.

Cable Shop is the first tele-shopping service on Viatel. Wine, publications, personal

computers, software and other services can be offered. Payment is made through Bankcard.

According to Cunningham, Telecom is very pleased with the response from the business community. Although its introduction was marred by years of political infighting, Viatel appears to be set for a good run.

## Local sonar stops subs

The first Australian designed and built sonar system was handed over to the RAN recently.

The sonar, code named the Mulloka, was manufactured by Thorn EMI at the Defence Research Centre in Salisbury, South Australia.

Currently, seven Mulloka systems have been ordered, two for training establishments

in Sydney and Adelaide, and five for River Class anti-submarine frigates.

The Mulloka is especially designed to operate in the warm waters of the Pacific. To do this it uses a higher frequency than units purchased from overseas.

According to Navy spokesmen, the cost of the order is \$50 million.

## Light brings end for optical telescope

One of the world's most famous optical telescopes, the 100-inch Mt Wilson telescope in California, USA, is to close shortly.

The 100-inch was the largest telescope in the world from 1917 to 1948, when the nearby Hale observatory was opened on Palomar Mountain. This period was probably the most fertile in the entire history of

optical astronomy.

The telescope is still one of the largest in the world, but its observation capacity is slowly being degraded by the light pollution from Los Angeles. Like many an Australian city, LA is creeping outward, bringing lights and smog with it.

The Carnegie institute, which owns the veteran, looking is for a buyer by July.

## Programming in space

NASA programmers have announced the completion of re-programming the world's remotest computer. Currently 2.5 trillion metres from earth, the Voyager 2 spacecraft is now set up for its Uranus encounter, due on 24 January, 1987.

There are three on-board computer systems, each consisting of two identical computers for redundancy. One is a command system, one is used for pointing and orientation and one is used for controlling experiments and transmission. Considerable connection exists between the six computers to provide back up computer power as necessary.

Voyager 2 has already passed Jupiter and Saturn, its prime targets. It was guided around Saturn in such a manner that gravity flung it at Uranus. NASA is hoping that the Uranus encounter can be arranged such that an encounter with Neptune will be possible in

August 1989.

The problem for NASA is that the Uranus system, consisting of the planet plus five large known satellites, is tilted at almost 90 degrees to the plane of the solar system. This means that Voyager will see the system as a bull's eye. No close encounters with any of the satellites will be possible and total transit of the system will take just five hours. Transit of the Jupiter system took 35 hours. Saturn was even longer: 13 days.

The problem is compounded by the fact that Uranus is two and a half light hours from earth at best. This means signals will take five hours for the round trip out to the spacecraft and back.

In the eight years since launch at least two major faults have developed in spacecraft systems. Only one of its two radio receivers is still operational and this has a failed tun-

ing capacitor. The result is that the automatic frequency correction that causes the receiver to tune itself to the Earth signal has failed. So the receiver is locked to a single frequency. Engineers on Earth have determined that this frequency depends in a rather complex way on the temperature on board and can, with a certain amount of luck, predict the frequency they should use for transmission. In any event they can no longer rely on instructions being received first time out.

The second problem is mechanical. One of the camera pointing motors has failed. This happened during the Saturn encounter. The fault has been duplicated in an engineering model on Earth and seems to have been caused by inadequate lubrication of one of the gears.

Partial movement of the platform is still possible however. Scientists have spent some time

working out ways to use the existing movements plus the spacecraft's limited manoeuvring ability, to obtain full pointing for the camera.

Because of all these problems it has been decided to radically alter the operations of Voyager 2 during the Uranus encounter. It will function very much as a stand alone unit, and use a new delta modulation method of sending back picture information.

The programs were tested first on Earth, and then on Voyager 1, currently heading out of the solar system and not due for its next encounter for 20 000 years. They had to work first time. According to Bill McLaughlin of the Voyager flight engineering office at the Jet Propulsion Laboratory: "Testing computers on spacecraft is like open heart surgery. If anything goes wrong, you don't get a second chance".



## COMPANY NEWS

Microsoft has announced the appointment of National Computer Services as its official distributor in WA. Managing director Linda Graham says the WA market has increased dramatically in recent years and a local distributor was necessary.

agent in Australia and New Zealand.

Arisa Electronics has released a new product catalogue to coincide with a move to new premises at 57 Yore St, Silverwater NSW 2141. (02)648-3488.

Data Parts has just set up a new retail store in 519 Burke Rd, Camberwell, Vic 3124. The store will handle components for most project kits as well as computer products.

The British company Citronics, maker of mixers and consoles of 19 Ashford Rd, Keswick SA 5035 (08)297-8932 as its sole

## LaserVision: inevitable

LaserVision, Phillips' video equivalent to the audio compact disc is now making an impact on the Australian business market.

The LaserVision concept is realized by a LaserVision disc (something like a spaceage 78), a disc player linked to a computer (micro, mini or mainframe) via an RS232 interface or alternatively a disc player with CPU option using an EPROM cartridge and a TV screen monitor.

The laser disc stores audiovisual information and with the player allows almost instantaneous access. The system provides for a teletext overlay, the information for which can be either stored on the laser disc or generated by the computer. The chief design feature of the LaserVision system (besides laser

discs!) is the computer facility to allow programming a combination of tracks with teletext, and allow interaction between the user and stored (and updated) information.

The programming facility of the LaserVision system comes into its own with the 'vidiwall' product built out of modules of nine monitors to form a wall of image. The image is controlled by the user's program which determines what each monitor will do with the video signal: build up a composite view, enlarge some particular aspect or all monitors can show the same picture.

As with other LaserVision products the vidiwall consists of a controlling computer, the LaserVision player, the monitor (or wall of monitors) and an

image controller distributing the signal to the particular monitor. More than one laser disc player can be linked to widen the choice of images.

The future for the vidiwall is assured in advertising — from where most interest has come. It is, after all, basically a huge billboard. For the other LaserVision products the near future

is not in the family home. Software is not available and the advantages of easy access, (analogue) information storage capacity and user interaction are not yet demands of the home user. The future seems to rather lie in education and sales — where interaction, illustration, information and quick access are the requirements.

## Letters to the Editor

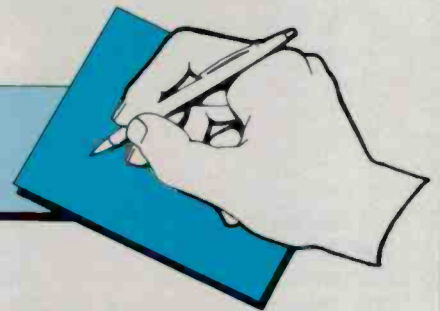

### No service manual

RECENTLY I TRIED to purchase a National VCR service manual from National at North Ryde. I was told service manuals for current models could not be sold to the general public until the warranty period for the model had expired.

Considering the current warranty is three years, and there is at least a further year of selling life, this effectively prevents purchase of a service manual for four years. When I asked why, I was told this was a policy decision by senior management in National Australia.

I cannot see what National has to fear from people who purchase service manuals. Perhaps someone can shed some light on this rather curious policy. Does National have something to hide?

David Hynd  
Bangor, NSW

### Not all get service

I WISH TO CORRECT a statement on page 25 of your January issue.

In your story "Broadcast Bungle" it is stated that the supplementary licence scheme will allow all radio broadcasters a second licence.

This is totally wrong. The Minister for Communications, Mr Duffy, has instructed the Australian Broadcasting Tribunal, through legislation, that a supplementary licence can only be granted if it is determined that it is not likely an independent station could be viable.

Nor can they grant a supplementary licence if it is established one would be against the community interest.

Therefore the supplementary licence scheme may allow some radio broadcasters to have a second licence.

Max Thorburn  
Mildura, Vic.

### ABC was on HF

PERMIT ME to differ with a head on page 118 of the March issue, Mr Editor.

The ABC was heading close to 20 years on HF before "Australia Calling" (which grew into Radio Australia) came up. Through VLQ, Brisbane, VLR, Melbourne, and VLW, Perth.

Ian Crompton  
Richmond, SA

Letters to the editor are welcomed, and should include the author's name, address and telephone number. They should be forwarded to:  
The Editor,  
Electronics Today,  
140 Joynton Ave,  
Waterloo, NSW 2017.

# Phone for telecommunications component innovations

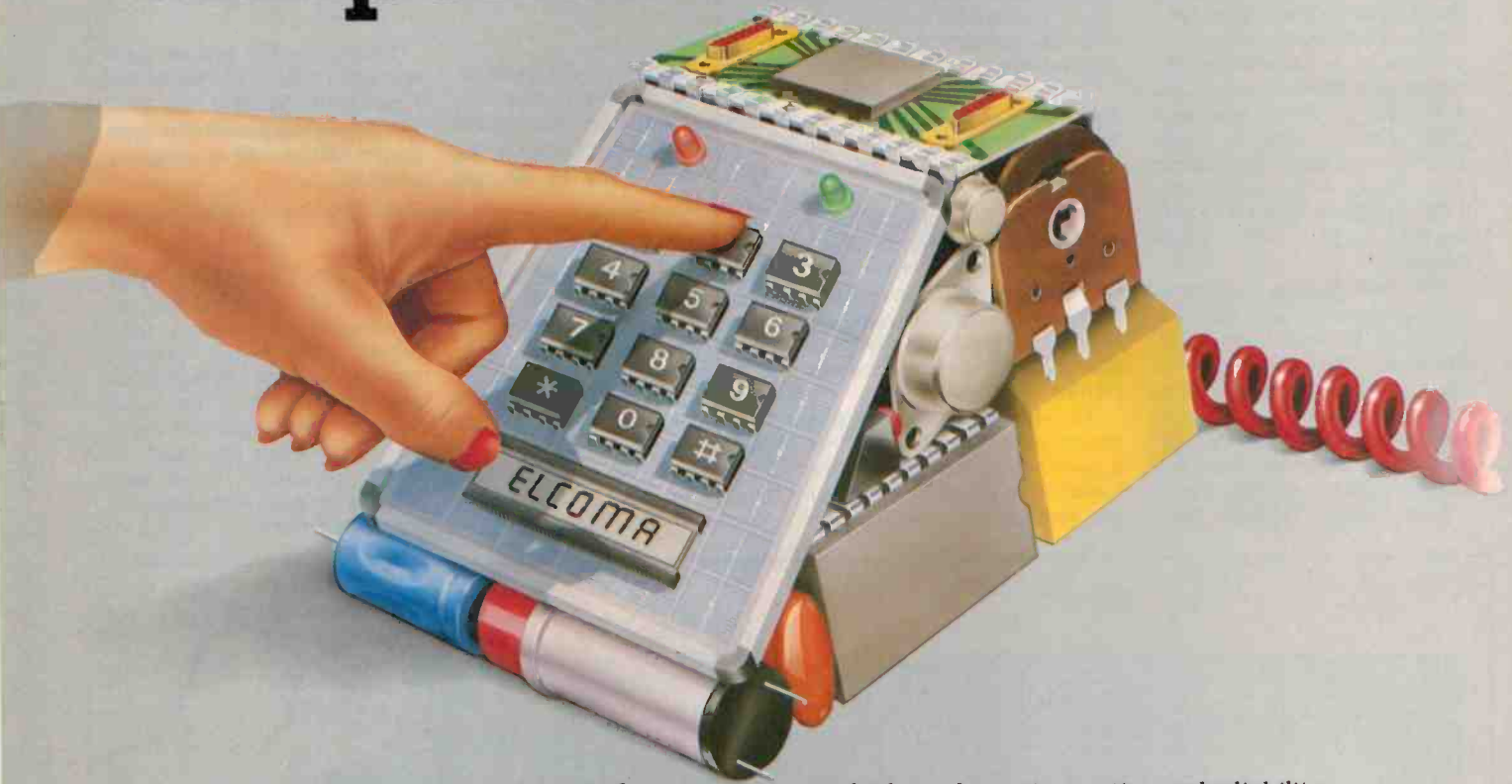

Telecommunication equipment manufacturers face constant pressure for more and more user features. These pressures are accompanied by complex technical problems imposed by the highly sophisticated integration of business communications and information systems.

"New" equipment frequently becomes obsolescent, virtually from the first production run.

Elegant technical solutions, design flexibility and inherent reliability stem from the very latest "chip" and component technologies. So the long-term winners will be the companies who employ the most up-to-date and reliable electronic technology right from the start - moving their new designs smoothly into production.

This is where Elcoma fits in. It is precisely the

area in which we shine - innovation and reliability.

Our research laboratories in the UK, West Germany, France, Holland, Belgium and the USA are long established and internationally acclaimed centres of fundamental research.

Considering that our catalogues contain 200,000 products for all branches of the electronics industry - and our turnover, globally, exceeds our nearest competitor by over 50% - it is highly likely that Elcoma are already efficient suppliers to your needs.

If not, why not use your telephone to take advantage of our experience?

Sydney	439 3322	Melbourne	542 3333
Adelaide	243 0155	Perth	277 4199
Brisbane	44 0191		

*We make electronics in Australia*



Electronic  
Components &  
Materials

**PHILIPS**

# The range of Hi-Fi equipment you thought was beyond your means is now within your grasp.

RECEIVERS

SEPARATE AMPS

CASSETTE DECKS

INTEGRATED AMPS  
TUNERS  
CASSETTE DECKS  
TURNTABLES  
RECEIVERS  
SEPARATE AMPS  
SPEAKERS  
CARTRIDGES  
HEADPHONES  
SYSTEM COMPONENTS

A Hundred Years of Musical Experience

YAMAHA  
HI-FI



Please send me the latest  
Yamaha Hi-Fi catalogue.

Name \_\_\_\_\_

Address \_\_\_\_\_

Postcode \_\_\_\_\_



Yamaha Hi-Fi Division, Rose Music Pty. Ltd.,  
17-33 Market St., South Melbourne. Victoria. 3205.

MCR/RM 3861 E/R

# HI-FI IN 1985

## a revival

Once or twice each decade high fidelity audio has a renaissance when makers dust off research of the earlier few years to offer buyers a seemingly endless array of new products. 1985 heralds the next revival . . .

Jon Fairall

I HAVEN'T TAKEN much interest in hi-fi over the last few years. Too many other things to do. But that changed recently when I realized just how bad the old system sounded. So I, like many another, began the long wander through hi-fi stores, peek-

ing into black boxes and brooding over glossy pictures.

What's changed in the last few years? At one level, not much. The manufacturers and their sales people are still talking up a storm, trying to confuse everybody with

their latest 'original' circuit. At another level, quite a lot has happened.

Digital has come. It has had an obvious effect in terms of transmission standards — the CD is one example. The Pulse Code Modulated (PCM) tape deck is another option; less popular, but just as viable. Less obvious, but just as significant, has been the growth of digital techniques in playback equipment. Generally, these control the analogue signal processing path in order to optimize it for the particular signal passing through it.

Variable bias is also making its effect felt in the performance of amplifiers and quite a few companies are starting to put out intelligent graphic equalizers that can tailor a system to your room.

Another trend has been the integration of components in novel ways. This is particularly true of video and audio. Typically, the sound from video productions is being handled by the hi-fi system. At the same time it is now possible to use a VCR for fully audio purposes.

Tuners have become more sophisticated, reflecting increased concern with fidelity by the broadcasters on both the FM and AM bands. AM, in particular, has had a good run lately with the introduction of AM stereo. FM broadcasters have gone increasingly to digital replay, going direct to air with CD and PCM recording.

The sad thing about AM stereo is that it's virtually impossible to get hold of an AM stereo tuner. A couple of manufacturers have put out AM stereo car radios, but hi-fi components are few and far between.

### Digital techniques

#### Cassette decks

The most notable examples of digital enhancement are to be found in cassette decks. That's not really surprising, since the manufacturers are fighting desperately to prevent them from becoming the poor cousins in the hi-fi family. The result of this trend has been that it is possible to get



reproduction approaching that of a CD player out of a cassette deck, but the price is horrendous.

A good example is the Nakamichi Dragon. This uses a processor to control the azimuth angle of the head and the motor transport mechanism. The azimuth angle is important since a mismatch between the angle at which the tape is recorded and the angle at which it is played back can result in an effective widening of the head gap. (See Figure 1.) However it is this head gap, among other things, that sets an upper frequency limit in the reproduced sound. The result is that misalignment of the head will be heard as attenuation of the high frequency signals.

Another interesting development has been the growth of systems that customise the playback system to the tape. The Luxman K05 uses a processor to fine tune head bias current, recording levels and equalization, depending on the nature of the specific tape in the machine at the time.

Processors also control the tape transport system. The Marantz SD 930 uses a processor and 2K of RAM to provide IC logic for the two transport motors, one of which drives the capstan direct. Apart from optimizing speed and minimizing wow and flutter, the computer also makes the system kind to the tape. It does things like take up the slack and reduce strain.

Other digital functions are involved with giving the cassette deck CD-like operator flexibility. Most manufacturers now have systems that detect the beginning and ends of tracks, so they can do things like index tracks (that is, play the first ten seconds of all tracks in succession), or play them in some predetermined order, or skip some of them, etc, etc.

#### Tuners

Most of the top line tuners are now using processors as a matter of course. They are being used to control the bandwidth of various sections of the circuitry to improve se-



**Brute force:** The Luxman M-OS 105 watts pure class A.



**Sheer simplicity:** One of the best preamplifiers on the market, the Perreux SA2.

lectivity and sensitivity, muting and AFC. Predictably they are also used for operator ease (or gimmicks, depending on your point of view). Tuning memory, for instance, which gives push button channel selection is very common.

One interesting tuner is the JVC TX900B. When the operator manually tunes in a station the computer goes through a number of steps. It checks the front end signal strength and reduces it by steps of 10dB to prevent overload distortion. It then checks the signal at the end of the IF chain. Under normal conditions it will select 'wide' IF bandwidth to bring in a good stereo signal. However, if there is another station within 300 kHz, interfering with the received signal, a 'narrow' setting is used to improve selectivity.

When all these are set for a particular station, the computer remembers all the settings, plus the noise reduction circuits that were necessary to optimize reception. You may elect to override the computer and make you own settings. In either case it is then possible to recall all the settings at the touch of a button.

Of course, applications like these take

only a small percentage of processor capacity. Adding extra functions is often simply an exercise in imagination. Take the Revox B780 for instance. As well as all the usual things, it uses a processor to monitor the temperature of the heatsinks and the speaker outputs. In the event that the temperature of either rises above certain limits, the computer interprets this as a malfunction, and shuts down the unit, so protecting the loudspeakers and the output stages from possible damage.

Another interesting digital application is digital decoding. It's been around for a while, but is only now starting to creep into domestic sound systems. As far as I could determine, the Sansui TU D99X is the first tuner to introduce these techniques into Australia. Sansui call the circuit the Super Linear Digital Decoder, and claim no multipath interference or RF intermodulation with 100% image frequency rejection.

#### Turntables

The turntable is in trouble. It is only kept afloat by the huge amounts of software available, and sentiment. (Which amounts



Audio Video Integration: video tuner on the right, preamp on the left.



Yamaha equalizers. On top is the 6E-60 with spectrum analyser and 10 bands.

to a pretty powerful combination.) The long playing record is still the cheapest way to access material, and most people have large numbers of them. The result is that turntables are still selling, in spite of their generally poor reproduction qualities compared to CD players.

Of course, this is not completely true, in

the sense that it is possible to get records and turntables that turn in reproduction indistinguishable from a CD player. But you pay for the privilege.

There is a relatively cheap option for the manufacturer, however, and that is to add gimmicks to the record player. As a result, makers now offer expensive, extremely well



Sheer cleverness: keeping the record player alive; The Dual PCR 50.

engineered, and very plain turntables that go a long way towards the fabled "no compromise" design, as well as cheaper units with more buttons.

Features that are common include track detection, record presence detection and index playing. It is possible to pre-program some decks to play tracks in a particular order, or to skip unwanted tracks.

### Variable bias

Another trend common to many manufacturers is dual class amplifiers. These are an attempt to solve the problem that dogged amplifier design for many years: efficiency versus fidelity. The problem is approximately this: Class A amplifiers are very inefficient. The output transistor is biased to half way between the supply rails, so it is always turned on. Current always flows even when no power is being delivered to the speaker.

The first effort towards solving this problem was the introduction of Class B amplification. Class B used two transistors. One was turned on for the positive cycle and one for the negative. The result was far greater efficiency, but at the cost of fidelity. As one transistor turned off and the other turned on there was a large non-linear response caused by the inherent non-linearity of the transistors themselves.

A modification to this was the introduction of Class AB. The idea here was that both the transistors in a Class B configuration would be biased to be sitting at the bottom of their linear slope. It's not quite as efficient as pure Class B but far more linear in response. However, there was no doubt that even the best Class AB delivered significantly more non linearities than the pure Class A.

A few manufacturers seem to have solved the problem of hi fidelity by biting the bullet and designing pure Class A amplifiers with "what inefficiency?" written all over them. Luxman is one example. They produce a line of amplifiers that look a little like Walerawang power station. The L550 for instance, has a huge transformer that delivers 400VA for 50 watts a side. This design philosophy at least has the advantage that it's not difficult to design good amplifiers for moderate cost.

The more traditional makers have chosen a different method involving variable bias. Typically, the amplifier operates in Class A while the output power is below a few watts. As soon as consumption gets up a bit the system switches over to Class AB. There are a number of names for this type of thing, Quarter A at Marantz, Super A at JVC, Dual Class A from Dual and Auto Class A at Yamaha. Pioneer weights in with Dynamic Power Supply and Kenwood with Dynamic Linear Drive. Take your pick.

Whatever it's called the basic outline is the same. There is some control circuitry, often digital, which samples the input to the amplifier and decides on the power requirement. Whenever this exceeds some predetermined level the amplifier switches to Class AB. The non-linearities of the switch over process are apparently not significant.

### Audio visual integration

Audio visual integration is taking a number of forms. At one level it can mean nothing more than sticking a "video" label where the "aux" used to be on the pre-amplifier. At the other it can mean redesigning the entire system around the monitor. Kenwood has the KVA 502 amplifier, which can deliver 55 watts a side to the speakers plus a colour picture to a TV set. It can also feed a monitor with RGB and accept input/output from two VCRs so you can use it for dubbing. All the normal inputs for an audio tuner and cassette decks, record player, etc. are provided.

Another particularly interesting unit is Sansui's S-X1130 audio-video receiver. It features a stereo AM/FM tuner, controls and connections for two VCRs and a video disc, as well as the normal MM/MC and cassette deck connections. There is video output for a monitor and RF output for a TV. It has sharpness and fader controls for the video, and sound mixing facilities on the audio tracks. There is even a stereo synthesizer so you can jazz up mono TV transmission.

Another permutation is the device that allows you to use a VCR as an audio source. Usually this is done with Pulse Code Modulation (PCM), where the superior bandwidth of the VCR allows you to make recordings as good as those you can get off a CD player.

For instance, Sansui has a line of devices called the Tricode PCM processors, the PCXI and PCXII. They can record successfully even using the extra slow mode on a VCR, so you can generate up to eight hours worth of music on a single cassette.

### Graphic equalizers

There is a very strong body of opinion that holds that one cannot make decisions about the optimum characteristics of a system without considering the acoustic environment in which it operates. This has led to the advent of intelligent spectrum analyzers. These are devices that generate pink noise internally and play it through the system speakers. The resulting sound is then

analyzed via a built-in microphone in the unit.

According to manufacturers this makes it possible to customize the system for the environment in which it will operate. The advantage of generating pink noise as opposed to the traditional method of setting up a graphic equalizer is just the difference between objective and subjective set ups. With a known noise source it is possible to use meters to obtain a response as close to optimum as possible.

The Technics SH 8055 uses this approach to display the received pink noise on an 8 channel bargraph display. The graphic equalizer is then used to equalize the response across the frequency range. ●

### WHAT'S BEST?

ETI invited some well known people within the audio industry to give us their opinions of the right way to go about buying a sound system. There was a large amount of unanimity among the people we approached on what constituted an ideal system, and where you should spend your dollar. Some of the details differed, however.

#### Journalist

Dennis Lingane, electronics journalist and hi-fi buff (1000 lps) was one of the first we approached. His reaction: "I'm not into buying furniture. I'd buy a CD player, an amplifier and a pair of good speakers".

Lingane's prescription for success: good speakers. He said that he would budget about \$700 for a CD player, \$600 for a class A amplifier and \$700 to \$800 for a set of "good English" speakers.

His reasoning is that the better the speakers, the less demands you place on the other components. A CD player has a dynamic range of about 90 dB, so a minimum requirement is for speakers that can produce that kind of sound pressure level.

The \$700 price for a CD player reflects a mistrust of cheap CD players. He is suspicious of both the mechanical and sonic qualities of the cheapies. There have been reports of mechanically suspect loading procedures, for instance, and he is concerned by the brick wall filtering effect associated with the 44.1 kHz sampling rate.

#### FM radio engineer

Graham Greenwood, the chief engineer at radio station 2DAY-FM in Sydney listed his order of importance: good speakers, a current delivery type amplifier, a good AM/FM tuner, a CD player and a Beta hi-fi VCR. And don't expect change from \$3000.

According to Greenwood, speakers are the most important part of the system because they dictate the sound, and the sound is very subjective. His advice: don't buy speakers off the showroom floor. If you do you will make a mistake. Get some music you know and like and spend some time listening to a set at home. He advises against trying to buy speakers by switching between a whole range of them. "Something happens to your ears."

Predictably, perhaps, Greenwood would spend a lot of money on an FM tuner, less on the

AM component. His thoughts: before committing money to AM stereo he would like to see programming on the AM band settle down a bit. Money spent on FM stereo is well worthwhile. Most programme material now comes of CD or PCM tape and it's worthwhile buying high quality to take advantage of it.

On CD players, it's difficult to make hard and fast rules. Things are still developing at such a pace that it is possible to buy quality cheaply, and lemons for twice the price. The Sony D50 portable, for instance, sells absurdly cheaply, but seems to have similar performance to \$1000 players.

#### AM radio engineer

Colln Crowe, chief engineer at Melbourne radio station 3XY was also infatuated with CD players from an engineering point of view, and even more emphatic on the importance of good speakers. His suggestion — three-quarters of the budget on the speakers.

He also said he wanted to see at least 50 watts in the amplifier, although he cautioned against worrying too much about the power rating. "I probably spend most of my time listening to music at less than a watt." The extra is necessary to handle the transients, but a good signal-to-noise ratio is probably more important.

Crowe said he thought the biggest single change in hi-fi was that ten years ago the most important element in the system was the record stylus. If that was bad not only would the system sound bad, but the records played on the system would be destroyed. CD has changed all that.

#### Industry pundits

The Consumer Electronics Suppliers Association has instituted a system of awards called the Hi-Fi Grand Prix Awards. They are to be held annually. Products were separated according to function and all the manufacturers present in Australia were invited to submit three different items for each category.

Conditions were that the product had to have been released in Australia during the last 12 months.

The results were: Best Amplifier — the Luxman CM05; Best Receiver — NAD 7140; Best Tuner — Yamaha T80; Best Cassette Deck — Alwa ADF 990; Best Compact Disk Player — Yamaha CD2; Best Loudspeakers — KEF 104.2.

# THE BRILLIANT SERIES 5000 PRICES SLASHED! FOR ONE MONTH ONLY!

By directly importing and a more technically orientated organisation, ROD IRVING ELECTRONICS can bring you these products at lower prices than their competitors. Enjoy the many other advantages of RIE Series 5000 kits such as "Super Finish" front panels at no extra cost, top quality components supplied throughout. Over 1,000 Sold.

For those who haven't that time and want a quality hi-fi, we also sell the Series 5000 kits Assembled and Tested.

**SAVE \$60 THIS MONTH ONLY!**

## POWER AMPLIFIER WHY YOU SHOULD BUY A "ROD IRVING ELECTRONICS" SERIES 5000 POWER AMPLIFIER.

- ★ 1% Metal Film resistors are used where possible.
  - ★ Aluminium case as per the original article.
  - ★ All components are top quality.
  - ★ Over 1000 of these kits now sold.
  - ★ Super Finish front panel supplied at no extra cost.
- Please note that the "Superb Quality" Heatsink for the Power Amplifier was designed and developed by ROD IRVING ELECTRONICS and is being supplied to other kit suppliers.

**SPECIFICATIONS:** 150 W RMS into 4 ohms  
**POWER OUTPUT:** 100 W RMS into 8 ohms (±55 V SUPPLY)  
**FREQUENCY RESPONSE:** 8 Hz to 20 KHz +0-0.4 dB 2.5 Hz to 65 KHz +0.3 dB NOTE: These figures are determined solely by passive filters.  
**INPUT SENSITIVITY:** 1 V RMS for 100 W output.  
**HUM:** 100 dB below full output (flat).  
**NOISE:** 1.16 dB below full output (flat, 20 KHz bandwidth).  
**2nd HARMONIC DISTORTION:** <0.001% at 1 KHz (0.0007% on Prototypes) at 100 W output using a 256 V SUPPLY rated at 4A continuous. <0.003% at 10 KHz and 100 W  
**3rd HARMONIC DISTORTION:** <0.0003% for all frequencies less than 10 KHz and all powers below clipping.

**TOTAL HARMONIC DISTORTION:** Determined by 2nd Harmonic Distortion (see above).  
**INTERMODULATION DISTORTION:** 0.003% at 100 W, (50 KHz and 7 KHz mixed 4:1).  
**STABILITY:** Unconditional.  
 Cat. K44771 Normally \$339, **SPECIAL PRICE \$279**  
 Packing and Post \$10 Assembled & Tested \$499

**SAVE \$60 THIS MONTH ONLY!**

## PREAMPLIFIER THE ADVANTAGES OF BUYING A "ROD IRVING ELECTRONICS" SERIES 5000 PREAMPLIFIER KIT ARE:

- ★ 1% Metal Film Resistors are supplied.
  - ★ 14 Metres of Low Capacitance Shielded Cable are supplied (a bit extra in case of mistakes).
  - ★ English "Lorlin" switches are supplied (no substitutes here).
  - ★ Specially imported black anodised aluminium knobs.
- Available Assembled and Tested. (We believe that dollar for dollar there is not a commercial unit available that sounds as good.)

**SPECIFICATIONS:**  
**FREQUENCY RESPONSE:** High-level input: 15 Hz-130 KHz, +0, -1 dB Low-Level input - conforms to RIAA equalisation, ±0.2 dB  
**DISTORTION:** 1 KHz <0.003% on all inputs (limit of resolution on measuring equipment due to noise limitations).  
**S/N NOISE:** High-Level input, master full, with respect to 300 mV input signal at full output (1.2V) >92 dB flat > 100 dB A-weighted. MM input, master full, with respect to full output (1.2V) at 5 mV input 50 ohms source resistance connected >86 dB flat >92 dB A-weighted. MC input, master full, with respect to full output (1.2V) and 200 uV input signal >71 dB flat >75 dB A-weighted.

Cat. K44791 Normally \$299, **SPECIAL PRICE \$239**  
 Packing and Post \$10 Assembled & Tested \$599

**THIRD OCTAVE GRAPHIC EQUALIZER**

**SPECIFICATIONS:**  
**BANDS:** 28 Bands from 31.5 Hz to 16 KHz.  
**NOISE:** <0.008 mV, sliders at 0, gain at 0 (-102 dB0).  
**20 KHz BANDWIDTH DISTORTION:** 0.007% at 300 mV signal, sliders at 0, gain at 0; maximum 0.01%, sliders at minimum.  
**FREQUENCY RESPONSE:** 12 Hz-105 KHz, +0, -1 dB, all controls flat.  
**BOOST AND CUT:** 14 dB.  
 1 Unit... **\$199**  
 Cat. K44590 2 Units... **\$379**  
 PACKING AND POSTAGE \$10

**SAVE! SAVE! SAVE!**



**RITRON 1**  
 Our most popular model in a steel cabinet to minimise R.F.I. interference.

1-4	5-9	10+
Green, Cat. X14500		
<b>\$169</b>	<b>\$165</b>	<b>\$159</b>
Amber Cat. X14500		
<b>\$179</b>	<b>\$175</b>	<b>\$169</b>



**KEYBOARD AND CASE**  
 Cat. X11080 **\$299**

Errors and Omissions Excepted

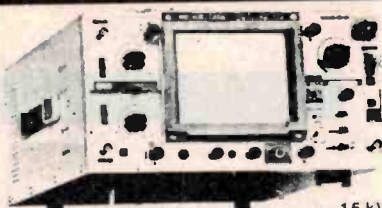

MODEL OS-645,  
15 kV, 45 MHz, 1 mV/div.

## "RITRON" DUAL TRACE OSCILLOSCOPES

- ★ LOW PRICE ★ HIGH QUALITY ★ EX STOCK
- ★ 12 MONTHS WARRANTY ★ ON DISPLAY ★
- ★ WIDE FREQUENCY BANDWIDTH: (70 MHz-6 dB)
- ★ OPTIONAL SENSITIVITY: All steps of vertical deflection factors are multiplied 5 times for the highest sensitivity of 1 mV/div.; 10 MHz.
- ★ DELAYED TRIGGER SWEEP: Any point of the waveform is addressed as a triggering start. So, any waveforms can be substantially and brightly magnified, thanks to the 5 kV bright CRT.
- ★ EXTREMELY BRIGHT DISPLAY: The metal back CRT (PDA) provides brightest trace display.
- ★ DELAY LINE: (for BS-625): Approximately 20 nsec before triggering point is displayed for real analysis of rise times.
- ★ SCALE ILLUMINATION
- ★ SINGLE SWEEP: A triggered sweep of a single waveform can be displayed.
- ★ TV SYNC.: TV composite signals can be easily synchronized.
- ★ MAGNIFIERS: Both vertical and sweep time are simply magnified to 5 times. (1 mV/div., 40 nsec/div.).
- ★ X-Y, or X-Y-Z OPERATION: Simply by turning the "sweep time/div. knob" to CH-B, this functions as a very high sensitivity X-Y oscilloscope (1 mV/div.) with intensity modulation.
- ★ HF REJ: High frequency noises can be rejected for the stable triggering by use of the low pass filter built in the triggering circuit.

**REMEMBER:** Ex stock, 12 month warranty, High quality components, Direct import, Flat face internal graphic screen, On view at both stores, Our 8th year of business!

CAT. NO.	MODEL	SCREEN	SENS	SIG TRIG	DEL	DEL	B'WIDTH	T'BASE	WITHOUT TAX	WITH TAX	PROBES	EXEMPT	COMMENTS
Q12110	645	150mm	1 mV	Y	45 MHz	0.75	0.550v	\$1465	\$1465	\$690	\$1,085	(70 MHz-6 dB)	
Q12105	620	150mm	5 mV	N	20 MHz	0.3	0.350v	\$1445	\$1445	\$509	\$1,054	(45 MHz-6 dB)	
Q12100	6155	95mm	5 mV	N	15 MHz	0.3	0.350v	\$895	\$895	\$785	\$1,680	(AC-DC Operation)	

★★★★★★★★★★★★★★★★★★★★

## AN AMAZING \$99!

## VOYAGER CAR COMPUTER NEW IMPROVED MODEL WITH MASSIVE SAVINGS!! ONLY \$125 COMPLETE!!

Originally \$199, the Voyager Car Computer represents absolutely outstanding value for money. The voyager is the only low-cost "full-function" car computer that will give you fuel consumption (the most important feature in a car computer) in both litres/100 km. and good old miles/gallon!  
 The voyager comes absolutely complete with all fitting hardware (even a roll of insulation tape!) Installation generally takes 4-6 hours depending on the vehicle.

### VOYAGER OPERATING FEATURES:

- ★ Instantaneous fuel consumption from sec. to sec. as you drive.
  - ★ Distance travelled since the log computer was last re-set.
  - ★ 5 digit display (10mm high).
  - ★ Fuel used since the log was last re-set.
  - ★ Average fuel consumption since the log computer was last re-set.
  - ★ Instantaneous speed as you drive from sec. to sec.
  - ★ Clock with 12 hour format. Can be used as a stop watch.
  - ★ Straight forward calibration.
  - ★ Metric and Imperial conversions.
  - ★ Light sensor automatically adjusts brightness of display.
  - ★ Average speed over trip.
  - ★ Elapsed time since the trip computer was last re-set. Can be used as a split lap timer.
  - ★ Distance travelled since the trip computer was last re-set.
  - ★ Lights left on alarm.
  - ★ Dimensions 200 (W) X 71 (H) X 90 (D) mm.
- Hundreds sold of the old version at \$199, now you can grab a new improved model, including a full 90 day warranty, for a mere \$125. That's a colossal saving of \$74!!  
 (As reviewed in EA Oct. '82 and ETI Nov. '82)

Cat. X12010 **ONLY \$99!** ~~\$125~~

**SPARE FLOW SENSORS:** We will be supporting this product for many years to come. To avoid problems changing cars, why not buy a spare fuel flow sensor? They are about the only thing that wears out!

Cat. X12036 **\$29.50**



**Rod Irving Electronics**  
 425 High Street,  
 NORTHCOTE, 3070  
 VICTORIA, AUSTRALIA  
 Phone (03) 489 8866  
 TELEX: AA 38897  
 48-50 A Beckett Street,  
 MELBOURNE, 3000  
 VICTORIA, AUSTRALIA  
 Ph. (03) 663 6151  
 Mail Order and  
 correspondence:  
 P.O. BOX 235  
 NORTHCOTE 3070

## MAIL ORDER HOTLINE



**(03) 481 1436**

**POSTAGE RATES**

\$1-\$99.99	.....	\$2.00
\$10-\$24.99	...	\$3.00
\$25-\$49.99	...	\$4.00
\$50-\$99.99	...	\$5.00
\$100-\$199	.....	\$7.50
\$200-\$499	...	\$10.00
\$500 plus	...	\$12.50

This is for basic postage only, Comet Road freight, bulky and fragile items will be charged at different rates.

Certified Post for orders over \$100 included "free"  
 Registered Post for orders over \$200 included "free"  
 Account orders from schools, Government Departments, Public Co., gratefully accepted. (Min. order of \$20).



## HAVE YOU BEEN INTO OUR CITY STORE???

Conveniently located on the edge of the city where parking is easy! Over 4,000sq. ft. of an extensive range of products and great "in store" bargains... for those interested in computers we have a wide range on display upstairs. For good advice and a good price, see Rod Irving Electronics.





SONY®

# DIGITAL DAWN.



ES

APM

COMPACT  
DISC  
DIGITAL AUDIO

It's a Sony

The world is waking up to the ultimate sound experience that only digital perfection can deliver.

And Sony's ES Series are the top of the range digital components.

The CDP-501ES Compact Disc Player with multi-function cordless remote control, featuring volume control.

The TA-F444ES integrated amplifier gives you the outstanding dynamic range of over 120dB and the channel separation of over 100dB (at 1KHZ) that digital audio demands.

The ST-S444ES FM stereo/AM tuner, the original direct comparator quartz frequency synthesis tuning for striking

S/N ratio of 88dB (stereo).

The TC-K555ES-MkII cassette deck, with three head laseramorphous record and playback heads plus closed loop dual capstan tape transport, assure the wide dynamic range and reduced modulation noise.

The SEQ-555ES programme equaliser automatically customises music to suit the

room and the full function wireless remote commander adds convenience.

APM-55W speakers, (from the APM range), with flat square diaphragms for clean, powerful sound.

For the best in sound it has to be digital and it has to be the Sony ES series.

**SONY DIGITAL AUDIO DEALERS:**  
BRISBANE,  
Reg Mills Stereo 391 5606;  
MACKAY,  
Mackay Stereo Sales 57 7512;

**SYDNEY,**  
Bery's Radio 969 3830,  
Chatswood Colour TV 411 2090,  
Sydney Hi-Fi Centre 29 1082;  
**CANBERRA,**  
Kent Hi-Fi 82 2874;

**MELBOURNE,**  
Beta Audio Video 509 6846,  
Encel Electronics 428 3761,  
Intercape Video Centre 63 3086;  
**ADELAIDE,**  
Grenfell Plaza Hi-Fi 51 5017;

**PERTH,**  
Audio Equip 330 3397,  
Vince Ross Audio 321 2644.

# CD PLAYERS: the developments go on with breathtaking speed

Louis Challis recently returned from Japan where he visited a number of the leading manufacturers of hi-fidelity equipment. This is his report on one specific aspect of the hi-fidelity market: the victorious CD.

Louis Challis

IN THE TWO YEARS since the simultaneous commercial release of CD players in Holland and Japan, we have witnessed an exciting game of 'economy leap frog' with one manufacturer after another upstaging his competitors in the market place. By the time I had planned a 'circle Pacific' trip overseas late last year, I realized that the

Japanese manufacturers of CD players had already made their crucial decisions as to how far the product would develop and, more importantly, at what pace.

As I soon discovered, the pace of development was not just fast, it was positively breathtaking. In order to be able to assess the trends I decided to visit three of the

firms who appeared to be the technological leaders: Nippon Gaki (whose products sell under the Yamaha brand name), Matsushita (whose products are known under both the National and Technics brands) and Sony.

The first of my inspections was at the Yamaha development laboratories at Hamamatsu. There I was able to explore one of the most important trends in CD development, the development of large scale integrated circuits. These are the veritable pillar stones on which both the majority of present CD players and all future development will be based.

## Design developments

The first generation of CD players used copious quantities of conventional transistors, dual-in-line ICs and small numbers of large scale integrated circuits. These provided the special control and playing functions required by every CD player. If you examine the block diagram of a Yamaha (or any other CD player) what you find is complex and often bewildering. The early designs and circuitry proved to be so complex and so costly to manufacture that Yamaha, Pioneer, Akai and many other Japanese manufacturers found that they were forced to sell their first generation CD players for less than they cost to produce.

Obviously, you can't keep on doing that for very long and still retain your viable position in the market place. The political decision to market those first CD players at less than cost, was an important one because most Japanese companies take the attitude that their image and status has an equal importance to their financial viability. In Japan to 'lose face' is totally unacceptable.

It did not take Yamaha or the leading Japanese manufacturers particularly long to

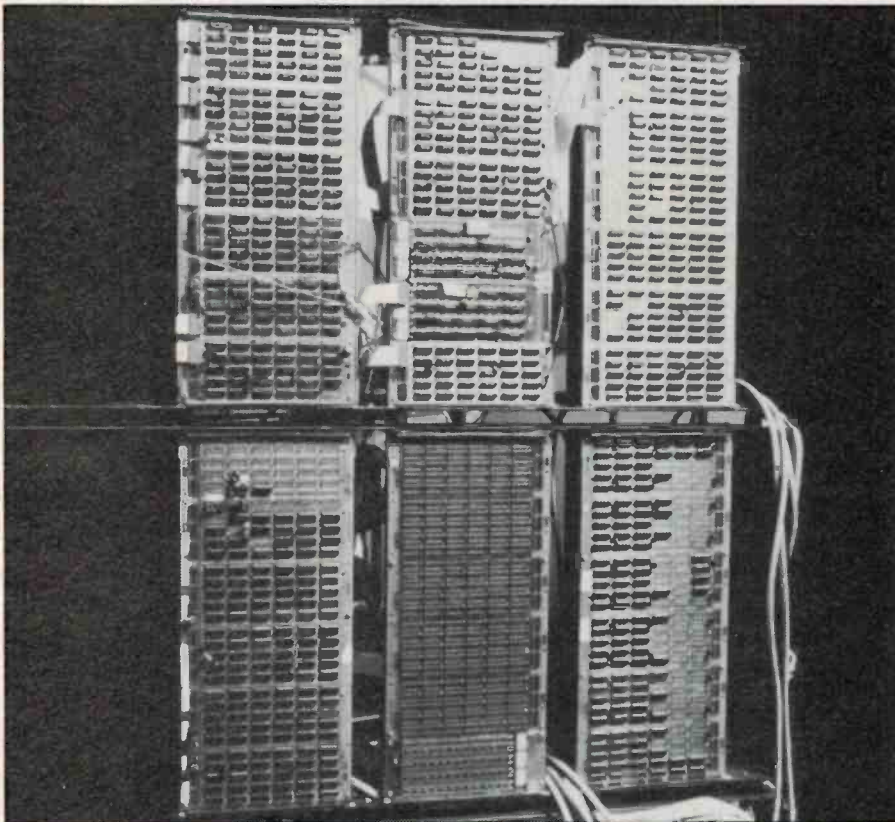

Yamaha's prototype breadboard from which its LSI circuits were developed.

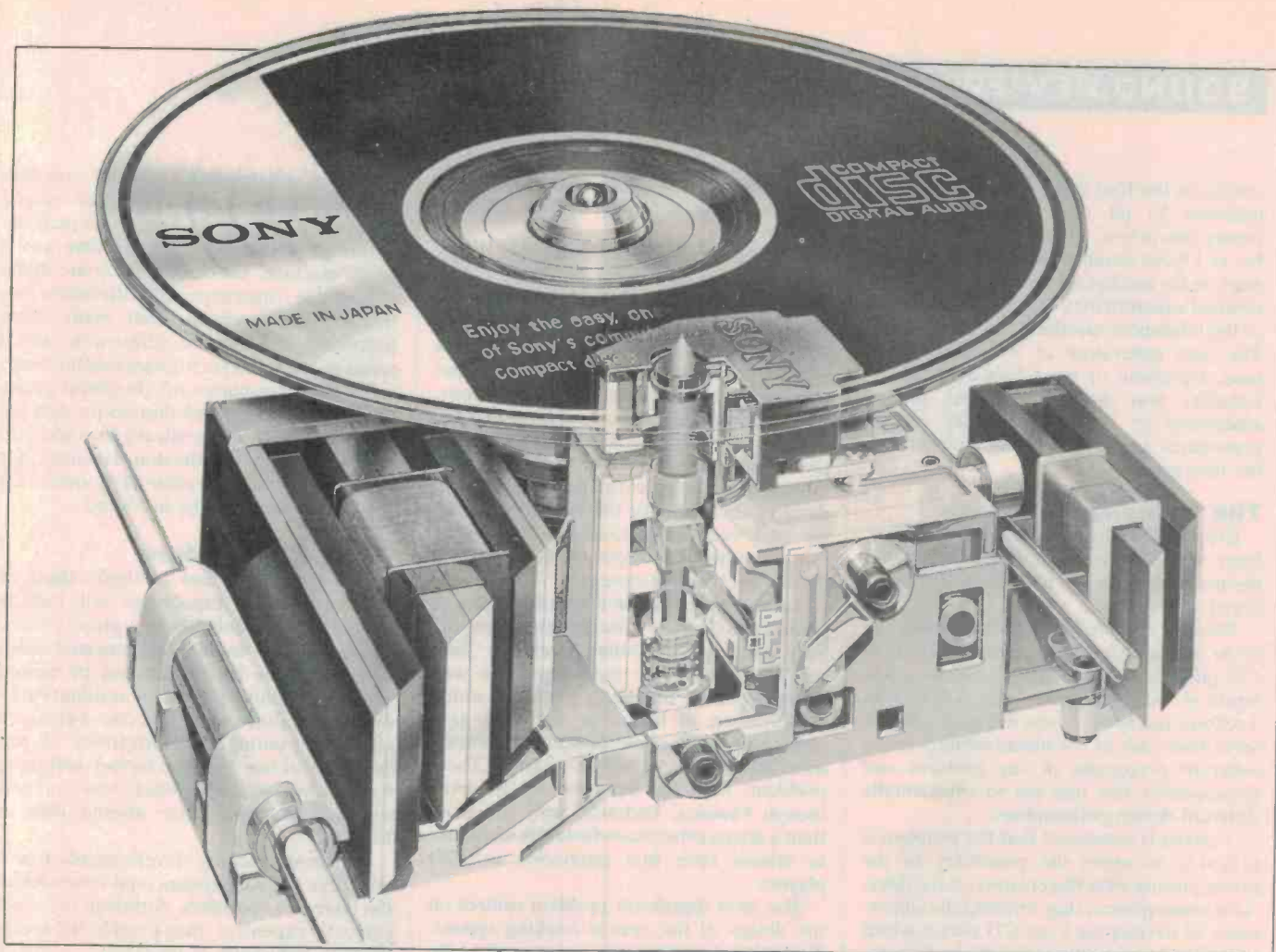

develop the only solution possible which would remove the problem. That solution was achieved through the development of a series of new special purpose, 'dedicated large scale integrated circuits' (LSIs). These 'monster chips' reduced the superficial complexity of the first generation of electronic circuitry, so that many dozens (or in some cases 100s) of separate integrated circuits, could be combined in one large package. This reduced the number of chips to five or six and in the most advanced cases, to only two very large LSIs. Electronic developments such as these were at the same time matched by some unusually clever and innovative development work on hardware, such as high performance laser tracking assemblies.

Few readers will be aware of the extent to which precision plastic moulding has been used to achieve significant manufacturing cost savings. The problem with plastics is that they are not a panacea and this is particularly true in the electronics industry. It didn't take the mechanical design engineers at Yamaha very long to find that there are some uses plastics cannot serve and even if they do, the cost penalties outweigh the suspected savings. This proved to be the case for CD players, as well as compact cassette players. The Yamaha engineers tried using various bolt-on configurations and combinations of plastic inserts to achieve a

solution but while these concepts initially proved to be functionally workable, they also proved to be far too expensive.

It was early in 1984 that someone at either Hamamatsu or in Osaka had the brainwave of the 'exsert' concept. (The reason why the location is in doubt is that each of the corporations I visited stated that the idea for the development was its own.) It's the concept that is important however, not the manufacturer, and this concept is based on the use of a conventional flat steel chassis system in which holes are drilled or punched with unusual precision. The external plastic elements which produce the special shapes are then inserted to achieve the 'exsert'.

These plastic elements have a shape and form producing a combination of external profiles with straight, curved or large add-on elements of the type normally achieved by much more expensive injection moulding, yet with comparable rigidity, strength and more significantly, at a fraction of the cost.

The resulting systems may look a trifle untidy, but they work exceptionally well. The Japanese decided that as you wouldn't see what it looked like, and as long as it works, then the appearance didn't really matter. So the 'exsert' concept has taken off and has achieved the essential cost reductions and enhanced efficiency through which the Japanese industry has been able

to progress.

The next most important development was in the field of laser transmitter and detector technology. Each of the three manufacturers that I visited had a different design philosophy, except they all closely followed the same set of basic rules contained in the Sony/Philips 'Red Book'. In practice, their approaches appeared to be poles apart, both in the physical appearance of their players, as well as the way they had developed their conceptual approaches. Nowhere was this more evident than in their servo tracking systems, and in their latent approaches to the linear actuation systems; they all seem to end up with radically different designs. By way of example, the latest generation of Yamaha laser detectors, as exemplified in the CD-X1 (see ETI review of August, 1984) is able to track a disc with a central eccentricity as high as 1 mm (1000 microns) which few other CD players have yet equalled.

By contrast, Sony has developed a laser detector which is able to track discs the skew angle of which may vary by as much as 0.4 degrees, which in optical terms, constitutes extremely long optical focusing distances at the outer extremities of the CD disc.

The need to evaluate and the need to design for such parameters, may not appear significant if one could presume that all the

criteria in the Red Book were being strictly followed by all disc manufacturers. In theory this is true, but in practice it is not, for as I have found a small number of the discs on the market are being marketed with residual eccentricities at the extreme limit of the tolerances specified in the Red Book. The next generation of American, Japanese, European or even Taiwanese manufacturers may well choose less precise equipment or less exact quality control procedures and may then say "to hell with the tolerances".

## The challenge of the car

Even if these problems don't materialize, there are new problems, which very few of the manufacturers (or their staff) were prepared to talk about.

Possibly the most important of these are to do with the development of the new car CD players. I probed this issue for many hours in technical discussions at Yamaha, Technics and Sony. It was interesting to observe that each of the manufacturers had a different perception of the problem and consequently this had led to substantially different design philosophies.

Yamaha is convinced that the problem is primarily to avoid the possibility of the driver putting dirty fingerprints on the discs. As a consequence, they stressed the importance of developing a car CD player which is designed to accept a series of 'loading cartridges' into which the driver would slip his precious CD discs and thereby avoid contaminating the surface of the disc.

While I examined the 'loading cartridge', Yamaha conjured up visions of a driver with his eyes glued to the road, trying to insert a

disc carefully held by its edges into a slot located on the front panel of the vehicle's dashboard.

When I asked "How would this design cope with the problems of dust or dust storms in the centre of Australia?" (or any other country for that matter), it was apparent that the Japanese had only really given serious consideration to cities and similar nominally 'clean' environmental conditions.

By contrast the key issue at Sony was the design of the vibration isolation system used to support the player from the car body. During discussions on the most appropriate design parameters for the isolation system, we reviewed the details for the testing procedure needed to prove the adequacy of the optical tracking system.

It was apparent again that in those design parameters serious consideration has not been given to Australian roads (or their conditions) which in most cases are well below Japanese standards. With the added complication of heat and dust, we have conditions which could dishearten even the most ardent designer of CD players. These problems have not yet been solved, even though Yamaha, Technics, Sony and more than a dozen other manufacturers are about to release their first generation car CD players.

The most significant problem centres on the design of the optical tracking system. Philips has developed the 'swing arm' mechanism to an advanced stage, but this system is particularly unsuited to mobile applications, because of its high mass and consequent inertia. Sony (and probably many other manufacturers) has developed a light weight linear motor system which is fast, cheap and much better suited to the needs of a car. This will undoubtedly enable them to overcome most of the worst vibration problems in cars.

From my observations and initial assessment of the design philosophies of the various manufacturers, I believe that the testing and reviewing of car CD players will also require a comprehensive evaluation of their resistance to dust, to vertical vibration (levels as high as 0.7 g) and will most probably require some form of 'blindfold' test for evaluating the problems of disc insertion, if they don't come up with their own integral 'loading cartridge'.

## Hidden models

During discussions with the Japanese manufacturers, I was surprised to find how many different models have been released in Japan that we have neither seen nor been made aware of in Australia. Sony has produced at least 12 different machines, while Technics has produced at least 13. The Japanese selling prices of these machines range between \$US250 at one end of the spectrum to more than \$US4000 at the

other end. It is doubtful whether in a subjective comparison test, many well trained listeners would readily be able to pick the difference between a \$250 machine and a \$4000 machine. Of course, there are many measurable (instrumental) differences between these machines, and many more functional and control differences, which result in price and performance differences.

The \$4000 machines will do almost everything, except open and shut doors, and are generally designed specifically for radio studios and music production facilities, for which the next generation of 'goodies' for the CD medium will be produced.

## The exciting future

The most important of these 'third or fourth generation capabilities' will include the ability to simultaneously project video still pictures on to an interconnected video monitor, where the picture may be viewed with high definition using the residual bandwidth capabilities of the CD disc. I viewed a series of exciting demonstrations of this capability at the Technics factory and these features will open up a 'whole new commercial ballpark' some time around 1986 or 1987.

The most exciting developments that I saw were the first commercial examples of the laser disc recorders. Although these are currently expensive, they provide the ability to store thousands of megabytes of digital information in the form of alpha numeric text, music or graphics data as part of a special dedicated retrieval system which you can then access through either a computer or even your \$250 (or your \$4000) CD player.

If you find the speed, complexity and even threats of such developments bewildering, you are not alone. The majority of the Japanese engineers with whom I discussed these developments made it clear that they are concerned that the future development of CD players and laser disc players is at the most delicate stage of its development.

At Sony, in particular, they made it clear to me how apprehensive they are and pointedly stated that any adverse criticism of the CD medium might well result in irreparable damage to the long term commercial development of compact discs.

I do not share all their fears as I believe that the CD concept is now firmly established as the pre-eminent hardware system for home audio entertainment and is about to irreversibly displace ordinary turntables and record players in the market place. As for CD players, I have yet to be shown a system which is as convenient as the compact cassette and consequently believe that combined radio and cassette players will give the CD player a tough run for its money in the foreseeable future. ●

Yamaha's car CD holder.  
View of a car CD cartridge.

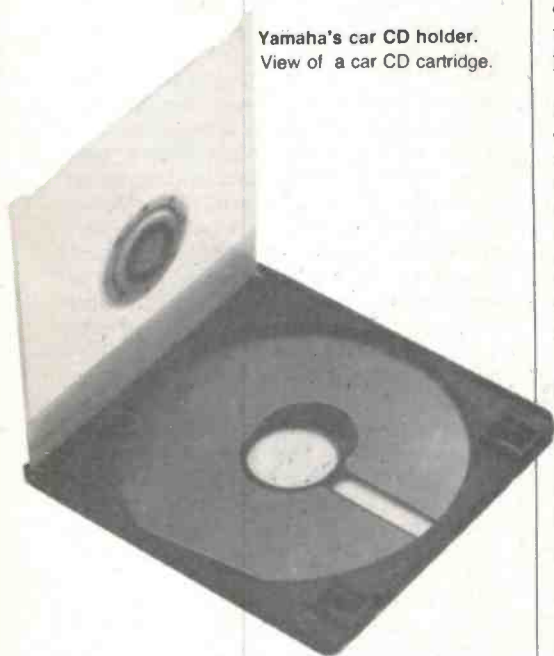

# NOW PIONEER PUTS TWICE AS MUCH STEREO FUN IN YOUR CAR.



Now with AM Stereo here, Pioneer puts twice as much stereo fun in your car with the launch of the KEA 433AM Electronic Tune AM/FM stereo cassette player.



## PIONEER. FIRST IN AM STEREO.

Pioneer has always led the way in car stereo sound.

From designing the most advanced tuner/deck combinations, graphic boosters and power amps to building the widest range of speakers in Australia.

KEA 433AM lets you listen to the widest range of AM and FM stations in brilliant stereo sound.

From the top rock and roll

stations to the classics. From talk-back radio to sports broadcasts, everything will sound twice as good because it's in stereo.

And like all Pioneer products the advanced features of the KEA 433AM are equally brilliant.

From AM/FM stereo, electronic station preset and seek, lock in fast forward and rewind, auto tape replay and metal tape facility to a built-in fader system for 4 speaker control.

You can own the Pioneer KEA 433AM stereo radio cassette for as little as \$349.\* It's a small price to pay, to make everything you listen to in your car twice as much fun as before.

 **PIONEER®**  
**The power to move you.**

# You'll save a fortune wh

# DSE

# KITS



## 70cm Amateur Transceiver

The one that started it all! Now almost 1000 DSE UHF Explorer transceivers have been built and, from the reports we've received, very few problems have been found: most constructors are delighted with the ease of assembly and the performance. It's definitely not a kit for the beginner (after all, you need an amateur licence to use it!) and we strongly advise both UHF and digital troubleshooting experience, as well as professional standard of construction (UHF is not kind to



sloppy constructors!) The result: you'll end up with a transceiver at least the equal of most commercial units, at a fraction of the cost (now that the dollar's gone through the floor!)  
Cat K-6300

**\$199**



## 2m Amateur Transceiver

The perfect mate for the UHF kit. The DSE Commander VHF transceiver has been developed in response to the huge number of requests from our customers; those who had the 'Explorer' under their belts and have been bitten by the old 'home brew' bug! (In fact, a number of customers said they didn't really need another 2m transceiver: they'd built it for the sheer fun of making something again!) The 'Commander' has specs which more than match most commercial transceivers selling for two and three times the price. It covers the full 144-148MHz band in 10kHz channels (with 5kHz offset), with full repeater

facilities built in, and it delivers around 10-15 watts with a receiver sensitivity of 0.5uV or better! The DSE Commander comes complete with a very comprehensive step-by-step construction manual (including a 'Sorry Dick it doesn't work' repair coupon) plus microphone and mobile mounting bracket. Nothing more to buy! Cat K-6308

**\$199**

## Repeater upgrade kit:

Add-on kit to give your Explorer full repeater operating capability, plus S-meter, an additional crystal filter and a new front panel to take S-meter and repeater switching. Cat K-6302

**\$24<sup>50</sup>**

## For the UHF or VHF transceiver 13.8V 2A Power Supply

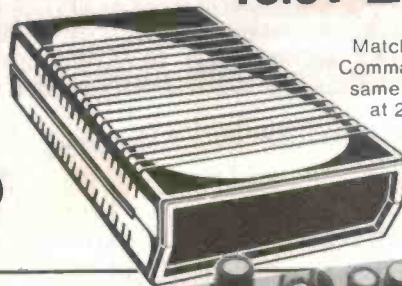

Matching supply for the Explorer UHF or Commander VHF transceivers. Built in the same style, supplies 13.8 volts regulated at 2 amps continuous. The perfect way to complete your home brew station. Cat K-6310

**\$49<sup>50</sup>**

## Led Level Meter

Here's the one the beginner can build — and add to a mono or stereo amplifier to give a level meter just like those found on \$\$\$ imported amplifiers! You can build one and use it to show either a mono amp, one channel of a stereo amp or sum the channel outputs and show that (instructions show how). Or you can build a pair and have a true stereo level meter.  
Cat K-3370

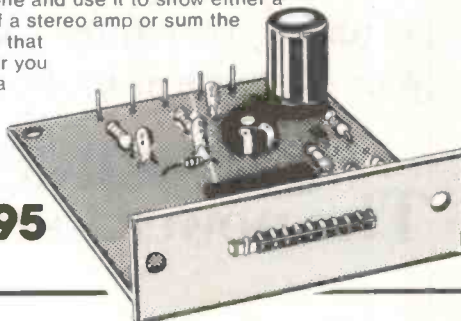

**\$16<sup>95</sup>**

## General Purpose Stereo Preamp

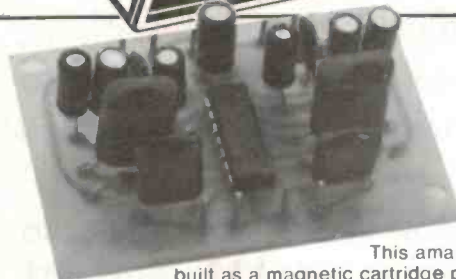

This amazingly versatile unit can be built as a magnetic cartridge preamp (for upgrading your stereo), a tape preamp or auxiliary preamp with 40, 55 or 80db gain. It is extremely simple: uses only one special IC and is very small, all parts fit on a PCB less than 65mm square. It does not need a special power supply as any reasonable power supply from 10 to 40V will do. Frequency response is well beyond 20kHz. Full instructions are supplied.  
Cat K-3427

**\$8<sup>90</sup>**

# en you build it yourself!

## Funway 1 Gift Box



All the components AND Fun Way 1 book in a great pack - everything needed to build any of the projects in Fun Way 1! PLUS our specially manufactured re-usable plastic 'breadboard' - a great way to build not only the Fun Way 1 kits, but also to 'mock-up' other circuits as you become more experienced.

AND EVEN MORE! Everything is housed in a multi-division plastic tray, which is fantastic for housing components both now and in the future.

The Fun Way 1 Gift Box makes an ideal birthday or Christmas present...and who knows: It could be the start of an absorbing lifetime hobby in electronics, or even an exciting career!

Cat K-2605

Over \$25 Value! **\$19<sup>95</sup>**

## Funway 2 Flasher

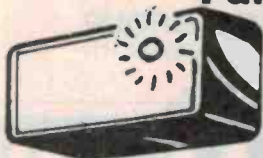

Make it as the latest in electronic jewellery or a burglar warning light, etc. The choice is yours and it's easy!

Cat K-2621

**\$2<sup>95</sup>**

Instructions are not

Included in the kit: see Funway 2 Cat B-2605 \$6.95

## FUNWAY

# 3

### Cricket

Here's a ton of fun! Hide the cricket: when the lights go out it starts chirping. Turn the lights on or make a noise and it stops. Makes it so hard to find! It really is infuriating!  
Cat K-2663

**\$9<sup>95</sup>**

### Mini Colour Organ

Your very own disco colour organ — but ours is battery operated — so it's much safer than mains devices! Connect it to your radio, cassette or stereo for a real lightshow!  
Cat K-2664

**\$6<sup>95</sup>**

### Binary Bingo

A great school project: it's a fun game — but even more it demonstrates binary numbers very well. And they're the basis of all computers! It seems pretty simple to play...but try it!  
Cat K-2668

**\$14<sup>95</sup>**

### Light and Sound

What versatility! It's really 6 projects in one: you just build the form you want — a LED flasher, a mini strobe flasher, police siren, motor boat sound effects, continuity tester and Morse Code practice oscillator.  
Cat. K-2665

**\$6<sup>95</sup>**

### Mini Stereo Amp.

Want an amplifier for your 'walkie' stereo or radio? Don't be tied to 'phones: use this project and listen in comfort! Or you can build this into a mini PA amplifier.  
Cat K-2667

**\$14<sup>95</sup>**

### Combination Time Lock Switch

You can make a game — or make a real electronic 'lock' with this one. Use it to control an alarm, a door control, etc. You set the combination you want — or change it when you wish.  
Cat K-2666

**\$8<sup>95</sup>**

### Mini Synth

It's a real beauty, this one: a real 'live' musical synthesiser — and it's live because it uses YOU as the note generator! You get an amazing range of control over the sound.  
Cat K-2669

**\$12<sup>95</sup>**

### Two Up

Australia's 'national game' has finally been converted to electronics. And you don't have to find any King George pennies! Simulates the throw, the spin and the final result. Come in spinner!  
Cat K-2661

**\$6<sup>95</sup>**

### Minder

C'mon, Guvnor - leave the auto alone! That's the Fun Way 3 Minder telling villains that it is looking after the car! It's actually doing much more — makes a great 'lights on' warning and 'door open' warning as well as a pseudo burglar alarm.  
Cat K-2660

**\$4<sup>95</sup>**

### Lil Pokey

You'll have a ball with this one — and you don't risk losing a single cent! A digital project which not only shows how the one armed bandit works — it teaches you how logic circuits work, too.  
Cat K-2662

**\$14<sup>95</sup>**

### And when you've finished Fun Way 3???

You're ready to build just about any of the kits from the Dick Smith range

You could even be ready for a career in electronics! And it all starts with Dick Smith's Fun Way Into Electronics.

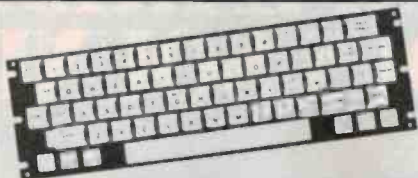

## Keyboard Kits

Standard 'QWERTY' typewriter layout keyboard with individually switched keys (no matrix necessary!) High tactile response, suitable for huge range of computers & allied projects. • 60 keys.  
Cat K-3601

**\$53<sup>90</sup>**

## Fluoro Starter

**\$4<sup>95</sup>**



Do your fluorescent lights go blink, blink, blinky blink when you switch them on? This substitute electronic starter solves that problem and gives a smooth rapid start EVERY time you switch on. And all the parts are housed in a standard starter case! Far outlasts conventional starters as well as prolonging tube life.  
Cat K-3082 As described in EA



## SPEEDY FAULT FINDING... Transistor Tester

Not just another Transistor Tester! This one tests bipolar transistors, diodes, F.E.T.'s and even S.C.R.'s and P.U.T.'s This practical low-cost test instrument is simple enough to be built by a beginner and then provide him with a valuable piece of test equipment.  
Requires 9V battery  
Cat S-3006 85c extra  
Cat K-3052

**\$19<sup>75</sup>**

## LED Tacho

Don't spend a fortune buying a tachometer — build your own and save! Displays engine speed in analogue form in an illuminated row of LED's. Instructions included — a great kit! Cat K-3240



**\$24<sup>50</sup>**

## Brake Lamp Flasher

You've seen those snazzy lamps that mount on the parcel shelf and flash when you brake? A great idea for road safety, too: you cannot avoid the flashing! Now you can build your own with this simple kit - and save \$\$\$ on the commercial units. Flashes the lamp three times before holding on. Uses our A-8525

Rear Window Brake Lamps (at extra cost)  
Cat K-3245

**\$14<sup>95</sup>**

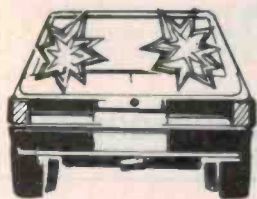

# DICK SMITH ELECTRONICS

PTY LTD

See page 98 for store addresses



Rockwell

# QUALITY SEMICONDUCTOR PRODUCTS 68000 — 6500

R68000C6	CPU Ceramic DIL .....	exempt \$50.72
R68000Q6	CPU Plastic Compact QUIP .....	\$33.42
	(8, 10 MHz avail. soon)	
R6502P	CPU, 40 pin .....	\$7.52
R6503P	R6504P R6507P CPU, 28 pin .....	\$6.56
R6511Q	Single chip microcomputer, 64 pin CPU, RAM ACIA I/O, Timers, 64k address	\$18.98
R6520P	PIA 40 pin .....	\$4.65
R6522P	VIA 40 pin, 20 I/O, 2 x Timer/Ctr S. Reg ...	\$6.68
R6532P	COMBO 40 pin, 128 byte RAM, 20 I/O, timer .....	\$8.35
R6541Q	Slave Processor, 64 x 8 RAM, 23 I/O, host slave I/F, timers, 4K external address	\$13.61
R6545-1P	Video controller .....	\$11.34
R6551P	ACIA integral Baud rate gener .....	\$8.00
R6592P	Single chip printer controller for Epson Low Cost Printer .....	\$13.73
<b>CMOS</b>		
R65C02 P1	CPU, 40 pin plastic, enhanced instruction set .....	\$9.07
R65C21 P1	PIA 40 pin .....	\$7.16
R65C24 P1	PIAT, I/O x Timer 40 pin 6821/6521 compatible .....	\$8.59
R65C51 P1	ACIA 28 pin .....	\$9.07

Plus \$5.00 P & P. All prices Tax exempt.  
 Note: Rockwell CMOS has superior latch up resistance compared to compatible designs from other makers using first generation masks.

Parts also available 2MHz.  
 Contact the office for prices and availability.



73 Eric Street, Goodna, Qld. Aust.  
 P.O. Box 6502, Goodna, Qld. 4300  
 Telephone (07) 288-2455.  
 Telex AA 43778 ENECON

# FAR AHEAD

The NAD 7140 receiver is today's most satisfying example of a high performance unit that is as superbly functional as it is honest.

Quite simply, it puts fidelity before frills.

If you want a barrage of flashing lights and tricky gizmos, this is not for you.

But if you want a powerful receiver incorporating the exceptionally sensitive FM tuner section designed by the famed Larry Schotz, examine the NAD 7140. And hear why NAD have won 10 Audio Grand Prix Awards.

Stereo Review U.S.A. called the 7140 "outstanding" with "amplifier and tuner sections incorporating valuable circuit features that place the unit far ahead of similarly placed competition."

Check out the NAD 7140 before you decide. It might look plain. But it's plainly the best for the money.



FALK ELECTROSOUND GROUP  
 BOX 234 ROCKDALE 2216. PHONE (02) 597 1111

# PETITE SPEAKER ENORMOUS SOUND



Andy Petite designed two of the all-time best-selling speakers in North America. Then, when he founded Boston Acoustics, his first design was voted "Speaker of the Year" in a nationwide poll of retailers.

New Petite has incorporated his genius for sound engineering in the Boston Acoustics A40... a small two-way acoustic suspension speaker with an astonishing BIG clean sound.

It is a triumph of what is called "stereo imaging" — that thrillingly real presence that almost has you ducking the violinist's bow.

But you get the presence.

**Boston Acoustics** FALK ELECTROSOUND GROUP  
 BOX 234 ROCKDALE 2216. PHONE (02) 597 1111



# GOOD LISTENING

## Technics SU-V6X Integrated Amplifier

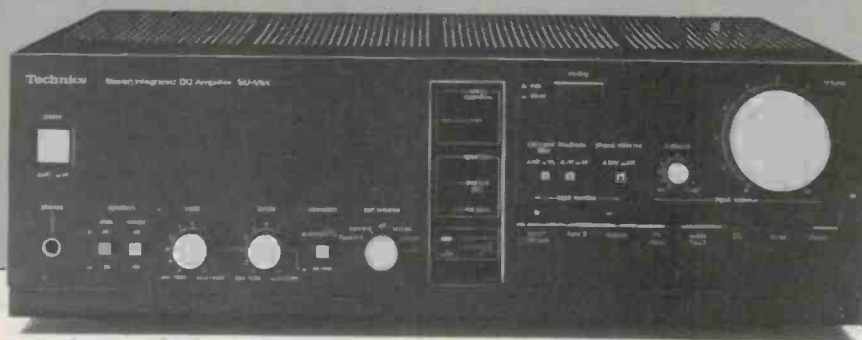

Louis Challis

Technics' designers have kept 'value for money' in mind with their "Computer Drive New Class 'A'" stereo amplifier. Attractive and well made, this new model provides low distortion performance that is almost unequalled at the price.

WHEN THE FIRST transistorized amplifiers were released in the 1950s, most of the final power output stages incorporated used class 'B' stages. That trend continued well into the 1970s because by using class 'B' output stages the designers ensured maximum power output with optimum efficiency for the chosen power transistors in the output stages.

Whilst the designers may have been happy with what they achieved, many of those who purchased the equipment they designed were not. The purchasers' most vocal complaints related to the distortion characteristics of those amplifiers and specifically the third order and cross-over distortion which was both audible and in most cases very disturbing. Subsequent improvements in the design of feedback and associated linearizing circuitry did much to improve those problems.

Such problems plagued the early amplifiers and quite a few of the later ones so that many purchasers still wanted to buy valve amplifiers which they claimed were "audibly superior".

In the late 1970s and early 80s, quite a few amplifier designers in Japan and America decided to incorporate class 'A' output stages either by themselves or with optional class 'B' stages so that the low level amplification requirements of classical music could be provided with minimal distortion. This provided a neat way of reducing the most significant second order distortion

components and particularly the cross-over distortion.

The most outstanding amplifiers with class 'A' output stages provided the option of variable bias so that the output could be converted to a class 'B' stage which then provided typically twice or three times the power output capabilities of the class 'A' biased output stage. Whilst that may have appeared to be a neat solution, in practical terms it created new problems for the user who had to decide whether he wanted extremely low distortion and moderately low output powers (as provided by the class 'A' output mode) or whether he preferred the benefits of the higher output power and the conflicting result of moderately low distortion (which was a natural result of the class 'B' output mode).

It didn't take the 'smarter' engineers at Technics very long to realize that it is just as easy to provide a little more electronics in the amplifier to automatically detect the bias requirements so that the amplifier selects the variable bias requirements appropriate for the signal, and 'low and behold' the concept of what they have called "computer drive new class 'A'" was born.

### Features

The Technics SU-V6X Stereo Integrated Amplifier is a particularly attractive and exceptionally well made example of the latest amplifiers produced by Technics. The amplifier features a brushed satin aluminium

### Technics SU-V6X Stereo Integrated Amplifier

Dimensions: 430 mm wide x 142 mm high x 380 mm deep.  
Weight: 11 kg  
Manufacturer: Matsushita Electric Trading Co. Ltd., Japan  
RRP: \$679

Measured performance figures for the Technics SU-V6X amplifier transient overload recovery test (IHF-A-202). 10 dB overload rated power into 8 ohms both channels driven. Overload duration: 20 ms; repetition rate: 512 ms.

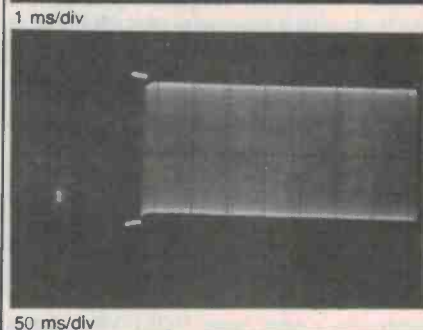
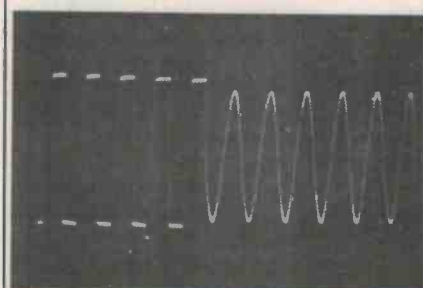

# SOUND REVIEW

fascia with the controls divided into two separate groups neatly divided by a recessed illuminated escutcheon.

On the left hand side of the panel is a large rectangular power ON/OFF switch, below which is a tip ring and sleeve headphone jack for normal stereo headphones. Adjacent to this are two separate switches for selecting the MAIN and REMOTE speakers. Adjacent to these are two small BASS and TREBLE controls with a mechanical indent for the central off position. These controls respectively provide  $\pm 10$  dB of boost and cut at 100 Hz, and 9 dB of boost and cut at 10 kHz. They are supplemented by a switch which provides a STRAIGHT DC circuit or the pre-amplifier chain VIA TONE controls. The last switch on the left hand side of the panel is the RECORD SELECTOR which provides outputs from SOURCE, PHONO, TUNER, TAPE 1-2, TAPE 2-1 and OFF. Surprisingly, there is no mention of CD connection in this line-up, which is strange considering the inclusion of a separate switch for CD selection on the right hand side of the panel.

The central control escutcheon provides clear indications of safety operation in terms of the presence of dc on the output, a short circuit of the output circuitry or other anomalous behaviour, which is clearly indicated by a rapid flashing of the light. When the circuitry is operating correctly, the light remains on and without flashing. In the middle of the escutcheon, two separate Light Emitting Diodes (LED) indicate whether the tone controls are activated or whether the circuit is "straight dc", which is a rather inappropriate form of description for the by-passing of the toning control circuits. At the bottom of the panel is the computer drive automatic indicator which is activated when the circuitry is operating in the correct manner.

On the top right hand side of the panel is a large and sensible MUTING switch which provides 20 decibels of attenuation. In the centre of the panel are three small switches which activate the SUBSONIC FILTER which provides 5 dB of attenuation at 20 Hz and 9 dB of attenuation at 10 Hz, a LOUDNESS ON/OFF switch. This provides a contouring of the low frequency end of the spectrum with a maximum of 8 dB boost at 50 Hz and a flat response from 10 Hz to 50 Hz (see curves). Last, but not least, there is a small switch for selecting moving magnet or moving coil cartridge, whichever you happen to select in your record player.

The phono pre-amplifier input stage acknowledges the impact of CD players by providing only one pair of phono input terminals in lieu of the previous two which would have been the norm only a year or two ago. A small BALANCE control is flanked by a very large VOLUME control

Characteristics as measured.

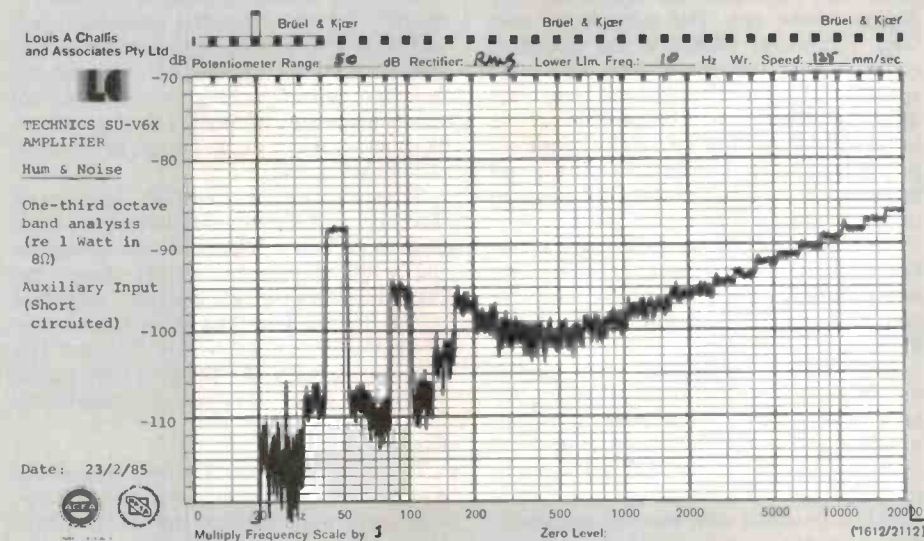
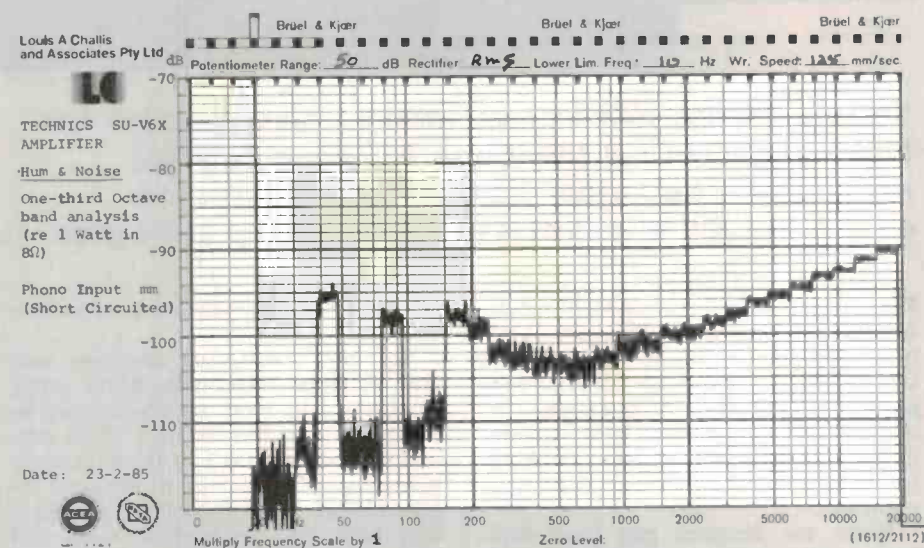
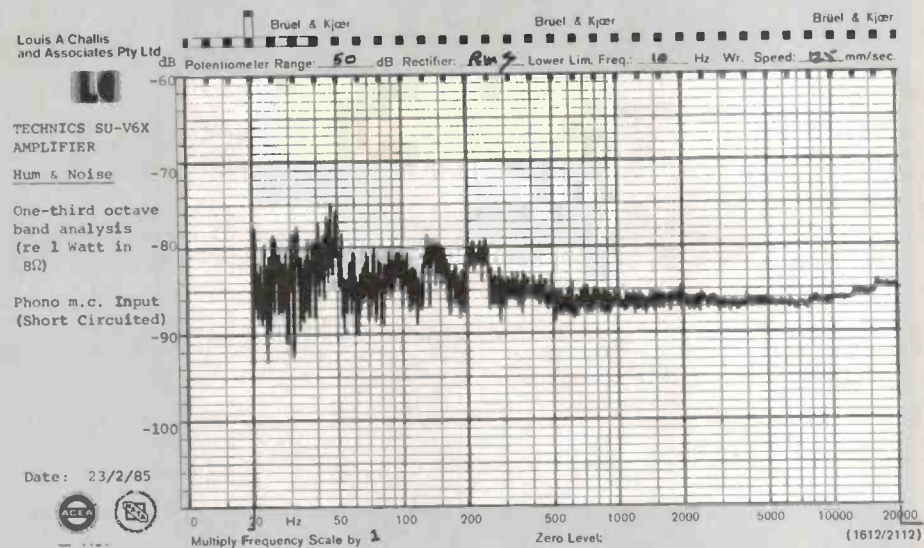

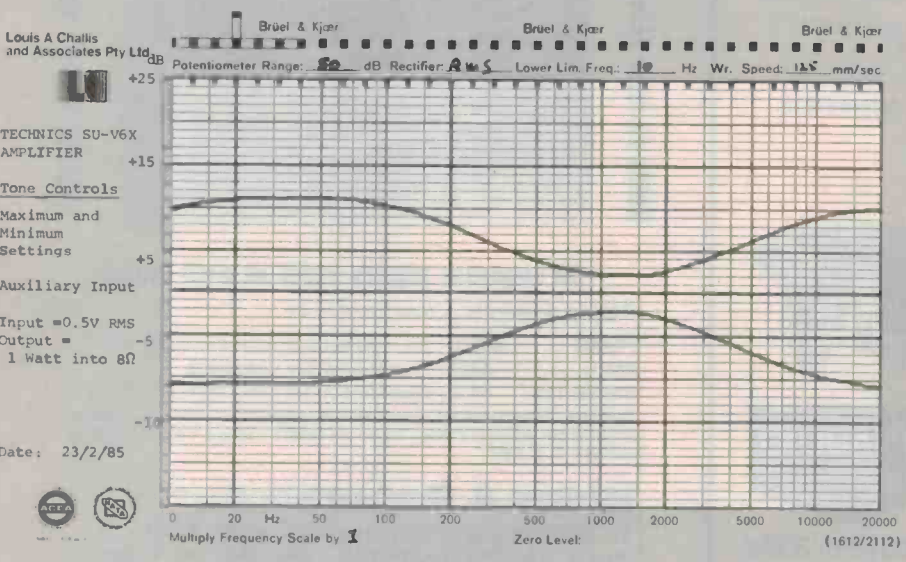
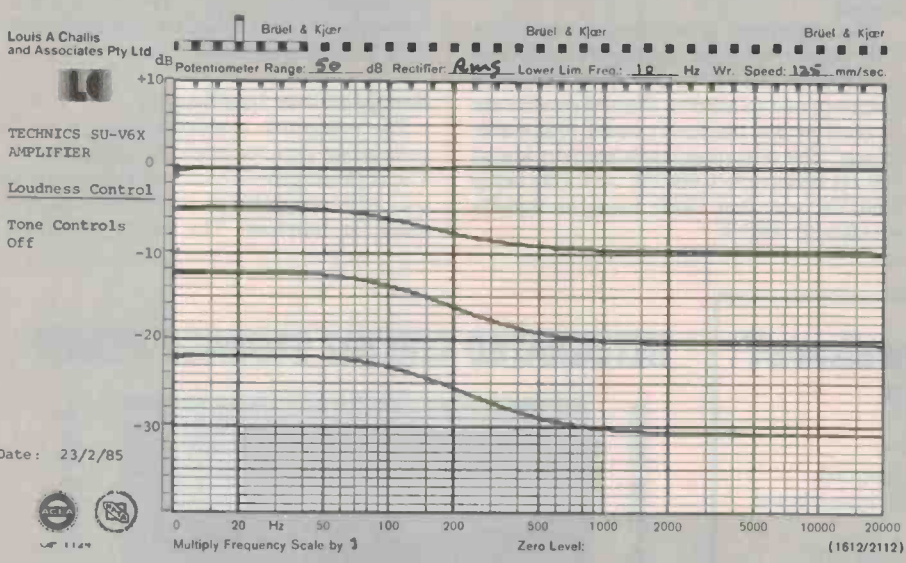
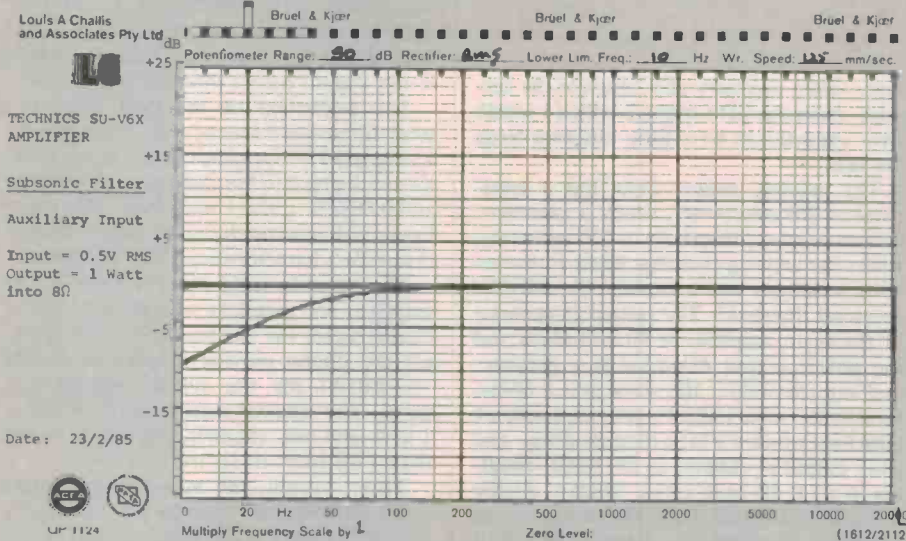

which contains no indents, as a pair of conventional potentiometers are located on the panel behind.

At the lower edge of the right hand side of the front panel are three tape monitor switches labelled TAPE 1/DA TAPE which designates that this is the tape monitor selector for the first tape recorder or Digital Audio processor, about which we will comment further in subsequent reviews. The second switch is labelled TAPE 2, whilst the third switch is labelled SOURCE. Each of the first two switches has its own indicating LED, whilst the SOURCE switch has a pair of arrowhead shaped LEDs to clearly designate what you are listening to.

The input selectors are provided by five separate switches designed TV/AUX 1, VIDEO/AUX 2, CD, TUNER and PHONO. These particular combinations and designations are a little out of the ordinary compared with what we have been used to seeing. They herald the change in philosophy and emphasis which will polarize the high fidelity industry, and the consumers, in the next two years.

The rear panel features a neat and somewhat different set of terminal connections from the conventional amplifier or pre-amplifier with which you may have grown accustomed. The same designations of those nominated for the tape monitor and input selector switches located on the front panel appear on the colour-coded pairs of RCA coaxial sockets, supplemented by a pair of linked input/output sockets for connecting an external graphic equalizer. These sockets simultaneously provide connections to the pre-amplifier output and main amplifier input.

Four sets of colour-coded rotating terminals are provided for the speakers into which bared speaker leads are intended to be inserted. These are clearly labelled with instructions that if one set of speakers are connected, they may be 4-16 ohms impedance, but if two sets are connected they must be 8-16 ohms. These instructions are supplemented by a speaker impedance switch which has to be used if the main or remote speakers are 8-16 ohm or 4-6 ohms.

The chassis on which the amplifier is constructed is extremely strong and well constructed from appropriately perforated 1.2 mm thick galvanized steel. The rear of the amplifier incorporates a very large heat-sink by means of a vapour phase heat exchanger tube connected to the four output transistors, which feature an unusual but very effective thermal dissipation stage. In the centre of the chassis is the main power output stage printed circuit together with the power supply which is mounted on one medium sized mother board. A small separate board is mounted on the mother board for the 'computer drive bias control' circuitry, which is both electrically and adhesively attached to ensure stable and positive retention.

Behind the front panel are a series of six, small individual printed circuit boards on which the circuitry for tone control, pre-amplifier, indicator and switching output

## SOUND REVIEW

stages are neatly mounted. On the right hand side of the amplifier is a large and very well screened power transformer.

The designers have considered a number of user requirements, which have been overlooked by most other manufacturers. One of these relates to the provision of supplementary locations for the mounting feet at the rear of the amplifier and the provision of effective rubber isolation elements between the perforated steel cover and the sides of the chassis to reduce the likelihood of electro-magnetic induction.

### Objective testing

The objective testing of the integrated pre-amplifier and amplifier provided a series of test results which are remarkably good considering the modest \$679 recommended retail price quoted for the unit. The frequency response was essentially the same with either the tone controls disconnected or with the tone controls centred. The frequency response extends from below 1 Hz to beyond 100 kHz and is ruler flat within the operating range of the amplifier. The sensitivities for the various inputs are all excellent with 13.6 millivolts being required for 1 watt output from such diverse inputs as

tape, tuner, auxiliary and, much to my surprise, from the CD terminals which I would have expected to be a little different from the rest.

The moving magnet input has a sensitivity of 205 microvolts, which is excellent, and an overload threshold of 220 millivolts, whilst the moving cartridge has a 16 microvolts sensitivity and a healthy 19 millivolts overload threshold. The output impedance of the main amplifier is 90 milliohms and the power output delivered is a genuine, and very desirable, 100 watts into 8 ohms. Exactly the same output is provided with a 4 ohm load which is a little disappointing. The peak output at clipping is 150 watts, resulting in a 1.8 dB head room, which is a trifle lower than I would really like to see for an amplifier specified as having 100 watt output.

The distortion characteristics at the 1 watt output level are extremely good and confirm that the basic class 'A' performance is maintained to achieve distortions that are as good as any consumer could reasonably expect. The distortion levels are very low at 100 Hz being only 0.0043%, at 1 kHz being 0.0013% and at 6.3 kHz being an equally excellent 0.0025%.

At the 100 watt output level (with both channels driven) the distortion figures are only slightly higher, so that at 100 Hz the total distortion is 0.005%, at 1 kHz only 0.0007% (which is lower than the 1 watt figure), whilst at 6.3 kHz it is 0.0033% which is only slightly higher than the 1 watt figure.

The evaluation of the high frequency total difference frequency distortion reveals a very good performance with a level of distortion being 0.013% distortion at 76 watts and 0.0032% at the 1 watt level. This lower figure is dominated by noise rather than by distortion characteristics of the amplifier.

The signal to noise characteristics of the amplifier are excellent with noise levels of 82 dB(A) for the auxiliary input, 86 dB(A) for the phono moving magnet input and 74.3 dB(A) for the phono moving coil input. The channel separation is 56 dB at 1 kHz and the channel balance is better than 1 dB from 10 Hz to 10 kHz.

Taken overall, the manufacturer's data sheet performance figures are essentially met or bettered in all significant areas and this amplifier has most of the objective performance attributes that the intending purchaser could reasonably desire.

### Subjective testing

The subjective evaluation proved to be even better than the objective performance. The controls proved to be extremely easy to use, with no problems in interpretation of usage or function. The ability to record

## Building your own speakers? Or updating your old?

Now available in Australia, are the famous DYNAUDIO loudspeaker drivers from Denmark. World leading loudspeaker brands use the magnificent drivers from DYNAUDIO.

All drivers are protected by US patent 4 048 713. They feature hexagonal wires for voicecoils, magnetic oil in voicecoils for high power handling, woofers with symmetrical drive, voicecoil sizes up to 4".

Crossovers use only the best components available. We stock woofers, dome midranges and tweeters as well as matching crossover networks.



Sole Australian Distributor:  
**SCAN AUDIO PTY. LTD.**  
P.O. Box 242, Hawthorn. 3122. (03) 819 5352

## INTEGRATED CIRCUIT STORAGE FRAME

Holds all sizes of ICs in their tubes



Each pigeon hole clearly labelled

60 separate pigeon holes in each frame

Call or write for a free brochure

FRAME . . . . \$28.00 Supplied flat with assembly instructions

P&P . . . . . \$4.00 Posted anywhere in Australia

SALES TAX . \$4.00 Applicable unless Sales Tax number quoted

To order: Please forward your order with payment, by cheque or money order to our address below. Sales tax must be paid unless a sales tax number is quoted.

**Hales & Rogers** (Incorporated in NSW)  
PTY LIMITED

17 Mobbs Lane Carlingford NSW 2118

Telex AA3870 (ALTYPE) Ph: (02) 85 7540

MEASURED PERFORMANCE OF : Technics SU-V6X  
 SERIAL NO : FA4L J4A010

**HARMONIC DISTORTION :**

**FREQUENCY RESPONSE (-3dB re 1 watt) :**

		Tone Controls Defeated	
Input to Aux = 0.5V	Left	1.0 Hz	to 100 kHz
	Right	1.0 Hz	to 100 kHz
		Tone Controls Centred	
Turnover Frequencies FIXED	Left	1.0 Hz	to 100 kHz
	Right	1.0 Hz	to 100 kHz

**POWER OF 1.0 WATTS INTO 8 OHMS**

	100Hz	1kHz	6.3kHz
2nd	-106.7	-100.5	96.0
3rd	-87.0	-101.4	96.0
4th	-	-	-
5th	-	-	-
T.H.D. %	0.0043	0.0013	0.0025
= dB	-86.9	-97.7	-93.0

**POWER OF 100 WATTS INTO 8 OHMS = 28.3 V**

	100Hz	1kHz	6.3kHz
2nd	-105.5	-104.2	-90.3
3rd	-85.3	-110.6	-97.2
4th	-114.6	-	-
5th	-111.7	-	-
T.H.D. %	0.005	0.0007	0.0033
= dB	-85.2	-103.1	-89.4

**SENSITIVITY (for 1 watt in 8 Ohms) :**

	Left	Right
CD Aux.	13.6 mV	13.0 mV
Tuner	13.6 mV	13.0 mV
Tape	13.6 mV	13.0 mV
Phono m/m	205 mV	205 mV
Phono m/c	16 mV	16 mV
Phono m/m	226 mV	220 mV
Phono m/c	19.0 mV	19.0 mV

**IEC HIGH FREQUENCY TOTAL DIFFERENCE FREQUENCY DISTORTION**

8 kHz and 11.95 kHz mixed 1:1	
At 76 w	0.013%
At 1 watt	0.0032% (in noise)

**INPUT IMPEDANCE (@ 1kHz) :**

	Left	Right
CD Aux.	18 k ohms	18 k ohms
Tuner	18 k ohms	18 k ohms
Tape	18 k ohms	18 k ohms
Phono m/m	47 k ohms	47 k ohms
Phono m/c	230 ohms	230 ohms

**OUTPUT IMPEDANCE (@ 1kHz) :**

90 milliohms

**NOISE & HUM LEVELS (re 1 watt in 8 ohms) :**

Input 0.5 V	Auxiliary	79.0 dB(Lin)	82.0 dB(A)
Input 5 mV	Phono m/m	82.5 dB(Lin)	86.0 dB(A)
Input 0.5 mV	Phono m/c	69.0 dB(Lin)	74.3 dB(A)

**MAXIMUM OUTPUT POWER AT CLIPPING POINT (IHF-A-202) :**

(20 mS burst repeated at 500 mS intervals)	98 V p-p
	= 150 watts
Dynamic Headroom (re 100 watts)	= 1.8 dB

from tape to tape whilst listening to a record player or CD is very desirable and an essential requirement of an amplifier of this type. The 'lack of' power output indication will not be missed by many users and all other desirable and possible features are incorporated.

I evaluated the unit with a number of different CD players, including the new Marantz CD44, the Sony CD P101 and the Sony D50. The discs I used for this evaluation included Rudolph Serkin playing Beethoven's Five Piano Concertos (Telarc CD80061), Maazel conducting Tchaikovsky's Symphony No. 4 (Telarc CD 80047), Respighi's "Pines of Rome" with the Montreal Symphony Orchestra (Decca 410 145-2), and Status Quo's "Never Too Late" (Vertigo 800 053-2), which provides exciting audible content and made my subjective assessment a pleasure.

I then connected the amplifier to a Nakamichi Dragon cassette recorder on which I played a series of pre-recorded cassettes recorded by CBS, Phonogram and Sony. These cassettes received all the punch and quality that one could reasonably ask for and provided sound pressure levels bordering on deafening.

Depending on the speakers you propose using, and quite apart from the environment in which the amplifier would be used, you can reasonably expect this amplifier to fully satisfy 98% of all consumer applications. This is one amplifier that is designed for superior fidelity, way above average power output and which provides both the power output and overall performance with a fidelity which is almost unequalled at the price.

IEC High Frequency Total Difference Frequency Distortion for Technics SU-V6X.

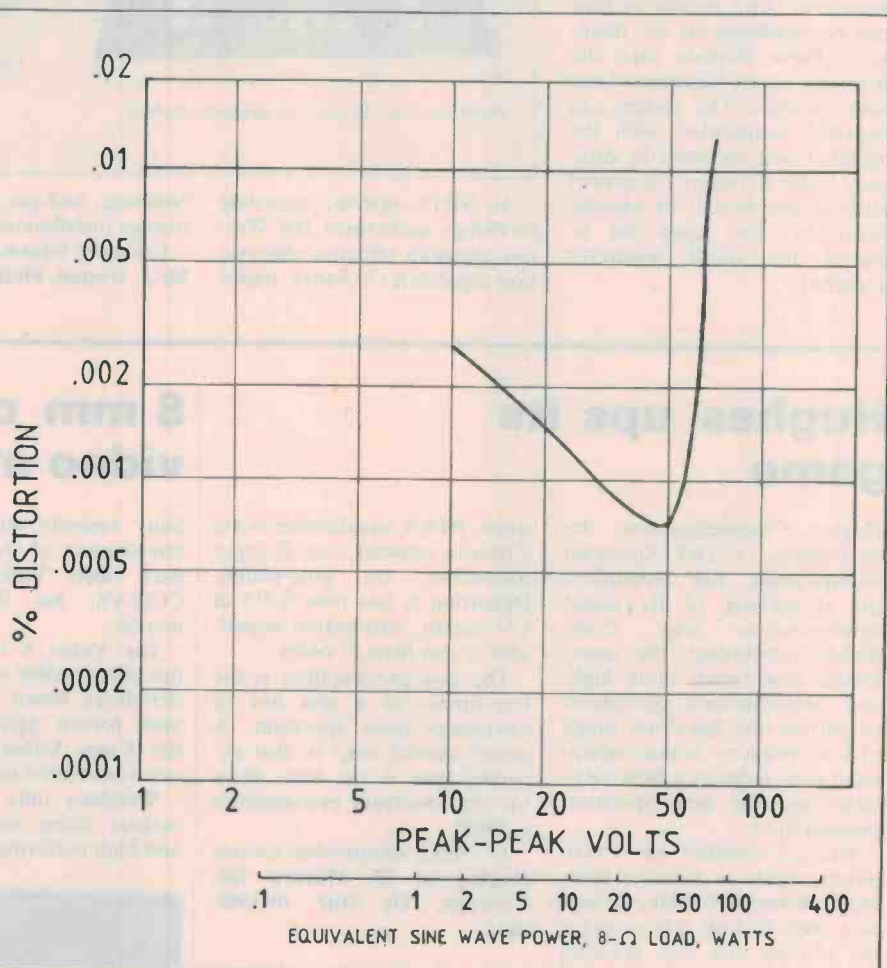

# Slow TV

Philips released its slow rate video transmission (SRTV) at the second Australian Telecommunications User Group Conference at the Sydney Hilton recently.

The SRTV provides an efficient means of detecting threats and maintaining effective observation and surveillance facilities in areas where it may normally be uneconomical to install video cabling for a normal closed circuit television system. With SRTV, pictures can be relayed using the public telephone system.

In the SRTV system, the interlaced signals from the cameras are relayed to a SRTV transmitter. The bandwidth of the signals is compressed so that they can be relayed over the telephone lines. At the control centre, a SRTV receiver converts the signals back into video format so they can be displayed on the monitors. These displays take the form of a steady sequence of real time pictures. The system can operate, unattended, with the signals being recorded by ordinary audio recording equipment such as reel-to-reel or cassette recorders. The tapes can be stored for recall whenever required.



An SRTV system, according to Philips spokesman Jeff Weston, provides effective observation capabilities in banks, public

buildings, and gas, oil or water storage installations.

For more information contact Mr J. Weston, Philips Communi-

cation Systems, 2 Greenhills Avenue, Moorebank, NSW 2170. (02)602-2000.

## Hughes ups its game

Hughes Communications, the distributors of TRP Spectrum loudspeakers, has announced the re-opening of its sound demonstration area. Completely refurbished, the sound lounge now boasts more high-end demonstration equipment to partner the Spectrum range of loudspeakers. Source equipment now includes a Sota turntable and the new Spectrum pre-amplifier.

The pre-amplifier has a twin power supply to preserve minimum channel crosstalk, as well as a high 78.5 db S/N ratio for the moving coil disc pre-amp

stage. RIAA equalization is via a passive network and all input connectors are gold-plated. Distortion is less than 0.012 at 1 V output, and output impedance is less than 27 ohms.

The new pre-amplifier is the fore-runner of a new line of electronics from Spectrum. A power mosfet amp is also expected later in the year. Price for the Spectrum pre-amplifier is \$998.

For more information contact Hughes at 58 Moonya Rd, Carnegie, Vic 3163. (03)568-0612.

## 8 mm compact video at last

Sony recently announced the introduction of its 8 mm compact video 'Video 8', model CCD-V8, for the Japanese market.

The Video 8 CCD-V8 is a one-piece video camera recorder/player based on the common format agreed upon by the 8 mm Video Standardization Committee in April 1984.

Weighing only 1.97 kg, the makers claim easy operation and high performance.

Its built-in CCD camera and record/play function enable one-push recording and immediate playback on the electronic viewfinder or any TV.

Video 8 promises to encourage the growing outdoors portable video market, but for conventional domestic and commercial use Sony said it will continue the refinement and development of the 1/2" Beta format range of products.

Tell them you read it in ETI

## Stereo rush

The high consumer demand for receivers following the recent public launch of AM stereo has led Pioneer to air-freight more than 2000 KEA433AM AM/FM stereo cassette players into Australia.

Pioneer's group product manager, Laurie Ruddock, said that the decision to speed up the supply stream of stereo AM units to Australia was a reflection of Pioneer's commitment to the new medium.

For further information please contact Laurie Ruddock at Pioneer Electronics, 178-184 Boundary Road, Braeside, Vic 3195. (03)580-9911.



## New Teac products

Teac has announced release of its V530X and V430X cassette decks. They are similar except that the 530 has a processor controlled program search mode. Frequency response is said to be 30-20 kHz: wow and flutter 0.045%.

Recommended selling prices are \$399 and \$329 respectively.

For further information contact Teac, 115 Whiteman St, South Melbourne, Vic 3205. (03) 699-6000.



## Craig car stereo

Craig's range of road-rated car stereos first appeared in Australia almost three years ago. Craig has just recently

launched a complete range of five new decks complemented by eight new speakers, with black cosmetic lines and high-

tech features.

The AM/FM radio cassette range starts at \$129 for the T504 and \$189 for the T506.

Both offer auto reverse, loudness, metal tape, and many other features.

The range also includes three new digital tuned radio cassettes ranging in price from \$289 to \$389.

The new speaker range incorporates such features as carbon filled polypropylene cones, directional tweeters, strontium magnets using a bayonet fit system. Prices start at \$49 through to \$169 for the power hungry V852 6" x 9", 3-way speaker system.

For more information contact Pace Enterprises, 4 Clarendon St, Artarmon, NSW 2064.



# THE MAIN MOVEMENT, by the Marantz CD44

The Marantz CD44 compact disc player was released on the Australian market late in 1984. That release announced loudly not only the demise of the microgroove but the consolidated position of the CD today.

**Louis Challis**

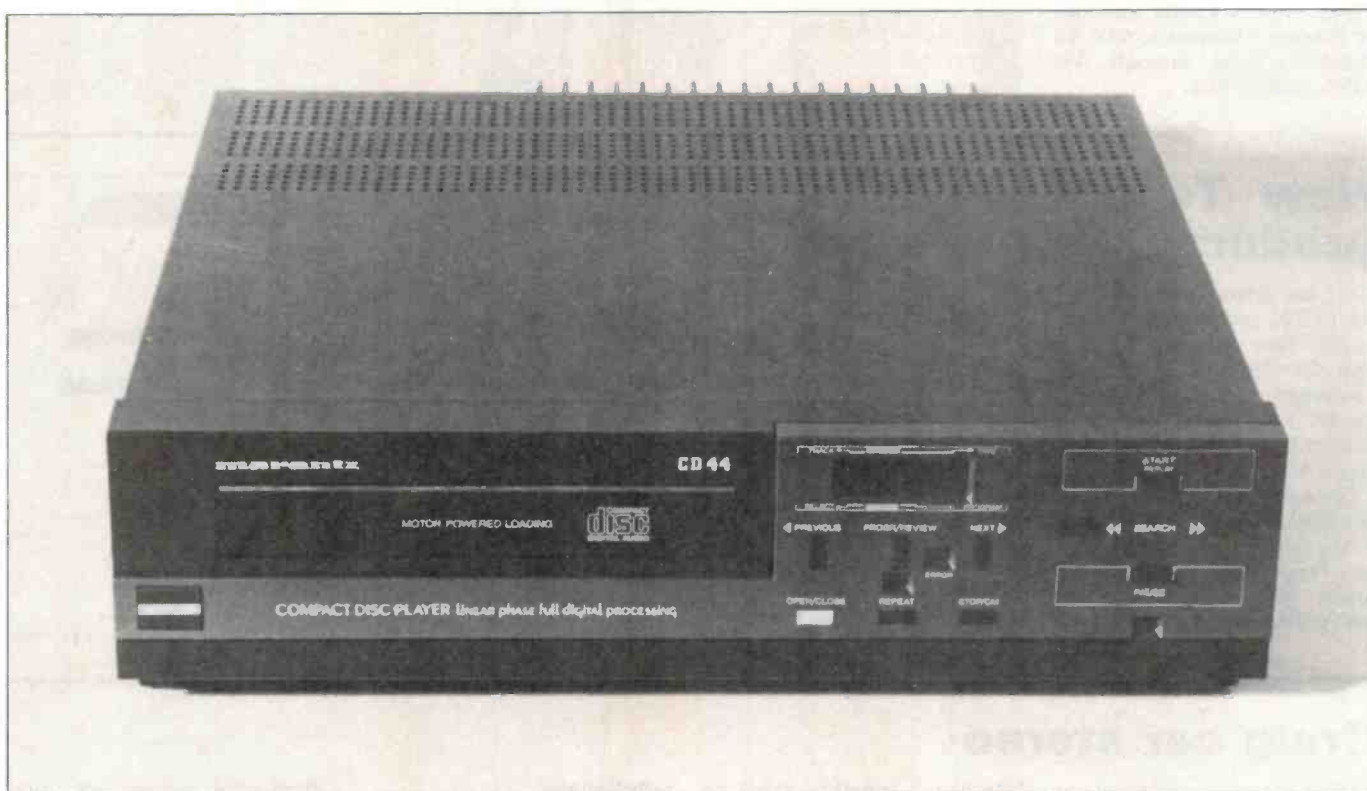

**MARANTZ CD44 COMPACT DISC PLAYER**

Dimensions: 320 mm (wide) x 199 (high) x 310 mm (deep)  
 Weight: 6.3 kg  
 Manufacturer: Marantz Belgium  
 RRP: \$499

JUST BEFORE CHRISTMAS, 1500 Australians who practice the art of impulse buying were lucky enough to snap up the first new Marantz CD44 compact disc players. These units, it should be noted, were also purchased at a 'bargain basement Christmas Special price'. More than

two months later, apparently only two of those 1500 machines have been returned for servicing under warranty. The rest are still in their new owners' homes providing unparalleled listening pleasure.

At the recommended selling price of \$499, Marantz expects to sell more than 10,000 of these players in Australia during the next year. This indicates that the total market for CD players in Australia in 1985 may well exceed 100,000 units which will require approximately 1 million CD discs, if the 'American rule of thumb' holds true. That 'rule of thumb' currently states that the purchaser of a new CD player buys 10 CD discs in the year following purchase.

The forecast number of CD discs being imported into Australia in 1985 is unlikely to equal the forecast market demands and consequently we look like experiencing some bottlenecks during the first part of 1985 when demand is likely to surpass the supply.

With those salutary thoughts in mind, it is time that we closely examined the new Marantz CD44.

**Outside**

The CD44 is probably the 'sharpest' and most remarkable CD player introduced by the Marantz company. The physical appearance of the unit is a 'little more technical' and regrettably not as visually at-



**Marantz CD44. Audio characteristics as measured.**

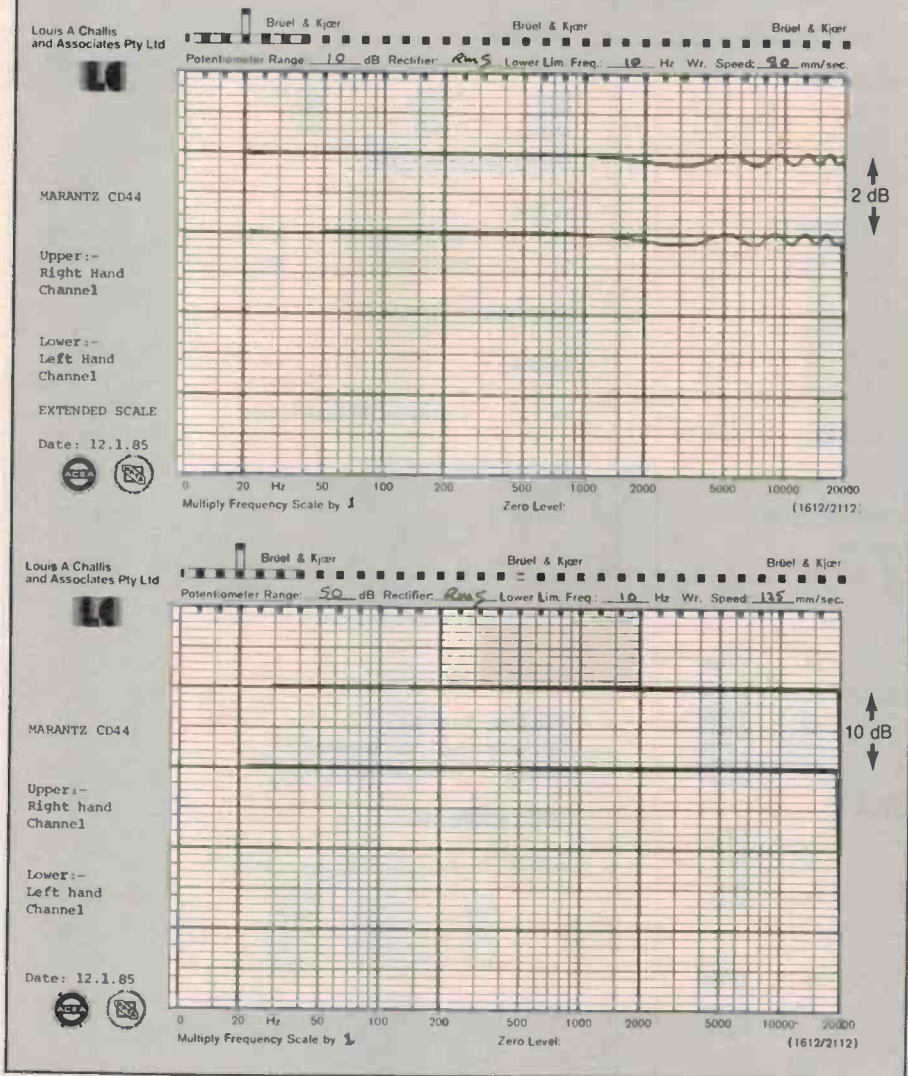

Measured square wave response of the Marantz CD44 at 100 Hz and 1 kHz using bands 37 and 38 on Sony Test Record Type 3.

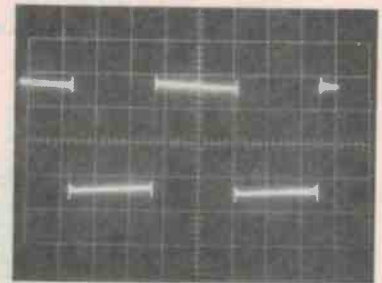

100 Hz

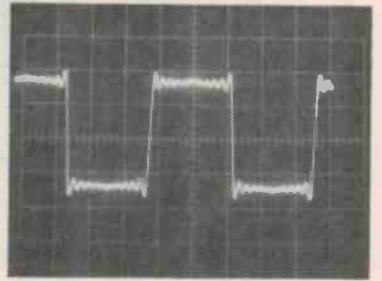

1 kHz

Measured impulse response of Marantz CD44.

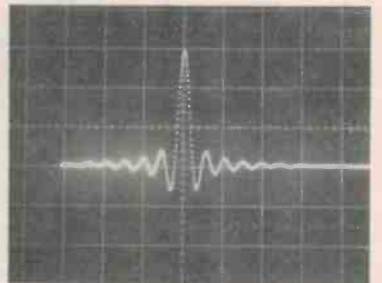

tractive as any of its predecessors, as a result of the use of 10 very small push buttons and a large ON/OFF switch on the front panel.

The left hand side of the unit incorporates the motorized front loading disc tray which is activated by a small bright yellow OPEN/CLOSE button on the front panel. The disc loading well is a little noisier in its operation than other previous Marantz players but that noise level in itself is not disturbing.

The type of controls provided are a little different from those we have become familiar with in the last two years. The primary controls are provided on the extreme right hand side of the deck with four well placed and clearly labelled black push buttons arranged in a cruciform fashion. The uppermost is the START and REPLAY button which when activated will also close the disc tray; the lower is the PAUSE button. The two buttons which form the side elements of the cruciform provide rapid forward and reverse cueing and searching of specific sections of

the disc. These cueing controls utilize the 'Philips system' of increasing the rate of search the longer one holds one's finger on the button. The PAUSE control is supplemented by a small rectangular green LED to indicate it is operating.

Between the primary controls and the disc tray the secondary functional controls and displays are incorporated. A numerical display, with bright green LEDs, shows the track number and track playing time, beneath which sit the secondary controls. As I didn't have a handbook, it took me quite some time to discover that these controls enable you to program a selection of tracks through the use of the PREVIOUS and NEXT buttons in conjunction with the PROGRAM REVIEW button control. These buttons are supplemented by a red ERROR signal which enables you to check the complete sequence you have selected. A maximum of 20 programmed entries is possible. The last two controls are a REPEAT button and a STOP button, which respectively enable the player to repeat the total program re-

corded on the disc, until cancelled.

The unit does not incorporate a headphone socket and within the scope of its design it is doubtful whether many of its prospective owners would really want that facility anyway.

The cabinet is solidly made of steel with a neat extensive area of perforations at the rear. The rear panel has connections for two cords, one being 1.5 m long with two RCA type coaxial sockets at the end while the other is a double insulated mains lead with a two pin plug. In the middle of the panel is a large thin heatsink which ensures adequate cooling under most operating conditions.

**Inside**

When the covers are removed, one quickly perceives that Marantz has not attempted to market a cheap or shoddy piece of equipment, rather its circuit designers have gone to extreme lengths to produce a precision piece of equipment.

The disc-drive assembly and its associated laser tracking head assembly in ▶

**MEASURED PERFORMANCE OF MARANTZ MODEL NO. CD44**  
**SERIAL NO. AH00448 100885**

1. **FREQUENCY RESPONSE** on Bruel & Kjaer QP1124 Paper & 10dB POT

SEE ATTACHED CURVES OF LEVEL RECORDING  
 20 Hz - 20 kHz ± 0.2 dB

2. **LINEARITY**  
 @ 1kHz

TRACK	NOMINAL LEVEL 0 dB	L. OUTPUT 0 dB	R. OUTPUT 0 dB
22	-1.0	-1.0	-1.0
23	-3.0	-3.0	-3.0
24	-6.0	-6.0	-6.0
25	-10.0	-10.0	-10.0
26	-20.0	-20.0	-20.0
27	-30.0	-30.0	-30.0
28	-40.0	-40.0	-40.0
29	-50.0	-50.0	-50.0
30	-60.0	-60.0	-60.0
31	-70.0	-70.5	-70.5
32	-80.0	-77.7	-78.4
33	-90.0	-86.0	-86.8

3. **CHANNEL SEPERATION**

FREQUENCY	RIGHT INTO LEFT dB	LEFT INTO RIGHT dB
100Hz	Below Noise	Below Noise
1kHz	-118.3	-118.3
10kHz	-98.1	-100.4
20kHz	-93.4	-94.4

4. **DISTORTION (@ 1kHz)**

Level	2nd	3rd	4th	5th	THD%
0	-	-96.6	-103.7	-100.7	0.0019
-1.0	-	-94.8	-101.0	-101.5	0.0022
-3.0	-90.9	-93.1	-102.4	-98.1	0.0039
-6.0	-	-102.5	-101.3	-101.5	0.0014
-10	-	-95.3	-95.8	-99.0	0.0026
-20	-83.2	-78.8	-84.2	-	0.015
-30	-70.8	-	Below Noise	-	-
-40	-	-	Below Noise	-	-
-50	-60.6	-50.7	-	-	0.31
-60	-44.8	-39.7	-44.4	-49.9	1.37
-70	-24.4	-35.3	-27.8	-31.0	8.0
-80	-28.5	-21.3	-27.1	-	10.4
-90	-16.6	-	-23.3	-14.3	25.2

**DISTORTION (@ 100Hz)**

Level	2nd	3rd	4th	5th	THD%
0	-	-87.1	-98.5	-107.7	0.0013
-20	-82.7	-81.1	-	-	0.011
-40	-	-	Below Noise	-	-
-60	-44.4	-40.5	-45.2	-51.5	1.27

**DISTORTION (@ 6.3kHz)**

Level	2nd	3rd	4th	5th	THD%
0	-88.7	-92.3	-99.1	out of range	0.0045

5. **EMPHASIS**

Frequency	Recorded Level	Output Level (L)	Output Level (R)
1kHz	-0.37dB	-0.4 dB	-0.4 dB
5kHz	-4.53dB	-4.6	-4.7
16kHz	-9.04dB	-9.4	-10.6

6. **SIGNAL TO NOISE RATIO**

TRACK	Without Emphasis	98.5 dB (Lin)	110.7 dB(A)
23	Without Emphasis	98.5 dB (Lin)	110.7 dB(A)
24	With Emphasis	105.0 (Lin)	111.5 dB(A)

7. **FREQUENCY ACCURACY**

TRACK	Result
24	- 0.1 Hz for 20 kHz test signal

8. **SQUARE WAVE RESPONSE**

TRACK	Frequency	Waveform	RESULT
37	100Hz	Square wave	_____
38	1kHz	Square wave	_____
	See attached photos		

9. **IMPULSE TEST**

Time Base = 0.1ms/div  
 Photograph using Tektronik digital CRO  
 settings Vertical Amplifier 1V/div.

**DIRTY RECORD TEST**

**INTERRUPTION IN INFORMATION LAYER**

TNO 3;	00'10"	up till	TNO 4;	00'36"
TNO 4;	00'36"	up till	TNO 6;	01'05"
TNO 6;	01'05"	up till	TNO 7;	00'20"
TNO 7;	00'20"	up till	TNO 8;	00'23"
TNO 8;	02'26;	up till	TNO 9;	01'20"

**BLACK DOT AT READ OUT SIDE**

TNO 10;	01'00"	up till	TNO 11;	00.00"
TNO 11;	last minute			
TNO 13;	first minute			
TNO 15;	Full Track			

**OUTPUT IMPEDANCE @ 1 kHz = 43 ohms**

particular, are beautiful examples of precision engineering, which although not micro-miniature like the Sony D50, are nonetheless exciting and functional.

The laser tracking head assembly utilizes a neatly conceived series of flexible ribbon cables for interconnecting the elements and much to my surprise this player was able to faithfully track our 1 mm eccentricity test disc without any real problems.

The other components within the chassis include two large fully screened printed circuit boards with eight large scale integrated circuits, a larger number of dual in-line chips, printed circuit motors and numerous other special integrated circuits, transistors and rectifiers. Some of the wiring uses conventional wire cable harnesses, all of which terminate in neat plugs and sockets for ease of assembly and maintenance.

### Testing

The objective performance tests which we performed on this unit proved to be something of an eye opener. Although at the time of its initial release it was undoubtedly the cheapest CD player in Australia, the objective performance results in no way correlate with that 'cheap' stigma.

The measured frequency response of the unit traced by the level recorder using a conventional 50 dB potentiometer produced a ruler flat response from 10 Hz to 20 kHz. This response did not substantially change its appearance until I examined the frequency response with the expanded scale provided by a 10 dB potentiometer. The resulting visual ripple which is only evident between 1.5 kHz and 20 kHz and encompasses a miniscule 0.2 dB range, is very impressive. The other measured parameters of the unit

are, if anything, more impressive.

The digital-to-analogue conversion linearity is ruler flat to -60 dB, 0.5 dB low at -70 dB, 2.3 dB low at -80 dB and is remarkably only 4 dB low at -90 dB. That transfer linearity performance is on a par with *any other* CD player we have yet seen and is a credit to the designers.

The channel separation is extremely good being better than 120 dB at 100 Hz, 118 dB at 1 kHz, 98 dB at 10 kHz and a very commendable 93 dB at 20 kHz. The distortion figures are also excellent being 0.0019% for 1 kHz at 0 dB and subsequently not rising significantly until -60 dB, where the distortion figure increases to 1.37%. At lower signal levels the distortion performance is on a par with other modestly priced CD players, rising to 10.4% at -80 dB and 25% at -90 dB.

At 100 Hz the distortion figures are lower at high signal levels and substantially higher at low signal levels when compared with other comparable machines. At 6.3 kHz the figures are better than those for other machines and this tends to be the general characteristic and objective performance trend with this particular player.

The linearity of the 'emphasis replay' characteristics of the unit is reasonably good and in general terms slightly better than that of the majority of other players that we have reviewed. The signal-to-noise performance is again outstanding with the unweighted performance being 98.5 dB, while the weighted performance is 110 dB(A) without emphasis; with emphasis these figures rise to a remarkable unweighted 105 dB and 111 dB(A) weighted.

If I had any qualms about this unit being 'cheap' by this stage they were being rapidly erased.

The frequency accuracy of the player proved to be outstanding. The consequent frequency deviation was only a paltry 0.1 Hz for the 20 kHz reference signal. That sort of accuracy is unlikely to be improved upon by any other player.

The square wave test results displayed the typical uniform leading edge and trailing edge ripple characteristics produced by the double sampling frequency digital filter. This same characteristic is also displayed by the impulse test response which produces a clean and exemplary symmetrical pulse.

The player readily tracked all of the standardized finger mark and black dot tests on the Philips test disc and also handled our 4° warp angle test disc with the same panache.

Taken overall the test results confirmed that this particular CD player is something of a 'wolf in sheep's clothing'. This sort of performance would be raved about by other manufacturers or their PR personnel as 'state of the art' performance!

The subjective testing proved to be delightful, using a wide range of tried and proven discs as well as some very new and exciting ones. Two of these were Albinoni's "Adagio" and Pachelbel's "Canon" played by the Berlin Philharmonic Orchestra (DGG 413 309-2) along with Respighi's "Pines of Rome" with the Montreal Symphony Orchestra (Decca 410 145-2).

Various members of my family and staff associates then proceeded to put the player 'through its paces' for an extended period of time. All agreed that some aspects of the functional controls and ergonomic design could be improved upon. Notwithstanding any such criticism, all were unanimous in their praise for the subjective performance characteristics of the unit.

Only one other minor comment related to a slightly higher level of audible noise emission produced by the disc tray motor drive and the level of noise emission from the disc drive at very close proximity. Even these faults were not felt to detract from the subjective rating and user features provided by the player.

The release of this CD player will have a similar end result to that of the Sony D50 player last month. It heralds the eclipse of the conventional microgroove stereo recording and its replacement by the new market leader — the CD player.

Finally, I perceive that the Marantz CD44 player is a 'bargain' not because of its price but rather because of its outstanding technical performance.

## ARROW ELECTRONICS

Proudly bring you the new range of **NEC** amplifiers which include a **CORRECTLY LOADED** input to match their new range of 3rd generation compact disc players.

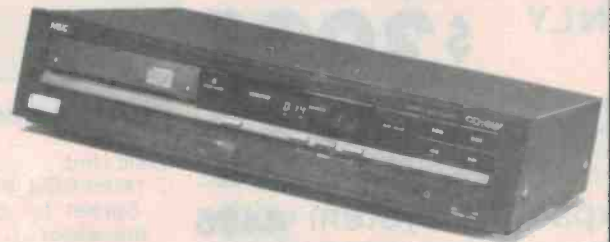

*Come and audition these excellent new products at our showroom and allow your ears to be the judge . . .*

**342 KENT STREET, SYDNEY (02) 29-6731 (02) 29-8580**

# The real alternative from Dick Smith Electronics!

## OLIVETTI/AT&T M24 PC

Yes! The finest alternative yet. Born of the most important partnership in the history of computing.

A fast, flexible, reliable personal computer that is much more than just a superior piece of hardware.

Behind it is a commitment to a better way of managing information and communications. One that can pay off handsomely in increased productivity and profits: Because it is designed to be flexible enough to meet all your business needs - today and in the future.

Whether you use it as a stand-alone work station or in a fully integrated system, you'll find the M24 a high performance machine. And a hard working addition to your office.

Its faster processing and high resolution graphics will help make any computer task a computing pleasure. In addition, you can expect more standard features. More expansion slots. More options for future growth.

As you'd expect, the M24 is also totally compatible with the MS-DOS operating system. It runs the most popular off-the-shelf software (including Symphony, Lotus 1-2-3, Framework and Flight Simulator) with no modification.

Financial analysis. Forecasting. Budgeting. Word processing. Inventory. The Olivetti-AT&T M24PC does it all.

And its flexibility means that when it's time to expand, the M24 will actually make your computer growing pains painless.

Now the Olivetti-AT&T PC is ready for business.

### Standard System

ONLY **\$3995**

Includes Olivetti M24 base unit with 128K RAM, one 360K disk drive, high res. green screen monitor, IBM-style keyboard, full MS DOS Operating system with GW Basic.

### Expanded system \$4495

As above with an extra 360K disk drive and a total of 256K RAM.

MS-DOS and Flight Simulator are trade marks of Microsoft Corporation. Lotus 1-2-3 and Symphony are trade marks of Lotus Corporation. Framework is a trade mark of Ashton Tait.

**6 MONTHS WARRANTY**  
**ON SITE SERVICE AVAILABLE**  
**ALL SERVICE & WARRANTY BY OLIVETTI AUSTRALIA - NATIONWIDE**



### Specifications

#### Basic Unit:

- 16-bit CPU (8Mhz)
- Socket for optional 8087 numerical processor.
- 16KB ROM for bootstrapping, power-on diagnostics and BIOS.
- Alphanumeric and graphic monochrome and colour display controller with 4 sim-

ultaneous "shades of grey" or colours from a palette of 16.

- Asynchronous serial port (RS232)
- Parallel port (Centronics)
- Sound circuitry
- Calendar/Clock with battery
- One expansion slot (7-slot bus optional)

#### Display:

- 80 x 25, 40 x 25 (col. x lines) characters.
- 640 x 400 pixel resolution

**Dick Smith Electronics Pty Ltd**

**COMPUTERSTOP**

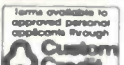
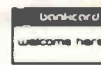

IAN J. TRUSCOTTS

## Electronic World

Kits, tools, components  
books etc.

Products from  
Dick Smith  
&  
Altronics

Everything for the  
electronic hobbyist

Now open till 9pm  
Friday evenings.

## Electronic World

Cnr. Lacey St. and  
Windsor Rd.

Croydon, 3136, Vic.  
Phone: (03) 723 3094

# GLORIOUS

When can this be said about  
the sound from so-called budget  
loudspeakers now on the market?

Yet for around the same price  
you can enjoy the glorious sound  
of KEF's world-acclaimed  
Standard Series.

As British manufacturers of  
the world's most thoroughly  
engineered speakers...with top  
speaker projects for the  
BBC...KEF do not compromise  
quality for a price. That's why we  
urge you to listen to the thrilling  
realism for the new KEF Standard  
Series loudspeakers.

They're for people who  
demand higher standards.

And glorious sound.



## KEF

FALK ELECTRO SOUND GROUP  
BOX 234 ROCKDALE 2216. PHONE (02) 597 1111

## eti CIRCUIT techniques

volume four

The how, what, when, where,  
why, and how (usual) anthology  
of electronic components,  
circuits and techniques

An ELECTRONICS TODAY INTERNATIONAL publication

The how, what, which, where, why and  
how much anthology of electronic  
components, circuits and techniques.

This book is packed with articles on  
Analogue Delay Lines, Gain Control,  
CMOS circuits and how to make them  
work plus much, much more.

Your copy is available by mail order for  
\$5.95 plus \$1 to cover postage and  
handling (add \$5 to these charges for  
air mail postage outside Australia) from:

Federal Marketing  
P.O. Box 227, Waterloo, NSW 2017

Trade enquiries welcome.

# HEAR NOTHING ...but the best!

All that needs to be said about Dual's famed turntable standards has  
been said.

So now we introduce the latest and finest Dual belt-drive — the CS 505-2.  
The pure sound produced by this superbly engineered unit is the result of excellent  
tracking and efficient noise suppression. From the totally floating chassis, anti-  
resonance turntable mat to the U.L.M. tone arm technology for cleaner, more wear-  
reducing tracking, the CS 505-2 offers the most decisive improvement in recent  
years.

From now on Dual ensures you hear nothing...but the pure sound of the  
music itself!

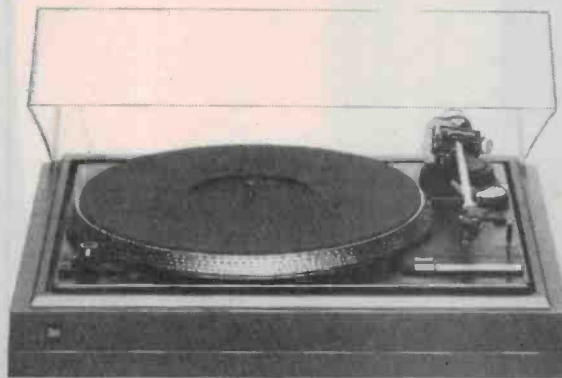

FALK ELECTRO SOUND GROUP  
BOX 234 ROCKDALE 2216. PHONE (02) 597 1111

# Philips/Sony stereo TV MORE REALITY

Something for both the hi-fi buff and the average family. That's how our reconsidered opinion of the Philips KR684 and Sony KV-2064EC apologetically goes. We've had some more to think about on the subject of those stereo TVs since that September '84 review . . .

WHEN WE REVIEWED the Philips model KR684 and the Sony model KV-2064EC stereo TV sets last year (ETI, September 1984), we did so with some trepidation as the test equipment that we were using was, for once, not our own. You may not have noticed, but because it was not possible to either calibrate or certify the accuracy of the test equipment used, we did not use the normal NATA labels on the results presented.

When writing the review we commented on the difficulties we experienced in achieving the separation figures claimed by the manufacturers as well as the distortions which measured far higher than we were able to audibly detect. The review in many respects panned both the units on the basis of the objective testing although, as we clearly stated, the subjective performance was considerably better than indicated by

our testing.

It was only after the review appeared in print that Lloyd Atkinson, Manager of the Consumer Products Division of Philips Australia, approached us to point out a number of technical anomalies in the review and that they had undertaken their own investigations as to why!

## Explanation

As we delved deeper we discovered that the design engineer and product manager of Philips had gone to considerable trouble to obtain the very receiver we had tested as well as the signal generator used. With some skilful detective work they determined why we had obtained these 'anomalous results' and the reasons were as follows:

1. The signal generator that we had used, a PM 5519 Colour TV Pattern Generator,

was unable to meet the prerequisite internal distortion figures when fed by an external audio signal generator when producing the prerequisite frequency deviation and at the required modulation levels.

2. Because, at the time of the original test we did not have a circuit diagram or a proper handbook for the Philips stereo TV receiver, we were unaware of a 'design feature' of the Philips stereo TV receiver which provides a SCART socket on the rear. This special multipin connector provides for attachment to a VCR with composite video output and input connections, RGB video inputs, plus stereo (left and right) audio inputs. But the feature we missed was the provision of 'non-spatial' or true stereo left and right audio outputs which can be connected to a stereo hi-fi amplifier system.

Without a SCART plug and associated circuit details, we were both unaware and unable to measure the very parameters that we most needed to measure in the original test.

In the case of the Sony model KV-2064EC stereo TV receiver, there was no such restriction as the unit came with an extremely well presented service manual to ease our burden. Notwithstanding, the limitations of the signal generator still made it impossible for us to measure its true performance.

When these factors were drawn to our attention, we were somewhat 'shame-faced' for inadvertently misleading readers as well as being over-critical of the two manufacturers. We had sought to obtain a circuit of the KR684 from Philips, but in the limited time available for the testing, and in our eagerness to present a review on this new development in Australian television, we went ahead with the only documentation with which we were provided.

## The changed results

Philips Australia were quick to suggest

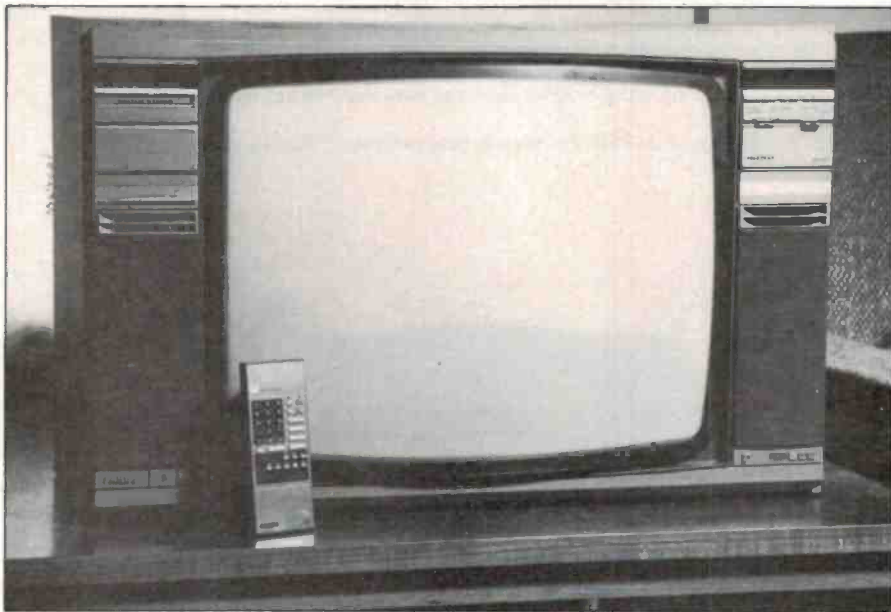

Philips KR684. The first stereo TV on the market in December 1983.

that we should use a Hewlett Packard RF signal generator model 5082B, of the type they themselves used to carry out evaluations. We accepted their recommendation, and borrowed one of the suggested signal generators to repeat the tests on both stereo TV receivers.

Lo and behold, with the appropriate SCART socket terminal data for the Philips set, and the appropriate signal generator, the measured parameters were entirely different to those we had previously presented.

The single most important improvement was that obtained for the audio frequency distortion at 30 kHz deviation.

Almost miraculously the distortion figures which we had originally quoted as being typically 4% at 1 kHz for the left and right channels had dropped to a figure of 0.3% with comparable distortions at 100 Hz and slightly higher distortions at 6.3 kHz. These figures were typically one-tenth of the values originally stated and were more in keeping with what we had been able to hear ('long live the golden ear!').

The measured distortion performance of the Sony receiver was not quite as good as that provided by the Philips receiver but was still less than 1% and less than one-quarter of the figures we had originally quoted. In both cases the separation was better than 30 dB in the full stereo (non-spatial) mode.

If our original review dissuaded some of our readers from considering the purchase of either the Philips model KR684 or the Sony model KV-2064ED, we are truly mollified. Each of these particular stereo TV receivers provided a picture quality which is particularly good and really equal to RGB monitor quality as I can now safely attest. The audio quality when used in the full stereo mode was almost as good, although not quite of the same standard as that provided by the latest generation of stereo hi-fi VCRs which we have subsequently reviewed.

Both of these stereo TV receivers provide exceptional visual and audible performance, especially when the self-contained stereo output connections are correctly used. Under such circumstances, and with a reasonable program content, the results can be outstanding. At least one Sydney TV station (Channel 9), and I believe one Melbourne station, have reconstructed their main TV production studios to accommodate the capabilities of the new medium and this augurs well for those of you who purchase a stereo TV receiver with the hope of viewing better quality local TV.

## Background

The KR684 is a wholly Australian design, built specifically for Australian conditions, and is manufactured entirely in

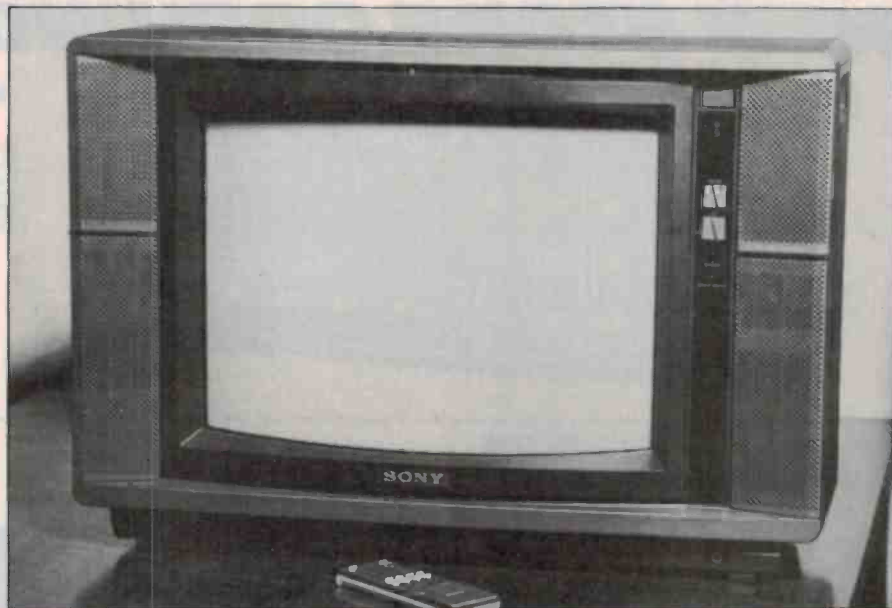

Sony KV-2064EC. A good picture quality equal to RGB monitor quality.

Philips' Clayton plant — the pc boards, the electronic assemblies, the cabinet and all!

The KR684 was the *first* stereo TV receiver on the market when the Minister for Communications, Mr Duffy, announced the official introduction of dual-channel TV sound transmissions in December 1983. How did they manage such a marketing coup?

Philips, naturally enough, maintained a keen interest in the industry debate which led to the adoption of the double sound carrier (or 'German') system here. In order to maintain its lead in the 'floor model' or 'furniture' end of the TV receiver market, Philips had to be first in the stores with a fully-featured receiver incorporating dual-channel (stereo/bilingual) sound when the announcement of the standard for Australian TV was made. As there is a considerable lead-up time between setting down design specifications and actually shipping the product to retailers in the manufacture of any consumer electronic equipment, this meant Philips had to take a punt on which dual-channel sound system would be chosen for Australia. As you could imagine, a lot of money rode on such a punt.

Undaunted by that, and backed by considerable engineering research and wide-ranging discussions with those TV stations involved in testing different systems here, Philips settled on the German dual-carrier sound system for their new receiver around a year ahead of the official announcement. Their punt was a good one, and it paid off.

The design of the receiver, electronically, ergonomically, and cosmetically was heavily influenced by the results of their considerable local market research. Australian consumers exhibit distinct differences from consumers in other countries in many regards. For example, large screen TV receivers — principally intended for installation in

the lounge room of the family home — *must* have legs or the Australian consumer will not consider them. *Nowhere else in the world does this matter.*

The results of Philips' market research led the designers of the KR684 to carefully review the control functions provided on the set, and they did not include a stereo/spatial selection switch. When using the internal speakers, adjudged the most common arrangement for viewing stereo TV programmes, the spatial mode subjectively provides the more realistic impression as the sound and vision images are more closely matched. If, through misunderstanding the controls or by inadvertently selecting the stereo only mode the viewer obtains a subjectively poor result, he or she will be dissatisfied and judge the set a poor performer. And that would ultimately reflect on Philips.

It's a subtle problem, but clearly an important one, especially with such a 'new' facility as stereo TV sound. It's a problem we clearly did not appreciate when reviewing the set last year.

However, for the more discerning owner/viewer, the designers decided to include true stereo (non-spatial) audio outputs via the SCART connector. With a suitable interconnecting cable, these can be hooked up to the auxiliary input on a hi-fi stereo amplifier.

The above only covers a few points among many in the factors which influenced the design of Philips KR684 receiver, and no doubt the designers of Sony's KV-2064EC receiver were involved in similar process.

In summary, it seems Philips' punt on the German dual carrier sound system and its careful market research paid off. Philips was first on the market with a stereo TV receiver and claims to have comfortably maintained the market lead in this area. ●

# NEW STORE OPENING SPECIALS



Cat. XC-2010

## VOYAGER CAR COMPUTER BELOW \$100!!!

For the month of MAY ONLY we are offering the famous Voyager Car Computer for only \$99.95. That's cheaper than what it sells for in England where it's made!  
This offer is STRICTLY LIMITED to MAY ONLY. DO NOT ASK FOR THIS PRICE AFTER MAY. It is to celebrate our new store opening at GORE HILL in Sydney.

**SAVE 50% ON  
CATALOGUE PRICE  
ONLY \$99.95**

## GREAT NEW KITS FROM ETI Modem Kit

Ref. ETI May 1985

This brilliant new design is a price breakthrough. Never has a modem with such SOPHISTICATED FEATURES been offered at such an incredibly low price. Now you can have no excuse to gain the tremendous benefits that a modem will offer viz.

- ★ Access to huge data banks
- ★ Networking
- ★ Telecommunications
- ★ Electronic shopping
- ★ Software exchange

Cat. KE-4695 **ETI 699**

★ And much more  
This ETI kit is a full modem with facilities similar to units costing hundreds of dollars more. It even includes a Telecom approved push button telephone! Now is your chance to use your electronic skills in your new hobby and save a fortune over ready built.

You can obtain this modem kit (which includes a telephone for us humans) for the incredibly low introductory price of only \$139. That's right! \$139 inc case, down to the last nut and bolt. But hurry! Stocks of the critical modem chip are very low and will severely limit kit supply.

**ONLY \$139**

NEW!

## ETI ECONOMY HOUSE/CAR ALARM MODULE

Ref. ETI May 1985

This low cost full feature module can form the basis of a sophisticated anti theft system!

**ETI 1527** Cat. KE-4698 **\$24.95**



## TWO PLUGPACK AND DC CONVERTOR BARGAINS!

**Plug Pack** This unit will give a DC output of 1 1/2, 3 or 4 1/2 V @ 250mA (max). A switch on the back of the unit changes the voltage. It is also supplied with a 1.6m cord, polarity reversing plug and multiway connecting plug. We have over 500 of them.

This voltage range is fairly useless except for small transistor radios, calculators etc. At this price however, it's worth having one or two for the inevitable occasion when such a power source is required.

Cat. MP-3002

**ONLY \$2.95**

You could pay over \$10 elsewhere!

**DC Convertor** This unit plugs into your car cigarette lighter socket and will provide up to 300mA at 6 and 9V DC. Ideal to power the Ghetto Blaster in your car! We only have just over 200 so hurry!

Cat. MP-3015

**Normally sell for around \$10. This month \$4.95 - 1/2 price!!**



## MAIL ORDER HOTLINE

To save you time (and therefore money) we have installed a special HOTLINE direct to the inner workings of our mail order dept. This saves you from going through our Head Office switchboard! If you wish to place an order, enquire about an order or simply check for more information, call.

**(02) 646 1300**

## MULTIMETER "PIN PLUGS" to

**EZ HOOKS** - Great multimeter probes that will fit the 2mm diameter pin tip sockets of your multimeter. (NOT "banana" type sockets).

Cat. WT-5314

**Normally \$3.95/set  
this month \$1.50  
WHACKO!** Only 430 available. Hurry!



## SM130 Midrange Speaker

★ BARGAIN ★

Upgrade your 2-way system with this economical but smooth unit!  
● 5 1/2" (152mm) midrange ● corrugated edge black cone ● silver dust cap ● sealed back ● effective frequency range 1k to 5k ● sensitivity 99dB ● power 5W nominal, 10W maximum ● impedance 8 ohm ● magnet weight 2.3oz  
Cat. CM-2060

**NORMALLY \$7.95 SLASHED TO  
\$4.95 each!!**



## BLANK PCB - BARGAIN OF THE CENTURY

We have secured massive stocks of high quality copper-clad PCB material in both single and double sided versions. Jaycar has NEVER had the opportunity to sell material at anything NEAR this price before. We suggest that you stock up NOW as we doubt that we will EVER be able to repeat this bargain again.

### OFFER 1

Blank, single sided board. Phenolic base. Dimensions approximately 350mm (14") x 330mm (13").

Cat. HP-9508 Limit 2 sheets per customer

**May Only \$3.95**

**(Normally \$6.95) - SAVE \$3.00**

### OFFER 2

Blank, single sided board. Fibreglass base. Dimensions 350 x 330mm

Cat. HP-9510

**May Only \$4.95**

**(Normally \$8.95) - SAVE \$4.00**

### OFFER 3

Blank, double sided board. Fibreglass base. Dimensions 300mm (12") x 300mm (12")

Cat. HP-9520

**May Only \$6.95**

**(Normally \$12.95) - SAVE \$6.00**

Note that the normal price is based on 300mm square sheets and not this larger size - an even greater saving!

Limit 4 sheets/customer

PCB dimensions may alter slightly.

## 3C-2V 75 Ohm COAX - 7 metres??

Seven metres? Well this is a pack of 7 metres of high quality coax cable. Why seven metres is beyond us except that it was thought to be the most asked for length and why not therefore prepack it? The bean counters got their sums wrong because it did not sell! 7 unterminated metres would normally cost \$3.50. Jaycar has a fair quantity of these fairly usefull lengths for only \$2.00 which amounts to a substantial saving!

**ONLY \$2.00/7 metres**

Cat. HP-1360

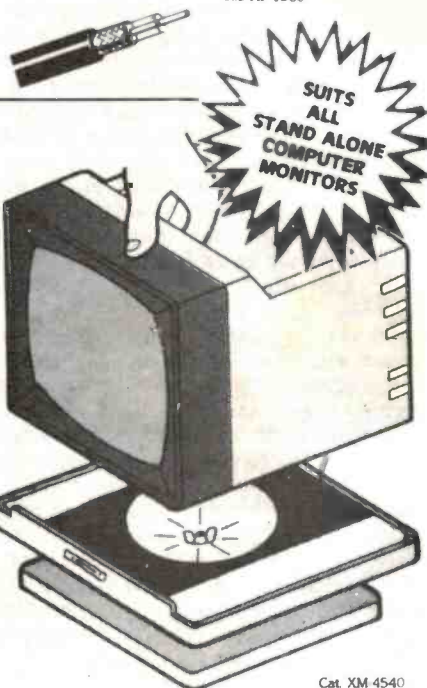

Cat. XM-4540

**TILT BASES for  
COMPUTER MONITORS  
1/2 PRICE MAY ONLY  
BELOW CURRENT COST!  
ONLY \$14.98**



**Call in to our NEW Gore Hill store. We have specials that will**  
 ☆ ☆ ☆ ☆ **BLOW YOUR MIND!** ☆ ☆ ☆ ☆

**4164-150ns DRAM 64K x 1  
 INCREDIBLE SPECIAL SALE**

We have made a scoop purchase of National Semiconductor brand new prime spec 64K DRAM. At the prices shown below we expect many manufacturers to buy so hurry! Quantities naturally are limited.  
**PLEASE NOTE** that these prices INCLUDE 20% sales tax which the hobbyist MUST PAY so don't be misled by offers that may appear cheaper!  
 Cat. ZZ-8420

**1-9  
 \$4.95 ea**

**10-24  
 \$4.50 ea**

**25-99  
 \$3.95 ea**

**100-249  
 \$3.75 ea**

**250+  
 \$3.60 ea**



**Only  
 50¢  
 ea  
 any quantity**

**COAXIAL BELLS**

The same bells that go in the Telecom "Gondola" phone. Beautifully engineered. Ideal extension bell as can be driven from Telecom line current.  
 Cat. LA-5270

**CARDBOARD PORT FOR  
 SUBWOOFERS - 1981 vintage**

This heavy duty cardboard port tube was specially made for the EA Subwoofer cabinet (Ref. EA July/Aug 1982). The tube is 150mm long EXACTLY, 90mm O.D. and 70mm I.D. We have a few surplus to requirements at a below cost price of \$3.00 each. Cat. CP-2450

**BELOW COST \$3.00 each**

Ask about our Fibro Liqueur Muscat!

**NOW OPEN  
 188-192 Pacific  
 Highway  
 GORE HILL  
 Phone 439 4799**



**SPECIAL QUARTZ CRYSTAL CLOCK**

**MOVEMENT** - Grab them while they last. Only \$9.94 - save one cent on last month's price. Hurry!  
 Cat. XC-0100

**ONLY  
 \$9.94**



Sweep second hand  
 115mm long

**SPECIAL**

**Low Cost Audio Cassette Recorder**

• Works well • mains/battery operation • special tape loading instructions • tape counter (a must) inbuilt • electret microphone • LED recording indicator.  
 Cat. XC-4905

**Special price  
 for MAY only  
 \$19.95  
 save \$10.00**



**HEART RATE MONITOR**

Not a kit. Built, tested and guaranteed. This fully self-contained unit enables you to monitor your pulse rate anywhere! The unit features large, easy to read LED display and comfortable finger grip pulse sensor. An exclusive feature is the bracket that enables you to mount the unit to tubular objects such as a bike (or exercise bike), weight training equipment etc. NOW you can monitor your heartbeat accurately and easily while in the middle of your exercise! The comprehensive booklet gives you explicit instructions plus mounting guidelines. Presented in a vinyl case and includes 9V battery.  
 Cat. QM-6110

**Normally \$89.50 MAY ONLY  
 \$79.50 save \$10.00**



**PLUGPACK** - Ferguson 240 volt to 12V DC 400mA plugpack - This quality Australian made plug pack used to sell for \$16.95. We had them on special for one month last year at \$4.95 and we sold a stack of them!

This is your second chance to SAVE and SAVE even more.  
 LIMITE OF 2 PER CUSTOMER

Cat. MP-3013

**ONLY  
 \$3.95**



**MAIL ORDER HOTLINE  
 (02) 646 1300**

**We're in a bind over Binders!**

Our magazine binders have never been so cheap! Are your ETIs and/or EAs (or any other monthly mags) in a mess? Keep them tidy with a Jaycar binder. Buy them this month and SAVE.  
 Cat. BB-7000



**USUALLY  
 \$4.95 each**

**ONLY  
 \$3.95  
 or 10 up  
 \$3.65 each**



**ROTARY DIALLERS** - As used in 'normal' telephones. Hundreds of uses.  
 Cat. XT-6900

**OTHERS SELL FOR \$4.95  
 JAYCAR NORMAL PRICE \$2.95  
 JAYCAR SUPER SPECIAL PRICE  
 ONLY \$1.00 each**

**Maiden's Prayers Answered**

But only if she wants to mount 2 1/4" speakers. You know, the little ones with no holes for mounting screws. How do you make them sit behind a panel. With our nifty little double-sided holes! Or rings to be more precise. Imagine a ring punched out of thick double-sided foam tape about 2 1/4" diameter. With a 1 1/4" diameter hole in the middle. You rip the backing from one side of the ring and stick it to the flange of the speaker. Remove the backing from the other side and presto! A 2 1/4" speaker wherever you want it!  
 They come in a pack of two even if you only need one because that's the way packs are.  
 Cat. HP-1227

**ONLY \$1.00 for 2**

**FULLY IMPORTED SX-2000  
 ELECTRONIC IGNITION KIT  
 NOW BACK IN STOCK**

This fully imported kit from the UK has a patented clip that attaches the unit to the coil itself which makes mounting really easy. It will fit all 12V negative earth vehicles and is very professional looking. Reactive discharge type.  
 Cat. KJ-6650

**ONLY  
 \$59.00**

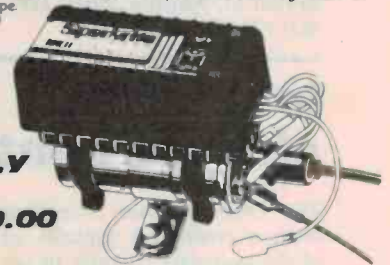

**FREE CATALOGUE**

Ask for a FREE copy of our 1985 Engineering Catalogue or send large SAE with 50¢ stamp.

**Jaycar  
 ELECTRONICS**

Incorporating ELECTRONIC AGENCIES  
**NUMBER 1 FOR KITS  
 MAIL ORDER HOTLINE (02) 646 1300**

**N.S.W. SHOWROOMS**  
 SYDNEY: 117 York Street Tel. (02) 267 1614  
 CARLINGFORD: Cnr. Carlingford & Pennant Hills Road Tel. (02) 872 4444  
 CONCORD: 115/117 Parramatta Road Tel. (02) 745 3077  
 HURSTVILLE: 121 Forest Road Tel. (02) 570 7000  
 GORE HILL: 188/192 Pacific Highway (Cnr Bellevue Avenue) (02) 439 4799

**QUEENSLAND BURANDA:** 144 Logan Road Tel. (07) 393 0777  
**MAIL ORDERS:** P.O. Box 480, AUBURN 2144. Tel. (02) 643 2000  
**HEAD OFFICE:** 7/9 Rawson Street, AUBURN 2144.

Tel: (02) 643 2000 Telex: 72293

**SHOP HOURS**  
 Castlingford, Hurstville & Gore Hill  
 Mon-Fri 9am - 5:30pm, Thurs 8:30pm, Sat 12pm  
 Sydney  
 Mon-Fri 8:30am - 5:30pm, Thurs 8:30pm, Sat 4pm  
 Concord  
 Mon-Fri 9am - 5:30pm, Sat 4pm

**POST & PACKING**  
 \$5 - \$9.99 \$1.50  
 \$10 - \$24.99 \$3.20  
 \$25 - \$49.99 \$4.50  
 \$50 - \$99.99 \$6.50  
 \$100 - \$198 \$8.00  
 Over \$199 \$10.00

COMET ROAD FREIGHT ANYWHERE IN AUSTRALIA ONLY \$12



**MAIL ORDER VIA  
 YOUR PHONE**

# New battery technology

Chloride Batteries has launched a comprehensive range of rechargeable batteries for systems support that it claims does just about everything a sealed nickel cadmium battery does at nothing like the price. The new series is called the 'Powerstone' range.

The batteries use RE (Recombination Electrolyte) to provide primary or standby power in neat, clean packages that resemble kiddies building blocks more than they do rechargeable batteries.

RE technology produces no gassing or charging. Gases are recombined electrochemically so that the Powerstore has no holes to leak, no water loss, and no need for top-up.

According to Chloride this makes the Exide Powerstore range ideal as standby power packs for memory back-up in computers and electronic office equipment, electronic cash registers, fire and security alarm systems, emergency lighting, telecommunications and uninteruptible power supplies.

Shelf life is at least two years. Total life is up to 10 years under recommended operating conditions.

For more information contact Chloride Systems Division, 55 Bryant St, Padstow, NSW 2211. (02) 774-0500.



## Integrated charger controller

The UC2906 series of battery charger controllers contains all of the necessary circuitry to optimally control the charge and hold cycle for sealed lead-acid batteries.

These integrated circuits monitor and control both the output voltage and current of the charger through three separate charge states: a high current bulk-charge state, a controlled over-charge, and a precision float-charge, or standby state.

Separate voltage loop and current limit amplifiers regulate the output voltage and current levels in the charger by controlling the on-board driver. The

driver will supply up to 25 mA of base drive to an external pass device. Voltage and current sense comparators are used to sense the battery condition and respond with logic inputs to the charge state logic.

Other features include a supply under-voltage sense circuit with a logic output to indicate when input power is present. In addition the over-charge state of the charger can be externally monitored and terminated using the over-charge indicate output and over-charge terminate input.

For more information contact VSI Electronics in Melbourne on (03) 819-5044.

## Resistors set 3 A regular voltage

The UA150/250/350 are adjustable 3-terminal positive voltage regulators capable of supplying in excess of 3 A over a 1.2 V to 33 V output range. They require only two external resistors to set output voltage.

A feature of the UA family is time-dependant current limiting. This allows peak currents of up to 6 A to be drawn from the regulator for short periods of time, so the UA150 can be used with heavy transient loads and speeds start-up under full-

load conditions. Under sustained loading conditions, the current limit decreases to a safe value protecting the regulator. Also included on the chip are thermal overload protection and safe area protection for the power transistor. Overload protection remains functional even if the adjustment pin is accidentally disconnected.

For further information contact Fairchild Australia, 366 Whitehorse Rd, Nunawading, Vic 3131. (03) 877-5444.

## Video cables

STC-Cannon Components which distributes Hitachi cables, has available the latest details on Hitachi LC-OFC video cables.

LC-OFC (Linear Crystal Oxygen Free Copper), is a superior material for signal transmission.

The range available from Hitachi includes the PCX-101C, a 75 ohm coaxial cable with terminals at both ends, and the VSX-102, a pair type shielded cord, also with terminals at both ends.

For full technical details contact STC-Cannon Components Pty Ltd, 248 Wickham Road, Moorabbin, Vic 3189.

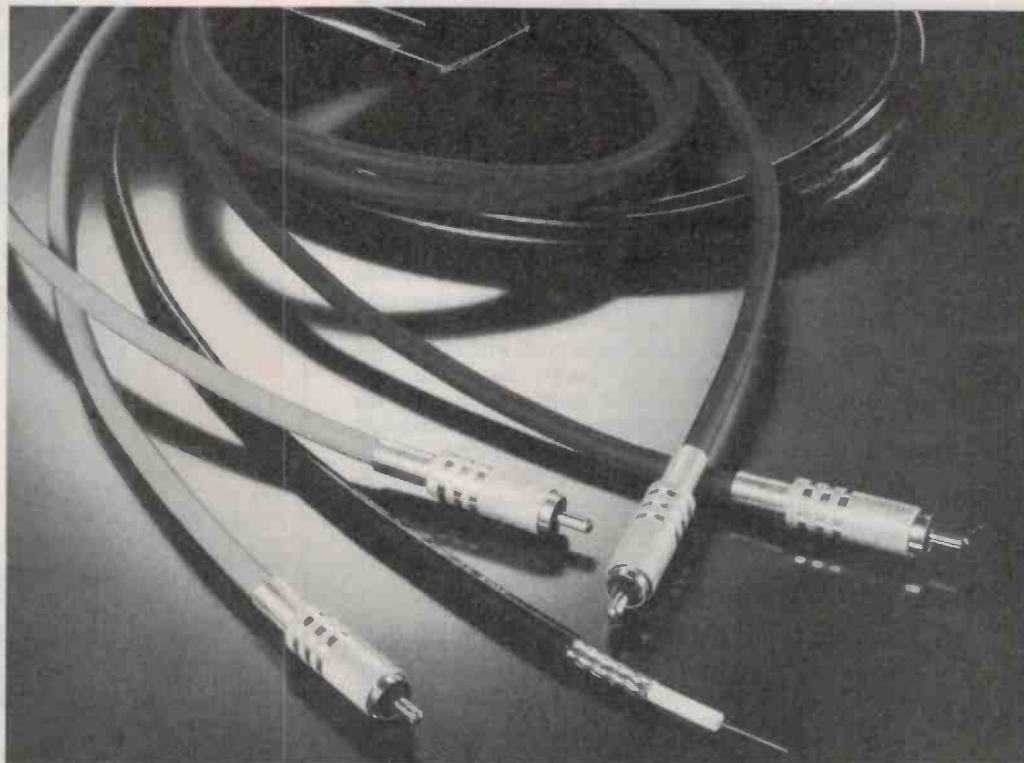

## TRW D-sub connector

An all plastic, D-subminiature connector for PC board application designated the Cinch Super D is being offered by Total. The latching block flange style designed EIA RS449 is available with either straight or right angle (1/16" or 1/8") DIP solder tails.

The new connectors are

available in 9, 15, 25 and 37 contact sizes, and are designed to withstand 1000 V RMS and operate at 3 A between -55°C and 125°C.

For further information, please contact Total Electronics, 9 Harker Street, Burwood, Vic 3125. (03)288-4044.

## Switchers

The GS-R400 Series is a family of high current, high voltage switch mode regulator modules for use in centralized and decentralized power supply systems.

Features include high input voltage (48 Vmax), high output current (4 A), and high efficiency (up to 90%). The series

is PC-card or chassis mountable with a reset output, a remote inhibit/enable and a remote output voltage sense. It also has short circuit and thermal protection.

For further information contact Ellistronics, 797 Springvale Road, Mulgrave, Vic 3170. (03) 561-5844.

QUALITY FROM ENGLAND

# CLIFF

AUSTRALIAN DISTRIBUTOR

## DELSOUND PTY. LTD.

1 WICKHAM TERRACE, BRISBANE 4000.

PH: (07) 229-6155

YOUR ONE-STOP ELECTRONICS SUPPLIER

**K9** 19 x 20 mm

**K9** — Matt black finish available in push-on or screw-fix. Push on caps, available colours red, black, white, blue, yellow, orange, grey or green.



<b>K9PF</b>	1+	100+
(incl. cap)	41c	31c
<b>K9SF</b>	57c	47c
(incl. cap)		

+ tax 20%

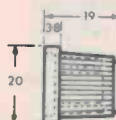

**I.C. Test Clip**

14-16	—	\$5.00
26-28	—	\$10.00
40	—	\$11.90

+ tax 20%



**Quicktest**

Ideal for w/shops and test depts.

**\$26.00**

plus tax 7.5%

**S2 Series**

S2 range 6.5 mm nylon mono and stereo sockets. High quality brass and Nickel contacts. Colours available.



	1+	100+
S2 BNB Mono	48c	39c
S2 SNB Mono	48c	39c
S2 BBB Stereo	61c	49c
S2 SSS Stereo	48c	36c

Specify colours

+ 20% tax

## NEW COMPONENTS

### Capacitor has built-in fuse

An electrolytic capacitor operated with reverse polarity can be a fire hazard. Siemens offers a tantalum electrolytic capacitor, the B 45185, which features a built-in overload fuse that automatically disconnects the capacitor from power before it can harm equipment.

The rectangular plastic package (designed for severe climates) with single-ended leads is

supplied in four types ranging from 0.1 to 330 $\mu$ F and from 6.3 to 50 V.

The integrated overload fuse consists of a solder wire connected between cathode and lead. Operation with reverse polarity quickly heats this wire until it melts, interrupting the cathode circuit and rendering the tantalum electrolytic capacitor open circuit. ▶

### Low power counter/timer circuit

The low-power CTC can be programmed for a broad range of counting and timing applications. Its four independently programmable channels satisfy common microcomputer system requirements for event counting, interrupt and interval timing, and general clock rate generation.

It features down-counters, reloading automatically at zero count and eliminating software timing loops; three channels

with zero count/timeout outputs capable of driving Darlington transistors; selectable positive or negative trigger for timer operation and standard Z80L family daisy chain interrupt structure fully vectored, with prioritized interrupts without external logic.

For further information contact **The George Electronics Group**, 174 Parramatta Road, Camperdown, NSW 2050. (02)519-5855, telex 21732.



### Alternative source for alphanumeric displays

With the introduction of the HPDL-2416 display, Hewlett-Packard Australia becomes an alternative source for alphanumeric displays.

The new display is a 4.1 mm, four character, 16 segment, red display.

The display performs at high speed over an operating temperature range of -20 to +70

degrees C.

Fast IC access time of 260 ns makes the HPDL-2416 directly compatible with a micro-processor.

The HPDL-2416 conforms to the industry standard of 5 volts, making it fully TTL compatible.

For further information, contact **Hewlett-Packard Australia**, (02)888-4555.

### PS Series connects

To meet the needs of more compact, smaller electronic equipment, STC-Cannon Components offers the "Pan Connection System" PS Series connectors.

These have been developed for connection between pcb and cable, and between pc boards, to provide a total connection system for various applications.

The series covers IDC socket connectors for flat ribbon cable,

crimp socket connectors for discrete wire, pin headers for mounting on pc board, dip socket receptacles for mounting on pc board, pc board transition connectors and two contact short circuit socket and low profile pin headers.

The PS Series connectors catalogue is available on request to **STC-Cannon Components**, 248 Wickham Rd, Moorabbin, Vic 3189.



# You've been waiting for

# Circuits

## COOKBOOK #5

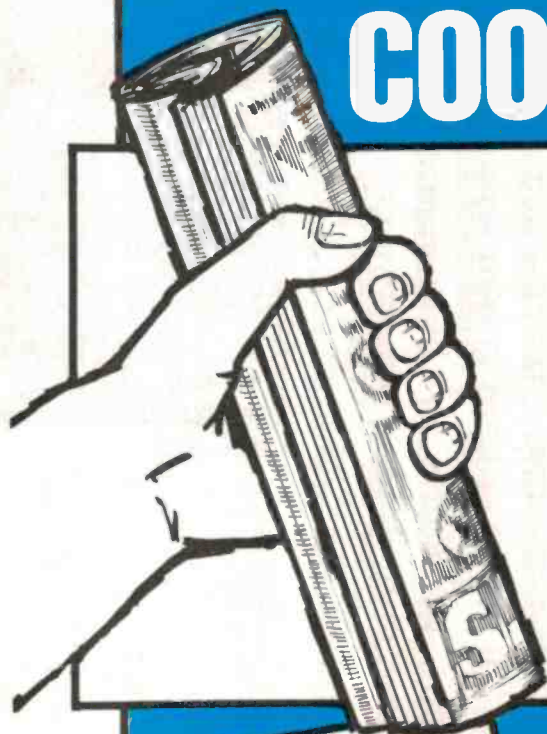

**200 Circuits & Ideas  
for the Engineer  
Technician and  
Hobby Enthusiast!!!**

**Computers + Audio + RF  
Electronic Music and  
Much, Much more . . .**

AN ELECTRONICS TODAY PUBLICATION

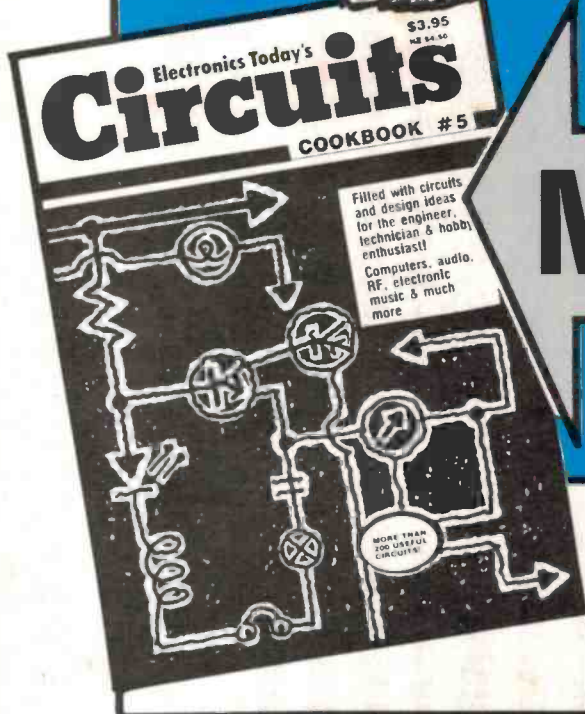

# NOW IT'S HERE!!!

## PICK UP YOUR COPY FROM YOUR NEWSAGENT

ALSO AVAILABLE BY MAIL ORDER  
\$3.95 plus \$1 postage

FEDERAL MARKETING  
P.O. BOX 227 WATERLOO, N.S.W. 2017

# Subscribe to Electronics Today now, and receive a 20-watt soldering iron worth \$9.95

# ABSOLUTELY FREE!

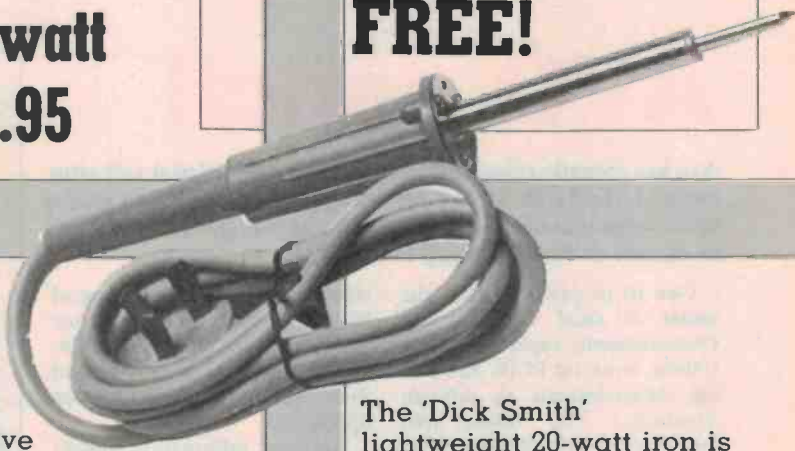

Right now is certainly the best time to take out a 12-month subscription to Electronics Today. You'll not only be ensuring that you receive each copy regularly each month, delivered direct to you, but you'll also receive a bonus gift: a free 'Dick Smith' soldering iron suitable for the electronics hobbyist, home handyman or technician. But don't delay — this offer is limited.

The 'Dick Smith' lightweight 20-watt iron is ideal for most general soldering work. It features interchangeable screw-in tips, a two-metre mains cord with moulded-on plug for safety and durability, and is fully S.E.C. tested and approved. It comes fitted with a plated conical tip, suitable for most general soldering. Normally this quality iron sells for \$9.95 — but currently we're offering it to you FREE with each 12-month subscription to Electronics Today!

### Australia's dynamic electronics monthly!

Electronics Today is your key to the exciting world of modern electronics — whether you're a professional, an enthusiast or an interested consumer. Electronics Today provides you with news and analysis of the latest developments, authoritative test reports and reviews of new equipment, down-to-earth information on electronics in theory and practice, and well-engineered construction projects.

Electronics Today is also written right here in Australia, so you know that it really does cover the local electronics scene.

## Electronics Today Subscription Offer

### YES!

Please send me one full year (12 issues) of Electronics Today, delivered to my home, PLUS my free Dick Smith soldering iron at the special offer price of just **\$27.00**



NAME: ..... JOB/TITLE: .....

ADDRESS: .....

POSTCODE: ..... ORGANISATION: .....

Please tick box to indicate method of payment:

Cheque\*/Money Order\*  American Express  Bankcard  Mastercard

\*Please make cheques and money orders payable to the Federal Publishing Company Pty Ltd. Credit Card No.

Card Expiry Date: ..... Signature: .....

Allow 4-6 weeks for delivery of first issue and soldering iron.

(Unsigned orders cannot be accepted)

Just  
**\$27.00**

*That's a \$3 saving on our regular 12-month subscription rate!*

**So don't delay — subscribe now in this issue!**

# AVO pencil

Avo has recently released its first 'probe style' digital volt-ohm meter — the TD20. It's an auto-ranging meter with four ranges that enable measurements to be made of voltages up to 500 Vac or dc and of resistances up to 2000k.

Due to its pencil design, the meter is ideal for in-circuit measurements, rapid continuity testing, work on PCBs and taking measurements in difficult situations. The display-hold facility enables a reading to be taken when it is not possible to make a measurement and view the display simultaneously.

Safety features include a

shrouded probe tip, a fused prod with shrouded lead connector and a crocodile clip for simplifying the connection of the prod thus providing one handed operation.

For more information contact Measurement & Control Division, Electrical Equipment Limited, Unit C, 8 Lyon Park Road, North Ryde NSW 2113.

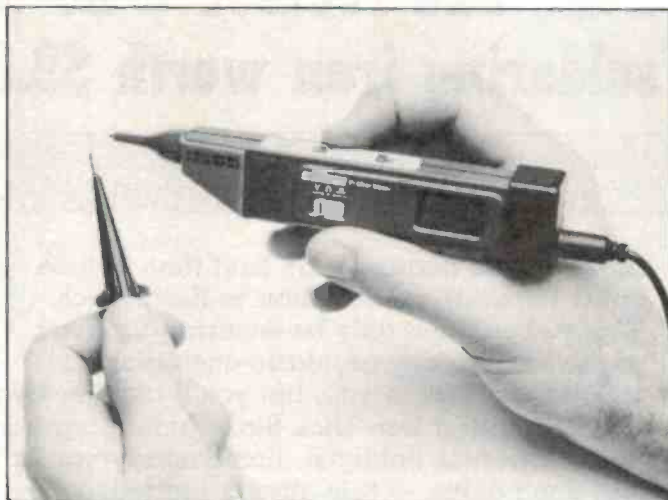

# CRO-logic analyzer

The new HP 1631A/D is a dedicated benchtop logic analyzer that provides state analysis, timing analysis and digital oscilloscope functions.

As a general-purpose system-integration tool for the digital hardware designer, the Hewlett-Packard product windows in on specific analogue events to provide information for troubleshooting.

The combination of logic analysis and oscilloscope functions in a single instrument will foster sale of the HP 1631A/D for applications where both a logic analyzer and oscilloscope would have been purchased, HP officials said.

The HP 1631A/D is a follow-on product to the HP 1639A/D/G line of stand-alone benchtop logic analyzers. The new model provides the full capability of the HP 1630A/D, including state and timing channels, inverse assembly and pre-processor support, but with more channels.

Two analogue channels are available with 200-megasample-per-second digitizing rate, allowing simultaneous single-shot capture and storage of waveforms up to 50 MHz bandwidth.

For further information contact Geoff Foley, Hewlett-Packard Australia. (03)895-2895.





## OEM power supplies

Semiconductor Circuits has increased the number of off-line switching power supplies in its product line. These units fall into three output power ranges: 10 to 75 W single output, 100 and 150 W single output and 12.5 to 50 Watt dual and triple outputs.

The 28 new 10 to 75 W single output models offer 5, 12, 15 and 24 Vdc outputs, and incorporate internal features to protect the input, load and supply.

There are 16 new 100 and 150 Watt units with 5, 12, 15 and 24 Vdc outputs. They feature switching frequency to 80 kHz. According to semiconductor circuits, this provides a near con-

stant 86% efficiency over a wide input range.

The remaining 21 units are dual and triple output models with an output power range from 12.5 to 50 W. Main output voltages are available in 5, 12, 15, and 24 Vdc.

All 65 new units are designed to comply with UL1012 and are suited for a wide variety of applications such as process controls, computer peripherals, data processing and test equipment.

For further information contact The George Brown Electronics Group, 174 Parramatta Road, Camperdown NSW 2050.

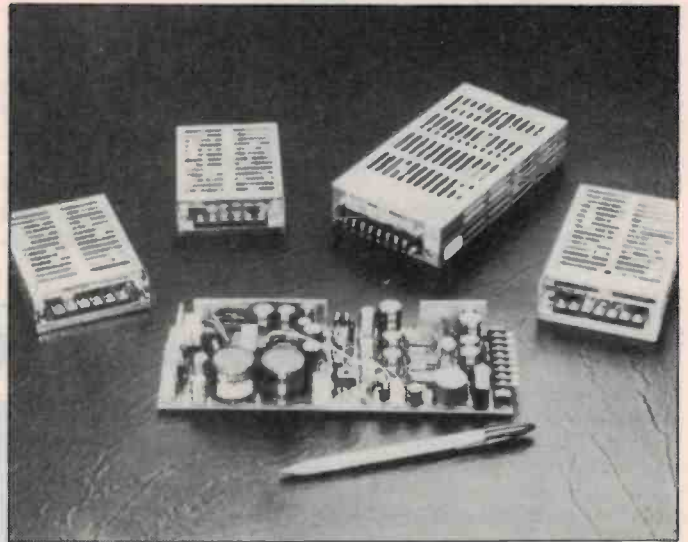

## Sprint dc fan

Using brushless dc technology, E. G. and G. Rotron have engineered a dc product — with many advantages over its ac counterpart. They claim that with equal reliability and air output, you get less noise and less power.

It has been designed from the ground up as a dc product. Thus, it is thinner (31.75 mm) than comparable ac products.

For further information please contact Total Electronics, 9 Harker Street, Burwood Vic. 3125. (03)288-4044.

## GPIB for the IBM pc

The power of the IBM PC as an instrument controller can be considerably increased by the use of the Ziotech GPIB interface card. Designated the ZT 1488, it plugs directly into one of the IBM pc expansion slots and allows the user to control up to 15 GPIB devices on one daisy chained cable. The interface also features a real time calendar clock with battery-backup and an on-board I/O multimodule socket. The multimodule facility allows the PC to be configured for particular I/O requirements such as analogue input/output, floating-point maths, streamer tape controller

or additional parallel channels.

A recommended accessory for the ZT 1488 is Ziotech's ZT 488 GPIB analyser tool. The ZT 488 is a low-cost diagnostic device which facilitates the development and debugging of GPIB communications.

The ZT 1488 GPIB interface offers easy to program BASIC language support and assembly language driver routines for use with other programming languages.

For further information on Ziotech's products contact A. J. Distributors, 44 Prospect Road, Prospect, SA 5082. (08)269-1244.

## Lab power supplies

The new Topward 2303 and 4303 power supplies both feature constant voltage and constant current capability; short circuit protection and extremely low ripple and internal resistance.

The single output model 2303 gives you 0-30 V and up to 3 A.

The model 2303 costs \$238 plus sales tax, and model 4303 costs \$460 plus sales tax. For more information, please contact Parameters, 41 Herbert Street, Artarmon. NSW. (02)439-3288.

## Eprom eraser

The DE-4 model EPROM eraser has been designed with the needs of the small operator, or the decentralized larger operator in mind.

Measuring only 22.9 cm x 9.4 cm x 6.6 cm overall, it fits conveniently on any desktop, and can hold from one to eight EPROMs. Operation is simplicity itself — load the drawer, slide it in, and press the red "on" button.

A safety feature of the DE-4 model is the captive drawer, which prevents UV exposure, so no interlock is needed. The in-

tensity generated by its 4 watt, 254 nm tube is approximately 6800  $\mu\text{W}/\text{cm}^2$  at the centre of the drawer.

Erasive time varies, depending on the erase energy of the EPROMs and the number in the drawer — for example one 6 W-s/cm<sup>2</sup> EPROM can be erased in 15 minutes and eight 15 W-s/cm<sup>2</sup> EPROMs can be erased in 51 mins.

For further information, contact: John Wilson, Australian Ultra Violet Services, Valley Road, Wattle Glen Vic 3096. (03)438-1279.

## Noise analysis

The 215-45 analyzer isolates and measures the frequency components of total noise and identifies them in specific octave bands. This isolation of individual noise components identifies the frequency bands of greatest noise and permits the most direct action in reducing the overall noise level.

It weighs 26 ounces, meets ANSI S1.4 Type 2 requirements and exceeds the most stringent ANSI requirements for octave band filter sets. It has a measuring range of 30 to 140dB re 20  $\mu\text{N}/\text{m}^2$ ; a frequency range of

20 kHz to 10 kHz; A, B, C, linear and external scale weighting with fast and slow response.

The OB-45 filter covers nine frequency ranges from 31 Hz to 8 kHz centre frequencies with full octave band width. The input from the sound level meter is 1.2 V rms plus 12 dB crest factor, 20 Hz to 10 kHz. The output ranges from 0 to 4 V rms with impedance less than 1 ohm.

For further information and pricing contact Paul Flynn, Associated Calibration Laboratories, 27 Rosella Street, Doncaster East Vic 3109. 842-8822.

## NEW EQUIPMENT

### 6½ digit multimeter

Tech Sales has released details of the new Solartron DMM. The new multimeter has all the usual functions, like voltage, current and resistance.

It also has a diode test facility and can make 2 or 4 wire measurements. There are 6½ digits to

give 100 nV sensitivity. The 7150 comes with an IEEE 488 interface built in for easy programming.

For more information about the Solartron 7150 contact Tech Sales at 12 Maroodah Highway, Ringwood Vic 3134.

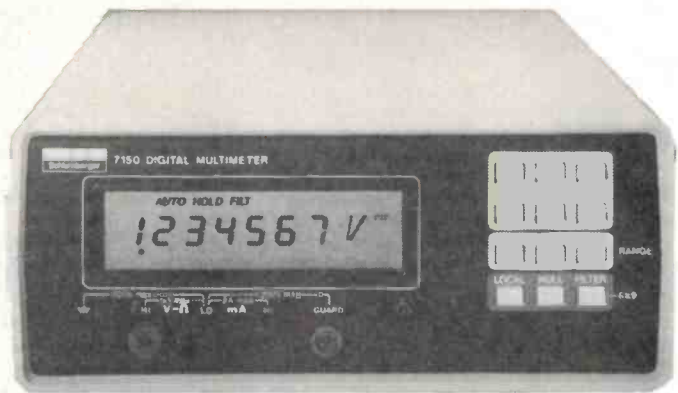

### HP releases the 'Pioneer' PC instrumentation

Hewlett Packard has recently released a range of computer controlled test and measurement equipment designed to be driven by either the IBM PC or the HP Touchscreen PC. Previously, most PC-controlled instrumentation has been based on the IEEE-488 protocol and allowed stand-alone test instruments to be interfaced to a computer for automatic monitoring and data collection.

The HP approach uses its own specially developed instrument bus to interface a series of 'soft' test instruments to the computer. The instruments are not stand-alone units and merely contain the necessary hardware to interface probes etc to the outside world. The conversion and display is all done on board the computer and several instrument faces can be displayed on screen at the one time. The advantage of this system is that a greater degree of automation and versatility is possible.

The key to the system is the advanced software it supports. The system software allows easy set up and design of automated



test routines, and allows the computer to automatically control the functions of the various instrument modules. A 'soft front panel' program displays simulated front panels for the various instruments to be displayed on the computer screen. In manual mode the various controls displayed can be manipulated by the keyboard or a mouse. The HP Touchscreen PC allows the user to select control function by merely touching the screen.

Traditionally, engineers have been suspicious of PC based instrument systems on the basis of

insufficient sophistication and accuracy and in the past this has been justified. Although the HP system could probably not compete on a spec basis with dedicated instruments, the cost and versatility of the system will make some engineering firms look twice at PC based instrumentation.

Some of the modules that will be available at the release of the system will be a digital multimeter, digitizing oscilloscope, function generator, universal counter, dual voltage DAC, digital I/O board and relay actuator board. HP plans to

greatly expand the range in the near future.

Software for the system is available for both the IBM-PC family and Hewlett-Packard's own touchscreen PC. The software allows for the control of the modules via the instrumentation bus either manually or automatically in the course of a programmed test procedure. Data acquisition and statistical programs allow the formatting and processing of the incoming data so that a comprehensive automatic data logging and analyzing system can be implemented.

With the advancing power and declining cost of the personal computer there is sure to be a lot of interest in a quality, well supported PC instrumentation line. The opportunities for electronics R & D and small manufacturing companies to implement these systems are vast and the launch of this line of products from Hewlett-Packard will undoubtedly see the start of an era of rapid development and interest in this area.

— Robert Irwin

### Optical fibre tester

Data Cable has introduced a new range of fibre optic converters from Fotec. The new C500 series is designed to allow computerized testing of fibre optic components.

They interface with computerized data acquisition systems to allow automatic power measurements for production and qualification testing. They provide a conversion from optical power to electrical voltage compatible with typical computer data ac-

quisition systems. Thus tests can be automated to provide more complete and accurate testing than using manual data collection. Typical applications include testing multiple cables or connectors under environmental stress and monitoring the output of sources undergoing life cycle or temperature testing.

For more information contact Data Cable, 538 Mountain Highway, Bayswater, Vic. 3153. (03)729-0044.

### Mains connector

The Quicktest solves the problem of connecting plugless leads to mains. Imported by Delsound from the UK, this unique device allows total isolation from the main supply when the lid is lifted.

With the lid opened, the wires of a plugless lead are inserted into the insulated clips. When the lid is closed, current passes to the equipment in use. The lid has a spring latch to hold it open when the Quicktest is wall

mounted. A neon light indicates that the connector is live and ready for use. The 13 amp fuse (BS1362) is easily accessible for replacement.

The Quicktest is made of tough safe materials. The base is phenolic moulded for insulation and rigidity. The lid is flame-retardant glass-filled thermoplastic.

For more information contact Delsound, 1 Wickham Terrace, Brisbane Qld. (07)229-6155.

# BUILD IT YOURSELF & SAVE!

With the exchange rate through the floor and imported goods rising in price, it really makes sense to build your own gear!

You save a fortune because you supply the labour. And you get the satisfaction of home brewing all over again!

## (1) 70cm amateur transceiver

Nearly 2000 now built: one of our most popular amateur kits. 40 channels on the 430-440MHz band. Everything supplied, including mic and full step-by-step instructions. Cat K-6300

**\$199**

### Upgrade kit for above:

Gives you repeater capability 'S' meter. Cat K-6302

**\$24.50**

### UHF Antenna Kit:

Suits above transceiver. Magna-base with co-axial mount, whip & cutting chart plus UHF grade co-ax & PL-259. Cat D-4014

**\$28.50**

## (2) amateur transceiver

The worthy 'brother' to the above set. Similar construction, (same case) with huge savings over the commercial rigs of the same standard. 40 channels & 5kHz offset. Cat K-6308

**\$199**

### VHF Antenna Kit

As above but with longer whip to suit 2m band (1/4 wave), and standard VHF antenna mount. Cat D-4024

**\$28.50**

### Matching Power Supply

To suit either UHF or VHF transceiver. 13.8V at 2A regulated.

Cat K-6310

**\$49.50**



## (3) 'Glass RTTY for the VZ-200/300 \$69.50

The low cost way to get into RTTY! Easy to build kit gives you full transceiver control and all 'wanted' RTTY features including WRU buffer, quick brown fox, etc. Works with the new VZ-300 too! Cat K-6318

## (4) VK Powemaster (short form) Supply \$99

What a supply! Used with M-2000 transformer, you can get a massive 14A continuous or 25A pk from this monster! Build it with the transformer you want for the power you want. Cat K-3448

14A cont. Transformer: Cat M-2010 \$54.50

6A cont. Transformer: Cat M-2000 \$24.95

## (5) 70cm preamp kit

Get more from your 70cm receiver. Preamp is easy to add, takes up minimal space and can be diode or relay switched. Cat K-6306

**\$19.95**

## (6) UHF Power Meter

A brand newey! Build a power meter for the 70cm band (also goes up to the CB band!) for top performance out of your UHF rigs. Cat K-6312

**\$49.95**

Available at all Dick Smith Electronics stores

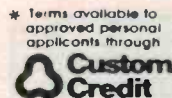

# DICK SMITH ELECTRONICS

PTY LTD

Have you got your new 1985 Dick Smith Electronics Catalogue yet?

Now out! The all new 1985 Dick Smith Electronics Supercatalogue. You can possibly last the rest of the year without one so race into your nearest newsagent for your Dick Smith Catalogue (you'll find it with a bonus issue of EA or ET!) Whoops. Try buying EA or ET! you'll get a free Dick Smith Electronics Catalogue. Or if you miss out, you can send the coupon at left for your very own copy!

NAME \_\_\_\_\_

ADDRESS \_\_\_\_\_

POSTCODE \_\_\_\_\_

Yes please! I missed out (or someone has already pinched it!) Please send me a copy of the new Dick Smith Electronics Catalogue. I've enclosed a dollar and understand you'll give me the dollar back with a bonus coupon. Send to DSXpress PO Box 321, North Ryde, NSW 2113.





# 300 BAUD DIRECT CONNECT MODEM

Geoff Nicholls

Modem? What do I want with a modem?

Can't afford a floppy disc? Use your telephone to access one for the cost of the call.

Bored with your old programs? Download hundreds of free programs.

Want to get in touch with fellow computer enthusiasts? Use 'electronic mail'.

Ever used a CP/M system? CP-DOS? UNIX? Well a modem will make your computer a remote terminal on some of the most exciting systems around. Read on.

COMPUTER COMMUNICATIONS is the new growth area in micros. We've been hearing about electronic mail, computerized shopping and the like for ages, but it's only been in the last few years that the average computer hobbyist has been able to afford the hardware to actually *do it*. This project brings the hardware cost down yet again — for around \$100 you can buy all the parts to build a 300 baud full duplex direct connect modem. Attach it to your computer and a vast new area opens up — the electronic office comes home!

## Ins and outs of modems

Why do we need modems at all? Why not connect the RS232 port directly to the phone lines? Well, apart from the need to isolate the telephone lines from any dangerous voltages (we need all the Telecom technicians alive), there are several reasons why that would not work with the switched telephone network.

The signals coming out of the RS232 port are digital, so they look like rectangular pulses of various lengths. To avoid distortion in transmission a signal path carrying such pulses would need to have a high frequency response such that the edges of the pulses were not rounded off too much, and a

low frequency response so that a long pulse didn't droop too much. Now at 300 bit/s the RS232 line produces one character every 1/30th of a second at maximum speed. This speed would be for a character made up of one start bit, eight data bits and one stop bit, that is 10 bits at 300 bits per second. If this character was 000000001 (which is possible), then the RS232 line would be at a high voltage for 9/300ths of a second and a low voltage for 1/300th of a second. To avoid excessive distortion of the pulse a high frequency response of 300 Hz is required. This represents the frequency at which the transmitted pulse reaches 90% of its final value in 0.35/300ths of a second, that is 35% of the bit time.

A second requirement is to have a limited droop or tilt of the pulse for the 9/300ths of a second when it's high. For the pulse to droop to 90% of its initial value, the required low frequency response is about 0.5 Hz! Unfortunately, the telephone system does not allow such low frequencies through it. Although there is a dc circuit back to most exchanges, once your signal gets there it has usually passed through transformer stages which roll off below 300 Hz. (The fact that the RS232 channel can sit at low or 'mark' for long periods

means the response would have to go right to dc.)

OK, we can't just feed RS232 signals down telephone lines, so what's the answer? Enter the modem! It converts the digital levels into audio signals that fall inside the frequency response of voice-grade telephone lines. There are many different techniques used for high-speed data transmission, but the low-speed modems are almost always FSK or Frequency Shift Keying. The concept is simple: assign one frequency to represent a '0' and another to represent a '1', and switch between them according to the digital data. The transmit frequency may be generated by having discrete oscillators and switching between them, or by having a single oscillator the frequency of which can be changed. The latter approach is the commonest for two reasons: it is easier to implement on integrated circuits, and it produces phase coherent signals that occupy a smaller bandwidth.

The receiver may be implemented in a number of ways. One approach is to use a phase-locked loop to track the incoming signal frequency. As the frequency changes, the PLL generates an error voltage which is used to vary an internal oscillator so that it follows the signal. The error voltage follows the modulation component of the signal, i.e., the data.

Other systems use separate bandpass filters tuned to each transmit frequency; the outputs of each filter are compared and whichever is the strongest determines the data output.

A practical data communication system is complicated by the need to transmit data in both directions: if both ends use the same transmit frequency then only one end can transmit at once and the possibility of clashes arises. The solution is to use separate frequencies at each end for transmission so that both ends may transmit simultaneously without interference. This means that some agreement must be reached be-





## LEGAL POSITION

There are a few legal points to be aware of before you connect a home-built modem to the switched network. Here's a summary of the position:

At present the Australian Telecommunications Commission ("Telecom"), by virtue of the Telecommunications Act 1975 ("The Act"), has control of what may be connected to the public telephone network. It is an offence under the act to attach any apparatus other than an approved device or an appliance rented from Telecom to a telephone line. There is nothing wrong with constructing and using the modem described here provided you do not attach it to Telecom lines without approval from Telecom. It may be used freely over a private Intercom system or as an RTTY modem by radio amateurs, for instance.

Authorizations for modems are granted by the Regulatory Branch Data Division, Commercial Services Department Headquarters, 199 William Street, Melbourne, 3000. Telephone (03)606-6939.

Applications for authorizations must be made on Form TS139, Data and Non-Voice Equipment Directly Connected to the Telecom Network.

Information on relevant publications may be obtained from the above address or by phoning (03)606-5770, telex AA30146.

The specifications relevant include 1050, 1053, 1222, 1240, 1302 and 1364.

Even if you don't intend connecting the modem to the switched network, I urge that you follow the constructional details and component specifications exactly to ensure a high degree of electrical safety — we don't want to lose any readers!

tween the communicating parties as to which frequency to transmit on. The usual approach is to make the party initiating the call the ORIGINATE end and the party receiving the call the ANSWER end.

The Australian standard frequencies for 300 baud operation are set down in a document called "CCIT V.21" and differ from the American 300 baud standard which is called "BELL 103".

The frequencies are defined in terms of the RS232 signal levels (which are detailed in CCIT V.24) in which a logic zero is a positive voltage over 3 volts (also called a space), while a logic one is a negative voltage less than -3 volts (called a mark).

The actual frequencies used are tabulated below:

MODE	-		+	
	Mark	Space	Mark	Space
Bell 103 ORIG.	1270	1070	2225	2025
Bell 103 ANS.	2225	2025	1270	1070
CCIT V.21 ORIG.	980	1180	1650	1850
CCIT V.21 ANS.	1650	1850	980	1180

### Answer tone

There is a further CCIT document relevant to the ETI-699. It is called "V.25" and deals with automatic calling and answering requirements. Apart from defining who should start transmitting first, V.25 covers the generation of ANSWER TONE which is a 2100 Hz signal used by Telecom to disable 'echo suppressors' on the line. I'm not familiar with the details of echo suppressors, but they seem to cause problems for modems if they are not turned off by the V.25 tone.

When the S3530 is being operated manually and is switched to ANSWER it waits 2.1 seconds then sends a 3.4 second burst of 2100 Hz tone followed by an 80 ms pause then a 1650 Hz tone. The other modem is expected to pick up the 1650 Hz tone and send a 980 Hz tone within 700 ms. The an-

swering S3530 will start sending data 640 ms after it detects the 980 Hz signal. If it does not pick up any carrier it will wait a few seconds before re-sending the 2100 Hz tone and repeating the cycle.

In ORIGINATE mode the S3530 will wait until it detects the 1650 Hz tone for about 426 ms before it activates the Carrier Detect signal. About 200 ms later the originate S3530 will send a 980 Hz tone for 640 ms before sending data.

### How to use the Modem

Firstly, you will need a communications program to run on your computer. There are simple programs available (or easily written) for almost all machines that make them behave as a serial terminal. Such a program will get you started, but sooner or later you will want a proper file transfer program that allows error-free exchange of programs and documents.

The most widely used microcomputer protocol is known as the Ward Christensen protocol after the American who defined it and placed it in the public domain for users everywhere. Communications programs supporting the Christensen protocol include MODEM7, YAM, RCPMLINK, TELCOM II, NETROM, PC-MODEM, MODEM86, and MITE. There are many more programs freely available from bulletin board systems and remote operating systems all over Australia. If you have any trouble getting a com program then write to one of the computer clubs or system operators of the bulletin boards and ask for help.

Some machines, such as the MicroBee, have built-in terminal and file transfer utilities in ROM. The 'Bees software is called either Netrom or Telcom, unless you have a very early 'Bee in which case you may have to write your own, or buy a new ROM.

### Calling up a bulletin board

You'll need an approved modem, a computer running a com program and a tele-

phone line. Put your computer into the following com mode:

- 300 bit/s FULL duplex
- 8 data bits
- 1 stop bit
- no parity

Switch your modem to CCIT V.21, ORIGINATE and PHONE. Now run the terminal program on your computer and dial up one of the bulletin board systems. On answer (it often takes ages to get through to the larger systems), listen for the carrier tone to confirm that you have the right number. (Occasionally you may get a person answering, perhaps the sysop if the system is being changed.) Once you hear the tone switch to the MODEM position. The CARRIER DETECT LED should come on within a few seconds; if it doesn't then don't wait too long before hanging up by switching back to phone and hanging up the receiver. If all is well you'll see a message come up like:

HOW MANY NULLS (0-9) DO YOU NEED?

If you see this, type 0 to continue. Many systems will display other sign-on messages, indeed some will do nothing unless you type a carriage return first. So if nothing happens after the CARRIER DETECT comes on, type a few CRs just in case.

From here on just answer the questions as they come up. In case you get stuck, try typing a question mark or "help" to get more information. Many of the systems have paying members and will ask for a ▶

# Project 699

membership number and password. They will usually allow a visitor a limited time on the system to find out how to join and what's available. The membership fees are typically \$20 a year, enough to discourage the computer vandals but not too steep for the serious enthusiast. It is a sad fact that some imbeciles always try and stuff things up for the rest of us, however it only takes a few seconds to disconnect an unwanted caller and they never know if the sysop is monitoring or not!

When you call a bulletin board your modem is always the **ORIGINATING** one, but if you are not talking to an auto-answer system then you will have to decide who will **ORIGINATE** and who will **ANSWER** before putting the modems on-line.

There is a great deal more you can do with the modem than I have said here, I suggest you read the computer sections of the electronics magazines and also buy computer magazines such as *Your Computer* (which operates the MiCC Bulletin Board out of this office! The phone number is available in the magazine).

## PARTS LIST — ETI-699

Resistors.....all 1/4 W 5% unless noted

- R1, 10, 13.....10k
- R2.....1k5
- R3.....27k
- R4.....68k
- R5, 26, 27.....330R
- R6.....15k
- R7.....47R 1W
- R8.....82R 1W
- R9, 12.....8M2
- R11, 17, 20, 21, 24, 28.....33k
- R14.....100k
- R15, 16.....47R
- R18.....39k
- R19, 22, 25.....22k
- R23.....680R

### Capacitors

- C1, 6, 8, 9.....15μ 16 VW tag tantalum
- C2, 3.....1,000μ 16 VW RB electrolytic
- C4.....22n greencap
- C5.....0.82μ 250 Vac metallized paper eg RIFA PME 267H
- C7.....100n greencap
- C10, 11.....22p ceramic
- C12, 13.....100n ceramic bypass (bluechip)

### Semiconductors

- IC1.....LM324
- IC2.....7805
- IC3.....7905
- IC4.....AMI S3530

- IC5.....TL072 etc
- Q1.....BC548
- D1, 2, 5, 6.....1N914 etc
- D3, 4.....1N4002 etc
- ZD1, 2.....3V9 1 W zeners
- LED1, 2.....5 mm red LEDs

### Miscellaneous

- T1.....Telecom approved line, Isolating transformer either Ferguson MT-620 or Arlec 45035
- PP1.....Telecom approved 12 Vac plugpack min 300 mA
- SW1, 2.....SPDT miniature toggle switch
- SW3.....DPDT 250 Vac miniature toggle
- XTL.....3.579 MHz crystal (NTSC type)
- SK1.....DB25S solder type chassis socket

ETI-699 pc board; plastic instrument case non-vented 200 x 160 x 70 mm; ETI-699 front panel; handset phone; 2 x 5 mm LED bezels; 2 nylon cable clamps (3/16" cable); 2 rubber grommets; mains-rated spaghetti to insulate line conductors; sealant eg Silastic; self tapping screws for mounting pc board and clamps; 250 Vac rated hookup wire.

Price estimate: \$99

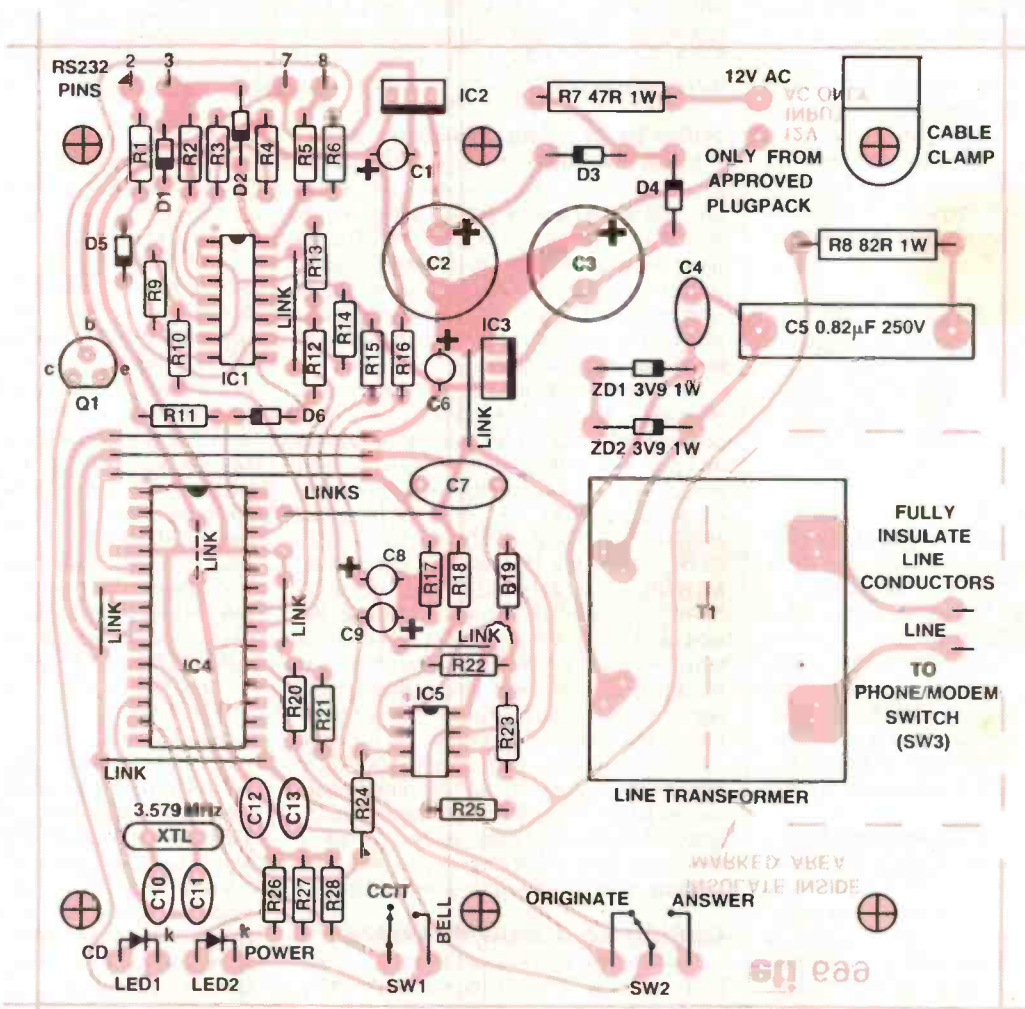



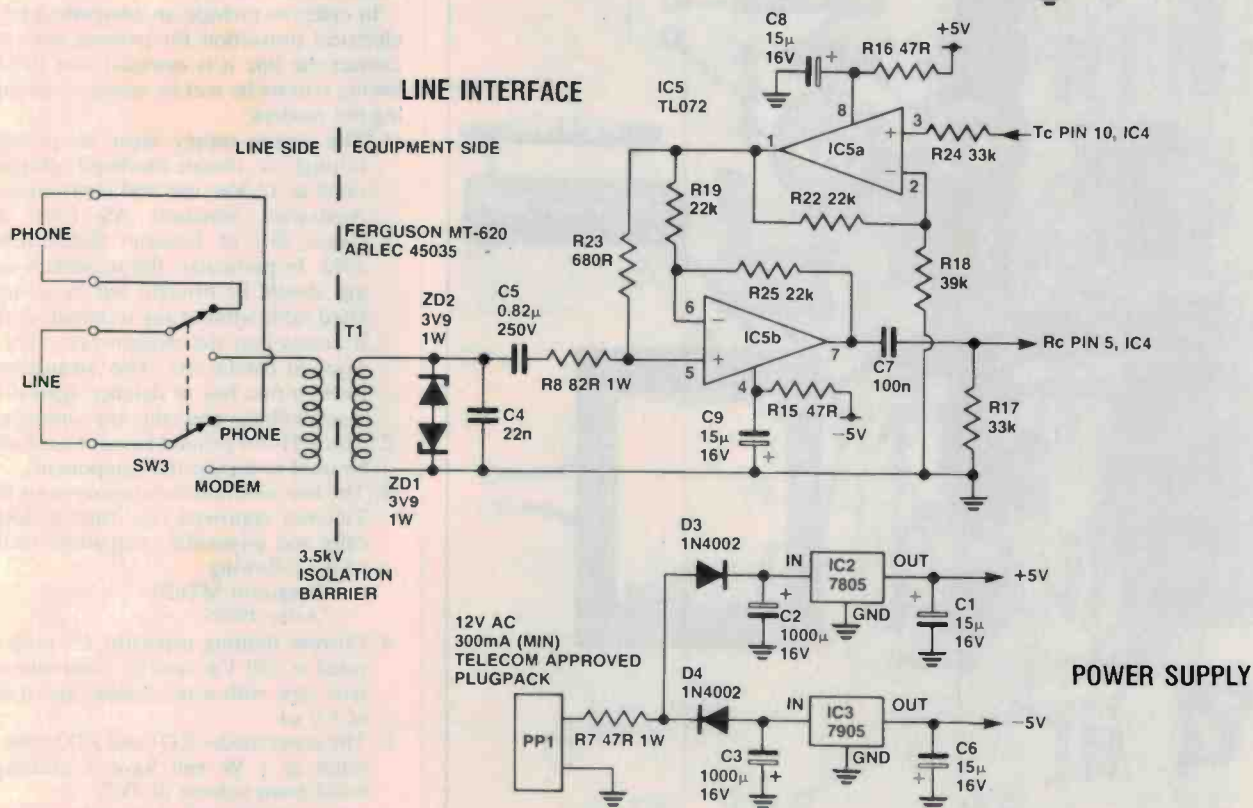
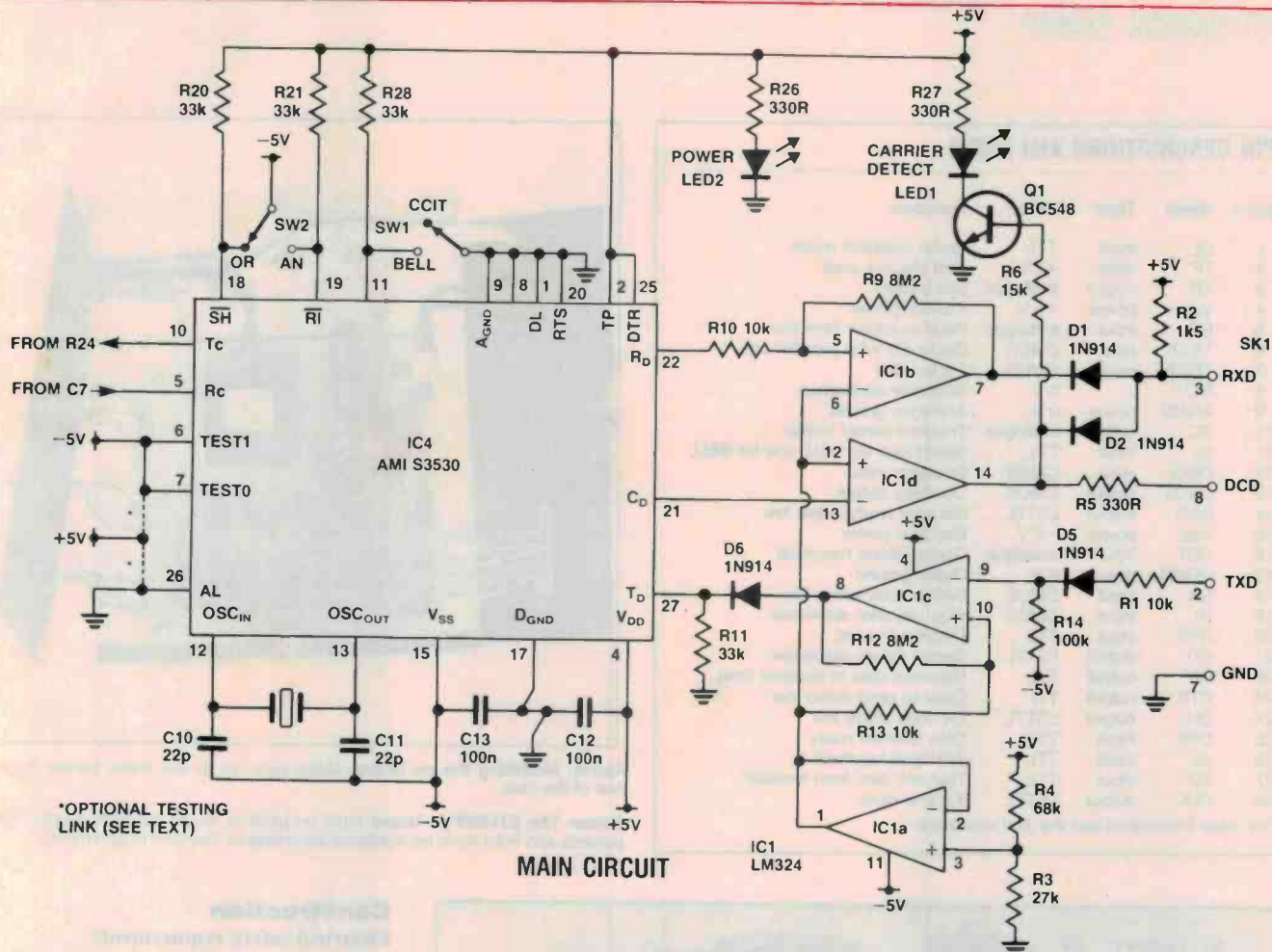

## PIN DESCRIPTIONS AMI S3530

pin #	Name	Type	Level	Function
1	DL	Input	TTL	digital loopback mode
2	TP	Input	+5 V	Test pin; not used
3	EP	output	analogue	Eye pattern
4	Vdd	power	+5 V	Positive power
5	RC	input	analogue	Receive carrier from line
6	TEST1	input	CMOS	Set to +5 V for passthrough
7	TEST0	input	CMOS	Tie to -5 V
8	NC ?	—	0 V	Substrate connection
9	AGND	power	0 V	Analogue ground
10	TC	output	analogue	Transmit carrier to line
11	SL	Input	TTL	Select high for CCIT, low for BELL
12	OSCi	Input	CMOS	Oscillator Input
13	OSCo	output	CMOS	Oscillator output
14	DSR	output	LSTTL	Data set ready active low
15	Vss	power	-5 V	Negative power
16	CDT	Input	analogue	Carrier detect threshold
17	DGND	power	0 V	Digital ground
18	SH	input	CMOS	Switch hook active low
19	RI	Input	CMOS	Ring Indicator active low
20	RTS	input	TTL	Request to send
21	CD	output	LSTTL	Carrier detect active low
22	RD	output	TTL	Received data to terminal (low)
23	CTS	output	TTL	Clear to send active low
24	OH	output	LSTTL	Off hook active low
25	DTR	Input	TTL	Data terminal ready
26	AL	Input	TTL	Analogue loopback
27	TD	Input	TTL	Transmit data from terminal
28	CLK	output	LSTTL	4.8 kHz clock

For more information see the AMI data book.

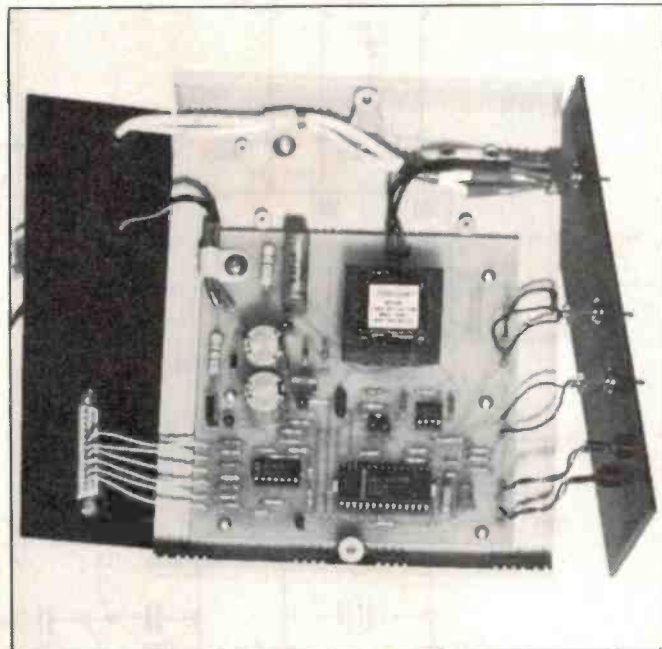

Above: Mounting the pc board. Make sure not to use metal panels front or rear of the case.

Below: The ETI-699 pc board must be used to mount the components. Components and links must be insulated according to Telecom requirements.

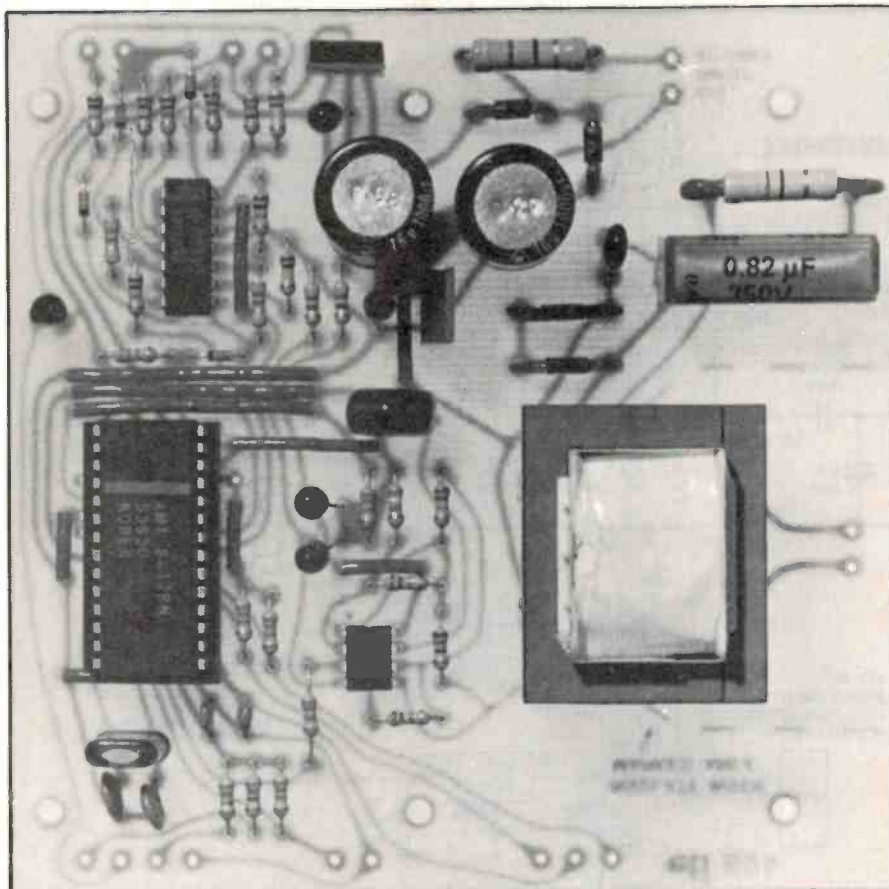

## Construction

### Electrical safety requirements

In order to provide an adequate level of electrical protection for persons who may contact the line it is essential that the following criteria be met by anyone constructing the modem:

1. The power supply must be provided through a double-insulated plugpack rated at 12 Vac rms and conforming to Australian Standard AS C126 and clause 10.7 of Telecom Specifications 1302. In particular, the secondary voltage should be brought out by an insulated cable without any terminals so that it passes into the modem case with no exposed conductors. This arrangement forms a first line of defence against the mains voltage powering the equipment.
2. The ETI-699 printed circuit board must be used to mount the components.
3. The line isolation transformer must be a Telecom approved type that is electrically and physically compatible to one of the following:  
Ferguson MT620  
Arlec 45035
4. Current limiting capacitor C5 must be rated at 250 Vac and be a non-electrolytic type with a maximum capacitance of 1.0 μF.
5. The zener diodes ZD1 and ZD2 must be rated at 1 W and have a maximum breakdown voltage of 4V7.
6. All terminals and pc board tracks as-

The modem circuit splits logically into five sections comprising the power supply, the line interface, the hybrid, the modem chip itself and the RS232 interface.

**The Power Supply**

Plugpack PP1 provides a nominal 12 volts ac that is double insulated from the mains voltage. This provides a first line of defence against the 250 volt supply.

The alternating current is half-wave rectified by D3 and D4 and filtered by R7, C2 and C3 to provide dual supplies for the two regulators IC2 and IC3. The regulators produce + and - 5 volts for the rest of the circuit. Capacitors C1 and C6 ensure that the regulators are stable.

The RC filters R16/C8 and R15/C9 decouple any noise on the power supplies to the signal amplifiers in the hybrid. C12 and C13 bypass the supply to the modem chip itself (IC4).

**The Line Interface**

The line is switched between the modem and the telephone by SW3, a 250 volt ac rated DPDT switch. This allows dialling as well as voice communication when required.

Isolation transformer T1 introduces a 3.5 kV insulation barrier between the modem circuit and the incoming line. The layout of the printed circuit board maintains this isolation by spacing the line-side tracks at least 10 mm from tracks on the modem side of the transformer.

Capacitor C5 and zener diodes ZD1 and ZD2 form a voltage limiting circuit to limit the maximum voltage that can be developed across the line terminals in the event of a short to the 250 volt mains. The mains may be introduced if the plugpack failed catastrophically or if the data terminal equipment (ie, computer) presented mains voltage at the RS232 socket. The impedance of the limiting capacitor C5 at 50 Hz is about 3.8k so if the full 264 volts (240 + 10%) was developed across it then the maximum current that would flow is less than 70 mA.

The two zener diodes would dissipate about 280 mW under these conditions, which is well inside their 1 W ratings. The voltage at the modem side of the line would therefore be around 5 volts rms, and so would the line side voltage.

Resistor R8 is specified at 1 W because it mounts next to C5 on the circuit board, and hence could damage the capacitor if not rated to handle the fault current.

**The Hybrid**

The hybrid must couple the transmit signal to the line, allow the received signal to pass to the modem with minimal interference from the transmit signal and terminate the line in the correct impedance.

The transmission signal from pin 10 of IC4 is amplified by IC5a and presented at low source impedance to R23 and passes through R8, C5 and T1 to the line at around -11 dBm. (A power level of 1mW into 600 ohms is 0 dBm or about 775 mV into 600 ohms. A level of -11 dBm is a power of 79

$\mu$ W or a voltage of about 220 mV into 600 ohms.)

IC5b amplifies the received signal from the line and rejects the transmitted signal from IC5a. The gain from the line to the output of IC5b (neglecting R8 and C5) is  $1 + R25/R19$  or 2.

The gain from the output of IC5a to the output of IC5b is given by (neglecting C5):

$$A = - \frac{R25}{R19} + \left( 1 + \frac{R25}{R19} \right) \frac{R8 + Rline}{R23 + R8 + Rline}$$

where Rline is the line impedance.

This equation will evaluate to zero if  $R25=R19$  and  $R23=R8+Rline$ . If the line impedance is 598 ohms resistive then the transmit signal will be nulled. In practice the line is rarely resistive, let alone near 600 ohms so the above should only be taken as a guide to understanding the principal of the hybrid circuit. One of the functions of R8 is to swamp some of the reactance of the line, though some received signal is lost by introducing it.

The hybrid should be assumed to provide about -10 dB of rejection on a typical line.

Capacitor C4 filters any high frequency interference from the line, while C7 and R17 couple the received signal to the modem chip.

**The AMI-S3530**

This device performs all of the modem functions of the ETI-699; the rest of the circuit interfaces it to the external line and terminal equipment.

A brief description of the pin functions is given in the table.

All timing and frequency selection is derived from the on-board crystal oscillator. An NTSC 3.579545 Mhz crystal connects to pins 12 and 13.

The S3530 is operated in manual mode in this design, so the ORIGINATE/ANSWER switch SW2 is connected to the SWITCH HOOK and RING INDICATOR inputs.

Switch SW1 selects the transmission format; if only CCIT is required then SW1 may be deleted and the pads on the pc board left open.

I have made provision for two testing modes to aid in servicing the modem. They have not been marked on the overlay so only experienced hobbyists should activate them.

The modes are as follows:

**Passthrough mode.** This disables the normal handshaking sequencing the modem employs and permanently enables the transmitter and receiver circuits. CARRIER DETECT, the ORIGINATE/ANSWER and CCIT/BELL select still operate. To activate this mode, cut the fine track between pins 6 and 7 of IC4. Then solder a link between the pad next to pin 7 and the pad next to pin 4. Another pad has been provided at pin 6 to

reconnect pin 7 for normal operation.

**Analogue Loopback.** This tests all of the analogue and digital functions in the S3530. The receiver filter frequencies are changed to match the transmitter and an internal switch connects the received carrier (pin 5) to the transmit carrier (pin 10). The modem can then be tested by sending characters in full duplex mode. This function is activated by removing the link from the pad near pin 27 (it normally goes to the ground pad near C7) and inserting a link from the pad near pin 27 to the pad near pin 25.

The received data is presented on pin 22, while the data to be transmitted is input on pin 27.

The S3530 provides a carrier detect output on pin 21 to indicate whether signal of sufficient strength is present on the expected frequency, which varies with operating modes.

The other pins on IC4 are either unused outputs, or are inputs that are tied to allow manual operation.

**NOTE** — We received an update from the manufacturers that is not mentioned in the AMI Data Book. Pin 8 is labelled NC for not connected in the book, but it is actually a substrate connection and must be tied to ground.

**The RS232 Interface**

The S3530 does not produce signals suitable for driving an RS232 port so some buffering and level translation is performed by IC1.

Resistors R3 and R4 form a voltage divider of which the 1.4 volt output is buffered by IC1a. This level is midway between the TTL high and low thresholds and is used to determine TTL levels.

Carrier detect from pin 21 and IC4 is converted to RS232 levels by the inverting comparator IC1c and presented to the port through R5. It also drives T1 to activate the CD LED1 when carrier is present.

The received data from pin 22 goes to the non-inverting comparator IC1b and is then ANDed with the carrier detect signal by D1, D2 and R2. This is necessary because of a minor oversight by the S3530 designers: the received data from the chip is clamped to positive or 'space' when no carrier is present and this confuses some computers and terminals. The convention is to have the communications line sitting in the 'mark' or negative voltage when data is not being transmitted.

The incoming data is converted to TTL levels by IC1c, an inverting comparator with hysteresis and enters the S3530 through pin 27.

**NOTE** — Some terminals or computers may require a CTS signal to operate correctly. If this is the case, connect pins 4 and 5 together on the DB25S socket. Also, the MicroBee does not have pin 8 (the defined RS232 Data Carrier Detect signal) connected, so MicroBee owners should connect DCD to pin 5 instead.

- 7. The modem must be enclosed in a case of non-conducting material and the pc board mounted rigidly within the case. It is strongly recommended to use the case listed in the parts list.

- 8. The double pole switch SW3 must be rated at 250 Vac.
- 9. The line wiring must enter the case through its own grommet and be securely clamped to the case. All line wiring should be routed as far as possible away from the pc board and other wiring inside the case, to be at least 15 mm away.

- 10. The cable from the plugpack must enter the case through its own grommet and be securely clamped to the case. The cable should be soldered directly to the pc board without any plug and socket arrangement to prevent the inadvertent connection of a dangerous voltage to the modem.
- 11. The data equipment (computer) that ▶

will be connected to the modem should comply with the IEC Publication 435.

- The dialler telephone (if) used with the modem should comply with Telecom Specification 1302, 1050 and 1053.

## Construction details

First check the pc board to see that there are no broken tracks, copper bridges (especially between IC pins) and that all holes have been correctly drilled. If all is OK then the 11 links can be installed. It is good constructional practice to insulate these links by either sleeving tinned copper wire with spaghetti or using insulated hook up wire to make them. Note that one of the links is under IC4 so don't forget to install it first! (It need not be insulated.)

The resistors may be soldered in next, all the 1/4 W types can mount down against the pc board, but the two 1 W resistors R7 and R8 should be mounted about 5 mm clear of the board to allow air flow around them. These two should be installed with spaghetti sleeves on their pigtails to reduce the chance of accidental shorts.

The diodes can go in next, the smaller 1N914 types can mount against the pc board, but the two 1 A diodes (D3, D4) and the 1 W 3V9 zeners should be mounted a few mm clear of the board with sleeves on their pigtails. Watch the polarity of the diodes, the end with the band should match the overlay diagram.

Six of the capacitors are polarized and should be checked carefully before soldering, the other five (C4, C5, C7, C12, C13) can go in either way. The 250 Vac capacitor C5 should mount right against the pc board so that the leads cannot be seen.

The transistor and the two regulators (Q1, IC2, IC3) also need to be inserted the right way around and soldered in. It is a good idea to stop construction at this point and temporarily solder the plugpack leads

to the pc board to check the supply rails for correct voltage. Set your meter to the 20 V dc range and clip the negative lead to the heatsink tab of IC2. After switching on the plugpack you should get +4.75 to +5.25 V on the positive lead of C8 and -4.75 to -5.25 V on the negative lead of C9. If you don't obtain these results then switch off and trace the fault before proceeding.

I recommend that an IC socket be used for IC4 and it is wise to also use sockets for the other two (IC1 and IC5). These don't add much to the cost but could save a lot of time if you are unlucky enough to have a fault later.

Solder in the 3.579 MHz crystal either way, it's not polarized.

The line transformer can go in now; if you have the Arlec 45035 you will find that it only goes in one way, with the closely spaced pins towards the centre of the pc board. The Ferguson MT-620 will fit in two ways, it does not matter which you use since its equipment and line terminals are interchangeable. Use a generous amount of solder and a hot iron here since the transformer is secured by the solder joints.

Cut 13 lengths of hookup wire each about 75 mm long and strip one end of each. Solder these to the LED1, LED2, SW1, SW2 and RS-232 terminal pads.

Cut two 150 mm lengths of 250 Vac rated hookup wire and solder to the line terminal pads. Make sure that the insulation goes right down to the pc board and that there are no loose strands on the top of the board. I pulled the wire through a little as I soldered each with a pair of pliers to ensure the insulation butted against the board. Slip a 20 mm sleeve of spaghetti over each wire to insulate the switch terminals after they are soldered later.

That's about all you can do with the pc board until the case is ready to mount it.

The recommended case has separate front and rear plastic panels — *do not substitute metal panels.*

The rear panel has to be drilled to take the two rubber grommets and a hole needs to be cut to take the DB25S socket. The 'plasticwork' diagram shows where to perform the surgery. The front panel may come pre-drilled and screen printed, but if not then you should get a 'Scotchcal' label to stick to it.

There are two ways to stick the label on, if you are feeling lucky then rip off the backing paper, align the marks with the corners of the panel and press it down. If Murphy plays a big role in your life then use the patented "Peter Ihnat" approach of wetting the sticky side of the label before contacting the panel. This gives you a few tries to get it right without tearing the label.

Drill the panel (carefully) through the label with a drill press according to the 'plasticwork' dimensions, starting with a small drill to get the centres aligned.

The pc board mounts to the left of the case as seen from the front. There are six mounting holes which should line up with some of the pillars in the recommended box. The other unused pillars under the pc board are best snipped off with a strong pair of side cutters, otherwise the solder joints will stop the board from sitting down properly. Don't cut off any pillars to the right of the pc board since they are required for the line cable clamp and a possible future auto-dialling pc board. (If enough readers ask for it.)

Trim the wires to the two SPST switches and solder them up. Most switches have the toggle opposite the closed contacts.

The LEDs can also be wired up now, again it is good practice to sleeve the connections. The anode lead of a LED is longest and goes to the terminal marked "A".

## Insulating the line wiring

Take the lead of the dialler phone and cut it to leave enough on the phone end to pick up and use the phone. Remember you can buy an extension for the plug end, so don't be too stingy with the length for the phone.

Carefully strip back the outer sheath for 20 mm or so on each cut end, and then strip the insulation off the two wires to expose about 5 mm of conductor on each wire.

Pass both wires through the grommet nearest the end of the back panel. Slip two 20 mm lengths of spaghetti over both ends to tie the leads together. Put a 30 mm length sleeve of smaller diameter heatshrink tubing separately over each lead. Finally put a 10 mm length of small diameter spaghetti over each individual wire (four in all). The latter sleeve is to be a tight fit over the switch terminals after the wires are soldered.

Solder the line side to the moving contacts of the double pole switch SW3 and the

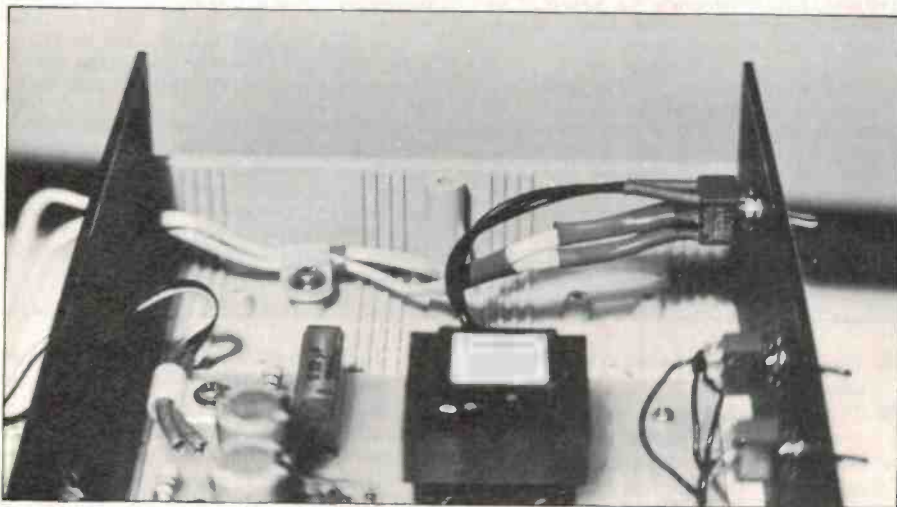

Insulation is particularly important on the telephone side of the board. Make sure that insulation goes right down to the pc board with no loose strands on the top of the board.

phone side to one of the fixed contact pairs. (The lower pair for most switches.)

Now slide the smallest sleeves over the soldered terminals so that no part of the terminals is exposed. Then push the heatshrink up over each pair of contacts and apply a hair dryer to shrink the tubing. The object of all this is to make accidental contact with the line impossible by covering all line terminals with 250 Vac insulation.

Slide one of the larger plastic sleeves back to one of the plastic mounting pillars near the back panel and slip a nylon cable clamp over the sleeve. Screw the clamp down with a washer and a self-tapping screw as in the photographs.

### Transmit level testing

At this point you should have the line and phone leads wired to switch SW3 and two loose wires coming from the isolating transformer. Strip these wires back 5 mm and temporarily solder a 600 ohm resistor across them. (Use 270R and 330R in series if you haven't got a 600R handy.)

Reconnect the plugpack lead and put the remaining ICs in their sockets. Be careful with IC4 as it is a static sensitive device. Before powering up, make sure there is nothing shorting the pc board underneath.

Set the switches to CCIT V.21 and ANSWER. Now monitor the voltage across the 600R resistance with a CRO or an ac voltmeter with a bandwidth of at least 3 kHz. Switch the plugpack on and note what happens. You should see nothing for a few seconds then a brief burst of 2100 Hz followed by a gap then another longer burst of 1650 Hz. The cycle then repeats as long as power is applied. The voltage should be less than 0.24 V rms or 0.69 V p-p when the tones are present. If all is well then proceed to the final assembly stage.

If you are getting more than 0.24 V rms then either your measuring equipment is inaccurate, the resistors around IC5 are incorrect or you have a freak AMI-S3530.

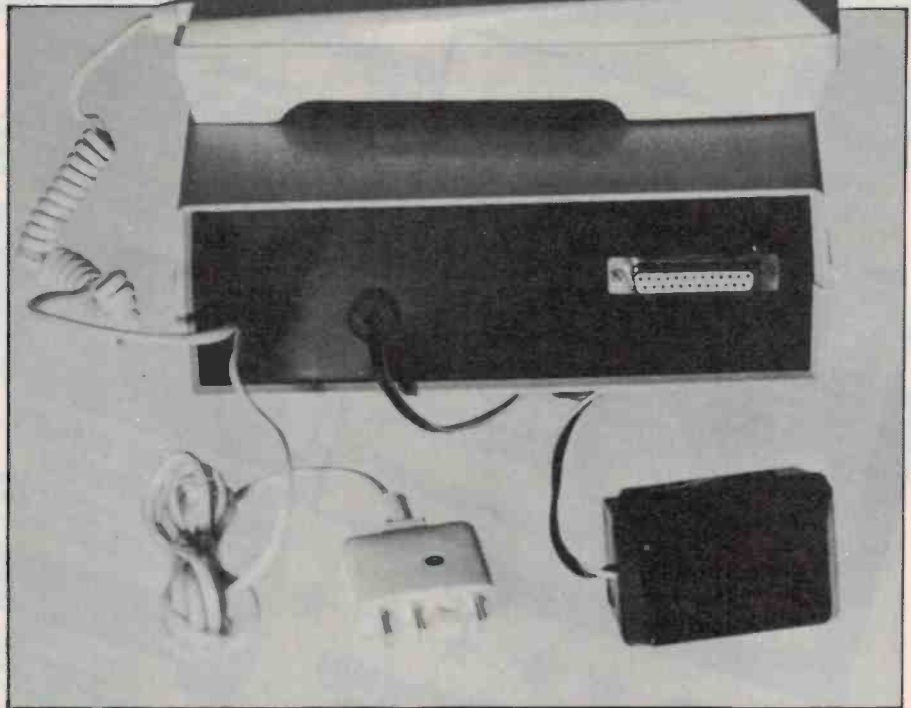

The level may be reduced by increasing R18 which is presently 39k.

If you are getting around 0.2 V rms then proceed to final assembly.

If you are getting nothing at all, first check pin 28 of IC with a CRO or frequency meter. There should be a 4.8 kHz square wave signal at LSTTL levels (about 0.5 to 3.5 V). If the latter signal is not there then IC4 may be faulty.

### Final assembly

Screw the DB25S socket to the back panel and wire it up. Run the plugpack lead through its grommet and slip a couple of lengths of spaghetti over the wires to allow the nylon clamp to grip properly. Solder the wires to the ac input pads, once again avoid leaving any exposed conductors on the component side of the board.

Remove the 600 ohm resistor and solder the wires to the remaining terminals on

SW3. Push the sleeving over the terminals as before to completely cover them. Lift up the pc board and either spray all tracks within the dashed area with an insulating coating or apply a sealant such as Silastic to completely insulate the line. The transformer will need a bit of the same on the exposed line terminals above the pc board to complete the job of isolating the line.

Slip the front and back panels into the slots provided in the base of the case and screw the pc board down with six self-tapping screws. Note that the back right hand screw passes through a washer and then the plugpack cable clamp.

Screw the switches to the front panel and install the LEDs with bezels.

Carefully go over everything to ensure that all electrical safety criteria have been met. When you are sure all is OK the lid may be fitted and the two halves screwed together.

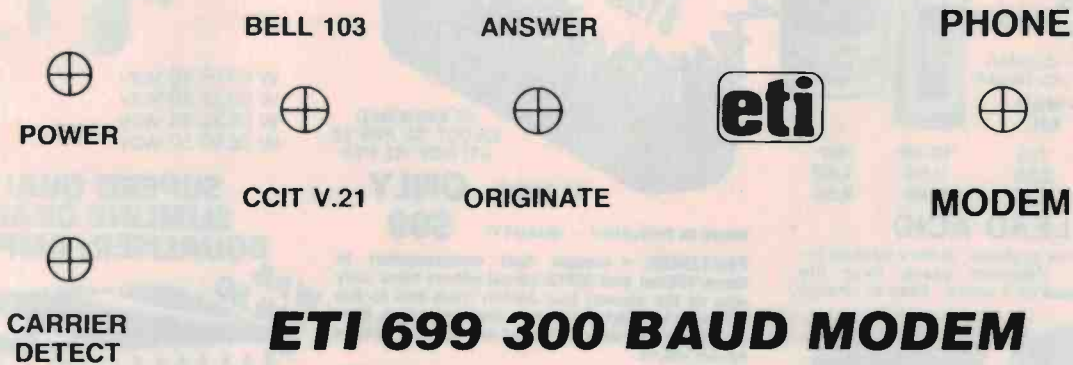

## ETI 699 300 BAUD MODEM

BANKCARD HOLDERS — PHONE ALTRONICS TOLL FREE 008 • 999 • 007

BANKCARD HOLDERS — PHONE ALTRONICS TOLL FREE 008 • 999 • 007



Dear Customer,  
As you are all aware the recent savage devaluation of the Australian dollar is real bad news for the Electronic enthusiast. As virtually all electronic components are imported from overseas you can expect to see huge price increases over the next few weeks. At Altronics we have been able to hold prices down during 1983/84 even though our currency drifted down approximately 15% through that period. But with this latest A\$ devastation we will be forced to increase prices shortly.  
These advertised items are all ex stock at pre-devaluation prices — this is definitely your last chance — so order now.

Regards,  
*Jack O'Donnell*

### DUBBING SET

ANY VIDEO TO ANY VIDEO  
This has got to be the most comprehensive cable and connector set ever sold! The Kit includes a 2 x RCA to 2 x RCA 1.5M audio lead and 5 pin din to 5 pin din (reversed for video) 1.5M lead. The following adaptors are provided to mate with these leads. • 6 pin din to 4 RCA female • 2 of 5 pin din to 2 RCA female • 2 of BNC male to RCA female • UHF PL259 male to RCA female.



### PANBRAKE SHEET METAL BENDER

Our Panbrake Sheetmetal bender continues to be one of our most popular tools. Just the shot for making up heatsinks, brackets, chassis etc.

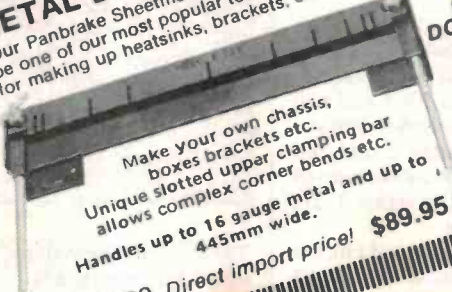

T 2400 Direct import price! **\$89.95**  
T 2330

### INSTANT SUPER TYPE GLUE

T3010  
**\$2.95**

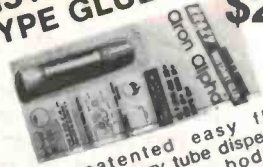

New patented easy flow Dispenser carry tube dispenses only when tube body is depressed—ensures no leaks. Many times the number of bonds over conventional tubes.  
Sticks In seconds—1000's of uses

### 13 PC SET OF DRILLS

Chrome Vanadium Steel  
DON'T PAY \$15 OR MORE  
**Only \$7.95**

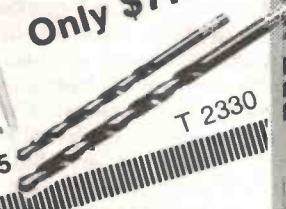

Major Competitor admits Altronics Mail Order Service "Consistently Excellent"

It appears that one of the "heavy weights" of the Electronics Industry has periodically placed anonymous "Test Mail Orders" with its competitors presumably to gauge the quality of its competition. When tackled by me as to "how we fared" the "heavy weight executive" solemnly admitted Altronics service was consistently excellent.

No prizes for guessing whol!

Pre-devaluation bargains —  
Just compare the massive savings on what you would pay with the typical industry heavy weight competition

# ALTRONICS COMPONENTS

NOW 1/2 PRICE ★ FAMOUS VOYAGER CAR COMPUTER

### NICAD RECHARGEABLE BATTERIES

Premium Grade—good for up to 1000 recharges.  
AA Size charge at 45-50MA  
C Size charge at 160-180MA



	1-9	10-99	100+
S 5020 AA	2.45	2.00	1.80
S 5022 C	5.95	5.40	4.98



AS REVIEWED  
EA OCT '82 P26-28  
ETI NOV '82 P26

D 1000 **ONLY \$99**

MADE IN ENGLAND! — QUALITY!

FEATURES: • Instant fuel consumption in litres/100km and MPG! (most others have only one of the above) just switch from one to the other as you drive along • Instant speed, time and other fuel data • Visual and audible excess speed alarm.

INSTALLATION: The Voyager comes complete with an unbelievable array of mounting configurations on dash under dash or stalk mount. All installation hardware is supplied (even a roll of Insulation tape!) as well of course as the speed and fuel sensors. A lavishly illustrated installation manual is provided as well as a comprehensive operators manual.



As used in security systems, battery backup for computers etc. Premium grade long life (typically in excess of 5 years). Easy to charge.

	ea.	5 Up
S 5065 12V 1.2AH	19.95	16.98
S 5067 12V 2.7AH	24.95	19.98
S 5069 12V 4.5AH	34.95	26.95

### 2N3055'S SLASHED

PRIME	SPEC	S.G.S.	
1 - 9	10 - 24	25 - 99	100+
<b>95¢</b>	<b>90¢</b>	<b>80¢</b>	<b>70¢</b>



### IDC CABLE



Per M 10M +

W 0616 16 way	1.75	1.65
W 0624 26 way	2.75	2.55
W 0634 34 way	3.60	3.35
W 0650 50 way	6.50	6.00

### SUPERB QUALITY SLIMLINE GRAPHIC EQUALISER / AMPLIFIER

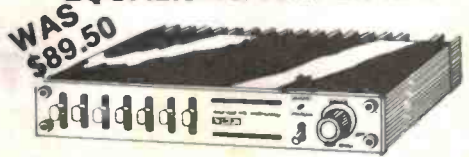

Incredibly compact 22H x 145W x 132D. 7 Key 30W/30W Led Level meters/Qual. Japan Marf. Freq. Response 20HZ-30KHZ.

C 9312 **ONLY \$55**

# ALTRONICS

COMPONENTS

105 STIRLING STREET, PERTH  
**FOR INSTANT SERVICE**  
**PHONE ORDER TOLL FREE**  
 008 999 007  
**PERTH METRO AND A/HRS**  
**ORDERING SERVICE**  
 (09) 328 1599

**ALL MAIL ORDERS**  
 Box 8280, Stirling St. Perth WA 6000

**PACKING AND DELIVERY CHARGE**  
**\$3.00 DELIVERY AUSTRALIA WIDE** - We process your order the day received and despatch via Australia Post. Allow approx. 7 days from day you post order to when you receive goods. Weight limited 10Kgs.

**\$5.00 OVERNIGHT JETSERVICE** - We process your order the day received and despatch via overnight jetservice Courier for delivery next day. Country areas please allow additional 24-48 hours. Weight limit 3Kgs.

**\$10.00 HEAVY HEAVY SERVICE** - All orders of 10kgs. or more must travel Express Road - Please allow 7 days for delivery.

**INSURANCE** - As with virtually every other Australian supplier, we send goods at consignees risk. Should you require comprehensive insurance cover against loss or damage please add 1% to order value (minimum charge \$1). When phone ordering please request "insurance".

**TOLL FREE PHONE ORDER** - Bankcard Holders can phone order toll free up to 6pm Eastern Standard Time. Remember with our Overnight Jetservice we deliver next day.

**ALTRONICS RESELLERS**

Wanted in All Areas of Australia—Phone Steve Wroblewski on (09) 381 7233 for Details

NSW	QUEENSLAND	VICTORIA
<b>CITY</b> David Reid Electronics ..... 267 1385 Jaycar ..... 264 6688	<b>CITY</b> Delsound P/L ..... 2296155 <b>SUBURBAN</b> <b>FORTITUDE VALLEY</b> McGraths Electronics ..... 832 3944 St Lucia Electronics ..... 523547 <b>SALISBURY</b> Colourview Wholesale ..... 2753188 <b>SLACKS CREEK</b> David Hall Electronics ..... 2088808 <b>TOOWONG</b> ECO Technics ..... 3710879	<b>CITY</b> Active Electronics ..... 602 3499 All Electronic Components ..... 662 3508 McGraths Electronics ..... 347 1122 <b>SUBURBAN</b> <b>BENTLEIGH</b> Absolute Electronics ..... 557 3971 <b>BOX HILL SOUTH</b> Eastern Communications 288 3107
<b>SUBURBAN</b> <b>CARLINGFORD</b> Jaycar ..... 745 3077 <b>HURSTVILLE</b> Jaycar ..... 570 7000 <b>LEWISHAM</b> Pre/Fax Electronics ..... 569 9770	<b>COUNTRY</b> <b>ALBURY</b> Webbs Electronics ..... 25 4066 <b>BATHURST</b> The Electronics Shop ..... 31 4421 <b>BROKEN HILL</b> Crystal TV ..... 4803 <b>COFFS HARBOUR</b> Coffs Harbour Electronics ..... 52 5684 <b>GOSFORD</b> Tomorrows Electronics ..... 24 7246 <b>KURRI KURRI</b> Kurri Electronics 37 2141 <b>NEWCASTLE</b> D.G.E. Systems ..... 69 1625 George Brown & Company ..... 69 6399 <b>NOWRA</b> Southern Communications 21 4011 <b>ORANGE</b> MW Electronics ..... 626 491 <b>PORT MACQUARIE</b> Hall of Electronics ..... 83 7440 <b>RAYMOND TERRACE</b> Altsack Electronics ..... 87 3419 <b>RICHMOND</b> Vector Electronics ..... 78 4277 <b>TAMWORTH</b> Landlink Communications 65 4622 <b>TENTERFIELD</b> Mather Ross ..... 36 2204 <b>TOUKLEY</b> TES Electronics ..... 96 4144 <b>WINDANG</b> Madjek Electronics ..... 96 5066 <b>WINDSOR</b> M & E Electronics Communications 77 5935 <b>WOLLONGONG</b> Newtek Electronics ..... 27 1620 Vimcom Electronics ..... 28 4400	<b>CHELTENHAM</b> Talking Electronics ..... 550 2386 <b>DONCASTER</b> Clipstone Electronics ..... 84 2868 <b>FOOTSCRAY</b> Acon Electronics ..... 689 1911 <b>SOUTH CROYDON</b> Truscot Electronics ..... 723 3860 <b>COUNTRY</b> <b>BENDIGO</b> K.C. Johnson ..... 41 1411 <b>MORWELL</b> Morwell Electronics ..... 34 6133 <b>ROBINVALE</b> John Mason Electronics ..... 26 3643 <b>SHEPPARTON</b> GV Electronics 21 8866
	<b>COUNTRY</b> <b>CAIRNS</b> Thompson Instrument Services ..... 512404 <b>BUNDABERG</b> PM Electronics ..... 728 272 <b>GLADSTONE</b> Crystal TV ..... 724321 <b>NAMBOUR</b> Nambour Electronics ..... 411604 <b>PADDINGTON</b> Jacqueline Electronics ..... 3698594 <b>PALM BEACH</b> The Electronic Centre ..... 341248 <b>ROCKHAMPTON</b> Purley Electronics 21058 <b>TOOWOOMBA</b> Hunts Electronics 329677 <b>TOWNSVILLE</b> Sole ..... 722015	<b>WA</b> <b>COUNTRY</b> <b>ALBANY</b> BP Electronics ..... 41 2681 <b>ESPERANCE</b> Esperance Communications 71 3344 <b>GERALDTON</b> R.B. Electronics & Marine ..... 21 2176 <b>KALGOORLIE</b> Todays Electronics ..... 21 2777 <b>MANDURAH</b> Kentronics ..... 35 3227 <b>WYALKATCHEM</b> D & J Pease ..... 81 1132
	<b>CITY</b> Force Electronic 212 2672 Protronics ..... 2123111 Gerard & Goodman 232322 <b>SUBURBAN</b> <b>BRIGHTON</b> Brighton Electronics ..... 296 3531 <b>CHRISTIES BEACH</b> Force Electronics ..... 382 3366 <b>PROSPECT</b> Jensen Electronics ..... 269 4744 <b>REYNELLA</b> Force Electronics ..... 381 2824 <b>COUNTRY</b> <b>MT. GAMBIER</b> South East Electronics ..... 250 034 <b>P.LINDOLN</b> West Coast Elect Supplies ..... 82 5802 <b>WHYALLA</b> Eyre Electronics ..... 45 4764 <b>TASMANIA</b> <b>HOBART</b> D & I Agencies ..... 34 7877 George Harvey ..... 342233 <b>LAUNCESTON</b> George Harvey ..... 31 6533 <b>LEGANA</b> Frank Beech Electronics ..... 301379	<b>NT</b> <b>DARWIN</b> Vantronics ..... 81 3491 <b>ALICE SPRINGS</b> Ascot Electronics ..... 52 1713 Farmer Electronics ..... 52 2967
<b>ACT</b> <b>CITY</b> Electronic Components ..... 80 4654 Sci/monics ..... 54 8334		

## BLOOD PRESSURE & HEART RATE MONITOR

### Why Risk Unnecessary Heart Attack?

A simple (take the reading yourself) periodic check of your blood pressure and pulse provides an "inward look" into a vital aspect of your bodily health. Heart disease strikes down many people in their early 40's (or even 30's). The tragedy remains that had such victims been alerted, remedial medical, physical and dietary action could have been prescribed to avoid illness and in many cases restore full bodily health.

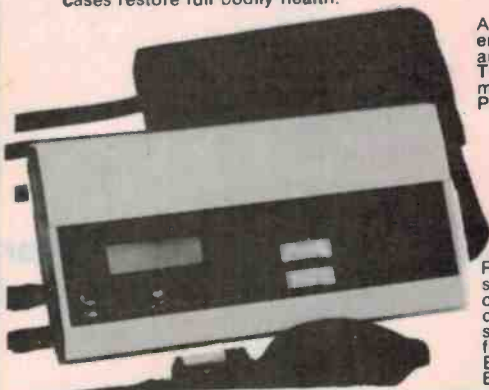

A Superb Gift for the dedicated fitness enthusiast. Absolutely essential for those over 40 and concerned with their health, or on Fitness Therapy. Use this easy to operate Monitor to measure your pulse (or heart rate) and Blood Pressure.

**DON'T PAY \$150**

X 3055

**Now Only \$89**

Remember high blood pressure is in itself symptomless and the usual forerunner to future chronic heart disease. Features include "error" display warning of incorrect use. Handbook supplied will enable anyone in your family to be fully conversant with this monitor in minutes. Easy to read display of Systolic and Diastolic Blood Pressure and Pulse Rate.

## BUILD THESE FABULOUS KITS

### OSCILLOSCOPE SENSATION!



(See EA Oct '84)

K 2000  
**Only \$249**

Over the years many people have asked, "Do you have a CRO kit?"—Our answer—up until now—has been that built and tested units were not dearer than kits, if you could get a kit at all. The Altronic K 2000 Cathode Ray Oscilloscope kit has a guaranteed 5MHz band width but should go to around 6.5MHz. It also features 75mm (3") CRT Blue Phosphor with accurate graticule, separate vertical and horizontal BNC type input sockets etc. Remember, a 5MHz scope is usually adequate to troubleshoot most micro processor and other digital circuitry as well! This is a wonderful opportunity to learn electronics and end up with a valuable piece of test equipment as well. The Altronic K 2000 kit is absolutely complete. The chassis is prepunched and every component including nuts and screws are provided, along with instructions.

### TRANSISTOR ASSISTED IGNITION WITH DWELL EXTENSION

#### KEEP YOUR ENGINE IN TOP TUNE

Yes, it's bad enough paying \$2.00 a gallon for petrol without wasting a fortune on an out of tune engine. Fit this transistor assisted Ignition kit in minutes and start saving money from the very next petrol stop.

K 4010

**\$35.00**

Value Plus



This unique electronic ignition system will easily double the interval between tune ups. Plugs and Points stay in top condition for much, much longer.

Greatly reduced plug breakdown at high rev's. Dead easy to build and (even better) there are only 3 electrical connectors required to the car wiring system.

### STATE OF THE ART

#### The Avtek MultiModem

a breakthrough in low cost modem design Using state-of-the-art VLSI integrated circuitry, the Avtek MultiModem provides the highest standards of reliability for data communications on public phone lines. Digital signal processing is used to achieve functions normally requiring analogue filters.



**MULTIMODEM NEVER REQUIRES ADJUSTMENT**

**MULTIMODEM WORKS RELIABLY ON LINES WHERE OTHER MODEMS CAN'T FUNCTION** Its digital filters are much sharper than on conventional modems. Line interference is screened out. You get error free data transfer, even on very noisy lines.

**MULTISTANDARD OPERATION**  
 CCITT and Bell Duplex and Half Duplex.  
**AUTO ANSWER OPTION (MODEL D 1205)**  
 Autoanswer is the ability of your computer/modem to receive when the phone rings. Some computer/software combinations do this. MultiModem offers the alternative for computers without this facility—hardware autoanswer. Leave your computer waiting for information.

**TEST FUNCTIONS**  
 DIG: This function enables the user to test the modem's operation over a line, testing both modem and line.  
 ANL: Provides testing of computer, software, cabling and modem.

**SPECIFICATIONS**  
**Data Standards:** CCITT V.21 & V.23 Bell 103 & 22  
**Data Rates:** 300, 600 & 1200 BPS  
**Backward Channel:** 75 BPS in conjunction with 1200 BPS

**Computer Interface:** CCITT V.24 (RS232C)  
**Power Requirements:** 240 VAC Power drain—3 watts

**TWO MODELS**  
**D 1200 (Standard) \$349.00**  
**D 1205 with auto answer \$389.00**

FOR NEXT DAY JETSERVICE DELIVERY

BANKCARD HOLDERS—PHONE ALTRONICS TOLL FREE 008 • 999 • 007

FOR NEXT DAY JETSERVICE DELIVERY

BANKCARD HOLDERS—PHONE ALTRONICS TOLL FREE 008 • 999 • 007

# HOME BURGLAR ALARM MODULE

Part 1

Having to pay out a lot of money for an expensive home burglar alarm control could leave you feeling . . . er . . . robbed. With this simple alarm module it will cost you precious little to set up a comprehensive alarm system.

Robert Irwin

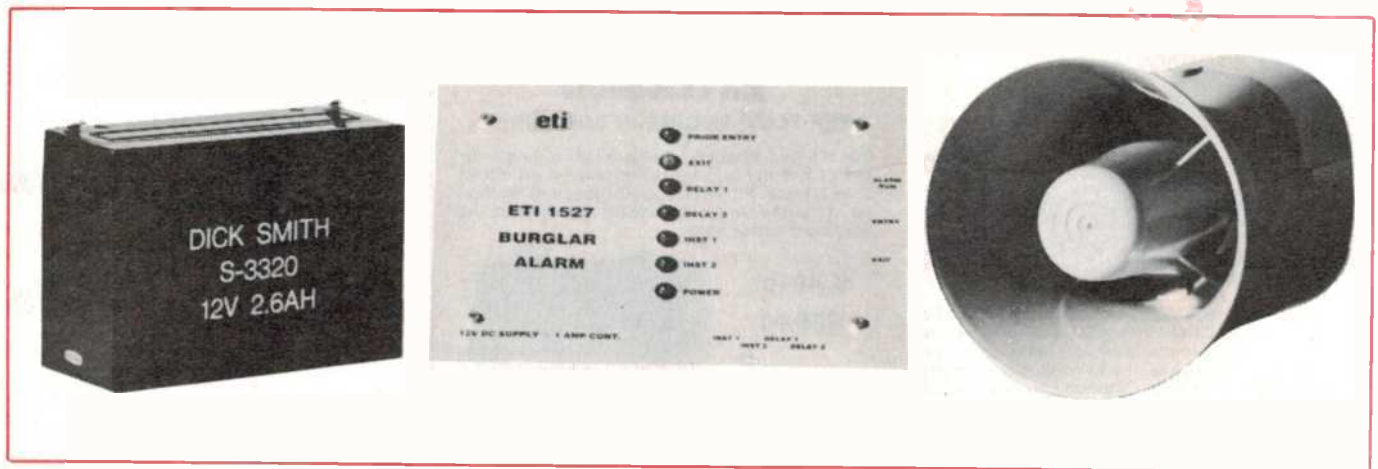

BURGLARY HAS, in recent times, become an all too common fact of life. City and suburban homes have become a favourite target for the break and enter thief. It is probably a safe bet that at least half our readers have come home from work or a night out somewhere only to find that their house has been broken into and their valuable and often personal possessions have been stolen.

A lot of people say that the worst aspect of a burglary is the feeling of violation, often much more traumatic than the actual loss suffered. The saddest thing is that most people still cling to that old adage "it doesn't matter what you do, if they want to get in they will".

While it is true that even the most sophisticated and expensive alarm system can be circumvented by very clever professional thieves, the statistics show that the majority of break and enters are done by rather clumsy amateurs who would probably have been put off by even the most rudimentary security measures.

The ETI-1527 burglar alarm module was

developed from a design by Dick Smith Electronics and is intended to be the control centre for a comprehensive low cost burglar alarm system which includes many features found only in the much more expensive commercial units.

The cost of having a burglar alarm installed in an average home can range from around \$500 to \$2000 or more. With the ETI-1527 module an average home can be protected for about \$100 or so depending on the type and number of sensors used. This board can form the basis of burglar alarm systems which can be as simple or complicated as you like.

## Design details

The alarm has four sectors, that is, four inputs, which allow four separate alarm circuits to be wired up. Each of these circuits can contain a number of sensors. This will allow plenty of flexibility in the design of a sensing system for your particular needs. The types of sensors available and the installation of sensors will be covered in detail in later sections of this article. For now, let

us examine the board itself.

The inputs are designed to be loaded by a 22k load resistor. Either shorting this resistor out or open circuiting the input will cause an alarm condition to be generated. This means that both N/O and N/C sensors can be used on the same input.

The use of four inputs allows the premises you are trying to protect to be divided up into four sectors which can then be treated as separate circuits and wired accordingly.

Two of the sectors are provided with an entry delay and these can be used for the front and back doors to allow you to enter the premises without setting off the alarm immediately. The other two sectors are triggered straight away if a sensor is disturbed.

Apart from entry and exit delays the circuit also provides for an adjustable alarm run time. This allows you to set the time the siren or bell sounds after the alarm is triggered. After the alarm has sounded for this preset time the circuit will automatically re-arm itself. If the input which triggered the alarm in the first place is still active then the



## HOW IT WORKS — ETI-1527

The circuit contains four input points. To ensure freedom from RF induction in the lines going out to the sensors two capacitors are paralleled up across the input terminals. A ceramic and a greencap were used in tandem to provide adequate suppression at all frequencies. The inputs are all identical and are connected to the inputs of four window comparators formed by the op-amps of IC1 and IC2. Each window comparator is made up from a pair of op-amps.

The threshold levels for the comparators is set by a resistive divider network formed by R5, R6 and R7. The voltage at the junction of R7 and R6 is 7.3 V and the voltage at the junction of R5 and R6 is 4.7 V. These are the upper and lower threshold voltages of the comparator respectively.

For the input of the alarm to be in the sealed state the input to the comparators must lie between the threshold voltages. This is accomplished with two 22k resistors. Each input has a 22k resistor connected between the input to the comparator and the positive supply rail (R1, R2, R3, R4). The external load resistor (not shown in the circuit diagram) is then used to connect from the comparator input to ground thus creating a voltage divider which holds the input at 6 V. If the load resistor is shorted out then the voltage will swing towards ground. If the resistor is open circuited then the voltage will swing to the positive rail. In either case a threshold will be exceeded causing the output of one or other of the op-amps in the window comparator to swing high. The diode pairs D1 and D2, D3 and D4, D5 and D6, D7 and D8, are used to OR the outputs of the op-amp pairs.

The output from the diodes is fed, via a capacitor, to one input of the flip-flops formed from pairs of cross-coupled NOR gates. The action of the capacitors is to provide the lock-out function but more will be said about this later. The remaining input on each of the flip-flops is tied via R16 and RV1 to ground. These resistors along with C13 provide the exit delay function.

At turn on the capacitor will initially be dis-

charged and will therefore have no voltage drop across it. The voltage at the junction of C13 and R16 will then initially be pulled up to the positive rail. This forces the output of the flip-flops low regardless of the state of the input circuitry thus disabling the alarm triggering circuitry. As C13 charges, the voltage at R16 will fall. When it falls below the switching point of the CMOS (around 6 V) the output of the flip-flops will be dependent on the input from the comparators and thus the circuit will be in the armed state. The time taken for C13 to charge will be dependent on the setting of RV1 and thus the exit delay can be varied by varying RV1.

IC5a forms an inverter to drive the exit delay LED which is turned on while the exit delay is active. While the exit delay is active the lock out facility can operate. If a particular input is in the sealed state initially then the output of the comparator for that input will be low and therefore the output from the flip-flop which is connected to the appropriate sector LED will be high and the LED will be off.

If, however, an input is unsealed in the exit period, the output from the corresponding comparator will be high. Since the coupling capacitors (C9, C10, C11 and C12) are initially discharged the voltage at the input of the flip-flops will be high also. This will cause the appropriate sector LED to light. The coupling caps will charge through the 470k resistors and the voltage will drop. When the voltage drops past the switching point of the CMOS the LED will go off. The input then looks sealed to the flip-flops and the alarm can then be armed without the unsealed input causing it to trigger. This sector will then be locked out until it is sealed.

The remaining gating circuitry is dedicated to the alarm triggering logic. The inputs are divided up into two instant trigger inputs and two delayed trigger inputs. The outputs of the flip-flops for the instant inputs are ORed together by D9 and D10 and fed to one input of a NOR gate, IC5b. The delayed input trigger signals are ORed by D11 and D12 and are then fed via R26 and RV2 to a capacitor, C14.

When a delay input is triggered the output of the appropriate flip-flop goes high and C14 will begin to charge.

The time taken to charge depends on the setting of RV2. The positive side of C14 is connected to the other input of the NOR gate, IC5b. This creates a time delay from when the input is triggered until the capacitor charges enough to switch the NOR gate.

Diode D14 provides a discharge path for C14 via R18. When the alarm is triggered the output of IC6c goes high. This provides a pulse which triggers the latch formed by IC6a and b. This has three effects. Firstly, the output of the inverter formed by IC6d goes low which turns on the siren and bell circuitry. Secondly, the output from IC6b goes low and resets the input flip-flops. The third thing that happens is that the latch formed by IC5c and d is set which causes the prior entry LED to light. This latch is only reset at power up by C21 and R29.

When the alarm is triggered the output of IC6a goes high. This causes C22 to begin charging through R28 and RV3. When the cap voltage reaches the CMOS switching level the latch is reset and the siren and bell is turned off. The alarm will then arm as if it were switched on again except that the prior entry LED will remain lit.

When the siren and bell circuit is triggered the transistors, Q1 and Q2, are turned on. Q2 then turns on Q3 which will activate a dc bell and will sink up to 1 A. Q1 enables the two LM555s which form the siren drive circuit. IC8 is configured as an astable which puts out a square wave signal. IC7 is used to modulate the frequency of IC8 by producing a low frequency sinusoidal type signal. The overall effect is to produce a piercing modulated siren type signal. This is then buffered by Q4 to provide the drive to run a 4 ohm speaker.

The board requires a nominal 12 V dc supply which is then filtered by C19 and C18. D1 provides protection against connecting the battery the wrong way round and ZD1 gives overvoltage protection.

circuit will lock this out and only re-arm those sectors which are not active. This feature also means that if you wish to leave a window open at night but you still want to have the rest of the house protected you can simply turn on the alarm with the appropriate window open and the circuit will lock out that input.

To indicate the state of the alarm, seven LEDs are provided. A power on indication is given to show that dc power is being applied. At turn on, four red LEDs indicate whether each sector is sealed or unsealed. After a short time any unsealed sectors are locked out and the LEDs are extinguished. Once armed these same LEDs will indicate which sector was triggered if an alarm is sounded.

If the alarm is triggered then another LED will light to indicate that there has been prior entry. The remaining LED indicates that the exit delay is active. This display will allow you to easily determine the state of the alarm and see if it has been triggered.

The circuit also has an on board siren

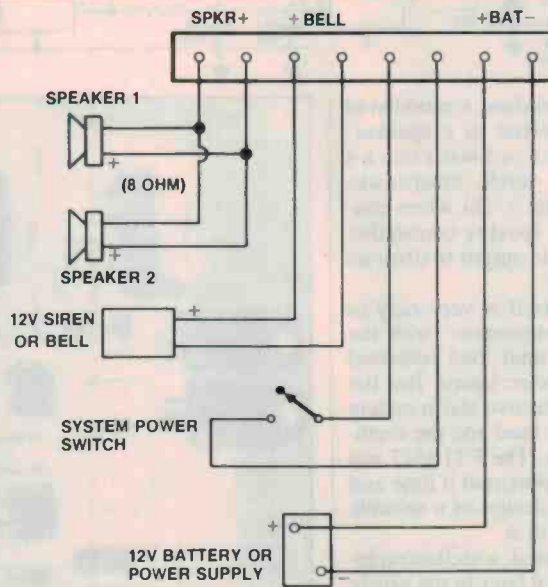
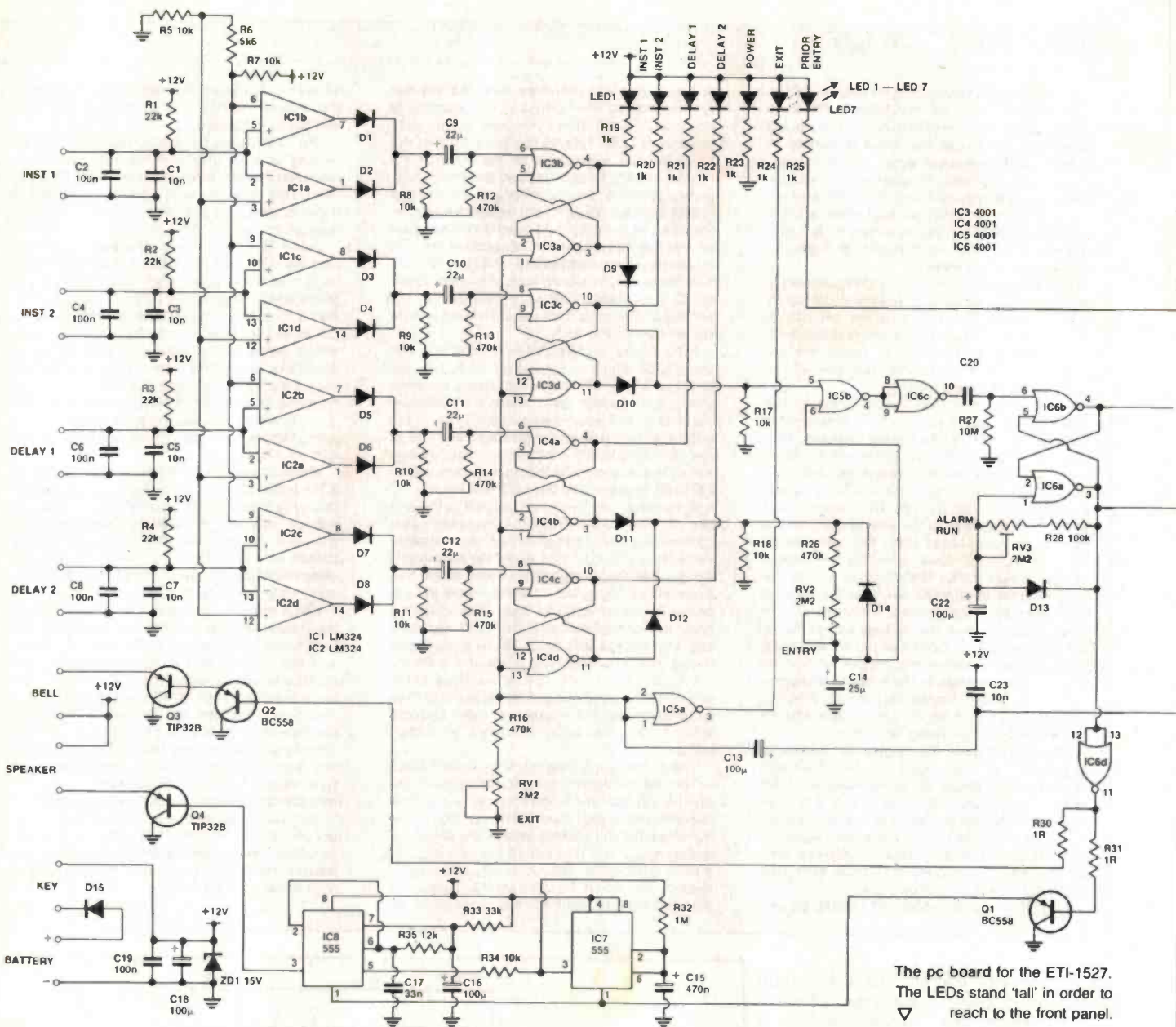

Figure 1. Wiring up the power supply and sirens to the module.



The pc board for the ETI-1527. The LEDs stand 'tall' in order to reach to the front panel.

generator which will produce a modulated siren tone when connected to a speaker. The circuit will produce 4 or 5 watts into a 4 ohm load and any small inexpensive speaker will create quite a din when connected. As well as the speaker connection there is a 12 V, 1 amp dc output to drive an alarm bell if you prefer.

The alarm module itself is very easy to construct as all the components (with the exception of the four input load resistors) are mounted on a single pc board. But the key to a reliable and effective alarm system is the quality of sensors used and the methods used to install them. The ETI-1527 will only perform to its full potential if time and thought is put into the design of a suitable sensing system to go with it.

As previously mentioned, a section on installation will be included later in the article but if you are seriously considering installing your own alarm system then a bit of background reading wouldn't go astray.

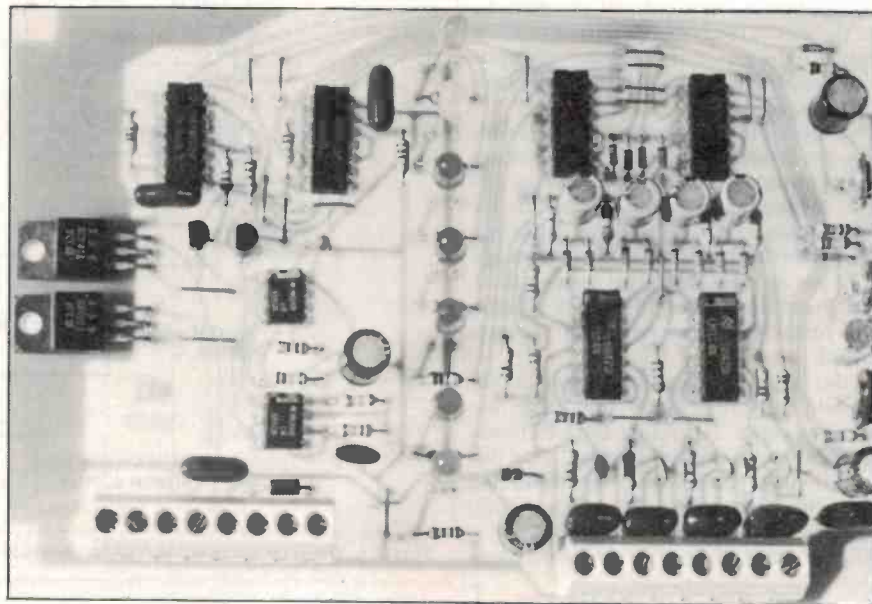

For a guide to components and kits for projects, see **SHOPAROUND** this issue.

## PARTS LIST — ETI-1527

### Resistors.....all 1/4 W, 5%

- R1, 2, 3, 4.....22k
- R5, 7, 8, 9, 10, 11, 17, 18, 34.....10k
- R6.....5k6
- R12, 13, 14, 15, 16, 26.....470k
- R19, 20, 21, 22, 23, 24, 25.....1k
- R27, 29.....10M
- R28.....100k
- R30, 31.....1R
- R32.....1M
- R33.....33k
- R35.....12k
- RV1, 2, 3.....1M miniature trim.

### Capacitors

- C1, 3, 5, 7.....10n ceramic
- C2, 4, 6, 8, 19, 20.....100n greencap
- C9, 10, 11, 12, 14.....22µ 16 V electro.
- C13, 16, 18, 22.....100µ 16 V electro.
- C15.....470n 16 V tag tantalum
- C17.....33n greencap

- C21, 23.....10n greencap

### Semiconductors

- IC1, 2.....LM324
- IC3, 4, 5, 6.....4001B
- IC7, 8.....LM555
- Q1, 2.....BC558
- Q3, 4.....TIP32B
- D1, 2, 3, 4, 5, 6, 7, 8, 9, 10, 11, 12, 13, 14.....1N914
- D15.....1N4004
- ZD1.....15V 400 mW zener
- LED1, 2, 3, 4.....5 mm red LED
- LED5, 7.....5 mm green LED
- LED6.....5 mm yellow LED

### Miscellaneous

ETI-1527 pc board; ETI-1527 front panel (if required); 7 x 5 mm LED mounting grommets and washers; 300 mm tinned copper wire; 2 x 1/2" 6BA nuts and bolts; 2 x 8 way pc board mount terminal block.

Price estimate: \$28-\$30

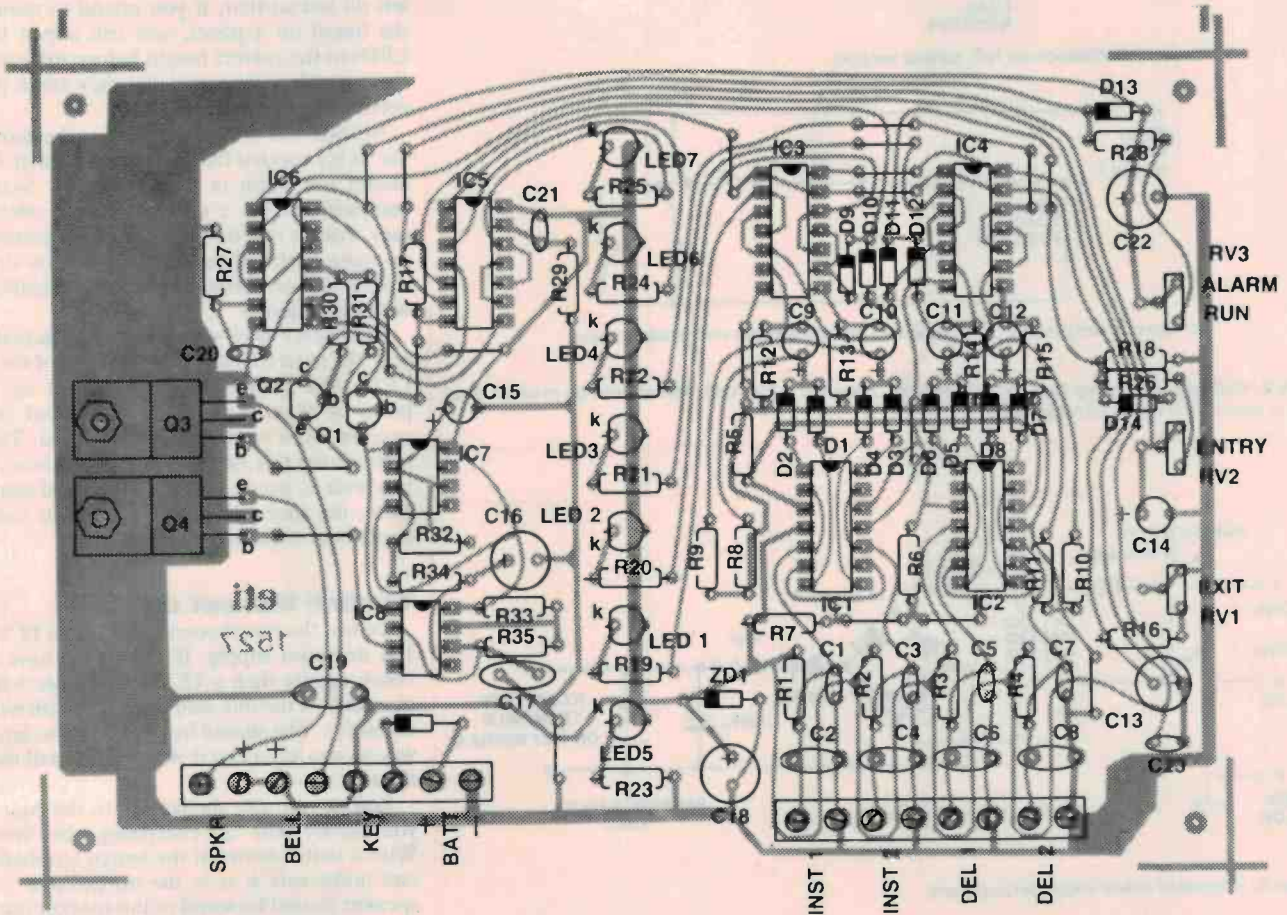
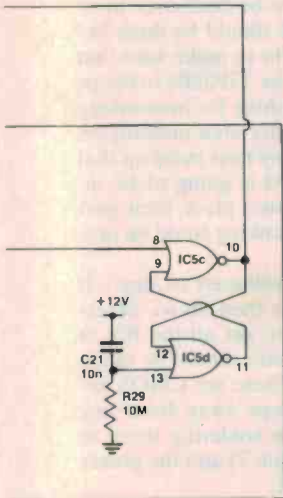

# Project 1527

The Australian Standards Association puts out a useful booklet called *A guide to the selection and application of intruder alarm systems*. This booklet can be obtained from the ASA and gives a good background to the types and uses of the various sensors available. The NRMA and other insurance companies may also be able to help you with information on security systems. For now, let's get on with the construction of the board.

## Construction

Begin by carefully examining the pc board. Make sure there are no broken or

shorted tracks. A magnifying glass is very handy for this. Once you are satisfied that the pc board is in good shape then you can start soldering in components. Start by soldering in the two eight-way terminal blocks. These should be located so that the connection clamp openings face the edge of the board.

Next you can locate and solder in the 20 wire links. These should be made with tinned copper wire. The resistors can then be soldered in followed by the capacitors. Take careful note of the polarity of all the electrolytics and the tantalum caps. These will only work if put in the right way round.

Solder in the three miniature trim pots. The diodes can be put in next. These also need to be put in the correct way round so take careful note of the overlay diagram.

The rectifier diode and the Zener should not be confused with the 1N914 small signal diodes. The four transistors can be soldered in next.

The TIP32Bs need to be bent over to sit flat on the board. This should be done before they are soldered in to make sure that the holes line up. Bolt the TIP32Bs to the pc board securely. This is done for heatsinking reasons. The large copper area underneath them acts to dissipate any heat build up that may occur. If the board is going to be installed in an unventilated place then perhaps a bit of extra heatsinking could be provided.

The ICs should be soldered in next. If you wish to use sockets then do so, otherwise take special care to get all the ICs in the right way. Special care should be taken with the HEF4001Bs. These are CMOS devices and should be kept away from any static discharges. When soldering them in solder the ground pin (pin 7) and the power supply pin (pin 14) first.

The only remaining components to be soldered in are the LEDs. These should be left till last so that, if you intend to mount the board on a panel, you can adjust the LEDs to the correct height before soldering them in. Also make sure that they are in the correct way round.

No box has been specified for the module. It is expected that everyone will wish to mount the alarm in their own way. Some may wish to use a security box or others may wish to rely on hiding it in a cupboard or some such procedure (this will be discussed in more detail in the section dealing with installation).

Whichever way you mount the module you will need to mark the functions of each LED. The prototype was mounted on a piece of aluminium plate with stand off spacers and a scotchcal label attached. The artwork for this label is reproduced here if you wish to use it. With the pc board complete, the time has come to test your constructional expertise . . .

## Testing and set up

To test the board you will require a 12 V, 1 A dc power supply. If you do not have a bench supply then a 12 V rechargeable battery such as the one sold by Dick Smith will do nicely. You should buy one of these anyway as you will need it when you install the alarm.

Before you wire the battery to the board you should wire up everything else first. Wire a switch between the switch terminals and make sure it is in the off position. A speaker should be wired to the speaker out-

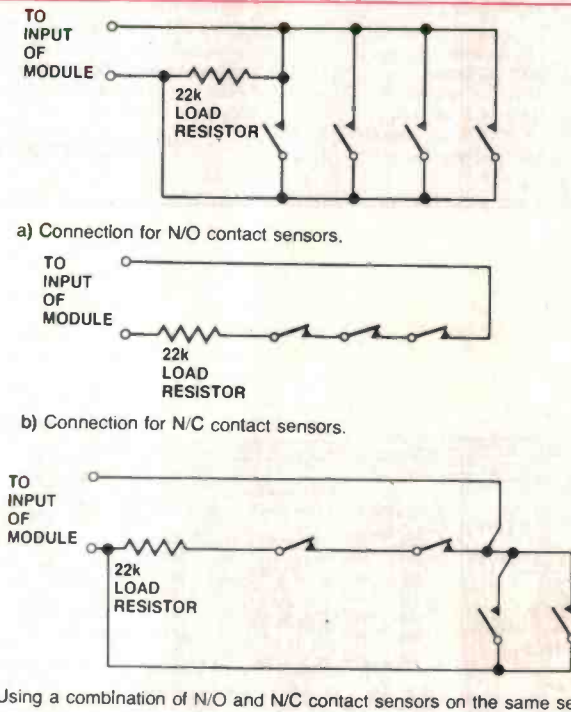

Figure 2. Methods of wiring up N/O and N/C sensors. Note that a 22k load resistor must be in circuit at all times to prevent the alarm from triggering.

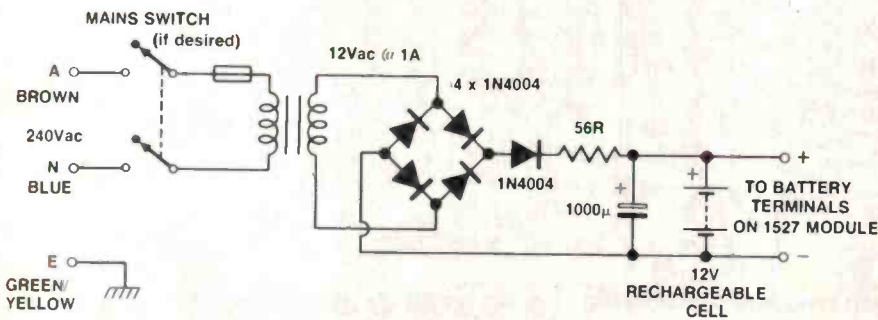

Figure 3. Suggested power supply arrangement.

put terminals in series with a 100 ohm resistor. The resistor will attenuate the volume of the siren so that you don't have the police arresting you for noise pollution.

All the trim pots should be set to minimum (fully counter-clockwise). The battery can now be connected. Make sure you connect it the right way round. OK! Brace yourself for any loud noises and/or smoke and flick the switch. If you are lucky the board will be still intact and all the LEDs except for the prior entry LED will be lit. The siren should not go off. If this is the state of affairs then so far so good.

After a few seconds the four red LEDs should go out. After about 30 seconds or so the yellow exit delay LED should go out leaving the power indicator as the only LED lit. If all this happens correctly then heave a sigh of relief and switch off.

Wire in 22k load resistors across each of the four input terminals. Make sure they are in securely and are not touching one another. Switch on again. This time only the power and exit delay LEDs should light. After the exit delay has expired the yellow LED should go out. The alarm is now in the armed state.

Short out the resistor on one of the instant inputs and leave it shorted. The siren should sound immediately and the appropriate red LED should light to show that that sector is unsealed. The green prior entry LED should also come on and stay on. After about 20 seconds or so the siren should stop and the alarm will re-arm itself as if it had just been switched on.

The sector LED should go out about five seconds after the siren has turned off. This indicates that the sector has been locked out. The other three sectors will be re-

activated after the exit delay period has expired. The prior entry LED will stay on to indicate that the alarm has been triggered. It will only be reset when the alarm is turned off.

The only thing left to do on the board is to set up the time delays. If you haven't yet decided where to install the module then you had better read the installation guide first and then come back to this section.

Firstly, get a watch with a second hand (or a digital watch if you would prefer a high tech approach!) and measure the time taken for you to leave the house from wherever the alarm will be situated. Also measure the time taken for you to open the front (or

back) door and get to the alarm. The exit and entry delays can now be set to cover these measured times. Give yourself a fair bit of leeway as you may come in with your hands full one day and not be able to get to the alarm in time.

The alarm run time is a matter to decide yourself. It should be long enough to ensure that someone will be alerted but not long enough to annoy the neighbours too much if a false alarm occurs in the middle of the night. Once you have set the alarm up satisfactorily you can turn your attention to the problems of installation. Read the installation section thoroughly before buying or attempting to mount any sensors. ●

*The installation section forms Part 2 next month.*

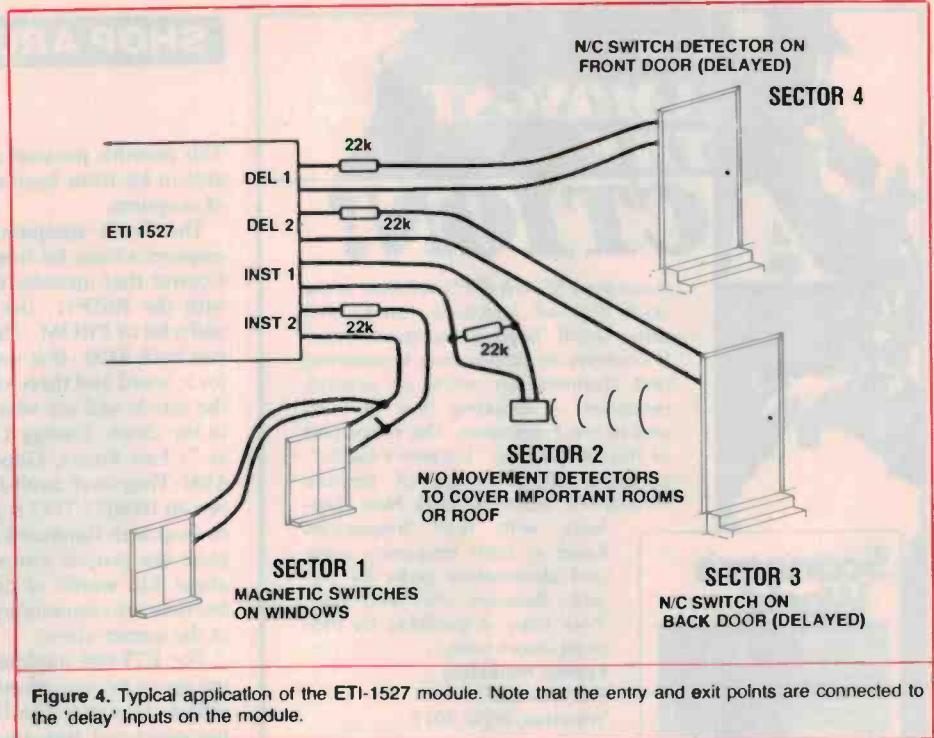

Figure 4. Typical application of the ETI-1527 module. Note that the entry and exit points are connected to the 'delay' inputs on the module.

When you're back indoors, there's still a lot of territory to cover. **overlander** will take you there. Don't go bush without it.



**overlander**  
MAGAZINE

ON SALE NOW AT YOUR NEWSAGENT

# GET AMONGST THE ACTION!

Australian SCANNER'S WORLD is the book that will introduce you to that other world 'beyond the shortwaves'. It contains an introduction to scanning and scanners, an article on scanner antennas — including how to build and to erect antennas. The major part of this book is the "Listener's Guide"; computer-sorted listings of services throughout Australia and New Zealand, with their frequencies listed in both frequency order and alphabetical order by service. Beacons are listed also. Your copy is available by mail order direct from:

**Federal Marketing**  
P.O. Box 227,  
Waterloo, NSW 2017

Please add \$1 to the cost of the magazine to cover postage and handling. (Add \$5 to these charges for air mail postage outside Australia.)

**For only \$5.95**

## Scanner's World



## SHOP AROUND

This month's projects are available in kit form from a number of suppliers.

The Forth computer project employs a basic kit from Energy Control that includes the board with the R65F11, the R65FR1 and a bit of PROM. This will set you back \$159. If it seems a lot for a board and three chips read the article and see what you get in the chips. Energy Control is at 73 Eric Street, Goodna, Qld 4300. They have a toll-free number on (008)77-7147 if you want to shop with Bankcard. To complete the project you will need about \$20 worth of extra bits, but they are commonly available at the corner store.

The ETI-699 modem is shaping up to be one of our hottest sellers. Designer Geoff Nichols has contacted just about every Australian bulletin board using it and our office Microbee. It really does work. The core of the project is the AMI 53530, worth \$18.50 from RIFA. They are at 2 Cross Street, Hurstville NSW 2220. Ring (02) 570-8122. Everything else in the project is as common as mud. Alternatively, contact your local kit supplier for the whole thing in one go. Jaycar in Sydney is selling kits for \$139. As we went to press All Electronic Components in Melbourne had indicated they would be doing it, but hadn't yet worked out a price. We estimate that if you make your own circuit boards and get good deals on the bits you should come out of it for less than \$100.

The four-sector house burglar alarm ETI-1527 is another much requested project. Kits are available from most of the usual outlets. DSE will be selling it for \$29.95, as will Jaycar. AEC in Melbourne will be around \$40. If you want to get your own things together, you shouldn't find any problems with availability.

### Artwork

For those constructors willing and able to make their own pc boards and/or front panels, we can supply same-size film transparencies of the artwork, positives or negatives as you require. From the list given below, select what you want and address your

request/order to:

'ETI-xxx Artwork'  
ETI Magazine  
Waterloo NSW 2017

When ordering, make sure you specify positives or negatives, according to the process you use. Your cheque or money order should be made payable to 'ETI Artwork Sales'. Prices for the artwork for this month's projects are as follows:

ETI-699 (front panel) ..... \$2.92  
ETI-699 (pcb) ..... \$5.72  
ETI-1527 (front panel) .... \$8.15  
ETI-1527 (pcb) ..... \$5.90

### Boards and panels

Front panels and pc boards for our projects may be obtained from the following suppliers:

**All Electronic Components**  
118 Lonsdale St  
Melbourne Vic 3000  
(03)662-3506

**RCS Radio**  
651 Forest Rd  
Bexley NSW 2207  
(02)587-3491

**Jemal**  
P.O. Box 168  
Victoria Park WA 6100  
(09)451-8726

**Mini Tech**  
PO Box 9194  
Auckland NZ

For pc boards produced in recent years, the following suppliers either keep stocks on hand or can supply to order:

**Acetronics**  
112 Robertson Rd  
Bass Hill NSW 2197  
(02)645-1241

**Jaetronics**  
58 Appian Drive  
St Albans Vic 3021

**Jaycar**  
117 York St  
Sydney NSW 2000

**Mini Tech**  
P.O. Box 9194  
Auckland NZ

**Rod Irving Electronic**  
425 High St  
Northcote Vic 3070



# Express Alarm Supplies

## WIRELESS HOME ALARM SYSTEM

- 465 Pacific Highway, Lane Cove 2066 N.S.W  
P.O. Box 558 Lane Cove  
Ph: (02) 427 1233 (3 lines)
- 87A Melville Road, West Brunswick 3055 Vic.  
P.O. Box 127 West Brunswick Ph: (03) 383 4088
- 51 Lemana Lane, Miami 4220 Qld.  
P.O. Box 166 Burleigh Heads Ph: (075) 35 3878.

DISTRIBUTORS — ADELAIDE, BRISBANE,  
DARWIN, NEWCASTLE.

Write or call for FREE short form price schedule.

# Electronics Today

INTERNATIONAL

SPECIAL OFFER —  
EXCLUSIVE TO  
ETI READERS!!!

# Win a

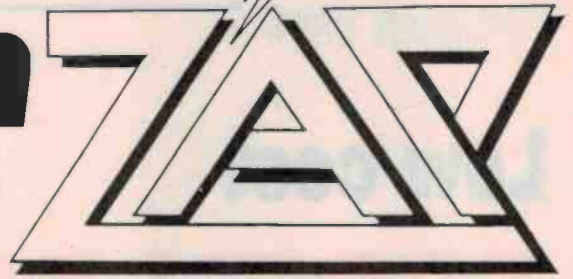

## Security System!

**Here's your chance to win a ZAP Electronics Home Security Alarm System in the ZAP-ETI Crossword competition.**

The ZAP Security System has been designed for commercial as well as residential usage. It comprises a lockable commercial-quality control panel, Cerberus passive Infra-red detector, Power supply and rechargeable battery, Weatherproof horn-siren, Magnetic Switches, Wire, Clips and instructions. Total System valued at \$299 and YOU can win it with this crossword competition!

Why put off installing an alarm system? Take this opportunity to obtain a complete commercial-quality alarm system with Infra-red movement detector and all parts. Kit supplied with satisfaction/money back 14-day guarantee, and delivered free to your home by Certified Post. Save up to \$150 on individual parts cost alone!

Simply fill in the crossword below, and send in with your order to ZAP Electronics Mail Order Service. On the 21st of June, 1985, the first correct entry drawn will have their purchase price refunded, or an additional ZAP Security System FREE... Winner's Choice!!!

### CLUES

- 1: Freedom from danger. 4: Style of Music. 5: Infra-red detector supplied with ZAP Alarm. 7: An electronic detection method. 9: Leading supplier of security alarms. 11: "The good ..." (colloquial). 12: Adjust this to vary entry/exit delay. 13: Eastern Suburbs Newspapers (abbrev.). 15: Prior to the First century. 16: One of ZAP's 5 retail stores.

### DOWN:

- 1: ZAP Electronic ..... System. 2: A long way. 3: Computer System Index (abbrev.). 4: Crossword ..... 6: Mistake. 8: Varies light intensity. 10: The Alarm button. 14: Place of research (abbrev.).

Send to: ZAP Electronics Mail Order Service

(02) 858-2288

PO Box 264, Eastwood, NSW 2122

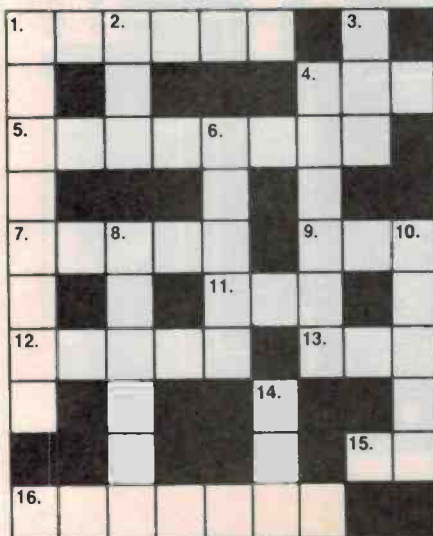

Name .....

Address .....

..... Postcode .....

Please send me ..... ZAP Security Alarm Systems at the special price of only \$299 ea., and enter me in the Crossword Competition draw.

My Payment is enclosed for \$ .....

by: Cheque ..... Money Order ..... Bankcard .....

Mastercharge ..... American Express ..... Visa .....

Card No.                  Expiry Date .....

Signature .....

All entries must be received by final post on 14th June, 1985. Crossword Competition drawn at ZAP, Eastwood office on 21st June, 1985. Winner will receive a full refund of \$299 or an additional FREE ZAP Security System valued at \$299. The judge's decision is final and no correspondence will be entered into. Lotteries Act Permit TCNO 85660. Purchase is not a condition of entry.

CHATSWOOD, BURWOOD, LIVERPOOL, PARRAMATTA, HORNSBY, Other ZAP stores at: —

## Low cost

# FORTH DEVELOPMENT SYSTEM

Peter Ihnat

Go FORTH and you will multiply — and add and divide and . . .

FORTH is one of those computer languages you may have heard about but kept away from. However, if you're into controlling

robots, mechanical arms, washing machines, train sets, etc, then it's about time you looked more seriously at Forth. It is a language which was developed with control in mind and is more flexible than either Fortran and Basic when it comes to whizzing stepping motors around or checking the status of sensors.

To briefly summarize its features, Forth is a language in which you add your own operations by defining them in terms of previously defined operations until a single word (or operation) represents your whole program. It is a structured language. It uses the concept of Reverse Polish Notation (RPN) and is quite easy to learn. Most peo-

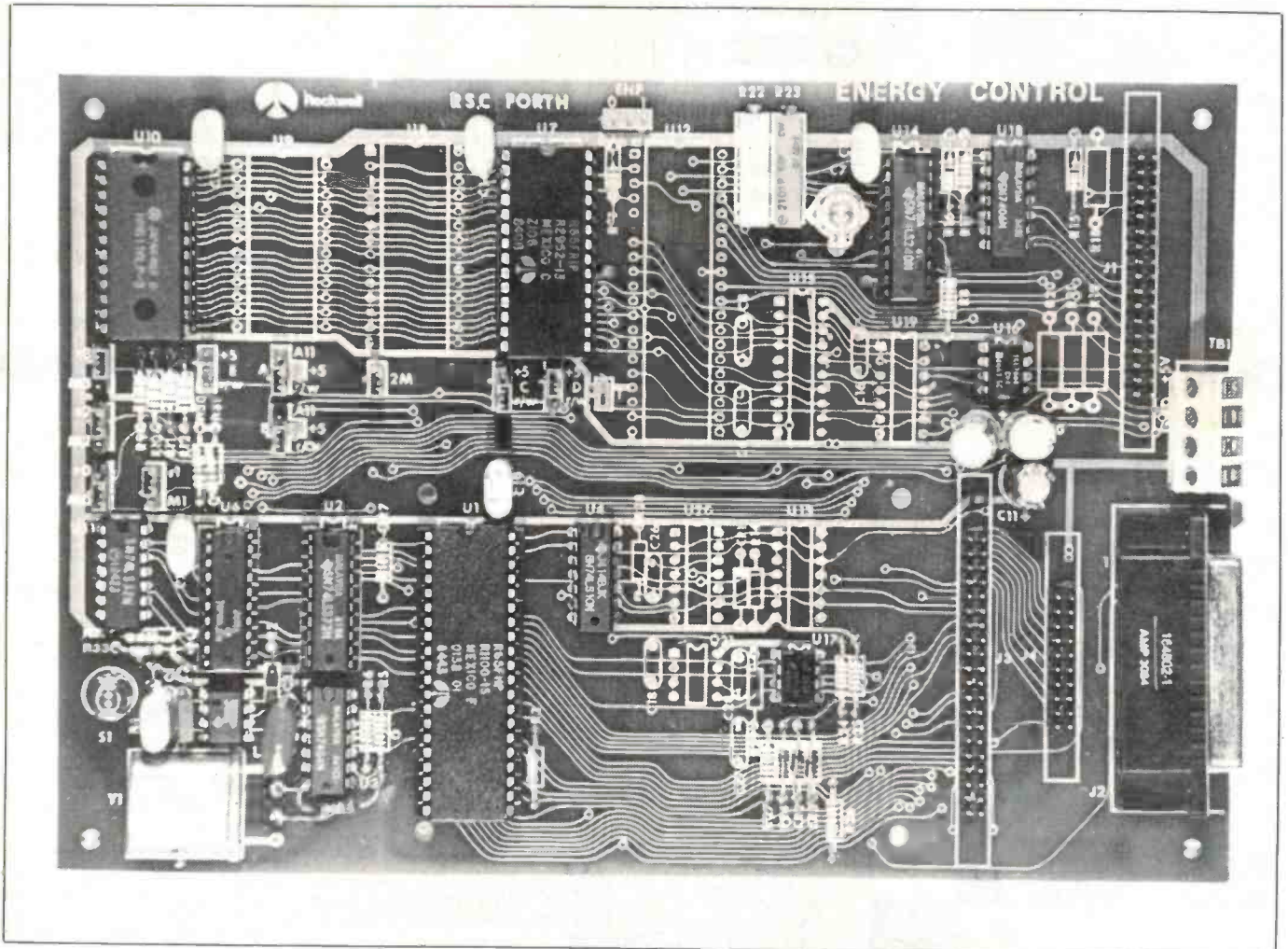



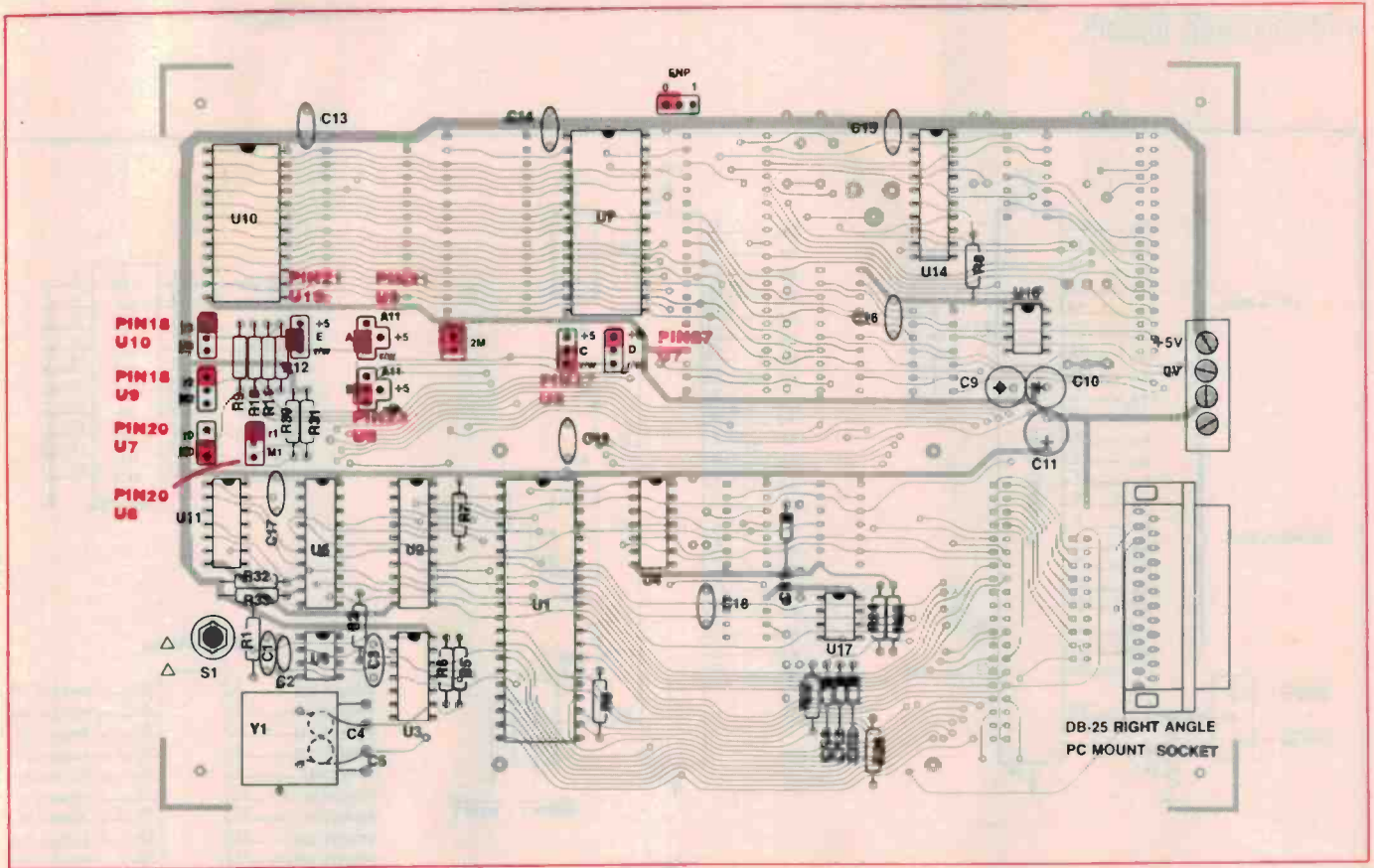

ple agree that it is simpler to use than Assembler yet has many of its advantages.

For those curious about the language or who would like to learn it, there are two excellent books that I can recommend. The first is *Starting Forth* by Leo Brodie which takes you through programming, etc using drawings, cartoons and the like. Certainly a good beginner's book but not recommended for anyone who already knows about computers. The second book is the *RSC-Forth User's Manual* which comes with the kit from Energy Control\*. It describes the Forth development system and language extremely well and saves you from having to plough through loads of rubbish to find relevant information. I can fully recommend it.

Up until now, the way of getting hands on experience with Forth was to purchase a disk or tape and load it into your home computer. Rockwell, however, recently developed a complete ROM based Forth system consisting of the CPU, memory, I/O facilities and the RSC-Forth software integrated into a single chip. Thanks to Energy Control in Queensland, the Rockwell agents here in Australia, a low cost single board microcomputer which runs Forth is now available.

The kit from Energy Control consists of a double-sided pc board with plated-through holes, a Rockwell R65FR1 CPU, a R65FR1 development ROM, a bipolar PROM for memory decoding, and RSC-Forth literature (user's manual and data sheets). To complete the system, the bits listed in the parts list are also required. They are not in-

cluded with the basic kit since all are standard LSTTL chips, resistors and caps most of which the digital hobbyist will have in a junk box. In other words, Energy Control is providing a kit of the specialized, and therefore hard-to-get, parts.

An upgrade to the kit is also available and will be discussed at a later date. It consists of a double-sided, 40 track disk drive, 2793 disk controller, cable and connectors and the disk drive power supply.

### The system

The basic system allows an external user program to be executed from external EPROM or the development of such a program under the control of the R65FR1 development ROM. Mask programmed into a 3K ROM in the CPU is the Rockwell Single Chip Forth (RSC-Forth) operating system and the run-time portions of the RSC-Forth language. The other portions of the RSC-Forth software not required at run-time are provided in the development ROM.

To put this more simply, the R65FR1 development ROM is only required for program development — that's why it comes in the kit from Energy Control. If the system ever needs to run permanently under the control of one of your programs then place it in an EPROM and remove the development ROM. At power-up, your program takes over due to a unique power-procedure by the operating system. This is discussed in greater depth in the user's manual.

Also included on the board is an RS232C

### PARTS LIST — ETI-694

<b>Resistors</b> .....	all 1/4 W, 5%
R1, 2.....	1M
R3, 9-12.....	4k7
R5, 6, 8, 25-27.....	1k8
R7.....	330R
R24.....	2k2
R30-33.....	4k7
<b>Capacitors</b>	
C1, 13-19.....	100n ceramic bypass
C2.....	10n
C3.....	220n
C4, 5.....	10p
C9, 10.....	10µ 16 V RB electro
C11.....	100µ 16 V RB electro
<b>Semiconductors</b>	
CR1-4.....	1N914
U2.....	74LS373
U3.....	74LS04 (must be LS)
U4.....	74LS10
U5.....	'555
U8-10.....	6116 2K RAM
U11.....	74LS32
U14.....	74LS240
U16.....	ICL7660
U17.....	LM1458
Y1.....	2 MHz crystal
<b>Miscellaneous</b>	
1 x 40-pin IC socket; 2 x 24-pin IC sockets; 2 x 28-pin IC sockets; 1 x 20-pin IC socket; DB-25 female connector (right angle pc mount) normally open push button; and the RSC-Forth development kit which includes:	
U1.....	R65FR1
U6.....	256 x 8 bipolar PROM
U7.....	R65FR1 development ROM
pc board and literature.	

**Price estimate: \$179**

# Project 694

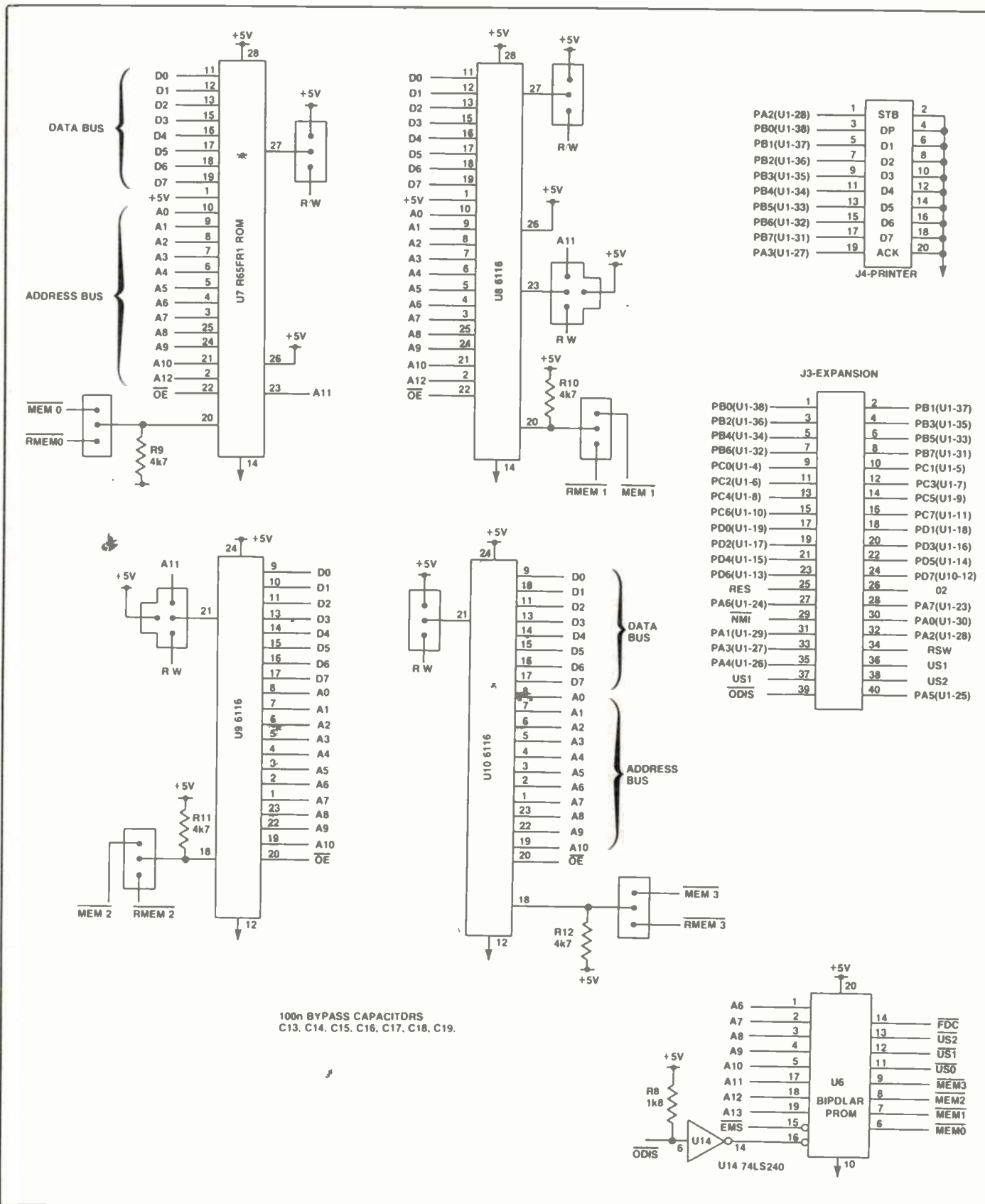

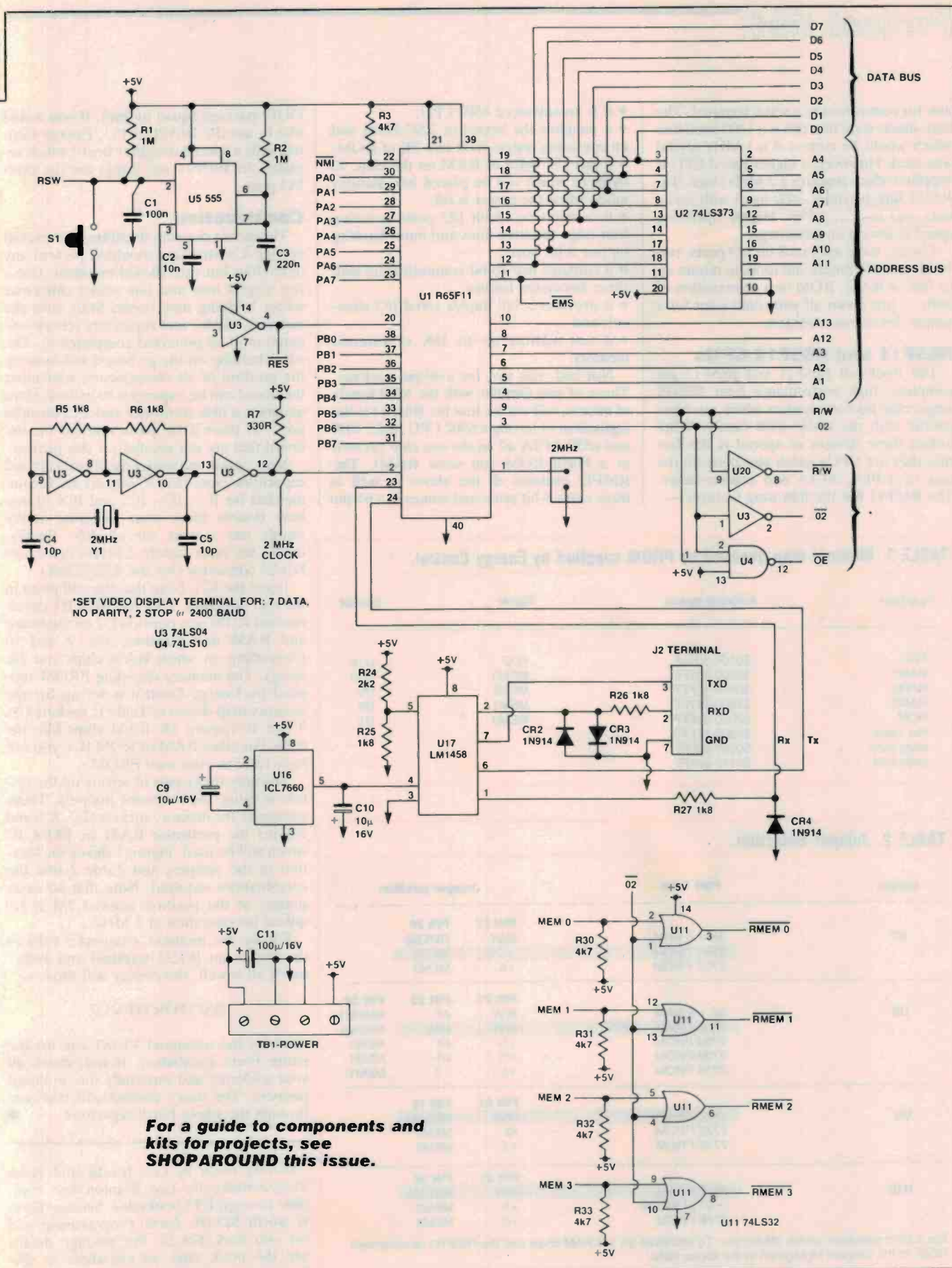

**For a guide to components and kits for projects, see SHOPAROUND this issue.**

link for connection to a serial terminal. The data sheets state that this is a 1200 baud link which would be correct if a 1 MHz crystal was used. However, a higher speed CPU is supplied which requires a 2 MHz clock. The RS232 link becomes 2400 baud with seven data and two stop bits. Higher operating speed is always an advantage.

Finally, there are two 8-bit I/O ports, two 16-bit counter/timers and room to mount up to 16K of RAM, ROM or a combination of both — just about all you could want for a simple development system.

## R65F11 and R65F12 CPUs

The Rockwell R65F11 and R65F12 are complete, high performance 8-bit NMOS single chip microcomputers which are compatible with the whole 6500 family. What makes these devices so special is the fact that they are CPUs which also perform the task of a PIA, ACIA and counter-timer. The R65F11 has the following features —

- it is an enhanced 6502 CPU;
- it contains the kernel of RSC-Forth and an operating system built into 3K of ROM;
- it has 192 bytes of RAM on the chip, 32 bytes of which can be placed into standby mode when the power is off;
- it contains two 8-bit I/O ports including four edge sensitive lines and input latching on one 8-bit port;
- it contains two 16-bit counter/timers with three associated latches;
- it provides a full duplex serial I/O channel; and
- it can address up to 16K of external memory.

Not bad, you say, for a 40-pin package. Those of you familiar with the 6500 family of micros, will realize that the R65F11 is the equivalent of having a 6502 CPU, 6522 VIA and 6550 ACIA *all on the one chip* (as well as a Forth ROM and some RAM). The R65F12 contains all the above as well as three extra 8-bit ports and comes in a 64-pin

QUIP package (quad in-line). If you would like to use the R65F12 CPU, Energy Control sells a special daughter board which replaces the R65F11 and brings out the extra I/O pins.

## Construction

The circuit diagram illustrates the overall system. Construction shouldn't present any difficulties but care should be taken. Use a fine tipped iron and fine solder otherwise solder bridging may occur. Start with the resistors, diodes and capacitors (check orientation of all polarized components). The silk screening on the pc board will indicate the position of all components; remember the board can be expanded to include extra memory, a disk controller and a Centronics port, so there'll be parts marked on the board that are not needed for this project.

Next, insert and solder the IC sockets and capacitors. Note that IC sockets are recommended for IC1, IC6, IC7 and IC8. If you have doubts about your soldering ability simply use sockets for all ICs. Finally, mount the reset switch, 2 MHz crystal and DB-25 connector (for the RS232 link).

Insert the ICs. Note that they all point in the one direction. Plug the R65FR1 development ROM into position U7 on the board and RAM into positions U8, 9 and 10 (depending on which RAM chips you are using). The memory decoding PROM supplied by Energy Control is set up for the memory map shown in Table 1. Sockets U8, 9 and 10 require 2K RAM chips like the 6116. For other RAM or ROM ICs, you will have to blow your own PROM.

The only tricky part of setting up the system is fitting the on-board jumpers. These customize the memory sockets (U7, 8, 9 and 10) for the particular RAM or ROM IC which will be used. Figure 1 shows the location of the jumpers and Table 2 lists the combinations required. Note that an extra jumper at the position marked 2M is required for operation at 2 MHz.

Finally, the moment. Connect 5 volts to the board, an RS232 terminal and switch on. If all is well, the display will show —

RSC-FORTH V1.7

Entering the command VLIST will list the entire Forth vocabulary. If not, check all your soldering and especially the on-board jumpers. The user's manual will take you through the whole Forth repertoire. ●

\*Starting Forth by Leo Brodie and Forth Programming by Leo Scanlon are available through ETI booksales. Starting Forth is worth \$25.00. Forth Programming will set you back \$24.25. For postage details see the book sales ad elsewhere in this issue.

**TABLE 1. Memory map decoded by PROM supplied by Energy Control.**

Function	Address space	Signal	Socket
FDC	\$0100-\$013F	FDC	U12
RAM1	\$0200-\$07FF	MEM3	U10
RAM2	\$0800-\$0FFF	MEM2	U9
RAM3	\$1000-\$17FF	MEM1	U8
ROM	\$2000-\$3FFF	MEM0	U7
Not used	\$1800-\$1FFF		
page zero	\$0000-\$00FF		
page one	\$0140-\$01FF		

**TABLE 2. Jumper Selection.**

Socket	Part Type	Jumper position		
		PIN 27	PIN 20	PIN 23
U7	8K x 8 RAM	R/W	RMEM0	
	2764 PROM	+5	MEM0	
	2732 PROM	+5	MEM0	
U8	8K x 8 RAM	PIN 27	PIN 23	PIN 20
	2K x 8 RAM	R/W	All	RMEM1
	2764 PROM	+5	R/W	RMEM1
	2732 PROM	+5	All	MEM1
	2716 PROM	+5	+5	MEM1
U9	2K x 8 RAM	PIN 21	PIN 18	
	2732 PROM	R/W	RMEM2	
	2716 PROM	All	MEM2	
U10	2K x 8 RAM	PIN 21	PIN 18	
	½ 2732 PROM	R/W	RMEM3	
	2716 PROM	+5	MEM3	
		+5	MEM3	

For 2 MHz operation, install 2M jumper. To use three 2K x 8 RAM chips and the R65FR1 development ROM, fit the jumpers highlighted in the above table.

# WIRELESS INSTITUTE OF AUSTRALIA

FOUNDED 1910

The W.I.A. represents the Radio Amateur at Local, National and International level and offers following services:

- ★ Monthly "AMATEUR RADIO" Magazine, included in membership fee.
- ★ Most REPEATERS have their licence, power and site cost paid by the institute.
- ★ World wide QSL-service.
- ★ Assistance to members in legal problems arising out of the pursuit of their hobby.
- ★ A Weekly Sunday Broadcast to Amateurs and Short Wave Listeners.
- ★ Assistance in dealing with Interference Problems (TVI-RFI etc.)
- ★ Novice and full call courses.
- ★ Trial Novice and AOCB theory exam papers.
- ★ Advice on Radio Mast approvals
- ★ The ONLY representation of the RADIO AMATEUR in legislative matters.



Join the 8,600 Amateur members in the W.I.A. by forwarding this coupon to:  
W.I.A. P.O. BOX 300,  
CAULFIELD SOUTH, VIC. 3162

Please forward a membership application form and further details to:

Mr, Mrs, Miss, Ms .....

Address .....

Callsign .....

Postcode .....

## PROGRAMMABLE POCKET SCANNER

—MICROCOMM—

### SX-155

## PROFESSIONAL POCKET SCANNER WITH OVER 45,000 CHANNELS & 160 MEMORIES



The Microcomm SX-155 represents the latest developments in State-of-the-art LSI CMOS technology as applied to scanning monitor receivers. It incorporates many features, a lot of which are not even found in today's larger base scanners.

For example the SX-155 has 160 memory channels which can be programmed in either of two modes. The first allows you to manually program the entire 160 channels. The second mode provides for manual programming of the first 40 channels with the top 120 reserved for use by the SX-155 while in its SEARCH mode. It uses these channels to automatically store frequencies on which it has found signals during the search phase.

The SX-155 also features a Priority Channel (for that important frequency). An LCD display providing readout of all receiver functions including an accurate crystal controlled 24 hour clock.

Supplied complete with rechargeable Nicad batteries charger, and rubber duck antenna, the SX-155 is a must for anybody with an interest in monitoring.

# \$399

AUSTRALIAN DISTRIBUTOR

## GFS ELECTRONIC IMPORTS

Division of DERIBAR Pty. Ltd.

17 McKeon Road, Mitcham, Vic. 3132  
PO Box 97, Mitcham, Vic. 3132

Telex: AA 38053 GFS

Phone: (03) 873 3777 3 Lines



Disco World Pty. Ltd.

300 Main Street, Lilydale  
P.O. Box 509, Lilydale, 3140  
(03) 735-0588

**AMPLIFIERS**  
ZPE Series II (500W) \$1300.00  
**DISCO MIXERS**  
Citronic SM 330 \$695.00  
Arista \$330.00

**JUMBO STROBE**  
FLA 701 \$153.48  
Scanner S101 \$99.45  
Scanner Bar S104S \$342.86

**HELICOPTER**  
2 ARM Spinner \$198.00  
4 ARM Spinner \$289.00  
8 ARM Spinner \$497.89  
UFO 324 "unreal" \$1698.55

**PINSPOT**  
PS 112S \$48.94  
PS 112L \$58.99

**MIRROR BALLS**  
MB 008-8" \$37.20  
MB 012 \$64.58  
MB 014 \$93.54  
MB 018 \$125.34  
MB 020 \$153.79

**SMOKE MACHINE**  
Great for Special Effects \$328.00  
[fluid at \$15 per litre]

**MIRROR BALL MOTORS**  
AC 240V \$29.99

**ROLLING LIGHTS**  
8 x 4515 lamps \$958.95  
24 x 4515 lamps \$1985.45

**COSMOS LIGHT**  
24 lamps \$1980.68  
Half Ball rotary light \$357.28  
6 lamps

**CONTROLLERS**  
Audio/Chaser (DW 4LC 4000) \$295.00  
Pre-set Programmed Controller 4 Channels each 1000W.

**LIGHT COMPUTER (DW 7LC 4200)** \$488.00  
Programmable 7 channel with e-prom (16 programmes). Ideal for Advertising signs and Disco lighting.

**VU LIGHT BAR (DW 12LC 480)** \$394.00  
12 channel L.E.D. like display controller. Triggered by sound signals. Exciting new product!

**CHASER (DW LC 4000)** \$155.00  
4 channel each 1000W with speed and mode switching.

**MUSICAL (DW M 4000)** \$130.00  
4 channel each 1000W sound to light.

PLEASE NOTE: ALL CONTROLLERS COME WITH 6 MONTHS WARRANTY.

**LAMPS all colours, soft glass**  
ES 240V 60W box of 25 \$75.00  
BC 240V 40W box of 100 \$77.00  
BC 240V 25W box of 100 \$75.00

Bankcard & Mail Orders  
Power Cords not included  
Trade Enquiries Welcome  
Send S.A.E. for free price list.

10% discount with all orders over \$1000 received by 1/6/85

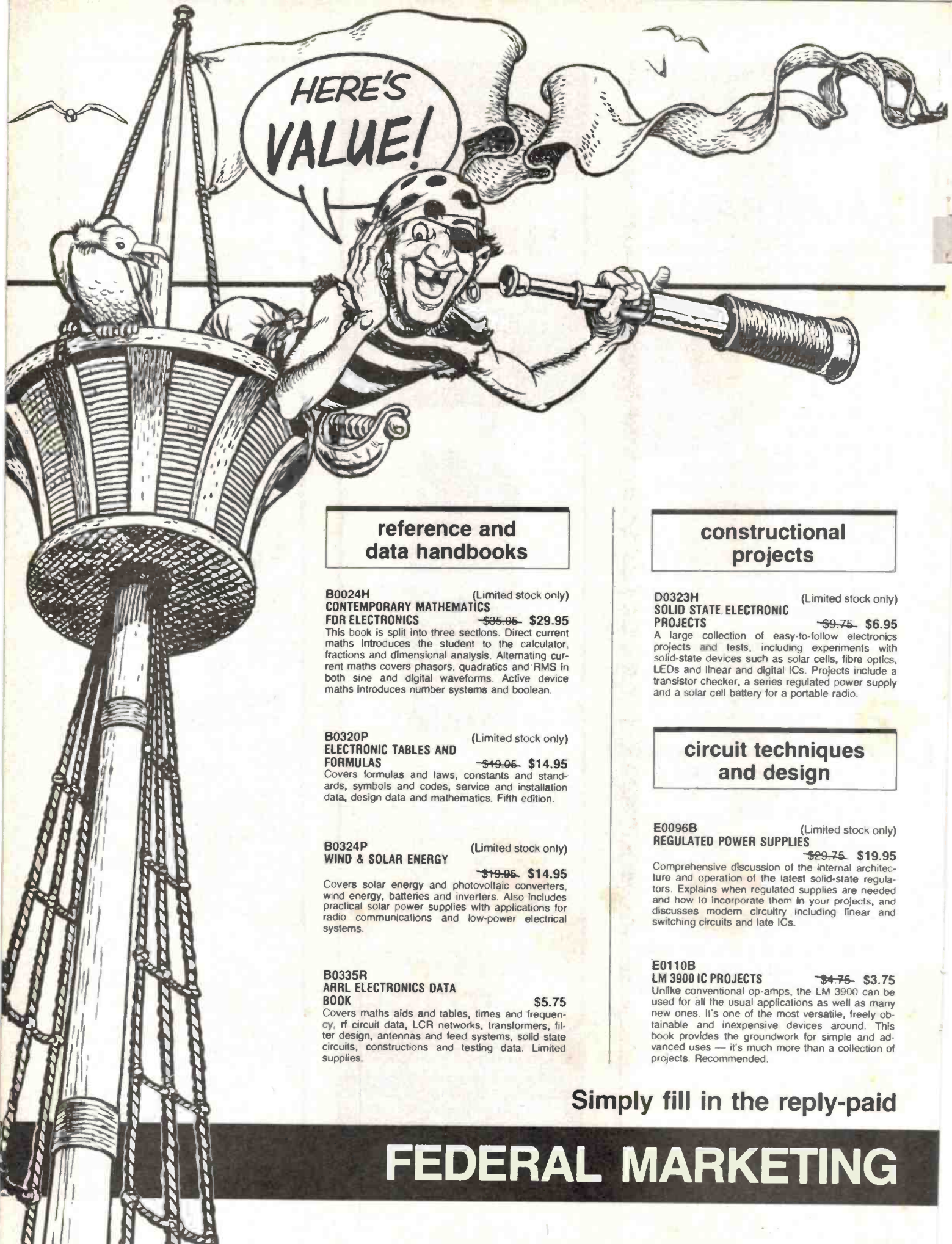

HERE'S  
VALUE!

**reference and  
data handbooks**

**B0024H** (Limited stock only)  
**CONTEMPORARY MATHEMATICS  
FOR ELECTRONICS** ~~-\$35.05~~ **\$29.95**  
This book is split into three sections. Direct current  
maths introduces the student to the calculator,  
fractions and dimensional analysis. Alternating cur-  
rent maths covers phasors, quadratics and RMS in  
both sine and digital waveforms. Active device  
maths introduces number systems and boolean.

**B0320P** (Limited stock only)  
**ELECTRONIC TABLES AND  
FORMULAS** ~~-\$19.05~~ **\$14.95**  
Covers formulas and laws, constants and stand-  
ards, symbols and codes, service and installation  
data, design data and mathematics. Fifth edition.

**B0324P** (Limited stock only)  
**WIND & SOLAR ENERGY** ~~-\$19.05~~ **\$14.95**  
Covers solar energy and photovoltaic converters,  
wind energy, batteries and inverters. Also includes  
practical solar power supplies with applications for  
radio communications and low-power electrical  
systems.

**B0335R**  
**ARRL ELECTRONICS DATA  
BOOK** **\$5.75**  
Covers maths aids and tables, times and frequen-  
cy, rf circuit data, LCR networks, transformers, fil-  
ter design, antennas and feed systems, solid state  
circuits, constructions and testing data. Limited  
supplies.

**constructional  
projects**

**D0323H** (Limited stock only)  
**SOLID STATE ELECTRONIC  
PROJECTS** ~~-\$9.75~~ **\$6.95**  
A large collection of easy-to-follow electronics  
projects and tests, including experiments with  
solid-state devices such as solar cells, fibre optics,  
LEDs and linear and digital ICs. Projects include a  
transistor checker, a series regulated power supply  
and a solar cell battery for a portable radio.

**circuit techniques  
and design**

**E0096B** (Limited stock only)  
**REGULATED POWER SUPPLIES** ~~-\$29.75~~ **\$19.95**  
Comprehensive discussion of the internal architec-  
ture and operation of the latest solid-state regula-  
tors. Explains when regulated supplies are needed  
and how to incorporate them in your projects, and  
discusses modern circuitry including linear and  
switching circuits and late ICs.

**E0110B**  
**LM 3900 IC PROJECTS** ~~-\$4.75~~ **\$3.75**  
Unlike conventional op-amps, the LM 3900 can be  
used for all the usual applications as well as many  
new ones. It's one of the most versatile, freely ob-  
tainable and inexpensive devices around. This  
book provides the groundwork for simple and ad-  
vanced uses — it's much more than a collection of  
projects. Recommended.

Simply fill in the reply-paid

**FEDERAL MARKETING**

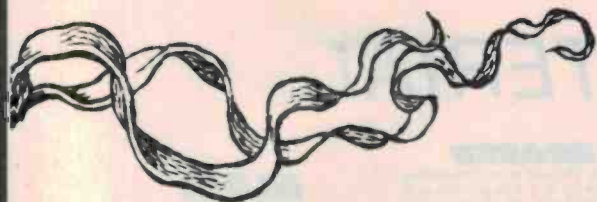

# LOOK!

## great book buys priced to clear the decks...

### test equipment and fault-finding

**F0114B**  
**HOW TO GET YOUR PROJECT WORKING** \$6.95  
Helps you to overcome the problems of a circuit that doesn't work by indicating how and where to start looking for many of the common faults that can occur when building up a project.

**F0258P**  
**EFFECTIVELY USING THE OSCILLOSCOPE** \$16.95  
Describes the potential uses of the scope, ranging from audio and television tests and measurements to performance tests.

**F0282B**  
**HOW TO BUILD YOUR OWN S/S OSCILLOSCOPE** \$6.95  
This book comprises a project divided into sections for builder to individually construct and test — then assemble into complete instrument. Includes short section on scope usage.

### electronic music and audio/video

**G0124B**  
**AN INTRO TO VIDEO** \$6.95  
This book is written in layman's language and is for anyone who is thinking about buying or renting or who has just bought or rented a video recorder and wants to get the best out of the machine.

**G0128P**  
**MODERN RECORDING TECHNIQUES** \$22.95  
Explains the equipment controls and techniques found in a modern recording studio and how to use them creatively and correctly to produce a desired result. Numerous photographs, diagrams and charts.

**G0129P**  
**SOUND-SYSTEM ENGINEERING** \$35.50  
Dealing with audio systems as a whole, it includes installing and equalising the sound system and interfacing the electrical and acoustic systems. Instrumentation, the acoustic environment and designing for acoustic gain.

**G0130P**  
**TUBE SUBSTITUTION HANDBOOK** \$8.75  
Complete, accurate, up-to-date guide to direct substitutes for receiving and picture tubes. Contains more than 6000 receiving tube substitutes, 4000 monochrome and colour picture tube substitutes, and 600 communications substitutes. Also includes pinouts for quick operational checks.

**G0131P**  
**HOW TO BUILD SPEAKER ENCLOSURES** \$9.95  
A guide to the 'whys' and 'hows' of constructing top-performance loudspeaker enclosures.

**G0135B**  
**ELECTRONIC MUSIC PROJECTS** \$5.95  
Provides constructors with practical circuits for the less complex music equipment including fuzz box, waa-waa pedal, sustain unit, reverb and phaser, tremolo generator, etc. Text covers guitar effects, general effects, sound generators, accessories.

**G0136B**  
**ELECTRONIC MUSIC & CREATIVE RECORDING** \$6.95  
Shows how electronic music can be made at home with the simplest and most inexpensive of equipment. Describes how the sounds are generated and how these may be recorded to build up the final composition.

**G0385B**  
**CHOOSING AND USING YOUR HI-FI** ~~\$4.95~~ \$3.95  
Provides basic information on the technical specifications of hi-fi equipment. Offers advice on what to look for in equipment in order to obtain real high-fidelity sound and reproduction.

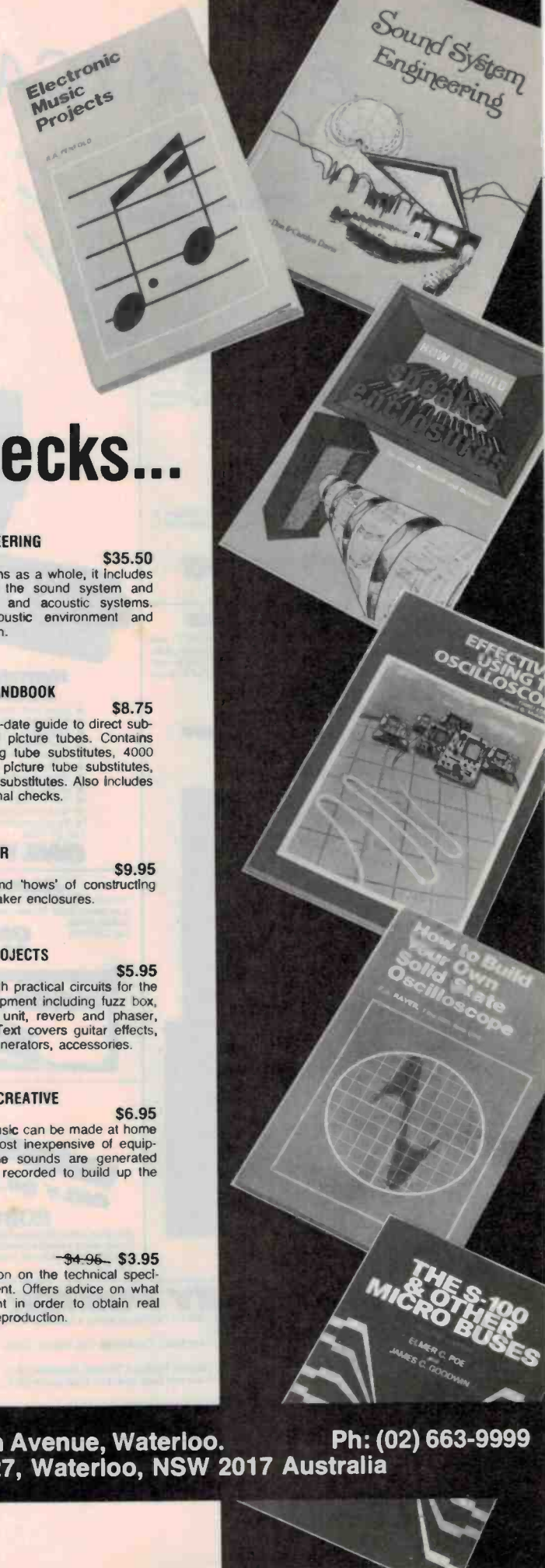

card insert & send to:

# BOOK SALES

140 Joynton Avenue, Waterloo.  
P.O. Box 227, Waterloo, NSW 2017 Australia

Ph: (02) 663-9999

# ALL JAYCAR MATERIAL

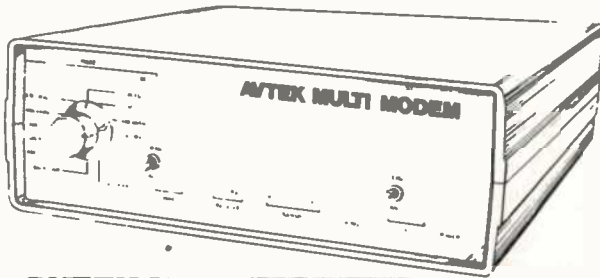

**AVTEK MULTIMODEMS**  
 State-of-the-art multimodem - has the following data standards CCITT V.21 & V.23, BELL 103 & 202 - Data rates 300, 600 & 1200 BPS - Backward channel 75 BPS in conjunction with 1200 BPS - Computer interface CCITT V.24 (RS232C) - Power requirements 240V AC 3 watts. Talk to the world with this line Multimodem.  
 Cat. XC-4820

**INCLUDES PHONE**  
**\$349.00**  
**MiniModem**

★ 300 Baud full duplex ★ Answer/originate ★ Plugs straight in (hardware phone) ★ Superior VLSI chip performance (identical to Multimodem) ★ Telecom approval CB4/37/1173  
 Cat. XC-4825

**ONLY \$199.00**  
**INCLUDES PHONE**

**SQUEAKY CLEAN MAINS FILTERS** - Two fantastic low cost models. MS-4010 will supply up to 4 appliances. Each 240V socket is isolated from the other, i.e. interference from disc drives is de-coupled from the CPU power supply etc. It will supply up to 4 outlets with a total load of 6 amps (unswitched).  
 Cat. MS-4010

**ONLY \$99.00**

**Single 10 amp line socket type filter (unswitched).**  
 Cat. MS-4012

**ONLY \$29.95**

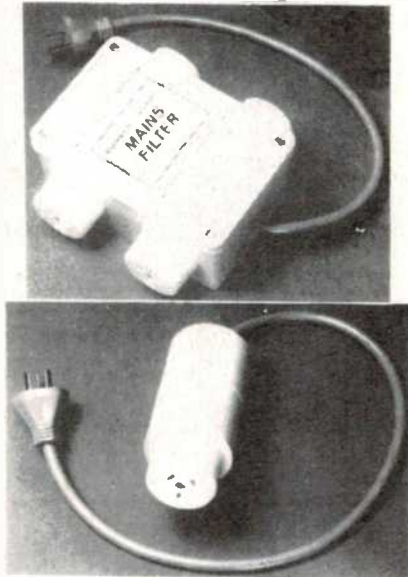

## UV EPROM ERASER

Erase your EPROMs quickly and safely. This unit is the cost-effective, solution to your problems. It will erase up to 9 x 24 pin devices in complete safety, in about 40 minutes for 9 chips (less for less chips)

- Erase up to 9 chips at a time
- Chip drawer has conductive foam pad
- Mains powered
- High UV intensity at chip surface ensures thorough erase
- Engineered to prevent UV exposure
- Long life UV tube
- Dimensions 217 x 80 x 68mm
- Weight 670 grams

Cat. XE-4950

**ONLY \$79.50**

**MAIL ORDER HOT LINE (02) 646 1300**

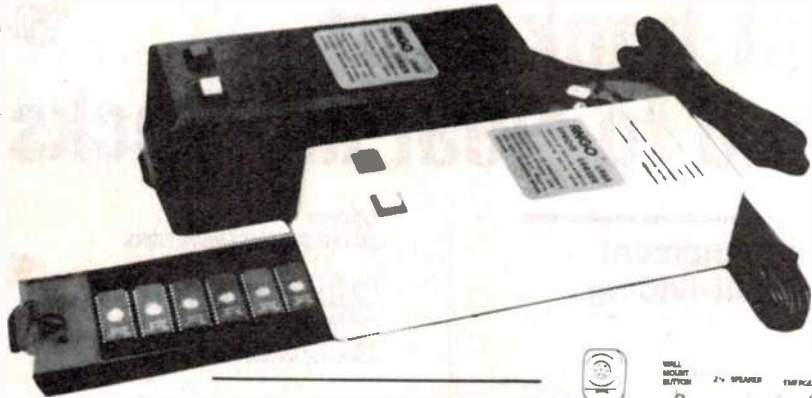

## Hands-free 10 Memory Desk/Wall Telephone

- Loud and clear fully duplex handsfree 2 way speaker
- 10 direct access memories
- Telephone line powered
- Unauthorised call restriction lock (optional)
- Adjustable volume control switch on handset
- Adjustable speaker volume control
- Privacy muting button
- Ringer Hi-Lo control
- Ten 18 digit memories plus one 22 digit last number redial
- Wall mounting or table use
- Programmable PABX pause

Cat. YF-7082

**ONLY \$149.95**

## ALARM STICKER

Durable, self-adhesive sticker that clearly tells would-be thief that there is an alarm fitted. Sticker does not refer to a specific alarm which creates further doubt.  
 Cat. LA-5100

**ONLY 95¢ each**  
**10 or more 85¢ each**



**ONLY \$4.95 each**

## ROBOT WATCH

Just what every child would love. It's a military look digital watch, which breaks away from the band to form a Robot. The robot has movable legs and arms with pop-out hands.  
 Cat. XW-0340

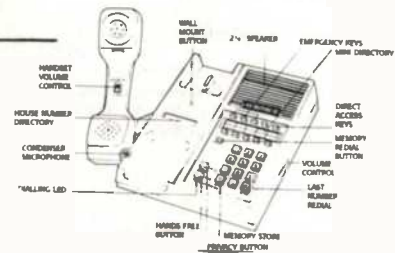

## FREE CATALOGUE

Ask for a FREE COPY of our 1985 Engineering Catalogue or send large SAE with 50¢ stamp.

## FM TRANSMITTER MODULE

FEATURES.

- ★ Ultra low noise output (-60dB or better attainable with suitable tuner)
- ★ Excellent frequency stability
- ★ NOT a ldt - ready for immediate use
- ★ Connections required: (A) Power supply or battery (B) Antenna (C) Audio input
- ★ Full instructions supplied
- ★ Suits any application where a stable low noise FM link is required

SPECIFICATIONS:

- Frequency 88 - 108MHz
- Useable range - 50 metres
- Supply - 6 to 9V @ 20mA
- Input sensitivity - adjustable, max. 30mV
- Pre-emphasis - 50µs standard
- Dimensions 90 x 22 x 15mm (approx)

Cat. DT-5450



**ONLY \$59.95**

## WALL MOUNTED PUSH BUTTON PHONE

This phone may look like those cheapies you see everywhere, but this one is different. It's Telecom approved and is supplied complete with plug. The sound quality is superb, it doesn't sound like you are talking into a shoe box, like some do. It's supplied complete with wall bracket and has a memory redial. Great as a second phone.  
 Cat. YF-7090

**ONLY \$24.95**

**approved**

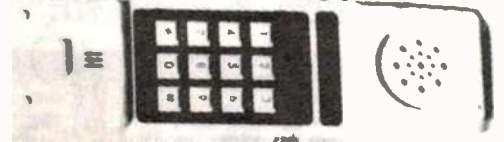

## SILICON VALLEY POSTER

This is a full colour caricature poster measuring 760(W) x 575(H)mm and is a full map of the famous 'Silicon Valley' area south of San Francisco.

The entire area spans from Mountain View thru Sunnyvale, Cupertino, Los Gatos, Santa Clara, San Jose, Fremont, etc!!

Famous semiconductor factories such as Fairchild, Hewlett-Packard, Intersil, Siliconix, NEC, Signetics, American Micro Systems and dozens you have not even heard of. Each factory is in its correct location.

The poster is full of cartoon characters and statements. You could stand in front of it for an hour and not take it all in!

We are convinced that you will be delighted with this poster. It is printed on very heavy art quality paper and is not cheap. Each one is supplied in a cardboard mailing tube. (No room for a picture). Cat. BP-9220 **The cost is \$9.95 + \$3 postage (sorry)**





# POSSESSIONS COST LESS

## ULTRASONIC PEST REPELLER

Which of these do you need to get rid of?  
 mice, blowflies, birds, spiders, bats, rats, cockroaches, flies, moths or fleas?  
 The VermineX ultrasonic insect pest repeller creates a sonic environment which is totally hostile to the creatures mentioned above.

### HOW DOES IT WORK?

The environment is relatively devoid of ultrasonic sounds. Evolution has not had a compelling reason to protect non-acoustic sensory mechanisms from ultrasonic stimulation. By subjecting an insect or rodent to a high level ultrasonic soundwave of a particular pattern the creature begins to behave in a typical fashion. The pest becomes disoriented, lethargic and bewildered. The natural reaction is to escape from the sound affected area. The sonic pattern is the secret and this pattern is a combination of scores of frequencies mixed together. The pattern was developed by Professor J.L. Stewart - the man who invented the Bionic ear. It works!

Like us, you would be skeptical at first that this would work. Our first reaction was, "If they are so good why haven't we heard about them before?" or "Surely a product like this - if it was any good - would have been around years ago." There have been ultrasonic repellents around but none of them have the patented soundwave pattern of the VermineX. We have on our file many, many letters of testimony to the fact that the VermineX is effective. The letters are from Australian Universities, Animal Husbandry research institutions, commercial Piggeries, restaurants etc. Many of them had several pest problems!

Your pest problem may not be as bad but it may still be a nuisance, which is why the domestic VermineX unit was developed. We are so confident of the VermineX units' effectiveness, we make the following offer: Buy the VermineX from us and use it for up to 14 days (21 days for mail order customers). If you are not happy with product after using it as directed, return it to us in clean, original condition and we will refund your money in full! (Less post/packing). What have you got to lose?

The VermineX covers an area of 2000 sq. ft. (uninterrupted) and is not cheap. But if the idea of dangerous chemicals, sprays, baits etc. worries you it's a great solution. It is supplied with a 240V plug pack but can be battery powered.  
 Cat. VS-5500

**WHAT HAVE YOU GOT TO LOSE EXCEPT THE BUGS?**

**ONLY \$69**



### 'WHAT ARE MICROCHARTS?'

Microcharts are professional, comprehensive, plastic summary cards packed with key time-saving information on: microprocessors, electronics, programming, and tools of the business. Colourful 100% plastic Microcharts are carefully organised for fast use at work, home, and in the classroom.

**WORDSTAR** - Much more info than keyboard overlays and can be flipped over faster. Allows large text window and avoids sub-menu-hopping. For beginners and advanced users. Covers full manual and more.  
 Cat. BM-8506

**Z80 CPU** - Full instruction set, ASCII hex and decimal conversions, flags, cycle times, interrupt structure, pinout, disassembly table, reg map, addressing, code for comparisons, powers of 2, diagrams and more.  
 Cat. BM-8500

**HOW TO SAMPLE** - Lets you estimate how many articles or people have a characteristic by examining only a small sample. No math background needed. For manufacturing, QC, research, etc.  
 Cat. BM-8514

**'C' LANGUAGE** - Comprehensive and concise summary of the efficient 'C' language for those using or learning 'C'. Avoids referring to manuals which can break concentration when programming.  
 Cat. BM-8512

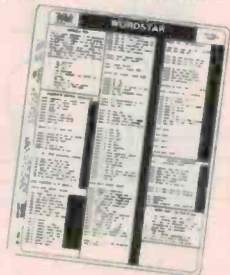

**ALL ONE  
 LOW PRICE  
 \$9.95  
 each**

### INFRA RED MOVEMENT DETECTOR

The Infra-red or IR detector for short, falls into the Black magic category. It basically is a high gain passive tuned receiver of a particular IR band. The heart of the unit consists of a high gain lens (antenna?) which has a "Commutated" field of view. Its reception pattern is comb like, but highly tuned to the IR wavelength of human bodies.

When a human passes within proximity of the pickup area, the lens will selectively pick up IR radiation and then not. Movement across the pickup area will result in a series of pulses sent to a detector circuit.

IR detectors are very reliable as they do not transmit and will not respond to non heat radiating objects. Curtains, for example, can wave about without tripping the alarm. Even the cat is unlikely to trip the unit.

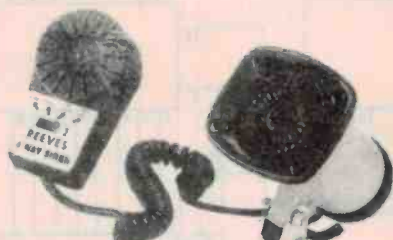

### GREAT TOY

#### Kids Bike "Emergency" Siren

CB-type microphone with siren/speaker/horn 4-way switch on the microphone gives you: Police, Fire and Ambulance sirens (all distinctive) PLUS Public Address! (it doesn't make enough noise to be a nuisance, but is great fun!)  
 Cat. AS-3190

**ONLY \$8.95**



Cat. TS-1550

**ONLY  
 \$19.50**



### FEATURES

- 12V DC powered
- Small 4 1/2" x 2" x 1 1/2"
- Double sensor
- Computerised OC to lower failure rate
- Built-in test lamp
- Tamper switch included
- Alarm output SPST 30V DC @ 1A

### STEREO AUDIO MIXER

Brilliant mixing console is packed with features. It allows the blending of microphone, 2 phono inputs and either 2 tape or 2 tuner inputs. Some of its many features include: Right and left VU meters • separate bass and treble controls • 5 slide level controls • headphone monitoring switch • talkover facility • Frequency response 20Hz to 20kHz • Dimensions: 318(L) x 217(W) x 85(H)mm • operates from 240V mains  
 Cat. AM-4200

**ONLY \$99.50**



### MICRON PROFESSIONAL 20W IRON

#### 240V AC SOLDERING IRON

This great iron has all the features of those costing a lot more.

- 370°C fixed temperature
- High efficiency patented heating element
- Iron clad, chrome plated, long life interchangeable tips

### IRON CLAD TIPS

This soldering iron uses high grade iron clad, chrome plated and pre-tinned tips. Tip life expectancy is many times that of conventional plated tips.

Cat. TS-1552 \_\_\_\_\_ MICRO CHISEL - 1mm  
 Cat. TS-1553 \_\_\_\_\_ MINI CHISEL - 1.5mm  
 Cat. TS-1554 \_\_\_\_\_ STANDARD CHISEL - 3mm

**ALL Tips \$3.50 each**

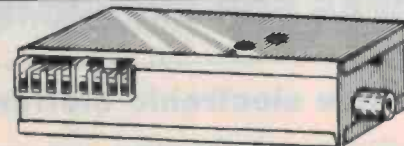

### VHF VIDEO/AUDIO RF MODULATOR

\* At long last a good quality, stable video/audio-to-RF modulator. It even will enable you to connect a Commodore VIC 20 to a VHF TV set! Note that this module is specially tuned for Australian TV (VHF Channel 0 & 1.55MHz sound subcarrier). A full data sheet and connection diagram is included.  
 Cat. LT-3802

**ONLY \$9.95 each**

# Jaycar

## ELECTRONICS

Incorporating ELECTRONIC AGENCIES  
**NUMBER 1 FOR KITS**

**MAIL ORDER HOTLINE (02) 646 1300**

**N.S.W. SHOWROOMS**  
 SYDNEY: 117 York Street Tel. (02) 267 1614  
 CARLINGFORD: Cnr. Carlingford & Pennant Hills Road Tel. (02) 872 4444  
 CONCORD: 115/117 Parramatta Road Tel. (02) 745 3077  
 HURSTVILLE: 121 Forest Road Tel. (02) 570 7000  
 GORE HILL: 188/192 Pacific Highway (Cnr. Bellevue Avenue) (02) 439-4799

**QUEENSLAND**  
 BURANDA: 144 Logan Road Tel. (07) 393 0777  
**MAIL ORDERS:** P.O. Box 480, AUBURN 2144. Tel. (02) 643 2000  
**HEAD OFFICE:** 7/9 Rawson Street, AUBURN 2144.  
 Tel. (02) 643 2000 Telex: 72293

### SHOP HOURS

Carlingford, Hurstville & Gore Hill  
 Mon-Fri: 9am - 5:30pm, Thurs 8:30pm; Sat 12pm  
 Sydney  
 Mon-Fri: 8:30am - 5:30pm, Thurs 8:30pm; Sat 4pm  
 Concord  
 Mon-Fri: 9am - 5:30pm; Sat 4pm

### POST & PACKING

\$5 - \$9.99	\$1.50
\$10 - \$24.99	\$3.20
\$25 - \$49.99	\$4.50
\$50 - \$99.99	\$6.50
\$100 - \$199	\$8.00
Over \$199	\$10.00

**COMET ROAD FREIGHT ANYWHERE IN AUSTRALIA ONLY \$12**



**MAIL ORDER VIA  
 YOUR PHONE**

## IDEA OF THE MONTH

### Peripheral Switch

**William Perry, Hurstville, NSW**

This circuit allows up to four user-selectable peripherals to be plugged into the 'Bee at any one time.

One of the four output ports is selected by an IN/OFF/OUT switch, the information being decoded by four 74LS20 quad NAND gates. Output from the NAND gates selects one of four bidirectional buffers. The direction of data flow through the buffer is also determined by the switch. The control buss is similarly buffered by half of a 74LS126.

The buffers are necessary to present a high impedance to the buss when the chips are not selected.

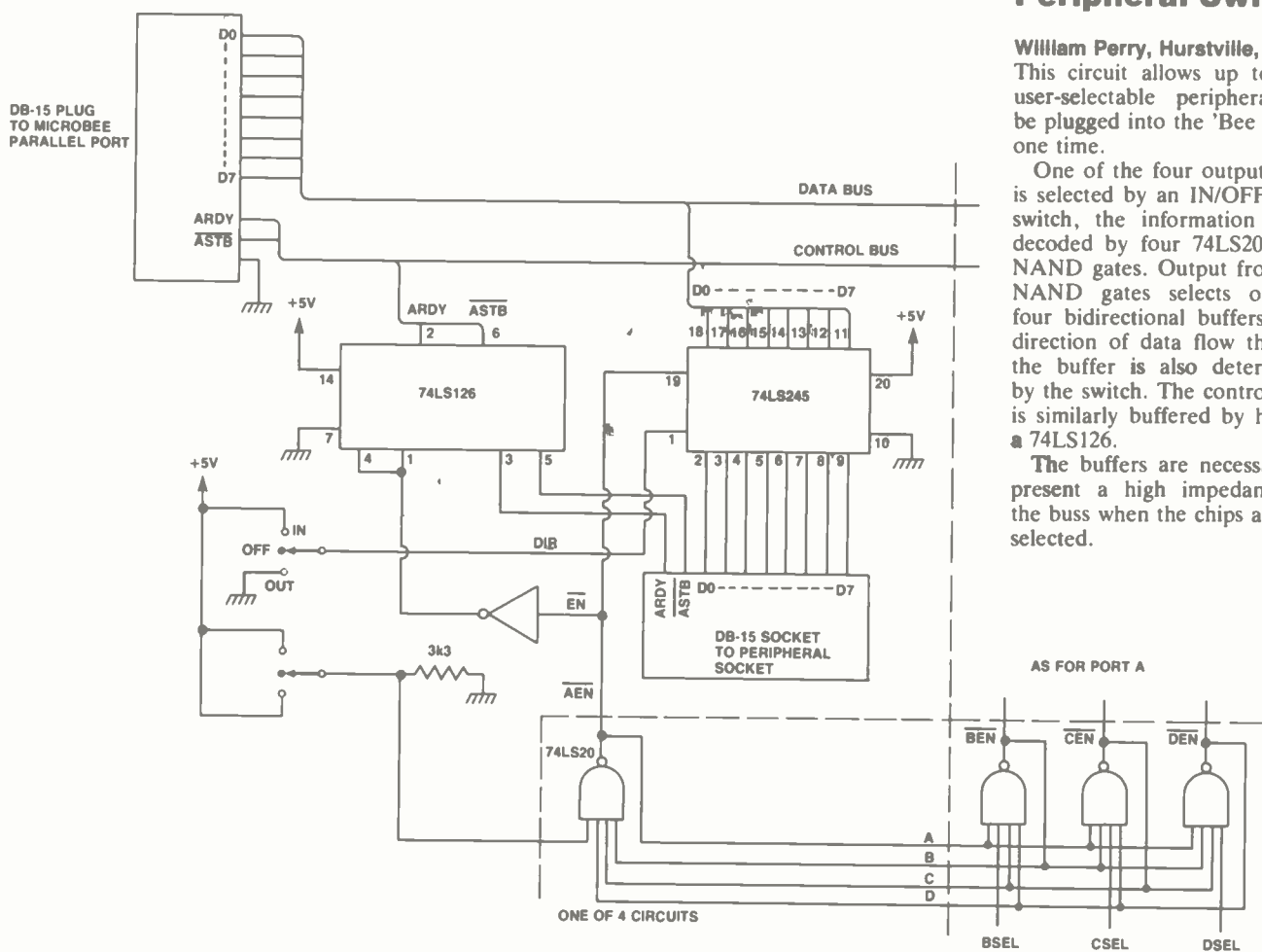

## IDEAS FOR EXPERIMENTERS

### Simple electronic metronome

A 555 timer wired for astable operation drives a speaker directly in this idea by R. Huntley of St Albans, Vic. The period is set by a 500 kohm (log) switch-pot with a 75 kohm series resistor, charging a 3.3 µF capacitor. This gives a range of about 30 to 230 beats per minute when an eight ohm speaker is connected.

The dial should be calibrated with the speaker connected, as the speeds obtained depend on the speaker's impedance. The pulse width is about 1 ms, as the discharge pin of the timer is connected directly to the timing

capacitor. This gives a clean, sharp click, very similar to the sound of a mechanical metronome.

A 5V regulator is used to keep the calibration independent of the battery voltage (the speed varies by only 5% for battery voltages between 5V and 15V). Current drain is about 10 mA, giving about five hours of operation from a single 50 mAh battery. A phono output is provided via a 10 µF capacitor. This may also be amplified by a hi-fi set to provide an output with any desired volume and tone.

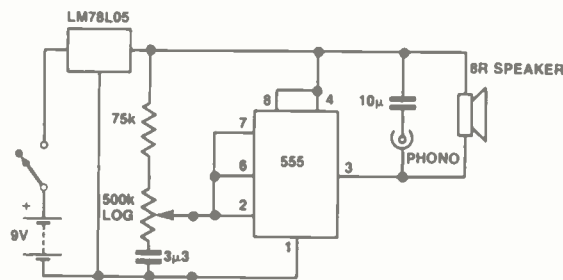

## 'IDEA OF THE MONTH' CONTEST

Scope Laboratories, which manufactures and distributes soldering irons and accessory tools, is sponsoring this contest with a prize given away every month for the best item submitted for publication in the 'Ideas for Experimenters' column — one of the most consistently popular features in ETI Magazine. Each month we will be giving away a 60 W Portable Cordless Soldering Iron, a 240 Volt Charging Adaptor together with a Holder Bracket. The prize is worth approx. \$100.

Selections will be made at the sole discretion of the editorial staff of ETI Magazine. Apart from the prize, each person will be paid \$20 for an item published. You must submit original ideas of circuits which have not previously been published. You may send as many entries as you wish.



### RULES

This contest is open to all persons normally resident in Australia, with the exception of members of the staff of Scope Laboratories, The Federal Publishing Company Pty Limited, ESN, The Litho Centre and/or associated companies.

Closing date for each issue is the last day of the month. Entries received within seven days of that date will be accepted if postmarked to and including the date of the last day of the month.

The winning entry will be judged by the editor of ETI Magazine, whose decision will be final. No correspondence can be entered into regarding the decision.

The winner will be advised by telegram the same day the result is declared. The name of the winner, together with the winning idea, will be published in the next possible issue of ETI Magazine.

Contestants must enter their names and addresses where indicated on each entry form. Photostats or clearly written copies will be accepted but if sending copies you must cut out and include with each entry the month and page number from the bottom of the page of the contest. In other words, you can send in multiple entries but you will need extra copies of the magazine so that you send an original page number with each entry.

This contest is invalid in states where local laws prohibit entries. Entrants must sign the declaration on the coupon that they have read the above rules and agree to abide by their conditions.

### COUPON

Cut and send to: Scope/ETI 'Idea of the Month' Contest, ETI Magazine, P.O. Box 227, Waterloo NSW 2017.

"I agree to the above terms and grant *Electronics Today International* all rights to publish my idea in ETI Magazine or other publications produced by it. I declare that the attached idea is my own original material, that it has not previously been published and that its publication does not violate any other copyright."

\* Breach of copyright is now a criminal offence.

Title of Idea .....

Signature ..... Date .....

Name .....

Address .....

Postcode .....

# What is better than NiCad for memory back-up?

## NEC



COMPARATIVE SIZE

# SUPERCAP of course!

Unlike NiCad —

- It never needs replacing or maintenance.
- It does not exhibit discharge memory.
- It can be wired either way. Lack of polarity enables this.
- It can be soldered onto P.C.B.s with other components.
- It can be charged at high and low current rates, i.e. microamps to amps.
- It is completely safe. It will not explode under extremes of temperature, nor will it leak.
- It is small and compact.

Catalogue No.	Cap. (Farad)	Rated V. (V.D.C.)	Max. W.V (V.D.C.)	Max. ESR* (Ω at 1 kHz)
FA0H105Z	1.0	5	5.5	2.5
FZ0H223Z	0.022	5	5.5	50
FZ0H473Z	0.047	5	5.5	40
FZ0H104Z	0.1	5	5.5	45
FZ0H224Z	0.22	5	5.5	25
FZ0H474Z	0.47	5	5.5	13
FZ0H105Z	1.0	5	5.5	7

\* Equivalent series resistance

TECHNICAL INFORMATION AVAILABLE ON REQUEST. JN

# SOANAR

SOANAR ELECTRONICS PTY. LTD.  
INCORPORATED IN VICTORIA

30-32 Lexton Road, Box Hill, Vic., 3128, Australia.

VICTORIA: 895 0222  
N.S.W.: 789 6744  
S.T.H. AUST. 297 0811

QUEENSLAND: 852 1133  
WEST. AUST.: 381 9522  
TASMANIA: 31 6533

# More modems

If you can't be bothered to make your own, consider buying a new low cost 1200/75 and 300 baud direct connect modem for the Commodore 64. It's one of two new products just unveiled by Melbourne based ACME Software. The new products have been developed and will be totally manufactured in Australia.

The Micromodem III allows users of Commodore 64 and Commodore VIC 20 computers to access telephone computer databases. An RS232 adaptor will also be available to allow use with nearly all computers.

What separates the Micromodem III from the rest is that as well as the common 300 baud mode it also has the 1200/75 baud mode which is coming into prevalent use, and is the standard adopted by Telecom for its new Viatel electronic database — which promises to be a true public access system.

The modem is direct connect — all that is required is to plug it into the phone line and into the rear of the computer, load your software, and you are ready to enter the exciting world of computer communications.

Acme Software also produces communications software to allow Commodore 64 and Vic 20

users to take full advantage of the features of the Micromodem III modem. It's called 64 NET, and is of special interest to educational users as it has features which make it directly compete with more expensive systems.

64 NET allows users to converse with each other via the network, with Basic or machine language programs. The teacher may retrieve any students' screen (or program) to assess progress or offer help.

Bill Dimech of ACME Software told us that the desired capabilities of 64 NET were determined after talking to a range of teachers to get their opinions.

Further information on these products may be obtained from most Commodore computer dealers or directly from ACME Software at PO Box 3, Brighton North, Victoria 3186.

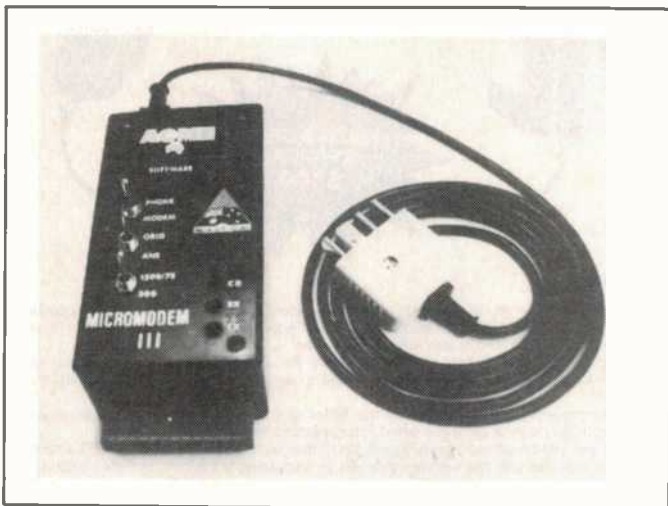
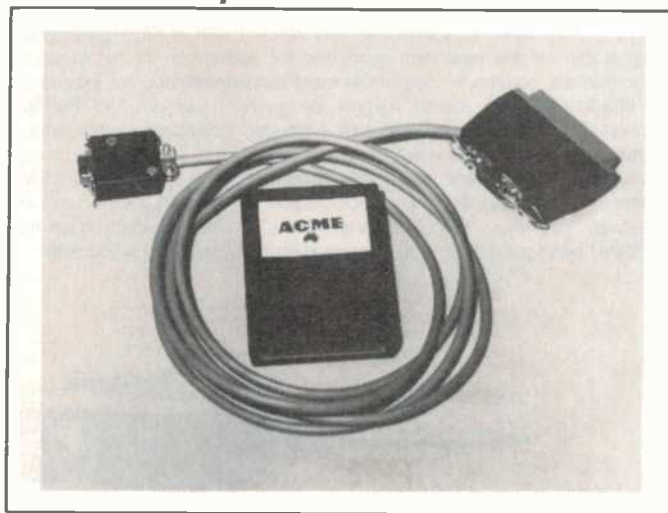

## PC of the year

ETI's computer based stablemate, *Your Computer* magazine, has just announced the winner of the 1985 Computer of the Year Awards. It's the HP110, a portable computer from Hewlett Packard.

In its citation, YC noted that the first IBM delivered to the University of New South Wales in 1964 had 128k bytes of memory, cost \$1m, was two metres tall and came complete with an IBM engineer and a staff of white coated high priests in a false floored, specially air condi-

tioned environment. The HP, twenty years on, costs less than \$5000, is 10 cms tall and fits into a normal executive briefcase — which doesn't have room for engineers, high priests or air conditioning.

The software prize was taken away by the Microsoft flight simulator, beating a whole lot of business software in the process. Interestingly, the shortlist included the only other low cost package in the contest, Borland International's \$89 Sidekick.

Tell them you read it in ETI



## Computer protection memory

Westinghouse Systems have taken over the marketing of the Computer Protector, formerly sold by Edor Electronics.

The Computer Protector is designed to protect computer memory against spikes, glitches, lightning, on-off electric motors, electric welding plants, switching of relay contactors etc.

It ensures attenuation performances at frequencies up to 300 MHz. Maximum peak surge current is up to 4500 amps for

(8/20 microseconds). Transient energy absorption is up to 75 joules for (10/1000 microseconds).

The Protectors are completely sealed to ensure safety for the user and are available in 1, 3, 6 and 10 amp versions. It plugs into any 3 pin wall socket. Special types are available with an earth line choke.

Enquiries to Westinghouse Systems, PO Box 267, Williamstown, Vic. 3016.

## Viatel via Apple

Apple Computer Australia and the Sydney-based developer, NetComm, have released some new communications software for the Apple Macintosh personal computer.

Developed in Australia by NetComm, the new software will enable users to access Telecom Viatel services, other existing Prestel-type services such as AFTEL and CYBERTEL, and any available overseas Prestel services.

The MacVidotex package fully uses the windows and Icon interface of the Macintosh, with "exceptional graphic resolution", according to NetComm

managing director, Chris Howells. The software complements the Apple communications program, MacTerminal, which is now available for asynchronous communications on the Apple.

Users will be able to print videotex images to disk or to printer, as required, using a standard 128K Macintosh.

Both MacTerminal and MacVidotex packages use the capabilities of Apple's intelligent Modem 1200, which was launched late last year.

For more information contact Apple Computer, 37 Waterloo Rd, North Ryde NSW. (02)888-5888.

### Club Call

Southern Districts Commodore Users Group meets on the first and third Wednesday of every month in the API Hall, Kurrajong Rd, Prestons in Liverpool NSW. Meetings start at 6 pm and all are welcome. The SDCUG puts out a newsletter for 50c edited by Geoff Knight.

Apple owners might like to get along to the AUSOM meetings held first Saturday of the month at 2pm on the Victoria College campus, building E. It's situated on the Burwood Highway at Bennetswood, Melbourne.

## BRIEFS

### Pascal compiler

Software City, 1/27 Forge St, Blacktown, NSW 2148, is selling Turbo Pascal, a full Pascal Compiler with built-in Wordstar editor. It includes a full source code and spread sheet.

### Apple drum machine

Thinking Systems has released Drum key, a digital drum machine for the Apple II. It is menu driven and uses the computer and an external audio unit to produce the sounds. Contact Thinking Systems, 29 Belmore St, Surry Hills, NSW 2010.

### A word for Mackintosh

Microsoft has announced that Word, a wordprocessor package, is now available for the Mackintosh. It makes use of the capabilities of the Mac to allow full visual presentation of the text, while driving most popular printers. Word also allows the user to use the mouse and window features of the Mac.

### New modem

Pulsar Computers in Melbourne has released a Telecom approved direct connect modem for local and US protocols. It includes auto dial, auto answer with error detector and extremely fast call detection. It is designed to handle V21, V23 mode 1 and mode 2 as well as the main US standards. For information contact Pulsar Electronics (03) 330-2555.

### IMS even faster

IMS International has announced what it claims is an industry breakthrough with substantial improvements to the S100 computer architecture. The new architecture uses the master/slave environment of TurboDOS to achieve transfer speeds of up to one megabyte a second. Contact IMS, 5th Floor, 23 Berry St, North Sydney, NSW 2060.

### New Ericsson PCs

RIFA has been appointed national distributor for the new series of Ericsson personal computers. Richard Knehan of RIFA promised a national demonstration campaign to coincide with the release of the new machine in Australia.

## Smart Cable

Ectron has released an intelligent cable to interconnect RS 232 equipment. It configures itself to match your computer to your printer or other peripheral.

According to the makers, the intelligent cable solves 90% of the traditional problems associ-

ated with interfacing RS 232 equipment. It senses the distribution of protocols on the lines on both sides and makes the appropriate connections.

For more information contact Ectron at 8 Hinkler Rd, Morialoc, Vic 3195. (03)580-9677.



# ACTIVE ELECTRONICS

289 LATROBE STREET, MELBOURNE 3000 PH. (03) 602 3499  
887 SPRINGVALE ROAD, SPRINGVALE 3171 PH. (03) 547 1046

8.30am - 5.30pm MON-THURS      8.30am - 8.00pm FRIDAYS      9am-12noon SATURDAY  
ALL YOU HAVE EVER WANTED IN AN ELECTRONIC STORE - AND MORE!

## SPRINGVALE SUPER STORE NOW OPEN!

### CHECK THESE 2 GREAT LOCATIONS

#### SPRINGVALE



#### CITY

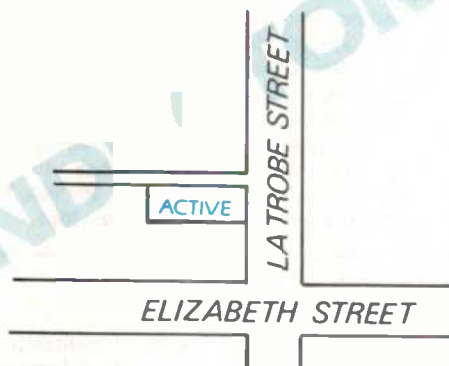

### DISK DRIVE SPECIALS

CHINON 3 1/2"	S.S.D.D	40 TRACK	F351 (250K)	\$149
CHINON 5 1/4"	S.S.D.D	40 TRACK	F051 (250K)	\$149
CHINON 5 1/4"	D.S.D.D	40 TRACK	F052 (500K)	\$195
MITSUBISHI 5 1/4"	D.S.D.D	40 TRACK	M4851 (500K)	\$215
MITSUBISHI 5 1/4"		80 TRACK	M4853 1 MEG	\$260
MITSUBISHI 5 1/4"	D.S.H.D	77 TRACK	M4854 1.6 MEG	\$350
MITSUBISHI 5 1/4"	D.S.H.D	77 TRACK	M4855 2 MEG	\$385

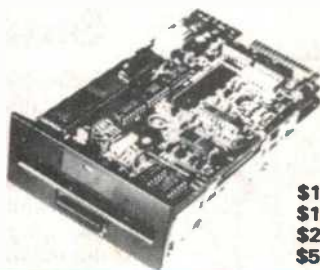
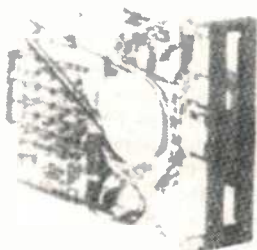
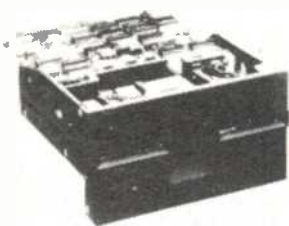

MAIL ORDER  
HOT LINE

(03) 671312



#### POSTAGE RATES

\$1-\$9.99	\$1.50	\$100-\$199	\$5.00
\$10-\$24.99	\$2.00	\$200-\$499	7.50
\$25-\$49.99	\$3.00	\$500 plus	\$10.00
\$50-\$99.99	\$3.50		

**MAIL ORDERS LA TROBE STORE ONLY**



# ACTIVE ELECTRONICS

289 LATROBE STREET, MELBOURNE 3000 PH. (03) 602 3499  
887 SPRINGVALE ROAD, SPRINGVALE 3171 PH. (03) 547 1046

8.30am - 5.30pm MON-THURS

8.30 am-8.00 pm FRIDAYS

9am-12noon SATURDAY

ALL YOU HAVE EVER WANTED IN AN ELECTRONIC STORE - AND MORE!

## CHECK OUR SEMICONDUCTOR PRICES - YOU WON'T DO BETTER (JUST PART OF OUR LARGE IN-STORE RANGE)



6116P3



4164 (150NS)



2732 (250NS)

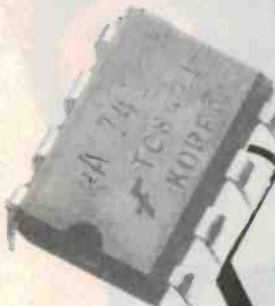

LM741



LM555

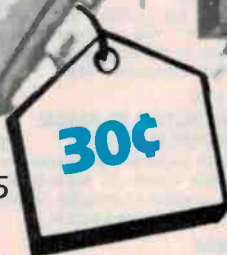

LM324

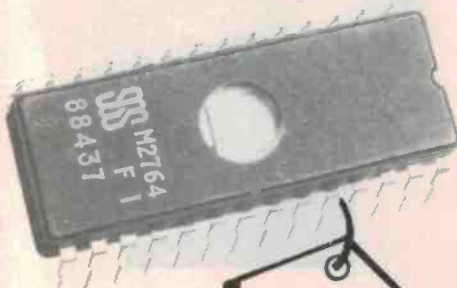

2764 (250NS)



4093B



2N3055



ACTIVE - JUST ABOUT EVERYTHING ELECTRONIC



# Ahoy Mates! — get in for here's more great books all

## computers for beginners

### H0423A YOUR FIRST BASIC PROGRAM

~~\$16.00~~ \$9.95

Imagine — in just one hour you'll be writing your first BASIC program! This very entertaining book requires no computer experience at all. It's a fun, easily-understood introduction to computing — loaded with bright illustrations and simple diagrams. Anyone, from 8 to 88 years old, should make this their first BASIC computer book.



## computer hardware and techniques

### J0157P MICROPROCESSOR CIRCUITS

\$14.75

Presents basic microprocessor concepts in simple language for beginners and teaches you to construct a useful microcontroller system. Offers 30 demo circuits which take you through assembly, operation and programming of a microcontroller.

### J0159P DON LANCASTER'S MICRO COOKBOOK

(Limited stock only)  
~~\$22.20~~ \$19.95

This 'cookbook' starts with the very fundamentals of microprocessors and microcomputers and takes you through number systems, codes, etc., till you can work intelligently with micros.

### J0160P THE \$100 AND OTHER MICRO BUSES

\$14.50

The key to successful computer expansion is a complete understanding of the bus system, through which the computer communicates with peripherals. This book will give you that understanding.

### J0161P MICROCOMPUTER DESIGN & TROUBLESHOOTING

\$26.75

Tells you how to design microcomputer systems and make them work without an expensive commercial development system or the need for costly test instrumentation. Includes a complete description of two microprocessors — the 8085 and the 6502.

### J0162H IAPX 88 HANDBOOK

(Limited stock only)  
~~\$20.25~~ \$14.95

This book from Intel itself describes the unique Intel 8088 microprocessor in total detail. Invaluable for all involved with the 8088.

### J0163P USING THE 6800 MICRO-PROCESSOR

\$13.25

Guides the reader through the conception, configuration, writing and running of a variety of programs that demonstrate practical use of a 6800 system.

### J0164P STD BUS INTERFACING

\$21.75

Explains what the STD bus is, in easy-to-understand language.

### J0360H IBM PERSONAL COMPUTER INTRO

(Limited stock only)

~~\$21.05~~ \$19.95

Designed for beginners, this book offers an informal introduction to programming in BASIC. Also covers applications for business, graphics, games and word processing and includes comprehensive tables and charts.

### J0393P VIC-20 PROGRAMMER'S REFERENCE GUIDE

(Limited stock only)

~~\$22.95~~ \$18.95

An all-purpose reference guide for first-time users and experienced programmers. Includes a BASIC vocabulary guide, programming tips, machine-language programming guide and a section on input/output operations.

### J0395B THE ART OF PROGRAMMING THE ZX SPECTRUM

(Limited stock only)

~~\$7.95~~ \$4.95

For beginners and seasoned programmers. Covers low- and high-resolution graphics, sound, moving graphics, PEEK and POKE and advanced graphics.

## computing software

### K0106A INTRODUCTION TO THE UCSD P-SYSTEM

(Limited stock only)

~~\$22.45~~ \$18.95

Explains the UCSD Pascal operating system, or "p-system". You will learn how to enter a Pascal program in the computer, edit it, store it on a file and then manipulate files.

### K0113A INTRODUCTION TO PASCAL: UCSD PASCAL

~~\$26.95~~ \$19.95

For both beginners and experienced programmers, this book covers all aspects of Pascal, from the basic concepts of program development. Extensive appendices. Second edition.

### K0189A INSIDE BASIC GAMES

~~\$19.95~~ \$14.95

The medium of games teaches readers how to design error-free, interactive BASIC programs. Rules, algorithms and coding differences for the PET, Apple II and TRS-80 are also included.

### K0200A THE PASCAL HANDBOOK

~~\$23.50~~ \$19.95

Summarises the entire Pascal vocabulary, including the variations introduced by different commercial versions of Pascal. All in dictionary format.

### J0166A DIGITAL CIRCUITS WITH MICRO APPLICATIONS

(Limited stock only)

\$46.50 \$29.95

An introductory text, this book provides readers with the basic ideas and tools needed to analyse and design digital circuits and computer systems. Discusses microprocessor computer organisation, machine-language number systems and gate circuits.

### J0167A MICROPROCESSOR INTERFACING TECHNIQUES

\$29.95

Teaches you how to interconnect a complete microprocessor system and interface it to the usual peripherals. The hardware and software skills needed to effectively interface peripheral devices are covered along with various buss standards and A/D conversion. Third edition.



Simply fill in the reply-paid

# FEDERAL MARKETING BOOK SALES



# your cut of the treasure, priced to clear the decks...

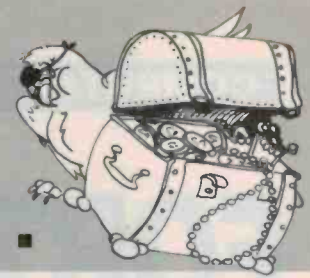

**J0170P**  
**6809 MICROPROCESSOR PROGRAMMING** \$21.95  
Gives a solid understanding of how to program and interface the high-performance 6809 microprocessor. The author completely explores internal structure, addressing modes, data movement instructions, registers, arithmetic logic and test instructions for the 6809.

**J0171P**  
**Z80 MICROCOMPUTER HANDBOOK** \$20.50  
This handbook covers hardware, software and microcomputers built around the Z80.

**J0273P**  
**APPLE INTERFACING** \$15.95  
Using this book, you will be able to perform useful experiments which will provide a much clearer understanding of the fundamentals of computer interfacing and computer electronics.

**J0283B**  
**A Z80 WORKSHOP MANUAL** \$8.95  
Intended for those who want to progress beyond BASIC programming to topics such as machine-code and assembly language programming or who need hardware details of the Z80-based computer.

**J0285B**  
**EASY ADD-ON PROJECTS FOR SPECTRUM, ZX81 AND ACE** \$7.75  
The projects include a pulse detector, picture digitiser, five-key pad, model controller, bleeper, lamp flasher, light pen, etc, etc.

**J0303P**  
**HOW TO PROGRAM AND INTERFACE THE 6800** \$22.95  
An in-depth introduction to microprocessors and microcomputers in general and the Motorola 6800 microprocessor family in particular. Includes experiments for the Heath ET3400 and Motorola MEK6800D2 learning systems designed to demonstrate 'real world' applications. Limited supplies.

**J0328P** (Limited stock only)  
**16-BIT MICROPROCESSOR USER'S MANUAL** ~~\$20.00~~ \$14.95  
In this third edition, Motorola offers the latest information to design engineers, software architects and computer designers in order to complete software systems using Motorola's MC68000 microprocessors.

**J0342P**  
**16-BIT MICROPROCESSORS** \$22.20  
A guide to the most popular of the 16-bit microprocessors, including the Intel 8086, the Zilog Z8001 and 8002 chips, the DEC LSI-11, Texas Instruments 9900, the Motorola 68000 and the National Semiconductor 16000 family.

**J0350P** (Limited stock only)  
**Z80 MICROPROCESSOR PROGRAMMING BOOK 1** ~~\$17.99~~ \$14.95  
Covers Z80 software, assembly-language and machine-language programming. Requires no background in computer science, programming or digital electronics.

**K0201P** (Limited stock only)  
**TRS-80 COLOUR COMPUTER GRAPHICS** ~~\$21.95~~ \$17.95  
Explore the creative and imaginative blending of computers and colour. Shows how to create dynamic and interesting graphics to enhance your programs.

**K0202A** (Limited stock only)  
**INTRODUCTION TO TRS-80 GRAPHICS** ~~\$22.95~~ \$18.95  
It begins with the basic concepts of line drawing and leads the reader on to geometric shapes, moving figure animation and other more advanced topics.

**K0204P** (Limited stock only)  
**MOSTLY BASIC: TRS-80 — BOOK 1** ~~\$19.25~~ \$14.95  
8 ready-to-use BASIC programs which have been completely tested and debugged. Programs include a telephone dialler, digital stopwatch, spelling test, house buying guide, gas mileage, and others. Complete with explanations of each program, sample runs, and complete program listing.

**K0222A** (Limited stock only)  
**32 BASIC PROGRAMS FOR THE PET** ~~\$29.50~~ \$19.95  
Each chapter fully documents a different bug-free program. If readers have a good working knowledge of BASIC, they can devise their own program changes.

**K0232A** (Limited stock only)  
**PROGRAMMING THE Z8000** ~~\$25.95~~ \$19.95  
A complete introduction to programming concepts and techniques for use with the 16-bit, Z8000 microprocessor. Presents detailed descriptions of the architecture and functions of this 'super chip'.

**K0233H** (Limited stock only)  
**START WITH BASIC ON THE VIC-20** ~~\$14.75~~ \$9.95  
Helpful exercises and step-by-step instructions show you how to program in BASIC utilising all the graphic functions on the VIC-20.

**K0357P** (Limited stock only)  
**PASCAL PRIMER** ~~\$29.95~~ \$18.95  
Includes popular USCD Pascal, tear-out reference card, machine-language Interfacing, progress quizzes and graduated examples.

**K0378H** (Limited stock only)  
**LEARNING LOGO ON THE APPLE II** ~~\$12.50~~ \$9.95  
An introduction to the Logo language. Includes starting up the turtle, editing and debugging procedures, secret codes and recursion.

**K0380H** (Limited stock only)  
**THE POWER OF VISIPILOT** ~~\$19.95~~ \$9.95  
VisiPlot enables the user to display data graphically; with line graphs, bar graphs, area and circle graphs and even two graphs on the same page for comparison.

**K0390H** (Limited stock only)  
**INSIDE ATARI BASIC** ~~\$16.50~~ \$11.95  
Takes the confusion out of learning to operate a home computer. Avoiding unnecessary technical details and flow charts, it explains in plain language (and witty illustrations) how to start with BASIC on the Atan.

## computing for business

**L0316H** (Limited stock only)  
**THE POWER OF VISICALC** ~~\$19.95~~ \$9.95  
Exercises designed especially for users of the VisiCalc program.

**L0329H** (Limited stock only)  
**THE POWER OF SUPERCALC** ~~\$21.95~~ \$17.95  
Step-by-step exercises designed especially for users of SuperCalc.

**L0369H** (Limited stock only)  
**DEVELOPING MICRO-BASED BUSINESS SYSTEMS** ~~\$16.50~~ \$11.95  
Directed specifically at intending developers of small computer-based business systems who are not data-processing professionals.

**L0372E**  
**BUYING YOUR COMPUTER** \$4.25  
Contractual details for the first-time purchaser.

**L0376H** (Limited stock only)  
**DEVELOPING COMPUTER SOLUTIONS** ~~\$19.25~~ \$14.95  
A manager's guide to effective planning, implementation and evaluation of automation alternatives.

## electronic calculators

**M0246B**  
**YOUR CALCULATOR & YOUR MONEY** \$4.75  
Starts with a basic revision of percentages and decimals, then deals with mortgages, cars, insurance, fuel, shopping, tax, etc. There's a section on investment and one on the calculator in a small business.

**M0370B**  
**FUN AND GAMES WITH YOUR CALCULATOR** \$2.50  
A collection of 101 jokes and riddles, several mind-boggling games for two or more players, and a dictionary of words with their corresponding numbers.

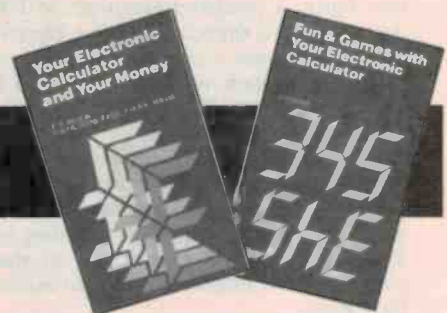

## amateur radio, dx communications

**N0287R**  
**THE BASIC BOOK OF HAM RADIO** \$5.75  
A comprehensive guide to the world of amateur radio.

card insert and send to:

140 Joynton Avenue, Waterloo  
P.O. Box 227, Waterloo, NSW 2017 Australia

Phone: (02) 663-9999

# FORTH . . . A COMPUTER LANGUAGE FOR HACKERS!

Tom Moffat

39 Pillinger Drive, Fern Tree 7101

Most of us have had the chance to play with some fancy microprocessor controlled hi-fi equipment or instrumentation. Chances are the code controlling that smart box was written in Forth, a very fast, no nonsense language ideal for control applications.

FORTH . . . where have we heard that name before? It keeps popping up all over the place, but quietly. An occasional mention in the ads in *ETI*. Sometimes the subject of an article in an overseas computer magazine. When we see the article we discover they're mostly gibberish, and we pass them over. Well, if you've got this far, hang on, because we're going to talk about Forth and try to make some sense of it!

Now why, you say, are we going to feature Forth, a computer language, in *ETI*? After all, this is supposed to be an electronics magazine, not a computer rag. The answer is that Forth was born and bred for hackers who would just as soon compute with a soldering iron as with a keyboard. Forth is an elegant, straightforward method of attacking various input/output ports on your computer to make them do something useful. It's also very clever at shuffling text around. The results are similar to those you'd get with machine code, but without the hassles.

Forth isn't new. It first surfaced in the late 70s when Charles Moore, an engineer at the Kitt Peak Observatory in Arizona, wanted to control the movements of a big telescope with a computer. He soon realized that the accepted languages of the day were a damn hard way to simply toggle a few data bits up and down. So he invented his own language. Moore saw it as a 'fourth-generation' computer language, but his computer must have been a few generations

earlier. It would only accept file names of five characters, so the "u" bit the dust. From then on Forth was with us to wrap its addictive tentacles around many an unwary hacker.

As an aside, if you ever happen to be in Arizona it's worth a trip to Forth's birthplace. Kitt Peak is a lofty mountain poking out of the desert near Tucson. The collection of gadgetry on top would keep an *ETI* reader occupied for weeks. And most of it's open to the public. The prize exhibit would be a giant solar telescope that projects a two-metre image of the sun onto a table. You can stand there watching the sunspots dancing around, live. It's not known whether there's a monument to Forth . . . the language didn't exist the last time I visited Kitt Peak.

## Talking Forth

Forth is a strange language. It's been described as a "write-only" language. If you look at some of the program listing material with this article you'll see why. Gibberish! But much of Forth's efficiency stems from the fact that it's short and sweet. Each of those words and symbols represents a powerful routine made up of other words and symbols. You take what's there and build on it. It's a roll your own computer language.

Forth comes in as many different versions as there are computers. That is, what you get with your Apple may differ slightly from

CP/M, but if some feature you want is missing, you can make it yourself. We will be looking at a version of Forth for the Microbee. But Forth is such a universal language that anything you learn here can be applied to just about any version.

Building new routines out of existing ones is called "compiling a definition" and what results is called a "word". That's right, Forth is a compiled language, and since it doesn't have to work out how to do everything afresh every time it's run, it goes like the wind. But it can also run as an interpreter as well, as a completely interactive mode.

When you're 'interacting' with Forth, actions it doesn't like are signalled by a numbered error message. Remember, this is a do-it-yourself language, so you are expected to look up the message meanings, or memorize them. Serious transgressions usually bring about a monumental crash. If you're good, however, Forth says "OK! Do this. OK! Do that." OK! The same "OK" is in Microsoft Basic. It reminds me of some of the graffiti around Hobart. "GIRLS WILL RULE, OK!" . . . "TASSIE GREEN'S OK!" (perhaps a reference to one of Tasmania's illegal agricultural products).

Now we come to the most important fact about Forth: it uses Reverse Polish Notation, the stuff used on most Hewlett Packard calculators. It's also known as "postfix" notation. It means that, when performing

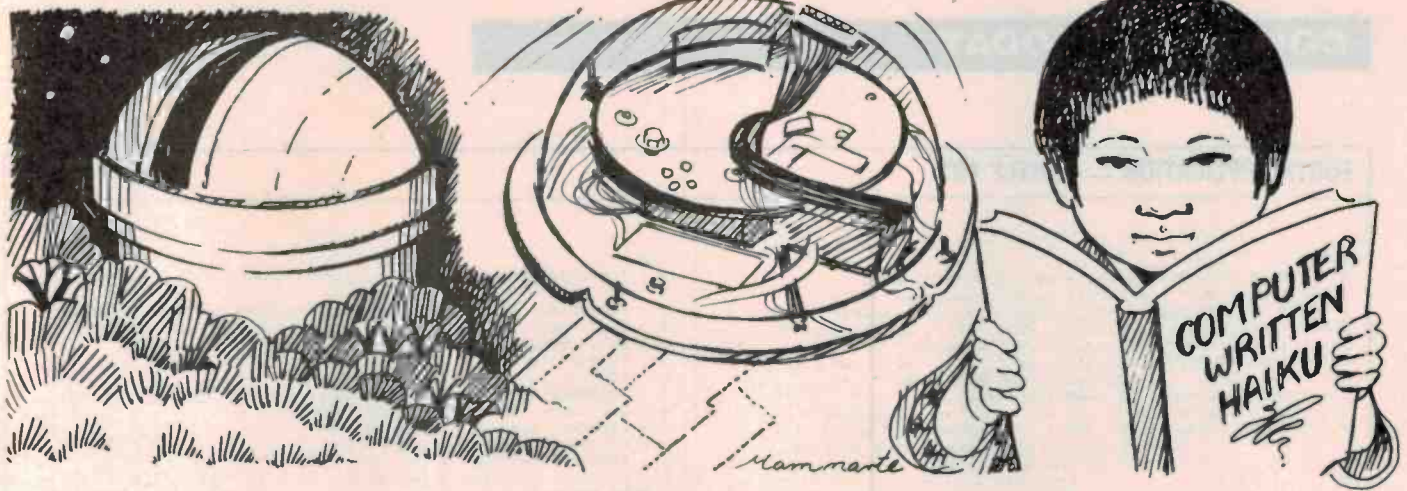

an operation on a number, you first specify the number and then what's going to happen to it. In the more familiar algebraic notation, you say "2 + 2 =" and hopefully come up with 4. In RPN, you say "2 2 +". In other words, take two, and another two (you've now got the numbers), and add them.

What's happened to the answer? It's on the stack! That great super efficient high speed number store. In Forth, if you want to look at the answer, you have to pop it off the stack and send it to the screen, with the Forth word ".", a full stop. (Punctuations are just as valid as anything else as Forth words.) Or you can leave the number on the stack to subject it to further operations.

The stack is just what its name implies . . . a stack of numbers arranged so that the last number stored is the first one you get back when you access it. If you store one, two and three on a stack, and then say "pop-pop-pop", what you get back is three, two and one. The beauty of the stack concept is that it takes only a few microseconds to put something on, or take something off. Pushing into the stack, and popping off, are direct machine code instructions on just about every microprocessor ever made.

Now to see how RPN speeds things up in Forth, let's make the above mathematical task a little harder. Let's add two and two together and then multiply the result by five. First in standard algebraic notation: I've got a two. What will I do with it? Add it. Add it to what? Another two. Now I've got four. What will I do with it? Multiply it? Multiply it with what? A five. Now I've got twenty. What now? Print it!

Let's try it in Forth: I've got a two. And another two. Add. I've got four. And now a five. Multiply. I've got twenty. Print it! Seen in Forth style, this is "2 2 + 5 \* ." Forth goes right down the line and takes care of each item as it's encountered, leaving results on the stack. The first "2" goes onto the stack, then the second "2". When "+" comes along it removes the first two stack items, adds them, and puts the result back on the stack. Now we have a "5", and that goes onto the stack, leaving two items there once again. When "." comes along it

removes the first two stack items, multiplies them, and puts the result back on the stack. Now "." comes along, removes the top (and only) item from the stack, and prints it on the screen. The result: an answer to the problem, and an empty stack ready for the next operation.

In a practical Forth system, the above problems would be trivial tasks. A standard Forth number is a 16-bit integer. A 'double' Forth number is a 32-bit integer. Note that they're only integers; floating point arithmetic does not exist, and most Forth programmers feel there's no need for it. There are ways to achieve floating point type results with the available integers, but we won't detail them in this short introduction to Forth. Suffice it to say that you can get some pretty big results when you've got 32-bit numbers to play around with.

Charles Moore's problem of driving a telescope mount would seem trivial at first as well. After all, he simply had to send some pulses out to some stepper motors to make the mount move. But the computer had to work out when to move, how much to move, and in which direction. It had to take into account the movement of the earth, calculation of azimuth and elevation of the target object, and all the other variables that make astronomy so interesting. Now you could do this quite easily in Basic; it's built for number crunching. But the telescope would require many new values every second to keep moving smoothly. Forth's integer arithmetic can supply these values at lightning speed.

### Forth and the Turtle Tot

Our experiments in using Forth for real-time machine control have involved the use of a Tasman Tot Turtle robot. This little gadget, used in schools as a teaching aid, has two wheels mounted symmetrically near the edges of a round plastic base. Each wheel is driven directly by a stepper motor. If you set both motors to go in the one direction and then send 'step' pulses to them simultaneously, the turtle will move forward. If you set one motor for forward and the other for reverse and then pulse them, the robot will rotate about its centre in the

one place. There is a pen in the centre of the turtle that allows it to leave a trail where it's been. Signals are sent to the turtle by an RS232 serial link.

Although the above functions have many times been implemented in Basic, it's a messy business. In Forth it's dead easy. In the latest version of Microbee Forth you have 16 'screens', or 1K blocks of memory in which to compose your Forth words. In a disk based computer these blocks are on disk instead of in RAM. When you think a block is ready to try out, you tell the computer to LOAD it and Forth begins compiling/issuing error messages wherever you messed up. A successfully compiled block earns you an OK.

The Turtle program listed is shown as individual 'screens'. To get the Turtle going you establish communication with it via the Microbee's RS232 routines. The two CREATE words lay some machine code into the compiled Forth 'dictionary'. Every time SEND is mentioned, a number is popped off the stack and its lower eight bits are sent to the Turtle. When RECV is invoked, eight bits are collected from the Turtle's sensor switches and pushed onto the stack. The switches provide feedback from the Turtle as it finds its way through mazes, etc.

With communication channels established, it's an easy matter to write Forth routines to get the Turtle to do anything you want. An early routine is MOVE; this toggles a selected bit up and down to produce one movement. Similarly, DOFUNCTION puts the Turtle's pen to paper or raises it, or makes its 'eyes' flash on and off. With MOVE established you can make the turtle go forward a given number of steps with the word 'TFD' which uses the previously defined word 'MOVE'. Other movements are similar except that they toggle different bits. You tell the Turtle how far to move by pushing an appropriate number onto the stack before invoking the word: 20 TFD would move the turtle forward 20 centimetres.

Users of the Logo language may feel there's something familiar here. They're right. The Turtle words shown in the Forth

## FORTH APPLICATION — TURTLE TOT

```

SCR # 1
0 ( TURTLE TOT PROCEDURES: START UP WITH "1 LOAD")
1 CR ." HOLD ON! I'm compiling my procedures..."
2 ( Set up 1200 baud RS-232 communication channels)
3 HEX CREATE SEND E1 C, 7D C, CD C, 7F C, A8 C, E3 C, E3 C,
4 C3 C, 2C C, 10 C, SMUDGE
5 CREATE RECV CD C, 31 C, A8 C, 26 C, 00 C, 6F C, C3 C,
6 2B C, C0 C, SMUDGE DECIMAL
7 : ?SEND ?TERMINAL IF WARM THEN SEND ;
8 2 LOAD 3 LOAD 4 LOAD ( get the other three screens)
9 : SIGNON 240 150 DO 255 I - 15 PPLAY LOOP CLS
10 ." Forth procedures for the TURTLE TOT" CR
11 ." - by Tom Moffat" CR
12 ." Flexible Systems" CR
13 ." Hobart, Tasmania" CR CR CR
14 ." LET'S GO!" CR ;
15 SIGNON ;S

SCR # 2
0 ( Begin TURTLETOT control primitives)
1
2 0 VARIABLE FUNCTION 192 VARIABLE TEMP 11 CONSTANT CALIBDIST
3 174 CONSTANT CALIBTURIP 174 CONSTANT CALIBTURNL
4 : MOVE FUNCTION @ + TEMP 0 DO TEMP @ DUP
5 ?SEND 5 + SEND LOOP ;
6 : TFD CALIBDIST + 200 MOVE ;
7 : TBK CALIBDIST + 194 MOVE ;
8 : TRT CALIBTURIP 100 + 192 MOVE ;
9 : TLT CALIBTURNL 100 + 202 MOVE ;
10 : DOFUNCTION DUP FUNCTION 192 + ?SEND ;
11 : TPD FUNCTION @ 32 OR DOFUNCTION ;
12 : TPD FUNCTION @ 223 AND DOFUNCTION ;
13 : EYESON FUNCTION @ 15 OR DOFUNCTION ;
14 : EYESOFF FUNCTION @ 239 AND DOFUNCTION ;
15 ;S
16

SCR # 3
0 ( TURTLETOT control primitives continued...)
1
2 : FLASHES 0 DO EYESON 20 DELAY EYESOFF 20 DELAY LOOP ;
3 : SAY ?SEND BEGIN RECV 10 AND 0= WHILE 192 SEND REPEAT ;
4 : SAYL BEGIN SAY SP@ 15132 = UNTIL ;
5 : TOOTH 05 SAY ;
6 : TOOTLO 06 SAY ;
7 : TOOTANDFLASH 0 DO EYESON TOOTLO EYESOFF TOOTH LOOP ;
8 : SWITCHES TEMP @ SEND RECV 15 AND ;
9 : LTOUCH? SWITCHES 1 AND 0= ;
10 : RTOUCH? SWITCHES 2 AND 0= ;
11 : FTTOUCH? SWITCHES 4 AND 0= ;
12 : BTOUCH? SWITCHES 8 AND 0= ;
13 HERE FENCE ' ;S
14
15

SCR # 4
0 ( Applications programs for the TURTLE TOT)
1 283 @ VARIABLE RND
2 : RANDOM RND @ 31421 + 6927 + DUP RND ' U+ SWAP DRDP ;
3 : MORDER BEGIN 1 TFD SWITCHES
4 DUP 1 AND 0= IF 128 SEND 2 TBK 45 TRT THEN
5 DUP 2 AND 0= IF 99 SEND 2 TBK 45 TLT THEN
6 11 XOR 0= IF 76 SEND 2 TBK 08 200 RANDOM 2 /MOD DROP
7 IF TRT ELSE TLT THEN THEN AGAIN ;
8 : WALLWALKER BEGIN 2 TFD SWITCHES DUP 1 AND 0=
9 IF 1 FLASHES 30 TRT 1 TFD THEN 4 AND 0=
10 IF 45 TRT ELSE 12 TLT THEN AGAIN ;
11 : TALKING ." KEYBOARD - TYPE SOME KEYS" CR BEGIN KEY 32 - DUP
12 0= IF 132 SEND 255 THEN 10 - DUP
13 0= IF 31 SEND 255 THEN DUP 10
14 ' IF SEND 255 THEN DUP 43
15 < IF 15 + SEND 0 THEN DROP AGAIN ; ;S
16
17
18
19
20
21
22
23
24
25
26
27
28
29
30
31
32
33
34
35
36
37
38
39
40
41
42
43
44
45
46
47
48
49
50
51
52
53
54
55
56
57
58
59
60
61
62
63
64
65
66
67
68
69
70
71
72
73
74
75
76
77
78
79
80
81
82
83
84
85
86
87
88
89
90
91
92
93
94
95
96
97
98
99
100
101
102
103
104
105
106
107
108
109
110
111
112
113
114
115
116
117
118
119
120
121
122
123
124
125
126
127
128
129
130
131
132
133
134
135
136
137
138
139
140
141
142
143
144
145
146
147
148
149
150
151
152
153
154
155
156
157
158
159
160
161
162
163
164
165
166
167
168
169
170
171
172
173
174
175
176
177
178
179
180
181
182
183
184
185
186
187
188
189
190
191
192
193
194
195
196
197
198
199
200
201
202
203
204
205
206
207
208
209
210
211
212
213
214
215
216
217
218
219
220
221
222
223
224
225
226
227
228
229
230
231
232
233
234
235
236
237
238
239
240
241
242
243
244
245
246
247
248
249
250
251
252
253
254
255
256
257
258
259
260
261
262
263
264
265
266
267
268
269
270
271
272
273
274
275
276
277
278
279
280
281
282
283
284
285
286
287
288
289
290
291
292
293
294
295
296
297
298
299
300
301
302
303
304
305
306
307
308
309
310
311
312
313
314
315
316
317
318
319
320
321
322
323
324
325
326
327
328
329
330
331
332
333
334
335
336
337
338
339
340
341
342
343
344
345
346
347
348
349
350
351
352
353
354
355
356
357
358
359
360
361
362
363
364
365
366
367
368
369
370
371
372
373
374
375
376
377
378
379
380
381
382
383
384
385
386
387
388
389
390
391
392
393
394
395
396
397
398
399
400
401
402
403
404
405
406
407
408
409
410
411
412
413
414
415
416
417
418
419
420
421
422
423
424
425
426
427
428
429
430
431
432
433
434
435
436
437
438
439
440
441
442
443
444
445
446
447
448
449
450
451
452
453
454
455
456
457
458
459
460
461
462
463
464
465
466
467
468
469
470
471
472
473
474
475
476
477
478
479
480
481
482
483
484
485
486
487
488
489
490
491
492
493
494
495
496
497
498
499
500
501
502
503
504
505
506
507
508
509
510
511
512
513
514
515
516
517
518
519
520
521
522
523
524
525
526
527
528
529
530
531
532
533
534
535
536
537
538
539
540
541
542
543
544
545
546
547
548
549
550
551
552
553
554
555
556
557
558
559
560
561
562
563
564
565
566
567
568
569
570
571
572
573
574
575
576
577
578
579
580
581
582
583
584
585
586
587
588
589
590
591
592
593
594
595
596
597
598
599
600
601
602
603
604
605
606
607
608
609
610
611
612
613
614
615
616
617
618
619
620
621
622
623
624
625
626
627
628
629
630
631
632
633
634
635
636
637
638
639
640
641
642
643
644
645
646
647
648
649
650
651
652
653
654
655
656
657
658
659
660
661
662
663
664
665
666
667
668
669
670
671
672
673
674
675
676
677
678
679
680
681
682
683
684
685
686
687
688
689
690
691
692
693
694
695
696
697
698
699
700
701
702
703
704
705
706
707
708
709
710
711
712
713
714
715
716
717
718
719
720
721
722
723
724
725
726
727
728
729
730
731
732
733
734
735
736
737
738
739
740
741
742
743
744
745
746
747
748
749
750
751
752
753
754
755
756
757
758
759
760
761
762
763
764
765
766
767
768
769
770
771
772
773
774
775
776
777
778
779
780
781
782
783
784
785
786
787
788
789
790
791
792
793
794
795
796
797
798
799
800
801
802
803
804
805
806
807
808
809
810
811
812
813
814
815
816
817
818
819
820
821
822
823
824
825
826
827
828
829
830
831
832
833
834
835
836
837
838
839
840
841
842
843
844
845
846
847
848
849
850
851
852
853
854
855
856
857
858
859
860
861
862
863
864
865
866
867
868
869
870
871
872
873
874
875
876
877
878
879
880
881
882
883
884
885
886
887
888
889
890
891
892
893
894
895
896
897
898
899
900
901
902
903
904
905
906
907
908
909
910
911
912
913
914
915
916
917
918
919
920
921
922
923
924
925
926
927
928
929
930
931
932
933
934
935
936
937
938
939
940
941
942
943
944
945
946
947
948
949
950
951
952
953
954
955
956
957
958
959
960
961
962
963
964
965
966
967
968
969
970
971
972
973
974
975
976
977
978
979
980
981
982
983
984
985
986
987
988
989
990
991
992
993
994
995
996
997
998
999
1000

```

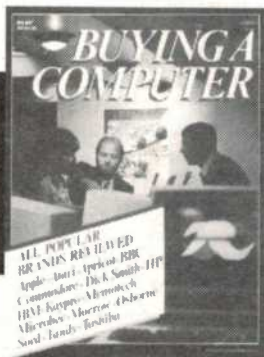

## Buying a computer?

*Here's a magazine that's sure to help you!*

We aim to provide you with the information you'll need to compare, evaluate — and make the right decision on which computer is right for you.

We've collected a wealth of articles, written by rank beginners as well as those deeply experienced in the computer industry. All of them have gone through the drama of buying a personal computer ... and they'll share their experiences with you.

*Available at your newsagent now*

**only \$4.50**

listings are much the same as those supplied with the versions of Logo that support the Turtle Tot, such as Apple and Commodore Logo. This isn't surprising since the Logo and Forth procedures were written by the same author (me). There are many similarities between the two languages. In fact the full version of Logo being prepared for the Microbee is being written in Forth. And most of Forth, of course, is written in itself.

### Curious?

I know this brief discussion of Forth has probably raised more questions than it's answered, but hopefully by now at least you'll know what the language is all about, and you'll have an idea about what all those cryptic words are supposed to represent. If you want to press on with Forth, be prepared to be thought of as a nut-case by more conventional programmers. Admitting you use Forth is like admitting you don't take baths. Why is this? I don't really know, but it might have something to do with the fact that Forth people with their funny language and little computers are getting results that rival those from the 'professionals' with their seemingly unlimited budgets and years of training.

If you'd like to learn more about the Forth there's a book you should have. *Starting Forth\** is by a fellow named Leo Brodie. His little text is filled with strange cartoons, disgusting puns, and even some information about Forth. Brodie is one of those people who admits to enjoying elderly

# FORTH APPLICATION — HAIKU POETRY COMPOSITION

## SCR # 1

```
0 ( Haiku poetry composer, Tom Moffat, Aug. 30, 1984)
1
2 0 VARIABLE STORE 2 ALLOT
3 : RANDOM 283 0 31421 * 4927 + DUP 283 ! U* SWAP DROP !
4 : (STASH BLK 0 IN 0 STORE 2! ; ; STASH) STORE 20 IN ! BLK ! ;
5 : .WORD ( nr, blk) BLK ! 16 * IN ! 124 WORD HERE COUNT TYPE ;
6 : NOUN 50 RANDOM 3 .WORD ; ; VERB 13 RANDOM 50 + 3 .WORD ;
7 : ADJ 50 RANDOM 4 .WORD ; ; PREP 7 RANDOM 50 + 4 .WORD ;
8 : BUZZ 4 .WORD ;
9 : ARTNOUN 3 RANDOM 50 + BUZZ NOUN ;
10 : ARTADJ 50 RANDOM 2 RANDOM IF 59 BUZZ ELSE DUP 6 < IF
11 57 BUZZ ELSE 58 BUZZ THEN THEN BUZZ ;
12
13 2 LOAD
14 !S
15
```

## SCR # 2

```
0 : PATT0 ARTADJ NOUN ." ..." CR 18 SPACES ARTNOUN VERB
1 PREP ARTNOUN CR 21 SPACES ADJ ADJ NOUN ;
2 : PATT1 NOUN PREP ARTNOUN ." ;" CR 18 SPACES ARTADJ
3 NOUN PREP ARTNOUN CR 21 SPACES ADJ NOUN ;
4 : PATT2 ARTADJ ADJ NOUN ." ;" CR 18 SPACES PREP
5 ARTADJ NOUN CR 21 SPACES ARTNOUN VERB ;
6 : PATT3 ARTADJ NOUN VERB ." ;" CR 18 SPACES ARTADJ
7 ADJ NOUN CR 21 SPACES PREP ARTADJ NOUN ;
8
9 : POEM CLS 33 226 C! (STASH BEGIN 4 0 DO CR 15 SPACES
10 4 RANDOM DUP 0 = IF PATT0 THEN DUP 1 = IF PATT1
11 THEN DUP 2 = IF PATT2 THEN 3 = IF PATT3 THEN CR
12 LOOP KEY 3 = UNTIL STASH) 1 226 C! ;
13
14 POEM
15 ;S
OK
```

## SCR # 3

```
0 bird ~ breeze ~ bush ~ butterfly ~
1 cloud ~ crow ~ dawn ~ dew ~
2 dust ~ feather ~ field ~ firefly ~
3 flower ~ forest ~ glade ~ glitter ~
4 grass ~ hill ~ lake ~ leaf ~
5 meadow ~ moon ~ morning ~ mountain ~
6 night ~ pine ~ pine cone ~ pond ~
7 rain ~ river ~ scarecrow ~ sea ~
8 shade ~ shadow ~ shape ~ silence ~
9 sky ~ snow ~ snowflake ~ sound ~
10 sun ~ sunset ~ surf ~ thunder ~
11 violet ~ water ~ waterfall ~ wave ~
12 wildflower ~ wind ~ creeps ~ drifts ~
13 flutters ~ has fallen ~ has passed ~ has risen ~
14 has turned ~ is falling ~ is floating ~ is trickling ~
15 quivers ~ shakes ~ sleeps ~ struggles ~
```

## SCR # 4

```
0 autumn ~ azure ~ empty ~ icy ~
1 old ~ orange ~ billowing ~ bitter ~
2 black ~ blue ~ broken ~ cold ~
3 cool ~ crimson ~ damp ~ dappled ~
4 dark ~ dawn ~ delicate ~ dry ~
5 falling ~ frosty ~ green ~ hidden ~
6 late ~ limpid ~ lingering ~ little ~
7 long ~ misty ~ morning ~ muddy ~
8 quiet ~ red ~ silent ~ small ~
9 sparkling ~ spring ~ still ~ sudden ~
10 summer ~ throbbing ~ twilight ~ wandering ~
11 white ~ wild ~ winter ~ wispy ~
12 withered ~ young ~ behind ~ in ~
13 of ~ on ~ through ~ under ~
14 with ~ an ~ a ~ the ~
15 the ~
OK
```

a broken morning ...  
the moon creeps of a glitter  
sudden bitter crow

a wandering forest drifts ;  
the silent dark sky  
with a red glade

dust of the dawn ;  
the wild moon under the night  
red snowflake

a hidden billowing feather ;  
through the winter sky  
the dew is falling

an orange snowflake ...  
the scarecrow sleeps of a violet  
broken dawn sun

a cold cloud ...  
a mountain quivers behind the scarecrow  
sudden dappled butterfly

a dark dappled silence ;  
under the lingering grass  
the night sleeps

a morning feather ...  
a violet quivers through the field  
late red sunset

a morning scarecrow ...  
the mountain has fallen with a shade  
empty twilight meadow

the old pine has turned ;  
the black cool river  
in the sparkling sound

a limpid withered wildflower ;  
under a white sun  
a bush is trickling

silence behind a river ;  
a little mountain of a hill  
long dust

feather with a sunset ;  
the winter shadow with the night  
old flower

a still glade is floating ;  
an autumn old lake  
under the wispy morning

the dark pine ...  
the wildflower flutters on a waterfall  
late falling breeze

bush under a bird ;  
a dappled moon on the rain  
delicate silence

Volvos and music of the 1950s (I wonder if he's heard that new compact disc of all the old Chuck Berry songs? . . .). *Starting Forth* has been roundly panned as "insignificant" by many reviewers in the main-stream computer press. Anyhow I loved it, and it taught me most of what I know of Forth. It's like reading an issue of *ETI* made up mostly of Dregs columns, with just a bit of electronics thrown in. [1st prize, "digression of the month" — ed.]

As for getting hold of the Forth language, you're probably going to be pleasantly surprised. Forth is generally cheap and plentiful. The latest price for Microbee Forth is \$30 for an EPROM from Applied Technology. There was also a version from Mytek, but that may no longer be around. Anyhow, Applied Tech's has those 16 screens to play with. Although its advertizing doesn't make it clear, you *must* have a

32K Microbee or larger, because the memory for the screens is in the upper 16K region.

Forth has also been advertized fairly cheaply for most other popular computers. There's even one computer called "Jupiter Ace" that has Forth as its native language, as Basic would be with most other computers. It's also been reported that Forth inventor Charles Moore is now working on a 'Forth Engine' to produce 400 million operations per second, with a selling price of around \$10,000.

A driving force behind all this activity is the Forth Interest Group in California that seems intent on propagating the language as far and wide as possible. It's also got an address listed in Melbourne. A letter brought back a list of various language packages, utilities and books available from the Californian FIG, and the names of some other

people in Hobart who are into Forth.

After reading all this ranting and raving are you ready to forsake Basic forever and dedicate your life to the advancement of Forth? Probably not, Forth isn't for everyone. But if you give it a try you'll probably find it's something new, a refreshing breath of air in a world of drabby sameness.

Just to send you on your merry way, the second listing is a Forth program that composes Japanese Haiku poetry. Contributions from this electric poet have already appeared in the Hobart Mercury, and others have been submitted to a national literary magazine for their consideration (not letting on, of course, that a computer was responsible). Stay tuned for further episodes! ●

\*See footnote to ETI-694 elsewhere in this issue.

# ADVANCED MATHS PACKAGE

## for the Sharp PC-1401

For the engineering student — a welcome new alternative package for Sharp portable computers.

Robert Irwin

"CONGRATULATIONS! You are now the owner of a very powerful and sophisticated Advanced Mathematics Package . . ." or so go the opening lines of the instruction booklet that comes with Portacom's new software offering for Sharp portable computers. The version sent in for review was for the Sharp PC-1401 pocket computer but versions are also available for the PC-1500A and PC-1350.

The package consists of a tape and a small 14 page booklet describing the operation of the programs. Nine functions are provided for in the software. These are:

- 1) *matrix* — which calculates the determinant and inverse of a matrix and the solution to a system of linear equations expressed in matrix form;
- 2) *interpolation* — which uses the Lagrange method to interpolate numerically between a series of points on a curve of graph;
- 3) *base conversion* — which converts numbers from one base to another for bases from 2 to 16;
- 4) *complex numbers* — which turns the machine into a complex numbers calculator.
- 5) *real root solver* — which calculates the roots of polynomials using Newton's method;
- 6) *rectangular-spherical conversion* — which converts between three dimensional rectangular and spherical coordinates;
- 7) *area of a polygon* — to calculate area from the X, Y coordinates of the corner points of a polygon;
- 8) *triangle solutions* — for unknown sides or angles in a triangle; and
- 9) *integration* — which uses Simpson's rule to numerically integrate a function which can be entered as an equation or a sequence of points.

All nine functions worked extremely well and, after getting a few old maths assignments out and recalculating some problems

using the maths package, I could find no fault in the accuracy of the results (only a lack of accuracy in my assignments!).

Seemingly, a good deal of work has been put into making the package as user friendly as a pocket computer can be. All the functions make generous use of prompts and I found that after one or two run throughs with each program I could almost dispense with the manual. The hardest problem was remembering the appropriate letter needed to call up the function I was after; I dare say they would eventually be remembered as most bear some relation to the function they refer to. For example, "matrix" is labelled "M" and "complex numbers" is labelled "C". This is not uniform, however, as "triangle solutions" is labelled "V"! Perhaps a directory should have been included in the program.

The speed of the programs is quite good. I compared the speed of the "matrix" and "root solve" functions with that of the same function keys on an HP15C and found that PC-1401 was generally quicker with the solution. With the prompts on the PC-1401 it was also easier to enter the matrices. The "matrix" program itself, though, was rather limited as only one matrix at a time could be dealt with. The inclusion of a subroutine for matrix multiplication would have been extremely useful especially for engineering students.

The one major criticism I have of the package comes in the area of documentation. The booklet provided is quite adequate in its description and demonstration of each function but lacks any additional information to help the user in familiarizing her/himself with the depth of the software. The most glaring omission is in the "root solver" and "integration" functions which require an equation to be programmed into an unused line number. There is no mention in the booklet of the line numbers used by



the Advanced Maths Package itself. Even though this information could be elicited by stepping through the program I think that its inclusion in the manual would be greatly appreciated.

The amount of memory used in storing the program would also be a useful piece of information to include. The introduction states that "This instruction manual assumes that the user is familiar with both the computer, its accessories and the advanced mathematics operations". Even so, I feel that the level of familiarity Portacom is assuming may exclude a few too many potential buyers.

Nevertheless, in general, the Advanced Mathematics Package is a very worthwhile addition to the Sharp portable computer range and is indispensable for any engineering or mathematics student who owns a compatible computer. In fact the addition of this software may make some students reconsider when buying a new calculator (or should I say pocket computer?). The price of the Maths Package is under \$30 and at this price represents good value for money.

# The microbee Computer-in-a-Book represents a novel, practical effective low cost way of advancing to disk drive capability



The microbee 3.5 inch 400K high speed/high density Drives are very compact, extremely tough and represent the best value-for-money 'Real Disk Drive' on the market today. The Computer-in-a-Book comes complete with all the software you will need to get started including demo program, MW Basic, Wordbee Wordprocessing, Telcom communications and CP/M with utilities.

**Microbee 64K with Single Disk Drive** \$995 incl. Tax  
**Add-on Disk Drive in matching volume** \$345 incl. Tax  
**Ask about Modems, Printers and Business Software.**



# microbee computer

Designed and manufactured  
in Australia by  
Applied Technology

PHONE ORDERS  ACCEPTED

## microbee technology centres

N.S.W.  
1 Pattison Ave, Waitara 2077  
Phone (02) 487 2711

VIC.  
729 Glenferrie Rd, Hawthorn 3122  
Phone (03) 819 5288

W.A.  
141 Stirling Highway, Nedlands  
Phone (09) 386 8289

S.A.  
151 Unley Rd, Unley 5061,  
Phone (08) 272 1384

QLD  
455 Logan Rd, Stones Corner, 4120  
Phone (07) 394 3688

FACTORY  
Koala Crescent, West Gosford 2250  
Phone (043) 24 2711

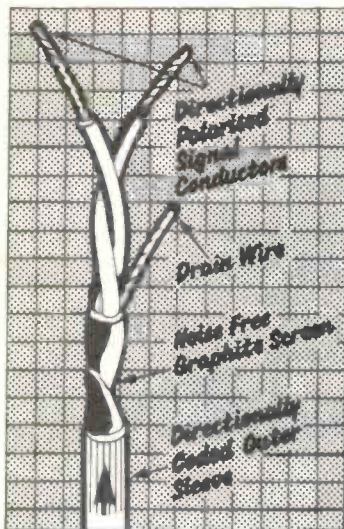

For more information:  
LEISURE IMPORTS,  
401 Pacific Hwy, Artarmon.  
2064. (02) 438 4166

*genuine*  
**QED**  
INCON CABLE

The new QED interconnecting cable consists of a directionally coded twisted pair of balanced conductors sheathed in a graphite impregnated outer sleeve. The directional nature of the copper strands is due to a special extrusion technique which effectively aligns the "grain" of the copper. The sonic benefits of this directionality can be readily appreciated by comparing the results when connecting the cable the "wrong" way round followed by the correct way.

Using INCON the sound is 'louder' but at the same time the background noise level is lower, with a much clearer more open sound quality and better instrument definition. QED INCON reveals the full potential of Compact Disc players.

# PULSAR

## Little Big Board

**Now reduced from \$750 to \$450**

thousands sold

PULSAR ELECTRONICS PTY. LTD.  
19 Catalina Drive, Tullamarine. 3043  
Phone 330 2555.

# Allen-Bradley MOD POT® - Now you can have the best when you want it.

Because the Allen-Bradley Mod Pot, which has a world-wide reputation for consistent quality and performance, is assembled right here in Australia at our newly-established Mod Pot assembly centre. The entire standard Mod Pot range is now available for extra fast delivery to anywhere in Australia - Allen-Bradley, the company you can rely on.

#### FEATURES:

- Hot moulded Carbon.
- Cermet.
- Conductive Plastic.
- Single or Concentric shafts.
- Push/Pull or Rotary switches.
- PC Pin Type or Lug terminals optional.
- Vernier Drives, 4 or 16 turns.



The most versatile standard potentiometer available today - mix and match the amazing Mod Pot Modules for over 1 billion possible control combinations.



These pre-engineered, pre-tested modules form 1, 2, 3 or 4 control sections - one family of variable resistors to solve your unique control problems.

Call your Allen-Bradley Electronic Components Sales Centre today, and you'll be amazed at how fast we will deliver.

Allen-Bradley, 75 years of cost effective, innovative electronic component manufacturing.



## ALLEN-BRADLEY

Design excellence and quality in the best tradition.

VIC. 188 Whitehorse Road, Balwyn, 3103. Ph. 80 6171  
N.S.W. 22 Parramatta Road, Lidcombe, 2141. Ph. 648 2652  
QLD. 1925 Logan Road, Upper Mt. Gravatt, 4122. Ph. 343 7900  
W.A. P.O. Box 23, Subiaco, 6008. Ph. 387 1702  
S.A. K. D. Fisher, P.O. Box 170, St. Mary's, 5042. Ph. 277 3288



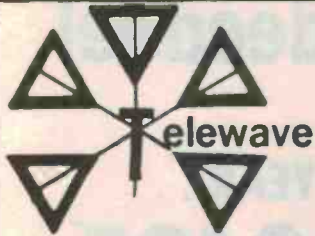

# BROADBAND RF WATT METER

Model 44A

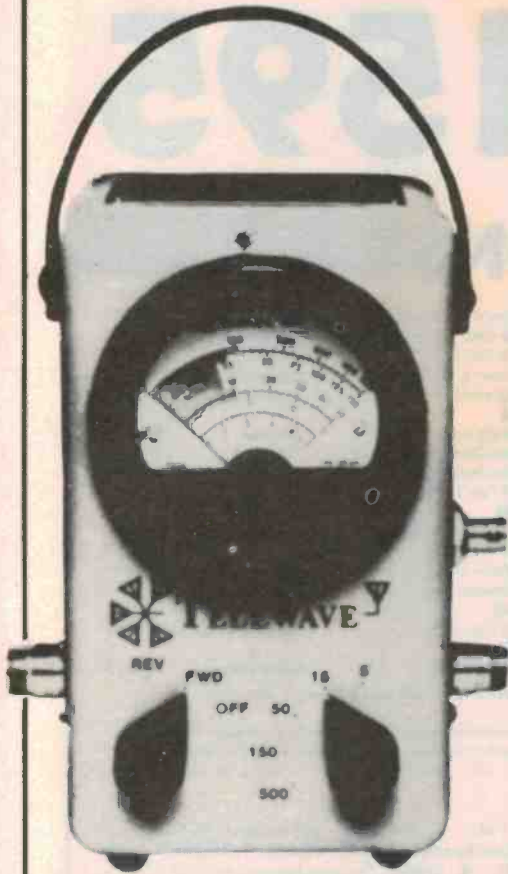

- Requires no inserts
- No bandswitching
- Measures 1 to 500 watts
- Five power ranges
- Five watts full scale
- Frequency range: 25 to 1000 MHz
- Measures incident and reflected power
- Shock mounted meter movement
- Available with type N or UHF interchangeable connectors
- Light weight: Easy to carry

The Model 44A RF Watt Meter is a compact, versatile instrument for measurement of radio frequency power which reads directly in incident and reflected power. A truly wide band and dynamic range instrument that does not require inserts or bandswitching.

It is ideal for mobile radio installation in aircraft or ground vehicles as well as base stations. The metal die-cast case is constructed to withstand rugged field use.



SCIENTIFIC DEVICES AUSTRALIA PTY. LTD.  
 VIC. 2 JACKS RD., SOUTH OAKLEIGH, 3167  
 PHONE: (03) 579 3622 TELEX: AA32742  
 N.S.W. 559A WILLOUGHBY ROAD,  
 WILLOUGHBY, 2068  
 PHONE: (02) 95 2064 TELEX: AA 22978  
 S.A. 31 HALSEY RD., ELIZABETH EAST, 5112  
 PHONE: (08) 255 6575 TELEX: AA 88125.

## PCB TRANSFORMERS



2.5/3VA

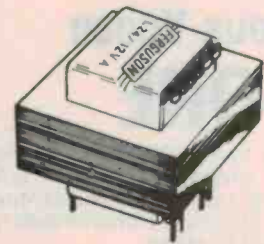

12/15VA

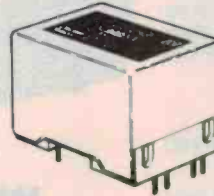

5/7 & 7.5/10VA

- Manufactured to AS3126 and Telecom approved
- Suit standard PCB grids and simplify construction

## POWER TRANSFORMERS

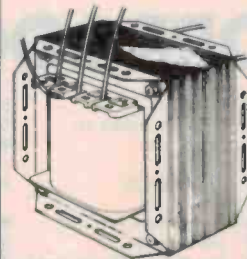

Conventional

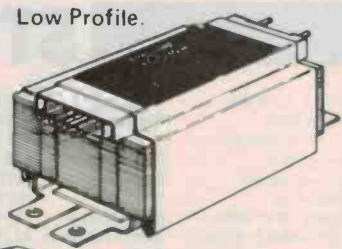

Low Profile.

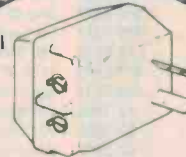

Plug Pack  
Adaptor



- Wide range of secondary voltages from 1.5V to 115V
- Stock range has ratings up to 1000VA
- Special types for microprocessors, 115V etc

## AUDIO TRANSFORMERS

PCB mounted  
phone patch

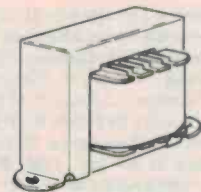
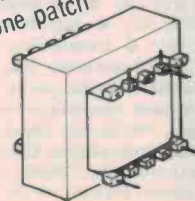

75 ohm to 300  
or 600ohm matching transformer

- Line and Matching transformers up to 150W
  - Power transformers for high power amplifiers
  - Transistor drivers
  - Special 'C' core transformers
- Ask for MAL VK2BMS  
or DOUG VK2BPX

TALK TO FERGUSON - THE AUSTRALIAN COMPANY  
 WITH NEARLY 50 YEARS EXPERIENCE OF MANUFACTURING  
 IN AUSTRALIA FOR AUSTRALIAN CONDITIONS

Ferguson Transformers Pty. Ltd.  
 331 High Street, Chatswood 2067. Tel: (02) 407-0261.  
 Telex: AA25728. Melbourne: (03) 561-6699.

# FERGUSON

# The below-cost bargain of the decade!

## Famous Yaesu FT-ONE

Amazing value! Yaesu's incomparable FT-ONE: probably the best transceiver you'll ever own! Fully guaranteed shop demo units (never transmitted!) now way below cost to clear!

You reap the benefit!!!

Very limited supply, first come, first served. If you're too late...

Not necessarily in all stores (ask at your local store and they might be able to order one from another store for you.)

Country Customers: Order Direct from DSXpress on our toll-free orderline. Phone (008) 22 6610 - for the price of a local call from anywhere in Australia (except Sydney).



LAST YEAR . .

~~\$2495~~

~~\$1995~~

WHILE  
STOCKS  
LAST

\$1595

Cat D-2852

## STORE LOCATIONS

### NSW

Cnr. Swift & Water Sts.  
755 Terrace Level  
Shop 1, 65-75 Main St  
613 Princess Hwy  
Oxford & Adelaide Sts  
531 Pittwater Rd  
Campbelltown Mall, Queen St  
Shop 235, Archer St Entrance  
147 Hume Hwy  
162 Pacific Hwy  
315 Mann St  
4 Florence St  
Elizabeth Dr & Bathurst St  
450 High St  
173 Maitland Rd, Tighes Hill  
Lane Cove & Waterloo Rds  
George & Smith Sts  
The Gateway, High & Henry Sts  
818 George St  
6 Bridge St

**Albury** 21 8399  
**Bankstown Sq.** 707 4888  
**Blacktown** 671 7722  
**Blakehurst** 546 7744  
**Bondi Junction** 387 1444  
**Brookvale** 93 0441  
**Campbelltown** 27 2199  
**Chatswood Chase** 411 1955  
**Chullora** 642 8922  
**Gore Hill** 439 5311  
**Gosford** 25 0235  
**Hornsby** 477 6633  
**Liverpool** 600 9888  
**Maitland** 33 7866  
**Newcastle** 61 1896  
**North Ryde** 88 3855  
**Parramatta** 689 2188  
**Penrith** 32 3400  
**Railway Sq** 211 3777  
**Sydney** 27 5051

125 York St  
Brisbane St & Kable Ave  
263 Keira St  
ACT  
96 Gladstone St  
VIC  
Creswick Rd & Webster St  
145 McCrae St  
Shop 46, Box Hill Central, Main St  
Cnr Hawthorn Rd & Nepean Hwy  
260 Sydney Rd  
1150 Mt Alexander Rd  
Nepean Hwy & Ross Smith Ave  
205 Melbourne Rd  
291-293 Elizabeth St  
Bridge Rd & The Boulevarde  
Springvale & Dandenong Rds  
QLD  
293 Adelaide St  
166 Logan Rd

**Sydney** 267 9111  
**Tamworth** 66 1961  
**Wollongong** 28 3800  
  
**Fyshwick** 80 4944  
  
**Ballarat** 31 5433  
**Bendigo** 43 0388  
**Box Hill** 890 0699  
**East Brighton** 592 2366  
**Coburg** 383 4455  
**Essendon** 379 7444  
**Frankston** 783 9144  
**Geelong** 78 6766  
**Melbourne** 67 9834  
**Richmond** 428 1614  
**Springvale** 547 0522  
  
**Brisbane** 229 9377  
**Branda** 391 6233

Gympie & Hamilton Rds  
Cnr Queen Elizabeth Dr & Bernard St  
Cnr Gold Coast Hwy & Welch St  
Bowen & Ruthven Sts  
Ingham Rd & Cowley St, West End  
SA  
Wright & Market Sts  
Main South & Flagstaff Rds  
Main North Rd & Darlington St  
24 Park Terrace  
WA  
Wharf St & Albany Hwy  
68 Adelaide St  
William St & Robinson Ave  
Centreway Acde, Hay St  
TAS  
25 Barrack St  
NT  
17 Stuart Hwy

**Chermside** 359 6255  
**Rockhampton** 27 9644  
**Southport** 32 9863  
**Toowoomba** 38 4300  
**Townsville** 72 5722  
  
**Adelaide** 212 1962  
**Darlington** 298 8977  
**Enfield** 260 6088  
**Salisbury** 281 1593  
  
**Cannington** 451 8666  
**Fremantle** 335 9733  
**North Perth** 328 6944  
**Perth City** 321 4357  
  
**Hobart** 31 0800  
**Stuart Park** 81 1977

Watch for a new store opening in your area!

### Dear Customers,

Quite often, the products we advertise are so popular they run out within a few days, or unforeseen circumstances might hold up shipments so that advertised lines are not in the stores by the time the advert appears. And very occasionally, an error might slip through our checks and appear in the advert (after all, we're human too!) Please don't blame the store manager or staff: they cannot solve a dock strike on the other side of the world, nor fix an error that's appeared in print. If you're about to drive across town to pick up an advertised line, why not play it safe and give them a call first just in case! Thanks

Dick Smith Electronics

### MAJOR RESELLERS

NSW: ● **Ballina:** A. Cummings & Co. 91-93 River St 86 2284 ● **Bathurst:** Electronic Shop, Shop 5 Half Case Plaza, Howick St, 31 4421 ● **Bowral:** Barry Gash Electronics, 370 Bong Bong St 61 2577 ● **Broken Hill:** Hobbies & Electronics, 37 Oxide St 88 4098 ● **Charlestown:** Newtronics 131 Pacific Hwy 43 9600 ● **Coffs Harbour:** Coffs Harbour Electronics, 3 Coffs Plaza, Park Ave, 52 5684 ● **Deniliquin:** Oni Electronics, 220 Cressy St 81 3672 ● **East Maitland:** East Maitland Electronics, 99 High St 33 7327 ● **Gosford:** Tomorrows Electronics & HiFi, 68 William St 24 7246 ● **Inverell:** Lyn Willing TV, 22A Evans St 22 1821 ● **Lismore:** Oecro 3A/6-18 Carrington St 21 4137 ● **Port Macquarie:** Hall of Electronics, Horton Centre, Horton St 83 7440 ● **Orange:** Fyte Electronics 173 Summer St 62 6491 ● **South Tweed Heads:** Shop 1, Inessa Court, Blundell Bvde 36 1077 ● **Swansea:** Swansea Electronics, 184 High St 71 1874 ● **Wagga:** Wagga Wholesale Electronics 89 Forsythe St. VIC: ● **Hamilton:** John Thompson and Co, 138-148 Gray St 72 2000 ● **Echuca:** Webster Electronics, 220 Pakenham St 82 2956 ● **Mildura:** McWilliams Electronics 110A Langtree Ave 23 6410 ● **Morwell:** Morwell Electronics, 95 George St 34 6133 ● **Shepparton:** GV Electronics Centre 100 High St 21 8866 QLD: ● **Atherton:** Maartens Music Centre 55 Main St 91 1208 ● **Bundaberg:** PM Electronics, Takalvan St 72 8272 ● **Cairns:** Electronic World Shop 27 K-mart Westcourt Plaza 518 555 ● **Gladstone:** Purely Electronics Shop Cnr Herbert & Auckland Sts 72 4321 ● **Mackay:** Stevens Electronics, 42 Victoria St 51 1723 ● **Maryborough:** Keller Electronics, 218 Adelaide St 21 4559 ● **Rockhampton:** Purely Electronics, 15 East St 21 058 SA: ● **Mt Gambier:** Hutchessons Communications, 5 Elizabeth Street 25 6404 ● **Whyalla:** Eyre Electronics Shop 2 Forsythe St 45 4764 WA: ● **Albany:** Micro Electronics 133 Lockyer Ave 41 3432 TAS: ● **Launceston:** Advanced Electronics 5A The Quadrant 34 1399 NT: ● **Darwin:** Ventronics 24-26 Kavanagh St 81 3491

### HEAD OFFICE & DS XPRESS ORDER SERVICE

P.O. Box 321, North Ryde, N.S.W. 2113. Tel: 888 3200

### SPEEDY PHONE/BANKCARD ORDER SERVICE

Just phone your order and Bankcard — it's so simple! (008) 226610 orders only on this number. Enquiries: (02) 888 3200

### POST & PACKING CHARGES

Order Value	Charge	Order Value	Charge
\$ 5.00 - \$ 9.99	\$2.00	\$50.00 - \$99.99	\$6.00
\$10.00 - \$24.99	\$3.50	\$100 or more	\$8.00
\$25.00 - \$49.99	\$4.50		

Terms available to approved applicants  Custom Credit



PTY LTD

SA Customers: Credit facilities available through C.C.C.  
722 King William Street, Adelaide

# VZ200 VIDEO HARDWARE INTERRUPT

Steve Olney



This article details how to use the video hardware interrupt on the VZ200 and gives three simple examples of its usefulness.

THE HARDWARE INTERRUPT is a very useful feature of a computer's capability, with many different applications. The usefulness comes from the ability to 'interrupt' the normal flow of software execution, diverting the operation of the CPU by external means. The CPU can then be made to execute a separate, independent program before returning to the original program execution.

This description may sound like a GOSUB call to a subroutine in Basic, or a CALL to a subroutine in a machine code program, but there is an important difference. The difference is that the interrupt can occur asynchronously to the normal program execution (that is, it can occur at any time unrelated to the progress of normal program execution).

This capability is extremely useful when the computer has to serve some external device which can't wait for an action by the computer during normal program execution. Such devices range from a digital-to-

analogue converter (which must sample data at strictly regular intervals), to a software clock counter which needs to be incremented by an external hardware clock pulse. By using a hardware interrupt these devices can be served almost immediately, in the time it takes the CPU to complete the current instruction.

The interrupt is called a hardware interrupt because there is a special pin on the CPU chip itself, which, when taken to ground potential (low or zero), initiates the interrupt sequence. This action is also performed by some external hardware device.

The VZ200 uses a Z80 CPU chip, which has three different responses to this interrupt signal depending on the interrupt mode set in the internal interrupt register (IR). Note that we are talking about the INT case, not the NMI). For the VZ200 the interrupt register is set to interrupt mode 1 (by an IM1 instruction) during the initialization sequence.

The response to an interrupt in Interrupt

Mode 1 is to complete the current instruction, save the program counter register (PCR) contents on the stack (allowing resumption of execution at that point upon returning from the interrupt) and then jump to location 0038 HEX. This could be viewed as a hardware version of the software RST 38 instruction.

## The VZ200 video interrupt

Those of you who have access to a circuit diagram of the VZ200 will see that the interrupt pin (pin 16 INT) of the Z80 CPU is connected to pin 37 (FS) of the 6847 video controller chip. Reference to the 6847 data sheets shows that pin 37 of the 6847 chip is the video field sync output pin. This pin is pulled low by the 6847 chip during the vertical retrace period of the video output signal. That is, the field sync output pin goes low every 1/50 of a second (video frame rate of 50 per second) causing the Z80 CPU to be interrupted and diverted to location 0038 HEX every 20 ms.

Scrutiny of the machine code (in ROM) at location 0038 HEX reveals a JUMP instruction to location 2EB8 HEX. This jump is referred to as interrupt vector.

The machine code at 2EB8 HEX contains several CALLs to various locations before returning to the original program execution. I haven't looked at these in detail, but most likely they are concerned with cursor control and perhaps screen scrolling during listing.

In any case, the code in which we are interested is near the start of the code at 2EB8 HEX. The first CALL after saving affected registers is to location 787D HEX. There are two interesting points to note here. The first is that location 787D HEX is in RAM, and secondly, this is the memory location referred to in the VZ200 Technical Manual (under System pointers) as the "interrupt exit".

By PEEKING location 787D HEX (eg ►

LISTING 1

```

HEX CODE      MNEMONIC
F5             PUSH AF          ; Save 'AF' register because we alter it
JE 2A         LD  A,2AH        ; Load 'A' register with code for '*'
J2 1F 70      LD  (701FH),A    ; Put it in the top right-hand corner of screen
F1            POP AF          ; Restore 'AF' register
C9            RET              ; Return
    
```

LISTING 2

```

100 S = -32768 : F = S + 7 : ' START AT 8000 HEX
200 FOR I = S TO F : ' POKE THE 8-BYTE MACHINE CODE PROGRAM
300 READ D : ' INTO MEMORY STARTING AT 8000 HEX
400 POKE I,D : '
500 NEXT I : '
600 POKE 30846,00 : ' ENTER THE START ADDRESS OF THE MACHINE
700 POKE 30847,128 : ' CODE PROGRAM INTO INTERRUPT JUMP
800 POKE 30845,195 : ' EXIT AT 787D HEX.
900 DATA 245,62,42,50,31,112,241,201: ' DECIMAL EQUIVALENT OF HEX
    
```

LISTING 3

```

HEX CODE      MNEMONIC
F5             PUSH AF          ; save registers
C5             PUSH BC          ; we destroy
E5             PUSH HL          ;
3A 3B 70      LD  A,(783BH)    ; load latch contents
96 08         LD  B,8          ; bit counter
21 18 70      LD  HL,7018H    ; start of screen display
17           LOOP RLA          ; rotate into carry and test
30 07         JR  NC,ZERO      ;
36 31         LD  (HL),31H     ; output '1'
23           INC HL           ; adjust to next display position
10 F8         DJNZ LOOP       ; go until all bits are done
10 05         JR  EXIT         ; exit if done
36 30         ZERO LD (HL),30H ; output '0'
23           INC HL           ; adjust to next screen position
10 F1         DJNZ LOOP       ; go until all bits are done
E1           EXIT POP HL      ; exit
C1           POP BC          ;
F1           POP AF          ;
C9           RETURN          ;
    
```

LISTING 4

```

100 S = -32768 : F = S + 29 : 'START AT 8000 HEX
200 FOR I = S TO F : ' POKE THE 8-BYTE MACHINE CODE PROGRAM
300 READ D : ' INTO MEMORY STARTING AT 8000 HEX
400 POKE I,D : '
500 NEXT I : '
600 POKE 30846,00 : ' ENTER THE START ADDRESS OF THE MACHINE
700 POKE 30847,128 : ' CODE PROGRAM INTO INTERRUPT JUMP
800 POKE 30845,195 : ' EXIT AT 787D HEX.
900 DATA 245,197,229,58,59,120,6,8
1000 DATA 33,24,112,23,48,7,54,49
1100 DATA 35,16,248,24,5,54,48,35
1200 DATA 16,241,225,193,241,201
    
```

PRINT PEEK[30845]) you should find it contains 201 DECIMAL (0C9 HEX) which is the Z80 RETURN instruction.

Using the video interrupt

Let's just back up to summarize what we've discussed so far. Every 20 ms the Z80 CPU is interrupted by the 6847 video controller chip. The interrupt mode (mode 1) causes the Z80 to jump to location 0038 HEX. From here execution jumps to 2EB8 HEX where a CALL to 787D HEX is encountered. Location 787D HEX (in RAM) contains a RET instruction and so execution returns immediately and continues until 2EDA HEX where a return from interrupt instruction (RETI) is found. Execution is now RETURNed to the original program flow.

Now, because location 787D HEX is in RAM, we can change the RET instruction at that location to a JUMP to some other selected location. At this location we can insert our own interrupt servicing code.

Here is a very simple example to illustrate this procedure. Starting at location 3450 HEX in the Basic ROM is a subroutine which generates the 'beep' whenever you press a key. We can alter location 787D, 787E and 787F HEX to contain a JUMP to 3450 HEX to execute this 'beep' routine every time a video interrupt occurs (every 20 ms).

To do this we POKE the following machine code into memory starting at location 787D HEX:

Hex Code	Mnemonic
C3 50 34	JP 3450H

Note: Remember location 787D HEX is CALLED every 20 ms, so you must not alter the RET at this location until you have entered a valid jump address in the following two bytes. Otherwise the Z80 will jump to some indeterminate address depending on what random data was contained in 787E and 787F HEX.

- The following strict order should be used:
- POKE 30846,80 (POKE 50 HEX into location 787E HEX)
- POKE 30847,52 (POKE 34 HEX into location 787F HEX)
- POKE 30845,195 (POKE C3 HEX into location 787D HEX)

Type in the above commands via the immediate mode (without line numbers). The text within the brackets should *not* be typed in as it is for information only.

Once you have done this you should hear an almost continuous beep from the internal speaker. Notice that there is nothing which interferes with this beeping. Well, almost nothing, as will be explained a little later. However, you can enter a Basic program as normal (except for the distraction of the beeping) and even RUN or LIST it. In fact, you can do all the normal operations (ex-



cept tape operations — see below) without affecting the beeping. This is because the interrupt has priority over other software execution. So we see it is possible to have a Basic program running in the 'foreground' with a separate machine language program running in the 'background' being executed at regular intervals.

To stop the beep all that is necessary is to change the JUMP instruction (0C3 HEX) at location 787D HEX back to a RET (0C9 HEX) by:

```
POKE 30845,201
```

**Tape operations**

As mentioned earlier, there is another action which will disable the 'beep'. During tape operations, interrupts are disabled to ensure that accurate timing delays in the tape function's machine code are not disturbed. So while you are CSAVEing, CRUNning or CLOADing data to or from tape the beeping will stop. However, once the operation is over the interrupts are enabled once again and the beeps return.

To enable the 'beep' again, enter —  
POKE 30845,195

Note: Before typing the above, make sure that locations 787E and 787F HEX contain the correct jump address (3450 HEX)!

**Non erasable video display**

Next we'll look at an example which shows how the video interrupt can be used to put 'non-erasable' information on the video screen.

Normally, any information displayed on the screen can be overwritten, cleared or scrolled off the screen, either during program execution or in the immediate execution mode. By using the video interrupt you can display information which cannot be overwritten.

The machine language source code is shown in Listing 1.

Use the Basic program shown in Listing 2 to enter and then to enable the machine code program shown in Listing 1.

After you have entered Listing 2, CSAVE it before RUNning it. You should see an '\*' in the top right-hand corner of the screen. Try to erase this by any means you like and you will find the best you can do is to erase it momentarily (in fact a maximum of approximately 20 ms, the time taken between successive interrupts). The only way to erase the '\*' is to disable the interrupt itself, or to disable the machine code program by:

```
POKE 30845,201
```

which POKES a RET instruction (0C9 HEX) back into location 787D HEX.

**Real-time system pointer display**

When programming in Basic a useful feature would be to see a constantly updated display of various system pointers (eg start

of program, end of program, start of free space etc) to aid in keeping track of the progress of these parameters.

To illustrate this principle simply, we will display the contents of the output latch. A copy of the latch contents is maintained at location 783B HEX (307779 decimal). The latch controls the following:

BIT	FUNCTION	0	1
0	speaker O/P #1	see note below	
1	unused		
2	cassette O/P	toggles according to data O/P	
3	mode control	Mode 0	Mode 1
4	background colour	green	buff
5	speaker O/P #2	see note below	
6	unused		
7	unused		

Note: During a key press 'beep' or execution of the SOUND command, the software toggles bit 0 and bit 5. When it does this, it first looks at the state of each bit and then inverts that state. Normally each bit (0 and 5) are the complement of each other, and the inversion of both at the same time gives a 'push-pull' like drive signal to the speaker. However, if both bits were the same, there would be no differential change when they are inverted, and so no output. You can therefore disable the 'beep' and the SOUND command by looking at both bits and then POKING a value into location 783B HEX (30779 decimal) which makes them equal. That is, if the contents of 783B HEX are even, then POKE back into 783B HEX a value equal to (contents + 1). Conversely, if the contents are odd, POKE back a value of (contents - 1).

Getting back to the latch display — to indicate the state of each bit, we will display a '0' or '1' for each bit in the top right-hand corner of the screen.

The machine language source code is shown in Listing 3.

The Basic program in Listing 4 will enter and enable the machine code program of Listing 3. Note that Listing 4 is similar to Listing 2, so if you have already entered Listing 2 you can modify it to Listing 4. Once again, enter the Basic program (Listing 4), and CSAVE it before RUNning it. You should see the contents of the output latch displayed in binary in the top right-hand corner of the screen, reading from left to right, starting with bit 7 across to bit 0. Change the background colour (COLOR,0 and COLOR,1) and note the change in bit 4 in the display.

**Cursor position pointer**

Edit line number 900 to:  
900 DATA 245,197,229,58,166,120,6  
ReRUN the program.

This will display the horizontal cursor position pointer (0-31) from location 78A6 HEX (30886 decimal). Use the left/right cursor position arrows to move the cursor and observe the display.

**Basic program pointers**

Now edit line number 900 to:  
900 DATA 245,197,229,58,249,120,6  
ReRUN the program again.

This will display the LSB (Least Significant Byte) of the 'end of Basic program' pointer. Try adding extra lines to the Basic program and note the change in the display. For example, add the line:

```
1500 REM TEST
```

Note down the binary value displayed and then edit line 1500 to:

```
1500 TEST
```

Compare the new display value with the previous value.

This exercise reveals that although the short form remark symbol (\*) occupies two screen spaces less than the long form REM command, it needs two more program memory spaces to store it than the long form!

**What next?**

These given examples are very simple ones designed to illustrate the basic principle of using the video interrupt and do not show the full potential of the technique. I have written two programs which utilize this technique in a more complex fashion. The first of these is a real-time clock which is controlled by the internal clock of the VZ200. This gives a digital readout display in the upper right-hand corner of the screen. The real-time clock is implemented entirely in software (no need for extra hardware or modifications).

The second program demonstrates a split-screen graphics mode with one part of the screen having text and lo-res graphics, with the remainder in hi-res graphics.

**Other applications**

These are but a few of the many possible uses of the video interrupt. Other applications include:

- arcade games — synchronizing movement with the video raster rate to give smooth action. Mixed hi-res graphics and text for scoring, simulating instrumentation etc;
- stopwatch — event timer or lap-scorer;
- frequency counter — using the internal VZ200 clock to give the timing gate period; and
- real-time control — using the VZ200 as a component in a control system, eg burglar alarm.

The list could go on, as anything which requires a reasonably accurate time-keeping function or synchronization with the video display, is a possible candidate. Which all goes to show that it's not always rude to interrupt!

# The microbee PC85 puts advanced computer technology in the hands of Hackers, Hobbyists and Horticulturalists at a cost below any competitors



The new microbee PC85 features a new high level of user friendliness. At the touch of a button you choose from a menu of built-in programs — Wordprocessing, Basic, A Calculator, Telecommunications and more. You can even have your own software built-in! Check out the new microbee PC85. You'll be impressed with the quality and surprised at the price.

**Microbee PC85** \$499 incl. Tax  
**with Green Monitor** \$599 incl. Tax  
Ask about Printers, Modems and more.

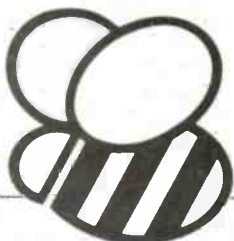

# microbee

## computer

Designed and manufactured  
in Australia by  
Applied Technology

PHONE ORDERS  ACCEPTED

### microbee technology centres

N.S.W.  
1 Pattison Ave, Waitara 2077  
Phone (02) 487 2711

VIC.  
729 Glenferrie Rd, Hawthorn 3122  
Phone (03) 819 5288

W.A.  
141 Stirling Highway, Nedlands  
Phone (09) 386 8289

S.A.  
151 Unley Rd, Unley 5061,  
Phone (08) 272 1384

QLD  
455 Logan Rd, Stones Corner, 4120  
Phone (07) 394 3688

FACTORY  
Koala Crescent, West Gosford 2250  
Phone (043) 24 2711

# at the leading edge

## **SHARP 25 line x 80 CHARACTER/GRAPHICS LCD**

Liquid Crystal Displays take one step closer to emulating the attributes of the C.R.T. with Sharp's **LM64004G**. Its **640x200 dot** capacity will give word processing and spreadsheet capabilities to laptop and portable computers and increased graphics flexibility to instrumentation and monitoring equipment. The LM64004G is supported by the Sharp **LR3692 L.S.I. controller**.

## **MEGAVAULT LAUNCHES 330 AND 660 MEGABYTE WINCHESTERS**

An average seek time of **18 ms** puts these **8" hard disks** in a high performance class normally the preserve of 14" and "washing machine" storage units. OEMs and mainframe installers can look forward to big savings right across the board. Cost, weight, power drain and size are way down on these **SMD** and **SCSI** interfaced devices.

## **FLOPPY INTERFACE TAPE STREAMER BACKS UP 10 MBYTE**

Configured like two 5Mbyte floppy drives **Interdyne's ID1010** provides a rapid and economical back up for the most popular hard disk configurations. **Track access is totally electronic** overcoming offset problems associated with the head positioning mechanism used in most streamers.

## **REDUCTIONS ALL ROUND ON MINISCRIBE HARD DISKS**

Miniscribe follows the release of their low power, half height **3212 10MByte** Winchester with a **25MByte** model designated the **3425**. Average access time for both units has been reduced to **88 msec**, putting them among the fastest stepper positioned drives commercially available.



**daneva australia pty ltd**  
64-66 Bay Road Sandringham Victoria 3191  
Australia PO Box 114 Sandringham 3191  
Telephone (03) 598 5622 Telex AA34439

Sydney: E&M Electronics (02) 51 5880  
Adelaide: DC Electronics (08) 223 6946  
Brisbane: Baltec (07) 369 5900

# ETI-638 Modification

F. Arundell, Talbot Vic.

Having recently built the ETI-668 Programmer (February '83) I wondered whether the ETI-638 programmer for the 2708 EPROM (July '78) could be modified by a similar arrangement.

It turns out it can be. Elimination of the '638's serial data transfer system and its replacement with a parallel system direct from a Microbee's parallel port results in much improved data transfer. This is not insignificant since the ETI-638 takes 70 minutes to program all 1k of the 2708.

A number of modifications are necessary to the '638 circuit. For a start, all the ICs associated with the

serial data transfer can be eliminated. This includes IC1, IC2 and IC3, plus all their associated resistors and capacitors. The data buss can now be taken directly to the Microbee, together with pin 19 of the IC3 socket, which must be connected to the 'Bee clock output, Pin 7 and 15 of the port.

It is also necessary to produce a DPDT switch. In the 'Read' mode, one pole must short the collector off Q3 to ground (through R17). The other one must short pin 20 of the 2708 socket to ground. When in the write mode they should be connected through the switch as they are.

```

ADDR  CODE  LINE  LABEL  MNEM  OPERAND
-----
          00100  IETI 638 EPROM Programmer for 2708's
          00110  modified by F.Arundell, 16/8/84
          00120
0E00      00130      ORG      0E00H
0E00  F3      00140      DI
0E01  ED57    00150      LD      A,I
0E03  F5      00160      PUSH   AF
0E04  21F0F  00170      LD      HL,INT
0E07  7C      00180      LD      A,H
0E08  ED47    00190      LD      I,A
0E0A  7D      00200      LD      A,L
0E0B  D301    00210      OUT    (I),A
0E0D  010004  00220      LD      BC,400H ;CLEAR SCREEN
0E10  210F0  00230  START LD      HL,0F00H
0E13  3620    00240  CLR   LD      (HL),20H
0E15  23      00250      INC    HL
0E16  0B      00260      DEC    BC
0E17  76      00270      LD      A,B
0E18  81      00280      OR     C
0E19  20F8    00290      JR     NZ,CLR
          00300  Enter START address
0E1B  3ECF    00310      LD      A,0CFH ;Set ARDY low to let
0E1D  D301    00320      OUT    (I),A ;Address generator reset
0E1F  3EFF    00330      LD      A,0FFH ;All bits input
0E21  D301    00340      OUT    (I),A
0E23  3E07    00350      LD      A,07H ;Disable interrupt
0E25  D301    00360      OUT    (I),A
0E27  210DF  00370      LD      HL,MSG ;Point to messages
0E2A  010DF0  00380      LD      BC,0F00DH
0E2D  CD640F  00390      CALL   MESS
0E30  0115F1  00400      LD      BC,0F15H
0E33  CD640F  00410      CALL   MESS
0E36  CD130F  00420      CALL   ADDR
0E39  D5      00430      PUSH   DE
0E3A  0115F2  00440      LD      BC,0F215H
0E3D  CD640F  00450      CALL   MESS
0E40  CD0600  00460  COM  CALL   0006H
0E43  FE10    00470      CP     10H ;^P
0E45  2015    00480      JR     Z,PROG
0E47  FE12    00490      CP     12H ;^R
0E49  2050    00500      JR     Z,READ
0E4B  FE14    00510      CP     14H ;^T
0E4D  2064    00520      JR     Z,TEST
0E4F  FE16    00530      CP     16H ;^V
0E51  206E    00540      JR     Z,VERIFY
0E53  FE03    00550      CP     3 ;Break
0E55  2099    00560      JR     NZ,COM
0E57  011F02  00570      LD      BC,21FH
0E5A  10E4    00580      JR     START
0E5C  21CE0F  00590  PROG LD      HL,INTP
0E5F  22F00F  00600      LD      (INT),HL
0E62  21060F  00610      LD      HL,PROGM
0E65  0120F2  00620      LD      BC,0F220H
0E68  CD640F  00630      CALL   MESS
0E6B  E1      00640      POP    HL
0E6C  0E70    00650      LD      C,70H ;112 Loops
0E6E  3E0F    00660      LD      A,0FH ;Byte output
0E70  D701    00670      OUT    (I),A
0E72  3E07    00680      LD      A,07H ;Enable interrupt
0E74  D301    00690      OUT    (I),A
0E76  C5      00700  PROG1 PUSH   BC
0E77  E5      00710      PUSH   HL
0E79  110004  00720      LD      DE,400H ;1k
0E7B  FB      00730      EI
0E7C  7A      00740      LD      A,D
0E7D  B3      00750      OR     E
0E7E  20FC    00760      JR     NZ,*-2 ;Loop until all bytes out.
0E80  F3      00770      DI
0E81  CD480F  00780      CALL   DELAY
0E84  E1      00790      POP    HL
0E85  C1      00800      POP    BC
0E86  0D      00810      DEC    C
0E87  20ED    00820      JR     NZ,PROG1 ;For total no. of loops
0E89  3ECF    00830  FIN  LD      A,0CFH ;ARDY low again
0E8B  D301    00840      OUT    (I),A
0E8D  3EFF    00850      LD      A,0FFH
0E8F  D301    00860      OUT    (I),A
0E91  3E07    00870      LD      A,07H
0E93  D301    00880      OUT    (I),A
0E95  011F02  00890      LD      BC,21FH
0E98  C3100E  00900      JP
0E99  21DA0F  00910      LD      HL,INTR
0E9E  22F00F  00920      LD      (INT),HL
0EA1  21BC0F  00930      LD      HL,READM
0EA4  CD540F  00940  LOOP CALL   HL
0EA7  E1      00950      POP    HL
0EA8  110004  00960      LD      DE,400H
0EA8  FB      00970      EI
0EAC  7A      00980      LD      A,D
0EAD  B3      00990      OR     E
0EAE  20FC    01000      JR     NZ,*-2 ;Loop until all read
0EB0  F3      01010      DI
0EB1  10D6    01020      JR     FIN
0EB3  21E00F  01030  TEST LD      HL,INTV
0EB6  22F00F  01040      LD      (INT),HL
0EB9  21C20F  01050      LD      HL,TESTM
0EBC  10E6    01060      JR     LOOP
0EBE  21EAF0  01070  VERIFY LD      HL,INTV
0EC1  22F00F  01080      LD      (INT),HL
0EC4  21C00F  01090      LD      HL,VERIFYM
0EC7  10DB    01100      JR     LOOP
0EC9  21A90F  01110  ERROR LD      HL,ERRM
0ECC  0115F2  01120      LD      BC,0F215H
0ECF  CD640F  01130      CALL   MESS
0ED2  0607    01140      LD      B,7
0ED4  CD0C00  01150      CALL   000CH
0ED7  CD0600  01160      CALL   0006H
0EDA  FE03    01170      CP     3
0EDC  20EB    01180      JR     NZ,ERROR
0EDE  110000  01190      LD      DE,0 ;To terminate loop
0EE1  F1      01200      POP    AF
0EE2  ED4D    01210      RETI
0EE4  F1      01220  EXIT  POP    AF
0EE5  ED47    01230      LD      I,A
0EE7  C3EBDA  01240      JP     0DAEBH ;Returns me to monitor
0EEA  00      01250      NOP
0EEB  0125F2  01260  SHOWLOC LD      BC,0F225H ;Show location
0EEE  3EA0    01270      LD      A,0A0H
0EF0  02      01280      LD      (BC),A
0EF1  03      01290      INC    BC
0EF2  23      01300      INC    HL
0EF3  7C      01310      LD      A,H
0EF4  CDFF0E  01320      CALL   SHOW
0EF7  7D      01330      LD      A,L
0EF8  CDFF0E  01340      CALL   SHOW
0EFB  3EA0    01350      LD      A,0A0H
0EFD  02      01360      LD      (BC),A
0EFE  C9      01370      RET
0EFF  F5      01380  SHOW  PUSH   AF
0F00  0F      01390      RRCA
0F01  0F      01400      RRCA
0F02  0F      01410      RRCA
0F03  0F      01420      RRCA
0F04  CD000F  01430      CALL   *+4
0F07  F1      01440      POP    AF
0F08  E60F    01450      AND    0FH
0F0A  C609    01460      ADD    A,90H
0F0C  27      01470      DAA
0F0D  CE40    01480      ADC    A,40H
0F0F  27      01490      DAA
0F10  02      01500      LD      (BC),A
0F11  03      01510      INC    BC
0F12  C9      01520      RET
0F13  CD170F  01530  ADDR  CALL   *+4
0F16  53      01540      LD      D,E
0F17  CD2C0F  01550      CALL   KEY
0F1A  07      01560      RLCA
0F1B  07      01570      RLCA
0F1C  07      01580      RLCA
0F1D  07      01590      RLCA
0F1E  5F      01600      LD      E,A
0F1F  CD2C0F  01610      CALL   KEY
0F22  83      01620      OR     E
0F23  5F      01630      LD      E,A
0F24  C9      01640      RET
          01650  ICLEAR RET OFF STACK AND RESTART
0F25  E1      01660  RST   POP    HL

```





**A special opportunity for our readers to save at least 20% on the regular price of Professional Magnetic Media disks by**



*Plastic library case included in purchase price*

# Nashua

Could you ever place a value on the information you store on your computer disks ... let alone the time it took to put it there? With so much at stake, don't settle for anything less than the very best disks available — **Nashua Professional Magnetic Media.**

What is the Nashua difference? Simply this: their disks are strictly monitored during every stage of production. They don't rely solely on an inspection of the finished product to detect flaws. Nashua build their product right in the first place. If a disk doesn't stay within narrowly defined quality margins ... well, it's just not good enough to carry the Nashua name!

Nashua disks offer you quality with **unequaled** consistency. And by special arrangement, we proudly offer our readers an opportunity to save on this superb product.

We are dealing directly with Nashua on your behalf ... so their superb Professional Magnetic Media disks are available to you at prices at **least 20%** (more, for some of the varieties shown) below recommended retail. **Don't miss this opportunity!**

**Complete and send your order form today!**

*We regret that disks can be sold in boxes of ten ONLY. Smaller quantities cannot be supplied.*

CODE	DESCRIPTION	PRICE per box
MD1	5 1/4" single sided single density	<b>\$30.00</b>
MD1D	5 1/4" single sided double density	<b>\$33.00</b>
MD2D	5 1/4" double sided double density	<b>\$43.20</b>
MD2F	5 1/4" double sided 96 tracks per inch	<b>\$49.80</b>
FD1	8" single sided single density	<b>\$45.00</b>
FD1D	8" single sided double density	<b>\$51.00</b>
FD2D	8" double sided double density	<b>\$52.80</b>

## FEDERAL MARKETING MAIL ORDER FORM

### Nashua Floppy Disk Offer

Send completed coupon to: Federal Marketing, PO Box 227 Waterloo NSW 2017.

Name .....

Address .....

Postcode .....

Signature .....

American Express  Bankcard  Cheque\*

\* Please make cheques payable to the Federal Publishing Company Pty Ltd

Credit Card No:

\_\_\_\_\_

Card Expiry Date: ..... Allow four weeks for delivery

CODE	QUANTITY	PRICE

Plus \$2.50 postage & handling per box

TOTAL

\_\_\_\_\_



# Sealed lead acid & nickel cadmium rechargeable batteries

**MAINTENANCE FREE**



**COMPLETE RANGE OF BUTTON CELL STACKS**  
assembled in Australia to customers specifications.



I.E.I. (AUST.) PTY. LTD.

15-17 Normanby Road, Clayton, Vic. 3149 Phone (03) 544 8411  
31 Phillips Street, Thebarton, S.A. 5031 Phone (08) 352 2066  
248 Johnston Street, Annandale, N.S.W. 2038 Phone (02) 692 0999

## RADIO CONTROL

### REMOTE SWITCH

3 MODELS AVAILABLE!  
FOR THE CAR, a single channel model turns on/off alarms etc from outside - comes with two pocket transmitters...\$95.00  
SINGLE or DUAL CHANNEL models avail. for other applications, e.g. garage doors, alarms etc These have extended range to 100 metres, 13,000 programmable codes, supplied with 1 pocket transmitter - European import.  
SINGLE CHANNEL.....\$115.00  
Extra transmitters...ea \$32.00  
DUAL CHANNEL.....\$125.00  
Extra transmitters...ea \$40.00

## NEW CAR ALARM

Keyless car alarm with inbuilt siren and entry/exit and reset delay. Ideal for use with ultrasonic below!



## ULTRASONIC CAR BURGLAR DETECTOR

Protects the interior of your vehicle from illegal entry. NO/NC cont

**\$44**

## SPECIAL MAY-JUNE ANTI-INFLATION PRICES

# PRICES HELD TILL 30TH JUNE



### NEW PROFESSIONAL

## ALARM CONTROL UNIT



**\$99**

Similar alarm boxes sell for upto \$199. Built for Aust. home, office, factory!  
● Heavy duty steel cabinet (lockable).  
● Sophisticated & versatile circuitry.  
● Adj. entry, exit & adj. reset delay  
● N.O./N.C. instant, N.C. delay oper.  
● Inbuilt siren, add horn speaker(s).  
● 6x LED status indicators, all modes  
● Inbuilt 24hr panic or fire circuit.  
Lots more features. send for brochure

### SCOOP BUY!

HALF PRICE ALARM CONTROL BOX - JUST \$99 Built/tested.

## ULTRASONIC



FOR HOMES, SHOPS, and OFFICES. Covers 40 sq. metres, ceiling or wall mounting, sensitivity adjustable, 12V DC operation, suit alarm control unit above.

## BURGLAR DETECTOR

Does not normally detect the smaller animals, range to 12 metres LED movement indicator N.O./N.C. contacts, tampered, very reliable and guaranteed!

**\$59**

SAVE \$10 WAS \$69



## INFRA-RED PEOPLE DETECTOR

Does not normally detect the smaller animals, range to 12 metres LED movement indicator N.O./N.C. contacts, tampered, very reliable and guaranteed!

**\$79**

SAVE \$30 WAS \$109

PACK/POST: \$2.00 PLUS 5% OF ORDER VALUE.

## ELECTRO-MAGNETIC COUNTERS

BEST QUALITY FAMOUS MAKERS WAY BELOW NORMAL COST!

24V DC NON-RESETTABLE PANEL MOUNTING...\$4.95 \$4.40  
110v AC CHASSIS MTG...\$2.50 \$2.20  
220v AC CHASSIS MTG...\$4.95 \$4.40  
15-30v DC OPEN TYPE \$3.00 \$2.55  
All above either 5 or 6 digit readout.

## Transformers

9-7Vx2 20A  
MAINS INPUT: 0, 240V, 265V  
OUTPUT: 2 windings 8V-10V depending on primary tap.  
WERE \$69 135x110x110mm  
**Ideal 13.8V 20A**

## 2Kg handy SURPRISE KIT

WORTH UP TO \$60  
Transformers, Electros, Poly & ceramic caps, Resistors, Switches, Semiconductors, Pots.  
INTER-STATE POST- ADD \$3.00

## FANS

5 inch  
MUFFIN. 115v \$6.00  
ROTRON. 220v \$8.00  
Ex-computer  
I.T.C.

## 3 INCH AC/DC BELLS

3-4.5v OR 24v  
**\$5** 10+ \$4.50 ea.  
High quality English alarm bells by Chloride-Gent in either 3-4.5V or 24V AC/DC models. Ideal for warning indicators, doorbells, etc.

## STEREO PHONES

8 Ohm  
Not \$19.95  
2 PAIRS FOR **\$3.99**  
PARTLY WATER-DAMAGED STOCK - Should be 1 or 2 prs working!

## TV ANTENNA AMPLIFIER

VHF/UHF/FM Dual Outputs  
6dB GAIN!  
**\$19**

**PRE-PAK electronics p/l**

**1a WEST ST, LEWISHAM, NSW**

**569-9797**  
24 HR PHONE ORDER SERVICE

**Phone or mail order**  
**BANKCARD accepted**

**SIEMENS**

# 64K DRAM IC4164

**NOW  
JUST  
\$2.99\*  
EACH!**

While stocks last.



## 180,000 Components for Peanuts!

Siemens, a world leader in high technology electronic components is even better known for relentless quality control. And now Siemens is offering memory I.C.'s at a lower price.

Both 128 and 256 refresh cycle I.C. memory parts are available immediately.

Each 16 pin dual in line package delivers 180,000 components – mostly transistors and capacitors – in its silicon chip. That's more than 600 components for less than 1 cent!

Siemens Ltd.  
544 Church Street, Richmond, Vic. 3121.  
Telephone: 420 7318 Sydney 436 8730

**Siemens Memory I.C.'s. High quality. New low price.**

\*Minimum order of 100 + pieces, plus sales tax if applicable.

Cash sales facilities available for non account customers.

A5/85

CSA 2430/744

# Competition answers



## GFS C-90 Talkman Communicator

In November 1984 we advertised a competition for a pair of GFS transceivers. You were required to answer two questions: who invented the triode apart from De Forest and Fleming, and who successfully specified FM radio back in 1936.

The answer to question 1 was Von Leiden, (1978-1914) in Vienna. He was working on the problem of amplifying telephone signals when he heard of Fleming's work on valves and realized its application to his problem. He stuck a control grid between the anode and cathode and called it a triode.

He did this completely

separately from the American, Lee De Forest (1873-1961) who developed an essentially similar device called an Audion. One of De Forest's assistants was a man by the name of Babcock, a common, but wrong, answer to our competition.

The prize went to John Blackie of North Carlton, Vic 3054, who wants to use the transceiver for setting up TV aerials. Congratulations!

## Philips VR6849 VCR

We also ran a contest sponsored by Philips for a stereo VCR. The questions related to the VCR. We asked why it had three heads instead of two, what was unique about the infrared remote control and to tell us, in 50 words, the difference between hi-fi and normal VCRs.

The reason it has three heads is to provide better picture quality in slow or still picture modes. The unique feature of the infrared control is that it has a docking mechanism which allows it to be located safely in the VCR when not in use.

The difference between this recorder and previous VCRs is the way the sound tracks are

laid down. In a standard VCR they are laid in linear fashion up one side of the tape. The Philips scheme involves heads mounted on the spinning audio drum. Thus the audio tracks parallel the video tracks and a much higher writing speed pertains.

There were only a small number of people who got this all correct and used 50 words or less. Of these we selected Richard Szewzyk of Hamersley, WA 6022, on the basis that his entry floated longest when we threw them all up in the air. Such is the fall of fate. Enjoy the VCR, Richard.

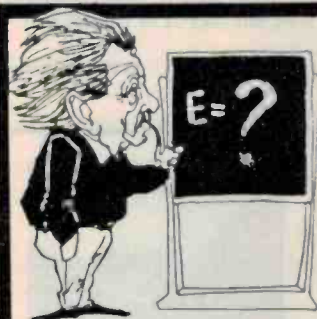

## Loss of memory can be disastrous especially in Computers. Install our **COMPUTER PROTECTOR**

... protects your computer memory against spikes, glitches, lightning, on-off switches, electric motors etc. Max peak surge current up to 4500 amps; transient energy absorption up to 75 joules.



**Westinghouse Systems**

P.O. Box 267,  
Williamstown, Vic. 3016  
(03) 397 1033

Please forward  Computer Protector(s)

Name: \_\_\_\_\_

Address: \_\_\_\_\_ P'code: \_\_\_\_\_

Chq \$  \_\_\_\_\_



MAX. 6 Amp  
COMPUTER PROTECTOR  
RFL. - FILTER  
WITH MOVING SURGE LIMITER  
MANUFACTURED BY WESTINGHOUSE  
WESTINGHOUSE BRIDGE & SIGNAL  
LONDON W1C 2JX AUSTRALIA LTD  
MA31427

PIF 3-1A	3 AMPS	2 STAGE	+ E.L.C.	\$82
PIF 3-3A	3 AMPS	2 STAGE	+ E.L.C.	\$85
PIF 3-6A	6 AMPS	2 STAGE	+ E.L.C.	\$90
PIF 3-10A	10 AMPS	2 STAGE	+ E.L.C.	\$95

Plus Sales Tax if applicable Add \$4 pack/post

WS2

# One hundred years of time zones

In January 1885 following a meeting in Washington to look at a better structuring of time across the world, the division of the globe into twenty-four time zones was adopted.

The present world time zones which are known as GMT or in more recent times UTC were the idea of Sir Sanford Fleming, a Canadian who worked with vigour on the idea of better time reference throughout the world.

Sir Sanford Fleming came to Canada from his native Scotland in 1845 and began life as a surveyor in Ontario and then worked with the Canadian Railways. In 1851 he designed Canada's first postage stamp and also planned the city of Toronto. He progressed to become chief engineer in the Inter-colonial Railways in 1863, at the same time as he was chief engineer of the Canadian Pacific Railway.

As trains and ships got faster Fleming realized that it was essential to have a more satisfactory time system. Each railway station had its own local time. In the province of Ontario there were four different times recognized in four cities within six hundred kilometres of one another. In the United States over one hundred time standards were in use.

It was in 1876 that Fleming proposed a time system of

twenty-four hourly time zones around the world. Because of confusion between am and pm Fleming saw the value of a twenty-four hour clock which deleted this type of time reference.

In 1884 twenty-five nations met in Washington to adopt his concept of Standard Time. At that conference twenty-two countries agreed, one country voted "no" and two abstained. Because the conference was international and there was a certain amount of national pride, many were reluctant to adopt Greenwich as the prime meridian. But already some sixty percent of charts used by the world's shipping was based on Greenwich so it seemed natural that the Greenwich meridian be adopted. This meant that every clock throughout the world was on the same minute and second, the only difference was the hour.

In November 1883 the railway systems in the United States and Canada adopted the twenty-four hour system and time zones so that there was a working example of the system at the 1884 conference. National jealousy stood



This early map of the world issued as a verification by Radio Portugal, was drawn in the days before adoption of the 24 hour time zones across the world.

in the way of quick adoption but by 1890 the system had been accepted by almost all countries.

Earlier time calculations from a sundial and the stars has progressed into an era of atomic time, which is accurate. Atomic time loses only a milli-second every ten thousand years. Present time calculations are now known as UTC (co-ordinated universal time) which has replaced Greenwich Mean Time in name only.

Fleming's interests not only covered the twenty-four hour time zones but the twenty-four hour clock which is well-known to short-wave listeners as used in international broadcasting and in many other fields of commerce and communication. The first two figures denote the hour and the second two figures the minutes, so that 0950 is actually 9.50 am and 2150 is 9.50 pm.

Arthur Cushen

## Communications in the information age

'Communications 85', The Australian International Electronic Communications and Information Technology Exhibition will be staged at Sydney's Centrepoint from 6-9 August 1985.

'Communications 85' is designed to reflect the converging technologies of telecommunications, computers and micro-electronics.

The show is aimed at the defence forces, transport and navigation control authorities and

radio and TV organizations, as well as data processing professionals, information managers, and businessmen who may neither be qualified nor particularly interested in the genius behind the technology but who want to know how the latest communications equipment will save time, money and improve efficiency and productivity.

'Communications 85' will be the largest specialized communications exhibition ever held

in Australia. The theme for the show is 'communicating in the information age' and visitors will be able to view an extensive range of equipment including facsimile, paging and PABX systems, computers, LANs through to exciting new areas including videotext and teleconferencing.

Further details are available from Australian Exhibition Services Pty Ltd, (03)267-4500, telex AA39329.



## Smallest 9-band portable receiver

Sony has announced development of a 9-band portable receiver of virtual pocket size (134 x 74 x 23 mm weighing 235 g).

The ICF-4900 uses single-chip IC design. It is the first multi-band radio receiver to incorporate the single-chip ICs used in Sony's portables.

Its dual conversion system provides superior shortwave reception and reduces image interference. The SW band-spread system facilitates tuning. Wide SW frequency range enables reception of standard frequency stations and local broadcasts outside international meter bands.

The new unit comes with a rotating rod antenna and can pull in high-information MW broadcasts, FM programming and seven shortwave bands. Power output is 100 mW. The unit

comes with a 5 cm diameter speaker.

Supplied accessories for the ICF-4900 include earphone, soft case, and SW guide to the major frequencies. The dc in jack enables ac operation with optional adaptor.

### Announcing

The 1985 South East Radio Group Convention will be held on June 8 and 9, 1985 at the Show Hall, Pick Avenue, Mt Gambier.

This year Nos 2 and 3 Halls have been procured enabling the convention to be conducted under one roof and giving extra space for bigger and better trade displays, with an area set up for a sit and chat and coffee.

The weekend will have all the usual events with novel events for the children on Sunday.

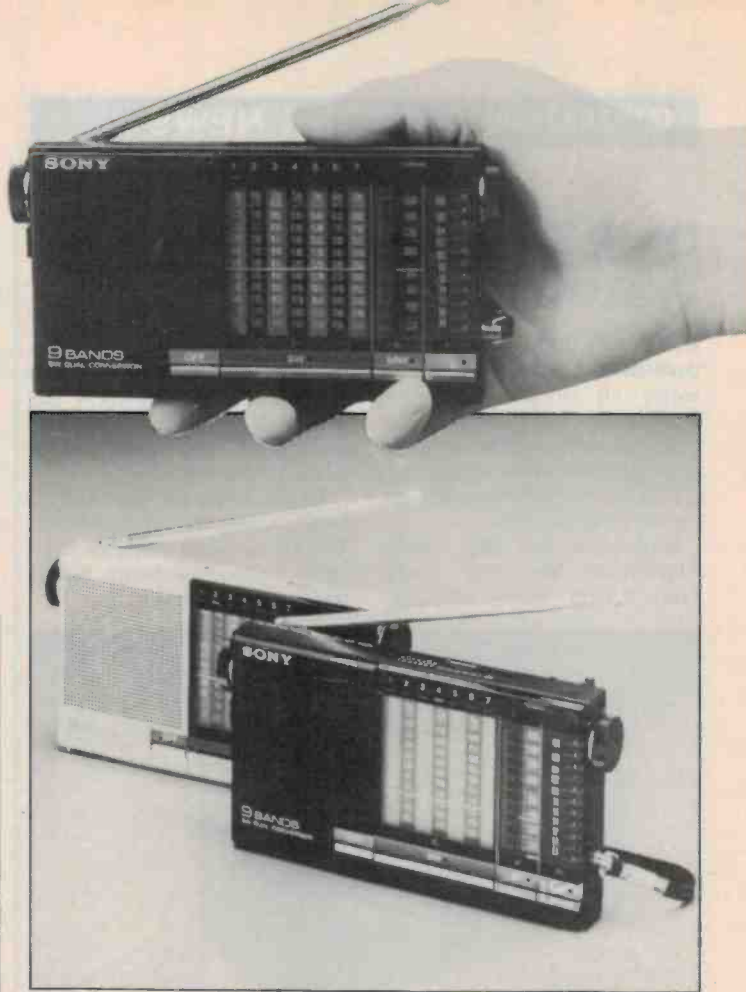

## KILOHERTZ COMMENT

**BELGIUM:** The Belgium Radio has extended its transmissions to 55 minutes.

Broadcasts in English are 0800-0855 UTC on 9880 and 21820 kHz Monday to Friday. A transmission to North America 0030-0125 UTC is broadcast on 5910 and 9925 kHz. During the Wednesday transmission a programme called Radio World-DX is broadcast, which includes information for the shortwave listener.

**CHINA:** Radio Beijing is using new frequencies and has left the out-of-band channels for its broadcast to Australia 0830-0925 UTC and repeated 0930-1025 UTC. Transmissions are now on 9700, 11755 and 15190 kHz and include a mailbag session on the broadcast on Sunday and Tuesday.

**INDONESIA:** Jakarta has been received on the new frequency of 11815 kHz from 0200 to past 0400 UTC. Radio Republik Indonesia stations are now operating 24 hours a day on most transmitters. RRI news bulletins are now carried by all private stations in Indonesia according to a recent BBC report. The private stations now carry RRI news on relay from 2200 UTC and also relay commentaries.

**NEW ZEALAND:** Dunedin Radio 4XD operated by the Otago Radio Association commenced broadcasting from Dunedin in 1922, as a non-commercial station. For many years the station used 1431 kHz with low power, but has now moved to

1305 kHz with 2 kW and a new transmitting mast at Highcliff near Dunedin. As 1305 kHz is a clear frequency, and 4XD the only operator in the South Pacific, the station is being heard on the east coast of Australia.

At 1030 UTC each Sunday the station presents Arthur Cushen's Radio World, a seven minute magazine feature. This is to be extended to 30 minutes with station personalities including Jack Fox, patron of the NZ Radio DX League who will provide a special programme for Australian listeners.

**SPAIN:** Spanish Foreign Radio has been heard using two out-of-band channels in English at 1930-2030 UTC. The broadcast to Africa is on 11690 kHz and to the Middle East on 9780 kHz. Reception reports are requested to Spanish Foreign Radio, PO Box 156202, Madrid, 28080 Spain. The broadcasts on 11690 kHz are very well received but 9780 kHz has some interference from Moscow. The programmes include news and commentary and each day at the end of the transmission, Spanish-English lessons.

**SWEDEN:** Radio Sweden's transmissions to Australia and New Zealand in English (1100-1130 UTC) have been moved from 17820 kHz to 15115 kHz because of interference from Radio Pakistan. The writer suggested this new channel after a request from Radio Sweden for an

interference free outlet in the 19 metre band.

**SWITZERLAND:** Swiss Radio International has been testing with continuous music on four frequencies and according to an announcement the broadcasts are in the 75, 49, 31 and 25 metre bands. Signals have been observed on 9535 and 12030 kHz, the latter frequency giving the best reception.

**SYRIA:** Radio Damascus has now commenced an External Service with broadcasts to Europe and North America. The transmissions in Arabic have been reportedly heard in Australia recently on 12085 kHz (verified by the writer). This new External Service uses 9485 and 12085 kHz. English broadcasts are 1200-1300 UTC and 1935-2030 UTC, to North America and Europe respectively. A new service to Latin America in Arabic, Spanish and Portuguese from 2200 UTC is carried on the same frequency. The transmitters have a power of 500 kW. Damascus has returned to shortwave after a period of seven years.

**UNITED NATIONS:** The United Nations has extended its programme service broadcasting daily to Africa from 1900-2000 UTC, on 21710 and 15120 kHz (Greenville), 15360 kHz (Tangler), 15330 kHz (Philippines). The broadcasts are in English and French. During the meetings of the General Assembly the UN Radio, using the facilities of

the Voice of America, broadcasts in 13 languages. The rest of the year the broadcasts have been weekly and the UN Radio now plans daily transmissions. The transmission from the United Nations to the Pacific is heard each Saturday 0930-1030 UTC on 9565 and 15250 kHz in Japanese, Chinese and English.

**UNITED STATES:** The Voice of America's weekly programme for shortwave listeners which is part of the Thursday Magazine Show has been renamed "Worldwide Shortwave Spectrum" and the address is Voice of America, Washington DC, 20547. During the programme the producer chooses the most interesting question received for which the writer receives a complimentary copy of the 1985 World Radio & Television Handbook. The VOA has also announced that two new verification cards are available for confirmation of its programme, one which pictures the space shuttle, and the other the Statue of Liberty. The broadcast is heard on Thursdays at 1330 UTC and this broadcast beamed to the Pacific can be heard on 6110 and 15425 kHz.

This item was contributed by Arthur Cushen, 212 Earn St, Invercargill, New Zealand, who would be pleased to supply additional information on medium and shortwave listening. All items quoted are UTC (GMT) 10 hours behind Sydney time, all frequencies are in kilohertz (kHz).

## Dick Smith UHF wattmeter kit

Dick Smith Electronics has introduced the K 6312 UHF wattmeter kit to the Australian market.

The unit designed for accurate power measurements relies primarily on its strip line layout for reproducible accuracy.

Spokesman for Dick Smith Electronics, Mr Gary Crapp said, "After many enquiries

from the now successful 'Explorer' UHF transceiver kit, it seemed logical to present the project at this time, as there are over 1000 'Explorers' operational in the field."

Retail price for the K 6312 UHF wattmeter kit is \$49.95. The kits are now available in all Dick Smith Electronics Stores throughout Australia.

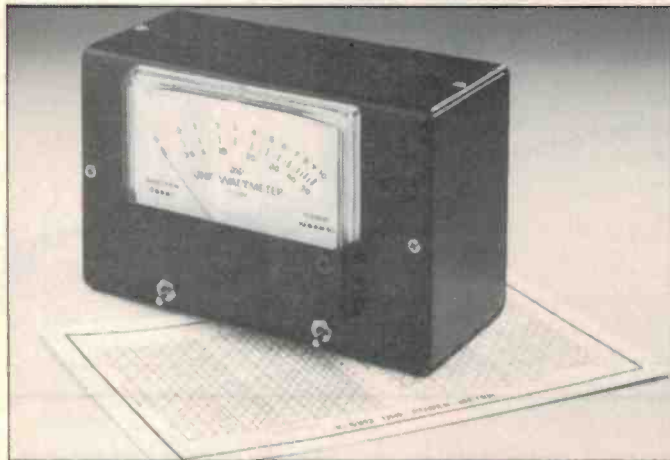

## HX 2000 hand-held scanner

Dick Smith Electronics has available throughout Australia the new HX 2000 AM/FM programmable hand-held scanning monitor receiver.

Performance is as good or better than from most 'fixed' scanners but with the added bonus of being a hand-held unit.

Features include 20 channel memories — for full coverage and easy selection; choice of over 15,000 frequencies by just pushing a button; seven bands; a scan for frequencies you have entered or search for new frequencies; and an LCD sidelight for night use.

Bandwidths extend from 90 MHz (VHF) to 525 MHz (UHF 'T') with search frequency increments of 5 kHz, 10 kHz, 12.5 kHz (VHFR) and 12.5 kHz (UHF). Sensitivities range from 0.5  $\mu$ V at mid VHF to 1.0  $\mu$ V air band.



## DOC news

Sydney taxi drivers with **illegal linear amplifiers** in their cabs are to come under close departmental scrutiny.

Penalties include confiscation of equipment and a fine of up to \$1000 which may be increased to \$10,000 under the Radio-communications Act which will take effect this year. Under this act it will also be illegal to install such equipment without authorization.

"The Department does not want to wield a big stick, but ..." So if you don't want to keep to the approved 25 watts for transmitters watch out for departmental officers and officers from the NSW Department of Motor Transport. They will soon begin inspecting taxis at depots and ranks to check for installation and operation of linear amplifiers.

To protect privacy AMFAR would not include street addresses of licensees; the last three digits of a fixed transmitter's geographical co-ordinates would be deleted to limit accuracy of identification of a transmitter site to one square kilometre; and references to state or federal police forces would not be specific.

The modified version of AMFAR would initially be available from State Offices of the Department's Radio Frequency Management Division at a cost of \$20 for a complete set of microfiche or \$7 per page for paper copies. It will be updated periodically.

The Minister for Communications, has issued a **warning to prospective buyers of satellite receiving systems** (earth stations) to make sure they understand fully the capability of the various systems before finalizing pur-

chasing arrangements.

He said "It should be made quite clear that earth stations which are designed to pick up signals from the Intelsat IVA satellite system will not be able to pick up signals from Aussat."

The ABC will cease Intelsat relays from 1986 to use Aussat exclusively. Commercial Services will also use Aussat.

The Department of Communications is to make its register of **radio frequency assignments** of licensed radio communications operators available to the public in a modified form.

Mr Duffy said that in July 1984 his Department advertised its proposal to release AMFAR (Australian Master Frequency Assignment Register) and received a generally favourable response. Comments had been taken into account including minority concern about increased interception of transmissions.

Adelaide will receive **multicultural television** in June 1985 — exclusively on Ultra High Frequency (UHF).

As with existing services, the multicultural television service, provided by the Special Broadcasting Service will operate from two transmitting sites. The main transmitter will be at Mt Lofty (on Channel 28) and a translator will operate from the Grenfell Building (Channel 43) to cover the Adelaide foothills.

A new **ABC FM station** to serve the Bega area, on the South Coast of NSW, makes the 37th in the network in Australia.

The ABC FM transmitter is located on Brown Mountain, about 40 km west of Bega, at the same site as the television transmitter for ABC ABSN-8.

The station broadcasts on a frequency of 105.7 MHz. Programs originate in Adelaide to be relayed to the transmitter by land links.



Introducing the newest member of HP's logic analyser family.

# The HP1630G...65 channels and advanced software analysis help you maximise 16-bit system performance.

First came the HP1630A and the HP1630D. One, a low-cost general purpose logic analyser suited to the needs of the full development cycle. The other, with 16 channels of timing analysis and 27 of state, an invaluable tool for the hardware design engineer.

Now Hewlett-Packard introduces the HP1630G. With up to 65 channels of state analysis, it is the new standard for software design engineers working on complex new 16-bit microprocessor-based products.

Plus, the ability to configure 8 of those lines for 100 MHz timing analysis gives you a logic analyser system with investigative power and versatility for virtually all your needs.

**Three new software overview modes let you non-intrusively monitor software performance and hardware/software interactions in real time.**

**Time tagging gives you added insights into system functions.**

**Floppy disc interface and popular 16-bit microprocessor support.**

**Our HP1630G upgrade kit protects your previous HP investment.**

If you've already invested in an HP1630A or HP1630D, but you feel you need the added capabilities of the HP1630G, you'll be glad to know that an upgrade kit is available.

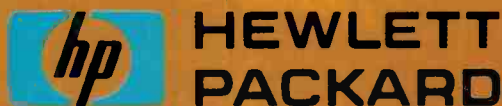

Melbourne: 895 2895. Sydney: 888 4444. Adelaide: 272 5911. Perth: 383 2188.  
Brisbane: 30 4133. Canberra: 80 4244. Auckland: 68 7159. Wellington: 87 7199.

# THE STRATEGIC DEFENCE INITIATIVE

When the US President dreamed up the Starwars proposal two years ago some were not sure whether it was science fact or fiction. Practical or not, this scientific proposal still dominates US-Soviet relations.

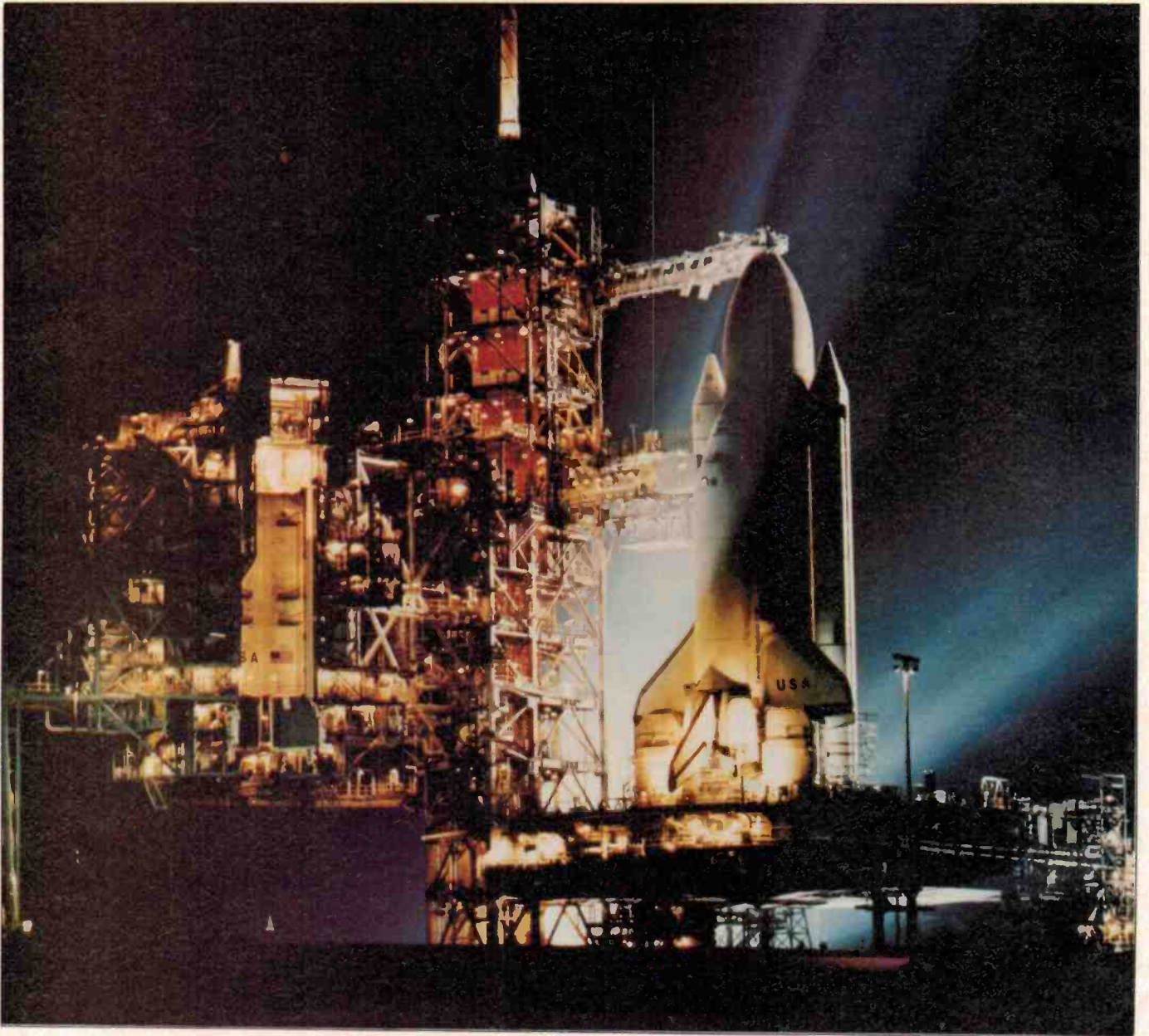

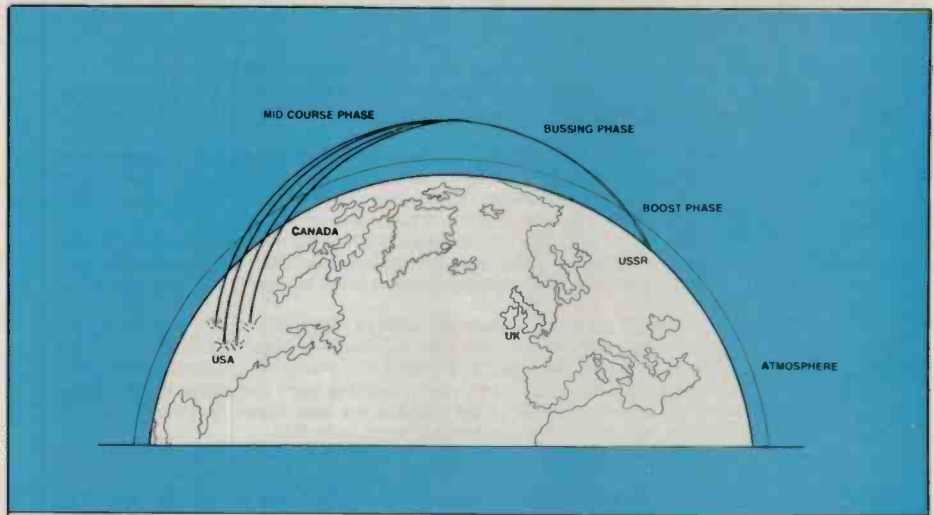

The trajectory of a MIRVed missile launched in Russia against targets in the USA. Interception must occur before the warheads start to separate, but after the rocket has left the atmosphere. Detection will be easiest during the boost phase, while the rocket motors are still firing.

## Jon Fairall

ON THE 22ND MARCH 1983, the President of the United States, Mr Ronald Reagan, stood up and delivered a speech. He argued for the end of the defence policy known as MAD (Mutually Assured Destruction) and for the setting up of a defence system for the United States. He called it the Strategic Defence Initiative. The newspapers called it Starwars.

Reagan challenged his scientists to come up with a shield to protect the USA against missile attack. As the President outlined it, satellite mounted lasers would destroy the missiles during their flight between the USSR and the USA.

It was seen as an attempt to rid the world of nuclear terror, an attempt to end a thirty year stalemate between the superpowers. But how practical is the President's dream?

### Starwars

To understand exactly what is involved consider the flight of a ballistic missile. It can be divided up into four phases. First there is the boost phase, during which the rocket motors fire and the rocket lifts out of the atmosphere. During this phase the rocket is extremely hot and emits large amounts of infra red radiation.

The second period is called bussing. Each rocket contains a number of warheads (typically ten) contained in a 'bus'. The bus has sufficient intelligence to be able to make mid course corrections and to eject warheads into predetermined orbits.

In the third phase, the mid course phase, the warheads drift towards the atmosphere. Re-entry is called the terminal phase.

To destroy such a rocket there are a number of strategies that might be suggested. It's clear, firstly, that attack should begin as the rocket leaves the atmosphere. The laser will operate much more effectively without the atmosphere to attenuate it.

Secondly, it's clear that the rocket must be destroyed before the beginning of the bussing phase. Once warheads are ejected, problems multiply as rapidly as warheads.

There are a number of scenarios here. One is that infra-red lasers would be used.

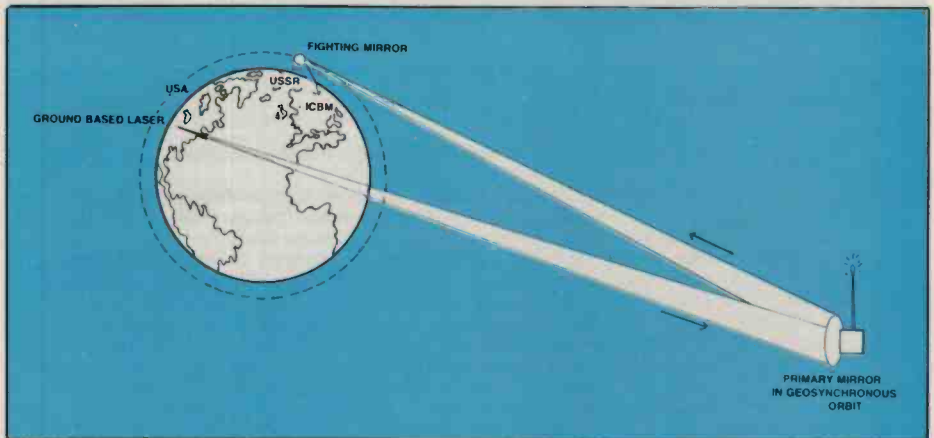

The fighting mirror scenario envisages a single laser on the ground, where power supply problems would be manageable. The use of a mirror in geosynchronous orbit means the beam can be deflected to the fighting mirrors in low earth orbit above the missile fields in Russia. The optical problems are phenomenal.

The energy of the laser would be coupled directly into the warhead as heat, either disintegrating it, or turning it into a lump of molten scrap iron.

Alternatively, an ultra violet laser could be used to destroy the molecular bonds in the warhead material.

A third alternative is to use X-ray wavelengths. The laser energy would then pass directly through the outer shield of the bus and interact directly with the silicon in the integrated circuits of the guidance system. An expensive killing machine becomes instant junk.

An alternative scenario has also been suggested. In this the lasers are based on the ground. The beam is then directed by mirrors in orbit. In some schemes there is a primary mirror in geostationary orbit which then directs the beam down to mirrors closer to the ground. In other schemes there is only one mirror used to direct the beam

onto the rocket. All these schemes are known as "fighting mirror" scenarios.

In any case the plan would be to destroy the missiles during the boost phase. We can get some idea of what this will mean by considering the flight trajectory of the newest US weapon, the MX missile. For the MX, the boost phase amounts to a period of about three minutes after launch. Of this the first minute or so would be spent in the earth's atmosphere. This leads to a destruction "window" of about two minutes. With current deployment of Soviet Missiles there would be about 1400 targets.

So the essence of the problem is to develop the technology to destroy 1400 missiles in about two minutes. That's about eleven missiles a second from a distance of a few thousand kilometres. It's true that the missiles that survive those first two minutes still have 15 or 20 minutes to go before the terminal phase, but they multiply like rab-

## Pointing the bone

Unlike a conventional weapon, near enough is not good enough when it comes to lasers. It must be pointed at the target accurately. This implies that the detection apparatus on the satellite must be good enough to fix the position of the target to an uncertainty of less than the dimensions of the target.

The primary concept here is resolution — the ability to distinguish between two points very close together. The better you can do that, the better you can determine the position of an object. Resolution depends on a whole lot of mechanical parameters within an optical system, but if these are optimised, it is ultimately limited by wavelength and the size of the receptor.

Everything else being equal, the bigger the receptor the better the resolution. Also, the shorter the wavelength the better the resolution. So, from the point of view of designing a system with resolution in mind we want something that operates on very short wavelengths with a very large receptor.

Unfortunately, other factors have to be taken into account. There is an upper limit to the size of the receptor, set by the means of transport into orbit and mechanical considerations. There are also constraints on the wavelength: the rocket is brightest in the infra red, especially during the boost phase. It is essentially invisible at optical wavelengths during much of its flight. We also need to consider that the dimensional tolerances of the receptor are also related to wavelength. The shorter the wavelength the more accurately the receptor needs to be built.

All of this leads to some design compromises. Radar would provide easy detection and tracking, but the size of the dish required would be extremely large, making it very vulnerable, and also very difficult to set up. Infra red would be nice, since it is where the rocket emits most of its energy, but detection would require an optically perfect mirror 100 metres across. Reducing the mirror size somewhat, at the cost of increasing the accuracy with which it was manufactured, would lead to optical contact. The trouble here is that the rocket is not inherently bright at optical wavelengths, and could be made darker very easily.

Whichever way it is done, detection will require major advances in optics and light gathering systems. It is not impossible, and would have worthwhile side benefits in applied optics and astronomy. Whether the cost of doing so can be justified even on national security grounds is another question.

## The absentee factor

One of the key questions in the debate over the Strategic Defence Initiative is: How many satellites do you need?

In principle, all you need do is provide continuous surveillance of the entire surface of the earth. This could be achieved with three satellites in geosynchronous orbit (as indeed is the case with comsats). The problem is that the geosync orbit is some 35,000 km away.

There is a whole group of problems that multiply rapidly with distance. Detection and pointing difficulties, in fact, will rise with the square of the distance. As a result, most practical proposals envisage the laser satellites in low earth orbit, say of the order of a thousand kilometres or less.

But this leads to another problem. It's called the absentee factor, and stems directly from the fact that at low orbit the satellite can see considerably less of the earth's surface than in high orbit.

There is a considerable amount of disagreement over the figures, but it seems that on the most optimistic forecast the absentee factor at this altitude is about 10. That is, you need ten satellites in orbit to guarantee that one will always be over any given point on the earth's surface.

That's not to say that only 10 satellites will do the trick. In the event of a launch you need a certain number of satellites within striking distance of the launch sites in order to guarantee destroying them all.

The way to approach the problem seems to be to work out how many satellites you need to destroy the existing Soviet fleet, and then multiply that number by 10.

The exact figures here are the subject of intense debate, but we can come up with some approximate figures to work with. It seems inconceivable that a system could be built that could detect, track and destroy a missile in under a second. So let's make that assumption in the knowledge that we are being extremely optimistic. Then on the figures presented in the text, we have a requirement for eleven satellites. (That's one missile per second for 120 seconds for each of 12 satellites.)

So on these figures, we would need a total of 120 satellites. That's a minimum figure. In the early stages of the technology we would almost certainly need more. Many more.

bits. If you can't stop them here, you can't stop them anywhere.

## Reaction

Politically, and in the press, the reaction to Starwars was one of almost universal hostility. For one reason or another, most of America's friends, and all of her enemies, opposed the idea. At the very least there was agreement that the existence of Starwars research would make arms control talks more difficult.

In the science community, there was, and still is, continuing disagreement over whether Starwars is possible or practi-

cal. A convergence of views seems to be occurring over time, though. The received view seems to be that it is possible, but not practical.

## Possible

The history of science is replete with examples of pundits who proclaimed this or that "impossible". Most have wound up with egg on their faces. There is no essential bit of technology in the Starwars plan that is not scientifically understood. Lasers can be made. Power plants can be built. The sensors and communications necessary to control the system can be put together.

In fact, the leading edge of this technology may already be within orders of magnitude of necessary values. According to Dr George Paul of the University of New South Wales, the latest developments at the Lawrence Livermore laboratories in the USA indicate that enormously powerful lasers are already fully functional. Scientists at Livermore have been using lasers to impart energy into small particles of matter in an attempt to start nuclear fusion. Requirements here are for extremely high power, the type of power that could possibly heat a missile to destruction.

Less developed, but in principle, developable, are the optic systems necessary to focus the laser beams. Special optics are necessary because, although a laser is by definition a device that emits a parallel beam of light, there is some divergence from perfection. The amount of divergence is related to the size of the aperture. The bigger the better.

Some figures are in order. According to Dr Paul a laser with a one meter aperture, operating at a wavelength of  $10^{-6}$  metres will diverge 10 cms over a distance of  $10^6$  metres. Thus the power intensity will be reduced by 10%. Of course, the real thing will operate over much greater distances, probably with smaller apertures.

In order to improve things somewhat, most scenarios have mirrors to focus the beam to make it more nearly parallel. However this needs optics of very high order. Apart from the precision necessary to focus the beam accurately, the mirrors and lenses must pass very close to all the energy supplied to them. If faults develop that cause the optics to absorb any of the incident energy, the entire system will self destruct.

According to Dr Ian Faulkner of Sydney University's Physics Department, the requirements of a laser weapon would lead to a whole new type of optics. Presumably much of the money allocated for Starwars would be spent in this area. However, says Faulkner, there is no physical principle that suggests it can't be done.

## Power supplies

Perhaps the biggest problem for proponents of the Starwars scenario relates to the power supply. According to the Fletcher panel, a study group set up in 1983 by the US Defence Department, the simplest "failure mode" of a rocket can be assumed to require the application of around 200 MJ per square metre to the surface of the rocket. This is sufficient energy to evaporate a layer of carbon three millimetres thick.

We can assume that this energy is delivered so fast that there are no inefficiencies created by the ability of the rocket to dissipate the energy by re-radiation. We can also make the highly unrealistic assumption that there are no losses in the optical systems or due to the divergence of the beam, and that all the energy emitted by the laser is coupled into the target.

With these simplifications we can calculate the power requirements of providing a

laser umbrella against the existing Soviet missile fleet.

There are 1400 missiles, therefore we require  $2.8 \times 10^{11}$  Joules. Assuming that the overall efficiency of the laser systems is 30% we then need access to  $9.3 \times 10^{11}$  Joules. This, of course, is a highly unrealistic assumption. A more realistic figure for the efficiency of the laser is probably only 1%.

This energy requirement needs to be delivered over the two minutes of the launch window. Therefore we can do some more arithmetic to find the power requirements of the system, and come up with an answer of 7.75 gigawatts.

How much power we actually need depends on what scenario we adopt. If we are talking about the fighting mirror strategy, we need to increase the power requirements by a factor of at least 10 to accommodate losses in the atmosphere.

Alternatively, if the power supplies are mounted on the satellites themselves we need to multiply the power requirements by the absentee factor. (See box.)

No matter which way you look at it, we still need to multiply our power requirements by a factor of 10. That is at least 60 gigawatts of power.

To give this some kind of physical meaning, consider that the huge New South Wales Electricity Commission power station at Liddel in the Hunter Valley puts out 2000 megawatts at full capacity. So you need at least thirty of them to run Starwars. Liddel is not a tiny power station.

It appears that a realistic price for electricity generation in the USA at the moment is around \$300 per kilowatt. If this is so then the power supply for Starwars will cost  $1.5 \times 10^{10}$  dollars. This, of course, is a highly unrealistic price because of the optimistic assumptions we have made. Most pundits seem to think that more realistic estimates will increase it by a factor of between 10 and 100.

We have also ignored the technical and economic difficulties of getting 25 Liddel type power stations into earth orbit.

### Costs

What the final cost of developing and deploying all the elements of Starwars might be is anyone's guess. Robert Jastrow, founder of the Goddard Space Flight Center, and one of the proponents of Starwars, is on record as saying that it is not unreasonable to suggest that each laser satellite will cost as much as an aircraft carrier, say a billion or so dollars.

At present the USA can afford to run a fleet of about 10 or so carriers, and many of these are obsolete. Starwars would involve at least 100 satellites (on the most optimistic assumptions about aiming rate and absentee factor) and none of its satellites could ever

be allowed to become obsolete.

Starwars has spawned a new word in Pentagonese. It's T-dollar. A T-dollar is  $1 \times 10^{12}$  U.S. dollars. The cry is: "Give us a T-dollar for Starwars!" And some even question whether that is enough.

### Practicalities

Those who argue against Starwars, and there are many, see an incredible range of difficulties in these plans.

Firstly, it can't stop low level delivery of atomic weapons. Whether by terrorists, low flying bombers or cruise missiles, the USA would be just as vulnerable as it has always been. MAD again. Foreshadowing this, Caspar Weinberger, the US Secretary of Defence, announced on January 18, 1985, that the Defence Department was considering reinstating the network of fighter stations and low level defences that protected the USA against just such a threat during the 1950s.

A second, even more profound, argument against the idea of total defence is that no matter how big it is made, or how many satellites are deployed, it will always be possible for the Soviet Union to build one more rocket than necessary to overload the system.

It's worth bearing in mind that for Starwars to be of any value it must work perfectly. It can't be fifty percent effective, or seventy percent, or ninety percent, or even ninety-nine percent. One percent of 1400 is 14. Fourteen rockets, say 140 atomic warheads landing on the USA would effectively mean the end of the nation.

Even if the defences are not overrun, and even if they work perfectly, there are all sorts of things the opposition can do to protect their missiles. The problem with Starwars is that it's so expensive, its technology so advanced, that it will always be easier and cheaper to upgrade the Russian offensive capacity than the US defensive one.

For instance, no matter how powerful the laser, there is always some thickness of material that will attenuate it to a comfortable level. Of course, that could quickly get to be an impractical method of protecting a satellite. It would be easier to try reflecting rather than absorbing the incoming radiation. This can be very easily accomplished. In fact studies have shown that a coat of highly reflective paint will do the trick.

An embellishment of this idea might be to develop a mirror that could reflect the incident beam right back to the battle satellite.

There are other tricks. In order to aim the laser at the missile, it will be necessary to firstly detect the flame of the rocket exhaust, and then aim, not at the exhaust itself, but a little above it. Heating the body of the rocket, by burning fuel in a skirt near

the nose would fool the sensors into believing that the target was actually higher in the sky than it was.

In fact, it's probably not even necessary to build real rockets with real warheads. Decoys can be used just as well.

The decoys could take the form of rockets with dummy upper stages and no warhead, which would save a considerable amount of money. Alternatively, dummy's could be deployed from the bus as soon as the rocket was outside the atmosphere. This would work much the same way as the "chaff" used during World War 2 to blind German radar to the presence of British bombers.

Another cheap and unsophisticated ploy: jam the command systems. There has to be some way for workers on the ground to interpret data from the satellites signifying that an attack is under way. These workers then have to have some way of ordering the satellites to initiate their defence.

If you can disable the communications flow, you have disabled the satellites. Electronic warfare, jamming and counter jamming electronic communications, is one of the more arcane of military arts, but it is reasonably well understood by its practitioners. It's not particularly expensive, or difficult.

Another way of stressing the defence system would be to alter the physical characteristics of the rockets themselves. There has been a trend in recent years towards building rockets with much reduced boost times. One may expect that the existence of Starwars will lead to increased effort in this area. With such a system the destruction window will effectively shrink from 120 seconds down to perhaps tens of seconds.

This all presupposes the ultimate implausibility, that the Soviet Union would not attempt to attack the laser satellites themselves. Once you bring such a factor into the equation, you really are right back at the beginning of the spiral. All the same considerations that led to the arms race in the first place will apply in space. The only difference will be the price.

And, of course, all of this presupposes that the system will actually work as required. Remember that you can't really test a system like this. The Russians, after all, are unlikely to stage a mock launch of a thousand or so missiles just to test the Yankee defences. When it happens it happens for real.

The problem with Starwars is that it is an attempt to find a technological fix for a human dilemma. There is no technological fix. The world will only become a safer place when arms control talks lead to disarmament. Don't hold your breath. ●





# "SO WHAT'S NEW IN CRS?"

...THE ANSWER IS IN THE PALM OF YOUR HAND

Now you don't have to leave your communications behind when you leave your vehicle. The ICOM IC-40 is a compact 40 channel UHF CRS field proven hand held, with optional 3 Watts output power, the same as many mobile radios.

The IC-40 is perfect for jobs on the land, water or business.

Contact your local dealer for a demonstration of the most advanced CRS portable available in Australia.

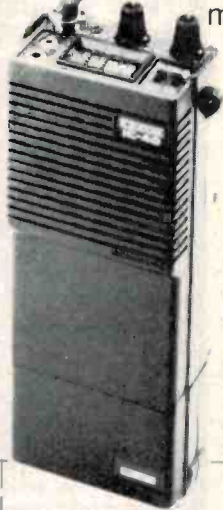

Please post to:

ICOM AUSTRALIA PTY. LTD.  
7 DUKE STREET WINDSOR 3182.  
VICTORIA.

Name \_\_\_\_\_

Address \_\_\_\_\_

City \_\_\_\_\_ Postcode \_\_\_\_\_

or phone ICOM on (03) 51 2284



## ICOM

### The World System

IC0012

## MINI MART

### AUDIO

FOR SALE: B & W DM70 monitor speakers, recently recond. woofers and electrostatic panels. These speakers sound like a \$3000 pair. Sacrifice \$920 offers. (02)869-1840.

### COMMUNICATIONS

FOR SALE: SCANNER LISTING of Australian civil/military VHF/UHF aeronautical frequencies, approx. 500 sorted freq/location/service format. \$5 D. Vale VK3CDI QTHR PO Box 2395 Mildura Vic. 3500.

### COMPUTERS

FOR SALE: MICROBEE Wordbee, wordprocessor on ROM \$15. Microbee Pascal on ROM \$20. All manuals included. Ian, 12 Saligna Way, Macquarie Fields, NSW 2564. (02)605-5323, after 4 pm.

FOR SALE: THE RARE AY-3-8500 and AY-3-8760 game chips. Open to offers. Write to R. J. Heaton, 32 Begonia Ave, Bayswater, Vic 3153 with an offer and address. Will reply if deal made.

FOR SALE: SYSTEM 80 with modifications, monitor, GP-80 printer and joystick. 18 books and 36 programs on tape. Value \$2500 asking \$800. (02)59-1067.

FOR SALE: \$100 CARD FRAME and mother board 10 slot fitted with 5 connectors \$100. Two \$100 prototype boards 1 used, \$30 for 2. \$100 extender board \$30 SA400 5 1/4" disk drive \$100. Two Friden Flexowriter teleprinters \$30 each. Cheltenham Vic (03)584-4749.

FOR SALE: TECHNICO TMS9900 microcomputer board 16-bit, 2K RAM, assembler and documentation \$200 ono. Michael Cvetanovski, 9 Main Rd, Cardiff Hts, NSW 2285. (049)54-8135.

FOR SALE: MICROBEE 32K with 4 MHz mod. Green screen monitor, cassette, dot matrix printer (with cable and paper), light pen, cassette and ROM based software (with carry case). All manuals supplied. Exc. condition. All for \$790 ono. Simon 8 am-12 pm on (02)99-2357.

FOR SALE: VZ200 SOFTWARE. Excellent ext BASIC for 25 more commands. Utilities, protect, monitor-debugger, educational. VZDTR, RAM packs. SASE to J. D'Alton, 39 Agnes St, Toowoomba, Qld 4066. (07)371-3707.

FOR SALE: CROSSWORD GENERATOR, Crosslotto Analysis, Race, Handicapper. Tapes for TRS-80 model I, SEGA 3000 \$15 ea. Listing for all other computers \$10. G. Egel, 18 Sturt St, Loxton, SA.

FOR SALE: \$100 COMPUTER. 5 cards (1-VDU, 1-DGZ80 + 3 memory) plus M/board with on-board power supply. Any offer considered. Ph Tony b.h. (089)81-8499 a.h. (089)27-5539.

FOR SALE: MEMORY CHIPS. 2102LIPC 20 off \$2 ea, 2114LP3 100 off \$2.50 ea, 6116P3 or LP3 100 \$5.50 ea, 2708 \$4 ea, 2716 \$6 ea. Mr J. Wicks, (03)547-7787 7-9 pm only.

WANTED: ZX81 will pay up to \$20. Damien Barnard, 11 Raneagh St, Woodville, SA. (08)243-0466.

FOR SALE: SUPER 80 Assembler with full screen monitor on cassette \$16. Disassembler \$9. R. Vowels, 93 Park Drive, Parkville, Vic 3052.

FOR SALE: SINCLAIR ZX81 — 16K RAM, full size keyboard, green monitor, cassette recorder, plenty software, mags. Package \$350 ono. Will sell individually. (03)49-5587.

### VIDEO

FOR SALE: MOVIE PROJECTORS. Two identical 16 mm. Early Cinevox sound/silent, suit collector or restorer. One complete, working except amplifier, other disassembled. \$60 the lot. (02)660-3269.

### MISCELLANEOUS

FOR SALE: ONE Jaycar Hall effect breakerless triggering system. Includes instructions. \$16 post paid. P. Steffania, PO Box 411, Griffith, NSW 2680.

FOR SALE: 19" RACK FRAMES, removable mounting brackets, card guides, screws etc supplied. 3U \$15 ea, 6U \$20 ea. Mr J. Wicks (03)547-7787 7-9 pm only.

WANTED: TRIMAX pwr/trans TP2435 (Williamson amp), Trimax audio transf MS 860, A&R choke Z956, A&R pwr/trans 1783 (Mullard 5-20 amp) (03)669-4309 b.h. (03)387-1860 a.h.

FOR SALE: BUSINESS opportunity in tax-free Vanuatu for electronic technician. \$A98,000 negotiable for large building. No charge for goodwill and advice. Contact advertiser, Box 229 Port Vila.

FOR SALE: OSCILLOSCOPE BWD model 820 dual trace with probes unused, bandwidth 30 MHz. \$720. (02)449-6420.

FOR SALE: AWA DISTORTION and noise meter F242A, AWA ultra low distortion oscillator G233, \$2000. Phone Mike (02)868-2260.

FOR SALE: TEKTRONIX 524 oscilloscope, 10 MHz dual input, TV field line sync separator, mint condition \$400. (02)869-1840.

FOR SALE: TEKTRONIX/LAVOIE 545 oscilloscope. 30 MHz bw, dual channel, full delayed sweep, new crt, differential plug in. 4 plugs ins. Mint condition manuals. \$950 offers (02)869-1840.

• We'll publish up to 24 words free of charge for you. Copy must be with us by the first of the month preceding the month of issue. Please print or type advertisements clearly! Every effort will be made to publish all advertisements received; however, no responsibility for so doing is accepted or implied. We reserve the right to refuse advertisements considered unsuitable.

• Conditions: Your name and address plus phone number (if required) must be included with the 24 words. Reasonable abbreviations, such as 25 W RMS or 240 Vac, count as one word. Advertisements must be private and relate to electronics, audio, communications, computing, etc — general advertisements cannot be accepted. Send your advertisement to: ETI Mini-Mart, P.O. Box 227, Waterloo NSW 2017.



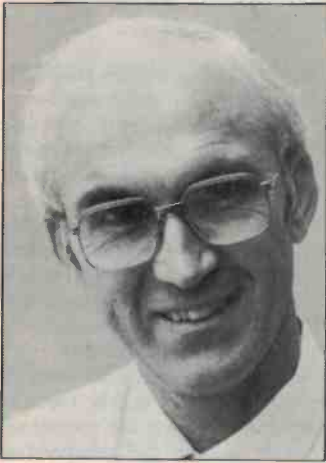

## Computer software, copying and protection

Jim Rowe

I SEE THAT BRITAIN'S parliament has been the latest forum for a debate on the thorny subject of computer software copyright. Apparently William Powell, a British Tory MP has introduced a Private Member's Bill aimed at making copying of software a criminal offence — with convicted offenders liable to either heavy fines or a jail sentence of up to two years. According to *New Scientist*, the Bill has the support of all parties, and is expected to become law by June.

Two of the UK's big software industry pressure groups are apparently champing at the bit to test the new law out. They've already chosen which 'pirates' they're going to use for the first test cases, and have made it clear these will be used as "an example to deter others". The jackboots are out of the cupboard, and polished ready for action.

What surprises me is that all of Britain's political parties are apparently giving the Bill their support. Whatever happened to the good old Pom tradition of defending the rights of all parties in a dispute? It all sounds like Germany in the 30s, not Britain in the 80s.

Don't get me wrong. I'm *not* saying that computer software is fair game, and that people should be able to copy it as much as they like. I know that a lot of hard work goes into producing good software, and that the people who produce it must be able to reap a fair return from their labour. You obviously can't let it be copied willy-nilly, particularly on a commercial basis.

What I am saying is that if anything could justify this kind of drastic legal action, it would be a situation where the issues were very simple and clear cut. And the plain fact of the matter is that when we're talking about computer software, the issues are anything but clear cut. In fact they can be very complicated indeed.

One of the best discussions of this I've read recently was a column by the American science fiction writer and columnist Jerry Pournelle, in last December's issue of

*Popular Computing*. If you can, try to read it, because he draws attention to a lot of the issues that the software industry isn't too keen to discuss. And not before time.

Things like the exorbitant cost and vastly overrated (if not lousy) performance of so much commercial software; the large amount of incredibly poor documentation; the way an awful lot of software is sold on a 'caveat emptor' basis, with no real warranty or guarantee that it will perform the stated job; and the way so many products are accompanied by all sorts of weird and unreasonable 'licence agreements', which at times seek to prevent the user from making even backup safety copies of working disks. In short, all of the tricks that software vendors have been using to rip off the customers, while at the same time crying crocodile tears at the way those nasty customers are robbing them through copying.

One of the important points that Pournelle makes about those unreasonable 'licence agreements' is that because they *are* so vendor-biased and unreasonable, they actually *discourage* honest and decent customers — the kind who do take their legal obligations seriously. As he points out, these people will read all the legal gobble-dygoon, realize that it gives them virtually no rights (and often commits them to an unreasonable sacrifice of normal freedoms), and decide not to buy the product concerned. In fact the only ones who *are* likely to buy it are the ones who ignore all the legal talk, and decide that they'll use the product exactly as they wish. That's precisely why copying is so rife.

It's also why quite a few software suppliers have gone to copy-protected disks, to try to make copying impossible. But this brings further problems. Often it makes the software less reliable, and prevents the user from making legitimate backup copies. It also acts as a challenge to bored software hackers, to see if they can 'crack' the protection system. And whatever the mind of one human eye can dream up to protect

something, the mind of another can generally dream up a way around it . . .

Frankly, I for one would *never* buy a piece of software which was copy-protected. This is because I regard copy protection as an admission that the vendor is charging a rip-off price and is dead scared that someone will latch on to his goldmine.

Quite rightly, Jerry Pournelle points out that the *real* answer to the copyright problem is not Draconian laws, prison sentences, weird and wonderful licensing agreements or fancy copy protection schemes. These only intensify the 'us-and-those-bastards' polarization between vendor and buyer.

The real answer is to bring down the price of software and improve its quality, so that it represents good value for money. And make it so that you can use it to do the desired job, reliably and easily. That's all.

It's happened with books and records, and it's gradually happening with videotapes of movies. When these things were overpriced and poor value for money, a lot of people had no compunction about copying them. But when the price is lowered, the copying stops. If you can own something and use it legally for a reasonable price, there's no incentive to steal it.

Videotapes are a very good example of this. While prices were at exorbitant over-\$100 prices, sales were very slow. People were obviously copying from movies on TV, or borrowing another VCR and copying from rental cassettes. But when one of the distributors tried putting out "Raiders of the Lost Ark" with a much more reasonable \$49 price tag, sales rocketed. I rest my case, your Honour!

Seriously though, it's commonsense we need in tackling computer software copying, not harsh laws and prison sentences. I believe the Poms are on entirely the wrong track, and I hope none of the Aussie polities try to bring in the same kind of law here.

**PROBLEM:** You are a Telecom linesman (stop crying, yer poor auld sod) and have to lay a multipair cable across a river. You have an off-sider, (nice kid, pity about the brains) and you tell him to twist all the pairs together so you can sort them out on the other side. The pairs are all the same colour, so you can't sort them out by sight.

You twist your pairs together and use a continuity tester to identify the pairs on the other end of the cable. Then you stick the kid and the cable drum in a boat and send them both to the other side.

Disaster. As the kid is getting out of the boat he is attacked by a mad bull crocodile. (This story was told to the Dregs Hack by a Territorian.) End of kid.

By dint of much shouting you manage to chase the croc away, and taking your life in your hands, you swim (quickly) across the river. You discover that not satisfied with spoiling the day for the kid, the crocodile has also savaged the cable drum, thus spoiling the day for you too. The drum is completely wrecked. Which wire is which! How can you sort out which wires are pairs? Indeed, can you sort out which pair is which?

You only have a continuity meter in your hand. The river is alive with crocodiles, so you want to go back and forth as little as possible. What would you do? How would you identify the wires?

**Scarecrows III**

Regular readers on this page will no doubt be aware that the Hack is obsessed with electronic scarecrows. Your editor, malevolent sod that he is, thus approached the cave where the Hack is tethered and threw in a small black object. "It's a scarecrow," he said. "Review it."

Now if there is one thing a red blooded journo likes it's being told to review things. Conjure up images of luxurious days on the harbour, free lunches in the Ritz, freebees galore, as some 'prominent business identity' tries to buy your favours.

Salivating slightly at the thought, the Hack approached this small black Thing and inspected it closely. It looked like the top of a hi-lighter pen with a battery in it. He picked it up gingerly; not heavy. He sniffed it and concluded the slightly fishy smell was more likely due to the remains of the calamari and chips he had for lunch than anything intrinsically fish-like in the scarecrow.

Images of days on the harbour began to fade.

He listened. Lo! The scarecrow sings! A high pitched squeal, almost beyond the limits of hearing, issued forth. "It scares away mosquitoes" said the editor, laughing as he strode off to pacify yet another advertiser. "Silly bugger's probably got a mosquito net" thought the Hack.

Well, the Hack is a true professional. Girding up his loins, (as it were) he went

home and installed the scarecrow in a prominent position over the matrimonial pit. And in due course he yawned, stretched, threw the cat out of the window and went to bed.

The scarecrow, vigilant as ever, whistled away up there in the ultrasonics.

Now, gently reader, consider some of the facts of life. Beyond the occasional whisper, giggle, and more suspicious noise, a bedroom is a pretty quiet place. In the normal course of events, dogs and cats, and even mosquitoes think it's pretty quiet too.

But on this particular night, was the bedroom quiet? Like hell! To every dog in the neighbourhood it sounded as if there was a siren in there. And mosquitoes? Well figure it out. When the female mosquito is on heat, she makes an ultrasonic buzz. So if

you were a male mosquito on this particular night, just cruising the neighbourhood, looking for a bit of blood to suck, and you happened to hear a sound like a million lady mossies all yelling for a bit on the side, what would you do? Too right!

At three thirty the love of the Hack's life made a major feminist statement about men in general and the Hack in particular and disappeared downstairs. At three forty-five the Hack worked out on which side his bread was buttered and followed her.

In the bedroom the mosquitoes buzzed, puzzled and no doubt, let down. Outside the dogs howled on, dodging the occasional bad tempered stone. On the lounge room floor, the Hack slept, at last. As a great Australian once said: "such is life". ●

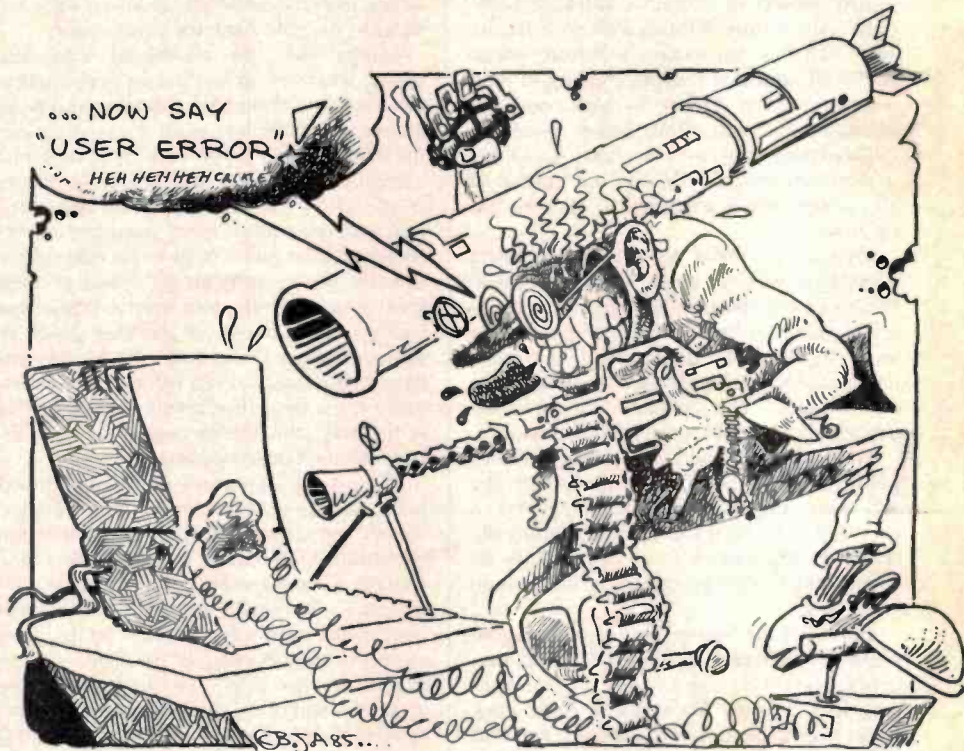

**Solution**

The key to the problem is the river. It is each end of the cable.  
 You begin by selecting one wire, tagging it A and placing it in the water. The remaining wires can be paired at random and joined. Now go to the other side. Stick one end of the continuity meter in the water, and test the wires. When you get continuity you have found wire A. Now use the continuity meter to find the other pair. Select one of the conductors, tag it B and its mate  
 Return to the other side. Pull wire A out of the water, and test the pairs until you find continuity. Disconnect them and you can find B and C. Now use C in the same fashion to find D and E. Continue until you have identified them all.  
 Thanks to Max Sim of Box Hill North, Vic 3129 for this brain teaser.

C. Join A to B. Identify the next pair. Call them C and D. Join B to C. Carry on in this fashion until all the wires are accounted for.  
 Return to the other side. Pull wire A out of the water, and test the pairs until you find continuity. Disconnect them and you can find B and C. Now use C in the same fashion to find D and E. Continue until you have identified them all.  
 Thanks to Max Sim of Box Hill North, Vic 3129 for this brain teaser.

# SPECIALISED SCOPE TOOLS for the Electronic Work Bench

CODE STS

CODE TC60

**PORTABLE SOLDERING STATION**  
with continuous adjustment of temperature

CODE SB2 (2mm wide)  
SB3 (3mm wide)

**SOLDER BLOTTER**  
That Avoids Burnt Fingers

**2 Metres** in windback dispenser

**FLUSHCUTTERS**

CODE 170 - 1  
175 - 1  
007S

with slice action and cushion grip handle for production use.

TILT ACTION

360° ROTATION

CODE 333

**INDEXING PCB HOLDER**  
rotates and locks in 32 positions.

FOR A FREE CATALOGUE  
SEND YOUR NAME AND ADDRESS TO:  
FREEPOST No.2  
SCOPE LABORATORIES  
P.O. BOX 63, NIDDRIE, VICTORIA, 3042  
AUSTRALIA  
No Stamp Required

**CONTACT  
YOUR NEAREST  
SCOPE RESELLER**

**N.S.W.**  
Avtek Electronics (02) 427 6688  
A E Baker & Co Pty Ltd (02) 621 0044 AA26788  
J Boomer & Co Pty Ltd (069) 21 4644  
Geo Brown (02) 519 5855  
Sheridon (02) 699 6912  
Martin De Launay Pty Ltd (02) 267 1055 AA26679

**S.A.**  
A.J.F. Electrical (08) 269 1244  
Gerard & Goodman Pty Ltd (08) 223 2222 AA 88983

**QLD.**  
Auslec-Austral (07) 262 2811 AA40418  
Delsound (07) 229 6155  
Dunlop IBC (07) 892 0011 AA41561  
Elphinstones Ltd (07) 52 0171 AA42503  
Haymans Electrical Pty Ltd (07) 369 8400 AA44311  
St Lucia Electronics (07) 52 7466 AA42883

**W.A.**  
Atkins Carlyle Ltd (09) 321 0101 AA93750  
Letco Trading Company (09) 387 4966 AA94396

**VIC.**  
The Australian School of Electronics Pty Ltd  
(03) 523 5622 AA30625  
Ballarat Electronics Supplies (053) 31 1947 AA37435  
Ellistronics Pty Ltd (03) 561 5844 AA37758  
Radio Parts Group (03) 329 7888 AA32980  
Teleparts Investments Pty Ltd (052) 21 7085  
McGraths Electronics (03) 347 1122 AA31001  
R.D. Irving (03) 489 8131

**TAS.**  
GHE Electronics (002) 34 2233 (003) 31 6533



# SIEMENS

## The better the drive, the smaller the disc

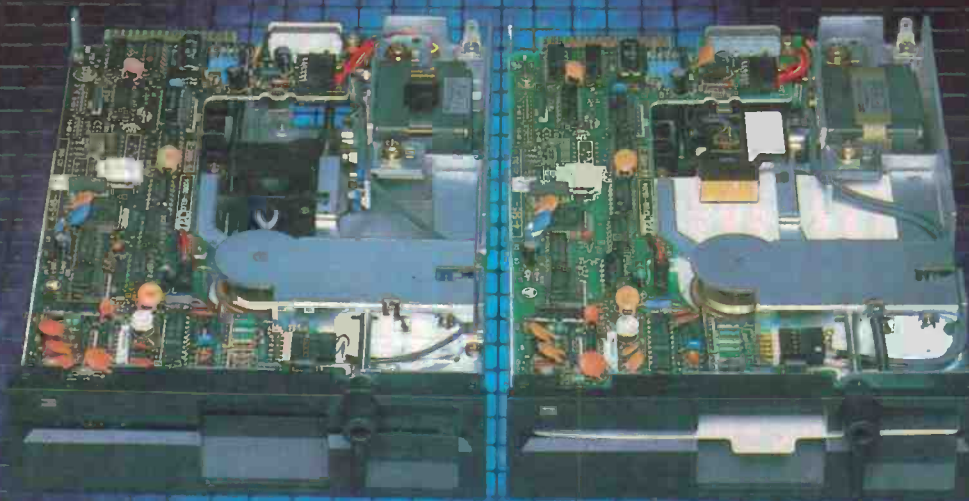

True half height 5 $\frac{1}{4}$ " floppy disc drives competitively priced from Siemens.

Designed for office electronics, business computers and OEM applications, this slim-line FB500 series has four versions with unformatted storage capacities from 250K to 1M bytes. Apart from compactness, these drives offer

fast access time by an advanced stepping motor and steel belt mechanism. The brushless direct drive DC motor is highly reliable and very quiet. The full range is now in stock together with Siemens relentless determination to provide complete service and technical assistance throughout Australia.

### Siemens Ltd.

544 Church Street, Richmond, Vic.  
Melbourne: 420 7318. Sydney: 436 8730.  
Brisbane: 369 9666. Perth: 362 0123.

### Distributors:

Auckland: Delphi Industries Limited. 567 258  
Adelaide: R.G. Pank Pty. Ltd. 51 2411  
Adelaide: Protronics Pty. Ltd. 212 3111  
Brisbane: ECO Electronics. 376 5677  
Melbourne: Promark Electronics Pty. Ltd. 878 1255  
Perth: Reserve Electronics. 328 9755  
Sydney: Promark Electronics Pty. Ltd. 439 6477

**Siemens. The discs may be flexible, but never our standards.**