

OCT. 1981

\$1.95\* NZ \$2.50

# eti

ELECTRONICS  
TODAY  
INTERNATIONAL

Win a ZX81  
COMPUTER

# SOLDERING

Getting it  
RIGHT!

LEARNERS'  
MICROCOMPUTER  
to build  
SERIES 5000  
STEREO  
PREAMP



CP/M explained  
JANDS 2x500W amp reviewed

# Cleans your heads twice a play.



At Maxell, we give you 25 centimetres of head cleaner at the start and finish of every tape we make.

It's right there on our leader.

Our leader also tells you which side of the tape you're playing, A or B.

And it also gives you a five second

cueing mark, so you can set your recording levels without wasting tape.

Then there is the tape itself. Maxell is recognised by most critics as the finest recording tape money can buy.

What else would you expect to follow our leader?

**maxell®**



# ELECTRONICS TODAY INTERNATIONAL

Registered by Australia Post—  
Publication No. NBP0407  
ISSN No. 0013-5216

THE FEDERAL BUDGET was brought down a week before I wrote this. In it, the Treasurer, Mr Howard, has sought to broaden the base of the Government's tax collection. Amongst a variety of other products, a 2½% tax has been slapped on books, magazines and newspapers. A veritable tempest of protest following the Parliament's budget session saw to it that the Bible was exempt — religious groups seeing it as a matter of principle. A host of other religious publications are to follow, it seems.

Electronics Today is hardly in the same category, but I think a protest against this tax should be raised too, as a matter of principle. Firstly, this magazine serves as a source of information and stimulation to electronics hobbyists. The hobby of electronics, and the industry that has evolved around it, exists because there is a group of people with enough personal motivation to pursue practical self-education in the subject. By the 'industry' that has grown up around the hobby, I mean the kit and component suppliers, magazine and book publishers. Our experience is that hobbyists' hunger for information is *insatiable*. If it were not, we would have folded long ago. Now, of the people pursuing a career in electronics, the majority owe their career choice to an early interest in electronics as a hobby. Many retain that interest, and the motivation it generates, for the rest of their life. There are *few industries* in which the workforce is so motivated.

This 2½% tax, paltry though it seems in individual circumstances — a few cents on the cover price of this magazine or on the books which we produce — is iniquitous because it is a tax on self-motivation and self-education. Self-education costs the state nothing, yet returns much. It is a tax on an inestimable resource, a resource of great value to this country because, for the size of Australia's population we have an inordinate number of people pursuing self-education in electronics. It is iniquitous because a tax, once introduced, has the nasty habit of increasing as time goes on. Australia, to keep pace with changing technology, needs a vital electronics industry fed by people interested in keeping pace with the changing technology, if not contributing to those changes. A tax such as this is a tax on a *vital* resource — self-motivated people. As the tax rises (as it surely will) so the cost of an interest in electronics will rise, dampening that essential motivation.

A pox on your tax, Mr. Howard.

Roger Harrison  
Editor



## QUICK INDEX

### FEATURES

- 7 Prestel Contract Awarded
- 14 The Flat Pocket TV
- 18 A Good Joint is Hard to Find
- 79 Amateurs Aid Aircraft Search
- 113 Win a ZX81!
- 162 Dregs

### PROJECTS & TECHNICAL

- 33 Series 5000 Preamp, Part 3
- 57 760: Video RF Modulator
- 63 147: Crystal Marker Generator
- 100 660: Learners' Microcomputer
- 159 Printed Circuit Artwork
- 76 Shoparound

### COMPUTING TODAY

- 83 The Home Computer Arrives!
- 87 Printout — News and Views
- 91 For Sorcerer Apprentices
- 100 660: Learners' Microcomputer
- 113 ZX81 Contest!
- 118 What is CP/M?
- 126 Shellsort Program

### SIGHT & SOUND

- 137 Stereo TV Arrives!
- 139 Sight & Sound News
- 146 Fosgate Car Sound Amp/Preamp
- 154 Jands J1000 CS Amplifier

### GENERAL

- 7 News Digest
- 52 Babani Books for Hobbyists
- 78 ARRL Books by Mail Order
- 160 Mini-Mart — Readers' Adverts
- 161 ETI Services

# advertisers

Adcola	30
Australia Government	150-151, 158
Applied Technology	84-85
Altronics	56
Archive Computers	97
Acoustic Foundry	17
Alfatron	104
All Electronic Components	49
AED	117
Audio Engineers	131
A & R Soanar	31, 129
BWD	111
Bishop Graphics	105
Bright Star Crystals	59
Best Vision	76
Boffin	74
Communications Power Inc	153
Consolidated Marketing	123, 124-125
Commodore	110
C.A.S.H. Computers	114
Computallor	86
Computer Country	74
Computerware	74
Cooper Tools	17
Cletronics	138
Calc. Comp. Disc.	74
Convoy	132, 145, 149, 157
Dick Smith	6, 13, 50-51, 60-61, 64-65, 75, 80-81, 92-93, 98, 123, 128
David Reid	69
Danish Hi-Fi	130
Direct Comp. Retail	117
Electronic Agencies	45
Ellistronics	62
ELSEMA	13
Emona	72
Electromark	68
Energy Control	104
Electromedical	120
Electrocraft	68
Electronic Concepts	133
Electronic Developments	72
Ferguson	112
Hagemeyer/IFC	163
Hitachi	134-135, 142-143
Jaycar	55, 77
Jensen	99
John F. Rose	89
Kitparts	104
Logic Shop	114
Looky Video	104
Moss	138
Microtrix	96
Magnetic Media	68
Micro80	82
Marantz	136
Maurice Chapman	72, 90
Multicore	25
McWilliams	144
Nutek	122
North Point Hi-fi	130
Nilson Rowe	129
N.V. Dale	152
Philips	11
Pre-Pak	73
Q.T. Computers	90
Raimar	149, 157
Radofin	164
Rod Irving	32, 109, 115, 116, 121
Radio Despatch	13
Rakon	120
Radio Parts	127
Sansui	9
Software Source	88
Shaeffer Pens	158
Semiconductor Imports	70
Sony	141
Scope	29
S.I. Microcomputers	96
Stolmack	138
TCT Micro	89
Warburton Frank	94



# ELECTRONICS TODAY INTERNATIONAL

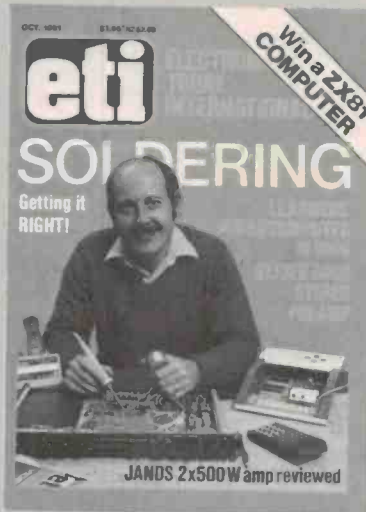

It is finished! David Tilbrook with his 'masterpiece' — the Series 5000 Stereo Control Preamp. On his left is the ETI-660 Learners' Microcomputer and in his hands are the 'tools of the trade' related to our feature article on soldering.

Cover design by Ali White.

\*Recommended retail price only.

# features

**THE FLAT POCKET TV** 14  
According to its UK producers, the slimline pocket TV "is here and is going into production". This article explains how it's done.

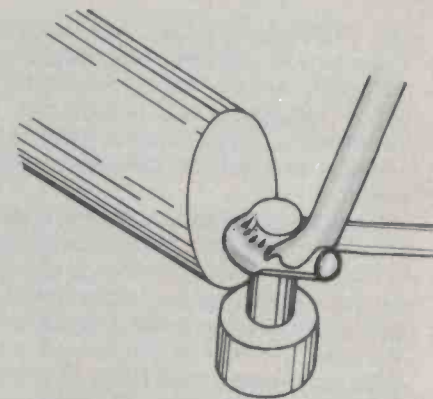

**A GOOD JOINT IS HARD TO FIND ...** 18  
This comprehensive article on all aspects of soldering should help you improve your soldering technique, tell a good joint from a bad one, and even how to desolder if you make a blunder.

# computing



**COMPUTING TODAY** 83  
A look at the ever-growing market of home computers, with particular scrutiny of the new Commodore VIC and the Atari 400.

**ZX81 CONTEST** 113  
Win a ZX81 for yourself in this simple competition.

# news

**NEWS DIGEST** 7  
Prestel videotex for Australia; Electric car tested; New Ion generators from Alronic; Electricity and heat from solar generator; etc.

**COMMUNICATIONS NEWS** 79  
Amateurs aid search for downed aircraft; QEX — new technical newsletter; etc.

**PRINTOUT** 87  
For Sorcerer apprentices; Bubble memory on cassettes; New range of Beehive terminals; Single-board Australian microcomputer; and more.

**SIGHT & SOUND** 137  
Stereo TV; Bang & Olufsen Beosystem 8000; Janzsen electrostatic speakers available; Noise reduction for car cassettes; etc.

## WHAT IS CP/M?

118

CP/M has been with us for some time now, and is quickly becoming a domestic computer standard — but few people actually know what it is. Phil Cohen explains.

## SHELLSORT

126

Whilst bubbles just drift along in a sort routine, the Shellsort really speeds things up — as much as five times.

## projects



## SERIES 5000 PREAMPLIFIER

33

In the third and final article on David Tilbrook's Series 5000 preamp he concentrates on the high-level switching, line and monitor amplifiers, muting and power supply, and completes the construction details.

## 760: VIDEO RF MODULATOR

57

This modulator, although designed to team with our ETI-660 Learners' Microcomputer, will find many applications in such things as video games, TV pattern generators, etc.

## 157: CRYSTAL MARKER GENERATOR

63

This simple but useful piece of test equipment can be used for calibrating and aligning receivers, transceivers and oscilloscopes.



## 660: LEARNERS' MICROCOMPUTER

100

With this long-awaited article we commence construction details of the microcomputer, which is built step by step and checked at each stage to ensure success.

## sight & sound



## FOSGATE AMPLIFIER PUNCH PR-250

146

The sound quality of FM radio and quality cassette players in cars has often been a disappointment, but according to Louis Challis this amplifier/equaliser system changes all that.

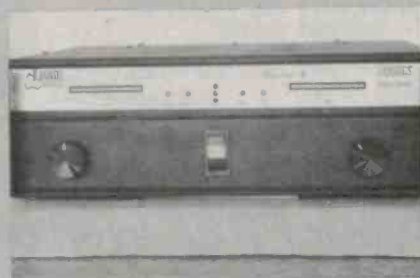

## JANDS J1000 CS AMPLIFIER

154

The Jands J1000 amp is really designed for live performance, but according to Louis Challis hi-fi enthusiasts would not be disappointed with it; he found that "it provides really excellent objective test results and we could not fault it".

## general

### ELECTRONICS BOOKS FROM ETI

52

Beginners' books, data books, circuit books, etc.

### SHOPAROUND

76

### ARRL BOOKS — DIRECT FROM ETI

78

### PC BOARDS

159

### MINI-MART

160

### ETI SERVICES

161

### DREGS

162

## next month

### ETI-660 LEARNERS' MICRO

Getting down to the nitty gritty of finishing the project to the B&W video/1K RAM stage and testing it, plus adding colour and full RAM. Test programs included.

### ETI-158 LOW OHMS METER

A useful and inexpensive instrument for testing pc board tracks, cable joints, setting up low value resistors made from wire, etc. Uses commonly available components.

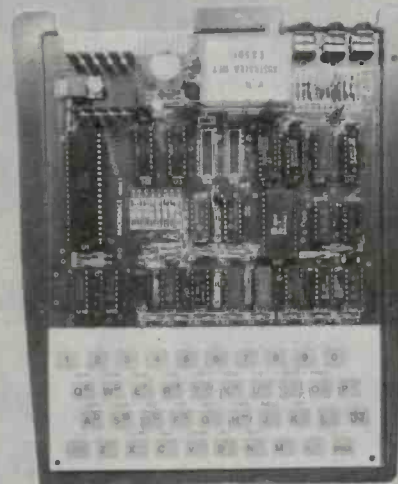

### MICROACE REVIEW

A review of this low-cost kit computer that turns up a few surprises amongst the 'no surprises'.

### HIGH PERFORMANCE AMPLIFIER DESIGN

A description of a 15/25 W bipolar audio amplifier design that achieves very good performance using commonly available transistors.

Although these articles are in an advanced state of preparation, circumstances may affect the final content. However, we will make every attempt to include all features mentioned here.

# Find out how easy it is to shop by mail order

Over the past years there have been many 'fly-by-night' mail order companies that have given mail orders a bad name. During the past 14 years there has been a mail order service with a difference. With over 62 000 satisfied customers & 200 000 mail orders despatched, Dick Smith Mail order dept. takes pride in giving the 'red carpet' treatment to all our valued customers. So here's the chance to take that first big step; why not phone in with your Bankcard no. or fill in the form below.

With a 24 hr. turn-around service & 14 day satisfaction guarantee (if not completely satisfied) - you can't go wrong. You'll quickly gain the confidence you may lack with many other mail order companies.

14 YEARS OF RELIABLE MAIL ORDER SERVICE

14 DAY SATISFACTION GUARANTEE

SHOP BY PHONE

OVER 200,000 SUCCESSFUL MAIL ORDERS

24 HOUR TURNAROUND



## DICK SMITH MAIL ORDER CENTRE



PO Box 321 North Ryde  
NSW, 2113.  
Australia. Ph. 888 3200

**FREE**

Fantastic full colour wall chart of the resistor & other colour codes.  
Invaluable to the amateur or pro.  
Limited quantity only with this mail order

Why not make this your first mail order & get your **FREE** wall chart

Delivery instructions

Heavy and bulky items cannot be sent by post.

- MAIL ORDER (see table bottom right)
- AIRMAIL (Add \$3 to P&P value)
- REGISTERED MAIL (\$2 extra)
- ROAD FREIGHT COMET (\$7 anywhere in Australia.)
- ROAD FREIGHT INSURANCE (\$1 per \$100 value, \$300 max.)
- AIRFREIGHT \$5.50 air envelope to 3kg, \$9.50 air Superpack to 10kg - to NZ & Papu New Guinea \$19.50 to 10kg.

Name \_\_\_\_\_

Address \_\_\_\_\_

Postcode \_\_\_\_\_

Have you bought by mail order from us before YES  NO

Cat. No	Qty	Description	\$	¢

### Postage & packing charges

ORDER VALUE	CHARGES
\$ 5 - \$9.99	\$1.20
\$ 10 - \$24.99	\$2.20
\$ 25 - \$49.99	\$3.30
\$ 50 - \$99.99	\$4.40
\$100 - or more	\$6.00

These rates are for goods sent by post in Australia only

### Check your mail order

Is the name & address clear?

Send to:  
**Dick Smith Electronics**  
PO Box 321 North Ryde  
NSW. 2113 Australia.



Crossed Cheque  Money Order

Bankcard No. 496. ....

Shipping/Packing

**TOTAL**

Signature .....

## Prestel service contract won by publishing group

The contract to market British Telecom's Prestel International videotex service has been won by Publishing and Broadcasting Ltd, a subsidiary of Consolidated Press Holdings.

**Videotex is an interactive communications system employing a terminal that accesses a central computer library of information via the telephone service and displays the information on a TV receiver (see Viewdata, ETI July '80, p.81).**

Head of the new Prestel division within Publishing and Broadcasting is Mr. Geoff Paxman, currently publisher of Australian Business, Australian Playboy and The Bulletin.

Prestel International has been operating on trial in Australia for the past year to nearly 30 corporate subscribers.

PBL won the Prestel tender in competition with 14 other local companies. The company intends to sell the service to members of the Australian business community with an interest in overseas markets. Royalties will be paid to PBL based on customer usage.

Subscribers will have access to information from an international data bank. PBL will seek subscribers throughout Australia and local companies who wish to provide information through the international videotex service. The service is aimed primarily at multinational companies including banks, travel companies and airlines.

Features of the service offered by Prestel include:

- Unlimited storage of information to augment needs of society in commerce, industry, trade and the home.
- Information from a wide range of independent sources.
- Transmission of information on standard telephone lines.

- Information displayed on screens of users by text, and graphics in colour.
- Users control what they want by a keypad — pages are received instantly.
- Information providers have full editorial control and determine price charged.
- Information can be easily and rapidly updated at any time by the information provider.
- Two-way communication permits goods to be ordered and messages to be sent to information providers.

With the simple touch of a button, thousands of people all over the world can simultaneously and instantaneously call up information which would normally take countless hours to find.

Information available in Prestel computers is in six categories.

- Finance: Exchange rates, money markets, stock markets, commodity prices and company results.
- Marketing: International and national trade statistics, names of commercial attaches, exhibitions, current research papers and names and addresses of suppliers and agents.
- News: International news, weather, future events, personalities and viewpoints.
- Travel: Airline timetables, fares, hotels and restaurants, tourist exchange rates, traveller briefings, entertainment and sport directories.
- Personal: Cost of living statistics, living abroad data, visa requirements, conferences, and business courses available.
- Fun: Demonstrations,



games, amusements.

Information is programmed into the computer by publishers and news organisations around the world.

News Corporation, which provided news and business information during the past year's trial of Prestel International, will continue to do so on the fully fledged service.

This is already available in the UK, US, West Germany, Sweden, Hong Kong, Holland and Switzerland.

The Prestel International service became operational in Australia from July 1. However, Telecom Australia has not yet received approval from the Minister for Communications, Ian Sinclair, to permit establishment of a domestic videotex information service.

Prestel was originally developed by British Telecom as a mass market information medium.

According to British Telecom, Prestel in the UK now has over 10 000 users, of whom almost 9500 are businesses. Travel agencies in particular

have made great use of Prestel, with over a third of Britain's travel agents said to use the system.

Prestel's UK customers have access to over 185 000 'pages' of information supplied by more than 500 independent organisations, with updated commodity prices and foreign exchange rates being two particularly well-used areas.

Telecom's deputy chairman, Mr Peter Benton, said that recent Prestel developments such as alpha-geometric graphics display capability and transform coding showed that Telecom was still "streets ahead of our foreign competitors". Alpha-geometric graphics display capability is achieved through geometric drawing techniques and gives higher definition. Transform coding enables the viewer to bring up full-colour still photographs to full quality on the TV screen.

The publishers of ETI, Murray Publishers Ltd, are an associated company of Consolidated Press Holdings, of which PBL is a subsidiary.

## Cheap equipment!

**Symbicon Associates of Nashua, New Hampshire USA, are at present offering new and used electronic equipment from many well-known manufacturers at significantly reduced prices.**

Equipment available includes pressure, temperature and proximity indicators, recorders, transducers, transient recorders, graphic plotters and terminals, wave analysers, oscilloscopes, plus thousands of other state-of-the-art devices. You can get the summer 1981 catalogue by writing to Symbicon Associates Inc, 17 Airport Rd, Nashua, New Hampshire 03063, USA. Telex: 953 059.

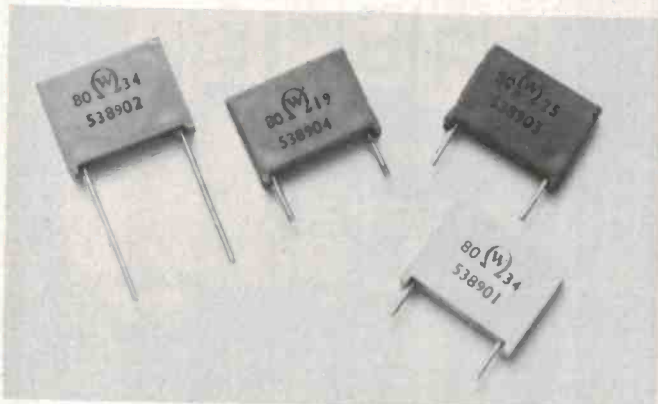

## Range of spark gaps from Welwyn

Spark gaps are generally used for the protection of expensive components in electronic circuits. The Welwyn series 5389 is designed to handle medium-energy discharges at relatively high voltages, particularly where cathode ray and video display tubes are used.

These Welwyn spark gaps are totally enclosed devices, but not hermetically sealed. This obviates contamination from dust, but allows the unit to remain at atmospheric pressure as the ambient temperature changes and also enables free gaseous ions to escape from the device.

Rated discharge voltages range from 7 to 12 kV, with maximum peak discharge current at 1.5 kA.

For further details contact Total Electronics, GPO Box 1286K, Melbourne Vic. 3001. (03)67-9306.

## Jaycar stock Weller and Xcelite

Jaycar now stock a large range of Weller soldering products and Xcelite quality servicing tools.



Among the lines stocked are:

- Weller EC2000 D fully adjustable electronically controlled soldering station, with variable temperature and LED display.
- Xcelite TC-200 S/T attache tool case — this is said to be a service technician's dream, with well over 40 useful service tools and room for more.

For further information on lines stocked contact Jaycar on (02)264-6688.

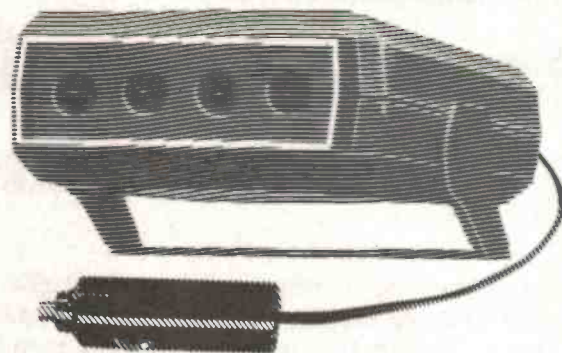

## New ion generators from Aironic

**Belle Lumiere have just extended their range of Australian-made Aironic negative ion generators to include a car model and a large high-powered wall-mounted unit.**

The car Aironic operates from 12 Vdc and can be used in restaurants, shops, computer rooms, darkrooms, etc, and contains a swivelling ball joint which enables the unit to be pointed in any direction required. The lead is plugged into the cigarette lighter socket, producing an output of between 5.75 kV to 7.25 kV, depending on the state of battery charge. This is said to produce liberal quantities of negative ions from the four emitters, and the effect is said to be marked, reducing both fatigue and reaction times.

The wall-mounted Aironic is designed for larger offices, restaurants, shops, computer rooms, darkrooms, etc, and contains a swivelling ball joint which enables the unit to be pointed in any direction required. The wall unit has an output of 7.25 kV on its five emitter pins.

For further information contact Belle Lumiere Pty Ltd, 79 Mars Rd, Lane Cove NSW 2066. (02)428-1334.

The wall-mounted Aironic is

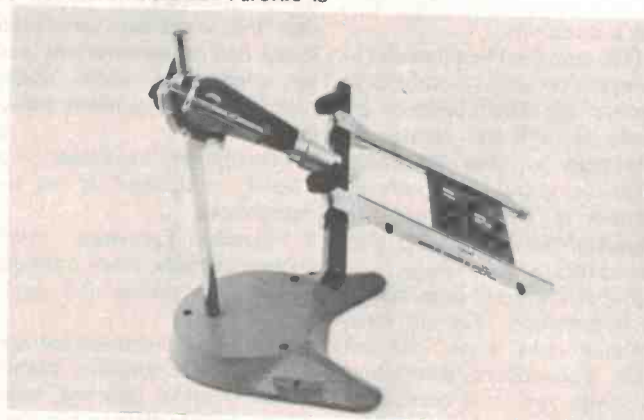

## Scope's new pcb holder

**Scope Laboratories have added a new tilt and turn circuit board work holder to their Panavise range — Model No. 333.**

The new work holder:

- rotates and locks in 45° increments
- tilts and locks at four angles — vertical, 45°, 90°, 120°
- offers 200 mm of vertical adjustment to the work height
- has a heavy cast-iron base with bench-mounting holes as option
- retains the quick load facility of spring mounted arms to hold the pcb
- offers cross bars to 750 mm for large or multiple board work using extra sets of arms.

Trade prices around \$60 complete are anticipated. For further details contact Ian Pittman, Scope Laboratories, 3 Walton St, Airport West, Vic. 3042. (03)338-1566.



# Q. Will wireless remote control and micro-computer memories reduce distortion by even 0.000001%?

## A. A flat no!

Q. Then why should I be interested in Sansui's memorable Super Compo?

A. Because distortion-free reproduction isn't an end in itself. Enjoying that reproduction is what Sansui's system is all about.

Keep in mind that all Super Compo units were specifically designed for "in-depth matching." That means specs which easily challenge or surpass those of comparable unmatched separates. Features include Quartz PLL digital synthesizer tuning, direct-drive turntable with computerized random 7-program track selection, metal tape compatible deck with AMPS (Automatic Music Program Search), stereo graphic equalizer, and a host of other features for the finest in fidelity.

Let's leave the superb specs aside for a moment. Let's be realistic. Isn't it nicer to just relax and select your music source without leaving your comfortable seat? Isn't it easier to pre-program the record selections you'd like our patent-

pending D-O-B arm to play? Just think of the time and nerves you save with 12 preset tuner stations activated by instant one-touch buttons — from your favorite listening chair.

We'll bet you'll be a happier audiophile with all these micro-computer conveniences. After all, fiddling with controls is surely second fiddle to delighting in the subtle nuances of a violin from Sansui's Super Compo 9900.



FR-D55: Computerized Track Sequence Selection Full Auto DD Turntable RS-7: Infrared Remote Control System RG-7: Stereo Graphic Equalizer Console with reverb/mixer T-9: Digital Quartz-PLL Synthesizer Tuner with 12 FM/AM Station Pre-sets and Auto Search Tuning A-9: Integrated DC-Servo Amplifier, 65W RMS x 2 D-300M: Full-logic Metal-Compatible Cassette Deck GX-95: Audio Cabinet with Headphone Jack S-65: 4-Way Speaker System 12 1/4" Woofer, 105W

**SUPERCOMPO 9900**

SANSUI ELECTRIC CO., LTD. 14-1 Izumi 2-chome, Suginami-ku, Tokyo 168, Japan  
VANFI (AUST.) PTY. LTD. 297 City Road, South Melbourne, Victoria 3205, Australia Tel: 690-6200  
283 Alfred Street, North Sydney, N.S.W. 2060, Australia. Tel: 929-0293

**Sansui**

## POWERMOS transistor family

Philips has introduced an extensive family of n-channel power MOSFETs with a voltage range from 50 to 1000 V and a current carrying capability up to 40 A.

Designated Pro-Electron types BUZ10 to BUZ84, the new Philips family of transistors will be known as POWERMOS.

Due to their construction, POWERMOS transistors are said to be intrinsically very fast, with turn-on and turn-off times of the order of 100 ns. POWERMOS transistors are also electrically and thermally rugged. Their extremely good safe operating area and thermal characteristics are claimed to enable devices to be paralleled without problems.

An important advantage of POWERMOS transistors is the low drive requirement. The

devices are LSI and micro-computer compatible; they can be driven from 5 V TTL or LSI output levels, or from micro-computer output ports.

It is expected that the 18 types so far released will cover the majority of currently known applications where the advantages of POWERMOS can be used. Extensions to the range will be made on the basis of market requirements.

Further information is available from Philips Electronic Components & Materials, 67 Mars Road, Lane Cove NSW 2066. (02)427-0888.



## Electricity and heat from solar energy

Sanyo Japan has announced the development of a new solar energy system that is capable of directly converting the sun's energy into electricity as well as accumulating its heat.

The 'Amorton Heat Pipe Solar Collector' is a hybrid solar collector on which amorphous silicon solar cells have been mounted. This single unit produces both heat and electricity simultaneously. The electricity produced by the process is used as a power source for the collector's circulating pumps in addition to powering home

appliances. The development of a heat-pipe glass tube collector in 1976 and an evacuated type in 1979 has led to this latest step.

Sanyo Japan is said to be placing high priority on the production of efficient solar energy to reduce dependence on the world's dwindling supply of fossil fuels.

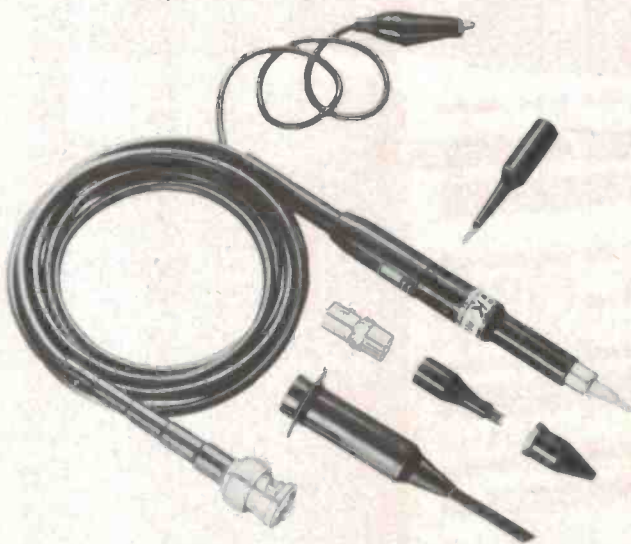

## Parameters provides probes

Two 100 MHz probes are now included at no extra cost with the popular Trio CS-1560A11 dual-trace triggered-sweep oscilloscope available from Parameters Pty Ltd.

Some of the CS-1560A11's features include:

- wide 15 MHz bandwidth
- excellent trigger capability — requires only a 0.5 division signal to 15 MHz, but will reliably trigger on larger signals to 27 MHz
- high sensitivity of 10 mV/division
- simple XY operation with matched amplifiers for easy Lissajous pattern testing.
- auto CHOP and ALT functions

- dc/dc power supply which eliminates power line fluctuation
- CH1, CH2, Dual, Add and Subtract nodes

The high-luminance screen produces a crisp, bright and clear trace throughout the full bandwidth and is constructed for long life.

For further information contact Parameters Pty Ltd, PO Box 573, Artarmon NSW 2064. (02)439-3288.

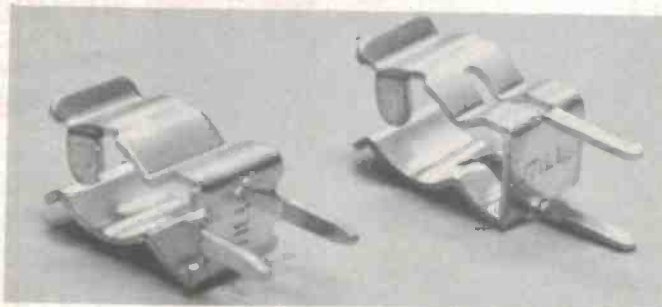

## Fuse clips

Two new pc board mounting fuse clips are now available from Utilux Pty Ltd, the Australian connector company.

Both styles are manufactured from electrotin plated brass and accommodate 3AG type fuses, the H3990 having terminals at right angles to the fuse axis and the H3991 with terminals in line with the fuse axis.

Both fuse clips are readily available and have been designed to withstand the most severe environmental and

mechanical conditions.

If required, the clips can be supplied to special order with platings other than tin.

For further information contact G. Bott, Marketing Services Manager, Utilux Pty Ltd, 14 Commercial Road, Kingsgrove NSW 2208. (02) 50-0155.

# Turn it **off** at the gate



# and turn **on** to a new world of power switching

Meet the 6.5A BTW58, the first in a range of unique power switches that use the new Philips gate-turn-off (GTO) technology. Like the thyristor and ASCR it can be turned ON at the gate. Unlike them it can be turned OFF at the gate as well. This means that when you use the BTW58 you get the fast easy-to-drive features of a bipolar transistor, with the added advantage that it can be directly driven by an IC. AND the usual high blocking voltage and high overcurrent capability of a thyristor.

It means that you open the door to a whole new world of fast power switching. A world where you can forget about commutation circuits, where a simple fuse gives you full device protection, where gate currents are low and where switching times are a fraction of a microsecond ..... a world where a dynamic  $dV/dT$  capability of  $1000 V/\mu s$  is commonplace and where device ruggedness isn't limited by SOAR curves.

Send for full data on this unique device, the first in the Philips range of GTO power switches.

For more information phone:  
**Sydney 427 0888 Melbourne 544 2444 Brisbane 44 0191**  
**Adelaide 45 0211 Perth 277 4199** or write to **Philips Electronic Components and Materials P.O. Box 50, Lane Cove, N.S.W. 2066.**

	BTW58-1500R	BTW58-1300R	BTW58-1000R	
Max. repetitive peak off-stage voltage	1500	1300	1000	V
Max. working peak on-state current	6.5	6.5	6.5	A
Max. non-repetitive peak on-state current	50	50	50	A
Max. controllable anode current	25	25	25	A
Typical turn-off time at a gain of 5	0.5	0.5	0.5	$\mu s$
Min. trigger requirements:				
Voltage	1.5	1.5	1.5	V
Current	120	120	300	mA



Electronic  
Components  
and Materials

# PHILIPS

## 3M antistatic measures

**3M Australia has introduced static shielding bags which protect printed circuit boards against known forms of static, but which are transparent to allow the contents to be examined without risking static damage by removal.**

The bag is a laminate material comprising an inner surface of antistatic polythene bonded to a coating of tough dielectric polyester. A vapour coating of nickel on the outside forms a conductive layer to produce a Faraday cage effect around the bag, and unlike aluminium coatings it cannot be reduced by corrosion.

static dissipative material for workbench or floor mats which is volume conductive, with a resistance to ground of about  $10^9$  ohms, a much higher figure than conductive mats. The high surface tension of the 3M material will not affect normal readings when used as a bench mat for testing a pc board, unlike conductive mats, which can affect resistance readings.

3M has also introduced a



## Electric car tested

**The South East Queensland Electricity Board's electric-powered Daihatsu Charade has passed the first official electric vehicle road tests, held in Surfers Paradise, with encouraging results.**

The Charade was fitted with a fifth wheel, which measured speed and distance, and an additional 68 kg of instruments, including an auxiliary battery and a multi-pen chart recorder. This weight, plus the driver, made up the equivalent of the weight of two people — the Charade's seating capacity. SEQEB were particularly interested to see how the Charade's performance compared with that of Daihatsu's four-seater electric van.

The Charade's performance was found to be "significantly better" than other electric vehicles under the same test conditions, which included two trips from Brisbane to Surfers

Paradise, once at 60 kph and once at 70 kph (on a single charge), and a stringent stop/start test designed to simulate the worst city driving conditions.

The Charade performed 80% better than the van on the 60 kph trip and 60% better at 70 kph, and even in the stop/start test had a range of 27-29 km.

The car also showed very good stability during cornering and had better road-holding capability than many petrol-driven SEQEB service vehicles.

The Charade is now being evaluated by SEQEB for in-service operation in several districts.

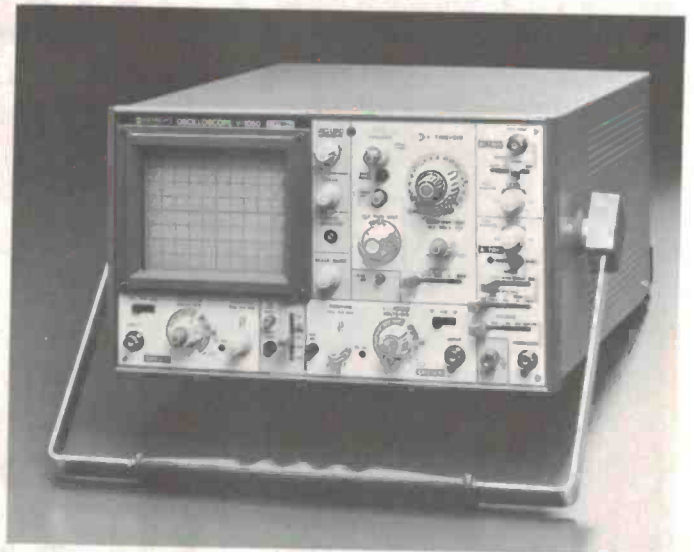

## New 100 MHz Hitachi oscilloscope

**Standard Components have added the V1050, a new 100 MHz Quad sweep oscilloscope, to their line of Hitachi models.**

The V1050 has four modes of Quad trace operation, and is said to have high sensitivity and calibration accuracy. Maximum sweep rate on x10 magnification is given as 2 ns/div, and horizontal accuracy as better than  $\pm 2\%$ .

The 15 cm CRT is equipped with an internal graticule and scale illumination, making it ideal for data photography.

For further information contact your nearest Standard Components dealer.

## General-purpose analogue multimeter

**An analogue multimeter for general-purpose professional use has been introduced by Philips Test and Measuring Instruments.**

The PM 2502 has 32 ranges, a high accuracy moving-coil meter movement, and is said to have high sensitivity with fool-proof overload protection, plus audible continuity test and linear ac readings.

Measuring ranges cover dc voltages from 100 mV to 1000 V full-scale, ac voltages from 1 V to 600 V, dc and ac currents from 100  $\mu$ A to 10 A, and resistances from 0.5 ohms to 10 Mohms.

The PM 2502 is said to be easy to use, and runs on standard 9 V and 1.5 V batteries, providing an average lifetime of over a year.



Further information is available from Philips Test and Measuring Instruments in your capital city.

# RADIO DESPATCH SERVICE

869 George Street,  
Sydney, NSW. 2000.  
(Near Harris Street)  
Phone 211-0816, 211-0191.

**FOR ALL YOUR  
SOLDERING WORK**

### ADCOLA

\$30 s/Iron 12 watt 240 V standard.....	\$15.80
\$50 s/Iron 16 watt 240 V standard.....	\$17.10
\$65 s/Iron 21 watt 240 V standard.....	\$18.30
D30 s/Iron 21 watt 240 V Duo-Temp.....	\$22.20
D50 s/Iron 30 watt 240 V Duo-Temp.....	\$23.75
T30 s/Iron 40 watt 240 V Thematic.....	\$43.10
T50 s/Iron 60 watt 240 V Thematic.....	\$43.70

TIPS, ELEMENTS, AND ACCESSORIES AVAILABLE

### LOTRING

3212 s/Iron 30 watt 240 V.....	\$13.55
4410 s/Iron 50/75 watt 240 V.....	\$13.55

SPARE TIPS AND ELEMENTS AVAILABLE

### WELLER

WTCPN s/Iron station unit 240 V.....	\$65.00
WC100DPK s/Iron cordless kit.....	\$34.75
8100DPK instant heat gunkit.....	\$26.17
TCPI s/Iron 12-14 V.....	\$36.35
SP125D s/Iron 25 watt 240 V Industrial type.....	\$18.84
SP140D s/Iron 40 watt 240 V Industrial type.....	\$20.43

LARGE RANGE OF TIPS, ELEMENTS, ETC. CARRIED

### MICO

4V/10 watt mini Iron DC.....	\$11.50
6V/10 watt standard Iron DC.....	\$10.99
12V/10 watt standard Iron DC.....	\$9.25

TRANSFORMERS, TIPS, ELEMENTS, ETC. AVAILABLE

### SCOPE

Superspeed deluxe s/Iron.....	\$21.45
Transformers to suit.....	\$21.42

PARTS AND ACCESSORIES AVAILABLE

### DE-SOLDERING TOOLS

#### SOLDA PULLT

DS017 deluxe model.....	\$18.95
US140 universal model.....	\$12.00
US240 micro tip model.....	\$14.80
PT309 long tip model.....	\$19.95
PT409 low static model.....	\$19.98

REPLACEMENT TIPS AVAILABLE

#### SOLDERING SPECIALS

ALTRONIC s/Iron stand.....	\$5.50
60/40 solder 0.8 mm X 250 gm roll.....	\$6.45
SAVBIT solder 1.25 mm X 250 gm roll.....	\$6.45
SERVISOL Solda-Mop heavy gauge.....	\$1.10 ea.
SERVISOL Solda-Mop light gauge.....	\$0.90 ea.
GOOT SM 2 De-Solder wick dispenser.....	\$2.10 ea.

DE-SOLDERING WICK SIZES 1-5 AVAILABLE

### MAIL ORDER CUSTOMERS

Packing.....	\$1.00
Minimum postage.....	\$1.00
Minimum interstate postage.....	\$1.50

OPEN: Mon-Fri 8 am to 5.30 pm.  
Thursday night late shopping until  
8.30 pm. Saturday 8 am to  
11.45 am.

# NEW ZEALAND CUSTOMERS!

## got your DICK SMITH catalogue?



If you haven't,  
you're missing  
the chance to  
make  
**BIG  
SAVINGS**  
on a wide range  
of electronic  
products.

Call or write for a copy.  
Only 75¢ plus 25¢  
postage.

**DICK SMITH  
Electronics**  
MAIL TO: Dick Smith  
Mail Order Centre  
98 Carlton Gore Rd.  
Newmarket Auckland, 1. NZ



## ELECTRONIC TECHNICIANS

We require the services of several electronic technicians to work in our Service Department at North Ryde. The work involves repair of an enormous variety of electronic equipment in our air conditioned workshops. Applicants should ideally possess the E&C certificate, have had several years experience in the industry and be able to work without supervision. Salary negotiable and generous staff benefits apply. If you think that you're the person that we need, please apply in writing to:

Gary Crapp  
Service Manager  
**DICK SMITH ELECTRONICS**  
P.O. Box 321, North Ryde  
N.S.W. 2113.



## 27 MHz RADIO CONTROLS

If you are looking for REMOTE CONTROLS for garage door controls, security systems, alarms etc.,

**TALK TO US FIRST!**

We are Australia's leading maker. Our range covers most of your requirements.

# ELSEMA

PTY. LTD.

73 Kootlingal Street,  
Greystanes, NSW. 2145.  
Phone (02) 636-3162

# The flat pocket TV — available soon?

The UK company Sinclair Radionics claims that the slimline pocket TV with the revolutionary miniature cathode ray tube "is here and is going into production". This article explains how it's done and further advances we can expect in the next few years.

THE pocket-sized computer system is now very close to being realised with the development of a new visual display unit which consumes little power and is roughly the size of a pocket calculator. It is now possible to construct a pocket computer with printer, central processor unit, visual display, and print-

out on photo-sensitive paper.

"The slim-line pocket TV is here and is going into production", says Clive Sinclair, founder and director of the small British company, Sinclair Radionics Ltd. The company, which is located in St. Ives, Huntingdon, has been responsible for developing pocket

calculators, small TVs, etc, and has now overcome the formidable problems of designing and producing a miniature (20 mm thick) cathode ray tube (CRT).

A manufacturing plant is being set up in conjunction with a larger firm to produce a pocket TV/radio with a 75 mm diameter black and white screen. Mr.



Sinclair expects this to be available in early 1982, and he predicts that a colour version will be produced shortly afterwards. Owing to the radical design of the flat CRT, the brightness of the screen is three times that of the conventional CRT. This makes it ideal for use in projection TVs with up to 1250 mm diameter wall-mounted screens.

A great deal of energy and money has been spent over the last decade to produce a miniature VDU which consumes low power. The announcement by Sinclair of a flat CRT, where the electron gun is mounted to the side of the screen, is a breakthrough because the development of a low cost solid state device still seems years away. It is certainly possible to construct a complete screen from individual LEDs or liquid crystal elements, but the cost of manufacturing such a matrix and the complex circuitry needed to control it is prohibitive at the moment. In addition, such a system would inevitably give poor visual definition and if liquid crystal displays were used the contrast would be unsatisfactory.

### Lateral thinking

The Sinclair CRT is shown in Figure 1. It measures 150 x 50 x 20 mm and is half the volume, three times as bright and consumes one quarter to one tenth the power of a conventional CRT of the same screen size. The device is constructed from a fairly conventional electron gun, collimator, and vertical and horizontal electrostatic deflection plates mounted at the side with the axis parallel to the phosphor screen. A positive electrode behind the screen and a negative electrode inside the front face cause electrons to be deflected towards the screen. The negative electrode at the front is made of a tin oxide coating which is transparent to light. The vacuum enclosure is made of glass and a plastic Fresnel lens is mounted outside the front surface.

Although the design concept is very simple, the fact that the electron beam does not strike the screen at right angles means that one or two tricks are needed to produce images which are well-defined and undistorted. First of all, good definition of a picture requires that the electron beam spot should be circular and as small as possible. The situation without the electrostatic field is shown in Figure 2a. It can be seen that at point A the angle of incidence is greater than at point B, so that the beam spot is much less elliptical here. Figure 2b shows the situation when an electrostatic field is applied. The angle of incidence is constant across the screen and the spot is therefore of constant size.

Achieving an undistorted image is difficult because the distance from the

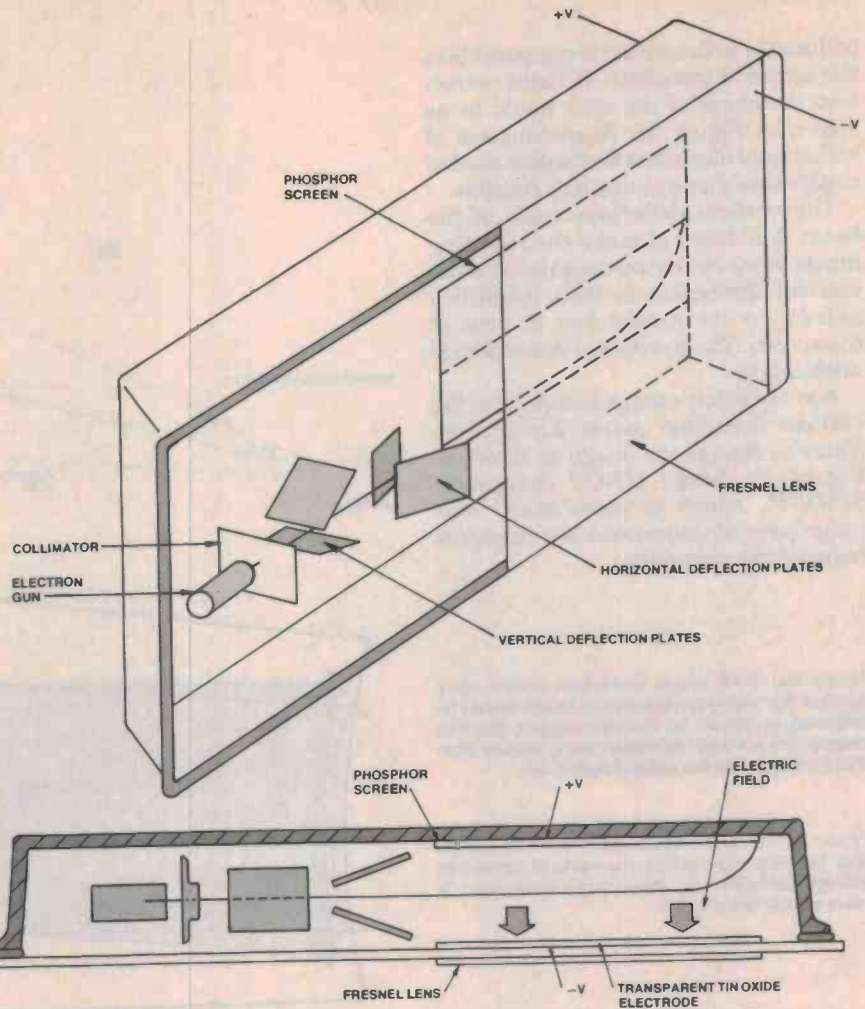

Figure 1. General construction (simplified) of the Sinclair miniature flat screen picture tube (see also picture over the page).

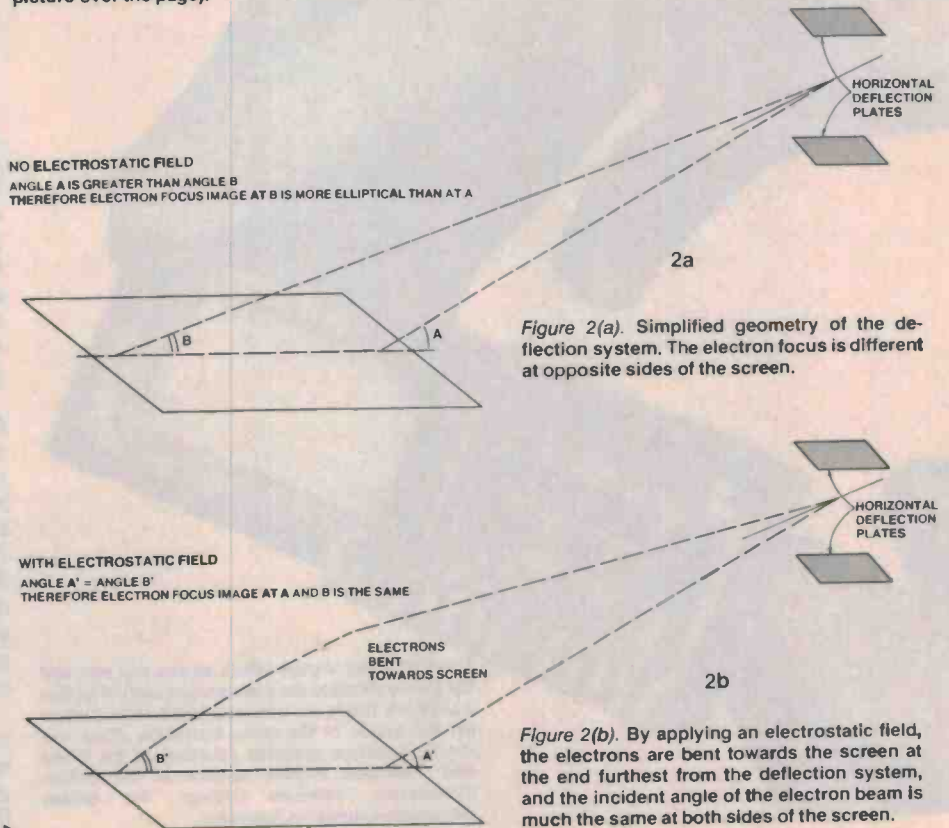

Figure 2(a). Simplified geometry of the deflection system. The electron focus is different at opposite sides of the screen.

Figure 2(b). By applying an electrostatic field, the electrons are bent towards the screen at the end furthest from the deflection system, and the incident angle of the electron beam is much the same at both sides of the screen.

collimator to the screen is comparable to the screen dimensions. Without correction the shape of the scan would be as shown in Figure 3a. A combination of optical and electronic methods is used to rectify this shape as much as possible.

The vertical deflection angle of the beam is reduced to make the resulting image more nearly rectangular and the vertical dimension is then magnified optically by the Fresnel lens in front of the screen. The horizontal dimension is unchanged.

A modulation voltage is applied to the vertical deflection plates during each frame to change the image as shown in Figure 3b. Image MNOP changes to M'N'O'P', which is more nearly rectangular and distortions are therefore reduced to a minimum.

Figure 3(a). If no image correction system were applied the normally rectangular image would be distorted as shown on the top diagram, the side nearest the vertical deflection being shorter than that furthest from the vertical deflection.

Figure 3(b). By both reducing the deflection angle and suitably modulating the vertical deflection voltage waveform an image is produced that is more nearly rectangular.

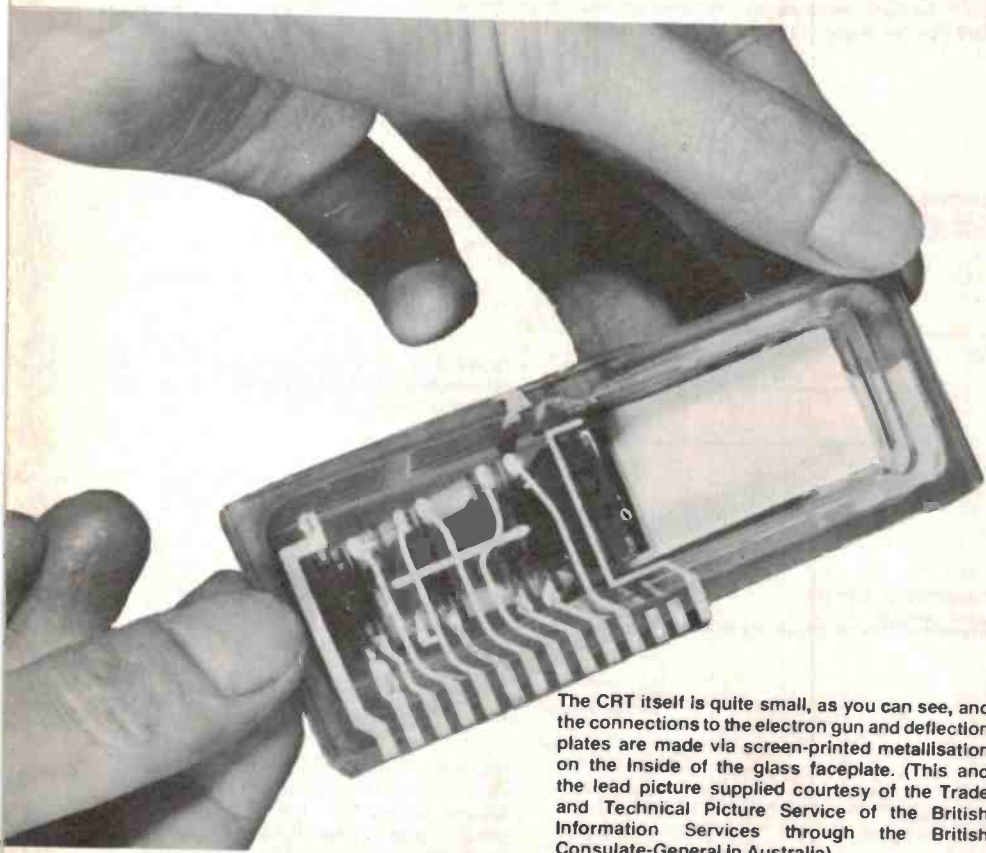
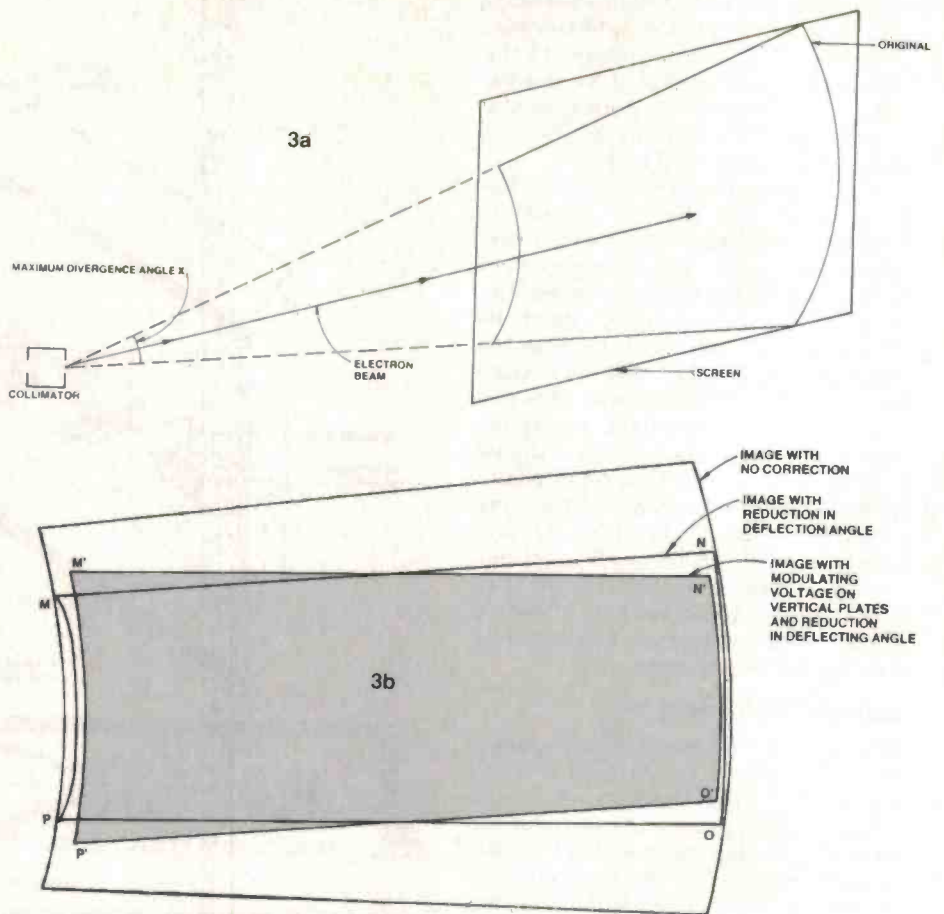

The CRT itself is quite small, as you can see, and the connections to the electron gun and deflection plates are made via screen-printed metallisation on the inside of the glass faceplate. (This and the lead picture supplied courtesy of the Trade and Technical Picture Service of the British Information Services through the British Consulate-General in Australia).

### Design advantages

Mr. Sinclair points out that the construction of the CRT lends itself to mass production technology in that, for example, connections to the electron gun and deflection assembly are screen-printed on the inside of the faceplate and the assembly is attached in a single operation by means of a conductive frit.

The feature that makes the CRT ideal for projection TV is that the image is viewed from the side of the phosphor that the electrons strike. This results in a much brighter image in comparison to the conventional CRT where the image is observed *through* the phosphor layer. It can be seen that a heatsink placed directly on the backing plate of the screen allows the phosphor to be driven much harder by the electron beam without thermal damage.

In the future the miniature CRT could well be used in pocket oscilloscopes and other test equipment once the techniques of obtaining perfectly distortion-free images are mastered.



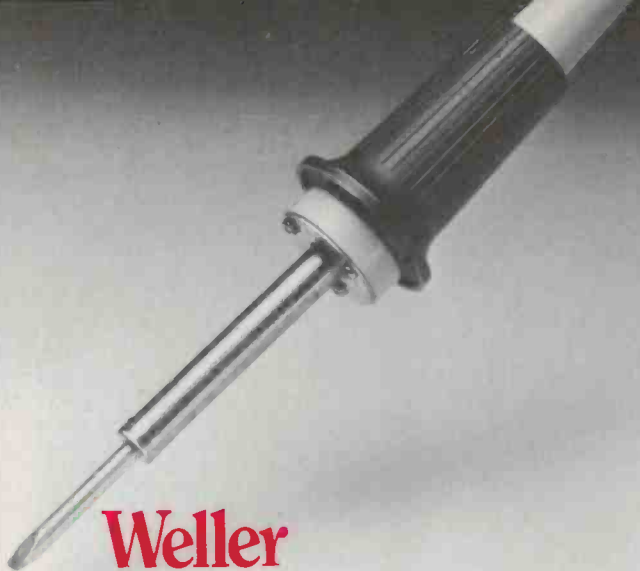

**Weller**



**Weller**

# The Tools. from Cooper The Toolmaker.

Weller industrial SPI non-temperature controlled line voltage soldering irons, with iron plated copper tips, stainless steel barrels. Impact and heat resistant handles are lightweight.

Available as SPI25D 25 watt or SPI40D 40 watt irons.

The Weller WTCPN soldering station is temperature controlled and combines high volume capability with precision performance. The low voltage TC201 soldering pencil employs the exclusive "closed" loop method to control maximum temperature and protect sensitive components.



**Lufkin**

Official Supplier of  
Measuring Tapes to the  
XII Commonwealth Games  
in Australia 1982.



**The Cooper Group**

CRESCENT-LUFKIN-NICHOLSON-PLUMB  
WELLER-WISS-XCELITE

The Cooper Tool Group Limited  
P.O. Box 366, Nungong Street  
Albury NSW 2640, Australia  
Tel: 215518 Telex: 56695

# Forging new frontiers in speaker performance

## Richard Allan

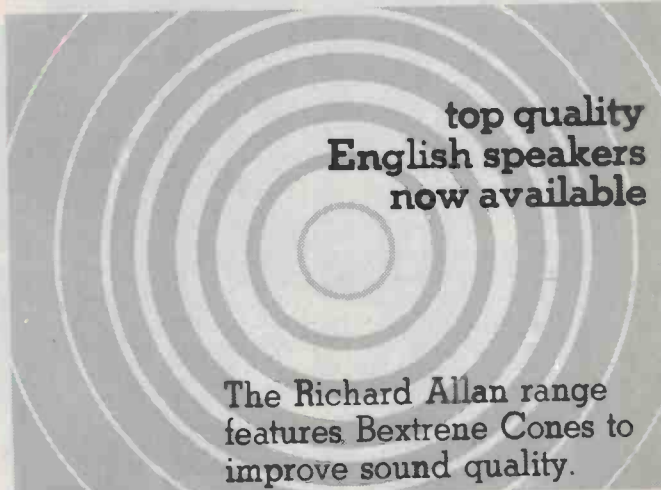

top quality  
**English speakers**  
now available

The Richard Allan range  
features Bextrene Cones to  
improve sound quality.

Now available DT20, DT30, LP5B, LP8B,  
HP8B, FB8, HP10B, CG12L, CG12, Super  
HP12B, HP12B Super.

Professional advice on all facets of speaker  
design and construction available.  
Come and inspect our unique  
experimental speaker design  
facility.



# The ACOUSTIC FOUNDRY Hi Fi

56 King William Road, Goodwood 5034  
(08) 2710276.

-----  
Please forward me further details  
on Richard Allan speakers.  
(Trade enquiries also welcome).  
NAME .....  
ADDRESS .....  
.....  
POSTCODE .....

# A good joint is hard to find...



## Roger Harrison

So you thought you could make a good joint, eh? This article might show you a thing or two about how to recognise the good, the bad and the indifferent among soldered joints. If you make a blunder then you'll need to know how to desolder, and we cover that, too.

**SOLDERING IS** somewhat of an art and is essential to the successful construction of electronic circuits. The beginner particularly *must* learn to solder correctly to achieve success and avoid frustration.

Components are supported by a variety of methods and connections rely on the soldered joint. The solder is not meant to provide mechanical support.

### Solder

Solder is an alloy of tin and lead that melts at fairly low temperatures. A joint is made using solder as a filler and bonding agent. Soldering creates a continuous intimate contact between the solder and the metal surfaces by the mechanical interlocking of the solder with the irregular surface texture of the metals. This process is called 'wetting', as the solder flows onto and into the

metal surfaces. The wetting of the metal surface by the solder is important in making a joint electrically and mechanically sound.

All metals oxidise, or tarnish, on the surface as a result of being exposed to air. This prevents the solder from wetting the metal surface, resulting in a poor joint; 'flux' is used to remove tarnish. For electronic work this is composed of resin (sometimes spelt

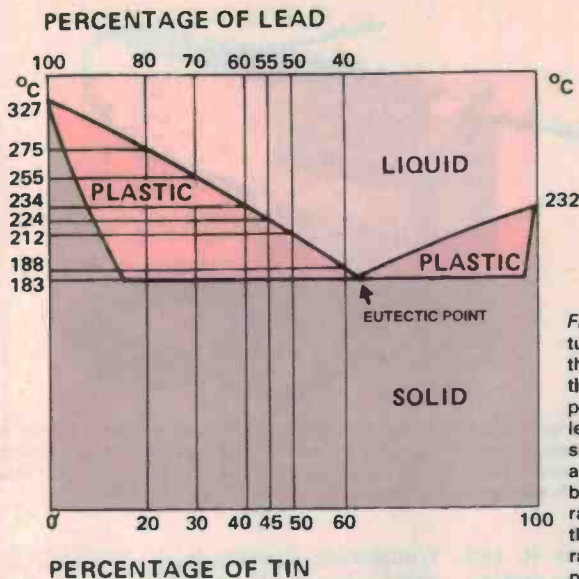

Figure 1. How the melting temperature and plastic range are affected by the relative percentages of lead and tin in a solder alloy. At the 'eutectic point', an alloy of 63% tin and 37% lead goes from the liquid to the solid state at 183°C without going through a plastic phase. This makes it very brittle, and different contraction rates of the parts of the joint cause the solder to fracture. A small plastic range, such as for 60/40 solder, prevents this.

rosin), which is obtained from the sap of pine trees plus additives called 'activators'. At soldering temperatures, the activators decompose, liberating an acid that dissolves the tarnish faster than pure rosin. Other fluxes are also made for non-electronic uses, usually sheet-metal work, copper and brass-ware manufacture. These fluxes are usually highly corrosive (such as hydrochloric acid) and must *never* be used for electronics work as even minute amounts rapidly corrode component leads and printed circuit board tracks.



Figure 2. Construction of a 5-core multicore solder. The flux cores are located near the surface so that they melt faster, giving rapid fluxing action.

Solder for electronics work is made as different gauge wires. Most have a resin core along their length, some have up to five separate cores.

The resin core melts before the solder and flows onto the joint, wetting both the joint and the solder, excluding the air. At the same time the activators dissolve the tarnish on the surface, allowing the solder to flow freely and properly wet the joint. When the solder melts, the increase in temperature deactivates the flux, limiting the possibility of corrosion. It is important to thoroughly heat activated resin during soldering to ensure the complete decomposition of the activators, otherwise they remain corrosive at normal temperatures.

A new flux for flux-cored solders has recently become available, called 'Xersin' (pronounced zersin). This is a chemically compounded flux containing no resin. Developed by Multicore Solders Ltd, it has characteristics very similar to resin at room temperature, melts at 90°C and produces a lot fewer fumes than ordinary resin fluxes when heated to soldering temperatures. The fumes of resin fluxes can cause bronchial irritation and, occasionally, allergic sensitivity in some people, if they work in a situation where the fumes do not readily escape. Xersin is claimed to overcome these problems. Xersin is a very heat-stable flux, claimed to be almost unchanged after a normal soldering process. Residues are virtually colourless, with a composition similar to the original material. Resin flux will lose about 50% of its weight in two minutes by fuming when applied to an iron at 330°C. Xersin will only lose about 15% of its weight in that time.

Resin-cored solder is obtainable in a variety of wire gauges. For general and heavy work, such as on sockets, chassis, switch contacts, etc, 16 gauge is suitable. For fine work on printed circuit boards, miniature components, etc, 20 or 22 gauge is best. It pays to have several different gauges handy. Experience will show which is the best under different circumstances.

As already mentioned, solder is an alloy of tin and lead. Tin melts at 327°C and is plastic down to 283°C. Lead melts at 232°C and is plastic from 183°C to 232°C. Either by itself is unsuitable as any movement of the joint while the soldering metal is in its plastic state will result in a faulty joint. An alloy of appropriate proportions has a plastic

state temperature range that is much smaller, and a lower melting point (see Figure 1). With a composition of 63% tin and 37% lead, the alloy has *no* plastic region. It goes from solid to liquid at exactly 183°C. This is undesirable as a small region of plasticity reduces brittleness under practical circumstances. The most common composition of solder for electronics work is therefore 60% tin — 40% lead, often called 60/40 solder. It melts at a temperature of 188°C and has a plastic range of about 5°C. It combines optimum strength with lowest electrical resistance. Another type of solder used in electronics work includes about 1.5% copper and is known under the trade name of Savbit. Soldering irons with copper tips corrode rapidly when used with straight 60/40 solder as some of the copper is absorbed into the molten solder. Savbit solder prevents this and can extend the life of copper bit soldering irons by up to ten times. Some soldering tools have iron-plated tips to reduce this sort of wear and the use of Savbit is not necessary with these irons.

Ordinary solders, such as 60/40 solder, are also referred to as 'soft solder'. Joints that have to withstand high temperatures, or that need greater mechanical strength than obtained with 60/40 solder, are joined with 'hard' solders that melt at higher temperatures. Hard solder contains either 30/70 or 20/80 tin-lead and melts at 255°C and 275°C respectively.

'Silver' solder, containing 5% tin/93.5% lead/1.5% silver, melts at about 300°C and is mostly used in fabricating brass or copper chassis, etc. Silver solder is usually melted with a gas-burning torch. A special flux is also used.

Low-temperature solder is also obtainable and is used where components may be damaged or where it is necessary to solder onto a joint that is already soldered without melting the existing joint. This has most applications in special servicing jobs. It consists of 50% tin/33% lead/17% cadmium and melts at 145°C. It requires care in soldering as it tends to fracture the instant it solidifies.

## Soldering irons

It is important to select a suitable soldering iron — after all, it will probably be the tool you use the most! A bewildering variety of types and sizes are available.

## Continuous heat irons

These are probably the most widely used despite a few drawbacks. They are heated by a wire resistance element located in the barrel just behind the tip. ▶



Figure 3. A popular continuous heat general purpose soldering iron, from Lotring. It has a heating element in the barrel and a tapered solid copper bit fits inside this, secured by a small grub screw at the end of the barrel. You can make your own bits for this sort of iron from copper rod.



Figure 4. A quick-heat iron, Scope Lab's 'Mini Scope'. It operates from a 3 V/30 A transformer and is rated at 20-75 watts. Pressing the bar puts a carbon element against the tip, rapidly heating the element and the tip. This sort of iron is very useful for desoldering applications using solder 'wick'.

The most suitable rating for electronics work is between 15 and 30 watts. Tools below this rating generally do not have sufficient heat capacity, while those above have high tip temperatures that can result in damaged components and poor joints. Irons of the continuous heat type that have ratings above 80 watts are best for sheet metal work. Irons advertised as 'universal' (mostly having a rating of 40 or 50 watts) should be avoided as they are usually too bulky for electronics work, particularly on printed circuit boards, and have too much heat capacity and high tip temperatures with the likelihood of component damage. The handle also usually gets too hot for comfort.

Choose an iron which is comfortable to hold. As well as being light, the iron should preferably have a lightweight power cord to reduce drag on your wrist when moving the iron around. The length of the cord should be adequate — about 1.5 m to 2 m is a good length.

Continuous heat irons are slow to heat to soldering temperature — they are usually left running continuously. This causes tip oxidation which therefore requires constant maintenance and fairly frequent replacement. These are minor drawbacks, however, if you cannot afford a more expensive iron.

Some irons of this type are obtainable with a temperature select switch in the handle. This usually doubles the power when needed to provide sufficient heat to make the occasional heavy joint. They are normally used on the lower power position for routine soldering.

### Quick heat irons

These irons operate from a low voltage at a high current, usually supplied from a transformer, and take only a few seconds to reach soldering temperature. They take only a few more seconds to reach red heat if the operating button is held on too long!

Quick heat irons are made in two basic styles — the soldering gun and the low-voltage iron.

Soldering guns have a transformer mounted in the handle that passes about 50 amps at 0.5 volts through a short length of heavy copper wire — the bit — thus heating it rapidly to high temperatures. Some irons of this type include a reel of solder which is automatically fed to the tip each time the trigger is pressed — but for good joints that's not where you want the solder; it needs to be applied to the joint.

Low-voltage irons have a push-ring or lever on the handle which pushes a carbon contact against the rear of the tip, passing a current of about 30 amps at 3 volts. The contact, having a higher resistance than the rest of the circuit, rapidly heats up, passing its heat to the tip, which reaches soldering temperature in a few seconds. An external transformer supply is the necessary power.

Quick heat irons are suitable for intermittent handyman use or applications requiring their large heating capacity. They are not recommended for general electronics use, particularly on printed circuit boards. They require some skill to control the heat so as not to damage components by overheating. Some do not have an electrostatic screen on the transformer, and ICs and some

transistors (particularly MOSFETs) can be damaged by leakage currents.

Despite their limitations, quick heat irons can be useful in an electronics workshop. If you contemplate purchasing one make sure the transformer has an electrostatic screen.

Soldering guns have the disadvantage that the transformer in the handle tends to make them a little unwieldy, especially for prolonged use.

Battery-operated soldering irons have become widely available, and these find application where power is unavailable or inconvenient to supply. These irons can be used where components sensitive to leakage currents (i.e.: MOS devices, CMOS ICs, etc.) are employed. Rechargeable nickel-cadmium batteries, usually contained in the handle, supply the current. They are not suitable for prolonged use.

### Temperature-controlled irons

Temperature-controlled irons are made specifically for electronics work. They are unsurpassed for good soldering, convenience and minimum possible damage to components. They are more expensive than the other types but get one if you can afford it.

There are several ways of controlling the tip temperature. One method (used in the Weller iron) is illustrated in

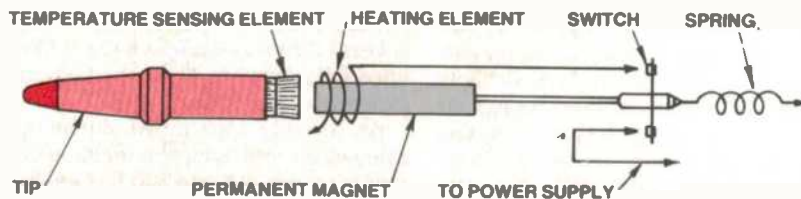

Figure 6. Temperature control system that exploits the 'Curie point temperature' of a magnet to turn the power on and off to the heating element. The magnet is attracted to the rear of the tip, closing the switch. The element heats the tip, and when the temperature reaches the Curie point of the magnet, the magnet loses its magnetism and the spring opens the switch. When the temperature drops below the Curie point, the cycle is repeated. Some models of the Weller soldering irons employ this technique of temperature control.

HEATING ELEMENT



Figure 5. A battery-operated soldering 'gun' (this one is by Scope, too). Construction is similar to the Mini Scope. Such irons are useful where power is unavailable.

Figure 6. A spring-loaded switch within the handle is operated by a magnet and temperature-sensitive sensor assembly located in the barrel. The temperature-sensing element consists of a ferromagnetic material, which at a certain temperature (called the Curie point temperature), loses all magnetic properties. The actual Curie point temperature depends on the composition of the ferromagnetic material. The Curie point for iron is typically 1000°K, 633°K for nickel and 1393°K for cobalt. An alloy of these and other ferromagnetic materials can be selected to produce any temperature required.

When the tip is cold the magnet is attracted to the sensor, which actuates the switch, applies power to the element, and heats the tip. When the tip reaches the Curie point temperature the sensor releases the magnet, opening the switch and removing power from the heating element. When the tip cools slightly, the magnet is again attracted to the sensor and the whole cycle is repeated, maintaining the tip within a few degrees of the selected temperature. The iron can be heard to emit a small click as the magnet goes through its attract-release cycles.

The tips are removable and sensors having different Curie point temperatures are available. One can select tip temperatures in the range 260°C to 430°C. A variety of shapes is also available to suit different applications. The Weller irons operate from a 24 volt transformer which is moulded into the stand supplied.

Another type of controlled-temperature iron has circuitry in the stand supplied with it which monitors the tip temperature and controls the supply to the heating element, thus maintaining a constant tip temperature. In this type, a control knob is provided in the stand which allows the operator to set the desired tip temperature (Figure 7).

Where 60/40 solder is used for construction work, a tip temperature of 250°C (500°F) is recommended. This is sufficiently above the melting point of 215°C to allow for heat conducted away by the joint and still melt the solder. If using Savbit solder, it melts at a slightly higher temperature and a tip rated at 275°C (550°F) is recommended.

For desoldering, such as in servicing work, a tip temperature of 315°C (600°F) or more is necessary; up to 370°C (700°F) is recommended where large connections are involved.

### Soldering bits

The soldering iron bit conducts heat from the iron's element to the joint. A typical bit is shown in Figure 8.

The tip temperature and the amount of heat it stores are important factors in obtaining a good soldered joint. The tip temperature will drop when making a joint due to heat being conducted away

by the parts of the joint. Just how much the temperature drops and how fast depends on the capacity of the bit to store heat and the mass of the parts being joined. The larger the bit, the more heat it will store and transfer to a joint, and the less will be the temperature drop. Temperature-controlled irons minimise these problems to a large extent. ▶



Figure 8. A typical replaceable soldering iron bit. This one screws onto the end of the iron barrel, and the cylindrical tip has a 'flat' on the end at an angle of about 60° to the axis.



Figure 7. This iron, Weller's model EC2000D, employs a temperature sensor in the tip and electronic control of the power to the heating element to maintain the tip temperature within very close limits. The desired temperature is set by a knob and displayed in the three-digit readout.

For an adequately rated iron, the correct bit for the job will remain above soldering temperature (without burning the joint) and cause the solder to flow properly. If the tip is too small, too much heat will be conducted away, and the solder, while it may melt a little initially, will not melt and flow properly and a poor joint results. The effect of proper bit size is shown in Figure 9.

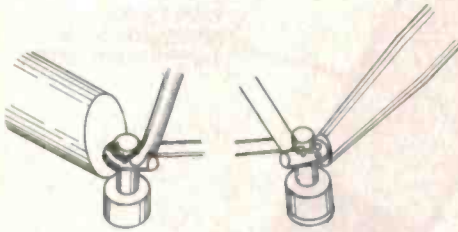

Figure 9. The bit should be large enough for the job, otherwise too much heat is conducted away from it by the joint and the solder will not flow properly. The bit on the left is OK, that on the right is too small.

Bits are usually made of copper, copper alloy or iron-plated copper. A plated bit is shown in Figure 10.



Figure 10. Plated bits last longer because they do not oxidise as rapidly as unplated bits. They are usually iron-plated.

Unplated bits transfer heat more effectively but oxidise rapidly, reducing their efficiency. Their life is much shorter than plated bits and they require more frequent maintenance.

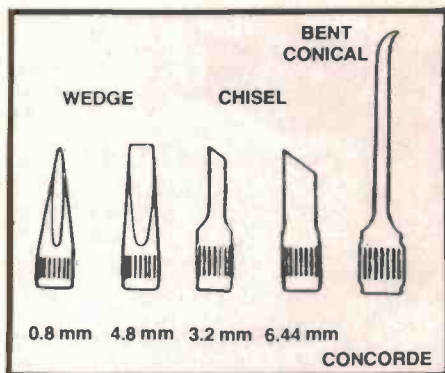

Figure 11. Bits can be obtained in a variety of shapes to suit the job, such as conical, wedge, bevel, chisel, etc. The most common bit shapes are the wedge (or chisel) and the bevel. They can be different diameters and lengths, giving different heat capacities.

The area of the tip face determines the rate of heat transferred to the joint. A small area will have a higher temperature but less heat reserve (or capacity) than a large tip. Generally,

the more heat the work is likely to absorb, the larger the tip area should be. However, the area should not be so large that it obscures the work or damages adjacent parts.

The distance the bit protrudes from the barrel of the iron is also important. The shorter this distance, the higher the tip temperature. Usually, it is best to select a bit length as short as practicable to reduce the heat path from the element to the tip, and to minimise wobble and bending of the bit. It should not be so short that the barrel touches or radiates onto nearby components or that the tip temperature becomes too high. One way of reducing the temperature of a small-diameter bit is to increase the length beyond that used for the larger-sized bit — or vice versa. Bent bits can be used in awkward places where a straight bit cannot reach.

### Maintaining the iron and bit

For maximum efficiency and consistently good joints, the soldering iron and bit require frequent but simple maintenance. Heating produces oxidation of the barrel and bit, the oxide forming a scale on the parts. This reduces heat transfer as the scale is an insulator. Continuous heat irons are particularly affected. Excessive scaling is produced by high operating temperatures and by prolonged use without descaling.

To remove scale, remove the bit and tap both the barrel and bit firmly on the bench top. This should be done regularly. Only remove a plated bit from the barrel of an iron when it is quite cold.

For efficient transfer of heat from the bit to the work, the face of the bit should be smooth and coated with a shiny layer of resin-free solder. A bit in this condition is said to be 'tinned'. A clean, new bit is tinned by heating it to soldering temperature (test it by lightly touching solder on the face of the bit) and applying a small amount of solder to the face and letting it flow freely to cover the face. Any excess should be removed by wiping it on a lightly dampened sponge or cloth.

With use, the face of the bit becomes pitted and the solder layer takes on a dull grey appearance. During soldering, some of the copper from the face is absorbed into the solder and with repeated use the surface becomes uneven. There is less absorption with plated tips. Copper bits in good condition and in bad condition are illustrated in Figure 12. The 'pitting' can be removed by filing. Only file off as much as necessary to produce a smooth face again. Excessive filing reduces the heat capacity and increases the bit temperature. Remove any scaling as well. When a clean tip is obtained, re-tin the face,

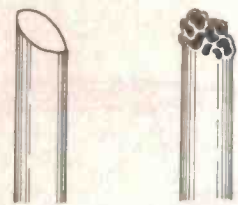

Figure 12. The tip should be in good condition, as at left, for good soldering, not worn, pitted or oxidised as at right.

Do not pull the tip further out from the barrel to compensate for reduced length as this overheats that section of the heating element not in contact with the bit, producing excessive scaling and eventually causing the element to fail.

Small surface irregularities on plated tips should be repaired with fine emery cloth when the tip is cold. Take care not to remove the plating. After cleaning, heat the bit and re-tin the face. Relatively large pitting on a plated bit means that some plating has come off. Attempts to remedy the situation usually result in more plating being removed. In such cases, replace the bit.

During normal soldering with a plated bit, the molten solder on the face should be replenished regularly while the tip is hot. The face can be cleaned by wiping it on a damp, fine-textured sponge (these are usually supplied with controlled temperature irons). Do not overdo it or you will remove all the molten solder. Wait a few seconds after wiping the bit to allow it to recover heat and then lightly re-tin the face. Plated bits should have a small amount of excess solder on the face while not being used.

With either plated or unplated bits, regular cleaning during use is a good practice, making soldering easier and ensuring good joints. A damp sponge pad is good for either type of bit. A fine textured wire brush may also be useful with copper bits. (Figure 13.)

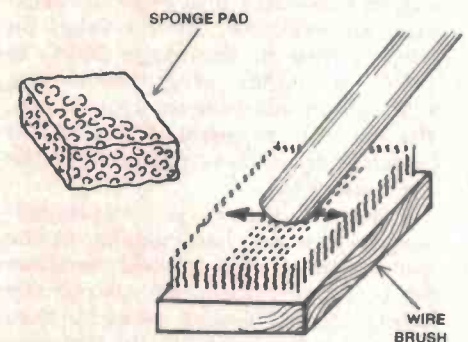

Figure 13. The tip should be cleaned regularly during use. A moist sponge pad (left) is good for frequent wiping, while for unplated tips an occasional scrub on a wire brush keeps the tip in good condition.

Soon after learning soldering, most people will use one of two methods to remove excess solder from the bit: viz: *flicking* or *wiping*. Wiping is the recommended method. Flicking causes blobs of molten solder to splatter on to all sorts of awkward places. If you're a flicker, don't wear shorts! Apart from ruining the carpet and prompting sudden leaps into the air, molten blobs of solder have a nasty habit of getting into equipment and causing short circuits — which may be disastrous. For habitual flickers, either cure yourself of the habit or screw a low, open-topped container to the bench top and aim in there from close quarters. It is even possible to recycle the solder thus collected — but not in your project.

## Basic soldering

Before use, the soldering iron should be turned on for long enough to allow the bit to reach soldering temperature. Irons vary quite a bit in this; some take quite a few minutes to warm up, whereas others are much quicker. The parts to be joined should be bright and clean; if not they should first be tinned (see 'Preparing Leads and Components').

When the parts to be joined are prepared, and with the iron at the correct temperature, apply the face of the bit to that part of the joint having the greatest mass (providing it isn't the most heat sensitive). Allow the joint to heat for a few seconds to raise it to soldering temperature, and then apply a little solder. If the parts are clean, the solder will flow freely as it melts, wetting the joint properly and making a smooth, shiny joint. Remember that the solder must be applied to the joint and *not* to the iron.

Figure 14 shows how to solder a component lead to a tag. Apply the iron to the tag as the tag has the greatest mass. To improve heat transfer and reduce soldering time, first apply a little solder

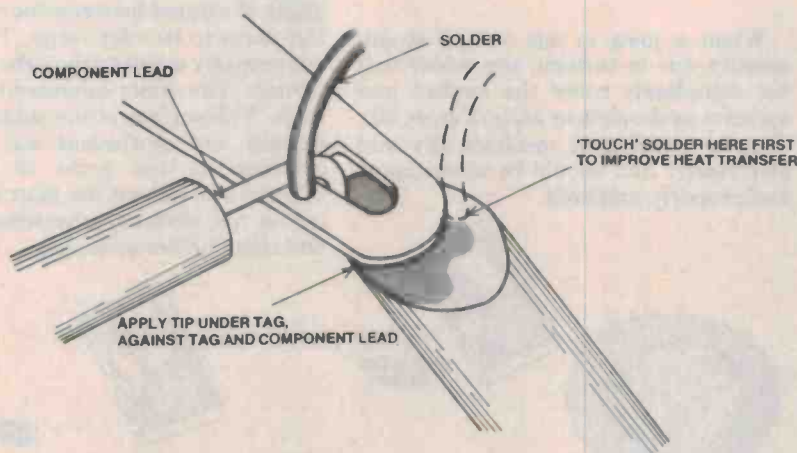

Figure 14. When soldering a component to a tag, apply the iron to the tag and the lead to heat them up. After a few seconds, touch the solder on the iron briefly and then apply the solder to the joint.

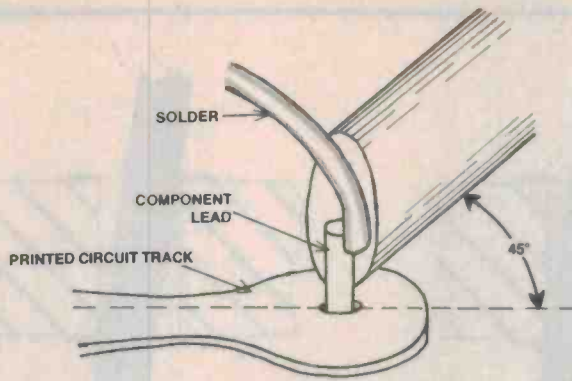

Figure 15. When soldering a component lead to a printed circuit board, apply the iron to the lead with the tip touching the copper track as well.

to the iron at the junction of the bit and the tag. Just a touch is sufficient. The flux removes any tarnish from the tag and the hot solder tarnish that forms on the face of the bit, allowing rapid heating of a small area. The molten solder improves the thermal contact by wetting both surfaces and filling the minute air spaces between them. Next apply the solder to the tag. The solder will only melt if the tag is at the correct temperature, thus ensuring proper wetting.

Soldering components to a printed circuit board is shown in Figure 15. Always take care not to overheat printed circuit boards as the copper track may lift, damaging the board and making subsequent connections difficult.

Always hold the iron on the joint for a second longer after sufficient solder has been applied. This ensures that all the solder is melted and that the flux has been de-activated. Allow the solder to cool naturally. Don't blow on it to cool it. Don't move the joint while the solder is solidifying — a poor joint may result.

Take care not to apply too much solder as it may conceal a poor joint. On printed circuit boards, too much solder may cause 'solder bridges' to form between tracks.

How much is the right amount of solder, and what does a good joint look like?

The size of the solder 'fillet' should be large enough to fill the area of the joint and the contours of the parts should be plainly visible. The surface of the solder should be smooth and bright and meet the parts of the joints at a tangent. This 'feathering' indicates good wetting. The characteristics of a good joint are shown in Figure 16.

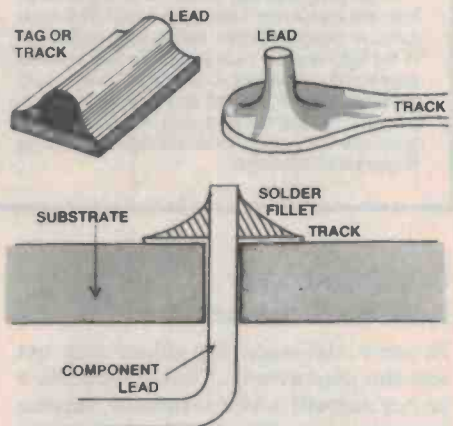

Figure 16. A good joint will be covered by a small fillet of solder which meets the parts of the joint at a tangent. The solder should be smooth and bright.

There must be sufficient solder filling the spaces of the joint to ensure a good mechanical bond. Insufficient solder results in a mechanically weak joint. The joint is likely to go open circuit or intermittent under slight mechanical stress (such as due to vibration or expansion and contraction with temperature changes). Joints having insufficient solder are shown in Figure 17.

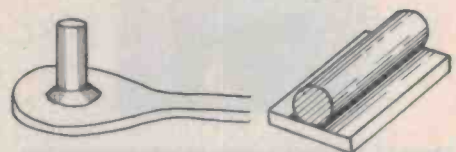
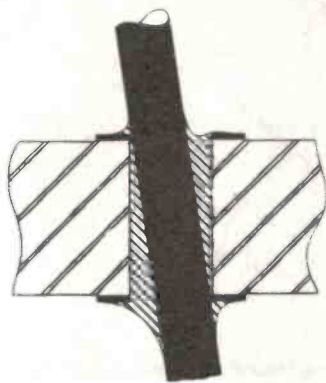
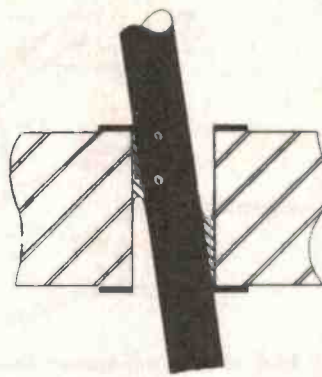

Figure 17. Insufficient solder leads to a weak joint which may become faulty.



(A) A properly made joint in a plated-through hole.



(B) Too little solder results in weak joint that may fracture and become intermittent or unreliable. When desoldering, a little solder will always adhere to the joint inside the hole in the positions shown, so the lead must be withdrawn while the solder is molten.

### THE PROBLEM OF PLATED-THROUGH HOLES

Double-sided pc boards with plated-through holes are becoming increasingly common. It is important that the correct technique be used to solder components to the board as well as when desoldering component leads.

In general, one can solder component leads from the component side of the board. The usual rules, as described here, about applying the iron to the lead and the track apply. Likewise with the appearance of the joint. Component leads should not be crimped or clinched as it is unnecessary. A properly made joint is illustrated in drawing A. The application of too little solder will result in a joint as illustrated in drawing B.

When desoldering leads from a through-plated hole, as much solder should be removed from the joint as possible. Vacuum-operated desoldering tools are best for this purpose. However, the lead should be removed while the iron is still applied to the joint and the solder is molten. Otherwise, you may damage the through-plating in the hole. The iron should not be pressed hard onto the pad as this too can result in damage to the through-plating. With ICs and/or IC sockets where a number of joints have to be desoldered simultaneously, special desoldering tool bits can be obtained, or else the pins of the package must be cut, destroying it.

### Bad joints and how to cure them

In some instances, the solder may not wet the joint evenly. The solder surface is not smooth and continuous, having irregular, round, non-wetted areas exposed. The solder may meet one surface abruptly in places. This condition is illustrated in Figure 19. It can often be remedied by reheating, although desoldering and cleaning may be necessary in some cases.

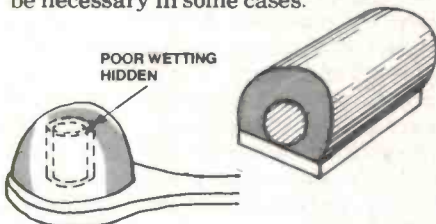

Figure 18. Too much solder can hide poorly wetted surfaces (top left), which results in a poor joint. On pc boards with close conductor spacing too much solder leads to 'bridging' (bottom).

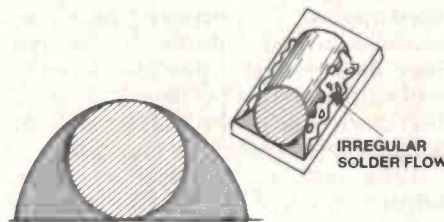

Figure 19. When poor wetting occurs, the solder meets one surface at an abrupt angle and the solder flows irregularly.

When a joint is not wetted at all, usually due to tarnish, the solder will not completely cover the surface and appears as droplets or balls (Figure 20). This is a bad joint mechanically and electrically and should be taken apart and properly prepared.

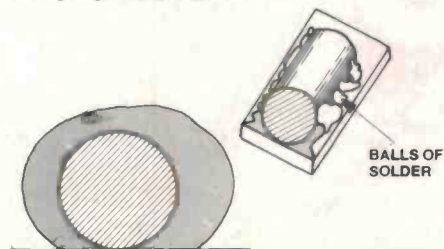

Figure 20. Tarnished surfaces prevent wetting altogether. Balls of solder sit on the surface.

Sometimes during soldering, the molten solder will run along the metal and then withdraw towards the fillet

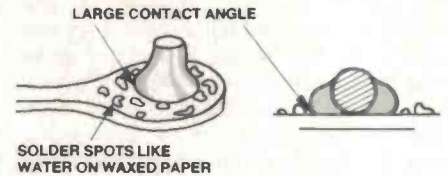

Figure 21. Dewetting. The solder appears to flow properly, then withdraws when the iron is removed from the joint.

when the iron is removed (Figure 21). This 'dewetting' is another problem caused by tarnish that the flux is unable to remove. The joint has to be desoldered and thoroughly cleaned before resoldering. Applying more heat and excess solder may make the joint look all right but it may conceal a bad joint.

A 'cold' or 'dry' joint is usually caused by movement of the parts during soldering or as the solder is solidifying. It is also caused by the solder running onto surfaces cooler than the soldering temperature. A cold joint has a frosty appearance, as shown in Figure 22, but may otherwise look like a good joint.

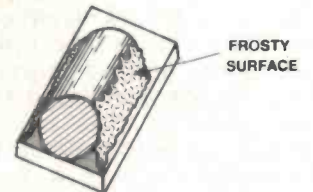

Figure 22. A 'cold' joint. The solder surface has a frosty appearance but looks good otherwise.

The trap with cold joints is that they may perform quite well for a considerable period and then suddenly become intermittent or go open circuit. They are repaired quite simply by reapplying heat or desoldering the joint and then resoldering.

If insufficient heat is applied to a joint, the solder solidifies before adequate wetting occurs, causing the angle of contact between the solder and the parts to be very large. The flux is not properly activated and the joint may tarnish. The solder can usually be pried loose. The surface of the solder may be smooth and continuous but it is not attached to the parts of the joint (Figure 23). Reheat the joint if tarnishing is not evident, otherwise desolder and clean before soldering.

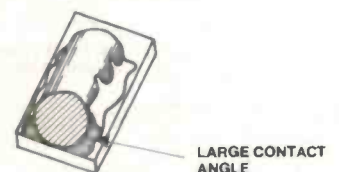

Figure 23. Too little heat. The solder forms a large contact angle with the surface and can be prised loose.





# XERSIN (Call me Zersin) MULTICORE SOLDER

**A NEW flux-cored solder wire for  
the electronics industry . . .**

XERSIN 2000 is a NON-ROSIN, non-corrosive, mildly activated flux-cored solder which has superior physical and chemical properties to halide-activated and halide-free activated rosin fluxes. It has adequate performance for most electrical/electronics applications with flux activity approaching that of the most active rosin fluxes and superior to that of the halide-free activated or mildly activated rosin fluxes.

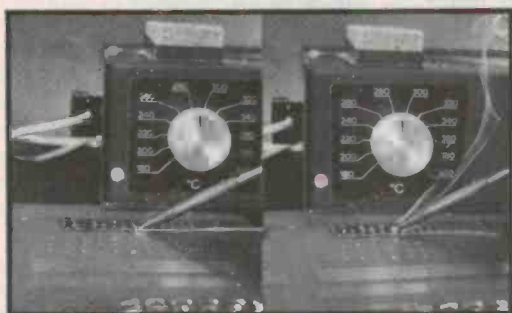

XERSIN                      ROSIN  
280°C (550°F)



XERSIN                      ROSIN  
370°C (700°F)

*These pictures were taken at a similar instant whilst making the tenth joint with the same soldering iron at the same temperature using XERSIN Multicore Solder (left) and rosin-cored solder (right) of the same diameter and flux content. The reduction of fumes using Xersin solder is clearly visible.*

XERSIN 2000, a compatible alternative to rosin-cored solder, has been developed by Multicore Solders the manufacturers of Ersin Multicore rosin-cored solders, who have been world leaders for 40 years and are constantly pushing forward the boundaries of soldering technology. Many people will prefer to continue using trouble-free Ersin Multicore activated rosin-cored solder for its superior activity but XERSIN 2000 could be preferred by manufacturers of equipment and components for one of the following advantages compared with rosin-cored solder:

- ★ First activated non-corrosive flux to be based on pure chemicals.
- ★ Acid value is only 20. Plain pure *non-activated* rosin is 180.
- ★ Fumes considered medically less irritating and less likely to cause allergic sensitisation. Contains no aldehydes which are now specified world-wide by Governments as a measure of the TLV for pyrolysis decomposition products of rosin.
- ★ Flexible clear post-soldering residues are vibration resistant.
- ★ The saving of cost of removing flux residues. Passes MIL-P-28809 Cleanliness Test without removal.
- ★ 60-80% reduction in fumes (dependent on temperature).
- ★ Activity adequate on parts of good solderability and passes all appropriate Standards.

**MULTICORE SOLDERS AUSTRALIA PTY. LTD.**

FACTORY & SALES OFFICE : 43 BIRMINGHAM ST. ALEXANDRIA (O2) 6672750. TELEX AA 20779.

In some cases, a resin bond is formed between the parts of a joint. In this case, the angle of contact of the solder is usually large and a layer of solidified resin forms the bond, as shown in Figure 24. There may be no electrical contact at all, the joint has little strength and may be prised apart. It

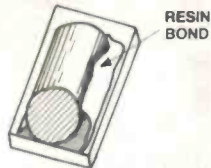

Figure 24. A resin bond. There may be no electrical contact at all. It can be cured by reheating the joint.

may be caused by excess flux or solder running onto surfaces cooler than soldering temperature but hot enough to melt the flux. It is usually cured by reheating the joint, making sure that all parts are brought up to soldering temperature.

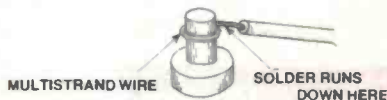

Figure 25. 'Wicking' is caused by solder running back up multistrand hookup wire. This makes the wire brittle at the joint and movement may break it.

When soldering multi-strand hookup wire, excess solder or long soldering time can cause solder to run along the strands. This is called 'wicking' (Figure 25) and can be reduced by soldering faster or by using a heatsink on the wire. Wicking makes the wire brittle and liable to break when it is moved.

When the soldering iron is withdrawn from a joint a spike of solder, called an 'icicle', is sometimes left behind, usually pointing in the direction in which the iron was removed (see Figure 26).

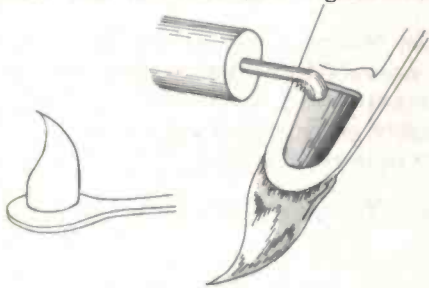

Figure 26. 'Icicles' sometimes form on a joint when you remove the iron. Reheat the joint with a clean tip to get rid of them.

Icicles may be caused by a variety of problems, including tarnished joints, too short soldering time, low soldering temperature or excess solder on the iron. Reapplication of the soldering iron usually remedies the problem, but make sure that there is not some other problem with the joint. If the joint is otherwise sound, small icicles are nothing to worry about.

## Preparing leads and components

Most modern components have leads which are tin-plated to aid soldering. The tin is readily absorbed into the solder, allowing rapid wetting and reducing soldering time. The plating will tarnish with time and handling. Unplated leads and unprotected printed circuit boards are particularly affected as oxidation is quite rapid.

It is always a good practice to tin the parts of a joint before putting them together. Component leads can be tinned by simply heating them with the iron and then applying a little solder. Only tin that part of the lead that is actually going to make the joint as component leads are usually trimmed after the joint is made. If the lead is tarnished, it can be cleaned by pulling it through a doubled-over piece of emery cloth or plain steel wool. Printed circuit board tracks do not need tinning. If the tracks are tarnished, clean the board with an abrasive powder cleanser (such as Ajax) and a moist cloth. Wash the board in clean water after cleaning and dry with a tissue or paper towel.

Stranded hookup wire is best prepared in the following manner. Strip away about 6-7 mm of insulation from each end. Twist the strands together, apply the hot iron for about one second and then a touch of solder. Don't overheat or apply too much solder. Solid hookup wire is prepared the same way as component leads.

Tarnished tags are best cleaned by rubbing with emery cloth or lightly scraping them with a penknife. Thoroughly heat the tag with the iron before applying a little solder to tin it.

Enamelled coil wire can be prepared by stripping the end back about 6-10 mm using a penknife, cutting blade, emery cloth or steel wool until the bright copper wire shows. Tin it quickly. Some modern coil winding wire is coated with an enamel that, although very tough, melts at soldering temperatures ('Bicalex' and 'Lewmex' are several trade names). A hot soldering iron is applied to the end to heat it first. Apply some solder to the face of the iron then to form a molten blob to cover the wire. Shortly, the insulation will smoke and burn off, allowing the wire to be tinned. A good hot tip is necessary for this operation.

## Mounting components on terminals

There are good and bad ways of attaching component leads to terminals before soldering. The correct method of attachment depends on the type of terminal. Pins are generally meant to have the lead bent around them, other

terminals have holes through which the component lead is inserted. The main principle to keep in mind is that the lead must always be easy to remove if subsequent servicing or modification is necessary. Also, the solder should not provide all the mechanical support for the component.

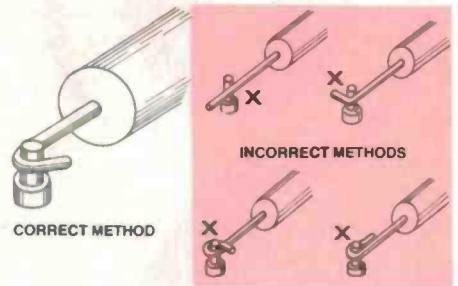

Figure 27. How to attach a component lead to a terminal pin before soldering.

**Terminal Pins** are often used with matrix board, being inserted into the holes at convenient positions. The component lead should be bent around the pin, making an angle of approximately  $135^\circ$ , as shown in Figure 27 (left). If the angle is too small, the connection is mechanically weak — it depends too much on the solder. If the lead is wrapped right around the terminal it is difficult to remove (Figure 27, right).

When mounting a component between two terminal pins, first bend each lead at the point corresponding to the position of the terminal, leaving sufficient slack in each lead for a little movement in the component. Tension each lead against the terminal during soldering (Figure 28).

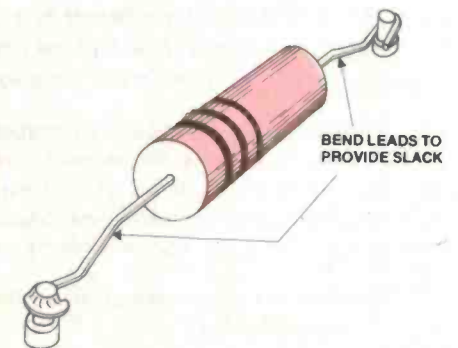

Figure 28. When mounting a component between terminal pins leave a little slack in the leads.

**Solder Tags and Terminals with Holes** are found on tagstrips, potentiometers, switches, etc. The best methods of connecting leads to them are shown in Figure 29(a). In each case, there is adequate contact between the lead and terminal and the lead can be easily removed if necessary later. Do not wrap the component lead right around the terminal as this makes subsequent removal difficult and

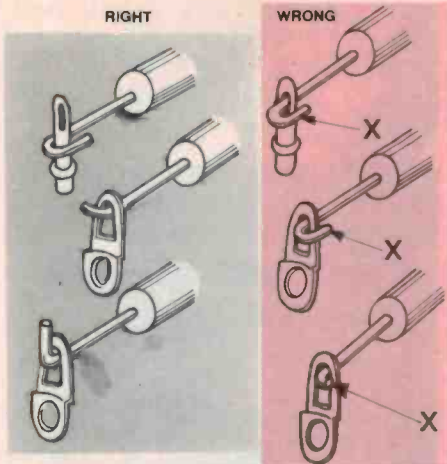

Figure 29. The best way to attach component leads to tags and terminals (left).

messy, but if the lead is not bent around the terminal at all too much dependence is placed on the solder for both mechanical and electrical connection. The *wrong* ways are illustrated in Figure 29(b).

The way a component is mounted between two terminals of this type depends on the orientation of the terminals. Where the holes are approximately parallel, bend each lead at right angles at the point corresponding to the position of the terminal hole. The lead is inserted without further bending (Figure 30). Leave a little slack in the leads for movement. Hold the lead firmly when soldering.

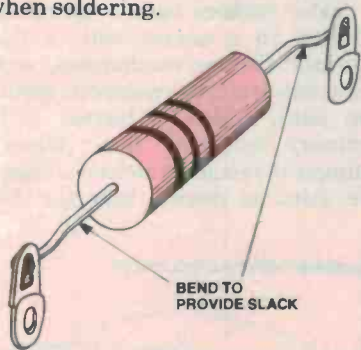

Figure 30. Mounting a component between tags with parallel holes.

Where the terminal holes are in line (i.e. coaxial), bend one lead around one terminal as illustrated in Figure 29 and pass the other lead through the other terminal without bending it. Solder the bent lead first. Tension it against the terminal while soldering. Arrange a little slack in the leads before soldering the remaining lead (Figure 31a). If the

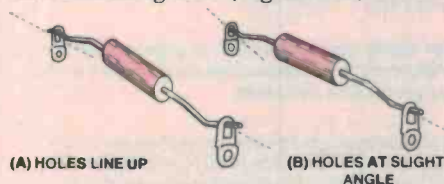

Figure 31. Mounting component leads where the tag holes line up, or nearly so. Bend the leads to provide some slack.

terminals are at a slight angle to one another, form one lead to pass along the side of the terminal closest to the body of the component before entering the hole. Don't bend it further. Pass the other lead through the other terminal hole without bending it either. Solder the bent lead first, tensioning it against the terminal to prevent movement. Again arrange a little slack in the leads before soldering the remaining lead. (Figure 31b).

To mount a component between a terminal pin and a solder tag, bend the leads around each terminal according to the principles outlined above.

When terminating several leads on one terminal, each lead should be connected separately, regardless of the type of terminal. This allows any single component to be easily removed. Don't twist the leads together as this prevents subsequent removal. Figure 32 illustrates the correct and incorrect methods of terminating several leads to one terminal.

When interconnecting two terminals use a length of wire between them. Don't use component leads.

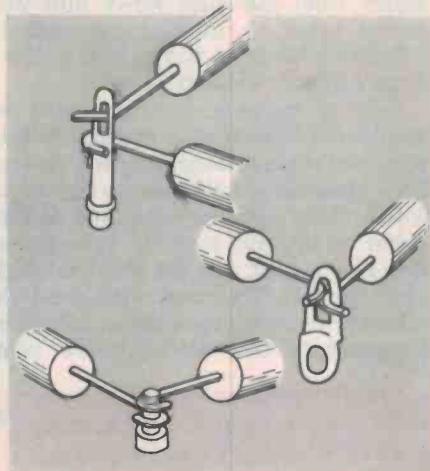

RIGHT

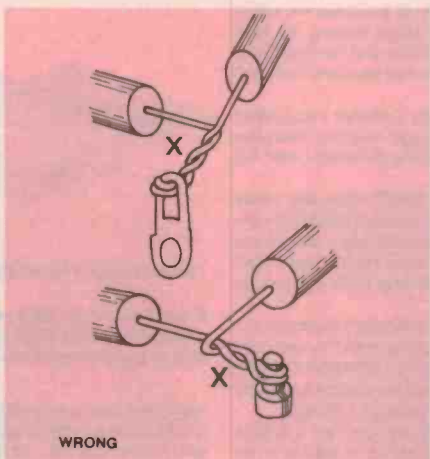

Figure 32. When several component leads go to one terminal, attach each lead separately.

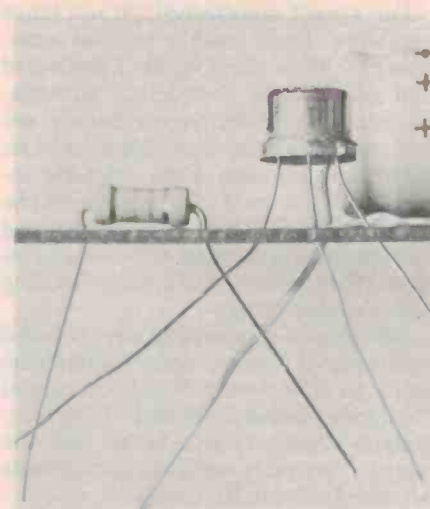

Figure 33. When mounting components to a printed circuit board, the leads may be splayed, before soldering, to hold them in position.

## Mounting components on printed circuit boards

Components should always be mounted on the *non-copper* side of a printed circuit board, unless especially noted otherwise. The component leads should be inserted in the correct holes and may be formed in a variety of ways before soldering. The leads may be splayed, as shown in Figure 33, to hold the components in position before soldering.

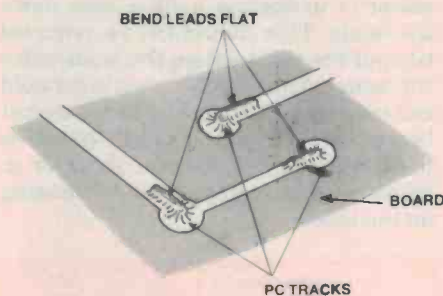

Figure 34. The leads may be cut off and bent to lie flat along the track on the board and then soldered.

This method allows all the components to be mounted before soldering. See Figure 34.

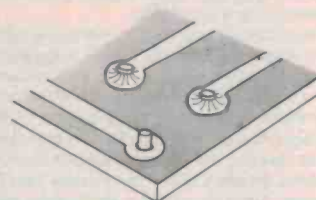

Figure 35. Alternatively, the leads may be cut so that they protrude a short way, and then soldered. They may be cut off after soldering if you wish.

Another method is to mount the components one at a time, cutting the leads close to the board before soldering, as in Figure 35. However, this necessitates holding the component steady whilst soldering.

For a neat appearance, do not leave excessive lead length on the components; place them against the board and align them parallel to an edge. Generally, printed circuit boards are laid out so that the components will lie parallel to an edge when correctly inserted. It is a good idea to position the components so that their value and voltage rating or type number can be seen. This greatly facilitates checking and later servicing.

Sometimes components are mounted vertically. It is best to splay or clinch the leads in this case and allow a small clearance between the end of the component closest to the board and the board. Vertically mounted components are illustrated in Figure 36.

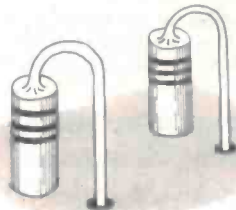

Figure 36. Whilst axial lead components (i.e. resistors) are generally mounted horizontally on a pc board, they are sometimes mounted vertically. Leave a millimetre or so clearance between the bottom end and the board.

Many capacitors, ceramic capacitors particularly, have their coating material extending a little way down the leads. This should not be removed beyond the point where the leads enter the component body. The coating should not enter the hole in the printed circuit board. Where double-sided board is used, allow a clearance of 2 mm or so between the circuit pad and the coating on the lead.

Components with metal bodies that are mounted on the copper side of a board, or on double-sided board, or that cross a track or jumper lead should be sleeved or otherwise insulated to prevent a short circuit.

## Desoldering

Where joints have to be desoldered there are two basic methods that can be used to effectively remove the solder — 'soaking' it up and sucking it up.

It is possible to remove leads while the solder is molten by just heating the joint. However, this is not the best method, as a component may be damaged by the amount of heat produced. Also, flexing the leads whilst trying to remove the component may damage the lead or the lead-body seal. A terminal or printed circuit can also be damaged by heat or attempts to prise the component loose while the solder is molten. It is much better to use a desoldering aid.

Desoldering 'wick' can be used to soak up molten solder from a joint. This consists of a copper braid impregnated with resin. When applied to a joint and heated with a soldering iron, molten solder from the joint flows into the fluxed braid by capillary attraction, effectively clearing the joint of solder. Figure 37 shows how it's done.

You lay the wick over the area to be desoldered. The iron is applied to the wick and some pressure applied. As the wick heats up it activates the flux in it, which flows onto the joint, and as the solder on the joint melts it replaces the flux in the wick, flowing into the braid quite quickly. The 'used' wick is cut off afterwards. A tip running at a higher temperature and having more heat



Figure 37. How to use desoldering wick. Lay it over the joint and apply the iron tip to the braid, using a little pressure. When the solder is drawn into the braid, remove the iron and the braid.

capacity than generally used for soldering is recommended. Desoldering wick is excellent for general use and on joints having a large area.

Sucking up the solder with a suitable tool is a very effective method. Hand-held 'solder suckers' are inexpensive and popular but a variety of desoldering irons with suction devices incorporated are also available.

Solder suckers have a spring-loaded plunger in a barrel with a thumb-operated release mechanism. A heat-resistant nozzle at one end is applied to the joint, which is heated with an ordinary soldering iron. When the plunger is released, molten solder from the joint is drawn into the barrel. ▶

## PRECAUTIONS WITH SEMICONDUCTORS

Most semiconductors are damaged by overheating. Always solder or desolder semiconductors quickly and cleanly. Make sure all parts to be joined are clean and/or tinned beforehand. If you don't feel confident about making the joint quickly, use a heat shunt (e.g. a pair of pliers) between the end of the lead being soldered and the transistor body to divert the heat. Special heatsink tools are obtainable for this purpose.

Integrated circuits require particular care when being soldered into printed circuit boards. If too much solder is applied, a 'solder bridge' may form between adjacent pins (see Figure 18). This necessitates removing the solder, with the risk of damaging both the board and the component.

Transistors and integrated circuits of the MOS or CMOS type are easily damaged by electrostatic charges or leakage currents from the soldering iron. These devices are normally supplied with their pins inserted into a conductive material, usually a black foam. Leave them in this until they are to be used. Avoid touching the pins, as even small static discharges from the body (caused by clothing) can cause damage.

Always fit MOS or CMOS components last. Insert the device into place quickly. Solder the power supply pins first. The devices are built so that this activates built-in protective circuitry. The remaining pins may then be soldered with little chance of damage. Sockets for ICs are worth using as they remove the necessity of soldering directly to the IC pins, thus reducing the possibility of damage.

To reduce leakage currents produced by a soldering iron, connect a flexible lead from the metallic part of the iron (make sure it connects to the tip) to an alligator clip that can be attached to the equipment earth (0 V rail). Soldering

TERMINAL CONNECTED TO BARREL AND TIP

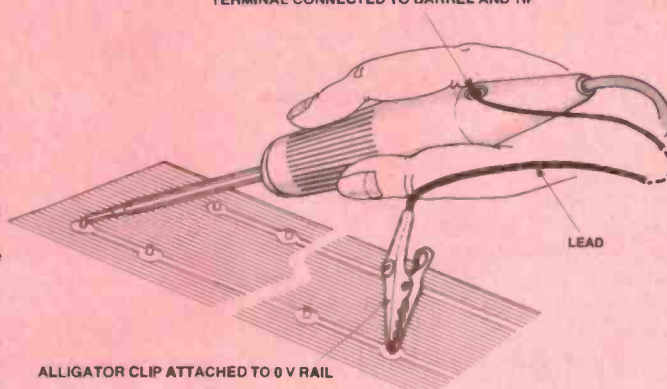

A precaution to take when using mains-operated or unprotected low-voltage irons on MOS components is to connect the metallic part of the iron to the 0 V rail of the equipment with a clip lead.

Irons that use a step-down transformer should have an earthed electrostatic shield between the windings. It is wise to check this when buying. Alternatively, with an iron that has sufficient heat capacity, disconnect the iron when soldering components that are sensitive to leakage currents.

# What's new from SCOPE

## PROFESSIONAL P.C.B. IRON . . . The Improved Model TC60

OFFERS THE ECONOMY OF DIRECT 240V MAINS OPERATION AND THE SOLDERING MUSCLE OF 60 WATTS.

### COMPARE THESE FEATURES:

- AVOIDS THE COST AND WEIGHT of a 24V Transformer and offers greater portability.
- REDUCES SWITCHING PROBLEMS of contact wear and R.F. discharge. Mains voltage ensures 8 to 10 times less current to be interrupted.
- STEPLESS TEMP. ADJUSTMENT 20°-400°C. — no need to change tips to vary temperature.

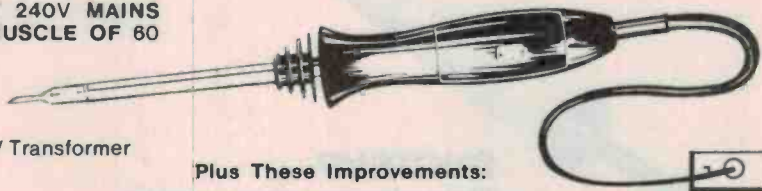

### Plus These Improvements:

(Compared with previous Model)

- 15% THINNER POWER LEAD — lighter & more flexible.
- LONGER TIP LIFE — new aluminium coating of iron plated copper, cuts heat and flux damage.

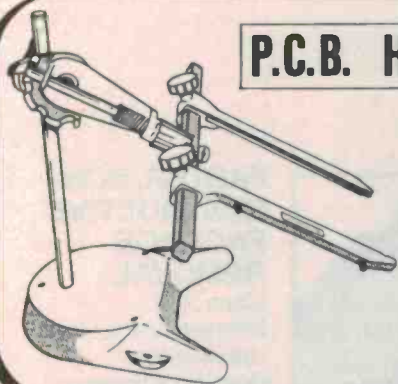

## P.C.B. HOLDER — Rotates, Tilts & Locks

### Scope Panavise — Model 333

#### COMPARE THESE FEATURES:

FIRM — NO SLIP WORK ANGLES.

- Choose from 4 pre set angles of tilt and 8 axial positions at 45° increments.
- FLEXIBLE CAPACITY
- Holds single or multiple boards to 750mm. (using extra arms and longer bars) yet allows full rotation.

## SOLDER REMOVER — Without Burnt Fingers

Scope SOLDER BLOTTER in a metal tipped dispenser

#### COMPARE THESE FEATURES:

- Keeps your finger tip away from heat, yet places braid precisely.
- Pull braid to dispense — rotate pack to re roll surplus braid.



## SIDECUTTERS

### High Speed

NEW 'SHEAR' CONCEPT CUTS FATIGUE



### Scope Flushcutters

#### COMPARE THESE FEATURES:

- LOW EFFORT CUTTING ACTION aids speed. Radical 'shear' action needs about 50% less force than traditional 'crush' method.
- CUSHION GRIP extends further to protect finger and thumb tip.
- OPERATIVES CAN SUSTAIN SPEED due to Spring Loading & low mass (43 gm.).

### FOR FURTHER INFORMATION — CONTACT OUR AGENTS LISTED BELOW:

N.S.W.

SYDNEY (02) 546-6144

TAS.

HOBART (002) 34-2811

LAUNCESTON (003) 31-5545

S.A.

ADELAIDE (08) 223-2261

W.A.

PERTH (09) 387-4966

QLD.

BRISBANE (07)52-5231

ROCKHAMPTON (079) 27-3370

TOWNSVILLE (077) 71-3448

P.N.G.

LAE 42-2172

PORT MORESBY 257796

N.Z.

AUCKLAND 574037

WELLINGTON 859578

DUNEDIN 51-163

CHRISTCHURCH 63-041



SCOPE

BOX 63 NIDDRIE,  
VIC., 3042  
TEL.: (03) 338-1566  
TLX: AA38318

# The ROYEL touch . . .

## . . . for high reliability soldering

... for the  
beginner or  
home hobbyist



**DUOTEMP**  
Manual temperature control  
3 mm . . . D 30  
5 mm . . . D 50  
Fitted with non-seize tip.

... for the  
professional  
engineer, or  
technician on  
the move.



**THERMATIC**  
Line voltage. Sensitive  
in-handle electronic  
circuitry for feedback  
temperature control.

... for the workshop that  
demands state-of-the-art  
soldering equipment.

**ECT...  
DIAL DIRECT**  
for controlled  
temperature  
soldering and  
desoldering.

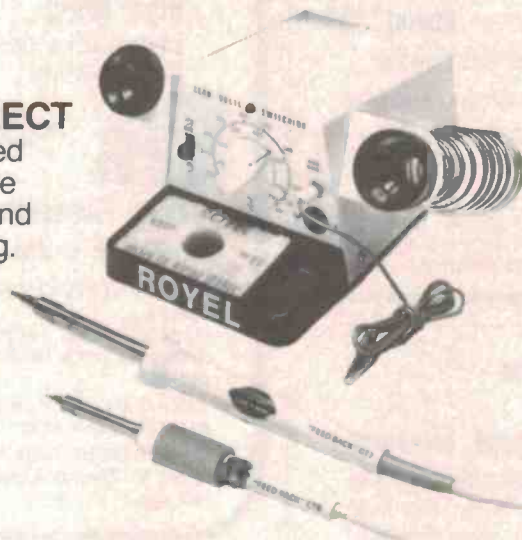

Power unit contains double wound transformer with electrostatic shield for low voltage tools. Infinitely variable direct reading temperature control. Inbuilt temperature lock.  
Features: Zero voltage switching, zero tip potential and auxiliary ground connection for maximum component protection. Large tip-wiping sponge.  
\*Accepts soldering tools CT6 (1/8" tip) or CT7 (3/16" tip).



**FASTER, NON-DESTRUCTIVE PACKAGE REMOVAL**  
Controlled temperature, all-lead reflow solder/desolder accessory enables multi-pin packages to be removed and/or replaced in PC boards at safe temperatures in 2-6 seconds.  
• Operates from ECT power unit.  
CAT. No. AL 130.

Available through trade resellers . . .

# ROYEL

**Royston Electronics**

N.S.W. (02) 709 5293 QLD. (07) 277 4311  
VIC. (03) 543 5122 S.A. (08) 42 6655  
TAS. (002) 34 2233

RT 001/A

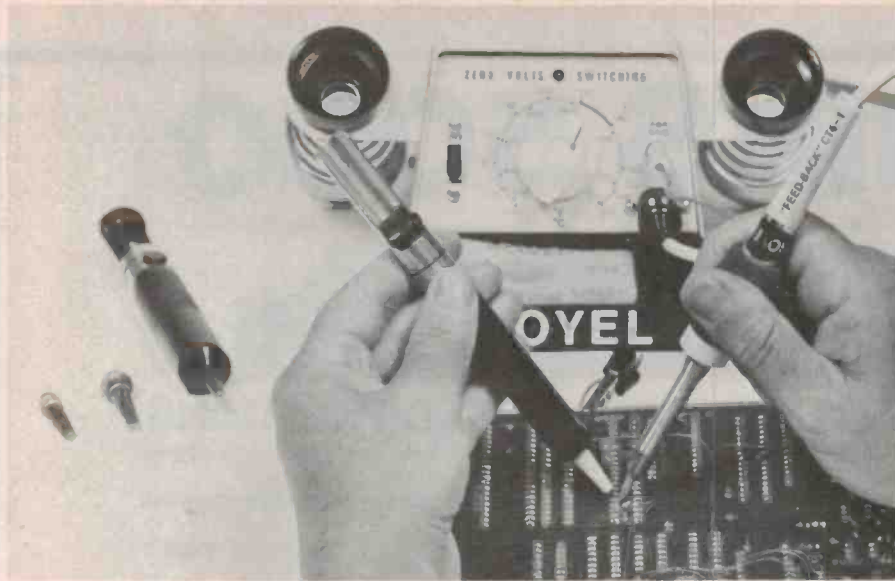

Figure 38. Using a handheld solder sucker. The nozzle is made of Teflon (PTFE), a heat-resistant plastic, and is replaceable. To use it, load the plunger in the tool. Heat the joint until the solder melts, apply the sucker's nozzle to the joint and release the plunger.

Figure 38 shows how it's done. They are excellent for general use with pc boards.

That's the general technique, and it's fine for equipment using bipolar devices, but it can be extremely dangerous for MOS devices. A US maker of solder suckers, Anderson Effects, points out that standard plastic solder suckers have been found to

produce a static surge of 5 kV to 10 kV at the tip. This is invariably in contact with the device's leads when the surge occurs and may damage or destroy the device. To obviate the problem static-free metallised plastic nozzles may be obtained. Otherwise, use desoldering wick or a vacuum-operated desoldering iron.

A variety of desoldering irons having a hollow tip through which the molten solder is drawn by a vacuum pump are available. These are particularly useful for servicing work. An example is shown in Figure 39.

(Material for preparing this article was derived from Australian Post Office technical training publication ETP 0276, 1972, and The Art of Soldering, ETI April 1975. Additional material and photographs were kindly supplied by Royston Electronics, Multicore Solders Pty Ltd, The Cooper Tool Group Ltd, Scope Laboratories and General Electronic Services).



Figure 39. This Hakko 'Vac Ace' desoldering tool from G.E.S. employs a small vacuum pump to draw molten solder from the joint into the glass barrel atop the gun handle. A steel wool wad absorbs the solder. This tool is particularly effective on through-hole plated pc boards.

## AR LEC 75000 SERIES

# P.C.B. TRANSFORMERS

*Ideal for electronic instruments, power supplies, emergency lighting systems, industrial control circuits etc.*

### Features

- Designed to suit standard 0.1" P.C.B. grid
- Lightweight and convenient. Simply solders into position.
- Insulated to Australian standard C 126.
- Low price.
- Available in 7 ratings — 1, 2, 3, 5, 7, 10 and 12 V.A.
- Can be supplied in multi-tapped or dual winding form.
- Telecom approved.
- Readily available in large or small quantities (min 50).

**Specially designed for printed circuit board mounting.**

SEND FOR DATA SHEET

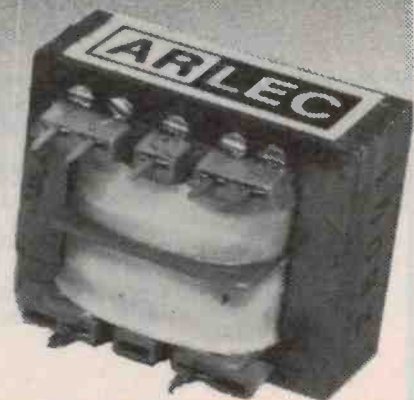

## AR LEC

QUALITY PRODUCTS

## A & R ELECTRONICS PTY. LTD.

A MEMBER OF THE A & R SOANAR ELECTRONICS GROUP

30 Lexton Road, Box Hill, Vic., 3128, Australia. Telex; 32286

VICTORIA: 89 0661  
 N.S.W.: 789 6733  
 STH. AUST.: 51 6981  
 QUEENSLAND: 52 1131  
 WEST. AUST.: 381 9522  
 TASMANIA: 31 6533

# SERIES 5000

As designed by ETI



## SERIES 5000 PREAMPLIFIER — SPECIFICATIONS

Frequency response:	High-level input: 15Hz-130 kHz, +0, -1 dB Low-level input — conforms to RIAA equalisation, $\pm 0.2$ dB
Distortion:	1kHz <0.003% on all inputs (limit of resolution on measuring equipment due to noise limitation).
S/N noise:	High-level input, master full, with respect to 300 mV input signal at full output (1.2V): >92 dB flat >100 dB A-weighted. MM input, master full, with respect to full output (1.2V) at 5 mV input, 500 ohm source resistance connected: >86 dB flat >92 dB A-weighted. MC input, master full, with respect to full output (1.2V) and 200 $\mu$ V input signal: >71 dB flat >75 dB A-weighted.

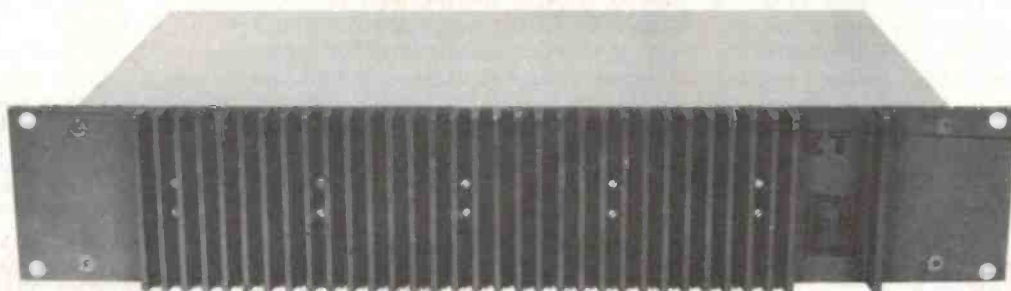

## SERIES 5000 POWER AMPLIFIER — SPECIFICATIONS

Power output:	100W RMS Into 8 ohms ( $\pm 55$ V supply).
Frequency response:	8 Hz to 20 kHz, +0 -0.4 dB 2.8 Hz to 65 kHz, +0 -3 dB. NOTE: These figures are determined solely by passive filters.
Input sensitivity:	1V RMS for 100W output.
Hum:	-100dB below full output (flat).
Noise:	-116 dB below full output (flat, 20 kHz bandwidth).
2nd harmonic distortion:	<0.001% at 1 kHz (0.0007% on prototypes) at 100 W output using a $\pm 56$ V supply rated at 4 A continuous. <0.003% at 10 kHz and 100 W.
3rd harmonic distortion:	<0.0003% for all frequencies less than 10 kHz and all powers below clipping.
Total harmonic distortion:	Determined by 2nd harmonic distortion (see above).
Intermodulation distortion:	<0.003% at 100 W. (50 Hz and 7 kHz mixed 4:1).
Stability:	Unconditional

## SERIES 4000 SPEAKERS FROM ETI

### SERIES 4000/2 3-WAY SYSTEM

Another design from David Tilbrook, for those who require a smaller, lower cost system but retaining good performance. Using the same set of drivers as the 4-way system but less the seven-inch lower midrange driver. The crossover network was designed specifically to suit this system, published in the June 1980 ETI. Will handle 100 W safely.

### SERIES 4000/1 4-WAY SYSTEM

A no compromise, top-line system designed by David Tilbrook and described in the February 1980 ETI. Those who own them or have heard them universally praise them for clarity of sound, superb stereo imaging and smoothness of response. Employing Philips' latest range of low distortion drivers and a specially-designed crossover network (another Tilbrook masterpiece) these speakers are the equal of other systems costing up to three times the price. The 4000/1 will handle 100 W continuous, up to 400 W peak.



# ROD IRVING ELECTRONICS

425 HIGH STREET NORTHCOTE 3070 MELBOURNE (03) 489-8131



# Series 5000 stereo control preamplifier

## Part 3

This is the final article describing the design and construction of the Series 5000 preamp. Last month we described the low-level amplifiers — the moving magnet and moving coil input stages. In this article we concentrate on the high-level switching, line and monitor amplifiers, muting and power supply, and complete the construction details.

David Tilbrook

A COMPLETE circuit diagram of the preamp is included in this article, with the sections described in previous issues shown simply as blocks (LED level meters were described in 'ETI-458 peak/average audio LED level meter', published in June 1981; overall block diagram and features were described in part 1 of the Series 5000 preamp, published in the July issue; moving coil and moving magnet input stages were described in the September issue).

As can be seen from the circuit diagram the preamp has three low-level inputs. The moving coil input is connected directly to the input of the MC head amp. The capacitors C17 and C18 are soldered between shield and active on each of the input sockets. The output of this amplifier is fed to the low-level selector switch on the front panel, together with shielded cables from the two moving magnet inputs. Once again resistors R13 to R16 and capacitors C19 to C22 are soldered on the input sockets. The output of the low-level selector switch is fed to the input of the MM input stage, which incorporates RIAA equalisation as described last month. The input of this stage has an input impedance around 470k, defined by

### SERIES 5000 PREAMPLIFIER — SPECIFICATIONS

Frequency response:	High-level input: 15 Hz-130 kHz, +0, -1 db Low-level input — conforms to RIAA equalisation, ±0.2 dB (see text).
Distortion:	1 kHz <0.003% on all inputs (limit of resolution on measuring equipment due to noise limitation).
S/N noise:	High-level input, master full, with respect to 300 mV input signal at full output (1.2 V): >92 dB flat >100 dB A-weighted  MM input, master full, with respect to full output (1.2 V) at 5 mV input, 500 ohm source resistance connected: >86 dB flat >92 dB A-weighted  MC input, master full, with respect to full output (1.2 V) and 200 µV input signal: >71 dB flat >75 dB A-weighted

resistor R2 in the MM circuit diagram (published last month). Since the input differential pair in the NE5534N requires approximately 200 nV into its bases, a voltage drop around 100 mV will appear across this resistor. Capacitor C2 (MM circuit diagram) is used to isolate this dc voltage from the cartridge. If the source resistance is changed rapidly, however, by unplugging the cartridge or otherwise open circuiting the source resistance, a rapid dc shift will occur, producing a loud thump in the loudspeakers. To overcome this problem the low-level input selector should be a make-before-

break type and all unused low-level inputs should be shorted. The best way to do this is to construct shorting plugs by soldering the active and earth terminals together on an RCA plug. For convenience we have specified all switches in the preamp as three-pole four-position, make-before-break, rotary switches, manufactured by C&K. This was the switch used in the Series 4000 amplifier so availability should be no problem, although the most common type seems to be that with solder lugs rather than pc mount pins. If you are supplied with the solder lug type, the ends of the pins can be cut off with a pair ▶



UNUSED LOW LEVEL INPUTS SHOULD BE PROVIDED WITH SHORTING PLUGS

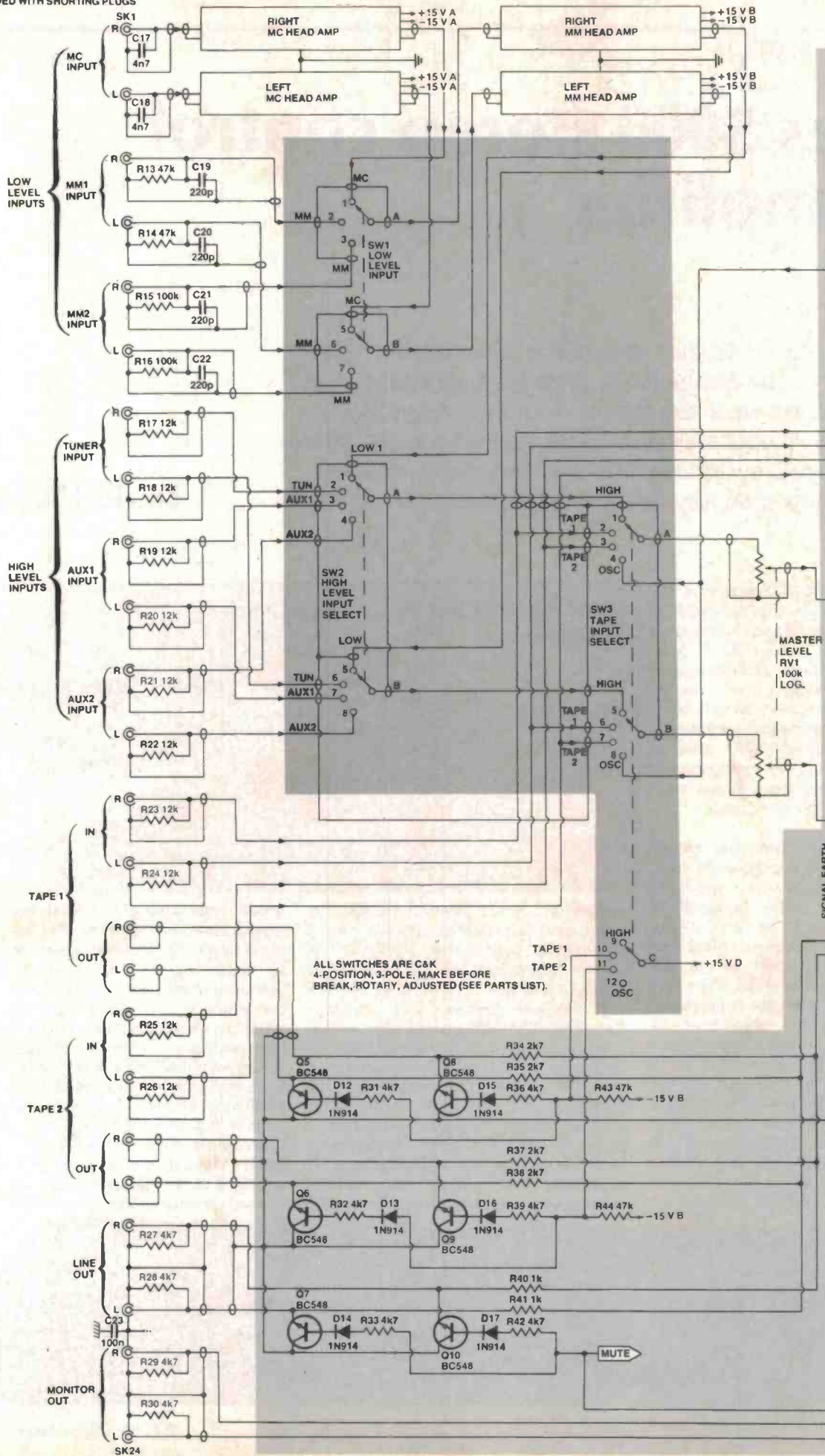

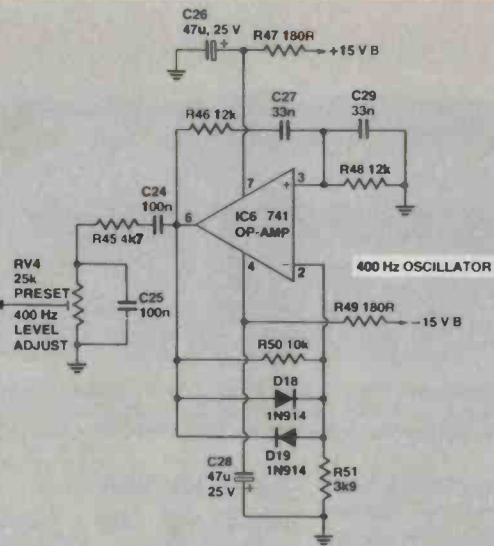

N.B. INPUT RESISTORS IN LED LEVEL METER SHOULD BE CHANGED TO 470k — SEE TEXT.



R90, R91 REPLACE THE 22k RESISTORS ON THE INPUTS OF THE LED LEVEL BOARDS

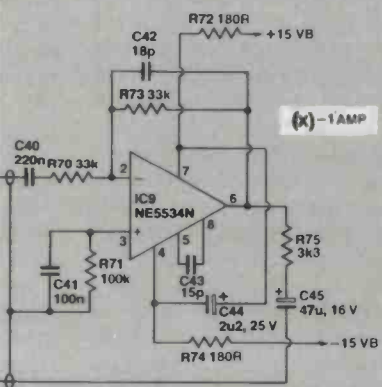
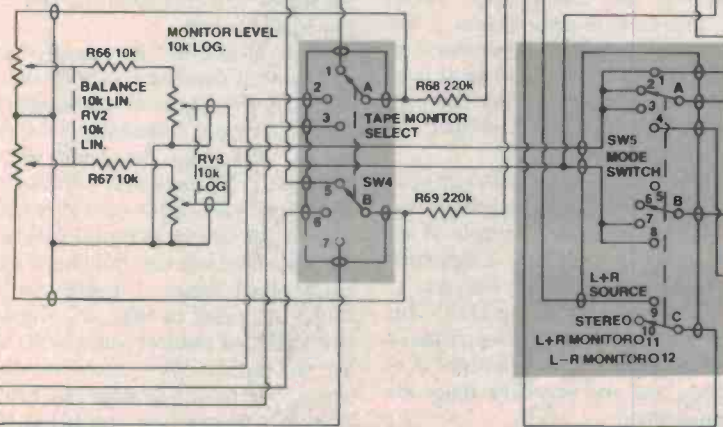
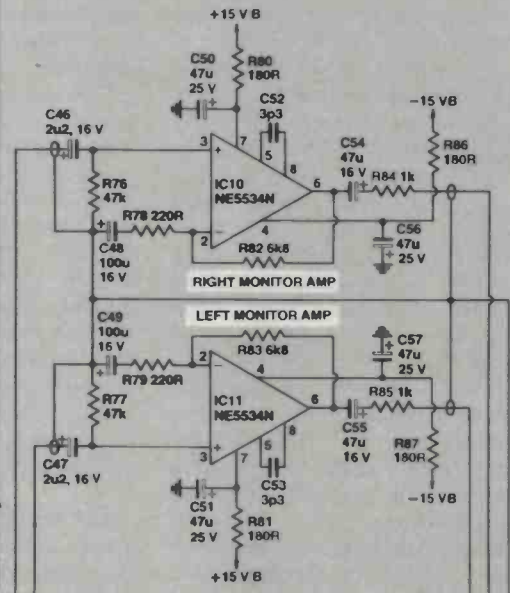
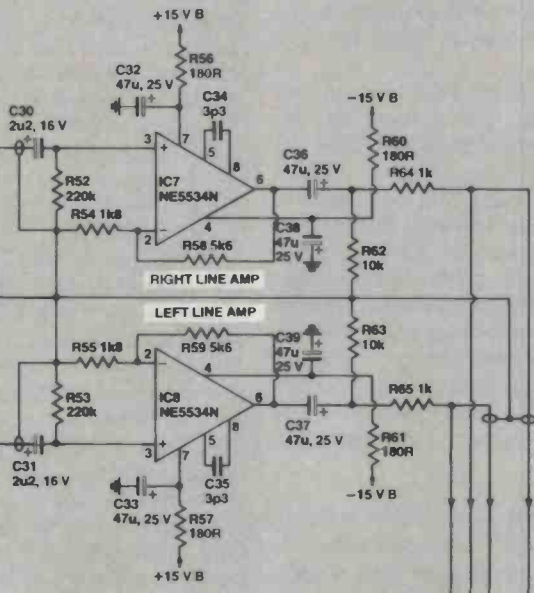



View of the rear of the sub-panel assembly, which holds all the switches and potentiometers. Wiring to the switches is from small pc boards mounted on the rear of each switch. This greatly simplifies the

interconnecting wiring, which must be via shielded cable (I used 3 mm dia. cable). This also ensures that the correct signal earth is preserved throughout the wiring, avoiding hum and noise problems.

of side cutters. There is just enough pin left to fit through the switch pc boards, so cut as closely as possible to the solder eye.

All switches are soldered to pc boards to bring the necessary contacts to the top of the chassis to facilitate ease of wiring. The wiring in the preamp is reasonably complicated, although not difficult thanks to the switch pc boards. I tried it originally by soldering directly to the back of the switches, but the resulting maze of shielded cable would have made it extremely difficult to fault-find and placed excessive strain on the centre lead solder connections. The circuit boards overcome this problem and provide a secure anchor for both the centre lead and the shield on the shielded cable used for most of the wiring inside the preamp. Furthermore, these circuit boards connect the necessary shields together to maintain the integrity of the signal earth, but more about this later.

The output of the MM amplifier is fed to the 'low' position on the high-level input selector (i.e. selecting 'low' selects the low-level input selector), together with tuner, aux 1 and aux 2 inputs. The output of the switch is fed to the tape input selector on the switch pc board and appears at the switch position marked 'high' on the front panel. The third set of contacts on this switch are used to drive the tape 1 and tape 2 muting transistors Q5 to Q9. If tape 1 for example is selected as an input, pin 10 on the tape input selector is taken high, driving the bases of transistors Q5 and Q8 via diodes D12 and D15 and resistors R31 and R36. R43 acts as a pull-down resistor to ensure that the transistor base-emitter junctions cannot be forward biased by large signal excursions. The diodes prevent this reverse voltage from driving the base-emitter junctions into reverse zener action. The operation of the muting transistors is a little unusual since the transistors are used 'upside down'. It is

not commonly known that bipolar transistors can be operated by forward biasing the base-collector junction and using this as the control junction of the transistor. This forms a low gain transistor that has the advantage of a lower on resistance, which is ideal for this situation.

The mute transistors for the line and monitor outputs are driven by the muting control circuitry that senses the presence of the 30 volt ac supply voltage from the power amp. When the amp is turned on, the circuit mutes the line and monitor outputs, turns on the main supply rails and then releases the muting. This eliminates the problem of turn-on thump, although a slight click will be heard as the muting transistors are switched. Similarly at turn-off the muting circuit mutes outputs until the main supply voltage has dropped sufficiently.

The output of the high-level selector is fed via the master level control to the line amplifiers. From the line amplifiers the signal is fed through the tape monitor switch to the balance and monitor level potentiometers, through the mode switch to the monitor amplifiers. When the mode switch is switched to the L-R position the left channel monitor volume wiper is connected to the output of the unity gain phase inverter. The output impedance of the inverter has been set to correspond to that of the left monitor pot when it is at full volume, so turn the monitor fully up when using this facility and use the master as the volume control.

The 400 Hz oscillator is based around the 741 op-amp IC6 and its associated circuitry. The design is a simple Wien bridge oscillator with amplitude stability achieved through the use of back to back diodes, D18 and D19. This results in an output waveform that is not really a sine wave although it is reasonably close and entirely adequate in this application.

## Construction

Commence the construction by assembling the LED level meters and the MM and MC input stages. Full construction details for these boards have been given in earlier articles (see above). Ensure that sufficient shielded cable has been soldered to the low-level amplifiers before they are mounted in the separate low-level amp sub-chassis. The bolts used to mount these pc boards are also used to mount the sub-chassis itself, so leave the mounting of the sub-chassis until later.

In this project the LED level meters are mounted with their track sides closest to the top of the preamp. In this way the LEDs run from left to right. This has the disadvantage, however, that calibration of the level meters must be done before mounting. Alternatively drill holes through the level meter pc boards, large enough to take a small screwdriver, immediately behind the three preset pots on each board. In this way adjustment of the level meters can be done after mounting, which is considerably easier. A second modification which must be done to the LED level meters is to increase their input impedance. This is done by removing the 22k parallel input resistor, R1 on the level meter circuit diagram, and replacing it with a 470k. These additional resistors are included on the main pc board parts list.

Next assemble the main pc board; a component overlay has been included to simplify this stage of construction. First make a visual inspection of the circuit board, checking for open circuits or short circuits between adjacent tracks. This is a reasonably complex board and any faults are best found at this stage. Check also that the holes are drilled to convenient sizes. I prefer to enlarge holes intended to take the shields from the shielded cables, and the three holes for the preset RV4 must also be large enough to accommodate the fairly wide pins. There are five mounting holes for

# stereo control preamp

the circuit board itself; these should be 6BA clearance (approx. 3 mm). Similarly, the mounting of the IC regulators is done with 6BA nuts and bolts. The LED level meters mount on their own pillars, two of which pass through the main pc board. These holes (see overlay) should be large enough to allow a 6BA bolt without interference from the main pc board.

If all is correct mount the wire links, resistors and nonpolarised capacitors such as greencaps and ceramics. Next mount the transistors and diodes, ensuring that they are inserted the correct way around. Note that in the row of diodes near the power switch, diodes D3 and D4 are mounted in the reverse direction to the other diodes. Mount the integrated circuits, again making sure the orientation is correct. The voltage regulator ICs are best mounted by bending the leads with a pair of side cutters first, then inserting the pins through the pc board and securing the regulators with 6BA nuts and bolts. Pass the bolts through the pc board from the underside (i.e. nut on top). Finally solder the pins. The regulator IC3 runs the warmest of these regulators since it supplies the positive rail to the LED level meters.

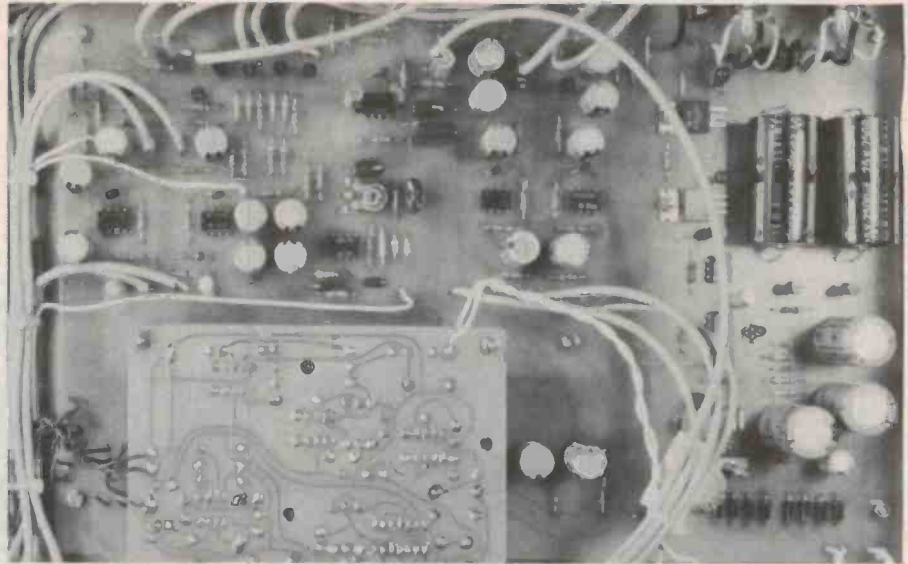

The completed motherboard (ETI-478 MB) assembled in the chassis. This board contains all the power supply circuitry, muting, line amplifiers and the unity gain inverting amplifier ('x-1 amp').

Mount the preset RV4. The last components to be mounted on the main pc board are the electrolytic and tantalum capacitors. Once again be careful of the orientation of these components.

The final stage in the construction of the main board is to solder the connect-

ing cables. These are left as 'flying leads' at this stage but with sufficient length to allow them to run to their respective positions within the preamp. If the main board is positioned roughly on the bottom panel an estimate of the necessary lengths is easily made. ▶

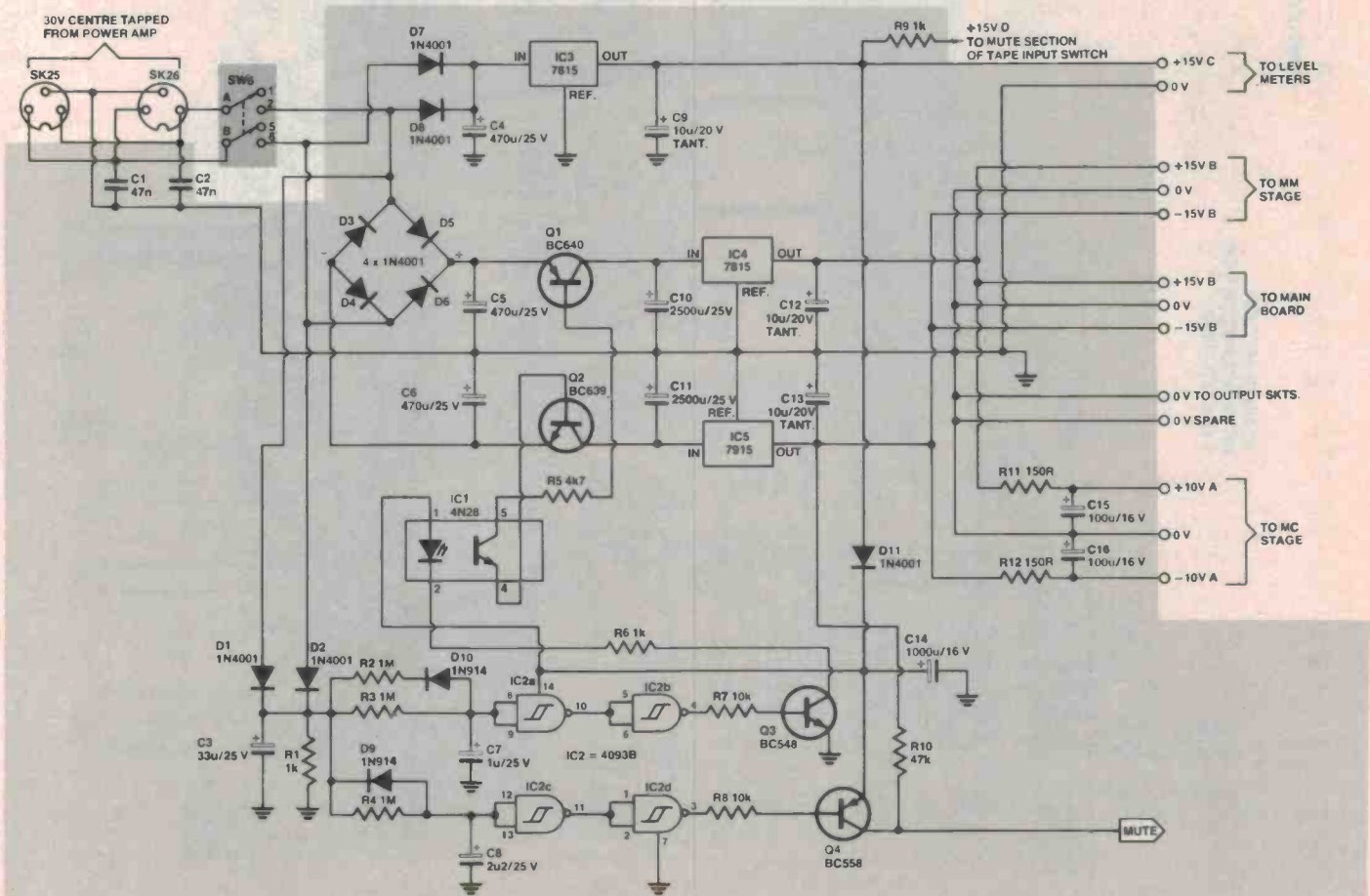

# Series 5000

## COMPONENT OVERLAY FOR THE MOTHERBOARD ETI-478 MB

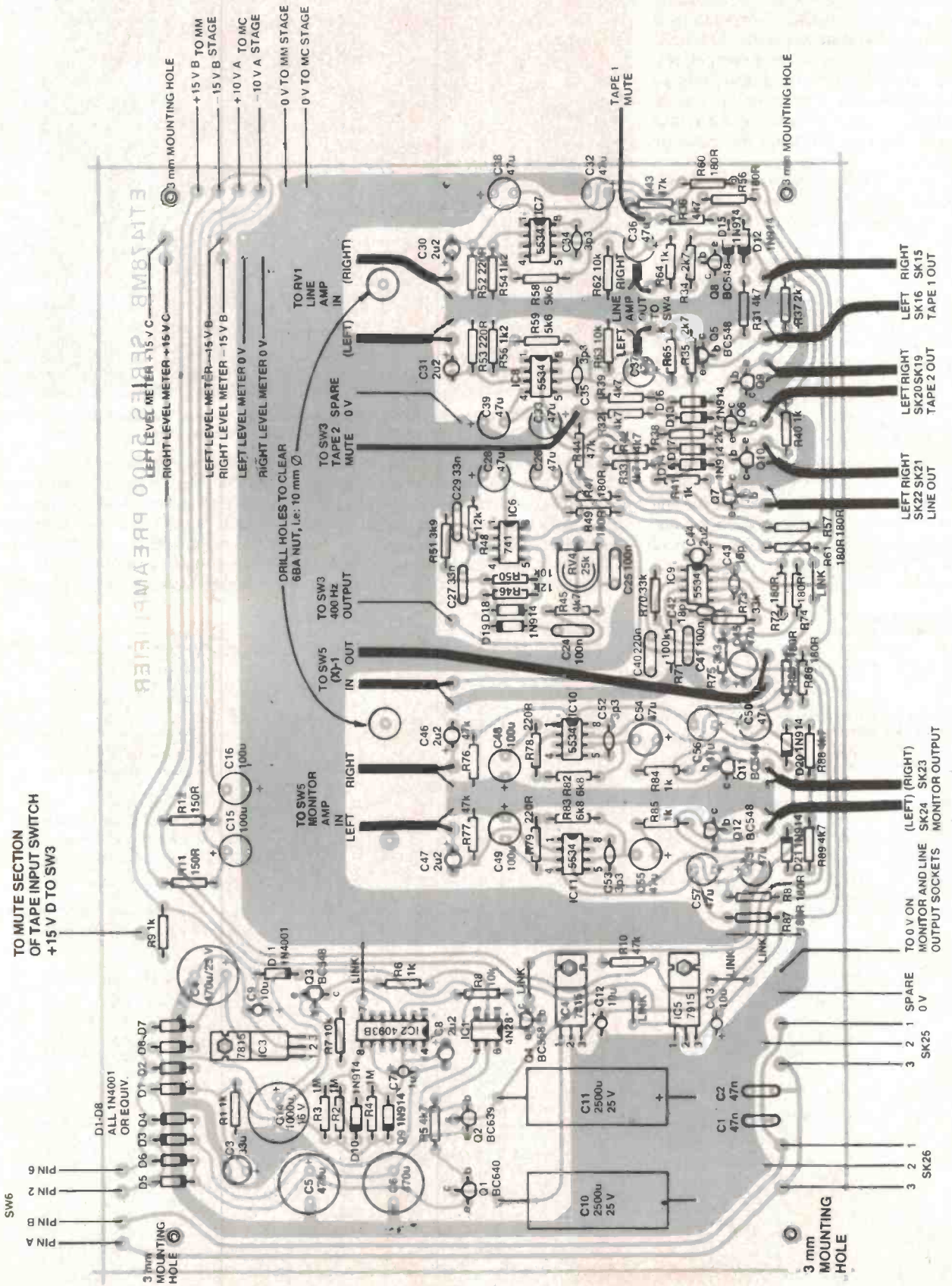

# stereo control preamp

The connections marked +VA, -VA, +VB, -VB and the two 0 V connections at the extreme right edge of the pc board supply power to the MC and MM input stages. These leads are already soldered to the MC and MM pc boards, so leave them empty at this stage. The power supply leads to the LED level meters, however, should be soldered to the main board and left flying for the time being. Notice that all signal-carrying leads are shielded cable, and provision has been made on the pc board to accommodate the shields. The connections to the mute lines and the 400 Hz oscillator are done with conventional hookup wire (see overlay and relevant photographs).

Next construct the rear panel assembly. Start by disassembling the chassis so that you can work on the panel without interference from the

bottom panel or side bars. All inputs and outputs are done with RCA-type sockets, with the exception of the two three-pin DINs. The RCA sockets must be insulated from the chassis. This is done by first fitting rubber grommets to the drilled holes in the rear panel and then mounting the sockets through the grommets. Ensure that the earth lug points toward the top of the rear panel. This was the technique used for the input sockets to the Series 5000 power amp and forms an effective and inexpensive insulated socket.

Once all the RCA sockets have been mounted, fit the two three-pin DIN sockets. All the leads to the rear panel come from either the main board or the front panel assembly so no leads need to be soldered to the rear panel at this stage. Instead solder all the resistors

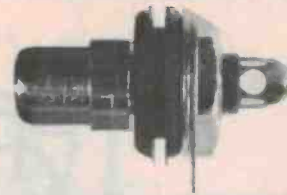

The RCA sockets mount through the hole of rubber grommets fixed to the rear panel, electrically isolating them from the panel.

and capacitors as shown in the rear panel assembly drawing. Note that all the sockets with the exception of the four tape outputs have parallel resistors and/or capacitors. The overlay drawing included shows the position of these components.

The next stage is the assembly of the front panel. Once again start by disassembling this part of the chassis; the wiring is fairly complicated and is much easier to do with the sub-panel separate.

## PC BOARD ARTWORK AND CABINET DRAWINGS

We do not have sufficient room to reproduce the pc board artwork (boards are ETI-478 MB, SA, SB, SC, SD) and the cabinet metalwork drawings. A complete set may be obtained by sending a 300 x 250 mm stamped, self-addressed envelope to:

SERIES 5000 ARTWORK & DRAWINGS  
ETI MAGAZINE  
15 BOUNDARY ST  
RUSHCUTTERS BAY NSW 2011

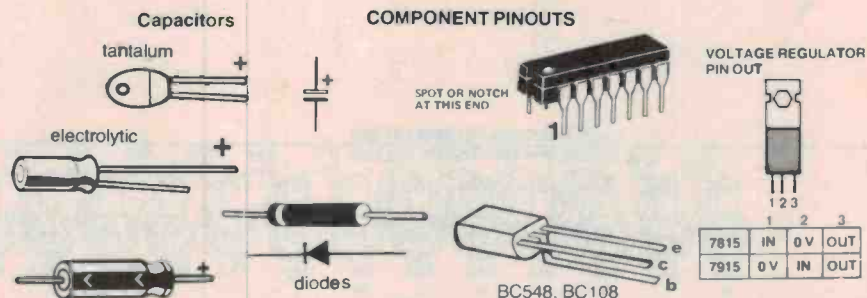

## PARTS LIST ETI-478MB SERIES 5000 PREAMP MOTHERBOARD AND CASE ASSEMBLY

### Resistors

R1, 6, 9, 40, 41, 64, 65, 84, 85	all 1/2W, 5%
R2, 3, 4	1k
R5, 27 to 33, 36, 39, 42, 45, 88, 89	4k7
R7, 8, 50, 62, 63, 66, 67	10k
R10, 13, 14, 43, 44, 76, 77	47k
R11, 12	150R
R15, 16, 71	100k
R17 to 26, 46, 48	12k
R34, 35, 37, 38	2k7
R47, 49, 56, 57, 60, 61, 72, 74, 80, 81, 86, 87	180R
R51	3k9
R52, 53, 68, 69	220k
R54, 55	1k8
R58, 59	5k6
R70, 73	33k
R75	3k3
R78, 79	220R
R82, 83	6k8
R90, 91	470k NOTE: R90, 91 replace R1 (22k) in each ETI-458 LED level display.
RV1	100k/C dual log. pot.
RV2	10k/A dual linear pot.
RV3	10k/C dual log. pot.
RV4	25k trimpot.

### Capacitors

C1, 2	47n greencap
C3	33u/25 V RB electro.
C4, 5, 6	470u/25 V RB electro.
C7	1u/25 V RB electro.
C8, 44	2u2/25 V RB electro.
C9, 12, 13	10u/20 V tantalum
C10, 11	2500u/25 V axial electro.
C14	1000u/16 V RB electro.
C15, 16, 48, 49	100u/16 V RB electro.
C17, 18	4n7 greencap
C19, 20, 21, 22	220p mica or styroseal
C23, 24, 25, 41	100n greencap
C26, 28, 32, 33, 36, 37, 38, 39, 50, 51, 56, 57	47u/25 V RB electro.
C27, 29	33n greencap
C30, 31, 46, 47	2u2/16 V RB electro.
C34, 35, 52, 53	3p3 ceramic
C40	220n greencap
C42	18p ceramic
C43	15p ceramic
C45, 54, 55	47u/16 V RB electro.

NOTE: electrolytic and tantalum capacitors have been specified with the minimum working voltage rating and the pc board has been laid out to suit. Higher voltage rating capacitors may not fit. RBLL types may be substituted where we have specified electrolytics, but where tantalums are specified no substitution may be made.

### Semiconductors

D1 to D8, D11	1N4001, 1N4002 etc.
D9, 10, 12 to 21	1N914, 1N4148 etc.
IC1	4N28 opto isolator
IC2	4093B quad Schmitt NAND
IC3, IC4	7815 +15 V 3-terminal reg.
IC5	7915 -15 V 3-terminal reg.
IC6	741 op-amp.
IC7 to 11	NE5534N op-amp.
Q1	BC640
Q2	BC639
Q3, Q5 to 12	BC548
Q4	BC558

### Miscellaneous

SW1, SW4	3-pole, 3-position rotary
SW2, SW3, SW5	3-pole, 4-position rotary
SW6	3-pole, 2-position rotary

All switches are C&K Lorlin 3-pole, 4-position rotary make-before-break types with stops set as

Printed circuit boards — ETI-478MB, SA, SB, SC, SD; 24 panel-mount RCA sockets; 24 rubber grommets 6 mm bore; two 3-pin DIN sockets; two 3-pin DIN plugs; shielded cable 4 mm dia.; metalwork as per cabinet drawings; front and rear Scotchcal panels; nine fancy knobs to suit; two ETI-458 LED level meters; ETI-478MM and ETI-478MC stages and metalwork; nuts, bolts, solder, hookup wire, etc.

# Series 5000

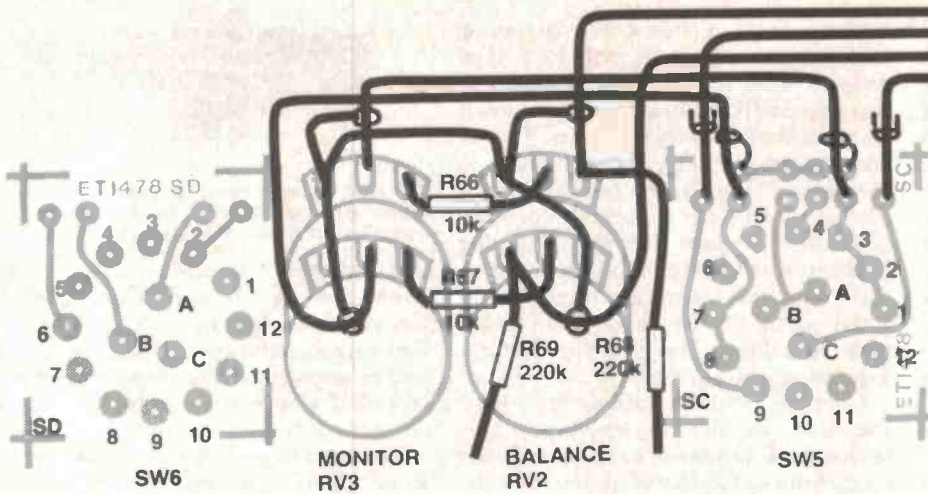

ALL SUB-PANEL ASSEMBLY WIRING IS DONE ON THE NON-TRACK SIDE OF THE PC BOARDS, i.e: BETWEEN PC BOARDS AND SUB-PANEL.

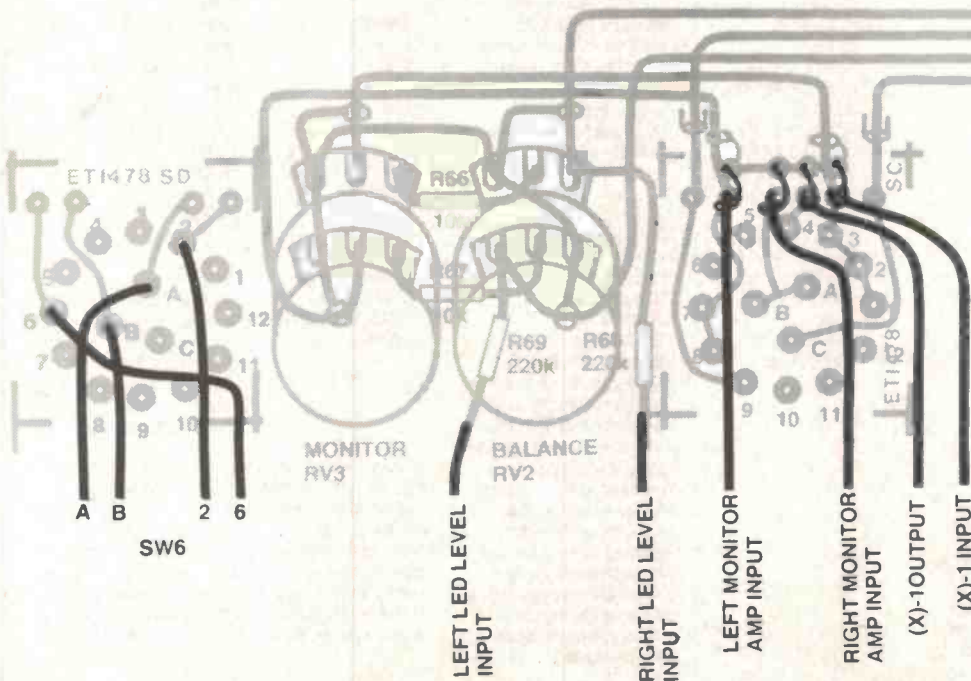
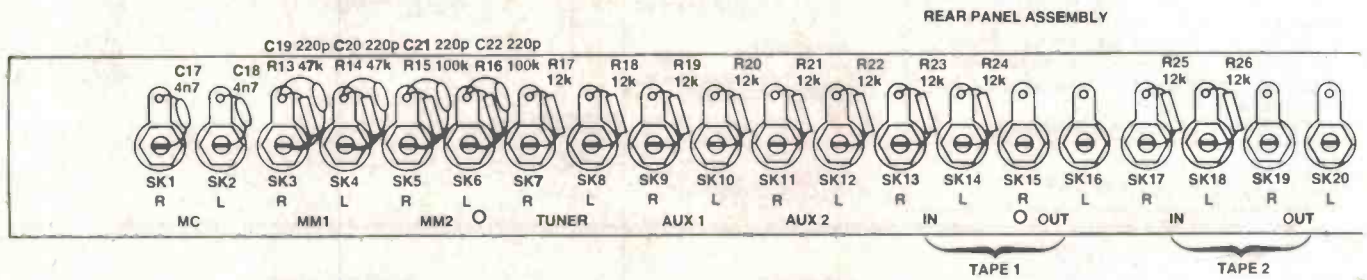



# stereo control preamp

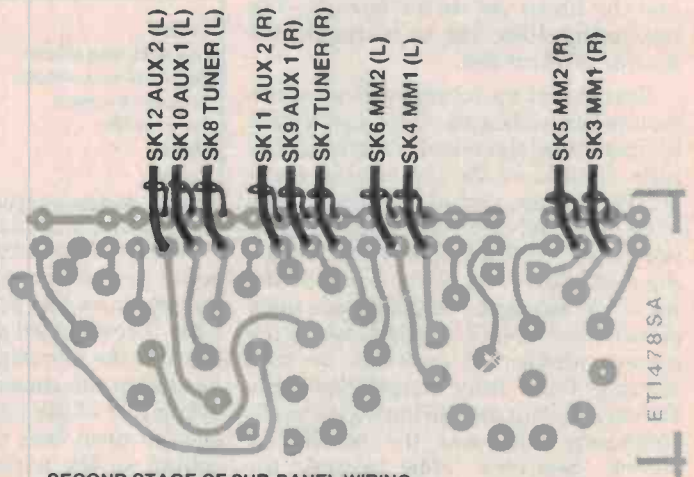
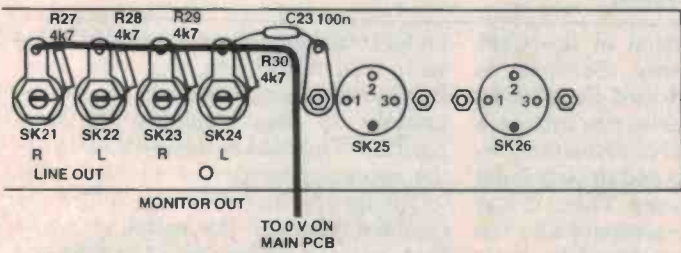
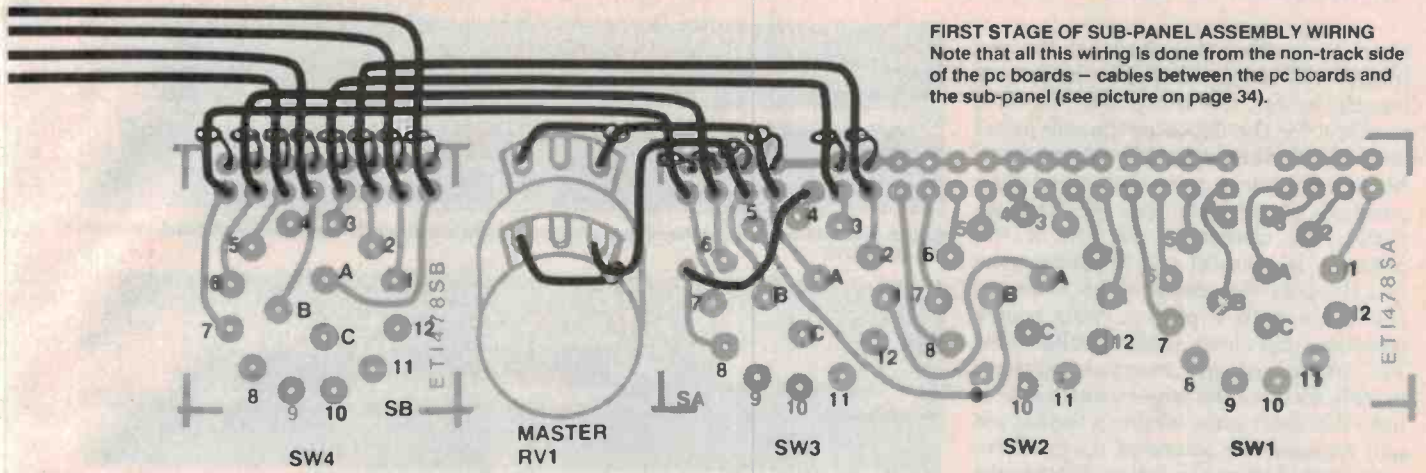

**SECOND STAGE OF SUB-PANEL WIRING**  
 This too is done from the non-track side of the board (refer also to picture on page 34).

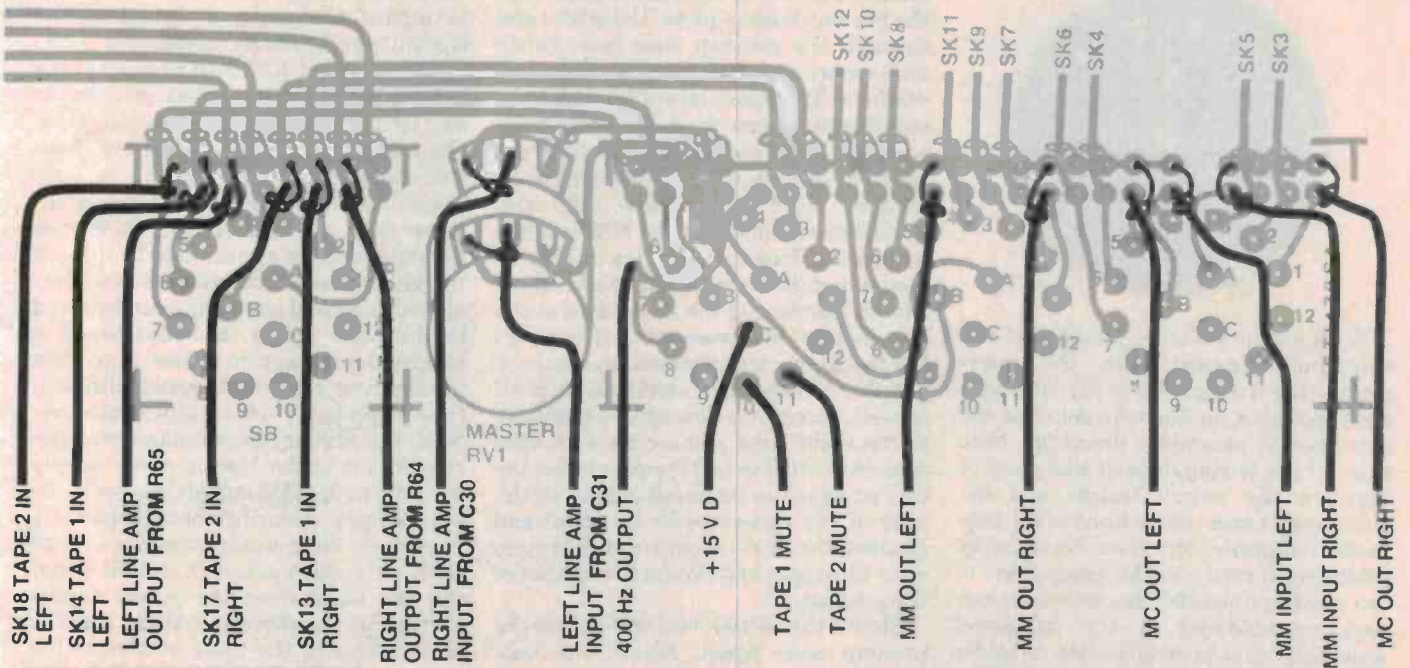

**THIRD STAGE OF SUB-PANEL WIRING**  
 This is done from the track side of the pc boards (see also picture on page 34).

# Series 5000

Start by cutting the shafts of the potentiometers and switches to the correct lengths to suit the knobs used. Be sure to allow for the depth of the sub-panel and the thickness of the front panel. Mount the three pots with their pins pointing toward the top of the sub-panel, i.e: closest to the lid of the preamp. Be careful not to confuse the two 10k pots. If in doubt which is the log pot, place both wipers at their centre positions and check with a multimeter. The linear pot will measure approximately 5k from the wiper (centre pin) to both the outer pins, whereas the log pot will measure 1k to one of the contacts and around 9k to the other. The log pot is used for the monitor volume control and the linear pot as the balance. The remaining 100k log is of course the master level control.

Next mount the rotary switches to the four switch pc boards. Once again start by inspecting the boards carefully. The rows of pads at the top edge of these boards are intended to take the shields of the shielded cable, so enlarge them if necessary. Solder the switches, ensuring that the correct pin is closest to the top of the sub-panel assembly (see table of switches). Adjust the switches to the correct number of positions by first turning them fully counterclockwise. Remove the nut and spring washers; the remaining ring sets the number of switch positions. Now mount the switches to the sub-panel.



With all the switches mounted to the sub-panel, proceed with the inter-connecting wiring. This is all done with shielded cable, as shown in detail on the sub-chassis assembly drawing. Note that all the wiring done at this stage is between the switch boards and the sub-panel. Later connections to the sub-panel assembly can then be done by soldering directly to the track sides of the switch pc boards. There are also four resistors soldered to the sub-panel assembly; it is probably wise to solder the two 10k resistors before the shielded cables. (See pages 40-41).

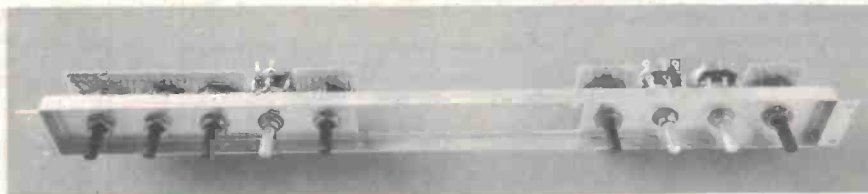

Switch assemblies and potentiometers, with their shafts cut to length to suit the knobs used, mounted to the sub-panel.



Rear view of the sub-panel assembly, prior to wiring.

Switch	Number of Positions	PC Board	Pin Closest to Top
Low level input selector	3	SA	3,4
High level input selector	4	SA	4
Tape input selector	4	SA	4
Tape monitor	3	SB	3,4
Mode	4	SC	4
Power	2	SD	3

Table 1. Switches and positions.

With the construction of the front panel assembly complete, the wiring to the input switch pc board can now be done. The shielded cables run from this board to the rear panel between the low-level amp sub-chassis and the left hand side panel of the preamp. There is just enough room here to accommodate the cables, so the wiring should be neat, avoiding twists or crossovers between cables. The best way to do this is to first mount the low-level sub-chassis onto the preamp bottom plate. Use 6BA bolts through the preamp base from below and secure them with eight nuts and washers. The base plate of the low-level sub-chassis is now placed on these bolts with its open end closest to the front panel of the preamp, and secured with another eight nuts. These nuts also double as standoffs for the MM and MC pc boards. This does not leave a great deal of height between the track side of the pc boards and the base plate of the sub-chassis, so ensure that all wires on the track side are trimmed as closely as possible to the solder connections. If all is well, mount the low-level amplifiers to the eight bolts and secure with 6BA nuts. As stated in last month's issue, the MC pc board is mounted closest to the rear of the chassis with its input end against the rear. Mount the MM amp with its output end closest to the front of the preamp.

Mount the bottom two side bars to the preamp base panel. Mount the sub-panel assembly onto the bottom panel using three self-tappers through the

panel into the sub-panel assembly, and with two bolts into the side bars. Position the rear panel at the back of the preamp in approximately its final position. This makes it easy to estimate the necessary lengths of shielded cable to cut for the input wiring. Solder the shielded cables to the switch pc board first, run the cables down the side and behind the sub-chassis, trim and solder to the input sockets.

The next stage in the construction is to mount the main pc board to the bottom panel. Before doing this, however, pass four 1.25 inch (32 mm) 6BA bolts through the base plate from below and secure with a nut to act as pillars for mounting the LED level meters. Pass five shorter 6BA bolts through the base plate and secure with nuts. Once again these nuts act as standoffs, so ensure that wire ends on the main pc boards are trimmed close to the solder joints. If required, a second set of nuts can be fitted to the bolts before the main board is mounted in order to space it a little further from the bottom panel, although this is probably not really necessary. With the main pc board placed roughly in position, solder the six power supply leads from the MM and MC stages to the main board, ensuring that the polarity is correct. Now secure the main board with nuts and washers. Cut and solder the six leads from the power supply section to the three-pin DINs and the three wires to the mute section of the tape input selector, as well as from the output of the 400 Hz oscillator (see

## stereo control preamp

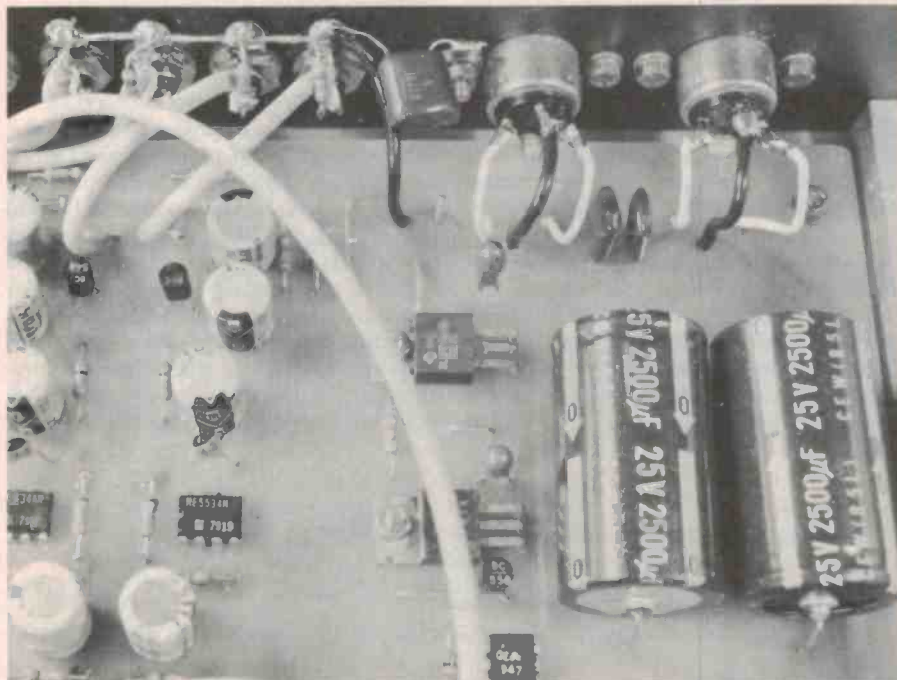

View of the rear panel and motherboard showing the output RCA sockets wiring and ac input/output DIN sockets wiring.

overlay diagram). Solder the leads to the power switch and the 0 V connection to the output socket earth.

The remaining wiring to the pc board consists of shielded cables. Before soldering these, however, run cable from the rear panel tape input sockets to

the tape monitor switch. These cables are terminated directly to the track side of the switch pc board. The connections are shown in the rear panel and sub-panel assembly (p.40-41), followed by the monitor amp inputs and the unity gain inverter's input and output leads. As

above, all of these cables solder to the panel assembly drawings. Then solder the line amp inputs and outputs to the track side of the switch boards. Cut and solder the output leads from the main pc board to the rear panel. Pass the input leads to the MC stage through the hole in the rear of the sub-chassis, which should be fitted with a rubber grommet, and solder to the MC input sockets. With all the wiring done to the rear panel it can be bolted to the chassis, together with the top two side bars. Solder the remaining shielded cables to the low-level amps to the track side of the input switch pc boards.

The final stage in the construction of the preamp is to mount and calibrate the LED level meters. If the added holes have been drilled to allow calibration through the pc board, the first level meter can be mounted. The height of the pc board is set by four nuts and washers, which can be adjusted to the correct height on the bolts. Alternatively, screw a further three nuts and a washer onto each mounting bolt. This is close to the correct height and ensures that strain is not placed on the pc board by different-height nuts. Secure with a further four washers and nuts. The mounting holes should be drilled well oversize so that

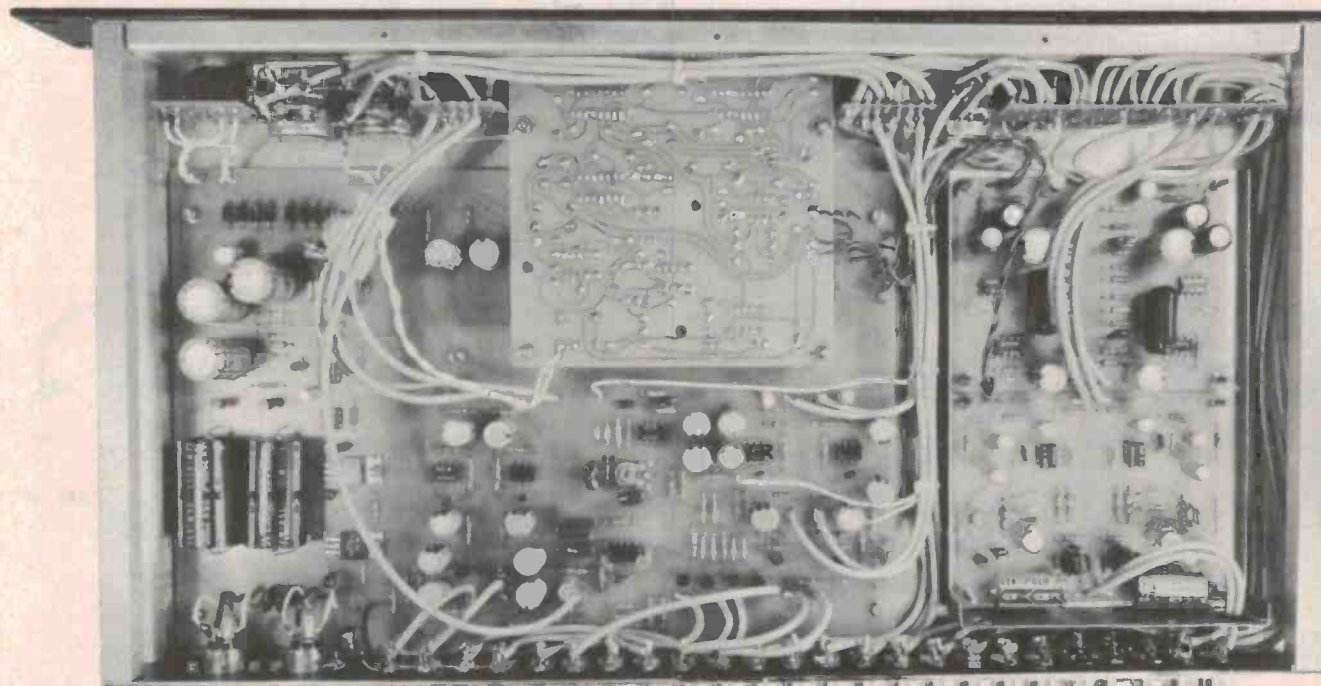

The completed project, prior to installing the low-level stages' top shield cover and the cabinet cover. The wiring looks complicated, but it's not as bad as it looks! Note the holes drilled in the top LED level meter board so that the adjustments may be easily reached (see text).

# Series 5000

final adjustment of the position of the LEDs can be carried out.

Now mount the front panel. If the LEDs are not in a perfectly straight line it is extremely difficult to get the front panel on, so it is well worth the effort of getting these as straight as possible. Solder the power supply wiring to the board and the input connection to the appropriate resistor on the sub-panel assembly.

## Powering up

At this stage the preamp must be powered up, so check as much as is

possible. In particular check the polarity of diodes, transistors and electrolytic and tantalum capacitors. Check also the power supply connections, especially those to the MM and MC preamp stages. If all is well construct a three-pin DIN lead using twisted hookup wire and apply power to the preamp from the 30 volt centre-tapped supply on the rear of the Series 5000 power amplifier. If you are not using the preamp with an ETI power amp, a separate 15-0-15 volt transformer must be used. Switch the tape input selector to the 400 Hz position, the tape monitor switch to the source

position and the mode switch to stereo. Centre the balance pot and turn both master and monitor volume control fully on. Ensure that the three flying leads that will take power to the second level meter are not touching each other or anything else in the preamp. If the preamp is now turned on, the LED level meters should indicate the presence of the 400 Hz tone by moving swiftly to the right. If all is well, turn the monitor volume fully down and adjust the LED level meter dc offsets as described in the original article on the level meters. Ensure that the monitor level control is fully up, and by using a multimeter and



Reproduction of the front panel artwork (above) and rear panel artwork (below).

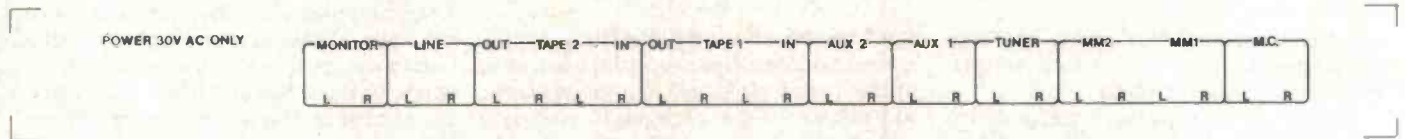

How the case chassis assembles together.

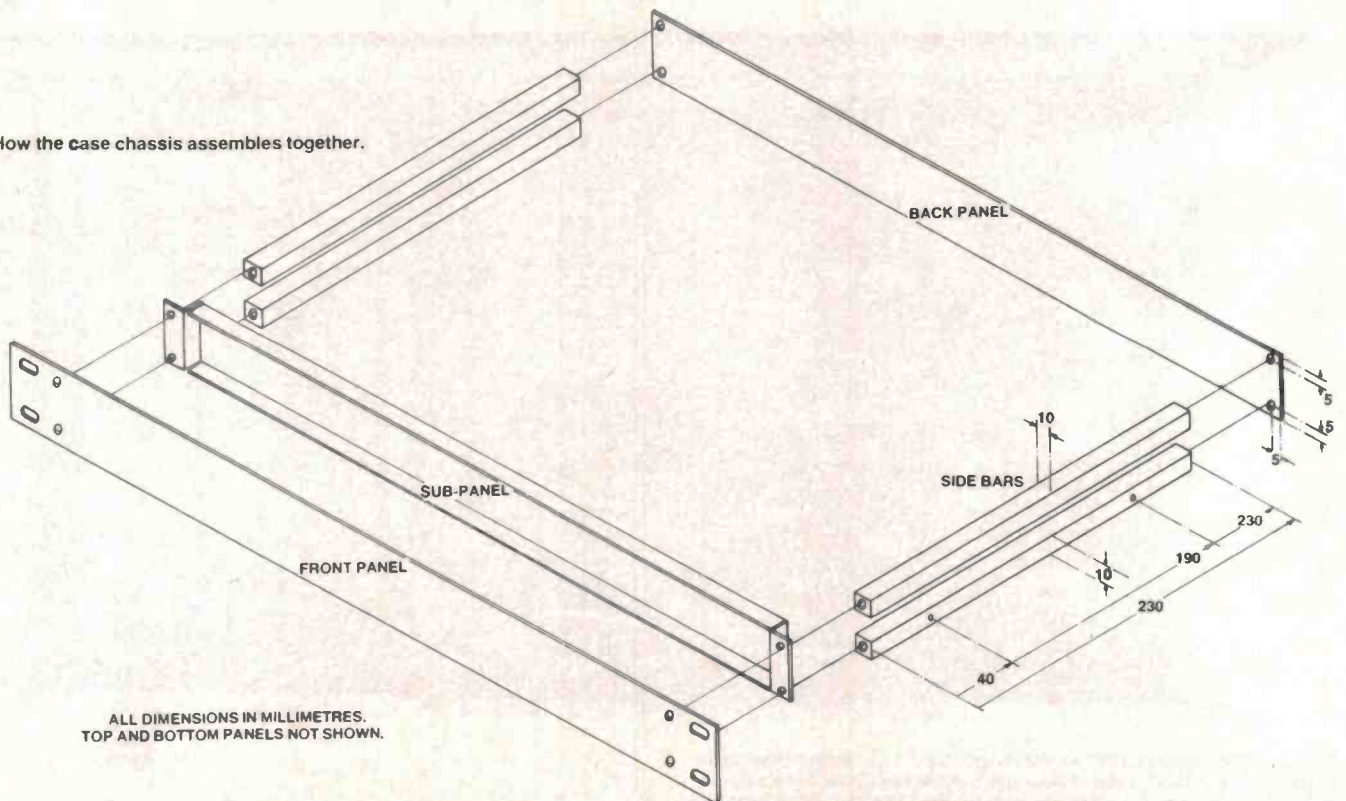

ALL DIMENSIONS IN MILLIMETRES.  
TOP AND BOTTOM PANELS NOT SHOWN.

# Bill Edge's ELECTRONIC AGENCIES

115-117 Parramatta Road Concord 2137  
(Corner Parramatta Road & Lloyd George Ave)  
Telephone: (02) 745 3077 (two lines)

All prices correct & goods in stock at time of going to press. Please phone to check current availability



Mail orders:  
PO Box 185  
Concord  
2137

TRADING HOURS  
Mon-Fri ..... 9am-5.30pm  
Saturday ..... 9am-noon  
Sunday ..... 10am-2pm

MAIL CHARGES  
\$5-\$9.99 ..... \$1.00  
\$10-\$24.99 ..... \$2.00  
\$25-\$49.99 ..... \$3.00  
\$50-\$99.99 ..... \$4.00  
\$100 or more ..... \$5.50  
All heavy or bulky items (over 20kg) sent  
Comet Road Freight \$8.00  
Anywhere in Australia

what else do we carry? HI-FI★KITS★PA EQUIPMENT★MIKES★HARDWARE★TOOLS★WIRE★SEMIS★

## Electros at dirt cheap prices UP TO 90% OFF!

Top quality electrolytic capacitors at prices you won't believe. All are brand new, prime spec devices from distributor's liquidated stock—their loss is your gain! But you'll have to be quick as the stock is strictly limited.

Axial lead Value & Voltage	Cat. No.	Approx. Normal Price	Special Price	Quant. Avail.
uF/v			3c	290
1/50	RE5300	28c	8c	88
3.3/100	RE5301	35c	20c	163
8/350	RE5302	55c	12c	35
10/160	RE5303	45c	24c	71
16/350	RE5304	90c	22c	600
22/160	RE5305	80c	4c	642
33/16	RE5306	28c	8c	156
33/50	RE5307	35c	8c	56
47/6.3	RE5308	28c	8c	53
47/100	RE5309	45c	12c	72
330/25	RE5310	84c	20c	95
330/63	RE5311	95c	30c	150
2200/35	RE5312	\$1.70	50c	150
2200/16	RE5313	\$1.20	40c	600

RB (PC Mount)	Cat. No.	Approx. Normal Price	Special Price	Quant. Avail.
1/50	RE5320	20c	4c	89
2.2/16	RE5321	20c	20c	50
10/315	RE5322	90c	16c	150
22/160	RE5323	75c	5c	36
100/10	RE5324	28c	18c	48
330/63	RE5325	\$1.20	20c	280
470/63	RE5326	\$1.20	20c	38
2500/16	RE5327	\$1.20	25c	600
2500/25	RE5328	\$1.30	45c	12
4700/25	RE5329	\$2.00		

limited stock—stock up now!

## SCOOP PURCHASE Aluminium project cases

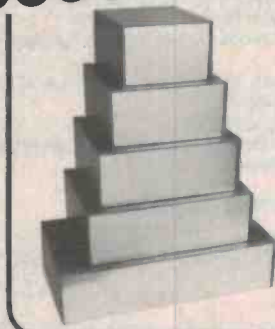

Special purchase of top quality aluminium boxes. Woodgrain finish top and sides. Save about 50% on equivalent cases. We have approximately 40 of each so get in quick for these never to be repeated prices.

Now you can afford to house all your projects

## This month only LED SPECIALS

All brand new, top quality LEDs—at rock bottom prices. Save up to 50% on our normal low prices. All colours, all shapes and sizes.



	Cat. No.	Normal Price	This month
3mm Red	ZE1811	20c	12c
3mm Green	ZE1819	28c	15c
3mm Yellow	ZE1821	28c	15c
5mm Red	ZE1832	16c	10c
5mm Green	ZE1836	28c	18c
5mm Yellow	ZE1840	34c	20c
5mm Orange	ZE1844	34c	20c
Rect. Red	ZE1850	40c	20c
Rect. Green	ZE1854	40c	20c
Rect. Yellow	ZE1856	40c	20c

## GREAT DEAL ON ET15000

### ET15000 PREAMP

- The latest and greatest. Full kit to ETI specifications (see this month's issue) includes:
  - Full pre-punched chassis in black anodised aluminium
  - Silk screened front and rear panels
  - Quality black solid metal knobs
  - Includes moving coil and moving magnet preamps and LED level meters
  - Matches our ET15000 Power amp beautifully
- Don't buy kits that don't include absolutely everything!
- Cat. KE5050 Complete kit \$245.00

### ET15000 POWER AMP

- What can we say about this fantastic amplifier. The Electronic Agencies kit includes specially designed black anodised folded case to make it one of the best looking amps on the market. Don't buy kits with inferior cases.
- Cat. KE5000 Absolutely complete kit \$295.00



BUY BOTH KITS TOGETHER  
FOR ONLY \$520  
FIGURE OUT THE SAVINGS!

This is a special introductory offer SO HURRY!

## pH meter

ETI's fantastic digital pH meter gives a direct readout of pH for laboratory, industrial or household use. Complete kit including pH meter specified by ETI and both buffer solutions. 3 1/2 digit liquid crystal display for easy reading in any light. See ETI December 1980.

KE4050  
\$99.50



## Clarion Tweeters

One of our most popular economy tweeters—over 400 sold! Ideal for upgrading that twin cone to a two-way system. Power handling of 3W continuous (about 15W system power), 50mm cone, 2kHz to 13kHz, 8 ohm impedance. And look at our price! Cat. CE2000 ONLY \$1.99. \$1.50 each for 10 or more

## Foster 250mm woofer

Here's a speaker that didn't get into our catalogue. The Foster C250L09 is a top quality 250mm woofer with power handling of 50W, resonant frequency of 30Hz and sensitivity of 92dB (1W, 1m).

\$25.50



Cat. CE2119

NOW  
A computer for \$99! Available October

ETI 660

No one would have believed it a few years ago. Features include: colour capability, operates from optional 9V plugpack, 1K memory expandable to 3K on-board, single board construction, cassette interface, audio output (play tunes), simple to program (uses Chip-8). Expansion projects coming up include: ASCII keyboard, light pen, games software etc.

Starter Kit (1K RAM, B&W video)	\$99.00
9V, 200mA plugpack to suit	\$6.50
Colour video option	\$8.00
RAM expansion (add to PCB)	\$17.00
Pre Programmed 2716 ROM	\$18.50

We expect this kit to be in stock in October. Please phone for precise details. Cat. KE6600

## Plugs into any TV!

## Sound effects kits

The brand new ET1607 series based on the Texas SN76488 IC. Kits include PCB and all parts.

KE0200 Bomb & explosion	\$11.95
KE0210 Steam train/whistle	\$10.95
KE0220 Phaser & alarm	\$9.95
KE0230 Phaser & explosion	\$10.95
KE0240 Gun shot	\$10.95

## Microwave oven leak detector

Simple to build kit that lets you make absolutely sure your oven is safe. ETI design.

KE1100	\$14.95
--------	---------

NEW

MISSED OUT ON OUR CATALOGUE LAST MONTH? If you haven't got your copy of the Electronic Agencies 32 page catalogue, just send us 75c (to cover postage and packing). See postal address at the top of this page.

# Series 5000

## LM394

### GENERAL DESCRIPTION

The LM194 and LM394 are junction-isolated ultra-well-matched monolithic NPN transistor pairs with an order of magnitude improvement in matching over conventional transistor pairs. This was accomplished by advanced linear processing and a unique new device structure.

Electrical characteristics of these devices such as drift versus initial offset voltage, noise, and the exponential relationship of base-emitter voltage to collector current closely approach those of a theoretical transistor. Extrinsic emitter and base resistances are much lower than presently available pairs, either monolithic or discrete, giving extremely low noise and theoretical operation over a wide current range. Most parameters are guaranteed over a current range of 1  $\mu$ A to 1 mA and 0 to 40 V collector-base voltage, ensuring superior performance in nearly all applications.

To guarantee long term stability of matching parameters, internal clamp diodes have been added across the emitter-base junction of each transistor. These prevent degradation due to reverse biased emitter current — the most common cause of field failures in matched devices. The parasitic isolation junction formed by the diodes also clamps the substrate region to the most negative emitter to ensure complete isolation between devices.

The LM194 and LM394 will provide a considerable improvement in performance in most applications requiring a closely matched

transistor pair. In many cases, trimming can be eliminated entirely, improving reliability and decreasing costs. Additionally, the low noise and high gain make this device attractive even where matching is not critical.

The LM194 and LM394/394B are available in an isolated header 6-lead TO-5 metal can package. The LM194 is identical to the LM394 except for tighter electrical specifications and wider temperature range.

### FEATURES

- Emitter-base voltage matched to 50  $\mu$ V
- Offset voltage drift less than 0.1  $\mu$ V/ $^{\circ}$ C
- Current gain ( $h_{FE}$ ) matched to 2%
- Common-mode rejection ratio greater than 120 dB
- Parameters guaranteed over 1  $\mu$ A to 1 mA collector current
- Extremely low noise
- Superior logging characteristics compared to conventional pairs

### CONNECTION DIAGRAM

Metal Can Package

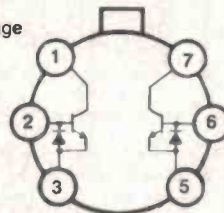

TOP VIEW

INPUT VOLTAGE NOISE vs. FREQUENCY

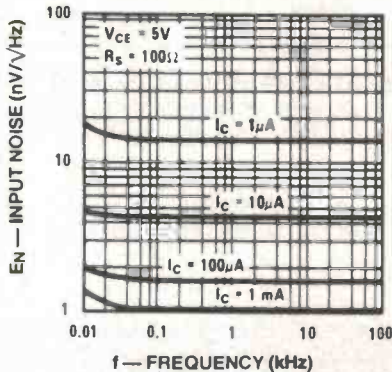

BASE CURRENT NOISE vs. FREQUENCY

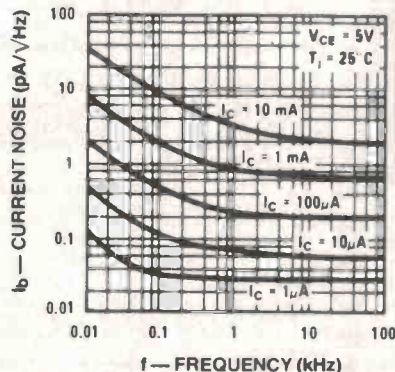

NOISE FIGURE vs. COLLECTOR CURRENT

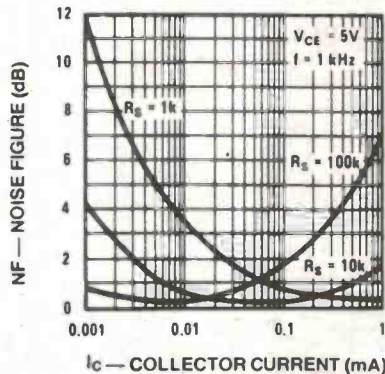

## NE5534

### DESCRIPTION

The 5534 is a single high-performance low-noise operational amplifier. Compared to other op-amps, such as TL083, it shows better noise performance, improved output drive capability and considerably higher small-signal and power bandwidth. This makes the device especially suitable for application in high quality and professional audio equipment, in instrumentation and control circuits and telephone channel amplifiers. The op-amp is internally compensated for gain equal to or higher than three. The frequency response can be optimized with an external compensation capacitor for various applications (unity gain amplifier, capacitive load, slew rate, low overshoot, etc). If very low noise is of prime importance, it is recommended that the 5534A version be used, which has guaranteed noise specifications.

### FEATURES

- Small-signal bandwidth: 10 MHz
- Output drive capability: 600R, 10 V (RMS) at  $V_S = \pm 18$  V
- Input noise voltage: 4 nV/ $\sqrt$ Hz
- dc voltage gain: 100 000
- ac voltage gain: 6000 at 10 kHz
- Power bandwidth: 200 kHz
- Slew rate: 13 V/ $\mu$ s
- Large supply voltage range:  $\pm 3$  to  $\pm 10$  V
- Pinout: 741
- Configuration: Single

### N PACKAGE

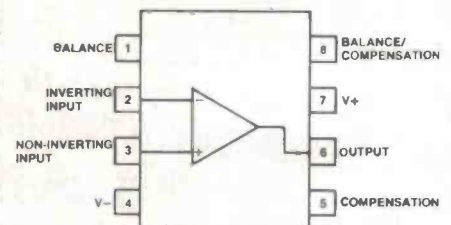

### ABSOLUTE MAXIMUM RATINGS

PARAMETER	RATING	UNIT
$V_S$ Supply voltage	$\pm 22$	V
$V_{IN}$ Input voltage	$\pm V$ supply	V
$V_{DIFF}$ Differential input voltage <sup>1</sup>	$\pm 5$	V
$T_A$ Operating temperature range	SE5534/5534A 5534/5534A	-55 to +125 0 to 70 $^{\circ}$ C
$T_{STG}$ Storage temperature	-65 to +150	$^{\circ}$ C
$T_J$ Junction temperature	150	$^{\circ}$ C
$P_D$ Power dissipation at 25 $^{\circ}$ C <sup>2</sup>	5534N 5534T	500 800 mW
Output short circuit duration <sup>3</sup>	indefinite	
Lead temperature (soldering 10 sec)	300	$^{\circ}$ C

### NOTES

- Diodes protect the inputs against over-voltage. Therefore, unless current-limiting resistors are used, large currents will flow if the differential input voltage exceeds 0.6V. Maximum current should be limited to  $\pm$  mA.
- For operation at elevated temperature T package must be derated based on a thermal resistance of 150 $^{\circ}$  C/W junction to ambient, 45 $^{\circ}$  C/W junction to case. Thermal resistance of the N package is 240 $^{\circ}$  C/W junction to ambient.
- Output may be shorted to ground at  $V_S = \pm 15$ V,  $T_A = 25^{\circ}$  C. Temperature and/or supply voltages must be limited to ensure dissipation rating is not exceeded.

# stereo control preamp

**ELECTRICAL CHARACTERISTICS**  $T_A = 25^\circ\text{C}$ ,  $V_S = \pm 15\text{V}$  unless otherwise specified.

PARAMETER	TEST CONDITIONS	5534			5534A			UNIT
		Min	Typ	Max	Min	Typ	Max	
Input noise voltage	$f_o = 30\text{ Hz}$		7			5.5	7	nV/ $\sqrt{\text{Hz}}$
	$f_o = 1\text{ kHz}$		4			3.5	4.5	nV/ $\sqrt{\text{Hz}}$
Input noise current	$f_o = 30\text{ Hz}$		2.5			1.5		pA/ $\sqrt{\text{Hz}}$
	$f_o = 1\text{ kHz}$		0.6			0.4		pA/ $\sqrt{\text{Hz}}$
Broadband noise figure	$f = 10\text{ Hz} - 20\text{ kHz}$ , $R_S = 5\text{ k}\Omega$					0.9		dB
Channel separation	$f = 1\text{ kHz}$ , $R_S = 5\text{ k}\Omega$		110			110		dB

**AC ELECTRICAL CHARACTERISTICS**  $T_A = 25^\circ\text{C}$ ,  $V_S = \pm 15\text{V}$  unless otherwise specified.

PARAMETER	TEST CONDITIONS	SE5534/5534A			5534/5534A			UNIT
		Min	Typ	Max	Min	Typ	Max	
$R_{OUT}$ Output resistance	$A_V = 30\text{ dB}$ closed loop $f = 10\text{ Hz}$ , $R_L = 600\Omega$ , $C_C = 22\text{ pF}$		0.3			0.3		$\Omega$
Transient response	Voltage follower, $V_{IN} = 50\text{ mV}$ $R_L = 600\Omega$ , $C_C = 22\text{ pF}$ , $C_L = 100\text{ pF}$							
$T_R$ Rise time			20			20		ns
Overshoot			20			20		%
Transient response	$V_{IN} = 50\text{ mV}$ , $R_L = 600\Omega$ $C_C = 47\text{ pF}$ , $C_L = 500\text{ pF}$							
$T_R$ Rise time			50			50		ns
Overshoot			35			35		%
AC Gain	$f = 10\text{ kHz}$ , $C_C = 0$		6			6		V/mV
	$f = 10\text{ kHz}$ , $C_C = 22\text{ pF}$		2.2			2.2		V/mV
Gain bandwidth product	$C_C = 22\text{ pF}$ , $C_L = 100\text{ pF}$		10			10		mHz
Slew rate	$C_C = 0$		13			13		V/ $\mu\text{s}$
	$C_C = 22\text{ pF}$		6			6		V/ $\mu\text{s}$
Power bandwidth	$V_{OUT} = \pm 10\text{ V}$ , $C_C = 0$		200			200		kHz
	$V_{OUT} = \pm 10\text{ V}$ , $C_C = 22\text{ pF}$		95			95		kHz
	$V_{OUT} = \pm 14\text{ V}$ , $R_L = 600\Omega$		70			70		kHz
	$C_C = 22\text{ pF}$ , $V_{CC} = \pm 18\text{ V}$							

**DC ELECTRICAL CHARACTERISTICS**  $T_A = 25^\circ\text{C}$ ,  $V_S = \pm 15\text{V}$  unless otherwise specified. <sup>1,2</sup>

PARAMETER	TEST CONDITIONS	SE5534/5534A			5534/5534A			UNIT
		Min	Typ	Max	Min	Typ	Max	
$V_{OS}$ Offset voltage	Over temperature		.5	2		.5	4	mV
				3			5	mV
$I_{OS}$ Offset current	Over temperature		10	200		20	300	nA
				500			400	nA
$I_B$ Input current	Over temperature		400	800		500	1500	nA
				1500			2000	nA
$I_{CC}$ Supply current Per op amp	Over temperature		4	6.5		4	8	mA
				9				mA
$V_{CM}$ Common mode input range		$\pm 12$	$\pm 13$		$\pm 12$	$\pm 13$		V
$CMRR$ Common mode rejection ratio		80	100		70	100		dB
$PSRR$ Power supply rejection ratio			10	50		10	100	$\mu\text{V/V}$
$A_{VOL}$ Large signal voltage gain	$R_L \geq 600\Omega$ , $V_O = \pm 10\text{V}$ Over temperature		50	100		25	100	V/mV
			25			15		V/mV
$V_{OUT}$ Output swing	$R_L \geq 600\Omega$ $R_L \geq 600\Omega$ , $V_S = \pm 18\text{V}$		$\pm 12$	$\pm 13$		$\pm 12$	$\pm 13$	V
			$\pm 15$	$\pm 16$		$\pm 15$	$\pm 16$	V
$R_{IN}$ Input resistance		50	100		30	100		k $\Omega$
$I_{SC}$ Output short circuit current			38			38		mA

**NOTES**

- For 5534/5534A.  $T_{MIN} = 0^\circ\text{C}$ ,  $T_{MAX} = 70^\circ\text{C}$
- For SE5534/5534A.  $T_{MIN} = -55^\circ\text{C}$ ,  $T_{MAX} = +125^\circ\text{C}$

## Series 5000

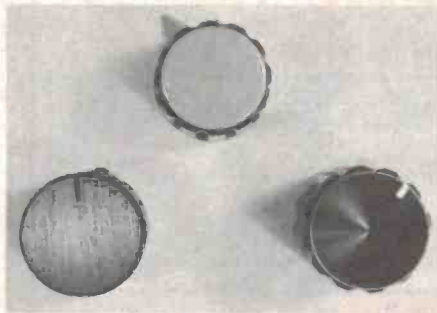

You can make your choice of knobs to suit yourself. A wide variety is available and just three different styles are shown here. At left is an anodised aluminium knob with a slot - this is the type we used, simply because we had nine on hand! At top is a plastic collet knob with pointer (C&K and Associated Controls handle collet knobs), and at right is a fluted, anodised aluminium knob with white indicators, which is very common.

adjusting the master and balance controls obtain a voltage of 1.2 Vac at the monitor output sockets. Adjust the LED level meters to read 0 dB. The preamp can now be turned off and the other level meter fitted. Once again the height of the pc board can be set by nuts on the bolt, adjusting to give the correct height. Alternatively, fit two nuts and another washer to all four bolts. This

should give the correct height. Solder the input and power supply connections. Note that this board can be difficult to get through the slots on the front panel unless the mounting holes have been drilled large enough.

Power up the preamp again, and with the master turned fully down adjust dc offsets as before. Once again adjust the master and balance pots to achieve 1.2 V at the monitor output sockets with the monitor volume control set at full. Adjust the second level meter calibration control to read 0 dB. This aligns the two level meters approximately only. If the master is now varied slowly the LEDs on each display will probably turn on at slightly different times. Adjust the top level meter calibration preset so that the LEDs come on at the same time. With the preamp set in this way the level meters indicate dB below full power when the monitor volume is set at full and the master is used as the volume control. Although this is not the usual mode of operation it is a useful feature, especially when running power amps near their maximum output powers. The usual mode of operation is to adjust the master level to give a reading on the level meters around 0 dB and then use the monitor as the volume

control.

All that requires to be done at this stage is to fit the sub-chassis top panel and the preamp top panel. Don't forget to use shorting plugs on all unused low-level inputs in order to avoid thumps in the loudspeakers when the low-level input selector is switched.

### Performance

The aim of this project has been to design a high-quality preamplifier suitable for home construction that will not degrade the performance of the best available power amps. To do this the conventional parameters of frequency response, noise and distortion must be good. In these respects the Series 5000 is extremely good, as can be seen from the specifications quoted elsewhere in this article. Of equal importance, however, are the less-known parameters such as cartridge impedance interaction. This problem is overcome through the use of a separate linear gain stage at the input to the MM amplifier.

The final test of any audio amplifier is of course subjective, but for me the Series 5000 preamplifier offers a significant improvement over many other designs, offering a detail and clarity that is seldom heard. ●

# THE ORIGINAL

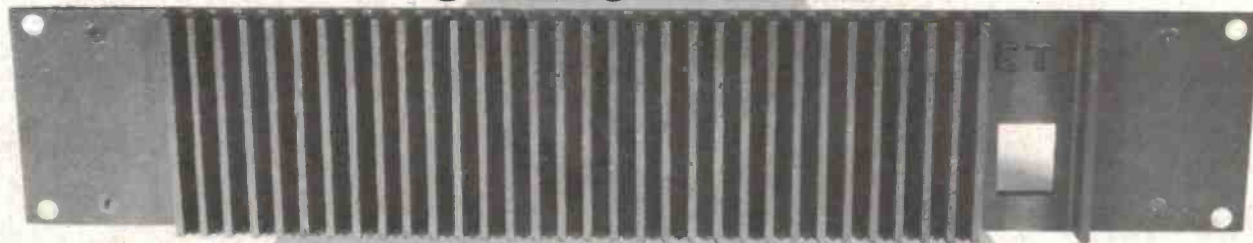

## ETI SERIES 5000 HEATSINK PANEL

Designed by David Tilbrook to suit the Series 5000 MOSFET stereo amp., and manufactured for ETI these cast aluminium heatsinks have a good finish, are drilled and tapped to take the mounting bracket which holds two ETI-477 100W MOSFET modules and are finished in a tough matt black paint. If you are unable to obtain one from your local supplier, you can obtain one direct from ETI or by mail order.

**COST: \$42.50**

Please add \$1.50 post & handling, within Australia, \$3 to New Zealand and New Guinea. Send your cheque or money order to cover the number you require to:

**SERIES 5000 HEATSINK/FRONT PANEL**

ETI Magazine, 15 Boundary St, Rushcutters Bay, NSW 2011. Please allow up to four weeks for delivery.



# ALL ELECTRONIC COMPONENTS

*That's our name . . . that's our game!!!*

MAJOR STOCKISTS OF ALL GENERAL RADIO AND ELECTRONIC COMPONENTS

"CHECK AUGUST ISSUE OF ET1 FOR OUR RANGE OF KITS"

## NEW RELEASE — AEC DMM-803 MINIATURE LCD DIGITAL MULTIMETER KIT

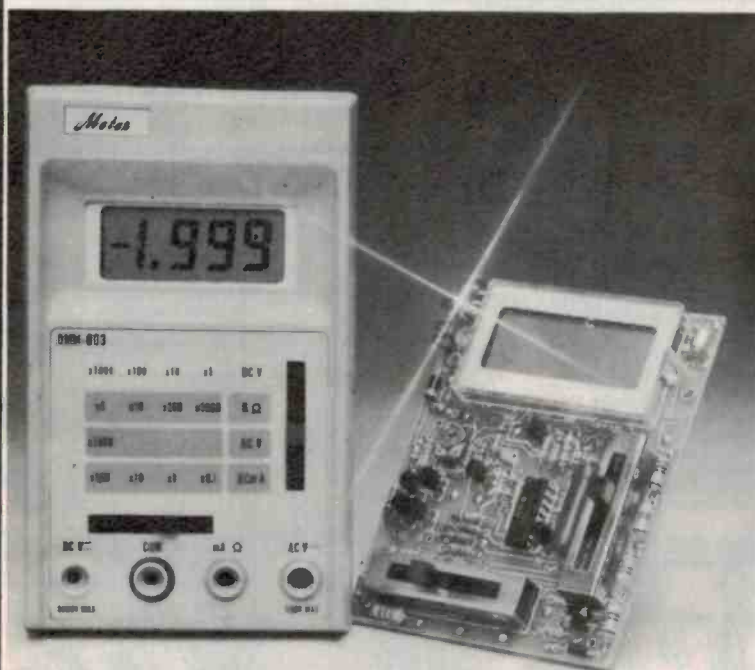

The DMM-803 Digital Multimeter is a compact, hand-held instrument designed for both field and laboratory use. Measurement functions include DC voltage, AC voltage, DC current and Resistance. All functions are protected by diodes and transistors against overload. The large LCD read-out features easy-to-read numerals, polarity indication and low-battery warning. The DMM-803 is available in kit form containing all the parts necessary for making a finished Digital Multimeter and a detailed assembly manual to ensure easy assembly by yourself.

**Features:** ● Measurement functions: DCV, ACV, OHM & DCmA. ● 0.5" 3½ digit liquid crystal display. ● Overload protection. ● Polarity indication. ● Battery life: approx. 250 hours (Alkaline battery). ● Single 9V battery operation with low battery warning "LO-BAT" indicator in the last 20% of battery life. ● Size: 8.4(w) x 14(l) x 3(h) cm.

### Measurement Ranges:

Function	Accuracy	Range	Resolution	Overload
DC V	± (0.8% of rdg + 1 dgt)	2 V	1 mV	DC 1000 V
		20 V	10 mV	
		200 V	100 mV	AC 1000 Vrms
		2000 V	1 V	
AC V	± (1% of rdg + 0.3% F.S. + 1 dgt)	500 V	1 V	AC 1000 Vrms
		2 KΩ	1 Ω	
		20 KΩ	10 Ω	DC 250 V
		200 KΩ	100 Ω	
OHM	± (0.5% of rdg + 1 dgt)	2 MΩ	1 KΩ	AC 250 Vrms
		200 μA	100 nA	
		2 mA	1 μA	1 A
		20 mA	10 μA	
DC mA	± (1% of rdg + 1 dgt)	200 mA	100 μA	

● Operating Temperature: 0°C-40°C. ● Storage Temperature: -20°C-60°C. ● Accurate Temperature: 1 year warranty at 20°C±10°C. In addition to having a reliable Digital Multimeter, by purchasing in kit form you learn the details of circuit structure and gain handy experience in the assembly of your Digital Multimeter.

**Ideal for School Projects, etc.**

**ONLY \$81.60** including tax ● \$5.00 P&P

Resellers enquiries welcome

E. D. & E. (SALES) PTY. LTD., NOW

**ALL ELECTRONIC COMPONENTS**

118 LONSDALE STREET, MELBOURNE, VIC. 3000. TEL: 662-3506.

# We offer a career - not just a job!

Enjoy electronics as a hobby? Why not make it a career... At Dick Smith Electronics, hundreds of electronic enthusiasts just like you have found satisfying and rewarding positions. We're expanding - and we need more people in all facets of our operation. The following positions are vacant NOW: if you'd like to work for us, why not give us a call!

## Opportunities:

### Store Staff:

Junior, self motivated staff for our stores. Basic knowledge of electronics required.

### Trainee Managers:

Dynamic sales people interested to be managers of new stores.

Please contact store managers in your area.

NEW DIGITAL

## DICK SMITH WORLD CLOCK

Ever missed a 'sked? With this superb world clock that can give you accurate time anywhere in the world, you won't be missing those important appointments ever again.

Y-1054

ONLY \$19<sup>95</sup>

A POCKET SIZE

## PRINTER/CALCULATOR

Yes! Here it is - the fantastic hand-held miniature calculator printer. Check these features: ● Percentage, Square Root, Tab (floating decimal point) keys, ● 10 digit LCD display, ● Print/No print function, etc etc. Outstanding!

Paper to suit 60¢ (Q-3021).

ONLY \$6<sup>7</sup>

Q-3020

## 1981 CALLBOOK



OUT NOW!  
NEW

If you're an amateur you need one of these! Gives a complete listing of amateurs in Australia and Papua New Guinea. An essential part of your radio shack!

ONLY \$3<sup>95</sup>

B-2321

## UNDERSTANDING DC POWER SUPPLIES



NEW

232 pgs

If you're a radio/electronic apprentice or technician, or even a hobbyist, this book is a MUST. It gives a comprehensive guide to power supplies. An invaluable tool to the student who is preparing to take on any examination which includes power supply principles

ONLY \$9<sup>95</sup>

B-3623

## AMATEUR OPERATORS HANDBOOK

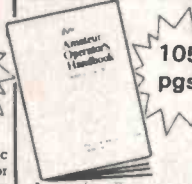

105 pgs

A must for all amateurs or persons sitting for the AOCOP & LAOCOP. Gives valuable information of all aspects of amateur operation. Essential!

ONLY \$3<sup>60</sup>

B-2310

# HALF PRICE SOFTWARE!

		WAS	NOW
GAMES FOR YOUR SORCERER	VOODOO CASTLE (X-3636)	\$12.50	\$6.25
	WUMPUS (X-3604)	\$9.95	\$4.97
	SMART ALEC (X-3632)	\$14.95	\$7.47
	ADVENTURELAND (X-3633)	\$12.50	\$6.25
AND YOUR SYSTEM 80/ TRS 80.	MISSION POSSIBLE (X-3635)	\$12.50	\$6.25
	PAINTBRUSH (X-3654)	\$17.95	\$8.97
	BRIDGE CHALLENGER (X-3656)	\$17.95	\$8.97
	BLOCKADE (X-3659)	\$17.95	\$8.97
	MATH/SPELL (X-3662)	\$9.95	\$4.97

## HOBBYIST'S SAVE ON BIMBOARD!



Over 500 sockets that will accept component leads of 0.25 to 0.85mm, spaced 2.54. Designed to carry up to 1 amp. Even supplied with a component mounting panel for pots etc. Fantastic value!

ONLY \$23<sup>50</sup>

P.4612

## GIANT H'BOOK OF ELECTRONIC CIRCUITS

880 pages of circuits relating to virtually all aspects of electronics. There are circuits for hams, auto buffs, radar & sonar, games, inverters, power supplies plus many, many more. Ideal for the study or workshop!

B-1780

ONLY \$18<sup>95</sup>

TOP-VALUE!

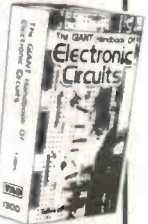

# SAVE UP TO 50%

## DICK SLASHES THE PRICE OF GENUINE 'CANNON' PLUGS!

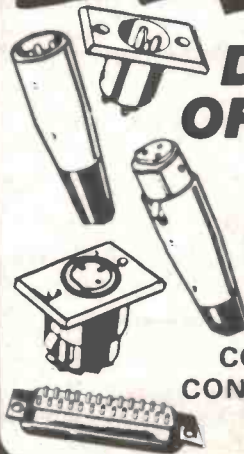

	TYPE	CAT. No.	WAS	NOW
CANNON	3 pin line socket	P-1620	\$3.60	\$2.95
AUDIO	3 pin panel plug	P-1622	\$3.50	\$1.95
PLUGS	3 pin line plug	P-1624	\$3.80	\$2.00
	3 pin panel socket	P-1626	\$4.00	\$3.20
CANNON	25 pin 'D' type plug	P-2690	\$5.60	\$4.75
CONNECTORS	25 pin 'D' type socket	P-2691	\$7.95	\$6.20

YOU REAP THE BENEFIT!

## TOP VALUE PRECISION DIECAST ALUMINIUM BOXES

Cat. H-2201	
190(d) x 60(h) x 110(w)mm	1-9 ... \$12.90ea
10 or more ...	\$12.00ea
Cat. H-2206	
150(d) x 50(h) x 80(w)mm	1-9 ... \$8.95ea
10 or more ...	\$8.00ea
Cat. H-2211	
120(d) x 40(h) x 65(w)mm	1-9 ... \$5.20ea
10 or more ...	\$4.75ea
Cat. H-2221	
100(d) x 25(h) x 50(w)mm	1-9 ... \$3.50ea
10 or more ...	\$3.20ea

Cat. D-1802

THE FANTASTIC

# APOLLO NOW IN STOCK! UHF CB 40 ch.

Now is the time to switch to UHF CB with the Apollo. Has all of the features including light dimmer, tone, squelch, RF gain etc., plus advanced electronics. Why wait until 1982 - get UHF CB NOW!

ALL THIS FANTASTIC COMMUNICATION **\$389**



ANTENNA TO SUIT APOLLO \$9.50

# AM/SSB 18 Ch. SUPER PANTHER

This fully approved class 18 Ch. radio is packed with heaps of features. Has LED readout, PA, NR, Local/DX switching. Also contains light dimmer for LED readout, maximum legal power on AM & SSB. The bands won't be the same once you get on with this little beauty! Mic, mounting bracket, spare fuse included.

NEW ONLY **\$235**

D-1711

# NEW 60° SOLAR CELLS

These incredible cells have a very high output level for their size - 450mV @ 95mA (43mW per cell) Join 6 together & form 60mm dia. circle with over 2.5V output (or over 1/2 amp in parallel) Get your FREE power now!

VALUE ONLY AT **\$2.95**

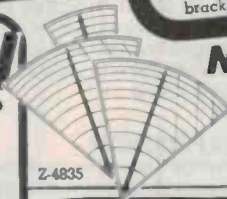

Z-4835

# TACHOMETER I.C.

Hey experimenters! Check this amazing tachometer IC. Ideal for many applications. Have a go! build your own tachometer with this SAK 140 IC.

SAVE 33% ONLY **\$2.28**

Z-6230

# TOP VALUE! METAL/DOLBY DECK

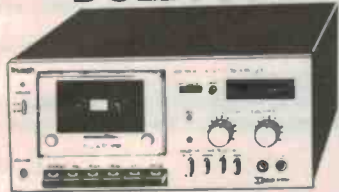

Due to our direct import buying we're proud to offer you this remarkable metal/dolby deck. This superb deck has normal, chrome dioxide, metal tape facilities. L & R recording level controls, LED meter, tape counter, & oil damped doors. With impressive looks & top quality electronics, makes this unit an attractive buy to anyone.

LOOK AT THIS PRICE **\$115**

A-3503

# SAVE A FORTUNE ON TRANSFORMERS

## MODEL 2851

Specs Primary-240V AC, Secondary voltage-126V CT, Secondary current-150mA, Termination flying leads

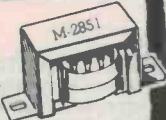

**\$3.90**



## MODEL 6672

Primary-240V AC, Tapped secondary-15, 17.5, 20, 24, Voltages-27.5, 30 volts, Secondary current-1A, Termination-solder lugs.

**\$1.75**

## MODEL 2840

Primary-240V AC, Secondary voltage-9V CT, Secondary current-150mA, Termination-flying leads.



**\$3.90**

MANUFACTURERS, ASK FOR QUANTITY PRICE

# NEW! YAESU PA-2 Mobile charger/Power Supply

The Yaesu PA-2 is a mobile charger come pwr supply. Suited for the FT-207R & FT-208R - uses power from your 12V battery when mobile. Also recharges nicads in your battery pack

ONLY

**\$29.90**



D-894

# SOLDER A LOT ON PCB'S? MINISCOPE IRON'S FOR YOU!

Ideal for service on PCB's. Has all the advantages of the bigger scopes but is small in size with fingertip control. Supplied with spare tip and element. A bargain at this price!

ONLY **\$26.50**

T-1660

# DON'T THROW AWAY MONEY! NICADS

## WATCH THIS SPACE

Caught with flat batteries? Well DON'T be caught again. Because this cell can be recharged, you can use them again & again - so stop wasting your money! Ideal for all types of equipment. (1.2V).

## LOOK AT THESE:

At last we have a range of nicads in 'C' and 'D' size cells. They both rate at 1.2Ah and are suitable for use with a multitude of battery operated devices.

**\$8.75** ONLY **\$8.00** pr.



'D' SIZE S-3304



'C' SIZE S-3302

## BELOW COST SPECIAL

## LAST MONTH: BONDZA SUPER GLUE

ONLY **93¢**

**\$2.25**

NORM

SAVING YOU \$1.32

NEXT MONTH: ? ? ? ?

# MAJOR DICK SMITH RE-SELLERS

These re-sellers stock a large range of our products. However we cannot guarantee they will have all items in stock, or at the prices we advertise

ATHERTON, QLD: Joe Sue's Radio Service 55 Main St Phone 951 208

BENDIGO, VIC: Sumner Electronics 95 Mitchell Street Phone 431 977

BALLINA, NSW: A. Cummings & Co. 91-93 River St. Phone: 862 285.

BLACKHEATH, NSW: Goodwin Electronics 123 Station Street Phone 878 375

BROKEN HILL, NSW: Crystal TV Rentals 66 Crystal Street Phone 6897

CAIRNS, QLD: Thompson Instrument Services 79-81 McLeod Street Phone 512 404

COFFS HARBOUR, NSW: Coff's Harbour Electronics 3 Coff's Harbour Plaza, Park Ave Phone 525 684

DARWIN, NT: Kent Electronics 42 Stuart Highway Phone 814 745

DUBBO, NSW: Dubbo Electronic Services 187 Brisbane St Phone 829 355

EAST MAITLAND, NSW: East Maitland Electronics Cnr Lanes & High Streets 327 377

FAIRY MEADOW, NSW: Trilogy Wholesale Elect. 40 Princes Hwy Phone 631 215

GERALDTON, WA: KB Electronics & Marine 361 Main Terrace Phone 212 176

GOSFORD, NSW: Tomorrow's Electronics & Hi Fi 68 William Street Phone 247 246

HOBART, TAS: Aero Electronics 123 Bathurst Street Phone 348 232

KINGSTON, TAS: Kingston Electronics & Records Channel Court Phone 236 802

LAUNCESTON, TAS: Advanced Electronics 5a The Quadrant Phone 317 075

LISMORE, NSW: Decro Electric Magellan St b Brunner Hwy Phone 214 137

MACKAY, QLD: Stevens Electronics 42 Victoria Street Phone 511 723

MARYBOROUGH, QLD: Keller Electronics 218 Adelaide Street Phone 214 559

MORUYA, NSW: Coastal Electronics 43 Vulcan Street Phone 742 545

MT GAMBIER, SA: Hutchesson's Communications 5 Elizabeth Street Phone 256 404

MUSWELLBROOK, NSW: Silicon Chip Electronics Suite 3, 98 Bridge Street Phone 43 1095

NAMBOUR, QLD: Nambour Electronic Shop Shop 4, Lower House, Ann St Phone 411 604

NEWCASTLE, NSW: Elektron 2000 181 Wharf Road Phone 287 644

ORANGE, NSW: M&W Electronics 48 McNamara Street Phone 626 491

ROCKHAMPTON, QLD: Purely Electronics 15 East Street Phone 21 058

SOUTHPORT, QLD: Amateur's Paradise 121 Norang Street Phone 325 644

TAMWORTH, NSW: Sound Components 78 Brisbane Street Phone 661 363

TODDWOOLBA, QLD: Hunts Electronics 18 Mail Street Phone 325 677

TOWNSVILLE, Qld: Tropical TV 49 Fulham Rd Vincent Village Phone 791 421

TRARALGON, VIC: Power 'N' Sound 147 Argyle Street Phone 743 638

WAGGA, NSW: Wagga Wholesale Electronics 87 Foreyth Street

WODDONGA, VIC: A & M Electronics 78 High Street Phone 244 588

WHYALLA MORRIE, SA: Walker Enterprises Shop 2, Foreyth Street Phone 454 764

## Dear Customer:

Quite often, the products we advertise are so popular they run out within a few days. Of, unforeseen circumstances might hold up goods so that advertised lines are not in the store by the time the advert appears. Please don't blame the store manager or staff, they cannot solve a dock strike on the other side of the world, or even locate a shipment that has gone astray. What we are trying to say is that, if you are about to drive across town to pick up a particular line at a Dick Smith Store, why not give the store a ring first (addresses/phone numbers below) just in case! Thanks. Dick Smith & Staff.

# DICK SMITH Electronics

MAIL ORDER CENTRE: P.O. Box 321 North Ryde, NSW 2113. Ph. (02) 888 3200

NSW: 145 Parramatta Rd Auburn 648 0558; 813 Princes Hwy Blakehurst 546 7744; 818 George St Broadway 211 3777; 531 Pittwater Rd Brookvale 93 0441; 147 Hume Hwy Chullora 642 8922; 162 Pacific Hwy Gore Hill 439 5311; 30 Grose St Parramatta 683 1133; 125 York St Sydney 290 3377; 173 Maitland Rd Tighes Hill 61 1896; 263 Keira St Wollongong 28 3800.

ACT: 96 Gladstone St Fyshwick 80 4944. QLD: 166 Logan Rd Buranda 391 6233; 842 Gympie Rd Chermids 59 6255. SA: 60 Wright St Adelaide 212 1962. VIC: 399 Lonsdale St Melbourne 67 9834; 656 Bridge Rd Richmond 428 1614; Cnr Dandenong & Springvale Rds Springvale 547 0522. 260 Sydney Rd Coburg 383 4455. WA: Cnr Wharf St & Albany Hwy Cannington 451 8666; 414 William St Perth 328 69 44.

Order Value Charges  
\$5-\$9.99 \$1.20  
\$10-\$24.99 \$2.20  
\$25-\$49.99 \$3.30  
\$50-\$99.99 \$4.40  
\$100 or more \$6.00  
These charges for goods sent by Post in Australia only - Not airmail, overseas or road freight.

DSE A038RB



# Babani Books

## 1ST BOOK OF TRANSISTOR EQUIVALENTS & SUBSTITUTES

Complete transistor equivalents. Plus 25 000 transistors with alternatives and equivalents. Covers devices from UK, USA, Germany, France, Europe, Hong Kong etc. See also 211 and BP14.

**BP1** \$2.25

## HANDBOOK OF RADIO, TV, INDUSTRIAL & TRANSMITTING TUBE & VALVE EQUIVALENTS

Equivalents book for amateurs and serviceman. More than 18 000 old and new valves from UK, USA, Europe, Japan et al. CV (military) listings with commercial equivalents included.

**BP2** \$2.25

## COLOUR CODE & DATA CHART

A very useful wall chart containing resistor and capacitor colour codes and how to read them, audio connector colour codes, transformer wires colour codes, battery cord colour codes, PLUS — charts and formulae for resistors, capacitors and inductors in parallel and series; resistor power ratings chart, 50/75 ohm attenuator tables and more ...

**BP7** \$1.50

## 2ND BOOK OF TRANSISTOR EQUIVALENTS & SUBSTITUTES

Data on devices not included in BP1. This book supplements BP1, i.e. no data is duplicated.

**BP14** \$4.05

## FIRST BOOK OF PRACTICAL ELECTRONIC PROJECTS

Full constructional data, circuits, components lists for many practical projects including audio distortion meter, super FET receiver, guitar amp, metronome, etc. etc.

**BP23** \$2.75

## 52 PROJECTS USING IC 741

A must for those interested in any way in this inexpensive and versatile IC. European best seller!

**BP24** \$3.50

## GIANT CHART — RADIO, ELECTRONICS, SEMI-CONDUCTOR & LOGIC SYMBOLS

Identify those symbols at a glance. A must for beginners and advanced enthusiasts alike. Professionals can always hide it in their desks! A steal at only ...

**BP27** \$2.20

## ELECTRONIC CALCULATOR USERS' HANDBOOK

Invaluable for all calculator users. Presents formulae, data, methods of calculation, conversion factors etc, often with examples. Includes way to use simple calculator for trig functions (sin, cos, tan); hyperbolic functions (sinh, cosh, tanh); logs; square roots, and powers.

**BP33** \$4.60

## 50 CIRCUITS USING GERMANIUM, SILICON & ZENER DIODES

Contains 50 interesting and useful circuits and applications in many different branches of electronics.

**BP36** \$2.75

## 50 PROJECTS USING RELAYS, SCRs & TRIACS

Relays, SCRs and Triacs are used in motor speed control, dimming, heating, timers, light sensitive devices, warning circuits, light modulators, priority indicators, circuit breakers etc. Book gives tried and proven circuits allowing easy modification to suit special needs.

**BP37** \$4.60

## FUN AND GAMES WITH YOUR CALCULATOR

Amazing collection of 101 jokes and riddles, several quite mind-boggling games for two or more players and a dictionary of numbers which are words if the calc. is read upside down.

**BP38** \$2.75

## DIGITAL ICs & PIN CONNECTIONS

Equivalents and pin connections of popular user-orientated digital ICs. Details of packaging, families, functions, manufacturer, and countries of origin. Includes Fairchild, Ferranti, Harris, ITT, Motorola, National, Philips, RCA, Signetics, Sescocem, SGS-Ates, Siemens, SSSI, Stewart Warner, AEG-Telefunken, Texas, Teledyne. Companion volume to BP41.

**BP40** \$9.00

## LINEAR IC EQUIVALENTS & PIN CONNECTIONS

Similar to BP40 but deals with linear ICs.

**BP41** \$10.00

## HOW TO MAKE WALKIE-TALKIES

Practical circuitry and construction of transmitters, receivers and antennas. A book of great interest to the licenced operator especially. This book was written with the UK licencing regulations in mind. Some parts may not accord with local regulations.

**BP43** \$5.50

## IC555 PROJECTS

One wonders how life went on before the 555! Included are basic and general circuits, motor car and model railway circuits, alarms and noise makers plus section on subsequent 556, 558 and 559s.

**BP44** \$6.45

## PROJECTS IN OPTO-ELECTRONICS

Included are simple circuits using LEDs as well as sophisticated designs such as infra-red transmitters & receivers, modulated light transmission and photo projects.

**BP45** \$4.95

## LM 3900 IC PROJECTS

Unlike conventional op-amps, the LM 3900 can be used for all the usual applications as well as many new ones. It's one of the most versatile, freely obtainable and inexpensive devices around. This book provides the groundwork for simple and advanced uses — it's much more than a collection of projects. Very thoroughly recommended.

**BP50** \$4.95

## ELECTRONIC MUSIC & TAPE RECORDING

Shows how electronic music can be made at home with simple and inexpensive equipment. Describes how sounds are created and recorded to build up final compositions. Includes how to build a small studio including mixer and effects units

**BP51** \$4.60

## LONG DISTANCE TV RECEPTION (TV-DX).

Written by UK authority, the book includes many units and devices made by active enthusiasts. A practical and authoritative intro to this unusual aspect of electronics.

**BP52** \$4.60

## PRACTICAL ELECTRONIC CALCULATIONS & FORMULAE

For the practical person's workbench. Bridges gap between technical theory and cut-and-dried methods which work but leave the experimenter unfulfilled. There's a strong practical bias. Tedious and higher maths avoided where possible. Many tables included. This one's a beauty!

**BP53** \$8.25

## RADIO STATIONS GUIDE

Eight sections covering: European LW/AM; European, Near East and N. African MW/AM; World-wide SW/AM; European FM/VHF; Broadcast band USA; Broadcast band Canada; Local UK; Wavelength/frequency conversion. Book shows station site, country, frequency, wavelength, effective radiated power and, in some cases, call sign.

**BP55** \$6.45

## ELECTRONIC SECURITY DEVICES

Simple and also sophisticated alarms using light, infra-red and sonics; also gas and smoke detectors, flood alarms, doorphone and baby alarms etc.

**BP56** \$5.35

## HOW TO BUILD YOUR OWN SOLID-STATE OSCILLOSCOPE

Project divided into sections for builder individually to construct and test — then assemble into complete instrument. Includes short section on 'scope usage.

**BP57** \$5.50

## 50 CIRCUITS USING 7400 SERIES ICs

7400 ICs are freely obtainable, inexpensive and very versatile. Here's 50 interesting and useful circuits using this IC.

**BP58** \$4.95

# Babani Books

## PRACTICAL CONSTRUCTION OF PRE-AMPS, TONE CONTROLS, FILTERS, & ATTENUATORS

How to construct a variety of magnetic tape recording, microphone, and disc pre-amps; plus tone controls, rumble & scratch filters, attenuators and pads etc etc.

**BP60** \$5.30

## BEGINNER'S GUIDE TO DIGITAL ELECTRONICS

Covers all essential areas including number systems, codes, constructional and sequential logic, analog/digital/analog conversion.

**BP61** \$3.50

## ELEMENTS OF ELECTRONICS

This series provides an inexpensive intro to modern electronics. Although written for readers with no more than basic arithmetic skills, maths is not avoided — all the maths is taught as the reader progresses.

The course concentrates on the understanding of concepts central to electronics, rather than continually digressing over the whole field. Once the fundamentals are learned the workings of most other things are soon revealed. The author anticipates where difficulties lie and guides the reader through them.

**BOOK 1 (BP62):** All fundamental theory necessary to full understanding of simple electronic circuits and components.

**BOOK 2 (BP63):** Alternating current theory.

**BOOK 3 (BP64):** Semiconductor technology leading to transistors and ICs.

**BOOK 4 (BP77):** Microprocessing systems and circuits.

This series constitutes a complete inexpensive electronics course of inestimable value in hobby or career.

**Books 1/2/3** \$8.25 (each)

**Book 4** \$10.80

## BEGINNERS' GUIDE TO MICROPROCESSORS & COMPUTING

Introduction to basic theory and concepts of binary arithmetic, microprocessor operation and machine language programming. Only prior knowledge assumed is very basic arithmetic and an understanding of indices.

**BP66** \$6.40

## COUNTER DRIVER AND NUMERAL DISPLAY PROJECTS

Well-known author F.G. Rayer features applications and projects using various types of numerical displays, popular counter and driver ICs, etc.

**BP67** \$6.10

## ELECTRONIC GAMES

How to build many interesting electronic games using modern ICs. Covers both simple and complex circuits for beginner and advanced builder alike. Good one!

**BP69** \$6.40

## TRANSISTOR RADIO FAULT-FINDING CHART

How to trace most common faults quickly. Top of chart indicates faults — users then follow arrows indicating checks in correct sequence until fault is cleared. Clever one!

**BP70** \$1.85

## A MICROPROCESSOR PRIMER

This small book takes the mystery out of microprocessors. It starts with a design for a simple computer described in language easy to learn and follow. The shortcomings of this basic machine are then discussed and the reader is shown how these are overcome by changes to the instruction set. Relative addressing, index registers follow as logical progressions.

An interesting and unusual approach.

**BP72** \$6.40

## REMOTE CONTROL PROJECTS

Covers radio, infra-red, visible light, ultrasonic controls. Full explanations are provided so that the reader can adapt the projects for domestic and industrial as well as model use.

**BP73** \$7.15

## ELECTRONIC TEST EQUIPMENT CONSTRUCTION

Describes construction of wide range of test gear including FET amplified voltmeter, resistance bridge, field strength indicator, heterodyne frequency meter etc.

**BP75** \$6.40

## POWER SUPPLY PROJECTS

Designs for many power supplies including simple unregulated, fixed and variable voltage regulators — particularly for electronics workshops. Also included are cassette power supply, Ni-Cad charger, voltage step-up circuit, and simple inverter, plus info on designing your own supply. All designs are low voltage types for semiconductor circuits.

**BP76** \$6.40

## PRACTICAL COMPUTER EXPERIMENTS

How to build typical computer circuits using discrete logic. This book is a useful intro to devices such as adders and storers as well as a general source book of logic circuits.

**BP78** \$6.50

## RADIO CONTROL FOR BEGINNERS

How complete systems work with constructional details of solid state transmitters and receivers. Also included — antennas, field strength meter, crystal controlled superhet, electro-mechanical controls. Ideal for beginners. Section dealing with licencing etc not applicable to Australia.

**BP79** \$6.40

## POPULAR ELECTRONIC CIRCUITS — BOOK 1.

Yet more circuits from Mr. Penfold! Includes audio, radio, test gear, music projects, household projects and many more. An extremely useful book for all hobbyists offering remarkable value for the designs it contains.

**BP80** \$7.15

## ELECTRONIC SYNTHESIZER PROJECTS

For the electronic music enthusiast, an invaluable reference. This book is full of circuits and information on how to build analogue delay lines, sequencers, VCOs, envelope shapers, etc, etc. The author takes a clear and logical approach to the subject that should enable the average enthusiast to understand and build up what appears to be a quite complex instrument.

**BP81** \$6.45

## VMOS PROJECTS

A book to suit the dyed-in-the-wool experimenter. Though primarily concerned with VMOS power FETs and their applications, power MOSFETs are dealt with too in a chapter on audio circuits. A number of varied and interesting projects is covered under the headings: Audio Circuits; Sound Generator Circuits; DC Control Circuits and Signal Control Circuits. Learn while you build.

**BP83** \$7.20

## DIGITAL IC PROJECTS

Companion to No. 225 Practical Introduction to Digital ICs and BP61 Beginners' Guide to Digital Electronics. The projects included in this book range from simple to more advanced projects — some board layouts and wiring diagrams are included. The more ambitious projects have been designed to be built and tested section by section to help the constructor avoid or correct any faults that may occur.

**BP84** \$7.20

## INTERNATIONAL TRANSISTOR EQUIVALENTS GUIDE

Companion to BP1 and BP14 equivalents books, but contains a huge amount of information on modern transistors produced by over 100 manufacturers. Wherever possible, equivalents are subdivided into European, American and Japanese types. Also shown are the material type, polarity, manufacturer and indication of use or application.

**BP85** \$2.95

## HI-FI LOUDSPEAKER ENCLOSURES

Data for building corner reflex, bass reflex, exponential horn, folded horn, tuned port, Klipschorn labyrinth, tuned column, loaded port and multi speaker panoramics. Clear dimensioned diagrams included.

**205** \$3.50

# Babani Books

## PRACTICAL ELECTRONIC SCIENCE PROJECTS

Unusual projects including laser, electronic gas detector, ultra high voltage generator, digital clock, reaction timer, geiger monitor, ultrasonic receiver and transmitter, electrocope etc.

207 \$2.75

## DIODE CHARACTERISTICS, EQUIVALENTS & SUBSTITUTES

Includes signal, zener, rectifier diodes etc. Full interchangeability data and characteristics of thousands of diodes of all types with every possible alternative. Includes UK, USA, European, Russian, and Far Eastern devices.

211 \$4.60

## ELECTRONIC CIRCUITS FOR MODEL RAILWAYS

Constructional details of a simple model train controller; a controller with simulated inertia, a high-power controller, an electronic steam whistle and a 'chuff generator'. Signal systems and train lighting and RF suppression also covered.

213 \$3.65

## BUILD YOUR OWN ELECTRONIC EXPERIMENTER'S LAB USING ICs.

Includes many circuits and designs for constructing test and measuring instruments mostly using modern ICs. Includes AF osc, TTL pulse detector, hi-impedance Vm, square-wave osc/pulse gen, logic probe, lo-range ohmmeter, bridge, signal tracer etc.

218 \$3.10

## BUILD YOUR OWN HI-FI & AUDIO ACCESSORIES

Essential for keen hi-fi & audio enthusiasts. Projects include stereo decoder, three channel mixer, FET pre-amp for ceramic p.u.s, mic pre-amp with adj. bass, stereo dynamic noise limiter, loudspeaker protector, voice operated relay etc.

220 \$3.10

## 28 TESTED TRANSISTOR PROJECTS

Some circuits are new, others are familiar designs. Projects can be split and/or combined for specialised needs.

221 \$4.60

## SOLID STATE SHORT WAVE RECEIVERS FOR BEGINNERS

Design and construction of several solid-state short-wave receivers giving high level of performance yet utilising relatively few inexpensive components. See also 226.

222 \$4.60

## 50 PROJECTS USING CA 3130 ICs.

The CA 3130 is an advanced operational amplifier capable of higher performance than many others; circuits often need fewer ancillary components. Interesting and useful projects in five groups. Audio projects, RF projects. Test equipment. Household projects. Misc. projects

223 \$4.60

## 50 CMOS IC PROJECTS

Many interesting and useful projects — multivibrators; amplifiers and oscillators; trigger devices; special devices.

224 \$4.60

## PRACTICAL INTRO TO DIGITAL ICs

Introduction to digital ICs (mainly TTL 7400). Besides simple projects, includes logic test set to identify and test digital ICs. Also includes digital counter-timer.

225 \$4.60

## HOW TO BUILD ADVANCED SHORTWAVE RECEIVERS

Full practical constructional details of receivers with performance equal to commercial units. Also 'add-on' circuits of Q meter, S meter, noise limiter etc.

226 \$4.60

## BEGINNERS GUIDE TO BUILDING ELECTRONIC PROJECTS

Enables total beginners to tackle electronic projects. Includes component identification, tools, soldering, building methods, cases, legends etc etc. Practical basic projects are included.

227 \$4.60

## ESSENTIAL THEORY FOR THE ELECTRONICS HOBBYIST

This book supplies hobbyists with background knowledge, tailored for his or her specific requirements and presented in a readable manner with minimum maths. Purpose-designed examples illustrate applications.

228 \$4.60

## ORDER FORM

ALL TITLES SUBJECT TO AVAILABILITY

Please forward

Book	Qty	BP1	...	BP45	...	BP67	...
205	...	BP2	...	BP50	...	BP69	...
207	...	BP7	...	BP51	...	BP70	...
211	...	BP14	...	BP52	...	BP72	...
213	...	BP23	...	BP53	...	BP73	...
218	...	BP24	...	BP55	...	BP75	...
220	...	BP27	...	BP56	...	BP76	...
221	...	BP33	...	BP57	...	BP77	...
222	...	BP36	...	BP58	...	BP78	...
223	...	BP37	...	BP60	...	BP79	...
224	...	BP38	...	BP61	...	BP80	...
225	...	BP40	...	BP62	...	BP81	...
226	...	BP41	...	BP63	...	BP83	...
227	...	BP43	...	BP64	...	BP84	...
228	...	BP44	...	BP66	...	BP85	...

Trade enquiries welcomed

Send to: ETI 'Book Sales', 4th Floor,  
15 Boundary St, Rushcutters Bay NSW 2011.  
Please allow 4 - 5 weeks for delivery.

Post & handling:

1 - 4 books: \$1.35      11 - 20 books: \$3.50  
5 - 10 books: \$2.70      over 20 books: \$5.00

I enclose \$ ..... (inc. p & h.)

Name .....

Address .....

..... postcode .....

# MORE GREAT SPECIALS FROM JAYCAR!

## ELECTRET INSERT



**ONLY \$1.49**  
SAVE NEARLY 40%

Electret inserts back on special!!  
For those who missed out in July. These are normally \$2.45 each. GRAB THEM NOW ONLY \$1.49!!  
SAVE NEARLY 40%!!!!

### OM350

Philips Hybrid  
Wide Band RF  
Amp

**WAS \$9.50 NOW \$6.50**  
**SAVE \$3**

We're scarce - now we're bullish in them!!!  
We need the cash so you get a bargain!!!

## 8 CHANNEL MIXER KIT

A few specs:

- 19" rack or console mount
- Balanced inputs and 2 outputs
- Equalisation on each input
- Uses latest NE5534 Op amps
- Very low noise
- Effects (e.g. "Echo" etc)
- Foldback send
- Switchable line and mic. level inputs with separate attenuation control

Don't buy a mixer until you have seen this one!  
Send SAE for more information.

## DIP EXTRACTION TOOL

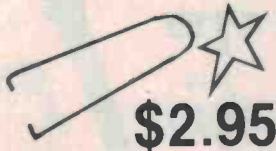

**\$2.95**

Ideal for the hobbyist or laboratory engineer. One piece spring steel construction. Will extract from 8-24 pin devices safely.

## DIP INSERTION TOOL

Industrial quality. Narrow profile enables work in densely packed areas. Tool includes a remarkable pin straightener built into the handle.

**\$5.95**

## XURO GRIP



**\$4.95**

"Mind Shear" pliers \$5.50  
Fine nose pliers \$4.95  
Both feature:  
- Made in the USA quality  
- Fantastic soft grip cushion handles  
- Spring loaded  
Why buy South Asian junk when you can have the best for no more?

## 19" RACK CABINET

\*\*\*\*\*  
**\$45**  
\*\*\*\*\*

19" black anodised rack boxes are back! We have had trouble keeping up with the demand for these 5 1/2" x 19" rack cabinets. They feature a magnificent 3mm black anodised and finished front panel.  
**BEWARE OF RACK BOXES THAT DO NOT CONFORM TO STANDARD RACK DIMENSIONS!!! OURS ARE ONLY \$45.00 EACH**

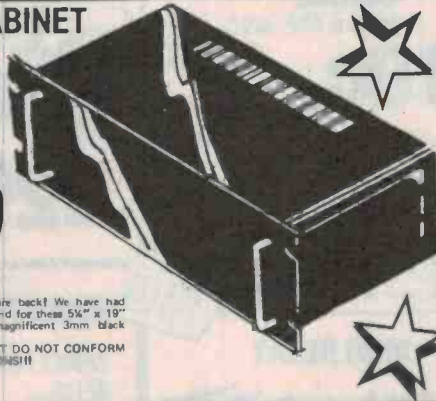

## \* great new ABS & DIECAST boxes \*

IMPORTED FROM CANADA  
We are pleased to announce that you can obtain a QUALITY small project box from Jaycar. At long last we have found a source of supply of ABS (not cheap styrene) plastic project cases. These cases feature a matching moulded lid (not a flimsy aluminium panel) and brass inserts for the metal thread countersunk retaining screws. Sizes range from 85 x 56 x 29 to a massive 190 x 110 x 54 in (would you believe!) the COLOURS of black, grey and orange! They look great and start from \$2.79 each.  
Die Cast boxes with a quality finish. We also have a range of these from 91 x 38 x 25 to 185 x 185 x 64. Prices start from a low \$2.95  
**AT JAYCAR YOU PAY NO MORE FOR QUALITY**

**top value**

POST AND PACKING		
\$5 - \$9.99		\$1.00
\$10 - \$24.99	<b>\$100 up</b>	\$2.00
\$25 - \$49.99	<b>\$5.50</b>	\$3.00
\$50 - \$99.99		\$4.00

## EA & ETI BELOW COST

We make no secret of the fact that we are in a out of the way location. To encourage you to call in to our store you can pick up the latest copy of EA or ETI at ONLY

**\$1.00**  
**THAT'S BELOW OUR INVOICE COST**  
We will subsidise the sale of these magazines until further notice. Remember that's nearly a 50% saving! (We also have back issues of EA and ETI for only \$1)

## AUDIO AMPLIFIER IC's SLASHED!!

TYPE	POWER	NORMALLY	THIS MONTH
TAA611B	2W	\$2.50	0.50c
TBA810	6.5W	\$4.50	0.95c
TBA651	AM Tuner IF	\$6.50	0.50c

FREE DATA SHEET WITH EACH UNIT!

## \* HOBBY BLOX \*

The most versatile breadboarding system in the world is now at Jaycar.  
Breadboard strips start from ONLY \$3.95

The Hobby Blox system is so expandable it could be called FROM "Electronic Lego"!!!!

**ONLY \$3.95**

## WELLER & XCELITE

Jaycar is now an official Weller and Xcelite tool distributor for these quality tools. Call in and see the fabulous Weller Electronic Soldering Station (it will cost you \$245) or the Xcelite tool kit in attractive case at only \$195. Naturally we carry the range of Weller products that you see everywhere else - but at great savings on other prices!

## NEW exciting range

## ARLEC SUPER SWITCH

**SUPER XXXX SPECIAL!!**  
NORMALLY \$23.50  
OCTOBER ONLY \$17.50  
**BE QUICK**

**ONLY \$17.50**

HAVE YOU SEEN OUR \$49.95 AUTO RANGING DMM?? IT'S A PRICE BREAK THROUGH

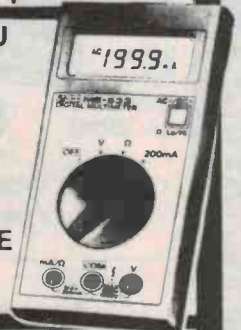

**\* \* AT LAST \* \***

**programmable master rhythm generator fully imported!!**

This project was originally described in the UK publication "Practical Electronics". We have the fully imported "Ciel" kit version. This attractive kit is presented in an attractive metal cabinet with silkscreened front panel.  
The Master Rhythm can be programmed (in RAM) to play back:  
- Twenty four Rhythm patterns  
- Eight parallel tracks  
- Twelve instrumental  
It is also capable of Sequence operation  
**THIS IS THE ULTIMATE RHYTHM GENERATOR!!!**

**complete \$199** **LOW POWER BATTERY DRIVEN**

# Jaycar

NOTE! NEW SHOP HOURS  
Mon - Sat 9am - 5.30pm  
Sun - 10am - 2pm  
Open Thursday night until 8pm



**380 Sussex St Sydney 2000**

Ph. 2646688 Telex 72293  
Mail Orders To: Box K-39 Haymarket 2000

# NOBODY BUT NOBODY BEATS OUR SERVICE AND LOW PRICES

**1. MAIL ORDER DELIVERY SAME DAY DESPATCH**  
 \$2.00 flat charge regardless of size or order TO ANYWHERE IN AUSTRALIA

**2. NEW OVERNITE JETSERVICE**  
 An amazing Altronics customer service \$4.00\* flat charge DELIVERY NEXT DAY TO ALL CAPITAL CITY AND MOST COUNTRY CENTRES \*Limit 3.5 Kgs.

**3. INCREDIBLE PHONE ORDER JETSERVICE**  
 Phone our Hotline (09) 328 1599 with your order by 4 pm (est.)\* FOR DELIVERY TO YOUR ODDR NEXT DAY \*Available to Bankcard customers Govt. dept's, schools, universities and public companies.

AT LAST THE FABULOUS ETI 5000 STEREO PRE AMP  
 (Brilliantly designed by Australia's top audio engineer David Tilbrook)



EXCLUSIVE metal film 1% resistors supplied throughout. EXCLUSIVE torin low noise high reliability switches supplied. Kit includes absolutely all components and full instructions and includes superb instrument rack cabinet. COMPLETE KIT ONLY \$245.00

### DIODE SUPER BUYS

IN914	5c	100 up	3c
IN4002	6c		5c
IN4004	8c		6c
IN4007	10c		8c
IN5404	30c		25c
IN5408	40c		32c

### GERMINIUM DIODES

Equiv to OA91 SPEC  
**10c** each **\$8.00** for 100

PRINTING CALCULATOR  
 VOESA 1871 P.D.

This portable Or mains powered adding machine and calculator has in-built rechargeable batteries with modern silicon chip technology for home or business



**\$65**

### 8 WAY DIL SWITCH

quality Japan manf



10 up  
**\$2.00** just **\$1.80** each

### DALO PENS

Great PC art-work aid.

DIRECT IMPORT PRICE

**\$1.50**

12 up

**\$1.20**



ANTHONY IS BACK!

### OEM PRIME SPEC LEDS

DIRECT IMPORT PRICE

3mm Red	15c	10 up	13c
Green	20c		15c
Yellow	25c		20c
5mm Red	10c		8c
Green	25c		20c
Yellow	30c		25c
Orange	30c		25c
RECT Red	.25c		.20c
Green	.30c		.25c

### MINI RELAY

PCB mount 8-15v coil 1 amp SPOT contacts 1000's sold

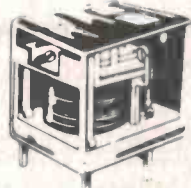

AMAZING VALUE

**\$1.50** 10 up **\$1.00**

### HARD TO GET SEMIS AT BARGAIN PRICES

2N6027 PUT	65c	MPF105	50c	BF470	\$1.00
BF115	75c	LM380	\$1.60	VN88AF VMOS	\$3.95
MPF102	55c	CA3140	\$1.25	MEL12 PHOTO	
HF/VHFFET		BF469	\$1.00	DARLINGTON	95c
MPF104	50c			LAM3915 LEO	
				BAR/DOT DRVR	\$3.50

### AC ADAPTOR

240/3.4-5.6.7-5. 9.12 @ 300ma SCOOP BUY



**5.00**

### INFRA RED LED

SAVE 60%

Philips COY89A



1-24 25-99 100 up  
**75c 65c 55c**

### PRICE CRASH ON AA NICADS

Quality Matsushita manufacture 1.2v 500mah

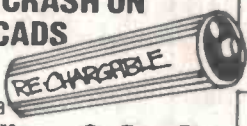

**\$1.15** FROM

1-9	10-99	100+
\$1.50	\$1.30	\$1.15

### MOLEX PINS

SAVE 50%

**\$1.00** Pack 100



### BLACK IS BEAUTIFUL



19 INCH RACK BOX (483mm W x 132mm H) Get a professional finish like Namakichi and Technics with your projects.

**\$39.95** each 5 up **\$35.00**

### MOSFET BARGAINS

As used in the current mosfet amp projects SAVE 33%

Hitachi 25K134 Hitachi 25J49



**\$6.00** ea

### NEW OP AMPS

Used in the 5000 series preamp



NE5534N	\$1.25	10 up	\$1.15
NE5534AN	\$1.95		\$1.85

### Bitsav RESIN CORE SOLDER

\$1.00 OFF 200g reel Lab grade 1mm diam BARGAIN



**\$3.95** 10 up **\$3.50**

### PC STAKES (PINS)

SAVE 33%

Pack 100 (ave)

**\$2.00** only

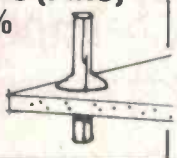

### NICAD CHARGER



Charges 4 aa nicads VALUE **\$7.50**

### ALTRONICS

105 Stirling St. PERTH (09) 328 1599 for instant service

All MAIL ORDERS: BOX 8280 PERTH Stirling St. WA 6000

Rush in your order NOW, we will rush it back

ALTRONICS ... ALTRONICS ... ALTRONICS ... ALTRONICS ... ALTRONICS ... ALTRONICS ...

ALTRONICS ... ALTRONICS ... ALTRONICS ... ALTRONICS ... ALTRONICS ... ALTRONICS ...



# Video RF modulator

Graeme Teesdale

This modulator, though designed to team with our ETI-660 Learners' Microcomputer, will find many applications in such things as video games, TV pattern generators, etc. It features a very stable oscillator and low modulation distortion.

BY FAR the cheapest way to provide a visual display unit (VDU) for a home-built computer is to press the family television set into service. To do this you need to modulate the computer's video output onto a suitable RF 'carrier' produced by an oscillator operating on an unused TV channel frequency. The TV set treats the signal as it would a normal TV signal and *voila!* — instant VDU!

Whilst this project was designed to be used in conjunction with the ETI-660 Learners' Microcomputer, it is suitable for any application requiring a video RF modulator, e.g. video games, TV pattern generator or what have you.

## Design

The circuit is quite straightforward, but there are a number of unusual features we should draw to your attention. The oscillator is a series-tuned Colpitts, otherwise known as a Clapp circuit. It is a simple, stable oscillator where the frequency stability is largely independent of variations in the parameters in the active device due to temperature or voltage. Secondly, the LC network, being a series resonant circuit, is essentially low impedance and is not particularly sensitive to hand capacitance effects, etc. The oscillator frequency may be set to channels 1, 2 or 3.

A dual-gate FET is employed as the mixer, or modulator. Gate one is driven from the output of the oscillator, while video is applied to gate 2 from an inverter stage employing a junction FET. Most video modulators employ a single transistor or FET and the video modulation is applied to the emitter or source, respectively. This eliminates the need for phase inversion but the modulation linearity is not good and distortion disturbs colour video signals. The circuit used here, while not as simple as most modulators, has superior modulation linearity, and good colour signals result when composite colour video is applied. The modulator requires a video signal of about one volt peak-to-peak.

Video-modulated RF output is taken from the drain of the dual-gate MOSFET mixer via a wideband transformer wound on a TV balun core.

## Construction

Construction is quite straightforward. We recommend you use our pc board as it avoids wiring errors and you will be assured of correct operation.

If not already done, drill out the two mounting holes first. One is adjacent to the Belling & Lee output socket, the other is located in the enlarged area of the 0 V track between R3 and R4. Each is circled on the component overlay. ▶



# Project 760

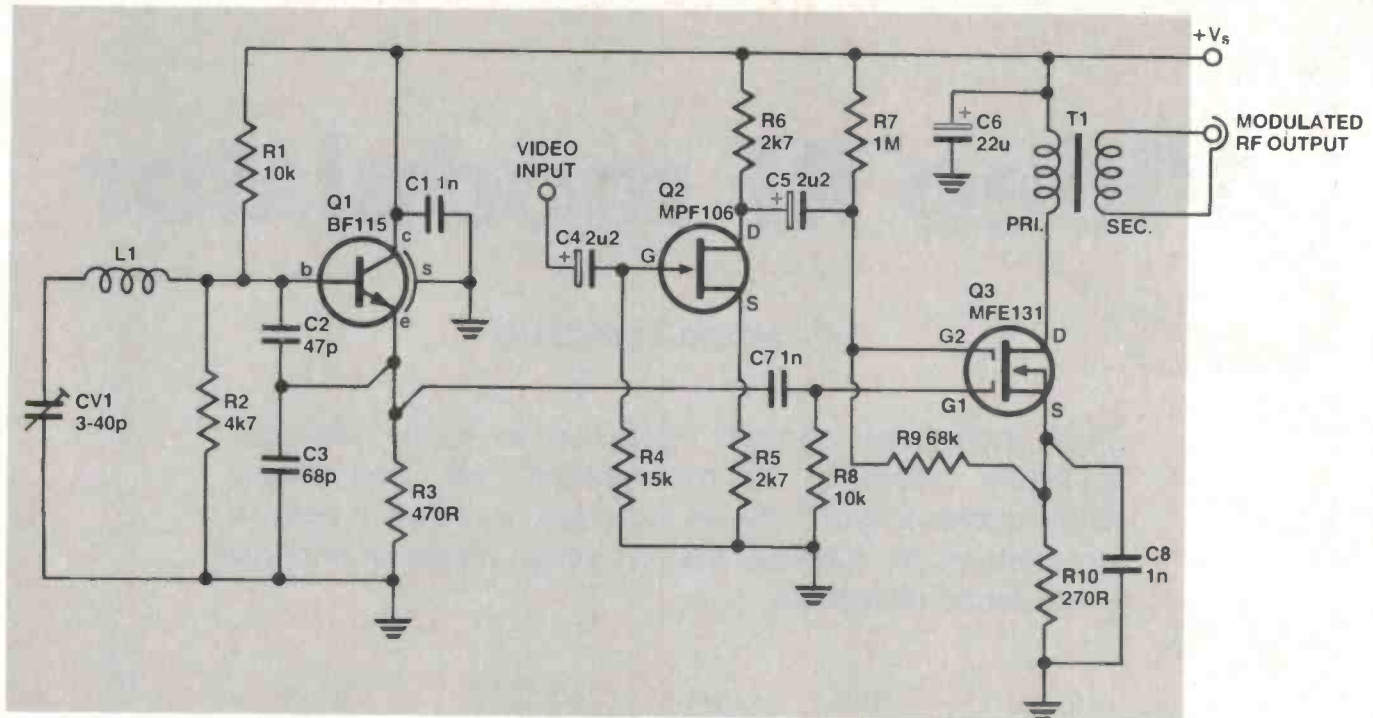

Once the mounting holes are drilled you can use the pc board as a template to mark out the drilling positions in the box for the mounting bolts. Drill out the hole to take the coil former next. You will notice the Neosid 722/1 former has two 'keys' on the base. Either file two slots in the hole in the pc board to accommodate them, or file them off. Don't mount the former yet.

Insert the semiconductors first. Identify which way each one is oriented before inserting them. If you observe the top view pinout drawings accompanying the circuit drawing above, you should have little difficulty inserting them correctly.

The resistors and capacitors may be inserted next. Watch the polarity of C4, C5 and C6. Note that either an electrolytic or a tantalum capacitor may be used for C6. Some trimmer capacitors have two pins (one for the fixed, one for the moving plates) and some have three pins (two for the moving plates). Two holes have been provided on the pc board for CV1, so cut off one of the moving plate pins if you use a type with three pins. Identify the pin that connects to the moving plates and insert this in the hole that is in the common (0 V) track. This ensures that the adjusting tool does not affect the tuned circuit when you're adjusting it.

The coil, L1, may now be wound on the former and the former glued into the pc board. Strip and tin the ends of the coil leads before mounting the coil. Wind T1 next. You can wind the

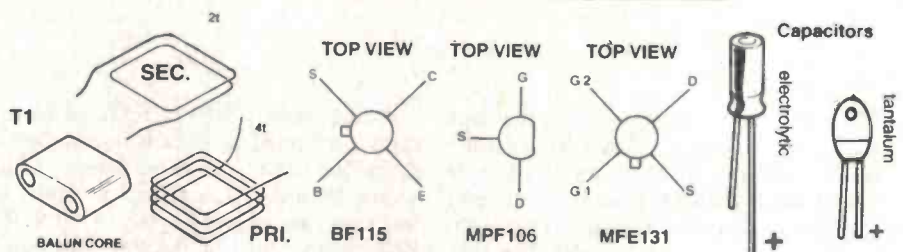

## HOW IT WORKS ETI-760

The circuit comprises an oscillator, an inverter (to provide the correct video modulation) and a mixer or modulator. The oscillator provides the carrier frequency and is set to the frequency of the desired TV channel. The mixer modulates the video signal onto this carrier so that the TV set treats the output as it would a TV signal.

The oscillator circuit is built around Q1. A series-tuned Colpitts, or Clapp, circuit has been used for reasons explained in the text. L1 and CV1 comprise the tuned circuit, which determines the oscillator frequency. The frequency may be varied by adjusting CV1. Capacitors C2 and C3 provide positive feedback. The collector of Q1 is 'grounded' for RF via C1. Resistors R1 and R2 provide base bias, while R3 provides emitter bias and acts as an output load. Output from the emitter is capacitively coupled to gate 1 of the mixer, Q3, via C7.

The mixer circuit employs an MFE131 dual-gate FET, Q3. The RF signal from the oscillator is applied to gate 1 and the video modulating signal is applied to gate 2. Varying the voltage on gate 2 varies the transconductance of the FET and the modulating signal will thus appear as sidebands about the carrier signal. A small amount of dc bias is applied to gate 2 via R7.

Some dc positive feedback between gate 2 and the source, via R9, helps to keep the modulation linear, avoiding video distortion, which is important if colour video is applied.

A simple common-source inverter, built around a junction FET, Q2, inverts the video input to apply the correct modulation to the carrier signal. Thus, what is known as 'inverse video' is applied to the video input. Where correct video is available, Q2, R4, R5, R6 and C4 can be dispensed with and the input applied to the positive terminal of C5.

The modulated RF output is taken from the drain of Q3 via a wideband transformer, T1, which also matches the 75 ohm output impedance to the drain of Q3.

Capacitor C1 serves as a dual-purpose bypass — for the collector of Q1 and as an RF bypass for the positive supply rail. Capacitor C6 is a low frequency bypass for the positive supply rail. It is located close to the drain connections of Q2 and Q3 so that video sync pulses do not modulate the supply rail, which can upset the operation of the oscillator. The inductance of the positive supply rail track on the pc board isolates the primary of T1 from the supply rail for RF.

Capacitor C8 is an RF bypass for the source bias resistor of Q3 (R10).

primary and secondary around the centre 'leg' of the balun core or you may wind the primary through one hole and around the outside of the core and the

secondary in the same way through the other hole. Either way will work.

Mount the RF output socket last. You don't have to mount this on the board,

# video RF modulator

but if you do, note that the three pc board holes that take the lugs of the socket need to be drilled out to about 2 mm diameter.

You can try out the modulator at this stage. Connect the output to your TV set. Switch the tuner to an unused lower channel. If you have a source of video with sync then apply that to the video input (amplitude will need to be a volt or so). Adjust CV1 until you get some sensible picture on the screen. With no video modulation applied, you should get a snow-free raster on the TV screen when CV1 is correctly adjusted.

I mounted the modulator in the base of a small diecast box. I put a nut and washer on each mounting bolt, underneath the board, to space it off the bottom of the box. Before mounting the board in the box I drilled a 9 mm diameter cable entry hole in the end of the box adjacent to L1. It's a wise idea to insert a rubber grommet in the hole to prevent the cables chafing on the hole edges. The box will be connected to the 0 V rail on the board via the mounting bolt located between R3 and R4.

I dispensed with the box's top cover when mounting the modulator in the ETI-660 Learners' Microcomputer. If you are using this project in some other application a top cover is recommended to avoid stray radiation. It will be necessary to drill a 15 mm diameter hole in the box lid above the Belling & Lee output socket to enable a coax plug to reach the socket.

The 'outer' connection on the output socket may be connected to the 0 V line on the board if you wish. Bridge the track which connects to the outer of the output socket to the 0 V line where it runs under T1. Do it with a short length of tinned copper wire.



Picture of T1 wound up as per drawings at left.

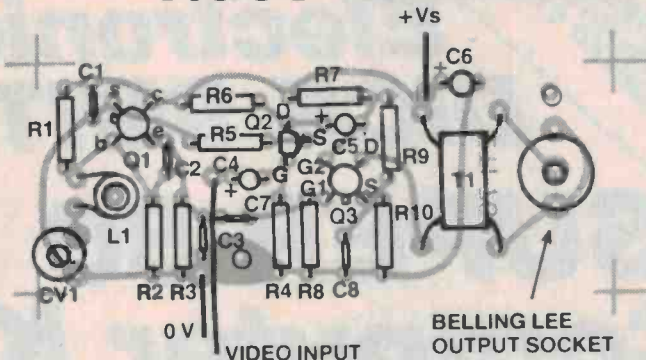

Component overlay for the video RF modulator. Artwork for the ETI-760 pc board is reproduced on page 159, the page behind being printed all in blue so that you can make a Scotchcal negative by exposing through the page. You can then use the negative to make your own pc board.

## PARTS LIST — ETI 760

**Resistors** ..... all 1/2W, 5%  
 R1, R8 ..... 10k  
 R2 ..... 4k7  
 R3 ..... 470R  
 R4 ..... 15k  
 R5, R6 ..... 2k7  
 R7 ..... 1M  
 R9 ..... 68k  
 R10 ..... 270R

**Capacitors**  
 C1, C7, C8 ..... 1n ceramic  
 C2 ..... 47p ceramic  
 C3 ..... 68p ceramic  
 C4, C5 ..... 2u2/16 V tant.  
 C6 ..... 22u/16 V electro.  
 CV1 ..... 3-40p film or ceramic trimmer

**Semiconductors**  
 Q1 ..... BF115  
 Q2 ..... MPF106  
 Q3 ..... MFE131, 40673, 40841, etc.

**Miscellaneous**  
 L1 ..... 10 turns of 22 swg enamelled copper wound on a 5 mm diameter former, Neosid type 722/1

T1 ..... Primary — four turns of hookup wire around centre leg of balun core. Secondary — two turns of hookup wire around centre leg of balun core. Take the leads out opposite faces. Balun core is Neosid type 1050/2/F14 (or 42-002-31) 6 mm long by 13 mm wide.

ETI-760 pc board (fibreglass); RCA or Belling & Lee RF output connector; diecast box 100 x 25 x 50 mm (or similar all-metal box); hookup wire, nuts & bolts, etc.

### Price estimate

We estimate the cost of purchasing all the components for this project will be in the range:

**\$7.50 - \$12.50**

Note that this is an estimate only and not a recommended price. A variety of factors may affect the price of a project, such as — quality of components purchased, type of pc board (fibreglass or phenolic base), type of front panel supplied (if used), etc — whether bought as separate components or made up as a kit.

HAPPY

36th

ANNIVERSARY

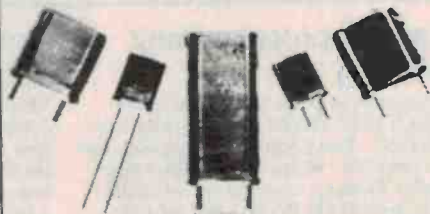

Quantity Orders of Quartz Crystals 100 off or more available at very competitive prices.

Ring 546 5076 for quotes.

**Bright Star Crystals** Pty. Ltd.

PO Box 42, Springvale, Ph (03) 546-5076 Telex AA36004

**FIRST CONSIGNMENT SOLD  
OUT IN 2 1/2 DAYS!  
STRICTLY LIMITED STOCKS**

# **Electronics Australia/ DICK SMITH**

## **SUPER 80 Computer Kit**

**from \$289<sup>50</sup>**

**THE MOST  
POPULAR KIT  
WE'VE EVER  
PRODUCED!**

*If, like me, you are fed up with purchasing built-up products, here's your chance! Just imagine being able to tell your friends that you **ACTUALLY BUILT** your own full size computer — they probably won't believe you!*

**Very advanced design - but works with any TV set!**

The 'Super 80' offers a specification that we believe just cannot be bettered at the price. It uses the popular Z80 Microprocessor IC, a professional keyboard and has a direct RF output so that you can use the computer with any TV set (you don't need to purchase a special video monitor).

### **Easy to build.**

Even though we would not recommend this kit to the raw beginner, this kit is extremely straightforward and easy to build. Any person who can use a small soldering iron and can solder neatly should have no difficulty in construction. This is because of the unique double side board design which means there is virtually no other wiring. The board is covered with professional 'solder mask'; this makes soldering much easier without the problems of bridges, etc. Once the components are soldered onto the board in their marked positions over 98% of the construction is completed. Even if you cannot get the completed kit to work, we have a special "Sorry Dick it doesn't work" repair service to assist you.

### **Lower price, higher specification - how is it done?**

Most computers sold in Australia are manufactured in the U.S.A. where extremely high labour rates prevail - and you pay dearly for this on built up units. With this computer kit, you provide the labour and therefore save a fortune. And remember, this computer does not have a small toy-like calculator keyboard but a full size professional typewriter keyboard.

Cat. K-3600

Inbuilt power supply: just add a transformer

Enormous 16K RAM on board lets you load large programs (pcb allows for up to 48K)

Inbuilt cassette interface: 300 baud Kansas City Standard allows you to load your BASIC interpreter from any cassette player. You can also swap programs

Full size professional 60 key keyboard allows ease of operation

### **THE ABOVE PHOTO SHOWS THE BASIC BOARD WITH THE FOLLOWING**

#### **Advanced programming capability.**

One of the most popular computers in the world (the Tandy TRS80 Level 1) only has 4K of BASIC. The BASIC we have with this unit is a large 9K. When you consider that our popular Sorcerer computer (over 2,000 sold) only has an 8K BASIC and sells for over \$1,000, it is obvious that by building yourself, you are saving real money.

#### **Electronics Australia/ Dick Smith design.**

This is not a half baked design with no back up. The resources of Electronics Australia, Australia's most popular electronics magazine, and Dick Smith Electronics have combined to design and bring you this kit in the interests of computer enthusiasts actually building and not just buying. The design is fully Australian.

#### **Imagine how much you will learn!**

Most computer enthusiasts can program a computer but would have absolutely no idea of how to build one. By building this kit you will learn both the technical side of construction, how it works and then how to program. What a fantastic background for a future...

#### **Sectional construction.**

We have designed this kit not only for the serious computer user but also for first time users like the student or hobbyist. This is why we have a short form kit which may be added to as you build (and as you have the money!). For example, you may build the computer originally and operate it with 'BASIC on tape' and then add 'BASIC in ROM', add the S-100 and provide other parts at a later stage.

Relay to operate cassette unit automatically

2K Monitor program supplied

Character generator giving a full 64 characters  
32 character x 14 line screen

Spare IC positions for prototyping  
and user customising

IC sockets available as  
an optional extra

RF modulator inbuilt: connects  
to any TV set.

Optional S-100 provision: simply  
add socket and IC's

Professional double sided PC board with  
plated thru holes for ease of construction,  
fully masked and with component overlay

Special design allows keyboard to be  
mounted remotely: simply cut board here

12MHz quartz crystal

Optional 9K SUPER BASIC in ROM simply  
plugs in here

Famous Z-80 microprocessor as used in  
Tandy & System 80 computers

\*Copy of articles will be included  
when available from EA.

OPTIONAL EXTRAS ADDED: S-100 EXPANSION, IC SOCKETS, FULL 48K RAM

## 'Sorry Dick, It Doesn't Work'

All parts with this kit are guaranteed tested and new, but we cannot guarantee the labour content provided by you. If, after completion, your Super 80 fails to operate, you may take advantage of our 'Sorry Dick, It Doesn't Work' service.

Our Service Centre will check and repair your Super 80 for the cost of \$100. This fee includes any necessary replacement of components, etc.

If you send your Super 80 to us under the 'Sorry Dick, It Doesn't Work' service, it must have been constructed using IC sockets. If we receive a kit which does not use IC sockets, or if the kit is so badly constructed as to make effective repair impossible, we reserve the right to return your kit in the condition received, together with the service fee.

Under our 7 day satisfaction guarantee, you may return any kit in its original condition for a full refund of the purchase price. We cannot give a refund once construction has commenced, if any internal packs of components are opened or if the carton or kit is damaged.

## 7 DAY SATISFACTION GUARANTEE

Purchase this kit and inspect it for up to 7 days. If you do not wish to go ahead and construct this kit, simply return to us in condition as supplied and your money will be refunded in full.

# DICK SMITH Electronics

DSE/A019/LM

NSW AUBURN 648 0558 • BLAKEHURST 546 7744 • BROADWAY 211 3777 • BROOKVALE 93 0441 • CHULLORA 642 8922 • GORE HILL 439 5311 • NORTH RYDE 888 3200 • PARRAMATTA 683 1133 • SYDNEY 290 3377 • TIGHE'S HILL 61 1896 • WOLLONGONG 28 3800 ACT FYSHWICK 80 4944 QLD BURANDA 391 6233 • CHERMSIDE 69 9834 SA ADELAIDE 212 1962 VIC COBURG 383 4455 • MELBOURNE 67 9834 • RICHMOND 428 1614 • SPRINGVALE 547 0522 WA CANNINGTON 451 8668 • PERTH 328 6944

Mail Order Centre: PO Box 321, North Ryde 2113. Phone: (02) 888 3200

## Comprehensive manuals available:

The construction details will be given in Electronics Australia magazine and full copy\* of the EA article will be supplied with each kit. We also have available two very comprehensive manuals to assist in construction and programming:

Combined construction, assembly  
and technical manual.



Cat B-3602

\$14.50

## Super 80 Basic does this:

Over 50 separate versatile commands. Features: arithmetic and integer functions user-defined functions, machine language routines, text editing, string operations. Also contains 25 error codes to assist you in programming.

'Super 80 Basic' reference manual

## Short Form Kit

Designed for computer applications where 'Basic' programming is not required. Kit supplied with Eprom Monitor and 16K RAM. Cat. K-3600 **\$289.50**

Add these items to make a fully operating computer system to your own requirements:

Transformer to suit ..... M-2325 **\$22.50**  
BASIC program (interpreter) on cassette. .... K-3602 **\$24.50**  
IC Socket set (recom.) ... K-3603 **\$12.50**  
BASIC program in EPROM (set of 3 IC's) ... K-3604 **\$99.50**  
S-100 Expansion ..... K-3606 **\$19.50**

Yes, this makes the full 16K computer with 9K basic on tape, transformer and IC Sockets — only — **\$349!**



**SUPER 80  
EXCLUSIVE TO  
DICK SMITH'S**

289 LATROBE ST., MELBOURNE 3000  
 PHONE (03) 602 3282 - 602 3836 TELEX AA 37758 LSTRON

## HOBBY CRO!

### SPECIFICATIONS

Weight: About 3.8kg  
 Size: 202mm(w) × 160mm(h) × 306mm(d)  
 Usable Bandwidth: D.C. to 6.5 MHz plus.  
 Vertical deflection sensitivity: 10mV per division  
 Horizontal deflection sensitivity: 500mV per division  
 Time base sweep frequency: 10Hz to 100kHz in 4 ranges  
 Synchronisation: internal and external.



**\$155** EXEMPT  
**+178<sup>25</sup>** INC TAX **\$6<sup>00</sup>** Freight

ALL PRICES PLUS TAX IF APPLICABLE

Sales Tax Code:

**A: 27½%**

**B: 15%**

**2 NEW LOGIC PROBES**

**\$14<sup>00</sup>**

**\$16<sup>00</sup>**

inc. tax

**DLP-1**



Max Input 1.5MHz  
 Strong Aluminium case  
 LEDs: HI - LOW - PULSE  
 80cm leads  
 KEY to LEDs on back of probe  
 Input Impedance 300k

**3800A**

**\$22<sup>00</sup>**

**\$25<sup>30</sup>**

inc. tax

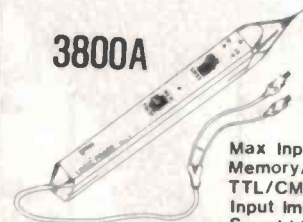

Max Input 10MHz  
 Memory/Pulse Sw.  
 TTL/CMOS Sw.  
 Input Impedance 300k  
 Smart black plastic case  
 53cm leads

### NEW! BREAD BOARDS

Now DIRECTLY imported at ½ cost of other breadboards!



WB-DN 100 Holes  
**\$198** **\$228** INC. TAX



WB-TN 640 Holes  
**\$757** **\$870** INC. TAX



WB-2N 100 + 640 Holes  
**\$965** **\$1110** INC. TAX



WB-2N 200 + 640 Holes  
**\$1121** **\$1290** INC. TAX



WB-4N-3 100 + 1280 Holes  
**\$1959** **\$2253** INC. TAX

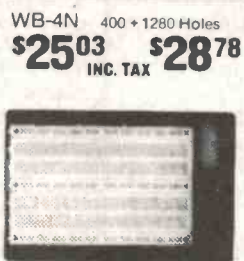

WB-4N-1 300 + 1280 Holes  
**\$2350** **\$2703** INC. TAX



WB-6N 500 + 1920 Holes  
**\$3558** **\$4092** INC. TAX



NOW IN STOCK —  
**LUTRON DIGITAL LCD MULTIMETER**  
 3½ Digit, 5" Display, 10 meg input, Transistor HFE Tester up to 10 amp. DC current 1% accuracy.  
 \$62 plus 15% Tax if applicable.

	1-24	25-99	100 plus		1-24	25-99	100 plus
2708	4.50	3.55	3.25 B	BC547-8-9	.11	.09	.07 B
2716 5V	4.75	3.95	3.50 B	BC557-8-9	.11	.09	.07 B
2732 5V	8.50	7.95	7.50 B	RED LEGS 5mm	.12	.09	.07B
2114 300NS	1.95	1.75	1.50 B	IN 4002	.05	.04	.035 B
4116 200NS	1.95	1.80	1.50 B	IN 4004	.07	.05	.04 B
4116 250NS	1.35	1.28	1.20 B	IN 4007	.12	.09	.07 B
8264 64 x 1K RAM	45.00	P.O.A.	P.O.A.	2N 3055	.65	.55	.49 B
8414 x 4 CMOS RAM	5.20	P.O.A.	P.O.A.	PACK & POST UP TO \$25 = \$2			
Z80CPU 2 MEG	10.76	7.16	6.73 B	PACK & POST UP TO \$50 = \$3			
Z80ACPU 4 MEG	13.50	9.59	9.01 B	PACK & POST UP TO \$100 = \$5			
Z80 P10	6.95	5.17	4.86 B				
Z80A P10	9.18	6.64	6.24 B				
Z80 CTC	6.95	5.19	4.88 B				
Z80A CTC	8.48	6.09	5.73 B				

ALL COMPONENTS ARE PRIME SPEC AND ARE FULLY COVERED BY MANUFACTURERS' GUARANTEE.

ELLISTRONICS • ELLISTRONICS • ELLISTRONICS • ELLISTRONICS • ELLISTRONICS • ELLISTRONICS • ELLISTRONICS • ELLISTRONICS • ELLISTRONICS • ELLISTRONICS

ELLISTRONICS • ELLISTRONICS • ELLISTRONICS • ELLISTRONICS • ELLISTRONICS • ELLISTRONICS • ELLISTRONICS • ELLISTRONICS • ELLISTRONICS • ELLISTRONICS

## Crystal marker generator for receiver and CRO calibration

A simple but very useful piece of test equipment for calibrating and aligning receivers, transceivers and oscilloscopes. It is portable, battery operated and inexpensive to build.

Design: **Ray Marston**

Development: **Simon Campbell**

**THIS SIMPLE** piece of test gear will help you calibrate receivers or transceivers which don't incorporate a crystal calibrator, set up and calibrate low-cost oscilloscopes, and even provide an accurate calibration source for frequency/period counters (especially if you've made it yourself).

Many of the older 'budget' shortwave receivers do not have dial calibrations which are sufficiently accurate to read out to even 10 kHz, and few ever had a crystal calibrator of any sort (see 'Receivers for the Budget-Minded Shortwave Enthusiast', by Bob Padula, ETI June '80, p.26). In addition, their calibration drifts with time. This project not only allows you to set a receiver's dial calibration from time to time but you can dial up a particular frequency to an accuracy of 1 kHz.

If you're keen on VHF and operate suitable converters in front of your HF receiver then this project will be useful there too, as it provides harmonics to over 150 Mhz. (See 'Modern Solid-State Converters', by Roger Harrison, ETI Feb. '76, p.63 and 'Aircraft Band Converter', ETI March 1979, p.39).

A variety of low-cost solid-state oscilloscopes, aimed at the hobbyist, has become available recently, and while useful in a general way, suffer somewhat because they do not have a calibrated timebase. You can use this project to overcome this problem and this application was one of the reasons the 100 Hz output facility was included.

This marker generator can also be



used to calibrate the timebase oscillators of frequency counters and period timers simply by plugging the marker output into the counter's input and setting the timebase frequency to obtain the correct display!

### Design

The circuit design is fairly straightforward, but quite different to our earlier crystal marker generator, the ETI-706 (Feb. '76, p.53). The latter used a 4 MHz crystal and provided fundamental outputs of 4 MHz, 2 MHz, 1 MHz, 100 kHz and 10 kHz. It had useful harmonics to 30 MHz or so.

The microprocessor industry has pro-

vided a range of components that were not common a few years ago, among them 1 MHz quartz crystals. We've used one of these as the basis of this project because they're cheap and common. As they are generally meant for series-mode operation, we've used an aperiodic Butler oscillator (for more details on crystals and crystal oscillators, see 'Modern Crystal Oscillators', by Roger Harrison, ETI Jan. '76, p.46, or ETI Circuit Techniques Vol.1).

The output of the crystal oscillator is buffered by Q1, which drives one stage from a hex Schmitt inverter (40106). This 'squares up' the signal and drives the four cascaded decade dividers (all ►

# Bulk buying & quality make Dick's Kits the

**Building a Dick Smith Kit is as easy as ABC!**



Everything you need is supplied — parts, solder, even nuts and bolts. And most kits include detailed instruction manuals, making construction a breeze!



It goes together so easily: you don't have to be an expert to build a kit. Just follow the instructions!



And it's finished! Sit back and enjoy your project; because you did it yourself!

**and they look so good your friends won't believe you built it!**

**Will negative ions improve your health?** find out with this **ION GENERATOR**

This easy to build kit breaks down dust and cigarette smoke particles, aids to a healthier and happier life. Comes complete with exclusive Dick Smith emitter head.

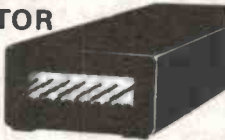

**\$38<sup>50</sup>**

Cat. K-3335

**BUILD YOUR OWN TEST GEAR!**

**& SAVE!**

**AUDIO OSCILLATOR**

**\$37<sup>50</sup>**

Cat. K-3469



An essential piece of test gear for the serious hobbyist. Covers frequencies from 15Hz to 150kHz in four overlapping ranges. Distortion is less than 0.1% max. between 20Hz and 20kHz. Useful piece of equipment for the experimenter's bench. Simple design and easy to build. Parts supplied include specially printed front panel, attractive 'Zippy' case and full instructions.

**DICK SMITH'S EXCLUSIVE SILK SCREENED FRONT PANEL!**

**RLC BRIDGE**

Check the values of new and used components and determine the actual value of wide tolerance capacitors such as electrolytics and ceramics. 10 measurement ranges from 10 ohms to 10 megohms; from 10 picofarads to 10 microfarads. Kit includes specially printed front panel.

**\$37<sup>50</sup>**

Cat. K-3468



**LOW DISTORTION OSCILLATOR**



Cat. K-3467

**\$67**

This audio oscillator provides a low distortion sine wave output and covers a frequency range of 15Hz to 150kHz in four overlapping ranges.

**SOUND DB METER**

Cat. K-3476

**\$35<sup>50</sup>**

Keep potentially harmful noise levels in check, in your home or factory! This meter will measure sound levels of less than 20dB, to over 120dB.

**AND YOU REAP THE BENEFIT!**

**build your own synthesizer!**

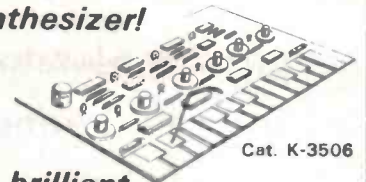

Cat. K-3506

**the brilliant**

**Electrochune**

A versatile keyless monophonic organ that uses the circuitry of a synthesizer! It has variable attack/decay, tremolo and mixing control. Plus its own inbuilt amp and speaker with separate volume control. Touch sensitive keyboard. Ideal for people who like to experiment!

**ONLY \$69<sup>90</sup>**

**AND FOR YOUR BENCH**

**BENCHMATE**

An indispensable tool for the bench. Combination 1W audio amplifier and 1.25 — 16V power supply @ up to 1A. Great value!

Cat. K-3478



**\$46**

**EARTH LEAKAGE ELECTRONIC CIRCUIT PROTECTOR**

Cat. K-3315

**\$49<sup>50</sup>**



Avoid electrocution! Build yourself a core-balance leakage detector and you could save a life — maybe your own! Less than half the price of built-up units!

**POOLS/LOTTO SELECTOR**

Picks your winning numbers at random!

Cat. K-3392 **\$19<sup>50</sup>**

**HOT CANARY**

An electronic bird whistle that sounds authentic. Keeps the kids amused for hours!

Cat. K-3395 **\$15<sup>50</sup>**



# control tops!

## AUDIO KITS

### General Purpose Pre-amp

This versatile unit can be built up as a magnetic cartridge pre-amp for upgrading your stereo, a tape or auxiliary pre-amp with 40, 55 or 80dB gain. Extremely simple: uses only one special IC and is very small — all parts fit on a PCB less than 65mm square. Needs no special power supply, from 10 to 40V will do, full instructions supplied.



**\$8<sup>90</sup>**

Cat. K-3427

### Mixer Pre-amp

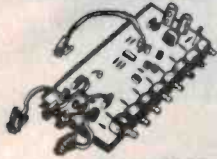

Completely adaptable mixer for all uses. Has 4 inputs, each with 100k impedance (suitable for guitars, microphones), also provides bass, treble, presence controls plus a master level control. Does not include power transformer, case or any mains wiring, so it's great for 'building in' to other equipment.

Cat. K-3035

**\$29<sup>50</sup>**

### LIGHT CHASER



One of the 'most asked for' projects. This chaser design not only makes the lights chase each other, it can also invert the action and make the 'shadows' chase each other. Even reverses direction or varies the flash rate.

Cat. K-3145

**\$71<sup>50</sup>**

### INFRA RED BEAM RELAY

Pre-activated relay is set off once beam is cleared. Ideal for burglar alarms, door minder, etc.

Cat. K-3375

**\$38<sup>50</sup>**

### INFRA RED REMOTE CONTROL

Uses remote control to switch on and off any appliance within 10 metre range. Controls appliances up to 1200 watts.

Cat. K-3380

**\$65<sup>95</sup>**

### CHEAP PROTECTION! CAR ALARM!

New improved design. Without false triggering problems. Simple installation. Protect your valuable property from would-be thieves!



**\$28<sup>50</sup>**

Cat. K-3253

### LEDS & LADDERS

Electronic version of the popular game. Can you climb out of the well without being plummeted down again! Was \$16.75 in 1976!

**\$16<sup>50</sup>**

Cat. K-3390



## LOOK AT THESE GREAT NEW KITS

### Build the fantastic new SUPER 80 computer

Cat. K-3600

It was worth the wait! The Super 80 is by far the best value you'll find in a computer... and you'll be able to tell your friends you built it yourself!

"No matter how you look at it, the Super 80 must be a winner."  
(Electronics Australia, August, 1981)

For more details of this exciting new kit, see our **\$289<sup>50</sup>** double page advert elsewhere in this issue.



### UNIVERSAL TIMER

An incredibly versatile, 7 function timer. Can be used as a kitchen timer, stop watch, rally timer and industrial timer — with bright 4 digit, 7 segment LED display.

ONLY

**\$39<sup>50</sup>**

Cat. K-3435



### DIGITAL CLOCK/THERMOMETER

Short Form Kit

Huge bright red digital display, 6 display modes. Time and temperature display, alarm and control for clock, radio, etc. 12/24 hour — C/F Battery back up facility.

Cat. K-3436

**\$49**

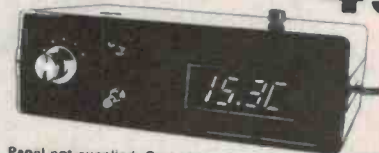

Panel not supplied; Case shown optional (Cat. H-2505)



Includes our famous 'Sorry Dick It Doesn't Work' Guarantee

**\$89**

### MUSICOLOR Mk. IV

Musicolor IV is a flexible light controller. It has all the features of the Mk III, plus lots more! Including 4 controlled channels, plus a light chaser with four chase patterns and a reverse switch for startling effects. Connects to speaker terminals of your amp. Completely safe — adds another amazing effect to your stereo — LIGHT!

Cat. K-3143

## PARTS FOR NEW KITS Printed Circuit Boards

### Semiconductors

Cat. Y-1053	MA1026 ALR Clock/Therm Module	\$29.50
Cat. Z-6816	MM5865N Uni Timer IC	\$9.75
Cat. Z-6300	ICL7106 3.5 Digit Driver	\$9.50
Cat. Z-5747	ICM7216B Frequency per counter	\$29.95
Cat. Z-6823	SN76488N Uni synthesiser IC chip	\$4.95
Cat. Z-6083	LM394B Dual diff. super mix pre-amp	\$4.50
Cat. Z-6810	LM334Z Temp./Sensor	\$1.95
Cat. Z-4175	LCD Display — 4 digit	\$8.95
Cat. Z-6030	TL 071 Bifet Op. Amp.	95c
Cat. Z-6034	TL 074 Quad Bifet Op. Amp.	\$2.75

E.A. OCTOBER		
Cat. H-8414	Wind Speed Indicator	\$2.50
Cat. H-8415	Audio Test Unit	\$2.95
E.A. SEPTEMBER		
Cat. H-8640	Uni Sound Synthesiser	\$2.50
E.A. AUGUST		
Cat. H-8411	81SM7 Pavlov's Bagatelle	\$2.95
Cat. H-8410	Musicolor Mk IV	\$9.95
Cat. H-8402	Super 80 Computer	\$97.50
Cat. H-8410	Musicolor/Chaser	\$9.95
E.A. JULY		
Cat. H-8404	Electrochune	\$11.50
Cat. H-8403	Pools/Lotto Selector	\$2.50

## DICK SMITH Electronics



DSE/A039/LM



NSW AUBURN 648 0558 • BLAKEHURST 546 7744 • BROADWAY 211 3777 • BROOKVALE • CHULLORA 642 8922 • GORE HILL 439 5311 • NORTH RYDE 888 3200 • PARRAMATTA 683 1133 • SYDNEY 290 3377 • TIGHE'S HILL 61 1896 • WOLLONGONG 28 3800 ACT Fyshwick 80 4944 QLD BURANDA 391 6233 • CHERMSIDE 59 6255 SA ADELAIDE 212 1962 VIC MELBOURNE 67 9834 • COBURG 383 4455 • RICHMOND 428 1614 • SPRINGVALE 547 0522 WA CANNINGTON 451 8666 • PERTH 328 6944  
Mail Order Centre: PO Box 321, North Ryde 2113. Phone (02) 888 3200

# Project 157

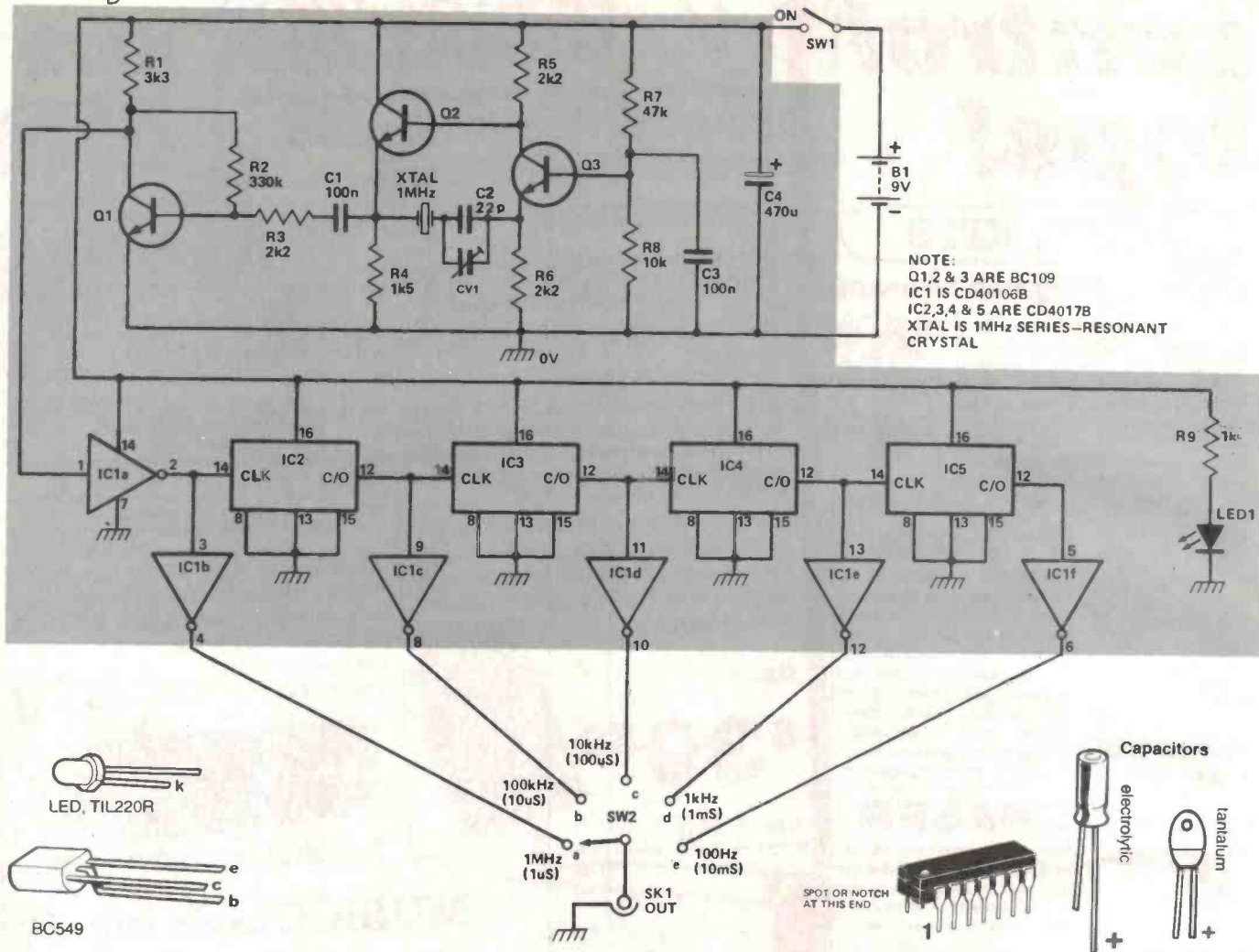

4017s). The first Schmitt inverter provides 1 MHz output, which is buffered by another Schmitt inverter to provide the 1 MHz output to the output selector switch. The output of each decade divider stage is also buffered by a Schmitt inverter to provide, respectively, the 100 kHz, 10 kHz, 1 kHz and 100 Hz outputs to SW2.

## Construction

We constructed the project on a pc board and housed it in a conveniently sized jiffy box. The two switches, the LED and the RCA output socket we mounted on the metal front panel of the jiffy box. Layout of the panel is not important, and if you aren't going to use a Scotchcal of our panel, you can place these com-

ponents to suit yourself. Note that, whilst we used an RCA socket for the output, you could use any suitable coaxial output socket or just a pair of banana sockets, if you wished. If you are using a Scotchcal of our front panel, it can be used as a drilling template. An all-metal box, such as the K&W C642, could be used if you wish.

## HOW IT WORKS ETI-157

The crystal marker generator consists of a 1 MHz crystal oscillator driving a series of four decade dividers connected in cascade. Outputs are provided at 1 MHz, 100 kHz, 10 kHz, 1 kHz and 100 Hz. As each output is essentially a square wave (but not a perfect square wave), harmonics extending into the VHF region are generated. A switch is used to select the desired output.

The crystal oscillator comprises Q2, Q3, R4 to R8 and C3. The circuit is an aperiodic Butler oscillator. Q2 and Q3 form an amplifier with the output linked to the input via the crystal. Positive feedback only occurs at the series resonant frequency of the crystal where the phase shift of the crystal is zero. Q3 is configured as a common-base amplifier. Its collector is direct-coupled to the base of Q2, an emitter follower (common-collector). The crystal is connected from the emitter of Q2 to the emitter of Q3, via a series capacitance

comprising C2 and CV1. Thus the output of the non-inverting amplifier formed by Q2 and Q3 is connected to the input via the crystal. When the phase shift from input to output is zero, there is positive feedback, and thus oscillation occurs. CV1 is effectively in series with the equivalent series capacitance of the crystal. Varying CV1 varies the effective phase shift between the emitters of Q2 and Q3 and thus varies the frequency of oscillation.

The output of the crystal oscillator is coupled to a buffer amplifier comprising Q1, via C1 and R3. The buffer avoids loading effects on the oscillator 'pulling' the frequency. Q1 is a common emitter amplifier. R1 is the collector load and R2 provides bias to the base. As R2 is connected between collector and base, any dc drift in the collector current changes the base current in the same direction, which then opposes the drift in collector current, affecting compensation of

any drift (dc negative feedback).

Q1 raises the oscillator output level sufficiently to provide the required drive to the input of IC1a, one stage from the 40106 hex inverting Schmitt trigger IC. This 'squares up' the signal. The output of IC1a drives the input to the first divider in the decade divider chain and the input of another stage from IC1, IC1b. This provides a buffered 1 MHz output to SW2. The divider chain consists of IC2, IC3, IC4 and IC5. Each is a 4017 decade divider, the carry output of the preceding stage driving the clock input of the next. The carry output of each stage also drives the input of a Schmitt buffer. Thus the output of IC1c provides a buffered 100 kHz output to SW2, IC1d provides the 10 kHz output, IC1e the 1 kHz output and IC1f the 100 Hz output.

Capacitor C4 provides a low frequency bypass for the supply rail, while LED1 serves as an on indicator.



LED, TIL220R



BC549

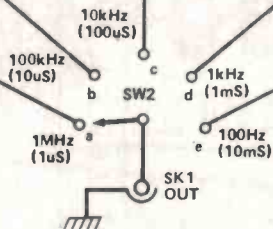

SPOT OR NOTCH AT THIS END

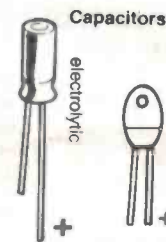
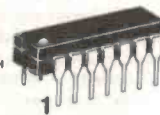

Capacitors

electrolytic

tantalum

# crystal marker

## PARTS LIST — ETI 157

Resistors	
all 1/2W, 5%	
R1	3k3
R2	330k
R3,5,6	2k2
R4	1k5
R7	47k
R8	10k
R9	1k
Capacitors	
C1, C3	100n ceramic
C2	22p ceramic
C4	470u/16 V electro.
CV1	5-40p film or ceramic trimmer
Semiconductors	
IC1	40106B
IC2,3,4,5	4017B
Q1,2,3	BC549, BC109 etc.
LED1	TIL220R or sim. red LED
Miscellaneous	
XTAL	1 MHz crystal
SW1	SPST miniature toggle switch.
SW2	single pole, five position rotary switch
SK1	RCA coax socket
ETI-157 pc board; jiffy box 160 x 95 x 50 mm (or similar); knob to suit; nuts, bolts, wire etc.	

The finished pc board for the crystal marker generator. Note that all the ICs face the same way. Artwork for the ETI-157 pc board is reproduced on page 159, along with the full-size artwork for the front panel. The page behind is printed all in blue, so you can make a Scotchcal negative from these by exposing through the page; then use the negatives to make your pc board and panel.

Assemble the components to the pc board, resistors first, then the capacitors followed by the transistors and ICs. Leave the crystal till last. The board has been laid out to take either of the two common crystal sizes. The HC18/U style holder has a pin spacing of 12.5 mm, while the smaller HC36/U holder has a pin spacing of 5 mm. They can be obtained with pins, meant for socket mounting, or flying leads, for soldering in place. Whilst a suitable socket could be mounted on the board we soldered the crystal in place. Do it quickly to avoid possible damage to the crystal. Make sure the base of the crystal sits flat on the board, to prevent movement.

There are five links to be installed, which can now be soldered in place, along with hookup wire to go to the

switches, LED and battery. Follow the overlay/wiring diagram to complete this.

The pc board and battery we mounted in the box with double-sided sticky pads. It's simple, effective and saves drilling.

Having got it all together, connect the battery and try it out.

You can check that it's working with an ordinary broadcast band receiver, such as a transistor portable radio. Place the marker generator near the receiver and turn it on. Tune the receiver to around 10 on the dial and you should be able to hear a strong 'carrier' signal. You may hear a loud, high-pitched whistle if a broadcast station operates near this frequency in your vicinity.

### Price estimate

**\$18 - \$25**

Note that this is an estimate only and not a recommended price. A variety of factors may affect the price of a project, such as — quality of components purchased, type of pc board (fibreglass or phenolic base), type of front panel supplied (if used), etc — whether bought as separate components or made up as a kit.

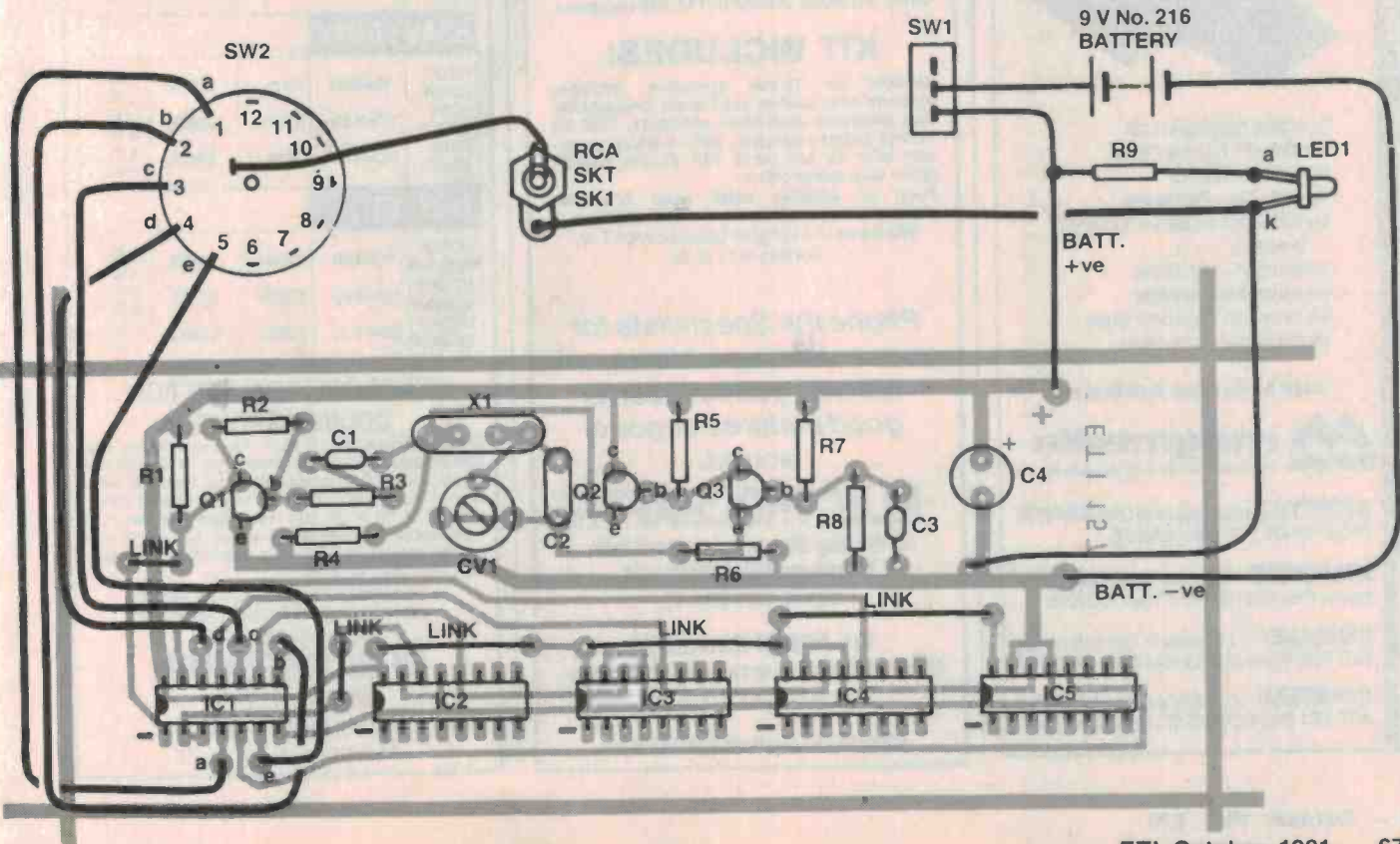

# Verbatim Datalife

Means 7 data-shielding improvements  
for greater durability, longer life

World's largest manufacturer of quality Digital Recording Media. Supplying the broadest range of Diskettes and Mini Diskettes, Cassettes and Mini Cassettes, Cartridges and Mini Cartridges for scientific, business and personal computer applications.

All Verbatim Media sets industry standards for long-life, error-free data storage, now with Datalife.

That's why Verbatim storage media is the choice of leading manufacturers of Digital Systems. Now it's available to you when you put your data into storage you get it back Verbatim!

Now a comprehensive manufacturing operation is located in Melbourne, Australia. Complete laboratory and QC test facilities are available to provide customer service and testing for most Verbatim products.



- Complete range available
- Verbatim 8" Flexible Disks
- Verbatim Cassettes
- Verbatim Data Cartridges
- Verbatim Optima Series Alignment Diskettes
- Verbatim 5 1/4" Mini Disks
- Verbatim Mini Cassettes
- Verbatim Mini Data Cartridges
- Verbatim Test Instruments

Sole Australian distributor



**SYDNEY:** 5 Apollo Place Lane Cove NSW 2066  
Phone (02) 428 1100 Telex AA22703

**MELBOURNE:** 100 Park Street South Melbourne  
Phone (03) 699 9688 Telex AA35968

**BRISBANE:** 123 Leichhardt Street Brisbane  
QLD 4000 Phone (07) 229 1941 Telex AA42367

**CANBERRA:** 25 Lonsdale Street Braddon  
ACT 2601 Phone (062) 48 6751 Telex AA22703

## ELECTROCRAFT will put you in the picture

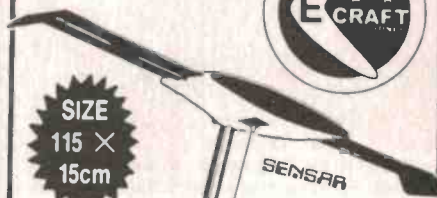

**SIZE**  
115 X  
15cm



**IDEAL FOR:  
CARAVANS,  
BOATS AND  
CAMPING  
TRAILERS**

### A BREAKTHROUGH IN TELEVISION AERIALS

The rugged construction, super strong anodized elements and weather tight Cycloc housing makes it durable in all kinds of weather. Does not require elaborate mounting hardware, yet Sensar installations are stronger than that of conventional antennas with comparable performance. Unique bi-directional characteristics of Sensar antennas provide excellent reception in areas where stations are in different directions... eliminates the need for an antenna rotor in most locations. Reception is excellent... up to 40 miles over land... much, much farther over water. Provides VHF/UHF/FM-AM reception.

#### KIT INCLUDES:

SR-20M for 12-volt operation. Includes antenna with built-in solid-state preamplifier and anodized aluminium elements, SBP-20 12-volt battery adaptor, MSJ-5 band separator with TV set cord, 15ft 75ohm coaxial cable with connectors.

Push up antenna mast, mast brackets, clamps, screws, instruction sheet supplied.

We have the largest selection of T.V. Aerials in N.S.W.

*Phone the Specialists for  
your antenna problems, we  
will help you to receive  
good pictures or good  
sound.*

**ELECTROCRAFT PTY LTD**  
68 Whiting Street, Artarmon N.S.W.  
Telephone 438-4308 (ext. 6)  
or 438-3266 (ext. 6)

**WE ARE SPECIALISTS**  
30 years in the antenna business.  
Hours: 8am to 5pm.

Prices subject to alteration without notice.



### WHICH AMPLIFIER?

I.L.P. Amplifiers now come in three basic types, each of which is now available with or without heatsink. Having decided the system you want home hi-fi (models HY 30, 60 or 120 for example) super quality hi fi with extra versatility (MOS 120, MOS 200) or Disco/PA/Guitar (HD 120, HD 200 or HD 400) you will then decide whether amplifiers housed within their own heatsinks or plate amplifiers for bolting to a metal chassis will suit. With choice such as this and a brilliant new range of I.L.P. functional modules to choose from you now have the chance to build the finest audio system ever offered to the constructor — write for details.



MODEL NUMBER	OUTPUT POWER WATTS RMS	DISTORTION		SUPPLY VOLTAGE TYP/MAX
		TNB TYP at 1kHz	IMD 60Hz/7kHz 4:1	
HY30	15w/4.8Ω	0.015%	<0.006%	± 18 ± 20
HY60	30w/4.8Ω	0.015%	<0.006%	± 25 ± 30 ± 35
HY120	60w/4.8Ω	0.01%	<0.006%	± 40 ± 45
HY200	120w/4.8Ω	0.01%	<0.006%	± 50 ± 55
HY200P	120w/4.8Ω	0.01%	<0.006%	± 45 ± 50
HY400	240w/4. Ω	0.01%	<0.006%	± 45 ± 50
HY400P	240w/4. Ω	0.01%	<0.006%	± 45 ± 50

#### HEAVY DUTY

HD120	60w/4.8Ω	0.01%	0.006%	± 35 ± 40
HD120P	60w/4.8Ω	0.01%	0.006%	± 45 ± 50 ± 55
HD200	120w/4.8Ω	0.01%	0.006%	± 45 ± 50
HD200P	120w/4.8Ω	0.01%	0.006%	± 45 ± 50 ± 55
HD400	240w/4. Ω	0.01%	0.006%	± 45 ± 50
HD400P	240w/4. Ω	0.01%	0.006%	± 45 ± 50

#### MOSFET

MOS120	60w/4.8Ω	0.005%	0.006%	± 45 ± 50
MOS120P	60w/4.8Ω	0.005%	0.006%	± 55 ± 60
MOS200	120w/4.8Ω	0.005%	0.006%	± 80 ± 85
MOS200P	120w/4.8Ω	0.005%	0.006%	± 55 ± 60
MOS400	240w/4. Ω	0.005%	0.006%	± 55 ± 60
MOS400P	240w/4. Ω	0.005%	0.006%	± 55 ± 60

### FP480. BRIDGING UNIT FOR DOUBLING POWER

Designed specially by I.L.P. for use with any two power amplifiers of the same type to double the power output obtained and will function with any I.L.P. power supply in totally sealed case, size 45 X 50 X 20 mm with edge connector. It thus becomes possible to obtain 480 watts rms (single channel) into 8 ohm. Contributory distortion less than 0.005%.

POWER SUPPLY UNITS AND  
TOROIDAL TRANSFORMERS  
ALSO AVAILABLE

**ELECTROMARK  
PTY. LTD.**  
40 Barry Avenue,  
Mortdale, NSW 2223

# David Reid Electronics

**LOWEST**  
Full Autoranging  
Digital Multimeter



\$49.95  
Model ME533

★  
**HOWS THIS FOR VALUE**

HY-10MX  
Stereo-mixer with cue control.



Normally priced at \$115  
**OCTOBER ONLY \$99.50**  
SAVE-SAVE-SAVE

★  
**START RIGHT**

Replace that old clock movement with the Modern Movement



**OUR PRICE \$11.50**

We are also resellers of the well known

**BK PRECISION**

instruments, these are just a few:

Sweep/Function Generator



Portable Digital Capacitance Meter

MODEL 820 \$172.72



80MHz Counter with Period Function

MODEL 1820 \$468.82



510 ..... \$129.25  
830 ..... \$251.45  
2810 ..... \$179.77

3 1/2-Digit Portable DMM

MODEL 2800 \$151.57



2831 ..... \$334.87  
2815 ..... \$223.25  
TP28 ..... \$89.30  
2845 ..... \$229.12  
3010 ..... \$305.50

now better than ever.  
**sinclair ZX81**  
Personal computer

**\$250**



Complete with mains adaptor, leads & basic manual

New, improved specification

- Z80 a microprocessor — new faster version of the famous Z80 chip,
- Unique 'one-touch' key word entry: the ZX81 eliminates a great deal of tiresome typing.
- Graph drawing and animated display facilities.

Coming soon — the ZX Printer

Designed exclusively for use with the ZX81 (and ZX80 with 8K BASIC ROM).



Ready assembled ZX81 Sinclair Personal Computer incl. mains adaptor, leads, Basic manual \$250  
16K-BYTE RAM pack ..... \$150  
8K-ROM ..... \$75  
ZX Printer (to be announced)

Yes we are also stockist of the

**ATARI 400**  
PERSONAL COMPUTER SYSTEM



**YOUR COST ONLY \$599.00**

The 400 is supplied with 8K bytes of RAM, and offer a 10K ROM Operating System and an 8K ATARI BASIC Language Cartridge.

The 400 features 4 independently programmable sound synthesizers and a built-in speaker.

**Talking about ATARI we stock And sell a full range of Cassettes for the T.V. Game Computer System.**



System Priced \$265.00  
Cartridges @ \$39.95  
\$49.95  
\$59.95

**WRITE IN FOR FREE CATALOGUE.**

**DAVID REID ELECTRONICS PTY. LTD.**

SYDNEY:  
127 York Street  
Sydney 2000 N.S.W.  
G.P.O. Box Q103  
Sydney 2000 N.S.W.  
Phone: (02) 29 6601

Enclose your personal cheque, Money Order or Bankcard Numbers as specified below. Check and fill in

Cheque or Money Order Enclosed  
 Charge to my Bankcard No. CARD HOLDER'S NUMBER

496

Signature

Card Expiry Date

Part No.	Description	Quantity	Price	Total
Please print clearly. Date _____ Minimum Postage Packing charge				1.00
Tel. _____ Plus Postage Packing surcharge				
Name _____			Subtotal	
Address _____				
Postcode _____				TOTAL

exact original replacement Japan-made

# Semiconductors

Now you can obtain exact original replacement Japan-made semiconductors to service CB's, Hi-Fi Equipment, TV's, Car Radio/Stereos, Industrial and Professional Electronic Equipment manufactured in Asia.

Available in large or small quantities, the extensive availability includes over 2,000 items from Japan's leading original manufacturers - Sanyo, Toshiba, Hitachi, NEC, Toyo, Matsushita, Sony, Sanken, Oki, Fujitsu. etc.

Available in Australia

NEW LOW PRICES



**DISCOUNTS** (Semiconductors only) Orders over \$25, less 10 percent — over \$50, less 15 percent — over \$100, less 20 percent — over \$250, less 25 percent.

**LATEST JAPANESE SEMICONDUCTOR MANUALS**

Up to 20% more new listings.

1. TRANSISTOR SUBSTITUTION MANUAL
2. TRANSISTOR MANUAL

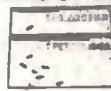

**\$9.95**

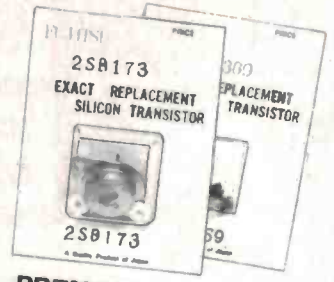

**PREMIUM QUALITY COMPONENTS**

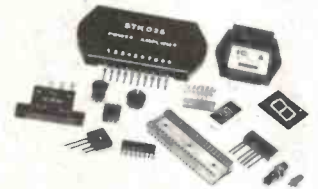

**CUT OUT THIS PAGE AND KEEP FOR FUTURE REFERENCE**

Due to advertising lead times and international exchange rate fluctuations, prices are subject to change without notice



# CUT IT OUT

## NEW 1981 LIST

2SA SERIES	2SA740..... 4.37	2SB561..... 0.56	2SC840..... 2.95	2SC1312.... 0.37	2SD198..... 2.95	TOSHIBA TA IC'S	M51841P.... 2.90
2SA49..... 0.45	2SA815..... 1.49	2SB595..... 2.50	2SC867.....10.74	2SC1317.... 0.42	2SD199..... 4.75	TA7045W.... 4.00	M5320P.... 0.99
2SA53..... 0.48	2SA841..... 0.66	2SB618..... 2.48	2SC870..... 1.98	2SC1318.... 0.54	2SD213....10.45	TA7061AP... 1.70	M53273P... 1.78
2SA122.... 0.70	2SA844..... 0.44	2SB755..... 7.95	2SC897..... 4.96	2SC1345.... 0.47	2SD234.... 1.56	TA7074P.... 5.90	M53274P... 1.78
2SA124.... 0.68	2SA949..... 0.84	<b>2SC SERIES</b>	2SC900..... 0.48	2SC1358....12.50	2SD235.... 1.45	TA7120P.... 1.25	M53393P... 5.20
2SA182.... 0.75	2SA1015... 0.44	2SC372..... 0.29	2SC930..... 0.44	2SC1359.... 0.40	2SD261.... 0.59	TA7200P.... 4.60	SANYO LA IC'S
2SA192.... 0.78	<b>2SB SERIES</b>	2SC380..... 0.44	2SC932.... 0.58	2SC1364.... 0.66	2SD313.... 1.40	TA7201P.... 5.05	LA1202.... 2.78
2SA201.... 0.52	2SB22..... 0.46	2SC383.... 0.44	2SC933.... 0.52	2SC1390.... 0.45	2SD315.... 2.10	TA7202P... 5.05	LA3300.... 4.10
2SA203.... 0.52	2SB54..... 0.49	2SC403.... 0.70	2SC945.... 0.32	2SC1407.... 0.98	2SD325.... 1.20	TA7203P... 4.70	LA3301.... 3.05
2SA279.... 0.74	2SB56..... 0.59	2SC458.... 0.39	2SC959.... 2.10	2SC1417.... 0.58	2SD330.... 1.39	TA7204P... 3.56	LA3350.... 3.57
2SA323.... 0.66	2SB75..... 0.64	2SC461.... 0.38	2SC960.... 2.38	2SC1419.... 1.25	2SD350.... 6.20	TA7205P... 3.39	LA4030P... 3.30
2SA329.... 0.66	2SB89.... 0.46	2SC495.... 0.87	2SC973....29.50	2SC1444.... 3.88	2SD358.... 1.55	TA7210P... 7.45	LA4031P... 3.20
2SA330.... 0.80	2SB134.... 0.52	2SC496.... 0.96	2SC995.... 3.30	2SC1446.... 1.48	2SD359.... 0.84	TA7214P... 7.80	LA4032P... 3.65
2SA354.... 0.98	2SB135.... 0.56	2SC509.... 0.88	2SC1000... 0.52	2SC1447.... 1.48	2SD360.... 1.05	TA7222P... 4.20	LA4050P... 3.40
2SA456.... 0.78	2SB136.... 0.56	2SC515A... 1.79	2SC1011...14.60	2SC1448.... 1.98	2SD361.... 1.49	TA7310P... 2.05	LA4051P... 3.75
2SA471.... 0.82	2SB173.... 0.56	2SC535.... 0.87	2SC1013... 1.10	2SC1449.... 0.86	2SD380....10.50	NEC uPC IC'S	LA4400.... 4.30
2SA482.... 6.00	2SB175.... 0.52	2SC536.... 0.37	2SC1017... 1.57	2SC1472K... 1.25	2SD388.... 5.56	uPC554C.... 2.52	LA4430.... 3.60
2SA484.... 3.60	2SB178.... 0.62	2SC538.... 0.87	2SC1018... 1.74	2SC1475.... 1.10	2SD389.... 2.17	uPC574J.... 1.40	MATSUSHITA AN
2SA493.... 0.60	2SB186.... 0.48	2SC563.... 1.17	2SC1030... 3.95	2SC1509.... 0.74	2SD414.... 0.98	uPC575C2... 2.44	AN214Q.... 3.20
2SA495.... 0.44	2SB187.... 0.48	2SC620.... 0.55	2SC1060... 1.45	2SC1520.... 1.74	2SD415.... 1.89	uPC587C2... 4.86	AN217.... 3.15
2SA496.... 0.98	2SB263.... 0.58	2SC645.... 1.04	2SC1061... 1.48	2SC1550.... 2.10	2SD467.... 0.52	uPC1009C... 3.90	AN329....10.50
2SA518.... 0.70	2SB270.... 0.82	2SC674.... 0.61	2SC1096... 1.10	2SC1624.... 1.60	2SD525.... 2.20	uPC1020H... 5.65	AN241.... 3.15
2SA550.... 1.20	2SB324.... 0.59	2SC681.... 4.40	2SC1098... 1.54	2SC1628... 1.57	2SD526.... 1.88	uPC1025H... 3.30	AN245.... 6.80
2SA562.... 0.52	2SB378.... 0.80	2SC710.... 0.39	2SC1114...10.10	2SC1669... 2.09	<b>2SK SERIES FET</b>	uPC1028H... 2.60	AN274P.... 5.95
2SA564.... 0.44	2SB380.... 0.82	2SC711.... 0.37	2SC1116... 7.83	2SC1674.... 0.42	2SK19..... 1.05	uPC1032H... 3.30	AN264.... 2.95
2SA565.... 0.66	2SB382.... 0.86	2SC712.... 0.39	2SC1128... 1.17	2SC1675.... 0.44	2SK30A.... 0.85	uPC1156H... 3.40	AN277.... 3.15
2SA606.... 2.98	2SB383.... 0.84	2SC730.... 6.44	2SC1129... 1.19	2SC1678... 1.75	2SK34..... 0.75	uPC1185H... 5.80	AN313.... 7.30
2SA607.... 3.40	2SB405.... 0.70	2SC732.... 0.54	2SC1162... 1.18	2SC1728... 1.28	2SK40..... 0.99	HITACHI HA IC'S	AN315.... 4.10
2SA634.... 1.28	2SB415.... 0.96	2SC733.... 0.59	2SC1166... 0.87	2SC1760... 1.20	2SK49..... 1.09	HA1137W... 4.30	AN331.... 6.85
2SA636.... 1.50	2SB435.... 2.10	2SC734.... 0.59	2SC1169...11.20	2SC1909... 2.95	3SK45..... 1.88	HA1156W... 3.10	AN7115... 3.20
2SA640.... 0.60	2SB439.... 0.95	2SC735.... 0.46	2SC11728... 9.68	2SC1951... 1.42	FUJITSU MB IC'S	HA1199... 3.84	AN7150... 4.70
2SA671.... 1.87	2SB457.... 0.95	2SC738.... 0.46	2SC1173... 1.17	2SC1957... 0.86	MB3705.... 3.00	HA1306W... 4.15	SANYO STK IC'C
2SA673.... 0.53	2SB492.... 1.29	2SC741.... 4.78	2SC1175... 0.64	2SC1964... 1.50	MB3708.... 3.00	HA1322.... 4.87	STK011... 8.40
2SA678.... 0.84	2SB507.... 3.50	2SC756.... 3.49	2SC1195... 7.30	2SC1969... 3.98	MB3712.... 2.90	HA1342AR... 4.00	STK015... 9.60
2SA683.... 0.65	2SB514.... 1.95	2SC772.... 0.54	2SC1211... 0.47	2SC1974... 2.49	MB3713.... 2.90	HA1366W... 4.35	STK016...11.90
2SA684.... 0.68	2SB523.... 1.39	2SC784.... 0.48	2SC1212... 1.29	2SC1975... 2.60	MISCELLANEOUS	HA1452M... 2.68	STK024...17.40
2SA697.... 0.74	2SB526.... 1.54	2SC789.... 2.16	2SC1213... 0.61	2SC2028... 1.48	LM1820.... 2.25	MITSUBISHI IC'S	STK433...11.20
2SA705.... 0.98	2SB527.... 1.54	2SC792.... 4.40	2SC1226... 1.15	2SC2029... 2.95	LM2902A... 3.66	M5115AP... 6.55	STK439...14.25
2SA706.... 2.20	2SB528.... 1.84	2SC799.... 8.59	2SC1239... 6.15	2SC2091... 1.36	TBA120S... 9.90	M5116A... 2.50	RHOM 8A IC'S
2SA715.... 1.17	2SB529.... 1.40	2SC815.... 0.65	2SC1243... 1.09	<b>2SD2092... 3.18</b>	TBA810SH... 3.60	M5152L... 1.95	BA301.... 2.10
2SA719.... 0.68	2SB536.... 1.70	2SC828.... 0.30	2SC1295... 5.95	<b>2SD SERIES</b>	PLLO2AG... 7.20	M5153P... 7.30	BA511A... 3.54
2SA725.... 0.48	2SB548.... 1.98	2SC829.... 0.32	2SC1306... 2.17	2SD72..... 1.60	SG613....12.00	M51513L... 3.22	BA521.... 4.14
2SA733.... 0.45	2SB557.... 5.90	2SC839.... 0.44	2SC1307... 6.60	2SD180.... 4.93	A3101.... 3.90	M51515L... 6.67	

## SEMICONDUCTOR IMPORTS

P.O. BOX 43, CROYDON, NSW 2132  
Pack, Post and Handling Charge — \$2



Items ex stock will be despatched within 48 hours; Items not immediately available will be ordered ex Japan by Air Mail delivery and should be received within max. 4-6 weeks. All enquiries must include SAE for reply.

SALES AGENT:

**PRE-PAK electronics p/l**  
1a West St, Lewisham NSW  
**PHONE: 569-9797**



## Setting it up

To set the oscillator as accurately as possible to 1 MHz, a trimmer capacitor, CV1, in series with the crystal has been provided. Adjusting this will 'pull' the crystal frequency slightly. To set the oscillator you will need to have, or obtain access to, a shortwave receiver that covers the frequency range from 7 MHz to 15 MHz. A number of 'standard' time and frequency broadcasts can be received in this range. VNG Australia broadcasts on 7.5 MHz and 12 MHz within this range, while the US stations WWV and WWVH broadcast on 10 MHz and 15 MHz. The transmission frequencies are maintained to an incredible accuracy and you can use them to set your marker accurately on frequency.

Tune in one of the stations on 10, 12 or 15 MHz on the receiver. Plug a length of hookup wire into the marker's output socket and drape it near the antenna input of the receiver. Set SW2 to 1 MHz, turn the marker on and you should hear a strong whistle or 'beat' note. Using an insulated adjusting tool, adjust CV1 to decrease the pitch of the beat note until the frequency is so low you can't hear it. Doing this with headphones plugged in helps. As you approach 'zero beat', the receiver's signal strength meter will begin to oscillate, rapidly at first and then slowly. Carefully adjust CV1 until

the S-meter stops wavering or beats as slowly as possible.

This calibration method is independent of the receiver accuracy. Switch to the 10 kHz output and you should hear frequency 'pips' every 10 kHz. The 100 Hz output sounds like a 'burr' all over the dial.

If you have access to a six or, preferably, an eight-digit readout frequency counter, it is a simple matter to set the oscillator on frequency. Connect the marker's output to the counter's input, set SW2 to 1 MHz and adjust CV1 so that the display reads 1 000 000.0! Use an insulated adjusting tool, as before. Switch through the other outputs to check that the divider is working. You can further trim the oscillator accuracy on the lower frequency output.

Say for example that you want to tune your receiver to 14 150 kHz. First select 1 MHz on SW2 and loosely couple the marker's output to the input of the receiver. Tune the receiver to the marker, which will be found at 14 MHz. If your receiver is *grossly* off calibration (or has no dial markings!), tune in one of the standard frequency broadcasts at 10 MHz or 12 MHz, and count the required number of 1 MHz markers as you tune up in frequency until you reach 14 MHz. Once located, confirm that it is indeed coming from the marker

generator by switching it on and off. Now switch to the 100 kHz markers and tune the receiver upwards to locate the first marker past 14 MHz (14 100 kHz). Now select the 10 kHz markers and tune upwards through five markers to locate 14 150 kHz. Note that if this tuning procedure is carefully carried out it is quite simple to locate any position on the dial with great accuracy.

Note that the output square wave has an amplitude of 8 V peak-to-peak and should not be directly coupled to the input socket of a receiver. Some solid-state receivers may suffer front-end damage at the lower frequencies if directly connected to the marker output. Use a coupling capacitance of several pF or loosely couple a wire from the marker output near the receiver antenna input.

To calibrate a CRO timebase, set the marker to the appropriate output range and plug the output into the Y input. Set the input attenuator to obtain a display of a convenient height. Set the CRO timebase range switch to obtain one complete cycle on the screen. One cycle of a square wave is the time between two successive rising edges or two successive falling edges. Adjust the 'fine' variable control on the CRO timebase so that the two rising (or falling) edges of the cycle are aligned on the left and right extremes of the graticule. And there you have it! ●

Only audio-technica can offer a dual moving-coil cartridge



### AT 32E

Designed to bring the state-of-the-art to moving-coil cartridge performance, the AT32E incorporates independent left and right coils oriented at 45°/45° angles to the walls of the record groove. Because only Audio-Technica can boast of this unique mirror-image of the actual path of the record cutter head, this model is capable of extremely wide separation imagery, and its high trackability also ensures accuracy at any record cutting level. A 0.12 mm square shank elliptical natural nude diamond stylus is mounted on a high-quality beryllium cantilever for extra tracking precision. To prevent the housing from adding undesirable coloration to the pristine tone quality, an acoustically neutral aluminium alloy material is used for the cartridge housing.

available at all quality hi-fi dealers

However, if you have a supply problem you can order by mail. Simply enclose your cheque or money order and details of requirements to PO Box 328, Artarmon NSW 2064. We will then arrange for the dealer nearest your address to forward your purchase at once by registered mail.

#### THE MAURICE CHAPMAN GROUP PTY LIMITED

44 Dickson Ave, Artarmon, NSW 2064. Phone (02) 438-3111 • 150 Burwood Rd, Hawthorn, Vic 3122. Phone (03)818-1730 • Perth (09) 446-5679 • Brisbane (07) 261-1513 • Adelaide (08) 272-8011



## MEASURING AND TEST INSTRUMENTS

### BEST OSCILLOSCOPE VALUE IN '81

For lab, school & W/shop  
GOS-955 (\$216 plus S.T.)

- CRT-5" (130mm)
- B/width 6.5MHz
- Sensitivity 10mV/div.
- H/sweep 10Hz-100KHz
- Internal voltage and freq. calibration



### AC MILLIVOLT METER (\$146 plus S.T.)

GDM-706A • 1mV-300V, -60 ~ +50dB

### DIGITAL MULTIMETER

GDM-8035

- AC/DC, V, A, OHM • 3 1/2 digit
- 0.5" LED
- 200mV-1200V
- 5 ranges • Acc. 0.1% rdg. + 1 digit
- Imp. 10Mohm



### AUDIO SIGNAL GENERATOR (\$164 plus S.T.)

GAG-808A

- 10Hz-1MHz • Sine/Square Wave

### FREQUENCY COUNTERS

GFC-8025A, 10Hz-250MHz

(\$250 plus S.T.)

GFC-8055A,

10Hz-550MHz

(\$366 plus S.T.)

- Sens. 10mV
- Imp. 1Mohm
- 30pF and 50ohm



### OTHER GW INSTRUMENTS

Function Generator, 0.2Hz-2MHz; Sine, Square, Triangle, Pulse and Ramp (\$160 plus S.T.)

### REGULATED DC POWER SUPPLIES

GPS-3020, 30V/2A (\$113 plus S.T.) GPS-1820, 18V/2A (\$100 plus S.T.) GPS-3060, 30V/6A (\$244 plus S.T.) GPD-3020, Dual Tracking, 30V/2A (\$263 plus S.T.) GPD-1820, Dual Tracking, 18V/2A (\$249 plus S.T.)

- Milliohm Meter • AF/RF Attenuator • Capacitance Meter
- Leakage Current Meter • Line filter • Puncture/Insulation Tester

### "STANDARD" MULTIMETERS



ST-303TR

\$30.35 + S.T.

YN-360TR

\$21.70 + S.T.

SP-100

\$16.09 + S.T.

ST-5

\$10.39 + S.T.

ST-303TR, 20Kohm/V, Cc'1 protec. Trans. Test, 12ADC. YN-360TR, 20Kohm/V, Cc'1 protec. Trans. Test. SP-100, 4Kohm/V, 0.25-1000V AC/DC, 0.25-0.5A, 0-1M ST-5, Pocket Type, Up to 1000V AC/500V DC, 0.25A, 600Kohm.

ALSO — Bench meters, portable meters, clamp testers, switchboard instruments panel meters and VU-meters.

ADD 15 PERCENT SALES TAX TO ALL ABOVE PRICES.



Sole Australian Agent:

## EMONA ENTERPRISES PTY. LTD.

CBC Bank Bldg, 661 George Street, Haymarket, Sydney. (02) 212-4815.

Available from:

NSW: Radio Despatch Service, 211-0191. Emtronics 211-0531. David Reid Electronics 29-6601. Pre Pack Electronics 569-9797. Martin de Launay (Wollongong) 28-6020. (Newcastle) 24-741. VIC: Radio Parts 329-7888. SA: Int. Communication Systems P/L 47-3688 WA: Letco Trading Co. 387-4966. ACT: Electronic Components P/L 80-4654. TAS: D&I Agencies 23-2842.

## ELECTRONIC REFRIGERATION



### NEW LOW COST TEMPERATURE CONTROL DEVICE

CAMBION introduces a new Low Cost general purpose thermo-electric module, suitable for water coolers, small refrigerators, hot and cold temperature sources and a host of other low cost temperature control applications.

### OPERATING CHARACTERISTICS

at hot side temp. = 50°C

Maximum Temperature Difference ( $\Delta T$ )	= 60°C or greater
Maximum Current	= 6.0 Amperes
Nominal Voltage	= 8 VDC at max. current
Maximum Heat Pumping Capacity (Qc)	= 27 Watts or greater
Maximum Operating Temperature	= 150°C



## ELECTRONIC DEVELOPMENT SALES PTY LIMITED

92 CHANDOS STREET, ST. LEONARDS  
P.O. BOX 217 ST. LEONARDS, N.S.W. 2065  
AUSTRALIA  
TELEPHONE: 438 2500 438 2412  
TELEX AA 25963

### DISTRIBUTORS A.C.T.

ORTEX PTY LTD

Mr Trewin (062) 82 4995  
VIC.

STEWART ELECTRONIC COMPONENTS PTY LTD

Mr J. Day (03) 543 3733  
S.A.

GRAPHIC ELECTRONIC INDUSTRIES PTY LTD

Mr E. Dawes (08) 42 6655  
W.A.

RESERVE ELECTRONICS

Mr J. Gardner (09) 275 2377  
QLD.

FRED HOE & SONS PTY LTD

Mr R. Heelan (07) 277 4311



# PRICE CHOP!

## UP TO 50% OFF

REGULAR PRICES ON SELECTED ITEMS

### Philips TRIPLERS

FOR COLOUR TV  
BEST QUALITY  
SIEMENS/VARD \$9

As used in Pye, Philips, Kriesler and most German colour TV's.

### EHT Trans

Brand new Philips  
EHT Transformers,  
NOW REDUCED \$1.50

NT3100 \$4  
NT3101  
NT3122

### HEAVY DUTY SCR's

200v...25A..\$1.00  
100v...60A..\$5.00  
200v...110A..\$5.50

LOTS MORE AVAILABLE AT THE RIGHT PRICE!

### RECTIFIERS

100v...60A..\$5.00  
50v...250A..\$6.00  
200v...250A..\$8.00

### TV PCB'S

From MA, these new circuit boards have over 80 parts incl. 8 trans. (25C1014, 25C711, 25A673, 25A670, 25C620), 10 diodes, caps, resistors, triodes, etc. GREAT VALUE HERE!

EACH \$10 FOR \$8.00

### Push-Button TUNER BOARDS

Copies 2 boards, one has 8xDPDT push-button switches, similar to Escent - the other has 8x1000 multi-turn triodes with 3 position band-change switches. LTD. QTY.

\$3 EACH \$25.

### PRE-AMP KITS

\$21.99

330mm long

BUILD YOUR OWN STEREO AMP AT NEXT-TO-NOTHING PRICES. We still have a limited quantity of these new SINCIAIR pre-amps with pre-punched chassis and lettered front panels. Featured are VOL/BASS/TREBLE/BAL. controls, an ON-OFF switch and PHONO/TUNER/AUX. inputs and it operates on 9-40V DC at about 20mA. You can build your own power amp and power supply or use it as a 3 input Disc Player or to improve an existing sound system. SAVE!

### STOP THIEF!

### Ultra-sonic BURGLAR ALARM

ONLY \$49

WAS \$65. NOW SAVE \$16

Ideal for your home, office or shop, the General Electric ultra-sonic alarm is small, self-contained and inconspicuous. The beam detects at up to 30ft, and emits a very loud, shrill tone which can be heard for over 100 metres. A 5-digit push-button selector cuts off the alarm which resets after 5 mins, and a 35second test and exit delay and instant "ON" or delay "ON" (10secs) are included.

### FANS

Ex-computer

5 Inch 115v \$8  
220v \$10

### BNC PLUGS

High Quality \$2

### SOCKETS

PANEL MOUNT \$2

### TRIMPOTS

10 for \$1

### CERAMIC CARTRIDGE

POPULAR MODEL \$2.50  
Stellar BSR C-1 \$5 FOR \$10

### ex-computer filter capacitors

TESTED AND GUARANTEED

27,000uF..5v..\$1.50	10v..\$2.00
25,000uF..10v..\$2.00	15v..\$3.00
90,000uF..10v..\$3.00	15v..\$3.00
15,000uF..15v..\$3.00	15v..\$3.75
35,000uF..15v..\$3.75	15v..\$4.50
84,000uF..15v..\$4.50	20v..\$3.00
10,000uF..20v..\$3.00	20v..\$4.00
46,000uF..20v..\$4.00	20v..\$5.00
72,000uF..20v..\$5.00	25v..\$4.00
22,000uF..25v..\$4.00	25v..\$4.75
50,000uF..25v..\$4.75	30v..\$5.50
71,000uF..25v..\$5.50	30v..\$2.00
5,200uF..30v..\$2.00	30v..\$3.50
12,500uF..30v..\$3.50	30v..\$4.50
30,000uF..30v..\$4.50	30v..\$5.00
43,000uF..30v..\$5.00	35v..\$3.75
15,000uF..35v..\$3.75	40v..\$3.00
8,300uF..40v..\$3.00	40v..\$4.50
60,000uF..40v..\$4.50	40v..\$4.00
8,000uF..50v..\$4.00	50v..\$5.00
15,000uF..50v..\$5.00	50v..\$3.00
5,000uF..50v..\$3.00	50v..\$5.50
15,000uF..63v..\$5.50	64v..\$3.75
4,500uF..64v..\$3.75	75v..\$4.50
10,000uF..75v..\$4.50	75v..\$5.50
22,000uF..75v..\$5.50	100v..\$2.00
900uF..100v..\$2.00	200v..\$6.00
4,800uF..200v..\$6.00	350v..\$6.00
1,600uF..350v..\$6.00	500v..\$2.00
200uF..500v..\$2.00	

HALF PRICE!

### VALU ASSORTMENTS

LUCKY-DIP PACKS 2EA

- 500 1/4WATT RESISTORS
- 200 1WATT RESISTORS
- 50 1/2 HI-STAB RESISTORS
- 20 MIXED POTENTIOMETERS
- 25 PRESET POTS ASST.
- 30 POLY. GREENCAPS
- 100 CERAMIC CAPACITORS
- 45 ELECTROLYTIC CAPS
- 12 VARIOUS SWITCHES
- 40 RADIO/TV KNOBS
- 50 ASST TAGSTRIPS

\$2 EACH PACK

### SPECIALS

- 200 1/2 watt assorted resistors.....\$1.95
- 250 sized-up resistors.....\$1.95
- 25 various RF, video, peaking chokes.....\$1.95
- 12 various triaser caps, range 3-120pf.....\$1.95
- 25 sized triaser pots, range 100-20k.....\$1.95
- 20 various non pots, sgle.gang,switched,etc.....\$1.95
- 15 inst. knobs,precision,black,for std. shaft.....\$1.95
- 45 assorted valve sockets, 7,9 pin etc.....\$1.95
- 10 mixed switches, rotary,toggle,slider,DPDT.....\$1.95
- 1 centre desoldering wick in dispenser.....\$1.95
- 20 assorted zener diodes, 40mA,1M,5M, etc.....\$1.95
- 4 3055 power transistors, TO-3 60V 115W.....\$1.95
- 48 electrical terminal connectors,blocks of 12.....\$1.95
- 2 DPDT mini toggle switches.....\$1.95
- 1 1.2V ni-cad pencil batteries 50mAh,gted.....\$1.95
- 6 metres grey 3 core mains lead.....\$1.95
- 25 silicon diodes 1N914 and 1N4148.....\$1.95
- 25 6N401 silicon rectifiers 100 PIV 1 AMP.....\$1.95
- 15 assorted types, colours, LED's 1000 gted.....\$1.95
- 3 2 core mains power leads with 3 pin plug.....\$1.95
- 1 5 pin din to 5 pin din audi lead.....\$1.95
- 20 sized 3AG fuses, in range 3A to 20A.....\$1.95
- 10 asst. types 3AG fuseholders, chassis, lins.....\$1.95
- 30 metres hook-up wire, 5 asst cols.....\$1.95
- 1 ignition filter kit for CB, car stereo,etc.....\$1.95
- 1 universal cable connector kit, for car hi-fi.....\$1.95
- 1 1000V 63W sig-tall electro capacitors.....\$1.95
- 1 grey foam speaker grille.....\$1.95
- 4 Bourne 2koha 1W W mini precision pots.....\$1.95
- 16 alligator clips, asst sizes, red & black.....\$1.95
- 4 asst relays, various voltages, types.....\$1.95
- 10 ign noise suppressor resistors for HiCables.....\$1.95
- 1 24V DC 430 plug-in relay, 3 pole 10M COB.....\$1.95
- 4 50ohm 2W W pots with knobs,tweeter con.....\$1.95
- 3 thermal cut-out switches, approx. 70PC oper.....\$1.95
- 1 PCB etc resist Dalo pen for marking PCB's.....\$1.95
- 1 set CB radio crystals, trans/rct,asst chan.....\$1.95
- 1 90/200pf MSP 2 gang tuning cap.....\$1.95
- 4 2uf non-polar polyester spher. filter caps.....\$1.95

### 5" CRO (130mm)

### 6.5 MHz by Goodwill

ALL NEW SOLID STATE HIGH SENSITIVITY COMPACT AND RELIABLE SAVE \$10.00

\$249

- Retrace blanking gives a much clearer display
- Lower threshold triggering: less than 1/2 division at 5MHz
- Sharper focus - especially at high frequencies
- Fibreoptic pcb
- AND A USABLE RESPONSE TO BEYOND 6.5MHz!

VERT. DEFLECT. - 10mv/Div  
HORIZ DEFLECT. - 500mv/Div

TIME BASE - 10Hz-100kHz  
INT/EXT SYNCHRONIZATION

14 DAY TEST & PROVE, MONEY REFUNDED!

### Dynamic stereo headphones

20-20kHz 320HMZ

\$12

SUPER-LIGHT ULTRA-THIN!

ONLY \$18.00 SAVE \$6.00

40GMS 6.5MM STEREO PLUG

BONUS: DUAL-PURPOSE 3.5 TO 6.5mm ADAPTOR FREE!

### SPEAKERS

3 Way

35W

WERE \$109 \$99

New to our range, these MAGNETIC Speakers are ideal either for HOME HI-FI or CAR STEREO use. 35 watts power rating with 20oz magnets, woofer, mid-range and 2x tweeters plus mid and hi level controls and crossovers. Ready to mount in boxes or car!

### RADIOS

AM/LW BATTERY/ELECTRIC WERE \$18

\$9

AM Portable

Several models avail. at HALF PRICE! WERE \$5.99

\$2.95 EA.

\$1.95 \*SAVE \$\$\$

PACK

LOOK!

### High quality ex-computer gear!

### OIL-FILLED capacitors

TESTED, GUARANTEED ALL FAMOUS MAKERS.

2uf.....1,500VDC.....\$3.00	4uf.....330VAC.....\$3.00
4uf.....330VAC.....\$3.00	5uf.....370VAC.....\$3.00
5uf.....370VAC.....\$3.00	6uf.....600VDC.....\$3.00
6uf.....600VDC.....\$3.00	7uf.....600VDC.....\$3.00
7.5uf.....440VAC.....\$3.50	8uf.....800VDC.....\$3.50
8uf.....800VDC.....\$3.50	9uf.....660VAC.....\$4.00
9uf.....660VAC.....\$4.00	10uf.....300VDC.....\$3.00
10uf.....300VDC.....\$3.00	18uf.....250VAC.....\$4.50
18uf.....250VAC.....\$4.50	40uf.....370VAC.....\$7.50

### HEATSINKS

HUGE RANGE AVAILABLE!

- 3"x4" WITH 1xT03 TRANS. \$2.50
- 6"x4" WITH 2xT03 TRANS. \$3.00
- 9"x4" WITH 4xT03 TRANS. \$4.00
- 12"x4" WITH 5xT03 TRANS. \$5.00

WE HAVE LOTS MORE INCLUDING REALLY HEAVY DUTY 12"x8" FOR 10xT03 TRANS. (\$12.00), PLUS OTHERS SUITABLE FOR LARGE POWER SUPPLIES AND POWER AMPS - EVEN SMALL ONES, TOO!

### EDGE CONNECTOR

0.1" inch 35 Way

LAST FEW Pye 0.1" pitch PCB edge Connectors with 70 Gold-plated contacts at about HALF the usual price! BUT 10-\$3.90ea, 100-\$3.50

\$4.50

23 WAY EDGE CONNECTOR \$3

### mini SPEAKER SYSTEM

\$99

New model, it's FANTASTIC 50W handling power (min. 30W RMS) 8 ohms, 60-20,000Hz HI-FI response, 4" driver with soft dome tweeter. Heavy duty cabinet, metal grille. Size:210x130x130mm, 2.7kgm

### FM wireless mikes.

NEW MODEL 68-100kHz OMNI-DIRECTIONAL ELECTRET CONDENSOR MKEE. Ideal for stage, church, school, home-parties etc. Tune in on your FM radio. Save \$5 on our regular \$28.50 price.

\$23.50

### LED DISPLAY PANEL FILTER

68mm x 38mm size

BLACK PLASTIC FRAME WITH RED PERSPECTIVE FILTER FOR LED DISPLAYS - ALSO INCLUDES MOUNTING KIT - FOLLOWS NORTH TWICE THIS SPECIAL PRICE BUY 10: \$2.50 ea. 100: \$2.25 ea.

WERE \$2.99 \$1.99

**\$10 \$10 \$10 \$10 \$10 \$10**

# BOFFIN MAIL ORDER

	Less Tax	Inc. Tax	P&P
ITOH 8300 Dot Matrix	\$666	\$765	\$25
ITOH 1500 Daisy Wheel QUME	\$1554	\$1826	\$30
8" Double Sided Disc Drives KAGA MONITORS	\$582	\$684	\$15
18 MHz Green Phos	\$223	\$262.26	\$15
Special SOAR ME533 Digital Multimer	\$41.68	\$48.95	

Our prices for 5 1/4" Disc Drives are too good to advertise.  
Please write or phone for details.

**BOFFIN  
MICRO-COMPUTER  
DESIGN AND SYSTEMS**  
P.O. Box 88 Thornbury, Vic., 3071  
Phone (03) 480 5407

This Advert. is worth \$10 if sent with your order.

Please allow  
14 days for delivery.

**\$10 \$10 \$10 \$10 \$10 \$10**

# GREAT VALUE

EPSON MX-80 Printer . . .  
\$825 + Sales Tax

Apple II Plus . . .  
Call for prices

CBM 4016 Upgrade to 32k . . .  
\$185

Superboard II, 4K . . .  
\$365 + Sales Tax  
(for 8K add \$20)

Casio MG660, game  
calculator . . .  
\$26 + Sales Tax

Casio FX-3500P,  
programmab scientific  
calculator with statistics . . .  
\$40 + Sales Tax

## COMPUTERWARE

305 LaTrobe St., Melbourne 3000  
Telephone (03) 602 1006

## Apple Microcomputer Buyers Apple Microcomputer Owners

# IMPORTANT NOTICE

It is not necessary to trade off good service and technical back-up for low prices. At **COMPUTER COUNTRY** we give you both.

Call now for our new low prices on **everything**.

COME TO . . .

# COMPUTER COUNTRY

PTY. LTD.  
338 Queen Street,  
Melbourne, Vic. 3000  
Phone: (03) 329 7533

## SPECIALS!!! TEXAS

Ti 59 and PC 100C  
Package Deal



ONLY \$440 Excl. Tax  
\$495 Incl. Tax

---

Ti 58c



\$135 excl. Tax  
\$152 incl. Tax  
ALL POST FREE!

## Calculator & Computer

DISTRIBUTORS

## COMPUTERS YOU WILL BE PROUD TO OWN — OUR INDIVIDUALLY CUSTOMISED SOFTWARE AND TOTAL INSTALLATION SUPPORT WILL SOLVE YOUR PROBLEMS.



### SORD

**M100 ACE  
M203 III  
M223 III  
M223 IV**



### DIABLO

**3000  
3100  
3200**

DIABLO 3000  
BROCHURES AND FULL DETAILS AVAILABLE

**3 ROWLEY ST  
SEVEN HILLS  
NSW 2147**

## NEW FROM CASIO

602P POCKET PROGRAMMER  
512 STEPS  
88 MEMORIES  
FUNCTION  
ALPHA KEYBOARD  
AND DOT MATRIX  
DISPLAY



\$172.<sup>95</sup> Excl. Tax  
\$189.<sup>95</sup> Incl. Tax  
POST FREE

---

VL 1 CALCULATOR AND  
SYNTHESISER —  
5 INSTRUMENTS  
10 RHYTHMS  
3 OCTAVES



**\$89.<sup>95</sup>**  
POST FREE

**PHONE: 8.30 A.M. TO 3.30 P.M.  
(02) 624 8849  
(02) 624 8400**

# LOW PRICES FOR TOP TOOLS

SAVE!!

## 12V ECONOMY IRON

This superb iron works on 12 volts AC and 12 volts DC, so it can be used in the home, car, boat etc. Comes complete with car cigarette-lighter plug attached to a lead.

Cat. T-1910  
**\$3<sup>95</sup>**

**DICK SMITH**

## 12V MINIATURE SOLDERING IRON

Not much larger than a pencil in length and not much thicker either. What an ideal iron for those really small PC board jobs, it is so light & easy to handle. Comes complete with lead & is rated 6W. T-1920.

ONLY **\$6<sup>95</sup>**

## DICK WICK

Specially treated copper braid used to remove solder from PC board. Clean and efficient. Cat. N-1682

NOW ONLY **\$2<sup>00</sup>**

## SOLDER HOBBY PACK

1.25mm (18g) hobby pack. N-1638

0.71mm (22g) hobby pack. N-1636

**\$1<sup>20</sup> ea. VALUE!**

Yes! We have large rolls of solder for the serious hobbyist or professional! Just ask at your nearest Dick Smith Centre.

## CABINET OF DRAWERS

This cabinet is ideal for small components, screws, nuts and bolts plus many other items. 16 drawer cabinet measures 300 x 180 x 140mm. Cat. H-2588



**\$1<sup>75</sup>**

**\$13<sup>25</sup>**

## TOOLBOX

This rugged polypropylene toolbox has a multitude of uses for the fisherman, technician, tradesman or automotive bits and pieces. A generous 427 x 230 x 200mm size with 2 trays, 15 compartments. Rustproof and lightweight.

Cat. H-2600

GREAT VALUE  
**\$27<sup>25</sup>**

## BUILDING THE SUPER 80? YOU NEED THIS SUPERB

### WELLER SOLDERING STATION

Transformer powered soldering station, complete with a low voltage, temperature controlled soldering pencil. The special Weller 'closed loop' method of controlling maximum tip temperature is employed, thereby protecting temperature sensitive components while the grounded tip protects voltage and current sensitive components e.g. CMOS. Definitely the best we've seen!

Cat. T-1000

**\$62<sup>50</sup>**

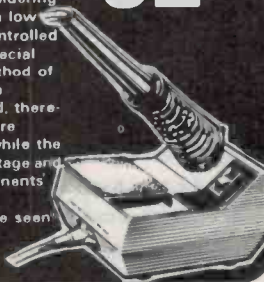

## HOBBYIST SOLDERING CENTRE

If you're going to build a super 80 one of these is a MUST! Holds your PCB securely & firmly, while being able to turn over. Also holds a roll of solder and your iron. No more burnt fingers! Cat T-5700

**\$19<sup>50</sup>**

## NEON TEST DRIVER

Ideal tool to carry in your pocket (it has a pen clip!) for testing the presence of AC. At this price, why take chances? Completely insulated. Cat. T-4005

**\$1<sup>00</sup>**



## LUG CRIMPING TOOL

Complete with a pack of lugs ready to use. Also will strip & cut wire. Great value!

**\$1<sup>99</sup>**

Cat. T-3520

## NIPPERS \$5<sup>50</sup>

Transistor Nipper. Ideal for PC work. Cat. T-3200

Mini Diagonal Cutting Nipper. Drop forged steel construction.

**\$3<sup>95</sup>**

Cat. T-3561



# DICK SMITH Electronics

- AUBURN 648 0558
- BLAKEHURST 546 7744
- BROADWAY 211 3777
- BROOKVALE 93 0441
- CHULLORA 642 9822

- GORE HILL 439 5311
- PARRAMATTA 683 1133
- SYDNEY 290 3377
- NEWCASTLE 61 1896
- WOLLONGONG 28 3800

- CANBERRA 80 4944
- BURANDA 391 6233
- CHERMSIDE 59 6255
- ADELAIDE 212 1962
- MELBOURNE 67 9834

- RICHMOND 428 1614
- SPRINGVALE 547 0522
- CDBURG 383 4455
- PERTH 328 6944
- CANNINGTON 451 8666

MAIL ORDER CENTRE: P.O. Box 321 North Ryde, NSW. 2113. Ph. (02) 888 3200



DSE/A007/LM  
**NOW IS THE TIME TO BUY!**

# Shoparound

## ETI-157 crystal marker

This project is straightforward enough. Constructors will find 1 MHz crystals plentiful enough amongst firms specialising in microprocessor equipment. We know Rod Irving in Melbourne stocks a suitable 1 MHz crystal, and Victorian readers might also try All Electronic Components. In NSW, the well-known Radio Despatch may be able to supply your needs, along with Applied Technology. Interstate readers may have to obtain crystals by mail order.

Printed circuit boards will be widely available for the Crystal Marker. In Victoria, try All Electronic Components, Rod Irving Electronics and Ellistronics. In NSW, try RCS Radio and Radio Despatch Service. In West Australia, try Jemal. Scotchcal front panels should also be available from the same sources.

## Series 5000 preamp

This project will be widely stocked as a kit. At time of going to press we understand the following firms intend stocking kits: In Melbourne — All Electronic Components and Rod Irving Electronics; In Sydney — Electronic Agencies and Jaycar; In Perth — Altronics.

Intending constructors have no doubt seen the details in previous issues' Shoparounds concerning the ETI-458 LED Level Displays (June) and the ETI-478 MM and MC stages (September). If you're not building your

Series 5000 preamp into the sort of case we did and are just after the individual boards, then you should find them readily available. The previously mentioned kit suppliers should be able to supply you with boards and components, but boards should also be available from such other firms as RCS Radio (651 Forest Rd, Bexley NSW), Radio Despatch Service (869 George St, Sydney NSW) and Ellistronics (289 Latrobe St, Melbourne Vic.).

All the C&K switches specified are commonly available so constructors should experience little difficulty obtaining them.

## ETI-660 computer

As with the Series 5000 preamp, this project will be widely stocked as a kit — but in various forms. The following firms have indicated they will be stocking kits and/or components, pc board, etc, for this project: In NSW — Kit Parts (Aust.), Applied Technology, Electronic Agencies and J.R. Components. In Melbourne — All Electronic Components and Rod Irving Electronics. As with the Series 5000 project, pc boards will be available from a variety of suppliers. Refer to the previous item.

If you want to get your teeth into the project right away, start shopping around now. Other constructors may prefer to wait until the construction is completed next month.

## ETI-760 modulator

Nothing special with this one, and as it is intended to team with our ETI-660 Learners' Microcomputer, constructors should be able to find kits and/or components at the firms mentioned in the previous item.

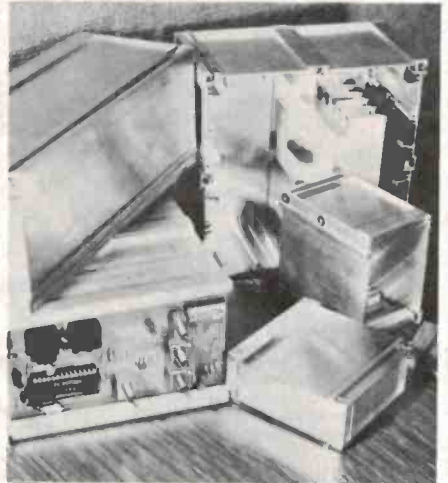

## A NIFTY NEW ENCLOSURE

Enthusiasts may be interested in a unique new Australian-designed and manufactured aluminium extrusion system suitable for housing projects.

Employing an ingenious interlocking design, extruded aluminium panel sections provide the capability to form a vast array of enclosure sizes. By screw fixing end sections the enclosure is completed. There are two basic parts — side panels, designated 'Nifty 1', and end panels designated 'Nifty 0'.

Component mounting hassles are reduced or eliminated as printed circuit boards and screw-fixed components are provided for in the design by means of multiple location slide mounting facilities and continuous threads.

Other interesting facts about this nifty new development as well as ordering information can be obtained by writing to: Delesco, P.O. Box 54, Pennant Hills NSW 2120.

## Channel King

## MATV Systems 75 OHM 100% SHIELDED COAXIAL CABLE

### FEATURES:

- Color-Duct is the lowest loss RG-59 type cable made for color TV reception.
- Electrically stable in high moisture and humidity.
- Available in high grade vinyl black and white jacket.
- Uses standard "F" fittings.
- 100% swept — meets all non-contamination requirements.

### ALSO AVAILABLE FROM CHANNEL KING —

is an extensive range of Antenna including Channel Master Color Crossfire series Models CX9 to CX28. All of your hardware requirements including Amplifiers and M-A-T-V Distribution Equipment which can be seen at our showroom.

## CHANNEL KING

1117 Burwood Highway, Ferntree Gully, Victoria, 3156  
or telephone (03) 758 9111 for your local Channel Master Dealer.

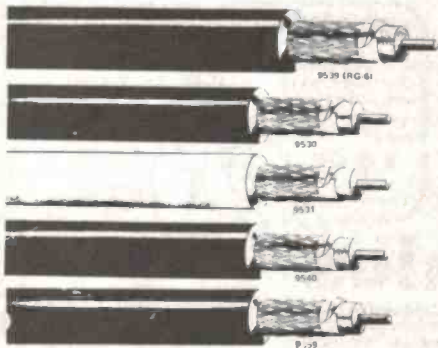

# etone Loudspeakers



## LOUDSPEAKER SENSATIONS!!!

Since introducing ETONE speakers to our city showroom we have been staggered by the interest. Why? Because they are about the most underrated product made in Australia today.

Call in today and find out why so many people are switching over to ETONE for both P.A. and Hi Fi applications.

### P.A. SPEAKERS

SIZE	MODEL	DESCRIPTION	POWER HANDLING (RMS)	FREE AIR RESONANCE Hz	PRICE
25 CM (10")	131	GUITAR, BASS GUITAR, GENERAL AMPLIFIED INSTRUMENTS AND GENERAL PURPOSE P.A.	60	50	\$51.50
30 CM (12")	246	EXTENDED RANGE SPEAKER FOR GENERAL P.A., SPEECH REPRODUCTION, STAGE MONITORS, AMPLIFIED MUSICAL INSTRUMENTS, DISCO SOUND.	80	65	\$78.00
	267	WHEN COMBINED WITH SUITABLE HIGH-FREQUENCY DRIVER, THIS SPEAKER HANDLES THE BASS AND MIDS RANGE OF SYSTEMS FOR LIVE BAND P.A., SPEECH REPRODUCTION, THEATRE SOUND, STAGE MONITORS, DISCO SOUND. BY ITSELF, THIS SPEAKER CAN BE USED FOR AMPLIFIED INSTRUMENTS, SUITABLE FOR USE IN HORN TYPE ENCLOSURES AS MIDRANGE SECTION OF BAND P.A.	150	50	\$131.00
38 CM (15")	801	WHEN USED IN HORN TYPE ENCLOSURE THIS SPEAKER HANDLES THE LOWER MID FREQUENCY RANGE (250-1,200 Hz) OF LARGE LIVE BAND P.A. SYSTEMS. WHEN USED IN COMPACT BASS-REFLEX ENCLOSURES TOGETHER WITH SUITABLE HIGH FREQUENCY DRIVER, THIS SPEAKER HANDLES THE BASS AND MIDS RANGE OF SYSTEMS FOR LIVE BAND P.A., STAGE MONITORS, THEATRE AND DISCO SOUND.	200	30	\$214.00

\*We believe that this is the best speaker that ETONE makes. Its a worldbeater.



### ETONE HI FI SPEAKERS

Call in for free advice regarding your custom Hi Fi speaker system.

15 CM (6")	600	PASSIVE RADIATOR DESIGNED SPECIFICALLY FOR USE WITH 608 WOOFER IN THE PLAYMASTER 3-13L SPEAKER SYSTEM. SYSTEM DETAILS AVAILABLE ON REQUEST.	\$18.50
	605	HI-FI MIDRANGE FOR USE IN HIGH QUALITY SYSTEMS. CAN BE CROSSED OVER AS LOW AS 200Hz, BUT GENERALLY USED TO COVER THE RANGE 500-5,000Hz.	120 when crossed over at 500 and 5,000Hz \$32.00
	608	HI-FI WOOFER DESIGNED SPECIFICALLY FOR USE WITH 600 PASSIVE RADIATOR IN THE PLAYMASTER 3-13L SPEAKER SYSTEM. THIS SYSTEM OFFERS EXTENDED LOW BASS RESPONSE IN A SUPER COMPACT ENCLOSURE (13 LITRES)	80 when used in Playmaster 3-13L System \$34.55
25 CM (10")	108	HI-FI WOOFER MAINLY INTENDED FOR USE IN SEALED ENCLOSURES OF 25 TO 35 LITRES.	50 30 \$33.00
30 CM (12")	518	HI-FI WOOFER DESIGNED MAINLY FOR USE IN SEALED ENCLOSURES OF 50 TC 80 LITRES.	100 30 \$49.00



## ETI 5000 PREAMP & POWER AMP & Super Finish

The Jaycar Front Panel



\$245



\$299

It even works better than it looks!!!  
 If you have read the articles on this project you could not help but be impressed with the amazing low hum and noise figures for this amp. It is our business to keep abreast of audio developments around the world and we can say that nothing anywhere compares to this Do-it-Yourself preamp.  
 The Jaycar kit is supplied complete down to the last screw and washer. Included is a high quality 1 1/2" x 19" rack cabinet with quality finished, anodised and silkscreened front panel with specially imported matching knobs.  
 Metal film resistors are used THROUGHOUT (even where not specified). English "Lorlin" rotary switches are also used. The Jaycar 5000 preamp is a cut above the rest but costs no more at only \$245.  
 (Parts are available separately)

The kit amplifier of the decade. Virtually distortionless (0.0005%). This amplifier is converting jaded audio enthusiasts over to MOS-FET technology. You can own a 5000 amp with ETI front panel for ONLY \$289 (complete kit) or for \$10 extra you can have the Jaycar SUPERFINISH front panel - total \$299 (complete kit).

SUPERFINISH front panel. Special fine grain aluminium machined, drilled and tapped and finished in special low-gloss black enamel ONLY \$49.50. This panel stands up to a close inspection!

OTHER 5000 parts available separately - check our earlier ads or call.



### PIEZO HORN TWEETERS

Sensational Frequency Response.

Model	Description	Freq. Resp.	Price
KSN1005A	3.5" super horn	3kHz-40kHz	\$15
KSN1025A	2" x 6" super horn	2kHz-22kHz	\$24

## Jaycar

NOTE! NEW SHOP HOURS  
 Mon - Sat 9am - 5.30pm  
 Sun - 10am - 2pm  
 Open Thursday night until 8pm



380 Sussex St Sydney 2000

Ph. 2646688 Telex 72293

Mail Orders To: Box K-39 Haymarket 2000

Jaycar Dealer:

D.E.S. ELECTRONICS 157 Brisbane St. Dubbo Ph. 829355

SEE OUR OTHER ADS FOR P&P CHARGES

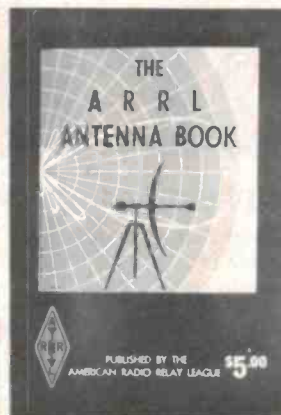
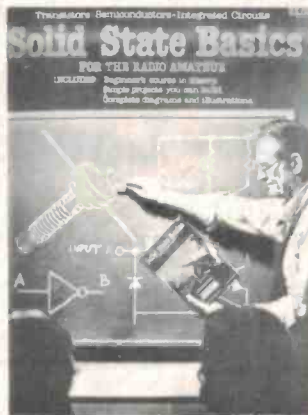
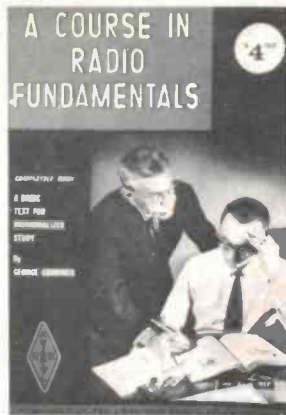

# ARRL PUBLICATIONS

Now you can order a selection of popular and useful publications put out by The American Radio Relay League, direct from ETI by mail order.

## A COURSE IN RADIO FUNDAMENTALS

Written by the world-renowned author, George Grammer, this book is recommended reading for anyone studying for their amateur licence, be it Novice, Limited or Full. In fact, it's a very good reference text for any enthusiastic hobbyist. The book contains 26 chapters, covering a considerable amount of basic theory from electric and magnetic fields to ac and dc circuits, resistance, reactance, transformers, RF circuits, filters, etc, to vacuum tubes and transistors, amplification, feedback and amplifier circuits. A chapter on practical experiments is included and each chapter has associated problems to work out (answers given).

**180 pages** **\$7.00**

## SOLID STATE BASICS

An essential book for everyone who wants to understand solid state circuits and how to design them. This book takes you from simple solid state theory to transistor circuit design. Then follows an introduction to linear and digital ICs and how to work with them. It's crammed with practical circuits designed using the techniques discussed.

**160 pages** **\$6.75**

## ARRL WORLD MAP

This is a modified equidistant azimuthal projection map showing all areas of the world with political boundaries, call areas, IARU continental subdivisions, ITU regional boundaries, world time zones and cities. A valuable addition to any shack.

**1020 x 780 mm** **\$6.75**

## LEARNING TO WORK WITH INTEGRATED CIRCUITS

An invaluable book for the beginner or newcomer to digital circuitry. In nine chapters Jerry Hall and Charles Watts take you through the basics of commonly used linear and digital ICs, binary arithmetic and counting, frequency counters and digital voltmeters — and show you how to build a frequency counter/DVM as you go along! Written in a clear, easy-to-follow style; complete construction details, pc board artwork, etc, are included.

**50 pages** **\$3.75**

## ARRL ANTENNA ANTHOLOGY

This book is a compilation of the best of recent HF antenna articles and theory presentations published in QST magazine. Its five chapters cover Vertical Antennas, Yagi Antennas, Quad Antennas, Miscellaneous Antenna Types and Antenna Theory and Test Methods. Construction of more than 30 antennas is described along with a range of matching networks and systems.

**152 pages** **\$7.00**

## ARRL ANTENNA BOOK

A basic reference text that should be in every enthusiast's and amateur's library. In 18 chapters, this book covers such topics as Wave Propagation, Transmission Lines, Long-Wire Antennas, Multiband Antennas, VHF/UHF Antennas, Rotatable Antennas, Specialised Antennas and Antenna Measurements. It is a comprehensive text chock-full of tables, charts and construction information.

**336 pages** **\$8.75**

## ARRL ELECTRONICS DATA BOOK

A must for every electronics enthusiast's or radio amateur's bookshelf. Its 10 chapters cover Math Aids and Tables, Time and Frequency, RF Circuit Data, LCR Networks, Transformers, Filter Design, Antennas and Feed Systems, Catalogue of Solid State Circuits, Constructions and Testing Data, Data Potpourri. How could you do without it?

**128 pages** **\$6.75**

## BASIC BOOK OF HAM RADIO

A basic guide of what the hobby's all about. Though written for the American scene, the theme is universal. Ten chapters tell it all, from what hams do to a guide to the equipment, how to get on the air to how to speak the jargon.

**128 pages** **\$7.75**

## SOLID STATE DESIGN FOR THE RADIO AMATEUR

Written as a series for QST, this book is an anthology of the work of Wes Hayward and Doug DeMaw — two world-renowned technical authors. The Collins Radio Division of Rockwell regard this book as recommended reading for their junior engineers. Considered generally as a landmark text, it is just the thing for those interested in actually building high performance equipment, as it contains practical information not found elsewhere in sources available to the professional or non-professional. In nine chapters, the book covers Semiconductors and the Amateur, Basics of Transmitter Design, Power Amplifiers and Matching Networks, Receiver Design, Test Equipment, Modulation Methods and Portable Gear, etc. An extensive and very handy bibliography is included.

**258 chock-full pages** **\$12.00**

Please send me (tick as applicable):

- |  |   |
|--|---|
| <input type="checkbox"/> A Course in Radio Fundamentals            | <input type="checkbox"/> Solid State Basics         |
| <input type="checkbox"/> Solid State Design for the Radio Amateur  | <input type="checkbox"/> ARRL Antenna Anthology     |
| <input type="checkbox"/> Learning to Work with Integrated Circuits | <input type="checkbox"/> ARRL Antenna Book          |
|  | <input type="checkbox"/> ARRL Electronics Data Book |
|  | <input type="checkbox"/> Basic Book of Ham Radio    |
|  | <input type="checkbox"/> ARRL World Map             |

I enclose \$ ..... plus 90¢ per book postage and packing (Australia only). Please allow up to four weeks for delivery.

TOTAL \$ .....

NAME .....

ADDRESS .....

..... Postcode .....

Signature .....

Send coupon to: ETI Book Sales, 15 Boundary St, Rushcutters Bay NSW 2011.



## Amateurs aid search for downed aircraft

On Sunday August 9, a light aircraft with five people on board reported severe icing and turbulence as they headed towards Sydney. At 1940 all contact with the plane was lost while it was 200 km north of Sydney in the Barrington Tops area, some of the most rugged and heavily forested terrain in NSW.

**Air and ground searches commenced but NSW police, responsible for the ground search, had difficulty planning the search operation, as they had no direct communication between the rescue co-ordination centre at Mascot Airport and the search headquarters at Berrico Trig. At 0930 on Wednesday, NSW police decided to call in the NSW Wireless Institute Civil Emergency Network (WICEN), as well as the army, to try and establish a direct link to allow conversation between the two sites.**

Sydney South and Hunter Region WICEN prepared to establish a link using 7050 kHz but, due to poor propagation conditions at the time, signals were extremely weak when the link was first established using helical whip antennas at each end.

When a dipole was set up at Mascot good signals were received at Berrico Trig, but no dipole was available there, which meant that a relay station had to be used to provide signals strong enough to overcome the noise at the airport. Similar problems were affecting the army, who were also operating via a relay station. However, this still meant a delay in passing messages and provided little improvement over the telephone and police radio link that had been used for the previous two days.

On Wednesday afternoon an attempt was made to access Sydney repeaters from Berrico Trig. Surprisingly, it was found that despite the 200 km path, reliable access could be made into the Sydney South repeater at Heathcote, 15 km south of Mascot. At last this enabled direct conversation between the officer in charge of the rescue co-ordination centre and the officer directing the search in the field.

Co-operation from the amateurs using repeater 6800 was excellent. Normal amateur use continued, but by following good operating practices of keeping transmissions short and leaving a three-second break before transmitting, there was little delay when the channel was required for WICEN traffic. This proved to be an excellent example of how useful the amateur repeater network can be in providing reliable emergency communications.

As reliable communication was now possible using only a handheld transceiver at Mascot, the army decided to close down their HF operations at 0900 on Thursday. Berrico Trig is also the site of a Department of Transport communications station, and by 1100 on Thursday they had been able to use a spare channel to provide a link to Mascot, allowing WICEN to be stood down. Had the field headquarters been located elsewhere, WICEN would have had to maintain their link for many more days.

On Friday, NSW police called in Bushwalkers Search and Rescue, a member of the Volunteer Rescue Association like WICEN, to carry out a close ground search. Bushwalkers S&R has its own HF portables for search parties, but called on WICEN to provide a link from its field base to the police field control and back to Sydney. Again Sydney, Hunter and Taree WICEN were activated from Friday afternoon until Sunday night, providing reliable links using 7050 kHz and the Newcastle two-meter repeater.

By Thursday August 20, no trace of the aircraft had been found and air searches were terminated. The only hope of finding the aircraft appears to be by close ground searching and WICEN is likely to be called in again to provide support communications.

The effort made by the following



### UHF CB base console

**The Sawtron 200 base console, designed to blend neatly into the home or office, could be an extremely useful addition to CBers' equipment, especially for professional users.**

The microphone, speaker, keyboard and other controls are all conveniently located on the sloping front control panel, as are LED displays for channel indication, 'on air' indication, and SELECALL use.

SELECALL enables the system's own SELECALL tones to be preset (any of the 810 tone combinations may be entered through the keyboard), so that the user can call and be called by any other Sawtron 200 SELECALL system. This can even act as a kind of silent phone number if the user elects not to make his SELECALL call tones generally known.

The Sawtron 200 also has an

automatic 'answer-back' facility, so that if a mobile transceiver calls its respective base console, the base console will automatically retransmit the call tones and light the decode lamp. In this way the mobile transceiver will know the call has been 'registered'.

The Sawtron 200 base console is designed to be connected to the Sawtron 880 transceiver section, and a dc power supply is inbuilt to provide the necessary 13.8 Vdc voltage.

For further information contact Imark Pty Ltd, 167 Roden St, West Melbourne Vic. 3003. (03)329-5433.

### QEX — new technical newsletter

**The ARRL recently launched a new technical newsletter called 'QEX: The ARRL's Experimenter's Exchange', carrying a high technical content considered above the general appeal of QST readers.**

The newsletter is to appear bi-monthly initially, and the first issue is planned to appear "late this year". A 12-issue subscription will cost US\$6 for members, US\$12 for non-members. A subscription announcement should appear soon in QST, the official journal of the American Radio Relay League.

**Thanks to HR Report**

amateurs in preparing themselves to provide emergency communications ensured that this activation was a success: VK2s — DKP DHH ABL DKC ZMK ZJA/VLR KBN NZW BUL AVO ZMK DCW BVI AGS AAB YLX/NOB BMZ AHF ZAX NL.

The support of the amateur

population in keeping the frequencies in use clear for WICEN traffic, even during the Remembrance Day contest, was most commendable.

**Mike Richter (VK2BMM)**  
NSW WICEN  
Deputy Co-ordinator

# UNBEATABLE

*"DICK SMITH guarantees to advertised Australian YAESU*



Cat. D-2862

## FT 101Z SERIES

Look at this superb FT-101Z. And what a transceiver! It includes variable IF bandwidth, built-in RF speech processor, all current HF bands (inc. WARC), 180W input (SSB/CW) & AM/CW/SSB operation.

**FANTASTIC OFFER:** With every purchase of a 101Z a **FREE** digital display worth \$139 will be included. (2 MONTHS ONLY)

**LOOK AT THIS PRICE!**

FT 101Z  
**\$795**

**FT 101ZD** Reduced to \$849, this unit is packed with features such as RF speech processor, IF bandwidth, & much, much, more. Was selling for \$889, now selling for \$849, saving you \$40. So be quick, these certainly won't last long at this price.

Cat. D-2859



## FT-707

What a performer packed into such a tiny package. This brilliant new FT-707 is one of our fastest sellers. And why not, it's a full power all HF band (including WARC) multi mode transceiver not much bigger than the average 2 metre mobile. Look at what you get: digital display, LED S/power meter, push button operation... all the things the amateur needs for safe, reliable mobile operation. Teamed with the D-2895 power supply makes it a must for the discerning amateur. Do yourself a favour & check it out at one of our stores & compare it with other similar units on the market today. You'll be pleasantly suprised!

**ONLY \$769**  
SOLID STATE  
WAS \$785.00

**OUR MOST POPULAR TRANSCEIVER**

Cat. D-2869



**THIS COULD BE YOUR LAST CHANCE TO BUY**

The incredible  
**FT-7B**

There aren't many transceivers in Australia which are particularly suited to novices - but which won't disgrace them either. The Yaesu FT-7B suits the novice as well as the full call amateur. It gives you the current HF bands, with a variable power output of 50 watts. You have the option of AM, CW or SSB, with the choice of VFO or a crystal locked channel. The FT-7B is ready when you are: just hook up your power & antenna, & away you go. Makes a great base or mobile.

**STILL ONLY WAS \$599.00**

SAVE \$30.00  
**\$569**

Cat. D-2868

**NEW! NEW! NEW! NEW! NEW!**

## VHF Handy FM Transceiver **FT-208R**

The FT-208R transceiver brings a new flexibility to today's active 2M operator. An easy to read LCD display is coupled with a 4-bit microprocessor, bringing 10 memories & a scanning function. Only with Yaesu can you get these important features at such an economical price. Check it out NOW!

**INC. CHARGER**

Cat. D-2889

**ONLY \$369**



2 METRE PORTABLE

## FT 290R

The FT-290R is a highly sophisticated compact multi-mode transceiver for the 2M amateur band. Featuring PLL synthesis in 100Hz, 1kHz, 5kHz, or 10kHz steps. The FT-290R utilizes a Liquid Crystal Display for digital readout for the operating frequency. 10 memories, scanning of the band or memory channels, two VFOs, & receiver offset tuning makes the FT-290R a significant breakthrough in technology. So be quick, these are going to go fast! Don't miss out!

ALL MODE

☆ FM ☆ SSB ☆ CW

**ONLY \$395**

Cat. D-2885



# YAESU PRICE!

beat or match any genuine price\*\*

\* OUR POLICY ON YAESU PRICES: If you produce a copy of a current advertisement appearing in the national media, with a Yaesu price below our advertised price AND the advertiser has the goods in stock, Dick Smith Electronics guarantee to match or better that price. Verbal or written quotations are not acceptable.



## FT 720RVH

Yaesu brings you the flexibility and performance you need in today's amateur world. The FT-720RVH not only gives you top performance, it's also the most flexible Yaesu transceiver. It comes apart - so you can locate the microprocessor-controlled 'works' close by you, with the 'RF' end out of the way. Or just as easily snap the two sections back again for a complete transceiver. That's versatility! This great little performer gives you scanning, 5 memory channels, LED Pwr/S meter, 25W output & full 144 - 148MHz operation & much, much more. A must for the person who lacks space in the mobile!

WAS \$450.00

**NOW \$370**

**SAVE \$80<sup>00</sup>**

Cat. D-2890

## YAESU'S FT 227RB

WAS \$379.00

One of the most popular Yaesu transceivers we have ever had the pleasure to operate: the incredible FT-227R. This classy PLL scanner will take you anywhere within the 2 metre band instantly - just press the scan button on the microphone - not bad hey! No need to worry about reaching for the selector switch in heavy traffic. And you have 4 memory channels to choose from, with a 600kHz repeater split for working standard repeaters, or 4MHz split for unusual repeaters or requirements. For value-for-money, you can't go past the FT-227R. It's a winner!

**NOW \$329**

**SAVE \$50<sup>00</sup>**

Cat. D-2891

## 2 Metre Handheld FT 207R INC. CHARGER

Imagine a hand-held 2 metre transceiver with all the punch of the big guns - with digital display, 800 channels, 4-bit CPU chip for frequency control, 4 memory channels, repeater splits, auto scan (up or down), weighing just 680g. How does it perform? How about 0.32uV sensitivity or 7.5kHz selectivity (-60dB), or a power output of 2.5W (min). So what are you waiting for, go on, indulge yourself with this little beauty!

WAS \$358.00

**NOW \$308**  
Cat. D-2888

**SAVE \$50<sup>00</sup>**

THIS COULD BE YOUR **LAST CHANCE TO BUY!**

**DICK SMITH ELECTRONICS**

SEE OUR OTHER ADS FOR ADDRESS DETAILS



CREDIT TERMS AVAILABLE TO APPROVED APPLICANTS

Prices correct and stock available at press time.

DSE A041RB

## CAN YOU AFFORD NOT TO SUBSCRIBE TO MICRO-80?

MICRO-80 is a monthly magazine dedicated to users of SYSTEM 80 and TRS-80 microcomputers. Owned and produced entirely in Australia, each issue of MICRO-80 contains at least six programs, articles, useful hints and answers to readers' problems; all designed to help YOU get the most out of your SYSTEM 80 or TRS-80. Since MICRO-80's first issue in December 1979, we have published over 80 major pieces of software and 10 hardware projects. Most of the programs and articles are written by our readers to whom we pay publication fees thus enabling them to make their hobby pay. MICRO-80 readers can save money by buying Tandy products at 10% discount from an authorised dealer — for details see any issue of MICRO-80. Our sister business, MICRO-80 PRODUCTS, sells Australian designed and produced software and high quality, imported goods at low, sensible prices. We repeat, if you own a SYSTEM 80 or TRS-80,

**CAN YOU AFFORD NOT TO SUBSCRIBE TO MICRO-80? . . . . . 12 month subscription delivered to your door, only \$25.00**

**CASSETTE EDITION only \$60.00 for 12 months**

If you do not have enough time at the keyboard to type in the program listings which are published in MICRO-80 each month, then you need a cassette subscription. As well as MICRO-80 magazine, you receive a cassette each month containing all the programs listed in the magazine.

### SPECIAL OFFER TO ALL NEW SUBSCRIBERS TO MICRO-80

A FREE cassette containing 6 programs (3 Level I + 3 Level II), together with complete documentation, will be sent to every new subscriber to MICRO-80.

Suspicious of mail order? Then send \$2.50 for a single copy of MICRO-80 and see for yourself that this is the magazine for you!

## Daisy Wheel Typewriter/Printer

MICRO-80 has converted the new OLIVETTI ET-121 DAISY WHEEL typewriter to work with the TRS-80 and SYSTEM 80 or any other microcomputer with a Centronics parallel port (RS 232 serial interface available shortly). The ET-121 typewriter is renowned for its high quality, fast speed (17 c.p.s.), quietness and reliability. MICRO-80 is renowned for its knowledge of the TRS-80/SYSTEM 80 and its sensible pricing policy. Together, we have produced a dual-purpose machine: an attractive, modern, correcting typewriter which doubles as a correspondence quality Daisy-wheel printer when used with your micro-computer.

How good is it? - This part of our advertisement was typeset using an ET-121 driven by a TRS-80. Write and ask for full details.



### MPI DISK DRIVES

MPI is the second biggest manufacturer of mini floppy disk drives in the world. They produce a family of high quality 5¼" drives with super-fast track-to-track access times (5ms!)

40 TRACK SINGLE HEAD . . . . . \$339  
40 TRACK DUAL HEAD . . . . . \$449  
80 TRACK SINGLE HEAD . . . . . \$499  
80 TRACK DUAL HEAD . . . . . \$599

Dual head drives use both sides of the disk and occupy two drive positions — It is like having two drives for little more than the price of one!

Prices quoted are for bare drives. Add \$10 per drive for a cabinet and \$30 per drive for a power supply.

### DISKETTES FOR TRS-80

NASHUA 40 track single side . . . \$4.50 ea  
VERBATIM 40 track double side . . \$5.90 ea  
VERBATIM 77 track single side . . \$5.90 ea

### THE FABULOUS NEWDOS 80 IN STOCK NOW!

ND-80 . . . . . \$149

The disk operating system that gives:

- New basic commands that support variable record lengths up to 4095 bytes long.
- Mix or match disk drives — supports any number of tracks from 18 to 80. Use 35, 40 or 77 track 5" mini disk drives or 8" disk drives, or any combination.
- A security boot-up for basic or machine code programs. User never sees "Dos-ready" or "Ready" and cannot "break" clear screen or issue any direct basic statement including "List" . . . . . and much, much more

### 77 TRACK DISK DRIVES

DOUBLE YOUR CAPACITY

DD-7S . . . . . \$775

Micropolis Floppy Disk, 77 Track, 100% larger capacity than most mini-floppy drives, complete with cable, power supply, chassis, and includes NEWDOS '80.

### SYSPAND 80 FOR THE SYSTEM 80 \$119.00

SYSPAND 80 is a self-contained module which connects to the expansion port on your SYSTEM 80 and gives you a CENTRONICS parallel port to drive a printer PLUS the TRS-80 40 line bus. SYSPAND 80 allows you to connect all Tandy peripheral, including the expansion interface, disk drives, MICROTEK MT-32 memory expansion unit and the fabulous EXATRON STRINGY FLOPPY.

### TRS-80 MEMORY EXPANSION UNIT MT-32 . . . \$149.00

The MT-32 is manufactured by MICROTEK Inc., USA. It provides a CENTRONICS printer port and sockets for up to 32K of dynamic RAM. It comes complete, ready to plug into the expansion port of your Level II 16K machine. (Will also work with your SYSTEM 80 via SYSPAND 80).

MT-32A without RAM . . . . . \$149.00  
MT-32B with 16K RAM . . . . . \$179.00  
MT-32C with 32K RAM . . . . . \$209.00

### 16K MEMORY EXPANSION KIT

ONLY \$30 incl. p&p

These are prime, branded, 200 ns (yes, 200 ns!) chips. You will pay much more elsewhere for slow, 350 ns chips. Ours are guaranteed for 12 months. A pair of DIP shunts is also required to upgrade the CPU memory — these cost an additional \$4.00. All kits come complete with full, step-by-step instructions, no soldering is required. You don't have to be an electronic type to instal them.

### DISK DRIVE HEAD CLEANING DISKETTES

\$29.00 plus \$1.20 p & p

Disk drives are expensive and so are diskettes. As with any magnetic recording device, a disk drive works better and lasts longer if the head is cleaned regularly. In the past, the problem has been, how do you clean the head without pulling the mechanism apart and running the risk of damaging delicate parts. 3M's have come to our rescue with SCOTCH BRAND, non-abrasive, head cleaning diskettes which thoroughly clean the head in seconds. The cleaning action is less abrasive than an ordinary diskette and no residue is left behind.

ONLY \$1995 INC. S.T.

To: MICRO-80  
P.O. Box 213, Goodwood, S.A. 5034

Please rush me the items checked below:

- 12 month subscription to MICRO-80 and my free software cassette . . . . . \$24.00
- 12 month subscription to MICRO-80 and the cassette edition, plus my free software cassette . . . . . \$60.00
- The latest issue of MICRO-80 . . . . . \$2.50

PLUS THE ITEMS LISTED BELOW

DESCRIPTION	PRICE
TOTAL ENCLOSED	

Name .....

Address .....

Post Code .....

bankcard No. . . . .  
welcome here

Please debit my Bankcard \$ .....

Expiry date .....

Signature .....

ETI

# MICRO 80 PRODUCTS

(08) 272 0966

433 MORPHETT STREET.

ADELAIDE S.A. 5000

### AUSTRALIAN SOFTWARE

We have a wide range of Australian software available. Send for a free catalogue

TRS 80 and SYSTEM 80 OWNERS TRS 80 and SYSTEM 80 OWNERS

# COMPUTING TODAY

## Home computers set to storm market



This year will see the personal computer make the transition to a genuine home computer. The release of the Commodore VIC and the Atari 400 will bring low-priced, colour-capable home computers that will plug into the home television, offer extensive games centres and educational programs, and won't send dad broke.

**The Commodore VIC will sell for around \$399 and will have a base memory of 5K. An expansion plug-in module will offer another 3K to take the VIC to 8K for another \$80.**

A printer will be available for around \$450, and the cassette data storage unit will cost around \$100. Plug-in solid state ROM cartridges will be available for the VIC which will also take all the Atari game paddles and controls.

The Atari 400 will be the VIC's main competitor, offering 16K of memory for around \$599. Both have pluses and minuses, which should ensure that one doesn't wipe out the other in the marketplace.

The Atari has a better screen display, offering a 40-character display as against the VIC's 23-character system. The Atari also comes with a bigger working memory of 16K compared to the VIC's 5K system.

On the other hand the VIC keyboard is a conventional typewriter-style keyboard, while the Atari's is a small touch-sensitive board. The VIC also can draw from the vast bank of PET computer software, while Atari, although offering a range of software, is relying on its company to stir up the computer enthusiasts to produce suitable software for the Atari.

Both units take ROM cartridges for special games and educational programs. In the Atari electronic games centre the cartridge with the program in a solid state form is loaded straight into the control centre.

Both VIC and Atari 400 will basically be a more expensive games centre on one hand and a cheap computer on the other. Both have excellent colour and high resolution graphics. As Roger Davis from Commodore says, "The two computers are an upmarket version

of electronic games centres and a cheap introduction to computer technology".

Atari is aware of its weakness in the software department and has launched a US\$100 000 program competition in the US to encourage computer people to produce software for Atari. According to the head of Atari's computer division in San Francisco, Mr Peter Rosenthal, the competition is being run over a full year with prizes awarded on a quarterly basis. Atari will keep the winning programs and market them themselves. They will also encourage and help other entrants who don't win a prize to market their programs.

Mr. Rosenthal says that Atari has already got 60 games and educational and management programs available to Atari buyers, and that there are around 250 more titles available for the Atari from outside sources.

Warner, which owns Atari, is extremely keen to get computers into the home. They have cable TV, satellite TV, and the CUBE two-TV system that is being developed for future talk-back TV and voting systems. The missing link in the

Warner Communications system is a computer in the home. So the Atari executives have been told to get the computer into the home of people around the world.

Obviously the cost doesn't matter. Warner has given satellite communication to Atari engineers to enable quick and efficient servicing of their computers. When an Atari home computer malfunctions, a technician plugs it into a modem and dials up a mother computer in San Francisco via Warner's satellite. The mother computer analyses the sick home computer and then sends a telex to the engineer instructing him which plug-in modules to replace.

Mr Rosenthal says that Atari is not interested in developing the Atari computer for small business applications. They plan only to develop and market the computer for home installation, and all software and hardware development will be to this end.

The Atari computer has been available in the US NTSC TV system for about 18 months; only in the last few months have a limited number of Pal-standard units been made. Futuretronics launched these here in August. ▶ (To page 87)

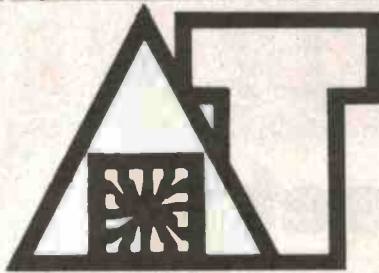

# APPLIED TECHNOLOGY PTY. LTD.

Office/Showroom: 1a Pattison Avenue, Waitara 2077  
 Hours: 9-5 Monday to Saturday. Telephone: (02) 487 2711  
 Mail orders to: PO Box 355, Hornsby 2077  
 Please add \$2.00 per order to cover packing and postage.  
 Prices correct and goods in stock at time of going to press.

## PROFESSIONAL Z80 / S100 COMPUTER \$1095 ANNOUNCING SYSTEM Z.A.T.

Here it is at last! A fully built and tested business quality computer system at less than the cost of its single board non S100 competitors. The Applied Technology SYSTEM Z.A.T. offers the business and home computer user an unbeatable combination of computing power both in the basic machine and in flexible and inexpensive hardware and software expansion. Our extensive range of S100 support cards, peripherals and world standard software means the SYSTEM Z.A.T. will suit the most demanding user now and in the future.

The basic SYSTEM Z.A.T. is supplied with our fast Z80A single board computer, 16K of RAM, MW640 memory-mapped VDU with 16 lines of 64 characters (upper/lower case plus graphics), a 10 slot mother board and a heavy duty power supply. The whole machine is mounted in a professional rack width EURO-STYLE desk cabinet (illustrated). The keyboard is a stand alone unit featuring full 70 key set and its own attractive case. The Z.A.T. comes with the powerful DGOS monitor resident in ROM so you can enter programmes, set the in-built real time clock, save and load on cassette as well as make block moves, compare memory and search for bytes in memory. The system Z.A.T. requires only a video monitor or modified TV for immediate use. Peripherals such as serial printers and various I/O devices can be interfaced directly with the Z80A card—no extra interfaces are needed. Programmes can be run and developed in powerful MICROWORLD LEVEL II BASIC, either from cassette with our fantastic USCII Interface or you can fit the MW2516 EPROM CARD and have your programmes in EPROM. The MW1632 S100 EPROM programmer allows programmes you have developed to be put into ROM for immediate access!

Our machine differs fundamentally from single board computers such as SORCERER and APPLE. It uses all S100 plug in boards right from the start. For \$1095 you are not buying a machine which is basically one big PC board. You are buying a powerful S100 machine with a very heavy power supply and seven slots waiting for expansion. Your S100 expansion unit is built in at no extra cost.

When you buy our machine, you are investing in the best value, most flexible personal computer on the market today.

### SYSTEM Z.A.T. FOR BUSINESS

With the addition of extra memory, disc drives, a printer and support software, a system Z.A.T. can form the ideal basis of an office system. A configuration for virtually any small or medium size business is pictured. It comprises a SYSTEM Z.A.T. with

48K RAM, word processor daisy wheel printer, Micropolis 1053 Mod II 630K Disk Drive system, high resolution green screen monitor and support software including CP/M 2.2 disk operating system, MDOS, 24K MBASIC, and various utility programmes. With the addition of any of the widely available programme packages for accounting, inventory control, word processing etc., the SYSTEM Z.A.T. (48K/WP/DD) configuration is equal to and in some cases superior to commercial systems being marketed for over \$10,000. Because the SYSTEM Z.A.T. is on the S100 bus and will run CP/M without modification, you are assured of a machine which will not become obsolete and which will run the finest business and scientific packages.



The comparison chart below shows clearly why the SYSTEM Z.A.T. is the best value Z80/CPM computer available today.

BASIC UNIT	Apple II 16K	Sorcerer 32K	SYSTEM Z.A.T.
Memory	16K	32K	16K
Cost (with tax)	\$1524	\$1395	\$1095
Processor	6502	Z80	Z80A
Memory type	dynamic	dynamic	static
VDU	40 x 16	64 x 30	64 x 16
S100 expansion	n/a	\$575	built-in
48K CP/M	\$3664(1)	\$4116(2)	\$3170

NOTES: For comparison we have selected the 48K/CP/M configuration as this is the most common basis for business systems. Popular ROM/BASIC machines such as the TRS80 and SYSTEM 80 need substantial conversion and a special version of CP/M and the reader is asked to make his own comparison. Prices used have been taken from current advertising for all models.

(1) To convert the Apple you need 32K of RAM (\$110), Z80 softcard (\$330), disks (\$786 + \$594), CP/M (\$160).

(2) To convert the Sorcerer we used S100 expansion interface (\$575), 16K RAM card (\$199), MICROPOLIS 1043 (\$1149) and 1023 (\$649) disk drives and CP/M (\$149).

(3) To equip the SYSTEM Z.A.T. you need 32K RAM (\$400) and MICROPOLIS 1053 MOD II 615K package with CP/M 2.2 (\$1,675).

# WHY CP/M?

CP/M is a powerful disk operating system from DIGITAL RESEARCH that has become the industry standard system for virtually all 8 bit microcomputers. Although only suited to Z80/8080 processors you can now buy a Z80 plug-in for the APPLE (about \$300), the SOFTBOX for the PET (\$900), mods for the TRS80

and no doubt the Atari in the near future. Hewlett Packard's new HP-125 uses the Z80A and CP/M and also the Xerox Model 820 features CP/M with the Z80! This formidable line-up suggests that to produce a worthwhile computer system you really need a system capable of running CP/M on a Z80. The enormous library of powerful and proven software is fully transportable between CP/M systems and means that any CP/M user has this at his fingertips.

The SYSTEM Z.A.T. is available with customised BIOS program to suit any configuration required. The soon-to-be released MICROWORLD MEGAMEMORY hard disk system will come with multi-user MP/M and will pave the way for networking under CP/M as well.

In the fast-moving world of micro-computing, three significant milestones have been the Z80 chip, the S100 bus and CP/M operating system and SYSTEM Z.A.T. employs them ALL.

APPLIED TECHNOLOGY have a wide range of cost-effective S100 cards which make expansion exciting and painless.

## MEMORY

We offer two choices of proven reliable static memory. Both cards have very low power consumption, one voltage (between +7 and +14 Volts) and suit all S100 systems as well as SORCERER, TRS80 and SYSTEM 80.

## AT16K

Uses reliable 2114 static RAMS and may be configured to any 16K boundary using on-board select logic. Board also has bank select, provision for write select and phantom line memory priority control. Fully built and tested. Assembled and tested \$199.00

## TCT 16K

Memory arranged in four independent 4K blocks. Three DIP switches locate memory at any location in 64K address space. Can be configured to higher or lower priority memory through use of phantom line. Kit form \$209.00

## ROM CARD

MW2516 S100 ROM card stores programmes permanently in up to 16K of low cost 2516 EPROMS. Built and tested \$99.00  
Also available with MICROWORLD 12K BASIC plugged in \$160.00

## HIGH RESOLUTION GRAPHICS

Our TCTPCG (programmable character generator) will expand your graphics to a fantastic 512 x 256 bit resolution! You can produce graphs, bar charts, even develop your own TV game! Board comes complete with extensive documentation, joystick interfaces and controls and even two game programmes on cassette. Kit price \$140.00

## INPUT/OUTPUT

With the powerful DG750 I/O card you can connect 3 further programmable 8-bit ports, 2 serial interfaces and have on board baud rate generation. Kit price \$195.00

## SERIAL TERMINAL

The SCVT100 (as described in EA Oct. 1980) gives a serial input and output, keyboard port, cassette interface and RS232 on one board. Kit price \$190.00

## DIGITALKER

Give your computer a voice for under \$150.00 The MICROWORLD DIGITALKER uses the latest speech processing unit and speech ROMs from NATIONAL SEMICONDUCTOR. Although it is on S100, the DIGITALKER can be readily adapted to interface with virtually any micro, including SORCERER, TRS80 and SYSTEM 80.

DIGITALKER comes complete with applications notes and typical software. DIGITALKER Kit with notes and full instructions \$149.50

# SOFTWARE NEW RELEASES

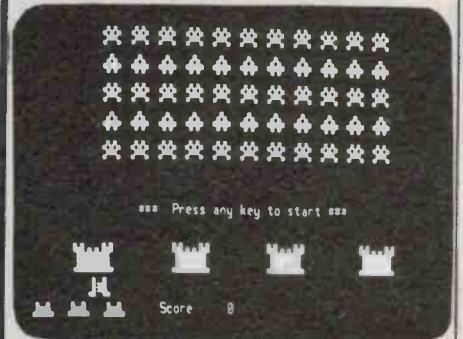

DGOS format on Cassette Tape.

Cassette with documentation.

WUMPUS. The popular cave hunting game. \$5.50

LIFE. A fascinating use of graphics on the

VDU. \$5.50

CALENDAR-MAKER. Prints calendars for any

year you want to. \$5.50

MAZE-MAKER. Prints mazes to any specified

width and length. \$5.50

BANNER-PRINT. Prints your name in big

characters. \$5.50

BIG VDU. Converts the MW640 to produce large

characters on the screen. \$5.50

BYORITHM. Impress your friends and print out

their points at a party game. \$5.50

TYPE DRILL - Teach yourself to touch type. \$5.50

ELIZA. The first artificial intelligence

program. \$5.50

HEXAPAWN. A chess type game, but the com-

puter learns by its mistakes. \$5.50

PILOT. The simplest to use language. Ideal for

education and string oriented appli-

cation. \$14.75

MICROWORLD LEVEL II. Basic 12K of powerful

program on cassette. \$19.75

Or in ROMS. \$75.00

# PERIPHERALS

## PRINTERS

NEW RELEASE. ITOH 8500

GRAPHICS/DOT MATRIX.

A little beauty! This latest printer from ITOH is a clever microprocessor controlled unit that uses a dot matrix head to produce top quality characters and graphics.

Printing at a rate of 100 characters/second (44 lines/minute full 80 character print) this is an ideal printer which has built in friction feed and sprocket feed for all paper types. Features true descenders and logic seeking circuitry for extra speed. \$895.00

## FOR WORD PROCESSING

TEC TE 1500 Daisy wheel printer accepts sheet paper, Company letterheads etc. or continuous stationery up to 400 mm wide. Uses standard DIABLO print wheels and ribbon cartridges.

A wide range of fonts is available. Prints about twice as fast as a golfball printer and is now available with RS232 or Centronics interface.

TEC TE 1500 RS232 \$1,895.00

TE 1500 Centronics \$1,865.00

## DISK DRIVES

Proven Micropolis Quad Density Drives are one of the best known 5 1/4" drive packages on the market. They store 315K on a single disk and are fully S100 compatible.

## 1043 MOD II.

S100 controller, drive package in cabinet with power supply, and full software includes 24K BASIC, M DOS and MICROWORLD RES.

\$995.00

Add on Drive \$645.00

## 1053 MOD II.

Dual drive package has 630K of storage in top quality case with power supply and S100 controller.

Now available with full software plus CP/M 2.2 and MICROWORLD RES. \$1,675.00

# REAL COMPUTERS START FROM \$399

Do you want to build a computer which won't end up limiting your needs and interests? Then the SUPER INSTRUCTOR 80 offers you the finest take-off point in personal computing today. While offering you unparalleled facilities for learning computer basics now, the SUPER INSTRUCTOR has the built-in S100 facilities of the Z.A.T. system, but without the power supply, case and memory board of the latter. It gives you an ultra powerful CPU board with built-in printer and other interfaces, and a professional VDU board with upper and lower case (and a screen which doesn't flicker each time you key something in).

The SUPER INSTRUCTOR 80 includes

RCA touch keyboard \$89.50

4 slot motherboard with two S100 sockets \$45.00

DGZ80 CPU card kit \$199.00

DGOS monitor ROM with manual \$40.00

MW640 VDU (built and tested) \$159.00

Normal full price \$532.50

Package Price \$399.00

SAVE: \$133.50

## ADVANCED 16K BASIC SYSTEM

As a special deal to SUPER 80 buyers, we are offering our AT16K RAM card plus the MW2516 ROM card with MICROWORLD BASIC in ROM for an all-up price of only \$269, a saving of \$90 on the normal price for the two boards. Your INSTRUCTOR 80 with BASIC 80 pack outclasses TRS80, SYSTEM 80 and SORCERER and you don't have to spend \$500 if you want to expand memory or go to disk.

INSTRUCTOR 80 \$399 plus  
BASIC 80 PACK \$269 equals

POWERFUL 16K/BASIC S100/Z80 processing

# 12K BASIC + 16K RAM \$269





# THE S-100 BUS MULTI USER EXPERT

NORMANBY CHAMBERS, 430 LITTLE COLLINS STREET, MELBOURNE, 3000

Telephone: (03) 602 3946

We are skilled specialists in customized software and hardware computer systems.  
We provide a generous guarantee, full maintenance and a satisfying back up service for all our customers.

### INTRODUCING:

- WORD PROCESSING with Wordstar ..... \$395
- NETWORKING with CP/NET (Up to 16 slave processors per master processor) ..... \$220
- HIGH LEVEL LANGUAGES Including —  
CBASIC-11 — \$150 Pascal/Z — \$450
- ACCOUNTING SYSTEMS — tailored to your needs including General Ledger, Accounts Receivable, Accounts Payable, Inventory Control, Invoicing, Payroll
- ITOH PRINTERS — a full range —  
M-8500 full graphics, lower case descenders ..... \$825  
100 CPS, friction/sprocket feed, incremental printing
- 8300 dot matrix 7x9, 125 CPS, 9.5 inch ..... \$750  
1540 dot matrix 7x9, 125 CPS, 15 inch ..... \$995  
FP-1500 "Daisy" wheel 25 CPS, 15 inch ..... \$1720

### STAND-ALONE Z80 COMPUTER

Z80 Starter Kit. \$390 — Kit. \$450 — A&T.

Z80 CPU with 158 Instructions, On-Board Keyboard and 7 segment Display, On-board PROM Programmer for single voltage PROMs (2716, 2758, T12516), Kansas City standard cassette Interface with simple controlled load and dump, expansion provision for two S-100 connectors (sockets not included), wire wrap area for custom circuitry, single step through RAM and PROM, memory examine and change, port examine and change, Z80 CPU register and change, 2K byte ZBUG monitor in ROM, 1K bytes of RAM (expandable to 2K bytes), counter timer (Z80-CTC), parallel I/O ports (Z80-P10), up to 5 programmable breakpoints, switch selectable PROM or monitor restart, vectored interrupts provided by Z80-CTC and Z80-P10.





Computer Monitor PROM (2716): \$95. FREE: with every SBC-200 sold.

Features commands to develop machine language programs including the manipulation of memory locations and I/O port data, and multiple breakpointing. In combination with the computailor BIOS PROM it provides a comprehensive range of disk management primitives.

Computailor BIOS PROM (2716): \$95. FREE: with every SBC-200 sold.

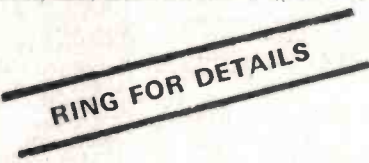
Features routines to execute disk operation for single density, double density, single sided, double sided, 5¼" and/or 8" drives. Obey's CP/M BIOS calling conventions and is hence suitable for SOOS, CP/M, COSMOS and MP/M operating systems. Contains comprehensive cold boot routine for most disk operating systems.

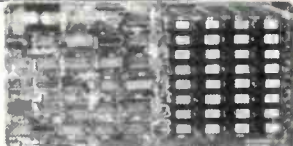
### S-100 BUS SINGLE/MULTI USER MICROCOMPUTER SINGLE BOARD GUIDE

Number of boards per system.	Board	Features	UNIT COST	
			Kit \$	A & T \$
	 <p>Any \$100 Standard Board Prom Programmers, A/D - D/A Converters, Expandoproms, Hard-Disk Controllers, General I/O Boards.</p>	 <p>RING FOR DETAILS</p>		
4 Boards for 16 User System	 <p>MPC-4 Multi-Port Communicator</p>	Z80-CPU, Real Time Clock, Progr. Baud Rate Gen, 1K RAM (Static), 2 x Z80-Darts, 2K PROM (2716), Fifo Buffer, Z80-CTC.	\$600	\$680
1 Board for single or 16 User System.	 <p>VERSAFLOPPY II Floppy Disk Controller.</p> <p>Free: Computailor Bios PROM (2716).</p>	2K Bios PROM (2716), IBM 3740 Standard Single Density or Double Density, Single or Double Sided Drives, 5¼" and/or 8" Drives, up to 4 Drives.	\$370	\$430
1 Board for Single User, 8 Boards for 16 User System.	 <p>EXPANDORAM II Dynamic Ram Card</p>	Expandable Dynamic Memory 16K-256K, Selectable Boundaries, Up to 4MHz Operation, Phantom Output Disable, Page Mode Operation, Uses 16K (4116) or 64K (4164) Memory Devices.	\$325 \$360 \$395 \$430	\$395 \$430 \$465 \$500
1 Board for Single or Multi-User System.	 <p>VDB-8024 Video Display Board</p>	80 characters x 24 lines, 7 x 10 Matrix, Composite or TTL Video Output, Keyboard Power & Interface, Forward & Reverse Scrolling, Blinking, Underlining, Field Reverse, Field Protect and Combinations, Full Cursor Control, 96 Upper and Lower Case Characters, 32 Special Character Set, 128 Additional User Programmable Characters (Optional), On-Board Z80-CPU, 2K BYTES Independent On-Board Ram Memory, Glitch-free Display.	\$450	\$520
1 Board for Single or Multi-User System.	 <p>SBC-200 Single Board Computer</p> <p>Free: Computailor Monitor PROM (2716).</p>	Computailor Monitor 2K PROM (2716), Z80-CPU, 1K RAM, 16K EPROM, Serial I/O, Parallel I/O, Z80-CTC, 4MHz Operation, Optional Vectored Interrupts, Power-on jump to 4K boundaries, On-board memory can be switched out under programme control.	\$390	\$460

### FULL SYSTEMS:

Any configuration from a simple dedicated system or a single user system to the most complex multi user system. Arranged with a selection of floppy disk drives, hard disk drives, printers and VDUs.

### PERIPHERALS:

VDUs, printers, disk drives, etc.

### SOFTWARE:

- Single user SDOS 1.8 operating system ..... \$200
- Single user CP/M 2.2 operating system ..... \$160
- Multi user COSMOS operating system ..... \$380
- Multi user MP/M 1.1 operating system ..... \$310

Enquire for customized operating systems. Pascal, BASIC, FORTRAN, Word processor (Wordstar) and Utility programs are also available on request.

Ask for our short form catalogue.  
All prices are tax free; add 17½% sales tax if applicable.  
Mail orders are welcome, add \$3 — postage.

Prices and specs. subject to change without notice.



# Print-out

## For Sorcerer Apprentices

Disk operating systems on the Sorcerer are becoming quite common these days, and this month's program review also deals with disk programs, although the game Rubix is also available as a tape version.

Everyone changing over to disk is faced with a myriad of problems and a wealth of information, and I have been asked by quite a lot of people to include hints on disk operating procedures as well as normal Sorcerer information.

There are several disk-operating systems on the market and several disk drives. All information contained in this and future issues will relate to one disk operating system only — the CP/M 2.2 (Control Program for Microcomputers Version 2.2 and higher), running on the Sorcerer and on Micropolis 5¼-inch disk drives.

The reason for this choice is twofold. Firstly, CP/M is establishing itself as the industry's standard, with a great variety of programs specifically written for this operating system, while Micropolis disk drives seem to be the most commonly used (95% of disk owners I know use this combination). The second reason is that I happen to have this system and I simply do not know any other drives or operating systems, therefore I cannot relay information on other systems!

The first thing you notice when you get your disk operating system is how little you know. Second observation is how hard it is to think logically. The increasing ability to think logically will certainly ease the growing pains encountered by all of us, you'll be pleased to know. I was seriously considering packing up and never even looking at a computer again when I changed over to disk.

The problems I had could be classified into two sections. The majority came into the first section: I did not read the manual thoroughly enough. Fair enough, the manual could be written in a better way, but the fact remains that all the information required to operate CP/M is in the manual somewhere. The second source of my problems was of an entirely different nature: I did not understand the terminology used. Chances are pretty high that some readers will fall into the same category, so I decided to start by explaining the terminology.

CP/M handles user-interactive commands in two different ways: inbuilt commands and user-supplied commands. In Exidy BASIC you have inbuilt commands, for example CLOAD. The next command would be the file-name. CP/M has the following inbuilt commands:

Command	Function
DIR	shows files on disk
ERA	erases files on disk
REN	renames files on disk
SAVE	saves files to disk
TYPE	display an ASCII file
USER	changes user level

All above commands are processed by CP/M's CCP (console command processor), i.e. they are not files on your disk.

Other standard CP/M commands are:

Command	Function
ASM	assemble a file
DDT	debug (Dynamic Debugging Tool)
DUMP	dump file to terminal in hexadecimal format
ED	Edit a file (ASCII file)
LOAD	Load a ".HEX" file into an executable command
MOVCPM	Move or reconfigure your CP/M to a different size
PIP	Peripheral Interchange Program
STAT	Display status information
SUBMIT	Execute a batch of commands
SYSGEN	Generate a copy of CP/M to a disk
XSUB	Extended Submit facility

If you examine your CP/M systems disk (the one provided when you buy CP/M), you'll find the above files as ASM.COM, DDT.COM, etc, on your disk. Thus, if you issue the command PIP:CR, CP/M will read the file called PIP.COM from disk, place it from location 100hex onwards and start executing from 100hex onwards. CP/M will do this to all files which end in .COM. Your manual lists the above commands as 'transient commands'. Location 100hex is called the TPA (transient program

area). Remember all '.COM' files will be loaded and executed from 100hex. If you have a tape program with a start and go-address of 100hex you can simply load it into memory and save it without any changes required. But if your program starts anywhere else and has a different go-address, things become a bit more complicated. Here is how to do it (remember, I assume that you have CP/M version 2.2, a Micropolis Drive and an Exidy Sorcerer).

Boot your disk, then exit to Exidy Monitor. (RESET will do if you don't have Software Source's CP/M.) Now enter the following command, where "NAME" is the name of your file on cassette and "n" the cassette unit number (1 or 2):

```
>LO NAME n 110 <CR>
```

The monitor will respond:

```
FOUND NAME x aaAA bbBB ccCC
```

```
LOADING —
```

When loading is finished, enter the following:

```
EN 100 <CR> (aa,AA,bb,BB,cc,CC are the values shown on loading)
```



(From p.83)

Warner anticipates that the home computer market is going to be its biggest business in the 1980s. Researchers say that 90% of all homes will have a computer by 1990, and both the Atari 400 and the Commodore VIC are expected to be the stepping stone to that big boom.

However, nobody is neglecting the hobbyist and small business market. Atari's 800 computer and the Commodore PET will be competing head-on with the Apple, which has dominated the market until now.

The Atari will take the plug-in modules of the Atari games and educational cartridges and the Atari paddles, and will offer all the colour and high resolution of the Apple, whilst retailing in Australia at around \$200 cheaper at \$1300.

Meanwhile Commodore has upgraded its 4000 series. Instead of a 230 mm (9") screen the unit will

come with a 300 mm (12") green phosphor screen display terminal. The price will be the same as before at \$999 with 16K memory. The cassette terminal will be around \$100, and a single-floppy drive is due to be released later this year for around \$900.

Another contender, Mattel's Intellivision 'master component' games centre (Pal version), was launched here in September (see September ETI, p.17) by Lifestyle Electronics. This unit converts to a 16-bit microcomputer with the addition of a 'keyboard component', but we're not likely to see that here until some time next year. All the other home computers are 8-bit machines so Mattel are starting a whole new ballgame.

There is no doubt the home computer is here to stay, and that in the next couple of years it is going to precipitate a lot of activity in the marketplace. ●

## Computerland goes west

Computerland Australia has announced the opening of Sydney's third Computerland store, in Parramatta in the Western Suburbs.

This brings the total of Computerland stores world-wide to over 180, and "reflects the growing awareness ... of the capabilities of small computers in Australia by people in business and education as well as personal users," according to a Computerland press release.

Apple computers and Cromemco systems are among the large range of hardware available

from Computerland and now on show at the Parramatta store.

Ray Green, owner and manager of the store, has a high degree of computer and management experience, and will be able to assist people in choosing the right computer for their needs.

Contact Ray Green at 2/382 Church St, Parramatta NSW 2150. (02)683-3199.

## More spelling checks

A spelling verifier facility is supplied as standard with Memorite III word processing software, which runs on CP/M 2.2 and is available from Vector Graphics.

Memorite III has a base vocabulary of 30 000 words and is said to be very easy to use. The program simply scans the text until a mismatch is displayed in reverse video. At each mismatch the operator types in the correct version or hits RETURN to add the word to the dictionary.

Memorite III gives you word processing, mail list merging and spelling verification, all at only \$600 (tax included) — quite a bargain.

Contact Mentat Computer Systems, Suite 3, 366 Whitehorse Rd, Nunawading Vic. 3131, (03) 878-1255, for further information.

(From previous page)

```
0100:21 "CC" "cc" E5 21 10 01 11 "BB" "bb" 1 "AA" "aa" <CR>
010D:C3 19 EB <CR>
0110: /
```

Then enter:

```
>GO 0 <CR>
```

```
A>SAVE xx NAME.COM <CR> where "xx" is the decimal number of "aa" + 1.
```

If "AA" is greater than F1hex, then you must add 1 to "xx" as computed above to allow for the loader residing from 100hex to 110hex.

You now have an automatically executable program; next time you key in "NAME", "NAME" will load itself at 100hex, up or download itself and execute from there on. Next month I'll list the procedure for automatically executing Exidy BASIC programs.

While you're moving your programs from cassette to disk, which is quite time-consuming, you have plenty of time to read those manuals. If you find the CP/M manuals hard to master, I strongly recommend the following Sybex book: The CP/M Handbook (with MP/M) by Rodney Zaks. The few dollars invested for the book are certainly worthwhile. (Available from ETI Book Sales, 4th Floor, 15 Boundary St, Rushcutters Bay NSW 2011.)

### Product reviews

This month's program was submitted by Calmer Software Services, who inform me that they have appointed Software Source as their sole distributors. You can contact Software Source at P.O. Box 364, Edgecliff NSW 2027 for further information.

The program is a game, available for CP/M or cassette and called Rubix. Rubix is outstanding in several ways. There is no point-scoring or 'enemies' to be eliminated. Rubix is simply a computer version of the famous Rubik's Cube, entirely in machine language. Its graphic presentation of the cube's different colours is another showpiece of what can be done with Sorcerer Graphics. As with the cube itself, there is only one solution to the game. You can start off with a random position, a previously saved position or simply let Rubix make a few moves, then stop it and try to get it back to its original state. I've had a Rubik's cube for a long time now, and Rubix finally enabled me to see exactly how the sides get so mixed up and how to go about restoring it. I've had a copy of Rubix for several weeks now and must admit that I am spending a bit too much time enjoying this program. I highly recommend it to anyone who wants to think and play at the same time.

That's all for now, happy computing.

A.P.F. Fry

## CISA releases Whisperdisc

CISA Microcomputing has been appointed agents for the Olympia range of electronic Whisperdisc computer terminal/typewriters.

According to CISA, the Whisperdisc is the answer to the problem of finding a printing unit for a word processing system that is capable of producing a letter-quality image without costing \$3000 or more. The Whisperdisc will retail at \$2200, which includes a selection of typing fonts, all cables and necessary software to interface to a TRS-80 disk system.

The Whisperdisc can act either as a stand-alone daisy-wheel typewriter or, at the flick of a switch, be

converted to an automatic computer terminal. In this format they attract a full 30% depreciation as opposed to only 15% when purchased solely as a typewriter.

The Whisperdisc carries CISA's 90-day parts and labour warranty and pre-delivery testing. A tractor-feed attachment will be available shortly.

For more information contact CISA Microcomputing Pty Ltd, 159 Kent St, Sydney NSW 2000. (02)231-1813.

## New hard disk configuration reduces costs

Microprocessor Applications Pty Ltd, a distributor of microprocessor-based computer systems, has announced a new hard disk configuration that reduces the cost of its Micromation M/NET systems by \$1650. The same component enables the company to expand system capacity while reducing the number of modules.

The new system uses Fujitsu's M2302 Winchester-type hard disk drive, with 23.4M of unformatted data storage capacity. The disk is divided into 512-byte sectors, giving faster program execution and better overall system performance, plus a more efficient use of disk storage capacity.

The new configuration also reduces the original three-cabinet system to two compact, horizontal units — one containing the computer with a 17-slot motherboard and one holding both the floppy and the eight-inch hard disk drive.

M/NET uses the CP/M compatible MP/M operating system, so that a wide variety of application and

development software is readily available for use with the system. Microprocessor Applications recently doubled Micromation M/NET capacity by increasing the maximum number of users from four to eight.

Basic unit prices range from \$11 500 to \$23 210 for a full eight-user system with 21.5M of storage capacity. An additional hard disk package can be purchased separately as an upgrade to this system at a basic unit price of \$6150.

For more information contact Microprocessor Applications Pty Ltd, Maskell's Hill Road, Selby Vic. 3160. (03) 754-5108, (03) 754-7233.

Software  
Source

## WE ARE MOVING

Come and visit us in our new

SHOWROOM

89 OXFORD ST, BONDI JUNCTION

and see the most complete range of

**SORCERER**

products

anywhere in Australia!

Anything that will fit INTO or ONTO a Sorcerer —  
we have it!

Write for new FREE catalogue.

P.O. Box 364, Edgecliff. 2027 — phone (02) 389 6388



**JOHN F ROSE COMPUTER SERVICES PTY LTD** has extensive experience in introducing "FIRST-TIME USERS" to the CP/M MICROCOMPUTER.

## A - SOFTWARE

We supply a number of software packages for the following applications:

- 1) Word-Processing — Wordstar/Mail-Merge/Spellstar
- 2) Accounting — General Accounting Package
- 3) Information Management — FMS-80
- 4) Development — Large range of languages, sorting and ISAM utilities.

SOFTWARE is now produced in-house for the following systems:

Apple (with CP/M, 16 sector) SUPERBRAIN (Dos 3, Quad) VECTOR GRAPHICS MZ (CP/M 2) NORTHSTAR (Quad, 64K CP/M). All 8" CP/M systems capable of reading IBM 3740 CP/M format.

Full descriptions of these packages and many others are described in our SOFTWARE OMNIBUS (\$5.00).

## B — HARDWARE

We MANUFACTURE the OPAL 2000 (64k RAM, 2 x 1.2 Megabyte Disk Drives, CP/M 2.2) The OPAL can be supplied with the NDK S-4000 printer and the DIALOGUE-80 terminal.

**A + B = A solution to your needs. (O.E.M. ENQUIRIES WELCOME)**

# JOHN F. ROSE COMPUTER SERVICES PTY. LTD.

33-35 ATCHISON STREET, ST. LEONARDS, N.S.W., 2065, AUSTRALIA.

TELEPHONE: (02) 439 1220    TELEX: AA 27901

**PRICES AND SPECIFICATIONS ARE SUBJECT TO CHANGE WITHOUT NOTICE**

## 48k RAM FOR \$295\*

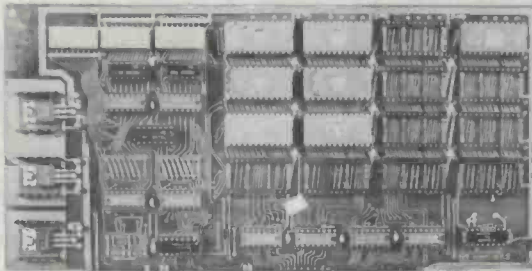

## GOODBYE STATICS

Just look at these kit prices for our 64k S100 Dynamic memory board.

	inc. tax	ex. tax
16K bytes	\$259	\$225
32K bytes	\$299	\$260
48K bytes	\$339	\$295
64K bytes	\$379	\$330
8 x 4116 (200ns)	\$ 40	\$ 35
Manual only	\$ 7	

**Add \$50 for Assembled & Tested.**

Please add \$3 for post and packing.

\* Plus sales tax.

## 2716 (+5V) \$6.10\*

Yes! We sell the TCT "Universal" Prom board (ETI-682.) Take a look at these prices!

	inc. tax	ex. tax
Complete kit	\$115	\$100
Board only	\$ 69	\$ 60
2716 (+5V,450ns)	\$ 7	\$ 6.10
Manual only	\$ 7	

### TCT Micro Design Pty. Ltd.

P.O. Box 263 Wahroonga, 2076, N.S.W.

Phone: (02) 48-5388

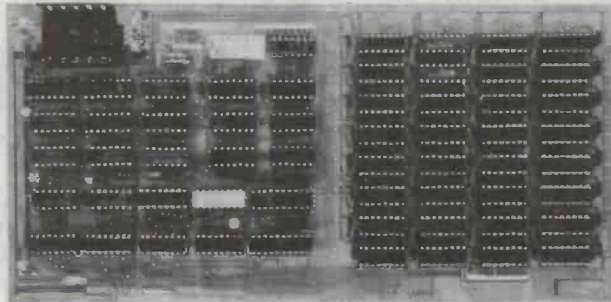

# THE SONIC BROOM RECORD CLEANER

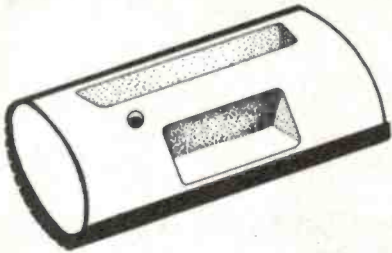

by AUDIO TECHNICA

It looks like any other record cleaner yet it cleans like no other record cleaner. Not only is it very easy to hold as you brush the surface of records (ever had one slip and scratch...?) the pad is ribbed to enable the fibres to get all the way down to the bottom of the grooves, lifting dirt and storing it between the ribs of the pad. After all, the object is to *remove* dirt and not simply move it around.



CONVENTIONAL PAD



SONIC BROOM  
CONTROLLED DENSITY PAD

Plus, the Sonic Broom kit includes a scientifically developed fluid to eliminate static — ensuring that dust and dirt particles are soundly removed. Buy the Sonic Broom. If you're really serious about sound reproduction and preserving your discs.

Rec. Retail \$17.90

**BUY A SONIC BROOM**

available at all quality  
hi-fi dealers

However, if you have a supply problem you can order by mail. Simply enclose your cheque or money order and details of requirements to PO Box 328, Artarmon NSW 2064. We will then arrange for the dealer nearest your address to forward your purchase at once by registered mail.

THE  
MAURICE CHAPMAN GROUP  
PTY LIMITED

44 Dickson Ave, Artarmon, NSW 2064.  
Phone (02) 438-3111 • 150 Burwood Rd,  
Hawthorn, Vic 3122. Phone (03) 818-1730  
• Perth (09) 446-5679 • Brisbane (07)  
261-1513 • Adelaide (08) 272-8011

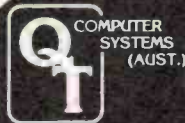

# UPGRADE SPECIALIST

283 CLARENCE ST  
SYDNEY NSW 2000  
TEL: 29-2402, 922-1709  
ASSOCIATED WITH QT USA

## SYSTEM + II (2MB +)

Computer System with 8" Dual Sided Drives (uses Y-E DATA YE-174 Disk Drives) No Terminal.

A&T (6 slot) .....\$3883.00  
A&T (8 slot) .....\$4083.00

## MINI-SYSTEM + (1/2MB +)

Computer System with 5 1/4" Single Sided Drives (uses TEAC FD-50A Disk Drives) No Terminal.

A&T (6 slot) .....\$3048.00  
A&T (8 slot) .....\$3073.00

QT Systems are designed for both businessmen and engineers in accordance with the latest IEEE standards. Among other functions, they can be used for accounting and word processing as well as a variety of scientific applications. The systems are available with MP/M or OASIS operating systems to allow multi-user, multi-tasking operations. QT also offers a full line of business and applications software, ranging from a business package to word processing.

Technical specifications: 4 MHz Z-80 CPU • Dbl-sided, dbl-den. 5 1/4" or 8" floppy disk controller (handles both drives simultaneously) • CP/M 2.2 included • 64K RAM, expandable per your requirements • Comes complete in single mainframe • RS232C serial port • Parallel port • Hard disk compatible • Monitor program & disk routines included on EPROM • Power-on/reset jump to monitor program • Documentation Included. • Extensive software available

## SOFTWARE +

Word processing • System utilities and diagnostics • Games • CP/M users group diskettes \$10.00 each, catalogue \$6.00 • Pascal, Fort, Tarbell Basic, Fortran, and most other compilers and utilities are available • Complete range of business software • Custom programming can be arranged on a fixed price or hourly basis.

## PERIPHERALS +

We have fantastic specials on printers, terminals and disc drives. Also card cages and mainframes. Call or write for details and pricing.  
Monitor Eprom (2716) .....\$30.00  
64K A&T .....\$450.00

## SBC + 1/4 SINGLE BOARD COMPUTER

1K RAM (which can be located at any 1K boundary) plus one each serial and parallel I/O ports • Power on jump to on board EPROM (2708 or 2716) addressable on any 1K or 2K boundary • Full 64K use of RAM in shadow mode • Programmable Baud rate selection 110-9600 • 2 or 4 MHz SWTCH selectable • DMA capability allows MWRT signal generation on CPU board or elsewhere in system under DMA or front panel control • Two programmable timers available for use by programs.

Bare board .....\$66.00  
A&T .....\$269.00  
Monitor Eprom (2716) .....\$30.00

## RAM + 16

16KX8 bit static RAM • 2 or 4 MHz • Uses 2114 static RAM chip • 4K step addressable • 1K increment memory protection • Deactivates up to six 1K segments to create "holes" for other devices • DIP switch selectable wait states • PHANTOM line DIP switch • Eight bank select lines.

Bare Board .....\$41.00  
4MHz A&T .....\$199.00

## CLOCK/CALENDAR + FOR APPLE II S-100 OR TRS-80

Date/Month/Year • Day of week • 24 hours time or 12 hours (a.m./p.m) selectable • Leap year • 4 interval interrupt timers • On board battery backup • Simple time and date setting • Simple software interface • Time advance protection while setting.

S-100 or APPLE TRS-80  
Bare Board ..\$66.00 A&T only .....\$167.00  
A&T .....\$162.00

## EXPANDABLE + REV II DYNAMIC MEMORY BOARD

Runs at 4 MHz • 3242 refresh controller with delay line • Four layer PC board insures quiet operation • Supports 4x16K blocks of memory • 24 IEEE specified address lines • Optional M1 wait state allows error free operation with faster processors • Optional PHANTOM disable • Uses Z80 or on board refresh signal • Bank on/off signal selected by I/O port 40 (HEX) • DIP switch selection of data bus bits determines bank in use • LED indication of bank in use • 3 watts low power consumption.

Bare board .....\$81.00  
16K A&T .....\$350.00  
64K A&T .....\$450.00

## SILENCE + MOTHER BOARD

These mother boards are among the quietest on the market • A unique grounding matrix — with each line completely surrounded by ground shielding — eliminates need for termination and give high crosstalk rejection • They are customer proven, without crosstalk sometimes operating at 14 MHz.

6 SLOT 8 SLOT  
Bare Board ...\$31.00 Bare Board ...\$33.00  
A&T .....\$61.00 A&T .....\$84.00

12 SLOT 18 SLOT  
Bare Board ...\$39.00 Bare Board ...\$61.00  
A&T .....\$108.00 A&T .....\$168.00

S-100 Sockets — Gold Plated .....\$5.00

## DISK CONTROLLER

CCS2422A features ROM bootstrap loader and monitor • CP/M 2.2 with documentation included • Accepts 5 1/4" and 8" disk drives • Double sided/single sided select • Read/write IBM 3740 or system 34 single or double density • Fast seek available for voice coil operation • Automatic disk density determination • ROM bootstrap phantom.

CCS2422A A&T .....\$399.95  
CP/M 2.2 with documentation included

PRICES DO NOT INCLUDE SALES TAX OR DELIVERY, AND ARE SUBJECT TO CHANGE WITHOUT NOTICE.



# Print-out

## ERRATA

A few errors have crept into Phil Cohen's 'Back Door Into BASIC' series.

In ETI, February '81, p.95, Figure 3: Table entries have variable subscripts in reverse — e.g. E(2,1) should be E(1,2).

In ETI, March '81, p.113: In the centre column, the 16th line from the bottom should read "result of 'A\*A = 3\*3 and AY0' will be "

In ETI, March '81, page 109: Line 190 should be 'R = V3'.

Please amend your issues now.

Thanks to H.D. Smith of Lower Templestowe in Victoria for bringing the errors to our attention.

## Fujitsu bubbles

IRH Components Division has released two new bubble memory systems in cassette form from Fujitsu. System 1 has a capacity of 8K bytes (65 536 bits effective) and System 2 a capacity of 32K bytes (1033 bits in 265 loops).

Fujitsu are also producing a cassette holder and control card to suit each system.

The main advantages of the cassettes are said to be their portability and the fact that the memory is non-volatile. The magnetic memory holds data even if the power is removed. Preventive maintenance is eliminated since there are no moving parts in the cassettes. Typical access times for loop

systems is as low as 6 ms, with easy reading and writing.

The Fujitsu bubble memory cassette can be used on systems currently using paper tape and cards or MT cassettes, program loading for test equipment and numerical control systems.

Further information is available from IRH Pty Ltd, Component Division, 53 Garema Circuit, Kingsgrove NSW 2208. (02)750-6444.

## New single-board all-Oz micro

The Datamax 8000, a powerful low-cost single-board desk-top microcomputer, has been designed and developed at Datamax Pty Ltd in Manly, NSW, by Chinese-born Australian electronics engineer Chin K. Kwong.

It is the first in a line of Datamax computers designed and built in Australia for Australian conditions, and because of its single-board construction can be mass produced, lowering assembly costs. The Datamax 8000 retails for around \$6000.

On the single 400 x 250 mm board are fitted a CPU with 256K of RAM, six peripheral ports, double density floppy disk controller, Winchester hard disk adaptor, calendar clock and floating point arithmetic processor. Further expansion is possible through the

built-in IEEE 488 GPIB and the S100 buss adaptor.

System software comprises CP/M and a full range of supporting high-level languages.

Because everything is on a single board rather than the twelve which have previously been required, maintenance back-up is also simplified and downtime minimised; the board is simply replaced and the original taken to the factory for diagnostic tests.

For further information contact Chin Kwong, Datamax Pty Ltd, 34-40 Central Ave, Manly NSW 2095. (02)977-6522, 977-6955.

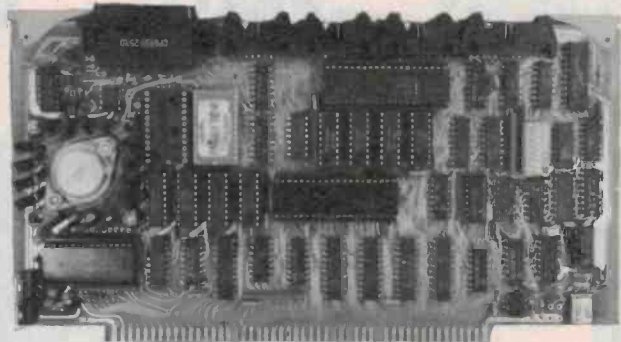

## ETI-685 2650 SINGLE BOARD COMPUTER FOR S100 BUSS

\*\*\* COMING SOON \*\*\*

RIGHT NOW we are preparing the drawings and construction details for a new CPU card that fits in with our series of S100 computer projects. Designed by Ron Koehn, this board features:

- 2650A (1 MHz) or 2650A-1 (2 MHz) microprocessor
- 4K of on-board RAM (switchable to any 4K boundary)
- 4K of on-board EPROM featuring:-
  - 1K, 2K or 4K of EPROM commencing at 0000.
  - multirail or single rail 2708s or 2716s.
  - selected on-board EPROM has priority over RAM.
  - ROM can be software enabled or disabled.
- Serial port supported as EIA RS-232C and current loop.
- A latched 8-bit parallel-in 'keyboard' port.
- One PPI on-board provides three programmable ports allowing combinations of static or strobed I/O, strobed bi-directional or serial I/O and 16-bit timer operations.
- One PIC on-board provides eight levels of programmable vectored interrupts.
- Full S100 processor and status signal generation (IEEE-696).
- Fully buffered status, address and data lines.
- Direct memory address (DMA) capability using pHOLD and pHLDA.
- Can address up to 512K of memory using a full 16-bit S100 address buss and the on-board bank select logic.
- A variety of monitor ROMs available ('BINBUG', 'PIPBUG', 'MULTIBUG', etc).
- Compatible with past ETI S100 projects (e.g. ETI-640 VDU, ETI-681 PCG and ETI-682 PROM Board).

This project could be the start of something big! We don't need to extol the virtues of having S100 buss computing gear. Apart from our previous projects that you can use in conjunction with this CPU, further support projects and articles are already under way. This project is *not* a review of someone else's design. It will be presented as a fully-fledged ETI project, complete with technical support from the author and magazine staff. Whether you're a hobbyist, professional or an OEM, don't do anything rash with your money until you've seen this project, scheduled to be published in the December issue.

## Memorex expands 2078 range

Memorex has added three new models — the 2078 models 3, 4 and 5 — to its 2078 display station range, and has released a new controller and printer.

All the models are interchangeable with the corresponding models of the IBM 3278 display station.

The Memorex 2076 remote cluster controller, also available for the first time in Australia, is the functional BSC equivalent of the IBM 3276 and certain 3274 models. The 2076 will attach up to eight category A devices, e.g. display stations, printers or a combination of both.

The 2087 matrix printer is

functionally interchangeable with the IBM 3287 printer family. The microprocessor-controlled print mechanism produces a highly legible dot matrix character printout up to 132 characters per line at ten characters per inch, and the unit has a bidirectional printing head.

For further information contact Mr Peter Thompson, Business Planning Manager, Memorex Pty Ltd, 61 Barry St, Neutral Bay NSW 2089. (02)908-2211.

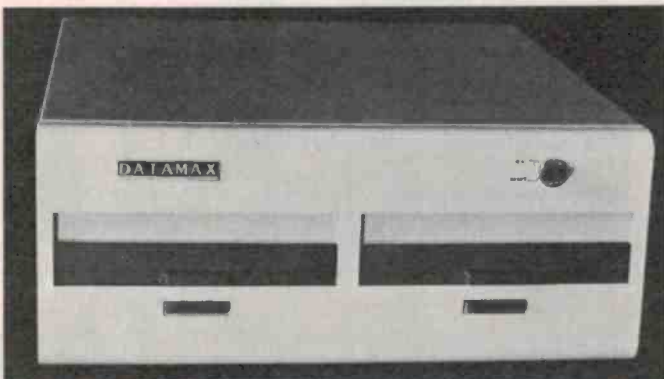

*The affordable computer!*

*the brilliant*  
**DICK SMITH  
 SYSTEM 80**



**OVER 3000  
 SOLD**

**ONLY  
 \$750\***

Note: price includes increased Government Sales Tax

**Outstanding value for money . . .  
 plus programs especially written  
 for Australia!**

Cat. X-4005

**Australia's fastest selling  
 computer — and small wonder!**

**Compare the System 80 with its  
 competitors: you'll see why!**

**And now it's even better: with new  
 features to make your computing  
 even better.**

**Join the thousands of system 80  
 users now: turn yourself into a  
 computer expert!**

\*Monitor and Expansion Unit not included.

**REMEMBER: OUR COMPUTER COMES WITH AN INBUILT CASSETTE, DON'T PAY EXTRA!**

**Compare the  
 features —  
 the System 80  
 comes out  
 in front!**

PARAMETER	SYSTEM-80	TRS-80 (Level II)
1 CPU type	Z-80	Z-80
2 Speed	1.7MHz	1.7MHz
3 S-100 compatible (with expansion unit)	Yes	No
4 Amount of RAM (basic computer)	16K	16K
5 Built-in cassette recorder	Yes	No
6 Built-in video RF modulator (use with any TV)	Yes	No
7 Capacity of BASIC ROM	12K	12K
8 Cassette recorder ports (basic machine)	2	1
9 Motor control for cassette recorders	Yes (2)	Yes (1)

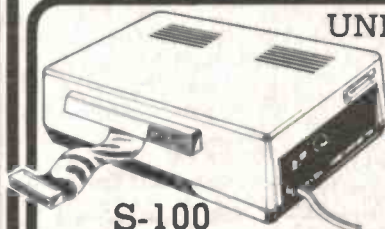

**S-100  
 EXPANSION**

**ONLY \$509**

**UNLEASH THE FULL  
 POTENTIAL  
 OF YOUR  
 COMPUTER . . .**

To get the most from your computer, you need to add peripherals. This expansion unit gives you this capability. Made to world standard S-100 system, so you aren't tied to any one supplier for your add-ons.  
 Cat. X-4010

**LOOK AT DICK'S  
 PRICE FOR A GREEN  
 PHOSPHOR MONITOR!**

For the professional user — or even the hobbyist who uses his system for long periods, a Green Screen Monitor is a must. Superb definition, with bright, sharp print that can be looked at for hours longer with less fatigue.  
 Cat. X-1198



**STILL AT  
 PRE-BUDGET  
 PRICE!**

**\$199**

**NOW WITH IN-BUILT AMPLIFIER FOR  
 PROGRAMS WITH SOUND EFFECTS!**

# & we've got the software!

Learning's easy with these great educational programs

## Typing Tutor

Cat. X-3682



This program teaches you to touch type. Claimed to teach typing skills faster than any other method. Widely acclaimed by business colleges. It monitors your typing skill continuously and adjusts your progress to suit. Requires 16K.

**\$19<sup>95</sup>**



## LEARN MUSIC

Written by an experienced music teacher, this program helps the beginner learn to read music and finds notes on the piano keyboard — quickly and easily. Requires 16K.

ONLY

**\$34<sup>95</sup>**

Cat. X-3640

## SPEED READING COURSE

Two cassettes, with 4 programs to help readers of all ages improve their reading skills. Can be set for reading skills as high as 0.1 seconds per line. Requires 16K.

**\$19<sup>95</sup>**

Cat. X-3692

Children, have fun and learn too, with Learning Fun

## Scurve Invaders

A unique program that combines maths drill with the ever popular 'Space Invaders' game. Tremendous fun yet very effective in developing proficiency in maths. Three levels of difficulty, sound effects. Requires 16K. Cat. X-3694



**\$9<sup>95</sup>**

## HANGMAN/CONCENTRATION

Help to increase your familiarity with words. Hangman and Concentration, both are computerised versions of the well known games. What a fun way to learn! Requires 16K.

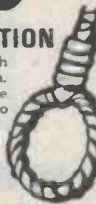

**\$9<sup>95</sup>**

Cat. X-3696

## ALPHABET COUNTDOWN/ RHYME TIME

Alphabet Countdown — place a large group of words in alphabetical order in the shortest time. Rhyme Time — a series of unfinished rhymes, you fill in the missing word from the clues supplied. Both require 16K. Cat. X-3698

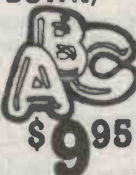

**\$9<sup>95</sup>**

## Poker Pete

ONLY

**\$15<sup>95</sup>**

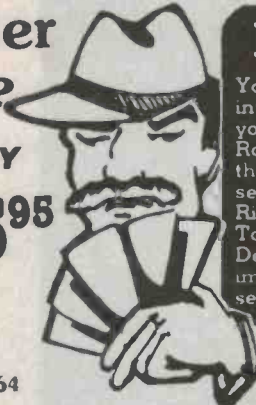

Cat. X-3664

Like to play a game of poker with Pete? He's a pretty shrewd player — hard to beat. Maybe you can be the one to beat him! This program has some quite intriguing graphics. Requires 16K.

## SIMUTEX PACKAGE ONE

**\$17<sup>95</sup>**

Cat. X-3685

Not one, but five space fantasy games! Avoid the Klingon torpedoes, stop the Worg invasion of Earth, plant your bomb on the Death Star and much more! Complete with instruction booklet. Requires 16K.



## SUPER MAZE

The maze game to end all maze games! Generates mazes up to 100 x 100 elements — it could take you hours to find your way out. Requires 16K.

Cat. X-3672

**\$17<sup>95</sup>**

## RESCUE AT RIGEL

You're Sudden Smith, the intrepid space adventurer, and your beautiful friend Delilah Rookh has been captured by the evil High Tollah inside a secret base on the moonlet Rigel. Can you overcome the Tollah and escape with Delilah? One of the most impressive programs we've seen! Requires 16K.

**\$22<sup>50</sup>**

Cat. X-3649



## FLIGHT SIMULATOR

A surprisingly good simulation of flying a small plane — has excellent real time graphics. Learn basic flight control, including take-offs and landings, then play the exciting British Ace 3D battle game. Requires 16K.

Cat. X-3684



**\$34<sup>90</sup>**

GREAT VALUE!

## SPACE INVADERS

The ever-popular arcade game that has become a cult. Can you shoot down the aliens before they destroy you and the Earth? Fast moving, good graphics (written in machine language). Requires 16K.

Cat. X-3699

**\$9<sup>95</sup>**

ONLY

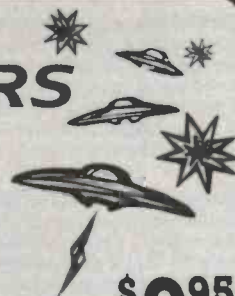

## INTERLUDE

A game for adults only. How's your love life — getting a little dull? When the kids have gone to bed, run this program on your broadminded System 80 and it will come up with some imaginative ideas for the rest of the evening.

ONLY

**\$22<sup>50</sup>**

Cat. X-3675



For sale to those 18 years of age and over.

## DICK SMITH Electronics



Prices correct and stock available at press time.

NSW 145 Parramatta Rd AUBURN 648 0558 • 613 Princes Hwy BLAKEHURST 546 7744 • 818 George St BROADWAY 211 3777 • 531 Pittwater Rd BROOKVALE 93 0441 • 147 Hume Hwy CHULLORA 642 8922 • 162 Pacific Hwy GORE HILL 439 5311 • 396 Lane Cove Rd NORTH RYDE 888 3200 • 30 Gross St PARRAMATTA 683 1133 • 125 York St SYDNEY 290 3377 • 173 Maitland Rd TIGHES HILL 61 1896 • 263 Keira St WOLLONGONG 28 3800 ACT 96 Gladstone St FYSHWICK 80 4944 QLD 166 Logan Rd BURANDA 391 6233 • 842 Gympie Rd CHERMSIDE 59 6255 SA 60 Wright St ADELAIDE 212 1962 VIC 399 Lonsdale St MELBOURNE 67 9834 • 260 Sydney Rd COBURG 383 4455 • 656 Bridge Rd RICHMOND 428 1614 • Cnr Dandenong & Springvale Rds SPRINGVALE 547 0522 WA Cnr Wharf St & Albany Hwy CANNINGTON 451 8666 • 414 William St PERTH 328 6944  
Mail Order Centre: PO Box 321, North Ryde 2113. Phone: (02) 888 3200

DSE/A040/LM

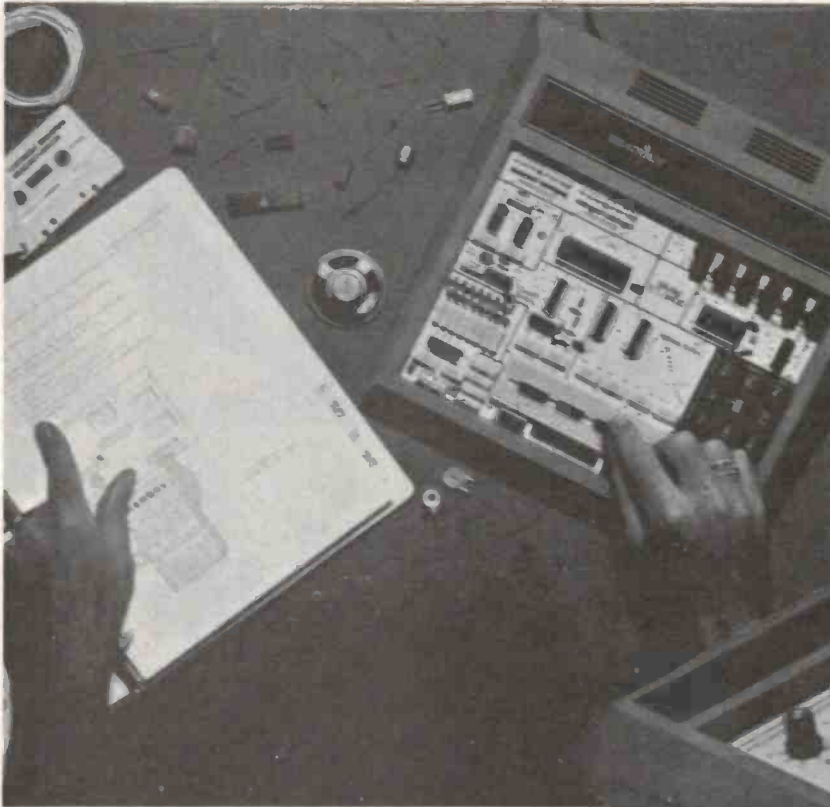

# everyone can learn electronics . . . the effective **Heathkit<sup>®</sup>** way!

There's never been a better, faster, lower cost way to learn electronics than these Heathkit Programs! Learning electronics could very well be the most important step you'll ever take, so, naturally, there are many factors to consider in choosing your method of learning. If you're like most people, you don't have the time for conventional learning institutions. The Heathkit Continuing Education Series was conceived to make learning electronics more convenient and affordable for everyone. Thousands of people just like you are finding out what makes Heathkit learning programs so tremendously successful. Simple, easy-to-use and EFFECTIVE!

Among the many reasons for the wide acceptance of these programs is their simplicity. Each learning program is simply and logically arranged for easy, step-by-step "programmed" learning. Progressing at your own established pace, you learn in an unhurried environment free from pressure. No facet of the material is omitted and nothing is assumed. Each program includes everything you need for a high degree of understanding. Audio records (or optional cassettes) reinforce the text material and an optional final examination lets you test your overall comprehension.

The Continuing Education Programs are economical too. The first four programs use the same trainer so you can get a complete education in fundamental electronics at substantial savings. The advanced programs, Digital Techniques and Microprocessors, require separate trainers, but they still cost less than competitive courses.

Get "Hands-on" experience for a better understanding of electronics. Learning electronics and being able to apply what you've learned are, of course, the goals you seek to achieve with

the Heathkit Continuing Education Series. For that reason, we have spared no effort in assuring your complete comprehension. Our optional Electronic Trainers, designed for use with each program, perfectly illustrate the Heath approach to learning. These trainers give you actual "hands-on" experience with electronic components and circuitry. It's an acknowledged fact that you learn best by doing and the trainers let you do exactly that. You get a better grasp of circuit concepts and perform the program projects quicker and easier as well. Solderless connectors on the trainer panel make hookup of the components supplied with the program quick and neat. Built-in power supplies and signal sources provide convenient operation. The trainers are available in both kit and assembled form.

When you've finished the program, the trainer still serves as the ideal device for breadboarding circuits of your own design. We highly recommend these trainers as supplements to the Heathkit Individual Learning Programs. A record (or cassette) player is needed to play the audio portion of the material. A VOM for measuring voltages is also needed, and an oscilloscope is required for some of the experiments in the Electronic Circuits and Digital Techniques Programs.

to find  
out more  
send for your  
**FREE CATALOG**  
today!

#### Recommended Order

The Heathkit Self-Instruction Programs are Designed to let you Progress from DC Electronics to AC Electronics to Semiconductor Devices to Electronic Circuits. These are the Four Basic Programs. For Optional Advanced Study, The Digital Techniques Program Provides the Background for the Microprocessor Program.

There are many courses in the HEATHKIT Continuing Education Program designed to effectively expand your electronic horizons including:—

EE 3101	DC Electronics	\$89.00
EE 3102	AC Electronics	\$92.00
EE 3103	Semiconductors	\$92.00
EE 3104	Electronic Circuits	\$109.00
EE 3201	Digital Techniques	\$127.00
EE 3401	Microprocessor Program	\$168.00
ET 3100	Experimenter/Trainer	\$150.00
ET 3200	Electronic Trainer	\$166.00
ET 3400	Computer Trainer	\$412.00



### ORDER BY COUPON NOW OR COME TO OUR SHOWROOM

Please rush me the Heathkit of my choice. My cheque for \$..... is enclosed plus \$7.00 for package and post.

Name .....

Address ..... P/Code .....

Send to: W. F. Heathkit Centre

220 Park St., South Melb. 3205. Phone 699 4999.

- EE 3101
- EE 3102
- EE 3103
- EE 3104
- EE 3201
- EE 3401
- ET 3100
- ET 3200
- ET 3400

- Please rush me my Free catalog containing full details on the complete range of Heathkit Learning Programs.



Credit Card No:

--	--	--	--	--	--	--	--	--	--	--	--	--	--	--	--	--	--	--	--

Bankcard

Expiry Date

Signature

# Printout

## Expanding Applesoft

A new software aid specifically tailored for the Apple range of microcomputers has been released by Cybernetics Research. Graphpack 1.0 allows the user to enhance the current Apple BASIC (Applesoft) by the addition of 30 useful commands, providing the user with greater flexibility when creating programs written in Applesoft.

Two major areas of 'Graphpack' enable the user to intermix graphics and text within the high-resolution screen mode and define 'windows' within the screen area with simple, foolproof commands. Another area of major enhancement gives the user the facility of the 'Print Using' statement that was originally designed and implemented for ANSI standard COBOL.

Included in the package is a music command, which will allow the user to call for the pitch, duration and timbre of a required note within the one command.

Utility programs are supplied with the package, allowing the user to re-define the character set to his requirements under software control, define his screen forms/shapes and save to either disk or tape. A reasonably sophisticated function plotter enables the user to build and expand his own plotting routines.

Supplied complete with a 32-page manual giving step by step instructions, this software package costs \$95.00 and is available from Cybernetics Research, 120 Lawson Street, Redfern NSW 2066, (02)698-8286, and most Apple dealers.

## New 5¼" micro-Winchester to revolutionise disk storage

Inca Data Systems now have available Irwin International's 5¼" Winchester disk drive system with integrated cartridge tape back-up, which Inca claim will eventually replace floppy disks in most commercial applications.

President and Chairman of Irwin International, Sam Irwin, maintains that the new disk drive provides greater storage capacity, reliable back-up, faster access time and a low price.

The memory capacity of the new Irwin 510 Micro-Winchester unit is 12.3M unformatted, 10.02M formatted, which is equal to or greater than many 8" Winchester and almost 30 times the capacity of the industry-standard mini-floppy.

The system offers fully integrated cartridge tape back-up, as opposed to separate mini-floppy back-up. All 10M of formatted data can be

dumped or restored in less than four minutes on the back-up tape cartridge, said to be a fraction of the time it would take to write that much information onto a series of diskettes.

The average access time of the Irwin 510 is said to be 25 ms, twice as fast as most 8" Winchester.

Inca Data Systems have appointed Datatel Pty Ltd of Raglan St, South Melbourne, as their major distributor in the southern region for the Irwin product range. For further information contact Dieter Retz at Datatel on (03)699-7614, or John Barsing at Inca on (02)411-7844.



## Range of Beehives

Datatel released the new range of Beehive International DM5 smart terminals at Data '81 in Sydney.

The DM5 features a detached IBM-style intelligent keyboard with edit functions, block and character transmission, memory lock (split screen), non-glare green CRT, line-drawing capability and a programmable status line. It is priced below \$1000 for quantity purchases.

The DM5A has extra features, including a 12-key numeric pad, 16

program function keys, an auxiliary printer port and 10 mA current loop. There are plans to extend the range further.

For more information contact Datatel Pty Ltd, 3 Raglan St, South Melbourne Vic. 3205, (03)690-4000, or 80 Chandos St, St Leonards NSW 2065, (02)439-4211.

## Ten new peripheral circuits from TI

Ten new peripheral linear integrated circuits have been introduced by Texas Instruments Incorporated, including quadruple high-current drivers and quadruple high-voltage, high-current Darlingtons and transistors.

The UDN2841 and UDN2845 are quadruple high-current drivers designed for dc motor drivers, discharge printers, relay drivers, and other applications.

The ULN2064, ULN2066, ULN2065, ULN2067, ULN2068, ULN2069, ULN2074 and ULN2075 are quadruple high-voltage, high current (1.5 amperes maximum)

Darlington transistor switches designed for applications in relay drivers, hammer drivers, lamp drivers, display drivers, line drivers, and logic buffers.

All devices are available through Texas Instruments Field Sales Offices or from TI authorised distributors throughout Australia and Asia.

## George Brown Group to distribute Zilog

Zilog Incorporated, a member of the US giant Exxon group, has franchised the George Brown Electronics Group as their Australian distributor.

Zilog manufactures microcomputers in every form, from components and development systems to board level products and complete general purpose micro-computer systems.

Zilog components include the 8-bit Z80 microprocessor family, the Z8 family of 'single chip' microcomputers and the 16-bit Z8000 microprocessor and its family of intelligent peripherals. A vast range

of development systems and emulators is available.

The G.B. group will concentrate their efforts on components, board level products and development systems, with stocks being held in each of their companies across Australia: Browntronics — Melbourne; George Brown & Co — Sydney; George Brown & Co — Canberra; Protronics P/L — Adelaide; Protronics P/L — Perth.



# you may have guessed it

Over  
**6 Megabyte on a**  
**IMS 5000**

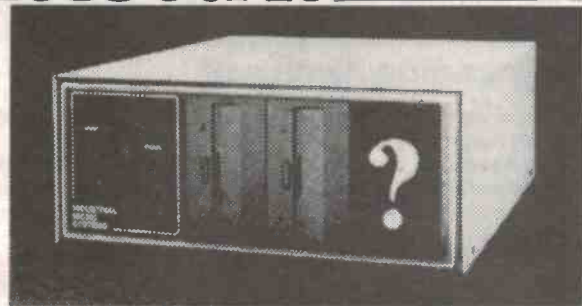

**But it's the speed & reliability that counts**

The IMS5000 with hard disk was benchmarked against all the other hard disk systems at the NCC Chicago USA '81 exhibition. On average 5.25 inch hard disk operates 15% faster than 8 inch Winchester and up to 5 times faster than other 5 inch Winchester, and it will not cost a fortune.

The demonstration system at the NCC was dropped and punctured in transit by a forklift, and it still came up first time without an error! This is the sort of rugged reliability users have come to expect from IMS International Computers.

Isn't this what you NEED? — A machine so reliable, its manufacturers warrant it for TWO years. — A machine so versatile, it operates under CP/M, MP/M, MVT-EFAMOS, USCD-PASCAL, MARC, MICROCOBOL;

— Yet a machine which is inexpensive and powerful. What system are you looking at purchasing? IMS I hope is at least on your short list. If not, Contact S.I. Micro and discuss your requirements with them. (The face is becoming familiar).

**SERIES  
8000  
SERIES  
5000**

**IMS**  
INTERNATIONAL  
COMPUTERS

**S. I. MICROCOMPUTER PRODUCTS PTY LTD**  
GPO BOX 72 SYDNEY 2001 92 PITT ST SYDNEY (02) 2314091 232 6804  
Melbourne (03) 26-5522. Brisbane (07) 52-8455. Perth (09) 368-1800

**INTRODUCING**

## S100 MULTIUSER SYSTEMS

Microtrix continues to present state-of-the-art microcomputer products. Our extremely popular single-user system can now be easily expanded to cater for two, or up to five, users.

This has been made possible by a new intelligent multiuser input/output board. Known as the MPC-4, it provides four serial I/O channels with individual baud rate selection, and an input and output buffer for each port. Data transfers are efficiently handled by interrupt driven techniques.

An on-board Z-80 Microprocessor controls the functions of the MPC-4, freeing the main CPU to complete other tasks. This creates a more efficient and higher performance system.

But that's not all! The hardware is backed up by a sophisticated multiuser operating system: COSMOS. CP/M compatibility is maintained, but file protection is greatly enhanced. Both global and local files are supported. An editor, Z-80 assembler, linker, loader, CBASIC 2, and a full set of utility programs are provided. These, together with a time-of-day clock, make the system appear like more expensive minicomputers. And COSMOS will also support a hard disc when required.

The MPC-4 and COSMOS are available separately, or complete systems can be configured to suit your requirements.

So, for the latest in microcomputer technology, contact us now.

**DEALERS REQUIRED AUSTRALIA-WIDE**

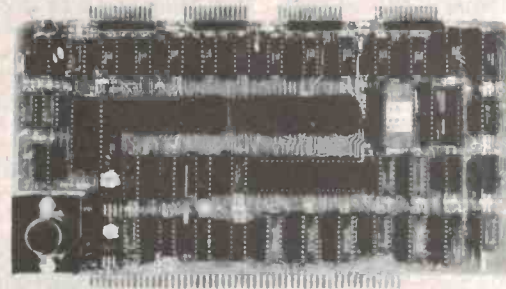

### SYSTEM PRODUCTS

SBC 200 Single Board Computer .....	\$400 kit	\$470 A/T
Versafloppy 2 Double density controller.....	\$375 kit	\$435 A/T
Expandoram 2 Dynamic RAM 16K ...	\$330 kit	\$400 A/T
Expandoram 2 Dynamic RAM 64K ...	\$435 kit	\$505 A/T
VDB8024 Video card with Z-80.....	\$460 kit	\$530 A/T
PROM 100 PROM programmer .....	\$250 kit	\$295 A/T

**microtrix**



**MICROTRIX**

**PO Box 158, Hurstbridge, Victoria 3099  
Phone (03) 718-2581**

A complete catalogue of all our products is available for the asking. Please add 15 percent sales tax to the above figures if applicable. Postage on any single board is \$3.





# archive

## COMPUTER SERVICES

P.O. Box 13, 23 Wagner Road, Clayfield 4011, Queensland, Australia Ph(07)262 2911

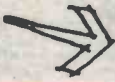

'LIVERMORE' **STAR**<sup>TM</sup>  
ACOUSTIC COUPLER  
**\$250**

NEVADA COBOL  
NEW VERSION  
ENHANCED FEATURES  
**\$150.00**

4 APPLICATIONS  
IN BOOK FORM \$30  
ON DISK \$100

PEARL 1 \$130  
PEARL 2 \$325  
PEARL 3 \$600

SSM VB3 VIDEO BOARD  
**\$499**

SSM SB1 MUSIC SYNTHESIZER  
**\$350**

WORDSTAR \$445

MAILMERGE \$135

SPELLSTAR \$225

ALL (3) \$775

MILESTONE \$275

DATEBOOK \$275

S BASIC \$225

PASCAL MT+ \$450

PASCAL M \$225

Check our  
Catalogue  
for a large  
range of CCS  
S100 boards

**"NEW" SUPERCALC**  
SORCIMS

**\$275.00**

All of Visicalc<sup>TM</sup> and more for CP/M.\*

ALL CP/M\* SOFTWARE AVAILABLE

MOST ITEMS IN STOCK



Trademark Apple Computers

MICROSOFT SOFTCARD \$325  
VIDEX 80x24 VIDEO \$CALL  
WORDSTAR \$350  
MAILMERGE \$120  
BOTH \$460  
SUPERSORT \$200

### CP/M DATA BASES

D Base II..... \$650  
FMS 80..... \$800  
Selector IV..... \$500  
G Lector IV..... \$400  
(Both)..... \$850  
FABS..... \$175  
BT-80..... \$200

SEND FOR OUR **LARGE** CATALOGUE

SEND \$1.00 FOR POSTAGE

Dealer inquiries invited \*cp/m a trademark of Digital Research

All prices are FOB and subject to change without notice. Prices do not include Sales Tax.

# THE MOST POWERFUL MICROCOMPUTER



**SORCERER NOW HAS 32K RAM AT NO EXTRA COST!**

Yes! With every 16K Sorcerer computer, we now include at no extra charge, an additional 16K of RAM! Here's your chance to buy the superb Sorcerer, and save money at the same time.

## Plus these other winning features:

- Built-in serial and parallel ports — standard!
- 2 cassette control ports — both with motor control!
- Unbelievable graphics capabilities.
- Expandable to 48K on board.
- Uniquely versatile ROMPACS™ — instant change to dedicated processor, and back again!
- Built-in 4K ROM resident monitor.
- Economic disk storage now available (optional) with Exidy's new FDS — floppy disk subsystem (does not need expansion interface).

**All this for only \$1395**

including 32K memory and standard BASIC ROMPAC™  
Cat. X-3002

## ROMPACS™

Give the Sorcerer its incredible versatility

One moment it's a word processor. Then it's a production controller. Or a standard computer running a program. All you do is plug in the Rompac™. The Sorcerer does the rest!



### Word Processor Pac™

Not only more powerful than most other systems: it's far cheaper! It features auto text wrap-around, auto checking of drastic commands, a search function, auto commands & macro programming etc etc. (X-3085).

**\$279<sup>50</sup>**

### EPROM PAC™

Designed for users who want to use the Sorcerer for a dedicated job & can program their own EPROMs to do it. Up to 16K of ROM available. (X-3095).

**\$75<sup>00</sup>**

### Development Pac™

A powerful dedicated development tool: contains a debug, text editor, linking loader, assembler & I/O routines. Complete with 90p manual. (X-3090).

**\$139<sup>50</sup>**

### Standard BASIC

(Supplied with Sorcerer computer in basic price - not available as a separate item).

## UTILITY SOFTWARE ON CASSETTE

### Z-80 DISASSEMBLER \$17<sup>95</sup>

This program 'disassembles' Z-80 machine language programs i.e. it translates them back into easier to follow assembly language. It is a BASIC program, but may be used to examine any machine language program in the Sorcerer's memory. X-3622

### DEBUG \$17<sup>95</sup>

Designed to make it much easier to troubleshoot Sorcerer machine language programs. Lets you run programs one instruction at a time, examine contents of processor registers & insert breakpoints into the program wherever needed. X-3624.

### DUMB TERMINAL \$9<sup>95</sup>

Allows your Sorcerer to act as a 'dumb' communications terminal for X-3637. Communication with a larger computer or with other terminals via the RS-232C serial port. Allows both duplex & half duplex operation.

## DISK UTILITIES FOR FDS & MICROPOLIS

### EXIDY CP/M with EXBASIC \$445

Identical with Eandy CP/M EX. X-3710  
BASIC is an extended disk version of Microsoft™ BASIC 80. Complete with comprehensive documentation.

### DSKCITOH/P/PRINT \$99 (Hard Sector).

Disk driver & proportional printing driver for the Sorcerer Word Processor. Check these features: ability to save & load word processor files on disk, perform proportional spaced & bold faced printing.

### MICROSOFT EXT. \$350 DISK BASIC FOR X-3712

FDS. The most extensive version of BASIC available for Z-80 based computers. Features: full line editing, all normal disk facilities & commands, & much more!

## SORCERER GAMES SOFTWARE ON CASSETTE

### Tank Trap

An enemy tank is on the rampage. Your job is to build a wall around it - without getting run over. Fascinating! X-3628

**\$14<sup>95</sup>**

### Martian Invaders

Very similar to 'Space Invaders'. A very challenging game, requiring skill & a fast mind. X-3626

**\$17<sup>95</sup>**

### \* Voodoo Castle

An action packed adventure in the Voodoo castle. Hours of fun! But beware of the Voodoo Man. X-3636

**\$6<sup>25</sup>**

### \* Wildmessa

Here you trudge through the uncharted wilderness fighting foul monsters of many types. Great fun! X-3639

**\$12<sup>50</sup>**

### \* The Count

One of the most challenging games ever written! You awaken in a bed in Transylvania. You don't know why you're there but you'd better solve the puzzle before it's too late! X-3638

**\$12<sup>50</sup>**

### Magic Maze

Ten levels of play. You wander through a maze trying to stay on the right path and avoid pitfalls. Fantastic! X-3620

**\$14<sup>95</sup>**

## \* LIMITED STOCKS

# DICK SMITH Electronics

DSE 990RB NSW



Mall Order Centre: PO Box 321, North Ryde 2113, Phone (02) 888 3200

145 Parramatta Rd	AUBURN	648 0558	QLD 166 Logan Rd	BURANDA	391 6233
613 Princes Hwy	BLAKEHURST	546 7744	842 Gympie Rd	CHEMERSIDE	89 6255
818 George St	BROADWAY	21 3777	80 Wright St	ADELAIDE	212 1962
531 Pittwater Rd	BROOKVALE	93 0441	399 Lonsdale St	MELBOURNE	67 9834
147 Hume Hwy	CHULLORA	642 8922	260 Sydney Rd	COBURG	383 4455
162 Pacific Hwy	GORE HILL	439 5311	656 Bridge Rd	RICHMOND	428 1614
396 Lane Cove Rd	NORTH RYDE	888 3200	Cnr Dandenong & Springvale Rds	SPRINGVALE	547 0522
30 Grose St	PARRAMATTA	683 1133	Cnr Wharf St & Albany Hwy	CANNINGTON	451 8666
125 York St	SYDNEY	290 3377	414 William St	PERTH	328 6944
173 Marland Rd	TIGHESS HILL	61 1896			
263 Keira St	WOLLONGONG	28 3800			
ACT 96 Gladstone St	FYSHWICK	80 4944			



## A learners' microcomputer

With this installment we commence construction details of the microcomputer. To ensure success, it is built step by step and checked at each stage.

Design: **Hugh Anderson**  
Development: **Graeme Teesdale**

**Part 3**

BEFORE commencing construction, no doubt just about every constructor is going to ask "what will it cost?". The answer is, "that depends"! This project can be built up in a number of forms. You can elect to construct it with only the minimum amount of memory (RAM), 1K, and monochrome video output. This saves some component costs. If you have a suitable power transformer or plug pack, then you won't need to buy one, saving something there. A standard hex keypad can be used, rather than the one we have designed which uses individual pushbuttons, and this saves a few dollars too. Rather than a metal case with wooden ends, etc, the project can be mounted on a piece of chipboard, thus saving the cost of the case. You can also make your own pc board and save on that too. It all depends on how resourceful you are. If you shop around for the best prices in components, particularly the ICs, you can save a considerable amount. If you're game, or experienced, the IC sockets can be dispensed with, too (except for the ROM, IC11, but you'll see why later).

Let us suppose a 'minimum' version would consist of all the components required to produce monochrome video, a ready-made pc board, the ETI-760 Video RF Modulator kit and a suitable plug pack or low voltage transformer. With a little shopping around you can obtain it all for a total price that ranges from around \$98 to \$105. Without attempting to get best prices, it may cost up to \$130. Case hardware would cost extra. The case to be described is quite simple and can be built with a minimum of tools, but we'll get to that later.

The 'complete' project, which shall we say includes the colour expansion com-

ponents and full 3K of RAM, IC sockets and case, we calculate may cost from \$130 up to \$180. It is obvious that the variation in component prices can be enormous, and this accounts for the wide variation. For example, the extra four 2114 RAM ICs to provide a memory capacity of 3K on-board may cost as low as \$8 or as much as \$19.80. A set of IC sockets may cost as little as \$3 or as

much as \$9. We would expect kit suppliers to offer kits in differing versions so it's a little hard to predict what a kit may cost you.

### The board

The pc board has been designed so that a constructor with experience in producing his own at home can do so. It is a double-sided board and connections

---

### FEATURES

---

- Low cost
- Simple construction
- Widely available components
- Both colour and B&W video
- RF modulator permits connection to any TV set
- Powered from a plug pack (battery possible too!)
- 3K of on-board memory (expandable to 64K off-board)
- Cassette interface on-board
- Audio output (tones programmable)
- Hex keyboard for simple programming, games playing
- Audible tone indicates key being depressed
- Additional 8-bit input/output port
- CHIP-8 monitor program
- User socket for prototyping, additions, etc.
- Learn as you build
- Teach yourself programming (articles to follow)

---

### EXPANSION

---

- Standard ASCII keyboard
  - Additional RAM
  - Light pen
  - Sound effects
  - + more!
-

from the top side to the bottom side are made with feedthrough links. All the pads for the IC pins are on the bottom side of the board so that no IC pins have to be soldered both sides. You will notice that these pads are quite small as tracks pass between them on the board. Take care not to over-etch the board otherwise you may have tracks disappearing!

Our pc board design includes a keyboard which is made up using individual pushbuttons (Fujisoku, type FES 310 from IRH Components). If you elect to use a standard hex keypad then this section of the board is unnecessary. Dotted lines adjacent to the 8 Vac input and the location of R2 and R3 indicate where the board finishes if you dispense with our keyboard.

If you're making your own board, the next step after etching is a visual inspection for bridges between tracks and breaks in tracks. Having done that and fixed up any problems, the board can be drilled. This has to be done in stages. First, drill *all* holes with a No. 73 drill. The pads for the IC pins are quite small, to allow tracks to run between them, hence the small size drill bit. Drill the holes from the *bottom side* of the board. It is important to drill accurately.

When you think you have finished this part of the drilling, hold the board up to the light — and see which holes you've missed! Having completed this stage, another visual inspection is necessary. Carefully examine *both sides*

## ETI-660 PCB ARTWORK

**NOTE:** The pc board artwork is too large to reproduce in the magazine, unfortunately. However, home constructors intending to make their own boards may obtain prints by sending a large (at least 300 x 250 mm) stamped, self-addressed envelope to ETI-660 PCB, ETI Magazine, 15 Boundary St, Rushcutters Bay NSW 2011.

of the board and see that no tracks have been cut through by the drill. Mark any suspects with a chinagraph pencil or a dab of paint, for fixing later.

The next stage is to drill holes to take component leads and sundry other holes. To identify these holes we have provided an overlay drawing. Feedthrough connections between the top and bottom of the board are also shown on this diagram, but we'll get to them shortly. On this diagram, holes marked with a circle are to be drilled to take component leads. Use a No. 60 drill bit for these. Where the component pad is

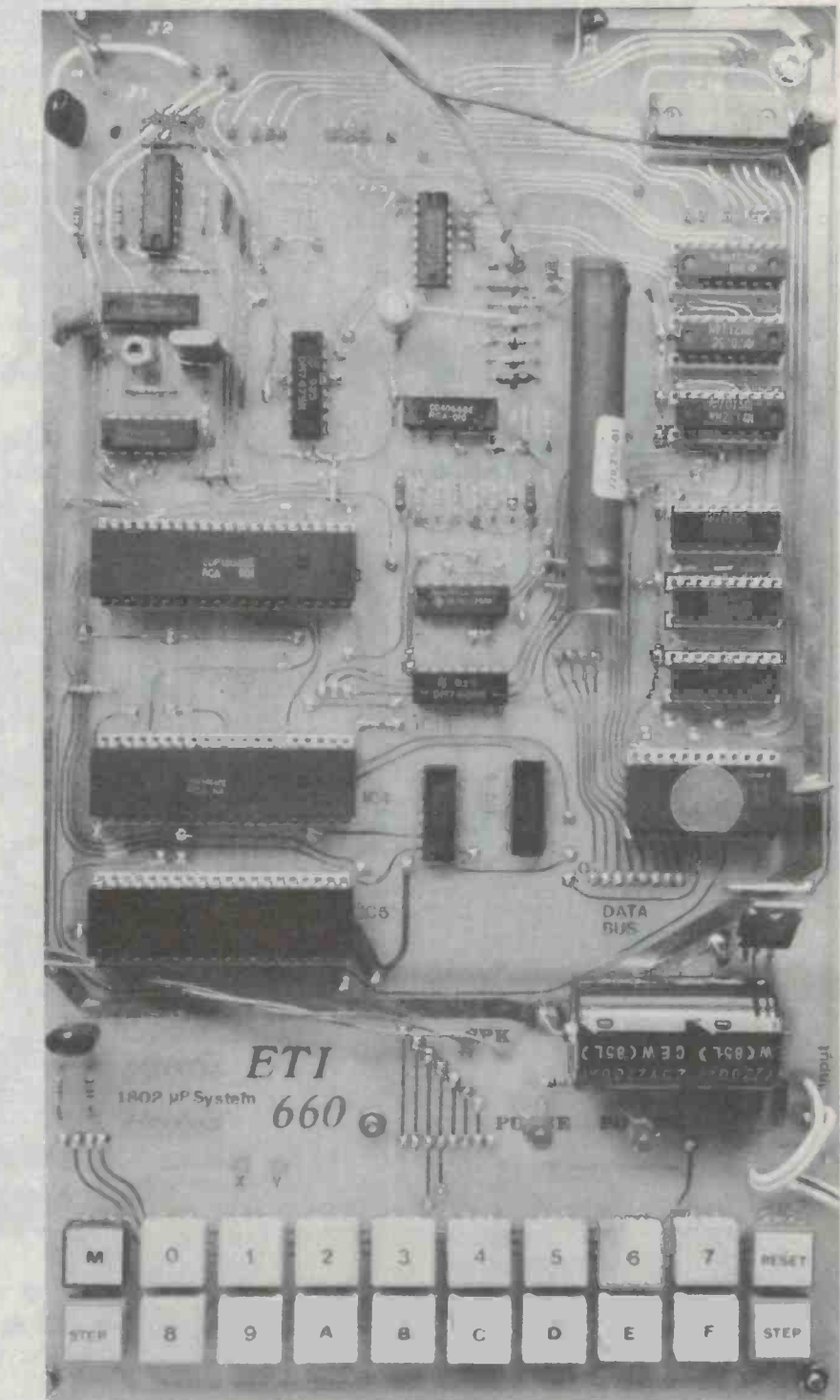

The fully assembled board, less IC22 and IC23, which are only necessary with later expansions. The long cylindrical object at upper right is the 400 ns colour delay line. The IC at middle right is the EPROM containing the CHIP-8 monitor program.

on the bottom side of the board, drill from the bottom side. Likewise, where it is on the top, drill from the top. Where there is a pad to a track on both sides you may drill from either side. The feedthrough link holes may be left as they

are, in which case 26 swg wire is used for the links (see later). If you are to use 22 swg wire for the links, drill the feedthrough holes with the No. 60 bit also.

Seven holes are marked with a

● FEEDTHROUGH LINK HOLES, DRILL EITHER NO. 60 OR NO. 73, 188 HOLES  
ALL OTHER HOLES DRILLED NO. 73

□ MOUNTING HOLE, DRILL 3 mm DIA., 7 HOLES  
△ DRILL 4 mm DIA., 2 HOLES  
○ COMPONENT LEAD HOLES, DRILL NO. 60, 153 HOLES

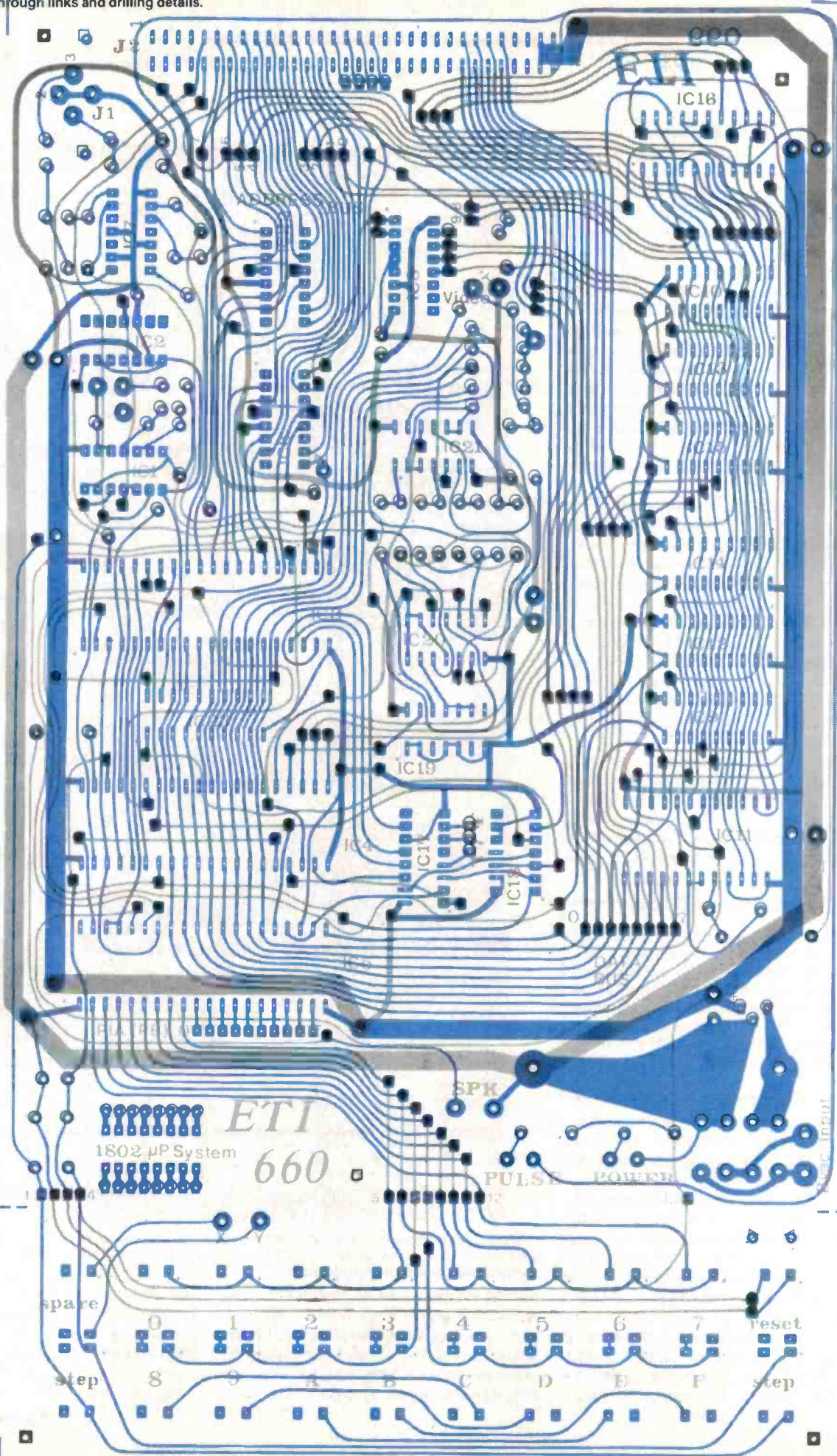

square. These are for mounting bolts and should be drilled to 6 BA clearance (say, 3 mm). Note that the cassette interface socket, J1, can be mounted on-board and two bolt holes are provided. Two holes adjacent to the 8 Vac input are marked with triangles. These should be drilled to 4 mm diameter and serve to secure the input lead from the plug pack.

Having completed the drilling, once again make a visual inspection to see that nothing has gone amiss and check that you have drilled all the necessary holes.

Even if you have purchased a ready-made pc board it is a good idea to make a thorough visual inspection of the board to ensure that there are no cut tracks and no bridges between tracks. It will save hassles later.

You will note that we have provided some annotation on the pc board. All the IC positions are identified. Pin 1 of each IC is marked with an adjacent 'spot' on the top side of the board. The data buss and address buss lines are identified in convenient positions. The cassette interface socket, J1, and the expansion socket, J2, are both identified (even though they may be mounted off-board). The video output connection is identified as is the +5 V rail at the output of the three-terminal regulator. The 'power' indicator (LED1) and the 'pulse' indicator (LED2) are both indicated as well as the speaker connections (SPK). At the keyboard end of the board you'll find a number of pads in a row marked '1 ... 4', '5 ... 12' and '13'. These are connections for an external hex keypad and 'step' and 'reset' pushbuttons. All the keys for our on-board hex keyboard are identified. Connections to the 'spare' key are designated 'X' and 'Y'. Adjacent to IC6 is a terminal marked 'Z'. This is an output signal from the 1802 micro-processor and you don't have to worry about that for some time to come. Between IC17 and IC18 are three terminals marked '1', '7' and '4'. These are decoded outputs from the 1802 and again, you don't have to worry about them. The 8-bit 'user port' (I/O port from the PIA, IC5) is identified, adjacent to IC5.

Have a good look at the pc board and familiarise yourself with all the annotations so you can 'find your way around' as you construct the project.

## Feedthrough links

The next stage of construction is to install all the feedthrough links. The board was designed this way so that the IC pins only need to be soldered on the bottom side of the board (non-

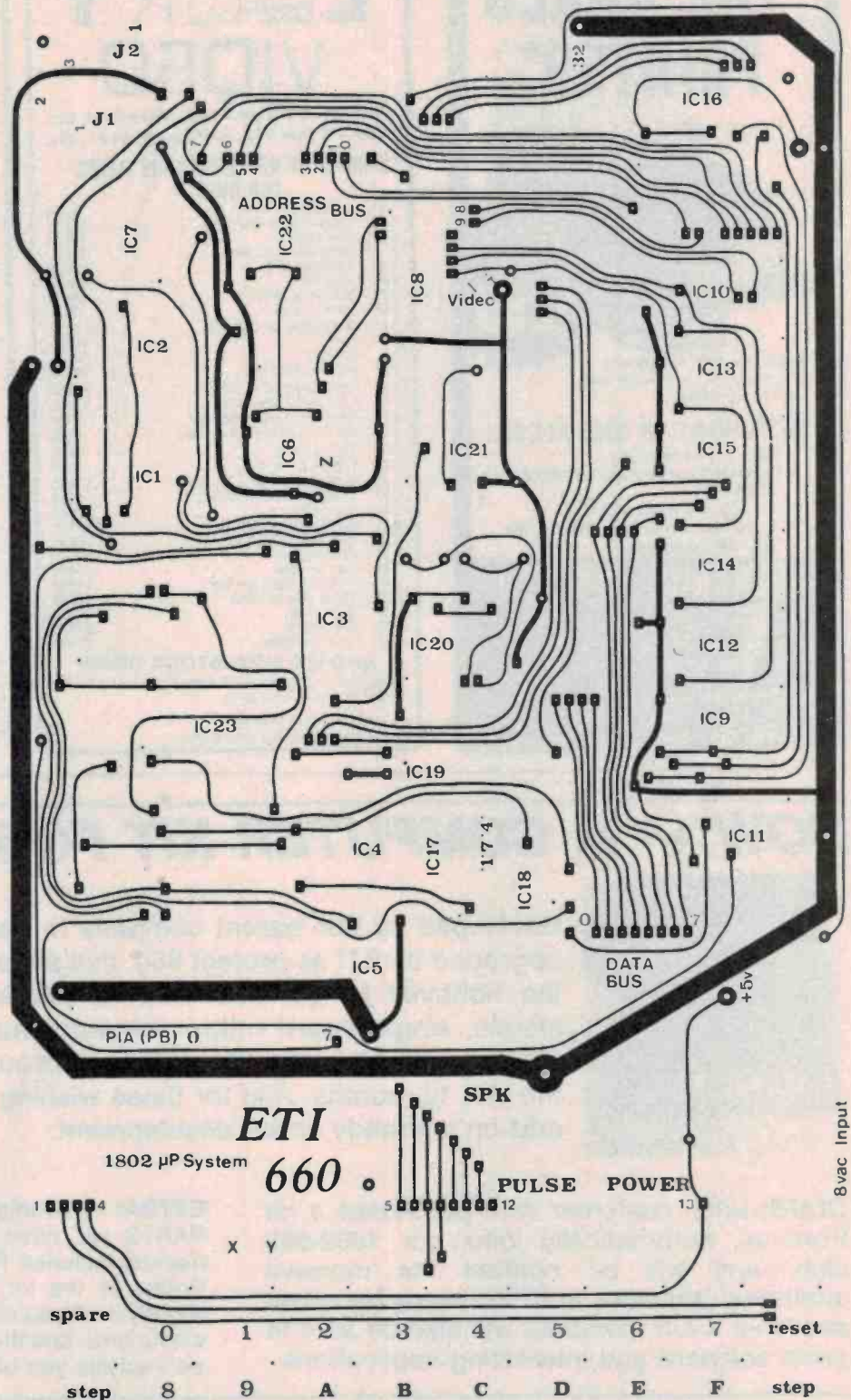

Reproduction of the topside of the pc board (not to scale) showing the annotation included to aid assembly and major component identification.

component side). This makes the ICs easy to remove later if you get one in the wrong way round or if a fault necessitates later removal. We recommend you fit sockets for about half the ICs in any

case, but we'll get to that shortly.

Obtain two strips of wood or plastic about three or four millimetres thick (two rulers are ideal!). Place them on the bench or table about 250-260 mm

# "THE NAKED PRINTER"



**\$299\***

\* Sales Tax 15% if applicable.  
Prices subject to change and  
exclude delivery.

## BETAPRINT IN THE FLESH!

- Plain paper printing
- Standard parallel or opt. RS 232 interface.
- 12 volt DC operation.
- Software selectable 20, 34, 40, 64 80 char/line.

## ALFATRON PTY. LTD.

1761 Ferntree Gully Rd.,  
Ferntree Gully, 3156  
Ph. 758 9551 or 758 7581

Sydney: M.A.C.E., Ph 86 4060  
Perth: PRO-SPEC  
DISTRIBUTORS. Ph. 275 3411

# LOOPY VIDEO

Shop: 418 Bridge Road, Richmond, Vic.  
Mail: PO Box 347, Richmond, 3121, Vic.

## "SAMPLE OF NEW SOFTWARE TITLES FOR OHIO"

G.44	Collide M/C	\$9.95
G.45	Vampire Castle (Adventure)	\$18.95
G.46	Alien IV M/C	\$18.95
G.47	Minos (Maze, 3D View)	\$11.95
G.48	Interceptor M/C	\$14.95
G.49	Labyrinth	\$14.95
G.50	Monster Maze M/C	\$11.95
G.51	Rocket Jockey	\$9.95
B.6	Bookkeeping the Easy Way	\$129.00
B.7	Payroll	\$49.95
B.8	Inventory	\$59.95
B.9	Accounts Receivable	\$99.95
T.6	*Forth Language — 3 Books	\$19.95
T.7	CIP Series, 2 User Manual	\$10.00
K.1	Hardware Catalogue INC. P&P	\$1.00
K.2	The First 100 Items of Software	\$1.95
L.27	TTL Level Port	\$4.95
L.28	EPROM Burner Instr.	\$6.95
U.15	Disassembler Plus	\$14.95
U.23	32 x 64 Swap Tape SERIES 2	\$8.95
U.24	Sound Effects	\$9.95
U.25	FUL Editor/Assembler	\$19.95
U.26	High Speed SAVE/LOAD	\$14.95
U.27	Renuberer M/C	\$11.95
U.28	*Forth on Tape	\$34.95
U.29	*FORTH 3 Books and Tape	\$49.95
U.30	*Pascal Tape and Book	\$34.95
U.31	Sound Driver	\$8.95
U.33	Tiny Compiler	\$19.95
U.34	Trace-Single Step	\$12.95

## AND WE NOW STOCK DISKS

Allow postage on software: 1-2 items \$1.00, 3-5 \$1.50, 6-9 \$2.00, 10 or more items \$2.50.

All prices INCLUDE sales tax.  
Prices subject to change without notice

## AIM-65 — SYM-1 AFFORDABLE INSTRUMENTATION

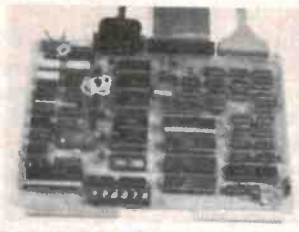

## COMPUTERIST FLOPPY DISC CONTROLLER

### FLEXI PLUS \$445 A7T

Up to 56K ROM/RAM; WD1791;  
Up to four 8" or three 5 1/4" drives.  
Options include 6809E, RS232, and  
IEEE488 controller

## SPECIALS

1791-02 floppy controller	\$32.00
4X2516 EPROM	\$23.40
4X2532 EPROM	\$50.44
2X2128 — 12K X 8 static Ram	\$22.10



P.O. BOX 6502  
GOODNA 4300  
Phone  
(07) 288-2757

BANKCARD available for Australia & N.Z. customers. Same P & P for N.Z. & Australia. Prices subject to change without notice. Plus sales tax if applicable.

# NOW — A COMPUTER KIT FOR APPROX \$99!



Developed by our parent company in New Zealand (Hug 1802) and upgraded by ETI as project 660, this simple state-of-the-artkit allows the hobbyist to get into micro-processors at minimal cost. This simple, single board micro-computer has already become the top selling micro kit in New Zealand — thoroughly tested & proven during the last 12 months. And for those wishing to expand, there are many add-on's already under development.

**CLUB:** Each customer who purchases a kit from us, automatically joins our 1802-660 club, and will be notified the moment additional software and hardware becomes available. Club members will also be able to swap software and interesting applications.

**EXTRA:** In addition, each kit purchased from KIT PARTS will have the original 30 page HUG1802 manual included FREE OF CHARGE! (usually \$10). Prices of the kit plus colour add-on's may vary slightly, so if you're interested in project 660, drop us a note now, and the moment we have the kit in stock, we'll advise you of the exact details.

# KIT PARTS (AUST) PTY LTD.

Private Bag, Noosa Heads, Qld 4567

NEW ZEALAND CUSTOMERS WRITE TO: HUG ELECTRONICS, BOX 6544 TE ARO, WELLINGTON.



# TIRED OF ERASING AND REDRAWING P.C. LAYOUTS?

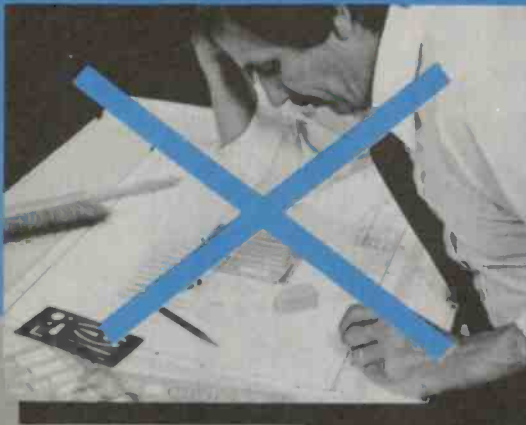

## puppets™ REDUCE YOUR P.C. LAYOUT TIME BY UP TO 75%!

Now...create a printed circuit layout or make changes instantly! **NO TEMPLATES, NO ERASING** and **NO REDRAWING**, with PUPPETS, the revolutionary printed circuit design and layout system from Bishop Graphics.

Manufactured of a strong, thin, transparent vinyl material and individually die-cut, PUPPETS represent a variety of commonly-used electronic components. PUPPETS are specially treated to adhere... *without adhesive*... to any non-matte drafting film, such as Bishop Graphics' ACCUFILM® so you can instantly position, reposition or replace them! PUPPETS require no drawing, erasing, or

redrawing, effectively reducing your printed circuit layout time by as much as 75%.

Using PUPPETS couldn't be easier, simply "peel & press", and instantly your layout takes shape. Need to make a change? No problem. Merely peel and reposition your PUPPETS...without erasing or redrawing. Economical as well as versatile, PUPPETS are even reusable. Available in individual packets or complete designer kits, in 2 x or 4 x scale. You can even design your own custom component patterns with PUPPETS blank material. For your next printed circuit layout, try PUPPETS, used by printed circuit designers worldwide, and spend your time creating, not erasing.



**TO GET YOUR FREE PUPPETS DEMONSTRATION AND THE COMPLETE STORY... INCLUDING A FREE PUPPETS SAMPLE AND TECHNICAL BULLETIN NO. 1015R, CONTACT YOUR LOCAL BISHOP GRAPHICS DEALER TODAY.**



The Innovators

**Bishop Graphics, Inc.**

**VICTORIA**  
STEWART  
ELECTRONIC  
COMPONENTS  
PTY. LTD.  
44 Stafford Street,  
Huntingdale 3166  
Tel: 543 3733  
Telex: AA 36908

**WESTERN AUSTRALIA**  
W. J. MONCRIEFF  
PTY. LTD.  
176 Wittenoom Street,  
East Perth W.A. 6000  
Tel: 325 5722  
Telex: AA 93022

**QUEENSLAND**  
L. E. BOUGHEN  
& CO.  
Cnr. Baroona &  
Milton Rds.  
Milton Qld. 4064  
Tel: 36 1277  
Telex: AA 41500

**SOUTH AUSTRALIA**  
GRAPHIC  
ELECTRONIC  
INDUSTRIES  
PTY. LTD.  
41A Rundle Street,  
Kent Town S.A. 4067  
Tel: 42 6655  
Telex: AA 88646

**NEW SOUTH  
WALES**  
CIRCUIT  
COMPONENTS  
(A/Asia) PTY. LTD.  
P.O. Box 70  
383 Forest Road,  
Bexley N.S.W. 2207  
Tel: 59 6550 59 3720  
Telex: AA 27 197  
CIRCUM

**A.C.T.**  
GEORGE  
BROWN  
& CO. PTY. LTD.  
23 Whyalla Street  
Fyshwick A.C.T.  
2609  
Tel: 80 4355  
Telex: AA 62128

OVERLAY DRAWING #2  
Location of power supply components.

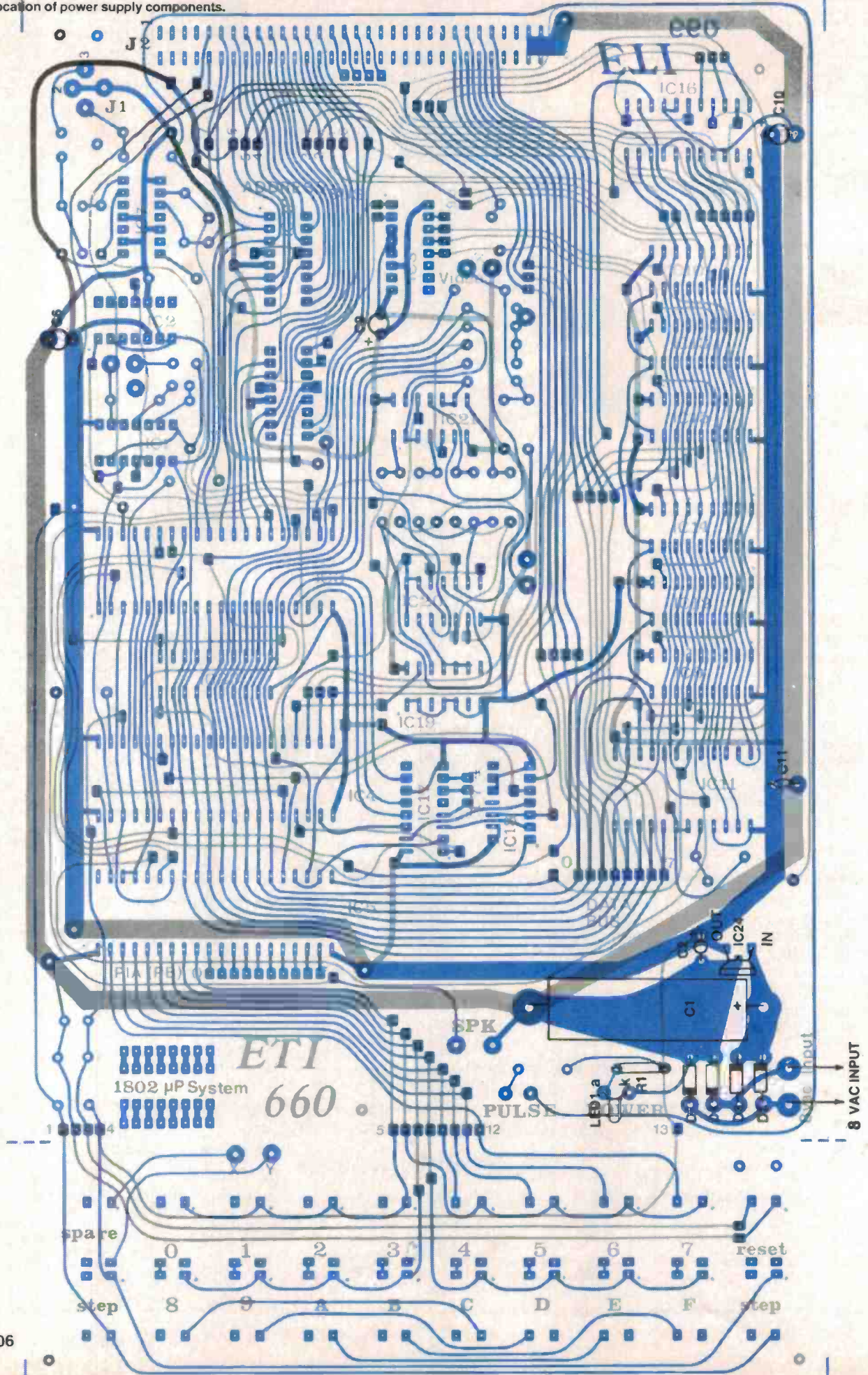

apart and lay the pc board on them, component side up (i.e. annotations up) For linking wire we used 26 swg (0.455 mm dia.) tinned copper wire. If you find 22 swg tinned copper wire easier to obtain then all the linking holes should be drilled with a No. 60 bit too, as for the component lead holes.

Note that, on the component side of the board, the track pads for the links are all square types. Component lead pads are round.

Referring to overlay drawing 1, which details the feedthrough links, insert the wire into each hole, passing it through until it stops against the bench or table top, solder it to the pad and then cut the wire. When you think you have done all the links, check carefully against the drawing — to find the ones you've missed! Now you can turn the board over and solder the links to the pads on the bottom side. Trim off the excess wire. Solder quickly and cleanly with a clean, hot iron with a small radius tip and you should have little difficulty. Turn the board over and check the top side to see that no joints have been disturbed or become frosty in appearance, indicating a possible dry joint. Check that those links *under* the ICs are installed. Once you have an IC socket or an IC in place, you'll find it very difficult to fit any missed links underneath them!

If you are going to use IC sockets, install them now. Even if you're not, we recommend you install an IC socket for IC11 (the EPROM). We fitted sockets for IC3, IC4, IC5 and IC9 to IC16 inclusive.

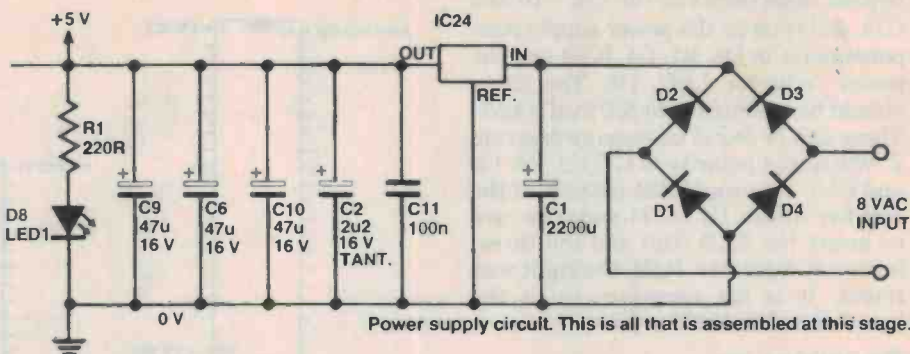

Power supply circuit. This is all that is assembled at this stage.

## COMPONENT PINOUTS

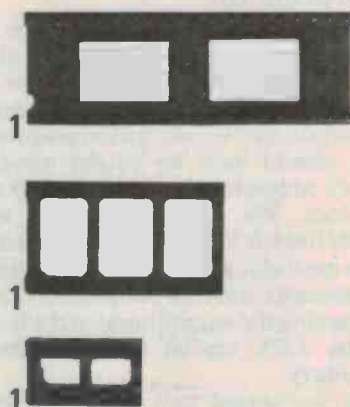
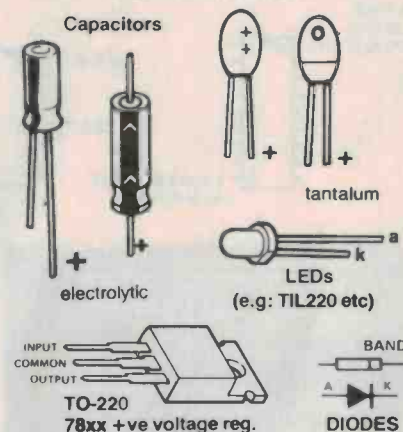

IC sockets showing how to identify pin 1.

Make sure you fit each socket the right way round and that no pins get folded under the socket. The accompanying picture shows how to identify pin 1 on a socket. Remember that on the pc board pin 1 on each IC position is identified by an adjacent spot on the top side of the board.

Take care when soldering to IC pads that have conductors running between them. It is easy to get a solder 'bridge' across the tracks that will later cause the project to malfunction. A visual check after soldering and/or using an ohmmeter to check that no bridging has occurred is recommended.

## COMPLETE PARTS LIST ETI-660 LEARNERS' MICROCOMPUTER

Parts marked with \* are only used when colour expansion is included. Parts marked \*\* change when colour expansion added.

### Resistors

R1	220R
R2,R27,R30	120k
R3	47k
*R4,R6,R19	4k7
*R5	1k
**R7	3k3 (2k2 for colour)
*R8	680R
*R9	68R
**R10	1k2 (470R for colour)
*R11,R16,R17	2k2
**R12	10k (5k6 for colour)
*R13,R18	1k2
*R14	1k5
*R15	2k7
R20,R21,R22	390R
R23	15k
R24	1k2
R25	8k2
R26	180R
R28,R32	22k
R29	10k (only for high-order EPROM, see text)
R31,R33	1M
R34	180k

### Capacitors

C1	2200u/16 V axial electro.
C2	2u2/16 V tant. or RBLL
C3,C8,C11	100n greencap
C4	10n greencap or ceramic
C5	3-30p film or ceramic trimmer
C6,C9,C10	47u/16 V tant. or RBLL
C7	470p ceramic

### Semiconductors

D1-D4	1N4001, EM401 or sim.
D5,D6	1N914, 1N4148 (only for higher order EPROM, see text)
D7	(LED2) TIL220R or sim. red LED
D8	(LED1) TIL220G or sim. green LED
IC1	74LS00
IC2	7490
IC3	CDP 1802
IC4	CDP1864
IC5	MM6821
IC6	7475
IC7	LM3900
IC8	74LS138
IC9,IC10	2114
IC11	2516, 2716 EPROM (with CHIP8)

IC12-IC15	2114 (optional, for RAM expansion)
*IC16	MM2101, 5101, CDP 1822 etc.
IC17	4028
*IC18	74LS00
*IC19	74LS68
*IC20	74LS74
*IC21	4066

NOTE: IC22, IC23 are only used with subsequent additions to this project and while provision has been made for them on-board they are not used at this stage.

IC24 ..... LM340T/5, 7805 +ve 5 V reg.

### Miscellaneous

\*DLY ..... 400 ns colour delay line, Plessey 220-252-01

ETI-660 pc board; 3-pin 180° DIN socket; 3-pin 180° DIN plug; 18 type FES-310 pushbuttons or standard HEX keypad; 50 or 75 mm diameter 8 or 16 ohm speaker; 8.867238 MHz crystal; three 40-pin IC sockets; six 18-pin IC sockets; one 22-pin IC socket; one 24-pin IC socket; Ferguson plug pack type PPB 8/1000 or similar (8 Vac @ 1 A output); aluminium top and bottom panels as per drawings; heatsink for IC24 as per drawing; wooden end cheeks as per drawing; mounting hardware, etc. (Mechanical drawings next month.)

Next step is to fit the supply rail bypass capacitors C2, C6, C9, C10 and C11, followed by the power supply components D1 to D4, R1, C1, IC24 and the power indicator LED, D8. The latter should be mounted *with full lead length*. These can be found on overlay diagram 2. Watch the polarity of C1, C2, C6, C9 and C10. Also watch the polarity of the rectifier diodes D1 to D4 and take care to insert the LED (D8) and the three-terminal regulator, IC24, the right way round. It is not necessary to fit the heatsink to IC24 at this point.

## Powering up

At this stage you're ready to 'fire up' the power supply and check that all is OK. Temporarily attach a length of figure-eight flex to the 8 Vac input terminals and connect up the plug pack. This should have an output rated to supply around 8 Vac at up to 500 mA or more. We used a Ferguson type PPB8/1000 (8 Vac at 1 A, for door bells). Alternatively, you could use a multitap transformer such as the popular 2155, connecting the supply input to the board to the 7.5 V tap on the transformer secondary.

Having sorted that out, place your trusty multimeter nearby and apply power. Check that there are no wisps of smoke rising from anything. The power indicator LED should be on. If it's not, switch off and check that it's inserted the right way round. If it is, check that the rectifier diodes are inserted the right way round, along with IC24. If they seem OK, then something else is likely to be wrong. To check, remove IC24 and apply power once again. Measure the voltage across C1 (negative lead of multimeter to negative lead of capacitor, positive lead of multimeter to positive lead of capacitor). You should get around 12-14 V. If you don't, you've got one or more of the rectifier diodes inserted incorrectly. Switch off and correct it if necessary. If all is OK, switch off and check that you haven't got a short somewhere around the supply rail tracks on the pc board. Turn the board over. Take your multimeter and measure the voltage across the supply pins of each IC socket or position on the board. You should get 5 V connecting your meter as follows:

- IC1, IC7, IC18, IC19, IC20, IC21 pin 7 (negative lead) and pin 14 (positive lead).
- IC17 pin 8 (negative lead) and pin 16 (positive lead).
- IC6, IC22 pin 12 (negative lead) and pin 5 (positive lead).
- IC2 pin 10 (negative lead) and pin 5 (positive lead).
- IC3 and IC4, pin 20 (negative lead) and pin 40 (positive lead).

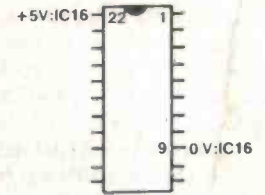
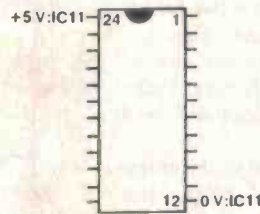

+5 V: IC9, IC10, IC12, IC13, IC14, IC15

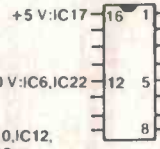

+5 V: IC1, IC7, IC18, IC19, IC20, IC21

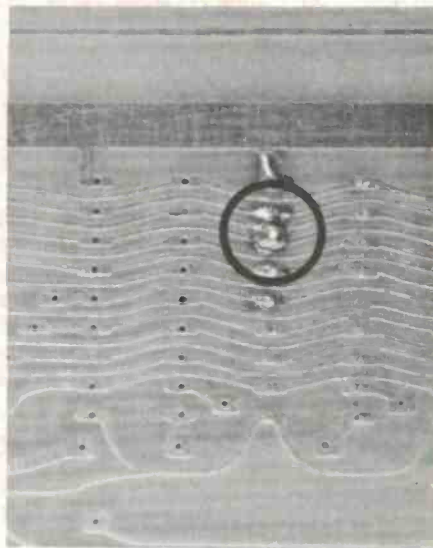
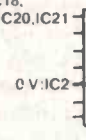

Watch for solder 'bridges' across adjacent tracks when you are soldering IC pins or IC socket pins. This is particularly important around IC3, IC4, IC5 and ICs 9 to 16. Remove any bridges that you find with a solder sucker or solder wick, then carefully re-solder the pins.

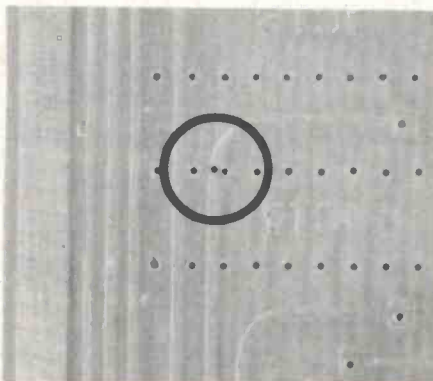

Take care when drilling the board that your aim is not off and the drill cuts a track, as shown here. A careful visual examination of the board will show up such problems.

UNDERSIDE VIEW OF ICs showing where power supply pins are located.

- IC5 pin 1 (negative lead) and pin 20 (positive lead).
- IC9, IC10, IC12, IC13, IC14, IC15 pin 9 (negative lead) and pin 18 (positive lead).
- IC11 pin 12 (negative lead) and pin 24 (positive lead).
- IC16 pins 8/9 (negative lead) and pin 22 (positive lead).

Checking at the pins of each IC location like this eliminates ground (0 V rail) return errors.

Next to check are the data and address buss lines. Connect the negative probe of your multimeter to the 0 V (ground) rail — that's the wide track that runs around the top of the board from the 'pin 32' end of J2 to near IC2. Now, with the positive probe of your multimeter, check that there is *no voltage* on each of the following:

- Address buss lines 0 to 9
- Data buss lines 0 to 7

The address buss lines are identified near IC22 and the data buss lines are identified adjacent to IC18 and IC11, on the top of the board.

This test should be repeated in the following way: connect the multimeter positive probe to the +5 V rail (see the pad adjacent to IC24 — it says "+5 V") and check that no voltage appears on the address or data buss lines using the negative probe of the multimeter.

If you have any faults, trace them and clear them now. Most likely you will find them to be solder bridges between tracks at IC socket pins, but you may find small 'fingers' bridging tracks where the copper has not been etched away. This is something to watch if you have made your own board.

If all checks out well, you're ready to go on with the next stage.

(Continued next month).

# ROD IRVING ELECTRONICS

425 HIGH STREET, NORTHCOTE 3070. MELBOURNE. PH (03) 489-8131

## THIS MONTHS KITS

**KITS**  
Please phone  
or write for full  
list of kits  
available

**NOW  
A \$99  
Computer!**

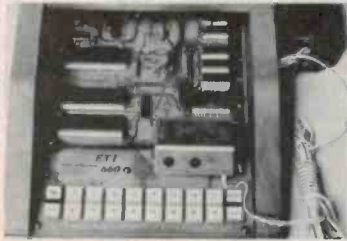

Plugs into any TV!  
**ETI 660**

No one would have believed it a few years ago. Features include: colour capability, operates from optional 9V plugpack, 1K memory expandable to 3K on-board, single board construction, cassette interface, audio output (play tunes), simple to program (uses Chip-8). Expansion projects coming up include: ASCII keyboard, light pen, games software etc. (So we are told)

Starter Kit (1K RAM, B&W video)	\$99.00
9V, 200mA plugpack to suit	\$6.50
Colour video option	\$8.00
RAM EXPANSION (add to PCB)	\$16.00

As with all new kits, please phone first to check stock. We expect the kit to be in stock some time in Oct 1981



**ETI-157 CRYSTAL MARKER**

A useful project for aligning receivers, calibrating CROs and counters, etc.  
P.O.A.

**SERIES 5000  
STEREO  
CONTROL  
PREAMPLIFIER**  
Truly state-of-the-art performance in a no-compromise design from the incomparable David Tilbrook.  
**\$239**



**EA DIGITAL  
STORAGE CRO KIT**



**\$78**

**ETI 256  
HUMIDITY METER**



**\$19.50**

**ETI330  
CAR  
ALARM**



**\$32.00**

**ETI-258  
MINI DRILL CONTROLLER**



**\$8**

**ETI 458  
LED LEVEL  
METER**



**\$38.00**

**ETI 572  
Digital  
PH Meter**



**\$97.50**

**ETI 567 Core-Balance  
Relay**



**\$48.00**

**UNIVERSAL  
RELAY BOARD  
ETI 257**



**\$12.50**

**\$100  
Prom  
Board**



**ETI 682  
KITS \$115.00  
PCB \$65.00**

**ETI 475 AM Tuner**



Case slightly different from one shown. **\$89.00**

**ETI-154  
LOGIC  
PULSER**



**\$11.00** KIT DOES NOT INCLUDE CASE.

**Sound Effects (ETI-607 D&E)  
Phasor & Explosion plus  
Gunshot as described in this  
issue.  
P.O.A.**



**ETI 568 Light & Sound  
Flash Kit**



**\$25.00**

**Series 5000 Mosfet  
Complete Amplifier Kit \$275.00**



**ETI 477 Series 5000 Mosfet Power Amp**  
All parts individually available **\$58.00**  
COME IN AND HEAR THE SOUND

**ETI 599 Infra-Red  
Remote Control**



**\$76.00**

**ANALOGUE &  
DIGITAL STORAGE  
CRO KIT**

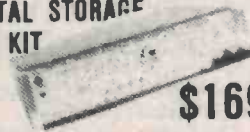

**\$169**

**ETI 729  
UHF TV  
Masthead**



**\$34.00**

**ETI1501  
Negative Ion  
Generator**



**\$42.00**

**Bankcard Mail Orders Welcome**  
Please debit my Bankcard

Bankcard No .....  
Expiry Date.....  
Name.....  
Signature ..... ET

**TO ORDER:** Heavy items sent Comet Freight on. Mail Order phone 481-1436. Wholesale Customers phone: RITRONICS WHOLESALE 489-7099. Mail Orders to P.O. 235 Northcote 3070. Minimum P&P \$2. Add extra for heavy items, registration and certified mail. Prices, spec. subject to change without notice.

ROD IRVING ELECTRONICS  
425 HIGH STREET, NORTHCOTE 3070. MELBOURNE. PH (03) 489-8131

ROD IRVING ELECTRONICS  
425 HIGH STREET, NORTHCOTE 3070. MELBOURNE. PH (03) 489-8131



# In the world of personal computers there is just one that is known as the best: the PET

**NOW  
16K RAM  
AT 8K PRICE  
\$999**

The Commodore PET has become the standard for the Personal Computer Industry.

The Pet is completely integrated, with the processor, memory, keyboard and visual display unit contained within a robust housing, allowing easy transportation with no interconnecting cables necessary. In order to retrieve and save your data and programs, a storage device is used which operates like a cassette recorder, with your information recorded reliably on standard cassettes. The PET has 16k bytes of RAM. Optional equipment permits expansion to 32k. Also, it has 14k bytes of ROM.

The Pet communicates in BASIC—the easiest computer language. Easy to learn and easy to use, BASIC has now become the standard for personal computers, with literally thousands of programmes available. The PET is also programmable in machine language, allowing more efficient use of the system.

The full-size keyboard is capable of producing letters, numbers and graphic symbols. Upper and lower case is standard. Characters appear

on the screen in a pleasant green colour designed to reduce eye fatigue and may be displayed in normal or reverse print.

PET's IEEE-488 Bus—just like H.P.'s mini and full size computers—permits direct connection to over 200 pieces of compatible equipment such as counters, timers, spectrum analysers, digital voltmeters and printer plotters from H.P., Philips, Fluke, Textronix and others.

The full range of Commodore Disk Drives and Printers are plug-compatible with the PET and a comprehensive range of cassette and disk based programmes are available through the extensive network of Commodore Dealers.

## APPLICATIONS

The Commodore PET is a creature of many faces. Its applications are limited only by the user's imagination.

The future of the PET is virtually unlimited; its present capabilities are already many and impressive. As a personal computer, the PET can teach languages and mathematics; play games; create graphic designs; store meal recipes and change

number of portions; maintain budgets, personal records and checkbooks; operate appliances and temperature controls.

As a management tool, it delivers the information the executive needs, in the form he can use, and available to him alone. Trend analyses charts and graphs can be almost instantly available.

The professional may use the PET for maintaining appointment schedules, recording income and expenditures and filing all the specialized information and forms he may need to make his work more efficient—from medical records for a doctor to income tax computations for an accountant.

The engineer, mathematician, physicist, has a tool far superior to the very best programmable calculators yet developed... at a cost that is comparable...and with almost infinitely greater versatility.

And the businessman has a computer that can maintain inventories, keep payroll records, operate accounts payable and receivables, issue cheques and handle correspondence.

## Commodore PET 4016 Computer Technical Specifications.

### Computer/Memory

Read/Write Memory (RAM) 16K bytes available to the user.

Read Only Memory (ROM) 14K bytes in total, divided into:

8K BASIC interpreter available immediately you turn on your PET.

5K Operating System

1K Test Routine

The 6502 micro-processor chip makes the PET one of the fastest and most flexible BASIC systems. Significant features of Commodore BASIC are:

- 960 simple variables
- 960 integers
- 960 string variables
- 960 multi-dimensional array fields for the above 3 types of variables
- Up to 80 characters per program line with several statements per line
- Upper/Lower case characters and graphics capability
- Built in clock
- 9-digit floating point binary arithmetic
- True random number generator
- Supports multiple languages; machine language accessibility

### Keyboard

74-Key professional keyboard.

Separate calculator/numeric pad.

Upper-case alphabetical characters with shift key to give 64 graphics characters.

Can be set for lower case and shifted upper case characters.

### Screen

40 characters wide by 25 lines (1000 characters in 8 × 8 dot matrix).

23 cm screen phosphor screen.

Brightness control.

64 ASCII plus 64 graphics characters.

Blinking cursor with full cursor control, including programmable control.

### Screen editing capabilities

Full cursor control (up, down, left, right).

Character insert and delete.

Reverse character field.

Overstriking.

Return key sends the entire line to the CPU regardless of cursor position.

### Input/Output

8 bit parallel input/output port.

IEEE-488 Bus (HP-IB and IEC Bus) allows up to 12 other peripherals to be connected.

Two cassette ports.

Video signals for additional displays.

Serial output port.

### Technical Data

Dimensions: Height 355 mm (14"), Width 419 mm (16.5"), Depth 185 mm (18.5"). Shipping Weight 20.9 kg (46 lbs).

Power requirements 240V ± 10%. Frequency

50 Hz. Power 100 Watts.

## Commodore BASIC

APPEND	GOSUB..RETURN	STOP	SPC
BACKUP	IF..THEN	SYS	LEFT\$
CLOSE	INPUT	VERIFY	RIGHT\$
CLR	INPUT *	WAIT	MID\$
CMD	LET		CHR\$
COLLECT	LIST	SGN	ASC
CONCAT	LOAD	INT	LEN
CONT	NEW	ABS	VAL
COPY	ON..GOSUB	SQR	STR\$
DATA	OPEN	SIN	TI
	POKE	COS	TI\$
DEF/FN	PRWT	TAN	ST
DIM	READ	ATN	DS
DIRECTORY RECORD		LOG	DS\$
DLOAD	REM	EXP	+
DOPEN	RENAME	AND	-
DSAVE	RESTORE	OR	*
END	RUN	NOT	/
FOR/NEXT	SAVE	TAB	↑
GET	SCRATCH	POS	π

# Commodore microcomputers

For details of your local dealer send to: Commodore Information Centre, Box 336, Artarmon, NSW 2064, Australia. Phone (02) 437 6296

Mvl 469

# A VERSATILE COMPETITOR IN THE FIELD... or the lab.

**\* JUST RELEASED**

The BWD 830 Dual Trace oscilloscope provides these outstanding facilities -

- 35MHz band width ● 1mV/div sensitivity
- 20mS/div to 5 sec/div time range
- <50MHz triggering ● Delay line
- Delayed trigger or sweep
- Simultaneous alternate line or frame video displays
- Variable trigger hold off
- Floating ground operation
- AC, DC or battery with fast or trickle charge.

#### CHECK THESE ADDITIONAL BENEFITS:

- \* The BWD "All buttons out for normal operation" facility.
- \* Internal graticule CRT.
- \* <3% calibration 0-40%/C 95% RH.
- \* Designed to IEC 348.
- \* Factory backed service.



**NEW FEATURE PACKED  
BWD 830**

AB 830/7/81.

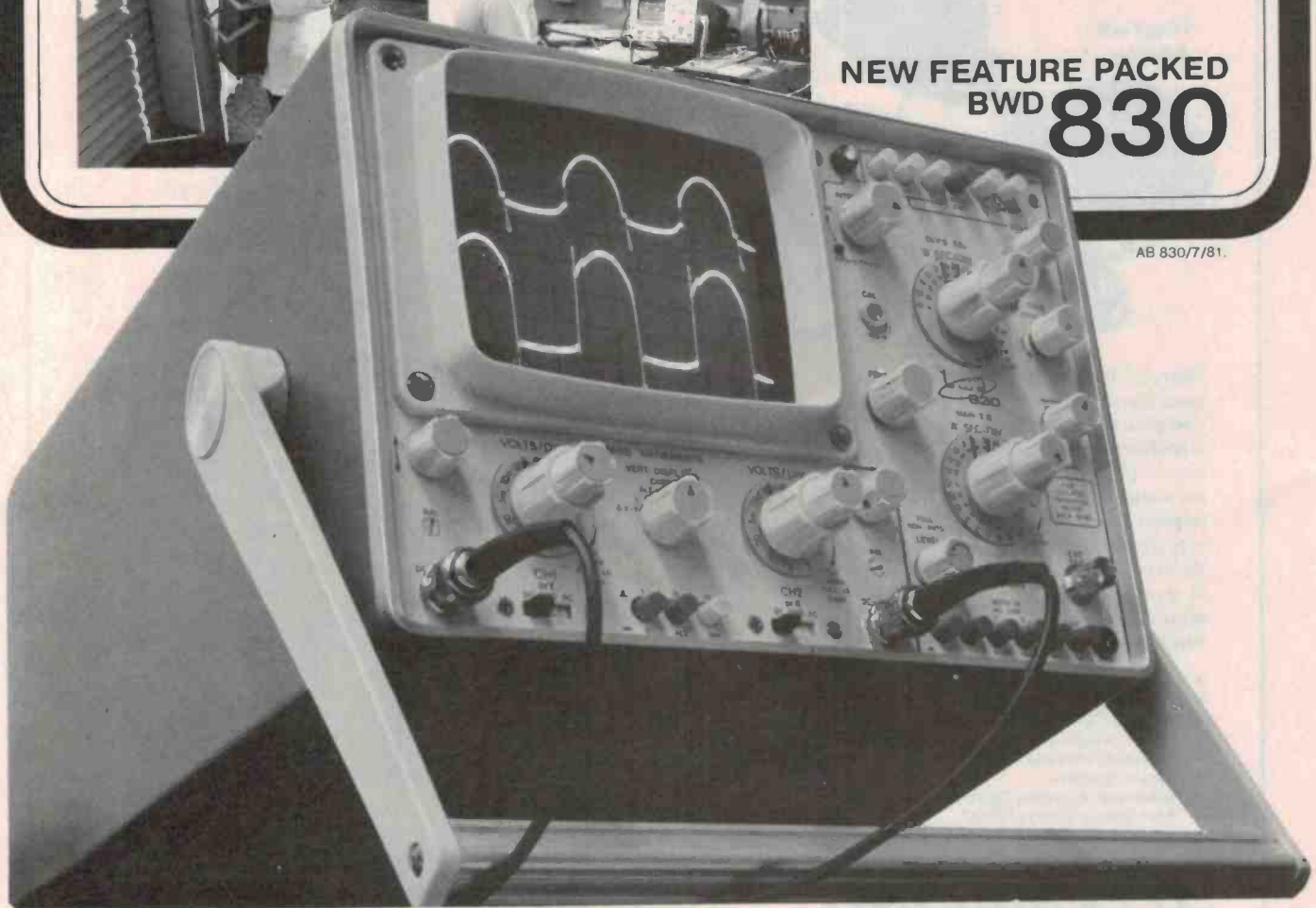

**BWD**  
INSTRUMENTS

Victoria BWD Instruments Pty. Ltd.,  
Melbourne Ph: 561 2888  
New South Wales Amalgamated Wireless  
(A/sia) Ltd. Sydney Ph: 888 8111  
New South Wales George Brown & Co.  
Pty. Ltd. Sydney Ph: 519 5855  
South Australia Werner Electronic Industries  
Pty. Ltd. Adelaide Ph: 268 2766

Queensland L.E. Boughen & Co.  
Brisbane Ph: 36 1277  
Western Australia Warburton Franki,  
Perth Ph: 277 7000  
Tasmania D & I Agencies, Hobart  
Ph: 23 2842  
New Zealand W. Arthur Fisher Limited,  
Auckland Ph: 59 2629





# SINCLAIR ZX81 COMPUTER TO WIN!



When the Sinclair ZX80 was released in Australia last year it caused a sensation — here was a complete personal computer, featuring BASIC programming with single keystroke entering of key words, for the unheard-of price of \$295. We ran a contest in the December 1980 issue of ETI in which a ZX80 was offered as first prize. It was one of the most successful contests we've ever run.

Sinclair Research Ltd have further improved the design of their phenomenal little computer, and this year launched the ZX81. We announced its arrival on page 86 of the May issue. Consolidated Marketing, who market Sinclair products in Australia, have only just released the ZX81 here, and at \$250 it's selling for less than the original price of the ZX80!

Once again, to help launch this latest marvel from Sinclair, Consolidated Marketing has offered to donate a ZX81 as a prize for a contest to be run in ETI.

Here is your opportunity to win one of these powerful little computers. Complete the contest coupon here, answering all five questions, and return it before the due date. It's as simple as that!

#### RULES

This contest is open to all persons normally resident in Australia with the exception of members of the staff of Consolidated Marketing, Murray Publishers, Offset Alpine, Australian Consolidated Press and/or associated companies.

Closing date for the contest is 30 November 1981. Entries received within seven days of that date will be accepted if postmarked prior to and including 30 November 1981.

The winning entry will be drawn by the Managing Editor of ETI, whose decision will be final. No correspondence can be entered into regarding the decision.

Winner will be advised by telegram the same day the result is declared. The name of the winner, together with the winning answers, will be published in the next possible issue of ETI.

Contestants must enter their names and address where indicated on each entry form. Photostats or clearly written copies will be accepted but if sending copies you must cut out and include with each entry the month and page number from bottom of the page of the contest. In other words you can send in multiple entries but you will need extra copies of the magazine so that you send an original page number with each entry.

This contest is invalid in states where local laws prohibit entries.

Entrants must sign the declaration, accompanying this contest, that they have read the above rules and agree to abide by their conditions.

You may enter as many times as you wish but you must use a separate entry form for each entry and include the month and page number cut from the bottom right hand portion of this page. You must put your name and address on the entry form and sign it where indicated.

Please read the contest rules carefully, especially if sending multiple entries.

All entries received by the due date will be placed in a barrel. First all-correct entry then drawn is the winner.

TC81/1319

Which mathematical functions does the ZX81 provide on the keyboard?

Can the ZX81 do animated graphics?

The Sinclair ZX Printer can be attached to the ZX81. How many columns wide is the print?

When the ZX Printer is attached to the ZX81, what happens when you press the COPY key?

What microprocessor is used in the ZX81?

Entries should be addressed to ETI/Sinclair ZX81 contest, Electronics Today International, 15 Boundary St, Rushcutters Bay NSW 2011.

Name .....

Address .....

Postcode .....

I have read the rules of the contest and agree to abide by them

Signed .....

Date .....

## APPLE HARDWARE DISCOUNTED

Double Sided, Double Density, 8 Inch Drive Capability For the Apple is Here . . . NOW!



Our new LOBO 8" DSDD floppy disc drives now enable you to realise the full potential of your APPLE, to handle all your personal and business computing needs. By simply plugging in one dual drive unit you obtain 2.2 megabytes of instant on-line storage. These 8" drives operate like the 5 1/4" drives, but give you

15 times the capacity completely compatible with DOS 3.3, Pascal and CP/M with a 1 year 100% parts and labour warranty. CP/M available soon.

**SERVICE:** We fully support all manufacturers warranties and provide complete after warranty service, should it ever be necessary.

**PAYMENT:** Strictly cash: 1) Bank Cheque; 2) Personal Cheque — will be cleared; 3) Letter of Credit.

If you wish to check our stock out phone: 387 3841 — to book an appointment. We can deliver throughout Australia.

ADD 3% FOR DELIVERY OUTSIDE SYDNEY WITHIN AUSTRALIA.

	Without Sales Tax
Apple 11 plus, with all latest keyboard and motherboard modifications, with 48K memory.....	\$1320
5 1/4" LOBO floppy disc drive with disc controller .....	\$570
5 1/4" LOBO floppy disc drive (add-on drive) .....	\$420
Dual 8" Double Sided, Double Density, LOBO floppy disc drive unit with controller (2.2 Megabyte) .....	\$3068
Dual 8" Single Sided, Double Density, LOBO floppy disc drive unit with controller (1.1. Megabyte).....	\$2340
16K RAM expansion card (Microsoft).....	\$240
Z-80 processor card with CP/M system. (Microsoft).....	\$325
80 column, Upper/Lower case character card, Sup'R Terminal, with programmable character fonts .....	\$370
CCS Serial Communications Cards .....	\$170
Epson Parallel Interface Card .....	\$110
Magic Wand Wordprocessor Program .....	\$350
5 1/4" Hard Disk (LOBO) with DSDD floppy disc backup unit inbuilt with controller. (5mb).....	\$5100
8" Hard Disk (LOBO) and DSDD floppy disc backup unit inbuilt with controller.(10mb).....	\$6200

All LOBO equipment carries a full 12 month, 100% parts and labour warranty against defects. We service all the equipment we sell and maintain all manufacturers' warranties. Prices shown may be subject to change, at any time. Add 17 1/2% sales tax.

ALL MAIL ORDERS TO

**C**omputer  
**A**utomation  
**S**oftware &  
**H**ardware.



Call or write to us at:  
P.O. Box 171  
Bondi Junction  
N.S.W. 2022  
Phone: (02) 387 3541  
Telex: AA 71303

**NOW!**



Apple II Computers are now available at The Logic Shop, at a special Logic Shop price!  
We have a full range of Software programmes for home or business, including Visicalc, games and business systems written in Australia for small businesses, insurance brokers, farmers, doctors; almost everyone! And Education too! We have systems, especially for schools with our professional level of support and service.

When you add The Logic Shop's range of quality printers we offer an unbeatable package.

Call in or phone for The Logic Shop's Special price on Apple!

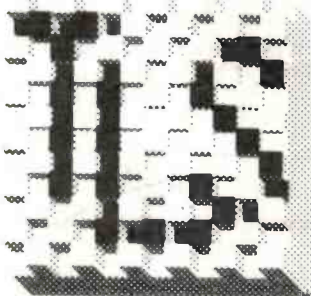

# The Logic Shop

## Computer Systems.

212A High Street, Prahran. 03 51 1950.  
91 Regent Street, Chippendale. 02 699 4910.  
Shop 16, Civic Arcade, Adelaide Street, Brisbane. 07 31 2330.

# OUR LOWEST PRICES EVER BOTH ON SEMI-CONDUCTORS AND TRIO OSCILLOSCOPES

	1-24	25-99	100 Plus	IN4148	.04	.03	.025B
2708	4.20	3.30	3.10B	IN4148	.04	.03	.025B
2716 5V	4.80	4.00	3.50B	IN5404	.20	.018	.017B
2732 5V	9.00	8.20	7.90B	IN5408	.25	.023	.021B
2114 300NS	2.10	1.90	1.80B	BU126	1.90	1.70	1.50A
2114 450NS	1.90	1.75	1.50B	BUX80	4.50	4.10	3.90A
8164 64x1K DYN. RAM	38.00	32.00	29.00B	TIP50	.99	.89	.81A
Z80CPU 2MEG	10.50	7.10	6.70B	BD139	.40	.35	.31A
Z80ACPU 4 MEG	12.50	9.50	9.00B	BD140	.40	.35	.31A
Z80P10	5.00	4.50	4.00B				
Z80AP10	9.00	6.50	6.10B				
Z80CTC	6.90	5.10	4.80B				
Z80ACTC	8.40	6.00	5.70B				
Z80S10/0	25.00	23.00	21.00B				
Z80AS10/0	29.00	26.00	23.00B				
8212	3.00	2.50	2.10B				
8214	6.00	5.50	4.90B				
8224	4.90	4.50	4.20B				
8251	4.90	4.50	4.20B				
8255	5.50	4.30	4.00B				
6800	8.50	8.00	6.50B				
6802	11.00	10.00	9.00B				
6821	4.50	4.20	3.90B				
6850	4.50	4.20	3.90B				
FD1771	17.00	16.00	14.90B				
FD1791	59.00	57.00	56.00B				
FD1795	59.00	57.00	56.00				
8080A	6.00	5.50	4.90B				
8085	12.00	11.00	9.00B				
7400	.18	.17	.16B				
7410	.18	.17	.16B				
7421	.15	.12	.11B				
74LS00	.18	.17	.16B				
74LS10	.18	.17	.16B				
74LS32	.18	.17	.16B				
74LS74	.45	.41	.39B				
74LS240	1.40	1.30	.90B				
74LS241	1.40	1.30	.90B				
74LS242	1.40	1.30	.90B				
74LS244	1.40	1.30	.90B				
74LS245	1.80	.170	1.40BN				
81LS95	1.70	1.50	1.40B				
81LS96	1.70	1.50	1.40B				
81LS98	1.70	1.50	1.40B				
8131	2.10	1.90	1.70B				
BC547-8-9	.10	.09	.07B				
BC557-8-9	.10	.08	.07V				
RED LEDS 5mm	.10	.08	.07B				
IN4001	.04	.035	.032B				
IN4002	.05	.04	.035B				
IN4003	.05	.04	.035B				
IN4004	.06	.04	.039B				
IN4007	.11	.09	.07B				
				<b>LINEARS</b>			
				LM308	.60	.45	.40A
				LM555	.24	.22	.19B
				LM741	.24	.23	.20A
				LM317K	2.90	2.50	2.30B
				LM350K	6.50	5.50	4.90B
				LM380-14	1.10	1.00	.90A
				LM324	.80	.65	.55A
				CA313OT	1.20	1.00	.90A
				CA314OT	1.20	1.00	.90A
				RO-3-2513	11.00	10.90	9.50B
				7805	.80	.70	.62B
				7812	.80	.70	.62B
				7815	.80	.70	.62B
				7905	1.00	.95	.85B
				792	1.00	.95	.85B
				7915	1.00	.95	.85B
				MDA3501	2.80	2.70	2.40B
				MDA3502	2.90	2.80	2.50B
				MDA3504	3.00	2.90	2.60B
				FND357	1.00	.95	.85B
				FND500	.95	.90	.85B
				FND507	1.00	.95	.90B
				78H05	6.50	5.90	5.00B
				78HGKC	6.90	6.50	5.90B
				78P05	9.90	9.50	8.90B
				4001	.19	.18	.16B
				4002	.19	.18	.16B
				4007	.19	.18	.16B
				4011	.19	.18	.16B
				4077	.19	.18	.16B
				4081	.19	.18	.16B
				4093	.60	.55	.50B
				4082	.19	.18	.16B
				4017	1.20	1.00	.80B
				2SK134	4.90	4.75	4.30A
				2SK49	4.90	4.75	4.30A
				MJ802	2.70	2.50	2.30A

TAX A 30% TAX B 17½%

ALL SEMICONDUCTORS & TRIO CROS ARE PLUS TAX. TRIO CRO PRICES DO NOT INCLUDE PROBES

## TRIO OSCILLOSCOPES



Model	Screen Size	Bandwidth	Sensitivity	Sweep Time	Trace	ALL PRICES Plus 17½% Sales Tax
CO-1303D	75mm	DC- 5MHz	10MV/DIV	—	Single	\$ 219.00
CO-1303G	75mm	DC- 5MHz	10MV/DIV	—	Single	\$ 264.00
CS-1559A	130mm	DC-10MHz	10MV/DIV	1uS/DIV .5S/DIV	Single	\$ 448.00
CS-156A MKII	130mm	DC-15MHz	10MV/DIV	5uS/DIV .5S/DIV	Dual	\$ 498.00
CS-1562A	130mm	DC-10MHz	10MV/DIV	1uS/DIV .5uS/DIV	Dual	\$ 528.00
CS-1566	130mm	DC-20MHz	5MV/DIV	5uS/DIV .5uS/DIV	Dual	\$ 645.00
CS-1572	130mm	DC-30MHz	5MV/DIV	2uS/DIV .5S/DIV	Dual	\$ 929.00
CS-1575	130mm	DC- 5MHz	1MV/DIV	5uS/DIV 2MS/DIV	Dual	\$ 537.00
CS-1577	130mm	DC-35MHz	2MV/DIV	1uS/DIV .5S/DIV	Dual	\$ 983.00
CS-1830	130mm	DC-35MHz	2MV/DIV	2uS/DIV .5S/DIV	Dual	\$1163.00

MINIMUM PURCHASE \$10.00  
MINIMUM P&P \$ 2.00

Bankcard Mail Orders Welcome

Please debit my Bankcard

Bankcard No. ....

Expiry Date .....

Name .....

Signature .....



## RITRONICS WHOLESALE

425 HIGH ST., NORTHCOTE, VIC., 3070  
(03) 481 1923, (03) 489 7099. P.O. BOX 235.

# sinclair :you're the greatest, now better than ever.

# ZX81



## Personal computer,

**\$245**  
\$220 TAX EX.

Incl. sales tax,  
pack/post.

**COMPLETE WITH  
MAINS ADAPTOR,  
LEADS & BASIC MANUAL**

### ROD IRVING ELECTRONICS

425 HIGH STREET NORTHCOTE 3070 MELBOURNE PHONE (03) 489 8131

QUANTITY	ITEM	ITEM PRICE	TOTAL
	Ready assembled ZX81 Sinclair Personal Computer including mains adaptor, leads, BASIC manual	\$245	
	16K-BYTE RAM pack	\$150	
	8K-ROM	\$ 75	
	ZX Printer (to be announced)		

Total \_\_\_\_\_

I enclose cheque/Bankcard/Diners

Name \_\_\_\_\_

Address \_\_\_\_\_ Postcode \_\_\_\_\_

Signature \_\_\_\_\_

ET1



### NEW BASIC MANUAL SINCLAIR ZX81

Every ZX81 comes with a comprehensive, specially written manual — a complete course in BASIC programming, from first principles to complex programs.

# FROM THE S100 SPECIALISTS

## What Makes AED's S100 SuperComputer Different?

— IEEE S100 construction — 4 or 6MHz Z80 or 5MHz 8085 and 8088 operation — Super Reliable Static RAM, drawing less power than Dynamic — Super Fast Memory Mapped "Un-Serial" Terminal — CP/M 2.2 plus SUPERAED — Realistic System Pricing.

### SUPERAED features:

— Automatic Background Memory Testing — Keyboard Lockout with Password Re-Entry: A cold boot is not enough to bypass the password, either! — Automatic Memory Corruption monitoring during lockout — Help: Menu driven user assistance program — Smartkey: Keyboard Intelligence system — Monaed: Advanced Monitor program, accessible from within CP/M! — Keyboard and Software selection of up to 8 printers — Keyboard and Software controlled display speed — Chunky Graphics — Alternate character sets available — Keyboard Substitution: Now your BASIC or machine code (or whatever) program can perform CP/M keyboard entries, and hence console functions directly — has to be seen to be believed.

*Drop in to our Showroom at GUILDFORD for a demonstration of the AED SUPERCOMPUTER, other AED Turnkey systems, the STARTER System, and the Exidy Sorcerer.*



**MICROCOMPUTER  
PRODUCTS**  
OPEN 9-6 MON-SAT

130 MILITARY ROAD  
GUILDFORD NSW 2161  
PHONE (02) 681 4966  
TELEX AA70664



MAIL ORDER  
TO  
AUSTRALIA

32 Lloyd Avenue, Cremorne,  
Sydney 2090.  
(02) 908-2235. Tlx AA20149.

**BUSINESS HOURS:** Our office is open between 9 and 5 weekdays and also 7 to 10pm Monday through Thursday so that our Australia wide clients can use STD when it's cheap (after 9pm save 60 percent on your call).

**SERVICE:** We provide full service, equal to any in the business, on all our lines. We support fully the manufacturer's warranty and provide complete after warranty service.

#### PAYMENTS:

- Local Letter of Credit — ask your bank.
- Personal cheque — allow time to clear.
- For organizations who must receive delivery before payment we are strictly 7 days with a surcharge of 3 percent of the total invoice value applying for 30 days.

A receipt will be issued immediately for all monies received.

If you desire the protection of a written contract between us we can issue you with a Proforma Invoice (or quote).

#### DELIVERY: (door to door)

- Customer pick-up from our premises.
- To capital cities — everything except big printers, colour monitors and peripheral cards — \$15.00 each article.  
To all other places — NSW \$15; Vic, Qld, SA, Tas \$20; WA, NT \$25.
- Peripheral cards — \$4.00 each by certified mail.

These prices include full insurance and also apply each way for goods returned for post warranty service.

## APPLE DISCOUNTED

and now

### MOUNTAIN COMPUTER'S MULTIFUNCTION CARD

The famous M.H. Clock is now combined with a serial and parallel interface

**FOR \$287** (Introductory price)

We have stocks and can send you its full specs. The same goes for Epson's new 15" printer, the MX-100 which sets new standards in price and performance.

For all our other lines which include the full Apple product line of CCS, Mountain Computer, Microsoft and of course Apple; the Seikosha, Anadex, the two Paper Tigers and the Sanders printers and many of the little things you need,

- \* we are rarely out of stock of hardware items,
- \* we offer free freight on warranty repairs,
- \* can mail you full specifications on all our lines,
- \* and offer most of the best prices — here's some:

16k Apple II Plus	\$1220	Disk + Controller	\$630
16k Apple II + 32k	\$1340	Disk add-on	\$476
Pascal Language System	\$433	Graphics Tablet	\$744
CCS Serial Interface	\$180	Pal Colour Card	\$198
CCS Printer Interface	\$176	M.H. A/D-D/A	\$399
Dick Smith's Daisy Wheel	\$1695	(tax paid = \$1874)	

Prices quoted are tax free. For tax paid prices add 17½%.  
Prices subject to change and exclude delivery charges.

Our software and hardware catalogues have our complete range with prices and contain helpful information on the products listed — It's free and available on request.

**PLEDGE.** Any order that cannot be supplied ex-stock we will specify a despatch date on our receipt. Failure to despatch by this date will require us to immediately issue a full refund, unless otherwise instructed by the customer.

# What is CP/M?

CP/M has been with us for some time now, and is quickly becoming a domestic computer standard — but few people (other than CP/M users) actually know what CP/M is. Phil Cohen found out ...

**Phil Cohen**

CP/M MEANS 'control program for microprocessors' and describes two things; firstly, it is a standard for recording information on disks (in the same way that the S100 buss is a standard for transmitting information along wires). It also stands for a series of programs that go to make up an 'operating system' — a collection of software that looks after disk storage and the other 'nitty gritty' bits of computing — and lets the user get on with writing software or whatever.

CP/M was developed by a company called Digital Research in California (where else?). In order to use CPM, you need an 8080-compatible computer with at least 16K of RAM and at least one disk drive.

CP/M comes as a disk with all the related programs on it, and a full set of manuals. All you have to do to 'install' CP/M in your system is to insert the disk into one of your system's drives.

The CP/M 'suite' of programs includes software that allows you to alter the



basic version of CP/M that comes on the disk to suit your system's requirements. For example, the supplied version of CP/M can be reconstructed to handle up to 64K.

Similarly, parts of CP/M which handle input and output, say to printers or to a terminal, can be 'patched' to suit it to any given type.

The parts of CP/M which do not change when it is 'tailored' to a new environment are the file structure (the way in which information is stored on disk) and the 'commands' that CP/M will respond to.

So, CP/M is a series of pieces of software that allow the user to forget all the details of the computer system he is working on, and to get on with the job of programming. Similarly, software which has been designed to work in a CP/M environment will work on *any* system in which CP/M is installed — this means more readily available software for general consumption.

## How does it work?

First let me define the word 'file'. A file of information — in the computing sense — is a string of characters (including carriage returns, with no effect), which (in CP/M) is up to 8 Mbytes long. The file is known to the user by a 'filename', which is a sequence of up to 11 characters. For example, a file which holds the data for a lotto draw might be called "datalott".

These files are stored on disk, and CP/M allows the user to shift them from disk to disk, into and out of RAM, etc. The user specifies which file he wants to move by referring to it by its filename.

Now, as well as containing one or more of these files, a disk may also contain a version of CP/M. When a disk of *this* type is put into one of the disk drives and the system is 'booted' at this drive, the first thing that happens is that CP/M is loaded from the disk into RAM — any further input to the terminal is then treated as a command to CP/M.

There are two types of commands to CP/M. The first type is 'built-in command' — these are commands which are executed by CP/M on its own. The second type of command is a 'transient' command (I'll explain why later). Transient commands are actually files which contain machine code programs. Giving CP/M a command of this type will cause it to load the file from disk into part of RAM, and then send the processor into the RAM.

The files which hold the standard CP/M 'transient' commands come on the 'distribution disk' (the one that comes with the handbooks). The user can also generate his own transient commands later.

Two of the transient commands which come with CP/M can be used to generate new CP/M systems. The first is MOVCPM, which allows the user to generate a version of CP/M for use with a particular amount of RAM; for example, the version of CP/M which comes on the distribution disk is configured for 16K of RAM (the minimum in which CP/M will run). The MOVCPM can be used to generate CP/M systems which operate anywhere up to 64K of RAM. The MOVCPM program can even find out how much RAM is available automatically!

Another transient command of this type is SYSGEN. This puts CP/M onto an otherwise blank disk, so that the system can be 'booted' from any disk the user chooses.

## Internals

When CP/M is loaded into RAM, it looks like Figure 1. The areas of RAM are split up as follows:

**BIOS\***: Basic I/O System — this is the part of CP/M that tells it how to drive your printer, terminal, etc.

**BDOS\***: Basic Disk Operating System — this part describes how to run your disk drive(s).

**CCP**: Console Command Processor — analyses the commands that you enter into your system and executes them as CP/M commands (see later).

**TPA**: Transient Program Area — this is the rest of your RAM, an area where programs can be run.

(\*The BIOS and BDOS described above are combined into a program called **FDOS**, and this resides at the top of your system memory.)

As I said before, one of the most important features of CP/M is the way in which it stores files on the disk. Not that there's anything unique about the method used — it's just that it has become very common, and that's a virtue in itself.

Up to 64 files can be stored on a disk. CP/M allows the user to call up the 'directory' of the disk (i.e. a list of all of the files currently on the disk).

That's why machine language program files are called 'transient', by the way — because they are loaded into the TPA before execution.

Although it appears to the user that the files are *all* that is on the disk, the directory *itself* is a file, and there are other things on the disk which are 'opaque' to the user. This is the real power of such a system — it allows the user to forget about the way things

## MP/M

MP/M is an operating system somewhat similar to CP/M (and in fact fully compatible with CP/M). The difference is that it allows more than one user to access the system *at the same time*.

This doesn't only mean more than one person using a machine — it means that even a single user can speed throughput by, for example, 'spooling' printout. This means that while you are printing one file you can be doing something else at the same time.

Not only does MP/M allow multi-user support, it can also be given tasks to perform at particular times (MP/M is 'aware' of the time). This means that, in large systems, a program can be entered *once* which will 'back up' all system files at three in the morning every morning, without operator intervention.

MP/M is really the last link in the chain — it holds almost all the features that up to now have separated domestic computers from 'mainframes'.

actually operate, and to get on with the job.

In order to simplify commands, the user is 'logged' into one disk drive at a time — this is shown by the 'prompt' on the screen. Drives are known as A, B, C, etc. When the system starts up, the user will be 'logged' into drive A — and an A> will appear on the left of the screen.

By typing in the letter of another disk (followed by a colon), the user can 'log' himself into another disk. Being logged into a disk means simply that any file names used in CP/M commands will be assumed to refer to the directory of the logged disk.

## Commands

The built-in commands of CP/M are as follows:

**ERA**: erases a file. In actual fact, this ►

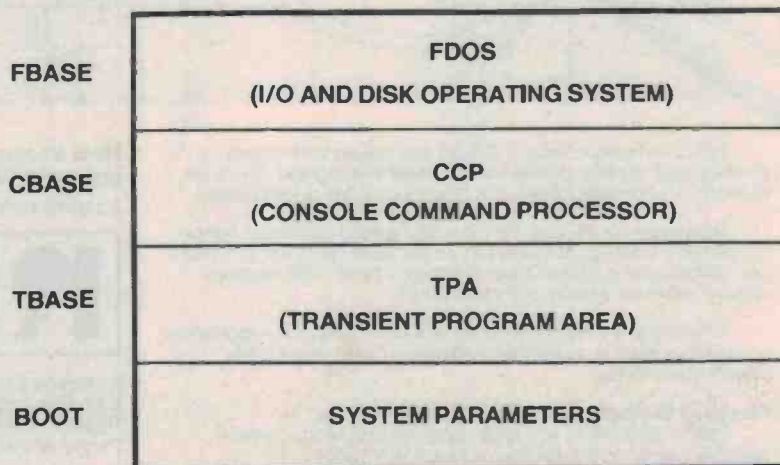

Figure 1. What CP/M looks like in RAM.

# APPLES TO APPLES

The personal computer can distribute information to where it's needed. This distribution of information will ultimately change the way we all make our decisions. The 700 Series modems allows immediate connection of your computer to one of the largest information distribution networks in the world — the telephone system.

The late 70's saw the power of computing being given to people who had never had the chance to use it. Now the 700 Series gives you even more power — the ability

to bring vast sources of information to your office, home, school or laboratory. **Call us for further information.**

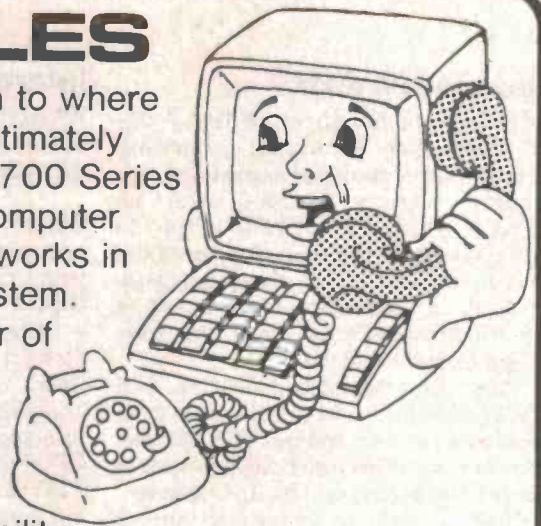
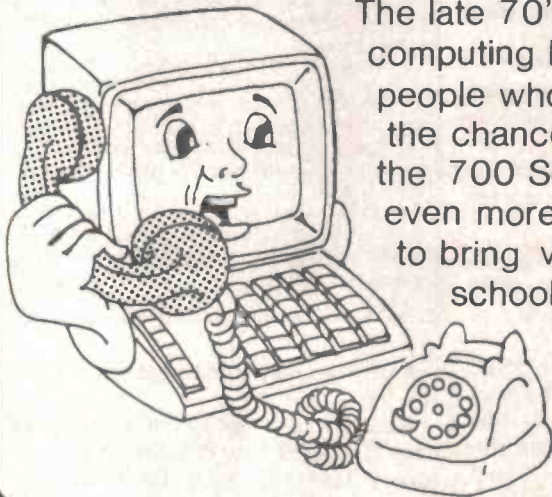

**ELECTRO-MED** ELECTRO-MEDICAL  
ENGINEERING P/L.

69 SUTHERLAND ROAD, ARMADALE, 3143.  
VICTORIA, AUSTRALIA.

TELEPHONE: (03) 509 5844 TELEX: A34008

## Crystal Clear?

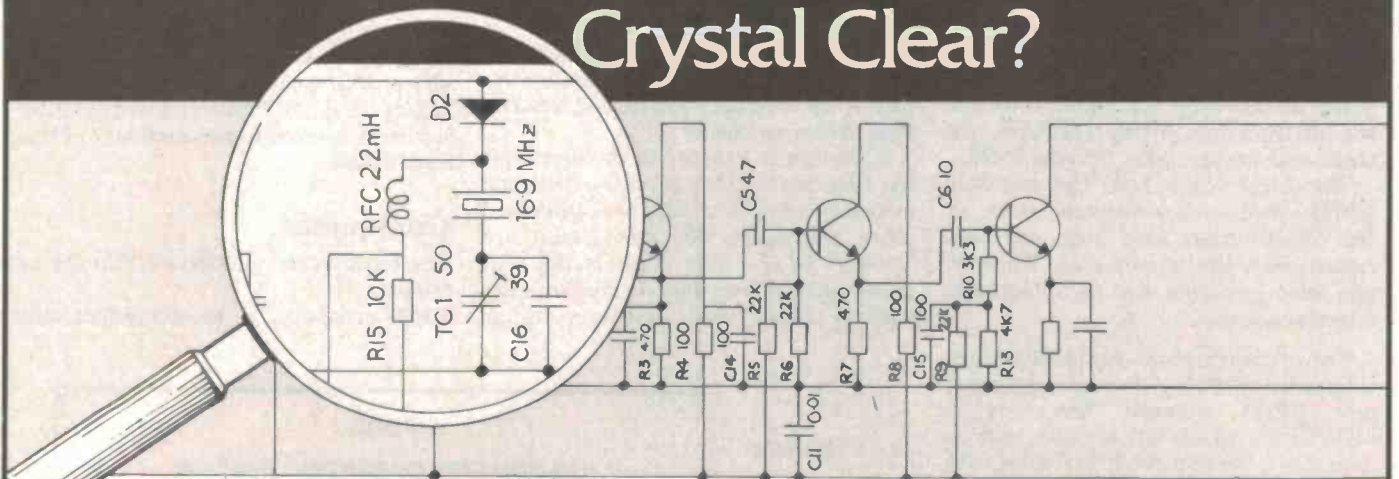

Rakon employs state of the art fabrication techniques to produce high quality crystals which meet the highest demands of modern communications and frequency control technology.

Supplied in a welded, hermetically sealed package, Rakon crystals are capable of operating within such limits as  $\pm 5$  parts per million over a temperature range of  $-10$  to  $+60$  degrees celsius, with low ageing characteristics.

Where the crystal parameters are unknown, our experienced engineering staff is available to advise on selection of the correct specification.

#### Standard Microprocessor Frequencies

Rakon also offers a quality range of low costs crystals specially designed for microprocessor applications.

**New Zealand manufactured crystals are competitively priced and duty-free in Australia.**

Inquiries concerning price and delivery should be forwarded to:

**RAKON INDUSTRIES**

9 George Street, Mt. Eden.  
P.O. Box 9308, Newmarket, Auckland.  
Cables: "RAKON". Telex: 21682.  
Phone (64-9) 605-010, 605-270.

Civil Aviation Department Approval No. AWB556



1 MONTH ONLY

# COMPUTER SPECIALS

FROM  
**RITONICS WHOLESALE P/L** (Computer Manufacturers & Designers)  
425 HIGH STREET, NORTHCOTE, 3070 — Phone: (03) 489 7099, (03) 489 1923

**SYSTEM 80 — \$675.00\*** (595.00 Tax Ex.)  
**SYSTEM 80 EXP UNIT — \$445.00\*** (395.00 Tax Ex.)  
**SORCERER MK2 (32K) — \$1250.00\***  
**SORCERER EXP UNIT — \$525.00**  
**ZX 81 — \$245.00**

## ITOH PRINTERS

830 P — \$690.00 + Tax  
8300 S — \$745.00 + Tax  
8510 P — \$815.00 + Tax\*  
1540 — \$1030.00 + Tax  
1540 — \$900.00 Tax. Ex.

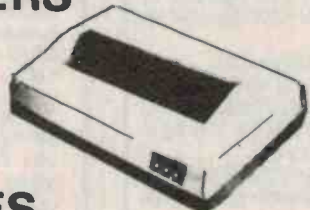

## DISC DRIVES

**M P I** — Ask for the best possible price on Whole range.  
**Y E DATA** — 8" Double sided double density — \$650.00 + Tax.  
**TANDON** — Ask for best possible price on Whole range.  
**SHUGART** — Phone for prices.

**NEC DAISY WHEEL — \$1690.00**  
(\$1490.00 Tax Ex.)  
(\$300.00 less than other suppliers)

**KEYBOARDS**  
**CLARE C70 — \$164.00**  
(\$143.00 Tax Ex.)

**VIDEO MONITOR** approx. 6 MH B.W.  
Normally \$149.00 NOW \$119.00  
(\$109.00 Tax Ex.)

**MONITOR & KEYBOARD HOUSING**  
**FIBREGLASS SHELL — \$110.00 + Tax**

**18MHZ GREEN PHOSPHOR MONITOR**  
— \$275.00  
(\$239.00 Tax Ex.)

\* Please note some items are shop soiled.  
Offer ends November 15, 1981.

## NOW AVAILABLE

**C.P.M. SOFTWARE-WORDSTAR \$495.00**  
**COMPLETE C.P.M. 2.2. SYSTEMS**

System available with ★ Debtors Software ★ 1.2 MHz Formated ★ 18 MHz Green Phosphor Monitor ★ Parallel, Serial Interfaces.

**FROM ONLY \$2950 +Tax**

Remember this is assembled and tested. It has a 90 day warranty so why not buy a **REAL SYSTEM**





**welcome here**  
Bankcard Mail Orders Welcome

Please debit my Bankcard

Bankcard No. ....

Expiry Date .....

Name .....

Signature .....

ETI 10/81

## NEW! EX-STOCK ADVANCED EPROM PROGRAMMER

Programs Single 5v AND three volt  
Supply type EPROMS from 1K to 8K BYTE capacity.

Connects to:—

- 6502 based uP Systems —  
APPLE II, AIM-65, COMMODORE CBM, SYM-1 & others.
- 6800 based uP Systems —  
SWTPC, SSB, MOTOROLA D2/D3, DREAM 6800, & others.
- Other uP Systems —  
TRS-80, SYSTEM 80, NOVA 80 etc.

Three interface types provided:—

**uP BUS INTERFACE** — Connector K2  
Model NEP-3/AB connects to your 6800/6502 uP System BUS via your System's "BUS EXPANSION" facility.

**PARALLEL INTERFACE** — Connector K1  
Model NEP-3/AP connects to your System's Parallel I/O PORT — needs only 8 Data, 2 Control lines (i.e. 1/2 6821, 1/2 6520, 1/2 6522 etc) to drive it.

**SS-50 INTERFACE** — Connector M1  
Model NEP-3/AS is a single PCB which plugs directly into your SS-50 System's I/O Slots. Powered from Bus D.C.



Models:  
NEP-3/AB, AP

Features: ● Internally generated Programming Voltage ● DIP SWITCH selection of EPROM type  
● 28 pin Zero Insertion Force EPROM Socket  
● PROGRAMS:  
TMS 2708, 2716, 2516, 2532, 2564;  
INTEL 2708, 2716, 2732, 2764;  
MCM 2708, 2716, 2532, 68764.  
POWER SUPPLY - 240v A.C. Mains  
INTERFACE CABLES - Standard & Custom  
Cables available to suit your System.

### POWERFUL SOFTWARE

NEPROM menu-driven Software —  
RELOCATABLE OBJECT in 2516/2708 EPROM  
— ready to plug into ANY spare 2K Address in your System.  
● Drives ALL NEP-3 Models ● Performs ERASE  
CHECK, READ, BLOW, VERIFY ● Single  
NEPROM Module handles ALL the above EPROM  
types.

NEPROM-3... for ALL 6800 family based uP  
Systems.

NEPROM-4 ... for ALL 6502 based uP Systems  
NEPROM-5 ... for ALL 6809 based uP Systems

Bare PCB & Documentation (NEP-3) ..... \$47\*  
Fully Ass & Test — including (NEP-3/AB) ... \$320\*  
Case (NEP-3/AP) ..... \$310\*  
Fully Ass & Test (NEP-3/AS) ..... \$205\*  
Standard Interface Cable (NEP-3/K1) ..... \$10\*  
(NEP-3/K2) ..... \$12\*  
Custom Interface Cable ..... \$18\*  
NEPROM-3, 4, 5 (2708/2516 please specify) . \$32\*  
User Manual (NEP-3/D) — Refundable on  
purchase of NEP-3 ..... \$12  
Regd Post & Pack ..... \$5  
\*Plus 17 1/2% Sales Tax.

## NUTEK SALES

P.O. BOX 95, EASTWOOD N.S.W. 2122  
Ph. (02) 871-7042

## THE CP/M HANDBOOK WITH MP/M. Rodney (336 pp, 100 illustr, 150 x 230 mm) Zaks

CP/M (Control Program for Microprocessors) is the industry standard in operating systems for small computers. CP/M is available on nearly all computers using the 8080, 8085, or Z80 microprocessors, as well as some computers using the 6502 microprocessor.

The CP/M Handbook is a simple, clear and practical introduction to the use of CP/M equipped computers, and a reference text. For beginners this book offers step-by-step instructions for using CP/M without fear. Everything like turning the system on, inserting a diskette, correct user discipline and remedial action for problem situations is explained in a clear, concise, and easy-to-read format. The book includes a comprehensive description of all CP/M facilities and resources for experienced programmers. It also includes a complete discussion of all versions of CP/M up to and including 2.2, MP/M and CDOS. Fifteen appendices feature complete summaries of all commands and facilities.

Contents include: an introduction to CP/M and MP/M, CP/M and MP/M facilities, handling files with PIP, using the editor, Inside CP/M and MP/M, reference guide to CP/M and MP/M commands and programs, practical hints, and the future.

The CP/M Handbook with MP/M is available from ETI Book Sales, 4th Floor, 15 Boundary St, Rushcutters Bay NSW 2011 for \$16.95 + \$2 postage and packing.



does not over-write the file on the disk — it just removes the entry in the directory file.

**DIR:** lists the directory of a disk. It can also list only those files starting with a particular letter, etc.

**REN:** renames a file.

**SAVE:** puts an area of RAM into a named file. The LOAD transient command (see later) allows the file to be put back into the area of RAM where it was taken from originally.

**TYPE:** lists a file on the terminal (or printer).

As I mentioned before, transient commands are merely files which happen to contain machine code programs, and so are not uniquely 'CP/M' — but the following come with the standard version:

**STAT:** allows the user to find out such things as how much area remains on a particular disk, etc.

**LOAD:** copies a file into RAM.

**PIP:** copies a file from one disk drive to another, or in fact, from any peripheral

**SYSGEN:** puts the current RAM-resident version of CP/M onto a disk.

**MOVCPM:** allows the user to generate new versions of CP/M of different sizes.

**DUMP:** lists a file in hex on the terminal (or printer).

In addition to the above, the manual lists the following as transient commands — but I think they deserve a deeper coverage:

**ASM:** is a fully-fledged 8080 assembler, using standard Intel mnemonics. It

takes in a file of assembly language statements and puts out a file which contains the hex machine code equivalent plus the original assembly statements. This output file can then be edited to separate the machine code characters and load them into RAM.

**ED:** is a powerful contextual editor, which allows the user to alter files, copy files, etc. One feature which is designed for use with ASM output files is the ability to remove the leftmost part of each line (i.e. the part which contains the machine code).

**SUBMIT:** the SUBMIT command passes a named file to the CCP — in other words, to CP/M it is as if the commands in that file were being input directly at the console. So whole sequences of CP/M commands can be stored, and executed one after the other automatically. This sort of thing is very useful for such 'operator' tasks as backing up the latest versions of files onto an 'archive' disk.

All in all, not only does CP/M contain all the commands and features necessary for the operation of a complete disk-based system, it also comes with enough utility software to keep most domestic users happy for some time.

CP/M is not only important because of its usefulness in an isolated system; in the same way that the S-100 buss has enabled the domestic computer industry to produce an enormous variety of compatible hardware, CP/M will allow software to suit.



## WANTED: A Professional Amateur

Are you a keen amateur radio hobbyist? Perhaps you're retired — but a bit bored with having nothing challenging to do.

You've probably built a lot of your own gear. You're active in the club circuit and maybe the WIA. You read CQ, QST, 73, etc. — and have a pretty good knowledge of electronics.

You may have had a business career — and miss the opportunity to use your entrepreneurial and marketing talents.

If we're talking about you, we could have the answer: you could become an advisor to the management team at Dick Smith Electronics.

Your job would include sourcing new amateur radio products — visiting the East to find the latest and best products for Australian amateurs.

You'd also assist in the marketing and merchandising of these products.

To learn more about this exciting position, please apply in writing to:

**THE MANAGING DIRECTOR  
DICK SMITH ELECTRONICS  
PO BOX 321,  
NORTH RYDE, NSW 2113**



## ELECTRONIC TECHNICIANS

We require the services of several electronic technicians to work in our Service Centre at North Ryde.

The work involves repair of an enormous variety of electronic equipment in our air conditioned workshop.

Applicants should ideally possess the E&C Certificate, have had several years experience in the industry and be able to work without supervision.

Salary is negotiable and generous staff benefits apply. If you think that you're the person that we need, please apply in writing to:

**Garry Crapp Service Manager  
DICK SMITH ELECTRONICS  
PO Box 321, North Ryde,  
NSW 2113**

# SINCLAIR ZX81

Available from the following  
leading stores —

### QUEENSLAND:

MYER — ALL BRANCHES

SOFTWARE 80

Shop 11/200 Mogill Rd., Taringa, 4068 (07) 371 6996

DATACOM

Shop 16, S.G.I.O. Arc., Bundaberg, 4670 (071) 71 4740

### A.C.T.:

COMPUTER WORLD

Shop G71, The Bridge, Woden Plaza (062) 81 1368

### TASMANIA:

J. WALSH & SONS PTY. LTD.

130 Macquarie St., Hobart, 7000 (002) 34 7511

BIRCHALLS

118-120 Brisbane St., Launceston, 2250 (003) 31 3011

### VICTORIA:

RADIO PARTS GROUP

562 Spencer St., West Melbourne, 3003 (03) 329 7888

ROD IRVING ELECTRONICS

425 High St., Northcote, 3070 (03) 489 8131

MINIT COMPUTER SERVICE

119 McCrae St., Bendigo, 3550 (054) 43 2589

Albury

(060) 21 5933

B.B.J. COMPUTER SHOP PTY. LTD.

88 Albert Rd., Sth. Melbourne, 3205 (03) 699 5622

### W.A.:

MICRO BASE

127 Fitzgerald St., Perth, 6000 (09) 329 9308

### S.A.:

ACUIS TRADING

185 Pirie St., Adelaide, 5000 (08) 223 1900

### N.S.W.:

B.B.J. COMPUTER SHOP PTY. LTD.

329 Pacific Hwy., Crows Nest, 2065 (02) 922 4022

CITY PERSONAL COMPUTER

75 Castlereagh St., Sydney, 2000 (02) 233 8992

ELECTRON 2000

181 Wharf Rd., Newcastle, 2300 (049) 26 2918

DAVID REID ELECTRONICS PTY. LTD.

127 York St., Sydney, 2000 (02) 29 6601

COMPUTER WAVE PTY. LTD.

Lwr. Ground Floor, Myer, Sydney, 2000 (02) 238 9111

Like to be the SINCLAIR  
stockist in your area?

Ring today —

**(03) 419 3033**

**Reach advanced computer comprehension in a few short hours with the new, mighty**

# **sinclair ZX81**

1980 saw a genuine breakthrough — the Sinclair ZX80, world's first complete personal computer for \$300, the ZX80 offered a specification unchallenged at the price.

Over 50,000 were sold, and the ZX80 won virtually universal praise from computer professionals.

Now the Sinclair lead is increased: for just \$250, the new Sinclair ZX81 means an even bigger saving. At \$250 it costs less than the ZX80.

## **Lower price; High capability**

With the ZX81, it's just as simple to teach yourself computing, but the ZX81 packs even greater working capability than the ZX80.

It uses the same microprocessor, but incorporates a new, more powerful 8K BASIC ROM — the 'trained intelligence' of the computer. This chip works in decimals, handles logs and trig, allows you to plot graphs, and builds up animated displays.

And the ZX81 incorporates other operation refinements — the facility to load and save named programs on cassette, for example, or to select a program off a cassette through the keyboard.

## **Higher specification, lower price — how's it done?**

Quite simply, by design. The ZX80 reduced the chips in a working computer from 40 or so, to 21. The ZX81 reduces the 21 to 4!

The secret lies in a totally new master chip. Designed by Sinclair and custom-built in Britain, this unique chip replaces 18 chips from the ZX80!

The ZX81 comes complete with all leads to connect to your TV (colour or black and white) and cassette recorder.

## **New, improved specification**

- Z80 a microprocessor — new faster version of the famous Z80 chip, widely recognised as the best ever made.
- Unique 'one-touch' key word entry: the ZX81 eliminates a great deal of tiresome typing. Key words (RUN, LIST, PRINT, etc.) have their own single-key entry.
- Unique syntax-check and report codes identify programming errors immediately.
- Full range of mathematical and scientific functions accurate to eight decimal places.
- Graph-drawing and animated-display facilities.
- Multi-dimensional string and numerical arrays.
- Up to 26 FOR/NEXT loops.
- Randomise function — useful for games as well as serious applications.
- Cassette LOAD and SAVE with named programs.
- 1K-byte RAM expandable to 16K bytes with Sinclair RAM pack.
- Able to drive the new Sinclair printer (not available yet — but coming soon)!
- Advanced 4-chip design, microprocessor, ROM, RAM, plus master chip — unique, custom-built chip replacing 18 ZX80 chips.

## **If you own a Sinclair ZX80 . . .**

The new 8K BASIC ROM used in the Sinclair ZX81 is available to ZX80 owners as a drop-in replacement chip. (Complete with new keyboard template and operating manual.)

With the exception of animated graphics, all the advanced features of the ZX81 are now available on your ZX80 — including the ability to drive the Sinclair ZX Printer.

## **16K-byte RAM pack for massive add-on memory**

Designed as a complete module to fit your Sinclair ZX80 or ZX81, the RAM pack simply plugs into the existing expansion port at the rear of the computer to multiply your data/program storage by 16!

Use it for long and complex programs or as a personal database. Yet it costs as little as half the price of competitive additional memory.



## **Coming soon — the ZX Printer**

Designed exclusively for use with the ZX81 (and ZX80 with 8K BASIC ROM), the printer offers full alpha- numerics across 32 columns, and highly sophisticated graphics. Special features include COPY, which prints out exactly what is on the whole TV screen without the need for further instructions. The ZX Printer will be available in Summer 1981.



**For your free catalogue on software, send stamped, self-addressed envelope to Sinclair Equipment (Australasia) P/L.**

**sinclair** : you're the  
*greatest, now  
 better than  
 ever.*

**ZX81**



*Personal  
 computer,*

**\$250**

Incl. sales tax,  
 pack/post.

**COMPLETE WITH  
 MAINS ADAPTOR,  
 LEADS & BASIC MANUAL**

**ORDER FORM — SINCLAIR EQUIPMENT (AUSTRALASIA) P/L**  
 86-88 Nicholson Street, Abbotsford, Victoria, 3067. Telephone: 419 3033.

QUANTITY	ITEM	ITEM PRICE	TOTAL
	Ready assembled ZX81 Sinclair Personal Computer including mains adaptor, leads, BASIC manual	\$250	
	16K-BYTE RAM pack	\$150	
	8K-ROM (only if required for ZX80)	\$ 75	
	ZX Printer (to be announced)		
		Total	

I enclose cheque/Bankcard/Diners/Amex

Name \_\_\_\_\_

Address \_\_\_\_\_ Postcode \_\_\_\_\_

Signature \_\_\_\_\_

ET1



**NEW  
 BASIC  
 MANUAL SINCLAIR ZX81**

Every ZX81 comes with a comprehensive, specially written manual — a complete course in BASIC programming, from first principles to complex programs.

**For your free catalogue on software, send stamped, self-addressed envelope to Sinclair Equipment (Australasia) P/L.**

# Faster than a speeding bubblesort . . . it's Shellsort!

Whilst bubbles just drift along in a sort routine, the Shellsort really speeds things up — as much as five times!

A. Daviel

IF YOU RUN Alphasort as we published recently, you will notice that, though it is very fast indeed for short lists, it takes disproportionately longer for large lists. To be exact the time taken is proportional to  $N^2$  for a random list of  $N$  records.

The following program, though somewhat more complex, takes a time proportional to  $N \log_2(N)$ . To give an idea of what this means, suppose it is necessary to sort a government census file of one million records. If, on a given machine, the Bubblesort and Shellsort each take 20 milliseconds to sort 64 records, the Shellsort would take half an hour to sort the census file. The Bubblesort — four months! On a more down-to-earth application the Shellsort will sort 250 records in one-fifth of the time.

## Using the Shellsort

The example program, written in Microsoft BASIC, illustrates how the routine is driven. You will observe that the routine does not actually sort the array, but instead returns the array SP as a pointer into the string array. This may sound unduly complicated at first, but by using this method it is not necessary to move the records around (which may be quite long) more than once. In the example program, the records being sorted consist of a single string, but in general they will consist of mixed string and numeric fields. The list will be sorted according to one of these fields, called the key. A\$ in line 8250 of Shellsort would be replaced by this field.

## How it works

The general principle is that of merging two sorted sequential files — the

method by which files are sorted which will themselves not fit into main store. The next record in the merged file is selected from the input file with the record next in order; see Figure 1. To apply this technique to an array of strings, the array is first split into  $N$  lists of one string each. These are merged in pairs to give  $N/2$  lists of two strings, and so on until the whole array has been sorted; see Figure 2. You will note  $N$  has to be a power of two, so that in the example program the array is preset to an artificially high value.

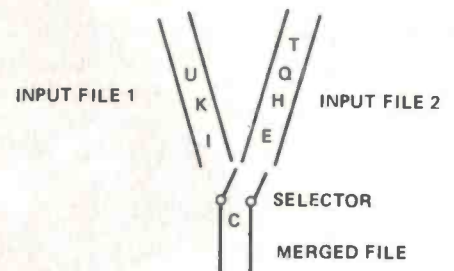

Figure 1. Using selection to merge files.

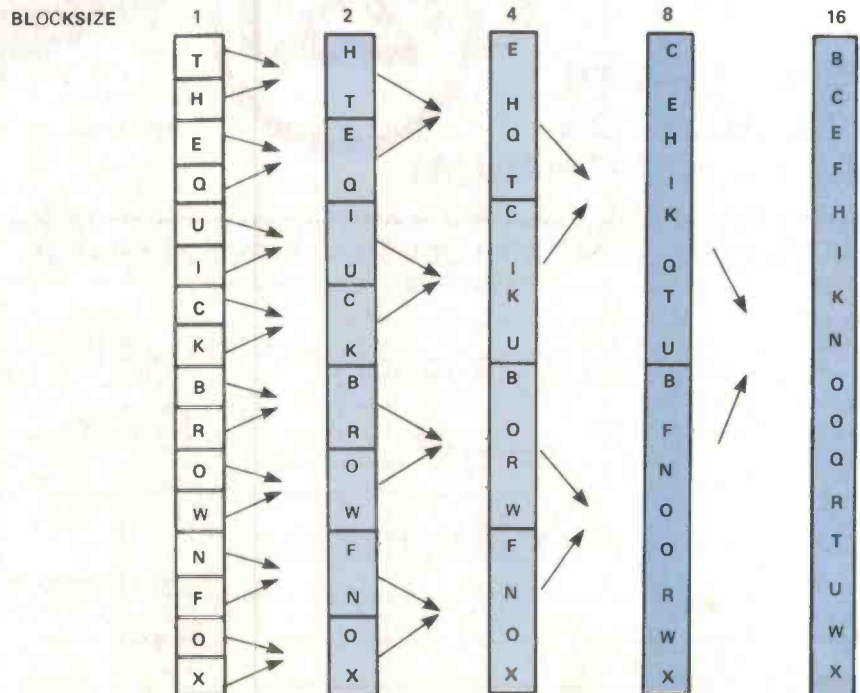

Figure 2. How the files are sorted and merged.

## Program listing

```

100 PRINT " [CLS ] STRINGSORT"
110 REM INITIALISATION
130 DIM A$(255) : EN = 255 : CT = 0
132 REM PRESET A$ TO MAXIMUM
135 I = 0 TO 255 : A$(I) = CHR$(255) : NEXT
140 PRINT "PLEASE INPUT NAMES, WHEN YOU
ARE"
150 PRINT "READY TO SORT TYPE'"
160 PRINT
170 REM INPUT ROUTINE
180 PRINT "YOU HAVE ROOM FOR "; EN; "MORF EN-
TRIES"
190 INPUT A$(CT)
200 IF A$(CT) = "" THEN 250
210 CT = CT + 1 : PRINT " [CLS ]"
220 IF CT > 254 THEN 250
230 EN = 255 - CT : GOTO 180
240 END
245 REM SET NUMBER OF ELEMENTS & CALL
SHELLSORT
250 SN = CT - 1 : GOSUB 8100
470 REM LINE LOOP OUTPUT
475 FOR KK = 0 TO 9:GET K$:NEXT
480 PRINT "HIT A KEY FOR LIST"
490 GET K$ : IF K$ = " " GOTO 490
510 LP = 0 : SL = 18
520 FOR P = LP TO LP + SL
525 IF P > CT THEN END
527 REM ARRAY SP GIVES POINTER INTO A$
530 PRINT A$(SP(P))
540 NEXT P
545 FOR KK = 0 TO 9:GET K$:NEXT
547 PRINT
550 PRINT " **HIT ANY KEY TO CONTINUE**"
560 PRINT " ***$' WILL BREAK***"
565 PRINT
570 GET K$ : IF K$ = " " THEN 570
580 IF K$ = "$" THEN END
590 LP = LP + SL + 1

```

```

600 GOTO 520
8000 REM SHELLSORT ROUTINE
8010 REM THIS ROUTINE WILL SORT A
8020 REM STRING ARRAY A$
8030 REM INTO ASCENDING ORDER.
8035 REM THE ROUTINE RETURNS SP(SN - 1)
8040 REM AS A POINTER ARRAY INTO THE
8045 REM LIST. THE ROUTINE USES
8050 REM VARIABLES PREFIXED 'S'.
8070 REM THE ROUTINE TAKES ABOUT 2 MIN.
8075 REM TO SORT A 256 ELEMENT LIST
8080 REM THE TIME TAKEN IS PROPORTIONAL
8085 REM TO 2*LOG2(N)*N.
8100 SS = (INT(LOG(SN)/LOG(2)) + 1)
8110 SN = 2I SS:REM SN MUST BE A POWER OF 2
8140 REM SS IS NO OF STEPS
8150 DIM SP(SN) : DIM SQ(SN)
8160 FOR SI = 0 TO SN - 1
8170 SP(SI) = SI : NEXT SI
8180 SB = 1 : SP = 1:REM BLOCKSIZE, STEP NO
8190 IF S > SS THEN RETURN
8195 PRINT " [CLS ]SORTING: BLOCKSIZE = "; SB
8200 SJ = SN/2:SI = 0:SK = 0
8210 SL = SB + SI : SM = SB + SJ
8220 IF (SJ > = SM) AND (SI > = SL) GOTO 8300
8230 IF (SJ > = SM) GOTO 8260
8240 IF (SI > = SL) GOTO 8280
8250 IF A$(SP(SI)) > A$(SP(SJ)) GOTO 8280
8260 SQ(SK) = SP(SI)
8270 SK = SK + 1 : SI = SI + 1 : GOTO 8220
8280 SQ(SK) = SP(SJ)
8290 SK = SK + 1 : SJ = SJ + 1 : GOTO 8220
8300 IF SK > SN - 1 GOTO 8320
8310 SM = SM + SB : SL = SL + SB: GOTO 8220
8320 FOR SI = 0 TO SN - 1
8330 SP(SI) = SQ(SI): NEXT
8340 SB = SB * 2 : SP = SP + 1
8350 GOTO 8190

```

**NEW  
FOR '81**

## FANTASTIC NEW PROGRAMMABLE COLOR T.V. GAME

**Signet UV1 System**  
One of the most sophisticated programmable  
T.V. Game available. Keyboard overlays come  
with each program cartridge to create exciting  
realistic action games.

Games	Cartridges
MG301	Soccer
MG302	Othello
MG303	Basketball
MG304	Space Mission
MG305	Baseball
MG306	Alien Invader
MG307	Star Chess

**\$199.00**  
**\$33.60 each**



MPT-03

**RADIO PARTS  
GROUP**

MELBOURNE AUSTRALIA

HEAD OFFICE: 562 SPENCER ST., WEST MELBOURNE, 3003  
TELEPHONE: (03) 329 7888. TELEX: 32980

SOUTHERN DEPOT: 1103 DANDENONG RD., EAST MALVERN, 3145  
TELEPHONE: (03) 211 8122



Enclose cheque/Bankcard/Diners/Amex

Name \_\_\_\_\_

Address \_\_\_\_\_ Postcode \_\_\_\_\_

Signature \_\_\_\_\_

# DICK SMITH'S SOUND VALUE!



## 3 WAY STEREO CAR SPEAKER SYSTEM

for the car  
**HI FI!**

These incredible speakers handle 30 watts per channel (max.) with quality tweeter, mid-range and woofer speakers for great sound! They'll make your stereo cassette or FM radio sound better than ever! Finished in strong grey plastic with mesh grille and angled bracket for mounting.

Cat. A-7082

**SOUND  
VALUE!**

**\$92 PER  
PAIR**

## STORE YOUR CASSETTES

This vinyl cassette case has carry handle and fastener and stores up to 16 cassettes in their cases. Ideal for the car or home.

**SOUND  
VALUE!**

Cat. C-3810

**\$3<sup>95</sup>**



## TOP VALUE! SHURE MAGNETIC CARTRIDGES

### Model M-91ED

The Shure M-91ED is a first class magnetic cartridge. It has high trackability with a recommended tracking weight of between 3/4 and 1 1/2 grams. Complete with elliptical diamond stylus. Cat. C-5515

**\$47<sup>50</sup>**

### Model M-70EJ

This cartridge has a tracking weight of 1 1/2 to 3 grams and a frequency response of 20 - 20,000Hz. Complete with elliptical stylus. Cat. C-5512

**\$18<sup>50</sup>**

### Model M-70B

The same superb specifications as the M-70EJ but has a spherical diamond stylus. The same stylus is supplied with the Dick Smith turntable. Cat. C-5511

**\$13<sup>50</sup>**

### Replacement Styli

for the M-91ED cartridge. Cat. C-5036

**\$19<sup>95</sup>**

for the M-70EJ cartridge. Cat. C-5034

**\$14<sup>50</sup>**

for the M-70B cartridge. Cat. C-5032

**\$9<sup>95</sup>**

## TOP VALUE HI FI STAND

A beautifully prepared kit cabinet, comes to you in knock-down form and complete with full instructions for easy assembly. Finished size: 370mm (d) x 470 (w) x 940mm (h). Wood grain finish. Cat. A-0105

**SOUND  
VALUE!** **\$72<sup>00</sup>**

## BUILD THIS TOP AMP AND SAVE!

This Playmaster Amplifier now includes the latest 'BI-FET' operational amplifiers in the input stages for the ultimate in low noise, high performance signal handling characteristics. Yet it costs less than it did in 1979! Save a fortune by building it yourself!



Cat. K-3412

**GREAT VALUE!!! \$77 OVER 10,000 SOLD!**

Transformer extra

## Head Demagnetizer

Ideal for use with all audio tape machines using magnetic tape. Simply plug into 240V AC and use like a wand to 'sweep' away excess magnetism! If excess noise is plaguing your recordings, this could be the answer!

**\$7<sup>75</sup>** Cat. C-7222



## DICK'S OWN QUALITY TAPE



Good quality cassette tape, at a lower price. Even greater savings if you buy 10 or more!

**C60 Low Noise**  
Cat. C-3350 **\$1<sup>50</sup>**

**C90 Low Noise**  
Cat. C-3352 **\$2<sup>00</sup>**

**C90 Extended  
Dynamic Range**  
Cat. C-3354 **\$2<sup>75</sup>**

**SOUND VALUE!**

## TRANSFORMERS FOR THE ABOVE AMP

Team this incredible 'C core' power transformer with the above and you've got a 40 w.p.c. amp for under \$100! M-0148

**\$22<sup>50</sup>**

SAVE \$30 ON LAST YEARS AMP & POWER SUPPLY PRICE.

Standard low noise transformer for 25 w.p.c. output. Cat. M-0146

**\$12<sup>50</sup>**



Cat. C-4103

## ECONOMY STEREO 'PHONES WITH

WITH VOLUME CONTROL

Great headphones at a great price! Volume control for left and right channels. Rated at 8 ohms

**\$9<sup>95</sup>**

Cat. A-2460



## TOP VALUE

Impressive speakers at a bargain price! Rated at 8 ohms impedance. 15 w.p.c. Why not buy a pair for the patio or rumpus room and have music all over the house!

## Extension speakers

VALUE

**\$19<sup>50</sup>**

Cat. C-4105



**SOUND  
VALUE!**

**\$47<sup>50</sup>  
EACH!**

## PHONE PICKUP

Record from phone to tape via suction pad fitting. Cat. C-7300

**\$1<sup>50</sup>**

Use subject to Telecom approval

All our stores carry a full range of audio leads and plugs.

## CASSETTE LIBRARY

Two cartons containing two cassette holders which lock together, can be screwed into the wall or made free standing (as illustration). Holds up to 32 cassettes horizontally or 20 cassettes vertically.



**SOUND  
VALUE!**

**\$6<sup>50</sup>**

Cat. C-3800

# DICK SMITH Electronics

NSW 145 Parramatta Rd AUBURN 648 0558 • 613 Princes Hwy BLAKEHURST 546 7744 • 818 George St BROADWAY 211 3777 • 531 Pittwater Rd BROOKVALE 93 0441 • 147 Hume Hwy CHULLORA 642 8922 • 162 Pacific Hwy GORE HILL 439 5311 • 396 Lane Cove Rd NORTH RYDE 888 3200 • 30 Grose St PARRAMATTA 683 1133 • 125 York St SYDNEY 290 3377 • 173 Maitland Rd TIGHE HILL 61 1896 • 263 Keira St WOLLONGONG 28 3800 ACT 96 Gladstone St Fyshwick 80 4944 QLD 166 Logan St BURANDA 391 6233 • 842 Gympie Rd CHERMSIDE 59 6255 SA 60 Wright St ADELAIDE 212 1962 VIC 399 Lonsdale St MELBOURNE 67 9834 • 260 Sydney Rd COBURG 383 4455 • 656 Bridge Rd RICHMOND 428 1614 • Cnr Dandenong & Springvale Rds SPRINGVALE 547 0522 WA Cnr Wharf St & Albany Hwy CANNINGTON 451 8666 • 414 William St PERTH 328 6944  
Mail Order Centre: PO Box 321, North Ryde 2113. Phone (02) 888 3200

DSE/A047/LM





# thandar

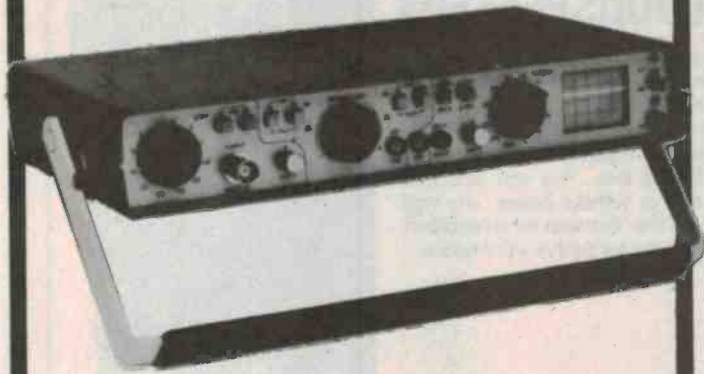

## SC110 LOW POWER PORTABLE OSCILLOSCOPE

The new Thandar SC110 represents a breakthrough in oscilloscope development. For the first time every engineer, serviceman and technician can carry the most fundamental piece of electronic test gear with him everywhere - an oscilloscope. The SC110 is less than 2 inches thick and weighs under 2 pounds, yet it has the performance of a standard bench oscilloscope.

Oscilloscopes have been described as portable before, but until now none has achieved the low weight, low power consumption, or good ergonomic design that are the essence of true portability.

### SC110 SINGLE TRACE LOW POWER 2" OSCILLOSCOPE

Bandwidth:	DC to 10MHz
Sensitivity:	10mV/division to 50V/division
Sweep Speeds:	0.1μsecs/division to 0.5 secs/division
Power Requirements:	4 to 10V DC from 4 'C' cells or AC adaptor
Size:	255 x 150 x 40mm
Weight:	800gms excluding batteries

SOLE AUSTRALIAN AGENTS:

## **N** NILSEN ROWE AUSTRALIA PTY. LTD.

200 Berkeley Street, Carlton, Vic. 3053  
P.O. Box 349, North Melbourne, Vic. 3051  
Phone: 347 9166 Telex: AA33254

### NILSEN ROWE AUSTRALIA PTY. LTD. OFFICES:

#### BRISBANE:

NILSEN ROWE AUSTRALIA PTY. LTD.  
8 Allison St, Mayne, Qld, 4006  
P.O. Box 682, Fortitude Valley, 4006  
Phone: (07) 52 5231. Telex: AA41074

#### MELBOURNE:

NILSEN ROWE AUSTRALIA PTY. LTD.  
200 Berkeley St, Carlton, Vic, 3053  
P.O. Box 349, North Melbourne, 3051  
Phone: (03) 347 9166. Telex: AA33254

#### PERTH:

NILSEN ROWE AUSTRALIA PTY. LTD.  
12 Roberts St, Osborne Park, W.A., 6017  
P.O. Box 209, Osborne Park, 6017  
Phone: (09) 443 1522. Telex: AA93618

#### SYDNEY:

NILSEN ROWE AUSTRALIA PTY. LTD.  
18 Newton St, Alexandria, NSW, 2015  
P.O. Box 139, Alexandria, 2015  
Phone: (02) 519 1422. Telex: AA20433

#### ADELAIDE:

NILSEN ROWE AUSTRALIA PTY. LTD.  
100 Regency Rd, Ferryden Park, S.A., 5010  
P.O. Box 111, Kilkenny, 5009  
Phone: (08) 268 2300. Telex: AA82154

Thandar - manufactured in England by Sinclair Electronics Ltd.

# SUPERTEX VMOS POWER FETS

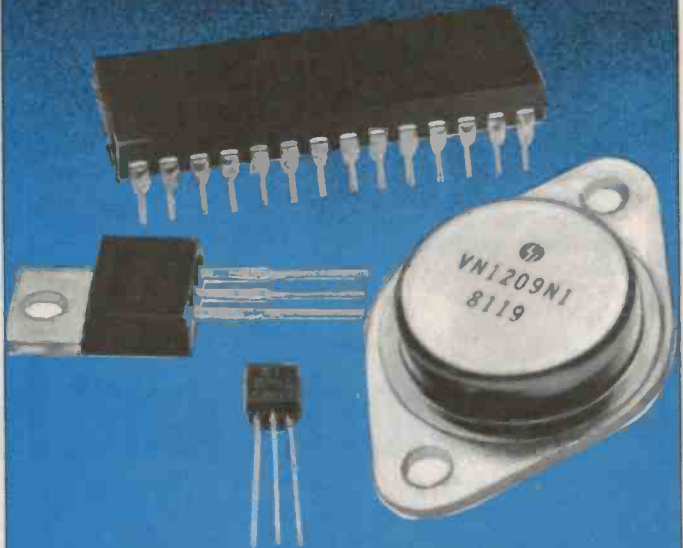

## P&N CHANNEL 10mA-50A 20v-800v

- HIGH SWITCHING SPEED. (NO STORAGE TIME DELAY).
- DIRECTLY INTERFACES TO CMOS, TTL AND MOS.
- HIGH GAIN.
- LOW DRIVE CURRENT.
- FREE FROM SECONDARY BREAKDOWN AND VOLTAGE DERATING.
- DRIVES INDUCTIVE LOADS.
- AVAILABLE IN T03, T0220, T039, T092 AND D.I.L. PACKAGES.

Technical information available on request.

# SOANAR

## Soanar Electronics Pty Ltd

A member of the A & R Soanar Electronics Group  
30 Lexton Road, Box Hill, Vic., 3128. Australia

VICTORIA: 840 1222 QUEENSLAND: 52 1131  
N.S.W. 789 6733 WEST. AUST. 381 9522  
Sth. AUST. 42 8918 TASMANIA: 31 6533

**NEW**

**THE 30 CM CONVERTIBLE:  
MONITOR AND T.V. SET**



**\$139.50**

If you need a monitor for your computer, consider this dual purpose set. A fully-fledged B/W TV set with RCA input for your computer. Alternatively, you could use the set in conjunction with a video camera as a closed circuit TV system. A simple switch allows easy change-over from TV to monitor. Available only from:

**PHILIPS  
LOUDSPEAKERS**

See us at Northpoint Hi-Fi for the new range of Philips loudspeakers and crossover networks. We have the ETI 4000 series speakers on display as well as other Philips kits. You can buy sets with or without boxes, any way you like. Come in for an audition, or write for further information.



**northpoint hi-fi**

100 Miller St, North Sydney.  
Ph 922-7780.

**Best bass yet  
from a kit!**

Now Peerless introduces another major advance to kit-set loudspeaker technology: A bass speaker with a rigid polypropylene cone that clearly outperforms traditional paper composite cone speakers, providing:

- cleaner, tighter bass sound reproduction
- low colouration and distortion
- high efficiency, suiting 25W to 100W amplifiers
- consistent rigid panel, low mass speaker cones.

Other outstanding features of Danish built Peerless speaker kit-sets are:

- sealed back mid-range with excellent linearity and low distortion
- latest Peerless 1" soft dome tweeter
- state-of-the-art crossover networks
- exceptionally flat response extending to 25,000 Hz.

Choose from these EA/Peerless speaker projects:

- PAS 100 12" 3 way 100W (100L) \$364.00 pr
- PAS 60 10" 3 way 90W (60L) \$214.00 pr
- PAS 25 8 1/4" 2 way 60W (25L) \$166.00 pr

Includes drivers, crossover, wiring and instructions.

Enjoy finer sound and avoid import duties by asking your nearest dealer for Peerless polypropylene loudspeaker kits or contact:

**G.R.D. GROUP Pty. Ltd.** 698 Burke Road,  
Camberwell, Victoria 3124 Phone: 82 1256

As featured in  
Electronics  
Australia Projects  
June and July  
1981.



**Peerless**



Please send me full details of Peerless Kit-set speakers and the name of my nearest dealer.

Name \_\_\_\_\_

Address \_\_\_\_\_

Postcode \_\_\_\_\_

CONCORD/P4106

**NEW**  
FROM  
**SHURE**

# StarMaker™

SERIES

**SM77 • SM78**  
**cardioid dynamic microphones**  
**that give you great sound,**  
**outstanding performance . . . and looks.**



Starmaker new light heavyweights are around 28% lighter than similar stage microphones. Yet they offer everything you've come to expect from Shure—consistently high performance, tailored frequency response, ruggedness and reliability. And they're available with or without cable.

**The Starmaker SM78** is "first choice" for rock, pop, R & B, country, gospel and jazz vocalists. Available in colour choice of black or tan.

**The SM77** is especially effective on instrumental pick-up where brilliant and defined sound is demanded. Available in colour choice of black or tan.

#### CHECK THESE GREAT FEATURES

**Lightweight, tough** . . . aluminium alloy case, 28% lighter, rugged as ever.

**Enhanced intelligibility and sound** . . . tailored frequency response, upper and mid-range presence peak.

**Durable, good looking finish** . . . exclusive SUEDECOAT™ finish—tough, non-reflective, rust and tarnish resistant.

**Custom designed carrying case** . . . cushions and protects against vibration or shock. Included at no extra cost.

For technical service and advice, contact the Audio Engineers representative at the office in your State:—

#### CHECK THESE SPECIFICATIONS

Frequency Response: 50-15,000 Hz.

Polar Pattern: Cardioid (unidirectional), rotationally symmetric about axis, uniform with frequency.

Impedance: Microphone rating impedance is 150 ohms (180 ohms actual) for connection to microphone inputs rated at 19 to 300 ohms.



send this coupon to:

AUDIO ENGINEERS, 342 Kent Street,  
SYDNEY, N.S.W. 2000. Tel. 29 6731.

Please send me your 'free' brochure on Shure  
"StarMaker" series. (PLEASE PRINT) Name & Address

Name: \_\_\_\_\_

Address: \_\_\_\_\_

Postcode: \_\_\_\_\_ ET1581

AUDIO ENGINEERS PTY. LTD.  
342 Kent Street,  
SYDNEY, N.S.W. 2000.

AUDIO ENGINEERS (Vic.)  
2A Hill Street,  
THORNBURY, Vic. 3071.

ATHOL M. HILL P/L  
Unit 5/66 Wellington Street,  
PERTH, W.A. 6000.

AUDIO ENGINEERS P/L (Qld.)  
51A Castlemaine Street,  
MILTON, Qld. 4064

NOMIS ELECTRONICS P/L  
689 South Road,  
BLACK FOREST, S.A. 5035.

# B&W DM 16

## THE DOMESTIC MONITOR



New concepts of design philosophy and new materials developed to optimise driver performance allow the DM 16 to take over where the DM 6 left off. Many of these innovations have been carried forward from the intense research for model 801 now widely acclaimed as one of the best reference monitor loudspeakers in the world.

The DM 16 employs a sloping custom tooled front panel to ensure accurate time delay correction complete with an integrated stand. The DM 16 offers an attractive visual appearance with minimal loss of acoustic perfection.

### Dimensions

950 mm high x 335 mm wide x 415 mm deep.

### Monitor Standard

Frequency linearity  $\pm$  2dB 65 Hz to 20 kHz.

### APOC-Protected

B&W's exclusive audio-powered overload circuit protects against accidental damage or overload.

**B&W**

LOUDSPEAKERS

For further information see your B&W dealer or contact  
Convoy International Pty Ltd  
4 Dowling Street Woolloomooloo NSW 2011  
Telephone (02) 358 2088

Available from: **N.S.W.**—Leisure Sound City • Artarmon • Parramatta. 29 1364 • Russin Electronics, Ashfield. 799 2421 • Duty Free Travellers Supplies, Sydney. 290 1644 • Dave Ryall Electronics, Dee Why. 982 7500 • Singleton Hi Fi, Singleton. (065) 72 2793 • Springwood Hi Fi, Springwood. (047) 51 3091 • Pitmans, Wagga Wagga. (069) 25 2155 • Wollongong Hi Fi, Wollongong. (042) 28 3773. **ACT**—Duratone Hi Fi, Phillip. (062) 82 1388. **VIC.**—Tivoli Hi Fi, Hawthorn. (03) 818 2872 • Steve Bennett Audio, Geelong. (052) 21 6011 • Boon Sound, Wodonga. (060) 24 3388. **QLD.**—John Gipps Stereo, Brisbane. (07) 36 0080 • Mackay Audio Centre, Mackay. (079) 575 035 • Premier Sound, Rockhampton. (079) 27 4004. **S.A.**—Soundcraftsman, Hawthorn. (08) 272 0341. **W.A.**—Audio Distributors, Mosman Park. (09) 384 5455 • Audio Centre, Perth. (09) 322 5177. **TAS**—Bel Canto, Hobart. (002) 342 008.

# B&W DM 22

## A BUDGET LOUDSPEAKER WITH A PEDIGREE!

To create the DM 22 we took the best features of the successful DM 4, DM 5 and DM 11, and combined them in a single system. To ensure top performance, B&W computer and laser technology, as used in the model 801, was liberally applied. DM 22 is suitable for amplifiers from 10 watts to a big 100 watts. And of course, in keeping with B&W DM series, attractively styled wood veneer cabinets are used.

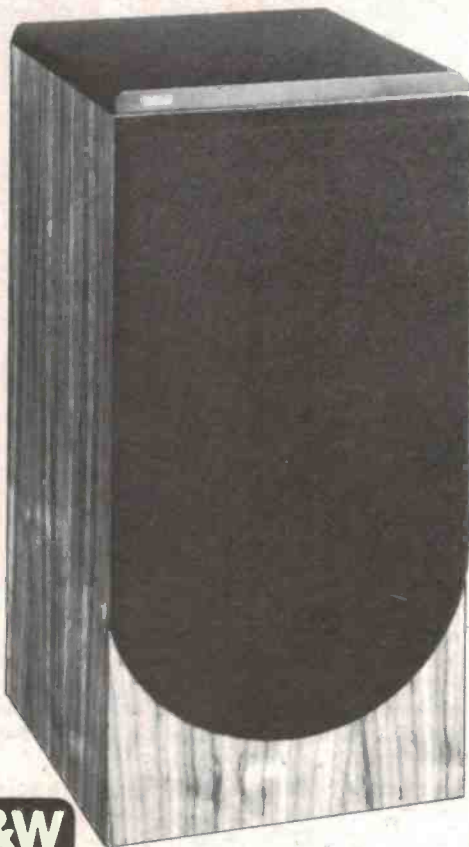

**B&W**

LOUDSPEAKERS



Optional stylish floor stand STAV 22 is also available if floor standing is required

### Compact Size

Just 504 mm high x 254 mm wide x 254 mm deep.

### High Sensitivity

Develops 106 dB sound pressure level at one metre. Frequency linearity  $\pm$  3 dB 70 Hz to 20 kHz.

For further information see your B&W dealer or contact

Convoy International Pty Ltd  
4 Dowling Street Woolloomooloo NSW 2011  
Telephone (02) 358 2088

Available from: **N.S.W.**—Leisure Sound City • Artarmon • Parramatta. 29 1364 • Russin Electronics, Ashfield. 799 2421 • Duty Free Travellers Supplies, Sydney. 290 1644 • Dave Ryall Electronics, Dee Why. 982 7500 • Singleton Hi Fi, Singleton. (065) 72 2793 • Springwood Hi Fi, Springwood. (047) 51 3091 • Pitmans, Wagga Wagga. (069) 25 2155 • Wollongong Hi Fi, Wollongong. (042) 28 3773. **ACT**—Duratone Hi Fi, Phillip. (062) 82 1388. **VIC.**—Tivoli Hi Fi, Hawthorn. (03) 818 2872 • Steve Bennett Audio, Geelong. (052) 21 6011 • Boon Sound, Wodonga. (060) 24 3388. **QLD.**—John Gipps Stereo, Brisbane. (07) 36 0080 • Mackay Audio Centre, Mackay. (079) 575 035 • Premier Sound, Rockhampton. (079) 27 4004. **S.A.**—Soundcraftsman, Hawthorn. (08) 272 0341. **W.A.**—Audio Distributors, Mosman Park. (09) 384 5455 • Audio Centre, Perth. (09) 322 5177. **TAS**—Bel Canto, Hobart. (002) 342 008.

# The Personal Computer

## Your information window

### An extension of your brain

An Apple Personal Computer puts you at the forefront of the technological revolution. Use it well and it will mediate the availabilities of a wealth of conceptual tools, data bases, communication channels and information processes. An Apple will help you simplify a myriad of tasks from ordinary data processing through information retrieval to economic forecasting.

### Apple is versatile

Your Apple is an extremely powerful and robust problem solver backed by a comprehensive set of software programmes. Already, over 300,000 Apples are used for business, domestic, educational research and recreational purposes.

### Apple as information processor

An Apple personal computer performs a full range of standard functions like statistics, word-processing, graphics, number crunching, filing, storage/retrieval and cross-referencing.

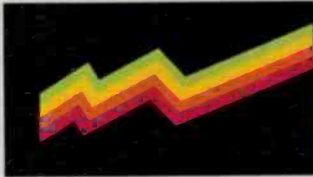
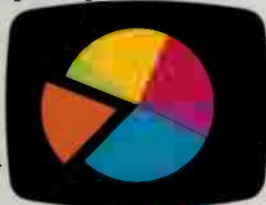

### Apple is cost-efficient

For roughly the price of a plain paper copier, you get a sophisticated, powerful machine, which not only processes numbers and words, but gives you direct access to a wealth of information through a rich network of data bases and direct communications with other computers.



### Apple as super-brain

Aside from the more pedestrian functions of retrieving and processing information, Apple performs other sophisticated functions such as econometric modelling, financial forecasting, graphics, topological modelling and trend analysis.

### Apple is convenient

Apple is portable. It can be used at home or in the office. You can address it in ordinary English or gain full computer literacy in BASIC PASCAL, COBOL, FORTRAN or PILOT. Full step-by-step training comes with your Apple. If you can use a calculator and speak English, Apple shows you the rest.

### Apple as communicator

Apple combines many of the functions of telephones, telexes, citizens' band radios and library access terminals. It allows you the very latest access to data bases and information services and mail electronically locally or world wide.

### Apple as challenger

Apple is fun. From a perfect game of Chess to Star Wars—not only for the children—preparing them for the future in this high-technology age.

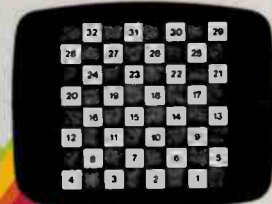

Mail this coupon for an "Apple Pack" brochure or talk to your local Apple authorised dealer about the specific applications for you.

If the coupon has been removed, send your name and address to:  
ELECTRONIC CONCEPTS PTY LTD,  
55 CLARENCE STREET,  
SYDNEY, NSW 2000



**apple computer**

Mail to: PFCB374B  
ELECTRONIC CONCEPTS PTY LTD,  
55 CLARENCE STREET, SYDNEY, NSW 2000  
Please send me a free "Apple Pack" brochure.

NAME \_\_\_\_\_  
ADDRESS \_\_\_\_\_  
POSTCODE \_\_\_\_\_  
PROFESSION \_\_\_\_\_

APPLE APPLE = PERSONAL COMPUTER PERSONAL COMPUTER = APPLE APPLE

# All Together Now

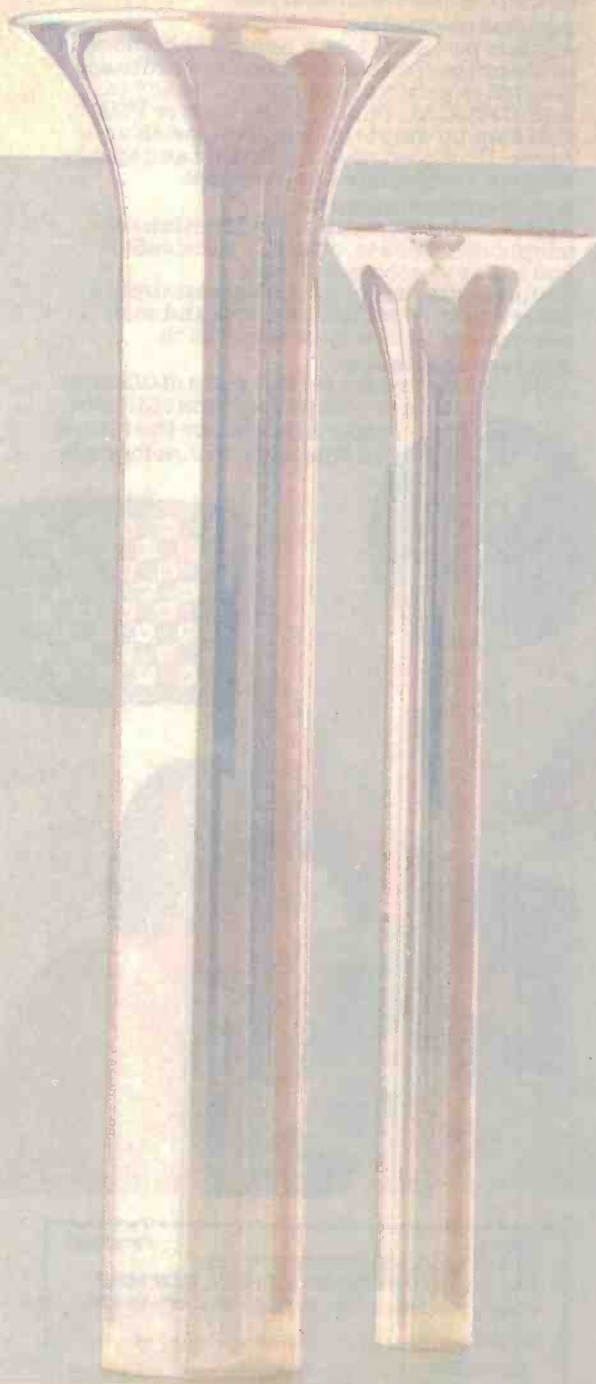

Five ways to bring your system to life and they are all Hitachi. Amplify your audio tastes. The Hitachi HA-6800 Power MOS FET Amp delivers 70W output — more than enough to satisfy. Get in line with the future — the HT 500 Turntable features Damped Straight Arm, Unitorque precision and Quartz Lock accuracy. There is the FT-5500 Digital Synthesizer Tuner with 10 station random access memory. Experience Hitachi metal tape technology. The D-E95 Microcomputer Controlled Cassette Deck handles all your cassettes — silently. And the HS-X38 Speaker System clearly demonstrates how Hitachi's sound engineering works. Perfectly.



Here's proof that the system sounds as good as it looks. Amp: 70 watts continuous RMS, 8 ohm, 20Hz — 20kHz, no more than 0.004% THD. Turntable: wow and flutter, 0.025% WRMS; 78 dB S/N. Speakers: output sound pressure level, 97 dB (1 W, 1 m). Cassette Deck: wow and flutter, 0.038%, 69 dB S/N with Dolby NR on. (Dolby is a trademark of Dolby Laboratories, Inc.) Tuner: 78 dB S/N in stereo.

# RARE ADDITIONS FROM MARANTZ. SLIMLINE AMPLIFIERS.



**Rare:** very valuable.

**Additions:** the things added.

**Marantz:** a range of ultra-high performance Slimline and three-quarter size Amplifiers which blend state-of-the-art engineering with operational versatility.

Although all units in a hi-fi system must be compatible in order to achieve optimum sound quality, there is no question that their final standard of performance relates directly to the main amplifier. It is the heart of the system and the point at which distortion is most likely to be introduced.

Marantz engineers have developed special techniques for reducing the various forms of distortion to miniscule levels. This is achieved by the use of a highly efficient negative feedback system and operation in class AB, with the careful selection of "shortest path" wiring to avoid interaction between different stages in circuitry and with the other channel.

The more powerful models are equipped with a heat-loop cooling system for the output stage transistors. This NASA invention enables the heat dissipated at high power levels to be rapidly removed so that a considerably improved power-to-size ratio is obtained.

If you see your hi-fi as an investment and, if you demand critical performance standards as well as the best value for money, listen to the future.

Listen to Marantz.

**marantz.**  
Now you're listening.

Distributed by MARANTZ (AUST) PTY. LTD.  
19 Chard Road, Brookvale, N.S.W. 2100  
Telephone (02) 939 1900 Telex AA24121  
Melbourne (03) 544 2011 Brisbane (07) 44 6478  
Adelaide (08) 223 2699 Perth (09) 276 3706



# SIGHT & SOUND

## At last — stereo TV!

Despite the introduction of colour and general improvement in picture quality and the addition of gimmicks like infrared remote control, very little has been done in the past to improve the sound of a TV set. Now the Second German Television Service (ZDF) has announced that from September this year about 65% of the West German public will be able to receive stereo sound from their TV sets.

**The prerequisite to this stereo TV sound is obviously a correspondingly equipped television set, and such sets will be displayed at the International Audio and Visual Fair in Berlin from September 4-13 this year. Various leading names in the manufacturing field will have sets on show.**

ZDF describes the introduction of stereo TV as "the most significant innovation since the introduction of colour in 1967", and claims that the TV viewer will now be able to expect and get stereo sound at hi-fi quality.

The two-channel sound process developed by the Institut für Rundfunktechnik (Institute for Broadcasting Technology) in conjunction with the industry and the broadcasting authorities is said to make use of a technical trick. The high frequency signal emitted by the transmitter contains, along with the picture signal, two parallel sound signals, which — completely separate from the picture — are divided in the television receiver with the aid of a stereo decoder and passed on to two loudspeaker units which are totally separate from each other.

This process not only enables the reproduction of stereo sound, but also permits the transmission of two completely separate sound channels. Thus one might, for example, be able to view a foreign movie without the aid of subtitles or dubbing; the original language could come through one channel, an English translation through the other, and the viewer would simply tune out the language not required.

This facility is said to give the German stereo sound process a decisive advantage compared to the matrix technique used in Japan, and certainly opens up very interesting possibilities for bilingual countries like Switzerland or Belgium.

Equipment manufacturers have a certain latitude with regard to design

of TV sets incorporating the new stereo sound. It is for example possible to use existing hi-fi speakers to obtain stereo TV sound, but this has drawbacks in that such speakers will not provide the best possible picture/sound synchronisation, volume will be adjustable only from the hi-fi unit, and two separate mains circuits must be constantly in operation (and who knows what the Government are going to start charging us for electricity!).

The use of hi-fi speakers may nevertheless be an acceptable solution for some users, but three other major design routes are open to the designers of the future stereo TV receiver:

- 'integrated' sets, with speaker boxes flange-mounted to the left and right of the screen or in the pedestal;
- television monitors with completely separate freestanding loudspeaker boxes;
- the combination of TV monitor, TV receiver unit, video recorder, videodisc player and audio components, all offering hi-fi quality in the so-called modular TV system of the future, operated by remote control via a buss system.

The idea of the complete 'home entertainment centre' visualised in this last suggestion may strike chords dear to the heart of home electronics manufacturers and dealers, but is hardly feasible or even desirable for many people today. It appears more likely that a TV set with attached stereo speakers would fit in best with the present set-up of most homes, keeping the TV in its traditional place separate from the audio set-up and integrating harmoniously into the living area. Perhaps people are less ready to be swept into such consumerism as the 'home entertainment centre' implies than the manufacturers would like to think.



### IT'S YOUR SHOUT

The world's loudest man (recorded in the Guinness Book of Records), Stan Lemkuil, drew as much attention at the Chicago CE Show as the porn queens, with his weird Viking dress and his 300 sound effects. He claims 117 dB sound pressure levels at 2.5 m (8' 2"), and an amazing 138 dB at 50 mm (2"). He is quite happy to demonstrate if you are prepared to risk your hearing.

## VCR prices down

Zenith recently contributed to the downward spiral in VCR prices in the United States with the introduction of two units priced under US\$1000.

The VR8500 will retail at US\$799.95 and the VR8900 at US\$850. Both are Beta 3-type recorders with up to five hours' record capability. The 8900 also includes a wired remote control unit and Beta 1 playback.

Zenith also introduced two players at the higher end-of the market — the VR9760 and a portable model, the VR9800, also

Beta 3 types. The 9760 has four-day, four-event record capability and will retail at US\$1250; the portable 9800 allows up to five hours of recording time over a two-week period and has a suggested list price of US\$1425. A fifth model will be available later in the year.

Two earlier models, the VR9000 and the VR9750, will be discontinued.

**MOSS  
COMPONENTS**

PO BOX 324, FAIRFIELD, NSW 2165.

**RESISTORS**

½W Carbon Film 5% .....4¢  
¼W Carbon Film 5% .....3¢

**DIODES**

IN4004 .....8¢ IN4007 ... 14¢  
IN5404 ... 38¢ IN4148 .....5¢

5mm RED LED.. 15¢

Mounting Holder.....4¢

**TAG TANTALUMS**  
60¢ each

Write for Catalogue  
Pack & Post 10%  
Min \$1.00 Max \$5.00  
Office. 68 Dawson St.,  
Fairfield. NSW.

**TRY THIS EXCITING  
HOBBY!**

Build your own Organ, at  
half the cost of a  
ready-built Organ.

**WITH WERSI ORGAN  
KITS**

Wide range of models:  
COMBO to large CHURCH ORGANS



Also  
available  
ready-built.

- Also
- STRING ORCHESTRA
  - BASS SYNTHESIZER
  - ELECTRIC PIANO
  - and the famous WERSIVOICE ROTATION SOUND

For a Colour Catalogue send 80c.  
Klaus Wunderlich Demonstration Record, music only with jacket  
notes — \$7.00 (incl. postage.)

**CLEFTRONICS PTY. LTD.**  
9 Florence St., Burwood, Vic. 3125  
Phone: (03) 288-7899

# Marriage Announcement

The Finest in Turntables and  
Loudspeaker Systems  
Along with  
The Most Technologically Advanced  
Amplification Equipment

To

The Person who loves, cherishes  
& understands them better than  
anyone in the Business.

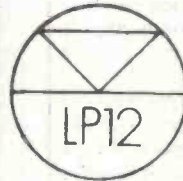

**LINN  
SONDEK**

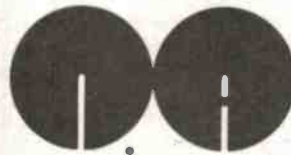

**naim audio**  
MANUFACTURERS OF AUDIO EQUIPMENT

Exclusive Australian Importers

## STOLMACK

44 ROMNEY ROAD, ST IVES, NSW. 2075. (02) 440 8441

"AIMING AT PERFECTION."



## Foldaway 'phones with microcassette player

**M-X33 is a super-compact (57 mm x 123 mm x 18.8 mm) stereo player with metal tape-compatible record/playback heads.**

It has a two-speed recording system and microphone mixing facility, inbuilt microphone and silent auto-stop tape mechanism. Functions include fast forward/cue/review and a slide tone control. A LED monitors battery life, and an ac power input is provided. The lightweight headphones can be easily folded to fit a pocket.

Power is either dc from two 'AA' size batteries or ac from an optional adaptor.

M-X33 is available now at a recommended retail price of \$219. For further information contact Mr. R. Hopwood, Sanyo Australia Pty Ltd, 225 Miller Street, North Sydney NSW 2060. (02)436-1122.

## Preview cassettes

**Video Classics recently released a one and a half hour videotape containing preview scenes from fifty of its best-selling video movies.**

The preview cassette lets you see approximately 2½ minutes of scenes from each movie. The recommended retail price of preview cassettes is \$24.95, just slightly more than a normal blank cassette, and the tape may be over-recorded after viewing.

Preview cassettes are also available for Video Classics' 'Nostalgia Merchant' range of movies from Hollywood's golden era of film making in the 1930 to 1950 period.

Cassettes are available now from 1000 Video Classics dealers throughout Australia.

For further information contact Mr. W. Lehne or Mr. G. Eather, Video Classics, 64 Arthur Street, North Sydney NSW 2060. (02)438-4866 — country and interstate calls toll-free 008-222 333.



## Noise reduction for car cassettes

**National Semiconductor Corporation has announced that Autotek Electronics will be using National's recently introduced dynamic noise reduction (DNR) system in their Hi-Tek series of high performance dashboard cassette players.**

The Hi-Tek series using DNR will be available to consumers in 1982, according to Sid Sheeber, president of Autotek Electronics.

National's DNR system is a single-chip, two-channel noise reduction system that does not require signal encoding. As a result, the DNR system is universally effective for all tape, AM and FM broadcast signals, and is said to be ideal for use in automotive entertainment systems.

Unlike other noise reduction systems that can only prevent the

equipment being used from adding more noise to the overall sound, DNR is a noise reduction method that eliminates noise that may already be present in the source program.

The Autotek Hi-Tek series is compatible with any system, and is available on a selective distribution basis.

National Semiconductor can be contacted at Cnr. Stud Rd and Mountain Hwy, Bayswater Vic. 3153. (03)729-6333.

## New Yamaha cartridge

**The new MC-5 moving coil cartridge from Yamaha is claimed to be a lightweight, highly responsive cartridge offering high efficiency linear output, low distortion and crosstalk, and great natural sound reproduction.**

Main features of the MC-5 are its special vertical-horizontal matrix system with a cross-shaped sendust core, and its tapered, tubular beryllium cantilever. Yamaha engineers originally developed the revolutionary tapered, hollow cantilever, made from high purity beryllium, for the top-of-the-line MC-1 cartridge.

Other features of the MC-5 cartridge include precision one-point

cantilever suspension and a diamond stylus tip polished to a special-contour 8 x 40 micron ellipse.

The suggested retail price of the MC-5 is \$170, and further information may be obtained from the Public Relations Manager, Yamaha/Rose Music, 17-33 Market St, South Melbourne Vic. 3205. (03)699-2388.



## New Sanyo cassette deck

**Sanyo's RD S45 is a slimline tape deck with fluorescent bar chart input monitoring. It is equipped with an AMSS tape program search system, soft-touch function controls and a logic transport system.**

A bias adjustment control enables optimum tape equalisation, and other features include Dolby noise reduction, a multiplex filter, an output level control, record mute, full auto stop, separate L-R microphone input sockets and two heads.

RD S45 provides a frequency response of 30-17 000 Hz (metal tape), 0.06% wow and flutter and 67 dB signal-to-noise ratio with

metal tape (Dolby on). Three LEDs indicate Dolby, AMSS and metal select functions.

Sanyo's RD S45 tape deck is available now at a recommended retail price of \$219.

For further information contact Mr. W. Fabiszewski, Sanyo Australia Pty Ltd, 225 Miller Street, North Sydney NSW 2060. (02)436-1122.

## Bang & Olufsen Beosystem 8000

**Bang & Olufsen recently released a complete music system made up of various high-class components: the Beomaster 8000 tuner/amplifier; Beocord 8000 cassette deck; Beogram 8000 tangential arm record player; and a pair of Beovox MS 150 loudspeakers.**

The music system can be operated centrally from the tuner/amplifier or remote-controlled by means of the Beolab terminal of the tuner/amplifier.

Distortion and noise in the Beomaster 8000 tuner/amp are claimed to have been reduced to a minimum, and many of the operating functions have been taken over by a microcomputer.

In the Beogram 8000 tangential arm record player, Bang & Olufsen claim to have combined uncompromising sound reproduction with ease of operation, and the player also contains a microcomputer, which allows complex functions to be activated by the means of one button. The turntable is not driven by a motor in any conventional sense, but by a new system comprising an aluminium ring and two sets of coils, activated by electricity.

The Beocord 8000 cassette deck also contains a microcomputer, which is programmed to calculate the consumption of cassette tape in minutes and seconds, among other things. Bang & Olufsen have

applied for a patent for this unique system. According to the company, many mechanical and electronic details have been improved in the cassette deck to give the best possible performance with the latest high-quality tapes.

The Beovox MS 150 speaker is the top of Bang & Olufsen's speaker range, and is a monitor system featuring a sub-woofer and a continuous load capacity of 150 watts. It is claimed to reproduce faithfully the frequency and dynamic range of digital records, metal particle tapes, direct radio transmissions and other high-quality sources. The MS 150 features a 10" sub-woofer, which functions as a bass reflex enclosure, an 8" bass/midrange unit, a 3" dome midrange unit, and a one-inch treble unit.

The recommended retail price for the Beosystem 8000 is \$7000. Further information may be obtained from GRD Group Pty Ltd, PO Box 351, Camberwell Vic. 3124. (03)82-1256.

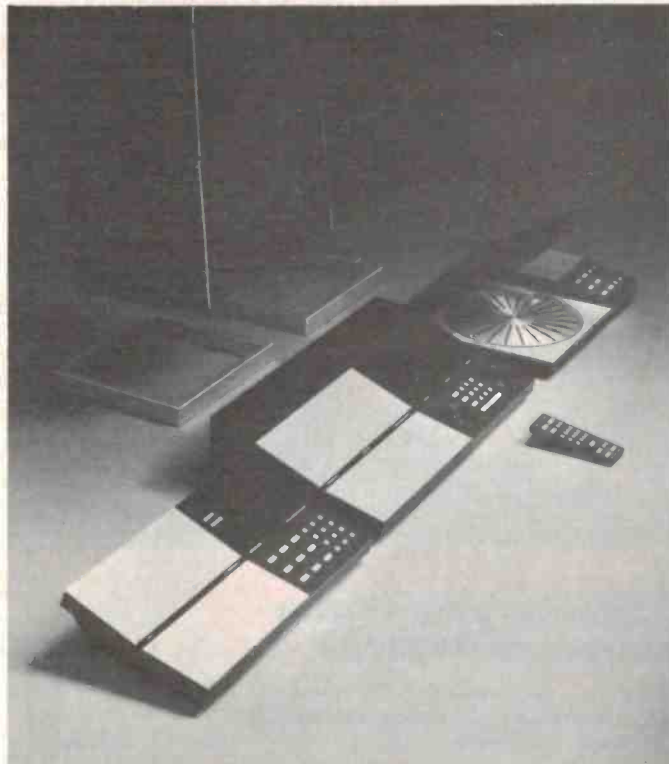

## They're giving it away!

**American distributors of the RCA SelectaVision videodisc system are offering software giveaway programs and cutting dealer prices to stimulate sales.**

Because of "consumer indifference" since the release of SelectaVision last year, many dealers have already cut into their own margins and discounted the systems, and RCA's plans for its distributors will ease the pressure on the dealers.

One plan calls for the distributors to sell discs at less than cost price to the dealer, who in turn will give away anything from one to three discs with each player sale. RCA is also encouraging distributors to offer dealers other amenities, such as a free popcorn popper, with each sale, and to offer financial support to

dealers to set up free at-home trials.

According to an RCA spokesman, "The problem ... is one of awareness. The programs are designed to make people more aware of the videodisc player."

RCA still believes its target of selling 200 000 players by the end of 1981 is achievable, and has no present intentions of cutting the list price of the player, which is US\$499.

However, the arrival of other suppliers on the market — Zenith, Toshiba, Hitachi, and others — is applying pressure for a reduction in price.

## Serex in Victoria

**Serex Instruments Ltd recently announced the opening of offices and showrooms in Victoria for its trading subsidiaries, Ralmar Agencies, Inkel (formerly Audio Reflex) and Sound Barrier. The office is located in the Prahran Market Centre in South Yarra.**

The Serex group is expanding rapidly, and has a projected sales increase of 61% this year as compared with the 1980-81 financial year.

A full range of the group's products will be permanently on display in the South Yarra showrooms.

## Janszen electrostatics available

**N.V. Dale electronics now has available the latest range of five electrostatic speakers from Janszen of the USA.**

Prices of the models range from around \$800 per pair to \$2000 per pair, all of which carry an unconditional five-year guarantee. Janszen has a 30-year history of manufacturing electrostatic speakers, and holds the base patents on the electrostatic driver system.

In theory, electrostatic speakers are the most perfect transducer, since the air is set in motion by a large surface area with a very low mass. This results in very good dispersion characteristics and excellent transient performance, plus a linear frequency response.

To match the electrostatic array, Janszen have teamed their newly designed Z woofer system. This uses a specially designed frame and diaphragm assembly which is said to permit extremely long excursions of the diaphragm without any mechanical interference, thereby ensuring total freedom of diaphragm movement.

The US magazine Hi-Fi Buyers' Review of August/September 1980

reviewed the Model Z40 Janszen speakers: "With these very good (laboratory tests) results in mind, we were anxious to audition the Z40s on our musical material. Perhaps the most critical test of any loudspeaker is the reproduction of a full orchestra, which pinpoints any deficiencies in power handling, transient responses and dispersion. We used the Telarc digital recording of Holst's 'Suites Numbers 1 and 2' as our first testpiece, and turned up the volume to concert hall level. Clarity and definition were outstanding, with every instrument precisely located. The Z40s' excellent transient response was evident in the reproduction of percussion passages, and low frequency power handling was very good. The Janszens were equally at home with other material, from live concerts to the spoken word."

For the name and address of your nearest stockists contact N.V. Dale Electronics on (03)387-6170 or 387-7076.

# The Highest Fi on Wheels.

Close the car door, turn on your Sony car stereo and let us give you the finest sound on wheels.

Imagine your car filled with the sound of the Sony XR-77 car Hi-Fi with built-in 20W + 20W power amplifier and loudness control. Imagine the cassette player with Dolby noise reduction, metal tape capability, an automatic music sensor, locking fast-forward and rewind.

Imagine the sound of the powerful AM/FM receiver with quartz-locked PPL synthesizer tuning, a digital frequency readout, 5FM + 5AM station memory presets, and auto-scan tuning. Top it all off with a built-in quartz clock, and you have a hi-fi set-up that will fill your car with some of the finest sounds money can buy.

Listen to it, and imagine how good it would sound in your car.



## SONY®

SON 0030



**H**itachi innovative technology:  
uncompromising quality, made to work  
better, longer.

For first time buyers of video systems, the quality of both sound and picture is the most important factor. But Hitachi portable and home systems offer far more than outstanding reproduction clarity— they deliver unequalled reliability and ease of operation.

Our portable system's colour camera has an optically precise 6X zoom lens that glides from wide angle to close up, automatic sound recording is built in as well as instant replay through the viewfinder, yet its low weight and simplicity make home movies child's play.

The portable recorder has a smooth-edit facility and the convenience of remote control, while its companion tuner/timer allows direct off-air recording (where copyright is not infringed) and acts as power source and battery charger for the portable recorder.

As an alternative to our compact and lightweight portable system, the Hitachi home video recorder is unmatched in technical innovation and smooth, trouble-free operation. Remote control, with visual search to get you to the action quicker—all with the ease of feather touch logic controls. Reliable operation and tape transport are taken care of with twin, quartz controlled direct drive motors.

Even our 34cm. portable colour television has such excellent picture quality and low interference in areas of poor reception that we guarantee it with a three year warranty.

Backed with fast, efficient after sales service, Hitachi video systems achieve a standard of precision and simplicity that others can only hope to equal.

Make sure you see an Hitachi before you buy anything else—it's not merely a matter of good judgement and sound common sense, it is the realisation that anything less is most certainly a compromise.

But because our standards also apply to our dealer network, you won't find our products on any street corner. However, you can discover your nearest franchised Hitachi dealer by ringing:

Melbourne 555 8722; Sydney 669 2200;  
Brisbane 275 2033; Adelaide 212 1300;  
Perth 458 1911; Hobart 28 0291.



 **HITACHI**  
Where quality comes first.

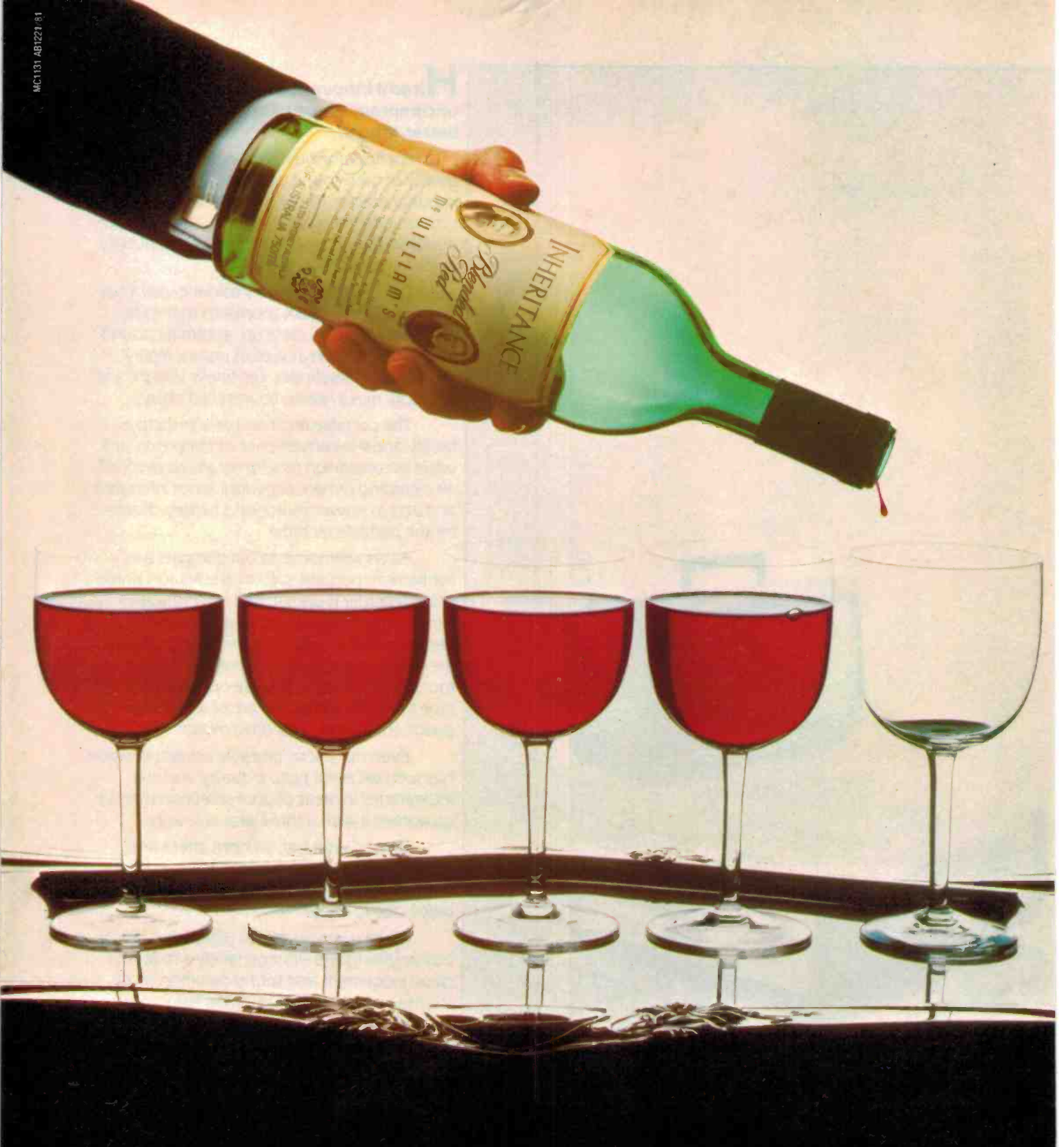

PITY THE POOR UNFORTUNATE  
WHO SQUANDERS HIS INHERITANCE.



# NAKAMICHI Z SERIES

One after another cassette recordings "insurmountable" barriers have fallen before Nakamichi innovation. Almost a decade ago, Nakamichi accomplished the "impossible" and developed a three head cassette deck. Continuing research extended cassette response to 20 kHz, to 22 kHz and now to 25 kHz. Today there are Nakamichi cassette recorders whose band width exceeds that of professional digital recording equipment.

It has been said that the current range of Nakamichi cassette decks represents the ultimate expression of the Nakamichi philosophy — "excellence in the fine art of recorded sound". But Nakamichi does not stand still. The second generation — Nakamichi Z Series — further pursues the philosophy.

## DOLBY B-C TYPE NOISE REDUCTION

The thorn in the side of cassette recordings has always been noise — the hiss that creeps in during quiet passages. Dolby B reduces this hiss by up to 10 dB with virtually no audible side effects but some hiss does remain.

In 1980, Dolby announced a new C-type system that is almost twice as effective in reducing high frequency noise as Dolby B while producing hardly any audible side effects. But to achieve full potential, Dolby C demands a high level of precision from the tape recorder with which it is used. Nakamichi believes that Dolby C will become the standard noise reduction system for the 80's and so it is incorporated in all Nakamichi Z series cassette decks.

## WIDE RANGE PEAK LEVEL METERS

Nakamichi recorders have been known for superior metering. In keeping with the greatly improved total dynamic range of the Z series, accurate peak level indication is essential. New peak responding electronic LED or FL displays with a meter range extending from -40 dB to 10 dB above "0" — sufficiently wide to give accurate indications on all musical signals — are incorporated in all Nakamichi Z Series decks.



**480Z** Dolby B-C type NR electronic LED metering, headphone output level control, bias tune control, Sendust R/P head with 20 kHz response.

**482Z** Dolby B-C type NR electronic LED metering, headphone output level control, bias tune control, discrete 3-head technology, off-tape monitoring.

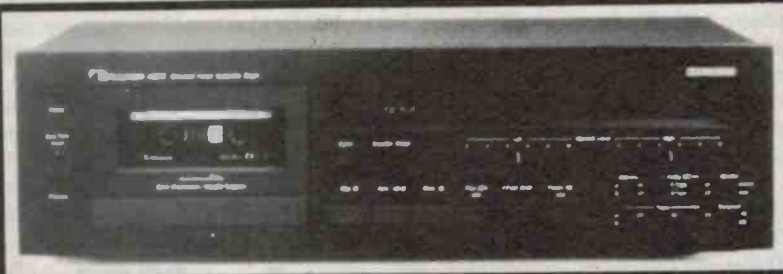

**582Z** Dolby B-C type NR electronic LED metering, bias and record calibration controls, built in twin-tone oscillator, discrete 3-head technology, off-tape monitoring.



**682ZX** Dolby B-C type NR azimuth alignment and auto record level calibration, adjustable bias and calibration tones, 50 dB high resolution FL metering, 9 programme RAMM, discrete 3-head technology with 22 kHz response, off-tape monitoring, removable rack mount. ▼



Hear the new Nakamichi Z series at your nearest authorised dealer or for further information contact Convoys International, 4 Dowling Street, Woolloomooloo 2011. Telephone (02) 358 2088.



**Nakamichi**

The word "Dolby" and the Double-D symbols are trademarks of Dolby Laboratories.

# Fosgate amplifier for superb motoring sound

Louis Challis

With the introduction of FM radios and quality cassette recorders into cars, the quality of the sound produced has nonetheless often still been a disappointment. The Fosgate amplifier Punch PR-250 and equaliser PR-2100 solve this problem excellently, according to Louis Challis.

THE AVERAGE Australian motorist has only recently become aware of the attributes of cassette recorders and FM tuners in cars. Those fortunate owners are just getting used to the amenity and driving pleasure that such 'goodies' can provide.

In Europe and America these pleasures have been known for well over a decade, with eight-track cartridge players and FM stations dominating the mobile music scene and creating a burgeoning market for the travelling hi-fi buffs.

Not content with the basic attributes of the medium, they have added a new dimension of 'power' to the scene to create the 'total acoustic environment'.

The average home high fidelity system has power capabilities ranging between 20 and 50 watts. Such power levels are now becoming a feature of the mobile scene as well, where, supplemented by efficient wide-band speakers, acoustic levels of the order of 110 decibels are easily achieved.

I too have an FM radio and cassette player in my car, but must admit that

the power and sound level capabilities have disturbed me since I purchased the car less than a year ago. I am obviously no exception in this matter as most people with whom I have discussed the problem also complain either about the power output of their unit, the quality of their speakers or the ability of the system to generate moderate or high level signals without gross distortion.

The problem is obviously two-fold and requires a more effective power amplifier stage as well as speakers with quality and performance approaching those which you would consider purchasing for your home. If we leave the issue of the speakers aside for just a moment, it is clear that what is needed is a power amplifier supplemented by a suitable preamplifier and equaliser, by which means the frequency limitations of the automobile, caravan or boat can be suitably corrected.

## Fosgate Punch PR-250

The Fosgate Punch PR-250 is an excellent example of the new generation of preamplifier equaliser/amplifiers

designed to provide a high level of performance coupled with practical features and operational flexibility.

The first and foremost feature is the ability to separate the preamplifier stage from the power amplifier. The preamplifier can thus be placed within the face of or under the edge of the dashboard, whilst the power amplifier stage may be placed in the boot of the car or in any other convenient place to which access is seldom required.

The preamplifier is small, black and features the minimum number of controls. These are a slider volume control, three sets of dual equaliser slider controls, a pushbutton switch for selecting radio in lieu of tape player, and a level indicator in the form of an array of green, red and amber LEDs, with a separate switch to disable the visual display.

The band equalisers operate at nominal 45 Hz at 175 Hz and at 20 kHz, with the 45 Hz and 20 kHz equalisers providing the ability to boost the output, whilst the 175 Hz equaliser provides an attenuation capability. These frequencies have been selected to provide compensation for the known deficiencies in normal small speaker enclosures of the type provided in cars. These speakers are normally deficient at frequencies below 100 Hz and above 8 kHz, and conversely generally provide excessive presence in the critical

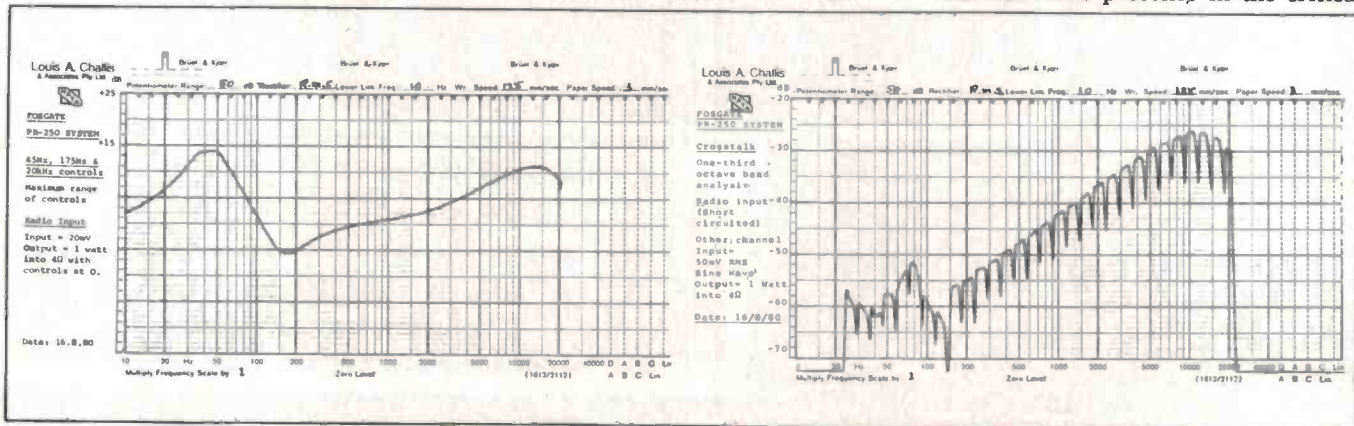

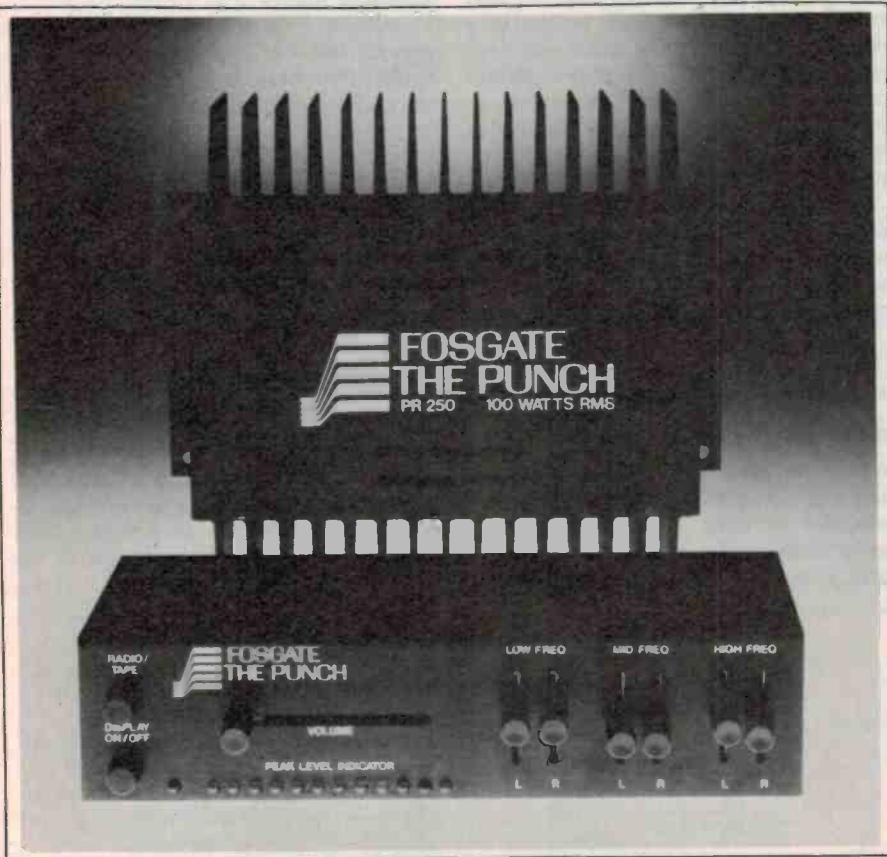

frequency region between 100 Hz and 400 Hz.

Each equaliser set has a left and right control enabling the driver to adjust the output to provide a fully balanced stereo effect, not only at the critical high frequency end but also in the mid to low frequency region.

The LEDs provide the ability to observe the power levels being fed to the loudspeakers. In the vehicle used for the subjective evaluation the red overload distortion level on the preamplifier corresponded closely to the overload

point for the array of speakers installed.

### Tests

A 50 watt amplifier operating at peak output can draw substantial current from a battery or a power supply, and our measurements quickly showed that our normal laboratory dc supplies were no match for the rapacious thirst for current of this amplifier with both channels driven to maximum output. Fortunately a battery supply soon solved that problem and we were able to confirm that the performance of the

units is almost as good as the manufacturers claim.

The power output is within +0.25 dB up to 15 kHz, whilst the manufacturer claims this is achieved all the way to 20 kHz. In a car this is no problem as the background noise level normally expected in the vehicle would make a mockery of the difference.

At the rated power output of 50 watts the distortion at 1 kHz is less than that claimed, but at 100 Hz and 6.3 kHz rises to 0.1% and 0.07% respectively, which is more than claimed but still totally inaudible.

The headroom under these conditions is 1.2 dB and it is readily possible to drive the amplifier, or more likely the loudspeakers, into overload conditions. The transient overload recovery of the amplifier is extremely good, but the speakers obviously will not be quite as good.

The transient intermodulation performance of the amplifier and preamplifier are excellent and the hum and noise capabilities are also extremely good.

Overall I could not fault the objective testing, but had to wait almost a year for the importers to provide a car in which the unit was installed to facilitate a subjective evaluation. Sometimes it is worth waiting for such things and this was one such occasion.

### Subjectively

The unit was coupled to an FM Tuner and a Hitachi cassette player which did not incorporate a Dolby system, together with a series of six loudspeakers. These were mounted with one 25 mm tweeter and a 112 mm mid-range driver on each of the front doors, and an additional set of wide-range loudspeakers mounted on the rear window sill. ▶

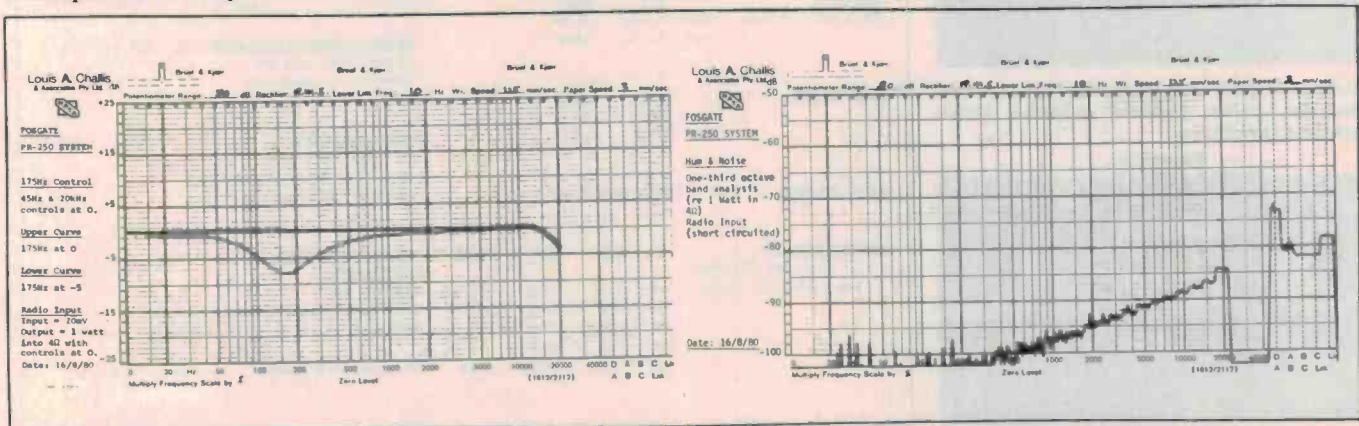

Whilst we did not actually measure the frequency response it was clear from the overall subjective impression that the general balance was reasonably good, even if slightly overbearing in the frequency region 8 kHz to 16 kHz.

I borrowed the car on an afternoon when I knew I would be driving some 60 km out of Sydney, during which time I would have approximately two hours to devote my attention to listening to selected cassettes and FM transmission (as opposed to the actual task of the driving).

After spending the first ten minutes reconciling myself to the extremely high performance of the engine and the lack of comparable performance of the brakes, I was able to settle down to listen to the system and assess its performance as I adjusted the controls. These controls soon proved to be deceptively simple, as some degree of adjustment really needs to be made for each type of pre-recorded cassette that is played, quite apart from the characteristics of various AM and FM transmissions.

My main efforts were devoted to the pre-recorded cassettes I took with me, including some favourites like Mason Williams' 'Classical Gas' from 'Hand Made', which is regrettably no longer available, and two classical cassettes from the World Record Club, Beethoven Symphony No. 3. 'The Eroica', catalogue 0063, and a Vivaldi trumpet

Measured performance of Fosgate Amplifier PR-250 Type II and Equaliser PR2100 Type II. Series nos. F6056 and F6056.

Transient overload recovery test (IHF-A-202).

1 ms/div.

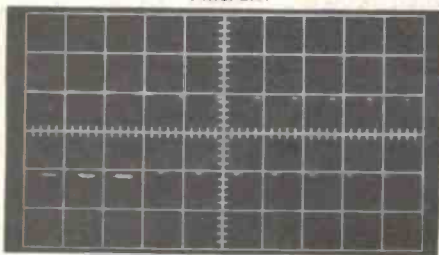

10 dB overload re rated power into 4 ohms — both channels driven. Overload duration: 20 ms; repetition rate: 512 ms.

50 ms/div.

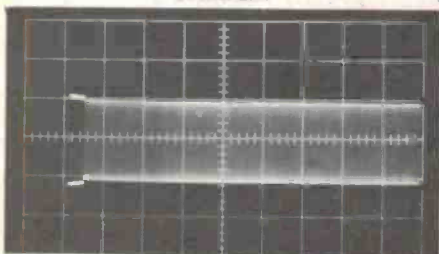

concerto. These all reproduced beautifully through the cassette recorder and amplified to concert hall proportions within that small padded glass and steel enclosure of the car. The trip of course was over too soon, for I was unable to listen to a number of my other favourite cassettes which I had taken along with me.

The performance of the amplifier section with the array of loudspeakers connected was positively devastating, and for the first time in a car I could reproduce the type of sound levels that I can achieve in my home with my 2 x 200 watt amplifier and various monitoring loudspeakers.

## In conclusion

The overall impression I am left with is that the Fosgate amplifier and pre-amplifier offer a superlative performance which obviously requires a good, if not excellent, speaker system,

and comparable driving components (cassette player and tuner) to match. There may be many other good systems around but the Fosgate system is undoubtedly amongst the best.

## FOSGATE AMPLIFIER PUNCH PR-250 TYPE II AND EQUALISER PR-2100 TYPE II

Amplifier: 193 mm wide x 45 mm high x 89 mm deep

Preamplifier: 196 mm wide x 46 mm high x 83 mm deep

Combined Weight: 2.4 kg

Manufactured: In Phoenix, Arizona, USA.

Distributor: Communications Power Inc, PO Box 246, Double Bay NSW 2028. (02)357-2022.

Price: Approx. \$500 the set

Absolute copyright in this review and accompanying measurements is owned by Electronics Today International. Under no circumstances may any review or part thereof be reprinted or incorporated in any reprint or used in any advertising or promotion without the express written agreement of the Managing Editor.

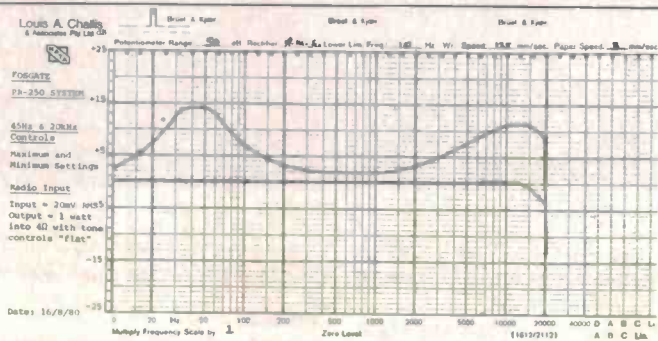

### MEASURED PERFORMANCE OF

#### FOSGATE AMPLIFIER PR-250 TYPE II AND EQUALISER PR-2100 TYPE II

S.NOS. F6056 AND F6056

#### FREQUENCY RESPONSE:

(-30dB re 1 watt, 50mv Input to Radio)

#### Tone Controls Defeated

Left < 10Hz to 20kHz  
Right < 10Hz to 20kHz

(B) (At 1 watt into 8 ohms)

	100Hz	1kHz	6.3kHz
2nd	-65.2	-85.2	-74.0dB
3rd	-70.2	-88.0	-75.3dB
4th	-73.0	-91.3	-
5th	-76.2	-83.4	-
THD	0.06	0.01	0.03%

#### SENSITIVITY:

(for 1 watt in 8 ohms)

#### Left Right

Radio 11.8 mv 12.0mv  
Tape 210 mv 180mv

#### TRANSIENT INTERMODULATION DISTORTION:

Very low 0.1%  
(3.15kHz square wave and 15kHz sine wave mixed 4:1)

#### INPUT IMPEDANCE:

#### Left Right

Radio 18k Ω 17k Ω  
Tape 21k Ω 18k Ω

#### NOISE & HUM LEVELS:

Radio -78dB(Lin) -81dB(A)  
(re 1 watt into 4 ohms)  
(with volume control set for 1 watt output with 50mv input radio)

#### OUTPUT IMPEDANCE:

8.0 milliohms @ 1kHz

#### HARMONIC DISTORTION:

(A) (At rated power of 50 watts into 4 ohms = 14.1 volts)

	100Hz	1kHz	6.3kHz
2nd	-60.8	-80.2	-81.7dB
3rd	-64.9	-78.1	-63.6dB
4th	-70.0	-92.4	-
5th	-70.8	-83.8	-
THD	0.11	0.017	0.07%

#### MAXIMUM OUTPUT POWER AT CLIPPING POINT:

(IHF-A-202)  
(20ms burst repeated at 500ms intervals) = 66 watts

Therefore Dynamic Headroom = 1.2dB (re 50 watts)

**The audio experts  
are raving about  
the Magnetic  
Field Amplifier**



M-400 Magnetic Field Amplifier

"Its distortion and noise levels are entirely negligible . . . it's hardly conceivable that a small, inexpensive lightweight cube such as this could deliver as much clean power as any but a few of the largest conventional amplifiers on the market."

That's what Julian Hirsch reported in Stereo Review about the Carver M-400 — the unique magnetic field power amplifier. It's a cube that weighs around 4 kgs and delivers 200 watts per channel. And costs a lot less than you think.

Equally startling, the M-400 can safely drive speaker-load impedance as low as 2 ohms. And in mono it can deliver more than 500 watts into an 8-ohm load, with peaks to 900 watts! (Bring on digital audio!)

To hear for yourself why all the audio experts have flipped over Carver, ask for a demonstration and descriptive literature. It will be a totally new experience for you.

**CARVER**  
CORPORATION

DISTRIBUTED BY CONVOY SYDNEY (02) 358 2088

Available from:  
N. S. W.: LEISURE SOUND City • Parramatta • Artarmon 29 1364  
VIC: TIVOLI HI-FI Hawthorn 818 2872  
QLD: STEREO SUPPLIES Brisbane 221 3623  
S. A.: SOUNDCRAFTSMEN Hawthorn 272 0341  
W. A.: THE SOUNDCRAFTSMAN Subiaco 381 5114

**REACH FOR  
RALMAR...**

**GIVE YOUR HEADS  
A GOOD CLEAN!**



**FOR IMPROVED  
PERFORMANCE.**

Special scientific and proven formula. Supplied with long nozzle for accurate work and to eliminate waste of product. Suitable for all reel to reel and cassette tape recorders. Aerosol can.

**OTHER TAPE CARE  
ACCESSORIES  
INCLUDE: EDITING  
KITS, SPLICERS,  
DEMAGNETIZERS, ERAZERS AND  
MAINTENANCE KITS.**

**FOR OVER 20 YEARS RALMAR  
HAS BUILT UP AN EXTENSIVE  
RANGE OF PRODUCTS FOR YOU.**

**Here are just a few...**

- Headphones
- Microphones
- Intercoms
- Transformers
- P.A. Equipment
- AC/DC Adaptors
- Tools
- Fuses
- Connectors
- Speakers
- Audio Mixers
- Switches
- TV Aerials
- Plugs/Socket

**PLUS  
HUNDREDS OF OTHER ITEMS!  
REACH FOR RALMAR!**

**TRADE ENQUIRIES...**

N.S.W. Ralmar Agencies P/Ltd (02) 439 6566  
Vic. Ralmar Agencies P/Ltd (03) 267 3028  
S.A. Charles Harwood P/Ltd (07) 264 1118  
QLD. Olbertz International P/Ltd (07) 261 1513  
W.A. Bruce Ingram & Assoc. P/Ltd (09) 381 7777  
TAS. George Harvey P/Ltd (003) 331 6533

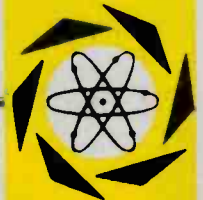

**RALMAR®**

RAL1/81



**'YOU'LL BE WET, YOU'LL BE  
AND FRIGHTENED, BUT  
KNOW THAT YOU'VE GOT**

# NAVY

THE PRIDE OF THE FLEET IS YOU.

‘In the days when our Navy was young,  
and the ship was the pride of the fleet.

You’d gaze out at her in wonder,  
made an old sailor’s heart skip a beat.

Well the ships have gone through  
some changes,

And the roles have changed a bit too.

You’ll be wet,

You’ll be homesick and frightened,

But the pride of the fleet will be you.’

Our ships are equipped with  
some of the finest and most  
advanced technology in the world.  
So it stands to reason that we’re  
proud of them.

It also stands to reason that we  
need the men to make them work.

Men who, in the Navy, have  
discovered what they do best and  
have been trained to achieve it.

Men with pride in themselves  
and what they can do. Whatever  
the conditions.

Because pride is what it’s all  
about really.

In the Navy we’re proud of the  
Fleet. But we’re prouder still of  
the men who work it.

Talk to a Navy Careers Couns-  
ellor. He’ll tell you about today’s  
Navy and the kind of men that it  
needs. It could be a proud moment  
for you both. So, pick up a phone  
now. Or write to G.P.O. Box XYZ  
in your state capital.

N. S.W.: Sydney 212 1011, Parramatta 635 1511, Newcastle 2 5476,  
Wollongong 28 6492. VIC.: Melbourne 61 3731. QLD.: Brisbane  
226 2626, Townsville 71 5253. S.A.: Adelaide 212 1455. W.A.:  
Perth 325 6222. TAS.: Hobart 34 7077, Launceston 31 4626.  
A.C.T.: Canberra 82 2333.

Auth. Director-General Recruiting, Dept. Defence. NGE249.DPS.21



HOMESICK  
YOU’LL  
A TOP JOB?

ROLLS ROYCE ?  
DUNHILL..... ?  
PIERRE CARDIN?  
DOM PERIGNON?  
CARTIER ..... ?

JANSZEN

ELECTROSTATIC HI-FI SPEAKERS



JANSZEN HI-FI SPEAKERS

Dear Customer,

A myriad of companies manufacturing high fidelity speakers seems to be limitless, and each company, including JANSZEN, vehemently claim that their product is the only accurate reproducer of music.

It must be confusing trying to decide which speaker system will give the highest degree of accuracy in relation to price. We would not be so pretentious as to say the JANSZEN ELECTROSTATIC is the only "Ultimate" reproducer. There are other companies utilizing electrostatics who deserve consideration, but, we believe it is generally accepted among knowledgeable people and technical experts, that by the laws of physics it is not possible for any speaker other than the electrostatic to achieve the ultimate goal: accurate reproduction. JANSZEN was the "original" electrostatic manufacturer in the United States, and holds the major base patents on electrostatics. JANSZEN has developed and manufactured electrostatic loudspeakers for over 30 years, considerably longer than anyone else in the industry.

We feel that JANSZEN electrostatics offer to the serious listener, a level of sophistication, manufacturing technology, and performance that is associated with the theoretical excellence of a speaker system that many strive for, but few accomplish.

Sincerely

A handwritten signature in black ink that reads "Nigel V. Cowan".

Nigel V. Cowan  
Managing Director  
N.V. DALE ELECTRONICS  
JANSZEN DISTRIBUTORS  
FOR AUSTRALIA

Mail this for the name and address of your nearest stockist and/or literature on the range of Janszen Electrostatic Speakers

Contact:

**n.v. dale electronics**

274 VICTORIA STREET, BRUNSWICK  
VICTORIA 3056 387 6170  
(03) 387 7076



# virginSound

At the beginning there was silence. Then noise. At first... simply whispers... breezes disturbing the lily pads. But it was beyond restraint... in time it grew louder. Thunderous. Distorted. Disturbing. An experience that aroused new senses. Hinting of new pleasures to come. It took on form... the noise became sound. The sound was a promise... expectations to be fulfilled. It took an eon of time. It has reached fulfillment. It is now... this instant. It is waiting. Beyond expression in the silence of words. A pure, sensory adventure, that you must hear... must feel... for yourself. VirginSound. Once in a lifetime... yours. Come. Hear. Take possession. Today!

Preamps, power amps, equalizers, and speakers. Car Stereopower to 100 watts per channel. 20 Hz to 20K Hz with less than .05% THD.



# FOSGATE

Communications Power Inc. (Aust.) Pty Ltd.

P.O. Box 246 Double Bay NSW 2028 Telephone (02) 357-2022

Telex: 23381 "COMPOW"



## Jands J1000 amp

The Jands J1000 amplifier is really designed for use by live rock bands, although hi-fi enthusiasts would not be disappointed by its performance. Louis Challis found that it "provides really excellent objective test results and we could not fault it".

**Louis Challis**

THE MOST widely sold high-powered amplifier in Australia has been the Jands J600, of which many thousands are now in use in Australia and New Zealand. At a typical selling price of \$900 they constituted one of the most popular amplifiers in commercial use with the big bands. They were designed with rock groups in mind and were not as suitable for the average hi-fi enthusiast because of the rack-mounting configuration.

The trouble with the J600 was that it was designed five years ago and at that time there were few available semi-conductors to meet the peak power requirements. The types of transistors now available have dramatically changed that situation, and the introduction of fan cooling has coped with the abuse of stacking amplifiers one above the other.

It was obvious that Jands would have to follow some of the criteria laid down by the overseas manufacturers and develop an amplifier with extremely effective fan cooling, if it was ever to be able to cope with operating in hotels and discos where the temperatures often exceed 30°C with limited ventilation and inadequate stacking space.

Instead of one basic large amplifier they decided to release three, the J1000, J700 and J400, and in two different versions.

This review relates only to the J1000 and to the CS or 'Concert Series' version of that particular model. Whilst occupying similar space to a J600, the J1000 is an entirely different breed of amplifier.

The most obvious difference is the frontal appearance, which incorporates an extruded aluminium channel, into which the designers have inserted an anodised aluminium escutcheon whose appearance does not do credit to the operational features and performance of the amplifier. This contains two separate arrays of rectangular LEDs to indicate the output power level in each channel; they cover the range -44 dB to 0 dB in 4 dB steps. These are supplemented by a series of LEDs to indicate output stage clipping, short circuit on the output and other fault conditions, and the operating conditions of the fan, which are indicated with LEDs for half speed and full speed. The only other controls on the front are two large, rotary volume controls with aluminium knobs, and an illuminated power on-off switch.

The front handles, which I deplored so strongly in my review of the J600 (ETI, April 1977, p.23), have inexplicably been continued on the J1000 series, to the possible embarrassment of the roadies who work with the bands or hi-fi buffs who may see fit to buy one of these amplifiers. They have chamfered the corners and edges of these handles since then but I must record my disappointment nonetheless.

The amplifier chassis is made from very heavy steel with ventilation slots across the top and both sides.

In the middle of the rear panel is a 100 mm diameter cooling fan which only comes into operation at half speed when the operating conditions become more demanding and at full speed under the most adverse operating conditions.

At the four corners of the rear panel the designers have sensibly placed four large rubber feet so that the unit may be dropped onto its back without destroying the fuses, fan or other sockets which are mounted in close proximity.

### Design

The electronic design of the amplifier is particularly interesting. The circuit makes use of full complementary-

symmetry, with direct-coupled circuitry from input right through to output. This complementary design provides balanced operation in each channel, achieving a very wide bandwidth and excellent phase and transient response.

Even though the amplifier is dc-coupled, the low frequency gain is rolled off rapidly below 5 Hz in order to protect the loudspeaker against dc offset voltages which could well be present on the input to the amplifier. As an added protection against this possibility, the CS version of the amplifier has an internal switching relay which disconnects the speaker lines if dc voltages appear on the amplifier output. This is particularly important in high-powered situations where the presence of such a dc with a normal superimposed ac signal can reduce the power handling capacity of the speakers quite dramatically or, more commonly, result in their premature demise.

A more exciting feature of this amplifier is the power output stage, which incorporates all the MJ15024/MJ15025 main output transistors on a massive aluminium heatsink. This has thermally bonded copper fins on each side to achieve the maximum cooling capability in the smallest possible space. The heatsink forms the bottom half of each channel amplifier module, with the top half being formed by the amplifier printed circuit board. The designers have made use of high voltage transistors in virtually every operational stage of this amplifier, with the basic aim of increasing its reliability and providing a greater ruggedness in the nasty environments where these amplifiers are likely to be used.

Each power output stage channel has its own separate power transformer and its own separate protection circuit, and incorporates the large filter capacitors within the cooling air path to enhance their life and reduce the likelihood of that frightening problem which most of us have observed, when an overloaded, aged electrolytic capacitor blows up with *diabolical* results. Following the same vein the rectifier and power supply circuits are also located in this cooling air stream.

The CS version of this amplifier has its metering, protection, relay and detection circuits located immediately behind the front panel of the amplifier. This printed circuit card, like all the others, is glass epoxy and is arranged with plug-in circuit cards and push-fit



There are four sets of Canon connectors on the back, two for inputs, two for outputs. The inputs are paralleled male/female to cater for these nasty situations where you get an opposite-sex plug.

connections to simplify servicing. By the same token the main amplifier printed circuit cards are arranged with heavy duty printed circuit connectors for rapid ease of removal, which makes access to the main power output stage extremely simple. The cheaper version does not provide this control circuitry and so the fan runs all the time, with consequent increase in noise and possibly shortened fan life as well.

When these printed circuit cards are removed the individual transistors are fully exposed and may be checked in situ. One unique feature of this amp is the use of high-speed diodes to protect and isolate the drive circuitry from the output stage. In most high-powered amplifiers, the most common cause of failure (probably 90% of all failures) is a blown output stage. When this occurs it normally carries off the driver stage and typically more than half of the transistors in the amplifier. This sensible approach to design of the J1000 CS protects the driver stage's transistors and thereby directly reduces the likely cost of faults and servicing.

It is interesting to note that all major power connections make use of high-powered automotive and industrial-type push-fit connectors in order to simplify servicing. It is clear that the designers have spent a lot of effort in refining the design to achieve improved reliability, which is now an essential feature in professional products.

## Performance

The performance of the amplifier is quite an eye-opener. The frequency response is essentially flat from dc to 10 kHz, is 0.5 dB down or less at 20 kHz, and is only 3 dB down at 63 kHz. We deliberately produced a number of our level recordings with a 10 dB dynamic range, in lieu of the more conventional 50 dB, to emphasise these characteristics. The hum and noise levels are at least -83 dB A-weighted

at the 1 W level (and obviously -110 dB re the 500 W level). Rather surprisingly, with a four ohm load the unit exhibits a dynamic headroom of 2.5 dB with both channels driven at full load. This corresponds to a peak output power of 903 W per channel on tone burst testing! *That's not really bad* for a 500 watt rating.

The total harmonic distortion is remarkably low at 1 kHz, being 0.0033% at the 1 W level into 8 ohms, and an extremely low 0.00135% at 500 watts. *This puts this amplifier in the real high fidelity class.*

The transient intermodulation distortion is typically 0.015% and the crosstalk between channels is quite excellent, being less than 50 dB all the way up to 10 kHz. The overload recovery test of the amplifier shows the best results we have ever seen from any amplifier, providing no trace of jitter and instantaneous response back to a steady-state level.

## Listen to this!

Overall, the amplifier provides really excellent objective test results and we could not fault it. The subjective evaluation of the amplifier involved using it with a series of conventional hi-fi components including the following:

Audio Technica AT30E moving coil cartridge.

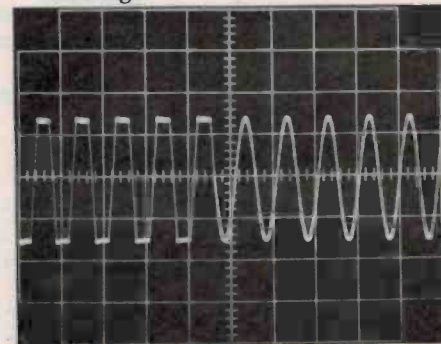

Transient overload recovery test (JHF-A-202). 1 ms/div.

# SOUND review

Technics 1200 direct-drive turntable fitted with SME tonearm.  
 AIWA 6900 cassette deck  
 Yamaha Model C4 preamplifier to provide the level control and frequency preamplification.

To monitor the output we used a set of B&W 801 speakers in parallel with a set of Fisher ST-550 monitors to handle the power. With this set-up it was possible to drive the amplifier close to the clipping point whilst still maintaining the speakers' output in some semblance of linearity. Under these conditions the sound pressure level in the monitoring room exceeded 115 dB peak and one really became aware of the brute force power which the J1000 CS is capable of

producing.

Fortunately, neither the speakers nor the amplifier blew up, and although both were driven particularly hard there was no sign of either amplifier distortion nor of significant loud-speaker distortion.

The J1000 CS is a remarkable amplifier. At a selling price of about \$1.5 per watt in the CS version and \$1.3 per watt in the standard version, it must be regarded as good value for money in terms of power. When one realises that they are Australian-designed and manufactured one really sits up and takes notice.

This amplifier may not set the world on fire but it may well prove to be the

foremost technical development in 1981 for rock music in Australia.

## JANDS J1000 (CS) 2 x 500 W AMPLIFIER

Dimensions: 480 mm wide by 430 mm deep by 134 mm high

Weight: 27.5 kg

Manufactured: In Australia by Jands (Australia) Pty. Ltd.

Distributor: Jands, 578 Princes Hwy, St. Peters NSW 2044.

Price: \$1583 rrp.

Absolute copyright in this review and accompanying measurements is owned by Electronics Today International. Under no circumstances may any review or part thereof be reprinted or incorporated in any reprint or used in any advertising or promotion without the express written agreement of the Managing Editor.

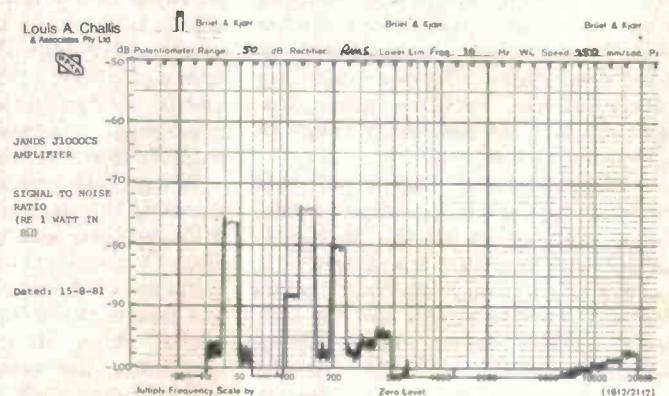
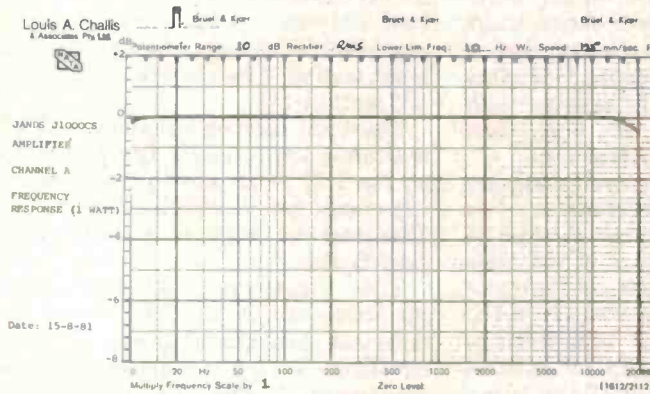

### MEASURED PERFORMANCE OF JANDS J1000 CS AMPLIFIER SERIAL NO 6498

#### FREQUENCY RESPONSE:

(-3dB re 1 Watt, 0.5V

Input to Aux)

Channel A DC - 63kHz

Channel B DC - 63Hz

#### SENSITIVITY:

(for 1 Watt in 8 Ω)

Channel A 92mV

Channel B 90mV

#### INPUT IMPEDANCE:

Channel A 50k

Channel B 49k

#### OUTPUT IMPEDANCE:

58 milliohms (@ 1kHz)

#### NOISE & HUM LEVELS:

(re 1 Watt into 8 ohms input 0.5V)

- 62.5 dB(LIN)

- 83.5 dB(A)

(re 1 Watt into 8 ohms, input 90mV, gain max)

- 71.0 dB(LIN)

- 84.5 dB(A)

#### MAXIMUM OUTPUT POWER AT CLIPPING POINT:

(1HF - A - 202)

(20 mS burst repeated at

500mS intervals)

170 VP-P

4 ohms load, both channels driven

903 Watts

Dynamic headroom

2.5dB re 500 Watts

#### HARMONIC DISTORTION:

@ 1 Watt into 8ohms

1kHz

2nd -104.2

3rd -94.2

4th -107.1

5th -92.1

T.H.D. .0033%

@ Rated Power of 500 Watts

1kHz

into 4 ohms = 44.7v

2nd -99.9

3rd -106.5

4th -103.1

5th -117.7

T.H.D. .0013%

Intermodulation distortion less than .015

# Not Just Speaker Wire



Conventional speaker wire limits the performance of your sound system by decreasing power output, restricting dynamic range, and reducing clarity and definition. You can significantly improve the performance of your audio system by switching from your present speaker wire to Monster Cable.

Constructed of over 500 strands of high purity copper in a unique configuration, Monster Cable is specifically engineered for low resistance, low capacitance, and low inductance. The Results?

- Deeper, tighter bass.
- Maximum power transfer.
- Increased clarity and definition.
- Wider dynamic range.

Even low-powered systems show a remarkable improvement. Recommended by leading audio manufacturers, Monster Cable is safe to use with all amplifiers and receivers, regardless of design.

Don't be deceived by imitations. If it doesn't say Monster Cable you're not getting all the performance you paid for.

## MONSTER CABLE

DISTRIBUTED BY CONVOY SYDNEY (02) 358 2088

Available from: N.S.W. Leisure Sound, City • Artarmon • Parramatta 29 1364 • Russin Electronics, Ashfield 799 2421 • Woollahra Electronics, Woollahra 389 9625 • Pitman's, Wagga Wagga 25 2155 • Wollongong Hi-Fi, Wollongong 28 3773; A.C.T. Duratone Hi-Fi, Phillip 82 1388 • Kingston Hi-Fi, Kingston 95 7895; VICTORIA Tivoli Hi-Fi, Hawthorn 818 2872 • Natsound, Melbourne 67 3484; QUEENSLAND Stereo Supplies, Brisbane 221 3623 • Disco & Stereo Supplies, Townsville 72 4226; SOUTH AUSTRALIA Sound Craftsman, Hawthorn 272 0341 • Track Hi-Fi, Adelaide 223 7285 • Grenfell Plaza Hi-Fi, Adelaide 51 5017 • Blackwood Sound, Blackwood 278 0341; WESTERN AUSTRALIA The Audio Centre, West Perth 322 5177 • Japan Hi-Fi, Victoria Park 362 1466 • Sound-craftsman, Subiaco 381 5114; NORTHERN TERRITORY Radio Parts, Darwin 81 8508.

## REACH FOR RALMAR...

### DECISION DIRECTORY

# A

- AC Connectors
- Adaptors - AC/DC; DC/DC
- Amplifier - Cable; Modules; P.A.
- Antennae - TV/FM; Car Boosters
- Attenuators

# B

- BNC Connectors
- Baluns
- Banana Connectors
- Battery - Adaptors; Charger; Eliminators; Holders; Nickel Cadmium
- Binding Posts
- Bulk Erasers

# C

- CB Microphones; Crystals.
- Cable
- Cannon Connectors
- Capacitors
- Car - Antennae; Battery Adaptors; Speaker Controls; Stereo Equipment
- Cartridges - Magnetic; Crystal; Ceramic
- Cassette - Erasers; Holders; Care Kits; Head Cleaner
- Co-Axial Fittings
- Connecting Cables
- Crossover Networks



# RALMAR®

JUST PART OF THE RANGE!  
AVAILABLE AT SELECTED  
STORES EVERYWHERE!

#### TRADE ENQUIRIES...

N.S.W. Ralmar Agencies P/Ltd (02) 439 6566  
Vic. Ralmar Agencies P/Ltd (03) 267 3028  
S.A. Charles Harwood P/Ltd (07) 264 1118  
QLD. Olbertz International P/Ltd (07) 261 1513  
W.A. Bruce Ingram & Assoc. P/Ltd (09) 381 7777  
TAS. George Harvey P/Ltd (003) 331 6533

RAL2/81



DEPARTMENT OF INDUSTRY  
& COMMERCE

GOVERNMENT AIRCRAFT  
FACTORIES

Fishermen's Bend, Victoria  
have several vacancies for:

## TECHNICAL OFFICER (ENGINEERING)

### GRADE 1

Salary \$13539 — 16495

**Duties:** Conduct electronic tests and measurements on a wide range of aircraft, guided weapons and associated support equipment. Calibrate and maintain laboratory test equipment.

**Qualifications:** An approved certificate from a technical college or institute of technology or its equivalent, or such other qualifications as the Public Service Board considers appropriate, together with requisite experience.

Applications will be considered from persons who do not possess the above qualifications, provided they have relevant experience over a minimum period of six years. Such an applicant, if selected, will be required to pass a test to establish eligibility for the position.

Experience in the construction and testing of electronic circuitry is highly desirable.

Australian Public Service conditions include four weeks recreation leave, cumulative sick leave, long service leave, superannuation and flexible working hours totalling 36½ hours per week.

To be appointed to these permanent positions, Australian citizenship or British citizenship, with permanent residence status, is required.

Applications, quoting Ref. No. VF.81/228 should be forwarded to:—

The Personnel Manager,  
Government Aircraft  
Factories,  
Private Bag No. 4 P.O.,  
PORT MELBOURNE. VIC.  
3207

By: 30th October, 1981

# SHEAFFER *Pen Portraits*



*Sheaffer 797 Classic styling in 23 Kt gold electroplate. The subtle fluting, the soft gleam, the feeling of perfect balance in the hand; all help you to sign with authority...and write with pleasure. For another \$28.50\*, there's a matching pencil. The fountain pen is \$48.50\*. Together, a life-time gift. Separately... well, if you don't*

*deserve it, who does?* **\$28.50\***

*Sheaffer 440 Black, burgundy, blue, red...go on - choose a colour. Cap it with brushed chrome and don't hesitate next time someone says "has anyone got a pen?" This Sheaffer beauty will impress in any company, as a long-lasting ballpoint (shown here), a precision propelling pencil, \$4.95\* or a fountain pen with stainless steel inlaid nib \$12.95\*. Write on!* **\$4.95\***

\*Recommended Retail Prices

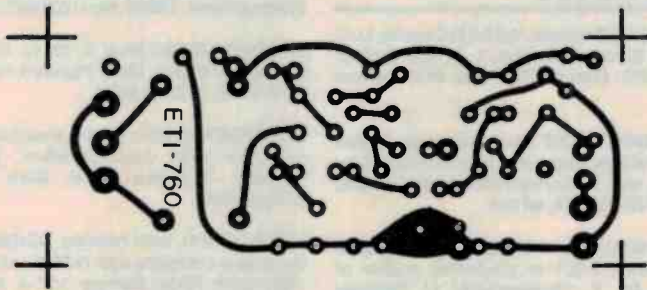
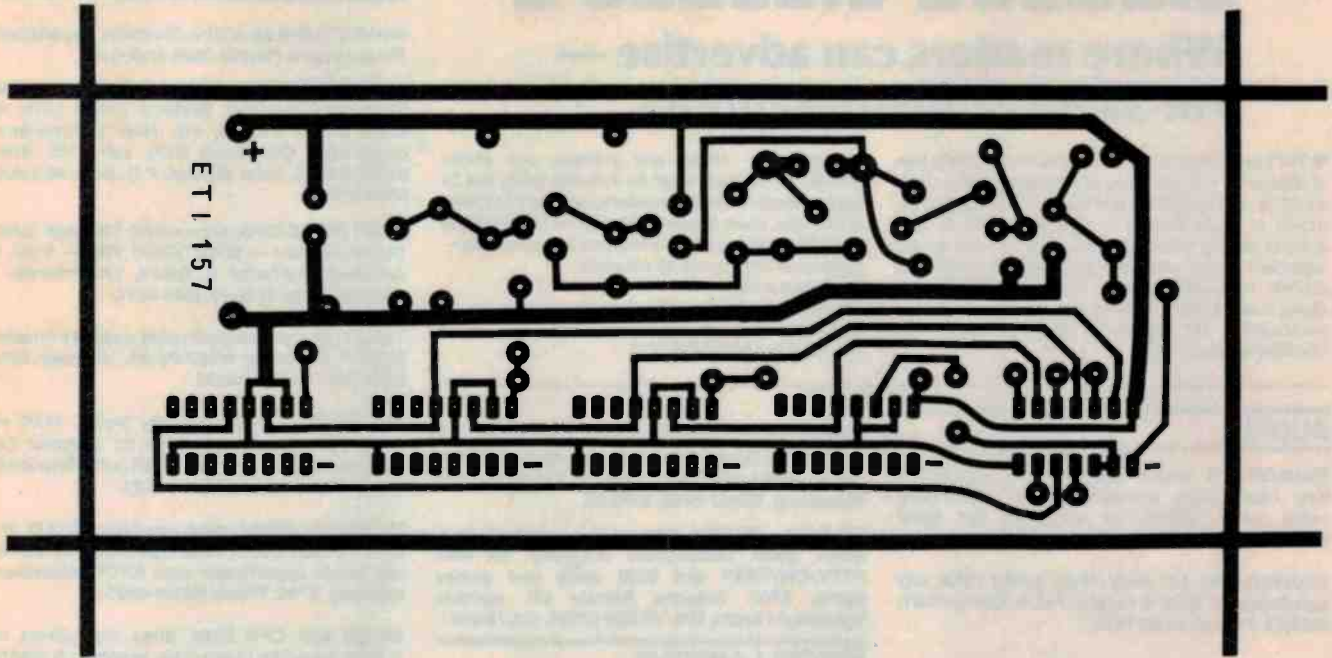

Instructions on how to make your own pc boards using the Scotchcal method and exposing through this page may be found on page 159 of the June '81 issue.

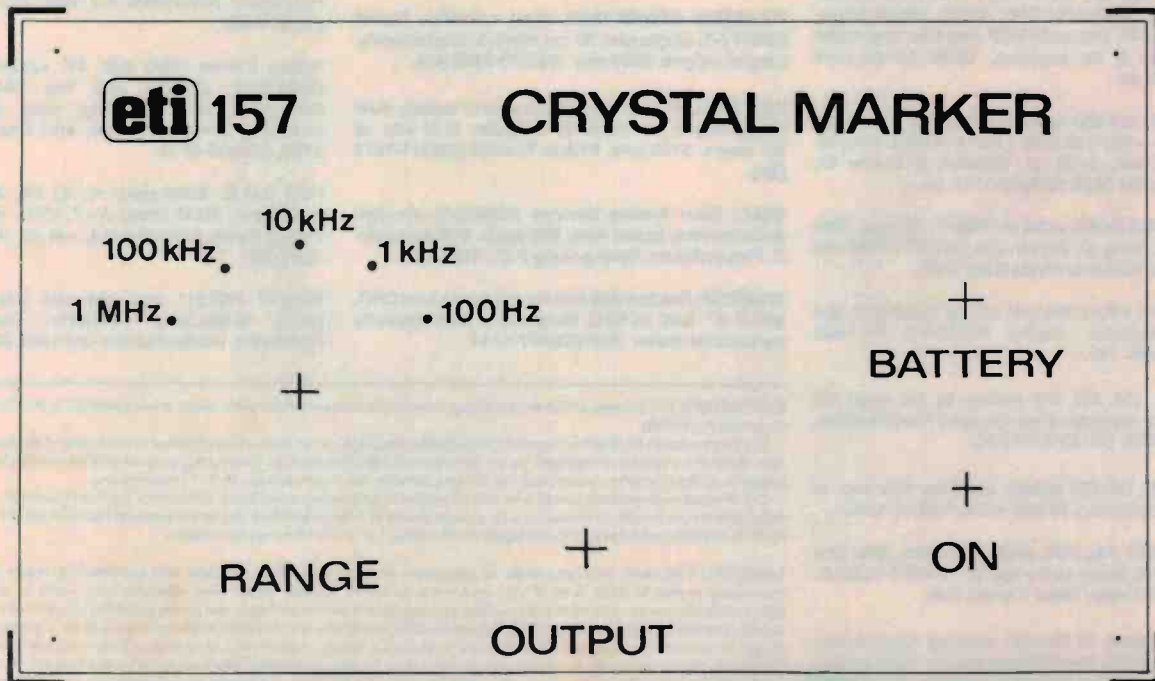

2689811

# MINI-MART

## Where readers can advertise — For Sale/Wanted/Swap/Join.

● We'll publish up to 24 words (maximum) totally free of charge for you, your club or your association. Copy must be with us by the 1st of the month preceding the month of issue. Please — please — print or type adverts clearly, otherwise it may not turn out as you intended! Every effort will be made to publish all adverts received; however, no responsibility for so doing is accepted or implied. Private adverts only will be accepted. We reserve the right to refuse adverts considered unsuitable.

● Conditions: Name and address plus phone number (if required) must be included within the 24 words. Reasonable abbreviations, such as 25 W RMS or 240 Vac, count as one word. Adverts must relate to electronics, audio, communications, computing etc — general adverts cannot be accepted. Send your advert to:  
ETI Mini-Mart, Modern Magazines  
15 Boundary St,  
Rushcutters Bay NSW 2011

### AUDIO

**SONOGRAPH** sound spectrograph, ex-CSIRO, Kay Electronics, comprising four connecting valve units. Offers, or exchange for good communication receiver. (02)625-0393.

**WANTED:** JBL 10" bass driver model 125A; any condition. W. Brill, 6 Furphy Place, Garran ACT. (062)52-5319 or ah 82-1948.

**WANTED:** SME 3009 II arm with detachable headshell. Write Glenn Stewart, 5/4 Elphinstone Rd, South Coogee NSW 2034, or phone (02) 665-5729.

**TECHNICS SB10** state-of-the-art speakers. See the July ETI review. New in sealed cartons. Save \$400 on list price. \$1200 ono. (02)387-1343.

**OPEN REEL** stereo tape decks, Brenell STB2, 3 motors, 3 heads, valve circuitry, \$150. Magnavox, 3 heads, with pre and power amplifiers, \$120. J. McDonough (03)435-5709.

### COMMUNICATIONS

**LINEAR** amplifier, 3 kW PEP, 1 kW continuous made by ETO, model 76P, \$1500. Drake transceiver TR4CW, 300 watts PEP Xtal filter and noise blander, ac & dc supplies, \$600. All as new (02)76-9647 ah.

**FOR SALE:** SX-200 scanning receiver, coverage 26-88 MHz +108-180 MHz +380-514 MHz, AM/FM, 5 months old, \$430. M. Whelan, 9 Steele St, Leongatha Vic 3953. (056)62-3714. ah.

**COMMUNICATIONS** receiver FRG-7, as new, little use, \$220. Ring K. Barton (bh) (02)631-7588. 94 Boronia St, Wentworthville NSW 2145.

**LAFAYETTE HE30:** Borrow or buy handbook and circuit diagrams. Gentry 05422515, bh (03) 317-9001, ext. 145.

**WANTED:** old AM CB radios to be used for emergency services work. Contact Tony Weedon, Gosford NSW. (02)25-3212 (bh).

**FOR SALE:** DX-160 comm. receiver, \$80 ono, in excellent condition. Phone Adrian (02)46-1848.

**USED RADIO VALVES,** good condition, also new valves. SAE. Many radio spares (003)94-4126. G. Bracey, PO Exeter West, Tamar, Tas.

**RTTY — Model 14 Baudot** printing reperforator and Model 14TD Baudot tape reader. With cables and 10 rolls of tape. \$50 the lot. Phone (02)94-6520 ah.

**LINEAR AMP:** Yaesu FL-2100B, 1.2 kW PEP, 3.5-27/28 MHz. Brand new finals, one spare 572 B. In carton with books. Jim Lupton, 20 Penshurst Ave, Penshurst. (02)57-5448. \$375.00.

**BELCOM** 432 MHz transceiver, unused condition, \$200. Commodore computer, 8K with RTTY/CW/SSTV and \$200 utility and games pgms, \$700. Antenna Rotator LD, suitable lightweight beam, \$85. VK2ZN QTHR. (02)76-9647.

### MISCELLANEOUS

**SELL:** Vols 2,6 ETI Projects, Vol 2 ETI Circuits, D.S. Funway into Electronics Vols 1, 2, ETI Project Electronics, \$10. Contact Tim, Box 917, Ingham Qld 4850.

**GENUINELY MOTIVATED** gent with radio trades cert. seeks break as asst. tech. in audio w/s. Sub-contract pref. due to daytime tech. commitment. Please ring (02)759-5174, all hrs.

**WANTED:** Instruction manual Palec Signal Generator Model S.G.1 or photostat copies of pages 7 to 14. V. Shuttleworth, 17 Stephen Crescent, Croydon Vic. 3136. (03)723-2713.

**HOUSTON OMNISCRIBE** chart recorder, Model EB5:17-5, single pen, 30 cm chart, 9 chart speeds, 5 input ranges, \$500 ono. (03)370-9568 (ah).

**FOR SALE:** Heavy-duty bench power supply, dual independent or tracking outputs: 0-35 Vdc at 0-5 amps. \$150 ono. Phone Russell (03)211-7671 (ah).

**SELL:** Four Analog devices AD2010/E 3½-digit panelmeters, brand new, \$60 each. Will separate. C. Frauenfelder, Spring Gully P.O., Vic 3550.

**WANTED:** Reasonably late model dual beam CRO, about 5" and 15 MHz bandwidth, also capacity Inductance meter. Karl (02)407-1744.

**COPYRIGHT:** The contents of Electronics Today International and associated publications is fully protected by the Commonwealth Copyright Act (1968).

Copyright extends to all written material, photographs, drawings, circuit diagrams and printed circuit boards. Although any form of reproduction is a breach of copyright, we are not concerned about individuals constructing projects for their own private use, nor by pop groups (for example) constructing one or more items for use in connection with their performances.

Commercial organisations should note that no project or part project described in Electronics Today International or associated publications may be offered for sale, or sold, in substantially or fully assembled form, unless a licence has been specifically obtained so to do from the publishers, Modern Magazines (Holdings) Ltd or from the copyright holders.

**LIABILITY:** Comments and test results on equipment reviewed refer to the particular item submitted for review and may not necessarily pertain to other units of the same make or model number. Whilst every effort has been made to ensure that all constructional projects referred to in this edition will operate as indicated efficiently and properly and that all necessary components to manufacture the same will be available no responsibility whatsoever is accepted in respect of the failure for any reason at all of the project to operate effectively or at all whether due to any fault in design or otherwise and no responsibility is accepted for the failure to obtain any components parts in respect of any such project. Further, no responsibility is accepted in respect of any injury or damage caused by any fault in the design of any such project as aforesaid. The Publisher accepts no responsibility for unsolicited manuscripts, illustrations or photographic material.

**WANTED:** Valves, 2 each of: 6F6G, 6B8G, 6U7G/6K7G, 6K8G. Must be OK. Budde (03)555-6714, evenings.

### COMPUTERS

**WANTED:** Aim 65 or Ohio Scientific Superboard II. Please phone (02)938-3690 after 6 pm.

**FOR SALE:** 16K S-100 4 MHz static RAM. California Computer Systems model 2016 with Bank Select Manual, etc. New & experienced guaranteed OK. Retail \$330, sell \$165. Phone (069)53-2848. John Watson, P.O. Box 108, Leeton NSW 2705.

**S100:** DG680 CPU, Microworld 12K tape BASIC, DGOS monitor — \$240; DG640 VDU — \$120. For details phone/write S. Gillott, 112 Princess St, Cleveland Qld 4163. (07)286-2274.

**TANDY** pocket computer plus cassette interface, \$270. P. Markham, 8/562 Pacific Highway, Killara NSW 2071. (02)498-8695.

**MICROPOLIS** double density Mod-1 143K disk drive. Ideal as add-on drive for Sorcerer (with Micropolis Controller) or TRS80 (with Newdos-80). \$350. Phone Valdis (08)268-8021.

**TELETYPE** ASR38, mint condition, RS232 interface, 15 inch tractor feed, tape reader and punch, red/black, upper/lower case ASCII, maintenance manuals, \$700. Phone (02)94-6520 ah.

**SIRIUS** 48K CPM S100, three disk drives with ½ MHz capacity, green tube, graphics & CBASIC, Epson printer, \$5900. New! (02)622-2550 (bh).

**WANTED:** TRS80 level II, 4K to 16K and SYM-1 board with BASIC. Dr. E. Plunkett, Hill St, Eugowra NSW 2806. (068)59-2472.

**SORCERER GAME:** 5 card stud poker. In BASIC, on tape with documentation, \$9.50. Gerald Dawson, Bradleys Lane, Glen Innes NSW. (067)32-2082.

**S100 BOARDS,** both running, DGI280 single-board computer complete with DGOS and manual, \$199. 16K static RAM. Morrow 16K-A Superram with manual, \$250. (063)51-2783.

**PLOTTER:** Honeywell X-T axis, \$75. Alan Peek (02)89-1450.

**SELL:** Dream 6800 with 8K expansion board, Dreamsoft EPROM and two PIAs; joystick controller; power supply; tons of software including Dream Invaders and Dream Rummy, \$199. (053)32-6733.

**FOR SALE:** Solid-state music 8K, 250 ns, S100 type static RAM board A+T, \$150, with manual. Phone Ross (03)338-0444, ext 45 (bh), (03)689-4893 (ah).

**SHARP PC1211** and cassette interface, \$240 (ono). R. Maclean, Formartin State School, Formartin, via Bowenville Qld 4404. (076)92-4263.



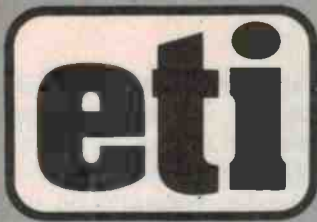

Electronics Today International is published by Murray Publishers Pty Ltd, 15 Boundary St, Rushcutters Bay NSW 2011. It is printed (in 1981) by Offset Alpine, cnr. Wetherill and Derby Sts, Silverwater NSW, and distributed by Gordon and Gpoch.

**Editor**  
**Roger Harrison VK2ZTB**

**Technical Editor**  
**David Tilbrook VK2YMI**

**Production Editor**  
**Jane Clarke B.A. (Hons)**

**Editorial Staff**  
**William Fisher B.Sc. (Hons)**  
**J.B. Scott B.Sc./B.E. (Hons)**  
**VK2YBN**  
**Jan Vernon B.A.**  
**Phil Wait VK2DKN**

**Layout**  
**Bill Crump**

**Typesetting**  
**Lin Booth**

**Reader Services**  
**Jan Collins**

**Managing Editor**  
**Collyn Rivers**

**Acoustical Consultants**  
**Louis Challis & Associates**

**Mail enquiries:** There is no charge for replies, but a foolscap-sized, stamped, addressed envelope must be enclosed. Queries relating to projects can only be answered if related to the item as published. We cannot advise on modifications to projects, other than errata or addenda, nor if a project has been modified or if components are other than specified. We try to answer letters as soon as possible. Difficult questions may take time to answer.

**Phone enquiries:** We can only answer readers' technical enquiries by telephone after 4.30 pm. In enquiring by telephone about back issues or photostats, please ask for the Subscriptions Department.

(02)33-4282

**Editorial and Sales Office:**  
**4th Floor, 15 Boundary St, Rushcutters Bay NSW 2011. Ph. 33-4282;**  
**Tlx: 27243**  
**Sales Manager: Bob Taylor**  
**Sales Admin: Jan Collins**  
 (address as above)

Melbourne: Virginia Salmon, 150 Lonsdale St, Melbourne Vic 3000. Ph: 662-1222; Tlx AA34543.

New Zealand: Frank Hargreaves, Circulation Marketing Manager, c/- ACP, 4th Floor, Sun Alliance House, 42-44 Shortland St, Auckland. Ph: (9)30311.

Adelaide: Admedia Group, 24 Kensington Rd, Rose Park SA 5067. Ph: 332-8144; Tlx AA82182.

United Kingdom: Australian Consolidated Press, Ludgate House, 107 Fleet St, London EC4A 2AL. Ph: 353-1040; Tlx: 267163.

Brisbane: Geoff Horne Agencies, 16 Bellbowrie Centre, Bellbowrie Qld 4070. Ph: 202-6813.

Japan: Genzo Uchida, Bancho Media Services, 15 Sanyei-cho, Shinjuku-Ku, Tokyo 160. Ph: 359-8866; Cable: Elbanchorito; Tlx: BMSINC J25472 Tokyo.

Perth: Aubrey Barker, 133 St Georges Terrace, Perth WA 6000. Ph: 322-3184; Tlx: AA93810

USA: Peter Samuel, Australian Consolidated Press, 444 Madison Avenue, New York NY 10022. Ph: 751-3383; Tlx: 620892.

The publisher accepts no responsibility for unsolicited manuscripts, illustrations or photographic material.

**ORDER FORM**

I enclose \$ . . . . . for (tick appropriate box/es). All prices include postage.  
 Send orders to: ETI, 4th Floor, 15 Boundary St, Rushcutters Bay NSW 2011. Phone: (02)33-4282.

<input type="checkbox"/>	<b>Subscriptions</b>	\$23.30 per year within Australia \$36.60 overseas (surface mail) Airmail rates on application	\$ . . . . .	<b>NAME (Please print)</b> .....
<input type="checkbox"/>	<b>Back issues</b>	\$2.50, available from November 1978.		<b>ADDRESS</b> .....
<input type="checkbox"/>	<b>or photocopies</b>	\$2.50 per article per issue		.....
	Project No. . . . .	Month . . . . . Year . . . . .	\$ . . . . .	.....
	Project No. . . . .	Month . . . . . Year . . . . .	\$ . . . . .	.....
	Project No. . . . .	Month . . . . . Year . . . . .	\$ . . . . .	.....
	Project No. . . . .	Month . . . . . Year . . . . .	\$ . . . . .	.....
	Please attach a list if more than four required.			
<input type="checkbox"/>	<b>Binders</b>	No. . . . . @ \$6.10 in NSW No. . . . . @ \$7.50 in other states	\$ . . . . . \$ . . . . .	<b>POSTCODE</b> .....

# DREGS



I've been in the Test & Measurement Division for 20 years, so I'm qualified to comment . . . I tell you, they were out to here and as firm as ripe melons!

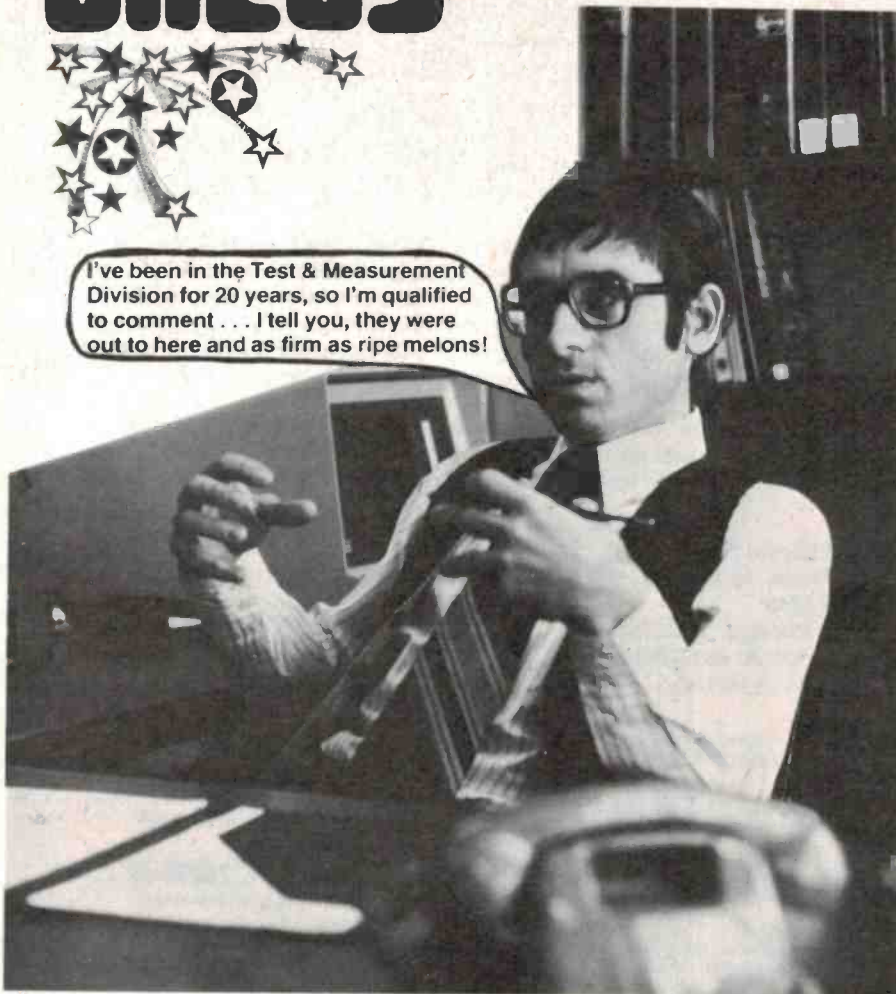

The photo printed below shows the device — dubbed a 'parallel-in, parallel-out' unit, or PIPO. The device comes in a 24-pin package, has negligible power consumption (it doesn't even need a power supply!) and the input impedance with no output is close to infinity. The applications note says that it can be used to effect from one to 24 interconnections and the input impedance will always equal the output impedance. Gain is determined from the equation:

$$\text{Gain} = 3/5 \times 5/8 \times 1/2 \times 1/\infty$$

Noise figure is said to be at least equivalent to a 15 mm length of tinned copper wire!

Mr Drew says that, unfortunately, stocks are limited — there's only one in existence. However, to help every true-blue hobbyist who may wish to construct a PIPO for himself, Mr Drew has kindly consented for us to publish the internal circuit diagram. Here it is:

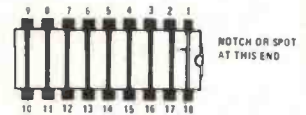

THE SPIRIT of creativity fuels the flame of inventiveness ever yet in the breasts of Australian hobbyists. Or so it seems, judging from the amount of mail we regularly receive detailing the products of readers' ponderings on perfidious problems that arise in the general course of an interest in electronics. Some ideas are best exploited in a commercial atmosphere, some are best suited to specialised applications, some we publish — and a very few have the mark of sheer brilliance.

Now, it is traditionally believed amongst east-coast Australians that west-coast Australians are somewhat more than just the two hours behind us that an accident of geography has relegated them to. In return, West Australians fervently strive to outdo the achievements of their east-coast brethren. After all, they point out, aren't Lang Hancock (of mining fame), Alan Bond (of corporate and sailing fame) and Jack O'Donnell (of Altronics

fame?) West Australians?

Reader Michael Drew of Cloverdale in Perth felt he had to contribute his bit to the promotion of West Australia and West Australians and sent us an example of a totally new electronic device developed in the lab in which he works. And we must give credit where credit is due; this is one of those rare ideas that show the mark of sheer brilliance!



## Phone flashers

No, videophones have not arrived along with the dirty videophone call — a short item in an American business publication headed thus caught our interest, and it seemed that Dregs readers would no doubt be interested (that is all of you, isn't it?).

A New York electronics firm has apparently devised, and is marketing, a gadget that detects telephone wire taps, warning you when the phone is bugged. The US\$50 device screws onto the phone receiver and flashes a red warning light when the "...level of electricity in the line changes...". They are reported to be selling like the proverbial hot cakes, mainly to businessmen worried about eavesdropping by business rivals.

(Please — no phone calls or letters to ETI asking for more details, we know nothing more about it.)



## WE CAN PUT ALL THIS IN THE PALM OF YOUR HAND.

What you are looking at is perhaps the most advanced VHS home video system you can buy.

The tape glides in and out of the machine, automatically.

The two-way shuttle search lets you view the picture at ten times the normal speed, so you can quickly find any segment you want to play again.

The variable speed playback lets you view the picture at double speed, in slow motion, frame by frame or freeze frame. The sound quality is always good because it is filtered through a Dolby noise reduction system.

If you go away, this home video system will record programmes for up to 14 days on up to eight channels.

In fact, this system has so many features, we don't have space enough to list them all.

It was made by JVC, the people who invented the VHS system. And being the inventors of VHS means that we are always one step ahead in refining the system.

For instance, look at our cordless remote control unit. With every function of the machine itself, there is no other remote control that gives you so much control.

If you'd like to know more about the many innovations JVC has brought to the VHS home video system and you live in Sydney, you can visit our Video Information Centre, at Garella Circuit, Kingsgrove.

There you can make use of our transfer and editing facilities.

If you live elsewhere, write to us for a brochure or call into any JVC dealer.

Then you'll see why JVC equipment is recognised as The State of the Art.



VHS

For further information, write to JVC Advisory Service, 5-7 Garella Circuit, Kingsgrove N.S.W. 2208, or phone (02) 750 3777.

JVC0227070011



# TELETEXT

The Information Computer  
you access on your own Television



- **STOCK BROKERS—SHARE MARKET ENTHUSIASTS**—Get the latest Stock Exchange and Futures market reports.
- **PUNTERS**—Get the latest odds on a race and the earliest actual results and dividends.
- Who won the cricket, football, league tennis—get all the important results.
- What were the lotto, lottery, pool numbers—how much did it pay?  
**DID YOU WIN?** The results are on Teletext.
- **MUM**—How much should you be paying for fruit and veggies, meat and poultry.
- **DAD**—Read the news at your leisure.
- **KIDS**—Enjoy mastermind, jokes, graphics and puzzles.
- What will the weather be like tomorrow in Brisbane, Sydney, Perth, New York, Athens, London—**IT'S ALL ON TELETEXT.**

**GET ALL THIS INFORMATION** and much more from the **FREE** electronic newspaper of the 80's—**YOUR OWN** television set with an **ADAM 180 TELETEXT ADAPTOR** by **RADOFIN ELECTRONICS (AUST).**

## THE ADAM 180 TELETEXT ADAPTOR

by

**RADOFIN ELECTRONICS (AUST)**

5 Curlewis Street, Bondi, NSW 2026, AUSTRALIA

Telephones: (02) 309 1957 or (02) 309 1904