

Ray Allsop and Don. B. Knock — Technical Editors

Wireless Weekly 3^d

INCORPORATING "RADIO IN AUSTRALIA & NEW ZEALAND"

MITCHELL LIBRARY,
13 FEB 1929

VOL. 13, NO. 8.

FRIDAY, FEBRUARY 15, 1929

(Registered at the G.P.O., Sydney, for transmission by post as a newspaper).



OF WORLD-WIDE REPUTE!

**Will
Demon Static
Ever Be
Conquered?**

**The Marnock
5 Valve Receiver**

**How to Build a
Simple Televisor**

**PHILIPS
RADIO**

The Supreme Achievement!

**RADIOKES NEW SCREEN GRID
SHORT WAVE COIL KIT**

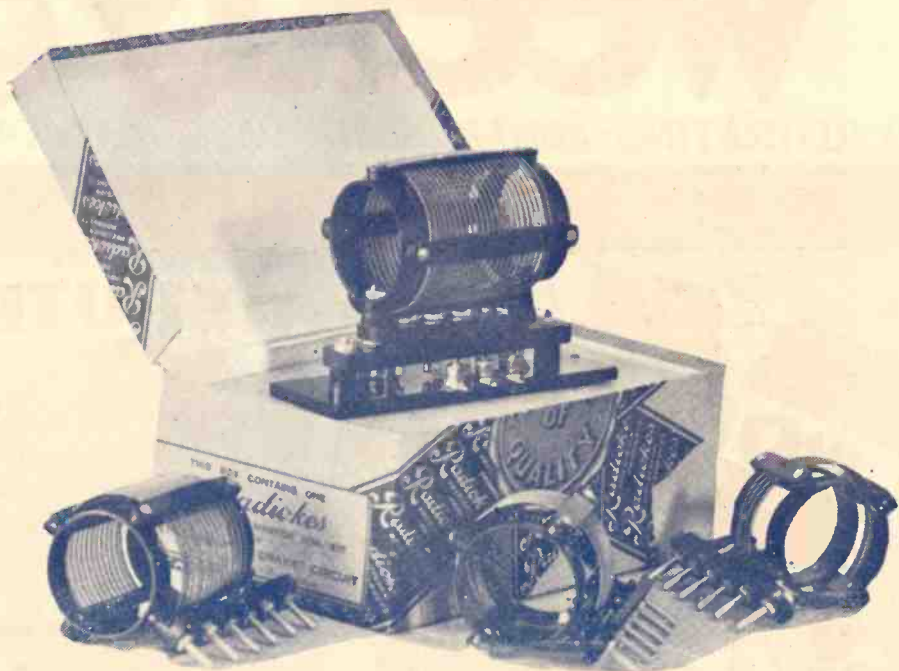

THE above kit represents the ultimate in Precision Short Wave Plug in Coil Kits. These coils have been built scientifically to meet all the exacting demands of high frequency work such as extremely low losses, rugged construction and permanency of calibration.

The skeleton pattern formers of highest grade bakelite support the windings with the best quantity of solid dielectric in the fields of the coils. The spacing between the turns makes for the lowest distributed capacity, and rigid rivetted framework tends to keep the mechanical properties and calibration as originally manufactured.

The interchangeable inductance units are fitted with six specially plated contact pins which engage in a suitable mounting base fitted with an accurate silver spring system.

This new mounting makes coil changing a pleasure because the velvety action of interchanging the coils in the base contacts is so simple, smooth and makes a positive electrical contact. This action can be repeated almost indefinitely without any risk of damaging the coil forms.

This kit, as illustrated, consists of four interchangeable R.F. transformers, mounting base and antenna coupling choke, and covers a range of 15 to 115 metres.

PRICE: 72/6 per Kit.

Obtainable from all High-class Radio Dealers or direct from

METROPOLITAN ELECTRIC CO., LTD.

"RADIOKES HOUSE,"

□ □ □

126-128-130 SUSSEX ST., SYDNEY

Now in the Frozen South!



COMMANDER RICHARD BYRD.

*Byrd speaks
with America
aided by*
**BURGESS
BATTERIES**

Byrd's feat of keeping in constant touch from near the South pole with America is only the result of absolute efficiency in his radio apparatus.

Here, Burgess plays a tremendous part, for these dependable batteries represent the radio power supply throughout the Expedition.

BURGESS BATTERIES

The same dependable batteries are sold by all high-class dealers.

Wholesale: NEW SYSTEM TELEPHONES
PTY., LTD.,

181-3 King St., 280 Castlereagh St., Charles St.,
Melbourne. Sydney. Adelaide.

Canada Cycle and Motor Agency (Q.), Limited,
Creek and Adelaide Sts., Brisbane.

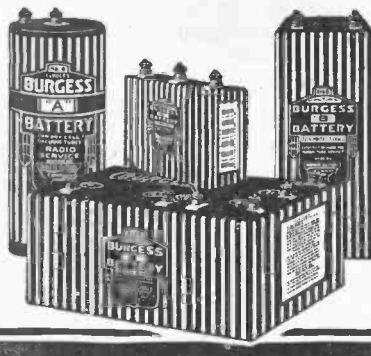

For the Manufacturer
and Amateur Constructor

PILOT RADIO PARTS

Products of the World's greatest
Radio Parts Plant

Variable Condensers

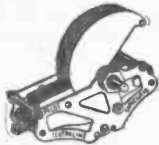

- No. 1623—00050 mfd., 23-plate, 14/6
- No. 1617—00036 mfd., 17-plate, 13/6
- No. 1613—00025 mfd., 13-plate, 12/-
- No. 1608—00016 mfd., 8-plate, 11/3
- Condenser Couplings, for Ganging together 2/6

Midget Condensers



- No. J7, Midget, 7-plate 5/6
- No. J13, Midget, 13-plate 6/6

Pilot Micrograd

- No. V.M. 80, 2-plate 5/-
- No. V.M. 81, 4-plate 5/6



Pilot Sockets

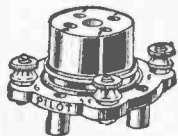

- No. 206 (illustrated), UX Spring Cushion Socket, 3/3 Each.

Pilot Drum Controls

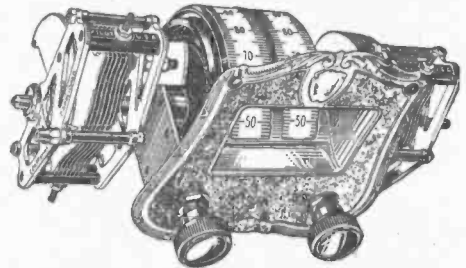

- No. 1284L—Single Illuminated Drum Controls, with bulb £1/2/6
- No. 1283L—Double Illuminated Drum Control, with bulb (illustrated) £1/19/6

Pilot Vernier Art Dials

- No. 1278—Black.
- No. 1279—Walnut. 7/6 each



SOLE AUSTRALASIAN AGENTS:

Harringtons LTD

"Goodwill built on Public Confidence since 1889."

Retail Radio Department and Showrooms:

386 George Street, Sydney.

Wholesale Warehouse:

213 Clarence Street, Sydney.

Also at Katoomba, Newcastle, Melbourne, Brisbane, Adelaide, Hobart, Auckland (N.Z.), Wellington (N.Z.).

Wireless Weekly

Incorporating "Radio in Australia & New Zealand"

Address:
 51 Castle-
 reagh St.,
 Sydney.
 'Phones:
 B7148-9.

RADIO NEWS IN PICTURE



Novel advertising stunt, carried out by British General Electric Co., when a 'plane flew over the city, carrying loud-speaker equipment in operation.



The speakers (see opposite picture) were mounted beneath the wings of the 'plane, and were heard by crowds below.

INDEX TO MAIN ARTICLES IN THIS ISSUE.

CRASH, BURH-H.	5
CRACKLE	5
Will Man Conquer Static?	5
BROADCASTING ANTICIPATED IN 1887	7
A SHORT WAVE RECEIVER, by Ray Allsop	8
HOW TO MAKE A SIMPLE TELEVISOR	9
WIRELESS WEAVING A WEB AROUND THE WORLD	11
By Capt. P. P. Eckersley	
THE MARNOCK 6-VALVE	

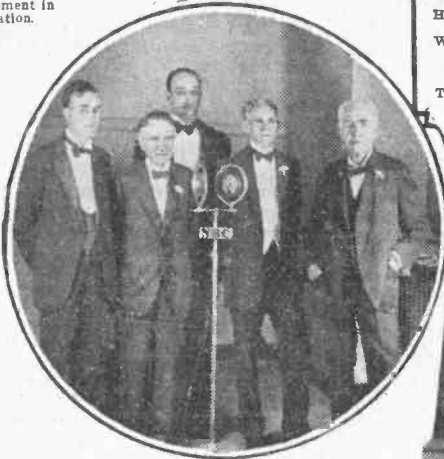

Some famous broadcasters.—(Left to right): Charles Edison, son of the inventor; Harvey Firestone, Henry Ford, and Thomas A. Edison. Behind is shown H. H. Frost, president of the Radio Manufacturers' Association of U.S.A.

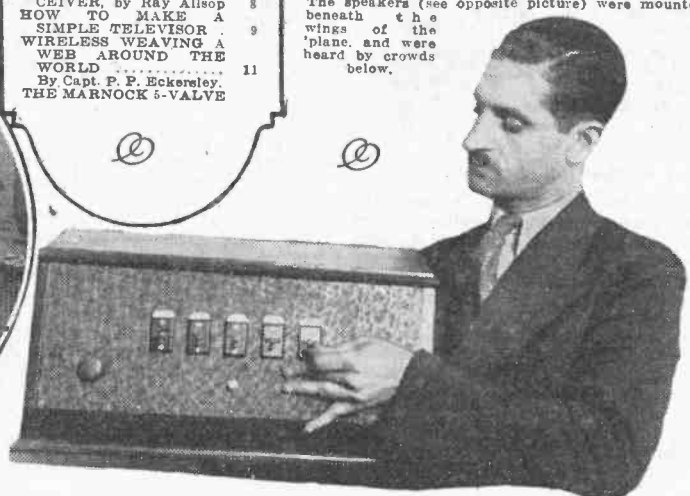

The Automatic Tuning Set.—All you do is press a switch and the station is tuned in. U.S.A. manufacturers are now turning these out.

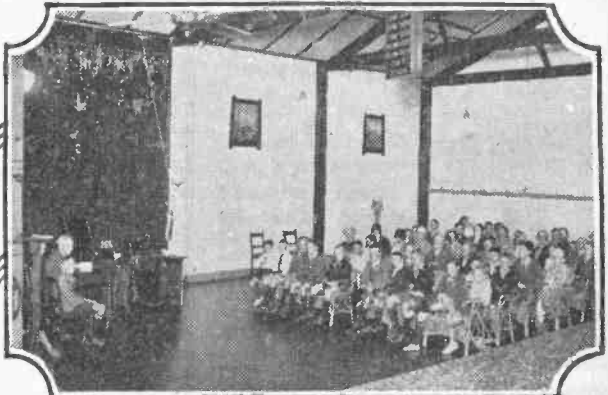
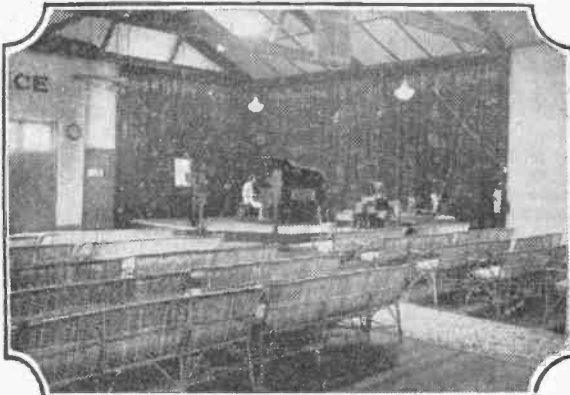

The spaciousness of the new studios at 5CL Adelaide, are shown above. The old studios were burnt down some time ago. Like the studio of 5LO, the 5CL studio provides for an audience.

BETWEEN YOU AND ME AND THE MICROPHONE

Feminism

IT is not unworthy of note that a woman writing in to the "Hello Man" signed herself "Yours fraternally."

Good-bye, Forever--

ONE reads with the appropriate sensation that the B.B.C. music library has a stock of 3500 orchestral numbers, which are not to be repeated in any form. One had no idea that there was so much bad music in the world.

We Mean to Say--

CONGRATULATING us on the success of the Laughing Competition, Mr. Basil Kirke suggests a Laughing Competition for women only. It seems that women laugh much better when they haven't got men to compete against. Although we don't see how leaving out men will add to their laughter. After all, a woman must have SOMETHING to laugh at, Mr. Kirke.



Anatomy of Hamelancholy

WHEN he heard the sad old joke about the woman who went into a butcher's shop and asked for a pound of radio ham a young radio enthusiast friend of ours felt very cut up. "One naturally dislikes to be associated with such piggish talk," he said, "and I feel that the common and vulgar use of signs peculiar to one of the highest of modern sciences is greatly to be deplored." The poor fellow was found dead among his instruments the next morning. It seems that he had been working too near the rotating propellers of a DX fan. Perhaps his death was not due entirely to carelessness, because he left a note to a local paper protesting against the rash habits of the public in jeering at the radio ham, which had wounded him severely. Still, in the circumstances, and as he was quite a promising young mechanic, we think that his (alleged) suicide was quite as rash as his description of the public's (alleged) jeerings. In fact, we consider this action by an otherwise reputable radio ham, even though he did feel cut up, to be very much rasher.



New Stations

THE doctor's small daughter had strayed into his office and was watching wide-eyed as he tested the heart and lungs of a patient. Suddenly a great light dawned upon her. "Daddy," she asked, "are you getting any new stations?"

Tadpoles!

WHAT problems these radio bugs can think up! Here is the latest:—

"Why do my boy's tadpoles, which have just grown hind legs, kick like blazes when the human voice comes out of the loud speaker, and 'freeze' like rabbits when orchestral music is heard?" Are they charmed or stunned?"

We Don't Know

A MAN rang up 2BL one evening and gave the names of three songs which he wanted to be broadcast exclusively to a woman who was listening-in. "She will understand," he said. It is quite possible that—

She Would
Have Understood
If she Could;

but as 2BL, having a set programme to broadcast, and having no means of broadcasting exclusively to one person, could not give her the opportunity, we are absolutely uncertain whether she

Could
Have Understood
If she Would.

We Shall Now Hear

IN Ireland broadcasting has more than the blessing of the aristocracy. The Marchioness MacSwiney of Mashanaglass broadcast a programme of her own music from 2RN (Dublin) in January. One imagines an Australian announcer's attempt to get round this name. And if it seems easy to you, perhaps you will pronounce for us the name Seamus MacAonghus, which appears over some bagpipe selections on the programme of the same station. We had a little difficulty with it ourselves.

RADIO TRAGEDY NO. 5.

*He was old, very old, with a long, long beard,
And he sat in the studio;
And he spoke through the mike, and he said, "I'm afraid
Of the terrible things I know!
The world's up the pole—
It's lost its soul;
No one has an aim; no one has a goal;
Money's kicking God and Religion from the land,
And Art does the Charleston to your big Jazz Band!"*

*Two great big tears trickle-trickled down his beard,
To the floor of the studio;
Then he spoke again, and he said, "I'm afraid
Of the horrible things I know!
You're drifting along
To your rotten Jazz Song,
While another war waits for the starting gong . . .
The Announcer cut him off with a motion of his hand—
"We'll now hear a Fox-trot from our big Jazz Band."*

IN the modern kitchen, where everything is cooked by electricity according to recipes broadcast over the radio, the bride can blame the high specific gravity and molecular construction of her biscuits on fluctuating line voltage and static.

General Purpose Valve



A VENERABLE old Scot purchased a little radio set, and a few days later his friends asked him how he liked it. "Weel, it's all right to listen to," he replied, "but those bulbs are nae sae gud to read by."

Duke's Voice

"DID you hear a real live Duke the other evening? I did, and I haven't got over it yet," writes an English correspondent.

"It was the Duke of Northumberland, to wit. An interesting talk, my lord, good matter, and a worthy subject; but, alas, you wouldn't pass a voice test! Kind hearts, etc., is good, but a pleasant voice is better!"

'Cellist Unstrung

MR. BRYCE CARTER wandered about the 2FC studios on the hot night of Madame Evelyn Grieg's concert, murmuring disconsolately. He wanted a cool breeze. That was what he wanted—a cool breeze. These so-and-so north-westerlies were awful. He wanted a cool north-easterly breeze. Just five minutes of cool north-easterly breeze. We said that a southerly was due, by the red light in the G.P.O. tower! (fearful oath). But southerlies were no good to Mr. Carter. What he wanted was a cool north-easterly breeze. "You don't know what the Strings have to put up with," he said. "I've got to play in a trio to-night, and the gut strings of my 'cello have shrunk, and the silver binding just rolls round when you pull the bow across 'em. I can't get a sound from my two lower strings." It appears that a cool northerly breeze from the sea will swell the gut strings in a very short time. Hence the weird Carterian Songs to the North-easterly Breeze.

Zoological Radio

THIS is quite genuine: "I have built a crystal set from the circuit published in your paper, and I cannot get results. I am certain all the wiring is correct. The only thing I can think what might be wrong is the catwhisker; the hair I cut off our cat's face is white; should the hair be black?" Our technical editor tells us that it really doesn't matter whether black or white hair is used. So we think it must be the wiring, after all.



CRASH! BURP-P! CRACKLE

THE RED DEMON WHO LINGERS UNSEEN IN THE AIR



A Fortune Awaits the Man who Invents or Discovers a Means of Conquering Static--Stray Electricity in the Air is an Eternal Problem--Solution has Baffled Scientists since First Clicks Were Heard on Wireless in 1890--Where the Disturbance Originates.

STATIC, as applied to radio reception, is a natural and eternal problem. It may never be possible completely to eliminate it from our radio activities, and the genius who solves the static problem has fame and fortune awaiting him. As long as static interferes with the reception of otherwise excellent broadcasting services, radio must suffer and appear to be an unfinished art. Scientific radio men everywhere admit they are little nearer a solution of this baffling problem than they were when the static was heard in wireless receivers back in 1890.

Radio reception is always at its best during the hours of darkness. It is then that broadcasting from distant stations has greater volume, and stations which cannot be heard in the day will come in loudly. But favorable radio nights, free from static and other natural imperfections, visit us at rare intervals. Radio fans, and they are legion, fully appreciate the possibilities of such nights. Here, at last, are long awaited opportunities for real DX radio listening. And the tales which will be told on the morrow will easily rival those sponsored by the golfing and angling fraternities.

It is not uncommon for a "fired-in-the-wool" radio fan to stay up until the wee hours of the morning on such occasions. And only the coming of the dawn causes the signals silently to fade away, and drive him to his bed. Perhaps it is for this reason that nature, with her kindly and motherly instincts, has feelingly prohibited the too

frequent occurrence of good radio nights. Since radio has come into our lives we have become well acquainted with the many hitherto unknown pranks of nature. Queer electrical disturbances take place in the air all about us, but it takes a radio set to bring them to our ears.

WHAT MARK TWAIN MIGHT SAY.

If Mark Twain were alive to-day most likely that genial old gentleman would be a radio fan. He is credited with a famous remark about the weather, but there is no doubt that he would soon change it to—"Everybody talks about static, but nobody does anything about it."

The fact is, nobody can do much about it except make the best of it. The question of perfect and static-free reception has gone beyond the ability of the engineers. They have miraculously perfected the apparatus within a short space of time, but are blocked by the inexorable and unconquerable moods of nature. Perhaps some day receiving sets will be immune to static outbursts, but that day is far distant, except in some few great laboratories where costly experiments are being made. Static eliminators, such as have been offered the radio public, cannot eliminate static from our radio sets, and they are therefore useless.

The public has quickly taken to the word "static." It has been popularly applied to all foreign and stray noises heard in the radio receiving set. And static, being the chief offender, gets all the blame for poor radio nights. We should be careful, however, not to overlook the fact that other phenomena, such as signal fading, freak reception conditions, blanketing, dead spots, and interference between station signals, tend to destroy that state of perfection we should like most any night.

Static is a creature of the air; it is with us always. At times it is scarcely noticeable, and again so severe that even powerful local broadcasting stations will be drowned out. Often, without warning or reason, clear and static-free signals will fade away so they cannot be heard, only to rise again to full volume. Occasionally broadcasting will seem weak, as though a blanket were spread over the country. For many of these freaks of radio reception science has little or no explanation; we can tolerate them if static is practically absent.

Static is more or less continuous in the tropics, and seldom noticed in the far south-

ern regions. It is stronger in hot weather or relatively warmer days in either summer or winter.

What is static? We know it is produced by some electrical disturbance, and that it may be detected by a radio set. While such disturbances are always current, listeners are totally unaware of their presence until they hear the sounds coming from the loud speaker. It is clearly indicated that static is the result of natural electrical actions which are quite similar to some waves propagated by broadcasting stations. This similarity lends to static a weapon capable of penetrating any tuning device of a radio set, however complicated it may be.

HOW STATIC ORIGINATES.

The atmosphere is a gas; it is composed of molecules and atoms of certain elements carried in mixture and suspension. Air that is quiet and free from molecules of water has little electrical effect, but as soon as it begins to move about because of other influences, many of the atoms become ionized under the stresses and strains of impact and friction between the molecules, atoms, and free electrons. The atmosphere is, therefore ionized to a certain degree most of the time, but there is no telling what kinds of ions are present, as they are rather mixed up into the homogeneous mass we are pleased to call the air. The lower atmospheric regions in which we live and our weather phenomena occur are uniformly ionized during the day due to the action of sunlight. This accounts, to a great extent, for the fact that radio waves do not carry so far by day. But it is when local or sporadic ionization of the air takes place that our radio sets pick up static impulses, and another bad radio night is at hand.

If a rubber fountain pen, after it has been charged by rubbing with a cloth, is touched to any part of the radio set or antenna, a loud static crash will be heard. This is due to the electric discharge passing through the set just as a static charge or wave passes through.

The molecules and atoms are in a state of constant turmoil; they are tossed about by the moving air currents; they gather together in groups and collect, with water vapor molecules, into droplets of rain, ice, or snow, constantly combining and breaking apart while falling to earth, and they collide with each other under the action of the sun's



rays, and other influences. Intense ionization is the result, but these actions, it must be remembered, take place in spotted areas throughout the atmosphere. Knowing this, we see that there are many distinct areas or regions of electrically charged atmosphere within a comparatively small region. This gives to the atmosphere an ever-changing electric value, and the intensity of these values determines the degree of static impulses registered by a radio set in the immediate neighborhood.

Comparing one of these charged masses of air to the electric charge on the fountain pen, it may be seen that when a charged mass of air comes into contact with the radio antenna it sends its bit of electricity into the radio set, and we have a static crashing sound as a result. When a single molecule of atmospheric gas becomes charged it alone cannot affect the radio receiver, as its power is too weak. But when billions and unspeakably more billions gather into a group, this group assumes the unit charge which is sufficient to cause a static discharge into the radio apparatus. The electric current produced may be less than a millionth of that required to light a pocket flashlight.

WHEN THUNDER SOUNDS.

The thunderstorm is the greatest source of static. If on a hot day in summer, and during the hottest part of the day, we have warm and moist air ascending, there is a likelihood of a thunderstorm. Even long before the storm clouds and first mutterings of thunder are seen and heard the air is filled with incessant static discharges as the air becomes more and more ionized. Now, as this warm and humid air arises because of convection, it comes into contact with over-running cool air currents above, and is chilled. This condenses the water vapor into steam, fog, or clouds. The cloud formations constantly build up and become dark and rolling, as they are twisted about by the many air currents.

When the moisture in the clouds becomes sufficiently chilled there is a further condensation into droplets, and soon the water falls to earth in the form of rain. These drops constantly break up and recombine, distributing their electric charges throughout the clouds and air. The clouds become charged, some positive and some negative. When the charges become great enough the natural insulation of the air cannot resist the strain of millions of volts, and a breakdown occurs. There is an immediate discharge of electricity, which we see as a tremendous flash. These flashes occur between highly-charged clouds, or between the clouds and the earth beneath.

Shorter lightning discharges occur within the clouds when heavy charges of opposite kinds are bound along the upper and lower



A heavy static crash is heard for every lightning flash—whether seen or unseen.

levels of single clouds. A heavy static crash is heard in the radio set for every lightning discharge that takes place. Minute sparks or simple discharges also occur in the clouds, air, or between large particles of falling rain, hail, or snow. These are sufficient to give off static impulses capable of carrying short distances.

The earth happens to be negatively charged since it has a great excess of free electrons. The passing clouds may be charged with either kind of electricity. When a cloud bearing a positive charge along its lower edge passes along at a distance above the earth's surface, an excess of electrons or negative electricity moves along the surface of the earth with a strength equal to the attracting power of the cloud. It is natural that this earth current should try to get as close to the cloud as possible, and, therefore, it flows upward into trees, hills, poles, houses, and any projection. Now, if we have a radio set connected to the ground on one side and an antenna on the other, we can see that some

of this earth current flowing along beneath the cloud will run up the ground wire through the radio set, and out into the antenna, where some will be dissipated into the air. This flow of current through the radio set will give off a severe static crash.

When we compare the great potential of a lightning flash, many millions of volts, and the heavy flow of current for the moment, we can realise that the power used by the average first-class radio station is only a very small fraction of that given off by nature in a single discharge of lightning. It is no wonder, therefore, that static is nearly always present to some degree in a sensitive radio receiving set. It has been established that thunderstorms are always in progress at some place on the earth, and that more than a thousand flashes of lightning occur ever minute. The distance that these static waves from lightning will carry is unknown, but it is believed to be many hundreds of miles.

OTHER FORMS OF STATIC.

There are forms of static in the atmosphere other than the types associated with thunderstorms. During clear weather static might be very severe as the charged masses of air give off discharges and come into contact with the antenna or any portion of the radio set. Free electrons from the earth surge up through the ground wire when an attracting charge passes overhead through the air. Atmospheric static in clear but humid and hot weather is usually intense; it is indicated by a steady stream of hisses and clicks. Thunderstorm static sounds are mostly of longer duration, as the length of the actual time interval of sound is equal to the duration of the spark.

One often sees a distant lightning flash while hearing it at the same time in the radio receiver. But the actual thunder, or sound produced by the expansion of the air when the spark takes place, may not be heard until many seconds later. This is because radio and light waves travel about 186,000 miles a second, and sound only carries about 1100 feet in the same time. If a vivid lightning flash is observed, count off the seconds until the sound of the thunder is heard. Roughly, to compute the distance, allow five seconds for each mile distant the lightning flash took place. The sound of the static is so simultaneous with the flash that it is impossible to compute the distance by radio. But, of course, static can be heard hundreds of miles, while thunder seldom carries over a few miles.

Dust storms are also very productive of static. The immense quantity of dust particles, in addition to the normal molecules in the atmosphere, create intense ionization and electrification. Such storms highly charge all metal objects in the vicinity.

THE PARABLE OF THE DICTATOR

ONCE upon a time, in the Kingdom of Diddle-de-dum, the wise legislators of the day did appoint a widely travelled man of much learning to act as broadcasting dictator—it being the age of Dictators.



"A dear old Lady—"

In red tape they bound him, and bade him heed the wishes of politicians, and bend to the desires of the loudest-voiced members of the multitude and particularly to those to the papers who wrote.

And it came to pass after many moons had shone that the Dictator formulated model programmes to please all the peoples of

land of the Diddle-de-dum.

But wisely though those were prepared after much thought, they were subjected to divers criticism from every quarter of the Kingdom.

A dear old lady called Madame Grundy, who sat high upon a barbed fence, said unto the Dictator, "Oh, dear, you should not do this, and you should not do that; it is not good for the growing innocents."

Accordingly the Dictator did prune from the programmes all racing and the noble art of wrestling, and suchlike.

Then saith the highbrows of the land, "We like not this Jazz, and all those tunes and songs sung and whistled by urchins in the streets, and would have them educated with something classical."

And lo, all popular songs and ditties loved by just ordinary folk were no longer broadcast.

And then there came to the Dictator people of all classes and creeds. Some objected to this and some to that, and in the end the Dictator found that nothing was left for him to broadcast. He heaved a heavy sigh, and said to the peoples, "They will be done; verily I have faithfully your wishes met, and now no broadcasting can there be; but it matters not, for no licenses now exist, and Listeners no longer search the ether for the magic waves of SLO, which once did charm the populace."

MORAL:

Remember, Ye who hath a grouch, your insignificance when multitudes must be served.

Broadcasting Anticipated in 1887

Here we publish an extract from a novel of the 'nineties, which aroused incredulity among readers, because of its picture of 2000 A.D. To-day the writer's vision has been realised—75 years before the author expected it.

By W. H. C. STUCHMANN

THE American author, Edward Bellamy, living from 1850 to 1898, astonished the educated world in the 'nineties of the former century with his novel, "Looking Backward, 2000-1887." His writing is a Socialistic Utopianism, which tries to remove in an agreeable manner of tale the inconveniences that the modern capitalism has brought.

Bellamy makes West, the hero of his tale, sleep in a death-like slumber in 1887, out of which he is awakened by Dr. Leete in 2000. The representation of particulars would go too far in this connection. Anyhow, West is introduced into a new social and economic arrangement; here is drawn a parallel between the former states to those of the year 2000.

In the treatise in question there is only interesting a part of the conversation between West and Edith, the daughter of his host, Dr. Leete, who had restored him to life. In Bellamy's book West says the following in the eleventh chapter, related as a dialogue between Edith Leete and himself:—

"Come, then, into the music-room," she said, and I followed her into an apartment finished, without hangings, in wood, with a floor of polished wood. I was prepared for new devices in musical instruments, but I saw nothing in the room which, by any stretch of imagination, could be conceived as such. It was evident that my puzzled appearance was affording intense amusement to Edith.

"Please look at to-day's music," she said, handing me a card, "and tell me what you would prefer. It is now five o'clock, you will remember."

The card bore the date: "September 12, 2000," and contained the longest programme of music I had ever seen. It was as various as it was long, including a most extraordinary range of vocal and instrumental solos, duets, quartettes, and various orchestral combinations. I remained bewildered by the prodigious list until Edith's pink fingertip indicated a particular section of it, where several selections were bracketed, with the words: "5 p.m." against them; then I observed that this prodigious programme was an all-day one, divided into twenty-four sections answering to the hours. There were but a few pieces of music in the "5 p.m." section, and I indicated an organ piece as my preference.

She made me sit down comfortably, and, crossing the room, so far as I could see, merely touched one or two screws, and at once the room was filled with the music of a grand organ anthem; filled, not flooded, for, by some means, the volume of melody had been perfectly graduated to the size of the apartment. I listened, scarcely breathing, to the close. Such music, so perfectly rendered, I had never expected to hear.

"Grand!" I cried, as the last great wave of sound broke and ebbed away into silence. "Bach must be at the keys of that organ; but where is the organ?"

"Wait a moment, please," said Edith. "I want to have you listen to this waltz be-



"What's wrong with this picture? Nothing. It's just Maisie and John in a preliminary hop before stepping out to the Old Timers' Ball."

fore you ask any questions. I think it is perfectly charming," and as she spoke the sound of violins filled the room with the witchery of a summer night. When this had also ceased she said: "There is nothing in the least mysterious about the music, as you seem to imagine. It is not made by fairies or genii, but by good, honest, and exceedingly clever human hands. We have simply carried the idea of labor-saving by co-operation into our musical service as into everything else. There are a number of music-rooms in the city, perfectly adapted acoustically to the different sorts of music. These halls are connected by telephone with all the houses of the city whose people care to pay the small fee, and there are none, you may be sure, who do not. The corps of musicians attached to each hall is so large that, although no individual performer, or group of performers, has more than a brief part, each day's programme lasts through the twenty-four hours. There are on that card for to-day, as you will see if you observe closely, distinct programmes of four of these concerts, each of a different order of music from the others, being now simultaneously performed, and any of the four pieces now going on that you prefer you can hear by merely pressing the button, which will connect your house-wire with the hall where it is being rendered. The programmes are so co-ordinated that the pieces at any one time simultaneously proceeding in the different halls usually offer a choice, not only between instrumental and vocal, and between different sorts of instrumentals; but also between different motives from grave to gay, so that all tastes and moods can be suited."

"It appears to me, Miss Leete," I said, "that if we could have devised an arrangement for providing everybody with music in their homes, perfect in quality, unlimited in quantity, suited to every mood, and beginning and ceasing at will, we should have considered the limit of human felicity already attained, and ceased to strive for further improvements."

"I am sure I never could imagine how those among you who depended at all on music managed to endure the old-fashioned sys-

tem for providing it," replied Edith. "Music really worth hearing must have been, I suppose, wholly out of the reach of the masses, and attainable by the most favored only occasionally, at great trouble, prodigious expense, and then for brief periods, arbitrarily fixed by somebody else, and in connection with all sorts of undesirable circumstances. Your concerts, for instance, and operas! How perfectly exasperating it must have been for the sake of a piece or two of music that suited you, to have to sit for hours listening to what you did not care for! Now, at a dinner one can skip the courses one does not care for. Who would ever dine, however hungry, if required to eat everything brought on the table? And I am sure one's hearing is quite as sensitive as one's taste. I suppose it was these difficulties in the way of commanding really good music which made you endure so much playing and singing in your homes by people who had only the rudiments of the art."

"Yes," I replied, "it was that sort of music or none for most of us."

"Ah, well," Edith sighed, "when one really considers, it is not so strange that people in those days so often did not care for music. I dare say I should have detested it, too."

"Did I understand you rightly," I inquired, "that this musical programme covers the entire twenty-four hours? It seems to me on this card, certainly; but who is there to listen to music between, say, midnight and morning?"

"Oh, many," Edith replied. "Our people keep all hours; but if the music were provided from midnight to morning for no others, it still would be for the sleepless, the sick, and the dying. All our bedchambers have a telephone attachment at the head of the bed, by which any person who may be sleepless can command music at pleasure, of the sort suited to the mood."

So in principle Bellamy anticipated broadcasting of our days, but his fancy did not suffice in the representation of the wireless. Much, what he had foreseen, has already grown into reality; let us wait, whether all will be realised or not.

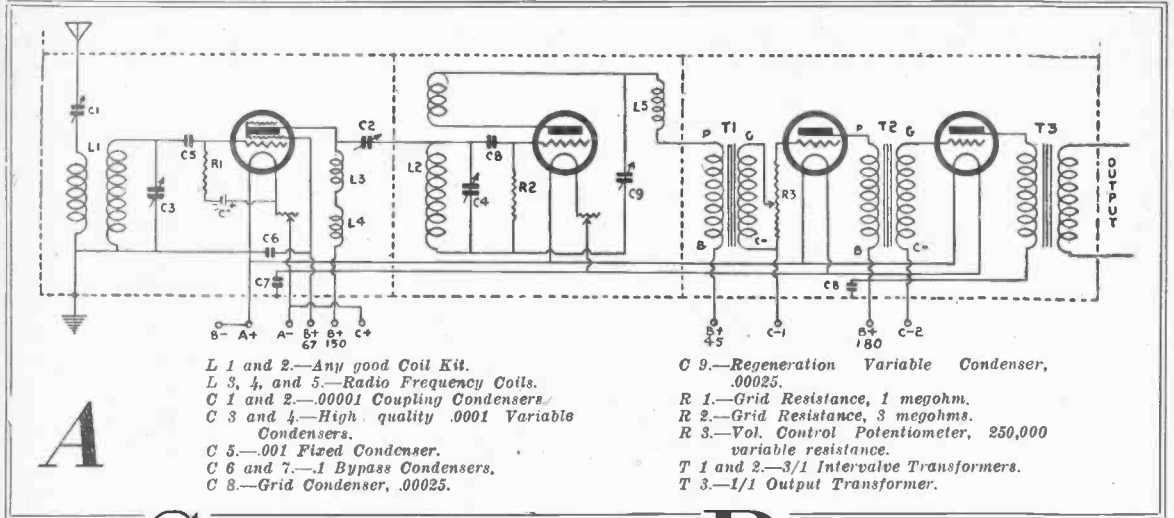

Short-wave Receiver

IN response to many requests for a short-wave receiver circuit I am putting forward a circuit similar in many respects to my present set.

It consists of a screen-grid, R.F. stage detector, and audio amplifier. Three screened compartments are required, the first to contain the screen-grid valve with its associated tuning and control units; the second compartment contains the detector and tuning units, and the third the audio amplification units.

The tuned circuit of the radio frequency amplifier tuning condenser and the radio frequency amplifier grid circuit inductance feeds to the control grid of the screen-grid valve through a coupling condenser. The rotating plates of the variable tuning condenser must be connected to the shield to eliminate hand capacity. The radio frequency amplifier grid obtains bias through a 1 megohm. resistance from a small battery housed in the container along with the other units.

The plate current to the screen-grid valve is fed through two radio frequency chokes to prevent R.F. currents getting back into the "B" battery circuits. The R.F. stage plate circuit is coupled to the detector circuit by a small coupling condenser.

This condenser is small enough to prevent reaction of the amplifying circuit on the oscillating detector circuit. The capacity value of this condenser is not detrimentally low to cause loss of signal strength.

The tuned detector circuit employs a plug in inductance similar to the R.F. stage; this coil will also include the reaction inductance. The tuning condenser is similar to that in the R.F. stage.

Regeneration is controlled by a .00025 variable condenser, the stator side of this condenser being connected to the tickler coil side of the R.F. choke L5, and the rotor or moving plates being connected to the shield filament (plus) positive.

The first audio frequency valve is fed from the first 3 to 1 audio transformer—this transformer having its secondary shunted by a variable resistance for volume control, while this valve plate circuit feeds into the primary of the second 3 to 1 transformer. The secondary winding of this transformer feeds the second audio valve, which should be one of the power variety; the plate of this valve will be fed through to primary of the one to one output transformer.

To construct this receiver first decide on the type of screen-grid valve you intend to employ, then construct the

metal shield to suit valve decided upon. If a valve of horizontal type is used a hole can be cut in the shield between the R.F. and det. compartments, allowing the valve to pass through. Then the R.F. chokes L3 and L4 may be mounted underneath the floor shield. If the constructor decides to use a valve with a standard socket, construct a shield around the valve, as recommended by the manufacturer, in the right-hand back corner of the R.F. compartment.

There are several good makes of plug-in coil kits on the market that will suit admirably for the inductances; two complete sets will be required to cover wave lengths from 14 to 80 metres.

Take the reaction inductances (fine wire winding out of the coils) that are to be used in the R.F. unit.

Before constructing consider the circuit well, and lay the components out to allow short wiring; also make sure your wiring is well insulated from the shield. Components at high tension plate supply must be perfectly insulated from the shielding.

It is important with a receiver of this type that only components of the best quality should be used. For instance, the variable condensers must be of the low-loss variety, fitted with slow-motion controls.

The low-loss requirement also applies to the radio frequency and detector inductance. It is also of considerable importance that the radio frequency choke used should be above reproach.

Another important point is the selection of the detector. This valve should have an impedance in the neighborhood of 15,000 to 20,000 ohms, a valve being chosen which will allow of oscillation being obtained over the whole scale of the reaction condenser without difficulty.

The low capacity series condenser in the aerial circuit has been employed because some aerials have a large capacity, possibly due to such causes as their proximity to buildings or trees.

The shielding may be constructed of aluminium or brass sheet. Aluminium may be purchased to the size required, and will be stiff enough for mounting the tuning condenser, etc. If brass sheet is employed, a bakelite or some other material will be necessary to stiffen up the front to take the variable condensers and rheostats.

**By
Ray
Allsop**
*(Associate
Technical
Editor)*

How to Make A Simple TELEVISOR

This televisor, simply and inexpensively made, will provide the listener with many interesting hours of experiment, "looking-in" to the ordinary modulated signals of local stations. It must be understood, however, that this televisor will not be suitable for receiving television signals should a television station be erected here shortly.

By W. G. NICHOLS and J. C. PINNELL

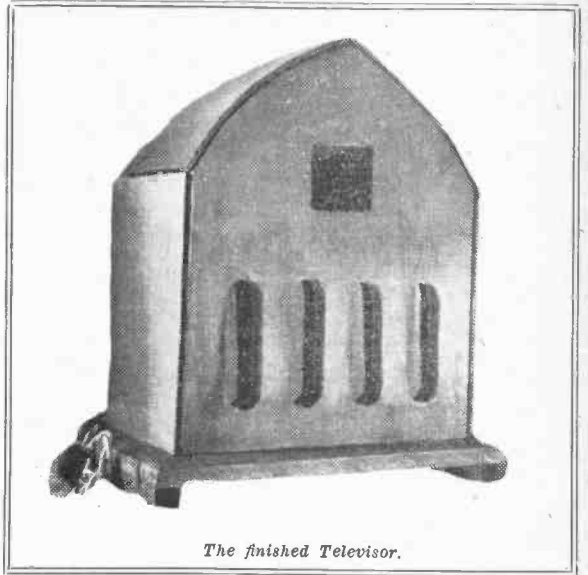

At the present time the facilities for actual television picture transmission in Australia are lacking, but for the enthusiast who would like to dabble in the science, "looking-in" at the transmissions of music and speech from the local broadcasting stations will offer much amusement and incidentally give the enthusiast a working knowledge of the science of television.

Amplified signals are converted into varying luminosities instead of into audible effects, and an endless production of musical patterns in response to the usual broadcast signals may be observed.

It must be understood, however, that the constructional of the small televisor described here is for experimental purposes only, and will not serve to receive actual broadcast images should a television station be erected here. It is an inexpensive experiment, and, in any case, should repay the builder many fold.

In order to make a suitable receiver, you need only a modest assembly of instruments, some of which you will probably find around the house. If you are living sufficiently near a broadcasting station to obtain good loud speaker results, all you require are a scanning disc, the construction of which will be dealt with later; a small fan or sewing machine motor, a neon lamp, and sufficient wood

to construct a cabinet suitable for housing the apparatus.

In the reception of actual television pictures, it is practically necessary to use a resistance coupled amplifier, as the band of frequencies used for television work is rather broad. The resistance coupled amplifier will amplify audio frequency impulses ranging from 50 to 5000 cycles more uniformly than does the transformer coupled type of amplifier. Television impulses cover this frequency range, and must be reproduced faithfully by the receiver and amplifier without emphasis on any particular frequency, in order that a recognisable picture can be seen. The transformer coupled amplifier has slight irregularities in its amplification over amplifying the impulses of a certain frequency, while under amplifying impulses of another frequency.

When used for receiving broadcast music the ear does not detect these faults to any great extent, but when television pictures are being reproduced, even the slightest irregularity will cause a poor reproduction of the image.

For the purpose we have in mind, however, an amplifier of either the transformer or the choke coupled type will be found quite suitable.

Now to start on the actual construction of

the "televisor" we will first give our attention to the scanning disc. This should be made from 22 gauge sheet aluminium or sheet brass, and has a diameter of 9in. Having cut out the disc, take a file and true up the edges, but, during this process, be sure you keep the metal flat, as bumps or twists will cause the finished disc to revolve unevenly, and this will cause vibration when the disc is revolving at a high speed.

Having cut out and finished the disc, we next give our attention to the drilling of the holes. This operation calls for great care and patience, as any tendency to rush the job will only result in an uneven scanning of the music. The disc has twenty-four holes drilled in a spiral, each hole being drilled with a 3/64in. drill.

Fig. 1 shows how the disc should be marked out for drilling. The circumference of the disc should be divided into twenty-four equal parts, and a line should be drawn from each of these points to the centre of the disc. Take a pair of dividers and describe a circle half an inch in from the edge of the disc; twenty-three more circles should be described, each circle having a radius 1/24in. less than the preceding circle. It will be noticed from Fig. 1 that when each preceding hole is marked on the disc, it drops down 1/24 of an inch. In the centre of the disc a hole must be drilled to correspond to the diameter of the armature shaft of the motor used.

In Fig. 2 you will see a suggestion for mounting the scanning disc to the motor shaft. The mounting can be made of metal or turned out of wood, but the metal would be best. The drawings make quite clear how the scanning disc is fitted on the mounting, and the mounting then fitted on to the shaft of the motor.

The making of the cabinet will next claim our attention.

In the design the sizes given are to suit the material we had on hand. Care should be taken to see that your own material will fit into this size cabinet. If it will not, make the same style of cabinet, but use measurements to suit your own requirements.

Cut out two pieces of wood to the measurements given in "A," Fig. 3—one piece for the back and one piece for the front. Both these pieces should be cut from half-inch timber, and the piece to be used for the front of the

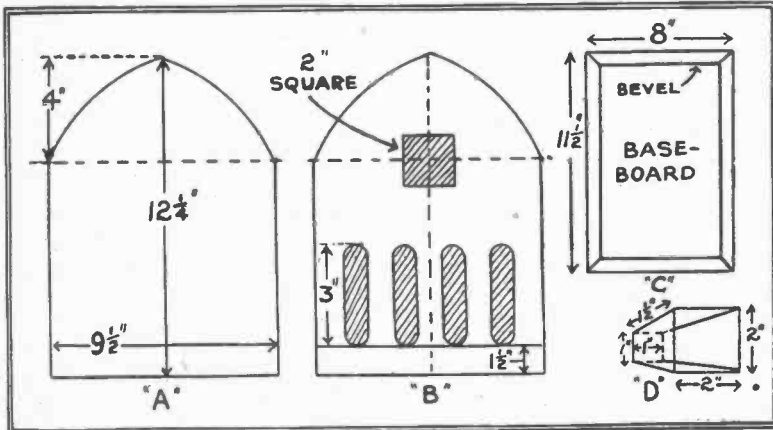

Fig. 3. Constructional details for the case.

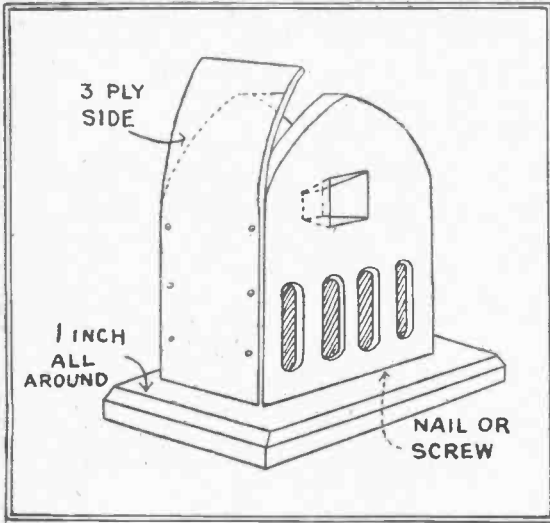

Fig. 4. The construction of the case.

cabinet should be cut out as shown in "B" Fig. 3.

The back of the cabinet should have the slots cut in the same as the front, but no viewing hole. The idea of these slots is to allow the passage of air into the cabinet and so help to keep the motor cool.

Still using the half-inch wood, cut out a baseboard to the dimensions given at "C," Fig. 3. A bevel is put round the edge of this baseboard for appearance sake. From a piece of three-ply wood cut two strips six inches wide and about fifteen inches long.

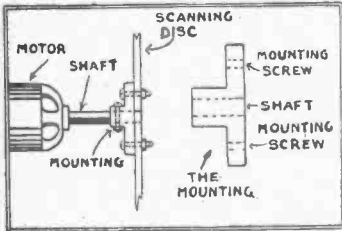

Fig. 2. The motor mounting.

Take the two pieces of wood to be used as the back and front of the cabinet and place in an upright position on the baseboard. If a distance of five inches is left between the front and back pieces the baseboard will be an inch bigger all round than the cabinet.

The back and front can be attached to the baseboard by nailing or screwing from the underneath side of the baseboard as indicated by the arrow in Fig. 4. Dip one of the three-ply pieces, already cut out, into some warm water. While warm, the three-ply will be found fairly easy to manage, and should be nailed to the uprights so as to form a side. This is clearly shown in Fig. 4. If the three-ply is too long, cut off level with the peaks of the back and front of the cabinet.

The second piece of three-ply is put on in the same manner, but not till the scanning disc, motor, and neon lamp have been placed inside the cabinet. A small viewing attachment shown at "D," Fig. 3, should now be made and fixed to the back of, and corresponding to the viewing hole in the front of the cabinet. This attachment should be painted black.

Having already fastened the scanning disc to the shaft of the motor, a shelf must now be made to hold the motor. This shelf is fastened to the back of the cabinet, and can

be supported underneath by a metal angle bracket. Care must be taken when fixing this shelf to see that it is placed in such a position as to allow the viewing hole to be completely scanned by the holes in the scanning disc when the disc is revolved.

The neon lamp is the next thing under discussion, and owing to the lack of demand here for television equipment, a neon lamp specially made for the job cannot be obtained. In the actual experiments carried out by us a beehive-type Osglim lamp was used. This lamp fits a standard bayonet type lamp socket. The socket should be screwed in such a position that, when the lamp is inserted, the beehive-shaped grid will cover that part of the scanning disc which is in front of the viewing hole, as in "B," Fig. 5. In actual experiments made by us, we found that the pattern caused by the beehive grid slightly marred the received impulses, but after trying several arrangements, it was found that a piece of celluloid (ground on one side by a piece of sandpaper) inserted between the scanning disc and the lamp overcame this difficulty.

A length of twin flex should be connected to the motor, and a telephone cord attached to the neon lamp. Give the motor and the

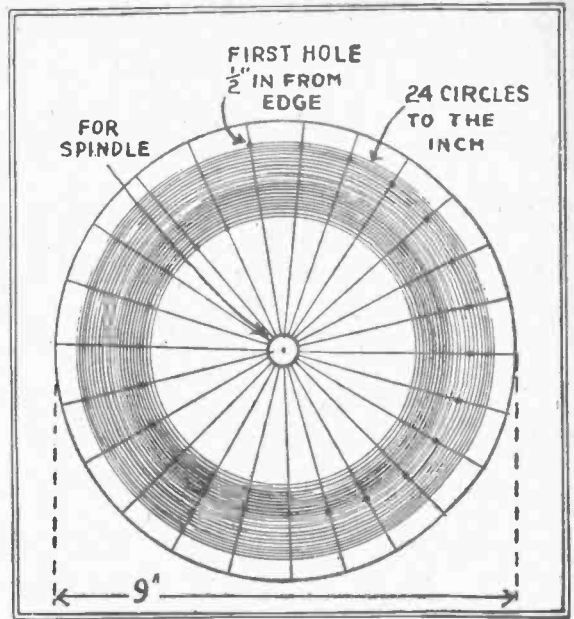

Fig. 1. The scanning disc.

lamp a preliminary test by plugging the motor leads into the 240-volt mains, and the lamp to a 150 to 200 volt "B" battery.

Having passed this test successfully the remaining side can be put on the cabinet, and the leads to the motor and neon lamp brought out, one on each side of the cabinet, the leads from the neon lamp being attached to an ordinary loud speaker plug. All that it is necessary to do to set the television in operation is to tune in the signals from your local broadcasting station, the louder the signals the better. Now switch on the television motor and put the plug of the neon lamp into the jack previously occupied by the loud speaker.

The leads from the neon lamp should be reversed, and a note made of which position gives the best results, as in one particular way a brighter and fuller illumination will be obtained. If you have a regenerative receiver care should be taken not to allow it to burst into oscillation, because if this should occur, an unvarying pattern will be seen in the viewing hole as long as the set is in oscillation. When there is no broadcasting between an announcement and an item, a flat illumination will be seen.

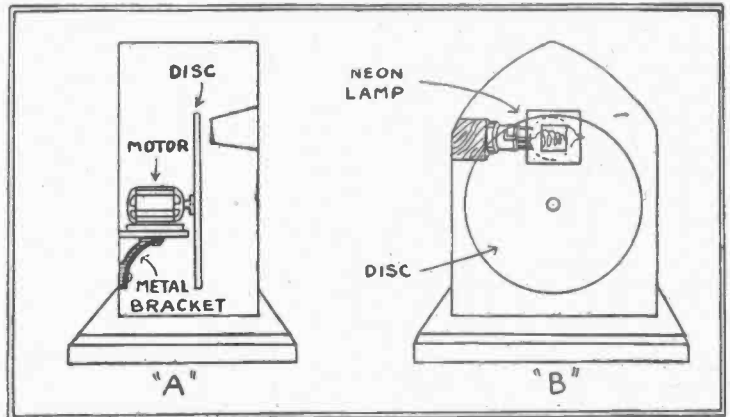

Fig. 5. How the neon tube is arranged.

The Web Which Wireless Is Weaving Across the World

Sound pictures "laid on" to every home--chains of broadcasting stations over the five continents and the five seas--the permanent recording of great events--these are some of the developments which Captain Eckersley, the Chief Engineer of the B.B.C., foreshadows in this absorbing article."

By Captain P. P. ECKERSLEY

SPECULATIONS as to the future are usually unsound—partly because they concern such intangible factors as human nature, and partly because it is impossible to forecast the progress of invention.

It is obvious that invention, following scientific research, determines, to a large degree, the course of all our lives. We have but to look back on the happenings of the last 100 years to realise that discovery and invention have made what is termed the industrial age. But human nature, with its fundamental attribute of greed, has used such invention for the benefit (if material gains can be so described) of the few and the detriment of the many.

The machine has become the master of the man, not man the master of the machine.

THE RESPONSIBILITY.

Human nature has mostly turned human discoveries into weapons against human progress.

Scientific invention, handled by human^s too stupid to be entrusted with such truly beautiful things, has made, for instance, war a far more terrible affair than ever before, and life, for most of us, more dreary, squalid, and non-individualistic.

All classes and creeds are responsible—our brains and our ingenuity have grown faster than our power to handle their products sensibly.

Is my dream of the future, therefore, to be a nightmare of the intensification of the present strife? Or am I to be allowed one of those roseate and Utopian dreams where peace and prosperity flow from the tip of an eloquent pen? It is just as I choose in what I write, and it is really just as simple for the world to choose if it would turn from sloppy conventional thinking to the application of logic to its actions. The responsibility lies with all of us.

Undoubtedly, however, there are inventions of the present day which on the lowest terms have potentialities of bringing about the Utopia that is in all our dreams. Without exaggeration, I believe that the invention of broadcasting has done a little, and must do much more, to bring about a better state of affairs.

Broadcasting allows millions of people to be simultaneously aware of a thought uttered by some one person. Up to now the broadcasting service has been chiefly used as a method of disseminating concerts and lectures of a somewhat academic character, and has, by insinuating the microphone into this or that place, given us an immediate sound record of concurrent events, football matches, cenotaph services, military tattoos, and what not.

The potential power of broadcasting seems to be in bringing the spoken word immediately to listening millions, or in conveying an idea of the width, and yet the essential sameness, of the world. It has done something, perhaps, to knit the world into a consciousness of world citizenship, instead of a feeling of blind and angry support of its own little communities.

So may I be permitted to dream of a future world in which broadcasting has been allowed to play its part? I dream, simply, of a world system of broadcasting, so that each and all of us can be aware of sound pictures originated anywhere on the planet. I dream of the day when broadcasting is "laid on" under a national authority (resembling in great measure the present B.B.C.) to every home.

The loud-speaker can be given its choice. Here with this plug is music all day and every day. Music performed by the very finest musicians; and better, because they are fine musicians, not because they play in a particular town! One time we have the folk singing of Bohemia, another Viennese opera, there is choral singing from Wales,

great symphonies from Berlin, jazz from America—we can hear the Russian Ciganne, or sugary sounds from a Paris music-hall.

AN AERIAL CHOICE.

There will be a choice of speakers—the President of the United States giving his ideas of American policy as it concerns Europe; the British Premier speaking on some measure of economic reform in the House; a great statesman in the hall of the League of Nations; a leader of thought giving us for once something to think about; or, more intimately, our local Town Council debating about a local housing scheme. Controversy of equal minds, eloquent readers of the world's great stories, plays of passion, of dialectic wit, of social satire, a great feast of real amusement to be had for a few shillings a year.

This is my dream of broadcasting in the future.

As Mr. Baldwin said the other day, and as some of us have been saying for years, friendly wireless will make us appreciate the world as populated throughout by human beings—not by foreigners and Englishmen. Human beings who make music, play football, go to church as we do, not savages leading unprincipled lives, ready to attack the inviolable shores of "our England." We shall hear their music, get to know the sound of their voices, and begin to be conscious of real Christianity.

And how is this dream of the future to be realised? It begins now. Wire and wireless are slowly weaving a network around the world. Filament by filament it knits us together. Its permutations are myriad, in time they will become infinite. Wire and wireless each performing its proper inter-related function to spread the same message everywhere.

ALL ON RECORD.

The broadcasting stations of the Continent will be linked by underground cable, impervious to storm or interference, more wave lengths will allow more and more stations giving more and more programmes, spreading the story over the wide countryside, finding the shepherd as easily as it finds the artisan. The continents will be linked by short wave stations flinging the same message across the oceans, to be picked up and diffused through another continental network until every electrical ear can be attuned simultaneously to the same sound.

Great events, the voices of great singers, all that is worth while, will be permanently recorded (something as a gramophone records to-day) for release at times suitable for different parts of the world, or, year by year, decade by decade, century by century, to keep a memory green.

Thus, nothing fine, noble, or worth while in the world should be allowed to die—everyone's loud-speaker will be a telescope to show him the wide world, and thus help him to be a citizen of that world, realising his liberty through service.

Such is my dream of the future. The instrument is nearly prepared. How will it be used?

Will my dream come true?

(Reprinted from the "Daily Herald," London.)

A RADIO FAN'S COMMENT

Why is it most announcers with lovely voices are married?

Why is it people think some high-voiced tenors are what they are not?

Why is it that most girls with beautiful voices have terrible faces? (Ask your 'phone operator! I dare you.)

Why do most of the songs you'd like to remember have such long titles?

Why is it so easy to get the station you don't want and so hard to get the station you want?

Why is it someone always insists on telling a bedtime story?

Why is it your battery runs dead just when someone you know you'll never hear again is broadcasting?

Why is it some singers rehearse when you expect to hear them sing?

Why is it the fellow who built a two-valve set keeps telling you he got Alaska?

Why is it some star you waited three hours to hear has to sing in a foreign language?

Why do some announcers try to be entertainers?

Why don't they ever tune the pianos in most of the studios?

Why do singers with false teeth pose for tooth paste ads?

Why do you think a girl singing on the air is a blonde when she's a brunette? (All gentlemen please answer.)

Why do some entertainers, who are not funny, laugh at their own jokes?

Why does some station you can't get have the best entertainment?

Why does the wife need something from the chemist just when you're listening to a good programme?

Why is it carpenters don't play musical saws?



Uncle Jack Prentice heard these days from 2UW.

Uncle Jack

MR. JOHN PRENTICE joined the staff of 2BL in November, 1924. Then the New South Wales listeners-in became acquainted with Uncle Jack, an expert in foreign affairs, and a well-informed lecturer on most subjects in general, and on music in particular. In fact, acquaintance was just ripening into friendship, when, in the otherwise cheerful month of October, 1926, Mr. John Prentice resigned, and floated off to New Zealand as chief announcer and organiser to the New Zealand Radio Broadcasting Company, Limited.

He was missed in New South Wales, because he had an original turn of mind, and had been in the habit of broadcasting questions received by the telephone, together with their answers. This was a novelty in Australia. And he had been associated with many stunt programmes.

However, it would seem selfish to begrudge New Zealand his services. He spent eight months there, visiting every part; and he spent one month in close contact with the Duke and Duchess of York, broadcasting their activities. When he felt it time to go he was given a public farewell in Auckland. Three thousand people crushed into the town hall. Traffic in that city was held up for one full hour, while New Zealanders, collectively and individually, said good-bye to Mr. John Prentice.

For a year after his return from New Zealand Mr. Prentice was engaged in other work. He made two long visits to Victoria.

Now he is located with 2UW, where he is building up a station remarkable for its high-class programmes. Here again he has instituted his system of telephone requests for special numbers. People write in or telephone during the programme for the compositions they would like to hear, and Mr. Prentice puts those compositions on the gramophone. The idea is catching on, and requests number up to one hundred every day. The Sunday night broadcasts of complete opera recordings have also captured the public fancy.

His speaking knowledge of English, French, and German gives him perfect pronunciation of the weird names tacked on to foreign music.

PROGRAMME PERSONALITIES

False Preference

O saxophone, that in the studio Warblest at eve, when all the air is still; Thou likenest the lover to be ill As thy sad notes foretell some brooding woe. —John Milton (?)

MISS RAE FOSTER has soubretted at 2FC for from six to nine months. Her's is the kind of voice that makes popular numbers even more popular. Occasionally she has taken part in a revue; and often, with Mr. Charles Lawrence, she has sung popular duets. She said, "I want you to say that Mr. Lawrence has helped me, and shown me how to sing to the microphone. I have to thank him for his kindness." We are pleased to make this acknowledgment. Mr. Lawrence's advice has improved many artists, as we know; and we are willing to wager a good few as we don't know.

Now this is Miss Foster's ambition; she wishes to sing popular melodies—well. No heights for her. No Marquerites, no Lucias—no operatic selections by Madame Foster! Just popular songs—well sung. O shades of passive placidity! O ghosts of satisfied perfection! At last we bring you a really dink-i-d! soubrette, who doesn't asplah to the high things. Nunc dimittis. . . . "Too many heartbreaks," said Miss Foster.

Now listen to Miss Foster's preference. "Rather," she said calmly, as though it didn't matter, "rather than sing I would like to play the saxophone. The saxophone," she continued, "is a very fine musical instrument. People are so used to associate it with jazz bands that they refuse to listen to it when it is really well played. But it can be used for really classical music. Good songs—Schubert's 'Ave Maria,' for instance, can be played on the saxophone."

This conversation was going on at 2FC during the evening session; and just at this moment Miss Blair and Mr. Jack Barnett strolled on the scene. A debate ensued on the question of the saxophone as a musical instrument. We don't remember exactly how it ended; but we think it was ultimately decided that the saxophone IS a musical instrument, and have the temerity to hope so. We remember that, during the course of an interesting speech, Mr. Barnett proclaimed bad classical music inferior to good jazz music. Then Mr. Charles Lawrence stepped out of the lift, and let the cat out of the bag. "Inter-viewing Miss Foster?" he asked. "Don't forget to say she plays the saxophone. One thing about playing the saxophone is, it makes the lips flexible. . . ."

Jules Van Der Klei

ENVY. Sad envy of the possessor of such a name as Jules Van der Klei. One pronounces it, and falls into reveries haunted by fairy castles, elfin music, and the mellow-

ed brown shadows of fanciful Gothic mysticism. Our fairy tales were written by such names, and the finest paintings in the world bear their signatures. Holland has been not unwisely termed "the cradle of the Renaissance." (By courtesy Oswald Spengler.)

Mons. Jules Van der Klei is characteristic of his name. So is his music, although our judgment in these matters is not expert. But if you were to meet him in the street, or see him in the studio, you would immediately say, "That man with the brown velvet eyes and dreaming air, MUST have a name like Jules Van der Klei!"

He studied at the Amsterdam Conservatorium, and was stamped with the mark of success during his two seasons with the Mangellberg Symphony Orchestra, at Amsterdam. He toured through the United States, Switzerland, Italy, and France; spent five years in Java; and has now been in Sydney for two years.

"Now I am married," he said, "I have to stay here. My children must be educated. Other countries are so very cold and wet, and . . . oh! But the climate and environment out here is very nice. Very nice. Already I have several good pupils, and am always busy—very little time for broadcasting. Broadcasting is very nice, but I like to see the audience. They give me inspiration."

Of Australia's musical taste he said: "You are growing at the moment. Australians are really musical, and with increasing education and the State Conservatorium are beginning to understand better what they hear. They have good musical ideas."

Mons. Van der Klei's cello, the tone of which has been admired everywhere, is quite a new creation, modom. The maker's name is Darche, and his secret is that of generation after generation of Darches.



RAE FOSTER.



JULES VAN DER KLEI.

New Programme Features

2FC---2BL

At Last

BROWNING MUMMERY, the famous Australian artist, has now arranged to broadcast in Sydney at the end of February, as he found that his engagements in the southern capital would not permit him to come to Sydney earlier. Arrangements have now been made for Mr. Mummery to sing through 2FC on February 28, March 2, 4, and 6, and through 2BL on March 1, 3, and 5. On the night of March 3 the programme will be broadcast from the Rose Bay Wintergarden, a new theatre capable of seating 2500 people. A large orchestra will be available, under the baton of Mr. Lionel Hart, so that an opportunity will be given of hearing Mr. Mummery in some well-known operatic numbers.

"The Bells" on the Air

THE famous old play, "The Bells," is in rehearsal by the H. W. Varna company, and will be produced through 2BL on Wednesday, February 27. Mr. Varna has now produced over 50 plays through 2FC and 2BL. This entails a large amount of work, as the cast generally consists of eight to ten players, and as the time allotted does not permit of the full presentation, it means that the complete play has to be gone through, and judiciously cut so that it can be presented in four sections of 15 minutes each, which will be sufficiently attractive to hold the interest of listeners by including the most important parts of the play.

A Thrilling Night Underground

ON Monday night, February 18, listeners are to be provided with a description of the men at work under the city, building the underground railway. Through the courtesy of Dr. J. J. C. Bradfield, chief engineer of metropolitan railway construction, arrangements have been made for some of the staff of the New South Wales Broadcasting Company, Limited, to be taken underground, when they will be guided by Mr. Farrow, superintendent of the constructional staff, in a tour of the underground workings. Commencing at 8 p.m., the inspection will take one hour, and during that time a description will be given of what is seen in the tunnels, and listeners will have an opportunity of hearing some big shots fired while blasting goes on, the noise of the cement guns as they throw the cement into the cavities. The rock drills will also be in operation, and the big hammers will tap out their story. It is anticipated that this will be one of the most thrilling and instructive outside broadcasts carried out by the company.

"The Bohemian Girl"

THE success attending the broadcasting of some of the old operas, such as "Mariana" and "Les Cloches de Corneville," has prompted the management of the New South Wales Broadcasting Company, Limited, to arrange further transmissions on these lines. Following the success of both of these operas, Mr Harry Sherlock and Madame Emily Marks have in preparation the production of the "Bohemian Girl," to be presented on Monday, February 25, through 2FC.



ARNOLD MOTE, the well-known organist and conductor, who is arranging a classical programme to be broadcast through 2FC on Wednesday evening, March 20.

Classical Programmes

THE Wednesday nights sets aside by 2FC for classical programmes are proving very popular, and it has been found an excellent way of presenting a programme comprising better-class music, arranged so as to give satisfaction to the critical listener. For this reason the New South Wales Broadcasting Company, Limited, has selected a number of well-known musicians in the State, and given them the right of presenting the whole programme. In this way programmes have now been submitted by Messrs. Oliver King, Horace Keats, Ewart Chapple, Alexander Sverjensky, Harold Whittle, and Madame Betts Vincent. On February 27 Mr. Oliver King presents a second programme, his first one being so well received. Then, in weekly sequence, will be heard programmes arranged by Madame Evelyn Grieg, Mr. Roland Foster, Mr. Arnold Mote, Madame Emily Marks, Madame Goossens, Mr. Frank Hutchens, Mr. Lindley Evans, Mr. Carlton Fay, and Miss Daisy Richards. This will bring the present scheme of classical concerts to May 7, by which time it will be possible to ascertain whether the support that is given to them by the listening public warrants a continuance.

Edith Harray

THE young Welsh composer-planiste, Edith Harray, who is in the happy position of spending most of her life travelling through various parts of the world, is due back in Sydney this month, and will broadcast through 2FC on Monday, February 25. In the children's session she will have some new songs to give, and then she will be heard in a more serious programme at night.

3LO---3AR

Philharmonic Society to Broadcast

A MUSICAL treat is promised from 3LO on February 19, when the Melbourne Philharmonic Society, under the conductorship of Mr. W. G. Steel, will give a fine programme of choral selections. Among the excerpts chosen, special attention is drawn to Brahms' "Requiem," "Worthy is the Lamb" (Handel), and passages from Mendelssohn's "Elijah."

Development of the Commonwealth

THE Pleasant Sunday Afternoon session broadcast by 3LO from Wesley Church on February 17 promises to be unusually interesting. Mr. Percy Blundell the well-known Melbourne vocalist, is the soloist, and the Hon. J. Gunn, of the Migration Commission, will give an address on "The Development of the Commonwealth." As this question is uppermost in the mind of many of our politicians, and actively concerns the individual, the lecture should command the attention of a wide circle of thoughtful listeners.

University Symphony Orchestra

A MOST attractive programme of orchestral music has been arranged on February 22, when the University Symphony Orchestra, under the direction of Mr. J. Sutton Crow, will be heard in excerpts from the works of the masters. Miss Marjorie Baird (mezzo-soprano) is the assisting vocalist, and orchestral selections include "Serenade for Strings in C," by Haydn, overture to "The Merry Wives of Windsor," and the ballet music from "Feramorz," by Rubinstein.

Famous 'Cellist

ONE of the finest 'cellists ever heard over the air is Ivan Berzinsky, of the Imperial Russian Trio.



Mr. DONOLD McINTOSH, former world's champion gun shot, who is preparing a series of talks for 3LO on "The Gun for Sport and Utility." The first of Mr. McIntosh's talks will be given from 3LO on February 19.

whose solo and concerted work reaches a high standard of artistic perfection. Mons. Berzinsky is a post-graduate of the Conservatorium at Moscow, and completed his studies at Leipzig, after which he became a member of a leading Continental orchestra. He is known throughout Russia as an instrumentalist of much ability, and has been associated with many world-famed artists. It is interesting to recollect that, apart from his artistic career, he is a highly-

qualified chemist, and, during the war, was much interested in the manufacture of high explosives and "tear" gas.

Wireless Weekly

Incorporating "Radio in Australia and New Zealand."

FRIDAY, FEBRUARY 15, 1929.

The Vast Radio Audience

IMAGINATION is a fine possession, and it is a tremendous attribute to the enjoyment of life; but it sometimes leads one astray, especially where the visualisation of an unseen audience is concerned.

This fact is frequently brought to mind when we hear bedtime storytellers and radio talkers speak of the tremendous thrill they get out of speaking to an audience of hundreds of thousands scattered all over Australia and "some, perhaps, on the other side of the globe." The thought of thousands of loud speakers in thousands of homes all reproducing each inflection of the speaker's voice seems to stimulate even further imaginative exaggerations.

The thought of millions (favorite comparative) naturally follows, especially if the short-waves are being used. But that millions, or in Australia, even hundreds of thousands of people listen is a pretty well exploded idea.

There may be nearly three hundred thousand licensed receivers and a third as many unlicensed receivers in Australia, and statisticians may estimate that there are four listeners to every set; but there are too many counter-attractions, both in the air and in daily life, for anything like a tenth of those people to be listening in at one moment—certainly not all to one station.

A radio event is a momentary flash. It lasts but a half-hour or an hour, and that is its weakness. That and the fact that it depends largely upon newspaper announcement for the public to know that it will happen.

An event like the "Southern Cross" transmission, of course, receives considerable prominence from the newspapers, and as a result many thousands may listen. But for events of less importance and interest a more diligent search is required to find mention, with the result that fewer people listen.

However, the belief that hundreds of thousands are listening to one's voice is a pardonable vanity. After all, why should not the speaker glow with the thought that his audience is a vast one? It stirs him perhaps to greater effort—to the greater enjoyment of those who are listening—and produces a pleasurable sensation in himself.

Need for Interference Amelioration

FROM time to time reference has been made to difficulties experienced by listeners in country districts—disabilities not suffered by their city cousins, who do not pay any greater subscription for the much better service they receive.

The cause of most of the disabilities is the distance from the station, atmospheric, fading, howling valves, disturbance from electrical machinery, and weak signal strength—all combine to make the lot of the listener not as happy as it might be. The only advantage he has over the city man is the comparative freedom from selectivity troubles; his set is not choked by transmissions from nearby high-power stations, which cause in many receivers an effect known as "blanketing" or smothering of weather signals from distant stations.

That advantage is poor compensation for the disadvantages. In summer time particularly the result is very poor service—or no service at all. Many listeners simply do not listen when atmospherics crackle and click and hiss to such an extent as to drown the performance of the station; or the performance goes out into a whisper or disappears altogether, only to come back again gradually or with a bang—the effect of fading.

The leakage from tramways or electric lighting systems or the radiations from certain types of electrical machines, and the whistles and howls from oscillating receivers add to the noise that takes the place of what should be the clear consistent performances received by the listener in the metropolitan districts.

The unfortunate owner of the set knows that the broadcasting company cannot do much. He also knows in Victoria that 3LO made repeated attempts to improve the con-

ditions. That improvement, of course, consisted in setting up more stations—relay stations, they were to be called—in selected centres, so that the areas now affected by all the complaints associated with weak signal strength would be better served. That is the only remedy for the evils; bring the station nearer the receiver by putting up relaying or repeating stations. The Government for some reason or other would not let the companies go on with that desirable—but necessary—scheme of improvement, and so the conditions remain unaltered.

There is one thing the Government authorities could do, however; that is, do something to remove the cause for complaint about howling valves and interference from electrical machinery or mains. In some towns those forms of interference and annoyance are very prevalent, and, despite repeated complaints and requests, the authorities are doing little or nothing to assist the long-suffering country subscriber. The guilty persons or firms should be brought to book—before the courts, if necessary—so that some precautions will be taken by others to prevent the cause for complaint.

JAVA TRANSMISSION.

ON JANUARY 8, 1929, the Javaneese stations, ANE and ANH, opened a daily radio-phone service between Java and Holland.

The times of transmission are 10 a.m. to 5 p.m. G.M.T. Duplex telephony is carried out with PCLL on a wavelength of 18.4 metres at Kootwijk, and ANE on 15.74 metres and ANH on 17 metres at Bandoeng, Java. It is hoped by the controllers of these stations to broadcast over ANE and ANH on Sunday from 12.40 a.m. to 2.40 p.m. G.M.T.

People a Radio Fan Meets No. 2

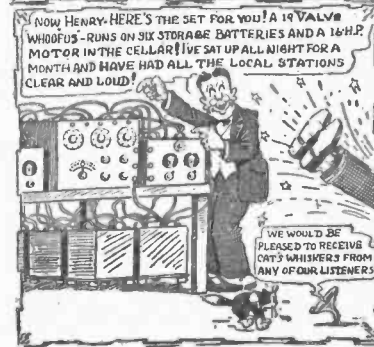
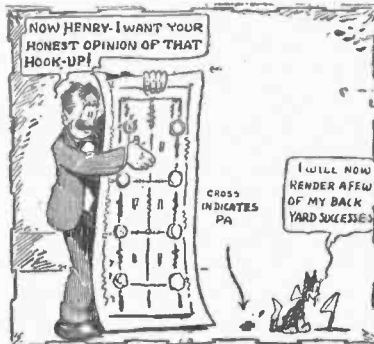

This week we introduce some of Henry's particular radio friends, who, unfortunately, lack a diversity of conversational subjects.

The Safety Valve



Readers are urged to express their opinions on matters pertaining to broadcasting. If you have some grievance, if you have some constructive criticism to offer, here is your chance for expression—your safety valve. The

editor assumes no responsibility for statements made by readers and published on this page, as opinions of correspondents do not represent our editorial policies or beliefs. Anonymous letters are not considered.

"We Are Not Wowers"

Dear Sir,—I am sick and tired of gassy sermons and hymns, with tunes like a cat's concert. Most religious people go to church in the morning. So do I, but it is agony to sit and listen to awful howling of hymns and DEAD sermons over the air. We are modern, and do not like to be acquainted with the dead.

We are Australians. What does this mean? It means that we are not WOWSERS, like those semi, or would-be, Aussies, who want a spilt service from both "A" class (?) stations on Sundays. Why not give the Wowers their piffing "hot air" church service from 2FC, and we AUSTRALIANS our DANCE MUSIC and modern programme from 2BL. 2UE used to put over a decent programme on Sundays, but I am sorry to say that their programme is now also badly adulterated by "snivelling stuff."

Yours etc.,
FEDUP 2.

Belmore.

Everyone Is Not Able-bodied

Dear Sir,—In reply to S. H. East's letter in "Wireless Weekly," of 18/1/29, I wish to advise him that I heard such a statement well over four years ago, and even during the past two years 2FC has occasionally broadcast the Catholic service, while 4QG, Brisbane, has also done so at regular periods.

With regard to the Theosophical Society, that should have read as follows:—

"The Theosophical Society have never, to my knowledge, had their service broadcast by either station."

The reason I did not correct the error in the following issue of "Wireless Weekly" was because I believed that any person of average intelligence, on reading my complaint, could see it was an error.

In reply to James Mullins (under the same heading), he states, "Would any able-bodied persons consider that they had fulfilled their duty by listening-in when within a reasonable distance of a church?" My answer is NO! But J.M. must remember that everyone is not able-bodied, nor does everybody live within a reasonable distance of a church. These people have the right to expect to receive equal service from the broadcasting stations to whom their license fees are paid, along with other members of the community.

Yours etc.,
CONSTANT READER.

Kuring-gal.

Tuned In KNX

Dear Sir,—In "Wireless Weekly," Vol. 13, No. 4, you asked readers to send to Paramount Headquarters, Sydney, as to whether any Australian had picked up KNX. As I do not know this address, would you kindly give them the following particulars.

The first time I picked up this station was about last September, or early in October. From then until about the second

week in December KNX was quite audible on a loud speaker. I did not hear KNX again until November 25, 1928. I just heard the announcer say, "KNX now closing down, broadcasting from Paramount Studios, Hollywood," and that the transmitter was situated at N.W. Los Angeles.

I again heard KNX on 13/1/29 and 22/1/29. This evening, 23/1/29, KNX was very strong. The programme was an all-request one, and the names of the people requesting the items could have been copied. The signals were strong enough to be sent over the telephone and heard six miles away.

The tone of the station has been very good all along. The station starts to come in about 6.15 p.m., and then continues to get louder until closing, about 7 p.m. I think it comes on again about 8 p.m., but as there are other local stations near the same wave-length, it is hard to understand the announcer. Of all the American stations I have received, KNX is the most constant.

A list of the other stations (American) I have received may be of interest—KFO, KZS, KGA, WLS, KDKA, JEO, WBBM, EGO, JHJ, (KHJ, KDH), WHXA, WLW. I have also received several others, but owing to their closeness to locals, was not able to get their call-signs.

Yours, etc.,
R. M. RUSSELL.

Tanja, via Bega.

In Defence of 2FC Plays

Dear Sir,—Noticing the remarks of a contributor in a recent issue of your representative journal there seems a certain disparagement of the efforts of my associates, if not of myself, when considering play production on the air from 2FC, with reference to the chrysalis stage.

These plays have been presented for over two years at fortnightly intervals, not the potboiler of one act, but those of three, four, and five, covering old English comedy, costume drama, historical, modern comedy, and drama, etc., and the writer remembers well the kindly managerial comment after the first—"The best we have ever had."

Also, there have been letters of appreciation from every Australian State, including Tasmania, and one writer recently said of one play, "He heard, nay, almost felt he saw," the representation.

Several times writers' comments have said "the best yet," and "better than ever, if that were possible," and asking for repetition at an early date.

Of course, "Effects," even at the West End Theatre, where the writer's curriculum was, under Beerbohm Tree, at His Majesty's Theatre, Haymarket, London. There were probably limitations to stage realism, in spite of the resources, and best histrionic and mechanical brains London and America and European continent could apply, so it may be allowed as national. The uncertainty of atmospheric, delicacy of receiving and transmission mechanism, where it is said that a single sudden and pronounced high register of the singer may adversely affect radio mechanism—verb sap.

But the artists alluded to have had some

years of training, and while non-professionals vie well with those who actually claim to be, and who do not merely sit round a table

Further, it may be considered not in the best interests to lay bare to the public and listeners how effects are obtained. For, as familiarity is said to breed contempt, it is best to leave something to the imagination of the lay mind, and not lay bare everything.

The writer regrets not having heard stupendous effects alluded to; not the faintest echo, either of the eventuation or the havoc alluded to; creaking ropes and blocks, etc. Perhaps there may be a revival when one may hope to hear.

Nor are our plays unrehearsed or idly read. They are carefully arranged, and studiously rehearsed. As to the merit of the "producer," the writer modestly admits he has been producing for about twenty-five years, mainly in London's "West End," mingling with the best artists there, from the main cities of the world, is still persevering, and willing to learn from anyone having superior knowledge and ability.

Yours, etc.,
H. W. VARNA.

Bellevue Hill.

5/ For Mr. Gunn's Set.

Dear Sir,—Reading over the remarks by Gunn in your paper and the wholesale condemnation of the broadcasting stations, I would like to suggest Mr. Gunn is receiving some interruption from a near-by telephone line, and not the broadcasting at all. I should like to submit an offer, not exceeding five shillings, for the purchase of his set. It will not cause him any more restless nights if he disposes of it, and SOME of the components may still be in working order.

Yours, etc.,
A.S.

P.S.—Please, Mr. Gunn, there is only one "S." Don't make another spelling mistake.

Back Numbers of "Wireless Weekly."

Dear Sir,—During a turnover of some old gear yesterday I found the following editions of your paper: Vol. 1: Nos. 1, 2, 3, 4, 5, 8, 9, 10, 11, 12, 13, 14, 15, 16, 17, 18. Should these interest any readers I should be glad to hand them over to them at any convenient time they like to pick them up.

Yours, etc.,
G. COLTON.

148 Bridge Road, The Glebe.

"I" Strain

Dear Sir,—Once upon a time there was an announcer who had to eat his own words, and the poor fellow choked to death when an "I" stuck crosswise in his throat.—Yours, etc.,
Manly, "NON-EGOTIST."

ARE YOU SATISFIED?

WITH YOUR RADIO SET

Is the Tone Right? Is it Out of Date? Or is it just an Ornament? **OUR SET CONSTRUCTION DEPARTMENT** will set it Right. **Highest Possible Workmanship---Lowest Possible Prices.**

<p>PHILIPS VALVES A 442 Screen Grid 30/- B605 13/6</p>	<p>CONTINENTAL LOW-LOSS CONDENSERS Size .0005 9/6</p>	<p>ECONOTRON VALVES UX201A 5/6 UV199 6/9 UX199 6/9 UX200A 9/6 Worth a Trial.</p>	<p>TRANSFORMERS Crescent 11/- A.W.A. 18/- Eccnotron 6/6 Mignon 9/6 Philips 27/6</p>	<p>PHILIPS VALVES A415, A615 . 15/- A409, B406 13/6 A609, A425 . 13/6 B409, C603 . 15/-</p>
<p>THE ORIGINAL ECONOMIC B'LIMINATOR KIT Does away with B Batteries. Parts cost .. 59/6</p>	<p align="center">Some Guaranteed Parts for "THE MARNOCK DE LUXE FIVE"</p> <p>Pilot Condensers, .0005 mf. 14/6 Pilot Condensers, .00035 mf. 13/6 Pilot Art Dials (vernier) 7/6 Ferranti A.F.5 Transformers £2/17/- Kelford Spring UX Sockets 2/6 Bradleystat Filament Controls 8/6 B.M.S. Fantail Single Circuit Jack 1/7 Gridleaks, various values to 10 meg. 1/0 By-Pass Condensers, 1 mf., tested 500 volt ... 4/0 By-Pass Condensers, 2 mf., tested 1000 volts .. 7/0 Everready 4½-volt C Batteries 9/6 Everready 30-volt Batteries 9/6 Imperia Toggle Battery Switches 1/0 Engraved Terminals (Black) 3d</p> <p align="center">SEE US OR WRITE REGARDING YOUR RADIO REQUIREMENTS. GOODS NOT IN STOCK WILL BE PROCURED</p>			<p>CRYSTAL DETECTORS G. & S. (70 catwhiskers) . 7/3 Silverex Adjustable 3/6 Liontron do. ... 7/6 Carborundum . 8/6</p>
<p>CHARGE YOUR BATTERY while you sleep with THE ECO BATTERY CHARGER KIT, 55/-</p>				<p>BELL-RINGING TRANSFORMERS Record, 3, 5, or 8 volts .. 7/6 Dongan, 6, 8, or 14 volts . 10/6</p>
<p>A LOUD SPEAKER for 10/- THE "ECON" BOX CONE</p>				<p>HEADSETS Single K. & C. 5/- Cannonball, 4000 ohms, Double 12/6 Brandes, 4000 ohms 19/6</p>
<p>BUY FRESH "B" BATTERIES and get a longer life from them. Burgess 45-volt. 26/-</p>	<p>WHILE THEY LAST EMMCO VERNIER REAR PANEL DIALS, 3/-</p>	<p>YOUR BOY CAN BUILD IT The Eco Simplex Crystal Set. Complete with 'phones, aerial, and full instructions, 19/11</p>	<p>BAKELITE DIALS, 4-INCH, 1/-</p>	<p>LOUD SPEAKERS Mozart 75/- Philips Baby Grand 75/- Philips Junior .. £5/5/- Philips P.C.J.J., £6/10/- Amplion Cone, £2/15/- Celestion, .. £10/10/- Ask to hear them</p>

"Yours for Lower Prices and Service that Satisfies"

THE ECONOMIC RADIO STORES,

Address Mail Orders, 492 George Street, Sydney

COUNTRY CLIENTS.—Our parts are absolutely guaranteed to give satisfaction. Send your orders to us conditionally that your money is refunded if you are not satisfied with the goods upon receipt of same. Goods must be returned to us within ten days. We Pay Carriage on All Orders of 10/- and over. Valves and goods specially procured cannot be exchanged. Terms Cash. No discounts.

SYDNEY
25 New Royal Arcade,
near
Palace Theatre.
'Phone, M6138.

NEWCASTLE
13 Union Street,
off
Hunter Street West.
'Phone, New. 1622.

PARRAMATTA
Corner Church and
Macquarie Streets.
'Phone, UW 9601.

ORANGE
120A Summer Street.
'Phone, Orange 735.

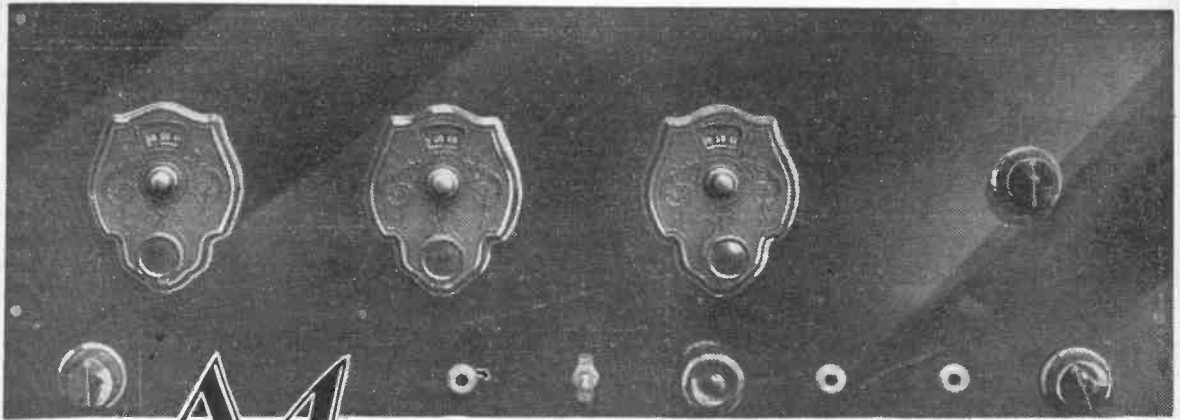

The MARNOCK 5

A de luxe receiver for perfect all-round reception. Every modern principle and development advantageous to better reception has been embodied in this circuit. Screen-grid valves provide the proper amplification and light aluminium the proper shielding. The Marnock 5 is a development of the Martin Dual 3 and the Martin Screen-grid receiver.

By DON B. KNOCK
(Associate Technical Editor)

"WIRELESS WEEKLY" readers do not remember the Martin Screen-grid Five, although they may have seen reference to it in our Query Columns from time to time. Those readers who subscribed to the former monthly, "RADIO," will remember it well, in view of the startling claims made for it. No exaggeration accompanied those claims, unusual as they may have been, and there are to-day many highly-satisfied users of similar instruments.

The Martin Screen-grid Five was the direct outcome of the adaptation of another very successful receiver to the use of screen-grid valves in place of the triodes constituting neutralised R.F. amplifiers. This predecessor was the Martin Dual Three, and it had aroused a tremendous amount of interest in radio circles owing to the fact that it was so sensitive as to need little or no aerial at all for good inter-State reception at speaker volume.

The reason why such a receiver was developed at all was purely a matter of location. In the workshop at Randwick the local station, 2BL, may be seen across the hollow with masts towering into the sky, and, as all residents of the district are aware, the shock excitation from this powerful transmitter is very considerable. Consequently Mr. Martin and myself were faced with the dire problem of selectivity, like many other people.

Instead of introducing trap circuits into the ordinary type of receiver and using it with a conventional outside aerial, it was decided to evolve a receiver which

would be sufficiently sensitive to use an extremely small closely associated aerial, and to deal with the audio side of the question later on.

This idea developed into concrete form with the Dual Three, which was so named for the reason that the final product was in two portions, with three valves in each. The first unit contained two radio frequency amplifiers and the detector, and the second a good quality audio amplifier, consisting of a Rauland Lyric Trio. It was possible, night after

night, in the winter time, to tune 3LO Melbourne and 2YA Wellington, New Zealand, in the speaker at good volume with a screw-driver as an aerial, but the trouble of neutralisation was very acute. The slightest touch on the neutralising condensers and the whole thing became anything but a pleasure, and it was very difficult to obtain the same previous degree of sensitivity without a lot of finicking.

I was bemoaning this state of affairs when the screen-grid valve arrived, after a lot of delay, in Australia, and the solution to our troubles was at once apparent. The existing set was scrapped, and the Martin Screen-grid Five was born—under a lucky star, for the results far exceeded the most hopeful expectations.

Gone was the instability, and the gain from the screen-grid amplifiers was so high as to render the use of a power valve as detector necessary in order to deal with the grid swing. The circuit was beautifully selective, so much so that it was found possible to use quite a fair-sized outside aerial and yet separate 2BL and 3LO.

In this original the Osram S-625's were used, and the performance of the receiver amply justified the claims which I had seen for these valves in English wireless journals.

With this receiver I listened at 3.30 in the morning, Sydney time, to the "Southern Cross" leaving Blenheim Aerodrome, in New Zealand, through 2YA. So powerful was the reproduction in a Dynamic speaker that it was hard to believe such great distance lay between, as I

List of Parts for the Marnock De Luxe Five:—

- | | |
|--|--|
| 1 Aluminium panel, 2½ by 7 inches, 14 gauge. | 1 Bradleystaf. |
| 1 Aluminium sub-panel, 2½ by 10 inches, 14 gauge. | 1 3 Circuit jack. |
| 3 partitions 9 by 7 inches, 14 gauge. | 2 Single circuit jacks. |
| 2 Covers, 9 by 6 inches, 14 gauge. | 1 10 Megohm grid leak |
| 1 Back cover, 12 by 7 inches, 1½ gauge. | 1 5 Megohm grid leak, with clip mountings. |
| 1 Bakelite panel, 2½ by 9 by ½ inches. | 1 Megohm grid leak. |
| 1 Pilot or J.B. .0005 mfd. S.L.F. variable condenser. | 4 TCC 1 mfd. condensers. |
| 2 J.B. (Jackson) .00035 mfd. S.L.F. variable condensers. | 1 TCC 2 mfd. condensers. |
| 1 Pilot .0001 mfd. midget variable condenser. | 3 Sangamo .0003 mfd. condensers. |
| 3 Pilot vernier art dials. | 1 Radiokes RF choke (or Leucos). |
| 1 Ferranti AF5 audio transformer (imperative). | 5 Amperites. |
| 1 Rauland R310 Impedance unit. | 1 4½ volt C battery. |
| 1 Radiokes Martin dual coil kit. | 1 30 volt C battery. |
| 5 U.X. valve sockets. | 1 Battery switch. |
| 1 Royalty 0 to 200,000 ohm variable resistance. | 17 Terminals. |
| 1 Royalty potentiometer, 0 to 500,000 ohms. | Valves recommended, 2 Philips A442 S.G. |
| | 1 Marconi D.E.P. 610. |
| | 1 Mullard P.M.6. |
| | 1B605 Philips, (N.B.—If Mullard P.M. 1½'s are used, English valve sockets will be required, as the present stock is supplied in English bases. This is no detriment, and present advantages in wiring and identification.) |

MARNOCK 5 IS EVEN MORE POWERFUL THAN MARTIN S.G. 5

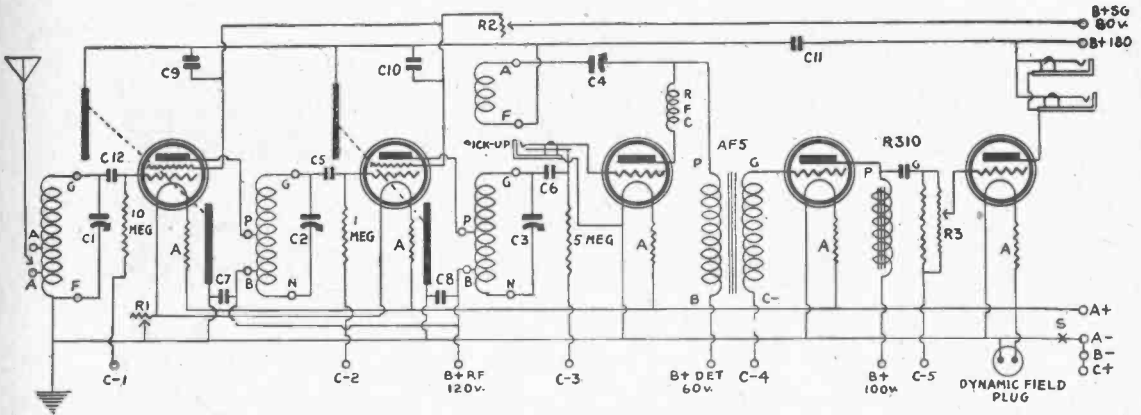

The circuit diagram.

heard the great machine take off and then roar over the hangar, heading out to the open sea.

Such has been the Martin Screen-grid Five, the most powerful and sensitive receiver it has ever been my pleasure to use—with the exception of its successor, the MARNOCK DE-LUXE FIVE.

Owing to the extensive research work done co-operatively on these receivers it was decided to give this latest a name representative of the two designers—hence the title.

This receiver is a very versatile affair. In the first place, it is very sensitive, and it is only on nights when static is overpoweringly bad that one cannot listen comfortably at full volume to all inter-State stations. Secondly, it has a real true tone quality audio amplifier, and is provided with a double output for two speakers.

A dynamic field plug to operate from the initial A battery supply is provided, and a pick-up jack is included in the grid circuit of the detector valve, so that the set may be used in a moment for electrical gramophone reproduction. It is the ideal of many constructors, and although it is a D.C. job so far as the valve filaments are concerned, it is always run from a Philips B and C Eliminator

with excellent results. Again—an all-aluminium job!

Someone recently jokingly asked if I have shares in an aluminium company somewhere, as all my receivers seem to arrive on the scene in this way now. Look at the photographs of this set and you may realise what a heavy affair it would be if I had used copper or brass. Even though aluminium is used, it is quite heavy enough by the time the components are fitted.

The MARNOCK DE-LUXE FIVE uses the same coil kit as the two previous receivers which is the Radiokes "Dual Three" kit, specially produced to enable a standardisation of the first receiver. This kit has been used throughout in our experimental work on these receivers, and it has been found ideal and satisfactory in every way. Time and time again readers will write to me and ask, in connection with some prominent receiver, to be supplied with the specifications for winding their own coils. My answer to this is that the time and trouble necessary to wind

diagram you will see that there are two screen-grid radio frequency amplifiers, these being built around the Philips A442 3G valves which have been used with such success in

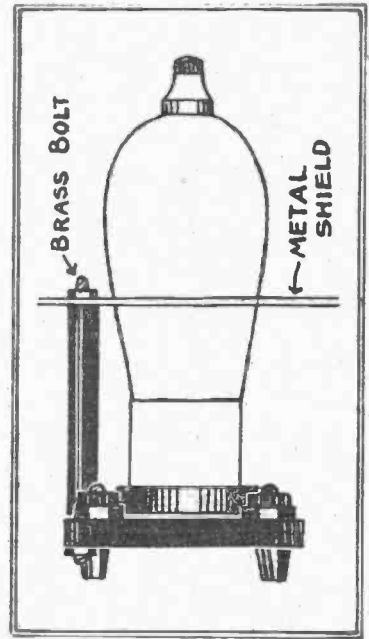

How the aluminium partition screens the valve. A plan view.

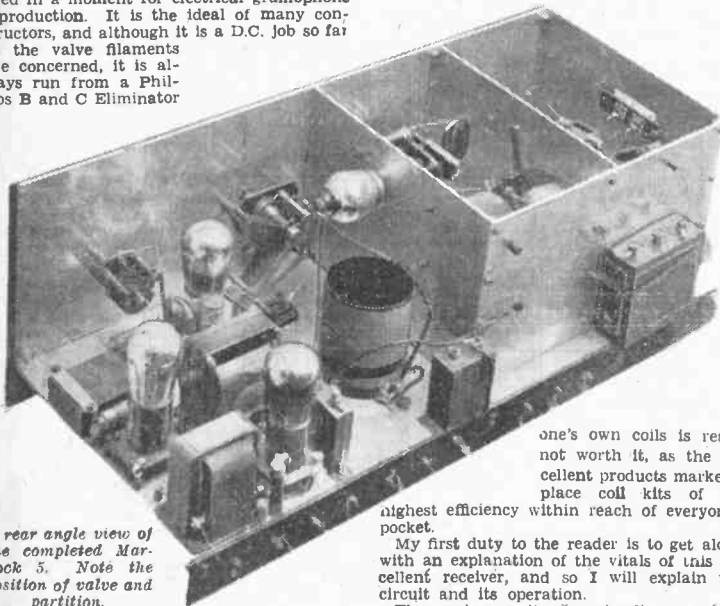

A rear angle view of the completed Marnock 5. Note the position of valve and partition.

one's own coils is really not worth it, as the excellent products marketed place coil kits of the highest efficiency within reach of everyone's pocket.

My first duty to the reader is to get along with an explanation of the vitals of this excellent receiver, and so I will explain the circuit and its operation.

The receiver, as its name implies, is a five-valver. Looking at the theoretical circuit

the Super R.F. Peridyne and All-Empire S.W. receivers.

Although no mention has yet been made of it in "Wireless Weekly," I am able to mention that the new Mullard screen-grid valves of the 4-volt type were also used in this receiver. The performance was all that could be desired, and these Mullard PM14 screen-grid valves should meet with a big demand. In characteristics they are very similar to the Philips A442, with the same physical arrangement, so that readers who are familiar with this now-standardised valve will have no difficulty in following a diagram in which it is included.

A standard UX valve socket is used, and the plate connection is taken from the screw

CARE REQUIRED IN CONSTRUCTION, BUT NOT UNUSUAL SKILL

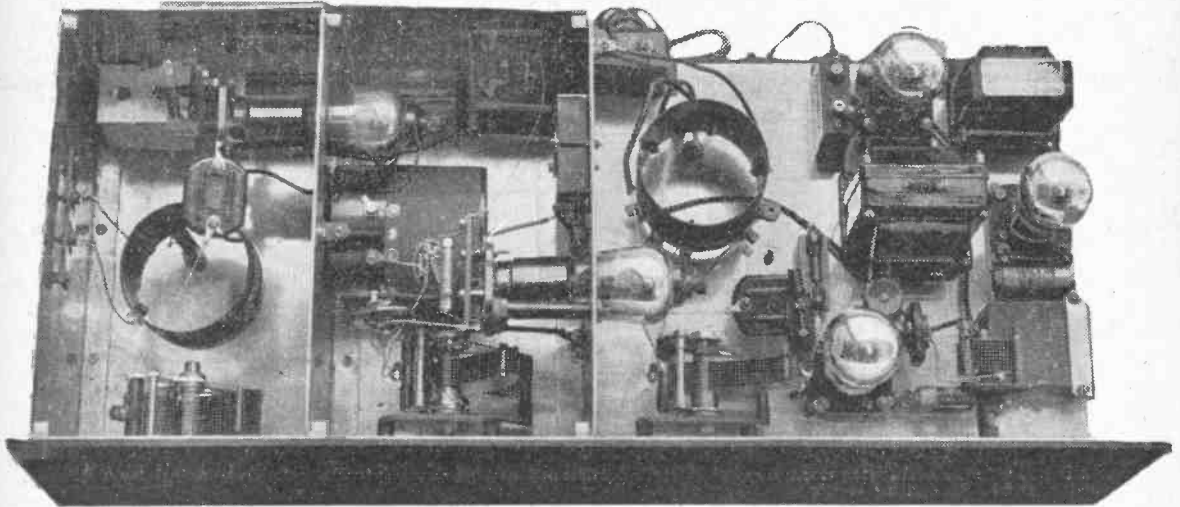

A plan view of the Marnock. This clearly shows the lay-out of parts.

terminal on the top of the valve, with the screening grid from the plate terminal of the socket. The Mullard valves are at present supplied in English bases. Both these R.F. amplifiers in the MARNOCK DE-LUXE FIVE are given a small negative bias on the grid.

If you look at the photographs of the back of the set you will see a 4½-volt grid battery mounted on the small ledge at the back of the R.F. compartments. This has nothing to do with the audio end of the receiver, considerably more voltage being required for this purpose owing to the valves used.

The first R.F. amplifier or aerial coupling circuit has 1½ volts negative bias to the grid, this being taken through a 10 megohm grid-leak, with a .0003 mfd. coupling condenser C12. The closed circuit is tuned by a .0005 S.L.F. variable condenser. This is one of the new Centralign type, and is mounted directly

in connection with the aluminium panel, as the rotor is common to A negative, B negative, and earth. You will notice that the aluminium front panel is covered by a 1-8 inch bakelite sheet—not at all necessary, but it enhances the appearance of the finished set considerably.

There are two tappings for aerial connections on the first coil unit, these governing selectivity according to the length and capacity of the aerial used. The second R.F. amplifier has a negative grid bias of 4½ volts, this being in series with a 1 megohm leak to the grid. A grid coupling condenser, C5, .0003 mfd., is also in this grid circuit.

The tuning condensers for this and the detector circuit are both now well known. Both have a capacity of .00035 mfd., and as they have the rotors at high potential must be insulated from the aluminium. This is done by drilling the usual clearance hole, and

mounting the condenser on a bakelite strip bolted to the back of the aluminium panel. The detector and audio valves are of the 6-volt types, so that it is necessary to include a voltage drop resistor for the A442's.

The diagram shows how this is done. A Bradleystat mounted under the sub-panel (R1) acts as a semi-fixed resistance to the two R.F. valves. This is in series with the A negative supply. In the A positive supply to each valve is a separate resistance of about 20 ohms. This may be better done by using amperites of the correct capacity, but in the original may readily be seen under the sub-panel the method employed.

A strip of bakelite about 8 inches long and 1 inch wide is bolted underneath. This strip is wound from the centre with twenty turns of 36-gauge Eureka resistance wire on each half. It is a convenient way of dealing with the filament supply for the home constructor,

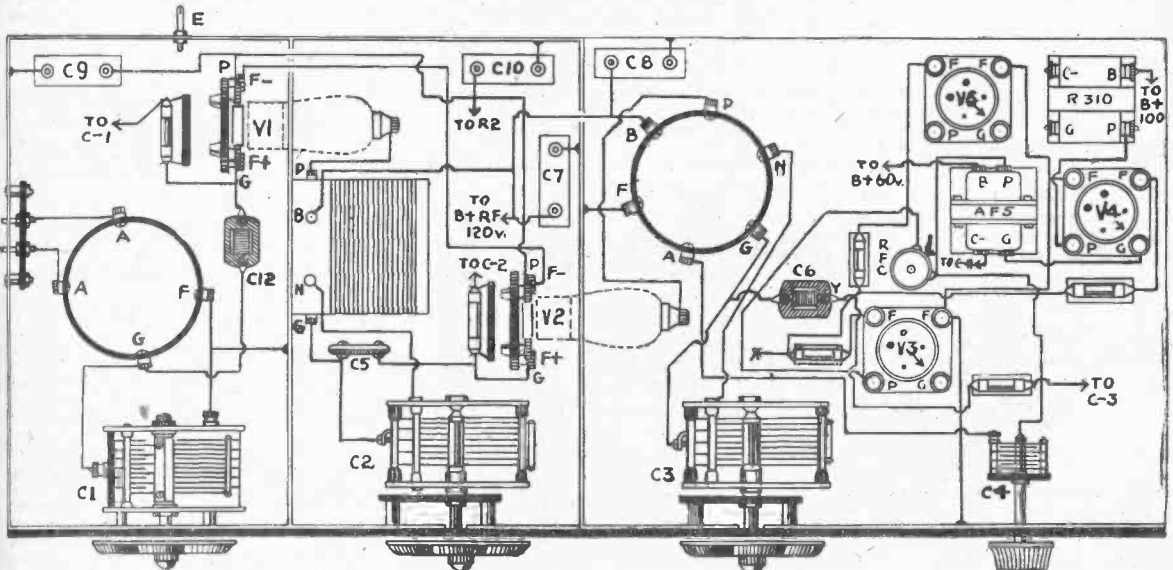

The wiring diagram. Compare with lay-out above.

TUNING EASY, DESPITE THE THREE DIAL CONTROLS

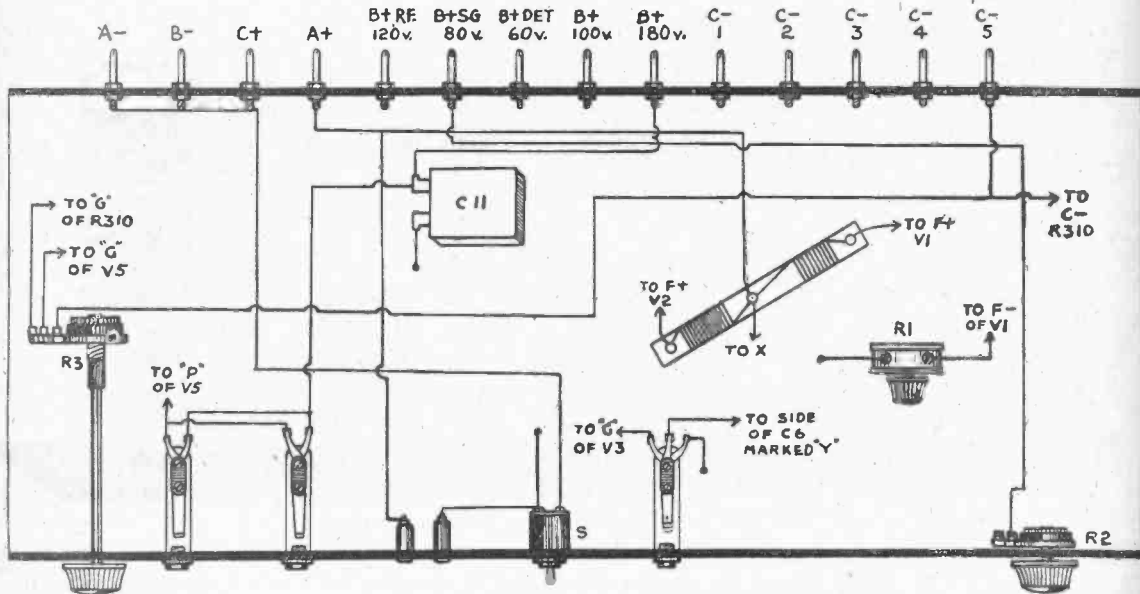

The sub-panel wiring diagram.

but amperites will be an easier solution, and will take up less room.

You will see that in series with the high voltage supply to the screening-grids is a variable resistance. This is marked R2, and has a value of 0 to 200,000 ohms. It is a very useful adjunct in getting the most out of the R.F. valves when an eliminator is used, as by varying it when a high voltage supply is the source the correct operating voltage may readily be found.

The plate and screen-grid voltage supplies to the screen-grid valves are by-passed by 1 mfd. T.C.C. condensers. These are marked C 7, 8, 9, and 10.

Dealing with the detector circuit, it will be seen that grid bias is also provided here, a 1½ to 4 volt negative bias being taken through a 5 megohm leak to the grid. In this circuit is included a three-circuit jack for gramophone pick-up use.

The coupling condenser C6 has also, like C12 and C5, a capacity of .0003 mfd. Any good make may be used. Reaction is provided in the detector circuit, and is of the capacity controlled Reinartz type, the vari-

able reaction condenser being a midget of .0001 mfd. capacity. This is marked C4.

The detector valve, like the audio valves, has the filament voltage censored by an amperite, and in series with the plate of the detector, which is a Marconi DEP610, is a Radiokes R.F. choke, to preserve stability of the audio amplifier by the exclusion of R.F. current. The first audio transformer is a Ferranti A.F.5, and the valve used in this position is appropriately a Mullard PM6.

Instead of using a transformer coupling for the last audio, a Rauland Lyric Impedance unit is used, type R310. Shunted across the secondary, or grid resistance, is a volume control in the form of a potentiometer (R3), 0 to 500,000 ohms. This has the variable contact connected to the grid of the output valve, which is a Philips B605. The PM6 in the first audio stage needs about 9 volts negative bias on the grid, and the B605 will operate best at about 18 to 20 volts, with 180 on the plate.

The twin output jacks are provided so that one reproducer may be used in the test room and the other in the house, 60 feet dis-

tant, at the same time. Shunted across the filament supply is a standard plug of the house power point variety. This is very useful where a Dynamic speaker is used, and enables the use of the same 6-volt supply without long leads from the battery.

The use of a bakelite front to cover the aluminium panel serves two purposes. In the first place, the appearance of the set is improved, and, secondly, by keeping the aluminium panel to the size confined to the space above the sub-panel, the bakelite front may be larger, to allow a two-inch space under the sub-panel. The idea of this is that the screen-grid voltage control R1, the potentiometer R3, and the jacks, etc., may be mounted on the bakelite itself without the necessity of drilling large clearance holes in the aluminium.

The screening of the low potential circuits is of minor importance, so any objection in this direction is ruled out. The plan photograph will give some idea of how the variable condensers C2, C3, and C4 are mounted. They are arranged with extension spindles of bakelite rod and distance pieces one inch in length, to keep them well away from the metal. Much longer screws than are usually necessary will be required to pass through those distance pieces.

The mounting of the screen-grid valves calls for some comment. Although these are of the U.X. socket type, they have been mounted horizontally through the screening partitions, just as one would treat the S625 double-ended type of valve. It is an easy matter to devise a supporting pillar of bakelite with a length of screwed rod running through, the whole being locked tightly through the base of the U.X. socket. The valve projects through the hole in the partition in the usual manner, so that when the valve is pressed into the socket the screening-grid will be in line with the partition itself.

The first coil unit is mounted right in the centre of the first R.F. compartment vertically, whereas the second R.F. unit is mounted horizontally. In order to allow ample room for the two valves. The detector coil unit is mounted vertically in the long unenclosed

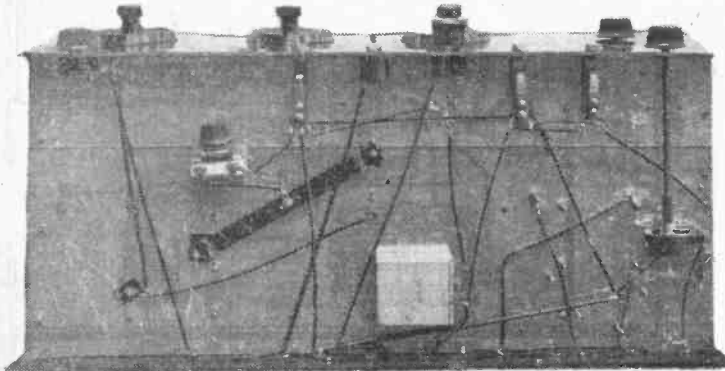

A sub-panel view. Compare with above.

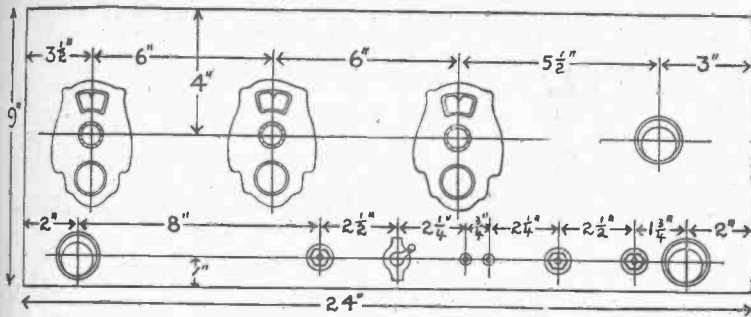

section of the receiver holding the detector and audio amplifier.

By checking up the photographs and the back-of-panel wiring diagram you will be able to see just where each component should go. The first R.F. compartment has a small slot cut in the side near the top, with a short strip of bakelite holding two terminals inside for the two aerial connections. Although the receiver may appear formidable, it is quite an easy one to construct, provided that you are already au fait with the ins and outs of these aluminium jobs.

Where any leads have to pass through the metal small bushes of bakelite are pressed into holes drilled in the metal. These bushes may be easily made from bakelite rod, drilled with a 1-8in. twist drill, and sawn off into lengths of about 3-8in. In the photograph of the back of the set, two of them may be seen projecting through the back cover of the two R.F. compartments and carrying the leads through from the 43-volt C battery to the grids of the two R.F. valves.

The list of parts shows the sizes of aluminium sheeting required for the front panel, sub-panel, partitions, and covers. The gauge of the sheeting is No. 14 throughout. In order that there shall be no confusion, it is necessary to point out that the dimensions in the front view template refer only to the bakelite covering panel so far as the 24 by 9 inches size is concerned.

The aluminium front panel measures 24 by 7 inches, and the extra two inches is taken up by the bakelite covering sheet. The first thing to attend to is the marking off and drilling of the bakelite sheet to conform with the template diagram. After this is done it may be used itself as a template for the aluminium front panel with more accuracy than may be the case in marking the aluminium off separately. Lay the bakelite on one side after using it for this purpose, and proceed with the assembly and drilling of the aluminium. There is no need to go into detail on this score, as only two weeks ago I explained fully the method of dealing with this.

Be sure to cut the holes in the two inside partitions first for the projection of the screen-grid valves, when you have ascertained exactly in what position you are going to place the valves. A separate diagram shows the simplicity of the mounting devised for these. All components will be bolted to the metal by 5 B.A. screws and nuts, and for the purpose of drilling holes in awkward positions you will find an Archimedeian hand drill very useful.

Note that there are two composite diagrams showing the wiring above and below the sub-panel. In the sub-view some of the terminals are shown without any apparent connection, but do not be misled by this, as if you glance at the other diagram the destination of each lead is at once apparent.

The wiring is done mostly with No. 18 gauge tinned copper wire enclosed in "spaghetti" for safety's, as well as appearances, sake. Follow both the theoretical and practical wiring diagrams, and deal first with all connections common to the A negative, B negative, C positive, and Earth. These are common with the aluminium throughout.

In the theoretical circuit diagram you will notice a dotted line passing through each R.F. valve. This is only a means of indicating that the metal screen on either side of the valve is in the same circuit. There are many points where, owing to the metal construction, many leads to A negative may be very short, and much of the wiring consequently simplified. This is one of the great advantages of an all-metal set.

When the assembly is well ahead you may attach the bakelite front, mounting the controls at the base in the order shown. No sub-panel brackets are used with the set, although they may be included if required. A bakelite strip carries the terminals for all connections to batteries at the rear of the sub-panel, and, this being mounted vertically, as seen in the photograph, it serves as an excellent support for the set. The wiring

diagrams are explicit enough to follow without verbal comment, apart from which I have often found recently that where I have described wiring from point to point my description has been misunderstood by many readers.

Use the valves specified for the best results, and run from a 6-volt accumulator. The average B eliminator will not deliver 180 volts, which is the best working voltage for this receiver, but it is an easy matter to include a 60-volt wet or dry B battery in series with the eliminator output to raise the voltage. Tuning is remarkably easy, despite the fact that there are three tuning controls. Tune the detector circuit first by means of C3 and C4, keeping the covers off the R.F. compartments. When you hear the carrier of a station put the covers in position and tune the two R.F. circuits C2 and C1 until resonance is reached. Back off on the reaction control if oscillation is present, at the same time adjusting carefully the screen grid voltage by means of R2. If you have built the set with care you will be surprised at the volume with which far distant stations are received with perfect tone quality, and the selectivity should leave nothing to be desired.

Do not, however, expect the set to be selective if you have made poorly-fitting screens, for, as I have said before, a poorly-shielded receiver is just a waste of time.

This receiver has been the most successful yet described in "Wireless Weekly," and although it requires more care in construction than the average run of receivers, it is worth the trouble, and I expect to hear of many satisfied users in the near future.

New Apparatus Tested & Approved



Horn Speakers Can Be Brought to Life Again

A SIMPLE LITTLE INVENTION by an Australian, Mr. Joseph George Coombs, Berwick Street, Guildford, should shortly bring back the popularity enjoyed by horn speakers until the cone became well known. The horn speaker in general has a tendency to give a hollow and tinny reproduction, which mars reception. This is also noticeable in gramophones which have a long tone arm.

It has already been proposed to fit contractions in the throat or narrow end of tone arms or speaker horns, and also to form bulbous or other enlargements therein, and in certain cases collapsible connectors of the concertina type have been used between a tone arm or speaker nipple and between a horn or trumpet throat.

Various methods have been tried, and until recently these methods were failures. Thus it was that the cone speaker came into prominence, and the horn speaker gradually sank into the background.

Any loud speaker may be fitted with the new contrivance. The change noticeable is little short of marvellous. The new invention is entirely different from other methods tried. It consists of a series of circlod contractions of unsymmetrical angular section in the throat of the tone arm, horn, or trumpet. The inner faces of these contractions are curved in the axial direction, and meet angularly, so that in longitudinal section the throat is corrugated unsymmetrically, the ridges and furrows being angular and their faces curved concavely. It has been found that when the throat of the reproducing instrument is thus shaped or is fitted with liners which so shape its bore, the reproduction obtained is that of unimpaired clarity and purity, with amplified volume.

What a lot this will mean to manufacturers who still market the old-fashioned horn type speaker. What a lot it will mean, too, to the listener who prefers the horn speaker. Even the gramophone horn may (with the aid of this invention) be used as a reproducer without tinny distortion.

A patent has been issued to Mr. Coombs. We may soon hear of further developments. Mr. Coombs, by the way, is an electrical mechanic.

Siemens' Long-life "B" Batteries

WE have received from Messrs. Siemens (Australia) Pty., Ltd., a sample of their 45-volt heavy duty B batteries for test. Siemens high tension dry batteries have long been recognised in England as one of the most efficient and reliable it is possible to produce, and for this reason British wireless manufacturers have standardised them.

The sample submitted to us showed more than the stated voltage, and when run under load in conjunction with other batteries on a five-valve receiver embodying two screen-grid valves, proved, after six hours' almost continual use, that the current flow was constant, and that there was no indication at the end of the test of the battery having been used. This may not seem an indicative test of the capacity of a dry battery, but the load taken was purposely very heavy. Over 50 years' experience lies behind Siemens dry batteries, and, with their powers of quick self-recuperation, they are one of the most powerful manufactured. For those who prefer the silent operation of their sets by reliable heavy duty B batteries, the Siemens high tension super radio and 45-volt large capacity batteries should find a great number of enthusiastic users.

MARNOCK DE LUXE FIVE

COUNTRY CLIENTS NOTE.—Postage Paid on Orders over 10/-, with the exception of Loud Speakers, Batteries, Aerial Wires, and Value Payable Parcels. All goods sold with a Money back Guarantee if not satisfied and returned within ten days, money will be refunded.

Below is a List of Suitable Parts for Building the "MARNOCK DE LUXE FIVE."

			£	s.	d.				£	s.	d.	
1	Aluminium Panel, 24 x 7in., 14 Gauge		6	7		2	Doz. Nickel-plated Screws and Nuts (½-inch)		2	0		
1	Aluminium Sub-Panel, 24 x 10		9	2		3	Sets Leak Mountings		3	9		
3	Aluminium Partitions, 9 x 7 x 16 Gauge		5	4		4	T.C.C. Imf. Condensers	1	2	0		
2	Aluminium Covers, 9 x 6 x 16 Gauge		3	0		OR 4	Imperial Condensers		18	0		
1	Aluminium Back-Cover, 12 x 7 x 16 Gauge		2	4		1	T.C.C. 2mf. Condenser		7	6		
1	Bakelite Panel, 24 x 9 x ½		9	0		OR 1	Imperia 2mf. Condenser		5	6		
1	Pilot .0005 Condenser		14	6		3	Sangamo .0003 Condensers		6	9		
2	Pilot .00035 Condensers	1	7	0		OR 3	Wetless .0003 Condensers		4	6		
1	Pilot .0001 Midget Condenser		8	6		1	Radiokes R.F. Choke		8	6		
3	Pilot Art Vernier Dials	1	2	6		5	Amperites	1	10	0		
1	Ferranti AF5 Transformer	2	17	0		1-4½-volt "C" Battery			2	9		
1	Rauland R310 Impedance Unit	2	5	0		1-30-volt "C" Battery			9	0		
1	Radiokes Martin Dual Coil Kit	1	12	6		1	Battery Switch Cutler-Hammer		3	9		
5	Emmco UX Sockets		12	6		OR Bat. Switch, Electrad			2	0		
OR 5	Pilot UX Sockets		16	3		17	Moulded Top Terminals		4	3		
1	Royalty 0-200,000 Ohms Variable Resistance		11	0		2	Philips 442 S.C. Valves	3	0	0		
1	Royalty 0-500,000 Potentiometer		13	0		1	DEP610		12	6		
1-30	Ohm Rheostat		3	6		1	Mullard PM6		13	6		
1-3	Circuit Jack		2	3		1	Philips B605		13	6		
1-10	Meg. Leak		2	0		½ doz.	Lengths Bus Bar		1	3		
1-1	Meg. Leak		1	3		4	Yards Spaghetti		1	8		
1-5	Meg. Leak		1	3		2	Yards Flex.		0	4		
						4	Doz. Nickel-plated Screws, with Nuts, ½-inch				2	6

IMPROVE YOUR RECEPTION

90% of Bad Reception is due to Faulty Batteries or Speaker. Eliminate these troubles, and you will have good reception always.

		Cash Price.				
		£	s.	d.		
Colmovox "A" Battery Charger		5	10	0	Deposit, 11/-	19 Weekly Payments of 5/6
Colmovox "A" and "B" Charger		6	10	0	Deposit, 13/-	19 Weekly Payments of 6/6
Emmco Trickle Charger		3	10	0	Deposit, 7/-	19 Weekly Payments of 3/6
Philips Trickle Charger		3	10	0	Deposit, 7/-	19 Weekly Payments of 3/6
Rectox Trickle Charger		5	10	0	Deposit, 11/-	19 Weekly Payments of 5/6
Philco Rechargeable Wet Battery		8	15	0	Deposit, 17/6	19 Weekly Payments of 8/9
Oldham Rechargeable Wet Battery		6	0	0	Deposit, 10/-	19 Weekly Payments of 5/-
Philips 372 Eliminator		7	15	0	Deposit, 15/6	19 Weekly Payments of 7/9
Amplion AC7 Speaker		7	15	0	Deposit, 15/6	19 Weekly Payments of 7/9
Philips, PCJJ		6	10	0	Deposit, 13/-	19 Weekly Payments of 6/6
Philips, Junior		5	5	0	Deposit, 10/6	19 Weekly Payments of 5/3
Philips, 3002 Eliminator		9	15	0	Deposit, £1/4/6	52 Weekly Payments of 3/8
Philips, 3003 Eliminator, B and C		11	15	0	Deposit, £1/9/6	52 Weekly Payments of 4/5
Emmco Eliminator		8	10	0	Deposit, £1/1/3	52 Weekly Payments of 3/-
Emmco Super Eliminator		12	15	0	Deposit, £1/11/6	52 Weekly Payments of 4/8
R.C.A. Speaker, Model 100A		8	10	0	Deposit, £1/1/3	52 Weekly Payments of 3/-
Amplion, A.C.9		9	9	0	Deposit, £1/5/-	52 Weekly Payments of 3/7

COLVILLE-MOORE WIRELESS SUPPLIES LIMITED,

10 Rowe Street (Next Hotel Australia), SYDNEY

'Phone: B2261.

'Phone: B2261.

HITTING BELOW the BROADCAST BELT



Short-wave and Amateur Notes by VK2NO

Experiments on Five Metres

THE steady reduction of wave-length during the past few years has demonstrated that short waves have certain habits of their own, which are not noticeably associated with the longer waves. For instance, there is the now well-known "skip-distance" effect whereby a short-wave signal, after leaving the transmitter, will be audible over a comparatively short distance; then, for a considerable distance the signal will be quite inaudible, after which it comes in strongly on a far distant receiver.

Experience has shown that as the wave-length is reduced the greater this skip-distance becomes, until, somewhere below ten metres, the signal does not appear to be audible anywhere on this earth except in the vicinity of the transmitter. One theory is that the propagated wave at this frequency travels outwards from the earth at a tangent, and penetrates the Heavieside Layer instead of being reflected from it back to earth, as is the case with longer waves.

The 5-metre wave is being experimented with to a considerable extent by amateurs today. Their experiments have demonstrated that the 5-metre wave shows some of the characteristics of light propagation. The signal follows a straight and unobstructed line. Thus, a receiver on a distant hill will pick up a strong signal, but the same receiver, placed on the other side of the hill so that it is not within the "line of vision" of the transmitter, will pick up a barely audible signal, whilst definite effects of a similar character are observable even with intercepting obstacles of comparatively small magnitude.

The hill or obstacle effect seems to cast a "shadow" through which the signal penetrates with difficulty. This effect is, of course, frequently met with when very much longer waves are being employed, but becomes less and less marked as the wave-length is raised. At about 5000 metres or a little over, the effect is no longer noticeable, unless the receiver is situated immediately behind a very high mountain containing a high percentage of mineral ore.

In the tests made on 5 metres, natural static was entirely absent, but man-made static, such as that from the ignition systems of motor cars, was very noticeable. Thus far experiments have shown that the best aerial system for a five-metre transmitter is one which is only eight feet long and consists of a half-wave radiator, voltage fed, connected to the oscillator by direct coupling.

The receiver generally in use is the regenerative detector and one stage of audio. The grid coil consists of five turns of wire, half an inch in diameter. The reaction coil is a quarter of an inch long, and is placed inside the grid coil. Very small condensers placed close together are used for tuning and reaction control, and low-capacity valves are an added advantage. Generally it is found that an aerial is unnecessary, the phone cords picking up sufficient energy. A five-metre wave represents a frequency of approximately 60,000,000 cycles!

Investigation of the 5-metre wave propagation has only just begun, but it is possible that in time radio engineers will find some practical use for such ultra-short waves. It will be interesting, too, to see how far ultra-short wave propagation conforms to the principle of light propagation.

Short Wave Notes

RECEPTION conditions on short waves are fluctuating a great deal at present. The Berlin S.W. station was heard on January 25, testing with 2ME. They were heard again on January 28, at about 9.50 p.m., on telephony. Music was about R4, but speech was indistinct. On January 31 he was heard at 6.15 p.m. calling Sydney. On this occasion he came through very clearly on a single detector.

PLG, the Javanese station, are coming through well lately. They were heard at 3 p.m. on February 1.

W2XG (America) were received at good volume, and with remarkable clarity, on January 25, at 6.50 p.m.

The new addition to short-wave transmitting stations, PH1, Holland, has also been coming through very well lately. He is gen-

erally heard on the loud-speaker, using a detector and two audios. The modulation on this transmitter is excellent.

Conditions were very bad last night (February 4). Thunder and rain caused enough interference, but the static carried by the thunderous clouds made short-wave work well-nigh an impossibility.

Station 2CX Closes Down

THE well-known amateur radio station, 2CX, is to be closed down, and all the gear sold. This station is one of the oldest in the State, the first license being issued to Mr. H. A. Stowe, in 1909, when there were only 6 or 7 other stations transmitting. It was then located in Drummoyne, under the call sign FN. It was later changed to XAS, and when the numbers were allotted the call sign 2CX was issued. This station has for some years, been the calibrating station for the W.I.A., and all the instruments of that body were located at this station. It was the first station in Australia to send out calibration signals, which was first carried out on the transmitter 2CX until 2W1 was installed at this station.

The present gear consists of the amplifier and oscillator section of a Master Oscillator outfit of 50 watt capacity, complete with tube rectified power supply. Provision is made on the transmitter for the addition of Helsing Modulation. The receiver is of the well-known 3-valve Schnell circuit. The station is equipped with a complete range of wave metres from 4 to 400 metres.

Modern Ship's Wireless

IT is a notable fact that, although the Adelaide S.S. Company's new motor ship "Manunda" is being built in Scotland, an Australian company, Amalgamated Wireless, has the contract to supply the wireless equipment, which has now been shipped from Sydney, and will be the most up-to-date of any vessel on the Australian register.

The equipment includes an I.C.W. valve transmitter, the first used on a vessel of the Australian coast, and representing a marked advance on the spark sets hitherto employed. The transmitter has a power of 1½ kilowatts, and covers the wave band of 580 to 800 metres set aside for commercial shipping. The emergency apparatus is also a departure from established practice, being a 3 k.w. quench-gap transmitter, superseding the small induction coil type. A commercial receiver is also part of the equipment, having a range of 220 to 26,000 metres. Amalgamated Wireless are fitting direction-finding apparatus, to enable the navigators to ascertain the ship's position in a fog. Also a broadcast receiver is being provided, to be worked in conjunction with a band repeater, so that concerts ashore or afloat may be heard all over the ship. The repeater would be useful in time of crisis, for the purpose of amplifying and repeating the orders of the ship's officers.

International Prefixes

The following table, supplied by the Radio Inspector of N.S.W., lists the new international call letters which prefix the call-signs of all stations.—

CI Chile.	PK Dutch East Indies
CF Canada	PP Brazil
CL Cuba	PZ Surinam
CN Morocco	RA Russia
CP Bolivia	RV Persia
CR Portuguese Colonies	RX Panama
CS Portugal	RY Lithuania
CV Rumania	SM Sweden
CW Uruguay	SP Poland
CZ Monaco	SU Egypt
D Germany	SV Greece
EA Spain	TA Turkey
EI Ireland	TF Iceland
EL Liberia, E.	TG Guatemala
ES Ethiothia	TI Costa Rica
ET Ethiopia	TS Sarre
F France and Colonies	UH Hejaz
G England	UI Dutch East Indies
HA Hungary	UL Luxemburg
HB Switzerland	UN Yugo-Slavia
HC Equador.	UO Austria
HH Haiti	VE Canada
HI Dominican Republic	VK Australia
HJ Columbia	VO Newfoundland
HP Honduras	VP English Colonies
HS Siam	VT India
I Italy	W United States
J Japan	XN Mexico
K United States	YG China
LA Norway	YA Afghanistan
LO Argentina	YH New Hebrides
LZ Bulgaria	YI Iraq
M England	YL Lettonia
N United States	YM Danzig
OA Peru	YN Nicaragua
OH Finland	YS San Salvador
OK Czechoslovakia	YV Venezuela
ON Belgium and Colonies	ZA Albania
OU Denmark	ZK New Zealand
PA Holland	ZP Paraguay
P.I Curacao	ZS South Africa

EMMCO TRANSFORMERS

PERFECT IN EVERY DETAIL

IMPREGNATED
MOISTURE PROOF
GUARANTEED

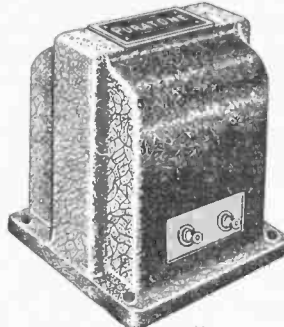

PURATONE.

PERFECT
TONE
QUALITY
VOLUME

A wonderfully efficient, medium priced audio transformer, with the maximum amount of amplification. Perfect Tone, ample Power and Volume, without blast or distortion. The results obtainable with a Puratone are a revelation.

Made up in a one-piece, all metal case in an Artic Crystal Finish.

Three Ratios: 5-1, 3½-1, and 2-1.

PRICE 15/6

GOLDEN VOICE.

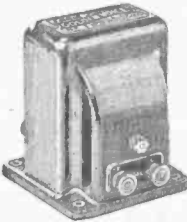

The Golden Voice Transformer could not have been more appropriately named. It is unsurpassed for tone and volume, whether it is speech, vocal, or instrumental music passing through. The rendition is perfect. Made up in a one-piece All Metal Moisture-proof Case, Artic Crystal finish. Three stages.

PRICE 42/3

PEP PUNCH.

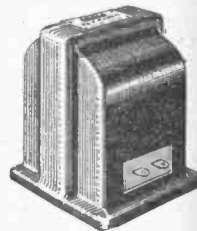

A wonderfully cheap little Transformer which gives excellent results. Perfect in Tone and ample Volume. There is no better Transformer value on the market.

Made up in a one-piece All Metal case and impregnated against moisture.

Ratios, 5-1, 3½-1, and 2-1.

Price 10/6

OTHER TRANSFORMERS

Cavalier ... 21/-	Midget ... 13/9.	Metal Case ... 17/6	Push Pull .. 25/- per pair
Ratios 2, 3½, and 5-1.	2, 3½, and 5-1.	2, 3½, and 7-1.	
Chokes 10, 20, 50, and 100 Henries			17/6.

A. C. TRANSFORMERS

Set of Transformers and Chokes, in separate Aluminium Frames, 85 M.A. ...	£6/10/-
350 Milliamp. Transformers	£6/-/-
Pair of Extra Heavy Chokes, as used in above	£5/-/-
Transformers for A.C. Valves	£2/2/6

ALL EMMCO PRODUCTS FULLY GUARANTEED

MADE BY ELECTRICITY METER MFG. CO., LTD.

EXCLUSIVE FACTORY AGENTS

139 Clarence St. Sydney
TELE. BW 1328

Manufacturers Products Pty Ltd

Sugden Place off Little Collins St.
MELBOURNE

PROVING RADIO!

No. 8. *What is an electron? How and why does electricity resemble a minute solar system? What is matter? What is a molecule? What is the nucleus? What is an atom? How are these things combined to make certain substances, and what happens when a current of electricity flows through these substances?*

BEFORE the novice can fully understand the principles involved in the design, construction, and operation of wireless apparatus, he must have a knowledge of the modern theory of electricity.

Contrary to general belief, the actual cause of electricity and its action is not known. Until quite recently it was believed by scientists that an electric current was a kind of fluid which travelled through a circuit from the positive pole of a battery to the negative, whereas actually it passes in the opposite direction. The more modern theory, which is far more reasonable, is termed the "Electronic Theory," or the "Atomic Theory." Remember these two names. A frequent question given the A.O.P.C. aspirant is, "What is the name given to the modern theory of electricity?"

All matter, whether solid, liquid, or gaseous (matter is anything except the aether, which has weight, size, or space) is made up of extremely small particles, called "atoms," a Greek word, meaning indivisible; that is, an atom is the smallest particle into which a substance can be divided without losing its properties. The Atomic Theory shows that there are certain substances, called "elements," which consist in their pure state entirely of atoms of one kind. Thus, copper is made up of copper atoms, and nothing else. Carbon is made up solely of carbon atoms.

Substances that are not "elements" are called "compounds," and they are made up of groups of atoms of various kinds. In water, which is made up from hydrogen and oxygen (as we discovered by experiment in Part 4) two atoms of hydrogen combine with one atom of oxygen to form a "molecule" of water.

That is the basis of the atomic theory, and it is correct up to a certain point. Modern investigation, however, has brought to light one big error: The atom is not indivisible. This discovery has revolutionised science; particularly is it important in the radio world, for it has shown that all things, elements and compounds, solid, liquid, and gas, have the same components, differently arranged. Looking from this point of view, the old mythical philosopher's stone, which transformed all metals into gold, is not such an absurdity as was formerly imagined.

We must get a good insight into the Electronic Theory (or Atomic Theory), for the action of the valve is based upon it.

Let us start off from the beginning. The atom is a body of unimaginable smallness. It has been calculated that if a drop of water were to be magnified to the size of the earth, the atoms composing it would appear to be about the size of a loaf of bread. In reality, of course, it is nothing like a loaf of bread. It is more like a miniature solar system, consisting of a sun and its attendant retinue of planets. The "sun," or central, body is called the nucleus, whilst the "planets" are known as electrons.

The electron is a minute charge of negative electricity. It is not matter negatively charged. It is electricity. The electrons revolve round the nucleus at a stupendous speed—in the neighborhood of 1000 miles per second. Were it not for this high speed of rotation, the nucleus, being of positive

charge, would attract the negative electrons (see attraction and repulsion under the heading, "Electrical Paradox," Part 1), and they would be pulled towards it, because, unlike kinds of electricity attract each other. As an analogy, we might say the earth would fall on the sun were it not for the high speed at which the earth rotates with the sun as its centre of rotation.

Matter, in its normal state, has all its atoms in a tranquil (i.e., still) condition. Each atom has its right and proper amount of electrons rotating round it, and there are no external electrical effects. If, by some means, one of these atoms LOSES an electron, its stability is upset. A little bit of negative electricity has been taken away, and there is too much positive electricity remaining. The whole assumes an excessive positive charge, and at once endeavors to attract and assimilate into its own system any free electron that may be in the neighborhood. In this condition it is known as a POSITIVE ION.

Similarly, if an atom is given an extra electron, then the atom has a superfluity of negative electricity, and becomes a NEGATIVE ION.

The construction of the atom, showing the nucleus and attendant electrons, is shown in Fig. 1.

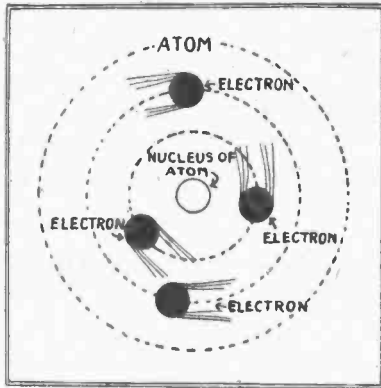

Fig. 1.

A conductor may be regarded as a substance containing electrons which are loosely bound to their respective nuclei, and which, under the influence of some force, are easily made to move from one atom to another in a systematic manner. In non-conductors (insulators) the electrons are bound tightly to their nuclei, and, under the influence of the same force, are very hard to move systematically, although they can be slightly displaced. This explains why, in the case of extremely high power currents, even a large insulator will allow a spark to jump across it.

Among good conductors of electricity are metallic substances, such as silver, copper, etc. the atoms of which will readily part with an electron.

A perfect insulator does not exist.

It has already been said that a force is required to bring about a systematic movement of electrons in a conductor. This force is known as Electro-Motive-Force, and is usually denoted by the three letters, E.M.F.

What is the action of electrons when a current flows along a wire? The E.M.F. in this case is supplied by a battery, and is analogous to a pump circulating water through a pipe, the water eventually returning to the pump.

In the battery, the place of the pump is taken by the chemical action of electrolyte (Parts 2 and 3), which removes electrons from the positive plate and transfers them to the negative, whence they travel via the outside circuit back to the positive terminal, since the current flows from negative to positive (as explained previously). At the negative terminal of the battery there is a superfluity of electrons. Let us trace one of them through a copper wire joined to each terminal. The electron rushes off the terminal, and hits a copper atom, knocking an electron out of its orbit, and taking its place. This displaced electron rushes against the next atom, driving out an electron as before, and occupying its orbit. Thus, a wave of collisions passes down the wire until the detachable electron nearest the positive terminal is driven from its place.

Remember, that when a conductor is not acted upon by an E.M.F., the electrons are free to move in any direction. As soon as the E.M.F. is exerted, the electrons can travel only in one direction, i.e., from negative to positive.

What a jumble the electronic theory is! Yet it's not hard to grasp if you settle down to it. If any point is not clear, don't leave it in doubt—write about it.

PROVING RADIO CLUBS

By now most of my readers will be familiar with the name Mr. C. Y. Hook, 29 Blairgowrie Street, Dulwich Hill. Mr. Hook now has two clubs running! One meets during the lunch hour, and this club consists of fellow employees. The other club has nine members (two from Concord, two from Arncliffe, one from Glebe Point, and three from Dulwich Hill). This club meets at Mr. Hook's home every Friday evening at 7.30, when "Proving Radio" experiments and chats are conducted. Mr. Hook extends a cordial welcome to those interested in the "Proving Radio" experiments. Take a Croydon Park 'bus to the end of Blairgowrie Street.

The club is looking up, too. Several well-known electrical engineers and transmitting amateurs have signified their willingness to assist the club with lectures and practical instruction. Arrangements are also being made to place before the Wireless Institute the suggestion that this society assist the club as regards lectures, etc. Mr. Hook will be introduced (as representative of the "Proving Radio Club") at the February meeting, by 2AR, Mr. W. Hudson. One of the present members of the club is an electrical engineer.

List of World's Broadcasting Stations Which Can be Received in Australia on Long and Short Waves

Table listing broadcasting stations from Australia, New Zealand, and various international regions including Japan, Dutch East Indies, and Europe. Columns include station call letters, frequency, and power.

International Short Wave Stations: Times Stated are S.M.T.

Table listing international short wave stations with columns for station call letters, frequency, and transmission times. Includes stations from Australia, New Zealand, Europe, and other regions.

Local Programmes, Friday, February 15

2FC

EARLY MORNING SESSION

Announcer: A. S. Cochrane.
7.0: "Big Ben" and announcements. 7.2: Official weather forecast, rainfall, river reports, temperatures, astronomical memoranda. 7.7: "Sydney Morning Herald" summary. 7.12: Shipping intelligence; mail services. 7.15: Studio music. 7.25: Investment market; mining sharemarkets; metal quotations; wool sales; breadstuffs markets; inter-State markets; produce markets. 7.40: Studio music. 8.0: "Big Ben." Close.

MORNING SESSION.

Announcer: A. S. Cochrane.
10.0: "Big Ben" and announcements. 10.2: Pianoforte reproduction. 10.10: "Sydney Morning Herald" news service. 10.25: Studio music. 10.45: A talk on home cooking and recipes by Miss Ruth Furst. 11.0: "Big Ben." A.P.A. and Reuter's cable services. 11.5: Close.

MIDDAY SESSION.

Announcer: A. S. Cochrane.
11.58: Announcements and official weather forecast, rainfall. 12.0: "Big Ben." From the Sydney Cricket Ground, description of the match, N.S.W. v. England. 1.30: From the studio, Stock Exchange, second call. 1.32: Rugby wireless news. 1.34: "Evening News" midday news service; Producers' Distributing Society's report. 1.51: Popular studio music. 2.0: "Big Ben." Close down.

AFTERNOON SESSION.

Announcer: Laurence Halbert.
Accompanist: Ewart Chapple.
2.30: Programme announcements. 2.32: Educational session, for the schools; short musical recital; a talk by Freda Sternberg, "Pawn Shops in Java and Elsewhere." 3.0: "Big Ben." Pianoforte reproduction. 3.15: A sketch by the students of the M'Cunn School. 3.30: Popular music. 3.45: A sketch by the students of the M'Cunn School. 4.0: "Big Ben." Studio music. 4.15: From the Sydney Cricket Ground, description of the cricket match, N.S.W. v. England. 5.40: Close down.
Note: Cricket description will be carried on through 2BL service until stumps drawn at 6 o'clock.

EARLY EVENING SESSION.

Announcer: A. S. Cochrane.
5.41: The chimes of 2FC. 5.45: The children's session, conducted by the "Hello Man"; letters and stories; music and entertainment. 6.30: Daigety's market reports (wool, wheat, and stock). 6.40: Fruit and vegetable markets. 6.43: Stock Exchange information. 6.45: Weather and shipping news. 6.48: Rugby wireless news. 6.50: Late sporting news. 7.0: "Big Ben." Late news service. 7.10: Special dinner music recital.

INDEX

To Local Programmes

Friday, February 15—	
3FC, 2BL, 2GB, 2UW	27
Saturday, February 16—	
3FC, 2BL, 2GB, 2UW	30
Sunday, February 17—	
2FC, 2BL, 2GB, 2UW	34
Monday, February 18—	
2FC, 2BL, 2GB, 2UW	38
Tuesday, February 19—	
2FC, 2BL, 2GB, 2UW	42
Wednesday, February 20—	
2FC, 2BL, 2GB, 2UW	46
Thursday, February 21—	
2FC, 2BL, 2GB, 2UW	50

EVENING SESSION.

Announcer: Laurence Halbert.
Accompanist: Ewart Chapple.
7.40: Programme announcements.
7.45: Impressions on cricket by M. A. Noble.
8.0: "Big Ben." By courtesy of J. C. Williamson, Ltd., a transmission will be arranged from one of Sydney's leading theatres.
9.0: From the studio, weather report.
9.1: The Light Music Four—(a) Overture, "Crown Diamonds" (Auber), (b) selection, "Sinbad" (Romberg).
9.16: Rae Foster and Charles Lawrence.
9.26: Brunton Gibb, entertainer.
9.34: The Light Music Four—(a) "A Day in Naples" (Byng), (b) selection, "Song of the Flame" (Gershwin).
9.49: Charles Lawrence and Rae Foster.
9.59: Brunton Gibb, entertainer.
10.6: The Light Music Four—(a) "The Lily of Killarney" (Benedict), (b) "Romyta" (Williamson), (c) selected.
10.27: To-morrow's programme.
10.30: National Anthem Close down.

2BL

MORNING SESSION.

Announcer: A. C. C. Stevens.
8.0: G.P.O. chimes; metropolitan weather report. 8.1: State weather report. 8.2: Studio music. 8.15: G.P.O. chimes; news from the "Daily Telegraph Pictorial." 8.30: G.P.O. chimes; news service continued. 8.40: Information, mails, shipping, arrivals, departures, and sailings. 8.45: Studio music. 9.15: Half an hour with silent friends. 9.45: Studio music. 1.0: G.P.O. chimes; close down.

MIDDAY SESSION.

Announcer: J. Knight Barnett.
11.0: G.P.O. clock and chimes; 2BL Women's Sports Association Session, conducted by Miss Gwen Varley. 11.30: Advertising hints. 11.40: Women's session, conducted by Mrs. Cranfield. 12.0: G.P.O. clock and chimes; special ocean forecast and weather report. 12.3: Pianoforte reproduction. 12.30: Shipping and mails. 12.35: Market reports. 12.48: "Sun" midday news service. 1.0: Studio music. 1.30: From the Sydney Cricket Ground, impressions on the cricket match, by M. A. Noble. 1.35: From the Studio, talk to children and special entertainment for children in hospital. 2.0: G.P.O. Clock and Chimes.

AFTERNOON SESSION.

Announcer: J. Knight Barnett.
Accompanist: Kathleen Roe.
3.45: G.P.O. clock and chimes, Pianoforte reproduction. 4.0: G.P.O. clock and chimes. From Romano's, Romano's Cafe Dance Orchestra, conducted by Bennie Abrahams. 4.10: From the Studio: A talk by Captain A. C. Stevens, "Nigeria: Land of the Crescent and Ju Ju." 4.25: Popular music. 4.30: Ann Stuart Gurr, contralto. 4.37: "Sun" news service. 4.40: From Romano's, Romano's Cafe Dance Orchestra, conducted by

Bennie Abrahams. 4.50: From the Studio, James Pedal, novelty pianist. 4.57: Ann Stuart Gurr, contralto. 5.4: Our Serial Story. 5.14: James Pedal, novelty pianist. 5.24: Pianoforte reproduction. 5.34: Poultry report. 5.37: Features of the evening's programme.

EARLY EVENING SESSION.

Announcers: J. Knight Barnett, Basil Kirke.
5.40: Children's Session, conducted by Uncle Peter. Music and entertainment. Letters and stories. 6.30: "Sun" news and late sporting. 6.40: Special Recital of Dinner Music. 7.10: Australian Mercantile Land and Finance Co's Report. Weather report and forecast, by courtesy of Govt. Meteorologist. Producers' Distributing Society's Fruit and Vegetable Market Report. Grain and Fodder Report ("Sun"). Dairy Produce Report ("Sun"). 7.25: Mr. Pim and Miss Pam in Advertising talks and nonsense. 7.55: Programme and other announcements.

EVENING SESSION.

Announcer: Basil Kirke.
Accompanist: G. Vern Barnett.
8.0: G.P.O. clock and chimes. Topical chorus.
8.2: From the Arcadia Theatre, Chatswood, Nicholas Robins at the Wurlitzer Organ.
8.22: From the Studio, Sydney Calland, baritone.
8.29: The Savoyans' Dance Band.
8.41: Sydney Calland, baritone.
8.49: The Savoyans' Dance Band.
9.0: G.P.O. clock and chimes. Last minute racing information, by C. R. Dexter.
9.15: Weather report.
9.16: The Savoyans' Dance Band.
9.28: Bernice Patterson, popular vocalist.
9.35: Livingstone Gille, trumpet solos.
9.42: The Savoyans' Dance Band.
9.54: Bernice Patterson, popular vocalist.
10.1: From the Arcadia Theatre, Chatswood, Nicholas Robins at the Wurlitzer Organ.
10.21: From the Studio: Late weather and announcements.
10.26: The Savoyans' Dance Band.
10.38: Announcements.
10.41: The Savoyans' Dance Band.
10.57: To-morrow's programme.
10.59: The Savoyans' Dance Band.

2UW

MIDDAY SESSION.

12.30: Music. 1.0: G.P.O. clock and chimes. Music. 2.30: Close down. 4.30: Musical programme

EVENING SESSION.

5.30: Children's hour, conducted by Uncle Jack. 6.30: Close down. 7.0: G.P.O. clock and chimes. Music. 8.0: To-day's anniversary. Music. 9.0: G.P.O. clock and chimes. Comments on foreign affairs, by Mr. J. M. Prentice. 9.10: Music and request numbers. 10.0: Close down.



Mr. BRUNTON GIBB, who is scheduled to entertain from 2FO at 9.59 to-night.



MR. SYDNEY CALLAND, baritone, who will be heard from 2BL at 8.41 to-night.

Interstate Programmes, Friday, February 15

3LO

EARLY MORNING SESSION

7.15: Morning melodies. 7.20: Morning exercises to music. 7.30: Stock reports; Stock Exchange information; market reports; general news; shipping and sporting information. 8.0: Melbourne Observatory time signal. 8.1: Morning melodies. 8.15: Close down.

MORNING SESSION

11.0: 3LO's difference in prices for daily dinner: Today's radio recipe: Apricot Jam (Dried apricots). 11.5: Captain Donald MacLean will speak on "Famous Women of History." 11.20: Musical Interlude. 11.25: "Au Fait" will speak on "Fashions." 11.40: Musical Interlude. 11.45: Under the auspices of the Health Department. Dr. Featonby will speak on "Vitamins."

MIDDAY SESSION

12.0: Melbourne Observatory time signal. Express train information. 12.1: Prices received by the Australian Mines and Metals Association from the London Stock Exchange this day. British official wireless news from Rugby. Reuter's and the Australian Press Association cables. "Argus" news service. 12.15: Newmarket stock sales. 12.20: The Associated Stock and Station Agents, Bourke Street, Melbourne. 12.20: The Station Orchestra: Overture, "Amilka" (Dorine). 12.30: Walter Whyte, tenor: "Faraway Bells" (Gordon). 12.35: Gertrude Gray, mezzo-soprano: (Thomson). 12.37: Stock Exchange information. 12.40: The Station Orchestra: Selection "Lucie à Lammormoor" (Donizetti). 12.50: John Byrne, bass: "When I Am Dying" (Finden). "Will the Red Sun Never Set?" (Finlay). 1.0: Dorothy Roxburgh, viola: "Romance" (Paul Juron). "Dusk on the Hawkesbury" (Alfred Hill). 1.1: The Station Orchestra: "Serenade Spanish" (Herbert). "Noielette" (d'Ambrosio). 1.11: Meteorological information. Weather forecast for Victoria, New South Wales, South Australia, and Tasmania. Ocean forecast. River reports. Rainfall. 1.18: Jovan Massonoff, tenor: "To a Miniature" (Brahe). "I Passed by Your Window" (Brahe). 1.20: The Station Orchestra: "Andante Symphonie in D" (Mozart). 1.30: John Byrne, bass: "The Puppet Showman" (Molloy). "The Vicar of Bray" (Old English). 1.37: The Station Orchestra: Suite, "Queen of Sheba" (Goldmark). 1.45: Close down.

AFTERNOON SESSION

Announcer: John Stuart. Accompanist: Mabel Nelson. 2.15: The Strat Trio, "Op 11 B Flat" (Beethoven). Allegro con brio. Adagio. Allegretto and Variations. 2.24: Gertrude Gray, mezzo-soprano: "Che Paro" (Gluck). "Homing" (Terresa Del Riego). 2.41: Frank Johnston, cello: "Titanic" (Schubert). "Guitar" (Moszkowsky). "Tarantelle" (Paque). 2.50: Gertrude Gray, mezzo-soprano: "Who is Sylvia" (Schubert). "Will Not Grieve" (Schumann). 2.57: The Strat Trio: "Chanson sans Paroles" (Tschalkowsky). 3.0: Unveiling of Mr. Will Lonsdale's painting, "The Ghosts of Menin Gate," at the Melbourne Town Hall. 3.15: Frances Freres, pianist: "Travels with Marco Polo." 3.35: Rev. Frank Gorman and Sadie McDonald, baritone & violinist: "Trennerie" (Schumann). "I'm Waiting for Ships" (Oldman). Patter, "Oh, Don't" (Harry Lauder). 3.52: The Station Orchestra: Selection, "Kissing Time" (Carroll). 4.0: Huxham's Serenades: The Quartette. "Gilla Galla Galoo"; Renn Millar, bass, "Cape St. Vincent" (Wormser). 4.52: Courtney Ford, humorist: "I Couldn't Heral" (Robey). "A Friend of a Sort" (Lee). 5.0: "Ereid" news service. Stock Exchange information. 5.10: Close down. During the afternoon progress scores of cricket matches. Football. New South Wales at Sydney, will be broadcast as they come to hand.

EVENING SESSION

6.0: Answers to letters and birthday greetings by the Evening Session. 6.15: Captain Donald MacLean will tell you some more plate stories.

NIGHT SESSION

Announcer: C. J. Conner. Accompanist: Mabel Nelson. 6.50: Madame Soward: "French Without Tears." 7.5: Stock Exchange information. 7.15: Official report of the Newmarket stock sales by the Associated Stock and Station Agents, Bourke Street, Melbourne. Latest market orders for next week's markets. Fish market reports by J. R. Borrett, Ltd. Market reports by the Victorian Producers' Co-operative Company, Ltd. Poultry, grain, hay, straw, jute, dairy produce, potatoes and onions. Market reports of fruit by the Victorian Fruitgrowers' Association. Retail prices. Wholesale prices of fruit by the Wholesale Fruit Merchants' Association. Citrus fruits. 7.30: News session. Stumps scores, England v. New South Wales, at Sydney, 7.43: Birthday greetings. 7.45: Out of the part. 7.46: Under the auspices of the Department of Agriculture, Mr. J. T. Ramsay, potato expert, will speak on "Potato Culture—Seasonable Hints." 8.0: A maker of records. 8.1: Mr. H. K. W. Taylor will speak on "Technicalities." 8.10: Collingwood Citizens' Band: March, "Steady On"; overture, "Napoleon." 8.20: Jovan Massonoff, tenor: Romance, "Una furtiva lagrima" (Donizetti). "Little Mother of Mine" (H. T. Burleigh). 8.27: Collingwood Citizens' Band: Selection, "La

Tarvata." 8.37: Gertrude Gray, mezzo-soprano: "Trees" (Rasbach). "I Love You Truly" (Jacobs-Bond). 8.44: French Bros., banjoists: Latest banjo melodies. 8.51: Collingwood Citizens' Band: March, "True Comrades"; Introduction to "Faust." 9.0: Huxham Serenader Quartette: The Quartette, "Stolen Melody"; Hugh and Edith Huxham, duet, "Is That So?"; Interlude, cornet solo, "Flower Song" from "Faust"; Madeline (Knight, contralto: "I Love You"; the Quartette, "It's Lovely by the Seaside"; Interlude, Mabel Nelson, piano, "Country Gardens" (Craininger); the Quartette, "The Nightingale." 9.30: Collingwood Citizens' Band: March, "Sans Souci." 9.37: Eric Welch will speak on to-morrow's V.A.T. races at Caulfield. 9.47: Collingwood Citizens' Band: Waltz song, "Chiquita." 9.53: Rev. Frank Gorman and Sadie McDonald, baritone and violinist: "Czarinas" (Monti). "Mighty Lak a Rose" (Bond), Patter, "You Brought Ireland Over to Me" (Ball). 10.8: French Bros., banjoists: "Light and Bright." 10.15: Jovan Massonoff, tenor: Romance, "La Laila." 10.20: "Marcheta" (Scherzinger). 10.22: "Argus" news service. British official wireless news from Rugby. Meteorological information. Road notes, supplied by the Royal Automobile Club of Victoria. Announcements. Weekly seasonal gardening reminders, supplied by Leslie Brunning. 10.32: Gertrude Gray, mezzo-soprano: "Steal Away" (Negro Spiritual). "Were You There?" (Negro Spiritual). 10.39: Collingwood Citizens' Band: "Chant Sans Paroles." 10.45: The Radi-Acees: "Gaily Rose" (Friend). "Sincerely I Do" (Davis). "The Prune Song" (Crumit). "Sleepy Baby" (Kahn). "Get Out and Get Under the Moon" (Tobias). 11.1: The Radi-Acees: "Out of the Dust" (Donaldson). "Mother I Still Have You" (Julson). "Dream House" (Fox). "Jeannine" (Gilbert). "Day Dreams" (Hallam). "Tin Pan Parade" (Whitney). "Mississippi Mud" (Harris). "I Can't Do Without You" (Berlin). "I Just Jog Along" (Rose). "Goodnight Waltz" (Bibb). 11.30: God Save the King.

INDEX

To Interstate Programmes

Friday, January 15	3LO 3AR 4QG 5CL 6WF 7ZL	28
Saturday, January 16	3LO 3AR 4QG 5CL 6WF 7ZL	32
Sunday, January 17	3LO 3AR 4QG 5CL 6WF	36
Monday, January 18	3LO 3AR 4QG 5CL 6WF 7ZL	40
Tuesday, January 19	3LO 3AR 4QG 5CL 6WF 7ZL	44
Wednesday, January 20	3LO 3AR 4QG 5CL 6WF 7ZL	48
Thursday, January 21	3LO 3AR 4QG 5CL 6WF 7ZL	52
CRASH BURR CRACKLE		56
Will Man Conquer Statie?		
BROADCASTING ANTICIPATION IN 1929		7
A SHORT WAVE RECEIVER, by Ray All'op		8
HOW TO MAKE A SIMPLE TELEVISION		9
WIRELESS WEAVING A WEB AROUND THE WORLD		11
(By Capt. P. P. Eckersley.)		
THE MARNOCK 5-VALVE RECEIVER		17

3AR

MORNING SESSION.

Announcer: Maurice Dudley. 10.0: G.P.O. clock says "Ten." 10.1: "Age" market reports—farm and station produce, fruit, fish, vegetables, etc. 10.25: "Age" shipping reports: ocean forecast. 10.30: Mail notices; express train information. 10.35: "Age" news service, exclusive to 3AR. 10.59: Weather forecast.

MORNING MUSICAL SESSION.

11.0: Ned Tyrrell's Radi-o-Acees: "Up and Down" (Rose). "Mississippi Mud" (Harris). "Tin Pan Parade" (Whitney). "Lollita" (Stoneham). "Without You, Sweetheart" (de Silva). 11.20: Beautiful ballads. 11.25: Ned Tyrrell's Radi-o-Acees: "Dressin' Kisses" (Yellen). "Lenora" (Gilbert). "Virginia Creeper" (Wade). "Little Log Cabin of Dreams" (Hanley). 11.46: Beautiful ballads. 11.52: Ned Tyrrell's Radi-o-Acees: "Happy Go Lucky Lonesome" (Lawley). "All Day Long" (Cross). "Don't Keep Me In the Dark, Bright Eyes" (Bryan). "Down Where the Sun Goes Down" (Jones). 12.4: Beautiful ballads. 12.10: Ned Tyrrell's Radi-o-Acees: "Dolores" (Kassell). "Mine, All Mine" (RUBY). "Rain" (Ford). 12.20: British official wireless news; announcements. 12.30: Close down.

AFTERNOON SESSION.

Announcer: Frank Hatherley. 6.0: A special programme of request records. 7.10: "Herald" news service. 7.15: Gramophone recital, continued.

EVENING SESSION.

Announcer: Frank Hatherley. 8.15: Eric E. Aikens will speak on "To-morrow's Events at the Motor-drome." 8.30: Community singing, transmission from Malvern Town Hall. Conductor, G. J. McKee. From the Studio, news session. 10.30: "Age" news service, exclusive to 3AR: results of cricket match, England v. New South Wales, at Sydney.

4QG

EARLY MORNING SESSION.

7.43: Time signal. 8.0: Special programme. 8.0: Special programme of request records. 8.15: News service. 8.30: Close down.

MORNING SESSION.

An Hour with the Ladies. Announcer: Rita Muirfe. 11.0: Music. 11.5: Social news. 11.15: "Cookery and Household" (Goaty). "The Etiquette Girl." 11.30: Music. 11.35: More social news. 11.50 (noon): Close down.

MID-DAY SESSION.

1.0: Market reports and weather information. 1.15: Lunch-hour music. 2.0: Close down.

AFTERNOON SESSION.

3.0: A programme of electrically reproduced records. 3.30: Main train running times. 4.15: This afternoon's news. 4.30: Close down.

EARLY EVENING SESSION.

Announcers: R. Wright and H. Humphreys. Dinner music. 6.0: Mail train running times; mail information; shipping. 6.15: Dinner music. 6.25: Commercial announcements. 6.30: Bedtime stories conducted by "The Sandman." 7.0: News in brief. 7.15: Stock Exchange news. 7.45: Metal quotations. 7.7: Market reports. 7.25: Fenwick's stock report. 7.30: Weather information. 7.40: Announcements. 7.43: Standard time signals. 7.45: To-morrow's sporting fixtures reviewed.

MID-EVENING SESSION.

8.0: From Dayboro—The 4QG Orchestra. March, "The Line Up" (Bertani). 8.5: The Orpheans (Conductor, Tom Muller). "We Meet Again To-night, Boys." 8.9: Fred Crane (baritone). "Kentish Hops" (Drummond). 8.14: Mrs. M. S. Williams (violinist). "La Galette" (Ewing), accompanied by 4QG Orchestra. 8.20: The Orpheans, "Come, Let Us March" (De Rille). 8.24: Joe Dwyer and his pal Jerry. Ten minutes fun. 8.34: The 4QG Orchestra. March, "Russian Rag" (Cobb). 8.40: J. P. Cornwell (baritone). "The Old Rustic Bridge" (Skelly), accompanied by The Orpheans. C. Hansen (saxophone). "Saxophobia" (Weidhoff), accompanied by the 4QG Orchestra. 8.50: George Williamson (tenor). "Love, Could I Only Tell Thee" (Capel). 8.55: Tom Muller (baritone). "Laugh, Clown, Laugh" (Florida), accompanied by The Orpheans. "Side" (Lamsdaine) (baritone). "King of the Night" (Stoneham). 9.5: The 4QG Orchestra. Fox-trot, "In the Woodshed She Said She Would" (Johnson). 9.10: Ray Bruce (tenor). "Can't Remember" (Goaty). 9.15: J. P. Cornwell (bass). "The Highwayman" (McCowan). 9.20: Joe Dwyer and Jerry—more fun. 9.25: The 4QG Orchestra. One-step, "Cheer Up" (Kausman). 9.30: Fred Crane (baritone). "The Orpheans" (Kausman), accompanied by The Orpheans. 9.34: The Orpheans. Overture, "Because" (D'Harlelot). 9.40: C. Rice (tenor). "The House at the End of the Lane" (Ball). 9.48: The 4QG Orchestra. One-step, "My Turkish Opal" (Gillespie). 9.50: The Orpheans. Overture, "John Peel." 9.55: From the Studio. Week-end road information for motorists, officially supplied by the R.M.C.G. 10.0: The Daily Mail news, the "Courier" news, weather news. Close down.

5CL

MORNING SESSION.

11.0: G.P.O. chimes. 11.15: "Economic." Kitchener and menu talk. 11.30: Sonora. 11.45: Mrs. W. Wade will speak on "Experiences in Central Australia." 12.0: G.P.O. chimes. 12.1: G.P.O. chimes. 12.15: General information. 12.35: Official wireless news. 12.40: Sonora, excerpts from favorite operas. 12.52: S.A. Railway information. 12.53: S. C. Ward and Co.'s Stock Exchange information. 12.55: G.P.O. chimes. 1.1: Sonora. 1.58: Meteorological information. 2.0: G.P.O. chimes and close down.

AFTERNOON SESSION.

3.0: G.P.O. chimes. 3.1: Miss N. Moore. A talk on "The House at the End of the Lane." 3.15: Sonora. 3.40: Jean Litchfield, pianist. 3.48: Stanley Toovey, tenor. 3.54: A. V. Noske, fustait. 4.0: G.P.O. chimes. 4.1: Bernard Manning, bass-baritone. 4.6: Harry Hutchins, violinist. 4.27: Victoria Wilson, soprano. 4.18: Jean Litchfield, pianist. 4.28: Stanley Toovey, tenor. 4.34: A. V. Noske, fustait. 4.40: Bernard Manning, bass-baritone. 4.46: Jean Litchfield, pianist. 4.50: Victoria Wilson, soprano. 4.55: S. C. Ward and Co.'s Stock Exchange information. 5.0: G.P.O. chimes and close down.

EVENING SESSION.

6.0: G.P.O. chimes. 6.1: Birthday greetings, correspondence. 6.2: An interlude of dinner music (Gramophone recordings). 6.35: International cricket scores, England v. New South Wales, at Sydney. 7.0: G.P.O. chimes. 7.1: S. C. Ward and Co.'s Stock Exchange information. 7.15: General market reports. Daisy and Co.'s wool and grain report. 7.10: SCL's Sporting Service, by "Silvius." 7.22: Mr. R. W. Bowley (president of the Australian Band of Hope Union) will give interesting talk. 7.35: Adelaide wool sales. A detailed report by Messrs. Daisy and Co. 7.45: F. H. Nicholls, Shakespearian series. "Measure for Measure."

NIGHT SESSION.

8.0: G.P.O. chimes. 8.1: Station Orchestra. Overture, "Mirella" (Gounod). 8.27: Bernard Manning, bass-baritone, selections from his repertoire. 8.13: William Davey, xylophonist. "Dancing Tambourine" (Galla). "Bouquet of Memories" (Kassell). 8.29: Windarra Male Quartet. "In Absence" (Buck). "Mosquitos" (Bliss). 8.35: Station Orchestra: "Subid Kasid" (Gower). 8.41: Victoria Wilson, soprano. "I Drink To Me Only" (Quilter). "Japanese Love Song" (Brahe). 8.47: Tom King, pianist. "Marionettes Espagnoles" (Cull). 8.50: Will Runge, entertainer. Selected humor. 8.0: G.P.O. chimes. 9.1: Meteorological information. 9.2: Overseas grain report. 9.3: International cricket scores, England v. New South Wales, at Sydney. 9.4: Windarra Male Quartet.

"Just Awearint' For You" (Bond), "Don't You Cry, My Honey" (De Koven), 9.10: A. V. Noske, flautist. "Les Fleurs" (Popp), 9.14: Bernard Manning, bass-baritone. Selections from his repertoire. 9.20: Station Orchestra. Suite, "Scenes Riviera" (Brook), 9.22: Victoria Wilson, soprano. "Vol Che Sapete" (Giacini), "Figaro", "Two Brown Eyes" (Grieg), 9.34: William Dayer, xylophonist. "The Doll Dance" (Bosni), "Tambour Arant" (Durand), 9.40: Ken Hughes, tenor. "The Garden of Your Heart" (Gardner), "Dreams of Long Ago" (Tosti), 9.48: Station Orchestra. "La Sonnambula" (Bellini), 9.56: W. Wickes, bass. "You Along o' Me" (Sandercock), "The Old Black Mare" (Squire), 10.2: Station Orchestra. "Rhapsodie No. 6" (Liszt), "Orientale Sun Dance" (Friedman), 10.15: Royal Automobile Association road notes. The "Advertiser" general news service. Adelaide wool sale report. 5CL's sporting service. Meteorological information. 10.41: Modern dance numbers by the Radi-o-Aces. 11.0: God Save the King.

6WF

10.30 p.m.: Tune in. 12.35: Markets, news, etc. 1.0: Time signal. 1.1: Weather notes. 1.3: Studio orchestra. 2.0: Close down. 3.30: Tune in. 3.35: Afternoon tea concert, relayed from the Beachside Cafe; vocal items from the studio. 4.30: Close down. 6.45: Tune in. 6.48: Bedtime stories for the kiddies by Uncle Duffy. 7.5: Light music by the Spring Trio. 7.30: Commercial and general information. 7.45: Racing anticipations by the Sporting Editor of the "Truth" Newspaper Co., Ltd. 8.0: Time signal. 8.1: Weather bulletin, supplied by the Meteorological Bureau of West Australia. 8.5: Vocal and instrumental artists from the studio; play of wrestling match from Subiaco Oval. 9.0: Late news items by courtesy of "The Daily News" Newspaper Co.; ships within range announcement; station announcements; late weather bulletin. 10.30: Close down. 104.5-Metre Transmission: Simultaneous broadcast on 104.5 metres of programme given on 1250 metres, commencing at 8.45 p.m.

7ZL

MID-DAY SESSION.

11.30: Selections. 11.34: Midlands Weather forecast. 11.35: Selections. 11.55: Tasmanian stations' p.m. weather report. 12.0: G.P.O. clock chimes the hour. 12.1: Shipping information. Ships within wireless range. Mail notices. Housewives' guide. Railway auction produce sales. 12.8: Selections. 12.11: British Official Wireless news. 12.20: Selections. 12.29: Announcements. 12.33: Selections. 12.55: News service. Railway auction produce sales. 1.10: Selections. 1.30: Close down.

AFTERNOON SESSION.

1.9: G.P.O. clock chimes the hour. 3.1: Selections. 3.4: Weather information. 3.5: Selections. 4.30: Close down.

EARLY EVENING SESSION.

6.15: Selections. 6.25: "The Story Lady" will tell a story to the children. 6.40: Selections. 7.0: Answers to letters and birthday greetings by "Uncle David". 7.5: Selections.

EVENING SESSION.

7.15: A. M. O'Leary will speak on "Cricket activities". 7.30: A studio concert by 7ZL artists and the Dues Ensemble. 7.30: Lella Read. Piano solo, "Selected". 7.35: Katie Rothwell, contralto. "A Banjo Song" (Homer), "Sunday". 7.42: Silver Stars Band. "Valse Triste", "Les Millions d'Adelquin". 8.40: Harry Guy, baritone. "Till the Bands of the Desert Grow Cold"; "The Trumpeter" (Dix). 7.56: The Silver Stars Band. "The Mikado." Parts 1 and 2. 8.3: Doreen Ellison, soprano. "Passing By" (Purcell), "Just Like a Lady" (Phillips). 8.10: Paul Whiteman and his Orchestra. "Just Like a Melody Out of the Sky" (Donaldson), "The Merry Widow" (Lehar). 8.17: Katie Rothwell, contralto. "Pleading" (Elgar), "A Peques" (Finden). 8.24: International Concert Orchestra. "Spring. Beautiful Spring" (Linke). 8.27: Harry Guy, baritone. "Land of Long Ago" (Ray); "The Song is Ended" (Berlin). 8.34: Cherniavsky Trio, violin, 'cello, piano. "Spring Song" (Mendelssohn). 8.37: Doreen Ellison, soprano. "The Robin's Song" (White), "So People Say" (Fisher). 8.45: J. Boyes (manager), H. C. Batt (skipper of the "Tasman"), W. P. Batt (skipper of the "Tassie Too") will speak on "Experiences in Australian Yachting Championships held at Brisbane." 9.0: J. M. Counsel. "A musical programme by the old masters"; "The History and Development of Music." 9.45: News session. "Mercury" news service. British Official wireless news. Railway auction produce sales, held at railway. Weather information. Hobart Stock Exchange quotations. Market reports from Messrs. Roberts and Co., Messrs. Wise and Stirling, and T. Thorpe and Co. Railway week-end information. 10.0: G.P.O. clock chimes the hour. God Save the King. Close down.

**FULLER
ACCUMULATORS**
For Efficiency
GILBERT-LODGE & CO., LTD.

GREATER EMISSION



That's the outstanding feature of Mullard P.M. valves—they give greater emission. In Mullard Valves alone is found the wonderful P.M. Filament, the long filament with the gigantic emission surface. This means longer life, bigger volume, and improved tone.

All you have to do to make these qualities part of your radio reception is to fit Mullard P.M. Valves. Just that—no more. And remember they consume only 0.075 amps; that means they save your batteries.

"Ask your Dealer to demonstrate the Mullard Speaker, the only Speaker with a Tone Control Switch"

Mullard
THE MASTER VALVE



Portable Voltmeter

Pattern 136: A most convenient De Luxe Portable Jewell Voltmeter. Beautifully finished of black bakelite, clock stand type of mount. Range of scale 0-7.5—150 volts. Push button switch mounted in the top of flange. Three long leads with phone tips. Connected permanently will show filament voltage. By pushing the button the "B" Battery voltage is read.

Write for

Radio Instrument Catalogue No. 15.c

STROMBERG CARLSON

Australasia, Limited,
76 William Street, Sydney.
Phone: F4184. Telegrams: "Strom."

WOULD YOU

Like to Hear REAL Radio Results In Your Home?

If so, arrange to have a Set demonstrated one night for your benefit.

There is no obligation to purchase, for we take a pleasure in showing you how near to perfection Resco Radio has come.

We specialise in bringing your old Set up to date. Let US quote you, as all Resco Remodelled Sets are covered by our unconditional twelve months Guarantee.

THE RESCO RADIO SUPPLY COMPANY.,

38A PITT STREET,
SYDNEY.

Phone: B 1817.

Local Programmes, Saturday, February 16

2FC

EARLY MORNING SESSION.

Announcer: A. S. Cochrane.

7.0: "Big Ben" and announcements. 7.2 Official weather forecast, rainfall, river reports, temperatures, astronomical memoranda. 7.7: "Sydney Morning Herald" summary. 7.12: Shipping intelligence; mail services. 7.15: Studio music. 7.25: Investment market; mining sharemarkets; metal quotations; wool sales; breadstuffs markets; inter-State markets; produce markets. 7.40: Studio music. 8.0: "Big Ben" Close down.

MORNING SESSION

Announcer: Laurence Halbert.

10.0: "Big Ben" and announcements. 10.2: Pianoforte reproduction. 10.10: "Sydney Morning Herald" news service. 10.25: Studio music. 10.30: Last minute sporting information by the 2FC Racing Commissioner. 10.40: Studio music. 10.45: A talk on "Gardening" by J. G. Lockley ("Bedgum"). 11.0: "Big Ben," A.P.A. and Reuters' cable services. 11.5: Close down.

MIDDAY AND AFTERNOON SESSIONS.

Announcers: Laurence Halbert. Ewart Chapple.

12.0: "Big Ben" From the Sydney Cricket Ground, description of the match, N.S.W. v. England. 12.30: From the studio, Stock Exchange information. 1.22: "Sydney Morning Herald" news service. 1.27: Rugby wireless news; weather and announcements. 12.50: From Warwick Farm. During the afternoon description of the races will be given. In the intervals the Glee Club Trio will play from the studio. 5.0: Close down.

EARLY EVENING SESSION.

Announcer: A. S. Cochrane.

5.40: From the Sydney Cricket Ground.

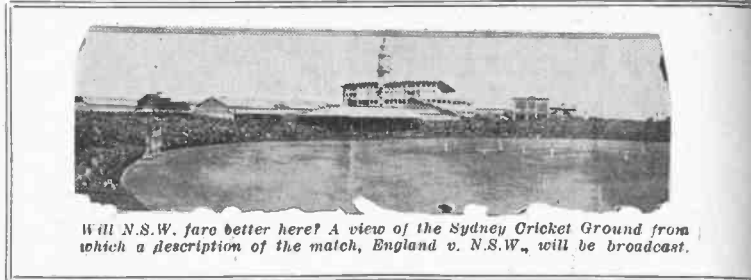

Will N.S.W. fare better here? A view of the Sydney Cricket Ground from which a description of the match, England v. N.S.W., will be broadcast.

description of the cricket match, England v. N.S.W. 6.0: Stumps drawn, cricket match, England v. N.S.W. 6.5: The children's session, conducted by the "Hello Man"; letters and stories; Music and entertainment. 6.30: Dalgety's market reports (wool, wheat, and stock). 6.40: Fruit and vegetable markets. 6.43: Stock Exchange information. 6.45: Weather and shipping news. 6.48: Rugby wireless news. 6.50: Late sporting news. 7.0: "Big Ben." Late news service. 7.10: The 2FC Dinner Quartette, conducted by Horace Kates—(a) "Festival Dance" (Delibes), (b) "Elegie" (Massenet), (c) "An Eastern Romance" (Taine), (d) "Cobweb Castle" (Lehmann), (e) "Chaconne" (Durrant), (f) "Only a Rose" (Friml)

EVENING SESSION.

Announcer: Laurence Halbert.
Accompanist: Ewart Chapple.

7.40: Programme announcements.
7.45: Impressions on the cricket by M. A. Noble.

8.0: "Big Ben." Studio Dance Band, conducted by Cec. Morrison.

8.12: E. A. Bartleman baritone (a) "The Rancher's Daughter" (Lehmann), (b) "Good Fellows" (Phillips).

8.19: Wally Baynes, entertainer.

8.26: Venetian Trio.

8.33: Studio Dance Band conducted by Cec. Morrison.

8.43: E. A. Bartleman, baritone—(a) "Kitty McGee" (Sommerville) (b) "Love and Wine" (Lehar).

8.50: Banjo solos by Artnur Wright.

8.57: Weather report.

8.58: Studio Dance Band conducted by Cec. Morrison.

9.0: "Big Ben."

9.1: Wally Baynes, entertainer.

9.8: Venetian Trio.

9.18: From the Speedway Royal, description of the races.

9.28: From the studio the Studio Dance Band, conducted by Cec. Morrison.

9.40: Vera Spaul.

9.47: Venetian Trio.

9.57: Vera Spaul.

10.4: From the Speedway Royal, description of the races.

10.14: From the studio, Dance Band, conducted by Cec. Morrison.

10.24: Late weather and announcements.

10.29: Studio Dance Band, conducted by Cec. Morrison.

10.57: To-morrow's programme.

10.59: The Studio Dance Band conducted by Cec. Morrison.

11.30: National Anthem. Close down

2BL

MORNING SESSION.

Announcer: A. C. C. Stevens.

8.0: G.P.O. chimes. Metropolitan weather report. 8.1: State weather report. 8.2: Studio music. 8.15: G.P.O. chimes. News from the "Daily Telegraph Pictorial." 8.30: G.P.O. chimes. News service continued. 8.40: Information, mails, shipping, arrivals, departures, and sailings. 8.45: Studio music. 9.15: Half an hour with silent friends. 9.45: Studio music. 10.0: G.P.O. chimes. Close down.

MIDDAY AND AFTERNOON SESSIONS

Announcers: A. C. C. Stevens, J. Knight Barnett.

11.0: G.P.O. clock and chimes. Women's session, conducted by Mrs. Cranfield. A few

Continental recipes for egg dishes. A story. What's on at the pictures and theatres. 11.30: Advertising hints. 11.40: Gardening talk by Mr. G. Cooper, City Park Superintendent. 12.0: G.P.O. clock and chimes. Special ocean forecast and weather report. 12.3: "Sun" news service. 12.13: Pianoforte reproduction. 12.30: From the Sydney Cricket Ground, description of the cricket match, England v. N.S.W. 1.30: Impressions on the cricket by M. A. Noble. 1.35: Continuation of description. 4.0: Impressions on the cricket by M. A. Noble. 4.5: From the studio, studio music. 4.15: From the Sydney Cricket Ground, description of the cricket match, England v. N.S.W. 5.40: Close down.

EARLY EVENING SESSION.

Announcer: Basil Kirke.

5.41: Children's session, conducted by Uncle Bas. Music and entertainment. Letters and stories. 6.30: "Sun" news and late sporting. 6.40: 2BL Dinner Quartette—(a) "Fleurette d'Amour" (Fletcher), (b) "The Golden Moth" (Novello), (c) "Chapiniana" (arr. Finck), (d) "Humoresque" (Dvorak), (e) "Gopak" (Moussoursky). 7.10: Australian Mercantile Land and Finance Co's report. Weather report and forecast, by courtesy of Government Meteorologist. Producers' Distributing Society's fruit and vegetable market report. Grain and fodder report ("Sun"). Dairy produce report ("Sun"). 7.25: Mr. Pim and Miss Pam in advertising talks and no-nonsense. 7.55: Programme and other announcements.

EVENING SESSION.

Announcer: Basil Kirke.

Accompanist: J. Vern Barnett.

8.0: G.P.O. clock and chimes. Topical chorus.

8.2: King's Mandolin Orchestra.

8.10: Billie Creswell, popular vocalist.

8.17: Josef Kaartinen, saxophonist.

8.24: J. Knight Barnett, entertainer.

8.34: Popular studio programme.

9.45: Weather report.

9.46: King's Mandolin Orchestra.

10.3: Josef Kaartinen, saxophonist.

10.10: J. Knight Barnett, entertainer.

10.20: From Romano's, Romano's Cafe Dance Orchestra, conducted by Bennie Abrams.

10.30: From the studio, late weather and announcements. Studio music.

10.40: From Romano's, Romano's Cafe Dance Orchestra, conducted by Bennie Abrams.

10.57: From the studio, to-morrow's programme.

10.59: From Romano's, Romano's Cafe Dance Orchestra, conducted by Bennie Abrams.

11.30: National Anthem. Close down.

Note: During intervals between dance music groups "Sun" news items will be broadcast.

2GB

5.30: Children's session by Uncle George. 7.15: Music. 7.20: Dance programme. 8.0: Request evening. 9.0: Grown-up Bedtime Stories. 10.0: Close down.

2UW

5.30: Children's hour, conducted by Uncle Jack. 6.30: Close down.

EVENING SESSION.

7.0 to 10.0: Musical programme. 10.0: Close down.



A FEW USEFUL PARTS
At Reasonable Prices

10005 Variable Condensers, with dials 6/6.
0063s Aluminium Plate Condensers, 6/6, 9-1 Crossley Transformers, 9/6, 30 ohm Rheostats, 2/6.
2-Coil Holders, movable, 3/9; 201A Valves, 5/6; UX199 Valves, 5/6; 4 mfd. Cond., 12/6; 1 mfd. Cond., 4/9; 2 mfd. Cond., 7/; Record Bell Ringing Trans., 7/6; Igranite Type B. Trans., 16/; UX Sockets 1/3; Reinartz Coils, 3/3; Murec Kits, 8/6; 3in. Dials, 8d; Voltmeters, 0-50, 4/; Voltmeter, suitable for "B" Eliminators, 25/; NEW SYSTEM HEADPHONES, 15/.

SLINGSBY & COLES, LTD.
THE RELIABLE RADIO HOUSE,
486 PITT STREET
(Under Central Railway).

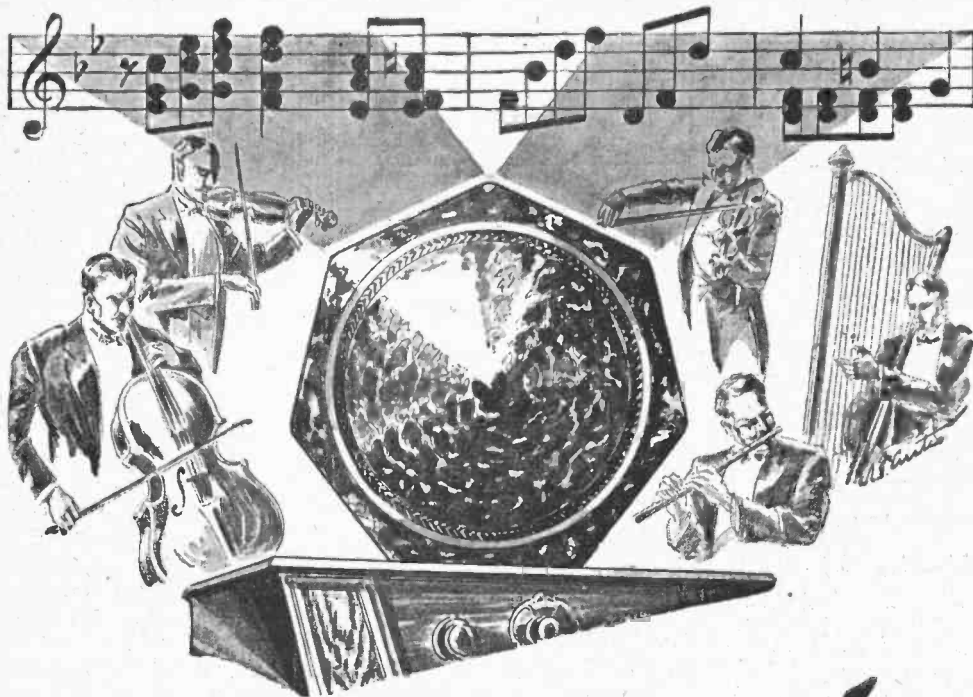

YOU CAN PICK THEM OUT!

VIOLIN, 'cello, flute, harp—they are all there with a Philips Speaker—all, just as if you were the band master yourself.

If you have a GOOD receiver, a Philips Loud-speaker will give you a new interest in radio, for their reproduction is natural—*vividly real*.

Concert Grand .. £9/0/0	Junior £5/5/0
(Cabinet Model)	
P.C.J.J. Senior .. £6/10/0	Baby Grand .. £3/15/0

The Steeper the Slope the Better the Valve!
The Slopes of Philips "Miniwatts" are SHEER!

PHILIPS

LOUD SPEAKERS

9R1

[Advt. of Philips Lamps (Australia) Ltd (Radio Dept.) Head Office and Showrooms : Corner Clarence and Margaret Streets, Sydney, N.S.W.]

Interstate Programmes, Saturday, February 16

3LO

EARLY MORNING SESSION.

7.15 to 8.15: See Friday.
MORNING SESSION
 Announcer: John Stuart. Accompanist: Mabel Nelson. 11.0: The Station Orchestra: Overture, "The Water Carrier" (Cherubini). 11.10: Jovan Massonoff, tenor: "Der Troem Von Poet" (Trapp). Selected. 11.17: The Station Orchestra: Selection, "La Favorita" (Donizetti). 11.27: Eric Welch will speak on to-day's V.A.T.C. races at Caulfield. 11.37: John Byrne, bass: "If Thou Wert Blind" (Johnson). "Don Juan's Serenade" (Tschalkowsky). 11.44: The Station Orchestra: Selection, "The Joy Rider" (Gilbert). 11.53: Jovan Massonoff, tenor: "Nirvana" (Adams), "The Rosary" (Nevin).

MIDDAY SESSION

12.0: Melbourne Observatory time signal. 12.1: Metal prices received by the Australian Mines and Metals Association from the London Stock Exchange this day. British official wireless news from Rugby. Reuters and the Australian Press Association cables "Argus" news service. 12.20: The Station Orchestra: Overture, "Orpheus in the Underworld" (Offenbach). 12.30: Rev. Frank Gorman and Sadie McDonald: "Poem Hongrois" (Ladere), "A Russian Lullaby" (Berlioz). Patter, "I Told Them All About You" (Friend). 12.45: Stock Exchange information. 12.48: The Station Orchestra: Selection, "Poppy" (Jones). 12.58: Diana Belmont, contralto: "My Son" (Del Rio), "A Wayside Flower" (D'Hardot). 1.5: Meteorological information. Weather forecast for Victoria, New South Wales, South Australia, and Tasmania. Ocean forecasts. River reports. Rainfall. 1.12: The Station Orchestra: "Largo from Sonata, Op. 7" (Beechovval). 1.17: Courtney Ford, humorist: "Fifty Million Frenchmen" (Fisher). "Hey Diddle Diddle". 1.24: The Station Orchestra: Selection, "Hamlet" (Ambrose Thomas). 1.34: Diana Belmont, contralto: "Rest Thee, Sad Heart" (Del Rio), Request number. 1.41: The Station Orchestra: "In termezzo, Symphonique" (Borch). 1.45: Close down. 1.58: Description of Warren Hurdle. 2 miles 65 yards, V.A.T.C. races at Caulfield, by Eric Welch. 2.5: Close down.

AFTERNOON SESSION

Announcer: John Stuart. 2.15: Description of pennant cricket match, South Melbourne v. Melbourne, at South Melbourne. 2.30: Description of Federal Stakes, 5 furlongs, V.A.T.C. races at Caulfield, by Eric Welch. 2.35: Description of pennant cricket match, South Melbourne v. Melbourne, at South Melbourne. 3.3: Description of

Bond Cup, 1 1/4 miles, V.A.T.C. races at Caulfield. 3.10: Description of Victorian track and field championship at the Motordrome. 3.25: Description of pennant cricket match, South Melbourne v. Melbourne, at South Melbourne. 3.38: Description of Oakfield Plate, 5 1/2 furlongs, V.A.T.C. races at Caulfield. 3.45: Description of pennant cricket match, South Melbourne v. Melbourne, at South Melbourne. 4.0: Sonora recital, from the studio. 4.13: Description of St. George's Stakes, w.i.a. 9 furlongs, V.A.T.C. races at Caulfield. 4.20: Description of pennant cricket match, South Melbourne v. Melbourne, at South Melbourne. 4.48: Description of Salisbury Welter, 1 mile, V.A.T.C. races at Caulfield. 4.55: Description of Victorian track and field championships, at the Motordrome. 8.10: "Herald" news service: Progress scores of cricket match, England v. New South Wales, will be broadcast as they come to hand, also results of Golf races. 8.20: Description of pennant cricket match, South Melbourne v. Melbourne, at South Melbourne. 5.30: Close down.

EVENING SESSION

5.50: Sporting results. 6.0: Answers to letters and birthday greetings by "Little Miss Kookaburra". 6.25: Musical interlude. 6.30: "Little Miss Kookaburra" will tell more about "Nellie and Billie in Moonland."

NIGHT SESSION

Announcer: C. J. O'Connor. Accompanist: Mabel Nelson. 6.50: Stock Exchange information. 7.0: Market reports. 7.10: News session. 7.27: Birthday greetings. 7.30: Out of the past. 7.31. Ed. S. Pescott will speak on "Plants—the Murderer and a Nettle". 7.45: A maker of history. 7.48: Dr. J. A. Leach will speak on "Cuckoo-Shrikes". 8.0: Programme announcement. Tasmanian letter to 3LO from the "Courier", Launceston. 8.5: The Station Orchestra: Overture, "Fingal's Cave" (Mendelssohn). 8.15: Gertrude Gray, mezzo-soprano: "Life and Death" (Coleridge Taylor). "If My Songs Were Only Words" (Hendel). 8.25: The Station Orchestra: Selection, "La Navarraise" (Massenet). 8.30: John Byrne, bass: "Silent Noon", "The Roadside Fire" (Vaughan Williams). 8.37: Guildford Bishop, violin: "Serenata" (Toselli). 8.41: The Radio Melody-makers: Twenty of Melody". 9.2: The Station Orchestra: Selection, "Paul and Virginia" (Masse). 9.12: Courtney Ford, humorist: Request Items. 9.20: Eric Welch will describe the events at the Stadium. 9.35: The Station Orchestra: "Rondo Pastorale" (Bach). 9.40: Jovan Massonoff, tenor: "Kol Nidrie" (Rabiner). "Cello obbligato by Tasma Tieren. From the Opera "Kol Nidrie". 9.50: Jovan Massonoff, tenor: "The Valse" (Chopin). Selected. 9.54: The Station Orchestra: "The Atone ment of Pan" (Handel). 10.0: Eric Welch will describe to-night's events at the Stadium. 10.15: Jovan Massonoff, tenor: "Shema Yisroel" (Rabiner). Cello obbligato by Tasma Tieren. Selected. 10.22: The Station Orchestra: Selection, "A Southern Maid" (Morgan). 10.32: Courtney Ford, humorist: Selections from his repertoire. 10.39: Late sporting. 10.45: The Radio-Aces: "Forever More" (Burnet), "Nebraska" (Revel), "Ramona" (Wayne). 11.1: The Radio-Aces: "I Love to Drink a Hunk of Sponge Cake" (Castili). "Because My Baby Don't Mean Maybe Now" (Donaldson). "Kahn". "Just Like a Melody Out of the Sky" (Donaldson). "Lazy Feet"—Piano solo (Masman). "That's What You Mean to Me" (Davis). Selected. 11.30: God Save the King.

3AR

MORNING NEWS SESSION.

10.0: G.P.O. clock says "Ten." 10.1: "Age" Stock Exchange reports; London metal market. 10.10: "Age" market reports—farm and station produce, fruit, fish, vegetables, etc. 10.25: "Age" shipping reports; ocean forecast. 10.30: Mail notices; express train information. 10.35: "Age" news service. 10.59: Weather forecast.

MORNING MUSICAL SESSION.

11.0: Ned Tyrrell's Radio-Aces—"Just Like a Melody Out of the Sky" (Donaldson). "Because My Baby Don't Mean Maybe Now" (Donaldson). "Guess Who's In Town" (Razay). "My Blackbirds Are Bluebirds Now" (Friend). "Louisiana" (Schafer). 11.20: Beautiful ballads: "I'll Be Right-Oh" (Donaldson). "Lonely In a Crowd" (Greer). "Chloe" (Kahn). "Parting With You" (Conley). "Kiss Before the Dawn" (Perkins). "Angela Mia" (Rappeel). 11.46: Beautiful ballads. 11.50: British official wireless news; rates of exchange, as supplied by Messrs. Thoas Cook and Sons. 12.0: Close down.

AFTERNOON SESSION.

3.0: Coburg City Band (conductor, T. B. Davison)—Waltz, "Waltz Dream" (Strauss) waltz, "Ricordanza". 3.10: Beautiful ballads. 3.18: Coburg City Band—"Ballet Music from Coppelia" (Delibes). 3.26: Beautiful ballads. 3.32: Coburg City Band—Selection, "Princes of Padua". 3.38: Beautiful ballads. 3.48: Announcements. 3.50: Coburg City Band—Fox-trot, "Broken Hearted", "Idyll—The Cuckoo" (Lithgow). 4.0: Beautiful ballads. 4.15: Coburg City Band—Selection, "Songs of the Past". 4.25: Beautiful ballads. 4.31: Coburg City Band—Cornet solo, "Home To Our Mountains", waltz, "Golden Sunbeams". 4.41: Beautiful ballads. 4.48: Coburg City Band—Fantasy, "Rustic Festival", waltz, "Fascination". 4.56: Announcements. 5.0: Close down.

EVENING SESSION.

8.0: Gramophone records. 8.0: All sporting results; announcements.

NIGHT SESSION.

Announcer: Frank Batherley. Accompanist: Reg. Brown. 8.31: Johnston's Studio Boys—March, "Col-

lingwood"; selection, "Comic Opera". 8.45: Diana Belmont, contralto—"A Roundel of Rest" (Cyril Scott). "I Don't Suppose" (Trotter). 8.52: Johnston's Studio Boys—Selection, "Lilac Time". 9.0: The Rev. Frank Gorman, tenor, and raconteur, and Miss Sadie McDonald, violinist—Voice and violin. "Absent"; Sadie McDonald, "Americana"; Frank Gorman (with monologue), "Am Waiting for Ships"; violin and voice, "Just a Tumble-down Shack". 9.15: Johnston's Studio Boys—Waltz, "Angel Mine". 9.25: Diana Belmont, contralto—"You Are My God" (Coetz). "Hindoo Song" (Bemberg). 9.32: Johnston's Studio Boys—Cornet solo, "La Falcata" march, "London Pride". 9.42: Hugh Huxham's Serenaders—"The Serenaders", "Dear Old Songs"; Renn Miller, "Stonecracker John", interlude; solo by one of the Studio Boys; humorous quartette, "Fussy in the Well"; duet, Hugh and Edith Huxham—"That's What I Think of You"; interlude; solo by one of the Studio Boys; quartette, "Castelane". 10.0: Transmission by the Church of England, Eastern Hill—Organ recital by C. E. Montach, "Choral No. 3 in A Minor" (Cesar Franck); "Morning" and "Aase's Death", from "Peer Gynt" suite (Grieg); Minuet from "Samson" (Handel); "Triumphal March" (Lemmens). 10.20: News session—"Age" news service, exclusive to 3AR; results of cricket match, England v. New South Wales, at Sydney; announcements. 10.30: God Save the King.

4QG

EARLY MORNING SESSION.

7.43: Time signal. 7.48: News service. 8.0: Some electric records. 8.15: News service. 8.30: Close down.

MORNING SESSION.

11.0: The complete morning service will be relayed from the Seventh Day Adventist Church, Buranda. 12.15: Close down.

AFTERNOON SESSION.

Race meeting. The race meeting will be described direct from the course. Transmission will commence with the start of the first race. Between races orchestral music will be relayed from the studio. 5.0: Close down.

EARLY EVENING SESSION.

6.30: Bedtime stories, conducted by "Uncle Ben." 7.15: To-day's race results in brief. 7.20: General sporting notes. 7.30: Sailing notes by Mr. Fred Smith.

NIGHT SESSION.

8.0: From the Savoy Theatre. Overture by the Savoy Orchestra. 8.10: From the studio. Hazel Williams (soprano), "The Dance on the Lawn" (Phillips). "Beauty's Eyes" (Tosti). 8.17: The Rio Grande Serenaders, in five minutes' Hawaiian music. 8.23: C. T. Birkbeck (tenor), "The English rose" (German). "My Dreams" (Tosti). 8.31: Hilda Woolmer (pianiste), "Valse Chromatique" (Leschetizky). 8.36: H. Humphries in a character impersonation. 8.42: The Rio Grande Serenaders. Hawaiian music. 8.50: From the Savoy Theatre. Orchestral music. 9.0: From the Speedway. Motor cycle races. 9.30: From Lennon's Ballroom. Dance music. 10.0: From the Studio. "The Sunday Mail" news, weather news. Close down.

5CL

MORNING SESSION.

12.0: G.P.O. chimes. 12.1: Last minute selections for Caulfield races, by Mr. Eric Welch, of 3LO, Melbourne. 12.3: Frank Gorman and Sadie McDonald for Caulfield races. 12.35: 5CL's sporting calendar. 12.35: General news service, British Official wireless news, 12.45: From Gawler Racecourse. Positions and riders for first race. 1.0: Description of Deane Frisco, from Gawler Racecourse, by Mr. Arnold Treloar. 1.5: Close down.

AFTERNOON SESSION.

1.30: Positions and riders, and description of second race, by Mr. Arnold Treloar. 1.45: From the Studio. Sonora. 2.10: Positions and riders, and description of third race, by Mr. Arnold Treloar. 2.25: Close down. 2.50: Positions and riders, and description of fourth race, by Mr. Arnold Treloar. 3.4: A resume of Caulfield racing results. 3.6: Sonora. 3.6: Positions and riders and description of fifth race, by Mr. Arnold Treloar. 3.8: Positions and riders, H.M.V. artists. 4.5: Resume of Caulfield race results. 4.10: Positions and riders for sixth race, and description by Mr. Arnold Treloar. 4.25: Resume of afternoon's sporting information. cricket scores, England v. New South Wales, at Sydney. 4.30: Close down.

EVENING SESSION.

6.0: G.P.O. chimes. 6.1: Resume of late sporting. 6.5: Birthday greetings, correspondence, songs and stories by "The Wattle Lady". 8.0: Parlophone recordings. 7.0: G.P.O. chimes. 7.1: S. C. Ward and Co.'s stock exchange information. 7.8: Cricket scores, England v. New South Wales, at Sydney. 7.10: Rev. G. E. Hale, B.A., talk on "How the Voice is Produced." 7.25: "Willow" will give a resume on South Australian cricket. 7.35: C. G. Riley talk on "Items of Interest." 7.45: 5CL's sporting service.

NIGHT SESSION.

8.0: G.P.O. chimes. 8.1: Boake Smith's Palais Royal Orchestra—"Adore", "Just Like a Melody Out of the Sky", "Cousin", "Victoria". 8.2: Boake Smith's Palais Royal Orchestra—"Poor Wandering One", "Cradle Song" (Schubert). 8.14: Hilda Riemann, violinist, "Adagio" (Ries). "Minuet" (Paderewski). 8.20: Don Fraser, comedian, in a droll humor. 8.25: Boake Smith's Palais Royal Orchestra, "Dream, Sweetheart", "Alabama Stomp", "Og Man Sunshine". 8.34: Bernard Manning, bass-baritone. Selections from his repertoire. 8.40: Jean Pina, pianist, "The Swan" (Palmgren). "Cups in a Sharp Minor". 8.45: Lyris Male Quartet. "A Basket of Chestnuts"; selected. 8.51: Boake Smith's



ELECTROLYTIC CONDENSER—1500 MFD.



The T.C.C. 1500 mfd. Electrolytic Condenser has made it possible for you to build your own "Stedipower" "A" Eliminator, which will operate 2, 4, or 6 volt valves equally well. It is the T.C.C. Condenser which makes the smoothing system which eliminates all ripple.

Build Your Own "Stedipower" "A" Eliminator

and save yourself much trouble and many 4/6's for re-charging. Get Free Booklet, "How to Build Your Own 'Stedipower' 'A' Battery Eliminator."

ALL RADIO DEALERS.

Palais Royal Orchestra. "Rag Doll." "Felix the Cat." "I Can't Do Without You." 9.0: G.P.O. chimes. 9.1: From Mayville Speedway. A description of the speed events by Mr. Walter J. Murphy. 9.15: Boake Smith's Palais Royal Orchestra. "Old-fashioned Locket." "Last Night I Dreamed You Kissed Me." "Girl of My Dreams." 9.23: Victoria Wilson, soprano. "Forgi Amor." "May Night" (Brahms). 9.29: Hilda Riemann, violiniste. "Sonata" (Beethoven). "Largo" (Handel). 9.36: Don Fraser, comedian. Comedy sketches. 9.42: Boake Smith's Palais Royal Orchestra. "Tired Hands." "I Just Roll Along." 9.48: Bernard Manning, bass-baritone. Selections from his repertoire. 9.52: Boake Smith's Palais Royal Orchestra. "You're a Real Sweetheart." "Counting the Days." 9.55: Lyric Male Quartet. "Lucky Jim"; selected. 10.0: From Mayville Speedway. A description of the final speed events by Mr. Walter J. Murphy. 10.20: From the Studio. 5CL's sporting service. 10.30: Modern dance numbers by the Radi-o-Aces. 11.0: God Save the King.

6WF

12 noon: Tune in. 12.5: Musical programme from the studio, including pianoforte solos by Miss Audrey Dean. 12.44: Commercial and general information. 1.0: Time signal. 1.1: Weather bulletin, supplied by the Meteorological Bureau of West Australia. 1.2: Close down. 2.30: Tune in—sporting session, commencing at 2.30 p.m.; racing chickens, and other sporting results will be broadcast each 15 minutes. 5.30 (approx): Close down. 6.45: Tune in. 6.48: Bedtime stories for the kiddies by Uncle Duffy. 7.12: Late sporting results. 7.20: Commercial and general information. 7.45: Talk on music. 8.0: Time signal. 8.1: First weather bulletin, supplied by the Meteorological Bureau of West Australia; relay from Temple Court Cabaret of Merr Lyon's Symphonic Orchestra; vocal items from the studio; Miss Audrey Dean (pianist). 9.0: Late news items, by courtesy of "The Daily News" Newspaper Co.; ships within range announcement; late weather bulletin; station announcements. 10.30: Close down. 104.5-Metre Transmission: Simultaneous broadcast on 104.5 metres of programme given on 1250 metres, commencing at 6.45 p.m.

7ZL

MIDDAY SESSION

11.30 a.m.: Music. 11.34: Midlands weather forecast. 11.35: Music. 11.55: Tasmanian Station's 9 a.m. weather report. 12.0: G.P.O. clock chimes the hour. 12.1: Shipping information, ships within wireless range; mail notices; housewives' guide; commerce news. Railway auction produce sales. 12.3: Music. 11.12: British official wireless news. 12.20: Music. 12.29: Announcements. 12.30: Anticipations—S.I.O. Melbourne, Commissioner's last-minute selections for the Melbourne races; also selections for the Sydney races by our special representative. 12.33: Music. 12.55: Nws service. Railway auction produce sales. 1.10: Music. 1.30: Running description of Warren Hurdle, 2 miles 65 yards, run at Caulfield Racecourse, Melbourne. 1.35: Close down. 2.30: Running description of Federal Stakes, 5 furlongs, Caulfield. 2.35: Close down.

AFTERNOON SESSION.

Speaker: A. M. O'Leary. Announcer: Jack Broadbent. 3.0: G.P.O. clock chimes the hour. 3.1: Music. 3.5: Running description of the Bond Cup, 1 1/2 mile, Caulfield. 3.10: Transmission from the T.O.A. Ground, cricket match, New Town v. Sandy Bay, described by A. M. O'Leary. 3.40: Running description of Onkleigh Plate, 5 1/2 furlongs, Caulfield. 3.45: Cricket match, New Town v. Sandy Bay. 4.15: Running description of St. George's Stakes, 1 mile 1 furlong, Caulfield. 4.20: Cricket match, New Town v. Sandy Bay. 4.50: Running description of Salisbury Welter, 1 mile, Caulfield. 4.55: All sporting results to hand. 5.0: Close down.

EARLY EVENING SESSION

Birthday greetings. "Uncle David." Announcer: Jack Broadbent. 6.9: All sporting results to hand. 6.15: Selections by the Melody Masters. 6.30: "Uncle David" will entertain the woe folk. 7.0: Answers to letters and birthday greetings by "Uncle David." 7.15: News session.

EVENING SESSION

7.30: F. L. Langford, director of the Y.M.C.A., will speak on "Surrounding Influences." 7.45: Mrs. O. Rodway will speak on "Life-Saving and Swimming." 8.0: G.P.O. clock chimes the hour. 8.6: Music. 8.13: Theo Pipkin and his Continental Orchestra. 10.20: News session. 10.50: Close down.

Gilbert and Sullivan Artist at 3LO

JOHN BYRNE, whose fine baritone voice has delighted listeners from 3AR and 3LO, comes from an artistic family, literally steeped in the traditions of Gilbert and Sullivan operas, so it is little wonder that he has scored a personal success in connection with many of the productions during the past few years. It is interesting to recollect that his aunt, Miss Marie St. Claire, was the original "Buttercup," and appeared in the first authentic production staged in Australia in 1879, under the banner of J. C. Williamson. Members of the family have appeared in connection with the production of every Gilbert and Sullivan opera staged in Australia, and Mr. John Byrne himself, as the youngest member of the family, created the role of "G. Adam" in "Ruddigore," thus completing the family association from the first opera in 1879 to the last original production "Ruddigore," in 1927. At the age of fifteen Mr. Byrne was playing roles with the Launceston Operatic Society, was brought to Melbourne by a member of the J. C. Williamson firm, and has more than fulfilled the promise of earlier years.

"FARMER'S THREE"

— DE LUXE CABINET MODEL —

is splendid value at—£20

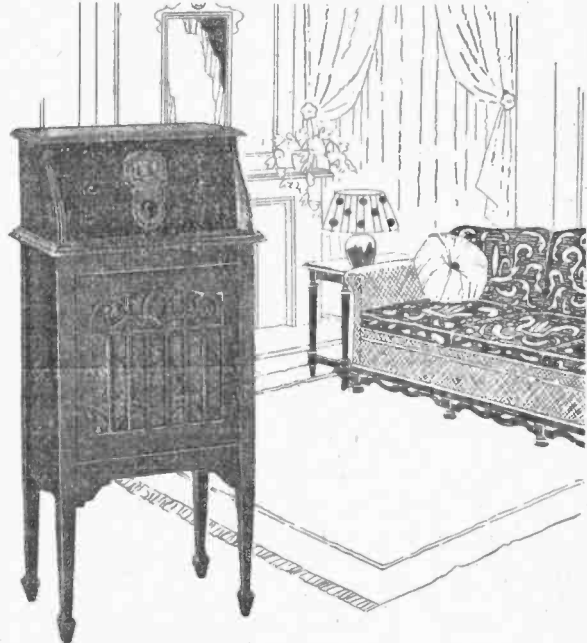

—and perhaps you're wondering why!

For even though the cabinet gives the impression of a £50 receiver it's more than outward show that counts in wireless—of course. And that's the remarkable feature about "Farmer's Three." Surprisingly moderate in price, yet, with nothing skimmed in cabinet work and an advanced design behind the panels. An exclusive design, too, that gives miraculous ease of tuning, a unique sharpness between wave lengths, a beautiful tone, a wide range with ample volume and an unquestionable reliability under all conditions. It's a 100 per cent. efficient receiver—"Farmer's Three." Come and hear it in the—

Wireless Department, First Floor, Market Street

A convenient system of deferred payment will be quoted on request.

FARMER'S

PITT, MARKET AND GEORGE STREETS, SYDNEY

Local Programmes, Sunday, February 17

2FC

MORNING SESSION.

Announcer: A. S. Cochrane.

- 10.0: "Big Ben" and announcements.
 10.2: Studio music.
 10.15: News service.
 10.30: Studio music.
 11.0: From St. Andrew's Cathedral: Morning Service, conducted by A. G. Talbot, Dean of Sydney.

Psalm 51.

Benedicite (Jeffrey).

Anthem, "How Lovely is Thy Dwelling Place" (Brahms).

Hymn 159.

Preacher: Canon Cakebread, Rector, St. Jude's Church, Randwick.

12.15 (approx.): Close down.

AFTERNOON SESSION.

Announcer: John Holland.

- 2.30: Programme announcements.
 2.32: Children's session, conducted by the "Hello Man." Letters and stories. Music and entertainment.
 3.0: Studio music.
 3.30: From the Band Rotunda, Manly Beach: The Manly Band, conducted by J. Pheloung.
 5.0: "Big Ben." Close down.

EVENING SESSION.

Announcer: Laurence Halbert.

- 6.0: "Big Ben" and programme announcements.
 6.5: "The Beauty of Holland," by Francis Jackson.
 8.20: Kathleen Roe, pianoforte solos—
 (a) "The Butterflies" (Couperin),
 (b) "The Bees" (Couperin).
 8.30: Richard Parry, baritone—
 Two songs of the Sea (Harrhy).
 8.37: Kathleen Roe and Wilfrid Thomas, novelty programme, a visit to the Zoo.
 Pianoforte solos—
 (a) "The Cuckoo" (Daglum),
 (b) "The Donkeys" (Crovlez).

Songs—

- (a) "Kangaroo and Dingo" (German),
 (b) "Five Eyes" (Gibbes).
 6.47: Richard Parry, baritone—
 Two Songs of the Welsh Mountains (Williams).
 6.54: Kathleen Roe and Wilfrid Thomas.

novelty programme—

Pianoforte solos—

(a) "The Swan" (Saint-Saens),

(b) "Jumbo's Lullaby" (Debussy),

Songs—

(a) "Lone Dog" (Erliebach),

(b) "The Monkey's Carol (Stanford).

7.15: From the Lyceum, Pitt Street. Evening service, conducted by Rev. H. C. Foreman, M.A.

Choir Master: Mr. V. W. Peterson.

Organist, Miss Constance Bardsley, L.T.C.L.
 Anthem, "The Sun Shall Be No More" (Woodward).

Introit, "Jesu. Stand Among Us."

Invocation.

Hymn 208, "Crown Him, with Many Crowns."

Prayer.

Hymn 106, "Jesu, Lover of My Soul."

Lesson.

Solo, "Gahlee (Adam), Miss Amy Flrth.

Prayer.

Intimations—Offering.

Anthem, "Hear My Prayer" (Mendelssohn).

Soloist, Miss Daisy Tollis.

Hymn 253, "Art Thou Weary?"

Sermon—Rev. H. C. Foreman, M.A., "Why do Men Want Money?"

Hymn 909, "Glory to Thee, My God, This Night."

Benediction and Vesper.

8.30: From the Band Rotunda, Manly Beach: The Manly Band, conducted by J. Pheloung.

9.30: From the Studio: David Craven, baritone.

9.37: Mabel Batchelor, soprano—

(a) "Ave Maria" (Lemnone),

(b) "Isle of Innisfree" (Pennicuck).

9.44: David Craven, baritone.

9.51: Mabel Batchelor, soprano—

(a) "Love's Coronation" (Alward),

(b) "One Spring Morning" (Nevin).

9.58: Programme announcements.

10.0: Record recital.

10.30: National Anthem. Close down.

2BL

Announcer: A. C. C. Stevens.

- 11.0: G.P.O. clock and chimes.
 Morning service, broadcast from Strathfield Presbyterian Church, conducted by Rev. V. C. Bell, B.A.

Hymn.

Prayer.

Hymn.

Scripture.

Solo by Miss Mitchell, "God who made the earth and heaven."

Scripture.

Hymn.

Prayer.

Anthem, "Praise the Lord."

Organ solo, "Ave Maria." Mr. Yatman.

Story for children.

Hymn for children.

Sermon on "What's in a Name?"

Hymn.

Benediction.

12.15: Approx., from the studio, "Sun" news service.

12.30: Studio music.

2.0: G.P.O. clock and chimes. Close down.

AFTERNOON SESSION.

Announcer: Basil Kirke.

- 3.0: G.P.O. clock and chimes. Studio music.
 3.30: From St. John's Church of England, Balmain, organ recital by H. E. Sheppard.

(a) "Polonaise" (Chopin).

(b) "Londonderry Air" (Traditional).

(c) Baritone solo, "Beyond the Dawn" (Sanderson), Mr. S. Butcher.

(d) "Finlandia" (Sibelius).

(e) "Berceuse" (Hanhforth).

4.0: From the studio, studio music.

4.10: From St. John's Church of England, Balmain, organ recital by H. E. Sheppard.
 (a) "March Militaire" (Schubert).

- (b) "Carillons of Dunkirk" (Carter).
 (c) Baritone solo, "The Lord is My Light" (Allitsen), Mr. S. Butcher.
 (d) "A Perfect Day" (Jacobs-Bond).
 (e) "March Triumphant" (Lemmens).
 4.40: From the studio, record recital.
 5.40: Close down.

EVENING SESSION.

Announcer: Basil Kirke.

- 6.0: G.P.O. clock and chimes.
 Children's session, conducted by Uncle Bas.
 6.20: Letters and stories.
 6.30: From Newtown Congregational Church, organ and orchestral recital.
 Organist: Allan Weekley.
 Orchestral leader: Miss Howsen.
 Orchestra, "Sacred Wreath No. 1" (Volti).
 Orchestra, "Sacred Wreath No. 18" (Volti).
 Orchestra, "Sacred Wreath No. 3" (Volti).
 Organ solo, Prelude Op. 80 (Harrington).
 7.0: Evening Service, broadcast from the Newtown Congregational Church.
 Call to worship.
 Doxology.

•Short Prayer.

Gloria (chanted).

Hymn 78, "Father in High Heaven Dwelling."

Scripture lesson.

Healing Prayer.

Solo, Miss Flrth Epping.

Hymn 43, "Look, Ye Saints, the Sight is Glorious."

Message to sick friends.

Announcements. Questions for February.

Offertory anthem, "Sun of My Soul" (Edmund).

Hymn 23, "O Love That Will Not Let Me Go."

Silent Prayer.

Sermon, "The Slinging Sufferer," Rev. Mearns Massie.

Hymn 39, "Pass Me Not."

Benediction.

Retiring, "Lily of the Valley."

8.30: From the studio, Monaco Quartet.

(a) "Il Trovatore" (Verdi).

(b) "Intermezzo" (Bizet).

8.45: Camille Alder, soprano.

8.52: Monaco Quartet.

(a) "Second Romance" (Yours).

(b) "Humoreske" (Dvorak).

9.2: Malsie Barnett, contralto.

(a) "The Old Plagued Path" (Arundak).

(b) "The Smoking Room" (Arundak).

(c) "The Night Nursery" (Arundak).

9.9: Monaco Quartet.

"Blue Mazurka" (Lehar).

9.19: Camille Alder, soprano.

9.26: Monaco Quartet.

Selection on Haydn Wood's popular songs (arr. Higgs).

9.33: Malsie Barnett (contralto).

(a) "Trees" (Rasbach).

(b) "Slumber Song" (MacDowell).

9.40: Studio music.

9.55: Late weather report and announcements.

10.0: National Anthem. Close down.

2GB

10.15: Organ music from St. Alban's Church, Redfern.

10.30: Morning service from St. Alban's Church, Redfern.

12 noon: Close down.

5.30: Children's session, by Uncle George.

6.30: Music from studio, 7.0.

Lecture from St. Alban's Church, Redfern, "Heaven," by the Rt. Rev. C. W. Leadbeater.

8.0: Music, from studio.

8.15: Concert from Adyar Hall. Songs by Mr. Robert Scott.

8.22: Songs by Miss Heather Kinnaird.

8.45: Songs by Mr. Clement Hosking.

8.52: Songs by Mr. Robert Scott.

8.59: Violin solos by Mr. Cecil Berry.

9.7: Songs by Miss Heather Kinnaird.

9.15: Songs by Mr. Clement Hosking.

9.22: Songs by Miss Nancy Watkin.

9.30: Close down.

2UW

10.30: Music. 1.0: Close down.

5.30: Children's hour, conducted by Uncle Jack.

6.30: Close down.

7.0: Musical programme. 10.0: Close down.

Reliable Fixed Condensers

for your electric sets
where reliability
is essential.

DOUBLE TESTED
700, 1000, 1500, 2000
4000 Volts.

All leading wholesalers
stock them.

Manufacturers' Representatives

H. HECHT & CO.

181 Clarence St., Sydney

WHOLESALE ONLY.

(Also at Melbourne.)

'Phone: MA 2892.

YOUR RADIO DEALER WILL NOW SELL YOU

A B405 FOR 15¢



**THE B405 IS THE
POWER VALVE
FOR YOUR RADIO**

If you have not a Power Valve in the last stage socket of your radio surely only the extra cost must have held you back. Now, however, the mightiest of Philips four-volt power valves, the B405, has been reduced to 15¢. This wonder tube will give you music as it SHOULD be heard, for it is designed to handle volume—without distortion—without effort.

Your nearest radio dealer sells Philips Valves.

**THE B405—THE TUBE WITH THE SHEER
SLOPE OF 2.4**

PHILIPS



Interstate Programmes, Sun., Feb. 17

Before Cock Crow

Ever run your car in cool misty air? It doubles its pep and halves its age.

Early morning air has just the same effect on human engines, provided, of course, that their fuel mixture has not too much alcohol in it causing the well-known "morning after" feeling.

From 1 a.m. to 6 a.m. the world is full of good fellows. Everyone you meet exclaims, "Good Morning," "Rotten Weather," etc. Speak cheerily to the same genial souls when the sun is up and they will sniff audibly and remark in passing, "Shot again!"

No one need be lonely at one o'clock in the morning. Even the policemen on the beat will lend you a match and tell you a new cure for stomach trouble.

If only we could carry that cock-crow camaraderie through the rest of the day, the whole world would bask in the Garden of Eden stage before the snake began the slogan "Eat More Fruit" and Eve told Adam she had nothing to wear.

Alas, the only certain restorative of pre-Fall days is a New System radio set, powered by the famous Burgess batteries. Never since Burgess first made batteries have they been in such delightful company.

If you doubt me, just drop in at 280 Castlereagh Street, Sydney, and listen to the new Duophase Six with Burgess batteries in its soul! Truly our New System friends have come closer to the one o'clock feeling than anything ever invented.

3LO

MORNING SESSION.

Announcer: C. J. O'Connor. 10.30: Bells from St. Paul's Cathedral. 10.45: Express train information; British official wireless news (from Rugby); news from yesterday's papers. 11.0: Morning paper from the independent Church, Collins Street, Melbourne; preacher, Rev. Fenryn Evans.—Hymn, prayer, Lord's Prayer (chaned), scripture lesson, hymn, prayer, anthem, notices, obituary, hymn, sermon, Rev. Fenryn Evans; hymn, Benediction. 12.15: Close down.

AFTERNOON SESSION.

Announcer: C. J. O'Connor. 2.0: Sonora recital of the world's most famous records. 3.0: Plesasant Sunday afternoon, from the Central Mission, Wesley Church; chairman, Rev. J. H. Cain. (1) Orchestral, "Don Juan," tone poem (R. Strauss, Op. 20), Parts 1, 2, 3, and 4. The Royal Philharmonic Orchestra, conducted by Bruno Walter. (2) Chorus, "Paris the Heart" (Spohr), soprano solo (Helen Talbot), Sheffield Choir, conducted by Sir Henry Coward; (3) Violoncello solo, "Berceuse de Jocelyna" (Godard), Barbara Maurel, mezzo-soprano; (5) Orchestral, "The Gipsy Baron," Parts 1 and 2 (Johann Strauss), John Strauss and Symphony Orchestra; (6) Song, "Sittin' Thinkin'" (The Old Shepherd's Song) (Tempest and Fisher), Malcolm McEachern; (7) "Il Bagio"—The Kiss (sung in Italian) (Arditi), Maria Kurenko, soprano; (8) Orchestral, (a) "Damnation of Faust," Bakovic; (b) "Marche Macabre" (Berlioz), The Helle Orchestra, conducted by Sir Hamilton Harty. Hymn, No. 25, "I Am Thine, O Lord"; prayer, orchestral selection, Mr. G. M. Williams, conductor; hymn, No. 31, "There's Not a Friend Like the Lowly Jesus"; solo, Mr. Percy Blundell; orchestra; solo, Mr. Percy Blundell; notices, offering, orchestra; address, The Hon. J. Gunn (Ministerial Commission) "The Development of the Commonwealth"; National Anthem; Benediction; orchestra. 4.30: Close down.

EVENING SESSION.

5.45: Shipping information. 6.0: Answers to letters and birthday greetings, by "Plain Peter." 6.25: "Brother Bill" will tell you about "Laugh and the World Laughs With You." 6.45: Adult birthday greetings and programme announcements. 6.47: Bells from St. Paul's Cathedral.

NIGHT SESSION.

Announcer: C. J. O'Connor. 8.30: The Strad Trio—The Serenade Suite; March—Menuetto, Adagio—Polacco. Variations (Beethoven). 8.48: Herbert Browne, tenor (by permission of J. C. Williamson, Ltd.), selections from his repertoire. 8.55: Cecil Parkes and May Broderick, violin and piano, "Sonata Op. 30, No. 2, in C Minor," Allegro con brio, Adagio Cantabile (continued). 9.5: Madame Gregor Wood, contralto, "The Holy Child" (Marta), "The Snowdrop" (Croxtan). 9.15: Cecil Parkes and May Broderick, violin and piano—"Sonata Op. 30, No. 2, in C Minor," Scherzo, Finale (concluded) (Beethoven). 9.24: Herbert Browne, tenor—Selections from his repertoire. 9.31: The Strad Trio—Menuetto, in E Flat. Andante, Menuetto from Septet (Beethoven). 9.40: Madame Gregor Wood, contralto—"Sunday" (Carew), "Love and Sleep" (Garabogi). 9.47: News session, announcements. 10.0: Close down.

3AR

Announcer: Maurice Dudley. 11.0: Morning service from Scots' Church, Collins Street, Melbourne. Psalm 77, "Lord, I have called." Psalm 152. Prayer. Prose Psalm 32, "Blessed is whose transgression is forgiven." Old Testament lesson, Malac. 6.1-8. Hymn, "God, Thou art my God alone." (Benedict). Bible Meditation, New Testament, Song 1, Cor. 13. Anthem, "The Lord's Prayer." Sermon, "The Simple Life," II. Cor. 11-3. Prayer. Imitations. Offering. Hymn 22, "The Lord's Prayer." "The Blessing of Mankind." Benediction. 12.10: British Official Wireless news. 12.15: Close down.

AFTERNOON SESSION.

Announcer: Maurice Dudley. 3.0: A Bravura of Beautiful Ballads and Orchestral Chef d'Ouvre, Royal Albert Hall Orchestra, cond. Eugene Goossens, "Concerto No. 5" (Beethoven). Evan Williams, tenor; "Then shall the righteous shine forth," from the "Elijah" (Mendelssohn). H.M. Coldstream Guards Band: "Evening Hymn" and "Last Post"; "The Moon hath raised" from the "Lily of Killarney" (Benedict). Percy Grainger, pianoforte, "Song in F Minor," Op. 5 (Brahms). The Don Cossack Choir, cond. Serge Jaroff, "Platoff's Song" (an old Cossack Song). "Waise thee, O Lord" (Tschalkowsky). Evan Williams, tenor, "O Holy Night" (Adolphe Adam). The Black Diamonds, English band "Hunting Scene" (Bucalossi), "Turkish Patrol" (Michaels). Enrico Caruso, tenor, "O Holy Night" (Adolphe Adam). "Avei a mc tu dato" (Carmen) (Bizet); "O Paradiso Dall'onde Uscito" (L'Africana), (Meyerbeer); Sir Henry J. Wood and the New Queen's Hall Orchestra: "Prelude in C sharp minor" (Bach); "Introduction Act 3 (Lohegrin), (Wagner). Theodor Oballapin, bass: "Farewell of Boris" (Moussorgsky), "Death of Boris" (Moussorgsky). Mischa Elman, violin; "Melodie" (Grieg) and "Euridice" (Chabzy); "Prize Song," Meistersinger (Wagner). Enrico Caruso, tenor: "Ah, Mon Sort," "Nero" (Rubenstein); "Serenade in A," Eugen Yeghin (Tschalkowsky). St. Mary le Bow Church, Chesapeake, London, Organ. J. Edgar Humphreys. "Litany" (Schubert). 4.30: Close down.

EVENING SESSION.

5.0: Brer Rabbit. Stories for the children. 5.30: Close down.

NIGHT SESSION.

Announcer: Maurice Dudley. Accompanist: Vera Howe. 7.0: A Special Recital of the works of the Master Musicians. The London Symphony Orchestra, Cond., Sir Thomas Beecham. "Symphony in D," No. 2 (Beethoven). Singing Choir, "Results of the 'Ave Maria.'" Ben Davies, tenor, "The May Night"

(Brahms), "In Summer Fields" (Brahms). London Symphony Orchestra. Cond., G. Schmeivoght. "Norwegian Dances" (Grieg). The Royal Philharmonic Orchestra, Cond., Felix Weingartner. "Symphony, No. 5 in C Minor" (Beethoven). Tudor Davies, tenor: "Yes, Let Me Like a Soldier Fall" (Maritana), (Wallace). "Spirit so Fair" (La Vavortta) (Donizetti). 6.0: Brunswick City Band. Serenade, "A Night in June" (by request); march, "The Rover," 8.10: Syd. Eaton, tenor: "The Living God" (O'Hara); "The Okei," a Christmas Legend (Fell). 8.17: Special presentation of songs from "Romeo and Juliet." Produced by Stephanie Deste. Cast: Herbert Brown, Ben Lewin, Stephanie Deste. 8.37: Brunswick City Band: Overture, "Romeo and Juliet." 8.47: Mary King, soprano: "The Wind's in the South To-day" (Sprou). "Dace While the World is Young" (Oliver). 8.51: A. S. Kenyon, the Ethnology of the Australian aboriginals, "Australia's Duty and Obligation." 9.10: Brunswick City Band: Cornet solo, "The Nightingale" (soloist, A. M'Ewen). Hymn, "Rock of Ages." 9.20: Syd. Eaton, tenor: "Just as I Am" (Hymn), "Christ, a Ponder" (Stephens). 9.27: Brunswick City Band: Selection, "Fra Diavolo." 9.37: Mary King, soprano: "Bird with the Broken Wing" (Golson). "June is in my Heart" (Vaughan). 9.54: News service. God Save the King.

4QC

MORNING SESSION.

11.0: The complete morning service will be relayed from St. Barnabas' Church of England. First Sunday in Lent. Holy Eucharist according to the Book of Common Prayer. Introit, hymn 84, "Once More the Solemn Season Calls"; Epistle 2, Corinthians, Chap. 6 to verse 10; Gradual, hymn 99, "Jesus, Our Lenten Fast of our Heart"; Gospel, "Just as I Am" (Hymn); sermon by Canon Garland; Offertory, solo, Mr. G. W. Ashlin; Communion, hymn 285, "Just as I Am"; Ablutions, hymn 107, "Glory Be To Jesus."

AFTERNOON SESSION.

3.15: The concert provided by the Brisbane Citizens' Band will be relayed from the Botanic Gardens. 4.30: Close down.

EARLY EVENING SESSION.

6.30: Greetings from little listeners and replies to letters.

NIGHT SESSION.

7.0: The complete evening service will be relayed from St. Barnabas' Church of England. Children's session. Hymns: 334, "Loving Shepherd of Thy Sheep"; 409, "Do No Sinners' Actions"; 352, "There is a Green Hill." Lesson, St. Luke, Chap. 4 to verse 13. Catechising of children by Canon Garland. 7.30: Evening song according to the Book of Common Prayer. Hymn 94, "Lord, in This Thy Mercy's Day"; Psalm 51; Lessons, Genesis, Chapt. 22 to verse 19, St. Mark's Chap. 14 to verse 26; hymn 92, "Forty Days and Forty Nights"; Litany of the Passion in Hymn Book, No. 467, solo; "There is a Green Hill" (Gounod). Miss E. Honnibal; sermon by Canon Garland; hymn 108, "When I Survey the Wondrous Cross"; Hymn Book at all services, "Ancient and Modern." At the conclusion of the church service the concert by the Brisbane Municipal Concert Band will be relayed from Wickham Park. 9.30: Close down.

5CL

MORNING SESSION.

10.45: Carillon of bells from the Adelaide Town Hall. 11.0: G.P.O. chimes. Divine service from Maughan Methodist Church. Preacher, Rev. W. H. Cann. 12.15: British official wireless news. 12.30: Close down.

AFTERNOON SESSION.

3.0: G.P.O. chimes. 4.15: Pleasant Sunday afternoon concert from Maughan Methodist Church, Franklin Street, Adelaide. Preacher, Rev. W. H. Cann. 4.0: G.P.O. chimes and close down.

EVENING SESSION.

6.0: G.P.O. chimes. 6.5: Railway information. 6.2: Birthday greetings, correspondence, songs and stories by "Miss Wireless." 6.30: A choral and story interlude by "The Lord Lady" and the Junior Choir. 7.0: G.P.O. chimes. 7.1: A religious service from Rose Park Congregational Church. Preacher, Rev. H. Watts Grimmett. In response to the Prime Minister's request, this Sunday is to be observed as "Industrial Sunday" in connection with the Australian Industrial Conference. 8.25: From the studio, orchestral descriptive and vocal concert, "Scenes from Hiawatha," by Samuel Coleridge-Taylor. Orchestral, "The Wooding," "Bird Music" (Coleridge-Taylor), Station Orchestra. Descriptive, orchestral and vocal, "The Wedding Feast" (Longfellow). Recital of songs by "Mourning" ballet music by Station Orchestra; lyric (tenor). "The Beloved," by Fred Williamson. Fred Williamson, tenor, "Life and Death" (Coleridge-Taylor). Station Orchestra, "Three Dream Dances" (Coleridge-Taylor). 5CL Choir (S.A.T.B.), "The King, pianist, "Scenes from Imagination" (Grieg). P. H. Nicholls, talk on "The Human Body." 10.0: G.P.O. chimes and "God Save the King."

6WF

10.25 a.m.: Tune in. 10.30: A special half-hour for the enthusiastic listener-in. 11.0: A relay of morning service from the Lake Street Church of Christ. 12.15: Close down. 3.30: Tune in. 3.35: Musical program from the main studio. 4.30: Close down. 7.5: Bedtime stories. Awake Close down. 7.0: Tune in. 7.30: Evening service relayed from St. George's Cathedral. 8.45: Band concert by the Perth City Band conducted by Mr. Les Price relayed from Government Gardens. Perth. 10.0: Close down. 104.5-Metre Transmission: Simultaneous broadcast on 104.5 metre of programme given on 1250 metres, commencing at 7.0 p.m.

AT LAST THE ASTOR SIX

A SHIELDED SIX VALVE RECEIVER GIVING AMAZING PERFORMANCE

FEATURES

ABSOLUTELY ONE CONTROL,
FOUR TUNED STAGES,
INDIVIDUALLY SHIELDED COMPONENTS
SPECIAL LAST STAGE POWER TRANSFORMER,
ALL METAL CHASSIS,
ELECTRIC "PICK-UP" CONNECTION,
SUPERB TONAL QUALITY,
AMAZING SELECTIVITY,
INTERSTATE RECEPTION GUARANTEED,
TOTAL FILAMENT CONSUMPTION, .4 AMPERES
ALL AUSTRALIAN MANUFACTURE.

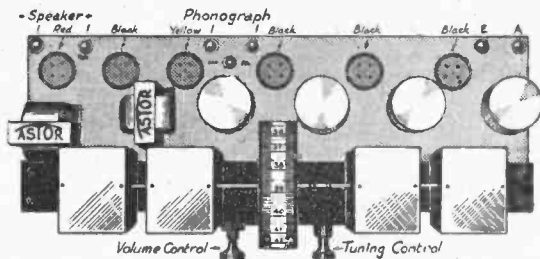

View of Chassis

	INSTRUMENT ONLY	COMPLETE
TABLE MODEL	£31/0/0	£46/10/0
CONSOLE MODEL	36/0/0	51/10/0

EASY TERMS, DEPOSIT FROM 95/-

DEALERS—WRITE FOR FULL PARTICULARS

AMPLION (Australasia) Ltd.

BRADBURY HOUSE, 53 YORK ST., SYDNEY

Please forward me full particulars of the
ASTOR SIX
NAME _____
ADDRESS _____

Local Programmes, Monday, February 18

2FC

Monday, February 18

EARLY MORNING SESSION

Announcer: A. S. Cochrane.

7.0: "Big Ben" and announcements. 7.3: Official weather forecast; rainfall, river reports; temperatures; astronomical memoranda. 7.7: "Sydney Morning Herald" summary. 7.13: Shipping intelligence; mail services. 7.15: Studio music. 7.25: Investment market; mining share markets; metal quotations; wool sales; breadstuffs markets; inter-State markets; produce markets. 7.40: Studio music. 8.0: "Big Ben"; close down.

MORNING SESSION

Announcer: A. S. Cochrane.

10.0: "Big Ben" and announcements. 10.2: Pianoforte selection. 10.10: "Sydney Morning Herald" news service. 10.25: Studio music. 10.30: A talk by the 2FC Racing Commissioner. 10.45: A talk on "Home Cooking and Recipes" by Miss Ruth Furst. 11.0: "Big Ben"; A.P.A. and Reuter's cable services. 11.5: Close down.

MIDDAY SESSION

Announcer: A. S. Cochrane.

12.0: "Big Ben"; from the Sydney Cricket Ground, England v. New South Wales. 1.30: From the studio, Stock Exchange, second call. 1.32: Official weather forecast; rainfall. 1.34: Rugby wireless news. 1.37: "Evening News" midday news service; Producers' Distributing Society's report. 2.0: "Big Ben"; close down. Note: Description of the cricket match from the Sydney Cricket Ground will be continued through 2BL.

AFTERNOON SESSION

Announcer: Laurence Halbert.

Accompanist: Ewart Chapple.
2.30: Programme announcements. 2.32: Educational session for the schools—a short musical recital; a reading. 3.0: Pianoforte reproduction. 3.15: Millie Outten, contralto—(a) "O, Dry Those Tears" (Del Riego), (b) "The Temple Bells" (Hope). 3.22: Popular music. 3.30: Enid D'Arcy, soprano—(a) "The Magic Month of May" (Newton), (b) "We'll Know We'll Understand" (Henry). 3.37: Studio music. 3.45: A reading. 4.0: "Big Ben"; Millie Outten, contralto—(a) "Soul of Mine" (Barns), (a) "A Castilian Lament" (Del Riego). 4.7: Enid D'Arcy, soprano—(a) "Boat Song" (Ware), (a) "Good Morning, Brother Sunshine" (Lehmann). 4.15: From the Sydney Cricket Ground, description of the cricket match, England v. New South Wales. 5.40: Close down. Note: Cricket descriptions will be given through 2BL service until 6.0.

EARLY EVENING SESSION

Announcer: A. S. Cochrane.

5.40: The chimes of 2FC. 5.45: The children's session, conducted by the "Hello Man"; letters and stories; music and entertainment—Edith Harry, pianoforte and vocal—(a) Selections from "Ten Little Verses for Children" (Harry), (b) Selections from "More Children's Songs" (Harry), (c) "The King's Breakfast" (Harry), (d) pianoforte solo, "Butterfly Dance" (Harry). 6.30: Delgaty's market reports (wool, wheat, and stock). 6.40: Fruit and vegetable markets. 6.43: Stock Exchange information. 6.45: Weather and shipping news. 6.48: Rugby wireless news. 6.50: Late sporting news. 7.0: "Big Ben"; late news service. 7.10: The 2FC Dinner Quartette, conducted by Horace Keats—(a) "Folly Dance" (Haines), (b) "Chant Sans Paroles" (Tschalkowsky), (c) "Ballet Russe" (Luigini), (d) "Abandonnee" (Franceschi), (e) "The Fiddler of June" (Elliot), (f) "Nicolette" (Connelly).

EVENING SESSION

Announcer: Laurence Halbert.

Accompanist: Ewart Chapple.
7.40: Pianoforte reproduction.
7.45: Programme announcements.

7.48: Impressions on the cricket by M. A. Noble.

Popular music.

8.0: "Big Ben"; Light Music Four—
(a) "Spanish Gipsy Dance" (Mowbray).
(b) "Valse Triste" (Sibelius).
(c) "Celebrated Canzonetta" (Mendelssohn).
8.15: Rita Lancaster's Choir.
8.25: Edith Harry, pianoforte recital and songs. Pianoforte solos—
(a) "Refrain de Berceau" (Palmgren).
(b) "Polonaise in A" (Chopin).

Songs—

(a) "Mary Magdalene" (Harry).
(b) "Roses for the King" (Harry).
8.35: Victor Evans, baritone.
(a) "Hindoo Song" (Bemberg).
(b) "Molly O'Donegal" (Austin).
8.42: Light Music Four—
(a) "Les Phéniciennes" (Massenet).
(b) "Samson et Dalila" (Saint-Saens).
8.57: Tales of a traveller, told by Rev. F. H. Raywood.

9.12: Weather report.
9.13: Rita Lancaster's Choir.
9.23: Light Music Four—
(a) "St. Anthony" (Somerville).
(b) "Barcarolle" (Rubinstein).
9.33: Victor Evans, baritone—
(a) "Drink to me only with Thine Eyes" (Old English).
(b) "Believe Me if All Those Endearing Young Charms" (Old Irish).
9.40: Edith Harry, pianoforte and vocal recital. Pianoforte—
(a) "Nocturne in F Sharp" (Chopin).
(b) "Waltz in E Minor" (Chopin).

Songs—

(a) "Friendship" (Harry).
(b) "Golden Wattle" (Harry).
9.50: Rita Lancaster's Choir.
10.0: G.P.O. chimes; Light Music Four—
"Fatima" (Friedman).
Selected.
10.27: To-morrow's programme.
10.30: National Anthem. Close down.

2BL

Monday, February 18

MORNING SESSION.

Announcer: A. C. C. Stevens.

8.0: G.P.O. clock and chimes. Metropolitan weather report. 8.1: State weather report. 8.2: Studio music. 8.15: G.P.O. chimes. News from the "Daily Telegraph Pictorial." 8.30: G.P.O. chimes. News service continued. 8.40: Information; mails; shipping, arrivals, departures, and sailings. 8.45: Studio music. 9.15: Half an hour with silent friends. 9.45: Studio Music. 10.0: G.P.O. chimes. Close down.

MIDDAY SESSION.

Announcer: A. C. C. Stevens.

11.0: G.P.O. clock and chimes. 2BL Women's Sports Association session, conducted by Gwen Varley. 11.30: Advertising hints. 11.40: Women's session, conducted by Mrs. Cranfield. 12.0: G.P.O. clock and chimes. Special ocean forecast and weather report. 12.3: Studio music. 12.30: Shipping and mails. 12.35: Market reports. 12.45: Cricket scores, England v. Tasmania, played at Hobart. 12.48: "Sun" midday news service. 1.0: Studio music. 1.30: Impressions on cricket, by M. A. Noble. 1.35: Talk to children and special entertainment for children in hospital. 1.57: Cricket scores. 2.0: G.P.O. clock and chimes. Close down.

Note:—Race results will be broadcast, by courtesy of "Sun" Newspapers.

AFTERNOON SESSION.

Announcer: A. C. C. Stevens.
Accompanist: Kathleen Roe.

2.15: From the Sydney Cricket Ground, description of the match, England v. New South Wales. 4.0: Impressions on the cricket, by M. A. Noble. 4.5: From the studio, popular music. 4.15: Talk by Captain Fred Aarons, "Sir Christopher Wren." 4.30: Irene Duncan, soprano—(a) "Life's Summertime" (Benyon), (b) "Hallowed Hour" (Wood). 4.37: "Sun" news service. 4.40: Romano's Cafe Dance Orchestra, conducted by Bennie Abra-

hams. 4.50: From the studio, Ireen Duncan, soprano—(a) "O for Wings of a Swallow" (Lohr), (b) "Turn Ye to Me" (North). 4.57: "Sun" news service. 5.0: Our serial story. 5.10: Pianoforte reproduction. 5.25: Popular music. 5.35: Complete racing resume. 5.37: Features of the evening's programme.

EARLY EVENING SESSION.

Announcer: Basil Kirke.

5.40: Children's session, conducted by Uncle Bas. Music and entertainment. Letters and stories. 6.30: "Sun" news and late sporting. 6.40: 2BL Dinner Quartette—(a) "The Dream Girl" (Finck), (b) "Some Day, Somewhere" (Rapee), (c) "Aida" (Verdi), (d) "At Dawning" (Cadman), (e) "Farewell, My Love" (Lehar). 7.7: Australian Mercantile Land and Finance Co.'s report. Weather report and forecast by courtesy of Govt. Meteorologist. Producers' Distributing Society's fruit and vegetable market report. Grain and fodder report ("Sun"). Dairy produce report ("Sun"). 7.25: Mr. Pim and Miss Pam in advertising talks and nonsense. 7.55: Programme and other announcements.

EVENING SESSION.

Announcer: Basil Kirke.

Accompanist: G. Vern Barnett.

8.0: From the King's Cross Theatre, the King's Cross Theatre Orchestra, conducted by E. J. Roberts.

FROM THE STUDIO:

8.20: Charles Lawrence, entertainer.
8.30: The Savoyans' Dance Band.
8.42: Grace Quine, popular vocalist.
8.49: Foster and Finlay, instrumentalists.
8.57: Sydney Butcher, baritone.
9.4: Weather report.
9.12: The Savoyans' Dance Band.
9.24: Charles Lawrence, entertainer.
9.34: Foster and Finlay, instrumentalists.
9.42: Grace Quine, popular vocalist.
9.49: The Savoyans' Dance Band.
10.1: Sydney Butcher, baritone.
10.8: From the King's Cross Theatre, Joseph Wayne, at the Wurlitzer organ.
10.28: From the studio, late weather and announcements.
10.32: The Savoyans' Dance Band.
10.57: To-morrow's programme.
10.58: The Savoyans' Dance Band.
11.30: National Anthem. Close down.

2GB

10.0: Music. 10.10: Happiness talk by A. E. Bennett. 10.20: Music. 10.30: Women's session, by Helen J. Beegling. 11.30: Close down. 2.0: Music. 2.5: Women's radio service, by Mrs. Dorothy Jordan. 2.50: Music. 3.15: Close down. 5.30: Children's session, by Uncle George. 7.0: Stock and market reports, by New Zealand Loan and Mercantile Agency, Ltd. 7.15: Music. 8.0: Songs by Mr. Leslie Herford. 8.10: Cornet solos by Mr. Phil Couchman. 8.20: Mr. Jack Win and Miss Nora Windie, in original selections from their repertoire. 8.30: Orchestral music. 8.40: Songs by Miss Dorothy Topplin. 8.50: Pianoforte solos by Miss Mavis Tindale. 9.0: Weather report. 9.3: Address by F. Houstone, B.A. 9.15: Songs by Mr. Leslie Herford. 9.25: Instrumental music. 9.35: A humorous interlude by Mr. Jack Win and Mr. Heath Burdock. 9.40: Cornet solos by Mr. Phil Couchman. 9.50: Mr. Jack Win and Miss Nora Windie. 10.0: Songs by Miss Dorothy Topplin. 10.10: Orchestral music. 10.30: Close down.

2UW

MIDDAY SESSION.

12.30: Music. 1.0: G.P.O. clock and chimes. Music. 2.30: Close down. 4.30: Musical programme

EVENING SESSION.

5.30: Children's hour, conducted by Uncle Jack. 6.30: Close down. 7.0: G.P.O. clock and chimes. Music. 8.0: To-day's anniversary. Music. 9.0: G.P.O. clock and chimes. Comments on foreign affairs, by Mr. J. M. Prentice. 9.10: Music and request numbers. 10.0: Close down.

Improve Your Radio Reception!

THESE ACCESSORIES INSURE PERFECTION

*Terms can be arranged if preferred.
Small Deposit. Easy Instalments.*



BRITISH MADE FERRANTI TRANSFORMERS

A.F.3.

(As illustrated.)

Uniform amplification from 100 cycles upwards. Over 80 per cent. amplification at 50 cycles.

PRICE 45/-

A.F.4.

Uniform amplification from 300 cycles upwards. 50 per cent. of maximum amplification. Over at 50 cycles.

PRICE 34/-

A.F.5.

Uniform amplification from 100 cycles upwards. Over 90 per cent. amplification at 50 cycles. One can almost say uniform amplification from 50 cycles upwards.

PRICE 57/-

THE FERRANTI BRITISH MADE PERMANENT TRICKLE CHARGER

For charging accumulators at home from the Alternating Current Mains. Suitable for use on voltages from 200 to 250 and 40 to 60 cycles.

OUTPUT: The Charger will supply 2 ampere continuously to 2 volt, 4 volt, or 6 volt cells.

The FERRANTI Trickle Charger consists of a step-down Transformer designed for operation from Alternating Current Mains having any voltage from 200 to 250, and frequencies from 40 to 60 cycles, feeding a Westinghouse patent metal rectifier. The Unit is silent in operation, and will last indefinitely. The Charger is simple and safe.

Dimensions: 7½ in. x 4½ in. x 4 in.

PRICE £4/15/-

THE FERRANTI BRITISH MADE TRUE EXPONENTIAL SPEAKER

The Ferranti Speaker is capable of giving good reproduction from any ordinary set.

It consists of a tone conduit of true exponential shape, suitably mounted, and connected to a FERRANTI Speaker Unit. The Unit, which has been carefully designed, has a large and flexible diaphragm, capable of good response to a wide range of frequencies. The shape of the sound box in conjunction with the tone conduit is such that there is no objectionable resonance

PRICE £5/5/-

OPEN UNTIL 9 p.m. FRIDAY

HOME RECREATIONS (Australia) LTD.
388 George Street, Opp. Beard Watson's, Sydney

Interstate Programmes, Monday, February 18

3LO

EARLY MORNING SESSION.

7.15 to 8.15: See Friday.

MORNING SESSION.

Announcer: Frank Hatherley. 11.0: 3LO's Different Dainties for the daily dinner; to-day's radio recipe—Sweet omelette. 11.8: Olga Parker—'What some famous' poets have written for children—'Shakespeare.' 11.20: Musical interlude. 11.25: Under the auspices of the St. John's Ambulance Society, Miss Edith Wells will speak on 'Home Nursing.' 11.40: Musical interlude. 11.45: Under the auspices of the Safety Council of Victoria, H. J. Book will speak on 'Some Aspects of Safety.'

MIDDAY NEWS SESSION.

12.0: Melbourne Observatory time signal; express train information. 12.1: British official wireless news from Rugby; Reuter's and the Australian Press Association cables; 'Argus' news service. 12.15: Newmarket stock sales; entries for the market for Tuesday, Wednesday and Thursday by the Associated Stock and Station Agents, Bourke Street, Melbourne. 12.20: Community singing, transmitted from the King's Theatre, Russell Street, Melbourne, conductor, G. J. MacKay; G. J. Crane, baritone (by permission, J. C. Williamson, Ltd.), 'The Ne-er Do Well,' 'Side by Side.' 12.40: Stock Exchange information. 12.43: Community singing, continued; Colin Crane, baritone, 'Jogging Along the Highway,' 'On the Road.' 1.45: Meteorological information; weather forecast for Victoria, South Australia, Tasmania, and New South Wales; ocean forecast; river reports; rainfall. 1.52: Close down.

AFTERNOON SESSION.

Announcer: Frank Hatherley. Accompanist: Mabel Nelson. 2.15: The Strat Trio (Cecil Parkes, violin; May Broderick, piano; and Frank Johnstone, 'cello) 'Trio, C Minor' (Lavater). Variations—Allegretto Scherzando, Andante—Allegro Moderato, 2.30: Jovan Massonoff, tenor—'La Donna e Mobile' (Verdi), 'Love is Mine' (Gartner). 2.37: Cecil Parkes, violin—'Ave Maria' (Schubert), 'Rosamunde Ballet Music' (Schubert); 'Gossavotte' (Goblin Dance' (Bazzini). 2.49: John Byrne, bass—'Had a Horse,' 'Long Ago.' Hungarian folk songs (Korbay). 2.58: May Broderick, piano—'Etude Op. 10, No. 2' (Chopin), 'Revolutionary Study' (Chopin). 3.3: The Strat Trio—'Songs Without Words' (Mendelssohn), 'The Blue Lagoon' (Millocker-Parkes), 'Scherzo' (Gade). 3.12: One-act play, 'Kiddie,' by Billy Wyford; William Vane, G. S. Cockerill; Helen Vane, Alice Best. Scene: A sitting-room in a railway hotel at Southampton—plugs of luggage, gun-cases, etc., scattered about; Vane dis-

covered, in his shirt sleeves, throwing things into a suit-case. 3.27: Huxham's Serenaders Quartette—'The Quartette, 'Mary Ann'; Madeline Knight (contralto), 'Homings'; orchestral interlude. The Quartette, 'Gaird's Walk, As You Can'; orchestral interlude; the Quartette, 'Inflammatus,' from 'Stabat Mater.' 3.37: The Station Orchestra—'Overture, 'Martiana' (Wallace). 4.7: Jovan Massonoff, tenor—'Damsels of Long Ago' (Caruso). 'My Little Irish Cottage' (Summers). 4.14: The Station Orchestra—'Chant de l'Alouette' (Tschakovsky), 'Indoue' (Friml). 4.20: Rev. Frank Gorman, baritone, and Sadie McDonald, violinist—'Poem Hongrois' (Laderer), 'A Russian Lullaby' (Berlin); patter: 'I Told Them All About You' (Friend). 4.34: The Station Orchestra—Selection, 'The Rainbow' (Gershwin). 4.45: John Byrne, bass—'Kashmiri Song' (Flinden), 'Simon the Cellarer' (Old English). 4.52: The Station Orchestra—Selection, 'Zion' (Phlips). 5.11: News service. Clock Exchange information. 5.10: Acceptance and New South Wales for the Moonee Valley races, to be held on Wednesday. 5.15: Close down. Progress scores of the cricket match, England v. New South Wales, will be broadcast as they come to hand.

EVENING SESSION.

Announcer: Maurice Dudley. 8.0: Answers to letters and birthday greetings by 'Billy Bunny.' 8.25: Musical interlude. 8.30: William Talsh will tell the children some Eskimo stories. 8.45: 'Billy Bunny' will entertain the children.

NIGHT SESSION.

Announcer: Maurice Dudley. Accompanist: Mabel Nelson. 7.5: Stock Exchange information. 7.15: Market reports. 7.30: News service, stumps scores of the cricket match, England v. New South Wales, at Sydney. 7.43: Birthday greetings. 7.45: Out of the past. 7.46: Under the auspices of the Department of Agriculture, C. T. Levick, Science Field Officer will speak on 'Control of Insect Pests.' 8.0: A maker of history. 8.1: R. H. Campbell will speak on the cricket match, England v. Tasmania, at Melbourne. 8.11: The Station Orchestra—'Overture, 'Euryantia' (Weber). 8.12: Mary Mack, contralto—'The Friend' (Hugo Wolf), 'Overnight' (Hugo Wolf). 8.24: Joseph Barrille, flute—'Tourbillon' (A. Reyer). 8.25: Jovan Massonoff, tenor—'Der treuherzig Poet' (Teehoper). 8.37: The Station Orchestra—'Mosaïque' (Beethoven). 8.47: J. Alexander Browne, baritone—'Star of Eve'—'Tannhauser' (Wagner). 8.54: The Imperial Russian Trio (Arved Norit, violin; Ivan Berzinsky, 'cello; Vassili Ilster, piano)—'Trio in F Sharp Minor,' Andante con moto, Scherzo allegro molto, Allegro maestoso (Cesare Franck). 9.0: Rev. Frank Gorman and Sadie McDonald, baritone and violinist—'The Serenade' (Drdla), 'The World is Waiting for the Sunrise'; patter: 'Too-ra-loo-ra-loo-ra' (Clotki). 9.30: The Station Orchestra—Selection, 'Wildflower.' 10.0: Description of the Melbourne Thousand foot-running Carnival, at the Motorrome. 10.15: Hugh Huxham's 'Serenader' quartette—'The Quartette, 'Bluetrid, Sing Me a Song' (Benn Millar), 'To Sea'; orchestral interlude; The Station Orchestra, 'Moonbeam' (Drigo); the Quartette, 'The Photographer' a sketch; The Station Orchestra, 'I Love You More' (Liszt); the Quartette, 'Love Maria' (Mascagni). 10.35: News service; meteorological information; British official wireless news from Rugby; announcements. 10.40: J. Alexander Browne, baritone—'Thick As the Darkness' (Mallinson), 'The Fuchsia Tree' (Quilter). 10.47: The Radi-o-Aces—'I Just Jog Along' (Rose), 'I Can't Do Without You' (Berlin), 'Ben Rappaport' (Whiting), 'Dreams' (Hallam), 'Jeannine' (Gilbert), 'Dream House' (Foxe), 'Mother, I Still Have You' (Johnson), 'Out of the Dawn' (Donaldson), 'Get Out and Get Under the Moon' (Tobias), 'Sleepy Baby' (Kahn), 'The Prune Song' (Crumit), 'Sincerely I Do' (Davis), 'Goodnight Waltz' (Blbot). 11.30:

3AR

Announcer: C. J. O'Connor. 10. G.P.O. Clock says 'Ten.' 10.1: 'Age' market reports, farm and station produce. 10.2: 'Age' shipping reports; ocean forecast. 10.3: Mail notices; express train information. 10.35: 'Age' news service, exclusive to 3AR. 10.59: Weather forecast.

MORNING MUSICAL SESSION

Announcer: C. J. O'Connor. 11.0: Beautiful ballads. 11.30: The Imperial Russian Trio, Arved Norit, violin; Ivan Berzinsky, 'cello; Vassili Ilster, piano. Violin solo, 'Danse No. 1' (Dvorak), Arved Norit. Cello solo, 'Rhapsody Hongrois' (Popper); piano solo, 'Requerdos de Vinaje' (Albeniz); 'Menuetto' (Bocherini). 11.52: Beautiful ballads. 12.30: British Official Wireless news; announcements. 12.30: Close down.

EVENING SESSION.

Announcer: John Stuart. 8.0: Sweet Solace on the Seraphina. 7.0: 'Age' news service, announcements. Acceptances for Moonee Valley races on Wednesday. 7.10: Records continued.

NIGHT SESSION.

Announcer: John Stuart. 8.0: E. C. H. Taylor will speak on 'School Life and School Sport.' 8.15: Under the auspices of the Historical Society of Victoria A. S. Kenyon will speak on 'Hume, Hovell, and Sturt.' 8.30: Alfred Pirman, 'Books of Yesterday, To-day, and To-morrow.' 8.40: Ned Tyrrell's Radi-o-Aces, 'Blue Berry' (Lambert), 'Delerium' (Schutt), 'Japansy' (Klennner). 8.50: John Byrne,

bass, 'The Leather Bottle.' 8.53: Ned Tyrrell's Radi-o-Aces, 'The Cat' (Mitsurumi), 'In a Woodshed she said she would' (Johnson), 'Boli' (Zamecnik). 9.3: Dorothy Eytton Jones, soprano, 'The Golden Handmaiden.' 9.8: Ned Tyrrell's Radi-o-Aces, 'Back in Your Own Back Yard' (Joison), 'Let a Smile be Your Umbrella' (Fau), 'Trill Me To-night' (Little). 9.16: Dorothy Eytton Jones, 'Rain' (Curran), 9.19: Ned Tyrrell's Radi-o-Aces, 'When you know me' (Baden), 'I'm sorry' (Kahn), 'Dream house' (Fox). 9.29: John Byrne, bass, request (item. 9.32: Ned Tyrrell's Radi-o-Aces, 'Jeannine' (Gilbert), 'Red Head' (Johnson), 'Rose of Monterey' (Guy). 9.42: Dorothy Eytton Jones, 'The Enchantress' (Haton). 9.45: Ned Tyrrell's Radi-o-Aces, 'Fanatics' (Nichols), 'In My Remembrance of memories' (Lewis), 'Jazz master' piano (Malyere), 9.55: Dorothy Eytton Jones, soprano, 'Golden Dawn' (Loth). 9.58: Ned Tyrrell's Radi-o-Aces, 'Hum and Strum' (Gayer), 'Don't cry, Baby' (Kahn), 'Constantinople' (Carlton). 10.8: John Byrne, bass, selected. 10.11: Ned Tyrrell's Radi-o-Aces, 'That melody of love' (Donaldson), 'Amidst you say' (Donaldson), 'In a bamboo garden' (Donaldson). 10.21: 'Age' news service, exclusive to 3AR; announcements.

4QG

EARLY MORNING SESSION

7.43: Time signals. 7.45: News service. 8.0: Some electric records. 8.15: News service. 8.30: Close down.

MORNING SESSION

11.0: Music. 11.5: Social news. 11.15: Lecturette. 11.30: Music. 11.35: More social news. 11.45: Wur-litzer organ. 11.45: Music. 12.2: Noon. Close down.

MIDDAY NEWS

1.0: Market reports and weather information. 1.20: Lunch-hour music. 2.0: Close down.

AFTERNOON SESSION

3.0: Orchestral music by the Tivoli Operatic Orchestra, under the baton of Mr. G. Groves, 3.30: Mail train running times; a program of electric, 3.40: Announcements. 4.0: Orchestra, music. 4.15: 1/2 this afternoon's news. 4.30: Close down.

EARLY EVENING SESSION

6.0: Mail train running times; mail information, shipping news. 6.5: Dinner music. 6.25: Commercial announcements. 6.30: Bedtime stories, conducted by 'The Sandman.' 7.0: News in brief. 7.3: Stock Exchange news. 7.6: Metal quotations. 7.7: Market reports. 7.25: Fenwick's stock report. 7.30: Weather information. 8.0: Announcements. 8.14: Standard time signals. 7.45: Lecturette, 'Pig Club Progress in Queensland,' Mr. E. J. Shelton (instructor in pig-raising).

NIGHT SESSION

Announcer: H. Humphreys—Radio mystery, 'The Eye of Tayo Lang.' The first portion of to-night's program will comprise the presentation of the second and concluding part of the radio mystery drama, 'The Eye of Tayo Lang,' which was staged during the studio on Friday, February 8. It will be remembered that the play told of the adventure of a party of tourists and residents, who, in Burma, became mixed up in a most mysterious case which revolved around the opening of the jewel eyes of a god. The play ceased at a baffling point, and listeners were asked to answer two questions—(1) Who has the magic eye? (2) How was the play revived? Arnold Preston's play will be summarised to-night, picked up at the mysterious point, and acted to a conclusion. The attempts of listeners who have been opening up the mystery of the first and second solution opened will receive a prize of £25. 8.0: From the studio: Sequel to the radio mystery, 'The Eye of Tayo Lang' (by W. S. Mew). Cast: Arnold Preston, 'The Eye of Tayo Lang' (by W. S. Mew); Cecil Colby (an American tourist), H. Collins; Marcus Marks (manager of the Jandak Hotel), R. Bruce; Inspector Brand (of the Mandalay police), W. S. Mew; Cecil Colby (an American tourist), H. Deans, Maisie Colby (his sister) and Angele Mendozza (a Creole), Mavis McFarlane. Act 1: Evening The lounge of the Jandak Hotel, Mandalay. Scene 1: After dinner. Scene 2: Fifteen minutes later. Scene 3: In less than two minutes. Scene 4: The lounge of the Jandak Hotel, Mandalay. Studio programme. 9.0: Bedtime weather forecast. 9.10: Frank Warlick (pianist), in a short recital, including, 'Spanish Dance' (Granados), 'Doll's Cradle Song' (Groveley), 'Humoresque' (Faure), 'The Blue Bird' (Brahms), 'Benedictus' (Mozart), 'The Swan' (Bach), 'The Swan' (Verdi), 'Until' (Sanderson). 9.33: Aeolian Vocalion, selected. 9.39: Hazel Williams (soprano), 'I Heard You Go Bye' (Wood), 'The Woodpecker' (Gardner), 'Hewitt'. 9.45: A quarter of an hour's recital of selected records. 10.0: Weather news. Close down.

5CL

MORNING SESSION.

11.0: G.P.O. chimes. 11.1: Sonora. Martial Moments by H.M. Coldstream Guards Band (H.M.V. recordings). 11.15: Kitchen chat and menu talk. 11.30: H.M.V. recordings. 12.15: General news service. 1.0: British official wireless news. 12.40: H.M.V. recordings. 12.52: S.A. railway information. S. C. Ward and Co.'s Stock Exchange information. 1.0: G.P.O. chimes. H.M.V. recordings. 2.0: G.P.O. chimes and close down.

AFTERNOON SESSION.

3.0: G.P.O. chimes. 3.1: Violation Quartet, 'Musical Jigsaw' (Jalowitz). 3.10: Violet Jackson, selections from her repertoire. 3.16: Marion Lightfoot, 'The Blue Bird' (Brahms), 'The Swan' (Verdi), 'The Swan' (Verdi), 'The Swan' (Verdi). 3.28: Station Quartet. 3.34: Nora Shilley,

WHY NOT?

have a Set Built Specially to Suit your Local Conditions if it Costs No More?

We will make a set to suit your locality, or to your own specifications, for less than it would cost to buy the parts and make it yourself—and at the same time you get a professional job covered with a twelve months' guarantee. Call or write for a quote, stating your requirements, locality, and specifications, etc.

EASY TERMS

ARRANGED ON ALL PAYMENTS.

SOME STANDARD MODELS.

- 5-Valve 'Solodyne' Set, one or three dial control, in polished maple cabinet. Price £14/15/-
 - 5-Valve 'Neutrodyne' Set, fitted as above. Price £10/12/6
 - '1928 Solodyne,' as described in 'Radio,' Chassis only £20
 - 'All Empire,' as described in 'Radio,' Chassis only £21/10/-
- All other sets built at similar reasonable prices.

HAVE THAT OLD SET REMODELLED!

We specialise in all rewiring, altering, repairing, etc. Our charges are low, and we guarantee all work for twelve months.

ALL "WIRELESS WEEKLY" AND "RADIO" SETS A SPECIALTY.

MAIL ORDERS RECEIVE CAREFUL ATTENTION.

Call, Telephone, or write to R. W. PATTERSON,

Radio Engineer, 90 Pitt Street, Sydney (near Martin Place). 'Phone, B2129.

3.45: Station Quartet. 3.56: Violet Jack-
 4.2: Vern Rogers, cornetist. 4.8: Linda Wald,
 soprano. 4.14: Marjion Lightfoot, instrumentalist.
 4.20: Bernard Manning. 4.26: Station Quartet.
 4.38: Linda Wald, soprano. 4.42: Tom King, piano.
 4.46: Station Quartet. 4.55: S. C. Ward and
 Co.'s Stock Exchange information. 5.0: G.P.O.
 chimes and close down.

EVENING SESSION.

8.0: G.P.O. chimes. 8.1: Birthday greetings, cor-
 respondence; songs and stories by "Aunty Peggy."
 8.30: Capt. Donald McLean will give an interesting
 talk "Bold Buccaneers and Plundering Pirates."
 8.45: H. K. recordings. 7.0: G.P.O. chimes. 7.1:
 S. C. Ward and Co.'s Stock Exchange information.
 7.5: General market reports.

NIGHT SESSION.

8.0: G.P.O. chimes. 8.1: Magill Vice-Regal Band
 (conductor, O. Lovell), overture "The Village
 Chimes," waltz "Ranona," 8.13: Bernard Manning,
 bass-baritone, selections from repertoire. 8.19:
 Marjion Lightfoot (instrumentalist), "Drum Major"
 (Miley), "Dashwood Quickstep" (Oakley), 8.25:
 Talc Jackson, soprano. 8.31: Magill Vice-Regal
 Band, descriptive, "In a Monastery Garden," cor-
 ceus solo, "The Rosary" (Nevin). 8.41: "Yo, ho, ho,
 for the Spanish Main," Captain Donald McLean, in
 series of pirates and plunder. 8.54: Jas. G. Glen-
 non, violinist, "Valse Brillant" (Chopin), "Chanson
 Francaise" (Tchakowsky). 9.0: G.P.O. chimes. 9.1:
 Meteorological information. 9.2: Overseas grain re-
 port. 9.5: Magill Vice-Regal Band, humorous,
 "Gregor's Wooing." 9.10: Bernard Manning, bass-
 baritone, selections from his repertoire. 9.16: Mar-
 jion Lightfoot, instrumentalist, "Mahina Waltz"
 (Smith), "Puuala Waltz" (Kaal) 9.22: Frank
 McCabe, baritone, "Red Devon by the Sea" (Clarke),
 "The Floral Dance" (Moss). 9.28: Magill Vice-Regal
 Band, selection, "Beethoven's Works." 9.38: Violet
 Jackson, soprano, selections from her reper-
 toire. 9.44: James G. Glennon, violinist, "Air on G String"
 (Mozart), "Souvenir" (Drda). 9.50: Magill Vice-
 Regal Band, selection, "A Musical Switch." 10.0:
 G.P.O. chimes. 10.1: Frank McCabe, baritone, "When
 Song is Sweet" (Sans-Souci), "Uncle Rome" (Homer).
 10.6: Magill Vice-Regal Band, air varie, "My Old
 Kentucky Home." 10.15: General news service;
 meteorological information. 10.30: Modes, dance
 numbers by the Radi-o-Aces. 11.0: God Save the
 King.

6WF

12.30 p.m.: Tune in. 12.35: Markets, news, etc.
 1.0: Time signal. 1.1: Weather bulletin, supplied
 by the Meteorological Bureau of West Australia.
 1.5: Patrope hour, relayed from Messrs. Mus-
 care's, Ltd, Lyric House. 2.0: Close down. 2.30:
 Tune in. 3.35: Afternoon tea music, relayed from
 the Carlton Cafe, vocal items from the studio. 4.30:
 Close down. 4.45: Tune in. 4.48: Bedtime stories
 for the kiddies by Uncle Duffy. 7.0: Light music
 by the Station Trio. 7.30: Commercial and general
 information. 7.45: Talk by Lieut.-Colonel Le
 Ford, Director, Zoological Gardens, South Perth.
 8.0: Time signal. 8.1: Weather bulletin, supplied
 by the Meteorological Bureau of West Australia. 8.3:
 Vocal and instrumental artists, from the studio.
 8.5: Late news items, by courtesy of "The Daily
 News" Newspaper Co.; ships within range announce-
 ment; late weather bulletin; station announcements.
 10.30: Close down. 104.5-Metre Transmission: Sim-
 ultaneous broadcast on 104.5 metres of programme
 via on 1250 metres, commencing at 6.45 p.m.

7ZL

MIDDAY SESSION.

11.30 to 1.30: See Friday.

AFTERNOON SESSION.

1.0: General Post Office clock chim's the
 hour. 3.1: Music. 3.4: Weather information.
 3.5: Music. 3.15: A popular programme by
 Patti Pianola and M'elie Columbia, Carra Hall,
 soprano. 3.22: Patti Pianola. 3.27: Goodrich Sher-
 town Quartet. 3.34: Patti Pianola. 3.39: Cecil Sher-
 town tenor. 3.45: Patti Pianola. 3.51: John McCor-
 mack, tenor. 3.58: Patti Pianola. 4.3: John Harrison,
 baritone. 4.10: Patti Pianola. 4.15: "Aunt Edna"
 will speak on "The Season's Forecast." 4.30: Close
 down. During the afternoon programme results will be
 given of the cricket match, English XI. v. New
 Wales at Sydney.

EARLY EVENING SESSION.

6.15: Music. 6.30: Little Shell Corral! will recite to
 the children: "Polly Dibbs," "Woodman's Daughter."
 6.45: Music. 7.0: Answers to letters and birthday
 greetings by "Uncle David." 7.5: Request numbers
 for the Little Ones by the Discus Ensemble. 7.15:
 News session; stumps drawn, English XI. v. New
 South Wales at Sydney.

EVENING SESSION.

7.30: George Collis, Tasmania's Champion Wrestler,
 will speak on "Physical Culture." 7.45: Anecdotes re-
 lating to the visit of the English cricketers. 8.0:
 G.P.O. clock chimes the hour. 8.6: Musical selec-
 tions. 8.15: A studio concert arranged by Madame
 Helen George and Monsieur Sonors—Madame Helen
 George, piano solo, "Andante Rondo Capriccioso"
 (Mendelssohn). 8.22: Madame Helen George, pianist,
 Hazel Guest, violinist, "Sonata, Op. 13" (Grieg);
 "Cresc. Movement." 8.29: John M'Cormack, tenor, "Die
 list die Bub" (Schubert), "I'll Sing These Songs of
 Arab" (Clay). 8.36: Madame Helen George, piano
 solo, "The Island Spell" (John Ireland), "Restless
 Dream" (Schumann). 8.42: John M'Cormack, tenor,
 "At Dawning" (Cadmán), "I Hear a Thrush at Eve"
 (Cadmán). 8.49: Hazel Guest, violin solo, "Tam-
 bourin" (Kreisler), "Slavonic Dance" (Kreisler). 8.56:
 Hazel Guest, Madame Helen George, piano, "The
 Dame Nellie Melba (soprano), John Brownlee
 (baritone), "Un Auge est Venu" (Bemberg). Dame
 Nellie Melba, soprano, "Swing Low, Sweet Chariot"
 (arr. Burleigh), 9.3: Ghosts: Barbara Storey will tell
 "The Story." 9.20: Madame Helen George, piano
 solo, "Largo and Rondo from Sonata, Op. 27, No. 1"
 (Beethoven). 9.27: Hazel Guest, violin solo, "Nobody
 Knows the Trouble I've Seen" (Negro Spiritual), "G-
 taro" (Mozzkowski). 9.34: John M'Cormack, tenor,
 "Ave Maria" (Mascagni), "Softly and Tenderly"
 (Schubert). 9.45: Madame Helen George,
 piano solo, "Hungarian Rhapsodie, No. 2" (Liszt).
 9.55: News session. 10.0: G.P.O. clock chimes the
 hour. 10.8: God Save the King.



**LONGER LIFE
 ABSOLUTE
 RELIABILITY
 GREATER
 ECONOMY**

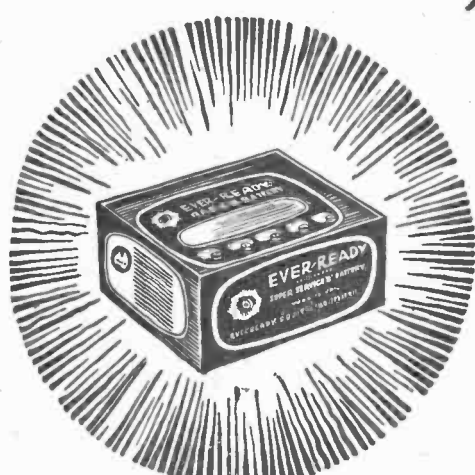

**EVER-READY
 RADIO BATTERIES**

**OBTAINABLE FROM ALL
 GOOD RADIO DEALERS**

Wholesale Distributors:
THE EVER-READY CO. (Gt. Britain) LTD.
 163 PITT STREET, SYDNEY.



Local Programmes, Tuesday, February 19

2FC

Tuesday, February 19 EARLY MORNING SESSION

Announcer: A. S. Cochrane.

7.0: "Big Ben" and announcements. 7.2: Official weather forecast, rainfall; river reports; temperatures; astronomical memoranda. 7.7: "Sydney Morning Herald" summary. 7.12: Shipping intelligence; mail services. 7.15: Studio music. 7.25: Investment market, mining share markets, metal quotations; wool sales, breadstuffs markets, inter-State markets, produce markets; studio music. 8.0: "Big Ben"; close down.

MORNING SESSION

Announcer: A. S. Cochrane.

10.0: "Big Ben" and announcements. 10.2: Pianoforte reproduction. 10.10: "Sydney Morning Herald" news service. 10.25: Studio music. 10.30: Last-minute sporting information by the 2FC Racing Commissioner. 10.40: Studio music. 10.50: Pianoforte reproduction. 11.0: "Big Ben"; A.P.A. and Reuter's cable services. 11.5: Close down.

MIDDAY SESSION

Announcer: A. S. Cochrane.

Note: Race results will be given. 12.0: "Big Ben"; from the Sydney Cricket Ground, description of the cricket match, England v. New South Wales. 1.30: From the studio, Stock Exchange, second call. 1.32: Official weather forecast, rainfall. 1.34: Rugby wireless news. 1.37: "Evening News" midday news service; Producers' Distributing Society's report. 2.0: "Big Ben"; close down. Note: Description of the cricket match from the Sydney Cricket Ground will be continued through 2BL.

AFTERNOON SESSION

Announcer: Laurence Halbert.
Accompanist: Ewart Chapple.

2.30: Programme announcements. 2.32: Educational session for the schools—a short musical recital. 2.45: A reading. 3.0: Pianoforte reproduction. 3.15: A talk by Freda Sternberg, "Are Interesting People Really Interesting?" 3.30: Esther Herford, soprano—(a) "With Courty Grace" (Phillips), (b) "Powder and Paiches" (Phillips). 3.37: Phillipa Alston, contralto. 3.45: A reading. 4.0: "Big Ben"; Esther Herford, soprano—(a) "Christina's Lament" (Dvorak), (b) "Baby Eyes" (Lohr). 4.7: Phillipa Alston, contralto. 4.15: From the Sydney Cricket Ground, description of the match, England v. New South Wales. 5.40: Close down.

EARLY EVENING SESSION

Announcer: A. S. Cochrane.

5.40: The Chimes of 2FC. 5.45: The children's session, conducted by the "Hello Man"; letters and stories; music and entertainment. 6.30: Dalgety's market reports (wool, wheat, and stock). 6.40: Fruit and vegetable markets. 6.43: Stock Exchange information. 6.45: Weather and shipping news. 6.48: Rugby wireless news. 6.50: Late sporting news. 7.0: "Big Ben"; late news service. 7.10: The 2FC Dinner Quartette, conducted by Horace Keats—(a) "Hungarian Dance" (Brahms), (b) "Idle Dreams" (Finck), (c) "Some Day, Somewhere" (Rapee), (d) "La Tosca" (Puccini), (e) "Songs My Mother Taught Me" (Dvorak), (f) Waltz, "The Sleeping Beauty" (Tschaiakowsky).

EVENING SESSION

Announcer: Laurence Halbert.
Accompanist: Ewart Chapple.

7.40: Pianoforte reproduction.
7.45: Programme announcements.
7.48: Impressions on the cricket by M. A. Noble. Popular music.
8.0: Metropolitan Band.
8.15: Theodore Atkinson, baritone—(a) "The Harlequin Song" (Oliver), (b) "Son of Mine" (Wallace).
8.22: Pianoforte solos by Maurice Arlen.
8.29: A sketch by R. D. Maunsell and Gwen Sherwood—"One Christmas Eve" (adapted).
8.44: Daisy Mangan, soprano.
8.51: Metropolitan Band.
9.6: Weather report and forecast.
9.7: Theodore Atkinson, baritone—(a) "Sigh No More" (Aikin)

(b) "A Shanty Ballad" (Sanderson).
9.14: Pianoforte solos by Maurice Arlen.
9.19: A sketch by R. D. Maunsell and Gwen Sherwood—"The House Agent" (adapted).
9.34: Metropolitan Band.
9.49: Daisy Mangan, soprano.
9.56: Metropolitan Band.
10.11: The Studio Dance Band, conducted by Cec. Morrison.
10.23: Late weather report and announcements.
10.30: Studio Dance Band, conducted by Cec. Morrison.
10.40: Announcements.
10.45: Studio Dance Band, conducted by Cec. Morrison.
10.57: To-morrow's programme.
10.59: Metropolitan Band.
11.30: National Anthem. Close down.

2BL

Tuesday, February 19 MORNING SESSION.

Announcer: A. C. C. Stevens.

8.0: G.P.O. clock and chimes. Metropolitan weather report. 8.1: State weather report. 8.2: Studio music. 8.15: G.P.O. chimes. News from the "Daily Telegraph Pictorial." 8.30: G.P.O. chimes. News service continued. 8.40: Information; mails; shipping, arrivals, departures, and sailings. 8.45: Studio music. 9.15: Half an hour with silent friends. 9.45: Studio Music. 10.0: G.P.O. chimes. Close down.

MIDDAY SESSION.

Announcer: A. C. C. Stevens.

11.0: G.P.O. clock and chimes. 2BL Women's Sports Association session, conducted by Miss Gwen Varley. 11.30: Advertising hints. 11.40: Women's session, conducted by Mrs. Cranfield. 12.0: G.P.O. clock and chimes. Special ocean forecast and weather report. 12.3: Pianoforte reproduction. 12.30: Shipping and mails. 12.35: Market reports. 12.45: Cricket scores, England v. Tasmania, played at Tasmania. 12.48: "Sun" midday news service. 1.0: Studio music. 1.30: Cricket impressions, by M. A. Noble. 1.35: Talk to children and special entertainment for children in hospital. 1.57: Cricket scores. 2.0: G.P.O. chimes. Close down.

AFTERNOON SESSION.

Announcer: A. C. C. Stevens.

Accompanist: Kathleen Roe.

2.15: From the Sydney Cricket Ground, description of the match, England v. New South Wales. 4.0: Impressions on the cricket, by M. A. Noble. 4.5: From the studio, James Pedal, pianoforte solos. 4.15: Thelma Houston, contralto—(a) "Hush'd is My Lute" (Phillips), (b) "Christians and Priests" (Godard). 4.22: Romano's Cafe Dance Orchestra, conducted by Bennie Abrahams. 4.32: From the studio, Thelma Houston, contralto—(a) "June Music" (Trent), (b) "Sincerity" (Clarke). 4.40: Romano's Cafe Dance Orchestra, conducted by Bennie Abrahams. 4.50: James Pedal, pianoforte solos. 5.0: Our serial story. 5.10: Pianoforte reproduction. 5.17: Popular music. 5.32: Producers' Distributing Society's poultry report. 5.34: Complete racing resume. Poultry report. 5.37: Features of the evening's programme.

EARLY EVENING SESSION.

5.40: Children's session, conducted by Uncle Bas. Music and entertainment. Letters and stories. 5.30: "Sun" news and late sporting. 6.40: 2BL Dinner Quartette—(a) "Scene Espagnol" (Lacome), (b) "Stanchen" (Pache), (c) "Indian Love Lyrics" (Finden), (d) "Waiting" (Ancliffe), (e) "My Inspiratoin" (Nicholls), (f) "In Bagdad" (Leigh). 7.7: Australian Mercantile Land and Finance Co.'s report. Weather report and forecast, by courtesy of Govt. Meteorologist. Producers' Distributing Society's fruit and vegetable market report. Grain and fodder report ("Sun"). Dairy produce report ("Sun"). 7.25: Mr. Pim and Miss Pam in advertising talks and nonsense. 7.55: Programme and other announcements.

EVENING SESSION.

Announcer: Basil Kirke.

Accompanist: G. Vern Barnett.

8.0: G.P.O. clock and chimes.
Pianoforte solos by Kathleen Roe, "Moonlight Sonata" (Beethoven).
8.10: From the Rose Bay Music Club, Memorial Hall, Rose Bay, programme arranged by Oliver King, president. Associate artists: Robert Harper, Heather Bell, Harold Whittle, Beatrice Tange, Rene Rich.
Violin solo, "Concerto No. 2" (Vieuxtemps), Rene Rich.
8.23: Mezzo-soprano solos—
(a) "La Zingara" (Donizetti).
(b) "Meine Ruh-ist-hin" (Hoffmann).
(c) "A Russian Folk Song."
Heather Bell.
8.33: Pianoforte solos—
(a) "Concerto Etude in D Flat" (Liszt).
(b) Variations on Theme, by Paganini (Liszt). Beatrice Tange.
8.45: Baritone solos—
(a) "I Attempt from Love's Sickness" (Purcell).
(b) "Good Fellows Be Merry" (Bach). Alfred Cunningham.
9.0: Violin solos—
(a) "Ronde des Lutines" (Bazzini).
(b) "Minuet" (Beethoven). Rene Rich.
9.6: Mezzo-soprano—
"A Hebridean Sea-Rievens Song"
Heather Bell.
9.10: From the studio, weather report and announcements.
9.15: A talk by "Bringa."
9.30: From the Rose Bay Music Club, second half of the programme arranged by the club.
Pianoforte solos—
(a) "Old Vienna" (Godowsky).
(b) "Liebesleid" (Rachmaninoff).
9.40: Baritone solos—
(a) "It Was a Lover and His Lass."
(b) "To An Englishman."
(c) "Young Richard" (Old English group). Alfred Cunningham.
9.50: Mezzo-soprano solos—
(a) "O Men from the Fields" (Hughes).
(b) "Carol of the Keddoe Yowds" (Gurney). Heather Bell.
10.0: Community singing.
10.15: From the studio, late weather and announcements. Celebrity record.
10.28: To-morrow's programme.
10.30: National Anthem. Close down.

2GB

10.0: Music. 10.10: Happiness talk by A. E. Bennett. 10.20: Music. 10.30: Women's session, by Helen J. Beegling. 12.30: Close down. 2.0: Music. 2.5: Women's radio service, by Mrs. Dorothy Jordan. 2.30: Music. 3.0: Close down. 5.30: Children's session, by Uncle George. 7.0: Stock and market reports by New Zealand Loan and Mercantile Agency, Ltd. 7.15: Music. 7.40: Talk from the radio service department, by Mr. S. Crittenden. 8.0: Violin solos by Mr. Cecil Berry. 8.10: Songs by Miss Gwytha Harbore. 8.20: A humorous interlude by Mr. Jack Win and Mr. Heath Burdock. 8.25: Instrumental music. 8.35: Songs by Mr. William Green. 8.45: Pianoforte solos by Mr. John Benson. 8.55: A humorous interlude. 9.0: Weather report. 9.3: Address. 9.15: Songs by Miss Gwytha Harbore. 9.25: Instrumental music. 9.35: A humorous interlude by Mr. Jack Win and Mr. Heath Burdock. 9.45: Violin solos by Mr. Cecil Berry. 9.55: Songs by Mr. William Green. 10.5: Orchestral items. 10.30: Close down.

2UW

MIDDAY SESSION.
12.30: Music. 1.0: G.P.O. clock and chimes. Music. 2.30: Close down. 4.30: Musical programme.

EVENING SESSION.

5.30: Children's hour, conducted by Uncle Jack. 6.30: Close down. 7.0: G.P.O. clock and chimes. Music. 8.0: To-day's anniversary. Music. 8.15: Film talk by Miss E. Baumberg. 8.25: Music. 9.0: G.P.O. clock and chimes. Comments on foreign affairs, by Mr. J. M. Prentice. 9.10: Music and request numbers. 10.0: Close down.

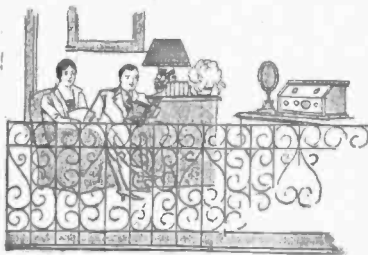

Columbia
Trade Mark

RADIO BATTERIES
GREATEST CLARITY, VOLUME & DISTANCE



*Improve
Radio
Reception*

COLUMBIA Radio Batteries insure the greatest clarity, volume and distance. Made in a correct size for every receiving set, they improve the reception of all sets, last longer and are the most economical.

Always insist upon Columbia. Obtainable at all first class dealers.



Factory Representatives:

ELLIS & COMPANY (Aust.) Ltd.
Aberdeen House, 204-206 Clarence Street
Sydney, N. S. W.

ELLIS & COMPANY (Aust.) Ltd
562-4 Bourke Street
Melbourne, Vict.

Interstate Programmes, Tues., Feb. 19

BRITISH MADE
FERRANTI
 TRANSFORMERS



Consider These Performances Before You Buy Audio Frequency TRANSFORMERS

A.F.4.
 Uniform amplification from 300 cycles upwards. 50% of maximum amplification, even at 50 cycles. Price 34/-

A.F.3.
 Uniform amplification from 100 cycles upwards. Over 80% amplification at 50 cycles. Price 45/-

A.F.5.
 Uniform amplification from 100 cycles upwards. Over 90% amplification at 50 cycles. One can almost say uniform amplification from 50 cycles upwards. Price 57/-

A.F.5
 is still and will remain for a very long time the best Intervalve Transformer that can be made.

A.F.3
 is still better than anything else offered (except the A.F.5) whatever its price.

A.F.4
 is still the best Intervalve Transformer in its price class.

DO NOT BUY AN AUDIO FREQUENCY TRANSFORMER UNTIL YOU HAVE EXAMINED ITS AMPLIFICATION CURVE DRAWN ON THE MUSICAL SCALE.

U2.

3LO

EARLY MORNING SESSION.
 7.15 to 8.15: See Friday.
MORNING SESSION.
 8.15: Frank Hatherly: 3LO's different dainties for the daily dinner—To-day's radio recipe, Chicken Brown. 11.35: Miss E. Noble will speak on "Gas Cookery." 11.20: Musical interlude. 11.25: Mrs. Dorey Silk will speak on "Home-crafts." 11.40: Description of the Sheffield Shield cricket match, Victoria v. Tasmania, at the M.C.C. by Rod McGregor. 12.40: Stock Exchange information. 12.45: Continuation of the description of the Sheffield Shield cricket match, Victoria v. Tasmania, at the M.C.C. 1.15: Meteorological information; weather forecast for Victoria, South Australia, New South Wales, and Tasmania; ocean forecasts; river reports; rainfall. 1.25: The Imperial Russian Trio (Arved Norik, violin; Ivan Berzinski, 'cello; Vassili Ister, piano)—"Menuetto" (Beethoven), "Synopation" (Krisler), "Schoen Rosmarin" (Krisler), "Berceuse" (Jaernefeldt). 1.45: Close down.

AFTERNOON SESSION.
 2.15: Description of the Sheffield Shield cricket match, Victoria v. Tasmania, at M.C.C., by Rod McGregor. 4.0: Sonora recital, for the world's most famous records. 4.15: Rod McGregor will continue his description of the Sheffield Shield cricket match, Victoria v. Tasmania. 5.15: "Herald" news service; Stock Exchange information. During the afternoon progress scores of the cricket match, England v. New South Wales, will be broadcast as they come to hand; so will the results of the Donald District Jockey Club races. 5.25: Further description of the Sheffield Shield cricket match, Victoria v. Tasmania, at M.C.C. 6.0: Stumps scores.

EVENING SESSION.
 6.5: Birthdays greetings; and answers to letters, by "Bobby Bluegum." 6.30: W. Groves, "The Peter Pan of the Pacific." 6.45: "Little Miss Kookaburra" will tell about "Nellie and Billie in Moonland."

NIGHT SESSION.
 7.0: Maurice Dudley, Accompanist: Mabel Nelson. 7.5: Stock Exchange information. 7.15: Market reports. 7.30: News service; stumps scores of the cricket matches, England v. New South Wales, at Sydney, and Victoria v. Tasmania, at M.C.C. 7.43: Birthdays greetings. 7.45: Out of the past. 7.48: Under the auspices of the University Extension Board, Rev. W. Bottomley, "The World's Greatest Enemy of the People," by Ibsen. 8.0: A maker of history. 8.1: The Salvation Army Headquarters Band—March, "Condler"; song, "Love at Home"; chorus, "And the Glory of the Lord." 8.15: J. Howard King, basso-baritone—"Myself When Young" (Lehmann), "Passing By" (Purcell). 8.22: The Salvation Army Headquarters Band—Selection, "Gems from Mendelssohn's Elijah," cornet solo, "Zelda" (Staff Bandsman R. Wilcox); march, "Keithley Citadel." 8.37: Dawn Harding, mezzo-soprano—"Wind Song" (Rogers), "In Heaven" (Elgar). 1.44: The Salvation Army Headquarters Band—Selection, "Army of the Brave"; hymn, "Innocence"; march, "Deliverance." 9.0: Donald Mackintosh will speak on "How I Became a Gunman." 9.15: Melbourne Philharmonic Society (Acting-Conductor, W. G. S. Steel)—"He Watching Over Israel," "Thanks Be To God," from "The Elijah" (Mendelssohn); "Blessed Are They That Mourn," "The Lord's Prayer," "Dwellings Fair," from "The Requiem" (Brahms); "Worthy Is the Lamb," "Amen," from "The Messiah" (Handel). 9.45: The Imperial Russian Trio (Arved Norik, violin; Ivan Berzinski, 'cello; Vassili Ister, piano)—Arved Norik, violin, "Rondo" (Mozart); Ivan Berzinski, 'cello, "Menuetto" (Becker); Vassili Ister, piano, "Young Girls in the Garden" (Mozart); the Trio, "Overture" (Domenico Scarlatti) news service; Stock Exchange information; Eric Welch's selections for to-morrow's races at Moonee Valley. 10.15: J. Howard King, baritone—"Had a Horse," "Shepherd See Thy Horses" (Korbay). 10.22: Dawn Harding, mezzo-soprano—"You Lay So Still," "The Rainbow Child" (Coleridge Taylor). 10.30: Announcements. 10.45: The Radi-o-Aces—"The Dance of the Blue Danube" (Fischer), "It Goes Like This" (Caesar), "Roses of Yesterday" (Berlin), "Forever More" (Runnett), "Nebraska" (Sisteen), "That's My Weakness Now" (Gretchen O'Connell), "Dances Under the Moon" (Tobias), "In a Bamboo Garden" (Donaldson), "Anything You Say" (Donaldson), "Goodnight Waltz" (Bibbo). 11.30: God Save the King.

3AR

ANNOUNCER: C. J. O'Connor. 10.0: G.P.O. clock says "Ten." 10.1: "Age" market reports, farm and station produce, fruit, fish, vegetables. 10.25: Age's shipping reports and forecasts. 10.30: Mail notices; express train information. 10.35: "Age" news service, exclusive to 3AR. 10.59: Weather forecast. 11.0: Ned Tyrrell's Radi-o-Aces—Domenico Scarlatti, "Mine, all mine" (Rubin), "Rain" (Ford), "Just like a melody out of the sky" (Donaldson). 11.20: Beautiful ballads. 11.26: Ned Tyrrell's Radi-o-Aces: "Because my baby don't mind my new now" (Hazelton), "Guess who's in town" (Razay), "My blackbirds are bluebirds now" (Friend), "Louisiana" (Schaefer). 11.46: Beautiful ballads. 11.52: Ned Tyrrell's Radi-o-Aces: "Lonely in a crowd" (Green), "Chloe" (Kahn), "Parting with you" (Conley), "Kiss before the dawn" (Perkins). 12.12: Beautiful ballads. 12.16: British Official Wireless news; announcements; Reuters and the Australian Press-association cables. 12.30: Close down.

AFTERNOON SESSION.
 2.15: The Station Orchestra: Overture, "The Carnival" (Dvorak), "Chant de L'Alouette" (Tchajkovsky). 2.30: Jovan Massonoff, tenor; Lullaby,

"Shlof, Mien Kind" (Rabiner), with 'cello accompaniment by Tasma Tiernan, "Dear Heart" (Mattell). 3.37: The Station Orchestra: Selection, "Oh, Lady, Lady" (Kern). 2.45: Hugh Huxham's Serenade Quartet, "I Just roll along." Hugh Huxham, "Old Mate"; interlude by the Strad Trio, Menuetto for Septet (Beethoven), "Rondo alla Turca" (Mozart) Quartet, "Drink up and have another one," bumper item, "Plappers," interlude by the Strad Trio, "Song of the Mountain" (Grieg) Quartet, "Fath waltz song," 3.11: The Station Orchestra: "Four American Indian Songs" (Cadman). 3.20: Beth Corrie, contralto, "Knowest thou that dear land" (Mortilioni), "Waltz Maori" (Hill). 3.27: The Strad Trio: "Trio in D Minor, Op. 32" (Arensky); Allegro Moderato; Scherzo; Elegie; Finale. 3.34: Jovan Massonoff, tenor; Scena, "Kol Nidre" (Habsine), with 'cello and viola accompaniment by Tasma Tiernan and Bertha Jorgensen; "Lullaby," Shina Yizrcil (Rabiner), with 'cello accompaniment by Tasma Tiernan. 4.3: The Silktone Orchestra: Selection, "Glooms" (Fonchelli), "In Love" (Friml). 4.15: Rev. Frank Gorman and Sadie M'Donald, Duet, "Pale Moon"; Frank Gorman, "Side by Side" violin, Brahms' "Hungarian March"; duet, "Willoway." 4.30: The Strad Trio: Violin and piano, "Sonata Op. 12 WS in E Major" (Beethoven), "Adagio," "Rondo," 4.39: Beth Corrie, contralto, "The Birth of Morn" (Leon), "Come Gentle Night," "Elgie" (Lloyd). The Station Orchestra: Overture, "Maritana" (Wallace), "Prelude" (Chopin). 5.0: Close down.

ANNOUNCER: John Stuart. 6.0: A. S. Kenyon of the Numismatic Society will give a lecture on "Postal Stamps." 8.30: Transmission from Town Hall, Warrnambool, cantata, "The Banner of St. George," by the Warrnambool Choral Society, to be followed by voice and orchestra items. 10.20: "Age" news service, exclusive to 3AR; announcements. Results of cricket, Victoria v. Tasmania, at M.C.C. 7.15: Cricket news continued.

40G

EARLY EVENING SESSION.
 7.43: Time signals. 7.45: News service. 8.0: Some electric records. 8.15: News service. 8.30: Close down.

MORNING SESSION.
 11.0: Music. 11.5: Social news. 11.15: Talk on "Home Crafts" by Mrs. R. L. Reid. 11.20: News. 11.35: More social news. 11.45: Music. 12.0 (noon): Close down.

MIDDAY SESSION.
 1.0: Market reports and weather information. 1.20: Wurlitzer organ. 2.0: Close down.

AFTERNOON SESSION.
 3.0: A programme of electrically reproduced records. 3.35: Adelaide running times. 4.15: This afternoon's news. 4.30: Close down.

EARLY EVENING SESSION.
 6.0: Mail train running times; information; shipping news. 6.5: Some electrically reproduced records. 6.25: Commercial announcements. 6.30: Bedtime stories, conducted by "Uncle Ben." 7.0: News in brief. 7.5: Stock Exchange news. 7.9: Metal quotations. 7.7: Market reports. 7.25: Fenwick's stock report. 7.30: Weather information. 7.40: Announcements. 7.43: Standard time signals. 7.45: Lecture—"British and Colonial Music." Mr. M. L. Cameron (Department of Agriculture and Stock).

NIGHT SESSION.
 8.0: Studio Concert—The Studio Instrumental Quartette (conductor, Fred C. Smith), in popular numbers. 8.5: The Silktone Apollo Club (conductor, Mr. T. Westwood)—chorus, "The Silktone Song." 8.9: Couso, xylophonist—Overture, "Orpheus in her Underwelt" (Offenbach). 8.15: T. Westwood, tenor—selected. 8.19: The Silktone Apollo Club—hymn tune, "Fierce Raged the Tempest." 8.25: Fred C. Smith, pianist—five minutes' symphonette. 8.30: Irene Elphinstone, contralto—"Slave Song" (Teresa del Riego). 8.34: T. Westwood and V. Morris—local electrically reproduced records. 8.35: Phonist—March, "True Blue" (Kenneth). 8.45: The Silktone Apollo Club—"Loch Leven Love Lament" (Robertson). 8.50: Mrs. Robert Bell, soprano—selected. 8.54: The Studio Instrumental quartette—"Fox-trot, 'She's My Daisy'" (Lauder). 9.0: Metropolitan weather forecast. 9.1: The Silktone Apollo Club—chorus, "Excelsior" (Baile). 9.7: A. Elliott, tenor—"Until I Will Collide"—concertina solo. 9.17: The Silktone Apollo Club—chorus, "Rolling down to Rio" (German). 9.21: Ben Cloirec, tenor—"The Sietta" (Squire). 9.25: Couso, xylophonist—waltz, "Glad My Dream" (Hansley). 9.30: Thelma Marsh, pianist—selected. 9.34: J. A. R. Thomson, baritone—"Will of the Wisp." 9.40: The Apollo Club Quartette, Party—male quartette, "Absence" (Gardner). 9.45: D. Owens, electrically selected items. 9.50: The Silktone Apollo Club—"It was a Lover and His Lass" (Morley). "Song of the Northmen" (Maunder). 9.55: The Studio Instrumental Quartette—popular numbers. 10.0: Weather; news for country listeners. 10.30: Close down.

5CL

MORNING SESSION.
 11.0: G.P.O. clock—Columbia recordings. 11.15: "Economist," kitchen craft and menu talk. 11.30: Columbia recordings. 11.45: Maggie Tulliver, "The Story of the Pied Piper of Hamelin." 12.0: G.P.O. clock. 12.15: Columbia recordings. 12.30: News service, British official wireless news. 12.52: S.A. railway information. 12.53: S. C. Ward and Co.'s Stock Exchange information. 12.57: Meteorological

1.0: Columbia recordings. 1.1: Columbia recordings. 2.0: Close down.

AFTERNOON SESSION.

1.1: G.P.O. chimes. 3.1: Rev. G. E. Hale, B.A., talk on "The Strong Silent Man." 3.15: From Regent Theatre. 3.46: From studio, Marion Lightfoot, instrumentalist. 3.53: Bernard Manning, bass-baritone. 4.0: G.P.O. chimes. 4.1: Violet Jackson, soprano. 4.8: From Regent Theatre. 4.38: From studio, Bernard Manning, bass-baritone. 4.44: Marion Lightfoot, instrumentalist. 4.50: Violet Jackson, soprano. 4.55: S. C. Ward and Co.'s Stock Exchange Information. 5.0: G.P.O. chimes and close down.

EVENING SESSION.

5.0: G.P.O. chimes. 6.1: Birthday greetings, correspondence, songs and stories by "The Wattle Lady"; some more pirate stories by Capt. Donald McLean. 6.45: Columbia recordings. 7.0: G.P.O. chimes. 7.1: S. C. Ward and Co.'s Stock Exchange Information. 7.2: General market reports. 7.3: Farmers, dairy produce; A. W. Sandford and Co. produce and poultry; A. E. Hall and Co. dairy produce and poultry; Dalgely and Co., wool and grain report; Retail Grocers, dairy produce. 7.19: SCL's sporting service by "Silvius," including Amateur Turf Club acceptances. 7.22: Miss Irene McLeod, a talk on "The Art of Dancing." 7.27: Dr. Herbert Easdown, an Australian address.

NIGHT SESSION.

7.30: G.P.O. chimes. 8.1: Lewis Jones, violinist, "Missa in G Minor" (Tartini). 8.6: Bernard Manning, bass-baritone, selections from his repertoire. 8.13: Seth Smith, banjoist, "Black Coquette" (Grimschaw), "Rugby Parade March" (Oakley). 8.18: Will Range, entertainer, selected comedy. 8.28: Fred Gibbons, violinist, "Aria," "Slumber Song" (E. Claude). 8.35: Violet Jackson, soprano, selections from her repertoire. 8.40: A playlet, "A Woman's Secret." Characters: Wife, Miriam Ralph; husband, Jack Burgess; father, Athol Lykke. 9.0: G.P.O. chimes. 9.1: Meteorological information. 9.2: Overseas grain report. 9.3: Lewis Jones, violinist, "Gavotte" (Gosling), "Romance" (Max Bruch). 9.9: Bernard Manning, bass-baritone, selections from his repertoire. 9.15: William Runge, humorist, selected comedy. 9.21: Marion Lightfoot, instrumentalist, "Drum Major" (Morley), "Dashwood Quickstep" (Oakley). 9.29: Capt. Donald McLean. 9.43: Fred Gibbons, violinist, "Berceuse" (Squire), "Simple Aveu" (Thome). 9.49: Violet Jackson, soprano, selections from her repertoire. 9.55: Marion Lightfoot, instrumentalist, "Mahina Waltz" (Smith), "Punalia" (Kaal). 10.1: Seth Smith, banjoist, "Humoreske" (Dvorak), "An entertainer at piano, "Gorgeous" (Davis), "That's My Mammy." 10.10: Fred Gibbons, violinist, "La Cigarette" (Marie). 10.15: General news service. 10.20: Official wireless news, meteorological information. SCL's sporting service by "Silvius." 10.30: Our Goodnight Thought, "Those who trust us educate us." 10.31: Dance numbers by the Radiogram. 11.0: God Save the King.

6WF

6.30 p.m.: Tune in. 12.35: Markets, news, etc. 1.0: Tune signal. 1.1: Weather bulletin. 1.3: From Studio 10 and vocal items. 2.0: Close down from the studio, including Piantele solo programme by Miss Evelyn Dean. 4.30: Close down. 6.45: News service. 7.0: Bedtime stories for the kiddies by Miss Westwood and Dream Daddy. 7.5: Music by the Station Trio. 7.30: Commercial and general information. 7.45: Talk. 8.0: Time signal. 8.1: Meteorological weather bulletin, supplied by the Meteorological Bureau of West Australia. 8.3: Vocal and instrumental items from the studio. 9.0: Late news items by courtesy of "The Daily News." Late news service. 9.15: Station announcements; late weather bulletin. 10.0: Within range announcement. 10.30: Close down. 10.4.5-Metre Transmission: Simultaneous broadcast on 104.5 metres of programme given on 105 metres, commencing at 6.45 p.m.

7ZL

EARLY EVENING SESSION

6.15: Musical selections. 6.25: Doreen Eisey will sing for the wee folk—"Eruba" (Backston), "Prince of Siles" (Stanton). 6.30: "The Story Lady" will tell a story to the wee folk. 7.0: Answers to letters and birthday greetings by "Uncle David." 7.5: Musical selections. 7.15: News session.

EVENING SESSION

7.30: W. E. Fuller will speak on "Literary Lapses and Library Lists." 7.45: T. W. Simpson, of the R.S.A., will speak on "How Tasmania is compared with the Mainland." 8.0: G.P.O. clock chimes the hour. 8.5: A programme by the Ritz Band and orchestra. 8.6: Ernest McKinley, tenor—"Walata Maori" (Hill). 8.13: Ritz Dance Band—"Luck in Love" (De Sylva); "I Goes Like This" (Caser); waltz "Just a Little Pond Affection" (Leslie). 8.18: De Rosta Quartet—"On Wings of Song" (Mendelssohn), "Adoration" (Berthoven). 8.25: Ritz Dance Band—"High on the Hill Top" (Beer); Yale, Anything You Want" (Donaldson); fox-trot, "Alabama Stamp" (Crease). 8.34: Seger Ellis, baritone—"Was It a Dream" (Coslow), "Last Night I Dreamed You Passed Me" (Coser). 8.41: Ritz Dance Band—"Ah! Sweet Mystery of Life" (Herbert); waltz "Jeannette"; waltz "Dream of Lilac Time" (Shilkret); fox-trot, "Cinnamon Cake" (vocal refrain sung by Billy Pope). 8.50: Flanagan Bros.—"The Sidewalk of New York" (Lawler); "Sweet Rose O'Grady" (Munroe). 8.57: Ritz Dance Band—"One Hundred Years from Now" (Silver); fox-trot, "I Still Love You" (Keller); Yale, "Dream House" (Foxe). 9.6: Ernest McKinley, tenor—"Beautiful Garden of Roses" (Schmid), "The Message" (Blumenthal). 9.13: Ritz Dance Band—"Just Like a Melody Out of the Sky" (Donaldson); Yale, "Love Lies" (Keller); fox-trot, "I Dream of You Anyway but Love" (Peters); waltz, "The Dream-River" (Brown). 9.25: Alfred O'Shea, tenor—"Love's Garden of Roses" (Rutherford), "When by Ships Come Sailing Home" (Stewart). 9.32: Ritz Dance Band—Yale, "Nebraska" (Revel); fox-trot, "Rio Rita"; waltz, "Tired Hands." 9.42: Jack Lumsdaine and Len Maurice—"Goo Night" (Wood). 9.45: News session. 10.0: G.P.O. clock chimes the hour. Close down.

THE BROWN "Mascot" Speaker

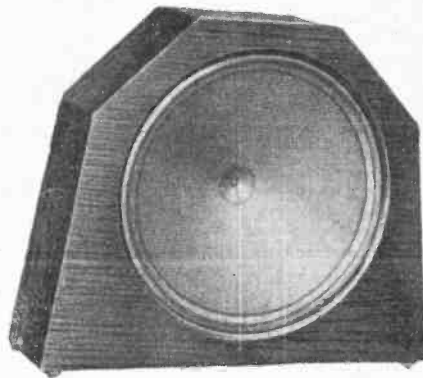

Price £6/10/-

If it's a Brown it's Good—and the "Mascot" speaker is one of the latest additions to the Brown family and, therefore, right up-to-date. Chaste in appearance, yet without dust-attracting ornamentation, it gives that realism in performance for which the Brown is justly famed. It will handle all the volume required for ordinary usage with the utmost clarity and no trace of rattle.

The "Duckling" Speaker

This is another new Brown product, modelled upon the Junior type, and expressly designed for those who require a really good speaker at a low price. The "Duckling" is made either in oak or mahogany. It stands 9½ in. high, is 11 in. wide and 3¼ in. deep.

From all Radio Dealers — Price £2/15/-

Write for Pamphlet B.W.W.

NOYES BROS.,

(SYDNEY), LTD.

Sydney: 115 Clarence Street.

Newcastle: 11 Watt Street.

Brisbane: Perry House, Elizabeth Street.

(MELBOURNE), PTY., LTD.

Melbourne: 495 Bourke Street.

Adelaide: 119 Pirie Street.

Hobart: 36 Argyle Street.

Launceston: 59 George Street.

PERTH: J. R. W. Gardam and Co.

Local Programmes, Wednesday, February 20

2FC

EARLY MORNING SESSION.

Announcer: A. S. Cochrane.

7.0: "Big Ben" and announcements. 7.2: Official weather forecast, rainfall, river reports, temperatures, astronomical memoranda. 7.7: "Sydney Morning Herald" summary. 7.12: Shipping intelligence; mail services. 7.15: Studio music. 7.25: Investment market; mining sharemarket; metal quotations; wool sales; breadstuffs markets; inter-State markets; produce markets. 7.40: Studio music. 8.0: "Big Ben." Close down.

MORNING SESSION.

Announcer: A. S. Cochrane.

10.0: "Big Ben" and announcements. 10.3: Pianoforte reproduction. 10.10: "Sydney Morning Herald" news service. 10.25: Studio music. 10.45: A talk on "Home Cooking and Recipes," by Miss Ruth Furst. 11.0: "Big Ben." A.P.A. and Reuter's cable services. 11.5: Close down.

MIDDAY SESSION.

Announcer: A. S. Cochrane.

12.0: "Big Ben" and announcements. 12.1: Stock Exchange, first call. 12.3: Official weather forecast; rainfall. 12.5: Studio music. 1.30: Stock Exchange, second call. 1.32: Weather forecast. 1.34: "Evening News" midday news service; Producers' Distributing Society's report. 1.42: Rugby wireless news. 1.45: Studio music. 2.0: "Big Ben." Close down.

Note:—Race results will be broadcast as received from Rosebery.

AFTERNOON SESSION.

Announcer: Laurence Halbert.

Accompanist: Ewart Chapple.

2.30: Programme announcements. 2.32: Musical recital. 3.0: "Big Ben." Pianoforte reproduction. 3.15: Popular music. 3.30: Aldyth Hern, soprano. 3.37: Florence Yates, contralto. 3.45: A reading. 4.0: "Big Ben." Aldyth Hern, soprano. 4.7: Popular music. 4.17: Florence Yates, contralto. 4.24: Studio music. 4.45: Stock Exchange, third call. 4.47: Studio music. 5.0: "Big Ben." Close down.

EARLY EVENING SESSION.

Announcer: A. S. Cochrane.

5.40: The chimes of 2FC. 5.45: The children's session, conducted by the "Hello Man," assisted by Uncle Ted and "Sandy." Letters and stories. Music and entertainment. 6.30: A chat about the Cheer-up Society, by Uncle Frank. 6.35: Dalgely's market reports (wool, wheat, and stock). 6.40: Fruit and vegetable markets. 6.43: Stock Exchange Information. 6.45: Weather and shipping news. 6.48: Rugby wireless news. 6.50: Late sporting news. 7.0: "Big Ben." Late news service. 7.10: The 2FC Dinner Quartette, conducted by Horace Keats—(a) "Minuet" (Schubert), (b) "Serenade" (Widor), (c) "Danse Macabre" (Saint-Saens), (d) "Extase" (Ganne), (e) "Valse" (Cui), (f) "Out of the Dawn" (Donaldson).

EVENING SESSION.

Announcer: Laurence Halbert.

Accompanist: Ewart Chapple.

7.40: Pianoforte reproduction. 7.45: Programme announcements. 7.48: Popular music. 8.0: "Big Ben." Classical programme, arranged by Harold Whittle. 9.0: Weather report. 9.1: A talk by C. R. Hall, "Out and About Iraq and Persia—Hamadan Days." 9.15: Second half of classical musical programme, arranged by Harold Whittle. 10.15: A talk by J. G. Lockley on "Old Sydney." 10.28: To-morrow's programme. 10.30: National Anthem. Close down.

2BL

MORNING SESSION

Announcer: A. C. C. Stevens.

8.0: G.P.O. chimes; metropolitan weather report. 8.1: State weather report. 8.2: Studio music. 8.15: G.P.O. chimes; news from the "Daily Telegraph Pictorial." 8.30: G.P.O. chimes; news service continued. 8.40: Information, mails, shipping, arrivals, departures, and sailings. 8.45: Studio music. 9.15: Half an hour with silent friends. 9.45:



MISS GWEN VARLEY, popular secretary of the 2BL Women's Sports Association, whose session will begin at 11.0 a.m. to-day.

Studio music. 10.0; G.P.O. chimes; close down.

MIDDAY SESSION

Announcer: A. C. C. Stevens.

11.0: G.P.O. clock and chimes; 2BL Women's Sports Association session, conducted by Miss Gwen Varley. 11.30: Advertising hints. 11.40: Women's session, conducted by Mrs. Cranfield. 12.0: G.P.O. clock and chimes; special ocean forecast and weather report. 12.3: Pianoforte reproduction. 12.30: Shipping and mails. 12.35: Market reports. 12.48: "Sun" midday news service. 1.0: Studio music. 1.30: Talk to children and special entertainment for children in hospital. 2.0: G.P.O. clock and chimes; close down. Note: Race results from Rosebery.



Mr. Basil Kirke is scheduled to speak on "Where the Foot of the White Man Really Treads," at 4.10 to-night. This is how Miss Marjorie Prichard believes Mr. Kirke must have appeared when adventuring in New Guinea.

"Sun" news service. 5.0: Our serial story. 5.10: Pianoforte reproduction. 5.25: Popular music. 5.30: Racing resume.

EARLY EVENING SESSION

Announcer: Basil Kirke.

5.40: Children's session, conducted by "Uncle Bas."; music and entertainment; letters and stories. 6.30: "Sun" news and late sporting. 6.40: 2BL Dinner Quartette—(a) "Apple Blossoms" (Siede), (b) "Rosemary" (Elliot), (c) "Memories of Youth" (Elliot), (d) "The Vagabond King" (Friml), (e) "By the Brook" (Boisdeffre), (f) "Everywhere Look" (Carew). 7.7: Australian Mercantile Land and Finance Co.'s report; weather report and forecast, by courtesy of Government Meteorologist; Producers' Distributing Society's fruit and vegetable market reports; grain and fodder report ("Sun"); dairy produce report ("Sun"). 7.25: Mr. Pim and Miss Pim in advertising talks and nonsense. 7.55: Programme and other announcements.

EVENING SESSION

Announcer: Basil Kirke.

8.0: G.P.O. chimes. The Music Makers—
(a) Suite, "Americana" (Thurban).
(b) "Cafe Chantant" (Fletcher).
(c) Entracte, "Mamselle Modiste" (Herbert).
8.15: John Warren, tenor.
8.22: Graham and Manning entertainers—
(a) "Ideal Homes" duet ("Rose").
(b) "Wherever You Go" ("Goodwin").
Dorothy Manning.
(c) "In the Beautiful Bye-and-Bye" (Gallatly), duet.
6.32: Lisle Lee, xylophone solos.
8.39: Laurel Streeter, popular vocalist.
8.46: General sporting talk by Claude Corbett.

9.0: G.P.O. chimes and weather.
9.1: The Music Makers—
(a) "Forget-me-not" ("Macbeth").
(b) "Can't You Hear Me Callin'" (Roma).
(c) "The Blue Paradise" (Romberg).
9.16: John Warren, tenor.
9.25: Euphoneum solos by Andrew Madden.
9.30: Graham and Manning, musical entertainers—
(a) "What Can the Matter Be?" (Rose).
(b) "Dance with Your Uncle Joe" (Hargreaves), Harry Graham.
(c) "Burglars" (Hocking), duet.
9.40: Laurel Streeter, popular vocalist.
9.47: The Music Makers—
(a) "Czardas" (Monti).
(b) "Baby Bunting" (Ayer).
(c) "I'll Sing Thee Songs of Araby" (Clay).
10.2: The Savoyans' Dance Band. 10.14: Announcements. 10.18: The Savoyans' Dance Band. 10.30: Late weather and announcements. 10.35: The Savoyans' Dance Band. 10.57: To-morrow's programme. 10.59: The Savoyans' Dance Band. 11.30: National Anthem. Close down.

2GB

10.0: Music. 10.10: Happiness talk by A. E. Bennett. 10.20: Music. 10.30: Women's session, by Miss Helen J. Beegling. 11.30: Close down. 2.0: Music. 2.5: Women's radio service, by Mrs. Dorothy Jordan. 2.30: Music. 3.0: Demonstration from Nock and Kirby, Special Labor Saving Demonstration. 4.0: Close down. 5.30: Children's session, by Uncle George. 7.0: Stock and market reports by New Zealand Loan and Mercantile Agency, Ltd. 7.15: Music. 8.0: Pianoforte solos by Miss Ruth Pearce Jones. 8.10: Songs by Miss Gladys Verona. 8.20: A humorous interlude by Mr. Jack Win and Mr. Heath Burdock. 8.25: Instrumental music. 8.35: Songs by Mr. Edward Barry. 8.45: Pianoforte solos by Miss Ruth Pearce Jones. 8.55: A humorous interlude by Mr. Win and Mr. Burdock. 9.0: Weather report. 9.3: Address. 9.15: Songs by Miss Gladys Verona. 9.25: Instrumental music. 9.35: Songs by Mr. Edward Barry. 9.45: Instrumental music. 9.55: Humorous interlude by Mr. Jack Win and Mr. Heath Burdock. 10.5: Orchestral items. 10.30: Close down.



BRITISH MADE

INTERFERENCE

There's no need for you to go on tolerating interference—you can get rid of it easily. The "Lewcos" Wave Trap has been specially designed to eliminate the interference bugbear from radio reception. No matter where you are situated, a "Lewcos" Wave Trap will cut out the stations you don't want, leaving you clear, uninterrupted reception.

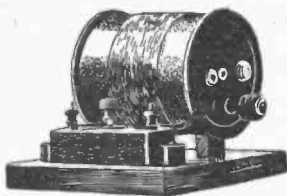

"Lewcos" Wave Trap

Highly necessary where interference is being experienced. Can be installed in a few minutes. Definitely cuts out unwanted stations. Ruggedly made, and efficient.

Price 25/-

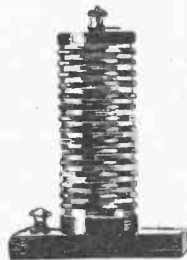

"Lewcos" High Frequency Choke

Designed to clear up reception and to prevent instability of the audio amplifier. There is no howling with the "LEWCOS" HIGH FREQUENCY CHOKE. Particularly recommended for use with screened grid receivers. May be fitted easily to your present broadcast receiver.

Price 12/6

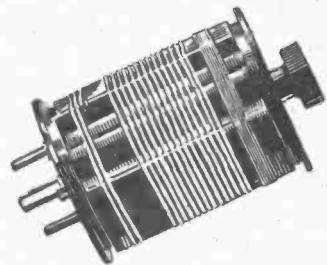

"Lewcos" Short Wave Coils

Every detail studied to ensure absolute efficiency. To reduce losses to a minimum the secondary is wound with silk insulated copper strip, giving rigidity and ultra fine tuning. Low loss design is embodied in the ribbed construction of the former. The solid construction of the "Lewcos" coils makes them essentially robust, so that they may be handled without risk of damaging.

Price 15/-

Base 3/6 Extra

OBTAINABLE ALL GOOD RADIO DEALERS

The Liverpool Electric Cable Co., Ltd.

In Conjunction with their Associated Company

LONDON ELECTRIC WIRE CO. & SMITHS LTD.

LEWCOS HOUSE, 233 CLARENCE ST., SYDNEY

Telephones { M 3821
MA 1966

Interstate Programmes, Wednesday, February 20

3LO

EARLY MORNING SESSION.

7.15 to 8.15: See Friday.

MORNING SESSION.

10.50: Eric Welch will speak on to-day's races at Moonee Valley. Announcer: Frank Hatherley. 11.0: 3LO's different diets for the daily dinner. To-day's radio recipe. Mint Jelly. 11.5: Mrs. Henrietta C. Walker.—The Art of Being a Settler.—Profitable Poultry. 11.55: Mrs. M. Callaway Macpherson—"Color in Decoration." 11.55: Mrs. Clarence Weber—"We Are What We Eat." 11.50: Description of Inter-State cricket match, Victoria v. Tasmania, at M.C.G., by Rod McGregor. 12.40: Stock Exchange information. 12.43: Description of Inter-State cricket match, Victoria v. Tasmania, continued. 1.15: Meteorological information; weather forecast for New South Wales, Australia, Tasmania, and New South Wales; ocean forecasts; river reports; rainfall. 1.25: Frank Gorman and Sadie McDonald, baritone and violinist—"Brindisi" (Alard). "T'm Lonesome" (Fryette). "Ireland Is Ireland To Me" (Ball). 1.45: Close down.

AFTERNOON SESSION.

Announcer: Frank Hatherley. 1.58: Description of Kalkallo Hurdle, 2 miles, Moonee Valley races, by Eric Welch. 2.05: Description of Sheffield Shield cricket match, Victoria v. Tasmania, at M.C.G., by Rod MacGregor. 2.28: Description of Mermaid Handicap, 5/4 furlongs. 2.35: Description of Sheffield Shield cricket match. 2.40: Description of Moreland Handicap, 7 furlongs. 3.5: Description of Sheffield Shield cricket match. 3.38: Description of Glen Elgin Handicap, 1 1/4 miles. 3.45: Description of Sheffield Shield cricket match. 4.48: Description of Sheffield Shield cricket match. 4.48: 4.55: Description of Sheffield Shield cricket match. 5.0: From the Studio—"Herald" news service; Stock Exchange information. During the afternoon results of the Donald Mackenzie Jockey Club department will be broadcast as they come to hand. 5.10: Description of Sheffield Shield cricket match, Victoria v. Tasmania, at M.C.G. Close down.

EVENING SESSION.

6.5: Answers to letters and birthday greetings by "Mary Mary." 7.30: Musical interlude. 6.35: "The Red Thread of Courage," and an old favorite for all—"Jack and the Beanstalk."

NIGHT SESSION.

Announcer: Maurice Dudley. Accompanist: Mabel Nelson. 7.5: Stock Exchange information. 7.15: Market reports. 7.30: News session; Description of Sheffield Shield cricket match, Victoria v. Tasmania. 7.43: Birthday greetings. 7.45: Out of the past. 7.48: Under the auspices of the Department of Agriculture, R. Crowe, Executive Superintendent, will speak on "Marketing Methods." 8.0: A maker of history. 8.1: The Station Orchestra—Overture, "The Carnival." 8.10: John Byrne, bass—"Oh, Bye, Bye, To Hear His Voice" (Tschakowsky). "Here's a Health Unto His Majesty" (Old English). 8.17: The Station Orchestra—Suite, "Riviera Scenes" (Brooke). 8.24: Myrtle Walscott, contralto—"The Lost Chord" (by request) (Sullivan). "Before the Dawn" (Lang). 8.31: Harold Elvins, piano—"Aragués in A Major." "Claire de Lune." "Pagodes." "Gardens Under Rain" (Debussy). 8.51: William Tainsh—"A Story About Abraham Lincoln." 9.8: The Station Orchestra—Selection, "Oh, Lady, Lady" (Hera). 9.13: Hugh Huxham's Serenader Quartette "The Quartette Para-Parade." 9.15: William, soprano, "Waiting Alone"; orchestral interlude; the Quartette, "Down On the Farm," humorous item; Renn Millar, bass; orchestral interlude; the Quartette, "The Home Rain." 9.35: The Station Orchestra—"Four American Indian Songs" (Cadden). 9.45: John Byrne, bass—"In Autumn" (Franz). "The Philanderer" (Lohr). 9.52: The Station Orchestra—"Reminiscences of Nellie Stewart" (arranged by Frederick Hall), by request. 10.2: News service; British official wireless news from Rugby; meteorological information. 10.12: Rev. Frank Gorman and Sadie McDonald, baritone and violinist—"Cannonetta" (Ambrose). "Bonnie Mary of Argyll" (Old Scotch); patter; "Jeannine" (Gilbert). 10.27: The Station Orchestra—Selection, "Moccasin" (Ponchielli). 10.37: Myrtle Walscott, contralto—"Music When Soft Voices Die." "An Epitaph" (Besley). 10.45: The Radi-o-Aces—"Old Man Sunshine" (Dixon). "My Dream Sweetheart" (Rial). "Queen's Who's Who" (Razali). "That Stolen Melody" (Fisher). "Lenora" (Gilbert). 11.1: The Radi-o-Aces—"Japanese Mammy" (Donaldson). "There's a Ricketty Ricketty Shack" (Turner). "What's the You Mean To Me" (Davis). "Lazy Feet—Piano Solo" (Masman). "Just Like a Melody Out of the Sky" (Donaldson). "Beloved" (Kahn). "I'm a Fruitee Fruitee" (I can't see who somebody said" (Woods). "Somebody's quick about you" (Murphy). 11.20: Beautiful ballads. 11.26: Ned Tyrrell's Radi-o-Aces: "Get out and get under the moon" (Tobias). "That's my weakness

3AR

Announcer: C. J. O'Connor. 10.0: G.P.O. clock says "Ten." 10.1: "Age" market reports; farm and station produce; fruit, fish, vegetable and stock. "Age" shipping reports; ocean forecast. 10.30: Mail notices; express train information. 10.35: "Age" news service, exclusive to 3AR. 10.59: Weather forecast.

MORNING MUSICAL SESSION.

11.0: Ned Tyrrell's Radi-o-Aces: "Nebraska" (Stenzel). "Forenight" (Barnett). "The Old I care who somebody said" (Woods). "Somebody's quick about you" (Murphy). 11.20: Beautiful ballads. 11.26: Ned Tyrrell's Radi-o-Aces: "Get out and get under the moon" (Tobias). "That's my weakness

now" (Sept). "What a baby" (Whitting). "Loved me" (Wilson). 11.46: Beautiful ballads. 11.49: Ned Tyrrell's Radi-o-Aces: "Why haven't we got the Sunday every day" (Summers). "Sticky paw" (Andrino). "Laugh, Clough, Clough" (New). "Never before, never again" (Chik). 11.59: Beautiful ballads. 12.4: Ned Tyrrell's Radi-o-Aces. Selected Radi-o-Aces. British wireless news from Rugby; Reuter's and the Australian Press Association cables; "Argus" news service. 12.30: Close down.

AFTERNOON SESSION.

Announcer: C. J. O'Connor. Accompanist: Mabel Nelson. 2.15: The Station Orchestra: Overture, "Zampa" (Herold). "Spirit of the Trees" (Hedley). 2.30: Rev. F. Gorman and Sadie McDonald, vocalist and raconteur and violinist; Violin and voice, "Old Pal, Old Pal"; violin solo, "Andantino"; violin and voice, "Mother Machree"; "My Task." 2.48: The Station Orchestra: "Butterflies" (Siller). 2.50: John Byrne, bass, by permission of J. C. Williamson, Ltd.: "Sands of Time" (Clay). "Requiem" (Homer). 2.57: The Station Orchestra: Selection, "Poppy" (Jovan Massonoff, tenor; "Doren" (Allon). "Ellie" (Bruch). 3.14: Station Orchestra: "Suite Romantique" (Ketyby). 3.24: Hugh Huxham's Serenaders: Quartet, "High up on the Hilltop"; Madeline Knight contralto "Golden Dancing Days"; Interlude, Dorothy Roxburgh, viola, Gavotte (Bach); humorous item, "The Farmer's" quartet, "The Prize Song"; Interlude, Percy Code, cornet solo, Babe o' Mine (Jessie Smith); quartet, "The Star." 3.44: The Station Orchestra: "Ballroom Chatters" (Albel). "Vivor" (Haddock). 3.54: Jessie Batchelor, contralto; "Yonder" (Oliver); "Three Green Bonnets" (d'Hardelet). 4.1: The Station Orchestra: "Dream Melody" (Herbert). "Lola" (Griml). 4.8: Announcements. 4.12: The Station Orchestra: Selection, "Il Trovatore" (Verdi). 4.22: John Byrne, bass: "Before the Crucifix" (Le Forge). The Lord is my Light" (Atsien). 4.27: The Station Orchestra: "Waltz" (Tschakowsky). 4.33: Jovan Massonoff, tenor: "Der Traum der Poet" (Trappe), with violin obligato by Guildford Bishop; request, item. 4.41: The Station Orchestra: Selection, "Cello." 4.49: Jessie Batchelor, contralto, "Dear Love of Mine" (Edith Hartry), "Mother's Song" (Edith Hartry). 4.58: The Station Orchestra: Selection, "Tenor" (Sewen). 5.0: Sweet solace on the Seraphina. 7.10: "Age" news service exclusive to 3AR; announcements. Results of cricket, Victoria v. Tasmania, at Melbourne. 7.15: Close down.

NIGHT SESSION.

Announcer: John Stuart. Accompanist: Mabel Nelson. 8.0: P. W. Pearce, physical culture expert, will speak on "Round Shoulders." 8.15: R. H. Owen, of the Welsh delegation, will speak on "The Welsh National Eisteddfod." 8.30: The Imperial Russian Trio, Arved Norit, violin; Ivan Bernzky, cello; Vassil Ister, piano. "Trio in F Sharp Major" (Cesar Franck). "Andante" (Grieg). 8.47: "The Wren" (Lehman). 8.47: The Imperial Russian Trio: "Trio in F Sharp Major." Scherzo allegro molto (Cesar Franck). 8.57: The Imperial Russian Trio: "Trio in F Sharp Major" (Cesar Franck), allegro maestoso. 9.14: Rev. Thomson, soprano. "The Sun" (Bumsted). "Ho, Sun" (Curran). 9.21: The Imperial Russian Trio, selected. 9.23: Syd. Epton, tenor: "If you would Transmission" (MacDermid). "Mars" (White). 9.30: The Orchestra under the baton of Henri Penn. 10.20: "Age" news service, exclusive to 3AR; announcements. Results of cricket, Victoria v. Tasmania, at M.C.G. God Save the King.

4QG

EARLY MORNING SESSION.

7.43: Time signals. 7.45: News service. 8.0: Some electric records. 8.15: News service. 8.30: Close down.

MORNING SESSION.

11.0: Music. 11.5: Social news. 11.15: Talk on "Artistic Uses of Sealing Wax and Crepe Paper, by "Denise." 11.30: Music. 11.35: More social news. 11.45: Wuritzer organ.

MIDDAY SESSION.

1.0: Market reports and weather information. 1.26: From the G.P.O., the Postal Institute Orchestra. 2.0: Close down.

AFTERNOON SESSION.

3.30: Orchestra under the baton of Mr. C. Groves. 3.30: Mail train running times; a programme of electrically-reproduced records. 4.30: Central music. 4.15: Afternoon news. 4.30: Close down.

EARLY EVENING SESSION.

6.0: Mail train running times; mail information; shipping news. 6.5: Wuritzer organ. 6.25: Commercial announcements. 6.30: Bedtime stories, conducted by "Little Miss Brisbane." 7.30: News in brief. 7.5: Stock Exchange news. 7.6: Metal quotations. 7.7: Market reports. 7.25: Fenwick's stock report. 7.30: Weather information. 7.40: Announcements. 7.45: Standard time signals. 7.45: Lecture, etc., arranged by the Queensland Agricultural High School and College.

NIGHT SESSION.

8.0: Alf Featherstone and His Orchestra, medley fox-trot "Dixie Ditties" (Black), medley fox-trot "The Blues" (Black). 8.10: Winnie Dunoon (soprano), "Irish Folk Song" (Foot). "Pierrot" (Rybner). 8.18: Alf Featherstone and His Orchestra, fox-trot "Old Man Sunshine" (Dixon), fox-trot "In the Woods" (The Blue Wound" (Johnson). 8.30: The Albert Trio, ten minutes fun. 8.40: Alf Featherstone and His Orchestra, jazz waltz "Japansy" (Klemmer). 8.45: Annie Adams (soprano), "Praise" (Haydn Wood), "They Say" (War-

wick Evans). 8.50: Alf Featherstone and His Orchestra, fox-trot "Tobias" (Miline), fox-trot "The Cot-Cot-Cotton Grows" (Le Solr). 9.0: Metropolitan weather forecast; movements of lighthouses; summer. 9.5: Edith Hartry. 9.45: Edith Hartry. "Quella" (Verdi). "Pale Moon" (Logan). 9.18: Alf Featherstone and His Orchestra, fox-trot "Sun-Boy" (Stamper). "Swinging Along" (Stamper). 9.25: The Albert Trio, ten minutes more fun. 9.35: Jeanette Smiles (soprano), "Love's Echo" (Norton). "Waltz Song" from "Tom Jones" (German). 9.40: Alf Featherstone and His Orchestra, jazz waltz "Moonlight and You" (Harvey). 9.45: Edith Hartry (soubrette), "Last Night I Dreamed You Kissed Me" (Lombaro). "Pleasant Dreams, Good-night" (Moline). 9.50: Alf Featherstone and His Orchestra, fox-trot "You've Got to Learn to Smile" (O'Hagan). fox-trot "Bill and Coo" (O'Hagan). 10.0: News weather. 10.15: Alf Featherstone and His Orchestra, three-quarters of an hour's dance music. 11.0: Close down.

5CL

MORNING SESSION.

11.0: G.P.O. chimes. 11.1: Parlophone recordings. 11.15: "Economist" market craft and menu talk. 11.30: Parlophone recordings. 11.45: Edith Hartry. M. E. Chambers (matron of Mothers and Babes Health Association)—(a) The Importance of Weighing Children. (b) Clothing for Children. 12.15: G.P.O. chimes. 12.1: Parlophone recordings. 12.15: General news service. 12.35: British official wireless news. 12.40: Parlophone recordings. 12.50: S. Railway information. 12.55: S. C. Ward and Co.'s Stock Exchange information. 12.58: Meteorological information. 1.0: G.P.O. chimes. 1.1: Parlophone recordings. 1.58: Port Broughton and Moonee Valley Lightfoot, instrumentalist. 4.0: G.P.O. chimes and close down.

AFTERNOON SESSION.

3.0: G.P.O. chimes. 3.1: Port Broughton and Moonee Valley Lightfoot, instrumentalist. 3.2: Station Quartet. 3.10: Bernard Manning, bass-baritone. 3.15: Miss Finlay, pianist. 3.22: E. J. Winnat, bass. 3.30: Station Quartet. 3.47: Violet Jackson, soprano. 3.57: Marion Lightfoot, instrumentalist. 4.0: G.P.O. chimes. 4.1: Port Broughton and Moonee Valley racing results. 4.3: Herbert King, tenor. 4.8: Station Quartet. 4.19: Bernard Manning, bass-baritone. 4.25: Geo. Goodwood, cello. 4.30: Violet Jackson, soprano. 4.36: Marion Lightfoot, instrumentalist. 4.41: Herbert King, tenor. 4.47: Station Quartet. 4.51: Moonee Valley and Port Broughton racing results. 4.57: C. Ward and Co.'s Stock Exchange information. 5.0: G.P.O. chimes and close down.

EVENING SESSION.

6.0: G.P.O. chimes. 6.1: Birthday greetings correspondence, songs and stories by "Miss Wire-lesse" Captain Donald Maclean, "Pirates and Men Pirates." 6.45: Parlophone recordings. 7.0: G.P.O. chimes. 7.1: S. C. Ward and Co.'s Stock Exchange information. 7.25: General market reports; Dalgety's stock market report. 10.0: "The Old Man." Kiek, M.A., B.D. 7.25: Boy Scouts' Corner. 7.45: S.O.A.'s Bluebird Girls' Club—entertainment by "The Bird Lady."

NIGHT SESSION.

8.0: G.P.O. chimes. 8.1: Jean Finlay, pianist-studio, "Black Note." 8.3: Bernard Manning, bass-baritone—selections from his repertoire. 8.8: Marion Lightfoot, instrumentalist—"Melodica" (The Blue Wound). "Water Nymphs" (Morley). 8.12: Violet Jackson, soprano—selections from her repertoire. 8.15: Humphrey Bishop and his musical comedy company—entertainment. 8.20: Meteorological information; stock market report. 9.33: Captain Donald Maclean, talk on "Stormy Seas and Plucky Pirates." 9.45: Humphrey Bishop and his musical comedy company. 10.0: General news service; meteorological information; Port Broughton and Moonee Valley racing results. 10.41: Dance numbers by the Radi-o-Aces. 11.0: "God Save the King."

7ZL

AFTERNOON SESSION.

3.0: Running description of Moreland Handicap, seven furlongs, run at Moonee Valley racecourse, Victoria. 3.5: Metropolitan forecast. 3.6: Music. 3.40: Running description of Glen Elgin Handicap 1 1/4 miles. 3.45: Metropolitan forecast. 3.50: News. 3.55: His Master's Voice in Moments Merry and Musical. 4.20: Running description of Magdala Welter Plate, six furlongs, run at Moonee Valley racecourse, Victoria. 4.25: Meteorological information. 4.30: Close down. 4.50: Running description of Magdala Welter Purse, six furlongs, run at Moonee Valley racecourse, Victoria. 4.55: All sporting results to hand. During the afternoon program results will be given of the cricket match, Victoria v. Tasmania, at Melbourne.

EARLY EVENING SESSION.

6.10: Moonee Valley race results. 6.15: Music. 6.30: Bertha Southey Brammell will tell a poem to the folk—"The Grass Grows Green in Greenland." 6.40: Little Teddy Richardson will sing to the little ones—"Selected" (Richardson). 6.9: G.P.O. clock chimes the wee folk by the Discus Ensemble. 7.0: Answers to letters and birthday greetings by Bertha Southey Brammell. 7.5: Music. 7.15: News session.

7.30: George Natton will give a chat on "Trees and Shrubs." 7.45: Major Henry E. Trousselot, Superintendent of the Hobart Fire Brigade, will speak on "Selected." 7.50: G.P.O. clock chimes the wee folk by the Discus Ensemble. 7.0: Answers to letters and birthday greetings by Bertha Southey Brammell. 7.5: Music. 7.15: News session. 10.0: G.P.O. clock chimes the hour. 10.1: Close down.



THOUSANDS OF PEOPLE HAVE FOUND THAT THEY GET BETTER RESULTS WITH THE 50% POPULAR PLAQUE THAN WITH OTHER SPEAKERS COSTING TWO OR THREE TIMES AS MUCH



Its amazing value and tone have astounded the critics and public alike. Substantially built, in either dark mahogany or oak, its success is due to patents exclusive to M.P.A. To hear it is to buy.

DISTRIBUTORS:—MANUFACTURERS PRODUCTS, PTY., SYDNEY AND MELBOURNE. FOX & MACGILLICUDDY, SYDNEY. T. H. MARTIN, BRISBANE.

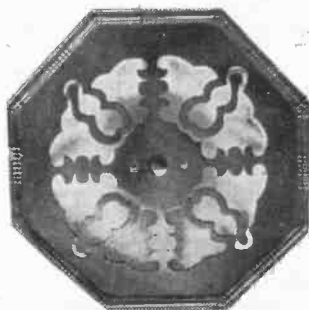

SOLE AUSTRALIAN CONCESSIONNAIRE:

CHARLES D. MACLURCAN
 PRATTEN BUILDING, 26 JAMIESON STREET, SYDNEY

PRICE'S

10%

BONUS

SALE

14th to 27th FEBRUARY

Wingello House - Angel Place - SYDNEY

Local Programmes, Thursday, February 21

2FC

Thursday, February 21

EARLY MORNING SESSION.

Announcer: A. S. Cochrane.
7.0: "Big Ben" and announcements. 7.2: Official weather forecast, rainfall, river reports, temperatures, astronomical memoranda. 7.7: "Sydney Morning Herald" summary. 7.12: Shipping intelligence; mail services. 7.15: Studio music. 7.25: Investment market; mining sharemarket; metal quotations; wool sales; breadstuffs markets; inter-State markets; produce markets. 7.40: Studio music. 8.0: "Big Ben." Close down.

MORNING SESSION.

Announcer: A. S. Cochrane.
10.0: "Big Ben" and announcements. 10.2: Pianoforte selections. 10.10: "Sydney Morning Herald" news service. 10.25: Studio music. 10.30: Last minute sporting information by the 2FC Racing Commissioner. 10.40: Studio music. 11.0: "Big Ben." A.P.A. and Reuter's cable services. 11.5: Close down.

MIDDAY SESSION.

Announcer: A. S. Cochrane.
12.0: "Big Ben" and announcements. 12.1: Stock Exchange, first call. 12.3: Official weather forecast; rainfall. 12.5: Studio music. 12.10: Summary of news, "Sydney Morning Herald." 12.15: Rugby wireless news. 12.18: A Dickens' reading by A. S. Cochrane. 12.30: Studio music. 1.0: From Martin Place, unveiling of statues on the Cenotaph. 2.0: "Big Ben." Close down.

AFTERNOON SESSION.

Announcer: Laurence Halbert.
Accompanist: Ewart Chapple.
2.30: Programme announcements. 2.32: Educational session for the schools. A short musical recital. 2.45: A talk by Raymond Wait "On the League of Nations." 3.0: Pianoforte reproduction. 3.15: Popular music. 3.30: Anne Luciano, soprano. 3.37: Studio music. 3.45: A reading. 4.0: Carlos Fakola, novelty pianist. 4.1: Studio music. 4.17: Anne Luciano, soprano. 4.24: Carlos Fakola, novelty pianist. 4.31: Popular music. 4.45: Stock Exchange, third call. 4.47: Studio music. 5.0: "Big Ben," close down.
Note:—Cricket results, England v. Western Districts, played at Bathurst, will be given at intervals during the afternoon.

EARLY EVENING SESSION.

Announcer: A. S. Cochrane.
5.40: The chimes of 2FC. 5.45: The children's session, conducted by the "Hello Man." Letters and stories. Music and entertainment. 6.30: Dalgety's market reports (wool, wheat, and stock). 6.40: Fruit and vegetable markets. 6.43: Stock Exchange information. 6.45: Weather and shipping news. 6.48: Rugby wireless news. 6.50: Late sporting news. 7.0: "Big Ben." Late news service. 7.10: The 2FC Dinner Quartette, conducted by Horace Keats—(a) "Amoretten Tanze" (Gungl), (b) "Come" (Dazar), (c) "Catherine" (Tschakowsky), (d) "As Once in Huffer Days" (Popper), (e) "The Magic Violin" (Nicholls).

EVENING SESSION.

Announcer: Laurence Halbert.
Accompanist: Ewart Chapple.
7.40: Pianoforte reproduction.
7.45: Programme announcements.
7.48: Cricket results. Popular music.
8.0: From the Capitol Theatre.
8.21: From the studio, to-night's competition, conducted by Scott Alexander.
8.36: Norman Wright, tenor.
8.43: Trio de Paris, vocal and instrumental.
(a) "Ave Maria" (Kahn). Song with obligato.
(b) "Valse" (Slinding). Piano solo.
(c) "Viennese Melody" (Gaertner). Violin solo.
(d) "Some Day, Somewhere" (Rapee). Trio.
8.56: Vignettes of Humanity, by the Story-teller.
9.11: Weather report and announcements.
9.13: From the Capitol Theatre.
9.30: From the studio, Ila Turnbull, soprano

9.37: Trio de Paris, vocal and instrumental.
(a) "Serenade" from "Don Giovanni" (Mozart). Baritone solo, with guitar.
(b) "Pale Moon" (Kreiser). Violin solo.
(c) "La Violette" (Padilla).
(d) "Angela Mia" (Rapee). Trio.
9.52: Norman Wright, tenor.
9.59: Ila Turnbull, soprano.
10.6: Trio de Paris, vocal and instrumental.
(a) "None but the Weary Heart" (Tschakowsky). Song with violin obbligato.
(b) "Gavotte" (Gossec). Violin solo.
(c) "Oh, Marie" (Di Capua). Finale.
10.16: From the Hotel Australia, Cec. Morrison's Dance Band.
10.26: From the studio, late weather.
10.30: From the Hotel Australia, Cec. Morrison's Dance Band.
10.57: From the studio, to-morrow's programme.
10.59: From the Hotel Australia, Cec. Morrison's Dance Band.
11.30: National Anthem. Close down.

2BL

Thursday, February 21

MORNING SESSION

Announcer: A. C. C. Stevens.

8.0: G.P.O. chimes; metropolitan weather report. 8.1: State weather report. 8.2: Studio music. 8.15: G.P.O. chimes; news from the "Daily Telegraph Pictorial." 8.30: G.P.O. chimes; news service continued. 8.40: Information, mails, shipping, arrivals, departures, and sailings. 8.45: Studio music. 9.15: Half an hour with silent trends. 9.45: Studio music. 10.0: G.P.O. chimes; close down.

MIDDAY SESSION

Announcer: A. C. C. Stevens.

11.0: G.P.O. clock and chimes; 2BL Women's Sports Association session, conducted by Miss Gwen Varley. 11.30: Advertising hints. 11.40: Women's session, conducted by Mrs. Cranfield. 12.0: G.P.O. clock and chimes; special ocean forecast and weather report. 12.3: Pianoforte reproduction. 12.30: Shipping and mails. 12.35: Market reports. 12.48: "Sun" midday news service. 1.0: Studio music. 1.30: Talk to children and special entertainment for children in hospital. 2.0: G.P.O. clock and chimes; close down.

AFTERNOON SESSION

Announcer: A. C. C. Stevens.

Accompanist: Kathleen Roe.
3.45: G.P.O. clock and chimes; cricket results and popular music. 4.0: Romano's Cafe Dance Orchestra, conducted by Bennie Abrahams. 4.10: From the studio—Glady's Gordon, popular vocalist—(a) "Leonore" (Cazabon), (b) "On Saturday Night" (Burke). 4.17: Studio music. 4.37: Anne Pyrk, soprano. 4.37: "Sun" news service. 4.40: Romano's Cafe Dance Orchestra, conducted by Bennie Abrahams. 4.50: From the studio, popular music. 4.57: "Sun" news service. 5.0: Our serial story. 5.10: Anne Pyrk, soprano. 5.17: Pianoforte reproduction. 5.25: Popular music. 5.37: Features of the evening's programme.

EARLY EVENING SESSION.

Announcer: Basil Kirke.

5.40: Children's session, conducted by Uncle Peter. Music and entertainment. Letters and stories. 6.30: "Sun" news and late sporting. 6.40: 2BL dinner quartette. (a) "Cinderella's Procession" (Dicker). (b) "The Cobbler" (Lohr). (c) "Humoresque" (Tschakowsky). (d) "Ambodied" (Schumann). (e) "At the Play" (York Bowen). (f) "Boating Song" (Mendelssohn). 7.7: Australian Mercantile, Land, and Finance Co.'s report. Weather report and forecast by courtesy of Government Meteorologist. Producers' Distributing Society's fruit and vegetable market reports. Grain and fodder report ("Sun"). Dairy produce report ("Sun"). Weekly traffic bulletin. 7.25: Mr. Plm and Miss Pam in advertising talks and nonsense. 7.55: Programme and other announcements.

EVENING SESSION.

Announcer: Basil Kirke.

Accompanist: G. Vern Barnett.

8.0: G.P.O. chimes.
Will Clark (basso).
8.10: From the Rose Bay Wintergarden Theatre. The Rose Bay Theatre Orchestra, conducted by Lionel Hart.
8.30: From the studio. Harry Graham's Snapshot Revue—
(a) Introductory Snapshot, "How Do You Do?" (Jordan).
(b) Concerted Snapshot, "Sing a Song of Sixpence" (Rose).
(c) Talkative Snapshot, "The Boarding house."
(d) Vocal Snapshot, "The Indian Love Call."
(e) Sketchy Snapshot, "Waiting."
(f) Concerted Snapshot, "Historical Tall-tails" (Rose).
(g) Sketchy Snapshot, "Mustard."
(h) Concerted Vocal Snapshot, "A Negro Medley" (Manuscript).
(i) Sketchy Snapshot, "The Cure."
(j) Burlesque Snapshot, "Granted" (Rose).
(k) Finale Snapshot, "Good-night" (Goodwins).

9.30: Weather report.
9.31: Ivy Green (soprano).
(a) "The Valley of Laughter" (Sanderson).
(b) "The Silver Ring" (Chaminade).
9.38: Ida Tear (pianist).
(a) "Prelude in A" (Chopin).
(b) "Valse in G flat" (Chopin).
(c) "Polonaise in A flat" (Chopin).
9.48: Cyril James (baritone).
9.55: Ida Tear (pianist).
(a) "Gavotte" (Brahms).
(b) "Frolle" (Calros-Rego).
(c) "Noel" (Gardiner). (d) "Turkish March" (Rubinstein).
10.5: Ivy Green (soprano).
(a) "Happy Song" (Del Riego).
(b) "Last Night" (Kjerulf).
10.12: From the Rose Bay Wintergarden Theatre. The Rose Bay Wintergarden Orchestra, conducted by Lionel Hart.
10.27: Features of to-morrow's programme.
10.30: National Anthem.
Close down.

2GB

10.0: Music. 10.10: Happiness talk by A. E. Bennett. 10.20: Music. 10.30: Women's session, by Miss Helen J. Beegling. 11.30: Close down. 2.0: Music. 2.5: Women's radio service, by Mrs. Dorothy Jordan. 2.30: Music. 3.0: Talk by G. H. Chappel. 3.15: Close down. 5.30: Children's session, by Uncle George. 7.0: Stock and market reports by New Zealand Loan and Mercantile Agency Ltd. 7.15: Music. 8.0: Songs by Miss Heather Kinnaird. 8.10: Pianoforte solos by Miss Jean Read. 8.20: A humorous interlude by Mr. Jack Win and Mr. Heath Burdock. 8.25: Songs by Mr. Robert Cotterill. 8.35: Instrumental music. 8.45: Songs by Miss Gladys Edwards. 8.55: A humorous interlude. 9.0: Weather report. 9.3: Address. 9.15: Songs by Miss Heather Kinnaird. 9.25: Pianoforte solos by Miss Jean Read. 9.35: Songs by Mr. Robert Cotterill. 9.45: Instrumental music. 9.55: A humorous interlude by Mr. Jack Win and Mr. Heath Burdock. 10.0: Songs by Miss Gladys Edwards. 10.10: Orchestral items. 10.30: Close down.

2UW

MIDDAY SESSION.

12.30: Music. 1.0: G.P.O. clock and chimes. Music. 2.30: Close down. 4.30: Musical programme.

EVENING SESSION.

5.30: Children's hour, conducted by Uncle Jack. 6.30: Close down. 7.0: G.P.O. clock and chimes. Music. 8.0: To-day's anniversary. Music. 8.15: Garden talk, by Mr. S. H. Hunt. 8.25: Music. 9.0: G.P.O. clock and chimes. Comments on foreign affairs, by Mr. J. M. Prentice. 9.10: Music and request numbers. 10.0: Close down.

What Battery

NO need to ponder the claims of this battery or that—no need to waste time considering the matter.

Behind CLYDE stands over forty years' prestige of one of the largest engineering organisations in the Empire.

With every confidence in both the makers and the battery, you may select a

CLYDE.

**For Cars Radio and
Home Lighting**

CLYDE

Clyde Batteries for cars, radio and home lighting, are made by The Clyde Engineering Co. Ltd., Granville, N.S.W., largest makers of storage batteries in Australia.

OBTAINABLE AT ALL RADIO DEALERS AND GARAGES THROUGHOUT THE COMMONWEALTH.

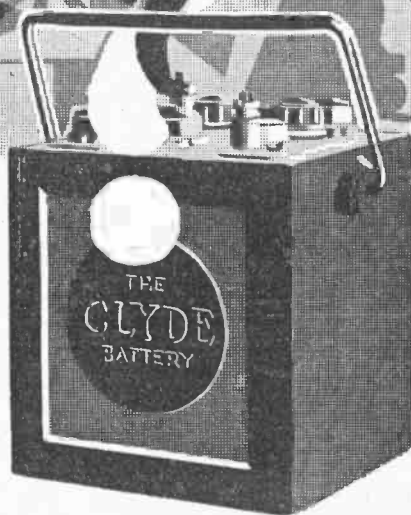

Wireless Weekly

52 ISSUES DELIVERED POST FREE FOR ONE YEAR

13/-

"WIRELESS WEEKLY" gives you the complete broadcasting programmes from every important station in Australia a week in advance in addition to topical news and articles and a technical constructive article by a qualified radio man.

SUBSCRIPTION FORM

To the Editor, "Wireless Weekly," 51 Castlereagh Street, Sydney.

Please forward "Wireless Weekly" for a period of
for which I enclose for
(Add Exchange to Country Cheques.)

NAME

ADDRESS

Subscription Rates: 12 months (52 issues), 13/- post free; 6 months (26 issues), 6/6 post free.

News and Notes from All Stations

Courtney Ford

AT one time a member of Branscombe's "Scarlet Troubadours" and the famous "Dandies," Courtney Ford has a wealth of humor with which he is entertaining listeners to 3LO. He has broadcast with marked success from 2FC, 2BL, Sydney; and latterly from 5CL, Adelaide. Many of his numbers are his own composition, and he has made quite a name for himself with snappy, one-act plays, written by him specially for broadcasting.

The Ever-popular Pat

PAT M'LEAN, who from time to time adds much to the brightness of the programme at 3LO, will be at the studio again on February 23, in some witty musical comedy songs, and her inimitable child impersonations. This time Pat will be armed with her ukulele, and will accompany her own vocal numbers. This versatile little artist always scores heavily at the many concerts that claim her services, and it is generally agreed that as a child impersonator she "stands alone."

Control of Insect Pests

UNDER the auspices of the Department of Agriculture, a talk will be given on the "Control of the Insect Pest," by G. T. Levick, science field officer for the department. In view of the fact that a heavy toll is taken each season after season from all crops by various pests, this talk, which will deal with their control and destruction, should prove of great value to the farming community.

"Abo." Talks from 3AR

OF special interest is the talk to be broadcast by A. S. Kenyon from 3AR on Sunday, February 17, when he will discuss "The Original: Australia's Obligation and Duty." Kenyon has made a wide study of the "Abo.," viewing the position from all viewpoints, and in view of the recent faming scare from the far north his remarks should throw some light on the subject.

The World Beyond

AS Miss Dulcie Blair struck out the last notes of Cesar Cui's "Orientale," a motor horn sounded in the street below. Not blatantly, but in perfect harmony, although the two sounds coming through the loud speaker gave a somewhat bizarre effect. People who sit in the control room at 2BL hear strange and weird mixtures. Often, during a quartette number, the songs of innumerable bagpipes float up and mingle with Mozart. Sometimes a dance orchestra at the National Club, just over the way, competes with a loud-speaker song of Schubert. And the tramcars have no respect whatever for Chopin, Brahms, or Wagner. Mr. Jack Barnett when he said, after an announcement of "Annie Laurie," that it would probably be Motor Lorry.

Nature's Announcer

YEA! Even Mr. Basil Kirke, on the stormy night of Monday, February 4. "At the present moment," he said, "a severe electric storm is passing over the city. Thunder, with vivid flashes of lightning, is illuminating the city." . . . Crash! At that moment, with a most discomfoting banging and scratching of the loud speaker, 2BL went off the air for the night.

and Exton Again

AND EXTON, who is always a welcome visitor to the broadcasting studio, will be heard from 3AR on February 17 in some old English melodies. Though Mr. Exton is heard to equal advantage in opera, oratorio, and modern ballads, he receives so many requests for old English melodies, such as "My pretty Jane" and "Come Into the Garden." . . . and, that he always makes a point of including one or two of these in his broadcasting programmes.

Harold Elvins and 3LO

HAROLD ELVINS, who, as one of Melbourne's leading pianists, needs no introduction to listeners, is programmed to give another recital from 3LO on Wednesday, February 20. Mr. Elvins recitals are always greatly appreciated, especially by a wide circle of students, who regard them in the light of an excellent lesson, displaying perfect touch, technique, and interpretation.

The WIRELESS WEEKLY

INFORMATION

Under the direction of

Ray Allsop
and
Don B. Knock

Associate Technical Editor

Correspondence Answered

only through
these
Columns

(See Coupon Below)

A.M. (Mackville). "I have read (up to date) the articles written by you under the heading "Proving Radio." Whilst writing this way, I want to tell you it is what I have been wanting—hungrily—and I appreciate your efforts to guide and help such as myself that need a little guidance. However, in Article 1, the first of your series, you refer only to frictional electricity, and not to chemical. When shall we have chemical electricity? Re the electroscopes (Article 2), you do not show how it comes these ends of the gold leaf DO separate and draw together—what is the theory? In Article 3, you mention polarisation. What IS polarisation and de-polarisation as you proceed with the articles you will be more explicit and describe the actions more fully, as I am anticipating your articles, being a great boon to me. I do not ask you to treat this at length, but only as a sincere request for knowledge of a lot that is puzzling."

Answer: I am glad you frankly stated your difficulties. I shall pay more attention to detail in future. Chemical electricity will follow in a later series—nothing will be missed. All phases of electricity will be treated in turn. It would not be advisable to discuss chemical electricity further just yet, as the reader may become confused. Learn the theory of simple static electricity first. There is "Method in Madness." As sugar dust falls on the electroscope, the leaves are drawn towards each other because a current of electricity is generated. One-half of the gold leaf becomes charged with negative, and the other half with positive electricity—for where electricity exists, there must be two polarities (negative and positive). The reason why the leaves diverge, is because unlike signs, i.e., unlike kinds of electricity attract, therefore the negatively charged leaf will attract the positively charged leaf. The leaf becomes a simple magnet of the horseshoe type. The same happens with the broken end of the stick of sealing wax is held against the electroscope. When a glass rod is rubbed with silk, the silk takes on a charge of negative electricity, and the glass rod a positive polarity. As the leaves are attracted towards the glass rod (when placed near the electroscope), will cause the leaves to fly apart, as there is an abundance of positive electricity, and the negatively charged leaf takes on the negative polarity. As the leaves draw near to one another, and as both leaves are then positively electrified, they repel each other. Polarisation is the effect caused by gas bubbles forming on the carbon rod, thereby insulating it from the action of the electrolyte, and causing a poor current to flow. De-polarisation is the effect of so making the positive rod immune from the effects of these bubbles, yet sensitive to the action of the electrolyte, as explained with the article on the improved cell. Glad to hear you like the series.

G.L.D. (Rosenfeld). "Re the instructions for making a simple cell which appeared in "Proving Radio" No. 2, could you please tell me where I can obtain the necessary zinc rod for this cell? I have been unable to obtain it."

Answer: John Daniels, Swans, Ltd., or Selby's can supply.

S.E.S. (Enfield). "Please find enclosed a copy of "B" eliminator circuit. I would be obliged if you would tell me, via the Radio Information Service, if this circuit is correct. What are the resistance values? Would an ordinary receiving valve do? I think the new "Wireless Weekly" is a boon to nugs and experts alike. "Proving Radio" is what we nugs have been praying for this last two years. I also get invaluable help from your Radio Information Service, which should encourage set-owners."

Answer: The circuit is incorrect. Follow out the circuit of An Inexpensive "B" Eliminator. Values of resistances are stated in the article. Glad you like "Proving Radio."

"A Constant Reader" (Casino). "Would you kindly answer a few questions, re "Proving Radio" through your valued paper? I understand these articles are for those who wish to sit in for the A.O.P.C., and would like to know how long the course in "Wireless Weekly" will last; when and where the A.O.P.C. is held; what is the fee? Would it be convenient for you to publish a complete list of apparatus and parts used in the course to be published in your paper for the benefit of country

readers, who, like myself, are too far from Sydney to get the required parts as the weekly instalments come out, quickly or conveniently. The necessary things could then be bought in bulk to last the whole course."

Answer: The articles are intended for those who intend studying for the A.O.P.C. and also for those who desire a little more knowledge of the mysteries of radio. The course itself will follow later. The complete course will last approximately a year or eighteen months. It is very hard to say yet, because every matter is to be thorough, treated, and it is impossible to make up all the articles ahead, and new rules and conditions are constantly coming forward. The fee made by the P.M.G.'s Department (Radio Section, Castlereagh Street), when the examination is held, is £/-. The transmitter's license costs 20/-. It is hardly possible to give a complete list of all parts that will be used. They will not be costly. Here is a good guide—none of these things will be wasted if you buy them: A pound of 24-gauge D.C.C. copper wire, a bar magnet, a horseshoe magnet, some carbon rods, some zinc rods, a torch globe and holder, half a dozen yards of flex, a couple of test tubes, some shellac, sealing wax, cheap voltmeter, etc. You will be taught how to make your own buzzers, headphones, microphones, etc. Mr. O. V. Hook, 28 Blairgowrie Street, Dulwich Hill, wishes to get in touch with you.

GENERAL: Owing to the tremendous number of queries received since the first issue of our new series, readers must not be disappointed if their answers do not appear so soon as they might wish, as, owing to limited space, it becomes extremely difficult to crush all answers in the one issue.

J.B. (Glebe Point). "About eighteen months ago (it may be a little more), you published the circuit of a four-valve Browning Drake. After getting the set assembled, and ready for wiring, I lost my copy. I wired up the best I could by copying from other circuits, but have not been able to get satisfactory results. Have you a back number of this particular issue? The number was 283."

Answer: Sorry; there are no copies left. Some reader may be able to oblige. Name and address. J. Burton, 2 Mary Street, Glebe Point.

W.C.F. (Armidale). "Would you please advise me of the best method of increasing volume during daylight? My set is a six-valve Atwater Kent. Reception after about 6.30 p.m. is good, but during day reception curiously enough can only be had from 2FC—distinguishable at times, but too weak to be of any use. Batteries have been charged and tested. Aerial and earth are O.K."

Answer: Do not advise you to alter or in any way add to your set. Daylight reception of distant stations is always poor. The most likely explanation is that the heavy dielectric expands with the heat of day, and as electromagnetic or other waves must first reach this band before it can be reflected to earth, there is a great deal of dissipation by the time a distant listener has received the signals.

J.G.H. (Woy Woy). "Yes, the question marks referred to your letter. Sorry, but I can't make head

or tail of any of your letters—I have four of them here—no one can read them."

T.L.J. (Bondi). "I have just finished my "Nicolos" receiver, and had good results. All "A" and "B" local stations good speaker strength, and 120 volts 2BL had closed down, with good 'phone delivery. I wired it according to your diagram for 'phone service. You mentioned a grid-battery for speaker service. I built my Gloomchaser with four B40s and one B400. It improved the set? I happened to have a Grid Double Rotor Tuner, which I incorporated in the Gloomchaser and had good local strength, but not much satisfaction from interstate. There are so many components in this beautiful set to find which is faulty—if any. I tried one Philips B418, two A425, one B403, and one B406, but found that four B406 and one B403 (in the detector socket) gave better results. I used O.A.V. loud speaker (three years old) suitable for the "Nicolos." The little "Nicolos" seems to cheer the big follow up. Perhaps you could advise me on these points, just picking out the Gloomchasers. (Once again, will readers please quote queries at the head of the letter, and follow with explanations, etc.—Ed.) I don't wish to convert my Gloomchaser into a Screen Grid, as at present it wouldn't do justice to the "valves."

Answer: Disconnect the wire which goes to the filament connection of the transformer, and connect the F terminal of the transformer to the negative terminal of the "O" battery. Connect O plus to a minus. I would improve quality of tone, and length on the life of the "B" batteries. Place a .001 mfd. condenser across the primary of the transformer. This may help you to increase the volume on distant stations. The speaker will be suitable for the Gloomchaser if it is in order. Has it been tested? Did you try reversing the crystals? Did you try half a dozen crystals before he finds a sensitive one. Try knocking on one and sharply.

Mr. Thomas L. Johnston, 5 Brighton Flats, 68 O'Connell Street, Bondi, has kindly offered to let me have back numbers, if they care to call for them. Mr. Johnston has back numbers for over a year.

T.Y. (Mascot). "Would you advise me to carry out the idea explained in the accompanying diagram? I am experiencing a lot of hum—how could I remedy it?"

R.K.F. (Cremorne). "I am building a "B" battery eliminator for my receiving set. The local power is 240 volts D.C. Can you tell me how to step this down to 120 volts?"

Answer: D.C. cannot be stepped down, though resistance placed in the circuit may be used to drop the voltage. A filter will be required, and a 1 mfd. condenser must be placed in the aerial and earth leads. Under no conditions use an earth that is not connected through a 1 mfd. condenser. Use a potential divider for the resistance. A circuit is shown in these columns.

"R.R.L.—No letter was received with your circuit, which is a Rehnartz. You stuck the circuit inside as well as outside, and the battery is placed upside down. It. Where's your letter and coupon?"

T.K. (Maroubra). "Please call for your crystal set. We have had photographs taken."

M.P. (Woolahra). "The Interference Eliminator appeared in these columns on January 4, 1929."

F.C. (Goulburn). "In "Proving Radio" the author discusses wet and "dry" batteries, and tells how to make them. Will these batteries work valve sets?"

Answer: Yes, providing you use the correct number. Allow 1.5 volts per cell, and connect in series to increase the voltage. As the amperage is rather low, it would be advisable to connect some in parallel also—the number connected in parallel makes no difference to reception, but gives longer service.

G.F. (Mosman). "When did the last A.O.P.C. exams take place?"

Answer: February 2.

(1) "At what time do these exams commence?"

Answer: 9 a.m.

(2) "What is the Radio Inspector's address?"

Answer: 219 Castlereagh Street, Sydney.

(3) "Please give some sample questions that are asked."

Answer: Using copper foil and mica, compute the number of dielectrics required to construct a .001 mfd. condenser. Take S.I.C. mica as 5, its thickness as .002 inches, and an area per dielectric of 1 square inch. Explain fully the operation of a Colpitts and a Tuner circuit. Give some important considerations in designing a choke coil for use as a 50-cycle filter. Explain the use of a counterpoise.

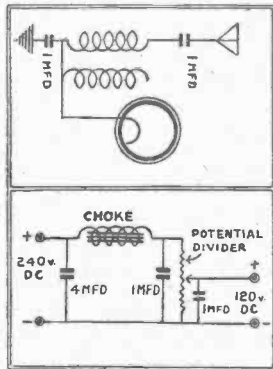

The diagram requested in explanation for R.K.F. (Cremorne).

How would you tune a counterpoise? Explain fully the beating modulation system. Explain the difference between A.C. and D.C. Write what you know about chemical cells. When do you understand the abbreviation "R.R." as from a ship to a coast station? In the address, how would you count letters, N.S.W., New York, 1234? In the text, how would you count (no doubt) and (89)? What is the value of the signal, become doubtful? How would you cancel a radio-telegram? What classes of messages are not admitted in radio-telegraphic service? State the order of priority of messages.

Q. "What elements must one have to pass?"
 Answer: 75 per cent.
 Q. (South Brisbane).—"Would you please give me the instructions on how to make a crystal set?"
 Answer: Wind 30 turns of 24-gauge D.C.C. wire on a former, 3 inches in diameter. In the centre of this wire and an additional 10 turns. Connect the aerial to the first turn of the 50 coil, and thence to one side of the crystal and to one side of the phones. The other side of the phones should be connected to the other end of the 50-turn coil, and thence to the other side of the crystal. Take a lead from the 10 coil to the fixed plates of a .0005 mfd. condenser. Connect the moving plates of this condenser to the other end of the small coil. You will find this circuit gives plenty of volume and is very sensitive.

Q.C.L. (Lane Cove).—"Is Cocky's one valve selection correct? Yes, and it can be made more so by using a .001 fixed condenser in the aerial-lead, as suggested in the article for city listeners."
 Q. "Could I add regeneration to it?"
 Answer: Yes, simply by making the coil variable, and using a condenser of .00025 in parallel with the reaction coil.
 Q. "Could I use Philips' A415 valve in place of the 2L19?"

Answer: Yes. Any good detector valve will suffice.
 Q. "Do you think it advisable to use a carbonium detector in place of the grid leak?"
 Answer: No. The resistance of a crystal varies considerably with the humidity of the air.
 Q. "Will 22-gauge wire do in place of 24?"
 Answer: Yes.
 Q. "PUZZLED" (Baradine).—"Would you please inform me as to the gauges of the pieces of wire enclosed?"
 Answer: No. 1, 38 gauge S.S.C.; No. 2, 33 gauge S.S.C.; No. 3, 30 gauge S.S.C.; No. 4, 34 gauge S.S.C.; No. 5, 26 gauge D.C.C.

A.W.W. (Leadville).—"I have recently purchased a wireless set, and I would like to get a license. Would you be so good as to inform me to whom I have to apply for a license, and what is the cost?"
 Answer: Through the local post office. The annual license costs 24s.
 R.F. (P.H.).—"Would it be possible to set aside at the conclusion of each volume a page detailing the contents of the volume, and so assisting those of your readers who keep their 'Wireless Weeklies' from year to year to find matters of interest without having to go through each copy? I also hope that Mr. R. Meadows will incorporate in his series such matters as to give to the approximate capacity of variable condensers—value of capacity when fixed condensers are connected in series and parallel; how to find the resistance in ohms of rheostats, potentiometers, etc.; and other matters of interest to your readers who are professors of mathematics. I would also like to see a little more detail regarding coil construction. My only criticism may be considered constructive and not destructive, and I wish your journal very much improved."
 Answer: The Index Page is a good idea. It will be considered. Glad you like "Proving Radio." Condensers and other components mentioned will all be treated in full as to their use in the next issue. We appreciate well-meant criticism. Thanks for your kind remarks regarding the paper.

P.G.O. (Toowoomba).—"Proving Radio" is just what most of us have been waiting for. However, the book does not contain enough detail. They are particularly clear, and, though I understand it is practically impossible to tell one everything about say, condensers, I should like to know a little more of the nature of the writer is giving us.
 Answer: Of course you do; but first you must get an idea of how each component functions. It will be time to discuss mathematical conditions. The "Proving Radio" series is leading up to this. We assure you nothing will be missed. Glad you wrote us your own ideas.
 J.L.G. (Brisbane).—"As a constant reader of your excellent journal for the past four years I am writing to ask if you would be kind enough to assist me through the columns of your Radio, 15/2/29. I wish to secure a copy of the first issue of 'Radio' (in Australia and New Zealand), published May, 1927. I have the other 19 issues, but unfortunately missed the first issue, and though I have made several attempts to get a copy of it I have been unsuccessful. I will greatly appreciate and esteem a copy if any reader can supply, and will pay a reasonable price for it if any of your readers can oblige me. The address is Robert Street, Wellington.
 Answer: Your request is published above, Mr. Carr. Hope you obtain the copy. Thanks for your kind remarks.
 H.S. (South Lismore).—"I wish to add a stage of green-grid R.F. to my present short wave adaptor, and to have it wired in 'Radio', 15/2/29. I am enclosing a circuit which I made up myself. Will you inform me if it will work O.K.? My coil kit is adequate. Would it be suitable?"
 Answer: The circuit is O.K., with one exception. A variable condenser of .00015 mfd. should be shunted across the primary coil, which should be inductively coupled. Make certain you connect "B" negative to the negative, otherwise you will short the 1 mfd. condenser. The R.F. stage kit is O.K. For the aerial lead in the R.F. stage use a few more turns than shown in use on the secondary of the detector.

K.D.D. (Moree).—"I am having trouble with the output of my Peridyne. This crystal will not function at all. When it is in position there is a continual hiss in the speaker, and reception is impossible. When the crystal is removed and crystal clips short circuited, reception becomes about equal to the ordinary five-valve set. I have tried several O.K. valves, various 'B' voltages and another crystal."
 Answer: In spite of the fact that you have tried another crystal I think you will find the trouble lies here. Unfortunately a batch of "dead" crystals were recently on the market. Some readers tried as many as ten crystals before they found a good one. Try tapping one end of the crystal sharply. If this has no effect try another crystal. A new batch has just arrived on the market, and these O.K. Your dealer will probably change the defective ones for you. Use the same voltage on the plate of the S.G. as you are using on the 6 amplifiers. Try an R.F. choke in series with the B plus amplifier leads, and another in series with the plate of the S.G. valve.
 F.O.D. (Lismore).—"I am enclosing a rough sketch of a set just up from Sydney. I can get Sydney, Brisbane, and Melbourne 'A' stations at good speaker strength on cool nights; but, unless I keep my hand on the knob of the condenser, the set squeals. How can I correct matters?"
 Answer: The trouble may be due to a faulty "B" battery or a damaged valve.
 S.K. (Queensland).—"I have a three-valve set on which I get excellent results on 3LQ, 3AV, 3UZ, 2BL, 2FC, 2GB, 2UE, 2KY, and 4QG—good speaker strength. I use 135 volts on A615, 609 valves. Will this do any damage? Which set out of list attached do you consider best?"
 Answer: No, voltage O.K.; though, of course, it is always advisable to use the least amount of "B" battery possible. If you reduce the "B" voltage to 120 you will not notice any difference. The Marco Four is the better receiver.
 R.H.F. (Concord).—"I am forwarding you a schedule of W2XAD and 2XAF. This differs from the one published in 'Wireless Weekly.' What receiver using the S.G. valve would give me good results on the broadcast band, and be capable of tuning down to 200 metres? I am getting good results on short wave at present. Why is this?"
 Answer: The schedule you forwarded was in G.M.T. We received the same schedule, and altered times to S.M.T. This explains the difference. S.M.T. is approximately ten hours ahead of G.M.T. The Martini Screen Grid Five would suit your requirements. Short-wave reception varies with conditions. They are very favorable at present.
 B.K.V. (Port Kembla).—"I have just built the Marco Four, which is giving me results. This set, however, certainly comes up to the high standard claimed for it. However, I am unable to bring in 2UW. What might I do to help me receive this station?"
 Answer: Try various fixed condensers in series with the aerial lead. This will reduce the capacity without having to alter the coil.
 D.E.T. (Sydney).—"We have a four-valve electric receiver. We can hear the stations very plainly, but there is always a whistling going on. Would you be so kind as to inform me what should be done?"
 Answer: Reduce the voltage placed on the detector valve, and see that the speaker is not placed on top of the cabinet or facing the valves. Place the cabinet on shock absorbers, such as sponge rubber.
 D.G.C. (Kygoe).—"Do you think speaker 'B' is better than speaker 'A'?"
 Answer: There is little to choose between the two. Speaker "B," however, accentuates the high notes, and is best on the low; whilst speaker "A" is a little weak on the high notes, but good on the low.
 F.S. (Inverell).—"Which would be better: Dry batteries, accumulator, or an eliminator for 'B' supply? If an eliminator, would Philips' be O.K.?"
 Answer: A matter of taste. Dry batteries are expensive. Accumulators are cumbersome and messy (especially "B" batteries), and charging becomes a nuisance unless you have your own charger. Eliminators have their little faults, too. An accumulator or eliminator would be better than dry batteries. The eliminator mentioned is O.K.
 Q.L.E. (Wenworth Falls).—"I had whilst at Cheltenham a crystal set which gave excellent results, and on coming here was advised to install a one-valve receiver. I have built a set, but cannot get any results. My aerial is attached to a high tree on one side and an iron post at the other end. It is earthed to a piece of galvanised iron, 18 inches in the ground. The only result is a loud burr."
 Answer: An open grid circuit evidently. Test grid leak, grid condenser, and grid bias battery and leads

(if "C" battery is used). Also see that the valve is making good contact in the socket. Presume aerial is insulated from the iron pole. The galvanised iron should be buried at least two feet deep. The Countryman's One Valve would be a good set for you to build.

R.L. (Toowoomba).—"I am greatly interested in the Marco Four appearing in last week's issue, and desire to build same. Can I use .00035 variable condensers in place of those specified, i.e., .0005?"
 Answer: No, the capacity is too small.

To
**RADIO
 AND
 PHONOGRAPH
 Manufacturers!**

PATENT RIGHTS FOR SALE

of a New Invention for Radio Horn Speakers and Phonograph Tone Arms. Does away entirely with that hollow, tinny sound. Gives, instead, unimpaired clarity and purity, with amplified volume. Fills a long-felt want, and is inexpensive to manufacture. Big profits for the manufacturer who secures this patent.

For further particulars, write to
SPRUSON & FERGUSON,
 Patent Attorneys,
**DAILY TELEGRAPH BUILDING,
 SYDNEY.**

**FULLER
 QUALITY
 ACCUMULATORS**
 GILBERT-LODGE & CO., LTD.

RADIO CABINETS
 Before Building your next Set, come along and inspect our wonderful variety of ART CABINETS. Also combined Radio and Gramophone Console Cabinets, polished any color to match your furniture.
 WRITE FOR CATALOGUE.
PRIMA DONNA RADIO & CABINET CO.,
 264 OXFORD ST., WOOLLAHRA.
 PHONE: FW2328.

TRANSFORMERS.
 Built up to a specification and wound, insulation iron cut to any size from stock. Prices and estimates on application.
O'DONNELL, GRIFFIN, CO., Ltd.,
 53 Druitt Street, Sydney.
 Phones: M 2991 (3 lines).

W. FURNESS,
 1st Floor, Furness Chambers,
KING'S CROSS, DARLINGHURST.
 Shields, Coils, and all Component Parts used in the Test Set 1928 Solodyne. Coils are guaranteed to proper specification.
 Shields assembled if desired.
 Terms may be arranged.

QUERY COUPON

If you are in difficulties about reception or set-construction, let us know, and we will endeavor to set you right. Make your questions brief to the point, and, where possible, show lay-out and wiring design. Under no circumstances will answers to queries be made by letter or by telephone. All answers will appear in the columns of this department in the order in which they are received.

Use the Radio Information Service, the Information Service Department, at WARRYLBS W.B.B.K. in your own interest. Enclose this coupon in order to indicate that you are a bona-fide reader.

A.R.W. (Sydney).—"Regarding Harringtons' Popular Three, new style, I have been informed by Messrs. Harringtons that the above set is a Reinartz Three with their own modifications; but they refused to supply me with a circuit. As I would prefer to understand what my set is doing so that I can appreciate your articles I shall be obliged if you will supply same. There is no R.F. choke in the set, and I have been advised to place one in the receiver. My inquiries are prompted by the fact that I am compelled to detune all stations but 2UW, as they are too loud. Will you please answer the following question? (1) Where should the R.F. choke be connected?"

Answer: One side of the choke should be connected to the plate of the first stage, the other end to the other side of the choke should be connected to the plate of the first audio transformer.

(2) "Would a stage of R.F. added to my set convert it into a Marco Four, and thus enable me to get inter-State comfortably?"

Answer: Yes.

(3) "You advised H.G.W. (Concord) in 'Wireless Weekly,' February 1, 1929, to add a stage of R.F. to his Reinartz three, but I am unable to understand how and where such a stage is to be attached to my set. Can the R.F. stage be placed inside, behind the door of the cabinet, and the rest of your articles are always interesting, even to a novice."

Answer: See the Marco Four published last week. You need not advise you to place the R.F. stage as suggested, as there would be long leads. Thanks for your kind remarks. Regret we cannot supply you with Harringtons' diagram, which is more or less a "trade secret." The conventional circuit will be seen in the Marco Four.

H.P. (Wallerawang).—"I have a three-valve receiver, layout enclosed. The volume comes and goes, and I find it very annoying, and this is being said at times. Daylight reception is bad, at night-time not much better."

Answer: Your district is a bad one for reception of Sydney stations, and you are not getting through fading. Also look to the "A" battery, which may be run down. The aerial may also be touching a tree or other earthed object. Advise you to add a stage of R.F. to the set.

H.T. (Allandale).—"I am a reader of your valuable paper, and think it just the thing. I built the three-valve set as shown in August 10th issue, in the R.T.S. of the last issue, a certain Mr. Y.E., of Yanco, says he has built a crystal set from directions shown in the Service columns. I am desirous of knowing the circuiting of a good crystal set. Would it be asking too much to have the circuit reprinted? Reference has been made to the issue of December 7, 1928, as having contained the circuit of a crystal set which was published on this issue. Would two stages of radio frequency increase the range of a crystal set?"

Answer: The circuit is reprinted here. Some reader may be able to supply you with "W.W." December 7, 1928. (The address is Mr. H. Teasdale, Railway Station, Allandale.) Two stages of radio frequency amplification on a crystal receiver would increase the range of the receiver considerably.

W.M.C. (Punchbowl).—"It is with much pleasure that I take the pen to offer yourself and the management of 'W.W.' my sincere congratulations on the success of 'W.W.' The latest issue is indeed one to be proud of. I have been a regular reader since July, 1925, and I will be pleased to supply back numbers to any reader who writes on receipt of postages. (All extraneous matter and non-technical articles have been cut out.) I have derived much information, amusement, and sometimes sorrow, at the amazing intolerance of the correspondents to the query columns. I was pleased to learn from last week's 'W.W.' the date of publication of the Christmas Three. I would like to know just where I can get it. I have tried a few Sydney shops, but without success."

Answer: Thanks for your kind remarks. Perhaps some reader may be able to supply you with the copy you require. (Address Mr. W. McCallie, Balmoney, Roberts Road, Punchbowl.)

C.E. (Wallerawang).—"I have a spare copy of 'W.W.' 1/1/29. If so, I would like to obtain it. My address is Mr. C. Rayner, Junction Street, Wallerawang, N.S.W."

Answer: Reply to your request. We also have a few copies left here if you make prompt application.

T.E.F. (Bateman's Bay).—"Please quote names of two reliable radio firms in Sydney from whom I can get apparatus for the Peridyne."

Answer: Colville-Moore and Economic Radio Stores.

A.G.D. (French's Forest).—"One of my valves (which is supposed to have a glowless filament) lights brilliantly when the 'A' battery only is connected. Why is this?"

Answer: The filament has sagged or broken, and part of it is touching the grid. Therefore, only part of the filament is receiving the voltage from the 'A' battery, and this piece, having less resistance, will glow.

R.P. (Sydney).—"I'm not like the boy who said 'A hole is nothing with something else all round it.' I merely want to know the performance in ohms of the following valves:—B605, A410, and A106."

Answer: B605, 2800ohms; A410, 20,000ohms; A106, 15,000ohms.

(2) "By the way—without looking at the dictionary (this is non-technical)—how would you explain a 'hole'?"

Answer: Well, I should say a hole was a gap, an aperture, an open space, a pit, or a—well, a hole.

B.Y. (Babinda).—"I always understood that there were three coils in the Reinartz. Every diagram I have seen shows only two coils, i.e., the primary and secondary. Where does the third coil come in?"

Answer: The third coil (reactor) is joined to the secondary coil—the last turn of the latter coil being joined to the first turn of the former coil. Thus, actually the secondary coil is tapped for reaction.

R.D.W. (Brisbane).—"I have built a two-valve amplifier (transformer coupled) for my one valve set. Using two A.W.A. transformers, everything is O.K., but using one A.W.A. and one English transformer, there is a loud squeal. Thinking the trouble was in the English transformer, I bought two new ones. Results were still the same. I then tried two transformers using the English transformers only—results excellent. I then placed one A.W.A.

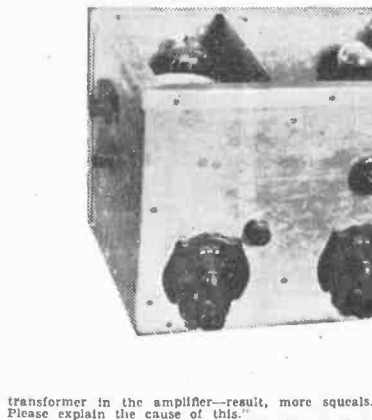

transformer in the amplifier—result, more squeals. Please explain the cause of this."

Answer: The reason is that the transformer windings are in opposite directions. All you need do is to reverse the connections to the primary of the first transformer, when the two types may be used together.

J.E.P. (Bankstown).—"Could you please inform me where I could obtain a blue print wiring circuit of a Reinartz three-valve set?"

Answer: Economic Radio Stores, or Colville-Moore.

J.R.W. (Croydon).—"I have built a crystal set from the circuit published in your paper, and I cannot get results and am certain all the wiring is correct. The only thing I can think of that may be wrong is the catswhisker, this hair I cut off our cat's face is white. Should the hair be black? Kindly answer in your help."

Answer: We have opportunity here to read some very amusing letters. Yours wins easily this year! Almost as funny as the reader whose aerial was attached to the guttering of his house, and his earth was a peach tin filled with water—for a crystal set—miles away from a broadcasting station.

P.H. (Waverley).—"I have an old three-valve set which was made to bring in 2FC and 2BL when they were on the higher wavelengths, but since they changed over, the set has been useless. I am enclosing a layout of the components, and would like to know if the tuning coil was altered if I could get any results on present transmissions. If so, will you kindly give me some idea as to the alterations necessary?"

Answer: A layout of components is not of much use to us. What circuit are you using? What is the coil system? Do you have a special valve, would be to insert a Reinartz coil bit they can be bought very cheaply from Economic Radio Stores and other advertisers in place of the coil system at present in use. If you would like a complete circuit, let us know.

H.T.K. (Hamilton).—"I have a six-valve King Neurodyne. All the valves are 201A (R.C.A.). Should I have a special detector valve and a power valve?"

Answer: It is not necessary. There may be a slight improvement in volume using the power valve.

(2) "I have a Philips 'B' Eliminator of the 3002 type, and have only three tappings for the five leads, the third lead being on the bottom tap in the second bottom hole, and the correct?"

Answer: Depends on what you term the 'third lead.' Where does this lead come from?"

(3) "Would you recommend an 'A' socket power unit? I have a Gluyde six-volt 'A' battery which only lasts two weeks. The set is used for about 24 hours only during that fourteen days."

Answer: Either your accumulator is faulty, or the amperage is too low for requirements. For good long service, your accumulator should be one of eighty ampere hours. An 'A' power unit would be O.K., but since you propose going in this way, not completely electrically equip your set?

Colville-Moore can make the necessary alterations in about twenty minutes or less. There is nothing to alter in your set.

Uarbyrite (Uarby).—"After reading in 'Proving Radio' your descriptions of wet and dry cell making, I am disappointed to find that you did not describe the making of a complete battery of, say, 90 volts, and give description not only of cells, but also how they should be insulated from one another. Also method of connecting, wire used, etc. However, I must say your articles on 'Proving Radio' are interesting and instructive."

Answer: If you had followed the series carefully, you would know how to make a battery of dry cells reading 80 volts, sixty dry cells as discussed should be connected in series, i.e., the negative of the first connecting to the positive of the next, and so on. The reason why sixty cells must be used is because each single cell gives only 1 1/2 volts. As we require 90 volts, we divide the 90 by 1 1/2, which gives us the number of cells required, i.e., 60. As regards insulating, sealine wax, paper, or any other insulating substance could be used. The wire used to connect up the batteries may be of any reasonable gauge—in fact anything from sixteen to thirty gauge wire would do further information, please write again.

(2) "Reference in one 'Proving Radio' article to a kite aerial and danger has caused me to wonder if a kite aerial of 100 feet would be likely to be dangerous, and if not, would it be efficient? If you think it would make a good aerial, will you give me a description of a kite suitable for holding 100 feet of aerial up in the air?"

An All-Empire Receiver built by a "Wireless Weekly" reader.

Answer: Any kite aerial—or any aerial, for that matter—is likely to accumulate a charge, but this can be made safe by inserting a fixed condenser in series with the lead-in. The condenser must not, of course, be touched until it has been shunted through to earth, as it accumulates a very heavy charge. One hundred feet of aerial would be O.K. An ordinary box kite would hold the aerial up for you. The kite you require should be of a heavy type. Your suggestions re 2BL service have been passed on to this station.

F.R.E. (Five Dock).—"Re the Marco Four. I intend using the following valves—A425, A415, B4M, and A409. Economy considered, what do you think of this choice? What will be the necessary alterations to the plate coil? I recently purchased a variable condenser of 30005mf. As I do not want it to lie idle, could I use it for reaction in the Marco Four? If so, what alterations will be necessary in the reaction coil?"

Answer: Re the above—good selection. No alterations will be necessary to the plate coil. The .00025 variable condenser may be used to tune the reaction coil. Add five turns to this coil.

F.G.S. (Singleton).—"Thanks for the Countryman's One-valver, I only got my set going last night, and pulled in 2FC, 2BL, 2UE, 2UW, 2GE, 2KY, 3LO, 3AR, 4QG, 5CL, and another station whose call sign I did not catch."

Answer: An imposing list of stations for a one-valve receiver. Glad you like this little on-valver.

Modern Microphones at 5CL

"The heart of a broadcasting station!" This has been described the wonderful piece of apparatus which was merely a development and improvement of mics for broadcasting; and the description is a most fitting one. In the early days of broadcasting the usual microphone in use was the carbon microphone, which was merely a development and improvement of the ordinary telephone transmitter mouthpiece; but recently there was developed a most intricate and elaborate apparatus—the electrostatic or condenser microphone.

This microphone works on a totally different principle to the older types, and is much more sensitive. 5CL was the first broadcasting station in the Commonwealth to employ one of these new microphones about 12 months ago, and it proved so successful that several more have since been constructed by the station's engineers under the supervision of the chief engineer, Mr. E. A. Kauper.

Their extreme sensitivity, coupled with their lack of any hissing or frying sounds common to other and older types of microphones, renders them particularly adaptable for theatre broadcasts; and an example of this was afforded when 5CL broadcast a performance of "Lilac Time" from the Theatre Royal some time ago. Only one condenser microphone was employed, whereas to catch all of the artist's words and the accompaniment of the orchestra would have necessitated several of the older types, which even then would not have been as satisfactory as the one condenser microphone.

When it is explained that each condenser microphone carries inside its little cabinet a complete stage of audio frequency in addition to the microphone some idea of the intricacy of the microphone may be obtained, and the latest development on the condenser microphone at 5CL has been the construction of a microphone for outside work, which is equipped with two-volt valves, thus rendering it much more portable, as the large accumulator—hitherto necessary—can be dispensed with. This development is yet another example of the constant efforts that are being made by 5CL's engineers to keep the station in the position it holds of being one of the most up-to-date in the world.

Subtle Humorist at 3LO

THOUGH he has but lately made his bow before the microphone in studio 3LO the quiet humor of Courtney Ford has already proved to the liking of the thousands of listeners who enjoy a subtle joke. Mr. Ford, who is tremendously popular at 3CL was connected with leading concert parties for many years, and is a familiar figure in South Australia, where, apart from a busy professional life, he has done much to raise funds for various charities. The radio offered him a still wider scope as an entertainer, and with his clever and original character sketches and witty remarks, he has made thousands of people forget, even if only for a moment, that there is such a bugbear as worry.

SILENT



CONTROL

OTHER ELECTRAD PRODUCTS.

Electrad fixed condensers, .0001 to .006. Prices 2/- to 5/-.

Electrad Metallic Grid Leaks, 1-10th to 10 megohms. Price 3/6.

Electrad Plain Grid Leaks, $\frac{1}{2}$, $\frac{1}{4}$, 1 and 2 megohms. Price 2/-.

Electrad Jacks, open and closed. Prices 1/3, 1/6.

Electrad Lightning Arresters. Price 3/6.

Electrad Royalty Resistances. Types A, B, C, D, J, and L. Price 11/-.

Electrad Tonatrol. 14/-.

Electrad Phasatrol. 17/6.

Electrad Filament Switch. Price 2/-.

Obtainable at all Radio Dealers.

IT'S silent! As you turn the arrowhead knob, the contact arm moves smoothly round, giving firm, positive contact the whole way.

And it's air cooled. Electrad has also a genuine bakelite former, nickel-plated fittings and soldering lugs. Easily fitted because of the one-hole mounting.

Made in resistances of 6, 10, 20 and 30 Ohms.

PRICE 3/6 EACH.

Amalgamated Wireless
Australasia Ltd

Sydney



Melbourne



Adelaide



Wellington, N.Z.

February 1—
HERALDS
Price Reductions
in the Cone Models

AMPLION CONE SPEAKERS
BRITISH and BEST



Chippendale Mahogany. Model AC9 (Senior). Old Price £9/10.
New Price £7/10/-



Junior Bronze Hanging Cone. Model AC2 (Junior). Old Price £3/5/-.
New Price £2/15/-



Jacobean Oak. Model AC7 (Senior). Old Price £7/15/-.
New Price £6/17/6



Junior Bronze Open Cone. Model AC1. Old Price £4/10/-.
New Price £3/17/6



Senior Silver Open Cone. Model AC3. Old Price £6/0/0.
New Price £4/17/6

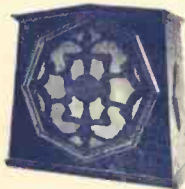

Dark Oak (Senior). Model AC5. Old Price £7/10/-.
New Price £6/10/-

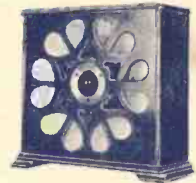

Junior Cabinet. Model AC4 Oak. Old Price £5/5/-.
New Price £4/7/6

Mahogany. Old Price £5/10/-.
New Price £4/12/6

Whether you already have a Speaker or are thinking about getting one, the unprecedented value as represented by the new Amplion prices, will attract you. Throughout the world Amplion is the recognised standard, giving reproduction of the finest quality yet attained.

AMPLION
 (A/sia) Ltd.

**Bradbury House, 53-55 York St.,
 SYDNEY**

COUPON:

Please mail me illustrated literature describing Amplion Cone Speakers, etc.

Name

Address

State