

The Queensland Radio News

"Your Own Wireless Journal"

6⁰



Tuesday, 1st NOVEMBER, 1927

No. 10

Registered at the G.P.O., Brisbane for transmission by Post as a Newspaper.

A filter circuit is necessary

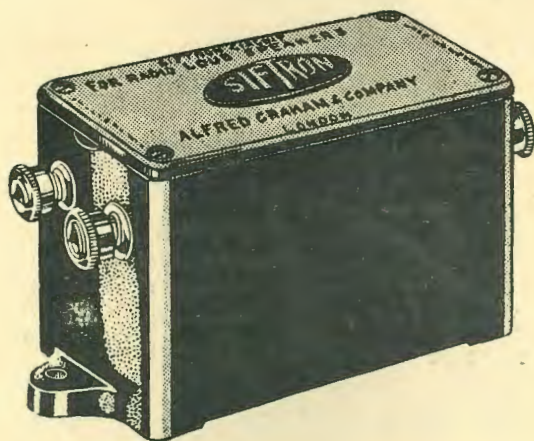

Size—
4in. x 2½in. x 2½in.
Weight, 1½ lbs.

In Polished Bakelite
Casing,
PRICE: £2/15/-.

In all cases where a cone type loud speaker is used, makers recommend the use of a filter circuit, whilst the use of such a device is absolutely imperative if the anode current exceeds 10 milliamps, i.e., when a super-power valve is incorporated in the circuit. The AMPLION SIFTRON is correctly designed, is compact and can be used without any alteration to the existing circuit and with any loud speaker.

— Use an Amplion Siftron

THE WONDERFUL P.M. FILAMENT

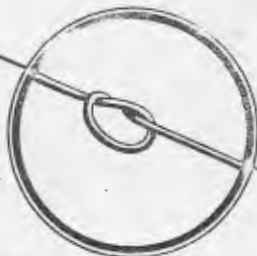

THE MASTER FILAMENT

UNBREAKABLE

The Mullard P.M. Filament, huge in proportions and gigantic in emission surface. . . . ough and always ductile so that it can be tied in knots. . . . proved by the British National Physical Laboratorv Test to be constant and lasting. . . . gives majestic volume free from microphonic noise too economical even to glow The Filament in all Mullard P.M. Valves—the valves which serve you best.

Obtainable from Every Radio Dealer in Australia

For 2-volt accumulator

P.M.1 H.F. 0'1 amp. 13/6
P.M.1 L.F. 0'1 amp. 13/6
P.M.1 A. (Resist. Cap.) 0'1 amp. 13/6
P.M.2 (Power) 0'15 amp. 13/6

For 4-volt accumulator or 3 dry cells

P.M.3 (General Purpose) 0'1 amp. 13/6
P.M.3 A. (Resist. Cap.) 0'1 amp. 13/6
P.M.4 (Power) 0'1 amp. 13/6

For 6-volt accumulator or 4 dry cells

P.M.5 (General Purpose) 0'1 amp. 13/6
P.M.5B (Resist. Cap.) 0'1 amp. 13/6
P.M.6 (Power) 0'1 amp. 13/6

Super power valves for last L.F. St.

P.M.254 4 volts 0'25 amp. 15/6
P.M.256 6 volts, 0'25 amp. 15/6

SAY P.M. AND YOU SAY PURE MUSIC

Mullard

THE MASTER VALVE

ARKS 11A

ADVT. THE MULLARD WIRELESS SERVICE CO., LTD., MULLARD HOUSE, DENMARK STREET, LONDON, W.C.2, ENG

Mullard P.M. Valves are British Made—BUY BRITISH



THE ability to choose your own programme from the various stations is a great boon; It means that if you do not care for the jazz from here, or the lecture from there, you can tune in elsewhere—WITHOUT INTERFERENCE.

Selectivity depends primarily upon the kind of condenser your set possess. Any condenser may permit you to tune in 4QG, 2FC, 3LO, 5CL, and other stations, but if you logging of them is all crowded on one small section of the dial, you are apt to have the lecture from this station elbowing its way into the concert programme from that.

Choose the "ADVANCE" STRAIGHT LINE FREQUENCY CONDENSER, WHICH DOES AWAY WITH ALL STATION BUNCHING. It is designed for multiple mounting, is in a one-piece frame, and is most rigid. Don't forget the name—"Advance." Your dealer has it.

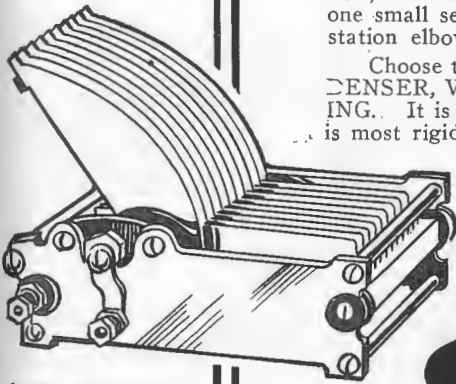

.0005	10/6
.00035	10/-
.00025	9/6

ADVANCE
Improved
STRAIGHT LINE
FREQUENCY CONDENSER

Wholesale Distributors
for Queensland:
EDGAR V. HUDSON
Charlotte Street,
BRISBANE.

Manufactured in Australia by

RADIO CORPORATION OF AUSTRALIA PTY. LTD.
MELBOURNE : SYDNEY : ADELAIDE : BRISBANE

Brandes Matched Tone Phones

22/6

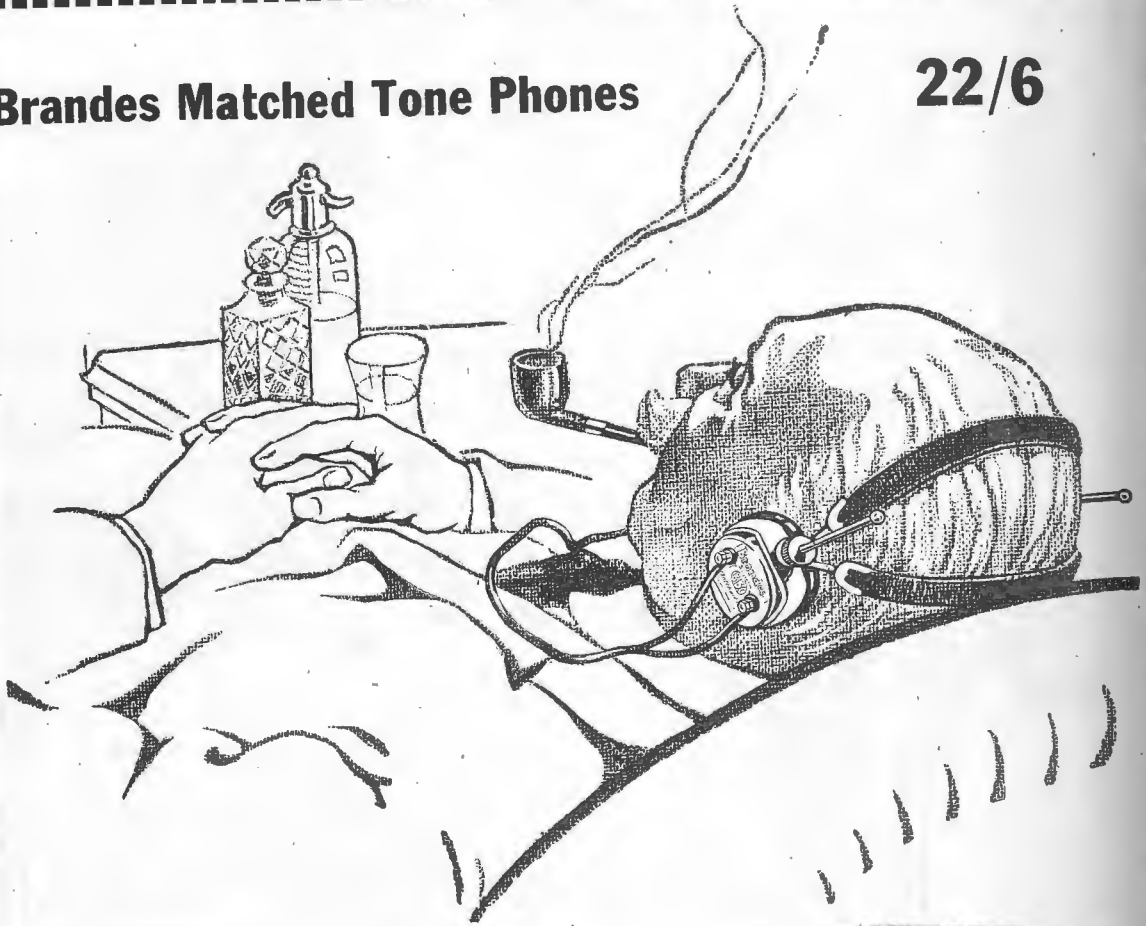

Two Masterpieces of Brandes Acoustics ~

The Brandes Matched Tone Phones, and Brandes Ellipticone

Tone, Quality and Volume—are their outstanding features. Brandes Quality Components bring new and keener enjoyment of radio by the true fidelity of their production.

Ellipticone	£6 10 0	Table Talker	2 5 0.
Brandes Brandola ..	4 10 0	Brandes Condensers. 1 10 0	(.0003, .0005)
Table Cone	2 19 6		

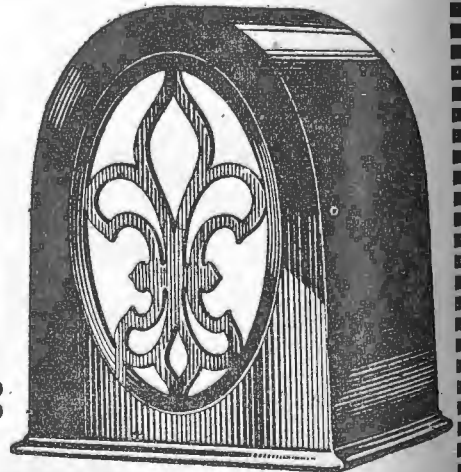

THE ELLIPTICONE

Agents Wanted ~ Send for our Free Catalogue

INTERNATIONAL RADIO CO.

229 Castlereagh Street, Sydney

Boosting Ballarat

Three Days' Wireless Festival arranged by 3LO

It is not uncommon for 3LO Melbourne to broadcast from Ballarat two or three times a month, but for three days consecutively early in November, that City is to be kept very much in the spotlight. 3LO is going to make the people of Australia talk, think, speak and sing "Ballarat". Natives of Ballarat do it already. Its popular Chief Magistrate—Cr. Alex. MacKenzie, is one of a long line of patriots who, in assuming Mayoral responsibility undertook the upholding of the time honored traditions of a great city, the history of which is brimful of stirring episodes and noble deeds.

Ballarat has an immense civic pride which is the chief source of its premier position among the provincial cities of Australia. It may safely be said that no other city in the Commonwealth has worked so hard at the job of city building and no other city has such wonderful potentialities.

Beauty and utility walk hand in hand in Ballarat. It is a great centre of Art and Industry. It is fitting, therefore, that it should be chosen by 3LO for a three days' wireless festival.

The great concert arranged for the evening of November 9th, will be sent all over Australia and beyond to New Zealand and the South Seas. It will be a concert worth broadcasting, too, for Ballarat has a fine taste in music and many talented artists who will be added to by Joe Aronson's Symphony Orchestra. They are being sent along specially by 3LO.

On the following day, 10th November, besides the opening of the Annual Show, a Charity Ball is to be held. This is to be something extra-special, the like of which has never been seen before out of the metropolis. A description of this and the music, which will be provided by Joe Aronson's Band, will be broadcast. The third day will be distinguished by an immense Community Singing festa and this will also be put on the air, together with other events in the intervals.

Bendigo will no doubt refuse to take this lying down It will immediately commence to organise something along the same lines, a proceeding which will galvanise Geelong into action. Warrnambool, the fourth of the provincial cities will then enter the lists and it may safely be prophesied that many other great provincial festivals will demand the publicity 3LO can give. No finer advertisement could be devised. Broadcasting by 3LO Melbourne to whom half a million people listen every day, is now acknowledged as the greatest medium of publicity in Australia.

FOR SALE.

CHARGING DYNAMO, 15 volts, 8 amps.
(less if run slower), guaranteed good order. Take £4/10/- or near offer. L. S. Cuffe, Constitution Road, Windsor, Brisbane.

Latimers CHAPIN

5-VALVE

Broadcast Receivers

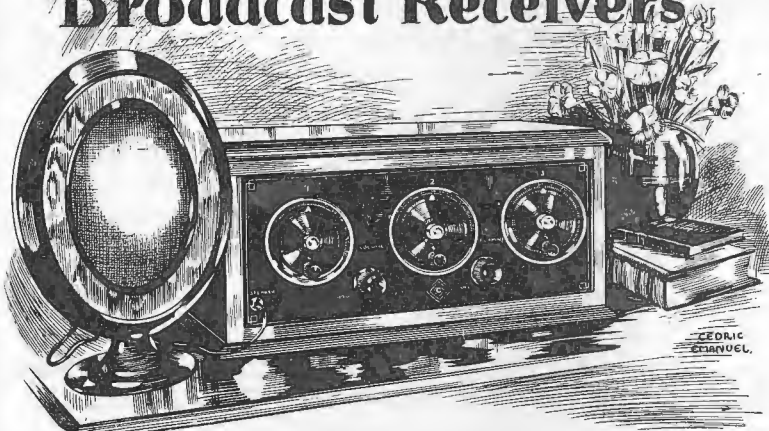

Give
Exceptional
Interstate
Reception

5-VALVE, in Cabinet (as illustrated),
Supplied with 5 Best
Quality Valves.

£10/10/0

Complete with Manhattan Junior
Speaker.

£19/10/0

Call and Inspect this
Remarkable Value

RADIO SUPPLIES UNLIMITED

T. & G. BUILDING
ALBERT ST. BRISBANE

Have You Secured Your Copy of—

“ WIRELESS ”

by

J. W. ROBINSON

(Director, Queensland Radio Service)

and

G. WILLIAMS

(Instructor, Marconi School of Wireless, Sydney).

PRICE—Only 3/6 Posted 4/-

“Wireless” is, without a doubt, the most up-to-date and comprehensive text book yet published.

It takes the radio enthusiast step by step from the earliest stages up to the complications of modern multi-valve receivers.

“Wireless” has been written in terms which make the most difficult technical matters quite easily understandable to the merest novice.

The Chairman of the All Radio Clubs' Council (Mr. H. Kington), in referring to “Wireless,” said:—“Here is a book which every buyer or owner of a radio set should possess.”

The first edition is rapidly being sold out.

Secure your copy while a few remain.

Single Copies obtainable from all Bookstores
and Radio Dealers or from The Read Press Ltd.,
Adelaide Street, Brisbane.

Order Your Copy To-day!

Sole Wholesale
Distributors—

A. McLEOD

101 Elizabeth Street
BRISBANE

McLeod's are always up-to-date with the newest books and diagrams on radio.
When there is something you want to know, come and ask us where to find it.



Battery Eliminators

THE advertising and trade review pages of leading overseas radio journals have, in recent months, placed the Battery Eliminator conspicuously in the limelight. To-day practically every manufacturing concern in the radio industry is making eliminators.

The immense field that exists for such a desirable device is causing hundreds of thousands of pounds to be invested in this branch of radio manufacturing.

Among the first to realise the potency of the Battery Eliminator were the battery companies, whose products the new device threatened with extinction. These concerns are now building and advertising "B" Battery Eliminators, Trickle Chargers, and "A," "B," and "C" Battery Eliminators under the same trade name that made their batteries famous.

Upon the surface of things it would appear foolish for these companies to market a new device that is right in opposition to their present products. Going deeper, however, it will be observed that these battery companies are acting with wisdom. The supremacy of the eliminator must be admitted, and by marketing these devices they are planning to retain at least a portion of the business which the eliminator is so rapidly diverting away from the old channels.

Of course the eliminator will never entirely displace batteries. In centres where a reliable power supply is not available, the accumulator and dry cell will, as now, render faithful service. But in towns and cities where a good house supply is available, the battery eliminator will in future play a very prominent and important part in radio reception.

With the present line fluctuations experienced within the Greater Brisbane area, due to overloaded mains, none but the best eliminators will render efficient service. Fortunately this trouble is only temporary. With the erection of new power houses, line voltage will soon be restored to normal, and the battery eliminator will then surely come into its own.

OLDHAM

Requires no
first charge—
Merely add
Acid

Supplied in
2-Volt Cells.

Solid moulded
Glass Containers



Price
10/6
Each

Capacity:
20 amp. hours
at slow discharge.

ORDER THROUGH YOUR RADIO DEALER

Write to the Sole Agents for full Oldham Price List

NOYES BROS. (Sydney) Ltd.

PERRY HOUSE ELIZABETH STREET BRISBANE

(SYDNEY) LTD.

Sydney 115 Clarence Street
Newcastle Devonshire Street
Brisbane Perry House, Elizabeth Street

Agent for W. Australia

(MELBOURNE) PTY. LTD.

Melbourne 495 Bourke Street
Adelaide Darling Building, Franklin Street
Hobart 145 Macquarie Street
Launceston 123A Charles Street
..... J. R. W. GARDHAM, PERTH.

Transformer Construction as Applied to B BATTERY ELIMINATORS

Transformers, operating from the alternating current house lighting or power circuits may be put to a variety of uses, such as—stepping down the voltage for battery charging, stepping up the voltage for "B" battery eliminators, lighting small lamps for decorative effects, and so forth. The cost of building a small transformer is not high, and the experimenter will be well repaid for the little trouble taken.

Theory of Transformer.

Suppose a coil of wire (a) connected to an alternating source be placed near a second coil (b) Fig. 1. The alternating current passing through (a) sets up an alternating flux, which threads through (b) and so induces an electro motive force in it.

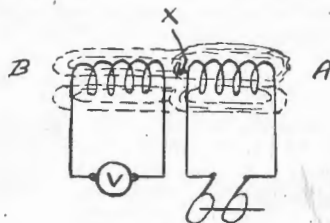

Fig. 1.

Now, upon referring to the diagram (Fig. 1) it will be seen that some of flux does not cut the second coil, but leaks back through space; this is known as the leakage flux. So far, however, we have only been dealing with an air core, and it now becomes necessary to insert one of iron in order to increase the flux flowing.

A further improvement can still be made by providing for the flux a return path of iron, the idea being to reduce the reluctance of the magnetic path. (It must be remembered, however, that we still have a certain amount of leakage flux present.)

In order to illustrate clearly the operation of a transformer, let us imagine a closed iron core, which has wound upon it two coils of insulated wire. Fig. 2.

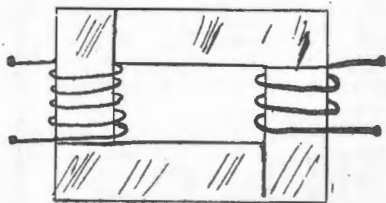

Fig. 2.

One of these coils, as previously pointed out, is connected to the supply; this coil is known as the primary winding.

The alternating current passing through this coil causes a series of impulses first in one direction, and then in the other, these impulses in turn magnetizing

the core, and bringing about a varying field. That is to say, the lines of force build up to maximum, die down, and then build up again, only this time with reversed polarity.

Certain electrical laws tell us, that a change in the number of lines of force in a magnetic circuit, will induce an electro motive force in a coil of wire surrounding it; therefore, a current will be induced in the second coil. This coil is known as the secondary winding.

The amount of energy that can be drawn from the output side, however, can never quite equal the applied energy, as certain work is done in magnetizing the core, and whenever work is done, losses must occur.

The losses in this case take the form of I^2R (copper losses) eddy current and hysteresis losses, and usually amount to 10 to 15% in small home made transformers.

Transformer cores may be divided into two principal classes:—core and shell type, the former being by far the best for the amateur, as it is much easier to construct.

Having arrived at this stage, it would perhaps be advisable in order to simplify matters, to take the actual laying out of a small transformer, such as may be used in a "B" Battery eliminator.

Now the first step is to ascertain in what capacity we will need, as the actual amount of energy consumed by even the largest receiver would not exceed 10 to 12 watts. It is advisable, however, to make the transformer capacity moderately high, as this will allow us to add an extra winding for lighting the filament of a power valve, or if a filament type rectifier is used, light its filament.

We will, therefore, rate our transformer at 50 V.A.C. (volt ampere capacity).

Assuming that the line voltage E , is 240, and the frequency is 50 (this is the usual voltage and frequency) we may proceed:—

Allowing 10% core and copper loss, the primary wattage would have to be 50 + .10%, or 55 watts.

Now to find the actual primary current, we cannot in this case use ohms law, as the current and voltage in a practical A.C. circuit are always slightly out of phase, we must, therefore, consider the power factor, which can be assumed at about .85 (or 85%) for the transformer primary.

First find the current as though we were dealing with a D. C. circuit, then divide this current by the power factor.

55
 Ex/1 equals $\frac{55}{240v}$ equals .22 amps. $.1 - .22 - .85 - .25$
 amperes. 1 equals .22 divided by .85 equals .25 This
 (current figure) will be used a little later.

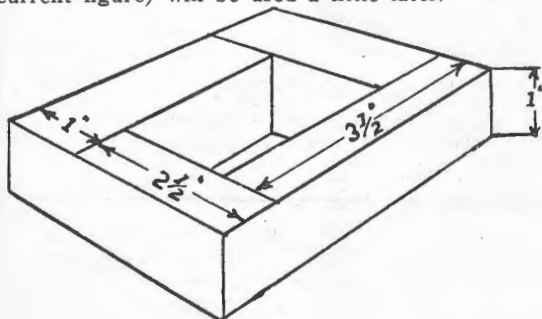

Fig. 3.

A well-proportioned core is shown in Fig. 3, and may be made up of laminations of good quality stove iron, stalloy, or silicon steel.

Below is a table which gives the flux densities for the various materials:—

- Stove Iron 40,000 lines per sq. inch.
- Stalloy Iron 50,000 lines per sq. inch.
- Silicon Steel 60,000 lines per sq. inch.

A smaller and lighter core can be used if silicon steel or high grade transformer iron is available, as it is possible to work either of these at a much higher flux density.

If a core can be secured from a toy transformer, or some other piece of electrical apparatus, the building of the transformer will be very much simplified.

If not available, then a sheet of iron or steel will have to be cut into strips $3\frac{1}{2}$ inches long and $2\frac{1}{2}$ inches long by 1 inch wide, as shown in Fig. 3. After cutting it will be necessary to remove any burr from the edges of the strips by means of a file or emery wheel; If this is not done, the eddy current losses will be fairly high.

When a sufficient quantity of laminations have been cut and trimmed, each should be given a thin coat of shellac, and allowed to dry.

The core is assembled in the manner shown in the diagram Fig. 4. Each successive layer of the core overlapping.

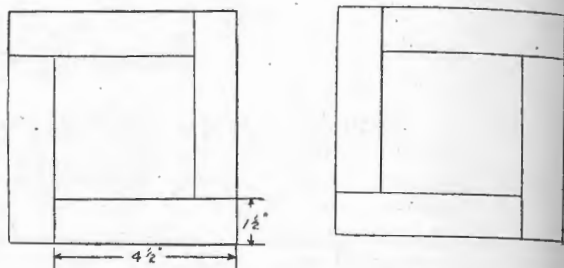

Fig. 4.

We now have a very good idea of the various factors which come into the design of a transformer, so may use the fundamental formula which will enable us to start the work:—

$$N - (E \times 10^8) \text{ divided by } (4.44 \times F \times B \times A).$$

where

- N - Number of primary turns (unknown)
- E - Primary Voltage (known)
- F - Frequency of Supply (known)
- B - Number of lines of force (flux) through transformed core (assumed)
- A - Cross-sectional area of core (known)

The number of primary turns N can now be calculated:—

$$N - (240 \times 100,000,000) - (4.44 \times 50 \times 50,000 \times 1) - 2162 \text{ (approximately)}$$

The above figure may be safely reduced to 2000 if good quality core steel is being used, as we allowed 50,000 lines per sq. inch, which is a very conservative figure for Silicon Steel.

Before going farther, the proper size of primary wire must be determined.

The full load current was found to be .25 amperes, so we must now choose a gauge of wire that will carry this current without overheating. Refer to the table below.

Super-seeded S.W.G. Size.	Standard Diameter.		Calculated Sectional Area.		Weight per 1000 yards. Pounds.	Standard Resistance at 60deg. F.		Current rating Amperes at	
	Inch	mm.	Square Inch	Square mm.		Per 1000 yds ohms.	Per lb. Ohms.	1000 per Sq. Inch	I.E.E.
50	.0010	.0254	.0000007854	.0005067	.009083	30568	3365000	.0007	
48	.0016	.0406	.000002011	.0012972	.02325	11941	513500	.0020	
46	.0024	.0610	.000004524	.002919	.05232	5307	101440	.0045	
44	.0032	.0813	.000008042	.005189	.09301	2985	32090	.0080	
42	.0040	.1016	.000012566	.008107	.14533	1910.5	13146	.0125	
40	.0048	.1219	.000018096	.011675	.2093	1326.7	6430	.0180	
38	.0060	.1524	.00002827	.018241	.3270	849.1	2597	.0282	
36	.0076	.1930	.00004536	.02927	.5246	529.2	1008.7	.0453	
34	.0092	.2337	.00006648	.04289	.7688	361.2	469.8	.0664	
32	.0108	.2743	.00009161	.05910	1.0594	262.1	274.4	.0916	
30	.0124	.3150	.00012076	.00791	1.3966	198.80	142.35	.1207	
28	.0148	.3759	.00017203	.11099	1.9895	139.55	70.14	.1720	
26	.018	.4572	.0002545	.16417	2.943	94.35	32.06	.2545	
24	.022	.5588	.0003801	.2453	4.396	63.16	14.366	.3801	
22	.028	.7112	.0006158	.3973	7.121	38.99	5.475	.6158	2.5
20	.036	.9144	.0010179	.6567	11.772	23.59	2.004	1.0179	4.0
18	.048	1.2192	.0018096	1.1675	20.93	13.267	.6340	1.8096	7.2
16	.064	1.6256	.003217	2.0755	37.20	7.463	.2006	3.217	12.9

Looking down the current rating column we find that a 26 gauge wire will carry .2545 amperes at 1000 amperes per square inch, which is a very safe figure considering that the transformer is not to be used continuously so we will use 26 gauge wire for the primary winding.

As the voltage on the input side is not excessive we may use enamel wire, which is a decided advantage as it takes up very little room when compared with D.C.C.

The secondary winding is calculated from the proportioned formula, that is to say, the secondary voltage depends absolutely upon the ratio between the primary and secondary turns.

However, before we can calculate the number of secondary turns, it will be necessary to fix the secondary voltage, which will, of course, need to be fairly high as there is always a voltage drop across the rectifier tube, and the filter choke coils.

The usual practice is to wind the transformer secondary for a total voltage of from 500 to 600 volts, that is, 250 to 300 volts per side; This voltage, when rectified, and filtered, will yield a voltage of 130 to 180 volts. (approximately).

Now it has already been stated that the applied primary voltage was 240 volts, and the number of primary turns 2000, therefore:—

$$\begin{array}{r} \text{For 240 volts 2000 turns are required.} \\ \text{For 600 volts X turns are required.} \\ \frac{600 \times 2000}{240} \text{ equals 5000} \end{array}$$

The constructor will, of course, have to calculate the number of turns that will best meet his requirements.

The full load secondary current may be taken as 60 milliamperes; it is not likely that a greater current than this will be required, as the largest receiver, provided the valves were properly biased, would not draw more than 30 to 40 milliamperes.

Turning once again to the wire tables we find that a 34 gauge wire will carry .0664 amperes at 1000 amperes per sq. inch. The secondary will, therefore, consist of 5000 turns of 34 gauge D.S.C. copper wire.

Double silk covered wire should be used for the secondary winding, as the voltage in this case is rather high.

Care should be exercised when winding D.S.C. wire, as the silk insulation is easily damaged; and if the wire becomes bare there is always a chance of short circuited turns, which mean trouble.

The secondary winding may be wound over the primary; if this is done, it will be necessary to use plenty of insulation between windings. Another method is to wind the primary and secondary winding on opposite limbs of the transformer core. This method is not as efficient as the former, but is probably the best for the beginner.

A wooden former with detachable sides, so that the finished windings can be easily removed, will be required (see Fig. 5.)

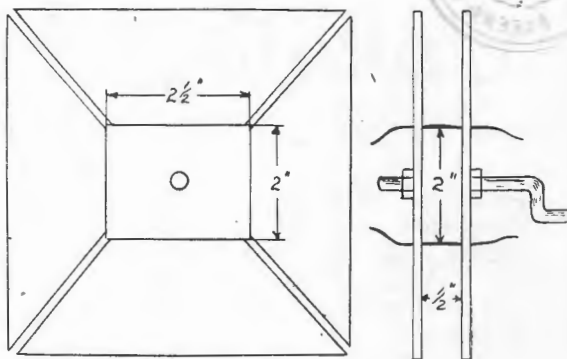

Fig. 5.

The measurements of this former will, of course, depend upon the size of core that is being used.

When the required number of turns have been wound on the former the winding should be removed, and taped with ordinary cotton tape. It is also advisable to give the taped coil a coat of good insulating varnish, in order to keep out the moisture.

Here are the specifications for the above home made transformers (Silican Steel Core).

Leg sheets 1in. x 3 1/2 in.
Yoke sheets 1in. x 2 1/2 in.

The primary of the transformer consists of 2000 turns of 26 gauge enamel copper wire, while the secondary consists of 5000 turns of 34 gauge D.S.C. wire.

The primary winding should be layer wound with paper insulation between layers; this is not necessary in the case of the secondary winding, which may be wound jumble fashion.

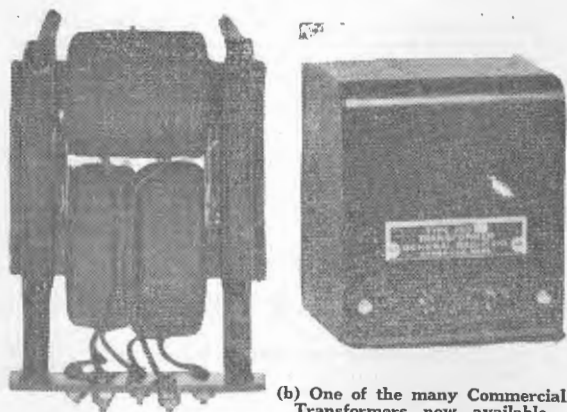

(a) A Home-made Transformer.

(b) One of the many Commercial Transformers now available.

"B" BATTERY ELIMINATORS.

"B" battery eliminators, or power supply devices, have been on the market for many months, yet it is surprising to find the comparatively small number of listeners that are using them.

Essentially the "B" power supply device comprises:

Unfailing Power Always!

WITH EMMCO ELIMINATORS

PUNCH! POWER! SNAP! The clear, steady flow of strong, silent radio house power direct from your light socket into your set; hour after hour, as long as you care to use it. And at such little cost. When you instal an EMMCO Eliminator you cut out for all time the constant replacing of expensive dry batteries. Your set is always ready to give you full, clear volume. You just hook it up to your set without making any changes in your wiring.

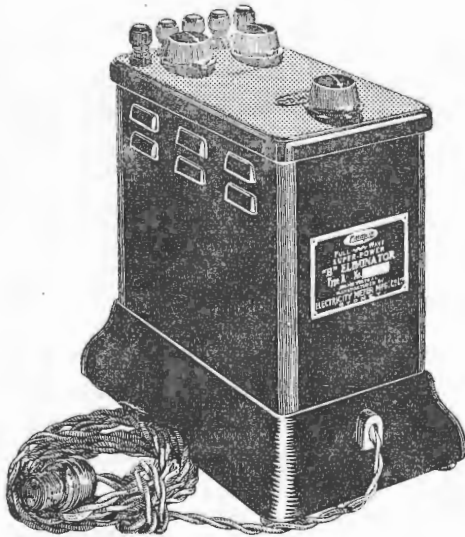

THE EMMCO SUPER POWER "B" ELIMINATOR is constructed particularly for supplying high tension current for multi-valve sets. It delivers 85 milliamps at 180/200 volts, and is supplied with a Raytheon B.H. tube. It is especially adapted for the current and voltages of Australian Electric A.C. Lighting Mains and rectifies both halves of the A.C. Cycle. Adaptable for all valves. The Emmco Super Power "B" Eliminator has a special output control for varying A.C. voltages from 180/240 volts.

It is a scientifically made job, sturdily built, in a neat metal case, with bakelite top, the whole measuring 10½ x 9½ x 6½, weight 23lbs., and complete with cord and attachment plug, attractive aluminium base, bakelite top and well insulated.

Price £12/12/0

Kit of Transformer and Chokes, in separate aluminium frame £6/10/-

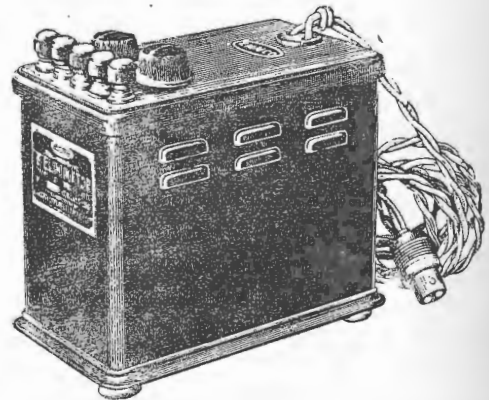

THE EMMCO "B" BATTERY ELIMINATOR is especially designed for supplying high tension current to sets employing any type or make of valves, up to a maximum of five. Like the Super Power Eliminator, it is especially designed for Australian Electric A.C. Lighting Mains, and rectifies both halves of the A.C. Cycle. Several thousand of these Eliminators have been sold and are in successful operation throughout Australia and New Zealand. This Eliminator is supplied for both 230/240 and 200/220 volts.

A scientifically made job, sturdily built, in a neat metal case, with bakelite top. Compact, 8½-in. x 5in. x 8½-in., weight 14½lbs., and complete with cord and attachment plug. Handsomely finished case, bakelite top, complete with cord and plug.

Price £10/10/0

Kit, containing Transformer and Chokes, in one aluminium frame 24/10/-

For Sale at All Dealers

Made by ELECTRICITY METER MFG. CO. LTD.

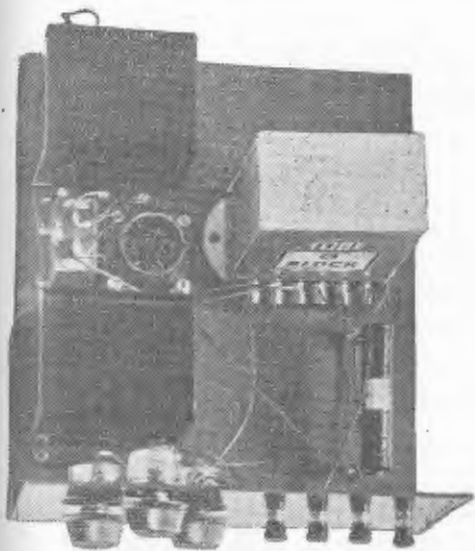

Completed "B" Eliminator.

(1) A Transformer, to step up the line voltage in order that sufficient voltage will be obtainable after it has passed through the rectifier, and filter circuits.

(2) A rectifier element to change the alternating current to direct current.

(3) Choke coils and condensers to filter or smooth out the rectifier's output.

(4) A suitable voltage splitting device which will allow different voltage to be obtained.

Probably the most popular unit is the one employing the well-known Raytheon type of rectifier, as this type needs very little attention once it has been installed.

A good example of this type of power supply device is shown in the accompanying illustrations, and diagrams.

Following is a list of the parts employed in the construction of the power supply device described here. The transformer and choke in this case are not home made, however, the layout and wiring may remain the same when home made transformers and chokes are used.

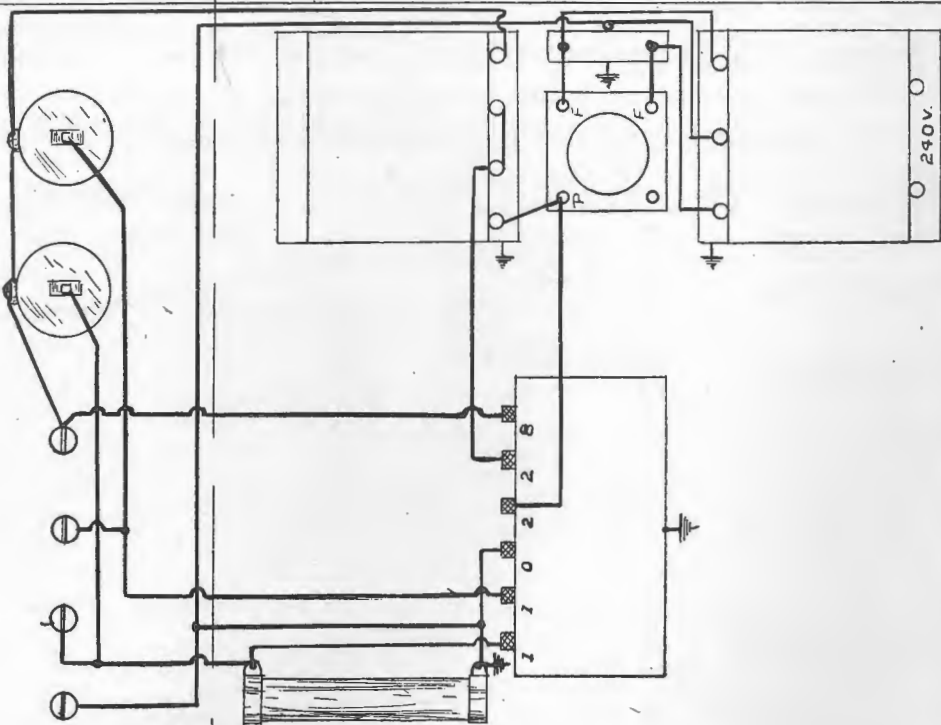

Fig. 6—Semi-Pictorial Layout for "B" Battery Eliminator.

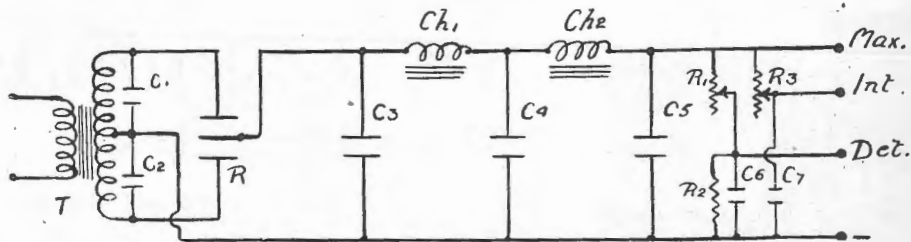

Fig. 7.—Circuit Diagram of "B" Battery Eliminator.

- T— General Radio Step-up Transformer
- C.H.1 & 2—General Radio Chokes (Double)
- C3
- C4
- C5
- C6
- C7
- C1 and 2— Tobe .1 Buffer Condensers

- R1 & R3—Clarostats 0-5 megohms
- R2— AmSCO 10,000 ohm, Fixed Raytheon Tube Rectifier
- R— Standard U.X. Socket Piece Bakelite Terminals Screws, Bus Bar, etc.

CHOKE COILS.

The choke coils may consist of 5000 to 8000 turns of 34 gauge enamel copper wire wound jumble fashion, or an iron core of liberal dimensions.

If a couple of burnt out transformers are available they can be used, though it is essential that they have a core cross section of not less than .75 sq. inches.

A number 36 gauge wire will carry a current of 40 milliamperes without overheating, so that if the constructor thinks that it is not possible to get the required number of turns in the space when 34 gauge is used, he may safely use 36 gauge.

The gauge of wire mentioned in each case is S.W.G.

CONDENSERS.

Upon inspecting the circuit diagram it will be noticed that the two buffer condensers are subjected to the higher voltage. They should therefore have a high insulation resistance, for if one should break down, it will immediately short circuit one half of the transformer winding and probably burn it out.

An Improved Transmitter at 4QG

Recent alterations to Station 4QG's transmitter have improved the strength and clarity of 4QG's transmission to even greater perfection than before.

Chatting the other day to Mr. Stevens, 4QG's Chief Engineer, he said: "The increase in our range is not due to any increase in power supply. The results have been brought about by a new system of aerial tuning." We are naturally very pleased with the results."

Following the alteration the station was deluged with congratulations from distant listeners. We publish below a few extracts from some of the letters received.

One listener outside Cairns says: "Your efforts to increase your usefulness to far-away listeners appears to be successful. To-night the other stations are completely blotted out by atmospherics, but your market reports are quite intelligible, although atmospherics are very strong."

The other condensers should also be of good quality otherwise objectionable noises will soon develop which is most annoying.

RESISTANCES.

There are many makes and types of variable resistances on the market to-day. Only a few of these however are suitable for "B" eliminator construction.

Another important point is that these resistances should remain absolutely constant and should not be affected by a rise in temperature.

In conclusion it must be remembered that the foregoing article is written with the sole purpose of making the theory of the transformer clear and easy to understand. Some of our advanced readers may claim that the matter is not technically perfect. It is not intended to be. We have tried to explain an intricate subject in simple language, so that our readers may at least grasp the principles. If we have succeeded in this direction, then we are quite satisfied.

Another listener from Kingston, S.A., writes: "All present considered the change after nine o'clock much more satisfactory, and worthy of high praise."

A Townsville fan says: "Undoubted increase in strength and improvement in modulation."

Perhaps the best indication of the punch 4QG now has is contained in a letter from a gentleman living only three-quarters of a mile from the Victorian station at Footscray. He says: "After the change came in more than twice as loud as before. I believe about three-quarters of a mile from 3LO and up to the present have always been interfered with by him when listening to your station. Now I am able to loosen the aerial coupling to such an extent that I can cut him out altogether and bring you in at much better strength than before. The excellence of your modulation has not been in the least impaired by the increase in power."

From Mosman, Sydney, comes the report that "after the alteration to 4QG last night your station was so remarkably clear and free from static that we most thoroughly enjoyed every item broadcast from the Exhibition Hall."

What Is Re-Radiation

By R. J. Browne, 4RB.

Nowdays, a popular misconception among a number of crystal set owners is the meaning of the term "Re-radiation." If they have their aerial near another belonging to a neighbour whom, they know, has a multi-valve receiver hooked on to it, they feel almost certain they are getting better results and longer distance than had friend neighbour succumbed to some other hobby (or frenzy), because "multi-valve sets re-radiate like the very dickens." I have heard a youthful fan inform a prospecting novice who was thirsting for "information."

Yet again, it is wrongly held by a large percentage of listeners that a receiver in the state of oscillation is re-radiating. When a receiver "oscillates" it becomes simply a low-power transmitter radiating (not re-radiating mind you Claude), an unmodulated wave, independent of energy "picked up."

There are still a few cynics to whom the idea of re-radiation is a myth and like the man who didn't believe in ghosts they will tell you "there aint no such". They may be partly right, as genuine cases of **Beneficial** re-radiation are indeed very rare but it may come as a surprise to them to learn that **every** conducting body, irrespective of its length, size, etc., is a re-radiator of its own particular electrical frequency.

The theory of re-radiation is that a conducting object tuned (unconsciously or otherwise) to a certain

frequency (wavelength) will absorb or "pick up" energy transmitted at that frequency and it will be thus caused to oscillate, resulting in the formation of an electric field around this conductor, the density of the field, of course, varying with the amount of energy picked up.

It can be seen from this, that the aforementioned conductor is now acting the same as a transmitter. It is oscillating in step with the received energy and transmitting it again, but the "transmitted" energy would be a good deal weaker than that received because of the resistance losses in the conductor. For this latter reason it is evident that for a "re-radiator" to be beneficial it would have to pick up several times the amount of energy that the receiving aerial would ordinarily absorb; otherwise no noticeable effects would result.

Some common forms of favourable "re-radiators" are very high steel structures, masts and such like.

When a valve receiver is oscillating strongly and is tuned to the wavelength of a distant or weak broadcasting station it is quite possible for crystal sets in the neighbourhood to pick up this station also, but the hetrodyming effect of both the waves of the oscillating receiver and the distant broadcaster will result in a "beat note," which may be politely referred to as a sort of a whistle—but in reality is quite an unprintable noise—will dominate in volume above the music and speech which will be badly distorted and unintelligible. This condition has merely the effect of producing a regenerative action in the crystal receivers and has nothing at all to do with re-radiation.

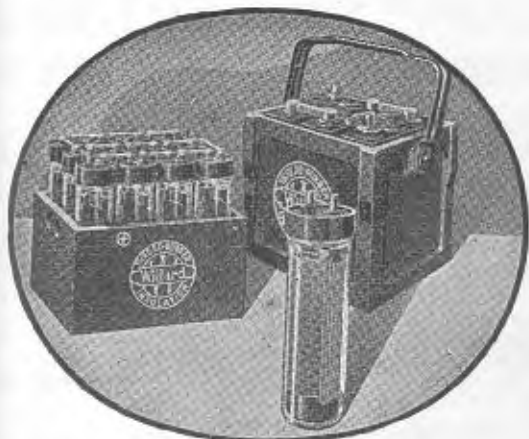

Order your Willard Battery from

MOTOR SUPPLIES LTD.

Perry Street Petrie Bight, BRISBANE

The Most Advanced Radio "A" Battery in Design and Construction— "WILLARD"

The Willard All Rubber Radio "A" Battery, with monobloc rubber case and Threaded Rubber Insulation is the farthest advance in "A" Battery design and construction. When you can get a Willard "A" Battery at such a low price there's no reason for not having the best.

Willard "B" Batteries are also outstanding in performance—let us prove it to you.

**WILLARD
RADIO
BATTERIES**

A Chain of EVIDENCE!

"Your new Model L5 Udisco is a marvel. I can log as many as 30 stations in one night, all on the loud speaker, except two. 4QG, 2FC, 2BL and 3LO day sessions received at good volume."

F. S. LORD, Brooklands, Nanango, Q.

"I am delighted with my Udisco L5, especially in view of the poor results previously obtained here. All Australian stations, Japan and Manila on the speaker. The volume is so great that it needs toning down."

W. C. BOURKE, Stationmaster, Cloncurry.

"He Gave His Old Five Valve Set Away"

Mr. F. E. Smith, our Roma agent, writes us: "Please forward one only L5 Udisco with Phillips Valves and equipment, less both "A" and "B" Batteries. This set is for a client who already has a five-valve set, but after hearing the L5 decided to GIVE IT AWAY and get a UDISCO."

"Fixed up rough indoor aerial and tuned in all stations at full speaker strength with best results ever obtained here on any set. Everybody is talking about the Udisco L5."

H. J. SOLLY, Longreach.

"Good speaker strength from 3LO at noon. At 3 p.m. I tuned in 3LO, 2BL, 4QG, 2FC and 5CL. On first four stations had to cut the volume back. 5CL was clear and loud. Night reception is wonderful from all stations."

S. S. CORRIGAN, Blackall.

ASK YOUR DEALER

If there is a Udisco Dealer in your town or district, ask him to demonstrate this wonder set to you. If you do not know of a Udisco Dealer, write direct to us. Don't be put off with something alleged to be "just as good."

"I sent a Model L5 about 60 miles north of Roma on Wednesday last, and have just had a phone call from this delighted client, who reports very strong reception ALL DAY FROM ALL STATIONS."

F. E. SMITH, Roma.

Money-Back Guarantee

Buy the Udisco Five. Try it for a fortnight. If it does not do all we claim of it, return it and we will refund your money. No other set is covered by this guarantee — another proof of Udisco superiority.

PRINTED across this page are five links from the huge chain of evidence that is being lengthened daily by the host of enthusiastic UDISCO FIVE owners. These letters come to us unsolicited. They are simply spontaneous appreciation of the most remarkable five-valve radio receiver yet marketed.

What could you write of your receiver? Can you receive ALL stations easily, quickly and clearly? If you wish for better reception, decide NOW to own Australia's Greatest Radio Receiver—THE UDISCO FIVE.



NOTE:—The two small balancing condensers shown beneath selector dial have now been eliminated.

Which Set Shall I Buy?—

Which Set to buy? This Set has one advantage; that Set another; a dozen others shout their claims. Put out of it all this fact stand clear—the UDISCO FIVE is "MASTER OF THE AIR," embodying every known advantage in radio design. It outperforms any other five on the market, whether it be imported or made in this country. There are no "ifs" or "buts" about UDISCO performance. It sells itself purely on its merits. Below are printed a few Udisco's many advantages. Study them, and make a vow that your new set shall be a

UDISCO FIVE

"Master of the Air"

- Selectivity** — Broad wavebands do not bother the Udisco. It does not matter where you live; we guarantee reception from all Australian stations without a trace of interference. Every Udisco Five is calibrated and the dial settings for Australian and N.Z. stations are given on a card applied.
- Range** — A remarkable degree of sensitivity gives the Udisco enormous night range and excellent daylight reception. You'll be astounded when first you hear Udisco's big volume on distant stations. Truly the Udisco is a wonderful set.
- ECONOMY** — The Udisco Five consumes LESS THAN HALF the current of the average THREE-VALVE RECEIVER — it can be operated from accumulators or dry cells without any loss of efficiency. This solves the battery trouble in country centres, and means better reception at lower cost.
- Purity** — Good range and volume are sometimes secured at the sacrifice of tonal purity. Not so the Udisco. The announcer's voice from 1YA (N.Z.) comes through clear-cut and true. A violin sonata from 5CL registers as mellow and sweet as though the artist were before you.
- Simplicity** — Could anything be simpler than one-dial tuning? A turn of the wrist brings you all stations without effort. The Udisco Five is neutralised, simple to handle and smooth to tune. Small wonder then that novices report such good results.

The Udisco Five will bring you a Lifetime of Joy.

Send your order to us to-day

UNITED DISTRIBUTORS LTD.

ALL AUSTRALIAN STATES AND NEW ZEALAND.

43 QUEEN STREET, BRISBANE

Price £47/10/-

Complete with Concert Speaker, Clyde Accumulator, 2 "Ray-O-Vac" Master "B" Batteries, Valves, Aerial Equipment, Hydrometer and Voltmeter for testing batteries.



MISS META MACLEAN

This young and well-known composer pianist is now attached to Uncle Ben and Co. in the office of accompanist, verse writer and song composer.

Miss MacLean's originality is reflected in the very clever verses that are sung by Uncle Ben and Co. each Saturday evening, while her compositions, "The Hello Song," "Hip-Hip-Hoorah Song," "Birthday Verse," and various other melodies sung by Uncle Ben and Co. from time to time, prove her ability as a composer of lilting refrains.



MISS META MACLEAN

who is collaborating with Mrs. Sarah Sheldon in producing songs that have been highly commended.

In a recent issue "The Daily Mail" in an item dealing with local composers said:—

"Mrs Sarah Sheldon and Miss Meta Maclean are collaborators in producing songs that are attracting much local interest and receiving high praise from eminent singers visiting Australia.

"Two of Mrs Sheldon's songs were produced most successfully in Brisbane, as was Wonderful Moth of Moonbi, by Miss Maclean, and the latter's musical setting to Brisbane's Welcome Song to the Duke and Duchess of York appeared in The Daily Mail at the time of the Royal visit.

"But it is since their collaboration that these two Queenslanders have produced work that has attracted the attention of such people as Toti dal Monte, Elsa Stralia, Alfred O'Shea, and William James, the eminent composer, while in connection with their patriotic anthem, "God Bless Australia," they received word from the Duchess of York that she was delighted to possess a copy of the work, and a letter of appreciation and encouragement was received by the composers from Dame Nellie Melba.

Miss MacLean and Mrs Sheldon have now interested themselves in children Choral and Dramatic Classes.

This Society meets every Friday evening in the Hall of the Muses, George Street, where children whose talents lean towards music or drama are trained along the right lines.

Free Holiday Trip in Tasmania

3LO's Christmas Trip

Of course everyone would like a trip to the beautiful Isle which is noted for gorgeous scenery, pretty girls, and apples. Well 3LO Melbourne is giving such a trip, which will commence on Tuesday, 20th December, when the lucky winner will leave Melbourne and it will end on Wednesday, 4th January. Everything is prearranged—two first class fares from Melbourne to Tasmania and return, rail fares in Tasmania, local trips and accommodation included. Oh! No, there is no catch either, everything is to be free of expense of any kind to the winner. "Well, that sounds alright," said one prospective competitor, "but how am I to go about getting this trip". Listen—and then be careful to comply with the conditions that are very necessary.

The winner will be selected from a drawing, which will take place at the Studio of 3LO Melbourne on Saturday, 10th December. Any listener who desires to enter for the trip must send in his or her name and address and the number of the licence of the set to which he or she usually listens. The outside of the envelope containing name and address must be marked "Spend Christmas in Tasmania", and it must be addressed to 3LO, Melbourne Place, Russell Street, Melbourne. That is all, quite simple, and the lucky winner will be announced immediately after the drawing on the evening of Saturday, 10th December.

Canned Music

The term "canned" or "bottled" music is usually applied to gramophone records. Certain broadcasting stations resort to gramophone records to a considerable extent in building up their programmes and in many cases listeners are misled by announcements not being made to the effect that they are gramophone records. For instance to the astonishment of many listeners one evening recently one of the world's greatest singers was announced thus—"We are now to have a song by so and so" without any reference to the fact that it was a gramophone record.

It is interesting to note that the "Federal Radio Commission of the United States of America, after an exhaustive enquiry, has taken the stand that while there is nothing reprehensible in the broadcasting of gramophone or player piano music, it should be clearly announced as such.

3LO Melbourne very seldom uses "bottled" music for broadcasting, and when gramophone records are played, they are always distinctly announced as such. There is however a decided objection to gramophone music for broadcasting and 3LO Melbourne, only uses it in cases of emergency, and to accede to very special requests.

Notes from 4QG

"SOMETHING DIFFERENT."

A novelty-entertainment, in the form of a Nigger Minstrel Show, was recently provided in the studio of Station 4QG by the St. Augustine Male Party.

Plantation melodies, interspersed with humorous dialogues, were the chief features, and the party acquitted itself very well in putting over "something different" for listeners.

* * * *

THE QUEENSLAND STATE AND MUNICIPAL ORCHESTRA.

On Tuesday, November 1st, 4QG will relay the full concert of the Queensland State and Municipal Orchestra from the Exhibition Hall. The Queensland State and Municipal Orchestra was founded in 1907 by Mr. George Sampson and was carried on by him for about 17 years at his own risk. Until 1924 it was known as "The Sampson Orchestra." The expenses becoming too great for Mr. Sampson to cope with single-handed, a Queensland State and Municipal Orchestra Trust was founded in 1924. Starting with a modest request for £1000, Mr. Sampson succeeded in obtaining a grant from the Queensland Government and a similar grant from the Municipality of Brisbane. Mr. Sampson's own contributions to the trust was a very valuable orchestral library which he had slowly and at great trouble acquired during the 17 years of the orchestra's existence. The library at the present day could not be replaced under £700. The trust fund was established to be held in perpetuity for the sole use of the State Orchestra. Mr. Sampson's idea in attempting to inaugurate this fund was his firm belief in the opinion that there is no possibility of a permanent orchestra being established in any town unless there is a permanent indestructible fund, the income of which is sufficient to support a first-class orchestra. No man has worked harder in the cause of music than Mr. George Sampson and listeners who are keen on this particular type of music will doubtless have a very pleasant evening on Tuesday, November 1st, when Station 4QG broadcasts the full concert from the Exhibition Hall.

* * * *

4QG LECTURETTES.

A listener writing re lecturettes, says:—"The lecturettes broadcast by 4QG are very helpful to us. I have four sons 12 to 18 years of age, and although we have only had a wireless set six months, there is a marked improvement in the speech and general knowledge of my boys. We can find something in every lecture to interest us."

In the allocation of dates for lecturettes 4QG endeavours to cater for all classes of social and economic thought. These lecturettes are not what might be termed "filling-up stuff," but are an honest endeavour to render a service that (as in the opinion of the writer of the extract) may result in enlightening both the young and adult mind on subjects upon which they have little or no knowledge.

THE SLEATH TRIO.

Lovers of harp music will be pleased to learn that on Saturday, the 5th November next, solos will be rendered by Mrs. L. Corrigan, one of Brisbane's well-known harpists, in conjunction with Mr. and Mrs. Sleath. Mr. Sleath, who is a violinist of repute, will also render solos on the 'cello and viola. Mrs. Sleath will be at the piano. An interesting feature of this one hour's musical entertainment is that some of the music to be played has not yet been heard from Station 4QG.

* * * *

4QG'S DIGGER PLAYLETS.

Much interest has been evinced in the digger playlets appearing in 4QG's programmes of recent weeks. These playlets are the product of Miss Thelma Champion and seek to give a word portrayal of the indomitable spirit of the A.I.F. Whenever diggers meet they love to recall humorous incidents of their experiences in the World War, the gloom of those critical days being forgotten in reminiscences of a brighter nature. Under the most irksome and tragic circumstances one could always be found amongst them who with a quip or jest would set up roars of merriment, and it is this side of the digger's life that these playlets seek to express.

OREGON WIRELESS MASTS

IN the use of Masts to carry Wireless Aerials, Rosenfeld's Oregon has proved to be the most serviceable. The Oregon for these masts is specially selected.

Call, 'phone 5991, or write to us for further particulars and prices of Wireless Masts.

You can purchase your Masts in one length of Oregon Pine, from 30ft. lengths of 3 x 3, to 80ft. lengths of 6 x 6, also 4 x 4, and 5 x 5 to any length.

ROSENFELD & Co. (Qld.) Ltd.

"The Oregon Specialists"

TIMBER MERCHANTS.

Moray Street, New Farm, Brisbane

Phone C. 5991.

THE NEW **FERRANTI** PRODUCT

41/-



41/-

ISOLATE YOUR LOUD SPEAKER
WITH A



OUTPUT TRANSFORMER

Type OPI—(Ratio 1 to 1) for use with ordinary Loud Speakers of the diaphragm and cone type. Type OP2—(Ratio 25 to 1) for operating Loud Speakers of the coil driven cone type.

The use of a FERRANTI Output Transformer is preferable to a choke filter unit because (a) the majority of chokes are inefficient with a large plate current passing through them, and (b) the blocking condenser has to be large if the lower notes are to be reproduced properly. The result is that the lag caused by charging and discharging the condenser as the signal varies, spoils music involving sharp changes such as given by drums, plucked strings, the harp and even the piano.

Obtainable from every Radio Dealer in Australia.

Dealers please communicate with:—A BEAL PRITCHETT (Aust.) LTD., Sydney & Melbourne.
WEDMA, LTD., Adelaide - - EDGAR V. HUDSON, Brisbane - - GIBBS BRIGHT & CO., Perth.



A Talk About Valves

There is now such a variety of valves available that most people are bewildered when it comes to buying a new valve, and usually they order one the same as the one which is being replaced, although it may be possible that a newer and more suitable valve for their circuit has since been placed on the market.

Valves can generally be divided into three classes, namely, those that operate from 2, 4 and 6 volt. accumulators. There is no difficulty in deciding which of these classes your valves are in, as it is only necessary to note the voltage of the accumulator. In each of these voltages classes will be found, valves which have various filament consumption, for instance, in the 2 volt. class there are valves which take .3 amps. and others which take only .1 amps. In the 4 volt. class the various valves take .06, .1 and .3 amps. and the 6 volters take .1, .25 amps.

From the point of view of economy of upkeep, it is desirable to choose valves with the lowest filament consumption possible, provided the other characteristics are suitable to the circuit. The .1 amp. valves in each of the voltage classes are the latest to be introduced and are probably the best, for while being very economical in filament current, they are at the same time very robust and have excellent characteristics.

The classes of valves may be subdivided again into the various impedances and amplification factors and it is choosing the correct one amongst those that the uninitiated have difficulty.

Generally the amplification factor of a valve varies with the impedance and it is impedance which decides a valve's suitability in any particular circuit. There seems to be a tendency to divide valves into five classes of impedance especially in the .1 amp. class. Each of these classes is suitable for a particular purpose and great care should be taken in choosing a valve of the correct impedance at the success of the receiver depends on it to a large extent.

Commencing at the high impedance end we have those known as resistance coupling valves with impedance above about 50,000 ohms. These are primarily intended for resistances coupled circuits, and may also be used successfully with neutralised tuned anode coupling and low frequency choke coupling. The second or medium impedance class have impedances between 20,000 and 30,000 ohms, and is one of the most used varieties being suitable for tuned anode or transformer high frequency couplings and for low transformer or low frequency coupling where the transformer is a good one with a high inductance capacity such as the Igranic-Pacent Super Audio transformer. Where the transformer is of a cheaper type, the third or low frequency classes with an impedance of from 10,000 to 15,000 ohms, is preferable. Then there remains the two classes of power valves which are always used in the last stage. The ordinary power valve is suitable for handling moderate volume and has an impedance of about 5000 to 8000 ohms. The super power valves have very low impedance ranging from about 2500 to 5000 ohms, and should always be used for large volume to prevent overloading but it

should be pointed out that these usually take rather more filament current and require large capacity high tension batteries or alternating Main Supply Units,

A.C. FILAMENT VALVES.

Batteries and accumulators are being superseded gradually by less troublesome and expensive devices and it is now possible to use a receiver without any batteries at all except perhaps for the grid battery which causes no trouble.

These substitutes obtain current from the electric lighting mains and convert it to a form suitable for the particular purpose it is used for. When the main supply is direct (coupled) current there is no difficulty in eliminating the batteries for the voltage has only to be broken down by resistances and then the supply smoothed by chokes and condensers, but when the main supply is alternating current then it has to be rectified or converted to direct current and smoothed before it can be used instead of either the H.T. or L.T. with the ordinary valves.

Suitable rectifying valves are available which have an emission large enough for both the H.T. and L.T. supply and they are now generally used for the H.T. supply, but unfortunately when employed for the L.T. supply there is difficulty in smoothing the output in order to enable the valve to work silently.

This difficulty has been overcome by the introduction of special receiving valves which use alternating current for lighting the filaments and there is, therefore, no need to rectify and smooth the power supply. The first example of this type of valve to appear on the market is known as the K.L.I. The principle difference between it and the ordinary valve is that the filament is not connected to the receiver circuit and does not emit electrons. It merely acts as a heater to heat the cathode which is in the form of a cylinder enclosing the filament. This cylinder of cathode takes the place of the filament in the ordinary valve and emits electrons when heated. The rest of the valve is conventional.

The heater filament operate at 3.5 volts, and each valve takes 2 amps. It is necessary to step down the main voltage to 3.5 volts, by means of a special transformer. If this transformer does not step down to within 5% of 3.5 volts, then it is necessary to connect a heavy current carrying rheostat in series and use a voltmeter to denote when the correct voltage is being obtained.

The filament transformer manufactured by the Igranic Electric Co. has the special feature of always supplying a voltage within 5% of the 3.5 volts, when any number of valves from one to four are used and it is therefore, unnecessary to use a rheostat and voltmeter. The valve filament may be connected directly to the output of the transformer.

It is advantageous to connect two 1 mfd. condensers in series across the output of the transformer and earth the points between them. This helps to eliminate any "hum" caused by the A.C. current.

BRANDES



Two years ago the name "Brandes" was known to a few people who just happened to buy a pair of "Brandes" phones. When we look at it to-day this seems remarkable as Brandes have been acoustic components designers and manufacturers since 1908.

Now—well what a difference! Even here in Australia that wonder reproducer "The Ellipticone"—recently won the Holland Acoustic Medal against all comers—has been heard and applauded by thousands whilst its small confrere "The Tablecone," naturally appeals to those of more moderate means.

Brandes have not confined themselves to their world known speakers—The Table Talker—The Brandola—The Tablecone and the Ellipticone—but have recently branched out and carried their master craftsmanship to condensers and sets.

As an example of the way Brandes goods are being received in Australia the photograph shows rather a remarkable thing. It happens to be one of six trucks carrying goods for shipment to Australia. The weight probably with the name and size of the shipment were too much for the truck, so it gave up the ghost.

Now—we can enjoy Pure
Clear Music

*Made in Australia
for Australians*

Thanks to **EVER-READY**

Radio "B" Batteries

PRICE LIST
W.P. 40-volt 12/6
W.P. 60-volt 18/9
HEAVY SERVICE.
X.P. 40-volt 23/-
EXTRA HEAVY SERVICE.
Super 40-volt 30/-

Ever-Ready "B" Batteries take the "ire" out of wireless. They are ever ready to deliver a strong, even flow of current to your receiver and render longer service.

Their lower prices are not an indication of inferiority, but of **GREATER VALUE**, for Every-Ready Batteries are made in Australia and have not to face the heavy import tariffs imposed upon imported batteries.

Sold by all Radio
Dealers

Wholesale Distributors—
**Edison Swan Electric
Co. Ltd.**

156 CREEK ST., BRISBANE



Trans-Oceanic Telephony

(By J. Decomade.)

When a London telephone subscriber makes use of the new radio-link between England and U.S.A., his voice passes first through underground cables to the Trunk Exchange, where it is jacked through the long-distance telephone line to the Rugby radio transmitter.

Here the low-frequency currents are used to modulate the high-frequency waves radiated from the huge antennae system at that station. The actual process of modulation is not that used for broadcasting, but is of a special kind designed to render the interception of private messages by unauthorised listeners as difficult as possible. The outgoing wireless signal is, in fact, carried by the single side-band, the full carrier-wave being eliminated as explained below.

After crossing the Atlantic, the wireless signals are picked up by the American Telephone and Telegraph Company's receiving aerial at Houlton, Maine, where they are rectified by a special heterodyne valve set. From the Houlton station the rectified signals pass over a 500-mile stretch of trunk line to the Central Exchange in New York.

Incoming Signals.

Incoming signals from America reach the London telephone subscriber along a different path. From New York the low-frequency currents are trunked through to the coast wireless station on Long Island, where they are transformed into high-frequency waves.

These are picked up on the Post Office receiving aerials at Wroughton, near Swindon, and after being converted into the original speech are fed into the trunk line connecting Wroughton with the Trunk Exchange in London.

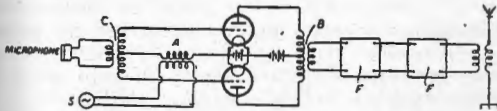

Fig. 1.

The combined receiving and transmitting system is illustrated in Fig. 1. the actual bridge arrangements which connect the outgoing and incoming signals at the London and New York Exchanges being merely indicated in blank.

It is, however, quite clear from the diagram that the powerful transmitting valves at Rugby must be linked with the receiving valves at Wroughton through the circuits located in the London Exchange, otherwise a private telephone subscriber would not be able to send and receive messages.

"Singing" Round the Loop.

This gives rise to a peculiar difficulty known as "singing round the loop," due to interaction between the local transmitting and receiving systems. The effect is similar to that produced by using too tight a coupling between the grid and plate coils of a valve receiver, or to the sustained note created by holding the earpiece close to the mouthpiece of an ordinary telephone set.

For instance, speech currents from the London subscriber reach the transmitter at Rugby and are

radiated outwards. Some of this radiated energy is picked up by the home receiving aerial at Wroughton, which is obviously much closer at hand than the distant Houlton station.

These "unwanted" signals will then be rectified and passed through the trunk line back to the London Exchange, where they will tend to pass outwards again to the Rugby transmitter.

If this were permitted, a vicious circle would be set up between the Rugby and Wroughton stations, where by all outgoing signals would tend to be rapidly amplified up into a continuous roar, owing to mutual interaction. The same difficulty, of course, applies to the loop circuit existing between Houlton, Rocky Point, and New York.

Balanced "Bridge" Junctions.

In order to prevent this defect, the incoming and outgoing lines from each London subscriber are branched across the opposite diagonals of a balanced Wheatstone bridge circuit located in the Exchange. The voltages due to the "unwanted" home signals picked up by Wroughton from Rugby are thus balanced out, so far as the other bridge diagonal is concerned, and cannot be reimposed upon the Rugby line.

In other words, the vicious circle between the two home stations is broken or open-circuited, whilst at the same time the necessary two-way working connection between the home and distant stations is preserved.

"Eavesdropping."

From time to time newspaper reports have appeared claiming the interception by outside listeners of private messages sent by the London-New York radio service. It is no doubt possible, at the present stage of development, for a skilful wireless operator to overhear trans-atlantic speech, but it is by no means a simple undertaking, and it is likely to be made more difficult in the near future.

In broadcast transmission, the voice or musical frequencies are superposed upon a high-frequency carrier-wave, and the results of the mixture or "modulation" is radiated as a whole. In the Trans-atlantic Service the carrier-wave is eliminated, and only a part of the high-frequency energy, viz., the upper side band, is actually radiated.

Secret Telephony.

The consequence is that no intelligible reception can take place unless the "side band" radiation is reinforced, at the receiving end, by local oscillations corresponding in frequency to the missing carrier-wave. This entails the use of a heterodyne, or more strictly speaking, a "homodyne" valve at the receiving end, tuned to the carrier frequency.

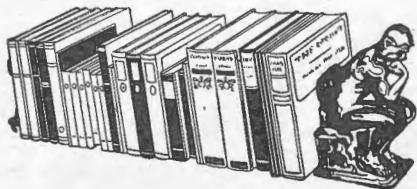

For your Radio Books

Here are just a few which we recommend

- James, Amateur Wireless Valve Transmitters 12/- (post 9d).
- James, Home Constructors' Wireless Guide. 4/6 (post 5d).
- Lescarboua, Radio for Everybody. 10/- (post 6d).
- Bangay, the Oscillation Valve, 8/- (post 3d).
- Ballantine, Radio Telephony for, Amateurs, 11/6 (post 8d).
- Balbi, Loud Speakers—their construction, performance and maintenance, 4/6 (post 3d).
- Ainsley, Mast and Aerial Construction for amateurs, 2/- (post 2d).
- J. W. Robinson and G. Williams, Wireless, 3/6 (post 3d).
- J. W. Robinson, Story of Broadcasting in Australia, 1/6 (post 2d).

For All Requirements in Books—Technical, General and Educational—

A. McLEOD

"Brisbane's Best Bookstore"

107 Elizabeth Street,

BRISBANE.

An ordinary crystal set, or a standard type of valve receiver, even if tuned in to the 1,560 metres wavelength used for communicating with America, would only receive an unintelligible medley of sounds. A valve set of the superheterodyne type could, however, be successfully used to restore the side-band transmission to its original speech form.

Experiments are at present being carried out with the object of making the American wireless service absolutely secret. For instance, by transmitting the lower side-band instead of the upper, the normal speech frequencies can be inverted so that the high notes are transformed into low notes and vice versa. Valve demodulators of a special type then become necessary at the receiving end in order to make the transmitted speech intelligible.

Cutting Out the Carrier.

The arrangement used at Rugby for sending out single side-band radiation with the carrier wave eliminated is illustrated diagrammatically in Fig. 2.

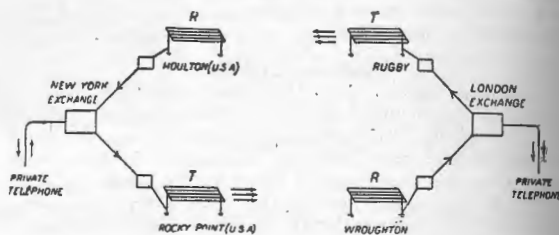

Fig. 2.

Two high-frequency amplifying valves are mounted in push-pull relation as shown. The carrier wave is generated separately at S and is fed to the amplifiers through a coupling coil A, located in the common grid-filament lead.

Owing to the position of the coil A, the voltage of both of the valves is varied in phase. In other words, both grids are thrown positive or negative simultaneously by the applied carrier oscillations. As a result, the plate current in both valves rises and falls in step, so that there is no resultant transfer of energy across the output coupling B. The magnetic flux-variation due to one valve balances out that due to the other, and no carrier-wave energy gets through to the aerial.

The effect, however, of applying speech current from a microphone across the input coil C upsets this state of balance. The voltage variations thrown on to the two grids are now 180 deg. out of phase. When the upper end of coil C is positive the lower end is negative, and the two grids are therefore affected differentially.

The resultant high-frequency output is then passed through Filter circuits F, F, tuned to the required band frequency, and is radiated by the aerial in this form—"The Broadcaster."

International Law of the Ether

The ether "as a medium for the transmission of radio-telegraphic correspondence" has already raised important questions of international law, and will continue to do so more and more as power over it is developed. Of these there are two types. Firstly what disputes are likely to arise from injudicious broadcasting? Secondly, what benefits may accrue from international co-operation?

Clearly, if all countries have absolutely unbridled power to use the air space above their neighbour's lands, many serious disputes will inevitably ensue. Nations must, therefore, have some power to control the transmission of messages over their territory, but within what limits is still doubtful.

"How far has a State power to prevent a violation of its neutrality by means of wireless, and how far is it responsible if it fails?" asks Reginald W. Goff in "The Broadcaster". During the World War many neutrals took whatever action seemed best for this purpose—for example, the establishment of a wireless censorship, and of various safeguards for ensuring that the ships of belligerent countries should not use their wireless while in neutral waters. It is possible that very wide powers will be allowed in this direction, and it may even be settled as the clear duty of belligerents to refrain from using their wireless apparatus anywhere within neutral jurisdiction. One case has already been decided on these lines, for during the Russo-Japanese War, 1904-1905, the Russians, desiring to communicate with their forces, erected a broadcasting station in China, and the Chinese authorities dismantled it. Thereupon the Second Hague Conference definitely decided that it should be illegal for belligerents to erect wireless stations in neutral States or on their territorial waters. Should they construct apparatus quite properly on their own ships or aircraft, and then make use of it in neutral jurisdiction, it is difficult to believe this could be differently regarded.

The same conference declared it "illegal" for neutrals to "suffer the establishment" of such wireless apparatus. It seems probable, therefore, not only will neutrals have wide powers, but also will be their duty to exercise them.

Again, what action can a belligerent take if it respects the use to which wireless telegraphy is being put by the subjects of neutral States? This question also was raised during the same war. The Russian authorities, fearing that an English reporter, equipped with wireless apparatus, might communicate with the Japanese, issued a decree that they would treat all such persons as spies. This action appears, however, to have been improper, because the First Hague Conference decided that persons sent in balloons to deliver despatches were not to be deemed spies, and it would be unreasonable if reporters, employing the ether for the same purpose, were to be treated differently. It was further agreed that newspaper correspondents and reporters were army followers who might lawfully be made prisoners of war. Probably, then, the proper action in such circumstances is to arrest the offenders.

Difficulties much greater than these are likely to arise. States may desire to prevent the broadcasting of matter which they consider injurious to the public or moral orders, or merely because transmission interferes with their own service. This is of the utmost importance, since, if powers be allowed to interfere with broadcasting on this latter ground, the possibility of an international wireless service will be virtually at an end.

The Institute of International Law, 1906, recognised the right of every State "to oppose the transmission of wireless messages through the ether space" above it, in order to protect its security. Probably any country would be justified in so doing, if the matter were seditious, or otherwise calculated to undermine the public order, whether issuing from a national or private station, because transmission of such material is merely a new type of unfriendly act. Therefore, if, the Home Government does not suppress it, the offended nation has a justifiable cause of complaint, for, if a Government deliberately refuses to restrain its subjects from injuring other countries, it must accept responsibility for the harm produced.

It has already been disputed, but unfortunately not settled, whether interference with the service of one country caused by broadcasting from another is a sufficient reason for diplomatic action. In 1905 England desired to establish radio-communication with Italy, but the French Government objected on the grounds that the attempt would seriously impair their own service. The English denied this, but the scheme was abandoned through failure to agree with the Italian Government.

The matter has since been considered by official conferences, but there seems considerable controversy as to the conclusions arrived at. The actual decision was "that the working of the wireless telegraphy stations shall be organised as far as possible in such a manner as not to disturb the service of other stations." Though some writers consider this gives no general power of interference, others take the contrary view, but to allow any State to prevent another employing the ether space above her territory merely because such use interfered with her own service, were but to cripple one of the greatest modern inventions at the outset. Probably the solution will be found in the appropriation of different wavelengths to various countries, any State whose service is impaired because another fails to conform to the code being empowered to take action against her.

We have still to determine what rights a country has to prevent the broadcasting of obscene literature, and this raises very sharply the question of "private stations." If the matter is so immoral as to be unlawful alike in the country of origin and in others, it will best be suppressed by the action of the Home Government. What if it is there recognised as proper? Then it may be argued the Government is in no way responsible, should it be received where it is not so regarded. The answer to this must remain a matter of doubt till the development of wireless forces its solution. It

may be found in agreement between the States concerned, and there is a precedent for this in the Soviet-Japanese relations in North Saghalien. Plenipotentiaries from both countries decided that the Japanese stations should be adjusted in a manner consistent with the existing laws of the Union of Soviet Republics, prohibiting private and foreign establishment of wireless stations.

If not satisfactory so arranged, the task of defining the various rights and duties may fall to the "League of Nations", which could settle by international agreement a code of rules regulating broadcasting. Then the possibility of recalcitrant States would arise, and two methods of dealing with these have been suggested, namely coercion, which is extremely dangerous, and so similar to war that it cannot be very effective, and a general boycott. Should two nations disagree as to the interpretations of any rules which may be laid down, or on fresh matters, their claims could be heard by the Permanent Court of International Justice established by the League in 1920.

One of the first things is to provide against jamming. With the steady growth of wireless, congestion increases, and it will soon be vitally necessary to organise international broadcasting to prevent messages conflicting. For this purpose two schemes have been proposed. One is differentiation on a percentage basis; the other, separation in cycles.

In most estates adequate security is already afforded to playwright and copyright duly obtained in any one country. Now, a copy taken from a broadcast being as much a copy as if taken in any other way, presumably such a reproduction of a protected work would be a piracy. Yet, until 1924 there was nothing to prevent a broadcast being recorded in a gramophone receiver. An Act of that year, however, rendered it criminal in England to make records therefrom for the purposes of trade. This had been done already on a small scale, fairly clear and accurate reproduction being obtained, but the dangerous prospect more than anything else moved the framers of the Act. The whole question of author's rights, as affected by wireless, will receive attention at the International Conference of the "Union Litteraire et Artisque" at Rome in October.

Great benefit should be derived from the use of wireless telegraphy in "detecting crime," but how far



A CROSS in this square denotes that your subscription expires with this issue.

Subscription 6/6 Year

it will be employed must remain a matter of speculation until wireless is more fully developed. At present the police forces of various countries do communicate with one another, and messages can be sent through the ether to many States at once, while, provided a code be used, no undue risks are incurred. Further connection can be established, if necessary, between a flying squad at sea or in the air and the police authorities in any country. The distinct possibilities which open up cannot, however, be properly appreciated before the development of wireless television, which is at present much too immature for general use. Yet the ability to send not mere descriptions but also actual photographs of wanted criminals would be of the very greatest value.

A second benefit is the enhanced possibility of communication, which must always make for peace, partly because people live more happily together the better they understand one another, and the broadcast renders possible free interchange of ideas, partly because many crises which have led to war might have been averted had communication been more rapid.

It follows, therefore, that the international law of the ether is of very real importance. On its careful preparation and administration may hang the greatest benefit or harm for mankind.

Readers!

This is your Radio Journal. Boost it—Tell your friends about it. It's the grandest sixpenn'orth in Radio literature.

A Product of Great Britain

This all-British C.A.V. BATTERY is manufactured by the well-known and the earliest established electrical equipment manufacturers in the British Empire. British thoroughness in construction is their guarantee of long life.



Radio
'A' & 'B'
Batteries

BARNES AUTO CO.

Queen Street (opp. Treasury Buildings),
BRISBANE.

Everything in Radio at CHANDLERS

"Everything in Radio," aptly describes Chandler's Radio Service. Whether it be a small component for an inexpensive crystal set or a multi-valve receiver of the latest design Chandler's lead the way in Radio value and quality. The lists below explain the reason why.

For the Crystal Set Owner

Just arrived large shipment of new crystals at the lowest prices ever offered in Queensland.

Super-Neutron	1/6
reduced from 2/3	
Galena in tubes	3d.
Q.S.A. in tubes	3d.
Hertzite in tubes	6d.
Package of seven assorted pieces of crystal 9d.	
Renew that worn out crystal whilst these prices last	
Sliders and Bars	1/3
Headphones 4,000 ohms, German Phones, of excellent tone, particularly suited for Crystal work	11/9

For the Valve Set Owner

20ft. LOUD SPEAKER CORDS. Extensions to put the speaker on the verandah or in another room 2/3

VOLTMETERS to test "B" Batteries 0-50 v. 3/9

VOLTMETERS to test "A" and "B", Batteries 4/9

"A" BATTERY TESTERS. Pocket type for testing accumulators—about the same size as a watch 4/9

HYDROMETERS. For testing accumulators 3/3

HUNDREDS OF OTHER LINES.

For the New Set Buyer

TWO VALVE SETS—in table cabinet 45/-
Made by Crosley—sound, and well constructed—loud, speaker reception of 4QG certain.

Complete with Valve, Batteries, Phones, Aerial and Earth equipment. PRICE £6/1/3.

For Scientific Loud Speaker instead of headphones 15/- extra.

THREE VALVE SETS 79/6

In the Crossley we are offering without question the greatest value in radio. This set is first of all a great performer, with excellent Tone and quality, and distance-getting ability. Its appearance in its compact table cabinet is pleasing.

UNPARALLEL VALUE AT 79/6

Complete with Valves, Batteries, Speaker, Aerial and Earth equipment. PRICE £9/14/-

Value in Radio Parts

At the price-level that only Chandler's can offer.

VERNIER DIALS W.R.C. 5/3

Convert your set into one of modern appearance—simplify the tuning, and separate those jumbled stations with this new dial. Suitable for clock and anti-clockwise condensers.

VARIABLE CONDENSERS W.R.C. Straight Line Type.

.0005	10/3
.00035	9/3
.00025	8/9

A masterpiece of mechanical construction of the highest quality brass, with practically no di-electric losses. Stations are spread equally, without crowding.

S.C. Jacks, 1/3; D.C. Jacks, 2/-; Phone Plugs, 1/6; Rheostats, 1/6 and 2/6; Sockets W.X. 1/3 and 1/6.

Hundreds of other parts at equally low prices.

Amplion "CARBONCEL" Rechargeable 'B' Batteries

Amplion Carboncel "B" Batteries can be simply and easily recharged at home, without trouble, by anyone. No electrical knowledge required. Simply add more salts from time to time, and when the zinc plates are worn, replace them with spares obtained from us. No fuss, no bother, no waiting, complete independence, and the knowledge that the battery is practically indestructible and will give service for years.

PRICE 3/- per Cell (over one volt each).

MAIL ORDER SERVICE

Country residents may depend on our fast and accurate service. Goods move out of our warehouse every hour—orders are filled the same day if received in the morning. Avail yourself of Chandler's Radio Mail Order Service.

J. B. CHANDLER & CO.

Queensland's Largest Radio Store

45 ADELAIDE ST. [Next Allan & Stark's] BRISBANE

A Good Move!

Buy Your Radio Requisites

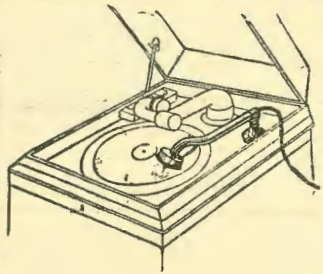

At last!

A perfect Pick-up Device that sells at a sensible price—

The 'Magnaphon'

Recreates recorded music into something hitherto unapproached by either the radio on the gramophone. Play your records through your radio. The perfect reproduction will astound you. The cheapest portable machine gives the same results as expensive consoles.

Hitherto Pick-up Devices have been priced in the region of £10. The Magnaphon comes to you complete for only

Price £3 15/0

A limited stock has just been received. Most of these are already booked up. Order now while supplies are available. Equipment includes Tone-arm, Tone-arm Rest, 20 feet Cord and Detector Plug.

WIRELESS HOUSE LIMITED

Edward Street BRISBANE

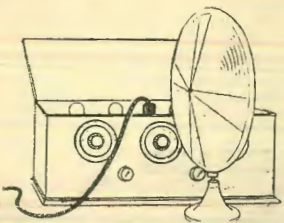

"Acme" B Eliminator
incorporating Raytheon B.H. Type Tube,
£12-10-0

Emmco B Eliminator
A Splendid Job— Australian Made.
£10-10-0

"Acme" A Charger
incorporating Raytheon B.A. Cartridge Tube
£4-17-6

Powerplus Headphones
4000 ohm.
Astounding Value at—
12/9

Neutron Crystal
Famed the World Over.
Now 1/6

Mighty Atom Crystal
A Firm Favourite.
1/3

"Tobe" Block Condenser
For "B" Eliminator Construction.
Now £2-17-6

Jefferson Transformer
Type 41. Ratio 3.75 to 1.
Now 15/-

Brandes Matched-Tone Headphones
22/6

English Terminals
N.P. Large.
4d. Each

H. & H. 30 ohm. Rheostat
With Calibrated Dial.
Now 2/9

"Pilot" Art Dial
For Panel Beautifully Accurately Made.
7/6

"Celasite" Stranded Wiring Wire
Essential for Short-Wave Set Construction.
5/- Per 25ft. Coil

"Pansin" Variable Condenser
.001 Capacity.
Without Vernier 7/6
With Vernier 9/6

Readrite Volt-ammeter
Reading 0-50 volts; 0-40 amps.
Now 4/-

Igranic Fixed Condensers
.0001 to .0005 2/3
.001 to .002 2/9
.005 4/6
.006 4/6
.01 6/-

Sangamo Fixed Condensers
.0001 to .0005 2/3
.001 to .002 2/9
.005 3/9
.006 4/6
.01 6/-

Columbia 1.5 Volt Dry Cell
3/-

Columbia 45 Volt Heavy Duty "B" Battery
25/-

Burgess 1.5 Volt Dry Cell
2/11

Burgess 45 Volt Heavy Duty "B" Battery
26/-

Minuet Portable 3-valve Receiver
With 3 Weeco Valves.
£8-5-0

Dulcephone 3-Valve Receiver
Complete with B.T.H. C.2 Speaker.
£24-10-0

Model 20 R.C.A. 5-Valve Receiver
Complete with Model R.C.A. Speaker.
£56

Dulcephone 4-Valve Crouning-Drake Receiver
Complete with A.R.19 Amplion Speaker.
£32-10-0

Crosley 3-Valve Portable Receiver
Bare
£3-0-0

Winchester 45-Volt Heavy Duty "B" Battery
25/-

Wireless House Ltd.

Something New!
THE
"PHASATROL"

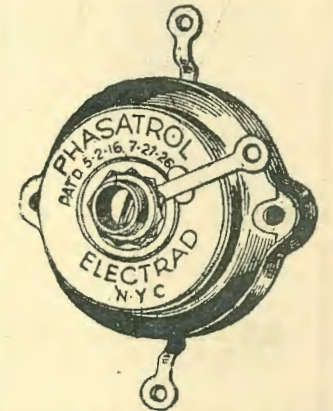

A New and Wonderful R.F. Stabilising Unit.

Connection is made between the plate of the R.F. tube and the plate connection of the R.F. Transformer.

Full instructions enclosed in every packet.

Price 17/6

RAYTHEON TUBES

Type B.H.— 85 milliamps — for "B" Eliminator construction.
25/-

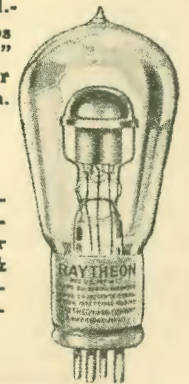

Type B.A.— 350 milliamps, — for "A," "B" & "C" Eliminator construction.
32/6

WIRELESS HOUSE LIMITED

Edward Street BRISBANE

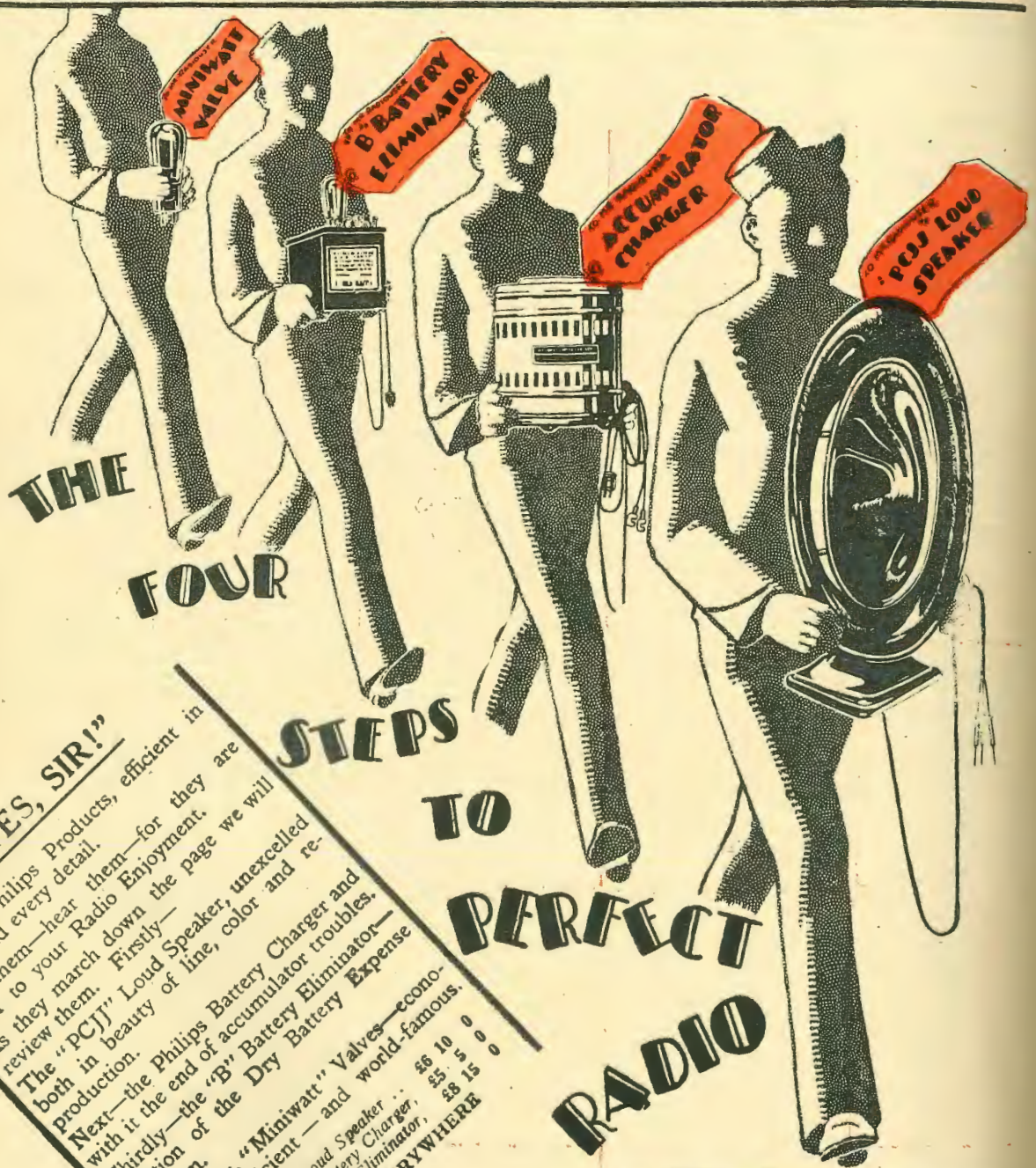

THE FOUR

STEPS TO PERFECT RADIO

RECEPTION

"YES, SIR!"

Four Philips Products, efficient in each and every detail. See them—hear them—for they are vital to your Radio Enjoyment. As they march down the page we will review them. Firstly—

The "PCJJ" Loud Speaker, unexcelled both in beauty of line, color and re-production.

Next—the Philips Battery Charger and with it the end of accumulator troubles. Thirdly—the "B" Battery Eliminator—solution of the Dry Battery Expense problem. And lastly, "Miniwatt" Valves—econo-

Philips Loud Speaker ..	£6 10 0
Philips Battery Charger ..	£5 5 0
Philips "B" Eliminator ..	£3 15 0

SOLD EVERYWHERE

PHILIPS RADIO

Club Activities



RADIO CLUBS OF QUEENSLAND.

- AUCHENFLOWER AND DISTRICT**—Secretary, L. Cribb, "Frampton," Ridley Street, Auchenflower.
- CAIRNS AND DISTRICT**—Secretary, Mr. Tarbit, c/o Mr. Les. Fitzsimmons, Cairns.
- EASTERN SUBURBS.**—Secretary, J. Burns, Longland Street, East Brisbane.
- GRACEVILLE.**—Secretary, H. Carter, Cr. Molonga Terrace and Wylie Streets, Graceville.
- IPSWICH.**—Secretary, S. J. Aspinall, Brisbane Street, Ipswich.
- SOUTH BRISBANE.**—Secretary, W. R. Gilbert, Gordon Street, Coorparoo.
- TOOMBUL.**—Secretary, T. Starkie, Sandgate Road, Nundah.
- TOWNSVILLE.**—Secretary, E. J. Jefferies, Fletcher Street, West End, Townsville.
- WIRELESS INSTITUTE (Queensland Division).**—Secretary, Charles Dunn, Perry House, Elizabeth Street, Brisbane; telephone No. Central 7260; postal address Box 689K, G.P.O., Brisbane.
- WOOLOOWIN.**—Secretary, C. J. Grant, Old Sandgate Road, Wooloowin.
- WYNNUM AND MANLY.**—Secretary, P. J. Golden, c/o Trackson Bros., Ltd., Elizabeth Street, Brisbane.

Wireless Institute of Aust. [Q'd Div]

In order to more suitably accommodate the transmitting set and other experimental gear, the Institute has removed to another room in the Courier Buildings, Brisbane, and after having completed the re-erection of the transmitting set has again taken to the air on Sunday morning between the hours of 10 and 11 o'clock. The first transmission from the new room was made on 16th October and reports have come to hand of the satisfactory modulation etc. of the set. Many comments have been made on the popularity of the "Morse practice" and "talk on radio" sessions of the programmes, and with a view of continuing to assist amateurs and enthusiasts in their Morse courses and radio matters, the Institute has decided to make these sessions a regular feature.

The broadcasting arrangements are entirely in the hands of the Transmitting Committee comprising Messrs. W. I. Monkhouse, A. A. Jackson, C. H. Casperson, and R. B. Browne whose policy it is to adhere strictly to the Institute's object of assisting the amateurs and radio enthusiasts in furthering their knowledge of the science of Radio Telegraphy and Telephony, together with advancing the science in general.

To those amateurs and enthusiasts who are looking for enlightenment in radio problems the Institute offers an excellent opportunity for discussions with experts and the solving of many problems, and those people should avail themselves of the opportunity of becoming members of the Queensland Division.

Full particulars regarding application for membership will be gladly given by the Hon. Secretary, Box 689K G.P.O., Brisbane.

Wooloowin Radio Club [oa-4WN]

Hubert Kington was recently summoned before the above club to answer a charge of having deserted his post of President. Proceedings opened by the Prosecuting Counsel, 4LJ, alleging collusion between the accused and 'is 'onour, Harry Jiear, and claimed the finding of (soft?) drink bottles both in the dock and under the Magistrate's bench as proof of this. Unfortunately both bottles were empty, which prevented the whole court from getting "colluded." 'Is 'onour gave an assurance that there was no collusion, and assured the prisoner that he would get justice, adding that he had already decided he was guilty.

Several witnesses, bound under pain of being cursed with burnt-out filaments and eternal static, to tell the whole truth and everything but the truth, told how Kington had frequently been away from the district for months at a time, and eventually left it to take up his abode in slums of Toombul. He only stayed there for a few months, sold his wireless poles, and departed for the wilds of Sherwood. It was stated that he had scraped the paint from the poles to put on the new shack at Sherwood! The prisoner was then sentenced to wear a gold medal displaying a 4WN badge for the term of his natural life. He was further burdened with a pair of engraved silver serviette rings to convey home to his wife as a mark of the club's appreciation for her many kindnesses to it.

The club's transmitter has been on the air a number of times lately on a wavelength of approximately 34 metres, and good reports have been received from South Australia and Victoria and a number of amateur stations in those States have been communicated with, a five-watt valve being used. One or two low-power short-wave phone tests have also been carried out between the club room and the operator's home, and proved very interesting—to one or two members who were listening-in. The principal test was carried out during a very heavy thunderstorm on a recent Sunday afternoon and evening. It was impossible, because of the static, to use an aerial, but a few venturesome listeners were entertained by a debate at 4RG's home as to whether Harold should have his tea or continue letting brother Charlie at 4WN know how good the modulation was or was not. However, Harold (stout fellah!) stuck to his post and the test concluded to their mutual satisfaction. By this time, however, it was raining in torrents, and Charlie lay down on a seat at the club, had a snooze and woke up at nine o'clock to find it still raining, so he made himself more comfortable and had a second snooze. When he again aroused himself the stars were shining, so home he sped on his motor bike, arriving there at 3 a.m. He was stiff for a week after this, and it is now proposed to take up a subscription with the object of purchasing a stretcher for the use of operators working (or sleeping) night shifts. Dhog, the club's mascot, approves of this, and claims that there is often a very strong draught through the half-inch cracks in the floor on which he has to lie when attending meetings, and considers he would be more comfortable lying on a stretcher.

You're there with a Crosley~

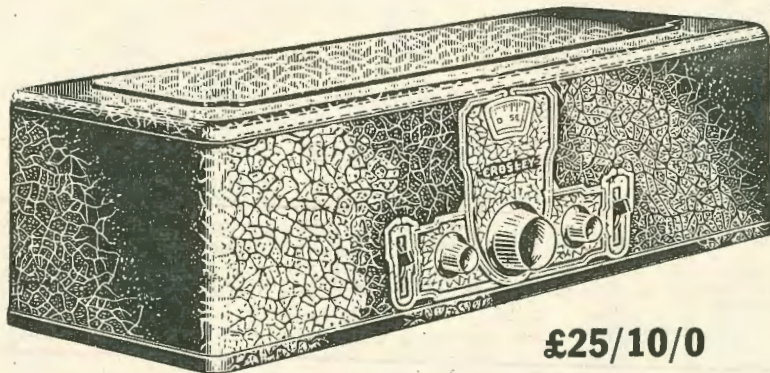

£25/10/0

The "BANDBOX" A Phenominal Crosley Radio Receiver for the complete enjoyment of 1927-28 Radio season

Here are the seven big things which represent Radio's greatest advancement, brought together by Crosley and combined with the experience, mass production, method and leadership of the Crosley Organization. No wonder a waiting radio world pronounces the "Bandbox" at the unprecedented price of £25/10/0, Crosley's paramount achievement.

THE BANDBOX IS SHIELDED.

Radio coils are surrounded by magnetic fields similar in every respect to the magnetic field around the earth that moves the needle of a compass, but around radio coils these fields make nuisances of themselves by feeding back on each other. Heretofore it has been customary to make inefficient coils with such feeding back. The Crosley Bandbox incorporates copper shields around each coil to prevent such feeding back. The coils consequently can be made, and are very much more efficient. The amplification of the receiver is, therefore, much higher the sensitivity is greatly increased. Condensers are also completely shielded from each other in separate metal compartments. Hitherto only very high-priced sets have enjoyed this super-radio advantage.

THERE IS NO OSCILLATION.

The Bandbox employs completely balanced or neutralized stages to prevent oscillation, instead of the common form of lossier method. Costly to be sure, but extremely necessary in achieving such results as are obtained by this marvel of radio reception, "The Bandbox."

RADIO DEALERS—We have a special proposition for you—Write NOW!

INTERNATIONAL RADIO CO. LTD.

299 Castlereagh Street, SYDNEY

Agents Everywhere.

Send for Our Free Catalogue.

FOR SHARPNESS—THE ACUMINATORS.

"Bandbox acuminatoirs enable "Fishers for distant stations to bring them in loud and clear. As powerful telescopes magnify distant scenes, acuminators increase the volume of far-away signals so they seem like local programs.

VOLUME CONTROL.

This is another big "Bandox" feature which permits full brass band power for those who want their dance notes strong and loud. For others it cuts volume down to a soft and gentle murmur without distortion.

ILLUMINATED DIAL.

A Master Station Selector has an illuminated dial for easy reading in shadowy corners. A single knob permits full tuning for ordinary reception of local, nearby and super-powered stations.

INSTALLATIONS SIMPLIFIED.

A Woven Cable, containing vari-coloured, rubber-covered leads, makes installation and hook-up easy for the veriest novice. No waiting for the radio service man should the batteries be changed.

EASILY ADAPTED TO CONSOLES.

Simply remove screws in escutcheon and in base of set. Lift off metal case. Chassis now stands ready for installation in console cabinet. Opening in console cabinet permits control shafts to protrude. Escutcheon screws in place, and Presto! the console radio is complete.

The repainting of the interior of the club-room has been postponed from time to time for some months past owing to the Toombul Club having graciously promised to favour Wooloowin with a visit, and it being confidentially expected that they would purloin the few remaining spots of paint. At the present time only about one dab and a spot and three-quarters of paint remain, so Toombul had better hasten if they desire to annex from Wooloowin any other rubbish besides the scalps of the Acting Deputy Assistant Publicity Engineer.

Eastern Suburbs Radio Club

Having tired of hearing people ask "Is the Eastern Suburbs Radio Club dead?" we would like to let "Q.R.N." readers know we are very much alive. Dead? why there's as much spark of enthusiasm in every member as in a freshly-charged battery. Like the white ants we're silent workers—only not quite so destructive. In fact we're very constructive—witness the new transmitter room with its brightly painted and panelled walls.

Of course during the alterations, meetings have been held under difficulties owing to the litter of paints pots, tools, timber etc., strewn about the floor. At times the chairman has been completely hidden from the rest of the gang, but howsoever things proceeded merrily on. Everything is labelled "Wet Paint" and one has to be very careful where he dumps his stetson. Most of the lads forget their good manners for the time being and keep their hats on during the meeting.

While the carpenters and painters have been "doing their stuff," the rest of the members have been busy working on the transmitter. Out of the masses of much wire and iron, much queer apparatus has taken shape. The transmitter is now completed and has been tested with highly satisfactory results. Elsewhere in this issue will be found photographs and descriptions of the transmitter.

Now that "the old home" has been overhauled and we are settling down again, lectures and Morse classes will have to be arranged and we are expecting a very interesting syllabus from the technical committee.

Whilst on the subject of lectures this club would like to see the inter-club lecture scheme continued. Only one series of lectures saw the light under this

SUBSCRIPTION FORM

"QUEENSLAND RADIO NEWS."

Box 1095N, G.P.O., Brisbane.

Please send me the "Queensland Radio News" for 12 months. I enclose cheque or P.N. for 6/6.

Name

Address

scheme and the idea seems to have "fizzled out" If other clubs are still interested, the E.S.R.C. will be only too pleased and ready to co-operate in helping to get the scheme on the move again.

The Eastern Suburbs Radio Club meets every Wednesday evening and enquires should be addressed to The Secretary, J. Burns, Toneland Street, East Brisbane.

Toombul Radio Club

At the eleventh annual show of the Nundah District, A. H. and I. Association held at Nundah on 1st. October, a successful display of radio apparatus and a demonstration of duplex radio telephony was given by the Toombul Radio Club. Features of the display included some five-metre apparatus (the property of 4AW), a medical coil (from which free shocks were dispensed to any of the public who desired them), and several home-made accumulators "B" batteries which were being used on 4NW's transmitter, which was operated from the exhibit. It should be stated in passing that accumulators were used exclusively for transmission at both 4NW and 4TC. It is understood that the Association has decided to repeat the show on Saturday, 19th November, and it is likely that two new classes will be formed in the radio section for the show. The judging of the competitive exhibits on 1st October, resulted as follows:—Valve sets, Mr. Skyring 1, Mr. Costin 2; crystal set, Mr. O'Mara 1, Mr. A. Walz 2; Accessories, Mr. A. Walz.

On 9th October, the club organized a field day at the Reserve, Nudgee. Traffic was handled expeditiously over half a mile or so with oscillating portable receivers at each end. Telephony was carried over a quarter-mile or so by land line, the line comprising for the most part a barbed-wire fence (crude, with good points).

A working bee was arranged for 15th October to erect benches, shelves, aerial etc., at the clubrooms which now look much more respectable than certain ill-informed persons would have us believe. Incidentally 4TC's walls are painted, paint being more durable and better-looking than whitewash.

Toombul Radio Club considers itself to be an organization to foster and further the public interest in radio and does not consider itself a debating society, hence its refusal to debate with another "radio" club on anything but a purely radio subject. The subject, "Thermionis v. Mechanical Rectification" (chosen by 4TC some eight months ago and subsequently approved and rejected by 4WN) will be the subject for debate (if any) with 4WN on 27th October.

The Club meets every Wednesday evening in the clubrooms at the corner of Sandgate Road and Eton Street, Nundah. If you are interested why not pay them a visit?

The Q.R.T.L.

October with its approaching static offensive still sees the Q.R.T.L. carrying on with the good work. Two members (4LJ and 4CG), established contact with Brazil, they being the first Australians to contact with S6—2AJ. Both received reports of steady r5 with

good note. No 3 test started on 15th and at the time of writing the code message is going round in good style. This test starts the counting for the annual trophies, one of which, a cup, has been donated by 4CG.

The Journal "Q.T.C." is being enthusiastically received and the, Radio Society of Great Britain has offered to supply its "G & R Bulletin" in return for "Q.T.C." each month, an offer which the League has gladly accepted. Reciprocity is now being arranged with the South African Radio Relay League.

The President 4MM accompanied by 4NG spent some weeks at Bribie Island with a portable station an some extremely interesting observations were made. A full report of these appear in "Q.T.C." for October, issued on the 29th.

Several more observers have been enrolled among them being one from West Australia and one from Sydney. The previously enrolled observers continue to do good work.

The lectures from 4QG recommence 1st November and the dates for this year are 1st, 8th, and 22nd November, 6th and 20th December, at 6.15 p.m. Don't fail to tune in on those dates to hear some good advice on set management.

Inquires regarding the League should be addressed to the secretary, Leo. J. Feenaghty oa-4LJ, C/o Main Roads Commission, Brisbane. Visitors may attend League meetings by arrangements with the secretary.



MISS M. MULLIGAN,

One of the prize-winners in the Table Talk Musical Comedy Actress Competition, who is to broadcast from 3LO.

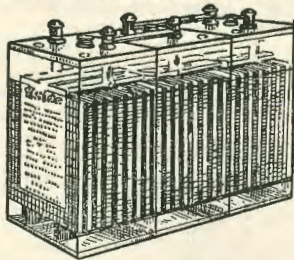

EXIDE Low Tension wireless Battery Type CZ

Made up and sold in separate 2-volt units in numerous capacities, the Exide Type C.Z. Low Tension Wireless Batteries are suitable for use with any type of Wireless Valve. Ask for them by name.

Remember that every EXIDE Battery sold has EXIDE SERVICE behind it!

Exide WIRELESS BATTERIES

Exide BATTERY SERVICE (Q) LTD.
PETRIE BIGHT BRISBANE

EXIDE BATTERIES are sold at all Wireless Stores and any Exide Dealers.

EXIDE Battery gives Satisfactory Service at Thursday Island—

READ what this enthusiastic user at Thursday Island has to say about EXIDE WIRELESS BATTERIES:—

"September last year I got through my employers from your house two C.Z. Type Cells, and I have been using these on a five-valve receiver since I got them, and they are still giving good service, but what I want to know is, when will I have to re-fill with new acid; would you please advise me about same.

"I must say a few words of praise with regards to the "EXIDE" Cells. I think that they are second to none after the use that they have given me. Since I received them I have had myset going this last 12 months on an average of four hours a night—the only interval was when the Battery was at the charge depot. Wishing you further success."

(Name of Writer on Request.)

How Increased Plate-Voltage May Decrease Volume

E. R. Stoekle, Ph. D. Member I.R.E.

A peculiar effect recently observed in testing a tuned radio frequency receiver employing a high resistance for controlling regeneration in the R.F. tubes illustrates how easy it is to ascribe a defect to some part of a set when the real cause lies entirely outside the receiver.

The receiver employed a popular five tube circuit. The plate voltage control resistance was a 200,000 ohm Centralab Radiohm which has proved generally satisfactory for this type of control. In this circuit the radio-frequency current of each of the R.F. tubes is by-passed by $\frac{1}{2}$ mfd. condensers, so that no high-frequency current is obliged to pass through the high resistance. In other words, the resistance serves merely to vary the D.C. plate voltage applied to these tubes.

The phenomenon showed itself as follows:—With 20,000 ohms in the Radiohm, good volume was received on a given station. Then, as the knob was turned to the right, lowering the resistance and raising the voltage on the radio frequency tubes, the signal strength rapidly decreased and with the full 90 volts. on these tubes, the volume had dropped to practically nothing. Normally, the reverse action is to be expected. The operator's first conclusion was that the high resistance had probably been burned out or otherwise proved defective at the low resistance end. Since the Centralab Radiohm is of a type which allows variation down to zero resistance, however, this did not seem reasonable, for the zero resistance position was a metal contact and could not have been easily burned out.

To investigate further a milliammeter was placed in the circuit of the R.F. tubes. This instrument showed that as the resistance was decreased from the point where maximum volume had been obtained, the current rose very slowly which was as it should be. The slow rise of plate current with increasing voltage remarkable part was that increasing signal volume. Indicated that the R.F. tubes must be reaching voltage saturation as the resistance was decreased. A further investigation showed that the filament pressure was only a trifle over four volts, indicating a badly run down "A" battery.

An operator who discovers an apparently unnatural behaviour of any instrument on his receiver usually concludes that there must be a defect in that particular instrument. The above described phenomenon in which an increase in the plate current of a vacuum tube result in a decrease in the amplitude of the radio frequency out put certainly is misleading unless carefully analyzed. The following discussion explains the observed effect:—

In order that a vacuum may function as an amplifier, it is important that the electron emission from the filament be sufficient to maintain a space charge in the form of a cloud of electrons between the grid and the filament. Furthermore, the number of electrons emitted by the grid and the filament is limited

by its temperature. If the plate voltage is sufficiently high to attract all of these electrons to the plate as fast as they are emitted there will be no accumulation of space charge between the grid and the filament. Obviously, a further increase in the plate voltage cannot increase the current since there are no more electrons available for producing more current. In other words, the plate current remains practically constant for further increase in plate voltage. Variations in the grid voltage under these conditions will produce only a very slight effect on the passage of electrons from the filament to the plate, and therefore, such variations of grid voltage will not be reproduced or amplified in the plate circuit. If, however, the plate voltage be lowered sufficiently to again allow the accumulation of space charge between the grid and the filament, the variations of grid potential will again effect the flow of electrons between the filament and the plate, and the tube will again function as an amplifier.

This explains why, in the above instance, increasing the resistance to lower the plate voltage increased the signal strength, whereas, decreasing the resistance to raise the plate voltage decreased the signal strength. The proper correction of this condition in the above instance was, of course, to raise the filament temperature again to the point where the electron emission was sufficient to maintain a space charge between the grid and the filament for the maximum plate voltage used.

The above experience indicates how important it is for the set owner to be sure that the "A" and "B" voltages on his set be kept at their correct value. It also shows how dangerous it is to jump at conclusions as to defects in the set when the cause of the apparent defect lies entirely outside the set, and may be easily corrected by the simple expedient of keeping one's batteries charged.

* * * *

AN INTERESTING EVENING

A very enjoyable evening was spent at the Eastern Suburbs Radio Club Rooms on Wednesday evening, 19th October, when the transmitter room was officially opened. Representatives from all Radio Clubs were invited, but only a few were able to get along.

The President welcomed the visitors and Messrs. Feenaghty (Q.R.T.L.) and Vining (Toombul Club) spoke on behalf of the visitors.

A visit of inspection to the new room and transmitter followed when some tests were conducted and favourable reports received.

Supper was served and all went home feeling that it had indeed been an evening well spent.

FOR SALE

FOUR-VALVE SET—all British Components, Tun-
gar Home Charger, Accumulator, two 45v. B. Bat-
teries, Loud Speaker, Phones. Also quantity of mis-
cellaneous Radio Parts. Going very cheap for cash.
Apply F. Mansbridge, Annerley Road, opp. S.B.
Cemetery.

4QG Programmes for November

Tuesday, 1st November:—State Orchestra concert relayed from the Exhibition Hall.

Wednesday, 2nd November:—Classical music by Mr. Archie Day and party. The Myona Quartette.

Thursday, 3rd November:—First portion of programme will be relayed from Olsen and Goodchaps, Woolloongabba. Second portion of programme, studio programme.

Friday, 4th November:—The Studio Orchestra. Special item by Australian Commonwealth Band. The Sleath Trio.

Saturday, 5th November:—Dance music from Lennon's ballroom.

Sunday, 6th November:—Complete morning and evening services from Wharf Street Congregational Church. Band music from the Botanic Gardens. Municipal Band from Wickham Park.

Monday, 7th November:—Organ recital by Mr. George Sampson. Studio concert.

Tuesday, 8th November:—Mr. Erich John's party

Wednesday, 9th November:—Mr. Sharman's party. Radio play, "Samuel Goes Swimming."

Thursday, 10th November:—Wynnum Bowling Club concert.

Friday, 11th November:—Wynnum Eisteddfod.

Saturday, 12th November:—Studio programme. Lennon's dance music; and Speedway.

Sunday, 13th November:—Complete morning service from St. Barnabas Church of England, Ithaca. Band concert from the Botanic Gardens. Complete evening service from St. John's Cathedral. Municipal Concert Band from Wickham Park.

Monday, 14th November:—Pianoforte recital from Mr. Erich John's Studio. St. Augustine's Male Party.

Tuesday, 15th November:—Cadenza Plectral Club.

Wednesday, 16th November:—The Hamilton Quartette.

Thursday, 17th November:—The programme will be relayed from the Acacia Gardens (Australian Hotel), Queen Street.

Friday, 18th November:—Radio play, "Our Relations." Mr. A. Sharman's party.

Saturday, 19th November:—Studio concert. Dance music from Lennon's ballroom.

Sunday, 20th November:—Complete morning service from Ann Street Presbyterian Church. Band music from the Botanic Gardens. Complete evening service from Ann Street Presbyterian Church. Municipal Concert Band from Wickham Park.

Monday, 21st November:—Recital by Miss Lena Hammond and Miss Gladys Frost. The Studio Orchestra.

Tuesday, 22nd November:—Mr. Erich John's party.

Wednesday, 23rd November:—Classical music by Mrs. George Sampson. Studio programme.

Thursday, 24th November:—One-act play.

Friday, 25th November:—Silkstone Apollo Club.

Saturday, 26th November:—Blackstone St. David's Society.

Sunday, 27th November: St. Andrew's Church and Danish Church. Band concerts.

Monday, 28th November:—Studio programme and Excelsior Band.

Tuesday, 29th November:—Full night from Ipswich.
Wednesday, 30th November: Exhibition Hall.

* * * *

4QG Playlets for November

As a "break" from the usual form of musical entertainment, the musical playlets provided by Station 4QG are much appreciated by listeners generally.

In response to numerous requests Station 4QG is making arrangements for a number of these one-act plays to be broadcast every month.

It is interesting to note that these plays are entirely original, being written by Miss Thelma Champion, a young lady of Brisbane who, together with a versatile group of vocalists, put forward a very creditable performance.

The "Digger Playlets" broadcast during recent weeks, have now come to an end. During November two further plays by the same author are to be broadcast as follows:—

November 9th—"Samuel Goes Swimming."

November 18th—"Our Relations."

Listeners should make a point of hearing these two entertainments which are stated to be very humorous.

EMMCO RADIO HANDBOOK

The 1927 edition of the Emmco Radio Handbook far surpasses the handbook which was produced by that Company last year. It contains 32 pages together with an art cover printed in two colours, and with most attractive designs, front and back. There is a full detailed list of Australian and New Zealand Radio calls signs including Broadcasting Stations A and B class, Amateur Transmitters, special call signs etc. There also appears a world of short wave stations in addition to a chart showing the comparative differences in time of various points in different parts of the world. There are circuits of Reinartz receivers, Browning-Drakes, Short Waves, Neutrodynes, Super Heterodynes etc., besides a number of circuits illustrating the method of hooking up ABC eliminators to them. The rest of the book is devoted mainly to a description of the many Emmco parts, including several new lines which are just now appearing on the market. There is also an illustration of the new Emmco factory, which is just nearing completion, and which will have a total plant and equipment to the value of over £200,000. The book throughout is excellently printed, and distinctly informative, so much so that we recommend all Radio enthusiasts to procure a copy. It is supplied free to users of Emmco products.

The Children's Corner

A Letter from "The Sandman"

Dear Children,—

I was very pleased indeed when the Editor asked me to take the Children's Page this month. Every day I receive hundreds of letters from boys and girls and, of course, it is quite impossible for me to answer all these individually, so I wish all my little readers to take this as my answer to their messages to me.

Not so long ago "Uncle Ben" and I visited a sick little boy. Now, this little boy had a motor car—not a big truly motor car, but one quite big enough to carry himself and one passenger. It was very strongly built, so this little boy asked "Uncle Ben" to take me for a drive around the garden. Of course we



thought that our weight would break it, but we sat in very carefully and "Uncle Ben" drove me up and down the concrete paths, and we really had a jolly time. On this page you will see a snapshot of "Uncle Ben" and I taken in the car.

Now my little friend "Percy" is getting very popular among the children. Soon, I'm afraid his mail will be getting greater than mine; if this happens I think I'll have to put "Percy" in charge of the bedtime stories and I'll take his place as the "little boy."

Fancy—only eight weeks to Xmas! Doesn't time fly? It seems but a few months since I wished my little friends "A Happy Xmas" over the air.

I don't suppose I shall have the opportunity of wishing "Radio News" readers the Compliments of the Season again, so I'll do it now, and wish you all a Happy Xmas.

"Percy" is at my elbow now. He wants to know if he can write a note to the children. He says the Editor is a personal friend of his (quite right.—Ed.), and he's sure he wouldn't go to press without a few words from his old pal "Percy."

So, children, I'll close now. "Percy" is sharpening his pencil and I mustn't keep him waiting.

Don't forget to write—I love your letters.

Your old friend,

"SANDY."

A Letter from "Percy"

Dear Children,—

Well, here I am. Hope you're the same. Gee! "Sandy's" greedy, isn't he? See—he's nearly filled the whole page and left me this little corner. Still, I'm glad, 'cause I'm no good at writing long "gas-baggy" letters.

One of these nights "Sandy" and me are going to have a singing competition. "Sandy" hasn't got a bad voice, mind you. It would pass in a crowd, but without patting myself on the back or anything like that, you know, I reckon I can sing better than him.

Anyway, we'll see when the time comes.

Well, I think that is all the news this time. Don't forget to write to me. Hooray. Yours truly,
"PERCY."

"The Sandman's" Competition

First Prize 7/6
Second Prize 5/-

At Station 4QG there are two big birthday books, from which birthdays of little children residing in all parts of Australia are called every night.

How many children's names do you think are contained in these books?

"That's hard to guess," you say. Oh, no, not so very hard. Here's a plan that will put you on the right track. Count the number of birthdays called every night for a week. Divide this number by seven and you will have a fair daily average. Then multiply this number by 365 and you should be somewhere near the mark.

Write your answer on a piece of paper and put it into an envelope marked "Sandman's Competition," and addressed to The Editor, "Queensland Radio News," Box 1095, G.P.O., Brisbane.

Results of "Grandfather's" Buried Queensland Towns Competition

The answers are as follows:—

- (1) I saw him from afar and knew him at once.
Answer: ROMA.
- (2) A ram actually chased him out of the yard.
Answer: ARAMAC.
- (3) "Let us have all or a part of it," she said.
Answer: ALLORA.
- (4) Bring all the smiling lads to next week's dance.
Answer: GLADSTONE.
- (5) His harsh tones killed all the love she had for him.
Answer: ESK.
- (6) The snakes lay right across the track enjoying the heat of the sun.
Answer: AYR.

FIRST PRIZE (7s. 6d.):

George Wiggins, Wakefield Street, Albion.

SECOND PRIZE (5s.):

Maureen O'Connor, Talford Street, Rockhampton.

The prizes will be posted in the course of a few days.

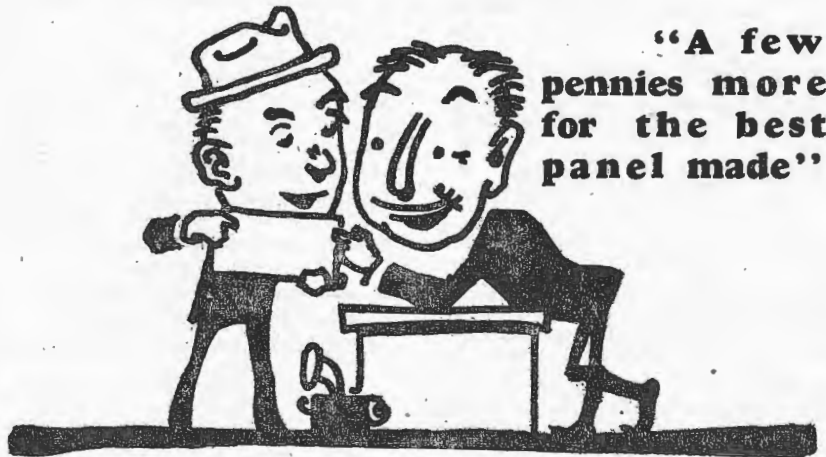

Slight Extra Cost but
Big Extra Value

Even if you paid more you could **not** get a better panel than RADION. There's a "whale of a difference" in insulating compounds. The makers of RADION developed this material exclusively for radio and never use it for any other purpose. The radio current is slippery. It travels at tremendous speed and only the best insulation can hold it within the circuit.

There is everything in favor of RADION PANELS—not only their famous insulating values but their easy working qualities and beautiful surface finish. A highly polished surface has a direct advantage in discouraging surface leakage besides being better looking.

Your Dealer has RADION PANELS or can get them for you. But **don't** buy an ordinary panel and afterwards wish you had insisted on RADION.

free!

INTERNATIONAL RADIO COMPANY, LTD.
200 Castlereagh Street 91-92 Courtney Place
Sydney, N. S. W., Australia Wellington, New Zealand



"BRIGHTYES"

This is the little lady who assists Uncle Ben at station 4QG every Saturday night.

She is Miss Gladys Cooling, a daughter of the late Norman Cooling, who was for many months announcer at 4QG before the opening of the big station.

It seems fitting that this little girl should be chosen for this work, in view of her father's close relationship with and assistance in the establishing of Radio Service in Queensland.

True to name, "Brighteyes" is a gay little girl of 10 years, whose eyes and voice are always full of fun. She enters into the session with great enthusiasm and takes her part very well. Her voice is well adapted for the microphone and she sings very nicely.

Country Broadcasting Comprehensive Service at 3LO Melbourne

The idea of extending broadcasting operations throughout the country is by no means new. In fact 3LO Melbourne adopted the policy of decentralisation over 3 years ago, and have extended it so consistently and successfully that during the course of one week recently, places so far separated as Warracknabeal, Hepparton, Port Fairy, Echuca, Benalla, Bendigo, Colac, Ballarat, Horsham and Camperdown were put on the air, so to speak, for the world to hear of their activities.

It often happens that 3LO has a country relay nearly every day in the week, and sometimes events are broadcast from several centres on the same day.

COUNTRY SHOW AND RACES.

Country shows have received much attention from 3LO lately, and opening speeches have been or are being broadcast from those at Warracknabeal, Benalla, Geelong, Kyabram, Bendigo, Ballarat, Bairnsdale and other places.

Listeners have long since taken as a matter of course the descriptions of experts of all important country racing and sporting meetings which 3LO have been broadcasting for years without ostentation, although they involve considerable trouble and expense.

SPECIAL STAFF FOR COUNTRY

A special staff is employed by 3LO to carry out these country broadcasts. Recently at Geelong, no less than three different events had to be put on the air during one afternoon. This necessitated the use of three sets of apparatus, and required the attendance of three Engineers, and four expert describers. Often it happens that relays are broadcast on several consecutive days from the same provincial city.

NATURAL DEVELOPMENT.

The Directors of 3LO Melbourne do not look upon these decentralized transmissions as particularly novel or enterprising, but as a natural development of broadcasting, and the fulfilment of their obligations to provide listeners with the most comprehensive service possible. To provide this great country service, 3LO relies mainly upon telephone land lines for relaying, but it happens sometimes that one is not available. This does not deter 3LO Melbourne, whose engineers have constructed a portable transmitter, which can be erected at the location, whether it be on land or sea at a moments notice.

THE FUTURE.

3LO Melbourne is always on the look out for fresh conquests of the air, and with the present perfection of the relaying system, distance is no obstacle, which recent transmissions from Warracknabeal and Sydney strikingly demonstrated. Listeners may therefore look forward to a continuance of the great country service of 3LO Melbourne, in accordance with policy which was adopted by that station at the very commencement of wireless broadcasting.

READERS

The Editor is always pleased to receive suggestions from readers. If there is some feature you would like to see added to QRN— or something you would like taken out—write.

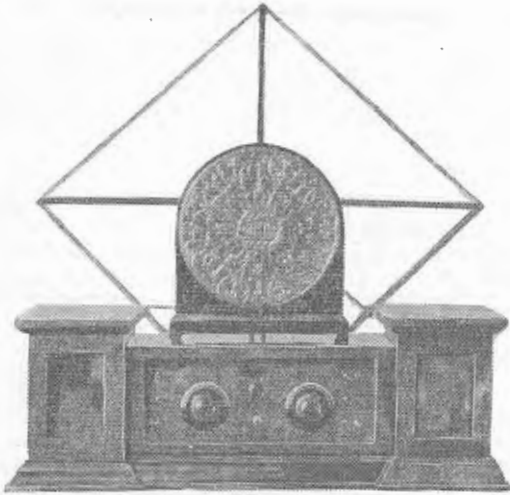

An Unusual Receiver

The illustration shows a most unusual receiver particularly in-so-far as the cabinet-work is concerned.

The entire cabinet is made of oxidised copper, as is also the Radiolux speaker. The effect is nothing short of beautiful and is certainly most novel.

But beauty and novelty are not the main reasons for enclosing this 8-valve super-het. in such an elaborate cabinet. Efficiency rather than effect is the goal.

In far Western Queensland climatic conditions are so severe as to make ordinary cabinets of timber at times inefficient. The excessive heat sometimes warps and cracks the timber, and the dust finds easy access to vital parts of the receiver.

This oxidised copper cabinet is built especially for such climates. It is dust-proof and of course, will not warp or crack. The two spacious compartments at either end house the batteries. The back, top and front of the cabinet are in one piece, there being no lid. As a result the base-board of the receiver is reversed and suspended from beneath the top of the cabinet. The valves are held in place by the use of anti-microphones sockets. Access to the interior of the cabinet is gained by pulling out a tight fitting copper tray which forms the bottom of the cabinet.

The cabinet was made in Brisbane to the order of Messrs. Saville & Co. of Charleville, whose motor van

travels through the far western districts of the state installing and servicing their "Eureka" radio receivers. Mr. Saville maintains that the oxidised copper cabinet is the only solution to the excessive climatic conditions experienced in the West, and he intends to standardise on this cabinet, building and fitting three, four, five up to eight valve receivers as desired.

3LO Melbourne and Research

(By "Hello.")

I have just been reading an interesting pamphlet by Mr. Cherry (the Research Physicist at the Melbourne University) on "Signal Strength Measurement of 3LO."

Few people who put on their headphones, or turn on the loud speaker, realise that to give them the pleasure of a programme a tremendous deal of research and experiment are necessary.

3LO Melbourne maintains a staff of radio experts whose care are problems of "fading" and the like which must be solved to make broadcasting 100 per cent. efficient.

Special Grant.

To obtain the best advice on the matter, 3LO Melbourne gives the sum of £500 to the University for radio research annually. In the University are two renowned physicists, Professor Laby and Mr. Cherry, and these two men have been doing important work on measuring the signal strength of 3LO Melbourne. The practical value of the work lay in getting knowledge through which "fading" could be located and attacked.

For their work they used a measuring set, so constructed that it could be dismantled and transported from place to place on the carrier of a motor-cycle to be set up afresh at different places in the field. The scientists point out that it will soon become necessary to give signals of a specified intensity. A very high signal strength has two disadvantages. The first is high cost; the second is its interference with signals from other and particularly remote stations.

On the other hand a weak signal will not be audible above the "noise level." This phrase is used to indicate the mean field intensity of natural and artificial electrical disturbances which interfere with reception. The audibility of a signal depends on the ratio of its intensity to that of the noise. No measurements of this "noise level" in Melbourne have been made. Day and night measurements of this were made for a time in England and America before the establishment of trans-Atlantic telephony, in order to determine the signal intensity.

There is a ratio between high frequencies and "noise level," and the study of this will have important bearing on broadcasting. It appears, so far, that in Australia a short-wave will have a higher ratio of signal to noise than a long wave, assuming signal strength in each is equal.

The experiments in signal measurement by these two scientists will continue at greater distances,

REPAIRS

We do rewinding and overhauling of all kinds of Electrical Apparatus, including Armatures, Meters Loud Speakers, Coils, etc., and guarantee the work. Also Panel Engraving.

HAMILTON & PASS

BURNETT LANE, BRISBANE.

'Phone CRO50.

The Washington Radio Conference

Will It Affect Australia?

By "Ray Dio"

A world conference is sitting at Washington discussing radio legislation problems. Representatives of 51 countries have assembled under the presidency of the well known Mr. Hooyer, head of the Department of Commerce. Australia is represented by Mr. H. P. Brown, director of the postal services.

The conference is a very important one, and the discussions are expected to last six or eight weeks. One may wonder what can occupy the delegates for such a long time, and it is interesting to see how we are likely to be affected by the conference decisions.

Regulating Radio Traffic for the World.

The object of the Conference is to draw up a code of laws for the regulation of all kinds of radio activities in every country. That is so far as all countries are concerned. The domestic problems of individual countries will not be legislated for at Washington. Those problems will be left for the local legislatures.

But there are many phases of radio that are international in character. The use of radio by ships and the conditions under which the SOS signal should be used and obeyed, for instance must have a common and well known basis in all countries. Thus the captain of a ship of any country in any ocean near any territory knows that the approved means of calling for assistance in time of distress or danger will meet with a ready response.

This SOS call procedure was the cause of the first international radio conference which was held in London in 1913. That conference dealt with radio in all its phases then known. But there was no broadcasting in those days. Thus the laws agreed to in 1913 are either obsolete or incomplete for present day practice.

Wave Lengths will be Agreed to.

The important aspect will be the apportioning of wave lengths for broadcasting and for other purposes. Different services such as ship transmission, aircraft transmission, broadcasting service etc. must have certain wavelengths set aside so that interference will not result. For instance the wave length of 600 metres is reserved for the use of ships—it cannot be used for broadcasting. The necessity is manifest therefore for a common international understanding on the points.

There has been no understanding hitherto on the question of broadcasting wave lengths. Hence there is nothing to prevent adjacent countries using the same wavelengths, to the confusion and disadvantage of the service in the respective countries. Such an undesirable state of affairs has actually occurred already between Canada and the United States and in Europe.

In Australia we are in danger of similar confusion unless there is some international understanding on the point.

We have already experienced interference in the reception of 3LO Melbourne by a station in Japan using a wave length nearly the same as that used by 3LO Melbourne. And there is nothing to prevent New Zealand using wave lengths similar to or nearly the same as those used by Australian stations.

That will be the subject that will interest Australian broadcast listeners most. Both in the local service and in the short wave international broadcasting will the conference decisions be of considerable interest.

No Vital Alterations Expected.

It would be a serious matter if our wave lengths were to be altered. But there does not appear to be any danger of any radical changes. Probably that is one reason why the authorities have not yet made the very desirable changes in separating the wave lengths of some stations that are now too close to be really satisfactory.

There are many more subjects concerning commercial and experimental wireless on which the decisions of the Conference will affect Australia, but probably the question of wave lengths for broadcasting is the most interesting.

4QG's Short-Wave Station

SECRET TESTS NOW PROCEEDING.

We have heard from a very reliable source that engineers at Station 4QG are at present carrying out secret tests with a short-wave transmitter.

Two wavelengths, we believe, are to be used simultaneously, one approximately 32 metres (for long-distance broadcasts), and another of 100 metres (for improving the service, particularly the day sessions, to far northern listeners, during the static season).

Great success has attended all efforts to date, and we believe it will not be long before 4QG's short-wave station will be heard on the air.

* * * *

CLASS B STATIONS SHOULD DO THE SECTIONAL BROADCASTING.

If we must have programmes for a section or sections of the general public, then the station to provide the programme should not be a class A station. The second class of stations apparently was legislated for so as to enable that kind of publicity, propaganda or advertisement to be given. The policy of a class A stations, so it appears to us, should be to provide a comprehensive service of general utility. No broadcaster can hope to please everybody, but a reasonable attempt can be made, as is being made now by most stations.



The Cornet Player steps into the room ... when Cossor Valves are used

USE the new COSSOR POINT ONE VALVES and you will enjoy the thrill of true-to-life Radio. No longer an inanimate and mechanical reproduction but life itself. Every vibrant passage is reproduced with great mellowness. From the French horn to the cornet and from the 'cello to the violin, each instrument is heard in all its natural beauty. No harshness, no discordant sounds—no distortion. And the underlying reason for such marked superiority in tone and volume lies in the Wonderful Kalenised filament used in combination with the method of construction employed. This is an exclusive Cossor feature—no other valve has it. No other valve gives such long service with such a meagre consumption of current.

2, 4 and 6 Volt
UX Bases **13/6** Each

Queensland Distributors:

J. B. CHANDLER & CO.,

ADELAIDE STREET, BRISBANE.

UNITED DISTRIBUTORS LTD.,

343 QUEEN STREET, BRISBANE.

Cossor "The British Valve which serves you longest"



AMONG THE AMATEURS

Well, fellows, things have been fairly active during October and among the things noticed was the return of the Western DX India etc., ai-2KT Lieut. Rodman of the British Army in India stationed at Jubblepore was heard QSO oa-3WWM (who had just finished talking to ai-2KW incidentally) and the Indian's sigs. were reported r5 steady dc although he told 3WM that he was using an indoor aerial! Up here he was a modest r2 with tons of QRM all round him. FB, 2KT!

More phone is to be reported, the following having been heard on the 30 band:—7CW, 5BG and another who was not heard working duplex—just like a land-line telephone conversation; 4WN, 2UK, 2RC, 4AW (input 5 watts in daylight gives r max. sig. well modulated FB); and last but not least our old friend oz-2AQ who still puts out some of the best amateur phone that I have been privileged to listen to.

4AW's QSB is about ten million times better than it was last month—what happened? Sandpaper?

Some new ones have been heard lately. They are 4PM, Russell Roberts, Cambridge Street, West End; 4RM, Ray McIntosh, care 4QG; and 4ER, QRA? pse. 4RM is going in for High power tis said. Gee, what-oh!

Say, have you heard the noos? Lil ole Brisbane has come on the map! Heard sb-2AJ who hails from Brazil where they make the nuts. QSO local 4LJ and 4CG and calling 4MP t'other nite. He told 4LJ that he was his first oa contact and only the second heard. Howcum, then, that he heard 3 Brisbane men and worked two of them the same night FB Brisbane!

Did anyone hear 4MM-HG while they were at Bribie Island? They had a few days down there and did some DX tis reported. The 80 band was used mostly for apparently contract on 30 is not possible with Brisbane. Welcome back to civilisation OMs. They had a new one 4AT, Alf Bauer of 4QG also with them. Say, that makes 3 in 4QG for 4RG the oach' helps the lil ole electrons to elect up there too.

Alas and alack, pore old Harold Walsh is QSO hospital and they tell me that he is likely to be off the air for good. No, he's not dead but the YLs over there are proving a very strong (r9 in fact) attraction for him. Goodee-bye Harold!

Talking about indoor aerials 4DO has come to that stage too. What, License not renewed? Or just QRP etc., FB sigs. anyrate for an indoor job.

Say, I'm on the warpath again. Whyinell must some Aussies call CQ and then listen on the Martian or Jupiterian waveband? Be sports OM's, and give an indication of what you want. Its only the YLs who are supposed not to know their own minds!

Despite the QRN and storms lately there has been quite some activity on the 80 band. The Test recently organised in the South should give that area a boost. The message got as far as Queensland and it was a shopper. 300 words. Oh. Boy! This band is the best

for local and Aussie work although QRN is worse but there should be less QRM and skip is reduced. Try it gang.

Some of the QSA-vy lot heard recently—2RB, with-key clicks at times; welcome back to audibility OM haven't heard you for moons; 2NO r9 and dc, guess he has a quarter kilo tube like 3WWM who is also QSA but with an AC note. 2JW also 9 with CC note; 2YI sounds like a local specially when he calls aj-4ZZ everyone round here starts to wonder who the new 4 is Hi; 2NS r max with vy gud rac and fb stdy. Good work. Trevor, more RCC to you OM.

Can anyone tell me what we're going to get out of the Wireless Commission Report There's a prize for the most optimistic reply and it might 'be a nice good loud bunch of static, so it's worth trying for!

The odd CC gang is increasing, 3BQ and 5BG having been joined by 7CW and 4AN. This last station puts out some good CC even though the set is not properly fixed up.

4RO Percy Wood of Ipswich is getting on quite well for a new one and he puts an r5 sig into several Aussie states. His note is just saved from being called AC even though he has a Raytheon. More filter OM.

Tears, lamentations, weps and groans from Bulimba. 4AL has "blued" his Raytheon and his UX refuses to UX. Well, if you must put 9,000 jolts on em Bruce, you must take the consequences. The gear is your own you know so don't treat it like you do the Navy apparatus.

How many are there who ever "go up" and listen about 50-65? There's quite some interesting stuff there. VIS with a vy ruff note calls GDZV the "Makura" while VLW Wellington with a very nice DC though QRZ note calls GBE. Samarai VIJ was QSO Cooktown VIC on 34 metres but although the note was dc it was very QRZ and QRM was bad.

DGK r2 battery dc is Kenndy(?) Ellice Islands—give him a call gang. Another query—does the "ss" after the sign-off of some Victorian stations mean "send single" or "slick sender". Please advise me someone.

Scare Headlines. "Russian Invasion" "Occupation of the Ether by Bolshevists"—no, not actually, but after hearing the words (Naughty little words) sent out by the QRTL stations during the past few weeks in what was apparently a Test one must come to the conclusion that they are learning Russian—talk about words! Gee, some Welsh ones look like single letters alongside them. Who is teaching them Russian?

Talking about Russian, 4WA is putting out a note just like a commercial. It is a case of imitation is the sincerest form of flattery?

Well, now, fellahs, this is quite a long screed this month and as my battery is running down I guess QRU hr till next month. GB and may your spacers never fall on another man's main wave. 73.

Among the Q.R.T. Leaguers

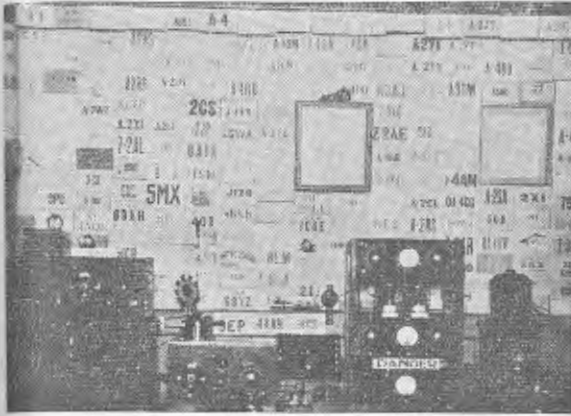

OA-4NW.

This station is owned and operated by T. W. Markie, Sandgate Rd., Nundah, Brisbane.

The transmitter uses the popular Hartley circuit, using one or two 210 UX valves with inputs varying from 15 to 50 watts.

Rectifiers used at the station are "S" tubes and one Raytheon "B.H." tube, the latter being most used. No chokes are used but across the high tension supply an 18 mfd. tested condenser is shunted and from this combination the sigs are always reported d.c.

Wavelengths of 20, 33, 88 and 245 metres are used and no doubt many listeners have heard 4NW on the 245 metre tests of a Sunday afternoon from 4.45 p.m. onwards.

Just lately 4NW has installed Hering modulation using another UX 210 tube and results have been very good indeed.

On short wave 6 Australian states, 2 New Zealanders and one Japanese station have been QSO on 7000. The Japanese station giving a report of r7 on 7000.

The receivers used are a 3-valve P1-B.C.L. set and 20-100 metre Schnell receiver. The Transmitting and receiving sets are worked off the same aerial, namely an inverted L type 110 feet - 55 feet.

All batteries are of the accumulator type and are recharged by a Tungar charger which has given no trouble in 3 years work.

The DX communication by 4NW includes—Australia, New Zealand, Hawaii, New Caledonia, Jamaica, Philippine Islands, New Hebrides, U.S.A., Canada, Mexico, Japan and China.

4NW is always pleased to help any amateur at any time and always welcomes any visitors.

Second District Notes

(By "O.A.")

The second district hams have decided to emulate their northern brothers and form a N.S.W.R.T.L.

All second district hams have been circularised, and almost without exception full support has been promised. The initial meeting is being held at the Y.M.C.A. Pitt Street, Sydney, on 27/10/27.

The annual subscription is 5s. And all interested are invited to get into touch with the acting secretary, OA-2JY. The whole thing has been organised by the Croydon Radio Club.

The once active station oa-2RJ, has just imported a fine little receiver and QRP transmitter. These, I believe, were built for him by Schnell of NRRL fame. If you want to see what the transmitter looks like, turn to page 37 of the July number of QST.

"RJ" has been off the air, for many moons, but I believe this is due to the fact that he has been rebuilding the Baronial mansion; also suffers severe QRM from the "Jumbucks"—i.e., a graminivorous animal covered with wool.

'Tis rumoured that one of our oldest stations, 2YG, has just finished a super-ham crystal controlled phone set; it has a 210 at one end and finishes with a 500 watter at the other. Many will doubtless remember the fine phone this station used to turn out on 80 metres back in 1925—in fact this station was the first to phone across to U.S.A.

oa-6AG is putting out some wonderful phone, which is second to none in quality and is, in this scribe's humble opinion, easily the best phone on this land.

oa-5HG puts out a beautiful D.C. signal which should be world-wide, so why in the name of the great "Wouf Hong" do you repeatedly call CQ for thirty or more times before signing on . . . — — . . . ?

oa-2NO gets out well with pair of UX.210's using the usual Zepp., into which he shoves a little over an amp.

3LP has not been heard for some time. What's up, com—has the ham spirit departed from you or are you too QRN with motor bikes or YL's? We miss your bug; let's hear it again, ob.

2RX has QRM of a new sort as there is a proud possessor a P.1 or some such contraption, who lives next door, so whenever poor old RX starts up his friendly neighbour collects a few stones and takes some pot shots at RX's prex lead in bowls.

oz-2AT uses one of the new UX.852 75 watters with 1400 volts on the plate; his sigs. were very QSA when heard here, but slightly unsteady; also tries phone, but insufficient modulation. Phone from both oz-3AV and oz-1AI comes in quite well.

oa-3RB, having been QSO 14 countries, says he has given up the short waver for 240 X phone, but don't believe him.

Some thoughtless person has given oa-3ES a 50 watter; we all know what his sigs. are like now when he is only using one of the 7½ variety, so in future any hams desiring to QSO Yorston are advised to rewind their cans with 18 gauge asbestos covered wire.

NJ-2PZ is at present staying with his friend NU-2AG and is operating the latter's Xtal control outfit. If you want a rag chew just QSO him.



In An Accumulator Factory

A View of the "Pasting Shop" in the C.A.V. Accumulator Factory, England.

DUAL TRANSMISSIONS

A week or two ago a very interesting test was carried out between Station 4QG Brisbane and 2BL Sydney, when a vocalist at 2BL sang "The Fishermen of England" to the accompaniment of a piano from 4QG's studio.

Those who listened-in to 4QG simply heard a piano-forte solo. Those whose sets were selective enough to tune in 2BL heard both vocalist and accompaniment.

The method of the test was as follows:—Arrangements were previously made between the stations for the test to take place on the stroke of 9 p.m. At this hour the pianist at 4QG played the opening bars of the song, which engineers at 2BL picked up, amplified and superimposed the signals on their transmitter. Meanwhile Mr. Lewis, a 2BL vocalist stood before the microphone wearing a pair of headphones attached to a receiver picking up 4QG's transmission, and sang to the accompaniment so received. Both voice and accompaniment were then put on the air from 2BL.

Though very brief, the experiment was highly successful. It was something of a novelty to tune to 4QG and hear the accompaniment alone, and then to

switch across to 2BL and hear the song sung in Sydney to the self-same accompaniment.

Letters of congratulation from all Australian States poured into both stations for days afterwards, reporting perfect reception.

Another Similar Test.

A week or two prior to this test a unique broadcast was arranged by 4QG, which called for delicate control work on the part of the Chief Engineer (Mr. F. W. Stevens).

Upon this occasion Miss Champion and Signor Corti sang in the studio of 4QG to the accompaniment of the Tivoli Operatic Orchestra, which was being relayed from the Tivoli Theatre.

The songs were orchestrated by Mr. Chas. Grove (conductor of the orchestra) and played during screening of a picture. The Tivoli microphone picked up the music, which was conveyed by land-line to the station. The artists stood in the studio before the microphone, wearing headphones attached to the studio receiver. For all the listener knew, both artists and orchestra could have been performing from the same hall, so perfect was the balance.



THE IPSWICH VICE-REGAL BAND.

Who are to appear at 4QG on Saturday, November 12th, assisting "Uncle Ben" & Co. in a Special Session.

In honour of Armistice Day (November 12th) "Uncle Ben" and Co. are organising a very special bedtime story session. They have been fortunate in securing the services of the Ipswich Vice-Regal Band for the occasion. The band will visit the studio in its complete force, and will render hymns, marches, popular numbers, etc. Band parts for the ever-popular "Sw-do-you-do" verses have been written, and the band will accompany the story-tellers as they sing their verses.

The party will visit the Cenotaph in London, where a big Armistice Service is being held. The roll of the drums as the soldiers and sailors march past, and the playing of "Abide With Me" and other such hymns will be heard. From thence the party will journey to the pier at Margate, where they will meet the Ipswich Vice-Regal Band which is supposedly touring Great Britain.

Altogether the session should be one of great interest for both old and young alike.

MR. A. WADE
(Conductor of the Ipswich Vice-Regal Band),

Has had a most successful musical career. Since 1897 he has been conducting bands and choirs. He was first appointed conductor of the Vice-Regal Band in 1916, and led them to victory, winning the Championship of Queensland in 1916-18-20-22 and 23; also Championship of Australia at Sydney in 1919. In Brisbane, 1923, they were again victorious—winning the highest cash prize on record (£300).

In 1905 Mr. Wade was engaged by the Ballarat South St. Society to come from England and adjudicate the big band contests then held in Ballarat. Since that time Mr. Wade has judged at Ballarat on four occasions. He has also adjudicated at all chief contests in Australia and New Zealand.

Mr. Wade's contesting record stands as follows: 102 contests—results: 72 firsts, 20 seconds, 7 thirds, 3 fourths.

4QG Bedtime Story-tellers Again to Visit Ipswich

Following upon their recent highly-successful appearance at the Ipswich Town Hall, when thousands of people were unable to gain admittance, the bedtime story-tellers of Station 4QG are again to visit "the roof of churches" on Tuesday, November 29th, to give further entertainment.

This time the entertainment is to be given in the new Tivoli Theatre—the largest building in the city—and the proceeds devoted towards the Ambulance Brigade. The theatre, together with the services of the story-tellers, are being given gratis by the management, Victor Hobler & Coy.

The whole undertaking is being organised by Station 4QG in conjunction with Messrs W. Haigh & Co.,

Ltd., of Ipswich, who are planning things on an even bigger scale than the last occasion.

This time the one charge of admission will cover the whole entertainment, which will comprise: Bedtime stories, 6.30 to 7.15 p.m.; radio concert 8 p.m. to 10 p.m. In the interlude between the broadcast sessions, community singing will be carried on. The charge of admission will be 2/- and 1/-.

As previously reported in these columns the last entertainment was screamingly funny. Doubtless an equally fine programme will be presented by the company on this occasion, and all who can attend should make an effort to do so.



Some Spanshote of Uncle Ben's Car upon the occasion of their last visit to Ipswich.

HELLESENS

The Super

DRY CELL

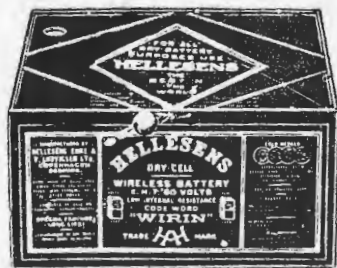

The Battery that RECUPERATES when idle!

The world's oldest battery introduces the century's latest dry cell improvement—the wonderful

No. 7 Recuperating Agent

This exclusive feature is to be found in no other dry cell. It ensures longer life and full value for every penny spent.

See for yourself how superior the New HELLESENS are. Connected one up to your set and take regular voltmeter readings. You'll be surprised.

PRICES

Standard Capacity—	
45V.	14/-
60V.	18/6
Triple Capacity—	
45V.	21/-
60V.	27/6

At All Good Radio Dealers

or 'Direct from—

BRISBANE ELECTRICAL CO.

(T. Tonks)

ELIZABETH STREET (Next to 4QG),
BRISBANE.



The Synco-Boys at 3LO

By Ruby Sykes Lyon.

The world is full of ups and downs,
Of happiness, and pain;
The days we want the sun to shine
It always seems to rain;
But though the rain in torrents falls,
And life is full of woe,
Why, nothing matters, when we tune
The "Synco-boys"—and Joe.

Who has not heard the "Ice-man's" call,
Come ringing o'er the air;
Or heard the "Doll-dance" up the keys
To see "The Animal Fair",
Or "Gimme just a little kiss"—
Is living far too slow,
When trouble hits you, smile, and tune
The "Synco-boys"—and Joe,

For you, of highbrow cultured taste
Who scorn the jazz-made rows,
And, if you listened to such noise,
Would wrinkle up your brows:
To you, I give this good advice
Because you ought to know—
You'll hear the "Classics", if you tune
The "boys"—at 3LO.

Time, Lampe, Time

This was the whispered warning of Maurice Dudley the other evening, when Mr. H. E. F. Lampe was inclined to exceed his time limit with one of his talks at 3LO Melbourne on time-pieces. These talks of Mr. Lampes are proving just as interesting as his famous talks on Diamonds. "Sundials" was the subject selected by him a few days ago, and he brought into a short discourse all the romance of lavender and of lace of a poetical age long past, when sundials were set in terraced gardens by peacocks and beautiful though elaborately frocked maidens.

Radio Conference

Convened by The Prime Minister, Mr. S. M. Bruce

During the past few days an important conference, convened by the Prime Minister, Mr. S. M. Bruce, and attended by representatives of class "A" broadcasting stations in the Commonwealth, has held sittings in Melbourne, and has given consideration to the various points raised in the report of the Royal Commission, which recently investigated wireless in all its branches in Australia. It will be remembered that some little time ago the Commonwealth Government appointed a Commission, the chairman of which was Mr. J. H. Hammond, K.C., to conduct a searching inquiry into all branches of wireless activity within the Commonwealth. This Commission sat in various States and was for two or three days in Brisbane. A lengthy report was issued by it, and full details of this report have appeared in recent issues of the "Queensland Radio News."

The report of the Commission was, of course, in the nature of a series of recommendations to the Federal Government, and these covered broadcasting, coastal radio stations, copyright fees, patent royalties, etc.

Before making any decision in regard to the accepting or rejecting of any or all of these recommendations, the Federal Government, through its Prime Minister, apparently determined to consult the various parties affected and hear their views. It was in furtherance of this policy that a conference was held in Melbourne some days ago.

The Prime Minister (Mr. Bruce) occupied the chair, and the Postal Department was represented by Mr. W. Gibson (Postmaster-General) and Mr. J. Malone (Chief Inspector of Wireless). Representatives of the following stations attended:—4QG, 2FC, 2BL, 3AR, 3LO, 7ZL and 5CL.

Although the conference was held in camera, it is understood that the main point which came under discussion was the question of financial arrangements affecting broadcasting stations.

Broadcasting stations in the States with a limited population have been struggling along recently at a loss, whilst other stations in more thickly populated centres have received a very much larger amount of revenue. The Royal Commission, in its report, recommended a new method of financing stations, this system in brief being one which would result in some of the revenue from the larger stations being used for the purpose of helping along the smaller ones. The station most greatly affected was, of course, 3LO Melbourne.

The representatives of the various stations present were asked to state their views on the matter.

Major Condor, of 3LO, strongly opposed the Commission's recommendations, claiming that were revenue to be taken from 3LO, it would mean a reduction in service. The representatives of other stations, however, expressed themselves as being quite in accord with the Commission's recommendations.

The Queensland Station 4QG was not interested in the proposals to the same extent as other stations, its representative (Mr. J. W. Robinson) pointing out that 4QG was quite a self-supporting institution, was able to give a service of good quality, and at the same time pay its way. He did, however, strongly urge that some revenue should be allotted to 4QG from the amount received in license fees from the northern portion of New South Wales, which was extensively catered for by 4QG.

After considerable discussion those present were unable to voluntarily agree upon some scheme of finance, and the matter was left in the hands of Mr. Bruce for decision.

Press reports which appeared at the conclusion of the conference were slightly misleading. A decision regarding the reallocation of revenue was not altogether in the hands of the representatives present, but was entirely a matter for decision by the Government. Paragraphs which were published made it appear as if the method to be adopted in regard to revenue was the one agreed upon by the broadcasters themselves. It is understood that the Prime Minister made it quite clear at the conference that he and his officers intended to make the decision, but that he sought the advice and help of those most interested in order to act fairly.

At the conclusion of the conference, Mr. Bruce said that he was desirous of making a statement in regard to policy within a few days.

The Royal Commission recommended the appointment of an Australian Wireless Committee to control radio in general within the Commonwealth. This recommendation the conference unanimously opposed, claiming that the Wireless Branch of the Postmaster-General's Department had controlled the movement so efficiently and effectively in the past that a change was not needed.

Senia Chostiakoff

The remarkable singing of Senia Chostiakoff at 3LO Melbourne, upon his first appearance before the microphone, created quite a sensation. Although he is world-famous as the tenor soloist of the Don Cosacks, it was not expected that his voice would have such outstanding qualities for broadcasting. It may be said with truth that no voice ever broadcast has been more suitable for the purpose. Senia Chostiakoff has a charming personality, and this seems to be picked up to a remarkable degree by the microphone, so that his singing is surrounded by an atmosphere of romance and tragedy, which have marked the life of this picturesque Russian of the Czar's ill-fated white army. Listeners will be pleased that he is to broadcast from 3LO Melbourne for a season of three weeks, commencing on 14th November.



Your Satisfaction is Our First Consideration

The radio enthusiast who names Mick Simmons Radio Department as his buying centre is assured of satisfaction as long as he cares to patronise it. For the satisfaction of every client is one of the many Golden Rules that have helped build the business into a huge organisation. For all that is NEW in Radio—consult Mick Simmons Ltd.

For Summer Radio

MUTER

Interference Eliminator and Static Reducer

At last an effective remedy has been found for the two great bug-bears of radio—interference and static.

The Muter Device eliminates interference by the induction method, and reduces static by absorption. Satisfaction guaranteed.

Connections are provided for dealing with either interference or static, and may be easily connected to any receiver.

PRICE 15/9

Special Valves

Two extra-special Radiotrons that we heartily recommend:

SPECIAL DETECTOR.

UX.200-A. 33/6

SPECIAL AMPLIFIER.

UX.112 35/-

Philips B.406 (ideal for dry cell operation — consumption only.06 amps.) 13/6

Valve Bargains

PHILIPS VALVES.

D.4	2/6
D.1	1/6

Our Service Dept.

Send or bring your sets to us for overhaul or rebuilding work. We make old sets up-to-date, using any desired circuit. Whenever possible we utilise existing components. Our charges for this work is not great—a few pounds usually covering the cost of the work.

No matter where you live, send your set to us. We do the work quickly. Our charges are moderate, our workmanship guaranteed. We pay return freight on radio repair work.

Mick Simmons Ltd.

Queen Street (Opp. Town Hall.) BRISBANE

East Brisbane

Radio Club



An informal snapshot of the members who helped with the renovating of the club rooms and the building of the transmitter and mast.



The lofty mast which supports 4ER's aerial system.

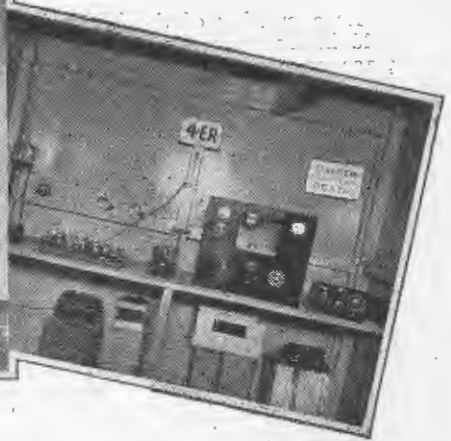

The newly-completed station described below. At the time the photograph was taken the transformer was not completed, and is not shown.

The above three photographs show just what has been and is being accomplished by a small but very enthusiastic body of young men who comprise the East Brisbane Radio Club.

The club's transmitter (4ER) has not long since been completed. The gear illustrated above is a tuned-plate arrangement, this circuit being selected for its reliability, efficiency and easy QSY. A plate glass window is included in the panel.

Both low and high tension supplies are obtained from a transformer which, in conjunction with a switching arrangement, will provide seven or ten volts with centre taps for low tension and 375 or 750 volts with centre taps for high tension. At present a Raytheon B.H. type tube is used for rectification.

A simple inductance and condenser with a flash-light bulb as indicator forms the wavemeter.

The aerial is suspended semi-vertically from a 70ft. mast, and consists of 60 feet of single strand of 10g. copper wire. This, together with a ground, forms the radiating system, and is fed on the third harmonic.

The receiver now in use is the club's old Schnell, using a detector and one stage of audio. In the near future this set will be remodelled.

At present the club has but one operator (A. Bauer), who is also engineer at Station 4QG, but now that the biggest part of the construction work is completed, time will be given to the preparation of other members for the A.O.P.C. examinations.

The club rooms, which have lately been remodelled by the members, are situated on the corner of King and Stanley Streets, South Brisbane. The transmitting gear is housed in a separate room, allowing of two classes to be conducted simultaneously if desired.



Mr. F. W. STEVENS,
Chief Engineer, Station
4QG, who has recently
been promoted to Deputy
Director.

ARMISTICE DAY.

Special arrangements have now been completed by Studio 3LO Melbourne to broadcast the many functions that are to take place on Armistice Day, November 11th. At 10.30 there will be the ceremony of laying the foundation stone of the "Shrine of Remembrance" in the Domain; also the dedication service which is to be conducted from the steps of Parliament House, and which will be described by Mr. Norman McCance. At 2.30 there will be another ceremony—the laying of the foundation stone of the Old Melbourne's War Memorial Hall, whilst at night there will be community singing broadcasted from Ballarat consisting of patriotic and sacred songs. For the remainder of the programme, special solos and orchestral items have been selected to form a fitting conclusion to such an eventful day.

Whispers from Maoriland

At a meeting of the Hawkes Bay Radio Society, held in Hastings recently, a lengthy discussion took place on the nuisance created by howling valves, induction from motors and morse. In regard to the lastnamed, it was decided to bring the matter under the attention of the Government, asking that steps be taken to keep the Morse operators on their proper waveband. A special committee was set up to deal with the other two subjects to report ways and means of eliminating the trouble.

Mr. F. W. Sellars (Northland) has added to his string of short-wave telephony scalps. 6AG Perth (West Australia) was heard on Tuesday about 10 p.m. on 32.9 metres; voice clear and well modulated. A few days back Mr. Sellars, being driven from listening to PCJJ by Morse interference, found a station on about 33 metres, good volume, but poor modulation; speech foreign, but included, "Hullo! West Indies. Hullo! India. Hullo! Holland."

Mr. A. E. S. Hanan, at Timaru, received a description of the Dempsey-Tunney fight from 2XAD on his short-wave receiving set. Some of the announcements were quite loud, and he heard the referee's remark and those of another expert after the fight.

An event of great interest to listeners throughout the country was the recent Dominion Conference of Radio Society Delegates, held in Wellington, for the purpose of forming a Dominion League of Listeners. All sections of the wireless world were represented, and beneficial results are sure to come of the unbounded interest and enthusiasm shown by all present. At the opening gathering, His Worship the Mayor of Wellington presided, and the speakers included the Postmaster-General, Secretary of the Post and Telegraph Department, and the general manager of the Broadcasting Company. Speaking of those who seemed to have made up their minds that the Government had hampered—instead of assisting—broadcasting, the Postmaster-General said: "Now, these gentlemen are quite entitled to their opinions, but such opinions indicate that in certain quarters the impression has been created that my department and the Broadcasting Company are indifferent to the interests of listeners. Such an impression is quite erroneous. It should be clearly understood by all those interested in this matter that the Government, represented in this case by myself with the Post and Telegraph Department, carry out the policy, is directly representative of every listener in the country; and the interest of every listener is and will be safeguarded in every possible way, consistent with the Government's duty to the public generally and to the Broadcasting Company."

Mr. McNamara, Secretary of the Post and Telegraph Department, said that the Broadcasting Company was always ready to meet the Department, and during the past six months there had been a very noticeable improvement all round. Every effort was being made to place broadcasting on a sound and firm basis. Urging upon listeners the necessity for taking out licenses, he pointed out that unless the income of the Broadcasting Company was assured, listeners

could not depend on good and regular programming. He warned "pirates" that they could expect no quarter from the department.

The main resolutions passed at the conference make interesting and informative reading:—

(1) That the Government be requested to engage the services of an expert radio engineer from overseas to advise them in respect of broadcasting in New Zealand.

(2) That the Department be requested to definitely prevent any dealer, wholesale or retail, from displaying in windows, selling to the public, or demonstrating receiving sets until the type or types of receiving sets it is proposed to sell to the public shall first have been approved by the Department.

(3) That the Government be requested to publish regularly the amount paid to, or held on account of, the Broadcasting Company, as representing listeners' and dealers' license fees.

(4) That the Postmaster-General be notified that station 2YA (Wellington) is not transmitting efficiently, as is proven by the widely-known fact that the reception of 2YA, even in Wellington, is, on the whole, most unsatisfactory. With crystal set reception the station frequently fluctuates in volume, and transmission is frequently distorted by 2YA. It is therefore manifest that if reception of 2YA is bad in Wellington, it is futile to hold fading tests and to blame atmospheric and other obscure causes for the vagaries of 2YA station as heard at more remote places in New Zealand.

(5) That this conference strongly deprecated the use of broadcasting for the purpose of political propaganda or advertising.

(6) That as the submission of wiring diagrams is quite ineffective for preventing interference the Department be asked to frame more suitable regulations to check the purchase and use of sets which can create interference.

A remit asking valve operators not to "howl" was passed.

If the above remits, when passed to the proper quarters, are taken heed of, every member of the conference should receive a gold medal from listeners.

The proposal for the formation of a Dominion League was not adopted, the main opposition coming from the Auckland delegates, who held the league could not do more than the annual conference could do. After lengthy debate the following motion was carried: "That this meeting of delegates from radio societies, whilst agreeing with the principles of a Dominion Radio Listeners' League, in view of the fact that as there is a difference of opinion on the question of the immediate formation of the Dominion League, resolves that all delegates will do their utmost to get their societies to agree with the said formation at the next conference, to be held on a date to be decided later, and that the Wellington Society be

asked to convey this resolution to all radio societies not represented at this conference."

American announcers do not mince matters, as recently the one from KFON, California, was heard to remark: "I've been told I use bad grammar; well, there's three reasons why I do. For one thing I do not know any better; for another, if I used good grammar half of you listeners wouldn't know what I was talking about; and in the third place, if I could use good grammar I'd be drawing a good salary from one of the big New York newspapers, and then you'd lose the best announcer in Long Beach."

SECTIONAL BROADCASTING

By "Ray-dio"

The political fight in New South Wales could not be complete without radio. Broadcasting was brought to the aid of the parties. One station broadcasted a speech from each of the leaders, and left it at that, but two other class B Stations, gave their listeners quite a surfeit of political addresses.

That arrangement of things was quite satisfactory. The class A station gave only one speech from each party leader, and thus not only did not over do it, but also gave each party an equal chance to get its views on the air. The class B stations on the other hand are not under the same obligation to listeners generally. No revenue from listeners licence fees is paid to that class of station, and consequently the general body of listeners have no real complaint.

AMERICAN IDEA OF SERVICE.

In this connection it is interesting to note the American idea of broadcasting service as set out by the National Broadcasting Company. In a recent announcement the freedom of broadcasting was defined as follows:—

(1) Public interest must determine the availability of every feature put on the air by the National Broadcasting Company. This must be reflected in the quality of the sponsored programmes in the character of the speakers, and in the subject of their remarks.

(2) No political, racial or religious lines must be drawn in allotting the facilities of the National Broadcasting Company.

(3) In order to maintain broadcasting upon the highest possible plane, and to protect the interests of listeners, the National Broadcasting Company must retain the right at all times to select the programme features broadcast by its originating stations.

(4) While maintaining the principle of free speech by radio, the duty devolves upon the National Broadcasting Company of obeying the laws of the United States.

The conditions of control and financing in the United States are of course different from ours, but the principle quoted above is of special interest.



Ask your dealer for Diamond

DIAMOND Radio Batteries

Ask your dealer for Diamond

Diamond Radio Batteries are powerful, silent, and outlast any other make of Dry Cell. More than a million are manufactured in Australia annually. Every cell is guaranteed, and should a fault be found in any Diamond Dry



Cell it will immediately be replaced. Remember, a Radio Set is no better than its battery, therefore it is most essential to choose a battery that will give long and honest service. Such are Diamond Dry Cells.

RETAIL PRICE LIST

- "A" Buzzer Cells, 1.5 volt 2/9 each.
- "B" 60 volt Super B. Battery, 27/6 each.
- 45 volt Super B. Battery, 22/6 each.
- 60 volt Standard B. Battery, 18/ each.
- 45 volt Standard B. Battery, 15/ each.
- "C" 4.5 volt "Bison" C. Battery, 3/3 each.

Wholesale only from:—
JOHN REID & NEPHEWS,
 CHARLOTTE STREET,
 BRISBANE.

Manufactured by
WIDDIS DIAMOND DRY
CELL COY. LTD.
 W. Melb., Vic.



SUPPLIED TO
ALL GOVERNMENT
DEPARTMENTS



The Cup Dresses

3LO Melbourne has been extremely fortunate in finding competent people to describe sports, public occasions and social events. This sort of "announcer" is comparatively rare. In the United States they earn large salaries on full-time jobs. It is the more gratifying to find that they crop up when they are wanted in this country, and justify 3LO Melbourne of their selection.

The new "find" is Miss Dorothy Dunckley, who was engaged by 3LO Melbourne to give a running description of the crowds at Henley. Mr. Norman McCance did the racing, and Miss Dunckley dealt with the human element.

She has remarkably fine equipment for the task, which was so successfully done that she has been entrusted with a similar work on Cup Day and the Oaks. She will supplement the description of frocks, as given by the social writers for the newspapers, and it is odds on that women listeners will strain their ears to hear what the wife of a prominent owner is wearing as much as will their husbands to know what price Thimblinger went out at.

Miss Dunckley, who is a well-educated woman of the world, with a gracious, winning personality, and a low, well-modulated voice, very suitable for broadcasting is not unknown to listeners in Victoria, for she has taken part in One-Act plays from the studio. That is not the limit of her accomplishments, for she came fourth in the recent One Act Play Competition. It was her success in other studio work that led to her selection for broadcasting descriptions of public functions of peculiar interest to women.

Tasmanian Holiday

Tasmania has figured largely in 3LO Melbourne's arrangements. It will be remembered that it was the honeymoon locale of the September Bride. Now it has been chosen as the place for a two weeks holiday for some lucky 3LO Melbourne Listener.

A competition that calls for the use of no gray matter is being arranged. The sole qualification is that the successful aspirant is a licence-holder, either by himself or his family (and "his" includes "her" in this case). Contestants do nothing but wait. Chance does all the work.

All you do, if you wish to enter, is to send your name and address and licence number of your wireless set, or that on which you habitually listen in to 3LO Melbourne.

Thousands of licencees will nerve themselves to this intellectual task. Then, on a certain date early in December, all the applications are heaped together, and one is drawn at random. The applicant whose name is on the letter will be packed off to Appleland. Simple, isn't it? isn't it? It doesn't matter whether it is man, woman, or child. Competitors however must endorse their envelopes "Spend Christmas in Tasmania."

Now
on the Press!

Uncle Ben's
**Book-o'-
Fun**
for
1928

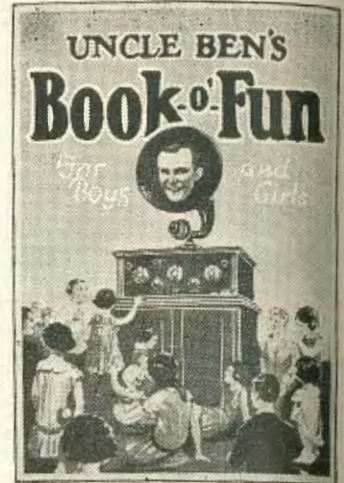

There is at present upon the press a story-book for children that is going to make a lot of young people happy this Xmas-tide—"Uncle Ben's Book-o'-Fun."

The 1928 edition is better, brighter, and cheaper than the last! Coloured pages are included, comic picture stories of "Sandy" and "Percy," "Uncle Jim" and "Tony," "Uncle Ben & Coy.," besides a wealth of stories and verse especially written by the bed-timers.

Scout adventure stories for the boys, wonderful stories for the girls, puzzle pictures, optical illusions, games and conundrums for evening hours, and pages of other absorbing reading.

This year the price has been reduced from 3/- to 2/- per copy, as it is expected more copies will be sold. The cover is beautifully executed in full colour, and every kiddie will want a copy.

Orders are being received by the distributors, "The Standard Press," Adelaide Street, Brisbane. Postage is 4d extra. The book will be available towards the end of this month, and readers are advised to place their orders with their newsagents or send two shillings, plus postage to-day to "The Standard Press," or direct to Station 40G.

WARDE MORGAN.

It is a very great delight to listen to the singing of Ward Morgan from 3LO Melbourne. It makes one shudder however to reflect upon the tragic railway accident which nearly robbed us of his beautiful voice for all time, and to recall Mr. Morgans' great endurance through a long period of intense suffering. His recovery so far has been almost a miracle, and the best wishes of his many friends and listeners generally, go out to him for his complete restoration to health.

How Long -

5-0-4.

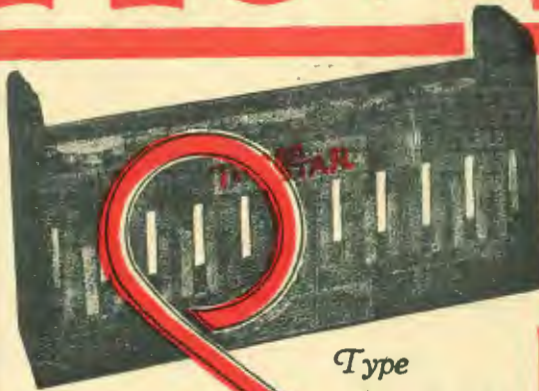

Type H.T.X. 20

Polished Wood
Crate with
Opened Sides

One Piece
Moulded
Glass
Container

Extra Thick
Specially
Designed
Plates

Moulded Glass
Separator
Incorporated in
Container.



Price 25/6



At all Radio Dealers.

Does Your Plate Battery Last Before The Wood Separators DECAY?

The "THREE STAR" STAR

High Tension Wireless "B" Battery has no Wooden Separators to Decay, as they are of Moulded glass. The plates are specially designed and are extra thick while the container is of one piece moulded glass.

The Three Star needs recharging only when the S.G. falls to 1,100. It has a capacity of 2,500 Milli-Ampere hours, and a Voltage of 20.

Provision is made for 2-Volt tappings.

A High Grade product of English
Manufacture

Amalgamated WORLD WIRELESS Wireless
(Australasia) Ltd.

SYDNEY, MELBOURNE, BRISBANE, ADELAIDE
WELLINGTON, N.Z.

"THREE STAR" BATTERY

The House
is known
by the
Radio it sells

EDGAR V. HUDSON

55 Charlotte Street, BRISBANE

A Man
by the
Radio he
uses.

Distributors for

MULLARD VALVES
RADIOES COILS
FERRANTI TRANSFORMERS
RIPAULTS BATTERIES
FEDERAL HEADPHONES
BRITELITE BATTERIES

ADVANCE RADIO PARTS
CYLDON TEMPRYTES
FELLOWS SPEAKERS
POLAR COMPONENTS
GRODAN SPECIALTIES
C.A.V. CONE SPEAKERS

B.T.H. SPEAKERS
ORMOND CONDENSERS
TELSEN TRANSFORMERS
BELLING-LEE TERMINALS
EMMCO COMPONENTS
MAJESTIC REPRODUCERS

Fellows Rotary Rectifier Battery Charger

Simplicity Itself

If you have electric light in your home the problem of charging your wireless or car accumulator is solved for ever.

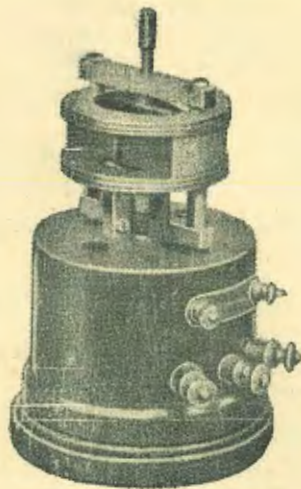

The Fellows Accumulator Charger, shown here, is a highly ingenious yet perfectly simple instrument which anyone can use successfully. It is simply plugged into any lamp-holder (by means of the adaptor which fits like an electric light bulb), a twist is given to a small knob, and the 6 or 4-volt accumulator is then connected up and left for a few hours, when it will be again fully charged. No danger at all is involved, no risk of damage to your lighting circuit, no carrying about of accumulators, no spilt acid or spoiled clothes and no vexatious delays because your garage "hasn't got your accumulator ready."

This charger will charge either 4 or 6 volt accumulators, and the cost (at a charging rate of 2 to 3 amperes), even in districts where the current is expensive, will only work out at about one penny for ten hours.

PRICE **£5-17-6** EACH

Distributed in
Australia by

EDGAR V. HUDSON, 55 CHARLOTTE STREET, BRISBANE

ALL RELIABLE RADIO DEALERS STOCK ALL THE ABOVE RELIABLE LINES