

**THE  
AUSTRALASIAN**

Registered at the G.P.O.,  
Sydney, for transmission  
by post as a periodical.

# Radio World

**1/-**

**VOL. 11 . . . . . NO. 12**

**MAY 15, 1947**



**Two Intermediate Frequencies  
used in "Ham" Superhet.**



**Design and Construction of  
Pre-amplifiers for Talkies.**



**Using Photo-electric Cells and  
Working Relays with them.**



**Notes on Experimental Stations  
and Overseas Broadcasters.**

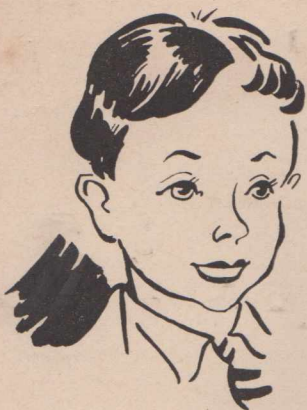

## Young John starts . . . on the Right Foot!

*LIKE thousands of other young Australians John is building a radio set. He is starting off in the right way by using sound dependable parts. Parts that have proved 100 per cent efficient under all conditions. In short, he is using Crown Parts.*

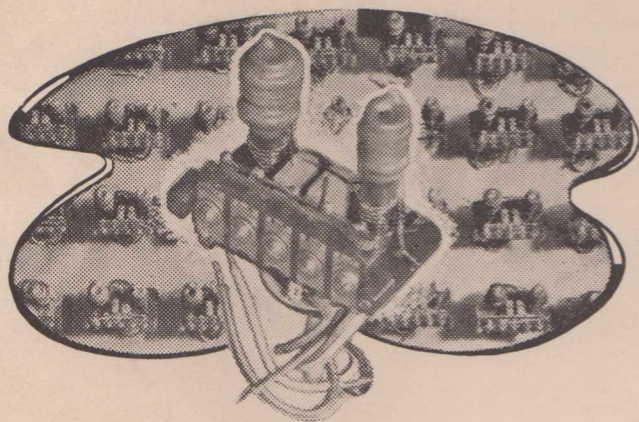

**THE "CROWN" RANGE** comprises: B/C Coils, S/W Coils, I/F Transformers, Tuning Dials, Padders, Trimmers and D.C. 2A. Tuning Units (illustrated).

"CROWN" Parts are built to rigid standards and are precision tested before they leave the factory. That is your guarantee of quality.

**Crown**   
**RADIO PRODUCTS PTY. LTD.**

**51-53 MURRAY ST.  
PYRMONT, SYDNEY. TELEPHONE: MW 2620**

# THE AUSTRALASIAN RADIO WORLD

Devoted entirely to Technical Radio

and incorporating  
**ALL-WAVE ALL-WORLD DX NEWS**

- ★ EDITOR
- ★ PUBLISHER
- ★ PROPRIETOR—

**A. G. HULL**

Balcombe St., Mornington,  
Vic.

- ★ SHORT-WAVE EDITOR—

**L. J. KEAST**

6 Fitzgerald Road, Ermington,  
N.S.W. 'Phone: WL1101

- ★ HAM NOTES By—

**D. B. KNOCK (VK2NO)**

43 Yanko Av., Waverley, N.S.W.

- ★ ADVERTISING  
REPRESENTATIVE FOR VIC.—

**W. J. LEWIS**

20 Queen St., Melbourne  
Phone: MU 5154

- ★ ADVERTISING  
REPRESENTATIVE FOR N.S.W.—  
AMALGAMATED PUBLICATIONS  
PTY. LTD.

**83 Pitt St., Sydney**

Phone: B 1077

- ★ SUBSCRIPTION RATES—

6 issues ..... 5/3

12 issues ..... 10/6

24 issues ..... £1

Post free to any address in  
the world.

Address for all correspondence:  
**AUSTRALASIAN RADIO WORLD**

Balcombe St.  
Mornington  
Victoria

Vol. 11.

MAY, 1947

No. 12

## CONTENTS

### TECHNICAL—

Problems of Trade Discount .....	5
Double Superhet for Ham Use .....	9
Preamplifiers for Talkie Work .....	11
Starting a Radio Business .....	13
Visual Tuning Indicators .....	16
Photo-Electric Cells .....	24
Disposal Bargains—And Otherwise .....	26
Service Problems in U.S.A. ....	30

### SHORTWAVE REVIEW—

Notes From My Diary .....	38
---------------------------	----

### THE SERVICE PAGES—

Answers .....	42
---------------	----

## EDITORIAL

In the April issue of a contemporary magazine are advertisements from various firms offering the Cosmocord pickup at prices of 59/6, 66/-, 67/11 and 75/-. The same item was advertised a few months ago at 77/6. The cartridges for this pickup are advertised in the same magazines at prices of 31/-, 37/6 and 45/-. The "Young Atom" pickup is also advertised at widely varying prices of 57/-, 57/6 and 70/9.

A number of our readers, who also read the other magazine in question, have written to me to ask if I can offer any explanation for the terrific difference in prices quoted. Some of them actually purchased pickups at the higher prices prevailing a few months ago; now they feel that they have been robbed.

Knowing that my little publication is completely independent, without any trace of trade association or obligation, and that I will give them the honest "low-down" on the position, they have come to me with confidence. I cannot betray that confidence, although it puts me in a tight corner.

I feel that the only way to handle the problem is to explain to my readers the whole background of the position. I feel sure that they have sufficient intelligence and logic to be allowed to know about these things. Most of them already know that Father Christmas does not necessarily climb down the chimney. Some even know that babies are not found under cabbage bushes. They are old enough to know about radio trade prices and discounts without being shocked.

So the first article of a series covering this subject appears in this issue.

—A. G. HULL.



**O**PERATING WITHIN TOLERANCES of  $1/1000$  part of an inch, these winding machines fabricate the "grid" coils for use in Australian-made Radiotron valves. Only through constant conformity to exacting specifications, can that uniformity of characteristics be achieved and maintained in Radiotron production — which, for over twenty-five years has established Radiotron valves as —  
the world's standard valve . . .



**AMALGAMATED WIRELESS  
VALVE COMPANY PTY. LIMITED**

Administration ..... 47 York Street, Sydney, N.S.W.  
Manufacture ..... Parramatta Road, Ashfield, N.S.W.  
Distribution ..... Crown Street, Glebe, N.S.W.

# PROBLEMS OF TRADE DISCOUNT

Taking his courage in both hands, the Editor prints herewith the first of a couple of articles on a subject which is seldom discussed "in the open." In this issue the problems are discussed. In next month's issue a few suggestions for a solution will be given.

**C**LOAKED in a veil of secrecy is one of the major problems confronting the future of the home builder of radio sets, the technical radio press, and certain sections of the radio industry. The problem goes under the title of "trade discount" and, although it has been with the radio trade ever

By

A. G. HULL

since such a trade was established, it is steadily getting worse and worse and sooner or later must be dealt with effectively in the open. Yet there are many in the trade who will be shocked to see such a subject openly discussed in a magazine which is sold to the public on the bookstalls. Some will be outgunning after me for daring to "reveal" to the public the inner secrets of the trade. Should their aim be better than I anticipate, I can only say, "No flowers, by special request."

I think that it is childish to imagine that there are any intelligent people in this world who really think that the grocer buys a tin of jam at the same price as he sells it over the counter. Anyone who has the slightest sign of logic will be able to reason out that if the grocer sells at the same price at which he buys he will not make any profit. If he makes no profit he will not be able to pay the rent of his shop or the wages of his assistants.

Surely it is now well-known that there are such things as wholesale prices, trade discounts and so on.

Under ideal conditions the set-up of the radio trade, or any other trade, runs something along the

lines of the manufacturer fixing a price for his goods, then allowing a big discount to the wholesale distributor. This allows the distributor to give the retailer a discount.

## COSTING AND PRICING

As a practical example of costing and pricing we will go back to the good old days before the war, before the imposition of sales tax. A manufacturer decides to manufacture a potentiometer or any similar component. He works out his material costs, wage costs for assembly and testing, allows a few per cent. for advertising, makes an allowance to cover his overhead ex-

penses, such as light, power, telephone, depreciation and so on, and finds that the total cost of production is to be, say, four shillings. He adds a shilling for his own profit, so that he will need to get five shillings clear from the sale of each unit. Being busily engaged on the production of potentiometers, he will find that he has his hands pretty full by the time he has kept an eye on his factory hands, made sure that his raw materials come to hand on time and so on. He won't want to spend any time on the minor details of selling, collecting accounts and so on. So he appoints

*(Continued on next page)*

## SPLENDID WINDOW DISPLAY BY PERTH SHOP



Nicholsons Pty. Ltd., of Perth, have the right idea about sound merchandising and make some splendid window displays. The one pictured above is devoted to Aegis kit-sets and the "Australasian Radio World" in which the constructional details were given.

**JUST OFF THE PRESS!**

**496** Pages

**250** Diagrams

**400** Formulae

**105** Charts and  
Tables

**122** Valve Curves



# PHILIPS MANUAL OF RADIO PRACTICE FOR SERVICEMEN

Compiled by E. G. Beard, M.I.R.E. (Aust.), and acclaimed by leading critics, including Sir Ernest Fisk, as a textbook of outstanding merit the Philips Manual of Radio Practice is a No. 1 "must" for all interested in radio.



Fully bound, it forms an easy-reference collection of up-to-the-minute information on modern radio technique.

**A COMPREHENSIVE RADIO LIBRARY UNDER ONE COVER**

## Contents

### SECTION 1: Broadcast Reception

The broadcasting circuit • Sound reproduction • Broadcasting stations • Propagation of a wave • The radio receiver — Input circuits • The radio receiver — Signal frequency amplifier • The radio receiver — Intermediate frequency circuits • The radio receiver — The detector circuits • The radio receiver — Low frequency (audio) amplifier • The radio receiver — Auxiliary circuits.

### SECTION 2:

#### Broadcast Receiver Technique

Aerial tuning and input circuits • Signal frequency amplifier • Single dial control • Frequency changing • Oscillators • Mixer or frequency changing valve • Intermediate frequency stages • The detector or demodulator • Diode peak voltage detector • Grid leak detector (Power Type) • Anode or plate detector • Negative feedback detector (infinite impedance detector) • Small signal detectors • Low frequency amplifiers •

Voltage amplifiers • Motor boating, decoupling and flutter • Power amplifiers • Triode power amplifiers • Pentode or beam valve amplifiers • Push-pull amplifiers (Class A) • Push-pull amplifiers (Class B1) • Push-pull amplifiers (Class AB1) • Push-pull amplifiers (Class B2) • Push-pull amplifiers (Class AB2) • A.C. rectifier power supplies • High tension power supplies from low voltage D.C. sources • Vibrator high tension power supplies • Genemotors or dynamotors • Rotary converters • Gain or volume controls • Automatic gain control (A.V.C.) • Tone controls • Visual tuning indicators • Muting • Automatic frequency control • Contrast expansion and contraction • Wave traps • Receiver characteristics and measurements.

### SECTION 3:

#### Principles and Components

Resistors • Insulators • Inductors (Coils) • Condensers • Tuned circuits and amplifiers • Impedance of non-resonant circuits • Transformers (untuned) • Time constants • Noise • Aerials • Valves • Negative feed-

back (Inverse feedback) • Oscillators • Regeneration or positive feedback • Super-regeneration or quenched receivers • Loudspeakers • Phonograph pick-ups • Miller effect • Transmission units • Ultra high frequencies • Frequency modulation • Pulse modulation • Acoustics • Stereophonic reproduction.

### SECTION 4:

#### Service to Radio Receivers

Measuring instruments • Service in the home • Service in the workshop • Practical service work • Reduction of Electrical Noises • Soldering • Design of masts.

### SECTION 5:

#### Technical Formulae, Tables and Charts

### SECTION 6:

#### Mathematical Formulae and Tables

### SECTION 7:

#### Valve Data — Appendix

**A 'MUST-HAVE' FOR**

**EVERY** { **SERVICEMAN  
ENGINEER  
AMATEUR  
EXPERIMENTER  
STUDENT**

**DON'T  
DELAY**

**PRICE  
22/6  
POSTAGE PAID**

**POST RIGHT AWAY FOR YOUR COPY**

TO . . Philips Electrical Industries of Australia Pty. Ltd.  
Box 2703 C, G.P.O., Sydney

Please forward post-free to the address below one copy of the Philips Manual of Radio Practice for which I enclose cheque/postal note for 22/6.

NAME.....

ADDRESS.....

(A.R.W.1)

**OR OBTAINABLE FROM ALL LEADING BOOKSELLERS**

## TRADE DISCOUNT

(Continued)

a wholesale distributor to handle his entire output. Possibly he appoints two or three distributors, but the principle is the same. At a conference with his distributor he mentions that he wants 5/- nett per unit, so a retail price is calculated to allow suitable discounts. Probably the retail price will be fixed at 10/-. The owner of a radio shop will sell the component over his counter at that price, buying it from the wholesale distributor at a discount of 33 per cent., or a nett trade price of 6/8. It will be seen that the shopkeeper will make a gross profit of  $\frac{3}{4}$  on the transaction, the wholesaler will make a gross profit of  $\frac{1}{8}$ .

So it is with all types of business from bicycles to beer or from cars to cantaloupes.

### RATES OF DISCOUNT

But the actual rates of discounts vary. Shopkeepers can operate successfully on discounts of from 5 per cent. to 50 per cent., mainly according to trading conditions and demand. For example, it would be possible to handle groceries on a fairly low margin because the public must eat. On the other hand, the selling of radio sets needed a big nominal margin of profit, especially in the days when to sell them you had to canvass from door to door, then leave them for weeks on end for "home demonstration" and eventually close the deal on a basis of no deposit and half-a-crown per week (perhaps). Many radio retailers found that even with discounts of 40 per cent. they could not make any real profit and soon went bankrupt.

### ENTER THE VILLIAN

Such long discounts, however, were a temptation, and so enters the villain, the pal who knows a chap who knows a man whose uncle has a radio shop and so will let him have a set at "trade price." These villains were much in evidence in the period 1934 to 1939. In those days I was often approached by

people who told me they intended to buy a new wireless. The second sentence of their opening conversation would be, "Can you get me a better discount than 40 per cent.?" Usually they would readily admit that they were not in the radio trade, not by any stretch of imagination legitimately entitled to a discount. Yet they got their discounts for the simple reason that they had the ready cash and soon found wholesalers who wanted that money.

Since the war the position has changed entirely. The slowness of production, coupled with the in-

tense demand, has changed the tune of the man-in-the-street. Today his question is where can he get a set, not how much discount can he get. The Prices Commissioner and the matter of sales tax have further tangled the present position, so that the problems of trade discount have little to do with the problems which were so much in evidence in pre-war days.

Today the big problem is to define the person who is entitled to discount. It is easy enough to say that any person who has a radio

(Continued on next page)

## WARTIME DEVELOPMENT

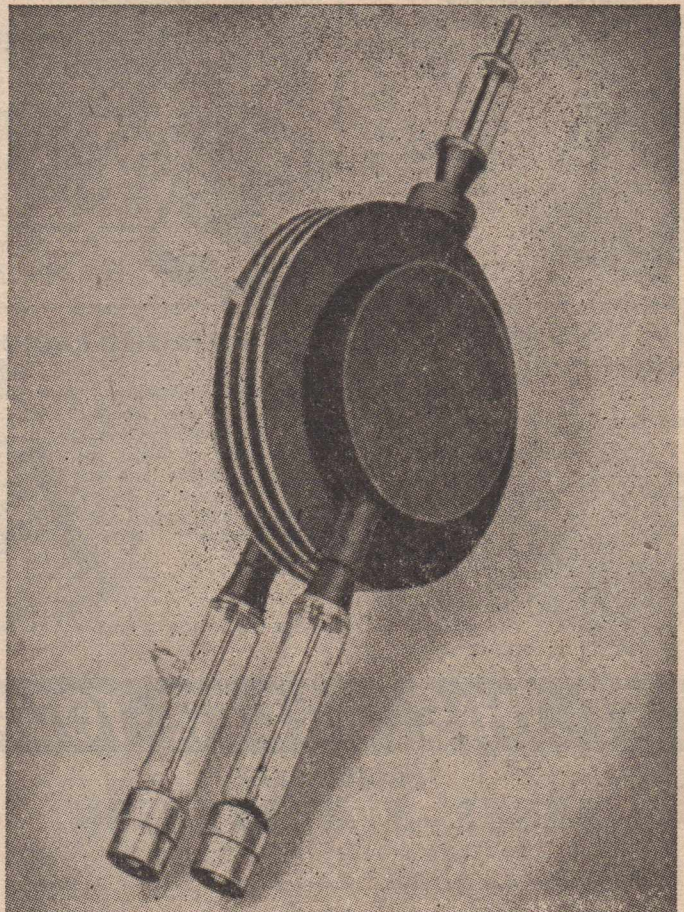

The radio trade in Eng'and did some wonderful work for the war effort. From a brochure on the subject recently issued by the British General Electric Co., we take this picture of the Osram copper-block magnetron, which was designed for use on wave-lengths of 9 centimetres.

# USEFUL RADIO BOOKS

## FROM ANGUS & ROBERTSON LTD.

### 1. Completely Revised Edition "RADIO HANDBOOK"

Thousands of radio amateurs have been waiting for this new edition of the original "Jones' Radio Handbook"—and they will not be disappointed. Latest information on dozens of wartime developments, F.M., U.H.F., Tube design, etc. 704 pages, hundreds of diagrams.



17/6 (Post 1/-)

### 2. Complete Radio Manual— "RADIO FOR THE MILLIONS"

Pop. Science Monthly Publ. Instructions for building 87 receivers, recorders, radio phonographs, etc.; from one tube to 8 tube sets; from vest pocket to floor models. Trouble-shooting, servicing, testing equipment. 100 wiring diagrams. 450 illustrations.



10/6  
(post. 6d.)

### 3. HOW TO BUILD AND REPAIR RADIO RECEIVERS

"EVERYBODY'S RADIO MANUAL," a "Pop. Science Monthly" publ. Crystal-clear, non-technical instruction on building or repairing any kind of set. Hints, short-cuts, a wealth of diagrams that are easy to follow. 256 pages.



7/6  
(post. 6d.)

### 4. Ninth Edition of F. J. Camm's "THE PRACTICAL WIRELESS ENCYCLOPEDIA"

An alphabetically compiled guide for the construction, operation, repair and principles of wireless receivers. Over 220,000 copies sold. Definitions, explanations, formulas, etc., rapidly consulted.

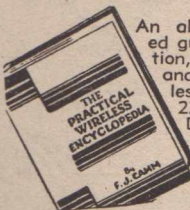

12/6 (Post 6d.)

### 5. Get This Complete RADIO SERVICING COURSE TODAY!

"Modern Radio Servicing—By A. A. Ghirardi; one of the foremost servicing experts in the U.S.A. 1300 pages. 706 illustrations. Everything is explained clearly, simply, step-by-step. Trouble-shooting, testing and servicing all types of home and auto-radio equipment.



40/- (Post 1/3)

### 6. SIMPLIFIED RADIO!

"The Outline of Wireless." By R. Stranger. One of the most popular books about radio ever written. Covers the whole field of radio thoroughly. A highly scientific subject discussed in simple language. 836 pages. 578 "easy-to-follow" illustrations.



17/6 (Post 10d.)

## POST THIS ORDER TODAY

### ORDER FORM ANGUS & ROBERTSON

89 CASTLEREAGH STREET, SYDNEY

Please send me the books whose numbers I have encircled

1      2      3      4      5      6

(A) for which I enclose payment, (B) charge to my account.

NAME .....

ADDRESS ..... (Tech. R.W. 5/47)

## TRADE DISCOUNT

(Continued)

shop is entitled to buy at trade price, but how about the returned man who finds it impossible to get the tenancy of a suitable shop. He erects a signboard over the back gate of his residence and operates from a shed in the back yard. He is also a genuine radio serviceman, and fully entitled to buy his components at trade price. But from there on there are many borderline cases which can only be decided on their own particular merits. During the war when technicians were mostly on priority work there came into recognition the part-time radio repairer, who was licenced as such by the Department of War Organisation of Industry. These Class "B" radio servicemen kept the radio sets in running condition in spite of component scarcity. They established good business connection. Now they want to continue with their part-time work. They have been buying at discount for years past. Can you imagine a harder task than getting them to pay retail list prices?

### POSITION OF THE W.I.A.

Adding complexity to the present trade discount problem is the way in which the Wireless Institute of Australia has managed to get the radio trade to agree to members of the Institute being entitled to trade discount on their purchases of radio components. Good luck to the W.I.A. for this move, but since no qualification is necessary for W.I.A. membership there is the possibility that joining the W.I.A. may become a short-circuit to discounts. It should tend to make W.I.A. members popular with their fellow enthusiasts.

### LOOSE TRADING METHODS

But possibly the biggest problem associated with trade discounts in the radio business is the background of years of loose trading methods. Back in 1924 and thereabouts the experimenter was a power in the trade. The opinions expressed by well-known experimenters were so

(Continued on page 37)





## HAM SUPER

(Continued)

bandsread was used, trimmers being used as bandset condensers. In the R.F. stage a 9003 was used. An 1852, EF50 and 954 were also tried, but the 9003 won out because A.V.C. could be applied. This stage definitely provides good gain on 10 metres.

A variety of mixers and oscillators were tried: 954 with 955 oscillator—6K8 with 6J5 oscillator; also 6J8, ECH35, 6L7, ECH4G, 1852, EF50 and 65J7. Then the 6J8, ECH35, ECH4 and 6K8 were tried as straight mixer oscillators. Eventually, either because of insufficient dope or comparably poorer performance, all methods were discarded in favour of the 6K8 used as a mixer oscillator, the oscillator section being plate tuned. This tube appeared to give the best performance on 10 metres.

The I.F. amplifier used was a 6SK7. This section is straight forward and needs no further explanation.

The second frequency changer was another 6K8. The second I.F. selected was 175 kcs. This frequency was chosen to keep as far away as possible from 1600 kcs., in order to escape the possibility of whistles and heterodynes due to interaction, and also for the better selectivity and gain available. In practice no trouble was experienced as far as interaction was concerned. An ordinary B/C 455 oscillator coil was used, tuned to 1775 kcs with a .0001 fixed pad across the grid coil, shunted by an ordinary trimmer set to about half capacity and peaked by means of the iron slug. Both 175 kc. I.F.'s were modified by melting the wax holding the coils and decreasing the coupling by increasing the spacing a further 5/8-in. Adequate gain is available to allow this and the selectivity is considerably increased.

The I.F. amplifier used was another 6SK7 feeding a 6H6 as diode detector and simple A.V.C., the second diode being used in a shunt type noise limiter circuit. This was

followed by a 6SF5 as first audio driving a 6SJ7 as output to phones and speaker, and 6C5 BFO. The 6SJ7 operated as shown will deliver about point 6 of a watt for 7 mills plat current, and will give ample output for a 5 or 6 inch speaker. Complaints from a store below our workshop fully confirmed our belief in this respect. A 60 mil, 285 a side power transformer and 6X-5GT (the 5 volt winding being rewound to 6.3 for this purpose) supply the power and two 6 henry 60 mil. chokes provide a hum-free supply.

In the original model a trimmer connected across the 175 kc. oscillator coil, as it was thought that drift might possibly need attention. In practice it was found that this control was unnecessary, and it has since been discarded.

### PERFORMANCE

The selectivity of this set is excellent and it certainly drags in the DX from far and wide. Unfortunately, no apparatus is available at the moment to measure the sensitivity of the receiver, but I imagine it is as good as that of the expensive American type communications receiver. As an indication of the selectivity, the 10 metre band is spread over approximately 7/8ths of a 7-in. dial and DX phone stations tune from edge to edge of the signal over approximately 1/16th to 1/8th of an inch, depending on signal strength.

It is hoped that you may find it convenient to publish this article in order that other experimenters who are contemplating rebuilding, may gain a little inspiration from the fact that this type of receiver is not difficult to build, is not over expensive and providing due care is paid to layout, no difficulty is experienced in getting it working according to plan. The results certainly justify the time and trouble taken over its construction.

**THE NAME  
TO KNOW  
IN RADIO!**

**RADIOKES D.W. UNITS.** Highly selective with exceptional wide range. To match 'H' type gang condenser. Incorporates 4-in-1 padder. Solidly mounted with coils. Ask for type DWO-1

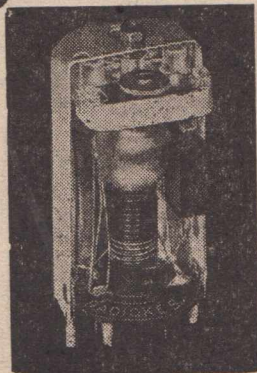

*When buying radio parts and components, follow the lead of amateurs and experts alike — specify Radiokes — your guarantee of test-set performance, precision construction and technical excellence.*

# RADIOKES

PTY. LTD.

P.O. BOX 90

BROADWAY — SYDNEY

R-56

# PREAMPLIFIERS FOR TALKIE WORK

Many of our readers are connected in some way with talkie operation, and having noticed many of our fine amplifier circuits, such as the recent F.F.R., want to know how to couple them up to the output of the P.E. cell of a talkie outfit. In answer to many requests we are happy to present this fine article on the subject from the pen of a man who has had considerable practical experience in this line.

OVER the past years, I, like many others, have been a keen reader of that splendid paper, the good old *Radio World*. I am, myself, a very keen amplifier enthusiast for as long as I can remember. During the period of my cinematograph operating both

photo-electric cells, etc. If you have another type of amplifier you can use the same circuit for your own talkie preamplifier which we shall now go ahead with.

Should you not have enough room on your present chassis you could make a small chassis to accommodate the pre-amplifier.

You will notice in the pre-amp. circuit it contains a 6J7G or better still a 6SJ7GT (which has higher gain) and the circuit is quite standard. For those who aren't quite sure of how to work it into their amplifier the circuit will give you a fair idea. The main thing is to get a correct meter reading of 90 volts at the tap on the 15,000 ohm voltage divider; this is then by-passed by an 8 uf of any suitable voltage. The idea of a 5 megohm photo-cell load resistor may seem pretty high to you, but as photo-cells only pass

a very low output voltage this is by no means too high. The idea is to give a better filtering of the D.C. component which in turn gives a better high response from the P.E.-Cell.

Concerning the lead from the pre-amplifier to the P.E.-Cell, any ordinary single shielded hook-up wire will do, but as you know there is a great loss of the high notes owing to the capacity of the wire. If you have a low capacity wire all the better. I have seen used the lead-covered wire which carries the high tension for neon signs.

If you try to get an ordinary 1000 ohm per volt meter to read the voltage at the photo-cell, you will be disappointed, as to get a reading through such a high resistance of 5 megohms requires a

(Continued on next page)

By  
**MAURICE H. WILLIS**

"Glen View,"

Chaley Street,

Reservoir, N.19

Phone: JU 3090

on mobile and fixed units, I have handled many types of machines and amplifiers.

This article is written for those lads who wish to know the right thing to do in hooking up to their present amplifiers the sound heads of various types of projectors.

I wish to sound a word of warning concerning the voltage applied to the photo electric cells. The voltage to these cells is very critical as regarded the correct voltage. Most photo cells are rated at 90 volts. Should an amount in excess to this be applied it will either ruin the cell or shorten its life by a great lot.

Most photo cells are very low in the output voltage and require considerable pre-amplification to bring the signal imposed on the grid of the first tube to a suitable level for use either in a theatre, home use, etc.

Many of you will be familiar with the 13-watt amplifier (Radio-tron A504). For reference sake we shall use this circuit, as to where we get the voltage for the

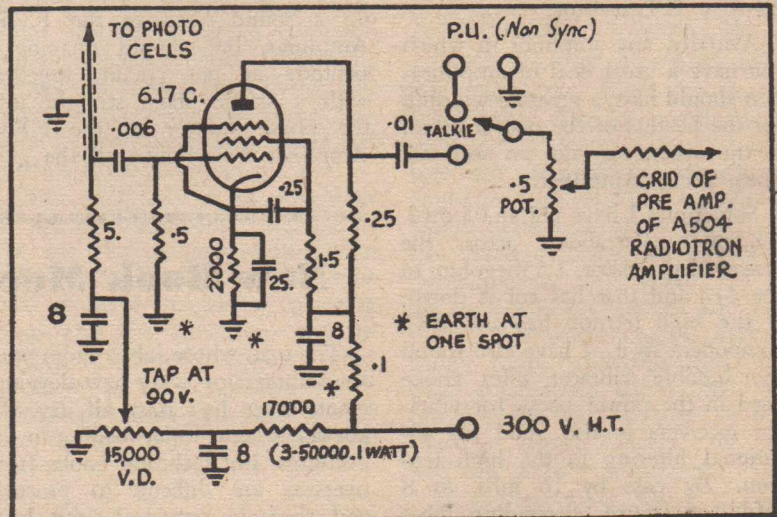

Circuit for a talkie pre-amplifier, suitable for adding to the F.F.R. and other amplifier circuits. It provides the required 90-volt high tension supply for the P.E. cell.

## PRE-AMP

(Continued)

meter of at least 20,000 ohms per volt or higher.

If you can get one of those valve shields with the cover over the grid of the 6J7G all the better. Should you be using the 6SJ7GT you can use any type of shield you like so long as it covers over the top part of the valve.

### HUM TROUBLE

Now the main part which usually worries most of us—HUM. There are several ways you can get over this. If you are only using a speaker field in H.T. supply for filtering, I strongly advise the insertion of a suitable choke, as once you start putting on additional stages in an amplifier the high tension isn't filtered properly. Well, it's just hopeless trying to do anything in this line, as the hum will give you that annoyed feeling. Now, with a suitable supply as the A504 uses and hum in the pre-amplifier still persists, try the following. Place the filament or heater supply above earth by putting an additional H.T. bleeder to the one in the talkie pre-amplifier and tap off at about cathode potential to raise the heater to that above earth, not of course forgetting to take out the 6.3v. C.T. resistor.

Actually, any amplifier in which you have a great deal of amplification should have a separate winding for the heaters of the output tubes, to the others, as you can well see in the F.F.R. Amplifier.

Sometimes I have put an .05 mfd. condenser thereabouts across the screen feed resistor, 1.5 megohm, to the 6J7 and that has cut it down, if the high tension has any A.C. component in it. I have also found the humble vibrator filter choke used in the power packs for vibrator receivers is also good for additional filtering in the high tension. By pass by 16 mfd. or 8 mfd., of course, depending what you have on hand. If you have many valves on the same high tension supply, you will find it will

work wonders to put a one or two-stage filter using the vibrator chokes, to keep things stable.

Probably you will wonder why tone compensation isn't used in talkies.

As you have probably gathered that most sound systems in the city and some (?) of the country towns have a fairly wide range as far as response goes, therefore if you have an efficient baffle around the bass speaker or speakers, you need no compensation, which I think goes for all amplifiers, baffle your bass speaker well and you'll find that very little bass boost is needed, more so in the F.F.R. Amp.

### BASS BOOST

For those of you who wish to give the bass section a lift, the circuit is for your use. The only disadvantage, that this requires another valve; any triode such as 6CS or 6J7 (triode) will do the job all right. The circuit was kindly given to me by Mr. Swales, who, you well know, is of Swales and Swann.

Should you wish to have a go at connecting the P.E.-Cells to the F.F.R. Amplifier, you could use the 300-volt high tension supply to your pre-amplifier, and take the heater leads from the same supply as the phase splitter and triode drivers get theirs.

To date I haven't tried hooking up a sound head to the F.F.R. Amplifier, but should imagine a pentode as per circuit, together with a triode stage straight into the phase splitter of the F.F.R. Amplifier would give all the gain

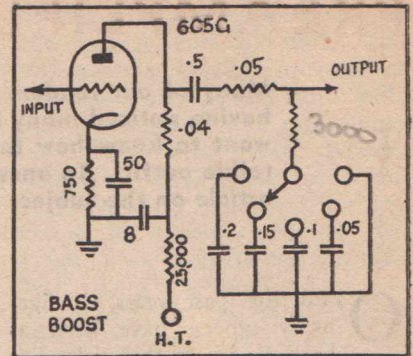

(and noise?) you want. I would suggest for preference a separate chassis to the F.F.R. one.

Perhaps some of you have also wondered about volume expansion. From memory, I think it was used in "Fantasia," when it was screened in New York. All films are recorded as per performance or take therefore with modern copies of the films. Well, I for one wouldn't like to be sitting in a theatre which used volume expansion when a band started to play. Volume expansion is all right for lateral recordings, but for film work, no. Comparing the lateral to film would be the same as the hill and dale or wide-range recordings broadcast over the air.

If you want to cut down, hum, the best solution to the problem is a separate power supply, using if necessary a three-stage filter. Should you be able to have a six-volt supply from an accumulator, all the better, but mind you disconnect the accumulator from the valves whilst being recharged, or it will shorten the life of the valves.

## New Book Meets Long-felt Want

The man whose job is radio must keep abreast of every new development. Since he's busy all day, the answer is some quiet reading in the evenings. But technical books from overseas are difficult to procure, and they do not deal with local conditions. Nor do these works "talk Australian."

However, an Australian radio en-

gineer has come to the rescue with "Philips' Manual of Radio Practice." Here, in one compact volume, E. G. Beard, M.I.R.E. (Aust.) covers radio from every conceivable angle. Whether it is the effect of wind pressure on wooden aerial masts or the proper application of the ECH35, the author deals with

(Continued on page 23)

# STARTING A RADIO BUSINESS

## SOUND ADVICE FROM WELL-KNOWN EXECUTIVE

DO you want to start in radio business, handling service and sales. Well, the idea is good, but have you given it every consideration, or have you looked at the bright side of it only, and expect to make a fortune in the first year. Let's see if we can give you a few tips and maybe help you in your decision.

(1) Have you a good practical

By

**JOHN BRISTOE**

Radio Manager

Denhams (M'boro) Pty. Ltd.

Maryborough, Q.

and technical knowledge of radio servicing, and are you capable of repairing any type and make of radio, irrespective of its age. Remember that in these days it is not always possible to obtain the exact parts for replacement, and it is very often necessary to substitute parts to keep many sets operating satisfactorily. At the same time, the customer does not expect to pay fantastic prices to have his set put in order, so you have to make or obtain substitutes as near to the cost of the original parts as possible, or you have a dissatisfied client and you lose his future business. We will deal with this problem later in this article, and at the same time give you a few practical examples of what you may expect to come up against.

### FINANCE REQUIREMENTS

Now, about the root of all evil, and a very necessary evil: money! Have you plenty of it, or none at all; or do you think you have enough to make a decent start? Well, in the first instance, if you have plenty, I suggest you take a long holiday, as you don't need to make any more, and give some of the less fortunate people a chance. If you have no money at all, my advice is to get a job where you

can save and maybe at a later date when you have some capital it may be worthy of consideration. Naturally, try to get a job directly connected with radio as you cannot expect to keep up to date unless you are at it all the time. Don't try to borrow money to start a business. You will put a rope round your neck right from the start.

Assuming you have some capital. Is it enough? We will try to sift this matter and get a rough idea of what is needed to start a small business that is capable of supporting you and one assistant.

You need some means of transport and this means of transport should be capable of carrying at least two console model radios. It must be reasonably reliable and pay its way. I know many radio men who are scratching for a living all the time as most of their earnings go out on car or other vehicle repairs.

We will assume that you have a vehicle, or are able to obtain one that will do the job satisfactorily.

### BUSINESS PREMISES

Now, about premises. Can you get a shop at a reasonable rental in a reasonable position? This is another important factor, although some servicemen work from their homes and make a good living. But unless you are very well and favourably known in your particular district, I don't advise it.

You will find it an advantage if you are right where the public can see you, so give this careful consideration, and at the same time bear in mind the cost of painting signs and any alterations and fittings that may be required. They all have to be considered in the initial costs, and you need to find out for yourself what these will amount to, as every case is different.

### TEST EQUIPMENT

I have been asked dozens of times, particularly since the war, by

many men who are considering starting up business for themselves: "What test equipment do I need?" Some of them think that a volt-ohm-milliammeter is sufficient. Others have the idea that they need enough equipment to fill a laboratory. You certainly can have too small an amount of test equipment, but you can have too much. You require sufficient equipment to enable you to service any type of radio set, that is all. This, in my opinion, is the minimum.

A good, reliable valve tester that will give you an indication of the condition of all types of valves used in Australian and imported sets, the former being most important as very few imported sets are in operation in Australia.

A reliable Signal Generator, or modulation oscillator of the all-wave variety. You don't need a huge laboratory model, but be wary of the very cheap ones. Get the best you can afford. You will find it will pay in the long run.

A good, sturdy volt-ohm-milliammeter that is portable and can be carried with you when you go out for jobs.

### SIGNAL TRACER DESIRABLE

These three articles are the absolute minimum. Even though the valve tester may have volts-ohms-mills incorporated in it, you still need the small unit as you cannot afford to carry your best equipment around with you all the time, and risk damage. Take the volt-ohm-milliammeter only when you go out servicing. Of course, you need pliers, side cutters, screw drivers, lining tools, soldering iron, and other small tools. Later, when you can afford it, build yourself or purchase, a Signal Tracer. You will find this of great importance.

A test speaker is handy but not essential, as it is better always to

*(Continued on next page)*

## STARTING IN BUSINESS

(Continued)

test each set on its own speaker. An output meter is useful but most of the good universal volt-ohm-milli-ampmeters and valve testers incorporate one of these.

Some mechanics like to have an oscilloscope. It certainly is very handy in design, experimental and laboratory work, but it has a limited application on repair work.

A final word about test equipment. There is a lot on the market these days in comparison with the war years, when it was practically non-existent. When you are buying new instruments, make sure you get those made by well known, reliable companies, as many so-called instruments being offered are rubbish.

### SPARE PARTS

You will require a basic stock of spare parts, depending to a large extent on the types of sets you will be called on to service most. For instance, if you live in a DC area, don't stock up with power

transformers, and you would hardly put a stock of barreter tubes and 25 volt rectifiers if you don't live in a DC area. However, wherever you are, there is always a certain number of battery sets, so a few valves, etc., for these should always be stocked. I will give you an idea of what parts are mostly needed and used for different areas, by giving a short list for AC towns, DC towns and country where no power is available other than a few lighting plants.

### A.C. SETS

Valves are mostly likely to be required in order of preference. 80, 5Y3G, 6A8G, 6A7, 42, 6F6G, 6V6G, 6U7G, 6J8G, 6K8G, EBF2, 6B6G, 75, 42, 6G8G, 6B8G, EL-3NG, 6B7S, 6B7, EBL1, 6D6, 6C6, 2A5, EZ2, EZ3, 24A, 6J7G, 6X5-GT, 57, 58, 59, 2A7, 47, 35, 45, 83V, 5V4G, 85, 71A, ECH35, 6B5, 6A6, 27, 56, 6J5, 6K7G, 6E5, 6U5, 6N7G, 6H6, 77, 78, AK1, AK2, AL2, AL3, AZ3, EF5, EM1.

### D.C. SETS

302, 25Z6, 25Z5, 25A6, 1941, 25L6, C1, 43, CY2, 6A7 6A8G,

6D6, 6U7G, 6K7G, 6B6G, 75, CK1, CL2, CF2, CL4, CBC1, EBF2, 6B7, 6B8G, CC1, CF1, CB1, 38.

### BATTERY SETS

1C6, 1D4, 1A7G, 1C7G, 1P5G, 19, 1Q5G, 1H5G, 1N5G, 1C4, 1M5G, 1K7G, 1B5/25S, 30, 1L-5G, 34, 1J6G, 1K6, 1D8GT, 1A4P, 1K4, 1C5G, 1A5G, 1D5GP, 1H4G, 32, 1H6G, KL3G, KL4, KK2, PM22A, KDD1, 38, 6D8G, 6S7, 6T7G.

I do not say you will require all these types, or that these types will cover all your requirements, but at least it gives you an idea of most of the types you may expect to need in your particular area. Doubtless you will find it very difficult to obtain a number of these types, but in most cases if you know your job, some satisfactory substitute can be used. Maybe, you don't agree with me. I know there are any amount of tough problems, and I am always ready to give advice if you have one, and remember the query page in this journal is for your benefit.

*Spare Parts and stock other than Valves*

### A.C. SETS

8 mfd. Electrolytic condensers 525 PV.  
16 mfd. electrolytic condensers, 525 PV.  
25 mfd. electrolytic condensers, 40 PVPV.  
10 mfd. electrolytic condensers, 40 PV.  
5 mfd. electrolytic condensers, 40 PV.  
Few assorted mica condensers.  
.1 tubular condensers 400V.  
.5 and .25 tubular condensers.  
.01 and .02 tubular condensers.  
Sundry tubular condensers.  
Assorted potentiometers, mostly .5.

An assortment of carbon resistors from 5000 to 5 megs.

Popular sizes w.w. resistors.  
15,000 and 25,000 voltage dividers.

Padders.  
Trimmers.

# SAVE MONEY WITH A SUBSCRIPTION!

Order Yours To-Day

Make sure you get every issue as soon as it is published. Place an order with your newsagent or send direct to us for a subscription.

IT SAVES YOU MONEY!  
IT SAVES YOU TIME!

We guarantee that every subscriber has his copy posted the same day it comes off the press.

Enclosed please find remittance for 10/6 in payment for an annual subscription to the "Australasian Radio World," commencing with the..... issue.

NAME .....  
STREET and NUMBER .....  
CITY ..... STATE .....

AUSTRALASIAN RADIO WORLD

Balcombe Street  
Morningson

RATES	
* 6 issues	5/3
* 12 issues	10/6
* 24 issues	20/-
<b>POST FREE</b>	

40, 60, and 80 mil power transformers.

Assorted speaker transformers.

Assorted filter chokes.

R.F. chokes.

Assorted field coils.

Replacement type coils and I.F.-T.S.

6.3 pilot lamps.

Assorted speaker cones.

Few assorted valve sockets.

Wave change switches and decks.

Aerial and earth wire.

Hookup wire.

Twin flex.

Shielded wire.

Radio dry batteries, all types.

#### DC SETS

These will require practically the same parts as A.C. sets, excepting power transformers, but ballast resistors are handy, about 620 ohms 525 PV.

#### BATTERY SETS

8 mfd. Electrolytic condensers, at least 80 watts.

16 mfd. electrolytic condensers, 525 PV.

25 mfd. electrolytic condensers, 40 PV.

10 mfd. electrolytic condensers, 40 PV.

5 mfd. electrolytic condensers, 40 PV.

500 mfd. electrolytic condensers, 12 PV.

Few assorted mica condensers. .1 tubular condensers, 400V.

.5 and .25 tubular condensers.

.01 and .02 tubular condensers.

Sundry tubular condensers.

Vibrator buffer condensers, high voltage type.

Assorted potentiometers, mostly .5.

Potentiometers with switches, mostly .5.

An assortment of carbon resistors from 5000 to 5 megs.

Popular sizes w.w. resistors.

Padders.

Trimmers.

Assorted speaker transformers.

B, class audio transformers.

Vibrator transformers.

Vibrators, assorted types.

H.T. vibrator chokes.

Assorted filter chokes.

R.F. chokes.

Replacement type coils and I.F.-T.S.

Assorted speaker cones.

Few assorted valve sockets.

Wave change switches and decks.

Semi-rotary switches.

2v. and 6v. accumulators.

Aerial and earth wire.

Hookup wire.

Twin flex.

Shielded wire.

Fuses.

B batteries.

C batteries.

1.4 A batteries.

Radio dry batteries, all types.

(Continued on page 25)

**A** AUSTRALIA'S  
**B** EST  
**A** MPLIFIER  
**C** OMPONENTS

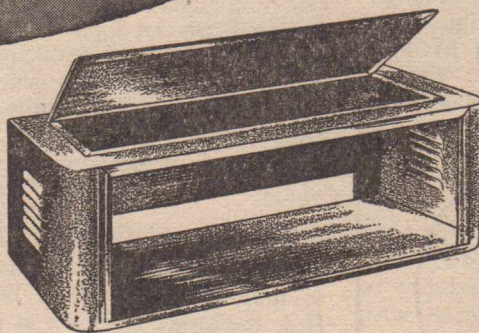

## ABAC STANDARD RECEIVER

Or Instrument  
Case. Takes  
19 x 8 $\frac{1}{2}$  panel  
with clear panel  
space 17 $\frac{1}{2}$  x  
7 $\frac{3}{8}$ . Depth of  
case 11-ins.

MANUFACTURED BY  
**TRIMAX TRANSFORMERS**

29-35 FLEMINGTON ROAD,  
NTH. MELBOURNE, VIC.  
(Division of Cliff & Bunting  
Pty. Ltd.)

# VISUAL TUNING INDICATORS

## PART 2

IN the previous article, the theory and applications of the shaded sector type tuning indicator were dealt with in some detail. Now in this, the second article of the series, the discussion will be continued and the main features of three other types of visual tuning indicators in general use will be described.

These are the Philips EM1, the

single indicating area as with the shaded sector type, the green fluorescent target of this valve has no less than four illuminated patches—each being shaped somewhat similar to a clover leaf. Correct tuning in this case is then indicated by the variable luminosity of the four patterns on the fluorescent target.

The general construction of the valve is illustrated in Fig. 1, being very similar to the 6E5, etc., in so far as there is a triode unit and a special cathode ray unit mounted at the top of the bulb. The cathode is common to both sections and is fitted with a small shield at the top to prevent any light from the cathode interfering with the viewing of the target.

The indicator proper consists of the target, conical in form and coated with a fluorescent substance which glows a brilliant green under the impact of electrons, and four deflecting plates or vanes. These deflecting vanes are placed between the cathode and target, being arranged radially so that a deflecting force can be applied to the electrons travelling to the target, and so produce shadows of variable width.

A diagrammatic sketch of the deflecting system used in this type of indicator is shown in Fig. 2. Here the target is shown as a cylinder surrounding the cathode with the deflecting vanes mounted radially between them. Now, then, how does the system work?

If the voltage of the deflecting vanes is lower than the target, electrostatic lines of force will be produced corresponding approximately to the broken lines between the vanes (V) and the target. Consequently an electron leaving

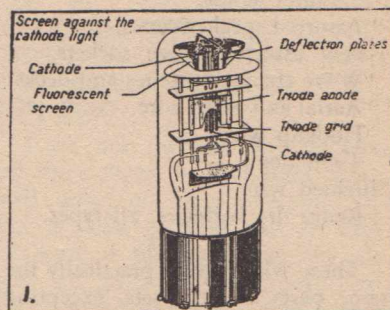

The EM1 is structurally very similar to the 6E5, consisting of a triode amplifier and special indicator contained in the one bulb.

the cathode, at, say, point "A", and travelling to point "B" will come under the influence of these lines of force and be deflected, describing a curved path as shown by the heavy line, eventually arriving at point "C" on the target.

If the difference of potential between the deflecting vanes and the target is very high, the deflecting force will also be very high, thus causing a large "blanketing" effect and resulting in a wide shadow being obtained on the target behind the vane. Since there are four vanes, each acting in a similar manner, there will be four such shadows produced.

On the other hand if the potential difference is zero, no deflection will take place—in fact the vanes will exercise an attractive force on the electrons, causing practically the whole target area to be illuminated. The illumination of the fluorescent screen under three different set of conditions is shown in Fig. 3. At (a) there is the condition when the deflection force is greatest—no signal conditions, at (c) when the deflection force is a minimum—resonance. The intermediate position at (b) would

By  
**C. E. BIRCHMEIER**

annular ring and dual indicator, and in addition to presenting the theoretical operation of these valves, typical circuits will be given so that they may be utilised in a receiver to the best advantage.

### PHILIPS EM1

Of these types the Philips EM1 is probably the most unorthodox, being of a particularly original and novel design. Instead of having a

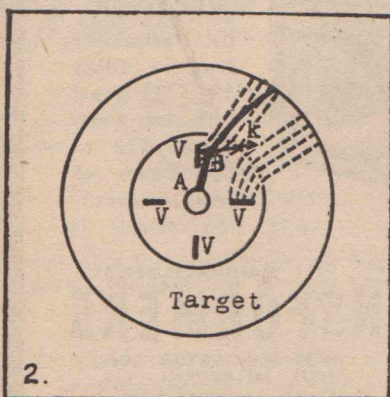

A diagrammatic sketch showing the relative positions of the four deflecting vanes. The electrostatic lines of force generated around two of these vanes and the deflecting effect on an electron travelling from A is clearly shown.



naturally indicate the set had not yet been tuned in correctly.

It should be mentioned here that in reality the paths of the lines of force are much more complex than the simple arrangement of figure suggests, since in this case the field existing between the cathode and target has not been considered. The introduction of this additional field would have only tended to complicate matters at this stage, and for the sake of clarity its effect has been ignored.

The circuit connection for this valve is very similar to those already discussed, and these are shown in Fig. 4. The triode plate, which is interconnected to the four deflecting vanes, is connected to B plus, 250 volts, through a 2 megohm resistor, whilst the target is fed directly from the same voltage source. Since A.V.C. control is usually employed to control the action of the valve, the triode grid is connected to this source. As the triode grid voltage varies, so then, will the plate current and also the voltage drop across the 2 megohm resistor vary.

When the A.V.C. voltage developed in the receiver is small, the plate current and consequent voltage drop across the plate-target resistor will be large—that is, there will be a large difference of potential existing between the deflecting vanes and the target. This will result in the maximum deflection in the indicator and consequently the luminous areas will be small.

The correct tuning of a station on the other hand will result in the

greatest negative voltage being developed in the A.V.C. system. This is applied to the triode grid resulting in a small plate current, and so the deflection produced by the vanes will be at a minimum. Hence for accurate tuning the luminous bands will have a MAXIMUM width.

The EM1 can be used on all mains operated receivers and a section of a typical delayed A.V.C. circuit incorporating this valve is given in Fig. 5. The voltage for the target and the triode plate is taken from the 250 volt supply. If this voltage is in excess of 250 volts, the EM1 should be fed from a tapping on a voltage divider so that the maximum rating for the indicator is not exceeded.

The A.V.C. voltage developed by the second diode of the duo-diode triode is stepped down by means of a resistor network before being applied to the EM1 grid so as to provide the desired grid voltage for the tuning indicator. It should be noticed in this particular circuit that the EM1 will only respond to signals which deliver a voltage in excess of the delay voltage at the A.V.C. diode, and as a result will not indicate on weak signals. Should it be desirable to give an indication for signals below this level then the EM1 grid should be taken direct to the detector diode return instead of the A.V.C. diode as shown.

In addition to the EM1, Philips also developed the C/EM2 and EM3 tuning indicators and the operation of these other types is

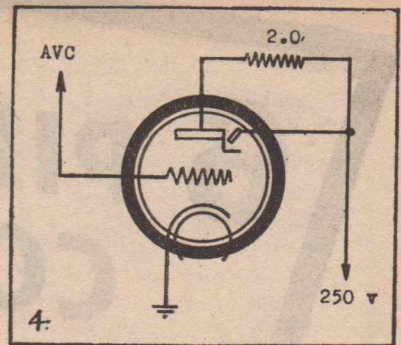

Typical connections for EM1 are similar to those given for the 6E5 types, except the plate target resistor in this case should be 2.0 meg.

practically identical to that outlined for the EM1. Their main difference lies in the fact that the grid voltage operating range varies for each one, so allowing a type to be chosen to suit any particular circuit arrangement.

#### ANNULAR RING TYPE INDICATOR

The annular ring type of visual indicator valve, of which the 6T5 is the sole representative, has been available for some considerable time, although its use has been limited when compared to the shaded sector types. Its main difference from these latter types is the manner in which it gives an indication.

Whereas with the 6E5 and associate type, an applied voltage caused a change in a shadow angle, the 6T5 has an unusual feature in that the movement in this case is an enlarging or contracting circle—the doughnut shaped pattern varying in size as the receiver is tuned to the station.

Somewhat similar to the shaded sector types, the 6T5 comprises two main sections—a triode unit to which the actuating voltages are applied, and this controls the second section—a special cathode ray unit. The general construction is shown in Fig. 6. The cathode (K) extends upwards, being common to both units, and it is fitted with a cathode shield (CS) so as to prevent any direct light from the hot cathode being visible and so inter-

(Continued on page 19)

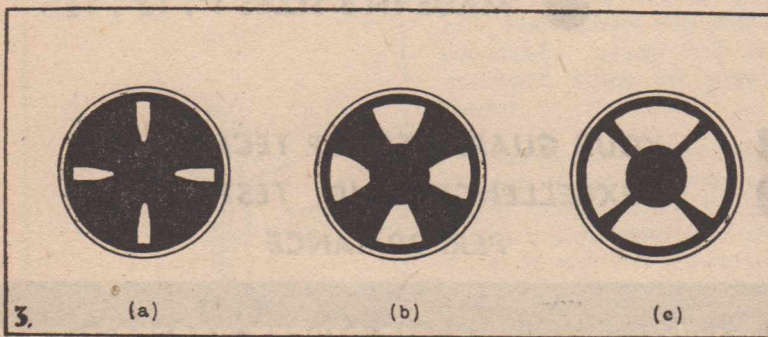

Indications given by the EM1 for three conditions of tuning. In (a) No signal; (c) station correctly tuned in, and (b) is an intermediate condition.

# 6 PIN PLUG-IN COIL-FORMERS

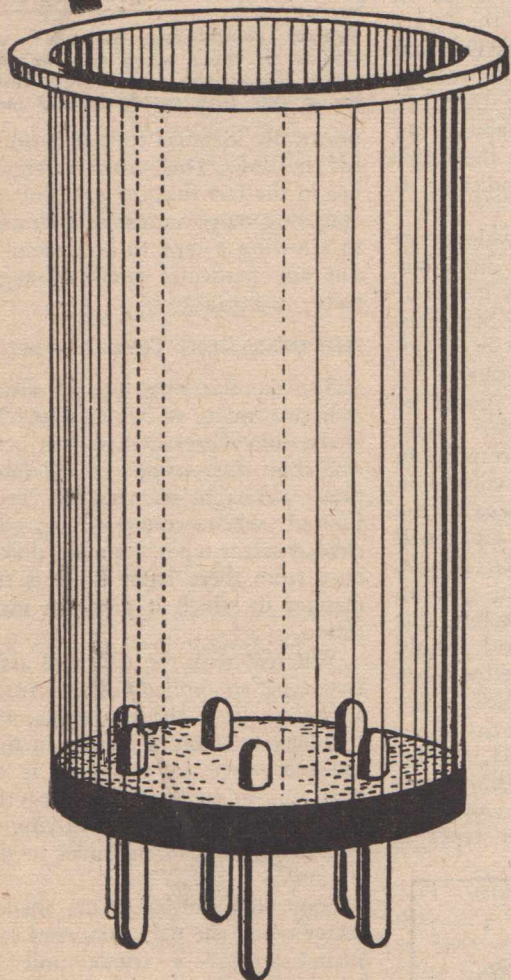

- MANUFACTURED FROM POLYSTERENCE POWDER (ENHANCING THE ELECTRICAL QUALITIES)
- ENGRAVED FOR FREQUENCY —ENGRAVED FOR TYPE
- INDENTATION FOR COLOUR SPOT SIMPLIFYING IDENTIFICATION
- CAN BE GROOVED FOR SPACE WINDING
- NICKEL PLATED VALVE PINS
- MADE IN 3 SIZES 1", 1¼", 1½".

**R.C.S.**

**YOUR GUARANTEE OF TECHNICAL  
EXCELLENCE AND TEST-SET  
PERFORMANCE**

*Order from your usual radio retailer.*

**NO DIRECT ORDERS PLEASE**

**R.C.S. RADIO PTY. LTD,**

174 CANTERBURY-ROAD, CANTERBURY

## MAGIC EYES

(Continued)

fering with the viewing of the fluorescent screen.

The ray control vane (V) comprises a flat metal ring, located near the bottom of the fluorescent target and separated from it by means of an insulating washer. This vane controls the size of the shaded annular ring pattern and is connected internally to the triode plate (P). The fluorescent target (T) is inclined at an angle with respect to the cathode—the viewing surface being one inch in diameter.

The valve is used in circuits similar to those outlined in the previous article—a 1.0 meg resistor being connected between the triode plate and the fluorescent target. The target is connected direct to 250 volts, and so the plate voltage as well as the ray control vane voltage, can be less than the supply voltage by the voltage drop across the plate-target resistor. The actual voltage drop across this resistor is naturally dependent on the triode grid voltage, in this case the A.V.C. voltage, since the grid is normally connected to this source of control.

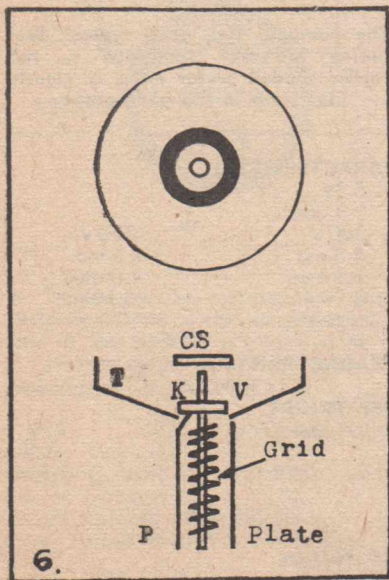

6. In the annular ring type indicator, the construction is generally similar to the shaded sector types.

When the triode grid is biased to plate current cut-off there will be no voltage drop across the plate target resistor, and therefore the plate and ray control vane will have the same potential as the target. Such a condition will result when the receiver is tuned exactly to the carrier frequency of a transmitting station, as then the maximum A.V.C. voltage is produced and applied to the triode grid.

Since the cathode is emitting electrons in all directions and the target is positive with respect to the cathode, it will attract these electrons. The target is coated with a fluorescent substance and under the impact of these electrons, the entire surface will glow a brilliant green. In actual practice complete plate current cut-off is not attained, with the result there is always a small voltage drop across the plate-target resistor. This makes the ray control vane slightly negative with respect to the target, resulting in an electrostatic field being produced between the target and ray control vane.

This being of a slightly negative nature, will repel electrons from it, and instead of the entire target surface being illuminated at resonance a narrow shaded annular ring occurs near the centre of the valve.

The extreme opposite to the case just mentioned occurs when the set is tuned so as not to receive any signal. Under these conditions there will be no A.V.C. voltage developed and consequent zero volts will be applied to the triode grid. Plate current will flow and a considerable voltage drop will be developed across the plate-target resistor.

Since the triode plate voltage and also the control vane voltage is the target voltage minus the voltage drop across the plate-target resistor, it can be seen that the ray control vane is a much lower potential with respect to the cathode than the target. Or, in other words, the ray control vane is **NEGATIVE** with respect to the target.

Under these conditions a strong

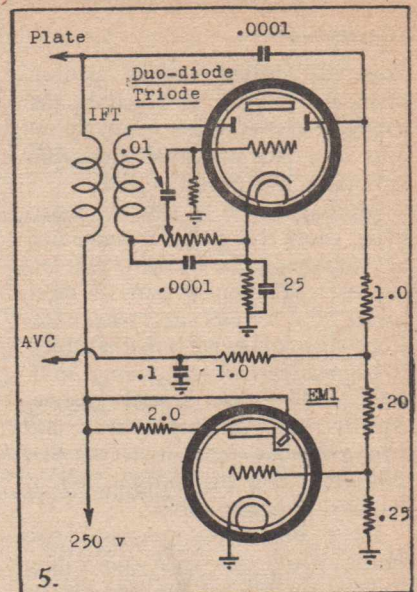

5. The EM1 fitted to a receiver incorporating delayed AVC. Note how the AVC voltage is stepped down by a resistor network to obtain desired grid voltage range for tuning indicator.

electrostatic field will exist between the target and ray control vane; and being negative in character, will cause a repulsion of any electrons near it. In consequence, the entire target surface will become shaded except for a narrow illuminated ring at the periphery where the electrons are still able to strike the target. The indications given by the valve for the resonant and non-resonant conditions are indicated in Fig. 7.

As mentioned earlier, the applications of the 6T5 are similar to those for the 6E5, etc., types, except that the valve is designed for 200-250 volt operation **ONLY**, and will not operate satisfactorily under 100 volt conditions. The electrical characteristics are identical with those of the 6G5, 6H5, and 6U5, (differs from the 6G5 and 6H5 in bulb shape only) and usually can be interchanged with these without any circuit modifications.

### DUAL VISUAL INDICATOR VALVES

The main disadvantage of visual indicator valves having only one control electrode is the necessity to adjust the A.V.C. voltage to just

# MAGIC EYES

(Continued)

close the shaded angular pattern when the receiver is tuned to the strongest carrier. This naturally results in a lack of visual indication sensitivity for weak signals.

Although such a lack of sensitivity could be partially remedied by employing the variable- $\mu$  triode as a component part of these valves, the results in many cases were still somewhat unsatisfactory. What was needed was a visual indicator valve that would operate equally well for both weak and strong signals—the answer to that problem being the introduction of the dual indicator valve.

Since this valve possesses two control electrodes, each controlling its own shaded pattern, one can be made to operate on weak signals and the other on strong signals. Whilst the principles of operation of the dual indicator valve are fundamentally the same as those outlined for the single shaded sector types, there are some important differences that should be mentioned.

You may recall all other types of indicators so far mentioned are composite structures—that is, they

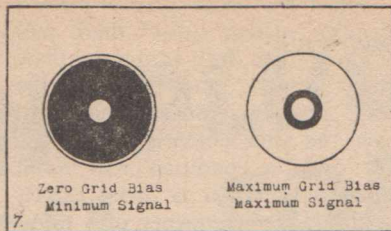

**The no signal and resonance conditions indicated by the 6T5 are quite different to all other types. Here we have an enlarging and contracting circle of light to assist in the tuning in process.**

comprise an indicator valve proper and a triode control valve, both being contained in the same envelope. The dual indicator valve, on the other hand, is only an INDICATING device and obtains its control voltages from a special SEPARATE valve.

Furthermore, whereas all other indicators are fitted with a standard 6 pin base (excepting, of course, the Philips EM1, EM2, EM3 and EM4 which have "P" bases) the dual indicator valve has a standard octal base.

The general construction of such a valve is clearly shown in Figs. 8 and 8a. The cathode (K) is enclosed by a target current control grid (to limit the target current to a safe value and prevent overheating) and this grid is connected internally to the cathode. A cathode shield (CS) is fitted to prevent

any direct light from the hot cathode being visible.

The ray control vanes (V1) and (V2) are thin metal plates of identical characteristics which are supplied with various potentials by the control valve, thus causing a change in the shaded angular patterns on the target. When the potential between the ray control vane and the cathode is zero the shaded sector will have an angular opening of approximately 90 degrees. If the ray control voltage is about half the voltage between the target and the cathode, the shadow angle will just close, whereas on the other hand, when the ray control volt-



**The compact size of a typical dual tuning indicator compared to the earlier shaded sector types is clearly illustrated in this photograph.**

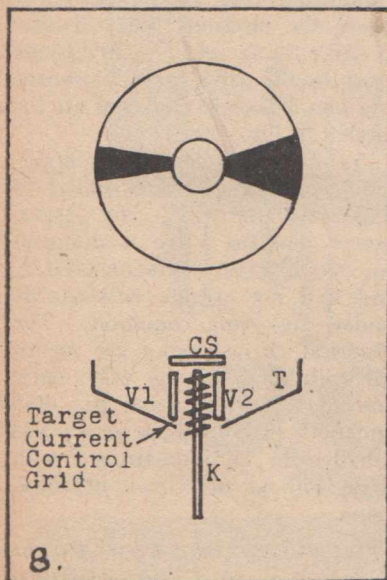

**The dual indicator type consists only of the cathode ray indicating section, requiring an external control valve for operation.**

### 6T5 OPERATING CHARACTERISTICS

Heater Voltage	6.3v	
Heater Current	0.3 amp	
Target Voltage	200 v	250 v
Target Current	4.5 ma	4.5 ma.
Plate Target Resistor	1.0 meg.	1.0 meg
Plate Current (Zero bias)	0.19 ma	0.19 ma
Grid Bias (min. shadow diam.)	-18.5 v	-22 v
Grid Bias (max. shadow diam.)	0	0

### 6AE6G OPERATING CHARACTERISTICS

Heater Voltage	6.3 volts at 0.15 amperes			
----------------	---------------------------	--	--	--

#### REMOTE CUT-OFF TRIODE

Plate Voltage	250	250	250	250
Grid Voltage	-35	-15	-6	-1.5
Plate Current	0.01ma	0.8ma	2.8ma	6.5ma
Amplification Factor	25			
Plate Resistance	25,000 ohms			
Mutual Conductance	1000 micro-mhos.			

#### SHARP CUT-OFF TRIODE

Plate Voltage	250	250
Grid Voltage	-9.5	-1.5
Plate Current	0.01 ma	4.5 ma
Amplification Factor	33	
Plate Resistance	35000 ohms	
Mutual Conductance	950 micro-mhos.	

age is negative with respect to the cathode the shaded angular pattern will exceed 90 degrees and may open up to approximately 160 degrees.

The degree of control any variation of the ray control vane voltage of a 6AD6G dual indicator valve, with 150 volts on the target, has over the shaded angular opening is clearly shown in Fig. 9. Notice as the control voltage becomes more negative the shadow angle progressively becomes greater, until with -100 volts on the ray control vane, the maximum opening is 160 degrees.

#### CONTROL VALVE

Although it is possible to use a dual indicator valve in certain

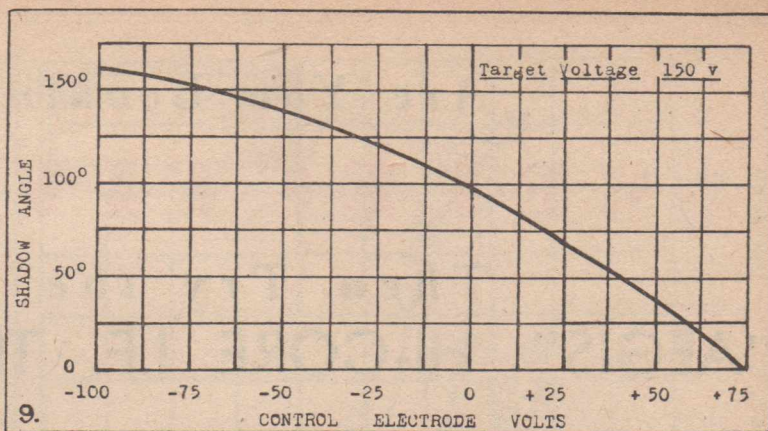

This graph indicates the degree any variation in ray control vane of a 6AD6G dual indicator valve with target voltage of 150 volts has over shaded angular opening.

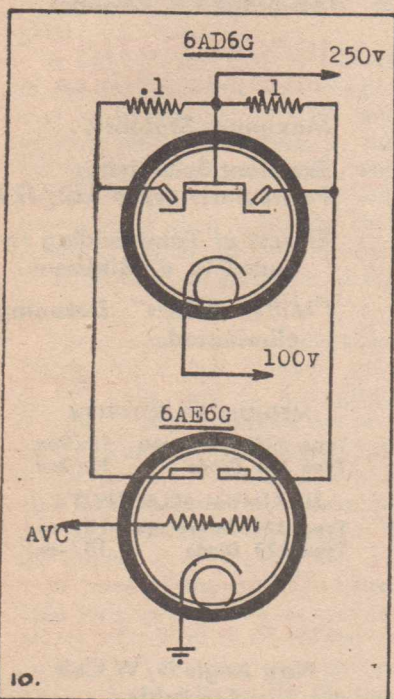

A Typical circuit suitable for dual indication. Note in this case the cathode of the 6AD6G is returned to a positive potential of 100 volts.

circuits without also requiring a special control valve, it is more general to employ a control valve, such as the 6AE6G, in order that the indicator may be operated to full advantage.

The 6AE6G control valve comprises a heater, single cathode, a single grid, wound in two parts and two plates. The special grid construction consists of one half being evenly spaced wires, the other of unevenly spaced grid wires, the effect being to provide a sharp and remote cut-off section respectively.

The evenly spaced portion of the grid controls the electron flow to the sharp cut-off plate P2, whilst the unevenly spaced section has variable-mu characteristics and controls the electron flow to the remote cut-off plate P1. The general operating conditions of this valve are given in table 3.

The circuit shown in Fig. 10 is intended for dual indication tuning—that is, one sector will close on weak signals and the other for

resonant conditions on strong signals. These two operations are coordinated so that the "strong signal shadow angle" begins to operate when the "weak signal shadow angle" has just closed. For a strong signal, therefore, both shadow angles will be closed.

The difference in response of  
(Continued on page 23)

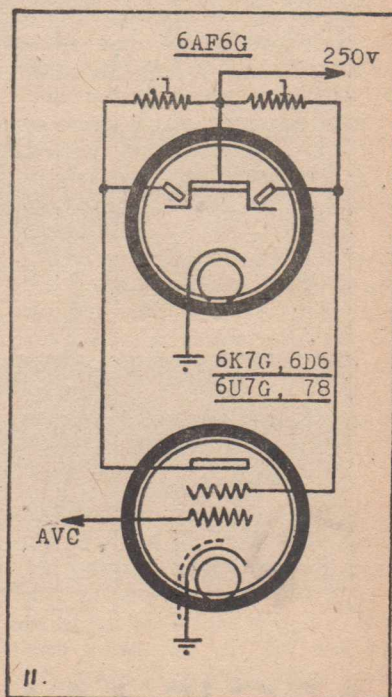

An alternative circuit utilizing a pentode for the control valve. Unlike the Figure 10, the cathode of the indicator is earthed instead of 100 volts.

#### PHILIPS TUNING INDICATORS

	EM1	C/EM2	EM3	EM4
Heater Voltage	6.3v	6.3v	6.3v	6.3v
Heater Current	0.2a	0.2a	0.2a	0.2a
Target Voltage	250v	250v	250v	250v
Target Current	0.13ma	0.15ma	0.3ma	0.75ma
Plate Target Resistor	2.0meg	2.0meg	1.0meg	Twin pattern type, 1.0 meg resistor in each plate
Triode Plate Current	0.095ma	0.1ma	0.2ma	0 to -16
Grid Bias Voltage	0 to -5	0 to -6	0 to -21	

Are You Looking for

# SELECTIVITY?

Then Try the NEW

## "AEGIS" HI-CORE I.F. TRANSFORMERS

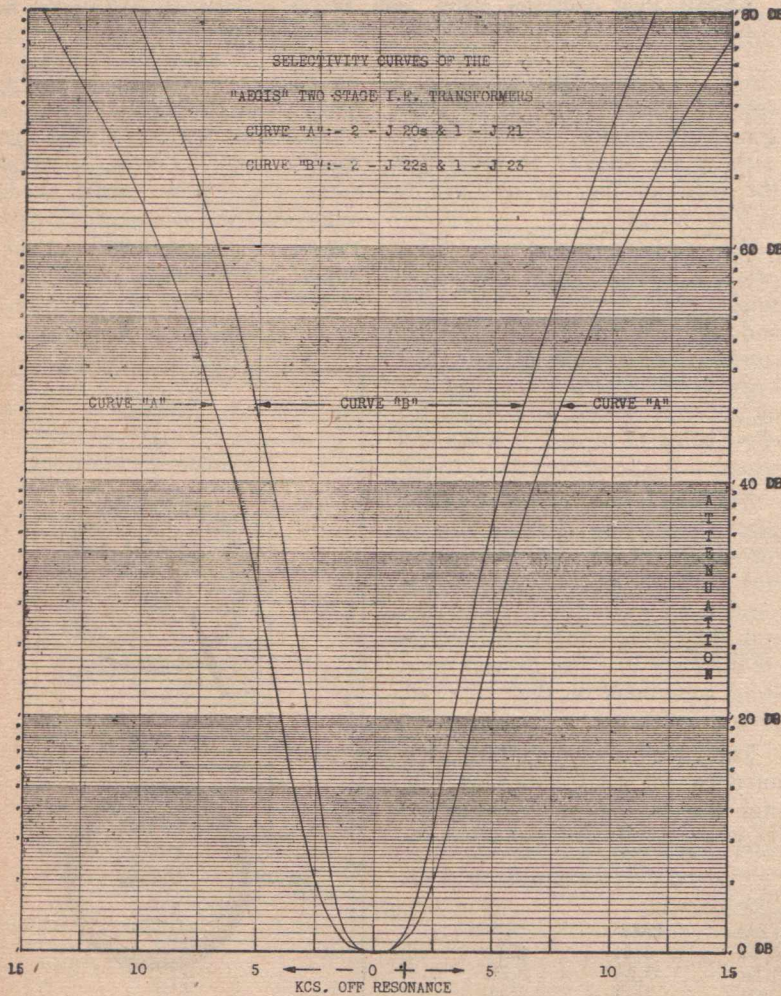

Scientifically Designed  
Expressly for the  
Two-Stage I.F. Channel.

### INCORPORATING THESE FEATURES

- 1 Maximum Stability.
- 2 Excellent Selectivity. Particularly types J22/J23
- 3 Effects of Tube loading reduced to a Minimum.
- 4 "Miller Effect" Detuning eliminated.

#### MEDIUM SELECTIVITY

Type J20 Interstage ... 13/9ea.  
Type J21 Diode ... 13/9ea.

#### MAXIMUM SELECTIVITY

Type J22 Interstage ... 15/-ea.  
Type J23 Diode ... 15/-ea.

### NOW AVAILABLE!

New Aegis D/W Coil  
Assembly  
Type K1S and K2S  
Specially designed for the new  
**6 S.A.7 SINGLE-ENDED TUBE**

No Extra for this advanced  
feature!

FROM ALL DISTRIBUTORS  
OF

**AEGIS MANUFACTURING CO. PTY. LTD.**

208 LITTLE LONSDALE ST., MELBOURNE

## MAGIC EYES

(Continued)

the two shaded sectors is due to the fact that the two output control voltages from the control valve are very different. Here the "weak signal plate" (sharp cut-off) is regulated by the evenly spaced section of the grid, whilst the "strong signal plate (remote cut-off) is influenced by the unevenly spaced section of the grid.

The weak signal shadow will just close with an A.V.C. potential of -7 volts, whereas approximately -27 volts is required to close the strong shadow angle. With the circuit shown each shadow angle will open to approximately 160 degrees.

It will be noted that the cathode of the dual indicator valve is operated at a potential of 100 volts positive, and this is done so that the ray control vanes may be made negative with respect to the cathode over part of their operating characteristic. The necessity for this will be understood on reference to Fig. 9.

The maximum permissible target voltage for a dual indicator valve is 150 volts, and at first glance it might appear this value has been exceeded in Fig. 10. However, such is not the case, as the cathode is 100 volts positive and therefore the target voltage with respect to the cathode is only 150 volts.

In place of the 6AE6G, a pentode variable- $\mu$  valve such as the 6K7G, 6U7G, 6D6, or 78 may be used as the control valve to provide the necessary voltages for the dual indicator valve. A typical circuit employing such a pentode is shown in Fig. 11.

In this case the screen grid gives a sharp cut-off characteristic, such

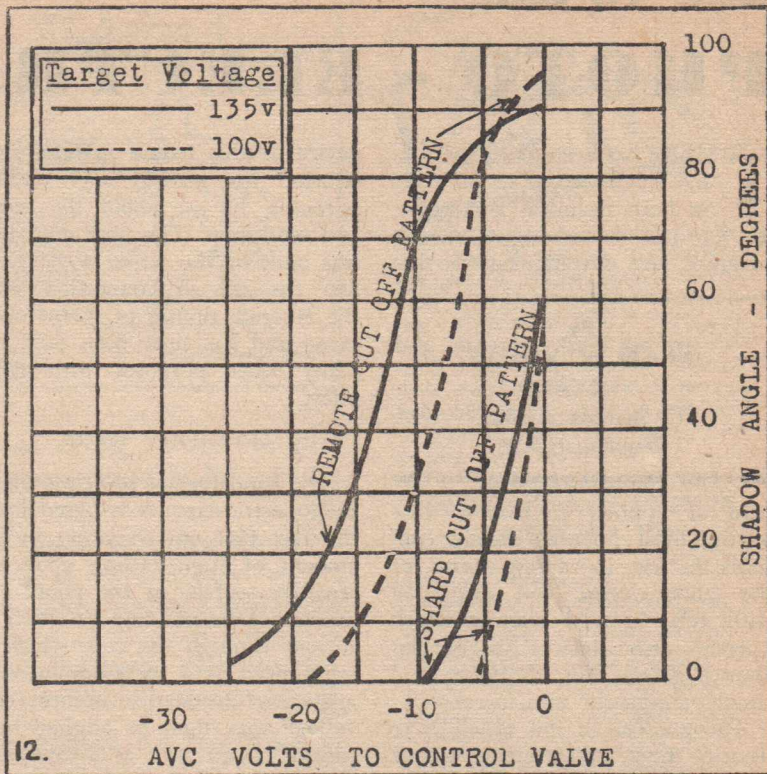

12.

that the ray control electrode, to which it is connected, will close the shadow angle for low A.V.C. voltages. The plate, on the other hand, gives a remote cut-off characteristic and the ray control electrode to which it is connected will cause practically no movement of the shadow for low A.V.C. voltages, but will start to close when the sharp cut off shadow angle is entirely closed.

The variation of shadow angle for different values of target voltage, plate-target resistor and A.V.C. voltages is given in Fig. 12.

PHILIPS EM4.

Another dual tuning indicator developed of late is the EM4, and

this differs from the 6AD6G and 6AF6G types in that the controlling valve and indicator sections are both contained in the one envelope. This feature makes it popular for receivers where dual indication is desired, but cannot be fitted due to the space being insufficient to accommodate the extra separate control valve.

The operating characteristics of this valve are given in the accompanying table and the applications are generally similar to those already outlined for the 6AD6G and 6AF6G.

## NEW BOOK

(Continued)

These lists of parts are a guide for you, and the firm from which you purchase your parts will probably be able to give you quite a lot of advice. Whilst three lists have been shown, i.e., AC DC and battery, you will probably be called on at some time or other to service any of these types, so you must know and understand how to repair all types.

NEXT MONTH:

## TWO FEATURE ARTICLES

- (1) 5-10 METER CONVERTER and
- (2) BATTERY PORTABLE RECEIVER

Order Now!

# HOW TO USE

# PHOTO - ELECTRIC CELLS

HERE has been much speculative discussion of recent years in both technical and popular journals concerning numerous advances and developments in the

By  
**ALAN W. WHITE**  
(VK2AWW)

12 Seaforth Avenue,  
Cronulla, N.S.W.

device of this nature may be constructed for general experimental purposes, or use about the home and workshop. The unit described was built by the writer some years ago for use in connection with the accurate timing of motor cycle races, and has since been used for many other purposes with good effect.

## HOW THEY WORK

field of applied electronics. One of the most popular themes concerns the use, in varying forms, of the photo-electric cell associated with relay control circuits which operate such devices as burglar alarms, garage and lift doors, and sundry automatic appliances.

The purpose of this article is to describe how an extremely simple

The fundamental principle of all photo-lectric circuits is based upon the fact that any variation in the amount of light falling upon the sensitive surface of the photo cell causes a corresponding variation in current through the cell, which is reproduced as a variation in voltage across the load resistance. This voltage may then be applied to a control circuit such as a thyretron,

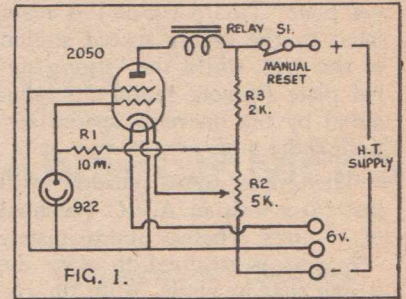

preferably of the tetrode type. Gas triodes such as 884 or 885 may be used, but owing to their comparatively low sensitivity, a voltage amplifier is usually necessary between the photo tube and the thyatron grid, thus greatly increasing the complication of the circuit, as well as increasing the minimum plate voltage required for satisfactory operation, an important factor if portability is desired.

In Figure 1 the relay is connected into the plate circuit of a 2050 gas tetrode, the grid of which is directly connected to the photo cell, type 922. The bias relations of the 2050 are set by the potentiometer R2, which is adjusted so that any small variation of light falling upon the cell will cause the tube to ionise and the relay to close. When the light falling upon the P.E. cell is reduced (for instance, by the interruption of the beam by any object) the current through the cell decreases, thus causing the grid of the thyatron to become less negative (i.e. more positive, although the grid being negative, the movement must be expressed as a negative one), until the point is reached where the tube fires and the relay closes. Once the gas has ionised, the grid completely loses control and therefore some other method of resetting the relay must be adopted. If manual reset is desired, the simple switch in Fig. 1 will suffice, but automatic reset is

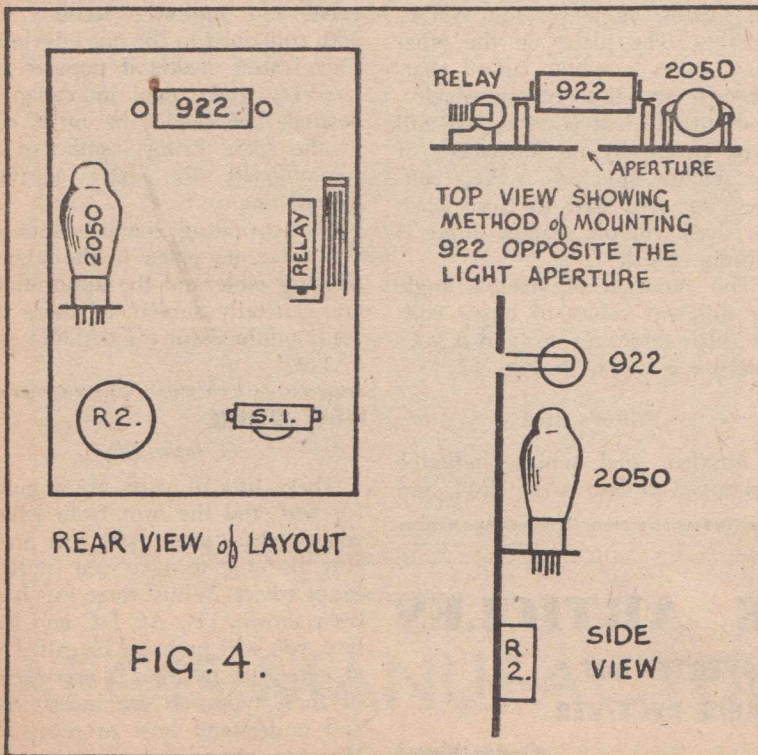

FIG. 4.



provided by Figs. 2 and 3, the time "on" of the relay being approximately .1 and 15 seconds respectively.

The relay used in the original circuit was a sensitive telephone type, but any type will suffice, so long as the source of H.T. is capable of supplying the necessary current and the ratings of the thyatron are not exceeded. With the circuit shown, and a 30 watt focussed light source placed 45 feet away, the passing of a pencil through the beam would close the relay. With a beam length of 30 feet, a piece of resin cored solder could be detected easily. The figures would easily be improved upon, by the use of a lens to focus the beam on to the cell, thus helping to exclude all extraneous light. Fig. 4, however, shows the extremely simple layout and construction of the present unit, the whole being enclosed in a wooden box, in order that the only light incident upon the cell is that which is directed through the aperture in the front panel.

Should it be desired that an increase of light should operate the circuit as, for instance, the shining of car headlights upon a garage door, it is merely necessary to reverse the connections of grid and

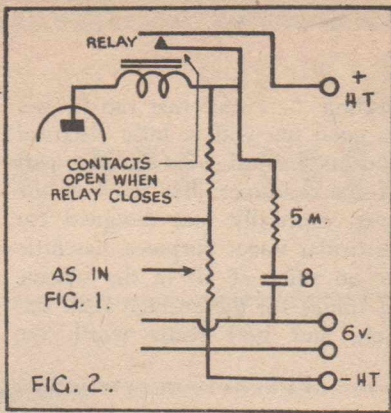

cathode in Fig. 1, that is, have the grid returned to R2, and the cathode connected to the P.E. cell. In the case of opening garage doors, a relay in this unit could operate small electric motors, a limit switch at the end of the doors' travel turning off the motor when required, and resetting the control circuit.

No mention has been made of the use of photo-electric cells in such fields as sound reproduction, spectrography, etc., as such applications constitute a separate subject on their own, and would only interest a minority of readers. Nor has any attempt been made to explain in any great detail the theory involved, as the actual operation of the unit is so simple as to be almost self apparent.

## STARTING A BUSINESS

(Continued)

each problem clearly and concisely. Servicemen have long awaited such a splendid work of reference. Divided into seven broad sections, Mr. Beard deals with reception, receiver technique, principles and components before moving on to the special service chapters. Technical tables, mathematical formulae, and a very detailed section covering valves complete a most authoritative book.

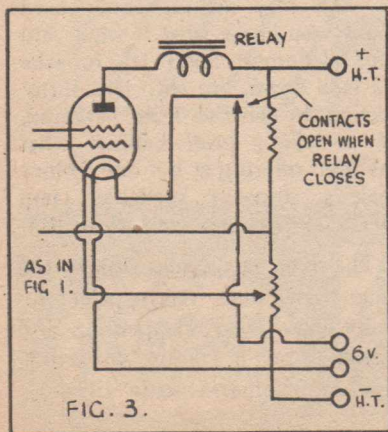

*Train for success with I.C.S.*

Success comes from training—the right sort of training. I.C.S. have put over 5 million people on the road to success through home training. *What about YOU?* I.C.S. can help you, too. There are over 400 I.C.S. home study courses. One of them means a success story for you and—SECURITY. Fill in and mail the coupon without delay. An enquiry costs nothing.

### INTERNATIONAL CORRESPONDENCE SCHOOLS

140 Elizabeth Street, Sydney  
Dear Sirs—Please send me free prospectus showing how I can succeed in the occupation I have marked.

- |                     |                            |
|---------------------|----------------------------|
| .....Advertising    | .....Accountancy Inst.     |
| .....Salesmanship   | .....Secretaries, Inst. of |
| .....Book Keeping   | .....Cost Accountancy      |
| .....Architecture   | .....Building Cont.        |
| .....Arch. Draw.    | .....Roof & Steel Sq.      |
| .....House Plan.    | .....Build. Plan Draw.     |
| .....Carpentry      | .....Struct. Steelwork     |
| .....Refrigeration  | .....Elect. Eng. or M.     |
| .....Electronics    | .....Radio Eng. or Serv.   |
| .....Plastics       | .....Auto Mechanics        |
| .....Civil Eng.     | .....Ind. Management       |
| .....Textiles       | .....Rayon Weaving         |
| .....Diesel Eng.    | .....Comp. Mech. Eng.      |
| .....Welding        | .....Fitting & Turning     |
| .....Ind. Chemist   | .....Heat Treat. Metals    |
| .....Story Writing  | .....Mech. D'sman.         |
| .....Radio Plays    | .....Reading B'prints.     |
| .....Com. Art       | .....Aero D. & Eng.        |
| .....Sketching      | .....General Education     |
| .....Landscape Ptg. | .....Coach. any Exam.      |
| .....Wind. Dress.   | .....Showcards, Tickets    |
| .....Dress Design   | .....Shorthand, Typing     |

If your subject is not above, write it here

Name.....

Address.....



## RADIO EXAM COACHING

Special courses of instruction, prepared by experts with individual correction of students' work, ensure success to all I.C.S. students studying for Radio Examinations.

- Aust. Radio Institute (A.M.I.R.A.)
- Commercial Operators' Certificates
- Amateur Operators' Certificates
- Electronics

7/6

# DISPOSAL BARGAINS — And Otherwise

As mentioned before in these columns, this is an era of plenty for the Ham with an eye to bargains from the counters of dealers handling Government liquidation stocks of radio material.

But all that glitters isn't gold. Plenty of the stuff presents bargains unsurpassed in the history of radio

dealing . . . stuff that can be put to good use with a little electrical and mechanical nous on the part of the consumer. But some of the gear, especially that designed for particular Radar purposes, has little or no value at all in the scheme of things for the average Ham station, and isn't really worth the

price asked for it. These comments are written from a Sydney viewpoint, but no doubt the position is similar in other cities. One realises of course, in a tour of dealer premises that he isn't in business just for the fun of things. He is there to make a profit. Point is that some dealers don't exhibit a reasonable line of demarcation between fair profit and the "fleecing" business. Such types are the "get-rich-quick" artists . . . they were never heard of in the history of prewar radio trading, and it's your own fault if you buy a "pig-in-a-poke"! You have no comeback in such a case. The long established dealer of favourable name and repute with the Ham gang—he also isn't there to trade in windows full of gear just because he likes it—he also is there with a purpose.

He might even build himself a big home on part of the proceeds (if he can get a permit, material, and labour), but all that is fair enough—because he trades fairly. He buys at the sales in keen and oft-times foolish competition, and he gets the material at a price. Then he sells it to the radio Ham public—but he doesn't slap on around 500 per cent. Quantity turnover at reasonable price to suit the Ham pocket pays fine dividends in the shape of a steady flow of customers and a reputation for being a good fellow with "the gang." In fact, he may be one of them, and his staff may include experienced Hams who know what is what, and most definitely don't try to take the lads down. So, with that introduction to what I have in mind, let us take a brief look at what has been offering at but one Sydney dealer's store—a veritable Ham Mecca (no names, no pack-drill!).

The items mentioned will, by the time these lines reach print, no doubt have been snapped up and vanished, but if I know the people concerned, other equally attractive

(Continued on page 29)

## VALVES FROM DISPOSALS — THE VR65

Among the many Disposals bargains to be picked up in and around the cities these days are to be found ex-British Navy I.F.F. (Identification Friend or Foe) equipments. In some cases these are complete with valves, and appear to be ex-Stores. They certainly do not seem to have been put to service, judging by the brand-new appearance. Valves used with these I.F.F. Units include, among other attractive things, three or four grey metallised types, marked VR65A. For the benefit of those who may not realise just what these valves are, they are the Mazda type SP41, R.F. Pentodes with characteristics running akin to the famous EF50. There are two Service types, VR65 and VR65A, the sole difference being that the VR65 has a 6.3-volt heater, and the VR65A a 4-volt heater. They both use the same socket . . . and . . . be warned . . . it is NOT the International Octal of American (and Australian) standard usage. The socket is the MAZDA OCTAL, and if you look closely you will see that the locator pin moulding in the centre of the valve is somewhat larger diameter than the usual Octal valve. Also the pin spacing and diameter differs. In other words, you need the sockets as well as the valves, and in Sydney at least, I have seen such sockets on the "sixpenny dip" counter in past months. They may be obtained, of course, in the I.F.F. Units offering (minus valves) for £2. One gets quite a lot of excel-

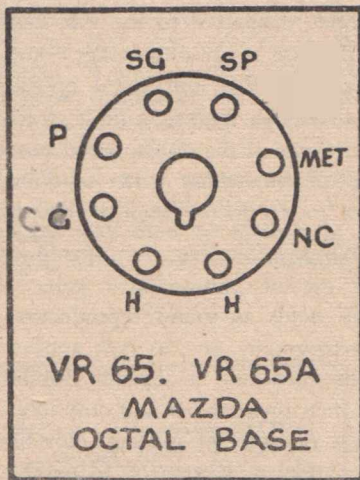

lent gear for that figure, by the way, including lots of VHF components and a splendidly-made combination genemotor-blower fan which those with electrical engineering experience can doctor for other purposes and voltages. VR65 and 65A valves are high gain pentodes well worth inclusion in Amateur Band superhets ahead of the Converter stage, or in I.F. positions for VHF receivers. Main characteristics are:

	VR65	VR65A
Heater voltage .....	6.3V	4.0V
Heater current .....	.3A	.65A
Anode voltage .....	250	250
Screen voltage .....	250	250
Grid voltage .....	-2.1V	-2.1V
Anode current .....	11.1Ma	11.1Ma
Screen current .....	2.8Ma	2.8Ma
Slope .....	8.4	8.4

—D.B.K.

# LET'S GET TO THE CORE OF THINGS

As with all **KINGSLEY** radio products the reason why "PERMACLAD" I.F.'s are now spoken of as the best in Australia is found in the ferromagnetic iron-dust cores used in their construction. Apart from the inherent technical superiority of iron-core tuning, every "PERMACLAD" I.F. is turned out on a production line that sets a particularly high standard of quality.

So from the first to the final step . . . that of oscillagraph testing and tuning . . . each I.F. is made to give the absolute maximum in performance. The use of the enclosed pot-type ferromagnetic cores give **KINGSLEY PERMACLAD** I.F.'s a particularly high degree of permeability, high "Q" and gain.

OBTAINABLE FROM  
AUTHORISED **KINGSLEY** DISTRIBUTORS

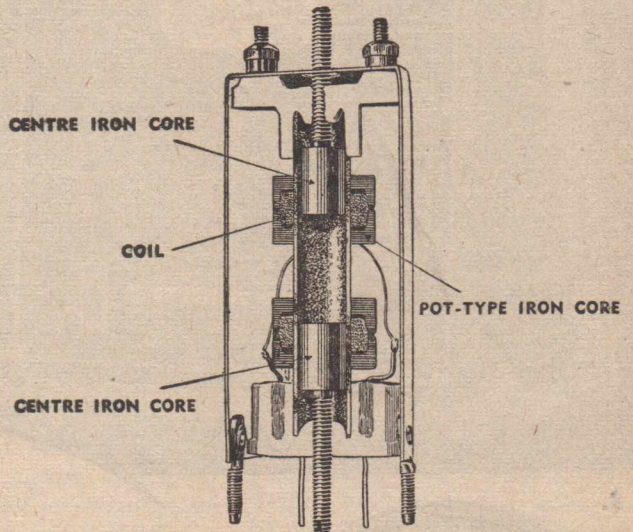

The above diagram is a cut away sketch of a **PERMACLAD** I.F. Tuning is done by the two centre iron-cores.

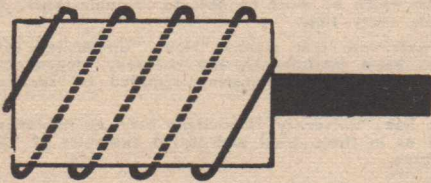

**F E R R O T U N E**  
FERRO-MAGNETIC IRON-CORE COILS, I.F.'s AND,  
GANGLESS TUNING UNITS



# KINGSLEY RADIO

KINGSLEY RADIO PTY. LTD.

380 St. Kilda Road, Melbourne, Victoria . Phones: MX 1159, MX 3653

1

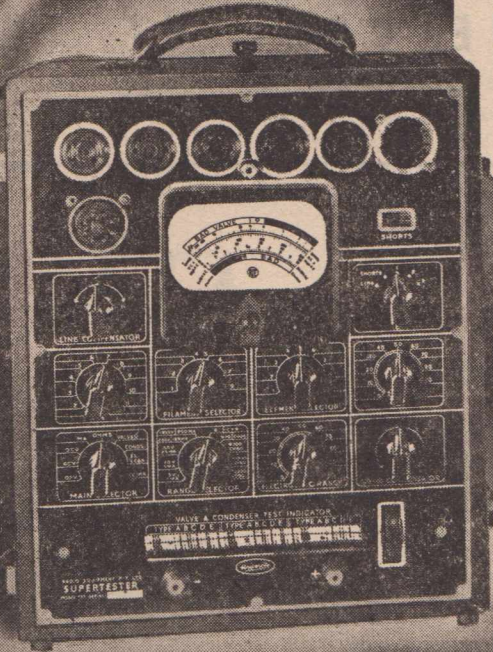

1. The modern, efficient Model T.S.T. supertester combines the functions of a multimeter, output meter, valve and condenser tester. It measures A.C., D.C. and output volts up to 1000 D.C. current is measured up to 250 m.a. and ohms up to 10 megohms. £28/10/- plus tax.
2. Model J.O.B. Oscillator is an extremely efficient instrument, provides R.F. and A.F. signal. Frequency range from 160 K.C. to 32 m'cycles. Carrier frequency quickly adjusted and read on clearly etched dial. Battery operated. £12/15/- PLUS TAX.

2

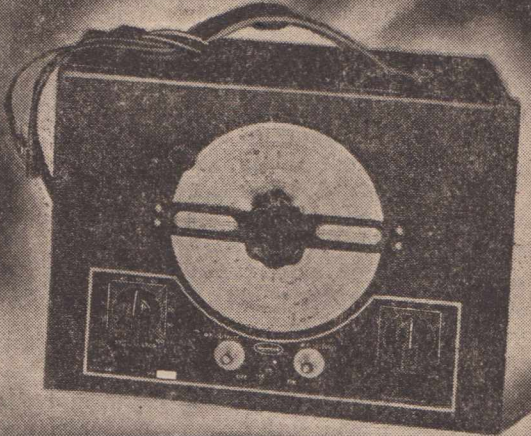

3.

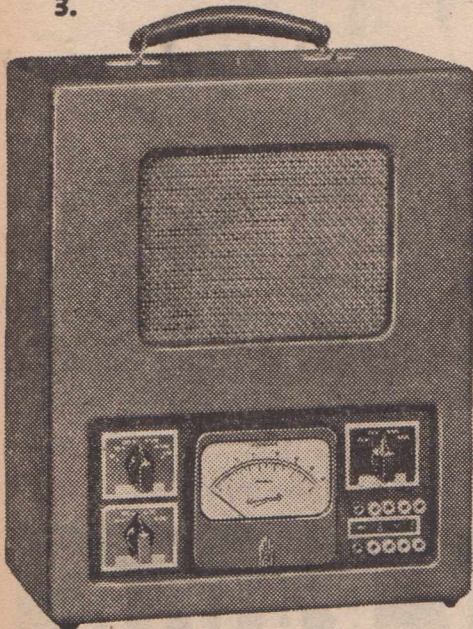

## The University "BIG THREE"

In Service Equipment

Successful radio servicemen today must have the best and most up-to-date test equipment. Modern conditions demand it for a very practical reason—the large volume of service work available which he must be able to "trouble-shoot" fast and accurately every time.

Delays and guesswork cost money. Now, "University" offers you, in three basic instruments, the accuracy, dependability and advanced electronic engineering, required by successful servicemen

Never before has "University" leadership been so impressively demonstrated as in these tried and tested examples of "University" research.

Write for our free illustrated brochures.

3. Model U.S.O. Universal Speaker and Output Meter makes set-testing and repair easy. Adaptable to any set. A range of output impedances are matched as needed by a simple switch. A built-in output meter calibrated in D.B. and Watts provides easy accuracy. Simply plug into speaker socket. £15/-/- plus tax.

## RADIO EQUIPMENT PTY. LTD.

5 NORTH YORK STREET, SYDNEY, N.S.W. Telephones: M6391-2

Telegrams: "Raquip," Sydney

DISTRIBUTED IN ALL STATES

## DISPOSALS

(Continued)

items will be putting in an appearance.

Early in March I wandered once or twice into this store, handy to lunchtime window gazers, and here are a few of the bargain offering at that time.

Firstly, a batch of ex-British Air Ministry Radar air-borne equipments and indicators, minus the valves, but chock full of excellent resistors, by-pass condensers, potentiometers, switches and other things, for the price of £1. On one of the chassis for this gear there is a gadget that has an adaptable use for those who ponder the problem of making up a switching system for coaxial feedlines to antennas. It is a motor driven affair that changed port and starboard aircraft antennas over in its Radar function, and from the casing of this project three or four coax connectors and leads. The mechanism is driven by a gearing assembly from the motor and it takes little imagination to realise that therein lies the handy wherewithal to put together a neat and properly designed rotary coaxial switch for antenna switching. Relay or solenoid operation wouldn't be hard to arrange. The items mentioned are useful for bits and pieces, and for £1 one couldn't go far wrong, anyway.

Next item, and one of interest to the VHF gang is something with a real appeal. These are I.F.F. (Identification Friend or Foe) units complete with valves and inclusive of RK34, HY615, several Loctal valves, and butterfly variable condensers, etc. They are offered at £5 and were certainly worth the figure asked. With a little "jiggery pokery" they won't take much doing over to put them on the 166-170 M/cs. band. There are two kinds, one American made, and the other British—the latter is the one I vote for—it has some very fine variable condensers in it. Underneath the chassis, incidentally,

is a very well made and powerful 24 volt DC motor-generator which drives the linked variable condensers in the I.F.F. operation. The motor won't be much use to the average Ham, but what about country Hams with 32 volts of accumulators handy in a home lighting plant? There may be a use or two in such a location. The motor would drive a handy little fan, anyway, in the summer heat!

Going to the pricey material—on a shelf in the same store I spotted a brand spanking new STC AMR300 receiver—looked as if it was just out of the carton—a real communications job anybody would be proud to own—the price, £60—quite a sum—but in these days of high prices, not so terrible upon contemplation of lots of things. You can pay 30 odd pounds for a suit of clothes these days, and no doubt a keen man would vote in favour of wearing out the old army togs for a bit longer!

At the time when Australia was between the Devil and the sea in '42, Radar, that offspring of radio grown suddenly to giant proportions, assumed highest priority in Service needs and industrial capacity. "Bat Catchers" studded the coastline, and invisible fingers reached out and spotted things that should be there and those that shouldn't. The gear that did these things came in a trickle that spread to a steady flow, and now, but a scant 5 years later, you can go into Disposal dealers' stores in the City of Sydney and buy, for the figure of £3/10/-, the identical gear, complete with valves, brand new, and in the original packing case.

Actually there is little of this particular gear that is of much use to the Ham, but on the other hand there may be. There is an oscillatory circuit made up with silver-plated anode lines and 3/8-inch antenna lines with two "micro-pups" (VT90's to you). That part of the equipment is applicable to 166 M/cs merely by shifting the anode line shorting bar and adjusting the grid tuning capacity.

VT90's are valves of a hungry disposition as to filament needs—8 volts at 8 amperes or so—and in consequence they are "blown" by air cooling. For that function an excellent blower fan is built into the equipment, and it is designed for alternative input of 24 or 12 volts. And let me give you a tip: it is a motor for AC operation—goes like a bomb on a substantial 12 volt filament transformer from 240 volts, 50-60 cycles and doesn't appear to heat up unduly. Such a motor can be adapted for quite a few uses, and that item takes care of the £3/10/- very nicely.

There's plenty more gear in the assembly—a nice 0-50 DC M/a meter—a pair of AV11 rectifiers (high peak voltage at low current) some .01 mfd. 6000 volt *working* by-pass condensers, plug connectors and lots of other things. Those who designed such equipment, and in such secrecy in those grim days must stand incredulous that it could ever reach a "Paddy's Market" finale. But that is the way of war—waste unlimited—and the small sum you pay for what is obviously a bargain, helps to retrieve a small fraction at least of that waste, so far as the Government Disposals people are concerned. That the dealer makes a fine and dandy thing out of it in the process—well—that is fair enough, *he* is the one that attends the Government Sales and takes the business chance on things. The items referred to are but the fringe of things offering or to be offered.

Some day in the future these things will all be but a memory, except in the shacks of those Hams with mechanical and electrical adaptability in their make-up. In another part of Sydney can be spotted lots of other useful gadgets—not designed for radio uses, but with plenty of appeal. For instance, bakelite-cased level action switches from aircraft control panels, made to British Air Ministry specifications, stacks of them at 1/- each! They would be cheap at three times that. Bomb release timing mechanism.

(Continued on page 31)

# SERVICE PROBLEMS IN U.S.A.

**Australian servicemen may think they have plenty to worry about, but conditions in the United States are also tough, as detailed in this article from "Universal Commerce." Incidentally it throws some interesting side-lights on the little tricks which manufacturers have been up to in order to get high production during the difficult months following the end of the war.**

**T**HE ingenuity displayed by radio engineers to effect economies in set production costs, yet retain, if not enhance, receiver sensitivity, is remarkable, to say the least. The "gimmick" is a well-known component in radio receivers. If you will recall its initial appearance many years ago, it was in the form of two short pieces of insulated wire twisted around each other, in that way forming an electrical condenser of small value. At that time, and for years after, its use was limited. In the 1946 crop of receivers, however, it is quite prominent in many positions.

Inasmuch as the constants of these devices are fairly critical, since the capacity they constitute is very small, it is important not only to recognize them, but if, during the repair of the receiver, some change is necessary, to restore them in their original form. For example, some of the small table-model sets employ two such wires twisted together to form capacitive coupling between the antenna and secondary windings of the input r-f transformer, in that way realising improved gain at the higher end of the band. If, by chance, this device is removed or altered during service operations, the receiver may display a pronounced drop in sensitivity over this portion of the band, yet all tests on the components will prove normal.

The use of such "gimmick" is quite prominent in the oscillator-mixer systems, to couple energy from the oscillator to the mixer grids. In the older sets, and in some of the new larger receivers, this coupling is accomplished by means of a fixed condenser and it is only natural to take for granted that similar methods are used in all sets. This brief reference to the use of an open-ended winding

joining the mixer grid and placed in close proximity of the oscillator tank coil to couple energy from the latter to the former, is made for two reasons: first, as a warning not to always expect to find a fixed condenser in this position, and, second, to be careful when changing such components.

Some combination am-fm receivers make use of dual-section i-f transformers, wherein the f-m primary is wound in series with the a-m primary and the two secondaries are made in the same way. Such transformers have only four terminals, despite the fact that two complete transformers are contained within the same housing. Such design is made possible by the fact that the high intermediate frequency used in the f-m system and the design of that winding has no effect on the conventional a-m winding which is resonated in the 455 kc-465 kc band. In turn, when the transformer is used for operation at the f-m intermediate frequency, the a-m transformer-section tuning condensers afford convenient paths for the f-m i-f signal across the a-m windings. Stated differently, both a-m and f-m windings are always connected in the circuit.

Receiver design employed in the Armed Forces communication equipments is making its presence felt in the new receivers. Not so much in circuitual arrangements, although some of the ideas are being employed, but more in the design of the components. Single housing for numerous components are in evidence, which means that careful circuit tracing will be necessary in the future, so as to locate the elements contained within transformer housings. For example, r-c filter circuits are contained within i-f transformer cans, and in some cases are assembled by an ingenious

method of condenser construction. For example, the stator plate of an i-f condenser is larger than the rotor and is adjacent to another stationary plate which is connected to ground. Since the stator joins prolongation on the stator of the i-f condenser forms one of the condensers in the r-f filter. The other condenser in the r-f filter is formed by still another plate in the low end of the transformer winding, which also connects to the grid filter resistor, the capacity between the ground plate and the proximity with the ground plate, thus a capacitance is created at the top and bottom of the grid filter resistor.

Wax impregnation of components is quite common in some of the new sets. That, however, is not of major import, except as a nuisance when it becomes necessary to solder and unsolder connections to the component or to find broken connections at the terminals. Of much more importance is the fact that the wax covers more than one component. In other words, tiny resistors which may be part of the choke system are found mounted on top of the windings and both covered with the wax. Since only two terminals show, one is apt to judge the component by its general shape and overlook the other components hidden in the wax.

The inability to secure an adequate supply of vacuum tubes has given rise to circuit modifications necessary to adapt certain components to changes in tube types. For example, some i-f transformers in one production run completed with certain types of tubes, may have shunt resistors across the respective primaries and secondaries. The reason for their use is to produce the required broadness of response,

but from the servicing viewpoint, the presence of the resistor must be taken into account during continuity measurements. Moreover, defects in these resistors may produce departures from the normal bandwidth, yet tests made on the transformer will produce entirely normal results.

The band-switching arrangements employed in some of the 1946 crop of receivers are very unique. Many pages would be required to describe these methods, but one of the unique arrangements which must be borne in mind is the system wherein the primary winding of an r-f transformer, employed by one band, becomes the secondary winding of another band. The interchange of windings, paralleling of one winding by another as the bands are changed, makes necessary a critical examination of the schematic wiring diagram prior to servicing. Above all, it is important not to take any one system for granted. A wide variety of coupling arrangements are found in the modern receivers. In fact, a single model may not be uniform

## DISPOSALS

(Continued)

isms with adjustable setting over a wide timing range—these comprise a beautifully made switch affair, with gears, etc., behind the panel and also one of the finest looking relays with solid contacts that I have seen—the price is 7/6—enough to make the designer white-haired. In one window I saw offered for £2/15/- a complete bomb sight, an elaborate affair with

---

in its circuitual arrangement, let alone tube and component complement. Shortages of components during 1946 has given rise to many changes in receivers. Tube shortages have caused not only delays but actual circuit modifications, so as to permit the use of tube types which were available at the time the manufacturer's supply of the original tube types became exhausted. All in all, the servicing of the 1946 crop of radio receivers is to be a very interesting process.

prismatic lenses and gadgets to boot, probably adaptable to tripod use for distant observation of objects such as a pair of expensive binoculars. And for those who have a yen for kite flying, for 35/- you can buy complete in the very solid yellow-painted casing, a complete Air Force emergency kite-supported radio aerial outfit. It includes a natty strong framework silk kite, aerial insulators, special aerial wire and winding reel.

These things your scribe has seen, and in the process has covered very little territory in one part of the city. I know that there are lots of dealers elsewhere, in other locations, even out in the suburbs, and that there is undoubtedly much that I don't even know about. Like you, Mr. Reader, I hear about so-and-so who bought a receiver de luxe for a mere handful of notes, like you, also, would appreciate ownership of a BC348N or SX28, or HQ129X, or any of those things. My casual wanderings apparently don't run in the direction of the right signposts!

# MARCONI SCHOOL OF WIRELESS

(Conducted by Amalgamated Wireless (Aust.) Ltd.)

FOR 33 YEARS AUSTRALIA'S LEADING WIRELESS COLLEGE



## COURSES

ALL P.M.G. CERTIFICATE EXAMINATIONS

Commercial Operators' Certificates

Broadcast Operators' Certificate

Amateurs Operators' Certificates

Service Mechanic



MARCONI SCHOOL OF WIRELESS

47 York Street  
SYDNEY

162 Queen Street  
MELBOURNE

# CALLING CQ!

By Don Knock, VK2NO

In Great Britain and U.S.A., "Band-planning" is an important topic now taking up space in the prominent amateur publications. By this is meant, planning for the future so that there may be a semblance of order arising from the chaos of congestion now in full swing on 14 and 7 Mc/s. The former band is the primary sufferer

... and the presence of the American 'phone band slap in the middle of the picture makes matters doubly difficult. Only way of straightening things out will be by International Conference. In Britain a Gallup Poll is being taken among the G's to indicate whether or not they are in favour of band-planning. Many are of the opinion that it is better

to let sleeping dogs lie, and to avoid seeking any form of regulatory restriction. The most obvious solution to band-planning would be to secure first of all WIDER bands. If Amateur radio could have another 200 or so Kc/s tacked on to 20 and 40, a fresh start could be made and there would be enough room for sub-division. But there are those who avoid mention of any kind of WIDER BANDS... THEY consider that Amateur Radio hasn't a chance. Ultimate fate of DX bands may be gradual self-strangulation, vide the Great Wurlitzer Organ recital in the middle of 20. He who gets a 100 per cent. phone QSO through in that screaming ants' nest may today be congratulated on no small achievement. Despite all these things, this scribe still thinks that Amateur Radio is morally entitled to more frequency consideration. That the amateur is not entitled legally is his own fault. Those who pioneered the way from the times of the early transatlantics didn't have the foresight to have "200 metres and below" voted exclusive amateur territory. It could have been done then... the commercial people weren't even interested.

## CONTESTS - - "Like All Wars!"

As this is written, after the week-end of March 22-23, 1947, most casual, and not so casual users of the popular DX bands, are recovering from the invasion of masses of stations, all falling over each other, engaged cheerfully in blotting each other out, and in creating the Merry Dickens in many instances by burbling around on the Magic Carpet of the VFO. For the benefit of those who may be relatively unaware of the fact by reason of having recently graduated to the ranks of Hamdon; this, my friends, was one of the periodical outbursts known to many as "Contest Madness." Don't get the idea that those who take part in these affairs don't enjoy it: they do, or at least one *assumes* so.

From the telephony point of view the procedure seems to be a case of "Hail fellow, well met, Bob's your Uncle, your number is 589XXX, Seventythree"—and—"Seekew Contest... SEEKEW CONTEST"... And so on... lots of it. The bloke that may have wanted to keep an ordinary sked with his clobber over in Cushlamochree or Islington, just hasn't got a ghost of a chance. He is cold-shouldered and trampled on all over the place. Then he gets really

annoyed and wishes HIS VFO around to try to find a chink in the Iron Curtain. In the CW theatre of Contest action, the dial is not so much like a maze of Wurlitzer organs as an aviary gone crazy... the birds are all chirping and pecking at each other all at once. There is one good point about the CW angle though... it is a good operator who can copy solid through the Dante's Inferno of it all. But as I said before... lots of fellows like the *Contests*... and anyway... they come to an end finally, like all wars! It is all one phase of Amateur Radio, and the Lord knows that if we don't get *wider* bands at the next International Gas-party instead of the likely narrow-gutted ones we seem to be threatened with... strangulation seems to be future state of affairs. Let nobody accuse me of being an arch enemy of Contests... I have just been responsible for recommending certain prize donations. The spirit of competition is always good, but my recommendation to the ordinary Ham during Contest periods is to get busy and do those odd jobs around the shack, or confine his QSO's to VHF channels with Jack and Bill across town.

\* \* \*

Heard a topical exposition of phoneticism of callsign the other day when a solid 20-metre phone station resolved itself into "this is CE3AB Calling CQ... CE THREE ATOMIC BOMBS! Well, it certainly attracts attention more emphatically than "Three Able Bakers" might do!

\* \* \*

Latest Old-timer to be heard back on the air in N.S.W. is VK-2AYG, Ray Ailsop, long known



## SQUEGGER MENTALITY N.B.G. ON "6"

as a pioneer of radio in this country. Ray was the man who built the original 2BL broadcaster, and later formed the Raycophone theatre-equipment concern. He was A2YG, but let the call go. Hence the new three-letter call sign.

\* \* \*

In my opinion, some dealers up and down the cities are asking far too much for ex-Radar gear. Those ex-RAAF indicators may have a few handy bits and pieces in them, but that is all . . . the Ham can't really do much with them. Before and after Disposals sales, such gear gets knocked about in trucks and stores . . . valves may suffer, etc., and the net result is that the Ham gets a mess of resistors and tubulars for much more than he really *should* pay. If he does pay the price, that is his own funeral, but a little care will show the bargains from the sell-outs. There are excellent bargains to be had, at the right kind of dealer, but there are also collections of gear that are fit only for museums, curio shops, or breaker's hammer. Britain has a way with such junk . . . it is taken and used to fill up disused mine shafts. And if anyone thinks it a workable proposition to recover anything dumped in such places, they don't know the miles-deep old mine shafts of North Western Britain!

\* \* \*

Money is tightening up . . . the lads aren't rushing around spending deferred pay right and left on ex-Service transmitters and receivers as much as they were. I actually saw a splendidly-engineered Australian-produced communications receiver, a job made to rigid specifications and replete with everything that a receiver should have . . . on a shelf at a price that was not cheap, nor extortionate. It was really worth the figure. But four weeks later it was still unsold. It went in the end but the slowness of movement was in distinct contrast to but a few weeks ago.

\* \* \*

Have just been glossing through the April issue of "Radio Listening Post," published by the "Short-wave League of Westralia," and as

In one metropolitan area the number of stations using Six Metres is on the increase, and the ranks of those who have been responsible for virtual development of the band are being swelled. Some of the newcomer stations take the advice of the experienced habitués and have started off with the correct type of gear. Others have been content to knock together "rush-box" receivers and two-stage MOPA's and to make their debut in such fashion. Presence of such transmissions on the dial of super-het receivers is demonstrated by a series of squawks and the destruction of the carrier, finishing up with a noise something like a power leak. If the station is very close, it may be possible to identify the transmission, and by dint of acrobatics with receiver tuning, make a measure of sense out of what is being said. Some stations have started off with this kind of gear and after a few nights of it, have quit the band, with the mistaken idea that it is run by a clique who won't work with others outside their own charmed circle. Truth of the matter is, that those with the normal receivers can't just make out what those heavily frequency modulated stations are saying . . . and they . . . those accused of being cliquey . . . have given up in disgust at trying to identify such transmissions. One station, just arrived on the band with a two-stage MOPA and heavy overmodulation, to the accompaniment of a super-regen receiver squeal when he changed over to listen, expressed the opinion "that one has to make a start of some kind to get going on the band." Yes and No! The same station wouldn't dream of starting up on 40, 20, or 10 metres with a modulated oscillator or equivalent and a squegger receiver . . . and there is no reason why

a source of information for SWL's interested in Ham doings, it is well to the forefront. This is a friendly little publication and one that the

50-54 Mc/s should be looked upon with a "Squegger Mentality." The idea of such gear is a throwback to the earlier 56 Mc/s days, when the pathways of VHF were being trodden pioneeringly, and when cause and effect were relatively unknown. In these enlightened times there is no excuse for people putting the wrong kind of equipment on 50-54 Mc/s, any more than on the next band lower, and the others. "Six" is an established *communication channel* and has long since grown past the stage where uncertainties of communication may exist. Stations using prehistoric gear and thereby causing needless QRM to others will court unpopularity and that is a state of affairs that should not exist. There is no mysterious technical obstacle to the making of inexpensive but fully-effective equipment for 50-54 Mc/s . . . the technique is virtually that of the HF's. On the next band, there is yet awhile more scope for the simpler kind of receivers and oscillator-type transmitters, and I suggest seriously that those who feel they would like a "short-haul" phone channel with their adjacent colleagues, should go to 166-170 Mc/s. There is no reason why MOPA's should not be made perfectly stable at 50 Mc/s, but don't be tempted to get away with the simpler two-stage version. Even with a Franklin oscillator ahead of the P.A., the pulling under modulation is excessive. MOPA's need at least one buffer stage in between. Even with a very stable VFO, the problem of *gradual* frequency drift is considerably magnified at 50 Mc/s. Crystal control is simple enough to get going, and 50 watts is more than ample power on the P.A. for reliable communication with all and sundry, provided that a good radiating system be applied.

keen SWL would be well advised to support. Postal address is PO Box P1179, Perth, W.A. Subscrip-  
(Continued on next page)

tion is 6/- per annum and life membership of the League is 5/- for those outside the Perth metropolitan area. Prominent contributors are Doc Gaden and Miss D. Sanderson, known to SWL's everywhere.

\* \* \*

Recently a military watercraft en route along Eastern N.S.W. coastline got into serious engine trouble, and began to drift toward rocks. Crew complement included a well-known Ham of long vintage who got busy on the radio gear and tried to raise Base through military channels. After two or three hours' calling with no reply, he gave up the fruitless quest and turned to the amateur 7 Mc/s region. There, in the small hours of the morning he raised a lone VK station, miles away in a country area. The lone Ham put through a long-distance phone call to the military Area where the craft was expected, and speedy safety measures were taken from the air. 'Tis understood that the Ham in question received the warm thanks of the authorities, and that the service operator who should have been keeping a watch on certain official channels, got a "please explain." Chalk up another one to the credit of Amateur Radio!

During a 14 Mc/s phone conversation with a Westralian of many years Ham band experience, he went off pop about Easterners who work with each other locally, inside the American 'phone band, because the DX is not prevailing at the time. Although such conditions

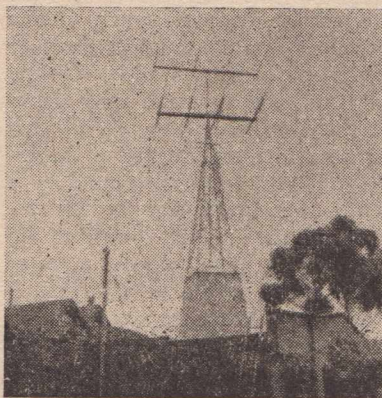

may be in evidence in VK2, 3 and 4, it is often likely that over in W.A. the VK6's are hearing the W's exceptionally well at the time, and because they may be also at the same time in a strong signal area from Eastern VK, their would-be

QSO's with the W's may be badly QRM'd. That's a thought to ponder over, and is certainly one of the arguments that could be put forward for the use of VHF channels for local chatter. Nobody is immune from the "off-DX period" chit-chatting on 20 . . . we nearly all are guilty at some time or other. Let us listen first to check on whether or not the VK6's are trying to work W's, even when the band seems dead in the East for the California Kilowatts.

\* \* \*

Pity the trials and tribulations of our G brethren in that ghastly WX the Old Country has endured. Was in QSO with G6XT on 14 Mc/s CW 't'other morn and he told me of trouble with his *telescopic* mast due to changes in wind and temperature. The mast gradually telescoped and reduced antenna height by 20 feet or so. Because of the infernal WX he couldn't get at it. Who, by the way, was the prominent G phone, a well-known 14 Mc/s habituee, who decided to brave the blizzard and do some antenna repairs? He was seen clad mightily; with a bowler hat on top of a balaclava helmet. And to top it all his XYL was holding a gamp over him whilst he attempted to fix things. You'll have some trouble in living that down with the early morning VK gangs, Harry!

\* \* \*

## WHO PIONEERED "TEN"?

Talking of Ten Metres. Who was the first Australian Amateur to get his signals overseas on Ten? Going back a couple of decades, my records show that 1928, OA-2UI stated in "Radio in Australia and New Zealand" . . . November issue of that year . . . "The first 10-metre signal sent out from 2UI was on August 26th (1928) when a Sunday morning schedule was being kept with 2RX. This transmission was heard by OZ1FT, also by Mr. N. A. Field, of Timaru, N.Z., who reported 2UI R5 and R6 respectively." For the information of Hams not acquainted with prefixes of those now far-off days, OA represented Australia and OZ

New Zealand. There was an unofficial method of inter-country calling that eliminated the "DE," but it was frowned upon at a subsequent International Conference, and was shelved. The idea was that an Australian working a New Zealander would call the latter thus, for example . . . "1FT 1FT 1FT, OZOA 2UI 2UI 2UI", and the reply would be "2UI 2UI 2UI OAOZ 1FT 1FT 1FT," and so on. It was a popular idea at the time. Incidentally, when OA2UI made the 10-metre transmission referred to here, he was using a pair of 201A's with an input of all of 5 watts.

Talking of early morning DX on 14 Mc/s . . . there is a fair spate of it just now, but by the same token 7 Mc/s has some very attractive prizes offering. At 5.15 a.m. Sydney time on 7/4/47, the much-maligned 40-metre band revealed one or two ZS phones at S8 and plenty of CW stations from the Dark Continent pounding through on CW. They were working among themselves, and probably didn't realise that they were reaching Eastern VK in fine style. "Forty" would be a lot better if those broadcasters were shooed off the band.

One of our enthusiastic SWL's, A. W. Wright, of South Plympton, S.A., goes off pop about Hams who don't QSL. Says he: "... during the past few months I have received cards from many overseas Hams, and from remarks thereon it is apparent that VK's are notorious for their failure to QSL stations they have worked. GW5YB in particular complained that he has not received a single VK card in reply to his cards." Seems strange... I have seen photos of VK Ham stations in overseas magazines and VK QSL cards seem to figure quite prominently among the variegated wallpaper. There is often extensive delay in routing via the various QSL Bureaux... and it is not always the fault of the VK individually.

\* \* \*

I heard whispers in a metropolitan area of pending formation of a new organisation parallel to the American "Veteran Wireless Operator's Association" which flourishes across the Pacific. If the Australian plans materialise it is possible they may include a section for "Veteran Amateur Operators." Such a scheme would be similar in effect to the

"20 Years and More" Club that started pre-war in U.S.A. in the pages of "QST."

\* \* \*

A letter from a country reader waxes indignant regarding this scribe's criticism of misusers of VFO's. Also the stand is taken that favour is shown for CW as against 'phone. If VFO's are deliberately used to the discredit of amateur radio, this writer will continue to criticise such practice, and knows that the majority of licensees will favour such criticism. As for the hoary old CW-'phone argument... there is none so far as the writer is concerned. Those who haven't noticed VK2NO using both 'phone AND CW are not very observant band-users. Both are desirable and equally of individual interest, but there are times when speech may not get through and when the key may be of real value. The one thing that militates against the misuse of 'phone on 40 and 20 is that Mr. Everyman can hear about it all on his dual-waver. He doesn't become aggressively aware of sloppy CW operation if he cannot read morse... and it may be assumed that the public *in general* does not.

## LOW POWER ON "80"

QRP can do a handy job on 3.5 Mc/s as "Mac" Hicks (VK2ADV) found when trying an ex-Army 208 Set. This little job has a 1Q5G oscillator and similar P.A., and with power .49 watt (70 volts at 7Ma) VK2ADV was QSO VK-3FX (another "Mac") with signal running from Q3-5 R4-6 on CW. The antenna? Nine feet of indoor wire! Remember what I said about making more use of "80"? Goes to show, doesn't it?

A tip for those using ex-Australian Army Reception Set No. 4. This receiver is a handy performer, but there are one or two improvements that can be undertaken by the Ham used to servicing receivers, etc. First is to substitute an ECH35 for the 6J8G (if you can get one). Quieter operation on CW results from this change. Another is to replace the 6U7G RF stage by a valve giving more lift. In my case I used an 1851 with marked advantage. There is a catch about the valve shield bases in these sets. The bases have a hole of sufficient size to pass the valves with the smaller moulded octal base, but if one tries a valve with the 1½-inch base, it won't push through the base to the socket. Only way out of it is to remove the shield base, and file or punch out the hole to about 1½-inch size. The larger hole is necessary also for metal valves. It was found that substitution of a 6K8 for the 6J8 Beat oscillator resulted in quieter BFO injection, but reason may have been the use of a quiet against a noisy valve. Nevertheless, all my 6J8G's seemed to be much noisier than the 6K8G in that position. For those who prefer speaker to headphone operation, the No. 4 Set needs an audio stage as an addition, using a 6F6G or 6V6G. Speaker operation is all right as it stands, but signals sound on the thin side.

—D.B.K.

## VERTICAL ANTENNAS FOR "TWENTY"

Listening to many of the VK4 and 3 phone regulars on 14 Mc/s, it is increasingly evident that good results are being obtained by many stations using half-wave vertical antennas. Methods of feed vary, according to the dictates of location, etc., but there is an important point about such radiating systems that should not be overlooked. If you study the ARRL Antenna Handbook, you will see that optimum height of the base above ground must be considered carefully. Theoretically, the best arrangement is for the bottom end of the lower half of the aerial to be right at ground level. This is usually not very convenient, and so the user hauls the aerial higher. If you go

much over 8 feet, the useful vertical angle is lost, so far as DX is concerned. Moral is to keep somewhere about the 5-foot mark to make most use of the 25-degree angle, but earth-conductivity also has a lot to do with results. Preference is being shown by many 14 Mc/s men just now for the "inductively-coupled" form of dipole. This is simply a half-wave split at the centre to include a suitable coil, to which is coupled inductively (by interwinding) a coil connected to the usual coaxial line. Effect is to remove much of the unbalance of coax line. Because of the loading effect in the centre of the half-wave, the dipole sections need to be appropriately shorter.

# AMATEUR CHATTERBOX!

## BLATHER ON THE 40-METRE BAND

When one has been punching a key and wielding a mike for nigh on 36 years, surely a goodly slice of time as a Ham, one may be pardoned for going off pop at some of the blather assailing the ears, mainly on "Forty." Most times, reaction is "what's the use?" and the pulling of switches in favour of a book by the fireside or something. Point is that if these things go on ad lib, and no "blue" is raised, they will continue to persist. So that if this old hand at this Ham game points the bone at times, let those who don't like criticism take note. Any criticism from this pen is with a constructive, not destructive aim. All is not well with the modus operandi of many amateur stations, and it is by no means just a VK peculiarity. In U.S.A. "QST" and "CQ" have a lot to say in Editorials about bad operation; the misuse of VFO's and the like; whilst G6FO's "Short-Wave Magazine" with G6QB at the DX helm, frequently raps the G's over the knuckles. Believe me, these writers don't do this kind of thing because they enjoy it . . . they are 100 per cent Hams themselves, of very long standing and unflagging enthusiasm. They hate the necessity for writing in anything but praiseworthy terms about Amateur Radio, but because the majority may suffer for the carelessness of a few, they are doing the appropriate thing and bringing to the notice of the majority these few lapses where the matter will do most good . . . in print.

Because of the blatherings of a minority, Amateur Radio as a whole may suffer badly at the hands of a few officials at International Conferences, where such officials are for reasons born probably from the dial-twisting of Dual-Wave receivers, not particularly friendly to amateurs. Such people, appointed, not in any shape or form because

of knowledge or experience of amateur radio, but from Public Service seniority alone, can have been influenced adversely because of chance tuning-in to a spate of blather and jargon . . . made evident by the *spoken word*. What goes on in the C.W. world is to such people probably a closed book . . . there are likely to be few telegraphists among them. But the spoken word and the manner in which it is spoken, can leave an indelible impression, and because the speaker can be but visualised, it can be a most unfavourable impression. Is it likely that such officials at Telecom Conferences will put up much of a show in the periodical battle for amateur frequencies? Not likely! And who is to blame? If you don't think such officials exist, then read the references in "QST" and British Amateur Radio magazines about the poor effort by the British representatives on behalf of the British amateurs at a recent conference in Moscow. That Conference was but a preliminary, but may be a portent of things to come. And I know, and so do others, that there are lots of people in important Communications positions who would have no hesitation in strangling amateur radio if given a chance. They would permit no operation at all below 50 M/cs. I know this, I say, because I have had such opinion expressed to me by such Very Important People. And when I may be asked to comment upon some quoted instance of overheard blah on 7 or 14 M/cs. 'phone, it takes a lot of doing to present a convincing front to these VIP's that such instances are not in the general scheme of things at

the average amateur station. For goodness sake, fellows, *think* before you go into a lot of microphone activity . . . you have no private line between you and the other chap on the DX bands . . . the public, and that means those VIP's, can hear everything you say.

A sample outburst from an irate Old Timer reads thus: ". . . It is damned near time something be done about the 40 metre phone business. From most of the 'bilge' I have heard swapped by mutts with the 'I want to be an announcer complex,' I wonder why the PMG doesn't come down solidly on the culprits, and why the W.I.A. doesn't organise against the malpractices." The Ham who wrote those words is no new hand at the game . . . he was punching a Ham key in 1926 and in the war before that era was a Royal Navy key-puncher. He has not long returned to VK after having been a guest of the Nazis for 5 years in a POW camp, and one can well imagine that something *must* have annoyed the OT well and truly for him to explode thus. His feelings are those of many who don't want to see amateur radio suffer because of the vapourings of a handful of irresponsibles. Keep the game clean, fellows, and don't be misled by loud-voiced people posing as virtual "owners of the band." If you operate your stations according to the Rules and Regs., you will be on the credit side of the ledger, and it is usually but a matter of a little forethought before speaking into a microphone.

D.B.K.

## TRADE DISCOUNT

(Continued)

valuable from a trading point of view that many of the early amateurs expected, and got, valves and other components free of charge. Even much later in the piece it became recognised that an amateur transmitter was the sort of person who would expect to buy a valve at half price, blow it up by running it at twice its normal plate voltage, and then expect to have it replaced free of charge.

Then came an era of cut-price merchants and retail-wholesalers.

Technical radio enthusiasts being a clanny type of human beings, they get together to discuss their problems and so the news is spread around. Someone boasts that by walking into such and such a warehouse and throwing his cash on the counter he manages to buy his parts at trade price. Those who hear the boast soon try their hand at the same tactics. For years past few people have paid retail prices for radio components. If they had the technical knowledge to use the components they had the trade knowledge on where and how to obtain discounts.

All of which was bad, we readily admit.

### ONE THREAT

Recently there have been efforts by certain radio retailers to get the trade on to a more conservative basis. Action by one group was to circularise the radio wholesalers with a threat that unless they stopped selling to the public at wholesale prices they would be faced with the opposition of a wholesale warehouse operated by the retailers on a co-operative basis.

Just exactly how this threat was worded I do not know, but I do know that it was effective, and effective in a way which is detrimental to the interests of all radio enthusiasts and to the publishers of technical radio journals.

As a result of the threat quite a number of wholesalers have decided to tidy up their policies by insisting on a more rigid application of rules to ensure that their slogan of

"wholesale only" is adhered to, at least to appearances. To further give the impression that they are doing the right thing by the retailers they are cancelling their advertising in those technical magazines which reach the public by way of the bookstalls and newsagents, such as Australasian Radio World.

### HIGH PRINTING COSTS

This is most unfortunate in these days of high printing costs, for the advertising revenue is highly desirable to keep the business on a sound footing. All that has been said about discounts and selling costs applies equally to magazines, so that the actual nett amount of cash which reaches the publisher as his share of the selling price is only a fraction of the price shown on the cover. It does not even equal the cost of paper and printing, let alone editorial expenses and so on.

### SOUNDLY BACKED

Fortunately, Australasian Radio World has been established a long time and worked up a backing of several thousand direct subscribers, so that, if necessary, it could be operated quite well without any retail sales or without any advertising. On the other hand, if supported with a greater amount of advertising it could be published with more pages. For every extra page of advertising it is possible to add three extra pages of reading matter.

Especially annoying is it to know that most of the wholesalers are quite keen to do business with non-trade enthusiasts at trade prices. We find that on checking with several of our readers it is clearly evident that most of them have the entree into warehouses and have little difficulty in buying at trade discounts.

Where can we look for extra advertising revenue to permit running bigger issues. The wholesalers are

afraid to advertise in a paper which sells to the public, the radio schools and colleges take the attitude that our readers are too intelligent, technically, to be greatly interested. The manufacturers of components seem to feel that it is up to the distributors and retailers to carry the baby of advertising, and so it goes.

Fortunately, there are those loyal supporters who know that a technical monthly is a wonderful tonic to pep up the radio enthusiast, to maintain technical interest in new developments, and generally keep the game going. Even set manufacturers know that so long as there is public appreciation of technical developments they can continue to appeal to the buying public in other ways than by offering cut-price sets of dubious quality.

So we keep on ticking along in our own modest way, but it is a bit of a heart-break to pick up an American technical monthly and note what scope the editor has on account of the advertising support which is offered. Many of the American journals are running over 400 pages per issue.

### CO-OPERATION NEEDED

If the radio trade as a whole would get together and co-operate instead of haggling over retail-wholesale discounts and such, it could easily support several technical radio journals worthy of Australia. They would pull their weight by encouraging interest in technical matters and experimentation generally. Take the ham radio field alone, where there is scope for at least 10,000 hams with an annual turnover of about £250,000 per annum. A properly-conducted campaign to encourage these hams should not cost the trade more than ten per cent. of this amount.

In next month's issue Mr. Hull will give the second of the articles on this subject, in which he will tell of some of the further problems which are now poking their ugly heads over the horizon, and will discuss suggestions for dealing with these problems.

# Shortwave Review

CONDUCTED BY

L. J. KEAST

## NOTES FROM MY DIARY

### RADIO AUSTRALIA

Since its inception, Radio Australia's weekly programme, "Australian DX-ers Calling," has met with a generous response from DX-ers throughout the world. Consequently arrangements have been made to dedicate these programmes to various overseas DX organisations. A list of the dates of these broadcasts appears elsewhere in these pages.

### A SAD HOLIDAY

A tragic ending to a well-earned brief respite from his work befell our old friend Dr. Keith Gaden when, on journeying to Inverell on Easter Saturday, his car overturned, and a lady passenger lost her life. The doctor was pinned in the car when rescuers arrived and he was treated at the Inverell hospital for severe bruises and lacerations.

After several weeks in this institution, he has now arrived back home and I am sure all the readers of these pages to whom the Doctor is known will wish him a speedy and complete recovery. I am afraid, however, it will a little while before we have any loggings from him.

### WATCH FOR IT

From "Radio Call" I learn a special broadcast from Sweden will take place on May 31 dedicated to the Australian DX Radio Club. Definite hour of transmission has not yet been decided but SDB-2, 10.780mc, 27.83, will be one of two transmitters to be used.

Tentative arrangements have been made for a special broadcast to the N.Z. DX Club and the suggested date is Saturday, July 5, from 5.30-6.30 a.m. The stations will most likely be SDB-2, 10.78 mc, and SBO, 6.065mc.

## WITHIN THE SOUND OF BOW BELLS

It is so seldom the BBC make a mistake that when they do it's news, so the story that appeared in the Daily Telegraph, Sydney, of April 16, is worth repeating:

"LONDON, Tuesday, April 15. —Bow Bells, which opens the BBC's morning programme at 6.30 and normally are cut off after a few seconds, were still ringing over the radio at 6.31 a.m. today. Then an announcer, completely out of breath, said: 'I'm awfully sorry, it's twenty-nine minutes to six.' He added: 'I must apologise for being out of breath, but I'm afraid none of us was called this morning.' A record was then hurriedly put on, without any announcement. Six minutes later the still-out-of-breath announcer said: 'I'm afraid I told you it was twenty-nine minutes to six. That should have been, of course, twenty-nine minutes to seven.' Still no day of the week, date, or programme had been announced. After a second record had been played, the announcer said, 'I'm afraid I can't remember what this is. I think it is 'After the Night of Carnival.' Listed name of this programme is 'Bright and Early.'"

## CHINA WILL TELL THE WORLD

Roy Graham Dunlop, a Canadian formerly associated with Canadian radio stations in Vancouver, B.C., and Moose Jaw, Saskatchewan, has been appointed director of English-language programmes for the Government-owned Chinese radio. Dunlop heads the Central Broadcasting Administration's international service and will prepare broadcasts for listeners in Canada, the United States, Australia and Britain. The Reuter dispatch says Dunlop in an interview said he believes there is "great future" in international broadcasting and

pointed to Canada, Britain, and Russia as countries which are doing an excellent job of telling the world about themselves." The dispatch continued, "Dunlop said China, in the next three years, plans to build powerful short-wave stations in Chungking, Shanghai, Canton and Changchun. They will be equipped to cover Europe, Australia, the South Seas and North America." The above information came to me by air-mail from Ken Boord of Chicago and I am sure listeners will welcome the possibility of better transmissions from China.

### DOT HALL

There is an excellent article in "The Reader's Digest" for May which will be of particular interest to DX-ers. It refers to Radio's most widely known "Ham," Mrs. Dorothy Hall, who operates W21-XY at Springfield, Long Island, U.S.A. It was during the time she was speaking to Andrew Young of Pitcairn Island, many years ago, that I was able to log and secure from Mr. Young one of my most cherished verification cards.

\* \* \*

## SAYS WHO?

Mr. G. H. Moss of Concord writes: Listening to Switzerland on April 15 I heard them announce that, commencing on Monday, April 21, they will transmit to Australia and New Zealand on 11.865mc, 25.28m, and 11.820mc, 25.39m. (This will be the transmission forecast in April issue of "A.R.W." Mr. Moss does not give the times but they are: 5.15-6.45 p.m. I heard them on their Monday opening and 11.865mc was good, but on the other there was interference from GSN, 11.82mc, and I think KCBR, 11.81mc, although Switzerland was on an announced frequency of 11.815mc. The programme was in English from opening till 5.45 when they

continued in French until closing. The times and frequencies mentioned above are now being used for the Monday, Tuesday, Thursday and Saturday broadcasts to the Pacific.—L.J.K.)

\* \* \*

Mr. Ern Suffolk, Lobethal, South Australia, advises XGOY, Chungking's International Station on 9.66 mc, 31.06m, is heard clearly at midnight with news in English, but owing to VLQ-3, Brisbane, sharing the same frequency, it cannot be heard earlier. A heterodyne note on VLQ-3 signifies that XGOY is in operation at 9 o'clock.

A verification card to hand from CBLX, 15.09mc, 19.88m, states that theirs is a 7½-kilowatt station. Studios are located at Montreal, but the transmitter is at Vercheres. They are on the air daily from 10 p.m. until 10.45 a.m.

Radio Brazzaville is heard in French programme at 3.45 p.m. on 17.845mc, 16.81m. Prior to the above time Radio Australia's station VLC-10 causes a blanket effect until the latter closes down.

Mr. Rex Gillett says: "This month I had the very great pleasure of receiving one of my best veries. This was 'Radio Martinique,' heard in July of last year on 9.705mc, when opening at 8.30 a.m. with the playing of 'Marseillaise' and 'March Lorraine.'

"The arrival of a verie from Radio Club Macao, Portuguese China, gave me my 74th verified country. The rather attractive card was for my report of October '45, when I heard them on 7.535mc. Other veries received during recent weeks are: Radio Andorra, 50.16m; Radio Leipzig, 9.73mc; XGOA, 5.918mc; WLKS, 6.105mc; PCJ, 11.735mc; RNB, 9.43mc; WRUS-A 15.35mc; and WRUL 11.73mc." (Nice work, Rex.—L.J.K.)

Rex continues: "Lourenco Marques on 3.49mc and 4.925mc now runs until 8 a.m. instead of 6 a.m. as previously. The latter is quite good strength on closing, but the former is not tuned at the same

time, although it is announced in relay.

"ZEA, Salisbury, on 3.66mc, has been heard with fair signals at 5 a.m. Programme is in English to sign off at 6 o'clock with 'God Save the King.' Daily sign off is at 6.30 a.m.

"The Norwegians, LKJ, LKQ and LLI on 9.54mc, 11.735 and 6.185 respectively now sign off fairly regularly at 8.05 a.m. LKQ is the best signal. Ten chimes are used as an interval signal. Identification is simply given as 'Oslo,' spoken as OSSLO.

"Leopoldville is heard signing off at 3 a.m. on 13.99mc, following programmes in Flemish and French.

"KZRH, Manila, now announces as 'The nation's most powerful station.' Radio Sofia is being heard again on both outlets with English at 6.30 a.m. Prior to sign off at 6.40 it is announced they now have verification cards.

"Radio Tananarive now signs off a little later than previously and is being received until 4.30 a.m. on 6.065 and 9.69mc." (Ern Suffolk is hearing the 28.26m outlet at 1.45 a.m. . . . presumably in relay.)

"On 11.765mc Algiers is being heard at 7 a.m. with V. of A. programmes. It is hard to log from GSD and the Radio Aussie on 25.53 and 25.49 respectively."

\* \* \*

And a letter from Arthur Cushen: "PCJ announcing as the International Programme Service, 9.59 and 6.025mc to 2.15 p.m. Saturday with weekly broadcast to U.S., stated they were on for the Pacific at 7.30 p.m. on 9.59 and 6.025mc. Regular Tuesday 6-7.30 p.m. transmission on 17.77, 15.22 and 6.025mc suspended on account of Eddy Startz visiting South America for KLM. Expect transmission to recommence in May.

"Mexicans are good here from 3-4 p.m. XEHH, 11.88mc, relays XERH from 3-4 p.m. XEQQ, 9.68

mc, relays XEQ till 3.45 p.m. XEBT, 9.63mc, relays XEB signing at 4 p.m. XERQ, 9.61mc, relays XEQR, 'Radio Continental,' and heard till after 5 o'clock. XEWW, 9.50mc, relays XEW—good at 4 p.m.

"On Easter Monday I heard Chilian elections on CE1180, Santiago, 11.97mc, and CE622, Santiago, 6.22mc, till after 4 p.m. CBRX, Vancouver, 6.15mc, very good with CBC news at 4 o'clock. Have now reached my 1100th verie and over 2000 stations reported."

\* \* \*

And here is a long and informative letter from Desmond Hickey of Petone, New Zealand:

"Here are details on verifications that I have received from Latin America since I wrote to you in January:

"HJCA, Bogota, Colombia, 'Radio Cristal,' operates on 4.855 mc with 1,000 watts, and relays HJCU, 720kc. Address: Apartado Nacional 16.36. (Veri by Spanish letter from station manager, Cristobal Paez G.)

"YSW, Santa Ana, El Salvador, 'La Radio Del Pueblo,' operates on 5.98mc. Power, 1,000 watts. Schedule is 4-6 a.m., 10.30 a.m.-2 p.m., 11 p.m.-midnight. Parallels 930kc. (Veri. by hand-written Spanish letter from Julio C. Calderon Vides. Further reports requested.)

"COBZ, Havana, Cuba, 'Radio Salas,' operates on 9.03mc. Relays CMBZ, 8.30kc. Address: Apartado 866. (Veri. by card showing pictures of studios.)

"ZPA5, Encarnacion, Paraguay, 'Radio Encarnacion,' operates on 11.95mc. Power, 2,500 watts. Relays ZP5, 920kc. Address: Compania Paraguaya De Radiodifusion. (Veri. by card with large call letters in black. Further reports requested.) Card was posted in Argentina, with Argentine stamps on envelope.

"XDY, Chapultepec, Mexico

City, 'Estacion Radio Central,' operates on 9.917mc. Power, 20,000 watts. Broadcasts telegraph bulletins to Latin America daily at midday and 1 a.m. (Veri. by Spanish letter from station manager, Heriberto A. Zarate.)

"XEBR, Hermosillo, Mexico, 'El Heraldo de Sohora desde Hermosillo,' operates on 11.82mc. Power, 1,000 watts. Relays XEBH, 920kc. Address: Apartado Postal 68. (Veri. by card showing map of Mexico.)

"YNPS, Managua, Nicaragua, 'La Voz De Nicaragua,' operates on 6.76mc. (Veri. by Spanish letter from station manager, Juan Velazquez Prieto. Returned IRC and requests further reports. Also sent me one dozen airmail stamps of Nicaragua.)

"YNOW, Managua, Nicaragua, 'La Voz De La America Central,' operates on 6.85mc. Address: Apartado 47. (Veri. by Spanish letter from Roberto Borge.)

"HP5H, Panama City, Panama, 'La Voz Del Pueblo,' operates on 6.122mc. Relays HOY, 700kc, and HOHA, 900kc. Address: Apartado 1045. (Veri. by Spanish letter from L. Rettally, who stated that have increased power and would appreciate reports. Schedule is 9.30 p.m.-3 p.m.)

"OAX4P, Huancayo, Peru, 'Radio Huancayo La Voz Del Centro Del Peru,' operates on 5.87mc. Power, 250W. Schedule is 3-4.30 a.m., noon-2.30 p.m. Address is

Apartado 187. (Veri. by very nice picture card.)

"Here are some details on new loggings here: 4.75mc, YVIRV, Maracaibo, 'Ecos Del Zulia,' opens 8.30 p.m. 4.865mc, HJEX, Cali, 'Radio Pacific,' opens 9 p.m.; good. 4.88mc, YV5RU, Caracas, 'Ondas Populares,' opens 8.55 p.m. 6.075 mc, CXA3, Montevidea, 'La Radio Prensa Del Uruguay,' opens daily at 8 p.m. 6.18mc, LRM, Mendoza, 'Radio Aconcagua,' opens 8 p.m.; relays LW2; gives address as Aven-

ida Civit 470. 6.25mc, YSU, San Salvador, 'Radio Mil Cincuenta,' signs off daily at 3 p.m. 6.62mc, TG2, Guatemala City, 'Radio Morse,' opens 10.30 p.m.; requests reports to be sent to Director General of Communications. 11.88 mc, LRR, Rosario, 'Radio Ovidio Lagos,' relays LT-8, 'Radio Rosario.' Opens with march, 8.55 p.m. Relays news from Radio Belgrano, Buenos Aires, at 9 p.m.

"Hope this information will be of interest to you."

## NEW STATIONS

—, Berne, 11.815mc, 25.39m: Commenced on Monday, April 21, in parallel with HER-5, 11.865mc, 25.28m, in programme to Australia and New Zealand. Schedule is 5.15-6.45 p.m. and operates on Mondays and Thursdays. See further remarks under "Says Who?"—L.J.K.

VLA-5, Shepparton, 15.32mc, 19.58m: This new transmitter for "Radio Australia" is scheduled as follows: 9.30-10.45 a.m., to North America (East) and Canada; 2.45-3.45 p.m., to North America (West), Canada and South Africa.

VLB-4, Shepparton, 11.81mc, 25.40m: Another new Dept. of Information station that opened on April 12 with programme for British Isles and Europe from 1-2 a.m. Is heard from 11.30 p.m.-1 a.m. to India and the Forces.

VLB-10, Shepparton, 11.74mc, 25.55m: Still another "Radio Australia" transmitter for D. of I. but does not appear to have a schedule at the moment.

VLA-10, Shepparton, 17.84mc, 16.82m: This is a new frequency also and replaced VLA-7, 17.80mc, in D. of I. programmes to North America (West Coast) from 2.45-3.45 p.m., doubtless as VLA-7 was badly interfered with by KRHO. However, VLA-10 seems to have been taken off and VLC-9, 19.84, is being used in parallel with VLA-5, VLB-8 and VLG-6 (the latter two are not used on Saturdays.)

### B.B.C. PACIFIC SERVICE

As predicted in April issue, winter timetable is now in force namely from 3-7 p.m. The same frequencies are in use but with slight variations as to actual period of time on

## GEORGE BROWN & CO. PTY. LTD.

267 CLARENCE STREET, SYDNEY. Phone: M 2544

DISTRIBUTORS TO THE TRADE FOR

ROLA SPEAKERS ● EVEREADY BATTERIES ● AEGIS

RADIO COMPONENTS ● ULTIMATE RADIOS ● MULLARD

VALVES ● I.R.C. RESISTORS

And All Brand Line Radio Components

★ AEGIS 4 VALVE AND 5 VALVE KIT SETS COMPLETE NOW AVAILABLE



the air. Here is complete schedule:  
3.00-7.00 p.m.

GRD	15.45mc	19.42m
GSG	17.79mc	16.86m
GSN	11.82mc	25.38m
GRX	9.69mc	30.96m
GVZ	9.64mc	31.12m
	3.45-7.00	
GVS	21.71mc	13.82m
GRQ	18.025mc	16.64m

#### RADIO CLUB MOZAMBIQUE

##### English Transmissions:

Daily 2-8 a.m.: CR7BV, Lourenco Marques, 4.90mc; CR7AB, Lourenco Marques, 3.49mc.

Sundays, 5-10 p.m.: CR7BE, Lourenco Marques, 9.58.

Mondays, 1-8 a.m.: CR7BV, Lourenco Marques, 4.90; CR7AB, Lourenco Marques, 3.49.

##### Portuguese Transmissions

Daily, 3-4 p.m., 7-9.30 p.m., 2-8 a.m.: CR7BJ, Lourenco Marques, 9.645; CR7BK, Lourenco Marques, (740kc B.C.); CR7BJ, Lourenco Marques, 9.645; CR7BK, Lourenco Marques, (740kc B.C.); CR7AA, Lourenco Marques, 6.137.

Sundays, 7-10 p.m.: CR7BK, Lourenco Marques, (740kc B.C.); CR7BJ, Lourenco Marques, 9.645. Noondays, 2-10 a.m., CR7BK, Lourenco Marques, (740kc B.C.); CR2AA, Lourenco Marques, 6.137.

All reports will be welcomed. (Above information supplied by Arthur Cushen.)

#### CANADIAN BROADCASTING CORPORATION

CBC International Service changed as from April 13 as follows:

CKNC, Sackville, 17.82mc, midnight-9.05 a.m.

CKCX, Sackville, 15.19mc, midnight-2 a.m.

CKCS, Sackville, 15.32mc, 2.05-9.05 a.m.

#### THE CROSSLEY CORPORATION BROADCASTS

From Cincinnati, Ohio, U.S.A.

Schedule for May, 1947

To Latin America

WLWK, 6.08mc, 49.3m: 9.30 a.m.-4 p.m.

WLWL, 21.65mc, 13.85m: 8 a.m.-noon; 9.52mc, 31.51m\*: 12.15 p.m.-1.15 p.m.

WLWO, 15.35mc, 19.54m: 7.45 a.m.-8 a.m.; 11.79mc, 25.45m: 10 a.m.-noon; 11.79mc, 25.45\*: 12.15 p.m.-1.15 p.m.

WLWR, 9.70mc, 30.93m: 8 a.m.-4 p.m.

WLWS, 15.20mc, 19.73m: 8 a.m.-4 p.m.; 11.71mc, 25.62m: 8 a.m.-4 p.m.

\* Daily except Monday

To Europe and or North Africa

WLWK, 17.80mc, 16.85m: 9.45 p.m.-7.45 a.m., Europe; 9.59mc, 31.30m: 8 a.m.-9.15 a.m., Europe.

WLWO, 11.71mc, 25.62m: 8.45

p.m.-1.30 a.m., Europe; 15.35mc, 19.54m: 2 a.m.-7.30 a.m., Europe.

WLWR, 15.25mc, 19.67m: 9.45 p.m.-7.45 a.m., North Africa.

WLWS, 21.65mc, 13.85m: 9.45 p.m.-7.45 a.m., Europe; 21.65mc, 13.85m: 9.45 p.m.-7.45 a.m., North Africa.

WLWL, 17.955mc, 16.70m: 9.45 p.m.-7.45 a.m., Europe; 17.955mc, 16.70m: 9.45 p.m.-7.45 a.m., North Africa.

The above schedules were received direct from Cincinnati.

## “Australian DX-ers Calling”

Special Programmes Dedicated to Various Overseas Organisations.

To British Isles and Europe

5 a.m. Sundays (G.M.T. 1900 hours. B.D.S.T. 2100 hours)

VLA-8, 11.76mc; VLC-11, 15.21mc.

June 1: Dedicated to British Shortwave League, London, England.

June 8: International Shortwave League, London, England.

June 15: Swedish Radio Club (SRK), Stockholm, Sweden.

June 22: Anglo-American Radio and Television Society, Uxbridge, England.

June 29: Danish Shortwave Club, Copenhagen, Denmark.

July 6: Daily Express Radio Club, Plymouth, Devon, England.

July 13: Malmo DX Club, Malmo, Sweden.

July 20: C.Q. Club of Jakobstad, Jakobstad, Finland.

July 27: Jonkoping-Huskvarna DX Club, Jonkoping, Sweden.

August 3: Indiana Radio Society, Karachi, India.

August 10: Ceylon and South India Radio Club, Colombo, Ceylon.

To North America, Canada, South Africa and New Zealand

3.25 p.m. Sundays (9.25 p.m. P.S.T.), (G.M.T. 0525 hours)

VLA-5, 15.32mc; VLB-8, 21.60 mc; VLG-6, 15.24mc; VLC-9, 17.84mc

10.20 a.m. Sundays (7.20 p.m., E.S.T.) (G.M.T. 0020 hours)

VLA-9, 21.60mc; VLC-9, 17.84mc

June 1: Radio News DX Club, Chicago, Illinois, U.S.A.

June 8: Universal DX Club, Oakland, California, U.S.A.

June 15: Newark News Radio Club, Newark, New Jersey, U.S.A.

June 22: National Radio Club, Buffalo, New York, U.S.A.

June 29: International Round-Table Club, Wanwatos, Wisconsin, U.S.A.

July 6: Grand National Shortwave Listeners' Club, Fort Wayne, Indiana, U.S.A.

July 13: New Zealand DX Radio Association, Wellington, N.Z.

July 20: DX-ers of South Africa.

July 27: New Zealand DX Club, Auckland, N.Z.

August 3: Cleveland Radio Club, Lakewood, Ohio, U.S.A.

August 10: DX-ers of Canada.

Note: Frequencies are subject to alteration. Details of frequency changes will be given on DX programmes from time to time.



# RED



# LINE

## EQUIPMENT

### Frequency Dividing Networks

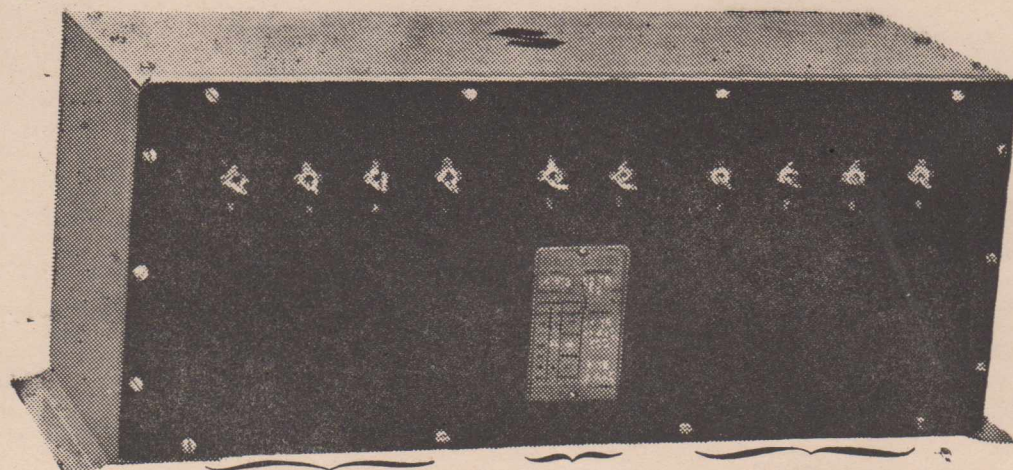

H. F. CHANNEL  
2 OHMS

500 OHM  
INPUT

L. F. CHANNEL  
8 OHMS

### GENERAL

Type D482 is specifically designed for High Fidelity radio gramophones and small talking picture sound installations. The unit consists of a shunt type cross-over network using high "Q" inductances and is intended for insertion in a 500-ohm line. Loud-speaker input transformers are incorporated in the unit, the voice coil winding being brought out for each channel to 4 terminals for connection either in series, for conventional operation, or in parallel for use with loading resistances for medium and high power circuits with wide range characteristics such as the "Full Frequency Range Amplifier."\* This latter method will present what is virtually a constant load to the output tubes with an extremely high damping factor and lead to a marked improvement in transient response.

### SPECIFICATIONS

OPERATING LEVEL: Plus 39 db max. INSERTION LOSS: Approximately .5 db. CROSS-OVER FREQUENCY: 500 cps. ATTENUATION: Low frequency channel—20 db at 1200 cps. High frequency channel—20 db at 150 cps. INPUT IMPEDANCE: 500 ohms. OUTPUT IMPEDANCES: Low frequency channel—8 ohms for 1 "Rola" Type G12 High frequency channel—2 ohms for 1 "Rola" Type 8M (if parallel connected, output impedances will be 2 ohms and .5 ohms and require to be shunted with resistances of 2.67 ohms and .66 ohms respectively). FREQUENCY RESPONSE (Both channels): Within 1 db from 30 cps to 12,000 cps.

Weight: 18 lbs.

Size: 13 x 5½ x 5.

LIST PRICE: £10/10/-.

\* Reprints of the article describing design and construction of this amplifier are available in pamphlet form from:

## SWALES & SWANN

Technical Service, Wholesale and  
Manufacturers

A. T. SWALES, Gen. 4773

2 Coates Lane, Melbourne



Trade Sales: Allen SWANN

MU 6895 (3 Lines)

157 Elizabeth Street, Melbourne

A GUARANTEE

OF DEPENDABILITY

# Leaders

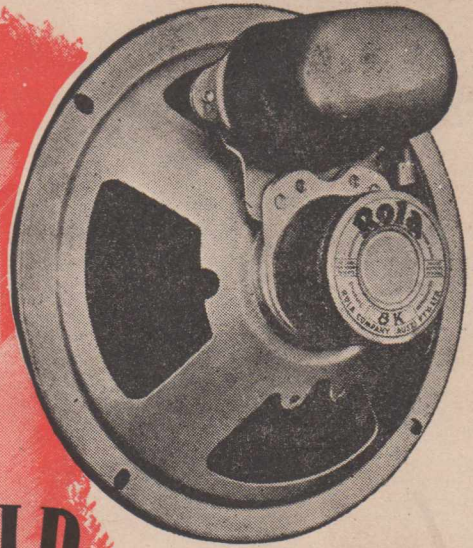

## IN THE SPEAKER FIELD

**ROLA 8K:** For consoles and table model receivers. Lighter and more compact than standard 8" speakers, the 8K does not dissipate heat owing to elimination of the field coil by use of an Anisotropic Alnico magnet.

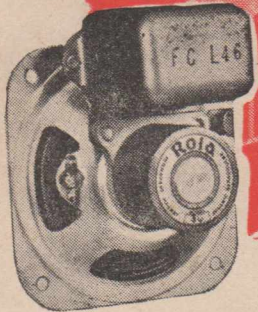

**ROLA 3C:** Australia's smallest loud speaker. Admirably suited for use in small portables and compact communication systems. A triumph in speaker design achieved by the use of Anisotropic Alnico.

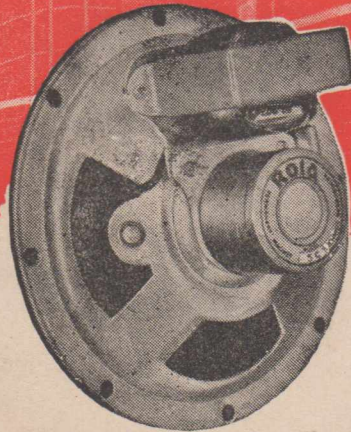

**ROLA 5C:** A 5" 12-oz. speaker ideally suited for A./C. and A.C.-D.C. midget receivers, and also finds useful application in vibrator and battery operated sets.

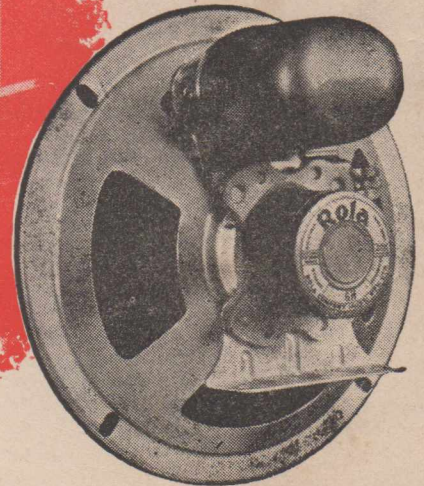

**ROLA 6H:** This 6" speaker is expressly designed for larger and better quality mantle receivers. Used with a chime choke (Rola 6/60), it replaces electrodynamic speakers in A./C. operated receivers.

Limited supplies of ROLA speakers are now reaching the trade, but do not be disappointed if the speaker you want is not immediately available.

# ROLA

## LOUD SPEAKERS with ANISOTROPIC ALNICO

ROLA CO. (AUST.) PTY. LTD., The Boulevard, Richmond, Victoria. 116 Clarence Street, Sydney

Printed by the Bridge Printery, 117 Reservoir St., Sydney, N.S.W., for the Proprietor of the "Australasian Radio World," Balcombe St., Mornington, Vic