

RCA VICTOR

SERVICE DATA

VOLUME VIII

1952

RADIO RECEIVERS

PHONOGRAPHS

TELEVISION

RADIO CORPORATION OF AMERICA

RCA Victor Division

Harrison, N. J., U. S. A.

RCA VICTOR



SERVICE DATA



- TELEVISION RECEIVERS
- RADIO RECEIVERS
- PHONOGRAPHS

This volume is a compilation of Service Data previously issued for the year 1952 with the latest changes and corrections.

Copyright, 1953, Radio Corporation of America

Trademarks   "RCA Victor," "Victor," "Victrola," "Radiola," "Radiotron," "Chanalyst," "VoltOhmyst." Reg. U. S. Pat. Off.

First Edition—First Printing

Printed in U. S. A.

PREPARED BY RCA SERVICE CO., INC.
FOR
RADIO CORPORATION OF AMERICA
RCA VICTOR DIVISION
HARRISON, N. J., U. S. A.

INDEX

The page numbers given in the index below refer to the number at the top of the pages. The numbers which are found in the text and at the bottom of some pages refer only to that particular Service Data. The regular Service Data will be found on the pages indicated by boldface numbers (1, 2, 3, etc.). Supplementary data is indicated by lightface numbers.

RADIO AND PHONOGRAPHS			<i>Model No.</i>	<i>Chassis No.</i>	<i>Page No.</i>
<i>Model No.</i>	<i>Chassis No.</i>	<i>Page No.</i>			
2B400, 2B401, 2B402, 2B403, 2B404, 2B405	RC-1114	1	21T159DE, 21T166DE, 21T174DE, 21T178DE, 21T179DE	KCS-68F	173
2BX63	RC-1115	5	21T176, 21T177, 21T178, 21T179	KCS-68C	173
2C511	RC-1118	9	21T197DE	KCS-68H, RC-1111A, RS-141A	180-193, 209
2C512	RC-1118A	9	21T207, 21T207G, 21T208, 21T217, 21T218, 21T227, 21T228, 21T229	KCS-72A	229
2C513	RC-1118B	9	21T242	KCS-72D-1, RC-1117B	236-249, 261
2C514	RC-1118C	9	21T244	KCS-72D-2, RC-1111B, RS-141C	236-249, 261
2C521	RC-1120, RC-1120B	13	U-1A	KRK-19A	285
2C522, 2C527	RC-1120A, RC-1120C	13	U-1B	KRK-19	285
2ES3	RS-142	17	U-2	KCS-79	289
2ES31	RS-142	19	U-2A	KCS-79A	289
2ES38	RS-142	17	U-70	KCS-70	295
2JS1	Record Player	21	Supplementary Information:		
2R51, 2R51A, 2R52, 2R52A	RC-1119	23	General notes on KCS-66, KCS-66A, KCS-68C, KCS-68E		
2S7	RC-1117D	25	Interchangeability of R-F tuners		
2S10	RC-1111, RS-141	29	Oscillator switch wafers		
2US7	RC-1117A, RC-1117C	37	R-F unit oscillator tracking		
2X61	RC-1080C	41	Use of WR39A and WR39B Television Cali- brators		
2X62	RC-1080D	41	Correcting pix i-f response		
2X621	RC-1085B	43	High-pass filter		
2XF91	RC-1121	47	High voltage arcs at kinescopes		
2XF931, 2XF932, 2XF933, 2XF934	RC-1121A	53	Adjustment of A-G-C control		
15E, 15E-1	RS-139A	59	Television receiver cross-reference		
RECORD CHANGERS					
930409 Series		63			
TELEVISION					
17T150, 17T151, 17T163	KCS-66C	77			
17T200, 17T201, 17T202, 17T211, 17T220	KCS-72, KCS-72M1, KCS-72M2	109			
17T250DE, 17T261DE	KCS-74, KCS-74M1	141			
21T159, 21T165	KCS-68E	173			
MISCELLANEOUS					
			Complete Index to Models—Vol. I to Vol. VIII		
			Index to Chassis Numbers		
			Model Number vs. Record Changer		
			Sales Name vs. Model Number		
			Fixed composition resistor stock number code		
			Crystal pickup cross-reference		

COMPLETE INDEX OF MODELS

NOTES:

†denotes "Radiola"

♦denotes "Victor"

All others "RCA" or "RCA Victor"

Refer to the index of the listed Volume for additional information contained in that Volume.

VOL. I	1923 to 1937
VOL. II	1938 to 1942
VOL. III	1943 to 1946
VOL. IV	1947 to 1948
VOL. V	1949
VOL. VI	1950
VOL. VII	1951
VOL. VIII	1952

Model	Chassis No. or Description	Vol.	Page	Model	Chassis No. or Description	Vol.	Page
AA-1400	Detector-Amplifier	I	238A	HF-2	RC-354B	II	14C
AA-1520	R-F Amplifier	I	238A	HF-4	RC-354A	II	14C
†AC	Audio Amplifier	I	2A	HF-6	RC-331A	II	124C
†AR	R-F Amplifier	I	1A	HF-8	RC-331	II	124C
AR-1300		I	238A	K-50	RC-418A, RC-497	II	504C
A-55	RC-1087	VI	1	K-60	RC-415	II	531C
A-78	RC-1084A	VI	5	2nd Prod.	RC-415B	II	537C
A-82	RC-1094	VI	11	K-61	RC-498F	II	548C
A-91	RC-1095	VI	15	K-62	RC-415B	II	537C
A-101	RC-1096, RC-1096B	VI	23	K-80	RC-415A	II	531C
A-106	RC-622	VI	33	2nd Prod.	RC-415C, RC-415D	II	537C
A-108	Correction to Parts List	VII	V	K-81, K-82	RC-415C	II	537C
	RC-1096, RC-1096B	VI	41	K-105	RC-476	II	664C
BC6-4		I	90B	K-130	RC-501A, RS-102C	II	498C
BC6-6		I	94B	MB-1, MB-2, MB-3	Repl. Motor Board	I	13A
BC7-9		I	122B	MI-8122	Power Unit	II	34C
BK-41	RC-449	II	458C	MI-13174	Coin Operated Radio	V	XV
BK-42	RC-408C	II	460C	M-30		I	118A
BP-10	RC-544	II	297C	M-32		I	135A
BP-55, BP-56, BP-85	RC-455	II	522C	M-34		I	287B
BT6-3		I	90B	M-50	RC-357 J	II	217C
BT6-5		I	94B	M-60	RC-357K	II	222C
BT6-10		I	90B	M-70	RC-394	II	560C
BT7-8		I	122B	M-101, M-104		I	409B
BT-40	RC-408	II	456C	M-105		I	420B
BT-41	RC-449	II	458C	M-107		I	437B
BT-42	RC-408A	II	460C	M-108		I	409B
BX-6	RC-1082, RC-1082A	VI	47	M-109		I	449B
BX-55	RC-1088, RC-1088B	VI	51	M-116		I	459B
BX-57	RC-1088A, RC-1088C	VI	55	M-123		I	480B
†B-50	RC-1004H	II	399C	OSC. 22	Phono. Oscillator	II	395C
†B-52	RC-1004D	II	407C	O-1	Portable Victrola	I	1B
B-411	RC-1098, RC-1098A	VI	43	O-2	Portable Victrola	II	20C
CRD-9 A.C.	Record Demonstrator	I	186B	O-3	Portable Victrola	II	33C
CRD-9 D.C.	Record Demonstrator	I	188B	O-6, O-10	Portable Victrola	II	20C
CV-8	Power Unit	I	160B	O-11	Portable Victrola	I	1B
CV-9	RS-79B	II	610C	O-12, O-14	Portable Victrola	II	20C
CV-40	RS-98	II	458C	O-15	Portable Victrola	I	1B
CV-42	RS-1000	II	404C	O-16, O-19	Portable Victrola	II	20C
CV-45	RS-1001	III	67	O-50	Record Player	II	509C
CV-110	RS-83C	II	34C	PLF-10	Power Line Filter	II	81C
CV-111	RS-95	II	44C	PSU-8A, PSU-8B,			
CV-112	RS-111	II	23C	PSU-8C	Power Unit	II	211C
CV-112X	RS-111A	II	87C	PSU-8E	Power Unit	II	213C
CV-120	Power Unit	V	XVI	PSU-10A, PSU-10B,			
C6-2		I	98B	PSU-10C	Power Unit	II	211C
C6-8		I	103B	PSU-10E	Power Unit	II	213C
C6-12		I	107B	PT-33	Record Player	I	149A
C7-6		I	127B	PX61-10	RC-1023B	III	III
C7-14		I	98B	PX-600	RC-1110	VII	45
C8-15		I	146B	†P-5	RC-465, RC-1020B	II	83C
C8-17		I	152B	P-31		I	128A
C8-19, C8-20		I	161B	QB-1	RC-529A	II	8C
C9-4		I	146B	QB-2	RC-529	II	23C
C9-6		I	152B	QB-3	RC-539D	II	34C
C11-1, C113		I	215B	QB-5	RC-563A	II	87C
C13-2, C13-3		I	230B	QB-6	RC-529D	II	23C
C15-3, C15-4		I	253B	QB-9	RC-529H	II	8C
D7-7		I	127B	QB-11, QB-12	RC-529A	III	7
D8-28		I	161B	QB-13	RC-612	III	7
D9-19		I	152B	QB-55	RC-563A	III	41
D11-2		I	219B	QB-55X	RC-563K	III	43
D22-1, D22-1A		I	262B	QB-60	RC-607	IV	113
♦E-35	Electrola	I	138A		Correction to Parts List	V	XVI
♦E-135	R-32 Amp. & Speaker	I		QH-1	Record Player	IV	1
♦E-152	R-32 Amp. & Speaker	I		QK-23	RC-507B	II	27C
G-8	Armchair Control	I	619B	QU-2C	RC-507C	II	27C
HF-1	RC-339	II	5C	QU-2M	RC-507D	II	27C

COMPLETE INDEX OF MODELS (Continued)

Model	Chassis No. or Description	Vol.	Page	Model	Chassis No. or Description	Vol.	Page
QU-3C	RC-507F	II	39C	◆RE-156	Similar to RE-45	I	
QU-3M	RC-507H	II	39C	RK-24	Phono. Osc. (Stock No. 9554)	I	281B
QU-5	RC-530, RS-110	II	89C	RK-137-1, RK-137-2	Ceramic Pickup Kit	V	XVI
QU-7	RC-551, RS-112A	II	147C	RO-23		I	94A
QU-8	RC-551, RS-112	II	147C	RP-132 Series	Automatic Record Changer	II	698C
QU-51C, QU-51M	RC-568	II	511C	RP-139 Series	Automatic Record Changer	II	698C
QU-52C	RC-507L	II	516C	RP-140	Automatic Record Changer	II	698C
QU-52M	RC-507N	II	516C	RP-145 Series	Automatic Record Changer	II	698C
QU-55	RC-568A	II	511C	RP-151	Automatic Record Changer	II	713C
QU-56C, QU-56M	RC-566A	II	526C	RP-152, RP-153, RP-155, RP-157	Automatic Record Changer	II	726C
QU-61	RC-568B	II	59	RP-158, RP-160, RP-161, RP-162	Automatic Record Changer	II	737C
QU-62	RC-602B	IV	119	RP-168 Series	Automatic Record Changer	V	109
QU-68	RC-601B	IV	28			VI	93
QU-72, QU-72A	RC-1035	III	103	RP-176 Series	Automatic Record Changer	III	121
Q-10, Q-10A, Q-10-2				RP-177	Automatic Record Changer	III	133
Q-10A-2	RC-594C	III	5	RP-177 Series	Automatic Record Changer	IV	151
Q-10-3	RC-594C	III	III	RP-178	Automatic Record Changer	IV	167
Q-11	RC-563E, RC-563F	II	309C	RP-190 Series	Automatic Record Changer	VI	107
Q-12	RC-563, -563B, -563C, -563D	II	309C			VII	33
Q-14, Q-15	RC-566	II	330C	RP-193	Automatic Record Changer	VI	119
Q-14E, Q-15E	RC-566B	II	330C	†RS	Detector-Amplifier	I	2A
Q-16	RC-561	II	361C	†RT	Antenna Coupler	I	1A
Q-16E	RC-561C	II	361C	R-3B		I	3B
Q-17	RC-561A	II	369C	R-3C		I	4B
Q-18	RC-477	II	62C	R-4		I	19A
Q-20, Q-21	RC-514	II	381C	R-5	Radiolette	I	22A
Q-22	RC-507	II	27C	R-5 D. C.		I	23A
Q-22A	RC-507	III	15	R-5X		I	24A
Q-23	RC-592	II	396C	R-6		I	19A
Q-24	RC-508	II	401C	R-7	Superette	I	27A
Q-25	RC-507A	II	27C	R-7A		I	32A
Q-26	RC-507J	II	39C	R-7 D. C.		I	34A
Q-27	RC-507K	II	27C	R-7 L. W.		I	36A
Q-30	RC-538B	II	438C	R-8		I	38A
Q-31	RC-538C	II	438C	R-8 D. C.		I	43A
Q-32	RC-507	III	15	R-9		I	27A
Q-33	RC-539	II	452C	R-9 D. C.		I	34A
Q-34	RC-539E	III	19	R-10		I	38A
Q-36	RC-585	III	23	R-10 D. C.		I	34A
Q-44	RC-531	II	462C	R-11		I	49A
Q-103, Q-103A, Q-103A-2, Q-103-2	RC-1044	III	107	R-12		I	38A
Q-103AX, Q-103AX-2, Q-103X, Q-103X-2	RC-1044B	III	107	◆R-14, R-15		I	60A
Q-109	RC-602	IV	143	R-17, R-17M, R-17W		I	259B
Q-109X	RC-602A	IV	143	R-18W		I	261B
Q-110	RC-594C	III	IV	R-21		I	49A
Q-121	RC-507, RC-507U	III	111	R-22		I	279B
Q-122	RC-601, RC-601D	III	115	R-24	R-71 with SW-3 Converter		
Q-122X	RC-601A, RC-601E	III	115	R-24A	R-73 with SW-3 Converter		
Radiola II	AR-800	I	3A	R-24A	R-73A with SW-3 Converter		
Radiola III, IIIA	AR-805, AR-806	I	4A	R-24B	R-71B with SW-3 Converter		
Radiola IV, V	AR-880, AR-885A	I	6A	R-25 D. C.		I	4B
Radiola VI	AR-895	I	7A	R-27		I	259B
Radiola VII, VIIB		I	8A	R-28 Series		I	282B
Radiola Super VIII	AR-810	I	9A	R-28P		I	282B
Radiola IX		I	10A	◆R-32		I	138A
Radiola X		I	11A	◆R-34		I	151A
Radiola Grand		I	3A	◆R-35		I	151A
Rad. Regenoflex		I	11A	R-37, R-38		I	290B
Rad. Superheterodyne	AR-804	I	98A	R-37P, R-38P		I	292B
RAE-26		I	49A	◆R-39		I	151A
RAE-59		I	77A	R-43		I	163A
RAE-68		I	195A	R-50		I	77A
RAE-79		I	77A	R-51B		I	295B
RAE-84		I	207A	◆R-52		I	138A
RAE-84-SW	RAE-84 with SW-3 Converter			R-53B		I	295B
†RC	Detector-Amplifier	I	1A	R-55		I	77A
◆RC-3	Victor R-15	I	60A	R-56	Record Player	II	530C
RE-16		I	27A	R-60	Record Player	II	509C
RE-16A		I	32A	†R-65BR9	RC-1045	III	IV
◆RE-17		I	60A	R-70		I	198A
RE-18, RE-18A		I	49A	R-71		I	304B
RE-19		I	38A	R-71B		I	307B
RE-20		I	77A	R-72		I	304B
RE-40, RE-40P		I	282B	R-73		I	310B
◆RE-45		I	138A	R-73A		I	313B
◆RE-57		I	151A	R-74		I	200A
RE-73		I	151A	R-75		I	310B
◆RE-75		I	138A	R-75A		I	313B
RE-80		I	310B	R-76, R-77		I	200A
RE-81		I	200A	R-78		I	207A
RE-81-SW	RE-81 with SW-3 Converter	I		R-78SW	R-78 with SW-3 Converter		
◆RE-154	Similar to RE-45	I		R-89	Record Player	II	568C

COMPLETE INDEX OF MODELS (Continued)

Model	Chassis No. or Description	Vol.	Page	Model	Chassis No. or Description	Vol.	Page
R-90, R-90P		I	378B	U-44	RC-486B, RS-102A	II	467C
R-91	Record Player	II	569C	U-45	RC-486C, RS-102D	II	467C
R-91B		I	382B	U-46	RC-501, RS-102B	II	498C
R-92	Recorder	I	383B	U-50	RC-414C	II	62C
R-93, R-93A	Record Player	I	385B	U-70	KCS-70	VIII	295
R-93B, R-93C	Record Player	II	571C	U-101		I	414B
R-93F	Record Player	II	572C	U-102E		I	326B
R-93S, R-93-2	Record Player	I	385B	U-103		I	414B
R-94	Record Player	I	385B	U-104	RC-354H	II	662C
R-94B	Record Player	II	594C	U-105		I	423B
R-95	Record Player	I	392B	U-106	RC-319B	I	429B
R-96, R-97	Record Player	I	395B	U-107		I	423B
R-98	Record Player	II	652C	U-108, U-109		I	441B
R-99	Record Player	I	398B	U-111	RC-341, RC-341M	II	677C
R-100	Record Player	II	572C	U-112	RC-341C, RC-341CM	II	677C
R-103S	Record Player	II	661C	U-115	RC-348E	II	680C
†R-560P	RC-517F	II	668C	U-119	RC-351E	II	683C
†R-566P	RC-517J	II	708C	U-121	RC-348J	II	687C
†SR		I	2A	U-122E	RC-351D	II	683C
SR-1, SR-2, SR-3	Two-speed Turntable	I	13A	U-123	RC-348H, RC-421	II	687C
SWA-2, SW-2	Short Wave Converter	I	16A	U-124	RC-351C	II	683C
SW-3	Short Wave Converter	I	5B	U-125	RC-386	II	694C
SW-10	Short Wave Converter	I	234A	U-126	RC-335D	II	444C
S-1000	KCS-31, RC-617B	VI	307	U-127E	RC-348L	II	687C
TA-128	KCS-42A, RK-135D	VI	223	U-128	RC-335D	II	444C
TA-129	KCS-41A, RK-135D	VI	243	U-129	RC-335K	II	444C
TA-169	KCS-43, RK-135D	VI	289	U-130	RC-354	II	14C
TC-124, TC-125, TC-127	KCS-34B	VI	221	U-132	RC-331C	II	124C
TC-165, TC-166, TC-167, TC-168	KCS-40A	VI	261	U-134	RC-331B	II	124C
TH-10	D.C. Inverter	I	213B	VA-15	Record Player	II	343C
TRK-5	KC-3, KC-3A, RC-429, RS-89A	II	93C	VA-20, VA-21	Wireless Record Player	II	392C
TRK-9, TRK-12	Television & Radio Comb.	II	251C	VA-22, VA-24	Wireless Record Player	II	343C
TRK-90, TRK-120	Television & Radio Comb.	II	251C	♦VE7-3 to VE15-1	Refer to numerical listing		
TT-5	KC-3, KC-3B	II	93C	VHR-202	RC-548	II	761C
T4-8, T4-9		I	14B	VHR-207	RC-547	II	761C
T4-8A, T4-9A		I	17B	VHR-212	RC-574	II	782C
T4-10		I	19B	VHR-307	RC-555	II	799C
T5	Record Player	I	25A	VHR-407	RC-547A	II	761C
T5-2		I	52B	VV2-35 to VV9-18	Refer to numerical listing		
T6-1		I	98B	V-30	Record Player	I	249A
T6-7		I	103B	V-100	RC-517	II	654C
T6-9		I	110B	V-101	RC-540	II	656C
T6-11		I	107B	V-102	RC-524	II	658C
T7-5		I	127B	V-105	RC-517C	II	668C
T7-12		I	98B	V-135	RC-517H	II	708C
T8-14		I	146B	V-140	RC-572A	II	710C
T8-16		I	152B	V-170	RC-523	II	749C
T8-18		I	161B	V-175	RC-582	II	753C
T9-7, T9-8		I	190B	V-200	RC-519	II	756C
T9-9		I	152B	V-201	RC-522	II	756C
T9-10		I	146B	V-205	RC-521	II	771C
T10-1		I	204B	V-209	RC-573	II	775C
T10-3		I	208B	V-210	RC-573A	II	775C
T11-8		I	208B	V-215	RC-564	II	789C
T-55, T-55S	RC-418	II	504C	V-219	RC-564A	II	789C
T-56	RC-418	II	504C	V-221	RC-564	II	789C
T-60	RC-425	II	543C	V-225	RC-564B	II	789C
T-62	RC-425D	II	543C	V-300	RC-518	II	794C
T-63	RC-472F	II	551C	V-301, V-302	RC-518A	II	794C
T-64, T-65	RC-416	II	554C	V-405	RC-521B	II	771C
T-80	RC-416A	II	554C	WCC-9	Carrying Case	V	XIV
T-100	KCS-38	VI	179	X-55	RC-473A	II	524C
T-120, T-121	KCS-34C	VI	193	X-60	RC-474D	II	546C
T-164	KCS-40	VI	261	X-551	RC-1089B	VI	59
UY-122E	RC-352B	II	692C		Added Resistor	VII	V
UY-124	RC-352C	II	692C	X-552	RC-1089C	VI	59
U1-A	KRK-19A	VIII	285		Added Resistor	VII	V
U1-B	KRK-19	VIII	285	X-711	RC-1070A	VI	61
U2	KCS-79	VIII	289	1AX, 1AX2	RC-1003A	II	1C
U2-A	KCS-79A	VIII	289	1R81	RC-1102, RC-1102A, RC-1102B, RC-1102C	VII	1
U-8	RC-404A	II	215C	1X, 1X2	RC-1003	II	1C
U-9	RC-482B, RC-482C	II	283C	1X51	RC-1104, RC-1104-1, RC-1104C	VII	13
U-10	RC-418B	II	299C	1X52	RC-1104A, RC-1104A-1, RC-1104D	VII	13
U-12	RC-425A	II	320C	1X53, 1X54, 1X55, 1X56	RC-1104B, RC-1104B-1, RC-1104E	VII	13
U-20	RC-498	II	384C	1X57	RC-1104A, RC-1104A-1, RC-1104D	VII	13
U-25, U-26	RC-386B	II	409C	1X591	RC-1079K	VII	17
U-30	RC-335KR	II	444C	1X592	RC-1079L	VII	17
U-40	RC-498A	II	384C				
U-42	RC-498B, RS-89B	II	384C				
U-43	RC-498E	II	384C				

COMPLETE INDEX OF MODELS (Continued)

<i>Model</i>	<i>Chassis No. or Description</i>	<i>Vol.</i>	<i>Page</i>	<i>Model</i>	<i>Chassis No. or Description</i>	<i>Vol.</i>	<i>Page</i>
2-B-400, 2-B-401, 2-B-402, 2-B-403, 2-B-404, 2-B-405	RC-1114	VIII	1	6K		I	60B
2-BX-63	RC-1115	VIII	5	6K1		I	63B
2-C-511	RC-1118	VIII	9	6K2		I	64B
2-C-512	RC-1118A	VIII	9	2nd Prod.		I	71B
2-C-513	RC-1118B	VIII	9	6K3		I	77B
2-C-514	RC-1118C	VIII	9	6K10		I	64B
2-C-521	RC-1120, RC-1120B, RC-1120D	VIII	13	6M		I	81B
2C-522, 2C-527	RC-1120A, RC-1120C, RC-1120E	VIII	13	6M2		II	81B
2-ES-3	RS-142	VIII	17	6QK8	RC-414B	II	76C
2-ES-31	RS-142	VIII	19	6QP3	RC-1067	V	13
2-ES-38	RS-142	VIII	17	6QU	RC-414	II	62C
2-JS-1	Record Player	VIII	21	6QU3	RC-1054C	IV	18
2-R-51, 2-R-51A, 2-R-52, 2-R-52A	RC-1119	VIII	23	6QV3	RC-1054D	IV	18
2-S-7	RC-1117D	VIII	25	6Q1	RC-441	II	107C
2S7ED	Record Player	IV	3	6Q4	RC-441A	II	111C
2-S-10	RC-1111, RS-141	VIII	29	6Q4X	RC-442	II	118C
2T51	KCS-45	VI	325	6Q7	RC-414A	II	62C
2T60	KCS-45A	VI	325	6Q8	RC-414B	II	76C
2T81	KCS-46 & RC-1090	VI	353	6Q33	RC-1054A	IV	11
2-US-7	RC-1117A, RC-1117C	VIII	37	6Q33X	RC-1054B	IV	14
2-X-61	RC-1080C	VIII	41	6T		I	60B
2-X-62	RC-1080D	VIII	41	6T2		I	64B
2-X-621	RC-1085B	VIII	43	6T5		I	86B
2-XF-91	RC-1121	VIII	47	6T10		I	64B
2-XF-931, 2-XF-932, 2-XF-933, 2-XF-934	RC-1121A	VIII	53	6T53, 6T54	KCS-47, KCS-47T	VI	367
2-19	Record Player	I	14A	6T64, 6T65, 6T71	KCS-47A, KCS-47AT	VI	367
1935 Prod.	Record Player	I	2B	6T72	KCS-40B	VI	401
2-25	Record Player	I	14A	6T74, 6T75, 6T76	KCS-47A, KCS-47AT	VI	367
2-35	Record Player	I	17A	6T84	KCS-48, KCS-48T & RC-1090	VI	413
2-55	Record Player	I	18A	6T86, 6T87	KCS-48, KCS-48T & RC-1092	VI	413
2-65	Record Player	I	15A	6X2	RC-1013	II	122C
4QB	RC-440	II	44C	7K		I	113B
4QB3	RC-1071	V	1	7K1		I	77B
4QB3X	RC-1071A	V	1	7QB, 7QBK	RC-496	II	142C
4QB4	RC-440A	II	44C	7QK4	RC-478B	II	111C
4T		I	8B	7QV5	RC-601B	IV	28
4T101	KCS-61	VII	49	7Q4	RC-478A	II	111C
4T141	KCS-62, RC-1090	VII	81	7Q4X	RC-502	II	138C
4X, 4X3, 4X4		I	11B	7Q51	RC-1055, RC-1055C	IV	22
5BT		I	21B	7Q51X	RC-1055D	V	19
5H	Record Player	III	1	7T		I	113B
5H1, 5H2	Record Player	III	1	7T1		I	77B
5M		I	24B	7T103, 7T104	KCS-47B	VII	99
5QA5	RC-1072	V	7	7T103B, 7T104B	KCS-47F	VII	99
5Q1	RC-315C	II	50C	7T111B	KCS-47GF-2	VII	99
5Q2	RC-325C	II	53C	7T112, 7T122	KCS-47C	VII	99
5Q2X	RC-325D	II	56C	7T112B, 7T122B	KCS-47G, KCS-47GF, KCS-47GF-2	VII	99
5Q4	RC-366	II	59C	7T123, 7T124	KCS-47C	VII	99
5Q5	RC-396, RC-477	II	62C	7T123B	KCS-47G, KCS-47GF, KCS-47GF-2	VII	99
5Q6	RC-477A	II	70C	7T125B	KCS-47G	VII	99
5Q8	RC-396B, RC-477B	II	73C	7T132	KCS-47D	VII	99
5Q12	RC-396D	II	70C	7T143	KCS-48A, RC-1092	VII	147
5Q12A	RC-396E	II	76C	7U		I	64B
5Q21	RC1053, RC1053A, RC1053B	IV	5	7U2		I	71B
5Q22, 5Q27	RC1053	IV	5	7X, 7X1		I	118B
5Q31	RC1054	IV	8	◆7-1	Alhambra I	I	75A
5Q31X	RC1054E	IV	XI	◆7-2	Alhambra II	I	103A
5Q55, 5Q56	RC-396	II	62C	◆7-3		I	75A
5Q66	RC-477C	II	79C	◆7-10	AR-1058	I	65A
5T		I	29B	◆7-11	AR-742	I	71A
5T1		I	32B	◆7-25	AR-1059	I	67A
5T4		I	35B	◆7-26	AR-744	I	71A
5T5		I	38B	◆7-30		I	75A
5T6, 5T7		I	42B	8BK, 8BK6		I	134B
5T7-O		I	42B	8BT, 8BT6		I	134B
5T8		I	42B	8BX5	RC-1059, RC-1059A	IV	37
5U		I	38B	8BX6	RC-1040C, RC-1040D	IV	43
5X, 5XA		I	45B	8BX54, 8BX55	RC-1059, RC-1059A	IV	37
5XA3, 5XA4		I	45B	8BX65	RC-1040C	IV	46
5X2		I	49B	8B41	RC-1069	IV	33
5X3, 5X4		I	45B	8B42	RC-1069A	IV	33
5X5-I	RC-406A	II	81C	8B43	RC-1069B	IV	33
5X5-W	RC-406	II	81C	8B46	RC-1069C	IV	XI
6BK, 6BK6		I	55B	8F43	RC-1037B	IV	47
6BT, 6BT6		I	55B	8K, 8K1		I	113B
6J, 6JM	Record Player	III	3	8K11		I	139B
				8M	RC-318	II	178C
				8M1	RC-320	II	181C
				8M2	RC-320A	II	181C

COMPLETE INDEX OF MODELS (Continued)

Model	Chassis No. or Description	Vol.	Page	Model	Chassis No. or Description	Vol.	Page
8M3	RC-321	II	186C	9TX-1 to 9TX-5	RC-401	II	230C
8M4	RC-321A	II	186C	9TX-21, 9TX-22	RC-403	II	239C
8PCS41	Projection Television Rec.	IV	365	9TX-23	RC-403A	II	239C
8QB, 8QBK	RC-336	II	206C	9TX-31	RC-405	II	241C
8QU5-C, 8QU5-M	RC-443B	II	196C	9TX-32	RC-405A	II	241C
8Q1	RC-337	II	191C	9TX-33	RC-405B	II	241C
8Q2	RC-443	II	196C	9TX-50, 9TX-50M	RC-435	II	243C
8Q4	RC-337A	II	201C	2nd Prod.	RC-454	II	246C
8R71	RC-1060	IV	49	9T57	KCS-49, KCS-49T	VI	437
	Change in Osc. Circuit	V	XIV	9T77, 9T79	KCS-49A, KCS-49AT	VI	437
8R72	RC-1060A	IV	49		Change in Parts List	VII	V
8R74, 8R75	RC-1060	IV	49	9T89	KCS-60, KCS-60T	VI	455
8R76	RC-1060A	IV	49		RC-1092	VI	455
8T		I	113B	9T105	KCS-49B, KCS-49BF,	VII	169
8TC270	KCS-29A	IV	513		KCS-49BF-2	VII	169
8TC271	KCS-29A	IV	513	9T126, 9T128	KCS-49C, KCS-49CF,	VII	169
8TK29	KCS-32A, KCS-32C,	IV	467		KCS-49CF-2	VII	169
	RK-135, RK-135A	IV	467	9T147	KCS-60A, RC-1092	VII	191
8TK320	KCS-33A, RK-135A	IV	545	9T240	KCS-28, KCS-28A	V	143
8TR29	KCS-32, KCS-32B, RK-135,	IV	467	9T246	KCS-28C, KCS-38	V	171
	RK-135A	IV	467	9T256	KCS-38C	V	217
8TS30	KCS-20J-1, KCS-20K-2	IV	271	9T270	KCS-29	V	235
8TV41	KCS-25D, KCS-25E,	IV	207	9U, 9U2		I	179B
	RK-117A, RS-123A	IV	207	9W51	RC-1079D	V	53
8TV321	KCS-30, RC-616C,	IV	487	9W57	RC-1084A	V	57
	RC-616K	IV	487	9W78	RC-618B	V	65
8TV323	KCS-30, RC-616B, RC-616J	IV	487	9W101	RC-618D	V	75
8T2		I	139B	9W102	RC-618B	V	65
8T10		I	113B	9W103	RC-618C	V	65
8T11		I	139B	9W105	RC-622	V	79
8T241, 8T243, 8T244	KCS-28	IV	435	9W106	RC-622	V	79
8T270	KCS-29	IV	513		Correction to Parts List	VII	V
8U, 8U2		I	139B	9X	RC-350	II	248C
8V7	RC-615	IV	57	9X-1 to 9X-4	RC-350	II	248C
8V90	RC-618, RC-618A	IV	59	9X-6	RC-350A	II	248C
8V91	RC-616A, RC-616H	IV	59	9X-11 to 9X-14	RC-350A	II	248C
	Alternate Speaker	V	XV	9X561	RC-1079B	V	89
8V112	RC-616, RC-616F	IV	71	9X562	RC-1079C	V	89
	Alternate Speaker	V	XV		Alternate Speaker	VI	XI
8V151	RK-121C & RS-123D	IV	81	9X571	RC-1079, RC-1079E	V	91
8X53	RC-1064	IV	97	9X572	RC-1079A, RC-1079F	V	91
8X71, 8X72	RC-1070	IV	99		Alternate Speaker	VI	XI
	Oscillation on FM	V	XIV	9X641	RC-1080	V	95
8X521	RC-1066	IV	105	9X642	RC-1080A	V	95
8X522	RC-1066A	IV	105	9X651	RC-1085	V	97
8X541, 8X542, 8X544,				9X652	RC-1085A	V	97
8X545, 8X546, 8X547	RC-1065, RC-1065A to	IV	107	9Y7	RC-1057B	V	101
	RC-1065D	IV	107	9Y51	RC-1077	V	105
	RC-1065F, RC-1065H	IV	XI	9Y510	RC-1077A, RC-1077C	VI	67
	RC-1065, RC-1065A to	V	23		Alternate Speaker	VII	V
	RC-1065M	V	23	9Y511	RC-1077B	VI	71
8X681, 8X682	RC-1061	IV	109	◆9-1	Florenza	I	103A
◆8-60	Record Player	I	45A	◆9-2	Borgia II	I	112A
9BX5	RC-1059B, RC-1059C	V	27	◆9-3	Borgia I	I	107A
9BX56	RC-1068	V	31	◆9-15		I	107A
9EY3	RS-132	V	35	◆9-16	AR-745	I	71A
9EYM3	RS-132	V	37	◆9-18	AR-776	I	180A
9EY31, 9EY32	RA-79	V	39	◆9-25	AR-1050	I	112A
9EY35, 9EY35U,				◆9-40	Borgia	I	112A
9EY36, 9EY36U	RS-132, RS-132A	V	41	◆9-54	AR-775	I	180A
	Record Player	V	43	◆9-55	AR-1055	I	112A
9JY	Record Player	V	45	◆9-56	AR-775A	I	180A
9JYM		V	45	10K		I	196B
9K		I	167B	10K1		I	201B
9K1		I	172B	10K11		I	196B
9K2		I	179B	10Q1	RC-337B	II	286C
9K3		I	172B	10T		I	196B
9K10		I	179B		2nd Prod.	I	201B
9M1	RC-357	II	217C	10T11		I	196B
9M2	RC-357A	II	222C	10X	RC-1001, RC-1001B	II	291C
9PC41	Projection Television Rec.	V	123	◆10-35		I	45A
9QK	RC-444A	II	227C	◆10-50	AZ-781	I	239A
9Q1	RC-444	II	227C	◆10-51	AZ-1071	I	46A
9Q4	RC-478	II	232C	◆10-69	AZ-773	I	47A
9Q53	RC-614	V	47	◆10-70	AZ-1073	I	48A
9SX-1 to 9SX-8		II	237C	11QK	RC-335C	II	302C
9T		I	179B	11QU	RC-335E	II	302C
9TC240	KCS-28B	V	143	11Q4	RC-335C	II	302C
9TC245	KCS-34B	V	161	11X1	RC-1001A	II	291C
9TC247, 9TC249	KCS-34, KCS-34B	V	161	12AX, 12AX2	RC-1001C	II	291C
9TC272, 9TC275	KCS-29C	V	235	12QK	RC-338	II	313C
9TW309	KCS-41, RK-135C	V	267	12QU	RC-338A	II	313C
9TW333	KCS-30, RC-616N	V	287	12Q4	RC-338	II	313C
9TW390	KCS-31, RC-617A	V	309	12X	RC-1001B, RC-1022A	II	291C

COMPLETE INDEX OF MODELS (Continued)

Model	Chassis No. or Description	Vol.	Page	Model	Chassis No. or Description	Vol.	Page
12X2	RC-1001B	II	291C	†26		I	98A
◆12-1	Cromwell	I	57A	26BP	RC-559	II	414C
◆12-2	Tuscany	I	57A	26X-1	RC-1014	II	416C
◆12-15	AZ-774, AZ-1077	I	58A	26X-3	RC-1014A	II	416C
◆12-25		I	59A	26X-4	RC-1014B	II	416C
13K		I	225B	27K	RC-567	II	421C
14A X, 14AX2	RC-1001E	II	324C	†28	AR-920, UP-972	I	112A
14BK	RC-525B	II	328C	†28 D.C.	AR-920, AR-969	I	107A
14BT-1	RC-525	II	328C	28T	RC-569	II	425C
14BT-2	RC-525A	II	328C	28X	RC-1002	II	429C
14X, 14X2	RC-1001D	II	324C	28X-5	RC-1002A	II	429C
15BP-1, -2, -4, -6	RC-527	II	333C	29K	RC-570	II	434C
15BP-3, -5	RC-527A	II	333C	29K2	RC-570C, RC-570D	II	434C
15BP-7	RC-527C	II	333C	†30	AR-921	I	122A
15BT	RC-526	II	335C	†30A	AR-906, AR-926	I	124A
15-E, 15-E-1	RS-139A	VIII	59	†30A D.C.	AR-912	I	124A
15K		I	236B	†32	AR-925	I	131A
15U		I	241B	†32 D.C.	AR-928	I	131A
15X	RC-462	II	337C	†33	AR-784	I	143A
(2nd Prod.)	RC-1011	II	341C	†33 D.C.	(110 V.)	I	147A
◆15-1	Hyperion	I	112A	†33 D.C.	(220 V.)	I	145A
†16	AR-924	I	65A	34X	RC-1001E, RC-1022	II	324C
16K	RC-509C	II	344C	35X	RC-1001C, RC-1022A	II	291C
16T2	RC-509B, RC-509J	II	344C	36X	RC-462A	II	337C
16T3	RC-509A, RC-509H	II	344C	36X	RC-1011	II	341C
16T4	RC-509, RC-509F	II	351C	40X-30	RC-405C	II	243C
16T152	KCS-47E	VII	204	40X-31	RC-405D	II	243C
16X-1, 16X-2	RC-462A	II	337C	40X-50 to -57	RC-436	II	243C
16X-3	RC-462B	II	337C	40X-52 (2nd Prod.)	RC-453	II	246C
16X-4	RC-462C	II	355C	40X-55 (2nd Prod.)	RC-453	II	246C
16X-11	RC-1000	II	357C	†41	AR-782	I	158A
16X-13	RC-1000A	II	357C	†41 D.C.	AR-871	I	161A
16X-14	RC-1000B	II	357C	†42		I	60A
†17	AR-927	I	67A	†44	AR-594	I	164A
17K	RC-512	II	365C	45-E Series	RC-435A	II	475C
17T-150, 17T-151	KCS-66C	VIII	77	45-EY	RS-132, RS-132A, RS-132F	VI	73
17T-153, 17T-154,				45-EY-1	RS-132F	VI	73
17T-155, 17T-160	KCS-66	VII	227	45-EY-2	RS-138A, RS-138H	VI	77
17T-162	KCS-66A	VII	227		RS-138A, RS-138F,		
17T-163	KCS-66C	VIII	77		RS-138H	VII	23
17T-172, 17T-173,				45-EY-3	RS-136, RS-136A, RS-136C	VI	79
17T-174	KCS-66A	VII	227		RS-136, RS-136A, RS-136C,		
17T-172K, 17T-173K,					RS-136E	VII	25
17T-174K	KCS-66D	VII	227	45-EY-4	RS-140	VII	29
17T-200, 17T-201,				45-EY-15	RS-132H	VI	73
17T-202, 17T-211,				45-EY-26	RS-138L, RS-138M	VII	31
17T-220	KCS-72	VIII	109	45-J	Record Player	VI	81
17T-250DE,				45-J-2	Record Player	VI	83
17T-261DE	KCS-74	VIII	141	45-J-3	Record Player	VI	84
†18	AR-936	I	71A	45-W-9	RC-1095A	VI	85
†18 D.C.	AR-891	I	74A	45-W-10	RC-1096A, RC-1096C	VI	89
18T	RC-511	II	372C	45X	RC-459L	II	477C
19K	RC-512A	II	377C	45X-1, 45X-2	RC-457, RC-457A	II	481C
†20	AR-918	I	75A	45X-3, 45X-4	RC-457E	II	481C
†21	AR-1258	I	92A	45X-5, 45X-6	RC-457D	II	484C
21T-159, 21T-165	KCS-68E	VIII	173	45X-11, 45X-12	RC-459, RC-459D, RC-459T	II	477C
21T-159DE,				45X-13	RC-459A, RC-459E	II	477C
21T-166DE,				45X-16, 45X-17	RC-459M	II	486C
21T-174DE,				45X-18	RC-541C	II	489C
21T-175DE,				45X-111, 45X-112	RC-459J	II	486C
21T-178DE,				45X-113	RC-459K	II	486C
21T-179DE	KCS-68F	VIII	173	†46	AR-596	I	164A
21T-176, 21T-177,				46 D.C.	AR-597	I	169A
21T-178, 21T-179	KCS-68C	VIII	173	46X-1, 46X-2	RC-459B, RC-459F	II	491C
21T-197DE	KCS-68H, RC-1111A,			46X-3	RC-459C, RC-459H	II	491C
	RS-141A	VIII	209	46X-11, 46X-12	RC-456	II	494C
21T-207, 21T-207G,				46X-13	RC-456A	II	494C
21T-208, 21T-217,				46X-21	RC-461B	II	496C
21T-218, 21T-227,				46X-23	RC-461A	II	496C
21T-228, 21T-229	KCS-72A	VIII	229	46X-24	RC-461	II	496C
21T-242	KCS-72D-1, RC-1117B	VIII	261	†47	AR-1147	I	171A
21T-244	KCS-72D-2, 1111B,			†48		I	60A
	RS-141C	VIII	261	†50	AR-910		Similar to Rad. 17
†22	AR-1265	I	92A	†51	AR-904		Similar to Rad. 18
†24	AR-804	I	98A	†51 D.C.		I	74A
24BT-1, -2	RC-1004F	II	399C	54B-1	RC-589, RC-589U	III	29
†25	AR-919	I	103A	54B-1N	RC-589D	III	29
†25 A.C.	AR-919, UP-971	I	105A	54B-2	RC-589A, RC-589UA	III	29
25BK	RC-1004B	II	404C	54B-3	RC-589B, RC-589UB	III	29
25BP	RC-527D, RC-1020	II	83C	54B-5	RC-1047	III	33
25BT-2	RC-1004A	II	407C	54B-6	RC-589UE	III	III
25BT-3	RC-1004B	II	404C	55F	RC-1004E	III	37
25X	RC-1003	II	1C				

COMPLETE INDEX OF MODELS (Continued)

Model	Chassis No. or Description	Vol.	Page	Model	Chassis No. or Description	Vol.	Page
55AU, 55U	RC-1017	III	39	86T-44		I	354B
55X	RC-1003C	II	520C	86X		I	358B
56X, 56X-2, 56X-3	RC-1011, RC-1011A, RC-1011B	III	45	86X-4		I	361B
56X-5	RC-1023	III	47	87EY		I	364B
56X-10	RC-1023B	III	47	87K		I	346B
56X-11	RC-1023A	III	49	87K-1, 87K-2	RC-319	I	368B
58AV, 58V	RC-604	I	51	87T		I	346B
59AV-1, 59V-1	RC-605	III	55	87T-1	RC-315A	I	351B
†60	AR-954	I	176A	87T-2	RC-319	I	368B
†61-1, 61-2, 61-3	RC-1011, RC-1011A, RC-1011B	III	III	87X, 87Y		I	364B
†61-5	RC-1023	III	III	88K		I	372B
†61-6, 61-7	RC-594D	III	63	88U, 88U-2		I	372B
†61-8, 61-9	RC-1034, RC-1064	III	IV	94BK	RC-333	II	574C
†61-10	RC-1023B, RC-1023C	III	III	94BK-1	RC-333B	II	576C
†62	AR-982	I	176A	94BK-2	RC-390	II	578C
†62-1	RC-1017A	III	III	94BP-4 Series	RC-410	II	585C
63E, 63EM	RS-127	III	65	94BP-61, 94BP-62, 94BP-64, 94BP-66, 94BP-80, 94BP-81	RC-407, RC-407B	II	582C
†64	AR-894	I	180A	94BT	RC-333	II	574C
64F-1, 64F-2	RC-1037	III	67	94BT-1	RC-333B	II	576C
64F-3	RC-1037A	III	67	94BT-2	RC-390	II	578C
65AU	RC-1017A, RC-1017B	III	73	94BT-6	RC-333A	II	587C
65BR-9	RC-1045	III	69	94BT-61	RC-333C	II	589C
65F	RC-1004E	III	71	94X	RC-332	II	591C
65U, 65U-1	RC-1017A, RC-1017B	III	73	94X-1, 94X-2	RC-340	II	591C
65X-1, 65X-2	RC-1034, RC-1064	III	75	95FT	RC-315C	II	50C
65X-8, 65X-9	RC-1034	III	75	95T, 95T-1	RC-323	II	595C
†66	AR-598	I	187A	95T-5	RC-348	II	597C
66BX	RC-1040, RC-1040A, RC-1040B	III	73	95T-5 L.W.	RC-348F	II	601C
66E	RS-126	III	83	95X	RC-345D	II	603C
66ED	RS-126	III	IV	95XL	RC-345E	II	603C
66E-1	RS-126	III	85	95X-L.W.	RC-345F	II	608C
66X-1, 66X-2	RC-1038	III	87	95X-1	RC-345C	II	605C
66X-3, 66X-7, 66X-8, 66X-9	RC-1038A	III	87	95X-6	RC-381A	II	603C
66X-11	RC-1046A, RC-1046C	III	89	95X-11	RC-381	II	605C
66X-12	RC-1046	III	89	96BK-6, 96BT-6	RC-392	II	610C
2nd Prod.	RC-1046D	III	IV	96E	RC-348C	II	597C
66X-13	RC-1046B, RC-1046E	III	89	96E2	RC-351L	II	614C
†67	AR-1168	I	191A	96K	RC-351	II	619C
67AV-1	RC-606, RC-606C	III	91	96K2	RC-351B	II	627C
67M, 67M-1, 67M-2, 67M-3		I	297B	96K5, 96K6	RC-351L	II	614C
67V-1	RC-606, RC-606C	III	91	96T	RC-348A	II	597C
68R-1, 68R-2, 68R-3, 68R-4	RC-608	III	99	96T1	RC-348D	II	597C
75X-11	RC-1050, RC-1050A, RC-1050B	IV	127	96T2	RC-351	II	619C
75X-12	RC-1050, RC-1050A	IV	127	96T3	RC-351B	II	627C
75X-14	RC-1050A, RC-1050B	IV	127	96T4, 96T5	RC-399	II	632C
75X-15	RC-1050A	IV	127	96T6	RC-399A	II	632C
75X-16, 75X-17, 75X-18, 75X-19	RC-1050B	IV	XII	96T7	RC-351L	II	614C
†75ZU	RC-1063A	IV	129	96X-1 to 96X-4	RC-400	II	635C
2nd Prod.	RC-1063B	IV	XII	96X-5	RC-490	II	637C
†76ZX-11, 76ZX-12	RC-1058, RC-1058A	IV	131	96X-11 to 96X-14	RC-400A	II	635C
77U	RC-1057A	IV	133	97E	RC-351A	II	627C
77V-1	RC-615	IV	135	97K	RC-351F	II	619C
77V-2	RC-606C	IV	137	97KG	RC-351A	II	627C
†80		I	215A	97K2	RC-351K	II	614C
†82		I	215A	97T	RC-351A	II	627C
84BT, 84BT-6		I	315B	97T2	RC-351K	II	614C
85BK, 85BT		I	319B	97X	RC-349	II	638C
85BT-6	RC-316	I	323B	97Y	RC-352A	II	640C
85E		I	326B	98EY	RC-352	II	640C
85K		I	330B	98K	RC-335A	II	644C
85T		I	333B	98K2	RC-386A	II	409C
85T-1		I	330B	98T	RC-386A	II	409C
85T-2		I	333B	98T2	RC-352D	II	649C
85T-5		I	336B	98X, 98YG	RC-352	II	640C
85T-8		I	339B	99K	RC-335B	II	644C
†86		I	215A	99T	RC-335H	II	644C
86BK		I	342B	100		I	405B
86BT		I	342B	100	Loudspeaker UZ-915	I	228A
86E, 86K, 86K-7		I	346B	100-A	Loudspeaker UZ-1076, UZ-1078	I	228A
86T, 86T-1		I	346B	100-B	Loudspeaker UZ-783	I	228A
86T-2		I	351B	101		I	405B
86T-3	RC-315	I	351B	102		I	419B
86T-4		I	354B	102	Loudspeaker UZ-913	I	228A
86T-6	RC-315B	I	564C	103		I	405B
				103	Loudspeaker UZ-749	I	228A
				104	Loudspeaker UZ-914	I	229A
				104 D.C.	Loudspeaker	I	229A
				105	Loudspeaker UZ-1082	I	231A

COMPLETE INDEX OF MODELS (Continued)

XI

<i>Model</i>	<i>Chassis No. or Description</i>	<i>Vol.</i>	<i>Page</i>	<i>Model</i>	<i>Chassis No. or Description</i>	<i>Vol.</i>	<i>Page</i>
106	Loudspeaker UZ-642	I	233A	711V-1, 711V-2,			
110		I	453B	711V-3	RK-117, RS-123	IV	173
110K, 110K-2	RC-513	II	670C	721TCS	KCS-26A-1, KCS-26A-2	IV	389
111		I	453B	721TS	KCS-26-1, KCS-26-2	IV	389
111K	RC-513A	II	673C	730TV-1	KCS-27-1, KCS-27-2,		
112, 112-A		I	457B		RC-610A	IV	417
114		I	279B	730TV-2	KCS-27-1, KCS-27-2,		
115		I	453B		RC-610B	IV	417
117		I	462B	741PCS	Proj. Telev. Receiver	IV	365
118		I	465B	810K, 810K-1		I	581B
119		I	471B	810T		I	581B
120		I	292B	810T-4		I	585B
121, 122		I	474B	811K, 811T		I	589B
124		I	292B	812K		I	595B
125		I	484B	812X		I	601B
126-B		I	488B	813K		I	606B
127		I	491B	816K		I	612B
128		I	497B	910KG	RC-335F	I	444C
128-E		I	504B	911K	RC-335	I	804C
135-B		I	122B	9606	Beat Frequency Osc.	I	623B
140		I	509B	9800	Automatic Record Changer	I	434B
141, 141-E		I	509B	9820	Automatic Record Changer	I	435B
142-B		I	517B	9844	Automatic Record Changer	I	698C
143		I	520B	41918	Victrola Junior	I	572C
210		I	453B	930409 Series	Automatic Record Changer	VIII	63
211		I	465B	960001 Series	Automatic Record Changer	III	169
211K	RC-571	II	779C	960015 Series	Automatic Record Changer	III	179
214		I	462B	960260-1, -2, -3, -4	Automatic Record Changer	III	187
220		I	530B	960276	Automatic Record Changer	IV	195
221		I	474B	960282 Series	Automatic Record Changer	VI	129
222		I	530B	960284-1, -2	Automatic Record Changer	VI	145
223		I	533B	960285-1	Automatic Record Changer	VI	163
224		I	497B				
224-E		I	504B	MISCELLANEOUS			
225		I	484B	Ballast Tube Data		I, II	XIV
226		I	497B	Barkhausen Oscillation		V	XI
235-B		I	122B			VI	XIII
236-B		I	537B	Broadcast Interference—KRK-5 & KRK-7,			
240, 240-E		I	509B	R-F Units		V, VI	XII
241-B		I	517B	Cabinet Touchup		IV	XVI
242, 243		I	520B	Console Loop Antennas		IV	XVII
260, 261		I	378B	Corona Interference—19" Models		VI	XVII
262, 263		I	540B			VII	V
280		I	550B	Correcting Pix I-F Response		VII	IX
281		I	559B	Crystal Pickup Tabulation		I, II	XII
300		I	574B			III	VIII
301		I	405B			VII	XII
310		I	453B	Defective 6F6G Tubes		IV	XVI
320, 321		I	474B	Deflection Yokes		VII	V
322		I	497B	Dial Drive Cord Tabulation		III	V
322-E		I	504B	External Antenna Connection		IV	XVII
327		I	491B	Fixed Composition Resistor Stock No. Code		VII	V
330, 331		I	576B	Focus Coil Troubles		V	XI
340, 340-E		I	509B			VI	XVIII
341, 342		I	520B	Fuse Data		I, II	XV
380, 380-HR		I	550B	High-pass Filter		VII	V
381		I	559B	High Voltage Arcs at Kinescope		VII	V
†500, 501	RC-464	II	481C	I-F Harmonic Interference		V	XII
†510	RC-459	II	486C			VI	XVI
2nd & 3rd Prod.	RC-1003B, RC-1003D	II	1C	I-F Transformers—Type 970441		IV	XVI
†511	RC-464A	II	486C	Index to TV Circuit Description		IV	VI
2nd Prod.	RC-1003B	II	1C	Ion Trap Magnets		V	V
†512, 513	RC-464B	II	486C			VII	V
†515	RC-1000C	II	357C	Matching Co-ax to Balanced Line		V	XI
2nd Prod.	RC-1014A	II	416C			VI	XVII
†516, 517	RC-1001C	II	291C	Model vs. Record Changer		V	IV
†520	RC-1003D	II	1C			VI	X
†522	RC-1001C, RC-1022A	II	291C	Oscillator Switch Wafers		VII	VIII
†526, 527	RC-1001E	II	324C	Phonograph Motors (Governor Type)		II	703C
610V-1	RC-610C	III	145	Phonograph Motors (Induction Disc & Universal)		I	248A
610V-2	RC-610, RC-610C	III	145	Phonograph Motors—Tabulation		I, II	XIII
612V-1, 612V-3, 612V-4	RK-121 & RS-123	III	153	R-F Unit—Alignment Hints		VI	XII
621TS	KCS-21-1	III	199	R-F Unit—Interchangeability		VII	VIII
630TCS	KCS-20B-1, KCS-20D-2	III	279	R-F Unit—Oscillator Tracking		VII	IX
630TS	KCS-20A-1, KCS-20C-2	III	235	R-F Unit—KRK-5, KRK-7, Prod. Changes		V, VI	XIII
641TV	KCS-25A-1, KCS-25C-2,			Sales Name vs Model Number		VII	XX
	RK-117A, RS-123A	IV	207	Socket Wrench for Pickup Styles		IV	XVI
648PTK	Proj. Telev.—Radio Comb.	IV	295	Substitute 12" PM Speakers		VI	XVII
648PV	Proj. Telev.—Radio-Phono. Comb.	IV	295	Television Calibrators		VII	IX
◆690	Rad. 82 with Aut. Record Changer			Television Interference, Causes & Cures		VI	XIV
710V-2	RC-613A	IV	177	Television Receiver Cross-reference		VII	X
				Vibrator Powered Receivers		IV	XVII
				Wave Trap Data		I, II	XV
				60 cycle Buzz in Sound		V	XIII
						VI	XVI
				60 to 50 cycle Phono. Conversion		IV	XV

INDEX TO CHASSIS NO'S

Identification numbers beginning with R (RC, RS, etc.) are used with all radios and some television receivers.
 Identification numbers beginning with K (KCS, KRS, etc.) are used exclusively with television.

RADIO CHASSIS

Chassis No.	Model	Chassis No.	Model	Chassis No.	Model
RK-117	711V1, 711V2, 711V3, R-F/I-F Chassis	RC-351C	U-124	RC-427F	TRK-120 Radio Tuner Unit
RK-117A	641TV, 8TV41 Radio R-F/I-F Chassis	RC-351D	U-122E	RC-427G	TRK-90 Radio Tuner Unit
RK-121	612-V1, 612V3, 612V4, R-F/I-F Chassis	RC-351E	U-119	RC-429	TRK-5 Radio Tuner Unit
RK-121A	648 PTK, 648PV Radio R-F/I-F Chassis	RC-351F	97K	RC-435	9TX-50, 9TX-50M
RK-121C	8V151, R-F/I-F Chassis	RC-351K	97K2, 97T2	RC-435A	45E, 45E-M, 45E-W
RK-135	8TR29, 8TK29 Radio Section	RC-351L	96E2, 96K5, 96K6, 96T7	RC-436	40X-50 to 40X-57
RK-135A	8TR29, 8TK29, 8TK320 Radio Section	RC-352	98EY, 98X, 98YG	RC-440	4QB
RK-135C	9TW309 Radio Section	RC-352A	97Y	RC-440A	4QB4
RK-135D	TA128, TA129, TA169 Radio Section	RC-352B	UY-122E	RC-441	6Q1
RC-315B	86T6	RC-352C	UY-124	RC-441A	6Q4
RC-315C	5Q1	RC-352D	98T2	RC-442	6Q4X
RC-318	8M	RC-354	U-130	RC-443	8Q2
RC-319	87K2, 87T2	RC-354A	HF-4	RC-443B	8QU5-C, 8QU5-M
RC-319B	U-106	RC-354B	HF-2	RC-444	9Q1
RC-320	8M1	RC-357	9M1	RC-444A	9QK
RC-320A	8M2	RC-357A	9M2	RC-449	BK-41, BT-41
RC-321	8M3	RC-357J	M-50	RC-453	40X-52, 40X-55 (2nd Prod.)
RC-321A	8M4	RC-357K	M-60	RC-454	9TX-50, 9TX-50M (2nd Prod.)
RC-323	95T, 95T1	RC-366	5Q4	RC-455	BP-55, -56, -85
RC-325C	5Q2	RC-381	95X-11	RC-456	46X-11, 46X-12
RC-325D	5Q2X	RC-381A	95X-6	RC-456A	46X-13
RC-331	HF-8, HF-8A	RC-386	U-125	RC-457	45X-1, 45X-2
RC-331A	HF-6	RC-386A	98K2, 98T	RC-457A	45X-1, 45X-2 (2nd Prod.)
RC-331B	U-134, U-134A	RC-386B	U-25, U-26	RC-457D	45X-5, 45X-6
RC-331C	U-132	RC-390	94BK2, 94BT2	RC-457E	45X-3, 45X-4
RC-332	94X	RC-392	96BK6, 96BT6 Tuner Unit	RC-459	45X-11, 45X-12
RC-333	94BK, 94BT	RC-394	M-70 Tuner Unit	RC-459A	45X-13
RC-333A	94BT6	RC-396	5Q5, 5Q55, 5Q56	RC-459B	46X-1, 46X-2
RC-333B	94BT1, 94BK1	RC-396B	5Q8	RC-459C	46X-3
RC-333C	94BT61	RC-396D	5Q12	RC-459D	45X-11, 45X-12 (2nd Prod.)
RC-335	911K	RC-396E	5Q12A	RC-459E	45X-13 (2nd Prod.)
RC-335A	98K	RC-399	96T4, 96T5	RC-459F	46X-1, 46X-2 (2nd Prod.)
RC-335B	99K	RC-399A	96T6	RC-459H	46X-3 (2nd Prod.)
RC-335C	11Q4, 11QK	RC-400	96X-1 to 96X-4	RC-459J	45X-111, 45X-112, Radiola 510
RC-335D	U-126, U-128	RC-400A	96X-11 to 96X-14	RC-459K	45X-113
RC-335E	11QU	RC-401	9TX-1 to 9TX-5	RC-459L	45X
RC-335F	910KG	RC-403	9TX-21, 9TX-22	RC-459M	45X-16, 45X-17
RC-335H	99T	RC-403A	9TX-23	RC-459T	45X-11, 45X-12 (3rd Prod.)
RC-335K	U-129	RC-404A	U-8	RC-461	46X-24
RC-335KR	U-30	RC-405	9TX-31	RC-461A	46X-23
RC-336	8QB, 8QBK Tuner Unit	RC-405A	9TX-32	RC-461B	46X-21
RC-337	8Q1 Tuner Unit	RC-405B	9TX-33	RC-462	15X
RC-337A	8Q4 Tuner Unit	RC-405C	40X-30	RC-462A	16X-1, 16X-2, 36X
RC-337B	10Q1 Tuner Unit	RC-405D	40X-31	RC-462B	16X-3
RC-338	12Q4, 12QK Tuner Unit	RC-406	5X5-W	RC-462C	16X-4
RC-338A	12QU Tuner Unit	RC-406A	5X5-1	RC-464	Radiola 500, 501
RC-339	HF-1	RC-407	94BP-1 Series (94BP- 61, -62, -64, -66, -80, -81)	RC-464A	Radiola 511
RC-340	94X-1, 94X-2	RC-407B	94BP-1 (2nd Prod.) (94BP-61, -62, -64, -66)	RC-464B	Radiola 512, 513
RC-341	U-111	RC-408	BT-40	RC-465	Radiola P-5
RC-341C	U-112	RC-408A	BT-42	RC-465A	Radiola P-5
RC-345C	95X-1	RC-408C	BK-42	RC-472F	T-63
RC-345D	95X	RC-410	94BP4, -B, -C, -R	RC-473A	X-55
RC-345E	95XL	RC-414	6QU	RC-474D	X-60
RC-345F	95XLW	RC-414A	6Q7	RC-476	K-105
RC-345H	U-104	RC-414B	6Q8, 6QK8	RC-477	5Q5 (2nd Prod.), Q18
RC-348	95T5	RC-414C	U-50	RC-477A	5Q6
RC-348A	96T	RC-415	K-60	RC-477B	5Q8 (2nd Prod.)
RC-348C	96E	RC-415A	K-80	RC-477C	5Q66
RC-348D	96T1	RC-415B	K-60 (Loop), K-62	RC-478	9Q4
RC-348E	U-115	RC-415C	K-80 (Loop), K-81, K-82	RC-478A	7Q4
RC-348F	95T5LW	RC-415D	K-80 (Loop)	RC-478B	7QK4
RC-348H	U-123 (1 band)	RC-416	T-64, T-65	RC-482B	U-9
RC-348J	U-121	RC-416A	T-80	RC-482C	U-9 (2nd Prod.)
RC-348L	U-127E	RC-418	T-55, T-55-S, T-56	RC-486B	U-44 Tuner Unit
RC-349	97X	RC-418A	K-50	RC-486C	U-45 Tuner Unit
RC-350	9X to 9X-4	RC-418B	U-10	RC-490	96X-5
RC-350A	9X6, 9X-11 to 9X-14	RC-421	U-123 (2 bands)	RC-496	7QB, 7QBK Tuner Unit
RC-351	96K, 96T2	RC-425	T-60	RC-497	K-50 (2nd Prod.)
RC-351A	97E, 97KG, 97T	RC-425A	U-12	RC-498	U-20
RC-351B	96K2, 96T3	RC-425D	T-62		
		RC-427	TRK-12 Radio Tuner Unit		
		RC-427A	TRK-9 Radio Tuner Unit		

INDEX TO CHASSIS NO'S (Continued)

RADIO CHASSIS (Continued)

Chassis No.	Model	Chassis No.	Model	Chassis No.	Model
RC-498A	U-40	RC-563D	Q12	RC-620B	Q641 (50/60 cy.)
RC-498B	U-42 Tuner Unit	RC-563E	Q11	RC-620C	Q641 (25 cy.)
RC-498E	U-43	RC-563F	Q11	RC-620D	4QV8C R-F/I-F Chassis
RC-498F	K-61	RC-563K	QB55X	RC-622	9W106, A106
RC-501	U-46 Tuner Unit	RC-564	V-215, V-221	RC-1000	16X11
RC-501A	K-130 Tuner Unit	RC-564A	V-219	RC-1000A	16X13
RC-502	7Q4X	RC-564B	V-225	RC-1000B	16X14
RC-507	Q22, Q22A, Q32, Q121 (EM)	RC-566	Q14, Q15	RC-1000C	Radiola 515
RC-507A	Q25	RC-566A	QU56C, QU56M	RC-1001	10X
RC-507B	QK23	RC-566B	Q14E, Q15E	RC-1001A	11X1
RC-507C	QU2C	RC-567	27K	RC-1001B	12X, 12X2
RC-507D	QU2M	RC-568	QU51C, QU51M	RC-1001B	10X (2nd Prod.)
RC-507F	QU3C	RC-568A	QU55	RC-1001C	12AX, 12A2, 35X, Radiola 516, 517, 522
RC-507H	QU3M	RC-568B	QU61	RC-1001D	14X, 14X2
RC-507J	Q26	RC-569	28T	RC-1001E	14AX, 14AX2, 34X, Radiola 526, 527
RC-507K	Q27	RC-570	29K	RC-1002	28X
RC-507L	QU52C	RC-570C	29K2	RC-1002A	28X5
RC-507N	QU52M	RC-570D	29K2 (2nd Prod.)	RC-1003	1X, 1X2, 25X
RC-507U	Q121 (PM)	RC-571	211K	RC-1003A	1AX, 1AX2
RC-508	Q24	RC-572A	V-140	RC-1003B	Radiola 510 (2nd Prod.), 511 (2nd Prod.)
RC-509	16T4	RC-573	V-209	RC-1003C	55X
RC-509A	16T3	RC-573A	V-210	RC-1003D	Radiola 510 (3rd Prod.), 520
RC-509B	16T2	RC-574	VHR-212	RC-1004A	25BT2
RC-509C	16K	RC-582	V175	RC-1004B	25BK, 25BT3
RC-509F	16T4 (2nd Prod.)	RC-585	Q36	RC-1004D	Radiola B-52
RC-509H	16T3 (2nd Prod.)	RC-589	54B1	RC-1004E	55F, 65F
RC-509J	16T2 (2nd Prod.)	RC-589A	54B2	RC-1004F	24BT1, 24BT2
RC-511	18T	RC-589B	54B3	RC-1004H	Radiola B-50
RC-512	17K	RC-589D	54B1-N	RC-1011	15X (2nd Prod.), 36X (2nd Prod.)
RC-512A	19K	RC-589U	54B1 2nd Prod.	RC-1013	6X2
RC-513	110K, 110K2	RC-589UA	54B2 2nd Prod.	RC-1014	26X1
RC-513A	111K	RC-589UB	54B3 2nd Prod.	RC-1014A	26X3, Radiola 515 (2nd Prod.)
RC-514	Q20, Q21	RC-589UE	54B6	RC-1014B	26X4
RC-517	V-100	RC-592	Q23	RC-1017	55U, 55AU
RC-517C	V-105	RC-594C	Q10, Q10A, Q10-2, Q10A-2, Q10-3, Q110	RC-1017A	65U, 65AU, 65U-1, Radiola 62-1
RC-517F	Radiola R-560P	RC-594D	Radiola 61-6, 61-7	RC-1017B	65U, 65AU (50 cycle)
RC-517H	V-135	RC-601	Q122 (EM)	RC-1020	25BP (2nd Prod.)
RC-517J	Radiola R-566P	RC-601A	Q122X (EM)	RC-1020B	Radiola P-5 (2nd Prod.)
RC-518	V-300 Tuner Unit	RC-601B	7QV5, QU68	RC-1022	34X (2nd Prod.)
RC-518A	V-301, V-302 Tuner Unit	RC-601D	Q122 (PM)	RC-1022A	12X (2nd Prod.), 35X (2nd Prod.), Radiola 522 (2nd Prod.)
RC-519	V-200	RC-601E	Q122X (PM)	RC-1023	56X5, Radiola 615
RC-521	V-205	RC-602	Q109	RC-1023A	56X11
RC-521B	V-405	RC-602A	Q109X	RC-1023B	56X10, Radiola 61-10, Postone (PX) 61-10
RC-522	V-201	RC-602B	QU62	RC-1023C	Radiola 61-10 2nd Prod.
RC-523	V-170	RC-604	58V, 58AV	RC-1034	65X1, 65X2, 65X8, 65X9, Radiola 61-8, 61-9
RC-524	V-102	RC-605	59V1, 59AV1	RC-1035	QU72, QU72A
RC-525	14BT-1	RC-606	67V1, 67AV1	RC-1037	64F1, 64F2
RC-525A	14BT-2	RC-606C	67V1, 67AV1 2nd Prod., 77V2	RC-1037A	64F3
RC-525B	14BK	RC-607	QB60	RC-1037B	8F43
RC-526	15BT	RC-608	68R1, 68R2, 68R3, 68R4	RC-1038	66X1, 66X2
RC-527	15BP-1, -2, -4, -6	RC-610	610V1, 610V2	RC-1038A	66X3, 66X7, 66X8, 66X9
RC-527A	15BP-3, -5	RC-610A	730TV1 Radio Section	RC-1040	66BX (3Q4 output)
RC-527C	15BP-7	RC-610B	730TV2 Radio Section	RC-1040A	66BX (3V4 output)
RC-527D	25BP	RC-610C	610V1, 610V2 2nd Prod.	RC-1040B	66BX (Selenium rect.)
RC-529	QB2	RC-612	QB-13 Tuner Unit	RC-1040C	8BX6, 8BX65
RC-529A	QB1, QB11, QB12 Tuner Unit	RC-613A	710V2	RC-1040D	8BX6 2nd Prod.
RC-529D	QB6	RC-614	9Q53	RC-1044	Q103, Q103A, Q103-2, Q103A-2
RC-529H	QB9 Tuner Unit	RC-614C	9QV5 R-F/I-F Chassis		
RC-530	QU5 Tuner Unit	RC-614D	9QV5 R-F/I-F Chassis		
RC-531	Q44	RC-615	77V1, 8V7		
RC-538B	Q30	RC-616	8V112		
RC-538C	Q31	RC-616A	8V91		
RC-539	Q33	RC-616B	8TV321 Radio Section		
RC-539D	QB-3	RC-616C	8TV323 Radio Section		
RC-539E	Q34	RC-616F	8V112 2nd Prod.		
RC-540	V-101	RC-616H	8V91 2nd Prod.		
RC-541C	45X18	RC-616J	8TV321 2nd Prod. Radio Section		
RC-544	BP-10	RC-616K	8TV323 2nd Prod. Radio Section		
RC-547	VHR-207	RC-616N	9TW333 Radio Section		
RC-547A	VHR-407	RC-617A	9TW390 Radio Chassis		
RC-548	VHR-202	RC-618	8V90		
RC-551	QU7, QU8 Tuner Unit	RC-618A	8V90 2nd Prod.		
RC-555	VHR-307 Tuner Unit	RC-618B	9W101, 9W103		
RC-559	26BP	RC-618C	9W105		
RC-561	Q-16	RC-618D	9W102		
RC-561A	Q-17	RC-620A	4QV8C R-F/I-F Chassis		
RC-561C	Q-16E				
RC-563A	QB5, QB55				
RC-563B	Q12				
RC-563C	Q12				

INDEX TO CHASSIS NO'S (Continued)

RADIO CHASSIS (Continued)

Chassis No.	Model	Chassis No.	Model	Chassis No.	Model
RC-1044A	Q103X, Q103AX, Q103X-2, Q103AX-2	RC-1065A	8X542, 8X546, 8X547	RC-1090	2T81, 4T141, 6T84
RC-1045	65BR9, Radiola R65BR9	RC-1065B	8X541, 8X544, 8X545 2nd Prod.		Radio Chassis
RC-1046	66X12	RC-1065C	8X542, 8X546, 8X547 2nd Prod.	RC-1092	6T86, 6T87, 9T89
RC-1046A	66X11	RC-1065F	8X541, 8X544, 8X545 3rd Prod.		7T143, 9T147
RC-1046B	66X13	RC-1065H	8X542, 8X546, 8X547 3rd Prod.		Radio Chassis
RC-1046C	66X11 2nd Prod.	RC-1065J	8X541 4th Prod.	RC-1094	A-82
RC-1046D	66X12 2nd Prod.	RC-1065K	8X542, 8X547 4th Prod.	RC-1095	A-91
RC-1046E	66X13 2nd Prod.	RC-1065L	8X541 5th Prod.	RC-1095A	45-W-9
RC-1047	54B5	RC-1065M	8X542, 8X547 5th Prod.	RC-1096	A-101, A-108
RC-1050	75X11, 75X12	RC-1066	8X521	RC-1096A	45-W-10
RC-1050A	75X11, 75X12 2nd Prod., 75X14, 75X15	RC-1066A	8X522	RC-1096B	A-101, A-108 2nd Prod.
RC-1050B	75X11 3rd Prod., 75X14 2nd Prod., 75X16, 75X17, 75X18, 75X19	RC-1067	6QP3	RC-1096C	45-W-10 2nd Prod.
RC-1053	5Q21, 5Q22, 5Q27	RC-1067A	QP63	RC-1098	B-411
RC-1053A	5Q21 2nd Prod. (117 v.)	RC-1068	9BX56	RC-1098A	B-411 2nd Prod.
RC-1053B	5Q1 2nd Prod. (234 v.)	RC-1069	8B41	RC-1100	Q520 (117V.)
RC-1054	5Q31	RC-1069A	8B42	RC-1100A	Q520 (234V.)
RC-1054A	6Q33	RC-1069B	8B43	RC-1101	QB421
RC-1054B	6Q33X	RC-1069C	8B46	RC-1102	1R81
RC-1054C	6QU3	RC-1070	8X71, 8X72	RC-1102A	1R81
RC-1054D	6QV3	RC-1070A	X711	RC-1102B	1R81
RC-1054E	5Q31X	RC-1071	4QB3	RC-1102C	1R81
RC-1054F	6QU3Y	RC-1071A	4QB3X	RC-1104	1X51
RC-1054G	Q531	RC-1071B	QB431	RC-1104-1	1X51
RC-1054J	QA531	RC-1072	5QA5	RC-1104A	1X52, 1X57
RC-1054K	35QU	RC-1077	9Y51	RC-1104A-1	1X52, 1X57
RC-1055	7Q51 (PM)	RC-1077A	9Y510	RC-1104B	1X53, 1X54, 1X55, 1X56
RC-1055C	7Q51 (EM)	RC-1077B	9Y511	RC-1104B-1	1X53, 1X54, 1X55, 1X56
RC-1055D	7Q51X	RC-1077C	9Y510 2nd Prod.	RC-1104C	1X51
RC-1055H	Q853 (117 v.—234 v.)	RC-1079	9X571	RC-1104D	1X52, 1X57
RC-1055J	Q853 (85—260 v.)	RC-1079A	9X572	RC-1104E	1X53, 1X54, 1X55, 1X56
RC-1055K	Q853 (117 v. 25 cy.)	RC-1079B	9X561	RC-1110	PX600
RC-1057A	77U	RC-1079C	9X562	RC-1111	2-S-10
RC-1057B	9Y7	RC-1079D	9W51	RC-1111A	21-T-197DE
RC-1058	Radiola 76ZX11, 76ZX12	RC-1079E	9X571 2nd Prod.	RC-1111B	21-T-244
RC-1058A	Radiola 76ZX11, 76ZX12 2nd Prod.	RC-1079F	9X572 2nd Prod.	RC-1114	2-B-400 Series
RC-1059	8BX5, 8BX54, 8BX55	RC-1079G	1X591	RC-1115	2-BX-63
RC-1059A	8BX5, 8BX54, 8BX55 2nd Prod.	RC-1079H	1X592	RC-1116	36QP (117 v.)
RC-1059B	9BX5	RC-1080	9X641	RC-1116A	36QP (117v.—234v.)
RC-1059C	9BX5 2nd Prod.	RC-1080A	9X642	RC-1117A	2-US-7
RC-1060	8R71, 8R74, 8R75	RC-1080C	2-X-61	RC-1117B	21-T-242
RC-1060A	8R72, 8R76	RC-1080D	2-X-62	RC-1117C	2-US-7
RC-1061	8X681, 8X682	RC-1082	BX6	RC-1117D	2-S-7
RC-1063A	Radiola 75ZU	RC-1082A	BX6 2nd Prod.	RC-1118	2-C-511
RC-1063B	Radiola 75ZU 2nd Prod.	RC-1084A	9W78, A78	RC-1118A	2-C-512
RC-1064	65X1, 65X2, Radiola 61-8, 61-9 2nd Prod., 8X53	RC-1085	9X651	RC-1118B	2-C-513
RC-1065	8X541, 8X544, 8X545	RC-1085A	9X652	RC-1118C	2-C-514
		RC-1085B	2-X-621	RC-1119	2-R-51, 2-R-51A, 2-R-52, 2-R-52A
		RC-1087	A55	RC-1120	2-C-521
		RC-1088	BX55	RC-1120A	2-C-522, 2-C-527
		RC-1088A	BX57	RC-1120B	2-C-521
		RC-1088B	BX55 2nd Prod.	RC-1120C	2-C-522, 2-C-527
		RC-1088C	BX57 2nd Prod.	RC-1120D	2-C-521
		RC-1089B	X551	RC-1120E	2-C-522, 2-C-527
		RC-1089C	X552	RC-1121	2-XF-91
				RC-1121A	2-XF-931 Series

AUDIO AMP. AND POWER UNITS

Chassis No.	Model	Chassis No.	Model	Chassis No.	Model
RA-79	9EY31, 9EY32	RS-89	CV-9X Electrifier	RS-111	CV-112 Electrifier
RS-77	R-98	RS-89A	TRK-5 Radio Power Unit	RS-111A	CV-112X Electrifier
RS-79B	CV-9 Electrifier	RS-89B	U-42 Power Unit	RS-112	QU8 Power Unit
RS-83-1	PSU-8A	RS-90	VA-21	RS-112A	QU7 Power Unit
RS-83-2	PSU-8B	RS-91A	O-50	RS-114A	VHR-307 Power Unit
RS-83-3	PSU-8C	RS-91B	R-60	RS-115	QB1, QB11, QB12, QB13, 6V. Power Unit
RS-83A-1	PSU-10A	RS-92	M-70 Power Unit	RS-115B	QB9 Power Unit
RS-83A-2	PSU-10B	RS-94A	OSC-22	RS-119	R-56
RS-83A-3	PSU-10C	RS-95	CV-111 Electrifier	RS-123	612V1, 612V3, 612V4, 711V1, 711V2, 711V3 Audio Amp. & Pow- er Supply
RS-83C	CV-110 Electrifier	RS-98	CV-40 Electrifier	RS-123A	64TV, 649PTK, 8TV41 Audio Amp. & Pow- er Supply
RS-83E	TRK-9, TRK-12, TRK-90, TRK-120 Radio Power Unit	RS-102A	U-44 Power Unit		
RS-84	R-91	RS-102B	U-46 Power Unit		
RS-85	PSU-8E	RS-102C	K-130 Power Unit		
RS-85A	PSU-10E	RS-102D	U-45 Power Unit		
RS-86	R-89	RS-102E	V-300, V-301, V-302 Power Unit		
		RS-110	QU5 Power Unit		

INDEX TO CHASSIS NO'S (Continued)

AUDIO AMP. AND POWER UNITS (Continued)

Chassis No.	Model	Chassis No.	Model	Chassis No.	Model
RS-123B	648PV Audio Amp. & Power Supply	RS-132F	45-EY, 45-EY-1	RS-138M	45-EY-26
RS-123C	741PCS, 8PCS41, 9PC41 Audio Amp. & Power Supply	RS-132H	45-EY-15	RS-138N	QEY4 (Min. tubes)
RS-123D	8V151 Audio Amp. & Power Supply	RS-136	45-EY-3	RS-139A	15-E, 15-E-1
RS-126	66E, 66ED, 66E-1	RS-136A	45-EY-3	RS-140	45-EY-4
RS-127	63E, 63EM	RS-136B	QEY5	RS-140A	QEY6
RS-130	9QV5 Power Unit	RS-136C	45-EY-3	RS-141	2-S-10
RS-130A	4QV8C Power Unit	RS-136D	QEY5	RS-141A	21T197DE
RS-132	9EY3, 93Y3M, 9EY35, 9EY36, 45-EY	RS-136E	45-EY-3	RS-141C	21T244
RS-132A	9EY35, 9EY36, 45-EY	RS-136F	QEY5 (Min. tubes)	RS-142	2ES3, 2ES31, 2ES31E, 2ES38, 2ES38E
RS-132C	QEY3	RS-138A	45-EY-2	RS-142A	2ES31Q, 2ES38Q
		RS-138B	QEY4	RS-1000	CV-42 Electrifier
		RS-138E	QEY4	RS-1001	CV-45 Electrifier
		RS-138F	45-EY-2		
		RS-138H	45-EY-2		
		RS-138L	45-EY-26		

TELEVISION CHASSIS

Chassis No.	Model	Chassis No.	Model	Chassis No.	Model
KC-3	TT-5	KCS-32	8TR29	KCS-62	4T141
KC-3A	TRK-5 TV Chassis	KCS-32A	8TK29	KCS-66	17T153, 17T154, 17T155, 17T160
KC-3B	TT-5 (50 cy.)	KCS-32B	8TR29	KCS-66A	17T162, 17T172, 17T173, 17T174
KC-3C	TRK-5 (50 cy.) TV Chassis	KCS-32C	8TK29	KCS-66C	17T150, 17T151, 17T163
KC-4	TRK-12 TV Tuner	KCS-33A	8TK320	KCS-66D	17T172K, 17T173K, 17T174K
KC-4A	TRK-9 TV Tuner	KCS-34	9TC247, 9TC249	KCS-68C	21T176, 21T177, 21T178, 21T179
KC-4B	TRK-12 (50 cy.) TV Tuner	KCS-34B	TC124, TC125, TC127, 9TC245, 9TC247, 9TC249	KCS-68E	21T159, 21T165
KC-4C	TRK-9 (50 cy.) TV Tuner	KCS-34C	T120, T121	KCS-68F	21T159DE, 21T166DE, 21T174DE, 21T175DE, 21T178DE, 21T179DE
KC-4F	TRK-120 TV Tuner	KCS-38	T100, 9T246	KCS-68H	21T197DE
KC-4H	TRK-90 TV Tuner	KCS-38C	9T256	KCS-70	U-70
KC-4J	TRK-120 (50 cy.) TV Tuner	KCS-40	T164	KCS-72	(17T200, 17T201, 17T202, 17T211, 17T220)
		KCS-40A	TC165, TC166, TC167, TC168	KCS-72-M1	
		KCS-40B	6T72	KCS-72-M2	
KCS-20A	630TS	KCS-41	9TW309	KCS-72A	21T207, 21T207G, 2T208, 21T217, 21T218, 21T227, 21T228, 21T229
KCS-20B	630TCS	KCS-41A	TA129	KCS-72D-1	21T242
KCS-20C	630TS (50 cy.)	KCS-42A	TA128	KCS-72D-2	21T244
KCS-20D	630TCS (50 cy.)	KCS-43	TA169	KCS-74	17T250DE, 17T261DE
KCS-20J	8TS30	KCS-45	2T51	KCS-79	U-2
KCS-20K	8TS30 (50 cy.)	KCS-45A	2T60	KCS-79A	U-2A
KCS-21	621TS	KCS-46	2T81		
KCS-24	648PTK TV R-F/I-F Chassis	KCS-47	6T53, 6T54	KK-7	TRK-12 TV Power Unit
KCS-24A	648PV TV R-F/I-F Chassis	KCS-47T	6T53, 6T54	KK-7A	TRK-9 TV Power Unit
KCS-24B	741PCS, 8PCS41 R-F/I-F Chassis	KCS-47A	6T64, 6T65, 6T71, 6T74, 6T75, 6T76	KK-7D	TRK-12 (50-cy.) TV Power Unit
KCS-24C	8PCS41, 9PC41 R-F/I-F Chassis	KCS-47AT	6T64, 6T65, 6T71, 6T74, 6T75, 6T76	KK-7E	TRK-9 (50 cy.) TV Power Unit
KCS-24D	9PC41 R-F/I-F Chassis	KCS-47B	7T103, 7T104	KK-7F	TRK-120 TV Power Unit
KCS-25A	641TV TV Chassis	KCS-47C	7T112, 7T122, 7T123, 7T124	KK-7J	TRK-90 TV Power Unit
KCS-25C	641TV (50 cy.) TV Chassis	KCS-47D	7T132	KK-7H	TRK-120 (50 cy.) TV Power Unit
KCS-25D	8TV41 TV Chassis	KCS-47E	16T152		
KCS-25E	8TV41 (50 cy.) TV Chassis	KCS-47F	7T103B, 7T104B	KRS-20	648PTK, 648PV Horiz. Defl. Chassis
KCS-26-1	721TS	KCS-47G	7T112B, 7T122B, 7T123B, 7T125B	KRS-20A	741PCS, 8PCS41 Horiz. Defl. Chassis
KCS-26-2	721TS (50 cy.)	KCS-47GF	7T112B, 7T122B, 7T123B, 7T125B	KRS-20B	8PCS41, 9PC41 Horiz. Defl. Chassis
KCS-26A-1	721TCS	KCS-47GF-2	7T111B, 7T112B, 7T122B, 7T123B	KRS-21	648PTK, 648PV TV Power Supply
KCS-26A-2	721TCS (50 cy.)	KCS-47T	6T53, 6T54	KRS-21A	741PCS, 8PCS41, 9PC41, TV Power Supply
KCS-27-1	730TV1, 730TV2 TV Chassis	KCS-48	6T84, 6T86, 6T87		
KCS-27-2	730TV1, 730TV2 (50 cy.) TV Chassis	KCS-48A	7T143		
KCS-28	8T241, 8T243, 8T244, 9T240	KCS-48T	6T84, 6T86, 6T87		
KCS-28A	9T240	KCS-49	9T57		
KCS-28B	9TC240	KCS-49A	9T77, 9T79		
KCS-28C	9T246	KCS-49AT	9T77, 9T79		
KCS-29	8T270, 9T270	KCS-49B	9T105		
KCS-29A	8TC270, 8TC271	KCS-49BF	9T105		
KCS-29C	9TC272, 9TC275	KCS-49BF-2	9T105		
KCS-30	8TV321, 8TV323, 9TW333 TV Chassis	KCS-49C	9T126, 9T128		
KCS-31	S1000, 9TW390 TV Chassis	KCS-49CF	9T126, 9T128		
		KCS-60	9T89		
		KCS-60A	9T147		
		KCS-60T	9T89		
		KCS-61	4T101		

SALES NAME v.s. MODEL NUMBER

Ainsworth 17-T-261DE
 Albury 17-T-220
 Ashley A-91
 Ashton 17-T-211
 Bancroft 21-T-174DE
 Belgrove 21-T-229
 Bentley 4-T-101
 Benton 21-T-175DE
 Blaine 1-X-51
 Brandon 21-T-228
 Brantley 45-W-10
 Brett 17-T-250DE
 Bristol 17-T-153
 Brookfield 21-T-217
 Calhoun 17-T-173
 Carlisle A-108
 Clarendon 21-T-179, 21-T-179DE
 Colby 17-T-150
 Covington 17-T-172
 Crafton 17-T-163
 Crandall 21-T-207, 21-T-207G
 Crestwood 612V1, 8V151
 Cumberland 2-T-60
 Donley 21-T-177
 Fairfax 6-T-84
 Fairfield 6-T-71, 6-T-72, 7-T-122
 Farmington 21-T-166DE
 Fenwick 2-S-10

Forbes 2-XF-91
 Gladwin 1-X-591
 Glenside 17-T-151
 Globetrotter 66BX, 8BX6, BX-6,
 PIX-600, 2-BX-63
 Grayson X-551
 Hadley 17-T-201
 Hampton 17-T-160
 Hartford 6-T-87
 Haywood 17-T-111B
 Highland 6-T-65, 7-T-112
 Hillsborough A-101
 Hillsdale 9-T-126
 Kendall 17-T-174
 Kent 6-T-54, 7-T-104
 Kentwood 17-T-202
 Kerby 2-X-621
 Lambert 21-T-208
 Lansford 21-T-218
 Lindale 21-T-227
 Lindsay 2-X-61
 Livingston 1-R-81
 Meredith 21-T-165
 Modern 6-T-75, 7-T-124
 Newport 6-T-53, 7-T-103
 Northampton 9-T-79
 Oakland 2-S-7

Penfield 21-T-244
 Personal 54B1, 8B41, B-411,
 2-C-511, 2-R-51
 Prentiss 8-X-541
 Preston 17-T-155
 Provincial 6-T-76, 7-T-125, 9-T-128
 Randolph 9X561
 Regency 6-T-74, 7-T-123
 Reveler BX-57
 Rockingham 21-T-178, 21-T-178DE
 Rutland 6-T-86, 7-T-143
 Sedgwick 9-T-89, 9-T-147
 Selfridge 21-T-159, 21-T-159DE
 Shelby 2-T-51
 Shelley 17-T-200
 Somervell 2-T-81, 4-T-141
 Suffolk 21-T-176
 Sunderland 21-T-197DE
 Super Personal 2-B-400
 Talbot 16-T-152
 Terrel A-82
 Torrance 9-X-571
 Townley 2-XF-931
 Westland 21-T-242
 Whitfield 17-T-154
 Winston 7-T-132
 York 9-T-57, 9-T-105

MODEL vs. RECORD CHANGER (1943 to 1952 incl.)

Model *Record Changer*
 A55 RP 168 & 960282-1
 A78 RP 168 & 960282-1
 A-82 RP 168 or RP 190-2
 & 960282-4 or -5
 A-91 RP 168 or RP 190-2
 & 960284-1 or -2
 A-101 RP 190-2 & 960282-4 or -5
 or 960284-1 or -2
 A-106 RP 168 & 960285-1
 A-108 RP 168 or RP 190-2
 & 960284-1 or -2
 QEY4 RP 190-5
 QEY5 RP 190-5
 QEY6 RP 190-5
 QJY RP 168
 QEY3 RP 168
 QU61 960001-4
 QU62 960001-4
 QU68 960001-4
 S1000 RP 168 & 960285-1
 TA128 RP 168 & 960282-1
 TA129 RP 168 & 960282-1
 TA169 RP 168 & 960285-1
 2-ES-3 930409-5
 2-ES-31 930409-5
 2-ES-31E 930409-5
 2-ES-31Q 930409-6
 2-ES-38 930409-5
 2-ES-38E 930409-5
 2-ES-38Q 930409-6
 2-JS-1 930409-5
 2-JS-1E 930409-5
 2-JS-1Q 930409-6
 2-S-7 930409-5, -10
 2-S-10 930409-5, -10
 2T81 RP 168 or RP 190-2
 & 960282-4 or -5
 2-US-7 930409-5, -10, -11
 4QV8C RP 168 & 960282-2
 4T141 RP 190-2
 & 960282-4 or -5
 6QU3 RP 178-3
 6QU3Y RP 168
 6QV3 RP 178-3

Model *Record Changer*
 6T84 RP 168 or RP 190-2
 & 960282-4 or -5
 or 960284-1 or -2
 6T86 RP 168 or RP 190-2
 & 960284-4 or -5
 6T87 RP 168 or RP 190-2
 & 960284-1 or -2
 7QV5 960001-4
 7T143 RP 190-2
 & 960284-1 or -2
 8TV41 RP 177A
 8TV321 RP 178
 8TV323 RP 178
 8V7 RP 178
 8V90 RP 178
 8V91 RP 178
 8V112 RP 178
 8V151 RP 177B
 9EY3 RP 168
 9EY31 RP 168
 9EY32 RP 168
 9EY35 RP 168
 9EY35U RP 168
 9EY36 RP 168
 9EY36U RP 168
 9JY RP 168
 9QV5 RP 168 & 960282-2
 9T89 RP 168 or RP 190-2
 & 960284-1 or -2
 9T147 RP 190-2
 & 960284-1 or -2
 9TW309 RP 168 & RP 178
 9TW333 RP 168 & RP 178
 9TW390 RP 168 & RP 177B
 9W51 RP 168
 9W78 RP 168 & RP 178
 9W101 RP 168
 9W102 RP 168
 9W103 RP 168
 9W105 RP 168 & RP 178
 9W106 RP 168 & RP 178
 9Y7 RP 168
 9Y51 RP 168
 9Y510 RP 190-1

Model *Record Changer*
 9Y511 RP 168
 15-E, 15-E-1 RP 190A-1 &
 Manual turntable
 21T197DE 930409-5, -10
 21T242 930409-5, -10
 21T244 930409-5, -10
 35QU 930409-4, -6
 45-EY RP 168
 45-EY-1 RP 168
 45-EY-2 RP 190
 45-EY-3 RP 190-1 or RP 190-3
 45-EY-4 RP 190-2
 45-EY-15 RP 168
 45-EY-26 RP 190A-2
 45-J RP 168
 45-J-2 RP 190-1
 45-J-3 RP 193
 45-W-9 RP 190-2
 45-W-10 RP 190-2
 55U, 55AU 960015
 58V, 58AV 960001-1
 59V1, 59AV1 960001-2
 Rad. 62-1 960260-2
 65U, 65AU 960260-2
 65U-1 960260-2
 67V1, 67AV1 960260-1
 Rad. 75ZU RP178 or 960276
 77U RP 178
 77V1 960260-1
 77V2 960260-1
 610V1 960001-5 or -6 or RP 177
 610V2 960001-5 or -6 or RP 177
 612V1 RP 176A or RP 176B
 612V3 RP 176 or RP 176A
 612V4 RP 176 or RP 176A
 641TV 960001-4 or -6
 648PV RP 176
 710V2 RP 177 or RP 177A
 730TV1 RP 177 or RP 177A
 730TV2 RP 177 or RP 177A
 711V1 960001-5
 711V2 960001-5
 711V3 960001-5

NOTES ON 17T150, 17T151, 17T153, 17T154, 17T155, 17T160, 17T162, 17T163, 17T172, 17T172K,
17T173, 17T173K, 17T174, 17T174K, 21T159, 21T165, 21T176, 21T177, 21T178
AND 21T179 TELEVISION RECEIVERS

SEPARATION OF SOUND AND PICTURE IN WEAK SIGNAL AREAS—Normally the picture carrier falls at 50% on the slope of the overall response curve as shown below. When receiving signals of less than 50 microvolts, on intercarrier receivers, it is common practice to adjust the fine tuning control so as to move the picture carrier up the slope to improve the signal to noise ratio. The actual amount which the carrier is moved depends upon the signal strength. On extremely weak signals, the picture carrier may be moved as high as 80% to 90% on the slope of the curve. This may represent a change of as much as .75 megacycles of all frequencies being passed through the pix i-f amplifier. Under such conditions the sound may become weak and noisy even on intercarrier receivers. The reason for this is shown in figure 1 below.

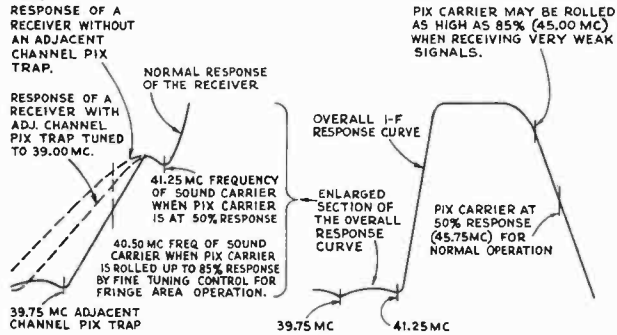

Figure 1—Details of Overall Response Curves

When the picture carrier is rolled up the slope and lowered in frequency by .75 mc., the sound carrier is also lowered in frequency by .75 mc. to become 40.50 mc. As can be seen by the enlarged section of the response curve, the sound carrier begins to fall into the adjacent channel picture trap with a consequent reduction of sound output. Receiver designs which do not incorporate an adjacent channel picture trap may avoid this difficulty at the expense of adjacent channel picture rejection.

It is possible to overcome the above described difficulty in many cases by a simple adjustment which can be made in the field without the aid of test equipment. When the picture carrier is rolled up the slope by .75 mc., the adjacent channel picture carrier is lowered in frequency to 39.00 mc. and no longer falls into the adjacent channel picture trap. If the trap is returned to 39.00 mc. it will permit the response at 40.50 mc. to rise somewhat and produce stronger sound and will produce greater adjacent channel picture rejection under the actual operating condition. If a strong signal is available on another channel and the fine tuning is adjusted to roll the picture carrier down the slope to the normal 50% point, the adjacent channel picture trap will appear mistuned. However, it is not likely that adjacent channel picture interference will be experienced on strong signals.

In addition to the above adjustment, T107, normally peaked at 41.8 mc., may be lowered in frequency to provide improved sound gain. Care should be taken in making this adjustment not to lower its frequency any more than necessary as it reduces adjacent channel picture rejection somewhat and might cause difficulty from sound in the picture if a strong signal is available on another channel.

The above adjustments may be made without removing the chassis from the cabinet. First, tune in the desired channel and adjust the fine tuning control for best picture. Then, since the adjacent channel picture trap is under the kinescope, disconnect the high voltage lead at the chassis to prevent getting a shock. Turn the T104 top core clockwise, approximately 1/2 turn if it is a threaded core type or approximately 1 1/2 turn clockwise if it employs a brass stud extending from the transformer shield. Restore the kinescope high voltage connection. Then, from the top of the chassis, adjust T107 clockwise 1/2 turn or less.

If adjacent channel picture interference is a severe problem, it may be necessary to remove the chassis from the cabinet and adjust T104 top core while observing the picture for minimum interference.

R-F AND I-F BIAS RATIOS—In medium field strength areas an occasional receiver may show some snow on signals in the 300 to 1000 microvolt signal range due to an improper ratio of r-f and i-f bias. If the r-f bias is high with respect to the i-f bias, the picture becomes snowy. If the i-f bias is too high with respect to r-f bias, the receiver may overload on strong signals.

To determine whether or not the biases are of the correct ratio, tune in a signal and measure the r-f bias, the i-f bias and the AGC amplifier plate voltage with a "VoltOhmyst". The signal must be steady during these measurements. Plot these points on the accompanying graph. The values should fall within the range of the dotted lines.

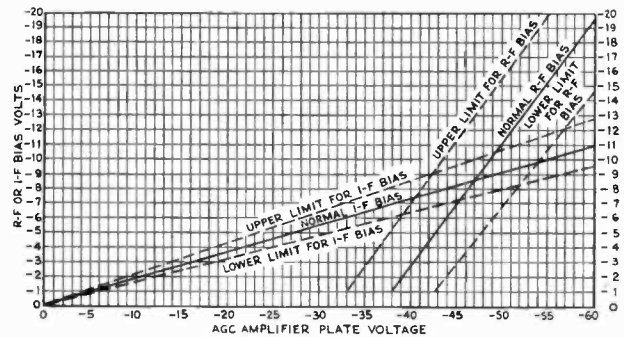

Figure 2—Chart of R-F, I-F Bias Ratios

According to the graph, when the AGC amplifier plate measures -45 volts, the i-f bias should be -8.2 volts. If the i-f bias actually measured -10 volts, it indicates that R143 or R145 is too low in value and/or R144 or R150 is too high. If, however, the i-f bias actually measured -6 volts it indicates R143 or R145 is too high in value and/or R144 or R150 is too low. The resistors originally employed in production were 10% tolerance units. However, if R143 and R145 are at one limit of their tolerance and R144 and R150 are at the other limit of their tolerance, a considerable error in i-f bias is produced.

Similarly at -45 volts AGC amplifier plate voltage the r-f bias should measure -6.8 volts. If the i-f bias should measure say -12 volts, it indicates that R128 or R129 is too low or R127 is too high or the R145 volt bus is too low. If the bias is too low, obviously the converse is true.

In several instances, r-f or i-f bias difficulties have been traced to leaky electrolytic capacitors C124 or C138. In two known instances, one of these two capacitors was connected into the circuit in reversed polarity due to a reversal of the polarity markings on the capacitor.

The above AGC bias circuit description is for the 17T153 series receivers. The 21T176 receivers are similar except for slight differences which cause the biases to occur at slightly different AGC plate voltages.

AGC THRESHOLD CONTROL ADJUSTMENT—The AGC control is adjusted at the factory to provide maximum possible gain without clipping sync for all signals above the receiver threshold up to 25000 microvolts. The adjustment of this control should not be touched in the field unless it is definitely known to be incorrect. If the control is misadjusted so as to increase the receiver gain, it may overload when a strong signal is received or when a weak signal temporarily increases in strength due to unusual propagation conditions. On the other hand, if the receiver gain is lowered by the AGC control, the sync noise immunity is reduced.

In order to reduce the prominence of snow on weak signals it is important that the picture control not be operated at its maximum clockwise position. Such an adjustment will provide a higher contrast picture but at the same time may produce an apparent poorer signal to noise ratio due to the fact that an excessive amount of signal on the kinescope grid causes the snow to bloom or defocus thus causing the flake particle to become larger and more prominent than normal. At the same time it is equally important that the receiver be focused to obtain the appearance of the least amount of

NOTES ON 17T150, 17T151, 17T153, 17T154, 17T155, 17T160, 17T162, 17T163, 17T172, 17T172K, 17T173, 17T173K, 17T174, 17T174K, 21T159, 21T165, 21T176, 21T177, 21T178 AND 21T179 TELEVISION RECEIVERS

snow in the picture. To do this, focus the receiver by the method directed in the Service Data. As a final adjustment, adjust the focus control for the appearance of minimum snow in the picture.

Only under two conditions can it be considered permissible to adjust the AGC control. In an area where the signal is so weak that the snow practically obscures the picture after having taken all the above precautions, then the AGC control may be adjusted to give the best signal to noise ratio. It should be recognized however, that trouble from loss of sync noise immunity might be experienced.

The other condition which would justify adjustment of the AGC control is where a signal of over 25,000 microvolts is received. Under this condition the AGC control should be adjusted until the receiver no longer overloads.

NOTES ON GERMANIUM CRYSTAL DETECTOR CR101—Several different types and makes of crystals are used, such as 1N60, 1N64 and CK706. These crystals have slightly different characteristics and may not be directly interchangeable. In production, these differences are taken care of by varying the value of R154 which is located in T109. This resistor is normally 10K. However, to take care of different crystals, this resistor may vary from 5600 ohms to 10K ohms.

If the crystal is to be replaced, it should be replaced by one of the same make and type. However, if desired, the entire T109 transformer and matching resistor may be installed. In any event, if T109 or CR101 is replaced, the over-all response should be checked.

If a crystal is replaced, care should be taken to get it connected in the proper polarity. Since germanium crystals are marked differently than selenium rectifiers, confusion may result. Selenium rectifiers are marked + and - to show the polarity of the d-c output voltage. Germanium crystals are marked to show the polarity of voltage that must be applied to obtain maximum current flow. The cathode end of a germanium crystal may be coded with green paint or marked -. The anode end may not be coded or may be coded +. In schematic symbols, the anode is shown as an arrow (◄) and the cathode as a flat bar. In T109, the anode (+) end is connected to terminal A and the cathode (-) end to terminal D. Care should also be taken not to overheat the crystal with the soldering iron as damage to the crystal may result.

As a protection against damage to the crystal detector, a 220 ohm, 1/2 watt resistor has been added in series with the screen of V110, the 6AG7 video amplifier. This resistor is designated as R174 in both 17 and 21 inch receivers and is carried under stock number 503122. It is shown in the latest editions of the receiver Service Data.

T104 FREQUENCY CHANGE—In late production receivers, the adjacent channel picture trap in T104 has been tuned to 39.25 mc. rather than 39.75 mc. This results in slightly more sound sensitivity when operating the receiver in fringe areas. It also provides slightly higher adjacent channel picture rejection when the fine tuning is adjusted so as to roll the picture carrier up on the slope of the i-f response as is done in receiving weak signals. This change, suggested as a field adjustment, was covered more fully in RPT Tip, Volume II, Issue 9, dated November 19, 1951.

KRK11 OSCILLATOR INJECTION VOLTAGE—If low oscillator injection voltage is encountered in KRK11 r-f unit, it may be necessary to select a 6X8 tube which will give proper injection when the r-f unit is properly aligned. Recent changes in the circuit and parts makes it easier to obtain sufficient injection with average 6X8 tubes. R-F units in which these changes are made are marked ML. The parts list of the 17 inch receiver Service Data lists parts for early and late production units.

FUSE CHANGE—Early production receivers employed a 0.25 ampere fuse. This was later changed to a 0.20 ampere slow blow type. The latest production receivers have reverted to the regular type 0.25 ampere fuse, stock number 73600. If a fuse requires replacement, it is recommended that the regular type be employed.

LEAD DRESS IN KRK11—In several early production units, difficulty has been reported due to the shield of the cable from T1 shorting against C28. When working on one of these units, take care not to disturb the dress of this cable so as to make this short more likely to happen in service. It may also be a worthwhile precaution to wrap the shield of the cable with several turns of tape at the point where it passes C28. In late production units, this lead has been dressed so that a short cannot occur.

VERTICAL SYNC AND HOLD IN 17T153 SERIES—In a few cases it has been found that C172 has changed value with time and temperature requiring resetting the vertical hold control during initial warm-up and causing the control to be operated at the extreme clockwise position. If such a condition is encountered, replace C172 with another capacitor which will permit normal operation of the control.

Several cases have been reported from the field that R191 was connected to the cathode side of R266 instead of the junction of R265 and R266. This results in 70 to 80 volts on the cathode pin 6 of V113 instead of the normal 100 volts, causing unstable vertical sync.

KCS68 VERTICAL SYNC INSTABILITY DUE TO REFLECTIONS—In some cases, reflections may cause vertical sync to be unstable. The following changes to KCS68 chassis are suggested as a possible cure for this condition at a slight detrement of sync noise immunity on weak signals.

1. Change R185 to 1.0 meg, $\pm 10\%$, 1/2 watt, Stock No. 503510.
2. Change R186 to 3.9 meg, $\pm 10\%$, 1/2 watt, Stock No. 503539.
3. Change R189 to 22K, $\pm 10\%$, 1/2 watt, Stock No. 503322.
4. Change C160 to .056 mfd, 400 volts, Stock No. 73791.
5. Add a 100 mmf capacitor, Stock No. 39628 from pin 4 of V113 to ground.

The above changes apply only to KCS68 and are not applicable to KCS66 series chassis.

SOCKET CONNECTIONS TO 1B3GT RECTIFIER (KCS66 SERIES)—In some KCS66 series chassis, the 1B3GT socket, terminal 5 has been used as a tie point. It has been found that some brands of tubes have an internal connection in the tube between pins 5 and 7. Such tubes will not operate in KCS66 series chassis which are wired as noted above.

When replacing the 1B3GT tube in the field, the serviceman may employ one of the three following methods to avoid difficulty.

1. Use a tube which does not employ a connection between pins 5 and 7. RCA tubes do not have this connection.
2. Rewire the 1B3GT tube socket so that terminal 4 is employed as the tie point instead of terminal 5.
3. If the tube has a connection between pins 5 and 7, clip pin 5 off of the tube base.

DEFLECTION TROUBLE SYMPTOMS IN 21-INCH RECEIVERS—Fold over or white bar in center of raster. This trouble may be caused by low screen voltage on the 6CD6 tube due to R253 or R235 being open.

Low brilliance, change in pix size and linearity, etc. This may be caused by a defective L106.

Poor interlace—To prevent coupling between the vertical and horizontal sweep circuits, thus causing poor interlace, dress the red lead from the yoke socket to the HV transformer under the lance on the side of the high voltage cage. To prevent parasitic oscillations in the horizontal sweep circuit, C185 should be connected from pin 2 of V116 to ground instead of from the nearby terminal board to ground.

17CP4, 21AP4 AND 17QP4 KINESCOPES—If certain kinescope "electron gun" parts become magnetized, "poor focus" may result. To demagnetize these tubes, connect a 630TS receiver EM focus coil to 110 volts a-c and pass the coil slowly over the kinescope neck, past the "gun" and slowly withdraw.

R-F TUNERS

The attached information lists the differences between the various types of KRK2, KRK5, KRK7 and KRK8 series r-f tuners. This information should be helpful in adapting one type of unit to another in event the correct type is not available.

KRK2 SERIES TUNERS

Receiver Model	R-F Unit	Detent Stock No.	Converter Transformer Tap	Conv. Trans. Cap.
621TS	KRK2	71463 (Short)	3rd or 4th Turn Down	62 mmf.
630TS	KRK2	71463 (Short)	4th Turn Down	68 mmf.
630TCS	KRK2	71463 (Short)	4th Turn Down	68 mmf.
641TV	KRK2	71463 (Short)	4th Turn Down	68 mmf.
648PTK	KRK2A	71463 (Short)	4th Turn Down	68 mmf.
648PV	KRK2A	71463 (Short)	4th Turn Down	68 mmf.
721TS	KRK2B-1	72743 (Long)	3rd Turn Down	62 mmf.
721TCS	KRK2B-1	72743 (Long)	3rd Turn Down	62 mmf.
730TV1 & 2	KRK2B-1	72743 (Long)	3rd Turn Down	62 mmf.
741PCS	KRK2A	71463 (Short)	4th Turn Down	68 mmf.
8TS30	KRK2	72743 (Long)	4th Turn Down	68 mmf.
8PCS41	KRK2A	71463 (Short)	4th Turn Down	68 mmf.
8TV41	KRK2	71463 (Short)	4th Turn Down	68 mmf.
9PC41	KRK2A	71463 (Short)	4th Turn Down	68 mmf.

NOTE #1—Converter transformers using 62 mmf. capacitors are aligned on the primary side to 22.8 mcs. and are recognized by a painted dot on top. All others are aligned to 21.8 mcs.

NOTE #2—There is no difference between the KRK2 and the KRK2A, except that "2A" unit is used in the projection receivers.

NOTE #3—Using the 621TS (KRK2) r-f unit in the 630TS or 8TS30 without the modification indicated may result in i-f oscillation. Using the 630TS (KRK2) r-f unit in the 621TS without modification indicated may result in insufficient sound.

NOTE #4—The KRK2 unit can be changed to a KRK2B-1 by changing the detent, tap on converter transformer, and converter shunt capacitor as listed above. All other parts are identical.

KRK5 AND KRK7 SERIES TUNERS

Receiver Model	R-F Unit	Front Plate	Chan. Sel. Shaft	Actuating Shaft	Shaft Length
8T241	KRK5	73436	73437	73439	Short
8TV321-3	KRK5	73436	73437	73439	Short
8T270	KRK5A	74166	74168	74167	Long
8TK320	KRK5A	74166	74168	74167	Long
8TR29 } 8TK29 }	KRK5	73436	73437	73439	Short
9T240	KRK5	73436	73437	74439	Short
9TC240	KRK5A	74166	74168	74167	Long
9TC245-47-49	KRK5	73436	73437	73439	Short
9T246	KRK7	74572	74573	{ 74574 74577	—
9T256	KRK7	74572	74573	{ 74574 74577	—
9T270 } 9TC272.5 }	KRK5A	74166	74168	74167	Long
9TW309	KRK5	73436	73437	73439	Short
9TW333	KRK5	73436	73437	73439	Short
9TW390	KRK5A	74166	74168	74167	Long
T100	KRK7	74572	74573	{ 74574 74577	—
T120	KRK5	73436	73437	73439	Short
T121	KRK5	73436	73437	73439	Short
TC124-5-7	KRK5	73436	73437	73439	Short
TA128	KRK5	73436	73437	73439	Short
TA129	KRK5	73436	73437	73439	Short
T164 } TC165-6-7.8 }	KRK5B	73436	73437	73439	Short
TA169	KRK5B	73436	73437	73439	Short
SI000	KRK5A	74166	74168	74167	Long
6T72	KRK5B	73436	73437	73439	Short

NOTE #1—KRK5 units may be converted to KRK5A by the replacement of the front plate, fine tuning shaft, and channel selector shaft. (Parts No. 73436, 73437 and 73439 are replaced by Parts No. 74166, 74167 and 74168.)

NOTE #2—KRK5, KRK5A and KRK5B* units may be converted to KRK7 by discarding the following parts:

Stock Number	Description
73465	Belt, fine tuning
73441	Cam, fine tuning
73634	Nut, speed nut
73436	Front Plate and Bushing
73464	Pulley, fine tuning
14343	Retainer for chan. sel. shaft
73437	Shaft, channel sel.
73438	Shaft, fine tuning
73439	Shaft, actuating
73454	Shield for belt
73456	Spring, belt tension
**74166	Front Plate and Bushing
**74167	Shaft, actuating
**74168	Shaft, channel selector

and replace with the following Parts:

Stock Number	Description
74572	Front Plate and Bushing
74573	Shaft—Channel Selector
74574	Shaft—Fine tuning and Cam Assembly
74577	Spring Washer

*The KRK5B unit is the same as the KRK5, except the inside front corner of the tuner shield is cut off diagonally.

**These parts used with KRK5A only.

KRK8 SERIES TUNERS

Receiver Model	R-F Unit	Chan. Sel. Shaft	Fine Tuning Shaft & Cam	Insulating Washer	Front Plate
2T51-60	KRK8	75159	75160	73466 (Round)	—
2T81	KRK8	75159	75160	73466 (Round)	—
4T101	KRK8C	76133	76134	73466 (Round)	76754
4T141	KRK8C	76133	76134	73466 (Round)	76754
6T53-54-64-65-71-74-75-76	KRK8B	75159	75160	75607 (Hex)	76135
6T84-86-87	KRK8B	75159	75160	75607 (Hex)	76135
7T103-103B-104-104B-111B-112-112B-122-122B-123-123B-124-125B-132	KTK8B	75159	75160	75607 (Hex)	76135
7T143	KRK8B	75159	75160	75607 (Hex)	76135
9T57-77-79	KTK8B	75159	75160	75607 (Hex)	76135
9T89	KRK8B	75159	75160	75607 (Hex)	76135
9T105-126-128	KRK8B	75159	75160	75607 (Hex)	76135
9T147	KRK8B	75159	75160	75607 (Hex)	76135
16T152	KRK8B	75159	75160	75607 (Hex)	76135
17T200-201-11-20	KRK8D	76519	76134	75607 (Hex)	76518
21T208-17-18-27-28-29	KRK8D	76519	76134	75607 (Hex)	76518

NOTE #1—Any KRK8 series r-f tuner can be changed from a KRK8 to a KRK8B or 8C, or vice-versa, by installing the proper parts as listed above for each unit. All other parts are identical.

NOTE #2—Front plate No. 76135 is for the KRK11 tuner, but can be used on the KRK8B tuner.

NOTE #3—The KRK8D r-f unit differs from the other units both mechanically and electrically. A KRK8D unit can be mechanically converted so as to be used in place of a KRK8, 8B or 8C provided that R13 is shorted out. However, the KRK8D has a wide range fine tuning control which might cause the fine tuning adjustment to be critical on non-intercarrier receivers. In general, electrical conversions are not recommended due to the nature and amount of work involved.

OSCILLATOR SWITCH WAFERS

Some switches have a wax treated wafer. Heat, due to soldering operations, melts the wax and loosens the switch terminal on which the inductances are mounted. Operation of the switch causes variations in inductance during switching operations. Tuning will vary, depending on the direction of approach of the channel selector switch. This is the result of compression and expansion of the coils mounted on the loose switch contacts. Therefore, when repairing r-f units, take care not to overheat the oscillator switch wafer. If the wafer is thus damaged, replacement of the wafer is the most practical solution.

R-F UNIT OSCILLATOR TRACKING

The frequency of the r-f unit oscillator is a function of the circuit inductance and capacity, and since the steps of inductance are fairly well fixed on Channels 7 to 12, inclusive, the only sizeable variables that are available are (1) the capacity and (2) Channel 13 inductance.

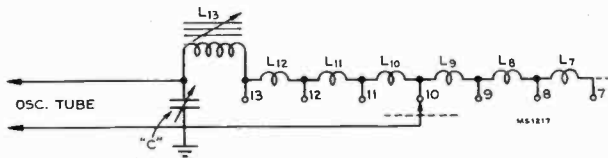

Figure 3—Simplified Schematic of R-F Oscillator.

On KRK2, "C" consists of stray capacity, fine tuning capacity and (in some units only a "gimmic", a piece of insulated wire about 1/4 inch long) between the plate pins on the tube socket.

On KRK5, KRK7 and new KRK8, "C" is composed of stray capacity and a real adjustable capacitor.

On KRK2, "C" becomes less with a counter-clockwise rotation of the fine tuning control.

On KRK5, KRK7 and KRK8, a clockwise rotation of the fine tuning control gives less capacity.

To properly track an r-f unit oscillator on the high channels, the following process may prove helpful:

1. Make sure that the adjustment screws for Channels 7 to 12, inclusive, are spaced about 1/32 of an inch (1 1/2 turns from full in position) away from the rivets holding the inductance strap.
2. Tune for correct Channel 13 oscillator frequency by using the readily available adjustments for the purpose (a capacity trimmer on the KRK8 and an inductance slug on the KRK5.)
3. Without moving the fine tuning control, turn the detent to Channel 7 position and note the oscillator frequency.
4. If the noted frequency is higher than it should be, the Channel 13 capacity should be increased and the Channel 13 inductance should be decreased. Go back to Channel 13 and make the necessary changes to give both the correct frequency and an approximation of tracking correction. See Chart below.
5. If, on the other hand, the Channel 7 oscillator frequency is lower than it should be, the Channel 13 capacity should be decreased and the inductance increased. See Chart below.

KRK2

To Increase Channel 13 Capacity	To Decrease Channel 13 Capacity
1. Pick oscillator tube to give lower frequency.	1. Pick oscillator tube to give higher frequency.
2. Add a "gimmic" between oscillator tube socket plate pins or move the existing "gimmic" closer. (Use a production sample for reference—some units already have a "gimmic".)	2. Move "gimmic" away from plate pins.
3. Check cross feed capacitors for correctness of value.	3. Check cross feed capacitors for value.
To Increase Channel 13 Inductance	To Decrease Channel 13 Inductance
The Channel 13 slugs are brass and normally inserted through the coil. If the slug screws stick out about 3/8 of an inch, they are in their minimum inductance position and any tuning, either in or out, gives a change toward the maximum inductance position.	
1. Move Channel 13 slug in if the stud protrudes 3/8 of an inch, or less. Move out if they protrude more than 3/8 of an inch.	1. Move Channel 13 slug out if the stud protrudes 3/8 of an inch, or less. Move in if they protrude more than 3/8 of an inch.

KRK5 AND KRK7

To Increase Channel 13 Inductance	To Decrease Channel 13 Inductance
1. Screw brass slug out of L1 and L2.	1. Screw brass slug into L1 and L2.
These slugs are available from the bottom of the r-f unit chassis and are normally cemented lightly.	

KRK8

To Increase Channel 13 Inductance	To Decrease Channel 13 Inductance
1. Screw brass slug out of coil.	1. Screw brass slug into coil.
This slug is available from front of unit only.	

On the KRK5, KRK7 and KRK8, the Channel 13 capacity adjustment is fairly obvious. Screwing the stud out gives less capacity; in, gives more capacity.

After the proper adjustments have been made to give oscillator tracking within 1.0 mc. or so from 13 to 7, each channel can be individually aligned by using the available screw trimmers.

For field use in areas having two or more high channel stations, a slightly different approach may be taken:

1. If the highest high channel is aligned with the fine tuning centered and the lowest high channel calls for a clockwise rotation of the fine tuning control, Step 4 applies for KRK2 and Step 5 for all other units.
2. If the highest high channel is aligned with the fine tuning centered and the lowest high channel calls for a counter-clockwise rotation of the fine tuning, Step 5 applies for KRK2 and Step 4 for other units.

Step 4 means an increase of Channel 13 capacity and a decrease of inductance.

Step 5 means a decrease of Channel 13 capacity and an increase of inductance.

USE OF WR39A & WR39B TELEVISION CALIBRATORS

In some instances it may be difficult to hear the heterodyne beat between the variable oscillator and the crystal standard in subject instruments, particularly at the high frequencies.

If the audio system of the receiver under test is in good condition, it is suggested that an audio lead can be run from the head phone jack of the calibrator to the "high" side of the volume control of the television receiver, thus utilizing the additional audio amplification available in the television chassis.

CORRECTING PIX I-F RESPONSE OF RECEIVERS USING KRK5, KRK7 or KRK8 R-F UNITS

Curve "A" below illustrates a normal pix i-f response. Curves "B" and "C" below, illustrate results that are obtained in some cases due to abnormal conditions in the i-f system.

"Correcting" Curve "B", by using the adjusting slugs, usually results in placing the pix carrier minus .75 mc. point at the top of the curve which, again, is not the proper alignment. "Correcting" Curve "C", usually results in very much reduced gain and an excessive amount of adjacent channel response.

To correct Curve "B" with the minimum amount of bad effects, the turns of the second pix I-F trap (T-102) should be moved away from the primary of the same transformer. Moving the whole trap coil about two or three nicks up the coil form is usually sufficient.

To correct Curve "C", the following must be checked:

1. Make sure that the cathode sound trap is not shorting.
2. Check the sound I-F alignment.
3. Check sweep and scope response by removing "blanking" on the sweep and checking for response overlap. (A defective scope cable or input can cause overshoot on this side of the response curve.)
4. If none of the above results in a satisfactory curve, then the sound take-off trap coil (T-103) should be moved up and away from T-103 primary. One notch on the coil form is usually sufficient.

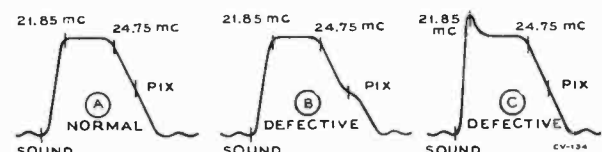

Figure 4—Overall Response Curves

HIGH PASS FILTER FOR REJECTION OF INTERFERING SIGNALS BELOW 50 MC.

If interference is experienced due to the presence of strong signals below 50 mc. it can usually be eliminated by the use of a high pass filter. To be effective, the filter must be installed at the r-f units with as short leads as possible and the case of the filter connected to the r-f unit chassis.

Figure 5 shows the method of attaching the antenna input connectors to the filter so that it can be "plugged" directly into the antenna matching units employed with KRK5, KRK7 and KRK8 r-f tuners.

Figure 6 shows the method of mounting the filter on receivers employing KRK2 r-f units.

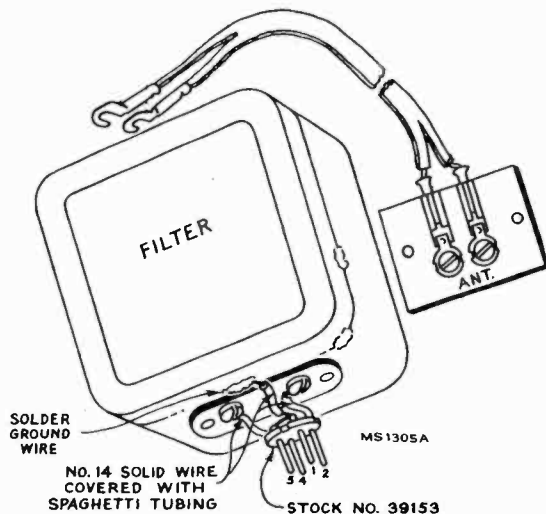

Figure 5—Filter for KRK5, KRK7 and KRK8 R-F Units

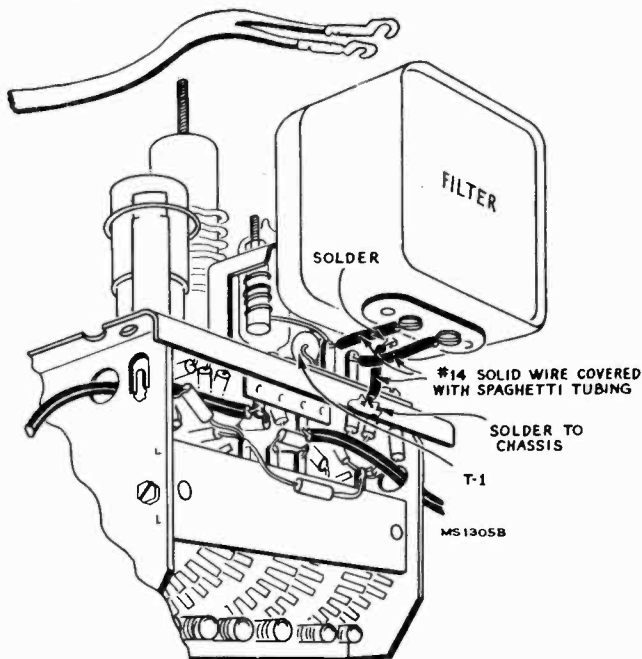

Figure 6—Filter for KRK2 R-F Units

ADJUSTMENT OF THE AGC CONTROL ON 17T200 AND 21T208 SERIES RECEIVERS

In setting the AGC control on these and other RCA receivers, care must be taken that the receiver is generating the maximum AGC voltage which will be required for that particular location of the receiver.

If the AGC control is adjusted on a weak signal, the receiver may overload, bend on sync etc. when a stronger signal is received.

One source of difficulty not likely to be suspected is the position of the fine tuning control. If the AGC control is adjusted with the fine tuning set so that the picture carrier is low on the slope of the i-f response curve, then the receiver may overload, bend on sync, etc. when the picture carrier is moved up the slope with the fine tuning control. The obvious cure is to set fine tuning so that the picture carrier is well up the slope (fine tuning ccw on KRK8) when making final adjustment of the AGC control.

HIGH VOLTAGE ARCS AT KINESCOPES

During days of humid weather, difficulty may be experienced with arcing across the bell of metal cone picture tubes due to a collection of dust and moisture around this area.

In the past, many remedies have been suggested, all of which have been helpful for a short period of time. The best field remedy found to date has been an application of "Car-Plate", mfd. by S. C. Johnson & Son, Racine, Wis.

The following procedure should be employed:

1. Remove the entire coating on glass bell, using methanol or acetone.
2. Wash the glass bell thoroughly with a good detergent.
3. Dry the glass bell thoroughly.
4. Apply a good coating of Johnson's "Car-Plate". Allow to dry, then wipe off the white residue. Brush application is satisfactory.

FIXED COMPOSITION RESISTOR STOCK NO. CODE

The RCA six digit stock number for fixed composition resistors.

The first digit will always be 5.

The second digit is to indicate the wattage. 0 = 1/2 watt, 1 = 1 watt, 2 = 2 watt.

The third digit is to indicate the resistor tolerance. 2 = 5%, 3 = 10%, 4 = 20%.

The fourth digit is for the number of zeros following the significant figures of the resistor value.

The fifth and sixth digits are for the significant figures of the resistor value.

Example 503268 is the stock number of a 1/2 watt, fixed composition resistor, 6800 ohms $\pm 10\%$.

A few resistors are still being listed in the Service Data under four or five digit stock numbers. This is because there are still some of these resistors in stock packaged under the old stock numbers. However, as these are depleted, the new stock will be carried under the six digit stock number system.

Wire wound or other special resistors will continue to carry four or five digit stock numbers.

TELEVISION RECEIVER MODELS AND CHASSIS

Receiver Models	Television Chassis	Radio Chassis	Record Changer	Kine-scope	R-F Tuner	Speaker Size	Television Power Supply	Audio Amplifier
TT5 (PRE WAR) TRK5 (PRE WAR)	KC-3 or KC-3B† KC-3A or KC-3C†	— RC429 & RS89A		5BP4 5BP4	5 channels 5 channels	None 12" EM		
TRK9 (PRE WAR) TRK90 (PRE WAR) TRK12 (PRE WAR) TRK120 (PRE WAR)	KC-4A or KC-4C† KC-4H KC-4 or KC-4B† KC-4F or KC-4J†	RC427A & RS83E RC427G & RS83E RC427 & RS83E RC427F & RS83E		9AP4 9AP4 12AP4 12AP4	5 channels 5 channels 5 channels 5 channels	12" EM 12" EM 12" EM 12" EM	KK-7A or KK-7E† KK-7H KK-7 or KK-7D† KK-7F or KK-7J†	
621TS	KCS21			7DP4	KRK2	4"x6" EM		
630TS	KCS20A or KCS20C-2†			10BP4	KRK2	5" EM		
630TCS	KCS20B or KCS20D-2†			10BP4	KRK2	12" EM		
641TV	KCS25A-1 or KCS25C-2†	RK117A	960001 (78 RPM)	10BP4	KRK2	12" EM		RS123A
648PTK	KCS24-1* KRS20-1** KRK1-1***	RK121A		5TP4	KRK2A	12" EM	KRS21	RS123A
648PV	KCS24A-1* KRS20-1** KRK1A***	RK121A	RP176 (78 RPM)	5TP4	KRK2A	12" EM	KRS21A-1	RS123B
721TS	KCS26-1 or KCS26-2†			10BP4	KRK2B-1	4"x6" EM		
721TCS	KCS26A-1 or KCS26A-2†			10BP4	KRK2B-1	12" EM		
730TV1 730TV2	KCS27-1 or KCS27-2†	RC610A RC610B	RP177 RP177	10BP4 10BP4	KRK2B-1 KRK2B-1	12" PM 12" PM		
741PCS	KCS24B-1* KRS20A-1** KRK1A-1***			5TP4	KRK2A	12" EM	KRS21A-1	RS123C
8PCS41	KCS24B-1* KRS20A-1** KRK1A-1***			5TP4	KRK2A	12" EM	KRS21A-1	RS123C
8PCS41B	KCS24C-1* KRS20B-1** KRK4***			5TP4	KRK2A	12" EM	KRS21A-1	RS123C
8PCS41C	KCS24C-1* KRS20A-1** KRK1A-1***			5TP4	KRK2A	12" EM	KRS21A-1	RS123C
8TS30	KCS20J-1 or KCS20K-2†			10BP4	KRK2	5"x7" PM		
8TV41	KCS25D-1 or KCS25E-2†	RK117A	RP177A (78 RPM)	10BP4	KRK2	12" EM		RS123A
8T241, 8T243, 8T244	KCS28			10BP4	KRK5	5"x7" PM		
8T270 8TC270, 8TC271	KCS29 KCS29A			16AP4 16AP4	KRK5A KRK5A	8" PM 8" PM		
8TR29 8TK29	KCS32 or 32B KCS32A or 32C	RK135 or 135A RK135 or 135A		10BP4 10BP4	KRK5 KRK5	5"x7" PM 12" PM		
8TK320	KCS33A-1	RK135A-1		16AP4	KRK5A	12" PM		
8TV321 8TV323	KCS30-1 KCS30-1	RC616C or K RC616B or J	RP178 RP178	10BP4 10BP4	KRK5 KRK5	12" PM 12" PM		
9PC41(a)	KCS24C-1* KRS20B-1** KRK4***			5TP4	KRK2A	12" EM	KRS21A-1	RS123A
9PC41(b), 9PC41(c)	KCS24D* KRS20B-1** KRK4***			5TP4	KRK2A	12" EM	KRS21A-1	RS123A
9T240 9T240K 9TC240	KCS28 KCS28A KCS28B			10BP4 10BP4 10BP4	KRK5 KRK5 KRK5A	5"x7" PM 5"x7" PM 12" PM		
9TC245, 9TC247, 9TC249	KCS34B or KCS34 in some 247 & 249			12LP4	KRK5	12" PM		
9T246	KCS28C or KCS38			10BP4 10BP4	KRK7 KRK7	5"x7" PM 5"x7" EM		
9T256	KCS38C			10BP4	KRK7	5"x7" EM		
9T270 9TC272, 9TC275	KCS29 KCS29C			16AP4 16AP4	KRK5A KRK5A	8" PM 12" PM		
9TW309	KCS41-1	RK135C	RP178 (78 RPM) RP168A-1(45RPM)	12LP4	KRK5	12" PM		
9TW333	KCS30-1	RC616N	RP178 (78 RPM) RP168A-1(45RPM)	10BP4	KRK5	12" PM		
9TW390	KCS31-1	RC617A	RP177B (78 RPM) RP168A-1(45RPM)	16AP4	KRK5A	12" PM		

†50 Cycle Chassis

*R-F, I-F, Video Chassis

**Deflection & HV Chassis

***Optical Barrel

TELEVISION RECEIVER MODELS AND CHASSIS

Receiver Models	Television Chassis	Radio Chassis	Record Changer	Kine-scope	R-F Tuner	Speaker Size	Television Power Supply	Audio Amplifier
T100	KCS38			10BP4	KRK7	5"x7" EM		
T120, T121	KCS34C			12LP4	KRK5	5"x7" PM		
TC124, TC125, TC127	KCS34B			12LP4	KRK5	12" PM		
TA128	KCS42A	RK135D	960282 (33/78) RP168 (45 RPM)	12LP4	KRK5	12" PM		
TA129	KCS41A-1	RK135D	960282 (33/78) RP168C (45 RPM)	12LP4	KRK5	12" PM		
T164 TC165, 166, 167, 168	KCS40 KCS40A			16GP4 16GP4	KRK5B KRK5B	8" PM 12" PM		
TA169	KCS43	RK135D	960285 (33/78) RP168C (45 RPM)	16GP4	KRK5B	12" PM		
S1000	KCS31-1	RC617B	960285 (33/78) RP168C (45 RPM)	16AP4	KRK5A	12" PM		
2T51 2T60	KCS45 KCS45A			12LP4 12LP4	KRK8 KRK8	5"x7" EM 12" PM		
2T81	KCS46	RC1090	960282 (33/78) RP168 (45 RPM)	12LP4	KRK8	12" PM		
4T101	KCS61			14EP4	KRK8C	5"x7" PM		
4T141	KCS62	RC1090	960282 (33/78) RP190-2 (45 RPM)	14EP4	KRK8C	12" PM		
6T72	KCS40B			16GP4	KRK5B	12" PM		
6T53, 6T54 6T64, 65, 71, 74, 75, 76	KCS47 or 47T KCS47A or 47AT			16GP4 16GP4	KRK8B KRK8B	8" PM 12" PM		
6T84	KCS48 or 48T	RC1090	960282 or 284 RP168 or 190	16GP4	KRK8B	12" PM		
6T86, 6T87	KCS48 or 48T	RC1092	960282 or 284 RP168 or 190	16GP4	KRK8B	12" PM		
7T103, 7T104 7T103B, 7T104B 7T112, 122, 123, 124 7T112B, 122B, 123B, 125B 7T112B, 122B, 123B 7T111B 7T132	KCS47B KCS47F KCS47C KCS47G or GF KCS47GF-2 KCS47GF-2 KCS47D		RP190	17CP4 17GP4 17GP4 17GP4 17GP4 17GP4 17CP4	KRK8B KRK8B KRK8B KRK8B KRK8B KRK8B KRK8B	8" PM 8" PM 12" PM 12" PM 12" PM 8" PM 12" PM		
7T143	KCS48A	RC1092	960284 (33/78) RP190 (45 RPM)	17CP4	KRK8B	12" PM		
9T57 9T77, 9T79	KCS49 or 49T KCS49A or 49AT			19AP4A 19AP4A	KRK8B KRK8B	8" PM 12" PM		
9T89	KCS60 or 60T	RC1092	960284 (33/78) RP168 or 190	19AP4A	KRK8B	12" PM		
9T105	KCS49B, 49BF or 49BF-2			19AP4A	KRK8B	8" PM		
9T126, 9T128	KCS49C, 49CF or 49CF-2			19AP4A	KRK8B	12" PM		
9T147	KCS60A	RC1092	960284 (33/78) RP190 (45 RPM)	19AP4A	KRK8B	12" PM		
16T152	KCS47E			16GP4	KRK8B	8" PM		
17T150 17T151, 17T163	KCS66C KCS66C			17QP4 17QP4	KRK11 KRK11	4"x6" PM 8" PM		
17T153, 154, 155, 160 17T162, 17T174 17T172, 17T173 17T172K, 17T173K 17T174K	KCS66 KCS66A KCS66A KCS66D KCS66D			17GP4 17GP4 17GP4 17CP4 17CP4	KRK11 KRK11 KRK11 KRK11 KRK11	8" PM 8" PM 12" PM 12" PM 8" PM		
17T200, 17T201, 17T202 17T211, 17T220	KCS72 KCS72			17QP4 17QP4	KRK8D KRK8D	5" PM 8" PM		
17T250DE 17T261DE	KCS74 KCS74			17QP4 17QP4	KRK11A KRK11A	8" PM 12" PM		
21T159 21T159DE 21T165 21T166DE 21T176, 177, 178, 179 21T174DE, 178DE, 179DE	KCS68E KCS68F KCS68E KCS68F KCS68C KCS68F			21AP4 21AP4 21AP4 21AP4 21AP4 21AP4	KRK11 KRK11A KRK11 KRK11A KRK11 KRK11A	8" PM 8" PM 12" PM 12" PM 12" PM 12" PM		
21T197DE	KCS68H	RC1111A	930409	21AP4	KRK11A	12" PM		RS141A
21T207, 21T207G 21T208, 21T217, 21T229 21T218, 21T227, 21T228	KCS72A KCS72A KCS72A			21AP4 21AP4 21AP4	KRK8D KRK8D KRK8D	5" PM 8" PM 12" PM		
21T242 21T244	KCS72D-1 KCS72D-2	RC1117B-1 RC1111B	930409 930409	21AP4 21AP4	KRK8D KRK8D	12" PM 12" PM		RS141C

RCA

One Dependable Source...

RCA RENEWAL PRODUCTS

RECEIVING TUBES AND KINESCOPIES

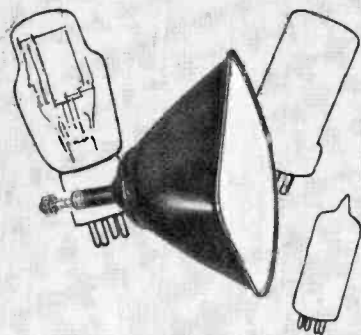

With RCA Receiving Tubes and Kinescopes, *Top Quality Control* makes the difference. The RCA brand on any tube is your best assurance of dependable performance in every AM, FM, television, and industrial application.

ELECTRONIC COMPONENTS, AND SERVICE PARTS

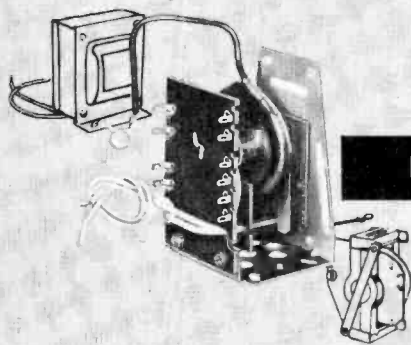

When you need one of the more than 40,000 exclusive RCA Service Parts or one of the versatile new RCA "Universal" type TV components, you can rely on RCA's unparalleled quality.

TEST EQUIPMENT

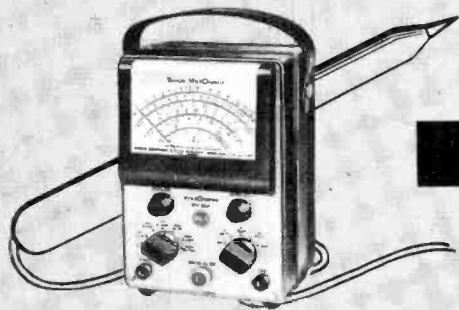

RCA Blue Ribbon instruments—preferred by professionals in servicing, production, and research. Manufactured to exacting standards by professionals... for professionals.

BATTERIES



Dealers and technicians who recommend RCA Radio Batteries help to build their own radio businesses. They sell a complete top-volume battery line of unsurpassed quality backed by the merchandising power of the famous RCA Monogram. Repeat business with satisfied customers is a valuable plus enjoyed by RCA Battery dealers.



For Genuine RCA RENEWAL PRO

for every TV-RADIO servicing need

RCA RADIO-TV Service Information



RCA VICTOR SERVICE DATA

- ★ Schematics
- ★ Alignment Procedures
- ★ Waveforms
- ★ Trouble-shooting Suggestions
- ★ Wiring Diagrams
- ★ Production Changes

Accurate servicing information on all RCA Victor Radio, Phono, and TV sets... data which can't be found elsewhere... is at your fingertips with the famous Bound Volumes of RCA Victor Service Data. Here is detailed, authoritative information for the rapid, profitable servicing of any RCA Victor home instrument.

Prepared by RCA servicing experts, RCA Victor Service Data will give you the information you need to know in the fastest possible time. Watch *your* job turn-over time on RCA Victor sets decrease once you use this authentic servicing aid.

You'll save time and dollars by maintaining a complete file of these handsome, sturdily bound volumes of RCA Victor Service Data. See your local RCA Parts Distributor today.

Authoritative - Complete

RCA's Comprehensive Literature Gives You The Servicing Information You Need.

For Quick, Ready Answers To All Your Servicing Problems ... Get Authentic RCA Literature From Your RCA Distributor!



See Your RCA Distributor



RCA CRYSTAL PICKUP DATA

CRYSTAL CARTRIDGE DRAWING CODE

- "A" Top Needle Hole
- "B" Viscoloid Damper
- "C" Thick (5/16-in.) Mtg. Hole
- "D" Thin (7/32-in.) Mtg. Hole
- "E" Grounded Lug
- "F" Small Weight
- "G" Large Weight
- "H" Large "Cut" Weight
- "I" 5/8-in. Needle Screw
- "K" 11/16-in. Needle Screw
- "L" 13/16-in. Needle Screw
- "M" 15/16-in. Needle Screw

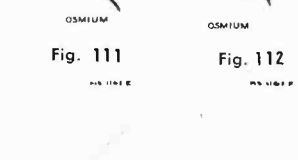
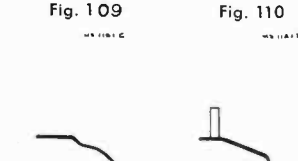
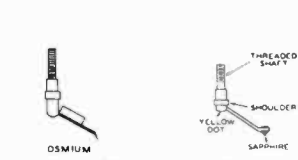
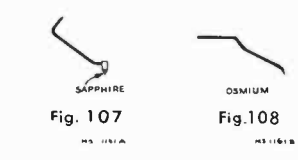
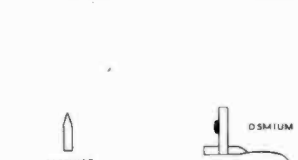
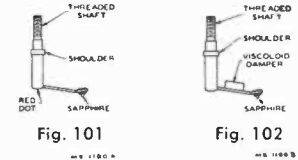
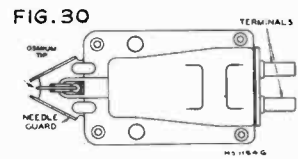
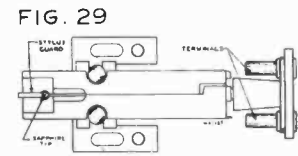
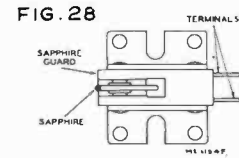
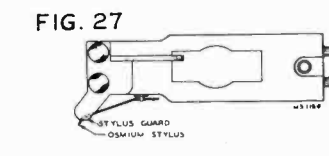
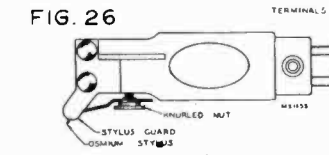
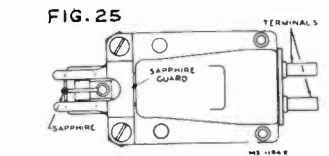
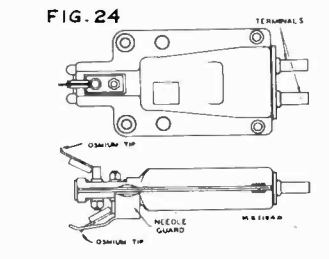
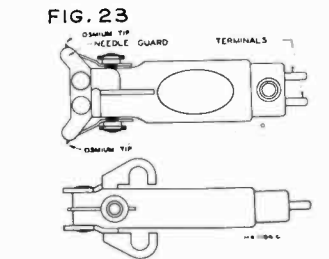
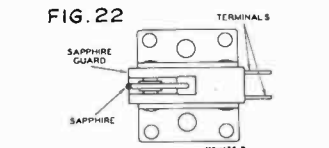
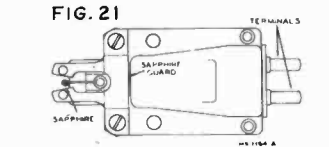
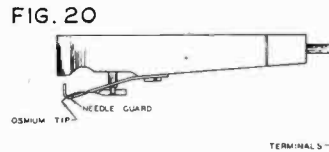
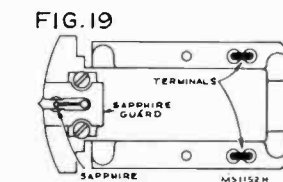
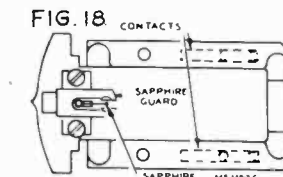
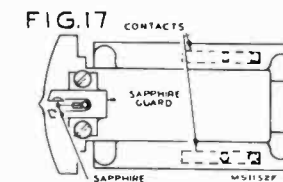
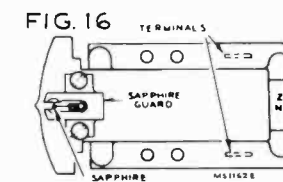
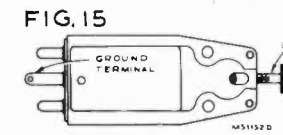
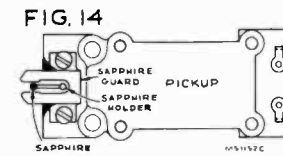
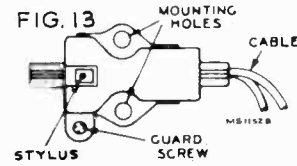
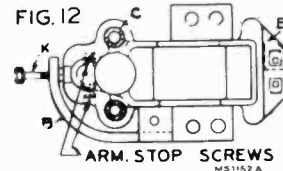
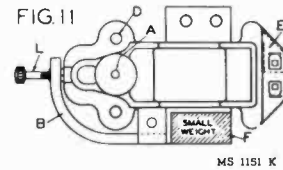
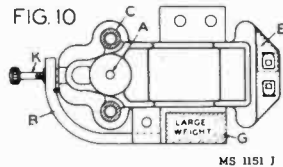
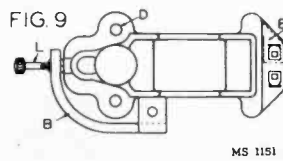
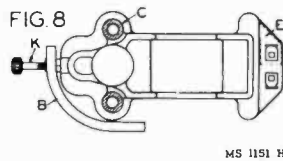
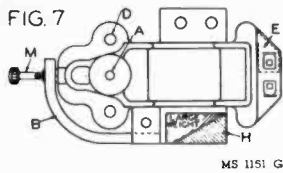
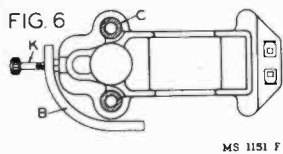
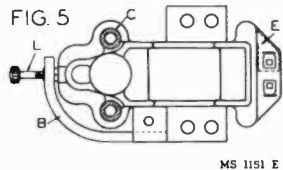
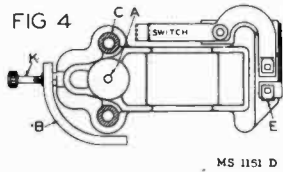
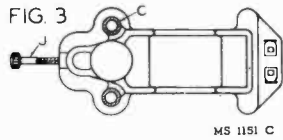
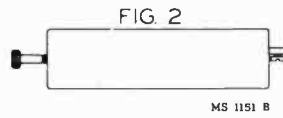
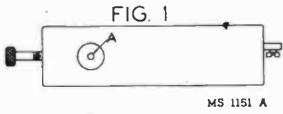

MODEL vs. PICKUP
CARTRIDGE

Table with columns: Model, Record Changer, Cartridge Stock No. Lists models from A-55 to U-124 and their corresponding record changers and cartridge stock numbers.

Table with columns: Model, Record Changer, Cartridge Stock No. Lists models from UY-124 to 9-EY-32 and their corresponding record changers and cartridge stock numbers.

Table with columns: Model, Record Changer, Cartridge Stock No. Lists models from 9-EY-35 to 711-V-2 and their corresponding record changers and cartridge stock numbers.

Table with columns: Model, Record Changer, Cartridge Stock No. Lists models 711-V-3, 730-TV-1, and 730-TV-2 with their respective record changers and cartridge stock numbers.

* = 45 r.p.m.
† = 78/33 r.p.m.
‡ = 78 r.p.m.

PICKUP CARTRIDGES
WITH NEEDLE SCREW

Table with columns: Stock No., Fig. No. Lists stock and figure numbers for pickup cartridges with needle screws, such as 14820 (Fig. 1) and 30708 (Fig. 2).

*Discontinued:
30708—use 14820
32632—use 31156
33122—use 9890
33217—use 9890
33905—use 37158
35171—use 37158
39686—use 9890

PICKUPS WITH
REPLACEABLE STYLUS

Table with columns: Pickup Stock No., Fig. No., Stylus Stock No., Fig. No. Lists pickup models and their replaceable stylus options, such as 9890 (Fig. 16-ZN) and 38453 (Fig. 17-AL).

PICKUPS WITH FIXED
STYLUS

Table with columns: Stock No., Fig. No. Lists pickup models with fixed stylus, such as 75475 (Fig. 24) and 75575 (Fig. 25).

ZN = Zinc case,
AL = Aluminum case
■Ceramic type pickup
*Discontinued:
38449—use 70915
38453—use 39919
39851—use 75976
39863—use 73345
70332—use 75976
74984—use 76297
75476—use 74067
76318—use 74067
©33 1/3 r.p.m.—RED
©78 r.p.m.—PLAIN
©For pickups marked 988370-1
©For pickups marked 988370-2
S-5652 and S-5578 are available
only thru RCA International Div.



RCA VICTOR

Battery Operated Personal Receiver

2B400 Series

Chassis No. RC-1114

SERVICE DATA

— 1952 No. 5 —



2 B 400 SERIES

2 B 400 Grey	2 B 401 Black	2 B 402 Ivory
2 B 403 Green	2 B 404 Tan	2 B 405 Red

PREPARED BY RCA SERVICE CO., INC.

FOR

RADIO CORPORATION OF AMERICA

RCA VICTOR DIVISION

CAMDEN, N. J., U. S. A.

Specifications

Tuning Range540-1600 kc

Intermediate Frequency455 kc

Tube Complement:

1. RCA 1R5Converter
2. RCA 1U4I.F. Amplifier
3. RCA 1U5Det. A.F.Amp. A.V.C.
4. RCA 3V4Output

Loudspeaker

Size and type2" x 3" P.M.

Voice coil impedance11¼ ohms at 1000 cycles

Weight (with batteries)approx. 3¾ lbs.

Batteries Required:

Type of Battery

Current Drain

Normal Pos.

Saver Pos.

"A"—1.5 volt (two)
RCA VS 236
"B"—67.5 volts
RCA VS 216

0.25 amp.

0.20 amp.

8.45 ma.

5.45 ma.

Battery life is approximately 100 hrs. intermittent service with battery-saver switch in "Normal" position. With switch in "Saver" position, battery life is increased approximately 30%.

Power Output:

Undistorted0.075 watt

Maximum0.10 watt

Dimensions (over-all)approx. 8¾" x 5½" x 2¼" ¹⁶/₁₆"

Case Back

To remove—insert small coin in the slot at top rear of case and pry open.

To replace—insert bottom edge into case and snap top edge in place.

Off-On Indicator

A window in the case (just below edge of volume control knob) indicates whether set is turned ON or OFF. "ON" appears in window when set is turned ON and disappears when set is turned OFF.

Battery-Life Saver Switch

Maximum power is obtained when the slider button is pushed toward left (outer edge of case). Extra battery life with slight effect on performance is obtained with the slider button pushed to the right (toward center of case).

Battery Life

The life of the "A" and "B" batteries is approximately equal. For best performance all batteries should be replaced at the same time.

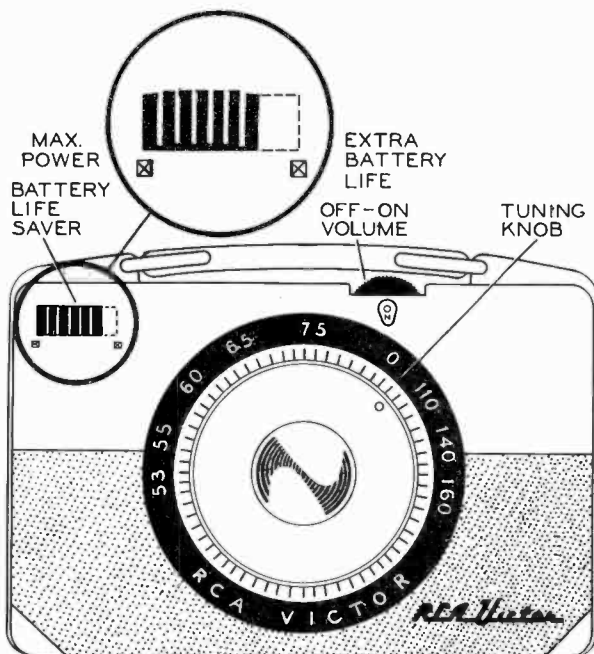

Controls

Alignment Procedure

Output Meter.—Connect meter to voice coil terminals. Turn volume control to maximum position.

Test-Oscillator.—For all alignment operations, connect the low side of the test-oscillator to the receiver chassis, and keep the oscillator output as low as possible to avoid a-v-c action.

Note:—The ant. coil is supplied pre-adjusted and cemented to rod. This makes further adjustment unnecessary. However when replacing ant. assembly make certain that the coil end of the rod is fully entered in its rubber mounting grommet but does not extend through the grommet more than is required to permit the opposite end to fit inside the case.

Replacement of Component Parts

I. To Remove Back Cover

- Depress top of case midway between the handle supports, until the top end of the back separates from the main case.
- Pull the back cover back and up, thereby unhooking the retaining lugs in the bottom of the main case.

II. To Replace Batteries

- Remove back cover.
 - Remove both "A" and "B" batteries. The "B" battery snap fasteners can best be removed by inserting a screwdriver under the snap fastener strip and prying upward.
 - The "A" batteries can easily be removed by pulling up on the spring wire clips.
- Note:** The "A" and "B" batteries have approximately equal life and therefore it is advisable to replace all batteries at one time.

III. To Remove Chassis

- Remove dial knob by grasping with finger tips at two sides and pulling.
- Remove back cover.
- Remove batteries.
- Remove "A+" contacts by squeezing against case and sliding out of slots in case.
- Remove the four screws "A."
- Grasp the assembly by the speaker and pull the bottom end down and outward to clear the volume control knob.

IV. To Replace Chassis

- Observe the position of the battery save button extension in relation to the "battery-save" switch. This extension must engage with the center of the battery save switch.
- Replace in reverse order to that given for chassis removal.

V. To Remove Handle

- Spread the square spring wire clips by pulling on one side of a clip.
- Allow the clip to return to its original shape but resting on the outside of the case.
- Pull the other side of the clip out of the case.

VI. To Replace Battery Save Switch Button

- Remove chassis.
- Spread the open end of the spring clip retainer no more than necessary to permit removal of clip.
- Slide the clip clear of the slider button.
- Turn slider button one-quarter turn and pull out of case.
- Replace button in reverse order—do not use excessive force in replacing spring clip.

Steps	Connect high side of test osc. to—	Tune test-osc. to—	Turn radio dial to—	Adjust the following for max. output—
1				Trimmers of 2nd I-F trans
2	High side of ant. coil (terminal lug on coil which is connected to Pin #6 of 1R5 tube)	455 kc	Quiet point near 1600 kc	Trimmers of 1st I-F trans.
3		Repeat steps 1 and 2		
4		1400 kc	14 Rock gang	C1-1T (osc.)
5	Short wire placed near ant. coil for radiated signal	600 kc	60 Rock gang	L2 (osc.)
6		Repeat steps 4 and 5		

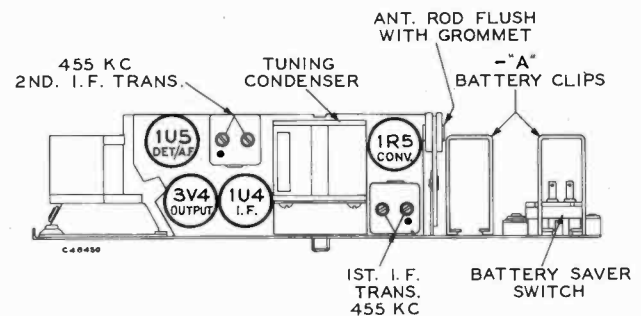
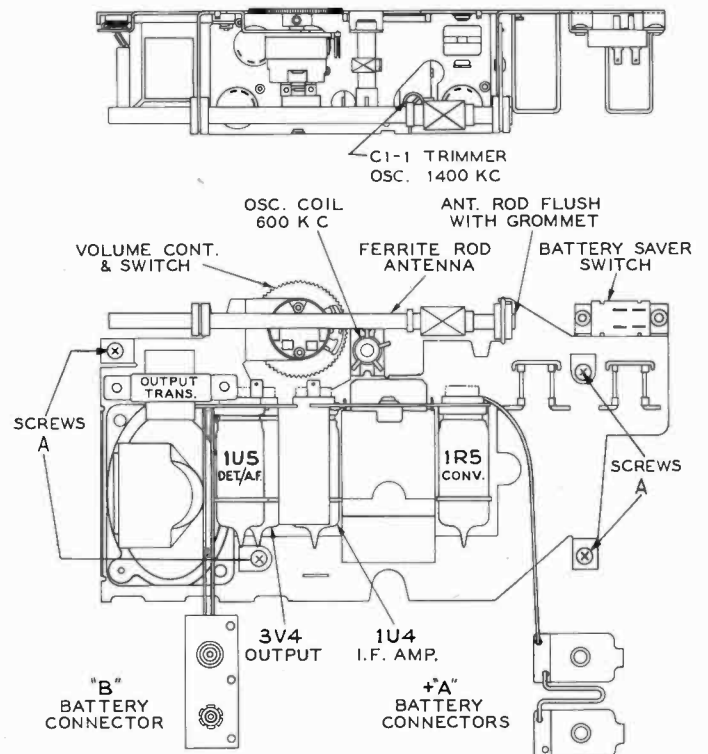

Tube and Trimmer Locations

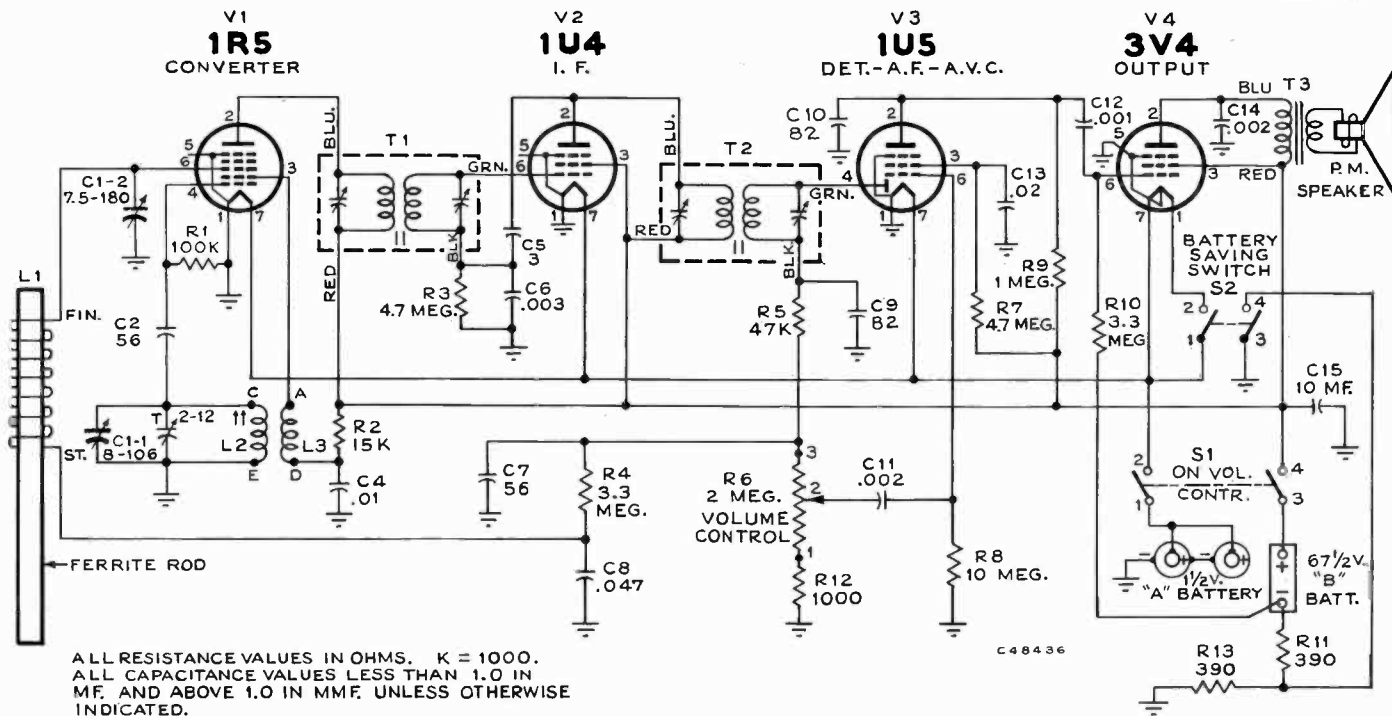

Schematic Diagram

In some chassis the on-off switch terminals are not in the order shown in the wiring diagram. USE CONTINUITY CHECK when connecting replacement control.

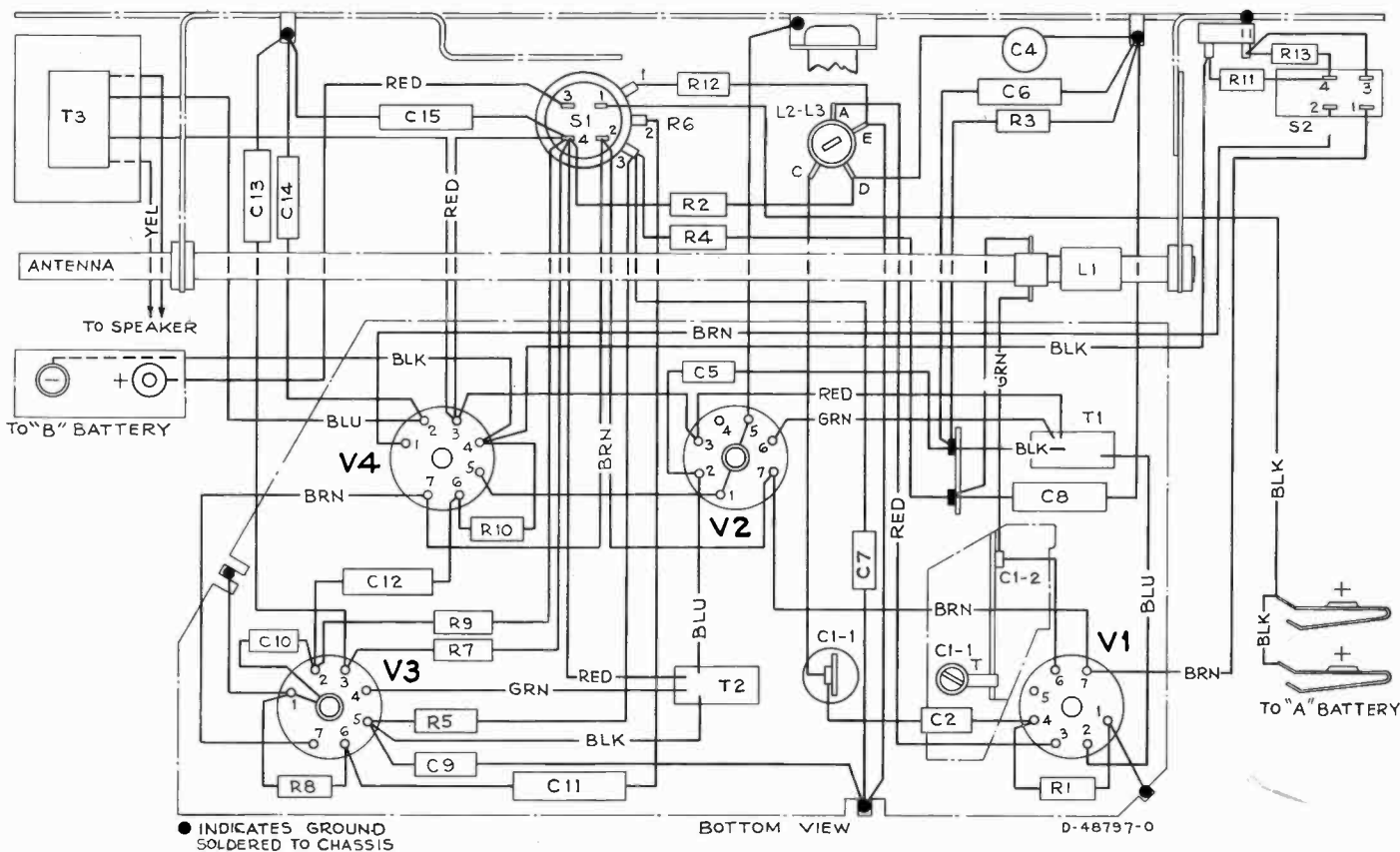

Connection Diagram

CRITICAL LEAD DRESS

1. Position Ferrite antenna rod as described above.
2. Dress all bus wires, pigtail leads and non-insulated components away from chassis base and away from each other.

3. Dress neutralizing capacitor C5 against front of chassis and with clearance under volume control knob. Utilize shielding effect of oscillator coil mounting bracket.
4. Dress all I-F transformer leads down to base.

Replacement Parts

STOCK No.	DESCRIPTION	STOCK No.	DESCRIPTION
CHASSIS ASSEMBLIES			
RC 1114			
76847	Antenna—Ferrite rod antenna (L1)	77163	Back—Case back—RED—for Model 2B405
76846	Capacitor—Variable tuning capacitor (C1-1, C1-2)	76859	Button—Battery saver switch slider button—GREY—for Model 2B400
57090	Capacitor—Ceramic, 3 mmf. (C5)	77164	Button—Battery saver switch slider button—BLACK—and spring clip for Model 2B401
75784	Capacitor—Ceramic, 56 mmf. (C2, C7)	77165	Button—Battery saver switch slider button—IVORY—and spring clip for Model 2B402
75785	Capacitor—Ceramic, 82 mmf. (C9, C10)	77166	Button—Battery saver switch slider button—GREEN—and spring clip for Model 2B403
73960	Capacitor—Ceramic, 10,000 mmf. (C4)	77167	Button—Battery saver switch slider button—TAN—and spring clip for Model 2B404
73964	Capacitor—Electrolytic, 10 mfd., 70 volts (C15)	77168	Button—Battery saver switch slider button—RED—and spring slip for Model 2B405
72792	Capacitor—Tubular, paper, .001 mfd., 200 volts (C12)	76838	Case—Case assembly—GREY—less handle, links and back for Model 2B400
73750	Capacitor—Tubular, paper, .002 mfd., 200 volts (C11, C14)	77154	Case—Case assembly—BLACK—less handle, links and back for Model 2B401
73961	Capacitor—Tubular, paper, .003 mfd., 200 volts (C6)	77155	Case—Case assembly—IVORY—less handle, links and back for Model 2B402
71928	Capacitor—Tubular, paper, .02 mfd., 200 volts (C13)	77156	Case—Case assembly—GREEN—less handle, links and back for Model 2B403
73558	Capacitor—Tubular, paper, .047 mfd., 200 volts (C8)	77157	Case—Case assembly—TAN—less handle, links and back for Model 2B404
76852	Clip—"A" battery mounting clip (formed spring wire) (2 required)	77158	Case—Case assembly—RED—less handle, links and back for Model 2B405
75010	Clip—"C" clip and screw to mount output transformer	76860	Clip—Retaining spring clip for battery saver switch slider button
75774	Coil—Oscillator coil complete with adjustable core (L2, L3)	76842	Dial—Polystyrene dial scale—GREY—for Model 2B400
76854	Contact—"A" battery contact (2 required)	77169	Dial—Polystyrene dial scale—BLACK—for Model 2B401
75773	Control—Volume control and power switch (R6, S1)	77170	Dial—Polystyrene dial scale—IVORY—for Model 2B402
37396	Grommet—Rubber grommet for antenna rod (2 required)	77171	Dial—Polystyrene dial scale—GREEN—for Model 2B403
76853	Insulator—Bakelite insulator for ferrite rod antenna	77172	Dial—Polystyrene dial scale—TAN—for Model 2B404
76851	Knob—Volume control and power switch knob—less set screw	77173	Dial—Polystyrene dial scale—RED—for Model 2B405
76855	Lead—"B" battery lead complete with connector	75844	Emblem—"RCA Victor" emblem
	Resistor—Fixed, composition:—	73843	Grille—Metal grille—perforated—GREY—for Model 2B400
503139	390 ohms, ±10%, 1/2 watt (R11, R13)	77179	Grille—Metal grille—perforated—GOLD—for Models 2B401 and 2B402
504210	1000 ohms, ±20%, 1/2 watt (R12)	77180	Grille—Metal grille—perforated—GREEN—for Model 2B403
503315	15,000 ohms, ±10%, 1/2 watt (R2)	77181	Grille—Metal grille—perforated—TAN—for Model 2B404
504347	47,000 ohms, ±20%, 1/2 watt (R5)	77182	Grille—Metal grille—perforated—RED—for Model 2B405
504410	100,000 ohms, ±20%, 1/2 watt (R1)	73839	Handle—Carrying handle—BLACK—for Models 2B400 and 2B401
504510	1 megohm, ±20%, 1/2 watt (R9)	77183	Handle—Carrying handle—BEIGE—for Model 2B402
504533	3.3 megohm, ±20%, 1/2 watt (R4, R10)	77184	Handle—Carrying handle—GREEN—for Model 2B403
504547	4.7 megohm, ±20%, 1/2 watt (R3, R7)	77185	Handle—Carrying handle—BROWN—for Model 2B404
504610	10 megohm, ±20%, 1/2 watt (R8)	77186	Handle—Carrying handle—RED—for Model 2B405
70527	Screw—#6-32, x 3/16" socket head set screw for volume control knob	76856	Knob—Tuning control knob—GREY—for Model 2B400
75780	Socket—Tube socket, 7 pin, miniature, saddle mounted	77174	Knob—Tuning control knob—BLACK—for Model 2B401
76848	Switch—Battery saver switch (S2)	77175	Knob—Tuning control knob—IVORY—for Model 2B402
76849	Transformer—First I.F. transformer (T1)	77176	Knob—Tuning control knob—GREEN—for Model 2B403
76850	Transformer—Second I.F. transformer (T2)	77177	Knob—Tuning control knob—TAN—for Model 2B404
75777	Transformer—Output transformer (T3)	77178	Knob—Tuning control knob—RED—for Model 2B405
SPEAKER ASSEMBLY			
92523-W			
76373	Speaker—2" x 3" P.M. speaker complete with cone and voice coil	77840	Link—Carrying handle link (2 req'd)
MISCELLANEOUS			
76841	Back—Case back—GREY—for Model 2B400	77858	Ring—Bearing ring for tuning knob
77159	Back—Case back—BLACK—for Model 2B401	7C857	Screw—#4-40 x 1/32" cross recessed binder head machine screw for mounting chassis (4 req'd)
77160	Back—Case back—IVORY—for Model 2B402	74734	Spring—Spring clip for tuning control knob
77161	Back—Case back—GREEN—for Model 2B403		
77162	Back—Case back—TAN—for Model 2B404		

APPLY TO YOUR RCA DISTRIBUTOR FOR PRICES OF REPLACEMENT PARTS

Incorrect Tube Location Label:

A few receivers were shipped with an incorrect tube location label in which the designation of 3V4 and 1U5 tubes were transposed. These may be readily identified by the label color. The incorrect label is BLUE, the correct label is YELLOW. The correct tube locations are illustrated below.

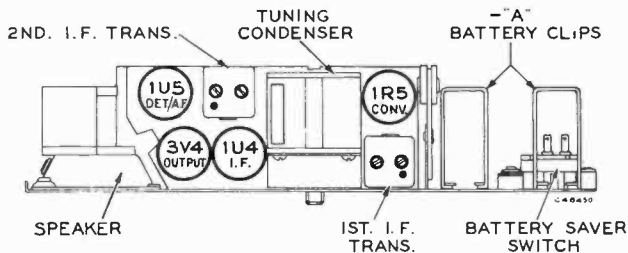

"A" Battery Lead:

A rubber band is used for the purpose of holding the "A" battery lead in a position where it will not be accidentally torn loose when replacing the battery. When servicing one of these receivers, make sure that this rubber band is around the i-f transformer shield can and holding the "A" battery lead against the chassis.

Correct Tonal Response:

For correct tonal response it is necessary that the holes in the case, where the metal grille is attached, be closed. This is done at the factory by covering the tabs, on the inside of the case, with tape. Absence of this tape will adversely affect the tonal response of these receivers.



RCA VICTOR

AC-DC-Battery Portable Receiver **MODEL 2 BX 63**

Chassis No. RC-1115

SERVICE DATA

— 1952 No. 8 —

PREPARED BY RCA SERVICE CO., INC.

FOR

RADIO CORPORATION OF AMERICA
RCA VICTOR DIVISION

CAMDEN, N. J., U. S. A.



PH 708

Specifications

Tuning Range 540-1,600 kc
Intermediate Frequency 455 kc
Power Supply Rating
Power Line Operation
115 volts, d. c. or 50 to 60 cycles a. c. 15 watts

Battery Operated using RCA VS 057W Battery
(Average battery life — 100 hrs. intermittent service)
Battery current "A" 50 ma., "B" 13 ma.

Tube Complement

(1) RCA 1T4 R.F. Amplifier
(2) RCA 1R5 Converter
(3) RCA 1T4 I.F.-Amplifier
(4) RCA 1U5 Det. — AVC — 1st A.F.
(5) RCA 3V4 Output

A selenium rectifier is used.

To Remove Hinges

Remove back from cabinet as described at right. Spread the hinge apart to remove it from the cabinet back.

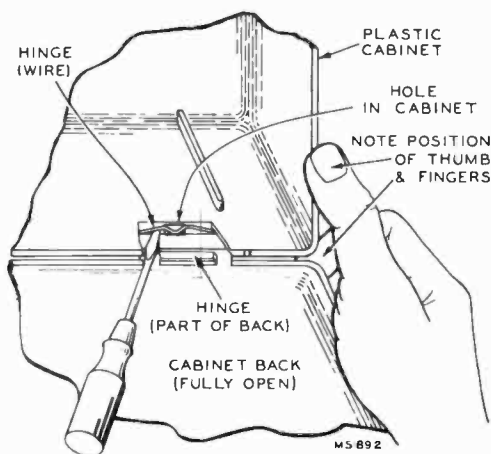

Removal of Cabinet Back

Weight (Approx.)
Without battery . . . 4 lb. 10 oz. With battery . . . 7 lb. 12 oz.
Power Output
Undistorted 0.170 watt
Maximum 0.320 watt
Loudspeaker 4 in. P.M.
Voice Coil impedance 3.2 ohms at 400 cycles
Cabinet Dimensions
Height . . . 8 in. Width . . . 12½ in. Depth . . . 5½ in.

To Remove Chassis:

1. Pull out battery and disconnect battery plug.
2. Unsolder the two loop antenna leads.
3. Remove the two large screws (under handle) in the top of the case.

To Remove Cabinet Back

With the back fully open, grip the cabinet as illustrated. Insert a screwdriver under one hinge and pry the center of the hinge out of the opening in the cabinet while maintaining pressure on the back with the fingers and on the cabinet with the thumb. Repeat this procedure with the other hinge. Pull the back straight to the rear using both hands.

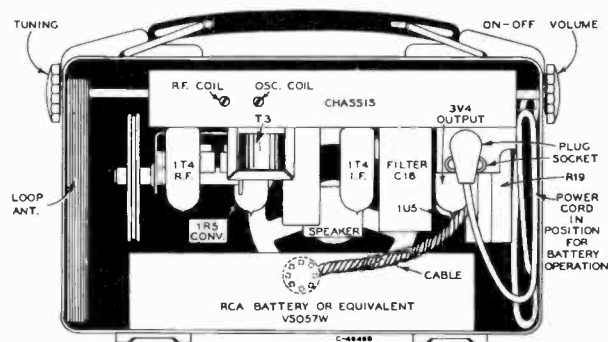

Rear View With Back Removed

Alignment Procedure

Output Meter Alignment—If this method is used, connect the meter across the voice coil and turn the receiver volume control to maximum.

Test Oscillator—For all alignment operations, connect the low side of the test oscillator to the receiver chassis and keep the oscillator output as low as possible to avoid AVC action.

Battery operation of the receiver is preferable during alignment; on AC operation an isolation transformer (117v./117v.) may be necessary for the receiver if the test oscillator is also AC operated.

Dial Pointer Position—With the tuning condenser fully meshed the center of the dial pointer should be in line with the score mark on the chassis.

Step	Connect High Side of Sig. Gen. to —	Sig. Gen. Output	Dial Pointer Setting	Adjust for Max. Output
1	Disconnect loop—remove chassis—remove bottom plate.			
2	Pin #6 of 1T4 I.F. Amplifier thru .005 mf.	455 kc	Quiet point near 1600 kc	2nd I.F. Trans. T2 Top & Bottom
3	Pin #6 of 1R5 Converter thru .005 mf.			1st I.F. Trans. T1 Top & Bottom
4	Replace bottom cover and install chassis in cabinet. Re-connect loop.			
5	Short wire placed near loop for radiated signal	1620 kc	min. cap.	1600 kc osc. trimmer C1-3T
6		1400 kc	1400 kc Signal	1400 kc r.f. & ant. trimmers*
7		Connect a 22,000 ohm resistor in parallel with r.f. tuning cond. C1-2		
8		600 kc	600 kc Signal	L4 osc. core* while rocking gang
9		Remove the 22,000 ohm resistor from r.f. tuning cond. C1-2.		
10		600 kc	600 kc Signal	L3 r.f. core
11	Repeat Steps 5, 6, 7, 8, 9 and 10.			

* The position of the battery affects loop inductance. The battery should be in place during steps 5 to 11.

Critical Lead Dress

1. Dress all filament leads next to chassis.
2. Use short pigtail leads on components to V1, Pin 6.
3. Dress gang leads direct to avoid excess lead length.
4. Dress loop leads away from gang tuning drum.
5. Dress capacitors C3, C4, C6 for RF shielding.
6. Use short pigtail lead on C21 to V3-2 and dress away from Pin 6.
7. Dress capacitors C13 and C17 direct and down to base.

CAUTION.—

Do not remove any tubes from the chassis with the set operating and the plug connected to the power line. Damage to tubes may result.

Dial-Indicator and Drive Mechanism

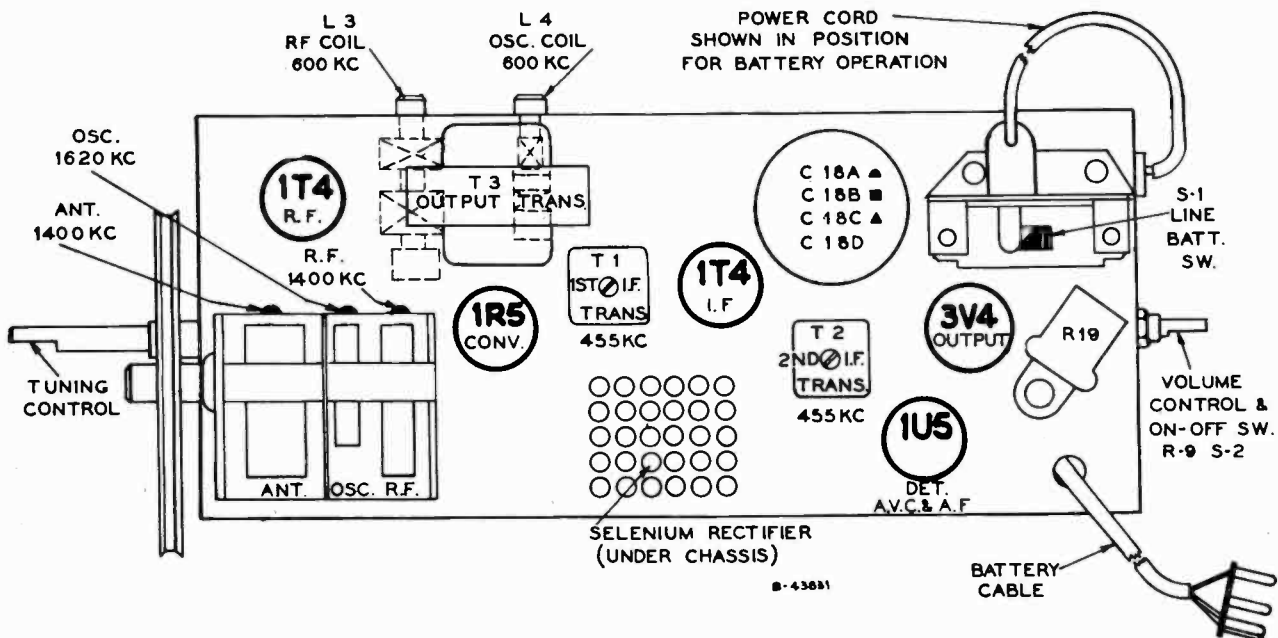
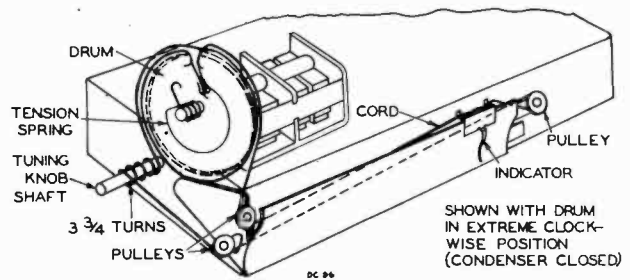

Tube and Trimmer Locations

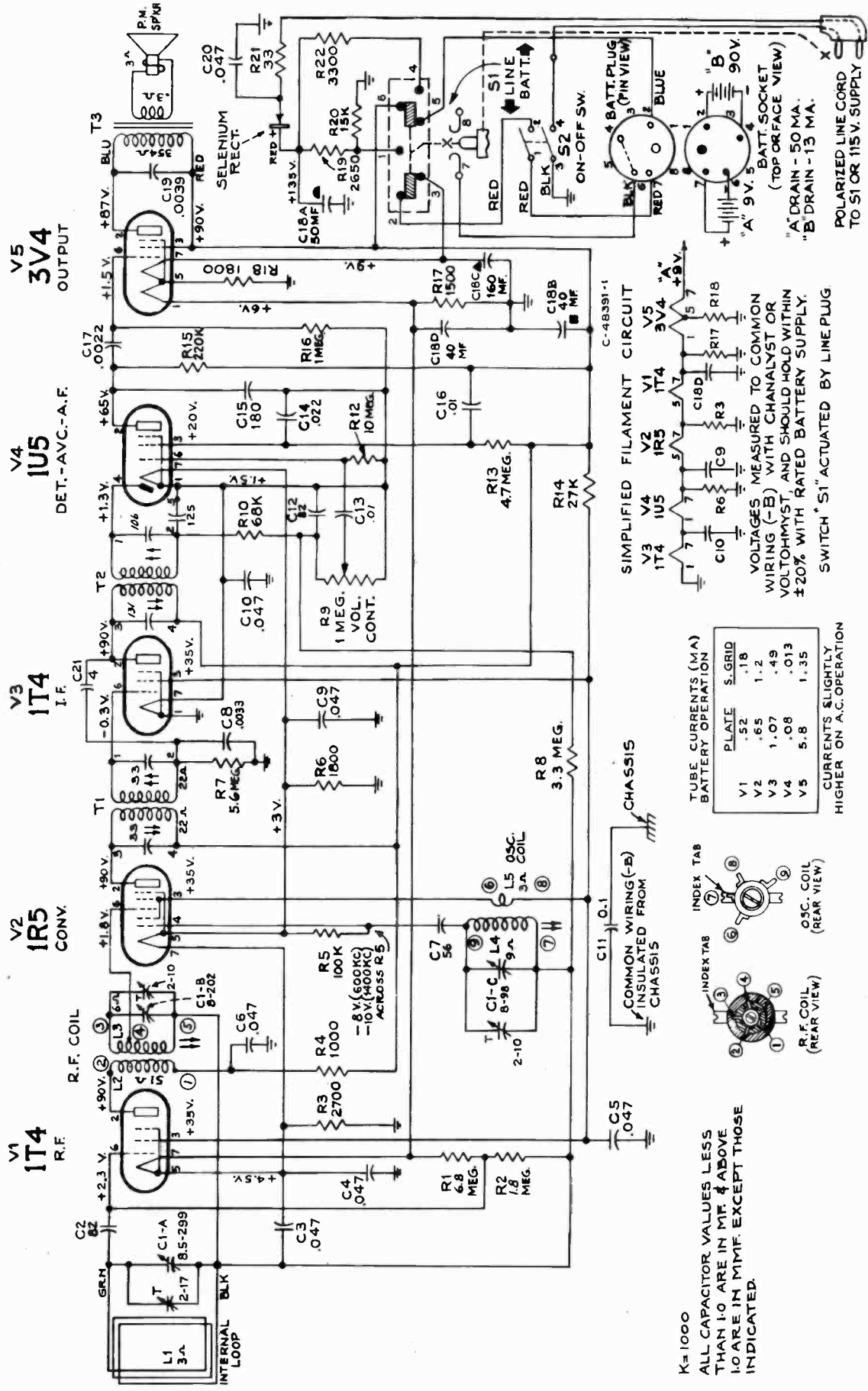

Schematic Diagram—Chassis No. RC-1115

Replacement Parts

STOCK No.	DESCRIPTION	STOCK No.	DESCRIPTION
	CHASSIS ASSEMBLIES RC-1115		
77054	Capacitor—Variable tuning capacitor complete with drive drum C1A, C1B, C1C	513233	3300 ohms, $\pm 10\%$, 1 watt R22
73153	Capacitor—Ceramic, 4 mmf. C21	504315	15,000 ohms, $\pm 20\%$, $\frac{1}{2}$ watt R20
39622	Capacitor—Mica, 56 mmf. C7	503327	27,000 ohms, $\pm 10\%$, $\frac{1}{2}$ watt R14
71514	Capacitor—Ceramic, 82 mmf. C2, C12	504368	68,000 ohms, $\pm 20\%$, $\frac{1}{2}$ watt R10
51416	Capacitor—Mica, 180 mmf. C15	504410	100,000 ohms, $\pm 20\%$, $\frac{1}{2}$ watt R5
76659	Capacitor—Electrolytic comprising 1 section of 50 mfd., 150 volts, 1 section of 40 mfd., 150 volts, 1 section of 160 mfd., 25 volts and 1 section of 40 mfd., 25 volts C18A, C18B, C18C, C18D	503422	220,000 ohms, $\pm 10\%$, $\frac{1}{2}$ watt R15
73595	Capacitor—Tubular, paper, .0022 mfd., 600 volts C17	504510	1 megohm, $\pm 20\%$, $\frac{1}{2}$ watt R16
73795	Capacitor—Tubular, paper, .0033 mfd., 600 volts C8	503518	1.8 megohm, $\pm 10\%$, $\frac{1}{2}$ watt R2
73796	Capacitor—Tubular, paper, .0039 mfd., 600 volts C19	503533	3.3 megohm, $\pm 10\%$, $\frac{1}{2}$ watt R8
73561	Capacitor—Tubular, paper, .01 mfd., 400 volts C13, C16	504547	4.7 megohm, $\pm 20\%$, $\frac{1}{2}$ watt R13
73562	Capacitor—Tubular, paper, .022 mfd., 400 volts C14	503556	5.6 megohm, $\pm 10\%$, $\frac{1}{2}$ watt R7
73558	Capacitor—Tubular, paper, .047 mfd., 200 volts C4, C5, C9, C10	503568	6.8 megohm, $\pm 10\%$, $\frac{1}{2}$ watt R1
73553	Capacitor—Tubular, paper, .047 mfd., 400 volts C3, C6	504610	10 megohm, $\pm 20\%$, $\frac{1}{2}$ watt R12
75071	Capacitor—Tubular, moulded paper, .047 mfd., 400 volts C20	73117	Socket—Tube socket, 7 pin, miniature
73551	Capacitor—Tubular, paper, oil impregnated, 0.1 mfd., 400 volts C11	76368	Spring—Drive cord spring
73935	Clip—Mounting clip for I.F. transformer	71039	Switch—"Line-Battery" switch S1
73114	Coil—Oscillator coil complete with adjustable core L4, L5	73129	Transformer—First I.F. transformer complete with adjustable cores T1
74992	Coil—RF coil complete with adjustable core L2, L3	75487	Transformer—Second I.F. transformer complete with adjustable cores T2
71041	Connector—5 contact male connector or battery cable	71047	Transformer—Output transformer T3
72776	Connector—Single contact pin connector or output transformer leads (2 req'd)	33726	Washer—"C" washer for tuning knob shaft
75474	Connector—Single contact male connector for output transformer leads		SPEAKER ASSEMBLIES
74285	Control—Volume control and power switch R9, S2		971495-7W RL-108B10
72953	Cord—250' Drive Cord Reel (approx. 50" required)	77055	Speaker—4" P.M. speaker complete with cone and voice coil (3.2 ohms)
70022	Cord—Power cord and plug		MISCELLANEOUS
77051	Dial—Metal dial scale complete with (3) pulleys	77068	Antenna—Antenna loop assembled to polystyrene frame and support L1
74838	Grommet—Power cord strain relief (1 set)	77060	Back—Cabinet back—polystyrene—complete with strikes
72283	Grommet—Rubber grommet for mounting variable capacitor	77061	Cap—Carrying handle cap and chassis support
18469	Plate—Bakelite mounting plate for electrolytic	77065	Case—Case front—less handle, handle support, caps, links and chassis mounting screw
77053	Pointer—Station selector pointer	77064	Emblem—"RCA Victor" emblem
72602	Pulley—Drive cord pulley	77057	Eyelet—Metal eyelet for mounting loop assembly
74322	Rectifier—Selenium rectifier	77066	Grille—Metal grille
74319	Resistor—Wire wound, 2650 ohms, 7 watts R19	77056	Grommet—Rubber grommet for mounting loop assembly
	Resistor—Fixed, composition:—	77063	Handle—Carrying handle
514033	33 ohms, $\pm 20\%$, 1 watt R21	74790	Hinge—Cabinet hinge (2 req'd)
504210	1000 ohms, $\pm 20\%$, $\frac{1}{2}$ watt R4	77248	Knob—Control knob
503215	1500 ohms, $\pm 10\%$, $\frac{1}{2}$ watt R17	77062	Link—Carrying handle link
503218	1800 ohms, $\pm 10\%$, $\frac{1}{2}$ watt R6, R18	77013	Nut—Speed nut for fastening "RCA Victor" emblem
503227	2700 ohms, $\pm 10\%$, $\frac{1}{2}$ watt R3	76671	Screw—#6 x $\frac{1}{2}$ " cross recessed self-tapping round head screw for mounting loop
		77058	Screw—#8-32 x $\frac{7}{16}$ " cross recessed pan head machine screw for mounting loop
		74734	Spring—Spring clip for knobs
		77467	Washer—Knob washer—felt
		77067	Window—Clear vinylite dial window

APPLY TO YOUR RCA DISTRIBUTOR FOR PRICES OF REPLACEMENT PARTS



RCA VICTOR



A-C Operated Clock Radio Receiver

2-C-511 SERIES

Chassis No. RC-1118

SERVICE DATA

— 1952 No. 12 —

PREPARED BY RCA SERVICE CO., INC.
FOR
RADIO CORPORATION OF AMERICA
RCA VICTOR DIVISION
CAMDEN, N. J., U. S. A.

2C511 Black & Gray 2C512 Ivory 2C513 Red 2C514 Two Tone Gray

SPECIFICATIONS

Tuning Range 540-1600 kc
Intermediate Frequency 455 kc
Tube Complement:
(1) RCA 12BE6 Converter
(2) RCA 6BJ6 I.F. Amplifier
(3) RCA 12AV6 Det.-AVC-A.F. Amp.
(4) RCA 6AK6 Output Rectifier
RCA Stock No. 77292.
Power Supply Rating:
115 volts a.c., 60 cycles 20 watts
CAUTION: DO NOT OPERATE ON D.C.

Loudspeaker:
Size and type 3 in. P.M.
Voice Coil impedance 3.2 ohms at 400 cycles
Power Output:
Undistorted 0.19 watts
Maximum 0.35 watts
Tuning Drive Ratio 1 to 1 (Direct Drive)
Weight 4 1/2 lbs.
Dimensions (overall):
Height... 6" Width... 8 1/2" Depth... 4 1/2"

OPERATING INSTRUCTIONS

This instrument contains a timer-type electric clock mechanism which may be used to automatically actuate the self-contained a.c. radio. The radio may also be operated independently of the clock mechanism.

CLOCK—1. Plug instrument into 115 v. a.c. outlet. The clock will start to operate immediately. Set the correct time by turning clockwise, the "TIME" knob located at the center of the instrument back. To set the alarm, turn the "ALARM" knob clockwise until the desired time is indicated by the alarm pointer extension on the hour hand. Pull knob out for alarm buzzer operation. To turn off buzzer, push knob in.

RADIO—1. To obtain radio operation independently of the clock, push the slide switch lever at the top of the cabinet to the left "ON" position. Adjust volume and tuning control knobs as required after approximately 30 second warm-up. To increase volume turn knob clockwise as viewed from volume control side panel. Push slide switch lever to the center "OFF" position when finished listening.

2. To automatically actuate the radio by the clock mechanism, make initial volume and station settings as described in section 1 above. Set the "ALARM" knob to the time desired. Push slide switch lever to the right "AUTO" position. If the alarm buzzer knob is pulled out, the alarm will sound approximately ten minutes after the radio starts operating. Push alarm knob in to turn off alarm. The radio will turn itself off after a period of approximately one hour if the slide switch remains in the "AUTO" position after start of playing.

CAUTION—Keep slide switch "ON-OFF-AUTO" lever in "OFF" position when instrument is not in use. Locate instrument so that "TIME" and "ALARM" knobs have free movement.

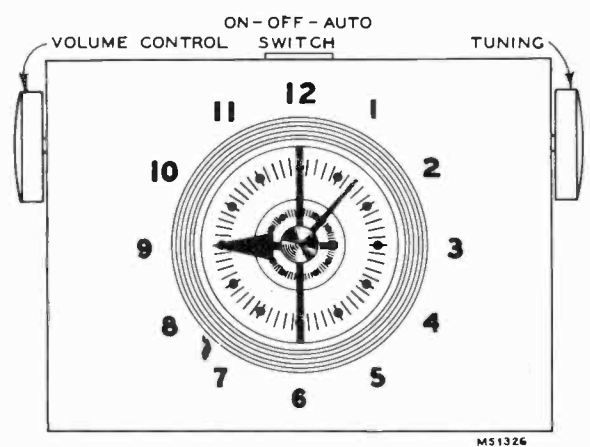

Clock Radio Controls

2-C-511 Series

ALIGNMENT PROCEDURE

Output Meter Alignment—If this method is used, connect the meter across the voice coil and turn the receiver volume control to maximum.

Test-Oscillator—For all alignment operations, connect the low side of the test-oscillator to the receiver chassis, and keep the oscillator output as low as possible to avoid AVC action.

On a.c. operation an isolation transformer (115 v./115 v.) may be necessary for the receiver if the test oscillator is also a.c. operated.

ALIGNMENT TABULATION

Step	Connect the high side of test-oscillator to—	Tune test-osc. to—	Turn radio dial to—	Adjust the following for max. output
1	6BJ6 I-F grid through .01 mfd. capacitor	455 kc	Quiet-point 1600 kc end of dial	T2 (top and bottom) 2nd I-F trans.
2	Stator of C1-A through .01 mfd.			T1 (top and bottom) 1st I-F trans.
3	Short wire placed near loop to radiate signal	1620 kc	Min. cap.	osc. trimmer C1B-T
4		1400 kc	1400 kc signal	ant. trimmer C1A-T
5		600 kc	600 kc (rock)	(osc. coil) Slug L3
6		Repeat steps 3, 4, and 5		

RADIO CHASSIS AND CLOCK SERVICE

TOOL REQUIREMENTS—A small #1 size cross-head screwdriver is required for disassembly of the radio into its major cabinet and chassis components.

TUBE SERVICE—Disassembly—To make tubes accessible for testing, remove the volume and tuning control knobs by pulling off. Unscrew counterclockwise the alarm and time knobs from their shafts. Invert the cabinet and remove only the two cross-head screws along the back underside of the cabinet. Place the cabinet in its normal position. Using only firm hand pressure, press down alternately at front right and left sides of the cabinet top, midway between the "ON-OFF-AUTO" slide switch lever and the cabinet sides, forcing down and backward, to disengage the molded-in plastic catches. Then lift off the cabinet rear cover.

Assembly—To reassemble, proceed in the reverse order, sliding the cabinet rear cover into its track on the cabinet base. Lift the front corners up slightly to clear the two molded-in pads at each front corner of the cabinet base. Then press down and snap-in the upper front edge of the cabinet rear cover under the top rim of the cabinet base. Make sure the slide switch and switch lever are in corresponding center "OFF" positions. Reassemble clock and radio knobs, and the two screws securing the cabinet rear cover.

RADIO CHASSIS SERVICE—Disassembly—To service chassis, open case as described above. In addition, remove the single cross-head screw remaining at the front underside of the cabinet and also the two cross-head screws located on the chassis near the tuning gang and the volume control. Lift out the chassis and remove the four self-tapping cross-head screws holding the bottom cover to the chassis. Lift off the bottom cover.

Assembly—Reassemble in the reverse order. Secure the bottom cover to the chassis with the four self-tapping screws. Next, insert the single self-tapping screw holding the chassis to the bottom of the cabinet base. Center the chassis mounting holes so that they line up with the holes in the cabinet and replace the two cross-head machine screws. Tighten just sufficiently to hold the chassis firmly. Do not turn the screws to the possible limit of travel unless this is necessary to hold the chassis firmly. The average receiver may have a $\frac{1}{32}$ " clearance between the chassis

metal panel and molded plastic boss. If any of the four foam rubber cushions on the bottom cover register in the clock face after assembly, push the excess length under the "Z" tabs of the bottom cover.

CLOCK SERVICE—Disassembly—To service clock, remove chassis and bottom cover as described above. In addition, remove the three screws holding the speaker to the speaker mounting bracket. Remove the two hex nuts holding the clock to the chassis pan recess. Lift the clock out. Unsolder the clock leads at the clock terminals.

Assembly—Proceed in the reverse order. Solder clock leads, and secure clock to chassis pan with two hex head nuts. Reassemble speaker to speaker mounting bracket.

CRITICAL LEAD DRESS

1. Filament leads should be dressed away from secondary output lead, terminal #1, of 2nd I.F. Transformer and secondary output lead, terminal #1, of 1st I.F. transformer.
2. Connect the outside foil of capacitors as shown on schematic.
3. Dress electrolytic capacitor leads and filament transformer leads away from selenium rectifier.
4. Plate and grid leads of 12BE6 and 6BJ6 tubes should be kept as short and direct as possible.

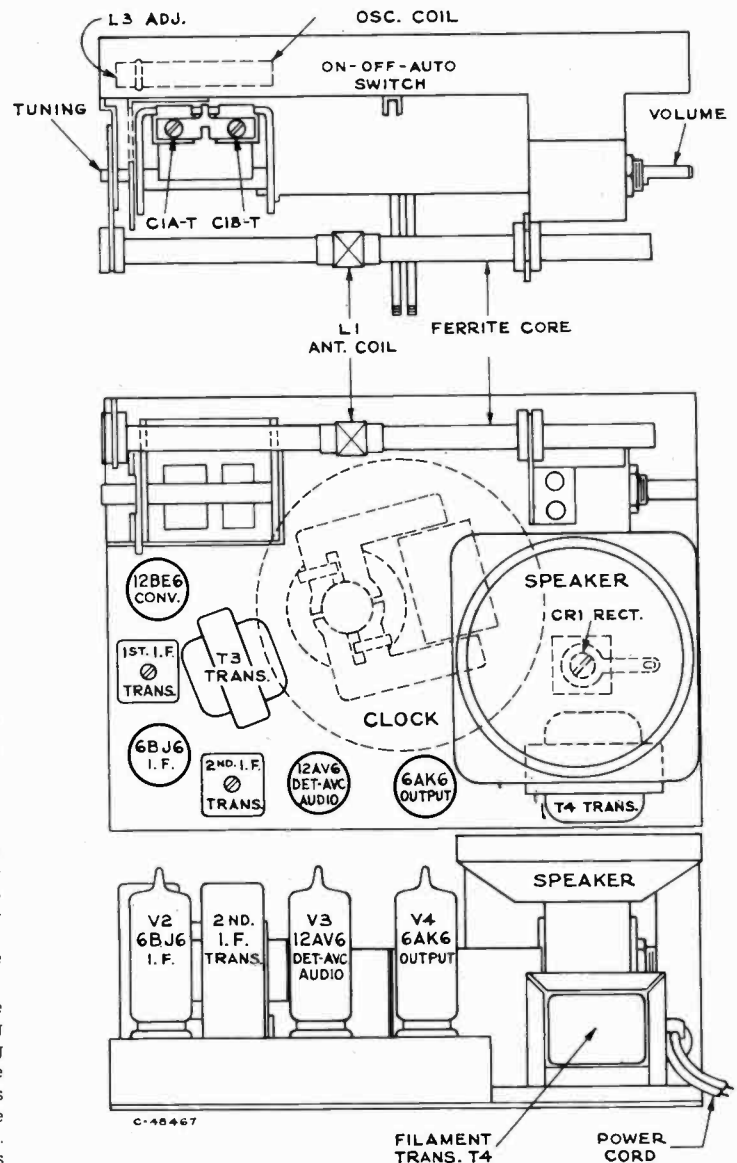

Tube and Trimmer Locations

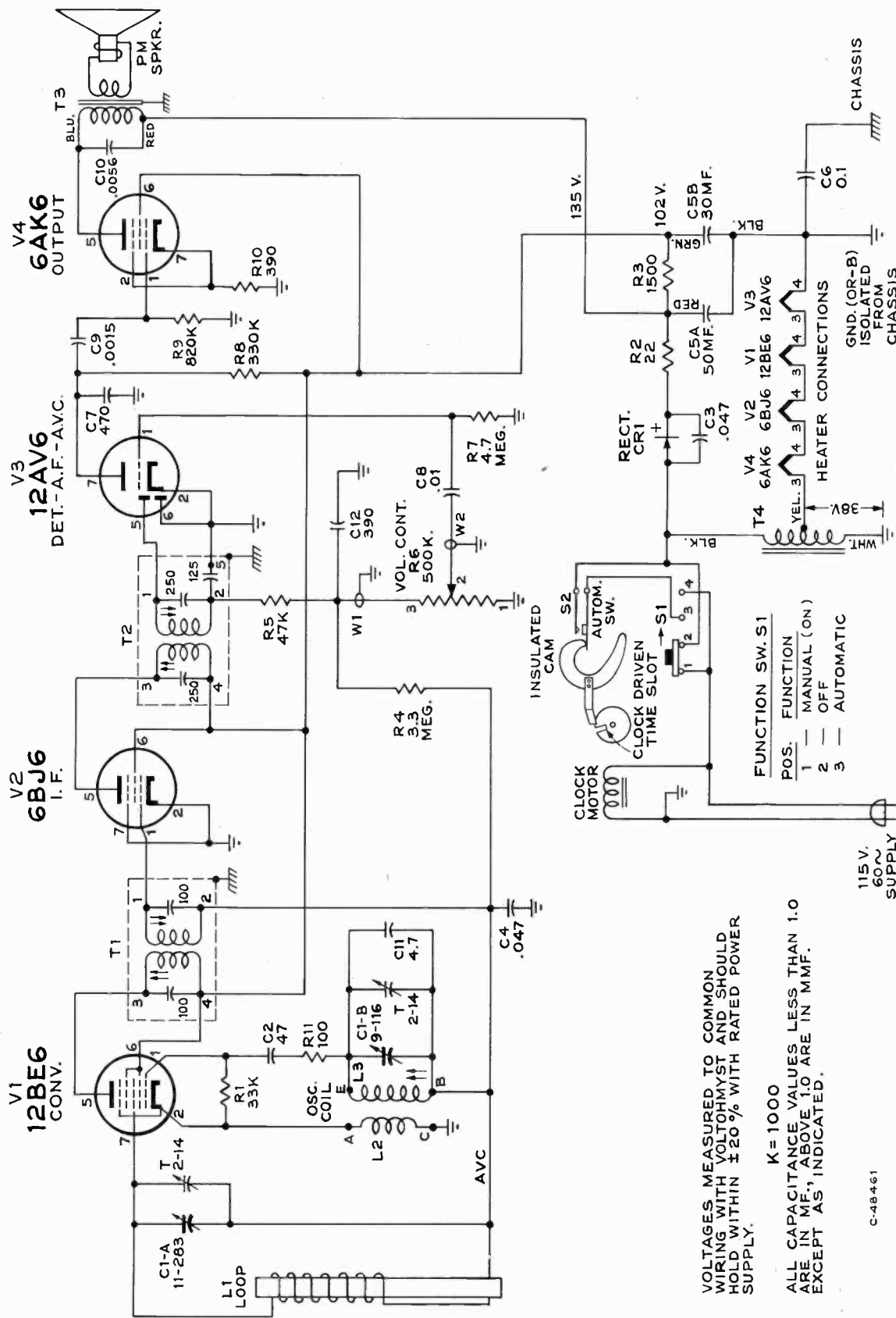

VOLTAGES MEASURED TO COMMON WIRING WITH VOLTOHMIST AND SHOULD HOLD WITHIN ±20% WITH RATED POWER SUPPLY.

K = 1000

ALL CAPACITANCE VALUES LESS THAN 1.0 ARE IN MF.; ABOVE 1.0 ARE IN MMF. EXCEPT AS INDICATED.

C-48461

Schematic Circuit Diagram—Chassis No. RC1118

2-C-511 Series

REPLACEMENT PARTS

STOCK NO.	DESCRIPTION	STOCK NO.	DESCRIPTION
CHASSIS ASSEMBLIES			
	RC 1118—Model 2C511 RC 1118A—Model 2C512	77414	Transformer—Output transformer T3
	RC 1118B—Model 2C513 RC 1118C—Model 2C514	77416	Transformer—1st. I.F. transformer complete with adjustable cores T1
77410	Antenna—Ferrite rod antenna complete with windings L1	77417	Transformer—2nd. I.F. transformer complete with adjustable cores T2
77408	Capacitor—Variable tuning capacitor . . . C1A, C1B	77420	Washer—Shoulder washer (nylon) for variable tuning capacitor mounting (3 req'd)
77471	Capacitor—Ceramic, 4.7 mmf. C11	SPEAKER ASSEMBLIES	
75609	Capacitor—Ceramic, 47 mmf. C2	971920-1	
75641	Capacitor—Ceramic, 390 mmf. C12	77428	Speaker—3" P.M. speaker complete with cone and voice coil (3.2 ohms)
75198	Capacitor—Ceramic, 470 mmf. C7	MISCELLANEOUS	
77427	Capacitor—Electrolytic comprising 1 section of 50 mfd., 150 volts and 1 section of 30 mfd., 150 volts C5A, C5B	77430	Back—Polystyrene cabinet back—gray tan—for Model 2C511
77425	Capacitor—Tubular, paper, .0015 mfd., 200 volts C9	77505	Back—Polystyrene cabinet back—ivory—for Model 2C512
77488	Capacitor—Tubular, paper, .0056 mfd., 400 volts C10	77507	Back—Polystyrene cabinet back—red—for Model 2C513
77424	Capacitor—Tubular, paper, .01 mfd., 200 volts . . . C8	77509	Back—Polystyrene cabinet back—gray—for Model 2C514
77422	Capacitor—Tubular, paper, .047 mfd., 400 volts . C4	77433	Button—Slide button for function switch less clip
75071	Capacitor—Tubular, moulded, .047 mfd., 400 volts C3	77429	Case—Polystyrene case front—black—complete with window less back for Model 2C511
77423	Capacitor—Tubular, paper, 0.1 mfd., 400 volts . . C6	77504	Case—Polystyrene case front—ivory—complete with window less back for Model 2C512
77421	Clip—"C" clip for mounting speaker	77506	Case—Polystyrene case front—red—complete with window less back for Model 2C513
75010	Clip—"C" clip for mounting output transformer	77508	Case—Polystyrene case front—gray—complete with window less back for Model 2C514
73935	Clip—Mounting clip for I.F. transformer	77434	Clip—Spring clip for function switch slide button
77411	Coil—Oscillator coil complete with adjustable core L2, L3	77431	Dial—Dial knob—gray tan—for Model 2C511
77409	Control—Volume control R6	77498	Dial—Dial knob—ivory—for Model 2C512
70392	Cord—Power cord and plug	77499	Dial—Dial knob—red—for Model 2C513
77404	Cover—Chassis bottom cover	77500	Dial—Dial knob—gray—for Model 2C514
77419	Cushion—Foam rubber cushion for speaker rim or bottom cover	77432	Knob—Volume control knob—gray tan—for Model 2C511
74838	Grommet—Power cord strain relief (1 set)	77501	Knob—Volume control knob—ivory—for Model 2C512
77418	Grommet—Rubber grommet for mounting ferrite rod antenna	77502	Knob—Volume control knob—red—for Model 2C513
77405	Insulator—Bakelite insulator for variable tuning capacitor	77503	Knob—Volume control knob—gray—for Model 2C514
77406	Insulator—Ferrite rod antenna mounting insulator—L.H.	77412	Knob—Timer knob
77407	Insulator—Ferrite rod antenna mounting insulator—R.H.	77437	Screw—#6 x $\frac{3}{16}$ " cross recessed truss head tapping screw for mounting chassis
77292	Rectifier—Selenium rectifier CR1	77436	Screw—#6-32 x $\frac{3}{16}$ " cross recessed truss head machine screw for mounting chassis to case
	Resistor—Fixed, composition:—	77435	Screw—#6-32 x $\frac{3}{16}$ " cross recessed truss head machine screw for fastening case assembly
503022	22 ohms, $\pm 10\%$, $\frac{1}{2}$ watt R2	74734	Spring—Spring clip for dial knob or volume control knob
503110	100 ohms, $\pm 10\%$, $\frac{1}{2}$ watt R11	77467	Washer—Knob Washer—felt
503139	390 ohms, $\pm 10\%$, $\frac{1}{2}$ watt R10	CLOCK ASSEMBLY	
532215	1500 ohms, $\pm 10\%$, 2 watts R3	* * *	
503333	33,000 ohms, $\pm 10\%$, $\frac{1}{2}$ watt R1	Clock—If clock mechanism repair becomes necessary, remove the clock from the radio. The RCA Victor Distributor in your area will advise you of the address of the nearest authorized service station for clock mechanisms. Repair facilities and replacement parts are available at these authorized service stations.	
503347	47,000 ohms, $\pm 10\%$, $\frac{1}{2}$ watt R5		
503433	330,000 ohms, $\pm 10\%$, $\frac{1}{2}$ watt R8		
503482	820,000 ohms, $\pm 10\%$, $\frac{1}{2}$ watt R9		
503533	3.3 megohm, $\pm 10\%$, $\frac{1}{2}$ watt R4		
503547	4.7 megohm, $\pm 10\%$, $\frac{1}{2}$ watt R7		
75780	Socket—Tube socket, 7 pin. miniature, saddle mounted		
77415	Switch—Function switch S1		
77413	Transformer—Filament transformer 117 volts A.C. input T4		

APPLY TO YOUR RCA DISTRIBUTOR FOR PRICES OF REPLACEMENT PARTS



RCA VICTOR

A-C Operated Clock Radio Receiver

2-C-521 SERIES

Chassis Nos. RC-1120, RC-1120A, RC-1120B,
RC-1120C, RC-1120D, RC-1120E

SERVICE DATA

— 1952 No. 10 —

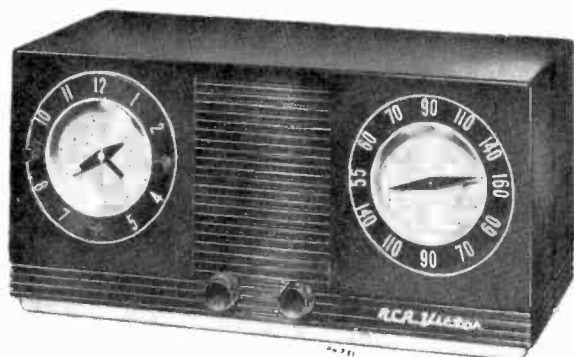

2C521
Maroon

2C522
Ivory

2C527
White

PREPARED BY RCA SERVICE CO., INC.

FOR

RADIO CORPORATION OF AMERICA
RCA VICTOR DIVISION

CAMDEN, N. J., U. S. A.

Specifications

Tuning Range	540-1600 kc
Intermediate Frequency	455 kc
Tube Complement:	
(1) RCA 12BE6	Converter
(2) RCA 12BA6	I.F. Amplifier
(3) RCA 12AV6	Det.-AVC-A.F. Amp.
(4) RCA 50C5	Output
(5) RCA 35W4	Rectifier
Power Supply Rating:	
115 volts a.c., 60 cycles	30 watts
CAUTION:—DO NOT OPERATE ON D.C.	
Appliance Rating	115 volts, 15 a.

Loudspeaker:	
Size and type	4 in. P.M.
Voice Coil impedance	3.2 ohms at 400 cycles

Power Output:	
Undistorted	1.2 watts
Maximum	1.6 watts

Tuning Drive Ratio	10 to 1 (5 turns of knob)
Weight	5½ lbs.

Cabinet Dimensions:			
Height .. 6½"	Width .. 11¾"	Depth .. 5½"	

Operating Instructions

This instrument can be used in any one of several ways. It may be used as a clock with alarm alone, radio, phonograph amplifier, or clock-controlled radio or appliance outlet. Instructions for the various uses follow:

Clock—Plug instrument into a.c. outlet. The clock will start to operate immediately. Set the correct time with the "TIME-SET" knob on the back panel of the instrument. To set the alarm, pull out the "ALARM" knob and turn counter-clockwise until the desired time is indicated by the alarm pointer. Leave knob out for alarm buzzer operation. Push knob in to turn off buzzer.

Radio—1. Push "RADIO" slide switch lever to the right, as viewed from the back. Turn "RADIO" knob on clock from "OFF" to "ON" position. Adjust volume and tuning knobs as required after 30 second warm-up. Turn clock "RADIO" knob to "OFF" position when finished listening.

2. To have radio turn itself off after a period of up to 60 minutes, set "SLEEP" knob to desired playing time. Turn clock "RADIO" knob "OFF."

3. To have radio turn itself on, turn tuning and volume knobs to desired position, and then set the alarm as explained above. Turn clock "RADIO" knob to "AUTO" position.

4. To have the radio turn itself off during any time within a 60 minute period and then turn itself on, after an off period of up to twelve hours, set the "SLEEP" and "ALARM"

knobs, and volume and tuning controls as explained previously. Turn clock "RADIO" knob to "AUTO" position.

Appliances—1. To use appliance outlet, plug appliance into rear receptacle, and turn clock "RADIO" knob to "ON" position. If operation of the radio is not desired at the same time, push radio slide-switch lever on the back panel to the off position (lever pushed to the left).

2. To start appliance automatically, proceed as above, except that the "ALARM" knob should be set to the desired starting time, and the clock "RADIO" knob set to the "AUTO" position. To turn off appliance, turn clock "RADIO" knob to "OFF" position, or remove appliance plug if radio operation is desired.

3. To operate appliance for any time within a 60 minute period, have appliance plugged in, with clock "RADIO" knob turned to "OFF" position. Set "SLEEP" knob for desired operating period. Appliance will be turned off automatically at the end of this period.

Phonograph—1. Make sure radio slide switch is on (lever pushed to the right). Plug phonograph attachment audio plug into jack provided. Turn clock "RADIO" knob to "ON" position. If a spare a.c. receptacle is not available for the record changer, the appliance outlet may be used to provide power.

CAUTION:—Keep clock "RADIO" knob "OFF" when instrument is not in use.

2-C-521 Series

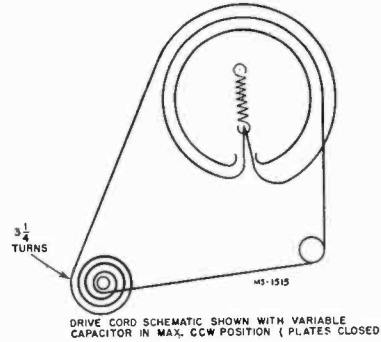
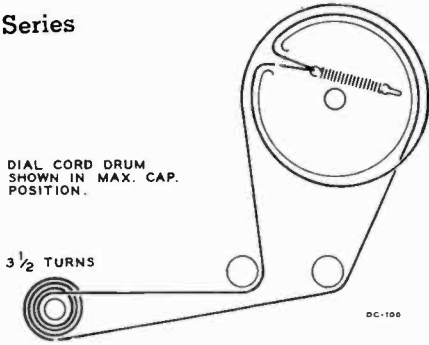

Dial Cord Drive
Chassis RC-1120, RC-1120A, B, C

Dial Cord Drive— Chassis RC-1120D, E

RADIO CHASSIS AND CLOCK SERVICE

Tube Service—To make tubes accessible for testing, remove the hex head screw at the lower right hand corner and the hex head screw at the left side of the appliance outlet on the back panel. The loop antenna and antenna trimmer are located on this back panel.

Radio Chassis Service—Proceed as above, removing the volume and tuning control knobs by pulling off, and also removing the three hex head screws and washers on the underside of the cabinet. Do Not remove the clock from the cabinet unless this is necessary for service. Lift off the shield on the underside of the chassis.

Clock Service—Proceed as above. Remove the three clock control knobs from the front of the cabinet by pulling off, taking care not to damage the clock control shafts. Using a small screwdriver or a small pry tool, remove the five sheet metal clips holding the clock to the cabinet. The clips will be found embedded in the plastic. The seal between the plastic and the metal teeth on the clips should be broken by lifting the metal edges till the teeth clear the plastic. To prevent scratching the plastic dial faces of the radio and clock, place the instrument face down on a thick soft cloth. When removing the clock, take care not to damage the molded-in plastic rim for mounting the clock.

In remounting the clock, new sheet metal clips should be used. These should be heated until hot enough to soften the plastic slightly upon contact. Place the clock in its mounting rim and push the heated clips on tightly, using a pair of pliers or other holding tool.

Attachment of Record Player

The audio output cable of the record player should be terminated with a pin plug.

Plug the cable into the receptacle which is accessible from the back of the cabinet.

Insertion of the cable plug into the receptacle removes radio signal from the volume control. The record player cable must be removed from the receptacle to permit radio operation.

Alignment Procedure

Step	Connect the high side of test-oscillator to—	Tune test-osc. to—	Turn radio dial to—	Adjust the following for max. output
1	12BA6 I-F grid through .1 mfd. capacitor	455 kc.	Quiet-point 1600 kc end of dial	T2 (top and bottom) 2nd I-F trans.
2	Stator of C1-B through .1 mfd.			T1 (top and bottom) 1st I-F trans.
3	Short wire placed near loop to radiate signal	1620 kc	Min. cap.	osc. trimmer
4		1400 kc	1400 kc signal	ant. trimmer
*5		600 kc	600 kc signal	osc. coil L1, L2 (rock gang)
6		Repeat steps 3, 4, and 5.		

*Necessary only on receivers having RC-1120D, E chassis.

Test-Oscillator—For all alignment operations, connect the low side of the test-oscillator to the receiver chassis, and keep the oscillator output as low as possible to avoid a-v-c action.

On a.c. operation an isolation transformer (115 v./115 v.) may be necessary for the receiver if the test oscillator is also a.c. operated.

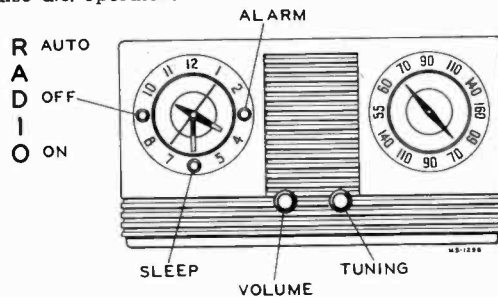

Clock Radio Controls

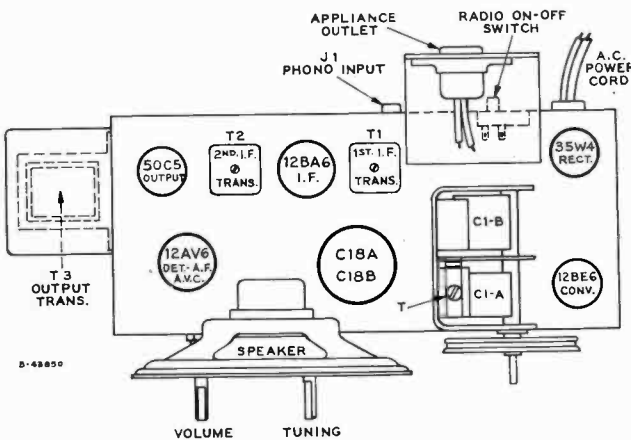
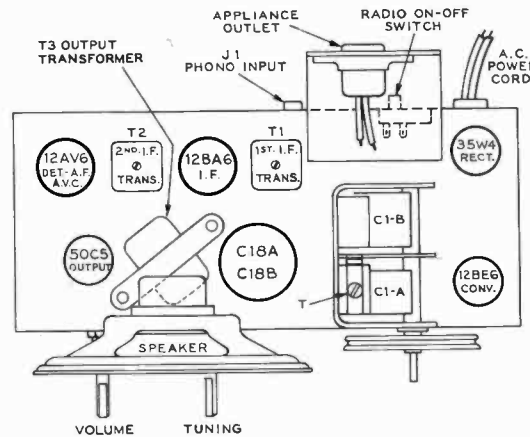

Chassis RC-1120, RC-1120A

Tube and Trimmer Locations

Chassis RC-1120B, C, D, E

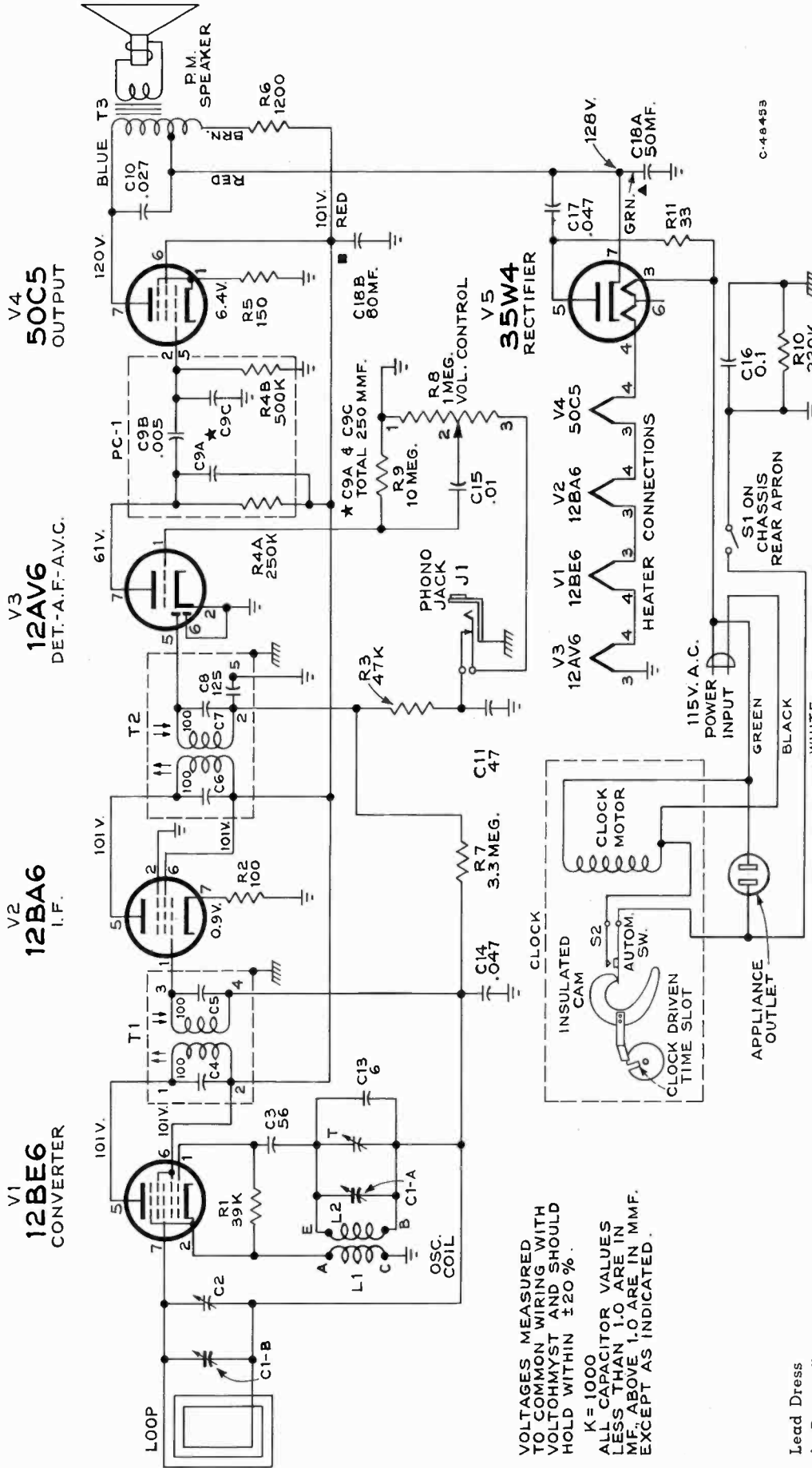

FOR CHASSIS RC-1120B
RC-1120C
C11 IS OMITTED
R10 IS OMITTED

FOR CHASSIS RC-1120D, RC-1120E
AS ABOVE, ALSO
OSC. COIL (L1, L2) HAS
ADJUSTABLE CORE.

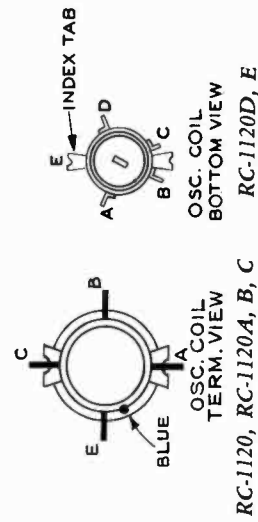

VOLTAGES MEASURED TO COMMON WIRING WITH VOLTOHMYST AND SHOULD HOLD WITHIN ±20%.

K = 1000
ALL CAPACITOR VALUES LESS THAN 1.0 ARE IN MF., ABOVE 1.0 ARE IN MMF. EXCEPT AS INDICATED.

Lead Dress

1. Dress all capacitors down against chassis.
2. C-15 must be located so that connection to Pin #1 of 12AV6 is short as possible and condenser butts against rim of volume control.
3. Connect outside foil of all condensers as indicated in schematic diagram.
4. Dress Filament, B+ and B- leads down against chassis.
5. Dress R2, 12BA6 cathode resistor, down against tube center post with leads to Pin 2 and Pin 7 as short as possible.
6. Dress R3 above and away from R7.

Schematic Circuit Diagram—Chassis No. RC-1120 Series

2-C-521 Series

REPLACEMENT PARTS

STOCK NO.	DESCRIPTION	STOCK NO.	DESCRIPTION
CHASSIS ASSEMBLIES			
	RC-1120, RC-1120B—Model 2-C-521 RC-1120A, RC-1120C—Models 2-C-522, 2-C-527	77903	Transformer—Output transformer (RC-1120B, C, D, E)
		33726	Washer—"C" washer for tuning knob shaft
77357	Capacitor—Variable tuning capacitor complete with drive drum . . . C1A, C1A-T, C1B		SPEAKER ASSEMBLIES
77364	Capacitor—Ceramic, 6 mmf. C13		B12A512 RL108E7
76348	Capacitor—Ceramic, 47 mmf. C11	77226	Speaker—4" P.M. speaker complete with cone and voice coil (3.2 ohms)
77116	Capacitor—Ceramic, 56 mmf. C3		MISCELLANEOUS
73520	Capacitor—Electrolytic comprising 1 section of 80 mfd., 150 volts and 1 section of 50 mfd., 150 volts, C18A, C18B	77367	Antenna—Antenna loop complete with back cover—maroon—for Model 2C521 (RC-1120, RC-1120A) Includes C2
73561	Capacitor—Tubular, paper, .01 mfd., 400 volts. . C15	77904	Antenna—Antenna loop complete with back cover—maroon—for Model 2C521 (RC-1120B, C, D, E)
73554	Capacitor—Tubular, paper, .027 mfd., 400 volts. C10	77368	Antenna—Antenna loop complete with back cover—ivory—for Models 2C522, and 2C527 (RC-1120, RC-1120A) Includes C2
73553	Capacitor—Tubular, paper, .047 mfd., 400 volts C14, C17	77905	Antenna—Antenna loop complete with back cover—ivory—for Models 2C522, 2C527 (RC-1120B, C, D, E)
73551	Capacitor—Tubular, paper, 0.1 mfd., 400 volts. C16	77367	Back—Cabinet back—maroon—and antenna loop for Model 2C521 (RC-1120, RC-1120A), Includes C2
73935	Clip—Mounting clip for I.F. transformer	77904	Back—Cabinet back complete with antenna loop—maroon—for Model 2C51 (RC-1120B, C, D, E)
77356	Coil—Oscillator coil L1, L2	77368	Back—Cabinet back—ivory—and antenna loop for Models 2C522 and 2C527 (RC-1120, RC-1120A), Includes C2
78586	Coil—Oscillator coil complete with adjustable core (L1, L2) RC-1120D, E only	77905	Back—Cabinet back complete with antenna loop—ivory—for Models 2C522, 2C527 (RC-1120B, C, D, E)
75482	Connector—Phono input connector J1	X3304	Baffle—Baffle board and grille cloth for Model 2C521
52131	Connector—2 contact female connector for appliance outlet (RC-1120, RC-1120A, D, E)	X3305	Baffle—Baffle board and grille cloth for Models 2C522 and 2C527
77901	Connector—2 contact female connector for appliance outlet (RC-1120B, RC-1120C)	Y2463	Cabinet—Plastic cabinet—maroon—complete with crystals (2) for Model 2C521
77359	Control—Volume control R8	Y2464	Cabinet—Plastic cabinet—ivory—complete with crystals for Model 2C522
72953	Cord—250' Drive Cord Reel (approx. 26" required)	Y2465	Cabinet—Plastic cabinet—white—complete with crystals for Model 2C527
70392	Cord—Power cord and plug	77372	Clip—Spring clip for mounting timer assembly (5 req'd)
28451	Cover—Insulating cover for electrolytic	77033	Emblem—"RCA Victor" emblem
77360	Grommet—Rubber grommet for mounting tuning capacitor	77369	Knob—Timer control knob—maroon—for Model 2C521
73693	Grommet—Power cord strain relief (1 set)	77370	Knob—Timer control knob—ivory—for Model 2C522
28452	Plate—Bakelite mounting plate for electrolytic	77371	Knob—Timer control knob—white—for Model 2C527
77355	Plate—Dial back plate complete with pointed escutcheon (RC-1120, RC-1120A)	77373	Knob—Tuning control or volume control knob—maroon—for Model 2C521
77900	Plate—Dial back plate (RC-1120B, RC-1120C)	77374	Knob—Tuning control or volume control knob—ivory—for Model 2C522
77354	Pointer—Station selector pointer	77375	Knob—Tuning control or volume control knob—white—for Model 2C527
77365	Printed Circuit . . PC1 (C9A, C9B, C9C, R4A, R4B)	77013	Nut—Speed nut to fasten "RCA Victor" emblem to cabinet
77363	Pulley—Drive cord idler pulley	77491	Window—Polystyrene window for radio or timer dials
	Resistor—Fixed, composition:—		CLOCK ASSEMBLY
513033	33 ohms, ±10%, 1 watt R11		Clock—If clock mechanism repair becomes necessary, remove the clock from the radio. The RCA Victor Distributor in your area will advise you of the address of the nearest authorized service station for clock mechanisms. Repair facilities and replacement parts are available at these authorized service stations.
503110	100 ohms, ±10%, 1/2 watt R2		
503115	150 ohms, ±10%, 1/2 watt R5		
513212	1200 ohms, ±10%, 1 watt R6		
503339	39,000 ohms, ±10%, 1/2 watt R1		
503347	47,000 ohms, ±10%, 1/2 watt R3		
503422	220,000 ohms, ±10%, 1/2 watt R10		
503533	3.3 megohm, ±10%, 1/2 watt R7		
503610	10 megohm, ±10%, 1/2 watt R9		
77358	Shaft—Tuning knob shaft (RC-1120, RC-1120A)		
77909	Shaft—Tuning knob shaft (RC-1120B, C, D, E)		
76870	Shield—Tube shield		
77115	Socket—Tube socket, 7 pin, miniature, moulded		
51955	Socket—Tube socket, 7 pin, miniature, moulded, saddle-mounted		
75780	Socket—Tube, 7 pin min., molded, saddle-mounted, for V1, V4, V5 (RC-1120D, E only)		
77306	Socket—Tube, 7 pin min., molded, saddle-mounted, for V2, V3 (RC-1120D, E only)		
77361	Spring—Drive cord spring (RC-1120, RC-1120A)		
77902	Spring—Drive cord spring (RC-1120B, RC-1120C)		
31418	Spring—Drive cord spring (RC-1120D, RC-1120E)		
32875	Switch—Radio power switch S1		
75486	Transformer—First I.F. transformer, complete with adjustable cores T1, C4, C5		
75487	Transformer—Second I.F. transformer, complete with adjustable cores T2, C6, C7, C8		
77362	Transformer—Output transformer (RC-1120, RC-1120A) T3		

APPLY TO YOUR RCA DISTRIBUTOR FOR PRICES OF REPLACEMENT PARTS

Model
2 ES 3



Model
2 ES 38



RCA VICTOR

Automatic Record Player

Models 2 ES 3, 2 ES 38

Chassis No. RS-142

Record Changer 930409-5

SERVICE DATA

— 1952 No. 4 —

PREPARED BY RCA SERVICE CO., INC.

FOR

RADIO CORPORATION OF AMERICA

RCA VICTOR DIVISION

CAMDEN, N. J., U. S. A.

SPECIFICATIONS

Tube Complement

- 1. RCA 12SQ7 A.F. Amplifier
- 2. RCA 50L6-GT Output
- 3. RCA 35W4 Rectifier

Power Supply Rating

115 volts, 60 cycles A.C. 50 watts

Loudspeaker

- Model 2 ES 3 4" x 6" PM
- Model 2 ES 38 8" PM
- Voice coil impedance 3.2 ohms at 400 cycles

Power Output

Undistorted ... 1.2 watts Maximum ... 1.5 watts

Dimensions (overall)

	Height	Width	Depth
Model 2 ES 3	10 3/4"	13 7/8"	13 1/2"
Model 2 ES 38	9 7/8"	16 1/2"	19"

Weight

Model 2 ES 3	15 lbs.
Model 2 ES 38	24 lbs.

Record Changer (930409-5)

- Turntable speed 33 1/3, 45 or 78 r.p.m.
- Record capacity Up to fourteen 7 inch RCA type
or twelve 10 inch.
or ten 12 inch.
or ten 10 in. and 12 in. intermixed.
- Pickup (Stock No. 75475) Crystal with replaceable styli.

REPLACEMENT PARTS

STOCK No.	DESCRIPTION	STOCK No.	DESCRIPTION
	AMPLIFIER ASSEMBLIES RS 142		<p>Note: If stamping on speaker in instruments does not agree with above speaker number, order replacement parts by referring to model number of instrument, number stamped on speaker and full description of part required.</p> <p style="text-align: center;">MISCELLANEOUS FOR MODEL 2ES3</p> <p>X1756 Cloth—Grille cloth</p> <p>77139 Knob—Control Knob.</p> <p>76895 Foot—Rubber foot (4 required)</p> <p>73634 Nut—Speed nut for No. 8 screw for speaker bracket mounting screws</p> <p>76887 Screw—No. 10-32 x 1 1/2" round head cross recessed machine screw complete with fibre washer and No. 10-32 hex nut for mounting changer (2 required)</p> <p>74734 Spring—Spring clip for knobs</p> <p style="text-align: center;">MISCELLANEOUS FOR MODEL 2ES38</p> <p>77128 Button—Plug button and ventilating screen (3 required)</p> <p>76890 Catch—Cabinet catch and lock (2 required)</p> <p>74273 Decal—"Victrola" decal</p> <p>74809 Emblem—"RCA Victor" emblem</p> <p>77126 Escutcheon—Knob well escutcheon</p> <p>77059 Fastener—No. 2 x 11/16" wood screw and stud for fastening pickup arm hold-down strap</p> <p>76891 Foot—Cabinet foot and glide (8 required)</p> <p>76555 Handle—Carrying handle only</p> <p>76889 Hinge—Cabinet lid hinge (2 required)</p> <p>75945 Knob—Control knob—maroon</p> <p>76520 Loop—Carrying handle loop and plate (2 required)</p> <p>76894 Nut—No. 10-32 spring nut for changer mounting stud</p> <p>73634 Nut—Speednut for speaker mounting screws (4 required)</p> <p>77127 Plate—Background plate (perforated) for knobs</p> <p>75902 Spring—Cable suspension spring (coil)</p> <p>14270 Spring—Retaining spring for knob</p> <p>76892 Strap—Hold down strap for pickup arm</p> <p>76893 Stud—No. 10-32 x 1 1/4" special stud for mounting changer (2 required)</p> <p>77125 Support—Lid support</p>
75980	Capacitor—Electrolytic comprising 1 section of 50 mfd., 150 volts and 1 section of 80 mfd., 150 volts C8A, C8B		
73595	Capacitor—Tubular, paper, .0022 mfd., 600 volts. C4		
73920	Capacitor—Tubular, paper, .0047 mfd., 600 volts. C3		
73561	Capacitor—Tubular, paper, .01 mfd., 400 volts. C2, C7		
73554	Capacitor—Tubular, paper, .027 mfd., 400 volts. C6		
73553	Capacitor—Tubular, paper, .047 mfd., 400 volts. C1, C5		
75562	Control—Tone control R4		
76885	Control—Volume control R1		
70392	Cord—Power cord and plug		
73693	Grommet—Output transformer leads strain relief (1 set)		
74838	Grommet—Power cord strain relief (1 set)		
72314	Resistor—Wire wound, 120 ohms, 5 watts R10		
	Resistors—Fixed, composition:		
514033	33 ohms, ±20%, 1 watt R9		
503115	150 ohms, ±10%, 1/2 watt R7		
503215	1500 ohms, ±10%, 1/2 watt R8		
503410	100,000 ohms, ±10%, 1/2 watt R2		
503427	270,000 ohms, ±10%, 1/2 watt R5, R6, R12		
503518	1.8 megohm, ±10%, 1/2 watt R11		
504547	4.7 megohm, ±20%, 1/2 watt R3		
70827	Socket—Tube socket, octal, wafer, for 12SQ7 and 50L6GT tubes		
73117	Socket—Tube socket, 7 pin, miniature, wafer for 35W4 tube		
75939	Transformer—Output transformer T1		
	SPEAKER ASSEMBLIES FOR MODEL 2ES3 922258-6 W RL 100 C7		
76886	Speaker—4" x 6" P.M. speaker complete with cone and voice coil (3.2 ohms)		
	SPEAKER ASSEMBLIES FOR MODEL 2ES38 92586-4 W RL 105C4		
75024	Cone—Cone and voice coil (3.2 ohms)		
74664	Speaker—8" P.M. speaker complete with cone and voice coil (3.2 ohms)		

APPLY TO YOUR RCA DISTRIBUTOR FOR PRICES OF REPLACEMENT PARTS

2 ES 3, 2 ES 38

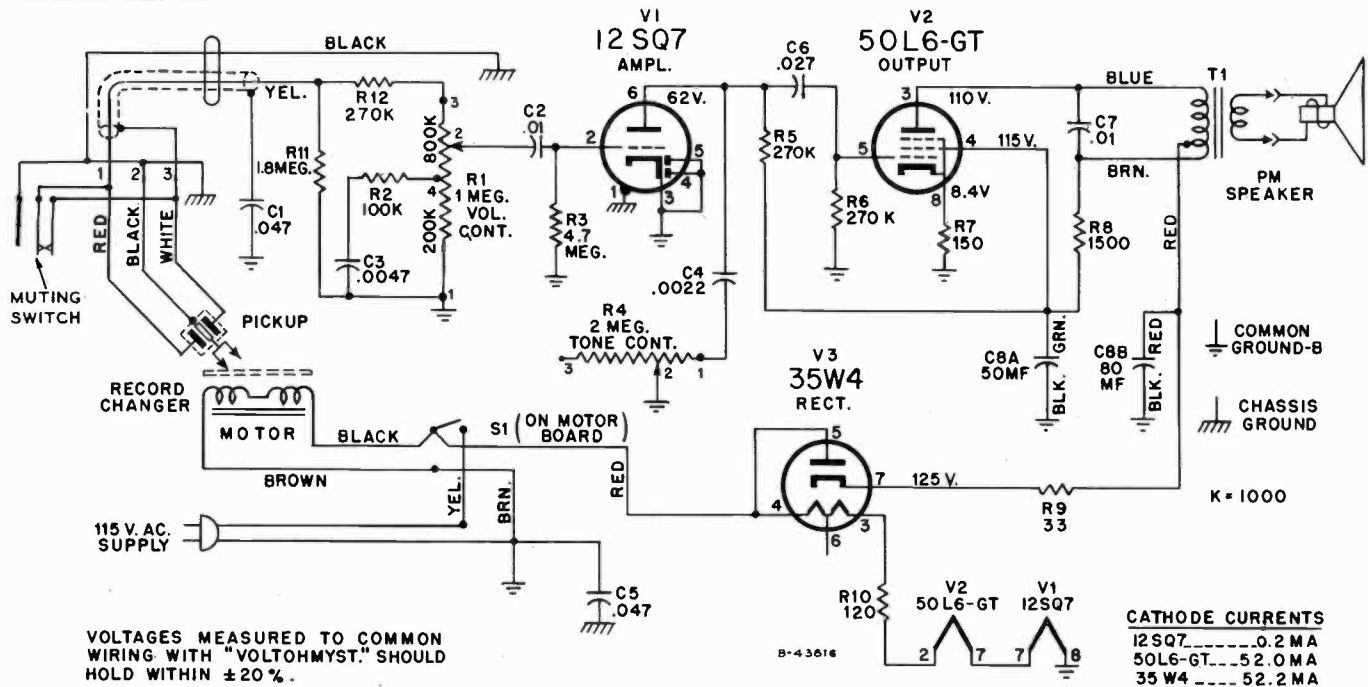

Schematic Diagram

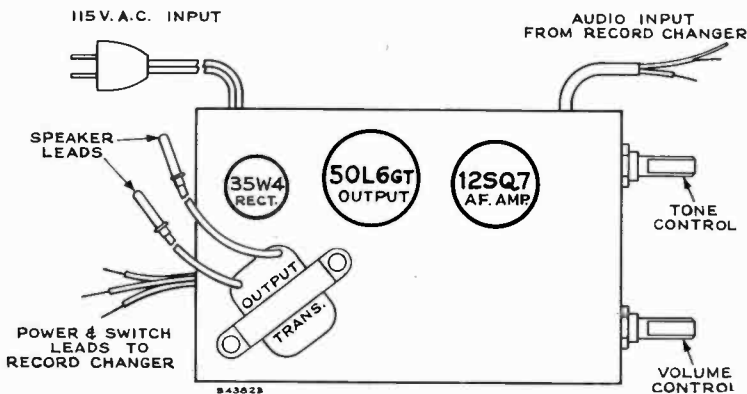

Amplifier Top View

CRITICAL LEAD DRESS

1. Dress R₃ down next to chassis.
2. Dress all leads away from R₉ and R₁₀.
3. Dress power cord and other A.C. leads down next to chassis.
4. Connect C₂ and C₄ with short leads.
5. Dress electrolytic capacitor leads away from audio input circuit.

FOR RECORD CHANGER
SERVICE INFORMATION —
REFER TO 930409 SERIES SERVICE DATA

CONTROLS

The record changer has a dual control on the motor-board and a stylus selector control on the pickup arm. The inner control (circular knob) is the OFF-ON-REJECT control. Turning this knob to the center position energizes the motor and starts the turntable, when turned to the right (clockwise) it starts the mechanism into complete automatic operation. The mechanism will shut off automatically after the last record has been played but can be shut off manually by turning this knob to the left (counter-clockwise).

The outer control (double ended lever) is the speed control. It has three positions; "33", "45", "78", to select the turntable speed desired.

The stylus control has two normal positions (right and left) and one shipping position (lever pointing up). When playing 33 1/3 or 45 r.p.m. records the lever is turned so that "33-45" is visible on the TOP of the lever; likewise for 78 r.p.m. records "78" should be visible on the TOP.

The removable centerpost is for use with 45 r.p.m. records having the large centerhole. It must be placed over the center spindle with the "RCA" trademark monogram FACING to the FRONT. When not in use it is placed in a well at the front of the motorboard.

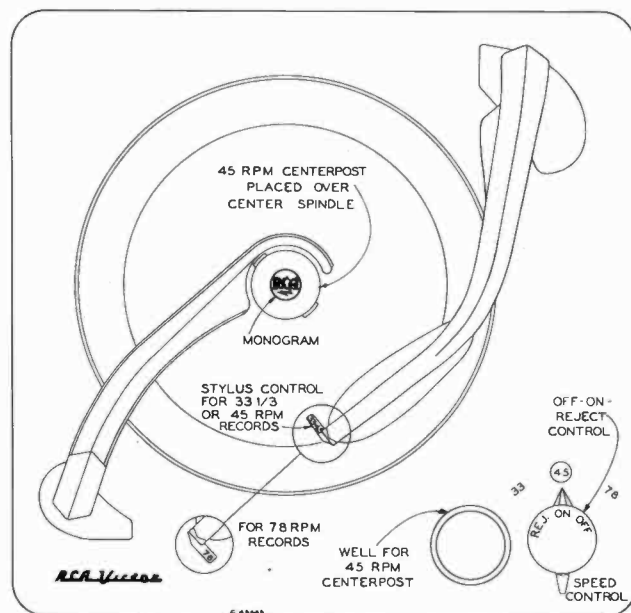

Record Changer Controls



RCA VICTOR



Automatic Record Player
Model 2 ES 31
 Chassis No. RS-142
 Record Changer 930409-5
SERVICE DATA
 — 1952 No. 7 —

PREPARED BY RCA SERVICE CO., INC.
 FOR
RADIO CORPORATION OF AMERICA
 RCA VICTOR DIVISION
 CAMDEN, N. J., U. S. A.

SPECIFICATIONS

Tube Complement

- 1. RCA 12SQ7 A.F. Amplifier
- 2. RCA 50L6-GT Output
- 3. RCA 35W4 Rectifier

Power Supply Rating

115 volts, 60 cycles A.C. 50 watts

Loudspeaker

Size and type 4" x 6" PM
 Voice coil impedance 3.2 ohms at 400 cycles

Power Output

Undistorted ... 1.2 watts Maximum ... 1.5 watts

Dimensions (overall)

Height 10 3/4" Width 13 3/8" Depth 13 1/2"

Weight

Net weight 15 lbs.

Record Changer (930409-5)

Turntable speed 33 1/3, 45 or 78 r.p.m.
 Record capacity Up to fourteen 7 inch RCA type
 or twelve 10 inch.
 or ten 12 inch.
 or ten 10 in. and 12 in. intermixed.

Pickup (Stock No. 75475) .. Crystal with replaceable styli.

REPLACEMENT PARTS

STOCK No.	DESCRIPTION	STOCK No.	DESCRIPTION
AMPLIFIER ASSEMBLIES			
RS 142			
75980	Capacitor—Electrolytic comprising 1 section of 50 mfd., 150 volts and 1 section of 80 mfd., 150 volts		C8A, C8B
73595	Capacitor—Tubular, paper, .0022 mfd., 600 volts		C4
73920	Capacitor—Tubular, paper, .0047 mfd., 600 volts		C3
73561	Capacitor—Tubular, paper, .01 mfd., 400 volts		C2, C7
73554	Capacitor—Tubular, paper, .027 mfd., 400 volts		C6
73553	Capacitor—Tubular, paper, .047 mfd., 400 volts		C1, C5
75562	Control—Tone control		R4
76885	Control—Volume control		R1
70392	Cord—Power cord and plug		
73693	Grommet—Output transformer leads strain relief (1 set)		
74838	Grommet—Power cord strain relief (1 set)		
72314	Resistor—Wire wound, 120 ohms, 5 watts		R10
Resistors—Fixed, composition:			
514033	33 ohms, ±20%, 1 watt		R9
503115	150 ohms, ±10%, 1/2 watt		R7
503215	1500 ohms, ±10%, 1/2 watt		R8
503410	100,000 ohms, ±10%, 1/2 watt		R2
503427	270,000 ohms, ±10%, 1/2 watt		R5, R6, R12
503518	1.8 megohm, ±10%, 1/2 watt		R11
504547	4.7 megohm, ±20%, 1/2 watt		R3
70827	Socket—Tube socket, octal, wafer, for 12SQ7 and 50L6GT tubes		
73117	Socket—Tube socket, 7 pin, miniature, wafer for 35W4 tube		
75939	Transformer—Output transformer		T1
SPEAKER ASSEMBLY			
922258-6 W RL 100 C7			
76886	Speaker—4" x 6" P.M. speaker complete with cone and voice coil (3.2 ohms)		
Note: If stamping on speaker in instruments does not agree with above speaker number, order replacement parts by referring to model number of instrument, number stamped on speaker and full description of part required.			
MISCELLANEOUS			
Y2400	Cabinet—Plastic cabinet—maroon		
X1756	Cloth—Grille cloth		
76888	Cover—Cabinet bottom cover less rubber feet		
76787	Foot—Rubber foot (4 req'd)		
77139	Knob—Control knob		
73634	Nut—Speed nut for #8 screw for speaker bracket mounting screws		
76894	Nut—#10-32 spring nut for changer mounting stud		
74734	Spring—Spring clip for knobs		
76893	Stud—#10-32 x 1 1/4" special stud for mounting changer (2 req'd)		

APPLY TO YOUR RCA DISTRIBUTOR FOR PRICES OF REPLACEMENT PARTS

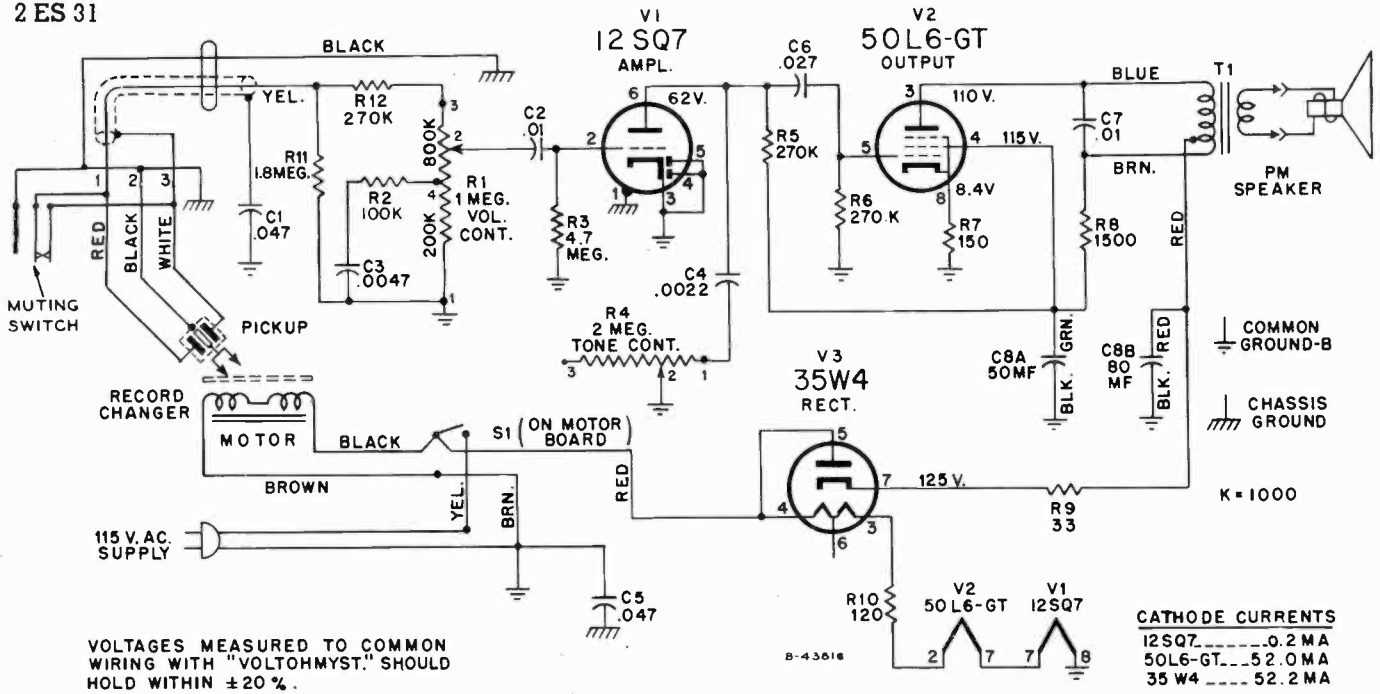

Schematic Diagram

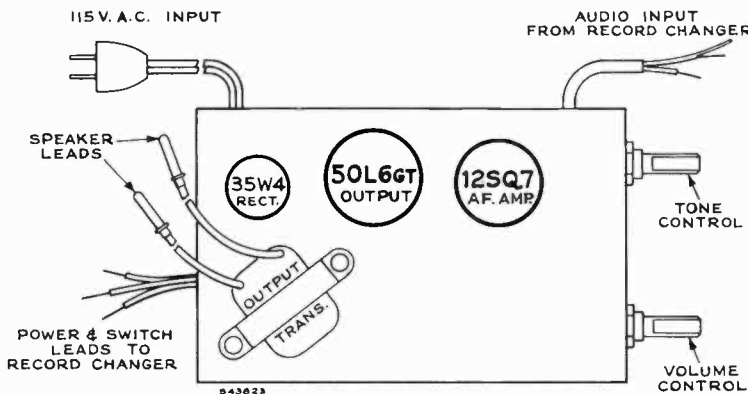

Amplifier Top View

CRITICAL LEAD DRESS

1. Dress R₃ down next to chassis.
2. Dress all leads away from R₉ and R₁₀.
3. Dress power cord and other A.C. leads down next to chassis.
4. Connect C₂ and C₄ with short leads.
5. Dress electrolytic capacitor leads away from audio input circuit.

FOR RECORD CHANGER SERVICE INFORMATION — REFER TO 930409 SERIES SERVICE DATA

CONTROLS

The record changer has a dual control on the motor-board and a stylus selector control on the pickup arm. The inner control (circular knob) is the OFF-ON-REJECT control. Turning this knob to the center position energizes the motor and starts the turntable, when turned to the right (clockwise) it starts the mechanism into complete automatic operation. The mechanism will shut off automatically after the last record has been played but can be shut off manually by turning this knob to the left (counter-clockwise).

The outer control (double ended lever) is the speed control. It has three positions; "33", "45", "78", to select the turntable speed desired.

The stylus control has two normal positions (right and left) and one shipping position (lever pointing up). When playing 33 1/3 or 45 r.p.m. records the lever is turned so that "33-45" is visible on the TOP of the lever; likewise for 78 r.p.m. records "78" should be visible on the TOP.

The removable centerpost is for use with 45 r.p.m. records having the large centerhole. It must be placed over the center spindle with the "RCA" trademark monogram FACING to the FRONT. When not in use it is placed in a well at the front of the motorboard.

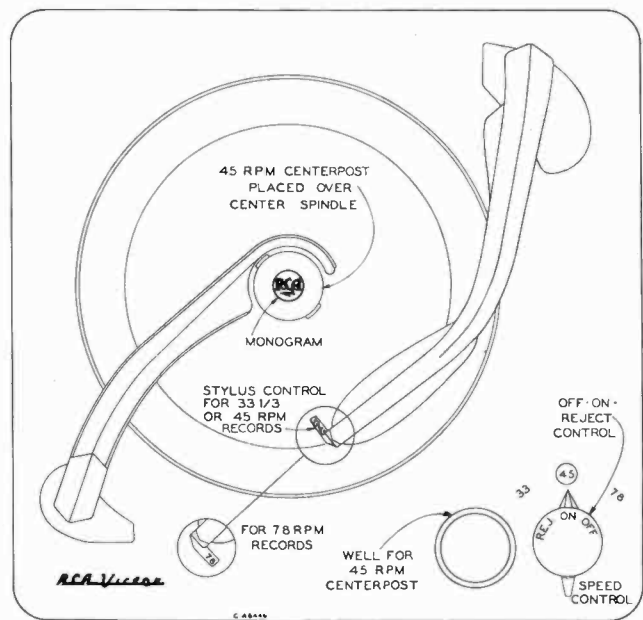

Record Changer Controls



RCA VICTOR

Record Changer Attachment

MODEL 2JS1 SERVICE DATA

— 1952 No. 2 —



PREPARED BY RCA SERVICE CO., INC.

FOR

RADIO CORPORATION OF AMERICA
RCA VICTOR DIVISION
CAMDEN, N. J., U. S. A.

SPECIFICATIONS

Record Changer (930409-5)

Turntable speed 33 $\frac{1}{3}$, 45 or 78 r.p.m.
Record capacity Up to fourteen 7 inch RCA type
or twelve 10 inch.
or ten 12 inch.
or ten 10 in. and 12 in. intermixed.

Pickup (Stock No. 75475) ... Crystal with replaceable styli.

Power Supply Rating

115 volts, 60 cycles A.C. 15 watts

Dimensions (overall)

Height 8 $\frac{3}{8}$ " Width 13 $\frac{1}{2}$ " Depth 13 $\frac{1}{4}$ "

**FOR RECORD CHANGER
SERVICE INFORMATION—
REFER TO 930409 SERIES SERVICE DATA**

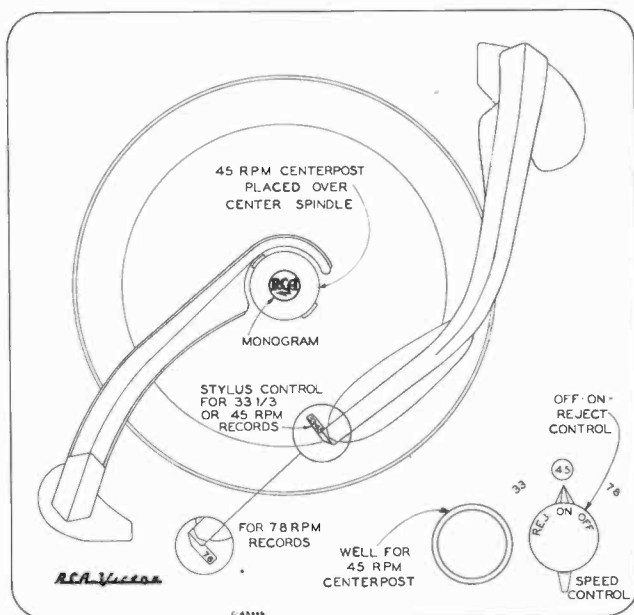

Controls

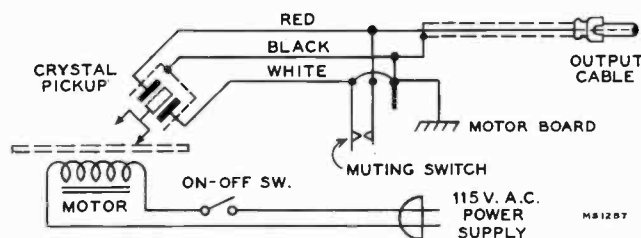

Schematic Diagram

CONTROLS

The record changer has a dual control on the motor-board and a stylus selector control on the pickup arm. The inner control (circular knob) is the OFF-ON-REJECT control. Turning this knob to the center position energizes the motor and starts the turntable, when turned to the right (clockwise) it starts the mechanism into complete automatic operation. The mechanism will shut off automatically after the last record has been played but can be shut off manually by turning this knob to the left (counter-clockwise).

The outer control (double ended lever) is the speed control. It has three positions; "33", "45", "78", to select the turntable speed desired.

The stylus control has two normal positions (right and left) and one shipping position (lever pointing up). When playing 33 $\frac{1}{3}$ or 45 r.p.m. records the lever is turned so that "33-45" is visible on the TOP of the lever; likewise for 78 r.p.m. records "78" should be visible on the TOP.

The removable centerpost is for use with 45 r.p.m. records having the large centerhole. It must be placed over the center spindle with the "RCA" trademark monogram FACING to the FRONT. When not in use it is placed in a well at the front of the motorboard.

REPLACEMENT PARTS

STOCK No.	DESCRIPTION
70392	Cord—Power cord and plug
77192	Foot—Rubber foot (4 required)
31048	Plug—Pin plug for audio output cable

APPLY TO YOUR RCA DISTRIBUTOR FOR PRICES OF REPLACEMENT PARTS.

Connecting Record Changer Attachment to Radio or Television Receivers

In general, the Record Changer Attachment must be used with receivers having at least two stages of high-gain audio amplification. The output of the Record Changer Attachment should be connected to the input of the first audio tube, and at the same time the output of the detector portion of the receiver should be shorted or opened, to prevent radio signals being heard while the Record Changer Attachment is in operation.

RCA Radios or Television Receivers with Phono Jack

Plug male connector on the end of the "Phono" lead into the female connector on the receiver chassis. If set is provided with a phono switch, push or turn the "Phono" switch to "Phono" position, and operate the Record Changer Attachment according to instructions. If no switch is provided, use minimum setting of receiver volume control which will give acceptable volume, and tune receiver off frequency from any very strong station. In some instances the radio volume control will have the effect of a tone control.

Radios Without Phono Jack

Methods of connecting the Record Changer Attachment to various types of audio systems are given in the accompanying text and illustrations. The data given requires that an RCA Type No. 240X1 (Formerly Stock No. 240) Radio-Phono switch be used for switching from radio to phonograph, as desired. For ease in connecting the "Phono" lead to the switch, the male plug on the end of the lead matches the phono jack on the switch.

Note:

If connected to a radio or television receiver as shown in Figures A or B, it will probably be necessary to add a volume control (1 to 2 megohm) to the Record Changer Attachment, since most receivers do not have a volume control following the first audio tube.

Installation of Switch

Fasten the bracket to the cabinet in such a position that the switch may be easily reached. For wooden cabinets, a suggested place is the upper rear edge of the cabinet. If the radio has a plastic cabinet, the bracket may be fastened to the chassis by self-tapping screws or soldering. In the case of a.c.-d.c. sets, the bracket should not be fastened to the chassis. In such cases, a wooden block may be fastened to the chassis and the bracket screwed to the wooden block, care being exercised that there is no metallic path from the bracket to the chassis.

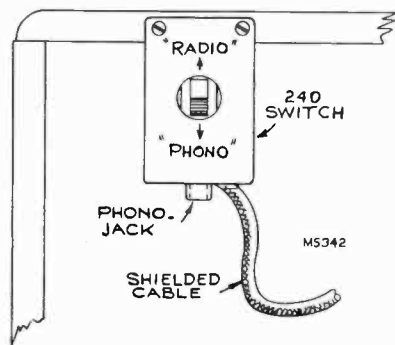

Connect the braided shield extension to the radio chassis by either soldering or placing the spade lug under a mounting screw.

On a.c.-d.c. sets it is necessary to isolate the cable shield from the chassis. This is best done by connecting the shield to the chassis through a .1 mf. 400-volt condenser. Care should be taken that the shield braiding and switch bracket do not come in contact with the chassis.

If the common-negative wiring in the a.c.-d.c. set is isolated from the set chassis, connect the cable shield, through a .1 mfd. capacitor, to the common-negative wiring, and not to the chassis.

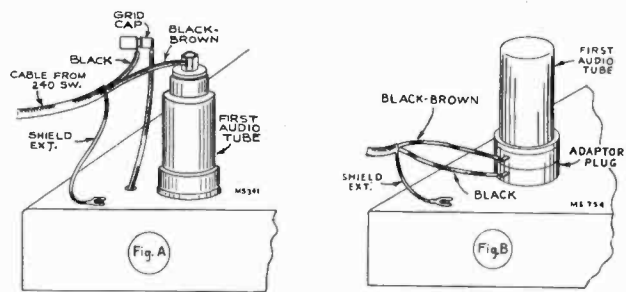

For receivers in which the 1st-audio tube has a top grid cap—see Fig. A:

1. Disconnect the grid lead from the first audio tube.
2. Connect the cap on the black lead to the clip on the grid lead, as shown above.
3. Connect the clip on the black-brown lead to the grid cap at the top of the 1st-audio tube, bending the terminal if necessary to proper size for a metal tube cap.
4. Insert the plug on the end of the record player lead into the jack on the bracket.
5. Secure or position the connection cable assembly so that the cap and clip terminals are well separated from each other and other metal parts.

For receivers in which the 1st-audio tube is type 6SQ7, 6SR7, 12SO7 or 12SR7—see Fig. B:

1. Use adaptor plug RCA Stock No. 37798.
2. Remove the 1st-audio tube.
3. Solder the switch leads to the adaptor plug terminals—black to bottom lug—black-brown to top lug.
4. Tape terminals to prevent short circuits when installed in set.
5. Insert the adaptor into the 1st-audio tube socket.
6. Insert the 1st-audio tube into the adaptor.
7. Insert the plug on the end of the record player lead into the jack on the bracket.

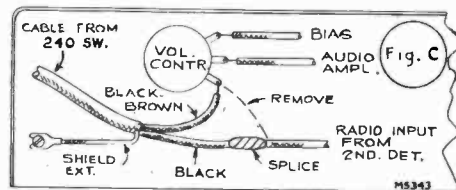

For other radio receivers in which the 1st-audio tube does not have a grid cap; connection to volume control input—see Fig. C:

1. Unsolder the lead from the volume control lug indicated in Fig. C. It is usually necessary to remove the chassis from the cabinet to do this.
2. Solder the black-brown lead (remove clip) to the lug or pin disconnected in Step 1.
3. Solder the black lead (remove plug) to the lead disconnected in Step 1. Tape the joint to prevent short circuits.
4. Insert the plug on the end of the record player lead into the jack on the bracket.

Radio-Phonograph Combinations

RCA Type 202-W-1 Record Player Selector Switch may be used to select the output of two record changers for connection to one phono input jack. A choice of two types of input jacks and output cable plugs are provided.

Most radio-phonograph combinations use resistors and/or capacitors in their phono input circuit for tone compensation purposes. This may result in unsatisfactory reproduction from Model 2JS1 when connected to the phono jack of such instruments. In such cases it is suggested that Model 2JS1 be connected as indicated for instruments not having a phono jack.



RCA VICTOR

A-C Operated Radio Receiver

Models 2-R-51, 2-R-52, 2-R-51A, 2-R-52A

Chassis No. RC-1119

SERVICE DATA

—1952 No. 13—

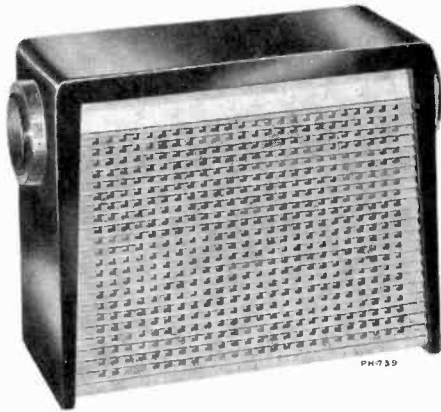

2R51
Black & Gray

2R52
Tan & Ivory

PREPARED BY RCA SERVICE CO., INC.
FOR
RADIO CORPORATION OF AMERICA
RCA VICTOR DIVISION
CAMDEN, N. J., U. S. A.

SPECIFICATIONS

- Tuning Range 540-1600 kc
- Intermediate Frequency 455 kc
- Tube Complement:
 - (1) RCA 12BE6 Converter
 - (2) RCA 6BJ6 I.F. Amplifier
 - (3) RCA 12AV6 Det.-AVC-A.F. Amp.
 - (4) RCA 6AK6 Output
- RCA Stock No. 77292 Rectifier
- Dial Lamp (1) Type No. 51, 6-8 volts, 0.2 amp.
- Power Supply Rating:
 - 115 volts a.c., 60 cycles 18 watts

CAUTION:—DO NOT OPERATE ON D.C.

- Loudspeaker:
 - Size and type 4 x 6 in. P.M.
 - Voice Coil impedance 3.2 ohms at 400 cycles
- Power Output:
 - Undistorted 0.30 watts
 - Maximum 0.45 watts
- Tuning Drive Ratio 1 to 1 (Direct Drive)
- Weight 4 lbs.
- Cabinet Dimensions:
 - Height... 5 $\frac{5}{8}$ "
 - Width... 8 $\frac{3}{8}$ "
 - Depth... 3 $\frac{5}{8}$ "

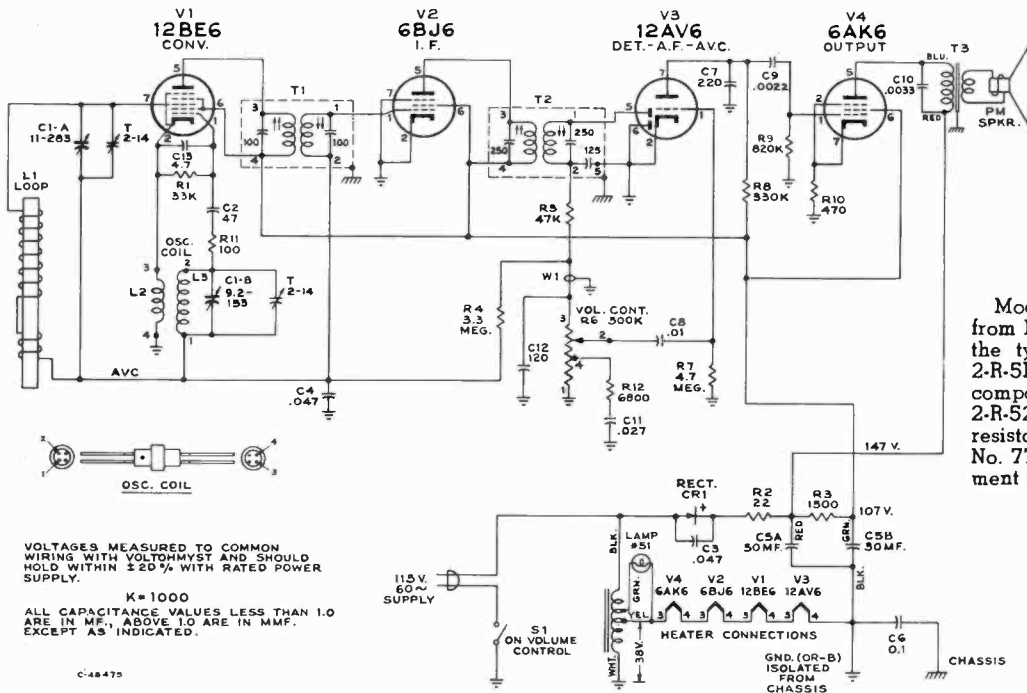

Models 2-R-51A and 2-R-52A differ from Models 2-R-51 and 2-R-52 only in the type of resistor used for R2. In 2-R-51 and 2-R-52 the resistor is a fixed composition type. In 2-R-51A and 2-R-52A it is a fuse type wire wound resistor. The fuse type resistor (Stock No. 77571) should be used for replacement in all models.

VOLTAGES MEASURED TO COMMON WIRING WITH VOLTOHM METER AND SHOULD HOLD WITHIN $\pm 2\%$ WITH RATED POWER SUPPLY.

K=1000

ALL CAPACITANCE VALUES LESS THAN 1.0 ARE IN MF., ABOVE 1.0 ARE IN MMF. EXCEPT AS INDICATED.

C-48475

Schematic Diagram

2-R-51, 2-R-52

Top View

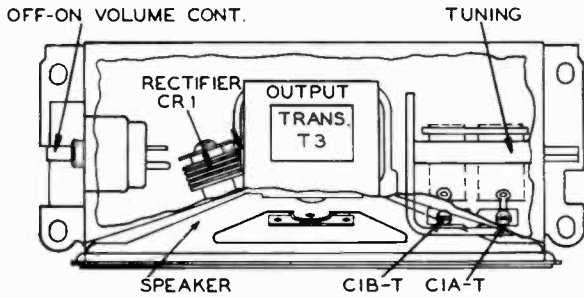

Tube and Trimmer Locations

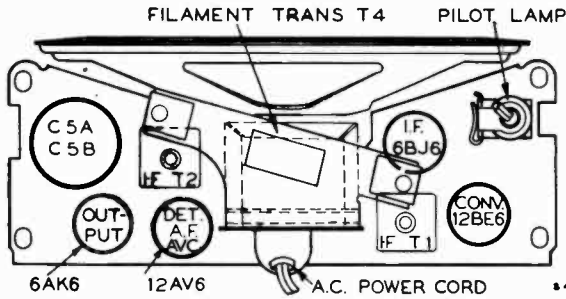

Bottom View

CRITICAL LEAD DRESS

- Oscillator coil should be centered in space provided and have at least 1/4 inch between winding and chassis.
- The filament wiring should be dressed down on chassis and away from audio leads and audio coupling condensers.
- The I.F. plate and grid leads, including the 2nd I.F. diode lead should be as short as practical.

- The output plate by pass condenser should be dressed against the side of the chassis and away from the 1st audio grid condenser and the diode filter resistor.
- Output transformer primary leads should be dressed away from the selenium rectifier.
- The loop antenna should be accurately centered in its position on the fishpaper cover. The ends must not project beyond the fishpaper.

ALIGNMENT PROCEDURE

Test-Oscillator—For all alignment operations, connect the low side of the test-oscillator to the receiver chassis, and keep the oscillator output as low as possible to avoid a-v-action.

On a.c. operation an isolation transformer (115 v./115 v.) may be necessary for the receiver if the test oscillator is also a.c. operated.

Output Meter—Connect meter across speaker voice coil. Turn volume control to maximum.

Step	Connect the high side of test-oscillator to—	Tune test-osc. to—	Turn radio dial to—	Adjust the following for max. output
1	6BJ6 I-F grid through .01 mfd. capacitor	455 kc	Quiet-point 1600 kc end of dial	T2 (top and bottom) 2nd I-F. trans.
2	Stator of CIA through .01 mfd.			T1 (top and bottom 1st I-F trans.
3	Short wire placed near loop to radiate signal	1620 kc	Min. cap.	osc. trimmer CIB-T
4		1400 kc	1400 kc signal	ant. trimmer CIA-T
5		Repeat steps 3 and 4		

REPLACEMENT PARTS

STOCK NO.	DESCRIPTION	STOCK NO.	DESCRIPTION
	CHASSIS ASSEMBLIES		
	RC 1119	503547	4.7 megohm, ±10%, 1/2 watt R7
77438	Antenna—Ferrite rod antenna complete with windings..... L1	76723	Socket—Lamp socket
77440	Capacitor—Variable tuning capacitor..... CIA, C1B	75780	Socket—Tube socket, 7 pin, miniature saddle-mounted
77471	Capacitor—Ceramic, 4.7 mmf..... C13	77441	Transformer—Filament transformer 117 volts AC..... T4
75609	Capacitor—Ceramic, 47 mmf..... C2	77445	Transformer—Output transformer..... T3
76347	Capacitor—Ceramic, 120 mmf..... C12	77416	Transformer—1st I.F. transformer complete with adjustable cores..... T1
75611	Capacitor—Ceramic, 220 mmf..... C7	77417	Transformer—2nd I.F. transformer complete with adjustable cores..... T2
77443	Capacitor—Electrolytic comprising 1 section of 50 mfd., 150 volts and 1 section of 30 mfd., 150 volts..... C5A, C5B	77420	Washer—Shoulder washer (nylon) for mounting variable tuning capacitor
77446	Capacitor—Tubular, paper, .0022 mfd., 400 volts..... C9		SPEAKER ASSEMBLIES
77447	Capacitor—Tubular, paper, .0033 mfd., 400 volts..... C10		922258-7
77424	Capacitor—Tubular, paper, .01 mfd., 200 volts..... C8	77451	Speaker—4" x 6" P.M. speaker complete with cone and voice coil (3.2 ohms)
77448	Capacitor—Tubular, paper, .027 mfd., 200 volts..... C11		MISCELLANEOUS
77422	Capacitor—Tubular, paper, .047 mfd., 400 volts..... C4	77457	Case—Polystyrene case—black & beige—complete with speaker baffle and screen assemblies less bottom cover for Model 2R51
75071	Capacitor—Tubular, moulded paper, .047 mfd., 400 volts..... C3	77465	Case—Polystyrene case—tan & ivory—complete with speaker baffle and screen assemblies less bottom cover for Model 2R52
77423	Capacitor—Tubular, paper, 0.1 mfd., 400 volts..... C6	77456	Clip—Spring clip to mount station selector pointer
73935	Clip—Mounting clip for I.F. transformer	77458	Cover—Bottom cover—beige—for Model 2R51
77450	Coil—Oscillator coil..... L2, L3	77466	Cover—Bottom cover—ivory—for Model 2R52
77442	Control—Volume control and power switch..... R6, S1	77453	Dial—Dial knob—black & gold—for Model 2R51
70392	Cord—Power cord and plug	77464	Dial—Dial knob—tan & gold—for Model 2R52
77439	Cover—Insulating cover for chassis	77452	Knob—Volume control and power switch knob—black & gold—for Model 2R51
74838	Grommet—Power cord strain relief (1 set)	77463	Knob—Volume control and power switch knob—tan & gold—for Model 2R52
77405	Insulator—Bakelite insulator for variable tuning capacitor	11765	Lamp—Pilot lamp—Mazda 51
77444	Nut—Speed nut for output transformer mounting screws	77455	Pointer—Station selector pointer
28452	Plate—Bakelite mounting plate for electrolytic	77454	Screw—#8-32 x 3/8" cross recessed truss head machine screw for fastening bottom cover
77292	Rectifier—Selenium rectifier..... CR1	76783	Shield—Pilot lamp shield
77571	Resistor—Wire wound, fuse type, 22 ohms, 0.4 amps..... R2	74734	Spring—Spring clip for volume control knob or dial knob
503110	100 ohms, ±10%, 1/2 watt..... R11		
503147	470 ohms, ±10%, 1/2 watt..... R10		
523215	1500 ohms, ±10%, 2 watts..... R3		
503268	6800 ohms, ±10%, 1/2 watt..... R12		
503333	33,000 ohms, ±10%, 1/2 watt..... R1		
503347	47,000 ohms, ±10%, 1/2 watt..... R5		
503433	330,000 ohms, ±10%, 1/2 watt..... R8		
503482	820,000 ohms, ±10%, 1/2 watt..... R9		
503533	3 3 megohm, ±10%, 1/2 watt..... R4		

APPLY TO YOUR RCA DISTRIBUTOR FOR PRICES OF REPLACEMENT PARTS



RCA VICTOR

Radio Phonograph Combination

Model 2-S-7

Chassis No. RC-1117D

SERVICE DATA

— 1953 No. 1 —

PREPARED BY RCA SERVICE CO., INC.

FOR

RADIO CORPORATION OF AMERICA

RCA VICTOR DIVISION

CAMDEN, N. J., U. S. A.

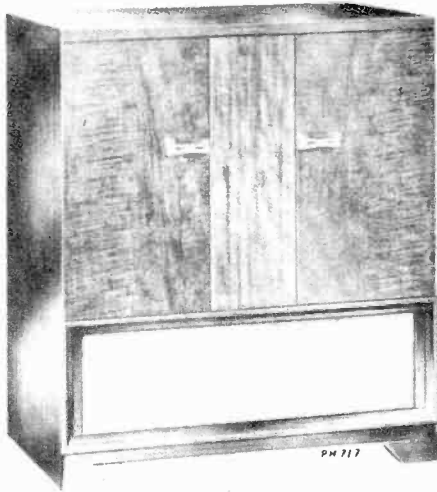

FOR RECORD CHANGER SERVICE INFORMATION—REFER TO 930409 SERIES SERVICE DATA.

SPECIFICATIONS

Tuning Range 540 - 1600 kc.

Intermediate Frequency 455 kc.

Tube Complement

- | | | |
|--------------|--------------------|-------------------------|
| 1. RCA 12BE6 | | Converter |
| 2. RCA 12BA6 | | I.F. Amplifier |
| 3. RCA 6AQ6 | | Detector—A.F. Amplifier |
| 4. RCA 6AQ6 | | Phase Inverter |
| 5. RCA 35C5 | } Push Pull Output | |
| 6. RCA 35C5 | | |
- A selenium rectifier Stock #76871 is used.

Power Supply Rating

115 volts A.C., 60 cycles 45 watts

Dial Lamps (2) Mazda type 51, 6-8 volts, 0.2 amp.

Loudspeaker

Size and type 8" P.M.
Voice coil impedance 3.2 ohms at 400 cycles

Power Output

At 10% distortion 2.0 watts
Maximum 2.9 watts

Cabinet Dimensions

Height 32 1/4" Width 28 1/2" Depth 19 1/8"

Tuning Drive Ratio

14 1/4 : 1 (7 1/8 turns of knob)

Record Changer (930409-5, or -10)

Turntable speed 33 1/2, 45 or 78 r.p.m.
Record capacity up to fourteen 7 inch RCA type
or twelve 10 inch
or ten 12 inch
or ten 10 in. and 12 in. intermixed.

Pickup (Stock No. 75475) Crystal with replaceable styli.

Weight 66 lbs. net

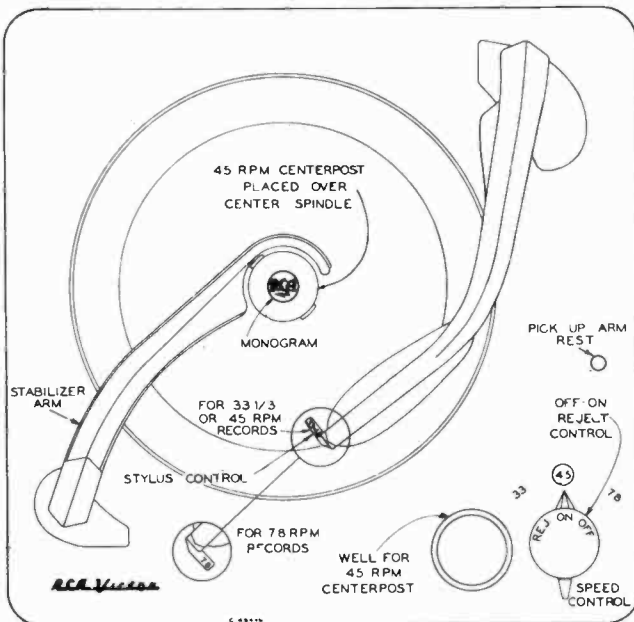

Record Changer Controls

RECORD CHANGER CONTROLS

The record changer has a dual control on the motorboard and a stylus selector control on the pickup arm. The inner control (circular knob) is the OFF-ON-REJECT control. Turning this knob to the center position energizes the motor and starts the turntable, when turned to the right (clockwise) it starts the mechanism into complete automatic operation. The mechanism will shut off automatically after the last record has been played but can be shut off manually by turning this knob to the left (counter-clockwise).

The outer control (double ended lever) is the speed control. It has three normal positions, "33", "45", "78" to select the turntable speed desired and a neutral position (midway between "45" and "78"). The control should be turned to this neutral position if the changer is not expected to be in use for an extended period of time.

The stylus control has two normal positions (right and left) and one shipping position (lever pointing up). When playing 33 1/3 or 45 r.p.m. records the lever is turned so that "33-45" is visible on the TOP of the lever; likewise for 78 r.p.m. records "78" should be visible on the TOP.

The removable centerpost is for use with 45 r.p.m. records having the large centerhole. It must be placed over the center spindle with the "RCA" trademark monogram FACING to the FRONT. When not in use it is placed in a well at the front of the motorboard.

To load or remove records, the record stabilizer is lifted and turned off-side. After loading it is turned to the center where it rests on top of the stack of records.

2-S-7

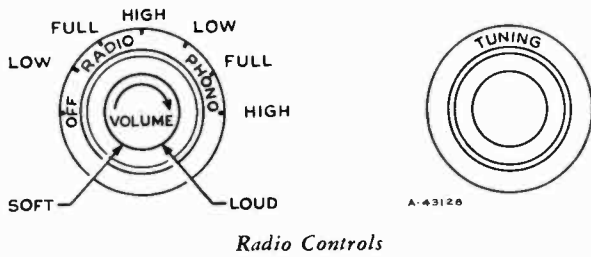

Radio Controls

Critical Lead Dress

1. Dress all leads away from R22.
2. Dress all filament leads down to chassis.
3. Dress output plate leads down to chassis.
4. Dress R12 close to chassis.

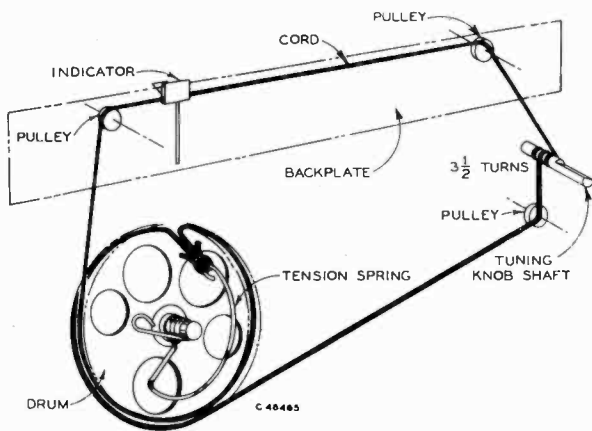

Dial Cord Layout

Alignment Procedure

Output Meter.—Connect meter across speaker voice coil. Turn volume control to maximum.

Test Oscillator.—Connect low side of test oscillator to common wiring in series with a .1 mf. capacitor. If the test oscillator is a.c. operated it may be necessary to use an isolation transformer for the receiver during alignment and the low side of the test oscillator connected directly to common wiring at the electrolytic capacitor. Keep the oscillator output low to prevent a-v-c action.

Steps	Connect the high side of test-oscillator to—	Tune test-osc. to—	Turn radio dial to—	Adjust the following for max. output
1	I.F. grid, in series with .1 mfd.	455 kc	Quiet point 1,600 kc end of dial	Pri. & Sec. 2nd I.F. transformer
2	Converter grid in series with .1 mfd.			Pri. & Sec. 1st I.F. transformer
NOTE.—ANTENNA LOOP MUST BE IN CABINET FOR THE FOLLOWING				
3	Short wire placed near loop for radiated signal	1,620 kc	Extreme R. H. end (gang open)	C22 (osc.)
4		1,400 kc	1,400 kc	C5 (ant.)
5		600 kc	600 kc Signal	L3 (Rock Gang)
6	Repeat steps 3, 4 & 5 if necessary			

Dial Pointer Adjustment.—Rotate tuning condenser fully counterclockwise (plates fully meshed). Adjust indicator pointer so that it is 3 1/4" from the left hand edge of the dial back plate.

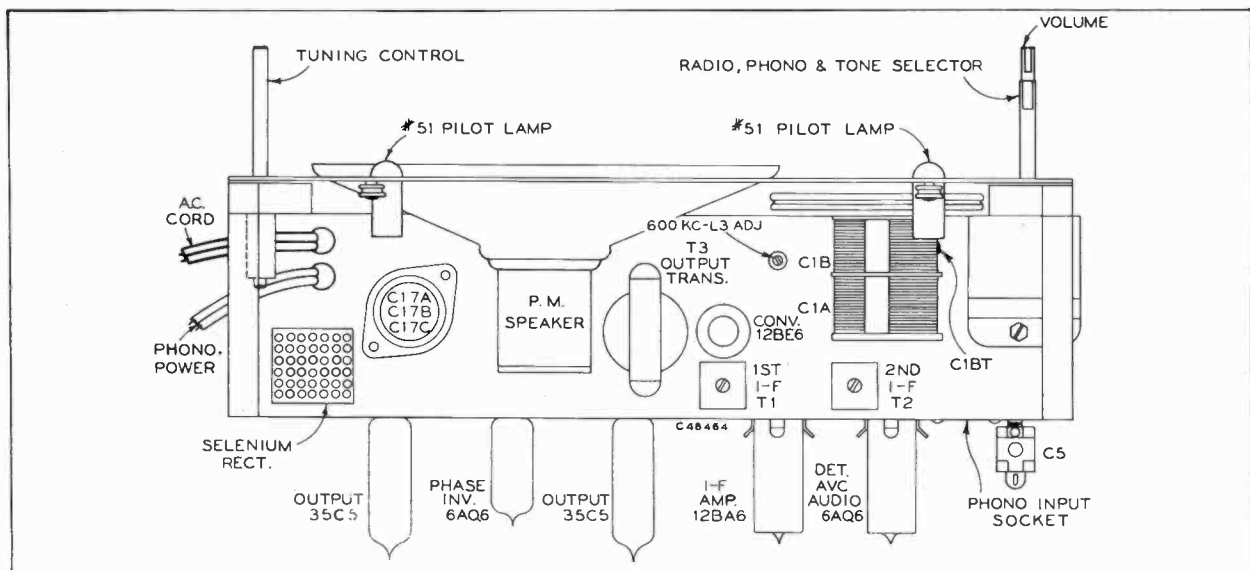

Tube and Trimmer Locations

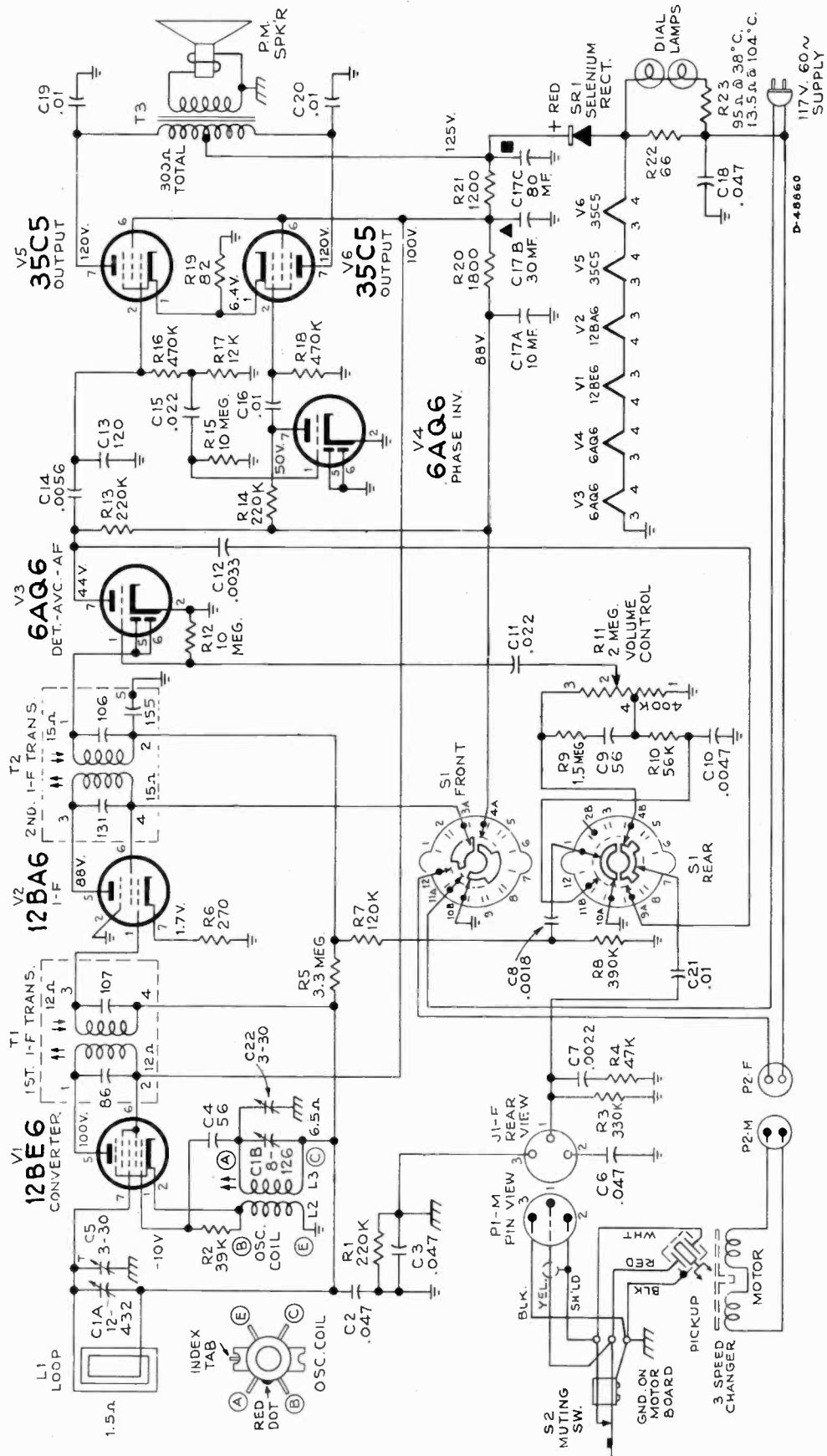

Schematic Diagram—Chassis RC-1117C

D-48860

REPLACEMENT PARTS

STOCK No.	PART DESCRIPTION	STOCK No.	PART DESCRIPTION
	CHASSIS ASSEMBLIES RC1117D		
76876	Antenna—Antenna loop and back cover, L1	74697	Socket—Dial lamp socket
76867	Capacitor—Variable tuning capacitor, C1A, C1B	77115	Socket—Tube socket, 7 pin, miniature, moulded
76872	Capacitor—Adjustable trimmer, 2.5—30 mmf., C5, C22	51955	Socket—Tube socket, 7 pin, miniature, moulded saddle-mounted
77116	Capacitor—Fixed, ceramic, insulated, temp. coef.—3300, 56 mmf., $\pm 20\%$, 500 volts DC, C4	76368	Spring—Drive cord spring
93603	Capacitor—Fixed, ceramic, insulated, high K type—56 mmf., $\pm 10\%$, 500 volts, C9	76873	Switch—Function switch less volume control, S1
76347	120 mmf., $\pm 20\%$, 500 volts, C13	77122	Transformer—Output transformer, T3
73013	Capacitor—Electrolytic: comprising 1 section of 80 mfd., 150 volts, 1 section of 30 mfd., 150 volts and 1 section of 10 mfd., 150 volts, C17A, C17B, C17C	74918	Transformer—First I.F. transformer complete with adjustable cores, T1
	Capacitor—Fixed, tubular, paper:	73037	Transformer—Second I.F. transformer complete with adjustable cores, T2
73851	.0018 mfd., 1600 volts, C8, C21	33726	Washer—"C" washer for tuning knob shaft
73595	.0022 mfd., 600 volts, C7		SPEAKER ASSEMBLIES 92586-4W RL10504 RMA-274
73795	.0033 mfd., 400 volts, C12	75024	Cone—Cone and voice coil (3.2 ohms)
73920	.0047 mfd., 400 volts, C10	74664	Speaker—8" P.M. speaker complete with cone and voice coil (3.2 ohms)
73788	.0056 mfd., 400 volts, C14		MISCELLANEOUS
73561	.01 mfd., 400 volts, C16, C19, C20	71892	Catch—Bullet catch and strike
73562	.022 mfd., 400 volts, C11, C15	70142	Clamp—Dial clamp (1 set)
73553	.047 mfd., 400 volts, C2, C3, C6	X3351	Cloth—Grille cloth for blonde mahogany instruments
75071	Capacitor—Fixed, tubular, moulded paper: .047 mfd., 400 volts, C18	X3350	Cloth—Grille cloth for mahogany or walnut instruments
73935	Clip—Mounting clip for I.F. transformer	30870	Connector—2 contact male connector for motor cable, P2
78586	Coil—Oscillator coil complete with adjustable core L2, L3	74192	Connector—3 contact male connector for pickup cable, P1
36422	Connector—Phono input connector, J1	77898	Decal—Control function decal for blonde mahogany instruments
77114	Connector—Single contact male connector for loop lead	77897	Decal—Control function decal for mahogany or walnut instruments
75474	Connector—Single contact male connector for speaker cable	74273	Decal—"Victrola" decal
30868	Connector—2 contact female connector for motor cable, P2	77889	Dial—Glass dial scale
76874	Control—Volume control, R11	74205	Escutcheon—Dial scale escutcheon less dial
72953	Cord—250' Drive Cord Reel (approx. 54" overall req'd)	74838	Grommet—Power cord strain relief (1 set)
73690	Cord—Power cord and plug	77402	Handle—Pullout handle for record changer mechanism
74838	Grommet—Power cord strain relief (1 set)	74308	Hinge—Door hinge (1 set)
72283	Grommet—Rubber grommet for mounting variable capacitor	77892	Knob—Function switch knob—beige—for blonde mahogany instruments (outer)
11765	Lamp—Dial lamp—Mazda 51	77891	Knob—Function switch knob—maroon—for mahogany or walnut instruments (outer)
28452	Plate—Bakelite mounting plate for electrolytic	77382	Knob—Tuning control knob—beige—for blonde mahogany instruments (inner)
77926	Plate—Dial back plate complete less dial	77386	Knob—Tuning control knob—beige—for blonde mahogany instruments (outer)
77378	Pointer—Station selector pointer	75945	Knob—Tuning control knob—maroon—for mahogany or walnut instruments (inner)
76871	Rectifier—Selenium rectifier, SR1	77385	Knob—Tuning control knob—maroon—for mahogany or walnut instruments (outer)
73072	Resistor—Normal value 95 ohms, @ 38°C with negative temperature coefficient, R23	75464	Knob—Volume control knob—beige for blonde mahogany instruments (inner)
77379	Resistor—Wire wound, 66 ohms, 5 watts, R22	74963	Knob—Volume control knob—maroon—for mahogany or walnut instruments (inner)
503082	Resistors—Fixed, composition:	77894	Pan—Record changer mounting pan—beige—for blonde mahogany instruments
503127	82 ohms, $\pm 10\%$, 1/2 watt, R19	77893	Pan—Record changer mounting pan—plum—for mahogany or walnut instruments
513212	270 ohms, $\pm 10\%$, 1/2 watt, R6	76421	Pin—Slide mechanism stop pin
503218	1200 ohms, $\pm 10\%$, 1 watt, R21	77896	Pull—Door pull
503218	1800 ohms, $\pm 10\%$, 1/2 watt, R20	74113	Screw—#8-32 x 1" trimit head screw for door pull
503312	12,000 ohms, $\pm 10\%$, 1/2 watt, R17	77895	Slide—Mounting pan slide mechanism
503339	39,000 ohms, $\pm 10\%$, 1/2 watt, R2	76422	Spring—Retaining spring for slide mechanism stop pin
503347	47,000 ohms, $\pm 10\%$, 1/2 watt, R4	30330	Spring—Retaining spring for knobs 74963 and 75464
503356	56,000 ohms, $\pm 10\%$, 1/2 watt, R10	76837	Spring—Retaining spring for knobs 75945, 77382, 77385, 77386, 77891, 77892
503412	120,000 ohms, $\pm 10\%$, 1/2 watt, R7	72936	Stop—Door stop
503422	220,000 ohms, $\pm 10\%$, 1/2 watt, R1, R13, R14		
503433	330,000 ohms, $\pm 10\%$, 1/2 watt, R3		
503439	390,000 ohms, $\pm 10\%$, 1/2 watt, R8		
503447	470,000 ohms, $\pm 10\%$, 1/2 watt, R16, R18		
503515	1.5 megohm, $\pm 10\%$, 1/2 watt, R9		
503533	3.3 megohm, $\pm 10\%$, 1/2 watt, R5		
503610	10 megohm, $\pm 10\%$, 1/2 watt, R12, R15		
76869	Shaft—Tuning knob shaft		
76870	Shield—Tube shield		

APPLY TO YOUR RCA DISTRIBUTOR FOR PRICES OF REPLACEMENT PARTS



RCA VICTOR



FOR RECORD CHANGER SERVICE INFORMATION—REFER TO 930409 SERIES SERVICE DATA.

AM-FM Radio-Phonograph Combination

MODEL 2-S-10

Radio Chassis RC1111 Audio Amplifier RS141
Record Changer 930409-5, or -10

SERVICE DATA

— 1952 No. 14 —

PREPARED BY RCA SERVICE CO., INC.
FOR

RADIO CORPORATION OF AMERICA
RCA VICTOR DIVISION
CAMDEN, N. J., U. S. A.

Specifications

Tuning Range

Standard Broadcast (AM)	540-1600 kc.
Frequency Modulation (FM)	88-108 mc.
Intermediate Frequency (AM)	455 kc.
Intermediate Frequency (FM)	10.7 mc.

Tube Complement

Tube Used	Function
Radio Chassis RC1111	
(1) RCA 6CB6	R-F Amplifier
(2) RCA 6J6	Mixer and Oscillator
(3) RCA 6BA6	I-F Amplifier
(4) RCA 6AU6	F-M Driver
(5) RCA 6AL5	Ratio Detector
(6) RCA 6AV6	AM Det.-AVC-A-F Amplifier
Audio Chassis RS141	
(1) RCA 6C4	Phase Inverter
(2) RCA 6V6GT	Audio Output
(3) RCA 6V6GT	Audio Output
(4) RCA 5Y3GT	Rectifier

Lamps

Dial (2)	#51, 6-8 volts, 0.2 amp.
Jewel (1)	#51, 6-8 volts, 0.2 amp.

Power Supply Rating..... 115 volts, 60 cycles, 100 watts

Audio Power Output Rating

Radio	undistorted 8 watts, maximum 9 watts
Phonograph	undistorted 10 watts, maximum 12 watts

Loudspeaker (92569-12W)

Size and Type	12 inch P.M.
Voice Coil Impedance	3.2 ohms at 400 cycles

Tuning Drive Ratio..... 9:1 (4½ turns of knob)

Net Weight..... 96 lbs.

Dimensions (overall)

Height... 35½ in. Width... 35 in. Depth... 23 in.

Record Changer (930409-5, or -10)

Turntable Speed... 33⅓, 45 or 78 r.p.m.

Record Capacity... Up to fourteen 7 inch RCA type
or twelve 10 inch
or ten 12 inch
or ten 10 inch and 12 inch intermixed

Pickup (Stock No. 75475)... Crystal with replaceable styli

General Description

This instrument is a Victrola combination having nine tubes, plus one rectifier. It has a modern style cabinet in either walnut, mahogany, or limed oak finish. The entire receiver (with the exception of the power supply and speaker) is built as a unit with the automatic record changer for "pull-out" operation. The three speed record changer is nested over the radio chassis on a plastic case. Record storage space is provided for both large and small diameter records.

For standard broadcast reception, a loop antenna is mounted on the roll-out unit back. A folded dipole is mounted inside the cabinet for use on the FM band. Provision is made for connecting an external antenna for either the broadcast or FM bands.

By rotating the function switch, the 2S10 can be operated as:

1. Phonograph sound channel for the three speed record changer.

2. Standard broadcast "A" band receiver (540-1600 kc).
3. Broadcast "FM" band receiver (88-108 mc).

The function switch controls the internal connections for:

- A. RF-IF stage AVC voltages from AM or FM detector.
- B. Audio amplifier input from any one of three channels.
- C. B+ voltage application to RF-IF circuits.
- D. Audio output tube bias voltage. In phonograph operation, R2 is disconnected from R107, increasing available power output for phonograph operation.
- E. Selection of tuned circuits for AM or FM operation.

A horizontal tilted slide rule type dial is located along the top front face of the plastic roll-out case. The dial is edge-lighted at both ends by dial lamps. An amber jewel lamp, visible at the bottom front, glows whenever the set is in operation.

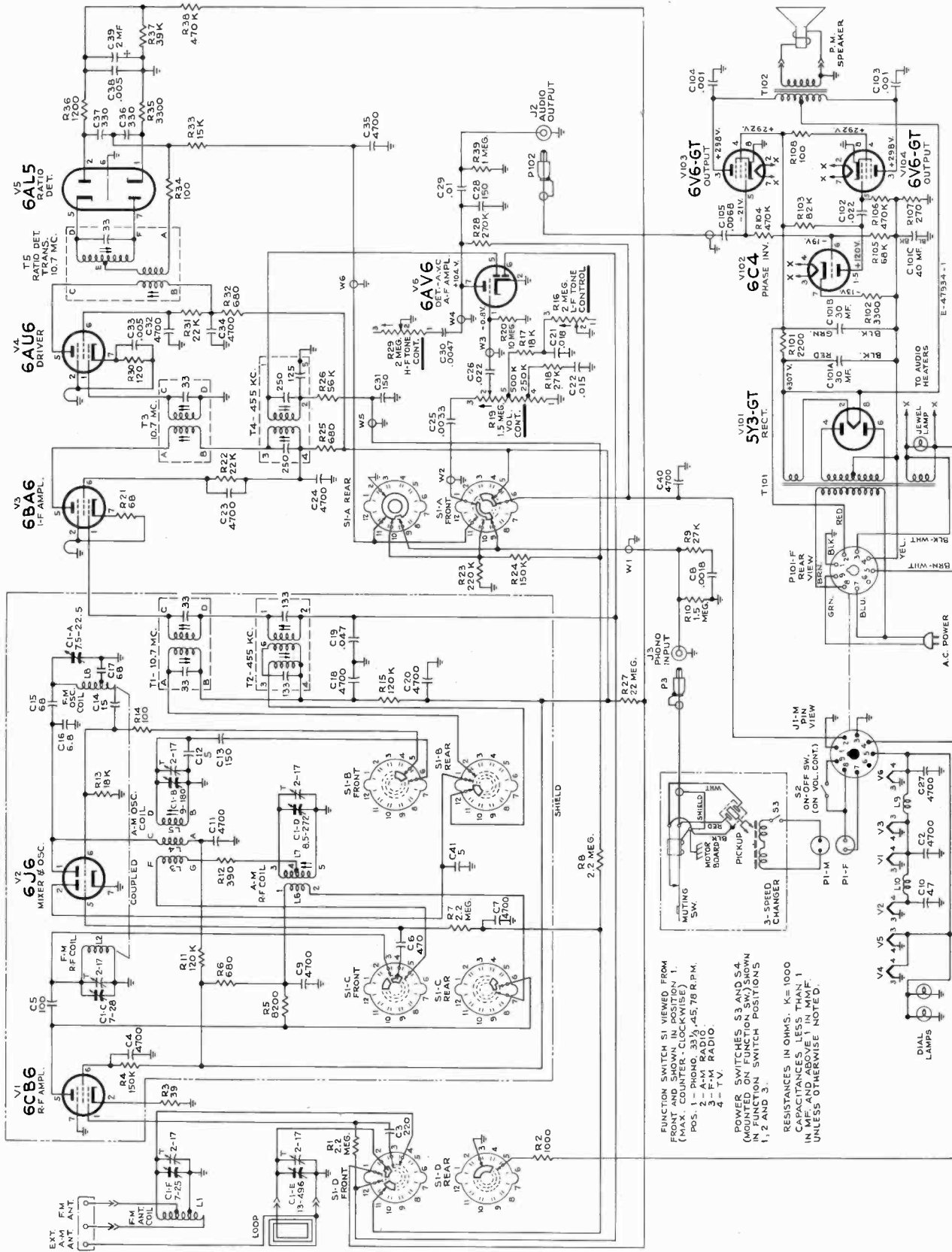

FUNCTION SWITCH S1 VIEWED FROM FRONT AND SHOWN IN POSITION 1. (MAX. CURRENT LOCATIONS) POS. 1 - AM RADIO 330-45,70 P.M. 2 - AM RADIO 330-45,70 P.M. 3 - F-M RADIO 4 - TV

POWER SWITCHES S3 AND S4 (MOUNTED ON FUNCTION SW.) SHOWN IN 2 AND 1 POSITION SWITCH POSITIONS 1, 2 AND S1

RESISTANCES IN OHMS. K=1000 CAPACITANCES LESS THAN 1 IN MF. AND ABOVE 1 IN MMF. UNLESS OTHERWISE NOTED.

Complete Schematic Diagram—Chassis RC1111 and RS141

Alignment Procedure

CORRECT ALIGNMENT OF THE AM R.F. STAGES REQUIRES THAT THE FM R.F. STAGES BE ALIGNED FIRST

Alignment Indicators:

An RCA VoltOhmyst or equivalent meter is necessary for measuring developed d-c voltage during FM alignment. Connections are specified in the alignment tabulation. An output meter is also necessary to indicate minimum audio output during FM Ratio Detector alignment. Connect the output meter across the speaker voice coil.

The RCA VoltOhmyst can also be used as an AM alignment indicator, either to measure audio output or to measure a-v-c voltage.

When audio output is being measured the volume control should be turned to maximum. Adjust tone controls for maximum highs and lows during alignment.

Signal Generator:

For all alignment operations connect the low side of the signal generator to the receiver chassis. The output should be adjusted to provide accurate resonance indication at all times. If output measurement is used for AM alignment the output of the signal generator should be kept as low as possible to avoid a-v-c action.

(A) AM Alignment

RANGE SWITCH IN AM POSITION

Steps	Connect high side of sig. gen. to—	Sig. gen. output	Turn radio dial to—	Adjust for peak output
1	Pin No. 1 of V3 in series with .01 mf.	455 kc. (mod.)	Quiet point at low freq. end	T4 bottom core (sec.) T4 top core (pri.)
2	To stator of C1-E			T2 top core (sec.) T2 bottom core (pri.)
PERFORM FM ALIGNMENT BEFORE PROCEEDING				
3		1620 kc. (mod.)	1620 kc.	C1B-T (osc.)
4		1400 kc. (mod.)	1400 kc.	C1D-T (ant.) C1E-T (rf.)
5	Short wire placed near loop for radiated signal	600 kc. (mod.)	600 kc.	L5 (osc.) with 10,000 ohm resistor from RF stator to grd. (rocking gang)
6				L7 (RF) with the 10,000 ohms removed.
7	Repeat steps 4, 5 and 6 until no improvement in sensitivity is obtained.			

Oscillator frequency is above signal frequency on both AM and FM.

ⓐ ⓑ ⓒ encircled letters indicate recommended alignment sequence.

FM Alignment

FUNCTION SWITCH IN FM POSITION—VOLUME CONTROL MAXIMUM

Steps	Connect high side of sig. gen. to—	Sig. gen. output	Turn radio dial to—	Adjust for max. output
1	Connect the d-c probe of a VoltOhmyst to the negative lead of the 2 mid. capacitor C39 and the common lead to chassis. Adjust sig. gen. output to provide approx. -4 v. indication during alignment.			
2	Pin #1 of 6AU6 (V4) in series with .01 mf.	10.7 mc AM modulated		Top of driver trans. T5 for max. d-c voltage
3				†Bottom of driver trans. T5 for min. audio output
4	Repeat steps 2 and 3			
5	Thru 470 ohms to C1-F. Connect grd. end of cable close to V2 cathode ground on r-f shelf	10.7 mc	88 mc	*Top (sec.) & bottom (pri.) cores of T3 *Top (sec.) & bottom (pri.) cores of T1
6		90 mc	90 mc	L8 (osc.)
7	To FM antenna terminals thru 120 ohms in each side of line	106 mc	106 mc Signal	C1-F trimmer (ant.) and C1-C trimmer (r. f.)
8		90 mc	90 mc Signal	L1 (ant.) and L2 (r. f.)
9	Repeat steps 6, 7 and 8			
10	Connect a sweep generator to the antenna terminals thru 120 ohms in each side of line. Connect an oscilloscope to junction of R33 and C35 to check response and linearity of FM band. Peak to peak separation should not be less than 180 kc.			

†Two or more points may be found which lower the audio output. At the correct point the minimum audio output is approached rapidly and is much lower than at any incorrect point.

*Use a 680 ohm resistor to lead the plate winding while the grid winding of the same trans. is being peaked. Then the grid winding is loaded with the 680 ohm resistor while the plate winding is being peaked. When windings are loaded, it is necessary to increase the 10.7 mc input to maintain the -4 volts indication.

L8, L1 and L2 are adjustable by increasing or decreasing the spacing between turns. Oscillator signal tracks above signal frequency.

The proper adjustment of the I.F. cores can be determined by starting the core all the way out. The first peak obtained is the correct one.

Tube Socket Voltages

Tube Type and Function	Tube Element	Pin No.	AM	FM	Phono
V1 6CB6 R-F Amp.	Plate	5	215	180	—
	Screen Cathode	2	74	62	—
	Grid	1	0.4	0.4	—
V2 6I6 Osc. and Mixer	Plate	2	55	58	—
	Grid	5	-1.2	-1.3	—
	Plate	1	43	46	—
V3 6BA6 I-F Amp.	Plate	5	210	210	—
	Screen Cathode	6	126	115	—
	Grid	7	0.9	0.7	—
V4 6AU6 Driver	Plate	5	216	216	—
	Screen Cathode	6	150	150	—
	Grid	7	1.5	1.5	—
V5 6AL5 Ratio Det.	—	—	—	—	—
	—	—	—	—	—
	—	—	—	—	—
V6 6AV6 Audio Amp.	Plate	7	88	88	104
	Grid	1	-0.7	-0.7	-0.8
6C4 Phase Inverter	Plate	5	87.5	88	120
	Screen Cathode	7	-11	-11	-13
	Grid	6	-16	-16	-19
6V6GT Audio Output	Plate	3	300	300	298
	Screen Cathode	4	224	224	292
	Grid	8	0	0	0
5Y3GT Rectifier	—	5	-17	-17	-21
	Fil.	8	305	305	307

Voltages measured with VoltOhmyst and should hold within ±20% with rated line voltage. Tuning condenser closed—no signal input.

Critical Lead Dress

1. The 1st F.M. I.F. plate lead should be dressed away from the R.F. plate.
2. Dress the 1st A.M. I.F. plate lead to S-2 wafer away from the A.M. R.F. coil.
3. The ground strap between the R.F. Shelf and the main chassis should be well soldered and kept as short as practicable but yet allow some flexibility for the R.F. Shelf.
4. Dress A.C. power switch wires away from all audio components.
5. Dress C-26 down toward base between terminal board and side apron.
6. C-18 bypass should ground as close to the R.F. Shelf ground strap as practicable.
7. Dress C-25 away from arm of volume control.
8. All leads, from the R.F. shelf, leaving through the shields must be kept as short as possible so as to minimize F.M. oscillator radiation.
9. Dress A.C. leads in the RS141 chassis away from audio input leads and components.
10. Dress all leads away from R1 in the RS141 chassis.
11. All leads for F.M. should be kept short especially on the R.F. shelf.

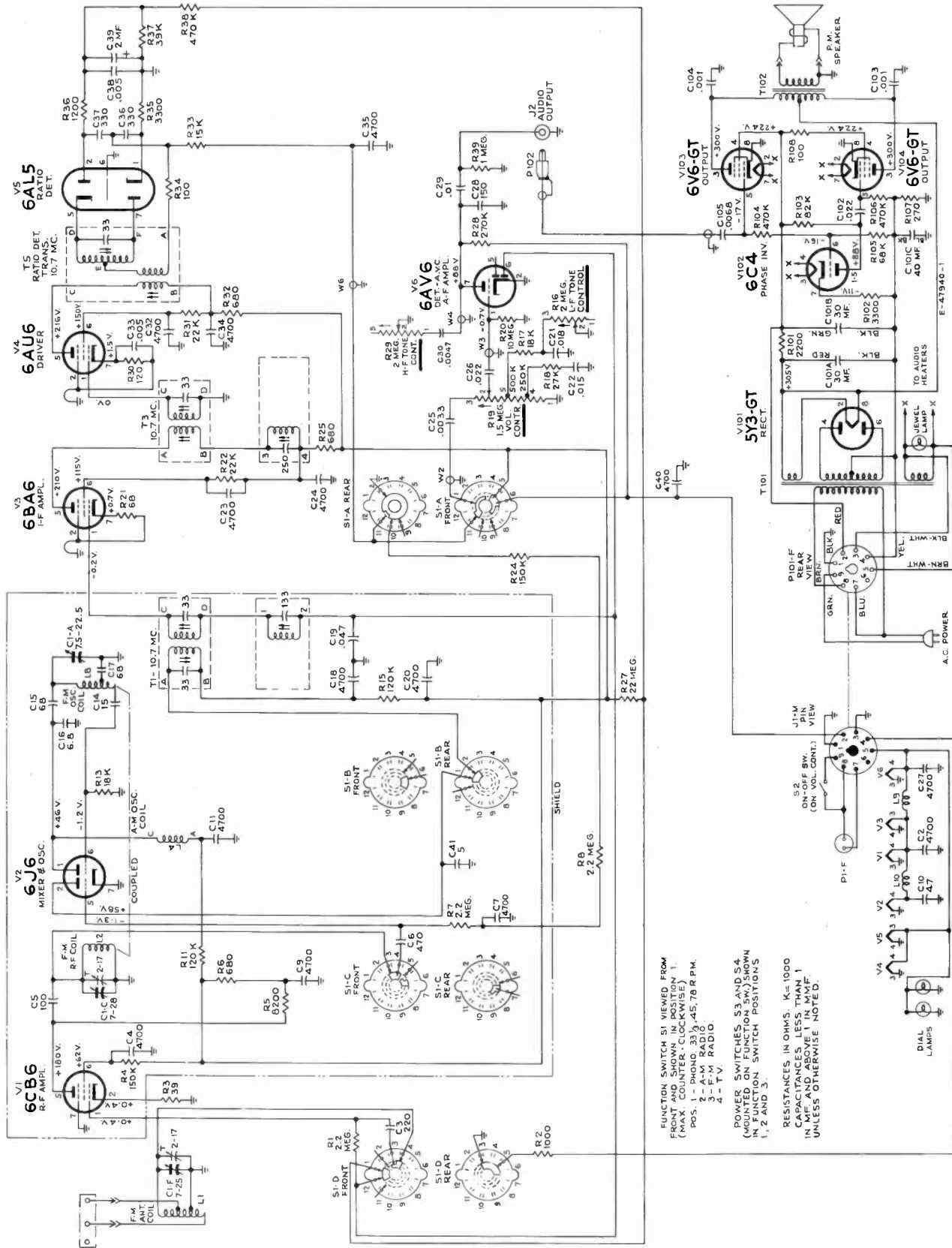

FUNCTION SWITCH S1 VIEWED FROM FRONT AND SHOWN IN POSITION 1. (MAX. COUNTER - CLOCKWISE)
 POS. 1 - PHONO, 33 1/3, 45, 78 RPM.
 2 - F-M RADIO
 3 - F-M RADIO
 4 - TV.

POWER SWITCHES S3 AND S4 (MOUNTED ON FUNCTION SW.) SHOWN IN FUNCTION SWITCH POSITIONS 1, 2 AND 3.

RESISTANCES IN OHMS, K=1000 IN MF AND ABOVE 1 IN MMF, UNLESS OTHERWISE NOTED.

Simplified Schematic Diagram—"FM" Position

2-S-10

Cathode Currents (Ma.)

Tube	Term.	Phono	A.M.	F.M.
V1 6CB6	2	—	6	6
V2 6J6	7	—	3	3
V3 6BA6	7	—	13.7	13.5
V4 6AU6	7	—	10.3	10.6
V5 6AL5	1 & 5	—	—	—
V6 6AV6	2	0.7	0.5	0.5
V7 6C4	7	2.2	1.7	17.1
V8 6V6GT	8	35.5	20.6	21.1
V9 6V6GT	8	35.5	20.6	21.1
V10 5Y3GT	2	74	76	77.5

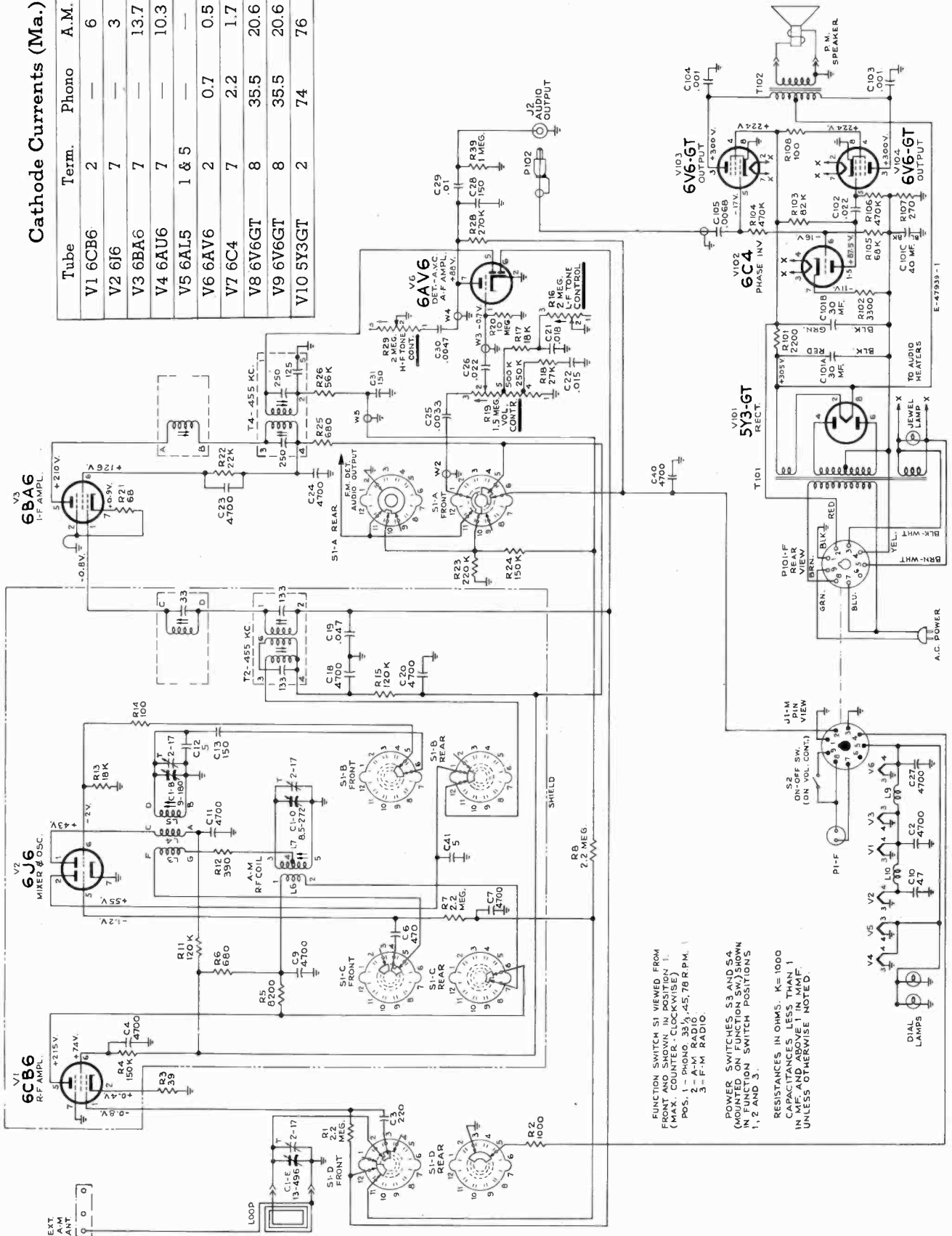

FUNCTION SWITCH S1 VIEWED FROM FRONT AND SHOWN IN POSITION 1 (MAX. COUNTER, CLOCKWISE). POS. 1 - PHONO, 3 1/2, 45.78 R.P.M. 1 2 - A.M. RADIO 3 - F.M. RADIO

POWER SWITCHES S3 AND S4 (MOUNTED ON FUNCTION SW.) SHOWN IN OFF POSITION. SWITCH POSITIONS 1, 2 AND 3. RESISTANCES IN OHMS. K=1000 IN MF. AND ABOVE 1 IN MMF. UNLESS OTHERWISE NOTED.

Simplified Schematic Diagram - "AM" Position

Record Changer

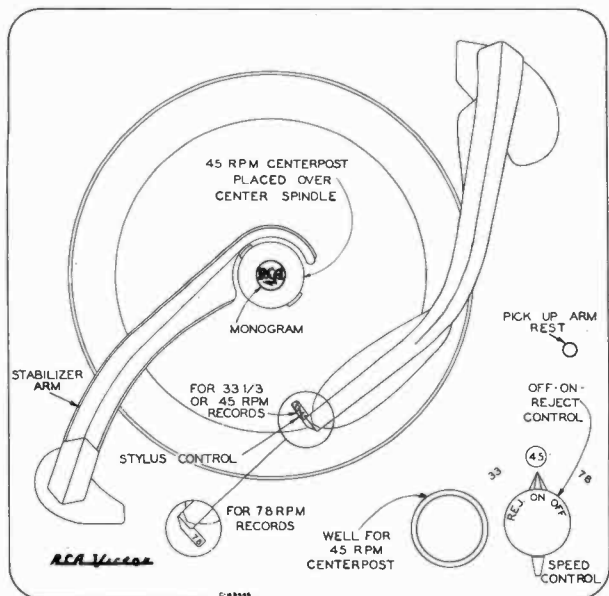

Controls

Record Changer Controls

The record changer has a dual control on the motorboard and a stylus selector control on the pickup arm. The inner control (circular knob) is the OFF-ON-REJECT control. Turning this knob to the center position energizes the motor and starts the turntable, when turned to the right (clockwise) it starts the mechanism into complete automatic operation. The mechanism will shut off automatically after the last record has been played but can be shut off manually by turning this knob to the left (counter-clockwise).

The outer control (double ended lever) is the speed control. It has three normal positions, "33", "45", "78" to select the turntable speed desired and a neutral position (midway between "45" and "78"). The control should be turned to this neutral position if the changer is not expected to be in use for an extended period of time.

The stylus control has two normal positions (right and left) and one shipping position (lever pointing up). When playing 33 1/3 or 45 r.p.m. records the lever is turned so that "33-45" is visible on the TOP of the lever; likewise for 78 r.p.m. records "78" should be visible on the TOP.

The removable centerpost is for use with 45 r.p.m. records

having the large centerhole. It must be placed over the center spindle with the "RCA" trademark monogram FACING to the FRONT. When not in use it is placed in a well at the front of the motorboard.

To load or remove records, the record stabilizer is lifted and turned off-side. After loading it is turned to the center where it rests on top of the stack of records.

Record Changer Adjustments

Landing Adjustment

Only one landing adjustment is necessary. The landing position of the stylus is adjusted by means of the eccentric stud (20A), mounted on the pickup arm support bracket. When adjusted for correct landing on one side of record, the landing position for other sizes of records is automatically corrected.

Pickup Arm Height Adjustment

The pickup arm height during cycle is adjusted by means of the hex head screw (17), located in the pickup arm.

Turn control knob to "REJ" and rotate turntable by hand until arm has risen to its maximum height. Adjust screw so that stylus is 1 3/8" above turntable.

Stylus Force Adjustment

Stylus force should be 7 1/2 to 9 1/2 grams. Loosen screw (14), and move slide until the correct force is obtained.

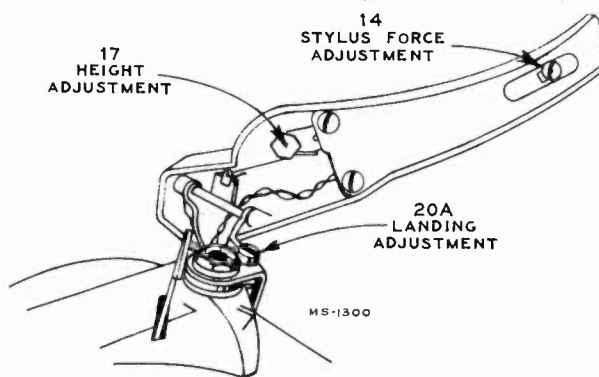

Adjustments

Tripping

The tripping method used in this mechanism is a velocity method. Velocity tripping is effective between 4 3/4" and 3 1/4" diameters, when the stylus moves inward 1/8" or more per revolution of the turntable. No adjustment is required.

Radio

Operating Instructions

RADIO—Turn extreme right hand FUNCTION knob to "AM" or "FM" radio position as desired. Turn OFF-VOLUME Knob "ON" and advance to mid-position for medium volume. Allow approximately 20 seconds for tube warm-up. With TUNING knob, select desired station indicated by dial pointer. Set tone controls for most pleasing reception. Turn BASS control counter-clockwise and TREBLE control clockwise for full tone. Adjust volume level as desired.

PHONOGRAPH—Turn extreme right hand FUNCTION knob to "PH" position. Turn OFF-VOLUME knob "ON" and advance to mid-position for medium volume. Set tone controls as indicated above for best tone. Refer to RECORD CHANGER section for operational information.



Radio Controls

Roll-Out Mechanism

Record Changer Mounting

The record-changer is mounted in a roll-out carriage. The changer mechanism is mounted on springs and should be free floating.

Roll-out Carriage Removal

Roll-out carriage has two stop pins, (one at the back end of each slide) held in place by retaining spring. To remove roll-out carriage, it is first necessary to pull the retaining springs out of the slides with a pair of long nose pliers, the stop pins are then easily removed. The roll-out carriage may then be removed from the front of the cabinet after disconnecting its connecting cables.

Roll-out Carriage Travel

The roll-out carriage has a normal movement limitation of approximately 10 inches. If it does not have this amount of movement, it may be due to an obstruction or from slippage or creeping of the balls of the slide mechanism. Travel restriction due to slippage or creeping of balls in the slide mechanism can be corrected by exerting slightly greater pull until the normal travel limitation is reached. The carriage should then operate to its full travel with normal pull.

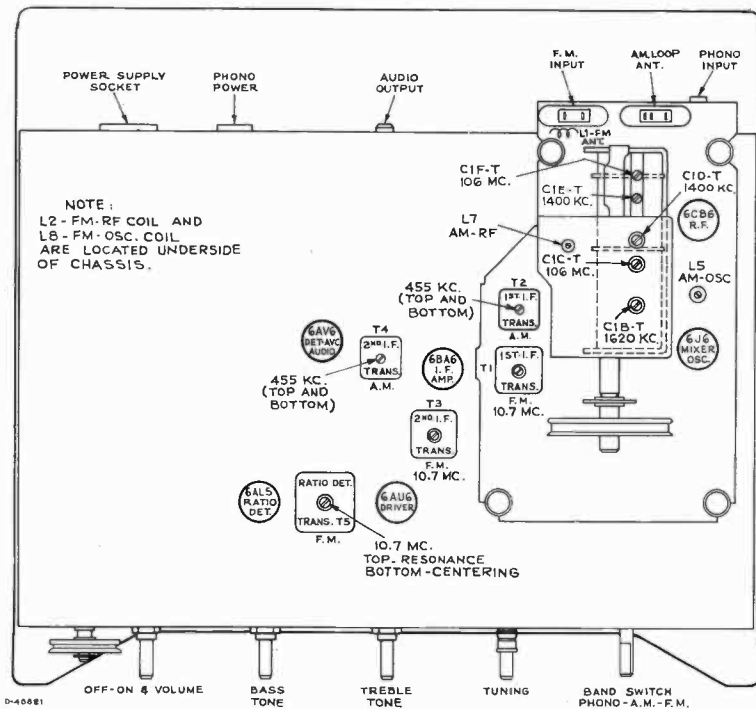

RC1111 Chassis—Tube and Trimmer Locations

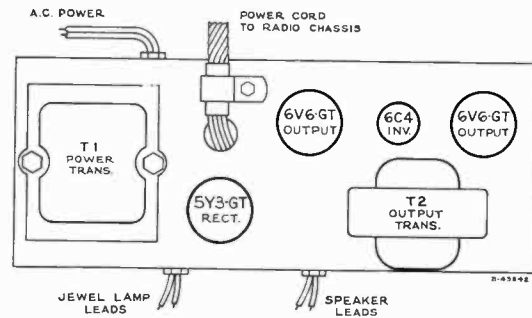

RS141—Audio Amplifier Chassis

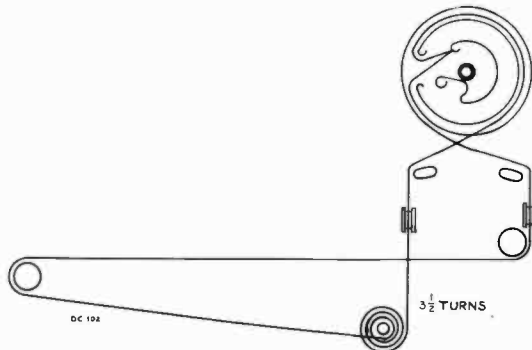

Dial Cord Drive

Replacement Parts

STOCK NO.	PART DESCRIPTION	STOCK NO.	PART DESCRIPTION
	CHASSIS ASSEMBLIES RC 1111		
77308	Capacitor—Variable tuning capacitor (C1-A, C1-B, C1-C, C1-D, C1-E, C1-F)	77315	Coil—Oscillator coil—FM (L8)
75613	Capacitor—Ceramic, 5 mmf. (C12, C41)	77305	Coil—R.F. coil—AM—complete with adjustable core (L6, L7)
77352	Capacitor—Ceramic, 6.8 mmf. (C16)	77314	Coil—R.F. coil—FM (L2)
39044	Capacitor—Ceramic, 15 mmf. (C14)	75543	Connector—2 contact female connector for phono power cable (P1)
76348	Capacitor—Ceramic, 47 mmf. (C10)	74879	Connector—2 contact female connector for antenna leads
75612	Capacitor—Ceramic, 68 mmf. (C15, C17)	75062	Connector—9 contact male connector for power input (J1)
39396	Capacitor—Ceramic, 100 mmf. (C5)	35787	Connector—Single contact female connector for audio cable (J2)
75614	Capacitor—Ceramic, 150 mmf. (C13, C28, C31)	33742	Connector—Single contact female connector for phono cable (J3)
75611	Capacitor—Ceramic, 220 mmf. (C3)	75562	Control—Tone control—H.F. (R29)
39640	Capacitor—Mica, 330 mmf. (C36, C37)	75561	Control—Tone control—L.H. (R16)
39644	Capacitor—Mica, 470 mmf. (C6)	75537	Control—Volume control and power switch (R19, S2)
73473	Capacitor—Ceramic, 4700 mmf. (C2, C4, C7, C9, C11, C18, C20, C23, C24, C27, C32, C34, C35, C40)	72953	Cord—250' Drive Cord Reel (approx. 57" overall req'd)
73747	Capacitor—Electrolytic 2 mfd., 50 volts (C39)	75564	Coupling—Spring coupling for function switch extension shaft
77468	Capacitor—Tubular, paper, .0018 mfd., 600 volts (C8)	74839	Fastener—Push fastener to fasten RF shelf (4 req'd)
73795	Capacitor—Tubular, paper, .0038 mfd., 600 volts (C25)	16058	Grommet—Rubber grommet for mounting RF shelf (4 req'd)
73920	Capacitor—Tubular, paper, .0047 mfd., 600 volts (C30)	75548	Grommet—Rubber grommet for mounting slides (4 req'd)
72490	Capacitor—Tubular, paper, .005 mfd., 200 volts (C33, C38)	11765	Lamp—Dial lamp—Mazda 51
73561	Capacitor—Tubular, paper, .01 mfd., 400 volts (C29)	77311	Latch—Bottom cover latch
73797	Capacitor—Tubular, paper, .015 mfd., 600 volts (C22)	77486	Nut—Speed nut for latch adjustment screw
77469	Capacitor—Tubular, paper, .018 mfd., 200 volts (C21)	76421	Pin—Slide mechanism stop pin
73562	Capacitor—Tubular, paper, .022 mfd., 400 volts (C26)	72602	Pulley—Drive cord pulley
73558	Capacitor—Tubular, paper, .047 mfd., 200 volts (C19)	35641	Pulley—Drive cord pulley—1 3/8" dia.
73935	Clip—Mounting clip for I.F. transformer for 75558 & 76328		Resistor—Fixed, composition:—
77313	Coil—Antenna coil—FM (L1)	503039	39 ohms, ±10%, 1/2 watt (R3)
71942	Coil—Filament choke coil (L9, L10)	503068	68 ohms, ±10%, 1/2 watt (R21)
75569	Coil—Oscillator coil—AM—complete with adjustable core (L3, L4, L5)	503110	100 ohms, ±10%, 1/2 watt (R14, R34)
		503112	120 ohms, ±10%, 1/2 watt (R30)
		503139	390 ohms, ±10%, 1/2 watt (R12)
		503168	680 ohms, ±10%, 1/2 watt (R6, R25, R32)
		503210	1000 ohms, ±10%, 1/2 watt (R2)
		502212	1200 ohms, ±5%, 1/2 watt (R36)
		502233	3300 ohms, ±5%, 1/2 watt (R35)



RCA VICTOR

Radio Phonograph Combination

Model 2US7

Chassis No. RC-1117A, RC-1117C

SERVICE DATA

—1952 No. 3—



FOR RECORD CHANGER SERVICE INFORMATION—REFER TO 930409 SERIES SERVICE DATA.

PREPARED BY RCA SERVICE CO., INC.

FOR

RADIO CORPORATION OF AMERICA
RCA VICTOR DIVISION
CAMDEN, N. J., U. S. A.

SPECIFICATIONS

Tuning Range 540 - 1600 kc.

Intermediate Frequency 455 kc.

Tube Complement

- | | |
|--------------|-------------------------|
| 1. RCA 12BE6 | Converter |
| 2. RCA 12BA6 | I.F. Amplifier |
| 3. RCA 6AQ6 | Detector—A.F. Amplifier |
| 4. RCA 6AQ6 | Phase Inverter |
| 5. RCA 35C5 | } Push Pull Output |
| 6. RCA 35C5 | |
- A selenium rectifier Stock #76871 is used.

Power Supply Rating

- 115 volts A.C., 60 cycles
(uses 930409-5 or -10 Changer) 45 watts
- 115 volts A.C., 50 cycles
(uses 930409-11 Changer) 45 watts

Dial Lamps (2) Mazda type 51, 6-8 volts, 0.2 amp.

Loudspeaker

Size and type 5" x 7" P.M.
Voice coil impedance 3.2 ohms at 400 cycles

Power Output

Undistorted 2.0 watts
Maximum 2.4 watts

Cabinet Dimensions

Height 10" Width 16 3/4" Depth 20 3/4"

Tuning Drive Ratio 14 1/4:1 (7 1/8 turns of knob)

Record Changer (930409-5, -10 or -11)

Turntable speed 33 1/3, 45 or 78 r.p.m.
Record capacity ... up to fourteen 7 inch RCA type
or twelve 10 inch
or ten 12 inch
or ten 10 in. and 12 in. intermixed.

Pickup (Stock No. 75475) ... Crystal with replaceable styli.

Weight 26 lbs. net

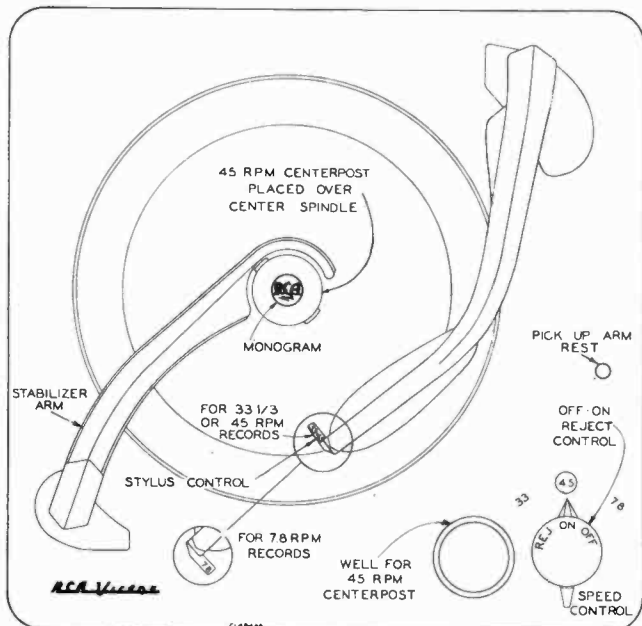

Record Changer Controls

RECORD CHANGER CONTROLS

The record changer has a dual control on the motorboard and a stylus selector control on the pickup arm. The inner control (circular knob) is the OFF-ON-REJECT control. Turning this knob to the center position energizes the motor and starts the turntable, when turned to the right (clockwise) it starts the mechanism into complete automatic operation. The mechanism will shut off automatically after the last record has been played but can be shut off manually by turning this knob to the left (counter-clockwise).

The outer control (double ended lever) is the speed control. It has three normal positions, "33", "45", "78" to select the turntable speed desired and a neutral position (midway between "45" and "78"). The control should be turned to this neutral position if the changer is not expected to be in use for an extended period of time.

The stylus control has two normal positions (right and left) and one shipping position (lever pointing up). When playing 33 1/3 or 45 r.p.m. records the lever is turned so that "33-45" is visible on the TOP of the lever; likewise for 78 r.p.m. records "78" should be visible on the TOP.

The removable centerpost is for use with 45 r.p.m. records having the large centerhole. It must be placed over the center spindle with the "RCA" trademark monogram FACING to the FRONT. When not in use it is placed in a well at the front of the motorboard.

To load or remove records, the record stabilizer is lifted and turned off-side. After loading it is turned to the center where it rests on top of the stack of records.

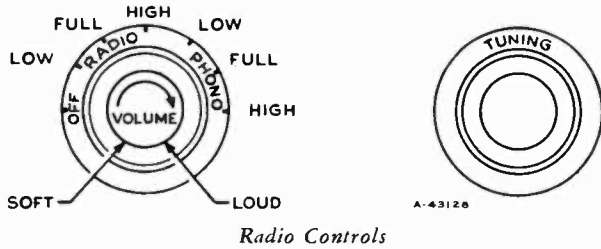

Service Hints

All tubes, except the 12BE6, are accessible for testing by lifting up one side of the cabinet and removing the tubes from the rear chassis apron. To service the 12BE6 tube and the pilot lights, remove the four wood screws holding the sloping panel at the front of the record changer compartment. This panel also holds the loop antenna.

To remove the radio chassis for service, first remove the push-on type knobs. Secure the record changer pickup arm to the center post and rest the cabinet on its side. Remove loop antenna connections, and pickup arm audio plug. Hook-on connectors are used to connect a.c. power from the radio chassis to the phono motor. These connectors are covered by taped-over black insulating sleeves located in one corner of the cabinet. Push back sleeves and unhook. Remove the four flat-head wood screws holding the chassis mounting board to the bottom of the cabinet. Slide chassis out of cabinet, then remove the three 1/4 inch hex head self-tapping screws holding the chassis to the panel.

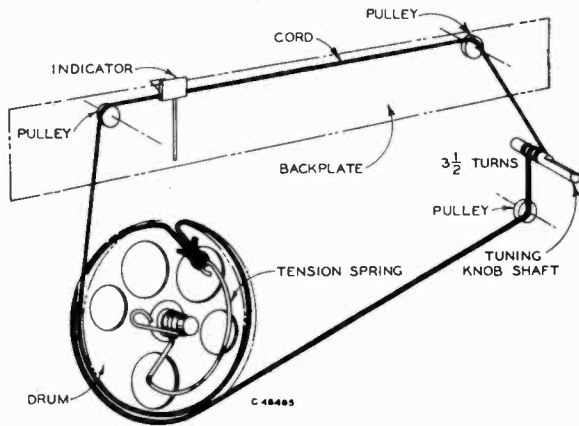

Dial Cord Layout

Alignment Procedure

Output Meter.—Connect meter across speaker voice coil. Turn volume control to maximum.

Test Oscillator.—Connect low side of test oscillator to common wiring in series with a .1 mf. capacitor. If the test oscillator is a.c. operated it may be necessary to use an isolation transformer for the receiver during alignment and the low side of the test oscillator connected directly to common wiring at the electrolytic capacitor. Keep the oscillator output low to prevent a-v-c action.

Steps	Connect the high side of test-oscillator to—	Tune test-osc. to—	Turn radio dial to—	Adjust the following for max. output
1	I.F. grid, in series with .1 mfd.	455 kc	Quiet point 1,600 kc end of dial	Pri. & Sec. 2nd I.F. transformer
2	Converter grid in series with .1 mfd.			Pri. & Sec. 1st I.F. transformer
NOTE.—ANTENNA LOOP AND RECORD CHANGER MUST BE IN CABINET FOR THE FOLLOWING				
3	Short wire placed near loop for radiated signal	1,620 kc	Extreme R. H. end (gang open)	C1B-T (osc.)
4		1,400 kc	1,400 kc	C5 (ant.)
5		600 kc	600 kc Signal	L3 (Rock Gang)
6	Repeat steps 3, 4 & 5 if necessary			

Critical Lead Dress

1. Dress C15 (.022 mfd. at grid of phase inverter) over tube socket away from filament leads.
2. Keep all filament leads close to chassis.
3. Keep leads of R26 (270 ohms at I-F amplifier cathode) short as possible.
4. Connect outside foil of all capacitors as indicated in schematic diagram.
5. Dress output plate bypasses, C19 and C20, as near chassis as possible.

Dial Pointer Adjustment.—Rotate tuning condenser fully counterclockwise (plates fully meshed). Adjust indicator pointer so that it is 3 15/16" from the left hand edge of the dial back plate.

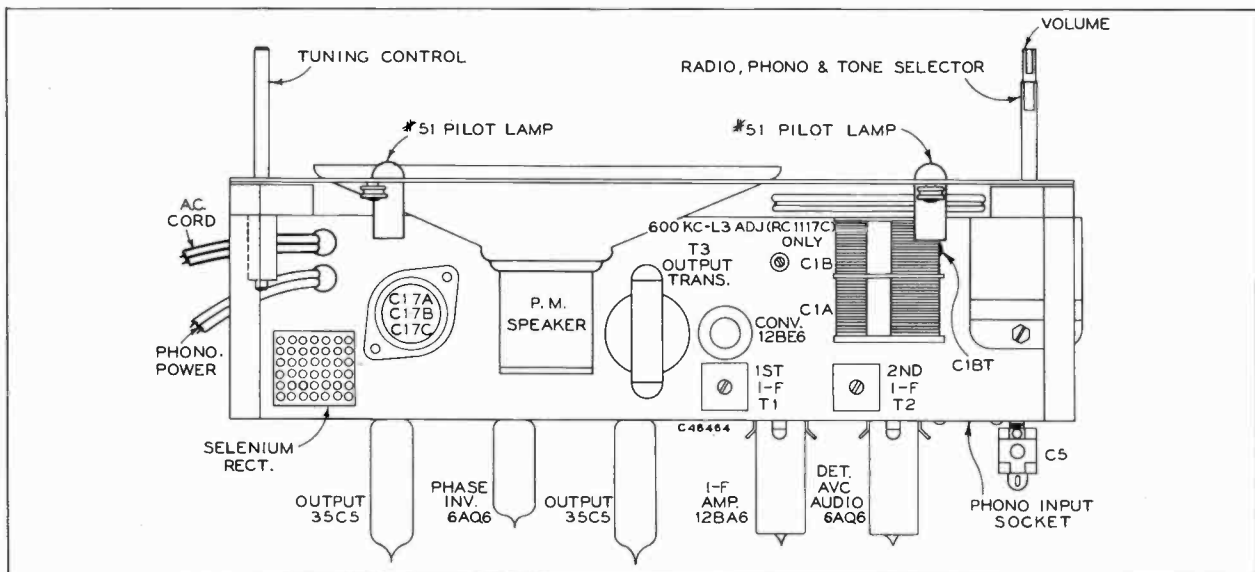

Tube and Trimmer Locations

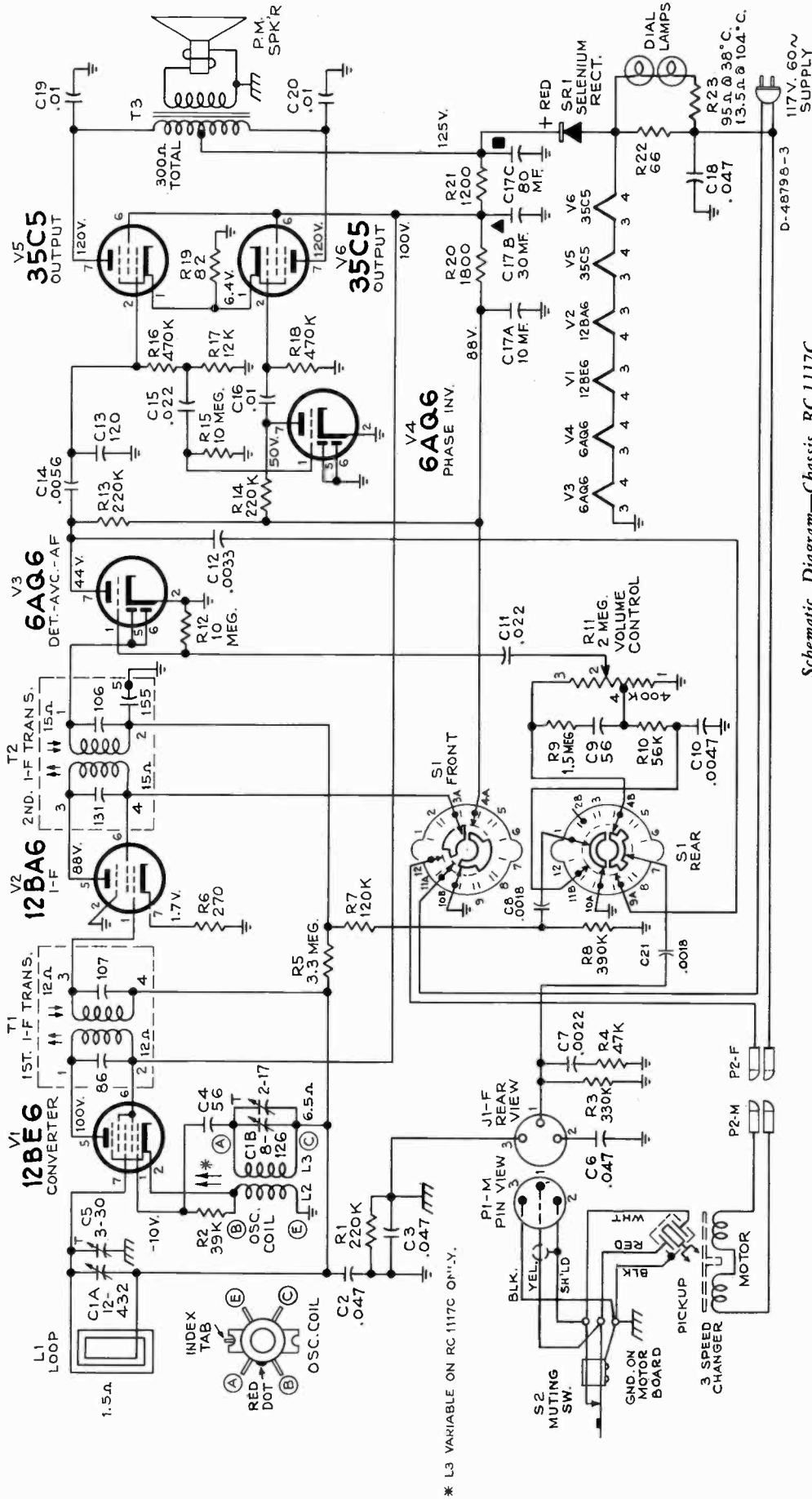

Schematic Diagram—Chassis RC 1117C

K = 1000
RESISTANCES IN OHMS.
CAPACITANCES LESS THAN 1
IN MF. AND ABOVE 1 IN MMF.
UNLESS OTHERWISE NOTED.

FUNCTION SW. S1 VIEWED FROM
FRONT, AND SHOWN IN POSITION NO.1
(MAX. COUNTER CLOCKWISE).
POS. 1 - OFF.
2 - RADIO - MIN. HIGHS
3 - " - " - NORMAL
4 - " - " - MAX. HIGHS
5 - PHONO - MIN. HIGHS
6 - " - " - NORMAL
7 - " - " - MAX. HIGHS

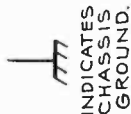

INDICATES COMMON
CHASSIS
WIRING INSULATED
FROM CHASSIS.

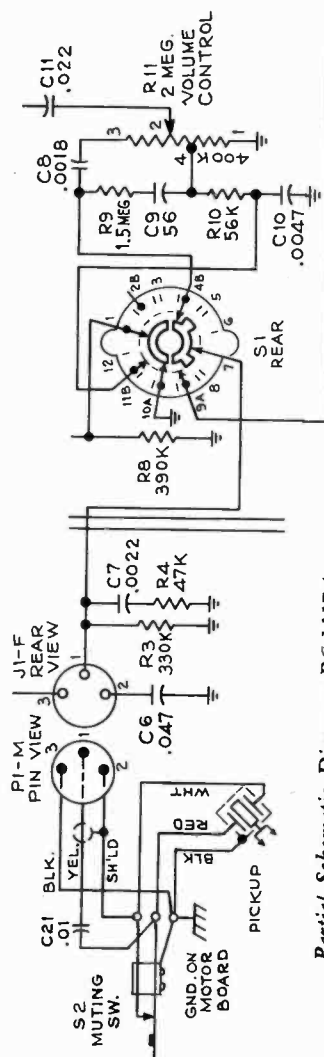

Partial Schematic Diagram RC-1117A

REPLACEMENT PARTS

STOCK No.	DESCRIPTION	STOCK No.	DESCRIPTION
	CHASSIS ASSEMBLIES RC1117A, RC1117C		
76867	Capacitor—Variable tuning capacitor complete with drive drum, C1A, C1B	503356	56,000 ohms, $\pm 10\%$, $\frac{1}{2}$ watt, R10
93603	Capacitor—Ceramic, 56 mmf., C9	503412	120,000 ohms, $\pm 10\%$, $\frac{1}{2}$ watt, R7
77116	Capacitor—Ceramic, 56 mmf., C4	504422	220,000 ohms, $\pm 20\%$, $\frac{1}{2}$ watt, R1, R13, R14
76347	Capacitor—Ceramic, 120 mmf., C13	503433	330,000 ohms, $\pm 10\%$, $\frac{1}{2}$ watt, R3
76872	Capacitor—Adjustable trimmer, 2.5—30 mmf., C5	503439	390,000 ohms, $\pm 10\%$, $\frac{1}{2}$ watt, R8
73013	Capacitor—Electrolytic comprising 1 section of 80 mfd., 150 volts, 1 section of 30 mfd., 150 volts and 1 section of 10 mfd., 150 volts, C17A, C17B, C17C	503447	470,000 ohms, $\pm 10\%$, $\frac{1}{2}$ watt, R16
73851	Capacitor—Tubular, paper, .0018 mfd., 1600 volts, C8, C21 (RC1117C only)	504447	470,000 ohms, $\pm 20\%$, $\frac{1}{2}$ watt, R18
73595	Capacitor—Tubular, paper, .0022 mfd., 600 volts, C7	503515	1.5 megohm, $\pm 10\%$, $\frac{1}{2}$ watt, R9
73795	Capacitor—Tubular, paper, .0033 mfd., 400 volts, C12	504533	3.3 megohm, $\pm 20\%$, $\frac{1}{2}$ watt, R5
73920	Capacitor—Tubular, paper, .0047 mfd., 600 volts, C10	504610	10 megohm, $\pm 20\%$, $\frac{1}{2}$ watt, R12, R15
73788	Capacitor—Tubular, paper, .0056 mfd., 400 volts, C14	76869	Shaft—Tuning knob shaft
73561	Capacitor—Tubular, paper, .01 mfd., 400 volts, C16, C19, C20	76870	Shield—Tube shield for V1, V2, V3
73562	Capacitor—Tubular, paper, .022 mfd., 400 volts, C11, C15	74697	Socket—Dial lamp socket
73553	Capacitor—Tubular, paper, .047 mfd., 400 volts, C2, C3, C6	51955	Socket—Tube socket, 7 pin, miniature, moulded, saddle-mounted
75071	Capacitor—Tubular, moulded paper, .047 mfd., 400 volts, C18	77115	Socket—Tube socket, 7 pin, miniature, moulded
76866	Coil—Oscillator coil without adjustable core L2, L3	76368	Spring—Drive cord spring
78586	Coil—Oscillator coil with adjustable core L2, L3	76873	Switch—Function switch less volume control, S1
74192	Connector—3 contact male connector for shielded pickup cable, P1	77113	Terminal—Phono lead assembly terminal (knife disconnect type)
77114	Connector—Single contact male connector for loop lead	74918	Transformer—First I.F. transformer complete with adjustable cores, T1
76874	Control—Volume control, R11	73037	Transformer—Second I.F. transformer complete with adjustable cores, T2
72953	Cord—250' Drive Cord Reel (approx. 54" required)	77122	Transformer—Output transformer, T3
70392	Cord—Power cord and plug	33726	Washer—"C" washer for tuning knob shaft (2 req'd)
74838	Grommet—Power cord strain relief (1 set)		SPEAKER ASSEMBLIES
72283	Grommet—Rubber grommet to mount variable tuning capacitor (3 req'd)	76875	Speaker—5" x 7" P.M. speaker complete with cone and voice coil (3.2 ohms)
11765	Lamp—Dial lamp—Mazda 51		MISCELLANEOUS
28452	Plate—Bakelite mounting plate for electrolytic	76876	Back—Cabinet back and antenna loop assembly (L1)
76865	Plate—Dial back plate complete with three (3) pulleys less dial	77350	Cable—Cable and Capacitor assembly (includes C21) (For RC1117A only)
76868	Pointer—Station selector pointer	74273	Decal—"Victrola" decal
76871	Rectifier—Selenium rectifier, SR1	76877	Dial—Polystyrene dial scale
73038	Resistor—Wire wound, 66 ohms, 5 watts, R22	76588	Emblem—"RCA Victor" emblem
73072	Resistor—Normal value, 95 ohms, @ 38°C with negative temperature coefficient R23	74225	Escutcheon—Dial escutcheon less dial
503082	Resistor—Fixed, composition: 82 ohms, $\pm 10\%$, $\frac{1}{2}$ watt, R19	76878	Escutcheon—Function switch escutcheon
503127	270 ohms, $\pm 10\%$, $\frac{1}{2}$ watt, R6	76879	Escutcheon—Tuning control escutcheon
513212	1200 ohms, $\pm 10\%$, 1 watt, R21	76895	Foot—Rubber foot (4 req'd)
503218	1800 ohms, $\pm 10\%$, $\frac{1}{2}$ watt, R20	72692	Hinge—Cabinet lid hinge
503312	12,000 ohms, $\pm 10\%$, $\frac{1}{2}$ watt, R17	76882	Knob—Function switch knob—light gray
503339	39,000 ohms, $\pm 10\%$, $\frac{1}{2}$ watt, R2	76881	Knob—Tuning control knob—(inner) light gray
503347	47,000 ohms, $\pm 10\%$, $\frac{1}{2}$ watt, R4	76883	Knob—Tuning control knob (outer)—light gray
		76880	Knob—Volume control knob—light gray
		71095	Nut—Speed nut to fasten dial escutcheon
		72765	Nut—Speed nut to fasten function switch or tuning control escutcheon
		76894	Nut—#10-32 spring nut for mounting stud
		30330	Spring—Retaining spring for volume control knob
		14270	Spring—Retaining spring for tuning control or function switch knobs
		76893	Stud—#10-32 x 1 $\frac{3}{4}$ " special stud to mount changer in cabinet (2 req'd)
		71824	Stud—Stud and screw (1 set) for cabinet lid hinge
		77221	Support—Lid Support

APPLY TO YOUR RCA DISTRIBUTOR FOR PRICES OF REPLACEMENT PARTS



RCA VICTOR

AC-DC Radio Receiver

Models 2X61, 2X62

Chassis No. RC-1080C RC-1080D

SERVICE DATA

— 1952 No. 9 —

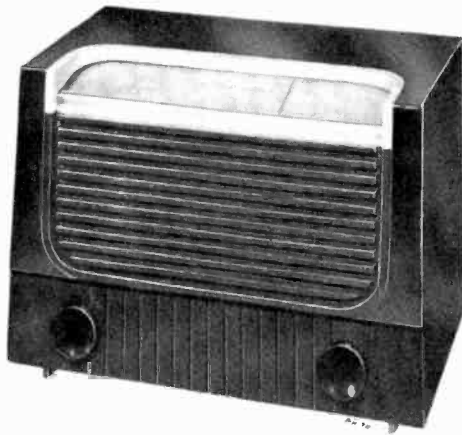

Model 2X61 Maroon

Model 2X62 Ivory

PREPARED BY RCA SERVICE CO., INC.

FOR

RADIO CORPORATION OF AMERICA

RCA VICTOR DIVISION

CAMDEN, N. J., U. S. A.

SPECIFICATIONS

Tuning Range	540—1600 kc
Intermediate Frequency	455 kc
Tube Complement	
(1) RCA 12SK7	R.F. Amplifier
(2) RCA 12SA7	Converter
(3) RCA 12SK7	I.F. Amplifier
(4) RCA 12SQ7	Det.-A.V.C.-A.F. Amp.
(5) RCA 35L6GT	Output
(6) RCA 35Z5GT	Rectifier
Power Supply Rating	
115 volts d. c. or 50 to 60 cycles a. c.	35 watts

Dial Lamp	2 Mazda type 1490, 3.2 volts, 0.15 amp.
Loudspeaker	
Size and type	4-in. P.M.
Voice coil impedance	3.2 ohms at 400 cycles
Power Output	
Undistorted	0.85 watt
Maximum	1.15 watts
Tuning Drive Ratio	8.5 to 1 (4¼ turns of knob)
Weight	8 lbs.
Cabinet Dimensions	
Height	8¾"
Width	11¾"
Depth	7½"

REPLACEMENT PARTS

STOCK No.	DESCRIPTION	STOCK No.	DESCRIPTION
CHASSIS ASSEMBLIES			
77143	RC 1080C—Model 2X61 RC 1080D—Model 2X62	503112	120 ohms, ±10%, ½ watt, R4, R11
77144	Antenna—Antenna loop and back cover assembly—maroon—for Model 2X61	503118	180 ohms, ±10%, ½ watt, R1
77143	Antenna—Antenna loop and back cover assembly—ivory—for Model 2X62	503127	270 ohms, ±10%, ½ watt, R15
77143	Back—Cabinet back cover and antenna loop assembly—maroon—for Model 2X61	513212	1200 ohms, ±10%, 1 watt, R12
77144	Back—Cabinet back cover and antenna loop assembly—ivory—for Model 2X62	503312	12,000 ohms, ±10%, ½ watt, R2
77145	Capacitor—Variable tuning capacitor complete with drive drum, C1, C2, C3, C4, C5, C6	503322	22,000 ohms, ±10%, ½ watt, R3
39042	Capacitor—Ceramic, 47 mmf., C8	503356	56,000 ohms, ±10%, ½ watt, R7
71924	Capacitor—Ceramic, 56 mmf., C9	503410	100,000 ohms, ±10%, ½ watt, R16
73501	Capacitor—Ceramic, 150 mmf., C12, C13	503422	220,000 ohms, ±10%, ½ watt, R5, R6
73473	Capacitor—Ceramic, 4700 mmf., C20	503447	470,000 ohms, ±10%, ½ watt, R10
74662	Capacitor—Electrolytic comprising 1 section of 80 mfd., 150 volts and 1 section of 50 mfd., 150 volts, C19A, C19B	503522	2.2 megohm, ±10%, ½ watt, R8
73595	Capacitor—Tubular, paper, .0022 mfd., 600 volts, C14	503547	4.7 megohm, ±10%, ½ watt, R9
73797	Capacitor—Tubular, paper, .015 mfd., 600 volts, C16	74691	Shaft—Tuning knob shaft
73562	Capacitor—Tubular, paper, .022 mfd., 400 volts, C15	74697	Socket—Dial lamp socket
73553	Capacitor—Tubular, paper, .047 mfd., 400 volts, C17, C18	54414	Socket—Tube socket
73551	Capacitor—Tubular, paper, 0.1 mfd., 400 volts, C10, C11	76368	Spring—Drive cord spring
73794	Capacitor—Tubular, paper, 0.22 mfd., 400 volts, C21	33634	Switch—"Radio-Phono" switch, S2
73935	Clip—Mounting clip for I.F. transformer	73036	Transformer—First I.F. transformer complete with adjustable cores, T1
74693	Coil—Oscillator coil complete with adjustable cores, L3, L4	73037	Transformer—Second I.F. transformer complete with adjustable cores, T2
73677	Coil—R.F. coil complete with adjustable cores, L1, L2	73976	Transformer—Output transformer, T3
35787	Connector—Phono input connector	35969	Washer—"C" washer for tuning knob shaft
75474	Connector—Single contact male connector for output transformer leads (2 req'd)	SPEAKER ASSEMBLIES	
38410	Control—Volume control and power switch, R14, S1	76391	Speaker—4" P.M. speaker complete with cone and voice coil (3.2 ohms)
72953	Cord—Drive cord (approx. 50" overall)	MISCELLANEOUS	
70392	Cord—Power cord and plug	Y2445	Cabinet—Plastic cabinet—maroon—complete with dial escutcheon for Model 2X61
73693	Grommet—Power cord strain relief (1 set)	Y2446	Cabinet—Plastic cabinet—ivory—complete with dial escutcheon for Model 2X62
72283	Grommet—Rubber grommet for mounting tuning capacitor	77146	Dial—Polystyrene dial scale
77142	Pointer—Station selector pointer	77241	Escutcheon—Dial escutcheon
72602	Pulley—Drive cord pulley	74931	Knob—Control knob—maroon—for Model 2X61
514033	Resistor—Fixed, composition:—33 ohms, ±20%, 1 watt, R13	72645	Knob—Control knob—ivory—for Model 2X62
		71116	Lamp—Dial lamp—Mazda 1490
		74301	Screw—#8 x ¾" binder head screw (cross recessed) for mounting dial
		30900	Spring—Retaining spring for knobs

† Stock No. 72953 is a reel containing 250 feet of cord.

APPLY TO YOUR RCA DISTRIBUTOR FOR PRICES OF REPLACEMENT PARTS

NOTE.—If reception is not obtained on d. c. operation, reverse plug in outlet receptacle. On a. c. operation this may reduce hum.

The position of the speaker is adjustable; the correct position is indicated on the illustration "Tube and Trimmer Locations."

ALIGNMENT PROCEDURE

Cathode Ray Alignment is the preferable method. Connections for the oscilloscope are shown on the schematic diagram.

Output Meter Alignment.—If this method is used, connect the meter across the voice coil and turn the receiver volume control to maximum.

Test Oscillator.—Connect low side of test oscillator to common wiring in series with a .1 mf. capacitor. If the test oscillator is a. c. operated it may be necessary to use an isolation transformer for the receiver during alignment and the low side of the test oscillator connected directly to common wiring at the electrolytic capacitor. Keep the oscillator output low to prevent a-v-c action.

Step	Connect high side of sig. gen. to—	Sig. gen. output	Turn radio dial to—	Adjust for peak output
1	Pin No. 4 of 12SK7 (V3 I.F.)	455 kc	Quiet point near 600 kc	Top and bottom cores of T2
2	Pin No. 8 of 12SA7 (V2 conv.)	1620 kc	Gang open	Top and bottom cores of T1
3	"External Antenna" terminal through 100 mmf. capacitor	1400 kc	1400 kc signal	C6 Osc. C5 R.F. C4 Ant.
4		Shunt C5 with 22,000 ohm resistor		L4 Osc. (Rock gang)
5		600 kc	600 kc	
6		Remove 22,000 ohm resistor from C5		L2 R.F.
7	Repeat steps 4, 5 and 6			

The position of the loop antenna in relation to the chassis affects adjustment of C4. The correct position is indicated on the illustration "Tube and Trimmer Locations."

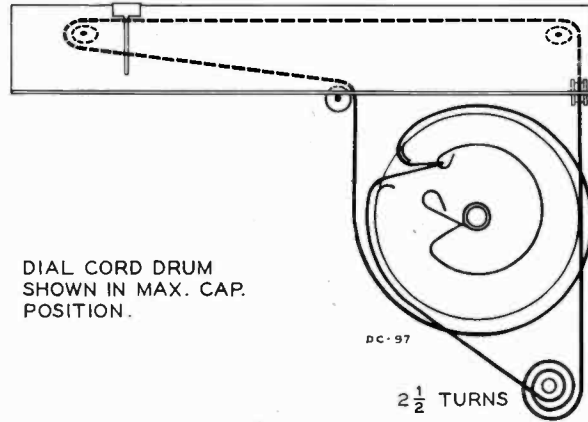

DIAL CORD DRUM SHOWN IN MAX. CAP. POSITION.

Dial Indicator and Drive Mechanism

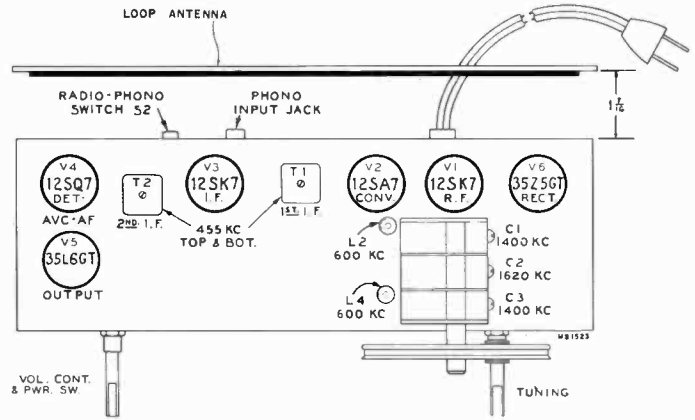

Tube and Trimmer Locations

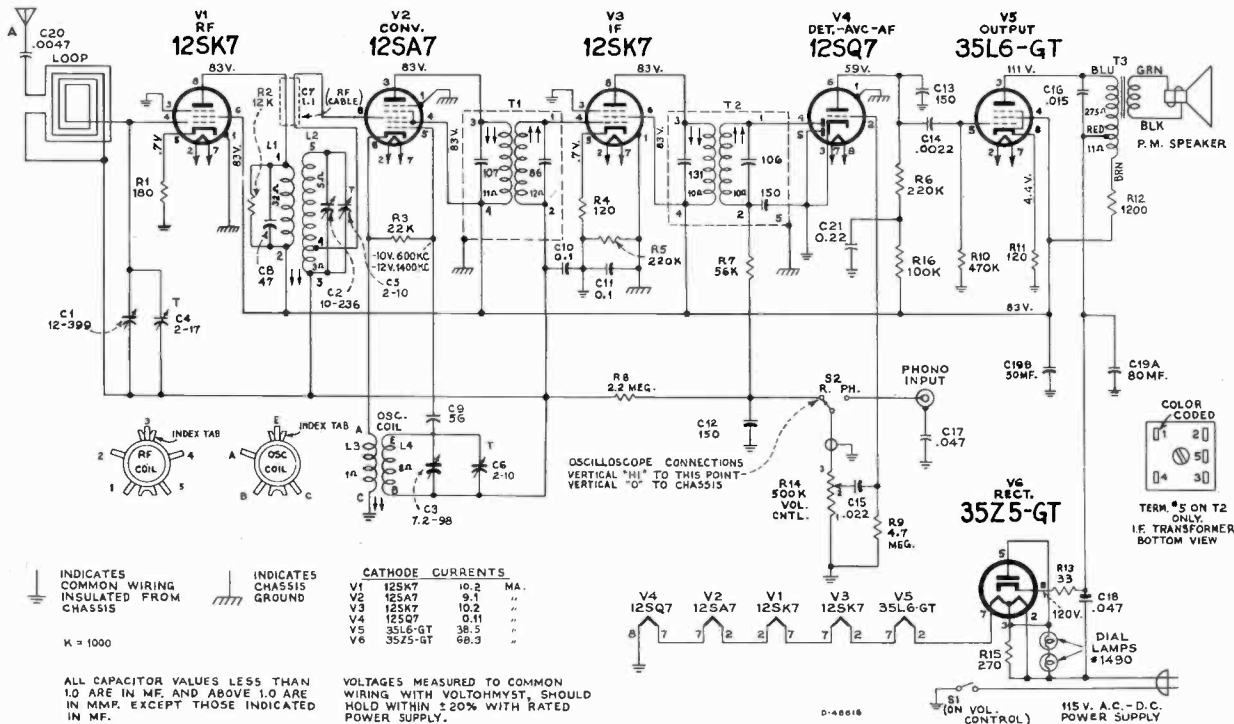

Schematic Diagram



RCA VICTOR

AC-DC Radio Receiver

MODEL 2-X-621

Chassis No. RC-1085B

SERVICE DATA

— 1952 No. 11 —

PREPARED BY RCA SERVICE CO., INC.
FOR

RADIO CORPORATION OF AMERICA
RCA VICTOR DIVISION
CAMDEN, N. J., U. S. A.



Specifications

Tuning Ranges

Standard Broadcast ("A" Band)..... 540-1600 kc
Short Wave ("C" Band)..... 5.8-18.0 mc

Intermediate Frequency 455 kc

Tube Complement

- (1) RCA 12BA6 R. F. Amplifier
- (2) RCA 12BE6 Converter
- (3) RCA 12BA6 I. F. Amplifier
- (4) RCA 12SQ7 Det. - A.F. - A.V.C.
- (5) RCA 35L6GT Output
- (6) RCA 35Z5 Rectifier

Dial Lamp 2 Type 1490, 3.2 volts, 0.15 amp.

Power Supply Rating

115 volts, D.C. or 50 to 60 cycles, A.C..... 35 watts

Loudspeaker

Type 971495-9W 4 in. P.M.
V. C. Impedance..... 3.2 ohms at 400 cycles

Power Output

Undistorted 0.85 watts
Maximum 1.2 watts

Weight

..... 8 lbs.

Cabinet Dimensions

Height...8 $\frac{3}{8}$ in. Width...11 $\frac{3}{4}$ in. Depth...7 $\frac{1}{2}$ in.

Tuning Drive Ratio.....11:1 (5 $\frac{1}{2}$ turns of knob)

NOTE: If reception is not obtained on DC, reverse plug in outlet receptacle. This may also reduce hum on AC operation.

Operating Instructions

Radio—Turn power on with POWER-VOLUME control and set about half-way for volume. Set the FUNCTION Control for the type of program desired and allow 30 to 40 second warm-up period when the dial will be fully illuminated.

Tune in desired station with TUNING Control making slow and careful setting in conjunction with volume control for Short Wave reception. Make final setting of VOLUME control to suit requirements.

Phonograph Operation—Plug in record changer attachment to phono socket on lower chassis apron. Set FUNCTION switch to "PH" (phono) position. Adjust VOLUME control for listening requirements.

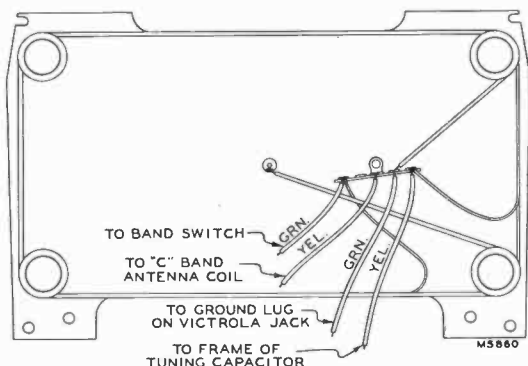

Loop Antenna Leads

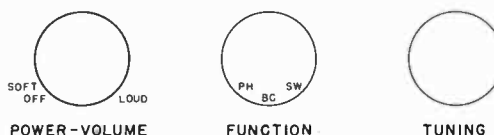
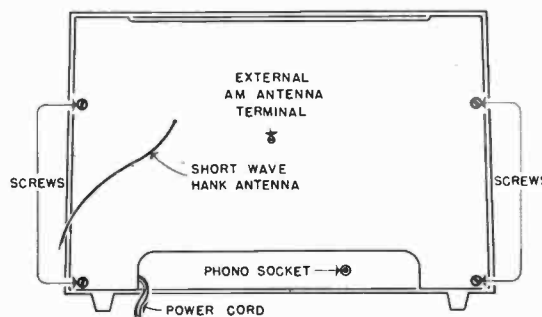

Radio Controls

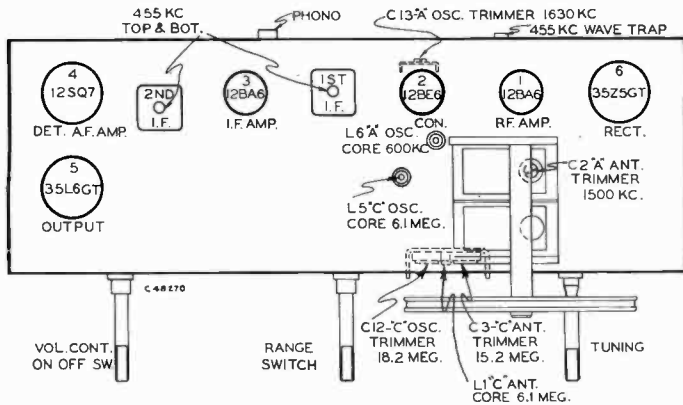

Tube and Trimmer Locations

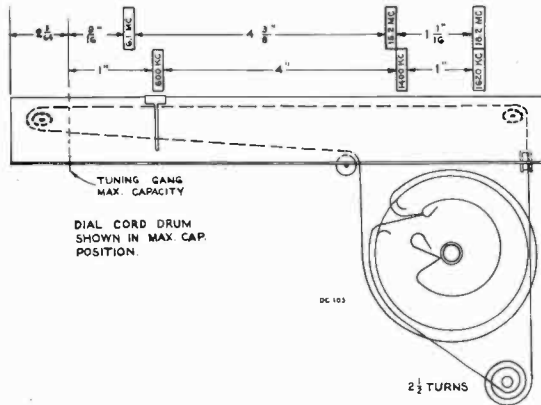

Dial Indicator and Drive Mechanism

ALIGNMENT PROCEDURE

Steps	Connect the High Side of The Test Osc. to—	Tune Test Osc. to—	Range Switch to—	Turn Radio Dial to—	Adjust for maximum output
1	Pin No. 1 of 12BA6 I.F. amp. tube in series with 0.1 mfd.	455 kc.	"A"	Quiet Point near 1600 kc.	Top and bottom T2 2nd I.F. Trans.
2	Pin No. 7 of 12BE6 Converter tube in series with 0.1 mfd.				*Top and bottom T1 1st I.F. Trans.
3	Pin No. 1 of 12BA6 R.F. tube in series with 0.1 mfd.				L2 wave trap for minimum output.
4	(Radiated signal) short piece of wire placed near ant.	1620 kc.	"A"	1620 kc. (Cap. min.)	C-13 "A" Osc.
5		1400 kc.		1400 kc.	C-2 "A" ant.
6		600 kc.		600 kc.	L6 "A" Osc. Rocking gang.
7	Repeat steps 4, 5 and 6.				
8	Center terminal on loop antenna Term. board through 47 mfd. Low side to loop primary terminal	18.2 mc.	"C"	18.2 mc. (Min. cap.)	**C-12 "C" Osc.
9		15.2 mc.		15.2 mc.	***†C-3 "C" Ant.
10		6.1 mc.		6.1 mc.	††L-5 "C" Osc. L-1 "C" Ant.
11	Repeat steps 8, 9, and 10 as necessary.				

*Use 18K resistor across primary when aligning secondary, across secondary when aligning primary.

**Two peaks should be found, use one having lowest capacity.

***Two peaks should be found, use one having highest capacity. Note: Check for image frequencies.

†Radio dial tuned to 15.2 mc. as in step 9, tune test osc. to 16.11 mc. where a weaker signal should be heard.

††Radio dial tuned to 6.1 mc. as in step 10, tune test osc. to 7.01 mc. where a weaker signal should be heard.

Test Oscillator—Connect low side of test oscillator to common wiring in series with a .1 mf. capacitor. If the test oscillator is a. c. operated it may be necessary to use an isolation transformer for the receiver during alignment and the low side of the test oscillator connected directly to common wiring at the electrolytic capacitor. Keep the oscillator output low to prevent a-v-c action.

Output Meter Alignment—If this method is used, connect the meter across the voice coil and turn the receiver volume control to maximum.

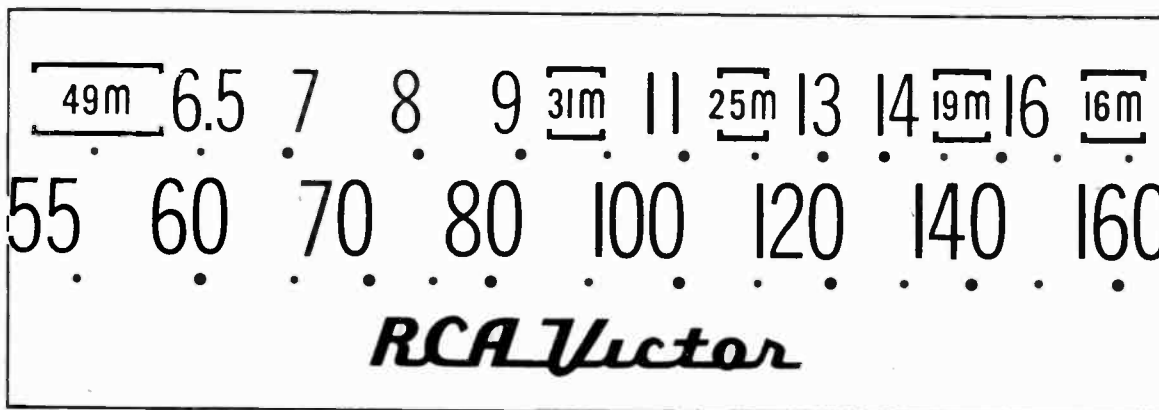

MAX. CAP.

Dial Scale Actual Size

CRITICAL LEAD DRESS

1. Dress all heater leads and pilot light leads down to chassis and away from all audio grid and plate wiring.
2. Dress all exposed leads away from each other and away from chassis to prevent short circuits.
3. Leads to loop antenna are long and draped to permit tube servicing by lowering loop back. They should be evenly spaced to maintain low capacity and dressed to prevent touching gang plates.
4. All R.F. leads to coils should be short and direct. Dress other leads and components away from coils.

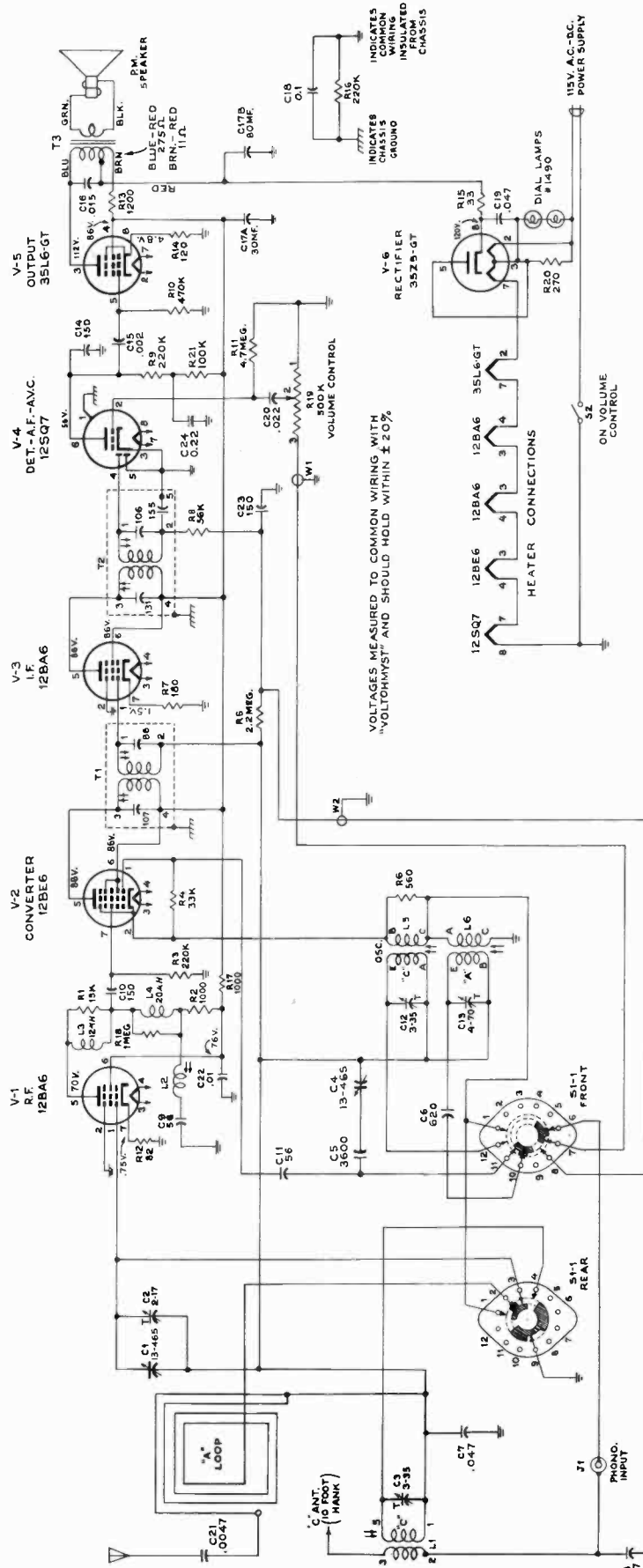

FRONT AND REAR SECTION OF S1-1 VIEWED FROM FRONT WITH THE CONTROL SHAFT IN EXTREME C/CLOCKWISE POSITION #1 (PHONO.)

POS.	S1-1 SEQUENCE	FUNCTION
1	PHONO.	
2	PHONO.	
3	PHONO.	
4	PHONO.	
5	PHONO.	

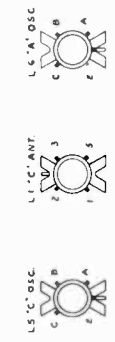

K=1000
ALL CAPACITANCE VALUES LESS THAN 1.0 ARE IN MF AND ABOVE 1.0 ARE IN MMF, EXCEPT THOSE INDICATED.

D-48923

Schematic Diagram—Chassis RC1085B

Replacement Parts

STOCK NO.	DESCRIPTION	STOCK NO.	DESCRIPTION
	CHASSIS ASSEMBLIES RC-1085B		Resistor—Fixed, composition:—
77217	Antenna—Antenna loop and back cover—maroon	514033	33 ohms, $\pm 20\%$, 1 watt R15
77217	Back—Cabinet back cover and antenna loop assembly—maroon	503082	82 ohms, $\pm 10\%$, $\frac{1}{2}$ watt R12
71042	Button—Plug button for trimmer adjustment hole	503112	120 ohms, $\pm 10\%$, $\frac{1}{2}$ watt R14
77216	Capacitor—Variable tuning capacitor complete with drive drum C1, C2, C4	503118	180 ohms, $\pm 10\%$, $\frac{1}{2}$ watt R7
74924	Capacitor—Mica trimmer, dual 3-35 mmf. C3, C12	503127	270 ohms, $\pm 10\%$, $\frac{1}{2}$ watt R20
74923	Capacitor—Mica trimmer, 4-70 mmf. C13	503156	560 ohms, $\pm 10\%$, $\frac{1}{2}$ watt R6
71924	Capacitor—Ceramic, 56 mmf. C9, C11	503210	1000 ohms, $\pm 10\%$, $\frac{1}{2}$ watt R2, R17
73501	Capacitor—Ceramic, 150 mmf. C10, C14, C23	513212	1200 ohms, $\pm 10\%$, 1 watt R13
38831	Capacitor—Mica, 620 mmf. C6	503333	33,000 ohms, $\pm 10\%$, $\frac{1}{2}$ watt R4
39665	Capacitor—Mica, 3600 mmf. C5	503356	56,000 ohms, $\pm 10\%$, $\frac{1}{2}$ watt R8
73473	Capacitor—Ceramic, 4700 mmf. C21	503410	100,000 ohms, $\pm 10\%$, $\frac{1}{2}$ watt R21
72312	Capacitor—Electrolytic comprising 1 section of 30 mfd., 150 volts and 1 section of 80 mfd., 150 volts C17A, C17B	503422	220,000 ohms, $\pm 10\%$, $\frac{1}{2}$ watt R3, R9, R16
73595	Capacitor—Tubular, paper, .0022 mfd., 600 volts ... C15	503447	470,000 ohms, $\pm 10\%$, $\frac{1}{2}$ watt R10
73561	Capacitor—Tubular, paper, .01 mfd., 400 volts ... C22	504522	2.2 megohm, $\pm 20\%$, $\frac{1}{2}$ watt R5
73797	Capacitor—Tubular, paper, .015 mfd., 600 volts ... C16	504547	4.7 megohm, $\pm 20\%$, $\frac{1}{2}$ watt R11
73562	Capacitor—Tubular, paper, .022 mfd., 400 volts ... C20	74922	Shaft—Tuning knob shaft
73553	Capacitor—Tubular, paper, .047 mfd., 400 volts C7, C8, C19	74697	Socket—Dial lamp socket
73551	Capacitor—Tubular, paper, 0.1 mfd., 400 volts ... C18	73117	Socket—Tube socket, 7 pin, miniature for V1, V2, V3
73794	Capacitor—Tubular, paper, 0.22 mfd., 400 volts ... C24	54414	Socket—Tube socket, octal, saddle-mounted for V4, V5, V6
73935	Clip—Mounting clip for I.F. transformer	76368	Spring—Drive cord spring
74927	Coil—Antenna coil—"C" band L1	74921	Switch—Selector switch S1
74925	Coil—Oscillator coil—"A" band—complete with adjustable core L6	74918	Transformer—First I.F. transformer complete with adjustable cores T1
74926	Coil—Oscillator coil—"C" band—complete with adjustable core L5	73037	Transformer—Second I.F. transformer complete with adjustable cores T2
74930	Coil—Peaking coil (12 muh.) L3, R1	73976	Transformer—Output transformer T3
72618	Coil—Peaking coil (20 muh.) L4, R18	35969	Washer—"C" washer for tuning knob shaft
74928	Coil—Series wavetrap coil (455 KC) complete with adjustable core L2		SPEAKER ASSEMBLIES 971495-9W
35787	Connector—Phono input connector J1	77218	Speaker—4" P.M. speaker complete with cone and voice coil (3.2 ohms)
75474	Connector—Single contact male connector for output transformer leads (2 req'd.)		MISCELLANEOUS
38410	Control—Volume control and power switch ... R19, S2	Y2447	Cabinet—Plastic cabinet—maroon—complete with dial escutcheon
72953	Cord—250' Drive Cord Reel (approx. 50" req'd.)	77220	Dial—Polystyrene dial scale
70392	Cord—Power cord and plug	77241	Escutcheon—Dial escutcheon
74838	Grommet—Power cord strain relief (1 set)	75761	Grommet—Rubber grommet for mounting speaker (4 req'd.)
33139	Grommet—Rubber grommet for chassis base	77219	Knob—Selector switch knob—maroon
16058	Grommet—Rubber grommet for mounting tuning capacitor	74931	Knob—Tuning control or volume control and power switch knob—maroon
70980	Lead—Antenna lead—"C" band	71116	Lamp—Dial lamp—Mazda 1490
77142	Pointer—Station selector pointer	74301	Screw—#8 x $\frac{3}{8}$ " cross recessed binder head screw for mounting dial
		30900	Spring—Retaining spring for knobs

APPLY TO YOUR RCA DISTRIBUTOR FOR PRICES OF REPLACEMENT PARTS



RCA VICTOR

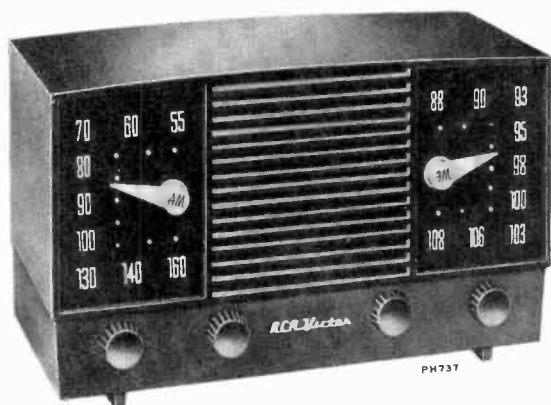

Model 2-XF-91 "Forbes"
Maroon

AM-FM Radio Receiver

MODEL 2-XF-91

Chassis No. RC1121

SERVICE DATA

— 1952 No. 16 —

PREPARED BY RCA SERVICE CO., INC.
FOR
RADIO CORPORATION OF AMERICA
RCA VICTOR DIVISION
CAMDEN, N. J., U. S. A.

SPECIFICATIONS

TUNING RANGE

Standard Broadcast (AM)..... 540-1600 kc
Frequency Modulation (FM)..... 88-108 mc
Intermediate Frequency (AM)..... 455 kc
Intermediate Frequency (FM)..... 10.7 mc

TUBE COMPLEMENT

- (1) RCA 6BJ6 R.F. Amplifier
 - (2) RCA 19X8 Mixer-Oscillator
 - (3) RCA 12BA6 I.F. Amplifier
 - (4) RCA 12AU6 FM I.F. Amplifier
 - (5) RCA 12AU6 FM I.F. Amplifier
 - (6) RCA 12AL5 F.M. Detector
 - (7) RCA 12AV6 AM Det.-AVC-Audio
 - (8) RCA 35C5 Audio Output
- RCA Stock No. 77519..... Selenium Rectifier

POWER SUPPLY RATING

115 volts, 50-60 cycles, or 115 volts d.c..... 35 watts

LOUDSPEAKER

Size and Type..... 5 1/4" P.M.
Voice Coil Impedance..... 3.2 ohms

AUDIO POWER OUTPUT

Undistorted 1.0 watt
Maximum 1.3 watts

TUNING DRIVE RATIO..... 9:1 (4 1/2 turns of knob)

NET WEIGHT..... 8 lbs.

DIMENSIONS (Overall)

Height..... 8 1/8" Width..... 13 9/16" Depth..... 7 3/4"

CIRCUIT DESCRIPTION

This instrument, an AM-FM table radio, has eight tubes, plus selenium rectifier. Individual dials are provided for AM and FM bands. RF circuits, contained on a two tube sub-chassis, include RF amplification for both bands and a combination mixer-oscillator circuit. The input circuit to the FM RF stage is broadbanded, and is tuned to the approximate FM band center at 100 mc. The mixer is pentode connected for AM operation; triode connected for FM operation. AM IF circuits use an IF amplifier and conventional diode detector with AVC. FM IF circuits include three IF amplifier stages and a discriminator detector. The two tube audio amplifier has an adjustable tone control circuit with combination bass and treble compensation. A hum-bucking circuit uses the tapped-winding output transformer. An inbuilt AM loop antenna, and line cord FM antenna, allow reception without the use of external antennas. A phono jack at the instrument rear permits the use of a record player attachment.

OPERATING INSTRUCTIONS

RADIO — Turn OFF-VOLUME control about half-way in a clockwise direction to turn receiver ON and provide for medium VOLUME. Allow a short warm-up period. Set FUNCTION control at desired service — AM or FM. Rotate TUNING control to move the pointers to the desired AM or FM frequency. Do not touch the pointers themselves. Adjust VOLUME and TONE controls as desired.

PHONOGRAPH — Connect attachment to PHONO jack at instrument rear. Switch the FUNCTION control to "PH" position. Turn on receiver and adjust VOLUME and TONE controls as desired.



Radio Controls

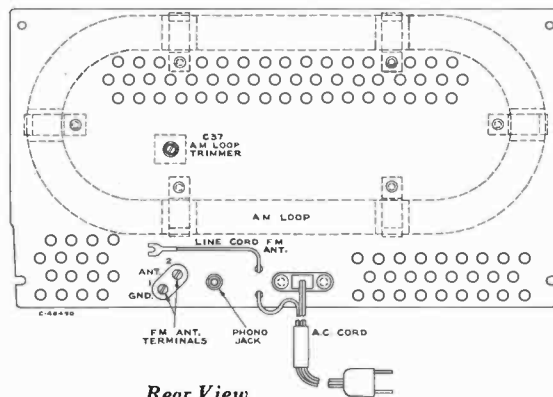

Rear View

2-XF-91

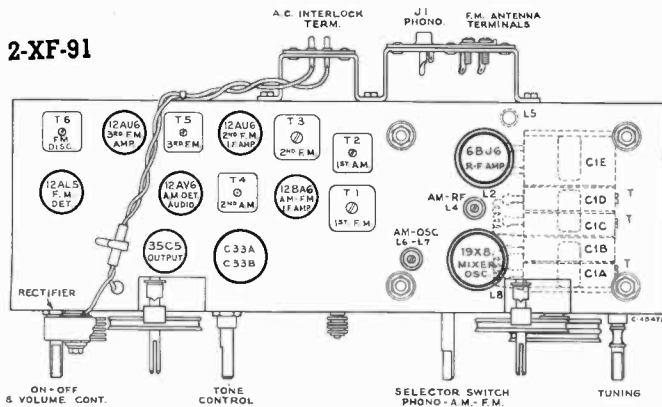

Tube and Trimmer Locations

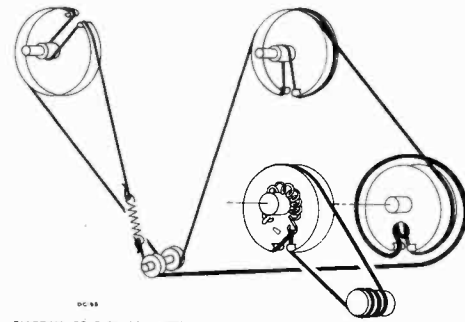

Dial and Drive Cord Drive

ALIGNMENT PROCEDURE

ALIGNMENT INDICATORS:

An RCA VoltOhmyst or equivalent meter is necessary for measuring developed d-c voltage during FM alignment. Connections are specified in the alignment tabulation. An output meter is also necessary to indicate maximum audio output during AM alignment. Connect the output meter across the speaker voice coil. The RCA VoltOhmyst can also be used as an AM alignment indicator, either to measure audio output or to measure AVC voltage. When audio output is being measured, the volume control should be turned to maximum. Adjust tone control to mid-position.

SIGNAL GENERATOR:

For all alignment operations, connect the low side of the signal generator to the receiver chassis. If output measurement is used for AM alignment, the output of the signal generator should be kept as low as possible to avoid AVC action.

If an FM sweep generator is used for FM alignment, adjust for 10.7 mc, 0.4 mc sweep. Connect oscilloscope across C26, adjusting discriminator T6 top core for 10.7 mc crossover, and T6 bottom core for balanced peaks. Peak separation should be approximately 330 kc. When aligning the other FM tuned circuits, connect oscilloscope lead through a 220K resistor to pin 1 of V5. Follow alignment table sequence, adjusting for maximum gain and symmetrical curves.

Tube Socket Voltages

Tube Type and Function	Tube Element	Pin No.	AM	FM	Phono
V1 6BJ6 R.F. Amp.	Plate	5	94	92	92
	Screen	6	94	92	92
	Cathode	2	0.7	0.9	0.5
	Grid	1	-0.5	0	-0.6
V2 19X8 Mixer	Plate	9	75	80	80
	Screen	8	75	80	80
	Cathode	6	0	0	0
	Grid	7	-1.6	-2.3	-2.3
Osc.	Plate	3	85	85.6	74
	Grid	2	-3.3	-3	-0.3
V3 12BA6 I.F. Amp.	Plate	5	94	92	90
	Screen	6	94	92.3	90
	Cathode	7	0.8	0.9	0.8
	Grid	1	-0.4	-0.2	-0.2
V4 12AU6 2nd I.F. Amp. (F.M.)	Plate	5	95	93.5	92
	Screen	6	95	94.1	92
	Cathode	7	0.8	0.8	0.8
	Grid	1	0	0	0
V5 12AU6 3rd I.F. Amp. (F.M.)	Plate	5	74	73	72
	Screen	6	74	73	72
	Cathode	7	0.3	0.3	0.4
	Grid	1	-0.2	-0.4	-0.2
V6 12AL5 F.M. Det.	Plate	2	—	—	—
	Cathode	5	—	—	—
	Plate	7	—	—	—
	Cathode	1	—	—	—
V7 12AV6 A.M. Det. Audio Amp.	Plate	7	58	57	57
	Grid	1	-0.8	-0.8	-0.8
	Plate	5	-0.5	-0.3	-0.3
	(Diode)	—	—	—	—
V8 35C5 Audio Output	Plate	7	130	130	130
	Screen	6	96	94.5	94.5
	Cathode	1	5.1	5.0	5.0
	Grid	2-5	—	—	—

Rectifier output should be approximately 139 volts, 70 ma.

AM Alignment

FUNCTION SWITCH IN AM POSITION

Steps	Connect high side of sig. gen. to—	Sig. gen. output	Turn radio dial to—	Adjust for peak output
1	Pin No. 1 of V3 in series with .01 mfd.	455 kc. (mod.)	Quiet point at high freq. end	T4 bottom core (sec.) T4 top core (pri.)
2	Tap lug 4 on AM RF coil			T2 bottom core (sec.) T2 top core (pri.)
3	Short wire placed near loop for radiated signal	1620 kc. (mod.)	1620 kc.	C1A-T (osc.)
4		1400 kc. (mod.)	1400 kc.	C37 (ant.) C1C-T (rf.)
5		600 kc. (mod.)	600 kc.	L6 (osc.) with 10,000 ohm resistor from C1C RF stator to gnd. (locking gang)
6				L4 (RF) with the 10,000 ohms removed
7		Repeat steps 4, 5 and 6 until maximum gain is obtained		

FM Alignment

FUNCTION SWITCH IN FM POSITION—VOLUME CONTROL MINIMUM—TONE CONTROL CENTER

Steps	Connect high side of sig. gen. to—	Sig. gen. output	Turn radio dial to—	Adjust for max. output		
1	Pin No. 1 of V5-12AU6	10.7 mc.	Quiet point at low frequency end	T6 top core for zero d.c. (across C26) T6 bottom core for maximum d.c. (junction of R24 and R25)		
2	Pin No. 1 of V4-12AU6			†T5 top core		
3	Pin No. 1 of V3-12BA6			T3 top core †T3 bottom core		
4	C1D Stator	90 mc.	90 mc.	T1 top core †T1 bottom core		
5	FM Ant. terminals thru 270 ohm resistor			†FM osc. L8		
6				106 mc.	106 mc.	†FM R.F. C1D-T
7				90 mc.	90 mc.	†FM R.F. L2
8		Repeat steps 6 and 7 until maximum gain is obtained				
9		100 mc.	100 mc.	†FM Ant. coil L5		

*If necessary for accurate peaking, the winding in the same transformer not being peaked should be loaded with a 680 ohm resistor.
†Connect VoltOhmyst to pin 1 of V5 through a 220K isolating resistor with ¼ inch maximum exposed lead at grid terminal end. Output adjusted for 1 volt d.c. Dress VoltOhmyst lead away from input circuits.

Oscillator frequency is above signal frequency on both AM and FM

CRITICAL LEAD DRESS

1. All FM IF Transformer grid and plate leads should be short and direct as possible and kept low, near chassis.
2. C26 leads should be kept as short as possible.
3. C32 leads should be kept as short as possible.
4. R24 and R25 leads should be kept as short as possible on T6 terminal 6 side.
5. T6 should ground in hole near terminal 5 of V6 with short leads.
6. AM oscillator coil should not be tilted over toward function switch when wrapping short bus leads to switch.
7. Keep leads V5 pin 5, to T6 term 1, as short as possible and low near chassis.
8. Dress C28 down on chassis and against terminal board. Run filament lead between V5 and V6 on side of V6 socket opposite C28.
9. All ceramic button 4700 uuf condensers should have leads as short as possible.
10. Green lead from AM oscillator stator gang terminal to AM oscillator coil should be dressed against front of shield box and up above filament choke.
11. RF plate choke L1, should be dressed at least 1/8" away from AM R.F. coil L4 and at least 1/8" from shield.
12. Mixer grid condenser C7 should be dressed away from FM oscillator gang stator terminal and away from leads connecting to terminals 8 and 9 of V2 socket.
13. Filament chokes L10 and L11 should be raised a minimum of 1/16" above chassis.
14. Use varnished tubing only on choke and coupling cond. leads coming through shield partition slot.
15. Condenser C2 should have lead on antenna terminal end not more than 3/16" long to prevent possible contact of lead or body to "Hot" chassis.
16. Condensers C3 and C35 should use varnished tubing, not vinyl, to prevent breakthrough crossing chassis edge.
17. Oscillator grid condenser C17 should have short leads and be dressed away from filament choke L10.
18. Leads from loop terminal to chassis terminal board should have a minimum of three twists.

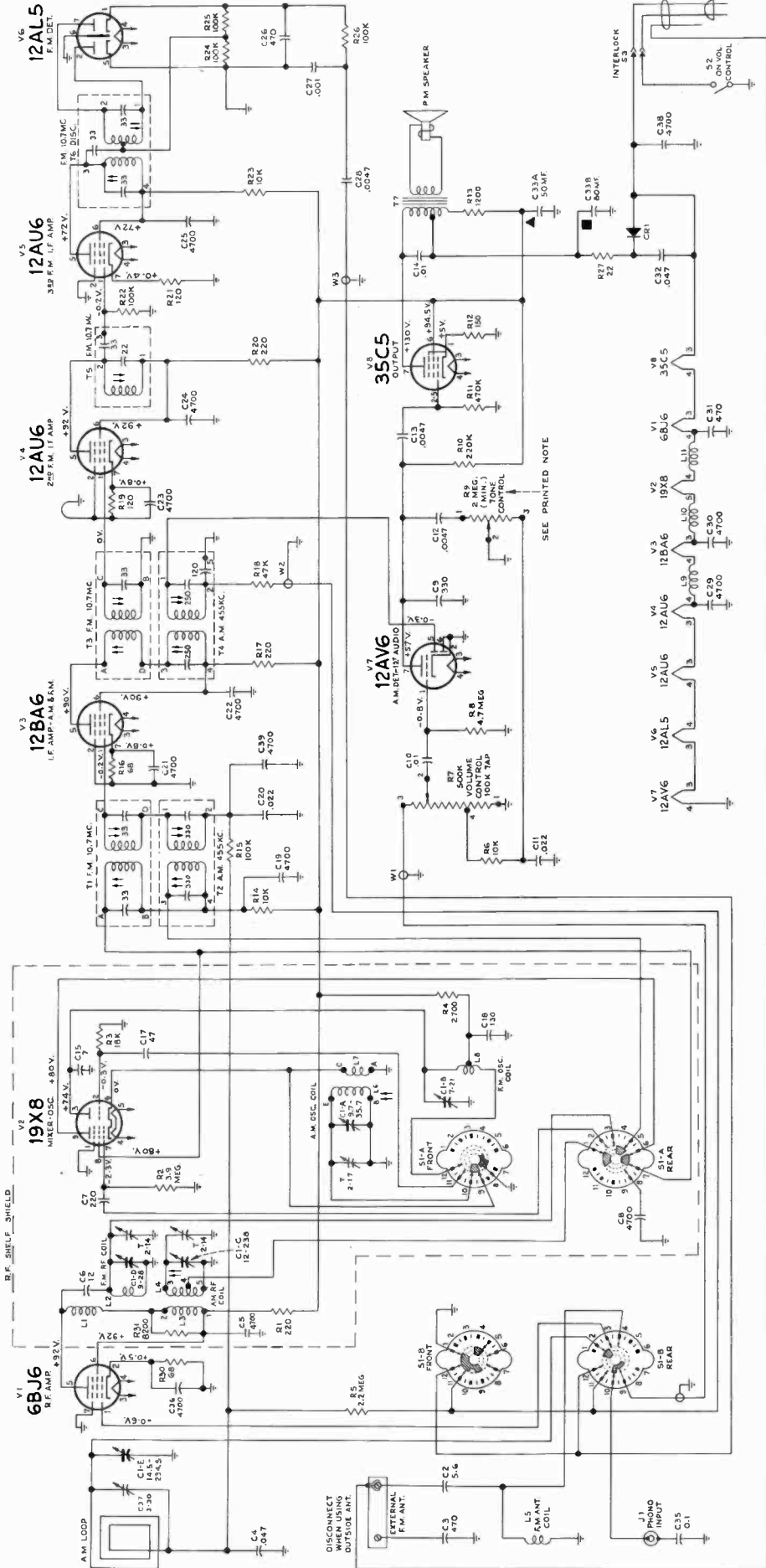

NOTES:
 FRONT AND REAR SECTIONS OF FUNCTION SWITCH S1-A AND S1-B
 POSITION 1 - A.M.
 POSITION 2 - PHONO
 POSITION 3 - F.M.
 COUNTER-CLOCKWISE POSITION #1 (PHONO)
 POSITION 1 - A.M.
 POSITION 2 - PHONO
 POSITION 3 - F.M.

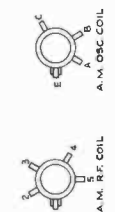

SEE PRINTED NOTE
 K = 1000
 ALL RESISTANCE VALUES IN OHMS AND ALL CAPACITANCE VALUES LESS THAN 1.0 IN MUF AND ABOVE 1.0 IN MMUF, UNLESS OTHERWISE NOTED.
 Acceptable value of R9 may be 2 to 50 megohms.

Schematic Circuit Diagram—Chassis No. RC1121

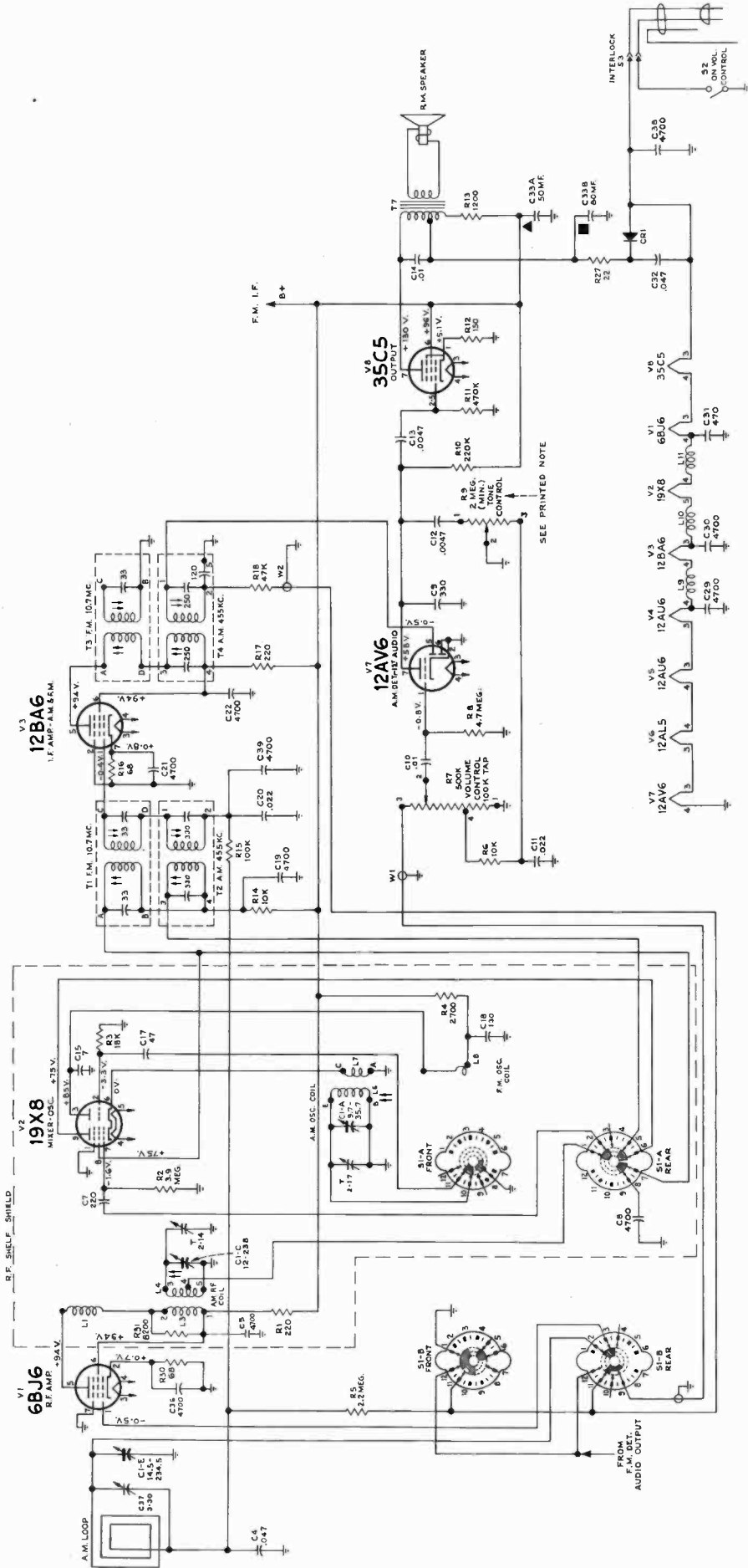

NOTES:
 FRONT AND REAR SECTIONS OF FUNCTION SWITCH S1-A AND S1-B ARE VIEWED FROM FRONT WITH THE SWITCH SHAFT IN EXTREME COUNTER-CLOCKWISE POSITION #1 (PHONO)
 POSITION
 1 PHONO
 2 A.M.
 3 F.M.

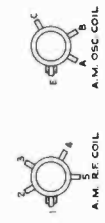

ALL RESISTANCE VALUES IN OHMS AND ALL CAPACITANCE VALUES LESS THAN 1.0 IN MF. AND ABOVE 1.0 IN MMF. UNLESS OTHERWISE NOTED.

EE 47933-1

Simplified Schematic—"AM" Position

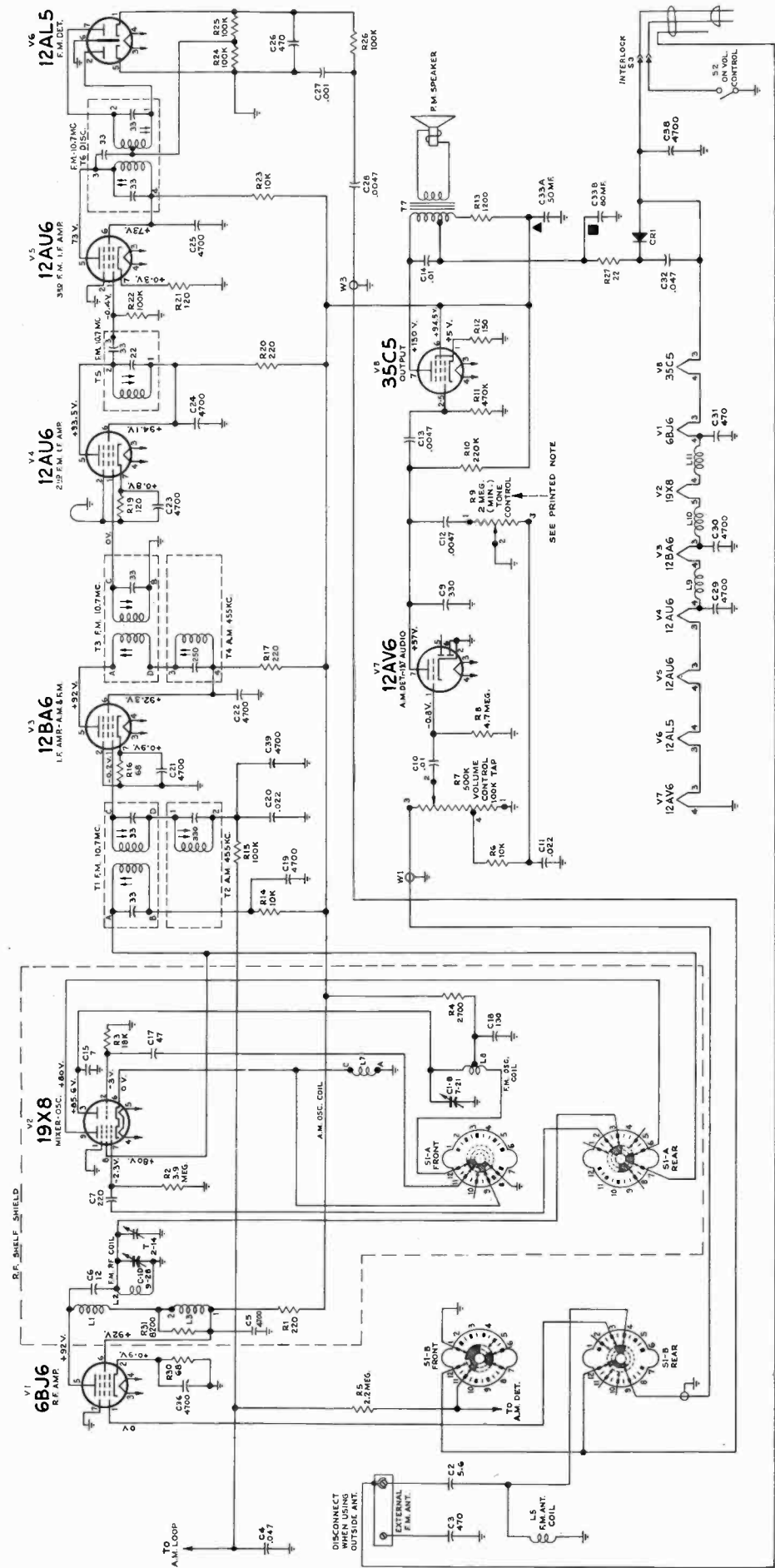

EE-47933-1

K-1000
ALL RESISTANCE VALUES IN OHMS AND ALL CAPACITANCE VALUES LESS THAN 1.0 IN M.F. AND ABOVE 1.0 IN MMF. UNLESS OTHERWISE NOTED.

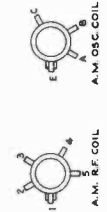

Simplified Schematic—"FM" Position

NOTES:
FRONT AND REAR SECTIONS OF FUNCTION SWITCH S1-A AND S1-B ARE VIEWED FROM FRONT WITH THE SWITCH SHAFT IN EXTREME COUNTER-CLOCKWISE POSITION #1 (PHONO)
FUNCTION POSITION
1 PHONO
2 A.M.
3 F.M.

REPLACEMENT PARTS

STOCK No.	PART DESCRIPTION	STOCK No.	PART DESCRIPTION
	CHASSIS ASSEMBLIES RC1121	77519	Rectifier—Selenium rectifier, 100 MA (CR1)
		76346	Resistor—Wire wound, 1200 ohms, 4 watts (R13)
77520	Bushing—Laminated bushing (5/8" long with shoulder) for station selector pointer pulley and shaft assembly.	503022	Resistor—Fixed, composition: 22 ohms, ±10%, 1/2 watt (R27)
77522	Capacitor—Variable tuning capacitor (C1A, C1B, C1C, C1D, C1E, C1A-T, C1C-T, C1D-T)	503068	68 ohms, ±10%, 1/2 watt (R16, R30)
70997	Capacitor—Fixed, ceramic, non-insulated, 5.6 mmf., ±1 mmf., 500 volts D.C. Temp. coef. = 0 (C2)	503112	120 ohms, ±10%, 1/2 watt (R19, R21)
77530	Capacitor—Fixed, ceramic, non-insulated, 7 mmf., ±.5 mmf., 500 volts D.C. Temp. coef. = 80 (C15)	503115	150 ohms, ±10%, 1/2 watt (R12)
33380	Capacitor—Fixed, ceramic, non-insulated, 12 mmf., ±5%, 500 volts D.C. Temp. coef. = 0 (C6)	503122	220 ohms, ±10%, 1/2 watt (R1, R17, R20)
77531	Capacitor—Fixed, ceramic, non-insulated, 47 mmf., ±10%, 500 volts D.C. Temp. coef. = 0 (C17)	503227	2700 ohms, ±10%, 1/2 watt (R4)
77532	Capacitor—Fixed, ceramic, non-insulated, 130 mmf., ±2 1/2%, 500 volts D.C. Temp. coef. = -750 (C18)	503282	8200 ohms, ±10%, 1/2 watt (R31)
39636	Capacitor—Fixed, mica, 220 mmf., 500 volts D.C. (C7)	503310	10,000 ohms, ±10%, 1/2 watt (R6, R14, R23)
75792	Capacitor—Fixed, ceramic, insulated, 330 mmf., ±20%, 500 volts D.C. High K (C9)	503318	18,000 ohms, ±10%, 1/2 watt (R3)
76992	Capacitor—Fixed, mica, 470 mmf., 300 volts D.C. (C26, C31)	503347	47,000 ohms, ±10%, 1/2 watt (R18)
39644	Capacitor—Fixed, mica, 470 mmf., 500 volts D.C. (C3)	502410	100,000 ohms, ±5%, 1/2 watt (R24, R25)
73473	Capacitor—Fixed, ceramic, 4700 mmf., +100%, -0%, 500 volts D.C. High K disc (C5, C8, C19, C21, C22, C23, C24, C25, C29, C30, C36, C38, C39)	503410	100,000 ohms, ±10%, 1/2 watt (R15, R22, R26)
73520	Capacitor—Electrolytic comprising 1 section of 80 mfd., 150 volts and 1 section of 50 mfd., 150 volts (C33A, C33B)	503422	220,000 ohms, ±10%, 1/2 watt (R10)
77533	Capacitor—Fixed, miniature, tubular, paper, .001 mfd., 200 volts D.C. (C27)	503447	470,000 ohms, ±10%, 1/2 watt (R11)
73920	Capacitor—Fixed, tubular, paper, .0047 mfd., 600 volts (C12, C13, C28)	503522	2.2 megohm, ±10%, 1/2 watt (R5)
73561	Capacitor—Fixed, tubular, paper, .01 mfd., 400 volts (C10)	503539	3.9 megohm, ±10%, 1/2 watt (R2)
73594	Capacitor—Fixed, tubular, paper, .01 mfd., 600 volts (C14)	503547	4.7 megohm, ±10%, 1/2 watt (R8)
73562	Capacitor—Fixed, tubular, paper, .022 mfd., 400 volts (C11)	77527	Shaft—Tuning knob shaft
73558	Capacitor—Fixed, tubular, paper, .047 mfd., 200 volts (C4)	75192	Shield—Tube shield for V1
75071	Capacitor—Fixed, tubular, moulded, .047 mfd., 400 volts (C32)	76331	Shield—Tube shield for V2
73551	Capacitor—Fixed, tubular, paper, 0.1 mfd., 400 volts (C35)	77087	Socket—Tube socket, 7 pin, miniature, moulded, saddle mounted for V1
73935	Clip—Mounting clip for I.F. transformers	76336	Socket—Tube socket, 9 pin, miniature, moulded, saddle mounted for V2
77538	Coil—Antenna coil—F.M. (L5)	73117	Socket—Tube socket, 7 pin, miniature, wafer for V3, V4, V5, V6, V7, V8
77534	Coil—Choke coil (L1)	31970	Spring—Dial cord spring
77535	Coil—Choke coil (L9, L10, L11)	31418	Spring—Drive cord spring
77526	Coil—Oscillator coil—A.M.—complete with adjustable core (L6, L7)	77524	Switch—Function switch (S1)
77537	Coil—Oscillator coil—F.M. (L8)	77517	Transformer—Output transformer (T7)
77525	Coil—RF coil—A.M.—complete with adjustable core (L3, L4)	77511	Transformer—Ratio detector transformer—complete with adjustable cores (T6)
77536	Coil—RF coil—F.M. (L2)	76335	Transformer—First I.F. transformer—A.M.—complete with adjustable cores (T2)
77528	Connector—Combination phono input connector and antenna terminal board (J1)	77514	Transformer—First I.F. transformer—F.M.—complete with adjustable cores (T1)
75474	Connector—Single contact male connector for speaker lead	76328	Transformer—Second I.F. transformer—A.M.—complete with adjustable cores (T4)
77529	Connector—Two (2) contact male connector for power cord	77513	Transformer—Second I.F. transformer—F.M.—complete with adjustable cores (T3)
77516	Control—Tone control (R9)	77512	Transformer—Third I.F. transformer—F.M.—complete with adjustable cores (T5)
77515	Control—Volume control and power switch (R7, S2)	33726	Washer—"C" washer for station selector pointer pulley and shaft or tuning knob shaft
72953	250' Dial Cord Reel—Dial cord (approx. 49" overall required)	34373	Washer—"C" washer to fasten idler pulleys
77523	Drive cord (approx. 11" overall required)		SPEAKER ASSEMBLIES 971933-1
77523	Drum—Variable tuning capacitor drive drum and hub	77539	Speaker—5 1/4" P.M. speaker complete with cone and voice coil (3.2 ohms)
16058	Grommet—Rubber grommet for mounting RF shelf (4 required)		MISCELLANEOUS
77521	Nut—Speednut for station selector pointer pulley and shaft bushing	77543	Antenna—Antenna loop and back assembly complete with power cord (includes C37)
72602	Pulley—Idler pulley for indicator cord (2 required)	77543	Back—Cabinet back complete with loop, capacitor and power cord (includes C37)
77510	Pulley—Pulley and shaft (split) for station selector pointers	Y2467	Cabinet—Maroon plastic cabinet less "RCA Victor" emblem and function decal
		77544	Capacitor—Adjustable, mica trimmer, 3-30 mmf. (C37)
		77545	Cord—Power cord and plugs
		77542	Decal—Control function decal
		77033	Emblem—"RCA Victor" emblem
		77548	Knob—Function switch knob
		77547	Knob—Tuning control, tone control or volume control and power switch knob
		73203	Nut—Speednut to fasten "RCA Victor" emblem to cabinet.
		77541	Pointer—Station selector pointer—A.M.
		77540	Pointer—Station selector pointer—F.M.
		73992	Retainer—Knob retainer (knob to cabinet)
		76837	Spring—Retaining spring for knobs (knob to shaft)

APPLY TO YOUR RCA DISTRIBUTOR FOR PRICES OF REPLACEMENT PARTS



RCA VICTOR

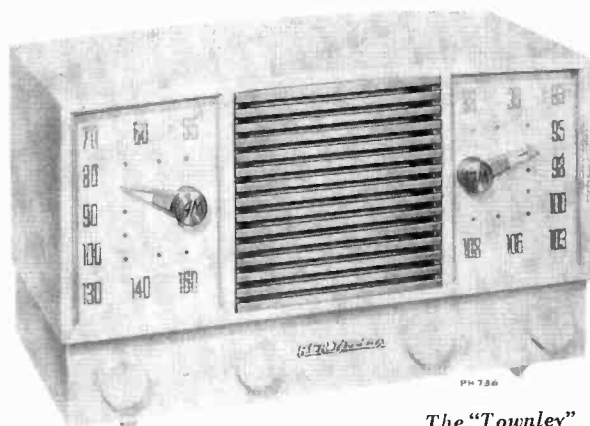

The "Townley"

2-XF-931
Maroon

2-XF-932
Ivory

2-XF-933
Green

2-XF-934
Red

2-XF-935
Beige

AM-FM Radio Receiver
2-XF-931 SERIES
Chassis No. RC1121A
SERVICE DATA
— 1952 No. 17 —

PREPARED BY RCA SERVICE CO., INC.
FOR
RADIO CORPORATION OF AMERICA
RCA VICTOR DIVISION
CAMDEN, N. J., U. S. A.

SPECIFICATIONS

TUNING RANGE

Standard Broadcast (AM)	540-1600 kc
Frequency Modulation (FM)	88-108 mc
Intermediate Frequency (AM)	455 kc
Intermediate Frequency (FM)	10.7 mc

TUBE COMPLEMENT

(1) RCA 6BJ6	R.F. Amplifier
(2) RCA 19X8	Mixer-Oscillator
(3) RCA 12BA6	I.F. Amplifier
(4) RCA 12AU6	FM I.F. Amplifier
(5) RCA 12AU6	FM I.F. Amplifier
(6) RCA 12AL5	F.M. Detector
(7) RCA 12AV6	AM Det.-AVC Audio
(8) RCA 35C5	Audio Output
RCA Stock No. 77519	Selenium Rectifier

CIRCUIT DESCRIPTION

This instrument, an AM-FM table radio, has eight tubes, plus selenium rectifier. Individual dials are provided for AM and FM bands. RF circuits, contained on a two tube sub-chassis, include RF amplification for both bands and a combination mixer-oscillator circuit. The input circuit to the FM RF stage is broadbanded, and is tuned to the approximate FM band center at 100 mc. The mixer is pentode connected for AM operation; triode connected for FM operation. AM IF circuits use an IF amplifier and conventional diode detector with AVC. FM IF circuits include three IF amplifier stages and a discriminator detector. The two tube audio amplifier has an adjustable tone control circuit with combination bass and treble compensation. A hum-bucking circuit uses the tapped-winding output transformer. An inbuilt AM loop antenna, and line cord FM antenna, allow reception without the use of external antennas. A phono jack at the instrument rear permits the use of a record player attachment.



Radio Controls

POWER SUPPLY RATING

115 volts, 50-60 cycles.....35 watts

CAUTION: DO NOT OPERATE ON D.C.

DIAL LAMPS..... 2 No. 47, 6-8 volts, 0.15 amp.

LOUDSPEAKER

Size and Type.....5 $\frac{1}{4}$ " P.M.
Voice Coil Impedance.....3.2 ohms

AUDIO POWER OUTPUT

Undistorted.....1.0 watt
Maximum.....1.3 watts

TUNING DRIVE RATIO.....9:1 (4 $\frac{1}{2}$ turns of knob)

NET WEIGHT.....8 lbs.

DIMENSIONS (Overall)

Height.....8 $\frac{1}{8}$ " Width.....13 $\frac{9}{16}$ " Depth.....7 $\frac{3}{4}$ "

OPERATING INSTRUCTIONS

RADIO — Turn OFF-VOLUME control about half-way in a clockwise direction to turn receiver ON and provide for medium VOLUME. Allow a short warm-up period. Set FUNCTION control at desired service — AM or FM. Rotate TUNING control to move the pointers to the desired AM or FM frequency. Adjust VOLUME and TONE controls as desired.

PHONOGRAPH — Connect attachment to PHONO jack at instrument rear. Switch the FUNCTION control to "PH" position. Turn on receiver and adjust VOLUME and TONE controls as desired.

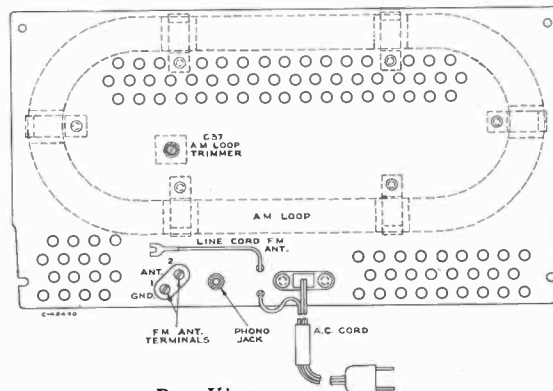

Rear View

2-XF-931 Series

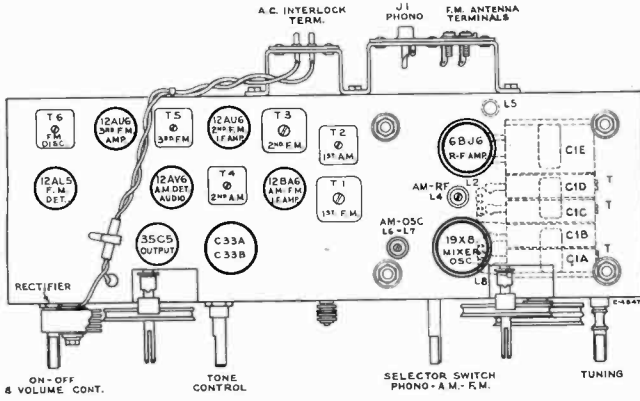

Tube and Trimmer Locations

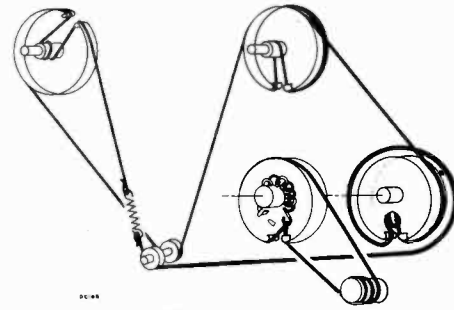

DIAGRAM OF DIAL CORD WITH GANG IN EXTREME COUNTER-CLOCKWISE POSITION (PLATES CLOSED)

Dial and Drive Cord Drive

ALIGNMENT PROCEDURE

ALIGNMENT INDICATORS:

An RCA VoltOhmyst or equivalent meter is necessary for measuring developed d-c voltage during FM alignment. Connections are specified in the alignment tabulation. An output meter is also necessary to indicate maximum audio output during AM alignment. Connect the output meter across the speaker voice coil. The RCA VoltOhmyst can also be used as an AM alignment indicator, either to measure audio output or to measure AVC voltage. When audio output is being measured, the volume control should be turned to maximum. Adjust tone control to mid-position.

SIGNAL GENERATOR:

For all alignment operations, connect the low side of the signal generator to the receiver chassis. If output measurement is used for AM alignment, the output of the signal generator should be kept as low as possible to avoid AVC action.

If an FM sweep generator is used for FM alignment, adjust for 10.7 mc, 0.4 mc sweep. Connect oscilloscope across C26, adjusting discriminator T6 top core for 10.7 mc crossover, and T6 bottom core for balanced peaks. Peak separation should be approximately 330 kc. When aligning the other FM tuned circuits, connect oscilloscope lead through a 220K resistor to pin 1 of V5. Follow alignment table sequence, adjusting for maximum gain and symmetrical curves.

Tube Socket Voltages

Tube Type and Function	Tube Element	Pin No.	AM	FM	Phono
V1 6BJ6 R.F. Amp.	Plate	5	94	92	92
	Screen	6	94	92	92
	Cathode	2	0.7	0.9	0.5
	Grid	1	-0.5	0	-0.6
V2 19X8 Mixer	Plate	9	75	80	80
	Screen	8	75	80	80
	Cathode	6	0	0	0
	Grid	7	-1.6	-2.3	-2.3
Osc.	Plate	3	85	85.6	74
	Grid	2	-3.3	-3	-0.3
V3 12BA6 I.F. Amp.	Plate	5	94	92	90
	Screen	6	94	92.3	90
	Cathode	7	0.8	0.9	0.8
	Grid	1	-0.4	-0.2	-0.2
V4 12AU6 2nd I.F. Amp. (F.M.)	Plate	5	95	93.5	92
	Screen	6	95	94.1	92
	Cathode	7	0.8	0.8	0.8
	Grid	1	0	0	0
V5 12AU6 3rd I.F. Amp. (F.M.)	Plate	5	74	73	72
	Screen	6	74	73	72
	Cathode	7	0.3	0.3	0.4
	Grid	1	-0.2	-0.4	-0.2
V6 12AL5 F.M. Det.	Plate	2	—	—	—
	Cathode	5	—	—	—
	Plate	7	—	—	—
V7 12AV6 A.M. Det. Audio Amp.	Plate	7	58	57	57
	Grid	1	-0.8	-0.8	-0.8
	Plate	5	-0.5	-0.3	-0.3
V8 35C5 Audio Output	Plate	7	130	130	130
	Screen	6	96	94.5	94.5
	Cathode	1	5.1	5.0	5.0
	Grid	2-5	—	—	—

Rectifier output should be approximately 139 volts, 70 ma.

AM Alignment
FUNCTION SWITCH IN AM POSITION

Steps	Connect high side of sig. gen. to—	Sig. gen. output	Turn radio dial to—	Adjust for peak output
1	Pin No. 1 of V3 in series with .01 mfd.	455 kc. (mod.)	Quiet point at high freq. end	T4 bottom core (sec.) T4 top core (pri.)
2	Tap lug 4 on AM RF coil			T2 bottom core (sec.) T2 top core (pri.)
3	Short wire placed near loop for radiated signal	1620 kc. (mod.)	1620 kc.	C1A-T (osc.)
4		1400 kc. (mod.)	1400 kc.	C37 (ant.) C1C-T (rf.)
5		600 kc. (mod.)	600 kc.	L6 (osc.) with 10,000 ohm resistor from C1C RF stator to gnd. (rocking gang)
6				L4 (RF) with the 10,000 ohms removed
7	Repeat steps 4, 5 and 6 until maximum gain is obtained			

FM Alignment
FUNCTION SWITCH IN FM POSITION—VOLUME CONTROL MINIMUM—TONE CONTROL CENTER

Steps	Connect high side of sig. gen. to—	Sig. gen. output	Turn radio dial to—	Adjust for max. output
1	Pin No. 1 of V5-12AU6	10.7 mc.	Quiet point at low frequency end	T6 top core for zero d.c. (across C26) T6 bottom core for maximum d.c. (junction of R24 and R25)
2				+T5 top core
3				T3 top core +T3 bottom core
4	C1D Stator			T1 top core +T1 bottom core
5	FM Ant. terminals thru 270 ohm resistor	90 mc.	90 mc.	+FM osc. L8
6		106 mc.	106 mc.	+FM R.F. C1D-T
7		90 mc.	90 mc.	+FM R.F. L2
8		Repeat steps 6 and 7 until maximum gain is obtained		
9		100 mc.	100 mc.	+FM Ant. coil L5

*If necessary for accurate peaking, the winding in the same transformer not being peaked should be loaded with a 680 ohm resistor. †Connect VoltOhmyst to pin 1 of V5 through a 220K isolating resistor with 1/4 inch maximum exposed lead at grid terminal end. Output adjusted for 1 volt d.c. Dress VoltOhmyst lead away from input circuits. Oscillator frequency is above signal frequency on both AM and FM

CRITICAL LEAD DRESS

1. All FM IF Transformer grid and plate leads should be short and direct as possible and kept low, near chassis.
2. C26 leads should be kept as short as possible.
3. C32 leads should be kept as short as possible.
4. R24 and R25 leads should be kept as short as possible on T6 terminal 6 side.
5. C27 should ground in hole near terminal 5 of V6 with short leads.
6. AM oscillator coil should not be tilted over toward function switch when wrapping short bus leads to switch.
7. Keep leads V5 pin 5, to T6 term 1, as short as possible and low near chassis.
8. Dress C28 down on chassis and against terminal board. Run filament lead between V5 and V6 on side of V6 socket opposite C28.
9. All ceramic button 4700 uuf condensers should have leads as short as possible.
10. Green lead from AM oscillator stator gang terminal to AM oscillator coil should be dressed against front of shield box and up above filament choke.
11. RF plate choke L1, should be dressed at least 1/8" away from AM R.F. coil L4 and at least 1/8" from shield.
12. Mixer grid condenser C7 should be dressed away from FM oscillator gang stator terminal and away from leads connecting to terminals 8 and 9 of V2 socket.
13. Filament chokes L10 and L11 should be raised a minimum of 1/16" above chassis.
14. Use varnished tubing only on choke and coupling cond. leads coming through shield partition slot.
15. Condenser C2 should have lead on antenna terminal end not more than 3/16" long to prevent possible contact of lead or body to "Hot" chassis.
16. Condensers C3 and C35 should use varnished tubing, not vinyl, to prevent breakthrough crossing chassis edge.
17. Oscillator grid condenser C17 should have short leads and be dressed away from filament choke L10.
18. Leads from loop terminal to chassis terminal board should have a minimum of three twists.

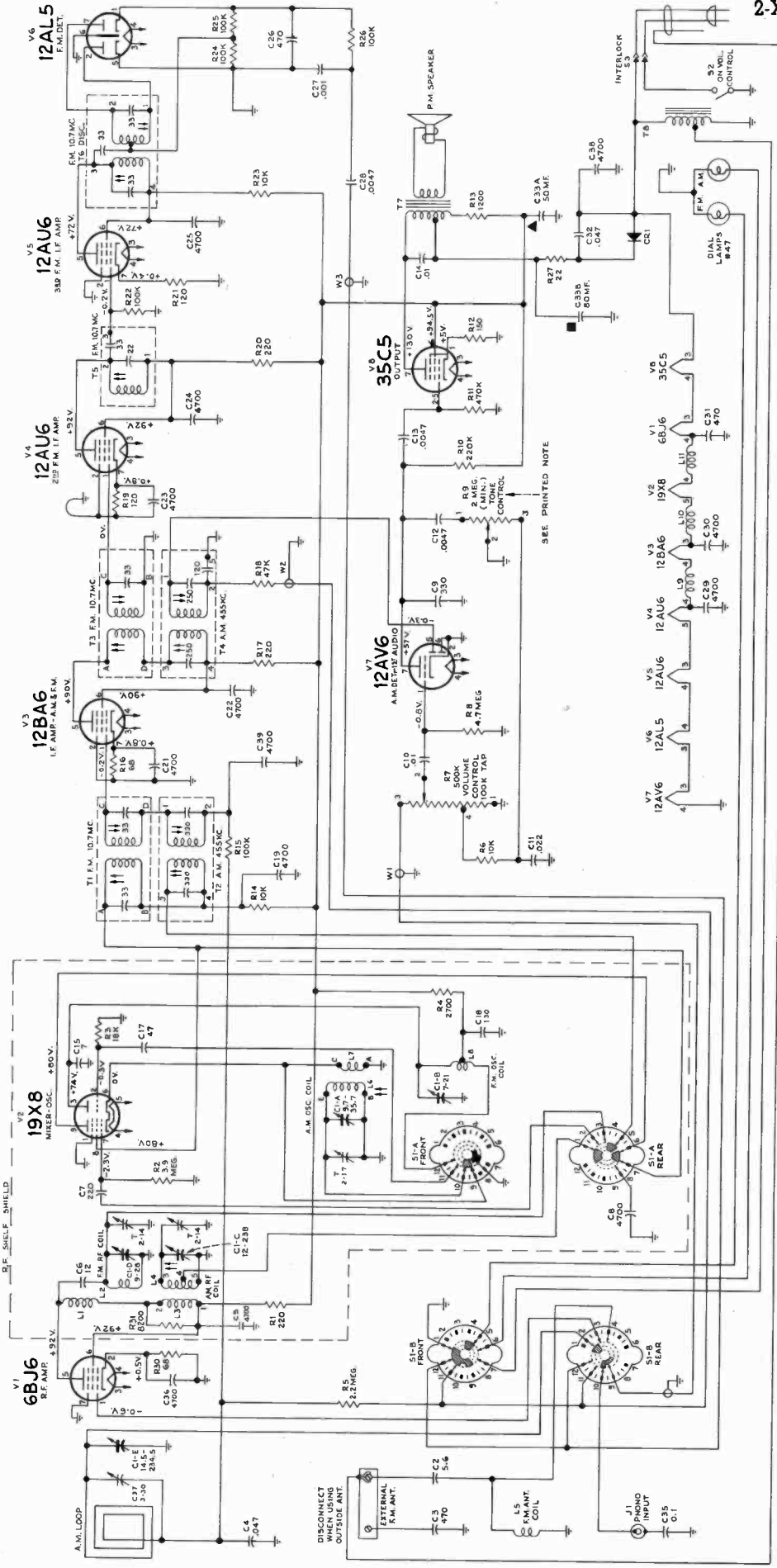

SEE PRINTED NOTE

K = 1000

ALL RESISTANCE VALUES IN OHMS AND ALL CAPACITANCE VALUES LESS THAN 1.0 IN MF. AND ABOVE 1.0 IN MMF. UNLESS OTHERWISE NOTED.

Acceptable value of R9 may be 2 to 50 megohms.

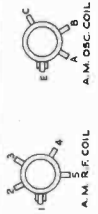

FRONT AND REAR SECTIONS OF FUNCTION SWITCH S1-A AND S1-B ARE VIEWED FROM FRONT WITH THE SWITCH SHAFT IN EXTREME COUNTER-CLOCKWISE POSITION (PHONO) POSITION

FUNCTION POSITION

1 PHONO

2 A.M.

3 F.M.

Schematic Circuit Diagram—Chassis No. RC1121A

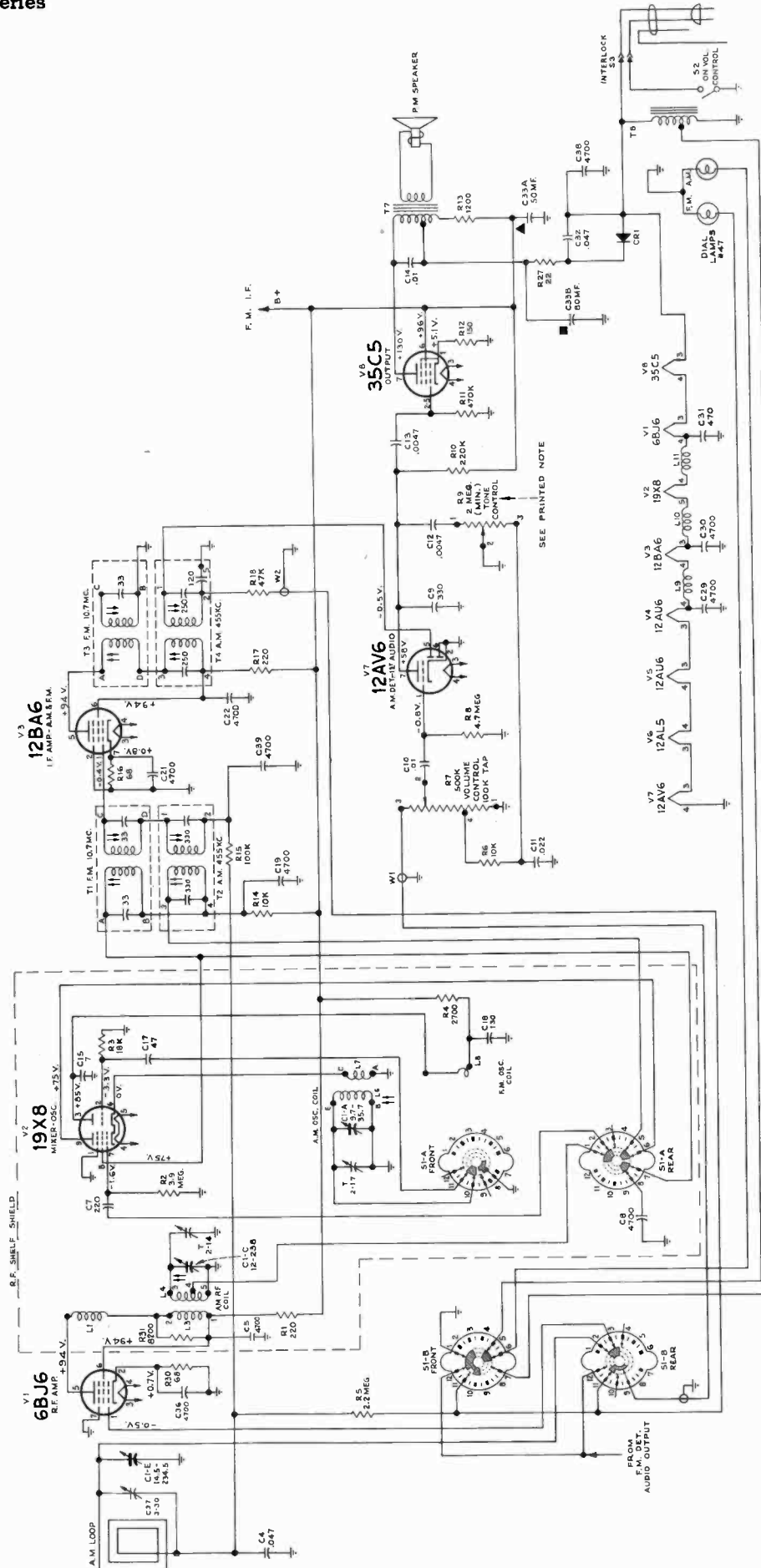

EE 47936-1

K = 1000
ALL RESISTANCE VALUES IN OHMS AND ALL CAPACITANCE VALUES LESS THAN 1.0 IN MF. AND ABOVE 1.0 IN MMF. UNLESS OTHERWISE NOTED.

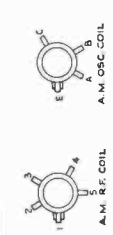

FRONT AND REAR SECTIONS OF FUNCTION SWITCH S1-A AND S1-B ARE VIEWED FROM FRONT WITH THE SWITCH SHAFT IN CENTER POSITION #2 A.M.

POSITION	FUNCTION
1	PHONO
2	F. M.
3	A.M.

Simplified Schematic—"AM" Position

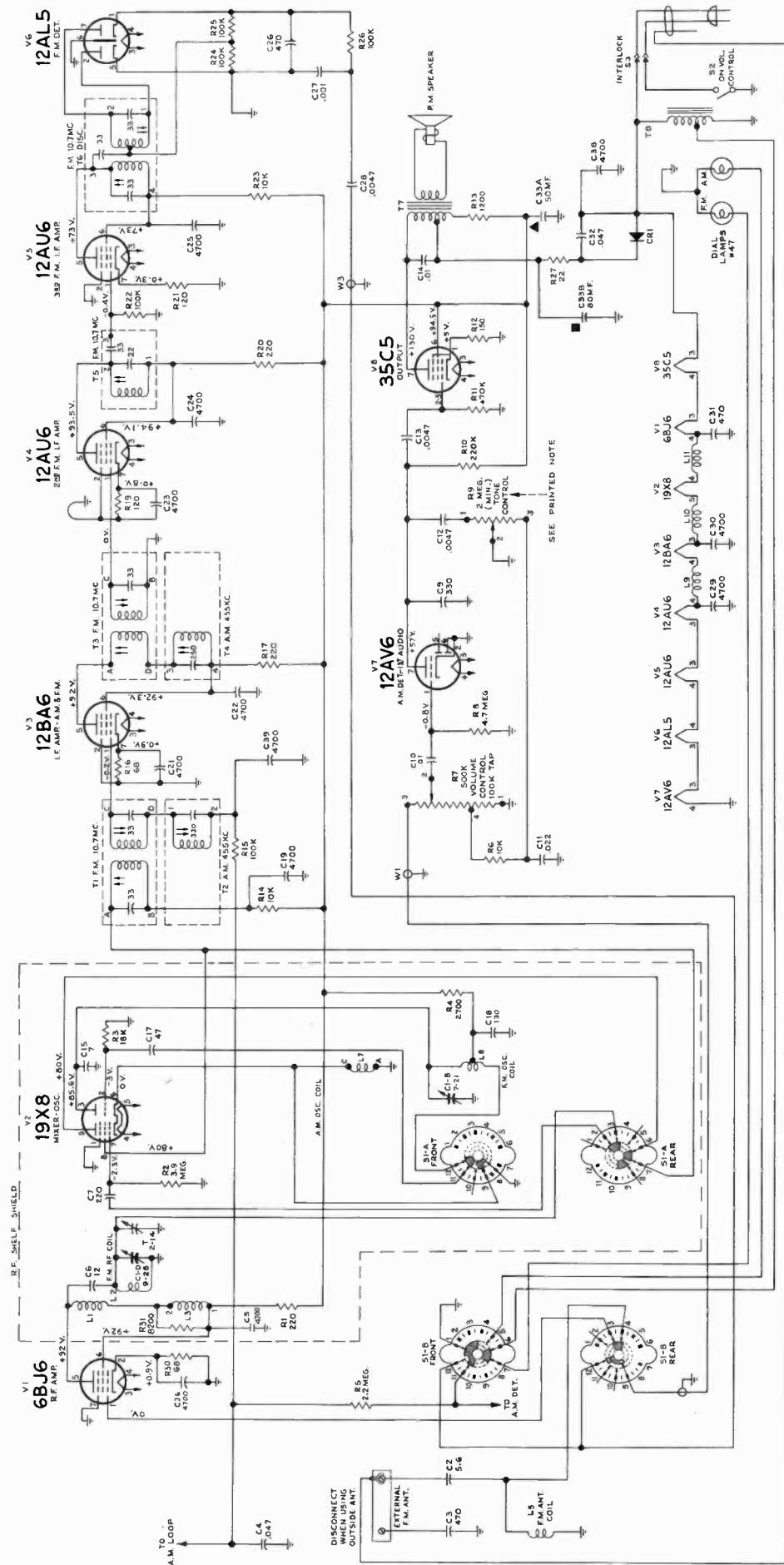

EE 47937-1

ALL RESISTANCE VALUES IN OHMS UNLESS OTHERWISE NOTED.
 ALL CAPACITANCE VALUES IN MICROFARADS UNLESS OTHERWISE NOTED.

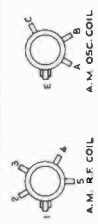

Simplified Schematic—"FM" Position

FRONT AND REAR SECTIONS OF FUNCTION SWITCH SI-A AND SI-B ARE VIEWED FROM FRONT WITH THE SWITCH SHAFT IN EXTREME COUNTER-CLOCKWISE POSITION #1 (PHONO)
 POSITION
 1 PHONO
 2 F.M.
 3 F.M.

STOCK No.	PART DESCRIPTION	STOCK No.	PART DESCRIPTION
	CHASSIS ASSEMBLIES		
	RC-1121A	77527	Shaft—Tuning knob shaft
77520	Bushing—Laminated bushing (3/8" long with shoulder) for station selector pointer pulley and shaft assembly.	75192	Shield—Tube shield for V1
77522	Capacitor—Variable tuning capacitor (C1A, C1B, C1C, C1D, C1E, C1A-T, C1C-T, C1D-T)	76331	Shield—Tube shield for V2
70997	Capacitor—Fixed, ceramic, non-insulated, 5.6 mmf., ±1 mmf., 500 volts D.C. Temp. coef. = 0 (C2)	77566	Socket—Dial lamp socket
77530	Capacitor—Fixed, ceramic, non-insulated, 7 mmf., ±.5 mmf., 500 volts D.C. Temp. coef. = 80 (C15)	77087	Socket—Tube socket, 7 pin, miniature, moulded, saddle mounted for V1
33380	Capacitor—Fixed, ceramic, non-insulated, 12 mmf., ±5%, 500 volts D.C. Temp. coef. = 0 (C6)	76336	Socket—Tube socket, 9 pin, miniature, moulded, saddle mounted for V2
77531	Capacitor—Fixed, ceramic, non-insulated, 47 mmf., ±10%, 500 volts D.C. Temp. coef. = 0 (C17)	73117	Socket—Tube socket, 7 pin, miniature, wafer for V3, V4, V5, V6, V7, V8
77532	Capacitor—Fixed, ceramic, non-insulated, 130 mmf., ±2½%, 500 volts D.C. Temp. coef. = -750 (C18)	31970	Spring—Dial cord spring
39636	Capacitor—Fixed, mica, 220 mmf., 500 volts D.C. (C7)	31418	Spring—Drive cord spring
75792	Capacitor—Fixed, ceramic, insulated, 330 mmf., ±20%, 500 volts D.C. High K (C9)	77524	Switch—Function switch (S1)
76992	Capacitor—Fixed, mica, 470 mmf., 300 volts D.C. (C26, C31)	77666	Transformer—Filament transformer, 117 volt A.C. input
39644	Capacitor—Fixed, mica, 470 mmf., 500 volts D.C. (C3)	77517	Transformer—Output transformer (T7)
73473	Capacitor—Fixed, ceramic, 4700 mmf., +100%, -0%, 500 volts D.C. High K disc (C5, C8, C19, C21, C22, C23, C24, C25, C29, C30, C36, C38, C39)	77511	Transformer—Ratio detector transformer—complete with adjustable cores (T6)
73520	Capacitor—Electrolytic comprising 1 section of 80 mfd., 150 volts and 1 section of 50 mfd., 150 volts (C33A, C33B)	76335	Transformer—First I.F. transformer—A.M.—complete with adjustable cores (T2)
77533	Capacitor—Fixed, miniature, tubular, paper, .001 mfd., 200 volts D.C. (C27)	77514	Transformer—First I.F. transformer—F.M.—complete with adjustable cores (T1)
73920	Capacitor—Fixed, tubular, paper, .0047 mfd., 600 volts (C12, C13, C28)	76328	Transformer—Second I.F. transformer—A.M.—complete with adjustable cores (T4)
73561	Capacitor—Fixed, tubular, paper, .01 mfd., 400 volts (C10)	77513	Transformer—Second I.F. transformer—F.M.—complete with adjustable cores (T3)
73594	Capacitor—Fixed, tubular, paper, .01 mfd., 600 volts (C14)	77512	Transformer—Third I.F. transformer—F.M.—complete with adjustable cores (T5)
73562	Capacitor—Fixed, tubular, paper, .022 mfd., 400 volts (C11)	33726	Washer—"C" washer for station selector pointer pulley and shaft or tuning knob shaft
73558	Capacitor—Fixed, tubular, paper, .047 mfd., 200 volts (C4)	34373	Washer—"C" washer to fasten idler pulleys
75071	Capacitor—Fixed, tubular, moulded, .047 mfd., 400 volts (C32)		SPEAKER ASSEMBLIES
73551	Capacitor—Fixed, tubular, paper, 0.1 mfd., 400 volts (C35)		971933-1
73935	Clip—Mounting clip for I.F. transformers	77539	Speaker—5¼" P.M. speaker complete with cone and voice coil (3.2 ohms)
77538	Coil—Antenna coil—F.M. (L5)		MISCELLANEOUS
77534	Coil—Choke coil (L1)	77543	Antenna—Antenna loop and back cover complete with power cord (includes C37)
77535	Coil—Choke coil (L9, L10, L11)	77543	Back—Cabinet back complete with loop, capacitor and power cord (includes C37)
77526	Coil—Oscillator coil—A.M.—complete with adjustable core (L6, L7)	Y2468	Cabinet—Maroon plastic cabinet less "RCA Victor" emblem and function decal for Model 2-XF-931
77537	Coil—Oscillator coil—F.M. (L8)	Y2469	Cabinet—Ivory plastic cabinet less "RCA Victor" emblem and function decal for Model 2-XF-932
77525	Coil—RF coil—A.M.—complete with adjustable core (L3, L4)	Y2470	Cabinet—Green plastic cabinet less "RCA Victor" emblem and function decal for Model 2-XF-933
77536	Coil—RF coil—F.M. (L2)	Y2471	Cabinet—Red plastic cabinet less "RCA Victor" emblem and function decal for Model 2-XF-934
77528	Connector—Combination phono input connector and antenna terminal board (J1)	Y2472	Cabinet—Beige plastic cabinet less "RCA Victor" emblem and function decal for Model 2-XF-935
75474	Connector—Single contact male connector for speaker lead	77559	Cap—Station selector pointer cap—A.M.
77529	Connector—Two (2) contact male connector for power cord	77558	Cap—Station selector pointer cap—F.M.
77516	Control—Tone control (R9)	77544	Capacitor—Adjustable, mica trimmer, 3-30 mmf. (C37)
77515	Control—Volume control and power switch (R7, S2)	77545	Cord—Power cord and plugs
72953	250' Dial Cord Reel—Dial cord (approx. 49" overall required)	77542	Decal—Control function decal
77523	Drive cord (approx. 11" overall required)	77033	Emblem—"RCA Victor" emblem
77523	Drum—Variable tuning capacitor drive drum and hub	77560	Grille—Metal grille
16058	Grommet—Rubber grommet for mounting RF shelf (4 required)	77548	Knob—Function switch knob—maroon—for Model 2-XF-931
31480	Lamp—Dial lamp (Mazda 47)	77550	Knob—Function switch knob—ivory—for Model 2-XF-932
77521	Nut—Speednut for station selector pointer pulley and shaft bushing	77552	Knob—Function switch knob—green—for Model 2-XF-933
72602	Pulley—Idler pulley for indicator cord (2 required)	77556	Knob—Function switch knob—red—for Model 2-XF-934
77510	Pulley—Pulley and shaft (split) for station selector pointers	77554	Knob—Function control knob—beige—for Model 2-XF-935
77519	Rectifier—Selenium rectifier, 100 MA (CR1)	77547	Knob—Tuning control, tone control or volume control and power switch knob—maroon—for Model 2-XF-931
76346	Resistor—Wire wound, 1200 ohms, 4 watts (R13)	77549	Knob—Tuning control, tone control or volume control and power switch knob—ivory—for Model 2-XF-932
503022	Resistor—Fixed, composition:	77551	Knob—Tuning control, tone control or volume control and power switch knob—green—for Model 2-XF-933
503068	22 ohms, ±10%, ½ watt (R27)	77555	Knob—Tuning control, tone control or volume control and power switch knob—red—for Model 2-XF-934
503112	68 ohms, ±10%, ½ watt (R16, R30)	77553	Knob—Tuning control, tone control or volume control and power switch knob—beige—for Model 2-XF-935
503115	120 ohms, ±10%, ½ watt (R19, R21)	73203	Nut—Speed nut to fasten "RCA Victor" emblem to cabinet
503115	150 ohms, ±10%, ½ watt (R12)	77563	Pad—Cork and rubber pad (1/32" x 3/16" x 3/16") for mounting metal grille to cabinet
503122	220 ohms, ±10%, ½ watt (R1, R17, R20)	77557	Pointer—Station selector pointer
503227	2700 ohms, ±10%, ½ watt (R4)	73992	Retainer—Knob retainer (knob to cabinet)
503282	8200 ohms, ±10%, ½ watt (R31)	76837	Spring—Retaining spring for knobs (knob to shaft)
503310	10,000 ohms, ±10%, ½ watt (R6, R14, R23)	77561	Window—Polystyrene window for L.H. side of cabinet
503318	18,000 ohms, ±10%, ½ watt (R3)	77562	Window—Polystyrene window for R.H. side of cabinet
503347	47,000 ohms, ±10%, ½ watt (R18)		
502410	100,000 ohms, ±5%, ½ watt (R24, R25)		
503410	100,000 ohms, ±10%, ½ watt (R15, R22, R26)		
503422	220,000 ohms, ±10%, ½ watt (R10)		
503447	470,000 ohms, ±10%, ½ watt (R11)		
503522	2.2 megohm, ±10%, ½ watt (R5)		
503539	3.9 megohm, ±10%, ½ watt (R2)		
503547	4.7 megohm, ±10%, ½ watt (R8)		

APPLY TO YOUR RCA DISTRIBUTOR FOR PRICES OF REPLACEMENT PARTS



RCA VICTOR

Record Demonstrator

MODELS 15-E, 15-E-1

Chassis No. RS-139A,
Record Changer RP-190A-1
and Two Speed Manual Turntable

SERVICE DATA

— 1951 No. 7 —



PREPARED BY RCA SERVICE CO., INC.

FOR

RADIO CORPORATION OF AMERICA

RCA VICTOR DIVISION

CAMDEN, N. J., U. S. A.

Specifications

Tube Complement				Weight	43 lbs. net
1. RCA 6SQ7	A.F. Amplifier			Cabinet Dimensions (overall)	
2. RCA 6SQ7	Ph. Inverter			Height ... 17 $\frac{1}{8}$ "	Width ... 21 $\frac{1}{2}$ "
3. RCA 6V6GT	Output			Depth ... 19 $\frac{1}{8}$ "	
4. RCA 6V6GT	Output			Record Players	
5. RCA 5Y3GT	Rectifier			Automatic (RP-190A-1)	
Power Supply Rating				Record capacity	up to 14 records
115 volts, 60 cycles			80 watts	Type of records	RCA "45"
Power Output				Pickup (Stock No. 75770)	crystal
Undistorted ... 10 watts	Maximum	11 watts		Turntable speed	45 r.p.m.
Loudspeaker				Manual	
Size and type	12 inch P.M.			Record capacity	1 record
Voice coil impedance	3.2 ohms @ 400 cycles			Type of records	up to 12 inch diameter
Pilot Lamp	Mazda #51, 6-8 volts, .2 amp.			Pickup (Stock No. 75475)	dual stylus crystal
				Turntable speed	33 $\frac{1}{3}$ or 78 r.p.m.

RP-190A-1 Record Changer:

The record changer will play up to fourteen 45 r.p.m. records having a 1 $\frac{1}{2}$ inch center hole. It is identical to RP-190-2a record changer except for the omission of the power switch.

**FOR RECORD CHANGER SERVICE DATA —
REFER TO RP-190 SERIES SERVICE DATA.**

VOLUME CONTROL STOP

This instrument is provided with a volume control stop to provide a pre-determined "maximum" volume level and yet allow normal volume control operation up to the pre-determined "maximum."

Adjusting "Maximum" Volume Level:

With the instrument operating, remove the volume control knob. Note the extending ends of two coil springs (one light and one heavy) on the volume control shaft.

TO INCREASE

Turn control fully clockwise and then, with end of a pencil or similar item, press counterclockwise on the end of the LIGHT spring. Rotate control shaft clockwise until desired level is reached. Release pressure on the spring and replace knob.

TO DECREASE

Turn control fully clockwise and then, with the end of a pencil or similar item, press clockwise on the end of the HEAVY spring. Rotate control shaft counterclockwise to a very low level. Increase volume to desired level as described above.

Manual Turntable:

The manual turntable will play one 33 $\frac{1}{3}$ or 78 r.p.m. record up to twelve inches in diameter. The speed is controlled by a knob on the motorboard. The correct stylus is selected by a lever knob on the end of the pickup arm.

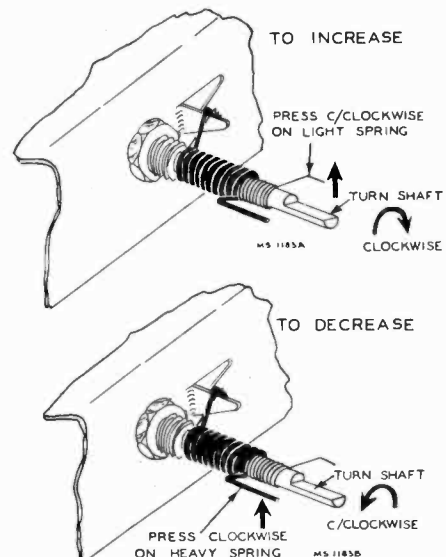

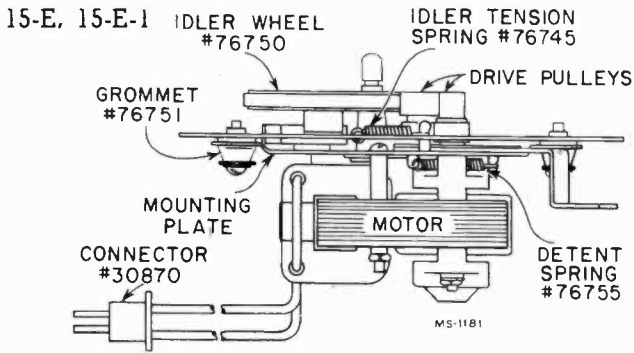

Manual Motorboard — Motor Assembly

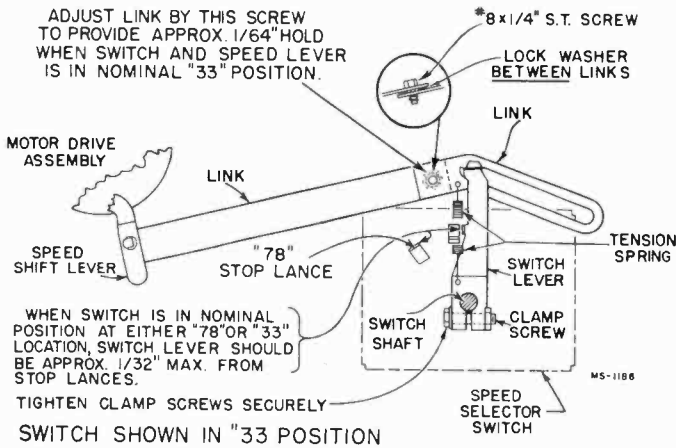

Speed Control Lever Assembly

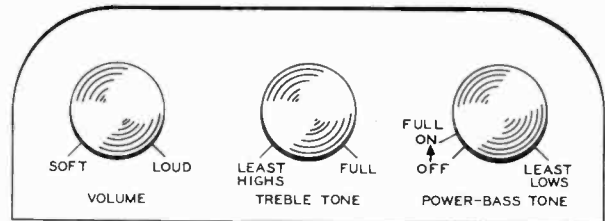
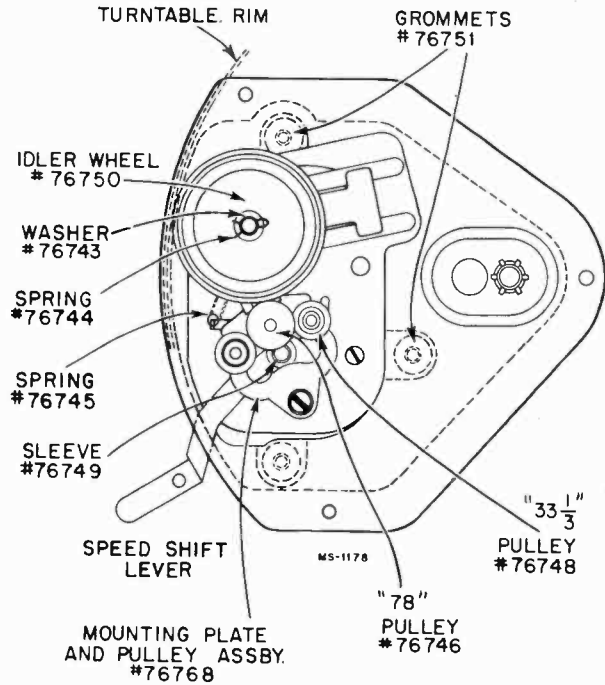

Controls

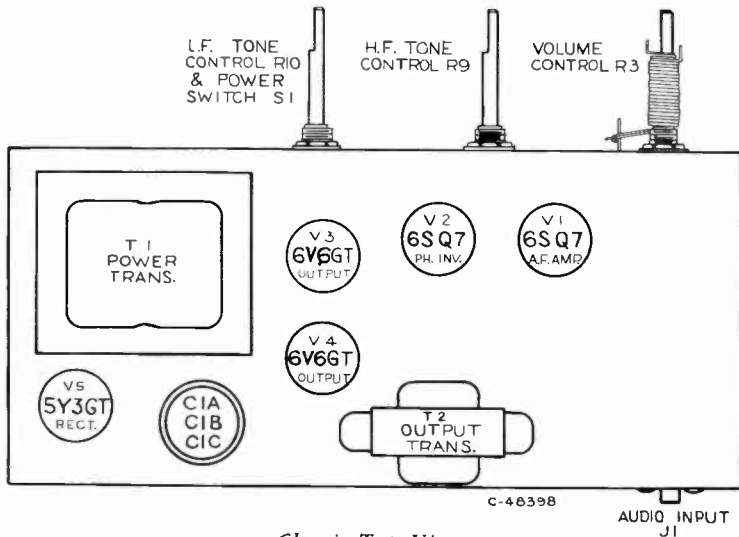

Chassis Top View

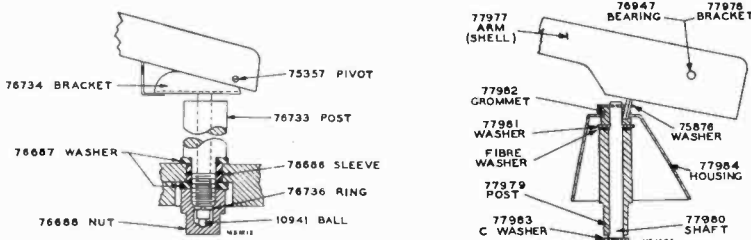

15-E Pickup Arm Mounting — Manual Motorboard 15-E-1

MANUAL MOTORBOARD SERVICE HINTS

- (a) Stylus force of pickup arm should be 8 to 10 grams. Insufficient force resulting from use of incorrect spring or pickup may allow stylus to jump groove. Excessive force may cause distortion and record wear.
- (b) Pickup arm pivots should be adjusted to provide a minimum of side play — yet allowing free vertical movement. Binding may cause stylus to jump groove.
- (c) Inner surface of turntable rim must be clean and smooth. Idler wheel and drive pulleys must have no rough spots and be free of oil and grease. Roughness may cause rumble — oil may cause wow.
- (d) Lubricate idler wheel and drive pulleys with a good quality light oil — one or two drops for each is sufficient.
- (e) The pickup arm pivot shaft may be lubricated with a film of light oil. The pivot post rubber mounting should not be excessively compressed. The bearing nut should be tightened only enough to elevate the pivot shaft 1/32" above the post with the steel ball in place. This ball must be in place to permit free lateral pickup arm movement.

CRITICAL LEAD DRESS

1. Dress all filament leads next to chassis.
2. Dress power cord lead, from strain relief grommet to on-off switch, along side apron.
3. Dress A.C. leads at ON-OFF switch away from all audio components.
4. Dress output tube plate leads next to chassis.
5. Dress C8 next to chassis and wire with as short leads as practical.
6. Dress lead from arm of low frequency tone control to grid of V-3 away from A.C. leads at ON-OFF switch.

MODIFICATION

Although designed and assembled for 3-speed operation, provision is made for modification of this instrument for 33 and 45 rpm performance only. To eliminate the use of the 78 SPEED control and 78 stylus, proceed as follows:

To alter SPEED SELECTOR control

Tie both pickup arms to their rests and place the instrument on its left side (not on control knobs) on a table. Through the opening in the bottom of the cabinet, disconnect the black power plug and the phono plug from its chassis connection. While supporting the top panel, remove the hex head screw and washer, centrally located beneath the top panel at the back of the cabinet.

Place cabinet upright, move SPEED SELECTOR to 45 position, then lift off top panel assembly.

From the back, the switch can be viewed from beneath the top panel and conversion effected as shown below. Bend the 33 stop to the vertical position of the adjacent 78 stop. The speed change lever (on left) should now halt against the vertical 33 stop, eliminating the 78 speed position.

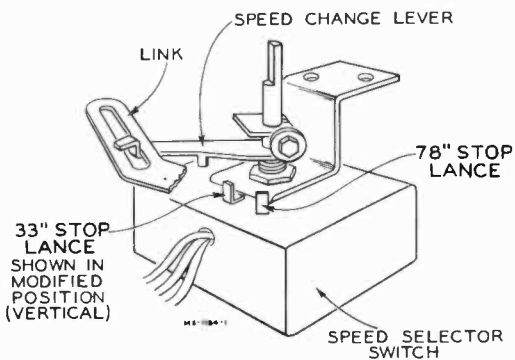

Replace top panel (rubber supporting grommets must be in place) and the hex head screw and washer.

NOTE: It is important that screw be tightened until top panel can be lifted approximately 1/16 inch only. The board should float freely on its mounts; there must be no restriction of movement.

Reconnect the black power plug and insert phono plug in the chassis socket. Place the instrument in the upright position and untie pickup arms.

To adapt STYLUS CONTROL LEVER —

With lever in 33 position, loosen left holding screw just enough to turn lug to the position shown below and tighten screw. This will prevent the 78 stylus from being turned for use.

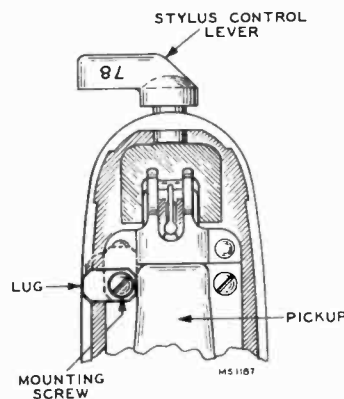

Before Operation —

Remove SPEED SELECTOR knob and turn over the CIRCULAR PLATE which will now show only 33 OFF 45 positions. Replace knob on shaft.

Reverse the left INSTRUCTIONS PLATE to read for 33 operation only.

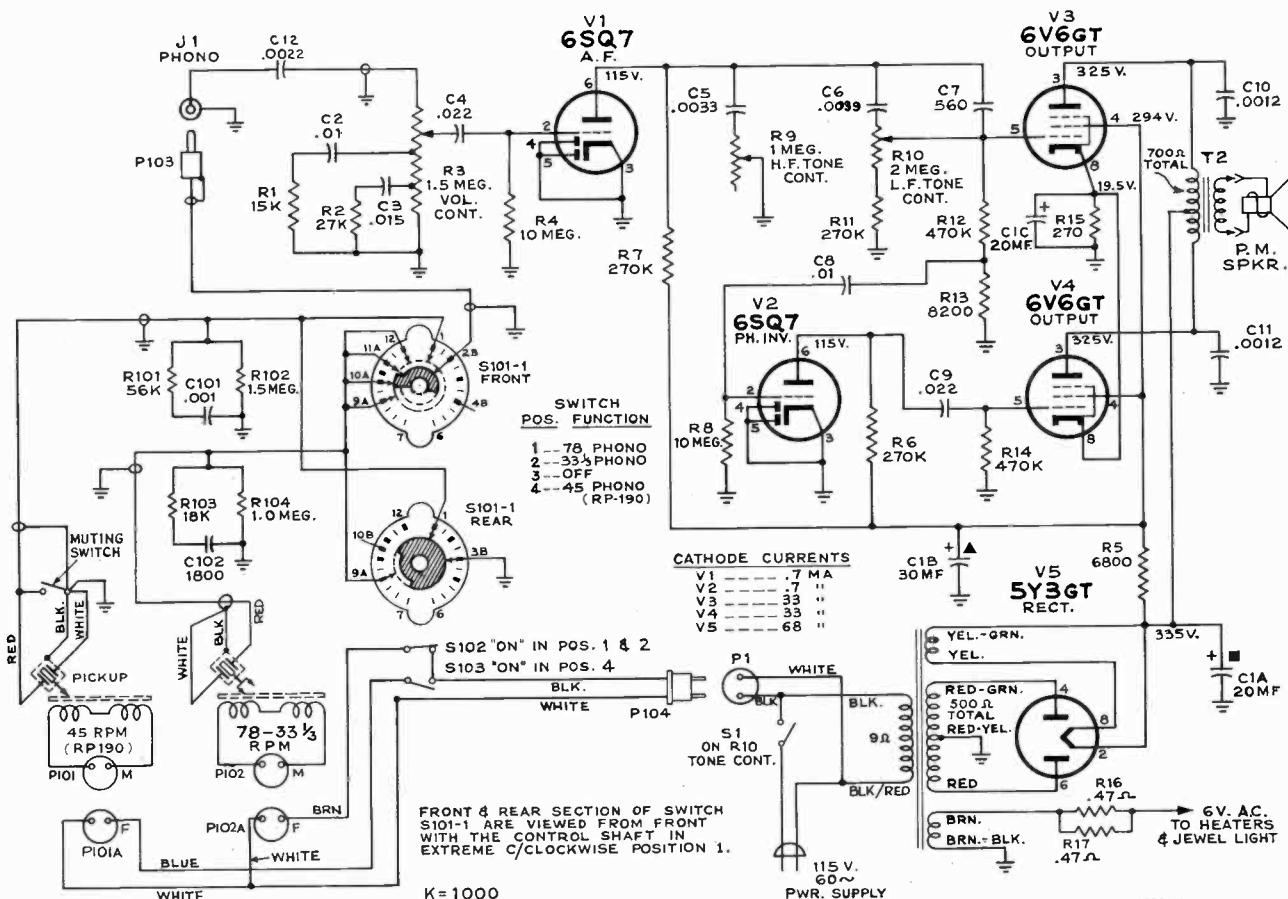

ALL RESISTANCE VALUES IN OHMS. ALL CAPACITANCE VALUES LESS THAN 1.0 ARE IN MF., AND ABOVE 1.0 ARE IN MMF. EXCEPT THOSE INDICATED. VOLTAGES MEASURED TO COMMON WIRING WITH CHANALYST OR VOLTOHMYST, AND SHOULD HOLD WITHIN ±20% WITH RATED POWER LINE SUPPLY.

IN MODEL 15E
 C12 MAY BE OMITTED.
 C6 MAY BE 0.01 MFD.
 R104 MAY BE 1.5 MEG.

Schematic Diagram

Replacement Parts

STOCK No.	DESCRIPTION	STOCK No.	DESCRIPTION
TWO SPEED MANUAL TURNTABLE Pickup Arm Assembly 15-E			
76731	Arm—Pickup arm shell—less cartridge, mount, and cable	73797	Capacitor—Tubular, paper, .015 mfd., 600 volts C3
76734	Bracket—Pickup arm mounting bracket complete with pivot pin and counterbalance spring	73562	Capacitor—Tubular, paper, .022 mfd., 400 volts C4, C9
76737	Cable—3 wire pickup arm cable complete with connectors	35787	Connector—Phono input connector (socket) J1
76738	Knob—Stylus selector knob complete with screw	72776	Connector—Single contact male connector for speaker leads (2 req'd)
76732	Mount—Pickup mount and swivel assembly	30868	Connector—2 contact female connector for motor power P1
74230	Nut—#00-112 nut and washer to mount stylus	38405	Control—H.F. tone control R9
75475	Pickup—Dual stylus pickup crystal cartridge complete with two stylus	38402	Control—L.F. tone control and power switch R10, S1
75366	Pin—Pivot pin for counterbalance spring	71980	Control—Volume control—less stop R3
75357	Pivot—Pickup arm pivot (2 req'd)	74838	Grommet—Power cord strain relief (1 set)
76733	Post—Pickup arm pivot post and stop pin	76684	Resistor—Wire wound, 0.47 ohms, 1 watt R16, R17
76736	Ring—Retaining ring for pickup arm mounting bracket	523127	Resistors—Fixed, composition:—
71097	Screw—#4 x 1/4" self tapping screw for pickup mount and swivel (4 req'd)	270 ohms, ±10%, 2 watts R15	
76735	Spring—Counterbalance spring	523268	6800 ohms, ±10%, 2 watts R5
75497	Stylus—Osmium tip stylus for 78 RPM (not coded)	503282	8200 ohms, ±10%, 1/2 watt R13
75496	Stylus—Osmium tip stylus for 33 1/2 RPM (coded red)	503315	15,000 ohms, ±10%, 1/2 watt R1
Pickup & Arm Assemblies 15-E-1			
77977	Arm—Pickup arm shell (plastic)	503327	27,000 ohms, ±10%, 1/2 watt R2
76947	Bearing—Pickup arm mounting bracket pivot bearing	503427	270,000 ohms, ±10%, 1/2 watt R6, R7, R11
77978	Bracket—Pickup arm mounting bracket	503447	470,000 ohms, ±10%, 1/2 watt R12, R14
75810	Bracket—Pickup arm weight adjustment bracket (slide)	504610	10 megohm, ±20%, 1/2 watt R4, R8
78227	Cable—Three wire cable complete with connectors	31364	Socket—pilot lamp socket
77982	Grommet—Rubber grommet for pickup arm post	54414	Socket—Tube socket
76738	Knob—Stylus selector knob	71979	Stop—Volume control adjustable stop (two springs)
74230	Nut—#00-112 nut and washer to mount stylus	76695	Transformer—Output transformer T2
77779	Pickup—Crystal pickup complete with two (2) styli	75566	Transformer—Power transformer, 117 volt 60 cycle T1
77979	Post—Pickup arm pivot post	FUNCTION SWITCH ASSEMBLY	
76898	Screw—#2-56 x 3/16" headless set screw for stylus selector knob	72437	Cable—Shielded audio cable complete with pin plug (switch to amplifier) P103
76899	Screw—#6-32 x 1/8" round head screw for pickup arm weight adjustment bracket	74850	Capacitor—Ceramic, 1800 mmf. C102
76948	Screw—Pickup arm mounting bracket pivot screw	75643	Capacitor—Tubular, paper, .001 mf., 1000 volts C101
77980	Shaft—Pickup arm pivot shaft	30868	Connector—Two contact female connector for motor cables P101A, P102A
75809	Spring—Pickup arm counterbalance spring	30870	Connector—Two contact male connector for motor power cable P104
75497	Stylus—Osmium tip stylus (.003 r. uncoded) for 78 r.p.m.	76693	Lever—Speed change lever (mounted on switch shaft)
77899	Stylus—Sapphire tip stylus (.001 r. coded red) for 33 1/2 r.p.m.	503318	Resistors—Fixed composition:
77976	Swivel—Pickup cartridge mount and swivel assembly	18,000 ohms, ±10%, 1/2 watt R103	
77983	Washer—"C" washer for lower end of pickup arm pivot shaft	503356	56,000 ohms, ±10%, 1/2 watt R101
75876	Washer—"C" washer for upper end of pickup arm post and shaft	503510	1.0 megohm, ±10%, 1/2 watt R104
77981	Washer—Metal washer for pickup arm post and shaft	503515	1.5 megohm, ±10%, 1/2 watt R102
Motor and Turntable Assembly			
30870	Connector—2 contact male connector for motor leads	76694	Switch—Function switch—less speed change lever S101, S102, S103
76751	Grommet—Rubber grommet to mount motor (3 req'd)	SPEAKER ASSEMBLIES	
76753	Motor—117 volt 60 cycle complete with mounting plate—less #76768 plate and idler wheel	971494-2W	RL111B1
76768	Plate—Speed control pulley mounting plate complete with pulleys	RMA274	
76746	Pulley—78 RPM pulley	75023	Cap—Dust cap
76748	Pulley—33 1/2 RPM pulley	76296	Cone—Cone and voice coil (3.2 ohms)
76749	Sleeve—Spring sleeve for motor shaft	76389	Speaker—12" P.M. speaker complete with cone and voice coil (3.2 ohms)
76755	Spring—Detent spring (below motor mounting plate)	SPEAKER ASSEMBLIES	
76744	Spring—Hairpin spring to retain idler wheel	92569-12W	RL111A1
76745	Spring—Idler wheel tension spring (above motor mounting plate)	RMA 274	
76752	Turntable—Finished turntable (9" dia.)	13867	Cap—Dust cap
76743	Washer—Flat fibre washer for idler wheel	75682	Cone—Cone and voice coil (3.2 ohms)
35969	Washer—"C" washer to retain turntable on shaft	76093	Speaker—12" P.M. speaker complete with cone and voice coil
76750	Wheel—Idler wheel	NOTE:—If stamping on speaker instrument does not agree with above speaker number, order replacement parts by referring to model number stamped on speaker and full description of part required.	
45 R.P.M. AUTOMATIC RECORD CHANGER RP 190A-1			
Same as listed for RP 190-2a in RP 190 Series Service Data except for the omission of the on-off switch and switch housing			
AMPLIFIER ASSEMBLIES RS139A			
76685	Capacitor—Ceramic, 560 mmf. C7	X3240	Baffle—Baffle board and grille cloth
71976	Capacitor—Electrolytic comprising 1 section of 20 mfd., 450 volts, 1 section of 30 mfd., 350 volts and 1 section of 20 mfd., 25 volts C1A, C1B, C1C	10941	Ball—Steel ball (1/8" dia.) for pickup arm mounting
73850	Capacitor—Tubular, paper, oil impregnated, .0012 mfd., 1000 volts C10, C11	71599	Bracket—Pilot lamp bracket
73595	Capacitor—Tubular, paper, .0022 mfd., 600 volts C12	13103	Cap—Pilot lamp cap
73795	Capacitor—Tubular, paper, .0033 mfd., 600 volts C5	72115	Foot—Rubber foot (4 req'd)
73796	Capacitor—Tubular, paper, .0039 mfd., 600 volts C6	75697	Grommet—Rubber grommet for mounting 45 RPM changer (3 req'd)
73561	Capacitor—Tubular, paper, .01 mfd., 400 volts C2, C8	72856	Grommet—Rubber grommet for motor board (4 req'd)
MISCELLANEOUS			
		77984	Housing—Pickup arm pivot shaft housing (15-E-1 only)
		74979	Knob—Selector switch knob—tan
		72118	Knob—Tone control or volume control knob—brown
		11765	Lamp—Pilot lamp—Mazda 51
		75692	Link—Motor speed change link (bent-end section only)
		76691	Link—Motor speed change link (slotted section only)
		76688	Nut—Pickup arm pivot shaft bearing nut (15-E only)
		73634	Nut—Speed nut for speaker mounting screws (4 req'd)
		76689	Rest—Pickup arm rest (for 33 1/2-78 RPM arm)
		76686	Sleeve—Rubber sleeve (39/64 O.D. x 7/16" I.D. x 11/32") for pickup arm pivot post (15-E only)
		14270	Spring—Retaining spring for knob 74057
		30900	Spring—Retaining spring for knob 72118
		76690	Spring—Speed change link and lever tension spring
		76687	Washer—Rubber washer (13/16" O.D. x 7/16" I.D. x 1/8") for pickup arm pivot post (2 req'd)

APPLY TO YOUR RCA DISTRIBUTOR FOR PRICES OF REPLACEMENT PARTS



RCA VICTOR

930409 SERIES

Automatic Record Changer

SERVICE DATA

— 1952 No. 6 —

PREPARED BY RCA SERVICE CO., INC.

FOR

RADIO CORPORATION OF AMERICA

RCA VICTOR DIVISION

CAMDEN, N. J., U. S. A.

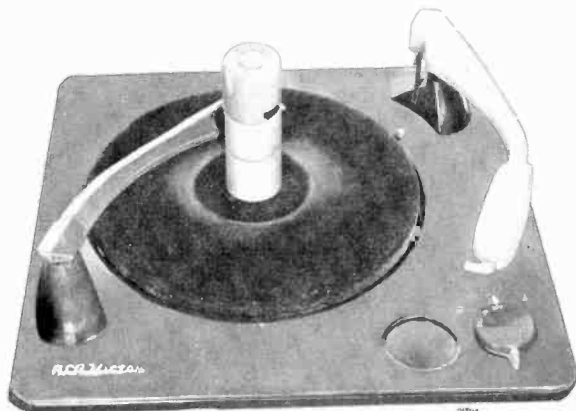

SPECIFICATIONS

Turntable speed	33 $\frac{1}{3}$, 45 or 78 r.p.m.
Record capacity	Up to 14 seven-inch or 12 ten-inch or 10 twelve-inch or 10 ten- and twelve-inch intermixed
930409-3	115 v. 60 cycle motor convertible to 50 cycles. Ceramic pickup Stock No. S-5652.
930409-4	115 v. 25 cycle motor. Ceramic pickup Stock No. 162A001. Used in Model 35QU.
930409-5	115 v. 60 cycle motor. Crystal pickup Stock No. 75475 or 77779. Used in Models 2ES3, 2ES31, 2ES38, 2ES38E, 2JS1, 2JS1E, 2S7, 2S10, 2US7, 21T197DE, 21T242 and 21T244.
930409-6	115 v. 60 cycle motor convertible to 50 cycles. Ceramic pickup Stock No. 162A001. Used in Models 2ES31Q, 2ES38Q, 2JS1Q and 35QU.
930409-9	230 v. 50 cycle motor convertible to 60 cycles. Crystal pickup Stock No. 75044.
930409-10	Same as 930409-5 except light color. Used in Models 2S7, 2S10, 2US7 and 21T242.
930409-11	115 v. 50 cycle motor convertible to 60 cycles. Crystal pickup Stock No. 75475 or 77779. Used in Model 2US7.

CONTROLS

The record changer has a dual control on the motor-board and a stylus selector control on the pickup arm. The inner control (circular knob) is the OFF-ON-REJECT control. Turning this knob to the center position energizes the motor and starts the turntable, when turned to the right (clockwise) it starts the mechanism into complete automatic operation. The mechanism will shut off automatically after the last record has been played but can be shut off manually by turning this knob to the left (counter-clockwise).

The outer control (double ended lever) is the speed control. It has three normal positions, "33", "45", "78" to select the turntable speed desired and a neutral position (midway between "45" and "78"). The control should be turned to this neutral position if the changer is not expected to be in use for an extended period of time.

The stylus control has two normal positions (right and left) and one shipping position (lever pointing up). When playing 33 $\frac{1}{3}$ or 45 r.p.m. records the lever is turned so that "33-45" is visible on the TOP of the lever; likewise for 78 r.p.m. records "78" should be visible on the TOP.

The removable centerpost is for use with 45 r.p.m. records having the large centerhole. It must be placed over the center spindle with the "RCA" trademark monogram FACING to the FRONT. When not in use it is placed in a well at the front of the motorboard.

To load or remove records, the record stabilizer is lifted and turned off-side. After loading it is turned to the center where it rests on top of the stack of records.

INDEX

Lubrication	2
Stylus Replacement	2
Record Stabilizer Arm	2
50/60 Cycle Conversion	2
Adjustments	3
Cycle of Operation	4 to 7
Exploded View of Mechanism	8
Replacement Parts	9 to 14

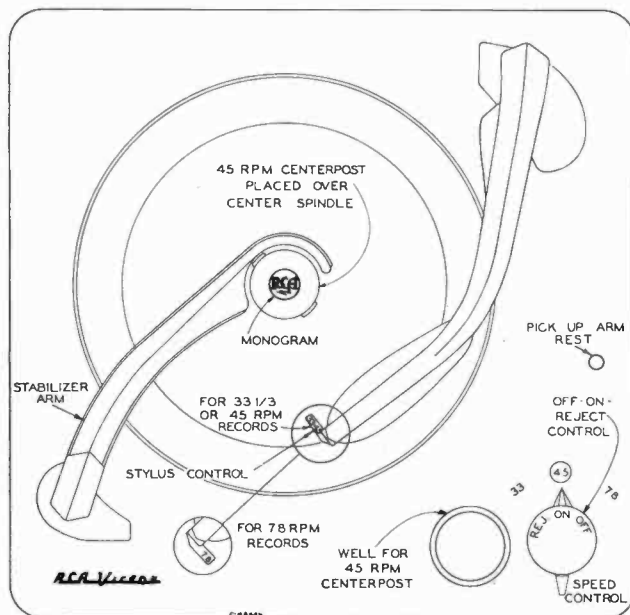

Controls

930409 Series

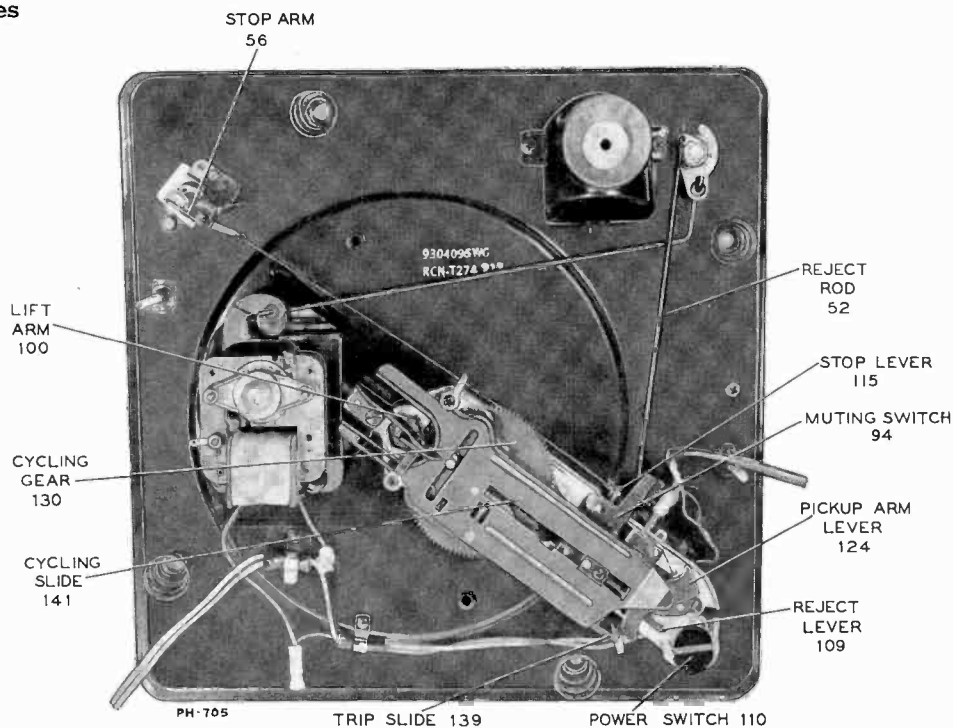

Figure 1—Bottom View

LUBRICATION

The mechanism is properly lubricated when it leaves the factory, additional lubrication should not be necessary for a long period of time. If the mechanism has unusual use or high operating temperatures, it may be necessary to lubricate more frequently.

It is suggested to use Lubriplate or STA-PUT No. 512 on:

1. Pickup arm pivot.
2. Points of sliding contact with cycling slide, including:
 - a. elevating rod
 - b. lift arm
 - c. roller on cycling cam
 - d. pickup arm return lever
 - e. pickup arm lever
3. End of selector lever contacting tab on cycling gear.
4. Turntable thrust bearing.
5. Sparingly on a trip slide.
6. All points of sliding contact.

Apply a small quantity of light machine oil to:

1. Trip pawl pivot.
2. Cycling engagement pawl pivot.
3. Bearing of record stabilizer.
4. Elevating rod.
5. Bearing of lift arm.
6. Bearing of reject lever.
7. Bearing of stop lever.
8. Bearing of cycling gear.
9. Motor bearings.

NOTE: Keep oil or grease away from all rubber parts.

Stylus Replacement

PICKUPS NO. 75044 and S-5652

The styli are held in position by small thumb nuts (one for each stylus). Loosen the nut to remove stylus.

PICKUP NO. 75475

The styli are held in position by small hex nuts (one for each stylus). Remove the nut and push threaded end of stylus through the cartridge.

PICKUP NO. 162A001

The styli are held in position by pressure fit. To remove stylus, grip with tweezers and pull straight to the front of pickup.

CAUTION:

The internal element of the pickups can be fractured by use of excessive force. It is advisable to grip stylus with pliers instead of holding pickup case while removing nuts.

Although the 78 and the 45-33 $\frac{3}{4}$ styli are mechanically interchangeable, they should be replaced in such manner that the stylus which is coded red will contact the record when "33-45" on the stylus selector knob is visible from the top.

Record Stabilizer Arm

Two types of stabilizer arms are in use. Type "A" when raised and moved outward will remain projected beyond the edge of the motorboard. Use Stock Number 76941 (plum) or Stock Number 76942 (beige) record stabilizer housing. Type "B" when raised and moved outward will return to within the edge of the motorboard. Use Stock Number 77256 (plum) record stabilizer housing, and Stock Number 77257 record stabilizer return spring.

The replacement stabilizer arm (plum) Stock Number 77255 can be used with either Type "A" or Type "B".

50/60 Cycle Conversion

Models 930409-3 and 930409-6 are made for 60 cycle operation but may be converted to 50 cycle operation.

Models 930409-9 and 930409-11 are made for 50 cycle operation but may be converted to 60 cycle operation.

To convert the above listed models it is necessary to remove the original spring sleeve from the motor shaft and install the alternate spring sleeve (in envelope attached to record changer). This is easily accomplished by holding the rotor of the motor while removing or installing the spring sleeve with a twisting motion.

ADJUSTMENTS

LANDING ADJUSTMENT

Only one landing adjustment is necessary. The landing position of the stylus is adjusted by means of the eccentric stud (20A), mounted on the pickup arm support bracket. When adjusted for correct landing on one size of record, the landing position for other sizes of records is automatically corrected.

PICKUP ARM HEIGHT ADJUSTMENT

The pickup arm height during cycle is adjusted by means of the hex head screw (17), located in the pickup arm.

Turn control knob to "REJ" and rotate turntable by hand until arm has risen to its maximum height. Adjust screw so that stylus is 1 1/8" above turntable.

STYLUS FORCE ADJUSTMENT

Stylus force should be 7 1/2 to 9 1/2 grams. Loosen screw (14), and move slide until the correct force is obtained.

TRIPPING

The tripping method used in this mechanism is a combination of velocity and fixed diameter. Velocity tripping is effective between 4 3/4" and 3 1/4" diameters, when the stylus moves inward 1/8" or more per revolution of the turntable. No adjustment is required.

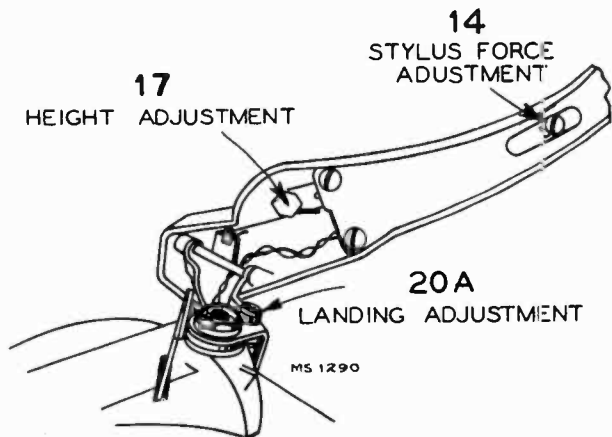

Figure 2—Adjustments

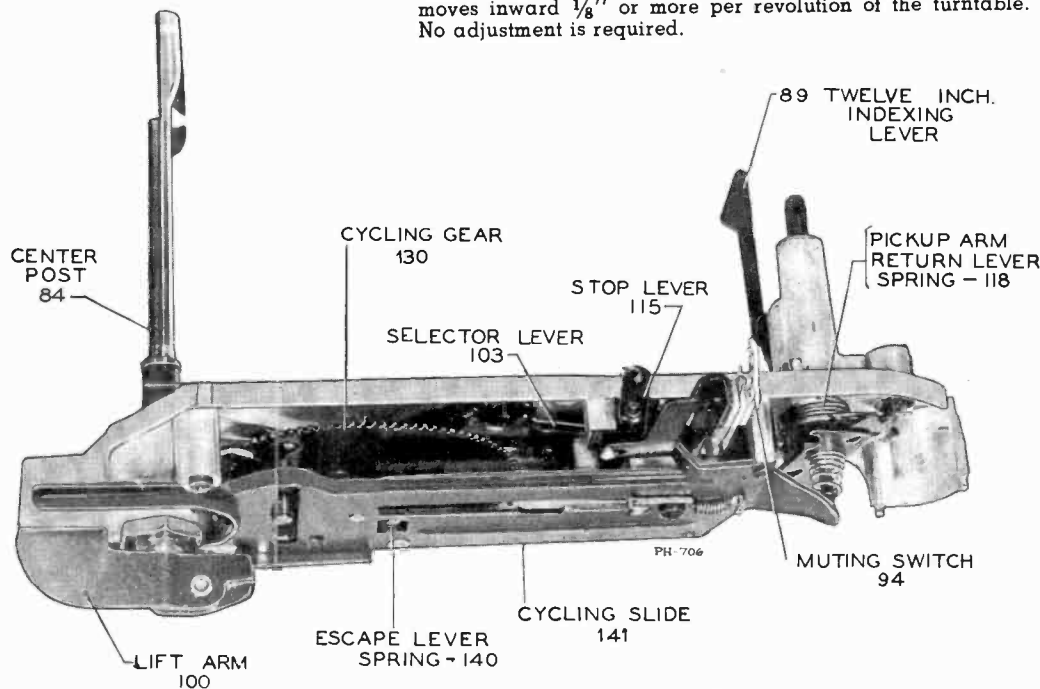

Figure 3—Slide Assembly (Complete)

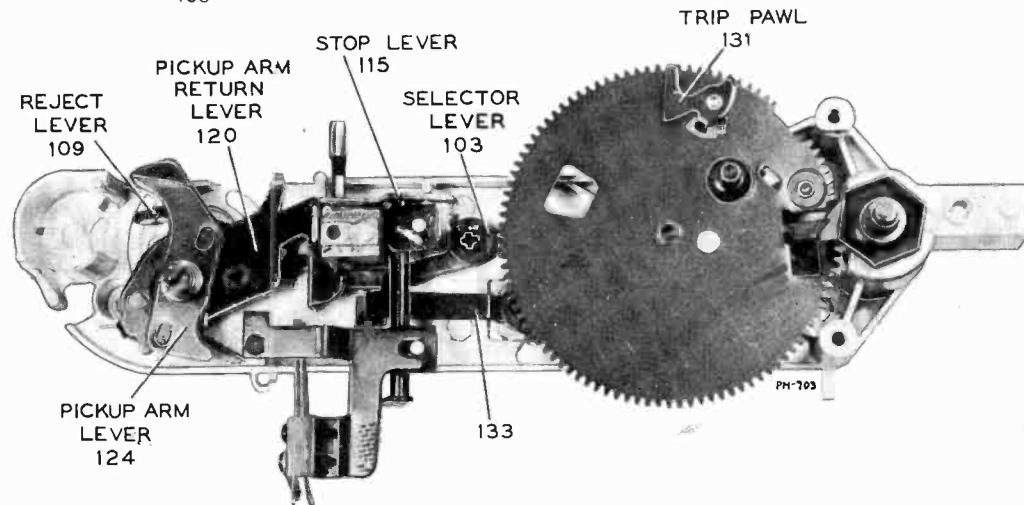

Figure 4—Slide Assembly (View with Slide Removed)

TURN ON-OFF-REJECT CONTROL KNOB TO REJECT POSITION & RELEASE

1. The on-off-reject control knob, through the linkage of the function control lever (54), reject rod (52), and reject lever (109) actuates the power switch and the trip slide (139).
2. The closing of the power switch energizes the motor and starts the turntable rotating.

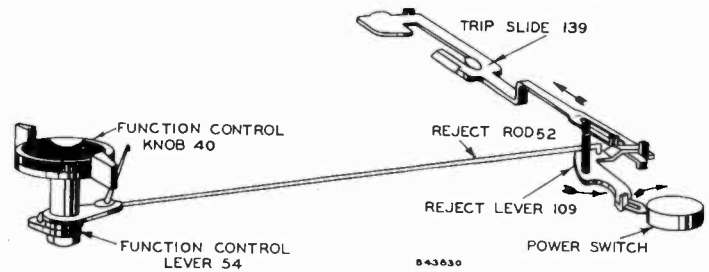

Figure 5

CYCLING STARTS

1. The trip slide (139) in its movement contacts the lower trip pawl (131) and moves both the lower and the upper trip pawls which are linked together. The movement of the upper trip pawl (129) actuates the cycling engagement pawl (130A) sufficiently to cause it to engage with the projection on the hub of the rotating turntable.
2. The contact between the cycling engagement pawl (130A) and the projection on the turntable hub gives the necessary push for the teeth in the cycling gear (130) to engage the teeth in the shaft of the turntable and thus start the change cycle.

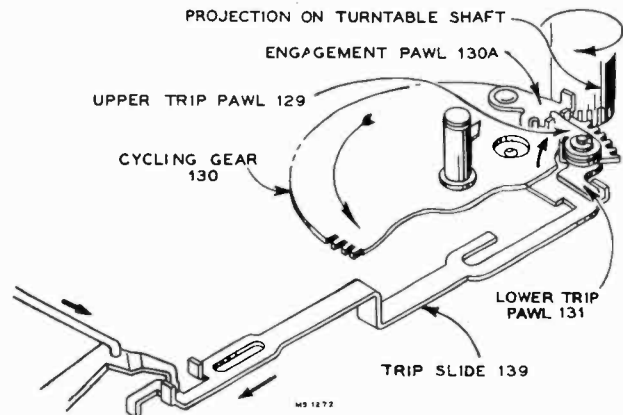

Figure 6

PICKUP ARM RISES & MOVES OUTWARD

1. As the cycling gear rotates, the stud (130B) mounted on the underside of the gear, rides inside a slot cut in the cycling slide (141). The rotation of the cycling gear pushes the cycling slide back, and later, allows it to return.
2. As the slide moves away from the center post, an incline formed on the end of the slide causes the elevating rod (123) to rise and lift the pickup arm.
3. At the same time that the elevating rod is pushed upward, the pickup arm lever (124) is also pushed up by the force transferred through the spring (125). The raising of the pickup arm lever causes the two formed dimples in the pickup arm lever to engage the two holes in the pickup arm return lever (120), and couple them together. This directs the movement of the pickup arm during change cycle.
4. The cycling slide continues to move away from the center post until the formed end of the slide pushes against the pickup arm return lever. This relieves the force of pickup arm return lever against stop lever (115). This permits the stop lever return spring (114) to return the stop lever to the normal (raised) position.
5. The end (115A) of stop lever (115) pushes trip slide back ready for the next change cycle.

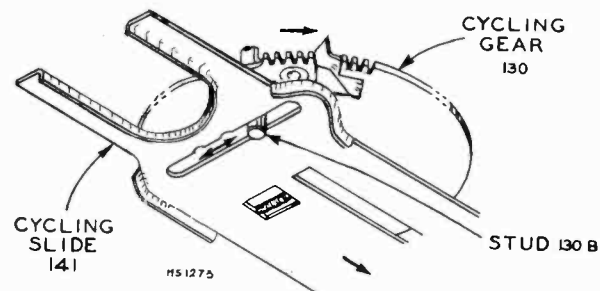

Figure 7

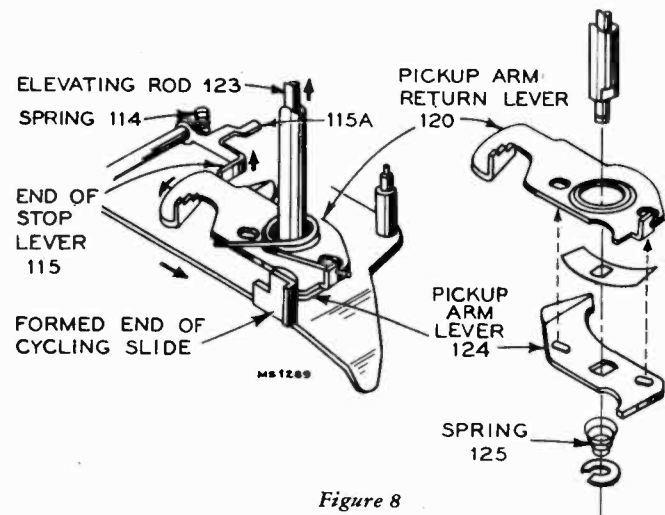

Figure 8

CYCLE OF OPERATION (Cont.)

930409 Series

RECORD DROPS TO TURNTABLE

1. After the cycling slide has raised the pickup arm and is moving it outward, the lift arm (100) is actuated by the cycling slide.
2. The lift arm pushes up on the shaft extending from the bottom end of the center post. This shaft actuates the push-off mechanism inside the center post, and the record drops to the turntable.

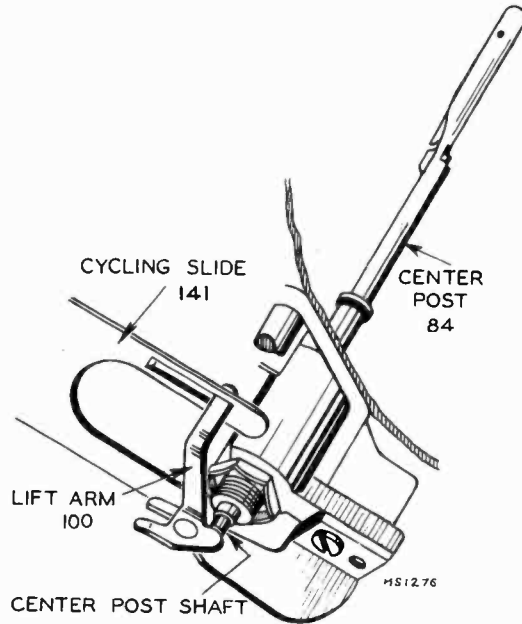

Figure 9

SELECTION OF LANDING POSITION

1. During rotation of the cycling gear the riveted tab (130C) near the center of the gear, pushes down on one end of the selector lever (103) (which is pivoted in the center) thereby raising the other end causing it to latch on the end (89A) of the twelve-inch indexing lever (89).
2. The mechanism is thus automatically indexed to land on a ten inch record unless the selector lever (139) is disengaged from the end of the twelve-inch indexing lever.

7 Inch Indexing:

The ten-inch indexing lever (133) is pivoted in the center and one end (133A) is held (by tension of spring) against the top surface of the cycling gear. A hole in the gear will permit the end of the indexing lever to lower and thus raise the opposite end of the lever. A projection (133B) on the lever will at the same time lift the selector lever, permitting it to engage the top step of the pickup arm return lever (120). This position allows the pickup arm to land on the edge of the seven-inch record.

10 Inch Indexing:

The ten-inch indexing lever will lift the selector lever unless a record on the turntable contacts the rubber tip of the ten-inch indexing lever (133), and prevents it from rising. When the lever is prevented from rising, the selector lever will remain in position to engage the middle step of the pickup arm return lever.

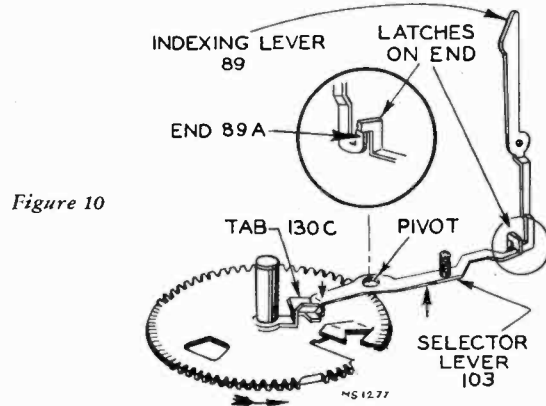

Figure 10

12 Inch Indexing:

When a twelve-inch record drops to the turntable, it strikes the twelve-inch indexing lever (89) and forces it backward. This disengages the end of the selector lever

(103) from the edge of the indexing lever and permits the selector lever to drop down into the recess (89B) at the end of the indexing lever. This position of the selector lever causes it to engage the bottom step of the pickup arm return lever (120) and will push the pickup arm to land on the edge of a twelve-inch record.

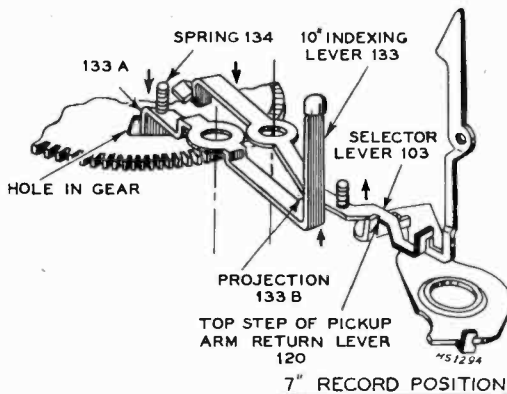

Figure 11

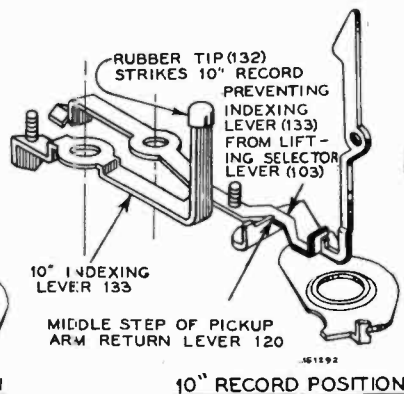

Figure 12

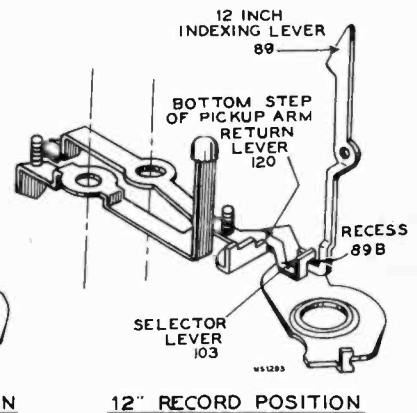

Figure 13

PICKUP MOVES IN FOR LANDING

1. As the cycling slide returns, the formed end (141A) on the slide moves back, permitting the pickup arm return lever spring (118) to expand. This causes the pickup arm return lever (120) to move the pickup inward until the pickup arm return lever comes against the selector lever (103). The pickup is now directly above the point of landing.

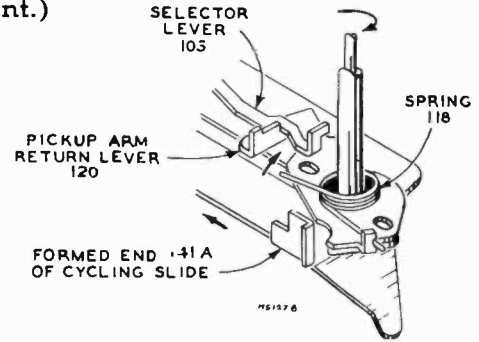

Figure 14

PICKUP LANDS ON RECORD

1. The elevating rod (123) slides down the incline on the slide permitting the pickup to land on the start of the record.
2. A cut-away portion (130D) of the teeth of the cycling gear stops the return movement of the slide before completion of cycle. The stud (130B) in the cycling gear rests in the first indentation (offset from center) of the slide to stabilize it in this position.
3. Just before the cycling gear completes cycle, a small tab (141C) on cycling slide makes contact with lower trip pawl (131) thereby moving upper trip pawl and cycling engagement pawl back. This prevents the re-engagement with the projection on the turntable hub which would start a new change cycle.
4. On the next revolution the projection on the hub of the turntable engages with a formed lug (130E) on the outer edge of the cycling gear. The cycling gear will then rotate until the second cut-away portion (130F) of the teeth again stops the movement of the slide, this time at completion of the cycle. The stud on the cycling gear rests in the second indentation (center) of the slide to stabilize it in this position.

The purpose of this pause in the cycle is to allow the pickup to enter the starting groove of the record before the full effect of the feed-in spring is applied to the pickup arm.

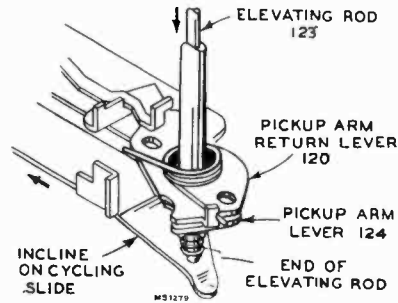

Figure 15

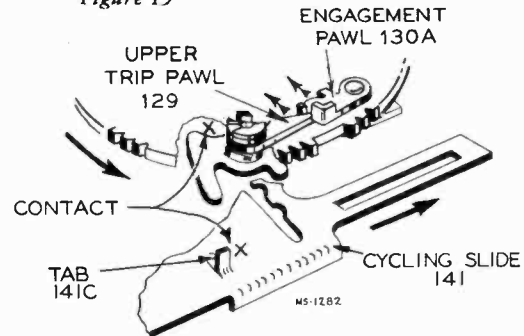

Figure 16

RECORD PLAYS

1. As the record plays, the pickup moves in toward the center of the record carrying the trip slide along. This is due to the contact made with the pickup arm lever which turns with the pickup arm pivot.
2. The trip slide contacts the lower trip pawl, causing both (lower and upper) trip pawls and the cycling engagement pawl to move slightly with each revolution of the record. This slight movement of the pawls is reversed each time the projection on the turntable hub comes in contact with the cycling engagement pawl. The back movement is taken up in the friction connection between the upper and lower trip pawls.

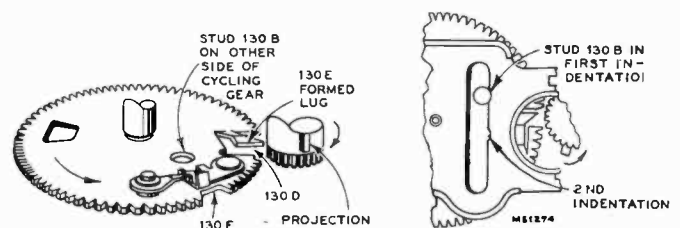
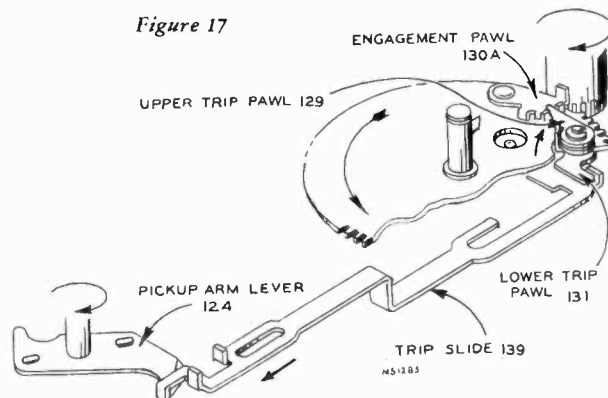

Figure 17

TRIPPING

This slight movement of the pawls continues as long as the pickup moves in at a constant rate of speed. When the stylus leaves the recorded section of the record, the rapid acceleration results in rapid movement of the cycling engagement pawl. The cycling engagement pawl assumes a position in which the projection on the turntable hub makes a positive contact and the cycling cam is pushed sufficiently for engagement between the teeth of the cycling gear and the teeth on the turntable hub. This starts change cycle.



MECHANISM STOPS AFTER PLAYING OF LAST RECORD

After the mechanism has been tripped it again follows the preceding sequence of cycling and playing the records until the last record of the stack has been played.

1. As the last record of the stack drops to the turntable the record stabilizer drops and actuates the stop arm (115). This stop arm in turn applies force to stop lever (115) through spring (115B) and connecting wire (137). At this moment the cycling slide is in the outermost position (away from centerpost) and the end (115B) of stop lever is forced against escape lever (141B) which prevents it from lowering any further.
2. As the cycling slide returns to the out of cycle position the end (115B) of stop lever slides off the escape lever permitting the end to extend down through the slot in the cycling slide. At this time the pickup arm return lever has rotated too far to be blocked by the other end (115C) of the stop lever and the pickup is permitted to land on the record.
3. After the last selection has been played the mechanism again goes into change cycle, and the cycling slide moves into its outermost position. At this moment the force which has been applied to the stop lever from the record stabilizer causes the end (115B) to lower, thus extending further through the cycling slide. The other end (115C) of stop lever raises and blocks the pickup arm return lever which at this moment is held back by the cycling slide.
4. As the cycling slide moves back, it carries the raised trip slide along until finally the formed end (139A) of the trip slide pushes reject lever which in turn actuates the power switch (110). This removes the power from the drive motor and mechanism stops.
5. The elevating rod (124) lowers the pickup arm to the rest.

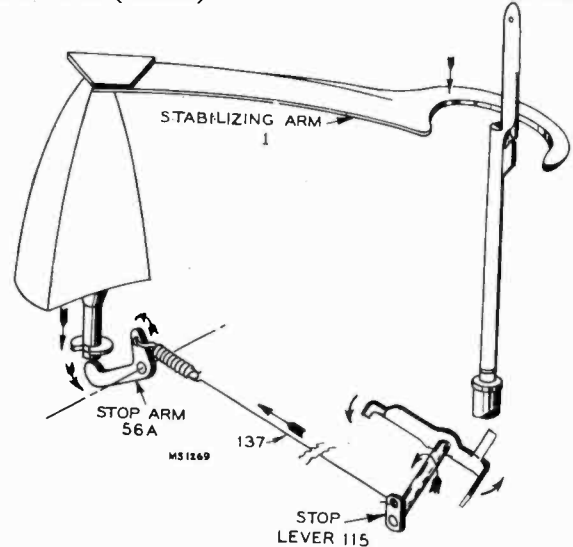

Figure 19

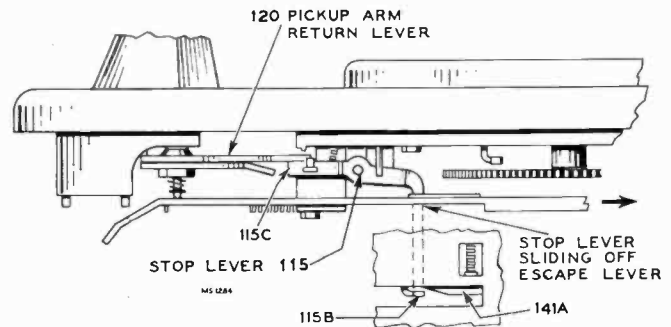

Figure 20

45 R.P.M. CENTERPOST

For playing of 45 r.p.m. records which have a 1 1/2 inch center hole, the 45 r.p.m. centerpost is placed over the 1/4 inch centerpost. The push-off finger (84A), which is part of the 1/4 inch centerpost actuates the slide (24), this slide actuates the separator knives (25A & 25B) and separator shelves (26A & 26B) of the 45 r.p.m. centerpost.

As the push-off finger moves up it engages a finger (24B) of the slide (24) in the 45 r.p.m. centerpost; and, as it moves horizontally, it pushes the slide against the tension of the slide return spring (27). A projecting pin (24C) on the bottom of the slide engages both shelves and both knives and forces them to turn on their pivots. The shelves are pivoted near their center and are caused to retract as the slide is forced to move by the push-off finger. The knives are pivoted at their ends and are forced outward at the same time that the shelves are retracted. A formed spring (28) returns the shelves to the extended position.

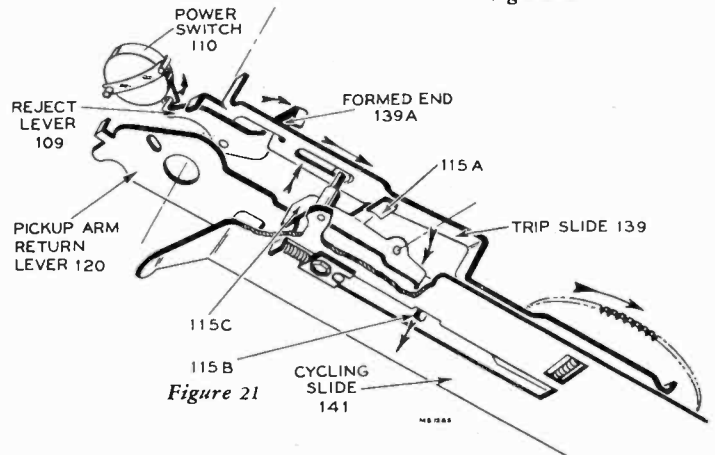

Figure 21

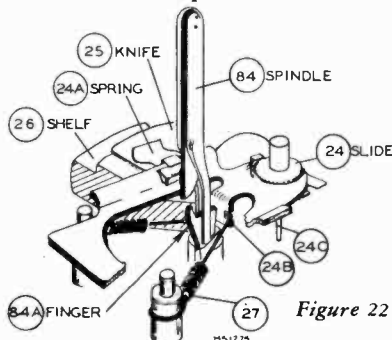

Figure 22

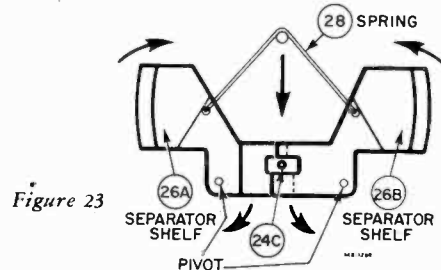

Figure 23

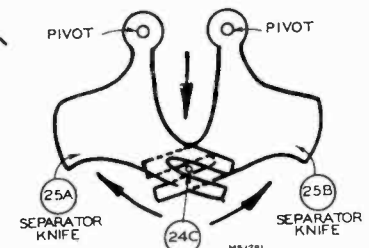

Figure 24

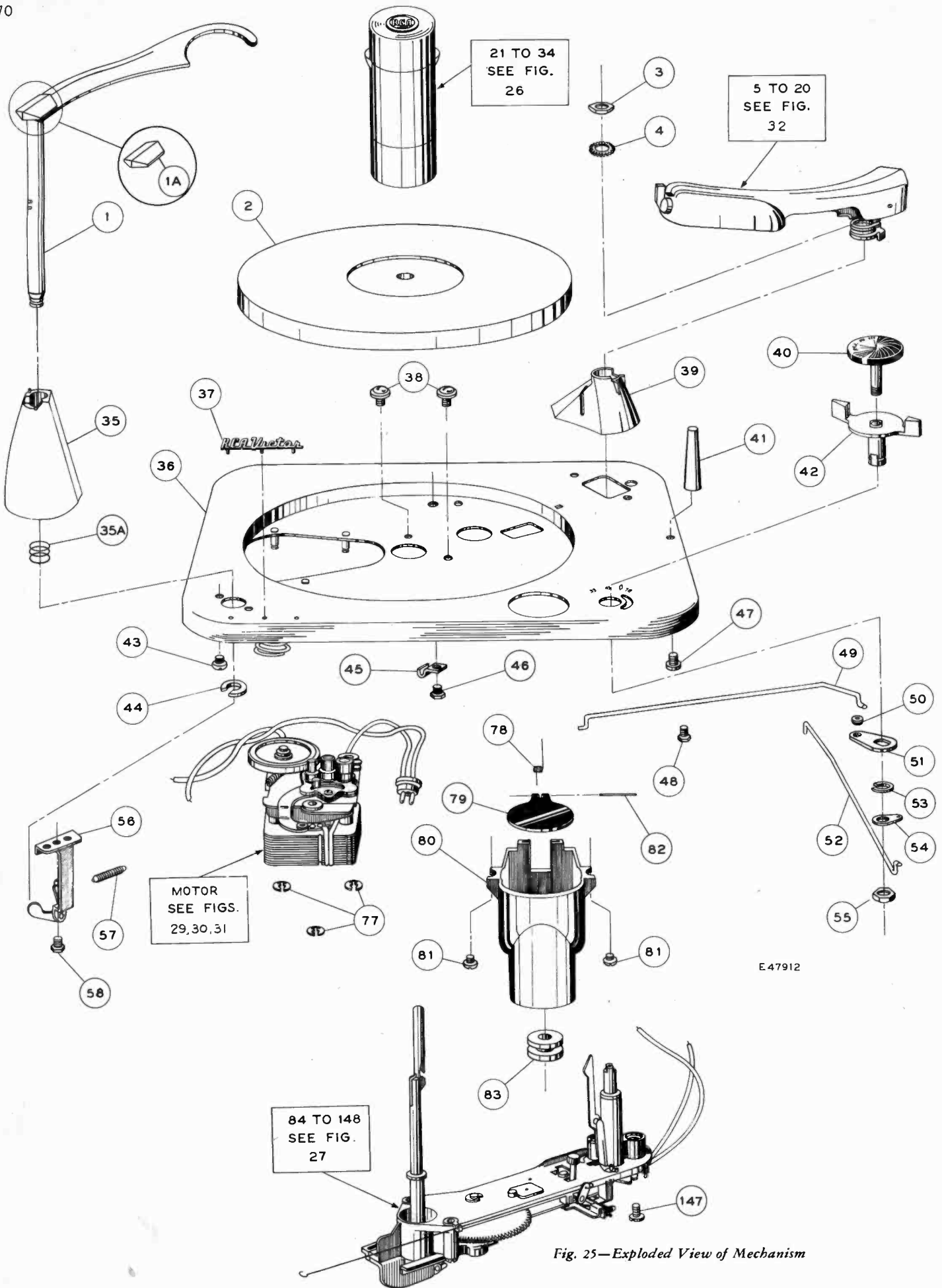

Fig. 25—Exploded View of Mechanism

REPLACEMENT PARTS

930409 Series

ILL. NO.	STOCK NO.	DESCRIPTION
1	76913	Stabilizer—Record stabilizer—plum—complete with plastic cap for 930409-3, -4, -5, -6, -9 and -11
1	76914	Stabilizer—Record stabilizer—beige—complete with plastic cap for 930409-10
1A	75804	Cap—Plastic cap—maroon—for record stabilizer for 930409-3, -4, -5, -6, -9 and -11
1A	75805	Cap—Plastic cap—beige—for record stabilizer for 930409-10
2	77118	Turntable—Turntable and hub assembly—maroon flock.
2	77119	Turntable—Turntable and hub assembly—tan flock—for 930409-10
3	76905	Nut—1/4—28 hex nut (jam) for pickup arm bracket
4	---	Lockwasher—1/4 external type lockwasher for pickup arm shaft
35	76941	Housing—Record stabilizer housing—plum—Type "A" (see Page 2) for 930409-3, -4, -5, -6, -9 and -11
35	77256	Housing—Record stabilizer housing—plum—Type "B" (see Page 2)
35A	77257	Spring—Record stabilizer return spring for use with Type "B" record stabilizer housing
35	76942	Housing—Record stabilizer housing—beige—for 930409-10
36	---	Motorboard—Motorboard—complete
37	74782	Emblem—"RCA Victor" emblem
38	---	Screw—#10-24 x 3/8" binding head machine screw and internal lockwasher
39	75829	Housing—Pickup arm pivot shaft housing—plum—for 930409-3, -4, -5, -6, -9 and -11
39	75873	Housing—Pickup arm pivot shaft housing—beige—for 930409-10
40	76915	Knob—Reject control knob and shaft—maroon—for 930409-3, -4, -5, -6, -9 and -11
40	76916	Knob—Reject control knob and shaft—beige—for 930409-10
41	75827	Rest—Pickup arm rest (maroon) for 930409-3, -4, -5, -6, -9 and -11
41	75828	Rest—Pickup arm rest (beige) for 930409-10
42	76937	Knob—Motor speed control knob and shaft
43	---	Screw—#6-32 x 1/4" hex head screw
44	75385	Washer—"C" washer to mount record stabilizer
45	---	Clamp—Cable clamp
46	---	Screw—Screw for mounting cable clamp
47	75830	Screw—#10 x 1/2 cross recessed pan head screw to mount pickup arm rest
48	---	Screw—#6-32 x 1/4" hex head screw
49	76920	Rod—Motor speed control rod
50	77229	Grommet—Rubber grommet for motor speed control rod
51	76918	Lever—Motor speed control lever
52	76919	Rod—"On-Off"—"Reject" rod
53	75825	Washer—"C" washer for motor speed control knob and shaft
54	76917	Lever—Switch control lever
55	77227	Nut—Pal nut for reject control knob and shaft
56	76927	Arm—Stop arm assembly
57	76926	Spring—Return spring (coil type) for stop arm (1/8" I.D. x 19/32)
58	---	Screw—6-32 x 5/16" cross recessed round head screw
77	75876	Washer—"C" washer to mount motor
78	76925	Spring—Spring for 45 r.p.m. centerpost housing hinge pin
79	76922	Lid—45 r.p.m. centerpost housing lid—maroon—for 930409-3, -4, -5, -6, -9 and -11
79	76923	Lid—45 r.p.m. centerpost housing lid—beige—for 930409-10
80	76921	Housing—45 r.p.m. centerpost housing lid well—less lid and rubber bumper
81	---	Screw—#10-32 x 3/16" cross recess pan head screw to mount 45 r.p.m. centerpost housing
82	76924	Pin—Hinge pin for 45 r.p.m. centerpost housing lid
83	76940	Bumper—45 r.p.m. centerpost housing rubber bumper
147	---	Screw—#10-24 x 3/8" binding head machine screw and internal lockwasher
45 RPM CENTERPOST ASSEMBLY		
---	76945	Centerpost—45 r.p.m. centerpost complete
21	76928	Cap—Nose cap
22	76930	Spring—Nose spring (formed)
23	76909	Screw—#4-40 x 1/4" cross recessed binding head screw for nose spring
24	76933	Plate—Slider plate assembly complete with springs 24A
25	76932	Knife—Record separator knife (1 set)
26	76931	Shelf—Record support shelf (1 set)
27	76934	Spring—Slider return spring (coil type—2 in 1)
28	76935	Spring—Shelf return spring (formed)
29	---	Body—Spindle body assembly
30	76936	Screw—#4-40 x 7/8" fillister head screw for nose cap
31	---	Rotor—Die-cast rotor
32	76954	Spring—Rotor lift spring (coil) (1.168" O.D. x 1"—4-5 turns)
33	---	Lift—Rotor lift
34	76929	Bearing—Bottom bearing

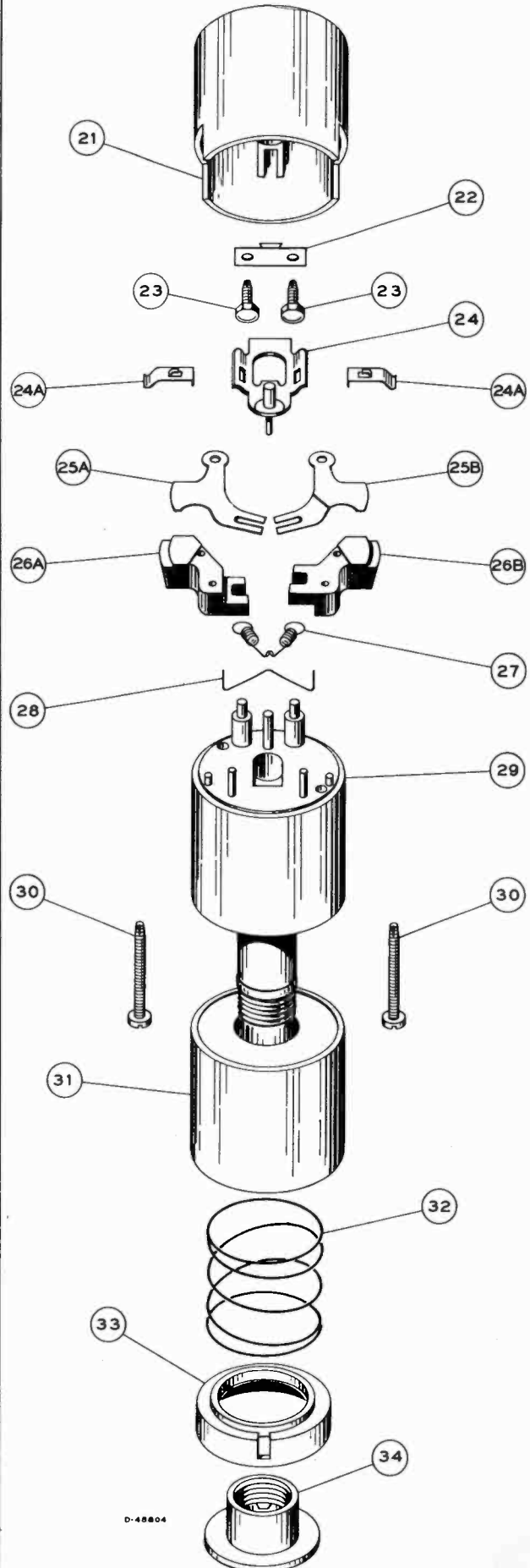
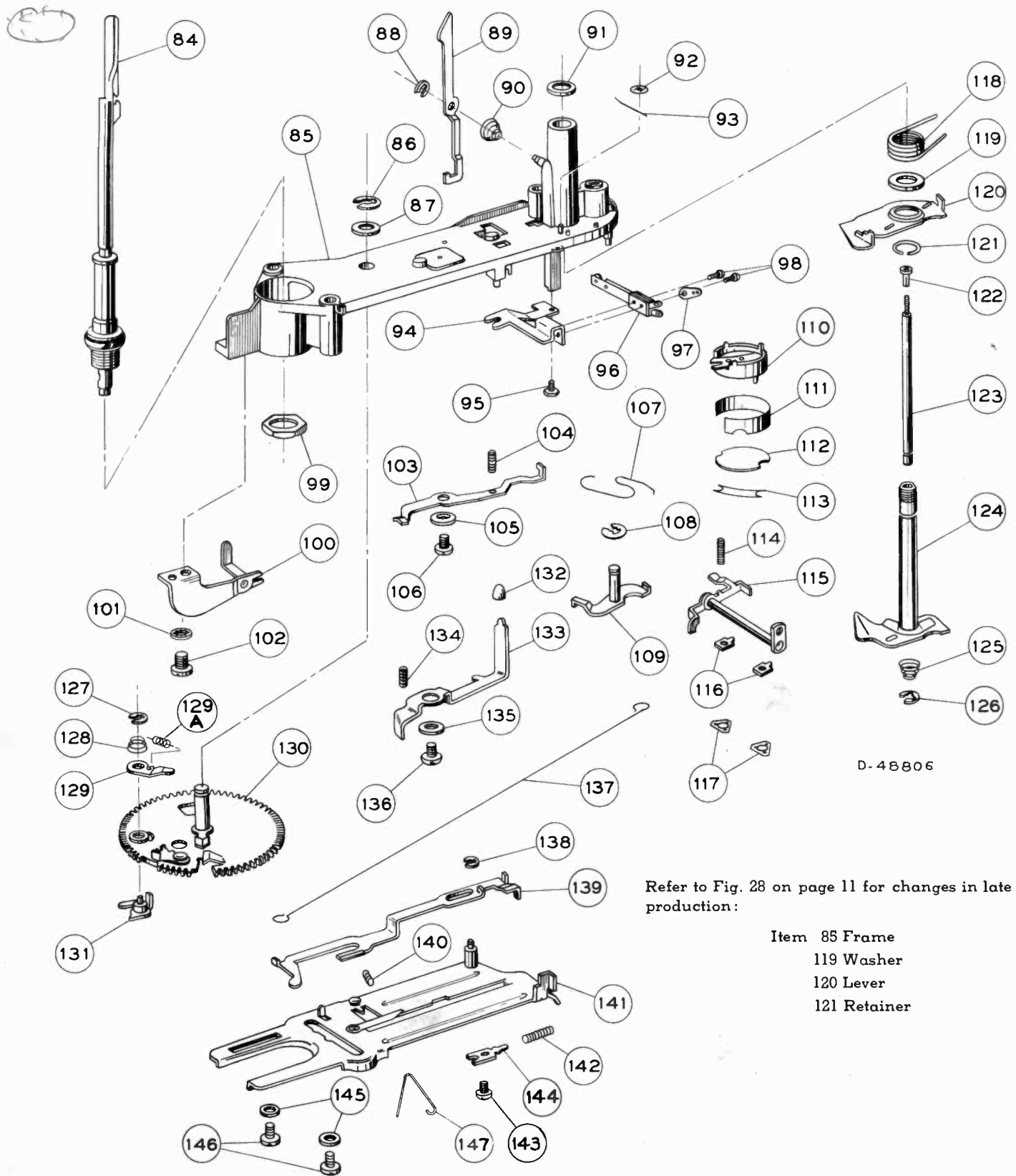

Fig. 26—45 r.p.m. Centerpost Assembly



Refer to Fig. 28 on page 11 for changes in late production:

Item 85 Frame
 119 Washer
 120 Lever
 121 Retainer

Fig. 27—Slide Assembly

REPLACEMENT PARTS (Cont.)

930409 Series

Late production record changers use a revised frame (Item 85) and pickup arm lever (Item 120). These items are not directly interchangeable but may be interchanged in a group as listed below.

Item No.	Early Part	Late Part	Description
85	76910	78635	Frame
119	75848	Not used	Washer
120	75849	78636	Lever
121	75850	78637	Retainer

Frames may be identified by a number which is cast into the frame (see Fig. 28 below).

Early frame is identified by number "2525".
Late frame is identified by number "6425".

Levers may be identified by having or not having a bearing collar staked to the lever (see Fig. 28 below).

Early lever does not have staked collar.
Late lever does have staked collar.

Retainers may be identified by size.
Early retainer is .312" I. D.
Late retainer is .390" I. D.

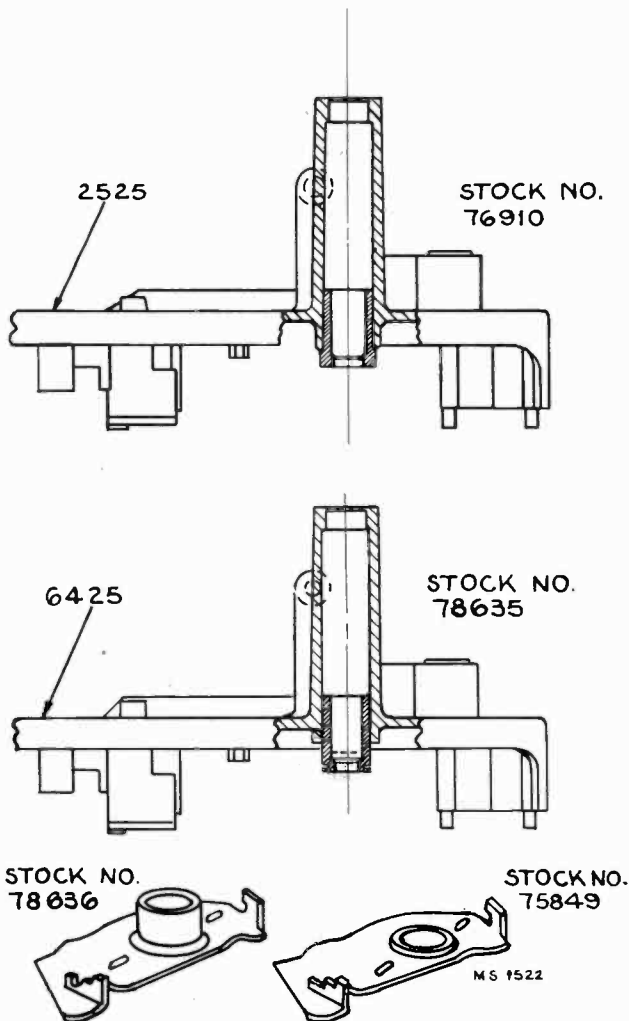

Fig. 28—Alternate Slide Plate Frame

ILL. NO.	STOCK NO.	DESCRIPTION
SLIDE ASSEMBLIES		
84	76904	Centerpost—33 $\frac{1}{3}$ -78 r.p.m. centerpost complete with bearing
85	76910	Frame—Main frame—(die-cast)
86	75373	Washer—"C" washer for mounting cycling gear
87	75845	Washer—Fibre washer for mounting cycling gear
88	75397	Washer—"C" washer for 12" indexing lever
89	75844	Lever—12" record indexing lever
90	76309	Spring—12" record indexing lever spring
91	76903	Washer—Pickup thrust washer (fibre)
92	75841	Nut—Speed nut for 12" indexing lever return spring
93	75842	Spring—12" indexing lever return spring (formed)
94	----	Bracket—Muting switch bracket
95	----	Screw—#4-40 x $\frac{1}{4}$ " hex head (indented) thread cutting screw to mount muting switch assembly
96	77191	Switch—Muting switch—less mounting bracket
97	----	Terminal—#4 locking terminal for muting switch assembly
98	----	Screw—#3-48 x 13/32" binding head machine screw for muting switch
99	----	Nut— $\frac{1}{2}$ -20 pal nut for mounting 33 $\frac{1}{3}$ -78 r.p.m. spindle
100	75864	Arm—Lift arm
101	----	Screw—#10-24 x $\frac{3}{8}$ " binding head machine screw and internal lockwasher
102	----	Screw—#10-24 x $\frac{3}{8}$ " binding head machine screw and internal lockwasher
103	75859	Lever—Landing selector lever
104	75860	Spring—Return spring (coil type) for landing selector lever (.110" O.D. x $\frac{3}{8}$ "—14 turns)
105	----	Washer—Metal washer (steel) (1/32" x 7/16" O.D. x .140)
106	----	Screw—#6-32 x $\frac{1}{4}$ " hex head screw
107	76312	Spring—Reject spring (special)
108	75392	Washer—"C" washer for mounting reject lever
109	75856	Lever—Reject lever
110	75857	Switch—"On-Off" switch complete with insulating strip (111) and cover (112)
111		
112		
113		
114	76908	Retainer—Switch cover retainer (flat)
115	76314	Spring—Return spring (coil type) (.125" O.D. x 7/16" —14 turns)
116	76313	Lever—Stop lever
117	77258	Strip—Bearing strip for stop lever shaft
118	76912	Nut—Speed nut for mounting stop lever bearing shafts
119	76944	Spring—Pickup arm return lever spring (coil) (.593" O.D.—3 $\frac{1}{2}$ turns)
120	75848	Washer—Fibre washer for pickup arm pivot shaft
121	75849	Lever—Pickup arm return lever
122	75850	Retainer—Retaining ring for pickup arm return lever
123	76952	Nut—Elevating rod adjustment nut
124	76951	Rod—Elevating rod
125	76946	Shaft—Pickup arm pivot shaft and lever
126	76906	Spring—Thrust spring (conical) for elevating rod
127	77269	Ring—Retaining ring
128	75397	Washer—"C" washer
129	76309	Spring—Trip pawl spring
129A	77250	Pawl—Trip pawl—upper
130	77249	Spring—Trip pawl cushion spring (coil)
131	76955	Gear—Cycling gear complete with shaft and engagement pawl 130A
132	76953	Pawl—Trip pawl—lower
133	76900	Bumper—Rubber bumper for 10" indexing lever
134	76901	Lever—10" indexing lever
135	76314	Spring—Return spring (coil type) (.125" O.D. x 7/16" —14 turns)
136	----	Washer—Metal washer (steel) (1/32" x 7/16" O.D. x .140)
137	----	Screw—#6-32 x $\frac{1}{4}$ " hex head screw
138	75862	Link—Control link
139	75397	Washer—"C" washer
140	76950	Slide—Trip slide
141	75861	Spring—Escape lever spring (coil) (.120" O.D. x $\frac{1}{2}$ " —21 turns)
142	76956	Slide—Cycling slide and cam assembly—less escape lever spring
143	77228	Spring—Stabilizing spring (coil) for cycling slide (.146" O.D. x $\frac{3}{4}$ "—14 $\frac{1}{2}$ turns)
144	----	Screw—#6-32 x $\frac{1}{4}$ " hex head screw
145	75872	Plate—Bearing plate for cycling slide
146	76897	Washer—Metal washer (brass) for cycling slide
147	----	Screw—#6-32 x $\frac{1}{4}$ " hex head screw
148	77934	Spring—Slide detent spring

930409 Series

REPLACEMENT PARTS (Cont.)

ILL. NO.	STOCK NO.	DESCRIPTION
MOTOR ASSEMBLIES		
Motors Stamped:		
5046—for 930409-3 & -6		
5355—for 930409-5 & -10		
5047—for 930409-9		
5432—for 930409-11		
59	76744	Spring—Hairpin spring for idler wheel
60	76743	Washer—Flat metal washer
61	76750	Wheel—Idler wheel
62	77132	Plate—Drive pulley mounting plate complete with three pulleys
62A	76746	Pulley—78 r.p.m. pulley
62B	76747	Pulley—45 r.p.m. pulley
62C	76748	Pulley—33 1/3 r.p.m. pulley
63	—	Screw—Screw to mount drive pulley plate
64	—	Lockwasher—Lockwasher for pulley plate screw
65	77685	Lever—Speed shift lever for #5046, #5047, and #5432 motors (930409-3, -6, -9 and -11)
65	77133	Lever—Speed shift lever for #5355 motor (930409-5 and -10)
66	77229	Grommet—Rubber grommet for speed shift lever
67	75432	Spring—Hairpin spring for idler wheel plate and support
68	▲	Plate—Idler wheel slide plate and support assembly
69	78374	Spring—Slide plate tension spring
70	76751	Grommet—Rubber grommet for motor mounting
71	76743	Washer—Slide plate bearing washer (metal)
72	76749	Sleeve—Spring sleeve pulley for 60 cycle operation
72	77686	Sleeve—Spring sleeve pulley for 50 cycle operation for motors #5432, #5046 and #5047 (930409-3, -6, -9 and -11)
73	30870	Connector—2 prong male connector
74	—	Motor—Motor assembly complete (Refer to page 13)
75	76755	Spring—Detent spring for speed shift lever
76	77134	Collar—Collar for speed shift lever mounting
	▲	Item 68 discontinued. Use Stock No. 78371 top plate and knuckle joint assembly described at right. Two other types of motors have been used as alternates for the above listed motors. See page 13.

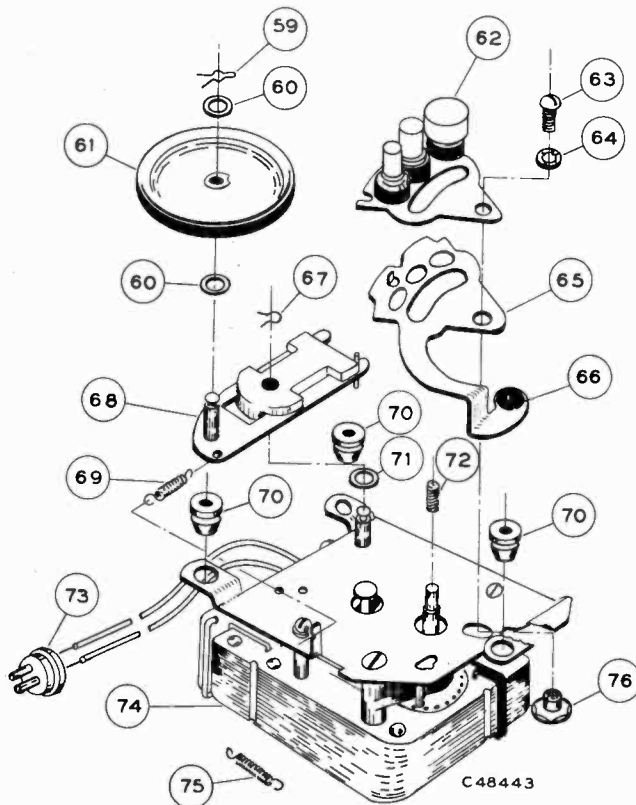

Fig. 29—Assembly of Motors
Stamped 5046, 5047, 5355 and 5432

"WOW" OR SLOW SPEED—

"Wow" or slow speed is generally most noticeable in the 33 1/3 RPM position but may also occur on the 45 RPM and 78 RPM positions. The most frequent causes of "wow" and slow speed are listed below. It is suggested that all these items be checked when servicing changers.

A. CHANGERS USING IDLER WHEEL SLIDE PLATE TYPE MOTOR ASSEMBLIES

1. PIN IN SLIDE PLATE RESTRICTS MOVEMENT OF SLIDE PLATE.

This prevents idler wheel from making firm contact with turntable rim. TO CORRECT—Remove pin from slide plate and discard—remove all burrs from around the hole after pin is removed.

2. BIND IN IDLER WHEEL SLIDE PLATE.

The slide plate must be completely free to move its full travel without binding. It must be flat and without burrs or scratches.

TO CORRECT—Straighten slide plate if necessary. Remove any burrs on slide plate. Thoroughly clean slide plate and slots of casting with carbon tetrachloride. *Lubricate slide plate with STA-PUT #320 to assure ample lubrication at all slide contact surfaces.*

3. OIL ON RUBBER TIRES.

TO CORRECT—Wash all rubber tires with carbon tetrachloride. Do not handle with oily fingers.

4. IDLER WHEEL TENSION SPRING TOO LONG.

TO CORRECT—Remove turns if necessary—there should be only 18 active turns. It may be necessary to remove as much as 5 turns. Stock No. 78374 spring should be used for replacement.

B. IDLER WHEEL TOP PLATE AND KNUCKLE-JOINT ASSEMBLY, STOCK NO. 78371

If the procedure in section "A" does not prove completely satisfactory for critical applications, the original slide plate assembly may be replaced with the idler wheel top plate and knuckle-joint assembly, Stock No. 78371 using the following procedure:

Disassembly

1. Remove turntable "C" washer and lift turntable up.
2. Remove idler wheel, two fiber washers, and hair pin retainer spring. (Items 59, 60, 61).
3. Remove motor (held by three "C" washers) (Item 77) from changer and disengage the speed shift linkage rod (Item 49).

Transfer of Usable Parts

1. Transfer rubber mounting grommets (Item 70) from old plate to new plate.
2. Remove motor top plate (held by three screws to motor laminations). Motor bearings are loose and must be kept intact during the transfer of plates.
3. Remove detent spring (Item 75) from detent lever on bottom surface of old top plate and transfer this spring to corresponding location on new plate.
4. Transfer the idler speed-changer mounting plate and speed-shift lever from old plate to new plate. (Held by screw, washer, and collar.)
5. Assemble new plate to motor laminations. Make sure motor bearings are properly positioned and that armature is free after screws are tightened.

Assembly of New Top Plate

1. Engage speed shift linkage rod, and re-assemble motor to changer.
2. Install idler wheel with fiber washers, top and bottom, and hair pin retainer spring to knuckle-joint lever, applying not more than one drop of STA-PUT #320 lubricant to the idler wheel bearing.
3. Thoroughly clean surface of idler wheel, pulleys on speed change plate, upper end of motor shaft, and inner rim of turntable with carbon tetrachloride to remove all traces of oil and grease.
4. Replace turntable and retaining "C" washer, making sure that idler wheel is pressed inward under the turntable before seating the turntable, to avoid damage to the idler or knuckle-joint assembly.

930409 Series

ILL. NO.	STOCK NO.	DESCRIPTION	ILL. NO.	STOCK NO.	DESCRIPTION
		MOTOR ASSEMBLIES Stamped: 5685—for 930409-9 5686—for 930409-5 & -10 5687—for 930409-11			MOTOR ASSEMBLIES Stamped 4638—for 930409-3, -5, -6, -10 and -11
1	76750	Wheel—Idler wheel	1	78508	Wheel—Idler wheel with fibre washer
2	75433	Washer—Fibre washer	2	78509	Washer—Fibre washer
3	76744	Retainer—Idler wheel retainer (hairpin spring)	3	78510	Washer—Felt washer
4	78645	Support—Idler wheel support	4	78511	Washer—"C" washer
5	78646	Retainer—Support retainer (hairpin spring)	5	78512	Spring—Idler spring
6	78647	Washer—Bearing washer	6	Screw—Holddown plate mounting screw
7	78648	Link—Idler wheel support link	7	Lockwasher—Holddown plate mounting screw lock-washer
8	Spacer—Metal spacer for link mounting	8	78513	Plate—Holddown plate
9	78374	Spring—Idler wheel tension spring	9	78514	Grommet—Motor mounting grommet
10	Screw—Screw for mounting plate	10	78515	Washer—Blued steel washer
11	Lockwasher—Lockwasher for mounting plate	11	78516	Plate—Idler plate assembly
12	76751	Grommet—Rubber grommet for motor mounting	12	78517	Link—Idler link
13	30870	Plug—Two (2) prong male plug	13	78518	Arm—Pulley plate latch arm
14	76755	Spring—Detent spring	14	78519	Spring—Pulley latch spring
15	77134	Collar—Speed shift lever collar (nut)	15	78520	Spring—Shifter latch spring
16	78371	Plate—Mounting plate assembly includes items 4, 5, 6, 7, 8, and 9	16	78521	Lever—Latch arm lever
17	76749	Sleeve—Spring sleeve pulley for 60 cycle operation of #5685, #5686 and #5687	17	78522	Sleeve—Spring sleeve pulley for 60 cycle operation
17	77686	Sleeve—Spring sleeve pulley for 50 cycle operation of #5685 and #5687	17	78523	Sleeve—Spring sleeve pulley for 50 cycle operation
18	77685	Lever—Speed shift lever	18	78524	Plate—Speed pulley mounting plate-less pulleys
19	77229	Grommet—Rubber grommet for shift lever	18A	78525	Pulley—33 1/3 r.p.m. pulley
20	77132	Plate—Speed pulley mounting plate with 3 pulleys	18B	78526	Pulley—45 r.p.m. pulley
20A	76748	Pulley—33 1/3 r.p.m. speed pulley	18C	78527	Pulley—78 r.p.m. pulley
20B	76747	Pulley—45 r.p.m. speed pulley	18D	78528	Washer—Speed pulley fibre washer
20C	76746	Pulley—78 r.p.m. speed pulley	19	78529	Lever—Speed shift lever
20D	75428	Washer—Felt washer	20	78530	Grommet—Speed shift lever grommet
20E	75427	Retainer—Retainer for speed pulleys	21	30870	Plug—2 prong male plug
21	—	Screw—Screw for mounting pulley plate	78531		Motor—Motor assembly COMPLETE—less mounting grommets and plug—for 115 volts, 60 cycles.
22	—	Lockwasher—Lockwasher for pulley plate			
460A001		Motor—Motor assembly (#5685) COMPLETE for 230 volts, 50 cycles			MOTOR ASSEMBLIES Motor Stamped: 5191—for 930409-4 Order by description
78372		Motor—Motor assembly (#5686) with mounting plate and idler support—LESS idler wheel, speed shift lever and pulley mounting plate for 115 volts, 60 cycles.			
78373		Motor—Motor assembly (#5687) COMPLETE for 115 volts, 50 cycles.			

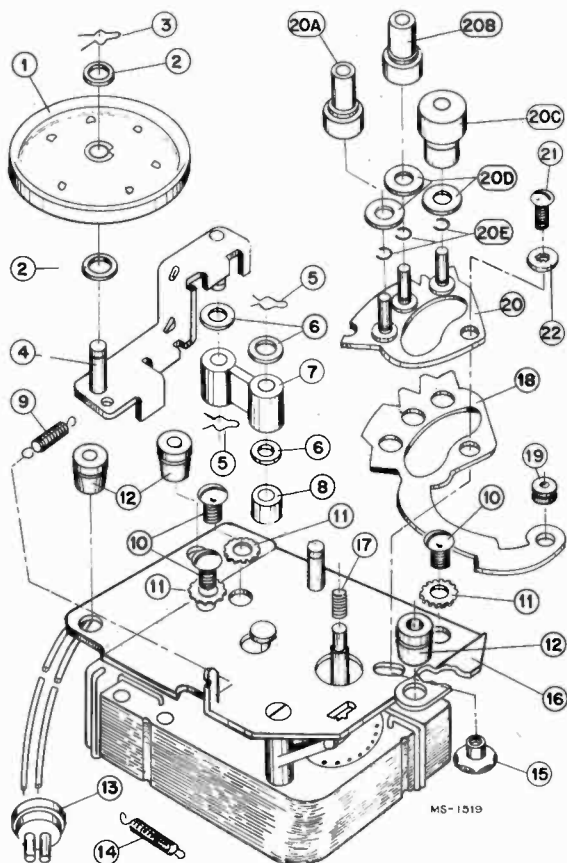

Fig. 30—Assembly of Motors Stamped 5685, 5686 and 5687

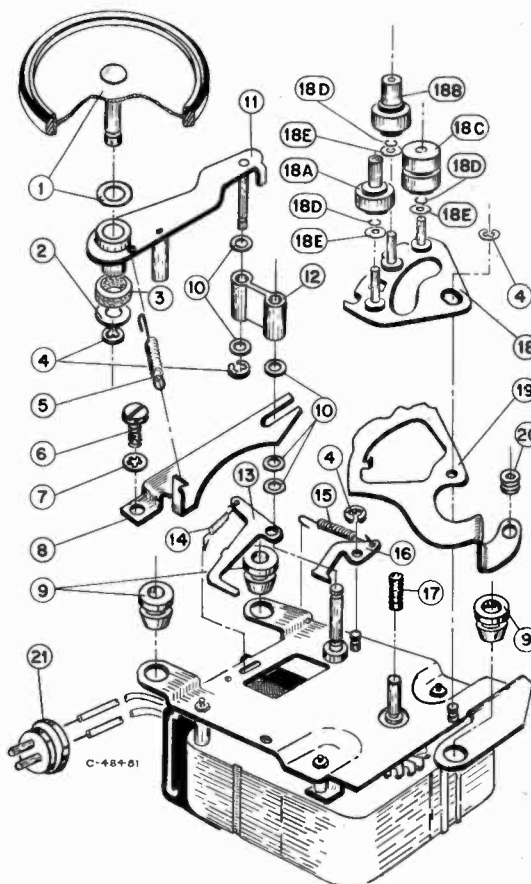

Fig. 31—Assembly of Motor Stamped 4638

930409 Series

REPLACEMENT PARTS (Cont.)

ILL. NO.	STOCK NO.	DESCRIPTION	ILL. NO.	STOCK NO.	DESCRIPTION
PICKUP ASSEMBLIES For 930409-3 and 930409-9			7	76949	Arm—Pickup arm shell (plastic) for 930409-5, -10 and -11
10	S-5652	Pickup—Ceramic pickup complete with two styli —for 930409-3	7	100A001	Arm—Pickup arm shell (plastic) for 930409-3, -4, -6 and -9
10	75044	Pickup—Crystal pickup complete with two styli —for 930409-9	7A	76948	Screw—Pickup arm mounting bracket pivot screw
10A	75046	Stylus—Osmium tip stylus and holder (.003" r., uncoded) for 78 r.p.m.	7B	76947	Bearing—Pickup arm mounting bracket pivot bearing
10B	75045	Stylus—Osmium tip stylus and holder (.001" r., coded red) for 45-33 1/3 r.p.m.	8	75808	Cable—Three (3) wire pickup cable complete with connectors for 930409-5, -10 and -11
10C	75274	Nut—Knurled nut to mount stylus	8	163A001	Cable—Three (3) wire pickup cable complete with connectors for 930409-3, -4, -6 and -9
PICKUP ASSEMBLIES For 930409-4 and 930409-6			9	---	Screw—#4-40 x 1/8" fillister head screw to mount pickup cartridge
10	162A001	Pickup—Ceramic pickup complete with two styli	11	76957	Swivel—Pickup cartridge mount and swivel assembly for 930409-5, -10 and -11
10A	490B001	Stylus—Osmium tip stylus (.003" r., uncoded) for 78 r.p.m.	11	130A001	Swivel—Pickup cartridge mount and swivel assembly for 930409-3, -4, -6 and -9
10B	490A001	Stylus—Osmium tip stylus (.001" r., coded red) for 45-33 1/3 r.p.m.	12	75809	Spring—Pickup arm counterbalance spring
PICKUP ASSEMBLIES For 930409-5, 930409-10 and 930409-11			13	75810	Bracket—Pickup arm weight adjustment bracket (slide)
10	75475	Pickup—Crystal pickup complete with two osmium styli	14	76899	Screw—#6-32 x 1/8" round head screw for pickup arm weight adjustment bracket
10	77779	Pickup—Crystal pickup complete with one osmium stylus and one sapphire stylus	15	76896	Screw—#4 x 1/4" binding head sheet metal screw to mount swivel assembly in arm
10A	75497	Stylus—Osmium tip stylus (.003" r., uncoded) for 78 r.p.m.	16	75812	Spring—Lock spring (coil type) for height adjustment screw
10B	75496	Stylus—Osmium tip stylus (.001" r., coded red) for 45-33 1/3 r.p.m.	17	75813	Screw—Height adjustment screw (hex head—#5-40 thread)
10B	77899	Stylus—Sapphire tip stylus (.001" r., coded red) for 45-33 1/3 r.p.m.	18	76943	Spring—Tension spring (coil) for landing adjustment stud
10C	74230	Nut—#00-112 nut and washer to mount stylus	19	76911	Cam—Landing adjustment cam
5	76902	Knob—Stylus selector knob less screw	20	76907	Bracket—Pickup arm mounting bracket complete with pin
6	76898	Screw—#2-56 x 3/16" headless set screw for stylus selector knob	20A	75816	Stud—Landing adjustment stud (eccentric)
			20B	75818	Nut—Speed nut for landing adjustment stud

APPLY TO YOUR RCA DISTRIBUTOR FOR PRICES OF REPLACEMENT PARTS

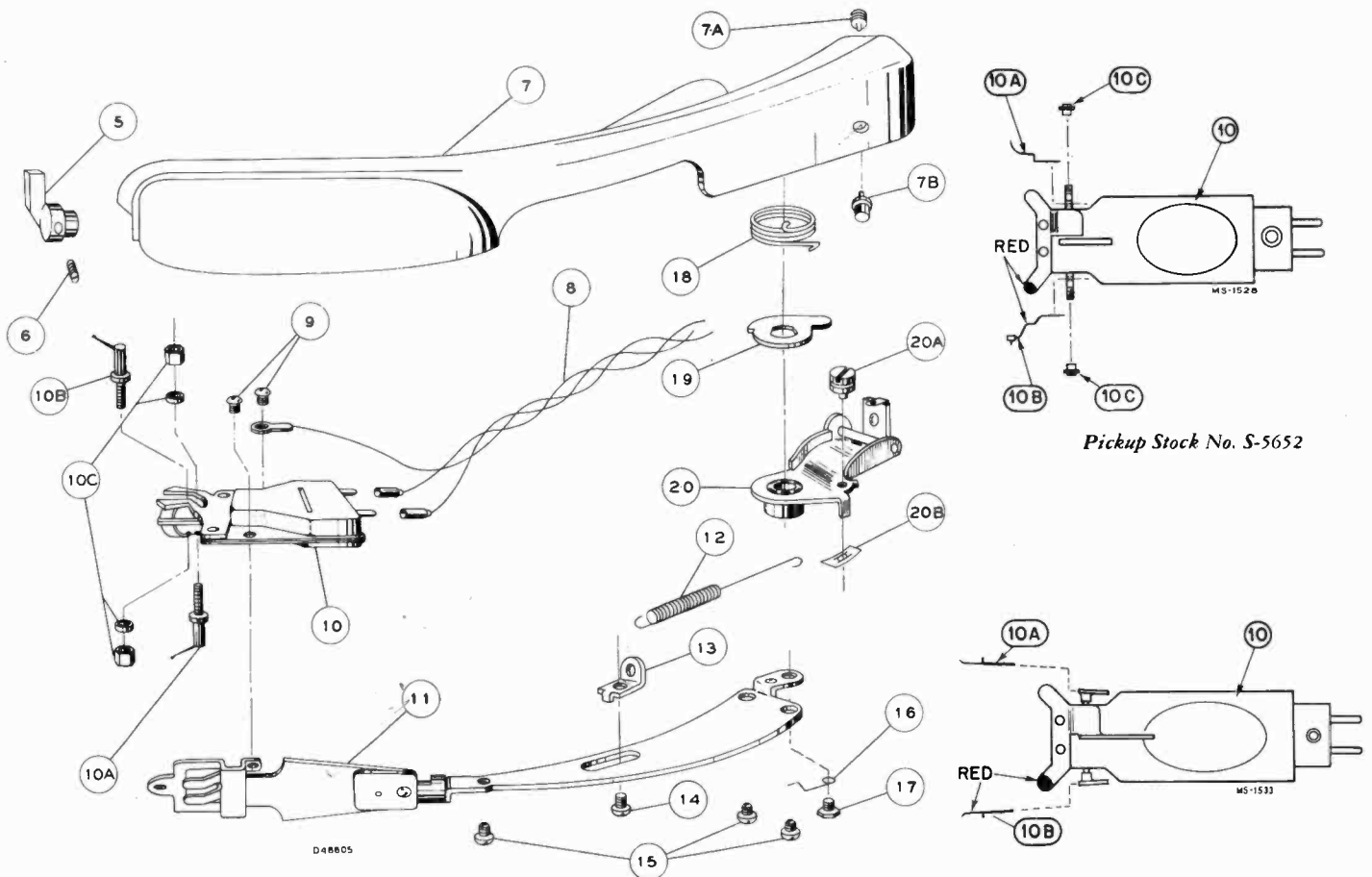

Fig. 32—Pickup Arm Assembly for 930409-5 and -10

Pickup Stock No. 162A001



RCA VICTOR

TELEVISION RECEIVERS MODELS 17T150, 17T151, 17T163

Chassis No. KCS66C

— Mfr. No. 274 —

SERVICE DATA

— 1952 No. T1 —

PREPARED BY RCA SERVICE CO., INC.
FOR

RADIO CORPORATION OF AMERICA
RCA VICTOR DIVISION
CAMDEN, N. J., U. S. A.



Model 17T150 "Colby"
Mahogany Finish Metal

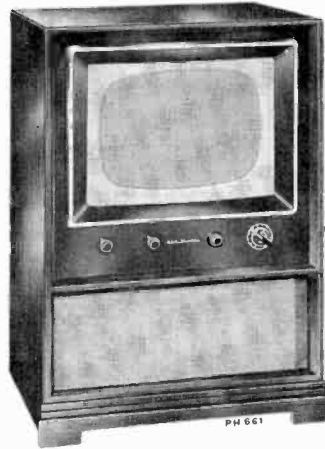

Model 17T163 "Crafton"
Walnut, Mahogany, Limed Oak

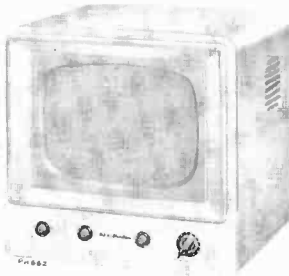

Model 17T151 "Glenside"
Mahogany Grained Metal

GENERAL DESCRIPTION

Models 17T150, 17T151, and 17T163 are deluxe "17 inch" television receivers. The receivers are identical except for cabinets, and speakers.

Features of the television unit are: full twelve channel coverage; "totem" r-f amplifier; intercarrier FM sound system; ratio detector; 40 mc picture i-f; improved picture brilliance;

pulsed picture A-G-C; A-F-C horizontal hold; stabilized vertical hold; compensated video gain control; noise saturation circuits; improved sync separator and clipper; four mc. band width for picture channel and reduced hazard high voltage supply. An auxiliary audio input jack is provided to permit the use of an external record playing attachment.

ELECTRICAL AND MECHANICAL SPECIFICATIONS

PICTURE SIZE. 146 square inches on a 17QP4 Kinescope

TELEVISION R-F FREQUENCY RANGE

All 12 television channels, 54 mc. to 88 mc., 174 mc. to 216 mc.

Picture I-F Carrier Frequency..... 45.75 mc.

Sound I-F Carrier Frequency..... 41.25 mc. and 4.5 mc.

VIDEO RESPONSE..... To 4 mc.

SWEEP DEFLECTION..... Magnetic

FOCUS..... Magnetic

POWER SUPPLY RATING

KCS66C..... 115 volts, 60 cycles, 190 watts

AUDIO POWER OUTPUT RATING

KCS66C..... 5.0 watts max.

CHASSIS DESIGNATIONS

KCS66C..... In Models 17T150, 17T151 & 17T163

LOUDSPEAKERS

Model 17T150..... (971614-1) 4" x 6" PM Dynamic, 3.2 ohms

Models 17T151 & 17T163. (971490-2) 8" PM Dynamic, 3.2 ohms

WEIGHT

Model	Chassis with Tubes in cabinet	Shipping Weight
17T150	88 lbs.	103 lbs.
17T151	88 lbs.	103 lbs.
17T163	95 lbs.	115 lbs.

RECEIVER ANTENNA INPUT IMPEDANCE

Choice: 300 ohms balanced or 72 ohms unbalanced.

RCA TUBE COMPLEMENT

Tube Used	Function
(1) RCA 6BQ7.....	R-F Amplifier
(2) RCA 6X8.....	R-F Oscillator and Mixer
(3) RCA 6AU6.....	1st Picture I-F Amplifier
(4) RCA 6CB6.....	2nd Picture I-F Amplifier
(5) RCA 6CB6.....	3rd Picture I-F Amplifier
(6) RCA 6CB6.....	4th Picture I-F Amplifier
(7) RCA 6AG7.....	Video Amplifier
(8) RCA 6AU6.....	1st Sound I-F Amplifier
(9) RCA 6AU6.....	2nd Sound I-F Amplifier
(10) RCA 6AL5.....	Ratio Detector
(11) RCA 6AV6.....	1st Audio Amplifier
(12) RCA 6AQ5.....	Audio Output
(13) RCA 6CB6.....	AGC Amplifier
(14) RCA 6SN7GT.....	Sync Separator
(15) RCA 6SN7GT.....	Vert Sync Amplifier and Vert Sweep Osc.
(16) RCA 6AQ5.....	Vertical Sweep Output
(17) RCA 6SN7GT.....	Horizontal Sync Amplifier
(18) RCA 6SN7GT.....	Horizontal Sweep Oscillator and Control
(19) RCA 6BQ6GT.....	Horizontal Sweep Output
(20) RCA 6W4GT.....	Damper
(21) RCA 1B3-GT/8016.....	High Voltage Rectifier
(22) RCA 17QP4.....	Kinescope

17T150, 17T151, 17T163

ELECTRICAL AND MECHANICAL SPECIFICATIONS

(Continued)

PICTURE INTERMEDIATE FREQUENCIES

Picture Carrier Frequency	45.75 mc.
Adjacent Channel Sound Trap	47.25 mc.
Accompanying Sound Traps	41.25 mc.
Adjacent Channel Picture Carrier Trap	39.25 mc.

SOUND INTERMEDIATE FREQUENCIES

Sound Carrier Frequency	41.25 mc. and 4.5 mc.
-------------------------------	-----------------------

VIDEO RESPONSE

To 4 mc.

FOCUS

Magnetic

SWEEP DEFLECTION

Magnetic

SCANNING

Interlaced, 525 line

HORIZONTAL SWEEP FREQUENCY

15,750 cps

VERTICAL SWEEP FREQUENCY

60 cps

FRAME FREQUENCY (Picture Repetition Rate) ..

30 cps

OPERATING CONTROLS (front Panel)

Channel Selector	}	Dual Control Knobs
Fine Tuning		
Picture	}	Dual Control Knobs
Brightness		
Picture Horizontal Hold	}	Dual Control Knobs
Picture Vertical Hold		
Sound Volume and On-Off Switch	}	Dual Control Knobs
Tone Control and Phono Switch		

NON-OPERATING CONTROLS (not including r-f and i-f adjustments)

Picture Centering	top chassis adjustment
Width	rear chassis adjustment
Height	rear chassis adjustment
Horizontal Linearity	rear chassis screwdriver adjustment
Vertical Linearity	rear chassis adjustment
Vertical Peaking Control	rear chassis adjustment
Horizontal Drive	rear chassis screwdriver adjustment
Horizontal Oscillator Frequency	rear chassis adjustment
Horizontal Oscillator Waveform	bottom chassis adjustment
Horizontal Locking Range	rear chassis adjustment
Focus	top chassis adjustment
Ion Trap Magnet	top chassis adjustment
Deflection Coil	top chassis wing nut adjustment
AGC Control	rear chassis adjustment

HIGH VOLTAGE WARNING

OPERATION OF THIS RECEIVER OUTSIDE THE CABINET OR WITH THE COVERS REMOVED, INVOLVES A SHOCK HAZARD FROM THE RECEIVER POWER SUPPLIES. WORK ON THE RECEIVER SHOULD NOT BE ATTEMPTED BY ANYONE WHO IS NOT THOROUGHLY FAMILIAR WITH THE PRECAUTIONS NECESSARY WHEN WORKING ON HIGH VOLTAGE EQUIPMENT. DO NOT OPERATE THE RECEIVER WITH THE HIGH VOLTAGE COMPARTMENT SHIELD REMOVED.

KINESCOPE HANDLING PRECAUTIONS

DO NOT REMOVE THE RECEIVER CHASSIS, INSTALL, REMOVE OR HANDLE THE KINESCOPE IN ANY MANNER UNLESS SHATTERPROOF GOGGLES, AND HEAVY GLOVES ARE WORN. PEOPLE NOT SO EQUIPPED SHOULD BE KEPT AWAY WHILE HANDLING KINESCOPES. KEEP THE KINESCOPE AWAY FROM THE BODY WHILE HANDLING.

The kinescope bulb encloses a high vacuum and, due to its large surface area, is subjected to considerable air pressure. For this reason, the kinescope must be handled with more care than ordinary receiving tubes.

The large end of the kinescope bulb—particularly that part at the rim of the viewing surface—must not be struck, scratched or subjected to more than moderate pressure at any time. During service if the tube sticks or fails to slip smoothly into its socket, or deflecting yoke, investigate and remove the cause of the trouble. Do not force the tube. Refer to the Receiver Installation section for detailed instructions on kinescope installation. All RCA replacement kinescopes are shipped in special cartons and should be left in the cartons until ready for installation in the receiver.

2

OPERATING INSTRUCTIONS

17T150, 17T151, 17T163

The following adjustments are necessary when turning the receiver on for the first time.

1. See that the TV-PH switch is in the "TV" position.
2. Turn the receiver "ON" and advance the SOUND VOLUME control to approximately mid-position.
3. Set the STATION SELECTOR to the desired channel.
4. Adjust the FINE TUNING control for best pix and the SOUND VOLUME control for suitable volume.
5. Turn the BRIGHTNESS control fully counter-clockwise, then clockwise until a light pattern appears on the screen.
6. Adjust the VERTICAL hold control until the pattern stops vertical movement.
7. Adjust the HORIZONTAL hold control until a picture is obtained and centered.

8. Adjust the PICTURE and BRIGHTNESS controls for suitable picture contrast and brightness.

9. In switching from one channel to another, it may be necessary to repeat steps 4 and 8.

10. When the set is turned on again after an idle period it should not be necessary to repeat the adjustment if the positions of the controls have not been changed. If any adjustment is necessary, step number 4 is generally sufficient.

11. If the positions of the controls have been changed, it may be necessary to repeat steps 2 through 8.

12. To use a record player, plug the record-player output cable into the PHONO jack on the rear apron, and set the TV-PH switch to "PH".

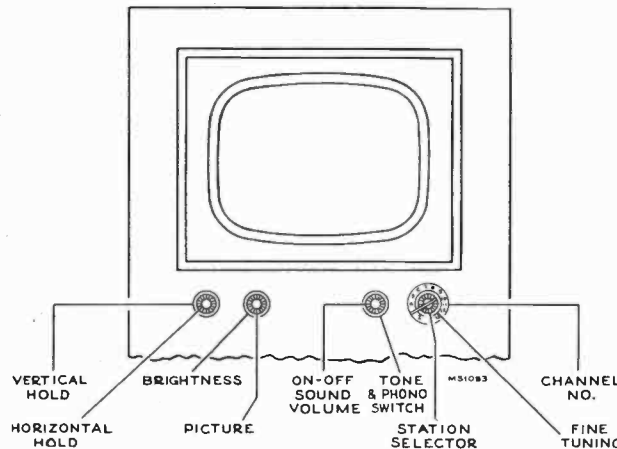

Figure 1—Receiver Operating Controls

INSTALLATION INSTRUCTIONS

UNPACKING.—These receivers are shipped complete in cardboard cartons. The kinescope is shipped in place in the receiver.

Take the receiver out of the carton and remove all packing material.

Make sure that all tubes are in place and are firmly seated in their sockets.

Check to see that the kinescope high voltage lead clip is in place.

Plug a power cord into the 115 volt a-c power source and into the receiver interlock receptacle. Turn the receiver power switch to the "on" position, the brightness control fully clockwise, and the picture control counter-clockwise.

ION TRAP MAGNET ADJUSTMENT.—Set the ion trap magnet approximately in the position shown in Figure 2. Starting from this position immediately adjust the magnet by moving it forward or backward at the same time rotating it slightly around the neck of the kinescope for the brightest raster on the screen. Reduce the brightness control setting until the raster is slightly above average brilliance. Turn the focus control (shown in Figure 2) until the line structure of the raster is clearly visible. Readjust the ion trap magnet for maximum raster brilliance. The final touches of this adjustment should be made with the brightness control at the maximum clockwise position with which good line focus can be maintained.

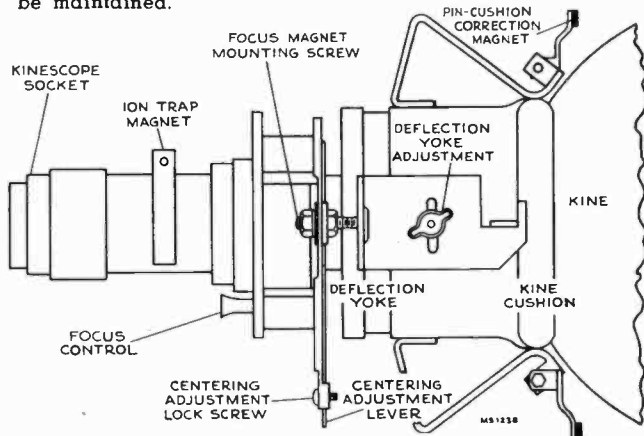

Figure 2—Yoke and Focus Magnet Adjustments

DEFLECTION YOKE ADJUSTMENT.—If the lines of the raster are not horizontal or squared with the picture mask, rotate the deflection yoke until this condition is obtained. Tighten the yoke adjustment wing screw.

PICTURE ADJUSTMENTS.—It will now be necessary to obtain a test pattern picture in order to make further adjustments. Connect the antenna transmission line to the receiver.

If the Horizontal Oscillator and AGC System are operating properly, it should be possible to sync the picture at this point. However, if the AGC control is misadjusted, and the receiver is overloading, it may be impossible to sync the picture.

If the receiver is overloading, turn R175 on the rear apron (see Figure 3) counter-clockwise until the set operates normally and the picture can be synced.

CHECK OF HORIZONTAL OSCILLATOR ALIGNMENT.—Turn the horizontal hold control to the extreme counter-clockwise position. The picture should remain in horizontal sync. Momentarily remove the signal by switching off channel then back. Normally the picture will be out of sync. Turn the control clockwise slowly. The number of diagonal black bars will be gradually reduced and when only 2 or 3 bars sloping downward to the left are obtained, the picture will pull into sync upon slight additional clockwise rotation of the control. Pull-in should occur before the control has been turned 120 degrees from the extreme counter-clockwise position. The picture should remain in sync for approximately 90

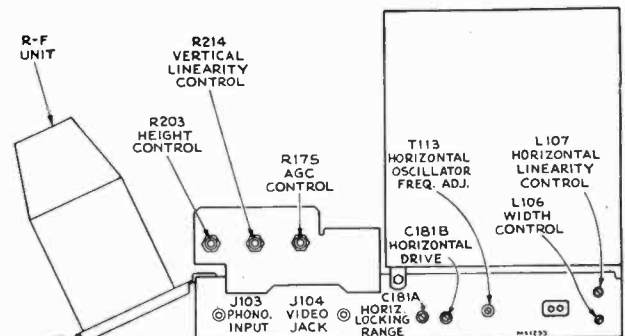

Figure 3—Rear Chassis Adjustments

degrees of additional clockwise rotation of the control. At the extreme clockwise position, the picture should remain in sync and should not show a black bar in the picture.

If the receiver passes the above checks and the picture is normal and stable the horizontal oscillator is properly aligned. Skip "Alignment of Horizontal Oscillator" and proceed with "Focus Magnet Adjustment."

ALIGNMENT OF HORIZONTAL OSCILLATOR.—If in the above check the receiver failed to hold sync with the hold control at the extreme counter-clockwise position or failed to hold sync over 90 degrees of clockwise rotation of the control from the pull-in point it will be necessary to make the following adjustments.

Horizontal Frequency Adjustment.—Turn the horizontal hold control to the extreme clockwise position. Tune in a television station and adjust the T113 horizontal frequency adjustment at the rear of the chassis until the picture is just out of sync and the horizontal blanking appears as a vertical or diagonal black bar in the raster. Then turn the T113 core until the bar moves out of the picture leaving it in sync.

Horizontal Locking Range Adjustment.—Set the horizontal hold control to the full counter-clockwise position. Momentarily remove the signal by switching off channel then back. The picture may remain in sync. If so turn the T113 rear core slightly and momentarily switch off channel. Repeat until the picture falls out of sync with the diagonal lines sloping down to the left. Slowly turn the horizontal hold control clockwise and note the least number of diagonal bars obtained just before the picture pulls into sync.

If more than 3 bars are present just before the picture pulls into sync adjust the horizontal locking range trimmer C181A slightly clockwise. If less than 2 bars are present, adjust C181A slightly counter-clockwise. Turn the horizontal hold control counter-clockwise, momentarily remove the signal and recheck the number of bars present at the pull-in point. Repeat this procedure until 2 or 3 bars are present.

Repeat the adjustments under "Horizontal Frequency Adjustment" and "Horizontal Locking Range Adjustment" until the conditions specified under each are fulfilled. When the horizontal hold operates as outlined under "Check of Horizontal Oscillator Alignment" the oscillator is properly adjusted.

If it is impossible to sync the picture at this point and the AGC system is in proper adjustment it will be necessary to adjust the Horizontal Oscillator by the method outlined in the alignment procedure on page 11. For field purposes paragraph "B" under Horizontal Oscillator Waveform Adjustment may be omitted.

FOCUS MAGNET ADJUSTMENT.—The focus magnet should be adjusted so that there is approximately three-eighths inch of space between the rear cardboard shell of the yoke and the flat of the front face of the focus magnet. This spacing gives best average focus over the face of the tube.

The axis of the hole through the magnet should be parallel with the axis of the kinescope neck with the kinescope neck through the center of the opening.

PIN CUSHION CORRECTION.—Two pin-cushion correction magnets are employed to correct a small amount of pin-cushion of the raster due to the lens effect of the face of the kinescope. These magnets are mounted on small arms, one on each side of the kinescope as shown in Figure 2. The arms hinge in one plane on self tapping screws which act both as a hinge and an adjustment locking screw. When the magnets are swung towards the tube, maximum correction is obtained. Minimum correction is obtained when the arms are swung away from the tube. To adjust the magnets, loosen the two self tapping screws and position the magnets until the sides of the raster appear straight. Tighten the screws without shifting the position of the magnets. In some cases it may be necessary to twist or bend the magnet support arms to obtain the appearance of straight raster edges.

CENTERING ADJUSTMENT.—No electrical centering controls are provided. Centering is accomplished by means of a separate plate on the focus magnet. The centering plates include a locking screw which must be loosened before centering. Up and down adjustment of the plate moves the picture side to side and sidewise adjustment moves the picture up and down.

If a corner of the raster is shadowed, check the position of the ion trap magnet. Reposition the magnet within the range of maximum raster brightness to eliminate the shadow and recenter the picture by adjustment of the focus magnet plate. In no case should the magnet be adjusted to cause any loss of brightness since such operation may cause immediate or eventual damage to the tube. In some cases it may be necessary to shift the position of the focus magnet in order to eliminate a corner shadow.

WIDTH, DRIVE AND HORIZONTAL LINEARITY ADJUSTMENTS.—Adjustment of the horizontal drive control affects the high voltage applied to the kinescope. In order to obtain the highest possible voltage hence the brightest and best focused picture adjust horizontal drive trimmer C181B counter-clockwise until the picture begins to "wrinkle" in the middle then clockwise until the "wrinkle" disappears.

Turn the horizontal linearity control L107 clockwise until the picture begins to "wrinkle" on the right and then counter-clockwise until the "wrinkle" disappears and best linearity is obtained.

Adjust the width control L106 to obtain correct picture width.

A slight readjustment of these three controls may be necessary to obtain the best linearity.

Adjustments of the horizontal drive control affect horizontal oscillator hold and locking range. If the drive control was adjusted, recheck the oscillator alignment.

HEIGHT AND VERTICAL LINEARITY ADJUSTMENTS.—Adjust the height control (R203 on chassis rear apron) until the picture fills the mask vertically. Adjust vertical linearity (R214 on rear apron) until the test pattern is symmetrical from top to bottom. Adjustment of either control will require a readjustment of the other. Adjust centering to align the picture with the mask.

FOCUS.—Adjust the focus magnet for maximum definition in the test pattern vertical "wedge" and best focus in the white areas of the pattern.

Recheck the position of the ion trap magnet to make sure that maximum brightness is obtained.

Check to see that the yoke thumbscrew and the focus magnet mounting screws are tight.

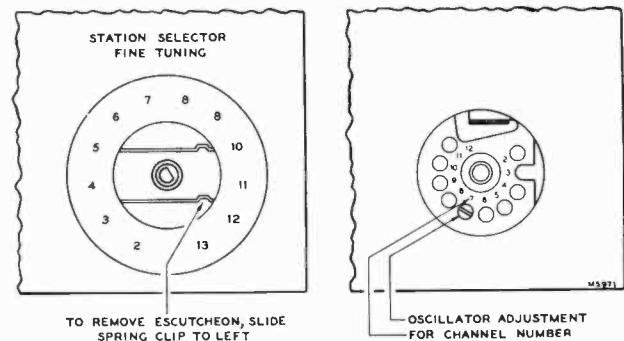

Figure 4—R-F Oscillator Adjustments

CHECK OF R-F OSCILLATOR ADJUSTMENTS.—Tune in all available stations to see if the receiver r-f oscillator is adjusted to the proper frequency on all channels. If adjustments are required these should be made by the method outlined in the alignment procedure on page 9. The adjustments for channels 2 through 12 are available from the front of the cabinet by removing the station selector escutcheon as shown in Figure 4. Adjustment for channel 13 is on top of the chassis.

AGC THRESHOLD CONTROL.—The AGC threshold control R175 is adjusted at the factory and normally should not require readjustment in the field.

To check the adjustment of the AGC Threshold Control tune in a strong signal and sync the picture. Momentarily remove the signal by switching off channel and then back. If the picture reappears immediately, the receiver is not overloading due to improper setting of R175. If the picture requires an appreciable portion of a second to reappear, or bends excessively, R175 should be readjusted.

INSTALLATION INSTRUCTIONS

17T150, 17T151, 17T163

Turn R175 fully counter-clockwise. The raster may be bent slightly. This should be disregarded. Turn R175 clockwise until there is a very, very slight bend or change of bend in the picture. Then turn R175 counter-clockwise just sufficiently to remove this bend or change of bend.

If the signal is weak, the above method may not work as it may be impossible to get the picture to bend. In this case, turn R175 clockwise until the snow in the picture becomes more pronounced, then counter-clockwise until the best signal to noise ratio is obtained.

The AGC control adjustment should be made on a strong signal if possible. If the control is set too far clockwise on a weak signal, then the receiver may overload when a strong signal is received.

FM TRAP ADJUSTMENT.—In some instances interference may be encountered from a strong FM station signal. A trap is provided to eliminate this type of interference. To adjust the trap tune in the station on which the interference is observed and adjust the L58 core on top of the antenna matching transformer for minimum interference in the picture.

CAUTION.—In some receivers, the FM trap L58 will tune down into channel 6 or even into channel 5. Needless to say, such an adjustment will cause greatly reduced sensitivity on these channels. If channels 5 or 6 are to be received, check L58 to make sure that it does not affect sensitivity on these two channels.

Replace the cabinet back and connect the receiver antenna leads to the cabinet back. Make sure that the screws holding it are up tight, otherwise it may rattle or buzz when the receiver is operated at high volume.

KINESCOPE SCREEN CLEANING.—The kinescope safety glass is held in place by four spring clips which may be removed from the back of the front panel. This permits removing the safety glass for cleaning without the necessity of removing the chassis and kinescope.

CHASSIS REMOVAL.—To remove the chassis from the cabinet for repair or installation of a new kinescope, remove the control knobs, the cabinet back, unplug the speaker cable, the kinescope socket, the antenna cable, the yoke and high voltage cable. Take out the chassis bolts under the cabinet. Withdraw the chassis from the back of the cabinet.

KINESCOPE HANDLING PRECAUTION.—Do not install, remove, or handle the kinescope in any manner, unless shatterproof goggles and heavy gloves are worn. People not so equipped should be kept away while handling the kinescope. Keep the kinescope away from the body while handling.

INSTALLATION OF KINESCOPE.—To remove the kinescope from the cabinet, loosen the two nuts and disengage the rods alongside the kinescope. Remove the wing screw which holds the yoke frame to the cabinet. Remove the kinescope, the yoke frame with yoke and focus magnet as an assembly.

Handle this tube by the portion at the edge of the screen. Do not cover the glass bell of the tube with fingermarks as it will produce leakage paths which may interfere with reception. If this portion of the tube has inadvertently been handled, wipe it clean with a soft cloth moistened with "dry" carbon tetrachloride.

INSTALLATION OF KINESCOPE.—Wipe the kinescope screen surface and front panel safety glass clean of all dust and fingermarks with a soft cloth moistened with "Windex" or similar cleaning agent.

Replace the kinescope and chassis by reversal of the removing process. The kinescope should be installed so that the high voltage contact is to the right when looking at it from the rear of the cabinet. The magnet of the ion trap magnet should be to the left.

CABINET ANTENNA.—A cabinet antenna is provided in model 17T163 receivers and the leads are brought out near the antenna terminal board. The cabinet antenna may be employed in place of the outdoor antenna in areas where the signals are strong and no reflections are experienced.

ANTENNAS.—The finest television receiver built may be said to be only as good as the antenna design and installation. It is therefore important to select the proper antenna to suit the particular local conditions, to install it properly and orient it correctly.

If two or more stations are available and the two stations are in different directions, it may be possible to make a compromise orientation which will provide a satisfactory signal on all such channels.

If it is impossible to obtain satisfactory results on one or more channels, it may become necessary either to provide means for turning the antenna when switching channels or to install a separate antenna for one or more channels and to switch antennas when switching channels.

In some cases, the antenna should not be installed permanently until the quality of the picture reception has been observed on a television receiver. A temporary transmission line can be run between receiver and the antenna, allowing sufficient slack to permit moving the antenna. Then, with a telephone system connecting an observer at the receiver and an assistant at the antenna, the antenna can be positioned to give the most satisfactory results on the received signal. A shift of direction or a few feet in antenna position may effect a tremendous difference in picture reception.

REFLECTIONS.—Multiple images sometimes known as echoes or ghosts, are caused by the signal arriving at the antenna by two or more routes. The second or subsequent image occurs when a signal arrives at the antenna after being reflected off a building, a hill or other object. In severe cases of reflections, even the sound may be distorted. In less severe cases, reflections may occur that are not noticeable as reflections but that will instead cause a loss of definition in the picture.

Under certain extremely unusual conditions, it may be possible to rotate or position the antenna so that it receives the cleanest picture over a reflected path. If such is the case, the antenna should be so positioned. However, such a position may give variable results as the nature of reflecting surfaces may vary with weather conditions. Wet surfaces have been known to have different reflecting characteristics than dry surfaces.

Depending upon the circumstances, it may be possible to eliminate the reflections by rotating the antenna or by moving it to a new location. In extreme cases, it may be impossible to eliminate the reflection.

INTERFERENCE.—Auto ignition, street cars, electrical machinery and diathermy apparatus may cause interference which spoils the picture. Whenever possible, the antenna location should be removed as far as possible from highways, hospitals, doctors' offices and similar sources of interference. In mounting the antenna, care must be taken to keep the antenna rods at least $\frac{1}{4}$ wave length (at least 6 feet) away from other antennas, metal roofs, gutters or other metal objects.

Short-wave radio transmitting and receiving equipment may cause interference in the picture in the form of moving ripples. In some instances it may be possible to eliminate the interference by the use of a trap in the antenna transmission line. However, if the interfering signal is on the same frequency as the television station, a trap will provide no improvement.

WEAK PICTURE.—When the installation is near the limit of the area served by the transmitting station, the picture may be speckled, having a "snow" effect, and may not hold steady on the screen. This condition is due to lack of signal strength from the transmitter.

RECEIVER LOCATION.—The owner should be advised of the importance of placing the receiver in the proper location in the room.

The location should be chosen—

- Away from bright windows and so that no bright light will fall directly on the screen. (Some illumination in the room is desirable, however.)
- To give easy access for operation and comfortable viewing.
- To permit convenient connection to the antenna.
- Convenient to an electrical outlet.
- To allow adequate ventilation.

CHASSIS TOP VIEW

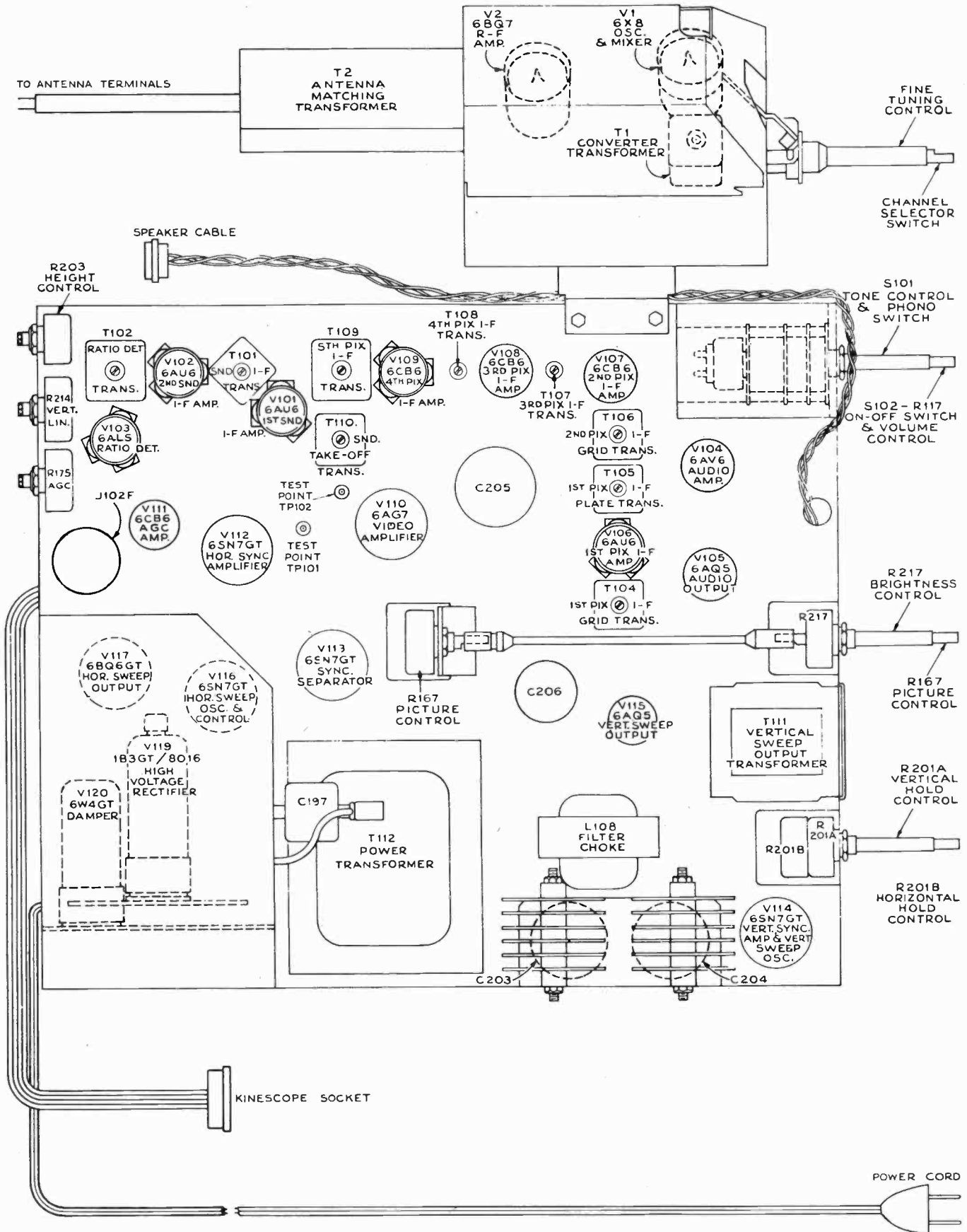

Figure 5—Chassis Top View

CHASSIS BOTTOM VIEW

17T150, 17T151, 17T163

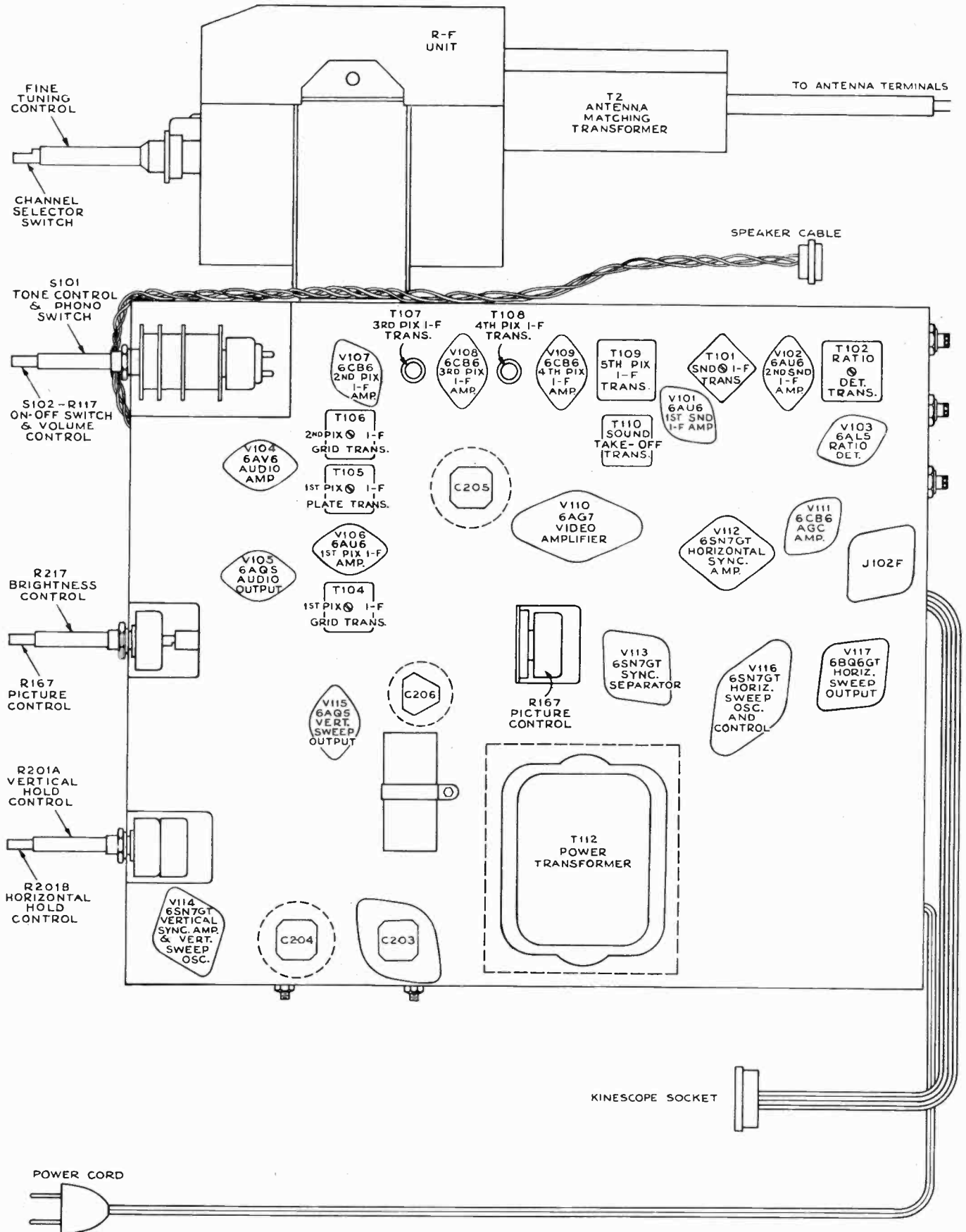

Figure 6—Chassis Bottom View

17T150, 17T151, 17T163

ALIGNMENT PROCEDURE

TEST EQUIPMENT.—To properly service the television chassis of this receiver, it is recommended that the following test equipment be available:

R-F Sweep Generator meeting the following requirements:

- (a) Frequency Ranges
 - 35 to 90 mc., 1 mc. to 12 mc. sweep width
 - 170 to 225 mc., 12 mc. sweep width
- (b) Output adjustable with at least .1 volt maximum.
- (c) Output constant on all ranges.
- (d) "Flat" output on all attenuator positions.

Cathode-Ray Oscilloscope.—For alignment purposes, the oscilloscope employed must have excellent low frequency and phase response, and should be capable of passing a 60-cycle square wave without appreciable distortion.

For video and sync waveform observations, the oscilloscope must have excellent frequency and phase response from 10 cycles to at least two megacycles in all positions of the gain control.

Signal Generator to provide the following frequencies with crystal accuracy.

- (a) Intermediate frequencies
 - 4.5 mc. sound i-f transformer
 - 39.25 mc. adjacent channel picture trap
 - 41.25 mc. sound trap
 - 45.75 mc. picture carrier
 - 47.25 mc. adjacent channel sound trap
- (b) Radio frequencies

Channel Number	Picture Carrier Freq. Mc.	Sound Carrier Freq. Mc.	Receiver R-F Osc. Freq. Mc.
2	55.25	59.75	101
3	61.25	65.75	107
4	67.25	71.75	113
5	77.25	81.75	123
6	83.25	87.75	129
7	175.25	179.75	221
8	181.25	185.75	227
9	187.25	191.75	233
10	193.25	197.75	239
11	199.25	203.75	245
12	205.25	209.75	251
13	211.25	215.75	257

- (c) Output of these ranges should be adjustable and at least .1 volt maximum.

Heterodyne Frequency Meter with crystal calibrator if the signal generator is not crystal controlled.

Electronic Voltmeter of Junior or Senior "VoltOhmyst" type and a high voltage multiplier probe for use with this meter to permit measurements up to 20 kv.

CAUTION: Do not short the kinescope second anode lead. Its short circuit current presents a considerable overload on the high voltage rectifier V119.

ORDER OF ALIGNMENT.—When a complete receiver alignment is necessary, it can be most conveniently performed in the following order:

- (1) Ant. Matching Unit
- (2) R-F Unit
- (3) Ratio Detector
- (4) Sound I-F Trans.
- (5) Sound Take-Off Trans.
- (6) Picture I-F Traps
- (7) Picture I-F Trans.
- (8) Sweep Alignment of I-F
- (9) Horizontal Oscillator
- (10) Sensitivity Check

ANTENNA MATCHING UNIT ALIGNMENT.—The antenna matching unit is accurately aligned at the factory. Adjustment of this unit should not be attempted in the customer's home since even slight misalignment may cause serious attenuation of the signal especially on channel 2. The r-f unit is aligned with a particular antenna matching transformer in place. If for any reason, a new antenna matching transformer is installed, the r-f unit should be realigned.

The F-M Trap which is mounted in the antenna matching unit may be adjusted without adversely affecting the alignment of the unit.

To align the antenna matching unit disconnect the lead from the FM trap L58 to the channel selector switch S5.

With a short jumper, connect the output of the matching unit through a 1000 mmf capacitor to the grid of the second pix i-f amplifier, pin 1 of V107.

Replace the cover on the matching unit while making all adjustments.

Remove the first pix i-f amplifier tube V106.

Connect the positive terminal of a bias box to the chassis and the potentiometer arm to the junction of R143 and R144. Set the potentiometer to produce approximately -6.0 volts of bias at the test point TP101.

Connect an oscilloscope to the video test point TP102 and set the oscilloscope gain to maximum.

Connect a signal generator to the antenna input terminals. Modulate the signal generator 30% with an audio signal.

Tune the signal generator to 45.75 mc. and adjust the generator output to give an indication on the oscilloscope. Adjust L59 in the antenna matching unit for minimum audio indication on the oscilloscope.

Tune the signal generator to 41.25 mc. and adjust L60 for minimum audio indication on the oscilloscope.

Remove the jumper from the output of the matching unit.

Connect a 300 ohm $\frac{1}{2}$ watt composition resistor from L58 to ground, keeping the leads as short as possible.

Connect an oscilloscope low capacity crystal probe from L58 to ground. The sensitivity of the oscilloscope should be approximately 0.03 volts per inch. Set the oscilloscope gain to maximum.

Connect the r-f sweep generator to the matching unit antenna input terminals. In order to prevent coupling reactance from the sweep generator into the matching unit, it is advisable to employ a resistance pad at the matching unit terminals. Figure 11 shows three different resistance pads for use with sweep generators with 50 ohm co-ax output, 72 ohm co-ax output or 300 ohm balanced output. Choose the pad to match the output impedance of the particular sweep employed.

Connect the signal generator loosely to the matching unit antenna terminals.

Set the sweep generator to sweep from 45 mc. to 54 mc. With RCA type WR59A sweep generators, this may be accomplished by retuning channel number 1 to cover this range. With WR59B sweep generators this may be accomplished by retuning channel number 2 to cover the range. In making these adjustments on the generator, be sure not to turn the core too far clockwise so that it becomes lost beyond the core retaining spring.

Adjust L61 and L62 to obtain the response shown in figure 12. L61 is most effective in locating the position of the shoulder of the curve at 52 mc. and L62 should be adjusted to give maximum amplitude at 53 mc. and above consistent with the specified shape of the response curve. The adjustments in the matching unit interact to some extent. Repeat the above procedure until no further adjustments are necessary.

Remove the 300 ohm resistor and crystal probe connections. Restore the connection between L58 and S5. Replace V106.

R-F UNIT ALIGNMENT.—An r-f unit which is operative and requires only touch up adjustments, requires no pre-setting of adjustments. For such units, skip the remainder of this paragraph. For units which are completely out of adjustment, preset all adjustments to the approximate center of their range with the following exceptions: Set C18 so that the screw head is approximately three-eighths of an inch above chassis. Set the T1 core for maximum inductance (core turned counter-clockwise). Set C11 near maximum capacity (one-quarter turn from tight). Do not change any of the adjustments in the antenna matching unit.

Disconnect the link from terminals "A" and "B" of T104 and terminate the link with a 39 ohm composition resistor.

The r-f unit is aligned with zero AGC bias. To insure that the bias will remain constant, take a clip lead and short circuit the r-f unit power terminal board terminal 3 to ground.

ALIGNMENT PROCEDURE

17T150, 17T151, 17T163

Connect the oscilloscope to the test point TP1 on top of the r-f unit. Set the oscilloscope gain to maximum.

Turn the receiver channel selector switch to channel 2.

Connect the output of the signal generator to the grid of the r-f amplifier, V2. To do this, remove the tube from the socket and fashion a clip by twisting one end of a small piece of wire around pin number 7. Replace the tube in the socket leaving the end of the wire protruding from under the tube. Connect the signal generator to this wire through a 1,500 mmf capacitor.

Tune the signal generator to 43.5 mc. and modulate it 30% with a 400 cycle sine wave. Adjust the signal generator for maximum output.

Adjust L65 on top of the r-f unit for minimum 400 cycle indication on the oscilloscope. If necessary, this adjustment can be retouched in the field to provide additional rejection to one specific frequency in the i-f band pass. However, in such cases, care should be taken not to adjust it so as to reduce sensitivity on channel 2.

Remove the wire clip from pin 7 of V2 and replace the tube and tube shield.

Set the channel selector switch to channel 8.

Turn the fine tuning control 30 degrees clockwise from the center of its mechanical range now and at all times when adjusting the oscillator frequency.

Adjust C1 for proper oscillator frequency, 227 mc. This may be done in several ways. The easiest way and the way which will be recommended in this procedure will be to use the signal generator as a heterodyne frequency meter and beat the oscillator against the signal generator. To do this, tune the signal generator to 227 mc. with crystal accuracy. Insert one end of a piece of insulated wire into the r-f unit through the hole provided for the adjustment for C11. Be careful that the wire does not touch any of the tuned circuits as it may cause the frequency of the r-f unit oscillator to shift. Connect the other end of the wire to the "r-f in" terminal of the signal generator. Adjust C1 to obtain an audio beat with the signal generator.

Connect the sweep generator through a suitable attenuator as shown in Figure 11 to the input terminals of the antenna matching unit.

Connect the signal generator loosely to the antenna terminals.

Set the sweep oscillator to cover channel 8.

Set the oscilloscope to maximum gain and use the minimum input signal which will produce a useable pattern on the oscilloscope. Excessive input can change oscillator injection during alignment and produce consequent misalignment even though the response as seen on the oscilloscope may look normal.

Insert markers of channel 8 picture carrier and sound carrier, 181.25 mc. and 185.75 mc.

Adjust C9, C11, C15 and C18 for approximately correct curve shape, frequency, and band width as shown in Figure 13.

The correct adjustment of C18 is indicated by maximum amplitude of the curve midway between the markers. C15 tunes the r-f amplifier plate circuit and affects the frequency of the pass band most noticeably. C9 tunes the mixer grid circuit and affects the tilt of the curve most noticeably (assuming that C18 has been properly adjusted). C11 is the coupling adjustment and hence primarily affects the response band width.

Set the receiver channel switch to channel 6.

Adjust the signal generator to the channel 6 oscillator frequency 129 mc.

Turn the fine tuning control 30 degrees clockwise from the center of its mechanical range.

Adjust L5 for an audible beat with the signal generator as before.

Set the sweep generator to channel 6.

From the signal generator, insert channel 6 sound and picture carrier markers, 83.25 mc. and 87.75 mc.

Adjust L48, L50 and L53 for proper response as shown in Figure 13.

L50 tunes the r-f amplifier plate circuit and primarily affects the frequency of the pass band. L53 tunes the r-f amplifier grid and is adjusted to give maximum amplitude of the curve between the markers. L48 affects the tilt of the curve but not quite the same as C9 adjustment. When the circuits

are correctly adjusted and L48 is rocked on either side of its proper setting, the high frequency (sound carrier) end of the curve appears to remain nearly fixed in amplitude while the picture carrier end tilts above or below this point.

Turn off the sweep and signal generators.

Connect the "VoltOhmyst" to the r-f unit test point TP1.

Adjust the oscillator injection trimmer C8 for -3.5 volts or at maximum if -3.5 volts cannot be reached. This voltage should fall between -2.5 and -5.5 volts on all channels when the alignment of all circuits is completed.

Turn the sweep oscillator and signal generator back on and recheck channel 6 response. Readjust L48, L50 and L53 if necessary.

Set the receiver channel selector switch to channel 8 and readjust C1 for proper oscillator frequency, 227 mc.

Set the sweep oscillator and signal generator to channel 8.

Readjust C9, C11, C15 and C18 for correct curve shape, frequency and band width.

Turn off the sweep and signal generators, switch back to channel 6 and check the oscillator injection voltage at TP1 if C9 was adjusted in the recheck of channel 8 response.

If the initial setting of oscillator injection trimmer C8 was far off, it may be necessary to adjust the oscillator frequency and response on channel 8, adjust the oscillator injection on channel 6 and repeat the procedure several times before the proper setting is obtained.

Turn off the sweep generator and switch the receiver to channel 13.

Adjust the signal generator to the channel 13 oscillator frequency 257 mc.

Set the fine tuning control 30 degrees clockwise from the center of its mechanical range.

Adjust L46 to obtain an audible beat. Slightly overshoot the adjustment of L46 by turning the slug a little more in the same direction from the original setting, then reset the oscillator to proper frequency by adjusting C1 to again obtain the beat.

Check the response of channels 7 through 13 by switching the receiver channel switch, sweep oscillator and marker oscillator to each of these channels and observing the response and oscillator injection obtained. See Figure 13 for typical response curves. It should be found that all these channels have the proper shaped response with the markers above 80% response.

If the markers do not fall within this requirement, switch to channel 8 and readjust C9, C11, C15 and C18 as necessary.

Turn off the sweep generator and check the channel 8 oscillator frequency. If C1 has to be readjusted for channel 8, the principle of overshooting the adjustment and then correcting by adjusting L46 should be followed in order to establish the L/C ratio for the desired oscillator tracking.

Turn the receiver channel selector switch to channel 6. Adjust L5 for correct oscillator frequency, 129 mc.

Turn the sweep oscillator on and to channel 6 and observe the response curve. If necessary readjust L48, L50 and L53.

Switch the receiver through channel 6 down through channel 2 and check for normal response curve shapes and oscillator injection voltage.

If excessive tilt in the same direction occurs on channels 2, 3 and 4, adjust C18 on channel 2 to overshoot the correction of this tilt, then switch to channel 6 and adjust L53 for maximum amplitude of curve between markers. This adjustment should produce "flat" response on the low channels if the other adjustments especially L48 are correct.

Likewise check channels 7 through 13, stopping on 13 for the next step.

With the receiver on channel 13, check the receiver oscillator frequency. Correct by adjustment of C1 if necessary.

Adjust the oscillator to frequency on all channels by switching the receiver and the frequency standard to each channel and adjusting the appropriate oscillator trimmer to obtain the audible beat. It should be possible to adjust the oscillator to the correct frequency on all channels with the fine tuning control in the middle third of its range. When employing WR39 calibrators to adjust the receiver oscillator, tune the calibrator to one-half the receiver oscillator frequency on channels 4, 5 and 6 and to one-fourth the receiver oscillator frequency on channels 11, 12 and 13.

Channel Number	Picture Carrier Freq. Mc.	Sound Carrier Freq. Mc.	Receiver R-F Osc. Freq. Mc.	Channel Oscillator Adjustment
2	55.25	59.75	101	L1
3	61.25	65.75	107	L2
4	67.25	71.75	113	L3
5	77.25	81.75	123	L4
6	83.25	87.75	129	L5
7	175.25	179.75	221	L6
8	181.25	185.75	227	L7
9	187.25	191.75	233	L8
10	193.25	197.75	239	L9
11	199.25	203.75	245	L10
12	205.25	209.75	251	L11
13	211.25	215.75	257	C1

Remove the 39 ohm resistor from the link and reconnect the link to terminals "A" and "B" of T104.

RATIO DETECTOR ALIGNMENT.—Set the signal generator at 4.5 mc. and connect it to the second sound i-f grid, pin 1 of V102. Set the generator for 30% 400 cycle modulation.

As an alternate source of signal, the RCA WR39B or WR39C calibrator may be employed. If used connect its output cable to the grid of the 4th pix i-f amplifier pin 1 of V109. Set the frequency of the calibrator to 45.75 (pix carrier) and modulate with 4.5 mc. crystal. Also turn on the internal AM audio modulation. The 4.5 mc signal will be picked off at T110A and amplified through the sound i-f amplifier.

Connect the "VoltOhmyst" to the junction of R110 and R114.

Connect the oscilloscope across the speaker voice coil and turn the volume control for maximum output.

Set the trimmer C226 (on the bottom of the V103 socket) for minimum capacity.

Tune the ratio detector primary, T102 top core for maximum DC output on the "VoltOhmyst." Adjust the signal level from the signal generator for 10 volts on the "VoltOhmyst" when finally peaked. This is approximately the operating level of the ratio detector for average signals.

Tune the ratio detector secondary T102 bottom core for minimum AM output on the oscilloscope.

Repeat adjustments of T102 top for maximum DC and T102 bottom for minimum output on the oscilloscope making final adjustment with the 4.5 mc. input level adjusted to produce 10 volts d-c on the "VoltOhmyst."

Connect the "VoltOhmyst" to the junction of R112 and C113 and note the amount of d-c present. If this voltage exceeds ± 1.5 volts, adjust C226 by turning the core in until zero d-c is obtained. Readjust the T102 bottom core for minimum output on the oscilloscope. Repeat the adjustments of C226 and T102 bottom core until the voltage at R112 and C113 is less than ± 1.5 volts when T102 bottom core is set for minimum indication on the oscilloscope.

Connect the "VoltOhmyst" to the junction of R110 and R114 and repeat the T102 top core for maximum d-c on the meter and again reset the generator output so that the meter reads minus 10 volts.

Repeat the adjustments in the above two paragraphs until the voltage at R112 and C113 is less than ± 1.5 volts when the T102 top core is set for maximum d-c at the junction of R110 and R114 and the T102 bottom core is set for minimum indication on the oscilloscope.

SOUND I-F ALIGNMENT.—Connect the sweep generator to the first sound i-f amplifier grid, pin 1 of V101. Adjust the generator for a sweep width of 1 mc. at a center frequency of 4.5 mc.

Insert a 4.5 mc. marker signal from the signal generator into the first sound i-f grid.

Connect the oscilloscope in series with a 10,000 ohm resistor to terminal A of T101.

Adjust T101 top and bottom cores for maximum gain and symmetry about the 4.5 mc. marker on the i-f response. The pattern obtained should be similar to that shown in Figure 14.

The output level from the sweep should be set to produce approximately 2.0 volt peak-to-peak at terminal A of T101 when the final touches on the above adjustment are made. It is necessary that the sweep output voltage should not exceed the specified values otherwise the response curve will be broadened permitting slight misadjustment to pass unnoticed and possibly causing distortion on weak signals.

Connect the oscilloscope to the junction of R112 and C113 and check the linearity of the response. The pattern obtained should be similar to that shown in Figure 15.

SOUND TAKE-OFF ALIGNMENT.—Connect the 4.5 mc. generator in series with a 1,000 ohm resistor to terminal "C" of T110. The input signal should be approximately 0.5 volts.

Short the fourth pix i-f grid to ground, pin 1 V109, to prevent noise from masking the output indication.

As an alternate source of signal the RCA WR39B or WR39C calibrator may be used. In such a case, disregard the above two paragraphs. Connect calibrator across link circuit, T104 A, B, and modulate 45.75 carrier with 4.5 mc. crystal.

Connect the crystal diode probe of a "VoltOhmyst" to the plate of the video amplifier, pin 8 of V110.

Adjust the core of T110 for minimum output on the meter.

Remove the short from pin 1 V109 to ground, if used.

PICTURE I-F TRAP ADJUSTMENT.—Connect the i-f signal generator across the link circuit on terminals A and B of T104.

Connect the "VoltOhmyst" to test point TP101.

Obtain a 7.5 volt battery capable of withstanding appreciable current drain and connect the ends of a 1 000 ohm potentiometer across it. Connect the battery positive terminal to chassis and the potentiometer arm to the junction of R143 and R144.

Set the bias pot to produce approximately -1.0 volt of bias at test point TP101.

Connect the "VoltOhmyst" to test point TP102 at the picture detector.

Set the signal generator to each of the following frequencies and adjust the corresponding circuit for minimum d-c output at TP102. Use sufficient signal input to produce 1.0 volt of d-c on the meter when the final adjustment is made.

39.25 mc.	T104 top core
41.25 mc.	T105 bottom core
47.25 mc.	T106 bottom core

PICTURE I-F TRANSFORMER ADJUSTMENTS.—Set the signal generator to each of the following frequencies and peak the specified adjustment for maximum indication on the "VoltOhmyst." During alignment, reduce the input signal if necessary in order to produce 1.0 volt of d-c at test point TP102 with -1.0 volt of i-f bias at test point TP101.

43.7 mc.	T109
45.5 mc.	T108
41.8 mc.	T107

To align T105 and T106 connect the sweep generator to the first picture i-f grid pin 1 of V106 through a 1,000 mmf ceramic capacitor. Shunt R141 R149 and terminals "A" and "F" of T109 with 330 ohm composition resistors. Set the i-f bias to -1.0 volt at test terminal TP101

Adjust T105 and T106 top cores for maximum gain and curve shape as shown in Figure 16. For final adjustments set the output of the sweep generator to produce 0.5 volts peak-to-peak at the oscilloscope terminals.

To align T1 and T104 connect the sweep generator to the mixer grid test point TP2. Use the shortest leads possible with not more than one inch of unshielded lead at the end of the sweep cable.

Set the channel selector switch to channel 4.

Connect a 180 ohm composition resistor from terminal B of T105 to the junction of R135 and C132. Connect the oscilloscope diode probe to terminal B of T105 and to ground.

Couple the signal generator loosely to the diode probe in order to obtain markers.

In most receivers, C221 is variable and is provided as a band width adjustment. Preset C221 to minimum capacity.

Adjust T1 top and T104 bottom for maximum gain at 43.5 mc. and with 45.75 mc. at 70% of maximum response.

Adjust C221 until 41.25 mc. is at 85% response with respect to the low frequency shoulder at approximately 41.9 mc. as shown in Figure 17.

In receivers in which C221 is fixed, adjust T1 top and T104 bottom for maximum gain and the response shown in Figure 16.

Disconnect the diode probe, the 180 ohm and three 330 ohm resistors.

SWEEP ALIGNMENT OF PIX I-F.—Connect the oscilloscope to the test point TP102.

Adjust the bias potentiometer to obtain -6.0 volts of bias as measured by a "VoltOhmyst" at test point TP101.

ALIGNMENT PROCEDURE

17T150, 17T151, 17T163

Leave the sweep generator connected to the mixer grid test point TP2 with the shortest leads possible and with not more than one inch of unshielded lead at the end of the sweep cable. If these precautions are not observed, the receiver may be unstable and the response curves obtained may be unreliable.

Adjust the output of the sweep generator to obtain 3.0 volts peak-to-peak on the oscilloscope.

Couple the signal generator loosely to the grid of the first pix i-f amplifier. Adjust the output of the signal generator to produce small markers on the response curve.

Retouch T108 and T109 to obtain the response shown in Figure 18. Do not adjust T107 unless absolutely necessary. If T107 is adjusted too low in frequency it will raise the level of the 41.25 mc. sound i-f carrier and may create interference in the picture. It will also cause poor adjacent channel picture rejection. If T107 is tuned too high in frequency, the level of the 41.25 mc. sound i-f carrier will be too low and may produce noisy sound in weak signal areas.

Remove the oscilloscope, sweep and signal generator connections.

Remove the bias box employed to provide bias for alignment.

HORIZONTAL OSCILLATOR ADJUSTMENT.—Normally the adjustment of the horizontal oscillator is not considered to be a part of the alignment procedure, but since the oscillator waveform adjustment may require the use of an oscilloscope, it can not be done conveniently in the field. The waveform adjustment is made at the factory and normally should not require readjustment in the field. However, the waveform adjustment should be checked whenever the receiver is aligned or whenever the horizontal oscillator operation is improper.

Horizontal Frequency Adjustment.—Tune in a station and sync the picture. If the picture cannot be synchronized with the horizontal hold control R201B, then adjust the T113 frequency core on the rear apron until the picture will synchronize. If the picture still will not sync, turn the T113 waveform adjustment core (under the chassis) out of the coil several turns from its original position and readjust the T113 frequency core until the picture is synchronized.

Examine the width and linearity of the picture. If picture width or linearity is incorrect, adjust the horizontal drive control C181B, the width control L106 and the linearity control L107 until the picture is correct.

Horizontal Oscillator Waveform Adjustment.—The horizontal oscillator waveform may be adjusted by either of two methods. The method outlined in paragraph A below may be employed in the field when an oscilloscope is not available. The service shop method outlined in paragraph B below requires the use of an oscilloscope.

A.—Turn the horizontal hold control completely clockwise. Place adjustment tools on both cores of T113 and be prepared to make simultaneous adjustments while watching the picture on the screen. First, turn the T113 frequency core (on the rear apron) until the picture falls out of sync and one diagonal black bar sloping down to the right appears on the screen. Then, turn the waveform adjustment core (under the chassis) into the coil while at the same time adjusting the frequency core so as to maintain one diagonal black bar on the screen. Continue this procedure until the oscillator begins to motorboat, then turn the waveform adjustment core out until the motorboating just stops. As a check, turn the T113 frequency core until the picture is synchronized then reverse the direction of rotation of the core until the picture begins to fall out of sync with the diagonal bar sloping down to the right. Continue to turn the frequency core in the same direction. Additional bars should not appear on the screen. Instead, the horizontal oscillator should begin to motorboat. Retouch the adjustment of the T113 waveform adjustment core if necessary until this condition is obtained.

B.—Connect the low capacity probe of an oscilloscope to terminal C of T113. Turn the horizontal hold control one-quarter turn from the clockwise position so that the picture is in sync. The pattern on the oscilloscope should be as shown in Figure 19. Adjust the waveform adjustment core of T113 until the two peaks are at the same height. During this adjustment, the picture must be kept in sync by readjusting the hold control if necessary.

This adjustment is very important for correct operation of the circuit. If the broad peak of the wave on the oscilloscope is lower than the sharp peak, the noise immunity becomes poorer, the stabilizing effect of the tuned circuit is reduced and drift of the oscillator becomes more serious. On the other hand, if the broad peak is higher than the sharp peak, the oscillator is overstabilized, the pull-in range becomes inadequate and the broad peak can cause double triggering of the oscillator when the hold control approaches the clockwise position.

Remove the oscilloscope upon completion of this adjustment.

Horizontal Locking Range Adjustment.—Set the horizontal hold control to the full counter-clockwise position. Momentarily remove the signal by switching off channel then back. The picture may remain in sync. If so turn the T113 frequency core slightly and momentarily switch off channel. Repeat until the picture falls out of sync with the diagonal lines sloping down to the left. Slowly turn the horizontal hold control clockwise and note the least number of diagonal bars obtained just before the picture pulls into sync.

If more than 3 bars are present just before the picture pulls into sync, adjust the horizontal locking range trimmer C181A slightly clockwise. If less than 2 bars are present, adjust C181A slightly counter-clockwise. Turn the horizontal hold control counter-clockwise, momentarily remove the signal and recheck the number of bars present at the pull-in point. Repeat this procedure until 2 or 3 bars are present.

Turn the horizontal hold control to the maximum clockwise position. Adjust the T113 frequency core so that the diagonal bar sloping down to the right appears on the screen and then reverse the direction of adjustment so that bar just moves off the screen leaving the picture in synchronization.

SENSITIVITY CHECK.—A comparative sensitivity check can be made by operating the receiver on a weak signal from a television station and comparing the picture and sound obtained to that obtained on other receivers under the same conditions. This weak signal can be obtained by connecting the shop antenna to the receiver through a ladder type attenuator pad.

RESPONSE CURVES.—The response curves shown on page 14 are typical though some variations can be expected.

The response curves are shown in the classical manner of presentation, that is with "response up" and low frequency to the left. The manner in which they will be seen in a given test set-up will depend upon the characteristics of the oscilloscope and the sweep generator. The curves may be seen inverted and/or switched from left to right depending on the deflection polarity of the oscilloscope and the phasing of the sweep generator.

NOTES ON R-F UNIT ALIGNMENT.—Because of the frequency spectrum involved and the nature of the device, many of the r-f unit leads and components are critical in some respects. Even the power supply leads form loops which couple to the tuned circuits, and if resonant at any of the frequencies involved in the performance of the tuner, may cause serious departures from the desired characteristics. In the design of the receiver these undesirable resonant loops have been shifted far enough away in frequency to allow reasonable latitude in their components and physical arrangement without being troublesome. When the r-f unit is aligned in the receiver, no trouble from resonant loops should be experienced. However, if the unit is aligned in a jig separate from the receiver, attention should be paid to insure that unwanted resonances do not exist which might present a faulty representation of r-f unit alignment.

A resonant circuit exists between the r-f tuner chassis and the outer shield box, which couples into the antenna and r-f plate circuits. The frequency of this resonance depends on the physical structure of the shield box, and the capacitance between the tuner chassis and the front plate. This resonance is controlled in the design by using insulating washers of proper thickness in the front plate to tuner chassis mounting. The performance of the tuner will be impaired if the proper washers are not used. Obviously then, if the r-f unit is removed for service, the washers should be replaced in the correct order when the unit is replaced.

17T150, 17T151, 17T163

ALIGNMENT TABLE

THE DETAILED ALIGNMENT PROCEDURE BEGINNING ON PAGE 8 SHOULD BE READ BEFORE ALIGNMENT BY USE OF THE TABLE IS ATTEMPTED

Step No.	CONNECT SIGNAL GENERATOR TO	SIGNAL GEN. FREQ. MC.	CONNECT SWEEP GENERATOR TO	SWEEP GEN. FREQ. MC.	CONNECT HETERODYNE FREQ. METER TO	HET. METER FREQ. MC.	CONNECT OSCILLOSCOPE TO	MISCELLANEOUS CONNECTIONS AND INSTRUCTIONS	ADJUST	REFER TO
ANTENNA MATCHING UNIT ALIGNMENT										
1	Do not adjust this unit unless fairly certain that it requires adjustment. Disconnect lead from L58 to S5. Connect output of matching unit through 1000 mmf. to pin 1 of V107. Replace cover on matching unit. Remove V106 from socket. Connect bias box to junction of R143 and R144 and set to produce -6 volts.									
2	Antenna terminals	45.75 mc. 30% mod.	Not used	—	Not used	—	TP102. Scope gain to max.	—	L59 for min. audio on scope	Fig. 7
3	"	41.25 mc. 30% mod.	"	—	"	—	"	—	L60 for min. audio on scope	Fig. 7
4	Antenna terminals loosely		Antenna terminals through pad	45 to 54 mc.	"	—	Scope a xtal probe to gnd.	Connect 300 ohms from L58 to gnd.	L61 and L62 to obtain response of Fig. 12	Fig. 7 Fig. 11 Fig. 12
R-F UNIT ALIGNMENT										
5	If unit is completely out of adjustment, preset all adjustments to center of range with following exceptions. Set C18 so that head is $\frac{3}{8}$ " above chassis. Set T1 max. counterclockwise. Set C11 $\frac{1}{4}$ turn from max. clockwise. Disconnect link from T104 and terminate with 39 ohms. Short r-f unit power terminal 3 to ground. Set fine tuning 30 degrees clockwise from mechanical center of its range for all oscillator adjustments.									
6	Grid, pin 7 of V2 through 1500 mmf.	43.5 mc. 30% mod.	Not used	—	Not used	—	TP1. Gain to maximum	Set r-f unit on channel 2	L65 for min. indication on scope	Fig. 7 Fig. 10
7	Not used	—	Not used	—	Loosely to r-f unit oscillator	227 mc.	Not used	R-F unit on channel 8	C1 for beat on het. freq. meter	Fig. 7
8	Antenna terminals loosely	181.25 and 185.75	Antenna terminals through pad	Channel 8	Not used	—	TP1. Gain to maximum	"	C9, C11, C15 and C18 for response shown in Fig. 13	Fig. 7 Fig. 13
9	Not used	—	Not used	—	Loosely to r-f unit oscillator	129 mc.	Not used	R-F unit on channel 6	L5 for beat on het. freq. meter	Fig. 8
10	Antenna terminals loosely	83.25 and 87.75	Antenna terminals through pad	Channel 6	Not used	—	TP1. Gain to maximum	"	L48, L50 and L53 for response shown in Fig. 13	Fig. 7 Fig. 13
11	Not used	—	Not used	—	Not used	—	Not used	On channel 6. Connect "VoltOhmyst" to TP1	C8 for -3.5 volts on meter	Fig. 7
12	Antenna terminals loosely	83.25 and 87.75	Antenna terminals through pad	Channel 6	Not used	—	TP1. Gain to maximum	R-F unit on channel 6	Check response. Readjust L48, L50 and L53 if necessary	Fig. 7 Fig. 13
13	Not used	—	Not used	—	Loosely to r-f unit oscillator	227 mc.	Not used	R-F unit on channel 8	C1 for beat on het. freq. meter	Fig. 7
14	Antenna terminals loosely	181.25 and 185.75	Antenna terminals through pad	Channel 8	Not used	—	TP1. Gain to maximum	"	Check response adjust C9, C11, C15 and C18 if necessary	Fig. 7
15	If C9 was readjusted in step 14, repeat step 11, step 13 and step 14 until the conditions specified in each step are fulfilled without additional adjustments.									
16	Not used	—	Not used	—	Loosely to r-f unit oscillator	257 mc.	Not used	Rec. on channel 13	L46 for beat on het. freq. meter. Overshoot L46 slightly and adjust C1 for beat.	Fig. 7
17	Antenna terminals loosely	211.25 215.75	Antenna terminals through pad	Channel 13	Not used	—	TP1. Gain to maximum	Rec. on channel 13 "VoltOhmyst" on TP1	Check to see that response is correct and -3.0 volts of osc. injection is present	Fig. 13
18	"	205.25 209.75	"	Channel 12	Not used	—	"	Rec. on channel 12	"	Fig. 13
19	"	199.25 203.75	"	Channel 11	"	—	"	Rec. on channel 11	"	Fig. 13
20	"	193.25 197.75	"	Channel 10	"	—	"	Rec. on channel 10	"	Fig. 13
21	"	187.25 191.75	"	Channel 9	"	—	"	Rec. on channel 9	"	Fig. 13
22	"	181.25 185.75	"	Channel 8	"	—	"	Rec. on channel 8	"	Fig. 13
23	"	175.25 179.75	"	Channel 7	"	—	"	Rec. on channel 7	"	Fig. 13
24	If the response of any channel (steps 17 through 23) is below 80% at either marker, adjust C9, C11, C15 and C18 as necessary to pull response up on the low channel yet maintain correct response on channel 8.									
25	Repeat step 13. If the oscillator is off frequency overshoot the adjustment of C1 and correct by adjusting L46.									
26	Repeat steps 16 through 25 until all adjustments are obtained.									
27	Not used	—	Not used	—	Loosely to r-f unit oscillator	129 mc.	Not used	Rec. on channel 6	L5 for beat on het. freq. meter	Fig. 7
28	Antenna terminals loosely	83.25 87.75	Antenna terminals through pad	Channel 6	Not used	—	TP1. Gain to maximum	Rec. on channel 6 "VoltOhmyst" on TP1	Check to see that response is correct and -3.0 volts of osc. injection is present	Fig. 7 Fig. 13
29	"	77.25 81.75	"	Channel 5	"	—	"	Rec. on channel 5	"	Fig. 13
30	"	67.25 71.75	"	Channel 4	"	—	"	Rec. on channel 4	"	Fig. 13
31	"	61.25 65.75	"	Channel 3	"	—	"	Rec. on channel 3	"	Fig. 13

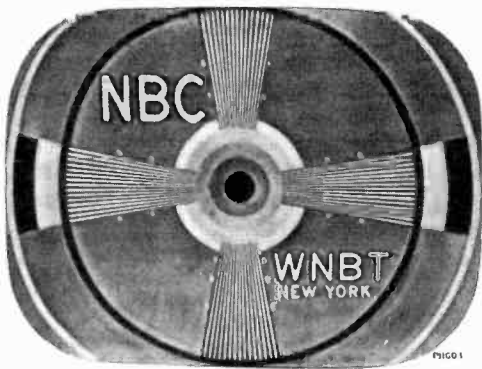

Figure 20—Normal Picture

Figure 21—Focus Magnet and Ion Trap Magnet Misadjusted

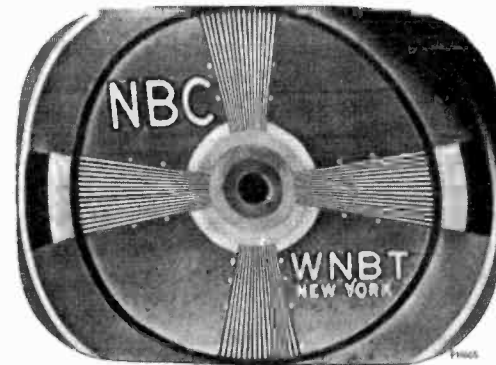

Figure 22—Horizontal Linearity Control Misadjusted (Picture Cramped in Middle)

Figure 23—Width Control Misadjusted

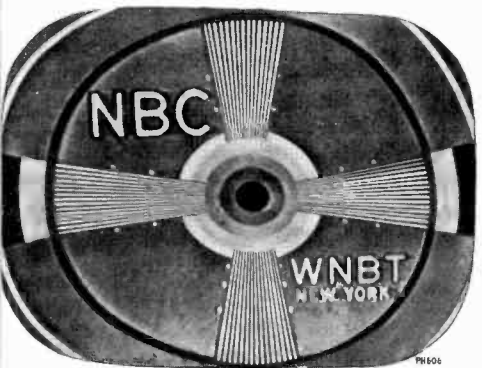
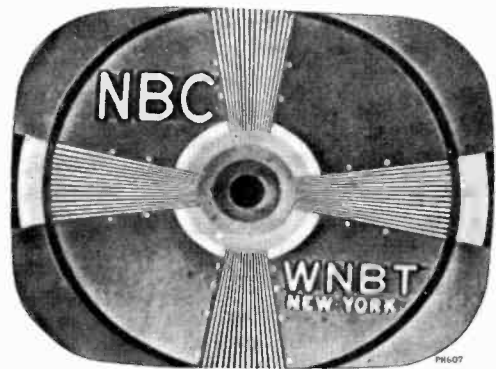

Figure 24—Horizontal Drive Control Misadjusted

Figure 25—Transients

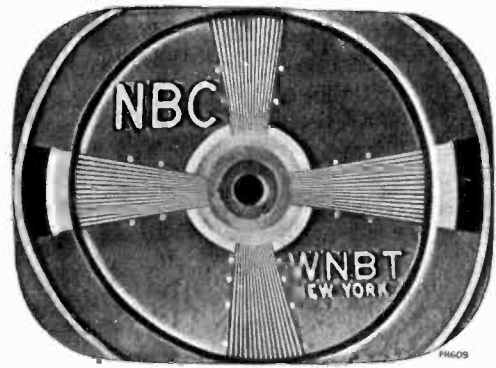

Figure 26—Test Pattern Showing Out of Sync Condition When Horizontal Hold Control Is in a Counter-clockwise Position—Just Before Pulling Into Sync

Figure 27—Test Pattern Showing Out of Sync Condition When Horizontal Hold Control Is at the Maximum Clockwise Position



Following is a list of symptoms of possible failures and an indication of some of the possible faults:

NO RASTER ON KINESCOPE:

- (1) Incorrect adjustment of ion trap magnet. Magnet reversed either front to back or top to bottom.
- (2) V116 or V117 inoperative. Check waveforms on grids and plates.
- (3) No high voltage—if horizontal deflection is operating as evidenced by the correct waveform on terminal 1 of high voltage transformer, the trouble can be isolated to the 1B3GT circuit. Either the T114 high voltage winding is open, the 1B3GT tube is defective, its filament circuit is open or C197 is shorted.
- (4) V110 circuit inoperative—Refer to schematic and waveform chart.
- (5) Damper tube (V120) inoperative.
- (6) Defective kinescope.
- (7) R218 open.
- (8) No receiver plate voltage—filter capacitor shorted—or filter choke open.

NO VERTICAL DEFLECTION:

- (1) V114B or V115 inoperative. Check voltage and waveforms on grids and plates.
- (2) T111 open.
- (3) Vertical deflection coils open.

SMALL RASTER:

- (1) Low Plus B or low line voltage.
- (2) V117 defective.

POOR VERTICAL LINEARITY:

- (1) If adjustments cannot correct, change V115.
- (2) Vertical output transformer T111 defective.
- (3) V114B defective—check voltage and waveforms on grid and plate.
- (4) C168, C170, C171, C172, C173 or C174 defective.
- (5) Low plate voltage—check rectifiers and capacitors in supply circuits.
- (6) If height is insufficient, try changing V114.

POOR HORIZONTAL LINEARITY:

- (1) If adjustments do not correct, change V117, or V120.
- (2) T114 or L107 defective.
- (3) C195 or C196 defective.

WRINKLES ON SIDE OF RASTER:

- (1) C199 defective.
- (2) Defective yoke.

PICTURE OUT OF SYNC HORIZONTALLY:

- (1) T113 incorrectly tuned.
- (2) R226, R227 or R201B defective.

TRAPEZOIDAL OR NON SYMMETRICAL RASTER:

- (1) Improper adjustment of centering of focus magnet or ion trap magnet.
- (2) Defective yoke.

RASTER AND SIGNAL ON KINESCOPE BUT NO SOUND:

- (1) T110 defective.
- (2) Sound i-f, ratio detector or audio amplifier inoperative—check V101, V102, V103 and their socket voltages.
- (3) Audio system defective.
- (4) Speaker defective.

SIGNAL AT KINESCOPE GRID BUT NO SYNC:

- (1) AGC control R175 misadjusted.
- (2) V111, inoperative. Check voltage and waveforms at its grid and plate.

SIGNAL ON KINESCOPE GRID BUT NO VERTICAL SYNC:

- (1) Check V114B and associated circuit.
- (2) Integrating network inoperative—Check.
- (3) V113 or V114A defective or associated circuit defective.
- (4) Gas current grid emission or grid cathode leakage in V114. Replace.

SIGNAL ON KINESCOPE GRID BUT NO HORIZONTAL SYNC:

- (1) T113 misadjusted—readjust as instructed on page 11.
- (2) V112 or V113 inoperative—check socket voltages and waveforms.
- (3) T113 defective.
- (4) C157, C181A, C182, C183, C184, C185, C186, C187 or C188 defective.
- (5) If horizontal speed is completely off and cannot be adjusted check R226, R227, R201B, R229, R230 and R231.

SOUND AND RASTER BUT NO PICTURE OR SYNC:

- (1) Picture, detector or video amplifier defective—check CR101 and V110—check socket voltages.
- (2) Bad contact to kinescope cathode.

PICTURE STABLE BUT POOR RESOLUTION:

- (1) CR101 or V110 defective.
- (2) Peaking coils defective—check resistance.
- (3) Make sure that the focus control operates on both sides of proper focus.
- (4) R-F and I-F circuits misaligned.

PICTURE SMEAR:

- (1) R-F or I-F circuits misaligned.
- (2) Open peaking coil.
- (3) This trouble can originate at the transmitter—check on another station.

PICTURE JITTER:

- (1) AGC control R175 misadjusted.
- (2) If regular sections at the left picture are displaced change V117.

ALIGNMENT TABLE

17T150, 17T151, 17T163

Step No.	CONNECT SIGNAL GENERATOR TO	SIGNAL GEN. FREQ. MC.	CONNECT SWEEP GENERATOR TO	SWEEP GEN. FREQ. MC.	CONNECT HETERODYNE FREQ. METER TO	HET. METER FREQ. MC.	CONNECT OSCILLOSCOPE TO	MISCELLANEOUS CONNECTIONS AND INSTRUCTIONS	ADJUST	REFER TO
32	"	55.25 59.75	"	Channel 2	"	"	"	Rec. on channel 2	"	Fig. 13
33	If excessive tilt in the same direction occurs on channels 2, 3 and 4, adjust C18 on channel 2 to overshoot the correction of this tilt then switch to channel 6 and adjust L53 for max. amplitude of response between carrier markers.									
34	Check r-f response and oscillator injection on channels 7 through 13 steps 23 back up through step 17 stopping on channel 13 for the next step.									
35	Not used	—	Not used	—	Loosely coupled to r-f oscillator	257 mc.	TP1. Gain to maximum	Rec. on channel 13	C1 for beat on het. freq. meter	Fig. 7
36	"	—	"	—	"	251 mc.	"	Rec. on channel 12	L11 as above	Fig. 7
37	"	—	"	—	"	245 mc.	"	Rec. on channel 11	L10 as above	Fig. 7
38	"	—	"	—	"	239 mc.	"	Rec. on channel 10	L9 as above	Fig. 7
39	"	—	"	—	"	233 mc.	"	Rec. on channel 9	L8 as above	Fig. 7
40	"	—	"	—	"	227 mc.	"	Rec. on channel 8	L7 as above	Fig. 7
41	"	—	"	—	"	221 mc.	"	Rec. on channel 7	L6 as above	Fig. 7
42	"	—	"	—	"	129 mc.	"	Rec. on channel 6	L5 as above	Fig. 7
43	"	—	"	—	"	123 mc.	"	Rec. on channel 5	L4 as above	Fig. 7
44	"	—	"	—	"	113 mc.	"	Rec. on channel 4	L3 as above	Fig. 7
45	"	—	"	—	"	107 mc.	"	Rec. on channel 3	L2 as above	Fig. 7
46	"	—	"	—	"	101 mc.	"	Rec. on channel 2	L1 as above	Fig. 7
47	Repeat steps 35 through 46 as a check. On completion, remove 39 ohm resistor and reconnect link to terminals A and B of T104.									
RATIO DETECTOR, SOUND I-F AND SOUND TAKE-OFF ALIGNMENT										
48	Grid 2nd Snd. I-F (pin 1, V102) or WR39B or C connect to grid 4th pix I-F (pin 1, V109.)	4.5 mc. 400 cy. mod. or 45.75 mc. mod. by 4.5 mc. and 400 cy.	Not used	—	Not used	—	Across speaker voice coil. Volume control set for max. volume.	"VoltOhmyst" to junction of R110 and R114. Set C226 for min. capacity. Set signal gen. to give -10 V on meter.	T102 top core for max. d-c on meter. T102 bottom core for min. audio on the oscilloscope.	Fig. 9 Fig. 10
49	"	"	"	—	"	—	"	"VoltOhmyst" to junction R112 and C113. If the meter reads more than ±1.5 volts, adjust C226 for zero on the meter and readjust T102 (bot.) for min. output on scope. Repeat steps 48 and 49 until all conditions are satisfied.	"	Fig. 9 Fig. 10
50	Sig. Gen. to 1st Snd. I-F	4.5 mc.	1st Sound I-F grid (pin 1, V101)	4.5 mc.	"	—	In series with 10,000 ohms to terminal A, of T101.	Sweep output reduced to provide 2 v p-p on scope.	T101 top and bot. cores for max. gain and symmetry at 4.5 mc.	Fig. 9 Fig. 10 Fig. 14
51	"	"	"	"	"	—	Junction of R112 and C113	Check for symmetrical response wave form (positive and negative).	"	Fig. 15
52	Sig. Gen. in series with 1000 ohms to T110-C or WR39 across T104 A and B.	"	Not used	—	"	—	"	"VoltOhmyst" xtal probe to pin 8, V110. If sig. gen. is used short pin 1, V109 to ground.	Adjust T110 for minimum reading on "VoltOhmyst".	Fig. 9
PICTURE I-F AND TRAP ADJUSTMENT										
53	Not used	—	Not used	—	Not used	—	Not used	Connect bias box to junction of R143 and R144 and to gnd. Adjust to give -1.0 v on "VoltOhmyst" at TP101.	"	Fig. 9
54	Sig. Gen. across T104 A and B	39.25 mc.	"	—	"	—	"	"VoltOhmyst" to TP102. Gen. output to give -1.0 volt d-c.	T104 top core to give min. d-c on meter.	Fig. 9
55	"	41.25 mc.	"	—	"	—	"	"	T105 bot. for min.	Fig. 10
56	"	47.25 mc.	"	—	"	—	"	"	T106 bot. for min.	Fig. 10
57	"	43.7 mc.	"	—	"	—	"	Sig. Gen. output to give -1.0 V d-c at TP102.	T109 for max.	Fig. 7
58	"	45.5 mc.	"	—	"	—	"	"	T108 for max.	Fig. 9
59	"	41.8 mc.	"	—	"	—	"	"	T107 for max.	Fig. 9
60	First pix i-f grid (pin 1, V106) loosely.	Various See Fig. 16	First pix i-f grid pin 1, V106 through 1000 mmf.	40 to 48 mc.	"	—	To test point TP102	Shunt R141, R149 and terminals A and F of T109 with 330 ohms, 0.5 v p-p on scope.	Adjust T105 and T106 top cores for max. gain and response shown in Fig. 16.	Fig. 9 Fig. 16
61	Connected loosely to diode probe.	Various See Fig. 17	Mixer grid test point TP2 with short lead.	40 to 48 mc.	"	—	Scope diode probe to T105-B and to gnd.	Rec. on chan. 4. Connect 180 ohms from T105-B to junction R135 and C132. Upon completion disconnect scope and shunting resistors.	Set C221 to min. Adjust T1 top and T104 bot. for max. gain at 43.5 mc. and 45.75 mc. at 70%. Adjust C221 until 41.25 mc. is at 80%.	Fig. 9 Fig. 17
62	Connected loosely to grid of 1st pix i-f.	Various See Fig. 18	"	"	"	—	Connect scope to TP102.	"VoltOhmyst" to TP101. Set bias box for -6.0 volts on the meter. Set sweep output to produce 3.0 volts p-p on scope.	Retouch T108 and T109 to obtain response shown in Fig. 18. Do not adjust T107 unless absolutely necessary.	Fig. 18

ALIGNMENT DATA

17T150, 17T151, 17T163

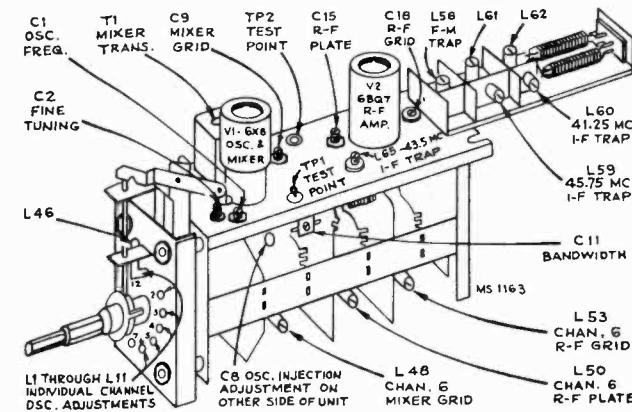

Figure 7—R-F Unit Adjustments

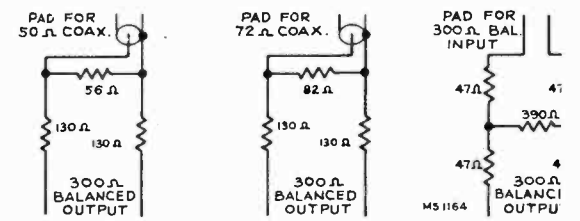

Figure 11—Sweep Attenuator Pads

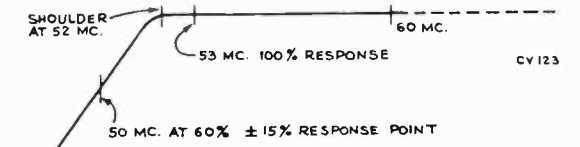

Figure 12—Antenna Matching Unit Response

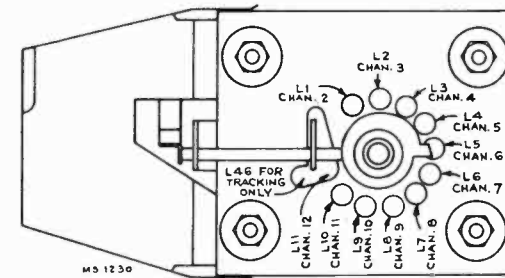

Figure 8—R-F Oscillator Adjustments

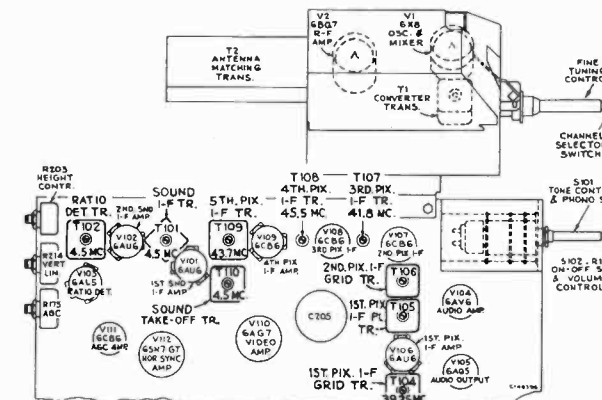

Figure 9—Top Chassis Adjustments

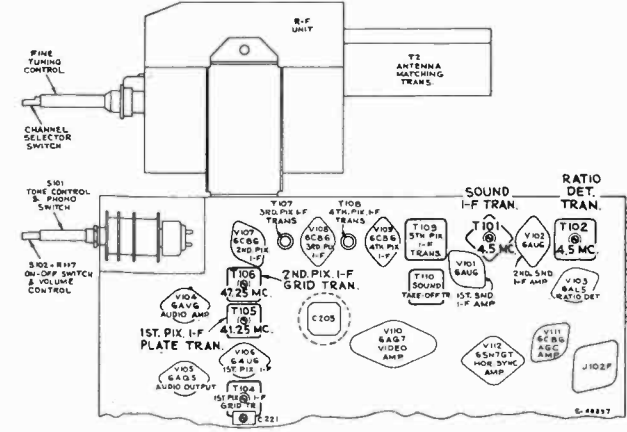

Figure 10—Bottom Chassis Adjustments

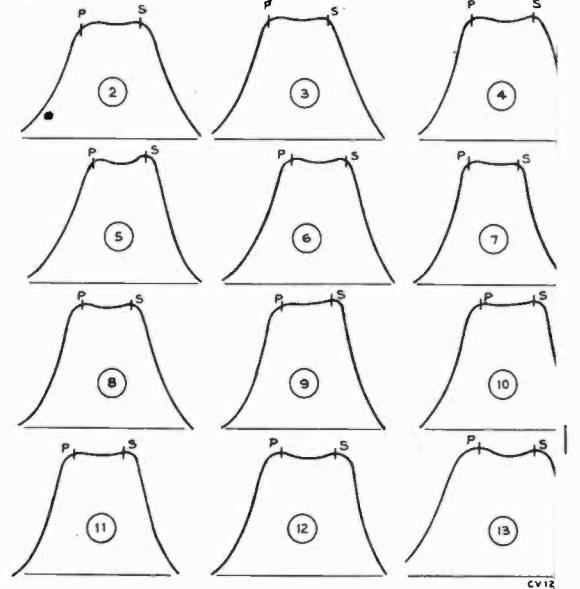

Figure 13—R-F Response

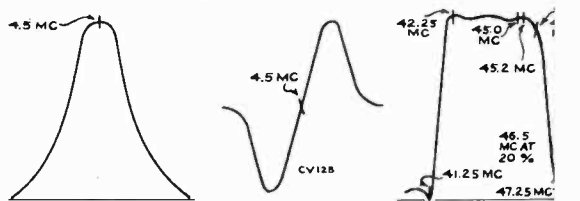

Figure 14 Sound I-F Response

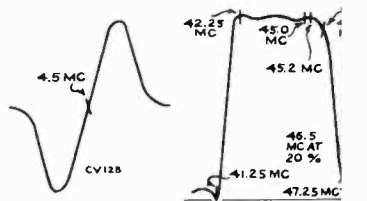

Figure 15 Ratio Det. Response

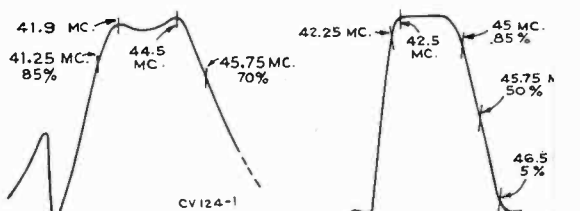

Figure 17 T1 and T104 Response

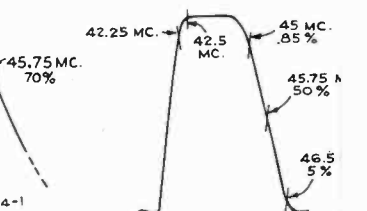

Figure 18 Over-all I-F Response

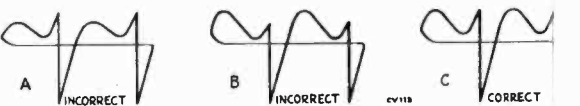

Figure 19—Horizontal Oscillator Waveforms

SERVICE SUGGESTIONS

17T150, 17T151, 17T163

- (3) Vertical instability may be due to loose connections or noise.
 (4) Horizontal instability may be due to unstable transmitted sync.

RASTER BUT NO SOUND, PICTURE OR SYNC:

- (1) Defective antenna or transmission line.
 (2) R-F oscillator off frequency.
 (3) R-F unit inoperative—check V1, V2.

DARK VERTICAL LINE ON LEFT OF PICTURE:

- (1) Reduce horizontal drive and readjust width and horizontal linearity.
 (2) Replace V117.

LIGHT VERTICAL LINE ON LEFT OF PICTURE:

- (1) C193 defective.
 (2) V120 defective.

PICTURE I-F RESPONSE.—At times it may be desirable to observe the individual i-f stage response. This can be achieved by the following method:

For T107, T108 or T109, shunt all i-f transformers with a 330 ohm carbon resistor except the one whose response is to be observed.

Connect a wide band sweep generator to the second pix i-f grid and adjust it to sweep from 38 mc. to 48 mc.

Connect the oscilloscope to test point TP102 and observe the overall response. The response obtained will be essentially that of the unshunted stage.

To see the response of transformers T1, T104 and T105, T106, follow the instructions given on page 10.

Figures 28 through 36 show the response of the various stages obtained in the above manner. The curves shown are typical although some variation between receivers can be expected. Relative stage gain is not shown.

RESPONSE PHOTOGRAPHS

Taken from RCA WO58A Oscilloscope

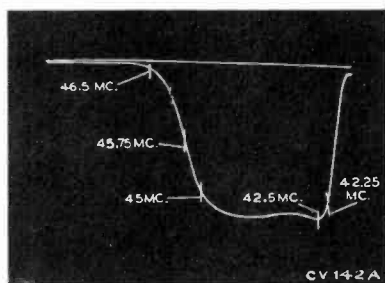

Figure 28—Overall Pix I-F Response

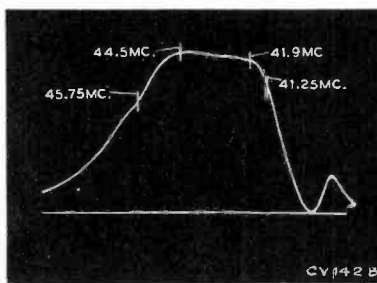

Figure 29—Response of T1-T104 Pix I-F Transformers

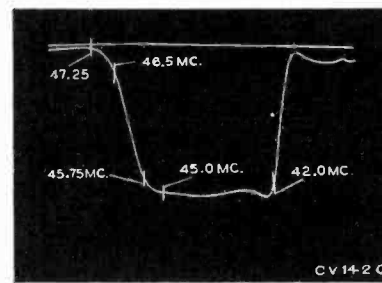

Figure 30—Response of T105-T106 Pix I-F Transformer

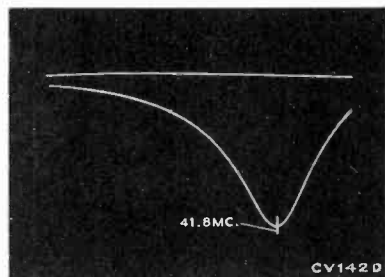

Figure 31—Response of T107 Pix I-F Transformer

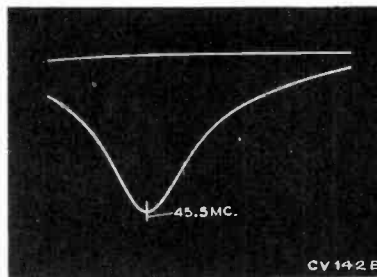

Figure 32—Response of T108 Pix I-F Coil

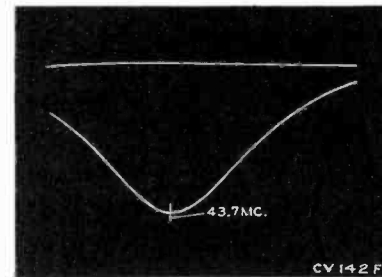

Figure 33—Response of T109 Pix I-F Coil

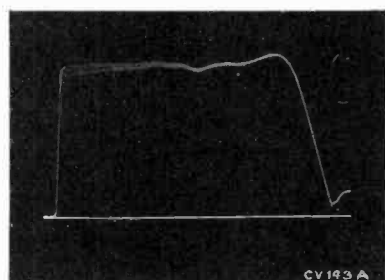

Figure 34—Video Response at Average Contrast

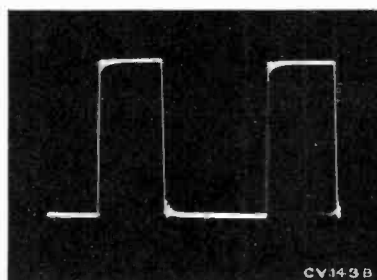

Figure 35—Video Response (100 KC Square Wave)

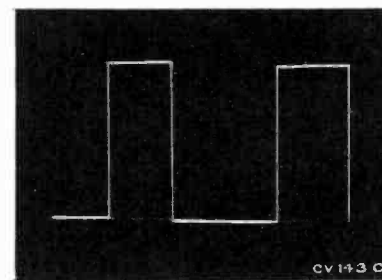
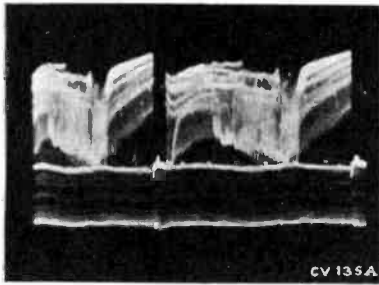

Figure 36—Video Response (60 Cycle Square Wave)

17T150, 17T151, 17T163

WAVEFORM PHOTOGRAPHS

Taken from RCA WO58A Oscilloscope



CV 135A

*Grid of 1st Video Amplifier
(Pin 4 of V110) (6AG7)
Voltage Depends on Picture
Figure 37—Vertical (Oscilloscope
Synced to 1/2 of Vertical Sweep
Rate) (6.0 Volts PP)*



*Figure 38—Horizontal (Oscilloscope
Synced to 1/2 of Horizontal Sweep
Rate) (6.0 Volts PP)*

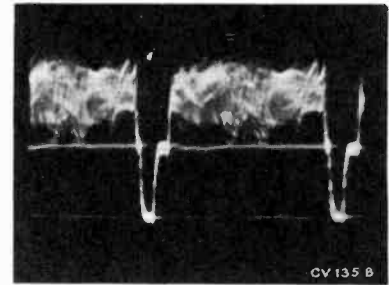

CV 135 B

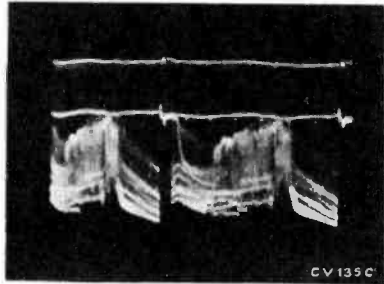

CV 135C

*Plate of 1st Video Amplifier
(Pin 8 of V110) (6AG7)
Voltage depends on picture
Figure 39—Vertical (105 Volts PP)*



Figure 40—Horizontal (105 Volts PP)

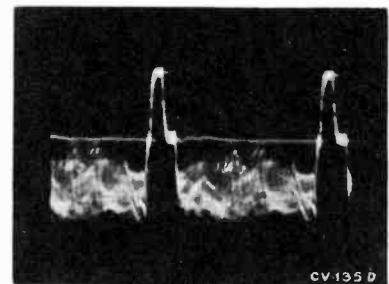

CV 135 D

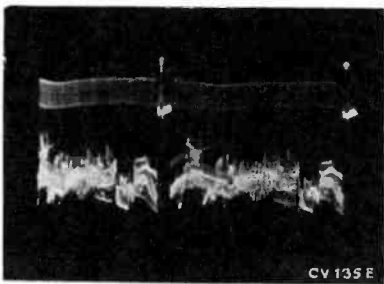

CV 135E

*Grid of Sync Separator
(Pin 4 of V113) (6SN7)
Voltage depends on picture*

Figure 41—Vertical (30 Volts PP)



Figure 42—Horizontal (30 Volts PP)

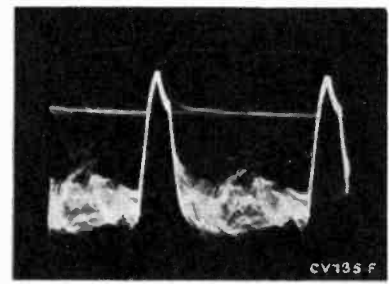

CV 135 F

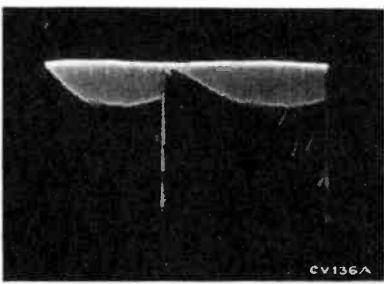

CV 136A

*Plate of Sync Separator
(Pin 5 of V113) (6SN7)
(.25 mfd in series with probe)*

Figure 43—Vertical (33 Volts PP)



Figure 44—Horizontal (8 Volts PP)

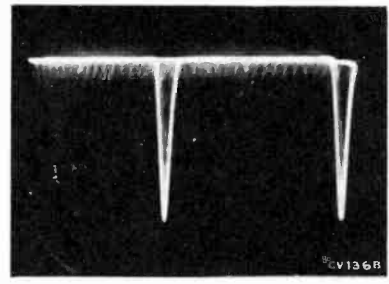

CV 136B

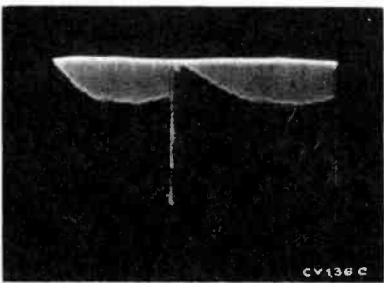

CV 136C

*Grid of Vertical Sync Amp.
(Pin 4 of V114A) (6SN7)*

Figure 45—Vertical (12 Volts PP)



Figure 46—Horizontal (5 Volts PP)

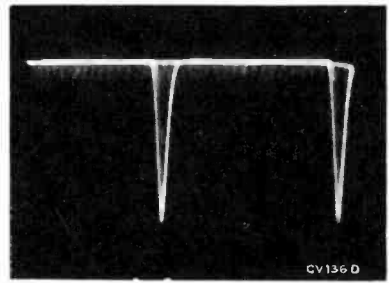

CV 136D

WAVEFORM PHOTOGRAPHS

Taken from RCA W058A Oscilloscope

17T150, 17T151, 17T163

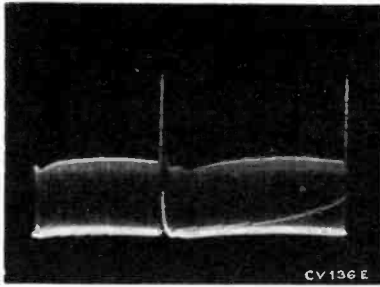
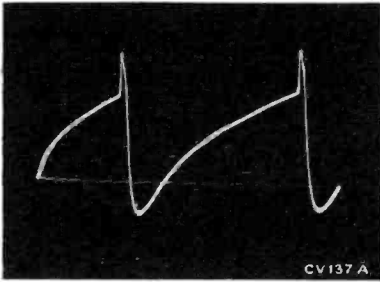
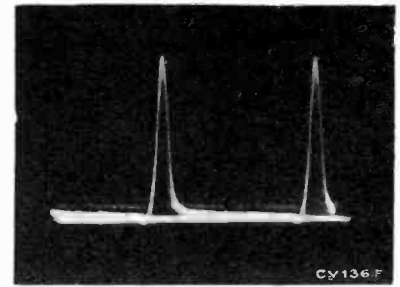

*Plate of Vertical Sync Amp.
(Pin 5 of V114A) (6SN7)*

Figure 47—Vertical (27 Volts PP)



Figure 48—Horizontal (16 Volts PP)



*Figure 49—Grid of Vertical
Sweep Osc. (Pin 1 of V114B) (6SN7)*



*Figure 50—Plate of Vertical
Sweep Osc. (Pin 2 of V114B)*

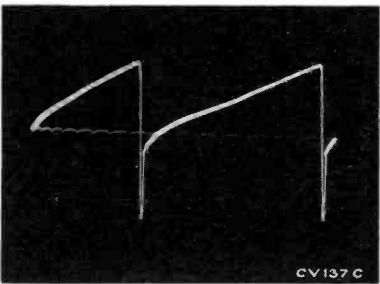
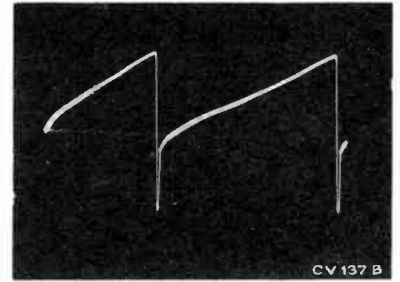

*Figure 51—Grid of Vertical
Sweep Output (Pin 1 of V115) (6AQ5)*



*Figure 52—Plate of Vertical
Sweep Output (Pin 5 of V115) (6AQ5)*

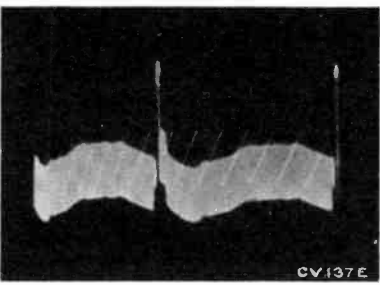
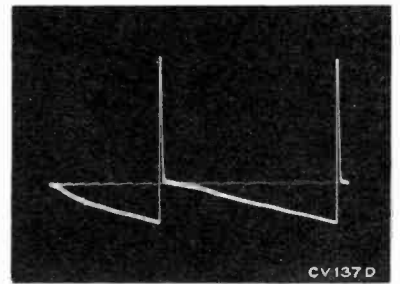

*Cathode of Sync Separator
(Pin 3 of V113) (6SN7)*

Figure 53—Vertical (11 Volts PP)



Figure 54—Horizontal (6 Volts PP)

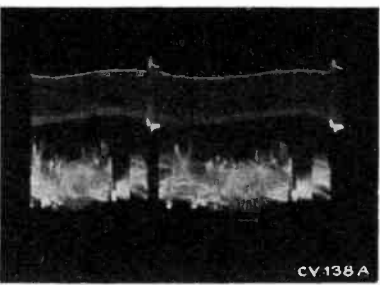
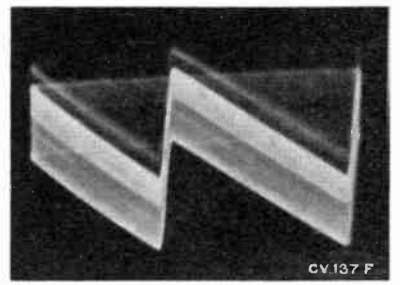

*Grid of Sync Separator
(Pin 1 of V113) (6SN7)*

Figure 55—Vertical (40 Volts PP)



Figure 56—Horizontal (40 Volts PP)

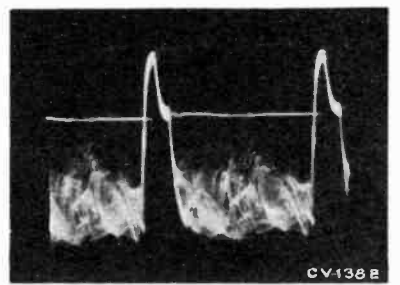

17T150, 17T151, 17T163

WAVEFORM PHOTOGRAPHS

Taken from RCA WO58A Oscilloscope

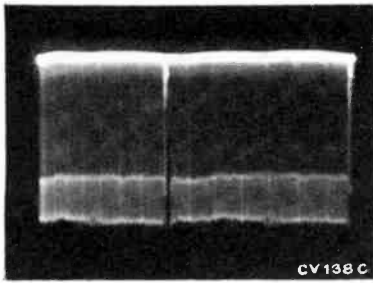

CV138C

*Plate of Sync Separator
(Pin 2 of V113) (6SN7)*

Figure 57—Vertical (15 Volts PP)



Figure 58—Horizontal (15 Volts PP)

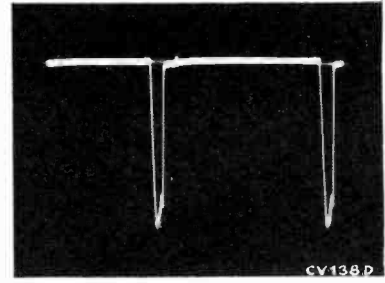

CV138D

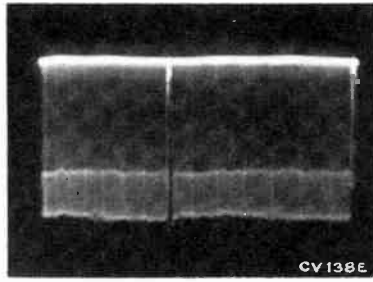

CV138E

*Grid of Hor. Sync Amp.
(Pin 4 of V112) (6SN7)*

Figure 59—Vertical (15 Volts PP)



Figure 60—Horizontal (15 Volts PP)

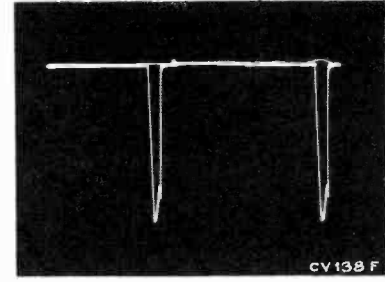

CV138F

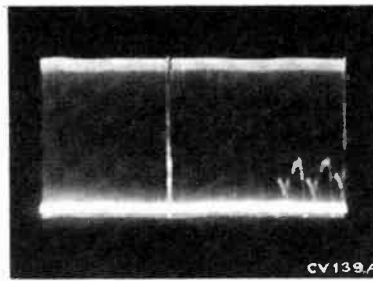

CV139A

*Plate of Hor. Sync Amp.
(Pin 5 of V112) (6SN7)*

Figure 61—Vertical (70 Volts PP)



Figure 62—Horizontal (70 Volts PP)

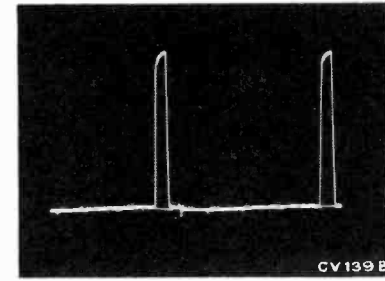

CV139B

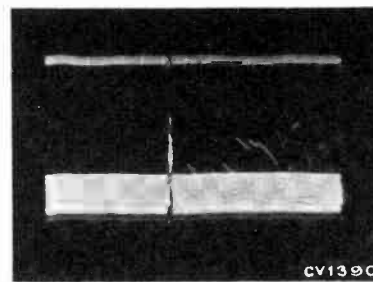

CV139C

*Grid of Hor. Sync Amp.
(Pin 1 of V112) (6SN7)*

Figure 63—Vertical (65 Volts PP)



Figure 64—Horizontal (65 Volts PP)

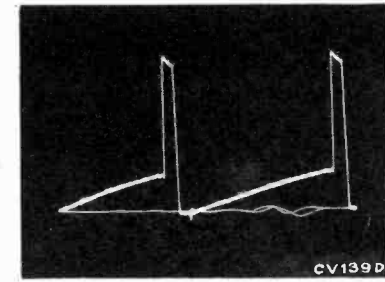

CV139D

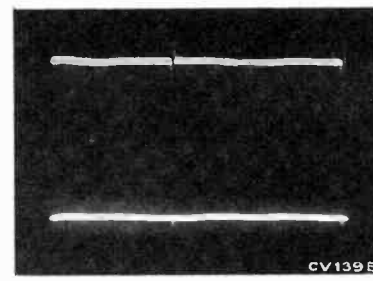

CV139E

*Cathode of Hor. Sync Amp.
(Pin 3 of V112) (6SN7)*

Figure 65—Vertical (18 Volts PP)



Figure 66—Horizontal (18 Volts PP)

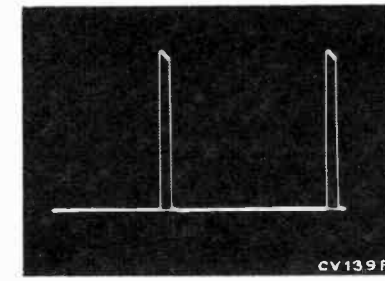

CV139F

WAVEFORM PHOTOGRAPHS

Taken from RCA WO58A Oscilloscope

17T150, 17T151, 17T163

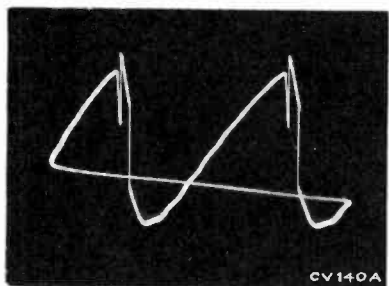

Figure 67—Grid of Horizontal Oscillator Control (Pin 1 of V116) (6SN7GT) (22 Volts PP)



Figure 68—Cathode of Horizontal Oscillator Control (Pin 3 of V116) (6SN7GT) (1.3 Volts PP)

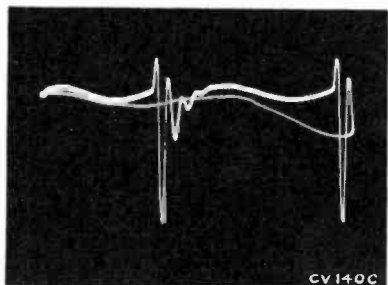
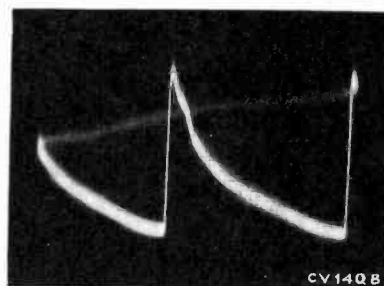

Figure 69—Grid of Horizontal Oscillator (Pin 4 of V116) (6SN7GT) (390 Volts PP)



Figure 70—Plate of Horizontal Oscillator (Pin 5 of V116) (6SN7GT) (140 Volts PP)

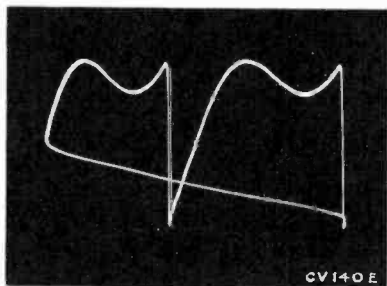
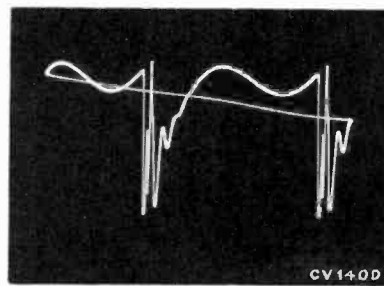

Figure 71—Terminal "C" of T113 (120 Volts PP)



Figure 72—Grid of Horizontal Output Tube (Pin 5 of V117) (6BQ6) (95 Volts PP)

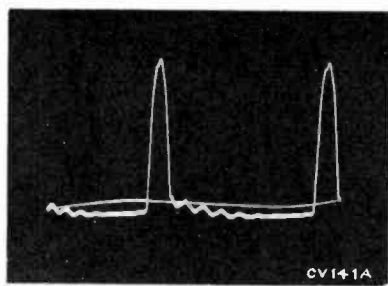
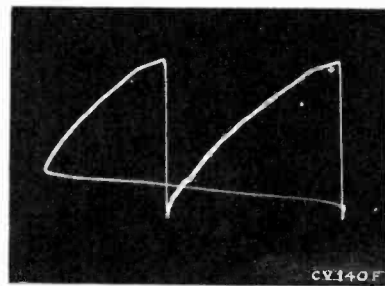

Figure 73—Plate of Horizontal Output (Approx. 4000 Volts PP) (Measured Through a Capacity Voltage Divider Connected from Top Cap of V117 to Ground)



Figure 74—Cathode of Damper (Pin 3 of V120) (6W4GT) (2300 Volts PP)

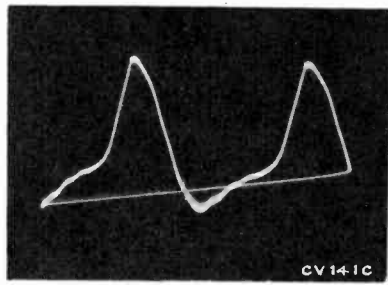
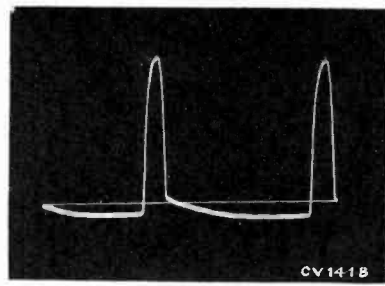
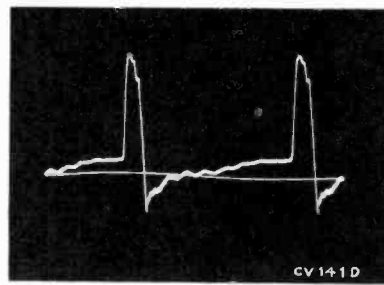

Figure 75—Plate of Damper (Pin 5 of V120) (6W4GT) (180 Volts PP)



Figure 76—Plate of AGC Amplifier (Pin 5 of V111) (6CB6) (600 Volts PP)



17T150, 17T151, 17T163

VOLTAGE CHART

The following measurements represent two sets of conditions. In the first condition, a 5000 microvolt test pattern signal was fed into the receiver, the picture synced and the AGC control properly adjusted. The second condition was obtained by removing the antenna leads and short circuiting the receiver antenna terminals. Voltages shown are read with a type WV97A senior "VoltOhmyst" between the indicated terminal and chassis ground and with the receiver operating on 117 volts, 60 cycles, a-c. The symbol < means less than.

Tube No.	Tube Type	Function	Operating Condition	E. Plate		E. Screen		E. Cathode		E. Grid		Notes on Measurements
				Pin No.	Volts	Pin No.	Volts	Pin No.	Volts	Pin No.	Volts	
V1	6X8	Mixer	5000 Mu. V. Signal	9	—	8	—	6	0	7	—	
			No Signal	9	145 to 150	8	145 to 150	6	0	7	-2.8 to -3.5	Depending on channel
V1	6X8	R-F Oscillator	5000 Mu. V. Signal	3	—	—	—	6	0	2	—	
			No Signal	3	88 to 108	—	—	6	0	2	-3.0 to -5.1	Depending on channel
V2	6BQ7	R-F Amplifier	5000 Mu. V. Signal	6	—	—	—	8	—	7	—	
			No Signal	6	133 to 138	—	—	8	1.1	7	—	Depending on channel
V2	6BQ7	R-F Amplifier	5000 Mu. V. Signal	1	—	—	—	3	—	2	—	
			No Signal	1	260	—	—	3	133 to 138	2	—	Depending on channel
V101	6AU6	1st Sound I-F Amp.	5000 Mu. V. Signal	5	255	6	185	7	0.8	1	-1.0	
			No Signal	5	245	6	165	7	0.9	1	0	
V102	6AU6	2d Sound I-F Amp.	5000 Mu. V. Signal	5	260	6	52	7	0.17	1	-24	
			No Signal	5	255	6	54.0	7	0.12	1	*-1.5	*Unreliable measuring point. Voltage depends on noise.
V103	6AL5	Ratio Detector	5000 Mu. V. Signal	7	0.54	—	—	1	15.1	—	—	7.5 kc deviation at 400 cycles
			No Signal	7	-0.85	—	—	1	*6.85	—	—	*Unreliable measuring point. Voltage depends on noise.
V104	6AV6	1st Audio Amplifier	5000 Mu. V. Signal	7	102	—	—	2	0	1	-0.3	At min. volume
			No Signal	7	100	—	—	2	0	1	-0.3	At min. volume
V105	6AQ5	Audio Output	5000 Mu. V. Signal	5	245	6	254	2	17	7	0	At min. volume
			No Signal	5	240	6	250	2	17	7	0	At min. volume
V106	6AU6	1st Pix. I-F Amplifier	5000 Mu. V. Signal	5	248	6	255	7	0.2	1	-6.7	
			No Signal	5	150	6	120	7	1.0	1	*0	*Unreliable measuring point. Make measurement at T104-D.
V107	6CB6	2nd Pix. I-F Amplifier	5000 Mu. V. Signal	5	249	6	232	2	0.15	1	-6.7	
			No Signal	5	145	6	108	2	0.8	1	0	
V108	6CB6	3d Pix. I-F Amplifier	5000 Mu. V. Signal	5	145	6	135	2	1.2	1	0	
			No Signal	5	130	6	127	2	1.1	1	0	
V109	6CB6	4th Pix. I-F Amplifier	5000 Mu. V. Signal	5	215	6	150	2	2.1	1	0	
			No Signal	5	210	6	140	2	2.0	1	0	
V110	6AG7	Video Amplifier	5000 Mu. V. Signal	8	135	6	150	5	1.35	4	-3.0	
			No Signal	8	100	6	125	5	1.65	4	*-0.6	*Depends on noise
V111	6CB6	AGC Amplifier	5000 Mu. V. Signal	5	-35.8	6	238	2	120	1	120	AGC control set for normal operation
			No Signal	5	4.0	6	265	2	100	1	80	AGC control set for normal operation

VOLTAGE CHART

17T150, 17T151, 17T163

The following measurements represent two sets of conditions. In the first condition, a 5000 microvolt test pattern signal was fed into the receiver, the picture synced and the AGC control properly adjusted. The second condition was obtained by removing the antenna leads and short circuiting the receiver antenna terminals. Voltages shown are read with a type WV97A senior "VoltOhmyst" between the indicated terminal and chassis ground and with the receiver operating on 117 volts, 60 cycles, a-c. The symbol < means less than.

Tube No.	Tube Type	Function	Operating Condition	E. Plate		E. Screen		E. Cathode		E. Grid		Notes on Measurements
				Pin No.	Volts	Pin No.	Volts	Pin No.	Volts	Pin No.	Volts	
V112	6SN7GT	Hor. Sync Amplifier	5000 Mu. V. Signal	2	150	—	—	3	1.2	1	-38.0	
			No Signal	2	143	—	—	3	0.68	1	*-18	*Unreliable measurement point. Voltage depends on noise.
			5000 Mu. V. Signal	5	77	—	—	6	0	4	-1.3	
			No Signal	5	75	—	—	6	0	4	*-0.8	*Voltage depends on noise.
V113	6SN7GT	Hor. Sync Separator	5000 Mu. V. Signal	2	269	—	—	3	118	1	100	
			No Signal	2	263	—	—	3	*90	1	*80	*Unreliable measurement points. Voltage depends on noise.
V113	6SN7GT	Vert. Sync Separator	5000 Mu. V. Signal	5	450	—	—	6	125	4	100	
			No Signal	5	400	—	—	6	100	4	80	
V114A	6SN7GT	Vert. Sync Amplifier	5000 Mu. V. Signal	5	12.0	—	—	6	0	4	-0.13	
			No Signal	5	11.0	—	—	6	0	4	-0.05	
V114B	6SN7GT	Vertical Oscillator	5000 Mu. V. Signal	2	*53	—	—	3	0	1	*-14.8	*Depends on setting of Vert. hold control. Voltages shown are synced pix adjustment.
			No Signal	2	*53	—	—	3	0	1	*-14.1	
V115	6AQ5	Vertical Output	5000 Mu. V. Signal	5	245	6	259	2	21.5	1	0	
			No Signal	5	240	6	252	2	21.6	1	0	
V116	6SN7GT	Horizontal Osc. Control	5000 Mu. V. Signal	2	182	—	—	3	+8.0	1	-12.5	
			No Signal	2	180	—	—	3	-3.0	1	-19.5	
			5000 Mu. V. Signal	2	135	—	—	3	+8.8	1	-13.5	Hor. hold counter-clockwise
			5000 Mu. V. Signal	2	225	—	—	3	+8.8	1	-12.5	Hor. hold clockwise
V116	6SN7GT	Horizontal Oscillator	5000 Mu. V. Signal	5	185	—	—	6	0	4	-58	
			No Signal	5	180	—	—	6	0	4	-67	
			5000 Mu. V. Signal	5	185	—	—	6	0	4	-58	Hor. hold counter-clockwise
			5000 Mu. V. Signal	5	185	—	—	6	0	4	-58	Hor. hold clockwise
V117	6BQ6GT	Horizontal Output	5000 Mu. V. Signal	Cap	*	4	168	8	18.0	5	-15.0	*High Voltage Pulse Present
			No Signal	Cap	*	4	168	8	18.5	5	-15.0	
V119	1B3GT /8016	H. V. Rectifier	5000 Mu. V. Signal	Cap	*	—	—	2 & 7	13,500	—	—	*High Voltage Pulse Present
			No Signal	Cap	*	—	—	2 & 7	13,200	—	—	
V120	6W4GT	Damper	5000 Mu. V. Signal	5	266	—	—	3	*	—	—	*High Voltage Pulse Present
			No Signal	5	261	—	—	3	*	—	—	
V121	17QP4	Kinescope	5000 Mu. V. Signal	Cone	13,500	10	475	11	140	2	90	At average Brightness
			No Signal	Cone	13,200	10	470	11	135	2	90	

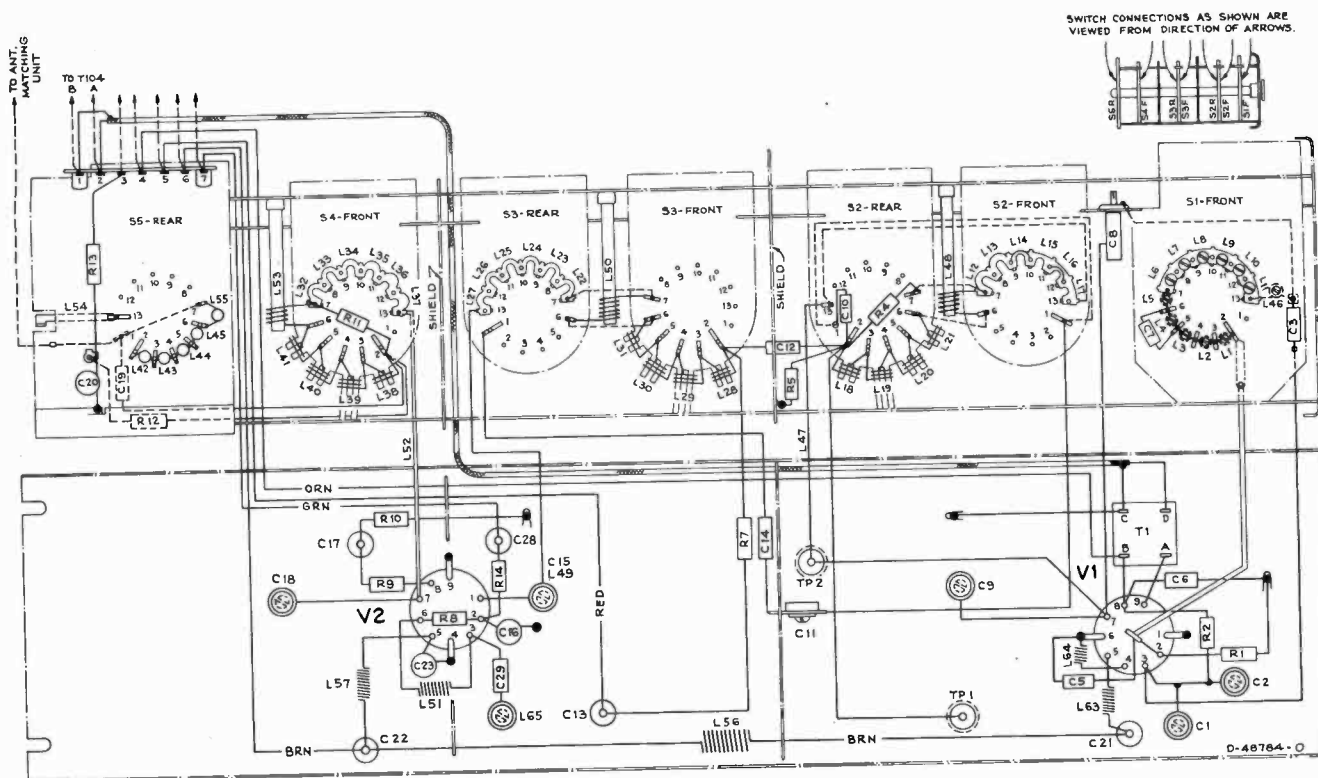

Figure 77—R-F Unit Wiring Diagram

CRITICAL LEAD DRESS:

- Keep all wiring in the pix i-f, sound i-f and video circuits as short as possible.
- Keep the leads on C110, C111, C112, C200, R109, R110, R111, R112, R114, R115 and R233 as short and direct as possible.
- Do not change the bus wire connection to pin 2 of V101 and V102. Sleeving is used on these wires to insure length and to prevent shorting.
- Dress C114 down between R117 (volume control) and water S101-2.
- Ground R130 to pin 3 of V106 and R138 to pin 7 of V107.
- Do not change the grounding of R141, R146 and R149.
- Keep the bus wire from T109-A to C146 (plug in capacitor) short and direct.
- Ground the filaments of sockets V107, V108 and V109 independently of the socket center pin. Use ground lances proved near each socket.
- Dress C198 straight up to act as a shield between T101-A and V110-4.
- Dress C153 and R170 (kine cathode) up in the air above the terminal board.
- Keep the leads connected to T113-C and T113-D (synchoguide) down so that they will not short out when the chassis is placed in the cabinet.
- Do not reroute any wires between T104 and the terminal board alongside it. Keep all leads on the foot side of the terminal board.
- Dress all wires routed past T104, shielded wires W102 and W103 under the big lances near T104.
- Dress all a-c leads to S102 under the large lances on the front apron.
- Dress R116 close to the chassis with leads as short as possible.
- Dress C212 and C221 up in the air and away from all other leads and components.
- The blue lead from pin 5 of V111 to the terminal board under the high voltage cage should be routed between V117 socket and the rear apron.
- Dress all 2 watt resistors away from each other and all other wires and components.
- Dress all wires away from damper tube V120.
- Blue wire from pin 5 V116 to T113-A should not be more than 5 inches long.
- Dress all peaking coils up and away from the base.
- Dress all leads in the high voltage compartment away from each other and away from the high voltage transformer.

STOCK No.	DESCRIPTION	STOCK No.	DESCRIPTION
76141	Magnet—Ion trap magnet (P.M. type)	503410	100,000 ohms, ±10%, ½ watt (R129, R206, R220, R268)
76633	Magnet—Pin cushion correction magnet complete with support arm	504410	100,000 ohms, ±20%, ½ watt (R136)
76728	Nut—Speed nut for trimmer capacitor 76800	30180	120,000 ohms, ±5%, ½ watt (R209)
18469	Plate—Bakelite mounting plate for electrolytic 75220	503412	120,000 ohms, ±10%, ½ watt (R190, R242, R245)
76464	Plate—Hi-voltage plate—bakelite—complete with tube socket and corona ring	503415	150,000 ohms, ±10%, ½ watt (R145, R150, R186, R221)
76675	Rectifier—Picture detector crystal rectifier (CR101)	504415	150,000 ohms, ±20%, ½ watt (R170, R217)
76452	Rectifier—Selenium rectifier (SR101, SR102)	512415	150,000 ohms, ±5%, 1 watt (R230)
76796	Resistor—Wire wound, 5.1 ohms, ½ watt (R241)	503418	180,000 ohms, ±10%, ½ watt (R257)
76639	Resistor—Wire wound, 180 ohms, 2 watts (R234)	503422	220,000 ohms, ±10%, ½ watt (R185, R219)
76465	Resistor—Wire wound, 330 ohms, 1 watt (R122, R123)	503427	270,000 ohms, ±10%, ½ watt (R193)
76469	Resistor—Wire wound, 2500 ohms, 10 watts (R131)	503433	330,000 ohms, ±10%, ½ watt (R120, R222)
76390	Resistor—Wire wound, 5600 ohms, 5 watts (R151)	512433	330,000 ohms, ±5%, 1 watt (R224)
76638	Resistor—Wire wound, 6000 ohms, 6 watts (R163)	503447	470,000 ohms, ±10%, ½ watt (R199, R232, R264)
	Resistor—Fixed, composition—	504447	470,000 ohms, ±20%, ½ watt (R121, R263)
502043	43 ohms, ±5%, ½ watt (R159)	503456	560,000 ohms, ±10%, ½ watt (R202, R270)
30732	47 ohms, ±5%, ½ watt (R109)	30562	680,000 ohms, ±5%, ½ watt (R127)
504047	47 ohms, ±20%, ½ watt (R233)	503482	820,000 ohms, ±10%, ½ watt (R200, R204, R223)
502056	56 ohms, ±5%, ½ watt (R138)	503510	1 megohm, ±10%, ½ watt (R189)
34763	68 ohms, ±5%, ½ watt (R105, R146)	504510	1 megohm, ±20%, ½ watt (R182)
13961	82 ohms, ±5%, ½ watt (R101)	503512	1.2 megohm, ±10%, ½ watt (R171)
502110	100 ohms, ±5%, ½ watt (R130)	503515	1.5 megohm, ±10%, ½ watt (R192)
504110	100 ohms, ±20%, ½ watt (R126, R133)	11769	1.8 megohm, ±5%, ½ watt (R266)
503118	180 ohms, ±10%, ½ watt (R152)	504522	2.2 megohm, ±20%, ½ watt (R207, R213)
503133	330 ohms, ±10%, ½ watt (R160)	503539	3.9 megohm, ±10%, ½ watt (R179)
503147	470 ohms, ±10%, ½ watt (R215)	503556	5.6 megohm, ±10%, ½ watt (R166)
504147	470 ohms, ±20%, ½ watt (R177)	503582	8.2 megohm, ±10%, ½ watt (R255)
513147	470 ohms, ±10%, 1 watt (R246)	504610	10 megohm, ±20%, ½ watt (R116)
513156	560 ohms, ±10%, 1 watt (R253)	71456	Screw—#8-32 x 7/16" wing screw to mount deflection yoke
34766	1000 ohms, ±5%, ½ watt (R111)	76455	Shaft—Connecting shaft (nylon) for picture and brightness controls
503210	1000 ohms, ±10%, ½ watt (R135, R137, R142, R153, R180)	73584	Shield—Tube shield
504210	1000 ohms, ±20%, ½ watt (R103, R108, R125, R140, R148, R156)	71508	Socket—Tube socket for 1B3GT/8016
30731	1200 ohms, ±5%, ½ watt (R110)	50367	Socket—Tube socket, 6 pin, moulded, saddle mounted
503212	1200 ohms, ±10%, ½ watt (R183)	73117	Socket—Tube socket, 7 pin, wafer, miniature
503222	2200 ohms, ±10%, ½ watt (R168)	73115	Socket—Tube socket, 7 pin, moulded, miniature, plate mounted
504233	3300 ohms, ±20%, ½ watt (R259)	75222	Socket—Tube socket, octal, ceramic, plate mounted
30694	3900 ohms, ±5%, ½ watt (R157)	76453	Socket—Tube socket, octal, moulded bakelite, plate mounted
503239	3900 ohms, ±10%, ½ watt (R228)	31251	Socket—Tube socket, octal, wafer
503247	4700 ohms, ±10%, ½ watt (R162)	75718	Socket—Channel indicator lamp socket and lead
504247	4700 ohms, ±20%, ½ watt (R147)	74834	Socket—Kinescope socket
503256	5600 ohms, ±10%, ½ watt (R164)	75173	Stud—Adjustable stud for trimmer capacitor 76800
14659	6800 ohms, ±5%, ½ watt (R114, R115, R141)	76636	Stud—Adjusting stud complete with guard for focus magnet
503268	6800 ohms, ±10%, ½ watt (R158, R176)	76428	Support—Bakelite support only—part of hi-voltage shield
513268	6800 ohms, ±10%, 1 watt (R155)	76446	Switch—Tone control and phono switch (S101)
523268	6800 ohms, ±10%, 2 watts (R235)	76795	Transformer—Hi-voltage transformer (T114)
502282	8200 ohms, ±5%, ½ watt (R229)	76440	Transformer—Horizontal oscillator transformer complete with adjustable cores (T113)
503282	8200 ohms, ±10%, ½ watt (R165, R196, R197, R212)	76429	Transformer—Power transformer, 115 volts, 60 cycle (T112)
503310	10,000 ohms, ±10%, ½ watt (R208)	76439	Transformer—Ratio detector transformer complete with adjustable cores (T102, C108, C109)
504310	10,000 ohms, ±20%, ½ watt (R172)	76438	Transformer—Sound i-f transformer complete with adjustable cores (T101, C103, C104)
503312	12,000 ohms, ±10%, ½ watt (R178, R181)	76437	Transformer—Sound take-off transformer complete with adjustable cores (T110, C148)
503315	15,000 ohms, ±10%, ½ watt (R258)	76431	Transformer—Vertical output transformer (T111)
523315	15,000 ohms, ±10%, 2 watts (R173)	76432	Transformer—First pix i-f grid transformer complete with adjustable cores (T104, C121, R124)
503318	18,000 ohms, ±10%, ½ watt (R106, R113, R271)	76434	Transformer—First pix i-f plate transformer complete with adjustable cores (T105, C130, C131, R134)
523318	18,000 ohms, ±10%, 2 watts (R161)	76435	Transformer—Second pix i-f grid transformer complete with adjustable core (T106, C133)
503322	22,000 ohms, ±10%, ½ watt (R118, R195)	76433	Transformer—Third or fourth pix i-f transformer (T107, T108)
71989	22,000 ohms, ±5%, 1 watt (R210, R211)	76436	Transformer—Fifth pix i-f transformer (T109, C145, C147, CR101, L102, R154)
513322	22,000 ohms, ±10%, 1 watt (R227)	76482	Trap—4.5 mc trap (L114, C137)
503327	27,000 ohms, ±10%, ½ watt (R102, R119)	76616	Yoke—Deflection yoke complete with 6 contact male connector (L109, L110, L111, L112, C199, R243, R244, R262, P102)
513327	27,000 ohms, ±10%, 1 watt (R184)		
503333	33,000 ohms, ±10%, ½ watt (R273)		
513333	33,000 ohms, ±10%, 1 watt (R169)		
503339	39,000 ohms, ±10%, ½ watt (R112, R194)		
503347	47,000 ohms, ±10%, ½ watt (R104, R191, R265, R267)		
513347	47,000 ohms, ±10%, 1 watt (R132, R139, R269)		
502356	56,000 ohms, ±5%, ½ watt (R149)		
503356	56,000 ohms, ±10%, ½ watt (R187, R236, R256)		
513356	56,000 ohms, ±10%, 1 watt (R107)		
503368	68,000 ohms, ±10%, ½ watt (R128, R143)		
504368	68,000 ohms, ±20%, ½ watt (R198, R205)		
513368	68,000 ohms, ±10%, 1 watt (R226)		
8064	82,000 ohms, ±5%, ½ watt (R144)		
512382	82,000 ohms, ±5%, 1 watt (R231)		
513382	82,000 ohms, ±10%, 1 watt (R225)		

STOCK No.	DESCRIPTION	STOCK No.	DESCRIPTION
	SPEAKER ASSEMBLY	76511	Decal—Control panel function decal for maroon, mahogany or walnut instruments
	971614-1W	76512	Decal—Control panel function decal for blonde or oak instruments
	RL100D3	75456	Escutcheon—Channel marker escutcheon—gold
	RMA-274	74889	Foot—Felt foot for cabinet (4 req'd) for Models 17T150, 17T151
	For Model 17T150	76806	Glass—Safety glass
5039	Connector—4 contact male connector for speaker (J101)	76595	Knob—Brightness control or vertical hold control knob—maroon (outer)
76834	Speaker—4" x 6" P.M. speaker complete with cone and voice coil less transformer and connector	76596	Knob—Brightness control or vertical hold control knob—beige (outer)
76156	Transformer—output transformer (T103)	76593	Knob—Channel selector knob—maroon (inner)
	SPEAKER ASSEMBLY	76594	Knob—Channel selector knob—beige (inner)
	971490-2W	76591	Knob—Fine tuning control knob—maroon (outer)
	RL105E8	76592	Knob—Fine tuning control knob—beige (outer)
	RMA-274	74963	Knob—Picture control, horizontal hold control or volume control and power switch knob—maroon (inner)
	For Models 17T151, 17T163	75464	Knob—Picture control, horizontal hold control or volume control and power switch knob—beige (inner)
75024	Cone—Cone and voice coil assembly (3.2 ohms)	76597	Knob—Tone control and phono switch knob—maroon (outer)
5039	Connector—4 prong male connector for speaker (J101)	76598	Knob—Tone control and phono switch knob—beige (outer)
75022	Speaker—8" P.M. speaker complete with cone and voice coil (3.2 ohms) less transformer and plug	11765	Lamp—Channel marker escutcheon—lamp—Mazda 51
75520	Transformer—Output transformer (T103)	75459	Mask—Channel marker escutcheon light mask—burgundy
	SPEAKER ASSEMBLIES	76589	Mask—Channel marker escutcheon light mask—medium dark beige
	971490 2R	76822	Nut—Speed nut to lock flexible straps
	RMA285	71455	Nut—#8-32 wing nut to fasten deflection yoke hood to hanger bracket
	For Models 17T151, 17T163	76177	Nut—#10-32 special nut for deflection yoke hood support rods (2 req'd)
77129	Cone—Cone and voice coil	76819	Pad—Rubber pad (channel) for flexible straps (2 req'd)
	Note:—If stamping on speaker in instrument does not agree with above speaker number, order replacement parts by referring to model number of instrument, number stamped on speaker and full description of part required.	76825	Pad—Rubber pad (channel) mounted on cradle support to cushion kinescope
	7CB8 CABINET BASE	76824	Panel—Metal front panel for mahogany or walnut instruments for Model 17T163
	For use with Model 17T150, 17T151	76826	Panel—Metal front panel for oak instruments for Model 17T163
X3249	Pull—Door pull—mahogany finish—for maroon bases	76828	Plate—Plate complete with weld bolts for kinescope cradle lower support for Model 17T163
X3250	Pull—Door pull—blonde finish—for mahogany bases	76816	Retainer—Safety glass retainer (2 req'd)
	MISCELLANEOUS	76809	Rod—"L" shape threaded rod to support deflection yoke hood assembly (2 req'd) for Models 17T150, 17T151
76805	Back—Cabinet back complete with power cord and terminal board for Models 17T150, 17T151	76810	Rod—"L" shape threaded rod to support deflection yoke hood assembly (2 req'd) for Model 17T163
76827	Back—Cabinet back complete with power cord for Model 17T163	76821	Screw—#10 x 1 3/8" hex head tapping screw to lock flexible straps
76184	Board—"Antenna" terminal board	76808	Sleeve—Polyethylene sleeve for insulating high voltage lead—on R.H. support rod
76811	Bracket—Hanger bracket for deflection yoke hood for Models 17T150, 17T151	73643	Spring—Channel marker escutcheon spring clip
76812	Bracket—Hanger bracket for deflection yoke hood for Model 17T163	76820	Spring—Formed spring for safety glass retainers (4 req'd)
76814	Bracket—Stiffening bracket for kinescope cradle (2 req'd) for Models 17T150, 17T151	30330	Spring—Retaining spring for knobs 74963 and 75464
76829	Bracket—Stiffening bracket for kinescope bracket (2 req'd) for Model 17T163	14270	Spring—Retaining spring for knobs 76593, 76594, 76595, 76596, 76597, 76598
76823	Clip—Spring clip for spacing ground braid	72845	Spring—Retaining spring for knobs 76591 and 76592
X3128	Cloth—Grille cloth for Models 17T150, 17T151	36580	Spring—Suspension spring (coil type) for ground braid
X3222	Cloth—Grille cloth for oak instruments for Model 17T163	76813	Strap—Flexible steel strap to secure kinescope
X3248	Cloth—Grille cloth for mahogany or walnut instruments for Model 17T163	76817	Support—Cradle support for kinescope
39153	Connector—4 contact male connector for antenna cable	76815	Support—Lower support for kinescope cradle support
75474	Connector—Single contact male connector for antenna cable (2 req'd)	75457	Washer—Felt washer—dark brown—between knob and channel marker escutcheon
71457	Cord—Power cord and plug	75500	Washer—Felt washer for cabinet back mounting screws
76818	Cushion—Rubber cushion (1/16" x 1" x 5/8" x 1/4") for kinescope and cradle support (4 req'd)	75458	Washer—Felt washer—beige—between knob and channel marker escutcheon
76807	Cushion—Vinylite cushion (formed) for picture opening	76836	Washer—Cellulose washer—gold—for knobs

The system of employing an asterisk before the stock number of new items has been discontinued.

APPLY TO YOUR RCA DISTRIBUTOR FOR PRICES OF REPLACEMENT PARTS.

CHASSIS WIRING DIAGRAM

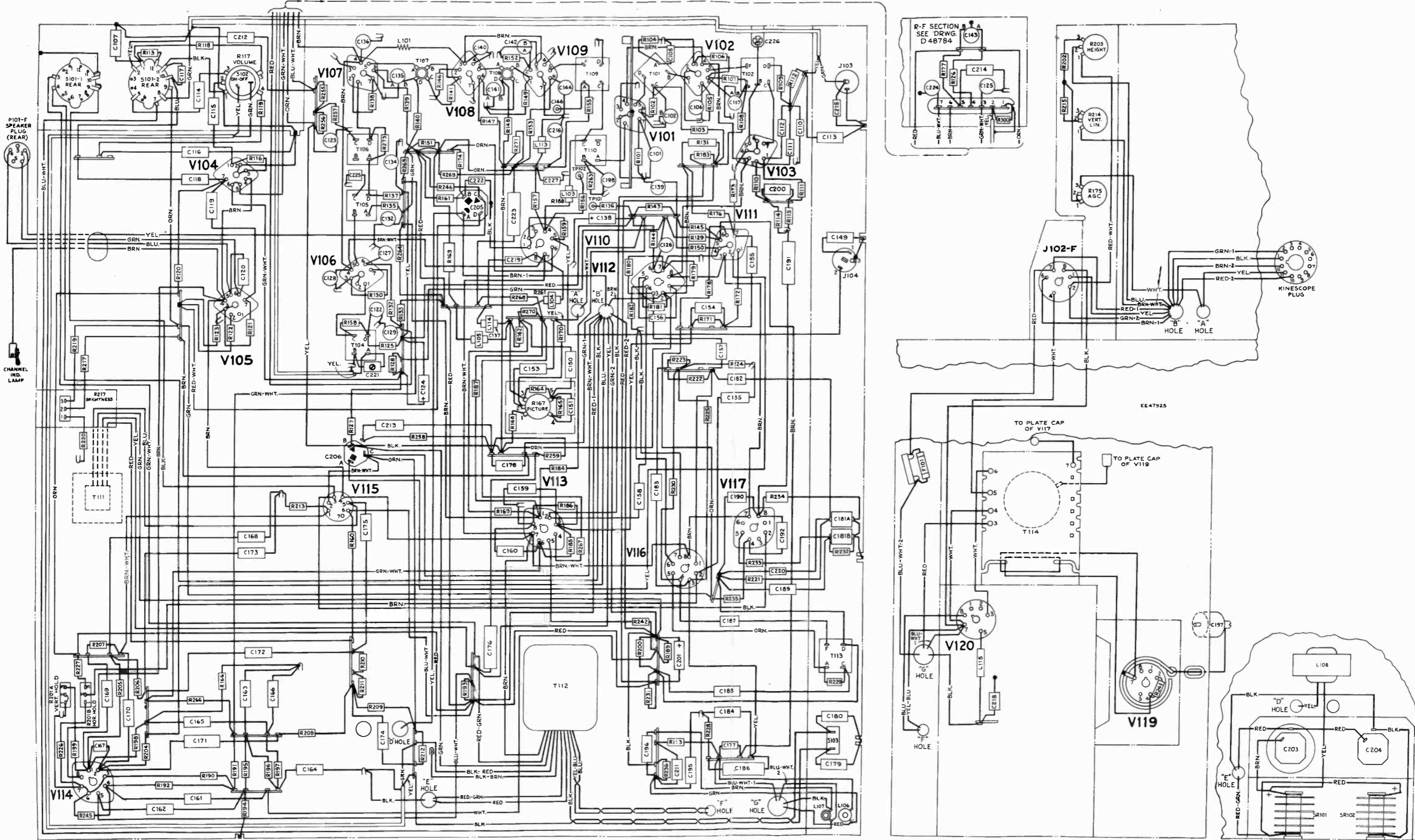
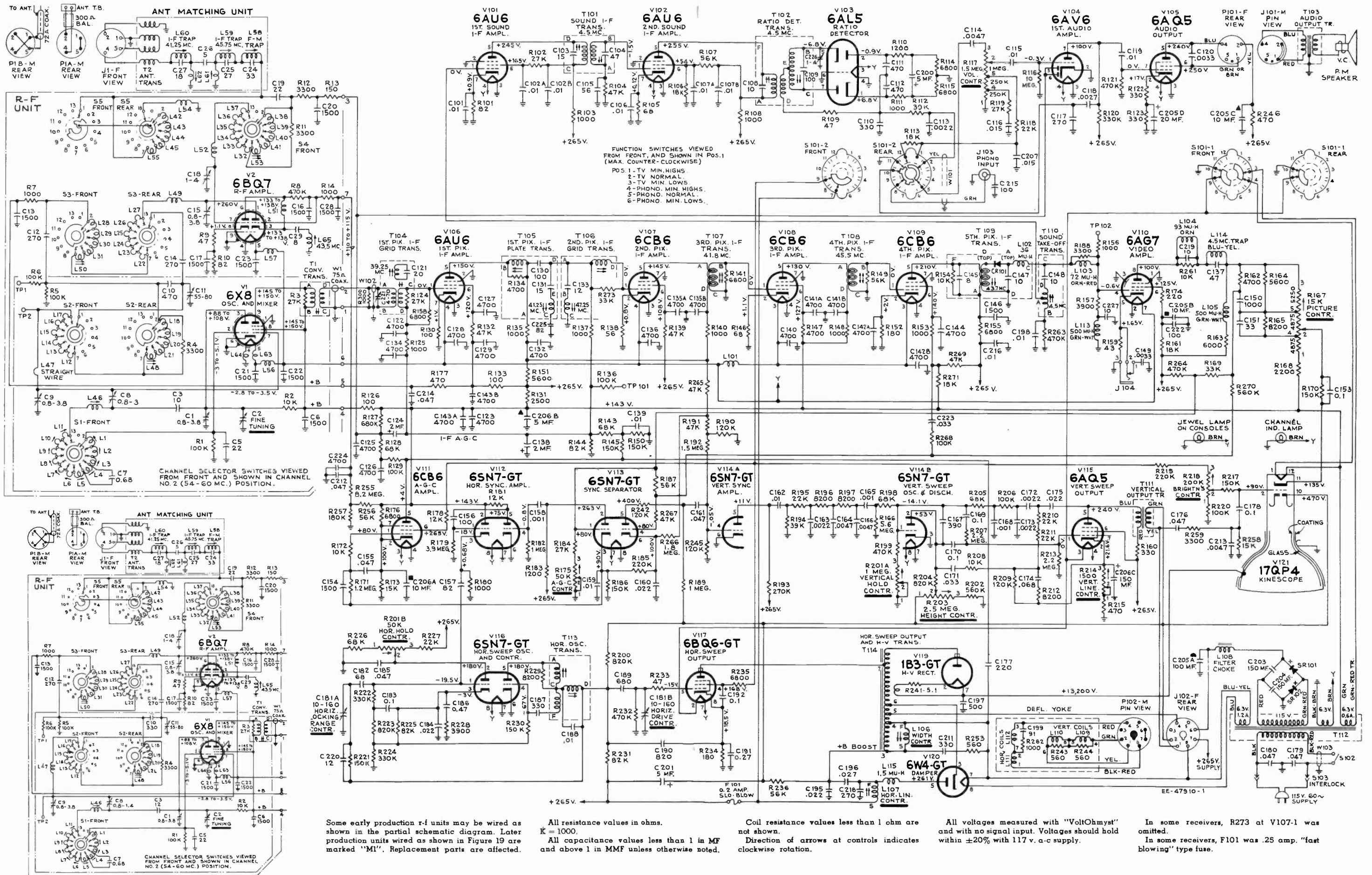

Figure 78—Chassis Wiring Diagram

CIRCUIT SCHEMATIC DIAGRAM

17T150, 17T151, 17T163



Some early production r-f units may be wired as shown in the partial schematic diagram. Later production units wired as shown in Figure 19 are marked "M1". Replacement parts are affected.

All resistance values in ohms. $K = 1000$. All capacitance values less than 1 in MF and above 1 in MMF unless otherwise noted.

Coil resistance values less than 1 ohm are not shown. Direction of arrows at controls indicates clockwise rotation.

All voltages measured with "VoltOhmyst" and with no signal input. Voltages should hold within $\pm 20\%$ with 117 v. a-c supply.

In some receivers, R273 at V107-1 was omitted. In some receivers, F101 was .25 amp. "fast blowing" type fuse.

Figure 79—Circuit Schematic Diagram

STOCK No.	DESCRIPTION	STOCK No.	DESCRIPTION
	R-F UNIT ASSEMBLIES		
	KRK11	504410	100,000 ohms, $\pm 20\%$, 1/2 watt (R1, R5, R6)
76539	Board—Antenna matching transformer terminal board less coils L58, L59, L60 and less capacitors C24, C25, C26, C27	504447	470,000 ohms, $\pm 20\%$, 1/2 watt (R8)
76531	Board—Terminal board, 5 contact and ground	14343	Retainer—Fine tuning shaft retaining ring
76522	Bracket—Vertical bracket for holding r-f OSC and mixer tube (6X8) shield (early production)	75164	Rod—Actuating plunger rod (fibre) for fine tuning link
76845	Bracket—Vertical bracket for holding oscillator-mixer tube shield (production marked "M1")	76547	Screw—# 4-40 x 1/4" adjusting screw for coils L6, L7, L8, L9, L10, L11
75186	Capacitor—Ceramic, variable, for fine tuning—plunger type (C2)	76548	Screw—# 4-40 x 5/16" adjusting screw for coils L1, L2, L3, L4, L46
93056	Capacitor—Ceramic, 5 mmf. (C26)	76549	Screw—# 4-40 x 3/8" adjusting screw for coil L5
70597	Capacitor—Ceramic, 8 mmf. (C29)	76519	Shaft—Channel selector shaft and plate
55326	Capacitor—Ceramic, 10 mmf. (C3) (production marked "M1")	76134	Shaft—Fine tuning shaft and cam
76550	Capacitor—Ceramic, 12 mmf. (C3) (early production)	76518	Shield—Front shield complete with shaft bushing and bracket
54207	Capacitor—Ceramic, 18 mmf. (C27)	76534	Shield—Tube shield (plain) for V2 (also V1 in "M1" production)
76557	Capacitor—Ceramic, 22 mmf. (C19)	76533	Shield—Tube shield (lead coated) for V1 (early production)
76558	Capacitor—Ceramic, 22 mmf. (C5)	76336	Socket—Tube socket, 9 pin, miniature, bakelite, saddle mounted
70935	Capacitor—Ceramic, 27 mmf. (C25)	76530	Socket—Tube socket, 9 pin, miniature, ceramic, saddle mounted
76739	Capacitor—Ceramic, 33 mmf. (C24)	75191	Spacer—Insulating spacer for front plate (4 req'd)
76527	Capacitor—Mica trimmer, 55-80 mmf. (C11)	75163	Spring—Friction spring (formed) for fine tuning cam
75199	Capacitor—Ceramic, 270 mmf. (C12, C14)	30340	Spring—Hairpin spring for fine tuning link
76552	Capacitor—Ceramic, 330 mmf. (C10) (early production)	76523	Spring—Retaining spring for oscillator mixer tube shield (early production)
75198	Capacitor—Ceramic, 470 mmf. (C10) (production marked "M1")	75068	Spring—Retaining spring for oscillator mixer tube shield (production marked "M1")
75166	Capacitor—Ceramic, 1500 mmf. (stand-off) (C13, C17, C21, C22, C28)	73457	Spring—Return spring for fine tuning control
73748	Capacitor—Ceramic, 1500 mmf. (C16, C20, C23)	76554	Stator—Antenna stator complete with rotor, coils, capacitor and resistor (S5, L42, L43, L44, L45, L54, L55, C20)
75610	Capacitor—Ceramic, 1500 mmf. (C6)	76551	Stator—Converter stator complete with rotor, coils, capacitors and resistors (S2, L12, L13, L14, L15, L16, L17, L18, L19, L20, L21, L48, C10, C12, R4, R5, R6) (early production)
71088	Capacitor—Ceramic, 0.68 mmf. (C7)	76780	Stator—Converter stator complete with rotor, coils, capacitors and resistors (S2, L12, L13, L14, L15, L16, L17, L18, L19, L20, L21, L48, C10, C12, R4, R5, R6) (production marked "M1")
75184	Capacitor—Ceramic, adjustable, 0.75-4 mmf. complete with adjusting stud (C1, C9)	76546	Stator—Oscillator stator complete with rotor, coils, and capacitor (S1, C3, C7, L1, L2, L3, L4, L5, L6, L7, L8, L9, L10, L11, L46) (early production)
76545	Capacitor—Tubular, steatite, adjustable 0.8-2.25 mmf. (C8) (early production)	76779	Stator—Oscillator stator complete with rotor, coils, and capacitor (S1, C3, C7, L1, L2, L3, L4, L5, L6, L7, L8, L9, L10, L11, L46) (production marked "M1")
76781	Capacitor—Tubular, steatite, adjustable 0.8-1.4 mmf. (C8) (production marked "M1")	76556	Stator—R-F grid stator complete with rotor, coils and resistors (S4, L32, L33, L34, L35, L36, L37, L38, L39, L40, L41, L53, C19, R11, R12)
76532	Capacitor—Adjustable trimmer, steatite, 1.0-4.0 mmf. (C18)	76553	Stator—R-F plate stator complete with rotor, coils, capacitor and resistor (S3, L22, L23, L24, L25, L26, L27, L28, L29, L30, L31, L50, C14, R7)
76143	Clip—Tubular, clip for mounting stand-off capacitors	76561	Strap—Channel #13 r-f grid strap (L52)
73591	Coil—Antenna matching coil (2 req'd)	76526	Strip—Coil segment mounting strip—L.H. lower
76560	Coil—Channel #13 converter coil (L47) (early production)	76544	Strip—Coil segment mounting strip—L.H. upper—less trimmer
73477	Coil—Choke coil (L57)	76525	Strip—Coil segment mounting strip—R.H. center
76763	Coil—Filament choke coil (L63, L64)	75446	Stud—Capacitor stud—brass—# 4-40 x 13/16" with 3/64" screw driver slot for trimmer coil L49, C15 uncoded and coded "ER"
76562	Coil—R-F amplifier coupling coil (L51)	75447	Stud—Capacitor stud—brass—# 4-40 x 13/16" with 3/64" screw driver slot for trimmer coil L49, C15 coded numerically and "Hi Q"
76537	Coil—Shunt coil complete with adjustable core (L61)	76740	Stud—# 6-32 x 1" adjusting stud for capacitor No. 76545 (early production)
76538	Coil—Shunt coil complete with adjustable core (L62)	75173	Stud—# 6-32 x 13/16" adjusting stud for capacitor No. 76781 (production marked "M1")
76529	Coil—Trimmer coil (3 turns) with adjustable inductance core and capacitor stud (screw adjustment) for r-f section (L49, C15)	76536	Transformer—Antenna matching transformer complete (T2, C24, C25, C26, C27, L58, L59, L60, L61, L62, J1)
76559	Connector—Oscillator grid connector	76528	Transformer—Converter transformer (T1, R3)
38853	Connector—4 contact female connector—part of antenna matching transformer	76540	Trap—FM trap complete with adjustable core (L58)
76460	Contact—Test point contact	76535	Trap—I-F trap (L65)
75187	Core—Adjustable core for fine tuning capacitor	76542	Trap—I-F trap (41.25 MC) complete with core (L60)
76543	Core—Adjusting core for FM trap	76541	Trap—I-F trap (45.75 MC) complete with core (L59)
76521	Detent—Detent mechanism and fibre shaft	75190	Washer—Insulating washer (neoprene) for mounting capacitor on coil strip
73453	Form—Coil form for coils L48, L50 & L53		
76524	Link—Link assembly for fine tuning		
	Resistor—Fixed, composition:—		
503047	47 ohms, $\pm 10\%$, 1/2 watt (R9)		
503082	82 ohms, $\pm 10\%$, 1/2 watt (R10)		
504115	150 ohms, $\pm 20\%$, 1/2 watt (R13)		
504210	1000 ohms, $\pm 20\%$, 1/2 watt (R7, R14)		
503233	3300 ohms, $\pm 10\%$, 1/2 watt (R4, R11, R12)		
504310	10,000 ohms, $\pm 20\%$, 1/2 watt (R2)		

STOCK No.	DESCRIPTION	STOCK No.	DESCRIPTION
	CHASSIS ASSEMBLIES		
	KCS-66C	73798	Capacitor—Tubular, paper, oil impregnated, .022 mfd., 600 volts (C175)
76456	Bracket—Channel indicator lamp bracket	73810	Capacitor—Tubular, paper, oil impregnated, .022 mfd., 1000 volts (C195)
76454	Bracket—Mounting bracket complete with insulator for picture control	73811	Capacitor—Tubular, paper, oil impregnated, .027 mfd., 1000 volts (C196)
76800	Capacitor—Adjustable trimmer, steatite, 1.-4. mmf. (C226)	73552	Capacitor—Tubular, paper, oil impregnated, .033 mfd., 400 volts (C223)
71496	Capacitor—Adjustable, 4-70 mmf. (C221)	73596	Capacitor—Tubular, paper, oil impregnated, .033 mfd., 600 volts (C171)
31709	Capacitor—Ceramic, 10 mmf. (C219, C227)	73558	Capacitor—Tubular, paper, oil impregnated, .047 mfd., 200 volts (C155)
75217	Capacitor—Mica trimmer, dual 10-160 mmf. (C181A, C181B)	73553	Capacitor—Tubular, paper, oil impregnated, .047 mfd., 400 volts (C212)
33380	Capacitor—Ceramic, 12 mmf. (C220)	75071	Capacitor—Tubular, moulded paper, .047 mfd., 400 volts (C179, C180)
38868	Capacitor—Ceramic, 33 mmf. (C151)	73592	Capacitor—Tubular, paper, oil impregnated, .047 mfd., 600 volts (C161, C185, C214)
71924	Capacitor—Ceramic, 56 mmf. (C105)	73597	Capacitor—Tubular, paper, oil impregnated, .047 mfd., 1000 volts (C176)
76475	Capacitor—Mica, 68 mmf. (C182)	73792	Capacitor—Tubular, paper, oil impregnated, .063 mfd., 200 volts (C174)
71514	Capacitor—Ceramic, 82 mmf. (C225)	73784	Capacitor—Tubular, paper, oil impregnated, 0.1 mfd., 200 volts (C153, C169)
76474	Capacitor—Mica, 82 mmf. (C157)	73551	Capacitor—Tubular, paper, oil impregnated, 0.1 mfd., 400 volts (C178, C183)
39396	Capacitor—Ceramic, 100 mmf. (C156, C215)	73557	Capacitor—Tubular, paper, oil impregnated, 0.1 mfd., 600 volts (C170, C192)
75437	Capacitor—Ceramic, 100 mmf. (C222)	73786	Capacitor—Tubular, paper, oil impregnated, 0.27 mfd., 200 volts (C191)
76673	Capacitor—Ceramic, 220 mmf. (C177)	73787	Capacitor—Tubular, paper, oil impregnated, 0.47 mfd., 200 volts (C186)
47617	Capacitor—Ceramic, 270 mmf. (C117)	76498	Choke—Filter choke (L108)
73091	Capacitor—Mica, 270 mmf. (C218)	73477	Coil—Choke coil (L101)
76473	Capacitor—Mica, 330 mmf. (C110)	76640	Coil—Choke coil (1.5 muh) (L115)
76476	Capacitor—Mica, 330 mmf. (C187, C211)	76442	Coil—Horizontal linearity coil complete with adjustable core (L107)
73094	Capacitor—Mica, 390 mmf. (C167)	76646	Coil—Peaking coil (72 muh) (L103, R188)
39644	Capacitor—Mica, 470 mmf. (C111, C112)	72619	Coil—Peaking coil (93 muh) (L104, R261)
76461	Capacitor—Ceramic, 500 mmf., 20,000 volts (C197)	75252	Coil—Peaking coil (500 muh) (L105, L113)
76477	Capacitor—Mica, 820 mmf. (C190)	76441	Coil—Width coil complete with adjustable core (L106)
75166	Capacitor—Ceramic, 1500 mmf. (stand-off) (C146)	74594	Connector—2 contact male connector for power cord
73473	Capacitor—Ceramic, 4700 mmf. (C122, C123, C125, C126, C127, C128, C129, C132, C134, C136, C140, C144, C224)	5040	Connector—4 contact female connector for speaker cable (P101)
76470	Capacitor—Ceramic, dual 4700 mmf. (C135A, C135B, C141A, C141B, C142A, C142B, C143A, C143B)	75542	Connector—6 contact male connector—part of deflection yoke (P102)
73960	Capacitor—Ceramic, 10,000 mmf. (C101, C106, C139, C198, C216)	50367	Connector—6 contact female connector for deflection yoke leads (J102)
75877	Capacitor—Ceramic, dual 10,000 mmf. (C102A, C102B, C107A, C107B)	76804	Connector—Anode connector for kinescope
76742	Capacitor—Electrolytic, 2 mfd., 10 volts (C124, C138)	35787	Connector—Phono input connector (J103)
74521	Capacitor—Electrolytic, 5 mfd., 50 volts (C200)	76457	Connector—Second anode lead connector mounted on hi-voltage capacitor
28417	Capacitor—Electrolytic, 5 mfd., 450 volts (C201)	76460	Contact—Test point contact
75218	Capacitor—Electrolytic comprising 1 section of 10 mfd., 350 volts, 1 section of 5 mfd., 350 volts and 1 section of 150 mfd., 50 volts (C206A, C206B, C206C)	76447	Control—AGC control (R175)
76451	Capacitor—Electrolytic comprising 1 section of 100 mfd., 350 volts, 2 sections of 10 mfd., 350 volts and 1 section of 20 mfd., 50 volts (C205A, C205B, C205C, C205D)	76444	Control—Brightness control (R218)
75220	Capacitor—Electrolytic, 150 mfd., 200 volts (C203, C204)	76448	Control—Height control (R203)
76479	Capacitor—Tubular, moulded paper, oil impregnated, .00068 mfd., 600 volts (C189)	76443	Control—Horizontal and vertical hold control (R201A, R201B)
75643	Capacitor—Tubular, paper, oil impregnated, .001 mfd., 1000 volts (C150, C158, C165, C168)	76445	Control—Picture control (R167)
73598	Capacitor—Tubular, paper, oil impregnated, .0015 mfd., 600 volts (C154)	76449	Control—Vertical linearity control (R214)
73595	Capacitor—Tubular, paper, oil impregnated, .0022 mfd., 600 volts (C113, C163, C173)	76171	Control—Volume control and power switch (R117, S102)
73803	Capacitor—Tubular, paper, oil impregnated, .0022 mfd., 1000 volts (C172)		Crystal—See Rectifier, Crystal Rectifier
73599	Capacitor—Tubular, paper, oil impregnated, .0027 mfd., 600 volts (C118)	74956	Cushion—Rubber cushion for deflection yoke hood
73795	Capacitor—Tubular, paper, oil impregnated, .0033 mfd., 600 volts (C120, C149)	74839	Fastener—Push fastener for mounting tube sockets
73920	Capacitor—Tubular, paper, oil impregnated, .0047 mfd., 600 volts (C114, C164, C166, C213)	76801	Fuse—0.2 amp., 250 volts
73561	Capacitor—Tubular, paper, oil impregnated, .01 mfd., 400 volts (C115, C119, C159, C162)	76459	Grommet—Rubber grommet for 2nd. anode lead exit
73594	Capacitor—Tubular, moulded paper, oil impregnated, .01 mfd., 600 volts (C188)	37396	Grommet—Rubber grommet for mounting tube sockets
73797	Capacitor—Tubular, paper, oil impregnated, .015 mfd., 600 volts (C116, C207)	76830	Hood—Deflection yoke hood less cushions
73562	Capacitor—Tubular, paper, oil impregnated, .022 mfd., 400 volts (C160, C184)	75482	Jack—Video jack (J104)
		76480	Lead—Anode lead complete with eyelet
		76168	Magnet—Focus magnet complete with adjustable plate and stud



RCA VICTOR

TELEVISION RECEIVERS MODELS 17T200, 17T201, 17T202, 17T211, 17T220

Chassis No. KCS72, KCS72M1 or KCS72M2

— Mfr. No. 274 —

SERVICE DATA

— 1952 No. T2 —

PREPARED BY RCA SERVICE CO., INC.

FOR

RADIO CORPORATION OF AMERICA

RCA DIVISION

CAMDEN, N. J., U. S. A.



Model 17T200 "Shelby"
Ebony
Model 17T201 "Hadley"
Maroon
(Shown on base)

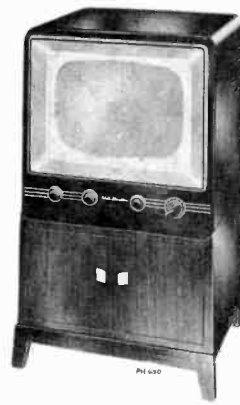

Model 17T202 "Kentwood"
Mahogany, Grained
(Shown on base)

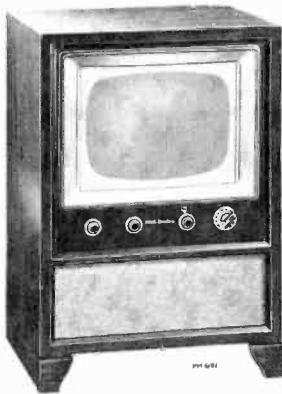

Model 17T211 "Ashton"
Walnut, Mahogany, Blonde

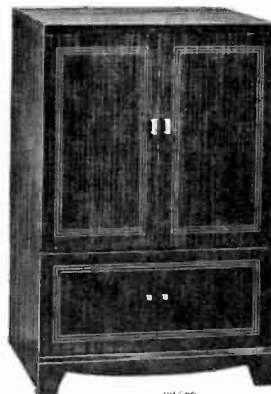

Model 17T220 "Albury"
Walnut, Mahogany

GENERAL DESCRIPTION

Models 17T200, 17T201, 17T202, 17T211, and 17T220 are "17 inch" television receivers. The receivers are identical except for cabinets, and speakers.

Features of the television unit are: full twelve channel coverage; intercarrier FM sound system; ratio detector; improved picture brilliance; pulsed picture A-G-C; A-F-C horizontal hold; stabilized vertical hold; noise saturation circuits; improved sync separator and clipper; 3.2 mc. band width for picture channel and reduced hazard high voltage supply. An auxiliary audio input jack is provided to permit the use of an external record playing attachment.

ELECTRICAL AND MECHANICAL SPECIFICATIONS

PICTURE SIZE . . . 146 square inches on a 17QP4 Kinescope

TELEVISION R-F FREQUENCY RANGE

All 12 television channels, 54 mc. to 88 mc., 174 mc. to 216 mc.
Picture I-F Carrier Frequency 25.50 mc.
Sound I-F Carrier Frequency 21.00 mc. and 4.5 mc.

POWER SUPPLY RATING . . . 115 volts, 60 cycles, 190 watts

AUDIO POWER OUTPUT RATING 4.0 watts max.

VIDEO RESPONSE To 3.2 mc.

SWEEP DEFLECTION Magnetic

FOCUS Magnetic

LOUDSPEAKERS

In Models 17T200, 17T201 & 17T202
. 971636-1 5" PM Dynamic, 3.2 ohms

In Models 17T211 & 17T220
. (971490-3) 8" PM Dynamic, 3.2 ohms

WEIGHT AND DIMENSIONS

Model	Net Weight	Shipping Weight	Width Inches	Height Inches	Depth Inches
17T200	88 lbs.	103 lbs.	21½	22	21¾
17T201	88 lbs.	103 lbs.	21½	22	21¾
17T202	88 lbs.	103 lbs.	21½	22	21¾
17T211	95 lbs.	116 lbs.	24½	35¼	21¾
17T220	106 lbs.	130 lbs.	23¾	35¼	23¾

RECEIVER ANTENNA INPUT IMPEDANCE

Choice: 300 ohms balanced or 72 ohms unbalanced.

RCA TUBE COMPLEMENT

Tube Used	Function
(1) RCA 6CB6	R-F Amplifier
(2) RCA 6J6	R-F Oscillator and Mixer
(3) RCA 6CB6	1st Picture I-F Amplifier
(4) RCA 6CB6	2nd Picture I-F Amplifier
(5) RCA 6CB6	3rd Picture I-F Amplifier
(6) RCA 12AU7	Picture 2nd Detector and Vert. Sync. Sep.
(7) RCA 6CL6 (6AC7) (6AG7)	*Video Amplifier
(8) RCA 6AU6	1st Sound I-F Amplifier
(9) RCA 6AU6	2nd Sound I-F Amplifier
(10) RCA 6AL5	Ratio Detector
(11) RCA 6AV6	1st Audio Amplifier
(12) RCA 6K6GT	Audio Output
(13) RCA 6AU6	AGC Amplifier
(14) RCA 6SN7GT	Horizontal Sync. Sep. and Sync. Output
(15) RCA 6J5	Vertical Sweep Oscillator
(16) RCA 6K6GT	Vertical Sweep Output
(17) RCA 6SN7GT	Horizontal Sweep Oscillator and Control
(18) RCA 6BQ6GT	Horizontal Sweep Output
(19) RCA 6W4GT	Damper
(20) RCA 1B3-GT/8016	High Voltage Rectifier
(21) RCA 17QP4	Kinescope
(22) RCA 5U4G	Rectifier
(23) RCA 5Y3GT	Rectifier

* (See Figure 67)

ELECTRICAL AND MECHANICAL SPECIFICATIONS
(Continued)

PICTURE INTERMEDIATE FREQUENCIES

Picture I-F Carrier Frequency 25.50 mc.
Adjacent Channel Sound Trap 27.00 mc.

SOUND INTERMEDIATE FREQUENCIES

Sound I-F Carrier Frequency 21.00 mc.
Sound I-F Frequency 4.5 mc.

VIDEO RESPONSE To 3.2 mc.

FOCUS Magnetic

SWEEP DEFLECTION Magnetic

SCANNING Interlaced, 525 line

HORIZONTAL SWEEP FREQUENCY 15,750 cps

VERTICAL SWEEP FREQUENCY 60 cps

FRAME FREQUENCY (Picture Repetition Rate) 30 cps

OPERATING CONTROLS (Front Panel)

Channel Selector }
Fine Tuning } Dual Control Knobs
Picture }
Brightness } Dual Control Knobs
Picture Horizontal Hold }
Picture Vertical Hold } Dual Control Knobs
Sound Volume and On-Off Switch }
TV Tone & Phono Switch } Dual Control Knobs

NON-OPERATING CONTROLS (not including r-f and i-f adjustments)

Picture Centering top chassis adjustment
Width rear chassis adjustment
Height rear chassis adjustment
Horizontal Linearity rear chassis screwdriver adjustment
Vertical Linearity rear chassis adjustment
Horizontal Drive rear chassis screwdriver adjustment
Horizontal Oscillator Frequency rear chassis adjustment
Horizontal Oscillator Waveform bottom chassis adjustment
Horizontal Locking Range rear chassis adjustment
Focus top chassis adjustment
Ion Trap Magnet top chassis adjustment
Deflection Coil top chassis wing nut adjustment
AGC Control rear chassis adjustment

HIGH VOLTAGE WARNING

OPERATION OF THIS RECEIVER OUTSIDE THE CABINET OR WITH THE COVERS REMOVED, INVOLVES A SHOCK HAZARD FROM THE RECEIVER POWER SUPPLIES. WORK ON THE RECEIVER SHOULD NOT BE ATTEMPTED BY ANYONE WHO IS NOT THOROUGHLY FAMILIAR WITH THE PRECAUTIONS NECESSARY WHEN WORKING ON HIGH VOLTAGE EQUIPMENT. DO NOT OPERATE THE RECEIVER WITH THE HIGH VOLTAGE COMPARTMENT SHIELD REMOVED.

KINESCOPE HANDLING PRECAUTIONS

DO NOT REMOVE THE RECEIVER CHASSIS, INSTALL, REMOVE OR HANDLE THE KINESCOPE IN ANY MANNER UNLESS SHATTERPROOF GOGGLES, AND HEAVY GLOVES ARE WORN. PEOPLE NOT SO EQUIPPED SHOULD BE KEPT AWAY WHILE HANDLING KINESCOPIES. KEEP THE KINESCOPE AWAY FROM THE BODY WHILE HANDLING.

The kinescope bulb encloses a high vacuum and, due to its large surface area, is subjected to considerable air pressure. For this reason, the kinescope must be handled with more care than ordinary receiving tubes.

The large end of the kinescope bulb—particularly that part at the rim of the viewing surface—must not be struck, scratched or subjected to more than moderate pressure at any time. During service if the tube sticks or fails to slip smoothly into its socket, or deflecting yoke, investigate and remove the cause of the trouble. Do not force the tube. Refer to the Receiver Installation section for detailed instructions on kinescope installation. All RCA replacement kinescopes are shipped in special cartons and should be left in the cartons until ready for installation in the receiver.

OPERATING INSTRUCTIONS

17T200, 17T201, 17T202,
17T211, 17T220

The following adjustments are necessary when turning the receiver on for the first time.

1. See that the TV-PH switch is in the "TV" position.
2. Turn the receiver "ON" and advance the SOUND VOLUME control to approximately mid-position.
3. Set the STATION SELECTOR to the desired channel.
4. Adjust the FINE TUNING control for best pix and the SOUND VOLUME control for suitable volume.
5. Turn the BRIGHTNESS control fully counter-clockwise, then clockwise until a light pattern appears on the screen.
6. Adjust the VERTICAL hold control until the pattern stops vertical movement.
7. Adjust the HORIZONTAL hold control until a picture is obtained and centered.

8. Adjust the CONTRAST and BRIGHTNESS controls for suitable picture contrast and brightness.

9. In switching from one channel to another, it may be necessary to repeat steps 4 and 8.

10. When the set is turned on again after an idle period it should not be necessary to repeat the adjustment if the positions of the controls have not been changed. If any adjustment is necessary, step number 4 is generally sufficient.

11. If the positions of the controls have been changed, it may be necessary to repeat steps 2 through 8.

12. To use a record player, plug the record-player output cable into the PHONO jack on the rear apron, and set the TV-PH switch to "PH".

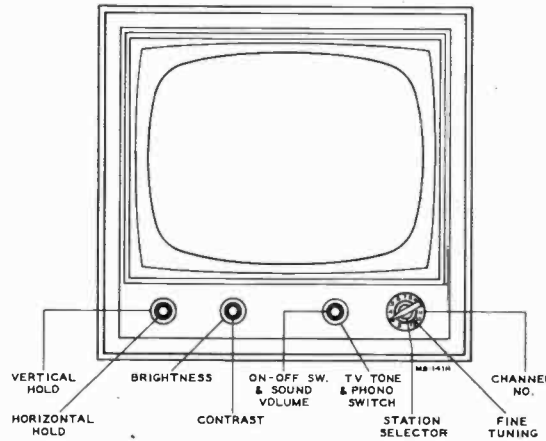

Figure 1—Receiver Operating Controls

INSTALLATION INSTRUCTIONS

UNPACKING.—These receivers are shipped complete in cardboard cartons. The kinescope is shipped in place in the receiver.

Take the receiver out of the carton and remove all packing material.

Make sure that all tubes are in place and are firmly seated in their sockets.

Check to see that the kinescope high voltage lead clip is in place.

Plug a power cord into the 115 volt a-c power source and into the receiver interlock receptacle. Turn the receiver power switch to the "on" position, the brightness control fully clockwise, and the picture control counter-clockwise.

ION TRAP MAGNET ADJUSTMENT.—Set the ion trap magnet approximately in the position shown in Figure 2. Starting from this position immediately adjust the magnet by moving it forward or backward at the same time rotating it slightly around the neck of the kinescope for the brightest raster on the screen. Reduce the brightness control setting until the raster is slightly above average brilliance. Turn the focus control (shown in Figure 2) until the line structure of the raster is clearly visible. Readjust the ion trap magnet for maximum raster brilliance. The final touches of this adjustment should be made with the brightness control at the maximum clockwise position with which good line focus can be maintained.

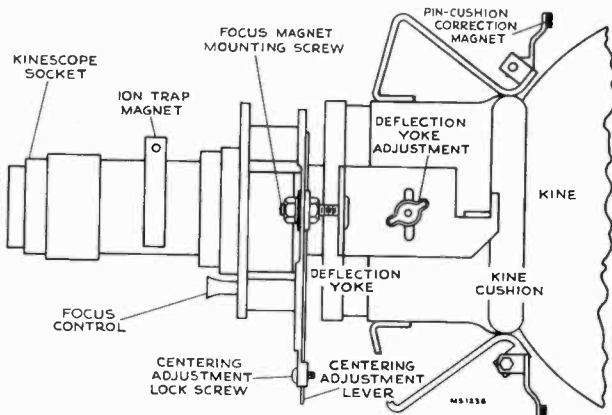

Figure 2—Yoke and Focus Magnet Adjustments

DEFLECTION YOKE ADJUSTMENT.—If the lines of the raster are not horizontal or squared with the picture mask, rotate the deflection yoke until this condition is obtained. Tighten the yoke adjustment wing screw.

PICTURE ADJUSTMENTS.—It will now be necessary to obtain a test pattern picture in order to make further adjustments. Connect the antenna transmission line to the receiver.

If the Horizontal Oscillator and AGC System are operating properly, it should be possible to sync the picture at this point. However, if the AGC control is misadjusted, and the receiver is overloading, it may be impossible to sync the picture.

If the receiver is overloading, turn R149 on the rear apron (see Figure 3) counter-clockwise until the set operates normally and the picture can be synced.

CHECK OF HORIZONTAL OSCILLATOR ALIGNMENT.—Turn the horizontal hold control to the extreme counter-clockwise position. The picture should remain in horizontal sync. Momentarily remove the signal by switching off channel then back. Normally the picture will be out of sync. Turn the control clockwise slowly. The number of diagonal black bars will be gradually reduced and when only 2 or 3 bars sloping downward to the left are obtained, the picture will pull into sync upon slight additional clockwise rotation of the control. Pull-in should occur before the control has been turned 120 degrees from the extreme counter-clockwise position. The picture should remain in sync for approximately 90

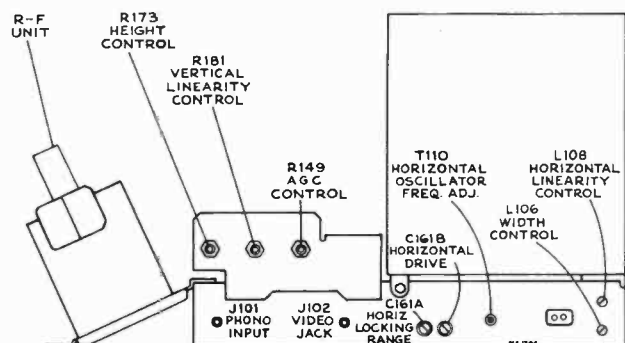

Figure 3—Rear Chassis Adjustments

17T200, 17T201, 17T202,
17T211, 17T220

INSTALLATION INSTRUCTIONS

degrees of additional clockwise rotation of the control. At the extreme clockwise position, the picture should remain in sync and should not show a black bar in the picture.

If the receiver passes the above checks and the picture is normal and stable, the horizontal oscillator is properly aligned. Skip "Alignment of Horizontal Oscillator" and proceed with "Focus Magnet Adjustment."

ALIGNMENT OF HORIZONTAL OSCILLATOR.—If in the above check the receiver failed to hold sync with the hold control at the extreme counter-clockwise position or failed to hold sync over 90 degrees of clockwise rotation of the control from the pull-in point, it will be necessary to make the following adjustments.

Horizontal Frequency Adjustment.—Turn the horizontal hold control to the extreme clockwise position. Tune in a television station and adjust the T110 horizontal frequency adjustment at the rear of the chassis until the picture is just out of sync and the horizontal blanking appears as a vertical or diagonal black bar in the raster. Then turn the T110 core until the bar moves out of the picture leaving it in sync.

Horizontal Locking Range Adjustment.—Set the horizontal hold control to the full counter-clockwise position. Momentarily remove the signal by switching off channel then back. The picture may remain in sync. If so turn the T110 rear core slightly and momentarily switch off channel. Repeat until the picture falls out of sync with the diagonal lines sloping down to the left. Slowly turn the horizontal hold control clockwise and note the least number of diagonal bars obtained just before the picture pulls into sync.

If more than 3 bars are present just before the picture pulls into sync, adjust the horizontal locking range trimmer C161A slightly clockwise. If less than 2 bars are present, adjust C161A slightly counter-clockwise. Turn the horizontal hold control counter-clockwise, momentarily remove the signal and recheck the number of bars present at the pull-in point. Repeat this procedure until 2 or 3 bars are present.

Repeat the adjustments under "Horizontal Frequency Adjustment" and "Horizontal Locking Range Adjustment" until the conditions specified under each are fulfilled. When the horizontal hold operates as outlined under "Check of Horizontal Oscillator Alignment" the oscillator is properly adjusted.

If it is impossible to sync the picture at this point and the AGC system is in proper adjustment it will be necessary to adjust the Horizontal Oscillator by the method outlined in the alignment procedure on page 11: For field purposes paragraph "B" under Horizontal Oscillator Waveform Adjustment may be omitted.

FOCUS MAGNET ADJUSTMENT.—The focus magnet should be adjusted so that there is approximately three-eighths inch of space between the rear cardboard shell of the yoke and the flat of the front face of the focus magnet. This spacing gives best average focus over the face of the tube.

The axis of the hole through the magnet should be parallel with the axis of the kinescope neck with the kinescope neck through the center of the opening.

PIN-CUSHION CORRECTION.—Two pin-cushion correction magnets are employed to correct a small amount of pin-cushion of the raster due to the lens effect of the face of the kinescope. These magnets are mounted on small arms, one on each side of the kinescope as shown in Figure 2. The arms hinge in one plane on self tapping screws which act both as a hinge and an adjustment locking screw. When the magnets are swung towards the tube, maximum correction is obtained. Minimum correction is obtained when the arms are swung away from the tube. To adjust the magnets, loosen the two self tapping screws and position the magnets until the sides of the raster appear straight. Tighten the screws without shifting the position of the magnets. In some cases it may be necessary to twist or bend the magnet support arms to obtain the appearance of straight raster edges.

CENTERING ADJUSTMENT.—No electrical centering controls are provided. Centering is accomplished by means of a separate plate on the focus magnet. The centering plates include a locking screw which must be loosened before centering. Up and down adjustment of the plate moves the picture side to side and sidewise adjustment moves the picture up and down.

If a corner of the raster is shadowed, check the position of the ion trap magnet. Reposition the magnet within the range of maximum raster brightness to eliminate the shadow and recenter the picture by adjustment of the focus magnet plate. In no case should the magnet be adjusted to cause any loss of brightness since such operation may cause immediate or eventual damage to the tube. In some cases it may be necessary to shift the position of the focus magnet in order to eliminate a corner shadow.

WIDTH, DRIVE AND HORIZONTAL LINEARITY ADJUSTMENTS.—Adjustment of the horizontal drive control affects the high voltage applied to the kinescope. In order to obtain the highest possible voltage hence the brightest and best focused picture, adjust horizontal drive trimmer C161B counter-clockwise until the picture begins to "wrinkle" in the middle then clockwise until the "wrinkle" disappears.

Turn the horizontal linearity control L108 clockwise until the picture begins to "wrinkle" on the right and then counter-clockwise until the "wrinkle" disappears and best linearity is obtained.

Adjust the width control L106 to obtain correct picture width.

A slight readjustment of these three controls may be necessary to obtain the best linearity.

Adjustments of the horizontal drive control affect horizontal oscillator hold and locking range. If the drive control was adjusted, recheck the oscillator alignment.

HEIGHT AND VERTICAL LINEARITY ADJUSTMENTS.—Adjust the height control (R173 on chassis rear apron) until the picture fills the mask vertically. Adjust vertical linearity (R181 on rear apron), until the test pattern is symmetrical from top to bottom. Adjustment of either control will require a readjustment of the other. Adjust centering to align the picture with the mask.

FOCUS.—Adjust the focus magnet for maximum definition in the test pattern vertical "wedge" and best focus in the white areas of the pattern.

Recheck the position of the ion trap magnet to make sure that maximum brightness is obtained.

Check to see that the yoke thumbscrew and the focus magnet mounting screws are tight.

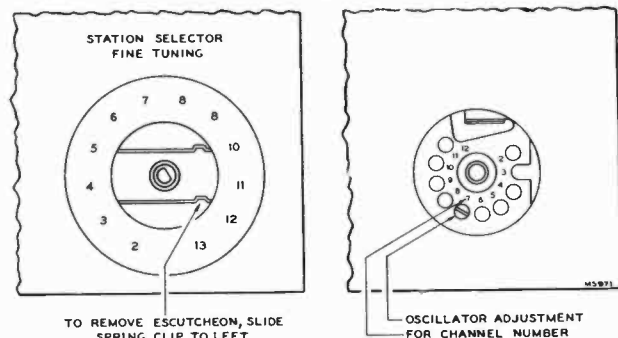

Figure 4—R-F Oscillator Adjustments

CHECK OF R-F OSCILLATOR ADJUSTMENTS.—Tune in all available stations to see if the receiver r-f oscillator is adjusted to the proper frequency on all channels. If adjustments are required, these should be made by the method outlined in the alignment procedure on page 9. The adjustments for channels 2 through 12 are available from the front of the cabinet by removing the station selector escutcheon as shown in Figure 4. Adjustment for channel 13 is on top of the chassis.

AGC THRESHOLD CONTROL.—The AGC threshold control R149 is adjusted at the factory and normally should not require readjustment in the field.

To check the adjustment of the AGC Threshold Control, tune in a strong signal and sync the picture. Momentarily remove the signal by switching off channel and then back. If the picture reappears immediately, the receiver is not overloading due to improper setting of R149. If the picture requires an appreciable portion of a second to reappear, or bends excessively, R149 should be readjusted.

INSTALLATION INSTRUCTIONS

17T200, 17T201, 17T202,
17T211, 17T220

Turn R149 fully counter-clockwise. The raster may be bent slightly. This should be disregarded. Turn R149 clockwise until there is a very, very slight bend or change of bend in the picture. Then turn R149 counter-clockwise just sufficiently to remove this bend or change of bend.

If the signal is weak, the above method may not work as it may be impossible to get the picture to bend. In this case, turn R149 clockwise until the snow in the picture becomes more pronounced, then counter-clockwise until the best signal to noise ratio is obtained.

The AGC control adjustment should be made on a strong signal if possible. If the control is set too far clockwise on a weak signal, then the receiver may overload when a strong signal is received.

FM TRAP ADJUSTMENT.—In some instances interference may be encountered from a strong FM station signal. A trap is provided to eliminate this type of interference. To adjust the trap tune in the station on which the interference is observed and adjust the L203 core on top of the antenna matching transformer for minimum interference in the picture.

CAUTION.—In some receivers, the FM trap L203 will tune down into channel 6 or even into channel 5. Needless to say, such an adjustment will cause greatly reduced sensitivity on these channels. If channels 5 or 6 are to be received, check L203 to make sure that it does not affect sensitivity on these two channels.

Replace the cabinet back and connect the receiver antenna leads to the cabinet back. Make sure that the screws holding it are up tight, otherwise it may rattle or buzz when the receiver is operated at high volume.

KINESCOPE SCREEN CLEANING.—The kinescope safety glass is held in place by four spring clips which may be removed from the back of the front panel. This permits removing the safety glass for cleaning without the necessity of removing the chassis and kinescope.

CHASSIS REMOVAL.—To remove the chassis from the cabinet for repair or installation of a new kinescope, remove the control knobs, the cabinet back, unplug the speaker cable, the kinescope socket, the antenna cable, the yoke and high voltage cable. Take out the chassis bolts under the cabinet. Withdraw the chassis from the back of the cabinet.

KINESCOPE HANDLING PRECAUTION.—Do not install, remove, or handle the kinescope in any manner, unless shatterproof goggles and heavy gloves are worn. People not so equipped should be kept away while handling the kinescope. Keep the kinescope away from the body while handling.

REMOVAL OF KINESCOPE.—To remove the kinescope from the cabinet, loosen the two nuts and disengage the rods alongside the kinescope. Remove the screw which holds the yoke frame to the cabinet. Remove the kinescope, the yoke frame with yoke and focus magnet as an assembly.

Handle this tube by the portion at the edge of the screen. Do not cover the glass bell of the tube with fingermarks as it will produce leakage paths which may interfere with reception. If this portion of the tube has inadvertently been handled, wipe it clean with a soft cloth moistened with "dry" carbon tetrachloride.

INSTALLATION OF KINESCOPE.—Wipe the kinescope screen surface and front panel safety glass clean of all dust and fingermarks with a soft cloth moistened with "Windex" or similar cleaning agent.

Replace the kinescope and chassis by reversal of the removing process. The kinescope should be installed so that the high voltage contact is to the right when looking at it from the rear of the cabinet. The magnet of the ion trap magnet should be to the left.

CABINET ANTENNA.—A cabinet antenna is provided in Models 17T211 and 17T220 and the leads are brought out near the antenna terminal board. The cabinet antenna may be employed in place of the outdoor antenna in areas where the signals are strong and no reflections are experienced.

ANTENNAS.—The finest television receiver built may be said to be only as good as the antenna design and installation. It is therefore important to select the proper antenna to suit the particular local conditions, to install it properly and orient it correctly.

If two or more stations are available and the two stations are in different directions, it may be possible to make a compromise orientation which will provide a satisfactory signal on all such channels.

If it is impossible to obtain satisfactory results on one or more channels, it may become necessary either to provide means for turning the antenna when switching channels or to install a separate antenna for one or more channels and to switch antennas when switching channels.

In some cases, the antenna should not be installed permanently until the quality of the picture reception has been observed on a television receiver. A temporary transmission line can be run between receiver and the antenna, allowing sufficient slack to permit moving the antenna. Then, with a telephone system connecting an observer at the receiver and an assistant at the antenna, the antenna can be positioned to give the most satisfactory results on the received signal. A shift of direction or a few feet in antenna position may effect a tremendous difference in picture reception.

REFLECTIONS.—Multiple images sometimes known as echoes or ghosts, are caused by the signal arriving at the antenna by two or more routes. The second or subsequent image occurs when a signal arrives at the antenna after being reflected off a building, a hill or other object. In severe cases of reflections, even the sound may be distorted. In less severe cases, reflections may occur that are not noticeable as reflections but that will instead cause a loss of definition in the picture.

Under certain extremely unusual conditions, it may be possible to rotate or position the antenna so that it receives the cleanest picture over a reflected path. If such is the case, the antenna should be so positioned. However, such a position may give variable results as the nature of reflecting surfaces may vary with weather conditions. Wet surfaces have been known to have different reflecting characteristics than dry surfaces.

Depending upon the circumstances, it may be possible to eliminate the reflections by rotating the antenna or by moving it to a new location. In extreme cases, it may be impossible to eliminate the reflection.

INTERFERENCE.—Auto ignition, street cars, electrical machinery and diathermy apparatus may cause interference which spoils the picture. Whenever possible, the antenna location should be removed as far as possible from highways, hospitals, doctors' offices and similar sources of interference. In mounting the antenna, care must be taken to keep the antenna rods at least $\frac{1}{4}$ wave length (at least 6 feet) away from other antennas, metal roofs, gutters or other metal objects.

Short-wave radio transmitting and receiving equipment may cause interference in the picture in the form of moving ripples. In some instances it may be possible to eliminate the interference by the use of a trap in the antenna transmission line. However, if the interfering signal is on the same frequency as the television station, a trap will provide no improvement.

WEAK PICTURE.—When the installation is near the limit of the area served by the transmitting station, the picture may be speckled, having a "snow" effect, and may not hold steady on the screen. This condition is due to lack of signal strength from the transmitter.

RECEIVER LOCATION.—The owner should be advised of the importance of placing the receiver in the proper location in the room.

The location should be chosen—

- Away from bright windows and so that no bright light will fall directly on the screen. (Some illumination in the room is desirable, however.)
- To give easy access for operation and comfortable viewing.
- To permit convenient connection to the antenna.
- Convenient to an electrical outlet.
- To allow adequate ventilation.

17T200, 17T201, 17T202,
17T211, 17T220

CHASSIS TOP VIEW

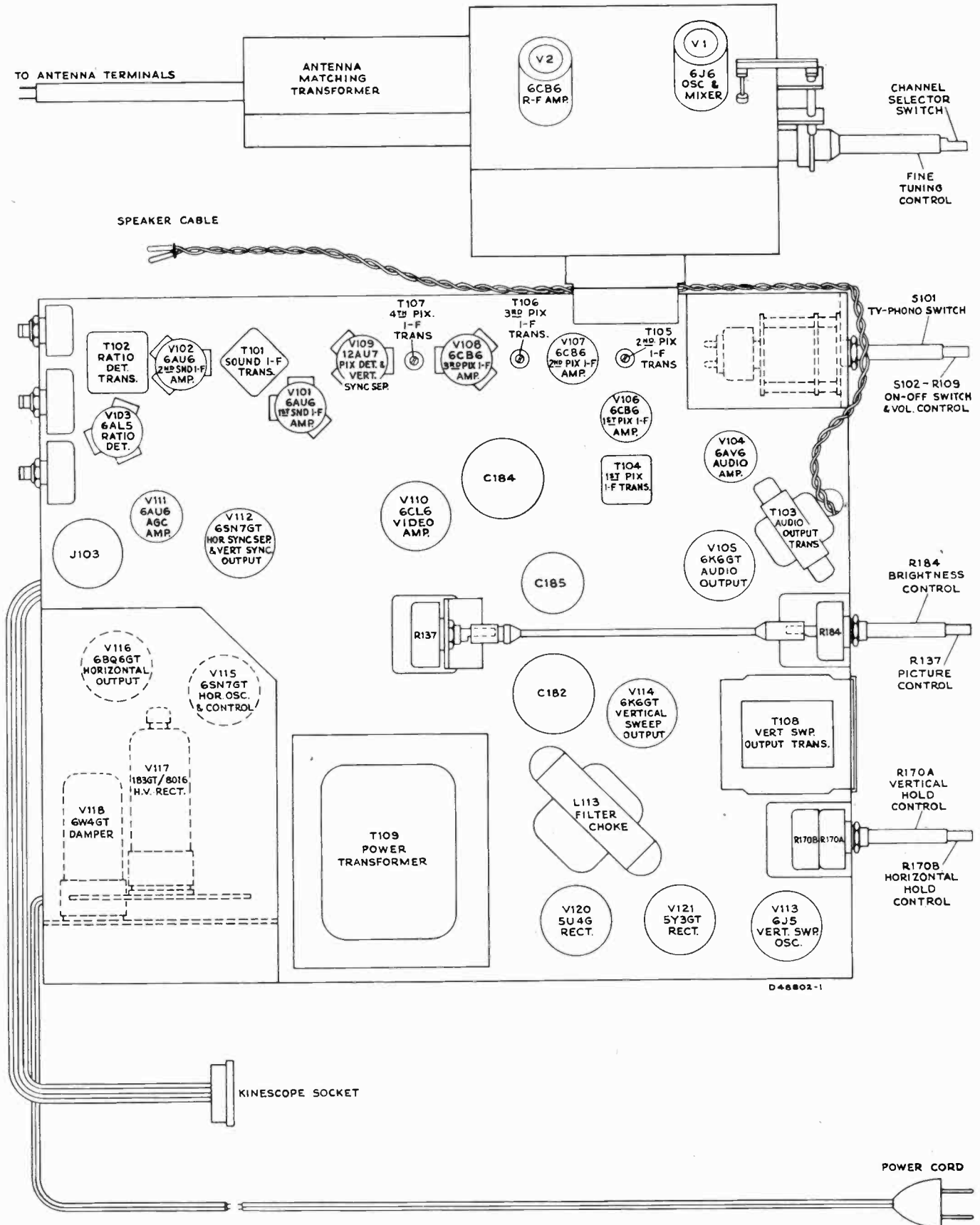

D48802-1

Figure 5—Chassis Top View

CHASSIS BOTTOM VIEW

17T200, 17T201, 17T202,
17T211, 17T220

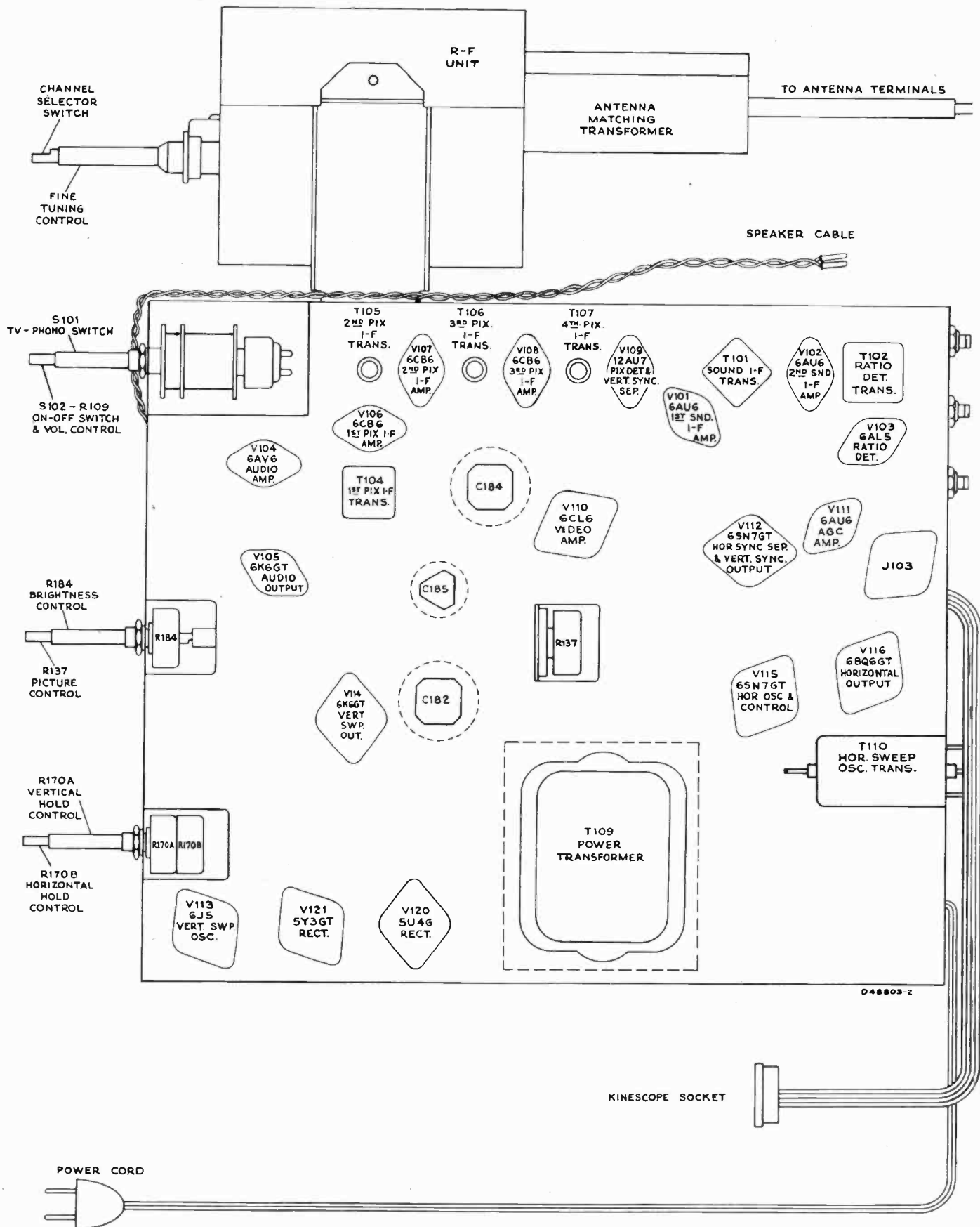

Figure 6—Chassis Bottom View

17T200, 17T201, 17T202,
17T211, 17T220

ALIGNMENT PROCEDURE

TEST EQUIPMENT.—To properly service the television chassis of this receiver, it is recommended that the following test equipment be available:

R-F Sweep Generator meeting the following requirements:

- (a) Frequency Ranges
 - 20 to 30 mc., 1 mc. and 10 mc. sweep width
 - 50 to 90 mc., 10 mc. sweep width
 - 170 to 225 mc., 10 mc. sweep width
- (b) Output adjustable with at least .1 volt maximum.
- (c) Output constant on all ranges.
- (d) "Flat" output on all attenuator positions.

Cathode-Ray Oscilloscope.—For alignment purposes, the oscilloscope employed must have excellent low frequency and phase response, and should be capable of passing a 60-cycle square wave without appreciable distortion.

For video and sync waveform observations, the oscilloscope must have excellent frequency and phase response from 10 cycles to at least two megacycles in all positions of the gain control.

Signal Generator to provide the following frequencies with crystal accuracy.

- (a) Intermediate frequencies
 - 22.25 and 25.5 mc. conv. and first pix i-f trans.
 - 22.75 mc. second picture i-f transformer
 - 24.25 mc. fourth picture i-f transformer
 - 25.5 mc. third picture i-f transformer
 - 25.50 mc. picture carrier
 - 27.00 mc. adjacent channel sound trap
- (b) Radio frequencies

Channel Number	Picture Carrier Freq. Mc.	Sound Carrier Freq. Mc.
2	55.25	59.75
3	61.25	65.75
4	67.25	71.75
5	77.25	81.75
6	83.25	87.75
7	175.25	179.75
8	181.25	185.75
9	187.25	191.75
10	193.25	197.75
11	199.25	203.75
12	205.25	209.75
13	211.25	215.75

- (c) Output of these ranges should be adjustable and at least .1 volt maximum.

Heterodyne Frequency Meter with crystal calibrator which covers the frequency range from 80 mc. to 109 mc. and from 200 mc. to 237 mc.

Electronic Voltmeter of Junior or Senior "VoltOhmyst" type and a high voltage multiplier probe for use with this meter to permit measurements up to 15 kv.

Service Precautions.—If possible, the chassis should be serviced without the kinescope. However, if it is necessary to view the raster during servicing, it would be a great convenience to have a bench mounted kinescope and speaker complete with a set of extension cables.

CAUTION: Do not short the kinescope second anode lead. Its short circuit current presents a considerable overload on the high voltage rectifier V117.

Adjustments Required.—Normally, only the r-f oscillator and mixer lines will require the attention of the service technician. All other circuits are either broad or very stable and hence will seldom require readjustment.

ORDER OF ALIGNMENT.—When a complete receiver alignment is necessary, it can be most conveniently performed in the following order:

- (1) R-F unit
- (2) Picture i-f transformers
- (3) Picture i-f trap
- (4) Sweep of picture i-f
- (5) Ratio detector alignment
- (6) Sound i-f alignment
- (7) 4.5 Mc Trap Adjustment
- (8) Check of overall response
- (9) AGC control adjustment
- (10) Horizontal oscillator alignment

R-F UNIT ALIGNMENT.—Disconnect the co-ax link from terminal 2 of the r-f unit terminal board and connect a 39 ohm composition resistor between lugs 1 and 2.

Detune T1 by backing the core all the way out of the coil.

Back the L44 core all the way out. Back the L203 core all the way out.

In order to align the r-f tuner, it will first be necessary to set the channel-13 oscillator to frequency. The shield over the bottom of the r-f unit must be in place when making any adjustments.

The oscillator may be aligned by adjusting it to beat with a crystal-calibrated heterodyne frequency meter. Couple the meter probe loosely to the receiver oscillator.

Set the channel selector switch to 13.

Adjust the heterodyne frequency meter to the correct frequency (236.75 mc).

Set the fine tuning control 30 degrees clockwise from the mechanical center of its range.

Adjust C1 for an audible beat on the heterodyne frequency meter.

Now that the channel-13 oscillator is set to frequency, we may proceed with the r-f alignment.

Turn the AGC control fully clockwise.

Obtain a 7.5 volt battery capable of withstanding appreciable current drain and connect the ends of a 1,000 ohm potentiometer across it. Connect the battery positive terminal to chassis and the potentiometer arm to terminal 3 of the r-f unit. Adjust the bias box potentiometer to produce -3.5 volts of bias at the r-f unit terminal board.

Connect the oscilloscope to the test point TPI on top of the r-f unit.

Connect the r-f sweep oscillator to the receiver antenna terminals. The method of connection depends upon the output impedance of the sweep. The P300 connections for 300-ohm balanced or 72-ohm single-ended input are shown in the circuit schematic diagram. If the sweep oscillator has a 50-ohm or 72-ohm single-ended output, 300-ohm balanced output can be obtained by connecting as shown in Figure 9.

Connect the signal generator loosely to the receiver antenna terminals.

Set the receiver channel switch to channel 8.

Set the sweep oscillator to cover channel 8.

Insert markers of channel 8 picture carrier and sound carrier, 181.25 mc. and 185.75 mc.

Adjust C9, C11, C16 and C22 for approximately correct curve shape, frequency, and band width as shown in Figure 11.

The correct adjustment of C22 is indicated by maximum amplitude of the curve midway between the markers. C16 tunes the r-f amplifier plate circuit and affects the frequency of the curve most noticeably. C9 tunes the converter grid circuit and affects the tilt of the curve most noticeably (assuming that C22 has been properly adjusted). C11 is the coupling adjustment and hence primarily affects the response band width.

Set the receiver channel switch to channel 6.

Adjust the heterodyne frequency meter to the correct frequency (108.75 mc.).

Set the fine tuning control 30 degrees clockwise from the mechanical center of its range.

Adjust L5 for an audible beat on the heterodyne frequency meter.

ALIGNMENT PROCEDURE

17T200, 17T201, 17T202,
17T211, 17T220

Set the sweep generator to channel 6.

From the signal generator, insert channel 6 sound and picture carrier markers, 83.25 mc. and 87.75 mc.

Adjust L42, L45 and L49 for proper response as shown in Figure 12.

L42 is adjusted to give maximum amplitude of the curve between the markers. L45 primarily affects the tilt of the curve. L49 primarily affects the frequency of response.

Connect the "VoltOhmyst" to the r-f unit test point TP1.

Adjust C7 for -3.0 volts at the test point.

Retouch L42, L45 and L49 for proper response if necessary. If necessary, retouch C11 for proper band width on channel 6. Continue these retouching adjustments until proper response is obtained and -3.0 volts of oscillator injection are present at the test point, TP1.

Set the receiver channel selector switch to channel 8 and readjust C1 for proper oscillator frequency.

Set the sweep oscillator and signal generator to channel 8.

Readjust C9, C16 and C22 for correct curve shape, frequency and band width. Readjust C11 only if necessary.

Switch the receiver, the sweep oscillator and signal generator to channel 13.

Adjust L52 for maximum amplitude of the curve midway between markers and then overshoot the adjustment by turning the slug in the same direction from the initial setting a little more than the amount of turning required to reach maximum amplitude of response.

Adjust C22 for maximum amplitude of response.

Turn off the sweep generator. Adjust the L43 core for correct channel 13 oscillator frequency, then overshoot the adjustment by turning the slug a little more in the same direction from the initial setting. Reset the oscillator to proper frequency by adjustment of C1.

Turn the sweep oscillator back on.

Check the response of channels 7 through 13 by switching the receiver channel switch, sweep oscillator and marker oscillator to each of these channels and observing the response and oscillator injection obtained. See Figure 11 for typical response curves. It should be found that all these channels have the proper shaped response with the markers above 80% response.

If the markers do not fall within this requirement, switch to channel 8 and readjust C9, C11, C16 and C22 as necessary. If C22 required adjustment, the adjustment should be overshoot a small amount and corrected by adjustment of L52 to give maximum amplitude of response between the sound and picture carrier markers. The antenna circuit (L52, C22) is broad so that tracking is not particularly critical.

If the valley in the top of the selectivity curves for the high channels is deeper than normal, the curve can be flattened somewhat by decreasing the inductance of L44 by turning the core stud in. Be sure to check for undesirable resonant suck-outs on channels 7 and 8 if this is done.

Turn the sweep oscillator off and check the receiver channel 8 r-f oscillator frequency. If the oscillator is off frequency overshoot the adjustment of C1 and correct by adjusting L43.

Turn the receiver channel selector switch to channel 6. Adjust L5 for correct oscillator frequency.

Turn the sweep oscillator on and to channel 6 and observe the response curve. If necessary readjust L42, L45 and L49. It should not be necessary to touch C11.

Check the oscillator injection voltage at the test point TP1. If necessary adjust C7 to give -3 volts injection. If C7 is adjusted, switch to channel 8, and readjust C9 for proper curve shape, then recheck channel 6.

Switch the receiver through channel 6 down through channel 2 and check for normal response curve shapes and oscillator injection voltage.

Likewise check channels 7 through 13, stopping on 13 for the next step.

With the receiver on channel 13, check the receiver oscillator frequency. Correct by adjustment of C1 if necessary.

Adjust the oscillator to frequency on all channels by switching the receiver and the heterodyne frequency meter to each channel and adjusting the appropriate oscillator trimmer to obtain a beat on the freq. meter. It should be possible to adjust the oscillator to the correct frequency on all channels with the fine tuning control 30 degrees clockwise from the mechanical center of its range.

Channel Number	Picture Carrier Freq. Mc.	Sound Carrier Freq. Mc.	Receiver R-F Osc. Freq. Mc.	Channel Oscillator Adjustment
2	55.25	59.75	80.750	L1
3	61.25	65.75	86.750	L2
4	67.25	71.75	92.750	L3
5	77.25	81.75	102.750	L4
6	83.25	87.75	108.750	L5
7	175.25	179.75	200.750	L6
8	181.25	185.75	206.750	L7
9	187.25	191.75	212.750	L8
10	193.25	197.75	218.750	L9
11	199.25	203.75	224.750	L10
12	205.25	209.75	230.750	L11
13	211.25	215.75	236.750	C1

Switch to channel 8 and observe the response.

Adjust T1 clockwise while watching the change in response. When T1 is properly adjusted, the selectivity curve will be slightly wider with a slightly deeper valley in its top.

Switch through all channels and observe response, oscillator injection and r-f oscillator frequency. Minor touch-ups of adjustments may be made at this time. However, if C7 or C9 are changed appreciably, then a recheck of the oscillator frequency on all channels should be made.

Reconnect the link from T101 to terminal 2 of the r-f unit terminal board.

Since T1 was adjusted during the r-f unit alignment it will be necessary to sweep the overall i-f response.

R-F UNIT TUBE CHANGES.—Since most of the circuits are low capacitance circuits the r-f unit may require readjustments when the tubes are changed.

If the 6CB6 r-f amplifier tube is changed, it may be necessary to readjust C16 and C22.

If the 6J6 oscillator and mixer tube is changed, then more extensive adjustments are required.

For good conversion efficiency, the oscillator injection to a triode mixer must be held reasonably close to the optimum value. Although there is some latitude in this level, it is nearly expended in the normal variation in injection from channel to channel. Consequently, the adjustment of C7 is limited primarily to establishing the conditions for good conversion. Since changes in oscillator injection affect conversion gain, it also affects the input capacity of the mixer, thus also affecting tracking of the mixer grid circuit. These tube variations with their consequent effect on circuit alignment thereby require readjustment of the r-f unit if maximum conversion efficiency is to be retained after the 6J6 tube is changed. It may be possible, however, to try several 6J6 tubes and select one which gives satisfactory performance without realignment.

PICTURE I-F TRANSFORMER ADJUSTMENTS.—Connect the "VoltOhmyst" to the junction of R142 and R143.

Turn the AGC control fully clockwise.

Obtain a 7.5 volt battery capable of withstanding appreciable current drain and connect the ends of a 1,000 ohm potentiometer across it. Connect the battery positive terminal to chassis and the potentiometer arm to the junction R142 and R143. Adjust the potentiometer for -5.0 volts indication on the "VoltOhmyst".

Set the channel switch to channel number 9, 10 or 11.

Connect the "VoltOhmyst" to pin 2 of V110 (Pin 4 if 6AC7 or 6AG7 is used) and to ground.

Connect the output of the signal generator to the mixer grid test point TP2 in series with a 1500 mmf ceramic capacitor.

Connect a separate -5 volt bias supply to TP1 with the positive terminal to ground.

Set the generator to each of the following frequencies and with a thin fiber screwdriver tune the specified adjustment for maximum indication on the "VoltOhmyst". In each instance the generator should be checked against a crystal calibrator to insure that the generator is on frequency.

17T200, 17T201, 17T202,
17T211, 17T220

ALIGNMENT PROCEDURE

Adjust the signal generator output to give 3 volts on the "VoltOhmyst" as the final adjustment is made.

- (1) 24.25 mc.—T107 (3) 22.75 mc.—T105
(2) 25.5 mc.—T106

PICTURE I-F TRAP ADJUSTMENT.—With the same connections as above, tune the generator to 27.00 mc. and adjust the T104 top core for minimum d-c on the "VoltOhmyst". Set the generator output so that this minimum is about 3 volts when final adjustment is made. If necessary, the i-f bias may be reduced in order to obtain the 3 volt reading on the "VoltOhmyst".

SWEEP ALIGNMENT OF PIX I-F.—To align T1 and T104, connect the sweep generator to the mixer grid test point TP2. In series with a 1500 mmf ceramic capacitor use the shortest leads possible, with not more than one inch of unshielded lead at the end of the sweep cable. Connect the sweep ground lead to the r-f unit outer shield.

Connect a separate -5.0 volt bias supply to TPI with the positive terminal connected to ground and by-pass TPI to ground with a 1500 mmf. ceramic capacitor.

Set the channel selector switch between channels 2 and 13.

Clip 330 ohm resistors across terminals A and B of T106 and T107.

Preset C115 to minimum capacity.

Adjust the bias box potentiometer to obtain -5.0 volts of bias as measured by a "VoltOhmyst" at the junction of R142 and R143. Leave the AGC control fully clockwise.

Connect a 180 ohm composition resistor from pin 5 of V106 to terminal A of T105. Connect the oscilloscope diode probe to pin 5 of V106 and to ground.

Couple the signal generator loosely to the diode probe in order to obtain markers.

Adjust T1 (top) and T104 (bottom) for maximum gain and with 25.5 mc. at 70% of maximum response.

Set the sweep output to give 0.3 volt peak-to-peak on the oscilloscope when making the final touch on the above adjustment.

Adjust C115 until 22.25 mc. is at 70% response with respect to the low frequency shoulder of the curve as shown in Figure 12.

Disconnect the diode probe, the 180 ohm and two 330 ohm resistors.

Connect the oscilloscope to pin 2 of V110 socket (or pin 4 of 6AC7 or 6AG7).

Leave the sweep generator connected to the mixer grid test point TP2 with the shortest leads possible.

Adjust the output of the sweep generator to obtain 3.0 volts peak-to-peak on the oscilloscope.

Couple the signal generator loosely to the grid of the first pix i-f amplifier. Adjust the output of the signal generator to produce small markers on the response curve.

Retouch T105, T106 and T107 to obtain the response shown in Figure 13.

It is especially important that the 22.4 mc. marker should fall at 55% on the overall i-f response curve. If the marker should fall appreciably higher than 55%, trouble may be experienced with sound in the picture. If the marker should fall appreciably below 55% response, the sound sensitivity may be reduced and may cause the sound to be noisy in weak signal areas.

RATIO DETECTOR ALIGNMENT.—Set the signal generator at 4.5 mc. and connect it to the first sound i-f grid, pin 1 of V101.

As an alternate source of signal, the RCA WR39B or WR39C calibrator may be employed. In such a case, connect the calibrator to the grid of the third pix i-f amplifier, pin 1 of V108.

Set the frequency of the calibrator to 25.50 mc. (pix carrier) and modulate with 4.5 mc. crystal. The 4.5 mc. signal will be picked off at L102 and amplified through the sound i-f amplifier.

Connect the "VoltOhmyst" to pin 2 of V103.

Tune the ratio detector primary, T102 top core for maximum d-c output on the "VoltOhmyst". Adjust the signal level from the signal generator for 6 volts on the "VoltOhmyst" when finally peaked. This is approximately the operating level of the ratio detector for average signals.

Connect the "VoltOhmyst" to the junction of R106 and C108.

Tune the ratio detector secondary T102 bottom core for zero d-c on the "VoltOhmyst".

Repeat adjustments of T102 top for maximum d-c at pin 2 of V103 and T102 bottom for zero d-c at the junction of R106 and C108. Make the final adjustments with the signal input level adjusted to produce 6 volts d-c on the "VoltOhmyst" at pin 2 of V103.

SOUND I-F ALIGNMENT.—Connect the signal generator to the first sound i-f amplifier grid, pin 1 of V101.

As an alternate source of signal, the RCA WR39B or WR39C calibrator may be employed as above.

Connect the "VoltOhmyst" to pin 2 of V103.

Tune the T101 top core for maximum d-c on the "VoltOhmyst".

The output from the signal generator should be set to produce approximately 6.0 volts on the "VoltOhmyst" when the final touches on the above adjustment are made.

4.5 MC. TRAP ADJUSTMENT.—Connect the signal generator in series with a 1,000 ohm resistor to pin 2 of V109. Set the generator to 4.5 mc. and modulate it 30% with 400 cycles. Set the output to approximately 0.5 volts.

Short the third pix i-f grid to ground, pin 1, V108, to prevent noise from masking the output indication.

Connect the crystal diode probe of an oscilloscope to the plate of the video amplifier, pin 6 of V110 (pin 8 when 6AC7 or 6AG7 is used).

Adjust the core of L103 for minimum output on the oscilloscope.

Remove the short from pin 1, V108 to ground.

As an alternate method, this step may be omitted at this point in the alignment procedure and the adjustment made "on the air" after the alignment is completed.

If this is done, tune in a station and observe the picture on the kinescope. If no 4.5 mc. beat is present in the picture, when the fine tuning control is set for proper oscillator-frequency, then L103 requires no adjustment. If a 4.5 mc. beat is present, turn the fine tuning control slightly clockwise so as to exaggerate the beat and then adjust L103 for minimum beat.

CHECK OF OVERALL RESPONSE.—If desired, the overall response of the receiver can be checked on each channel.

Connect the r-f sweep generator to the receiver antenna input terminals. If necessary, employ one of the pads shown in Figure 9 to match the sweep output cable to the r-f unit.

Connect the signal generator loosely to the first pix i-f amplifier grid.

Adjust the bias potentiometer to obtain -5.0 volts of bias as measured by a "VoltOhmyst" at the junction of R142 and R143.

Connect the oscilloscope to pin 2 of V110 (or pin 4 if 6AC7 or 6AG7 is used).

Check the response of channels 2 through 13 by switching the receiver channel switch and sweep oscillator to each of these channels and observing the response obtained. On each channel, adjust the output of the sweep generator to obtain 3.0 volts peak-to-peak on the oscilloscope.

I-F markers at 22.4 mc., 24.75 mc. and 25.5 mc. should be provided by the signal generator.

The response obtained in this manner should be very similar to that shown in Figure 13.

Some curves may show a 10% sag in the top between 22.75 mc. and 24.75 mc. while others may show a 10% peak in this region. This may be considered normal.

If the picture carrier is consistently high or low on all channels, T106 may be adjusted slightly. Do not adjust T105.

AGC CONTROL ADJUSTMENT.—Disconnect all test equipment except the oscilloscope which should be connected to pin 6 of V110 (pin 8 when 6AC7 or 6AG7 is used).

Connect an antenna to the receiver antenna terminals.

Turn the AGC control fully counter-clockwise.

Tune in a strong signal and adjust the oscilloscope to see the video waveform.

Turn the AGC control clockwise until the tips of sync begin to be compressed, then counter-clockwise until no compression is obtained.

ALIGNMENT PROCEDURE

17T200, 17T201, 17T202,
17T211, 17T220

HORIZONTAL OSCILLATOR ADJUSTMENT.—Normally the adjustment of the horizontal oscillator is not considered to be a part of the alignment procedure, but since the oscillator waveform adjustment may require the use of an oscilloscope, it can not be done conveniently in the field. The waveform adjustment is made at the factory and normally should not require readjustment in the field. However, the waveform adjustment should be checked whenever the receiver is aligned or whenever the horizontal oscillator operation is improper.

Horizontal Frequency Adjustment.—Tune in a station and sync the picture. If the picture cannot be synchronized with the horizontal hold control R170B, then adjust the T110 frequency core on the rear apron until the picture will synchronize. If the picture still will not sync, turn the T110 waveform adjustment core (under the chassis) out of the coil several turns from its original position and readjust the T110 frequency core until the picture is synchronized.

Examine the width and linearity of the picture. If picture width or linearity is incorrect, adjust the horizontal drive control C161B, the width control L106 and the linearity control L108 until the picture is correct.

Horizontal Oscillator Waveform Adjustment.—The horizontal oscillator waveform may be adjusted by either of two methods. The method outlined in paragraph A below may be employed in the field when an oscilloscope is not available. The service shop method outlined in paragraph B below requires the use of an oscilloscope.

A.—Turn the horizontal hold control completely clockwise. Place adjustment tools on both cores of T110 and be prepared to make simultaneous adjustments while watching the picture on the screen. First, turn the T110 frequency core (on the rear apron) until the picture falls out of sync and three or four diagonal black bars sloping down to the right appear on the screen. Then, turn the waveform adjustment core (under the chassis) into the coil while at the same time adjusting the frequency core so as to maintain three or four diagonal black bars on the screen. Continue this procedure until the oscillator begins to motorboat, then turn the waveform adjustment core out until the motorboating just stops. As a check, turn the T110 frequency core until the picture is synchronized then reverse the direction of rotation of the core until the picture falls out of sync with the diagonal bars sloping down to the right. Continue to turn the frequency core in the same direction. No more than three or four bars should appear on the screen. Instead, the horizontal oscillator should begin the motorboat. Retouch the adjustment of the T110 waveform adjustment core if necessary until this condition is obtained.

B.—Connect the low capacity probe of an oscilloscope to terminal C of T110. Turn the horizontal hold control one-quarter turn from the clockwise position so that the picture is in sync. The pattern on the oscilloscope should be as shown in Figure 14. Adjust the waveform adjustment core of T110 until the two peaks are at the same height. During this adjustment, the picture must be kept in sync by readjusting the hold control if necessary.

This adjustment is very important for correct operation of the circuit. If the broad peak of the wave on the oscilloscope is lower than the sharp peak, the noise immunity becomes poorer, the stabilizing effect of the tuned circuit is reduced and drift of the oscillator becomes more serious. On the other hand, if the broad peak is higher than the sharp peak, the oscillator is overstabilized, the pull-in range becomes inadequate and the broad peak can cause double triggering of the oscillator when the hold control approaches the clockwise position.

Remove the oscilloscope upon completion of this adjustment.

Horizontal Locking Range Adjustment.—Set the horizontal hold control to the full counter-clockwise position. Momentarily remove the signal by switching off channel then back. The picture may remain in sync. If so turn the T110 frequency core slightly and momentarily switch off channel.

Repeat until the picture falls out of sync with the diagonal lines sloping down to the left. Slowly turn the horizontal hold control clockwise and note the least number of diagonal bars obtained just before the picture pulls into sync.

If more than 3 bars are present just before the picture pulls into sync, adjust the horizontal locking range trimmer C161A slightly clockwise. If less than 2 bars are present, adjust C161A slightly counter-clockwise. Turn the horizontal hold control counter-clockwise, momentarily remove the signal and recheck the number of bars present at the pull-in point. Repeat this procedure until 2 or 3 bars are present.

Turn the horizontal hold control to the maximum clockwise position. Adjust the T110 frequency core so that the diagonal bar sloping down to the right appears on the screen and then reverse the direction of adjustment so that bar just moves to the left side of the screen leaving the picture in synchronization.

SENSITIVITY CHECK.—A comparative sensitivity check can be made by operating the receiver on a weak signal from a television station and comparing the picture and sound obtained to that obtained on other receivers under the same conditions.

This weak signal can be obtained by connecting the shop antenna to the receiver through a ladder type attenuator pad. The number of stages in the pad depends upon the signal strength available at the antenna. A sufficient number of stages should be inserted so that a somewhat less than normal contrast picture is obtained when the picture control is at the maximum clockwise position. Only carbon type resistors should be used to construct the pad.

RESPONSE CURVES.—The response curves shown on page 14 and referred to throughout the alignment procedure were taken from a production set. Although these curves are typical, some variations can be expected.

The response curves are shown in the classical manner of presentation, that is with "response up" and low frequency to the left. The manner in which they will be seen in a given test set-up will depend upon the characteristics of the oscilloscope and the sweep generator. The curves may be seen inverted and/or switched from left to right depending on the deflection polarity of the oscilloscope and the phasing of the sweep generator.

NOTE ON R-F UNIT ALIGNMENT.—Because of the frequency spectrum involved and the nature of the device, many of the r-f unit leads and components are critical in some respects. Even the power supply leads form loops which couple to the tuned circuits, and if resonant at any of the frequencies involved in the performance of the tuner, may cause serious departures from the desired characteristics. In the design of the receiver these undesirable resonant loops have been shifted far enough away in frequency to allow reasonable latitude in their components and physical arrangement without being troublesome. When the r-f unit is aligned in the receiver, no trouble from resonant loops should be experienced. However, if the unit is aligned in a jig separate from the receiver, attention should be paid to insure that unwanted resonances do not exist which might present a faulty representation of r-f unit alignment.

A resonant circuit exists between the r-f tuner chassis and the outer shield box, which couples into the antenna and r-f plate circuits. The frequency of this resonance depends on the physical structure of the shield box, and the capacitance between the tuner chassis and the front plate. In the KRK8 units, this resonance should fall between 120 and 135 mc. and is controlled in the design by using insulating washers of different thicknesses (in the front plate to tuner chassis mounting) to compensate for differences in the shield boxes of different models of receivers. The performance of the tuner, particularly on channels 7 and 8 will be impaired if the proper washers for the particular shield box involved are not used. Obviously then, if the r-f unit is removed for service, the washers should be replaced in the correct order when the unit is replaced.

17T200, 17T201, 17T202,
17T211, 17T220

ALIGNMENT TABLE

THE DETAILED ALIGNMENT PROCEDURE BEGINNING ON PAGE 8 SHOULD BE READ BEFORE ALIGNMENT BY USE OF THE TABLE
IS ATTEMPTED

STEP. No.	CONNECT SIGNAL GENERATOR TO	SIGNAL GEN. FREQ. MC.	CONNECT SWEEP GENERATOR TO	SWEEP GEN. FREQ. MC.	CONNECT HETERODYNE FREQ. METER TO	HET. METER FREQ. MC.	CONNECT "VOLTOHMYST" TO	MISCELLANEOUS CONNECTIONS AND INSTRUCTIONS	ADJUST	REFER TO
R-F UNIT ALIGNMENT										
1	Disconnect the co-ax link from terminal 2 of the r-f unit terminal board and connect a 39 ohm composition resistor between lugs 1 and 2. Detune T1 by backing the core all the way out of the coil. Back the L44 core all the way out. Back the L203 core all the way out. In order to align the r-f tuner, it will first be necessary to set the channel 13 oscillator to frequency. The shield over the bottom of the r-f unit must be in place when making any adjustments.									
2	Not used		Not used		Loosely coupled to r-f oscillator	236.75 MC.	Not used	Fine tuning 30 degrees clockwise from mechanical center of its range. Receiver on channel 13.	C1 for an audible beat on het. freq. meter	Fig. 7
3	"		"				Connect "Volt-Ohmyst" to terminal 3 of the r-f unit terminal board	Turn AGC control fully clockwise. Connect bias box to terminal 3 of r-f unit term. board	Adjust the bias box potentiometer for -3.5 volts.	
4	Antenna terminal (loosely)	181.25 185.75	Antenna terminals (see text for precaution)	Sweeping channel 8	Not used	—	Not used	Rec. on chan. 8. Connect oscilloscope to TP1. Adjust C9, C11, C16 and C22 for correct curve shape, frequency and band width. C22 is adjusted to give max. amplitude between markers. C9 affects tilt and C16 affects the frequency of response. C11 affects the response band width.		Fig. 7
5	Not used		Not used	Not used	Loosely coupled to r-f oscillator	108.75	"	Rec. on channel 6	L5 for audible beat on het. freq. meter.	Fig. 8
6	Antenna terminal (loosely)	83.25 87.75	Antenna terminals (see text for precaution)	Channel 6	Not used	—	"	Rec. on chan. 6. Adjust L42, L45 and L49 for proper response. L42 is adjusted to give max. amplitude between markers. L45 primarily affects tilt and L49 primarily affects freq. of response. If necessary, retouch C11 for proper width.		Fig. 11
7	Not used	—	Not used	—	Not used	—	Connect "Volt-Ohmyst" to r-f unit test point TP1	Rec. on channel 6	Adjust C7 for -3.0 volts at the test point	Fig. 7 Fig. 15
8	Repeat above steps until the specified conditions are obtained.									
9	Not used		Not used	—	Loosely coupled to r-f oscillator	206.75		Rec. on chan. 8	C1 for audible beat on het. freq. meter	Fig. 7
10	Antenna terminal (loosely)	181.25 185.75	Antenna terminals (see text for precaution)	Sweeping channel 8	Not used	—	Not used	Rec. on chan. 8. Readjust C9, C16 and C22 for correct curve shape, frequency and band width. Readjust C11 only if necessary.		Fig. 7 Fig. 11 (8)
11	"	211.25 215.75	"	Sweeping channel 13	Not used	—	Not used	Rec. on chan. 13. Adjust L52 for max. amplitude between markers, overshoot a little more than required to reach max. response. Adjust C22 to regain max. amplitude of response.		Fig. 7 Fig. 11 (13)
12	"	215.75	Not used	—	Loosely coupled to r-f oscillator	236.75		Receiver on chan. 13. Adjust L43 for correct channel 13 osc. freq. then overshoot. Reset the osc. to proper freq. by adjustment of C1.		Fig. 7 Fig. 8
13	"	205.25 209.75	Antenna terminals (see text for precaution)	channel 12	Not used	—	Connect "Volt-Ohmyst" to r-f unit test point TP1	Rec. on chan. 12	Check to see that response is correct and -3.0 volts of osc. injection is present	Fig. 11
14	"	199.25 203.75		channel 11	"	—	"	Rec. on chan. 11	"	Fig. 11 (11)
15	"	193.25 197.75		channel 10	"	—	"	Rec. on chan. 10	"	Fig. 11 (10)
16	"	187.25 191.75		channel 9	"	—	"	Rec. on chan. 9	"	Fig. 11 (9)
17	"	181.25 185.75		channel 8	"	—	"	Rec. on chan. 8	"	Fig. 11 (8)
18	"	175.25 179.75	channel 7	"	—	"	Rec. on chan. 7	"	Fig. 11 (7)	
19	If the response of any channel (steps 13 through 18) is below 80% at either marker, repeat step 10 and adjust C9, C11, C16 and C22 as necessary to pull response up on the low channel yet maintain correct response on channel 8. If C22 required adjustment, the adjustment should be overshoot a small amount and corrected by adjustment of L52 to give maximum amplitude of response between the sound and picture carrier markers.									
20	Repeat step 9. If the oscillator is off frequency overshoot the adjustment of C1 and correct by adjusting L43.									
21	Repeat steps 13 through 20 until all requirements are obtained.									
22	Not used	—	Not used	—	Loosely coupled to r-f oscillator	108.75		Rec. on chan. 6	L5 for zero beat on het. freq. meter	Fig. 8
23	Antenna terminals (loosely)	83.25 87.75	Antenna terminals (see text for precaution)	Sweeping channel 6	Not used	—	Not used	Observe response. If necessary readjust L42, L45 and L49. It should not be necessary to touch C11.		Fig. 7 Fig. 11
24	Not used	—	Not used	—	Not used	—	Connect "Volt-Ohmyst" to the r-f unit test point TP1	Check osc. injection. If necessary adjust C7 to give -3 volts. If C7 is adjusted, switch to channel 8, and readjust C9 for proper response then repeat step 23.		Fig. 7 Fig. 11
25	Antenna terminals (loosely)	77.25 81.75	Antenna terminals (see text for precaution)	channel 5	"	—	"	Rec. on chan. 5	Check to see that response is correct and -3.0 volts of osc. injection is present	Fig. 11 (5)

ALIGNMENT TABLE

17T200, 17T201, 17T202,
17T211, 17T220

STEP No.	CONNECT SIGNAL GENERATOR TO	SIGNAL GEN. FREQ. MC.	CONNECT SWEEP GENERATOR TO	SWEEP GEN. FREQ. MC.	CONNECT HETERODYNE FREQ. METER	HET. FREQ. METER MC.	CONNECT "VOLTOHMYST" TO	MISCELLANEOUS CONNECTIONS AND INSTRUCTIONS	ADJUST	REFER TO
26	Antenna terminals (loosely)	67.23 71.75	Ani. terminals (see text for precaution)	channel 4	Not used	—	Connect "VoltOhmyst" to the r-f unit test point TP1	Rec. on chan. 4	Check to see that response is correct and -3.0 volts of osc. injection is present	Fig. 11 (4)
27	"	61.25 65.75	"	channel 3	"	—	"	Rec. on chan. 3	"	Fig. 11 (3)
28	"	55.25 59.75	"	channel 2	"	—	"	Rec. on chan. 2	"	Fig. 11 (2)
29	Likewise check channels 7 through 13, as outlined in steps 18 back through 13, stopping on channel 13 for next step.									
30	Antenna terminals	215.75	Not used	—	Loosely coupled to r-f oscillator	236.75	Not used	Fine tuning 30 degrees clockwise from mechanical center of its range. Receiver on channel 13	C1 for zero beat on het. freq. meter	Fig. 7
31	"	209.75	"	—	"	230.75	"	Rec. on chan. 12	L11 as above	Fig. 8
32	"	203.75	"	—	"	224.75	"	Rec. on chan. 11	L10 as above	Fig. 8
33	"	197.75	"	—	"	218.75	"	Rec. on chan. 10	L9 as above	Fig. 8
34	"	191.75	"	—	"	212.75	"	Rec. on chan. 9	L8 as above	Fig. 8
35	"	185.75	"	—	"	206.75	"	Rec. on chan. 8	L7 as above	Fig. 8
36	"	179.75	"	—	"	200.75	"	Rec. on chan. 7	L6 as above	Fig. 8
37	"	87.75	"	—	"	108.75	"	Rec. on chan. 6	L5 as above	Fig. 8
38	"	81.75	"	—	"	102.75	"	Rec. on chan. 5	L4 as above	Fig. 8
39	"	71.75	"	—	"	92.75	"	Rec. on chan. 4	L3 as above	Fig. 8
40	"	65.75	"	—	"	86.75	"	Rec. on chan. 3	L2 as above	Fig. 8
41	"	59.75	"	—	"	80.75	"	Rec. on chan. 2	L1 as above	Fig. 8

Repeat steps 30 through 41 as a check.

43	Antenna terminals	181.25 185.75	Antenna terminals	Sweeping channel 8	Not used	—	—	Rec. on chan. 8 Oscilloscope at test point TP1. Adjust T1 clockwise. When properly adjusted, curve will be slightly wider with a slightly deeper valley in top.	—	Fig. 11 (8)
44	Switch through all channels and observe response, oscillator injection and r-f oscillator frequency. Minor touch-ups of adjustments may be made at this time. However, if C7 or C9 are changed appreciably, then a recheck of the oscillator frequency on all channels should be made.									
45	Remove 39 ohm resistor and reconnect link from T101 to terminal 2 of r-f unit terminal board.									

PICTURE I-F AND TRAP ALIGNMENT

STEP No.	CONNECT SIGNAL GENERATOR TO	SIGNAL GEN. FREQ. MC.	CONNECT SWEEP GENERATOR TO	SWEEP GEN. FREQ. MC.	CONNECT OSCILLOSCOPE TO	CONNECT "VOLTOHMYST" TO	MISCELLANEOUS CONNECTIONS AND INSTRUCTIONS	ADJUST	REFER TO
46	Not used	—	Not used	—	Not used	Junction of R142 & R143	Connect bias box to junction of R142 & R143 and to ground AGC fully clockwise	Adjust potentiometer for -3.0 volts on meter	Fig. 3
47	"	—	"	—	"	Test point TP1	Connect bias box to TP1 and to ground	"	Fig. 7
48	Mixer grid test point TP2 in series with 1500 mmf.	24.25	"	—	"	Pin 2 of V110 and to ground	Bias boxes connected as above	T107 (top) for max.	Fig. 15
49	"	25.5	"	—	"	"	"	T106 (top) for max.	Fig. 15
50	"	22.75	"	—	"	"	"	T105 (top) for max.	Fig. 15
51	"	27.00	"	—	"	"	"	T104 (top) for min.	Fig. 15
52	Connected loosely to diode probe	Various See Fig. 13	Mixer grid test point TP2 in series with 1500 mmf.	20 to 28 mc	Scope diode probe to pin 5 of V106 and to gnd. Connect a 180 ohm resistor from pin 5 of V106 to pin A of T105	Junction of R142 & R143	Shunt terminals A and B of T106 and T107 with 330 ohms. Bias boxes connected as above. .3v p-p on scope	Set C115 to min. Adjust T1 top and T104 bot. for max. gain with 25.5 mc. at 70%. C115 for 22.5 at 70%	Fig. 7 Fig. 16
53	Connected loosely to grid of 1st pix i-f. Adjust for small marker indication	Various See Fig. 14	"	"	Connect scope to pin 2 of V110. Remove shunt & diode probe used above	"	Remove shunts from T106 & T107	Retouch T105, T106 and T107 to obtain response shown in Fig. 13	Fig. 13

RATIO DETECTOR, SOUND I-F AND 4.5 MC TRAP ALIGNMENT

54	Grid 1st Snd. I-F (pin 1, V101) or WR39B or C connect to grid 3rd pix I-F (pin 1, V108)	25.50mc. mod. by 4.5 mc.	Not used	—	Not used	Pin 2 of V103	Set signal gen. to give 6V on meter	T102 top core for max. d-c on meter	Fig. 15
55	"	"	"	—	"	"	"	"	Fig. 15 Fig. 16
56	Sig. Gen. to 1st Snd. I-F grid	4.5 mc.	"	—	"	"	Signal generator output adjusted to provide 6v on meter	T101 top core for max. DC on meter	Fig. 15
57	Sig. Gen. in series with 1000 ohms to pin 2 of V109	4.5 mc. mod. 30% with 400 cy.	"	—	Diode probe to pin 6 of V110	Not used	Short pin 1 of V108 to ground	Adjust L103 for minimum output on oscilloscope	Fig. 15

ALIGNMENT DATA

17T200, 17T201, 17T202,
17T211, 17T220

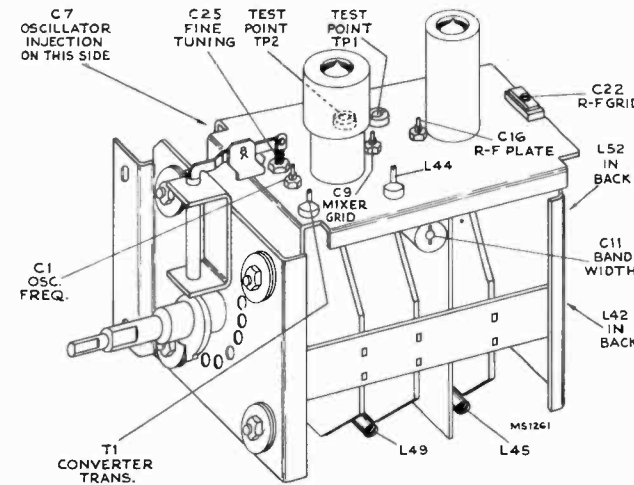

Figure 7—R-F Unit Adjustments

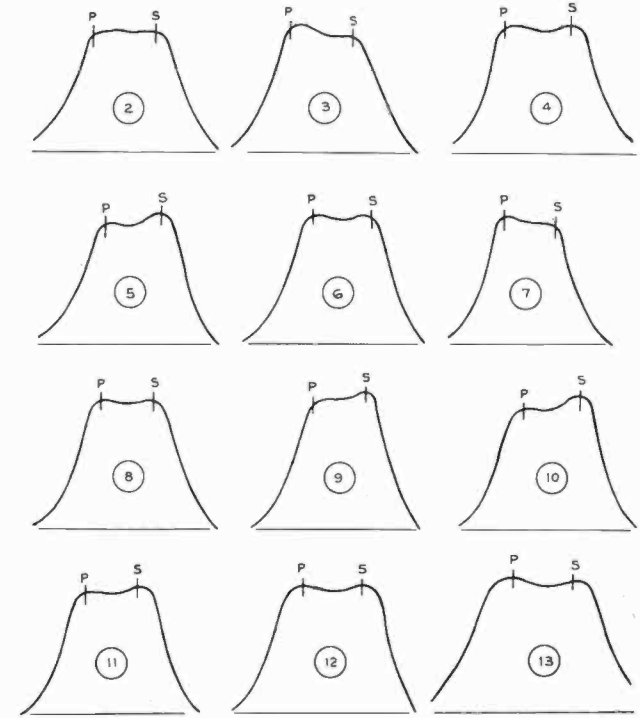

Figure 11—R-F Response

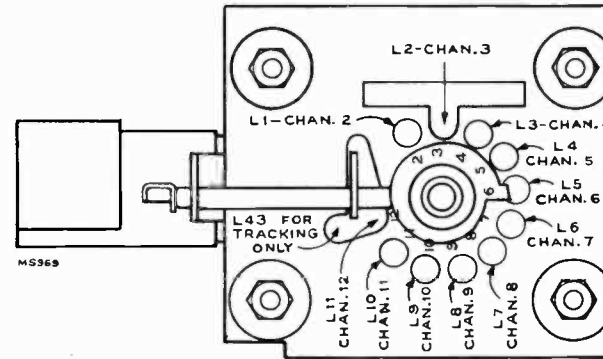

Figure 8—R-F Oscillator Adjustments

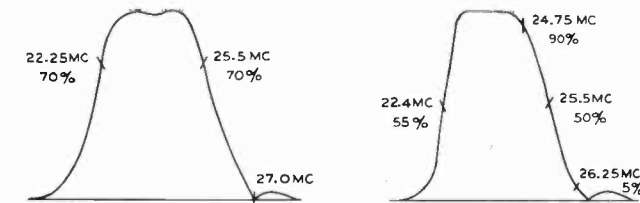

Figure 12
T1 and T104
Response

Figure 13
Over-all I-F
Response

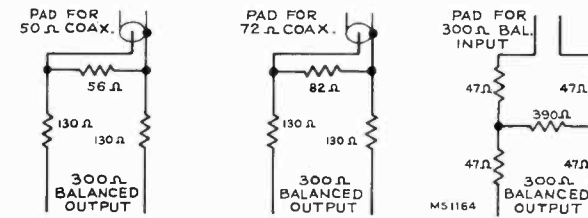

Figure 9—Sweep Attenuator Pads

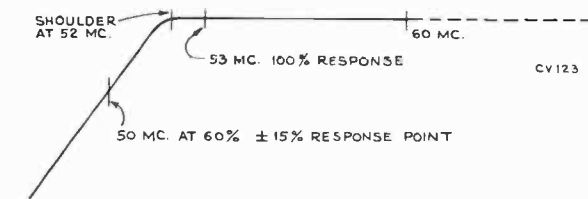

Figure 10—Antenna Matching Unit Response

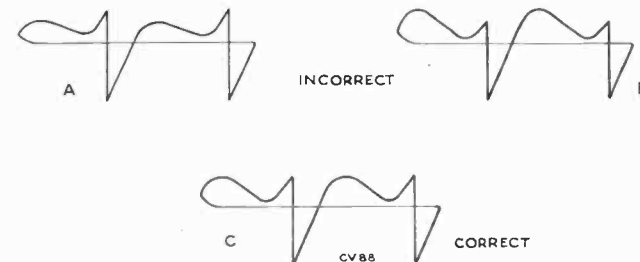

Figure 14—Horizontal Oscillator Wave Forms

ALIGNMENT DATA

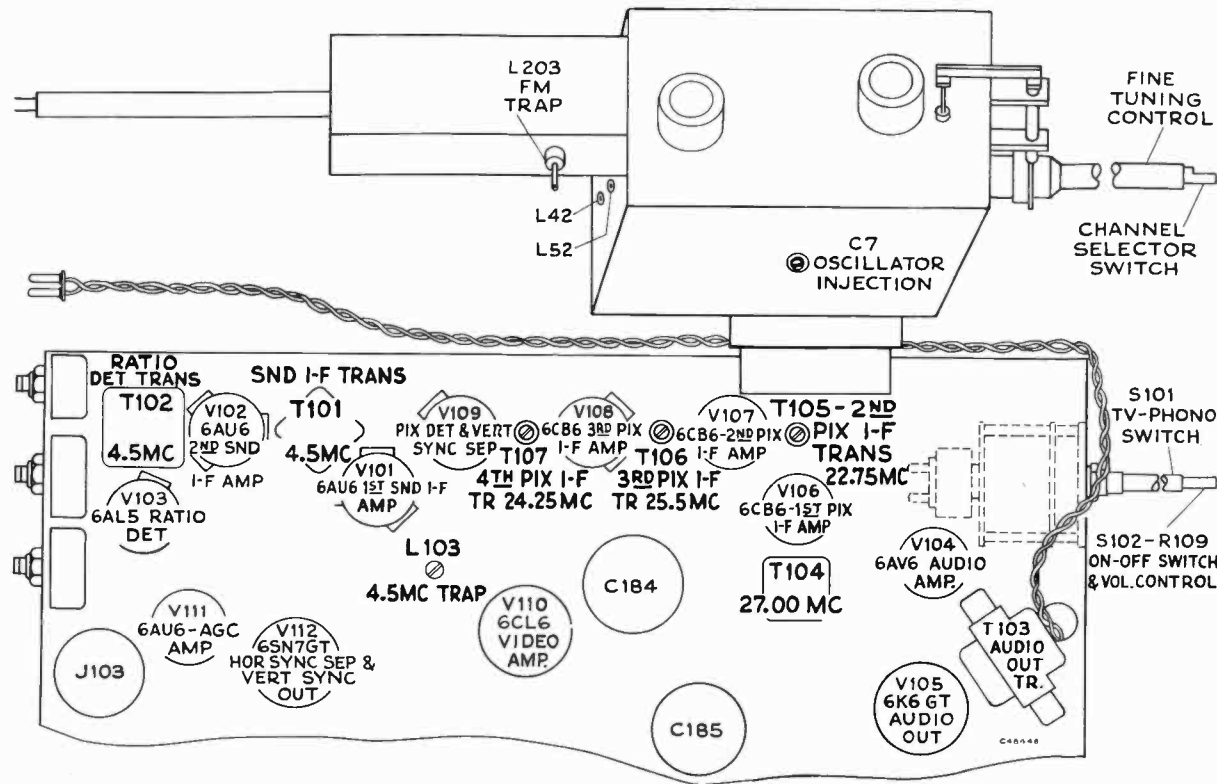

Figure 15—Top Chassis Adjustments

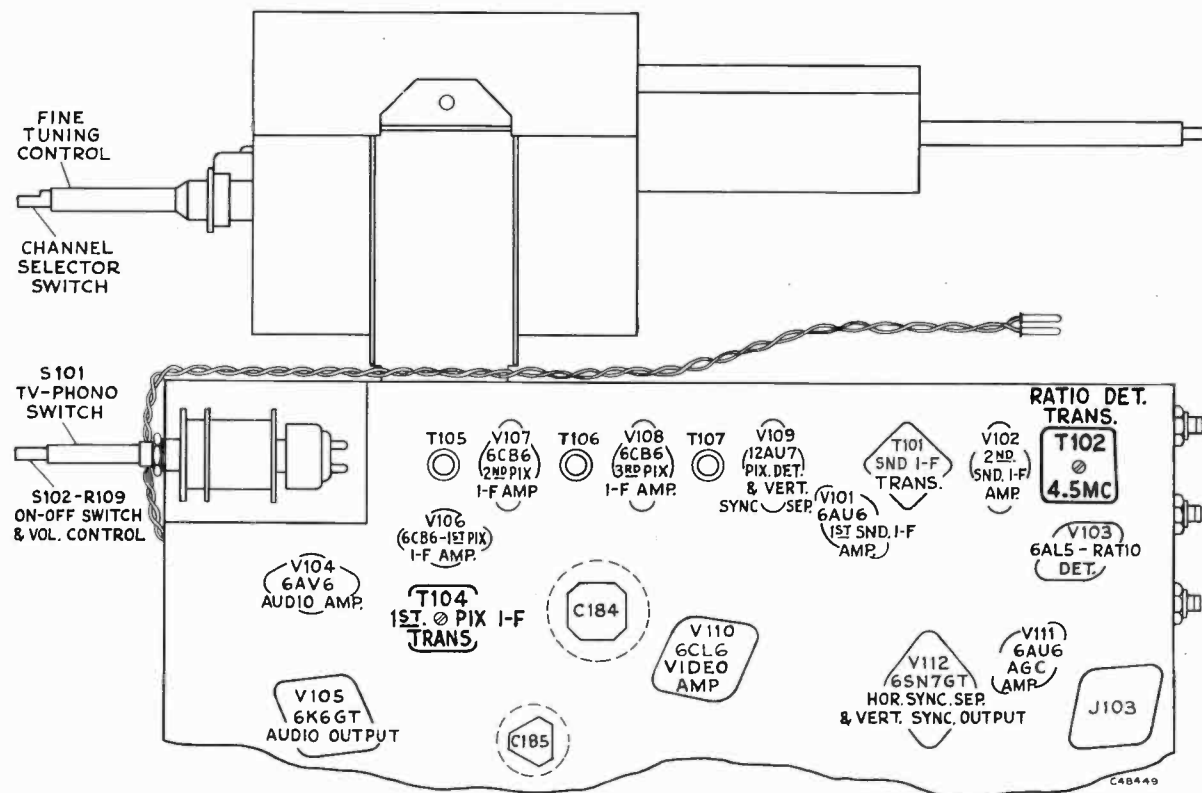

Figure 16—Bottom Chassis Adjustments

TEST PATTERN PHOTOGRAPHS

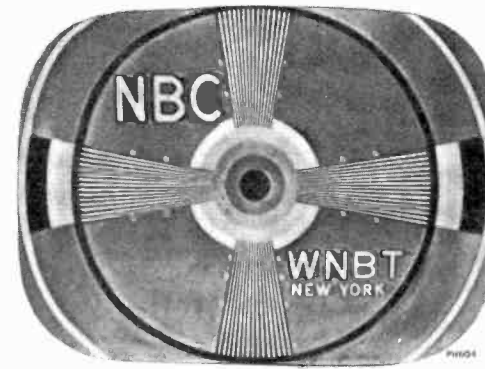

Figure 17—Normal Picture

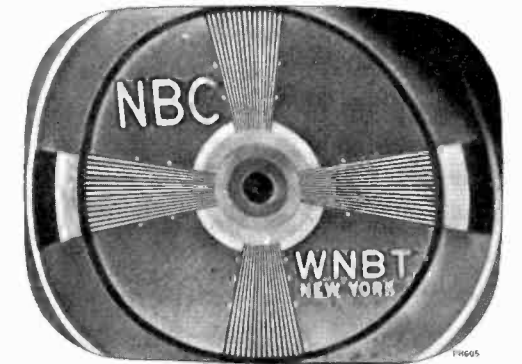

Figure 18—Focus Magnet and Ion Trap Magnet Misadjusted

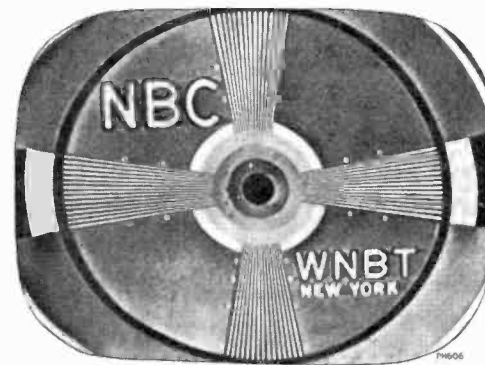

Figure 19—Horizontal Linearity Control Misadjusted (Picture Cramped in Middle)

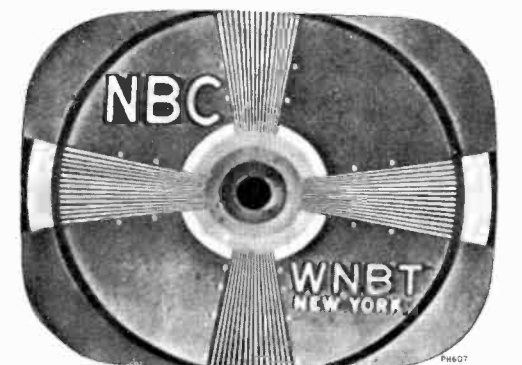

Figure 20—Width Control Misadjusted

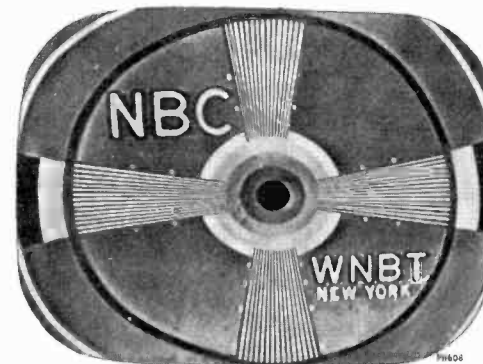

Figure 21—Horizontal Drive Control Misadjusted

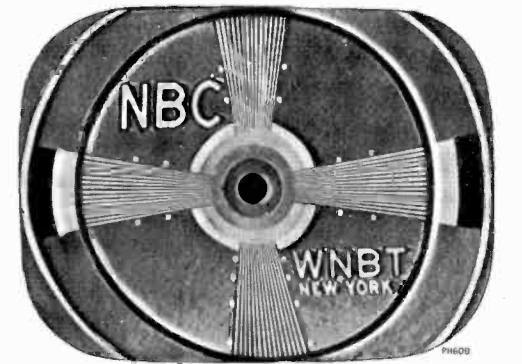

Figure 22—Transients

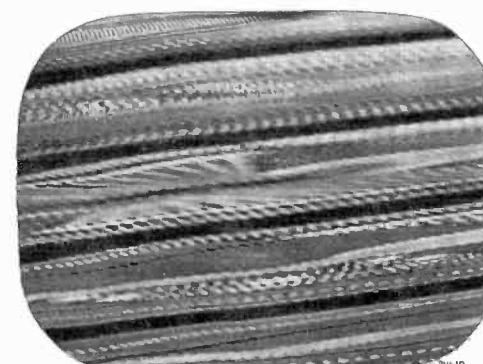

Figure 23—Test Pattern Showing Out of Sync Condition When Horizontal Hold Control Is in a Counter-clockwise Position—Just Before Pulling Into Sync

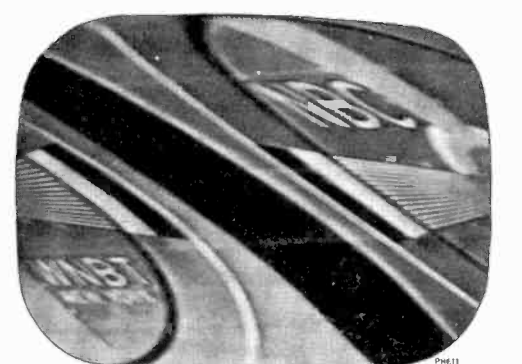

Figure 24—Test Pattern Showing Out of Sync Condition When Horizontal Hold Control Is at the Maximum Clockwise Position

SERVICE SUGGESTIONS

17T200, 17T201, 17T202,
17T211, 17T220

Following is a list of symptoms of possible failures and an indication of some of the possible faults:

NO RASTER ON KINESCOPE:

- (1) Incorrect adjustment of ion trap magnet. Magnet reversed either front to back or top to bottom.
- (2) V115 or V116 inoperative. Check waveforms on grids and plates.
- (3) No high voltage—if horizontal deflection is operating as evidenced by the correct waveform on terminal 1 of high voltage transformer, the trouble can be isolated to the 1B3GT circuit. Either the T111 high voltage winding is open, the 1B3GT tube is defective or its filament circuit is open.
- (4) V110 circuit, inoperative—Refer to schematic and waveform chart.
- (5) Damper tube (V118) inoperative.
- (6) Defective kinescope.
- (7) R184 open.
- (8) No receiver plate voltage—filter capacitor shorted—or filter choke open.

NO VERTICAL DEFLECTION:

- (1) V113 or V114 inoperative. Check voltage and waveforms on grids and plates.
- (2) T108 open.
- (3) Vertical deflection coils open.

SMALL RASTER:

- (1) Low Plus B or low line voltage.
- (2) V116, V120 or V121 defective.

POOR VERTICAL LINEARITY:

- (1) If adjustments cannot correct, change V114.
- (2) Vertical output transformer T108 defective.
- (3) V113 defective—check voltage and waveforms on grid and plate.
- (4) C151, C152, C153, C155, or C156 defective.
- (5) Low plate voltage—check rectifiers and capacitors in supply circuits.
- (6) If height is insufficient, try changing V113.

POOR HORIZONTAL LINEARITY:

- (1) If adjustments do not correct, change V116, or V118.
- (2) T108 or L108 defective.
- (3) C176 or C177 defective.

WRINKLES ON SIDE OF RASTER:

- (1) C181 defective.
- (2) Defective yoke.

PICTURE OUT OF SYNC HORIZONTALLY:

- (1) T110 incorrectly tuned.
- (2) R192, R193 or R170B defective.

TRAPEZOIDAL OR NON SYMMETRICAL RASTER:

- (1) Improper adjustment of centering of focus magnet or ion trap magnet.
- (2) Defective yoke.

RASTER AND SIGNAL ON KINESCOPE BUT NO SOUND:

- (1) L102 defective.
- (2) Sound i-f, ratio detector or audio amplifier inoperative—check V101, V102, V103 and their socket voltages.
- (3) Audio system defective.
- (4) Speaker defective.

SIGNAL AT KINESCOPE GRID BUT NO SYNC:

- (1) AGC control R149 misadjusted.
- (2) V111, inoperative. Check voltage and waveforms at its grid and plate.

SIGNAL ON KINESCOPE GRID BUT NO VERTICAL SYNC:

- (1) Check V113 and associated circuit.
- (2) Integrating network inoperative—Check.
- (3) V109B or V112B defective or associated circuit defective.
- (4) Gas current, grid emission or grid cathode leakage in V112. Replace.

SIGNAL ON KINESCOPE GRID BUT NO HORIZONTAL SYNC:

- (1) T110 misadjusted—readjust as instructed on page 11.
- (2) V112 inoperative—check socket voltages and waveforms.
- (3) T110 defective.
- (4) C142, C161A, C163, C165, C166, C167, C168, C169 or C170 defective.
- (5) If horizontal speed is completely off and cannot be adjusted check R192, R193, R170B, R195, R196 and R198.

SOUND AND RASTER BUT NO PICTURE OR SYNC:

- (1) Picture, detector or video amplifier defective—check V109A and V110—check socket voltages.
- (2) Bad contact to kinescope cathode.

PICTURE STABLE BUT POOR RESOLUTION:

- (1) V109A or V110 defective.
- (2) Peaking coils defective—check resistance.
- (3) Make sure that the focus control operates on both sides of proper focus.
- (4) R-F and I-F circuits misaligned.

PICTURE SMEAR:

- (1) R-F or I-F circuits misaligned.
- (2) Open peaking coil.
- (3) This trouble can originate at the transmitter—check on another station.

PICTURE JITTER:

- (1) AGC control R149 misadjusted.
- (2) If regular sections at the left picture are displaced change V116.
- (3) Vertical instability may be due to loose connections or noise.
- (4) Horizontal instability may be due to unstable transmitted sync.

RASTER BUT NO SOUND, PICTURE OR SYNC:

- (1) Defective antenna or transmission line.
- (2) R-F oscillator off frequency.
- (3) R-F unit inoperative—check V1, V2.

DARK VERTICAL LINE ON LEFT OF PICTURE:

- (1) Reduce horizontal drive and readjust width and horizontal linearity.
- (2) Replace V116.

LIGHT VERTICAL LINE ON LEFT OF PICTURE:

- (1) V118 defective.

17T200, 17T201, 17T202,
17T211, 17T220

RESPONSE AND WAVE FORM PHOTOGRAPHS

Taken from RCA WO58A Oscilloscope

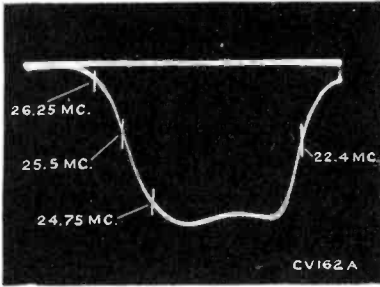

Figure 25—Overall Pix I-F Response



Figure 26—Response of T1-T104 Pix I-F Transformers

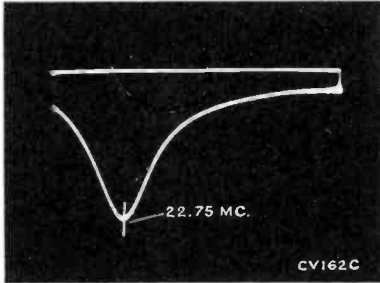
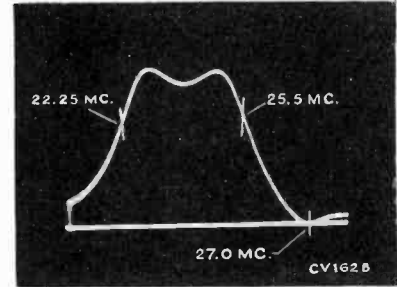

Figure 27—Response of T105 Pix I-F Transformer



Figure 28—Response of T106 Pix I-F Transformer

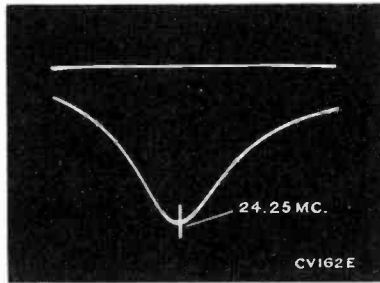
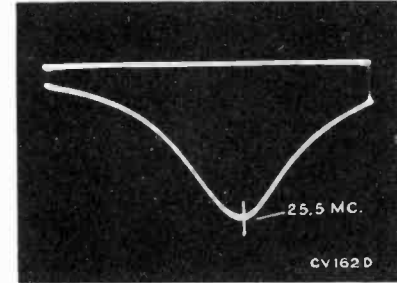
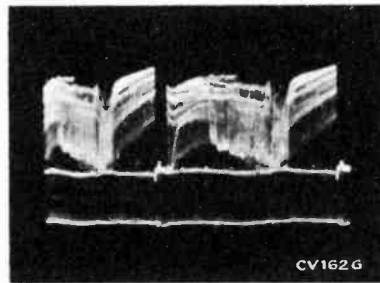
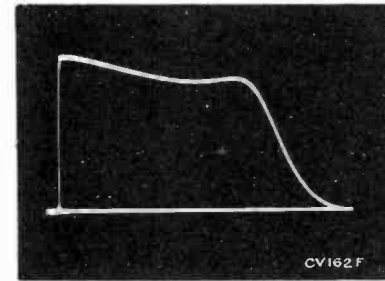

Figure 29—Response of T107 Pix I-F Transformer



Figure 30—Video Response at Average Contrast



Grid of Video Amplifier (Pin 2 of V110) (6CL6)
Voltage Depends on Picture

Figure 31—Vertical (Oscilloscope Synced to 1/2 of Vertical Sweep Rate) (1.5 Volts PP)



Figure 32—Horizontal (Oscilloscope Synced to 1/2 of Horizontal Sweep Rate) (1.5 Volts PP)

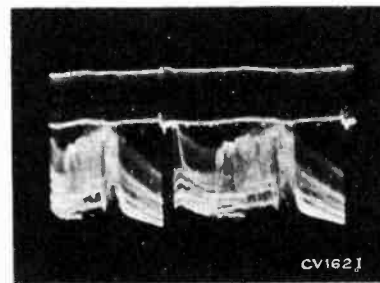
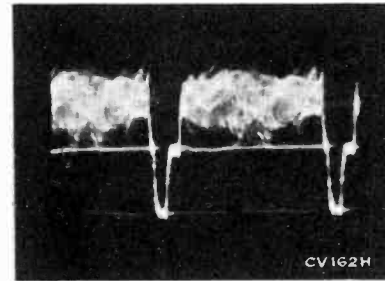
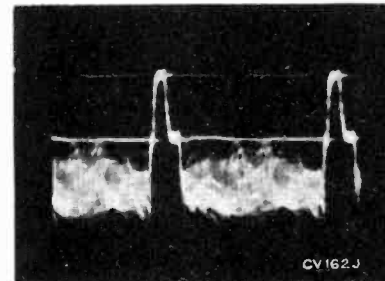

Plate of Video Amplifier (Pin 6 of V110) (6CL6)
Voltage depends on picture

Figure 33—Vertical (85 Volts PP)



Figure 34—Horizontal (85 Volts PP)



17T200, 17T201, 17T202,
17T211, 17T220

WAVEFORM PHOTOGRAPHS

Taken from RCA WO58A Oscilloscope

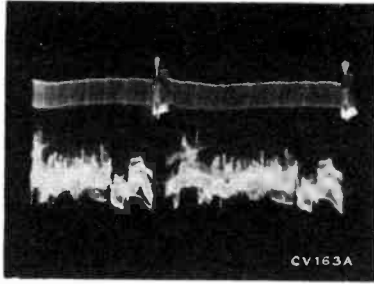

CV163A

*Grid of Horizontal Sync Separator
(Pin 1 of V112A) (6SN7)
Voltage depends on picture*

Figure 35—Vertical (85 Volts PP)



Figure 36—Horizontal (85 Volts PP)

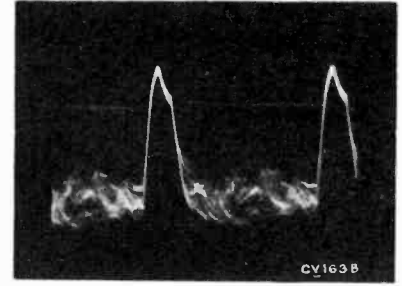

CV163B

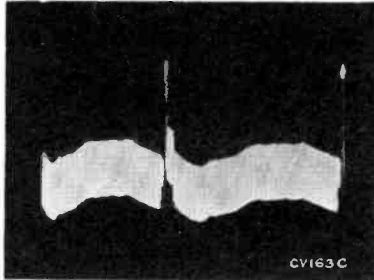

CV163C

*Cathode of Horizontal Sync Sep.
(Pin 3 of V112A) (6SN7)*

Figure 37—Vertical (7.5 Volts PP)



Figure 38—Horizontal (5 Volts PP)

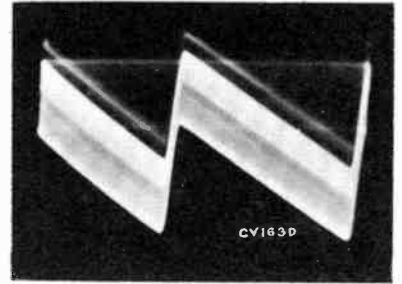

CV163D

*Plate of Horizontal Sync Separator
(Pin 2 of V112A) (6SN7)*

Figure 39—Vertical (45 Volts PP)



Figure 40—Horizontal (45 Volts PP)

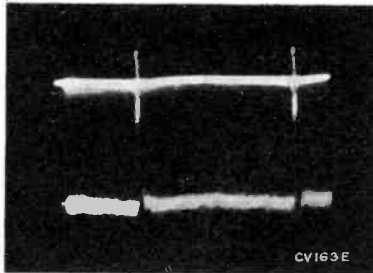

CV163E

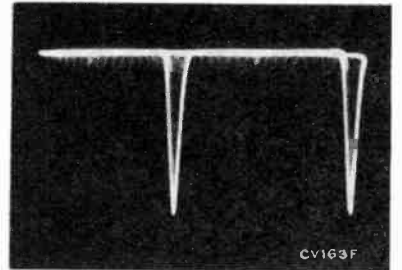

CV163F

*Grid of Vertical Sync Sep.
(Pin 7 of V109B) (12AU7)*

Figure 41—Vertical (55 Volts PP)



Figure 42—Horizontal (55 Volts PP)

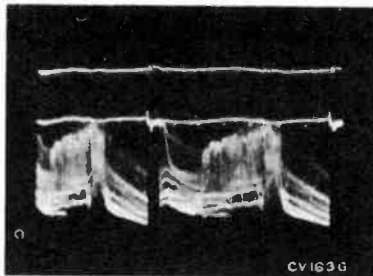

CV163G

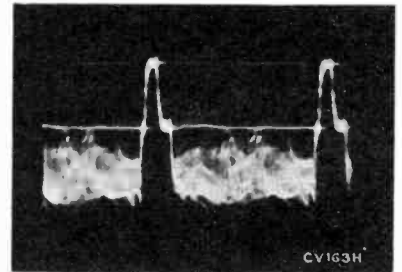

CV163H

*Plate of Vertical Sync Sep.
(Pin 6 of V109B) (12AU7)*

Figure 43—Vertical (65 Volts PP)



Figure 44—Horizontal (65 Volts PP)

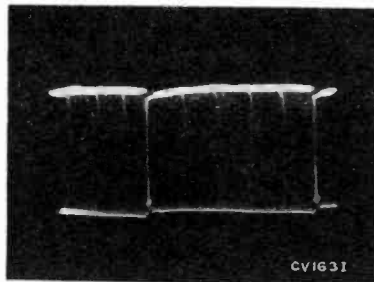

CV163I

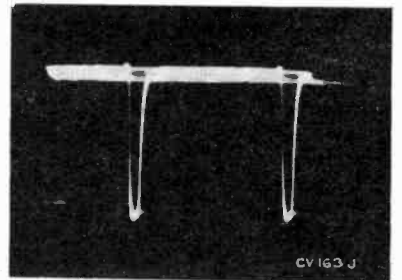

CV163J

17T200, 17T201, 17T202,
17T211, 17T220

WAVEFORM PHOTOGRAPHS

Taken from RCA WO58A Oscilloscope

*Grid of Sync Output
(Pin 4 V112B) (6SN7)*

Figure 45—Vertical (40 Volts PP)



Figure 46—Horizontal (40 Volts PP)

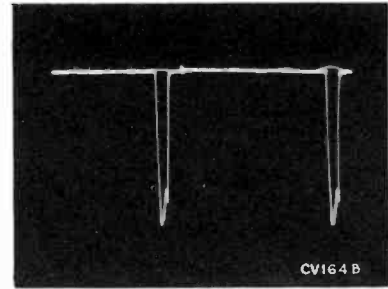
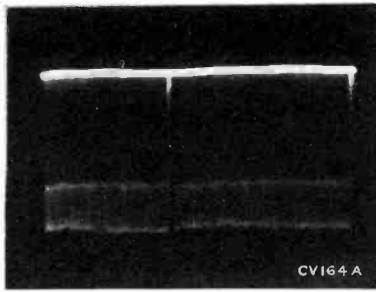
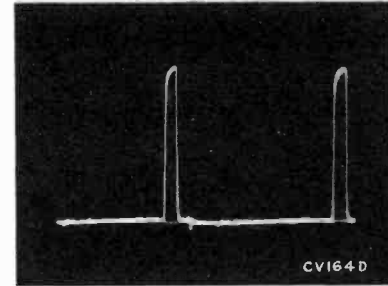
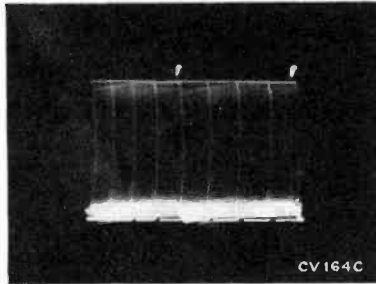

*Plate of Sync Output
(Pin 5 of V112) (6SN7)*

Figure 47—Vertical (47 Volts PP)



Figure 48—Horizontal (47 Volts PP)



*Figure 49—Grid of Vertical
Sweep Osc. (Pin 5 of V113) (6J5)
(30 Volts PP)*



*Figure 50—Plate of Vertical
Sweep Osc. (Pin 3 of V113)
(100 Volts PP)*

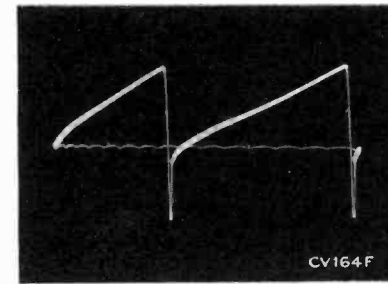
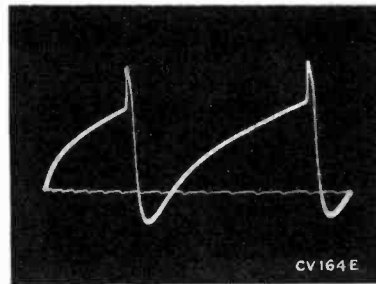

*Figure 51—Grid of Vertical
Sweep Output (Pin 5 of V114) (6K6)
(100 Volts PP)*



*Figure 52—Plate of Vertical
Sweep Output (Pin 3 of V114) (6K6)
(715 Volts PP)*

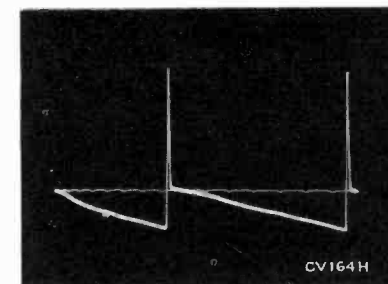
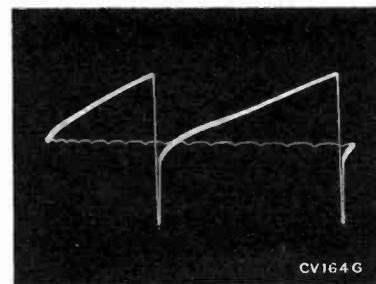

*Cathode of Kinescope
(Pin 11 of V119) (17QP4)*

Voltage depends on picture

Figure 53—Vertical



Figure 54—Horizontal

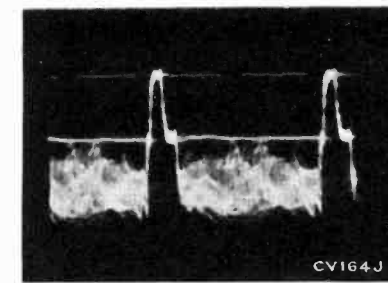
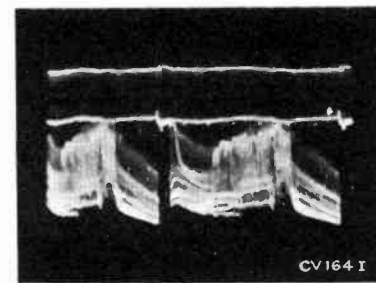

WAVEFORM PHOTOGRAPHS

Taken from RCA WO58A Oscilloscope

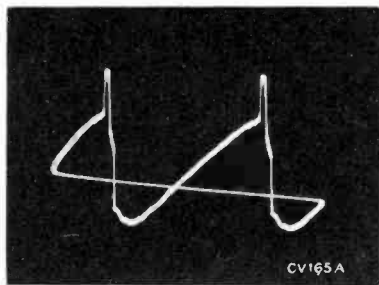

Figure 55—Grid of Horizontal Oscillator Control (Pin 1 of V115) (6SN7GT) (19 Volts PP)



Figure 56—Cathode of Horizontal Oscillator Control (Pin 3 of V115) (6SN7GT) (1.2 Volts PP)

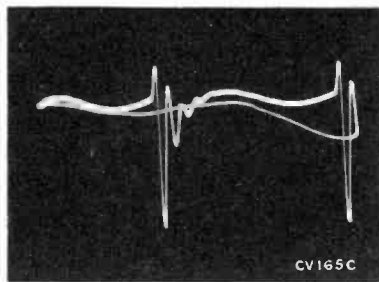
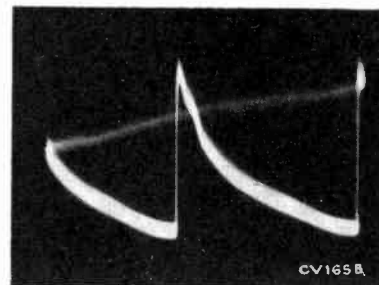

Figure 57—Grid of Horizontal Oscillator (Pin 4 of V115) (6SN7GT) (330 Volts PP)



Figure 58—Plate of Horizontal Oscillator (Pin 5 of V115) (6SN7GT) (140 Volts PP)

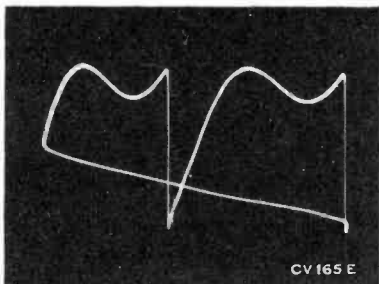
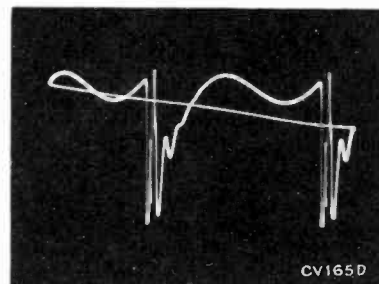

Figure 59—Terminal "C" of T110 (150 Volts PP)



Figure 60—Grid of Horizontal Output Tube (Pin 5 of V116) (6BQ6) (90 Volts PP)

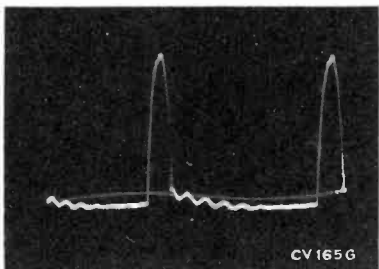
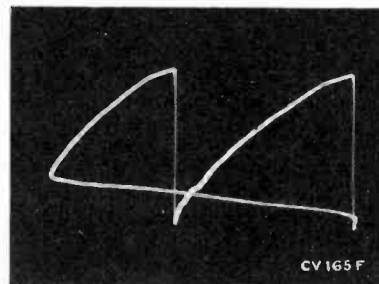

Figure 61—Plate of Horizontal Output (Approx. 4000 Volts PP) (Measured Through a Capacity Voltage Divider Connected from Top Cap of V116 to Ground)



Figure 62—Cathode of Damper (Pin 3 of V118) (6W4GT) (2350 Volts PP)

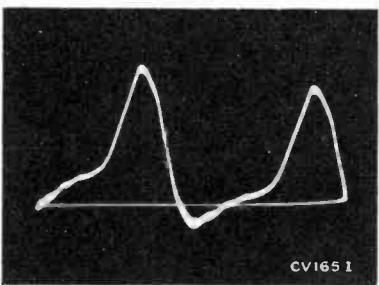
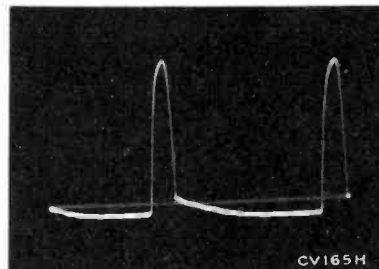
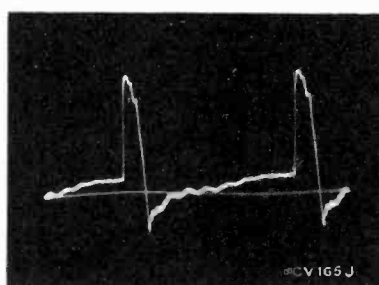

Figure 63—Plate of Damper (Pin 5 of V118) (6W4GT) (160 Volts PP)



Figure 64—Plate of AGC Amplifier (Pin 5 of V111) (6AU6) (560 Volts PP)



17T200, 17T201, 17T202,
17T211, 17T220

VOLTAGE CHART

The following measurements represent two sets of conditions. In the first condition, a 15000 microvolt test pattern signal was fed into the receiver, the picture synced and the AGC control properly adjusted. The second condition was obtained by removing the antenna leads and short circuiting the receiver antenna terminals. Voltages shown are read with a type WV97A senior "VoltOhmyst" between the indicated terminal and chassis ground and with the receiver operating on 117 volts, 60 cycles, a-c. The symbol < means less than.

Tube No.	Tube Type	Function	Operating Condition	E. Plate		E. Screen		E. Cathode		E. Grid		Notes on Measurements
				Pin No.	Volts	Pin No.	Volts	Pin No.	Volts	Pin No.	Volts	
V1	6J6	Mixer	15000 Mu. V. Signal	2	153	—	—	7	0	5	*-3 to -5	*Depending on channel
			No Signal	2	135	—	—	7	0	5	*-3 to -5	*Depending on channel
V1	6J6	R-F Oscillator	15000 Mu. V. Signal	1	100	—	—	7	0	6	*-3 to -5	*Depending on channel
			No Signal	1	85	—	—	7	0	6	*-3 to -5	*Depending on channel
V2	6CB6	R-F Amplifier	15000 Mu. V. Signal	5	260	6	150	2	.1	1	-5.8	
			No Signal	5	220	6	100	2	1.0	1	-0.1	
V101	6AU6	1st Sound I-F Amp.	15000 Mu. V. Signal	5	130	6	142	7	0.8	1	0	
			No Signal	5	116	6	129	7	0.6	1	0	
V102	6AU6	2d Sound I-F Amp.	15000 Mu. V. Signal	5	131	6	148	7	0	1	-5.1	
			No Signal	5	110	6	120	7	0	1	*-0.3	*Unreliable measuring point. Voltage depends on noise.
V103	6AL5	Ratio Detector	15000 Mu. V. Signal	7	0	—	—	1	12	—	—	7.5 kc deviation at 1000 cycles
			No Signal	7	0.7	—	—	1	*5.1	—	—	*Unreliable measuring point. Voltage depends on noise.
V104	6AV6	1st Audio Amplifier	15000 Mu. V. Signal	7	87	—	—	2	0	1	-0.7	At min. volume
			No Signal	7	76	—	—	2	0	1	-0.6	At min. volume
V105	6K6GT	Audio Output	15000 Mu. V. Signal	3	260	4	263	8	19	5	-0.7	At min. volume
			No Signal	3	250	4	251	8	18.5	5	-0.7	At min. volume
V106	6CB6	1st Pix. I-F Amplifier	15000 Mu. V. Signal	5	246	6	258	2	<0.1	1	-8.6	
			No Signal	5	108	6	108	2	0.7	1	*-0.2	*Unreliable measuring point. Make measurement at T104-B
V107	6CB6	2nd Pix. I-F Amplifier	15000 Mu. V. Signal	5	242	6	255	2	<0.1	1	-8.6	
			No Signal	5	108	6	108	2	0.5	1	-0.2	
V108	6CB6	3rd Pix. I-F Amplifier	15000 Mu. V. Signal	5	133	6	172	2	2.1	1	0	
			No Signal	5	115	6	162	2	1.9	1	0	
V109A	12AU7	Picture 2d Det.	15000 Mu. V. Signal	1	-8.4	—	—	3	0	2	-1.3	
			No Signal	1	-1.8	—	—	3	0	2	-0.6	
V109B	12AU7	Vert. Sync Separator	15000 Mu. V. Signal	6	71	—	—	8	0	7	-40	
			No Signal	6	*50 to 100	—	—	8	0	7	*-15	*Unreliable, depends on noise

VOLTAGE CHART

17T200, 17T201, 17T202,
17T211, 17T220

Tube No.	Tube Type	Function	Operating Condition	E. Plate		E. Screen		E. Cathode		E. Grid		Notes on Measurements
				Pin No.	Volts	Pin No.	Volts	Pin No.	Volts	Pin No.	Volts	
V110	6CL6 *(6AC7) *(6AG7)	Video Amplifier	15000 Mu. V. Signal	6	130	8	149	1	0.2	4	-1.3	AGC control set for normal operation
			No Signal	6	110	8	130	1	0.5	4	-0.6	*Refer to Fig. 67 for socket connections
V111	6AU6	AGC Amplifier	15000 Mu. V. Signal	5	-40	6	250	7	153	1	151	
			No Signal	5	+2.3	6	258	7	135	1	105	
V112A	6SN7GT	Hor. Sync Separator	15000 Mu. V. Signal	2	263	-	-	3	190	1	130	
			No Signal	2	258	-	-	3	138	1	110	
V112B	6SN7GT	Sync Output	15000 Mu. V. Signal	5	58	-	-	6	0	4	-2.1	
			No Signal	5	48	-	-	6	0	4	* +0.6	*Depends on noise
V113	6J5	Vertical Oscillator	15000 Mu. V. Signal	3	70	-	-	8	0	5	-15	*Depends on setting of Vert. hold control
			No Signal	3	68	-	-	8	0	5	-14	Voltages shown are synced pix adjustment
V114	6K6GT	Vertical Output	15000 Mu. V. Signal	3	265	4	270	8	30	5	-5	
			No Signal	3	253	4	260	8	28	5	-5	
V115	6SN7GT	Horizontal Osc. Control	15000 Mu. V. Signal	2	165	-	-	3	+1.5	1	-21	
			No Signal	2	160	-	-	3	-10	1	-24	
V115	6SN7GT	Horizontal Oscillator	15000 Mu. V. Signal	5	185	-	-	6	0	4	-80	
			No Signal	5	170	-	-	6	0	4	-88	
V116	6BQ6GT	Horizontal Output	15000 Mu. V. Signal	Cap	*	4	180	8	21.2	5	-13	*High Voltage Pulse Present
			No Signal	Cap	*	4	170	8	21.0	5	-13	*High Voltage Pulse Present
V117	1B3GT 8016	H. V. Rectifier	15000 Mu. V. Signal	Cap	*	-	-	2 & 7	14,000	-	-	*High Voltage Pulse Present
			No Signal	Cap	*	-	-	2 & 7	13,600	-	-	*High Voltage Pulse Present
V118	6W4GT	Damper	15000 Mu. V. Signal	5	270	-	-	3	*	-	-	*High Voltage Pulse Present
			No Signal	5	260	-	-	3	*	-	-	*High Voltage Pulse Present
V119	21AP4	Kinescope	15000 Mu. V. Signal	Cap	14,000	10	400	11	170	2	120	At average Brightness
			No Signal	Cap	13,600	10	385	11	150	2	115	At average Brightness
V120 V121	5U4G 5Y3GT	Rectifiers	15000 Mu. V. Signal	4 & 6	-	-	-	2 & 8	285	-	-	
			No Signal	4 & 6	-	-	-	2 & 8	275	-	-	

17T200, 17T201, 17T202,
17T211, 17T220

R-F UNIT WIRING DIAGRAM

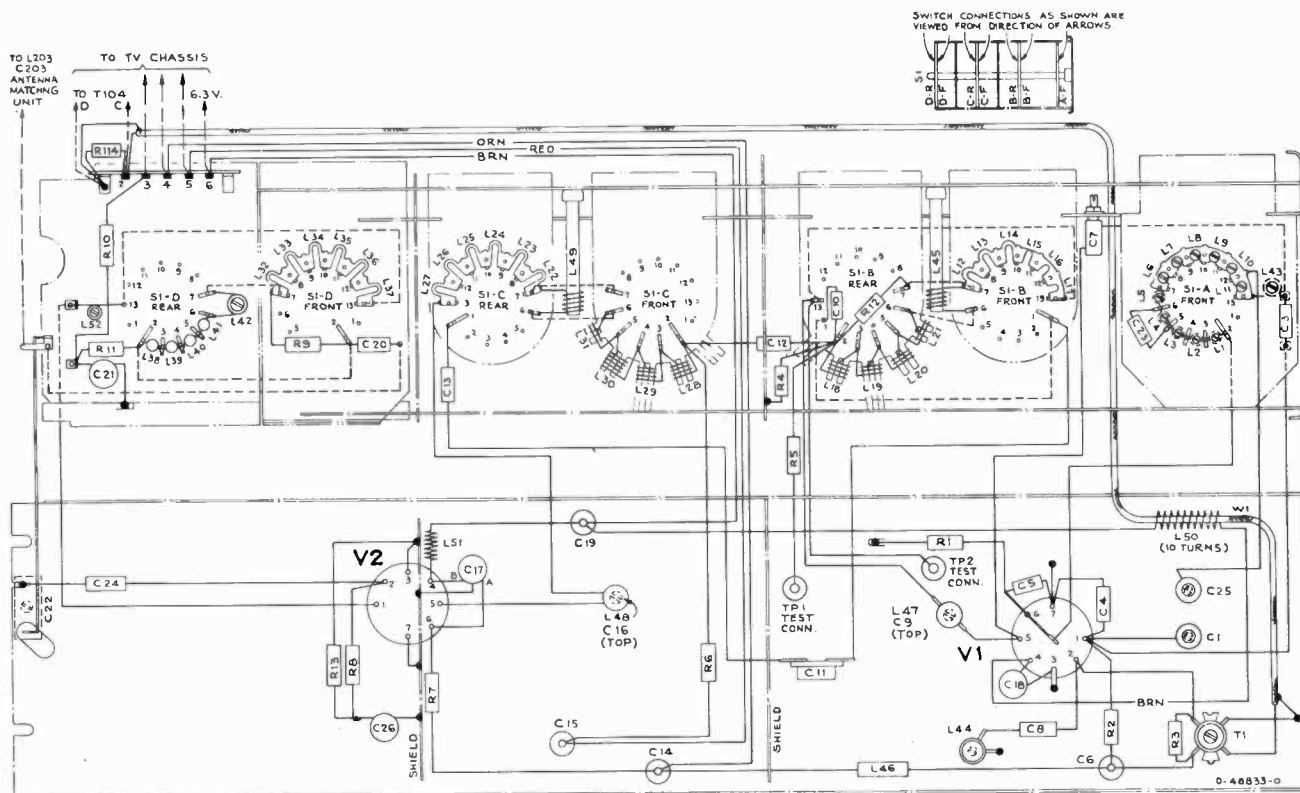

Figure 65—R-F Unit Wiring Diagram

CRITICAL LEAD DRESS:

- Keep all wiring in the pix i-f, sound i-f and video circuits as short as possible.
- Keep the leads on C118, C120, C122, C124, C126, R114, R121 and R123 as short and direct as possible.
- Do not run any leads under C115 trimmer capacitor.
- Dress C118 vertically parallel to terminals A and B of T104. Dress C135 parallel to terminals A and B of T104 close to the chassis.
- Keep C127 away from chassis with no more than $\frac{1}{4}$ inch leads at each end.
- Dress the lead from T105(C) to the terminal board, close to the chassis.
- Keep all filament leads dressed close to the chassis.
- Ground filaments of V106, V107 and V108 independently of tube shields (pin 8). Use ground lances provided near pins of each socket.
- Dress lead from pin 5 of V110 to J102-2 close to the chassis.
- Keep leads to L103 as short as possible.
- Dress C130, C132, L102, L104, L105, L114, R131, R133, R135 and R139 away from the chassis.
- Do not tape kinescope cathode lead in with other kinescope leads.
- Do not change the bus wire connections to pin 2 of V101 and V102. Sleeving is used to insure length and to prevent shorting.
- Keep leads on C136 short and direct. Dress the lead from C136 to pin 5 of V111 as shown in wiring diagram.
- Do not dress C170 in such a position that adjustment of T110 is inaccessible.
- Keep the leads on R201 as short and direct as possible.
- Dress the lead from pin 3 of V113 to C153 as shown in the wiring diagram.
- Mount C183 directly on the terminal board provided keeping it as far away from T109 as possible.
- Dress all leads in the high voltage compartment away from each other and away from the high voltage transformer.

REPLACEMENT PARTS (Continued)

17T200, 17T201, 17T202,
17T211, 17T220

STOCK No.	DESCRIPTION	STOCK No.	DESCRIPTION
76633	Magnet—Pin cushion correction magnet complete with support arm	503427	270,000 ohms, $\pm 10\%$, $\frac{1}{2}$ watt (R157)
76464	Plate—Hi-voltage plate (bakelite) assembly complete with tube socket and corona ring	503433	330,000 ohms, $\pm 10\%$, $\frac{1}{2}$ watt (R111, R188)
76796	Resistor—Wire wound, 5.1 ohms, $\frac{1}{3}$ watt (R205)	512433	330,000 ohms, $\pm 5\%$, 1 watt (R190)
76639	Resistor—Wire wound, 180 ohms, 2 watts (R202)	503439	390,000 ohms, $\pm 10\%$, $\frac{1}{2}$ watt (R168)
76988	Resistor—Wire wound, 820 ohms, 1 watt (R113)	503447	470,000 ohms, $\pm 10\%$, $\frac{1}{2}$ watt (R150, R200)
76469	Resistor—Wire wound, 2500 ohms, 10 watts (R115)	504447	470,000 ohms, $\pm 20\%$, $\frac{1}{2}$ watt (R112, R147)
76989	Resistor—Wire wound, 4650 ohms, 7 watts (R116)	503456	560,000 ohms, $\pm 10\%$, $\frac{1}{2}$ watt (R148, R171)
503033	Resistor—Fixed, composition— 33 ohms, $\pm 10\%$, $\frac{1}{2}$ watt (R130)	503468	680,000 ohms, $\pm 10\%$, $\frac{1}{2}$ watt (R154, R161)
502039	39 ohms, $\pm 5\%$, $\frac{1}{2}$ watt (R122)	503482	820,000 ohms, $\pm 10\%$, $\frac{1}{2}$ watt (R189, R199)
502047	47 ohms, $\pm 5\%$, $\frac{1}{2}$ watt (R119)	503510	1 megohm, $\pm 10\%$, $\frac{1}{2}$ watt (R155)
503047	47 ohms, $\pm 10\%$, $\frac{1}{2}$ watt (R105)	502511	1.1 megohm, $\pm 5\%$, $\frac{1}{2}$ watt (R136)
504047	47 ohms, $\pm 20\%$, $\frac{1}{2}$ watt (R201)	503512	1.2 megohm, $\pm 10\%$, $\frac{1}{2}$ watt (R180)
503082	82 ohms, $\pm 10\%$, $\frac{1}{2}$ watt (R101)	503515	1.5 megohm, $\pm 10\%$, $\frac{1}{2}$ watt (R172)
502118	180 ohms, $\pm 5\%$, $\frac{1}{2}$ watt (R125)	11769	1.8 megohm, $\pm 5\%$, $\frac{1}{2}$ watt (R140)
503139	390 ohms, $\pm 10\%$, $\frac{1}{2}$ watt (R182)	39063	1.8 megohm, $\pm 5\%$, 1 watt (R197)
503147	470 ohms, $\pm 10\%$, $\frac{1}{2}$ watt (R114)	503522	2.2 megohm, $\pm 10\%$, $\frac{1}{2}$ watt (R126, R159)
513156	560 ohms, $\pm 10\%$, 1 watt (R207)	504610	10 megohm, $\pm 20\%$, $\frac{1}{2}$ watt (R110)
504210	1000 ohms, $\pm 20\%$, $\frac{1}{2}$ watt (R102, R118, R120, R124, R127)	71456	Screw—#8-32 x 7/16" wing screw to mount deflection yoke
503222	2200 ohms, $\pm 10\%$, $\frac{1}{2}$ watt (R104, R212)	76455	Shaft—Connecting shaft (nylon) for picture and brightness controls
523222	2200 ohms, $\pm 10\%$, 2 watts (R131)	73584	Shield—Tube shield for V101, V102, V103, V108
504233	3300 ohms, $\pm 20\%$, $\frac{1}{2}$ watt (R211)	76972	Shield—Tube shield for V109
523223	3300 ohms, $\pm 10\%$, 2 watts (R131)	75718	Socket—Channel indicator lamp socket and leads
502239	3900 ohms, $\pm 5\%$, $\frac{1}{2}$ watt (R129, R164)	74834	Socket—Kinescope socket
503239	3900 ohms, $\pm 10\%$, $\frac{1}{2}$ watt (R194)	31251	Socket—Tube socket, octal, wafer for V105, V110, V112, V113, V116, V120, V121 for KCS72 (KCS72 uses 6AG7 for V110)
503256	5600 ohms, $\pm 10\%$, $\frac{1}{2}$ watt (R138)	71508	Socket—Tube socket, 6 pin, moulded—for V117
523268	6800 ohms, $\pm 10\%$, 2 watts (R203)	50367	Socket—Tube socket, 6 pin, moulded, saddle mounted for V118
503282	8200 ohms, $\pm 10\%$, $\frac{1}{2}$ watt (R176, R179)	73117	Socket—Tube socket, 7 pin, wafer miniature for V101, V102, V103, V104, V106, V107, V108, V111
513282	8200 ohms, $\pm 10\%$, 1 watt (R165)	76453	Socket—Tube socket, octal, moulded, saddle-mounted for V110 for KCS72-M1 (KCS72-M1 uses 6AG7 for V110)
502310	10,000 ohms, $\pm 5\%$, $\frac{1}{2}$ watt (R107, R108, R123)	50367	Socket—Tube socket, 8 pin, moulded saddle-mounted for V114
504310	10,000 ohms, $\pm 20\%$, $\frac{1}{2}$ watt (R152)	72627	Socket—Tube socket, 8 pin, steatite saddle mounted for V115
502312	12,000 ohms, $\pm 5\%$, $\frac{1}{2}$ watt (R121)	76971	Socket—Tube socket, 9 pin, wafer miniature for V109
503312	12,000 ohms, $\pm 10\%$, $\frac{1}{2}$ watt (R145)	77470	Socket—Tube socket, 9 pin, miniature, wafer for V110 for KCS72-M2 (KCS72-M2 uses 6CL6 for V110)
523312	12,000 ohms, $\pm 10\%$, 2 watts (R135)	76636	Stud—Adjusting stud complete with guard for focus magnet
503315	15,000 ohms, $\pm 10\%$, $\frac{1}{2}$ watt (R153)	77011	Switch—Tone control and phono switch less volume control and power switch (S101)
503318	18,000 ohms, $\pm 10\%$, $\frac{1}{2}$ watt (R128, R158, R166, R196)	76463	Terminal—Screw type grounding terminal
523318	18,000 ohms, $\pm 10\%$, 2 watts (R133)	76977	Transformer—Antenna matching transformer complete (T200, C200, C201, C202, C203, L200, L201, L202, L203, J200)
503322	22,000 ohms, $\pm 10\%$, $\frac{1}{2}$ watt (R167, R217)	76795	Transformer—Hi-voltage transformer (T111)
513322	22,000 ohms, $\pm 10\%$, 1 watt (R193)	76440	Transformer—Horizontal oscillator transformer complete with adjustable cores (T110)
503327	27,000 ohms, $\pm 10\%$, $\frac{1}{2}$ watt (R215)	76982	Transformer—Output transformer (T103)
513327	27,000 ohms, $\pm 10\%$, 1 watt (R218)	76984	Transformer—Power transformer, 117 volts 60 cycle (T109)
513333	33,000 ohms, $\pm 10\%$, 1 watt (R214)	77112	Transformer—Ratio detector transformer (T102, C105)
503339	39,000 ohms, $\pm 10\%$, $\frac{1}{2}$ watt (R106, R142)	76981	Transformer—Sound i-f transformer complete with adjustable core (T101, C102, C103, R103)
513339	39,000 ohms, $\pm 10\%$, 1 watt (R132)	76978	Transformer—Vertical output transformer (T108)
503347	47,000 ohms, $\pm 10\%$, $\frac{1}{2}$ watt (R160)	76979	Transformer—First pix, i-f transformer complete with adjustable cores (T104, C116, R117)
504347	47,000 ohms, $\pm 20\%$, $\frac{1}{2}$ watt (R144)	76980	Transformer—Second, third or fourth pix i-f transformer complete with adjustable core (T105, T106, T107)
512347	47,000 ohms, $\pm 5\%$, 1 watt (R148)	75449	Trap—FM trap complete with adjustable core and stud (L203, C203)
513347	47,000 ohms, $\pm 10\%$, $\frac{1}{2}$ watt (R132)	75242	Trap—I-F trap (L200, L201, C200, C201)
503356	56,000 ohms, $\pm 10\%$, $\frac{1}{2}$ watt (R146, R185, R204)	76983	Trap—4.5 MC trap (L103, C128)
512356	56,000 ohms, $\pm 5\%$, 1 watt (R178)	76616	Yoke—Deflection yoke complete with 6 contact male connector (L109, L110, L111, L112, C181, P103, R208, R209, R210)
503368	68,000 ohms, $\pm 10\%$, $\frac{1}{2}$ watt (R219)	SPEAKER ASSEMBLIES	
513368	68,000 ohms, $\pm 10\%$, 1 watt (R192)	971636-1W RL-101CS RMA-274	
513382	82,000 ohms, $\pm 10\%$, 1 watt (R191)	(For Models 17T200, 17T201 & 17T202)	
504410	100,000 ohms, $\pm 20\%$, $\frac{1}{2}$ watt (R213)	77000	Speaker—5" P.M. speaker complete with cone and voice coil (3.2 ohms)
513410	100,000 ohms, $\pm 10\%$, 1 watt (R175)		
30180	120,000 ohms, $\pm 5\%$, $\frac{1}{2}$ watt (R143)		
503415	150,000 ohms, $\pm 10\%$, $\frac{1}{2}$ watt (R174, R183, R187)		
504415	150,000 ohms, $\pm 20\%$, $\frac{1}{2}$ watt (R139)		
512415	150,000 ohms, $\pm 5\%$, 1 watt (R195)		
502418	180,000 ohms, $\pm 5\%$, $\frac{1}{2}$ watt (R141)		
502427	270,000 ohms, $\pm 5\%$, $\frac{1}{2}$ watt (R177)		

17T200, 17T201, 17T202,
17T211, 17T220

REPLACEMENT PARTS (Continued)

STOCK No.	DESCRIPTION	STOCK No.	DESCRIPTION	
SPEAKER ASSEMBLIES				
	971490-3W RL-105E6 RMA-274	76598	Knob—Tone control and phono switch knob—maroon—(outer)	
	(For Models 17T211 & 17T220)	77264	Knob—Brightness control or vertical hold control knob—ebony—(outer)	
		77261	Knob—Channel selector knob—ebony—(inner)	
75024	Cone—Cone and voice coil (3.2 ohms)	77262	Knob—Fine tuning control knob—ebony—(outer)	
75022	Speaker—8" P.M. speaker complete with cone and voice coil (3.2 ohms)	77265	Knob—Picture control, horizontal hold control or volume control and power switch knob—ebony—(inner)	
	NOTE: If stamping on speaker in instruments does not agree with above speaker number, order replacement parts by referring to model number of instrument, number stamped on speaker and full description of part required.	77263	Knob—Tone control and phono switch knob—ebony—(outer)	
	MISCELLANEOUS		11765	Lamp—Channel marker escutcheon lamp—Mazda #51
77189	Back—Cabinet back complete for Models 17T200, 17T201, 17T202	75459	Mask—Channel marker escutcheon light mask—burgundy	
77190	Back—Cabinet back complete for Models 17T211, 17T220	76589	Mask—Channel marker escutcheon light mask—beige	
76184	Board—"Antenna" terminal board.	77267	Mask—Channel marker escutcheon light mask—ebony	
76811	Bracket—Hanger bracket for deflection yoke hood for Models 17T200, 17T201, 17T202	76177	Nut—#10-32 special nut for deflection yoke hood support rods (2 req'd)	
77001	Bracket—Hanger bracket for deflection yoke hood for Model 17T211	76822	Nut—Speed nut to lock flexible straps for kinescope	
76812	Bracket—Hanger bracket for deflection yoke hood for Model 17T220	77013	Nut—Speed nut for fastening "RCA Victor" emblem on metal panel for Models 17T202, 17T211 & 17T220	
76814	Bracket—Stiffening bracket for kinescope cradle (4 req'd) for Models 17T200, 17T201, 17T202	73634	Nut—Speed nut for speaker mounting screws for Model 17T211	
76829	Bracket—Stiffening bracket for kinescope cradle for Models 17T211, 17T220	76825	Pad—Rubber pad (channel) mounted on cradle support to cushion Kinescope	
71892	Catch—Bullet catch and strike for Model 17T220	76819	Pad—Rubber pad (channel) for flexible straps (2 req'd)	
76823	Clip—Spring clip for spacing ground braid	77005	Panel—Metal front panel for mahogany or walnut instruments for Models 17T211 & 17T220	
X3128	Cloth—Grille cloth for Models 17T201, 17T202	77260	Panel—Metal front panel for blonde instruments for Model 17T211	
X3199	Cloth—Grille cloth for mahogany cabinet for Model 17T211	77187	Pull—Door pull for television compartment doors for Model 17T220	
X1756	Cloth—Grille cloth for mahogany and walnut instruments for Model 17T220	77188	Pull—Door pull for false door (2 req'd) for Model 17T220	
75474	Connector—Single contact male connector for antenna cable (2 req'd)	77002	Retainer—Safety glass retainer (2 req'd) for maroon, mahogany or walnut instruments	
39153	Connector—4 contact male connector for antenna cable	76816	Retainer—Safety glass retainer (2 req'd) for blonde instruments	
71457	Cord—Power cord and plug	76809	Rod—"L" shape threaded rod to support deflection yoke hood assembly (2 req'd) for Models 17T200, 17T201 & 17T202	
76818	Cushion—Rubber cushion (1/16" x 1" x 3/8" x 1/4") for kinescope and cradle support (4 req'd)	76810	Rod—"L" shape threaded rod to support deflection yoke hood assembly (2 req'd) for Models 17T211 & 17T220	
77014	Decal—Control panel function decal for mahogany or walnut instruments for Models 17T201, 17T202, 17T211 & 17T220	76632	Screw—#8 x 3/8" hex head screw for mounting front panel or hanger bracket for Models 17T211 & 17T220	
71984	Decal—Trade mark decal for Model 17T220	74113	Screw—#8-32 x 1" trinit head screw for door pull for Model 17T220	
77012	Emblem—"RCA Victor" emblem for Models 17T202, 17T211, 17T220	76821	Screw—#10 x 1 3/8" hex head screw to lock flexible straps for kinescope	
75456	Escutcheon—Channel marker escutcheon—gold	76808	Sleeve—Polyethylene sleeve for insulating high voltage lead—on support rod	
74889	Foot—Felt foot (4 req'd) for Models 17T200, 17T201 & 17T202	73643	Spring—Channel marker escutcheon spring clip	
76806	Glass—Safety glass	76820	Spring—Formed spring for safety glass retainers	
74308	Hinge—Cabinet door hinge (1 set) for Model 17T220	77006	Spring—Retaining spring for deflection yoke hood support rods	
76595	Knob—Brightness control or vertical hold control knob—maroon—(outer)	30330	Spring—Retaining spring for knobs 74963, 75464, 77265	
76593	Knob—Channel selector knob—maroon—(inner)	72845	Spring—Retaining spring for knobs 76591, 76592, 77262	
76591	Knob—Fine tuning control knob—maroon—(outer)	76837	Spring—Retaining spring for knobs 76593, 76594, 76595, 76596, 76597, 76598, 77261, 77264, 77263	
74963	Knob—Picture control, horizontal hold control or volume control and power switch knob—maroon—(inner)	74936	Spring—Suspension spring for kinescope socket leads	
76597	Knob—Tone control and phono switch knob—maroon—(outer)	36580	Spring—Suspension spring (coil) for ground braid	
76596	Knob—Brightness control or vertical hold control knob—beige—(outer)	72936	Stop—Cabinet door stop for Model 17T220	
76594	Knob—Channel selector knob—beige—(inner)	76813	Strap—Flexible steel strap to secure kinescope	
76592	Knob—Fine tuning control knob—beige—(outer)	76600	Strap—Ground strap (.005" x 1/2" soft copper strip) for Models 17T211 & 17T220	
75464	Knob—Picture control, horizontal hold control or volume control and power switch knob—beige—(inner)	77003	Support—Cradle support for kinescope	
		76836	Washer—Cellulose washer—gold—for knobs	
		75457	Washer—Felt washer—dark brown—between knob and channel marker escutcheon	
		75458	Washer—Felt washer—beige—between knob and channel marker escutcheon	
		77266	Washer—Felt washer—ebony—between knob and channel marker escutcheon	
		75500	Washer—Felt washer for cabinet back mounting screws	

CHASSIS WIRING DIAGRAM

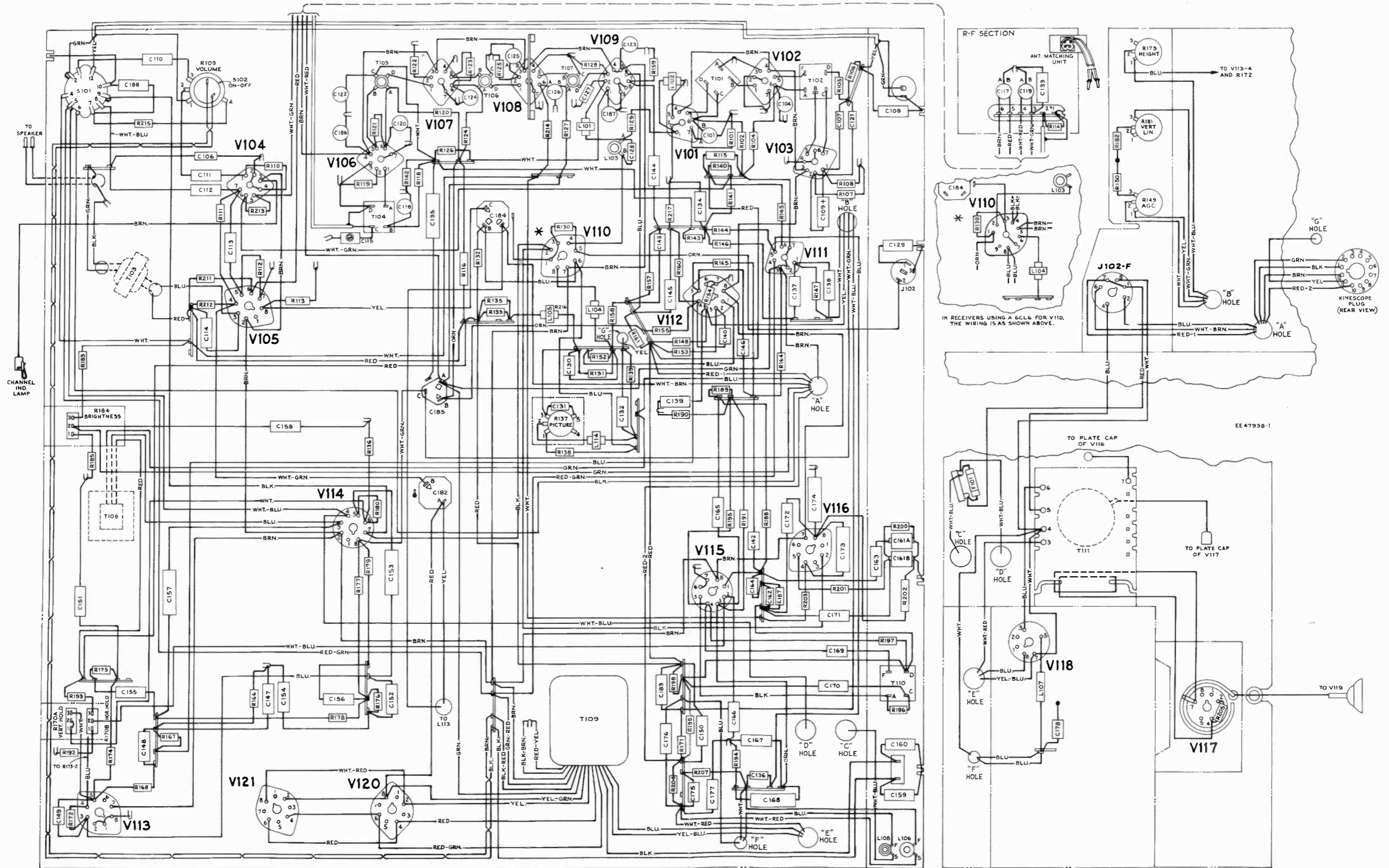
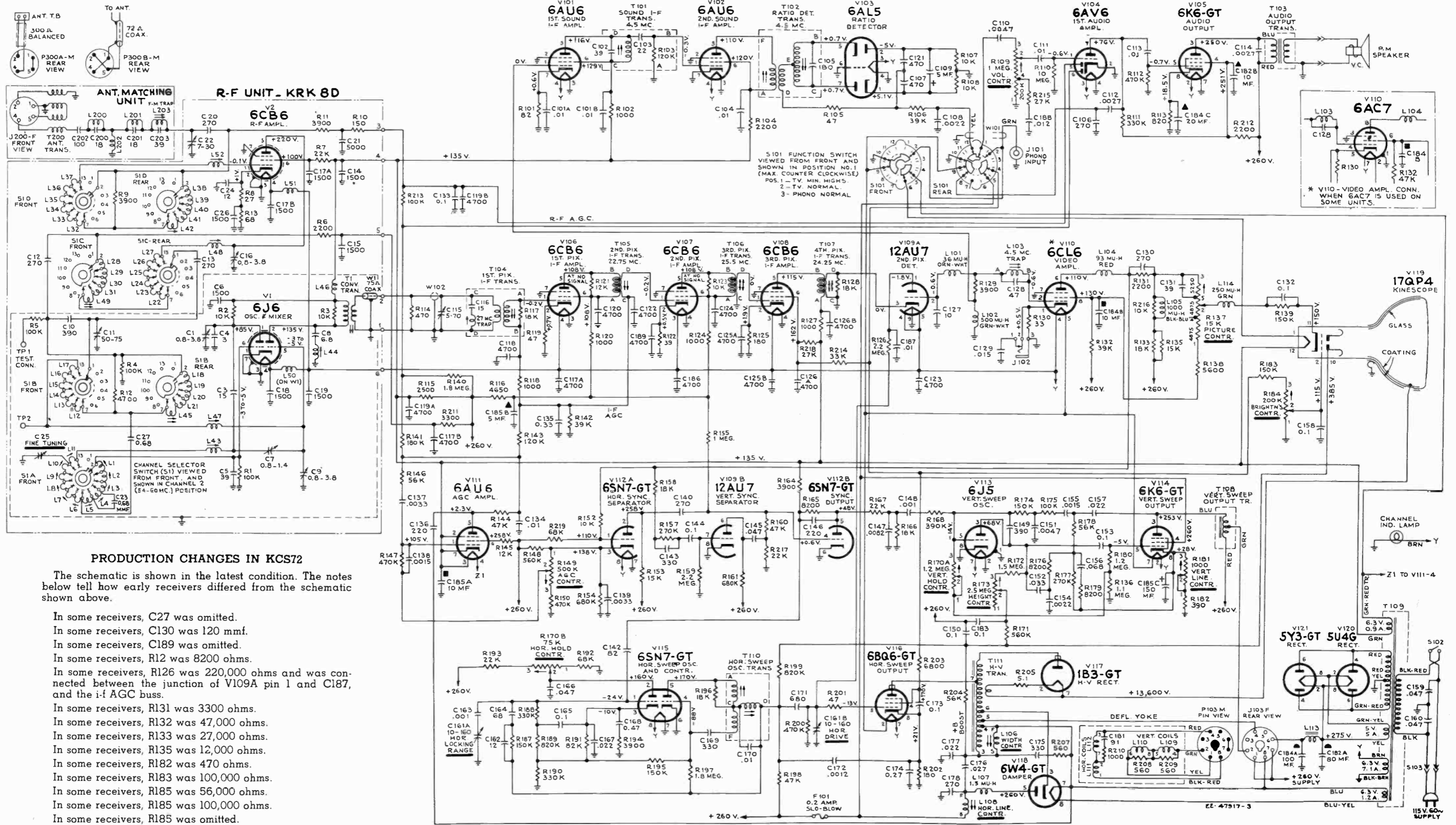

Figure 66—Chassis Wiring Diagram

CIRCUIT SCHEMATIC DIAGRAM KCS72M2



PRODUCTION CHANGES IN KCS72

The schematic is shown in the latest condition. The notes below tell how early receivers differed from the schematic shown above.

- In some receivers, C27 was omitted.
- In some receivers, C130 was 120 mmf.
- In some receivers, C189 was omitted.
- In some receivers, R12 was 8200 ohms.
- In some receivers, R126 was 220,000 ohms and was connected between the junction of V109A pin 1 and C187, and the i-f AGC buss.
- In some receivers, R131 was 3300 ohms.
- In some receivers, R132 was 47,000 ohms.
- In some receivers, R133 was 27,000 ohms.
- In some receivers, R135 was 12,000 ohms.
- In some receivers, R182 was 470 ohms.
- In some receivers, R183 was 100,000 ohms.
- In some receivers, R185 was 56,000 ohms.
- In some receivers, R185 was 100,000 ohms.
- In some receivers, R185 was omitted.
- In some receivers, R218 was omitted.
- In some receivers, R219 was omitted.
- In some receivers, V119-10 was connected to the junction of R171 and C183.

All resistance values in ohms. K=1000.
All capacitance values less than 1 in MF and above 1 in MMF unless otherwise noted.

Direction of arrows at controls indicates clockwise rotation.

All voltages measured with "VoltOhmyst" and with no signal input. Voltages should hold within ±20% with 117 v. a-c supply.

* In KCS72 V110 was a 6AC7. In KCS72M1 V110 was a 6AG7 (same pin connections as 6AC7).

Figure 67—Circuit Schematic Diagram

17T200, 17T201, 17T202,
17T211, 17T220

REPLACEMENT PARTS

STOCK No.	DESCRIPTION	STOCK No.	DESCRIPTION
	R-F UNIT ASSEMBLIES		
	KRK8D	75164	Rod—Actuating plunger rod (fibre) for fine tuning link
75188	Board—Terminal board, 5 contact and ground	71476	Screw—#4-40 x 1/4" adjusting screw for L6, L7, L8, L9, L10, L11
76845	Bracket—Vertical bracket for holding oscillator tube shield	75177	Screw—#4-40 x 3/8" adjusting screw for L1, L2, L3, L4, L43
75201	Cable—75 ohm coax cable (7/4") complete with coil (W1, L50)	75176	Screw—#4-40 x 7/16" adjusting screw for L5
76965	Capacitor—Ceramic, variable for fine tuning—plunger type (C25)	73640	Screw—#4-40 x 7/16" adjusting screw for L52
71088	Capacitor—Headed Lead, 0.68 mmf. (C27)	74575	Screw—#4-40 x .359" adjusting screw for L42
76968	Capacitor—Ceramic, 3 mmf. (C4)	76519	Shaft—Channel selector shaft and plate
75200	Capacitor—Ceramic, 12 mmf. (C24)	76134	Shaft—Fine tuning shaft and cam
45465	Capacitor—Ceramic, 15 mmf. (C3)	76962	Shield—Oscillator and converter sections shield—snap-on type
75196	Capacitor—Ceramic, 39 mmf. (C5)	76967	Shield—Tube shield for V1, V2
75199	Capacitor—Ceramic, 270 mmf. (C12, C13, C20)	75088	Socket—Tube socket, 7 contact, miniature, ceramic, saddle-mounted
75641	Capacitor—Ceramic, 390 mmf. (C10)	75191	Spacer—Insulating spacer for front plate
75166	Capacitor—Ceramic, 1500 mmf. (C6, C14, C15, C19)	75163	Spring—Friction spring (formed) for fine tuning cam
73748	Capacitor—Ceramic, 1500 mmf. (C18, C26)	30340	Spring—Hair pin spring for fine tuning link
75089	Capacitor—Ceramic, dual 1500 mmf. (C17A, C17B)	74578	Spring—Retaining spring for adjusting screws
73473	Capacitor—Ceramic, 5000 mmf. (C21)	76961	Spring—Retaining spring for oscillator tube shield
75172	Capacitor—Tubular, steatite, adjustable, 0.65 - 1.2 mmf. (C7)	73457	Spring—Return spring for fine tuning control
71504	Capacitor—Ceramic, 0.68 mmf. (C23)	75180	Stator—Antenna stator complete with rotor, coils, capacitors (C20, C21) and resistors (R9, R10, R11) (S1-4, C20, C21, L32, L33, L34, L35, L36, L37, L38, L39, L40, L41, L42, L52, R9, R10, R11)
75184	Capacitor—Ceramic, adjustable, 0.75 - 4 mmf., complete with adjusting stud (C1)	77459	Stator—Converter stator complete with rotor, coils, capacitors and resistors (S1-2, C10, C12, L12, L13, L14, L15, L16, L17, L18, L19, L20, L21, L45, R4, R5, R12)
75197	Capacitor—Ceramic, 6.8 mmf. (C8)	76963	Stator—Oscillator section stator complete with rotor, segment, coils, adjusting screws and capacitors C3, C23 (S1-1, C3, C23, L1, L2, L3, L4, L5, L6, L7, L8, L9, L10, L11, L43)
75189	Capacitor—Adjustable, 7-30 mmf. (C22)	76964	Stator—R-F amplifier stator complete with rotor, coils, capacitors (C13) and resistor (R6) (S1-3, C13, L22, L23, L24, L25, L26, L27, L28, L29, L30, L31, L49, R6)
75174	Capacitor—Ceramic, trimmer, 50-75 mmf. (C11)	75170	Strip—Coil segment mounting strip—L.H. lower
76143	Clip—Tubular clip for mounting stand-off capacitors	75171	Strip—Coil segment mounting strip—L.H. upper—less trimmer C7
73477	Coil—Choke coil (L51)	75169	Strip—Coil segment mounting strip—R.H. center
75202	Coil—Choke coil, .56 muh (L46)	75446	Stud—Capacitor stud—brass—#4-40 x 3/16" with 3/64" screw driver slot for trimmer coils L47, L48 and capacitor C1 uncoded and coded "ER"
75185	Coil—Converter plate loading coil (L44)	75447	Stud—Capacitor stud—brass—#4-40 x 3/16" with 3/64" screw driver slot for trimmer coils L47, L48 and capacitor C1 coded numerically and "Hi-Q"
75182	Coil—Trimmer coil (1 1/2 turns) with adjustable inductance core and capacitor stud (screw adjustment) for converter section (C9, L47)	75173	Stud—#6-32 x 13/16" adjusting stud for trimmer C7
75183	Coil—Trimmer coil (3 turns) with adjustable inductance core and capacitor stud (screw adjustment) for r-f section (L48, C16)	75181	Transformer—Converter transformer (T1)
76460	Contact—Test point contact	75607	Washer—Insulating washer (hex)
76966	Core—Adjustable core for fine tuning capacitor	75190	Washer—Insulating washer (neoprene) for trimmer C7
75162	Detent—Detent mechanism and fibre shaft		
73453	Form—Coil form for L45, L49		CHASSIS ASSEMBLIES
75165	Link—Link assembly for fine tuning		KCS72
76518	Plate—Front plate and shaft bearing Resistor—Fixed, composition—		
503027	27 ohms, ±10%, 1/2 watt (R8)	76456	Bracket—Channel indicator lamp bracket
503068	68 ohms, ±10%, 1/2 watt (R13)	76454	Bracket—Mounting bracket complete with insulator for picture control
504115	150 ohms, ±20%, 1/2 watt (R10)	71496	Capacitor—Adjustable, mica, 5-70 mmf. (C115)
503222	2200 ohms, ±10%, 1/2 watt (R6)	33098	Capacitor—Ceramic, 10 mmf. (C127)
503239	3900 ohms, ±10%, 1/2 watt (R9, R11)	33380	Capacitor—Ceramic, 12 mmf. (C162)
503247	4700 ohms, ±10%, 1/2 watt (R12)	75450	Capacitor—Ceramic, 39 mmf. (C203)
502310	1000 ohms, ±5%, 1/2 watt (R3)	73664	Capacitor—Ceramic, 39 mmf. (C131)
504310	10,000 ohms, ±20%, 1/2 watt (R2)	76475	Capacitor—Mica, 68 mmf. (C164)
503322	22,000 ohms, ±10%, 1/2 watt (R7)	76474	Capacitor—Mica, 82 mmf. (C142)
504410	100,000 ohms, ±20%, 1/2 watt (R1, R4, R5)	75437	Capacitor—Ceramic, 100 mmf. (C202)
14343	Retainer—Fine tuning shaft retaining ring		

17T200, 17T201, 17T202,
17T211, 17T220

REPLACEMENT PARTS (Continued)

STOCK No.	DESCRIPTION	STOCK No.	DESCRIPTION
76673	Capacitor—Ceramic, 220 mmf. (C136)	73553	Capacitor—Tubular, paper, oil impregnated, .047 mfd., 400 volts (C145, C166)
75248	Capacitor—Mica, 220 mmf. (C146)	75071	Capacitor—Tubular, moulded paper, .047 mfd., 400 volts (C159, C160)
47617	Capacitor—Ceramic, 270 mmf. (C106)	73792	Capacitor—Tubular, paper, oil impregnated, .068 mfd., 400 volts (C156)
39638	Capacitor—Mica, 270 mmf. (C130)	73784	Capacitor—Tubular, paper, oil impregnated, 0.1 mfd., 200 volts (C132, C133)
73091	Capacitor—Mica, 270 mmf. (C140, C178)	73551	Capacitor—Tubular, paper, oil impregnated, 0.1 mfd., 400 volts (C144, C150, C158, C165, C183)
76476	Capacitor—Mica, 330 mmf. (C169, C175)	73557	Capacitor—Tubular, paper, oil impregnated, 0.1 mfd., 600 volts (C153, C173)
39640	Capacitor—Mica, 330 mmf. (C143)	73786	Capacitor—Tubular, paper, oil impregnated, 0.27 mfd., 200 volts (C174)
73094	Capacitor—Mica, 390 mmf. (C149)	76994	Capacitor—Tubular, paper, oil impregnated, 0.33 mfd., 200 volts (C135)
39644	Capacitor—Mica, 470 mmf. (C107, C121)	73787	Capacitor—Tubular, paper, oil impregnated, 0.47 mfd., 200 volts (C168)
76990	Capacitor—Ceramic, dual 4700 mmf. (C117A, C117B, C119A, C119B, C125A, C125B, C126A, C126B)	76498	Choke—Filter choke (L113)
73473	Capacitor—Ceramic, 4700 mmf. (C118, C120, C122, C123, C124, C186, C189)	73591	Coil—Antenna matching coil (2 req'd) (Part of T200)
73960	Capacitor—Ceramic, 10,000 mmf. (C104, C187)	75241	Coil—Antenna shunt coil (L202)
76991	Capacitor—Ceramic, dual 10,000 mmf. (C101A, C101B)	76442	Coil—Horizontal linearity coil complete with adjustable core (L108)
74521	Capacitor—Electrolytic, 5 mfd., 50 volts (C109)	76441	Coil—Width coil complete with adjustable core (L106)
75218	Capacitor—Electrolytic, comprising 1 section of 10 mfd., 350 volts, 1 section of 5 mfd., 350 volts and 1 section of 150 mfd., 50 volts (C185A, C185B, C185C)	76640	Coil—Peaking coil (1.5 muh) (L107)
75217	Capacitor—Mica trimmer, dual 10-160 mmf. (C161A, C161B)	76011	Coil—Peaking coil (36 muh) (L101)
76987	Capacitor—Electrolytic, comprising 1 section of 80 mfd., 400 volts and 1 section of 10 mfd., 350 volts (C182A, C182B)	71527	Coil—Peaking coil (93 muh) (L104)
76970	Capacitor—Electrolytic comprising 1 section of 100 mfd., 400 volts, 1 section of 10 mfd., 350 volts and 1 section of 20 mfd., 50 volts (C184A, C184B, C184C)	71526	Coil—Peaking coil (250 muh) (L114)
76479	Capacitor—Tubular, moulded paper, oil impregnated, .00068 mfd., 600 volts (C171)	75252	Coil—Peaking coil (500 muh) (L102)
75643	Capacitor—Tubular, paper, oil impregnated, .001 mfd., 1000 volts (C148, C163)	77124	Coil—Peaking coil (1000 muh) (L105, R216)
76995	Capacitor—Tubular, moulded paper, oil impregnated, .0012 mfd., 600 volts (C172)	71789	Connector—Anode lead connector complete
76508	Capacitor—Tubular, paper, oil impregnated, .0015 mfd., 600 volts (C138)	35787	Connector—Phono input connector (J101)
77123	Capacitor—Tubular, moulded paper, oil impregnated, .0015 mfd., 1000 volts (C155)	75474	Connector—Single contact male connector for speaker cable
73595	Capacitor—Tubular, paper, oil impregnated, .0022 mfd., 600 volts (C108, C154)	75482	Connector—Video connector (J102)
73599	Capacitor—Tubular, paper, oil impregnated, .0027 mfd., 600 volts (C112)	74594	Connector—2 contact male connector for power cord
73818	Capacitor—Tubular, paper, oil impregnated, .0027 mfd., 1600 volts (C114)	38853	Connector—4 contact female connector for antenna transformer (J200)
73795	Capacitor—Tubular, paper, oil impregnated, .0033 mfd., 600 volts (C137, C139)	50367	Connector—6 contact female connector for yoke lead (J103)
73920	Capacitor—Tubular, paper, oil impregnated, .0047 mfd., 600 volts (C110, C151)	75542	Connector—6 contact male connector—part of deflection yoke (P103)
73808	Capacitor—Tubular, paper, oil impregnated, .0082 mfd., 1000 volts (C147)	76975	Control—AGC control (R149)
73561	Capacitor—Tubular, paper, oil impregnated, .01 mfd., 400 volts (C111, C113, C134)	76444	Control—Brightness control (R184)
73594	Capacitor—Tubular, moulded paper, oil impregnated, .01 mfd., 600 volts (C170)	76448	Control—Height control (R173)
74938	Capacitor—Tubular, paper, oil impregnated, .012 mfd., 200 volts (C188)	76974	Control—Horizontal and vertical hold control (R170A, R170B)
73797	Capacitor—Tubular, paper, oil impregnated, .015 mfd., 600 volts (C129)	76445	Control—Picture control (R137)
73562	Capacitor—Tubular, paper, oil impregnated, .022 mfd., 400 volts (C167)	76976	Control—Vertical linearity control (R181)
73798	Capacitor—Tubular, paper, oil impregnated, .022 mfd., 600 volts (C157)	77010	Control—Volume control and power switch (R109, S102)
73810	Capacitor—Tubular, paper, oil impregnated, .022 mfd., 1000 volts (C177)	71498	Core—Adjustable core and stud for FM trap 75449
73811	Capacitor—Tubular, paper, oil impregnated, .027 mfd., 1000 volts (C176)	76986	Cover—Back cover for hi-voltage compartment
73596	Capacitor—Tubular, paper, oil impregnated, .033 mfd., 1000 volts (C152)	76985	Cover—Side cover for hi-voltage compartment
		74956	Cushion—Rubber cushion for deflection yoke hood
		74839	Fastener—Push fastener for mounting tube socket 76453
		73600	Fuse—0.25 amps., 250 volts (F101)
		37396	Grommet—Rubber grommet for mounting tube socket 76453
		76459	Grommet—Rubber grommet for 2nd. anode lead exit
		76830	Hood—Deflection yoke hood less rubber cushions
		76168	Magnet—Focus magnet
		76141	Magnet—Ion trap magnet (P.M. type)



RCA VICTOR

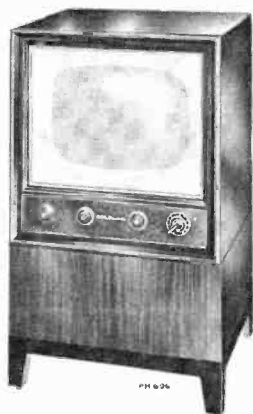

Model 17T250DE
"Brett"
Walnut, Mahogany
Shown on Base

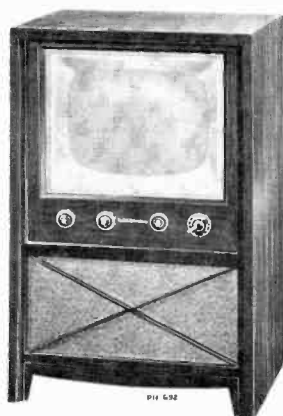

Model 17T261DE
"Ainsworth"
Walnut, Mahogany, Blonde

TELEVISION RECEIVERS MODELS 17T250DE, 17T261DE

Chassis No. KCS74 or KCS74M1

— Mfr. No. 274 —

SERVICE DATA

— 1952 No. T3 —

PREPARED BY RCA SERVICE CO., INC.
FOR
RADIO CORPORATION OF AMERICA
RCA VICTOR DIVISION
CAMDEN, N. J., U. S. A.

GENERAL DESCRIPTION

Models 17T250DE and 17T261DE are deluxe "17 inch" television receivers. The receivers are identical except for cabinets, and speakers.

Features of the television unit are: full twelve channel coverage; "totem" r-f amplifier; intercarrier FM sound system; ratio detector; 40 mc picture i-f; improved picture brilliance;

pulsed picture A-G-C; A-F-C horizontal hold; stabilized vertical hold; compensated video gain control; noise saturation circuits; improved sync separator and clipper; four mc. band width for picture channel and reduced hazard high voltage supply. An auxiliary audio input jack is provided to permit the use of an external record playing attachment.

ELECTRICAL AND MECHANICAL SPECIFICATIONS

PICTURE SIZE.....146 square inches on a 17QP4 Kinescope

TELEVISION R-F FREQUENCY RANGE

All 12 television channels, 54 mc. to 88 mc., 174 mc. to 216 mc.
Picture I-F Carrier Frequency.....45.75 mc.
Sound I-F Carrier Frequency.....41.25 mc. and 4.5 mc.

VIDEO RESPONSE.....To 4 mc.

SWEEP DEFLECTION.....Magnetic

FOCUS.....Magnetic

POWER SUPPLY RATING

KCS74.....115 volts, 60 cycles, 190 watts

AUDIO POWER OUTPUT RATING

KCS74.....5.0 watts max.

CHASSIS DESIGNATIONS

KCS74 or KCS74M1.....In Models 17T250DE and 17T261DE
*KCS74 (V110-6CL6)·KCS74M1 (V110-6AG7)

LOUDSPEAKERS

Model 17T250DE.....(971490-3) 8" PM Dynamic, 3.2 ohms
Model 17T261DE.....(92569-12) 12" PM Dynamic, 3.2 ohms

WEIGHT

Model	Shipping Weight	Width Inches	Height Inches	Depth Inches	
17T250DE....	88 lbs.	105 lbs.	21 3/8	22 5/8	22 3/4
17T261DE....	102 lbs.	126 lbs.	24	37 1/4	23 1/4

RECEIVER ANTENNA INPUT IMPEDANCE

Choice: 300 ohms balanced or 72 ohms unbalanced.

RCA TUBE COMPLEMENT

Tube Used	Function
(1) RCA 6BQ7.....	R-F Amplifier
(2) RCA 6X8.....	R-F Oscillator and Mixer
(3) RCA 6AU6.....	1st Picture I-F Amplifier
(4) RCA 6CB6.....	2nd Picture I-F Amplifier
(5) RCA 6CB6.....	3rd Picture I-F Amplifier
(6) RCA 6CB6.....	4th Picture I-F Amplifier
(7) RCA 6CL6 (6AG7).....	* Video Amplifier
(8) RCA 6AU6.....	1st Sound I-F Amplifier
(9) RCA 6AU6.....	2nd Sound I-F Amplifier
(10) RCA 6AL5.....	Ratio Detector
(11) RCA 6AV6.....	1st Audio Amplifier
(12) RCA 6AQ5.....	Audio Output
(13) RCA 6CB6.....	AGC Amplifier
(14) RCA 6SN7GT.....	Sync Separator
(15) RCA 6SN7GT...Vert. Sync Amplifier and Vert. Sweep Osc.	
(16) RCA 6AQ5.....	Vertical Sweep Output
(17) RCA 6SN7GT.....	Horizontal Sync Amplifier
(18) RCA 6SN7GT...Horizontal Sweep Oscillator and Control	
(19) RCA 6BQ6GT.....	Horizontal Sweep Output
(20) RCA 6W4GT.....	Damper
(21) RCA 1B3-GT/8016.....	High Voltage Rectifier
(22) RCA 17QP4.....	Kinescope

*(Refer to Figure 79)

17T250DE, 17T261DE

ELECTRICAL AND MECHANICAL SPECIFICATIONS

(Continued)

PICTURE INTERMEDIATE FREQUENCIES

Picture Carrier Frequency	45.75 mc.
Adjacent Channel Sound Trap	47.25 mc.
Accompanying Sound Traps	41.25 mc.
Adjacent Channel Picture Carrier Trap	39.25 mc.

SOUND INTERMEDIATE FREQUENCIES

Sound Carrier Frequency	41.25 mc. and 4.5 mc.
-------------------------	-----------------------

VIDEO RESPONSE	To 4 mc.
----------------	----------

FOCUS	Magnetic
-------	----------

SWEEP DEFLECTION	Magnetic
------------------	----------

SCANNING	Interlaced, 525 line
----------	----------------------

HORIZONTAL SWEEP FREQUENCY	15,750 cps
----------------------------	------------

VERTICAL SWEEP FREQUENCY	60 cps
--------------------------	--------

FRAME FREQUENCY (Picture Repetition Rate)	30 cps
---	--------

OPERATING CONTROLS (Front Panel)

Channel Selector	}	Dual Control Knobs
Fine Tuning		
Picture Brightness	}	Dual Control Knobs
Picture Horizontal Hold		
Picture Vertical Hold	}	Dual Control Knobs
Sound Volume and On-Off Switch		
Tone Control and Phono Switch	}	Dual Control Knobs

NON-OPERATING CONTROLS (not including r-f and i-f adjustments)

Picture Centering	top chassis adjustment
Width	rear chassis adjustment
Height	rear chassis adjustment
Horizontal Linearity	rear chassis screwdriver adjustment
Vertical Linearity	rear chassis adjustment
Horizontal Drive	rear chassis screwdriver adjustment
Horizontal Oscillator Frequency	rear chassis adjustment
Horizontal Oscillator Waveform	bottom chassis adjustment
Horizontal Locking Range	rear chassis adjustment
Focus	top chassis adjustment
Ion Trap Magnet	top chassis adjustment
Deflection Coil	top chassis wing nut adjustment
AGC Control	rear chassis adjustment

HIGH VOLTAGE WARNING

OPERATION OF THIS RECEIVER OUTSIDE THE CABINET OR WITH THE COVERS REMOVED, INVOLVES A SHOCK HAZARD FROM THE RECEIVER POWER SUPPLIES. WORK ON THE RECEIVER SHOULD NOT BE ATTEMPTED BY ANYONE WHO IS NOT THOROUGHLY FAMILIAR WITH THE PRECAUTIONS NECESSARY WHEN WORKING ON HIGH VOLTAGE EQUIPMENT. DO NOT OPERATE THE RECEIVER WITH THE HIGH VOLTAGE COMPARTMENT SHIELD REMOVED.

KINESCOPE HANDLING PRECAUTIONS

DO NOT REMOVE THE RECEIVER CHASSIS, INSTALL, REMOVE OR HANDLE THE KINESCOPE IN ANY MANNER UNLESS SHATTERPROOF GOGGLES ARE WORN. PEOPLE NOT SO EQUIPPED SHOULD BE KEPT AWAY WHILE HANDLING KINESCOPES. KEEP THE KINESCOPE AWAY FROM THE BODY WHILE HANDLING.

The kinescope bulb encloses a high vacuum and, due to its large surface area, is subjected to considerable air pressure. For this reason, the kinescope must be handled with more care than ordinary receiving tubes.

The large end of the kinescope bulb—particularly that part at the rim of the viewing surface—must not be struck, scratched or subjected to more than moderate pressure at any time. During service if the tube sticks or fails to slip smoothly into its socket, or deflecting yoke, investigate and remove the cause of the trouble. Do not force the tube. Refer to the Receiver Installation section for detailed instructions on kinescope installation. All RCA replacement kinescopes are shipped in special cartons and should be left in the cartons until ready for installation in the receiver.

OPERATING INSTRUCTIONS

17T250DE, 17T261DE

The following adjustments are necessary when turning the receiver on for the first time.

1. See that the TV-PH tone switch is in a "TV" position.
2. Turn the receiver "ON" and advance the SOUND VOLUME control to approximately mid-position.
3. Set the STATION SELECTOR to the desired channel.
4. Adjust the FINE TUNING control for best pix and the SOUND VOLUME control for suitable volume.
5. Turn the BRIGHTNESS control fully counter-clockwise, then clockwise until a light pattern appears on the screen.
6. Adjust the VERTICAL hold control until the pattern stops vertical movement.
7. Adjust the HORIZONTAL hold control until a picture is obtained and centered.

8. Adjust the PICTURE and BRIGHTNESS controls for suitable picture contrast and brightness.

9. In switching from one channel to another, it may be necessary to repeat steps 4 and 8.

10. When the set is turned on again after an idle period it should not be necessary to repeat the adjustment if the positions of the controls have not been changed. If any adjustment is necessary, step number 4 is generally sufficient.

11. If the positions of the controls have been changed, it may be necessary to repeat steps 2 through 8.

12. To use a record player, plug the record-player output cable into the PHONO jack on the rear apron, and set the TV-PH tone switch to a "PH" position.

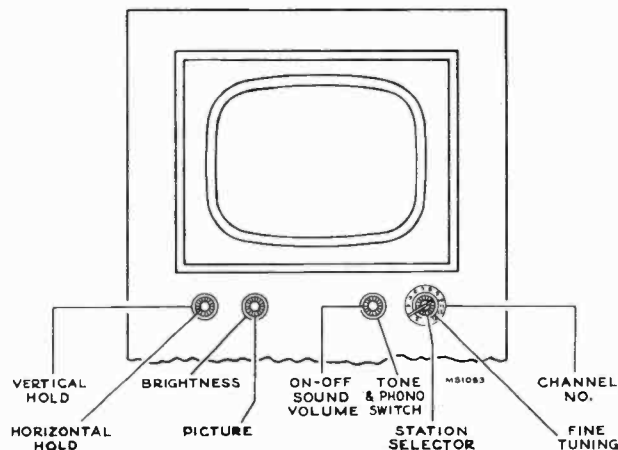

Figure 1—Receiver Operating Controls

INSTALLATION INSTRUCTIONS

UNPACKING.—These receivers are shipped complete in cardboard cartons. The kinescope is shipped in place in the receiver.

Take the receiver out of the carton and remove all packing material.

Make sure that all tubes are in place and are firmly seated in their sockets.

Check to see that the kinescope high voltage lead clip is in place.

Plug a power cord into the 115 volt a-c power source and into the receiver interlock receptacle. Turn the receiver power switch to the "on" position, the brightness control fully clockwise, and the picture control counter-clockwise.

ION TRAP MAGNET ADJUSTMENT.—Set the ion trap magnet approximately in the position shown in Figure 2. Starting from this position immediately adjust the magnet by moving it forward or backward at the same time rotating it slightly around the neck of the kinescope for the brightest raster on the screen. Reduce the brightness control setting until the raster is slightly above average brilliance. Turn the focus control (shown in Figure 2) until the line structure of the raster is clearly visible. Readjust the ion trap magnet for maximum raster brilliance. The final touches of this adjustment should be made with the brightness control at the maximum clockwise position with which good line focus can be maintained.

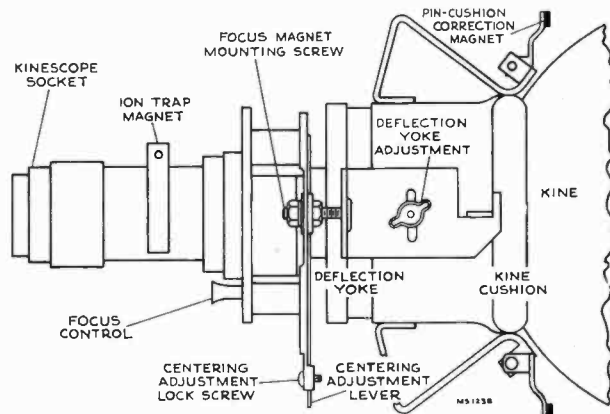

Figure 2—Yoke and Focus Magnet Adjustments

DEFLECTION YOKE ADJUSTMENT.—If the lines of the raster are not horizontal or squared with the picture mask, rotate the deflection yoke until this condition is obtained. Tighten the yoke adjustment wing screw.

PICTURE ADJUSTMENTS.—It will now be necessary to obtain a test pattern picture in order to make further adjustments. Connect the antenna transmission line to the receiver.

If the Horizontal Oscillator and AGC System are operating properly, it should be possible to sync the picture at this point. However, if the AGC control is misadjusted, and the receiver is overloading, it may be impossible to sync the picture.

If the receiver is overloading, turn R181 on the rear apron (see Figure 3) counter-clockwise until the set operates normally and the picture can be synced.

CHECK OF HORIZONTAL OSCILLATOR ALIGNMENT.—

Turn the horizontal hold control to the extreme counter-clockwise position. The picture should remain in horizontal sync. Momentarily remove the signal by switching off channel then back. Normally the picture will be out of sync. Turn the control clockwise slowly. The number of diagonal black bars will be gradually reduced and when only 2 or 3 bars sloping downward to the left are obtained, the picture will pull into sync upon slight additional clockwise rotation of the control. Pull-in should occur before the control has been turned 120 degrees from the extreme counter-clockwise position. The picture should remain in sync for approximately 90

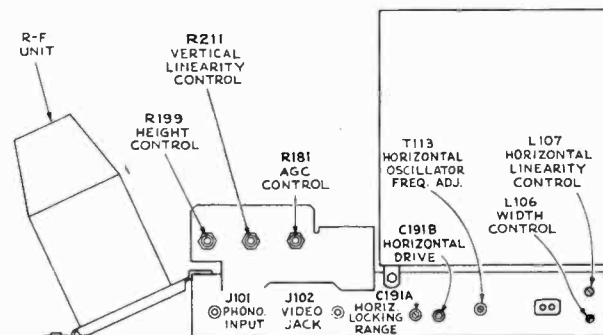

Figure 3—Rear Chassis Adjustments

degrees of additional clockwise rotation of the control. At the extreme clockwise position, the picture should remain in sync and should not show a black bar in the picture.

If the receiver passes the above checks and the picture is normal and stable, the horizontal oscillator is properly aligned. Skip "Alignment of Horizontal Oscillator" and proceed with "Focus Magnet Adjustment."

ALIGNMENT OF HORIZONTAL OSCILLATOR.—If in the above check the receiver failed to hold sync with the hold control at the extreme counter-clockwise position or failed to hold sync over 90 degrees of clockwise rotation of the control from the pull-in point, it will be necessary to make the following adjustments.

Horizontal Frequency Adjustment.—Turn the horizontal hold control to the extreme clockwise position. Tune in a television station and adjust the T113 horizontal frequency adjustment at the rear of the chassis until the picture is just out of sync and the horizontal blanking appears as a vertical or diagonal black bar in the raster. Then turn the T113 core until the bar moves out of the picture leaving it in sync.

Horizontal Locking Range Adjustment.—Set the horizontal hold control to the full counter-clockwise position. Momentarily remove the signal by switching off channel then back. The picture may remain in sync. If so turn the T113 rear core slightly and momentarily switch off channel. Repeat until the picture falls out of sync with the diagonal lines sloping down to the left. Slowly turn the horizontal hold control clockwise and note the least number of diagonal bars obtained just before the picture pulls into sync.

If more than 3 bars are present just before the picture pulls into sync, adjust the horizontal locking range trimmer C191A slightly clockwise. If less than 2 bars are present, adjust C191A slightly counter-clockwise. Turn the horizontal hold control counter-clockwise, momentarily remove the signal and recheck the number of bars present at the pull-in point. Repeat this procedure until 2 or 3 bars are present.

Repeat the adjustments under "Horizontal Frequency Adjustment" and "Horizontal Locking Range Adjustment" until the conditions specified under each are fulfilled. When the horizontal hold operates as outlined under "Check of Horizontal Oscillator Alignment" the oscillator is properly adjusted.

If it is impossible to sync the picture at this point and the AGC system is in proper adjustment it will be necessary to adjust the Horizontal Oscillator by the method outlined in the alignment procedure on page 11. For field purposes paragraph "B" under Horizontal Oscillator Waveform Adjustment may be omitted.

FOCUS MAGNET ADJUSTMENT.—The focus magnet should be adjusted so that there is approximately three-eighths inch of space between the rear cardboard shell of the yoke and the flat of the front face of the focus magnet. This spacing gives best average focus over the face of the tube.

The axis of the hole through the magnet should be parallel with the axis of the kinescope neck with the kinescope neck through the center of the opening.

PIN-CUSHION CORRECTION.—Two pin-cushion correction magnets are employed to correct a small amount of pin-cushion of the raster due to the lens effect of the face of the kinescope. These magnets are mounted on small arms, one on each side of the kinescope as shown in Figure 2. The arms hinge in one plane on self tapping screws which act both as a hinge and an adjustment locking screw. When the magnets are swung towards the tube, maximum correction is obtained. Minimum correction is obtained when the arms are swung away from the tube. To adjust the magnets, loosen the two self tapping screws and position the magnets until the sides of the raster appear straight. Tighten the screws without shifting the position of the magnets. In some cases it may be necessary to twist or bend the magnet support arms to obtain the appearance of straight raster edges.

CENTERING ADJUSTMENT.—No electrical centering controls are provided. Centering is accomplished by means of a separate plate on the focus magnet. The centering plates include a locking screw which must be loosened before centering. Up and down adjustment of the plate moves the picture side to side and sidewise adjustment moves the picture up and down.

If a corner of the raster is shadowed, check the position of the ion trap magnet. Reposition the magnet within the range of maximum raster brightness to eliminate the shadow and recenter the picture by adjustment of the focus magnet plate. In no case should the magnet be adjusted to cause any loss of brightness since such operation may cause immediate or eventual damage to the tube. In some cases it may be necessary to shift the position of the focus magnet in order to eliminate a corner shadow.

WIDTH, DRIVE AND HORIZONTAL LINEARITY ADJUSTMENTS.—Adjustment of the horizontal drive control affects the high voltage applied to the kinescope. In order to obtain the highest possible voltage hence the brightest and best focused picture, adjust horizontal drive trimmer C191B counter-clockwise until the picture begins to "wrinkle" in the middle then clockwise until the "wrinkle" disappears.

Turn the horizontal linearity control L107 clockwise until the picture begins to "wrinkle" on the right and then counter-clockwise until the "wrinkle" disappears and best linearity is obtained.

Adjust the width control L106 to obtain correct picture width.

A slight readjustment of these three controls may be necessary to obtain the best linearity.

Adjustments of the horizontal drive control affect horizontal oscillator hold and locking range. If the drive control was adjusted, recheck the oscillator alignment.

HEIGHT AND VERTICAL LINEARITY ADJUSTMENTS.—Adjust the height control (R199 on chassis rear apron) until the picture fills the mask vertically. Adjust vertical linearity (R211 on rear apron), until the test pattern is symmetrical from top to bottom. Adjustment of either control will require a readjustment of the other. Adjust centering to align the picture with the mask.

FOCUS.—Adjust the focus magnet for maximum definition in the test pattern vertical "wedge" and best focus in the white areas of the pattern.

Recheck the position of the ion trap magnet to make sure that maximum brightness is obtained.

Check to see that the yoke thumbscrew and the focus magnet mounting screws are tight.

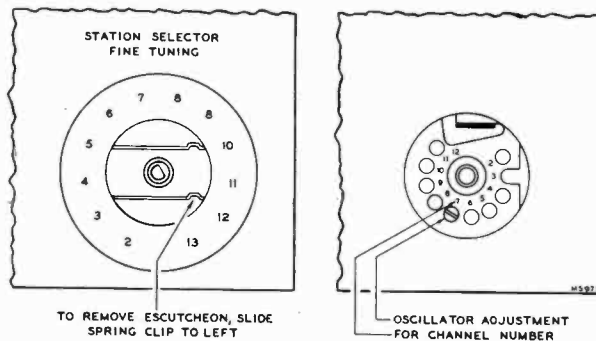

Figure 4—R-F Oscillator Adjustments

CHECK OF R-F OSCILLATOR ADJUSTMENTS.—Tune in all available stations to see if the receiver r-f oscillator is adjusted to the proper frequency on all channels. If adjustments are required, these should be made by the method outlined in the alignment procedure on page 9. The adjustments for channels 2 through 12 are available from the front of the cabinet by removing the station selector escutcheon as shown in Figure 4. Adjustment for channel 13 is on top of the chassis.

AGC THRESHOLD CONTROL.—The AGC threshold control R181 is adjusted at the factory and normally should not require readjustment in the field.

To check the adjustment of the AGC Threshold Control, tune in a strong signal and sync the picture. Momentarily remove the signal by switching off channel and then back. If the picture reappears immediately, the receiver is not overloading due to improper setting of R181. If the picture requires an appreciable portion of a second to reappear, or bends excessively, R181 should be readjusted.

INSTALLATION INSTRUCTIONS

17T250DE, 17T261DE

Turn R181 fully counter-clockwise. The raster may be bent slightly. This should be disregarded. Turn R181 clockwise until there is a very, very slight bend or change of bend in the picture. Then turn R181 counter-clockwise just sufficiently to remove this bend or change of bend.

If the signal is weak, the above method may not work as it may be impossible to get the picture to bend. In this case, turn R181 clockwise until the snow in the picture becomes more pronounced, then counter-clockwise until the best signal to noise ratio is obtained.

The AGC control adjustment should be made on a strong signal if possible. If the control is set too far clockwise on a weak signal, then the receiver may overload when a strong signal is received.

FM TRAP ADJUSTMENT.—In some instances interference may be encountered from a strong FM station signal. A trap is provided to eliminate this type of interference. To adjust the trap tune in the station on which the interference is observed and adjust the L58 core on top of the antenna matching transformer for minimum interference in the picture.

CAUTION.—In some receivers, the FM trap L58 will tune down into channel 6 or even into channel 5. Needless to say, such an adjustment will cause greatly reduced sensitivity on these channels. If channels 5 or 6 are to be received, check L58 to make sure that it does not affect sensitivity on these two channels.

Replace the cabinet back and connect the receiver antenna leads to the cabinet back. Make sure that the screws holding it are up tight, otherwise it may rattle or buzz when the receiver is operated at high volume.

KINESCOPE SCREEN CLEANING.—The kinescope safety glass is held in place by four spring clips which may be removed from the back of the front panel. This permits removing the safety glass for cleaning without the necessity of removing the chassis and kinescope.

CHASSIS REMOVAL.—To remove the chassis from the cabinet for repair or installation of a new kinescope, remove the control knobs, the cabinet back, unplug the speaker cable, the kinescope socket, the antenna cable, the yoke and high voltage cable. Take out the chassis bolts under the cabinet. Withdraw the chassis from the back of the cabinet.

KINESCOPE HANDLING PRECAUTION.—Do not install, remove, or handle the kinescope in any manner, unless shatter-proof goggles and heavy gloves are worn. People not so equipped should be kept away while handling the kinescope. Keep the kinescope away from the body while handling.

REMOVAL OF KINESCOPE.—To remove the kinescope from the cabinet, loosen the two nuts and disengage the rods alongside the kinescope. Remove the wing screw which holds the yoke frame to the cabinet. Remove the kinescope, the yoke frame with yoke and focus magnet as an assembly.

Handle this tube by the portion at the edge of the screen. Do not cover the glass bell of the tube with fingermarks as it will produce leakage paths which may interfere with reception. If this portion of the tube has inadvertently been handled, wipe it clean with a soft cloth moistened with "dry" carbon tetrachloride.

INSTALLATION OF KINESCOPE.—Wipe the kinescope screen surface and front panel safety glass clean of all dust and fingermarks with a soft cloth moistened with "Windex" or similar cleaning agent.

Replace the kinescope and chassis by reversal of the removing process. The kinescope should be installed so that the high voltage contact is to the right when looking at it from the rear of the cabinet. The magnet of the ion trap magnet should be to the left.

CABINET ANTENNA.—A cabinet antenna is provided in these receivers and the leads are brought out near the antenna terminal board. The cabinet antenna may be employed in place of the outdoor antenna in areas where the signals are strong and no reflections are experienced.

ANTENNAS.—The finest television receiver built may be said to be only as good as the antenna design and installation. It is therefore important to select the proper antenna to suit the particular local conditions, to install it properly and orient it correctly.

If two or more stations are available and the two stations are in different directions, it may be possible to make a compromise orientation which will provide a satisfactory signal on all such channels.

If it is impossible to obtain satisfactory results on one or more channels, it may become necessary either to provide means for turning the antenna when switching channels or to install a separate antenna for one or more channels and to switch antennas when switching channels.

In some cases, the antenna should not be installed permanently until the quality of the picture reception has been observed on a television receiver. A temporary transmission line can be run between receiver and the antenna, allowing sufficient slack to permit moving the antenna. Then, with a telephone system connecting an observer at the receiver and an assistant at the antenna, the antenna can be positioned to give the most satisfactory results on the received signal. A shift of direction or a few feet in antenna position may effect a tremendous difference in picture reception.

REFLECTIONS.—Multiple images sometimes known as echoes or ghosts, are caused by the signal arriving at the antenna by two or more routes. The second or subsequent image occurs when a signal arrives at the antenna after being reflected off a building, a hill or other object. In severe cases of reflections, even the sound may be distorted. In less severe cases, reflections may occur that are not noticeable as reflections but that will instead cause a loss of definition in the picture.

Under certain extremely unusual conditions, it may be possible to rotate or position the antenna so that it receives the clearest picture over a reflected path. If such is the case, the antenna should be so positioned. However, such a position may give variable results as the nature of reflecting surfaces may vary with weather conditions. Wet surfaces have been known to have different reflecting characteristics than dry surfaces.

Depending upon the circumstances, it may be possible to eliminate the reflections by rotating the antenna or by moving it to a new location. In extreme cases, it may be impossible to eliminate the reflection.

INTERFERENCE.—Auto ignition, street cars, electrical machinery and diathermy apparatus may cause interference which spoils the picture. Whenever possible, the antenna location should be removed as far as possible from highways, hospitals, doctors' offices and similar sources of interference. In mounting the antenna, care must be taken to keep the antenna rods at least $\frac{1}{4}$ wave length (at least 6 feet) away from other antennas, metal roofs, gutters or other metal objects.

Short-wave radio transmitting and receiving equipment may cause interference in the picture in the form of moving ripples. In some instances it may be possible to eliminate the interference by the use of a trap in the antenna transmission line. However, if the interfering signal is on the same frequency as the television station, a trap will provide no improvement.

WEAK PICTURE.—When the installation is near the limit of the area served by the transmitting station, the picture may be speckled, having a "snow" effect, and may not hold steady on the screen. This condition is due to lack of signal strength from the transmitter.

RECEIVER LOCATION.—The owner should be advised of the importance of placing the receiver in the proper location in the room.

The location should be chosen—

- Away from bright windows and so that no bright light will fall directly on the screen. (Some illumination in the room is desirable, however.)
- To give easy access for operation and comfortable viewing.
- To permit convenient connection to the antenna.
- Convenient to an electrical outlet.
- To allow adequate ventilation.

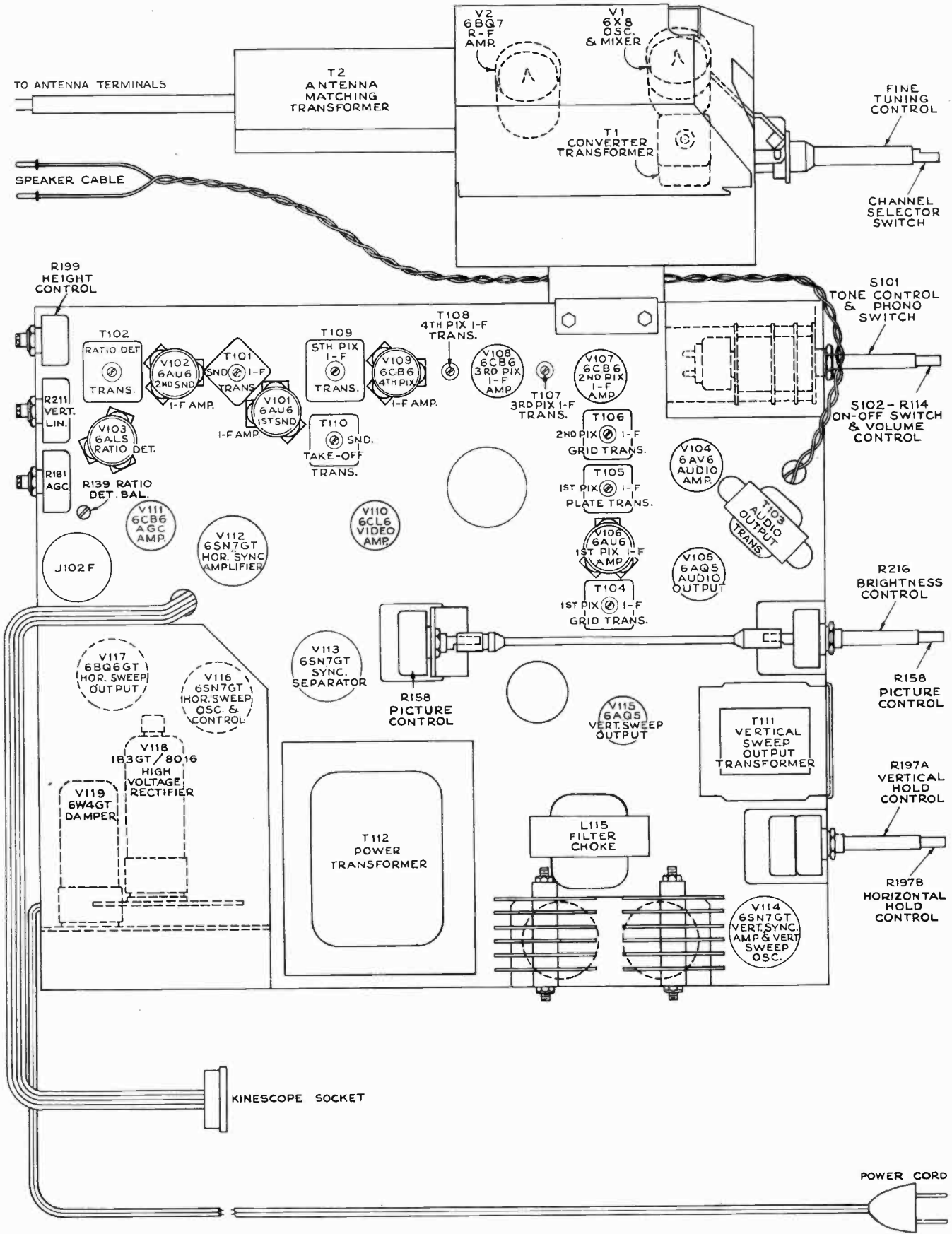

Figure 5—Chassis Top View

CHASSIS BOTTOM VIEW

17T250DE, 17T261DE

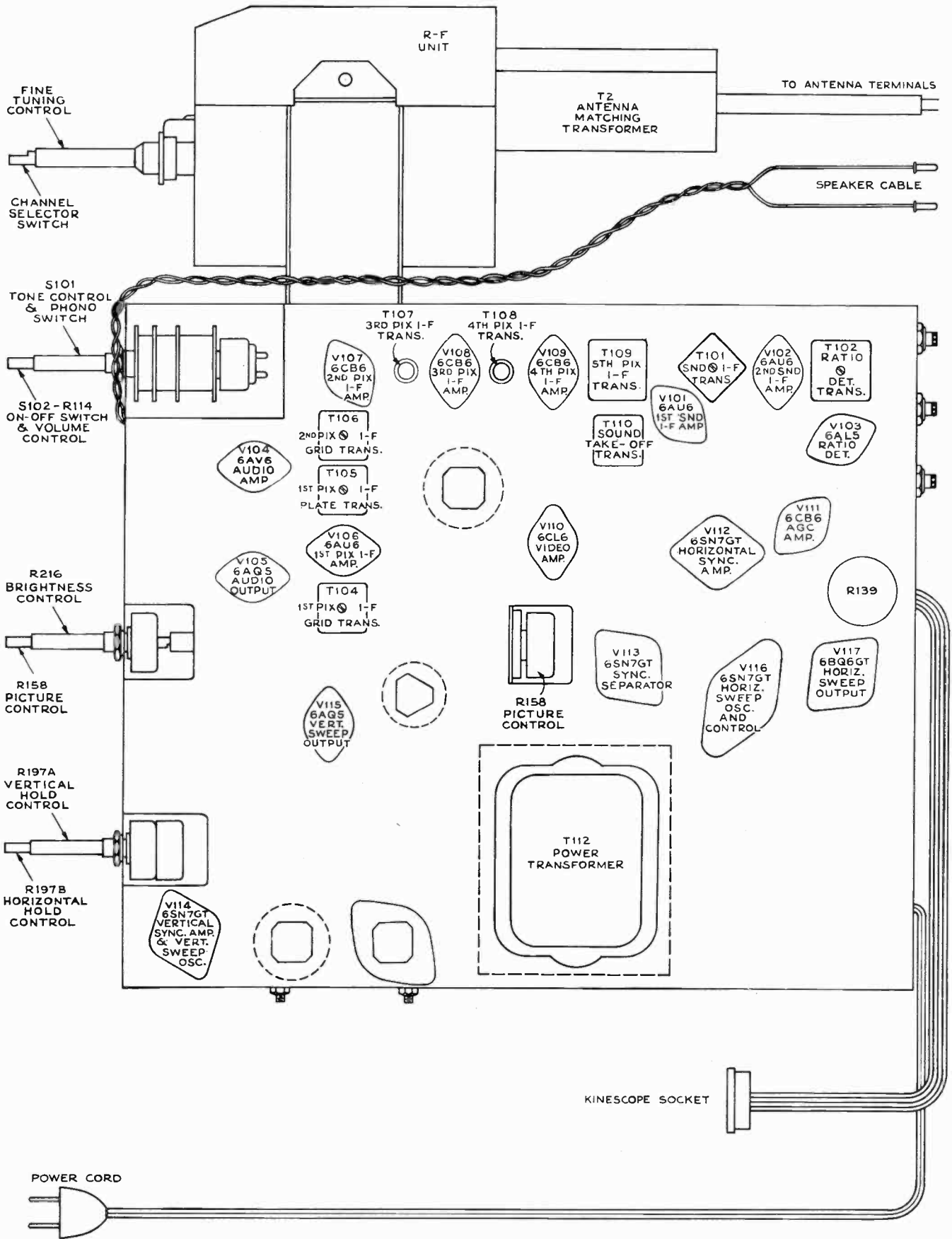

Figure 6—Chassis Bottom View

TEST EQUIPMENT.—To properly service the television chassis of this receiver, it is recommended that the following test equipment be available:

R-F Sweep Generator meeting the following requirements:

- (a) Frequency Ranges
 - 35 to 90 mc., 1 mc. to 12 mc. sweep width
 - 170 to 225 mc., 12 mc. sweep width
- (b) Output adjustable with at least .1 volt maximum.
- (c) Output constant on all ranges.
- (d) "Flat" output on all attenuator positions.

Cathode-Ray Oscilloscope.—For alignment purposes, the oscilloscope employed must have excellent low frequency and phase response, and should be capable of passing a 60-cycle square wave without appreciable distortion.

For video and sync waveform observations, the oscilloscope must have excellent frequency and phase response from 10 cycles to at least two megacycles in all positions of the gain control.

Signal Generator to provide the following frequencies with crystal accuracy.

- (a) Intermediate frequencies
 - 4.5 mc., 39.25 mc., 41.25 mc., 45.75 mc., 47.25 mc.
- (b) Radio frequencies

Channel Number	Picture Carrier Freq. Mc.	Sound Carrier Freq. Mc.	Receiver R-F Osc. Freq. Mc.
2.....	55.25.....	59.75.....	101
3.....	61.25.....	65.75.....	107
4.....	67.25.....	71.75.....	113
5.....	77.25.....	81.75.....	123
6.....	83.25.....	87.75.....	129
7.....	175.25.....	179.75.....	221
8.....	181.25.....	185.75.....	227
9.....	187.25.....	191.75.....	233
10.....	193.25.....	197.75.....	239
11.....	199.25.....	203.75.....	245
12.....	205.25.....	209.75.....	251
13.....	211.25.....	215.75.....	257

- (c) Output of these ranges should be adjustable and at least .1 volt maximum.

Heterodyne Frequency Meter with crystal calibrator if the signal generator is not crystal controlled.

Electronic Voltmeter of Junior or Senior "VoltOhmyst" type and a high voltage multiplier probe for use with this meter to permit measurements up to 20 kv.

ORDER OF ALIGNMENT.—When a complete receiver alignment is necessary, it can be most conveniently performed in the following order:

- | | |
|---------------------------|----------------------------|
| (1) Ant. Matching Unit | (6) Picture I-F Traps |
| (2) R-F Unit | (7) Picture I-F Trans. |
| (3) Ratio Detector | (8) Sweep Alignment of I-F |
| (4) Sound I-F Trans. | (9) Horizontal Oscillator |
| (5) Sound Take-Off Trans. | (10) Sensitivity Check |

ANTENNA MATCHING UNIT ALIGNMENT.—The antenna matching unit is accurately aligned at the factory. Adjustment of this unit should not be attempted in the customer's home since even slight misalignment may cause serious attenuation of the signal especially on channel 2. The r-f unit is aligned with a particular antenna matching transformer in place. If for any reason, a new antenna matching transformer is installed, the r-f unit should be realigned.

The F-M Trap which is mounted in the antenna matching unit may be adjusted without adversely affecting the alignment of the unit.

To align the antenna matching unit disconnect the lead from the F-M Trap L58 to the channel selector switch S5.

With a short jumper, connect the output of the matching unit through a 1000 mmf capacitor to the grid of the second pix i-f amplifier, pin 1 of V107.

Replace the cover on the matching unit while making all adjustments.

Remove the first pix i-f amplifier tube V106.

Connect the positive terminal of a bias box to the chassis and the potentiometer arm to the junction of R193 and R194. Set the potentiometer to produce approximately -6.0 volts of bias at the junction of R193 and R194.

Connect an oscilloscope to pin 2 of V110 (pin 4 if 6AG7 used) and set the oscilloscope gain to maximum.

Connect a signal generator to the antenna input terminals. Modulate the signal generator 30% with an audio signal.

Tune the signal generator to 45.75 mc. and adjust the generator output to give an indication on the oscilloscope. Adjust L59 in the antenna matching unit for minimum audio indication on the oscilloscope.

Tune the signal generator to 41.25 mc. and adjust L60 for minimum audio indication on the oscilloscope.

Remove the jumper from the output of the matching unit.

Connect a 300 ohm ½ watt composition resistor from L58 to ground, keeping the leads as short as possible.

Connect an oscilloscope low capacity crystal probe from L58 to ground. The sensitivity of the oscilloscope should be approximately 0.03 volts per inch. Set the oscilloscope gain to maximum.

Connect the r-f sweep generator to the matching unit antenna input terminals. In order to prevent coupling reactance from the sweep generator into the matching unit, it is advisable to employ a resistance pad at the matching unit terminals. Figure 11 shows three different resistance pads for use with sweep generators with 50 ohm co-ax output, 72 ohm co-ax output or 300 ohm balanced output. Choose the pad to match the output impedance of the particular sweep employed.

Connect the signal generator loosely to the matching unit antenna terminals.

Set the sweep generator to sweep from 45 mc. to 54 mc. With RCA type WR59A sweep generators, this may be accomplished by retuning channel number 1 to cover this range. With WR59B sweep generators this may be accomplished by retuning channel number 2 to cover the range. In making these adjustments on the generator, be sure not to turn the core too far clockwise so that it becomes lost beyond the core retaining spring.

Adjust L61 and L62 to obtain the response shown in Figure 12. L61 is most effective in locating the position of the shoulder of the curve at 52 mc. and L62 should be adjusted to give maximum amplitude at 53 mc. and above consistent with the specified shape of the response curve. The adjustments in the matching unit interact to some extent. Repeat the above procedure until no further adjustments are necessary.

Remove the 300 ohm resistor and crystal probe connections. Restore the connection between L58 and S5. Replace V106.

R-F UNIT ALIGNMENT.—An r-f unit which is operative and requires only touch up adjustments, requires no presetting of adjustments. For such units, skip the remainder of this paragraph. For units which are completely out of adjustment, preset all adjustments to the approximate center of their range with the following exceptions: Set C18 so that the screw head is approximately three-eighths of an inch above chassis. Set C11 near maximum capacity (one-quarter turn from tight). Do not change any of the adjustments in the antenna matching unit.

Disconnect the link from terminals "A" and "B" of T104 and terminate the link with a 39 ohm composition resistor.

The r-f unit is aligned with zero AGC bias. To insure that the bias will remain constant, take a clip lead and short circuit the r-f unit power terminal board terminal 3 to ground.

Connect the oscilloscope to the test point TP1 on top of the r-f unit. Set the oscilloscope gain to maximum.

Turn the receiver channel selector switch to channel 2.

Connect the output of the signal generator to the grid of the r-f amplifier, V2. To do this, remove the tube from the socket and fashion a clip by twisting one end of a small piece of wire around pin number 7. Replace the tube in the socket leaving the end of the wire protruding from under the tube. Connect the signal generator to this wire through a 1,500 mmf. capacitor.

Tune the signal generator to 43.5 mc. and modulate it 30% with a 400 cycle sine wave. Adjust the signal generator for maximum output.

ALIGNMENT PROCEDURE

17T250DE, 17T261DE

Adjust L65 on top of the r-f unit for minimum 400 cycle indication on the oscilloscope. If necessary, this adjustment can be retouched in the field to provide additional rejection to one specific frequency in the i-f band pass. However, in such cases, care should be taken not to adjust it so as to reduce sensitivity on channel 2.

Remove the wire clip from pin 7 of V2 and replace the tube and tube shield.

Set the channel selector switch to channel 8.

Turn the fine tuning control 30 degrees clockwise from the center of its mechanical range now and at all times when adjusting the oscillator frequency.

Adjust C2 for proper oscillator frequency, 227 mc. This may be done in several ways. The easiest way and the way which will be recommended in this procedure will be to use the signal generator as a heterodyne frequency meter and beat the oscillator against the signal generator. To do this, tune the signal generator to 227 mc. with crystal accuracy. Insert one end of a piece of insulated wire into the r-f unit through the hole provided for the adjustment for C11. Be careful that the wire does not touch any of the tuned circuits as it may cause the frequency of the r-f unit oscillator to shift. Connect the other end of the wire to the "r-f in" terminal of the signal generator. Adjust C2 to obtain an audio beat with the signal generator.

Note.—If on some units, it is not possible to reach the proper channel 8 oscillator frequency by adjustment of C2, switch to channel 13 and adjust L46 to obtain proper channel 13 oscillator frequency as indicated in the table on page 8. Then, switch to channel 12 and adjust L11 to obtain proper channel 12 oscillator frequency. Continue down to channel 8 adjusting the appropriate oscillator trimmer to obtain the proper frequency on each channel. Then again on channel 8, adjust C2 to obtain proper channel 8 oscillator frequency. Switch back to channel 13 and adjust L46 and back to channel 8 and adjust C2.

Set the T1 core for maximum inductance (core turned counter-clockwise.)

Connect the sweep generator through a suitable attenuator as shown in Figure 11 to the input terminals of the antenna matching unit.

Connect the signal generator loosely to the antenna terminals.

Set the sweep generator to cover channel 8.

Set the oscilloscope to maximum gain and use the minimum input signal which will produce a useable pattern on the oscilloscope. Excessive input can change oscillator injection during alignment and produce consequent misalignment even though the response as seen on the oscilloscope may look normal.

Insert markers of channel 8 picture carrier and sound carrier, 181.25 mc. and 185.75 mc.

Adjust C9, C11, C15 and C18 for approximately correct curve shape, frequency, and band width as shown in Figure 13.

The correct adjustment of C18 is indicated by maximum amplitude of the curve midway between the markers. C15 tunes the r-f amplifier plate circuit and affects the frequency of the pass band most noticeably. C9 tunes the mixer grid circuit and affects the tilt of the curve most noticeably (assuming that C18 has been properly adjusted). C11 is the coupling adjustment and hence primarily affects the response band width.

Set the receiver channel switch to channel 6.

Adjust the signal generator to the channel 6 oscillator frequency 129 mc.

Turn the fine tuning control 30 degrees clockwise from the center of its mechanical range.

Adjust L5 for an audible beat with the signal generator as before.

Set the sweep generator to channel 6.

From the signal generator, insert channel 6 sound and picture carrier markers, 83.25 mc. and 87.75 mc.

Adjust L48, L50 and L53 for proper response as shown in Figure 13.

L50 tunes the r-f amplifier plate circuit and primarily affects the frequency of the pass band. L53 tunes the r-f amplifier grid and is adjusted to give maximum amplitude of the curve between the markers. L48 affects the tilt of the curve but not quite the same as C9 adjustment. When the circuits are correctly adjusted and L48 is rocked on either side of its proper setting, the high frequency (sound carrier) end of the

curve appears to remain nearly fixed in amplitude while the picture carrier end tilts above or below this point.

Turn off the sweep and signal generators.

Connect the "VoltOhmyst" to the r-f unit test point TP1.

Adjust the oscillator injection trimmer C8 for -3.5 volts or at maximum if -3.5 volts cannot be reached. This voltage should fall between -2.5 and -5.5 volts on all channels when the alignment of all circuits is completed.

Turn the sweep generator and signal generator back on and recheck channel 6 response. Readjust L48, L50 and L53 if necessary.

Set the receiver channel selector switch to channel 8 and readjust C2 for proper oscillator frequency, 227 mc.

Set the sweep generator and signal generator to channel 8.

Readjust C9, C11, C15 and C18 for correct curve shape, frequency and band width.

Turn off the sweep and signal generators, switch back to channel 6 and check the oscillator injection voltage at TP1 if C9 was adjusted in the recheck of channel 8 response.

If the initial setting of oscillator injection trimmer C8 was far off, it may be necessary to adjust the oscillator frequency and response on channel 8, adjust the oscillator injection on channel 6 and repeat the procedure several times before the proper setting is obtained.

Turn off the sweep generator and switch the receiver to channel 13.

Adjust the signal generator to the channel 13 oscillator frequency 257 mc.

Set the fine tuning control 30 degrees clockwise from the center of its mechanical range.

Adjust L46 to obtain an audible beat. Slightly overshoot the adjustment of L46 by turning the slug a little more in the same direction from the original setting, then reset the oscillator to proper frequency by adjusting C2 to again obtain the beat.

Check the response of channels 7 through 13 by switching the receiver channel switch, sweep generator and marker oscillator to each of these channels and observing the response and oscillator injection obtained. See Figure 13 for typical response curves. It should be found that all these channels have the proper shaped response with the markers above 80% response.

If the markers do not fall within this requirement, switch to channel 8 and readjust C9, C11, C15 and C18 as necessary.

Turn off the sweep generator and check the channel 8 oscillator frequency. If C2 has to be readjusted for channel 8, the principle of overshooting the adjustment and then correcting by adjusting L46 should be followed in order to establish the L/C ratio for the desired oscillator tracking.

Turn the receiver channel selector switch to channel 6. Adjust L5 for correct oscillator frequency, 129 mc.

Turn the sweep generator on and to channel 6 and observe the response curve. If necessary readjust L48, L50 and L53.

Switch the receiver, the sweep and signal generators to channel 2 and adjust T1 clockwise to a point where there is no change in the channel 2 response as T1 is turned.

Switch the receiver through channel 6 down through channel 2 and check for normal response curve shapes and oscillator injection voltage.

If excessive tilt in the same direction occurs on channels 2, 3 and 4, adjust C18 on channel 2 to overshoot the correction of this tilt, then switch to channel 6 and adjust L53 for maximum amplitude of curve between markers. This adjustment should produce "flat" response on the low channels if the other adjustments especially L48 are correct.

Likewise check channels 7 through 13, stopping on 13 for the next step.

With the receiver on channel 13, check the receiver oscillator frequency. Correct by adjustment of C2 if necessary.

Adjust the oscillator to frequency on all channels by switching the receiver and the frequency standard to each channel and adjusting the appropriate oscillator trimmer to obtain the audible beat. It should be possible to adjust the oscillator to the correct frequency on all channels with the fine tuning control in the middle third of its range. When employing WR39 calibrators to adjust the receiver oscillator, tune the calibrator to one-half the receiver oscillator frequency on channels 4, 5 and 6 and to one-fourth the receiver oscillator frequency on channels 11, 12 and 13.

Channel Number	Picture Carrier Freq. Mc.	Sound Carrier Freq. Mc.	Receiver R-F Osc. Freq. Mc.	Channel Oscillator Adjustment
2.....	55.25.....	59.75.....	101.....	L1
3.....	61.25.....	65.75.....	107.....	L2
4.....	67.25.....	71.75.....	113.....	L3
5.....	77.25.....	81.75.....	123.....	L4
6.....	83.25.....	87.75.....	129.....	L5
7.....	175.25.....	179.75.....	221.....	L6
8.....	181.25.....	185.75.....	227.....	L7
9.....	187.25.....	191.75.....	233.....	L8
10.....	193.25.....	197.75.....	239.....	L9
11.....	199.25.....	203.75.....	245.....	L10
12.....	205.25.....	209.75.....	251.....	L11
13.....	211.25.....	215.75.....	257.....	C1

Remove the 39 ohm resistor from the link and reconnect the link to terminals "A" and "B" of T104.

RATIO DETECTOR ALIGNMENT.—Set the signal generator at 4.5 mc. and connect it to the second sound i-f grid, pin 1 of V102. Set the generator for 30% 400 cycle modulation.

As an alternate source of signal, the RCA WR39B or WR39C calibrator may be employed. If used, connect its output cable to the grid of the 4th pix i-f amplifier, pin 1 of V109. Set the frequency of the calibrator to 45.75 (pix carrier) and modulate with 4.5 mc. crystal. Also turn on the internal AM audio modulation. The 4.5 mc. signal will be picked off at T110A and amplified through the sound i-f amplifier.

Connect the "VoltOhmyst" to the junction of R110 and R150.

Connect the oscilloscope to the junction of R111 and C113.

Tune the ratio detector primary, T102 top core for maximum DC output on the "VoltOhmyst." Adjust the signal level from the signal generator for 10 volts on the "VoltOhmyst" when finally peaked. This is approximately the operating level of the ratio detector for average signals.

Connect the "VoltOhmyst" to the junction of R111 and C113.

Tune the ratio detector secondary T102 bottom core for zero d-c on the "VoltOhmyst."

Adjust R139 for minimum AM indication on the oscilloscope.

Retune the T102 bottom core to obtain zero d-c on the "VoltOhmyst."

Repeat the adjustment of T102 bottom core for zero d-c on the "VoltOhmyst" and R139 for minimum AM indication on the oscilloscope until both conditions are satisfied at the same settings of the adjustments. Final touches on these adjustments must be made with the input signal adjusted to produce 10 volts d-c on the "VoltOhmyst" at the junction of R110 and R150.

SOUND I-F ALIGNMENT.—Connect the sweep generator to the first sound i-f amplifier grid, pin 1 of V101. Adjust the generator for a sweep width of 1 mc. at a center frequency of 4.5 mc.

Insert a 4.5 mc. marker signal from the signal generator into the first sound i-f grid.

Connect the oscilloscope in series with a 10,000 ohm resistor to terminal A of T101.

Adjust T101 top and bottom cores for maximum gain and symmetry about the 4.5 mc. marker on the i-f response. The pattern obtained should be similar to that shown in Figure 14.

The output level from the sweep should be set to produce approximately 2.0 volt peak-to-peak at terminal A of T101 when the final touches on the above adjustment are made. It is necessary that the sweep output voltage should not exceed the specified values otherwise the response curve will be broadened, permitting slight misadjustment to pass unnoticed and possibly causing distortion on weak signals.

Connect the oscilloscope to the junction of R111 and C113 and check the linearity of the response. The pattern obtained should be similar to that shown in Figure 15.

SOUND TAKE-OFF ALIGNMENT.—Connect the 4.5 mc. generator in series with a 1,000 ohm resistor to terminal "C" of T110. The input signal should be approximately 0.5 volts.

Short the fourth pix i-f grid to ground, pin 1 V109, to prevent noise from masking the output indication.

As an alternate source of signal the RCA WR39B or WR39C calibrator may be used. In such a case, disregard the above two paragraphs. Connect calibrator across link circuit, T104 A, B, and modulate 45.75 carrier with 4.5 mc. crystal.

Connect the crystal diode probe of a "VoltOhmyst" to the plate of the video amplifier, pin 6 of V110 (pin 8 if 6AG7 used).

Adjust the core of T110 for minimum output on the meter.

Remove the short from pin 1 V109 to ground, if used.

PICTURE I-F TRAP ADJUSTMENT.—Connect the i-f signal generator across the link circuit on terminals A and B of T104.

Connect the "VoltOhmyst" to the junction of R193 and R194.

Obtain a 7.5 volt battery capable of withstanding appreciable current drain and connect the ends of a 1,000 ohm potentiometer across it. Connect the battery positive terminal to chassis and the potentiometer arm to the junction of R193 and R194.

Set the bias pot to produce approximately -1.0 volt of bias at the junction of R193 and R194.

Connect the "VoltOhmyst" to pin 2 of V110 (pin 4 of 6AG7).

Set the signal generator to each of the following frequencies and adjust the corresponding circuit for minimum d-c output at pin 2 of V110. Use sufficient signal input to produce 1.0 volt of d-c on the meter when the final adjustment is made.

39.25 mc.....	T104 top core
41.25 mc.....	T105 bottom core
47.25 mc.....	T106 bottom core

PICTURE I-F TRANSFORMER ADJUSTMENTS.—Set the signal generator to each of the following frequencies and peak the specified adjustment for maximum indication on the "VoltOhmyst." During alignment, reduce the input signal if necessary in order to produce 1.0 volt of d-c at pin 2 of V110 with -1.0 volt of i-f bias at the junction of R193 and R194.

43.7 mc.....	T109
45.5 mc.....	T108
41.8 mc.....	T107

To align T105 and T106, connect the sweep generator to the first picture i-f grid, pin 1 of V106 through a 1,000 mmf ceramic capacitor. Shunt R136, R143 and terminals "A" and "F" of T109 with 330 ohm composition resistors. Set the i-f bias to -1.0 volt at the junction of R193 and R194.

Connect the oscilloscope to pin 2 of V110 (pin 4 of 6AG7).

Adjust T105 and T106 top cores for maximum gain and curve shape as shown in Figure 16. For final adjustments set the output of the sweep generator to produce 0.5 volts peak-to-peak at the oscilloscope terminals.

To align T1 and T104, connect the sweep generator to the mixer grid test point TP2. Use the shortest leads possible, with not more than one inch of unshielded lead at the end of the sweep cable.

Set the channel selector switch to channel 4.

Connect a 180 ohm composition resistor from terminal B of T105 to the junction of R131 and C131. Connect the oscilloscope diode probe to terminal B of T105 and to ground.

Couple the signal generator loosely to the diode probe in order to obtain markers.

C122 is variable and is provided as a band width adjustment. Preset C122 to minimum capacity.

Adjust T1 top and T104 bottom for maximum gain at 43.5 mc. and with 45.75 mc. at 70% of maximum response.

Adjust C122 until 41.25 mc. is at 85% response with respect to the low frequency shoulder at approximately 41.9 mc. as shown in Figure 17.

Disconnect the diode probe, the 180 ohm and three 330 ohm resistors.

SWEEP ALIGNMENT OF PIX I-F.—Connect the oscilloscope to pin 2 of V110 (pin 4 where V110 is a 6AG7).

Adjust the bias potentiometer to obtain -6.0 volts of bias as measured by a "VoltOhmyst" at the junction of R193 and R194.

ALIGNMENT PROCEDURE

17T250DE, 17T261DE

Leave the sweep generator connected to the mixer grid test point TP2 with the shortest leads possible and with not more than one inch of unshielded lead at the end of the sweep cable. If these precautions are not observed, the receiver may be unstable and the response curves obtained may be unreliable.

Adjust the output of the sweep generator to obtain 3.0 volts peak-to-peak on the oscilloscope.

Couple the signal generator loosely to the grid of the first i-f amplifier. Adjust the output of the signal generator to produce small markers on the response curve.

Retouch T108 and T109 to obtain the response shown in Figure 18. Do not adjust T107 unless absolutely necessary. If T107 is adjusted too low in frequency it will raise the level of the 41.25 mc. sound i-f carrier and may create interference in the picture. It will also cause poor adjacent channel picture rejection. If T107 is tuned too high in frequency, the level of the 41.25 mc. sound i-f carrier will be too low and may produce noisy sound in weak signal areas.

Remove the oscilloscope, sweep and signal generator connections.

Remove the bias box employed to provide bias for alignment.

HORIZONTAL OSCILLATOR ADJUSTMENT.—Normally the adjustment of the horizontal oscillator is not considered to be a part of the alignment procedure, but since the oscillator waveform adjustment may require the use of an oscilloscope, it can not be done conveniently in the field. The waveform adjustment is made at the factory and normally should not require readjustment in the field. However, the waveform adjustment should be checked whenever the receiver is aligned or whenever the horizontal oscillator operation is improper.

Horizontal Frequency Adjustment.—Tune in a station and sync the picture. If the picture cannot be synchronized with the horizontal hold control R197B, then adjust the T113 frequency core on the rear apron until the picture will synchronize. If the picture still will not sync, turn the T113 waveform adjustment core (under the chassis) out of the coil several turns from its original position and readjust the T113 frequency core until the picture is synchronized.

Examine the width and linearity of the picture. If picture width or linearity is incorrect, adjust the horizontal drive control C191B, the width control L106 and the linearity control L107 until the picture is correct.

Horizontal Oscillator Waveform Adjustment.—The horizontal oscillator waveform may be adjusted by either of two methods. The method outlined in paragraph A below may be employed in the field when an oscilloscope is not available. The service shop method outlined in paragraph B below requires the use of an oscilloscope.

A.—Turn the horizontal hold control completely clockwise. Place adjustment tools on both cores of T113 and be prepared to make simultaneous adjustments while watching the picture on the screen. First, turn the T113 frequency core (on the rear apron) until the picture falls out of sync and one diagonal black bar sloping down to the right appears on the screen. Then, turn the waveform adjustment core (under the chassis) into the coil while at the same time adjusting the frequency core so as to maintain three or four diagonal black bars on the screen. Continue this procedure until the oscillator begins to motorboat, then turn the waveform adjustment core out until the motorboating just stops. As a check, turn the T113 frequency core until the picture is synchronized then reverse the direction of rotation of the core until the picture begins to fall out of sync with the diagonal bars sloping down to the right. Continue to turn the frequency core in the same direction. No more than three or four bars should appear on the screen. Instead, the horizontal oscillator should begin to motorboat. Retouch the adjustment of the T113 waveform adjustment core if necessary until this condition is obtained.

B.—Connect the low capacity probe of an oscilloscope to terminal C of T113. Turn the horizontal hold control one-quarter turn from the clockwise position so that the picture is in sync. The pattern on the oscilloscope should be as shown in Figure 19. Adjust the waveform adjustment core of T113 until the two peaks are at the same height. During this adjustment, the picture must be kept in sync by readjusting the hold control if necessary.

This adjustment is very important for correct operation of the circuit. If the broad peak of the wave on the oscilloscope is lower than the sharp peak, the noise immunity becomes poorer, the stabilizing effect of the tuned circuit is reduced and drift of the oscillator becomes more serious. On the other hand, if the broad peak is higher than the sharp peak, the oscillator is overstabilized, the pull-in range becomes inadequate and the broad peak can cause double triggering of the oscillator when the hold control approaches the clockwise position.

Remove the oscilloscope upon completion of this adjustment.

Horizontal Locking Range Adjustment.—Set the horizontal hold control to the full counter-clockwise position. Momentarily remove the signal by switching off channel then back. The picture may remain in sync. If so turn the T113 frequency core slightly and momentarily switch off channel. Repeat until the picture falls out of sync with the diagonal lines sloping down to the left. Slowly turn the horizontal hold control clockwise and note the least number of diagonal bars obtained just before the picture pulls into sync.

If more than 3 bars are present just before the picture pulls into sync, adjust the horizontal locking range trimmer C191A slightly clockwise. If less than 2 bars are present, adjust C191A slightly counter-clockwise. Turn the horizontal hold control counter-clockwise, momentarily remove the signal and recheck the number of bars present at the pull-in point. Repeat this procedure until 2 or 3 bars are present.

Turn the horizontal hold control to the maximum clockwise position. Adjust the T113 frequency core so that the diagonal bar sloping down to the right appears on the screen and then reverse the direction of adjustment so that bar just moves off the screen leaving the picture in synchronization.

SENSITIVITY CHECK.—A comparative sensitivity check can be made by operating the receiver on a weak signal from a television station and comparing the picture and sound obtained to that obtained on other receivers under the same conditions. This weak signal can be obtained by connecting the shop antenna to the receiver through a ladder type attenuator pad.

RESPONSE CURVES.—The response curves shown on page 14 are typical though some variations can be expected.

The response curves are shown in the classical manner of presentation, that is with "response up" and low frequency to the left. The manner in which they will be seen in a given test set-up will depend upon the characteristics of the oscilloscope and the sweep generator. The curves may be seen inverted and/or switched from left to right depending on the deflection polarity of the oscilloscope and the phasing of the sweep generator.

NOTES ON R-F UNIT ALIGNMENT.—Because of the frequency spectrum involved and the nature of the device, many of the r-f unit leads and components are critical in some respects. Even the power supply leads form loops which couple to the tuned circuits, and if resonant at any of the frequencies involved in the performance of the tuner, may cause serious departures from the desired characteristics. In the design of the receiver these undesirable resonant loops have been shifted far enough away in frequency to allow reasonable latitude in their components and physical arrangement without being troublesome. When the r-f unit is aligned in the receiver, no trouble from resonant loops should be experienced. However, if the unit is aligned in a jig separate from the receiver, attention should be paid to insure that unwanted resonances do not exist which might present a faulty representation of r-f unit alignment.

A resonant circuit exists between the r-f tuner chassis and the outer shield box, which couples into the antenna and r-f plate circuits. The frequency of this resonance depends on the physical structure of the shield box, and the capacitance between the tuner chassis and the front plate. This resonance is controlled in the design by using insulating washers of proper thickness in the front plate to tuner chassis mounting. The performance of the tuner will be impaired if the proper washers are not used. Obviously then, if the r-f unit is removed for service, the washers should be replaced in the correct order when the unit is replaced.

ALIGNMENT PROCEDURE

THE DETAILED ALIGNMENT PROCEDURE BEGINNING ON PAGE 8 SHOULD BE READ BEFORE ALIGNMENT BY USE OF THE TABLE IS ATTEMPTED

Step No.	CONNECT SIGNAL GENERATOR TO	SIGNAL GEN. FREQ. MC.	CONNECT SWEEP GENERATOR TO	SWEEP GEN. FREQ. MC.	CONNECT HETERODYNE FREQ. METER TO	HET. METER FREQ. MC.	CONNECT OSCILLOSCOPE TO	MISCELLANEOUS CONNECTIONS AND INSTRUCTIONS	ADJUST	REFER TO
ANTENNA MATCHING UNIT ALIGNMENT										
1	Do not adjust this unit unless fairly certain that it requires adjustment. Disconnect lead from L58 to S5. Connect output of matching unit through 1000 mmf. to pin 1 of V107. Replace cover on matching unit. Remove V106 from socket. Connect bias box to junction of R143 and R144 and set to produce -6 volts.									
2	Antenna terminals	45.75 mc. 30% mod.	Not used	—	Not used	—	TP102. Scope gain to max.	—	L59 for min. audio on scope	Fig. 7
3	"	41.25 mc. 30% mod.	"	—	"	—	"	—	L60 for min. audio on scope	Fig. 7
4	Antenna terminals loosely		Antenna terminals through pad	45 to 54 mc.	"	—	Scope a xtal probe to gnd.	Connect 300 ohms from L58 to gnd.	L61 and L62 to obtain response of Fig. 12	Fig. 7 Fig. 11 Fig. 12
R-F UNIT ALIGNMENT										
5	If unit is completely out of adjustment, preset all adjustments to center of range with following exceptions. Set C18 so that head is 3/8" above chassis. Set T1 max. counterclockwise. Set C11 1/4 turn from max. clockwise. Disconnect link from T104 and terminate with 39 ohms. Short r-f unit power terminal 3 to ground. Set fine tuning 30 degrees clockwise from mechanical center of its range for all oscillator adjustments.									
6	Grid, pin 7 of V2 through 1500 mmf.	43.5 mc. 30% mod.	Not used	—	Not used	—	TP1. Gain to maximum	Set r-f unit on channel 2	L65 for min. indication on scope	Fig. 7 Fig. 10
7	Not used	—	Not used	—	Loosely to r-f unit oscillator	227 mc.	Not used	R-F unit on channel 8	C1 for beat on het. freq. meter	Fig. 7
8	Antenna terminals loosely	181.25 and 185.75	Antenna terminals through pad	Channel 8	Not used	—	TP1. Gain to maximum	"	C9, C11, C15 and C18 for response shown in Fig. 13	Fig. 7 Fig. 13
9	Not used	—	Not used	—	Loosely to r-f unit oscillator	129 mc.	Not used	R-F unit on channel 6	L5 for beat on het. freq. meter	Fig. 8
10	Antenna terminals loosely	83.25 and 87.75	Antenna terminals through pad	Channel 6	Not used	—	TP1. Gain to maximum	"	L48, L50 and L53 for response shown in Fig. 13	Fig. 7 Fig. 13
11	Not used	—	Not used	—	Not used	—	Not used	On channel 6. Connect "VoltOhmyst" to TP1	C8 for -3.5 volts on meter	Fig. 7
12	Antenna terminals loosely	83.25 and 87.75	Antenna terminals through pad	Channel 6	Not used	—	TP1. Gain to maximum	R-F unit on channel 6	Check response. Re-adjust L48, L50 and L53 if necessary	Fig. 7 Fig. 13
13	Not used	—	Not used	—	Loosely to r-f unit oscillator	227 mc.	Not used	R-F unit on channel 8	C1 for beat on het. freq. meter	Fig. 7
14	Antenna terminals loosely	181.25 and 185.75	Antenna terminals through pad	Channel 8	Not used	—	TP1. Gain to maximum	"	Check response adjust C9, C11, C15 and C18 if necessary	Fig. 7
15	If C9 was readjusted in step 14, repeat step 11, step 13 and step 14 until the conditions specified in each step are fulfilled without additional adjustments.									
16	Not used	—	Not used	—	Loosely to r-f unit oscillator	257 mc.	Not used	Rec. on channel 13	L46 for beat on het. freq. meter. Overshoot L46 slightly and adjust C1 for beat.	Fig. 7
17	Antenna terminals loosely	211.25 215.75	Antenna terminals through pad	Channel 13	Not used	—	TP1. Gain to maximum	Rec. on channel 13 "VoltOhmyst" on TP1	Check to see that response is correct and -3.0 volts of osc. injection is present	Fig. 13
18	"	205.25 209.75	"	Channel 12	Not used	—	"	Rec. on channel 12	"	Fig. 13
19	"	199.25 203.75	"	Channel 11	"	—	"	Rec. on channel 11	"	Fig. 13
20	"	193.25 197.75	"	Channel 10	"	—	"	Rec. on channel 10	"	Fig. 13
21	"	187.25 191.75	"	Channel 9	"	—	"	Rec. on channel 9	"	Fig. 13
22	"	181.25 185.75	"	Channel 8	"	—	"	Rec. on channel 8	"	Fig. 13
23	"	175.25 179.75	"	Channel 7	"	—	"	Rec. on channel 7	"	Fig. 13
24	If the response of any channel (steps 17 through 23) is below 80% at either marker, adjust C9, C11, C15 and C18 as necessary to pull response up on the low channel yet maintain correct response on channel 8.									
25	Repeat step 13. If the oscillator is off frequency overshoot the adjustment of C1 and correct by adjusting L46.									
26	Repeat steps 16 through 25 until all adjustments are obtained.									
27	Not used	—	Not used	—	Loosely to r-f unit oscillator	129 mc.	Not used	Rec. on channel 6	L5 for beat on het. freq. meter	Fig. 7
28	Antenna terminals loosely	83.25 87.75	Antenna terminals through pad	Channel 6	Not used	—	TP1. Gain to maximum	Rec. on channel 6 "VoltOhmyst" on TP1	Check to see that response is correct and -3.0 volts of osc. injection is present	Fig. 7 Fig. 13
29	"	77.25 81.75	"	Channel 5	"	—	"	Rec. on channel 5	"	Fig. 13
30	"	67.25 71.75	"	Channel 4	"	—	"	Rec. on channel 4	"	Fig. 13
31	"	61.25 65.75	"	Channel 3	"	—	"	Rec. on channel 3	"	Fig. 13

ALIGNMENT PROCEDURE

17T250DE, 17T261DE

Step No.	CONNECT SIGNAL GENERATOR TO	SIGNAL GEN. FREQ. MC.	CONNECT SWEEP GENERATOR TO	SWEEP GEN. FREQ. MC.	CONNECT HETERODYNE FREQ. METER TO	HET. METER FREQ. MC.	CONNECT OSCILLOSCOPE TO	MISCELLANEOUS CONNECTIONS AND INSTRUCTIONS	ADJUST	REFER TO
32	"	55.25 59.75	"	Channel 2	"	-	"	Rec. on channel 2	"	Fig. 13
33	If excessive tilt in the same direction occurs on channels 2, 3 and 4, adjust C18 on channel 2 to overshoot the correction of this tilt then switch to channel 6 and adjust L53 for max. amplitude of response between carrier markers.									
34	Check r-f response and oscillator injection on channels 7 through 13 steps 23 back up through step 17 stopping on channel 13 for the next step.									
35	Not used	-	Not used	-	Loosely coupled to r-f oscillator	257 mc.	TP1. Gain to maximum	Rec. on channel 13	C1 for beat on het. freq. meter	Fig. 7
36	"	-	"	-	"	251 mc.	"	Rec. on channel 12	L11 as above	Fig. 7
37	"	-	"	-	"	245 mc.	"	Rec. on channel 11	L10 as above	Fig. 7
38	"	-	"	-	"	239 mc.	"	Rec. on channel 10	L9 as above	Fig. 7
39	"	-	"	-	"	233 mc.	"	Rec. on channel 9	L8 as above	Fig. 7
40	"	-	"	-	"	227 mc.	"	Rec. on channel 8	L7 as above	Fig. 7
41	"	-	"	-	"	221 mc.	"	Rec. on channel 7	L6 as above	Fig. 7
42	"	-	"	-	"	129 mc.	"	Rec. on channel 6	L5 as above	Fig. 7
43	"	-	"	-	"	123 mc.	"	Rec. on channel 5	L4 as above	Fig. 7
44	"	-	"	-	"	113 mc.	"	Rec. on channel 4	L3 as above	Fig. 7
45	"	-	"	-	"	107 mc.	"	Rec. on channel 3	L2 as above	Fig. 7
46	"	-	"	-	"	101 mc.	"	Rec. on channel 2	L1 as above	Fig. 7
47	Repeat steps 35 through 46 as a check. On completion, remove 39 ohm resistor and reconnect link to terminals A and B of T104.									

RATIO DETECTOR, SOUND I-F AND SOUND TAKE-OFF ALIGNMENT

48	Grid 2nd Snd. I-F (pin 1, V102) or WR39B or C connect to grid 4th pix I-F (pin 1, V109.)	4.5 mc. 400 cy. mod. or 45.75 mc. mod. by 4.5 mc. and 400 cy.	Not used	-	Not used	-	Across speaker voice coil. Volume control set for max. volume.	"VoltOhmyst" to junction of R110 and R114. Set C226 for min. capacity. Set signal gen. to give -10 V on meter.	T102 top core for max. d-c on meter. T102 bottom core for min. audio on the oscilloscope.	Fig. 9 Fig. 10
49	"	"	"	-	"	-	"	"	"	Fig. 9 Fig. 10
50	Sig. Gen. to 1st Snd. I-F	4.5 mc.	1st Sound I-F grid (pin 1, V101)	4.5 mc.	"	-	In series with 10,000 ohms to terminal A, of T101.	Sweep output reduced to provide 2 v p-p on scope.	T101 top and bot. cores for max. gain and symmetry at 4.5 mc.	Fig. 9 Fig. 10 Fig. 14
51	"	"	"	"	"	-	Junction of R112 and C113	Check for symmetrical response wave form (positive and negative).	"	Fig. 15
52	Sig. Gen. in series with 1000 ohms to T110-C or WR39 across T104 A and B.	"	Not used	-	"	-	"	"	Adjust T110 for minimum reading on "VoltOhmyst".	Fig. 9

PICTURE I-F AND TRAP ADJUSTMENT

53	Not used	-	Not used	-	Not used	-	Not used	Connect bias box to junction of R143 and R144 and to gnd. Adjust to give -1.0 v on "VoltOhmyst" at TP101.	"	"
54	Sig. Gen. across T104 A and B	39.25 mc.	"	-	"	-	"	"	T104 top core to give min. d-c on meter.	Fig. 9
55	"	41.25 mc.	"	-	"	-	"	"	T105 bot. for min.	Fig. 10
56	"	47.25 mc.	"	-	"	-	"	"	T106 bot. for min.	Fig. 10
57	"	43.7 mc.	"	-	"	-	"	"	"	"
58	"	45.5 mc.	"	-	"	-	"	"	"	"
59	"	41.8 mc.	"	-	"	-	"	"	"	"
60	First pix i-f grid (pin 1, V106) loosely.	Various See Fig. 16	First pix i-f grid pin 1, V106 through 1000 mmf.	40 to 48 mc.	"	-	To test point TP102	Shunt R141, R149 and terminals A and F of T109 with 330 ohms, 0.5 v p-p on scope.	Adjust T105 and T106 top cores for max. gain and response shown in Fig. 16.	Fig. 9 Fig. 16
61	Connected loosely to diode probe.	Various See Fig. 17	Mixer grid test point TP2 with short lead.	40 to 48 mc.	"	-	"	Rec. on chan. 4. Connect 180 ohms from T105-B to junction R135 and C132. Upon completion disconnect scope and shunting resistors.	Set C221 to min. Adjust T1 top and T104 bot. for max. gain at 43.5 mc. and 45.75 mc. at 70%. Adjust C221 until 41.25 mc. is at 80%.	Fig. 9 Fig. 17
62	Connected loosely to grid of 1st pix i-f.	Various See Fig. 18	"	"	"	-	"	Connect scope to TP102.	Retouch T108 and T109 to obtain response shown in Fig. 18. Do not adjust T107 unless absolutely necessary.	Fig. 18

ALIGNMENT DATA

17T250DE, 17T261DE

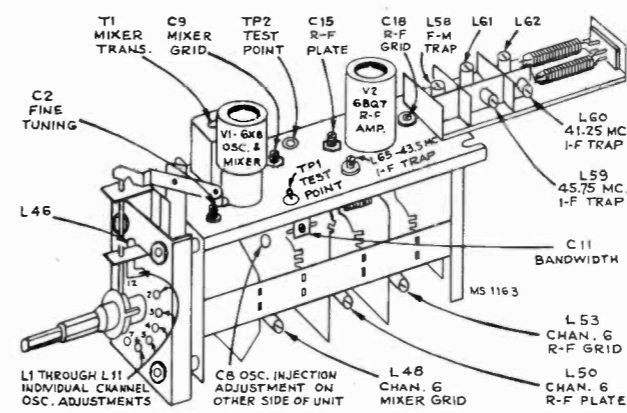

Figure 7—R-F Unit Adjustments

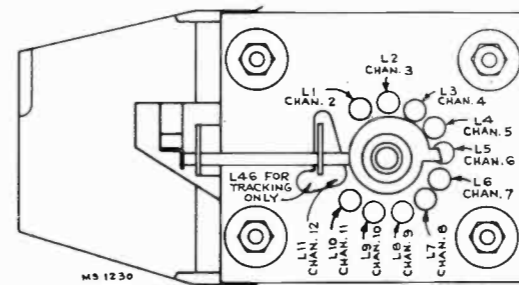

Figure 8—R-F Oscillator Adjustments

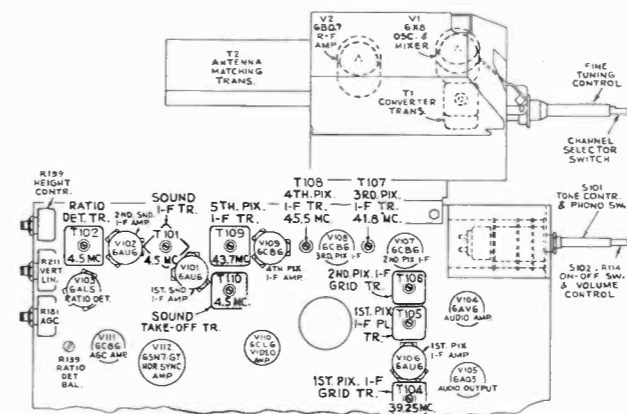

Figure 9—Top Chassis Adjustments

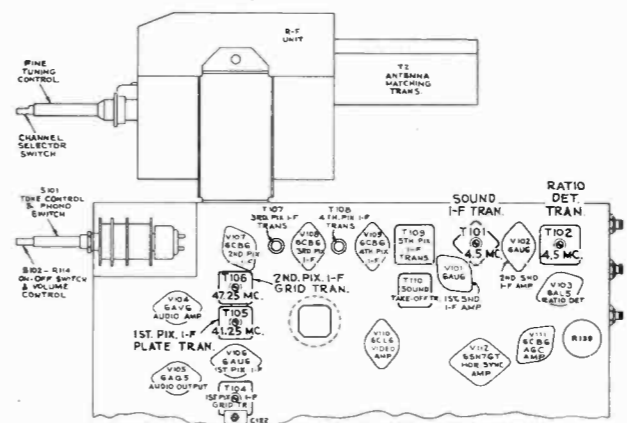

Figure 10—Bottom Chassis Adjustments

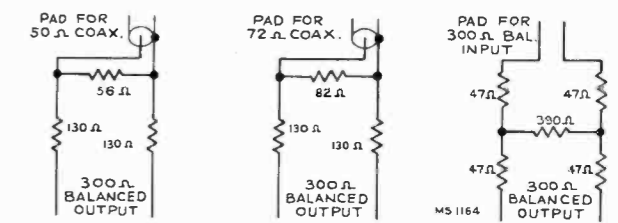

Figure 11—Sweep Attenuator Pads

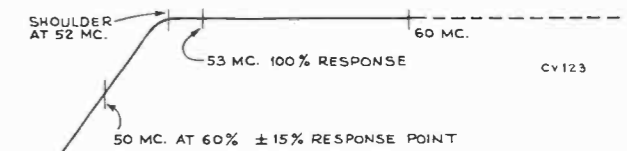

Figure 12—Antenna Matching Unit Response

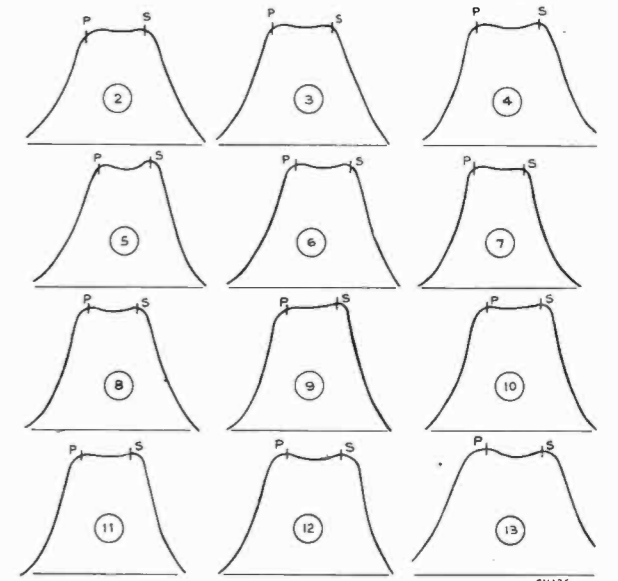

Figure 13—R-F Response

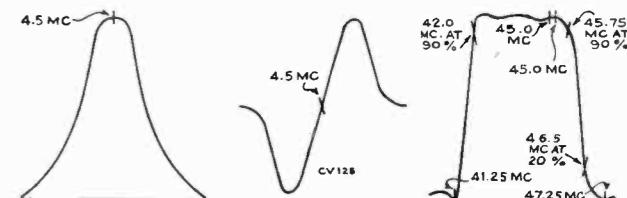

Figure 14
Sound I-F
Response

Figure 15
Ratio Det.
Response

Figure 16
T105 and T106
Response

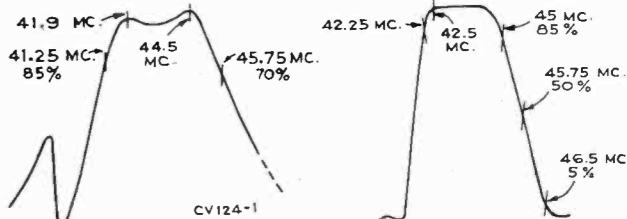

Figure 17
T1 and T104
Response

Figure 18
Over-all I-F
Response

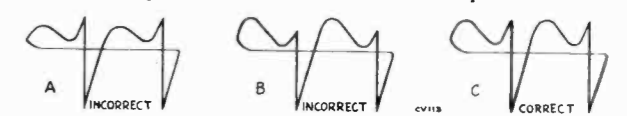

Figure 19—Horizontal Oscillator Waveforms



Figure 20—Normal Picture

Figure 21—Focus Magnet and Ion Trap Magnet Misadjusted

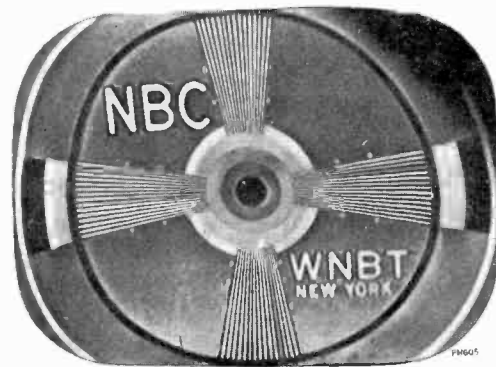

Figure 22—Horizontal Linearity Control Misadjusted (Picture Cramped in Middle)

Figure 23—Width Control Misadjusted

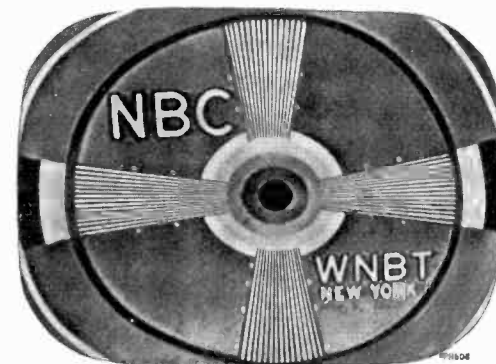
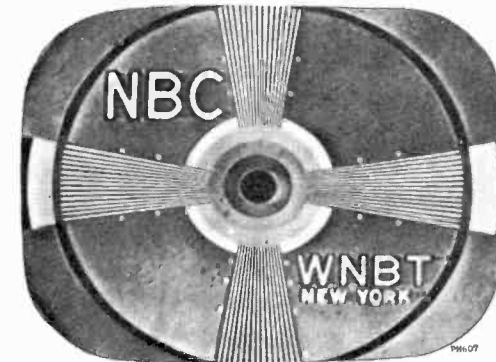

Figure 24—Horizontal Drive Control Misadjusted

Figure 25—Transients

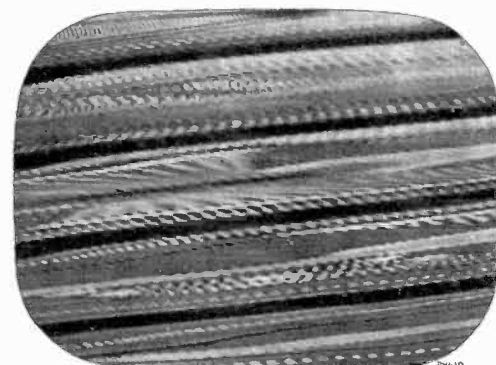
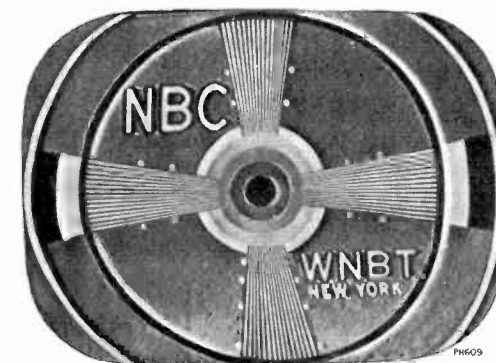
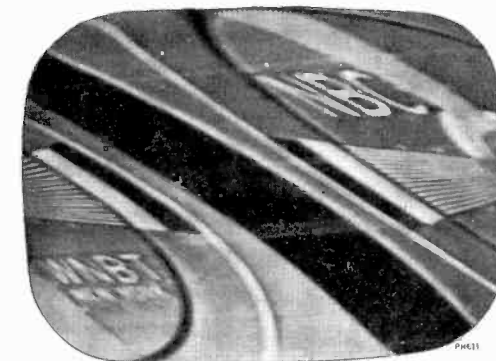

Figure 26—Test Pattern Showing Out of Sync Condition When Horizontal Hold Control Is in a Counter-clockwise Position—Just Before Pulling Into Sync

Figure 27—Test Pattern Showing Out of Sync Condition When Horizontal Hold Control Is at the Maximum Clockwise Position



Following is a list of symptoms of possible failures and an indication of some of the possible faults:

NO RASTER ON KINESCOPE:

- (1) Incorrect adjustment of ion trap magnet. Magnet reversed either front to back or top to bottom.
- (2) V116 or V117 inoperative. Check waveforms on grids and plates.
- (3) No high voltage—if horizontal deflection is operating as evidenced by the correct waveform on terminal 1 of high voltage transformer, the trouble can be isolated to the 1B3GT circuit. Either the T114 high voltage winding is open, the 1B3GT tube is defective or its filament circuit is open.
- (4) V110 circuit inoperative—Refer to schematic and waveform chart.
- (5) Damper tube (V119) inoperative.
- (6) Defective kinescope.
- (7) R216 open.
- (8) No receiver plate voltage—filter capacitor shorted—or filter choke open.

NO VERTICAL DEFLECTION:

- (1) V114B or V115 inoperative. Check voltage and waveforms on grids and plates.
- (2) T111 open.
- (3) Vertical deflection coils open.

SMALL RASTER:

- (1) Low Plus B or low line voltage.
- (2) V117 defective.

POOR VERTICAL LINEARITY:

- (1) If adjustments cannot correct, change V115.
- (2) Vertical output transformer T111 defective.
- (3) V114B defective—check voltage and waveforms on grid and plate.
- (4) C176, C180, C181, C178, C177 or C182 defective.
- (5) Low plate voltage—check rectifiers and capacitors in supply circuits.
- (6) If height is insufficient, try changing V114.

POOR HORIZONTAL LINEARITY:

- (1) If adjustments do not correct, change V117, or V119.
- (2) T114 or L107 defective.
- (3) C205 or C206 defective.

WRINKLES ON SIDE OF RASTER:

- (1) C208 defective.
- (2) Defective yoke.

PICTURE OUT OF SYNC HORIZONTALLY:

- (1) T113 incorrectly tuned.
- (2) R226, R227 or R197B defective.

TRAPEZOIDAL OR NON SYMMETRICAL RASTER:

- (1) Improper adjustment of centering of focus magnet or ion trap magnet.
- (2) Defective yoke.

RASTER AND SIGNAL ON KINESCOPE BUT NO SOUND:

- (1) T110 defective.
- (2) Sound i-f, ratio detector or audio amplifier inoperative—check V101, V102, V103 and their socket voltages.
- (3) Audio system defective.
- (4) Speaker defective.

SIGNAL AT KINESCOPE GRID BUT NO SYNC:

- (1) AGC control R181 misadjusted.
- (2) V111 inoperative. Check voltage and waveforms at its grid and plate.

SIGNAL ON KINESCOPE GRID BUT NO VERTICAL SYNC:

- (1) Check V114B and associated circuit.
- (2) Integrating network inoperative—Check.
- (3) V113 or V114A defective or associated circuit defective.
- (4) Gas current, grid emission or grid cathode leakage in V114. Replace.

SIGNAL ON KINESCOPE GRID BUT NO HORIZONTAL SYNC:

- (1) T113 misadjusted—readjust as instructed on page 11.
- (2) V112 or V113 inoperative—check socket voltages and waveforms.
- (3) T113 defective.
- (4) C163, C191A, C190, C194, C195, C197, C196, C198 or C199 defective.
- (5) If horizontal speed is completely off and cannot be adjusted check R226, R227, R197B, R228, R229, R230 and R232.

SOUND AND RASTER BUT NO PICTURE OR SYNC:

- (1) Picture, detector or video amplifier defective—check CR101 and V110—check socket voltages.
- (2) Bad contact to kinescope cathode.

PICTURE STABLE BUT POOR RESOLUTION:

- (1) CR101 or V110 defective.
- (2) Peaking coils defective—check resistance.
- (3) Make sure that the focus control operates on both sides of proper focus.
- (4) R-F and I-F circuits misaligned.

PICTURE SMEAR:

- (1) R-F or I-F circuits misaligned.
- (2) Open peaking coil.
- (3) This trouble can originate at the transmitter—check on another station.

PICTURE JITTER:

- (1) AGC control R181 misadjusted.
- (2) If regular sections at the left picture are displaced change V117.

SERVICE SUGGESTIONS

17T250DE, 17T261DE

- (3) Vertical instability may be due to loose connections or noise.
- (4) Horizontal instability may be due to unstable transmitted sync.

RASTER BUT NO SOUND, PICTURE OR SYNC:

- (1) Defective antenna or transmission line.
- (2) R-F oscillator off frequency.
- (3) R-F unit inoperative—check V1, V2.

DARK VERTICAL LINE ON LEFT OF PICTURE:

- (1) Reduce horizontal drive and readjust width and horizontal linearity.
- (2) Replace V117.

LIGHT VERTICAL LINE ON LEFT OF PICTURE:

- (1) V119 defective.

PICTURE I-F RESPONSE.—At times it may be desirable to observe the individual i-f stage response. This can be achieved by the following method:

For T107, T108 or T109, shunt all i-f transformers with a 330 ohm carbon resistor except the one whose response is to be observed.

Connect a wide band sweep generator to the second pix i-f grid and adjust it to sweep from 38 mc. to 48 mc.

Connect the oscilloscope to test point TP102 and observe the overall response. The response obtained will be essentially that of the unshunted stage.

To see the response of transformers T1, T104 and T105, T106, follow the instructions given on page 10.

Figures 28 through 36 show the response of the various stages obtained in the above manner. The curves shown are typical although some variation between receivers can be expected. Relative stage gain is not shown.

RESPONSE PHOTOGRAPHS

Taken from RCA WO58A Oscilloscope

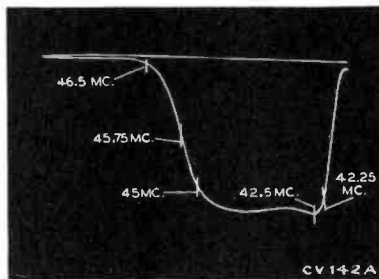

Figure 28—Overall Pix I-F Response

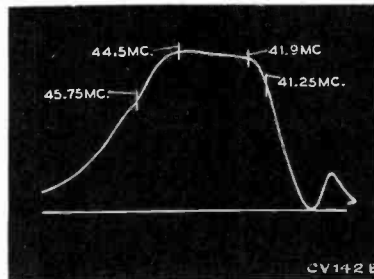

Figure 29—Response of T1-T104 Pix I-F Transformers

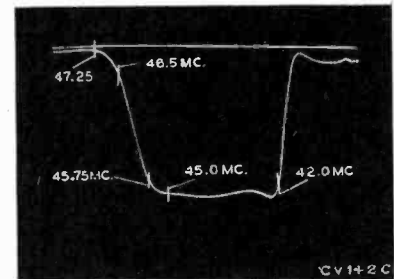

Figure 30—Response of T105-T106 Pix I-F Transformer

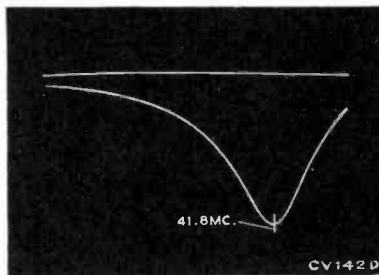

Figure 31—Response of T107 Pix I-F Transformer

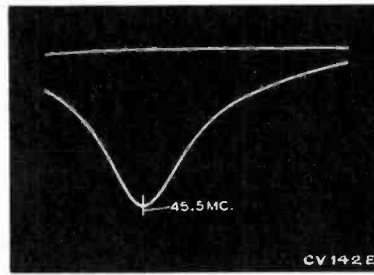

Figure 32—Response of T108 Pix I-F Coil

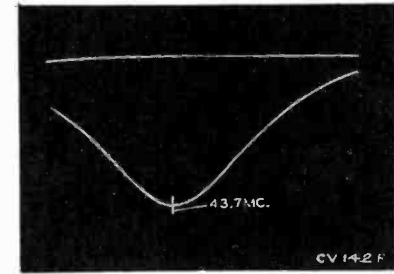

Figure 33—Response of T109 Pix I-F Coil

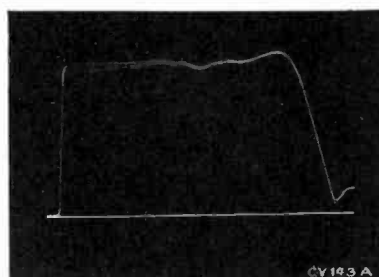

Figure 34—Video Response at Average Contrast

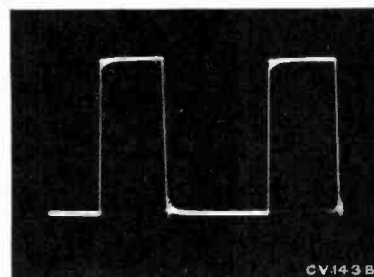

Figure 35—Video Response (100 KC Square Wave)

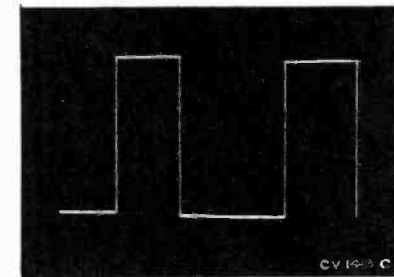
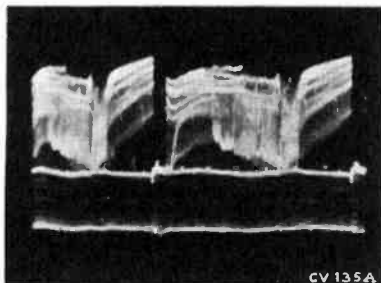

Figure 36—Video Response (60 Cycle Square Wave)

WAVEFORM PHOTOGRAPHS

Taken from RCA WO58A Oscilloscope



Grid of Video Amplifier
(Pin 2 of V110) (6CL6)
(Pin 4 of V110) (6AG7)
Figure 37—Vertical (Oscilloscope
Synced to 1/2 of Vertical Sweep
Rate) (6 Volts PP)



Figure 38—Horizontal (Oscilloscope
Synced to 1/2 of Horizontal Sweep
Rate) (6 Volts PP)

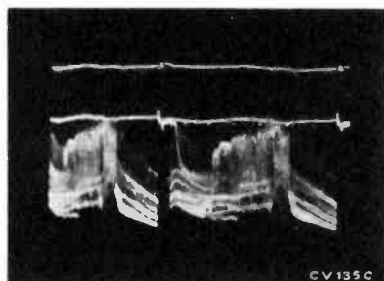
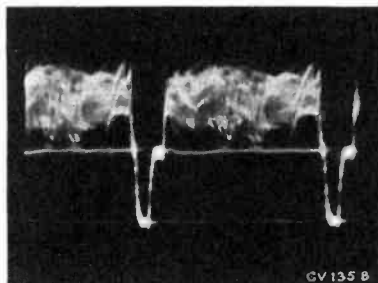
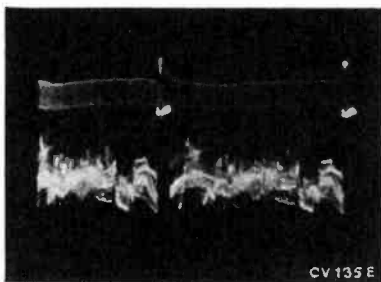
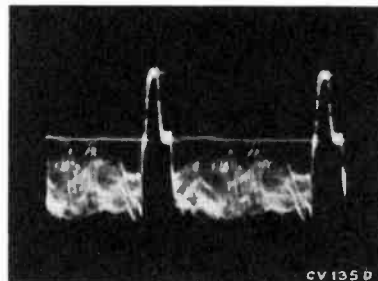

Plate of Video Amplifier
(Pin 6 of V110) (6CL6)
(Pin 8 of V110) (6AG7)
Voltage depends on picture
Figure 39—Vertical (105 Volts PP)



Figure 40—Horizontal (105 Volts PP)



Grid of Sync Separator
(Pin 4 of V113) (6SN7)
Voltage depends on picture
Figure 41—Vertical (30 Volts PP)



Figure 42—Horizontal (30 Volts PP)

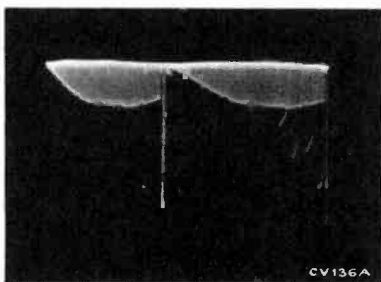
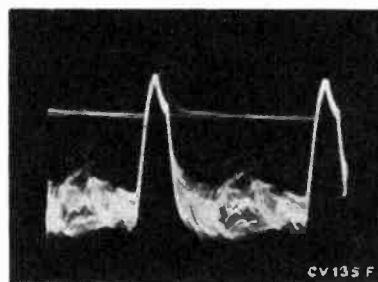
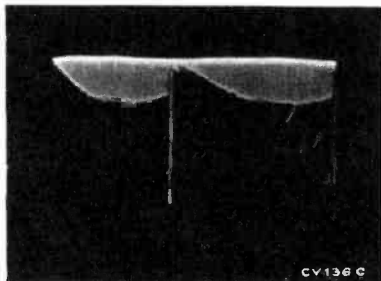
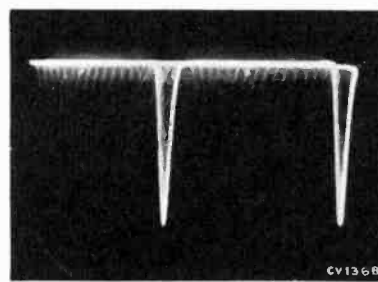

Plate of Sync Separator
(Pin 5 of V113) (6SN7)
Voltage depends on picture
Figure 43—Vertical (33 Volts PP)



Figure 44—Horizontal (8 Volts PP)



Grid of Vertical Sync Amp.
(Pin 4 of V114A) (6SN7)
Figure 45—Vertical (12 Volts PP)



Figure 46—Horizontal (5 Volts PP)

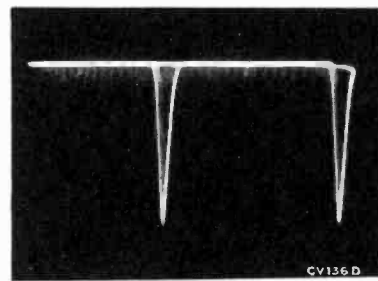

WAVEFORM PHOTOGRAPHS

Taken from RCA WO58A Oscilloscope

17T250DE, 17T261DE

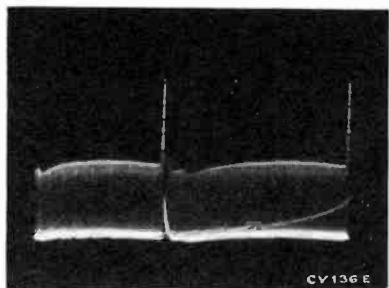

*Plate of Vertical Sync Amp.
(Pin 5 of V114A) (6SN7)*
Figure 47—Vertical (27 Volts PP)
←←←

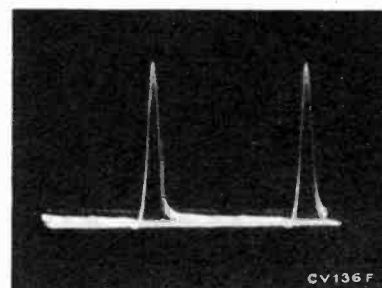
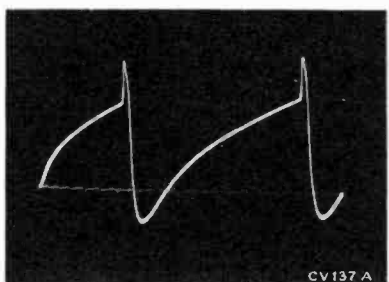
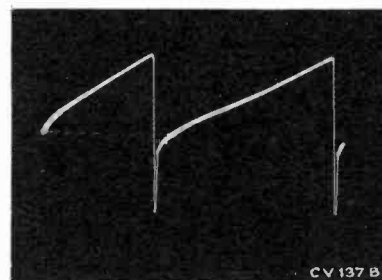

Figure 48—Horizontal (16 Volts PP)
→→→



**Figure 49—Grid of Vertical Sweep
Osc. (Pin 1 of V114B) (6SN7)**
(25 Volts PP)
←←←



**Figure 50—Plate of Vertical
Sweep Osc. (Pin 2 of V114B)**
(30 Volts PP)
→→→

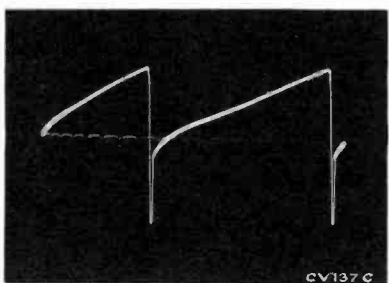

**Figure 51—Grid of Vertical Sweep
Output (Pin 1 of V115) (6AQ5)**
(35 Volts PP)
←←←

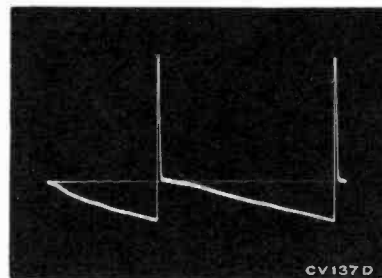

**Figure 52—Plate of Vertical Sweep
Output (Pin 5 of V115) (6AQ5)**
(800 Volts PP)
→→→

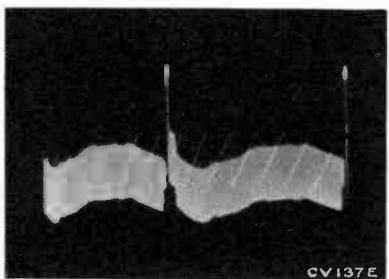

*Cathode of Sync Separator
(Pin 3 of V113) (6SN7)*
Figure 53—Vertical (11 Volts PP)
←←←

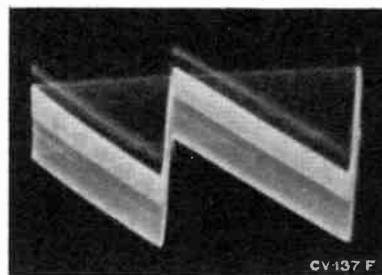
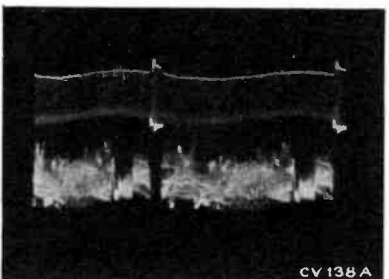

Figure 54—Horizontal (6 Volts PP)
→→→



*Grid of Sync Separator
(Pin 1 of V113) (6SN7)*
Figure 55—Vertical (40 Volts PP)
←←←

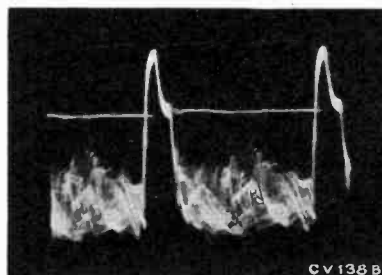

Figure 56—Horizontal (40 Volts PP)
→→→

WAVEFORM PHOTOGRAPHS
Taken from RCA WO58A Oscilloscope

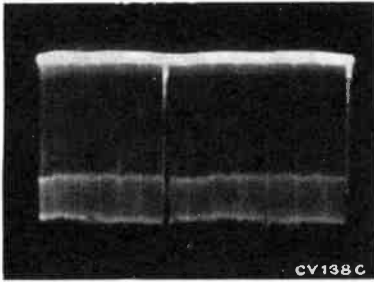
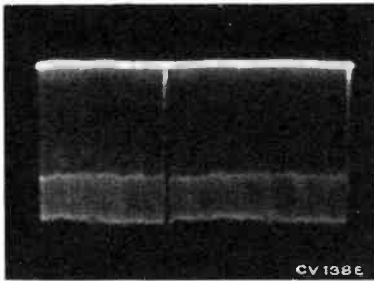
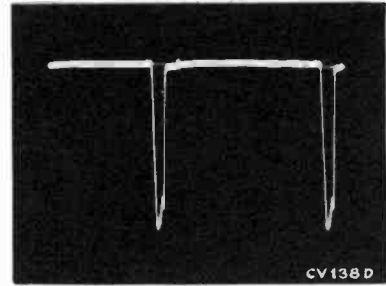

Plate of Sync Separator
(Pin 2 of V113)
Figure 57—Vertical (15 Volts PP)
←←←

Figure 58—Horizontal (15 Volts PP)
→→→



Grid of Hor Sync Amp
(Pin 4 of V112) (6SN7)
Figure 59—Vertical (15 Volts PP)
←←←

Figure 60—Horizontal (15 Volts PP)
→→→

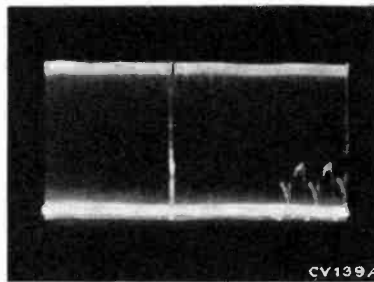
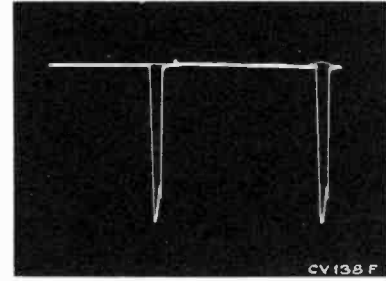
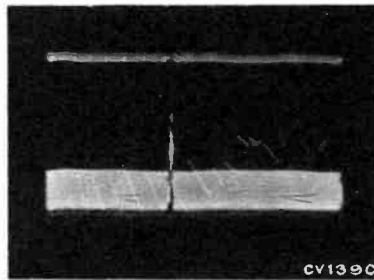
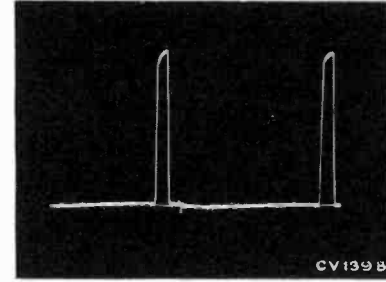

Plate of Hor Sync Amp
(Pin 5 of V112) (6SN7)
Figure 61—Vertical (70 Volts PP)
←←←

Figure 62—Horizontal (70 Volts PP)
→→→



Grid of Hor Sync Amp
(Pin 1 of V112) (6SN7)
Figure 63—Vertical (65 Volts PP)
←←←

Figure 64—Horizontal (65 Volts PP)
→→→

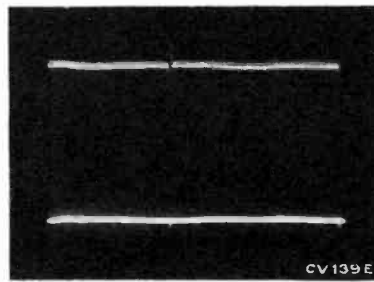
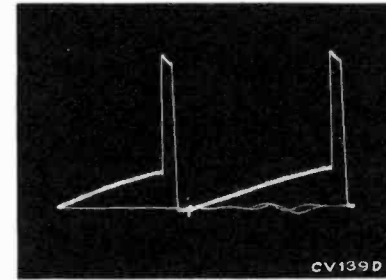

Cathode of Hor Sync Amp
(Pin 3 of V112) (6SN7)
Figure 65—Vertical (18 Volts PP)
←←←

Figure 66—Horizontal (18 Volts PP)
→→→

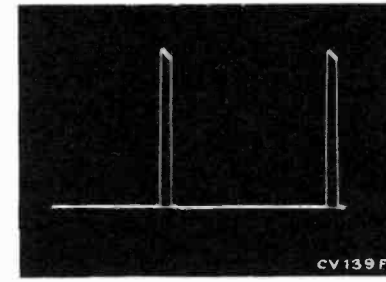

WAVEFORM PHOTOGRAPHS

Taken from RCA WO58A Oscilloscope

17T250DE, 17T261DE

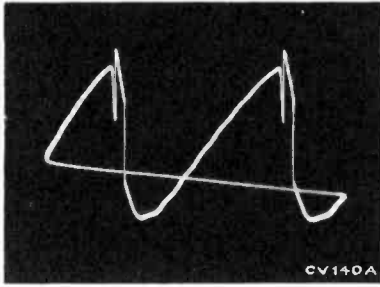

Figure 67—Grid of Horizontal Oscillator Control (22 Volts PP) (Pin 1 of V116) (6SN7GT)



Figure 68—Cathode of Horizontal Oscillator Control (1.3 Volts PP) (Pin 3 of V116) (6SN7GT)

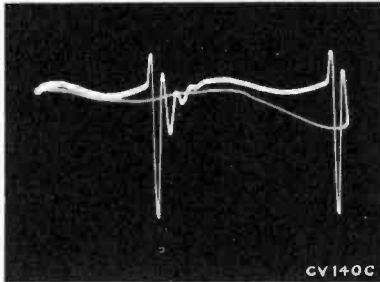
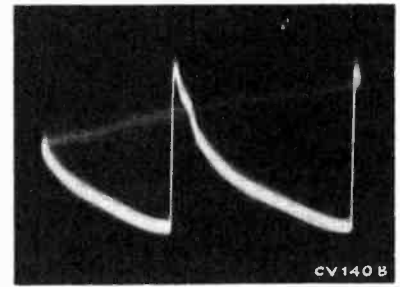

Figure 69—Grid of Horizontal Oscillator (390 Volts PP) (Pin 4 of V116) (6SN7GT)



Figure 70—Plate of Horizontal Oscillator (140 Volts PP) (Pin 5 of V116) (6SN7GT)

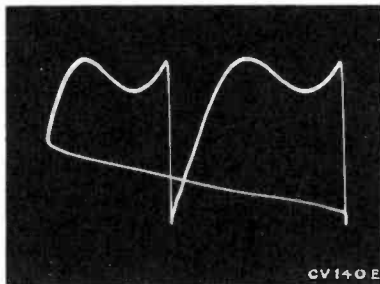
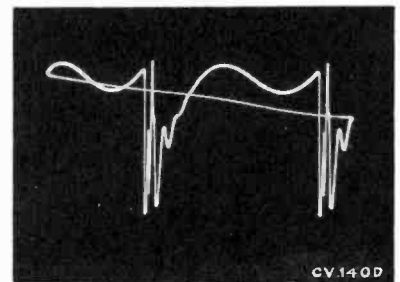

Figure 71—Terminal "C" of T114 (120 Volts PP)



Figure 72—Grid of Horizontal Output Tube (95 Volts PP) (Pin 5 of V117) (6BQ6)

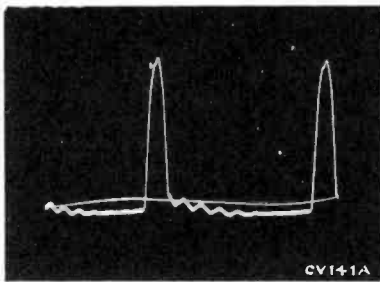
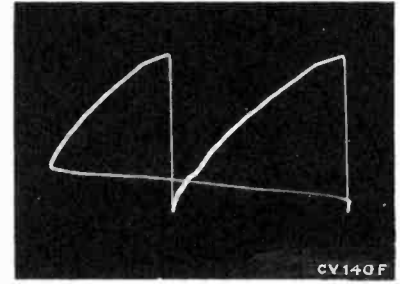

Figure 73—Plate of Horizontal Output (Approx. 4000 Volts PP) (Measured Through a Capacity Voltage Divider Connected from Top Cap of V117 to Ground)



Figure 74—Cathode of Damper (2300 Volts PP) (Pin 3 of V119) (6W4GT)

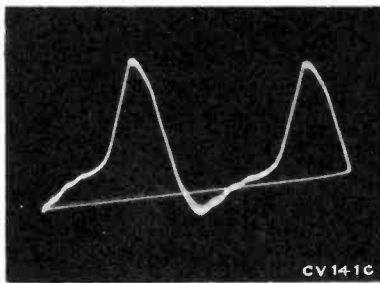
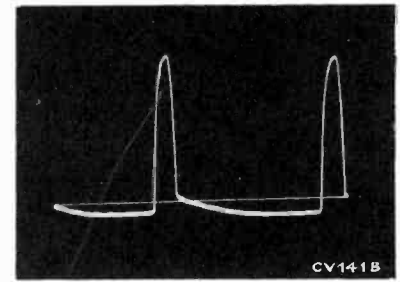
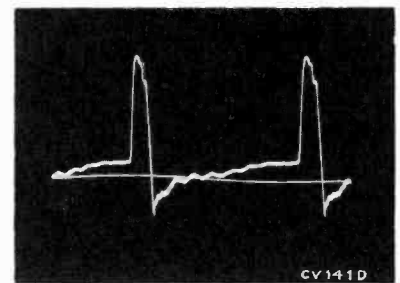

Figure 75—Plate of Damper (180 Volts PP) (Pin 5 of V119) (6W4GT)



Figure 76—Plate of AGC Amplifier (Pin 5 of V111) (6CB6) (600 Volts PP)



17T250DE, 17T261DE

VOLTAGE CHART

The following measurements represent two sets of conditions. In the first condition, a 5000 microvolt test pattern signal was fed into the receiver, the picture synced and the AGC control properly adjusted. The second condition was obtained by removing the antenna leads and short circuiting the receiver antenna terminals. Voltages shown are read with a type WV97A senior "VoltOhmyst" between the indicated terminal and chassis ground and with the receiver operating on 117 volts, 60 cycles, a-c.

Tube No.	Tube Type	Function	Operating Condition	E. Plate		E. Screen		E. Cathode		E. Grid		Notes on Measurements
				Pin No.	Volts	Pin No.	Volts	Pin No.	Volts	Pin No.	Volts	
V1	6X8	Mixer	5000 Mu. V. Signal	9	—	8	—	6	0	7	—	Depending on channel
			No Signal	9	145 to 150	8	145 to 150	6	0	7	-2.8 to -3.5	
V1	6X8	R-F Oscillator	5000 Mu. V. Signal	3	—	—	—	6	0	2	—	Depending on channel
			No Signal	3	88 to 108	—	—	6	0	2	-3.0 to -5.1	
V2	6BQ7	R-F Amplifier	5000 Mu. V. Signal	6	—	—	—	8	—	7	—	Depending on channel
			No Signal	6	133 to 138	—	—	8	1.1	7	—	
V2	6BQ7	R-F Amplifier	5000 Mu. V. Signal	1	—	—	—	3	—	2	—	Depending on channel
			No Signal	1	260	—	—	3	133 to 138	2	—	
V101	6AU6	1st Sound I-F Amp.	5000 Mu. V. Signal	5	140	6	152	7	0.3	1	-3.8	
			No Signal	5	112	6	122	7	0.8	1	-0.2	
V102	6AU6	2d Sound I-F Amp.	5000 Mu. V. Signal	5	258	6	58	7	0.19	1	-21	
			No Signal	5	255	6	55	7	0.22	1	*-2.5	
V103	6AL5	Ratio Detector	5000 Mu. V. Signal	7	0.4	—	—	1	16.8	—	—	7.5 kc deviation at 400 cycles
			No Signal	7	0.5	—	—	1	*9.35	—	—	*Unreliable measuring point. Voltage depends on noise.
V104	6AV6	1st Audio Amplifier	5000 Mu. V. Signal	7	95	—	—	2	0	1	-0.6	At min. volume
			No Signal	7	95	—	—	2	0	1	-0.6	At min. volume
V105	6AQ5	Audio Output	5000 Mu. V. Signal	5	263	6	273	2	18.2	7	0	At min. volume
			No Signal	5	262	6	272	2	18.2	7	0	At min. volume
V106	6AU6	1st Pix. I-F Amplifier	5000 Mu. V. Signal	5	242	6	279	7	0.06	1	-7.6	
			No Signal	5	140	6	135	7	1.03	1	*0	
V107	6CB6	2nd Pix. I-F Amplifier	5000 Mu. V. Signal	5	240	6	267	2	0.2	1	-7.6	
			No Signal	5	131	6	110	2	0.9	1	0	
V108	6CB6	3d Pix. I-F Amplifier	5000 Mu. V. Signal	5	127	6	112	2	0.92	1	0	
			No Signal	5	121	6	110	2	0.96	1	0	
V109	6CB6	4th Pix. I-F Amplifier	5000 Mu. V. Signal	5	194	6	159	2	2.4	1	0	
			No Signal	5	198	6	150	2	2.2	1	0	
V110	6CL6 *6AG7	Video Amplifier	5000 Mu. V. Signal	6	128	8	192	1	1.12	2	-3.5	*See Figure 79 for socket connections
			No Signal	6	72	8	142	1	1.48	2	†-0.9	†Depends on noise
V111	6CB6	AGC Amplifier	5000 Mu. V. Signal	5	-51	6	278	2	116	1	108	AGC control set for normal operation
			No Signal	5	0.9	6	282	2	100	1	54	AGC control set for normal operation

VOLTAGE CHART

17T250DE, 17T261DE

The following measurements represent two sets of conditions. In the first condition, a 5000 microvolt test pattern signal was fed into the receiver, the picture synced and the AGC control properly adjusted. The second condition was obtained by removing the antenna leads and short circuiting the receiver antenna terminals. Voltages shown are read with a type WV97A senior "VoltOhmyst" between the indicated terminal and chassis ground and with the receiver operating on 117 volts, 60 cycles, a-c.

Tube No.	Tube Type	Function	Operating Condition	E. Plate		E. Screen		E. Cathode		E. Grid		Notes on Measurements
				Pin No.	Volts	Pin No.	Volts	Pin No.	Volts	Pin No.	Volts	
V112	6SN7GT	Hor. Sync. Amplifier	5000 Mu. V. Signal	2	162	—	—	3	1.4	1	-40	
			No Signal	2	152	—	—	3	0.52	1	*-24	*Unreliable measurement point. Voltage depends on noise.
			5000 Mu. V. Signal	5	84	—	—	6	0	4	-1.38	
			No Signal	5	98	—	—	6	0	4	*1.08	*Voltage depends on noise.
V113	6SN7GT	Hor. Sync. Separator	5000 Mu. V. Signal	2	290	—	—	3	95	1	50	
			No Signal	2	285	—	—	3	*56	1	*38	*Unreliable measurement points. Voltage depends on noise.
V113	6SN7GT	Vert. Sync. Separator	5000 Mu. V. Signal	5	115	—	—	6	0	4	-58	
			No Signal	5	59	—	—	6	0	4	-11	
V114A	6SN7GT	Vert. Sync. Amplifier	5000 Mu. V. Signal	5	45	—	—	6	0	4	0.03	
			No Signal	5	43	—	—	6	0	4	0	
V114B	6SN7GT	Vertical Oscillator	5000 Mu. V. Signal	2	*72	—	—	3	0	1	*-15.3	*Depends on setting of Vert. hold control. Voltages shown are synced pix adjustment.
			No Signal	2	*70	—	—	3	0	1	*-15	
V115	6AQ5	Vertical Output	5000 Mu. V. Signal	5	270	6	290	2	27	1	0	
			No Signal	5	267	6	285	2	26	1	0	
V116	6SN7GT	Horizontal Osc. Control	5000 Mu. V. Signal	2	237	—	—	3	-10	1	-28.5	
			No Signal	2	228	—	—	3	-18	1	-29.5	
			5000 Mu. V. Signal	2	104	—	—	3	-36.3	1	-44	Hor. hold counter-clockwise
			5000 Mu. V. Signal	2	246	—	—	3	-11.5	1	-26	Hor. hold clockwise
V116	6SN7GT	Horizontal Oscillator	5000 Mu. V. Signal	5	200	—	—	6	0	4	-75	
			No Signal	5	197	—	—	6	0	4	-78	
			5000 Mu. V. Signal	5	193	—	—	6	0	4	-93	Hor. hold counter-clockwise
			5000 Mu. V. Signal	5	198	—	—	6	0	4	-74	Hor. hold clockwise
V117	6BQ6GT	Horizontal Output	5000 Mu. V. Signal	Cap	*	4	190	8	19.2	5	-16	*High Voltage Pulse Present
			No Signal	Cap	*	4	190	8	19.2	5	-15.3	
V118	1B3GT/8016	H. V. Rectifier	5000 Mu. V. Signal	Cap	*	—	—	2 & 7	15,150	—	—	*High Voltage Pulse Present
			No Signal	Cap	*	—	—	2 & 7	15,300	—	—	
V119	6W4GT	Damper	5000 Mu. V. Signal	5	287	—	—	3	*	—	—	*High Voltage Pulse Present
			No Signal	5	280	—	—	3	*	—	—	
V120	17QP4	Kinescope	5000 Mu. V. Signal	Cone	15,150	10	568	11	178	2	117	At average Brightness
			No Signal	Cone	15,300	10	560	11	151	2	101	

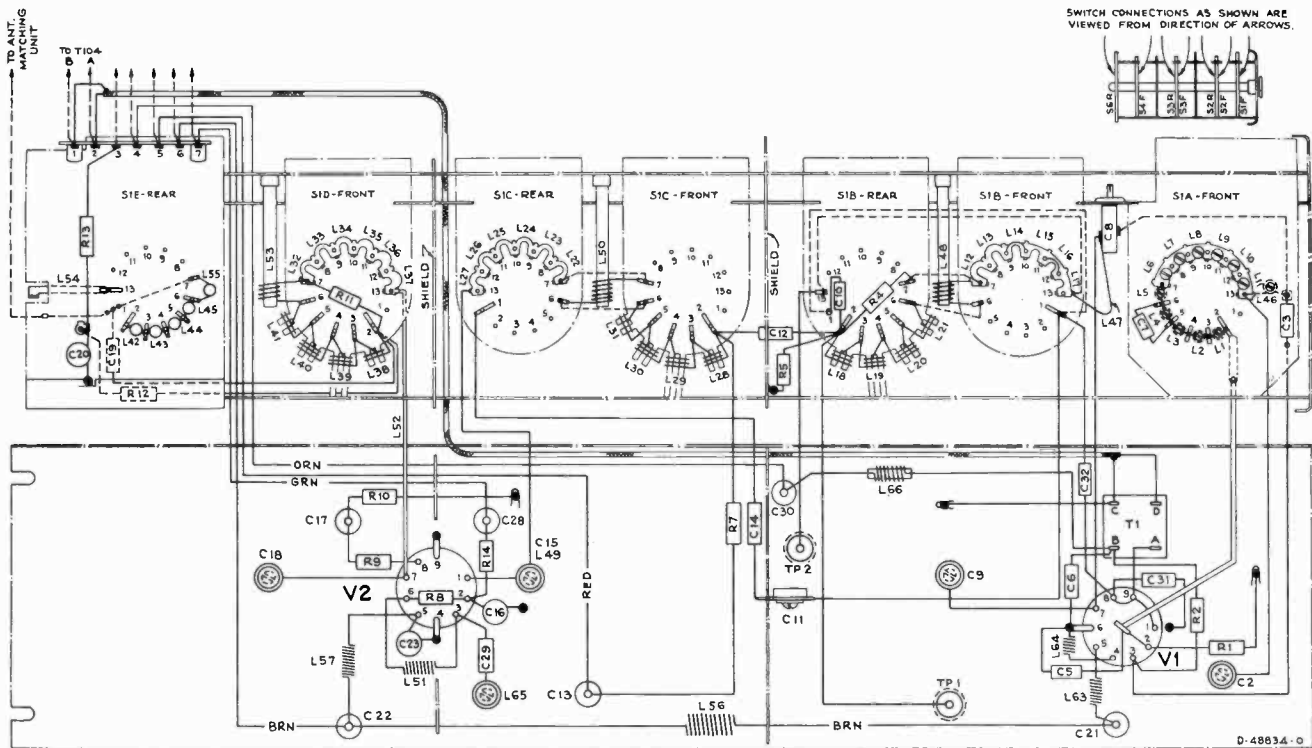

Figure 77—R-F Unit Wiring Diagram

CRITICAL LEAD DRESS

1. Keep all wiring in the pix i-f, sound i-f and video circuits as short as possible.
2. Keep the leads on C110, C111, C112, R108, R139, R150, R111, R109, R110 and R233 as short and direct as possible.
3. Do not change the bus wire connection to pin 2 of V101 and V102. Sleeving is used on these wires to insure length and to prevent shorting.
4. Dress C115 down between R114 (volume control) and wafer S101-B.
5. Ground R126 to pin 3 of V106 and R134 to pin 7 of V107.
6. Do not change the grounding of R136, R140 and R143.
7. Keep the bus wire from T109-A to C144 (plug in capacitor) short and direct.
8. Ground the filaments of sockets V107, V108 and V109 independently of the socket center pin. Use ground lances proved near each socket.
9. Dress C148 straight up to act as a shield between T101-A and V110-2.
10. Dress C155 and R160 (kine cathode) up in the air above the terminal board.
11. Keep the leads connected to T113-C and T113-D (synchoguide) down so that they will not short out when the chassis is placed in the cabinet.
12. Do not reroute any wires between T104 and the terminal board alongside it. Keep all leads on the foot side of the terminal board.
13. Dress all wires routed past T104, shielded wires W102 and W103 under the big lances near T104.
14. Dress all a-c leads to S102 under the large lances on the front apron.
15. Dress R113 close to the chassis with leads as short as possible.
16. Dress C158 and C122 up in the air and away from all other leads and components.
17. The lead from pin 5 of V111 to the terminal board under the high voltage cage should be routed between V117 socket and the rear apron.
18. Dress all 2 watt resistors away from each other and all other wires and components.
19. Dress all wires away from damper tube V119.
20. The wire from pin 5 V116 to T113-A should not be more than 5 inches long.
21. Dress all peaking coils up and away from the base.
22. Dress all leads in the high voltage compartment away from each other and away from the high voltage transformer.

STOCK No.	DESCRIPTION	STOCK No.	DESCRIPTION
76642	Resistor—Wire wound, 6750 ohms, 10 watts (R156)	503482	820,000 ohms, ±10%, 1/2 watt (R188, R200, R222, R231)
	Resistor—Fixed, composition:	503510	1 megohm, ±10%, 1/2 watt (R177)
503047	47 ohms, ±10%, 1/2 watt (R108, R154, R233)	11769	1.8 megohm, ±5%, 1/2 watt (R161)
502056	56 ohms, ±5%, 1/2 watt (R134)	39063	1.8 megohm, ±5%, 1 watt (R229)
34763	68 ohms, ±5%, 1/2 watt (R140)	503522	2.2 megohm, ±10%, 1/2 watt (R189, R204, R207)
502082	82 ohms, ±5%, 1/2 watt (R101)	503539	3.9 megohm, ±10%, 1/2 watt (R174)
502110	100 ohms, ±5%, 1/2 watt (R126)	503582	8.2 megohm, ±10%, 1/2 watt (R163)
503110	100 ohms, ±10%, 1/2 watt (R122, R129)	503610	10 megohm, ±10%, 1/2 watt (R113)
503118	180 ohms, ±10%, 1/2 watt (R144)	71456	Screw—No. 8-32 x 7/16" wing screw for mounting deflection yoke
503122	220 ohms, ±10%, 1/2 watt (R153)	76455	Shaft—Connecting shaft (nylon) for picture and brightness controls
503133	330 ohms, ±10%, 1/2 watt (R213)	73584	Shield—Tube shield for V101, V102, V103, V106, V107, V109
503147	470 ohms, ±10%, 1/2 watt (R123)	75718	Socket—Channel indicator lamp socket
513147	470 ohms, ±10%, 1 watt (R120, R212)	74834	Socket—Kinescope socket
503168	680 ohms, ±10%, 1/2 watt (R157)	75222	Socket—Tube socket, octal, ceramic, plate mounted for V116
502210	1000 ohms, ±5%, 1/2 watt (R150)	31251	Socket—Tube socket, octal, wafer, for V112, V113, V114, V117
503210	1000 ohms, ±10%, 1/2 watt (R107, R121, R125, R131, R133, R137, R142, R145, R175)	50367	Socket—Tube socket, 6 pin, moulded, saddle-mounted for V119
503212	1200 ohms, ±10%, 1/2 watt (R178)	71508	Socket—Tube socket, 6 pin, moulded for V118
503222	2200 ohms, ±10%, 1/2 watt (R159)	73117	Socket—Tube socket, 7 pin, wafer, miniature, for V101, V102, V103, V104, V105, V106, V107, V108, V109, V111
523222	2200 ohms, ±10%, 2 watts (R164)	73115	Socket—Tube socket, 7 pin, moulded, miniature, plate-mounted for V115
503233	3300 ohms, ±10%, 1/2 watt (R218)	76453	Socket—Tube socket, octal, moulded, saddle-mounted for V110 (6AG7) for KCS47M1
513233	3300 ohms, ±10%, 1 watt (R102)	76971	Socket—Tube socket, 9 pin, wafer, miniature, for V110 (6CL6) for KCS74
502239	3900 ohms, ±5%, 1/2 watt (R151)	76636	Stud—Adjusting stud complete with guard for focus magnet
503239	3900 ohms, ±10%, 1/2 watt (R225)	76428	Support—Bakelite support only—part of hi-voltage shield
513247	4700 ohms, ±10%, 1 watt (R155)	77215	Switch—Tone control and phono switch (S101)
502256	5600 ohms, ±5%, 1/2 watt (R136)	76463	Terminal—Screw type grounding terminal
503256	5600 ohms, ±10%, 1/2 watt (R172)	77198	Transformer—First pix i-f grid transformer complete with adjustable cores (T104, C125, R124)
14659	6800 ohms, ±5%, 1/2 watt (R109, R110)	77197	Transformer—First pix i-f plate transformer complete with adjustable cores (T105, C132, C133, R130)
513268	6800 ohms, ±10%, 1 watt (R147)	76435	Transformer—Second pix i-f grid transformer complete with adjustable core (T106, C134)
503282	8200 ohms, ±10%, 1/2 watt (R210)	76433	Transformer—Third or fourth pix i-f transformer (T107, T108)
503310	10,000 ohms, ±10%, 1/2 watt (R115, R205)	76436	Transformer—Fifth pix i-f transformer (T109, C143, C146, L102, R146, CR101)
513310	10,000 ohms, ±10%, 1 watt (R141)	76795	Transformer—Hi-voltage transformer (T114)
523310	10,000 ohms, ±10%, 2 watts (R236)	76440	Transformer—Horizontal oscillator transformer complete with adjustable cores (T113)
503312	12,000 ohms, ±10%, 1/2 watt (R171, R173)	76997	Transformer—Output transformer (T103)
513312	12,000 ohms, ±10%, 1 watt (R176)	76429	Transformer—Power transformer, 117 volt, 60 cycle (T112)
503315	15,000 ohms, ±10%, 1/2 watt (R219)	76438	Transformer—Sound i-f transformer complete with adjustable cores (T101, C103, C104)
503318	18,000 ohms, ±10%, 1/2 watt (R105, R184, R190, R228)	76437	Transformer—Sound take-off transformer complete with adjustable cores (T110, C147)
513322	22,000 ohms, ±10%, 1 watt (R227)	76439	Transformer—Ratio detector transformer complete with adjustable cores (T102, C108, C109)
503333	33,000 ohms, ±10%, 1/2 watt (R132, R183, R192)	76431	Transformer—Vertical output transformer (T111)
503339	39,000 ohms, ±10%, 1/2 watt (R111)	77225	Trap—4.5 MC trap (L105, C149)
513339	39,000 ohms, ±10%, 1 watt (R180)	76616	Yoke—Deflection yoke complete with 6 contact male connector (L111, L112, L113, L114, C208, P103, R239, R240, R241)
512343	43,000 ohms, ±5%, 1 watt (R209)		
30787	47,000 ohms, ±5%, 1/2 watt (R193)		
503347	47,000 ohms, ±10%, 1/2 watt (R103, R169)		
513347	47,000 ohms, ±10%, 1 watt (R127, R135, R191, R232)		
502356	56,000 ohms, ±5%, 1/2 watt (R143)		
523356	56,000 ohms, ±10%, 2 watts (R106)		
503368	68,000 ohms, ±10%, 1/2 watt (R195, R201, R202)		
513368	68,000 ohms, ±10%, 1 watt (R226)		
513382	82,000 ohms, ±10%, 1 watt (R224)		
503410	100,000 ohms, ±10%, 1/2 watt (R203, R217)		
512410	100,000 ohms, ±5%, 1 watt (R230)		
30180	120,000 ohms, ±5%, 1/2 watt (R206)		
503415	150,000 ohms, ±10%, 1/2 watt (R160, R179, R215, R220)		
3046	200,000 ohms, ±5%, 1/2 watt (R194)		
503422	220,000 ohms, ±10%, 1/2 watt (R214)		
502427	270,000 ohms, ±5%, 1/2 watt (R162)		
503427	270,000 ohms, ±10%, 1/2 watt (R185)		
503433	330,000 ohms, ±10%, 1/2 watt (R116, R221)		
512433	330,000 ohms, ±5%, 1 watt (R223)		
503439	390,000 ohms, ±10%, 1/2 watt (R196)		
503447	470,000 ohms, ±10%, 1/2 watt (R117, R148, R168, R234)		
503456	560,000 ohms, ±10%, 1/2 watt (R198)		
			SPEAKER ASSEMBLIES
			971490-3W RL-105E6 RMA-274
			(For Model 17T250DE)
		75024	Cone—Cone and voice coil (3.2 ohms)
		75022	Speaker—8" P.M. speaker complete with cone and voice coil (3.2 ohms)

STOCK No.	DESCRIPTION	STOCK No.	DESCRIPTION
	SPEAKER ASSEMBLIES	76594	Knob—Channel selector knob—beige—for blonde mahogany instruments (inner)
	92569-12W RL-111A1 RMA-274	76593	Knob—Channel selector knob—maroon—for mahogany or walnut instruments (inner)
	(For Model 17T261DE)	76592	Knob—Fine tuning control knob—beige—for blonde mahogany instruments (outer)
75682	Cone—Cone and voice coil (3.2 ohms)	76591	Knob—Fine tuning control knob—maroon—for mahogany or walnut instruments (outer)
76389	Speaker—12" P.M. speaker complete with cone and voice coil (3.2 ohms)	74963	Knob—Picture control, horizontal hold control or volume control and power switch knob—maroon—for mahogany or walnut instruments (inner)
	NOTE: If stamping on speaker in instruments does not agree with above speaker number, order replacement parts by referring to model number of instrument, number stamped on speaker and full description of part required.	75464	Knob—Picture control, horizontal hold control or volume control and power switch knob—beige—for blonde mahogany instruments (inner)
	MISCELLANEOUS	76598	Knob—Tone control and phono switch knob—beige—for blonde mahogany instruments (outer)
77213	Back—Cabinet back complete with terminal board and power cord for Model 17T250DE	76597	Knob—Tone control and phono switch knob—maroon—for mahogany or walnut instruments (outer)
77214	Back—Cabinet back complete with power cord for Model 17T261DE	11765	Lamp—Channel marker escutcheon lamp—Mazda 51
76184	Board—Antenna terminal board	76589	Mask—Channel marker escutcheon light mask—beige—for blonde mahogany instruments
76590	Bracket—Hanger bracket for deflection yoke hood assembly	75459	Mask—Channel marker escutcheon light mask—burgundy—for mahogany or walnut instruments
77028	Bracket—Support bracket ("L" shape) for kinescope masking panel (2 required)	77022	Mask—Polystyrene masking panel
76599	Bracket—"U" shape bracket for deflection yoke hood support rod	77013	Nut—Speednut for fastening "RCA Victor" emblem to cabinet (3 required)
77029	Clip—Retaining clip (top or bottom) for safety glass retainer	73634	Nut—Speednut for speaker mounting screws for Model 17T261DE
77030	Clip—Retaining clip (sides) for safety glass retainer	76177	Nut—No. 10-32 special nut for deflection yoke hood support rods
X1756	Cloth—Grille cloth for mahogany or walnut instruments for Model 17T250DE	76601	Pad—Kinescope edge support pad (2 required)
X3222	Cloth—Grille cloth for blonde mahogany instruments for Model 17T261DE	77027	Retainer—Safety glass retainer
X3199	Cloth—Grille cloth for mahogany or walnut instruments for Model 17T261DE	77024	Rod—"L" shape threaded rod to support deflection yoke hood assembly
75474	Connector—Single contact male connector for antenna cable	76632	Screw—No. 8 x 5/8" hex head wood screw for mounting hanger bracket
39153	Connector—4 contact male connector for antenna cable	76808	Sleeve—Polyethylene sleeve for insulating high voltage lead—on support rod
71457	Cord—Power cord and plug	73643	Spring—Channel marker escutcheon spring clip
77031	Cushion—Adhesive cushion (sponge rubber—3/8" dia.) for masking panel	76820	Spring—Formed spring for glass retainer clips (6 required)
76698	Cushion—Rubber cushion for kinescope masking panel support bracket	77025	Spring—Formed spring for kinescope masking panel
77034	Decal—Control function decal for mahogany or walnut instruments	77006	Spring—Retaining spring (coil) for deflection yoke hood support rod nut
76512	Decal—Control function decal for blonde mahogany instruments	30330	Spring—Retaining spring for knobs 74963, 75464
77244	Emblem—"Deluxe" emblem for mahogany or walnut instruments for Model 17T250DE	72845	Spring—Retaining spring for knobs 76591, 76592
77245	Emblem—"Deluxe" emblem for blonde instruments for Model 17T250DE	76837	Spring—Retaining spring for knobs 76593, 76594, 76595, 76596, 76597, 76598
77487	Emblem—"Deluxe" emblem for Model 17T261DE	77032	Spring—Suspension spring clip (formed) for ground braid
77012	Emblem—"RCA Victor" emblem	36580	Spring—Suspension spring (coil) for ground braid
75456	Escutcheon—Channel marker escutcheon	76600	Strap—Grounding strap (upper strip—1/2" x 18")
72113	Foot—Rubber foot (4 required) for Model 17T250DE	77023	Washer—Cellulose washer—gold—for knobs
77026	Glass—Safety glass	75500	Washer—Felt washer for masking panel or cabinet back mounting screws
37396	Grommet—Rubber grommet for mounting speaker for Model 17T261DE	75458	Washer—Felt washer—beige—between knob and channel marker escutcheon for blonde mahogany instruments
76596	Knob—Brightness control or vertical hold control knob—beige—for blonde mahogany instruments (outer)	75457	Washer—Felt washer—dark brown—between knob and channel marker escutcheon for mahogany or walnut instruments
76595	Knob—Brightness control or vertical hold control knob—maroon—for mahogany or walnut instruments (outer)		

CHASSIS WIRING DIAGRAM KCS74, KCS74M1

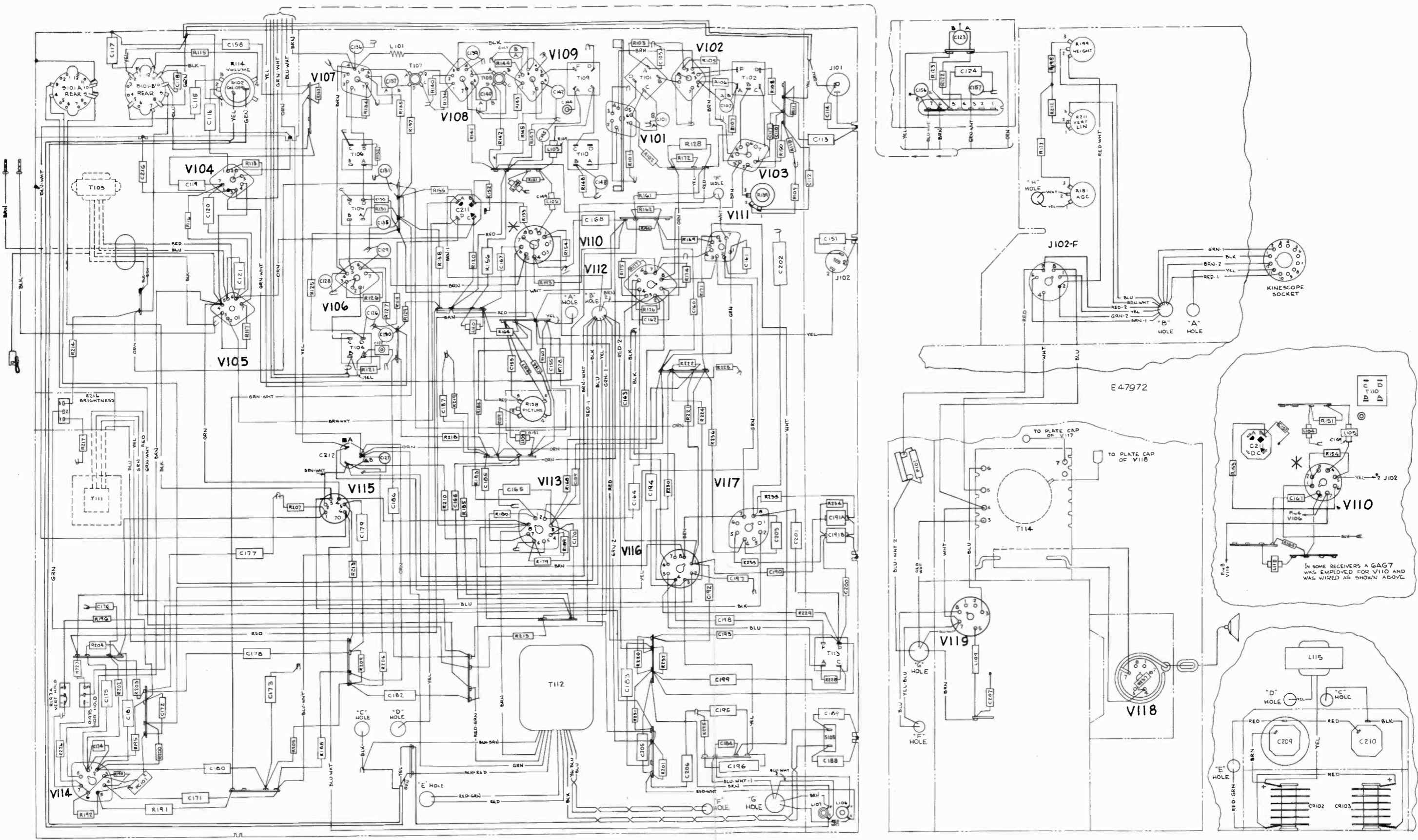
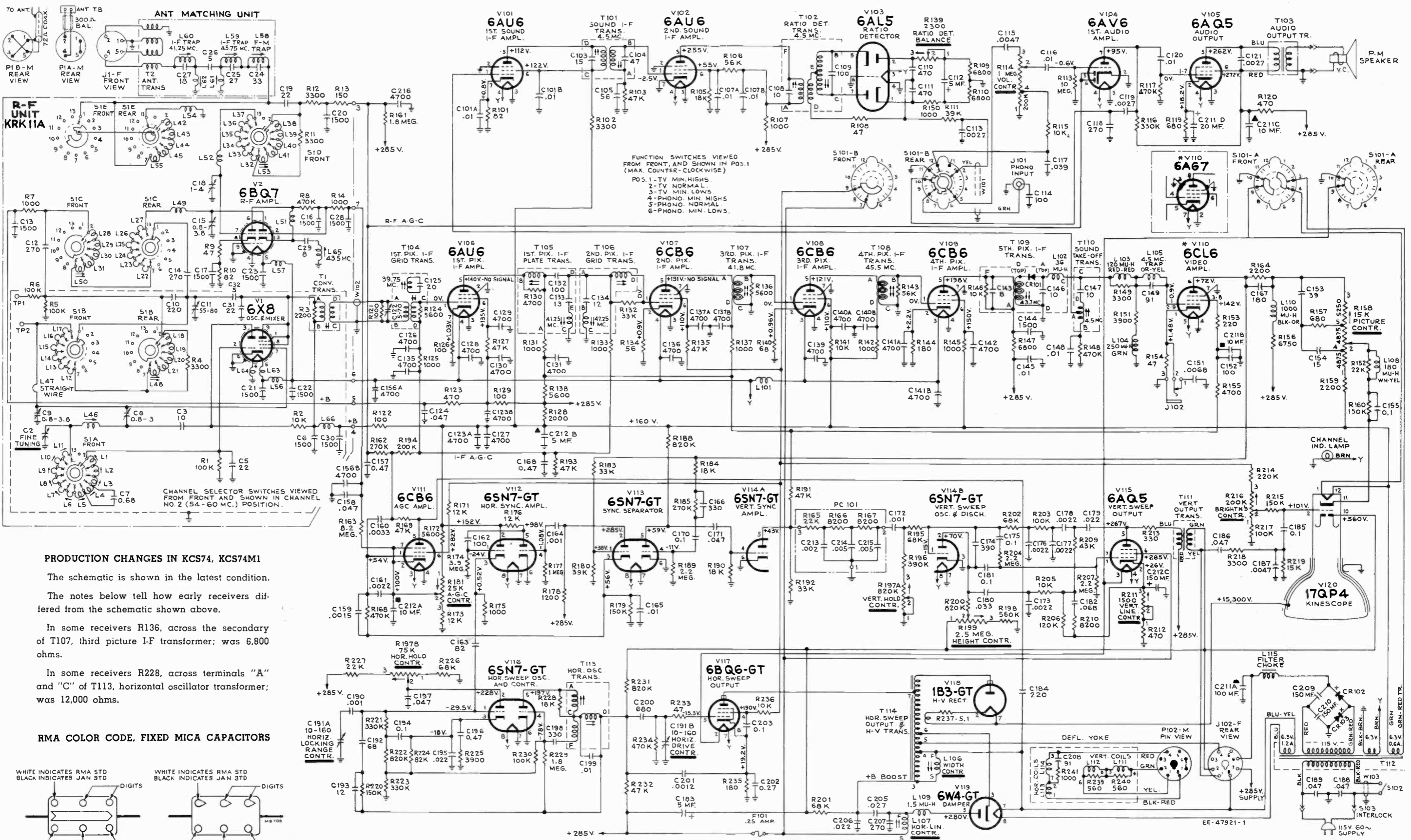

Figure 78—Chassis Wiring Diagram, KCS74, KCS74M1

KCS74 CIRCUIT SCHEMATIC DIAGRAM (*KCS74M1)

17T250DE, 17T261DE



PRODUCTION CHANGES IN KCS74, KCS74M1

The schematic is shown in the latest condition.

The notes below tell how early receivers differed from the schematic shown above.

In some receivers R136, across the secondary of T107, third picture I-F transformer; was 6,800 ohms.

In some receivers R228, across terminals "A" and "C" of T113, horizontal oscillator transformer; was 12,000 ohms.

RMA COLOR CODE, FIXED MICA CAPACITORS

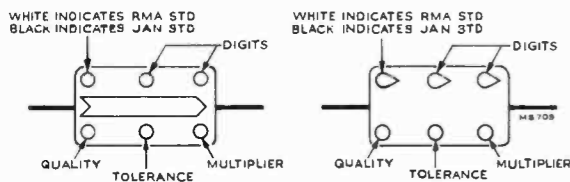

All resistance values in ohms. K = 1000. All capacitance values less than 1 in MF and above 1 in MMF unless otherwise noted.

Direction of arrows at controls indicates clockwise rotation.

All voltages measured with "VoltOhmyst" and with no signal input. Voltages should hold within ±20% with 117 v. a-c supply.

* In some receivers, a 6AG7 tube was employed in place of the 6CL6 video amplifier and was connected as shown in inset above

Figure 79—Circuit Schematic Diagram

STOCK No.	DESCRIPTION	STOCK No.	DESCRIPTION
	R-F UNIT ASSEMBLIES KRK11A	76548	Screw—No. 4-40 x 5/16" adjusting screw for coils L1, L2, L3, L4, L46
76539	Board—Antenna matching transformer terminal board less coils L58, L59, L60 and less capacitors C24, C25, C26, C27	76519	Shaft—Channel selector shaft and plate
76531	Board—Terminal board, 5 contact and ground	76134	Shaft—Fine tuning shaft and cam
76845	Bracket—Vertical bracket for holding V1 tube shield	77147	Shield—Front shield complete with shaft bushing and bracket
76965	Capacitor—Ceramic, variable, for fine tuning—plunger type (C2)	76534	Shield—Tube shield
93056	Capacitor—Ceramic, 5 mmf. (C26, C32)	76530	Socket—Tube socket, 9 pin, miniature, ceramic, saddle-mounted for V1
70597	Capacitor—Ceramic, 8 mmf. (C29)	76336	Socket—Tube socket, 9 pin, miniature, bakelite, saddle-mounted for V2
55326	Capacitor—Ceramic, 10 mmf. (C3)	77149	Spacer—Metal spacer for front plate
54207	Capacitor—Ceramic, 18 mmf. (C27)	75163	Spring—Friction spring (formed) for fine tuning cam
76557	Capacitor—Ceramic, 22 mmf. (C19, C31)	30340	Spring—Hairpin spring for fine tuning link
76558	Capacitor—Ceramic, 22 mmf. (C5)	75068	Spring—Retaining spring for tube shield
70935	Capacitor—Ceramic, 27 mmf. (C25)	77204	Spring—Return spring for fine tuning control
76739	Capacitor—Ceramic, 33 mmf. (C24)	76554	Stator—Antenna stator complete with rotor, coils, capacitors and resistor (S5, C20, L42, L43, L44, L45, L54, L55, R13)
77460	Capacitor—Ceramic, 220 mmf. (C10)	77353	Stator—Converter stator complete with rotor, coils, capacitor and resistors (S2, C10, C12, L12, L13, L14, L15, L16, L17, L18, L19, L20, L21, L47, L48, R4, R5, R6)
75199	Capacitor—Ceramic, 270 mmf. (C12, C14)	77205	Stator—Oscillator stator complete with rotor, coils and capacitors (S1, C3, C7, L1, L2, L3, L4, L5, L6, L7, L8, L9, L10, L11, L46)
75166	Capacitor—Ceramic, 1500 mmf. (stand-off) (C13, C17, C21, C22, C28, C30)	76553	Stator—R-F plate stator complete with rotor, coils, capacitor and resistor (S3, C14, L22, L23, L24, L25, L26, L27, L28, L29, L30, L31, L50, R7)
75610	Capacitor—Ceramic, 1500 mmf. (C6)	76556	Stator—R-F grid stator complete with rotor, coils, capacitor and resistors (S4, C19, L32, L33, L34, L35, L36, L37, L38, L39, L40, L41, L53, R11, R12)
73748	Capacitor—Ceramic, 1500 mmf. (C16, C20, C23)	76561	Strap—Channel No. 13 r-f grid strap (L52)
71088	Capacitor—Ceramic, 0.68 mmf. (C7)	76525	Strip—Coil segment mounting strip—RH center
77151	Capacitor—Tubular, steatite, adjustable, 0.8-3.0 mmf. (C8)	76526	Strip—Coil segment mounting strip—LH lower
75184	Capacitor—Ceramic, adjustable, 0.80-3.8 mmf., complete with adjusting stud (C9)	76544	Strip—Coil segment mounting strip—LH upper—less trimmer
76532	Capacitor—Adjustable trimmer, steatite, 1.4 mmf. (C18)	75446	Stud—Capacitor stud for trimmer coil L49, C15 (uncoded and coded "ER")
76527	Capacitor—Mica trimmer, 55-80 mmf. (C11)	75447	Stud—Capacitor stud for trimmer coil L49, C15 (coded numerically and "Hi Q")
76143	Clip—Tubular clip for mounting stand-off capacitors	76740	Stud—No. 6-32 x 1" adjusting stud for adjustable capacitor
73591	Coil—Antenna matching coil (2 required)	77152	Terminal—Terminal for mounting C8 trimmer
73477	Coil—Choke coil (L57)	76536	Transformer—Antenna matching transformer complete (T2, C24, C25, C26, C27, L58, L59, L60, L61, L62, J1)
76763	Coil—Filament choke coil (L63, L64)	77148	Transformer—Converter transformer (T1, R3)
77206	Coil—Filament choke coil (L56)	76540	Trap—FM trap complete with adjustable core (L58)
76562	Coil—R-F amplifier coupling coil (L51)	76535	Trap—I-F trap (L65)
77153	Coil—R-F choke coil (L66)	76542	Trap—I-F trap (41.25 MC) complete with core (L60)
76537	Coil—Shunt coil complete with adjustable core (L61)	76541	Trap—I-F trap (45.75 MC) complete with core (L59)
76538	Coil—Shunt coil complete with adjustable core (L62)	75190	Washer—Insulating washer (neoprene) for adjustable capacitor
76529	Coil—Trimmer coil (3 turns) with adjustable inductance core and capacitor stud (screw adjustment) for r-f section (L49, C15)		CHASSIS ASSEMBLIES KCS74
38853	Connector—4 contact female connector—part of matching transformer (J1)	76456	Bracket—Channel indicator lamp bracket
76559	Connector—Oscillator grid connector	76454	Bracket—Mounting bracket complete with insulator for picture control
76460	Contact—Test point contact	71496	Capacitor—Adjustable trimmer, 5-70 mmf. (C122)
77202	Core—Adjustable core for fine tuning capacitor	75217	Capacitor—Mica trimmer, dual 10-160 mmf. (C191A, C191B)
76543	Core—Adjusting core for FM trap	33380	Capacitor—Ceramic, 12 mmf. (C193)
76521	Detent—Detent mechanism and fibre shaft	39044	Capacitor—Ceramic, 15 mmf. (C154)
73453	Fqrm—Coil form for coils L48, L50, L53	73664	Capacitor—Ceramic, 39 mmf. (C153)
77203	Link—Link assembly for fine tuning	71924	Capacitor—Ceramic, 56 mmf. (C105)
76728	Nut—Speednut for mounting adjustable trimmer 76532	76475	Capacitor—Mica, 68 mmf. (C192)
	Resistor—Fixed, composition:	76474	Capacitor—Mica, 82 mmf. (C163)
503047	47 ohms, ±10%, ½ watt (R9)	39396	Capacitor—Ceramic, 100 mmf. (C114, C162)
503082	82 ohms, ±10%, ½ watt (R10)	75437	Capacitor—Ceramic, 100 mmf. (C152)
503115	150 ohms, ±10%, ½ watt (R13)	51416	Capacitor—Mica, 180 mmf. (C167)
503210	1000 ohms, ±10%, ½ watt (R7, R14)		
503233	3300 ohms, ±10%, ½ watt (R4, R11, R12)		
503247	4700 ohms, ±10%, ½ watt (R2)		
503410	100,000 ohms, ±10%, ½ watt (R1, R5, R6)		
503447	470,000 ohms, ±10%, ½ watt (R8)		
14343	Retainer—Fine tuning shaft retaining ring		
75164	Rod—Actuating plunger rod (fibre) for fine tuning link		
76547	Screw—No. 4-40 x ¼" adjusting screw for coils L6, L7, L8, L9, L10, L11		
76549	Screw—No. 4-40 x ⅜" adjusting screw for coil L5		

STOCK No.	DESCRIPTION	STOCK No.	DESCRIPTION
76673	Capacitor—Ceramic, 220 mmf. (C184)	73784	Capacitor—Tubular, paper, oil impregnated, 0.1 mfd., 200 volts (C155, C175)
73091	Capacitor—Mica, 270 mmf. (C207)	73551	Capacitor—Tubular, paper, oil impregnated, 0.1 mfd., 400 volts (C170, C185, C194)
47617	Capacitor—Ceramic, 270 mmf. (C118)	73557	Capacitor—Tubular, paper, oil impregnated, 0.1 mfd., 600 volts (C181, C203)
39640	Capacitor—Mica, 330 mmf. (C166)	73786	Capacitor—Tubular, paper, oil impregnated, 0.27 mfd., 200 volts (C202)
76476	Capacitor—Mica, 330 mmf. (C198)	73787	Capacitor—Tubular, paper, oil impregnated, 0.47 mfd., 200 volts (C157, C168, C196)
73094	Capacitor—Mica, 390 mmf. (C174)	76498	Choke—Filter choke (L115)
54003	Capacitor—Mica, 470 mmf. (C110, C111)	76143	Clip—Tubular clip to mount stand-off capacitor
75166	Capacitor—Ceramic, 1500 mmf. (stand-off) (C144)	73477	Coil—Choke coil (L101)
73473	Capacitor—Ceramic, 4700 mmf. (C126, C127, C128, C129, C130, C131, C135, C136, C139, C142, C216)	76442	Coil—Horizontal linearity coil complete with adjustable core (L107)
76470	Capacitor—Ceramic, dual, 4700 mmf. (C123A, C123B, C137A, C137B, C140A, C140B, C141A, C141B, C156A, C156B)	76441	Coil—Width coil complete with adjustable core (L106)
73960	Capacitor—Ceramic, 10,000 mmf. (C145, C148)	76640	Coil—R-F choke coil (1.5 muh) (L109)
75877	Capacitor—Ceramic, dual, 10,000 mmf. (C101A, C101B, C107A, C107B)	77195	Coil—Peaking coil (120 muh) (L103, R149)
74521	Capacitor—Electrolytic, 5 mfd., 50 volts (C112)	76647	Coil—Peaking coil (180 muh) (L108, R152)
28417	Capacitor—Electrolytic, 5 mfd., 450 volts (C183)	71526	Coil—Peaking coil (250 muh) (L104)
75218	Capacitor—Electrolytic, comprising 1 section of 10 mfd., 350 volts, 1 section of 5 mfd., 350 volts and 1 section of 150 mfd., 50 volts (C212A, C212B, C212C)	77194	Coil—Peaking coil (1000 muh) (L110)
76451	Capacitor—Electrolytic, comprising 1 section of 100 mfd., 350 volts, 2 sections of 10 mfd., 350 volts and 1 section of 20 mfd., 50 volts (C211A, C211B, C211C, C211D)	71789	Connector—Anode connector
75220	Capacitor—Electrolytic, 150 mfd., 200 volts (C209, C210)	35787	Connector—Phono input connector (J101)
76479	Capacitor—Tubular, moulded, oil impregnated, .00068 mfd., 600 volts (C200)	75474	Connector—Single contact male connector for speaker cable (2 required)
75249	Capacitor—Tubular, paper, oil impregnated, .001 mfd., 600 volts (C164, C172, C190)	75482	Connector—Video connector (J102)
76995	Capacitor—Tubular, moulded, oil impregnated, .0012 mfd., 600 volts (C201)	74594	Connector—2 contact male connector for power cord
73802	Capacitor—Tubular, paper, oil impregnated, .0015 mfd., 600 volts (C159)	50367	Connector—6 contact female connector for yoke leads (J103)
73595	Capacitor—Tubular, paper, oil impregnated, .0022 mfd., 600 volts (C113, C161, C173, C176, C177, C178)	75542	Connector—6 contact male connector—part of deflection yoke (P103)
73599	Capacitor—Tubular, paper, oil impregnated, .0027 mfd., 600 volts (C119)	77200	Control—AGC control (R181)
73818	Capacitor—Tubular, paper, oil impregnated, .0027 mfd., 1600 volts (C121)	76444	Control—Brightness control (R216)
73795	Capacitor—Tubular, paper, oil impregnated, .0033 mfd., 600 volts (C160)	76448	Control—Height control (R199)
73920	Capacitor—Tubular, paper, oil impregnated, .0047 mfd., 600 volts (C115, C187)	77201	Control—Horizontal and vertical hold control (R197A, R197B)
73789	Capacitor—Tubular, paper, oil impregnated, .0068 mfd., 400 volts (C151)	76445	Control—Picture control (R158)
73561	Capacitor—Tubular, paper, oil impregnated, .01 mfd., 400 volts (C116, C120, C165)	77199	Control—Ratio detector balance control (R139)
73594	Capacitor—Tubular, moulded, oil impregnated, .01 mfd., 600 volts (C199)	76449	Control—Vertical linearity control (R211)
73562	Capacitor—Tubular, paper, oil impregnated, .022 mfd., 400 volts (C195)	77010	Control—Volume control and power switch (R114, S102)
73798	Capacitor—Tubular, paper, oil impregnated, .022 mfd., 600 volts (C179)	76986	Cover—Back cover for hi-voltage compartment
73810	Capacitor—Tubular, paper, oil impregnated, .022 mfd., 1000 volts (C206)	76985	Cover—Side cover for hi-voltage compartment
73811	Capacitor—Tubular, paper, oil impregnated, .027 mfd., 1000 volts (C205)	74956	Cushion—Rubber cushion for deflection yoke hood
73596	Capacitor—Tubular, paper, oil impregnated, .033 mfd., 1000 volts (C180)	74839	Fastener—Push fastener for mounting tube socket for V116 and tube socket 76453
73790	Capacitor—Tubular, paper, oil impregnated, .039 mfd., 400 volts (C117)	73600	Fuse—0.25 amps. (F101)
73558	Capacitor—Tubular, paper, oil impregnated, .047 mfd., 200 volts (C171)	76459	Grommet—Rubber grommet for 2nd anode lead exit
73553	Capacitor—Tubular, paper, oil impregnated, .047 mfd., 400 volts (C158, C197)	37396	Grommet—Rubber grommet for mounting tube socket for V116 and tube socket 76453
75071	Capacitor—Tubular, moulded, .047 mfd., 400 volts (C188, C189)	76830	Hood—Deflection yoke hood less rubber cushions
73592	Capacitor—Tubular, paper, oil impregnated, .047 mfd., 600 volts (C124)	76168	Magnet—Focus magnet
73597	Capacitor—Tubular, paper, oil impregnated, .047 mfd., 1000 volts (C186)	76141	Magnet—Ion trap magnet (P.M. type)
73792	Capacitor—Tubular, paper, oil impregnated, .068 mfd., 400 volts (C182)	76633	Magnet—Pin cushion correction magnet complete with support arm
		18469	Plate—Bakelite mounting plate for electrolytic 75220
		76464	Plate—Hi-voltage plate—bakelite—complete with tube socket and corona ring
		77196	Printed Circuit—Consisting of 1 section of 22,000 ohms, 2 sections of 8200 ohms, 1 section of .002 mfd., and 2 sections of .005 mfd. PC101 (C213, C214, C215, R165, R166, R167)
		76675	Rectifier—Picture detector crystal rectifier (CR101)
		76452	Rectifier—Selenium rectifier (CR102, CR103)
		76796	Resistor—Wire wound, 5.1 ohms, 1/3 watt (R237)
		76639	Resistor—Wire wound, 180 ohms, 2 watts (R235)
		77193	Resistor—Wire wound, 680 ohms, 1 watt (R119)
		34473	Resistor—Wire wound, 2000 ohms, 10 watts (R128)
		76390	Resistor—Wire wound, 5600 ohms, 5 watts (R138)



Models 21T159, 21T159DE, "Selfridge"
Walnut, Mahogany, Lined Oak



Model 21T165 "Meredith"
Walnut, Mahogany, Lined Oak



Model 21T166DE "Farmington"
Walnut, Mahogany, Blond Mahogany



Model 21T174DE "Bancroft"
Walnut, Mahogany, Lined Oak



Model 21T175DE "Benton"
Walnut, Mahogany, Lined Oak



Model 21T176 "Suffolk"
Walnut, Mahogany, Lined Oak



Model 21T177 "Donley"
Walnut, Mahogany, Lined Oak



Models 21T178, 21T178DE, "Rockingham"
Walnut, Mahogany



Models 21T179, 21T179DE, "Clarendon"
Walnut, Mahogany, Maple

TELEVISION RECEIVERS—MODELS 21T159, 21T159DE, 21T165, 21T166DE, 21T174DE, 21T175DE, 21T176, 21T177, 21T178, 21T178DE, 21T179, 21T179DE

Chassis Nos. KCS68C, KCS68E or KCS68F
— Mfr. No. 274 —

SERVICE DATA

— 1951 No. T8 —

PREPARED BY RCA SERVICE CO., INC.
FOR
RADIO CORPORATION OF AMERICA
RCA VICTOR DIVISION
CAMDEN, N. J., U. S. A.

GENERAL DESCRIPTION

Features of these receivers are: full twelve channel coverage; "totem" r-f amplifier; intercarrier FM sound system; ratio detector; 40 mc picture i-f; improved picture brilliance; pulsed picture A-G-C; A-F-C horizontal hold; stabilized vertical hold; compensated video gain control; noise saturation circuits; improved sync. separator and clipper; four mc. band width for picture channel and reduced hazard high voltage supply. An auxiliary audio input jack is provided to permit the use of an external record playing attachment.

ELECTRICAL AND MECHANICAL SPECIFICATIONS

PICTURE SIZE 227 square inches on a 21AP4 Kinescope
 TELEVISION R-F FREQUENCY RANGE
 All 12 television channels, 54 mc. to 88 mc., 174 mc. to 216 mc.
 Picture I-F Carrier Frequency 45.75 mc.
 Sound I-F Carrier Frequency 41.25 mc. and 4.5 mc.
 POWER SUPPLY RATING 115 volts, 60 cycles, 300 watts
 AUDIO POWER OUTPUT RATING 5.0 watts max.
 CHASSIS DESIGNATIONS
 KCS68C In Models 21T176, 21T177, 21T178, 21T179
 KCS68E In Models 21T159, 21T165
 KCS68F In Models 21T159DE, 21T166DE, 21T174DE,
 21T175DE, 21T178DE, 21T179DE

Model Weight	Chassis with Tubes in Cabinet	Shipping Weight
21T159, 21T159DE	104 lbs.	125 lbs.
21T165	111 lbs.	149 lbs.
21T166DE	120 lbs.	152 lbs.
21T174DE	140 lbs.	172 lbs.
21T175DE	152 lbs.	184 lbs.
21T176	128 lbs.	159 lbs.
21T177	143 lbs.	174 lbs.
21T178, 21T178DE	148 lbs.	182 lbs.
21T179, 21T179DE	153 lbs.	187 lbs.

RECEIVER ANTENNA INPUT IMPEDANCE

Choice: 300 ohms balanced or 72 ohms unbalanced.

RCA TUBE COMPLEMENT

Tube Used	Function
(1) RCA 6BQ7	R-F Amplifier
(2) RCA 6X8	R-F Oscillator and Mixer
(3) RCA 6AU6	1st Picture I-F Amplifier
(4) RCA 6BC6	2nd Picture I-F Amplifier
(5) RCA 6CB6	3rd Picture I-F Amplifier
(6) RCA 6CB6	4th Picture I-F Amplifier
(7) RCA 6AG7	Video Amplifier
(8) RCA 6AU6	1st Sound I-F Amplifier
(9) RCA 6AU6	2nd Sound I-F Amplifier
(10) RCA 6AL5	Ratio Detector
(11) RCA 6AV6	1st Audio Amplifier
(12) RCA 6AQ5	Audio Output
(13) RCA 6CB6	AGC Amplifier
(14) RCA 6SN7GT	Sync Separator
(15) RCA 6SN7GT	Vert Sync Amplifier and Vert Sweep Osc.
(16) RCA 6AQ5	Vertical Sweep Output
(17) RCA 6SN7GT	Horizontal Sync Amplifier
(18) RCA 6SN7GT	Horizontal Sweep Oscillator and Control
(19) RCA 6CD6G	Horizontal Sweep Output
(20) RCA 6W4GT (2 tubes)	Dampers
(21) RCA 1B3-GT/8016	High Voltage Rectifier
(22) RCA 5U4G (2 tubes)	Rectifiers
(23) RCA 21AP4	Kinescope

21T159, 21T159DE, 21T165
21T166DE, 21T174DE, 21T175DE
21T176, 21T177, 21T178
21T178DE, 21T179, 21T179DE

ELECTRICAL AND MECHANICAL SPECIFICATIONS

(Continued)

LOUDSPEAKERS

Models 21T159, 21T159DE (971490-2) 8" PM dynamic, 3.2 ohms
Models 21T165, 21T166DE, 21T174DE, 21T175DE, 21T178DE,
21T179DE (92561-14W) 12" PM Dynamic, 3.2 ohms
Models 21T176, 177, 178 and 179
(971494-1W) 12" PM Dynamic, 3.2 ohms

PICTURE INTERMEDIATE FREQUENCIES

Picture Carrier Frequency 45.75 mc.
Adjacent Channel Sound Trap 47.25 mc.
Accompanying Sound Traps 41.25 mc.
Adjacent Channel Picture Carrier Trap 39.25 mc.

SOUND INTERMEDIATE FREQUENCIES

Sound Carrier Frequency 41.25 mc. and 4.5 mc.

VIDEO RESPONSE To 4 mc.

FOCUS Magnetic

SWEEP DEFLECTION Magnetic

SCANNING Interlaced, 525 line

HORIZONTAL SWEEP FREQUENCY 15,750 cps

VERTICAL SWEEP FREQUENCY 60 cps

FRAME FREQUENCY (Picture Repetition Rate) 30 cps

OPERATING CONTROLS (Front Panel)

Channel Selector } Dual Control Knobs
Fine Tuning }
Picture } Dual Control Knobs
Brightness }
Picture Horizontal Hold } Dual Control Knobs
Picture Vertical Hold }
Sound Volume and On-Off Switch } Dual Control Knobs
Tone Control and Phono Switch }

NON-OPERATING CONTROLS (not including r-f and i-f adjustments)

Picture Centering top chassis adjustment
Width rear chassis adjustment
Height rear chassis adjustment
Horizontal Linearity rear chassis screwdriver adjustment
Vertical Linearity rear chassis adjustment
Vertical Peaking Control rear chassis adjustment
Horizontal Drive rear chassis screwdriver adjustment
Horizontal Oscillator Frequency rear chassis adjustment
Horizontal Oscillator Waveform bottom chassis adjustment
Horizontal Locking Range rear chassis adjustment
Focus top chassis adjustment
Ion Trap Magnet top chassis adjustment
Deflection Coil top chassis wing nut adjustment
AGC Control rear chassis adjustment

HIGH VOLTAGE WARNING

OPERATION OF THIS RECEIVER OUTSIDE THE CABINET OR WITH THE COVERS REMOVED, INVOLVES A SHOCK HAZARD FROM THE RECEIVER POWER SUPPLIES. WORK ON THE RECEIVER SHOULD NOT BE ATTEMPTED BY ANYONE WHO IS NOT THOROUGHLY FAMILIAR WITH THE PRECAUTIONS NECESSARY WHEN WORKING ON HIGH VOLTAGE EQUIPMENT. DO NOT OPERATE THE RECEIVER WITH THE HIGH VOLTAGE COMPARTMENT SHIELD REMOVED. BE SURE THE GROUND STRAP, BETWEEN THE YOKE ASSEMBLY AND THE CHASSIS, IS SECURELY FASTENED BEFORE TURNING THE RECEIVER ON.

KINESCOPE HANDLING PRECAUTIONS

DO NOT REMOVE THE RECEIVER CHASSIS, INSTALL, REMOVE OR HANDLE THE KINESCOPE IN ANY MANNER UNLESS SHATTERPROOF GOGGLES ARE WORN. PEOPLE NOT SO EQUIPPED SHOULD BE KEPT AWAY WHILE HANDLING KINESCOPIES. KEEP THE KINESCOPE AWAY FROM THE BODY WHILE HANDLING.

The kinescope bulb encloses a high vacuum and, due to its large surface area, is subjected to considerable air pressure. For this reason, the kinescope must be handled with more care than ordinary receiving tubes.

The large end of the kinescope bulb—particularly that part at the rim of the viewing surface—must not be struck, scratched or subjected to more than moderate pressure at any time. During service if the tube sticks or fails to slip smoothly into its socket, or deflecting yoke, investigate and remove the cause of the trouble. Do not force the tube. Refer to the Receiver Installation section for detailed instructions on kinescope installation. All RCA replacement kinescopes are shipped in special cartons and should be left in the cartons until ready for installation in the receiver.

OPERATING INSTRUCTIONS

The following adjustments are necessary when turning the receiver on for the first time.

1. See that the TV-PH switch is in the "TV" position.
2. Turn the receiver "ON" and advance the SOUND VOLUME control to approximately mid-position.
3. Set the STATION SELECTOR to the desired channel.
4. Adjust the FINE TUNING control for best pix and the SOUND VOLUME control for suitable volume.
5. Turn the BRIGHTNESS control fully counter-clockwise, then clockwise until a light pattern appears on the screen.
6. Adjust the VERTICAL hold control until the pattern stops vertical movement.
7. Adjust the HORIZONTAL hold control until a picture is obtained and centered.

8. Adjust the PICTURE and BRIGHTNESS controls for suitable picture contrast and brightness.

9. In switching from one channel to another, it may be necessary to repeat steps 4 and 8.

10. When the set is turned on again after an idle period it should not be necessary to repeat the adjustment if the positions of the controls have not been changed. If any adjustment is necessary, step number 4 is generally sufficient.

11. If the positions of the controls have been changed, it may be necessary to repeat steps 2 through 8.

12. To use a record player, plug the record-player output cable into the PHONO jack on the rear apron, and set the TV-PH switch to "PH."

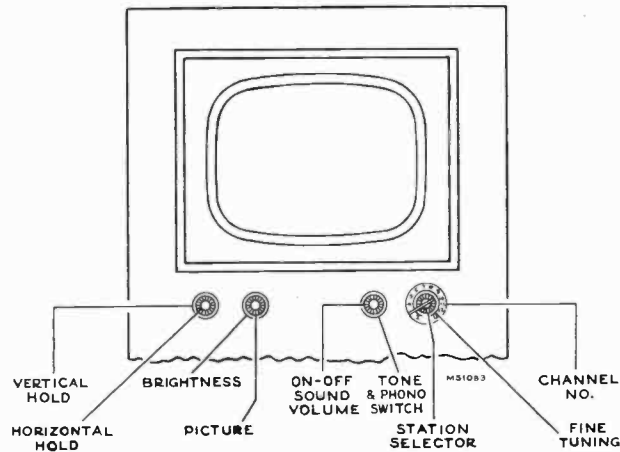

Figure 1—Receiver Operating Controls

INSTALLATION INSTRUCTIONS

UNPACKING.—These receivers are shipped complete in cardboard cartons. The kinescope is shipped in place in the receiver.

Take the receiver out of the carton and remove all packing material.

Install the control knobs on the proper control shafts.

Make sure that all tubes are in place and are firmly seated in their sockets.

Check to see that the kinescope high voltage lead clip is in place.

Plug a power cord into the 115 volt a-c power source and into the receiver interlock receptacle.

Turn the receiver power switch to the "on" position, the brightness control fully clockwise, and the picture control counter-clockwise.

ION TRAP MAGNET ADJUSTMENT.—Set the ion trap magnet approximately in the position shown in Figure 2. Starting from this position immediately adjust the magnet by moving it forward or backward at the same time rotating it slightly around the neck of the kinescope for the brightest raster on the screen.

DEFLECTION YOKE ADJUSTMENT.—If the lines of the raster are not horizontal or squared with the picture mask, rotate the deflection yoke until this condition is obtained. Tighten the yoke adjustment wing screw.

PICTURE ADJUSTMENTS.—It will now be necessary to obtain a test pattern picture in order to make further adjustments. Connect the antenna transmission line to the receiver.

If the Horizontal Oscillator and AGC System are operating properly, it should be possible to sync the picture at this point. However, if the AGC control is misadjusted, and the receiver is overloading, it may be impossible to sync the picture.

If the receiver is overloading, turn R175 on the rear apron (see Figure 3) counter-clockwise until the set operates normally and the picture can be synchronized.

CHECK OF HORIZONTAL OSCILLATOR ALIGNMENT.—Turn the horizontal hold control to the extreme counter-clockwise position. The picture should remain in horizontal sync. Momentarily remove the signal by switching off channel then back. Normally the picture will be out of sync. Turn the control clockwise slowly. The number of diagonal black bars will be gradually reduced and when only 2 bars sloping downward to the left are obtained, the picture will pull into sync upon slight additional clockwise rotation of the control. Pull-in should occur before the control has been turned 120 degrees from the extreme counter-clockwise position. The picture should remain in sync for approximately 90 degrees of additional clockwise rotation of the control. At the extreme clockwise position, the picture should remain in sync and should not show a black bar in the picture.

If the receiver passes the above checks and the picture is normal and stable, the horizontal oscillator is properly aligned. Skip "Alignment of Horizontal Oscillator" and proceed with "Centering Adjustment."

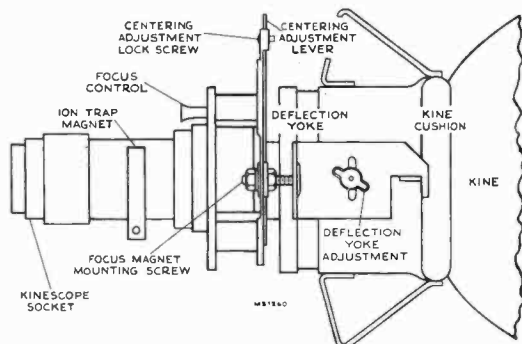

Figure 2—Ion Trap and Centering Magnet Adjustments

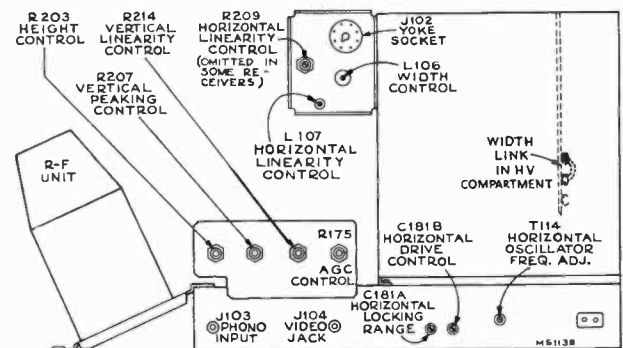

Figure 3—Rear Chassis Adjustments

21T159, 21T159DE, 21T165
 21T166DE, 21T174DE, 21T175DE
 21T176, 21T177, 21T178
 21T178DE, 21T179, 21T179DE

INSTALLATION INSTRUCTIONS

ALIGNMENT OF HORIZONTAL OSCILLATOR.—If in the above check the receiver failed to hold sync with the hold control at the extreme counter-clockwise position or failed to hold sync over 90 degrees of clockwise rotation of the control from the pull-in point, it will be necessary to make the following adjustments.

Horizontal Frequency Adjustment.—Turn the horizontal hold control to the extreme clockwise position. Tune in a television station and adjust the T114 horizontal frequency adjustment at the rear of the chassis until the picture is just out of sync and the horizontal blanking appears as a vertical or diagonal black bar in the raster. Then turn the T114 core until the bar moves out of the picture leaving it in sync.

Horizontal Locking Range Adjustment.—Set the horizontal hold control to the full counter-clockwise position. Momentarily remove the signal by switching off channel then back. The picture may remain in sync. If so turn the T114 rear core slightly and momentarily switch off channel. Repeat until the picture falls out of sync with the diagonal lines sloping down to the left. Slowly turn the horizontal hold control clockwise and note the least number of diagonal bars obtained just before the picture pulls into sync.

If more than 2 bars are present just before the picture pulls into sync, adjust the horizontal locking range trimmer C181A slightly clockwise. If less than 2 bars are present, adjust C181A slightly counter-clockwise. Turn the horizontal hold control counter-clockwise, momentarily remove the signal and recheck the number of bars present at the pull-in point. Repeat this procedure until 2 bars are present.

Repeat the adjustments under "Horizontal Frequency Adjustment" and "Horizontal Locking Range Adjustment" until the conditions specified under each are fulfilled. When the horizontal hold operates as outlined under "Check of Horizontal Oscillator Alignment" the oscillator is properly adjusted.

If it is impossible to sync the picture at this point and the AGC system is in proper adjustment it will be necessary to adjust the Horizontal Oscillator by the method outlined in the alignment procedure on Page 11. For field purposes paragraph "B" under Horizontal Oscillator Waveform Adjustment may be omitted.

FOCUS MAGNET ADJUSTMENTS.—The focus magnet should be adjusted so that there is approximately three-eighths inch of space between the rear cardboard shell of the yoke and the flat of the front face of the focus magnet. This spacing gives best average focus over the face of the tube.

The axis of the hole through the magnet should be parallel with the axis of the kinescope neck with the kinescope neck through the middle.

CENTERING ADJUSTMENT.—No electrical centering controls are provided. Centering is accomplished by means of a separate plate on the focus magnet. The centering plate includes a locking screw which must be loosened before centering. Up and down adjustment of the plate moves the picture side to side and sidewise adjustment moves the picture up and down.

If a corner of the raster is shadowed, check the position of the ion trap magnet. Reposition the magnet within the range of maximum raster brightness to eliminate the shadow and recenter the picture by adjustment of the focus magnet plate. In no case should the ion trap magnet be adjusted to cause any loss of brightness since such operation may cause immediate or eventual damage to the tube. In some cases it may be necessary to shift the position of the focus magnet in order to eliminate a corner shadow.

WIDTH, DRIVE AND HORIZONTAL LINEARITY ADJUSTMENTS.—Adjustment of the horizontal drive control affects the high voltage applied to the kinescope. In order to obtain the highest possible voltage hence the brightest and best focused picture, adjust horizontal drive trimmer C181B for maximum drive (minimum capacity) consistent with a linear raster. Compression of the raster due to excessive drive can be seen as a white vertical bar or bars in the right half of the picture. Besides compression caused by excessive drive, another item to watch for is the change in linearity at the extreme left with changes of brightness control setting. By proper adjustment of the linearity coil, the changes in linearity with changes in brightness can be made negligible. In general, to achieve this condition, the linearity coil should be set slightly on the high inductance side (core slightly clockwise) of the optimum

position and the linearity rheostat R209 should be as far clockwise as possible.

Note: In late production receivers, R209 has been omitted since it normally was operated at zero resistance.

Preset the following adjustments as directed:

A.—Place the width plug (P105) in the minimum width position (top).

B.—Set the width control coil L106 in approximately mid position.

C.—Set the linearity control coil L107 near minimum inductance (counter-clockwise).

D.—Set the linearity control rheostat near zero resistance (clockwise).

E.—Set the drive capacitor C181B in the maximum drive position (counter-clockwise).

If the raster is cramped or shows compression bars on the right half of the picture turn C181B clockwise until this condition is just eliminated.

Adjust the linearity control coil L107 clockwise until best linearity and maximum deflection or best compromise are obtained then turn one quarter turn clockwise from this position.

Retouch the drive trimmer C181B if necessary to obtain best linearity and maximum width.

Check the horizontal linearity at various settings of the brightness control R218. There should be no compression of the right half and no appreciable change of linearity especially at the extreme left of the picture. If objectional change does occur, turn linearity coil L107 slightly clockwise and repeat the test.

Adjust the width control L106 to fill the mask.

If the left side of the picture appears stretched, turn the linearity control rheostat R209 counter-clockwise. If the left side of the picture is cramped, turn R209 clockwise. Whenever possible, correct nonlinearity by adjustment of R209 rather than by reduction of drive.

If the line voltage is low and it becomes impossible to fill the mask, move the width plug P105 to the bottom position. The width coil L106 is inoperative in this position.

HEIGHT AND VERTICAL LINEARITY ADJUSTMENTS.—Adjust the height control (R203 on chassis rear apron) until the picture fills the mask vertically. Adjust vertical linearity (R214 on rear apron), until the test pattern is symmetrical from top to bottom. Adjustment of either control will require a readjustment of the other. If the top few lines of the picture are stretched or squeezed, adjust the vertical peaking control R207 until this condition is corrected.

FOCUS.—Adjust the focus magnet for maximum definition in the test pattern vertical "wedge" and best focus in the white areas of the pattern.

Recheck the position of the ion trap magnet to make sure that maximum brightness is obtained.

If necessary readjust centering to align the picture with the mask.

CHECK OF R-F OSCILLATOR ADJUSTMENTS.—Tune in all available stations to see if the receiver r-f oscillator is adjusted to the proper frequency on all channels. If adjustments are required, these should be made by the method outlined in the alignment procedure on page 7. The adjustments for channels 2 through 12 are available from the front of the cabinet by removing the station selector escutcheon as shown in Figure 4. Adjustment for channel 13 is on top of the chassis.

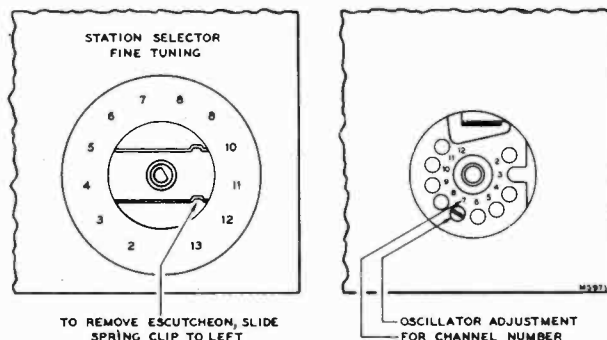

Figure 4—R-F Oscillator Adjustments

INSTALLATION INSTRUCTIONS

21T159, 21T159DE, 21T165
21T166DE, 21T174DE, 21T175DE
21T176, 21T177, 21T178
21T178DE, 21T179, 21T179DE

AGC THRESHOLD CONTROL.—The AGC threshold control R175 is adjusted at the factory and normally should not require readjustment in the field.

To check the adjustment of the AGC Threshold Control, tune in a strong signal and sync the picture. Momentarily remove the signal by switching off channel and then back. If the picture reappears immediately, the receiver is not overloading due to improper setting of R175. If the picture requires an appreciable portion of a second to reappear, or bends excessively, R175 should be readjusted.

Turn R175 fully counter-clockwise. The raster may be bent slightly. This should be disregarded. Turn R175 clockwise until there is a very, very slight bend or change of bend in the picture. Then turn R175 counter-clockwise just sufficiently to remove this bend or change of bend.

If the signal is weak, the above method may not work as it may be impossible to get the picture to bend. In this case, turn R175 clockwise until the snow in the picture becomes more pronounced, then counter-clockwise until the best signal to noise ratio is obtained.

The AGC control adjustment should be made on a strong signal if possible. If the control is set too far clockwise on a weak signal, then the receiver may overload when a strong signal is received.

FM TRAP ADJUSTMENT.—In some instances interference may be encountered from a strong FM station signal. A trap is provided to eliminate this type of interference. To adjust the trap tune in the station on which the interference is observed and adjust the L58 core on top of the antenna matching transformer for minimum interference in the picture.

CAUTION.—In some receivers, the FM trap L58 will tune down into channel 6 or even into channel 5. Needless to say, such an adjustment will cause greatly reduced sensitivity on these channels. If channels 5 or 6 are to be received, check L58 to make sure that it does not affect sensitivity on these two channels.

Replace the cabinet back and connect the receiver antenna leads to the cabinet back. Make sure that the screws holding it are up tight, otherwise it may rattle or buzz when the receiver is operated at high volume.

CABINET ANTENNA.—A cabinet antenna is provided in these receivers and the leads are brought out near the antenna terminal board. The cabinet antenna may be employed in place of the outdoor antenna in areas where the signals are strong and no reflections are experienced.

KINESCOPE HANDLING PRECAUTION.—Do not install, remove, or handle the kinescope in any manner, unless shatter-proof goggles and heavy gloves are worn. People not so equipped should be kept away while handling the kinescope. Keep the kinescope away from the body while handling.

Handle this tube by the metal rim at the edge of the screen. Do not cover the glass bell of the tube with fingermarks as it will produce leakage paths which may interfere with reception. If this portion of the tube has inadvertently been handled, wipe it clean with a soft cloth moistened with "dry" carbon tetrachloride.

To remove the kinescope from the cabinet, loosen the two nuts and disengage the rods alongside the kinescope. Remove the wing screw which holds the yoke frame to the cabinet. Remove the kinescope, the yoke frame with yoke and focus or centering magnet as an assembly.

INSTALLATION OF KINESCOPE.—Handle this tube by the metal rim at the edge of the screen. Do not cover the glass bell of the tube with fingermarks as it will produce leakage paths which may interfere with reception. If this portion of the tube has inadvertently been handled, wipe it clean with a soft cloth moistened with "dry" carbon tetrachloride.

Wipe the kinescope screen surface and front panel safety glass clean of all dust and fingermarks with a soft cloth moistened with "Windex" or similar cleaning agent.

Turn the tube so that the key on the base of the tube will be down and insert the neck of the kinescope through the deflection coil and focus magnet. If the tube sticks or fails to slip into place smoothly, investigate and remove the cause of the trouble. Do not force the tube.

Replace the kinescope and yoke frame assembly in the cabinet. Insert the wing screw and tighten. Engage the two side rods into the yoke frame and tighten the two nuts. Slide

the deflection yoke as far forward as possible. If this is not done, difficulty will be encountered in adjusting the ion trap and focus magnet because of shadows on the corner of the raster.

Slide the chassis into the cabinet, then insert and tighten the four chassis bolts.

Slip the ion trap magnet over the neck of the kinescope.

Connect the kinescope socket to the tube base and connect the high voltage lead from the rim of the kinescope into the high voltage bushing on the high voltage compartment.

Reconnect all other cables. Do not forget to replace the yoke frame grounding strap. Perform the entire set-up procedure beginning with the Ion Trap Magnet Adjustment.

ANTENNAS.—The finest television receiver built may be said to be only as good as the antenna design and installation. It is therefore important to select the proper antenna to suit the particular local conditions, to install it properly and orient it correctly.

If two or more stations are available and the two stations are in different directions, it may be possible to make a compromise orientation which will provide a satisfactory signal on all such channels.

If it is impossible to obtain satisfactory results on one or more channels, it may become necessary either to provide means for turning the antenna when switching channels or to install a separate antenna for one or more channels and to switch antennas when switching channels.

In some cases, the antenna should not be installed permanently until the quality of the picture reception has been observed on a television receiver. A temporary transmission line can be run between receiver and the antenna, allowing sufficient slack to permit moving the antenna. Then, with a telephone system connecting an observer at the receiver and an assistant at the antenna, the antenna can be positioned to give the most satisfactory results on the received signal. A shift of direction or a few feet in antenna position may effect a tremendous difference in picture reception.

REFLECTIONS.—Multiple images sometimes known as echoes or ghosts, are caused by the signal arriving at the antenna by two or more routes. The second or subsequent image occurs when a signal arrives at the antenna after being reflected off a building, a hill or other object. In severe cases of reflections, even the sound may be distorted. In less severe cases, reflections may occur that are not noticeable as reflections but that will instead cause a loss of definition in the picture.

Under certain extremely unusual conditions, it may be possible to rotate or position the antenna so that it receives the cleanest picture over a reflected path. If such is the case, the antenna should be so positioned. However, such a position may give variable results as the nature of reflecting surfaces may vary with weather conditions. Wet surfaces have been known to have different reflecting characteristics than dry surfaces.

Depending upon the circumstances, it may be possible to eliminate the reflections by rotating the antenna or by moving it to a new location. In extreme cases, it may be impossible to eliminate the reflection.

INTERFERENCE.—Auto ignition, street cars, electrical machinery and diathermy apparatus may cause interference which spoils the picture. Whenever possible, the antenna location should be removed as far as possible from highways, hospitals, doctors offices and similar sources of interference. In mounting the antenna, care must be taken to keep the antenna rods at least $\frac{1}{4}$ wave length (at least 6 feet) away from other antennas, metal roofs, gutters or other metal objects.

Short-wave radio transmitting and receiving equipment may cause interference in the picture in the form of moving ripples. In some instances it may be possible to eliminate the interference by the use of a trap in the antenna transmission line. However, if the interfering signal is on the same frequency as the television station, a trap will provide no improvement.

WEAK PICTURE.—When the installation is near the limit of the area served by the transmitting station, the picture may be speckled, having a "snow" effect, and may not hold steady on the screen. This condition is due to lack of signal strength from the transmitter.

21T159, 21T159DE, 21T165
21T166DE, 21T174DE, 21T175DE
21T176, 21T177, 21T178
21T178DE, 21T179, 21T179DE

CHASSIS TOP VIEW

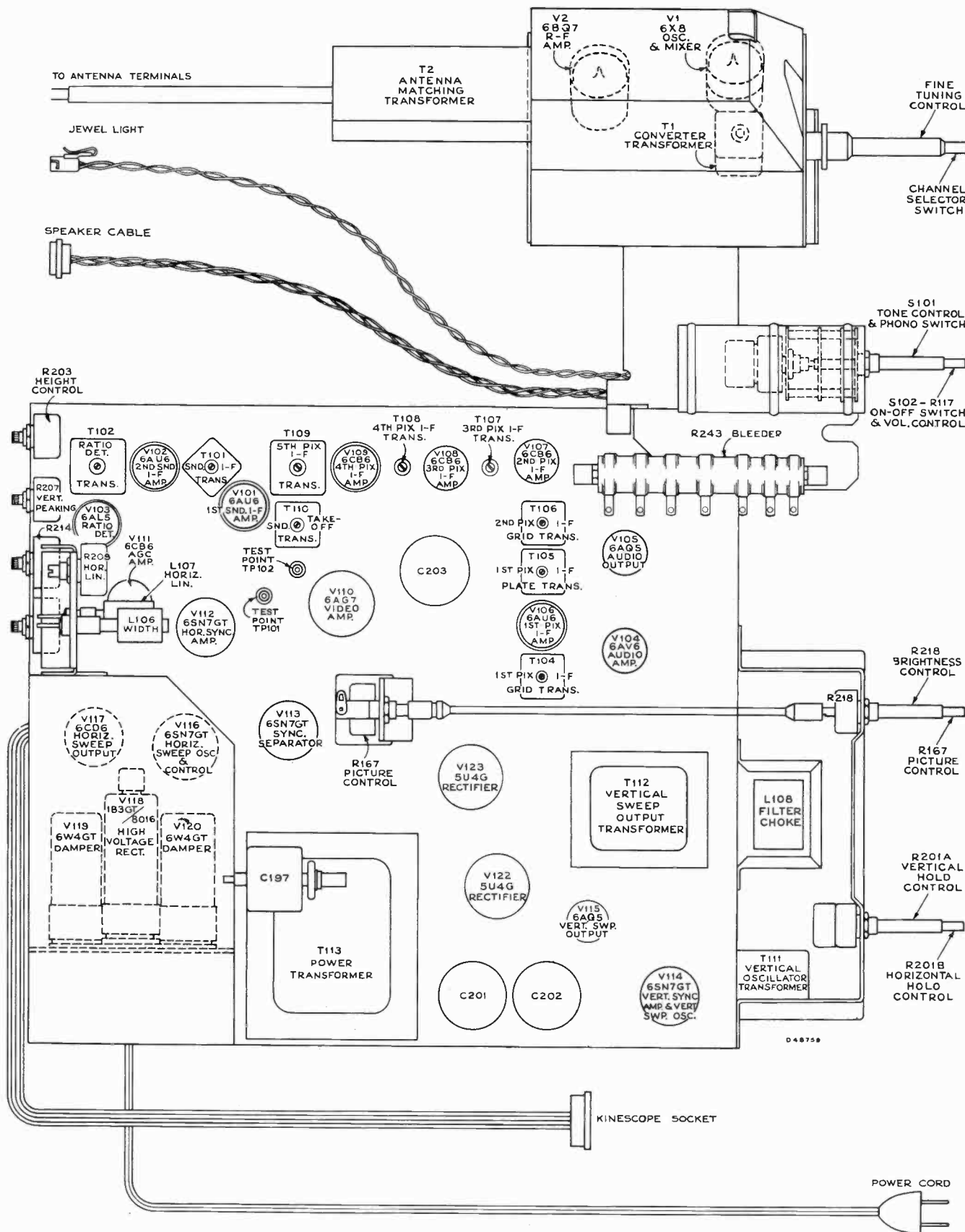

Figure 5—Chassis Top View

CHASSIS BOTTOM VIEW

21T159, 21T159DE, 21T165
21T166DE, 21T174DE, 21T175DE
21T176, 21T177, 21T178
21T178DE, 21T179, 21T179DE

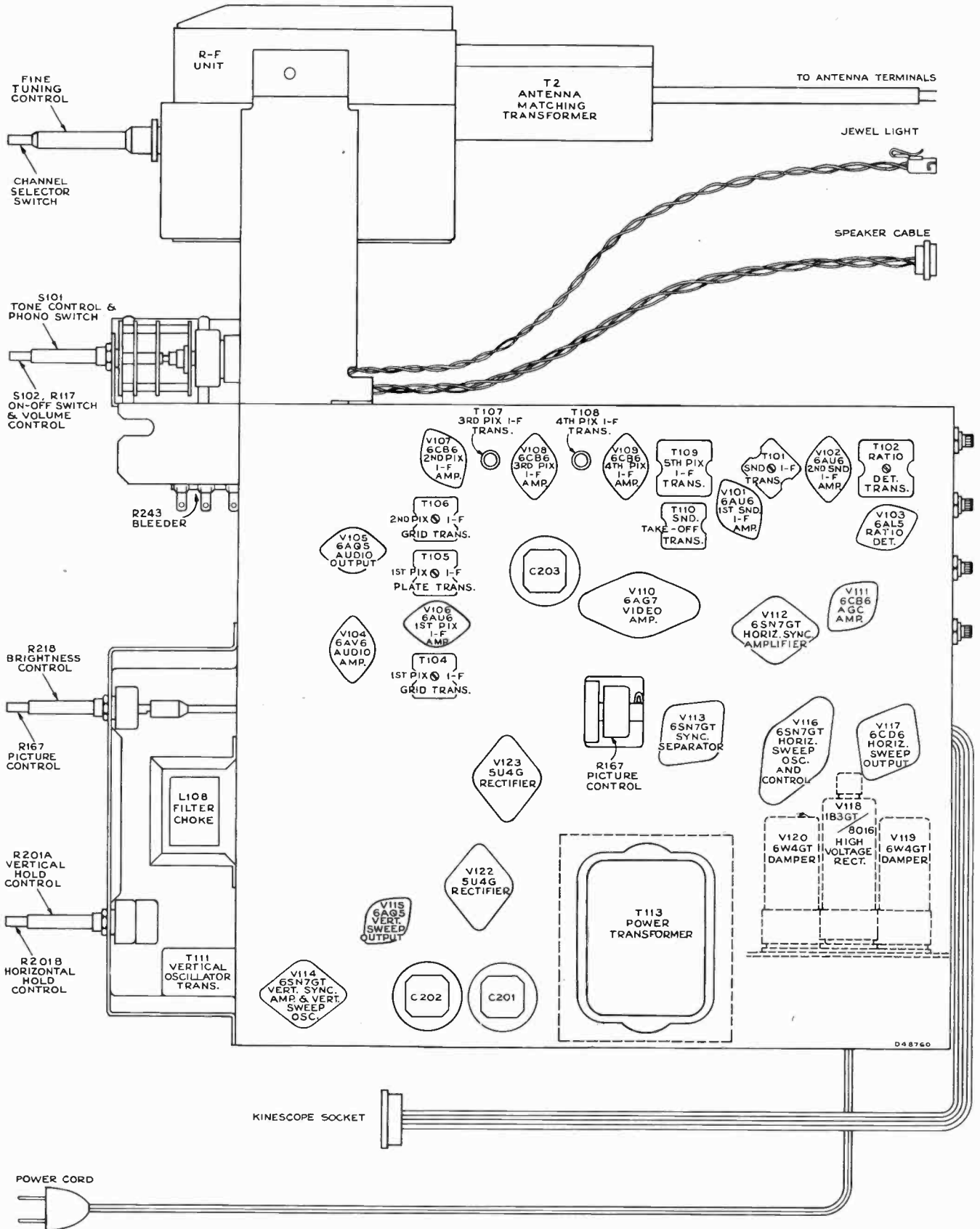

Figure 6—Chassis Bottom View

21T159, 21T159DE, 21T165
 21T166DE, 21T174DE, 21T175DE
 21T176, 21T177, 21T178
 21T178DE, 21T179, 21T179DE

ALIGNMENT PROCEDURE

TEST EQUIPMENT.—To properly service the television chassis of this receiver, it is recommended that the following test equipment be available:

R-F Sweep Generator meeting the following requirements:

- (a) Frequency Ranges
 - 35 to 90 mc., 1 mc. to 12 mc. sweep width
 - 170 to 225 mc., 12 mc. sweep width
- (b) Output adjustable with at least .1 volt maximum.
- (c) Output constant on all ranges.
- (d) "Flat" output on all attenuator positions.

Cathode-Ray Oscilloscope.—For alignment purposes, the oscilloscope employed must have excellent low frequency and phase response.

For video and sync waveform observations, the oscilloscope must have excellent frequency and phase response from 10 cycles to at least two megacycles in all positions of the gain control.

Signal Generator to provide the following frequencies with crystal accuracy.

- (a) Intermediate frequencies
 - 4.5 mc., 39.25 mc., 41.25 mc., 45.75 mc., 47.25 mc.
- (b) Radio frequencies

Channel Number	Picture Carrier Freq. Mc.	Sound Carrier Freq. Mc.	Receiver R-F Osc. Freq. Mc.
2	55.25	59.75	101
3	61.25	65.75	107
4	67.25	71.75	113
5	77.25	81.25	123
6	83.25	87.75	129
7	175.25	179.75	221
8	181.25	185.75	227
9	187.25	191.75	233
10	193.25	197.75	239
11	199.25	203.75	245
12	205.25	209.75	251
13	211.25	215.75	257

- (c) Output of these ranges should be adjustable and at least .1 volt maximum.

Heterodyne Frequency Meter with crystal calibrator if the signal generator is not crystal controlled.

Electronic Voltmeter of Junior or Senior "VoltOhmyst" type and a high voltage multiplier probe for use with this meter to permit measurements up to 20 kv.

ORDER OF ALIGNMENT.—When a complete receiver alignment is necessary, it can be most conveniently performed in the following order:

- (1) Ant. Matching Unit
- (2) R-F Unit
- (3) Ratio Detector
- (4) Sound I-F Trans.
- (5) Sound Take-Off Trans.
- (6) Picture I-F Traps
- (7) Picture I-F Trans.
- (8) Sweep Alignment of I-F
- (9) Horizontal Oscillator
- (10) Sensitivity Check

ANTENNA MATCHING UNIT ALIGNMENT.—The antenna matching unit is accurately aligned at the factory. Adjustment of this unit should not be attempted in the customer's home since even slight misalignment may cause serious attenuation of the signal especially on channel 2. The r-f unit is aligned with a particular antenna matching transformer in place. If for any reason, a new antenna matching transformer is installed, the r-f unit should be realigned.

The F-M Trap which is mounted in the antenna matching unit may be adjusted without adversely affecting the alignment of the unit.

To align the antenna matching unit disconnect the lead from the F-M trap L58 to the channel selector switch S1E or S5.

With a short jumper, connect the output of the matching unit through a 1000 mmf. capacitor to the grid of the second pix i-f amplifier, pin 1 of V107.

Replace the cover on the matching unit while making all adjustments.

Remove the first pix i-f amplifier tube V106.

Connect the positive terminal of a bias box to the chassis and the potentiometer arm to the junction of R143 and R144. Set the potentiometer to produce approximately -6.0 volts of bias at the junction of R143 and R144.

Connect an oscilloscope to the video test point TP102 or pin 4, V110 and set the oscilloscope gain to maximum.

Connect a signal generator to the antenna input terminals. Modulate the signal generator 30% with an audio signal.

Tune the signal generator to 45.75 mc. and adjust the generator output to give an indication on the oscilloscope. Adjust L59 in the antenna matching unit for minimum audio indication on the oscilloscope.

Tune the signal generator to 41.25 mc. and adjust L60 for minimum audio indication on the oscilloscope.

Remove the jumper from the output of the matching unit.

Connect a 300 ohm ½ watt composition resistor from L58 to ground, keeping the leads as short as possible.

Connect an oscilloscope low capacity crystal probe from L58 to ground. The sensitivity of the oscilloscope should be approximately 0.03 volts per inch. Set the oscilloscope gain to maximum.

Connect the r-f sweep generator to the matching unit antenna input terminals. In order to prevent coupling reactance from the sweep generator into the matching unit, it is advisable to employ a resistance pad at the matching unit terminals. Figure 11 shows three different resistance pads for use with sweep generators with 50 ohm co-ax output, 72 ohms co-ax output or 300 ohm balanced output. Choose the pad to match the output impedance of the particular sweep employed.

Connect the signal generator loosely to the matching unit antenna terminals.

Set the sweep generator to sweep from 45 mc. to 54 mc. With RCA type WR59A sweep generators, this may be accomplished by retuning channel number 1 to cover this range. With WR59B sweep generators this may be accomplished by retuning channel number 2 to cover the range. In making these adjustments on the generator, be sure not to turn the core too far clockwise so that it becomes lost beyond the core retaining spring.

Adjust L61 and L62 to obtain the response shown in figure 12. L61 is most effective in locating the position of the shoulder of the curve at 52 mc. and L62 should be adjusted to give maximum amplitude at 53 mc. and above consistent with the specified shape of the response curve. The adjustments in the matching unit interact to some extent. Repeat the above procedure until no further adjustments are necessary.

Remove the 300 ohm resistor and crystal probe connections. Restore the connection between L58 and S1E or S5. Replace V106.

R-F UNIT ALIGNMENT.—An r-f unit which is operative and requires only touch up adjustments, requires no presetting of adjustments. For such units, skip the remainder of this paragraph. For units which are completely out of adjustment, preset all adjustments to the approximate center of their range with the following exceptions. Set C18 so that the screw head is approximately three-eighths of an inch above chassis. Set C11 near maximum capacity (one-quarter turn from tight). Do not change any of the adjustments in the antenna matching unit.

Disconnect the link from terminals "A" and "B" of T104 and terminate the link with a 39 ohm composition resistor.

The r-f unit is aligned with zero A-G-C bias. To insure that the bias will remain constant, take a clip lead and short circuit the r-f unit power terminal board terminal 3 to ground.

Connect the oscilloscope to the test point TP1 on top of the r-f unit. Set the oscilloscope gain to maximum.

Turn the receiver channel selector switch to channel 2.

Connect the output of the signal generator to the grid of the r-f amplifier, V2. To do this, remove the tube from the socket and fashion a clip by twisting one end of a small piece of wire around pin number 7. Replace the tube in the socket leaving the end of the wire protruding from under the tube. Connect the signal generator to this wire through a 1,500 mmf. capacitor.

Tune the signal generator to 43.5 mc. and modulate it 30% with a 400 cycle sine wave. Adjust the signal generator for maximum output.

Adjust L65 on top of the r-f unit for minimum 400 cycle indication on the oscilloscope. If necessary, this adjustment can be retouched in the field to provide additional rejection to one specific frequency in the i-f band pass. However, in such cases, care should be taken not to adjust it so as to reduce sensitivity on channel 2.

ALIGNMENT PROCEDURE

21T159, 21T159DE, 21T165
21T166DE, 21T174DE, 21T175DE
21T176, 21T177, 21T178
21T178DE, 21T179, 21T179DE

Remove the wire clip from pin 7 of V2 and replace the tube and tube shield.

Set the channel selector switch to channel 8.

Turn the fine tuning control 30 degrees clockwise from the center of its mechanical range now and at all times when adjusting the oscillator frequency.

Adjust C1 in KRK11 or C2 in KRK11A for proper oscillator frequency, 227 mc. This may be done in several ways. The easiest way and the way which will be recommended in this procedure will be to use the signal generator as a heterodyne frequency meter and beat the oscillator against the signal generator. To do this, tune the signal generator to 227 mc. with crystal accuracy. Insert one end of a piece of insulated wire into the r-f unit through the hole provided for the adjustment for C11. Be careful that the wire does not touch any of the tuned circuits as it may cause the frequency of the r-f unit oscillator to shift. Connect the other end of the wire to the "r-f in" terminal of the signal generator. Adjust C1 in KRK11 or C2 in KRK11A to obtain an audio beat with the signal generator.

Note—If, on some KRK11A units, it is not possible to reach the proper channel 8 oscillator frequency by adjustment of C2, switch to channel 13 and adjust L46 to obtain proper channel 13 oscillator frequency as indicated in the table on page 10. Then switch to channel 12 and adjust L11 to obtain proper channel 12 oscillator frequency. Continue down to channel 8 adjusting the appropriate oscillator trimmer to obtain the proper frequency on each channel. Then again on channel 8 adjust C2 to obtain proper channel 8 oscillator frequency. Switch back to channel 13 and adjust L46 and back to channel 8 and adjust C2.

Set the T1 core for maximum inductance (core turned counter-clockwise).

Connect the sweep generator through a suitable attenuator as shown in Figure 11 to the input terminals of the antenna matching unit.

Connect the signal generator loosely to the antenna terminals.

Set the sweep generator to cover channel 8.

Set the oscilloscope to maximum gain and use the minimum input signal which will produce a usable pattern on the oscilloscope. Excessive input can change oscillator injection during alignment and produce consequent misalignment even though the pattern on the oscilloscope may look normal.

Insert markers of channel 8 picture carrier and sound carrier, 181.25 mc. and 185.75 mc.

Adjust C9, C11, C15 and C18 for approximately correct curve shape, frequency, and band width as shown in Figure 13.

The correct adjustment of C18 is indicated by maximum amplitude of the curve midway between the markers. C15 tunes the r-f amplifier plate circuit and affects the frequency of the pass band most noticeably. C9 tunes the mixer grid circuit and affects the tilt of the curve most noticeably (assuming that C18 has been properly adjusted). C11 is the coupling adjustment and hence primarily affects the response band width.

Set the receiver channel switch to channel 6.

Adjust the signal generator to the channel 6 oscillator frequency 129 mc.

Turn the fine tuning control 30 degrees clockwise from the center of its mechanical range.

Adjust L5 for an audible beat with the signal generator as before.

Set the sweep generator to channel 6.

From the signal generator, insert channel 6 sound and picture carrier markers, 83.25 mc. and 87.75 mc.

Adjust L48, L50 and L53 for proper response as shown in Figure 13.

L50 tunes the r-f amplifier plate circuit and primarily affects the frequency of the pass band. L53 tunes the r-f amplifier grid and is adjusted to give maximum amplitude of the curve between the markers. L48 affects the tilt of the curve but not quite the same as C9 adjustment. When the circuits are correctly adjusted and L48 is rocked on either side of its proper setting, the high frequency (sound carrier) end of the curve appears to remain nearly fixed in amplitude while the picture carrier end tilts above or below this point.

Turn off the sweep and signal generators.

Connect the "VoltOhmyst" to the r-f unit test point TP1.

Adjust the oscillator injection trimmer C8 for —3.5 volts or at maximum if —3.5 volts cannot be reached. This voltage should fall between —2.5 and —5.5 volts on all channels when the alignment of all circuits is completed.

Turn the sweep generator and signal generator back on and recheck channel 6 response. Readjust L48, L50 and L53 if necessary.

Set the receiver channel selector switch to channel 8 and readjust C1 in KRK11 or C2 in KRK11A for proper oscillator frequency, 227 mc.

Set the sweep generator and signal generator to channel 8.

Readjust C9, C11, C15 and C18 for correct curve shape, frequency and band width.

Turn off the sweep and signal generators, switch back to channel 6 and check the oscillator injection voltage at TP1 if C9 was adjusted in the recheck of channel 8 response.

If the initial setting of oscillator injection trimmer C8 was far off, it may be necessary to adjust the oscillator frequency and response on channel 8, adjust the oscillator injection on channel 6 and repeat the procedure several times before the proper setting is obtained.

Turn off the sweep generator and switch the receiver to channel 13.

Adjust the signal generator to the channel 13 oscillator frequency 257 mc.

Set the fine tuning control 30 degrees clockwise from the center of its mechanical range.

Adjust L46 to obtain an audible beat. Slightly overshoot the adjustment of L46 by turning the slug a little more in the same direction from the original setting, then reset the oscillator to proper frequency by adjusting C1 in KRK11 or C2 in KRK11A to again obtain the beat.

Check the response of channels 7 through 13 by switching the receiver channel switch, sweep generator and marker oscillator to each of these channels and observing the response and oscillator injection obtained. See Figure 13 for typical response curves. It should be found that all these channels have the proper shaped response with the markers above 80% response.

If the markers do not fall within this requirement, switch to channel 8 and readjust C9, C11, C15 and C18 as necessary.

Turn off the sweep generator and check the channel 8 oscillator frequency. If C1 or C2 was readjusted for channel 8, the principle of overshooting the adjustment and then correcting by adjusting L46 should be followed in order to establish the L/C ratio for the desired oscillator tracking.

Turn off the sweep generator and check the channel 6 oscillator frequency. Adjust L5 for correct oscillator frequency, 129 mc.

Turn the sweep generator on and to channel 6 and observe the response curve. If necessary readjust L48, L50 and L53.

For KRK11A units switch to channel 2 and tune T1 clockwise to a point where there is no change in the channel 2 response as T1 is turned.

Switch the receiver through channel 6 down through channel 2 and check for normal response curve shapes and oscillator injection voltage.

If excessive tilt in the same direction occurs on channels 2, 3 and 4, adjust C18 on channel 2 to overshoot the correction of this tilt, then switch to channel 6 and adjust L53 for maximum amplitude of curve between carrier markers. This adjustment should produce "flat" response on the low channels if the other adjustments, especially L48, are correct.

Likewise check r-f response and oscillator injection on channels 7 through 13, stopping on 13 for the next step.

With the receiver on channel 13, check the receiver oscillator frequency. Correct by adjustment of C1 in KRK11 or C2 in KRK11A if necessary.

Adjust the oscillator to frequency on all channels by switching the receiver and the frequency standard to each channel and adjusting the appropriate oscillator trimmer to obtain the audible beat. It should be possible to adjust the oscillator to the correct frequency on all channels with the fine tuning control in the middle third of its range. When employing WR39 calibrators to adjust the receiver oscillator, tune the calibrator to one half the receiver oscillator frequency on channels 4, 5 and 6 and to one fourth the receiver oscillator frequency on channels 11, 12 and 13.

21T159, 21T159DE, 21T165
21T166DE, 21T174DE, 21T175DE
21T176, 21T177, 21T178
21T178DE, 21T179, 21T179DE

ALIGNMENT PROCEDURE

Channel Number	Picture Carrier Freq. Mc.	Sound Carrier Freq. Mc.	Receiver R-F Osc. Freq. Mc.	Channel Oscillator Adjustment
2	55.25	59.75	101	L1
3	61.25	65.75	107	L2
4	67.25	71.75	113	L3
5	77.25	81.75	123	L4
6	83.25	87.75	129	L5
7	175.25	179.75	221	L6
8	181.25	185.75	227	L7
9	187.25	191.75	233	L8
10	193.25	197.75	239	L9
11	199.25	203.75	245	L10
12	205.25	209.75	251	L11
13	211.25	215.75	257	C1

Remove the 39 ohm resistor from the link and reconnect the link to terminals "A" and "B" of T104.

RATIO DETECTOR ALIGNMENT.—In order to obtain good ratio detector alignment an AM modulated signal generator that is exceptionally free from FM modulation must be employed. Set the signal generator at 4.5 mc. and connect it to the second sound i-f grid, pin 1 of V102. Set the generator for 30% 400 cycle modulation.

As an alternate source of signal, the RCA WR39B or WR39C calibrator may be employed. If used, connect it to the grid of the 4th pix i-f amplifier, pin 1, V109. Set the frequency of the calibrator to 45.75 (pix carrier) and modulate with 4.5 mc. crystal. Also turn on the internal AM audio modulation. The 4.5 mc. signal will be picked off at T110A and amplified through the Sound i-f amplifier.

Connect the "VoltOhmyst" to the junction of R110 and R114.

Connect the oscilloscope across the speaker voice coil and turn the volume control for maximum output.

Adjust C226 on the bottom of the V103 socket for minimum capacity.

Tune the ratio detector primary, T102 top core for maximum DC output on the "VoltOhmyst." Adjust the signal level from the signal generator for minus 10 volts on the "VoltOhmyst" when finally peaked. This is approximately the operating level of the ratio detector for average signals.

Connect the "VoltOhmyst" to the junction of R112 and C113.

Adjust the T102 bottom core for zero d-c on the meter. Then, turn the core to the nearest minimum AM output on the oscilloscope.

Repeat adjustments of T102 top for maximum DC and T102 bottom for minimum output on the oscilloscope making final adjustment with the 4.5 mc. input level adjusted to produce 10 volts d-c on the "VoltOhmyst" at the junction of R110 and R114.

Connect the "VoltOhmyst" to the junction of R112 and C113 and note the amount of d-c present. If this voltage exceeds ± 1.5 volts, adjust C226 by turning it in until zero d-c is obtained. Readjust the T102 bottom core for minimum output on the oscilloscope. Repeat adjustments of C226 and T102 bottom core until the voltage at R112 and C113 is less than ± 1.5 volts when T102 bottom core is set for minimum output on the oscilloscope.

Connect the "VoltOhmyst" to the junction of R110 and R114 and repeak T102 top core for maximum d-c on the meter and again reset the generator so as to have -10 volts on the meter.

Repeat the adjustments in the above two paragraphs until the voltage at R112 and C113 is less than ± 1.5 volts when the T102 top core is set for maximum d-c at the junction of R110 and R114 and the T102 bottom core is set for minimum indication on the oscilloscope.

SOUND I-F ALIGNMENT.—Connect the sweep generator to the first sound i-f amplifier grid, pin 1 of V101. Adjust the generator for a sweep width of 1 mc. at a center frequency of 4.5 mc.

Insert a 4.5 mc. marker signal from the signal generator into the first sound i-f grid. With the WR39B or WR39C calibrators the 4.5 mc. crystal signal may be obtained at the R-F out terminal by turning the variable osc. switch off, the calibrate switch to 4.5 mc. and the volume control with mod. off.

Connect the oscilloscope in series with a 10,000 ohm resistor to terminal A of T101.

Adjust T101 top and bottom cores for maximum gain and

symmetry about the 4.5 mc. marker on the i-f response. The pattern obtained should be similar to that shown in Figure 14.

The output level from the sweep should be set to produce approximately 2.0 volt peak-to-peak at terminal A of T101 when the final touches on the above adjustment are made. It is necessary that the sweep output voltage should not exceed the specified values otherwise the response curve will be broadened, permitting slight misadjustment to pass unnoticed and possibly causing distortion on weak signals.

Connect the oscilloscope to the junction of R112 and C113 and check the linearity of the response. The pattern obtained should be similar to that shown in Figure 15.

SOUND TAKE-OFF ALIGNMENT.—Connect the 4.5 mc. generator in series with a 1000 ohm resistor to terminal "C" of T110. The input signal should be approximately 0.5 volt.

Short the fourth pix i-f grid to ground, pin 1 V109, to prevent noise from masking the output indication.

As an alternate source of signal the RCA WR39B or WR39C calibrator may be used. In such a case, disregard the above two paragraphs. Connect calibrator across link circuit, T104 A, B, and modulate 45.75 with 4.5 mc. crystal.

Connect the crystal diode probe of a "VoltOhmyst" to the plate of the video amplifier, pin 8 of V110.

Adjust the core of T110 for minimum output on the meter.

Remove the short from pin 1 V109 to ground, if used.

PICTURE I-F TRAP ADJUSTMENT.—Connect the i-f signal generator across the link circuit on terminals A and B of T104.

Connect the "VoltOhmyst" to the junction of R143 and R144.

Obtain a 7.5 volt battery capable of withstanding appreciable current drain and connect the ends of a 1,000 ohm potentiometer across it. Connect the battery positive terminal to chassis and the potentiometer arm to the junction of R143 and R144.

Set the bias to produce approximately -1.0 volt of bias at the junction of R143 and R144.

Connect the "VoltOhmyst" to pin 4 of V110, the 6AG7 video amplifier.

Set the signal generator to each of the following frequencies and adjust the corresponding circuit for minimum d-c output at pin 4 of V110. Use sufficient signal input to produce 1.0 volt of d-c on the meter when the final adjustment is made.

39.25 mc.	T104 top core
41.25 mc.	T105 bottom core
47.25 mc.	T106 bottom core

PICTURE I-F TRANSFORMER ADJUSTMENTS.—Set the signal generator to each of the following frequencies and peak the specified adjustment for maximum indication on the "VoltOhmyst." During alignment, reduce the input signal if necessary in order to produce 1.0 volt of d-c at pin 4 of V110 with -1.0 volt of i-f bias at the junction of R143 and R144.

43.7 mc.	T109
45.5 mc.	T108
41.8 mc.	T107

To align T105 and T106, connect the sweep generator to the first picture i-f grid, pin 1 of V106 through a 1000 mmf. ceramic capacitor. Shunt R141, R149 and terminals "A" and "F" of T109 with 330 ohm composition resistors. Set the i-f bias to -1.0 volt at the junction of R143 and R144.

Connect the oscilloscope to pin 4 of V110.

Adjust T105 and T106 top cores for maximum gain and curve shape as shown in Figure 16. For final adjustment set the output of the sweep generator to produce 0.5 volt peak-to-peak at the oscilloscope terminals.

To align T1 and T104, connect the sweep generator to the mixer grid test point TP2. Use the shortest leads possible, with not more than one inch of unshielded lead at the end of the sweep cable.

Set the channel selector switch to channel 4.

Connect a 180 ohm composition resistor from terminal B of T105 to the junction of R135 and C132. Connect the oscilloscope diode probe to terminal B of T105 and to ground.

Couple the signal generator loosely to the diode probe in order to obtain markers.

In some receivers, C220 is variable and is provided as a bandwidth adjustment. Preset C220 to minimum capacity.

Adjust T1 (top) and T104 (bottom) for maximum gain at 43.5 mc. and with 45.75 mc. at 70% of maximum response.

ALIGNMENT PROCEDURE

21T159, 21T159DE, 21T165
 21T166DE, 21T174DE, 21T175DE
 21T176, 21T177, 21T178
 21T178DE, 21T179, 21T179DE

Adjust C220 until 41.25 mc. is at 85% response with respect to the low frequency shoulder at approximately 41.9 mc. as shown in Figure 17.

In receivers in which C220 is fixed, adjust T1 (top) and T104 (bottom) for maximum gain and the response shown in Figure 17.

Disconnect the diode probe, the 180 ohm and three 330 ohm resistors.

SWEEP ALIGNMENT OF PIX I-F.—Connect the oscilloscope to pin 4 of V110.

Adjust the bias potentiometer to obtain -6.0 volts of bias as measured by a "VoltOhmyst" at the junction of R143 and R144.

Leave the sweep generator connected to the mixer grid test point TP2 with the shortest leads possible and with not more than one inch of unshielded lead at the end of the sweep cable. If these precautions are not observed, the receiver may be unstable and the response curves obtained may be unreliable.

Adjust the output of the sweep generator to obtain 3.0 volts peak-to-peak on the oscilloscope.

Couple the signal generator loosely to the grid of the first pix i-f amplifier. Adjust the output of the signal generator to produce small markers on the response curve.

Retouch T108 and T109 to obtain the response shown in Figure 18. Do not adjust T107 unless absolutely necessary. If T107 is adjusted too low in frequency it will raise the level of the 41.25 mc. sound i-f carrier and may create interference in the picture. It will also cause poor adjacent channel picture rejection. If T107 is tuned too high in frequency, the level of the 41.25 mc. sound i-f carrier will be too low and may produce noisy sound in weak signal areas.

Remove the oscilloscope, sweep and signal generator connections.

Remove the bias box employed to provide bias for alignment.

HORIZONTAL OSCILLATOR ADJUSTMENT.—Normally the adjustment of the horizontal oscillator is not considered to be a part of the alignment procedure, but since the oscillator waveform adjustment may require the use of an oscilloscope, it can not be done conveniently in the field. The waveform adjustment is made at the factory and normally should not require readjustment in the field. However, the waveform adjustment should be checked whenever the receiver is aligned or whenever the horizontal oscillator operation is improper.

Horizontal Frequency Adjustment.—Tune in a station and sync the picture. If the picture cannot be synchronized with the horizontal hold control R201B, then adjust the T114 frequency core on the rear apron until the picture will synchronize. If the picture still will not sync, turn the T114 waveform adjustment core (under the chassis) out of the coil several turns from its original position and readjust the T114 frequency core until the picture is synchronized.

Examine the width and linearity of the picture. If picture width or linearity is incorrect, adjust the horizontal drive control C181B, the width control L106 and the linearity control L107 until the picture is correct.

Horizontal Oscillator Waveform Adjustment.—The horizontal oscillator waveform may be adjusted by either of two methods. The method outlined in paragraph A below may be employed in the field when an oscilloscope is not available. The service shop method outlined in paragraph B below requires the use of an oscilloscope.

A.—Turn the horizontal hold control completely clockwise. Place adjustment tools on both cores of T114 and be prepared to make simultaneous adjustments while watching the picture on the screen. First, turn the T114 frequency core (on the rear apron) until the picture falls out of sync and one diagonal black bar sloping down to the right appears on the screen. Then, turn the waveform adjustment core (under the chassis) into the coil while at the same time adjusting the frequency core so as to maintain one diagonal black bar on the screen. Continue this procedure until the oscillator begins to motorboat, then turn the waveform adjustment core out until the motorboating just stops. As a check, turn the T114 frequency core until the picture is synchronized then reverse the direction of rotation of the core until the picture begins to fall out of sync with the diagonal bar sloping down to the right. Continue to turn the frequency core in the same direction. Additional bars should not appear on the screen. Instead, the horizontal

oscillator should begin to motorboat. Retouch the adjustment of the T114 waveform adjustment core if necessary until this condition is obtained.

B.—Connect the low capacity probe of an oscilloscope to terminal C of T114. Turn the horizontal hold control one-quarter turn from the clockwise position so that the picture is in sync. The pattern on the oscilloscope should be as shown in Figure 19. Adjust the waveform adjustment core of T114 until the two peaks are at the same height. During this adjustment, the picture must be kept in sync by readjusting the hold control if necessary.

This adjustment is very important for correct operation of the circuit. If the broad peak of the wave on the oscilloscope is lower than the sharp peak, the noise immunity becomes poorer, the stabilizing effect of the tuned circuit is reduced and drift of the oscillator becomes more serious. On the other hand, if the broad peak is higher than the sharp peak, the oscillator is overstabilized, the pull-in range becomes inadequate and the broad peak can cause double triggering of the oscillator when the hold control approaches the clockwise position.

Remove the oscilloscope upon completion of this adjustment.

Horizontal Locking Range Adjustment.—Set the horizontal hold control to the full counter-clockwise position. Momentarily remove the signal by switching off channel then back. The picture may remain in sync. If so turn the T114 frequency core slightly and momentarily switch off channel. Repeat until the picture falls out of sync with the diagonal lines sloping down to the left. Slowly turn the horizontal hold control clockwise and note the least number of diagonal bars obtained just before the picture pulls into sync.

If more than 2 bars are present just before the picture pulls into sync, adjust the horizontal locking range trimmer C181A slightly clockwise. If less than 2 bars are present, adjust C181A slightly counter-clockwise. Turn the horizontal hold control counter-clockwise, momentarily remove the signal and recheck the number of bars present at the pull-in point. Repeat this procedure until 2 bars are present.

Turn the horizontal hold control to the maximum clockwise position. Adjust the T114 frequency core so that the diagonal bar sloping down to the right appears on the screen and then reverse the direction of adjustment so that bar just moves off the screen leaving the picture in synchronization.

SENSITIVITY CHECK.—A comparative sensitivity check can be made by operating the receiver on a weak signal from a television station and comparing the picture and sound obtained to that obtained on other receivers under the same conditions. This weak signal can be obtained by connecting the shop antenna to the receiver through a ladder type attenuator pad.

RESPONSE CURVES.—The response curves shown on page 14 are typical, though some variations can be expected.

The response curves are shown in the classical manner of presentation, that is with "response up" and low frequency to the left. The manner in which they will be seen in a given test set-up will depend upon the characteristics of the oscilloscope and the sweep generator.

NOTES ON R-F UNIT ALIGNMENT.—Because of the frequency spectrum involved, many of the r-f unit leads are critical in some respects. Even the power supply leads form loops which couple to the tuned circuits, and if resonant at any of the frequencies involved in the performance of the tuner, may cause serious departures from the desired characteristics. In the design of the receiver these undesirable resonant loops have been shifted far enough away in frequency to allow reasonable latitude in physical arrangement without being troublesome. When the r-f unit is aligned in the receiver, no trouble from resonant loops should be experienced. However, if the unit is aligned in a jig separate from the receiver, attention should be paid to insure that unwanted resonance does not exist which might present a faulty representation of alignment.

A resonant circuit exists between the r-f tuner chassis and the outer shield box, which couples into the antenna and r-f plate circuits. The frequency of this resonance depends on the structure of the shield box. This resonance is controlled by using insulating washers of proper thickness in the front plate to tuner chassis mounting. Obviously, if the r-f unit is removed for service, the washers should be replaced in the correct order.

21T159, 21T159DE, 21T165
21T166DE, 21T174DE, 21T175DE
21T176, 21T177, 21T178
21T178DE, 21T179, 21T179DE

ALIGNMENT TABLE

THE DETAILED ALIGNMENT PROCEDURE BEGINNING ON PAGE 8 SHOULD BE READ BEFORE ALIGNMENT BY USE OF THE TABLE IS ATTEMPTED

Step No.	CONNECT SIGNAL GENERATOR TO	SIGNAL GEN. FREQ. MC.	CONNECT SWEEP GENERATOR TO	SWEEP GEN. FREQ. MC.	CONNECT HETERODYNE FREQ. METER TO	HET. METER FREQ. MC.	CONNECT OSCILLOSCOPE TO	MISCELLANEOUS CONNECTIONS AND INSTRUCTIONS	ADJUST	REFER TO
ANTENNA MATCHING UNIT ALIGNMENT										
1	Do not adjust this unit unless fairly certain that it requires adjustment. Disconnect lead from L58 to S1E. Connect output of matching unit through 1000 mmf. to pin 1 of V107. Replace cover on matching unit. Remove V106 from socket. Connect bias box to junction of R143 and R144 and set to produce -6 volts.									
2	Antenna terminals	45.75 mc. 30% mod.	Not used	—	Not used	—	Pin 4, V110 Scope gain to max.	—	L59 for min. audio on scope	Fig. 7
3	"	41.25 mc. 30% mod.	"	—	"	—	"	—	L60 for min. audio on scope	Fig. 7
4	Antenna terminals loosely	—	Antenna terminals through pad	45 to 54 mc.	"	—	Scope a xtal probe to gnd.	Connect 300 ohms from L58 to gnd.	L61 and L62 to obtain response of Fig. 12	Fig. 7 Fig. 11 Fig. 12
R-F UNIT ALIGNMENT										
5	If unit is completely out of adjustment, preset all adjustments to center of range with following exceptions. Set C18 so that head is $\frac{3}{8}$ " above chassis. Set C11 $\frac{1}{4}$ turn from max clockwise Disconnect link from T104 and terminate with 39 ohms. Short r-f unit power terminal 3 to ground. Set fine tuning 30 degrees clockwise from mechanical center of its range for all oscillator adjustments.									
6	Grid, pin 7 of V2 through 1500 mmf.	43.5 mc. 30% mod.	Not used	—	Not used	—	TP1. Gain to maximum	Set r-f unit on channel 2	L65 for min. indication on scope	Fig. 7 Fig. 10
7	Not used	—	Not used	—	Loosely to r-f unit oscillator	227 mc.	Not used	R-F unit on channel 8	C1-KRK11, or C2-KRK-11A for beat on freq. meter	Fig. 7
8	Antenna terminals loosely	181.25 and 185.75	Antenna terminals through pad	Channel 8	Not used	—	TP1. Gain to maximum	R-F unit on channel 8 Set T1 max. counter-clockwise	C9, C11, C15 and C18 for response shown in Fig. 13	Fig. 7 Fig. 13
9	Not used	—	Not used	—	Loosely to r-f unit oscillator	129 mc.	Not used	R-F unit on channel 6	L5 for beat on het. freq. meter	Fig. 8
10	Antenna terminals loosely	83.25 and 87.75	Antenna terminals through pad	Channel 6	Not used	—	TP1. Gain to maximum	"	L48, L50 and L53 for response shown in Fig. 13	Fig. 7 Fig. 13
11	Not used	—	Not used	—	Not used	—	Not used	On channel 6. Connect "VoltOhmyst" to TP1	C8 for -3.5 volts on meter	Fig. 7
12	Antenna terminals loosely	83.25 and 87.75	Antenna terminals through pad	Channel 6	Not used	—	TP1. Gain to maximum	R-F unit on channel 6	Check response. Readjust L48, L50 and L53 if necessary	Fig. 7 Fig. 13
13	Not used	—	Not used	—	Loosely to r-f unit oscillator	227 mc.	Not used	R-F unit on channel 8	C1-KRK11, or C2-KRK-11A for beat on freq. meter	Fig. 7
14	Antenna terminals loosely	181.25 and 185.75	Antenna terminals through pad	Channel 8	Not used	—	TP1. Gain to maximum	"	Check response adjust C9 C11, C15 and C18 if necessary	Fig. 7
15	If C9 was readjusted in step 14, repeat step 11, step 13 and step 14 until the conditions specified in each step are fulfilled without additional adjustments.									
16	Not used	—	Not used	—	Loosely to r-f unit oscillator	267 mc.	Not used	Rec. on channel 13	L46 for beat on het. freq. meter. Overshoot L46 slightly and adjust C1-KRK11 or C2-KRK-11A for beat	Fig. 7
17	Antenna terminals loosely	211.25 215.75	Antenna terminals through pad	Channel 13	Not used	—	TP1. Gain to maximum	Rec. on channel 13 "VoltOhmyst" on TP1	Check to see that response is correct and -3.0 volts of osc. injection is present	Fig. 13
18	"	205.25 209.75	"	Channel 12	Not used	—	"	Rec. on channel 12	"	Fig. 13
19	"	199.25 203.75	"	Channel 11	"	—	"	Rec. on channel 11	"	Fig. 13
20	"	193.25 197.75	"	Channel 10	"	—	"	Rec. on channel 10	"	Fig. 13
21	"	187.25 191.75	"	Channel 9	"	—	"	Rec. on channel 9	"	Fig. 13
22	"	181.25 185.75	"	Channel 8	"	—	"	Rec. on channel 8	"	Fig. 13
23	"	175.25 179.75	"	Channel 7	"	—	"	Rec. on channel 7	"	Fig. 13
24	If the response of any channel (steps 17 through 23) is below 80% at either marker, adjust C9, C11, C15 and C18 as necessary to pull response up on the low channel yet maintain correct response on channel 8.									
25	Repeat step 13. If the oscillator is off frequency overshoot the adjustment of C1 in KRK11 or C2 in KRK11A and correct by adjusting L46.									
26	Repeat steps 16 through 25 until all adjustments are obtained.									
27	Not used	—	Not used	—	Loosely to r-f unit oscillator	129 mc.	Not used	Rec. on channel 6	L5 for beat on het. freq. meter	Fig. 7
28	Antenna terminals loosely	55.25 59.75	Antenna terminals through pad	Channel 2	Not used	—	TP1. Gain to maximum	Rec. on channel 2	Adjust T1 core clockwise to a point at which channel 2 response does not change	Fig. 7
29	"	83.25 87.75	"	Channel 6	Not used	—	"	Rec. on channel 6. "VoltOhmyst" on TP1	Check to see that response is correct and -3.0 volts of osc. injection is present	Fig. 7 Fig. 13
30	"	77.25 81.75	"	Channel 5	"	—	"	Rec. on channel 5	"	Fig. 13
31	"	67.25 71.75	"	Channel 4	"	—	"	Rec. on channel 4	"	Fig. 13

21T159, 21T159DE, 21T165
21T166DE, 21T174DE, 21T175DE
21T176, 21T177, 21T178
21T178DE, 21T179, 21T179DE

TEST PATTERN PHOTOGRAPHS



Figure 20—Normal Picture

Figure 21—Focus Magnet and Ion Trap Magnet Misadjusted

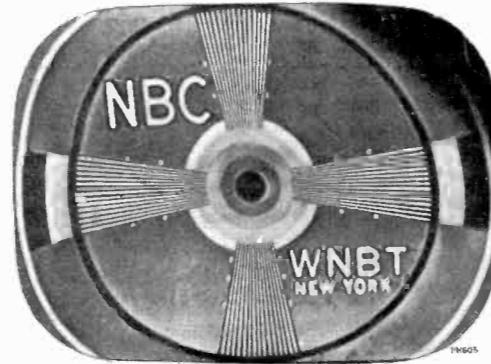

Figure 22—Horizontal Linearity Control Misadjusted (Picture Cramped in Middle)

Figure 23—Width Control Misadjusted

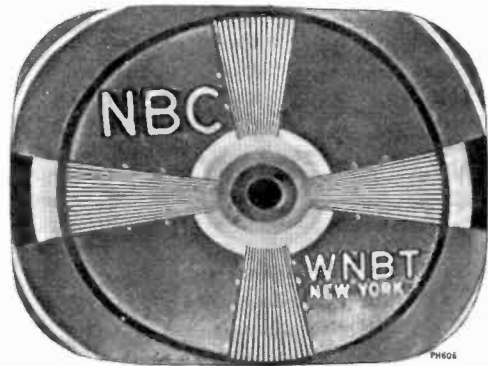
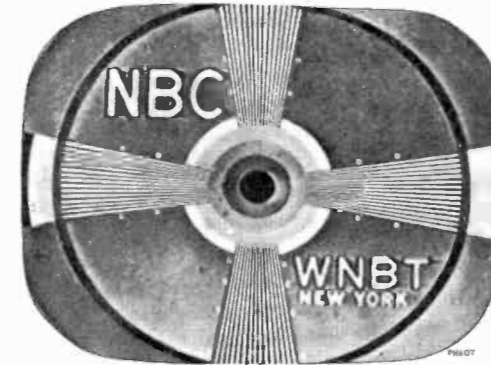

Figure 24—Horizontal Drive Control Misadjusted

Figure 25—Transients

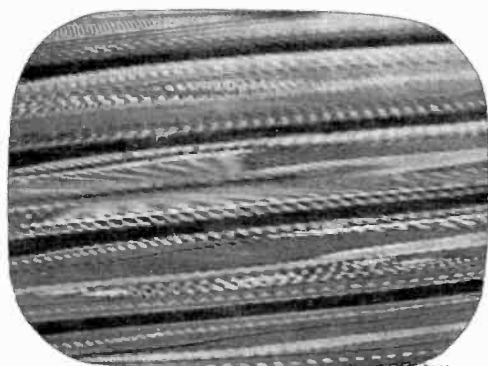
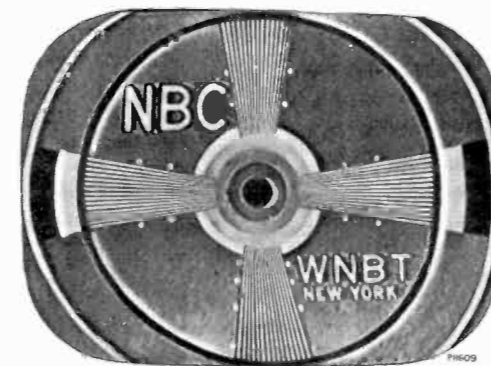

Figure 26—Test Pattern Showing Out of Sync Condition When Horizontal Hold Control Is in a Counter-clockwise Position—Just Before Pulling Into Sync

Figure 27—Test Pattern Showing Out of Sync Condition When Horizontal Hold Control Is at the Maximum Clockwise Position



21T159, 21T159DE, 21T165
21T166DE, 21T174DE, 21T175DE
21T176, 21T177, 21T178
21T178DE, 21T179, 21T179DE

SERVICE SUGGESTIONS

Following is a list of symptoms of possible failures and an indication of some of the possible faults:

NO RASTER ON KINESCOPE:

- (1) Incorrect adjustment of ion trap magnet. Magnet reversed either front to back or top to bottom.
- (2) V116 or V117 inoperative. Check waveforms on grids and plates.
- (3) No high voltage—if horizontal deflection is operating as evidenced by the correct waveform on terminal 1 of high voltage transformer, the trouble can be isolated to the 1B3GT circuit. Either the T115 high voltage winding is open, the 1B3GT tube is defective, its filament circuit is open or C197 is shorted.
- (4) V110 circuit inoperative—Refer to schematic and waveform chart.
- (5) Damper tubes (V119 or V120) inoperative.
- (6) Defective kinescope.
- (7) R218 open.
- (8) No receiver plate voltage—filter capacitor shorted—or filter choke open.

NO VERTICAL DEFLECTION:

- (1) V114B or V115 inoperative. Check voltage and waveforms on grids and plates.
- (2) T111 or T112 open.
- (3) Vertical deflection coils open.

SMALL RASTER:

- (1) Low Plus B or low line voltage.
- (2) V117 defective.

POOR VERTICAL LINEARITY:

- (1) If adjustments cannot correct, change V115.
- (2) Vertical output transformer T112 defective.
- (3) V114B defective—check voltage and waveforms on grid and plate.
- (4) C170, C171, C201D or C202B defective.
- (5) Low plate voltage—check rectifiers and capacitors in supply circuits.
- (6) If height is insufficient try changing V114.

POOR HORIZONTAL LINEARITY:

- (1) If adjustments do not correct, change V117, V119 or V120.
- (2) T115 or L107 defective.
- (3) C195 or C219 defective.

WRINKLES ON SIDE OF RASTER:

- (1) C193 defective.
- (2) Defective yoke.

PICTURE OUT OF SYNC HORIZONTALLY:

- (1) T114 incorrectly tuned.
- (2) R226, R227 or R201B defective.

TRAPEZOIDAL OR NON SYMMETRICAL RASTER:

- (1) Improper adjustment of focus magnet or ion trap magnet.
- (2) Defective yoke.

RASTER AND SIGNAL ON KINESCOPE BUT NO SOUND:

- (1) T110 defective.
- (2) Sound i-f, ratio detector or audio amplifier inoperative—check V101, V102, V103 and their socket voltages.
- (3) Audio system defective.
- (4) Speaker defective.

CRITICAL LEAD DRESS:

1. Keep all wiring in the pix i-f, sound i-f and video circuits as short as possible.
2. Keep the leads on C110, C111, C112, C200, R109, R110, R111, R112, R114, R115 and R233 as short and direct as possible.
3. Do not change the bus wire connection to pin 2 of V101 and V102. Sleeving is used on these wires to insure length and to prevent shorting.
4. Dress C114 down between R117 (volume control) and wafer S101-2.
5. Ground R130 to pin 3 of V106 and R138 to pin 7 of V107.
6. Do not change the grounding of R141, R146 and R149.
7. Keep the bus wire from T109-A to C146 (plug in capacitor) short and direct.
8. Ground the filaments of sockets of V107, V108 and V109 independently of the socket center pin. Use ground lances provided near each socket.
9. Dress C198 straight up to act as a shield between T101-A and V110-4.
10. Dress C153 and R170 (kine cathode) up in the air above the terminal board.

ALIGNMENT TABLE

21T159, 21T159DE, 21T165
21T166DE, 21T174DE, 21T175DE
21T176, 21T177, 21T178
21T178DE, 21T179, 21T179DE

Table with columns: Step No., CONNECT SIGNAL GENERATOR TO, SIGNAL GEN. FREQ. MC., CONNECT SWEEP GENERATOR TO, SWEEP GEN. FREQ. MC., CONNECT HETERODYNE FREQ. METER TO, HET. METER FREQ. MC., CONNECT OSCILLOSCOPE TO, MISCELLANEOUS CONNECTIONS AND INSTRUCTIONS, ADJUST, REFER TO. Rows 32-48.

RATIO DETECTOR, SOUND I-F AND SOUND TAKE-OFF ALIGNMENT

Table with columns: Step No., CONNECT SIGNAL GENERATOR TO, SIGNAL GEN. FREQ. MC., CONNECT SWEEP GENERATOR TO, SWEEP GEN. FREQ. MC., CONNECT HETERODYNE FREQ. METER TO, HET. METER FREQ. MC., CONNECT OSCILLOSCOPE TO, MISCELLANEOUS CONNECTIONS AND INSTRUCTIONS, ADJUST, REFER TO. Rows 49-53.

PICTURE I-F AND TRAP ADJUSTMENT

Table with columns: Step No., CONNECT SIGNAL GENERATOR TO, SIGNAL GEN. FREQ. MC., CONNECT SWEEP GENERATOR TO, SWEEP GEN. FREQ. MC., CONNECT HETERODYNE FREQ. METER TO, HET. METER FREQ. MC., CONNECT OSCILLOSCOPE TO, MISCELLANEOUS CONNECTIONS AND INSTRUCTIONS, ADJUST, REFER TO. Rows 54-63.

ALIGNMENT DATA

21T159, 21T159DE, 21T165
21T166DE, 21T174DE, 21T175DE
21T176, 21T177, 21T178
21T178DE, 21T179, 21T179DE

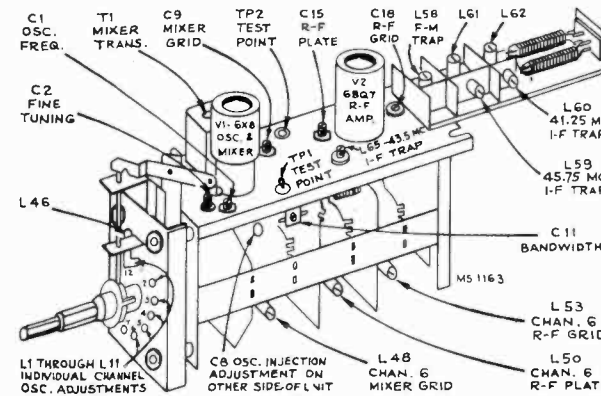

Figure 7 - R-F Unit Adjustments

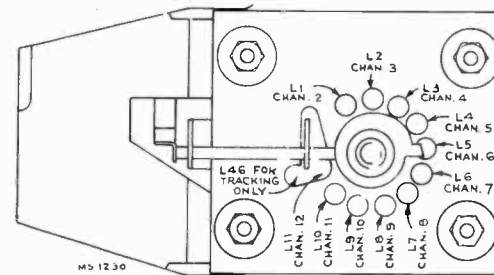

Figure 8 - R-F Oscillator Adjustments

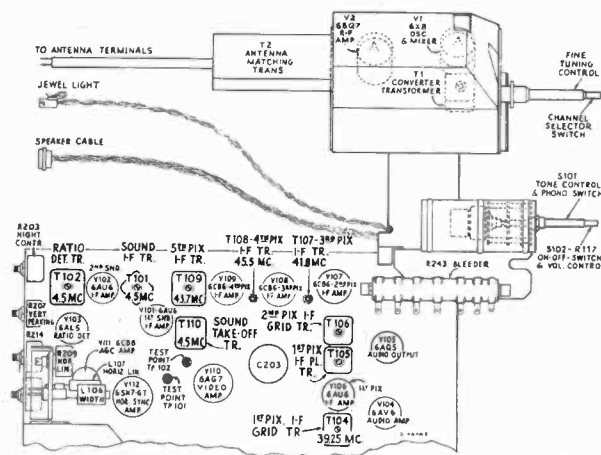

Figure 9 - Top Chassis Adjustments

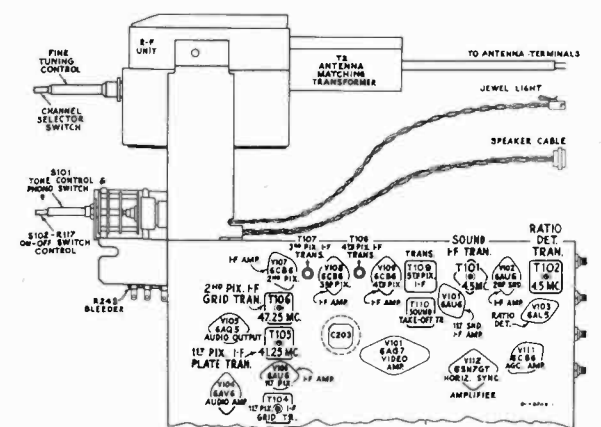

Figure 10 - Bottom Chassis Adjustments

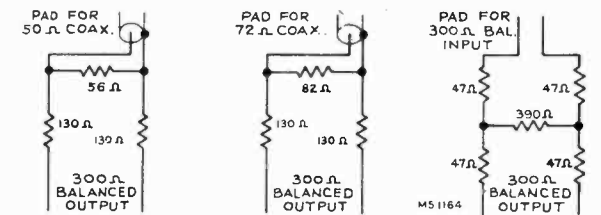

Figure 11 - Sweep Attenuator Pads

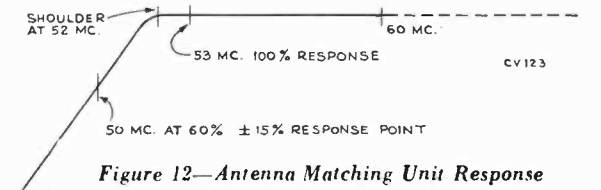

Figure 12 - Antenna Matching Unit Response

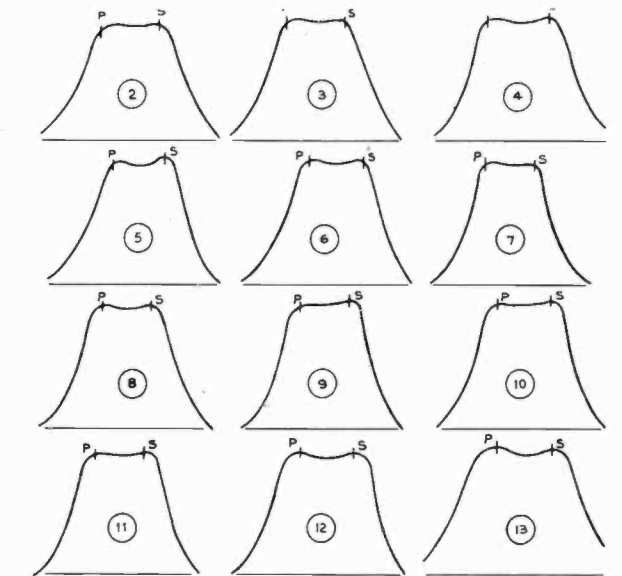

Figure 13 - R-F Response

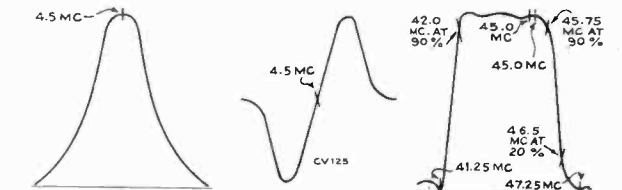

Figure 14 Sound I-F Response

Figure 15 Ratio Det. Response

Figure 16 T105 and T106 Response

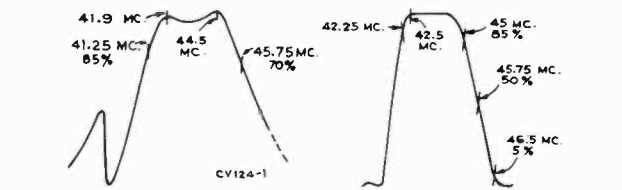

Figure 17 T1 and T104 Response

Figure 18 Overall I-F Response

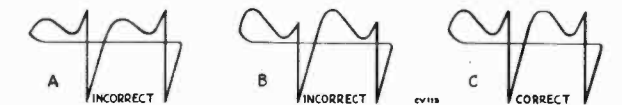

Figure 19 - Horizontal Oscillator Waveforms

21T159, 21T159DE, 21T165
 21T166DE, 21T174DE, 21T175DE
 21T176, 21T177, 21T178
 21T178DE, 21T179, 21T179DE

SERVICE SUGGESTIONS

11. Keep the leads connected to T114-C and T114-D (synchro-guide) down so that they will not short out when the chassis is placed in the cabinet.
12. Do not reroute any wires between T104 and the terminal board along side it.
13. Dress all wires routed past T104, shielded wires W102 and W103 under the big lances near T104.
14. Dress all a-c leads to S102 under the large lances on the front apron and away from R243.
15. Dress R116 close to the chassis using short leads.
16. Dress C206, C221 and C212 up in the air and away from all other leads and components.
17. Dress all leads away from bleeder resistor R243.
18. The blue lead from pin 5 of V111 to the terminal board under the high voltage cage should be routed between V117 socket and the rear apron.
19. Keep leads on C214 as short and direct as possible.
20. Dress R206 away from all other wires and components to prevent excessive heating.
21. Keep the wire from the vertical output transformer T114 away from the 5U4G rectifier tubes.
22. Dress all 2 watt resistors away from each other and all other wires and components.
23. Dress all wires away from damper tubes V119 and V120.
24. Keep blue wire from pin 5 V116 to T114-A under 5" long.
25. Dress all peaking coils up and away from the base.

PICTURE I-F RESPONSE

It may be desirable to observe the individual i-f stage response. To do this use the following method:

For T107, T108 or T109, shunt all i-f transformers with a 330 ohm carbon resistor except the one to be observed.

Connect a wide band sweep generator to the second pix i-f grid and adjust it to sweep from 38 mc. to 48 mc.

Connect the oscilloscope to TP102 and observe the overall response. It will essentially be that of the unshunted stage.

To see the response of transformers T1, T104 and T105, T106, follow the instructions given on page 10.

Figures 28 through 36 show the response of the various stages obtained in the above manner. The curves shown are typical although some variation between receivers can be expected.

RESPONSE PHOTOGRAPHS

Taken from RCA WO58A Oscilloscope

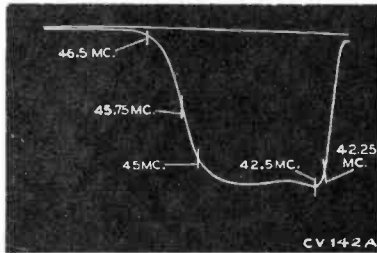

Figure 28—Overall Pix I-F Response

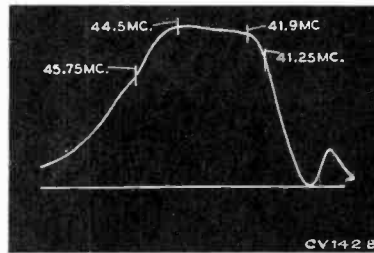

Figure 29—Response of T1-T104 Pix I-F Transformers

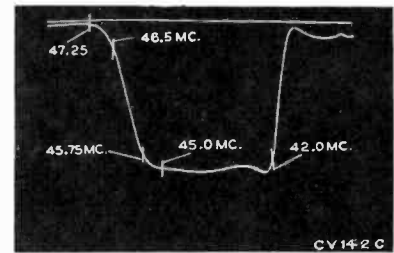

Figure 30—Response of T105-T106 Pix I-F Transformer

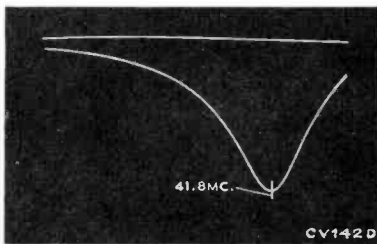

Figure 31—Response of T107 Pix I-F Transformer

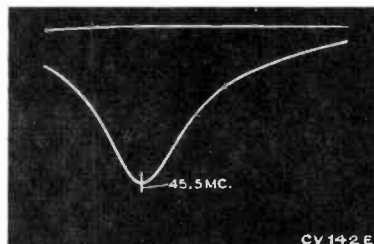

Figure 32—Response of T108 Pix I-F Coil

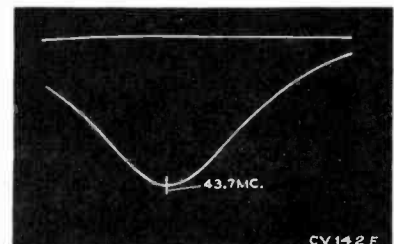

Figure 33—Response of T109 Pix I-F Coil

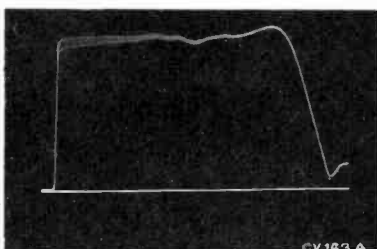

Figure 34—Video Response at Average Contrast

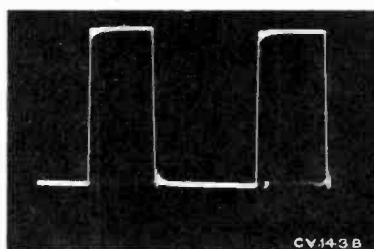

Figure 35—Video Response (100 KC Square Wave)

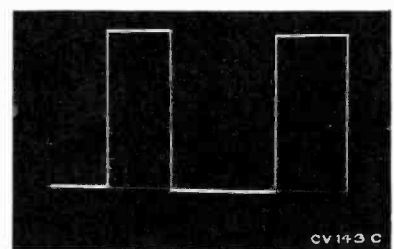
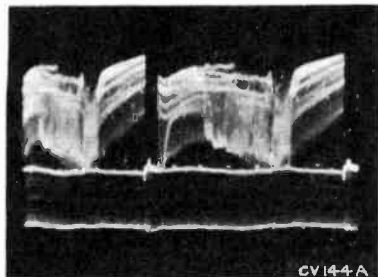

Figure 36—Video Response (60 Cycle Square Wave)

21T159, 21T159DE, 21T165
 21T166DE, 21T174DE, 21T175DE
 21T176, 21T177, 21T178
 21T178DE, 21T179, 21T179DE

WAVEFORM PHOTOGRAPHS

Taken from RCA WO58A Oscilloscope



*Grid of 1st Video Amplifier
 (Pin 4 of V110) (6AG7)*

*Figure 37—Vertical (Oscilloscope
 Synced to 1/2 of Vertical Sweep
 Rate) (5.5 Volts PP)*



*Figure 38—Horizontal (Oscilloscope
 Synced to 1/2 of Horizontal Sweep
 Rate) (5.5 Volts PP)*

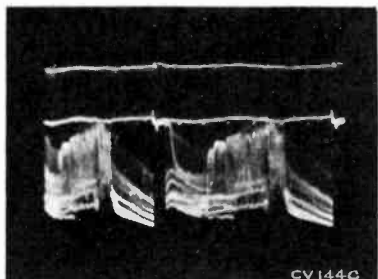
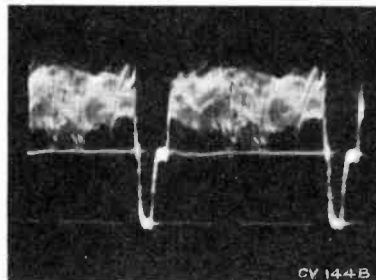

*Plate of 1st Video Amplifier
 (Pin 8 of V110) (6AG7)*

Voltage depends on picture

Figure 39—Vertical (110 Volts PP)



Figure 40—Horizontal (110 Volts PP)

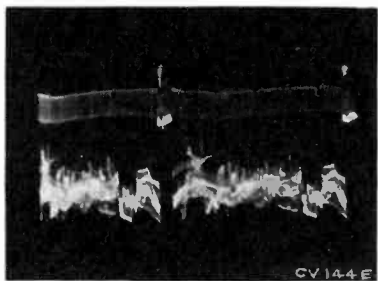
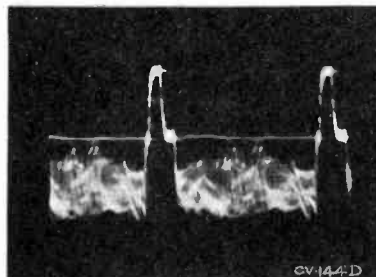

*Grid of Sync Separator
 (Pin 4 of V113) (6SN7)*

Voltage depends on picture

Figure 41—Vertical (75 Volts PP)



Figure 42—Horizontal (75 Volts PP)

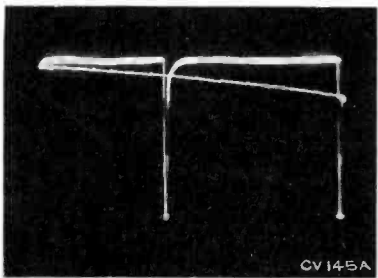
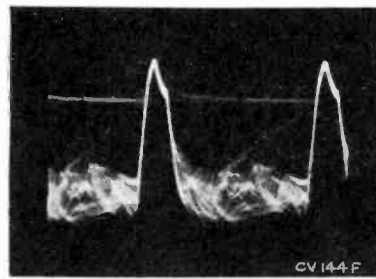
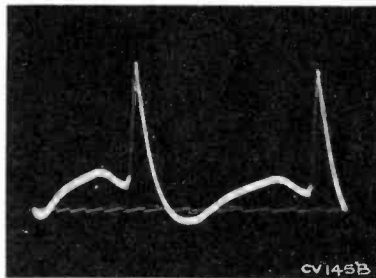

*Figure 43—Plate of Sync Separator
 (Pin 5 of V113) (6SN7) (35 Volts PP)*

Voltage depends on picture



*Figure 44—Cathode of Sync Separator
 (Pin 6 of V113) (6SN7) (10 Volts PP)*



*Figure 45—Grid of Vert. Sync Ampli-
 fier (Pin 4 of V114A) (6SN7)*

(12 Volts PP)



*Figure 46—Plate of Vert Sync Ampli-
 fier (Pin 5 of V114A) (6SN7)*

(100 Volts PP)

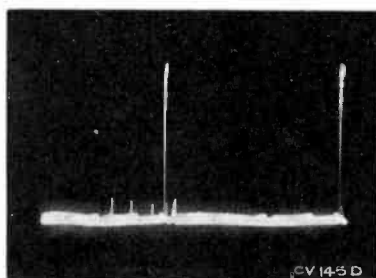
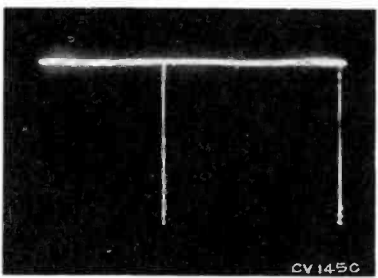

WAVEFORM PHOTOGRAPHS

Taken from RCA WO58A Oscilloscope

21T159, 21T159DE, 21T165
21T166DE, 21T174DE, 21T175DE
21T176, 21T177, 21T178
21T178DE, 21T179, 21T179DE

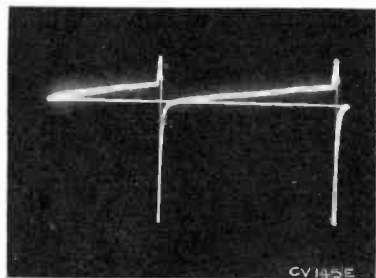

Figure 47—Grid of Vertical Oscillator
(Pin 1 of V114B) (6SN7)
(135 Volts PP)

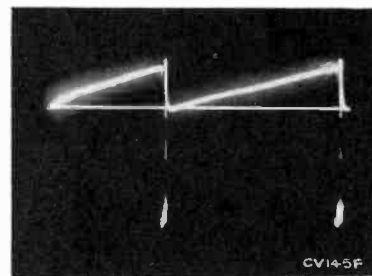

Figure 48—Plate of Vertical Oscillator
(Pin 2 of V114B) (6SN7)
(105 Volts PP)

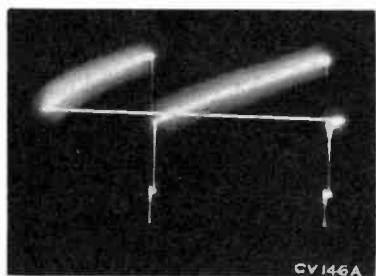

Figure 49—Grid of Vertical Output
(105 Volts PP) (Pin 1 of V115)
(6AQ5)

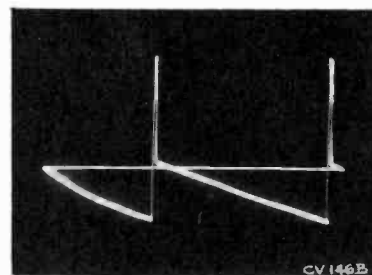

Figure 50—Plate of Vertical Output
(900 Volts PP) (Pin 5 of V115)
(6AQ5)

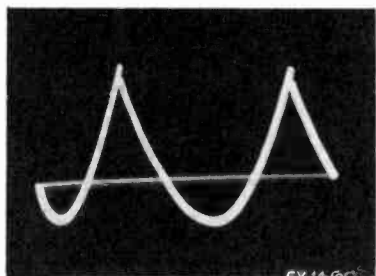

Figure 51—Cathode of Vertical Output
(1.0 Volts PP) (Pin 2 of V115)
(6AQ5)

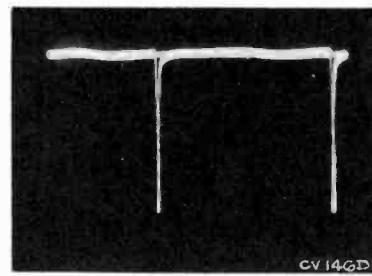
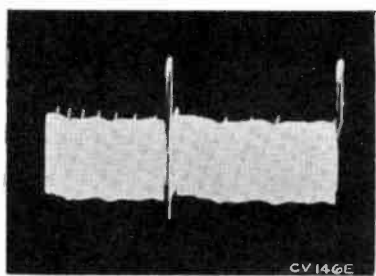

Figure 52—Grid of Kinescope
(Pin 2 of V121) (12 Volts PP)



Cathode of Sync Separator
(Pin 3 of V113) (6SN7)

Figure 53—Vertical (15 Volts PP)

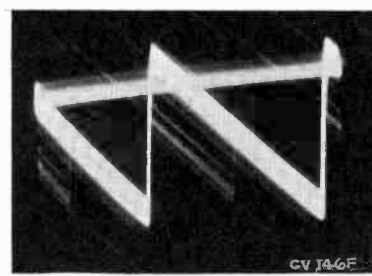
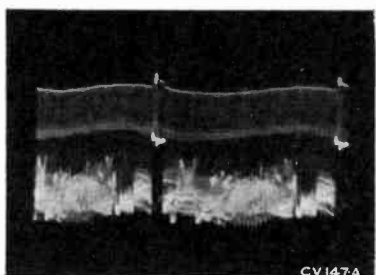

Figure 54—Horizontal (8 Volts PP)



Grid of Sync Separator
(Pin 1 of V113) (6SN7)

Figure 55—Vertical (110 Volts PP)

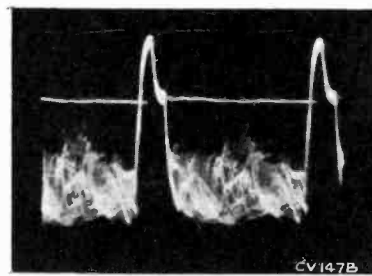

Figure 56—Horizontal (110 Volts PP)



21T159, 21T159DE, 21T165
 21T166DE, 21T174DE, 21T175DE
 21T176, 21T177, 21T178
 21T178DE, 21T179, 21T179DE

WAVEFORM PHOTOGRAPHS

Taken from RCA WO58A Oscilloscope

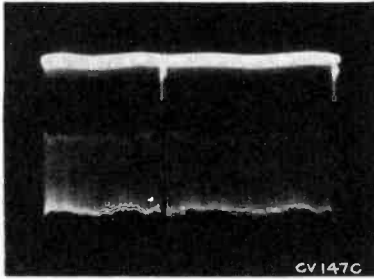

CV147C

*Plate of Sync Separator
 (Pin 2 of V113)*

Figure 57—Vertical (30 Volts PP)

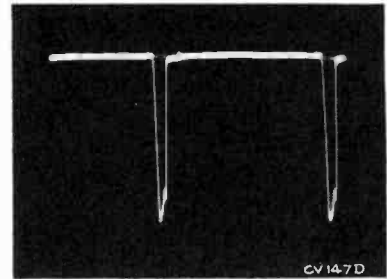

CV147D

Figure 58—Horizontal (30 Volts PP)

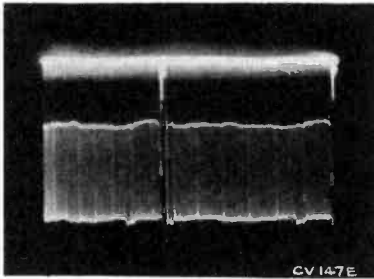

CV147E

*Grid of Hor Sync Amp
 (Pin 4 of V112) (6SN7)*

Figure 59—Vertical (30 Volts PP)

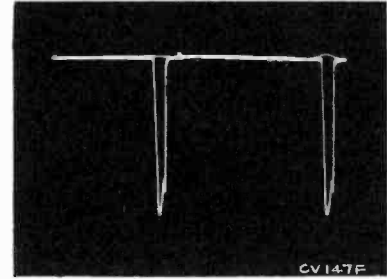

CV147F

Figure 60—Horizontal (30 Volts PP)

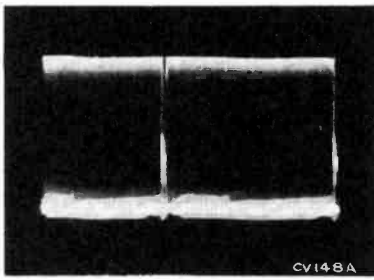

CV148A

*Plate of Hor Sync Amp
 (Pin 5 of V112) (6SN7)*

Figure 61—Vertical (85 Volts PP)

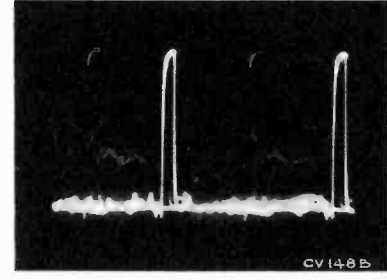

CV148B

Figure 62—Horizontal (85 Volts PP)

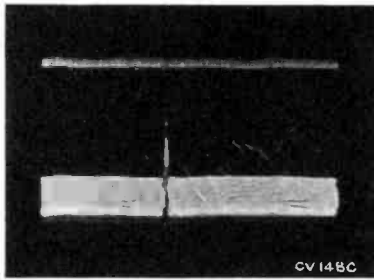

CV148C

*Grid of Hor Sync Amp
 (Pin 1 of V112) (6SN7)*

Figure 63—Vertical (75 Volts PP)

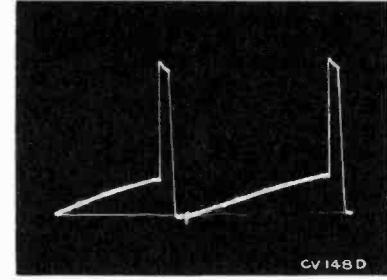

CV148D

Figure 64—Horizontal (75 Volts PP)

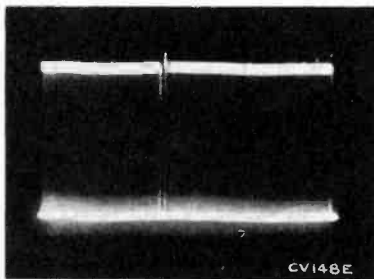

CV148E

*Cathode of Hor Sync Amp
 (Pin 3 of V112) (6SN7)*

Figure 65—Vertical (18 Volts PP)

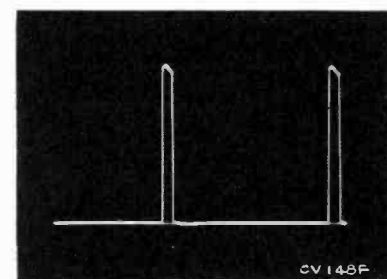

CV148F

Figure 66—Horizontal (18 Volts PP)



WAVEFORM PHOTOGRAPHS

Taken from RCA WO58A Oscilloscope

21T159, 21T159DE, 21T165
21T166DE, 21T174DE, 21T175DE
21T176, 21T177, 21T178
21T178DE, 21T179, 21T179DE

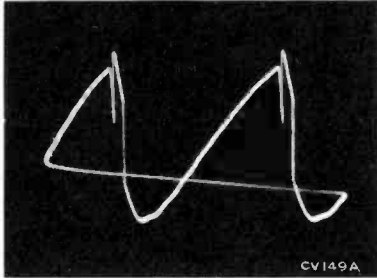

Figure 67—Grid of Horizontal Oscillator Control (25 Volts PP) (Pin 1 of V116) (6SN7GT)



Figure 68—Cathode of Horizontal Oscillator Control (1.3 Volts PP) (Pin 3 of V116) (6SN7GT)

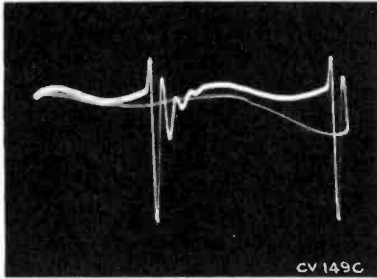
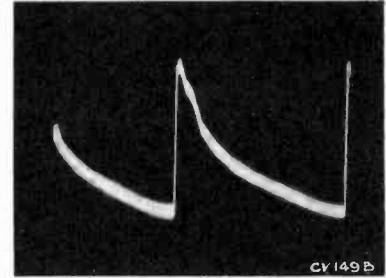

Figure 69—Grid of Horizontal Oscillator (550 Volts PP) (Pin 4 of V110) (6SN7GT)



Figure 70—Plate of Horizontal Oscillator (290 Volts PP) (Pin 5 of V116) (6SN7GT)

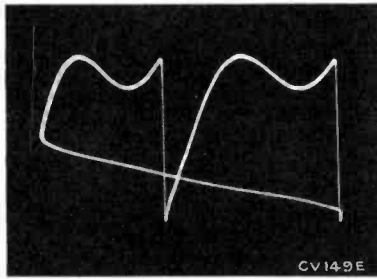
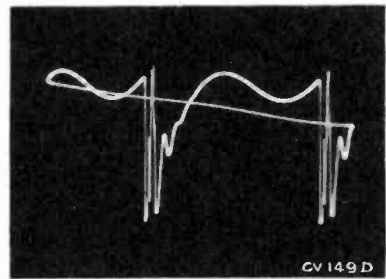

Figure 71—Terminal "C" of T114 (150 Volts PP)



Figure 72—Grid of Horizontal Output Tube (140 Volts PP) (Pin 5 of V117) (6CD6G)

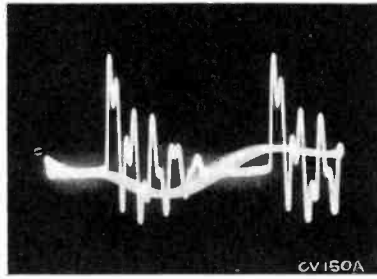
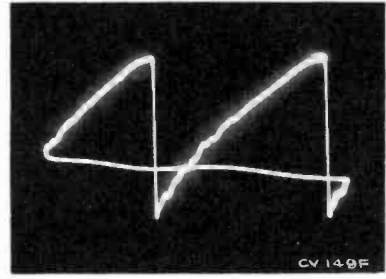

Figure 73—Plate of Horizontal Output (Approx. 5400 Volts PP) (Measured Through a Capacity Voltage Divider Connected from Top Cap of V117 to Ground)



Figure 74—Cathode of Damper (2300 Volts PP) (Pin 3 of V119) (6W4GT)

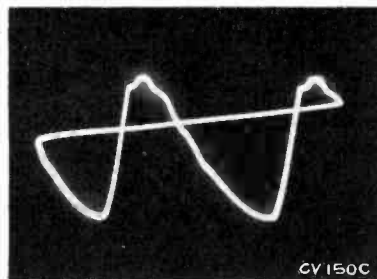
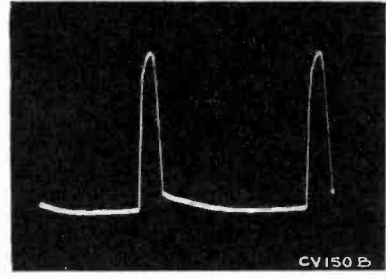
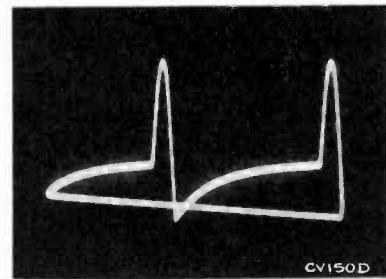

Figure 75—Plate of Damper (100 Volts PP) (Pin 5 of V119) (6W4GT)



Figure 76—Plate of AGC Amplifier (Pin 5 of V111) (6CB6) (700 Volts PP)



21T159, 21T159DE, 21T165
 21T166DE, 21T174DE, 21T175DE
 21T176, 21T177, 21T178
 21T178DE, 21T179, 21T179DE

VOLTAGE CHART

The following measurements represent two sets of conditions. In the first condition, a 5000 microvolt test pattern signal was fed into the receiver, the picture synchronized and the AGC control properly adjusted. The second condition was obtained by removing the antenna leads and short circuiting the receiver antenna terminals. Voltages shown are read with a type WV97A senior "VoltOhmyst" between the indicated terminal and chassis ground and with the receiver operating on 117 volts, 60 cycles, a-c.

Tube No.	Tube Type	Function	Operating Condition	E. Plate		E. Screen		E. Cathode		E. Grid		I Plate (ma.)	I Screen (ma.)	Notes on Measurements
				Pin No.	Volts	Pin No.	Volts	Pin No.	Volts	Pin No.	Volts			
V1	6X8	Mixer	5000 Mu. V. Signal	9	160	8	160	6	0	7	-2.4 to -3.0	—	—	
			No Signal	9	145	8	145	6	0	7	-2.8 to -3.5	—	—	
V1	6X8	R-F Oscillator	5000 Mu. V. Signal	3	95	—	—	6	0	2	-3.8 to -5.5	—	—	
			No Signal	3	90	—	—	6	0	2	-3.0 to -5.1	—	—	
V2	6BQ7	R-F Amplifier	5000 Mu. V. Signal	6	170	—	—	8	0.1	7		—	—	
			No Signal	6	133	—	—	8	1.1	7	0	—	—	
V2	6BQ7	R-F Amplifier	5000 Mu. V. Signal	1	270	—	—	3	170	2		—	—	
			No Signal	1	260	—	—	3	133	2		—	—	Depending on channel
V101	6AU6	1st Sound I-F Amp.	5000 Mu. V. Signal	5	127	6	124	7	0.7	1	-0.4	6.0	3.0	
			No Signal	5	126	6	123	7	0.5	1	-1.2	5.0	3.0	
V102	6AU6	2d Sound I-F Amp.	5000 Mu. V. Signal	5	132	6	60	7	0.14	1	-10	2.8	1.2	
			No Signal	5	131	6	65	7	0.14	1	-5	2.0	1.0	
V103	6AL5	Ratio Detector	5000 Mu. V. Signal	7	1.0	—	—	1	9.2	—	—	—	—	
			No Signal	7	0	—	—	1	8.0	—	—	—	—	
V104	6AV6	1st Audio Amplifier	5000 Mu. V. Signal	7	90	—	—	2	0	1	-0.7	0.45	—	At min. volume
			No Signal	7	86	—	—	2	0	1	-0.7	0.45	—	
V105	6AQ5	Audio Output	5000 Mu. V. Signal	5	350	6	360	2	150	7	116	30.0	2.0	At min. volume
			No Signal	5	346	6	356	2	145	7	114	30.0	2.0	
V106	6AU6	1st Pix. I-F Amplifier	5000 Mu. V. Signal	5	180	6	230	7	0.15	1	-6.5	1.5	0.3	
			No Signal	5	97	6	129	7	1.0	1	0	7.0	3.0	
V107	6CB6	2nd Pix. I-F Amplifier	5000 Mu. V. Signal	5	236	6	233	2	0.1	1	-6.5	1.5	0.14	
			No Signal	5	226	6	138	2	0.85	1	0	12.0	3.0	
V108	6CB6	3d Pix. I-F Amplifier	5000 Mu. V. Signal	5	149	6	144	2	0.9	1	0	11.0	3.0	
			No Signal	5	129	6	133	2	0.8	1	0	10.0	2.0	
V109	6CB6	4th Pix. I-F Amplifier	5000 Mu. V. Signal	5	178	6	163	2	2.2	1	0	8.9	2.1	
			No Signal	5	165	6	150	2	2.0	1	0	7.9	2.1	
V110	6AG7	Video Amplifier	5000 Mu. V. Signal	8	130	6	172	5	1.2	4	*-5.0	22.5	5.5	*Depends on picture
			No Signal	8	130	6	107	5	0.8	4	*-2.0	15.0	4.0	*Depends on picture

VOLTAGE CHART

195
 21T159, 21T159DE, 21T165
 21T166DE, 21T174DE, 21T175DE
 21T176, 21T177, 21T178
 21T178DE, 21T179, 21T179DE

Tube No.	Tube Type	Function	Operating Condition	E. Plate		E. Screen		E. Cathode		E. Grid		I Plate (ma.)	I Screen (ma.)	Notes on Measurements
				Pin No.	Volts	Pin No.	Volts	Pin No.	Volts	Pin No.	Volts			
V111	6CB6	AGC Amplifier	5000 Mu. V. Signal	5	-27	6	238	2	152	1	155	0.1	3.4	AGC control set for normal operation
			No Signal	5	4.5	6	218	2	135	1	118	0	0	
V112	6SN7GT	Hor. Sync Amplifier	5000 Mu. V. Signal	2	152	—	—	3	0.9	1	-44	1.1	—	*Depends on noise
			No Signal	2	135	—	—	3	*0.4	1	*-30	0.5	—	
			5000 Mu. V. Signal	5	86	—	—	6	0	4	-2.0	5.5	—	
V113	6SN7GT	Hor. Sync Separator	5000 Mu. V. Signal	2	374	—	—	3	216	1	155	1.2	—	
			No Signal	2	372	—	—	3	155	1	134	0.8	—	
V113	6SN7GT	Vert. Sync Separator	5000 Mu. V. Signal	5	345	—	—	6	205	4	135	<0.1	—	
			No Signal	5	340	—	—	6	160	4	130	<0.1	—	
V114A	6SN7GT	Vert. Sync Amplifier	5000 Mu. V. Signal	5	7.0	—	—	6	0	4	-0.2	0.6	—	*Depends on noise
			No Signal	5	*7.0	—	—	6	0	4	*0	0.5	—	
V114B	6SN7GT	Vertical Oscillator	5000 Mu. V. Signal	2	176	—	—	3	0	1	-27	0.2	—	
			No Signal	2	176	—	—	3	0	1	-27	0.2	—	
V115	6AQ5	Vertical Output	5000 Mu. V. Signal	5	359	6	359	2	30	1	0	17.3	1.2	
			No Signal	5	357	6	357	2	29	1	0	17.3	1.2	
V116	6SN7GT	Horizontal Osc. Control	No Signal	2	188	—	—	3	-24	1	-42	0.37	—	Hor. hold counter-clockwise
			5000 Mu. V. Signal	2	145	—	—	3	-18	1	-42	0.4	—	
			5000 Mu. V. Signal	2	230	—	—	3	-18	1	-42	0.4	—	
V116	6SN7GT	Horizontal Oscillator	5000 Mu. V. Signal	5	258	—	—	6	0	4	*-91	2.0	—	Depends on Oscillator Adjustment
			No Signal	5	256	—	—	6	0	4	*-94	2.0	—	
V117	6CD6G	Horizontal Output	5000 Mu. V. Signal	Cap *	8	165	3	12.5	5	-30	110	15.0	*High Voltage Pulse Present	
			No Signal	Cap *	8	165	3	12.5	5	-30	110	15.0		
V118	1B3GT /8016	H. V. Rectifier	5000 Mu. V. Signal	Cap *	—	—	2 & 7	16,000	—	—	0.2	—	*High Voltage Pulse Present	
			No Signal	Cap *	—	—	2 & 7	16,400	—	—	0.2	—		
V119	6W4GT	Dampers	5000 Mu. V. Signal	5	355	—	—	3	*	—	—	57	—	*High Voltage Pulse Present
			No Signal	5	353	—	—	3	*	—	—	57	—	
V121	21AP4	Kinescope	5000 Mu. V. Signal	Cone	16,000	10	555	11	140	2	82	0.2	—	At average Brightness
			No Signal	Cone	16,400	10	550	11	132	2	76	0.2	—	
V122	SU4G	Rectifiers	5000 Mu. V. Signal	4 & 6	388	—	—	2 & 8	389	—	—	*139	—	Per Tube
			No Signal	4 & 6	386	—	—	2 & 8	387	—	—	*145	—	

CHASSIS WIRING DIAGRAM, KCS68F

196 — 197
 21T159DE, 21T166DE
 21T174DE, 21T175DE
 21T178DE, 21T179DE

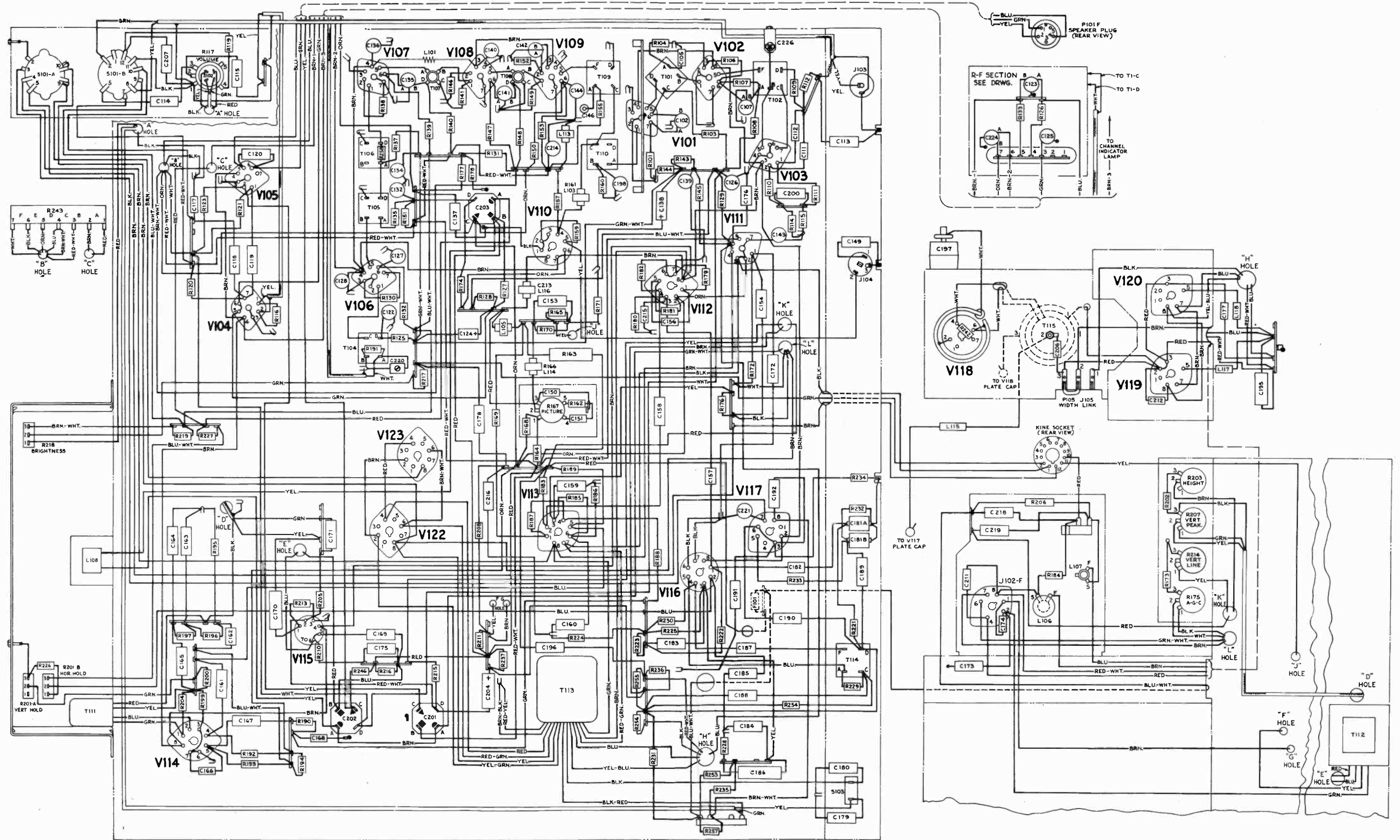

Figure 77—Chassis Wiring Diagram, KCS68F

CHASSIS WIRING DIAGRAM, KCS68C, KCS68E

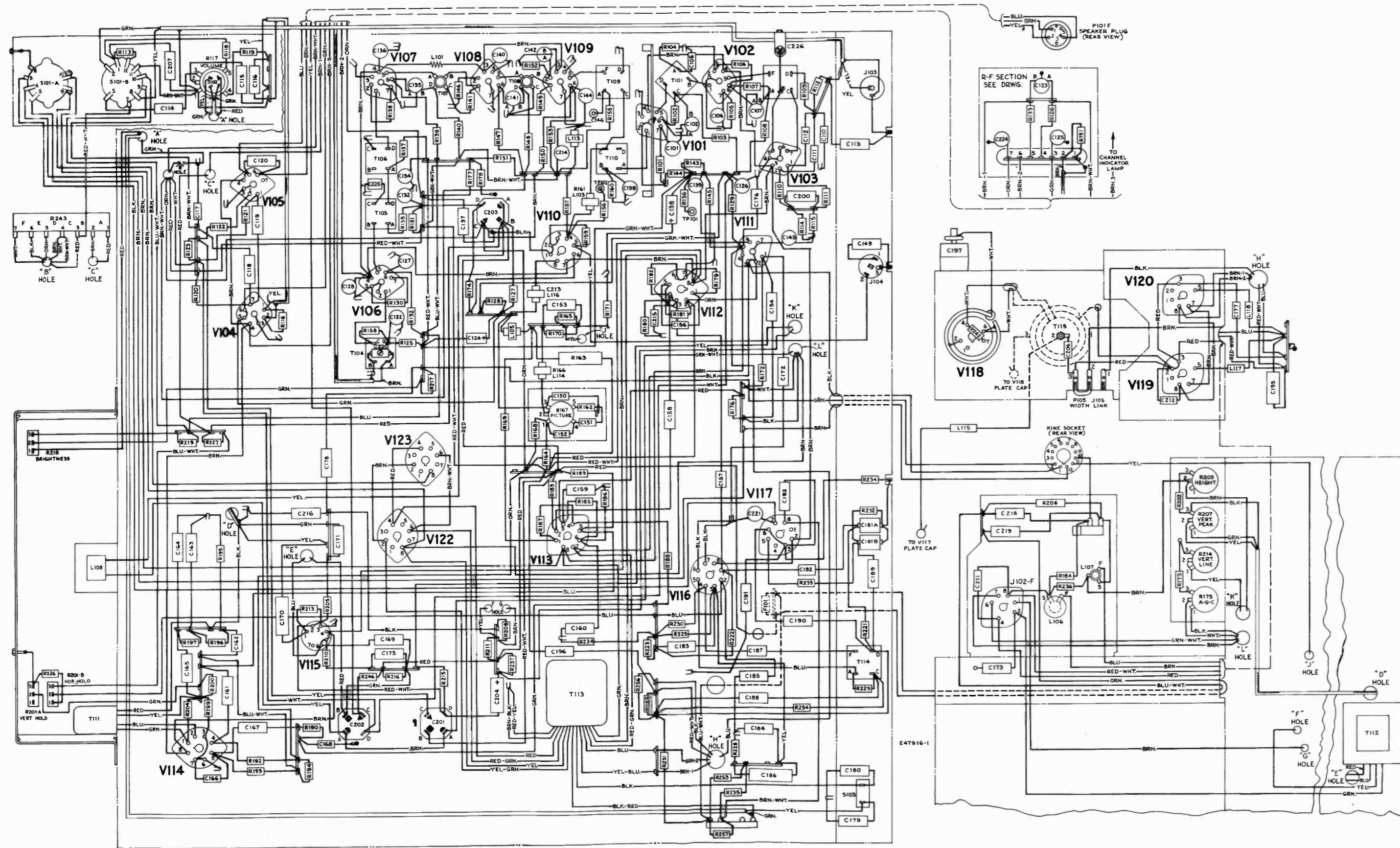

Figure 78—Chassis Wiring Diagram, KCS68C, KCS68E

R-F UNIT WIRING DIAGRAMS

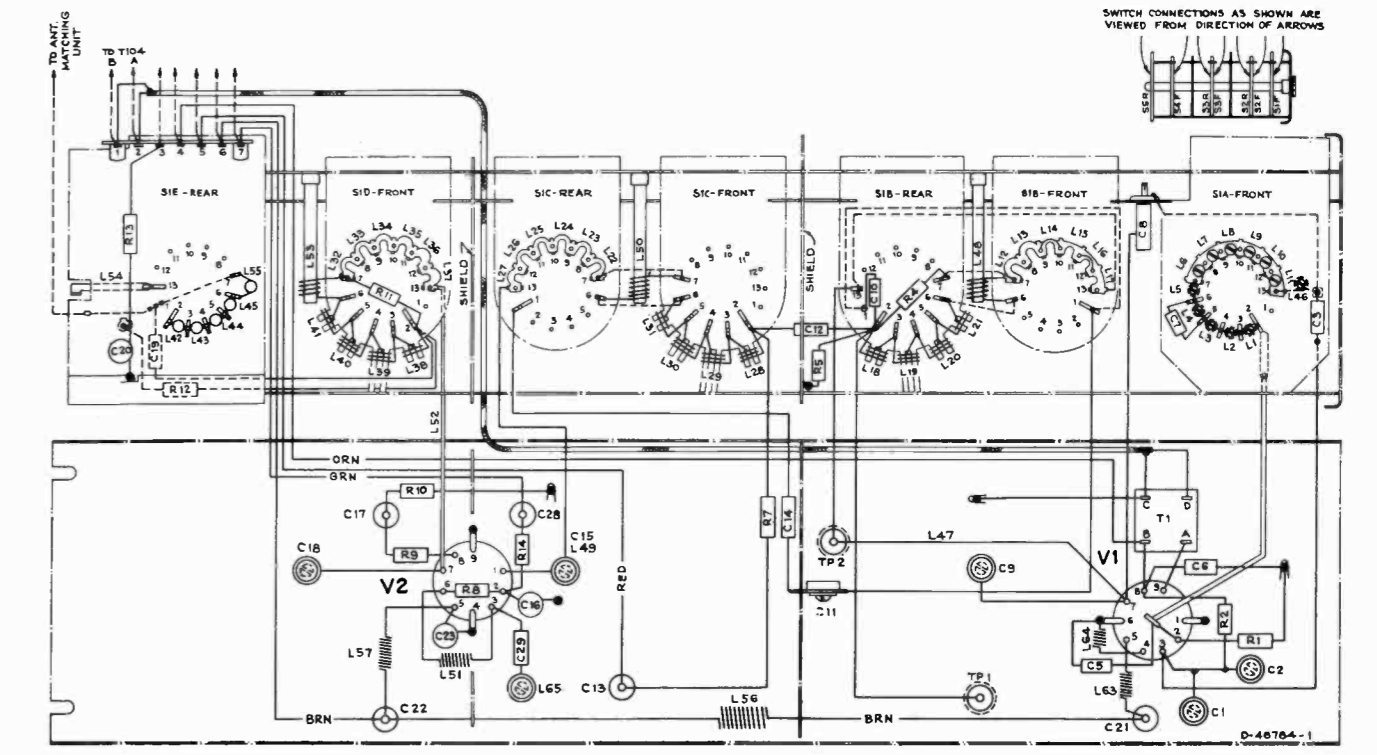

Figure 79—KRK11 R-F Unit Wiring Diagram

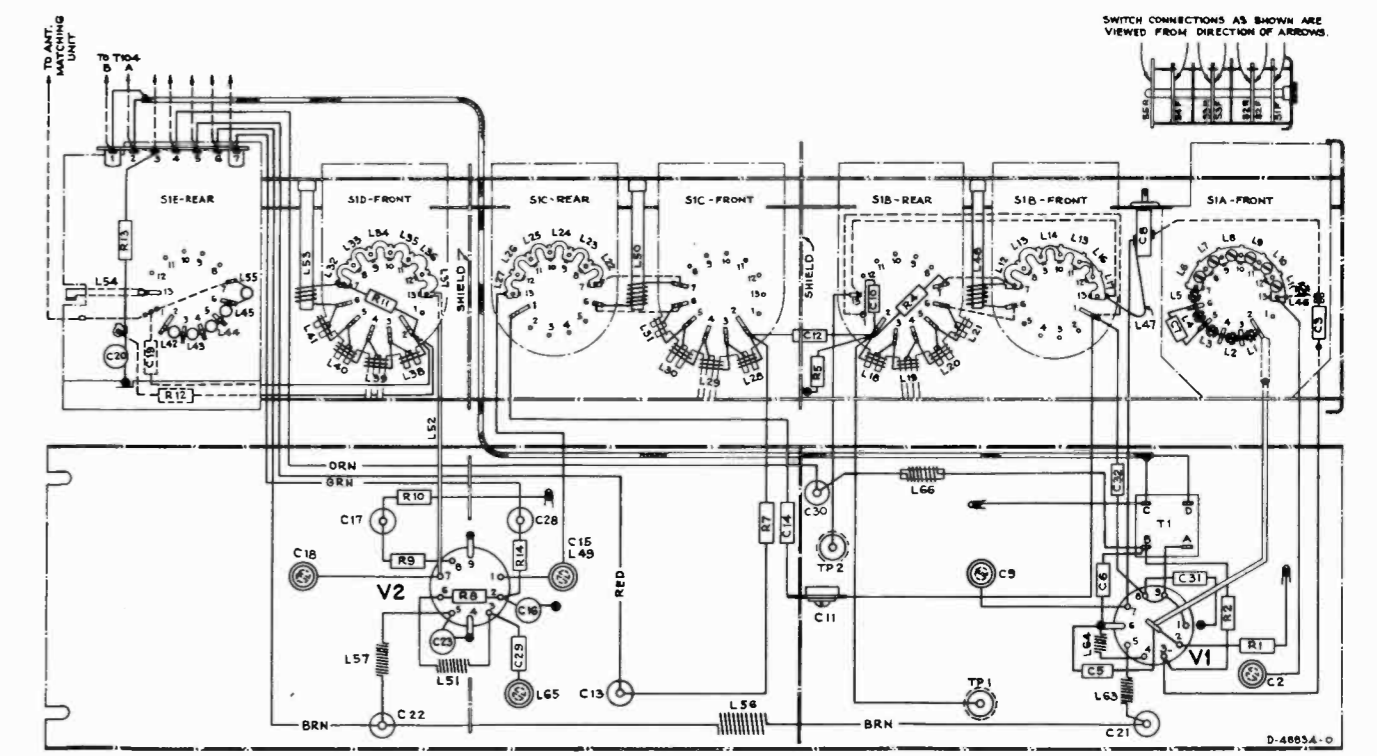
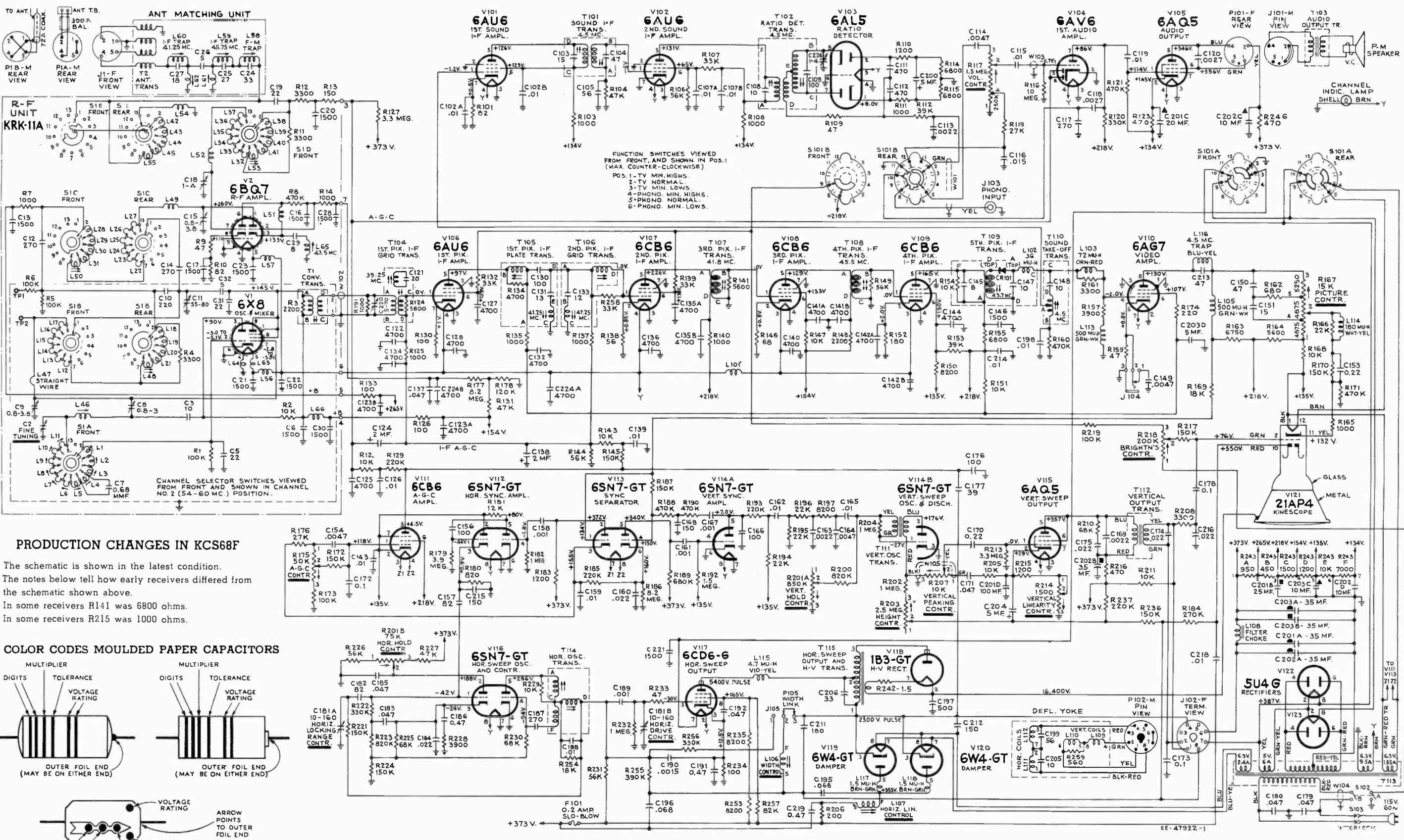

Figure 80—KRK11A R-F Unit Wiring Diagram

21T159DE, 21T166DE
21T174DE, 21T175DE
21T178DE, 21T179DE

21T159, 21T165
21T176, 21T177
21T178, 21T179



PRODUCTION CHANGES IN KCS68F

The schematic is shown in the latest condition. The notes below tell how early receivers differed from the schematic shown above. In some receivers R141 was 6800 ohms. In some receivers R215 was 1000 ohms.

COLOR CODES MOULDED PAPER CAPACITORS

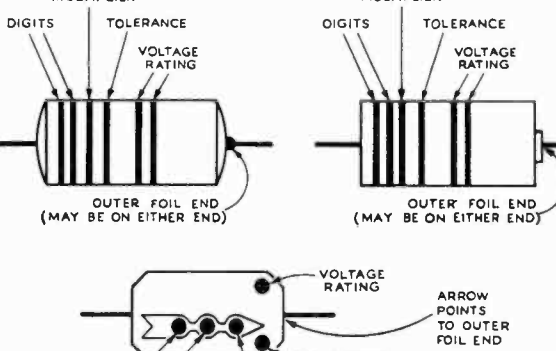

The schematic is shown in the latest condition at the time of printing. All resistance values in ohms. K = 1000.

All capacitance values less than 1 in MF and above 1 in MMF unless otherwise noted.

Direction of arrows at controls indicates clockwise rotation.

All voltages measured with "VoltOhmyst" and with no signal input. Voltages should hold within ±20% with 117 v. a.c. supply.

Figure 81—Circuit Schematic Diagram, KCS68F

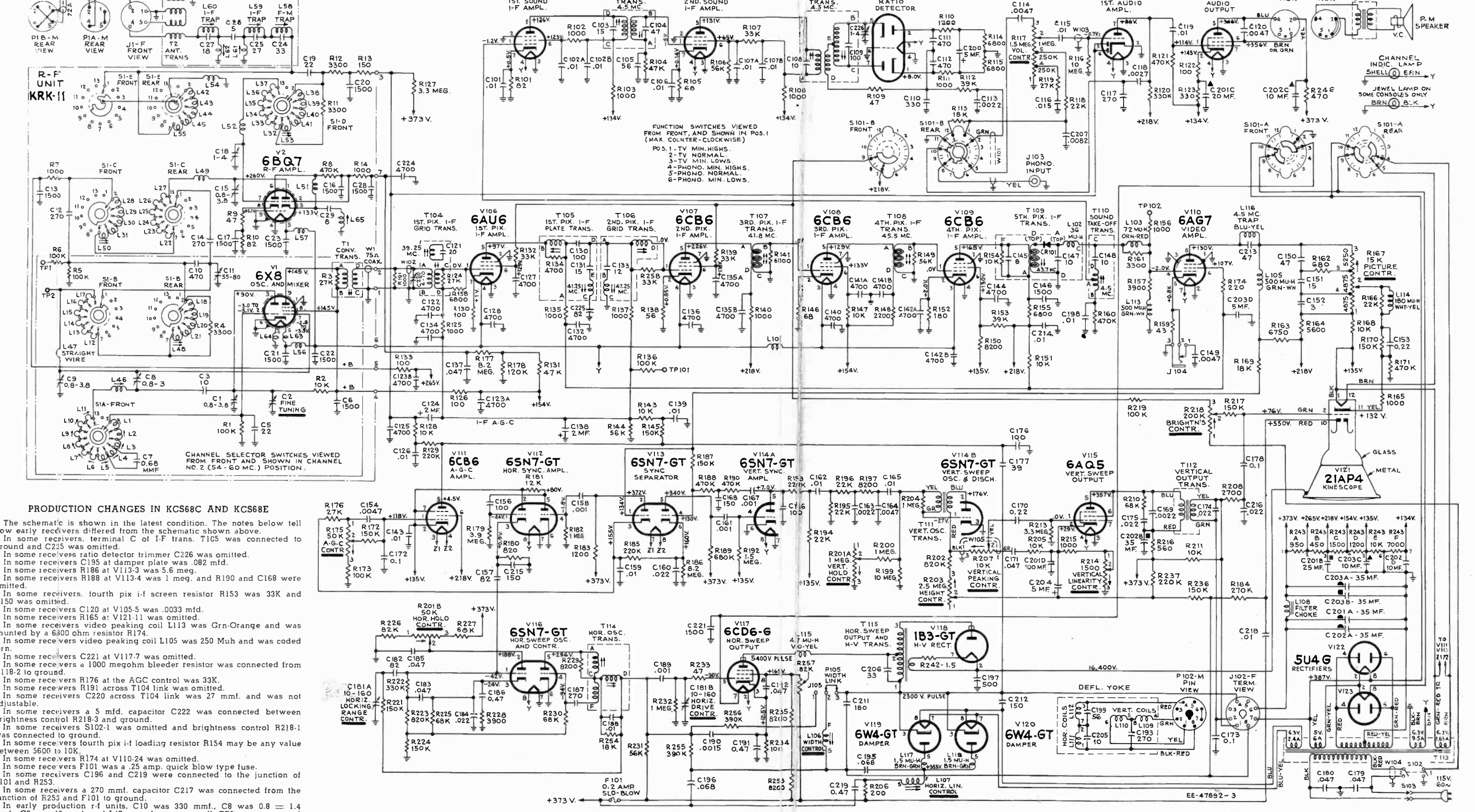

PRODUCTION CHANGES IN KCS68C AND KCS68E

The schematic is shown in the latest condition. The notes below tell how early receivers differed from the schematic shown above. In some receivers terminal C of I-F trans. T105 was connected to ground and C225 was omitted. In some receivers ratio detector trimmer C226 was omitted. In some receivers C195 at damper plate was .082 mfd. In some receivers R186 at V113-3 was 5.6 meg. In some receivers R188 at V114-4 was 1 meg. and R190 and C168 were omitted. In some receivers, fourth pix i-f screen resistor R153 was 33K and R150 was omitted. In some receivers R165 at V121-11 was omitted. In some receivers video peaking coil L113 was Grn-Orange and was shunted by a 6000 ohm resistor R174. In some receivers video peaking coil L105 was 250 Mch and was coded Grn. In some receivers C221 at V117-7 was omitted. In some receivers a 1000 megohm bleeder resistor was connected from V118-2 to ground. In some receivers R176 at the AGC control was 33K. In some receivers R191 across T104 link was omitted. In some receivers C220 across T104 link was 27 mfd. and was not adjustable. In some receivers a 5 mfd. capacitor C222 was connected between brightness control R218-3 and ground. In some receivers S102-1 was omitted and brightness control R218-1 was connected to ground. In some receivers fourth pix i-f loading resistor R154 may be any value between 5600 to 10K. In some receivers R174 at V110-24 was omitted. In some receivers F101 was a 25 amp. quick blow type fuse. In some receivers C196 and C219 were connected to the junction of R251 and F101 to ground. In early production r-f units, C10 was 390 mmf., C8 was 0.8 = 1.4 mmf., C9 was 12 mmf. and L47 was shown as a coil. T12 was connected at the junction of L47 and C9. Early production r-f units are unmarked. Late production r-f units are marked M1. Replacement parts are affected.

The schematic is shown in the latest condition at the time of printing. All resistance value in ohms. K = 1000.

All capacitance values less than 1 in FM and above 1 in MMF unless otherwise noted.

Direction of arrows at controls indicates clockwise rotation.

All voltages measured with "VoltOhmyst" and with no signal input. Voltages should hold within ±20% with 117 v. a.c. supply.

Figure 82—Circuit Schematic Diagram, KCS68C, KCS68E

21T159, 21T159DE, 21T165, 21T166DE, 21T174DE, 21T175DE, 21T176, 21T177, 21T178, 21T178DE, 21T179, 21T179DE

REPLACEMENT PARTS

Table with columns: STOCK No., DESCRIPTION, STOCK No., DESCRIPTION. Includes RF UNIT ASSEMBLIES, Board-Antenna matching transformer, Bracket-Vertical bracket for holding 6X8 tube shield, etc.

21T159, 21T159DE, 21T165, 21T166DE, 21T174DE, 21T175DE, 21T176, 21T177, 21T178, 21T178DE, 21T179, 21T179DE

REPLACEMENT PARTS (Continued)

Table with columns: STOCK No., DESCRIPTION, STOCK No., DESCRIPTION. Includes CHASSIS ASSEMBLIES, KCS 68C in Models 21T176, 21T177, 21T178, 21T179, Bracket-Channel indicator lamp bracket, etc.

21T159, 21T159DE, 21T165, 21T166DE, 21T174DE, 21T175DE, 21T176, 21T177, 21T178, 21T178DE, 21T179, 21T179DE

REPLACEMENT PARTS (Continued)

Table with columns: STOCK No., DESCRIPTION, STOCK No., DESCRIPTION. Includes Resistor-Wire wound, 200 ohms, 5 watts (R206), Resistor-Wire wound, 330 ohms, 1 watt (R123), etc.

21T159, 21T159DE, 21T165, 21T166DE, 21T174DE, 21T175DE, 21T176, 21T177, 21T178, 21T178DE, 21T179, 21T179DE

REPLACEMENT PARTS (Continued)

Table with columns: STOCK No., DESCRIPTION, STOCK No., DESCRIPTION. Includes 21C85 CABINET BASE, Pull-Door pull, Back-Cabinet back complete with power cord for Model 21T159, etc.

APPLY TO YOUR RCA DISTRIBUTOR FOR PRICES OF REPLACEMENT PARTS.



RCA VICTOR

TELEVISION, AM-FM RADIO, PHONOGRAPH COMBINATION

MODEL 21-T-197DE

Chassis Nos. Television Chassis KCS68H
Radio Chassis RC1111A, Audio Amplifier RS141A
Record Changer 930409-5

— Mfr. No. 274 —

SERVICE DATA

— 1952 No. T10 —

PREPARED BY RCA SERVICE CO., INC.
FOR

RADIO CORPORATION OF AMERICA
RCA VICTOR DIVISION
CAMDEN, N. J., U. S. A.

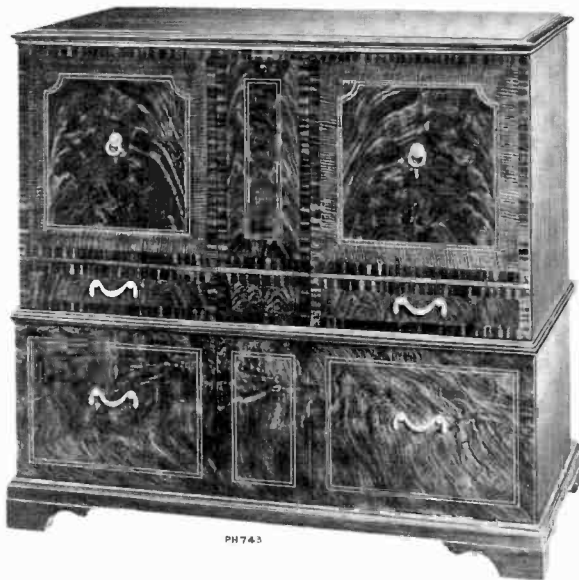

Model 21-T-197DE "Sunderland"
Mabogany

GENERAL DESCRIPTION

Model 21-T-197DE is a deluxe television—AM-FM radio phonograph combination. The receiver employs 29 tubes plus 4 rectifiers and a 21 inch kinescope.

A three speed record changer is provided to play 33 $\frac{1}{3}$, 45 and 78 RPM records.

The receiver is provided with cabinet antennas for AM, FM and television where local conditions permit their use.

ELECTRICAL AND MECHANICAL SPECIFICATIONS

PICTURE SIZE . . . 227 square inches on a 21AP4 Kinescope

TELEVISION R-F FREQUENCY RANGE

All 12 television channels, 54 mc. to 88 mc., 174 mc. to 216 mc.
Fine Tuning Range . . . ± 250 kc. on chan. 2, ± 650 kc. on chan. 13
Picture Carrier Frequency . . . 45.75 mc.
Sound Carrier Frequency . . . 41.25 mc.

RADIO TUNING RANGE

Broadcast . . . 540-1,600 kc.
Frequency Modulation . . . 88-108 mc.
Intermediate Frequency—AM . . . 455 kc.
Intermediate Frequency—FM . . . 10.7 mc.

POWER SUPPLY RATING

115 volts, 60 cycles, 410 watts max.

AUDIO POWER OUTPUT RATING . . . 10 watts max.

CHASSIS DESIGNATIONS

Television Chassis . . . KCS68H
Radio Chassis . . . RC1111A
Audio Chassis . . . RS141A
Record Changer . . . 930409-5
Refer to Service Data 930409 for record changer information

LOUDSPEAKER—92569-12 . . . 12 inch PM Dynamic
Voice Coil Impedance . . . 3.2 ohms at 400 cycles

WEIGHT

Chassis with Tubes in Cabinet . . . 222 lbs.
Shipping Weight . . . 281 lbs.

DIMENSIONS (inches) Width Height Depth
Cabinet (outside) 43% 39% 27%

RECEIVER ANTENNA INPUT IMPEDANCE

Choice: 300 ohms balanced or 72 ohms unbalanced.

RCA TUBE COMPLEMENT

Tube Used	Television Chassis	Function
(1) RCA 6BQ7		R-F Amplifier
(2) RCA 6X8		R-F Oscillator and Mixer
(3) RCA 6AU6		1st Picture I-F Amplifier
(4) RCA 6CB6		2nd Picture I-F Amplifier
(5) RCA 6CB6		3rd Picture I-F Amplifier
(6) RCA 6CB6		4th Picture I-F Amplifier
(7) RCA 6AG7		Video Amplifier
(8) RCA 6AU6		1st Sound I-F Amplifier
(9) RCA 6AU6		2nd Sound I-F Amplifier
(10) RCA 6AL5		Ratio Detector
(11) RCA 6AV6		1st Audio Amplifier
(12) RCA 6CB6		AGC Amplifier
(13) RCA 6SN7GT		Sync Separator
(14) RCA 6SN7GT		Vert Sync Amplifier and Vert Sweep Osc.
(15) RCA 6AQ5		Vertical Sweep Output
(16) RCA 6SN7GT		Horizontal Sync Amplifier
(17) RCA 6SN7GT		Horizontal Sweep Oscillator and Control
(18) RCA 6CD6G		Horizontal Sweep Output
(19) RCA 6W4GT (2 tubes)		Dampers
(20) RCA 1B3-GT/8016		High Voltage Rectifier
(21) RCA 5U4G (2 tubes)		Rectifiers
(22) RCA 21AP4		Kinescope

Radio Chassis RC1111A

(1) RCA 6CB6		R-F Amplifier
(2) RCA 6J6		Mixer and Oscillator
(3) RCA 6BA6		I-F Amplifier
(4) RCA 6AU6		F-M Driver
(5) RCA 6AL5		Ratio Detector
(6) RCA 6AV6		AM Detector AVC and Audio Amplifier

Audio Chassis RS141A

(1) RCA 6C4		Phase Inverter
(2) RCA 6V6GT (2 tubes)		Audio Output
(3) RCA 5Y3GT		Rectifier

ELECTRICAL AND MECHANICAL SPECIFICATIONS (Continued)

21-T-197DE

PICTURE INTERMEDIATE FREQUENCIES

Picture Carrier Frequency.....	45.75 mc.
Adjacent Channel Sound Trap.....	47.25 mc.
Accompanying Sound Traps.....	41.25 mc.
Adjacent Channel Picture Carrier Trap.....	39.25 mc.

SOUND INTERMEDIATE FREQUENCIES

Sound Carrier Frequency..... 41.25 mc. and 4.5 mc.

VIDEO RESPONSE..... To 4 mc.

FOCUS..... Magnetic

SWEEP DEFLECTION..... Magnetic

SCANNING..... Interlaced, 525 line

HORIZONTAL SWEEP FREQUENCY..... 15,750 cps

VERTICAL SWEEP FREQUENCY..... 60 cps

FRAME FREQUENCY (Picture Repetition Rate)..... 30 cps

OPERATING CONTROLS (Front Panel)

Channel Selector	}	Dual Control Knobs
Fine Tuning.....		
Picture	}	Dual Control Knobs
Brightness.....		
Picture Horizontal Hold	}	Dual Control Knobs
Picture Vertical Hold		
Sound Volume and On-Off Switch	}	Dual Control Knobs
Tone Control		

NON-OPERATING CONTROLS (not including r-f and i-f adjustments)

Picture Centering.....	top chassis adjustment
Width.....	rear screwdriver chassis adjustment
Height.....	rear chassis adjustment
Horizontal Linearity.....	rear chassis screwdriver adjustment
Vertical Linearity.....	rear chassis adjustment
Vertical Peaking Control.....	rear chassis adjustment
Horizontal Drive.....	rear chassis screwdriver adjustment
Horizontal Oscillator Frequency.....	rear chassis adjustment
Horizontal Oscillator Waveform.....	bottom chassis adjustment
Horizontal Locking Range.....	rear chassis adjustment
Focus.....	top chassis adjustment
Ion Trap Magnet.....	top chassis adjustment
Deflection Coil.....	top chassis wing nut adjustment
AGC Control.....	rear chassis adjustment

HIGH VOLTAGE WARNING

OPERATION OF THIS RECEIVER OUTSIDE THE CABINET OR WITH THE COVERS REMOVED, INVOLVES A SHOCK HAZARD FROM THE RECEIVER POWER SUPPLIES. WORK ON THE RECEIVER SHOULD NOT BE ATTEMPTED BY ANYONE WHO IS NOT THOROUGHLY FAMILIAR WITH THE PRECAUTIONS NECESSARY WHEN WORKING ON HIGH VOLTAGE EQUIPMENT. DO NOT OPERATE THE RECEIVER WITH THE HIGH VOLTAGE COMPARTMENT SHIELD REMOVED. BE SURE THE GROUND SPRING, BETWEEN THE YOKE ASSEMBLY AND THE CHASSIS, IS SECURELY FASTENED BEFORE TURNING THE RECEIVER ON.

KINESCOPE HANDLING PRECAUTIONS

DO NOT REMOVE THE RECEIVER CHASSIS, INSTALL, REMOVE OR HANDLE THE KINESCOPE IN ANY MANNER UNLESS SHATTERPROOF GOGGLES ARE WORN. PEOPLE NOT SO EQUIPPED SHOULD BE KEPT AWAY WHILE HANDLING KINESCOPIES. KEEP THE KINESCOPE AWAY FROM THE BODY WHILE HANDLING.

The kinescope bulb encloses a high vacuum and, due to its large surface area, is subjected to considerable air pressure. For this reason, the kinescope must be handled with more care than ordinary receiving tubes.

The large end of the kinescope bulb—particularly that part at the rim of the viewing surface—must not be struck, scratched or subjected to more than moderate pressure at any time. During service if the tube sticks or fails to slip smoothly into its socket, or deflecting yoke, investigate and remove the cause of the trouble. Do not force the tube. Refer to the Receiver Installation section for detailed instructions on kinescope installation. All RCA replacement kinescopes are shipped in special cartons and should be left in the cartons until ready for installation in the receiver.

OPERATING INSTRUCTIONS

21-T-197DE

The following adjustments are necessary when turning the receiver on for the first time.

1. Turn the radio FUNCTION switch to TV.
2. Turn the receiver "ON" and advance the SOUND VOLUME control to approximately mid-position.
3. Set the CHANNEL SELECTOR to the desired channel.
4. Adjust the FINE TUNING control for best sound fidelity and SOUND VOLUME for suitable volume.
5. Turn the BRIGHTNESS control fully counterclockwise, then clockwise until a light pattern appears on the screen.
6. Adjust the VERTICAL hold control until the pattern stops vertical movement.
7. Adjust the HORIZONTAL hold control until a picture is obtained and centered.
8. Turn the BRIGHTNESS control counterclockwise until the retrace lines just disappear.
9. Adjust the PICTURE control for suitable picture contrast.

10. In switching from one channel to another, it may be necessary to repeat steps numbers 4 and 9.

11. When the set is turned on again after an idle period, it should not be necessary to repeat the adjustments if the positions of the controls have not been changed. If any adjustment is necessary, step number 4 is generally sufficient.

12. If the positions of the controls have been changed, it may be necessary to repeat steps numbers 1 through 9.

13. For radio operation turn the radio FUNCTION switch to AM or FM and tune in station with the radio TUNING control.

14. For phono operation, turn the function switch to PH. Set the stylus on the phono tone arm to 78 or 33-45 whichever applies. Set speed control to the desired speed. Place a record on the turntable (for 45 RPM records place 45 RPM centerpost over spindle) and turn phono to "ON" position.

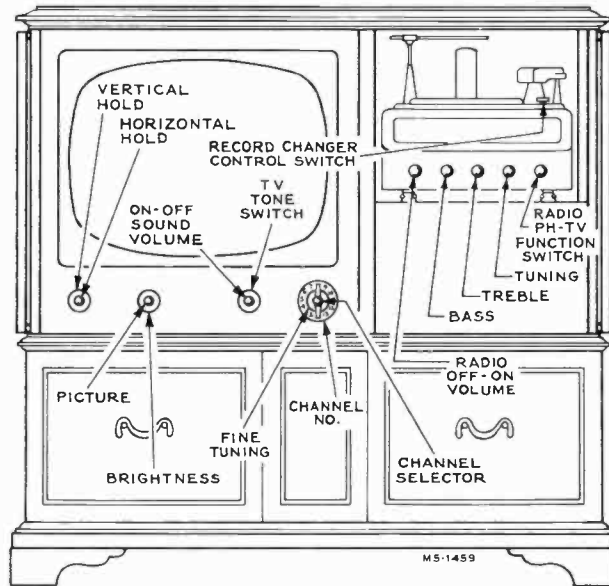

Figure 1—Receiver Operating Controls

REFER TO PAGES 180 TO 193 FOR TELEVISION ALIGNMENT PROCEDURE AND WAVE FORM PHOTOGRAPHS

INSTALLATION INSTRUCTIONS

ION TRAP MAGNET ADJUSTMENT.—Set the ion trap magnet approximately in the position shown in Figure 2. Starting from this position immediately adjust the magnet by moving it forward or backward at the same time rotating it slightly around the neck of the kinescope for the brightest raster on the screen. Reduce the brightness control setting until the raster is slightly above average brilliance. Turn the

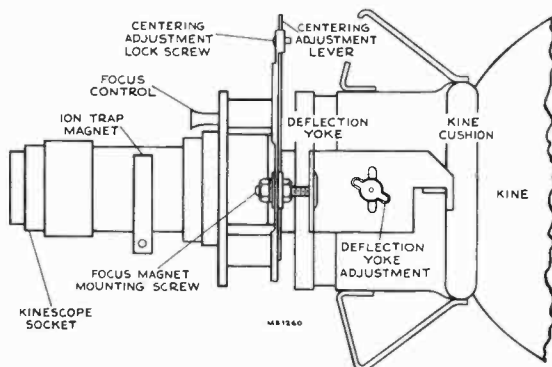

Figure 2—Ion Trap and Centering Magnet Adjustments

focus control (shown in Figure 2) until the line structure of the raster is clearly visible. Readjust the ion trap magnet for maximum raster brilliance. The final touches of this adjustment should be made with the brightness control at the maximum clockwise position with which good line focus can be maintained.

DEFLECTION YOKE ADJUSTMENT.—If the lines of the raster are not horizontal or squared with the picture mask, rotate the deflection yoke until this condition is obtained. Tighten the yoke adjustment wing screw.

PICTURE ADJUSTMENTS.—It will now be necessary to obtain a test pattern picture in order to make further adjustments. Connect the antenna transmission line to the receiver.

If the Horizontal Oscillator and AGC System are operating properly, it should be possible to sync the picture at this point. However, if the AGC control is misadjusted, and the receiver is overloading, it may be impossible to sync the picture.

If the receiver is overloading, turn R175 on the rear apron (see Figure 3) counterclockwise until the set operates normally and the picture can be synchronized.

CHECK OF HORIZONTAL OSCILLATOR ALIGNMENT.—Turn the horizontal hold control to the extreme counter-clockwise position. The picture should remain in horizontal sync. Momentarily remove the signal by switching off channel then back. Normally the picture will be out of sync. Turn the control clockwise slowly. The number of diagonal

black bars will be gradually reduced and when only 2 bars sloping downward to the left are obtained, the picture will pull into sync upon slight additional clockwise rotation of the control. Pull-in should occur before the control has been turned 120 degrees from the extreme counter-clockwise position. The picture should remain in sync for approximately 90 degrees of additional clockwise rotation of the control. At the extreme clockwise position, the picture should remain in sync and should not show a black bar in the picture.

If the receiver passes the above checks and the picture is normal and stable, the horizontal oscillator is properly aligned. Skip "Alignment of Horizontal Oscillator" and proceed with "Focus Magnet Adjustment."

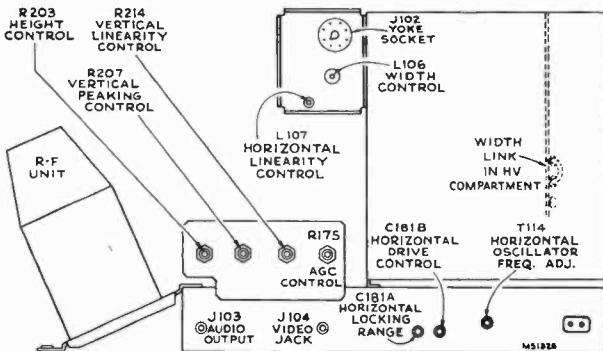

Figure 3—Rear Chassis Adjustments

ALIGNMENT OF HORIZONTAL OSCILLATOR.—If in the above check the receiver failed to hold sync with the hold control at the extreme counter-clockwise position or failed to hold sync over 90 degrees of clockwise rotation of the control from the pull-in point, it will be necessary to make the following adjustments.

Horizontal Frequency Adjustment.—Turn the horizontal hold control to the extreme clockwise position. Tune in a television station and adjust the T114 horizontal frequency adjustment at the rear of the chassis until the picture is just out of sync and the horizontal blanking appears as a vertical or diagonal black bar in the raster. Then turn the T114 core until the bar moves out of the picture leaving it in sync.

Horizontal Locking Range Adjustment.—Set the horizontal hold control to the full counter-clockwise position. Momentarily remove the signal by switching off channel then back. The picture may remain in sync. If so turn the T114 rear core slightly and momentarily switch off channel. Repeat until the picture falls out of sync with the diagonal lines sloping down to the left. Slowly turn the horizontal hold control clockwise and note the least number of diagonal bars obtained just before the picture pulls into sync.

If more than 2 bars are present just before the picture pulls into sync, adjust the horizontal locking range trimmer C181A slightly clockwise. If less than 2 bars are present, adjust C181A slightly counter-clockwise. Turn the horizontal hold control counter-clockwise, momentarily remove the signal and recheck the number of bars present at the pull-in point. Repeat this procedure until 2 bars are present.

Repeat the adjustments under "Horizontal Frequency Adjustment" and "Horizontal Locking Range Adjustment" until the conditions specified under each are fulfilled. When the horizontal hold operates as outlined under "Check of Horizontal Oscillator Alignment" the oscillator is properly adjusted.

If it is impossible to sync the picture at this point and the AGC system is in proper adjustment it will be necessary to adjust the Horizontal Oscillator by the method outlined in the alignment procedure. For field purposes paragraph "B" under Horizontal Oscillator Waveform Adjustment may be omitted.

FOCUS MAGNET ADJUSTMENTS.—The focus magnet should be adjusted so that there is approximately three-eighths inch of space between the rear cardboard shell of the yoke and the flat of the front face of the focus magnet. This spacing gives best average focus over the face of the tube.

The axis of the hole through the magnet should be parallel with the axis of the kinescope neck with the kinescope neck through the middle.

CENTERING ADJUSTMENT.—No electrical centering controls are provided. Centering is accomplished by means of a separate plate on the focus magnet. The centering plate includes a locking screw which must be loosened before centering. Up and down adjustment of the plate moves the picture side to side and sidewise adjustment moves the picture up and down.

If a corner of the raster is shadowed, check the position of the ion trap magnet. Reposition the magnet within the range of maximum raster brightness to eliminate the shadow and recenter the picture by adjustment of the focus magnet plate. In no case should the ion trap magnet be adjusted to cause any loss of brightness since such operation may cause immediate or eventual damage to the tube. In some cases it may be necessary to shift the position of the focus magnet in order to eliminate a corner shadow.

WIDTH, DRIVE AND HORIZONTAL LINEARITY ADJUSTMENTS.—Adjustment of the horizontal drive control affects the high voltage applied to the kinescope. In order to obtain the highest possible voltage hence the brightest and best focused picture, adjust horizontal drive trimmer C181B for maximum drive (minimum capacity) consistent with a linear raster. Compression of the raster due to excessive drive can be seen as a white vertical bar or bars in the right half of the picture. Besides compression caused by excessive drive, another item to watch for is the change in linearity at the extreme left with changes of brightness control setting. By proper adjustment of the linearity coil, the changes in linearity with changes in brightness can be made negligible. In general, to achieve this condition, the linearity coil should be set slightly on the high inductance side (core slightly clockwise) of the optimum position.

Preset the following adjustments as directed:

A.—Place the width plug (P105) in the minimum width position (top).

B.—Set the width control coil L106 in approximately mid position.

C.—Set the linearity control coil L107 near minimum inductance (counter-clockwise).

D.—Set the drive capacitor C181B in the maximum drive position (counter-clockwise).

If the raster is cramped or shows compression bars on the right half of the picture turn C181B clockwise until this condition is just eliminated.

Adjust the linearity control coil L107 clockwise until best linearity and maximum deflection or best compromise are obtained then turn one quarter turn clockwise from this position.

Retouch the drive trimmer C181B if necessary to obtain best linearity and maximum width.

Check the horizontal linearity at various settings of the brightness control R218. There should be no compression of the right half and no appreciable change of linearity especially at the extreme left of the picture. If objectional change does occur, turn linearity coil L107 slightly clockwise and repeat the test.

Adjust the width control L106 to fill the mask.

If the line voltage is low and it becomes impossible to fill the mask, move the width plug P105 to the bottom position. The width coil L106 is inoperative in this position.

HEIGHT AND VERTICAL LINEARITY ADJUSTMENTS.—Adjust the height control (R203 on chassis rear apron) until the picture fills the mask vertically. Adjust vertical linearity (R214 on rear apron), until the test pattern is symmetrical from top to bottom. Adjustment of either control will require a readjustment of the other. If the top few lines of the picture are stretched or squeezed, adjust the vertical peaking control R207 until this condition is corrected.

FOCUS.—Adjust the focus magnet for maximum definition in the test pattern vertical "wedge" and best focus in the white areas of the pattern.

Recheck the position of the ion trap magnet to make sure that maximum brightness is obtained.

If necessary readjust centering to align the picture with the mask.

CHECK OF R-F OSCILLATOR ADJUSTMENTS.—Tune in all available stations to see if the receiver r-f oscillator is adjusted to the proper frequency on all channels. If adjust-

INSTALLATION INSTRUCTIONS

21-T-197DE

ments are required, these should be made by the method outlined in the alignment procedure on page 9. The adjustments for channels 2 through 12 are available from the front of the cabinet by removing the station selector escutcheon as shown in Figure 4. Adjustment for channel 13 is on top of the chassis.

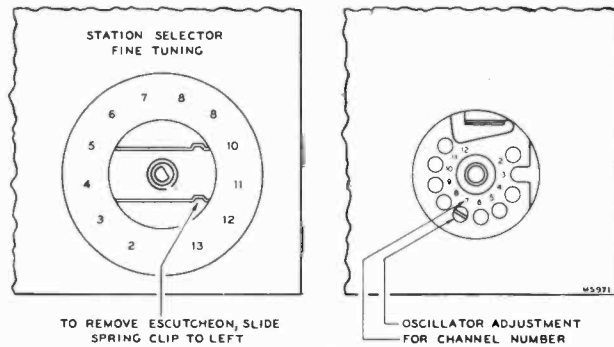

Figure 4—R-F Oscillator Adjustments

AGC THRESHOLD CONTROL.—The AGC threshold control R175 is adjusted at the factory and normally should not require readjustment in the field.

To check the adjustment of the AGC Threshold Control, tune in a strong signal and sync the picture. Momentarily remove the signal by switching off channel and then back. If the picture reappears immediately, the receiver is not overloading due to improper setting of R175. If the picture requires an appreciable portion of a second to reappear, or bends excessively, R175 should be readjusted.

Turn R175 fully counter-clockwise. The raster may be bent slightly. This should be disregarded. Turn R175 clockwise until there is a very, very slight bend or change of bend in the picture. Then turn R175 counter-clockwise just sufficiently to remove this bend or change of bend.

If the signal is weak, the above method may not work as it may be impossible to get the picture to bend. In this case, turn R175 clockwise until the snow in the picture becomes more pronounced, then counter-clockwise until the best signal to noise ratio is obtained.

The AGC control adjustment should be made on a strong signal if possible. If the control is set too far clockwise on a weak signal then the receiver may overload when a strong signal is received.

FM TRAP ADJUSTMENT.—In some instances interference may be encountered from a strong FM station signal. A trap is provided to eliminate this type of interference. To adjust the trap tune in the station on which the interference is observed and adjust the L58 core on top of the antenna matching transformer for minimum interference in the picture.

CAUTION.—In some receivers, the FM trap L58 will tune down into channel 6 or even into channel 5. Needless to say such an adjustment will cause greatly reduced sensitivity on these channels. If channels 5 or 6 are to be received check L58 to make sure that it does not affect sensitivity on these two channels.

Replace the cabinet back and connect the receiver antenna leads to the cabinet back. Make sure that the screws holding it are up tight otherwise it may rattle or buzz when the receiver is operated at high volume.

CABINET ANTENNA.—A cabinet television antenna is provided in these receivers and the leads are brought out near the antenna terminal board. The cabinet antenna may be employed in place of the outdoor antenna in areas where signals are strong and no reflections are experienced. However, if reception is unsatisfactory, it will be necessary to employ an outdoor antenna or an indoor antenna which can be oriented.

RADIO OPERATION.—Turn the receiver function switch to the AM and FM positions and check the radio for proper operation.

RECORD CHANGER OPERATION.—Turn the receiver function switch to the phono position and check the record player for proper operation.

KINESCOPE HANDLING PRECAUTION.—Do not install, remove, or handle the kinescope in any manner, unless shatter-proof goggles are worn. People not so equipped should be kept away while handling the kinescope. Keep the kinescope away from the body while handling.

Handle this tube by the metal rim at the edge of the screen. Do not cover the glass bell of the tube with fingermarks as it will produce leakage paths which may interfere with reception. If this portion of the tube has inadvertently been handled, wipe it clean with a soft cloth moistened with "dry" carbon tetrachloride.

To remove the kinescope from the cabinet, loosen the two nuts and disengage the rods alongside the kinescope. Remove the wing screw which holds the yoke frame to the cabinet. Remove the kinescope, the yoke frame with yoke and focus or centering magnet as an assembly.

INSTALLATION OF KINESCOPE.—Handle this tube by the metal rim at the edge of the screen. Do not cover the glass bell of the tube with fingermarks as it will produce leakage paths which may interfere with reception. If this portion of the tube has inadvertently been handled wipe it clean with a soft cloth moistened with "dry" carbon tetrachloride.

Wipe the kinescope screen surface and front panel safety glass clean of all dust and fingermarks with a soft cloth moistened with "Windex" or similar cleaning agent.

Turn the tube so that the key on the base of the tube will be down and insert the neck of the kinescope through the deflection coil and focus magnet. If the tube sticks, or fails to slip into place smoothly investigate and remove the cause of the trouble. Do not force the tube.

Replace the kinescope and yoke frame assembly in the cabinet. Insert the wing screw and tighten. Engage the two side rods into the yoke frame and tighten the two nuts. Slide the deflection yoke as far forward as possible. If this is not done, difficulty will be encountered in adjusting the ion trap and focus magnet because of shadows on the corner of the raster.

Slide the chassis into the cabinet, then insert and tighten the four chassis bolts.

Slip the ion trap magnet over the neck of the kinescope.

Connect the kinescope socket to the tube base and connect the high voltage lead from the rim of the kinescope into the high voltage bushing on the high voltage compartment.

Reconnect all other cables. Do not forget to replace the yoke frame grounding spring. Perform the entire set-up procedure beginning with the Ion Trap Magnet Adjustment.

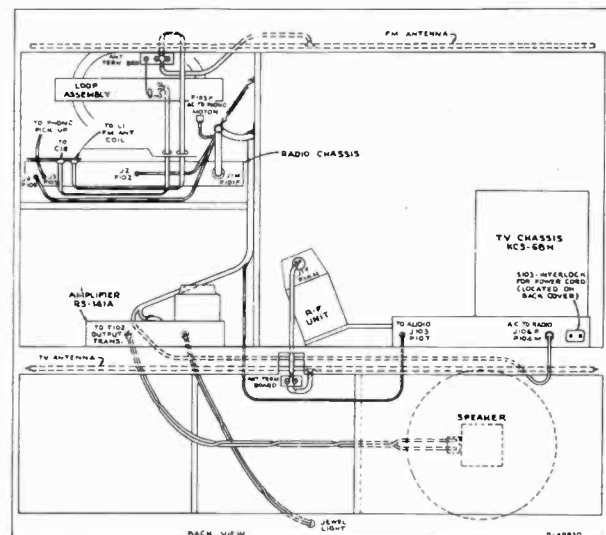

Figure 5—Instrument Cable Diagram

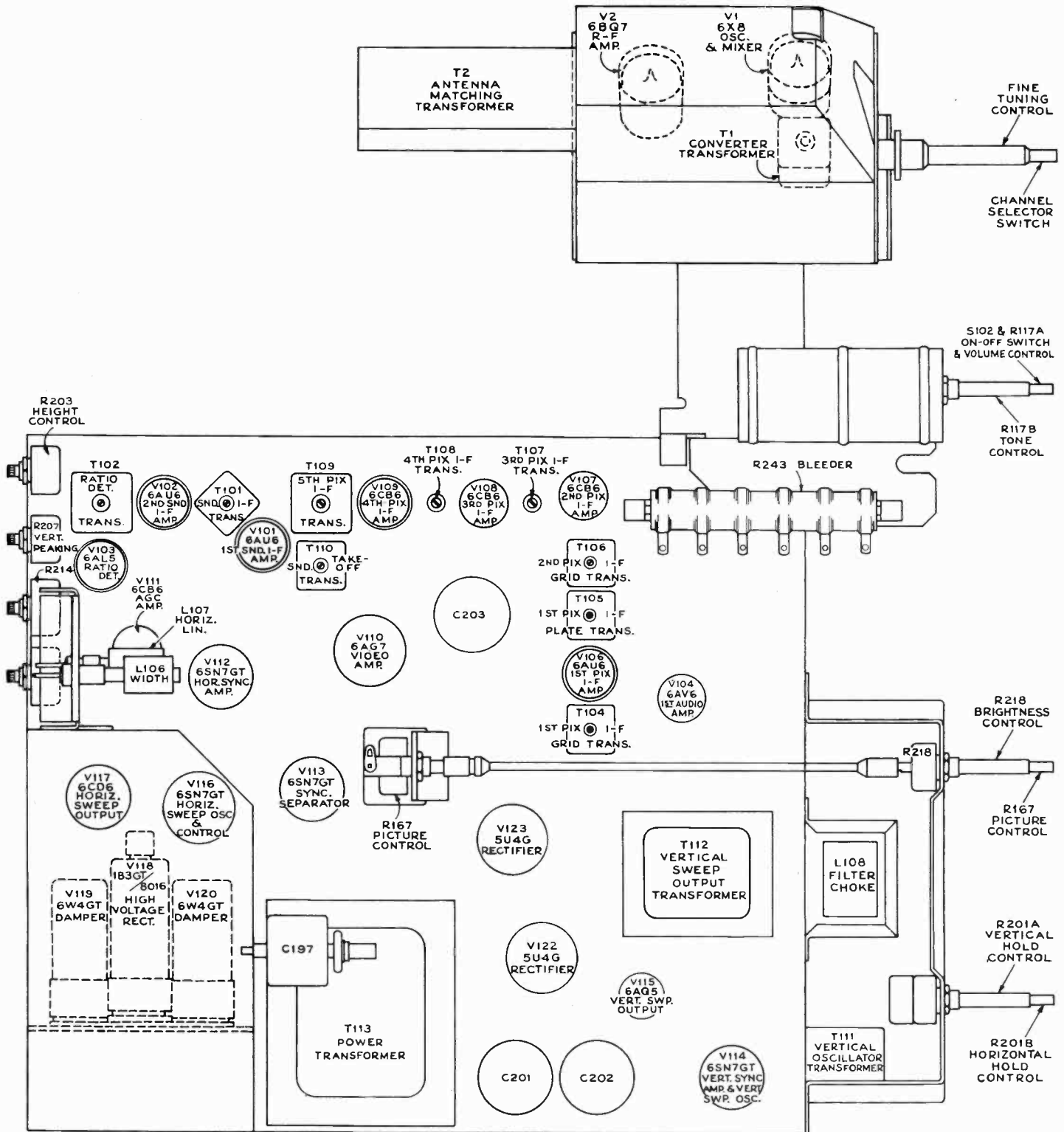

Figure 6—Chassis Top View

CHASSIS BOTTOM VIEW

21-T-197DE

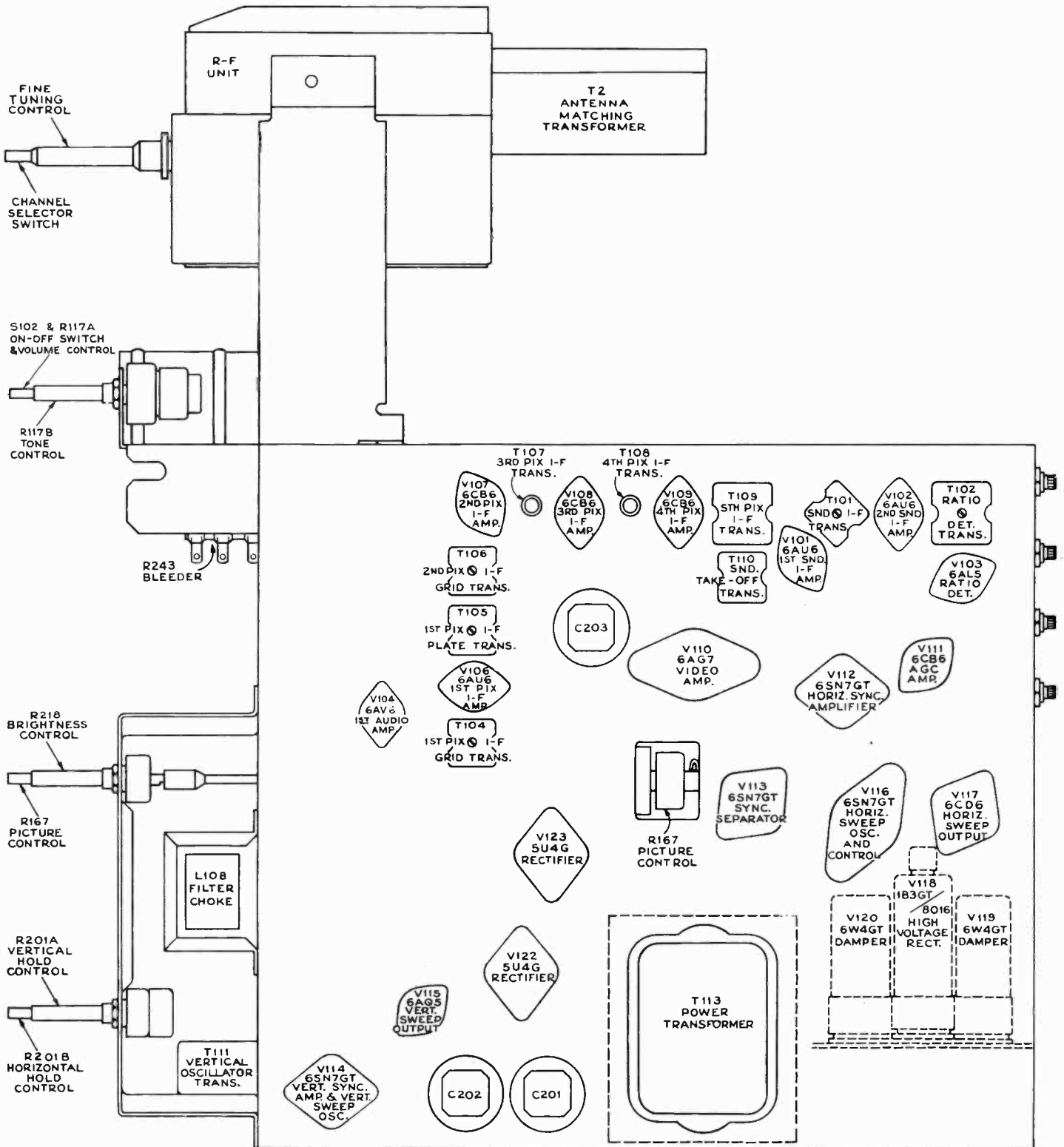

Figure 7—Chassis Bottom View

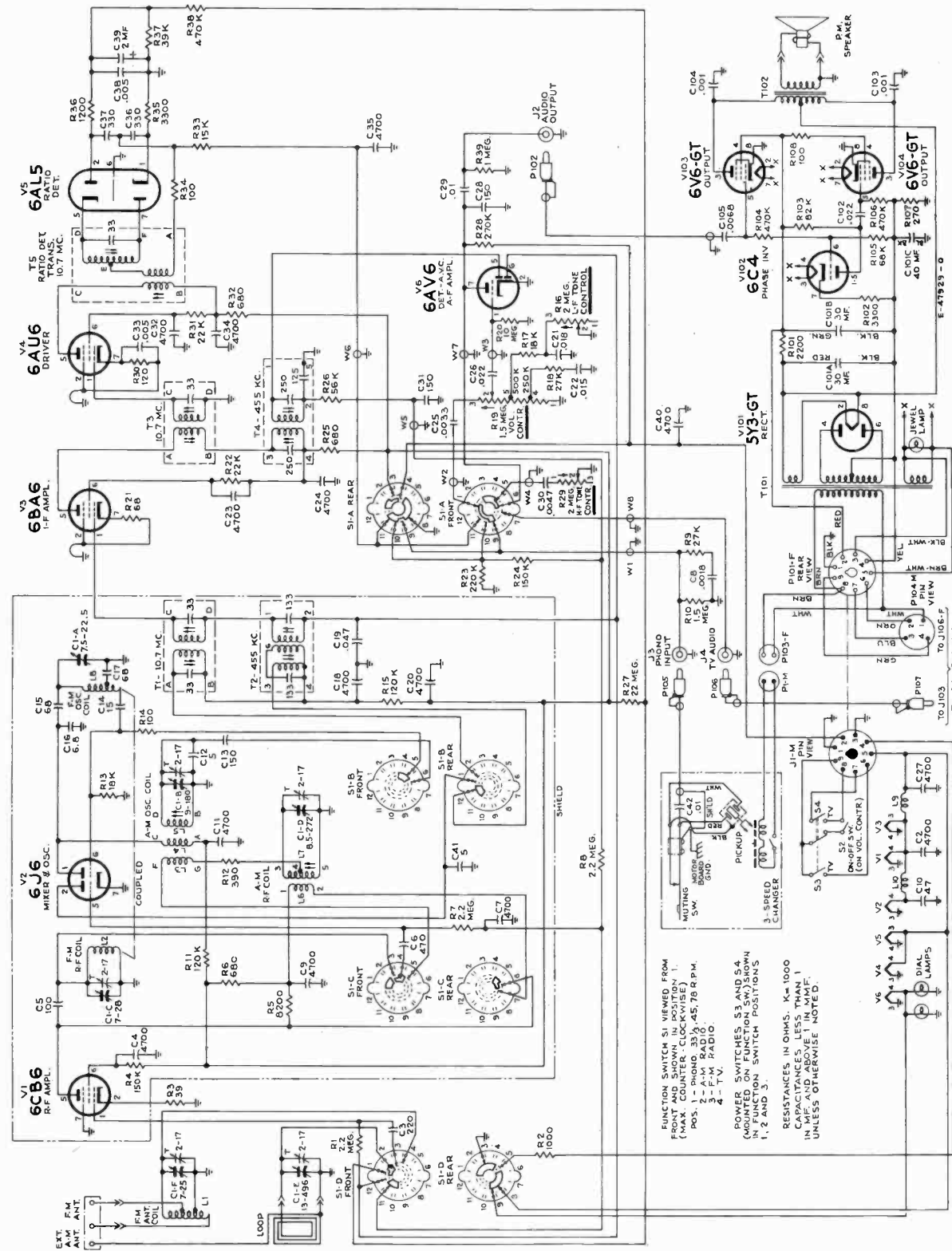

Figure 8—Radio Schematic Diagram

All resistance values in ohms, K = 1000.
All capacitance values less than 1 in MF and above 1 in MMF unless otherwise noted.
Direction of arrows at controls indicates clockwise rotation.

6. Dress C25 away from the arm contact of the volume control.
8. All leads from the r-f shield leaving through the shields must be kept as short as possible.
9. All leads for FM should be kept short especially on the r-f shelf.
10. Dress the a-c leads in the RS141 chassis away from the audio input leads and components.
11. Dress all leads away from RI01 in RS141.

CRITICAL LEAD DRESS

1. The 1st FM i-f plate lead should be dressed away from the r-f amp plate.
2. Dress the 1st AM i-f plate lead to the S2 wafer away from the AM r-f coil.
3. Dress the a-c power switch wires away from all audio components.
4. Dress C26 down toward the base between the terminal board and the side apron.
5. The C18 bypass ground should be as close to the r-f shelf ground strap as possible.

RADIO VOLTAGE CHART

Voltages shown are as read with "VoltOhmyst" between indicated terminal and chassis, with receiver operating on 117 volts, and with no signal input. Voltages should hold within ±20% with 117 v. a-c supply.

Tube	Pin No.	AM	FM	Phono.
V1	5	215	180	—
6CB6	6	74	62	—
R-F	2	0.4	0.4	—
Amp	1	-0.8	0.4	—
V2	2	55	58	—
6J6	5	-1.2	-1.3	—
Osc &	1	43	46	—
Mixer	6	-1.2	-1.2	—
V3	5	210	210	—
6BA6	6	126	115	—
I-F	7	0.9	0.7	—
Amp	1	-0.8	-0.2	—
V4	5	216	216	—
6AU6	6	150	150	—
Driver	7	1.5	1.5	—
	1	0	0	—
V5	—	—	—	—
6AL5	—	—	—	—
Ratio	—	—	—	—
Det.	—	—	—	—
V6	7	88	88	104
6AV6	1	-0.7	-0.7	-0.8
Audio	—	—	—	—
Amp	—	—	—	—
V102	5	88	88	120
6C4	7	-11	-11	-13
Phase	6	-16	-16	-19
Invert.	—	—	—	—
V103 & V104	3	300	300	298
6V6GT	4	224	224	292
Audio	8	0	0	0
Output	9	-17	-17	-21
V101	8	305	305	307
5Y3GT	—	—	—	—
Rect.	—	—	—	—

FUNCTION SWITCH S1 VIEWED FROM FRONT AND SHOWN IN POSITION 1.
POS. 1 - PHONO. 33.5, 45, 78 RPM.
2 - A-M RADIO.
3 - T-V RADIO.

POWER SWITCHES S3 AND S4 (MOTOR) SHOWN IN POSITION 1.
RESISTANCES IN OHMS, K=1000 IN MF, AND ABOVE 1 IN MMF, UNLESS OTHERWISE NOTED.

RADIO ALIGNMENT PROCEDURE

21-T-197DE

Before aligning set, completely mesh the gang and set the dial pointer to the mechanical max. calibration point at extreme left end of dial. When making a complete alignment follow the table below in sequence. Connect the output meter across the speaker voice coil, and turn the receiver volume control to max. Turn tone controls for maximum highs and maximum lows.

"AM" I-F ALIGNMENT

Test-Oscillator.—Connect low side of the test-osc. to the chassis, and keep the output as low as possible to avoid a-v-c action.

Steps	Connect the High Side of the Test Osc. to—	Tune Test Osc. to—	Function Switch	Turn Radio Dial to—	Adjust the following
1	Pin No. 1 of (43) in series with .01 mfd.	455 kc. Modulated	AM	Low Freq. end of Dial	†Top and bot. cores of T4 For max. voltage across voice coil.
2	Stator of C1-D in series with .01 mfd.	455 kc. Modulated	AM	Low Freq. end of Dial	†Top and bot. cores of T2 For max. voltage across voice coil.

†For proper adjustment of the i-f cores start with the cores all the way out. The first peak obtained will be the correct one.

"FM" ALIGNMENT PROCEDURE

Connect probe of "VoltOhmyst" to negative side of C39 and low side to chassis. Top shield must be on and the bottom shield off.

Steps	Connect the High Side of the Test Osc. to—	Tune Test Osc. to—	Function Switch	Turn Radio Dial to—	Adjust the following
3	Pin No. 1 of V4 in series with .01 mfd.	10.7 mc. 30% AM Modulated	FM	—	Top of Ratio d-c† Trans. T5 for maximum DC on "VoltOhmyst."
4	Pin No. 1 of V4 in series with .01 mfd.		FM	—	Bottom of Ratio d-c† Trans. T5 for minimum audio output on meter.
5	Repeat steps 3 and 4 as necessary making final adjustment with input set to give approx. -4.0 v. on "VoltOhmyst."				
6	Pin No. 1 of V3 in series with .01 mfd.	10.7 mc.	FM	88 mc.	†Top and bottom cores of T3 for maximum d-c across C39.
7	Stator of C1-C in series with .01 mfd.	10.7 mc.	FM	88 mc.	†Top and bottom cores of T1 for maximum d-c across C39.
8	Connect sweep generator cable to antenna terminals through 120 ohms in each side of line.	90 mc. 22.5 kc. FM mod.	FM	90 mc.	OSC, L8 for max. audio output.
9		106 mc. 22.5 kc. FM mod.	FM	Tune to signal	ANT, C1-FT and R-F C1-CT for max. voltage across C39.
10		90 mc. 22.5 kc. FM mod.	FM	Tune to signal	ANT, L1 and R-F L2 for max. voltage across C39.
11	Repeat steps 8, 9 and 10 as required.				
12	Connect a scope to junct. R33 and C35. Check response and linearity. Peak separation should be at least 180 kc.				

†For proper adjustment of the i-f cores start with the cores all the way out. The first peak obtained will be the correct one.

"AM" R-F ALIGNMENT

Steps	Connect the High Side of the Test Osc. to—	Tune Test Osc. to—	Function Switch	Turn Radio Dial to—	Adjust the following
13	External radiating loop and couple loosely to receiver loop.	1,620 kc.	AM	Min. capacity	*Osc. C1-BT for maximum output.
14		1,400 kc.	AM	Tune to signal	*C1-DT and C1-ET for max. output.
15		600 kc.	AM	Tune to signal	†Osc. L5 for max. output while rocking gang.
16		600 kc.	AM	Tune to signal	***R-F L7 for max. output.
17	Repeat steps 13, 14, 15 and 16 until no additional gain in sensitivity is obtained.				

†Clip a 10,000 ohm resistor across C1-D when making this adjustment.
 ***Be sure the resistor employed in step 15 is removed for this adjustment.

*All R-F shields must be in place.

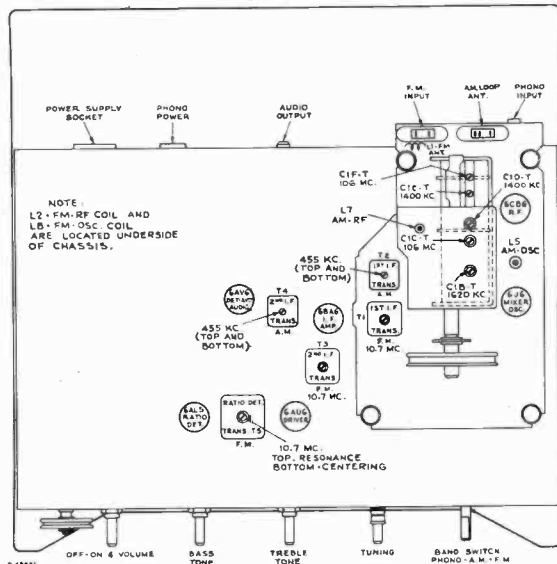

Figure 9—Radio Top View

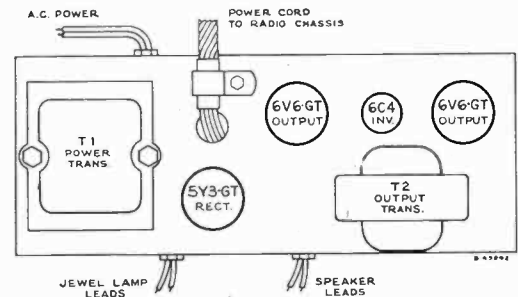
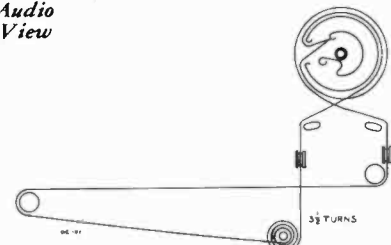

Figure 10—Audio Chassis Top View

Figure 11—Dial Cord



TELEVISION VOLTAGE CHART

The following measurements represent two sets of conditions. In the first condition, a 5000 microvolt test pattern signal was fed into the receiver, the picture synchronized and the AGC control properly adjusted. The second condition was obtained by removing the antenna leads and short circuiting the receiver antenna terminals. Voltages shown are read with a type WV 97A senior "VoltOhmyst" between the indicated terminal and chassis ground and with the receiver operating on 117 volts, 60 cycles, a-c.

Tube No.	Tube Type	Function	Operating Condition	E. Plate		E. Screen		E. Cathode		E. Grid		I Plate (ma.)	I Screen (ma.)	Notes on Measurements
				Pin No.	Volts	Pin No.	Volts	Pin No.	Volts	Pin No.	Volts			
V1	6X8	Mixer	5000 Mu. V. Signal	9	160	8	160	6	0	7	-2.4 to -3.0	—	—	
			No Signal	9	145	8	145	6	0	7	-2.8 to -3.5	—	—	
V1	6X8	R-F Oscillator	5000 Mu. V. Signal	3	95	—	—	6	0	2	-3.8 to -5.5	—	—	
			No Signal	3	90	—	—	6	0	2	-3.0 to -5.1	—	—	
V2	6BQ7	R-F Amplifier	5000 Mu. V. Signal	6	170	—	—	8	0.1	7	—	—	—	
			No Signal	6	133	—	—	8	1.1	7	0	—	—	
V2	6BQ7	R-F Amplifier	5000 Mu. V. Signal	1	270	—	—	3	170	2	—	—	—	
			No Signal	1	260	—	—	3	133	2	—	—	—	Depending on channel
V101	6AU6	1st Sound I-F Amp.	5000 Mu. V. Signal	5	127	6	124	7	0.7	1	-0.4	6.0	3.0	
			No Signal	5	126	6	123	7	0.5	1	-1.2	5.0	3.0	
V102	6AU6	2d Sound I-F Amp.	5000 Mu. V. Signal	5	132	6	60	7	0.14	1	-10	2.8	1.2	
			No Signal	5	131	6	65	7	0.14	1	-5	2.0	1.0	
V103	6AL5	Ratio Detector	5000 Mu. V. Signal	7	1.0	—	—	1	9.2	—	—	—	—	
			No Signal	7	0	—	—	1	8.0	—	—	—	—	
V104	6AV6	1st Audio Amplifier	5000 Mu. V. Signal	7	90	—	—	2	0	1	-0.7	0.45	—	At min. volume
			No Signal	7	86	—	—	2	0	1	-0.7	0.45	—	
V106	6AU6	1st Pix. I-F Amplifier	5000 Mu. V. Signal	5	180	6	230	7	0.15	1	-6.5	1.5	0.3	
			No Signal	5	97	6	129	7	1.0	1	0	7.0	3.0	
V107	6CB6	2nd Pix. I-F Amplifier	5000 Mu. V. Signal	5	236	6	233	2	0.1	1	-6.5	1.5	0.14	
			No Signal	5	226	6	138	2	0.85	1	0	12.0	3.0	
V108	6CB6	3d Pix. I-F Amplifier	5000 Mu. V. Signal	5	149	6	144	2	0.9	1	0	11.0	3.0	
			No Signal	5	129	6	133	2	0.8	1	0	10.0	2.0	
V109	6CB6	4th Pix. I-F Amplifier	5000 Mu. V. Signal	5	178	6	163	2	2.2	1	0	8.9	2.1	
			No Signal	5	165	6	150	2	2.0	1	0	7.9	2.1	
V110	6AG7	Video Amplifier	5000 Mu. V. Signal	8	130	6	172	5	1.2	4	*-5.0	22.5	5.5	*Depends on picture
			No Signal	8	130	6	107	5	0.8	4	*-2.0	15.0	4.0	*Depends on picture
V111	6CB6	AGC Amplifier	5000 Mu. V. Signal	5	-27	6	238	2	152	1	155	0.1	3.4	AGC control set for normal operation
			No Signal	5	4.5	6	218	2	135	1	118	0	0	

TELEVISION VOLTAGE CHART

21-T-197DE

Tube No.	Tube Type	Function	Operating Condition	E. Plate		E. Screen		E. Cathode		E. Grid		I Plate (ma.)	I Screen (ma.)	Notes on Measurements
				Pin No.	Volts	Pin No.	Volts	Pin No.	Volts	Pin No.	Volts			
V112	6SN7GT	Hor. Sync Amplifier	5000 Mu. V. Signal	2	152	—	—	3	0.9	1	-44	1.1	—	*Depends on noise
			No Signal	2	135	—	—	3	*0.4	1	*-30	0.5	—	
			5000 Mu. V. Signal	5	86	—	—	6	0	4	-2.0	5.5	—	
			No Signal	5	50	—	—	6	0	4	-1.8	4.6	—	
V113	6SN7GT	Hor. Sync Separator	5000 Mu. V. Signal	2	374	—	—	3	216	1	155	1.2	—	
			No Signal	2	372	—	—	3	155	1	134	0.8	—	
V113	6SN7GT	Vert. Sync Separator	5000 Mu. V. Signal	5	345	—	—	6	205	4	153	<0.1	—	
			No Signal	5	340	—	—	6	160	4	130	<0.1	—	
V114A	6SN7GT	Vert. Sync Amplifier	5000 Mu. V. Signal	5	7.0	—	—	6	0	4	-0.2	0.6	—	*Depends on noise
			No Signal	5	*7.0	—	—	6	0	4	*0	0.5	—	
V114B	6SN7GT	Vertical Oscillator	5000 Mu. V. Signal	2	176	—	—	3	0	1	-27	0.2	—	
			No Signal	2	176	—	—	3	0	1	-27	0.2	—	
V115	6AQ5	Vertical Output	5000 Mu. V. Signal	5	359	6	359	2	30	1	0	17.3	1.2	
			No Signal	5	357	6	357	2	29	1	0	17.3	1.2	
V116	6SN7GT	Horizontal Osc. Control	5000 Mu. V. Signal	2	145	—	—	3	-18	1	-42	0.4	—	Hor. hold counter-clockwise
			5000 Mu. V. Signal	2	230	—	—	3	-18	1	-42	0.4	—	Hor. hold clockwise
			No Signal	2	188	—	—	3	-24	1	-42	0.37	—	
V116	6SN7GT	Horizontal Oscillator	5000 Mu. V. Signal	5	258	—	—	6	0	4	*-91	2.0	—	* Depends on Oscillator Adjustment
			No Signal	5	256	—	—	6	0	4	*-94	2.0	—	
V117	6CD6G	Horizontal Output	5000 Mu. V. Signal	Cap	*	8	165	3	12.5	5	-30	110	15.0	*High Voltage Pulse Present
			No Signal	Cap	*	8	165	3	12.5	5	-30	110	15.0	
V118	1B3GT /8016	H. V. Rectifier	5000 Mu. V. Signal	Cap	*	—	—	2&7	16,000	—	—	0.2	—	*High Voltage Pulse Present
			No Signal	Cap	*	—	—	2&7	16,400	—	—	0.2	—	
V119 V120	6W4GT	Dampers	5000 Mu. V. Signal	5	355	—	—	3	*	—	—	57	—	*High Voltage Pulse Present
			No Signal	5	353	—	—	3	*	—	—	57	—	
V121	21AP4	Kinescope	5000 Mu. V. Signal	Cone	16,000	10	555	11	140	2	82	0.2	—	At average Brightness
			No Signal	Cone	16,400	10	550	11	132	2	76	0.2	—	
V122 V123	5U4G	Rectifiers	5000 Mu. V. Signal	4&6	388	—	—	2&8	389	—	—	*139	—	* Per Tube
			No Signal	4&6	386	—	—	2&8	387	—	—	*145	—	

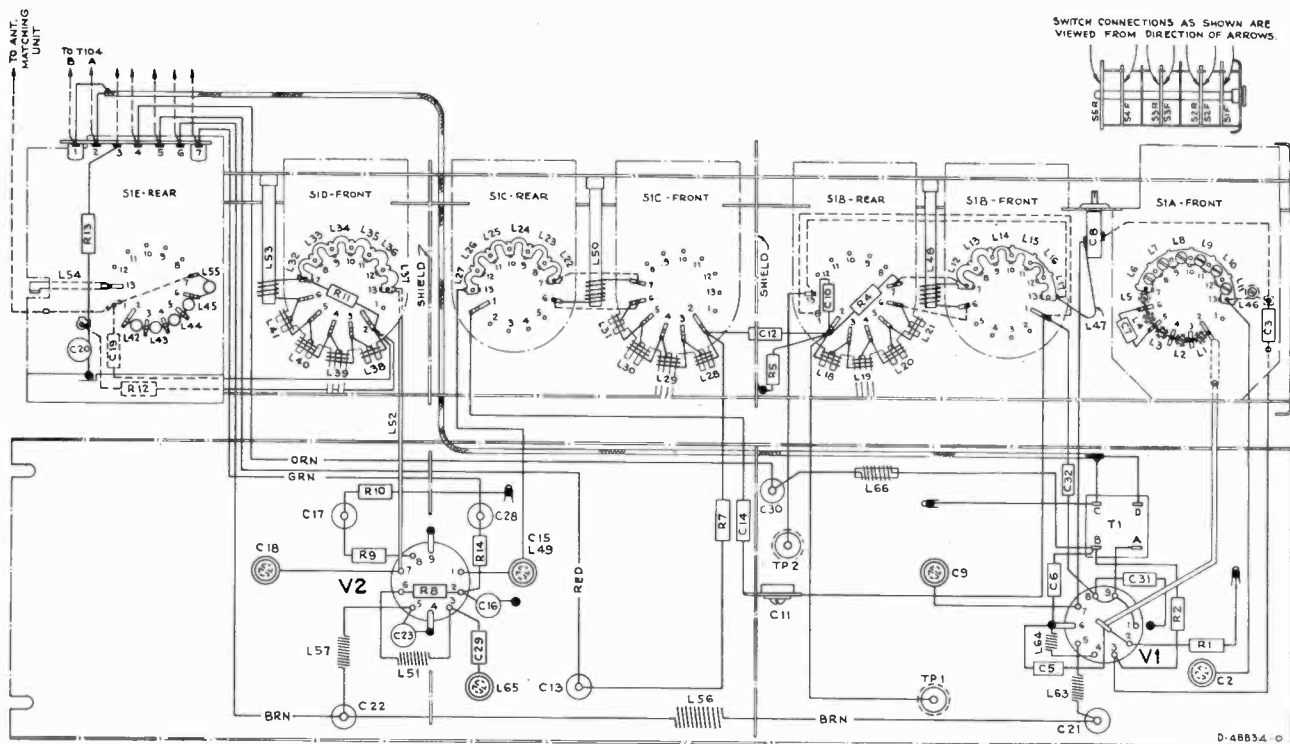

Figure 12—KRK11A R-F Unit Wiring Diagram

CRITICAL LEAD DRESS:

1. Keep all wiring in the pix i-f, sound i-f and video circuits as short as possible.
2. Keep the leads on C110, C111, C112, C200, R109, R110, R111, R112, R114, R115 and R233 as short and direct as possible.
3. Do not change the bus wire connections to pin 2 of V101 and V102. Sleeving is used on these wires to insure length and to prevent shorting.
4. Dress C114 down between R117 (volume control) and wafer S101-2.
5. Ground R130 to pin 3 of V106 and R138 to pin 7 of V107.
6. Do not change the grounding of R141, R146 and R149.
7. Keep the bus wire from T109-A to C146 (plug in capacitor) short and direct.
8. Ground the filaments of sockets of V107, V108 and V109 independently of the socket center pin. Use ground lances provided near each socket.
9. Dress C198 straight up to act as a shield between T101-A and V110-4.
10. Dress C153 and R170 (kine cathode) up in the air above the terminal board.
11. Keep the leads connected to T114-C and T114-D (synchro-guide) down so that they will not short out when the chassis is placed in the cabinet.
12. Do not reroute any wires between T104 and the terminal board alongside it. Keep all leads on the foot side of the terminal board.
13. Dress all wires routed past T104, shielded wires W102 and W103 under the big lances near T104.
14. Dress all a-c leads to S102 under the large lances on the front apron and away from R243.
15. Dress R116 close to the chassis with leads as short as possible.
16. Dress C206, C221 and C212 up in the air and away from all other leads and components.
17. Dress all leads away from bleeder resistor R243.
18. The blue lead from pin 5 of V111 to the terminal board under the high voltage cage should be routed between V117 socket and the rear apron.
19. Keep leads on C214 as short and direct as possible.
20. Dress R206 away from all other wires and components to prevent excessive heating.
21. Keep the wire from the vertical output transformer T114 away from the 5U4G rectifier tubes.
22. Dress all 2 watt resistors away from each other and all other wires and components.
23. Dress all wires away from damper tubes V119 and V120.
24. Blue wire from pin 5 V116 to T114-A should not be more than 5 inches long.
25. Dress all peaking coils up and away from the base.

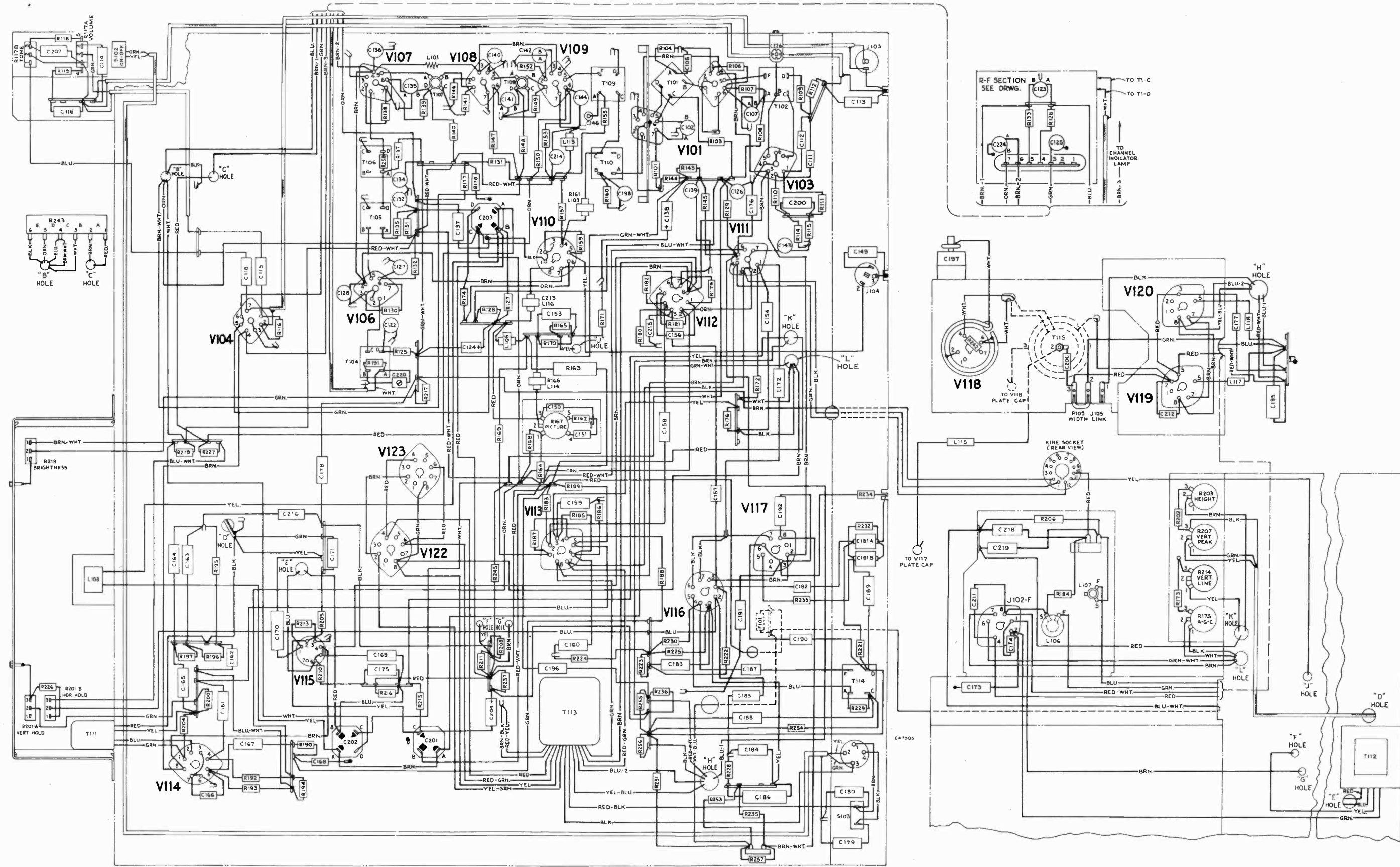
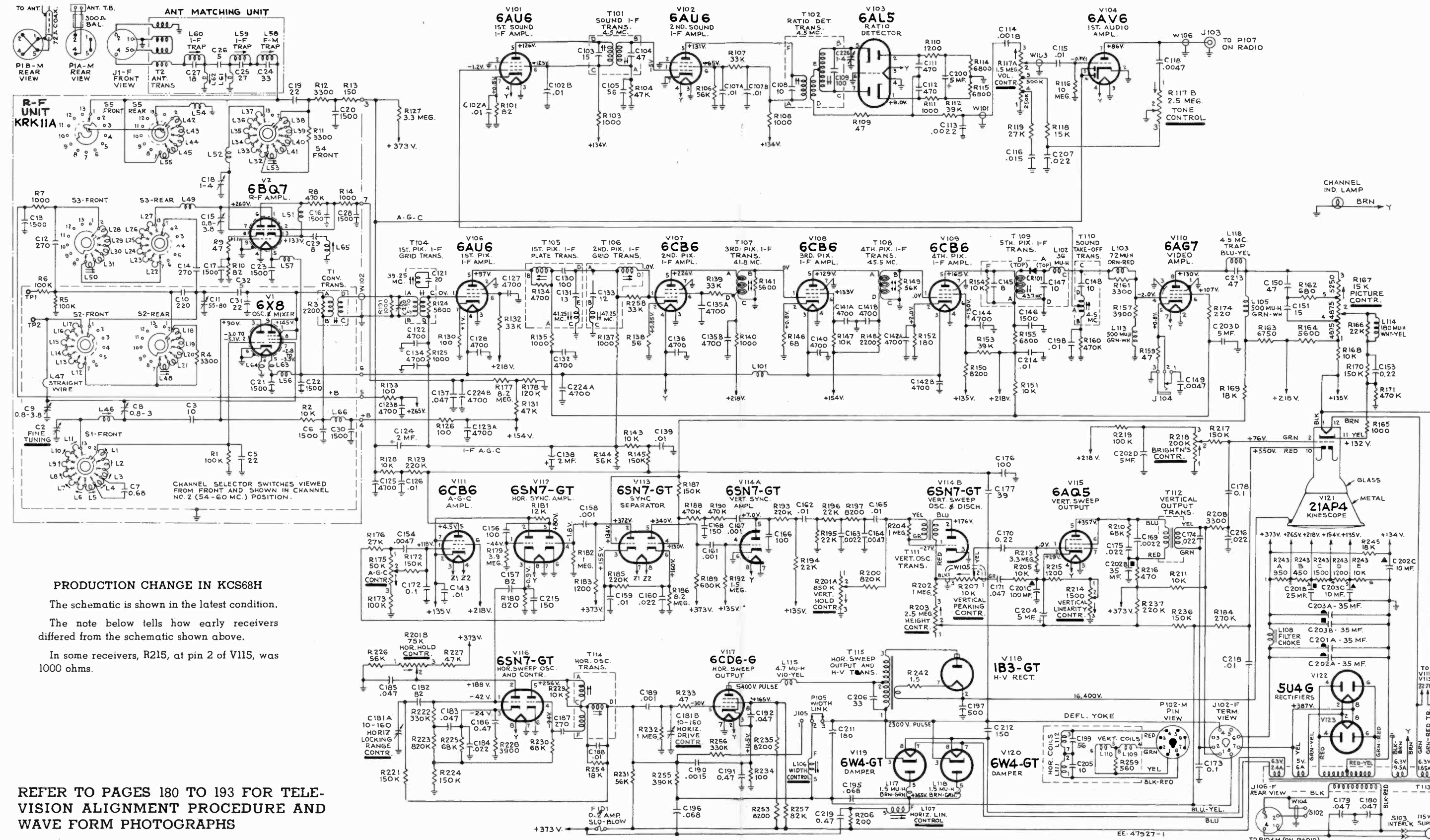

Figure 13—Chassis Wiring Diagram KCS68H



PRODUCTION CHANGE IN KCS68H

The schematic is shown in the latest condition.

The note below tells how early receivers differed from the schematic shown above.

In some receivers, R215, at pin 2 of V115, was 1000 ohms.

REFER TO PAGES 180 TO 193 FOR TELEVISION ALIGNMENT PROCEDURE AND WAVE FORM PHOTOGRAPHS

All resistance values in ohms. K=1000. All capacitance values less than 1 in MF and above in MMF unless otherwise noted.

Direction of arrows at controls indicates clockwise rotation.

All voltages measured with "VoltOhm-myst" and with no signal input. Voltages should hold within $\pm 20\%$ with 117 v. a-c supply.

Figure 14—Television Schematic Diagram

21-T-197DE REPLACEMENT PARTS

Table with 2 columns: STOCK No. and DESCRIPTION. Lists various electronic components like R-F unit assemblies, capacitors, resistors, and transformer parts.

21-T-197DE REPLACEMENT PARTS (Continued)

Table with 2 columns: STOCK No. and DESCRIPTION. Continuation of electronic components from the previous page, including various capacitors, resistors, and transformer parts.

21-T-197DE REPLACEMENT PARTS (Continued)

Table with 2 columns: STOCK No. and DESCRIPTION. Continuation of electronic components, including channel indicator lamp sockets, kinescope sockets, and various transformer and capacitor parts.

21-T-197DE REPLACEMENT PARTS (Continued)

Table with 2 columns: STOCK No. and DESCRIPTION. Continuation of electronic components, including roll-out mechanism assemblies, audio amplifier assemblies, and various mechanical and electrical parts.

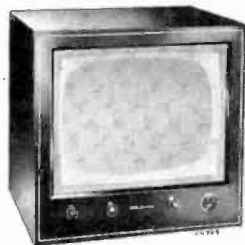

Models 21T207, 21T207G
"Crandall" Mahogany

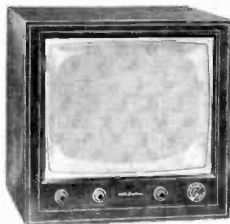

Model 21T208 "Lambert"
Walnut, Mahogany

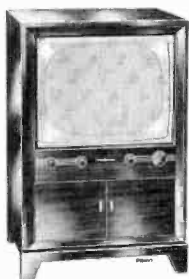

Model 21T217 "Brookfield"
Walnut, Mahogany

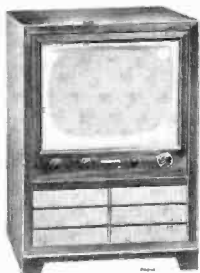

Model 21T218 "Lansford"
Walnut, Mahogany, Blonde



Model 21T227 "Lindale"
Walnut, Mahogany, Blonde



Model 21T228 "Brandon"
Walnut, Mahogany, Maple

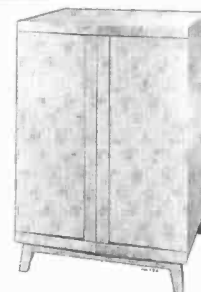

Model 21T229 "Belgrove"
Walnut, Mahogany, Lined Oak



RCA VICTOR

TELEVISION RECEIVERS MODELS 21T207, 21T207G 21T208, 21T217, 21T218, 21T227, 21T228, 21T229

Chassis No. KCS72A —Mfr. No. 274—

SERVICE DATA

—1952 No. T4—

PREPARED BY RCA SERVICE CO., INC.

FOR

RADIO CORPORATION OF AMERICA

RCA VICTOR DIVISION

CAMDEN, N. J., U. S. A.

ELECTRICAL AND MECHANICAL SPECIFICATIONS

PICTURE SIZE .227 square inches on a 21AP4 Kinescope

TELEVISION R-F FREQUENCY RANGE

All 12 television channels, 54 mc. to 88 mc., 174 mc. to 216 mc.

Picture I-F Carrier Frequency 25.50 mc.

Sound I-F Carrier Frequency 21.00 mc. and 4.5 mc.

POWER SUPPLY RATING 115 volts, 60 cycles, 190 watts

AUDIO POWER OUTPUT RATING 4.0 watts max.

VIDEO RESPONSE To 3.2 mc.

SWEEP DEFLECTION Magnetic

FOCUS Magnetic

LOUDSPEAKERS

Models 21T207, 207G. (971636-1) 5" PM Dynamic, 3.2 ohms

Models 21T208, 217, 229. (971490-3) 8" PM Dynamic, 3.2 ohms

Models 21T218, 227, 228. (92569-12) 12" PM Dynamic, 3.2 ohms

WEIGHT AND DIMENSIONS (inches)

Model	Net Weight	Shipping Weight	Width	Height	Depth
21T207	94	115	28½	28¼	27½
21T207G	105	126	28⅝	28¼	28⅝
21T208	94	115	25⅛	24¾	25⅛
21T217	104	132	26	39⅜	25⅛
21T218	112	144	27⅝	39¼	24
21T227	130	162	27½	40⅛	27⅛
21T228	132	164	27⅝	39⅝	26⅝
21T229	139	173	27⅛	40	26⅝

RECEIVER ANTENNA INPUT IMPEDANCE

Choice: 300 ohms balanced or 72 ohms unbalanced.

RCA TUBE COMPLEMENT

Tube Used	Function
(1) RCA 6CB6	R-F Amplifier
(2) RCA 6J6	R-F Oscillator and Mixer
(3) RCA 6CB6	1st Picture I-F Amplifier
(4) RCA 6CB6	2nd Picture I-F Amplifier
(5) RCA 6CB6	3rd Picture I-F Amplifier
(6) RCA 12AU7	Picture 2nd Detector and Vert. Sync. Sep.
(7) RCA 6AG7 (6AC7, 6CL6)	Video Amplifier
(8) RCA 6AU6	1st Sound I-F Amplifier
(9) RCA 6AU6	2nd Sound I-F Amplifier
(10) RCA 6AL5	Ratio Detector
(11) RCA 6AV6	1st Audio Amplifier
(12) RCA 6K6GT	Audio Output
(13) RCA 6AU6	AGC Amplifier
(14) RCA 6SN7GT	Horizontal Sync. Sep. and Sync. Output
(15) RCA 6J5	Vertical Sweep Oscillator
(16) RCA 6K6GT	Vertical Sweep Output
(17) RCA 6SN7GT	Horizontal Sweep Oscillator and Control
(18) RCA 6BQ6GT	Horizontal Sweep Output
(19) RCA 6W4GT	Damper
(20) RCA 1B3-GT/8016	High Voltage Rectifier
(21) RCA 21AP4 (21EP4)	Kinescope
(22) RCA 5U4G	Rectifier
(23) RCA 5Y3GT	Rectifier

21T207, 21T207G, 21T208, 21T217
21T218, 21T227, 21T228, 21T229

ELECTRICAL AND MECHANICAL SPECIFICATIONS

(Continued)

PICTURE INTERMEDIATE FREQUENCIES

Picture Carrier Frequency 25.50 mc.
Adjacent Channel Sound Trap 27.00 mc.

SOUND INTERMEDIATE FREQUENCIES

Sound Carrier Frequency 21.00 mc.
Sound I.F. Frequency 4.5 mc.

VIDEO RESPONSE To 3.2 mc.

FOCUS Magnetic

SWEEP DEFLECTION Magnetic

SCANNING Interlaced, 525 line

HORIZONTAL SWEEP FREQUENCY 15,750 cps

VERTICAL SWEEP FREQUENCY 60 cps

FRAME FREQUENCY (Picture Repetition Rate) . . . 30 cps

OPERATING CONTROLS (Front Panel)

Channel Selector }
Fine Tuning } Dual Control Knobs
Picture }
Brightness } Dual Control Knobs
Picture Horizontal Hold }
Picture Vertical Hold } Dual Control Knobs
Sound Volume and On-Off Switch }
TV Tone & Phono Switch } Dual Control Knobs

NON-OPERATING CONTROLS (not including r-f and i-f adjustments)

Picture Centering top chassis adjustment
Width rear chassis adjustment
Height rear chassis adjustment
Horizontal Linearity . . . rear chassis screwdriver adjustment
Vertical Linearity rear chassis adjustment
Horizontal Drive rear chassis screwdriver adjustment
Horizontal Oscillator Frequency . . . rear chassis adjustment
Horizontal Oscillator Waveform . . . bottom chassis adjustment
Horizontal Locking Range rear chassis adjustment
Focus top chassis adjustment
Ion Trap Magnet top chassis adjustment
Deflection Coil top chassis wing nut adjustment
AGC Control rear chassis adjustment
Pin Cushion Correction Magnets (21T207G only)
top chassis adjustment

HIGH VOLTAGE WARNING

OPERATION OF THIS RECEIVER OUTSIDE THE CABINET OR WITH THE COVERS REMOVED, INVOLVES A SHOCK HAZARD FROM THE RECEIVER POWER SUPPLIES. WORK ON THE RECEIVER SHOULD NOT BE ATTEMPTED BY ANYONE WHO IS NOT THOROUGHLY FAMILIAR WITH THE PRECAUTIONS NECESSARY WHEN WORKING ON HIGH VOLTAGE EQUIPMENT. DO NOT OPERATE THE RECEIVER WITH THE HIGH VOLTAGE COMPARTMENT SHIELD REMOVED.

KINESCOPE HANDLING PRECAUTIONS

DO NOT REMOVE THE RECEIVER CHASSIS, INSTALL, REMOVE OR HANDLE THE KINESCOPE IN ANY MANNER UNLESS SHATTERPROOF GOGGLES ARE WORN. PEOPLE NOT SO EQUIPPED SHOULD BE KEPT AWAY WHILE HANDLING KINESCOPIES. KEEP THE KINESCOPE AWAY FROM THE BODY WHILE HANDLING.

The kinescope bulb encloses a high vacuum and, due to its large surface area, is subjected to considerable air pressure. For this reason, the kinescope must be handled with more care than ordinary receiving tubes.

The large end of the kinescope bulb—particularly that part at the rim of the viewing surface—must not be struck, scratched or subjected to more than moderate pressure at any time. During service if the tube sticks or fails to slip smoothly into its socket, or deflecting yoke, investigate and remove the cause of the trouble. Do not force the tube. Refer to the Receiver Installation section for detailed instructions on kinescope installation. All RCA replacement kinescopes are shipped in special cartons and should be left in the cartons until ready for installation in the receiver.

OPERATING INSTRUCTIONS

21T207, 21T207G, 21T208, 21T217,
21T218, 21T227, 21T228, 21T229

The following adjustments are necessary when turning the receiver on for the first time.

1. See that the TV-PH switch is in the "TV" position.
2. Turn the receiver "ON" and advance the SOUND VOLUME control to approximately mid-position.
3. Set the STATION SELECTOR to the desired channel.
4. Adjust the FINE TUNING control for best pix and the SOUND VOLUME control for suitable volume.
5. Turn the BRIGHTNESS control fully counter-clockwise, then clockwise until a light pattern appears on the screen.
6. Adjust the VERTICAL hold control until the pattern stops vertical movement.
7. Adjust the HORIZONTAL hold control until a picture is obtained and centered.

8. Adjust the CONTRAST and BRIGHTNESS controls for suitable picture contrast and brightness.

9. In switching from one channel to another, it may be necessary to repeat steps 4 and 8.

10. When the set is turned on again after an idle period it should not be necessary to repeat the adjustment if the positions of the controls have not been changed. If any adjustment is necessary, step number 4 is generally sufficient.

11. If the positions of the controls have been changed, it may be necessary to repeat steps 2 through 8.

12. To use a record player, plug the record-player output cable into the PHONO jack on the rear apron, and set the TV-PH switch to "PH"

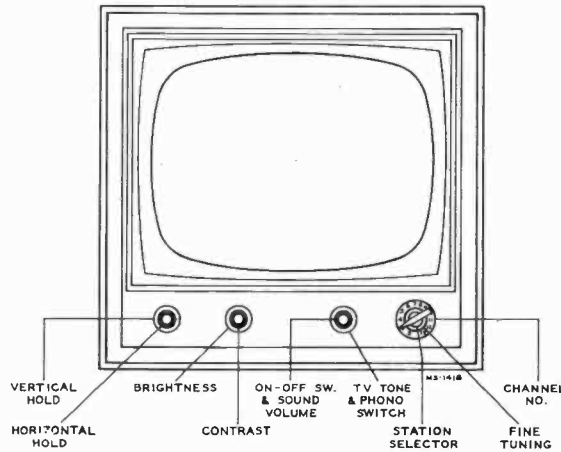

Figure 1—Receiver Operating Controls

INSTALLATION INSTRUCTIONS

UNPACKING.—These receivers are shipped complete in cardboard cartons. The kinescope is shipped in place in the receiver.

Take the receiver out of the carton and remove all packing material.

Make sure that all tubes are in place and are firmly seated in their sockets.

Check to see that the kinescope high voltage lead clip is in place.

Plug a power cord into the 115 volt a-c power source and into the receiver interlock receptacle. Turn the receiver power switch to the "on" position, the brightness control fully clockwise, and the picture control counter-clockwise.

ION TRAP MAGNET ADJUSTMENT.—Set the ion trap magnet approximately in the position shown in Figure 2. Starting from this position immediately adjust the magnet by moving it forward or backward at the same time rotating it slightly around the neck of the kinescope for the brightest raster on the screen. Reduce the brightness control setting until the raster is slightly above average brilliance. Turn the focus control (shown in Figure 2) until the line structure of the raster is clearly visible. Readjust the ion trap magnet for maximum raster brilliance. The final touches of this adjustment should be made with the brightness control at the maximum clockwise position with which good line focus can be maintained.

DEFLECTION YOKE ADJUSTMENT.—If the lines of the raster are not horizontal or squared with the picture mask, rotate the deflection yoke until this condition is obtained. Tighten the yoke adjustment wing screw.

PICTURE ADJUSTMENTS.—It will now be necessary to obtain a test pattern picture in order to make further adjustments. Connect the antenna transmission line to the receiver.

If the Horizontal Oscillator and AGC System are operating properly, it should be possible to sync the picture at this point. However, if the AGC control is misadjusted, and the receiver is overloading, it may be impossible to sync the picture.

If the receiver is overloading, turn R149 on the rear apron (see Figure 3) counter-clockwise until the set operates normally and the picture can be synced.

CHECK OF HORIZONTAL OSCILLATOR ALIGNMENT.—Turn the horizontal hold control to the extreme counter-clockwise position. The picture should remain in horizontal sync. Momentarily remove the signal by switching off channel then back. Normally the picture will be out of sync. Turn the control clockwise slowly. The number of diagonal black bars will be gradually reduced and when only 2 or 3 bars sloping downward to the left are obtained, the picture will pull into sync upon slight additional clockwise rotation of the control. Pull-in should occur before the control has been turned 120 degrees from the extreme counter-clockwise position. The picture should remain in sync for approximately 90

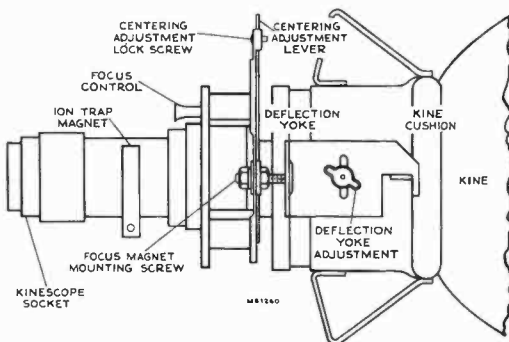

Figure 2—Yoke and Focus Magnet Adjustments

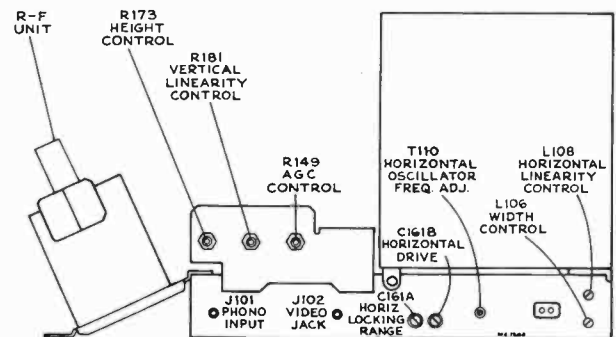

Figure 3—Rear Chassis Adjustments

21T207, 21T207G, 21T208, 21T217
21T218, 21T227 21T228, 21T229

INSTALLATION INSTRUCTIONS

degrees of additional clockwise rotation of the control. At the extreme clockwise position, the picture should remain in sync and should not show a black bar in the picture.

If the receiver passes the above checks and the picture is normal and stable, the horizontal oscillator is properly aligned. Skip "Alignment of Horizontal Oscillator" and proceed with "Focus Magnet Adjustment."

ALIGNMENT OF HORIZONTAL OSCILLATOR.—If in the above check the receiver failed to hold sync with the hold control at the extreme counter-clockwise position or failed to hold sync over 90 degrees of clockwise rotation of the control from the pull-in point, it will be necessary to make the following adjustments.

Horizontal Frequency Adjustment.—Turn the horizontal hold control to the extreme clockwise position. Tune in a television station and adjust the T110 horizontal frequency adjustment at the rear of the chassis until the picture is just out of sync and the horizontal blanking appears as a vertical or diagonal black bar in the raster. Then turn the T110 core until the bar moves out of the picture leaving it in sync.

Horizontal Locking Range Adjustment.—Set the horizontal hold control to the full counter-clockwise position. Momentarily remove the signal by switching off channel then back. The picture may remain in sync. If so turn the T110 rear core slightly and momentarily switch off channel. Repeat until the picture falls out of sync with the diagonal lines sloping down to the left. Slowly turn the horizontal hold control clockwise and note the least number of diagonal bars obtained just before the picture pulls into sync.

If more than 3 bars are present just before the picture pulls into sync, adjust the horizontal locking range trimmer C161A slightly clockwise. If less than 2 bars are present, adjust C161A slightly counter-clockwise. Turn the horizontal hold control counter-clockwise, momentarily remove the signal and recheck the number of bars present at the pull-in point. Repeat this procedure until 2 or 3 bars are present.

Repeat the adjustments under "Horizontal Frequency Adjustment" and "Horizontal Locking Range Adjustment" until the conditions specified under each are fulfilled. When the horizontal hold operates as outlined under "Check of Horizontal Oscillator Alignment" the oscillator is properly adjusted.

If it is impossible to sync the picture at this point and the AGC system is in proper adjustment it will be necessary to adjust the Horizontal Oscillator by the method outlined in the alignment procedure on page 11. For field purposes paragraph "B" under Horizontal Oscillator Waveform Adjustment may be omitted.

FOCUS MAGNET ADJUSTMENT.—The focus magnet should be adjusted so that there is approximately three-eighths inch of space between the rear cardboard shell of the yoke and the flat of the front face of the focus magnet. This spacing gives best average focus over the face of the tube.

The axis of the hole through the magnet should be parallel with the axis of the kinescope neck with the kinescope neck through the center of the opening.

PIN-CUSHION CORRECTION.—Two pin-cushion correction magnets are employed to correct a small amount of pin-cushion of the raster due to the lens effect of the face of the kinescope. These magnets are mounted on small arms, one on each side of the kinescope as shown in Figure 2. The arms hinge in one plane on self tapping screws which act both as a hinge and an adjustment locking screw. When the magnets are swung towards the tube, maximum correction is obtained. Minimum correction is obtained when the arms are swung away from the tube. To adjust the magnets, loosen the two self tapping screws and position the magnets until the sides of the raster appear straight. Tighten the screws without shifting the position of the magnets. In some cases it may be necessary to twist or bend the magnet support arms to obtain the appearance of straight raster edges.

CENTERING ADJUSTMENT.—No electrical centering controls are provided. Centering is accomplished by means of a separate plate on the focus magnet. The centering plates include a locking screw which must be loosened before centering. Up and down adjustment of the plate moves the picture side to side and sidewise adjustment moves the picture up and down.

If a corner of the raster is shadowed, check the position of the ion trap magnet. Reposition the magnet within the range of maximum raster brightness to eliminate the shadow and recenter the picture by adjustment of the focus magnet plate. In no case should the magnet be adjusted to cause any loss of brightness since such operation may cause immediate or eventual damage to the tube. In some cases it may be necessary to shift the position of the focus magnet in order to eliminate a corner shadow.

WIDTH, DRIVE AND HORIZONTAL LINEARITY ADJUSTMENTS.—Adjustment of the horizontal drive control affects the high voltage applied to the kinescope. In order to obtain the highest possible voltage hence the brightest and best focused picture, adjust horizontal drive trimmer C161B counter-clockwise until the picture begins to "wrinkle" in the middle then clockwise until the "wrinkle" disappears.

Turn the horizontal linearity control L108 clockwise until the picture begins to "wrinkle" on the right and then counter-clockwise until the "wrinkle" disappears and best linearity is obtained.

Adjust the width control L106 to obtain correct picture width.

A slight readjustment of these three controls may be necessary to obtain the best linearity.

Adjustments of the horizontal drive control affect horizontal oscillator hold and locking range. If the drive control was adjusted, recheck the oscillator alignment.

HEIGHT AND VERTICAL LINEARITY ADJUSTMENTS.—Adjust the height control (R173 on chassis rear apron) until the picture fills the mask vertically. Adjust vertical linearity (R181 on rear apron), until the test pattern is symmetrical from top to bottom. Adjustment of either control will require a readjustment of the other. Adjust centering to align the picture with the mask.

FOCUS.—Adjust the focus magnet for maximum definition in the test pattern vertical "wedge" and best focus in the white areas of the pattern.

Recheck the position of the ion trap magnet to make sure that maximum brightness is obtained.

Check to see that the yoke thumbscrew and the focus magnet mounting screws are tight.

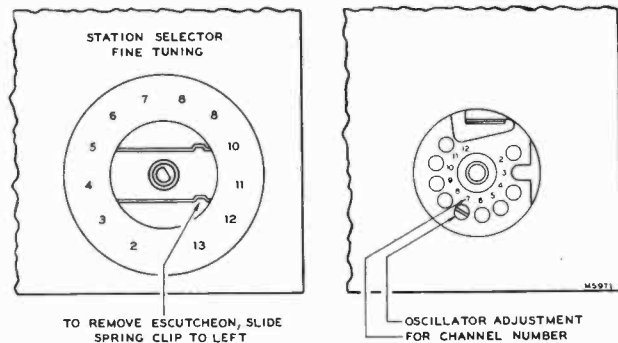

Figure 4—R-F Oscillator Adjustments

CHECK OF R-F OSCILLATOR ADJUSTMENTS.—Tune in all available stations to see if the receiver r-f oscillator is adjusted to the proper frequency on all channels. If adjustments are required, these should be made by the method outlined in the alignment procedure on page 9. The adjustments for channels 2 through 12 are available from the front of the cabinet by removing the station selector escutcheon as shown in Figure 4. Adjustment for channel 13 is on top of the chassis.

AGC THRESHOLD CONTROL.—The AGC threshold control R149 is adjusted at the factory and normally should not require readjustment in the field.

To check the adjustment of the AGC Threshold Control, tune in a strong signal and sync the picture. Momentarily remove the signal by switching off channel and then back. If the picture reappears immediately, the receiver is not overloading due to improper setting of R149. If the picture requires an appreciable portion of a second to reappear, or bends excessively, R149 should be readjusted.

INSTALLATION INSTRUCTIONS

21T207, 21T207G, 21T208, 21T217,
21T218, 21T227, 21T228, 21T229

Turn R149 fully counter-clockwise. The raster may be bent slightly. This should be disregarded. Turn R149 clockwise until there is a very, very slight bend or change of bend in the picture. Then turn R149 counter-clockwise just sufficiently to remove this bend or change of bend.

If the signal is weak, the above method may not work as it may be impossible to get the picture to bend. In this case, turn R149 clockwise until the snow in the picture becomes more pronounced, then counter-clockwise until the best signal to noise ratio is obtained.

The AGC control adjustment should be made on a strong signal if possible. If the control is set too far clockwise on a weak signal, then the receiver may overload when a strong signal is received.

FM TRAP ADJUSTMENT.—In some instances interference may be encountered from a strong FM station signal. A trap is provided to eliminate this type of interference. To adjust the trap tune in the station on which the interference is observed and adjust the L203 core on top of the antenna matching transformer for minimum interference in the picture.

CAUTION.—In some receivers, the FM trap L203 will tune down into channel 6 or even into channel 5. Needless to say, such an adjustment will cause greatly reduced sensitivity on these channels. If channels 5 or 6 are to be received, check L203 to make sure that it does not affect sensitivity on these two channels.

Replace the cabinet back and connect the receiver antenna leads to the cabinet back. Make sure that the screws holding it are up tight, otherwise it may rattle or buzz when the receiver is operated at high volume.

KINESCOPE SCREEN CLEANING.—The kinescope safety glass is held in place by four spring clips which may be removed from the back of the front panel. This permits removing the safety glass for cleaning without the necessity of removing the chassis and kinescope.

CHASSIS REMOVAL.—To remove the chassis from the cabinet for repair or installation of a new kinescope, remove the control knobs, the cabinet back, unplug the speaker cable, the kinescope socket, the antenna cable, the yoke and high voltage cable. Take out the chassis bolts under the cabinet. Withdraw the chassis from the back of the cabinet.

KINESCOPE HANDLING PRECAUTION.—Do not install, remove, or handle the kinescope in any manner, unless shatterproof goggles and heavy gloves are worn. People not so equipped should be kept away while handling the kinescope. Keep the kinescope away from the body while handling.

REMOVAL OF KINESCOPE.—To remove the kinescope from the cabinet, loosen the two nuts and disengage the rods alongside the kinescope. Remove the screw which holds the yoke frame to the cabinet. Remove the kinescope, the yoke frame with yoke and focus magnet as an assembly.

Handle this tube by the portion at the edge of the screen. Do not cover the glass bell of the tube with fingermarks as it will produce leakage paths which may interfere with reception. If this portion of the tube has inadvertently been handled, wipe it clean with a soft cloth moistened with "dry" carbon tetrachloride.

INSTALLATION OF KINESCOPE.—Wipe the kinescope screen surface and front panel safety glass clean of all dust and fingermarks with a soft cloth moistened with "Windex" or similar cleaning agent.

Replace the kinescope and chassis by reversal of the removing process. The kinescope should be installed so that the high voltage contact is to the right when looking at it from the rear of the cabinet. The magnet of the ion trap magnet should be to the left.

CABINET ANTENNA.—A cabinet antenna is provided in some receiver models and the leads are brought out near the antenna terminal board. The cabinet antenna may be employed in place of the outdoor antenna in areas where the signals are strong and no reflections are experienced.

ANTENNAS.—The finest television receiver built may be said to be only as good as the antenna design and installation. It is therefore important to select the proper antenna to suit the particular local conditions, to install it properly and orient it correctly.

If two or more stations are available and the two stations are in different directions, it may be possible to make a compromise orientation which will provide a satisfactory signal on all such channels.

If it is impossible to obtain satisfactory results on one or more channels, it may become necessary either to provide means for turning the antenna when switching channels or to install a separate antenna for one or more channels and to switch antennas when switching channels.

In some cases, the antenna should not be installed permanently until the quality of the picture reception has been observed on a television receiver. A temporary transmission line can be run between receiver and the antenna, allowing sufficient slack to permit moving the antenna. Then, with a telephone system connecting an observer at the receiver and an assistant at the antenna, the antenna can be positioned to give the most satisfactory results on the received signal. A shift of direction or a few feet in antenna position may effect a tremendous difference in picture reception.

REFLECTIONS.—Multiple images sometimes known as echoes or ghosts, are caused by the signal arriving at the antenna by two or more routes. The second or subsequent image occurs when a signal arrives at the antenna after being reflected off a building, a hill or other object. In severe cases of reflections, even the sound may be distorted. In less severe cases, reflections may occur that are not noticeable as reflections but that will instead cause a loss of definition in the picture.

Under certain extremely unusual conditions, it may be possible to rotate or position the antenna so that it receives the cleanest picture over a reflected path. If such is the case, the antenna should be so positioned. However, such a position may give variable results as the nature of reflecting surfaces may vary with weather conditions. Wet surfaces have been known to have different reflecting characteristics than dry surfaces.

Depending upon the circumstances, it may be possible to eliminate the reflections by rotating the antenna or by moving it to a new location. In extreme cases, it may be impossible to eliminate the reflection.

INTERFERENCE.—Auto ignition, street cars, electrical machinery and diathermy apparatus may cause interference which spoils the picture. Whenever possible, the antenna location should be removed as far as possible from highways, hospitals, doctors' offices and similar sources of interference. In mounting the antenna, care must be taken to keep the antenna rods at least $\frac{1}{4}$ wave length (at least 6 feet) away from other antennas, metal roofs, gutters or other metal objects.

Short-wave radio transmitting and receiving equipment may cause interference in the picture in the form of moving ripples. In some instances it may be possible to eliminate the interference by the use of a trap in the antenna transmission line. However, if the interfering signal is on the same frequency as the television station, a trap will provide no improvement.

WEAK PICTURE.—When the installation is near the limit of the area served by the transmitting station, the picture may be speckled, having a "snow" effect, and may not hold steady on the screen. This condition is due to lack of signal strength from the transmitter.

RECEIVER LOCATION.—The owner should be advised of the importance of placing the receiver in the proper location in the room.

The location should be chosen—

- Away from bright windows and so that no bright light will fall directly on the screen. (Some illumination in the room is desirable, however.)
- To give easy access for operation and comfortable viewing.
- To permit convenient connection to the antenna.
- Convenient to an electrical outlet.
- To allow adequate ventilation.

21T207, 21T207G, 21T208, 21T217,
21T218, 21T227, 21T228, 21T229

CHASSIS TOP VIEW

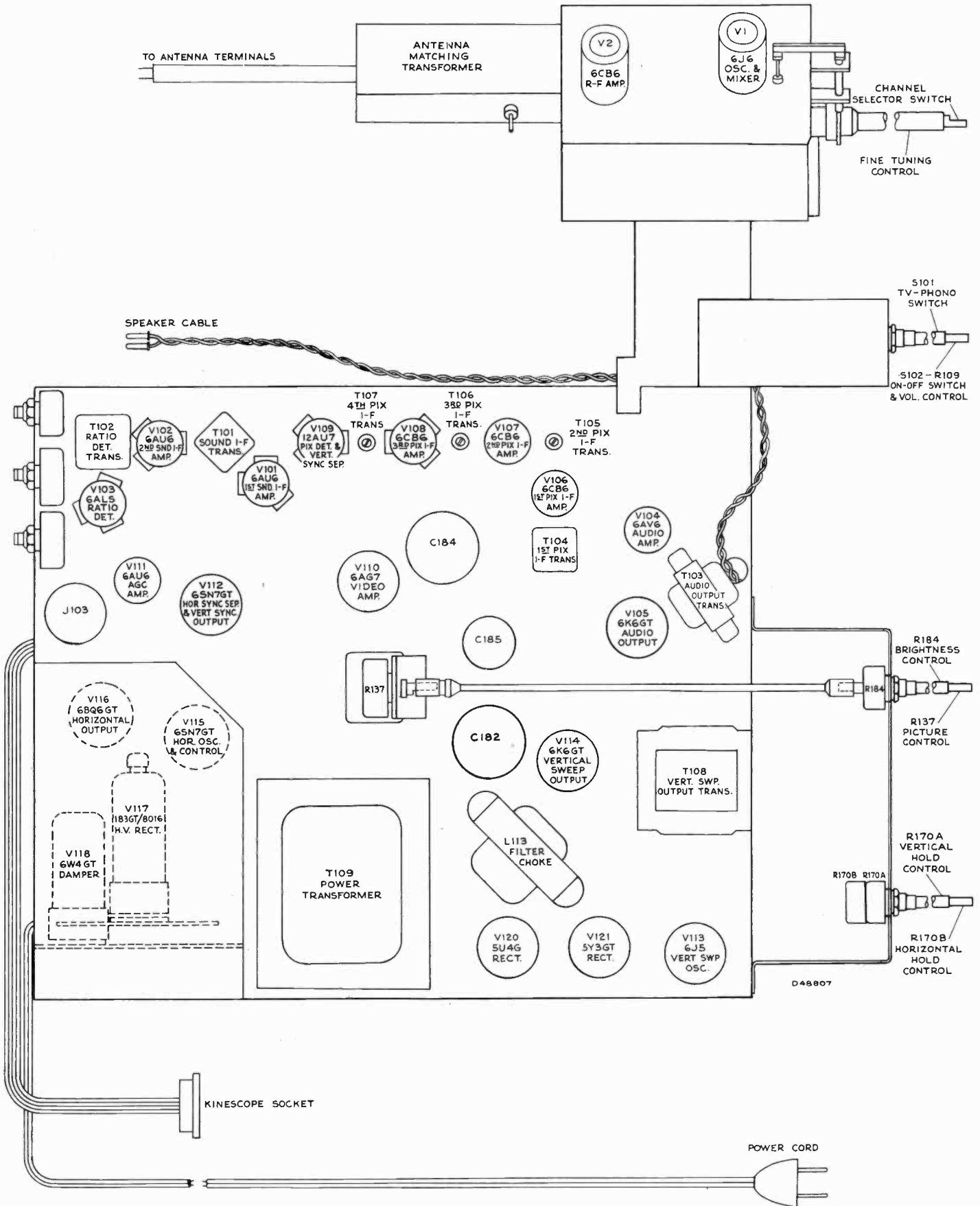

Figure 5—Chassis Top View

21T207, 21T207G, 21T208, 21T217,
21T218, 21T227, 21T228, 21T229

CHASSIS BOTTOM VIEW

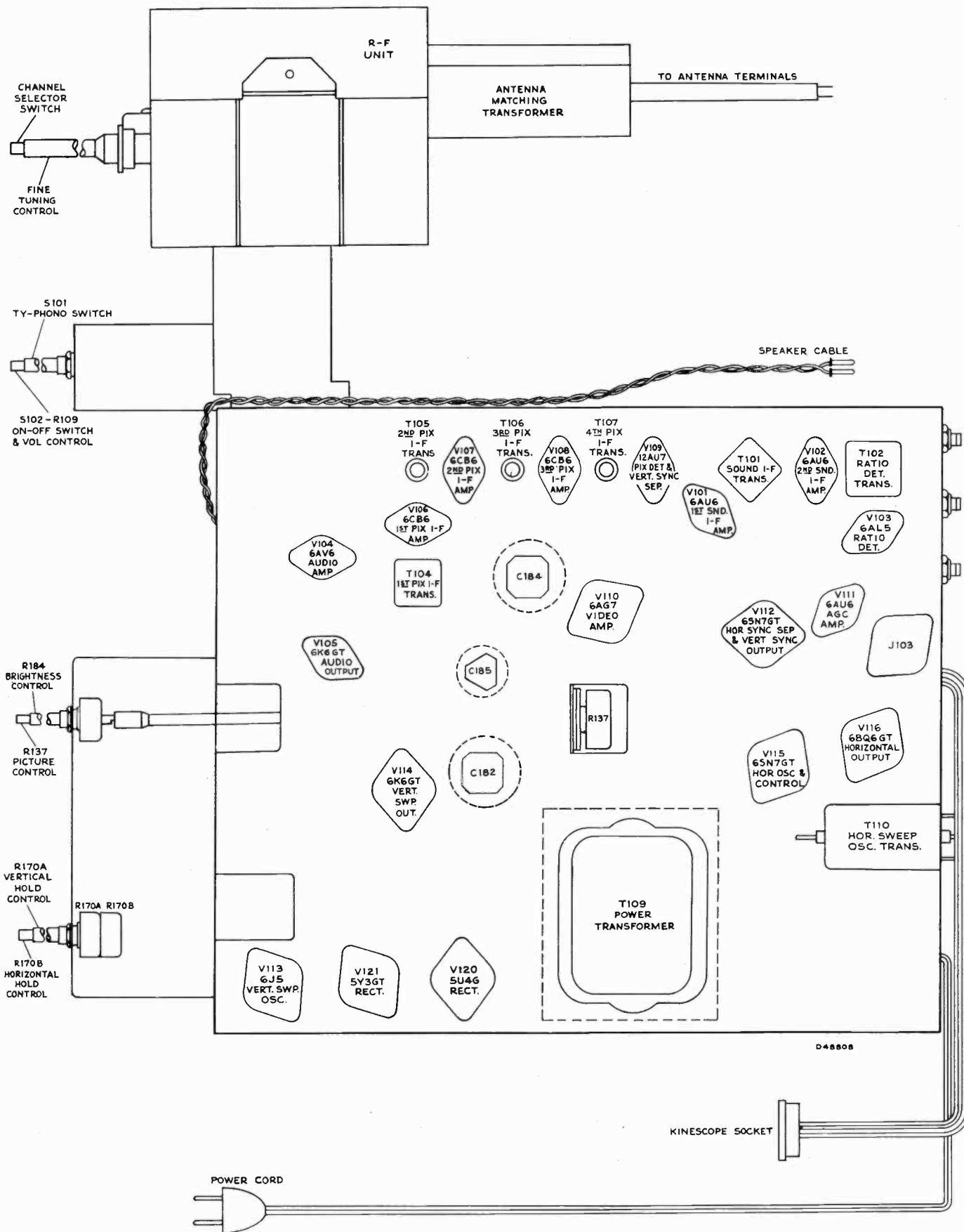

Figure 6—Chassis Bottom View

21T207, 21T207G, 21T208, 21T217,
21T218, 21T227, 21T228, 21T229

ALIGNMENT PROCEDURE

TEST EQUIPMENT.—To properly service the television chassis of this receiver, it is recommended that the following test equipment be available:

R-F Sweep Generator meeting the following requirements:

- (a) Frequency Ranges
 - 20 to 30 mc., 1 mc. and 10 mc. sweep width
 - 50 to 90 mc., 10 mc. sweep width
 - 170 to 225 mc., 10 mc. sweep width
- (b) Output adjustable with at least .1 volt maximum.
- (c) Output constant on all ranges.
- (d) "Flat" output on all attenuator positions.

Cathode-Ray Oscilloscope.—For alignment purposes, the oscilloscope employed must have excellent low frequency and phase response, and should be capable of passing a 60-cycle square wave without appreciable distortion.

For video and sync waveform observations, the oscilloscope must have excellent frequency and phase response from 10 cycles to at least two megacycles in all positions of the gain control.

Signal Generator to provide the following frequencies with crystal accuracy.

- (a) Intermediate frequencies
 - 22.25 and 25.5 mc. conv. and first pix i-f trans.
 - 22.75 mc. second picture i-f transformer
 - 24.25 mc. fourth picture i-f transformer
 - 25.5 mc. third picture i-f transformer
 - 25.50 mc. picture carrier
 - 27.00 mc. adjacent channel sound trap
- (b) Radio frequencies

Channel Number	Picture Carrier Freq. Mc.	Sound Carrier Freq. Mc.
2	55.25	59.75
3	61.25	65.75
4	67.25	71.75
5	77.25	81.75
6	83.25	87.75
7	175.25	179.75
8	181.25	185.75
9	187.25	191.75
10	193.25	197.75
11	199.25	203.75
12	205.25	209.75
13	211.25	215.75

- (c) Output of these ranges should be adjustable and at least .1 volt maximum.

Heterodyne Frequency Meter with crystal calibrator which covers the frequency range from 80 mc. to 109 mc. and from 200 mc. to 237 mc.

Electronic Voltmeter of Junior or Senior "VoltOhmyst" type and a high voltage multiplier probe for use with this meter to permit measurements up to 15 kv.

Service Precautions.—If possible, the chassis should be serviced without the kinescope. However, if it is necessary to view the raster during servicing, it would be a great convenience to have a bench mounted kinescope and speaker complete with a set of extension cables.

CAUTION: Do not short the kinescope second anode lead. Its short circuit current presents a considerable overload on the high voltage rectifier V117.

Adjustments Required.—Normally, only the r-f oscillator and mixer lines will require the attention of the service technician. All other circuits are either broad or very stable and hence will seldom require readjustment.

ORDER OF ALIGNMENT.—When a complete receiver alignment is necessary, it can be most conveniently performed in the following order:

- (1) R-F unit
- (2) Picture i-f transformers
- (3) Picture i-f trap
- (4) Sweep of picture i-f
- (5) Ratio detector alignment
- (6) Sound i-f alignment
- (7) 4.5 Mc Trap Adjustment
- (8) Check of overall response
- (9) AGC control adjustment
- (10) Horizontal oscillator alignment

R-F UNIT ALIGNMENT.—Disconnect the co-ax link from terminal 2 of the r-f unit terminal board and connect a 39 ohm composition resistor between lugs 1 and 2.

Detune T1 by backing the core all the way out of the coil.

Back the L44 core all the way out. Back the L203 core all the way out.

In order to align the r-f tuner, it will first be necessary to set the channel-13 oscillator to frequency. The shield over the bottom of the r-f unit must be in place when making any adjustments.

The oscillator may be aligned by adjusting it to beat with a crystal-calibrated heterodyne frequency meter. Couple the meter probe loosely to the receiver oscillator.

Set the channel selector switch to 13.

Adjust the heterodyne frequency meter to the correct frequency (236.75 mc.).

Set the fine tuning control 30 degrees clockwise from the mechanical center of its range.

Adjust C1 for an audible beat on the heterodyne frequency meter.

Now that the channel-13 oscillator is set to frequency, we may proceed with the r-f alignment.

Turn the AGC control fully clockwise.

Obtain a 7.5 volt battery capable of withstanding appreciable current drain and connect the ends of a 1,000 ohm potentiometer across it. Connect the battery positive terminal to chassis and the potentiometer arm to terminal 3 of the r-f unit. Adjust the bias box potentiometer to produce -3.5 volts of bias at the r-f unit terminal board.

Connect the oscilloscope to the test point TP1 on top of the r-f unit.

Connect the r-f sweep oscillator to the receiver antenna terminals. The method of connection depends upon the output impedance of the sweep. The P300 connections for 300-ohm balanced or 72-ohm single-ended input are shown in the circuit schematic diagram. If the sweep oscillator has a 50-ohm or 72-ohm single-ended output, 300-ohm balanced output can be obtained by connecting as shown in Figure 9.

Connect the signal generator loosely to the receiver antenna terminals.

Set the receiver channel switch to channel 8.

Set the sweep oscillator to cover channel 8.

Insert markers of channel 8 picture carrier and sound carrier, 181.25 mc. and 185.75 mc.

Adjust C9, C11, C16 and C22 for approximately correct curve shape, frequency, and band width as shown in Figure 11.

The correct adjustment of C22 is indicated by maximum amplitude of the curve midway between the markers. C16 tunes the r-f amplifier plate circuit and affects the frequency of the curve most noticeably. C9 tunes the converter grid circuit and affects the tilt of the curve most noticeably (assuming that C22 has been properly adjusted). C11 is the coupling adjustment and hence primarily affects the response band width.

Set the receiver channel switch to channel 6.

Adjust the heterodyne frequency meter to the correct frequency (108.75 mc.).

Set the fine tuning control 30 degrees clockwise from the mechanical center of its range.

Adjust L5 for an audible beat on the heterodyne frequency meter.

ALIGNMENT PROCEDURE

21T207, 21T207G, 21T208, 21T217,
21T218, 21T227, 21T228, 21T229

Set the sweep generator to channel 6.

From the signal generator, insert channel 6 sound and picture carrier markers, 83.25 mc. and 87.75 mc.

Adjust L42, L45 and L49 for proper response as shown in Figure 12.

L42 is adjusted to give maximum amplitude of the curve between the markers. L45 primarily affects the tilt of the curve. L49 primarily affects the frequency of response.

Connect the "VoltOhmyst" to the r-f unit test point TP1.

Adjust C7 for -3.0 volts at the test point.

Retouch L42, L45 and L49 for proper response if necessary. If necessary, retouch C11 for proper band width on channel 6. Continue these retouching adjustments until proper response is obtained and -3.0 volts of oscillator injection are present at the test point, TP1.

Set the receiver channel selector switch to channel 8 and readjust C1 for proper oscillator frequency.

Set the sweep oscillator and signal generator to channel 8.

Readjust C9, C16 and C22 for correct curve shape, frequency and band width. Readjust C11 only if necessary.

Switch the receiver, the sweep oscillator and signal generator to channel 13.

Adjust L52 for maximum amplitude of the curve midway between markers and then overshoot the adjustment by turning the slug in the same direction from the initial setting a little more than the amount of turning required to reach maximum amplitude of response.

Adjust C22 for maximum amplitude of response.

Turn off the sweep generator. Adjust the L43 core for correct channel 13 oscillator frequency, then overshoot the adjustment by turning the slug a little more in the same direction from the initial setting. Reset the oscillator to proper frequency by adjustment of C1.

Turn the sweep oscillator back on.

Check the response of channels 7 through 13 by switching the receiver channel switch, sweep oscillator and marker oscillator to each of these channels and observing the response and oscillator injection obtained. See Figure 11 for typical response curves. It should be found that all these channels have the proper shaped response with the markers above 80% response.

If the markers do not fall within this requirement, switch to channel 8 and readjust C9, C11, C16 and C22 as necessary. If C22 required adjustment, the adjustment should be overshoot a small amount and corrected by adjustment of L52 to give maximum amplitude of response between the sound and picture carrier markers. The antenna circuit (L52, C22) is broad so that tracking is not particularly critical.

If the valley in the top of the selectivity curves for the high channels is deeper than normal, the curve can be flattened somewhat by decreasing the inductance of L44 by turning the core stud in. Be sure to check for undesirable resonant suck-outs on channels 7 and 8 if this is done.

Turn the sweep oscillator off and check the receiver channel 8 r-f oscillator frequency. If the oscillator is off frequency overshoot the adjustment of C1 and correct by adjusting L43.

Turn the receiver channel selector switch to channel 6. Adjust L5 for correct oscillator frequency.

Turn the sweep oscillator on and to channel 6 and observe the response curve. If necessary readjust L42, L45 and L49. It should not be necessary to touch C11.

Check the oscillator injection voltage at the test point TP1. If necessary adjust C7 to give -3 volts injection. If C7 is adjusted, switch to channel 8, and readjust C9 for proper curve shape, then recheck channel 6.

Switch the receiver through channel 6 down through channel 2 and check for normal response curve shapes and oscillator injection voltage.

Likewise check channels 7 through 13, stopping on 13 for the next step.

With the receiver on channel 13, check the receiver oscillator frequency. Correct by adjustment of C1 if necessary.

Adjust the oscillator to frequency on all channels by switching the receiver and the heterodyne frequency meter to each channel and adjusting the appropriate oscillator trimmer to obtain a beat on the freq. meter. It should be possible to adjust the oscillator to the correct frequency on all channels with the fine tuning control 30 degrees clockwise from the mechanical center of its range.

Channel Number	Picture Carrier Freq. Mc.	Sound Carrier Freq. Mc.	Receiver R-F Osc. Freq. Mc.	Channel Oscillator Adjustment
2	55.25	59.75	80.750	L1
3	61.25	65.75	86.750	L2
4	67.25	71.75	92.750	L3
5	77.25	81.75	102.750	L4
6	83.25	87.75	108.750	L5
7	175.25	179.75	200.750	L6
8	181.25	185.75	206.750	L7
9	187.25	191.75	212.750	L8
10	193.25	197.75	218.750	L9
11	199.25	203.75	224.750	L10
12	205.25	209.75	230.750	L11
13	211.25	215.75	236.750	C1

Switch to channel 8 and observe the response.

Adjust T1 clockwise while watching the change in response. When T1 is properly adjusted, the selectivity curve will be slightly wider with a slightly deeper valley in its top.

Switch through all channels and observe response, oscillator injection and r-f oscillator frequency. Minor touch-ups of adjustments may be made at this time. However, if C7 or C9 are changed appreciably, then a recheck of the oscillator frequency on all channels should be made.

Reconnect the link from T101 to terminal 2 of the r-f unit terminal board.

Since T1 was adjusted during the r-f unit alignment it will be necessary to sweep the overall i-f response.

R-F UNIT TUBE CHANGES.—Since most of the circuits are low capacitance circuits the r-f unit may require readjustments when the tubes are changed.

If the 6CB6 r-f amplifier tube is changed, it may be necessary to readjust C16 and C22.

If the 6J6 oscillator and mixer tube is changed, then more extensive adjustments are required.

For good conversion efficiency, the oscillator injection to a triode mixer must be held reasonably close to the optimum value. Although there is some latitude in this level, it is nearly expended in the normal variation in injection from channel to channel. Consequently, the adjustment of C7 is limited primarily to establishing the conditions for good conversion. Since changes in oscillator injection affect conversion gain, it also affects the input capacity of the mixer, thus also affecting tracking of the mixer grid circuit. These tube variations with their consequent effect on circuit alignment thereby require readjustment of the r-f unit if maximum conversion efficiency is to be retained after the 6J6 tube is changed. It may be possible, however, to try several 6J6 tubes and select one which gives satisfactory performance without realignment.

PICTURE I-F TRANSFORMER ADJUSTMENTS.—Connect the "VoltOhmyst" to the junction of R142 and R143.

Turn the AGC control fully clockwise.

Obtain a 7.5 volt battery capable of withstanding appreciable current drain and connect the ends of a 1,000 ohm potentiometer across it. Connect the battery positive terminal to chassis and the potentiometer arm to the junction R142 and R143. Adjust the potentiometer for -5.0 volts indication on the "VoltOhmyst".

Set the channel switch to channel number 9, 10 or 11.

Connect the "VoltOhmyst" to pin 4 of V110 (pin 2 if 6CL6 is used) and to ground.

Connect the output of the signal generator to the mixer grid test point TP2 in series with a 1500 mmf ceramic capacitor.

Connect a separate -5 volt bias supply to TP1 with the positive terminal to ground.

Set the generator to each of the following frequencies and with a thin fiber screwdriver tune the specified adjustment for maximum indication on the "VoltOhmyst". In each instance the generator should be checked against a crystal calibrator to insure that the generator is on frequency.

21T207, 21T207G, 21T208, 21T217,
21T218, 21T227, 21T228, 21T229

ALIGNMENT PROCEDURE

Adjust the signal generator output to give 3 volts on the "VoltOhmyst" as the final adjustment is made.

- (1) 24.25 mc.—T107
(2) 25.5 mc.—T106
- (3) 22.75 mc.—T105

PICTURE I-F TRAP ADJUSTMENT.—With the same connections as above, tune the generator to 27.00 mc. and adjust the T104 top core for minimum d-c on the "VoltOhmyst". Set the generator output so that this minimum is about 3 volts when final adjustment is made. If necessary, the i-f bias may be reduced in order to obtain the 3 volt reading on the "VoltOhmyst".

SWEEP ALIGNMENT OF PIX I-F.—To align T1 and T104, connect the sweep generator to the mixer grid test point TP2. In series with a 1500 mmf ceramic capacitor use the shortest leads possible, with not more than one inch of unshielded lead at the end of the sweep cable. Connect the sweep ground lead to the r-f unit outer shield.

Connect a separate -5.0 volt bias supply to TP1 with the positive terminal connected to ground and by-pass TP1 to ground with a 1500 mmf. ceramic capacitor.

Set the channel selector switch between channels 2 and 13.

Clip 330 ohm resistors across terminals A and B of T106 and T107.

Preset C115 to minimum capacity.

Adjust the bias box potentiometer to obtain -5.0 volts of bias as measured by a "VoltOhmyst" at the junction of R142 and R143. Leave the AGC control fully clockwise.

Connect a 180 ohm composition resistor from pin 5 of V106 to terminal A of T105. Connect the oscilloscope diode probe to pin 5 of V106 and to ground.

Couple the signal generator loosely to the diode probe in order to obtain markers.

Adjust T1 (top) and T104 (bottom) for maximum gain and with 25.5 mc. at 70% of maximum response.

Set the sweep output to give 0.3 volt peak-to-peak on the oscilloscope when making the final touch on the above adjustment.

Adjust C115 until 22.25 mc. is at 70% response with respect to the low frequency shoulder of the curve as shown in Figure 12.

Disconnect the diode probe, the 180 ohm and two 330 ohm resistors.

Connect the oscilloscope to pin 4 (pin 2 if 6CL6 is used) of V110 socket.

Leave the sweep generator connected to the mixer grid test point TP2 with the shortest leads possible.

Adjust the output of the sweep generator to obtain 3.0 volts peak-to-peak on the oscilloscope.

Couple the signal generator loosely to the grid of the first pix i-f amplifier. Adjust the output of the signal generator to produce small markers on the response curve.

Retouch T105, T106 and T107 to obtain the response shown in Figure 13.

It is especially important that the 22.4 mc. marker should fall at 55% on the overall i-f response curve. If the marker should fall appreciably higher than 55%, trouble may be experienced with sound in the picture. If the marker should fall appreciably below 55% response, the sound sensitivity may be reduced and may cause the sound to be noisy in weak signal areas.

RATIO DETECTOR ALIGNMENT.—Set the signal generator at 4.5 mc. and connect it to the first sound i-f grid, pin 1 of V101.

As an alternate source of signal, the RCA WR39B or WR39C calibrator may be employed. In such a case, connect the calibrator to the grid of the third pix i-f amplifier, pin 1 of V108.

Set the frequency of the calibrator to 25.50 mc. (pix carrier) and modulate with 4.5 mc. crystal. The 4.5 mc. signal will be picked off at L102 and amplified through the sound i-f amplifier.

Connect the "VoltOhmyst" to pin 2 of V103.

Tune the ratio detector primary, T102 top core for maximum d-c output on the "VoltOhmyst". Adjust the signal level from the signal generator for 6 volts on the "VoltOhmyst" when finally peaked. This is approximately the operating level of the ratio detector for average signals.

Connect the "VoltOhmyst" to the junction of R106 and C108.

Tune the ratio detector secondary T102 bottom core for zero d-c on the "VoltOhmyst".

Repeat adjustments of T102 top for maximum d-c at pin 2 of V103 and T102 bottom for zero d-c at the junction of R106 and C108. Make the final adjustments with the signal input level adjusted to produce 6 volts d-c on the "VoltOhmyst" at pin 2 of V103.

SOUND I-F ALIGNMENT.—Connect the signal generator to the first sound i-f amplifier grid, pin 1 of V101.

As an alternate source of signal, the RCA WR39B or WR39C calibrator may be employed as above.

Connect the "VoltOhmyst" to pin 2 of V103.

Tune the T101 top core for maximum d-c on the "VoltOhmyst".

The output from the signal generator should be set to produce approximately 6.0 volts on the "VoltOhmyst" when the final touches on the above adjustment are made.

4.5 MC. TRAP ADJUSTMENT.—Connect the signal generator in series with a 1,000 ohm resistor to pin 2 of V109. Set the generator to 4.5 mc. and modulate it 30% with 400 cycles. Set the output to approximately 0.5 volts.

Short the third pix i-f grid to ground, pin 1, V108, to prevent noise from masking the output indication.

Connect the crystal diode probe of an oscilloscope to the plate of the video amplifier, pin 8 (pin 6 if 6CL6 is used) of V110.

Adjust the core of L103 for minimum output on the oscilloscope.

Remove the short from pin 1, V108 to ground.

As an alternate method, this step may be omitted at this point in the alignment procedure and the adjustment made "on the air" after the alignment is completed.

If this is done, tune in a station and observe the picture on the kinescope. If no 4.5 mc. beat is present in the picture, when the fine tuning control is set for proper oscillator-frequency, then L103 requires no adjustment. If a 4.5 mc. beat is present, turn the fine tuning control slightly clockwise so as to exaggerate the beat and then adjust L103 for minimum beat.

CHECK OF OVERALL RESPONSE.—If desired, the overall response of the receiver can be checked on each channel.

Connect the r-f sweep generator to the receiver antenna input terminals. If necessary, employ one of the pads shown in Figure 9 to match the sweep output cable to the r-f unit.

Connect the signal generator loosely to the first pix i-f amplifier grid.

Adjust the bias potentiometer to obtain -5.0 volts of bias as measured by a "VoltOhmyst" at the junction of R142 and R143.

Connect the oscilloscope to pin 4 (pin 2 if 6CL6 is used) of V110.

Check the response of channels 2 through 13 by switching the receiver channel switch and sweep oscillator to each of these channels and observing the response obtained. On each channel, adjust the output of the sweep generator to obtain 3.0 volts peak-to-peak on the oscilloscope.

I-F markers at 22.4 mc., 24.75 mc. and 25.5 mc. should be provided by the signal generator.

The response obtained in this manner should be very similar to that shown in Figure 13.

Some curves may show a 10% sag in the top between 22.75 mc. and 24.75 mc. while others may show a 10% peak in this region. This may be considered normal.

If the picture carrier is consistently high or low on all channels, T106 may be adjusted slightly. Do not adjust T105.

AGC CONTROL ADJUSTMENT.—Disconnect all test equipment except the oscilloscope which should be connected to pin 8 (pin 6 if 6CL6 is used) of V110.

Connect an antenna to the receiver antenna terminals.

Turn the AGC control fully counter-clockwise.

Tune in a strong signal and adjust the oscilloscope to see the video waveform.

Turn the AGC control clockwise until the tips of sync begin to be compressed, then counter-clockwise until no compression is obtained.

ALIGNMENT PROCEDURE

21T207, 21T207G, 21T208, 21T217,
21T218, 21T227, 21T228, 21T229

HORIZONTAL OSCILLATOR ADJUSTMENT.—Normally the adjustment of the horizontal oscillator is not considered to be a part of the alignment procedure, but since the oscillator waveform adjustment may require the use of an oscilloscope, it can not be done conveniently in the field. The waveform adjustment is made at the factory and normally should not require readjustment in the field. However, the waveform adjustment should be checked whenever the receiver is aligned or whenever the horizontal oscillator operation is improper.

Horizontal Frequency Adjustment.—Tune in a station and sync the picture. If the picture cannot be synchronized with the horizontal hold control R170B, then adjust the T110 frequency core on the rear apron until the picture will synchronize. If the picture still will not sync, turn the T110 waveform adjustment core (under the chassis) out of the coil several turns from its original position and readjust the T110 frequency core until the picture is synchronized.

Examine the width and linearity of the picture. If picture width or linearity is incorrect, adjust the horizontal drive control C161B, the width control L106 and the linearity control L108 until the picture is correct.

Horizontal Oscillator Waveform Adjustment.—The horizontal oscillator waveform may be adjusted by either of two methods. The method outlined in paragraph A below may be employed in the field when an oscilloscope is not available. The service shop method outlined in paragraph B below requires the use of an oscilloscope.

A.—Turn the horizontal hold control completely clockwise. Place adjustment tools on both cores of T110 and be prepared to make simultaneous adjustments while watching the picture on the screen. First, turn the T110 frequency core (on the rear apron) until the picture falls out of sync and three or four diagonal black bars sloping down to the right appear on the screen. Then, turn the waveform adjustment core (under the chassis) into the coil while at the same time adjusting the frequency core so as to maintain three or four diagonal black bars on the screen. Continue this procedure until the oscillator begins to motorboat, then turn the waveform adjustment core out until the motorboating just stops. As a check, turn the T110 frequency core until the picture is synchronized then reverse the direction of rotation of the core until the picture falls out of sync with the diagonal bars sloping down to the right. Continue to turn the frequency core in the same direction! No more than three or four bars should appear on the screen. Instead, the horizontal oscillator should begin the motorboat. Retouch the adjustment of the T110 waveform adjustment core if necessary until this condition is obtained.

B.—Connect the low capacity probe of an oscilloscope to terminal C of T110. Turn the horizontal hold control one-quarter turn from the clockwise position so that the picture is in sync. The pattern on the oscilloscope should be as shown in Figure 14. Adjust the waveform adjustment core of T110 until the two peaks are at the same height. During this adjustment, the picture must be kept in sync by readjusting the hold control if necessary.

This adjustment is very important for correct operation of the circuit. If the broad peak of the wave on the oscilloscope is lower than the sharp peak, the noise immunity becomes poorer, the stabilizing effect of the tuned circuit is reduced and drift of the oscillator becomes more serious. On the other hand, if the broad peak is higher than the sharp peak, the oscillator is overstabilized, the pull-in range becomes inadequate and the broad peak can cause double triggering of the oscillator when the hold control approaches the clockwise position.

Remove the oscilloscope upon completion of this adjustment.

Horizontal Locking Range Adjustment.—Set the horizontal hold control to the full counter-clockwise position. Momentarily remove the signal by switching off channel then back. The picture may remain in sync. If so turn the T110 frequency core slightly and momentarily switch off channel.

Repeat until the picture falls out of sync with the diagonal lines sloping down to the left. Slowly turn the horizontal hold control clockwise and note the least number of diagonal bars obtained just before the picture pulls into sync.

If more than 3 bars are present just before the picture pulls into sync, adjust the horizontal locking range trimmer C161A slightly clockwise. If less than 2 bars are present, adjust C161A slightly counter-clockwise. Turn the horizontal hold control counter-clockwise, momentarily remove the signal and recheck the number of bars present at the pull-in point. Repeat this procedure until 2 or 3 bars are present.

Turn the horizontal hold control to the maximum clockwise position. Adjust the T110 frequency core so that the diagonal bar sloping down to the right appears on the screen and then reverse the direction of adjustment so that bar just moves to the left side of the screen leaving the picture in synchronization.

SENSITIVITY CHECK.—A comparative sensitivity check can be made by operating the receiver on a weak signal from a television station and comparing the picture and sound obtained to that obtained on other receivers under the same conditions.

This weak signal can be obtained by connecting the shop antenna to the receiver through a ladder type attenuator pad. The number of stages in the pad depends upon the signal strength available at the antenna. A sufficient number of stages should be inserted so that a somewhat less than normal contrast picture is obtained when the picture control is at the maximum clockwise position. Only carbon type resistors should be used to construct the pad.

RESPONSE CURVES.—The response curves shown on page 14 and referred to throughout the alignment procedure were taken from a production set. Although these curves are typical, some variations can be expected.

The response curves are shown in the classical manner of presentation, that is with "response up" and low frequency to the left. The manner in which they will be seen in a given test set-up will depend upon the characteristics of the oscilloscope and the sweep generator. The curves may be seen inverted and/or switched from left to right depending on the deflection polarity of the oscilloscope and the phasing of the sweep generator.

NOTE ON R-F UNIT ALIGNMENT.—Because of the frequency spectrum involved and the nature of the device, many of the r-f unit leads and components are critical in some respects. Even the power supply leads form loops which couple to the tuned circuits, and if resonant at any of the frequencies involved in the performance of the tuner, may cause serious departures from the desired characteristics. In the design of the receiver these undesirable resonant loops have been shifted far enough away in frequency to allow reasonable latitude in their components and physical arrangement without being troublesome. When the r-f unit is aligned in the receiver, no trouble from resonant loops should be experienced. However, if the unit is aligned in a jig separate from the receiver, attention should be paid to insure that unwanted resonances do not exist which might present a faulty representation of r-f unit alignment.

A resonant circuit exists between the r-f tuner chassis and the outer shield box, which couples into the antenna and r-f plate circuits. The frequency of this resonance depends on the physical structure of the shield box, and the capacitance between the tuner chassis and the front plate. In the KRK8 units, this resonance should fall between 120 and 135 mc. and is controlled in the design by using insulating washers of different thicknesses (in the front plate to tuner chassis mounting) to compensate for differences in the shield boxes of different models of receivers. The performance of the tuner, particularly on channels 7 and 8 will be impaired if the proper washers for the particular shield box involved are not used. Obviously then, if the r-f unit is removed for service, the washers should be replaced in the correct order when the unit is replaced.

21T207, 21T207G, 21T208, 21T217,
21T218, 21T227, 21T228, 21T229

ALIGNMENT TABLE

THE DETAILED ALIGNMENT PROCEDURE BEGINNING ON PAGE 8 SHOULD BE READ BEFORE ALIGNMENT BY USE OF THE TABLE IS ATTEMPTED

STEP No.	CONNECT SIGNAL GENERATOR TO	SIGNAL GEN. FREQ. MC.	CONNECT SWEEP GENERATOR TO	SWEEP GEN. FREQ. MC.	CONNECT HETERODYNE FREQ. METER TO	HET. METER FREQ. MC.	CONNECT "VOLTOHMYST" TO	MISCELLANEOUS CONNECTIONS AND INSTRUCTIONS	ADJUST	REFER TO
R-F UNIT ALIGNMENT										
1	Disconnect the co-ax link from terminal 2 of the r-f unit terminal board and connect a 39 ohm composition resistor between lugs 1 and 2. Detune T1 by backing the core all the way out of the coil. Back the L44 core all the way out. Back the L203 core all the way out. In order to align the r-f tuner, it will first be necessary to set the channel 13 oscillator to frequency. The shield over the bottom of the r-f unit must be in place when making any adjustments.									
2	Not used		Not used		Loosely coupled to r-f oscillator	236.75 MC.	Not used	Fine tuning 30 degrees clockwise from mechanical center of its range. Receiver on channel 13.	C1 for an audible beat on het. freq. meter	Fig. 7
3	"		"				Connect "Volt-Ohmyst" to terminal 3 of the r-f unit terminal board	Turn AGC control fully clockwise. Connect bias box to terminal 3 of r-f unit term. board	Adjust the bias box potentiometer for -3.5 volts.	
4	Antenna terminal (loosely)	181.25 185.75	Antenna terminals (see text for precaution)	Sweeping channel 8	Not used	—	Not used	Rec. on chan. 8. Connect oscilloscope to TP1. Adjust C9, C11, C16 and C22 for correct curve shape, frequency and band width. C22 is adjusted to give max. amplitude between markers. C9 affects tilt and C16 affects the frequency of response. C11 affects the response band width.		Fig. 7 Fig. 8
5	Not used		Not used	Not used	Loosely coupled to r-f oscillator	108.75	"	Rec. on channel 6	L5 for audible beat on het. freq. meter.	Fig. 8
6	Antenna terminal (loosely)	83.25 87.75	Antenna terminals (see text for precaution)	Channel 6	Not used	—	"	Rec. on chan. 6. Adjust L42, L45 and L49 for proper response. L42 is adjusted to give max. amplitude between markers. L45 primarily affects tilt and L49 primarily affects freq. of response. If necessary, retouch C11 for proper width.		Fig. 12
7	Not used	—	Not used	—	Not used	—	Connect "Volt-Ohmyst" to r-f unit test point TP1	Rec. on channel 6	Adjust C7 for -3.0 volts at the test point	Fig. 7 Fig. 9
8	Repeat above steps until the specified conditions are obtained.									
9	Not used		Not used	—	Loosely coupled to r-f oscillator	206.75		Rec. on chan. 8	C1 for audible beat on het. freq. meter	Fig. 7
10	Antenna terminal (loosely)	181.25 185.75	Antenna terminals (see text for precaution)	Sweeping channel 8	Not used	—	Not used	Rec. on chan. 8. Readjust C9, C16 and C22 for correct curve shape, frequency and band width. Readjust C11 only if necessary.		Fig. 7 Fig. 12 (8)
11	"	211.25 215.75	"	Sweeping channel 13	Not used	—	Not used	Rec. on chan. 13. Adjust L52 for max. amplitude between markers, overshoot a little more than required to reach max. response. Adjust C22 to regain max. amplitude of response.		Fig. 7 Fig. 12 (13)
12	"	215.75	Not used	—	Loosely coupled to r-f oscillator	236.75		Receiver on chan. 13. Adjust L43 for correct channel 13 osc. freq. then overshoot. Reset the osc. to proper freq. by adjustment of C1.		Fig. 7 Fig. 8
13	"	205.25 209.75	Antenna terminals (see text for precaution)	channel 12	Not used	—	Connect "Volt-Ohmyst" to r-f unit test point TP1	Rec. on chan. 12	Check to see that response is correct and -3.0 volts of osc. injection is present	Fig. 8 Fig. 12
14	"	199.25 203.75	"	channel 11	"	—	"	Rec. on chan. 11	"	Fig. 12 (11)
15	"	193.25 197.75	"	channel 10	"	—	"	Rec. on chan. 10	"	Fig. 12 (10)
16	"	187.25 191.75	"	channel 9	"	—	"	Rec. on chan. 9	"	Fig. 12 (9)
17	"	181.25 185.75	"	channel 8	"	—	"	Rec. on chan. 8	"	Fig. 12 (8)
18	"	175.25 179.75	"	channel 7	"	—	"	Rec. on chan. 7	"	Fig. 12 (7)
19	If the response of any channel (steps 13 through 18) is below 80% at either marker, repeat step 10 and adjust C9, C11, C16 and C22 as necessary to pull response up on the low channel yet maintain correct response on channel 8. If C22 required adjustment, the adjustment should be overshoot a small amount and corrected by adjustment of L52 to give maximum amplitude of response between the sound and picture carrier markers.									
20	Repeat step 9. If the oscillator is off frequency overshoot the adjustment of C1 and correct by adjusting L43.									
21	Repeat steps 13 through 20 until all requirements are obtained.									
22	Not used	—	Not used	—	Loosely coupled to r-f oscillator	108.75		Rec. on chan. 6	L5 for zero beat on het. freq. meter	Fig. 8
23	Antenna terminals (loosely)	83.25 87.75	Ant. terminals (see text for precaution)	Sweeping channel 6	Not used	—	Not used	Observe response. If necessary readjust L42, L45 and L49. It should not be necessary to touch C11.		Fig. 7 Fig. 12
24	Not used	—	Not used	—	Not used	—	Connect "Volt-Ohmyst" to the r-f unit test point TP1	Check osc. injection. If necessary adjust C7 to give -3 volts. If C7 is adjusted, switch to channel 8, and readjust C9 for proper response then repeat step 23.		Fig. 7 Fig. 12
25	Antenna terminals (loosely)	77.25 81.75	Ant. terminals (see text for precaution)	channel 5	"	—	"	Rec. on chan. 5	Check to see that response is correct and -3.0 volts of osc. injection is present	Fig. 12 (5)

21T207, 21T207G, 21T208, 21T217,
21T218, 21T227, 21T228, 21T229 TOP AND BOTTOM CHASSIS ADJUSTMENTS

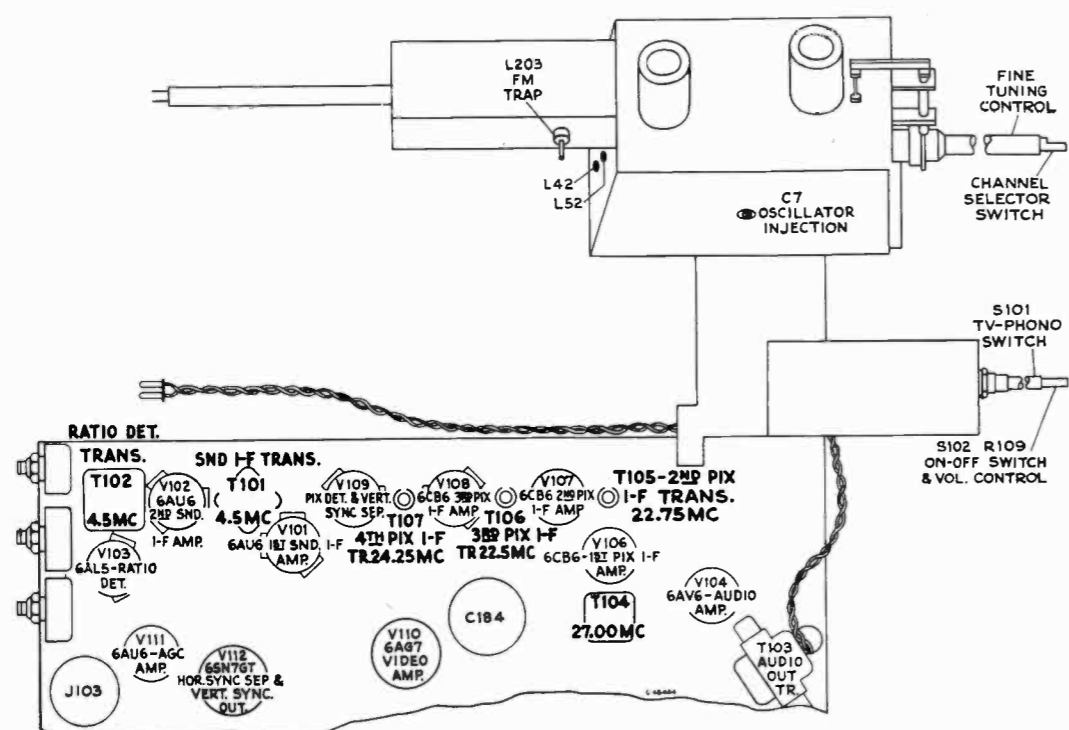

Figure 15—Top Chassis Adjustments

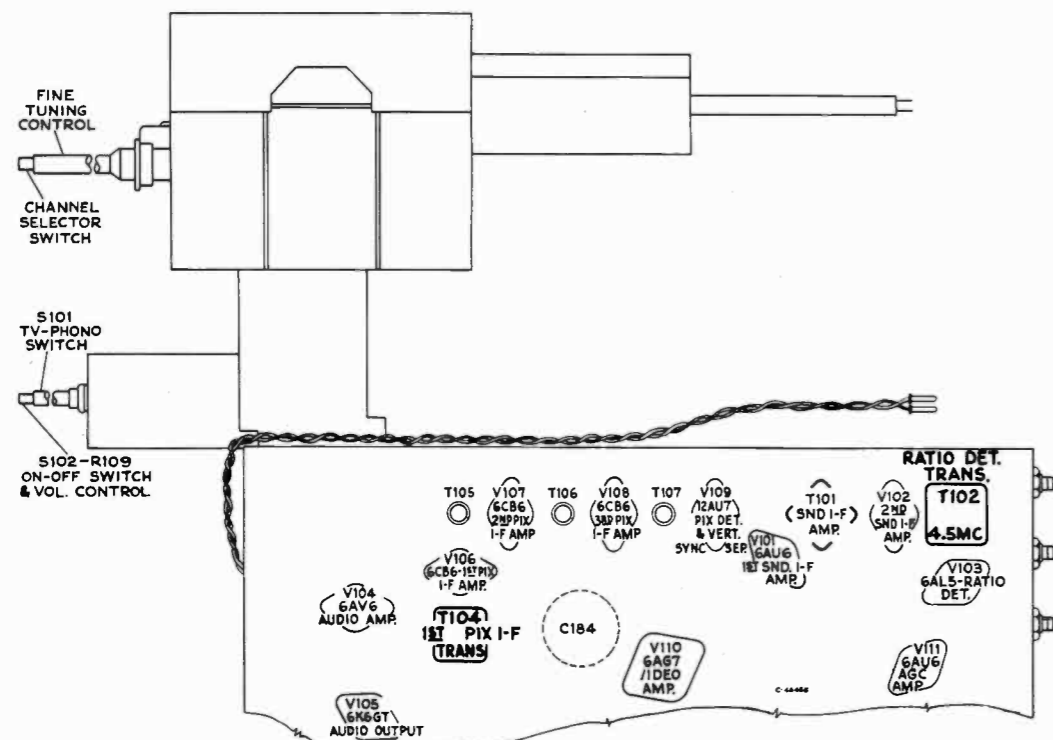

Figure 16—Bottom Chassis Adjustments

21T207, 21T207G, 21T208, 21T217,
21T218, 21T227, 21T228, 21T229 TEST PATTERN PHOTOGRAPHS

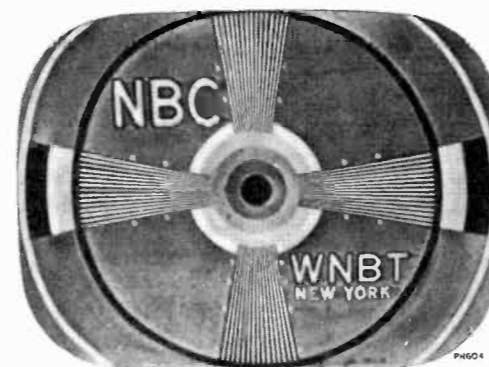

Figure 17—Normal Picture

Figure 18—Focus Magnet and Ion Trap Magnet Misadjusted

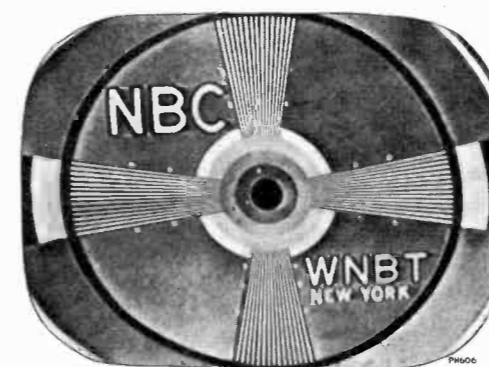
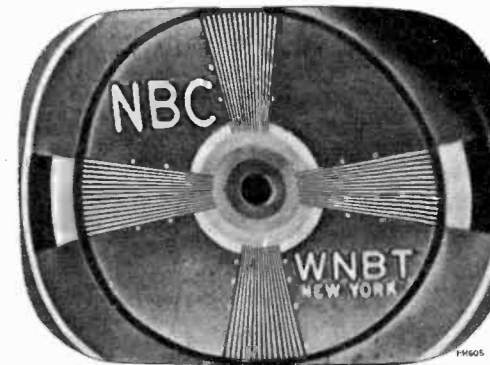

Figure 19—Horizontal Linearity Control Misadjusted (Picture Cramped in Middle)

Figure 20—Width Control Misadjusted

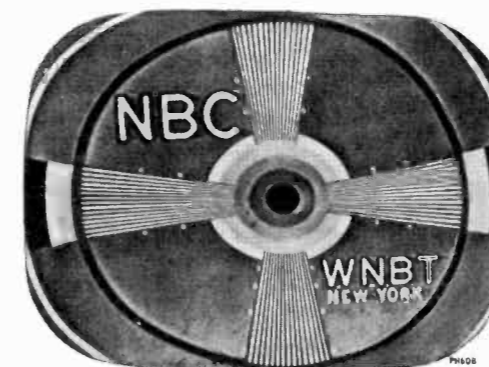
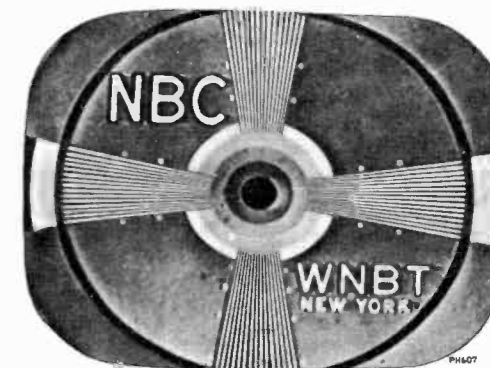

Figure 21—Horizontal Drive Control Misadjusted

Figure 22—Transients

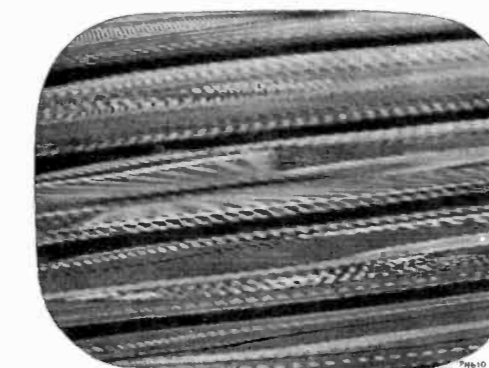
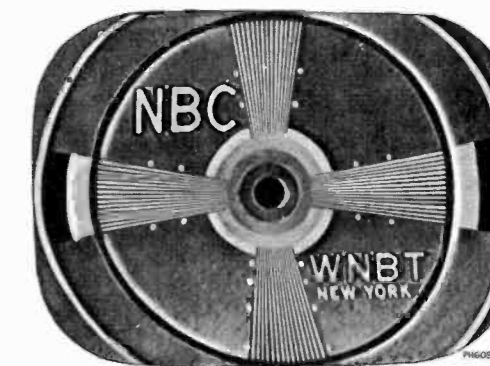
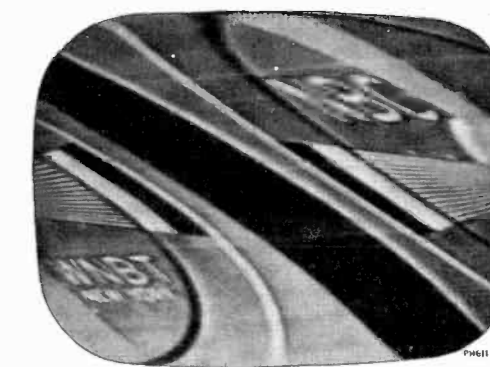

Figure 23—Test Pattern Showing Out of Sync Condition When Horizontal Hold Control Is in a Counter-clockwise Position—Just Before Pulling Into Sync

Figure 24—Test Pattern Showing Out of Sync Condition When Horizontal Hold Control Is at the Maximum Clockwise Position



ALIGNMENT TABLE

21T207, 21T207G, 21T208, 21T217, 21T218, 21T227, 21T228, 21T229

STEP No.	CONNECT SIGNAL GENERATOR TO	SIGNAL GEN. FREQ. MC.	CONNECT SWEEP GENERATOR TO	SWEEP GEN. FREQ. MC.	CONNECT HETERODYNE FREQ. METER	HET. FREQ. METER MC.	CONNECT "VOLTOHMYST" TO	MISCELLANEOUS CONNECTIONS AND INSTRUCTIONS	ADJUST	REFER TO
26	Antenna terminals (loosely)	67.25 71.75	Ant. terminals (see text for precaution)	channel 4	Not used	—	Connect "Volt-Ohmyst" to the r-f unit test point TP1	Rec. on chan. 4	Check to see that response is correct and -3.0 volts of osc. injection is present	Fig. 12 (4)
27	"	61.25 65.75	"	channel 3	"	—	"	Rec. on chan. 3	"	Fig. 12 (3)
28	"	55.25 59.75	"	channel 2	"	—	"	Rec. on chan. 2	"	Fig. 12 (2)
29	Likewise check channels 7 through 13, as outlined in steps 18 back through 13, stopping on channel 13 for next step.									
30	Antenna terminals	215.75	Not used	—	Loosely coupled to r-f oscillator	236.75	Not used	Fine tuning 30 degrees clockwise from mechanical center of its range. Receiver on channel 13	C1 for zero beat on het. freq. meter	Fig. 7
31	"	209.75	"	—	"	230.75	"	Rec. on chan. 12	L11 as above	Fig. 8
32	"	203.75	"	—	"	224.75	"	Rec. on chan. 11	L10 as above	Fig. 8
33	"	197.75	"	—	"	218.75	"	Rec. on chan. 10	L9 as above	Fig. 8
34	"	191.75	"	—	"	212.75	"	Rec. on chan. 9	L8 as above	Fig. 8
35	"	185.75	"	—	"	206.75	"	Rec. on chan. 8	L7 as above	Fig. 8
36	"	179.75	"	—	"	200.75	"	Rec. on chan. 7	L6 as above	Fig. 8
37	"	87.75	"	—	"	108.75	"	Rec. on chan. 6	L5 as above	Fig. 8
38	"	81.75	"	—	"	102.75	"	Rec. on chan. 5	L4 as above	Fig. 8
39	"	71.75	"	—	"	92.75	"	Rec. on chan. 4	L3 as above	Fig. 8
40	"	65.75	"	—	"	86.75	"	Rec. on chan. 3	L2 as above	Fig. 8
41	"	59.75	"	—	"	80.75	"	Rec. on chan. 2	L1 as above	Fig. 8
42	Repeat steps 30 through 41 as a check.									
43	Antenna terminals	181.25 185.75	Antenna terminals	Sweeping channel 8	Not used	—	—	Rec. on chan. 8. Oscilloscope at test point TP1. Adjust T1 clockwise. When properly adjusted, curve will be slightly wider with a slightly deeper valley in top.	—	Fig. 12 (8)
44	Switch through all channels and observe response, oscillator injection and r-f oscillator frequency. Minor touch-ups of adjustments may be made at this time. However, if C7 or C9 are changed appreciably, then a recheck of the oscillator frequency on all channels should be made.									
45	Remove 39 ohm resistor and reconnect link from T101 to terminal 2 of r-f unit terminal board.									

PICTURE I-F AND TRAP ADJUSTMENT

STEP No.	CONNECT SIGNAL GENERATOR TO	SIGNAL GEN. FREQ. MC.	CONNECT SWEEP GENERATOR TO	SWEEP GEN. FREQ. MC.	CONNECT OSCILLOSCOPE TO	CONNECT "VOLTOHMYST" TO	MISCELLANEOUS CONNECTIONS AND INSTRUCTIONS	ADJUST	REFER TO
46	Not used	—	Not used	—	Not used	Junction of R142 & R143	Connect bias box to junction of R142 & R143 and to ground AGC fully clockwise	Adjust potentiometer for -5.0 volts on meter	Fig. 3
47	"	—	"	—	"	Test point TP1	Connect bias box to TP1 and to ground	"	Fig. 7
48	Mixer grid test point TP2 in series with 1500 mmf.	24.25	"	—	"	Pin 4 of V110 and to ground	Bias boxes connected as above	T107 (top) for max.	Fig. 9
49	"	25.5	"	—	"	"	"	T106 (top) for max.	Fig. 9
50	"	22.75	"	—	"	"	"	T105 (top) for max.	Fig. 9
51	"	27.00	"	—	"	"	"	T104 (top) for min.	Fig. 9
52	Connected loosely to diode probe	Various See Fig. 13	Mixer grid test point TP2 in series with 1500 mmf.	20 to 28 mc	Scope diode probe to pin 5 of V106 and to gnd. Connect a 180 ohm resistor from pin 5 of V106 to pin A of T105	Junction of R142 & R143	Shunt terminals A and B of T106 and T107 with 330 ohms. Bias boxes connected as above. .3v p-p on scope	Set C115 to min. Adjust T1 top and T104 bot. for max. gain with 25.5 mc. at 70%. C115 for 22.5 at 70%	Fig. 7 Fig. 10
53	Connected loosely to grid of 1st pix i-f. Adjust for small marker indication.	Various See Fig. 14	"	"	Connect scope to pin 4 of V110. Remove shunt & diode probe used above	"	Remove shunts from T106 & T107	Retouch T105, T106 and T107 to obtain response shown in Fig. 14	Fig. 14

RATIO DETECTOR, SOUND I-F AND 4.5 MC TRAP ALIGNMENT

54	Grid 1st Snd. I-F (pin 1, V101) or WR39B or C connect to grid 3rd pix I-F (pin 1, V108)	25.50mc. mod. by 4.5 mc.	Not used	—	Not used	Pin 2 of V103	Set signal gen. to give 6V on meter	T102 top core for max. d-c on meter	Fig. 9
55	"	"	"	—	"	"	"VoltOhmyst" to junction R106 and C108. Adjust T102 bottom core for zero DC on meter. Repeat steps 54 and 55 until all conditions are satisfied.	Fig. 9 Fig. 10	
56	Sig. Gen. to 1st Snd. I-F grid	4.5 mc.	"	—	"	"	Signal generator output adjusted to provide 6 v on meter	T101 top core for max. DC on meter	Fig. 9
57	Sig. Gen. in series with 1000 ohms to pin 2 of V109	4.5 mc. mod. 30% with 400 cy.	"	—	Diode probe to pin 8 of V110	Not used	Short pin 1 of V108 to ground	Adjust L103 for minimum output on oscilloscope	Fig. 9

ALIGNMENT DATA

21T207, 21T207G, 21T208, 21T217, 21T218, 21T227, 21T228, 21T229

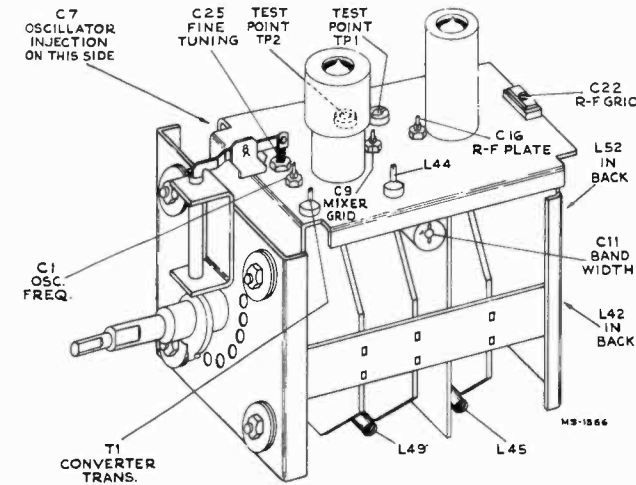

Figure 7—R-F Unit Adjustments

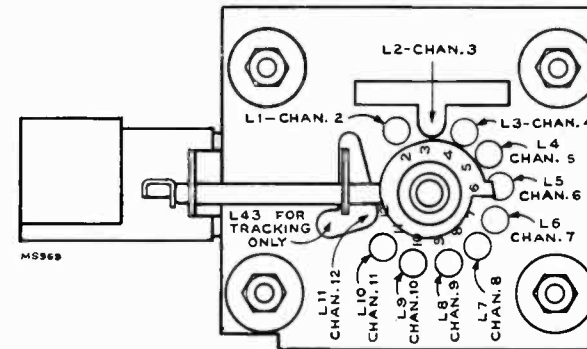

Figure 8—R-F Oscillator Adjustments

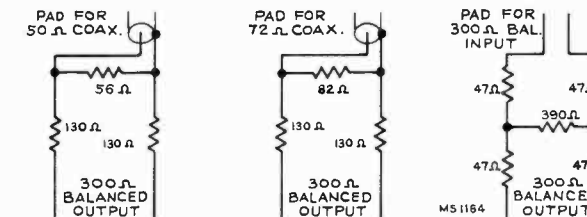

Figure 9—Sweep Attenuator Pads

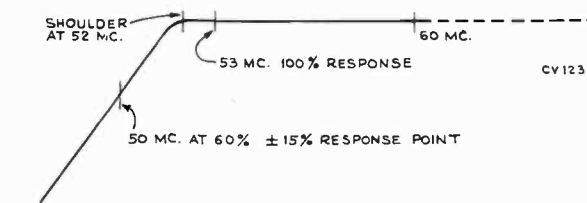

Figure 10—Antenna Matching Unit Response

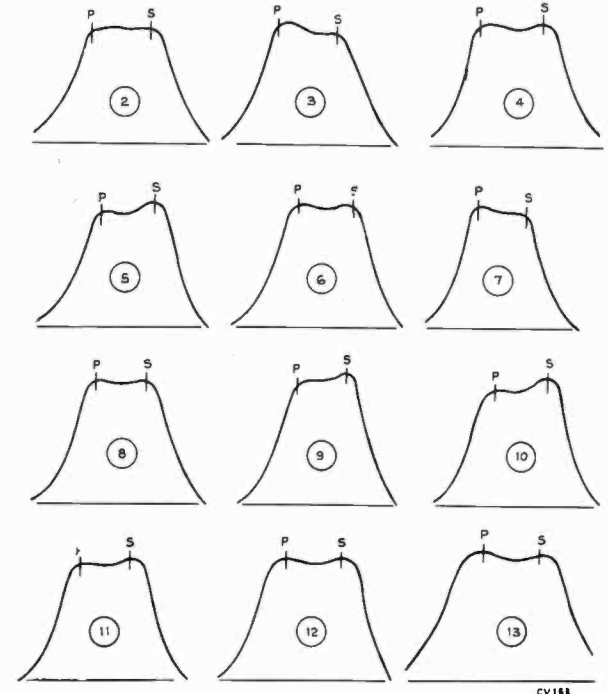

Figure 11—R-F Response

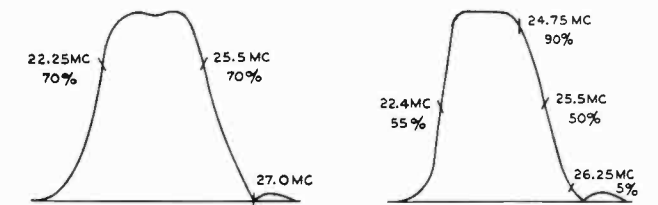

Figure 12
T1 and T104
Response

Figure 13
Over-all I-F
Response

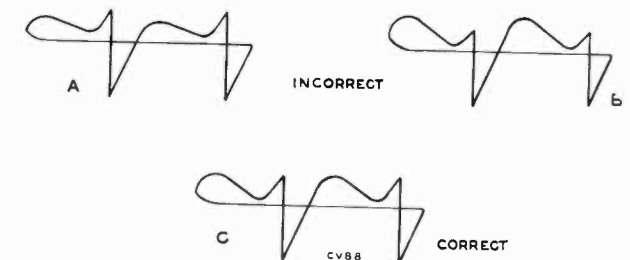

Figure 14—Horizontal Oscillator Wave Forms

SERVICE SUGGESTIONS

21T207, 21T207G, 21T208, 21T217,
21T218, 21T227, 21T228, 21T229

Following is a list of symptoms of possible failures and an indication of some of the possible faults:

NO RASTER ON KINESCOPE:

- (1) Incorrect adjustment of ion trap magnet. Magnet reversed either front to back or top to bottom.
- (2) V115 or V116 inoperative. Check waveforms on grids and plates.
- (3) No high voltage—if horizontal deflection is operating as evidenced by the correct waveform on terminal 1 of high voltage transformer, the trouble can be isolated to the 1B3GT circuit. Either the T111 high voltage winding is open, the 1B3GT tube is defective or its filament circuit is open.
- (4) V110 circuit, inoperative—Refer to schematic and waveform chart.
- (5) Damper tube (V118) inoperative.
- (6) Defective kinescope.
- (7) R184 open.
- (8) No receiver plate voltage—filter capacitor shorted—or filter choke open.

NO VERTICAL DEFLECTION:

- (1) V113 or V114 inoperative. Check voltage and waveforms on grids and plates.
- (2) T108 open.
- (3) Vertical deflection coils open.

SMALL RASTER:

- (1) Low Plus B or low line voltage.
- (2) V116, V120 or V121 defective.

POOR VERTICAL LINEARITY:

- (1) If adjustments cannot correct, change V114.
- (2) Vertical output transformer T108 defective.
- (3) V113 defective—check voltage and waveforms on grid and plate.
- (4) C151, C153, C152, C155, or C156 defective.
- (5) Low plate voltage—check rectifiers and capacitors in supply circuits.
- (6) If height is insufficient, try changing V113.

POOR HORIZONTAL LINEARITY:

- (1) If adjustments do not correct, change V116, or V118.
- (2) T108 or L108 defective.
- (3) C176 or C177 defective.

WRINKLES ON SIDE OF RASTER:

- (1) C181 defective.
- (2) Defective yoke.

PICTURE OUT OF SYNC HORIZONTALLY:

- (1) T110 incorrectly tuned.
- (2) R192, R193 or R170B defective.

TRAPEZOIDAL OR NON SYMMETRICAL RASTER:

- (1) Improper adjustment of centering of focus magnet or ion trap magnet.
- (2) Defective yoke.

RASTER AND SIGNAL ON KINESCOPE BUT NO SOUND:

- (1) L102 defective.
- (2) Sound i-f, ratio detector or audio amplifier inoperative—check V101, V102, V103 and their socket voltages.
- (3) Audio system defective.
- (4) Speaker defective.

SIGNAL AT KINESCOPE GRID BUT NO SYNC:

- (1) AGC control R149 misadjusted.
- (2) V111, inoperative. Check voltage and waveforms at its grid and plate.

SIGNAL ON KINESCOPE GRID BUT NO VERTICAL SYNC:

- (1) Check V113 and associated circuit.
- (2) Integrating network inoperative—Check.
- (3) V109B or V112B defective or associated circuit defective.
- (4) Gas current grid emission or grid cathode leakage in V112. Replace.

SIGNAL ON KINESCOPE GRID BUT NO HORIZONTAL SYNC:

- (1) T110 misadjusted—readjust as instructed on page 11.
- (2) V112 inoperative—check socket voltages and waveforms.
- (3) T110 defective.
- (4) C142, C161A, C163, C165, C167, C166, C168, C187 or C188 defective.
- (5) If horizontal speed is completely off and cannot be adjusted check R192, R193, R170B, R196, R195 and R198.

SOUND AND RASTER BUT NO PICTURE OR SYNC:

- (1) Picture, detector or video amplifier defective—check V109A and V110—check socket voltages.
- (2) Bad contact to kinescope cathode.

PICTURE STABLE BUT POOR RESOLUTION:

- (1) V109A or V110 defective.
- (2) Peaking coils defective—check resistance.
- (3) Make sure that the focus control operates on both sides of proper focus.
- (4) R-F and I-F circuits misaligned.

PICTURE SMEAR.

- (1) R-F or I-F circuits misaligned.
- (2) Open peaking coil.
- (3) This trouble can originate at the transmitter—check on another station.

PICTURE JITTER:

- (1) AGC control R149 misadjusted.
- (2) If regular sections at the left picture are displaced change V116.
- (3) Vertical instability may be due to loose connections or noise.
- (4) Horizontal instability may be due to unstable transmitted sync.

RASTER BUT NO SOUND, PICTURE OR SYNC:

- (1) Defective antenna or transmission line.
- (2) R-F oscillator off frequency.
- (3) R-F unit inoperative—check V1, V2.

DARK VERTICAL LINE ON LEFT OF PICTURE:

- (1) Reduce horizontal drive and readjust width and horizontal linearity.
- (2) Replace V116.

LIGHT VERTICAL LINE ON LEFT OF PICTURE:

- (1) V118 defective.

21T207, 21T207G, 21T208, 21T217,
21T218, 21T227, 21T228, 21T229

WAVEFORM PHOTOGRAPHS

Taken from RCA WO58A Oscilloscope

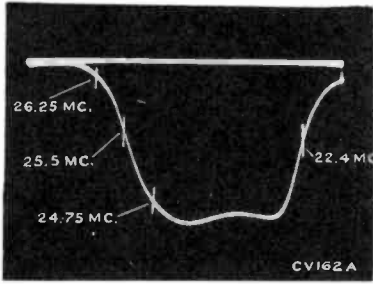

Figure 25—Overall Pix I-F Response



Figure 26—Response of T1-T104 Pix I-F Transformers

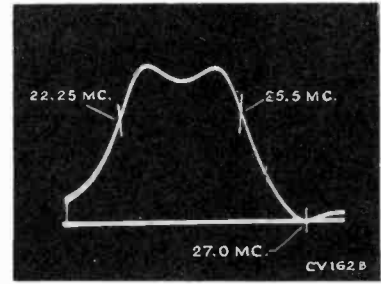

Figure 27—Response of T105 Pix I-F Transformer



Figure 28—Response of T106 Pix I-F Transformer

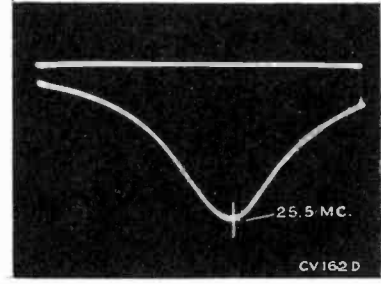
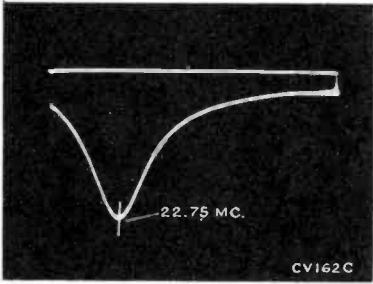
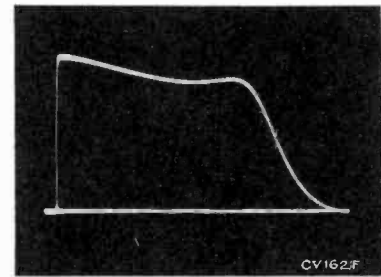
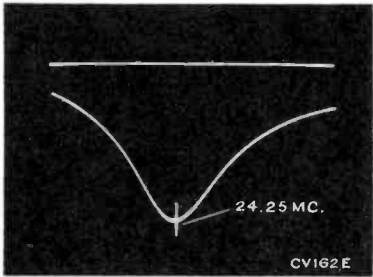

Figure 29—Response of T107 Pix I-F Transformer



Figure 30—Video Response at Average Contrast



Grid of Video Amplifier (Pin 2 of V110) (6CL6)
Voltage Depends on Picture

Figure 31—Vertical (Oscilloscope Synced to 1/2 of Vertical Sweep Rate) (1.5 Volts PP)



Figure 32—Horizontal (Oscilloscope Synced to 1/2 of Horizontal Sweep Rate) (1.5 Volts PP)

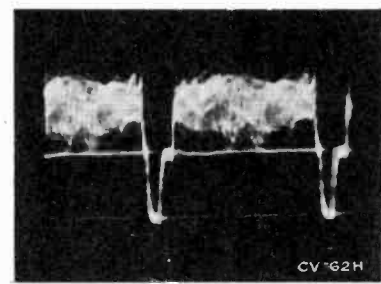
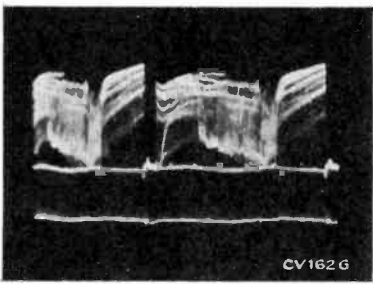
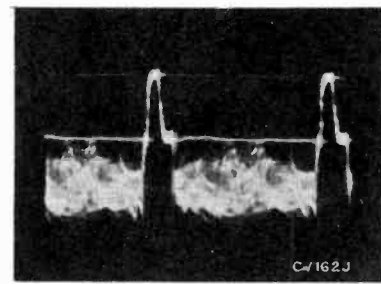
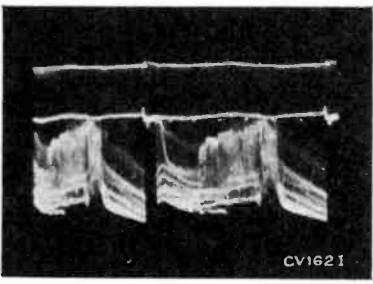

Plate of Video Amplifier (Pin 6 of V110) (6CL6)
Voltage depends on picture

Figure 33—Vertical (85 Volts PP)



Figure 34—Horizontal (85 Volts PP)



WAVEFORM PHOTOGRAPHS

Taken from RCA WO58A Oscilloscope

21T207, 21T207G, 21T208, 21T217,
21T218, 21T227, 21T228, 21T229

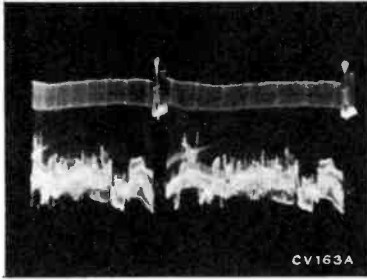

*Grid of Horizontal Sync Separator
(Pin 1 of V112A) (6SN7)
Voltage depends on picture*

Figure 35—Vertical (85 Volts PP)



Figure 36—Horizontal (85 Volts PP)

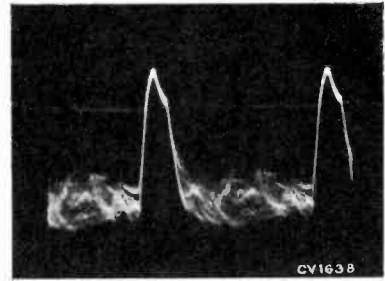

*Cathode of Horizontal Sync Sep.
(Pin 3 of V112A) (6SN7)*

Figure 37—Vertical (7.5 Volts PP)



Figure 38—Horizontal (5 Volts PP)

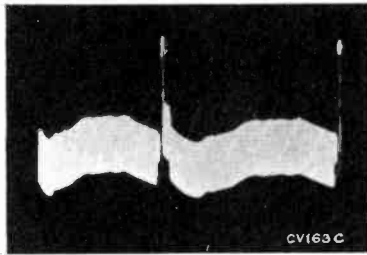
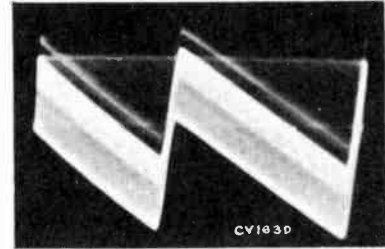
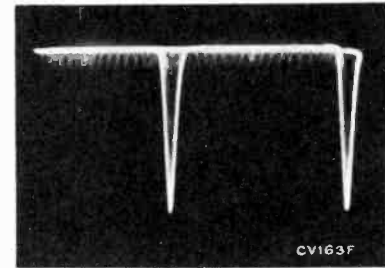

*Plate of Horizontal Sync Separator
(Pin 2 of V112A) (6SN7)*

Figure 39—Vertical (45 Volts PP)



Figure 40—Horizontal (45 Volts PP)



*Grid of Vertical Sync Sep.
(Pin 7 of V109B) (12AU7)*

Figure 41—Vertical (55 Volts PP)



Figure 42—Horizontal (55 Volts PP)

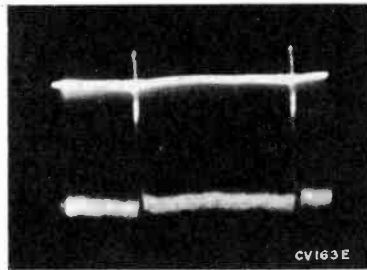
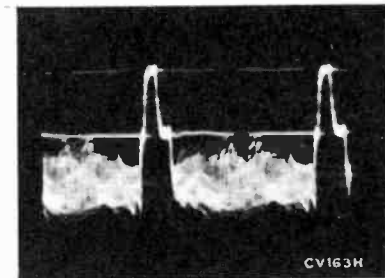
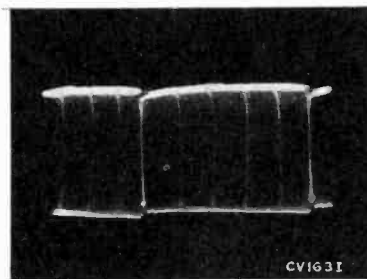
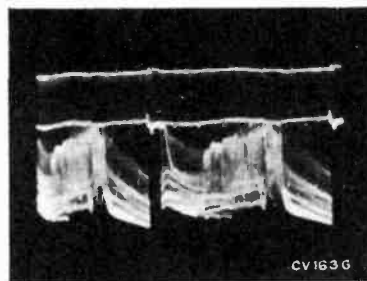
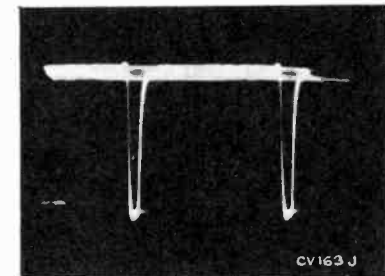

*Plate of Vertical Sync Sep.
(Pin 6 of V109B) (12AU7)*

Figure 43—Vertical (65 Volts PP)



Figure 44—Horizontal (65 Volts PP)



21T207, 21T207G, 21T208, 21T217,
21T218, 21T227, 21T228, 21T229

WAVEFORM PHOTOGRAPHS

Taken from RCA WO58A Oscilloscope

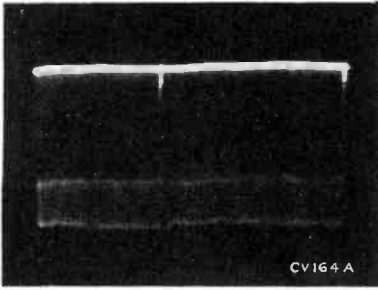

Grid of Sync Output
(Pin 4 V112B) (6SN7)

Figure 45—Vertical (40 Volts PP)



Figure 46—Horizontal (40 Volts PP)

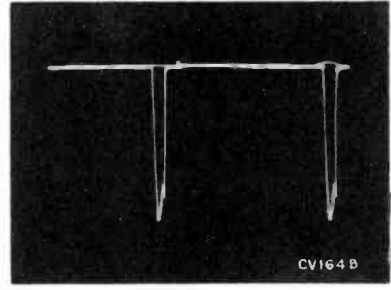

Plate of Sync Output
(Pin 5 of V112) (6SN7)

Figure 47—Vertical (47 Volts PP)



Figure 48—Horizontal (47 Volts PP)

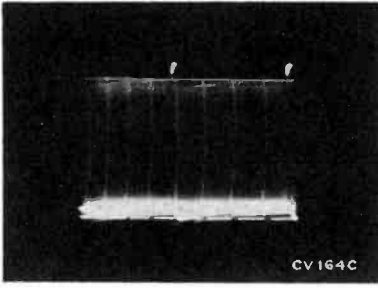
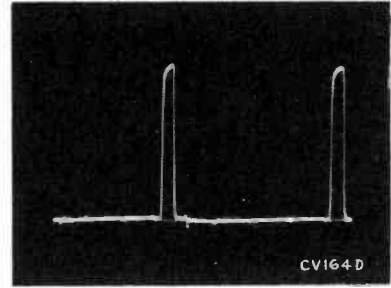

Figure 49—Grid of Vertical
Sweep Osc. (Pin 5 of V113) (6J5)
(30 Volts PP)



Figure 50—Plate of Vertical
Sweep Osc. (Pin 3 of V113)
(100 Volts PP)

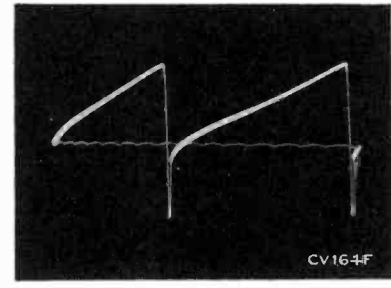
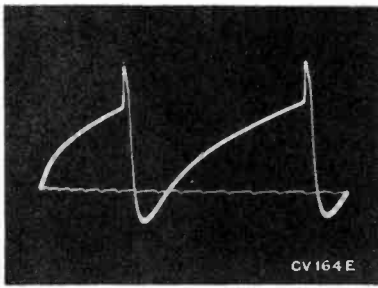
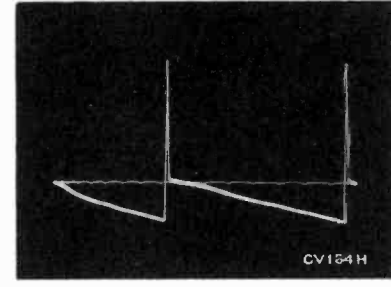
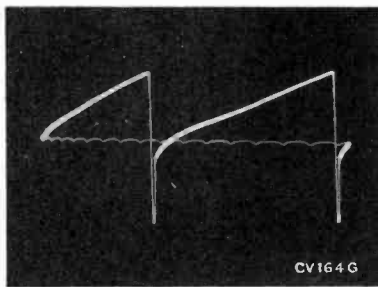

Figure 51—Grid of Vertical
Sweep Output (Pin 5 of V114) (6K6)
(100 Volts PP)



Figure 52—Plate of Vertical
Sweep Output (Pin 3 of V114) (6K6)
(715 Volts PP)



Cathode of Kinescope
(Pin 11 of V119) (17QP4)
Voltage depends on picture

Figure 53—Vertical



Figure 54—Horizontal

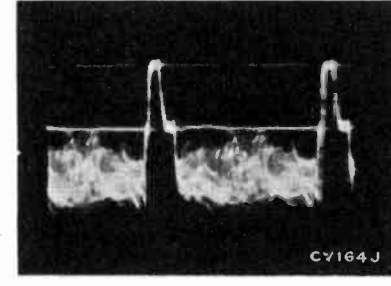
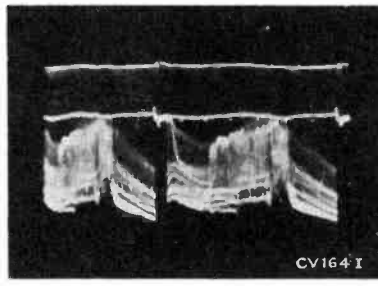

WAVEFORM PHOTOGRAPHS

Taken from RCA WO58A Oscilloscope

21T207, 21T207G, 21T208, 21T217,
21T218, 21T227, 21T228, 21T229

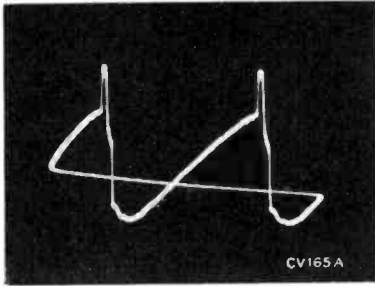

Figure 55—Grid of Horizontal Oscillator Control (Pin 1 of V115) (6SN7GT) (19 Volts PP)



Figure 56—Cathode of Horizontal Oscillator Control (Pin 3 of V115) (6SN7GT) (1.2 Volts PP)

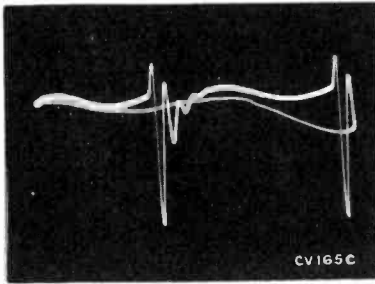
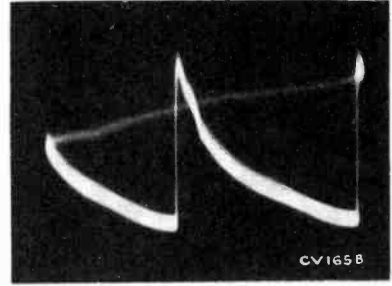

Figure 57—Grid of Horizontal Oscillator (Pin 4 of V115) (6SN7GT) (330 Volts PP)



Figure 58—Plate of Horizontal Oscillator (Pin 5 of V115) (6SN7GT) (140 Volts PP)

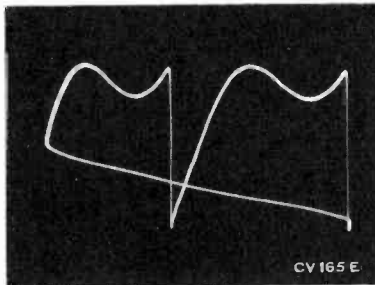
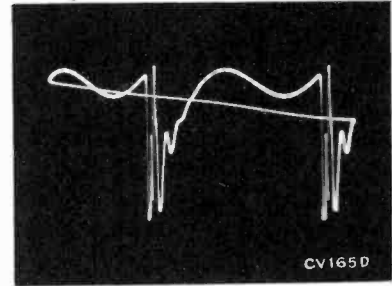

Figure 59—Terminal "C" of T110 (150 Volts PP)



Figure 60—Grid of Horizontal Output Tube (Pin 5 of V116) (6BQ6) (90 Volts PP)

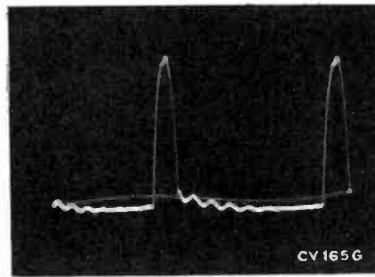
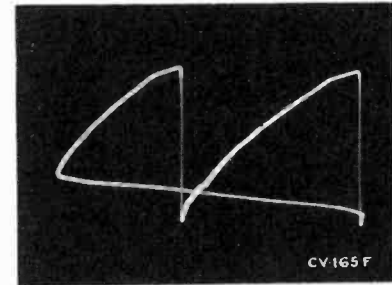

Figure 61—Plate of Horizontal Output (Approx. 4000 Volts PP) (Measured Through a Capacity Voltage Divider Connected from Top Cap of V116 to Ground)



Figure 62—Cathode of Damper (Pin 3 of V118) (6W4GT) (2350 Volts PP)

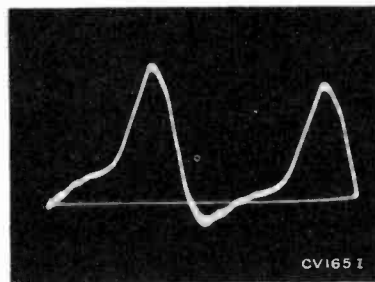
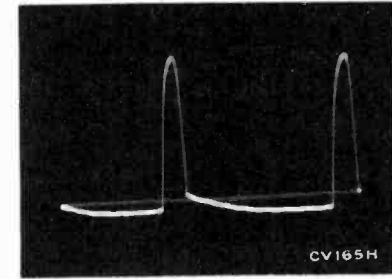
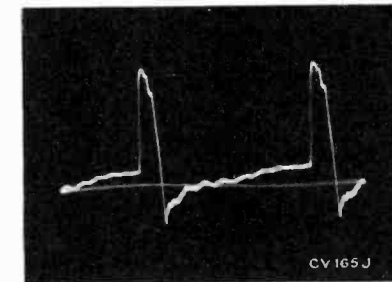

Figure 63—Plate of Damper (Pin 5 of V118) (6W4GT) (160 Volts PP)



Figure 64—Plate of AGC Amplifier (Pin 5 of V111) (6AU6) (560 Volts PP)



21T207, 21T207G, 21T208, 21T217,
21T218, 21T227, 21T228, 21T229

VOLTAGE CHART

The following measurements represent two sets of conditions. In the first condition, a 15000 microvolt test pattern signal was fed into the receiver, the picture synced and the AGC control properly adjusted. The second condition was obtained by removing the antenna leads and short circuiting the receiver antenna terminals. Voltages shown are read with a type WV97A senior "VoltOhmyst" between the indicated terminal and chassis ground and with the receiver operating on 117 volts, 60 cycles, a-c. The symbol < means less than.

Tube No.	Tube Type	Function	Operating Condition	E. Plate		E. Screen		E. Cathode		E. Grid		Notes on Measurements
				Pin No.	Volts	Pin No.	Volts	Pin No.	Volts	Pin No.	Volts	
V1	6J6	Mixer	15000 Mu. V. Signal	2	153	—	—	7	0	5	*-3 to -5	*Depending on channel
			No Signal	2	135	—	—	7	0	5	*-3 to -5	*Depending on channel
V1	6J6	R-F Oscillator	15000 Mu. V. Signal	1	100	—	—	7	0	6	*-3 to -5	*Depending on channel
			No Signal	1	85	—	—	7	0	6	*-3 to -5	*Depending on channel
V2	6CB6	R-F Amplifier	15000 Mu. V. Signal	5	260	6	150	2	.1	1	-5.8	
			No Signal	5	220	6	100	2	1.0	1	-0.1	
V101	6AU6	1st Sound I-F Amp.	15000 Mu. V. Signal	5	130	6	142	7	0.8	1	0	
			No Signal	5	116	6	129	7	0.6	1	0	
V102	6AU6	2d Sound I-F Amp.	15000 Mu. V. Signal	5	131	6	148	7	0	1	-5.1	
			No Signal	5	110	6	120	7	0	1	*-0.3	*Unreliable measuring point. Voltage depends on noise.
V103	6AL5	Ratio Detector	15000 Mu. V. Signal	7	0	—	—	1	12	—	—	7.5 kc deviation at 1000 cycles
			No Signal	7	0.7	—	—	1	*5.1	—	—	*Unreliable measuring point. Voltage depends on noise.
V104	6AV6	1st Audio Amplifier	15000 Mu. V. Signal	7	87	—	—	2	0	1	-0.7	At min. volume
			No Signal	7	76	—	—	2	0	1	-0.6	At min. volume
V105	6K6GT	Audio Output	15000 Mu. V. Signal	3	260	4	263	8	19	5	-0.7	At min. volume
			No Signal	3	250	4	251	8	18.5	5	-0.7	At min. volume
V106	6CB6	1st Pix. I-F Amplifier	15000 Mu. V. Signal	5	246	6	258	2	<0.1	1	-8.6	
			No Signal	5	108	6	108	2	0.7	1	*-0.2	*Unreliable measuring point. Make measurement at T104-B
V107	6CB6	2nd Pix. I-F Amplifier	15000 Mu. V. Signal	5	242	6	255	2	<0.1	1	-8.6	
			No Signal	5	108	6	108	2	0.5	1	-0.2	
V108	6CB6	3rd Pix. I-F Amplifier	15000 Mu. V. Signal	5	133	6	172	2	2.1	1	0	
			No Signal	5	115	6	162	2	1.9	1	0	
V109A	12AU7	Picture 2d Det.	15000 Mu. V. Signal	1	-8.4	—	—	3	0	2	-1.3	
			No Signal	1	-1.8	—	—	3	0	2	-0.6	
V109B	12AU7	Vert. Sync Separator	15000 Mu. V. Signal	6	71	—	—	8	0	7	-40	
			No Signal	6	*50 to 100	—	—	8	0	7	*-15	*Unreliable, depends on noise

VOLTAGE CHART

21T207, 21T207G, 21T208, 21T217,
21T218, 21T227, 21T228, 21T229

Tube No.	Tube Type	Function	Operating Condition	E. Plate		E. Screen		E. Cathode		E. Grid		Notes on Measurements
				Pin No.	Volts	Pin No.	Volts	Pin No.	Volts	Pin No.	Volts	
V110	6AG7 (6AC7, 6CL6)	Video Amplifier	15000 Mu. V. Signal	6	130	8	149	1	0.2	4	-1.3	AGC control set for normal operation
*	Refer to schematic for pin connections		No Signal	6	110	8	130	1	0.5	4	-0.6	*Refer to Fig. 67 for socket connections
V111	6AU6	AGC Amplifier	15000 Mu. V. Signal	5	-40	6	250	7	153	1	151	
			No Signal	5	+2.3	6	258	7	135	1	105	
V112A	6SN7GT	Hor. Sync Separator	15000 Mu. V. Signal	2	263	-	-	3	190	1	130	
			No Signal	2	258	-	-	3	138	1	110	
V112B	6SN7GT	Sync Output	15000 Mu. V. Signal	5	58	-	-	6	0	4	-2.1	
			No Signal	5	48	-	-	6	0	4	* +0.6	*Depends on noise
V113	6J5	Vertical Oscillator	15000 Mu. V. Signal	3	70	-	-	8	0	5	-15	*Depends on setting of Vert. hold control
			No Signal	3	68	-	-	8	0	5	-14	Voltages shown are synced pix adjustment
V114	6K6GT	Vertical Output	15000 Mu. V. Signal	3	265	4	270	8	30	5	-5	
			No Signal	3	253	4	260	8	28	5	-5	
V115	6SN7GT	Horizontal Osc. Control	15000 Mu. V. Signal	2	165	-	-	3	+1.5	1	-21	
			No Signal	2	160	-	-	3	-10	1	-24	
V115	6SN7GT	Horizontal Oscillator	15000 Mu. V. Signal	5	185	-	-	6	0	4	-80	
			No Signal	5	170	-	-	6	0	4	-88	
V116	6BQ6GT	Horizontal Output	15000 Mu. V. Signal	Cap	*	4	180	8	21.2	5	-13	*High Voltage Pulse Present
			No Signal	Cap	*	4	170	8	21.0	5	-13	*High Voltage Pulse Present
V117	1B3GT 8016	H. V. Rectifier	15000 Mu. V. Signal	Cap	*	-	-	2 & 7	14,000	-	-	*High Voltage Pulse Present
			No Signal	Cap	*	-	-	2 & 7	13,600	-	-	*High Voltage Pulse Present
V118	6W4GT	Damper	15000 Mu. V. Signal	5	270	-	-	3	*	-	-	*High Voltage Pulse Present
			No Signal	5	260	-	-	3	*	-	-	*High Voltage Pulse Present
V119	21AP4	Kinescope	15000 Mu. V. Signal	Cap	14,000	10	400	11	170	2	120	At average Brightness
			No Signal	Cap	13,600	10	385	11	150	2	115	At average Brightness
V120 V121	5U4G 5Y3GT	Rectifiers	15000 Mu. V. Signal	4 & 6	-	-	-	2 & 8	285	-	-	
			No Signal	4 & 6	-	-	-	2 & 8	275	-	-	

21T207, 21T207G, 21T208, 21T217,
21T218, 21T227, 21T228, 21T229

R-F UNIT WIRING DIAGRAM

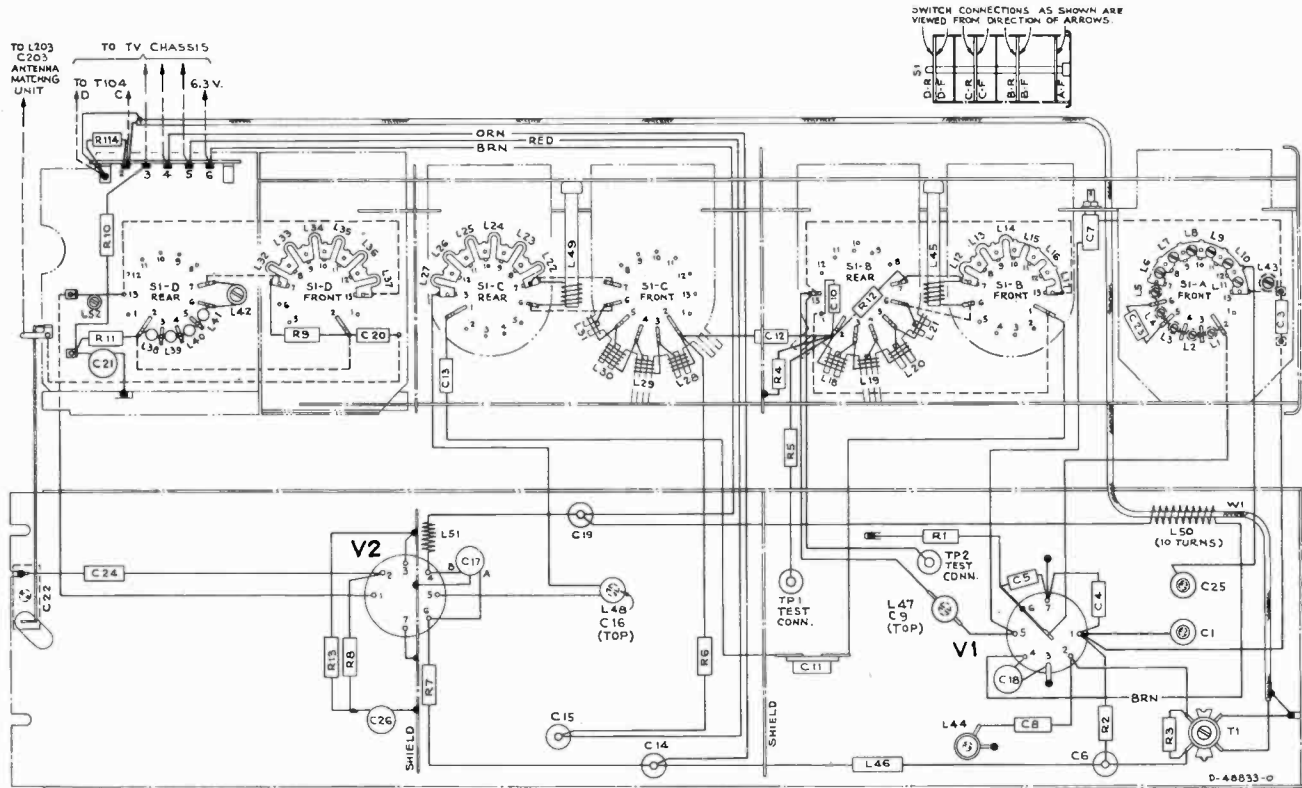

Figure 65—KRK-8D R-F Unit Wiring Diagram

CRITICAL LEAD DRESS:

- Keep all wiring in the pix i-f, sound i-f and video circuits as short as possible.
- Keep the leads on C118, C120, C122, C124, C126, R114, R121 and R123 as short and direct as possible.
- Do not run any leads under C115 trimmer capacitor.
- Dress C118 vertically parallel to terminals A and B of T104. Dress C135 parallel to terminals A and B of T104 close to the chassis.
- Keep C127 away from chassis with no more than $\frac{1}{4}$ inch leads at each end.
- Dress the lead from T105(C) to the terminal board, close to the chassis.
- Keep all filament leads dressed close to the chassis.
- Ground filaments of V106, V107 and V108 independently of tube shields (pin 8). Use ground lances provided near pins of each socket.
- Dress lead from pin 5 of V110 to J102-2 close to the chassis.
- Keep leads to L103 as short as possible.
- Dress L102, L104, L105, L114, C130, R131, R133, R135, R139 and C132 away from the chassis.
- Do not tape kinescope cathode lead in with other kinescope leads.
- Do not change the bus wire connections to pin 2 of V101 and V102. Sleeving is used to insure length and to prevent shorting.
- Keep leads on C136 short and direct. Dress the lead from C136 to pin 5 of V111 as shown in wiring diagram.
- Do not dress C170 in such a position that adjustment of T110 is inaccessible.
- Keep the leads on R201 as short and direct as possible.
- Dress the lead from pin 3 of V113 to C153 as shown in the wiring diagram.
- Mount C183 directly on the terminal board provided keeping it as far away from T109 as possible.
- Dress all leads in the high voltage compartment away from each other and away from the high voltage transformer.

STOCK No.	DESCRIPTION	STOCK No.	DESCRIPTION
75186	R-F UNIT ASSEMBLIES	75186	R-F UNIT ASSEMBLIES
75186	Board—Terminal board, 5 contact and ground	75186	Board—Terminal board, 5 contact and ground
75186	Bracket—Vertical bracket for holding oscillator tube	75186	Bracket—Vertical bracket for holding oscillator tube
75186	Cable—75 ohm coax cable (7/16"), complete with coil (W1, L50)	75186	Cable—75 ohm coax cable (7/16"), complete with coil (W1, L50)
75186	Capacitor—Ceramic, variable, for fine tuning—plunger type (C2)	75186	Capacitor—Ceramic, variable, for fine tuning—plunger type (C2)
75186	Capacitor—Headed lead, 0.68 mfmf. (C27)	75186	Capacitor—Headed lead, 0.68 mfmf. (C27)
75186	Capacitor—Ceramic, 3 mfmf. (C4)	75186	Capacitor—Ceramic, 3 mfmf. (C4)
75186	Capacitor—Ceramic, 12 mfmf. (C34)	75186	Capacitor—Ceramic, 12 mfmf. (C34)
75186	Capacitor—Ceramic, 15 mfmf. (C3)	75186	Capacitor—Ceramic, 15 mfmf. (C3)
75186	Capacitor—Ceramic, 39 mfmf. (C5)	75186	Capacitor—Ceramic, 39 mfmf. (C5)
75186	Capacitor—Ceramic, 270 mfmf. (C12, C13, C20)	75186	Capacitor—Ceramic, 270 mfmf. (C12, C13, C20)
75186	Capacitor—Ceramic, 380 mfmf. (C10)	75186	Capacitor—Ceramic, 380 mfmf. (C10)
75186	Capacitor—Ceramic, 1500 mfmf. (C8, C14, C15, C19)	75186	Capacitor—Ceramic, 1500 mfmf. (C8, C14, C15, C19)
75186	Capacitor—Ceramic, 1900 mfmf. (C18, C26)	75186	Capacitor—Ceramic, 1900 mfmf. (C18, C26)
75186	Capacitor—Ceramic, dual 1500 mfmf. (C17A, C17B)	75186	Capacitor—Ceramic, dual 1500 mfmf. (C17A, C17B)
75186	Capacitor—Ceramic, 5000 mfmf. (C21)	75186	Capacitor—Ceramic, 5000 mfmf. (C21)
75186	Capacitor—Ceramic, 1500 mfmf. (C17A, C17B)	75186	Capacitor—Ceramic, 1500 mfmf. (C17A, C17B)
75186	Capacitor—Ceramic, 0.68 mfmf. (C23)	75186	Capacitor—Ceramic, 0.68 mfmf. (C23)
75186	Capacitor—Ceramic, adjustable, 0.75-4 mfmf., complete with adjusting stud (C1)	75186	Capacitor—Ceramic, adjustable, 0.75-4 mfmf., complete with adjusting stud (C1)
75186	Capacitor—Ceramic, 6.8 mfmf. (C8)	75186	Capacitor—Ceramic, 6.8 mfmf. (C8)
75186	Capacitor—Adjustable, 7.30 mfmf. (C22)	75186	Capacitor—Adjustable, 7.30 mfmf. (C22)
75186	Capacitor—Ceramic, trimmer, 50-75 mfmf. (C11)	75186	Capacitor—Ceramic, trimmer, 50-75 mfmf. (C11)
75186	Clip—Throttle clip for mounting standoff capacitors	75186	Clip—Throttle clip for mounting standoff capacitors
75186	Coil—Choke coil (L45)	75186	Coil—Choke coil (L45)
75186	Coil—Choke coil, .58 mfmf. (L46)	75186	Coil—Choke coil, .58 mfmf. (L46)
75186	Coil—Converter plate loading coil (L44)	75186	Coil—Converter plate loading coil (L44)
75186	Coil—Trimmer coil (1 1/2 turns) with adjustable inductor core and capacitor stud (screw adjustment) for Converter section (C9, L47)	75186	Coil—Trimmer coil (1 1/2 turns) with adjustable inductor core and capacitor stud (screw adjustment) for Converter section (C9, L47)
75186	Coil—Trimmer coil (2 turns) with adjustable inductor core and capacitor stud (screw adjustment) for Coil—Trimmer coil (2 turns) with adjustable inductor core and capacitor stud (screw adjustment) for Converter section (C9, L47)	75186	Coil—Trimmer coil (2 turns) with adjustable inductor core and capacitor stud (screw adjustment) for Converter section (C9, L47)
75186	Coil—Trimmer coil (2 turns) with adjustable inductor core and capacitor stud (screw adjustment) for Converter section (C9, L47)	75186	Coil—Trimmer coil (2 turns) with adjustable inductor core and capacitor stud (screw adjustment) for Converter section (C9, L47)
75186	Contact—Feed point contact	75186	Contact—Feed point contact
75186	Core—Adjustable core for fine tuning capacitor	75186	Core—Adjustable core for fine tuning capacitor
75186	Detent—Detent mechanism and fibre shaft	75186	Detent—Detent mechanism and fibre shaft
75186	Form—Coil form for L45, L49	75186	Form—Coil form for L45, L49
75186	Link—Link assembly for fine tuning	75186	Link—Link assembly for fine tuning
75186	Plate—Front plate and shaft bearing	75186	Plate—Front plate and shaft bearing
75186	Resistor—10%, 1/2 watt (R8)	75186	Resistor—10%, 1/2 watt (R8)
75186	88 ohms, ±10%, 1/2 watt (R13)	75186	88 ohms, ±10%, 1/2 watt (R13)
75186	150 ohms, ±20%, 1/2 watt (R10)	75186	150 ohms, ±20%, 1/2 watt (R10)
75186	220 ohms, ±10%, 1/2 watt (R6)	75186	220 ohms, ±10%, 1/2 watt (R6)
75186	390 ohms, ±10%, 1/2 watt (R9, R11)	75186	390 ohms, ±10%, 1/2 watt (R9, R11)
75186	503247	503247	
75186	503410	503410	
75186	503422	503422	
75186	503430	503430	
75186	503432	503432	
75186	503434	503434	
75186	503436	503436	
75186	503438	503438	
75186	503440	503440	
75186	503442	503442	
75186	503444	503444	
75186	503446	503446	
75186	503448	503448	
75186	503450	503450	
75186	503452	503452	
75186	503454	503454	
75186	503456	503456	
75186	503458	503458	
75186	503460	503460	
75186	503462	503462	
75186	503464	503464	
75186	503466	503466	
75186	503468	503468	
75186	503470	503470	
75186	503472	503472	
75186	503474	503474	
75186	503476	503476	
75186	503478	503478	
75186	503480	503480	
75186	503482	503482	
75186	503484	503484	
75186	503486	503486	
75186	503488	503488	
75186	503490	503490	
75186	503492	503492	
75186	503494	503494	
75186	503496	503496	
75186	503498	503498	
75186	503500	503500	
75186	503502	503502	
75186	503504	503504	
75186	503506	503506	
75186	503508	503508	
75186	503510	503510	
75186	503512	503512	
75186	503514	503514	
75186	503516	503516	
75186	503518	503518	
75186	503520	503520	
75186	503522	503522	
75186	503524	503524	
75186	503526	503526	
75186	503528	503528	
75186	503530	503530	
75186	503532	503532	
75186	503534	503534	
75186	503536	503536	
75186	503538	503538	
75186	503540	503540	
75186	503542	503542	
75186	503544	503544	
75186	503546	503546	
75186	503548	503548	
75186	503550	503550	
75186	503552	503552	
75186	503554	503554	
75186	503556	503556	
75186	503558	503558	
75186	503560	503560	
75186	503562	503562	
75186	503564	503564	
75186	503566	503566	
75186	503568	503568	
75186	503570	503570	
75186	503572	503572	
75186	503574	503574	
75186	503576	503576	
75186	503578	503578	
75186	503580	503580	
75186	503582	503582	
75186	503584	503584	
75186	503586	503586	
75186	503588	503588	
75186	503590	503590	
75186	503592	503592	
75186	503594	503594	
75186	503596	503596	
75186	503598	503598	
75186	503600	503600	
75186	503602	503602	
75186	503604	503604	
75186	503606	503606	
75186	503608	503608	
75186	503610	503610	
75186	503612	503612	
75186	503614	503614	
75186	503616	503616	
75186	503618	503618	
75186	503620	503620	
75186	503622	503622	
75186	503624	503624	
75186	503626	503626	
75186	503628	503628	
75186	503630	503630	
75186	503632	503632	
75186	503634	503634	
75186	503636	503636	
75186	503638	503638	
75186	503640	503640	
75186	503642	503642	
75186	503644	503644	
75186	503646	503646	
75186	503648	503648	
75186	503650	503650	
75186	503652	503652	
75186	503654	503654	
75186	503656	503656	
75186	503658	503658	
75186	503660	503660	
75186	503662	503662	
75186	503664	503664	
75186	503666	503666	
75186	503668	503668	
75186	503670	503670	
75186	503672	503672	
75186	503674	503674	
75186	503676	503676	
75186	503678	503678	
75186	503680	503680	
75186	503682	503682	
75186	503684	503684	
75186	503686	503686	
75186	503688	503688	
75186	503690	503690	
75186	503692	503692	
75186	503694	503694	
75186	503696	503696	
75186	503698	503698	
75186	503700	503700	
75186	503702	503702	
75186	503704	503704	
75186	503706	503706	
75186	503708	503708	
75186	503710	503710	
75186	503712	503712	
75186	503714	503714	
75186	503716	503716	
75186	503718	503718	
75186	503720	503720	
75186	503722	503722	
75186	503724	503724	
75186	503726	503726	
75186	503728	503728	
75186	503730	503730	
75186	503732	503732	
75186	503734	503734	
75186	503736	503736	
75186	503738	503738	
75186	503740	503740	
75186	503742	503742	
75186	503744	503744	
75186	503746	503746	
75186	503748	503748	
75186	503750	503750	
75186	503752	503752	
75186	503754	503754	
75186	503756	503756	
75186	503758	503758	
75186	503760	503760	
75186	503762	503762	
75186	503764	503764	
75186	503766	503766	
75186	503768	503768	
75186	503770	503770	
75186	503772	503772	
75186	503774	503774	
75186	503776	503776	
75186	503778	503778	
75186	503780	503780	
75186	503782	503782	
75186	503784	503784	
75186	503786	503786	
75186	503788	503788	
75186	503790	503790	
75186	503792	503792	
75186	503794	503794	
75186	503796	503796	
75186	503798	503798	
75186	503800	503800	
75186	503802	503802	
75186	503804	503804	
75186	503806	503806	
75186	503808	503808	
75186	503810	503810	
75186	503812	503812	
75186	503814	503814	
75186	503816	503816	
75186	503818	503818	
75186	503820	503820	
75186	503822	503822	
75186	503824	503824	
75186	503826	503826	
75186	503828	503828	
75186	503830	503830	
75186	503832	503832	
75186	503834	503834	
75186	503836	503836	
75186	503838	503838	
75186	503840	503840	
75186	503842	503842	
75186	503844	503844	



RCA VICTOR

TELEVISION, RADIO, PHONOGRAPH COMBINATION MODELS 21-T-242, 21-T-244

Chassis No. KCS72D-1 or KCS72D-2
930409 and RC1117B or RC1111B and RS141C
—Mfr. No. 274—

SERVICE DATA

—1952 No. T9

PREPARED BY RCA SERVICE CO., INC.
FOR
RADIO CORPORATION OF AMERICA
RCA VICTOR DIVISION
CAMDEN, N. J., U. S. A.

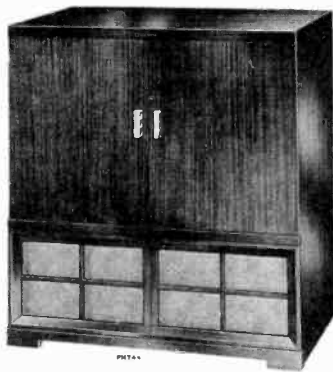

Model 21-T-242
"Westland"
Mahogany,
Blonde Mahogany

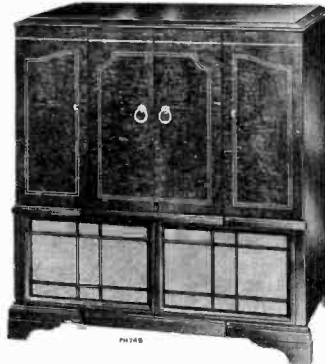

Model 21-T-244
"Penfield"
Mahogany

GENERAL DESCRIPTION

Models 21-T-242 and 21-T-244 are 21 inch television, radio, phonograph combinations. Model 21-T-242 features an AM radio and Model 21-T-244 features an AM, FM radio. Both models employ a three speed record changer and a 12" PM dynamic speaker.

ELECTRICAL AND MECHANICAL SPECIFICATIONS

PICTURE SIZE . . . 227 square inches on a 21AP4 Kinescope

TELEVISION R-F FREQUENCY RANGE

All 12 television channels, 54 mc. to 88 mc., 174 mc. to 216 mc.
Picture I-F Carrier Frequency 25.50 mc.
Sound I-F Carrier Frequency 21.00 mc. and 4.5 mc.

VIDEO RESPONSE To 3.2 mc.

SWEEP DEFLECTION Magnetic

FOCUS Magnetic

POWER SUPPLY RATING 115 volts, 60 cycles
21-T-242 190 watts max.
21-T-244 190 watts max.

CHASSIS DESIGNATIONS

In Model 21-T-242 . . . Television Chassis KCS72D-1, Radio Chassis RC1117B and Record Changer 930409-5 or -10.

In Model 21-T-244 . . . Television Chassis KCS72D-2, Radio Chassis RC1111B, Audio Amplifier RS141C and Record Changer 930409-5 (mah).
See Service Data 930409 for Record Changer information.

AUDIO POWER OUTPUT RATING. KCS72D, 4 watts max.
RC1117B 2.4 watts max., RS141C 10 watts max.

LOUDSPEAKER . . . (92569-12) 12" PM Dynamic, 3.2 ohms

WEIGHT

Model	Net Weight	Shipping Weight
21-T-242	163 lbs.	207 lbs.
21-T-244	186 lbs.	232 lbs.

RECEIVER ANTENNA INPUT IMPEDANCE

Choice: 300 ohms balanced or 72 ohms unbalanced.

RCA TUBE COMPLEMENT

Tube Used	Television Chassis	Function
(1) RCA 6CB6		R-F Amplifier
(2) RCA 6J6		R-F Oscillator and Mixer
(3) RCA 6CB6		1st Picture I-F Amplifier
(4) RCA 6CB6		2nd Picture I-F Amplifier
(5) RCA 6CB6		3rd Picture I-F Amplifier
(6) RCA 12AU7	Picture	2nd Detector and Vert. Sync. Sep.
(7) RCA 6AG7		Video Amplifier
(8) RCA 6AU6		1st Sound I-F Amplifier
(9) RCA 6AU6		2nd Sound I-F Amplifier
(10) RCA 6AL5		Ratio Detector
(11) RCA 6AV6		1st Audio Amplifier
(12) RCA 6K6GT		Audio Output
(13) RCA 6AU6		AGC Amplifier
(14) RCA 6SN7GT		Horizontal Sync. Sep. and Sync. Output
(15) RCA 6J5		Vertical Sweep Oscillator
(16) RCA 6K6GT		Vertical Sweep Output
(17) RCA 6SN7GT		Horizontal Sweep Oscillator and Control
(18) RCA 6BQ6GT		Horizontal Sweep Output
(19) RCA 6W4GT		Damper
(20) RCA 1B3-GT/8016		High Voltage Rectifier
(21) RCA 21AP4		Kinescope
(22) RCA 5U4G		Rectifier
(23) RCA 5Y3GT		Rectifier

Radio Chassis RC1111B

(1) RCA 6CB6	R-F Amplifier
(2) RCA 6J6	Oscillator and Mixer
(3) RCA 6BA6	I-F Amplifier
(4) RCA 6AU6	FM Driver
(5) RCA 6AL5	Ratio Detector
(6) RCA 6AV6	AM 2nd Det. and 1st Audio Amp.

21T242, 21T244 ELECTRICAL AND MECHANICAL SPECIFICATIONS (cont'd)

RCA TUBE COMPLEMENT

Tube Used	Radio Chassis 1117B	Function
(1) RCA 12BE6		Converter
(2) RCA 12BA6		I-F Amplifier
(3) RCA 6AQ6		2nd Det. and Audio Amp.
(4) RCA 6AQ6		Phase Inverter
(5) RCA 35C5		Audio Output (2 tubes)

Audio Chassis RS141C

(1) RCA 6C4	Phase Inverter
(2) RCA 6V6GT	Audio Output (2 tubes)
(3) RCA 5Y3GT	Rectifier

HORIZONTAL SWEEP FREQUENCY 15,750 cps

VERTICAL SWEEP FREQUENCY 60 cps

FRAME FREQUENCY (Picture Repetition Rate) . . . 30 cps

SCANNING Interlaced, 525 line

OPERATING CONTROLS (Front)

Channel Selector	}	Dual Control Knobs
Fine Tuning		
Picture	}	Dual Control Knobs
Brightness		
Picture Horizontal Hold	}	Dual Control Knobs
Picture Vertical Hold		
Sound Volume and On-Off Switch	}	Dual Control Knobs
TV Tone Switch		

NON-OPERATING CONTROLS (not including R-F and I-F adjustments)

Picture Centering	top chassis adjustment
Width	rear chassis adjustment
Height	rear chassis adjustment
Vertical Linearity	rear chassis adjustment
Horizontal Drive	rear chassis adjustment
Horizontal Oscillator Frequency	rear chassis adjustment
Horizontal Oscillator Waveform	bottom chassis adjustment
Horizontal Locking Range	rear chassis adjustment
Focus	top chassis adjustment
Ion Trap Magnet	top chassis adjustment
Deflection Coil	top chassis wing nut adjustment
AGC Control	rear chassis adjustment

HIGH VOLTAGE WARNING

OPERATION OF THIS RECEIVER OUTSIDE THE CABINET OR WITH THE COVERS REMOVED, INVOLVES A SHOCK HAZARD FROM THE RECEIVER POWER SUPPLIES. WORK ON THE RECEIVER SHOULD NOT BE ATTEMPTED BY ANYONE WHO IS NOT THOROUGHLY FAMILIAR WITH THE PRECAUTIONS NECESSARY WHEN WORKING ON HIGH VOLTAGE EQUIPMENT. DO NOT OPERATE THE RECEIVER WITH THE HIGH VOLTAGE COMPARTMENT SHIELD REMOVED. BE SURE THE GROUND STRAP, BETWEEN THE YOKE ASSEMBLY AND THE CHASSIS, IS SECURELY FASTENED BEFORE TURNING THE RECEIVER ON.

KINESCOPE HANDLING PRECAUTIONS

DO NOT REMOVE THE RECEIVER CHASSIS, INSTALL, REMOVE OR HANDLE THE KINESCOPE IN ANY MANNER UNLESS SHATTERPROOF GOGGLES ARE WORN. PEOPLE NOT SO EQUIPPED SHOULD BE KEPT AWAY WHILE HANDLING KINESCOPIES. KEEP THE KINESCOPE AWAY FROM THE BODY WHILE HANDLING.

The kinescope bulb encloses a high vacuum and, due to its large surface area, is subjected to considerable air pressure. For this reason, the kinescope must be handled with more care than ordinary receiving tubes.

The large end of the kinescope bulb—particularly that part at the rim of the viewing surface—must not be struck, scratched or subjected to more than moderate pressure at any time. During service if the tube sticks or fails to slip smoothly into its socket, or deflecting yoke, investigate and remove the cause of the trouble. Do not force the tube. Refer to the Receiver Installation section for detailed instructions on kinescope installation. All RCA replacement kinescopes are shipped in special cartons and should be left in the cartons until ready for installation in the receiver.

OPERATING INSTRUCTIONS

21T242, 21T244

The following adjustments are necessary when turning the receiver on for the first time:

1. Turn the radio FUNCTION switch to TV.
2. Turn the receiver "ON" and advance the SOUND VOLUME control to approximately mid-position.
3. Set the STATION SELECTOR to the desired channel.
4. Adjust the FINE TUNING control for best sound fidelity and the VOLUME control for suitable volume.
5. Turn the BRIGHTNESS control fully counter-clockwise, then clockwise until a pattern appears on the screen.
6. Adjust the VERTICAL hold control until the pattern stops vertical movement.
7. Adjust the HORIZONTAL hold control until a picture is obtained and centered.
8. Adjust the PICTURE and BRIGHTNESS controls for suitable picture contrast and brightness.
9. In switching from one channel to another, it may be necessary to repeat steps 4 and 8.
10. When the set is turned on again after an idle period it should not be necessary to repeat the adjustments if the positions of the controls have not been changed. If any adjustment is necessary, step No. 4 is generally sufficient.
11. If the positions of the controls have been changed, it may be necessary to repeat steps 1 through 8.

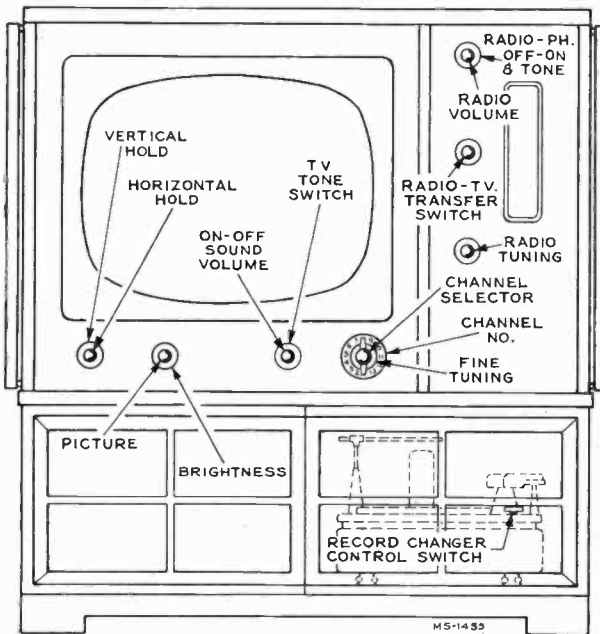

Figure 1—21T242 Operating Controls

RADIO OPERATION

Model 21T242

1. Turn the RADIO TRANSFER switch to RADIO-PHONO position.
2. Turn the RADIO-PHONO tone switch to a radio position.
3. Tune in the desired station with the TUNING control.
4. Adjust tone as desired.

Model 21T244

1. Turn the television TRANSFER switch to the RADIO position.
 2. Turn the radio FUNCTION switch to AM or FM position.
 3. Tune in the desired station with the TUNING control.
 4. Adjust BASS and TREBLE controls for desired tone.
- Normal tone is with the BASS control fully counter-clockwise and the TREBLE control fully clockwise.

PHONOGRAPH OPERATION

1. Turn the radio FUNCTION switch to the PHONO position.
2. Set speed control on changer to the desired speed.
3. Set stylus on tone arm to proper position for record to be used. (For 45 RPM records place 45 RPM centerpost over center spindle.)
4. Place a record on the changer and turn the changer power switch to "ON" position.

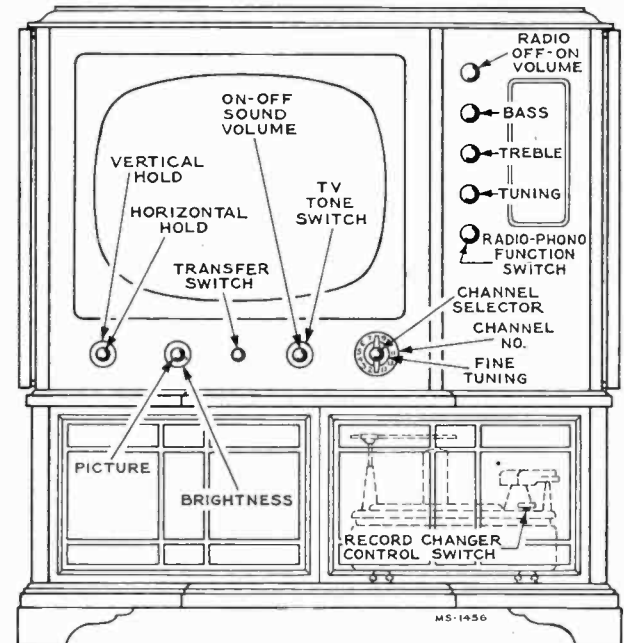

Figure 2—21T244 Operating Controls

REFER TO PAGES 236 TO 249 FOR TELEVISION ALIGNMENT PROCEDURE AND WAVE FORM PHOTOGRAPHS

INSTALLATION INSTRUCTIONS

ION TRAP MAGNET ADJUSTMENT.—Set the ion trap magnet approximately in the position shown in Figure 3. Starting from this position immediately adjust the magnet by moving it forward or backward at the same time rotating it slightly around the neck of the kinescope for the brightest raster on the screen. Reduce the brightness control setting until the raster is slightly above average brilliance. Turn the focus control (shown in Figure 3) until the line structure of the raster is clearly visible. Readjust the ion trap magnet for maximum raster brilliance. The final touches of this adjustment should be made with the brightness control at the maximum clockwise position with which good line focus can be maintained.

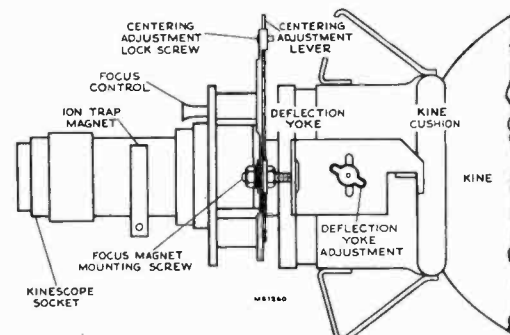

Figure 3—Yoke and Focus Magnet Adjustments

21T242, 21T244

INSTALLATION INSTRUCTIONS

DEFLECTION YOKE ADJUSTMENT.—If the lines of the raster are not horizontal or squared with the picture mask, rotate the deflection yoke until this condition is obtained. Tighten the yoke adjustment wing screw.

PICTURE ADJUSTMENTS.—It will now be necessary to obtain a test pattern picture in order to make further adjustments. Connect the antenna transmission line to the receiver.

If the Horizontal Oscillator and AGC System are operating properly, it should be possible to sync the picture at this point. However, if the AGC control is misadjusted, and the receiver is overloading, it may be impossible to sync the picture.

If the receiver is overloading, turn R149 on the rear apron (see Figure 4) counter-clockwise until the set operates normally and the picture can be synced.

CHECK OF HORIZONTAL OSCILLATOR ALIGNMENT.—Turn the horizontal hold control to the extreme counter-clockwise position. The picture should remain in horizontal sync. Momentarily remove the signal by switching off channel then back. Normally the picture will be out of sync. Turn the control clockwise slowly. The number of diagonal black bars will be gradually reduced and when only 2 or 3 bars sloping downward to the left are obtained, the picture will pull into sync upon slight additional clockwise rotation of the control. Pull-in should occur before the control has been turned 120 degrees from the extreme counter-clockwise position. The picture should remain in sync for approximately 90 degrees of additional clockwise rotation of the control. At the

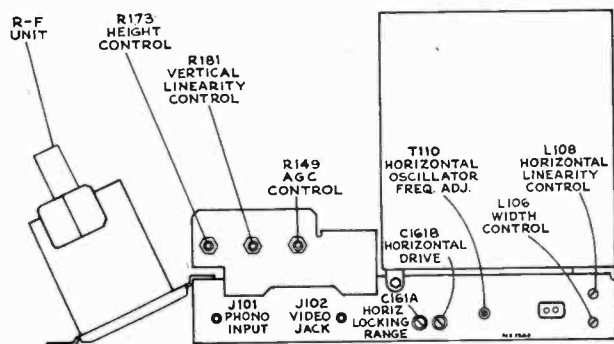

Figure 4—Rear Chassis Adjustments

extreme clockwise position, the picture should remain in sync and should not show a black bar in the picture.

If the receiver passes the above checks and the picture is normal and stable, the horizontal oscillator is properly aligned. Skip "Alignment of Horizontal Oscillator" and proceed with "Focus Magnet Adjustment."

ALIGNMENT OF HORIZONTAL OSCILLATOR.—If in the above check the receiver failed to hold sync with the hold control at the extreme counter-clockwise position or failed to hold sync over 90 degrees of clockwise rotation of the control from the pull-in point, it will be necessary to make the following adjustments.

Horizontal Frequency Adjustment.—Turn the horizontal hold control to the extreme clockwise position. Tune in a television station and adjust the T110 horizontal frequency adjustment at the rear of the chassis until the picture is just out of sync and the horizontal blanking appears as a vertical or diagonal black bar in the raster. Then turn the T110 core until the bar moves out of the picture leaving it in sync.

Horizontal Locking Range Adjustment.—Set the horizontal hold control to the full counter-clockwise position. Momentarily remove the signal by switching off channel then back. The picture may remain in sync. If so turn the T110 rear core slightly and momentarily switch off channel. Repeat until the picture falls out of sync with the diagonal lines sloping down to the left. Slowly turn the horizontal hold control clockwise and note the least number of diagonal bars obtained just before the picture pulls into sync.

If more than 3 bars are present just before the picture pulls into sync, adjust the horizontal locking range trimmer C161A slightly clockwise. If less than 2 bars are present, adjust C161A slightly counter-clockwise. Turn the horizontal hold control counter-clockwise, momentarily remove the signal and recheck the number of bars present at the pull-in point. Repeat this procedure until 2 or 3 bars are present.

Repeat the adjustments under "Horizontal Frequency Adjustment" and "Horizontal Locking Range Adjustment" until the conditions specified under each are fulfilled. When the horizontal hold operates as outlined under "Check of Horizontal Oscillator Alignment" the oscillator is properly adjusted.

If it is impossible to sync the picture at this point and the AGC system is in proper adjustment it will be necessary to adjust the Horizontal Oscillator by the method outlined in the alignment procedure on page 11. For field purposes paragraph "B" under Horizontal Oscillator Waveform Adjustment may be omitted.

FOCUS MAGNET ADJUSTMENT.—The focus magnet should be adjusted so that there is approximately three-eighths inch of space between the rear cardboard shell of the yoke and the flat of the front face of the focus magnet. This spacing gives best average focus over the face of the tube.

The axis of the hole through the magnet should be parallel with the axis of the kinescope neck with the kinescope neck through the center of the opening.

CENTERING ADJUSTMENT.—No electrical centering controls are provided. Centering is accomplished by means of a separate plate on the focus magnet. The centering plates include a locking screw which must be loosened before centering. Up and down adjustment of the plate moves the picture side to side and sidewise adjustment moves the picture up and down.

If a corner of the raster is shadowed, check the position of the ion trap magnet. Reposition the magnet within the range of maximum raster brightness to eliminate the shadow and recenter the picture by adjustment of the focus magnet plate. In no case should the magnet be adjusted to cause any loss of brightness since such operation may cause immediate or eventual damage to the tube. In some cases it may be necessary to shift the position of the focus magnet in order to eliminate a corner shadow.

WIDTH, DRIVE AND HORIZONTAL LINEARITY ADJUSTMENTS.—Adjustment of the horizontal drive control affects the high voltage applied to the kinescope. In order to obtain the highest possible voltage hence the brightest and best focused picture, adjust horizontal drive trimmer C161B counter-clockwise until the picture begins to "wrinkle" in the middle then clockwise until the "wrinkle" disappears.

Turn the horizontal linearity control L108 clockwise until the picture begins to "wrinkle" on the right and then counter-clockwise until the "wrinkle" disappears and best linearity is obtained.

Adjust the width control L106 to obtain correct picture width.

A slight readjustment of these three controls may be necessary to obtain the best linearity.

Adjustments of the horizontal drive control affect horizontal oscillator hold and locking range. If the drive control was adjusted, recheck the oscillator alignment.

HEIGHT AND VERTICAL LINEARITY ADJUSTMENTS.—Adjust the height control (R173 on chassis rear apron) until the picture fills the mask vertically. Adjust vertical linearity (R181 on rear apron), until the test pattern is symmetrical from top to bottom. Adjustment of either control will require a readjustment of the other. Adjust centering to align the picture with the mask.

FOCUS.—Adjust the focus magnet for maximum definition in the test pattern vertical "wedge" and best focus in the white areas of the pattern.

Recheck the position of the ion trap magnet to make sure that maximum brightness is obtained.

Check to see that the yoke thumbscrew and the focus magnet mounting screws are tight.

INSTALLATION INSTRUCTIONS

21T242, 21T244

CHECK OF R-F OSCILLATOR ADJUSTMENTS.—Tune in all available stations to see if the receiver r-f oscillator is adjusted to the proper frequency on all channels. If adjustments are required, these should be made by the method outlined in the alignment procedure on page 9. The adjustments for channels 2 through 12 are available from the front of the cabinet by removing the station selector escutcheon as shown in Figure 5. Adjustment for channel 13 is on top of the chassis.

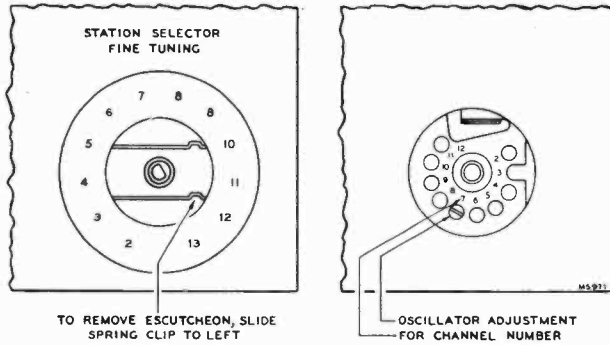

Figure 5—R-F Oscillator Adjustments

AGC THRESHOLD CONTROL.—The AGC threshold control R149 is adjusted at the factory and normally should not require readjustment in the field.

To check the adjustment of the AGC Threshold Control, tune in a strong signal and sync the picture. Momentarily remove the signal by switching off channel and then back. If the picture reappears immediately, the receiver is not overloading due to improper setting of R149. If the picture requires an appreciable portion of a second to reappear, or bends excessively, R149 should be readjusted.

Turn R149 fully counter-clockwise. The raster may be bent slightly. This should be disregarded. Turn R149 clockwise until there is a very, very slight bend or change of bend in the picture. Then turn R149 counter-clockwise just sufficiently to remove this bend or change of bend.

If the signal is weak, the above method may not work as it may be impossible to get the picture to bend. In this case, turn R149 clockwise until the snow in the picture becomes more pronounced, then counter-clockwise until the best signal to noise ratio is obtained.

The AGC control adjustment should be made on a strong signal if possible. If the control is set too far clockwise on a weak signal, then the receiver may overload when a strong signal is received.

FM TRAP ADJUSTMENT.—In some instances interference may be encountered from a strong FM station signal. A trap is provided to eliminate this type of interference. To adjust the trap tune in the station on which the interference is observed and adjust the L203 core on top of the antenna matching transformer for minimum interference in the picture.

CAUTION.—In some receivers, the FM trap L203 will tune down into channel 6 or even into channel 5. Needless to say, such an adjustment will cause greatly reduced sensitivity on these channels. If channels 5 or 6 are to be received, check L203 to make sure that it does not affect sensitivity on these two channels.

Replace the cabinet back and connect the receiver antenna leads to the cabinet back. Make sure that the screws holding it are up tight, otherwise it may rattle or buzz when the receiver is operated at high volume.

KINESCOPE SCREEN CLEANING.—The kinescope safety glass is held in place by four spring clips which may be removed from the back of the front panel. This permits removing the safety glass for cleaning without the necessity of removing the chassis and kinescope.

CHASSIS REMOVAL.—To remove the chassis from the cabinet for repair or installation of a new kinescope, remove the control knobs, the cabinet back, unplug the speaker cable, the kinescope socket, the antenna cable, the yoke and high voltage cable. Take out the chassis bolts under the cabinet. Withdraw the chassis from the back of the cabinet.

RADIO OPERATION

Model 21T242

Turn the RADIO-TV TRANSFER switch to radio. Turn the radio function switch to RADIO and check radio for proper operation.

Model 21T244

Turn the TELEVISION TRANSFER switch to the RADIO position. Turn the radio function switch to the AM and FM positions and check the radio for proper operation.

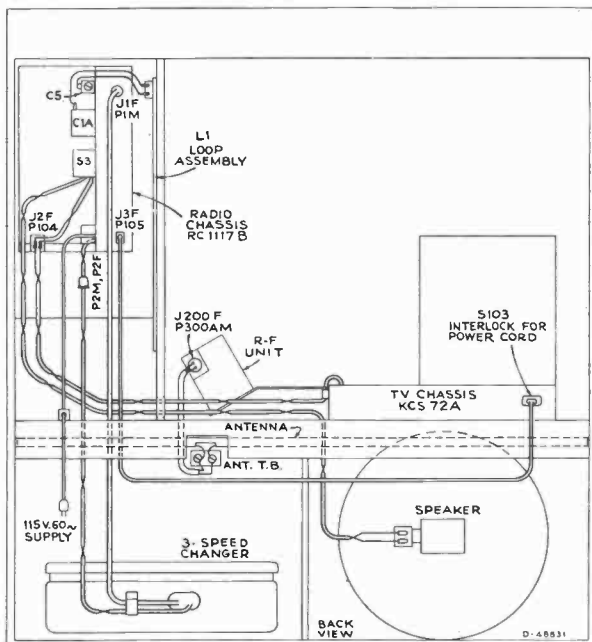

Figure 6—Model 21T242 Cable Diagram

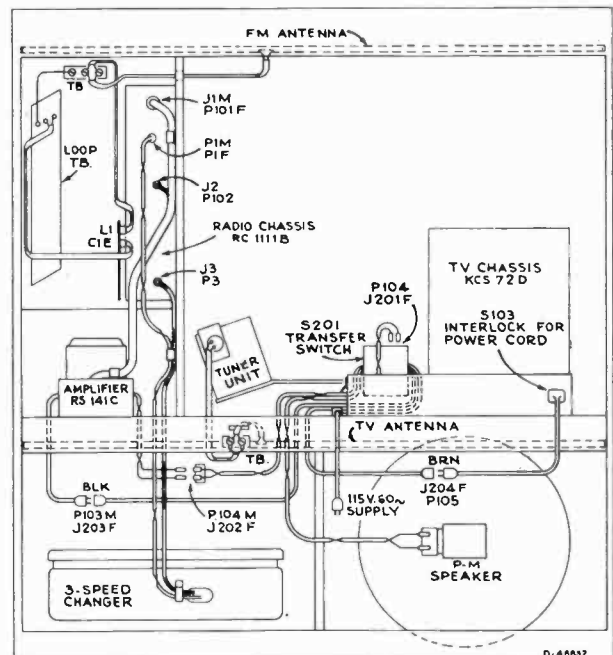

Figure 7—Model 21T244 Cable Diagram

TELEVISION CHASSIS TOP VIEW

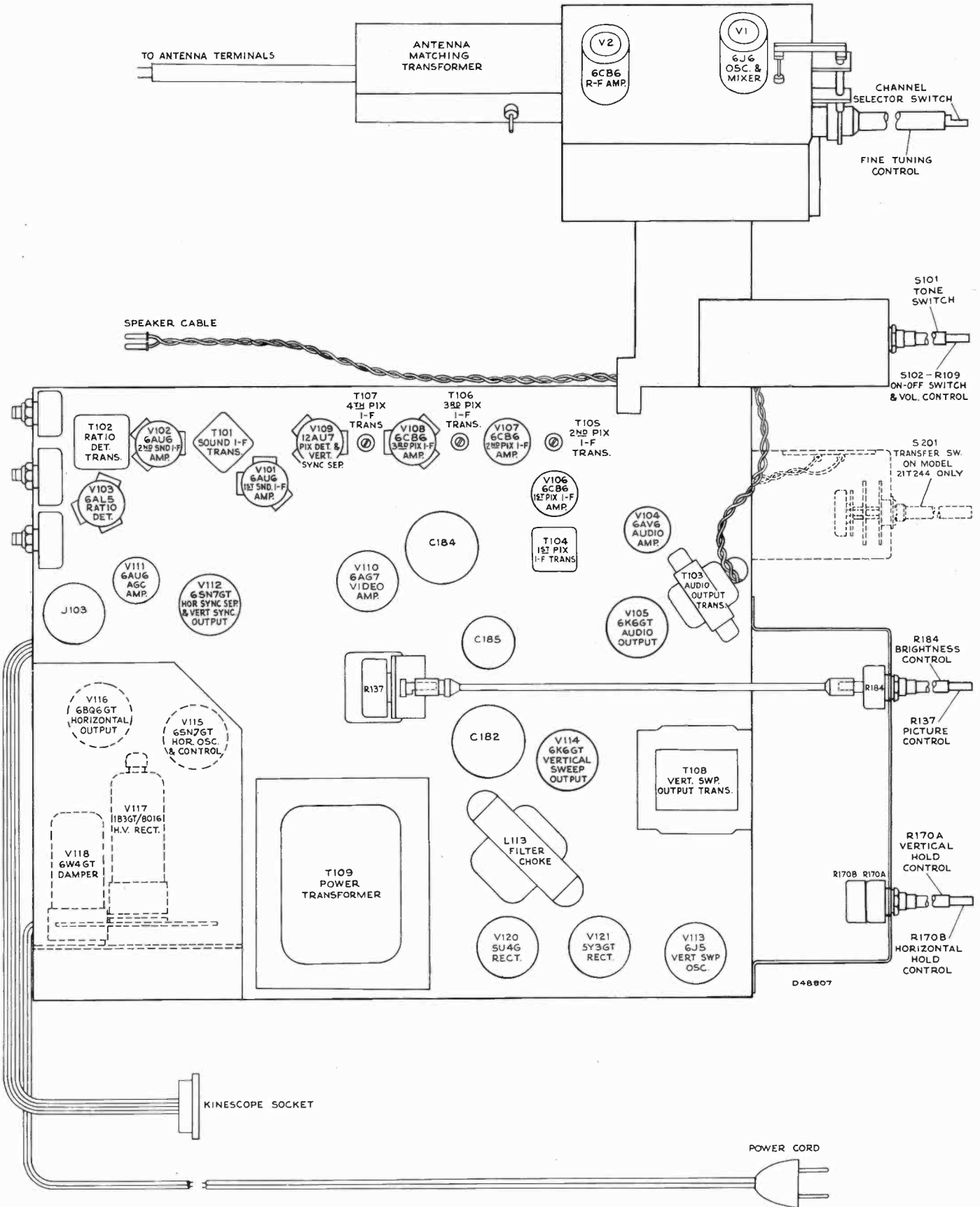

Figure 8—Television Chassis Top View

TELEVISION CHASSIS BOTTOM VIEW

21T242, 21T244

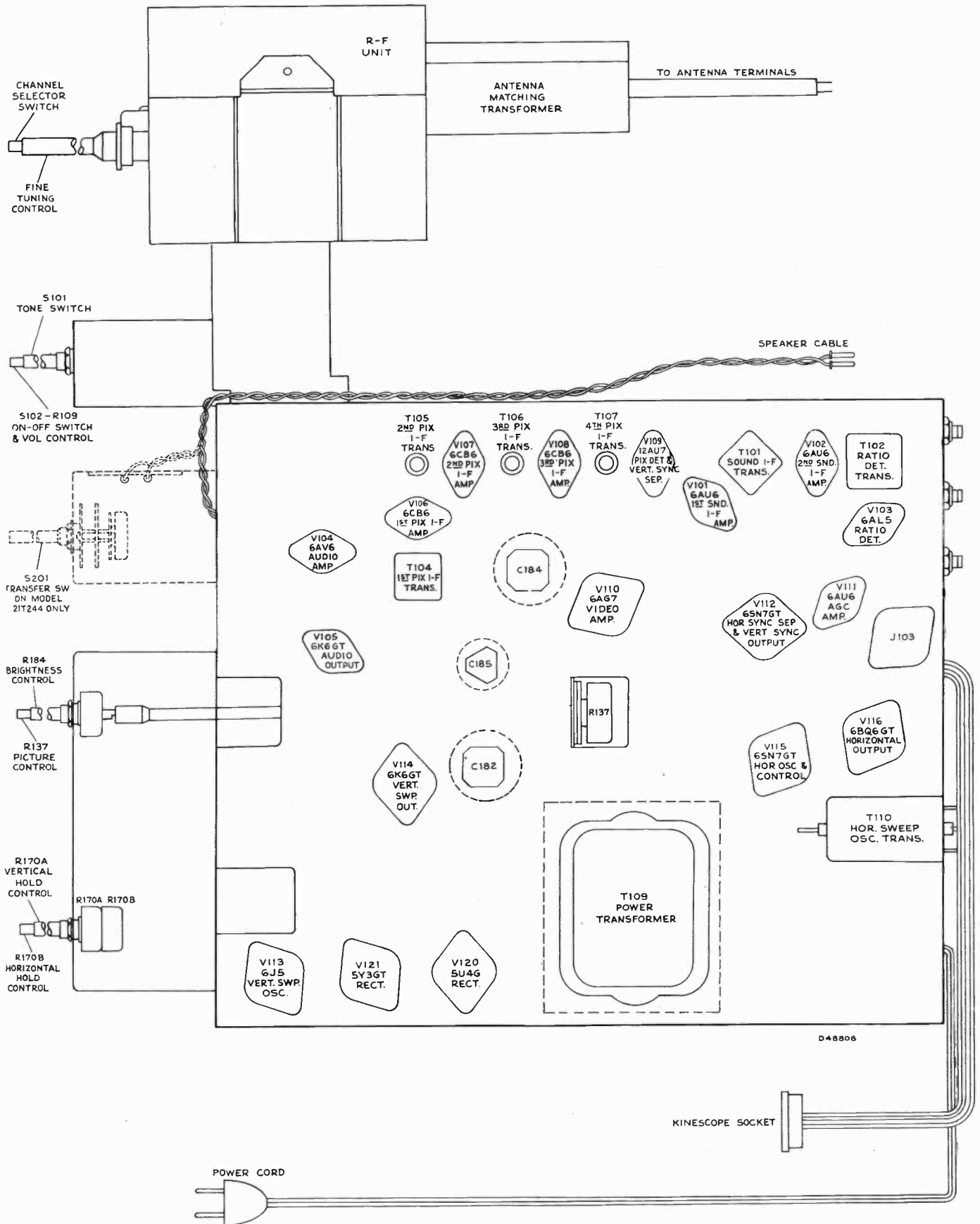

Figure 9—Television Chassis Bottom View

RADIO SCHEMATIC DIAGRAM

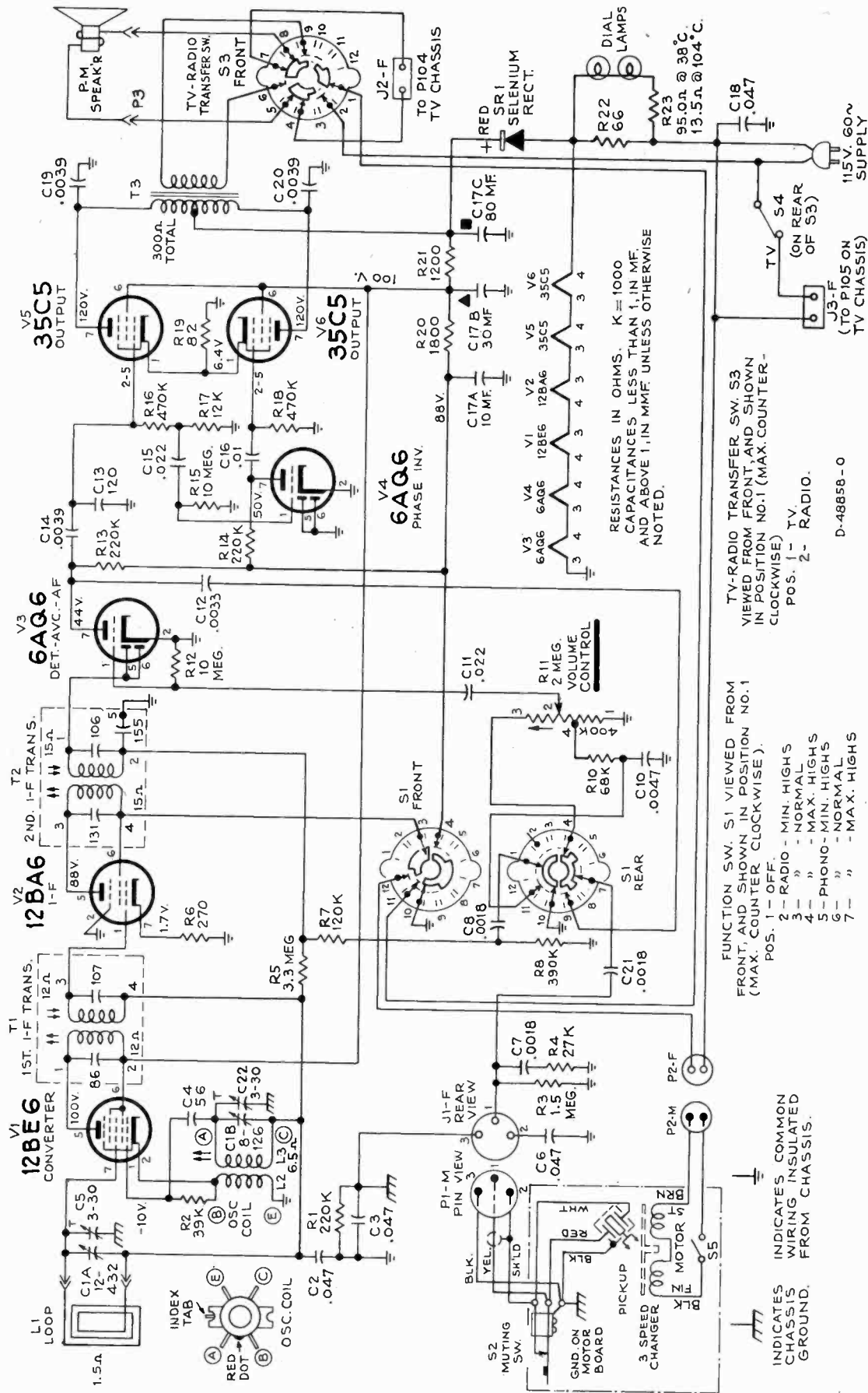

Figure 10—Radio Schematic Diagram
Chassis RC1117B

Critical Lead Dress

1. Dress C15 (.022 mfd. at grid of phase inverter) over tube socket away from filament leads.
2. Keep all filament leads close to chassis.
3. Keep leads of R26 (270 ohms at I-F amplifier cathode) short as possible.
4. Connect outside foil of all capacitors as indicated in schematic diagram.
5. Dress output plate bypasses, C19 and C20, as near chassis as possible.

RADIO DATA 21T242

Dial Pointer Adjustment.—Rotate tuning condenser fully counter-clockwise (plates fully meshed). Adjust indicator pointer so that it is 3¹⁵/₁₆" from the left hand edge of the dial back plate.

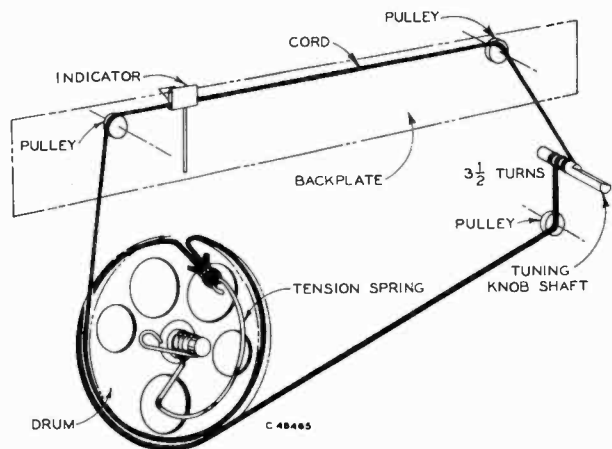

Figure 11—Dial Cord and Drive

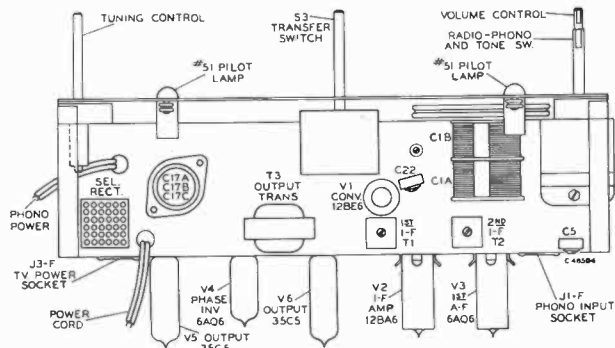

Figure 12—Chassis Top View

Alignment Procedure

Output Meter.—Connect meter across speaker voice coil. Turn volume control to maximum.

Test Oscillator.—Connect low side of test oscillator to common wiring in series with a .1 mf. capacitor. If the test oscillator is a-c operated it may be necessary to use an isolation transformer for the receiver during alignment and the low side of the test oscillator connected directly to common wiring at the electrolytic capacitor. Keep the oscillator output low to prevent a-v-c action.

Steps	Connect the high side of test-oscillator to—	Tune test-osc. to—	Turn radio dial to—	Adjust the following for max. output
1	I-F grid, in series with .1 mfd.	455 kc	Quiet point 1,600 kc end of dial	Pri. & Sec. 2nd I-F transformer
2	Converter grid in series with .1 mfd.			Pri. & Sec. 1st I-F transformer
NOTE.—ANTENNA LOOP AND RECORD CHANGER MUST BE IN CABINET FOR THE FOLLOWING				
3	Short wire placed near loop for radiated signal	1,620 kc	Extreme R. H. end (gang open)	C1B-T (osc.)
4		1,400 kc	1,400 kc	C5 (ant.)
5	Repeat steps 3 & 4 if necessary			

RADIO DATA 21T244

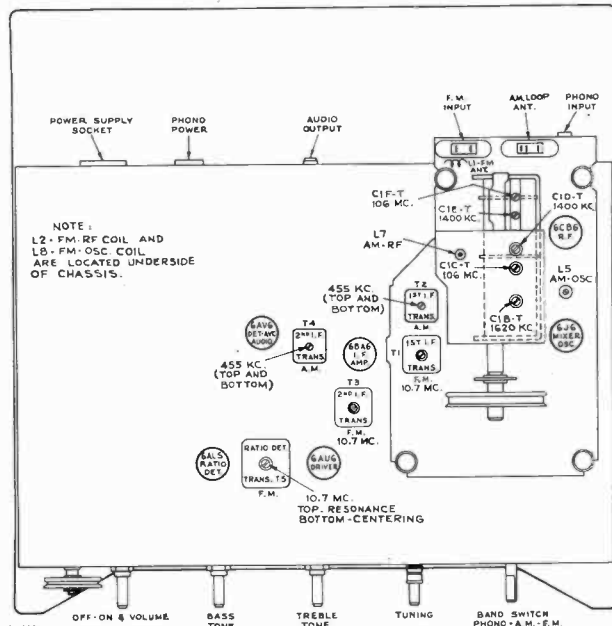

Figure 13—RC1111A Chassis Top View

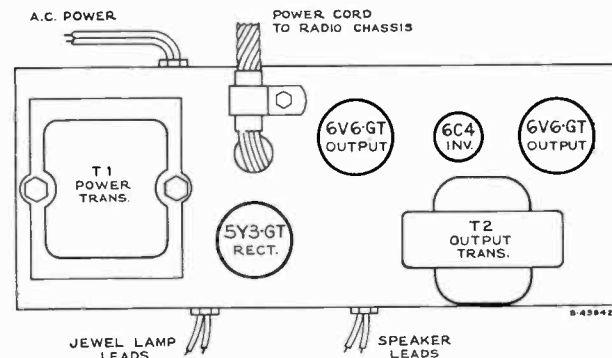
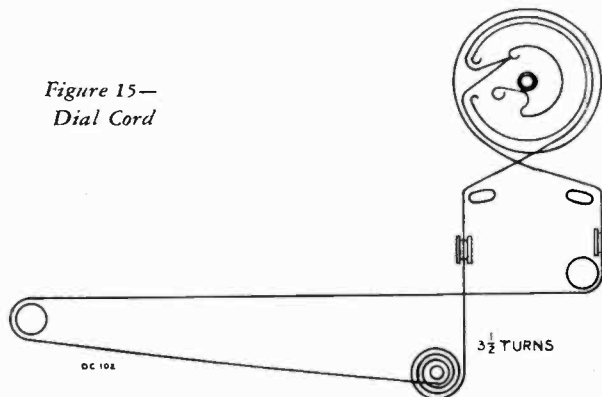

Figure 14—RS141C Chassis Top View

Figure 15—Dial Cord



CRITICAL LEAD DRESS

1. The 1st FM i-f plate lead should be dressed away from the r-f amp plate.
2. Dress the 1st AM i-f plate lead to the S2 wafer away from the AM r-f coil.
3. Dress the a-c power switch wires away from all audio components.
4. Dress C26 down toward the base between the terminal board and the side apron.
5. The C18 bypass ground should be as close to the r-f shelf ground strap as possible.
6. Dress C25 away from the arm contact of the volume control.
7. All leads from the r-f shelf leaving through the shields must be kept as short as possible.
8. Dress the a-c leads in the RS141 chassis away from the audio input leads and components.

21T244

RADIO ALIGNMENT PROCEDURE

Before aligning set, completely mesh the gang and set the dial pointer to the mechanical max. calibration point at extreme left end of dial. When making a complete alignment follow the table below in sequence. Connect the output meter across the speaker voice coil, and turn the receiver volume control to max. Turn tone controls for maximum highs and maximum lows.

"AM" I-F ALIGNMENT

Test-Oscillator.—connect low side of the test-osc. to the chassis, and keep the output as low as possible to avoid a-v-c action.

Steps	Connect the High Side of the Test Osc. to—	Tune Test Osc. to—	Function Switch	Turn Radio Dial to—	Adjust the following
1	Pin No. 1 of (43) in series with .01 mfd.	455 kc. Modulated	AM	Low Freq. end of Dial	†Top and bot. cores of T4 For max. voltage across voice coil.
2	Stator of C1-D in series with .01 mfd.	455 kc. Modulated	AM	Low Freq. end of Dial	†Top and bot. cores of T2 For max. voltage across voice coil.

†For proper adjustment of the i-f cores start with the cores all the way out. The first peak obtained will be the correct one.

FM ALIGNMENT PROCEDURE

Connect probe of "VoltOhmyst" to negative side of C39 and low side to chassis. Top shield must be on and the bottom shield off.

Steps	Connect the High Side of the Test Osc. to—	Tune Test Osc. to—	Function Switch	Radio Dial Tuned to—	Adjust
3	Pin No. 1 of V4 in series with .01 mfd.	10.7 mc.	FM	----	Top of Ratio d-c† Trans. T5 for maximum DC on "VoltOhmyst."
4	Pin No. 1 of V4 in series with .01 mfd.	30% AM Modulated	FM	----	Bottom of Ratio d-c† Trans. T5 for minimum audio output on meter.
5	Repeat steps 3 and 4 as necessary making final adjustment with input set to give approx. — 4.0 v. on "VoltOhmyst."				
6	Pin No. 1 of V3 in series with .01 mfd.	10.7 mc.	FM	88 mc.	†Top and bottom cores of T3 for maximum d-c across C39.
7	Stator of C1-C in series with .01 mfd.	10.7 mc.	FM	88 mc.	†Top and bottom cores of T1 for maximum d-c across C39.
8	Connect sweep generator cable to antenna terminals through 120 ohms in each side of line.	90 mc. 22.5 kc. FM mod.	FM	88 mc.	†OSC, L8 for max. audio output.
9		106 mc. 22.5 kc. FM mod.	FM	Tune to signal	ANT, C1-FT and R-F C1-CT for max. voltage across C39.
10		90 mc. 22.5 kc. FM mod.	FM	Tune to signal	†ANT, L1 and R-F L2 for max. voltage across C39.
11	Repeat steps 8, 9 and 10 as required.				
12	Connect a scope to junction R33 and C35, check response and linearity. Peak separation should be at least 180 kc.				

†For proper adjustment of the i-f cores start with the cores all the way out. The first peak obtained is the correct one.

‡Adjustable by increasing or decreasing spacing between turns.

"AM" R-F ALIGNMENT

Steps	Connect the High Side of the Test Osc. to—	Tune Test Osc. to—	Function Switch	Turn Radio Dial to—	Adjust the following
13	External radiating loop and couple loosely to receiver loop.	1,620 kc.	AM	Min. capacity	*Osc. C1-BT for maximum output.
14		1,400 kc.	AM	Tune to signal	*C1-DT and C1-ET for max. output.
15		600 kc.	AM	Tune to signal	†Osc. L5 for max. output while rocking gang.
16		600 kc.	AM	Tune to signal	**R-F L7 for max. output.
17	Repeat steps 13, 14, 15 and 16 until no additional gain in sensitivity is obtained.				

†Clip a 10,000 ohm resistor across C1-D when making this adjustment.

**Be sure the resistor employed in step 15 is removed for this adjustment.

*All R-F shields must be in place.

RADIO VOLTAGE CHART

Voltages shown are as read with "VoltOhmyst" between indicated terminal and chassis, with receiver operating on 117 volts, and with no signal input.

Tube Type and Function	Tube Element	Pin No.	AM	FM	Phono
V1 6CB6 R-F Amp	Plate	5	215	180	—
	Screen	6	74	62	—
	Cathode	2	0.4	0.4	—
	Grid	1	-0.8	0.4	—
V2 6J6 Osc. and Mixer	Plate	2	55	58	—
	Grid	5	-1.2	-1.3	—
	Plate	1	43	46	—
	Grid	6	-2.0	-1.2	—
V3 6BA6 I-F Amp	Plate	5	210	210	—
	Screen	6	126	115	—
	Cathode	7	0.9	0.7	—
	Grid	1	-0.8	-0.2	—
V4 6AU6 Driver	Plate	5	216	216	—
	Screen	6	150	150	—
	Cathode	7	1.5	1.5	—
	Grid	1	0	0	—

Tube Type and Function	Tube Element	Pin No.	AM	FM	Phono
V5 6AL5 Ratio Det.	—	—	—	—	—
	—	—	—	—	—
V6 6AV6 Audio Amp.	Plate	7	88	88	104
	Grid	1	-0.7	-0.7	-0.8
VI02 6C4 Phase Inverter	Plate	5	87.5	88	120
	Cathode	7	-11	-11	-13
	Grid	6	-16	-16	-19
VI03 6V6GT VI04 6V6GT Audio Power Output	Plate	3	300	300	298
	Screen	4	224	224	292
	Cathode	8	0	0	0
	Grid	5	-17	-17	-21
VI01 5Y3GT Rectifier	Fil.	8	305	305	307

RADIO SCHEMATIC DIAGRAM

21T244

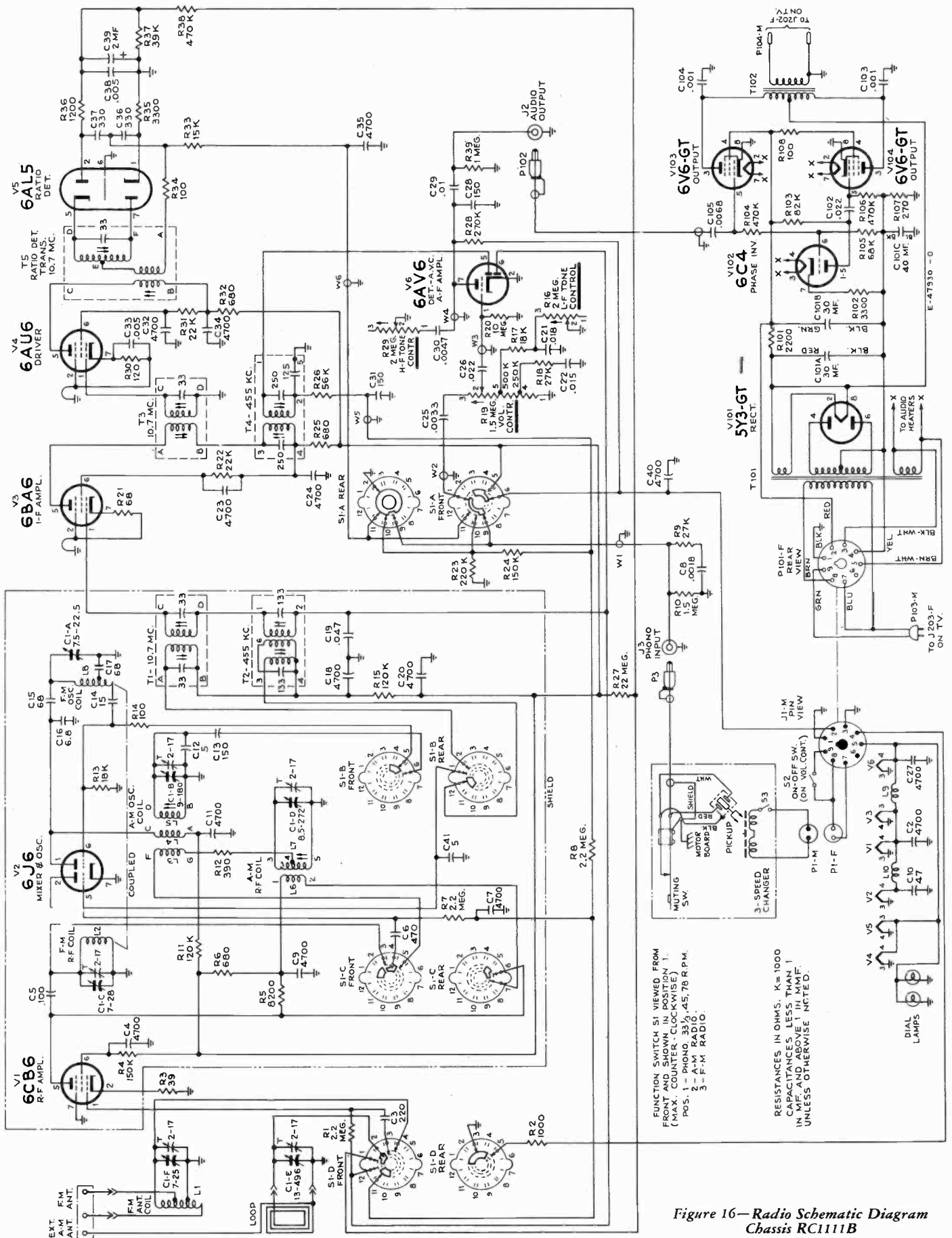

Figure 16—Radio Schematic Diagram Chassis RC1111B

21T242, 21T244

TELEVISION VOLTAGE CHART

The following measurements represent two sets of conditions. In the first condition, a 15000 microvolt test pattern signal was fed into the receiver, the picture synced and the AGC control properly adjusted. The second condition was obtained by removing the antenna leads and short circuiting the receiver antenna terminals. Voltages shown are read with a type WV97A senior "VoltOhmyst" between the indicated terminal and chassis ground and with the receiver operating on 117 volts, 60 cycles, a-c. The symbol < means less than.

Tube No.	Tube Type	Function	Operating Condition	E. Plate		E. Screen		E. Cathode		E. Grid		Notes on Measurements
				Pin No.	Volts	Pin No.	Volts	Pin No.	Volts	Pin No.	Volts	
V1	6J6	Mixer	15000 Mu. V. Signal	2	153	—	—	7	0	5	*-3 to -5	*Depending on channel
			No Signal	2	135	—	—	7	0	5	*-3 to -5	*Depending on channel
V1	6J6	R-F Oscillator	15000 Mu. V. Signal	1	100	—	—	7	0	6	*-3 to -5	*Depending on channel
			No Signal	1	85	—	—	7	0	6	*-3 to -5	*Depending on channel
V2	6CB6	R-F Amplifier	15000 Mu. V. Signal	5	260	6	150	2	1	1	-5.8	
			No Signal	5	220	6	100	2	1.0	1	-0.1	
V101	6AU6	1st Sound I-F Amp.	15000 Mu. V. Signal	5	130	6	142	7	0.8	1	0	
			No Signal	5	116	6	129	7	0.6	1	0	
V102	6AU6	2d Sound I-F Amp.	15000 Mu. V. Signal	5	131	6	148	7	0	1	-5.1	
			No Signal	5	110	6	120	7	0	1	*-0.3	*Unreliable measuring point. Voltage depends on noise.
V103	6AL5	Ratio Detector	15000 Mu. V. Signal	7	0	—	—	1	12	—	—	7.5 kc deviation at 1000 cycles
			No Signal	7	0.7	—	—	1	*5.1	—	—	*Unreliable measuring point. Voltage depends on noise.
V104	6AV6	1st Audio Amplifier	15000 Mu. V. Signal	7	87	—	—	2	0	1	-0.7	At min. volume
			No Signal	7	76	—	—	2	0	1	-0.6	At min. volume
V105	6K6GT	Audio Output	15000 Mu. V. Signal	3	260	4	263	8	19	5	-0.7	At min. volume
			No Signal	3	250	4	251	8	18.5	5	-0.7	At min. volume
V106	6CB6	1st Pix. I-F Amplifier	15000 Mu. V. Signal	5	246	6	258	2	<0.1	1	-8.6	
			No Signal	5	108	6	108	2	0.7	1	*-0.2	*Unreliable measuring point. Make measurement at T104-B
V107	6CB6	2nd Pix. I-F Amplifier	15000 Mu. V. Signal	5	242	6	255	2	<0.1	1	-8.6	
			No Signal	5	108	6	108	2	0.5	1	-0.2	
V108	6CB6	3rd Pix. I-F Amplifier	15000 Mu. V. Signal	5	133	6	172	2	2.1	1	0	
			No Signal	5	115	6	162	2	1.9	1	0	
V109A	12AU7	Picture 2d Det.	15000 Mu. V. Signal	1	-8.4	—	—	3	0	2	-1.3	
			No Signal	1	-1.8	—	—	3	0	2	-0.6	
V109B	12AU7	Vert. Sync Separator	15000 Mu. V. Signal	6	71	—	—	8	0	7	-40	
			No Signal	6	*50 to 100	—	—	8	0	7	*-15	*Unreliable, depends on noise

CHASSIS WIRING DIAGRAM KCS72D-1

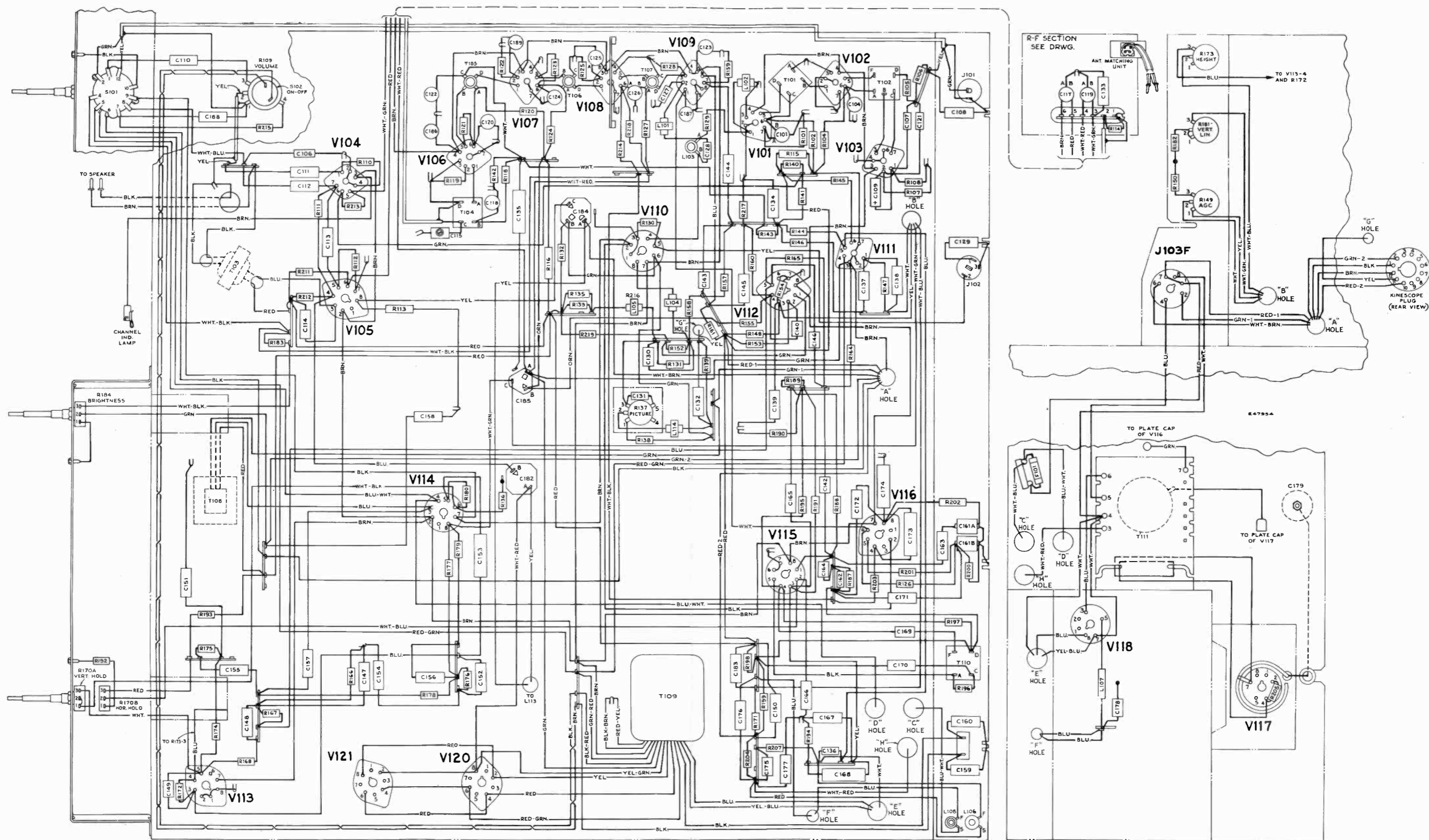

Figure 18—Chassis Wiring Diagram, KCS72D-1

TELEVISION VOLTAGE CHART

21T242, 21T244

Tube No.	Tube Type	Function	Operating Condition	E. Plate		E. Screen		E. Cathode		E. Grid		Notes on Measurements
				Pin No.	Volts	Pin No.	Volts	Pin No.	Volts	Pin No.	Volts	
V110	6AG7	Video Amplifier	15000 Mu. V. Signal	8	130	6	149	5	0.2	4	-1.3	AGC control set for normal operation
			No Signal	8	110	6	130	5	0.5	4	-0.6	AGC control set for normal operation
V111	6AU6	AGC Amplifier	15000 Mu. V. Signal	5	-40	6	250	7	153	1	151	
			No Signal	5	+2.3	6	258	7	135	1	105	
V112A	6SN7GT	Hor. Sync Separator	15000 Mu. V. Signal	2	263	-	-	3	190	1	130	
			No Signal	2	258	-	-	3	138	1	110	
V112B	6SN7GT	Sync Output	15000 Mu. V. Signal	5	58	-	-	6	0	4	-2.1	
			No Signal	5	48	-	-	6	0	4	+0.6	*Depends on noise
V113	6J5	Vertical Oscillator	15000 Mu. V. Signal	3	70	-	-	8	0	5	-15	*Depends on setting of Vert. hold control
			No Signal	3	68	-	-	8	0	5	-14	Voltages shown are synced pix adjustment
V114	6K6GT	Vertical Output	15000 Mu. V. Signal	3	265	4	270	8	30	5	-5	
			No Signal	3	253	4	260	8	28	5	-5	
V115	6SN7GT	Horizontal Osc. Control	15000 Mu. V. Signal	2	165	-	-	3	+1.5	1	-21	
			No Signal	2	160	-	-	3	-10	1	-24	
V115	6SN7GT	Horizontal Oscillator	15000 Mu. V. Signal	5	185	-	-	6	0	4	-80	
			No Signal	5	170	-	-	6	0	4	-88	
V116	6BQ6GT	Horizontal Output	15000 Mu. V. Signal	Cap	*	4	180	8	21.2	5	-13	*High Voltage Pulse Present
			No Signal	Cap	*	4	170	8	21.0	5	-13	*High Voltage Pulse Present
V117	1B3GT /8016	H. V. Rectifier	15000 Mu. V. Signal	Cap	*	-	-	2 & 7	14,000	-	-	*High Voltage Pulse Present
			No Signal	Cap	*	-	-	2 & 7	13,600	-	-	*High Voltage Pulse Present
V118	6W4GT	Damper	15000 Mu. V. Signal	5	270	-	-	3	*	-	-	*High Voltage Pulse Present
			No Signal	5	260	-	-	3	*	-	-	*High Voltage Pulse Present
V119	21AP4	Kinescope	15000 Mu. V. Signal	Cap	14,000	10	400	11	170	2	120	At average Brightness
			No Signal	Cap	13,600	10	385	11	150	2	115	At average Brightness
V120 V121	5U4G 5Y3GT	Rectifiers	15000 Mu. V. Signal	4 & 6	-	-	-	2 & 8	285	-	-	
			No Signal	4 & 6	-	-	-	2 & 8	275	-	-	

R-F UNIT WIRING DIAGRAM

21T242, 21T244

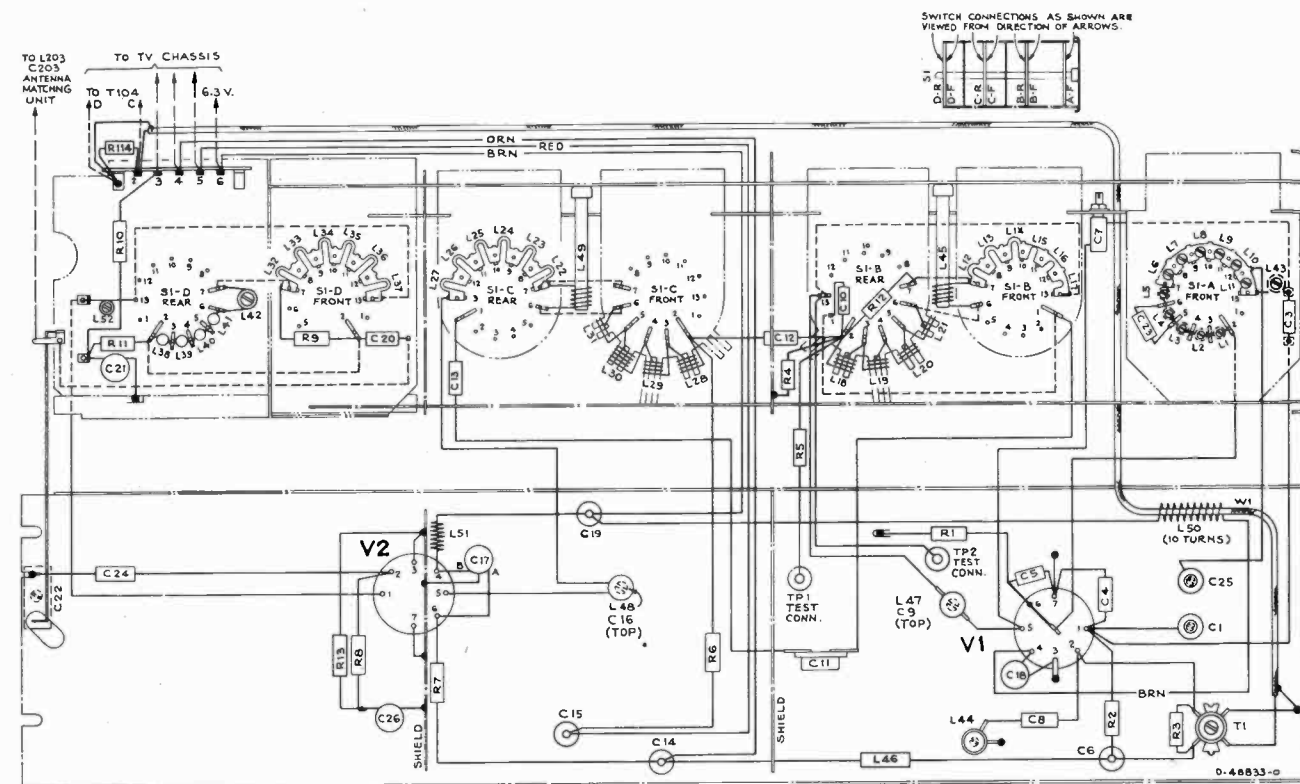

Figure 17—R-F Unit Wiring Diagram

CRITICAL LEAD DRESS:

1. Keep all wiring in the pix i-f, sound i-f and video circuits as short as possible.
2. Keep the leads on C118, C120, C122, C124, C126, R114, R121 and R123 as short and direct as possible.
3. Do not run any leads under C115 trimmer capacitor.
4. Dress C118 vertically parallel to terminals A and B of T104. Dress C135 parallel to terminals A and B of T104 close to the chassis.
5. Keep C127 away from chassis with no more than 1/4 inch leads at each end.
6. Dress the lead from T105(C) to the terminal board, close to the chassis.
7. Keep all filament leads dressed close to the chassis.
8. Ground filaments of V106, V107 and V108 independently of tube shields (pin 8). Use ground lances provided near pins of each socket.
9. Dress lead from pin 5 of V110 to J102-2 close to the chassis.
10. Keep leads to L103 as short as possible.
11. Dress C130, C132, L102, L104, L105, L114, R131, R133, R135 and R139 away from the chassis.
12. Do not tape kinescope cathode lead in with other kinescope leads.
13. Do not change the bus wire connections to pin 2 of V101 and V102. Sleeving is used to insure length and to prevent shorting.
14. Keep leads on C136 short and direct. Dress the lead from C136 to pin 5 of V111 as shown in wiring diagram.
15. Do not dress C170 in such a position that adjustment of T110 is inaccessible.
16. Keep the leads on R201 as short and direct as possible.
17. Dress the lead from pin 3 of V113 to C153 as shown in the wiring diagram.
18. Mount C183 directly on the terminal board provided keeping it as far away from T109 as possible.
19. Dress all leads in the high voltage compartment away from each other and away from the high voltage transformer.

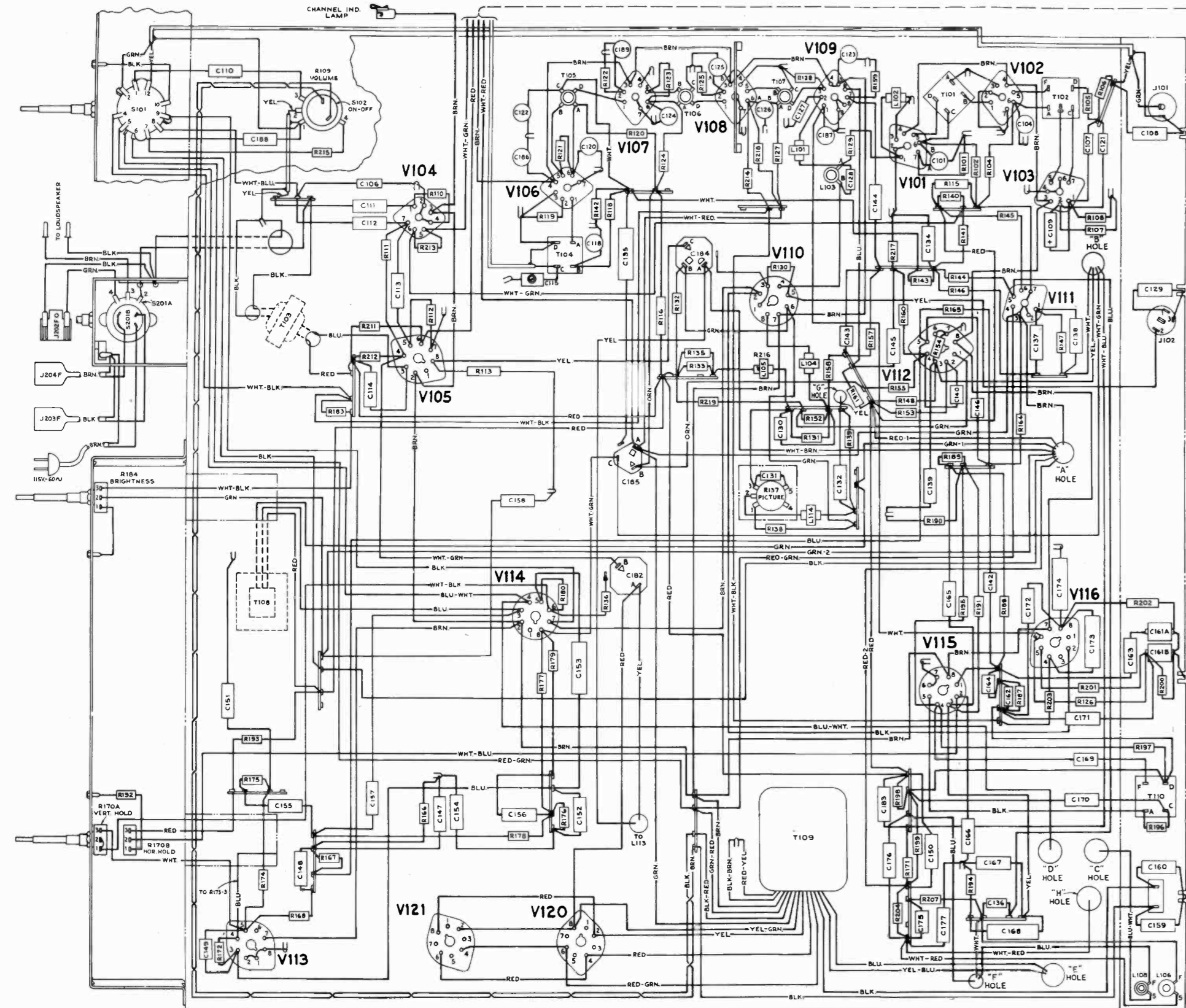
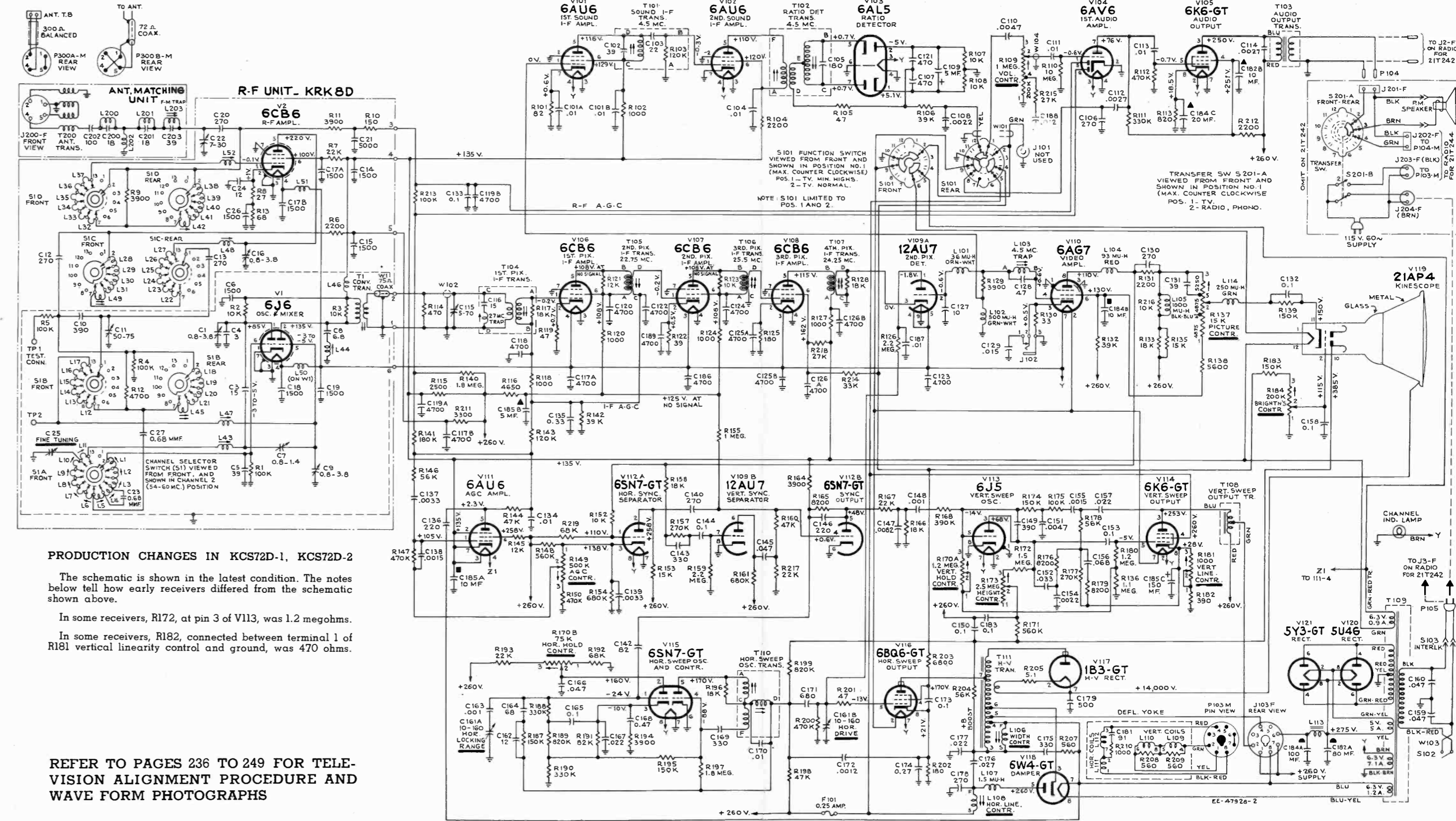
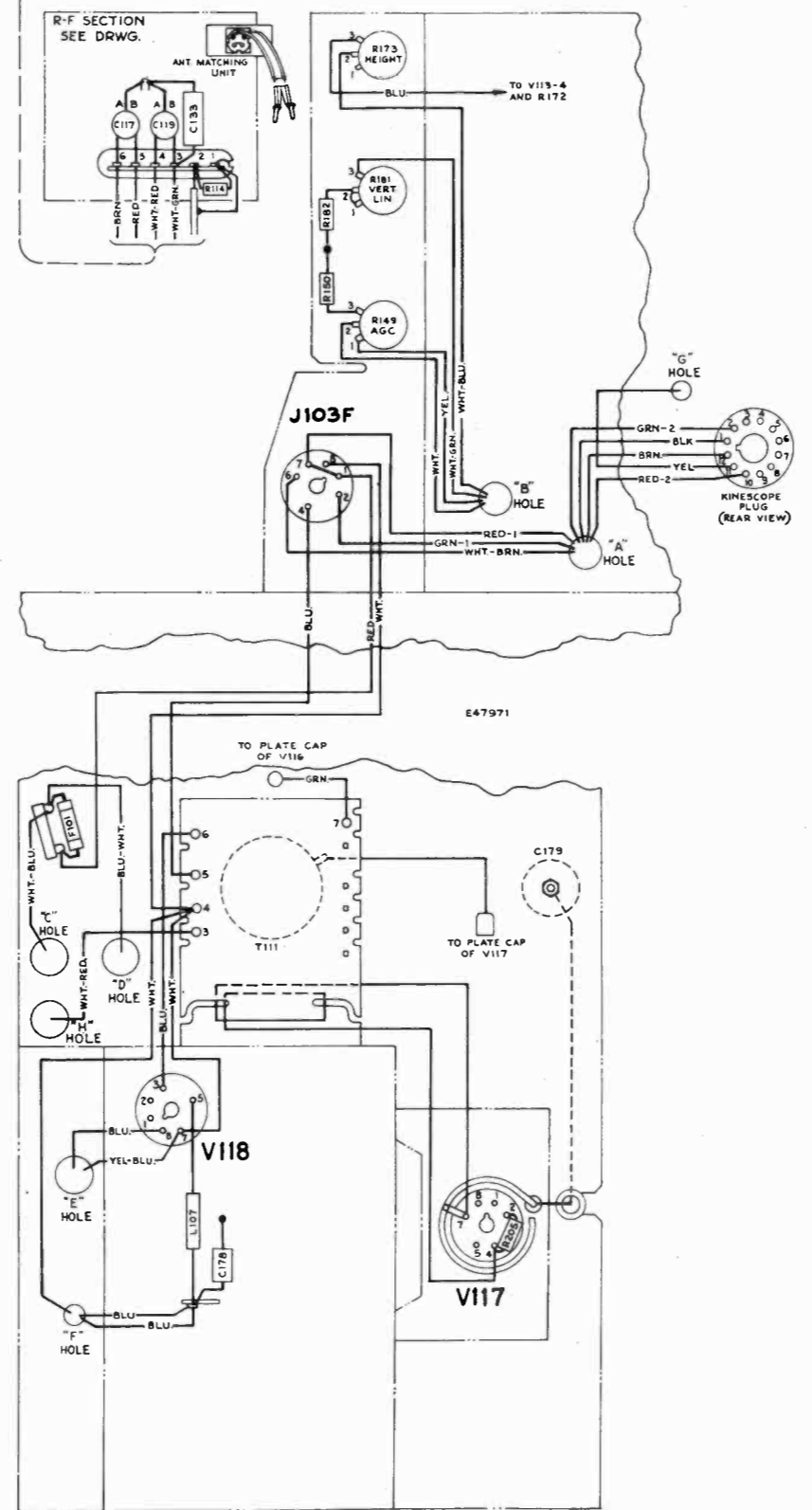

Figure 19—Chassis Wiring Diagram, KCS72D-2



PRODUCTION CHANGES IN KCS72D-1, KCS72D-2

The schematic is shown in the latest condition. The notes below tell how early receivers differed from the schematic shown above.

In some receivers, R172, at pin 3 of V113, was 1.2 megohms.

In some receivers, R182, connected between terminal 1 of R181 vertical linearity control and ground, was 470 ohms.

REFER TO PAGES 236 TO 249 FOR TELEVISION ALIGNMENT PROCEDURE AND WAVE FORM PHOTOGRAPHS

All resistance values in ohms. K=1000.

All capacitance values less than 1 in MF and above 1 in MMF unless otherwise noted.

Direction of arrows at controls indicates clockwise rotation.

All voltages measured with "VoltOhms" and with no signal input. Voltages should hold within ±20% with 117 v. a-c supply.

Figure 20—Television Circuit Schematic Diagram

21T242, 21T244 REPLACEMENT PARTS

Table with columns: STOCK No., DESCRIPTION, STOCK No., DESCRIPTION. Includes R-F UNIT ASSEMBLIES, CHASSIS ASSEMBLIES, and various electronic components like capacitors, coils, and transformers.

21T242, 21T244 REPLACEMENT PARTS (Continued)

Table with columns: STOCK No., DESCRIPTION, STOCK No., DESCRIPTION. Continuation of replacement parts for 21T242 and 21T244, including various electronic components and chassis assemblies.

REPLACEMENT PARTS (Continued)

Table with columns: STOCK No., DESCRIPTION, STOCK No., DESCRIPTION. Continuation of replacement parts, including speaker assemblies, miscellaneous parts, and amplifier assemblies.

21T242, 21T244 REPLACEMENT PARTS (Continued)

Table with columns: STOCK No., DESCRIPTION, STOCK No., DESCRIPTION. Continuation of replacement parts, including speaker assemblies, miscellaneous parts, and amplifier assemblies.

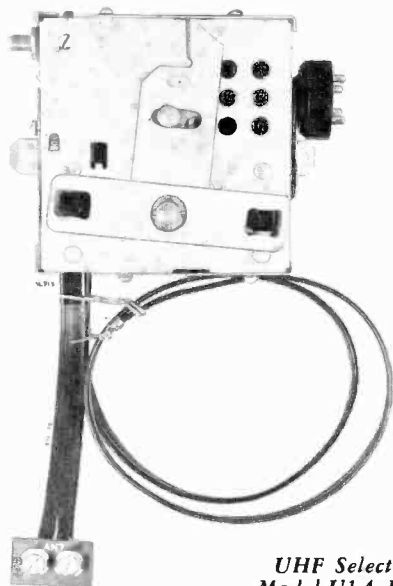

*UHF Selector
Model U1A, U1B*



RCA VICTOR

UHF SELECTOR MODELS U1A, U1B

Chassis Nos. KRK 19, KRK 19A

— Mfr. No. 274 —

SERVICE DATA

— 1952 No. T6 —

PREPARED BY RCA SERVICE CO., INC.
FOR
RADIO CORPORATION OF AMERICA
RCA VICTOR DIVISION
CAMDEN, N. J., U. S. A.

GENERAL DESCRIPTION

UHF Selectors Models U1A and U1B permit the reception of any one UHF television station within receiving range when employed with a VHF television receiver.

The unit employs one tube and a crystal rectifier. Filament

and plate power is obtained from the receiver to which it is attached. The two models are identical except for power cables. The UHF Selector units may be mounted on the back of the receiver cabinet or other convenient location, as long as the selector switch is accessible.

ELECTRICAL SPECIFICATIONS

TELEVISION R-F FREQUENCY RANGE

All 70 UHF television channels470 mc. to 890 mc.
I-F Output FrequencyChannel 5 or 6

POWER SUPPLY RATING

Filament6.3 volts, .225 amps.
PlateApprox. 10 ma at 70 to 370 volts (see text)

ANTENNA INPUT IMPEDANCE

72 ohms unbalanced.

TUBE COMPLEMENT

Tube Used	Function
RCA 6AF4	R-F Oscillator
CK 710	Crystal Mixer

INSTALLATION INSTRUCTIONS

UHF Selector U1A is provided with a 52 inch power cable with a 7 pin miniature adapter socket for use with television receivers which employ a 6AQ5 audio output stage.

UHF Selector U1B is provided with a similar power cable except that it employs an octal adapter socket for use with television receivers which use a 6K6GT or 6V6 audio output tube.

Table No. 2 on pages 3 and 4 lists all RCA Victor television receivers to date and the UHF Selector to be employed. Consult the table and select the proper selector for the receiver.

Mount the UHF Selector on the back cover of the cabinet with the adjustment screw holes facing up. Be sure to locate the selector so that the selector switch may be reached conveniently from the top or side of the cabinet and so that the cables may be easily attached.

Mount the selector VHF terminal board on the back of the cabinet.

To install the UHF Selector power cable, remove the television receiver audio output tube and plug the adapter socket into the receiver audio tube socket. In all television-radio combinations, except models 21T242 and 21T244 plug the adapter into the radio's audio output tube socket. Insert the audio output tube into the adapter socket. Ground the black lead with the spade terminal under the most convenient screw on the chassis. Dress the power cable out the back of the cabinet in the most convenient and orderly manner. With the end of the power cable hanging out the back of the cabinet, fasten the receiver back cover in place making sure that the cable is not pinched under at any point. Connect the power cable to the selector.

Connect the UHF antenna to the UHF Selector UHF antenna terminals.

Connect the VHF antenna to the Selector's VHF antenna terminals.

Connect the UHF Selector output leads to the television receiver antenna terminals.

The UHF Selector is wired with a jumper across R6 as shown in the schematic diagram for receivers which provide 270 volts at the adapter socket. If the receiver provides 370 volts at the adapter socket, the jumper across R6 should be removed. See Table 2 for recommendations for RCA Victor receivers.

USE ON OTHER MAKES OF RECEIVERS

The U1A and U1B UHF Selectors will provide satisfactory UHF reception on other makes of receivers provided that the proper voltages for operation of the selector can be obtained from the receiver.

The U1A and U1B UHF Selectors were designed for use on receivers in which the tube filaments are fed in parallel from a 6.3 volt transformer winding. Since the black lead of the selector power cable is connected to the selector chassis, the U1 series selectors should not be employed with any receiver in which a direct connection exists between the a-c power line and the receiver d-c power supply.

The plate voltage available from the receiver may not be optimum for operation of the selector as wired. It is very important that between 60 and 90 volts should be present at the junction of R2 and R6 in order to obtain optimum crystal current. The voltage at the junction of R2 and R6 should be measured with a "VoltOhmyst" and with the UHF Selector shield in place. To obtain proper voltage at R2 and R6, shunt R4, R5 and R6 as necessary with resistors of adequate wattage to obtain the desired voltage.

The television receiver operating voltages should not be materially altered by the installation of the UHF Selector.

In some makes of receivers it may be necessary to rewire the adapter socket and cable to suit the particular type of audio output tube. In some instances where filament wiring difficulties are encountered, it may be necessary to remove the adapter socket and wire the power cable into the television receiver.

ADJUSTMENT INSTRUCTIONS

The 6AF4 oscillator coil is provided with shorting Jumper "B" which is connected in place in a new UHF Selector unit. With this strap in place, the selector will tune from channel 45 through 83.

If the channel to be received is below channel 45, Jumper "B" must be clipped out and removed. The selector will then tune from channel 14 through 44.

Turn the receiver on and to channel 5 or 6, whichever is vacant in the operating area. Switch the UHF Selector switch to the UHF operating position. Set the television receiver fine tuning control to the middle of its range and the volume control clockwise until background noise is heard.

Adjust the UHF Selector Primary, Secondary and Oscillator adjustments to the approximate locations as indicated in Table 1.

Adjust the selector oscillator trimmer C13 until sound from the desired UHF station is heard. This adjustment must be made very slowly for it is easy to pass by the proper adjustment point without hearing the sound, particularly if the signal is weak.

Once the sound is obtained, adjust the primary trimmer C1 for the best sound and picture. Next, adjust the secondary trimmer C3 for best sound and picture.

Readjust the UHF Selector oscillator trimmer so that the best sound and picture occur when the television receiver fine tuning control is in the middle of its range. Repeat C1 and C3 for best sound and picture.

Note: In adjusting the UHF Selector oscillator, it may be possible to obtain sound in two positions of the oscillator trimmer. However, for proper reception of both sound and picture, the oscillator should be lower in frequency than the station picture carrier. Therefore, if sound is heard in two positions of the trimmer, the most clockwise position is the correct one.

The input circuits to the UHF Selector tune very sharply—particularly the primary. If the UHF signal is very weak, the primary and secondary trimmers C1 and C3 must be in approximately the correct adjustment in order to be able to hear the sound upon adjusting the oscillator trimmer C13. If it is not possible to hear the sound by the method described above, preset the primary and secondary trimmers one-quarter turn in the same direction from their previous position and search for the sound by adjustment of oscillator trimmer C13. Repeat this procedure until the sound is obtained. If the above method should not work, try connecting one side of the transmission line to the crystal at L2 and the other side to the chassis.

Under some conditions interfering beats may be obtained between the UHF Selector oscillator and harmonics of the television receiver oscillator which show up as lines in the picture. In some cases these may be eliminated by adjusting the receiver fine tuning for elimination of the beat, then retuning the selector oscillator core for best sound and picture. As an alternate method switch the television receiver to any vacant channel between 2 and 6 and retune the UHF Selector oscillator trimmer C13 to obtain sound and picture.

Under some conditions, adjacent channel interference may be experienced if the VHF station is strong and the UHF signal is weak. In such cases, it may be desirable to provide a

shielded cable between the UHF Selector unit and the television receiver r-f unit.

As a test for drift, turn the receiver off for five minutes then turn it on again. Within approximately one minute it should be possible to receive the UHF station by adjustment of the receiver fine tuning control and without the necessity of re-adjusting the UHF Selector oscillator.

When it is desired to receive a VHF station on the television receiver, switch the UHF selector switch to the VHF position and operate the receiver normally.

TABLE 1—ADJUSTMENTS VERSUS CHANNEL NUMBER

CHANNEL	PRIMARY & SECONDARY	OSCILLATOR
14	6.5 turns CW	1 turn CW
15-16	5.5 turns CW	1 turn CCW
17-19	5.0 turns CW	2 turns CCW
20-23	4.5 turns CW	3 turns CCW
24-27	3.5 turns CW	4 turns CCW
28-32	2.5 turns CW	5 turns CCW
33-37	2.0 turns CW	6 turns CCW
38-41	1.5 turns CW	7 turns CCW
42-44	1.0 turn CW	8 turns CCW
45-46	.5 turn CW	1 turn CW
47-50	.5 turn CCW	1 turn CCW
51-54	1.0 turn CCW	2 turns CCW
55-60	1.5 turns CCW	3 turns CCW
61-67	2.0 turns CCW	4 turns CCW
68-75	2.5 turns CCW	5 turns CCW
76-82	3.0 turns CCW	6 turns CCW
83	3.5 turns CCW	7 turns CCW

The above tabulation is based on the assumption that the Selector is aligned to 670 mc, the condition in which the unit leaves the factory. CW means clockwise. CCW means counter clockwise.

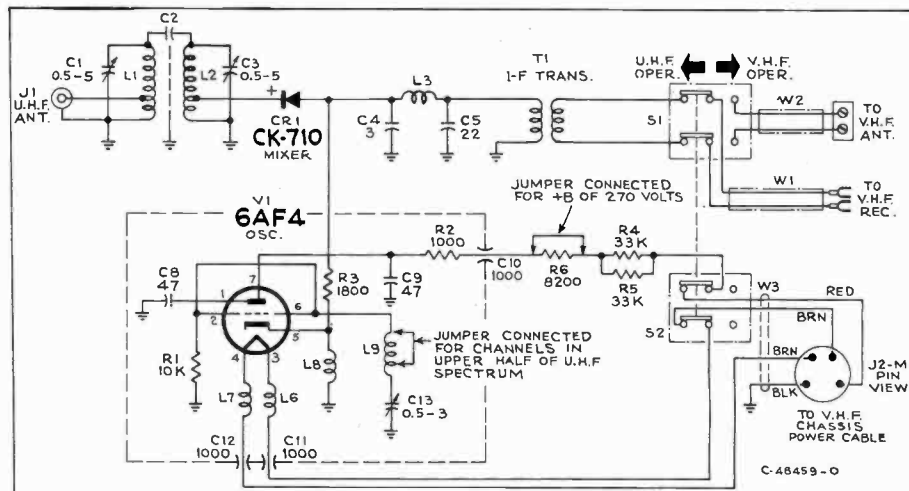
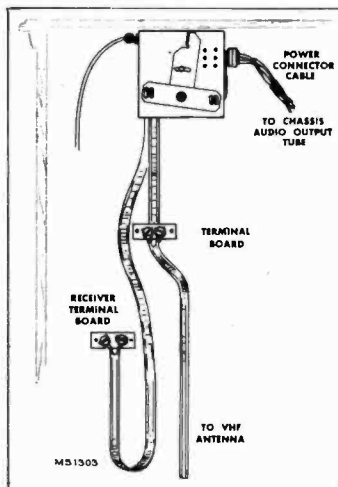
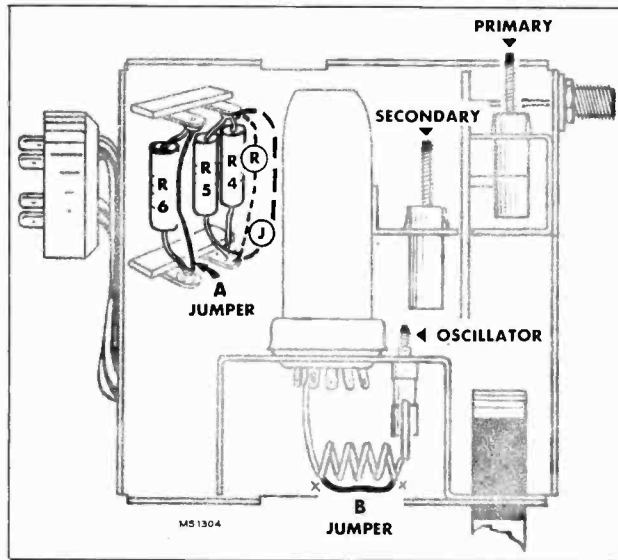

REPLACEMENT PARTS U1A, U1B

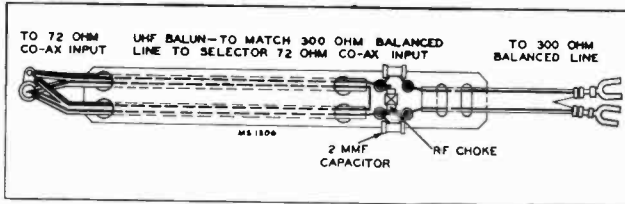

BALUN—In some cases it may be possible to employ the VHF antenna for UHF reception by connecting a balun to the selector VHF antenna terminal board and to J1. Check to insure that the permanently connected balun does not impair VHF reception.

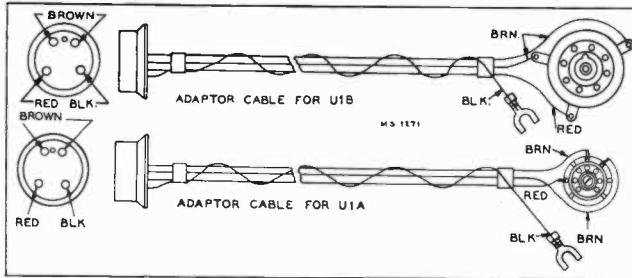

TABLE The table below lists all RCA Victor television receivers NO. 2 to date and data regarding the selector to be employed. The voltages in the receiver and hence the voltage at the selector may vary depending on the signal strength, the a-c line voltage and the particular chassis involved. In some cases, therefore, it may be necessary to employ slightly different values of resistors across R4 than that specified in the table below. In any event, the voltage at the junction of R2 and R6 should be between 60 and 90 volts as measured with a "VoltOhmyst" with the selector shield in place, with the receiver operating and the desired UHF channel being received.

STOCK No.	DESCRIPTION
77275	Adapter—7 pin miniature tube adapter for U1A
77276	Adapter—Standard octal tube adapter for U1B
74104	Board—"VHF Antenna" terminal board, less cable
77273	Capacitor—Tubular trimmer, 0.5—3 mmf., complete with adjustable core (C13)
77272	Capacitor—Tubular trimmer, 0.5—5.0 mmf., complete with adjustable core (C1, C3)
77277	Capacitor—Ceramic, 3 mmf. (C4)
76557	Capacitor—Ceramic, 22 mmf. (C5)
77278	Capacitor—Ceramic, disc, 47 mmf. (C8, C9)
77084	Capacitor—Ceramic, feed-thru, 1000 mmf. (C10, C11, C12)
77280	Coil—Cathode choke coil (L8, R3)
77279	Coil—Heater choke coil (L3, L6, L7)
77281	Coil—Oscillator coil (L9)
77088	Connector—Single contact, for antenna connection (J1)
5040	Connector—4 contact female, for adapter cable (J2)
5039	Connector—4 contact male connector for power cable
77271	Printed Circuit—Input printed circuit comprising two inductances and one capacitance (L1, L2, C2)
77282	Rectifier—Germanium crystal rectifier (CR1)
	Resistor—Fixed, composition:
503210	1000 ohms, $\pm 10\%$, 1/2 watt (R2)
523282	8200 ohms, $\pm 10\%$, 2 watts (R6)
503310	10,000 ohms, $\pm 10\%$, 1/2 watt (R1)
523333	33,000 ohms, $\pm 10\%$, 2 watts (R4, R5)
75192	Shield—Tube shield for V1
77274	Socket—Tube socket, 7 pin, miniature, steatite saddle-mounted for V1
76961	Spring—Retaining spring for tube shield
46760	Switch—"UHF-VHF" switch (S1, S2)
77283	Transformer—I-F transformer (T1)

RECEIVER MODELS	AUDIO OUTPUT		USE SELECTOR	JUMPER ACROSS R6	JUMPER OR RESISTOR ACROSS R4 AND R5
	TUBE	VOLTS			
621TS	6K6GT	200	U1B	Leave In	22K, 1 watt
630TS, 630TCS	6K6GT	265	U1B	Leave In	None
641TV	6F6G	270	U1B	Leave In	None
648PTK	6F6G	270	U1B	Leave In	None
648PV	6F6G	270	U1B	Leave In	None
721TS, 721TCS	6K6GT	200	U1B	Leave In	22K, 1 watt
730TV1, 730TV2	6K6GT	245	U1B	Leave In	None
741PCS	6F6G	250	U1B	Leave In	None
8PCS41	6F6G	250	U1B	Leave In	None
8TS30	6K6GT	245	U1B	Leave In	None
8TV41	6F6G	270	U1B	Leave In	None
8T241, 8T243, 8T244	6K6GT	80	U1B	Leave In	Jumper across R4
8T270, 8TC270, 8TC271	6K6GT	152	U1B	Leave In	6.8K, 0.5 watt
8TR29, 8TK29	6K6GT	80	U1B	Leave In	Jumper across R4
8TK320	6V6GT	152	U1B	Leave In	6.8K, 0.5 watt
8TV321, 8TV323	6V6GT	295	U1B	Leave In	None
9PC41	6F6G	250	U1B	Leave In	None
9T240, 9T240K, 9TC240	6K6GT	80	U1B	Leave In	Jumper across R4
9TC245, 9TS247, 9TC249	6K6GT	80	U1B	Leave In	Jumper across R4
9T246	6K6GT	80	U1B	Leave In	Jumper across R4
9T256	6K6GT	80	U1B	Leave In	Jumper across R4
9T270, 9TC272, 9TC275	6K6GT	152	U1B	Leave In	6.8K, 0.5 watt
9TW309	6V6GT	80	U1B	Leave In	Jumper across R4
9TW333	6V6GT	217	U1B	Leave In	33K, 1 watt

U1A, U1B

TABLE NO. 2—Continued

RECEIVER MODELS	AUDIO OUTPUT		USE SELECTOR	JUMPER ACROSS R6	JUMPER OR RESISTOR ACROSS R4 AND R5
	TUBE	VOLTS			
9TW390	6V6GT	210	U1B	Leave In	27K, 1 watt
T100	6K6GT	80	U1B	Leave In	Jumper across R4
T120, T121	6K6GT	80	U1B	Leave In	Jumper across R4
TC124, TC125, TC127	6K6GT	80	U1B	Leave In	Jumper across R4
TA128	6V6GT	80	U1B	Leave In	Jumper across R4
TA129	6V6GT	80	U1B	Leave In	Jumper across R4
T164, TC165, TC166, TC167, TC168	6K6GT	120	U1B	Leave In	5K, 1 watt
TA169	6V6GT	85	U1B	Leave In	Jumper across R4
S1000	6V6GT	210	U1B	Leave In	27K, 1 watt
2T51, 2T61	6AQ5	268	U1A	Leave In	None
2T81	6V6GT	210	U1B	Leave In	27K, 1 watt
4T101	6AQ5	270	U1A	Leave In	None
4T141	6V6GT	210	U1B	Leave In	27K, 1 watt
6T72	6K6GT	120	U1B	Leave In	5K, 1 watt
6T53, 6T54, 6T64, 6T65	6K6GT	360	U1B	Clip Out	None
6T71, 6T74, 6T75, 6T76	6K6GT	360	U1B	Clip Out	None
6T84	6V6GT	210	U1B	Leave In	27K, 1 watt
6T86, 6T87	6V6GT	290	U1B	Leave In	None
7T103, 7T103B, 7T104, 7T104B	6K6GT	360	U1B	Clip Out	None
7T11B, 7T112, 7T112B, 7T122	6K6GT	360	U1B	Clip Out	None
7T122B, 7T123, 7T123B, 7T124	6K6GT	360	U1B	Clip Out	None
7T125B	6K6GT	360	U1B	Clip Out	None
7T132	6AQ5	360	U1A	Leave In	None
7T143	6V6GT	290	U1B	Leave In	None
9T57, 9T77, 9T79	6K6GT	360	U1B	Clip Out	None
9T89	6V6GT	290	U1B	Leave In	None
9T105, 9T126, 9T128	6K6GT	360	U1B	Clip Out	None
9T147	6V6GT	290	U1B	Leave In	None
16T152	6K6GT	360	U1B	Clip Out	None
17T150, 17T151, 17T163	6AQ5	250	U1A	Leave In	None
17T153, 17T154, 17T155, 17T160	6AQ5	250	U1A	Leave In	None
17T162, 17T172, 17T172K, 17T173	6AQ5	250	U1A	Leave In	None
17T173K, 17T174, 17T174K	6AQ5	250	U1A	Leave In	None
17T200, 17T201, 17T202	6K6GT	250	U1B	Leave In	None
17T211, 17T220	6K6GT	250	U1B	Leave In	None
17T250DE, 17T261DE	6AQ5	250	U1A	Leave In	None
21T159, 21T159DE, 21T165	6AQ5	356	U1A	Clip Out	None
21T174DE, 21T176, 21T177	6AQ5	356	U1A	Clip Out	None
21T178, 21T178DE, 21T179, 21T179DE	6AQ5	356	U1A	Clip Out	None
21T197DE	6V6GT	290	U1B	Leave In	None
21T208, 21T217, 21T218	6K6GT	250	U1B	Leave In	None
21T227, 21T228, 21T229	6K6GT	250	U1B	Leave In	None
21T242 See note below	6K6GT	250	U1B	Leave In	None
21T244 See note below	6K6GT	250	U1B	Leave In	None

NOTE: Model 21T242 and 21T244 receivers have separate audio systems for radio and television operation. It is therefore necessary to plug the power cable adapter into the television audio output tube socket rather than into the radio audio system.

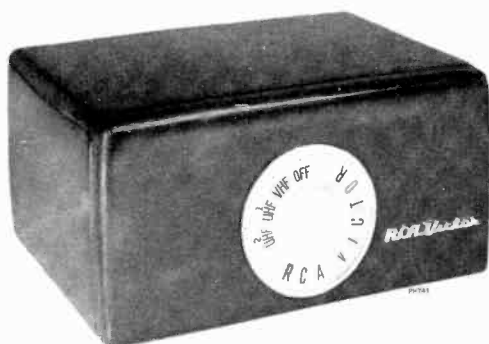

*UHF Selectors
Models U2, U2A*

RCA VICTOR

UHF SELECTORS

MODELS U2, U2A

Chassis Nos. KCS 79 or KCS 79A

— Mfr. No. 274 —

SERVICE DATA

— 1952 No. T7 —

PREPARED BY RCA SERVICE CO., INC.
FOR

RADIO CORPORATION OF AMERICA

RCA VICTOR DIVISION

CAMDEN, N. J., U. S. A.

GENERAL DESCRIPTION

UHF Selectors Models U2 and U2A permit the reception of any two UHF television stations within receiving range when employed with a VHF television receiver.

These units employ two tubes, a crystal rectifier and a selenium power rectifier. The units are housed in small metal cabinets and are operated by a single control knob.

ELECTRICAL SPECIFICATIONS

TELEVISION R-F FREQUENCY RANGE

All 70 UHF television channels..... 470 mc. to 890 mc.
I-F Output Frequency..... Channel 5 or 6

POWER SUPPLY RATING

WEIGHT AND DIMENSIONS

Net Weight	Shipping Weight	Width Inches	Height Inches	Depth Inches
5	6½	8¾	4¾	7¾

ANTENNA INPUT IMPEDANCE

UHF—300 ohms balanced (or 72 ohms unbalanced on U2).
VHF—300 ohms balanced.

TUBE COMPLEMENT

Tube Used	Function
CK 710.....	Crystal Mixer
6BQ7 (U2), 6BQ7A (U2A).....	R-F Oscillator
6CB6.....	I-F Amplifier

INSTALLATION INSTRUCTIONS

Remove the UHF Selector from the shipping carton. Make sure that all tubes are in place and firmly seated in their sockets. Place the selector on top of or near the VHF television receiver in a position which will permit convenient operation.

The UHF Selectors have been designed to operate from either of two or three types of antenna installations. They will operate from the VHF antenna, or from a separate UHF antenna with 300 ohm transmission line (or with the U2, from a separate UHF antenna with 72 ohm co-ax transmission line).

In all cases, the VHF antenna transmission line must be disconnected from the VHF receiver and reconnected to the selector VHF antenna terminals. A short length of 300 ohm line must then be connected between the VHF receiver antenna terminals and the selector terminals marked "Receiver".

If the UHF signals from the VHF antenna are strong and free from reflections, the above connections are all that are required.

Model U2

If a separate UHF antenna with 300 ohm transmission line is employed, connect the line to the terminal board marked "UHF". Then disconnect the 300 ohm line to the UHF terminal board TB1 on the inside of the selector. Make sure that the balun is connected to the terminal board marked "UHF" and is also connected to the selector input jack J1.

If a separate UHF antenna with 72 ohm co-ax transmission line is employed, remove the balun from J1, attach a male co-ax fitting to the UHF antenna transmission line and plug it into the selector co-ax input J1. Dress or tape the co-ax line so that it cannot be pulled out if the customer moves the selector.

See figures 1 2 and 3 for proper connections of the different transmission lines.

Model U2A

If a separate UHF antenna with 300 ohm transmission line is employed, connect the line to the terminal board marked "UHF ANT". Disconnect the 300 ohm jumper to the "UHF ANT" terminal board, at the UHF ANT terminal board TB4.

If desired a separate UHF antenna with 72 ohm co-ax transmission line may be employed. Remove the jumper from TB4 and connect the co-ax transmission line, through a "balun" to the "UHF ANT" terminal board.

See figures 4, 5 and 6 for proper connections of the different transmission lines.

Plug the television receiver power cord into the a-c receptacle on the back of the selector, and plug the selector power cord into the nearest 110 volt a-c outlet. With this connection, if the VHF receiver "on-off" switch is left in the on position, both the receiver and the selector will be controlled by the selector switch.

With the selector switch in the VHF position, the receiver is turned on, the selector is on but in standby condition and the VHF antenna is connected through to the receiver.

With the selector switch in the UHF 1 position, the selector is operating, the VHF antenna is disconnected from the receiver, the selector output is connected to the receiver and the antenna employed for UHF operation is connected to the selector input. A similar condition exists when the selector switch is in the UHF 2 position.

To receive a UHF station, switch the selector switch to UHF 1 or UHF 2 and the television receiver to channel 5 or 6, whichever is vacant in the receiving area. Tune the VHF receiver fine tuning control to obtain the best sound and picture.

U2, U2A

INSTALLATION INSTRUCTIONS

Model U2

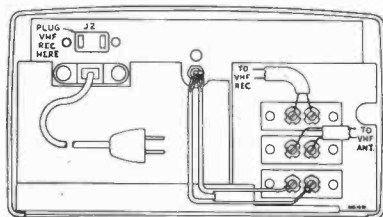

Figure 1—Connections for Employing VHF Antenna for UHF Reception

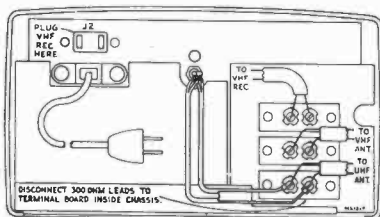

Figure 2—Connection for Employing Separate UHF Antenna with 300 Ohm Lead-In

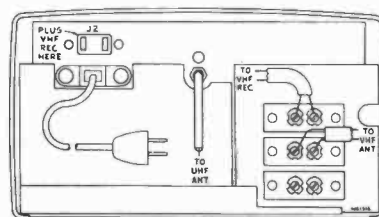

Figure 3—Connection for Employing Separate UHF Antenna with 72 Ohm Co-ax Lead-In

Model U2A

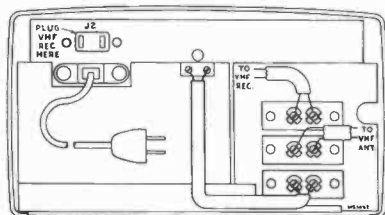

Figure 4—Connections for Employing VHF Antenna for UHF Reception

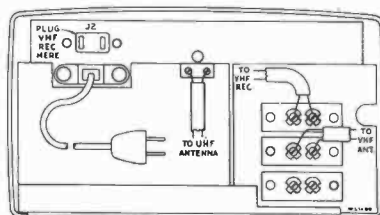

Figure 5—Connection for Employing Separate UHF Antenna with 300 Ohm Lead-In

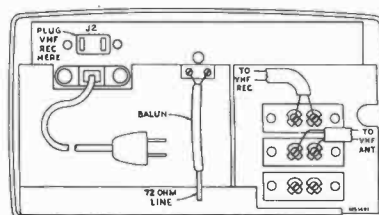

Figure 6—Connection for Employing Separate UHF Antenna with 72 Ohm Co-ax Lead-In

ADJUSTMENT INSTRUCTIONS

To adjust the UHF selectors to the particular UHF stations to be received, connect the antenna, selector and VHF receiver as indicated in the installation instructions on page 1.

Tune the VHF receiver to channel 5 or 6 whichever is vacant in the receiving area.

Set the UHF selector switch to UHF 1. Preset the oscillator tank capacitor C15 and the harmonic tank capacitor C19 as indicated in the table.

Temporarily connect the UHF antenna directly to the crystal CR1 as follows. Disconnect the balun matching stub from the input jack J1 (or the 300 ohm jumper on Model U2A from the UHF ANT terminal board). Connect a bus wire to the center conductor of the balun connector P1 (on U2A to right hand terminal of UHF ANT terminal board TB4). Insert the other end of the bus wire 1 1/2 inches straight into the 1/4 inch hole directly below J1 (or TB4) on the selector chassis rear apron. Make contact with the center of the black eyelet terminal.

Adjust C15 slightly until sound is heard, then retouch C15 and C19 for best sound and picture with minimum interference. The use of an insulated slotted tuning stick is recommended for these adjustments.

Remove the bus wire and reconnect the balun to J1 or jumper to TB4. Starting C2 and C4 at minimum capacity (maximum counterclockwise) turn both trimmers to obtain the best sound and picture.

To adjust the U2 UHF selector for a second channel, switch the selector switch to UHF 2. Preset the oscillator capacitor C14 and the harmonic tank capacitor C18 as indicated in the appropriate table.

Connect the antenna to the crystal as before.

Tune C14 slightly until sound is heard then adjust C14 and C18 until best sound and picture with minimum interference is obtained.

Then reconnect the antenna to J1 or TB4 and tune C1 and C3 for best sound and picture.

ADJUSTMENTS VERSUS CHANNEL NUMBER

Model U2

The turns listed in the table below are from the minimum capacity position of the trimmer—(maximum counterclockwise position).

UHF Channel	OSC Tank C14 or C15	Harmonic Tank C18 or C19
14-16	13.0 turns CW	12.5 turns CW
17-19	11.5 turns CW	11.5 turns CW
20-22	10.25 turns CW	10.25 turns CW
23-25	9.0 turns CW	9.5 turns CW

UHF Channel	OSC Tank C14 or C15	Harmonic Tank C18 or C19
26-28	8.25 turns CW	8.5 turns CW
29-31	7.25 turns CW	7.75 turns CW
32-34	6.25 turns CW	7.0 turns CW
35-37	5.5 turns CW	6.5 turns CW
38-40	4.75 turns CW	6.25 turns CW
41-43	4.25 turns CW	5.75 turns CW
44-46	3.5 turns CW	5.25 turns CW
47-49	13.0 turns CW	5.0 turns CW
50-52	12.25 turns CW	4.75 turns CW
53-55	11.25 turns CW	4.25 turns CW
56-58	10.5 turns CW	4.0 turns CW
59-61	9.5 turns CW	3.5 turns CW
62-64	9.0 turns CW	3.25 turns CW
65-67	8.25 turns CW	3.0 turns CW
68-70	7.75 turns CW	2.75 turns CW
71-73	7.0 turns CW	2.5 turns CW
74-76	6.5 turns CW	2.25 turns CW
77-79	6.0 turns CW	2.0 turns CW
80-83	5.5 turns CW	1.75 turns CW

ADJUSTMENTS VERSUS CHANNEL NUMBER

Model U2A

The turns listed in the table below are from the minimum capacity position of the trimmer—(maximum counterclockwise position).

UHF Channel	OSC Tank C14 or C15	Harmonic Tank C18 or C19
14-16	16.25 turns CW	11.0 turns CW
17-19	14.75 turns CW	9.75 turns CW
20-22	13.25 turns CW	8.75 turns CW
23-25	11.75 turns CW	8.0 turns CW
26-28	10.5 turns CW	7.25 turns CW
29-31	9.25 turns CW	6.5 turns CW
32-34	8.0 turns CW	5.75 turns CW
35-37	7.0 turns CW	5.25 turns CW
38-40	6.0 turns CW	4.75 turns CW
41-43	5.0 turns CW	4.5 turns CW
44-46	3.75 turns CW	4.0 turns CW
47-49	16.25 turns CW	3.75 turns CW
50-52	15.5 turns CW	3.5 turns CW
53-55	14.5 turns CW	3.25 turns CW
56-58	13.5 turns CW	3.0 turns CW
59-61	12.5 turns CW	2.75 turns CW
62-64	11.5 turns CW	2.5 turns CW
65-67	10.75 turns CW	2.25 turns CW
68-70	9.75 turns CW	2.0 turns CW
71-73	9.0 turns CW	1.75 turns CW
74-76	8.25 turns CW	1.5 turns CW
77-79	7.5 turns CW	1.25 turns CW
80-83	5.5 turns CW	1.0 turns CW

ALIGNMENT DATA

U2, U2A

Notes on Adjustments—For proper reception, the oscillator harmonic employed for conversion must be lower in frequency than the UHF station. If two slightly different positions of the oscillator core produce sound from the desired station, the most clockwise position is the correct one.

In tuning one oscillator it may occasionally happen that the oscillator tank of the circuit not in use may be tuned to the same frequency. If this occurs, the second oscillator tank may act as a trap absorbing energy from the first oscillator and causing poor operation. In such a case, detune the second oscillator tank until the first oscillator circuit is adjusted. Once adjusted for the proper channels no difficulty should be experienced from this source as it is extremely unlikely that both oscillators would be operating on the same frequency.

When properly aligned, the crystal current should be 0.75 for best noise figure. This current can be measured by disconnecting the test link on top of the chassis and inserting a 0.5 milliamper meter between the link and ground.

Under some conditions interfering beats may be obtained between the UHF Selector oscillator and harmonics of the television receiver oscillator which show up as lines in the picture. In some cases these may be eliminated by adjusting the receiver fine tuning for elimination of the beat, then returning the selector oscillator core for best sound and picture.

The oscillators in the selectors operate in the 200 mc. to 300 mc. range. The oscillator signal applied to the crystal mixer is taken from a harmonic tank in the oscillator circuits. The usual practice as listed in the table is to employ the oscillator second harmonic for reception of channels 14 through 46, and the third harmonic for reception of channels 47 through 83. In rare cases where interference is obtained due to a beat between the UHF selector oscillator and a harmonic of the VHF receiver oscillator, it may be possible to eliminate it by tuning the oscillator to a different frequency and employing a different harmonic.

Under some conditions, adjacent channel interference may be experienced if the VHF station is strong and the UHF signal is weak. In such cases, it may be desirable to provide a shielded cable between the UHF Selector unit and the television receiver r-f unit.

As a test for drift, turn the selector off for five minutes then turn it on again. Within approximately one minute it should be possible to receive the UHF station by adjustment of the receiver fine tuning control and without the necessity of readjusting the UHF Selector oscillator.

When it is desired to receive a VHF station on the television receiver, switch the selector switch to the VHF position and operate the receiver normally.

I-F ALIGNMENT

Construct a 300 ohm balanced detector as shown in figure 8 and connect it to the VHF selector terminal board marked "Receiver" (TB2).

Connect a high gain oscilloscope to the balanced detector and set the gain to maximum.

Connect an attenuator pad of the type shown in figure 9 to the output cable of the VHF sweep generator. Connect the output of the attenuator pad through a 470 mmf. ceramic capacitor to the cathode, pin 2 of V1.

Set the sweep generator to sweep from 70 mc. to 95 mc. As an alternate method when using RCA type WR59 sweep generators, switch the generator to channel 5 to see the low frequency side of the response curve and to channel 6 to see the high frequency side of the response curve.

Insert markers from a VHF marker generator by loosely coupling the generator output cable to the cathode, pin 2 of V1.

Adjust the primary and secondary cores of T2 until the response shown in figure 8 is obtained.

Check of R-F Circuits—Adjust the selector for the reception of 2 UHF stations as described in the adjustment instructions.

Connect a 0.5 milliamper meter to the crystal by opening the test connection on top of the chassis and connecting the meter in series with the test connection and ground.

The crystal current should be 0.75 ma. on each channel. The oscillator injection trimmers were set at the factory to

produce this value of current. However if it should become necessary to readjust the oscillator injection, this may be done by adjusting capacitors C26 and/or C27. These capacitors consist of a large metal headed tack mounted in a feed through bushing in the wall of the oscillator compartment. Adjustment is affected by sliding the head towards or away from the harmonic tank capacitors C18 or C19. To prevent the adjustment from changing, the body of the tack is then soldered in place.

The measurement of crystal current should be made with the selector adjusted for reception of a station but with no signal input and with the oscillator compartment bottom shield in place. Do not adjust the injection to compensate for a defective crystal or oscillator tube.

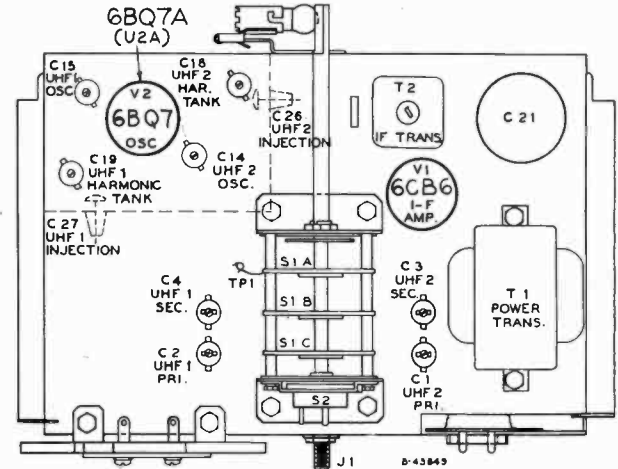

Figure 7—Chassis top view

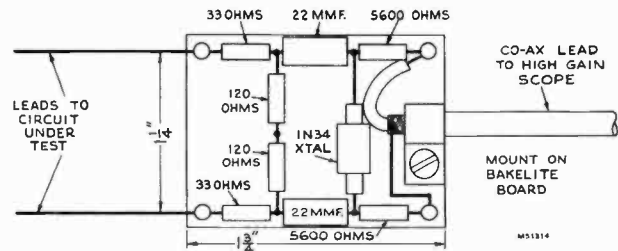

Figure 8—300 Ohm Balanced Detector

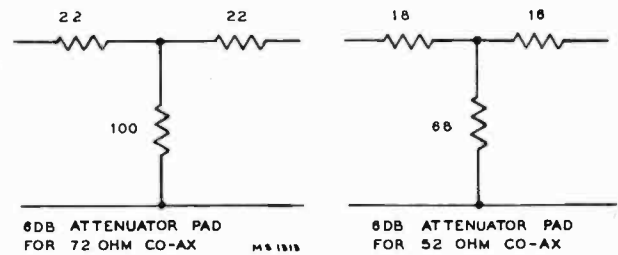

Figure 9—Attenuator Pad

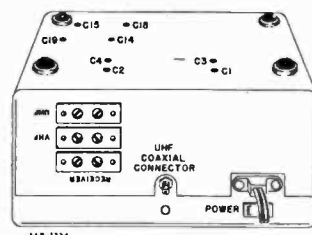

Figure 10—Adjustment Locations

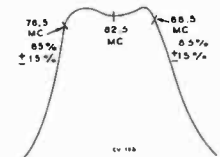

Figure 11—I-F Response

CIRCUIT SCHEMATIC DIAGRAMS

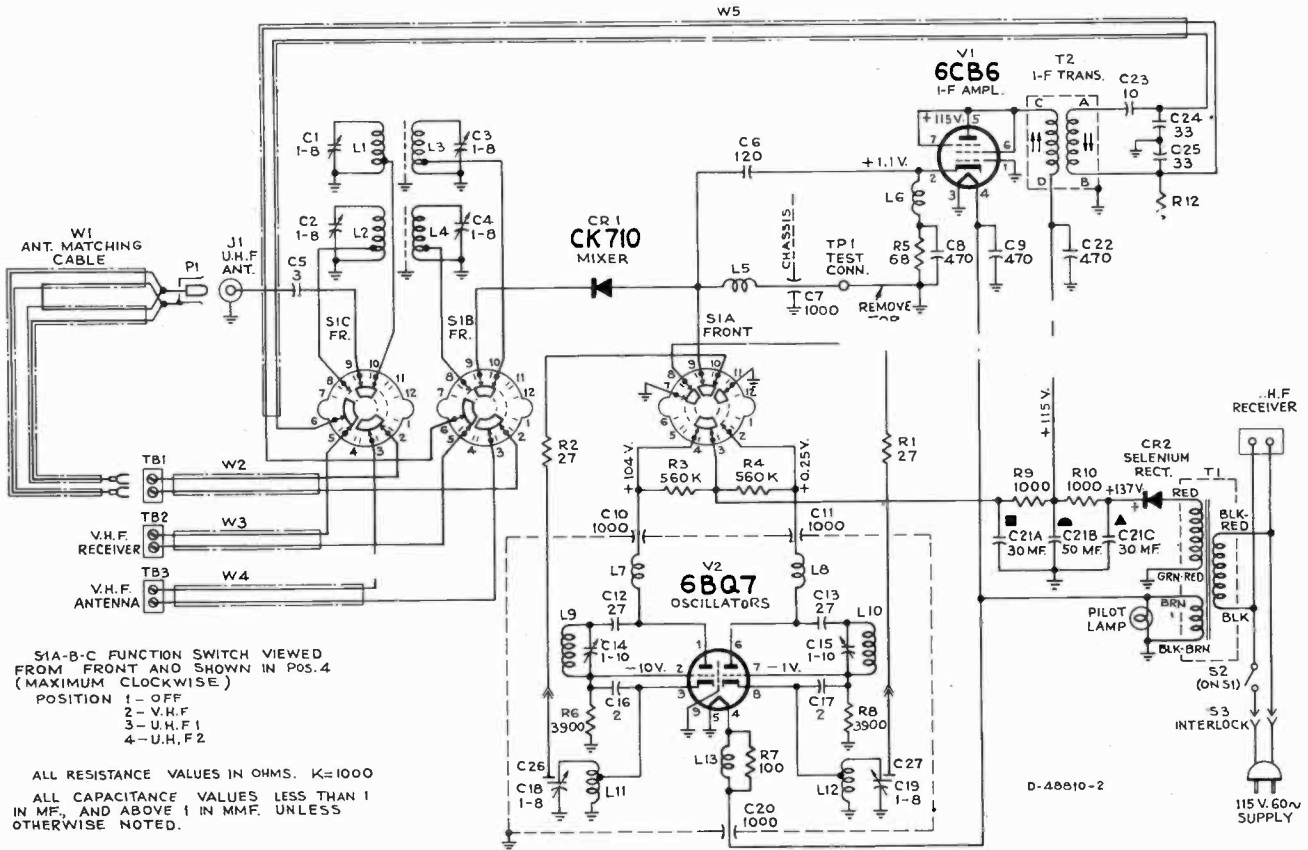

Figure 12—U2 Schematic Diagram, KCS79

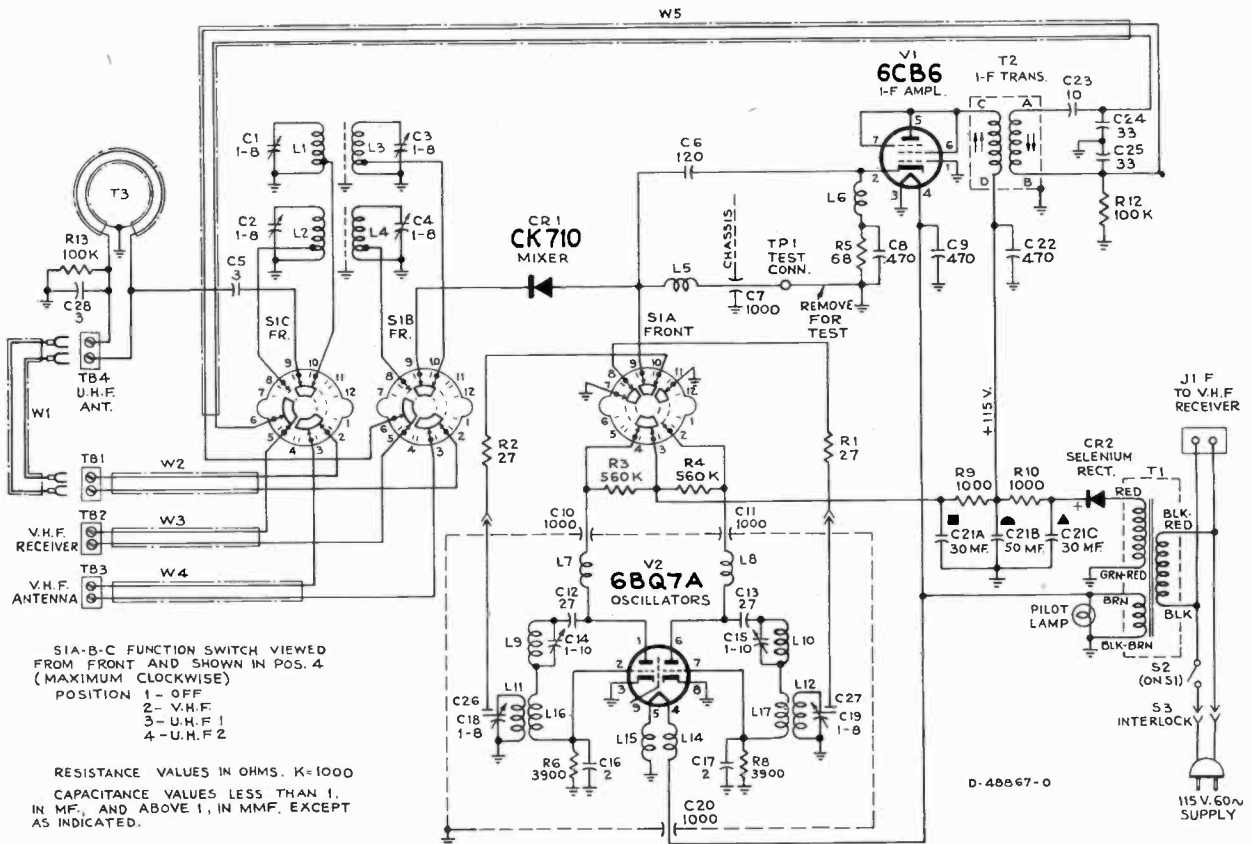

Figure 13—U2A Schematic Diagram, KCS79A

REPLACEMENT PARTS

U2, U2A

STOCK No.	DESCRIPTION	STOCK No.	DESCRIPTION
	CHASSIS ASSEMBLIES KCS79, KCS79A	11765	Lamp—Pilot lamp—Mazda #51
75039	Board—"Antenna" terminal board	77282	Rectifier—Germanium rectifier (CR1)
77290	Capacitor—Tubular trimmer, 1-8 mmf., complete with adjustable core (C1, C2, C3, C4, C18, C19)	77292	Rectifier—Selenium rectifier (CR2)
77210	Capacitor—Ceramic, 2 mmf. (C16, C17)		Resistor—Fixed, composition:—
77277	Capacitor—Ceramic, 3 mmf. (C5, C28)	513027	27 ohms, $\pm 10\%$, 1 watt (R1, R2)
77340	Capacitor—Tubular trimmer, 1.0-10.0 mmf., complete with adjustable core (C14, C15, L16, L17)	503068	68 ohms, $\pm 10\%$, $\frac{1}{2}$ watt (R5)
53511	Capacitor—Ceramic, 10 mmf. (C23)	513210	1000 ohms, $\pm 10\%$, 1 watt (R9)
72570	Capacitor—Ceramic, 27 mmf. (C12, C13)	523L10	1000 ohms, $\pm 10\%$, 2 watts (R10)
70596	Capacitor—Ceramic, 33 mmf. (C24, C25)	503239	3900 ohms, $\pm 10\%$, $\frac{1}{2}$ watt (R6, R8)
76347	Capacitor—Ceramic, 120 mmf. (C6)	503410	100,000 ohms, $\pm 10\%$, $\frac{1}{2}$ watt (R11, R12, R13, R14)
77293	Capacitor—Ceramic, 470 mmf. (C8, C9, C22)	503456	560,000 ohms, $\pm 10\%$, $\frac{1}{2}$ watt (R3, R4)
77084	Capacitor—Ceramic, feed-thru, 1000 mmf. (C7, C10, C11, C20)	77284	Shield—Oscillator shield for Model U2A
77086	Capacitor—Electrolytic comprising 1 section of 50 mfd., 200 volts and 2 sections of 30 mfd., 200 volts (C21A, C21B, C21C)	77285	Shield—r-f shield
77298	Coil—Choke coil (L13, R7)	76967	Shield—Tube shield for V1
77296	Coil—Fundamental oscillator coil (L9, L10)	76534	Shield—Tube shield for V2
77297	Coil—Harmonic tank coil (L11, L12)	35574	Socket—Lamp socket
77153	Coil—r-f choke coil (L5, L7, L8, L14, L15)	77087	Socket—Tube socket, 7 pin, miniature for V1
77279	Coil—r-f choke coil (L6)	76530	Socket—Tube socket, 9 pin, miniature for V2
77294	Coil—r-f coil (primary and secondary) (L1, L2, L3, L4)	77289	Switch—Selector switch (S1, S2)
77088	Connector—Single contact connector for UHF antenna (J1) for model U2	78578	Transformer—Antenna input transformer (T3)
52131	Connector—2 contact female connector for television power (J2)	77288	Transformer—i-f transformer (T2)
74594	Connector—2 contact male connector for power input	77287	Transformer—Power transformer, 117 volt, 60 cycle (T1)
76460	Contact—Test point contact		MISCELLANEOUS
77286	Cover—Oscillator section shielding Cover for Model U2A	77300	Back—Cabinet back complete with power cord
		77212	Connector—Single contact male connector for antenna matching assembly
		77033	Emblem—"RCA Victor" emblem
		74889	Foot—Felt foot
		77299	Knob—Selector knob
		77013	Nut—Speed nut to fasten emblem
		74734	Spring—Spring clip for knob

APPLY TO YOUR RCA DISTRIBUTOR FOR PRICES OF REPLACEMENT PARTS





RCA VICTOR



UHF Selector
Model U70

UHF SELECTOR MODEL U70

Chassis No. KCS70
— Mfr. No. 274 —

SERVICE DATA

— 1952 No. T8 —

PREPARED BY RCA SERVICE CO., INC.
FOR
RADIO CORPORATION OF AMERICA
RCA VICTOR DIVISION
CAMDEN, N. J., U. S. A.

GENERAL DESCRIPTION

UHF Selector Model U70 permits the reception of any UHF television station within receiving range when employed with a VHF television receiver. The unit employs three tubes plus rectifier and a crystal mixer.

ELECTRICAL SPECIFICATIONS

TELEVISION R-F FREQUENCY RANGE

All 70 UHF television channels..... 470 mc. to 890 mc.
I-F Output Frequency..... Channel 5 or 6

POWER SUPPLY RATING..... 115 volts, 60 cycles, 40 watts

WEIGHT AND DIMENSIONS

Net Weight	Shipping Weight	Width Inches	Height Inches	Depth Inches
10 lbs.	12 lbs.	11 1/8	8 1/4	9 21/32

ANTENNA INPUT IMPEDANCE

UHF — Choice: 300 ohms balanced or 72 ohms unbalanced.
VHF — 300 ohms balanced.

TUBE COMPLEMENT

Tube Used	Function
6AF4.....	R-F Oscillator
6CB6.....	1st I-F Amplifier
6CB6.....	2nd I-F Amplifier
5Y3GT.....	Rectifier

A 1N82 crystal is used as a mixer.

INSTALLATION INSTRUCTIONS

The UHF Selector has been designed to operate from either of three types of antenna installations.

In all cases, the VHF antenna transmission line must be disconnected from the VHF receiver and reconnected to the selector VHF antenna terminals. A short length of 300 ohm line must then be connected between the VHF receiver antenna terminals and the selector terminals marked "Receiver."

If the UHF signals from the VHF antenna are strong and free from reflections, the above connections are all that are required. See Figure 1.

If a separate UHF antenna with 300 ohm transmission line is employed, connect the line to the selector terminal board marked UHF. Then, disconnect the 300 ohm line which runs over the fiber back and into the selector. Tape the ends of these leads so that they will not short other terminals on the back and cause trouble. See Figure 2.

If a separate UHF antenna with 72 ohm co-ax transmission line is employed, remove the balun, attach a male co-ax fitting to the antenna transmission line and plug it into the selector co-ax input at the lower left hand corner on the selector rear apron. Dress or tape the co-ax line so that it cannot be pulled out if the customer moves the selector. See Figure 3.

Plug the television receiver power cord into the a-c receptacle on the back of the selector and plug the selector power cord into the nearest 110 volt a-c outlet. With this connection, if the VHF receiver "on-off" switch is left in the "on" position, both the receiver and the selector will be controlled by the selector function switch.

With the selector function switch in the VHF position, the receiver is turned "on," the selector is "on" but in stand-by condition and the VHF antenna is connected through to the receiver.

With the selector function switch in the UHF position, the selector is operating, the VHF antenna is disconnected from the receiver, the selector output is connected to the receiver and the antenna employed for UHF operation is connected to the selector input.

To receive a UHF station, switch the selector function switch to UHF and the television receiver to channel 5 or 6, whichever is vacant in the receiving area. Tune in the UHF station by adjusting the selector tuning knob. The selector dial is calibrated in channel numbers as an aid in locating the channel. Tune the selector for best sound and picture. In some instances interference may result if the receiver fine tuning control is not properly adjusted. If this should occur, adjust fine tuning until the interference is eliminated and retune the selector for the best sound and picture.

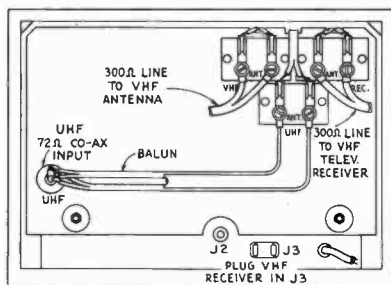

Figure 1—Selector Connections When VHF Antenna Is Employed For UHF Reception.

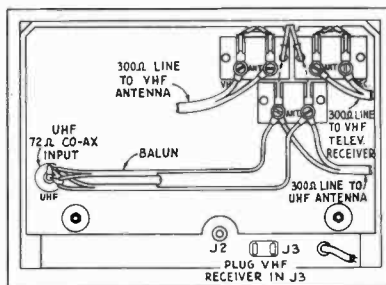

Figure 2—Selector Connections For Use of Separate UHF Antenna With 300 Ohm Lead-In.

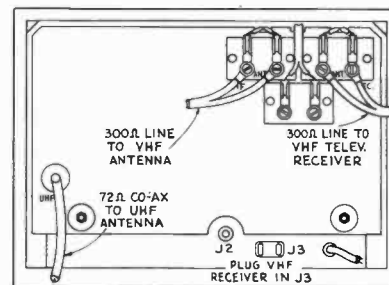

Figure 3—Selector Connections For Use of Separate UHF Antenna With 72 Ohm Co-Ax.

TEST EQUIPMENT The following test equipment is required for alignment of the U70 UHF Selector:

- A UHF sweep generator with a range of 470 mc. to 890 mc.
- A VHF sweep generator with a range of 70 mc. to 90 mc.
- A UHF marker generator for locating 480, 630 and 840 mc.
- A VHF marker generator capable of supplying 72.5 mc., 76.5 mc., 82.5 mc., 88.5 mc. and 92.5 mc. signals.
- An oscilloscope with a high gain vertical amplifier.
- A milliammeter with a 0-5 ma. range.
- A resistive pad for terminating the sweep generator cable.
- A 300 ohm balanced detector.
- A small protractor.

I-F ALIGNMENT

Second I-F Stage—Construct a 300 ohm balanced detector as shown in Figure 4 and connect it to terminal board TB3.

Connect a high gain oscilloscope to the balanced detector and set the gain to maximum.

Connect a jumper across terminals A and B of T1.

Connect a 72 ohm attenuator pad of the type shown in Figure 5 to the output cable of the sweep and connect the output of the pad to the grid, pin 1 of V2 and to ground.

Set the sweep generator to sweep from 72 mc. to 90 mc. As an alternate, an RCA WR59 sweep generator may be employed and switched to channel 5 to see the low frequency side of the response curve and to channel 6 to see the high frequency side of the response curve.

Insert markers from the VHF marker generator by loosely coupling the generator output cable to the grid of V2.

Adjust the T2 pri. and sec. cores and the bandwidth trimmer C22 to obtain response as shown in Figure 9A.

The bandwidth capacitors C22 (and C21 in T1) consist of a short piece of wire soldered to terminal A and the free end inserted into a ceramic tube capacitor. Adjustment is made by pushing the wire in further or pulling it out.

First I-F Stage—Remove the jumper from terminals A and B of T1 and reconnect it across terminals A and B of T2.

Connect the balanced detector across T2 terminals C and D. Connect the output cable of the sweep generator with the 72 ohm pad through a 1,500 mmf. capacitor to pin 2 of V1.

Connect the VHF marker generator loosely to pin 2 of V1. Adjust the T1 pri. and sec. cores and the bandwidth trimmer C21 to obtain the response shown in Figure 9B.

Overall I-F Response—Leave the sweep generator connected to the cathode of V1.

Remove the jumper across terminals A and B of T2.

Connect the balanced detector across terminal board TB3.

The overall i-f response should appear as shown in Figure 9C. The oscilloscope gain should be kept at maximum and the input kept low to prevent overloading the selector.

If excessive tilt of the curve is present, retouch the T1 and T2 pri. and sec. cores until the curve is reasonably flat.

R-F ALIGNMENT

If the selector needs only touch-up adjustments, no pre-setting of the tuning cores is required. However, if the selector is completely out of alignment, the tuning cores should be pre-set as follows. With the dial drive mechanism $1\frac{1}{4}$ turns from the low frequency stop (channel 14 end of the dial), set the C18 oscillator tuning core as shown in the Figure 6A. The cores of the r-f tuning capacitors C1 and C2 should be set as shown in Figure 6B. The tapered end of the L9 core should be set about $\frac{3}{4}$ of an inch from the closest end of the L9 coil as shown in Figure 6C.

Turn the dial drive mechanism until it comes up against the stop at the low frequency (channel 14) end of the dial. Turn the dial pointer on its shaft until the pointer coincides with the end marker on the dial back plate.

Turn the dial drive mechanism until the pointer is 17 degrees to the left of center of the dial when the selector is sitting in an upright position. This position should be located with a protractor to insure accuracy. Make a small mark on the dial back plate so that the dial can be returned to this position quickly and accurately throughout the remainder of the alignment procedure. This is the 630 mc. calibration point.

Connect the 300 ohm balanced detector across terminals A and B of T1 and shunt a 1,000 ohm resistor across terminals C and D of T1.

Connect the UHF sweep generator through a 6 db pad to the 72 ohm co-ax input to the selector at J1. It is necessary to

use the pad so that impedances will be matched. Otherwise standing waves on the sweep cable may become objectionable.

Connect the UHF marker gen. loosely to the selector input.

Connect a VHF marker generator loosely to the cathode of V1. Insert an 82.5 mc. marker into the selector.

630 Mc. Adjustments—Turn the dial drive mechanism until the dial pointer points to the 630 mc. calibration mark scribed on the dial back plate at 17 degrees left of center.

Insert a 630 mc. marker from the UHF marker generator.

Set the UHF sweep generator to sweep from 615 mc. to 645 mc. and observe the output on the oscilloscope. If the sweep generator is not sweeping the correct frequency range, it may be necessary to readjust the sweep in order to center the 630 mc. marker on the response curve.

The shields must be in place over the top and bottom of the r-f section when making any adjustments.

Adjust the C18 oscillator core until the markers for 630 mc. and 82.5 mc. coincide on the sweep pattern.

Adjust the cores of the r-f tuning capacitors C1 and C2 to obtain a maximum amplitude, symmetrical response curve centered about the 82.5 mc. marker.

Set the bandwidth adjustment L2 until the response bandwidth is 20 mc. at 70% response.

Tune L5 for max. response at the center of the bandpass.

Repeat the adjustments of C1, C2, L2 and L5 if necessary.

Plug the 0-5 milliammeter into the crystal current jack J2. The current should be between 0.8 ma. and 5 ma. If this current is not obtained, either the crystal is defective or the oscillator is not functioning properly. The bottom cover should be in place when measuring crystal current.

Turn off the sweep and marker generators. If the crystal current decreases by more than 10%, it indicates that excessive input signals are being employed. Proper alignment cannot be obtained under such conditions.

490 Mc. Adjustments—Set the UHF marker gen. to 490 mc.

Set the UHF sweep gen. to sweep 475 mc. to 505 mc.

Turn off the 82.5 mc. marker generator.

Turn the UHF selector toward the low frequency end of the band. Tune the selector and the sweep generator until the 490 mc. marker is centered in the bandpass.

Turn the 82.5 mc. marker back on.

Adjust C18 until the markers coincide. Then, overshoot the adjustment by an amount slightly less than the amount of adjustment required to get the markers to coincide. Then close or spread the turns on the L9 coil until the markers again coincide.

Repeat the adjustments in the section above labeled "630 Mc. Adjustments." C1, C2, L2 and L5 probably will not require retouching. Then repeat the adjustments in the section above labeled "490 Mc. Adjustments." Continue the repetition of the 630 mc. and 490 mc. adjustments until no further adjustments are required. Make the final adjustment at 630 mc. before proceeding with the next section.

840 Mc. Adjustment—Set the UHF marker gen. to 840 mc.

Turn off the 82.5 mc. marker generator.

Adjust the UHF sweep gen. to sweep 825 mc. to 855 mc.

Turn the UHF selector dial drive and the sweep generator until the 840 mc. marker is centered in the bandpass of the response curve on the oscilloscope.

Turn the 82.5 mc. marker back on.

Adjust the L9 core until the two markers coincide.

Check of Tracking—Turn off the UHF marker generator.

Tune the sweep generator across the band in small steps.

Tune in the sweep generator with the selector.

The response on the oscilloscope should not fall below 70% response between the 76.5 mc. and 88.5 mc. markers obtained from the VHF marker generator.

The crystal current should be between 0.8 and 5 ma. at all points between 470 mc. and 890 mc. when measured with the bottom shield in place and with no signal input.

Overall Response Check—Leave the sweep and signal generators connected as for r-f alignment. Remove the 1,000 ohm resistor from terminals C and D of T1. Connect the 300 ohm balanced detector across the output terminal board TB3 and observe the overall response which should be similar to that shown in Figure 9. If excessive tilt appears, it may cause the picture to be overpeaked or smeared depending on the direction of the tilt. The maximum tilt or sag of the curve should not exceed 30%.

ALIGNMENT DATA

U70

Air Check — As a final test, the selector should be tested on the air by receiving a known weak signal. If the picture obtained seems excessively snowy for a particular selector unit, it may be necessary to replace the mixer crystal CR1. If the crystal is changed, the r-f alignment should be retouched. A good crystal may perform no better than a defective one unless the r-f section is aligned for the good crystal.

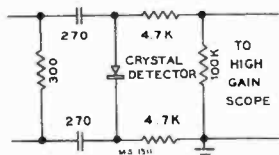

Figure 4 — 300 Ohm Balanced Detector

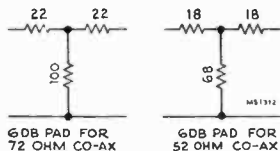

Figure 5 — Sweep Cable Attenuator

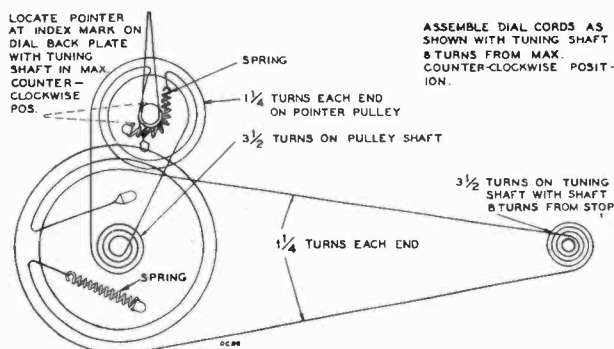

Figure 8 — Dial Cord and Drive

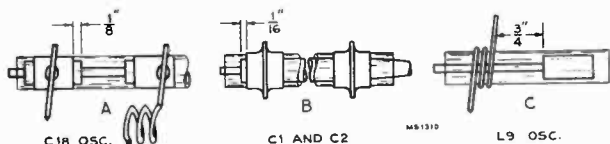

Figure 6 — Preset for R-F Adjustments

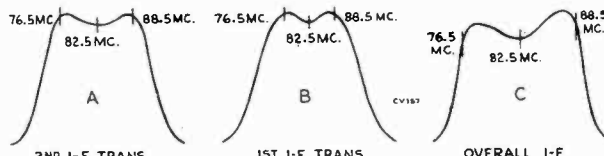

Figure 9 — Sweep Response Curves

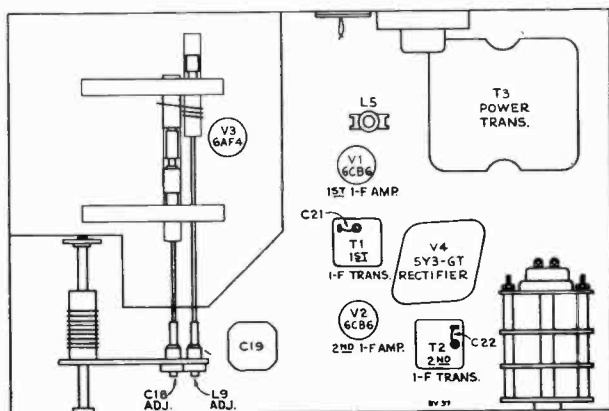

Figure 7 — Bottom Chassis Adjustments

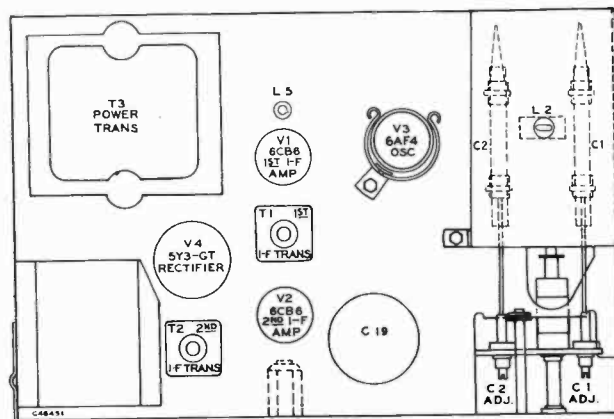

Figure 10 — Top Chassis Adjustments

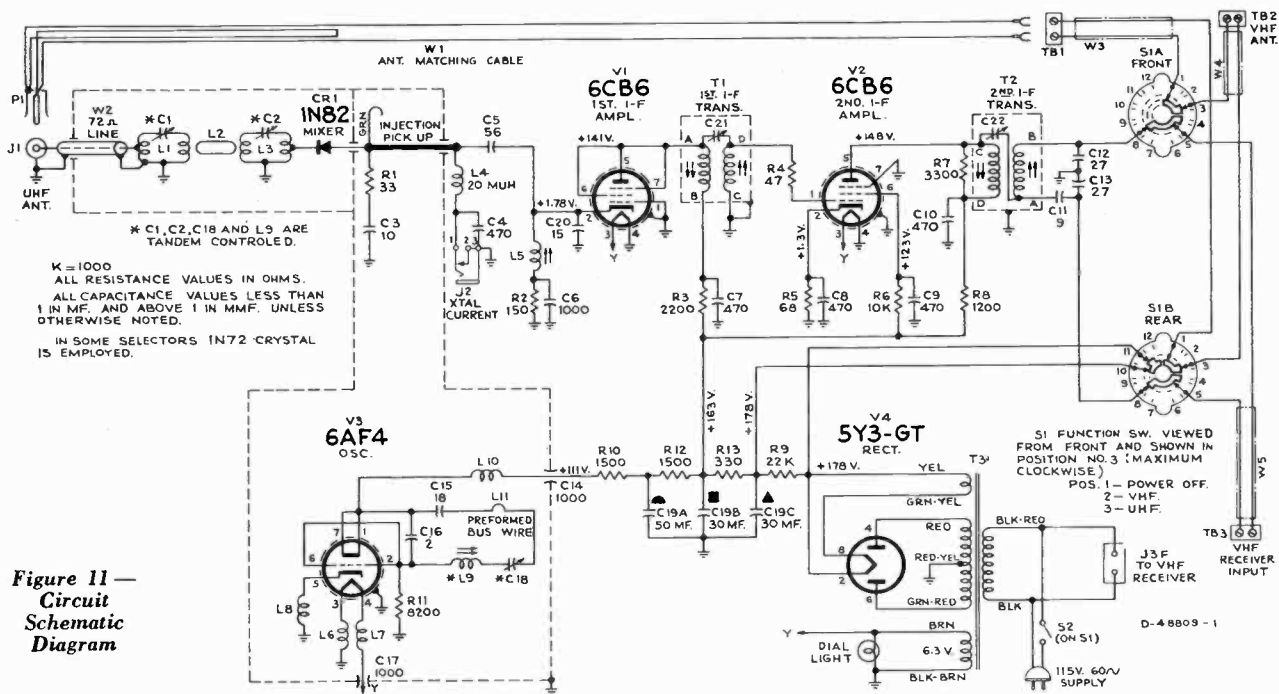

Figure 11 — Circuit Schematic Diagram

U70

REPLACEMENT PARTS

STOCK No.	DESCRIPTION	STOCK No.	DESCRIPTION
	CHASSIS ASSEMBLIES KCS70		
77097	Back—Back cover complete with three (3) terminal boards	503033	Resistor—Fixed, composition: 33 ohms, $\pm 10\%$, 1/2 watt (R1)
76184	Board—Terminal board for back cover	503047	47 ohms, $\pm 10\%$, 1/2 watt (R4)
77069	Bracket—Mounting bracket for r-f tuning assembly (includes L2 and part of L1, L3, C1, C2) less glass tubing	503068	68 ohms, $\pm 10\%$, 1/2 watt (R5)
76522	Bracket—Vertical bracket for tube shield for 6AF4	503115	150 ohms, $\pm 10\%$, 1/2 watt (R2)
77072	Bushing—Drive shaft bushing (in rear of coil spring)	523133	330 ohms, $\pm 10\%$, 2 watt (R13)
77210	Capacitor—Ceramic, 2 mmf. (C16)	503212	1,200 ohms, $\pm 10\%$, 1/2 watt (R8)
77108	Capacitor—Ceramic, 9 mmf. (C11)	523215	1,500 ohms, $\pm 10\%$, 2 watt (R10, R12)
77085	Capacitor—Ceramic, feed-thru, 10 mmf. (C3)	503222	2,200 ohms, $\pm 10\%$, 1/2 watt (R3)
45465	Capacitor—Ceramic, 15 mmf. (C20)	503233	3,300 ohms, $\pm 10\%$, 1/2 watt (R7)
77209	Capacitor—Ceramic, 18 mmf. (C15)	503282	8,200 ohms, $\pm 10\%$, 1/2 watt (R11)
70935	Capacitor—Ceramic, 27 mmf. (C12, C13)	503310	10,000 ohms, $\pm 10\%$, 1/2 watt (R6)
70599	Capacitor—Ceramic, 56 mmf. (C5)	513322	22,000 ohms, $\pm 10\%$, 1 watt (R9)
75198	Capacitor—Ceramic, 470 mmf. (C4, C7, C8, C9, C10)	77078	Shaft—Drive shaft
77084	Capacitor—Ceramic, feed-thru, 1,000 mmf. (C14, C17)	77092	Shield—Shield assembly for oscillator tuning assembly
77252	Capacitor—Ceramic, 1,000 mmf. (C6)	77091	Shield—Shield assembly for r-f tuning assembly
77086	Capacitor—Electrolytic comprising 1 section of 50 mfd., 200 volts and 2 sections of 30 mfd., 200 volts (C19A, C19B, C19C)	77090	Shield—Tube shield for 6AF4
77102	Clamp—Polystyrene clamp for oscillator tuning capacitor and coil (2 required)	76967	Shield—Tube shield for 6CB6
77109	Coil—Choke coil (L6, L7; L8, L10)	31251	Socket—Tube socket, octal, wafer
77083	Coil—Cathode peaking coil (L5)	31364	Socket—Dial lamp socket
77224	Coil—Oscillator tuning coil (L9)	77087	Socket—Tube socket, 7 pin, miniature, moulded phenolic, saddle-mounted
72618	Coil—Peaking coil (20 muh) (L4)	77207	Socket—Tube socket, 7 pin, miniature, steatite, saddle-mounted
77212	Connector—Single contact male connector for antenna matching assembly (P1)	77071	Spring—Drive shaft spring
75474	Connector—Single contact male connector for W3, W4, W5	77096	Spring—Drive cord spring
77088	Connector—Single contact connector for 72 ohm antenna connection (J1)	12007	Spring—Retaining spring for adjusting cores
52131	Connector—2 contact female connector (J3)	75068	Spring—Retaining spring for tube shield for 6AF4
72953	Cord—Drive cord (approx. 23" overall)	77208	Support—Oscillator tuning coil support (glass tube)
72953	Cord—Drive cord (approx. 38" overall)	77099	Support—Polystyrene support only for oscillator tuning coil and capacitor
70392	Cord—Power cord and plug	77089	Switch—Function and power switch (S1, S2)
77074	Core—Adjusting core assembly for r-f tuning assembly capacitors C1 and C2	76463	Terminal—Screw type grounding terminal
77075	Core—Adjusting core assembly for oscillator tuning capacitor C18	77080	Transformer—Power transformer, 117 volts, 60 cycles (T3)
77076	Core—Adjusting core assembly for oscillator tuning coil L9	77081	Transformer—First i-f transformer complete with adjustable cores (T1, C21)
77093	Cover—Bottom cover for oscillator tuning shield	77082	Transformer—Second i-f transformer complete with adjustable cores (T2, C22)
	Crystal—See Rectifier	77100	Tubing—Capacitor tubing (glass) for oscillator tuning capacitor (Part of C18)
77103	Cushion—Rubber cushion for mounting oscillator tuning coil (2 required) or oscillator tuning capacitor (2 required)	77070	Tubing—Capacitor tubing (glass) for r-f tuning assembly capacitors C1 and C2
74838	Grommet—Power cord strain relief (1 set)	2917	Washer—"C" washer for drive shaft and drive cord pulleys
77079	Holder—Holder for crystal rectifier	33726	Washer—"C" washer for plate and bushing retainer post
75482	Jack—Test jack (J2)	77098	Washer—Spring washer for drive shaft
11765	Lamp—Dial lamp—Mazda 51		MISCELLANEOUS
77106	Plate—Dial back plate and bushing less dial and pulley	77111	Clamp—Dial clamp (2 required)
77073	Plate—Plate complete with five (5) bushings for drive shaft and adjusting cores	77110	Dial—Glass dial scale
77095	Pointer—Station selector pointer	77033	Emblem—"RCA Victor" emblem
77077	Post—Retainer post for plate and bushing assembly	77492	Foot—Rubber foot (4 required)
77105	Pulley—Drive cord pulley (1 3/8" dia.) and shaft	77251	Knob—Function and power switch knob—maroon—for mahogany and walnut instruments
77094	Pulley—Drive cord pulley (2 3/4" dia.) and shaft assembly	77844	Knob—Function and power switch knob—beige—for blonde mahogany instruments
77489	Rectifier—Crystal rectifier 1N82 (CR1)	77140	Knob—Tuning control knob—maroon—for mahogany and walnut instruments
30340	Retainer—Retainer ring for drive shaft	77843	Knob—Tuning control knob—beige—for blonde mahogany instruments
		77013	Nut—Speednut to fasten emblem to cabinet
		74734	Spring—Spring clip for knobs

The system of employing an asterisk before the stock number of new items has been discontinued.

APPLY TO YOUR RCA DISTRIBUTOR FOR PRICES OF REPLACEMENT PARTS.



