

# RCA REVIEW

*A Quarterly Journal of Radio Progress*

## INDEX

Papers and Authors

Volume II

1937 - 1938

RCA INSTITUTES TECHNICAL PRESS

75 VARICK STREET NEW YORK

# INDEX TO VOLUME II

	<i>Issue</i>	<i>Page</i>
AMATEUR, TELEVISION CATHODE-RAY TUBES FOR THE—R. S. Burnap.....	Jan. 1938	297
AMPLIFIER DESIGN, SOME NOTES ON VIDEO—Albert Preisman.....	Apr. 1938	421
AMPLIFIERS, ANALYSIS AND DESIGN OF VIDEO—S. W. Seeley and C. N. Kimball.....	Oct. 1937	171
ANTENNA KIT DESIGN, A NEW—W. L. Carlson and V. D. Landon.....	July 1937	60
ANTENNA ON TELEVISION RECEPTION FIDELITY, EFFECT OF THE RECEIVING—S. W. Seeley .....	Apr. 1938	433
ANTENNA PERFORMANCE, MEASUREMENT OF BROADCAST COVERAGE AND—W. A. Fitch and W. S. Duttera.....	Apr. 1938	396
ANTENNA SYSTEMS, SOME FACTORS IN THE DESIGN OF DIRECTIVE BROADCAST—W. S. Duttera .....	July 1937	81
"BATALUM" A BARIUM GETTER FOR METAL TUBES—E. A. Lederer and D. H. Wamsley .....	July 1937	117
BROADCAST ANTENNA SYSTEMS, SOME FACTORS IN THE DESIGN OF DIRECTIVE—W. S. Duttera .....	July 1937	81
BROADCAST COVERAGE AND ANTENNA PERFORMANCE, MEASUREMENT OF—W. A. Fitch and W. S. Duttera.....	Apr. 1938	396
BROADCAST FACSIMILE SERVICE, EQUIPMENT AND METHODS DEVELOPED FOR C. J. Young .....	Apr. 1938	379
BROADCAST MOBILE-UNIT DESIGN, A NOVEL RELAY—M. W. Rife.....	Oct. 1937	141
BROADCAST RECEIVER DESIGN, NEW FEATURES IN—B. R. Carson, K. A. Chittick, D. D. Cole and S. V. Perry.....	July 1937	45
CATHODE-RAY ENGINE-PRESSURE MEASURING EQUIPMENT—H. J. Schrader.....	Oct. 1937	202
CATHODE-RAY TUBE FOR LARGE TELEVISION IMAGES, DIRECT-VIEWING TYPE—I. G. Maloff .....	Jan. 1938	289
CATHODE-RAY TUBES FOR THE AMATEUR, TELEVISION—R. S. Burnap.....	Jan. 1938	297
CIRCUITS, GRAPHICS OF NON-LINEAR, PART I—A. Preisman.....	July 1937	124
CIRCUITS, GRAPHICS OF NON-LINEAR, PART II—A. Preisman.....	Oct. 1937	240
CONSTANT SPEED, A REVIEW OF THE QUEST FOR—E. W. Kellogg.....	Oct. 1937	220
DIRECT-VIEWING TYPE CATHODE-RAY TUBE FOR LARGE TELEVISION IMAGES—I. G. Maloff .....	Jan. 1938	289
DIRECTION FINDERS, SMALL VESSEL—H. B. Martin.....	July 1937	69
DIRECTIVE BROADCAST ANTENNA SYSTEMS, SOME FACTORS IN THE DESIGN OF—W. S. Duttera .....	July 1937	81
DIVERSITY RECEIVING EQUIPMENT, RECENT DEVELOPMENTS IN—J. B. Moore.....	July 1937	94
EDUCATIONAL REQUIREMENTS OF THE MODERN RADIO INDUSTRY, TECHNICAL—PART II: THE FIELD OF RECEIVER SERVICING—F. L. Norman.....	Oct. 1937	213
EFFECT OF THE RECEIVING ANTENNA ON TELEVISION RECEPTION FIDELITY—S. W. Seeley .....	Apr. 1938	433
EFFECTS OF SPACE CHARGE IN GRID-ANODE REGION OF VACUUM TUBES—B. Salzberg and A. V. Haefl.....	Jan. 1938	336
FACSIMILE SERVICE, EQUIPMENT AND METHODS DEVELOPED FOR BROADCAST—C. J. Young .....	Apr. 1938	379
FIELD STRENGTH OBSERVATIONS OF TRANSATLANTIC SIGNALS, 40 TO 45 MEGACYCLES—H. O. Peterson and D. R. Goldard.....	Oct. 1937	161
GRAPHICS OF NON-LINEAR CIRCUITS, PART I—A. Preisman.....	July 1937	124
GRAPHICS OF NON-LINEAR CIRCUITS, PART II—A. Preisman.....	Oct. 1937	240
HORN LOUD SPEAKERS, PART II: EFFICIENCY AND DISTORTION—H. F. Olson.....	Oct. 1937	265
INDUCTANCES FOR FREQUENCIES BETWEEN 4 AND 25 MEGACYCLES, THE DESIGN OF—Dale Pollack .....	Oct. 1937	184
INTERNATIONAL CONFERENCES OF CAIRO, 1938—C. B. Jolliffe.....	Jan. 1938	283
LEGISLATION IN THE UNITED STATES, RECENT MARITIME RADIO—I. F. Byrnes and Willson Hurt .....	Jan. 1938	326
LOUD SPEAKERS, HORN, PART II: EFFICIENCY AND DISTORTION—H. F. Olson.....	Oct. 1937	265
MARITIME RADIO LEGISLATION IN THE UNITED STATES, RECENT—I. F. Byrnes and Willson Hurt .....	Jan. 1938	326
MEASUREMENT OF BROADCAST COVERAGE AND ANTENNA PERFORMANCE—W. A. Fitch and W. S. Duttera.....	Apr. 1938	396
MEASURING EQUIPMENT, CATHODE-RAY ENGINE-PRESSURE—H. J. Schrader.....	Oct. 1937	202
METAL TUBES, "BATALUM" A BARIUM GETTER FOR—E. A. Lederer and D. H. Wamsley .....	July 1937	117
METHODS DEVELOPED FOR BROADCAST FACSIMILE SERVICE, EQUIPMENT AND C. J. Young .....	Apr. 1938	379
MICROPHONES, REVIEW OF—Michael Rettinger.....	Oct. 1937	251

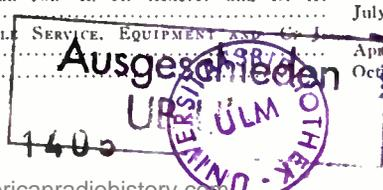

MOBILE RECEIVERS IN AMERICA, DESIGN TRENDS IN—PART I—L. M. Clement and F. X. Rettenmeyer.....	Jan. 1938	317
MOBILE RECEIVERS IN AMERICA, DESIGN TRENDS IN—PART II—L. M. Clement and F. X. Rettenmeyer.....	Apr. 1938	459
MOBILE-UNIT DESIGN, A NOVEL RELAY-BROADCAST—M. W. Rife.....	Oct. 1937	141
MONOSCOPE, THE—C. E. Burnett.....	Apr. 1938	414
NON-LINEAR CIRCUITS, GRAPHICS OF—PART I—A. Preisman.....	July 1937	124
NON-LINEAR CIRCUITS, GRAPHICS OF—PART II—A. Preisman.....	Oct. 1937	240
POWER TUBE, THE REQUIREMENTS AND PERFORMANCE OF A NEW ULTRA-HIGH-FREQUENCY—W. G. Wagener.....	Oct. 1937	258
RADIOTELEGRAPH TRANSMITTER, A 200-KILOWATT—G. W. Hansell and G. L. Usselman	Apr. 1938	442
RECEIVER DESIGN, NEW FEATURES IN BROADCAST—B. R. Carson, K. A. Chittick, D. D. Cole and S. V. Perry.....	July 1937	45
RECEIVERS IN AMERICA, DESIGN TRENDS IN MOBILE—PART I—L. M. Clement and F. X. Rettenmeyer.....	Jan. 1938	317
RECEIVERS IN AMERICA, DESIGN TRENDS IN MOBILE—PART II—L. M. Clement and F. X. Rettenmeyer.....	Apr. 1938	459
RECEIVING EQUIPMENT, SOME RECENT DEVELOPMENTS IN DIVERSITY—J. B. Moore..	July 1937	94
RELAY-BROADCAST MOBILE-UNIT DESIGN, A NOVEL—M. W. Rife.....	Oct. 1937	141
REMOTE CONTROL, A NEW SYSTEM OF—C. N. Kimball.....	Jan. 1938	303
REVIEW OF MICROPHONES—Michael Rettinger.....	Oct. 1937	251
REVIEW OF THE QUEST FOR CONSTANT SPEED, A—E. W. Kellogg.....	Oct. 1937	220
SCIENCE AND SOCIETY—David Sarnoff .....	July 1937	3
SERVICING, TECHNICAL EDUCATIONAL REQUIREMENTS OF THE MODERN RADIO INDUSTRY		
—PART II: THE FIELD OF RECEIVER—F. L. Horman.....	Oct. 1937	213
SMALL VESSEL DIRECTION FINDERS—H. B. Martin.....	July 1937	69
TELEVISION—David Sarnoff .....	Oct. 1937	139
TELEVISION CATHODE-RAY TUBES FOR THE AMATEUR—R. S. Burnap.....	Jan. 1938	297
TELEVISION IMAGES, DIRECT-VIEWING TYPE CATHODE-RAY TUBE FOR LARGE—I. G. Maloff .....	Jan. 1938	289
TELEVISION RECEPTION FIDELITY, EFFECT OF THE RECEIVING ANTENNA ON—S. W. Seeley .....	Apr. 1938	433
TELEVISION STUDIO DESIGN—R. M. Morris and R. E. Shelby.....	July 1937	14
TELEVISION TRANSMITTERS OPERATING AT HIGH POWERS AND ULTRA-HIGH FRE-		
QUENCIES—J. W. Conklin and H. E. Gihring.....	July 1937	30
TRANSATLANTIC SIGNALS, 40 TO 45 MEGACYCLES, FIELD STRENGTH OBSERVATIONS OF		
—H. O. Peterson and D. R. Goddard.....	Oct. 1937	161
TRANSMITTER, A 200-KILOWATT RADIOTELEGRAPH—G. W. Hansell and G. L. Usselman	Apr. 1938	442
TRANSMITTERS OPERATING AT HIGH POWERS AND ULTRA-HIGH FREQUENCIES, TELEVI-		
SION—J. W. Conklin and H. E. Gihring.....	July 1937	30
TUBE APPLICATIONS, SOME UNCONVENTIONAL VACUUM—F. H. Shepard, Jr.....	Oct. 1937	149
TUBE FOR LARGE TELEVISION IMAGES, DIRECT-VIEWING TYPE CATHODE-RAY—I. G. Maloff .....	Jan. 1938	289
TUBE, THE REQUIREMENTS AND PERFORMANCE OF A NEW ULTRA-HIGH FREQUENCY		
POWER—W. G. Wagener.....	Oct. 1937	258
TUBES, "BATALUM" A BARIUM GETTER FOR METAL—E. A. Lederer and D. H. Wamsley .....	July 1937	117
TUBES, EFFECTS OF SPACE CHARGE IN GRID-ANODE REGION OF VACUUM—Bernard		
Salzberg and A. V. Haefl.....	Jan. 1938	336
TUBES FOR THE AMATEUR, TELEVISION CATHODE-RAY—R. S. Burnap.....	Jan. 1938	297
ULTRA-HIGH FREQUENCIES, TELEVISION TRANSMITTERS OPERATING AT HIGH POWERS		
AND—J. W. Conklin and H. E. Gihring.....	July 1937	30
ULTRA-HIGH-FREQUENCY POWER TUBE, THE REQUIREMENTS AND PERFORMANCE OF		
A NEW—W. G. Wagener.....	Oct. 1937	258
VACUUM TUBE APPLICATIONS, SOME UNCONVENTIONAL—F. H. Shepard, Jr.....	Oct. 1937	149
VACUUM TUBES, EFFECTS OF SPACE CHARGE IN GRID-ANODE REGION OF—Bernard		
Salzberg and A. V. Haefl.....	Jan. 1938	336
VIDEO-AMPLIFIER DESIGN, SOME NOTES ON—Albert Preisman.....	Apr. 1938	431
VIDEO AMPLIFIERS, ANALYSIS AND DESIGN OF—S. W. Seeley and C. N. Kimball.....	Oct. 1937	171

## AUTHORS OF VOLUME II

BURNAP, ROBERT S.—Television Cathode-Ray Tubes for the Amateur.....	Jan. 1938	297
BURNETT, CARLOS E.—The Monoscope.....	Apr. 1938	414
BYRNES, IRVING F.—(Coauthor) Recent Maritime Radio Legislation in the United States .....	Jan. 1938	326

	<i>Issue</i>	<i>Page</i>
CARLSON, WENDELL L.—(Coauthor) A New Antenna Kit Design.....	July 1937	60
CARSON, BENJAMIN R.—(Coauthor) New Features in Broadcast Receiver Design.....	July 1937	45
CHITTICK, KENNETH A.—(Coauthor) New Features in Broadcast Receiver Design.....	July 1937	45
CLEMENT, LEWIS M.—(Coauthor) Design Trends in Mobile Receivers in America— Part I.....	Jan. 1938	317
——(Coauthor) Design Trends in Mobile Receivers in America—Part II.....	Apr. 1938	459
COLE, DAVID D.—(Coauthor) New Features in Broadcast Receiver Design.....	July 1937	45
CONKLIN, JAMES W.—(Coauthor) Television Transmitters Operating at High Powers and Ultra-High Frequencies.....	July 1937	30
DUTTERA, WILLIAM S.—Some Factors in the Design of Directive Broadcast Antenna Systems.....	July 1937	81
——(Coauthor) Measurement of Broadcast Coverage and Antenna Performance..	Apr. 1938	396
FITCH, WILLIAM A.—(Coauthor) Measurement of Broadcast Coverage and Antenna Performance.....	Apr. 1938	396
GIHRING, HERMAN E.—(Coauthor) Television Transmitters Operating at High Powers and Ultra-High Frequencies.....	July 1937	30
GODDARD, DEWITT R.—(Coauthor) Field Strength Observations of Transatlantic Signals, 40 to 45 Megacycles.....	Oct. 1937	161
HAEFF, ANDREW V.—(Coauthor) Effects of Space Charge in Grid-Anode Region of Vacuum Tubes.....	Jan. 1938	336
HANSELL, CLARENCE W.—(Coauthor) A 200-Kilowatt Radiotelegraph Transmitter....	Apr. 1938	442
HORMAN, FREDERICK L.—Technical Educational Requirements of the Modern Radio Industry—Part II: The Field of Receiver Servicing.....	Oct. 1937	213
HURT, WILLSON—(Coauthor) Recent Maritime Radio Legislation in the United States	Jan. 1938	326
JOLLIFFE, CHARLES B.—International Conferences of Cairo, 1938.....	Jan. 1938	283
KELLOGG, EDWARD W.—A Review of the Quest for Constant Speed.....	Oct. 1937	220
KIMBALL, CHARLES N.—A New System of Remote Control.....	Jan. 1938	303
——(Coauthor) Analysis and Design of Video Amplifiers.....	Oct. 1937	171
LANDON, VERNON D.—(Coauthor) A New Antenna Kit Design.....	July 1937	60
LEDERER, ERNEST A.—(Coauthor) "Batalum" a Barium Getter for Metal Tubes.....	July 1937	117
MALOFF, LOURY G.—Direct-Viewing Type Cathode-Ray Tube for Large Television Images.....	Jan. 1938	289
MARTIN, H. B.—Small Vessel Direction Finders.....	July 1937	69
MOORE, JOHN B.—Recent Developments in Diversity Receiving Equipment.....	July 1937	94
MORRIS, ROBERT M.—(Coauthor) Television Studio Design.....	July 1937	14
OLSON, HARRY F.—Horn Loud Speakers—Part II.....	Oct. 1937	265
PERRY, SYDNEY V.—(Coauthor) New Features in Broadcast Receiver Design.....	July 1937	45
PETERSON, HAROLD O.—(Coauthor) Field Strength Observations of Transatlantic Signals, 40 to 45 Megacycles.....	Oct. 1937	161
POLLACK, DALE—The Design of Inductances for Frequencies Between 4 and 25 Mega- cycles.....	Oct. 1937	184
PREISMAN, ALBERT—Graphics of Non-Linear Circuits—Part I.....	July 1937	124
——Graphics of Non-Linear Circuits—Part II.....	Oct. 1937	240
——Some Notes on Video-Amplifier Design.....	Apr. 1938	421
RETTENMEYER, F. X.—(Coauthor) Design Trends in Mobile Receivers in America— Part I.....	Jan. 1938	317
——(Coauthor) Design Trends in Mobile Receivers in America—Part II.....	Apr. 1938	459
RETTINGER, MICHAEL—Review of Microphones.....	Oct. 1937	251
RIFE, MARSHALL W.—A Novel Relay-Broadcast Mobile-Unit Design.....	Oct. 1937	141
SALZBERG, BERNARD—(Coauthor) Effects of Space Charge in Grid-Anode Region of Vacuum Tubes.....	Jan. 1938	336
SARNOFF, DAVID—Science and Society.....	July 1937	3
——Television.....	Oct. 1937	139
SCHRADER, HAROLD J.—Cathode-Ray Engine-Pressure Measuring Equipment.....	Oct. 1937	202
SEELEY, STUART W.—Effect of the Receiving Antenna on Television Reception Fidelity .....	Apr. 1938	433
——(Coauthor) Analysis and Design of Video Amplifiers.....	Oct. 1937	171
SHELBY, ROBERT E.—(Coauthor) Television Studio Design.....	July 1937	14
SHEPARD, FRANCIS H., JR.—Some Unconventional Vacuum Tube Applications.....	Oct. 1937	149
USSELMAN, GEORGE L.—(Coauthor) A 200-Kilowatt Radiotelegraph Transmitter.....	Apr. 1938	442
WAGENER, WINFIELD G.—The Requirements and Performance of a New Ultra-High- Frequency Power Tube.....	Oct. 1937	258
WAMSLEY, DELOS H.—(Coauthor) "Batalum" a Barium Getter for Metal Tubes.....	July 1937	117
YOUNG, CHARLES J.—Equipment and Methods Developed for Broadcast Facsimile Service.....	Apr. 1938	379

# RCA REVIEW

*A Quarterly Journal of Radio Progress*

Published in July, October, January and April of Each Year by

RCA INSTITUTES TECHNICAL PRESS

A Department of RCA Institutes, Inc.

75 Varick Street New York, N. Y.

---

VOLUME II

July, 1937

NUMBER 1

---

## CONTENTS

	PAGE
Science and Society.....	3
DAVID SARNOFF	
Television Studio Design.....	14
R. M. MORRIS AND R. E. SHELBY	
Television Transmitters Operating at High Powers and Ultra-High Frequencies .....	30
J. W. CONKLIN AND H. E. GIHRING	
New Features in Broadcast Receiver Design.....	45
B. R. CARSON, K. A. CHITTICK, D. D. COLE AND S. V. PERRY	
A New Antenna Kit Design.....	60
W. L. CARLSON AND V. D. LANDON	
Small Vessel Direction Finders.....	69
H. B. MARTIN	
Some Factors in the Design of Directive Broadcast Antenna Systems..	81
W. S. DUTTERA	
Recent Developments in Diversity Receiving Equipment.....	94
J. B. MOORE	
"Batalum" a Barium Getter for Metal Tubes.....	117
E. A. LEDERER AND D. H. WAMSLEY	
Graphics of Non-Linear Circuits.....	124
ALBERT PREISMAN	
Our Contributors .....	134

---

SUBSCRIPTION: \$1.50 per Year. Foreign, \$1.85. Single Copies 50 cents.

Copyright, 1937, by RCA Institutes, Inc.

Entered as second-class matter July 17, 1936, at the Post Office at New York, New York,  
under the Act of March 3, 1879.

Printed in U.S.A.

## BOARD OF EDITORS

*Chairman*

CHARLES J. PANNILL  
*President, RCA Institutes, Inc.*

RALPH R. BEAL  
*Research Supervisor  
Radio Corporation of America*

H. H. BEVERAGE  
*Chief Research Engineer,  
R.C.A. Communications, Inc.*

IRVING F. BYRNES  
*Chief Engineer,  
Radiomarine Corporation of America*

LEWIS M. CLEMENT  
*Vice President in Charge of  
Research and Engineering,  
RCA Manufacturing Company,  
Victor Division*

DR. ALFRED N. GOLDSMITH  
*Consulting Engineer,  
Radio Corporation of America*

HARRY G. GROVER  
*General Patent Attorney,  
Radio Corporation of America*

O. B. HANSON  
*Chief Engineer,  
National Broadcasting Company*

CHARLES W. HORN  
*Director of Research and Development,  
National Broadcasting Company*

WILLSON HURT  
*Assistant General Solicitor,  
Radio Corporation of America*

DR. CHARLES B. JOLLIFFE  
*Engineer-in-Charge,  
RCA Frequency Bureau*

FRANK E. MULLEN  
*Manager, Department of Information,  
Radio Corporation of America*

CHARLES H. TAYLOR  
*Vice President in Charge of Engineering,  
R.C.A. Communications, Inc.*

ARTHUR F. VAN DYCK  
*Engineer-in-Charge,  
Radio Corporation of America  
License Laboratory*

J. C. WARNER  
*Vice President  
RCA Manufacturing Company  
Radiotron Division*

W. S. FITZPATRICK  
*Secretary, Board of Editors*

---

Previously unpublished papers appearing in this book may be reprinted, abstracted or abridged, provided credit is given to RCA REVIEW and to the author, or authors, of the papers in question. Reference to the issue date or number is desirable.

Permission to quote other papers should be obtained from the publications to which credited.

## SCIENCE AND SOCIETY\*

BY

DAVID SARNOFF

President, Radio Corporation of America

IT is a high honor to be invited to address this gathering of men who search for the kind of knowledge on which our present industrial civilization is based. When we analyze the economic and social structure of the world in which we live, we find that it rests upon a vast foundation of scientific discovery. The steam engine, the development of electric power and its application, the internal combustion engine, the fundamental steps in chemistry and metallurgy which made large-scale steel manufacturing possible, were vital technological inventions. They brought in their train such social institutions as the factory, the large city, the trade union, advertising, installment selling, and mass production.

### TECHNOLOGICAL PROGRESS IS FOUNDED ON SCIENCE

Underneath these technological inventions there lies a painfully accumulated store of fundamental knowledge concerning the properties of matter. That is the domain of the physicist. Without the method of exact scientific thought, and the physical laws discovered and developed by the great physicists—Aristotle, Bacon, Newton, Faraday, Maxwell, and many others who lived before the present century—there would have been none of these inventions, or they would have been evolved at a much slower rate, and certainly not to the same degree of perfection.

The industrial revolution of the nineteenth century—the “machine age”—had its inception in the work of the physicist. Since the earliest days, it was he who led the way in the search for undiscovered facts and principles of nature. Upon these, piece by piece, we have reared our present economic structure.

Few of us fully realize the long, continuous chain of evolution that has led from the purely scientific and theoretical work of men like Newton and Maxwell to the technology which we see all about

---

\* An address delivered before the American Physical Society at Washington, D. C., on April 30, 1937.

us. Few men who are not professional physicists realize the implications for the future of humanity that lie in the theoretical and experimental work being done by the leaders in physical research today. The relationship of the physicist to the far-reaching social changes which follow his discoveries is one of great importance to all who are concerned with human progress, whether they be scientists, business men, or government officials.

#### RADIO BASED ON WORK OF PHYSICISTS

One could scarcely find a better example of the evolution of a scientific idea—starting in pure mathematical theory and achieving a practical result affecting the daily lives of all civilized people—than the one provided by the industry with which I happen to be associated, that of radio. It is one of the most recent fields of applied physics. But it is also one in which the debt to pure physics can be most clearly traced.

Radio had its origin in the purely theoretical reasoning of James Clerk Maxwell, a professor at King's College, London, where in 1865 he advanced reasons for the existence of electro-magnetic waves. Twenty-two years later, Professor Heinrich Hertz at Bonn University, inspired by Maxwell's theoretical work, proved by experiment the actual existence of these waves and their ability to travel through space. Following his publications other university scientists began experimenting with electric waves. Work went on in the laboratories, and crude transmitting and receiving arrangements were devised. At this point, Marconi, in Italy, became interested. In 1895 he invented the elevated radiator, or antenna as we now call it. By means of improved transmitting and receiving equipment, a ground connection, and a telegraph key, he put together the first commercially successful method of transmitting electric waves through the air over considerable distances, and gave to the world a practical system of wireless telegraphy. From that point, development of the new invention progressed rapidly.

The social results of radio have been far-reaching, and the end is not yet in sight. Dr. William F. Ogburn, Professor of Sociology at the University of Chicago, not long ago compiled a list of 150 social effects directly traceable to radio. From Maxwell's theory of electro-magnetic waves to 150 social results, the links in the chain are continuous.

Since the beginning of the twentieth century, many men in your profession have explored the physical phenomena which have given us the basis of the greatest developments in radio. You are all aware

of the tremendously important part the vacuum tube plays in our industry. This device is the direct result of early work by physicists in the study of electron emission from heated filaments. Their work stimulated further study in the application of high vacuum technique to the development of modern tubes. Many men who became famous in other fields of physics contributed substantially to the early growth of radio.

Today the radio industry includes not only countless radio devices as such, but sound-amplifying systems, sound-motion-picture machines, photo-electric apparatus, and all sorts of vacuum tube applications. Every branch of physics has contributed to the creation of these things: mechanics, heat, light, sound, atomic physics, electricity and magnetism. Mechanics is applied to obtain uniformity of movement in sound-motion-picture machines and in phonographs; heat, in the development of high-power vacuum tubes and loudspeakers; light, in the optical systems of photographic sound-recording and reproducing equipment; sound, in loud-speakers and other vibrating mechanisms, and in the design of broadcasting studios and auditoriums; atomic physics, in vacuum and cathode-ray tubes; and electricity and magnetism, in all circuit design, as well as in construction of all magnetically operated devices.

In our utilization of particles of the atomic system we stand today where the early astronomers stood in their exploration of the heavens. They studied the planets and the stars which seemed to be the heavenly bodies nearest them. In our knowledge of the atom, we first discovered and utilized the negative electron—the outermost and most easily accessible structural element, and the one which, in a sense, is nearest to us. Some day we shall know more about and doubtless utilize some of the other elementary nuclear particles which have been discovered in recent years—protons, neutrons, positrons, deuterons, and their various combinations. These new discoveries in turn may give us new vacuum tubes, new sources of power, new modes of travel and communication, new manufacturing processes, new forms of illumination, new cures of dreaded diseases, new highways to health.

Even as the astronomers penetrate farther and farther into the depths of space, using ever more powerful telescopes, so does the physicist, with his bombardment apparatus, penetrate deeper and deeper into the atom. The fact that one of his most powerful tools, the cyclotron, utilizes an ultra-short-wave radio transmitter as one of its basic elements, illustrates the relationship which exists among all the physical sciences and their applications.

## RADIO'S FUTURE DEPENDS ON SCIENCE

Radio—which grew from the seed planted by physicists to the point where it affects the life of nations—has “arrived,” but only at an early station on its journey. We are just beginning to enter, in any practical way, the fascinating domain of ultra-high frequencies—in which radio sight will be added to radio sound.

Short-wave transmission of pictures and printed or written material has been an accomplished fact for several years. It is now in daily service between Europe and America. The broadcasting of a facsimile newspaper into every business office and home—in half-hourly installments if desired—is perfectly feasible. The establishment of such a service is now an economic rather than a technical problem.

The new art of television is also making progress. For the past ten months we have been transmitting experimental television programs from the Empire State Tower in New York City to receivers in the hands of engineers at observation points throughout the metropolitan area. We believe that acceptable standards of picture-definition, to which transmitters and receivers will be synchronized, have been reached.

No field of applied science leans more heavily on all branches of physics than does television. This is particularly true with respect to the recent work in atomic physics. Unexplained electronic phenomena occur in “Iconoscopes,” the devices which convert light into electrical currents, and in the cathode-ray tubes, or “Kinescopes,” which convert electricity back into light. Here is an absorbing and fruitful field of research for the modern physicist.

The major obstacles to the public introduction of television are no longer in the field of research and engineering. They lie in a new domain. Television now demands the creation of a new art-form, allied with, yet distinctive from, the arts of the stage, of the motion picture, and of sound broadcasting. It requires new talent, new techniques of writing, direction, and studio control. It must set in motion an ascending spiral whereby good programs create a demand for receiving sets, thus creating a growing audience, which in turn will make possible better programs. Television must build networks, and justify an economic base capable of supporting an expensive program service. These are some of the problems of television, solution of which will one day make it a major industry. They are the kind of problems that sprout from a seed planted in the soil of pure physics.

An evolutionary sequence of thought, experiment, production, and use, similar to that which constitutes the history of radio, might be traced in almost every product or service at the command of mankind today. The food we eat, the clothes we wear, the roofs that shelter us—as well as our services of communication, transport, health, education, and recreation—all bear witness to the impact of scientific thought and processes upon human activities that are older than recorded history.

#### RECOGNITION OF THE SCIENTIST IS OF RECENT ORIGIN

Yet that impact had scarcely begun to make itself felt a century ago. Prior to the 19th century, technological advances were largely the result of ingenuity or guesswork or trial-and-error. The brave soul who dared to dream dreams and see visions in the realms of pure science was regarded as a sort of witch-doctor—possibly harmless, or perhaps a suitable subject for an inquisition and burning at the stake.

I congratulate, you gentlemen, upon having been born to your distinguished calling in a more enlightened age. Society today honors you and acknowledges its debt of gratitude to you. Our radio, the newspapers and the magazines reflect a new public taste for scientific subjects. They dramatize your discoveries. Every man who reads or listens can acquire a smattering of scientific knowledge, and converse about electrons and relativity and light-years. A light-year is something like a billion dollars: we have learned to talk about it even if we can't quite comprehend it.

The scientific approach to the solution of human problems, the cumulative effect of our ever-increasing store of knowledge, the speeding-up of technological improvements through the coordination of discoveries in diverse fields—these are assets of such recent origin that the ink with which mankind has entered them upon its balance sheet is scarcely dry.

#### PRODUCTS OF SCIENCE MAY BE USED OR MISUSED FOR SOCIETY

It is one thing, however, to have assets, and another to know how to use them. The inductive processes of thought by which science lays brick on brick—testing each as it goes along to make eventually an impregnable structure—are not the processes we use in our attempt to construct a better social order. Whereas the scientific world glorifies truth, the social world still operates largely with prejudice. Thus it comes about that we have assets which are products of the scientific

type of mind, but we do not yet know how adequately to use those assets to make them pay dividends to humanity.

Humanity's balance sheet is all right. It shows resources that are priceless, and a net worth that is beyond computation. But the value of assets without yields is purely theoretical. The document we need to be concerned about is the human profit-and-loss statement.

The scientist and the sociologist have viewpoints which are perhaps too widely separated. The scientist is engaged in the pursuit of truth, the knowledge of which is the most valuable of our acquired assets. The sociologist is concerned with the ultimate effects of truth upon human behavior. To the scientist the discovery of truth is an end in itself. To the sociologist it is only a means to an end. The scientist is interested in our balance sheet. The sociologist is interested in our profit-and-loss statement.

In an industrial age, the difference between profit and loss for humanity is the difference between use and misuse of the products of industry.

In bygone days the principal products of the industrial anvil were simple plough-shares, but, as science has given us infinitely richer and more varied materials with which to work, our modern industrial output has become more and more complicated. Today the sociologist rightly may claim that many of the gifts of science and industry are in the nature of a two-edged sword. It is a sword which, like the "Nothung" of Siegfried, can be used to slay the dragons of ignorance, intolerance, and greed; but there is always a chance that it will turn out to be a weapon with which civilization may destroy itself.

One does not have to go far to find illustrations of the blessings and dangers that go side by side in the discoveries of science. The chemical that safeguards the work of the surgeon can poison the city's water supply. The airplane, that speeds transportation and commerce, can drop bombs from the air to blow women and children to atoms.

There are other dangers, less obvious and more subtle. Radio, for example, can be used for propaganda and regimentation, as well as for education and entertainment. Science laid the same gift of radio at the feet of society in Europe as it did in America. It is true that in the United States there is room for improvement in some of the programs broadcast on the air, and that we still have to learn how to derive the greatest social benefit from radio. But no one raised in the tradition of liberty and democracy can doubt that our use of it is in the direction of social betterment, and that in certain parts of Europe, where radio has been commandeered by the forces of regimentation, its misuse points toward social degradation.

The new art of television has similar potentialities to build up or tear down social values. Like sound broadcasting, it can make friendly neighbors of people who differ in race, creed, politics, and language; while at the same time it offers a powerful weapon to the war-maker, and a medium of propaganda for the autocrat.

Fortunately, man's deliberate abuses of the gifts of science are the exception rather than the rule. Otherwise we would have to agree with the ancient and pessimistic philosopher who asserted that

*"He who increases knowledge increases sorrow."*

Such a belief would warrant converting our universities into trade schools, and our doctors of science into expert mechanics.

On the other hand, it is too optimistic to assume that the mere translation of a scientific discovery into a usable commodity or instrument always advances civilization; that just because humanity can travel faster, communicate more freely, cook, wash, iron, and gather ice cubes with less effort than ever before, it has reached the all-time peak of civilization. Giving a man a hoe or a microscope does not make him a farmer or a scientist, and giving him a radio or an automobile does not make him civilized. It is the use that society makes of the products of science and industry that determines whether civilization is advanced or retarded.

#### SOLUTION OF SOCIAL PROBLEMS CALLS FOR SOCIAL SCIENCE

Civilization depends for its advance upon our expanding knowledge of the social as well as the physical sciences, for society, no matter how benevolent its intentions, cannot solve its problems by intuition or rule-of-thumb. It must develop its own standards and technique. Yet it is only natural that the growth of social science should lag behind that of physical science, for the social scientist is dealing with human rather than inanimate materials; with moral rather than mathematical equations; with experiments which yield their final results, not in the course of days or years, but only in generations and centuries.

Experimentation in any field is an undertaking of the pioneering spirit—never that of the reactionary and the standpatter. The advance of social science, no less than that of physical science, calls for the creative imagination of a Newton and a Maxwell, an Edison and a Marconi. Obsolescence is a factor in social as well as in industrial machines. In society as in industry, to stand still is to go backward.

The social experimenter is important to society. But if he is ruled by his emotions, and abandons the spirit of research for that of crusading, there is danger for society. The spirit of the social crusader

is not always the spirit which seeks for truth. To attempt to cure the ills of society with untested remedies is not the method of science.

The social experimenter must be one who approaches the problems of society in the clear light of an unbiased mind. He must collect and analyze facts, seek to fathom causes and establish principles. He must always be willing to reconsider those principles in the light of their results.

It is, of course, impossible to draw a complete analogy between the world of science and society itself. The engineer deals with things that have no will of their own. His is the will, which can command them to take a certain shape and serve a certain purpose. He who would be an engineer of society must deal with human beings, who are flesh and blood, emotion and prejudice, dreams and aspiration. They each have a will, and in a democratic society people must be persuaded and not coerced. But the scientific spirit can direct the means of their persuasion. A surgeon does not try to persuade a patient to undergo an operation until he has made a careful diagnosis, and can convince the patient that the operation will help him. He appeals not to his prejudices or to his fears, but to his sense.

If the cause of civilization is to be advanced on a permanent basis, we must learn to follow a procedure similar to that of the experienced surgeon. We must not be afraid to operate; but it is vitally important to know when to operate and when to advocate a less spectacular and safer treatment. One decision may require as much courage as the other. We must investigate and verify social and economic facts; analyze them in order to arrive at logical conclusions; and obtain widespread acceptance of those conclusions through popular education and debate.

All these are slow, laborious processes, and may prove irksome in a fast-moving age. But they are necessary if we are to preserve a free society. The enlightened citizen accepts the fact that the momentum of society, like the momentum of physical bodies, is the product of mass times velocity. The velocity of the few often has to wait upon the inertia of the many, and it is only by overcoming that inertia that genuine social progress among a free people is achieved.

#### SCIENCE AND INDUSTRY HAVE UNLIMITED FUTURE

Industry today is following the vanguard of science into new and infinite realms of knowledge. It would be a rash astronomer who said that he had calculated the outermost limits of space, beyond which there is nothing. It would be a rash physicist who claimed that he had dissected the atom into its ultimate, indivisible fragments. Science and knowledge have no boundaries.

So it would be a rash economist who predicted any limit to the tangible results of scientific thought in the form of new goods and services placed at the disposal of mankind. In fact, it is only by a constant development of new goods and services that we may expect to re-engage the man-power released by technological improvements in established industries. The market for every new commodity eventually reaches a saturation point and becomes primarily a replacement market, so that a more efficient technology reduces the number of workers needed in that field.

But science is simultaneously creating new employment, both by the modernization of established industries and by the creation of new ones. In our own generation we have seen the automobile, the airplane, the motion picture, and the radio provide totally fresh fields of activity for millions of men and women. Many of our older industries have engaged scientists, with notable success, to develop new and remodel old products to meet the needs of a modern era.

The industry which has not learned how to employ scientists to make it new, and keep it new, is doomed. Few industries are so stagnant as not to be aware of this; but there are some so conservative that the scientist is called upon to turn salesmen and show them how modern science can rejuvenate them to meet present-day realities and survive.

In all respects, I hope we can bring about a closer understanding and cooperation between you, who seek new truths in the universities, and leaders of industry, who seek to make the truth you discover serve society. Not only research staffs but industrial managers should at all times be kept informed of your new discoveries. With such knowledge, promptly obtained, I am certain we can shorten the time-gap which now separates technological unemployment and useful re-employment.

Any measure of unemployment relief obtained by placing a check-rein upon technology, or by arbitrarily hampering men's efficiency, is unsound, uneconomic, and cannot endure.

#### SOCIAL SCIENCE HAS AN IMMEDIATE GOAL

The problems created by technical science must be solved by increasing and applying our knowledge of social science. Society cannot expect to see every detail of its future plotted in advance, any more than the scientist in his laboratory knows beforehand where each new experiment will lead him. But a study of the social strains and stresses in the world today points toward a clearly defined objective which should be the immediate goal of social science. That goal should be to achieve economic justice, peace and prosperity in a free democracy.

The autocracies of Europe have come into power by exploiting fears of insecurity and by promising impossible Utopias. Fear is an enemy of progressive development, whether of individuals or of nations: fear of economic and social forces too powerful to be struggled against; fear of insecurity, of injustice, of unpredictable economic changes.

The American pioneer in the pre-machine age did not know this kind of fear. His enemies were the forces of Nature from which he could wrest a living with the strength of his two hands.

That strength is no longer enough. The individual is no longer self-sufficient. The fears of today must be banished by the organized effort of an enlightened society, capable of bringing into equilibrium the economic forces that huge populations and the industrial age have set in motion.

#### FREEDOM BOTH OF SCIENCE AND SOCIETY MUST BE SAFEGUARDED

Because a collective effort is called for, however, it is a false and dangerous assumption to think that the freedom of the individual must be turned over to the state. The governments which have demanded such a price have not been able to deliver the economic security they promised in exchange. But even if they could make good their promises, the belief that any material gain is worth the loss of individual liberty denies the spirit and tradition of America, and ignores the bitter lessons of history.

Freedom of the individual is essential to the full expression of his creative faculties—whether in art, in science, or in technology. Only out of free minds has modern civilization been created; only out of free minds can it be advanced.

To reach our goal of economic and social freedom, it is not sufficient merely to have an idealistic viewpoint. Idealism is only wishful thinking until it is given shape and direction by fact-finding and logic. We must learn to apply science to the business of government and to the government of business.

At a time when the people of many countries are being encouraged by their leaders to believe that salvation lies in autarchy and self-sufficiency, it is well to remember that the minds of men in all nations have collaborated across all borders to advance the service of science to society. Without such collaboration, progress will be slowed up, and may even stop. Regardless of how the human emotions may operate, the human mind knows no national boundaries.

Science and Society depend upon each other for their welfare and advance. Science teaches a basic lesson—that knowledge of the truth, without fear or prejudice, is indispensable to progress. Where that

lesson is rejected, and scientists are ordered to shape their reasoning to fit the purposes of an autocratic government, science goes backward instead of forward. The tragic position of a scientist in a regimented society was recently revealed by a professor in one of Europe's oldest universities, when he made this public statement:

*"We do not know or recognize truth for truth's sake or science for the sake of science."*

Under such a doctrine, Science and Society can only serve each other badly. Democracy believes in a different philosophy, written in words of wisdom nearly two thousand years ago:

*"Ye shall know the truth, and the truth shall make you free."*

## TELEVISION STUDIO DESIGN

BY

R. M. MORRIS AND R. E. SHELBY

Engineering Department, Development and Research,  
National Broadcasting Company.

OVER a period of years the RCA policy with regard to the development of television has been characterized by a continuous program of laboratory research coupled with field demonstrations at suitable intervals to test the apparatus and circuit developments under operating conditions. The progress of this work has been recorded from time to time in a series of technical papers by various engineers of RCA companies.

Early in 1935 television apparatus had been developed, as a result of laboratory research, which showed considerable promise on small-scale demonstrations. It was therefore decided that another field test was not only appropriate, but essential to further progress toward a public television service. It was also agreed that this field test must be sufficiently comprehensive in nature to provide a representative indication of audience reaction, furnish information on the problems of program production and distribution, and test the fundamental, technical principles and reliability of the system under conditions approximating those which might obtain in actual public service.

Accordingly a field demonstration was inaugurated, involving the co-ordinated efforts of all of the associated companies of RCA. The general plans of this project and a brief description of the facilities employed have been given in a paper by Mr. R. R. Beal.\*

In a more recent paper by Mr. O. B. Hanson†, the planning of the television studios employed in this field test was discussed. It is the purpose of this present paper to discuss, from the viewpoint of the operating company, the engineering problems involved in the design of a plant for originating television broadcast programs.

---

\* RCA REVIEW, January 1937, "Equipment Used in the Current RCA Television Field Tests."

† RCA REVIEW, April 1937, "Experimental Studio Facilities for Television."

When design of the present television plant in Radio City was started a little more than two years ago, the model used as a starting point was a set of television equipment in the research laboratory in Camden. That layout consisted of one direct-pickup camera chain and one film camera chain operating on a basis of 343 lines interlaced and 30 picture frames per second. The studio was relatively small and the equipment was all located in three adjoining rooms so that problems such as would arise in a practical installation were relatively non-

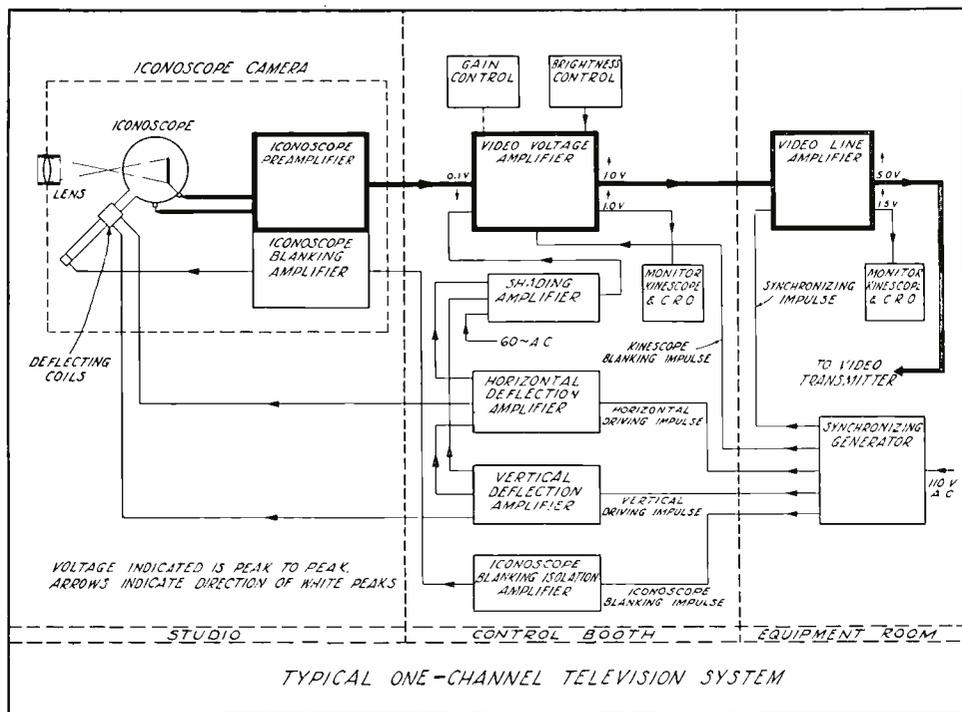

Fig. 1—Diagram showing elements of one video channel.

existent. From the fundamental system exemplified by this apparatus, it was necessary to design a television plan comprising a direct-pickup, live-talent studio equipped with three camera chains and a film studio having two projectors and camera chains, together with all necessary appurtenant apparatus such as synchronizing generators, video line amplifiers, etc. These facilities were to be installed in the Radio City plant of the National Broadcasting Company. Considerations governing the choice of this location and the general layout have been given in the paper by Mr. Hanson to which previous reference has been made.

The fundamental elements of a typical camera chain are shown in Figure 1. At each significant point in the circuit the polarity of the signal is shown by an arrow and the approximate peak-to-peak value of voltage is also given. It will be appreciated that only the bare essentials of a single video camera chain are indicated in this figure. The video signal generated in the "Iconoscope" is fed into a pre-amplifier located in the camera. In this amplifier the signal is built up to a value suitable for transmission from the camera to the video voltage amplifier in the studio control booth where it is amplified still further before being transmitted to the video line amplifier in the main equipment room. The main output of the line amplifier feeds either a coaxial cable or a link transmitter for transmission to the main video-broadcast transmitter. Average brightness and contrast (gain) of the picture are controlled in the video voltage amplifier. In addition to the main amplifier chain for the video signal, horizontal and vertical deflection systems must be provided for scanning both the "Iconoscope"\* and the monitoring "Kinescopes,"\* and a synchronizing generator must be provided to supply the various impulses required for synchronizing the scanning and blanking operations at the "Iconoscope" with those at the "Kinescopes" in the receivers. Monitors must be provided for viewing the transmitted picture just as monitoring loudspeakers are used in sound-broadcast operation. Shading amplifiers and controls are necessary to provide adjustment of relative light values in the various areas of the picture.

In expanding this relatively simple, fundamental television layout into a larger plant capable of producing programs under conditions suitable for a limited public service, a number of new problems arose. Decisions had to be made as to the location of the various pieces of video apparatus associated with the plant. Consistent with NBC experience in broadcast-plant design it was thought desirable to place as much of this equipment as possible in a centrally located main equipment room—the same equipment room in this case as was used for the sound-broadcast equipment. Study of the situation, however, indicated that because of the greater number and complexity of controls associated with video equipment, it would be necessary for most of the video equipment to be located in the studio control booths. In audio-broadcast-plant design, usual practice provides a number of microphones in the studio with individual preamplifiers which feed into a mixing system followed by one main amplifier which is placed in the equipment room. In video-plant design this plan is not at the present time considered feasible for several reasons. In the first place, sev-

---

\* Trade Mark Registered U. S. Patent Office.

eral control operations take place in the amplifier which follows the preamplifier. Another important consideration has to do with the difficulty of feeding and switching video circuits, particularly at low levels. The fact that a complete chain of amplifiers and deflection and power circuits must be provided for each camera means that a relatively large amount of apparatus must be installed in the control booth.

Controls necessary to the proper operation of a camera chain may be grouped under two classifications: those normally requiring adjustment but once at the beginning of a program, and those requiring adjustment during normal operation. In the first group are included those controls which regulate the amplitude of horizontal and vertical

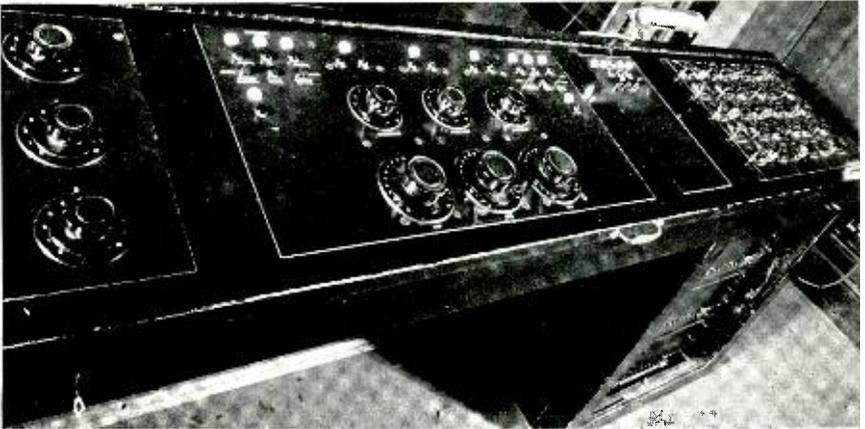

Fig. 2—Video console in Studio 3H, Radio City.

scanning for the "Iconoscope," keystone correction, focus and several others. Those controls which the operator must adjust frequently include gain control (contrast), blanking pedestal (brightness) control, and those controls which regulate shading of the transmitted picture.

The physical layout of these controls is shown in the photograph of Figure 2. This is a view of the top of the video-engineer's console located in the control booth of the direct-pickup studio. The three large knobs on the extreme left control electrical focus of the electron beams in the "Iconoscopes" of each of the three cameras. The three vertical groups of large knobs in the center control average brightness and contrast for the three cameras and the three panels of controls on the extreme right (ten knobs and six switches in each group) regulate shading. The shading amplifiers are mounted beneath the shading control panels. Push-buttons for switching cameras are located above

the brightness controls, and those for switching the two monitors are in the upper left and right hand corners of this panel. On the small panel to the right are located signal lights and "stand-by" keys for the camera positions. The console in the film studio has the same general arrangement, with controls for only two instead of three cameras. It has in addition controls for four film projectors. The photograph of Figure 3 shows the top of this console.

A unique feature of the video-gain or contrast controls used on both consoles is shown in Figure 4. The control knobs on the console are



Fig. 3—Video console in film studio 5A, Radio City.

attached to the shafts of Selsyn motors through suitable reduction gears. The other motor of each pair is built into the video voltage amplifier and connected to a potentiometer gain control. Rotation of the control knob and its associated motor causes an equivalent rotation of the other motor and its potentiometer. In this way control of amplification is effected with no compromise as to frequency response characteristics or convenience of operation. This method was selected after careful consideration of several ways of accomplishing this important function.

Monitoring of the output of the various video voltage amplifiers and video line amplifiers is afforded by a combination "Kinescope" and

oscilloscope monitor unit shown in Figure 5. This complete unit combines a 9-inch "Kinescope," a 5-inch oscilloscope tube, video amplifiers for each capable of operation from a minimum level of 0.5 volt peak-to-peak, a 250-volt regulated power supply, and a high-voltage power supply. The amplifiers must be located immediately adjacent to the tube panel to reduce capacity on video leads. The power supplies may, however, be conveniently located in a near-by auxiliary cabinet rack. In transmitting a normal program requiring frequent switching from one camera to another it is necessary to have at least two of these

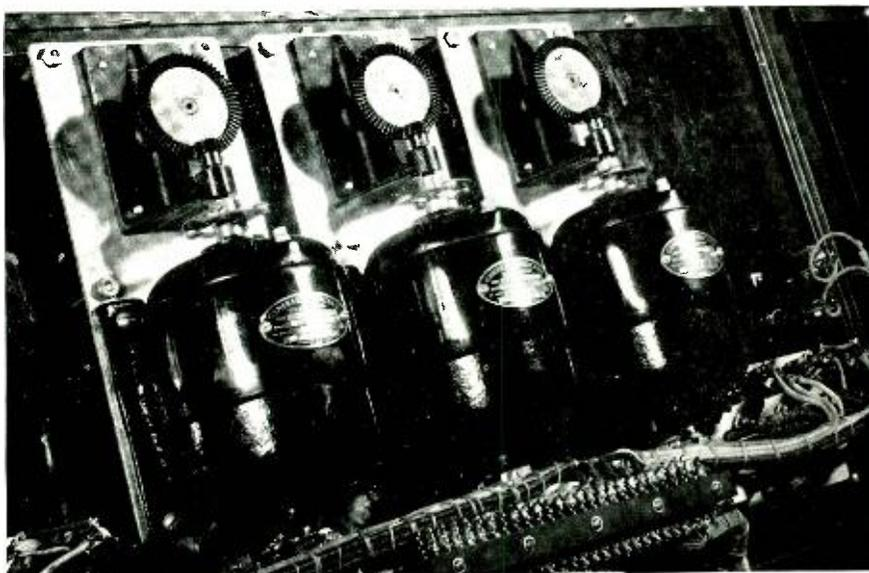

Fig. 4—Selsyn motor used for video gain control.

monitor units. This provides one monitor at all times on the outgoing picture and another which may be used for preliminary viewing of the other cameras. It also provides a spare monitor essential in case of failure during a television production. With the additional monitor the engineer can be sure that the camera which he is about to switch to the outgoing channel is properly focused and adjusted for signal level and brightness. Flexible relay switching is provided for these monitors which makes it possible to connect either or both to any of the camera chains in the studio. An automatic-switching arrangement may be cut in on either monitor so that this monitor will follow camera switching and always be connected to the chain transmitting the outgoing picture.

In addition to switching arrangements for the monitors it is neces-

sary that provision be made to switch the various cameras onto the outgoing line and also to switch between the direct pick-up studio and the film studio. Since both audio and video circuits must be simultaneously transferred when changing studios, the two control circuits are so interlocked that one push-button operation effects the switching of both. Remotely controlled relays are used for both video and audio switching.

The relays used for video switching must meet special requirements

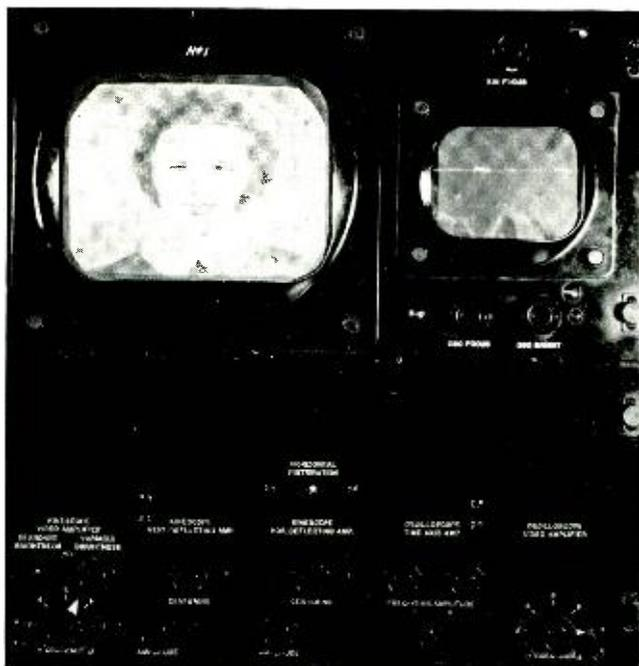

Fig. 5—Monitor showing "Kinescope" and oscilloscope in normal operation.

not imposed upon relays used for other purposes. The capacity to ground and capacity between springs of the relay must be as low as possible consistent with reliable mechanical design. The relays used in the Radio City installation employ two sets of contacts in series with an auxiliary contact for grounding the central springs when the circuit is open, thus obtaining electrostatic shielding between the incoming and outgoing video circuits. The camera-switching relays are interlocked in such a manner that dropping one camera and picking up another is accomplished by merely pressing one push-button. To provide smooth-switching action, these video relays must be so adjusted

that the proper make-break sequence is obtained in order to prevent surges from being transmitted which would momentarily upset receiver synchronization. Improper adjustment of the relays results in a very annoying surge in picture brightness and often will cause the receiver to slip a frame every time cameras are switched. The sche-

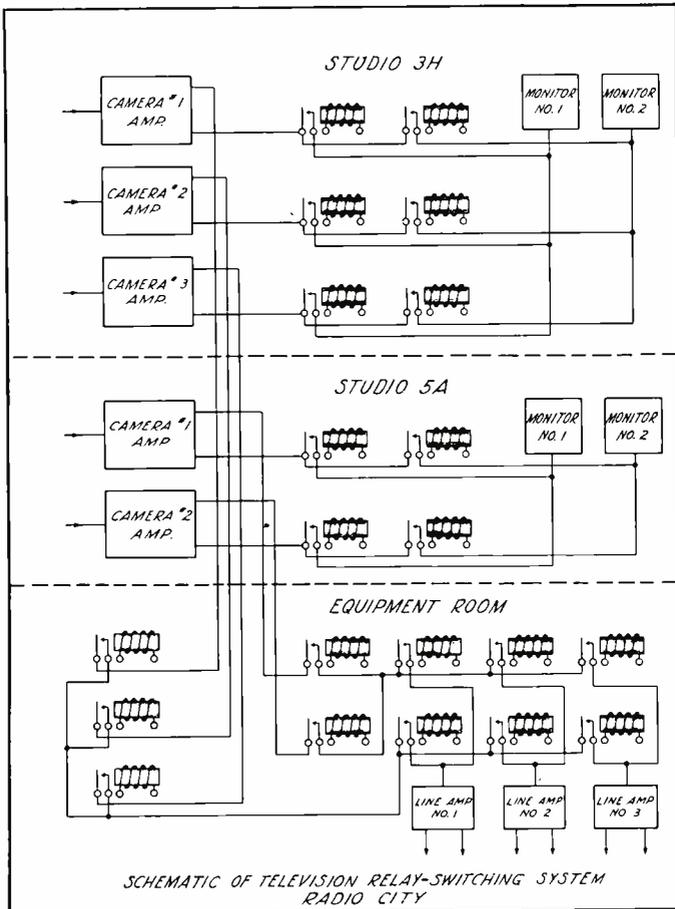

Fig. 6

matic arrangement of video relays used in Radio City is shown in Figure 6.

In addition to the normal switching facilities provided by the relays, it is desirable to have convenient means of connecting and disconnecting various units of the video system. To accomplish this, coaxial patch cords and jacks are provided in some circuits. The photograph in Figure 7 shows a coaxial jack strip. These patch cords and jacks

make possible the convenient changing of circuits without the introduction of an impedance irregularity in the 75-ohm coaxial conductors.

The design of a multiple studio plant for originating television programs is attended by many engineering difficulties of the same kind that are encountered in laying out a comparable plant for sound broadcasting. In addition there are many special problems which arise, due to the nature of the television signal. The extremely wide band of frequencies, extending from the lower audio frequencies to several million cycles per second, imposes severe limitations upon not

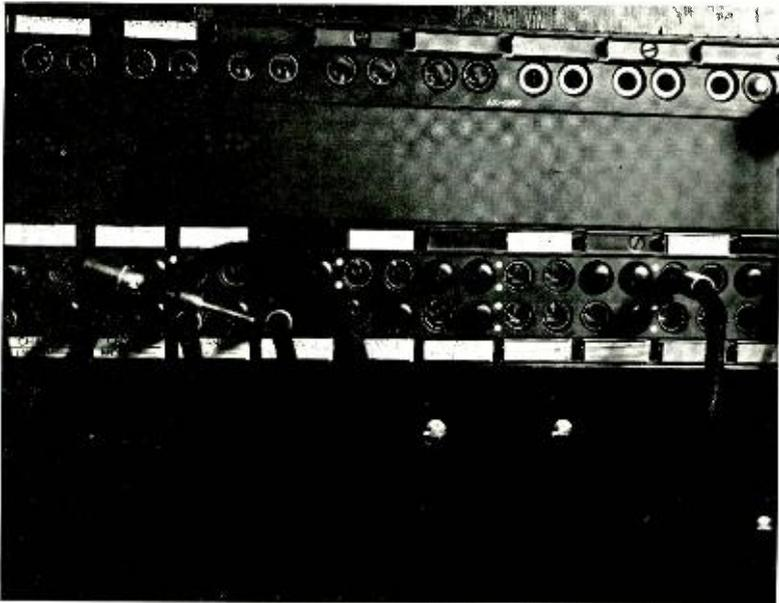

Fig. 7—Coaxial-cable jack panel and patch cord.

only the amplifiers themselves, but also upon the circuits used to connect them and the equipment used for monitoring, switching, and testing. At the present time, so far as we are aware, no transformers are available for handling satisfactorily the entire band of video frequencies required for a high-definition 441-line television picture. This means that rather severe mismatches of impedance must be tolerated between amplifier output tubes and the low-impedance coaxial cables which they feed, with the attendant loss of amplification made up by high gain in other stages of the amplifier chain.

One of the problems which arose in the design of this television plant which had not given serious trouble in previous installations was the difficulty caused by the length of coaxial-cable circuits for

the video signal between various groups of apparatus. Any appreciable mismatch of impedance at the receiving end of these cables produced reflections which in many cases have sufficient delay to produce objectionable multiple images. In those cases where switching relays were placed on the ends of such cables the low impedance at the higher video frequencies caused by the capacity-to-ground of several relays in parallel was found to produce serious reflections. In order to overcome this, it was necessary in some instances to provide isolating amplifiers between the resistance termination for these cables and the switching relays. In this connection it is pointed out that the attenuation of high frequencies produced by a shunt capacity such as this may be overcome in other amplifier circuits by suitable peaking of the high frequencies, but this correction will not compensate for the reflections.

All video amplifiers used in this project are of the resistance-capacity-coupled type with suitable corrective networks to obtain the wide-frequency response required. Amplifiers of this kind are usually susceptible to low-frequency interference arising in power-supply circuits, particularly those having stages which have low-impedance circuits where the power-supply impedance may be comparable to the load impedance. This may seem to be a condition which is unlikely to obtain in practice, especially where a large central storage battery is the source of plate supply. However, such a source of plate power together with the necessary lengthy wiring produces a sufficiently high impedance looking back from the amplifier into the power supply to cause "motorboating" of a video chain. This is not due to the resistance of the battery or wiring, but to the reactance of the line connecting the equipment to the battery. With no by-pass condensers and a nominal run of 100 to 200 feet the impedance can rise to over a thousand ohms in the frequency range of a video amplifier. By-passing with a moderate-size condenser to ground will eliminate this condition, but will raise the impedance above its previous value at some lower frequency. The question then resolves itself into putting on a sufficiently large condenser to lower the impedance at all frequencies in the video range below the value necessary for stable operation. The impedance can usually be reduced to a workable value by applying condensers of approximately 2000  $\mu f$  at the equipment end. Figures 8A and 8B show the measured impedance of the 250-volt circuit in Studio 3H and the effect of several sizes of condensers connected across the equipment end of the circuit. Any circuit-breaker impedance, particularly from the inductive-type overload breakers, must be eliminated from the circuit. Fuses have thus far been found superior to circuit breakers from this standpoint.

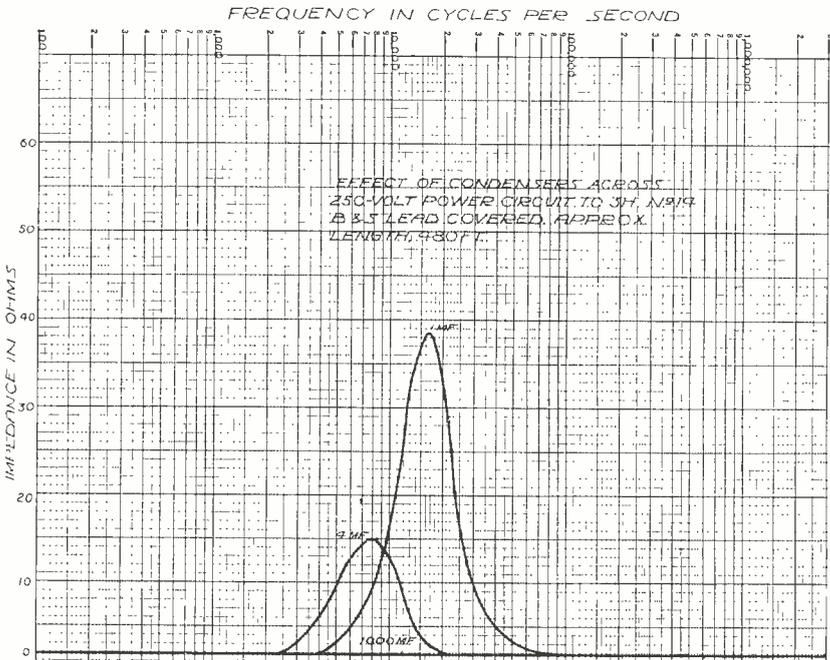
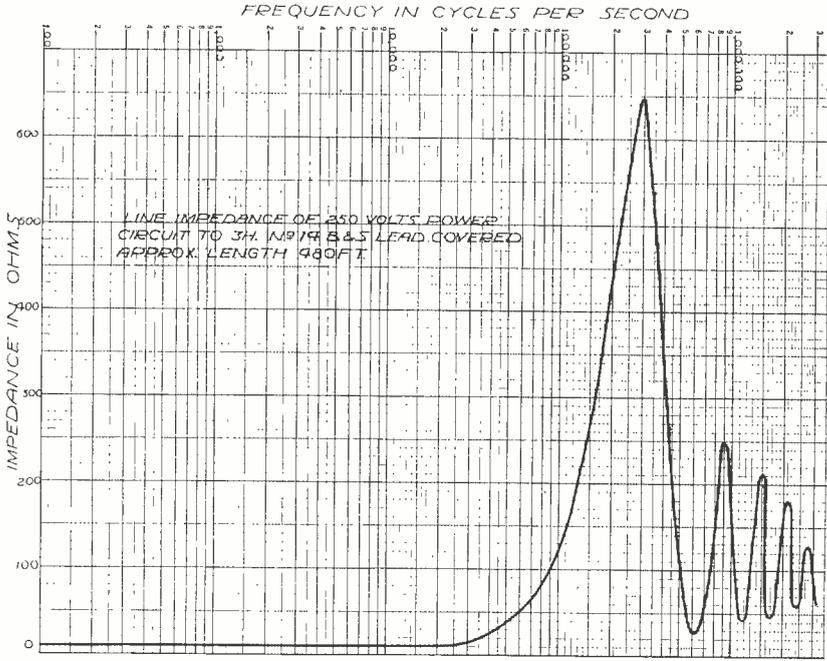

Figs. 8A and 8B—Impedance of power circuit used with video amplifiers as a function of frequency for various values of by-pass condenser.

Some of the problems involved in the wiring of a television plant such as this one have already been indicated in their relation to other problems. In order to provide low-loss circuits with good shielding for the high frequencies involved and with a minimum of impedance irregularity it was decided that coaxial cable would be used for all video-signal transmission circuits and also for all circuits carrying synchronizing and blanking impulses from the centrally-located synchronizing generator to the studios. The coaxial cable constitutes an unbalanced load to ground at its input terminal and is therefore suitable for direct connection to unbalanced amplifiers (i.e., amplifiers of the "single-ended" type as distinguished from those of the push-pull type). Because it is unbalanced the cable is subject to interference from stray ground currents flowing in its outer conductor. The intensity of this interference is of course dependent upon the length of the run and the difference in "ground" potentials at the two terminals. We have found that it is not serious under the conditions encountered in this installation.

In order to minimize cross-over between circuits and to guard against impedance irregularities, a specially shielded terminal block was developed for use with the coaxial cables. Each single-circuit compartment in the block is separately shielded on all sides by solid walls of copper. The heavy copper block is cadmium plated to facilitate good electrical contact at all points.

The production of a television program differs from the production of a motion-picture film in several important respects. Once the television program is started, the action is continuous until the end. There can be no retakes, no pauses, no correction of errors, and no re-editing. All equipment used in the studio must be extremely flexible and quiet in operation. Lighting must be altered, cameras moved and switched, and microphone positions changed without the television observer being aware of these activities throughout the entire production. This necessitates that the "Iconoscope" camera be extremely maneuverable and easily adjusted by properly and conveniently located controls.

The camera, which houses the "Iconoscope" with its lens system, an "Iconoscope"-blanking amplifier, and a video preamplifier, is mounted on a movable pedestal or a motion-picture type dolly. The pedestal has three rubber-tired wheels which are locked together with a chain drive and which may be steered with a conveniently located lever. The pedestal head contains pin jacks which connect the circuits to the camera proper. This head contains the mechanism for "panoraming" ("panning") and tilting, and either operation may be independently locked. Connections to the pin jacks are made from a corkscrew spiral cable which is mounted within the telescopic elevating tubes of the

pedestal. The other end of this corkscrew cable terminates in a 36-conductor flexible cable 60 feet long and approximately 2 inches in diameter. Elevation is accomplished by means of an electric motor which operates a windlass and a system of pulleys. In operating this type of pedestal, the engineer stands on the floor, and pushes the camera about as desired. A pair of shafts protrude from the rear of the camera and the engineer raises or lowers the camera by rotating the shaft on the left, and focuses by rotating the shaft on the right. These two shafts also serve as a means of "panning" and tilting the camera during operation. Signal lights on the front and rear of the camera indicate "stand-by" or "on the air". A headphone jack is also mounted on the camera so that the video engineer in the control booth may communicate with the engineer at the camera. When using the motion-picture type dolly the camera is removed from the pedestal and remounted. An assistant propels and steers this vehicle so that the camera engineer may devote his attention to more important duties.

In order to make it possible for the camera operator to follow moving action from varying camera angles and keep the scene always properly in focus, it is essential that a reliable "finder" be provided on the camera. In early television cameras a mirror was provided which made it possible for the operator to see directly the image focused upon the mosaic of the "Iconoscope". This had the disadvantage of low brilliance, since the mosaic surface is not a good reflector of light, and there was also some danger that light from the studio might reach the mosaic through this "finder". On the present cameras two identical lenses are used on each camera—one for focusing the image upon the mosaic and the other for focusing a duplicate image upon a ground glass for viewing by the camera engineer. The position of the ground glass is adjusted so that it is in an identical plane with the mosaic of the "Iconoscope," and thus adjustment of the focusing control to obtain sharp focus of the image on the ground glass also results in proper focus of the image on the mosaic. An advantage of this type of finder is that the lens used for the finder may be operated "wide open" for critical focusing regardless of the stop setting on the main lens.

Interchangeable lenses with focal lengths of 6½, 14, and 18 inches are provided for use with these cameras. They are mounted in pairs upon demountable lens plates so that lens combinations on the camera may be changed conveniently. The advantage of using long focal length lenses in studio work is that one camera utilizing wide-angle (short-focal-length) lenses may be employed to cover a large area of the set, while telephoto (long-focal-length) lenses are used on another

camera to obtain close-up shots without having the camera so close to the action that it would be within the viewing angle of the other camera.

In a system of the kind used in this project, it is essential that adequate communication channels be provided between the various engineers to maintain smooth program continuity. In a typical television program, two or more scenes in the direct pickup studio will be interspersed with several film scenes. The most pleasing effect is obtained if a smooth continuous performance is given with no interruptions when switching between various portions of the program. To achieve this the operators in the two studios must be in close contact with one another so that the studio show can begin the instant the film is ended or vice versa. The switch from the direct-pickup studio to the film studio is the more difficult of the two, since the film projectors must be started, brought up to speed, and the picture "framed" properly, within the proper number of seconds before the studio act is completed so that the start of the film will appear on the screen the moment the circuits are switched to the film studio. If the projectors are started too early the first part of the film will be lost, and if they are started too late, there will be an interval during which the screen will be dark. A thorough knowledge of the proper operating technique on the part of the operators is of course essential, but even with this, good continuity would not be assured without proper communication circuits. Figure 9 is a simplified diagram showing the several telephone and studio address systems employed to provide the desired co-ordination. A private-line telephone system is used to connect the control booths of the film studio, the direct-pickup studio, and the control room of the Empire State transmitter. This telephone circuit is connected prior to the start of the program and is monitored continuously throughout the duration of the program by one of the engineers at each location. It is over this circuit that "standby" warnings and switching cues are given. An independent one-way telephone circuit is provided between the video-control operator and each of the cameras in the direct-pickup studio. Over this circuit the video-control operator can give instructions to the camera man regarding location and adjustment of the camera while the show is on the air without interfering with the audio pickup. This circuit is also connected to the rear-projection booth. There is a studio address system provided for giving instructions from the control booth to personnel and actors in the studio during rehearsals. This system is automatically cut out when the studio goes on the air to prevent accidental interference with the audio pickup. A microphone-loudspeaker address system is provided from the control booth of the film studio to the projection room

so that the control operator can give instructions to the projectionist. A microphone is also provided in the projection booth so that the projectionist can warn the control operator of any emergency. Both of these loudspeakers are normally used for audio monitoring, except

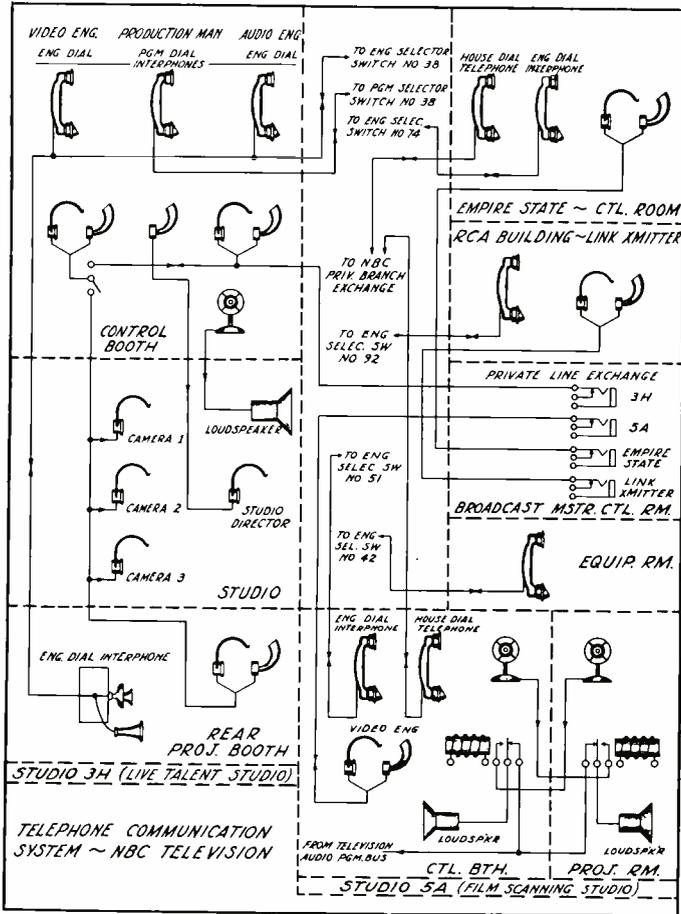

Fig. 9—Schematic of communications system used in conjunction with Radio City Television Studios.

when operated as an address system. Each studio control booth also has a branch on the Engineering Interphone system which connects the various studios and operating control points in the NBC plant. A Program Interphone is provided in the direct-pickup studio for use by the Program Department.

A separate telephone circuit is provided between the control booth and the direct-pickup studio so that the program production man can

communicate with his assistant in the studio while the show is on the air. House phones which may receive outside calls are available at the Empire State transmitter and at the film-scanning room. These are used to correlate information with the field receivers. In addition to the telephone communication circuits, other signal systems are provided. These include the two sets of signal lights on each camera mentioned previously, as well as the usual signal lights associated with the push-buttons which are used for camera and monitor switching.

The introduction of video apparatus into the broadcast plant brought with it an increased problem in the matter of safeguarding personnel. The voltages used for the "Iconoscopes" and "Kinescopes" while not extremely dangerous, since very low current is used, might, if direct contact were established, lead to a severe shock. Adequate protection against accidental contact with these voltages is obtained by a complete system of interlocking. All covers and doors giving access to voltages over 500 volts are equipped with interlocks which automatically remove the power when the covers or doors are opened. The studio cameras are equipped with manual keys and locks in addition to interlocks. When it is necessary for engineers to work on equipment, grounding sticks are available and used, and heavy rubber mats prevent standing on grounded equipment.

Additional interlocking is used to protect the "Iconoscope" tube since if either the horizontal or vertical deflection voltages or both are removed, the mosaic would be burned by the intensification of the electronic bombardment. To prevent this, protective relays are installed which apply a cut-off bias to the "Iconoscope" grid if either or both of the deflecting voltages are removed.

This paper has attempted to outline some of the major technical problems encountered in the design and operation of a multi-studio television plant and the solutions which have thus far been found most feasible. In general, it has been attempted whenever possible to carry over and incorporate into this new field those operational and design practices which experience in broadcasting has shown to be sound, modified where necessary by the new factors introduced by television.

# TELEVISION TRANSMITTERS OPERATING AT HIGH POWERS AND ULTRA-HIGH FREQUENCIES

By

J. W. CONKLIN AND H. E. GIHRING  
RCA Manufacturing Company, Inc., Camden, N. J.

THE advent of high-definition television, involving modulation frequencies up to several million cycles, has necessitated the development of high-power, ultra-high-frequency transmitters. The unique tube and circuit problems encountered and the practicability of line sections as circuit elements has resulted in radical departures from conventions in transmitter design as may be seen from the accompanying illustrations, showing features of high-power, ultra-high-frequency television transmitters.

## VACUUM TUBE PROBLEMS

In ultra-high frequency development the vacuum tubes have always been one of the major sources of difficulty. Vacuum tubes developed for lower frequencies have a number of limitations rendering them unsuitable for u-h-f applications. For low-power u-h-f transmitters and receivers, special tubes having low internal capacities, short leads, and other features are available, permitting conventional designs insofar as tubes are concerned. Television transmitters with carrier powers between five and ten kilowatts require tubes with dissipation capabilities of the order of thirty kilowatts. The Type 899 shown in Figure 2, is one of the tubes now used in these applications. Some of the problems of high-power u-h-f transmitters are due to the large physical size of tubes now available.

Water cooled tubes have glass envelopes to provide insulating supports for grid and filament structures in high-power tubes. For manufacturing reasons, these envelopes are made of considerable length since the resulting lengths of filament and grid leads do not present serious difficulties at low frequencies. At ultra-high frequencies the inductance of the leads, plus the loading effects of the inter-element capacities, result in potential and phase differences between the actual internal elements and their external terminals, which increase roughly with the square of the frequency. There exist, in effect, standing waves on the leads and as the frequency increases, a condition is reached

where the voltage nodes move inside the envelope, i.e., the effective lengths of the internal leads are greater than a quarter wavelength. In common high-power, water-cooled tubes, this condition occurs at frequencies from 30 to 50 megacycles. As a result, at ultra-high frequency it is impossible directly to ground the filaments for radio

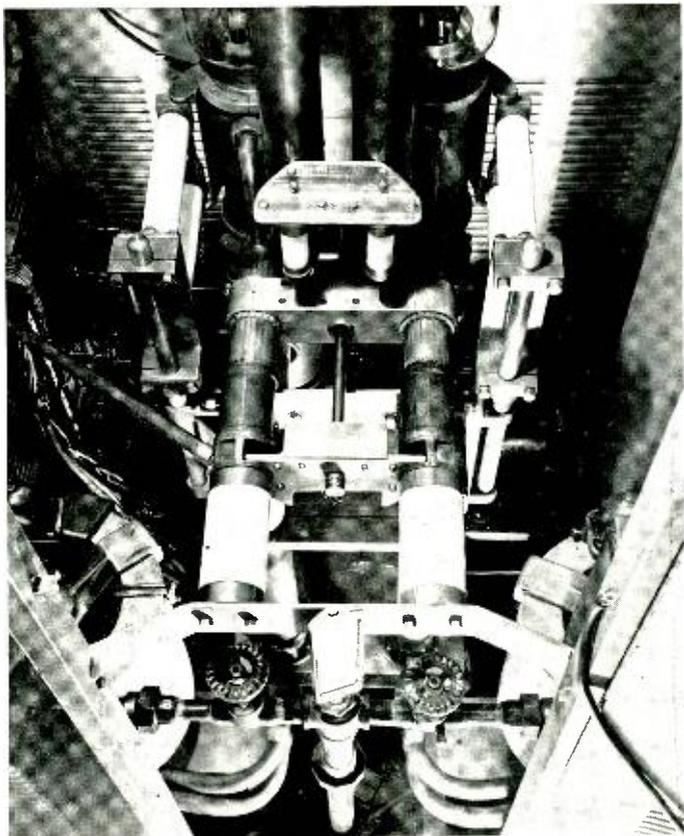

Fig. 1—Tank circuit of a fifty-megacycle television power amplifier. The inductive section is very short and tuned by an adjustable shorting bar. The two tubes dropping from the top carry the antenna coupling leads.

frequencies or achieve satisfactory neutralization, because of the length of the grid and filament leads.

In Figure 3-A are shown graphically the voltage gradients existing on the elements of Type 899 as observed in actual operation at 50 megacycles. Figure 3-B shows an approximate equivalent network representing the tube under these conditions. It will be noted that the external grid terminal is actually at a voltage nodal point.

In Figure 2 there are also shown two smaller water-cooled tubes which are used in ultra-high-frequency transmitters, Types 846 and 858. It will be noted that these tubes are of the single-ended type, that is, the filament and grid leads enter a common envelope, the opposite end of the anode being closed as contrasted with Type 899 which is double ended, that is, the grid and filament structures are supported by separate envelopes at opposite ends of the tube. The

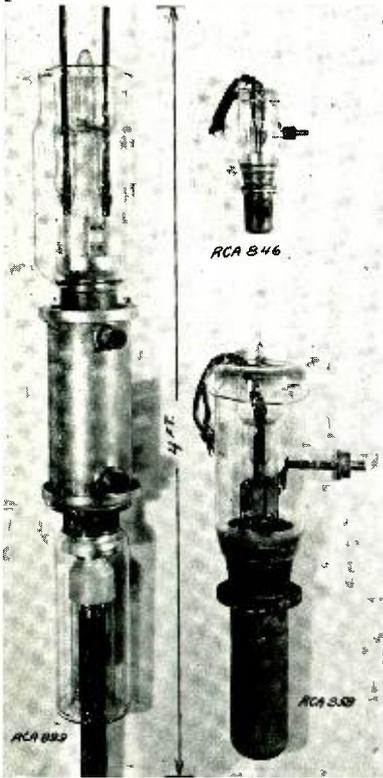

Fig. 2—Water-cooled vacuum tubes used in ultra-high-frequency television transmitters.

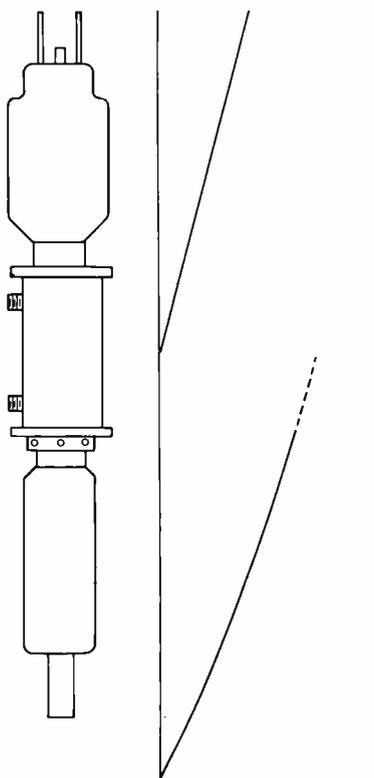

Fig. 3A—Voltage gradients in 899 Tube at 50 mc.



Fig. 3B—Approximate equivalent network.

single-ended construction has generally been found easier to handle at ultra-high frequency as the excitation is normally introduced as a grid-filament potential. For this reason it is convenient to have the external terminals for these elements close together. Also in ultra-high frequency circuits it has been found convenient to form the tank-circuit inductance from straight tubings which are a continuance of the water-jacket assemblies. Examples of this type of tube mounting are shown in Figures 6 and 7. Type 846 tube, because of its small

physical size, functions satisfactorily in conventional circuits at frequencies as high as 100 megacycles. Type 858, which is considerably larger, has been found most useful for frequencies below 40 to 45 megacycles.

#### REACTANCE OF FILAMENT LEADS

In operation the reactance of the filament leads is common to the plate and grid circuit, as shown in Figure 4-A, and in tubes of large physical size, the internal reactance is great enough to make satisfac-

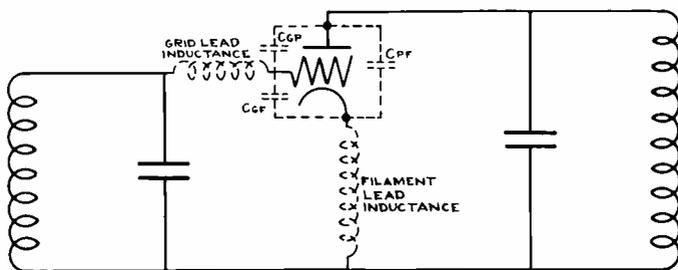

Fig. 4A—Circuit illustrating grid circuit-plate circuit coupling from filament-lead reactance.

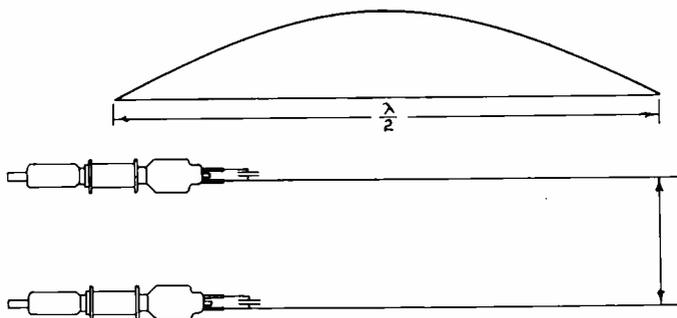

Fig. 4B—Showing how half-wavelength leads overcome internal filament-lead reactance.

tory neutralization difficult when the filaments are grounded directly. Even when satisfactory neutralization can be achieved, this filament-lead reactance prevents attainment of 100 per cent modulation of a modulated stage, as it permits radiation of the excitation power on negative-modulation peaks.

For several reasons to be discussed later, push-pull circuits are used almost entirely for large high-power u-h-f transmitter stages. This permits a simple method of overcoming the reactance of the filament leads by interconnecting the filaments of the opposing tubes through a pair of parallel conductors, as shown in Figure 4-B. These are inter-connected at a point effectively one-half wavelength from the

actual cathodes, giving an effect substantially the same as a direct inter-connection between filaments. In practice, the inter-connecting bar is made adjustable and the correct setting determined as a part of the neutralizing procedure. Figure 5 shows the installation of such filament lines. At 50 megacycles these filament lines are of the order of 10 feet in length and for convenience they are doubled back on themselves to reduce the size of the inclosure required.

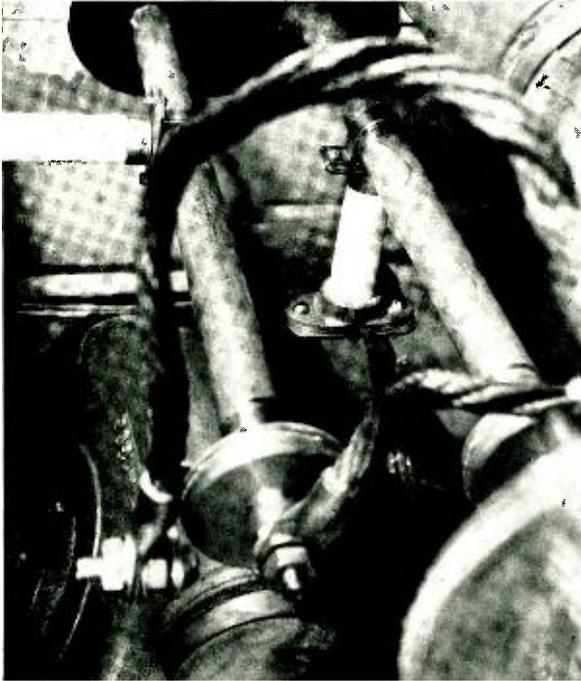

Fig. 5—Filament tuning lines used with Type 899 tubes on a 50-mc. transmitter. Note by-pass condensers which by-pass opposite side of filament to line. The heating current circuit is completed through an internal conductor.

#### NEUTRALIZATION PROBLEMS

Long internal grid leads result in difficulties in cross-grid, cross-plate neutralizing, which may be further increased by necessarily long external neutralizing leads. In the case of Type 899 the internal grid lead is effectively a quarter wavelength at 50 megacycles and this makes neutralization difficult through connections to the external grid terminal. Fortunately, the grid end of this tube is of such construction that it was found feasible to form the cross-grid or cross-plate neu-

tralizing capacity directly between the internal grid-lead and external concentric-sleeve fitting over the glass envelope. These neutralizing sleeves may be seen in Figure 8. Even with this arrangement it is not possible to form a true reactance bridge, because there is still left a considerable length of free grid reactance and the circuit is neutralized only over a small band near the operating frequency and has to be heavily loaded to prevent oscillation.

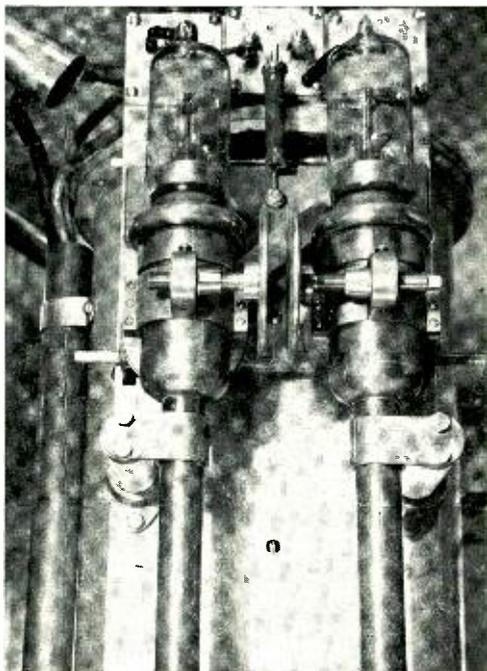

Fig. 6—A 50-megacycle amplifier. Tank circuit is of the parallel line type using a small disc condenser for fine adjustment. Compare the size of the tank conductors with the 90-mc. unit shown in Fig. 7.

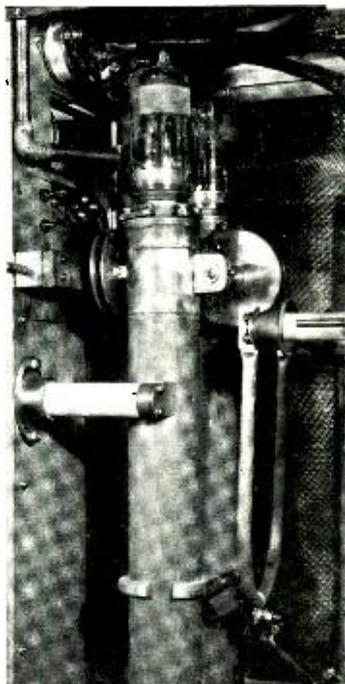

Fig. 7 — A five-kilowatt power-amplifier adjusted for operation at 90 megacycles. Note length of tank circuit as a result of using large diameter conductors.

#### INTER-ELECTRODE CAPACITIES

Inter-electrode tube capacities impose a number of u-h-f limitations on tube performance. In the case of high-power transmitting tubes, these limitations are of a different nature than those generally associated with low power and receiver applications. Large water-cooled tubes have high inter-electrode capacities, output capacities ranging from 25 to 50  $\mu\mu f$ . These capacities do not impose serious tuning difficulties as the physical size of the tube makes it convenient to use large tank circuits having very low inductance. Figure 7 is a

view of a tank circuit of the parallel-line type, using an adjustable shorting bar with a small vernier condenser to cover a tuning range from 40 to 90 megacycles. However, from the standpoint of neutralizing, high grid-plate capacities are awkward as the physical size of the neutralizing condensers necessitates long leads and increases stray capacity effects.

At ultra-high frequencies, the inter-electrode capacities have very low reactance values and, as a result, the circulating currents in the tubes become unusually high. These high currents cause excessive heating of the elements, leads, and seals and in general necessitate extra precautions in air cooling of all glass parts, particularly the seals. This heating is also increased at ultra-high frequencies by the increase of the radio-frequency resistance because of skin effect.

In television applications, inter-electrode capacities have a more serious effect particularly in r-f power amplifiers required to pass modulation side bands, which under present standards may be 2.5 megacycles from the carrier. It is not generally realized that for a desired tank-circuit frequency response, the tube, neutralizing and associated stray capacities, automatically determine the load resistance regardless of carrier frequency. In practical cases, this has generally necessitated operating tubes into load resistances considerably lower than normal with resulting poor plate efficiency.

In television power-amplifier applications, tube efficiency in one respect depends upon the ratio of tube capacity to plate conductance. Unfortunately, this ratio is a fundamental inherent relation in practical vacuum tubes of the triode type, and while tubes may be improved, it is doubtful if the present conception of a triode r-f power amplifier is the final answer for high-definition television applications.

The high side-band frequencies do not require 100 per cent modulation of the transmitter. It is thus possible to compensate partially for discrimination against high frequencies occurring in the radio-frequency circuits by equalizing at low levels in the video amplifier. However, excessive compensation in this type usually introduces objectionable phase shifts and transients. The problems of relaying a picture from the studio to the radiating transmitter and amplifying it to modulation power, is of itself a sufficient problem. It is therefore desirable that the radio-frequency circuits of the transmitter have a flat characteristic over the frequency band to be transmitted.

In one case of a 7.5-kilowatt, 50-megacycle television transmitter, in order to obtain a power-amplifier frequency response flat within 3 decibels over a 1.5-megacycle band, it was necessary to overload the power amplifier to a point where the plate efficiency was less than 15 per cent. The power amplifier used two Type 899 tubes in push-pull

and the total plate input was approximately 60 kilowatts when delivering 7.5-kilowatts carrier-wave output.

New tube developments increasing the ratio of output conductance to output capacity may partially alleviate the poor power efficiency at

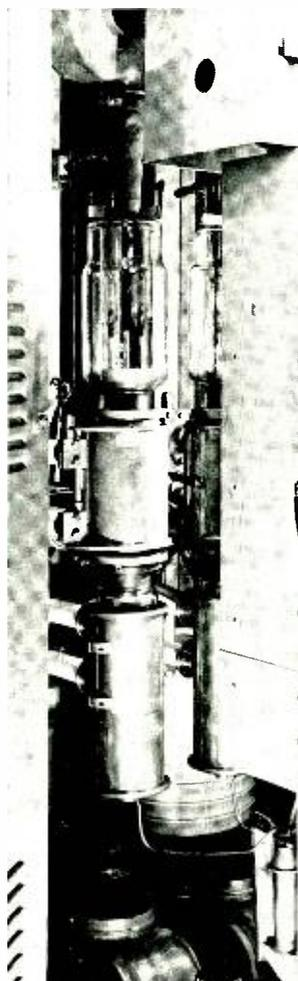

Fig. 8 — Showing neutralizing sleeves enclosing grid end of Type 899 tubes in a fifty-megacycle power amplifier. Note air blowers above and below tube to cool glass parts.

present obtainable in television transmitters. However, the difficulty is more or less fundamental with tubes of the triode type, and the ultimate solution will, more likely, be the development of entirely new types of power-amplifying tubes and modulation methods.

Because of the difficulties in producing high modulation power at the high side-band frequencies involved in television transmission, grid modulation in the power amplifier has been the most practical method of modulating high-power u-h-f television transmitters. Absorption modulation has been used successfully on low-power transmitters of one or two kilowatts carrier power. The principal advantage of absorption modulation as applied to television is that it removes the band-pass requirements from the power-amplifier circuits and consequently makes possible higher plate efficiency.

### CIRCUITS

At ultra-high frequencies, wavelengths reduce to a few feet and in high-power transmitters this fact introduces difficulties, but makes practicable circuits not adapted for lower-frequency design. In general, it becomes convenient to regard all circuit elements as sections of transmission lines and analyze them as such.

To begin with, at frequencies above 40 megacycles, it is found economical to use resonant line-controlled master oscillators as the primary frequency source. In such oscillators, the equivalent of a quarter-wavelength low-loss line resonator is used as the primary oscillatory circuit with power-oscillator tubes. Such resonators become of convenient size in the ultra-high frequency band and it has been found that the total transmitter tube complement is much less than would be required with a conventional frequency source such as a crystal oscillator and subsequent frequency multipliers and amplifiers.<sup>1</sup> Figure 10 shows a 50-mc. quarter-wave, line-controlled power oscillator.

Enclosures or mounting frames used for the high-power stages of u-h-f transmitters, because of their size approach major fractions of the operating wavelengths in dimensions. A true common r-f ground for the inclosed circuit is thus difficult to obtain, and considerable difficulty is experienced with single-tube circuits which necessarily are asymmetrical with respect to an enclosure. Troubles from this source largely disappear when push-pull circuits are used and mounted symmetrically in relation to a large plane-conducting surface. For these reasons, push-pull types of circuits are generally used in preference to single-tube circuits where the physical size is a major part of a wavelength.

At ultra-high frequencies quarter and half-wavelength line sections become reasonably short in length and it is practicable to take advan-

---

<sup>1</sup> "Frequency Control by Low-Power-Factor Line Circuits" by P. S. Carter and C. W. Hansell. *Proc. I.R.E.*, April 1936.

tage of some of their particular properties. Thus in u-h-f transmitters quarter-wave line sections are used as impedance transformers, "metallic" insulators, and impedance inverters. In Figure 9 is shown an assemblage of quarter and one-half-wave, coaxial-line sections forming a cross-coupling filter to permit the operation of both the picture and sound transmitters into a common antenna without objectionable cross modulation. A U-shaped section of coaxial line serving as a transformer to couple the 72-ohm coaxial line to a 500-ohm, two-conductor, open-wire line is also shown. Short sections of lines having open or

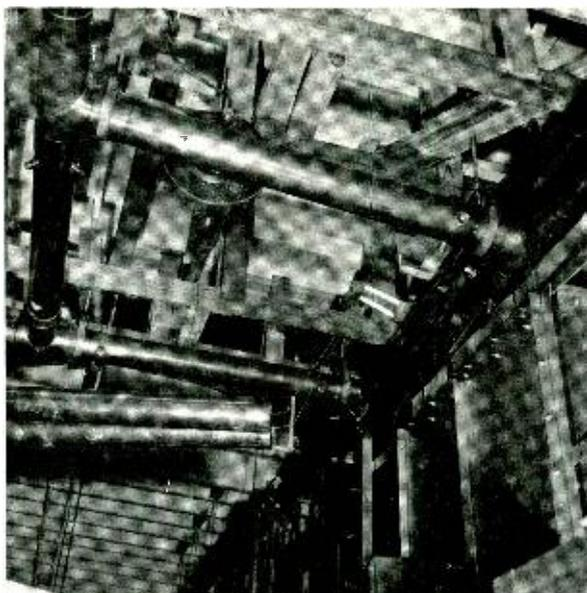

Fig. 9—Quarter and half-wavelength line sections used to form high-"Q" filter elements preventing cross coupling of "sound" and "picture" transmitters separated a few percent in frequency and operated on a common antenna.

short-circuited terminations are conveniently used as efficient reactances at ultra-high frequency. Examples of this type of application of stub-line sections are the use of parallel tubular conductors having lengths less than a quarter wavelength to form the inductive component in high-power tank circuits. Several such assemblies are shown in the accompanying illustrations.

At ultra-high frequencies in circuits of large physical size all currents may be assumed to flow in the surfaces of the conductor, that is, constrained to a skin of less than a thousandth of an inch deep. This makes possible the construction of circuit members from inexpen-

sive, easily fabricated materials such as steel which is subsequently plated with a highly conductive metal such as silver. A frequency-controlled resonator may be constructed entirely of cold-rolled steel and invar and silver plated. The actual conducting surface is thus formed of silver which has a very low electrical resistance, and at the same time, the structure is lighter and stronger and has a lower thermal

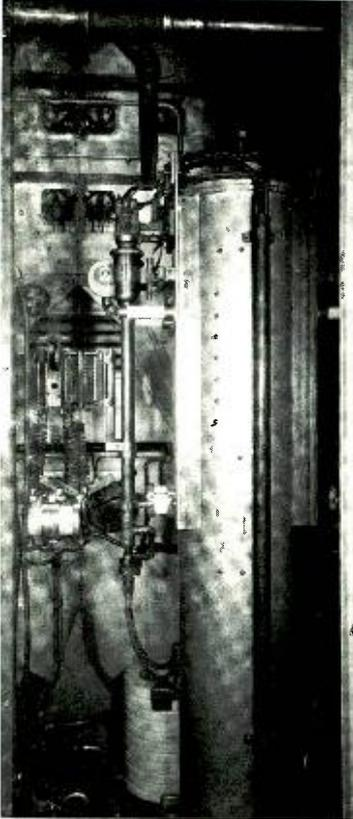

Fig. 10 — 50-megacycle "power" master oscillator. Frequency is stabilized by means of the quarter-wave coaxial line.

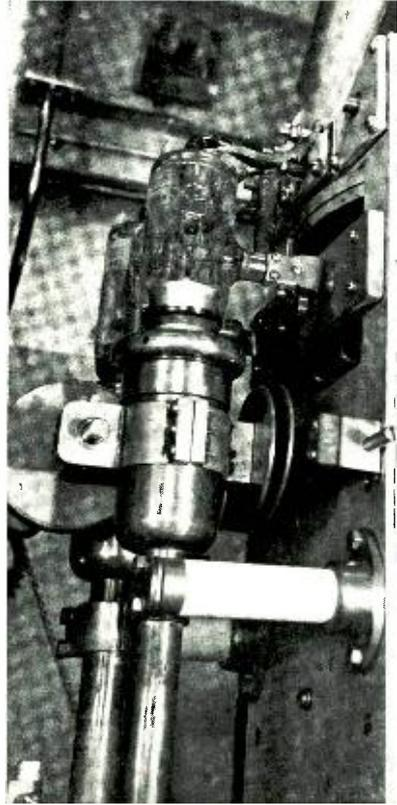

Fig. 11—A close-up of the oscillator shown in Fig. 10. Mechanical arrangement is simple and rugged and provides short electrical connections.

coefficient of expansion than copper, which formerly has been used for these devices. As the practical thickness of plating of this type is limited to a few thousandths of an inch, this type of construction could not be used at lower frequencies where the depth of penetration is greater. It is necessary to consider skin effect and current distribution in the design of u-h-f transmitter components, as these phenomena are of much more importance at these frequencies.

## AUXILIARY APPARATUS

The difficulties encountered with tubes for u-h-f work have been previously discussed. Other apparatus such as condensers, resistors, meters, insulators, etc., also have serious limitations.

## CONDENSERS

Variable condensers of the conventional type cannot be used at ultra-high frequencies primarily because both minimum and ground capacity values are too high and insulation paths are not very long. For most u-h-f work two circular disks arranged so that the distance between them can be varied continuously have been found to be satisfactory and can be mounted directly on a tank circuit without requiring insulating mountings. In most u-h-f circuits the tube and neutralizing capacities form the major part of the tank capacity. External capacities are added only for tuning purposes. Suitable fixed condensers for by-passing, and coupling present serious difficulties. It is frequently desirable directly to couple the plate circuit of one stage to the grid circuit of the next. A coupling condenser is required to block the d-c plate voltage from the bias voltage of the next stage. In high-power u-h-f transmitters the radio frequency currents in this circuit may reach magnitudes of 30 to 40 amperes or more. At 50 megacycles, 1000  $\mu\mu f.$  are required to obtain 3.2 ohms of reactance. A value as high as 15 to 20 ohms may be tolerated in coupling or by-passing, but a higher reactance will cause difficulties. Ultra-high-frequency circuits are usually constructed of low-reactance components, and higher-reactance blocking condensers will greatly disturb the circuit operation.

The condensers usually available for this service consist of a stack of copper sheets with mica insulation impregnated with wax. The dielectric losses in the wax and mica go up rapidly with frequency, resulting in excessive heating of the condenser at values much below its rated current. Another disadvantage with this type of construction is that it often results in having considerable inductance in series with the condenser proper. One alternative is to use high-current-rating condensers and operate them considerably below their rating. This is undesirable because of the bulkiness of the condensers, which is detrimental to good circuit design. Other dielectrics may have possibilities and a suitable condenser may be developed in the future.

Air has proven to be the most reliable dielectric, but has the disadvantage of having a dielectric constant of one, which results in bulky condensers for the conditions mentioned above; namely, 40 amperes r.f. at 50 megacycles, 10,000 volts d.c. and from 200 to 1000  $\mu\mu f.$  Com-

pressed air condensers may offer a solution to this problem since the spacing may be decreased approximately as the pressure is increased. However at ultra-high frequencies compressed air condensers present insulation difficulties that offset their advantages.

Vacuum condensers similar in construction to vacuum tubes have been tried in an effort to obtain high voltage rating in small physical space. These failed by going "gassy" as they do not have the "clean-up"

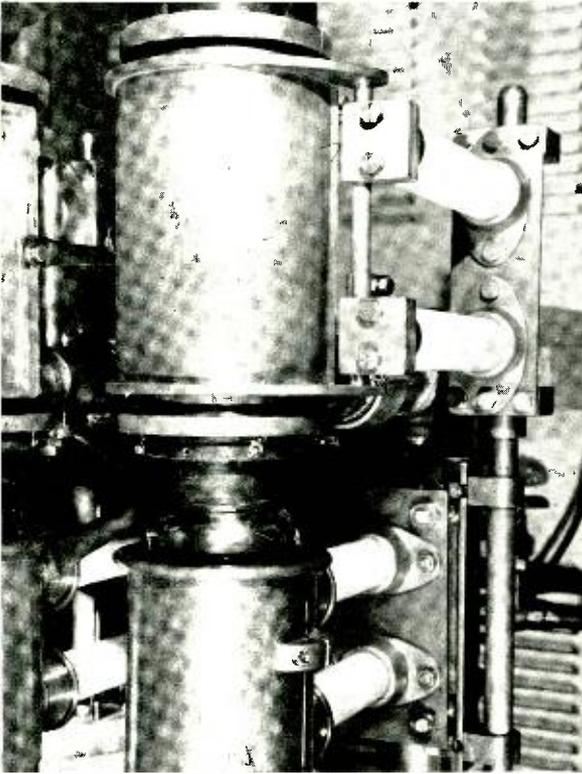

Fig. 12—A tube mounting including neutralizing sleeves and output coupling capacitors.

feature of vacuum tubes in operation. It is relatively easy to find standard condensers that will stand up for by-passing purposes, since for this condition the r-f current through the condenser is usually small. In many cases, however, the condenser will have considerable impedance to ground, because of its inductance. A case was encountered in which a parasitic oscillation existed with all types of standard condensers used for by-passing. A large parallel-plate condenser of extremely low inductance finally cured this condition.

## INSULATORS

Closely associated with condenser problems is the problem of insulation. Any insulator is in a sense a capacity with the insulating material as the dielectric. For lower frequencies, the admittance of an insulator is so slight as to be negligible, but at u.h.f. there are many cases in which the radio-frequency currents flowing through the insulator are of such magnitude as to shatter the insulator, due to the internal heat produced. Points of contact with metal were found to be glowing at white heat. The above conditions as a rule are true only when a metal button or screw extends into the insulating material. This results in internal heating of the insulator, causing it to shatter. A simple remedy lies in the use of a corona shield. The corona shield tends to divert the path of the r-f currents along the outside of the insulator where cooling may take place.

No really suitable insulating material is available for u-h-f high-power transmitter work combining good insulating properties with mechanical strength. For this reason u-h-f transmitters must be constructed to eliminate insulation in high-frequency fields.

## METERS

The measurement of u-h-f currents is a difficult problem. The ordinary calibration of thermocouple ammeters does not apply at u.h.f. because the skin effect in the couple causes the meter to read high. This, however, can be taken into account by applying a suitable correction factor.<sup>2</sup> A further difficulty, however, arises when the meter is actually placed in the circuit. In many cases the circuit is disturbed by the presence of the meter, resulting in erroneous readings. Lack of satisfactory voltage and current indicators increase the difficulties of studying problems in connection with u-h-f transmitters.

## RESISTORS

Resistors are often desirable in u-h-f television circuits. It is difficult to build good non-inductive resistors at lower frequencies and at u.h.f. the problem is still more difficult. Types that are satisfactory at lower frequencies develop "hot spots" through the presence of standing waves. Carbon resistors become capacities at u.h.f. because of their granular structure. Metal coated resistors are satisfactory for low-power work, but no satisfactory resistors of this type have been

---

<sup>2</sup> "Thermocouple Ammeters for Ultra-High Frequencies" by John H. Miller, *Proc. I.R.E.*, December 1936.

developed for high-power work. A pure resistance, free from reactance, is practically impossible to obtain at u.h.f. A possible exception to this statement may be an infinite line having no reflections.

Another method of obtaining a resistance free from reactance is to tune it out. For instance, load circuits have been constructed using a high-resistivity material as the inductance element of a tank circuit. This circuit may be tapped at any two symmetrical points and a pure resistance obtained, the value depending on the tapping points. This method may be used as an artificial load by circulating water through the conductor and measuring the temperature rise and water flow. It has been found desirable to arrange such loading circuits to avoid all coupling with associated circuits since the energy stored is extremely high and its field may interfere with the function of other circuits.

It has been the purpose of this article to give a general description of the problems encountered in the development of high-power television transmitters, and some of the methods used to overcome them. New vacuum tubes and equipment are now being developed with features intended to simplify these problems.

# NEW FEATURES IN BROADCAST RECEIVER DESIGN

By

B. R. CARSON, K. A. CHITTICK, D. D. COLE, AND S. V. PERRY

RCA Manufacturing Company, Inc., Camden, N. J.

## INTRODUCTION

THE radio industry has made tremendous progress in the past ten years. The average radio receiver of ten years ago was relatively high priced and was more or less a luxury. The standard of performance was not very high, the fact that it would receive distant as well as local stations with a certain degree of reliability caused it to be considered satisfactory and acceptable. Progress in the industry has resulted in a steady increase in standards of performance and an equally steady reduction of manufacturing costs. A receiver that sold for \$100 ten years ago can now be placed on the market for \$30 or less with equal performance. A radio set today is a necessity and the prices are well within reach of every family.

At the present time there are certain accepted standards of performance such as sensitivity, selectivity and fidelity from which manufacturers cannot deviate very far and still have a marketable receiver. In addition to these standards of performance, modern receivers must embody other qualities which are rapidly becoming important.

Manufacturers recognize the importance of proper styling of cabinets and dials of receivers. Cabinets are designed and styled to follow the general trend of furniture design. Specific styles such as "Moderne" and "Period" are not used because the receiver must harmonize with the furniture in the average living room. Various shapes and sizes of cabinets are resorted to in order to create eye appeal and to harmonize with any home setting regardless of use, whether in bedroom, kitchen or living room.

Dial scales are being made larger and more readable which tends toward less confusion on the part of the user. Station names are placed on the dial for added ease of locating desired programs. The styling of both the dial and cabinet is considered as a whole and the result is an entirely pleasing addition to the home.

In order to obtain the best performance from a receiver, it is necessary that it be accurately tuned to the station. The average user does not take the time to tune a receiver properly and, consequently, he is sometimes liable to lay the blame on the receiver itself for poor performance that is due to improper tuning. To remedy this and to insure customer satisfaction, numerous means of visually indicating proper tuning or resonance are used. Some of the more common of

these indicators are the "Magic Eye", "Target Tuning", "Shadow Tuning" and the "Colorama" tuning indicator. The use of these indicators insures proper tuning at all times.

### AUTOMATIC PROGRAM TUNING

Another step in the direction of simplifying the operation of radio receivers is the advent of so-called automatic tuning. There are two general types, mechanical and electrical. In the mechanical type the tuning is accomplished by operating a lever or disc similar to a telephone dial, for rotating the tuning element to a pre-determined setting; in the electrical type a motor is used for rotating the tuning element. In the latter the tuning is effected by pressing a push-button to obtain the desired station. The electrical type is generally conceded to be more satisfactory than the mechanical type inasmuch as it can

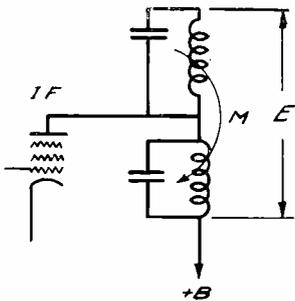

Fig. 1

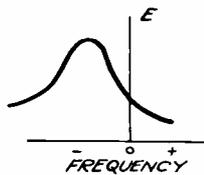

Fig. 1 (a)

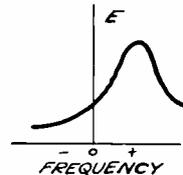

Fig. 1 (b)

easily be converted to work from a remote tuning attachment. Many of the new 1938 models use the electric type of tuning. One particular model is arranged to tune in eight pre-selected stations by merely pressing buttons. These buttons are conveniently located on the front escutcheon of the tuning dial and interlock so that it is unnecessary to hold the button depressed (for a particular station) until the station is tuned in by the tuning motor. An interlocking arrangement releases buttons already down when a new button is pressed.

The selector mechanism is a unit assembly mounted at three points on the rear end-plate of the variable condenser. The shaft of this unit is coupled to the variable condenser shaft through a flexible coupling. The reason for mounting this unit at three points and through the flexible coupling is to avoid setting up strains in the condenser structure that would cause deviation in the condenser calibration. The selector rotor consists of eight independently adjustable clutch assemblies made up by stacking washers and spacers on a shaft. Each of the adjustable clutch rings has a key slot at its periphery and directly

opposite this slot is an insulator for breaking the motor circuit at a contact brush. There are eight contact brushes wired to their respective push buttons at the front of the receiver. At the rear of the selector unit is mounted a toggle switch for reversing the motor and direction of condenser rotation at either extreme end of the condenser scale. This switching arrangement has simplified the design of the selector mechanism since it has reduced the number of contact brushes at each of the selector rings. Provision is made at the bottom of the selector mechanism to attach a remote tuning attachment.

At the top of the selector is a row of holes for a key used for setting up stations. By inserting the key in any one of the holes so that it registers with the key slot on the periphery of its respective clutch ring, it is possible to lock the clutch ring in position so that it will not turn when the condenser rotor is rotated. This enables the setting or logging of stations anywhere within the rotatable range of the con-

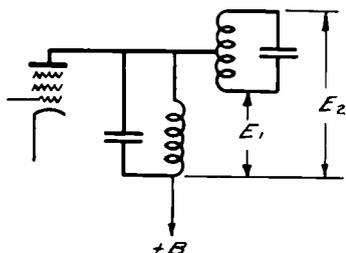

Fig. 2

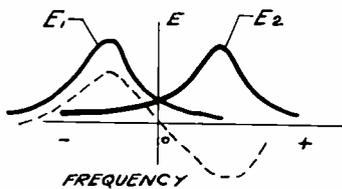

Fig. 2(a)

denser. The stations may be logged close together with this arrangement since the clutch rings are independent of one another, and when one is adjusted the other clutch ring settings are not disturbed.

The tuning motor is mounted on top of the variable condenser for the purpose of facilitating assembly and adjustment. The motor is of the shaded-pole type and reversible. The rotor of this motor is provided with longitudinal motion for two reasons: One, to operate the a-f-c and amplifier-suppression switches at the front end of the motor and second, to provide quick disengagement of the motor from the driving mechanism to the tuning condenser when the motor is de-energized. The motor engages with the drive mechanism through a pin and arm coupling.

#### AUTOMATIC-FREQUENCY-CONTROL CIRCUITS.

Automatic-frequency-control circuits are incorporated on the standard broadcast band in many of the new 1938 radio receivers. These circuits will correct for inaccurate station tuning whether tuned by

hand or some automatic means, by changing the frequency of the local oscillator in the receiver in such a manner that the resultant intermediate frequency formed will be at the approximately resonant frequency of the intermediate-amplifier circuits.

The successful commercial application of such a circuit depends almost entirely upon the stability of the receiver with respect to changes in humidity, temperature, and fatigue of the component parts. Unless the receiver circuits maintain their original factory adjustment over a considerable period of time, the automatic-frequency-control circuits are likely to mis-tune completely instead of accurately to tune the receiver to the desired station. The use of magnetite core i-f transformers and the elimination of compression-type mica trimmers reduces this tendency toward frequency drift in the intermediate amplifier to a minimum.

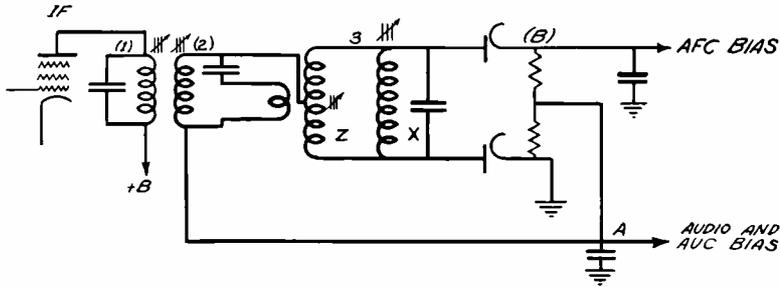

Fig. 3

Automatic-frequency-control circuits may be divided into two parts—the frequency discriminator and the oscillator control circuits. The frequency discriminator consists of an intermediate-frequency circuit that produces a direct potential, which is applied to the oscillator control tube to change the frequency of the local oscillator in the receiver. The discriminator generates a negative bias with respect to ground on one side of the i-f resonance curve, a positive bias on the other side of resonance, and a zero bias voltage at the resonant frequency. This phenomena depends upon the  $90^\circ$  phase difference that exists between the primary and secondary voltages of a double-tuned loosely-coupled transformer at resonant frequency, and the change in phase as the frequency is shifted through resonance.

Thus a circuit as shown in Figure 1, where both sections are tuned to the same frequency, will produce a voltage  $E$  of a magnitude indicated in Figure 1a. If the mutual inductance between the circuits is reversed, the resultant voltage characteristic is also reversed as shown in Figure 1b.

If a center-tapped circuit in Figure 2 is used, the magnitude of  $E_1$  and  $E_2$  would be similar to Figure 2a. Since the terminal connec-

tions of the output circuit are each connected to a diode rectifier, a differential voltage is obtained as indicated by the dotted curve.

The circuit employed in one of the new 1938 receivers is shown in Figure 3. Circuits 2 and 3 produce the discriminator voltage. Circuit 1 is added to improve the selectivity and to prevent excessive attenuation of side bands. Coil *X* is shunted across circuit 3 to adjust the inductance to i-f resonance without affecting the electrical position of the midtap on coil *Z*. The magnetite core in coil *Z* is centered within the coil to improve the "Q" and is not changed for alignment purposes. A-F-C voltage is obtained for the oscillator control tube at *B*. The audio voltage and a-v-c bias are obtained at *A*.

The circuit employed to change the frequency of the local oscil-

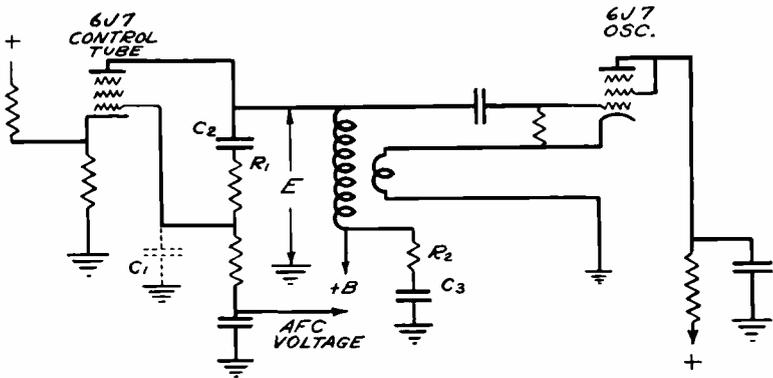

Fig. 4

lator is shown in Figure 4. The fundamental requirement for the control circuit is to convert the d-c voltage from the discriminator circuit into reactance variations to be shunted across the oscillator tuned circuit. The oscillator voltage *E* is impressed across the resistance-capacity network  $C_2 R_1 C_1$ . Condenser  $C_2$  is used only as a blocking condenser for d.c. and has practically no reactance at the oscillator frequency. Condenser  $C_1$  includes the input capacity of the control tube and the distributed capacity of the associated wiring. The value of  $R_1$  is so chosen with respect to the reactance of  $C_1$  that the proper amount of oscillator voltage is impressed upon the grid of the control tube. The voltage across  $C_1$  lags the voltage *E* by approximately  $90^\circ$ . The vector sum of the voltage across  $C_1$  and  $R_1$  is equal to *E*, the oscillator voltage. The voltage across  $C_1$  is amplified by the control tube and adds vectorially to the original oscillator voltage and results in a change in oscillator frequency.

The degree of frequency shift of the oscillator depends in a large measure upon the mutual conductance of the control tube and the strength of the oscillator voltage *E*. To obtain maximum frequency

variation, it is necessary that the discriminator circuit provide a range of bias voltage for the control tube from plate current cut-off to grid current point.

#### BAND-SPREAD CIRCUITS

Short-wave reception in the internationally assigned entertainment bands has become of greater importance to the American listener in the last few months. Signals from the principal European stations are stronger and more consistent due to increase in transmitter power and to the use of directive antennas directed toward the North American Continent. Station schedules have also been lengthened and more time is devoted by these stations to programs broadcast in English.

In an ordinary short-wave receiver with all-wave coverage, the short-wave bands are crowded into narrow spaces over the dial which makes correct tuning extremely difficult. The ability to identify a station or to re-tune the receiver to the same station requires considerable practice. The usual short-wave scale covers a frequency spread of 5,600 kilocycles to 22,000 kilocycles of which less than 5 per cent is required by the six international entertainment bands at 49, 31, 25, 19, 16 and 13 meters. It is desirable from the standpoint of ease of tuning to spread out these bands to the width of the standard broadcast scale. To accomplish this and still maintain a continuous frequency coverage requires 18 to 20 separate bands of 1,000 kilocycles each. Such a design is of course impractical and uneconomical for standard broadcast receivers.

Many of the new 1938 receivers incorporate a type of electrical band spread which brings to the customer the four principal short-wave entertainment bands with greater ease of tuning than for the standard broadcast band. Short-wave stations are spaced over 50 times further apart on the dial than on former short-wave receivers. The principal station names are printed directly on the dial together with their respective megacycle marking. The customer merely turns the dial pointer to the station name and then accurately tunes his receiver by the maximum deflection of the tuning indicator.

Each of these four spread bands is approximately 280 kilocycles in width and occupies a space on the dial about 10 inches in length. The exact ranges are as follows:

- 49-meter band: 5.97— 6.24 megacycles; width, 270 kilocycles
- 31-meter band: 9.41— 9.69 megacycles; width, 280 kilocycles
- 25-meter band: 11.68—11.92 megacycles; width, 240 kilocycles
- 19-meter band: 15.09—15.38 megacycles; width, 290 kilocycles

The 16- and 13-meter bands are not included on the band-spread scales since these bands are of lesser importance to listeners in this

country. These higher frequencies are only suitable for day-light transmission and reception over very long distances.

An improved simplified coil structure has been designed for these spread bands. The antenna and radio-frequency stages are each fixed in the middle of each band while the oscillator circuit is tuned over the entire band by a split section of the variable condenser. In this manner, higher inductance antenna and r-f circuits may be used which result in increased gain and greatly improved signal-to-noise ratio. Both the antenna and r-f stages use a special tapped-coil construction which avoids the cost of separate coils. The r-f stage has no primary coil and is inserted in the plate circuit of the radio-frequency tube. This type circuit increases the gain, reduces noise, and simplifies coil switching by the range switch.

The oscillator design requires separate coils with a magnetite core inductance adjustment for each coil except on the 49-meter band. Each oscillator circuit is aligned to its own dial calibration independently of the other bands. The circuit used is a compound Hartley circuit with the cathode connection tapped near the center of the lowest-frequency coil, and the higher-frequency oscillator coils then shunted across this coil without shifting the cathode tap. An air trimmer is used to align the dial calibration for the 49-meter band since any inductance adjustment of this band would be reflected to the higher-frequency oscillator coils.

Each oscillator circuit is tuned by a small variable section of the main variable condenser. The total capacity change of this section is approximately 15  $\mu\mu f.$  which results in a frequency change in each oscillator circuit of about 280 kilocycles. In order to obtain stability of the oscillator circuit with respect to small changes in capacity caused by vibration and movement of leads, a padding condenser of 100  $\mu\mu f.$  is connected in shunt with the small tuning condenser on the 49-meter band, and left connected for the higher-frequency band-spread ranges. To maintain the same width of tuning range, 280 kilocycles, on the higher-frequency bands, additional padding condensers are shunted across the oscillator circuits. A total capacity of 200  $\mu\mu f.$  is required for the 31-meter band and 300  $\mu\mu f.$  for the 25- and 19-meter bands.

One of the most serious difficulties to overcome in the design of such a spread-band system is due to frequency drift of the oscillator circuits caused by changes in humidity and temperature. Since each spread-band range is calibrated in station names and also in 10-kilocycle divisions spaced over  $\frac{1}{4}$  inch apart, it becomes of greatest importance that oscillator drift be reduced to a minimum. A change of 1  $\mu\mu f.$  in distributed capacity or an equivalent percentage change in

inductance will shift the dial calibration 20 to 25 kilocycles or about  $\frac{1}{2}$  inch on the dial scale.

To reduce frequency drift caused by humidity, all oscillator and radio-frequency coils, terminal boards, range switches, r-f sockets, variable condenser terminal boards, etc., are impregnated in a special high-grade wax and then cold dipped to form a heavy wax seal. The resistors used in the oscillator circuits are the insulated type to reduce capacity changes with humidity.

Frequency changes caused by the normal temperature rise of the chassis and variation in room temperature also present a serious problem. The coils expand with an increase in temperature which results in an increase in inductance. The distributed capacity of component parts including the variable condenser increases. Both of these effects lower the frequency of the oscillator circuit and tend to cause considerable shift in dial calibration. To compensate for this shift toward a lower oscillator frequency, the 100  $\mu\mu f.$  padding condensers are designed with the proper negative coefficients of capacity as the temperature increases. The oscillator frequency and therefore, the dial calibration for the spread-band scales remains fixed, after the short initial warm-up of the tubes, over the normal variations in room temperature and the additional increase in chassis temperature after the receiver has been placed in operation.

The design of compensating condensers having negative coefficients of capacity with increased temperature follows closely the standard design of the small mica condenser. Alternate layers of copper foil and mica are stacked together and clamped with a metal clamp. The assembled unit is then imbedded in a plastic material, the type of material used determining to a large degree the resultant negative coefficient of capacity. The connecting leads of the condenser are welded to the copper foils instead of soldered since the molding operation takes place at a higher temperature than the melting point of solder.

The shift of oscillator frequency caused by change in power-line voltage is reduced to a minimum in the spread-band oscillator circuits. The use of the Hartley type oscillator in conjunction with a low inductance-to-capacity ratio, and the proper choice of the values of the grid and plate blocking condensers results in an oscillator stability which is satisfactory over the usual variations in line voltage. The stability is further improved by the use of high-"Q" coils for the tuned circuits and the reduction of the external coupling to the first detector to a minimum. The addition of series resistances to the plate and screen circuits of the oscillator also reduces the frequency shift

since these resistors have a regulating effect on the voltage supply to the oscillator tube.

#### CABINET ACOUSTICS

Inasmuch as the entire purpose of a home-type radio receiver is to reproduce the original sounds as accurately as possible in the user's living room, the problem of sound reproduction is one of the most important phases of receiver design. Besides being one of the most important phases of performance, the sound-reproduction problem is also one of the most difficult to solve satisfactorily. One of the reasons for this is the great range of frequencies or pitch which we have to reproduce; the sound reproducer is expected to respond faithfully over a range of say 40 cycles to 6,000 cycles which is a frequency ratio of 150 to one or over seven octaves. In order to produce sounds over this great range in a piano or organ, about 85 different strings or pipes are required, each of which is a complete sound producing instrument in itself. Even with its 85 or more keys, the piano or organ can only produce 85 different notes (and combinations of them) and cannot produce fractional tones between these notes. Neither can it produce notes of an entirely different quality, as for instance those produced by a violin or trumpet or other instrument. In fact, the whole multiplicity of instruments and objects used in producing musical and other sounds is necessary because each one can produce only one sound unless it is manually (or otherwise) adjusted or manipulated so as to produce a different sound. The human voice is no exception to this rule, the only difference in this case being that the adjustments are performed without conscious effort.

Now a loudspeaker, even in the cheapest of receivers, is expected to reproduce all sounds and combinations of sounds which can be produced by any of the millions of different instruments and objects with which we are familiar in everyday life. That it fails to do so accurately should not be a matter of great surprise. Indeed, the surprising thing, even to those who are most familiar with the details of its operation, is that it succeeds in accomplishing this feat as well as it does.

In the low-frequency range there is a primary difference between a sound producer (musical or otherwise) and a reproducer (or loudspeaker). The original sound (which is air in vibratory motion) is usually produced by air (or steam or other gas) rushing alternately into and out of an air container such as an organ pipe, drum, fog horn or other device. In the case of a reproducer, of the ordinary vibrating diaphragm type, the reproduced sound is caused by the backward and forward motion of a diaphragm (conical or otherwise) which displaces the air adjacent to it as it moves. It is fairly obvious that as much

sound will be created by the back surface of this moving diaphragm as is produced by its front surface. Furthermore, when the diaphragm moves forward and pushes or compresses the air in front of it, it at the same time pulls or rarefies the air behind it. It is likewise fairly obvious that the sound from the back of the diaphragm is at any and all instances in opposite phase to the sound from its front surface, and if the two sounds are allowed to mix, cancellation will occur. It is for this reason that some sort of device (normally thought of as a "baffle") must be used to keep the back and front

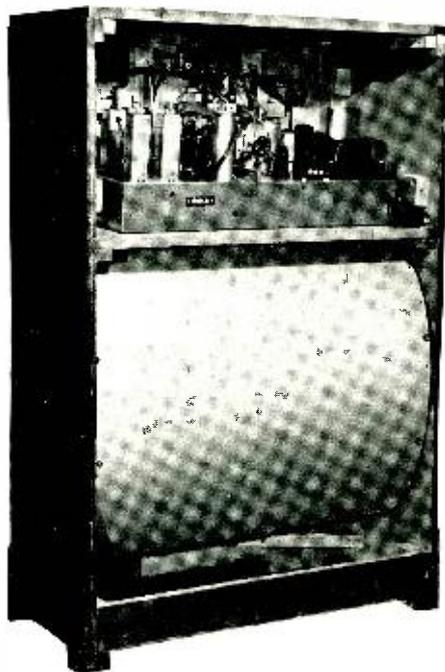

Fig. 5

waves separated. In home-type radio receivers, a flat baffle is not customarily used, for aesthetic or other reasons, but its edges are bent back to form an enclosure for the loudspeaker and chassis, so that it becomes a cabinet. Furthermore, at least the great majority of receivers of the console type are placed a few inches from a wall of the room in which they are used. This wall and the floor under the receiver together with the surfaces of the cabinet itself form not a simple baffle, but a rather complex acoustic system which gives to the reproduced sound a quality peculiar to its own geometrical configuration, in much the same fashion that the particular sound produced by a drum or bass viol or other instrument is the result of the size and shape of that particular instrument. Hence, the cabinet must be

considered as part of the sound reproducing system just as much as the loudspeaker itself. In fact we should not think of a radio receiver as a chassis and a loudspeaker housed for convenience and appearance in a cabinet, but rather as a chassis connected to an electro mechanical acoustic system, which also forms a container for the chassis.

It follows that one of the important problems of sound reproduction is the proper control of the acoustic properties of the cabinet in which the loudspeaker (and chassis) is placed. It further follows that proper control of these acoustic properties cannot be obtained with an open back cabinet, in which the user is free to vary its acoustic properties at will by varying its position with respect to the wall and surrounding objects. This condition can, of course, be remedied by closing the back of the cabinet which makes its performance much less dependent on its position with respect to its immediate surroundings.

Proper control of the acoustic properties of cabinets is sought by treatments involving the application of acoustic filter theory and circuits, and appears in many 1938 models in the form of single or multiple tone chambers, acoustic labyrinths, phase-inverting mechanical-filter cones, and similar devices. These devices are similar in that they seek to reduce the otherwise excessive response of the system in the "boom" region between 100 and 200 cycles, and to a varying degree to increase the response below 100 cycles.

One of the most interesting of these devices is illustrated in Figure 5. It utilizes a thin wood panel for closing the back and bottom of the cabinet. This panel confines the air in the cavity with sufficient rigidity despite its thinness, because of its curved shape which has much greater surface stiffness than a flat panel many times greater in thickness. Openings necessary to the operation of the device are provided in the form of a row of holes near the bottom front edge of the curved panel, together with certain openings in the corners of the cavity and around the chassis shelf. These openings are correctly proportioned to produce the best acoustic effects, having combined acoustic inertness necessary to resonate with the acoustic capacitance of the enclosed cavity at such a frequency (generally in the neighborhood of 70 cycles) as will produce the maximum low-frequency response. In some receivers using this device the openings are provided through pipes. This is an alternative form more suitable in certain cabinet constructions. The important property of these openings is their acoustic inertness which may be provided in a variety of shapes and forms.

The principle of operation of this type of acoustic control system will now be described. The desirability of enclosing the back and bottom of the cabinet has already been discussed. Having closed the

back of the cabinet, the air in the enclosed cavity forms an acoustic stiffness which would add to the stiffness of the cone-suspension members and cause the system to resonate at a higher frequency, thereby losing desirable low-frequency response. To prevent this action, openings are provided to relieve the pressure set up in the cavity by the motion of the cone. These openings form an acoustic inertness or mass reaction, and tune the cavity to some frequency usually in the neighborhood of 70 cycles. At frequencies below this resonance, the reactance of the system on the cone is a mass reactance which adds to the mass of the cone and causes it to resonate with its suspension system at some lower frequency, say about 45 cycles. At frequencies in this region, the cone motion will be large due to resonance, and more sound will be produced than without this acoustic

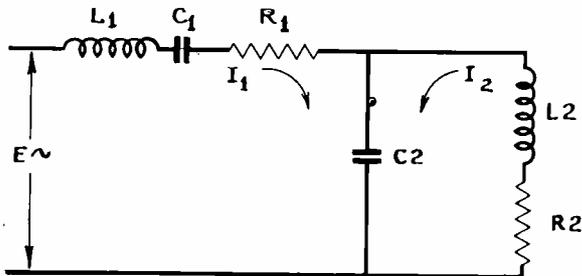

Fig. 6

arrangement. At frequencies in the neighborhood of 70 cycles, the cone motion will be low because of the anti-resonance of the cavity and its openings, but the sound emerging from the openings will have a component of the same phase as the sound from the front of the cone, so the two will add and produce more sound than if the openings were not there. At some still higher frequency, say 100 cycles, the cavity and its openings will have a stiffness reaction on the cone which will add to the stiffness of its suspension system and cause it to resonate, producing high motion and consequently high sound output. Thus, we see that the enclosed cavity with its properly proportioned openings will increase the sound output over the entire low frequency range from about 100 cycles down. In the ordinary open back (and usually open bottom) cabinet, the acoustic impedance of the total openings is so small that the cavity resonates at a comparatively high frequency, causing a peak in the response in the region of 100 to 200 cycles, which makes male voice reproduction quite "boomy." This effect is reduced by the baffle construction described.

Those who are more familiar with electric circuits than with acoustic systems may find the electric analogy more easily understood. Figure 6 gives the analogous electrical circuit in which  $L_1$

represents the mass of the cone,  $C_1$  its suspension stiffness,  $R_1$  the radiation resistance at its front surface,  $C_2$  the acoustic stiffness of the air in the closed cabinet,  $L_2$  the acoustic inertness of the air in the openings and  $R_2$  the radiation resistance at the openings. Now, if we apply constant voltage to this circuit (analogous to constant force in the acoustic system) and vary the frequency, the current (analogous to velocity in the acoustic system) will vary somewhat as shown in Figure 7. It is seen that the current is low where the circuit  $C_2 L_2$  resonates, and has a peak at a lower frequency where the combined inductance of  $L_1$  and the effective inductance of the parallel

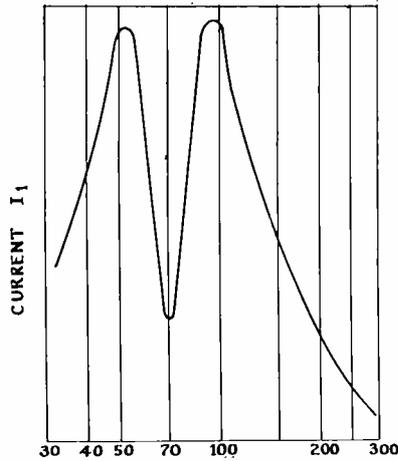

Fig. 7

circuit  $C_2 L_2$  resonate with the capacitor  $C_1$ , and another peak at a higher frequency where the inductance  $L_1$  resonates with the combined capacitance of  $C_1$  and the effective capacitance of the  $C_2 L_2$  circuit. A further study will show that at frequencies above the central dip the currents will have components in the direction shown by the arrows in Figure 6 which, while they appear to be opposite in direction, actually represent the same phase in the acoustic circuit since the current  $I_2$  is at the back of the cone while the current  $I_1$  is at its front. In other words, the two currents flow into the capacitor  $C_2$  at the same instant. In the acoustic circuits this means that air is flowing into the openings at the same time as the cone is moving back into the cabinet. Obviously, the sounds created by these motions will add.

A comparison between a cabinet treated by this method, and the same cabinet with no treatment (open back and bottom) is given in Figure 8, while Figure 9 shows the corresponding voice coil velocities.

It should be noted that this device is operative only in the low frequency range, and has only minor incidental effects at higher frequencies. Its chief effect is to increase the low frequency response, increasing the realism of reproduction of the very low instruments of the orchestra. Some reduction in "boom" of male voice reproduction is obtained by the reduction in response between 100 and 200 cycles.

#### RECENT TRENDS IN OVERALL ACOUSTIC PERFORMANCE

During the past several years work in the field of sound reproduction has been noteworthy because of:

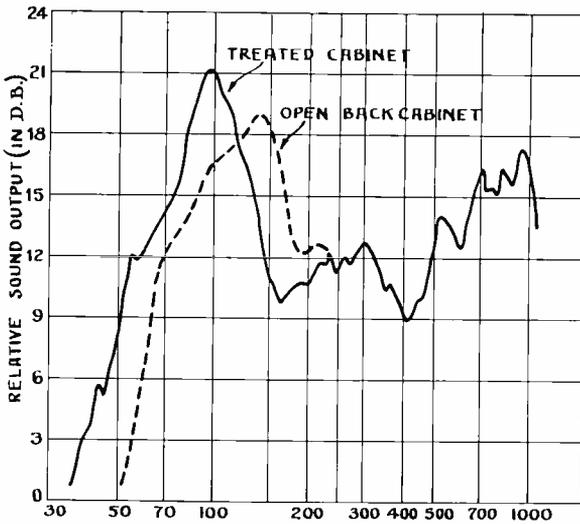

Fig. 8

- 1—Improvement in the frequency range of reproducers.
- 2—Reduction in distortion, especially that type due to an irregular frequency characteristic.
- 3—Increased efficiency of certain reproducer units.
- 4—Greater attenuation of output above the desired cut-off frequency, giving a reduction in undesirable beats and monkey chatter.
- 5—A more uniform reproduction characteristic throughout the industry.

These advances have been due to the following developments: The low-frequency range has been increased by cabinet treatment as described above. The high-frequency range has been increased and made smooth by:

- 1—Improvements in speaker-cone and voice-coil weight matching.
- 2—Improved cone materials.

High-frequency dispersion has made its appearance permitting a greater range without increased hiss and at the same time more uniform response throughout the room. This dispersion is accomplished by the use of diffusers in front of the speaker cone which operate either as simple reflectors or a group of short high-frequency horns pointed in different directions. Speaker units have higher sensitivities resulting from the newer cone materials and in the case of permanent magnet speakers from better iron. These permanent magnet speakers permit home battery receivers and others, such as ac-dc models in which the audio output and speaker field power is low, to compete with

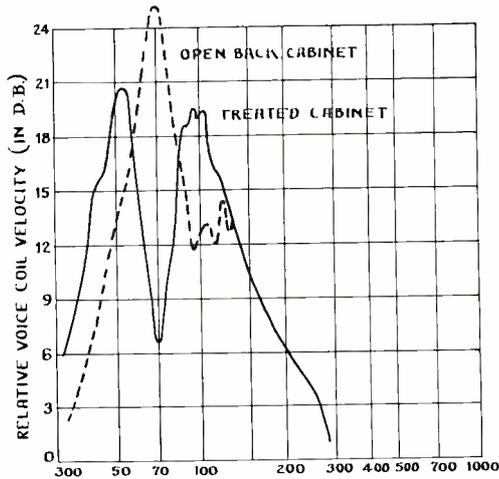

Fig. 9

the ordinary a-c receiver in sound power output. By means of mechanical and acoustical cut-offs and greater attenuation in the loud speaker above the desired range of say 5,000, 6,000 or 7,000 cycles a much higher signal-to-noise ratio results. These mechanical cut-offs may give much greater attenuation than several i-f stages for instance and permit higher frequency response or reception of an otherwise unusable signal. This improvement is most noticeable on 10-kilocycle beats and monkey chatter. Through greater commercial experience and better sound measuring equipment there is more uniformity of response characteristics in 1938 models and an avoidance of any possible impression that a set is too thin or too heavy in tone balance.

# A NEW ANTENNA KIT DESIGN

By

W. L. CARLSON AND V. D. LANDON

RCA Manufacturing Company, Inc., Camden, N. J.

## INTRODUCTION

**T**HIS paper deals with the design of a new noise-reducing antenna system of the all-wave type. The antenna proper consists of an inverted L or a vertical structure instead of the conventional dipole or group of dipoles. The polarization of international short-wave signals seems to have a random distribution so that on the average, reception is about equal on the vertical and horizontal components. In the broadcast band, signal strength compares favorably to that of previous designs, while the noise reduction is considerably improved, as will be explained later. Other advantages of the new design are its improved appearance, greater flexibility, and the ease of installation.

## THE ANTENNA PROPER

The antenna specification calls for a single or multiple-wire antenna of 150-micromicrofarad nominal capacity. The capacity may vary from 75 to 300 micromicrofarads without seriously affecting performance. The first three figures show typical antenna installations. Figure 1 shows an installation in which a single wire constitutes the antenna. The relative lengths of the vertical and horizontal portions may be changed to suit the particular installation. Figure 2 shows a design which requires no horizontal portion. A self-supporting metal pole, insulated from ground by wooden supports, is used for the antenna. In this case the transmission line may be buried if desired. Figure 3 shows the type of antenna which is recommended where the highest obtainable signal strength on short waves is desired. The lower *L-C* ratio of this antenna gives somewhat better signal strength at some points in the short-wave band.

## DESIGN OF THE TRANSFORMER SYSTEM

The circuit of the antenna system is given in Figure 4. The upper section of each transformer is for high frequencies and the lower section is for the broadcast band. Because of the great flexibility of the antenna specification, the impedance of the antenna for high frequen-

cies is a variable quantity. For this reason this part of the antenna transformer was designed while using a resistance for a dummy antenna.

In the line-to-set transformer, the high-frequency section is designed to match the 100-ohm transmission line to a 200-ohm receiver.

In designing the broadcast portion of the kit a capacitive dummy antenna was used. The design of the broadcast sections of the transformers is rather novel. No attempt was made to match the surge impedance of the line for this frequency band. Instead, the line is treated as a capacity. This capacity is used to resonate the windings to which it is connected.

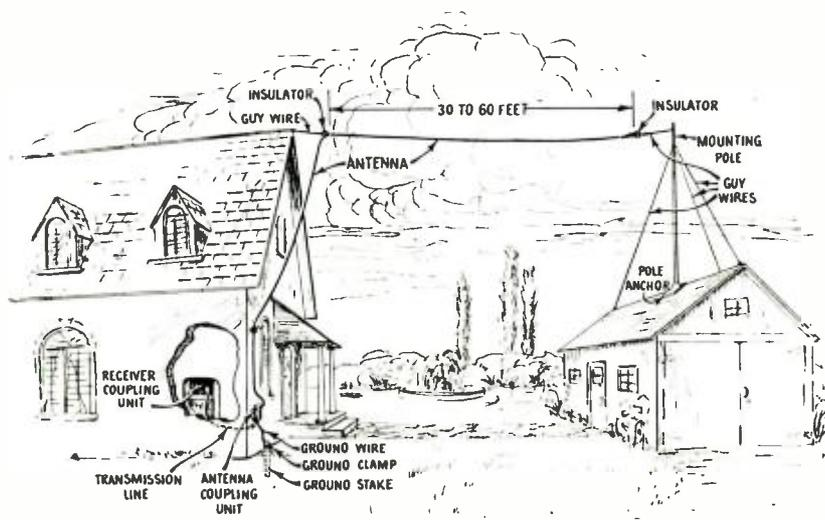

Fig. 1—Single-wire antenna installation.

The antenna circuit, the line circuit, and the set circuit are each resonant to the middle of the broadcast band. Tight coupling is used to broaden the response and the result is a three-peak response curve covering the broadcast band nicely. It is well known that when three identical circuits are coupled and used as a band-pass filter, the response curve has a typical head and shoulder shape. It is impossible with identical circuits to get the shoulders of the curve as high as the central portion. However, when the damping is largely concentrated at one end of the network, a relatively flat response may be obtained. This is true in the present case since the input impedance of the receiver constitutes a major portion of the damping of the network. This system results in an economy since it eliminates the need for the large capacitor which would otherwise be required to resonate each line winding in the broadcast band.

Due to the resonant condition of the line, the performance curve is changed somewhat by a change in line length. However, the effect is surprisingly small. A satisfactory curve is still obtained after changing the line length over wide limits. The line may be placed underground if desired with only a slight increase in the attenuation.

The performance data on the overall kit from dummy antenna to resistance load is given in Figure 5. For the broadcast band a resistance of 2000 ohms was used to represent the input resistance of a radio receiver. This is a common value of the input resistance at the frequency of resonance. Nevertheless, this curve is somewhat mis-



Fig. 2—Vertical antenna installation.

leading because this resistance is present as a load on the antenna system only at the frequency to which the receiver is tuned. At frequencies removed from resonance the impedance of the receiver is much higher. Thus the antenna system may resonate at frequencies differing from the frequency of reception, and reduce the apparent selectivity of the receiver. To reduce this effect a small amount of resistance is inserted in the antenna circuit. This resistance was not made as large as required by conventional filter theory as this would result in too great a sacrifice in signal strength. This resistance is obtained by using resistance wire in the primary winding of the broadcast section of the antenna transformer. The high-frequency performance is not affected.

## FACTORS AFFECTING THE SIGNAL-TO-NOISE RATIO

The most important electrical characteristic of a receiving antenna is the ratio of signal to noise which is obtained from it. Thus a low noise level is just as important as a high signal level. The principle of operation of noise-reducing antennas is as follows:

The antenna proper is located in a comparatively noise-free area. Signals are transmitted from the antenna through the antenna transformer, the transmission line and the line-to-set transformer to the receiver. In most systems, including the one under discussion, the

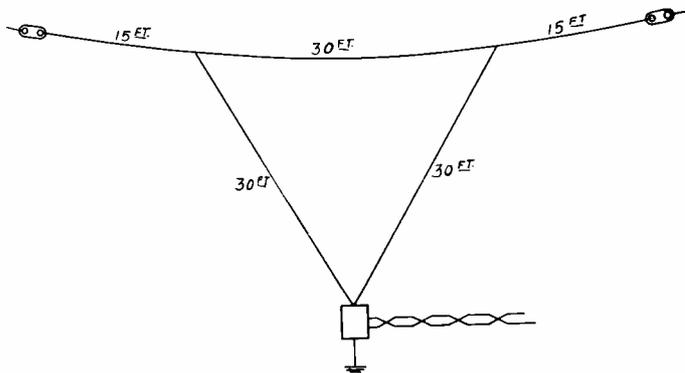

Fig. 3—Vertical "V" antenna.

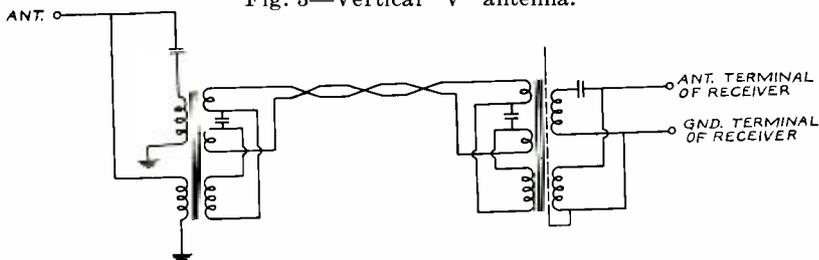

Fig. 4—Circuit diagram of the new antenna design.

transmission line is balanced to ground. The useful signals produce currents in the two sides of the line which are equal in amplitude and opposite in direction.

The noise, which is to be reduced or eliminated, arrives chiefly by way of the power cord of the receiver, though some noise is transferred from the power line or directly from the noise source to the transmission line by inductive or capacitive coupling. The noise coming in on the power cord puts a radio-frequency noise voltage on the chassis. In most locations it is difficult to reduce this voltage materially by grounding the chassis because the ground lead cannot be made short enough to have a low impedance.

The fact that the noise voltage appears on the chassis of the receiver does not necessarily mean that the voltage reaches the input terminal of the receiver providing the line-to-set transformer is properly shielded. If this transformer is well designed, then the only way of exciting the receiver is by means of a current in the primary. When the transmission line is balanced to ground, no primary current is produced by either a voltage on the chassis or a voltage induced on the transmission line. In each case equal currents flow on the two sides of the line, but these currents cancel each other in the primary.

In a practical set-up it is difficult to obtain complete-elimination of such disturbances. In general, the noise is attenuated a certain

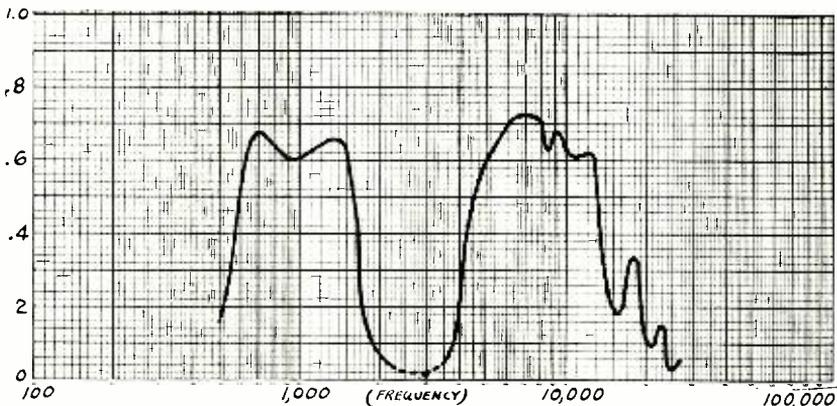

Fig. 5—Performance curve of new antenna kit design.

amount. The degree of attenuation depends on the care taken in designing the various components.

One important factor is the capacity shielding between the primary and secondary windings of the line-to-set transformer. This shielding should be very thorough for best results. The shield should be connected to the receiver chassis. If a separate ground were employed, line noise would not be eliminated due to the impedance in the ground wire.

Another important factor is the symmetry of the line winding. When a series condenser is used in the short-wave section, it should be placed in the center of the winding as shown. Otherwise the inequality of the capacities to ground throws the line out of balance. At best a certain residual unbalance will always exist. The effect of this unbalance is that the currents in the two sides of the line are not equal. A current equal to the difference between these two currents, flows in the primary winding inducing noise into the receiver. The effect of this residual capacity unbalance can be further minimized by a reduc-

tion in the capacity between the primary windings and the shield of the line-to-set transformer. This lowers the value of the noise currents in both sides of the line and hence lowers their difference. The magnetic balance is also improved by spacing the primary and secondary windings apart.

Figure 6 illustrates how these principles are utilized in the present design. This sketch is a cross section of the set-to-line transformer. The shield consists of a sort of fabric woven with wires running in one direction and threads at right angles. The wires are soldered together at one end and grounded to the chassis. This cloth is wrapped around the coil form outside of the primary windings. All primary connections go to the terminal board to the left. The secondary coils are outside the shield and all connections go to the terminal board to the right. Each of the primary coils is separated from the shield by

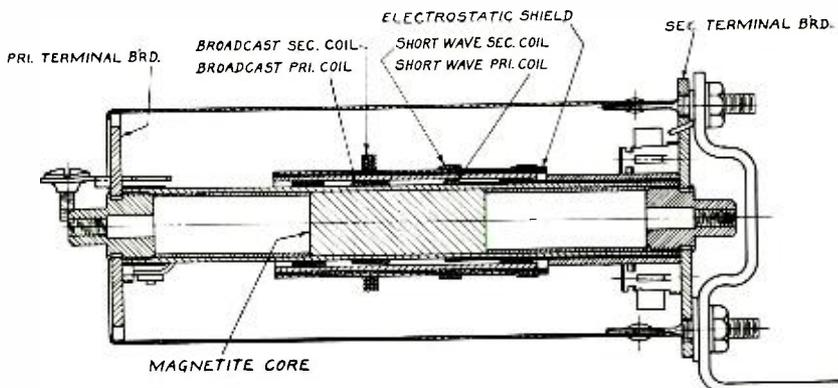

Fig. 6—Cross-sectional view of line-to-set transformer.

a considerable air space. This results in a low capacity to the shield and minimizes the leakage capacity through the shield. This leakage capacity would be quite appreciable if the windings were placed very close to the shield. The magnetic core is used to maintain tight couplings in spite of the comparatively large spacing between the windings.

It is also necessary to use care in designing the antenna transformer if good noise reduction is to be obtained. The line winding should be kept symmetrical in its capacity to ground. Otherwise, equal noise currents flowing up the two sides of the line are reflected unequally and the difference component is passed into the receiver.

The broadcast primary is a universal coil and is placed outside the secondary winding spaced 1/16 inch from it. The start of the primary coil is grounded and hence the first few turns act as a capacity shield for the rest of the winding. The use of a Faraday screen between

windings was found to do more harm than good in this transformer, because of the voltage drop across the impedance of the ground lead. Noise disturbances traveling up the transmission line cause a current to flow in the ground lead because of the capacity from the secondary windings to the shield. This current results in a voltage drop in the ground lead if the impedance of this lead is appreciable. The disturbance is then passed on to the line and to the receiver in the same manner as the desired signal. The methods of reducing this effect are to shorten the ground lead and to reduce the capacity between primary and secondary circuits. The ground lead is shortened by placing the transformer only a foot or two above the ground.

The capacity between windings has been reduced by employing small-diameter coils on a magnetite core and by spacing the coils from each other. A magnetite core is used to hold up the magnetic coupling. These features play a large part in accounting for the improved noise reduction obtained, particularly in the broadcast band.

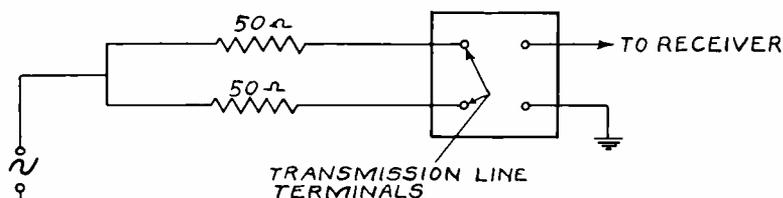

Fig. 7—Circuit for testing noise reduction in set-to-line transformer.

#### TESTING FOR NOISE REDUCTION

The final test of the antenna system should be a test of its ability to reduce noise under operating conditions. It is convenient, however, to be able to evaluate the noise-reducing performance of the component parts and of the entire kit by laboratory tests. The relative efficiency of various designs may then be compared. A series of such tests have been devised.

In testing line-to-set transformers for noise reduction, the circuit of Figure 7 is used. A voltage is applied to the two sides of the primary in parallel. A receiver is used to pick up and measure the weak signal which leaks through. The attenuation of this voltage is a measure of the noise-reducing efficiency of the transformer. Figure 8 is a curve obtained by this method. In the curve the attenuation applied to in-phase line voltages is plotted as a function of frequency. This test has several defects, but has been found quite useful nevertheless. The defects of the test are as follows:

First it is necessary to balance the two resistors very accurately to obtain valid results. Second the impedance of the line is not accu-

rately represented. In spite of these defects the test has been found very useful in comparing transformers. A similar test has been used on antenna transformers. In this case voltage is fed in on the two sides of the line as before and the leakage voltage is measured across the dummy antenna.

Tests have also been devised for evaluating the overall noise reduction under operating conditions. In one test a bifilar choke is placed in series with the power cord and a radio-frequency signal voltage is applied across the choke with a signal generator. The sensitivity of the receiver to this signal is measured. The ratio of this sensitivity to the normal sensitivity gives the noise-attenuation ratio.

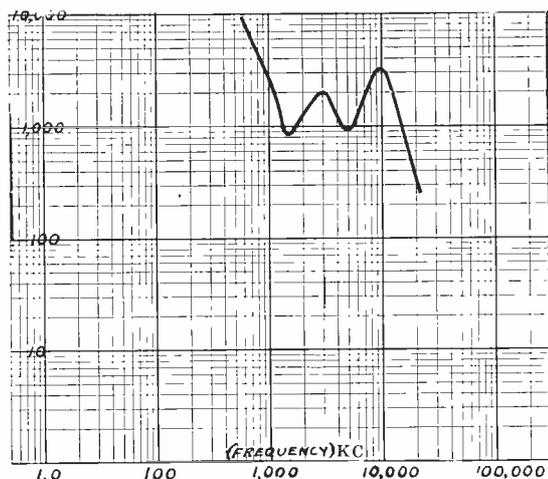

Fig. 8—Noise reducing performance of set-to-line transformer.

The ratio obtained in this manner will vary considerably from one installation to another because of variations in the impedance of the power line and ground leads. However, the ratios obtained for the broadcast band are in the order of 300.

In another test, the test voltage is applied to the two sides of the transmission line in a manner similar to that used for testing the transformers alone. The attenuation ratios obtained by this method are about three to one less than those obtained by applying the test voltage on the power cord. This shows the effectiveness of keeping the capacity small between the primary and the shield in the line-to-set transformer.

#### CHASSIS GROUND CONNECTION

The use of a ground connection on the chassis is of doubtful value with this antenna system. Noise reduction is sometimes better with

the ground, but just as frequently it is better without. The signal strength is not affected.

### RECEIVER POWER-LINE FILTER

In designing receivers, it is generally accepted as good practice either to use a shield between windings of the power transformer or to by-pass both sides of the power line to the chassis. This desirable practice should not be discontinued because of the availability of noise-reducing antenna kits. In fact a line filter of some sort is more necessary than ever when using a noise-reducing antenna. The function of such a filter is to prevent the noise from entering the radio circuits by way of the "B" supply. The importance of this function is increased when the noise is also prevented from entering through the antenna circuit.

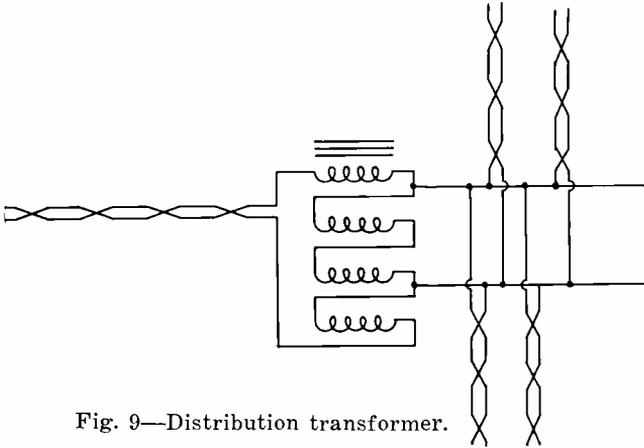

Fig. 9—Distribution transformer.

### DISTRIBUTION TRANSFORMER

There is a large demand for an antenna kit capable of feeding several receivers simultaneously. To accomplish this, a special distribution transformer has been designed. The circuit is given in Figure 9. The four coils shown are wound simultaneously turn for turn. This is accomplished by using a special four-strand litz wire. The four strands are connected in series as shown. A magnetite core is used to reduce the leakage reactance still further. The result is a balanced two-to-one, step-down transformer having extremely low leakage reactance. This transformer passes both broadcast band and short-wave signals with high efficiency. Having a two-to-one ratio, the transformer operates most efficiently into four outlets. Of course, each of the four branch lines may be split up into four outlets again, making a total of sixteen. Signal strength is down a little more than two-to-one with four outlets and four-to-one with sixteen outlets. Since the transformer is balanced, the noise reduction is not affected by its use.

## SMALL VESSEL DIRECTION FINDERS

BY

H. B. MARTIN

Engineering Department, Radiomarine Corporation of America

THE use of the radio direction finder or radio compass for navigation purposes is not new. For a period of several years hundreds of coastal, lake and ocean-going ships have realized excellent results from such equipment.

Equipment has recently been made available which permits the small boat owner also to take advantage of this radio aid to navigation. The apparatus, while no different electrically from that used aboard large vessels, is, however, specialized in certain features. The principal differences are the space required and ease of installation.

Figure 1 shows the normal manner of mounting the loop handwheel above the receiver so as to require the least table space. Since the small vessels for which this equipment was designed are invariably of wooden construction, the loop may be inside the cabin, thus avoiding the more elaborate loop-rotating mechanisms employed on larger craft which, of necessity, use an outside loop. Figure 2 shows a side view of the loop-mounting bracket as employed in Figure 1. In cases where the overhead room is limited, a loop mounting as in Figure 3 is used. The receiver would then be located to the right or left of the handwheel or on an adjacent shelf. Occasionally, table or shelf mounting of the loop is impractical. Figure 4 shows a loop bracket designed for bulkhead mounting in such cases.

Present-day rotating loop antenna usually consist of several turns of wire enclosed in some form of electrostatic shield. The shield is necessary to reduce the effect of local induction fields and to preserve electrical symmetry<sup>1</sup>. The loop may be considered as an inductance coil, having a relatively short length along its axis, but a large diameter. For purposes of explanation a single-turn loop having vertical and horizontal legs will be used. This is shown in Figure 5(a).

As the electromagnetic wave radiated by the transmitting station passes across the vertical legs of the loop as shown in Figure 5(b) voltages are induced in the vertical members of the loop which are slightly out of phase with each other, but of equal amplitude. This pre-supposes that the transmission path is along the surface of the earth, which is practically true at medium and low frequencies except during certain times of the year and day when occasional sky-wave reception occurs. Since the sky-wave comes down at an angle with the

earth's surface, voltages would be induced in the horizontal members of the loop, which are detrimental to sharp and finite "bearings" on the signal path. This effect, because it is worse at night, is called "night effect".

Figure 5(c) represents a cross-sectional view of the vertical members of the loop, the arrows representing the arrival path of signals from various directions. The signal, if it arrives from direction A

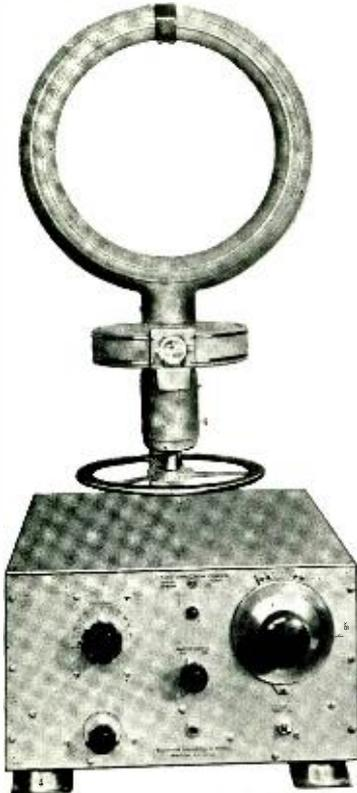

Fig. 1—Normal installation using standard mounting.

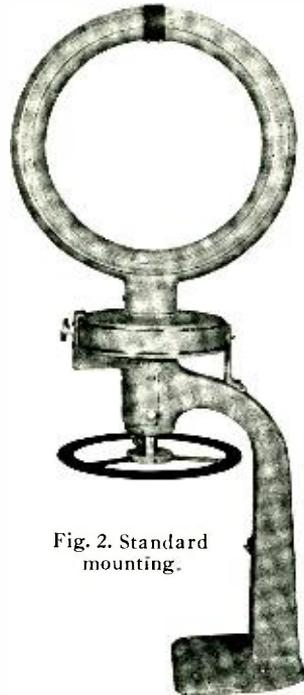

Fig. 2. Standard mounting.

(in the plane of the loop), would first produce a voltage in conductor No. 1 after which the wave front passes across conductor No. 2 and induces a like voltage. The distance between the conductors and the wavelength of transmission determine the actual phase relationship. If the signal is arriving from any direction other than in the plane of the loop, the wave-front does not have to travel so far from the time it crosses conductor No. 1 until it passes conductor No. 2. This is represented in Figure 5(d) as a signal wave arriving at an angle of  $45^\circ$  with the plane of the loop. Figures 5(e), (f), and (g) show

respectively the resultant loop voltages ( $e_R$ ) due to signal-arrival direction of  $A$  (loop plane),  $C$  ( $45^\circ$ ), and  $E$  (perpendicular to loop plane). Obviously, if a signal path is in the loop plane, the response or loop resultant voltage will be maximum whether it be coming from direction  $A$  or  $F$  Figure 5(c), and will be minimum or zero if arriving from directions  $E$  or  $G$ .

The resultant loop voltage acting to drive current around the loop is approximately<sup>2</sup>

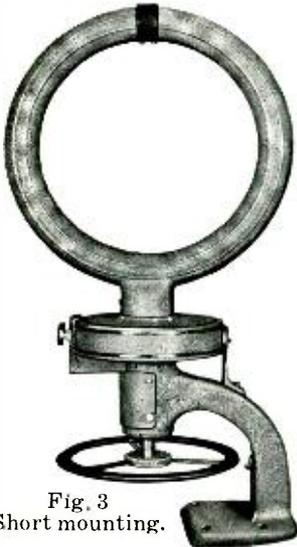

Fig. 3  
Short mounting.



Fig. 4—Bulkhead mounting.

$$e_R = 2\pi\epsilon N \frac{(\text{loop area})}{\lambda} \cos \theta \quad (1)$$

where  $e$  = field strength of radio wave in volts per meter.

$N$  = number of turns in loop.

$\lambda$  = wavelength in meters.

$\theta$  = angle of arrival with respect to plane of loop.

Obviously for any given loop and transmitting frequency (wavelength) the resultant voltage is dependent on the angle of the loop plane and the signal path or

$$e_R = k \cos \theta \quad (2)$$

If equation (2) be plotted on rectilinear coordinates for all values of  $\theta$  between 0 and 360 degrees, the resulting curve of response voltage is the familiar figure-of-eight or "loop characteristic" shown in Figure 6.

From a consideration of Figure 6 it will be seen that if the loop be rotated  $\pm 30$  degrees from that position giving maximum signal, the strength of signal in the indicator (head phones, meter, or whatever is used) will vary only from 100 per cent to 86.6 per cent, a change which is hardly perceptible in the headphones, and certainly the indication is too broad to give a good "bearing" regardless of the type of signal reproducer or indicator used. It is for this reason that the null point or point of zero reception is used for taking bearings since turning the loop a degree or so either side of the null produces a *large* percentage change in the received signal. Thus when the signal is

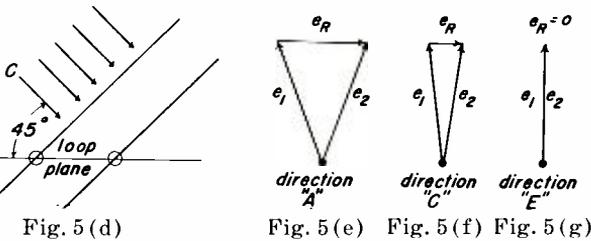
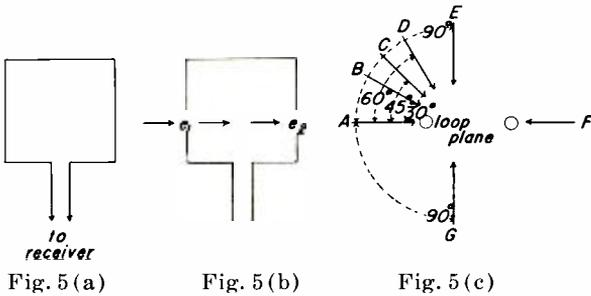

at a null point the loop plane is broadside or perpendicular to the wave front of the incoming signal. A pointer attached to the loop-rotating shaft will refer the bearing to a reference line such as the "keel line" or "lubber line" of a ship or to true north in cases where a gyro-compass repeater card is the direction-finder scale.

Figure 7(a) shows schematically a loop tuned and connected across the input elements of a vacuum tube. It would be possible to take only "rough" bearings with this arrangement since the two legs of the loop are unsymmetrical with respect to ground. Figure 7(b) considers one leg of the loop and shows the distributed capacity to ground. Obviously any voltage developed by the signal wave across the capacity to ground will be amplified equally well regardless of the direction of the incoming wave. This effect is known as "vertical" and obscures the minimum of the loop figure-of-eight characteristic<sup>3</sup>. This is shown

by Figure 7(c), the dotted line being the complete characteristic obtained by adding vectorially the voltage responses of the vertical effect and the loop. The elimination of "vertical" may be partially accomplished by arranging the loop circuit in a symmetrical manner as in Figure 8(a) or 8(b) and grounding the electrical center of the loop circuit. These circuits utilize only one-half the total loop resultant voltage as excitation for the grid-cathode circuit of the tube. The additional capacity of the rotor of the loop-tuning capacitor maintains

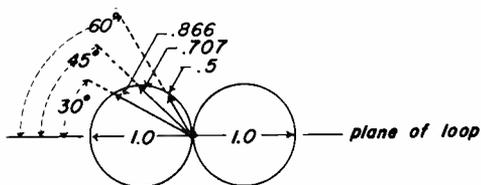

Fig. 6

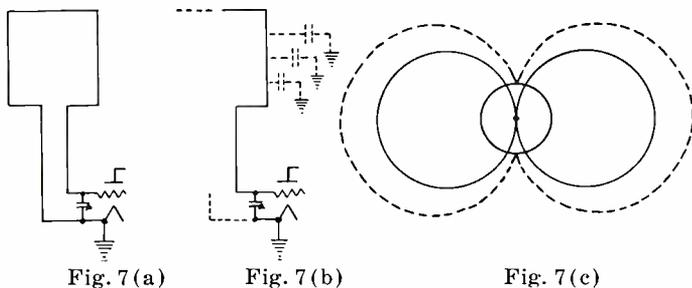

Fig. 7(a)

Fig. 7(b)

Fig. 7(c)

the symmetry at the tube input terminals. This is shown in Figure 8(c). The use of push-pull tubes would have the same effect except that the stator should be padded with capacity to ground to preserve the balance as in Figure 8(d). The use of a split-stator loop-tuning capacitor as in Figure 8(a) would be ideal except for the mechanical disadvantage that it requires four times the number of plates. The vertical antenna effect is still present to a certain degree, however, since the voltages induced in both legs of the loop are additive when their effect is considered across the grid-cathode elements of the tubes. This is shown more clearly by Figure 9.

The solid  $\pm$  signs and arrows are those indicating instantaneous polarities due to the circulating current in the loop while those shown dotted indicate the polarities produced due to "antenna" effect. It is obvious that if the voltages represented by the dotted arrows in the secondary of the r-f transformer  $T_1$  were equal and  $180^\circ$  out of phase the vertical effect of the loop is nil and a perfect zero or null would be obtained when the loop is turned broadside to the incoming signal.

A method of balancing the voltages induced in each loop leg due to reflections and spurious radiations from external metallic objects and not necessitating the use of push-pull tubes is shown in Figure 10.

$L_1C_1$  resonate at the loop frequency, but when the switch is on "balance" the additional inductance of  $L_2$  loads the balancer circuit to a frequency approximately 90 per cent of the signal frequency. Thus at the signal frequency the circuit composed of  $L_1$ ,  $L_2$ ,  $S_1$  and  $S_2$ , and  $C_1$  is predominantly inductive reactance, hence the currents flowing through the small rotors of the balancer unit ( $S_1$  and  $S_2$ ) are lagging the voltage induced in  $L_1$  by the vertical antenna almost 90 degrees. The small voltages induced in the stators  $P_1$  and  $P_2$  are then

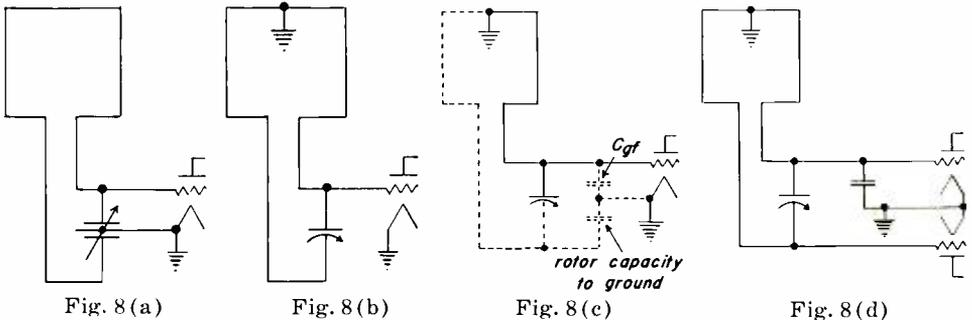

Fig. 8 (a)

Fig. 8 (b)

Fig. 8 (c)

Fig. 8 (d)

either approximately in phase with the loop leg voltages or out of phase  $180^\circ$ , depending on how the balancer rotor is adjusted when taking a bearing. Figure 11 shows vectorially how the balancer functions. The resultant loop voltage is exaggerated for clearness.

$e_a$  = voltage induced in vertical antenna by transmitter.

$i_a$  = antenna current (leads  $e_a$  by about 90 degrees since vertical antenna reactance at the signal frequency is highly capacitive).

$e_{L1}$  = voltage induced in  $L_1$  due to current in coupling coil  $L$ .

$e_1$  and  $e_2$  = loop-leg voltages induced by signal (in phase when loop broadside to signal, but of slightly different amplitude due to nearby objects)

$i_{L1}$  = current in balancer rotors (almost  $90^\circ$  behind  $e_{L1}$ )

$e_{P1}$  and  $e_{P2}$  = voltages induced in  $P_1$  and  $P_2$  to compensate for inequalities in the voltages induced in individual loop legs.

Therefore  $e_1 + e_{P1} = e_2 - e_{P2}$  (approximately) and an almost perfect balance or "null" occurs.

That a loop antenna receives or rejects equally well from either one of two directions is a well known fact. Referring to Figure 5(c) signals arriving from either direction  $E$  or  $G$  would produce no resultant loop voltage and from directions  $A$  or  $F$  would produce equal

maximum indications. This is known as the bi-lateral characteristic. If a loop can be made to indicate which of the two possible directions is correct, then it is said to have a unilateral characteristic or "sense". Referring to Figure 10 this is accomplished by turning the small rotors  $S_1$  and  $S_2$  so that voltages induced in stators  $P_1$  and  $P_2$  add and subtract to the loop leg voltages respectively. Resistor  $R$  is then placed in series with circuit  $L_1 C_1 S_1 S_2$  by the balance-sense switch. Since the load coil  $L_2$  is not in series with  $L_1 C_1$  etc., during sense

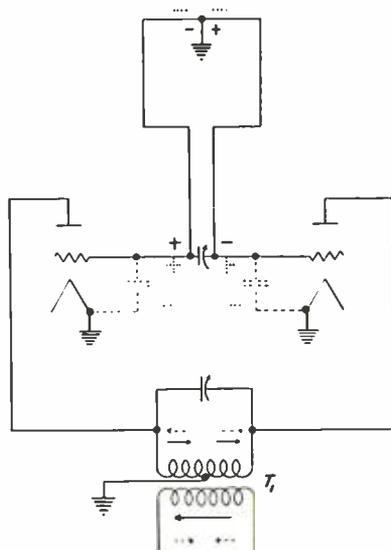

Fig. 9

determination, the circuit is tuned to the signal frequency and rotor currents (in  $S_1$  and  $S_2$ ) produce voltages in  $P_1$  and  $P_2$  which are approximately 90 degrees out of phase with the loop resultant voltage. This is shown by Figure 12. The vector subscripts are identical to those in Figure 11.

Figures 12(b) and (c) show how the vectors add to produce a louder signal, Figure 12(b) or a weaker signal, Figure 12(c), depending on which leg of the loop is the closer to the transmitting station. The response as explained above has the characteristic of a cardioid or heart-shaped diagram as shown in Figure 13.

Figure 13 illustrates how the cardioid is formed by assigning + and - values to each leg of the loop and an arbitrary + value to the voltages added by the sense circuit. Thus when the plane of the loop is in the path of the signal (or the loop is rotated so that direction "A" occurs) the total response is maximum; and conversely, when

rotated so that the signal appears to come from direction "B", the total response is zero. The choice of sense-antenna length, and particularly of the tuned circuit constants will materially affect the shape of the cardioid as shown in Figure 14 for different values of sense resistor  $R$  (Figure 10).

The sense resistor  $R$  not only serves as a method for adjusting the shape of the heart-shaped characteristic, but assures that circuit  $L_1C_1$  is "tuned" to the signal frequency or that the current  $i_{L1}$  is in phase with voltage  $e_{L1}$ , a condition necessary for the sense determination as in Figure 12.

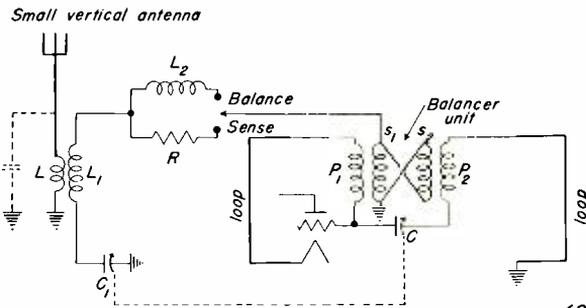

Fig. 10

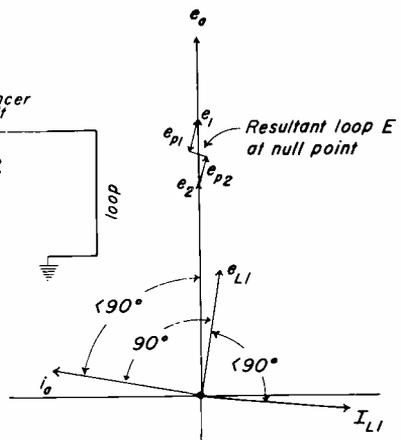

Fig. 11

Direction finders, when used on shipboard in particular, are subject to an error known as "deviation" or "displacement". This error is the difference between the observed radio bearing or apparent signal direction and the true direction and is caused by the fact that the loop is located close to stays, railings, funnels, etc. It is also due in no small degree to the effect of the hull, if of steel, on the electromagnetic field of the signal.<sup>1</sup> Displacement errors are usually quadrantal since bearings taken on signals arriving at angles of approximately 45 degrees with the ship's keel line are found to deviate most from the true bearing. The tendency is for observed radio bearings to be bunched or crowded toward the keel-line of the ship with minimum or no deviation fore and aft and abeam<sup>1</sup>. It is for these reasons that marine direction finders require calibration. For example: if the plane of the loop was making an angle of 40 degrees with the keel-line of the ship, but by process of calibration the signal was known to be arriving from a direction of 45 degrees referred to the keel-line, the corrected scale would actually indicate the correct bearing, or 45 degrees. The method used on

the equipment shown in Figures 1 to 4 is to provide a chart directly on the scale so that the correction at various angles is mentally added or subtracted at the instant of taking the bearing.

A brief mention of receiver requirements over and above those already discussed in connection with the antenna and input circuits would not be amiss. Around the coast-line of North America and on the Great Lakes the United States and Canadian governments operate

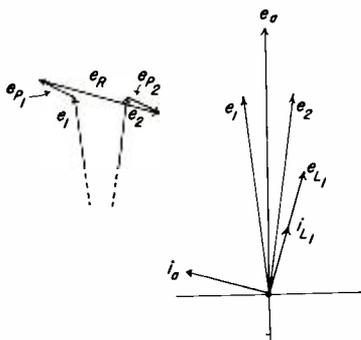

Fig. 12(b) Fig. 12(a)

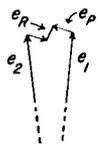

Fig. 12(c)

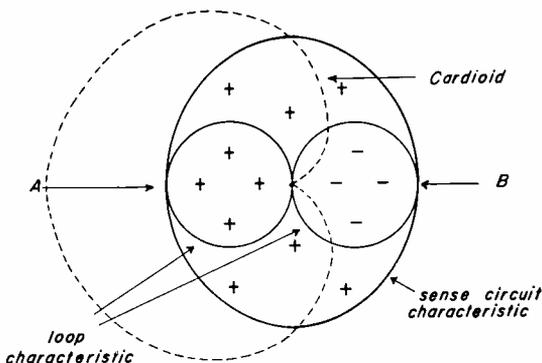

Fig. 13

*R too large*

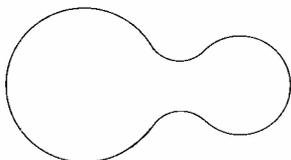

Fig. 14(a)

*R too small*

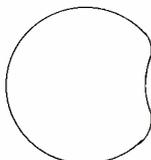

Fig. 14(b)

*R for true cardioid*

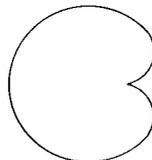

Fig. 14(c)

approximately 140 marine beacon stations which send a characteristic identification signal at specified periods during each hour. Beacon transmitters are arranged geographically in order that cross bearings may be taken to "fix" the ship's position. The frequencies used are in the special band allocated for this service only, i.e., 285 to 315 kc. Usually three stations situated at strategic points (on lightships or at lighthouses) use the same frequency in order that, when navigating in their vicinity, the direction-finder receiver will not require retuning when shifting from one beacon to another. Clear weather transmissions from each group are ordinarily twice each hour for ten-minute periods. The transmission time for any one station in the group is one minute, after which the two other stations in the group follow in succession, etc. During foggy weather each station is "on" every third minute.

The frequency separation of adjacent groups is always 8 or more kc. and since low power is used, the same group frequency may be used again if employed several hundred miles away. This reduces the chances of sky-wave interference. Frequency assignments are from 286 to 314 in 2-kc. steps. This allows for up to 1000-cycle modulation without side band interference with other services at the edges of the beacon band.

Figure 15 represents a section of Nantucket, Vineyard, and Long Island Sounds and shows 15 beacons, their frequency, time of transmission and identifying signal. Thus, Nantucket Lightship transmits

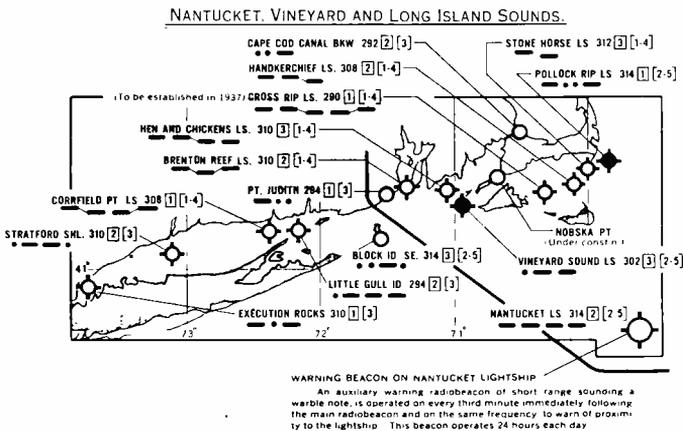

Fig. 15

the character — — — — for one minute as the second (2) station of the group on 314 kc. The other members of this group are Pollock Rip Lightship and Block Island SE. Clear weather transmission periods of this group are (2-5) or the second and fifth 10-minute periods after the hour, for example 10:10 to 10:20 and 10:40 to 10:50.

As additional protection during foggy weather, many of the beacon stations send a 1-second and 5-second blast on their fog horn and synchronized with a similar radio signal at the conclusion of each "one-minute" period (actually a 52-second period so as to finish the 5-second dash at the end of the one-minute period.) Thus by timing the space between a certain part of the radio signal and the corresponding part of the fog horn signal and dividing seconds elapsed by 5.5, the distance in nautical miles is ascertained to an accuracy of 10 per cent.

Modern direction-finder receivers attain a high degree of selectivity and sensitivity. These properties are necessary for the following

reasons. Since the bearing is necessarily taken at the "null point" of the desired signal for reasons already explained, as much sensitivity as is practical for the prevailing noise level is desirable so that a greater contrast between the null point and a few degrees off null is obtained. Thus an interfering signal, if coming from a point other than broadside to the loop plane, although considerably weaker in

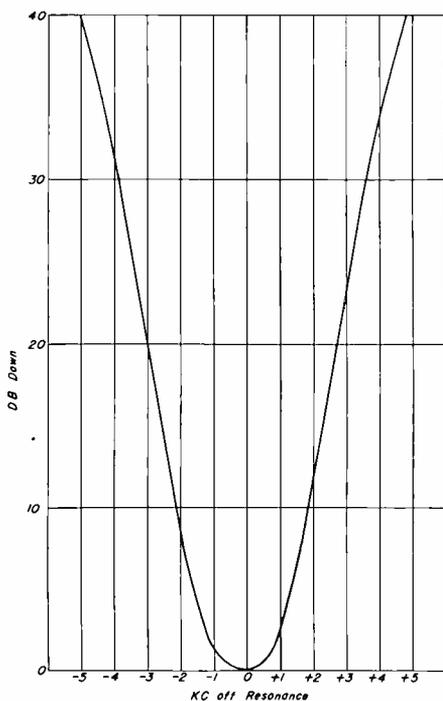

Fig. 16

field strength, might produce a loop resultant voltage comparable to the desired signal, were the selectivity insufficient. Satisfactory selectivity, bearing this feature in mind, has been found to be approximately as in Figure 16.

The receiver shown in Figure 1 utilizes 7 tubes in a superheterodyne circuit. A stage of r-f amplification is used for the reduction of image response and contributes to overall selectivity and sensitivity. In many cases a c-w ( $A_1$ ) signal is more readable through severe noise and static, therefore a separate c-w oscillator is provided to beat with the signal at the intermediate frequency. The receiver covers a frequency band of 270 to 520 kc.

The lighting supply voltage on small boats may be 6, 12, 32 or 110 volts d.c. In order to charge the 6-volt storage battery used for tube-heater supply, the battery is automatically connected to the boat's lighting supply through an appropriate size lamp bulb when the "on-off" switch on the receiver panel is "off". Two 45-volt dry-cell "B" batteries are used for plate supply to the vacuum tubes.

When the same nomenclature as for equation (1) is used, the effective height<sup>2</sup> of a loop antenna is:

$$h = 2\pi N \frac{(\text{loop area})}{\lambda} \cos \theta \quad (3)$$

Obviously for a loop of only a few turns, and having a small diameter compared to wavelength, the effective height is small. The need for a sensitive receiver is at once apparent since the field strength of a beacon transmitter may be only a few microvolts per meter.

#### BIBLIOGRAPHY

<sup>1</sup> Solt, *Proc. I.R.E.*, Vol. 20, No. 2.

<sup>2</sup> Terman, "Radio Engineering".

<sup>3</sup> Blair and Lewis, *Proc. I.R.E.*, Vol. 19, No. 9.

<sup>4</sup> Keen, "Wireless Direction Finding and Directional Reception".

# SOME FACTORS IN THE DESIGN OF DIRECTIVE BROADCAST ANTENNA SYSTEMS

BY

W. S. DUTTERA

Radio Engineering Department, National Broadcasting Company

*Summary*—This paper outlines a relatively simple method of analyzing the performance of a directional antenna system by determining the relative power radiated in equally distant zones at all angles above the earth, as well as the total radiated power. Directional systems composed of two or three antennas are specifically considered although the analysis may be extended to apply to more complicated arrays. It is shown that with short antennas, certain spacings and phasings accentuate the undesirable high-angle radiation characteristics of the single radiator while other spacings and phasings materially improve upon the high-angle characteristics of the single radiator. Directional systems comprising two radiators are considered in detail for 90-degree and 190-degree radiators having equal currents.

THE directional antenna system is assuming an increasingly important role in broadcast applications. This importance is due largely to two factors: namely, the desire to increase the signal intensity in one or more important directions and thereby secure better coverage with a given power, or the necessity of protecting other stations on the same or adjacent channels when the geographical separation is insufficient to prevent interference.

The directional antenna system has, for a great many years, been employed for the radiation of short-wave energy; in this case, the radiators are usually half-wave long and raised off the ground. The design and performance of these antenna systems has been well investigated<sup>1 2 3 4</sup>. In broadcast practice it has not been possible, because of the high cost, to employ directional systems similar to those employed for short-wave transmission. In broadcast applications, it is usually found desirable to employ two or three vertical radiating elements generally not exactly a half-wave high nor raised above the ground. It is such systems as these that will be analyzed.

When two or more radiators are separated and radiate energy of the same frequency, the field produced in space is no longer the same as that produced by any one of the individual radiators. That is, due to the spacing, phasing, and relative currents of individual radiators, a new space-voltage characteristic is obtained in all planes passing through the center of the system. If the radiation characteristics of

these radiators as well as the spacing, phasing, and relative currents are known, the relative space-voltage characteristics of the system may be determined. However, it is necessary to know the radiated power in order that the absolute values of these voltages may be obtained.

The radiated power may be obtained in one of two ways. The first method necessitates the determination of the mutual and self impedance of the radiating elements<sup>5</sup>. The second is by integrating the power radiated through a hemisphere about the antenna system. The first method of calculation gives only the power in the system with no indication as to how it is distributed. The second method, in addition to determining the total power in the system, shows the relative distribution of radiated power on the ground and at all angles above the ground. It is also somewhat simpler to apply to any directional system having different height radiators, or for radiators having such characteristics that the impedances have not already been calculated. Of course, the circuit elements must be calculated after the selection of the desired directional system from these values of self and mutual impedance. It should be noted that, if the radiators are more than approximately 130 degrees high, most theoretical data published do not give correct absolute values of the self and mutual impedance of the radiators, and strict reliance can be placed only in actual measurement of the radiators in the system, or in measurements made on a similar system.

#### DETERMINATION OF THE POWER RADIATED

From Poynting's theorem, the power radiated in the direction  $r_0$  through an element of surface  $dS$  perpendicular to  $r_0$  is

$$dp = K_1 E_0 H_0 dS = K_1 E_0^2 dS \quad (1)$$

$$\text{where } K_1 = \frac{c}{4\pi}$$

$E_0$  is the electrical intensity at the vertical angle  $\theta$ .

When the element of surface,  $dS$ , is a zone of infinitesimal width at the angle  $\theta$  the power becomes

$$\Delta p_{nd} = K_3 E_0^2 \cos \theta \Delta \theta \quad (2)$$

$$\text{where } K_3 = \frac{cr_0^2}{2}$$

The total power is

$$P_{nd} = K_3 \int_0^\pi E_0^2 \cos \theta d\theta \quad (3)$$

VERTICAL CHARACTERISTIC OF SINGLE ANTENNA

The vertical characteristics of each of the antennas in the system must be known or assumed. With measurements of current distribution, relative phase and the ground constants near the antenna, the vertical characteristic may be accurately computed. As this information is not usually available, the vertical characteristics may be approximately computed<sup>6</sup> for sine wave of current distribution from

$$f(\theta) = \frac{K}{\cos \theta} [\cos B \cos (A \sin \theta) - \sin B \sin \theta \sin (A \sin \theta) - \cos G] \tag{4}$$

where

$$K = \frac{1}{\cos B - \cos G}$$

A = Vertical height in degrees

B = Suppressed height in degrees (non-radiating)

G = A + B

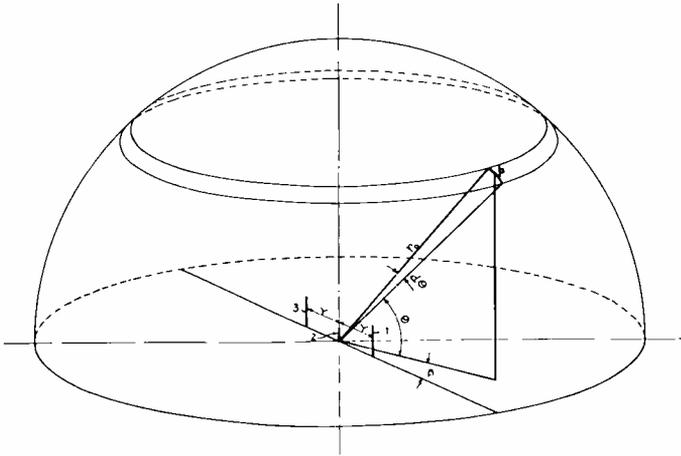

Fig. 1.

It is to be noted that the possible error arising by the use of Equation (4), due to the assumption of sine-wave distribution of current, is also present to the same extent when total power in the system is computed by the calculation of the self and mutual impedances of the antennas. This is due to the fact that this same assumption of sine-wave current distribution is made in order to obtain the self and mutual characteristics.

## DIRECTIONAL SYSTEMS COMPOSED OF THREE RADIATORS

Figure 1 represents three radiators, 1, 2 and 3, placed in the same vertical plane. These radiators are equally spaced  $Y$  degrees apart and phased  $X$  degrees, zero, and  $-X$  degrees respectively. The vertical characteristics of these individual radiators are  $f_1(\theta)$ ,  $f_2(\theta)$ , and  $f_3(\theta)$ . For  $\theta$  equal to zero, that is, on the ground, the radiators individually produce signal intensities of  $E_1$ ,  $E_2$ , and  $E_3$  at unit distances.

It can be shown that the voltage,  $E_p$ , at any point in space, where  $r_o \gg \lambda$  is

$$E_p^2 = \frac{1}{r_o^2} [E_{1o}^2 + E_{2o}^2 + E_{3o}^2 + 2E_{2o}(E_{1o} + E_{3o}) \cos \delta + 2E_{1o}E_{3o} \cos 2\delta] \quad (5)$$

where

$$\delta = (X + Y \cos \theta \cos \beta)$$

$$E_{1o} = E_1 f_1(\theta)$$

$$E_{2o} = E_2 f_2(\theta)$$

$$E_{3o} = E_3 f_3(\theta)$$

Equation (5) is the general expression for the solution of  $E_p$  when the vertical characteristics of the three radiators are dissimilar and the individual ground intensities of all three radiators are dissimilar. Equation (5) does not allow for attenuation or imperfectly conducting ground.

The maximum intensity on the ground, the case where  $\theta = 0$ , is obtained from Equation (5), when  $X^2 \leq Y^2$ , is

$$E_{max} = E_1 + E_2 + E_3$$

Thus with a maximum signal of unity on the ground,

$$E_p = \frac{1}{r_o (E_1 + E_2 + E_3)} [E_{1o}^2 + E_{2o}^2 + E_{3o}^2 + 2E_{2o}(E_{1o} + E_{3o}) \cos \delta + 2E_{1o}E_{3o} \cos 2\delta]^{1/2} \quad (6)$$

If  $X^2 > Y^2$ , the denominator of Equation (6) is replaced by,  $r_o [E_1^2 + E_2^2 + E_3^2 + 2E_2(E_1 + E_3) \cos (X - Y) + 2E_1E_3 \cos 2(X - Y)]^{1/2}$

The mean square voltage, existing about a zone, at any angle  $\theta$ , when the maximum ground voltage is unity, is

$$E_{ad}^2 = \frac{1}{r_o^2 \pi} \int_0^\pi E_{po}^2 d\beta \quad (7)$$

where  $E_{\nu\theta}$  is derived from Equation (6) for one value of  $\theta$ .

Upon integration between the indicated limits Equation (7) becomes

$$E_{\theta d}^2 = \frac{1}{r_o^2 (E_1 + E_2 + E_3)^2} [ E_{1\theta}^2 + E_{2\theta}^2 + E_{3\theta}^2 \tag{8}$$

$$+ 2E_{2\theta} (E_{1\theta} + E_{3\theta}) \cos X \cdot J_o (Y \cos \theta) + 2E_{1\theta} E_{3\theta} \cos 2X \cdot J_o (2Y \cos \theta) ]$$

where  $J_o (Y \cos \theta)$  and  $J_o (2Y \cos \theta)$  are Bessel functions of the first kind, of zero order, with the arguments  $(Y \cos \theta)$  and  $(2Y \cos \theta)$ , respectively.

For power computation the values of  $E_{\theta d}^2$  found in Equation (8) may be used in Equation (2) to give

$$\Delta p_d = K_s E_{\theta d}^2 \cos^2(\theta) \Delta \theta \tag{9}$$

Thus Equation (9) expresses the relative power in a zone at the angle  $\theta$  for a directional system composed of three radiators when each radiator produces a different ground signal, and when each radiator has a different vertical characteristic.

If the directional system is composed of three identical radiators Equation (9) then becomes

$$\Delta p_d = \frac{K_s \Delta \theta \cos \theta}{r_o^2} \cdot \frac{E_{1\theta}^2}{E_1^2 (1 + n_2 + n_3)^2} [ 1 + n_2^2 + n_3^2 \tag{10}$$

$$+ 2n_2 (1 + n_3) \cos X \cdot J_o (Y \cos \theta) + 2n_3 \cos 2X \cdot J_o (2Y \cos \theta) ]$$

where

$$n_2 = \frac{E_{2\theta}}{E_{1\theta}} = \frac{I_2}{I_1}$$

$$n_3 = \frac{E_{3\theta}}{E_{1\theta}} = \frac{I_3}{I_1}$$

$$\frac{E_{1\theta}^2}{E_1^2} = f_1^2(\theta)$$

Under these conditions it will be beneficial to simplify Equation (10) to

$$\Delta p_d = \frac{K_s f_1^2}{r_o^2} (\theta) N_o^2 \cos^2(\theta) \Delta \theta \tag{11}$$

where

$$N_{\theta}^2 = \frac{1}{(1 + n_2 + n_3)^2} [1 + n_2^2 + n_3^2 + 2n_2(1 + n_3) \cos X \cdot J_n (Y \cos \theta) + 2n_3 \cos 2X \cdot J_n (2Y \cos \theta)] \quad (12)$$

Thus  $N_{\theta}$  is an r-m-s coefficient influencing the relative amount of power radiated (or the relative mean-square voltage) at the angle  $\theta$  and is dependent only upon the spacing, phasing, and current ratio.

The ratio of the power in the directional system to that in a similar single radiator when both have the same maximum ground voltage, becomes from Equations (3), (9) and (11)

$$\frac{P_d}{P_{nd}} = \frac{\int_0^{\frac{\pi}{2}} f_1^2(\theta) N_{\theta}^2 \cos \theta d\theta}{\int_0^{\frac{\pi}{2}} f_1^2(\theta) \cos \theta d\theta} = \frac{\int_0^{\frac{\pi}{2}} E_{\theta}^2 \cos \theta d\theta}{\int_0^{\frac{\pi}{2}} E_{\theta}^2 \cos \theta d\theta} \quad (13)$$

These integrals may be easily solved graphically and it is generally sufficient to solve Equation (13) for about eight values of  $\theta$ , i.e., every 10 degrees. The total power ( $P_d$ ) in the directional system may be obtained by graphically integrating the numerator of Equation (13)

and multiplying by  $\frac{K_3}{r_0^2}$ .

#### DIRECTIONAL SYSTEMS COMPOSED OF TWO RADIATORS

Due to the fact that most directional antennas are composed of only two radiators, the performance of two-element arrays will be considered in more detail. These radiators will be assumed to have identical current amplitudes. Since the more the current ratio departs from unity, the more the directional system approaches the performance of a single antenna, and any analysis of its performance becomes proportionately less important.

With two identical radiators, 1 and 3, with different currents,  $N_{\theta}^2$  from Equation (12) becomes

$$N_{\theta}^2 = \frac{1}{(1 + n_3)^2} [1 + n_3^2 + 2n_3 \cos 2X \cdot J_n (2Y \cos \theta)] \quad (14)$$

For two identical radiators with the same current amplitudes,

$$N_{\theta}^2 = 0.5 [1 + \cos 2X \cdot J_n (2Y \cos \theta)] \quad (15)$$

90-DEGREE RADIATORS

For two radiators spaced 180 degrees and fed in phase, the ground pattern of Figure 2 is obtained. In order to determine the power in this system, using 90-degree radiators, Equation (13) is solved graphically. In Figure (3), curve (b) is  $N_o^2$  (Equation (15)); curve (a) is  $f(\theta)$ ; and curve (d) is  $N_o^2 f^2(\theta) \cos\theta$ ; and the area under this curve is the solution of the numerator of Equation (13). Also in Figure 3, curve (c) is  $f^2(\theta) \cos\theta$  and the area under this curve is the solution of the denominator of Equation (13). Thus the ratio of the area under curve (d) to the area under curve (c) is the same as

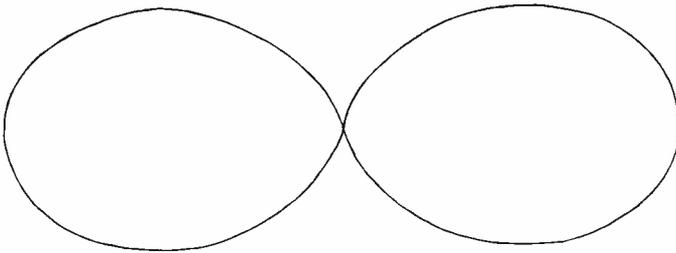

Fig. 2—Ground pattern with zero phasing and 180° spacing.

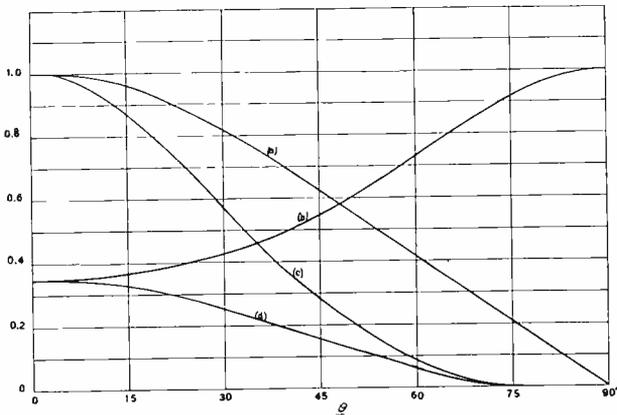

Fig. 3—90° antennas with zero phasing and 180° spacing  
 (a)  $f(\theta)$ ; (b)  $N_o^2$ ; (c)  $f^2(\theta) \cos\theta$ ; (d)  $N_o^2 f^2(\theta) \cos\theta$ .

the ratio of the power in the directional system, having the same maximum signal as the non-directional, to the power in the non-directional and is 0.418. This is a gain of 3.76 db.

A similar analysis is applied to two 90-degree radiators fed 180 degrees out of phase and separated 180 degrees. The ground pattern is shown in Figure 4. In Figure 5, curve (b) is  $N_o^2$ , curve (a) is  $f(\theta)$ , and curve (d) is  $N_o^2 f^2(\theta) \cos\theta$ . Also curve (c) is  $f^2(\theta) \cos\theta$ . The ratio

of the area under curve (d) to the area under curve (c) is 0.581. This represents a signal gain of 2.36 db and is of course less gain than that obtained from the in-phase system.

It is important to note that, in Figure 3,  $N_o^2$  increases with increasing values of  $\theta$ , indicating that this system cancels ground energy more effectively than it cancels the energy radiated at the higher angles. This fact is in general very undesirable since, at best, the high-angle energy is of little importance and may seriously limit the primary service range of a station after sunset. In Figure 5, however,

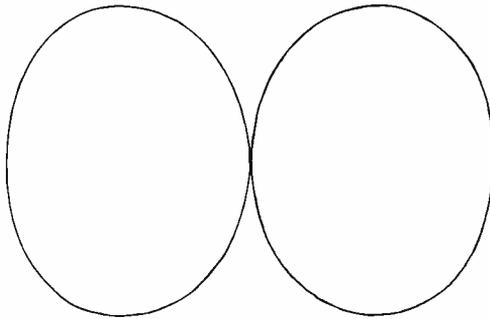

Fig. 4—Ground pattern with 180° phasing and 180° spacing.

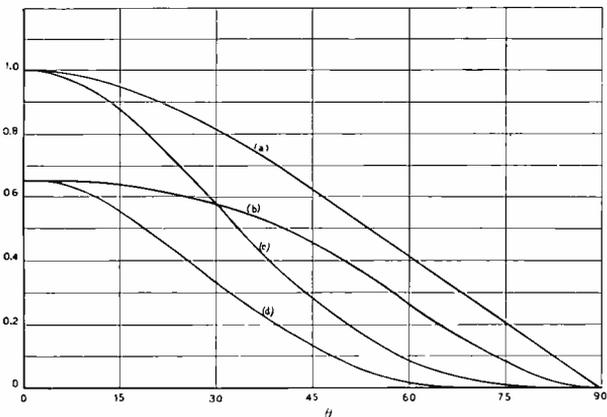

Fig. 5—90° antennas with 180° phasing and 180° spacing  
 (a)  $f\theta$ ; (b)  $N_o^2$ ; (c)  $f^2(\theta)\cos\theta$ ; (d)  $N_o^2 f^2(\theta)\cos\theta$ .

it will be seen that the out-of-phase system cancels the high-angle radiation much more effectively than the ground radiation.

An inspection of Figures 2 and 4 would indicate that there may be a difference in the relative amount of power radiated on the ground. To determine the relative power in the ground zone ( $\theta = 0$ ) it is only necessary to set  $\theta = 0$  and solve Equation (15). This solution is

shown in Figure 6 for the various ground patterns resulting from spacings of (a)  $45^\circ$ , (b)  $90^\circ$ , (c)  $135^\circ$ , (d)  $180^\circ$ , and (e)  $270^\circ$  as a function of the phasing. These patterns all have the same maximum signal. Thus for a non-directional pattern, having that maximum sig-

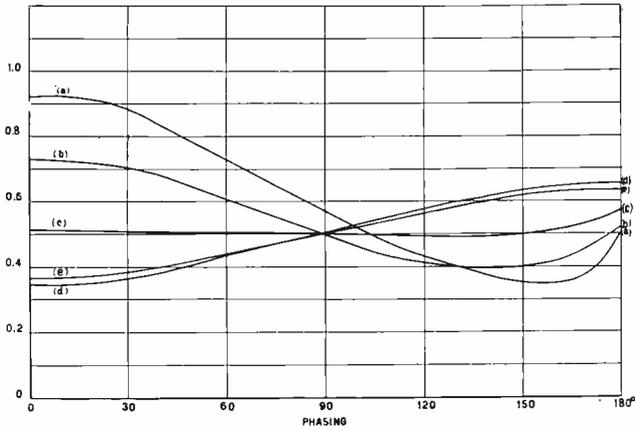

Fig. 6—Relative ground power in patterns having the same maximum intensity as a function of phasing with spacings of (a)  $45^\circ$ ; (b)  $90^\circ$ ; (c)  $135^\circ$ ; (d)  $180^\circ$ ; and (e)  $270^\circ$ .

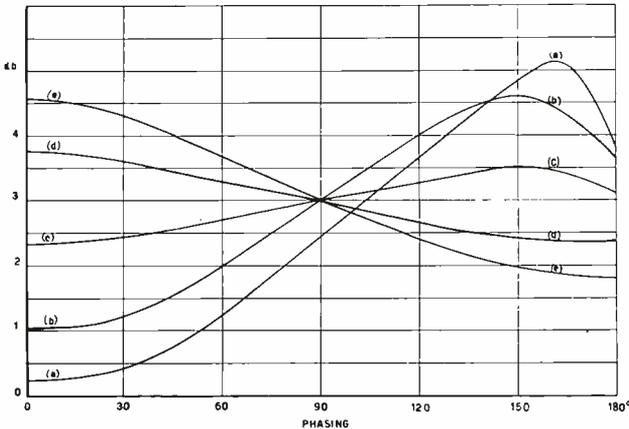

Fig. 7—Signal gain in db of directive systems using  $90^\circ$  antennas as a function of phasing for spacing of (a)  $45^\circ$ ; (b)  $90^\circ$ ; (c)  $135^\circ$ ; (d)  $180^\circ$ ; and (e)  $270^\circ$ .

nal in all directions, the power is one. This indicates that, with the same power in the out-of-phase system as in the in-phase system, the mean-square value of voltage of the out-of-phase ground pattern is 37 per cent greater than that of the in-phase system despite the fact that the maximum voltage of the in-phase system is the greatest.

The gain of various directional two-element systems has been cal-

culated from Equation (13), for 90-degree radiators and is shown in Figure 7. Curve (a) is for a spacing of 45 degrees, (b) is for 90 degrees, (c) is for 135 degrees, (d) is for 180 degrees, and (e) is for 270-degree spacing. The gain is expressed in db as a function of the phasing.

By combination of the data expressed in Figures 6 and 7 it is

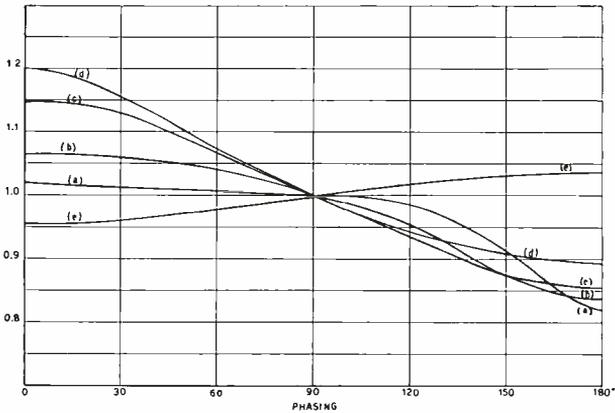

Fig. 8—Relative increase of high angle power with 90° antennas over that of a single antenna as a function of phasing with spacings of (a) 45°; (b) 90°; (c) 135°; (d) 180°; and (e) 270°.

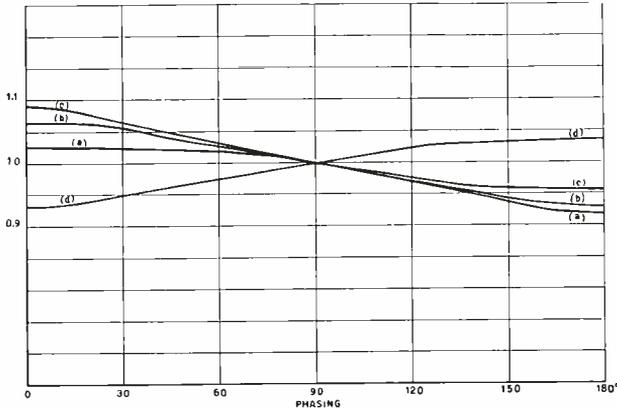

Fig. 9—Relative increase of high-angle power, with 190° antennas over that of a single antenna as a function of phasing with spacings of (a) 90°; (b) 135°; (c) 180°; and (d) 270°.

interesting to increase the ground signal until the ground power is the same as the ground power from a non-directional 90-degree radiator. The total power radiated by the directional system may then be compared with the total power radiated by the non-directional radiator. Obviously, if the ground power is the same in both instances, the

directional system must be radiating at high angles the difference between the two total radiated powers. Therefore, if the total power radiated by the directional system is less than that radiated by a single radiator, the directional system is improving upon the performance of the individual radiator by reducing the power radiated at the high angles. This effect is shown in Figure 8 where the ratio of power in the directional system to that in the non-directional

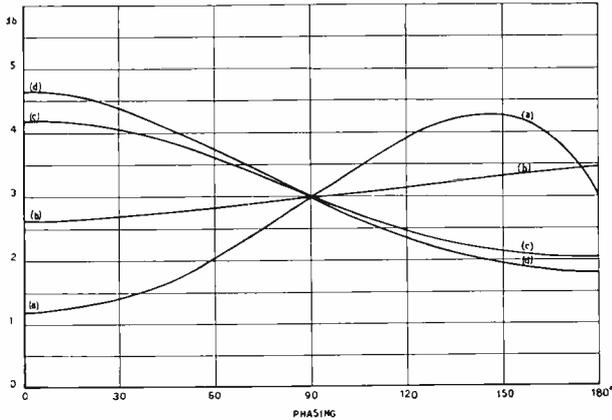

Fig. 10—Signal gain in db of directive systems using  $190^\circ$  antennas as a function of phasing for spacings of (a)  $90^\circ$ ; (b)  $135^\circ$ ; (c)  $180^\circ$ ; and (d)  $270^\circ$ .

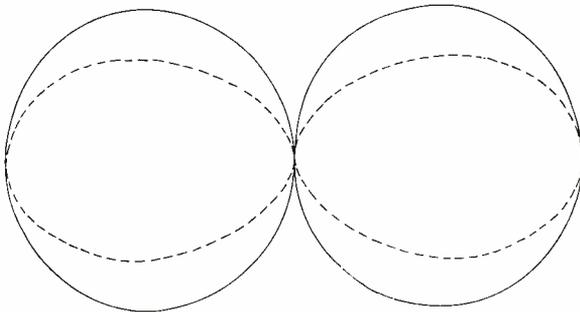

Fig. 11—Comparison of ground-signal intensities of systems using  $180^\circ$  phasing with  $60^\circ$  spacing and  $0^\circ$  phasing with  $180^\circ$  spacing—dashed line is  $0^\circ$  phasing with  $180^\circ$  spacing.

antenna is shown as a function of the phasing for spacings of (a) 45 degrees, (b) 90 degrees, (c) 135 degrees, (d) 180 degrees, and (e) 270 degrees.

#### 190-DEGREE RADIATORS

An analysis similar to that in Figure 8, except for 190-degree radiators, is shown in Figure 9 for spacings of (a) 90 degrees, (b)

135 degrees, (c) 180 degrees, and (d) 270 degrees. In comparing Figures 8 and 9, it is seen that the effect of the various spacings and phasings on the relative amount of energy radiated at the high angles is less pronounced. In other words, ideal radiators radiating only within a few degrees of the ground could be used equally efficiently in any directional system. Unfortunately, we have no such radiators, and the shorter the radiator the greater is the possibility of materially improving upon it in a directional system.

The gain of two 190-degree radiators when spaced, (a) 90 degrees, (b) 135 degrees, (c) 180 degrees, and (d) 270 degrees as a function of the phasing is shown in Figure 10.

Perhaps the best example of the desirability of a proper choice of a directional system arises when a "figure-eight" pattern is desired

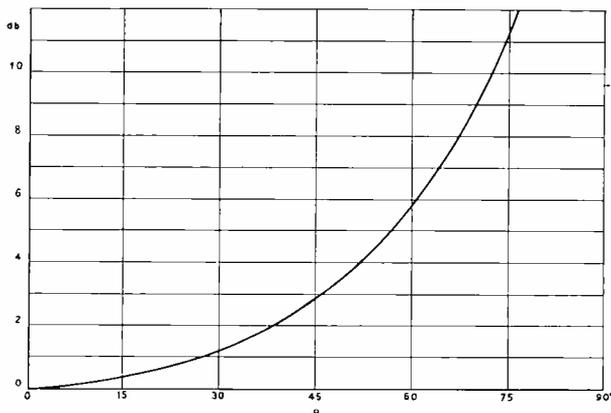

Fig. 12—Increase in radiation, in the vertical plane of maximum ground signal, of a system using zero phasing and  $180^\circ$  spacing over a system using  $180^\circ$  phasing and  $60^\circ$  spacing.

with 90-degree radiators. It is possible to obtain this pattern from radiators fed in phase and separated 180 degrees or from radiators phased 180 degrees and spaced up to 180 degrees. With the in-phase system a gain of 3.76 db is obtainable as previously shown and the pattern of ground-signal intensity is shown in Figure 11 as a dashed line. A similar gain is obtainable from an out-of-phase system when the spacing is 60 degrees and the pattern of ground signal intensity is then as shown in Figure 11 by the solid line. Obviously there is considerably more energy radiated on the ground by the out-of-phase system. The ratio of the mean-square voltages of the two patterns gives the out-of-phase system a 50-per-cent increase over the in-phase system. This additional ground energy must be taken from the higher-angle radiation. This fact is shown in Figure 12 when the increased radiation

from the in-phase system over that of the out-of-phase system is expressed in db as a function of the vertical angle  $\theta$ . The voltages compared in Figure 12 are in the planes of maximum ground voltage. It is thus seen that the out-of-phase system, in addition to radiating more of its energy on the ground, may be expected to have a considerably greater fading-free area than the in-phase system. This last illustration is perhaps one of the most effective comparisons of two directional systems that it is possible to make.

The author wishes to take this opportunity to express appreciation of Mr. Raymond F. Guy's valued suggestions and criticism.

#### REFERENCES

- <sup>1</sup> Pistol Kors, The Radiation Resistance of Beam Antennas, *Proc. I.R.E.* March, 1929.
- <sup>2</sup> Southworth, Certain Factors Affecting the Gain of Directional Antennas, *Proc. I.R.E.* September, 1930.
- <sup>3</sup> Bechmann, On the Calculation of Radiation Resistance of Beam Antennas and Antenna Calculations, *Proc. I.R.E.* August, 1931.
- <sup>4</sup> Carter, Circuit Relations in Radiating Systems and Application to Antenna Problems, *Proc. I.R.E.* June, 1932.
- <sup>5</sup> Brown, Directional Antennas, *Proc. I.R.E.* January, 1937.
- <sup>6</sup> Pierce, Electric Oscillations and Electric Waves.

# RECENT DEVELOPMENTS IN DIVERSITY RECEIVING EQUIPMENT

BY  
J. B. MOORE

Engineering Department, R. C. A. Communications, Inc.

## INTRODUCTION

THE space-diversity system, for the reception of high-frequency trans-oceanic radio signals, has been described in papers<sup>1</sup>, published in 1931. These papers also described the antenna system and equipment in use at that time. The general system of spaced antennas, three receivers, and combination of the final rectified outputs of the individual receivers, is still employed. Antennas and equipment have, however, been investigated and improved throughout the past five years.

During the years 1934 and 1935, a complete re-design of the diversity receiving equipment was worked out by engineers of R. C. A. Communications, Inc. This new type equipment is in operation at the various commercial stations of that company, and also at stations in several foreign countries. During 1936, further improvements were made. It is the purpose of the present paper to describe the most recent design of the receiving equipment.

## DIVERSITY RECEIVING SYSTEM

A brief description of the main features and functions of the space-diversity system of reception will first be given before proceeding to a more detailed treatment of the equipment proper.

High-frequency radio signals used for commercial telegraph, telephone, broadcast, and point-to-point program service, are practically always subject to fading. For the purposes of this paper, the term fading will be used to denote short-period variations in field strength, or in the amplitude of the signal entering or leaving the receiving equipment. On trans-oceanic, and other long distance circuits, both the rapidity and the depth of fading vary over wide ranges. It is this condition that often makes reliable reception, of such signals, so difficult.

---

<sup>1</sup> *Proc. I.R.E.* April 1931. Beverage and Peterson. *Proc. I.R.E.* April 1931. Peterson, Beverage and Moore.

Various schemes for eliminating, or at least minimizing, the effects of fading have been proposed and tried. These can all be said to fall into two broad classes. Those in one class depend upon the use of limiting, overloading, or automatic gain control in some portion of the receiving equipment; the purpose of which is to deliver a constant output, regardless of variations in input signal. Those in the second class depend upon the difference, or "diversity," of fading existing:—(1) on different carrier or side-band frequencies; (2) in different planes of polarization; or (3) at different locations. These are generally referred to as frequency diversity, polarization diversity, and space diversity. The system and equipment to be described in this paper are based on utilization of the space diversity of fading.

It may be useful, here, to point out some of the advantages of the space-diversity system, so that comparison with other systems can quickly and easily be made. Chief among its advantages are the following. Standard, present-day types of keyed or amplitude-modulated signals are employed. The carrier energy, in the case of telegraph or facsimile services, may be concentrated on a single frequency. This produces higher field intensities, a consequently higher signal-to-noise ratio, and a minimum of side-bands. On very deep fading, when the field intensity at any one antenna momentarily drops below the noise level, there is almost certain to be at least an average value of field intensity existing at the other one or two antennas. Simultaneous fading out of the signal at three, suitably spaced antennas is a very rare occurrence. Equipment designed to utilize chiefly the signal supplied by the antenna having the best signal-noise ratio at any instant will, therefore, deliver an output signal that contains a minimum of errors or distortion due to fading.

The antenna system normally employed consists of three separate antennas, with an r-f transmission line from each antenna to the receiving building. The antennas are spaced about 1000 feet apart and may be located at the corners of either a right-angled or an isosceles triangle. A group of three antennas spaced in this manner, has proven to be a very successful arrangement. The individual antennas may be of any type, but are generally of some form of the less expensive types of directive antenna. Examples of these are the horizontal rhombic and the RCA-C "fishbone" antennas.

The receiving equipment comprises three separate receivers; the input of each being connected to one of the three antennas mentioned above. The rectified outputs, from the final detectors (diodes) of the three receivers, are combined in a common load circuit. Voltage obtained from this combined signal is then utilized to supply, or to control, the final output signal.

It is this general scheme, of combining after rectification, that makes it possible to fully utilize the diversity of fading existing at the spaced antennas. If combination were attempted before rectification—either at the original carrier frequency or at an intermediate frequency—there would be both addition and cancellation, due to phase differences. By combining rectified outputs, only addition is obtained. It will be obvious that this reasoning applies, strictly, only to the case of a keyed carrier—such as used for telegraph service. In the case of amplitude-modulation telephony, phase differences do often exist between the modulation components of the rectified outputs of the several receivers. In such service, the benefits obtained by the use of the space-diversity system, and by the design of equipment to be described, can be briefly stated as follows. On extremely rapid and deep fading, which automatic-gain-control (a-g-c) systems do not follow, the signals supplied by the three antennas and receivers combine to give a final output which is no longer chopped up into signal and no-signal periods of a small fraction of a second each. Under such conditions, the resulting signal is far superior, in intelligibility and overall merit, to that obtained from a single receiver. On fading of more moderate rapidity, the improvement obtained is due to the selective action of the combining and gain-control circuits to be described later. This gives a signal-noise ratio determined by that existing at the antenna receiving the highest field intensity at the moment. Distortion due to phase differences between the modulation components of the rectified outputs of the several receivers is noticeable only for the brief instants when the outputs of two receivers are approximately equal—one increasing and the other decreasing, due to the diversity of fading.

#### DIVERSITY-RECEIVING EQUIPMENT — GENERAL SCHEME

The receiving equipment used in the space-diversity system of reception consists of three separate receivers and of certain auxiliary units for monitoring, combining and utilizing the outputs of the individual receivers. The block diagram of Figure 1 shows the fundamental connections of the equipment. The rectified output from the final detector of each receiver goes to the common load circuit. For telephone service, this is the input circuit of an a-f amplifier unit. For telegraph or facsimile service, it is the input circuit of a tone keyer unit. From this common load circuit, there is also obtained a-g-c bias voltage for automatically controlling the gain of the r-f amplifier stages.

It will be noted, from Figure 1, that the a-g-c bias voltage for all receivers is the same, and is derived from the common load circuit of

the final detectors. It is this arrangement that makes it possible to obtain the full benefits of the diversity of fading existing at the spaced antennas. The action of this common a-g-c system is as follows. The three receivers are adjusted to have approximately the same overall gain at some particular value of bias on the r-f stages. They will then have approximately the same gain at any instant as the a-g-c bias voltage rises and falls slightly in accordance with the value of the combined output of the final detectors. Since all receivers have the same sensitivity or overall gain at every instant, their individual outputs will be in proportion to the r-f input voltages delivered to them by their respective antennas. Therefore, the receiver at whose antenna the highest field intensity exists at the moment will contribute most to the combined output. This action is further accentuated by the voltage regulation inherent in the system consisting of the diode final detectors and their common load circuit. The result is

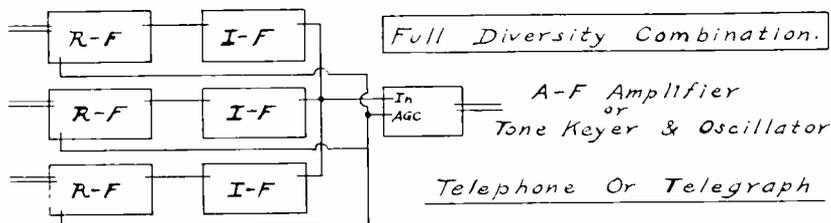

Fig. 1—Block diagram of essential circuit of diversity-receiving system.

that the receiver whose antenna is delivering the most signal voltage at the time will supply practically all of the total output signal. The action of the entire system, therefore, amounts practically to automatic selection and switching of antennas. There are the following added advantages, though: (1) partial or complete combining, when complete switching does not take place and during the “switching” interval; (2) the effect of simple combining, on certain types of very rapid fading; and (3) flexibility of equipment.

The a-f amplifier, which is used only for telephone service, amplifies the modulation components of the combined, rectified output from the several receivers. Its a-f output is the final output signal of the equipment. This goes to the telephone line.

The tone keyer unit is used only for telegraph and facsimile services in which the carrier is keyed full on and off. Its function is to key a local source of tone-frequency signal in accordance with the keying of the incoming radio signal. In this way a keyed tone signal, of constant frequency and amplitude, is made available. Such a keyed-tone signal is suitable for transmission over circuits containing quite

narrow, band-pass filters; and also for the operation of ink recorders, printing telegraph equipment, facsimile recorders, etc.

#### REQUIREMENTS FOR NEW DESIGN

The general requirements that were to be met by a new design can be rather broadly stated as: improved overall performance with respect to both fading and noise levels; flexibility of application to different types of service; and an improved mechanical design. Circuit improvements which had been developed as modifications of existing old-type equipment were, naturally, to be incorporated in the new design. In addition to such circuit details, the following specific requirements may be listed:

1. Operation from batteries or from a-c power supply.
2. Telegraph or telephone operation, or both.
3. A minimum of floor space required.
4. Choice of at least two i-f band widths; the change to be effected in a minimum of time.
5. Maximum selectivity practicable; on all band widths.
6. Rapidity and ease of operation.
7. Permanence of tuning calibrations and of i-f circuits.
8. Accessibility, for maintenance and repairs; without removing units from rack.
9. Racks to be of standard, cabinet type used in broadcast stations and studios.

#### GENERAL DESIGN

Since the equipment was intended for use in existing stations, as well as in ones being planned for the future, it was necessary to have the power supply requirements such that they could be met by existing storage-battery installations. Operation from a-c power supply should then require only a heater- (filament) supply transformer, and two rectifier units for plate and bias supply.

Simplification of the plate-supply rectifier system, and of the general wiring, fusing, and switching arrangements, dictated the use of but a single plate supply voltage. The normal 125-volt supply, from the center tap of existing 250-volt storage battery installations, was found to be satisfactory for all purposes. This was therefore chosen, and the a-c rectifier system designed to deliver the required current at a bus voltage of 125 volts. Lower voltages for screen grids, etc., are obtained from voltage dividers located in the individual units.

Bias supply was similarly designed to conform to existing storage-battery installations. This called for a bus voltage of — 14 volts. The use of a separate bias supply, rather than self bias on individual tubes,

results in a more straightforward design of circuit. This, in turn, simplifies the problem of obtaining reliable stability of the high-gain amplifier circuits necessarily used in this type of equipment.

Heater supply may be from 8-volt storage-battery installations with one terminal grounded, or from an 8-volt a-c source with its mid-point grounded. The latter is contained in the power supply unit which is provided for a-c operation.

Wiring, switching, general operation, and performance of the receivers are identical in the case of battery supply or of a-c power supply. For a-c operation, there is provided a single 21-inch power

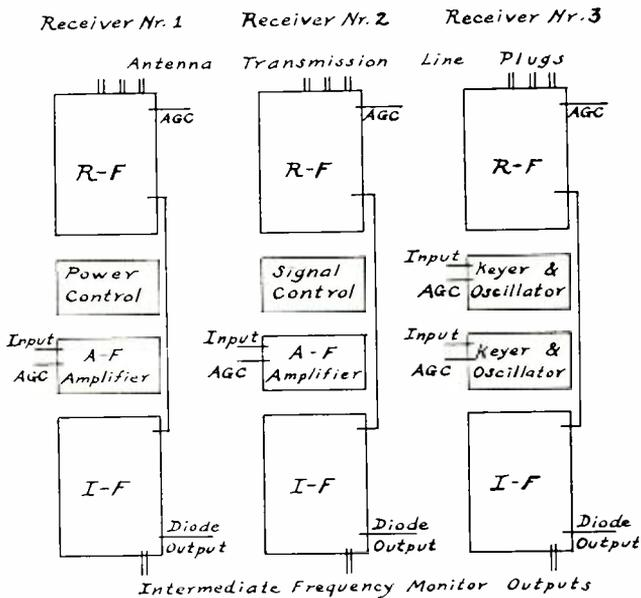

Fig. 2—Basic arrangement of units comprising a standard, diversity-receiver group.

supply unit. This operates from 100 to 120 volts, 50 or 60 cps, a-c mains, and supplies power for heater, plate and bias circuits for one complete diversity-receiver group.

Flexibility of application to various types of services and installations requires that the same equipment be capable of handling telegraph, facsimile, or telephone signals. Figure 2 is a block diagram showing the units and arrangements decided on for the basic design of this new equipment. Figures 3 and 4 are photographs of equipment built during 1935 and 1936. Figure 3 shows one complete diversity-receiver group arranged for telegraph and telephone service with an a-c power supply unit and voltage regulator unit in the added bay at

the left. Figure 4 is a photograph of similar equipment intended for operation from storage batteries.

Antenna-transmission-line panels, mounted on top of the receiver racks, will accommodate 4, 8, or 12 lines each, depending upon whether a single, double, or triple-tier panel assembly is installed. From here,

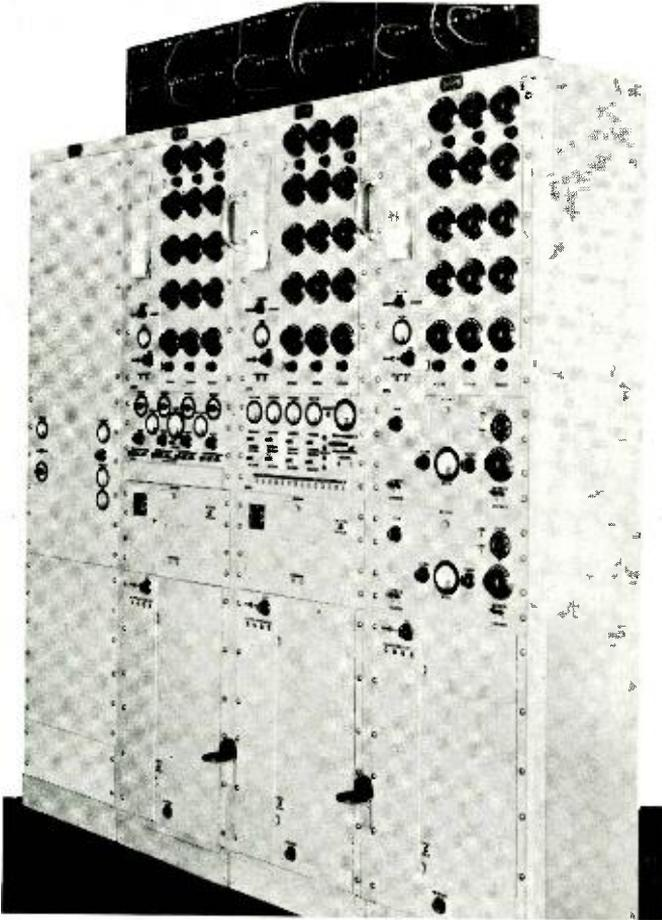

Fig. 3—Complete diversity receiving equipment with a-c power supply unit in left-hand bay.

the signal goes to the input of the r-f unit. Each of the r-f units contains three complete r-f systems for covering the nominal frequency bands 3 mc to 6 mc, 6 mc to 12 mc, and 12 mc to 24 mc, respectively. The desired band is selected by means of a three-position switch on the front of the unit. A visible "Kardex" unit, for tuning calibration cards, is mounted on the front of each r-f unit. This greatly facilitates

tuning operations. Provision of the three separate r-f systems, and of readily accessible tuning calibrations, considerably reduces the time required for shifting over from a day to an evening or night frequency signal. The output from the r-f heterodyne detector is conducted by means of a shielded lead to the input of the i-f unit at the bottom of the same bay. Rectified output from the final detector (diode) of each i-f unit goes to the signal control panel, where it can be switched around to tone keys or a-f units. Each i-f unit also has an audio-frequency beat-note output, which is used for monitoring and checking purposes. This is available at the signal control panel.

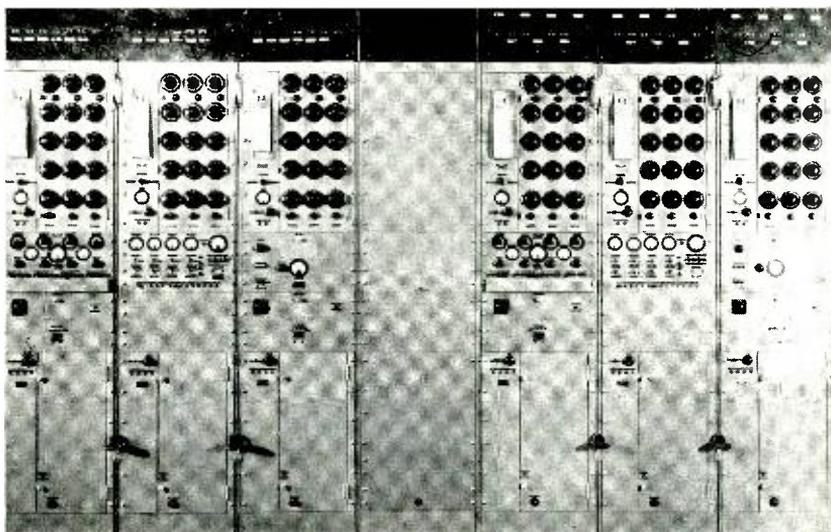

Fig. 4—Installation of two complete diversity-receiving equipments, separated by extra bay, at Riverhead—battery power supply.

Automatic bias for automatic control (agc) of the gain of the r-f amplifier stages is obtained from the combined, rectified output of the three receivers. Associated with the input circuit of each tone-keyer unit and a-f unit is a conventional time-constant circuit for supplying a-g-c bias voltage. Also associated with this circuit is a so-called “threshold”-bias-supply tube and circuit. This circuit is so arranged that a-g-c bias is supplied by the signal, as long as the carrier is being received, and is automatically replaced by a manually-adjustable “threshold” bias whenever the carrier is interrupted or shut off at the transmitting station. This gives satisfactory operation on signals ranging from very strong down to only slightly above the noise level. At the same time, it prevents the gain of the receiver

rising to high values during pauses in transmission and introducing noise into the output signal from the equipment.

The signal control panel might be termed the nerve center of the equipment. It is on this panel that all switching and monitoring of signals is accomplished. The rectified output from the final detector (diode) of each receiver passes through a milliammeter on this panel and, through the switches provided, to any one of the tone-keyer units or audio-frequency amplifier units. Any one receiver, or any two, or all three receivers may thus be used with either of the tone-keyer units or a-f units, for reception of telegraph or telephone signals, respectively. This makes it possible to use the normal three-receiver diversity combination for either telegraph or telephone service; or to split up the group and thereby handle:—(a) one signal on a two-receiver diversity combination and another signal on a single receiver, or (b) three separate signals on single receivers. It might be well to state here that all three receivers are normally used in diversity combination for the handling of regular traffic on long distance circuits.

Power supplies for each receiver and for the tone-keyer units, are individually fused and switched on the power-control panel. Means for rapidly checking voltages on the load side of all fuses are also provided on this panel. In addition, there is a double-range milliammeter and a drop cord for checking plate currents in the various units of the equipment, by inserting the plug into special jacks located on the individual units.

A few of the outstanding mechanical design features may well be mentioned before proceeding to a consideration of circuit details and performance characteristics. The panels of all units are of standard 19-inch rack mounted dimensions. Improved appearance has been obtained by the use of elongated mounting holes, and oval head screws with finishing washers in place of the old style open end slots and round head screws. Rack steps and handles, shown in the photographs of both Figure 3 and Figure 4, enable a man to reach the antenna transmission line panels. This facilitates the changing of input connections from various transmission lines to either of three input circuits of any r-f unit.

Access to tubes is had by opening the front doors of the units. Rear covers are normally provided for the r-f units, i-f units, a-f units, and tone-keyer units. Since these are relied upon for electrical shielding on the r-f and i-f units, they are constructed with a front flange that is clamped between the main panel and the rack. Access to the rear of each unit is by means of a full-size rear door, which is quickly removed by giving a few latches a quarter turn and lifting the door off. Internal arrangement and constructional details are such

that any maintenance and repair work that may be necessary can be done by one man, without removing the units from the rack.

The general construction of the smaller units is along more or less conventional lines, employing the usual flat sheet type of panel. In the r-f and i-f units, however, the construction differs radically from that of most other rack-mounted equipment. The chassis is formed by bending a sheet of  $\frac{1}{8}$ -inch stock into a trough-shaped section. At one side of the trough is a wide flange which becomes the front panel, while at the other side is a narrow flange which mounts against the rack. End plates are then riveted in place, across the ends of the trough, to form a rigid "bath tub" chassis. These end plates also extend across the rear of the wide, front panel to give to it additional support and strength. The general idea can be seen from the photographs. The r-f and i-f units will be seen to have a panel at the left side, a door, and a narrow mounting flange at the right. The "tub" is behind the door, and is just deep enough to accommodate the tubes and the shielding cans containing the various r-f circuits, i-f transformers etc., which are mounted in it. On the rear of the "tub" are mounted the tube sockets and all the necessary r-f and i-f filtering and bypassing of supply leads. The heavy filtering of the main power supply leads to the unit, for protection against low frequencies, is mounted behind the left hand panel. This general construction provides a simple chassis which combines with the required electrical shielding the equally desirable features of straightforward assembly, circuit layout, and wiring.

#### CIRCUITS AND CHARACTERISTICS — R-F UNIT

Ease of operation, and permanence of tuning calibrations, dictate the elimination of plug-in coils. There are then only two general methods for covering the total required frequency range of 3 mc to 24 mc; in the three ranges of 3 to 6, and 6 to 12, and 12 to 24 mc. One is switching of coils. The other is the use of entirely separate circuits and tubes for each range. When dealing with voltage gains averaging about 4500 (73 db), at frequencies from 3 mc to 24 mc, extreme care must be taken to avoid feed-back effects. This requires quite an elaborate mechanical design, if it is desired to employ switching of coils. Switches directly in the tuned r-f circuits also introduce the element of variable contact resistances being inserted in series in these low-loss circuits. If these contact resistances are appreciable, as compared to the series resistance of the resonant circuit, the result is decreased gain and impaired selectivity. These considerations led to the adoption of entirely separate r-f systems to cover the three bands. By housing these in one chassis and box, a single set of

main power supply circuits suffices for all three. Switching is accomplished by means of a three-position, rotary-packet switch which turns on the heaters of only those r-f amplifier tubes in the chain desired. This method is simple, rugged, and effective.

The advantages, and practical necessity, of using three stages of tuned r-f amplification ahead of the first heterodyne detector are at least twofold. First, proper protection against "image" and other spurious responses, with intermediate frequencies that satisfy other design requirements of the overall equipment, requires the use of four tuned circuits. Second, proper a-g-c action on phone signals requires a maximum voltage gain of approximately 3000 (70 db) from input terminals (200 ohms line impedance) to grid of the first hetero-

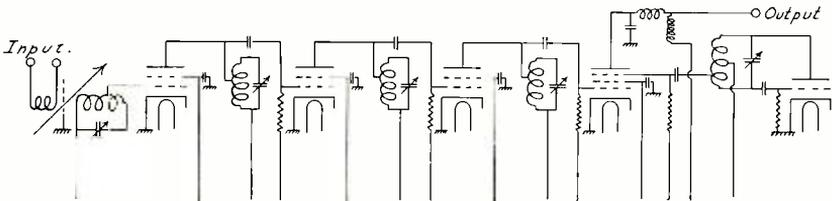

Fig. 5—Schematic of r-f circuits; one of three bands in the r-f unit; details of power supply and filtering circuits not shown.

dyne detector. To obtain this gain throughout the entire frequency range requires three stages of amplification. While it is possible to utilize a limited amount of a-g-c action in the i-f system it is necessary in this general design of the equipment to obtain most of the a-g-c action ahead of the first heterodyne detector or frequency converter. A third, and also important, function of the r-f stages is to prevent appreciable voltage from the r-f heterodyne oscillator getting out onto the antenna transmission line and thus into other receivers.

Figure 5 is a schematic diagram of the fundamental circuit of one chain of the r-f unit. Perhaps the outstanding feature of this circuit is the use of taps on the coils of the tuned circuits. The flexibility of this arrangement results in the following advantages. Suitable choice of tap on the first circuit gives a slight improvement in noise equivalent, as measured at the input terminals. Taps on the other circuits can be adjusted to give the desired maximum overall gain without having to resort to the use of undesirable values of screen- or control-grid bias voltages. At the higher frequencies, tapping down on the coil reduces the damping on the tuned circuit caused by the quite appreciable input conductance of the following tube. This naturally improves the selectivity. On the circuit supplying the grid of the heterodyne detector (modulator) tube a further advantage is that oscillator feed-back through the detector tube is greatly reduced.

This is due to the lowered impedance from grid to cathode, through the external circuit.

In a high-gain r-f system of this sort, intended for use in commercial equipment, shielding and filtering are major problems. Even feedback due to common coupling in return paths through the chassis must be guarded against. Filtering of the plate, screen, filament, and bias supplies to the various tubes and circuits is not shown on the schematic diagram. This is designed to insure stability of the amplifier itself, and to provide protection against r-f voltages on the supply busses. Care must be taken that the r-f filter chokes and bypass condensers do not build up high impedance anti-resonant circuits which will cause oscillation at some low radio or intermediate frequency. When such a condition exists, it will be found that all signals are modulated by the oscillation frequency, resulting in side-bands which are not recognized as such until serious trouble is encountered due to what appears to be interference.

Where a number of receivers are to be operated simultaneously in the same room, as is common practice in large commercial receiving stations, direct radiation and stray leakage from heterodyne oscillators must be kept down to a negligible level. A few actual figures will best show how severe this requirement is. In this particular equipment, the detector excitation is approximately 10 volts rms. The sensitivity of the receiver, especially when using a narrow i-f band width, is considerably better than 1  $\mu v$ . This means that stray oscillator leakage onto the antenna transmission line, either by way of direct radiation or by devious paths through the circuits or chassis of the r-f unit, must be kept well below 1  $\mu v$ . Expressed as a voltage ratio, this is considerably better than 10,000,000 to 1, or more than 140 db — obviously a severe requirement.

Noise equivalent, in terms of micro-volts of signal supplied through a 200-ohm dummy transmission line, depends upon: (1) band width of the receiver; (2) noise characteristics of first r-f tube; (3) number of turns on input coupling coil; and (4) location of tap on coil of first tuned circuit. Measured values, for a nominal 10-kc band width, are given in Table 1.

The number of turns on the input coupling coil is different for each frequency range. While there is, of course, an optimum for any particular frequency, this is not very critical over the 2-to-1 frequency range of each band. A satisfactory compromise can therefore be obtained for each band. The number of turns is chosen to give a low noise equivalent and also a minimum shunting effect on the line when receivers tuned to other frequencies are connected across the same antenna transmission line.

The required maximum r-f gain is arrived at from consideration of several factors, some of which are contradictory. For an i-f band width of 10 kc, the noise equivalent at the grid of the r-f heterodyne detector is approximately  $4.5 \mu v$ . The signal level at which this detector overloads ranges from perhaps 1 volt down to a minimum of about 0.3 volt. The signal level at this point must, therefore, be kept below 0.3 volt and must, at the same time, be sufficiently greater than  $4.5 \mu v$  to give satisfactory signal-to-noise ratios. In telephone or program service, the agc must also handle a wide range of signal strength. With an i-f gain setting which gives a low noise level on a

TABLE 1

Data given for effective height of the r-f unit are for the original model. These values have been still further reduced, in the latest (1936-1937) design.

Band mc	Freq. mc	Noise Equiv. $\mu v$	Max. r-f Gain	Image Ratio	Eff. Height Meters
3-6	3	0.57	2,640	*	.0000133
	4.5	0.48	7,260	*	.0000296
	6	0.53	11,450	19,400	.0000588
6-12	6	0.51	2,000	*	.000058
	9	0.58	4,570	**	.0000298
	12	0.72	6,100	6,450	.0000918
12-24	12	0.56	4,270	**	.000232
	18	0.81	5,280	8,000	.000289
	24	0.58	3,980	930	.000427

\* Over 50,000

\*\* Over 20,000

good strong input signal, the agc must be capable of following the signal down to the noise level as it fades. Experience and laboratory measurements show that the maximum r-f voltage gain of this type of equipment should preferably be not less than about 3000. Since this is not at all critical, however, the gain may be allowed to range considerably below and above this value, throughout the tuning ranges, without seriously affecting overall performance.

Shielding of the r-f unit, as protection against strong ambient fields, can best be stated in terms of effective height. The data given in Table 1 are for the receiver itself, with no antenna or transmission line connected to it. It will be apparent from an inspection of these data that pick-up on transmission lines and antennas will greatly exceed direct pick-up in the receiver itself.

In any superheterodyne, or multiple-detection receiver there is always the possibility of so-called image response. The higher the carrier frequency, the more difficult it is to keep this undesired response down to satisfactory levels. Just what ratios are considered satisfactory, however, depend considerably upon the type of service for which the receiving equipment is to be used. Ratios which might be entirely unsatisfactory for universal use in the 550-kc to 1500-kc broadcast band are quite all right for use in commercial short-wave receivers that are to be used in trans-oceanic and other long distance services. These ratios, in turn, must be better than the ones found in short-wave receivers now on the market for general broadcast and amateur use. A ratio of 1000 in voltage (60 db) is about the minimum that will be found generally satisfactory. A ratio of 10,000 may be considered quite safe for this type of equipment and service. To obtain image ratios on the order of 100,000 at all frequencies within the range of the receiver entails more expense and complication than is warranted.

In addition to the well-known image response, there are also what have been termed "harmonic point" responses. These are found at frequencies lying between that of the desired signal and that of the heterodyne oscillator. A signal half-way between, for example, will produce a beat with the local oscillator of one-half the intermediate frequency. The output of the heterodyne detector will contain this frequency and harmonics of it. The second harmonic will be the same frequency as the normal i-f signal, and will be passed by the i-f amplifier. This type of spurious response can best be minimized by proper design of the heterodyne detector, so that the harmonic content of its output is as low as practicable.

The relatively high noise equivalent ( $4.5 \mu v$ ), previously stated for the r-f heterodyne detector, is due to the fact that the tube is operated in such a manner as to minimize the harmonic content of its output rather than to obtain a minimum noise equivalent. An improvement of about 2-to-1 could be obtained, in noise equivalent at the grid of this detector, but only at the expense of a considerable and serious increase in the harmonic content.

A rather important point, in connection with "harmonic point" ratios, is that the ratio also depends on the absolute value of signal voltage at the detector grid. Measurements of such ratios must therefore be made at some standardized test level—either as measured at the receiver input terminals or at the detector grid. In making such measurements on this new diversity receiving equipment, the signal input to the r-f unit was adjusted to  $20,000 \mu v$ . This level was chosen because it is about the maximum signal input ever encountered in actual operation of high-quality trans-oceanic services.

The r-f heterodyne oscillator uses a triode in a conventional Hartley circuit. The desired excitation for the detector is obtained from a tap on the oscillator tank coil. Careful location of this tap and of the plate-supply (zero r-f potential) tap insures fairly uniform detector excitation throughout all tuning ranges, and good stability. Change in frequency, due to variations in plate-supply or heater-supply voltage, amounts to approximately 0.4 cycle per million per percent and 1.5 cycles per million per percent, respectively. The temperature coefficient of frequency ranges from about 60 to 100 cycles per million per degree Centigrade. More recent work on this indicates that it may be practicable to reduce very materially these temperature coefficients.

The frequency of the heterodyne oscillator is practically unaffected by tuning of the detector grid circuit, under all normal conditions. The worst case gives a variation of about 200 cps in the beat note. A greater variation can, of course, be produced by tuning the detector grid circuit actually through the oscillator frequency. This, however, is not an operating condition because the oscillator is normally tuned 300 kc off from the signal to which the detector grid circuit is tuned. This freedom from interaction between oscillator and r-f circuit tunings is due to the type of screen-grid tube and circuit employed, and to the detector grid being tapped down somewhat from the high-impedance end of the tuned-circuit inductance.

#### I-F UNIT

Since it is in the i-f system that the real selectivity of the receiver is obtained, it will be well to briefly consider the various factors entering into the determination of channel spacings, before proceeding to a discussion of circuit details and characteristics.

Channel spacing is determined, at least theoretically, by:—(1) band width required for the type of communication service to be handled; (2) frequency stability of transmitters; and (3) the guard band necessitated by limitations of the selectivity characteristics of practical receiving equipment.

Nominal useful band widths required for different types of services range from a theoretical minimum of about 500 cps for high-speed telegraphy up to 10,000 cps for high-quality telephony or broadcast program service. These figures are for trans-oceanic or other long-distance, high-frequency circuits where the effects of multi-path transmission and fading must be taken into consideration. These figures give the absolute minimum widths of band required by the type of modulation employed. To these must be added the tolerance in transmitter frequencies. The next step is up to the designer of receiving equip-

ment. The more nearly rectangular he can make the overall-frequency characteristic of the receiver, the less guard band will have to be allowed when determining permissible channel spacings.

Since frequency characteristics of practical receivers necessarily have rounded corners, or shoulders, and more or less sloping sides, it becomes a matter of just how much improvement can be obtained without going to unwarranted complication and expense. Obviously, the answer to this question will be different in the case of commercial equipment used on important over-seas communication services than it will be for broadcast, amateur, or shipboard receivers. As the demand for channels increases, and channel spacings must therefore be reduced, the problem of receiver selectivity becomes more and more important. Design of better i-f systems is therefore a major problem.

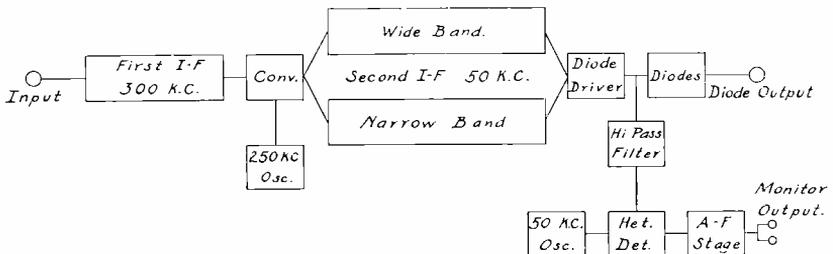

Fig. 6—Block diagram of i-f unit.

At the present time, a receiver for this type of commercial service must meet the following general requirements of selectivity. Image ratio at any frequency up to at least 20 mc must be not less than 1000 to 1. In the 3-mc to 6-mc band, sufficient selectivity must be available to eliminate effectively interference from adjacent channels having a nominal frequency separation, from the working channel of only 5 kc. The narrowest useful band width that is now practical, from a commercial operating standpoint, seems to be about 1 kc. The widest useful band width required is 10 kc.

To obtain the required image ratios with the r-f system previously described requires an intermediate frequency of not less than 300 kc. It is impracticable, though, to obtain a frequency characteristic having a flat top of from 1 to 2 kc, and reasonably sharp cut-off immediately outside this band, at such a frequency. The two requirements are best met, with practical electrical circuits, by the use of two intermediate frequencies. The first is made sufficiently high to obtain the required r-f image ratios. The second is so chosen that band widths ranging from 1 kc to 10 kc can be obtained. The actual frequencies chosen for this particular line of equipment are 300 kc and 50 kc. A block diagram of the complete i-f system is given in Figure 6.

In the first i-f system there must be provided sufficient selectivity to give an i-f image ratio of not less than 10,000 to 1. The same degree of protection must be had against i-f "harmonic point" responses. This is the same general problem as already discussed for the r-f system. The 300-kc first i-f signal is supplied to the i-f heterodyne detector, or frequency converter, which is also supplied with 250-kc excitation from an oscillator contained in the unit. The resultant 50-kc signal then goes through the 50-kc second i-f system, where all of the i-f amplification and the final selectivity are obtained. Signal levels throughout the first i-f system and the frequency-converter stage,

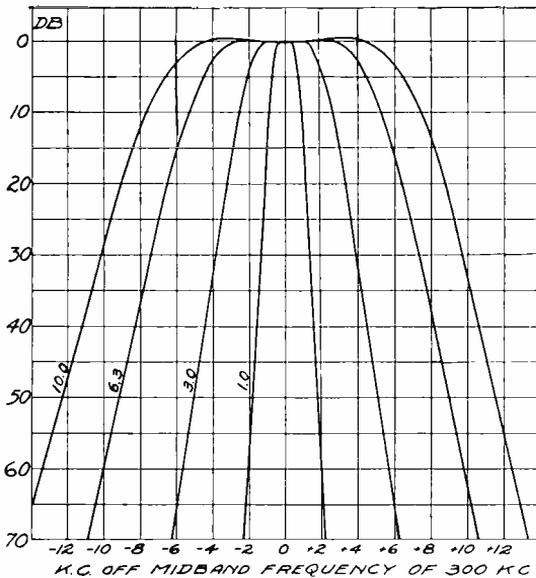

Fig. 7—I-F selectivity—Input for constant output  
—Nominal band widths: 1 kc, 3 kc, 6.3 kc, 10 kc.

are purposely kept low. This has been very simply accomplished in this particular model of the i-f unit, by the use of a multi-section, band-pass filter of the inductively coupled type. This filter provides all of the first i-f selectivity—without the use of any amplifier tubes. Where the first i-f system need only provide a fixed, 1:1 gain, the use of such a filter has several advantages. Among these may be mentioned simplification of both the mechanical construction and electrical circuits of the first i-f portion of the unit.

For the second i-f system, there are two general methods by which the required selectivity and gain can be obtained. From a purely theoretical viewpoint, the straightforward way is first to obtain the required selectivity and then the gain. This is accomplished by use of

a suitable band-pass filter followed by a wide-band amplifier. This method, and variations of it, have been employed with considerable success. Filters which will give the required performance have, however, generally been rather bulky. It was therefore decided to use a multi-stage amplifier employing tuned transformers for inter-stage coupling in the original design of this equipment. Five tuned transformers, with their associated screen-grid type tubes, provide both the selectivity and the gain.

The change from the narrow to the wide-band system is accomplished by switching the heaters of one chain of tubes on and those of the other chain off. This method is simple, rugged, and effective. The time required to effect the complete switching-over is only from 20 to 30 seconds.

Tuned transformers used in the 50-kc system are designed to retain their original characteristics under all atmospheric and climatic conditions, and to give reliable service for years. To insure this, the fixed mica condensers used are of a precision type that are aged and thoroughly tested before they are used. The optimum frequency characteristic for each band width is obtained by adjustment of the coupling between primary and secondary windings, and by the use of the proper value of terminating resistance across each. It is only by terminating both ends of each tuned transformer with the correct value of resistance that the optimum frequency characteristic can be obtained. This is why adjustment of coupling only can not be used successfully. Such a method gives the optimum characteristic for only one width of band. Tighter coupling will then give a wider-pass band with a bad dip in the middle; and looser coupling will give a narrower, but badly rounded, frequency characteristic. With proper coupling and terminations, a flat-topped characteristic with fairly sharp shoulders and steep cut-off is obtained for any band width. Typical frequency characteristics are shown in Figure 7.

The 50-kc tuned transformers which determine the final selectivity have, in this model of the i-f unit, been made adjustable. Band widths normally provided in the narrow system are 1 kc and 3 kc; and in the wide system, 6 kc and 10 kc. In this way, there is provided a choice of four band widths. Each of the five band-width-determining transformers, in both the narrow and the wide-band chains, is equipped with an external knob for changing the band width. The mechanism controlled by this knob is such that a positive adjustment is obtained for whichever band width is selected. The resulting frequency characteristics are shown by the graphs of Figure 7.

Diodes, in a push-pull circuit, are used as final detector to rectify the 50-kc signal. The advantages of this type of rectifier are well

known, and need not be gone into in this paper. A push-pull arrangement is used in order to double the ripple frequency and thereby simplify the filtering or smoothing problem. In the use of but a single receiver, this is no particular problem. When the diode outputs from two or three receivers are used in diversity combination, it is essential to have the i-f ripple effectively filtered out before the rectified outputs are combined. Otherwise, beat notes between the different i-f signals will appear in the common diode load circuit. These smoothing filters have been experimentally worked out to give complete freedom from such beats, and also to have a negligible effect on overall fidelity of the equipment regardless of whether one, two or three receivers are being used. Actual measurement in the case of telephony showed a loss of but 0.5 db at 5000 cps modulation for the full three-receiver diversity combination as compared to a single receiver.

There is a characteristic of diode driver stages which apparently has received little public discussion. This is that the output-vs.-input characteristic for the diode and its driver stage will be quite different for frequencies approaching the edges of the pass band than is that for the middle of the pass band. This is particularly true where a screen-grid tube in the driver stage is called on to deliver an appreciable amount of power. If, for example, the tuned transformer has a flat-top band width of 12 kc, it will be found that output-vs.-input characteristics taken at plus and minus 5 kc from mid-band will limit at considerably lower values than will a similar characteristic taken at mid-band. This is due to the fact that the input impedance of the tuned transformer varies with frequency, and thereby changes the dynamic characteristic of the plate circuit of the amplifier tube. The obvious remedy is to increase the nominal band width of this transformer.

The remainder of the i-f unit is the monitoring circuit. This provides an audio-frequency beat note from the 50-kc signal, which is used for tuning, for centering of the signal in the i-f pass band, for checking of interference, monitoring of the signal itself, and sometimes for aural copying of telegraph signals that are too poor to operate the tone keyer in the normal manner. The oscillator is adjusted to exactly 50 kc, so that zero beat indicates that the signal is properly centered in the pass band of the 50-kc second i-f system. A switch, operable from the front of the unit, permits of changing the frequency of this monitor heterodyne oscillator to approximately 49 kc, so as to provide a 1-kc beat note for monitoring purposes. This is used when employing a narrow i-f pass band, so that an audio frequency beat note can be obtained without having to throw the signal off the center of the i-f pass band.

AUXILIARY UNITS

Circuits of the smaller units, such as the signal control panel, power-control panel, a-f amplifier, and tone-keyer unit, contain no particularly novel features. Their functions have already been described under the section devoted to General Design. The same applies to the a-c power supply unit.

OVERALL CHARACTERISTICS

Sensitivity, selectivity, and fidelity are the characteristics of most general interest. Of these three, fidelity is the only one that can be fairly definitely stated in a simple manner. The reasons for this rather broad statement will be gone into in detail in following paragraphs.

Overall fidelity, as regards frequency, is given by the graph of Figure 8. The carrier frequency was 3000 kc, which is the nominal lower limit of the tuning range. The i-f band width of 10 kc, which

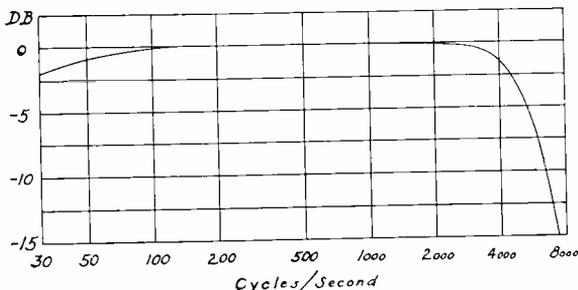

Fig. 8—Over all fidelity for amplitude modulated signal—i-f band width 10 kc—carrier frequency 3000 kc.

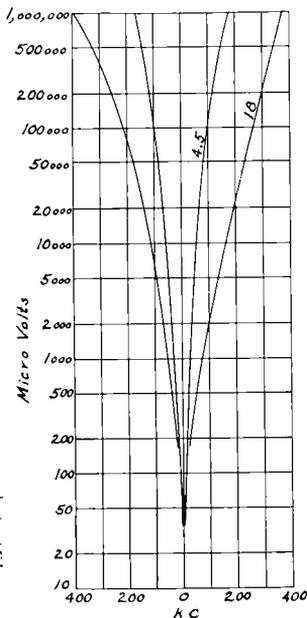

Fig. 9 (right)—Two-signal selectivity—strength of interfering 100-per-cent-modulated signal at input terminals of receiver. vs. frequency separation from desired signal: of 10  $\mu$ v on 4.5 or 18 mc.

was used in the test, is the one normally used for high quality telephone or program service. Narrower i-f band widths will, of course, give correspondingly restricted fidelity characteristics.

On high-speed telegraph keying, or facsimile transmission, in the carrier frequency range 3 mc to 24 mc, the factors chiefly limiting fidelity are radio propagation conditions and the i-f band width. The tone-keyer unit itself will satisfactorily pass keying at the rate of 1000 square cycles or dots per second. This naturally requires the use of a relatively high frequency for the locally supplied tone. This is

entirely practicable, as the keyed stage has a frequency characteristic which is flat within  $\pm 1$  db from 200 cps to 15,000 cps. The tone frequency oscillator, normally provided as a part of the tone-keyer unit, has a frequency range of 400 cps to 5000 cps, which is sufficient for practically all applications. Where special tone frequencies or sources are to be used, these are cut in by means of a switch on the tone-keyer unit, which simultaneously disconnects and shuts down the self-contained oscillator.

Selectivity of a receiver, in the absence of extremely strong signals on adjacent or nearby channels, and in the absence of deeply modulated signals on nearby channels, is specified by the frequency characteristic of the i-f system. This does not, however, tell the whole story. To find out what protection is afforded against a deeply modulated signal on a nearby channel, a two-signal test must be made on the

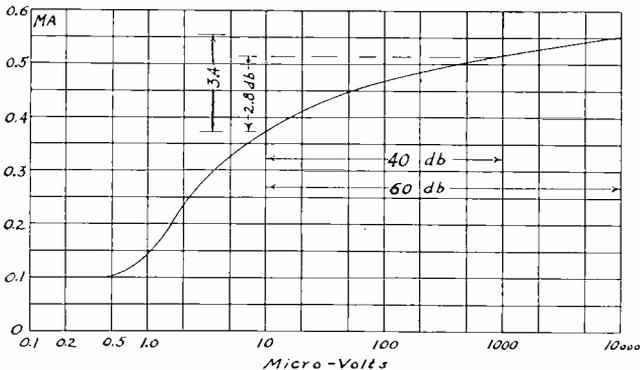

Fig. 10—Diode output vs. r-f input to receiver—a-g-c characteristic for phone operation; i-f gain adjusted for moderately strong signals.

receiver. The procedure is to supply a desired signal of specified strength to the receiver from an unmodulated-signal generator, and then to introduce an interfering signal from a 100-per-cent modulated-signal generator, the frequency and output of which can be adjusted at will. The selectivity is then judged by the amount of undesired modulation found to be present in the output of the receiver for stated frequency separations and strengths of the interfering carrier. The great difficulty encountered in trying to use the exact procedure outlined is that of obtaining a pure sinusoidal 100-per-cent amplitude-modulated signal from the signal generator.

A modification of the above-described two-signal method was used. The receiver was tuned to a desired signal of 10  $\mu v$  input, and of a specified frequency. The gain (fixed gain; not agc) of the receiver was then adjusted to give a definite rectified output from the diodes. Then a signal from a second signal generator — unmodulated — was

adjusted to frequencies differing from that of the desired signal by specified amounts, and the intensity adjusted in each case, to produce a specified change in the original reading of the diode output milliammeter. The 100-per cent modulation of the interfering signal was produced by simply switching it first off and then on, and taking one-half the on-value as the nominal unmodulated carrier strength. The effect on the desired signal was then calculated from one-half the total change in diode output current, divided by the average value. For the curves of Figure 9, a 10-per-cent modulation of the desired signal, by the interfering signal, was used.

It is believed that this modified form of two-signal test is superior to the use of a tone-modulated interfering signal from a signal generator in certain respects. Uncertainties regarding linearity or purity

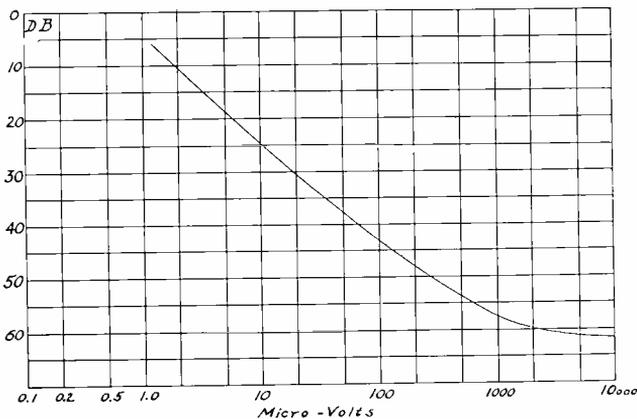

Fig. 11—AGC-Noise characteristic. Noise level in a-f output expressed in db below 100-per-cent modulation, vs. r-f carrier-input to receiver.

of the modulation are eliminated, as also are possibilities of appreciable frequency or phase modulation. Tests made according to the modified method described should therefore be easily reproducible by investigators using different types of test equipment.

Sensitivity is also difficult to specify in any simple statement; such as a single figure for each carrier frequency. This is especially true in commercial equipment such as the present, wherein gain controls for normal use are provided on both the i-f and the a-f systems, and maximum gain in either is rarely used or usable. The important considerations are, therefore, noise equivalent at the input terminals, diode noise output with maximum i-f gain, and AGC characteristics.

Noise equivalent data, for a 10-kc band width, have already been given. Diode noise output, with no r-f signal input, and with maximum i-f gain, is at least half the normal diode signal output, at any frequency within the tuning range of the receiver.

A-g-c characteristics are the final laboratory answer to the question of how a receiver will perform on fading phone signals. (The case of telegraph operation is not so readily analyzed.) When taking data for such characteristics, it is necessary to adjust the i-f gain in some arbitrarily agreed upon manner. A gain setting was used which gave a rectified noise output from the diodes, with zero r-f input signal, of 0.1 ma. The normal rectified carrier output from the diodes is approximately 0.5 ma. With this adjustment, the typical characteristics shown in Figures 10 and 11 were obtained.

Figure 10 gives diode output current — rectified carrier — versus r-f carrier input to the receiver. Using a reference point of 10  $\mu v$ , it will be seen that for an increase of 40 db in r-f input signal the diode output, and therefore also the voice-frequency output level on a phone signal, increases only 2.8 db. Likewise an increase of 60 db in r-f input results in an increase of only 3.4 db in output. At the lower values of r-f input signal, the diode output for a given r-f input can be raised or lowered considerably by changing the i-f gain adjustment.

Figure 11 gives the noise level in the audio output, expressed in db below 100-per-cent modulation of the carrier, for a 10-kc i-f band width. For these tests, the same adjustment of i-f gain, as previously described, was used. Lower or higher i-f gains will, of course, materially change such a characteristic; the chief differences being the values at which the curves tend to level off, as the input signal is raised higher and higher. Another factor affecting this levelling-off value of noise is the maximum r-f gain. If the i-f gain be adjusted in the manner described, or for some other standardized value of no-signal noise output, the levelling-off value for the agc-noise curves will be found to depend on the value of maximum r-f gain provided. The higher the r-f gain, the lower will the minimum agc-noise level be at high values of r-f input. The extent to which this can be carried in practical designs of equipment intended for universal commercial service is limited by overload considerations. For this reason the values of r-f gain and of minimum a-g-c noise levels must be somewhat of a compromise.

#### ACKNOWLEDGEMENT

Various members of the staff of the Riverhead Development Group of R.C.A. Communications, Inc. have participated in the work of developing this equipment. I wish to particularly acknowledge the work of Mr. H. A. Moore in carrying out a large portion of the experimental work and final tests; and the work of Mr. F. Schoenborn, and the staff of the Model Shop, in working out and executing the mechanical design.

# “BATALUM”, A BARIUM GETTER FOR METAL TUBES

BY

E. A. LEDERER AND D. H. WAMSLEY

Research and Engineering Department, RCA Manufacturing Company, Inc., Harrison, N. J.

THE limitations of vacuum pumps were recognized even in the early history of the commercial production of incandescent lamps. In order to improve the vacuum over that attainable with the pumps, small quantities of certain chemicals were introduced into the lamp where these materials were capable of combining with residual gas. Thus a chemical pump was built into the vacuum device and remained therein during its useful life. These chemical substances were later called “getters”. This term now has a still broader meaning, and refers to substances used for purposes other than the mere removal of residual gas, e.g., caesium as an emitter in phototubes. It has been found that gettering not only permits a reduction of the time of exhaust on the pump but also, because of the maintenance of the vacuum after sealing off, provides an increase in the useful life of the device. Because of this property getters are also called “keepers”. These obvious economic advantages encouraged the search for better getters and a study of their properties.

It is required that the getter material shall be chemically inert during the assembly of the vacuum device. After mechanical exhaustion it should become highly active chemically. The transformation from the inactive to the active state is carried out by the application of heat. The technique is as follows:

- (a) A change in the chemical modification; example: phosphorus<sup>1</sup>.
- (b) Evaporation of active metals, protected by oxide films; example: magnesium<sup>2</sup>.
- (c) Vaporization of active material from an alloy which is inert at room temperature; example: Ba-Al alloy.
- (d) Active material protected by metal case; example: copper-clad barium.
- (e) Production of active material inside the vacuum device by means of a chemical reaction; example: the caesium dichromate and silicon reaction to form caesium metal.

---

<sup>1</sup> Malagnani, U. S. Patent 537,693, 4/16/1895

<sup>2</sup> Fitzgerald, U. S. Patent 286,916, 10/16/1883

F. Soddy, Germ. Patent, 191,788, 3/20/1906

At the beginning of the production of commercial radio receiving tubes the methods of exhaust and gettering were closely patterned after the methods used in manufacturing incandescent lamps. However, the requirement of better vacuum soon led to the development of new getters.

In reviewing this development briefly we recall that tubes with pure tungsten filaments were made either without getter or used phosphorus getter. In tubes without phosphorus the evaporation of tungsten served to clean up the residual gas and after aging, or a short time of operation, the tubes became "hard", a term often used to indicate a high vacuum. Usually such tubes were degassed on the pump by electron bombardment. This produced sputtered electrode material on the glass envelope which aided in adsorbing gases liberated during operation.

The most radical departure from the established methods resulted from the commercialization of the thoriated filament. With this emitter, which used small amounts of chemically active thorium metal on its surface, all oxidizing influences had to be carefully eliminated before activation<sup>3</sup>. For the first time degassing of the tube elements by high-frequency heating came into extensive use. This source of heat was also used for flashing the magnesium getter, preferably delayed until the liberation of gas from the elements was completed. Often, especially with small filaments this technique was not sufficient, and deactivation of the emitter was observed, due to liberation of oxygen from imperceptible oxide films on the elements under electron bombardment. One method for the removal of these, probably monomolecular oxide films, used red phosphorus together with magnesium as a combination getter.

The same exhaust and gettering methods (excluding phosphorus) were used for the early production of receiving tubes with oxide-coated uncombined emitters. However, with the conception that the electron emission of such a cathode is caused by barium metal and with the refinements of modern radio receivers, requiring tubes with very low grid current, better getters were demanded. The most logical step was to use the same getter material as that causing the electron emission of the cathode—namely, barium metal.

Since barium metal is chemically very active, and, unlike magnesium, unprotected by its own oxide, a new technique for its introduction into the tubes had to be developed. Without discussing the merits and disadvantages, it may be stated that the methods for introducing barium are manifold. The following ones have been or are being used commercially.

---

<sup>3</sup> I. Langmuir, U. S. Patent 1244216 and 1244217, 10/23/1917

- (1) Thermal decomposition of barium azide.
- (2) Copper, nickel or aluminum-clad barium metal. (A metal tube filled with barium metal, ends of tube pinched nearly air tight.)
- (3) Barium-magnesium and barium-aluminum alloy, both of which are essentially unaffected by the atmosphere at room temperature.
- (4) Production of barium by means of chemical reaction carried out in vacuum. (For example, reduction of barium oxide by aluminum or silicon.)

The above methods were developed for use in receiving tubes with glass envelopes. "Flashing" or dispersal of the getter was carried out by high-frequency heating of a suitable getter holder.

With the introduction of the all-metal radio receiving tube, the technique of exhaust and gettering had to be modified to suit the properties of the metal envelope. The metal tube parts are heated by radiation from the envelope which in turn is heated by gas flames. Therefore, the envelope is the hottest part of the tube. Since high-frequency heating is no longer applicable, the getter, in the form of a barium alloy, has to be fastened at a convenient place to the inside of the envelope, and dispersal of the getter carried out by heating this place by means of a pointed flame. While the process as described has been used extensively in the manufacture of all-metal tubes, it requires very careful control. A gettering process better suited for mass production of all-metal tubes and less critical in control was, therefore, highly desirable. The requirements to be fulfilled are:

- (1) The getter deposit should consist mainly of barium metal.
- (2) Complete control with respect to time and quantity of getter flash is essential.
- (3) Complete control over place of deposition of getter flash is essential.
- (4) It is preferable to flash getter while metal envelope is cold after completion of degassing and exhaust.
- (5) Low vapor pressure of getter deposit at highest temperatures encountered during final processing and operation of tubes is essential.

During the course of some fundamental research work on thermionic emitters, a method of producing very pure alkali earth metals was discovered. This method has led to the development of "Batalum" getter which has been found to satisfy the requirements for a getter for vacuum tubes.

The "Batalum" getter consists essentially of a length of tantalum wire coated with a mixture of barium carbonate and strontium carbonate. The name "Batalum" was derived by a contraction of barium-

tantalum. Barium and strontium metal are obtained by heating the tantalum wire electrically. The carbonates of barium and strontium are changed to the respective oxides at 800°C-1100°C. The tantalum wire reduces the oxides to produce barium and strontium metal at a temperature above 1200°C. Approximately 40 per cent of the theoretical yield is obtained. This relatively low yield is probably explainable by the formation of stable tantalates of barium and strontium.

The best gettering metal is the one most favorable to cathode activation. Barium is considered to be the best gettering metal for oxide-coated cathodes because of the stability of the compounds formed and its high activity for cleaning up the gases present in a vacuum tube. It, however, has a distinct disadvantage in requiring a high tempera-

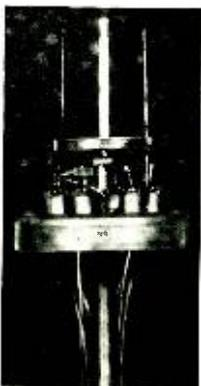

Fig. 1—View of header showing position of getter coil.



Fig. 2—Internal assembly of metal tube with "Batalum" getter.

ture of evaporation to produce it from the alloys of barium aluminum and barium magnesium. No practical method is known for electrically flashing these alloys in a metal tube. This fact has practically eliminated the use of barium in metal tubes.

However, by using the "Batalum" getter technique of reducing the metal from its carbonate, barium may be used. Barium carbonate is a satisfactory source of barium because it is a stable compound. It fuses, however, when heated. This action presents a mechanical disadvantage because, when this material is heated on a tantalum wire, the surface tension draws the fused carbonate into globules which crack off. This difficulty may be overcome by adding strontium carbonate to the coating. Strontium carbonate does not fuse and forms a matrix for the barium carbonate. Strontium as a getter is comparable with barium so that the combination gives a satisfactory mixture of getter materials.

Calcium, lithium and magnesium may be formed from their carbonates by the same technique, but they do not compare with barium and strontium for gettering rate and stability of compounds formed. However, the efficiency of the reduction of calcium from the carbonate by tantalum is approximately 60 per cent based on initial results which require further verification.

The efficiency obtained in reducing metals from the carbonates is dependent to quite an extent on the technique of liberating and removing the carbon dioxide. If a high concentration of carbon dioxide is allowed to develop while the tantalum is hot, a reaction will take place between the tantalum and the carbon dioxide, forming carbon monoxide and tantalum oxide. The better efficiency obtained from the reaction



Fig. 3—The shell of a metal tube with "Batalum" getter. A section of the shell is cut away to show the location of the getter deposit. Since the alkali-earth metal has changed to the carbonate, due to exposure to the atmosphere, the deposit appears white on the metallic background.

with calcium carbonate is considered to be due to the lower temperature at which the carbon dioxide is liberated.

In addition to the use of this technique to provide a getter, the technique may also be used in laboratory work wherever pure metals of the alkaline earths are required, as for example, barium to purify inert gases.

Barium and strontium evaporated from the tantalum wire can be directed where desired. The vapor travels in straight lines and the metal does not evaporate unless the temperature of the surface on which it is deposited exceeds 400°C. A shield may be provided to locate the deposit. The vapor pressure for barium at various temperatures is obtainable from the following expression:

$$\log p(\text{mm}) = 6.99 - 8980 \times \frac{1}{T} \quad (1)$$

The "Batalum" getter as now used in receiving tubes consists of a

<sup>1</sup> Rudberg. *Science Abst.* Vol. 38, 1935, p. 4635.

0.006-inch tantalum wire in the form of single helical coil. The coil is sprayed with the double carbonates of barium and strontium and mounted in a shield, as shown in Figures 1 and 2. A circuit is made from the ground lead through the coil to the header, Figure 1. On the exhaust machine, suitable contacts are provide to introduce current for breaking down the carbonates to the oxide. The technique is much the same as used in preparing the oxide-coated cathode. After the tube is

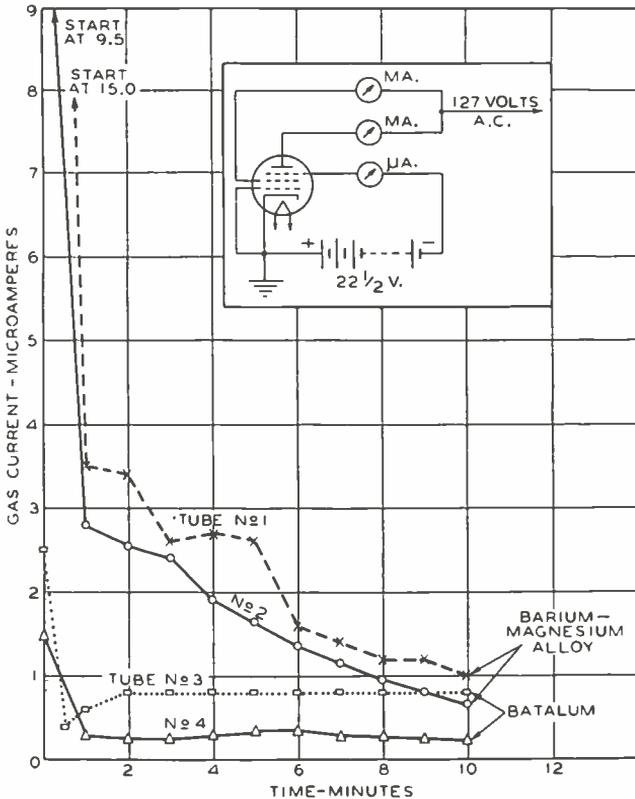

Fig. 4—Rate of gas clean-up during gas-step on aging of representative tubes with Barium-Magnesium with "Batalum" getter.

exhausted, the getter is flashed on the aging panel. The flashing and aging schedule is chosen to insure the best gas cleanup.

#### RESULTS OBTAINED WITH "BATALUM" GETTER

Comparison of gas conditions during aging between barium magnesium alloy getter and "Batalum" getter has been made on all-metal tubes with the circuit shown in Figure 4. The curves show the initial

gas content and the rate of gas clean-up during a part of the aging period. The circuit given in Figure 4 permits more sensitive gas measurements than provided by the conventional method. No gas current would be obtained on these tubes at the end of 10 minutes of testing by the conventional method. Tests were also made to show the rate of gas clean-up in the finished tubes. For this purpose a method of testing has been devised by W. A. Gray of the RCA Radiotron laboratory. The procedure is as follows:

The tube is operated under condition A for 3 minutes with 300 volts applied to plate and screen, the control grid biased to give 30 milliamperes of cathode current. At the end of this time, the gas current is read, then the plate and screen potentials are reduced to 150 volts, the cathode current adjusted to 20 milliamperes, and another gas reading made after one-half minute operation under the latter conditions, identified as condition B.

Gas readings on a large number of tubes, Type 6K7, containing barium magnesium alloy getter, were 6.7 microamperes for condition A, and 0.74 microamperes for condition B. Tubes made with "Batalum" getter showed corresponding readings of 0.7 and 0.1 microampere.

The directional flash of the "Batalum" getter has been demonstrated by making element-to-element leakage measurements with an electrometer set using a self-biased Type 32 tube, operated at low voltages, with a 100-megohm grid resistor. For these measurements, top caps and bases were removed from the tubes. A current of  $0.1 \times 10^{-10}$  amperes could be detected. Leakage values for Type 6K7 with pellet getter ranged from 0.2 to  $15 \times 10^{-10}$  amperes, with an average of  $3 \times 10^{-10}$  amperes. This value, it should be noted, represents an unusually excellent condition. The leakage current in Type 6K7 with "Batalum" getter could not be measured with this instrument.

#### CONCLUSION AND ACKNOWLEDGMENT

The "Batalum" getter has been used extensively in the manufacture of all-metal radio receiving tubes. Its properties, in the light of past experience, adequately meet the requirements for a getter for metal tubes as previously outlined.

The authors are indebted to Dr. G. R. Shaw and to their colleagues for helpful advice in carrying out this work.

general theoretically infinite, but in practice the curve is essentially closed after a few turns. This convergence depends, among other things, upon the skill in choosing the initial conditions, and the damping in the circuit. When the steady-state solution alone is desired, the transient spirals are a handicap, and are due to the generality of the method.

It is possible to prove analytically, the correctness of this construction for some simple forms of linear circuits, but due to lack of space, such proofs will be omitted.

### III. CAPACITY AND NON-LINEAR RESISTANCE

We now take the case of a capacity,  $C$ , in series with a non-linear resistance,  $r$ , and voltage,  $e$ . Assume, for simplicity, that there is no initial charge in  $C$ , nor current flow in the circuit. The equation, in differential form, is

$$e = f(t) = \frac{1}{C} \int i dt + \phi(i) \quad (9)$$

In finite increment form this becomes

$$(e + \Delta e) = \frac{\Delta t}{C} \Sigma (i) + \frac{\Delta t}{C} i + \phi(i) \quad (10)$$

The finite operator curve will now be  $\frac{\Delta t}{C}$ . We note that  $\frac{\Delta t}{C} \Sigma i$  is the total voltage  $E_c$ , built up in the condenser in the previous time intervals;  $\frac{\Delta t}{C} i$  is the additional voltage  $e_c$  built up in the present time interval by the current flow. We may, therefore, rewrite Equation (10) as

$$e + \Delta e - E_c = \frac{\Delta t}{C} (i) + \phi(i) \quad (11)$$

The graphical construction is as follows:

The voltage-time wave is broken up into small (preferably equal) time intervals  $\Delta t$ . Referring to Figure 3(A), we note that  $\Delta e_1$  is the first voltage increment,  $OC$ . At  $C$ , a line  $AC$  at the angle

$$\theta = \cot^{-1} \frac{\Delta t}{C} \quad (12)$$

is drawn, and it intersects the load line for  $r$  at  $A$ . We note that  $AC$  is the finite operator curve, straight because  $C$  was assumed a constant parameter. The first current increment,  $\Delta i_1$ , is evidently  $AB$ , while  $OB$  is the voltage across  $r$ , and  $BC$  is the voltage developed across  $C$ . The point  $D$  is the first one on the overall load line. We now lay off on



and  $M$  is the third point in the overall load line, while  $LN$  is the new value of current. This is laid off on the auxiliary diagram as  $LF$ , and the finite operator curve  $LQ$  drawn. Then  $BQ$  is the next value of  $E_c$ , which is laid off from the end of  $\Delta e_4$  on the (A) diagram, etc. Since  $E_c$  builds up quite rapidly as  $i$  continues to flow, it ultimately overtakes the impressed voltage  $e$ , so that the operator curve begins to move to the left, and  $i$  begins to decrease even if  $e$  is still increasing. The result is that the overall load line begins to fold over and spiral around clock-wise, which is the proper direction for a capacitive load line.

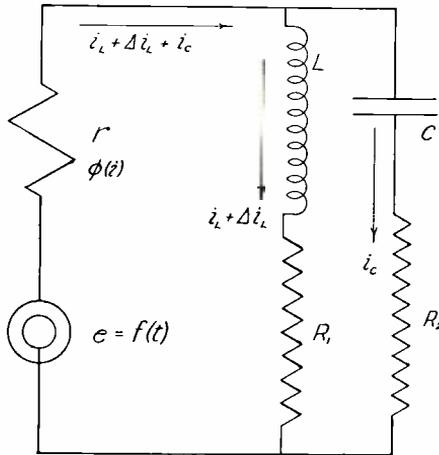

Fig. 4.

The auxiliary diagram (B) has more than constructional utility. The points  $D$ ,  $E$ , and  $P$  as shown are the points on the capacitive load line, i.e., they are the locus of current versus voltage across the condenser when the latter is in series with the given non-linear resistance  $r$  and the voltage  $e$  impressed.

#### IV. PARALLEL RESONANT CIRCUIT

This circuit is shown in Figure 4, and the non-linear resistance is  $r$ . We wish to solve for the incremental current in the case of  $L$ , and present current in  $C$ , and, therefore, may regard the previous currents  $i_L$  and  $\Sigma i_C$  as known, since they are the algebraic sums of  $\Delta i_L$  and  $i_C$  respectively, determined previously by the same method by which the present  $\Delta i_L$  and  $i_C$  are to be found. With this in mind we proceed to write down the equations.

$$e + \Delta e - \phi(i_L + \Delta i_L + i_C) = E \tag{14}$$

$$E = \frac{\Delta t}{C} \Sigma i_C + i_C \frac{\Delta t}{C} + i_C R_2 = i_L R_1 + (R_1 + \frac{L}{\Delta t}) \Delta i_L \tag{15}$$

where  $E$  is the voltage across the parallel portions of the total circuit. Equation (15) may be written, after some simple algebraic transformations, as

$$E = (\Delta i_L + i_C) \left( \frac{Z_1 Z_2}{Z_1 + Z_2} \right) + i_L \left( \frac{R_1 Z_2}{Z_1 + Z_2} \right) + \frac{\Delta t Z_1}{C (Z_1 + Z_2)} \Sigma i_C \quad (16)$$

where  $Z_1 = (R_1 + \frac{L}{\Delta t})$  and  $Z_2 = (R_2 + \frac{\Delta t}{C})$ .

Substituting the value of  $E$  from Equation (16) in Equation (14) we obtain

$$\begin{aligned} e + \Delta e - \phi(i_L + \Delta i_L + i_C) - i_L \left( \frac{R_1 Z_2}{Z_1 + Z_2} \right) - \left[ \frac{\Delta t Z_1}{C (Z_1 + Z_2)} \right] \Sigma i_C \\ = (\Delta i_L + i_C) \left( \frac{Z_1 Z_2}{Z_1 + Z_2} \right) \end{aligned} \quad (17)$$

This last equation forms the basis of our graphical construction. We have managed to introduce the branch currents  $i_L$ , and  $\Sigma i_C$  (which—as stated above—are known) in such a manner that their voltage effects are both subtractive from  $e + \Delta e$ , instead of individually subtractive from  $E$ . The graphical construction is shown in Figure 5. From  $A$  the finite operator curve  $BA$  is drawn so that

$$\sphericalangle BAO = \cot^{-1} \left( \frac{Z_1 Z_2}{Z_1 + Z_2} \right) \quad (18)$$

Then  $AC$  is drawn so that

$$\sphericalangle CAO = \cot^{-1} Z_1 \quad (19)$$

Then  $CD = \Delta i_{L1}$ , and  $BC = i_{C1}$ . These are then laid off on the auxiliary diagram on the right as  $D'C'$  and  $C'B'$ , respectively. Then  $D'M$  is drawn so that

$$\sphericalangle D'MC' = \cot^{-1} \left( \frac{R_1 Z_2}{Z_1 + Z_2} \right) \quad (20)$$

whereupon  $C'M = i_L \left( \frac{R_1 Z_2}{Z_1 + Z_2} \right)$ , where  $i_L$  is simply  $\Delta i_{L1}$ .

Also from  $B'$ ,  $NB'$  is drawn so that

$$\sphericalangle C'NB' = \cot^{-1} \left[ \frac{\Delta t Z_1}{C (Z_1 + Z_2)} \right] \quad (21)$$

Then  $C'N = \left[ \frac{\Delta t Z_1}{C (Z_1 + Z_2)} \right] \Sigma i_C$ , where  $\Sigma i_C$  is simply  $i_{C1}$  in this first time interval.

From the voltage during the next time interval, namely  $(\Delta e_1 + \Delta e_2)$ , both of these quantities must be subtracted, or a total distance  $MN$  (right-hand diagram) must be subtracted on the left-hand diagram. This length is shown in the latter diagram also as  $MN$ . From  $N$  we go up a distance  $\Delta i_{L1}$  to  $F$ , and draw  $FG$  parallel to  $AB$ . Then  $GL$  represents  $(i_c + \Delta i_L)$ , and  $J$  is the next point on the overall load line. To get  $\Delta i_L$ , and thus by subtraction from  $GL$ , the quantity  $i_c$ , we proceed as follows: From  $M$  we draw  $HM$  so that  $\angle HMO = \cot^{-1}R_1$ . From  $H$  we draw  $HI$  parallel to  $CA$ . Then  $IL$  is  $\Delta i_L$  in this second time interval, and hence  $GI$  is  $i_c$ . On the auxiliary diagram to the right we draw  $NP = GI$ , and  $QD' = IL$ . Then  $PS$  is drawn parallel to  $B'N$ ,

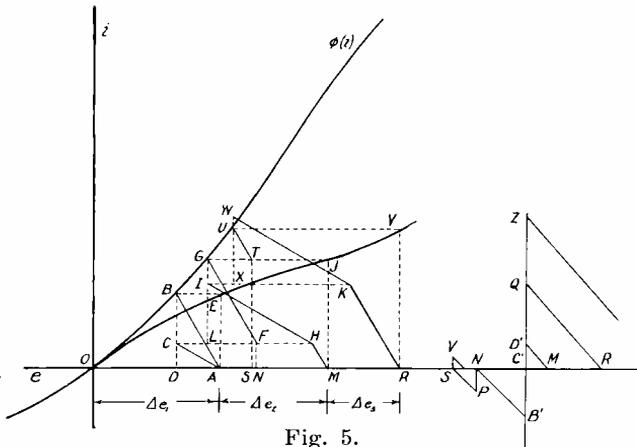

Fig. 5.

and  $QR$  parallel to  $D'M$ . Then  $SR$  is subtracted from  $(\Delta e_1 + \Delta e_2 + \Delta e_3)$  on the left-hand diagram, where it is represented by  $RS$  too. From  $T$  directly above  $S$  we draw  $TU$  to the load line of  $r$ , and  $V$  is the next point of the overall load line. Then from  $R$ , (as previously from  $M$ ) we draw  $KR$  parallel to  $HM$ , and then  $KW$  parallel to  $AC$ . The length  $WX$  represents the next value of  $\Delta i_L$ , which, when subtracted from  $UX$ , gives  $UW$ ,—a reverse or discharge current in the condenser. Thus, on the right-hand diagram, we draw  $VS = WU$ , and  $QZ = WX$ , and the construction continues in the manner described.

The construction is really simpler than the above detailed exposition would indicate. The actual operations are quite easy to perform, but the process is admittedly laborious. However, no other method will give the solution more quickly or easily to this rather complicated circuit. Indeed, if the load line for  $r$  is very irregular or broken, any other method is far more complicated or impossible to use, except, of course, a machine differential analyzer.

This construction can be applied to other circuits derivable from

the one shown in Figure 5. Thus, if  $C$  is infinite, and  $R_1 = 0$ , we have a non-linear resistance in series with a parallel group consisting of a resistance in one branch and an inductance in the other. On the other hand, if  $L = R_2 = 0$ , we have a circuit similar to the above, but with the condenser replacing the inductance. The constructions for these two circuits are, of course, considerably simpler than that for Figure 5.

V. NON LINEAR-PARALLEL BRANCH

The illustrative examples should afford a fairly good insight into the method of attack. Other and more complicated examples can be

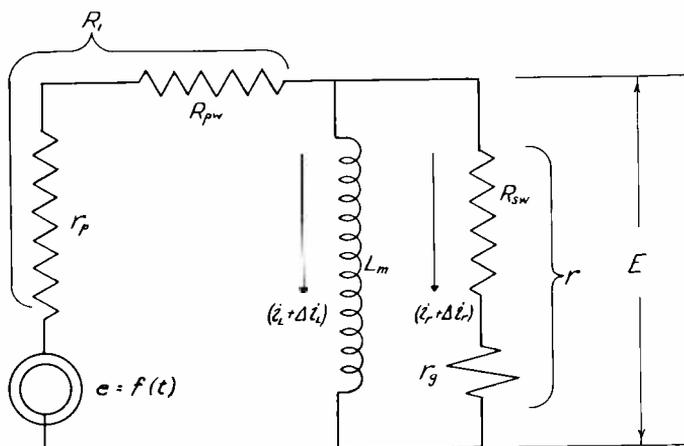

Fig. 6.

worked out, but it must not be overlooked that the process becomes very involved, just as an operational expression, or even ordinary integration, becomes very involved and almost impossible to evaluate. One other example will be given of practical and theoretical interest. The circuit is shown in Figure 6. This may represent a linear driver tube of constant plate resistance  $r_p$ , driving the grid of a succeeding tube positive, the latter's very non-linear resistance being represented by  $r_g$ . The equivalent voltage generated in the plate circuit of the driver tube is represented by  $e = f(t)$ . If this is of low frequency, then the driver transformer may be fairly accurately represented as shown, where  $R_{pw}$  represents the primary-winding resistance;  $R_{sw}$ , the secondary-winding resistance, and  $L_m$  the open-circuit inductance (assumed linear). For the purpose of construction, it is convenient to lump  $r_p$  and  $R_{pw}$  into one equivalent resistance  $R_1$ , and  $R_{sw}$  and  $r_g$  into an equivalent non-linear resistance,  $r$ . The equations are

$$e + \Delta e - (i_L + \Delta i_L + i_r) R_1 = E \tag{22}$$

$$E = \Delta i_L \frac{L}{\Delta t} = i_r r \tag{23}$$

from which we can obtain

$$E = (i_r + \Delta i_L) \left[ \frac{1}{\frac{\Delta t}{L} + \frac{1}{r}} \right] \tag{24}$$

so that

$$e + \Delta e - (i_L + \Delta i_L + i_r) R_1 = (i_r + \Delta i_r) \left[ \frac{1}{\frac{\Delta t}{L} + \frac{1}{r}} \right] \tag{25}$$

The expression  $\left[ \frac{1}{\frac{\Delta t}{L} + \frac{1}{r}} \right]$  is to be the finite operator curve which

will be used to intersect  $R_1$ . It will be noted that due to  $r$ , this operator is truly curved, and not a straight line, as has been the case in the preceding examples. It must be determined before we can proceed with the remainder of the construction.

Referring to Figure 7, we have the load line for  $r$  plotted. From any point  $A$  on the current-axis, a line  $AB$  is drawn so that

$$\sphericalangle BAO = \cot^{-1} \frac{\Delta t}{L} \tag{26}$$

The intersection,  $B$ , projected upward to  $C$  in line with  $A$ , is a point

on the finite operator curve  $\left[ \frac{1}{\frac{\Delta t}{L} + \frac{1}{r}} \right]$ . It means that if the volt-

age were to change from zero to the value  $AC$  in a time interval  $\Delta t$ , and  $L$  and  $r$  were in parallel, then the total current through the two branches would be  $AO$ , of which  $JO$  would be the portion through  $r$ , and  $AJ$  the portion through  $L$ . Similarly  $DE$  and  $GH$ , etc., are drawn parallel to  $AB$ , and give rise to the respective points  $F$  and  $I$ , etc., on the finite operator curve. This curve we shall designate as  $Z$  in subsequent reference to it.

We can now proceed with the remainder of the construction, which is shown in Figure 8. The load line for  $R_1$  is plotted. While in this example it is assumed a straight line ( $R_1$  linear), the method can be used even if  $R_1$  is non-linear as well as  $r$ . In other words, the driver tube may be regarded as non-linear, too. From the end of  $\Delta e_1$  (point  $A$ ), the finite operator curve  $AB$ , which was determined in Figure 7

as  $OCF$ , is drawn. Its intersection with the load line of  $R_1$  in  $B$  is projected over to  $H$ , which constitutes the first point of the overall load line. Then  $CA$  is drawn so that

$$\angle CAO = \cot^{-1} \frac{L}{\Delta t} \tag{27}$$

whereupon  $CJ = \Delta i_{L1}$ , and  $BC = i_{R1}$ . Then  $C$  is projected over horizontally to  $E$  directly over  $D$ , where  $OD = (\Delta e_1 + \Delta e_2)$ . The finite

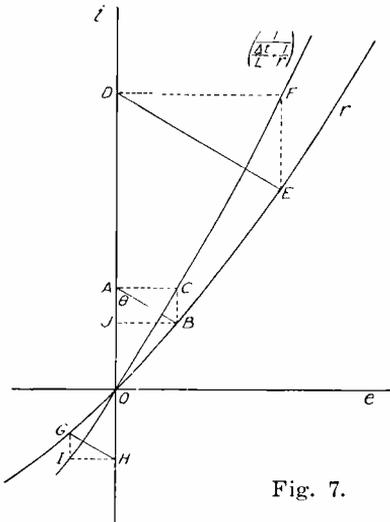

Fig. 7.

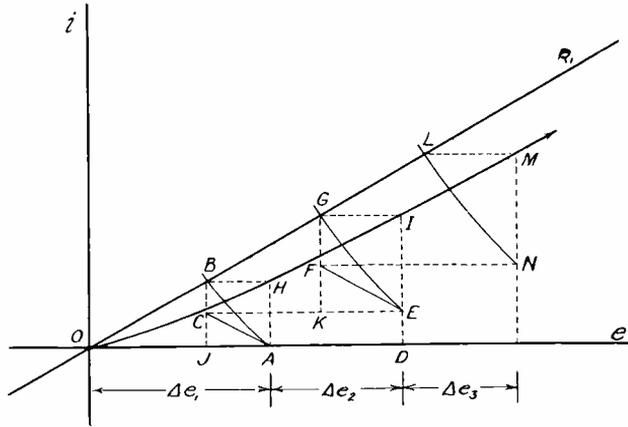

Fig. 8.

operator curve is shifted over so that it passes through  $E$ , and intersects the load line for  $R_1$  in  $G$ . Then  $FE$  is drawn parallel to  $CA$ , and  $FK$  is  $\Delta i_{L2}$ , while  $FG$  represents  $i_{R2}$ . Also point  $I$  is the second point of the overall load line. The finite operator curve is now shifted over so that it passes through point  $N$ , and its intersection  $L$  with the load line for  $R_1$  determines the next point  $M$  of the overall load line. In this way the successive points of the latter can be determined.

If  $R_1$  is a linear resistance, a modification in the graphical construction can be employed which will avoid the need for shifting the curved finite operator curve, and instead shift the straight load line for  $R_1$ . However, it is just as simple to cut out a template for the curved finite operator curve, and so the alternative construction will be omitted.

(To be continued.)

## OUR CONTRIBUTORS



WENDELL L. CARLSON was graduated from the Bliss Electric School in 1915. Since 1918 he has been engaged in radio receiver development, first at the Washington Navy Yard from 1918 to 1923; next with the General Electric Company at Schenectady from 1923 to 1930; and then in his present connection, the RCA Manufacturing Company, at Camden, N. J., which he joined in 1930.

BENJAMIN R. CARSON attended evening classes at Central High School, Philadelphia, the West Philadelphia High School, and Drexel Institute during a nine-year period. He went with the Standard Roller Bearing Company in the Pattern and Tool Design Departments in 1912, and in 1916 joined the Engineering Department of the Eddystone Rifle Plant of Midvale Steel. In 1918 he joined the Wright Roller Bearing Company; 1920, the Electric Service Supplies Company; 1923, the Miller Lock Company; 1924, the Victor Talking Machine Company; 1928, the Philco Radio Company; 1929, the M. Tucker Company; and the Engineering Department of the RCA Manufacturing Company in 1930.



KENNETH A. CHITTICK received his B.S. degree from Rutgers University in 1925. The same year he entered the General Electric Test Course on radio development. From 1927 to 1930 he was in the Radio Engineering Department of the General Electric Company, and since 1930 has been in charge of circuit development of broadcast receivers for RCA Manufacturing Company.

DAVID D. COLE attended the Michigan College of Mines from 1921 to 1923, and the University of Michigan from 1923 to 1926, graduating with the degree of B.S. in E.E. He joined the General Test Course of the General Electric Company in 1926, and the Radio Engineering Department of that Company in 1928. Transferring to RCA in 1930, he has since been in the Receiver Design Section of the RCA Manufacturing Company.



JAMES W. CONKLIN received his E.E. degree from Cornell University in 1927. The year of his graduation he joined RCA and, later, from 1929 to 1936 served with R.C.A. Communications, Inc. In 1936 he transferred to the Engineering Department of RCA Manufacturing Company where he has since been engaged in transmitter design and development.

WILLIAM S. DUTTERA, after receiving his E.E. degree from Gettysburg College in 1929, took the two years of Masters work at Union College in 1930 and 1931. He started in transmitter test work for the General Electric Company in 1929 and in 1930 became a member of the High Power Group in the Transmitter Engineering Department. His assignments included development of the power amplifier and rectifier for the television transmitter in the Empire State Building. He transferred to the National Broadcasting Company in 1931 on television.



## OUR CONTRIBUTORS

HERMAN E. GIHRING is a native of St. Louis, Mo. He received his B.S. degree from Washington University in 1926, and the following year entered the Government service. He became an RCA engineer in 1929, and has since been connected with the Engineering Department of the RCA Manufacturing Company at Camden.



VERNON D. LANDON, following his graduation from Detroit, Jr. College, became a Westinghouse engineer and for six years was in charge of their radio frequency laboratories. In 1929 he went with the Radio Frequency Laboratory in Boonton, N. J., as Assistant Chief Engineer, and in 1931 became Assistant Chief Engineer for Grigsby-Grunow. Since 1933 he has been with the Engineering Department of RCA Manufacturing Company.

ERNEST A. LEDERER received his Ph.D. degree from the University of Vienna in 1920 and was appointed assistant in the Department of Physics at that University. Later in the year Dr. Lederer joined the Westinghouse Lamp Company in Vienna, and in 1923 became research engineer for Westinghouse in New Jersey. Seven years later he became Chief Engineer of the National Union Radio Corporation and since 1934 has been an RCA engineer engaged in research work in the Radiotron Division of the RCA Manufacturing Company. In his several connections Dr. Lederer has engaged in tungsten filament preparation, gaseous rectifiers, phonofilm and thermionic vacuum tube research. He is a member of I.R.E.



H. B. MARTIN received a B.S. degree at the University of Illinois in 1928. Following graduation he was employed by Westinghouse at East Pittsburgh. In 1929 he became attached to the Signal Corps Procurement Office, New York, and was later transferred to the Signal Corps Laboratories, Fort Monmouth, N. J. In 1930 he was employed by the Radiomarine Corporation of America for flight testing of aircraft radio equipment. From 1932 to 1935 he was on the instruction staff of RCA Institutes. He is now Assistant Chief Engineer of Radiomarine Corporation and is active in developing new communication equipment.

JOHN B. MOORE is an alumnus of Carnegie Institute of Technology from where he received his degree of B.S. in E.E. in 1922. Since his graduation he has been connected with the Engineering Department of the Radio Corporation of America and R.C.A. Communications, Inc., for the first four years in the operating division, and since then in the design of receiving methods and equipment. Mr. Moore is an associate member of the Institute of Radio Engineers.



ROBERT M. MORRIS attended the Western Reserve University and the Case School of Applied Science, following which he joined the Western Electric Company. He became a member of the original staff of Broadcasting Station WEAf when that station was inaugurated by the American Telephone and Telegraph Co., in 1924, and has since been closely associated with it. He became a member of NBC's technical organization in 1927. Mr. Morris is a member of the Acoustical Society of America and an Associate Member of the Institute of Radio Engineers.



SYDNEY V. PERRY received his B.S. degree from Queen's University, Canada, in 1923 and joined the Westinghouse Company Engineering Department, entering the radio engineering division after completing the Graduate Student Training Course. In 1925 he became interested in the development and design of loudspeakers and actively contributed to the advancement of commercial loudspeakers for use in home radio receivers and similar applications. In 1930 he became associated with RCA Manufacturing Company and has since been engaged in development work on loudspeakers, cabinet acoustics, and the overall acoustic reproduction of radio receivers.

ALBERT PREISMAN received his A.B. and E.E. degrees from Columbia University in 1922 and 1924, respectively, and is now taking graduate courses at Columbia University and the Brooklyn Polytechnic Institute for a Doctor's degree. After working a year with the Wagner Electric Corporation of St. Louis and three and one-half years with the New York Edison Company, he joined the RCA Photophone organization in January, 1929. He spent three years there, first as Installation and Service Engineer, then as Division Inspector (Central Division) and finally as Assistant Liaison Engineer in the National Office. In February, 1932, he was transferred to RCA Institutes, Inc. While teaching a variety of subjects, he has specialized in audio frequency engineering and vacuum tube theory and design.



DAVID SARNOFF, President of the Radio Corporation of America, has been continuously identified with radio since 1906. He received his early education in New York public schools and later was graduated from Pratt Institute, where he took the electrical engineering course. He is a Fellow, Institute of Radio Engineers, and served as Secretary and Director of I.R.E. for three years. Mr. Sarnoff is a Member, Council of New York University; Member, Academy of Political Science and Member, American Institute of Electrical Engineers. He holds the honorary degrees of Doctor of Science from St. Lawrence University, Doctor of Science from Marietta College, and

Doctor of Literature from Norwich University. He is an honorary Member of Beta Gamma Sigma and an honorary of Tau Delta Phi. He is a Colonel SC—Res., U. S. Army.

ROBERT E. SHELBY received his B.S. in Electrical Engineering from the University of Texas in 1927; B.A. in 1928, and M.A. in 1930. He joined the National Broadcasting Company as a student engineer in 1929. In 1930, as a member of the Development Group of the Engineering Department, he was placed in charge of the Empire State television transmitter until March 1935, at which time he was made supervisor of television activities at Radio City. He is a member of the I.R.E., A.I.E.E., and Eta Kappa Nu.



DELOS H. WAMSLEY was graduated from Alfred University with a B.S. degree in 1930, and received his M.S. degree from the University of Illinois in 1932. He joined RCA in 1933 and has since been engaged as a research engineer of the Radiotron Division of the RCA Manufacturing Company.