

RCA

Ham Tips

VOL. 28, NO. 2

JULY, 1968



An Audio Control System for SSB

By George D. Hanchett, W2YM*

RCA Electronic Components

AUTHOR'S PREFACE: Although the radio amateur who likes to construct his own equipment is a vanishing breed, there are still lots of "Indians" left in the tribe of "Do-It-Yourselfers." For those of us who like the smell of rosin, there is especially happy news in a 224-page book just published by RCA. Titled the "RCA Solid-State HOBBY CIRCUITS MANUAL, HM-90" (Suggested Price \$1.75), this book contains at least a baker's dozen of circuits that the radio amateur can build for use in his ham shack. In all, the new Hobby Circuits Manual contains 35 circuits covering also the interests of the motorist, the photographer, the music buff, the home owner, and the maker of electronic novelties and gadgets.

To acquaint the radio amateur with the material offered by the Manual in his direct interest, the following article first outlines the various circuits designed exclusively for applications in the ham shack. Following this, a concrete example of a useful project is provided in the discussion of a complete audio control system. This system — consisting of a microphone preamplifier, an audio oscillator, and an audio mixer, compressor, and line driver — is especially valuable for the amateur who operates SSB.



Figure 1: Exterior view of assembled audio control system for SSB, consisting of a microphone preamplifier, audio oscillator, and an audio mixer, compressor, and line driver.

Circuits for Hams

In addition to the circuits covering the construction of an audio control system for SSB, the new "RCA Hobby Circuits Manual" contains numerous other circuits that can be used to advantage by the radio amateur. Complete, detailed instructions are provided for the construction of an integrated-circuit code-practice oscillator; a semi-automatic electronic keyer; an automatic keyer; a frequency-selective AF amplifier; an audio amplifier; a dip/wave meter; a variable-frequency oscillator; a VFO calibrator; an audio-frequency-operated switch; and power supplies. Included with the construction information for these circuits are layout diagrams and full-size drilling templates for circuit boards, as well as operating and adjustment data.

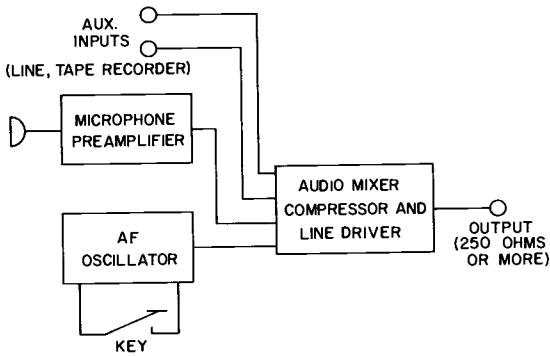

Figure 2: Block diagram of three circuits combined as an audio control system for SSB.

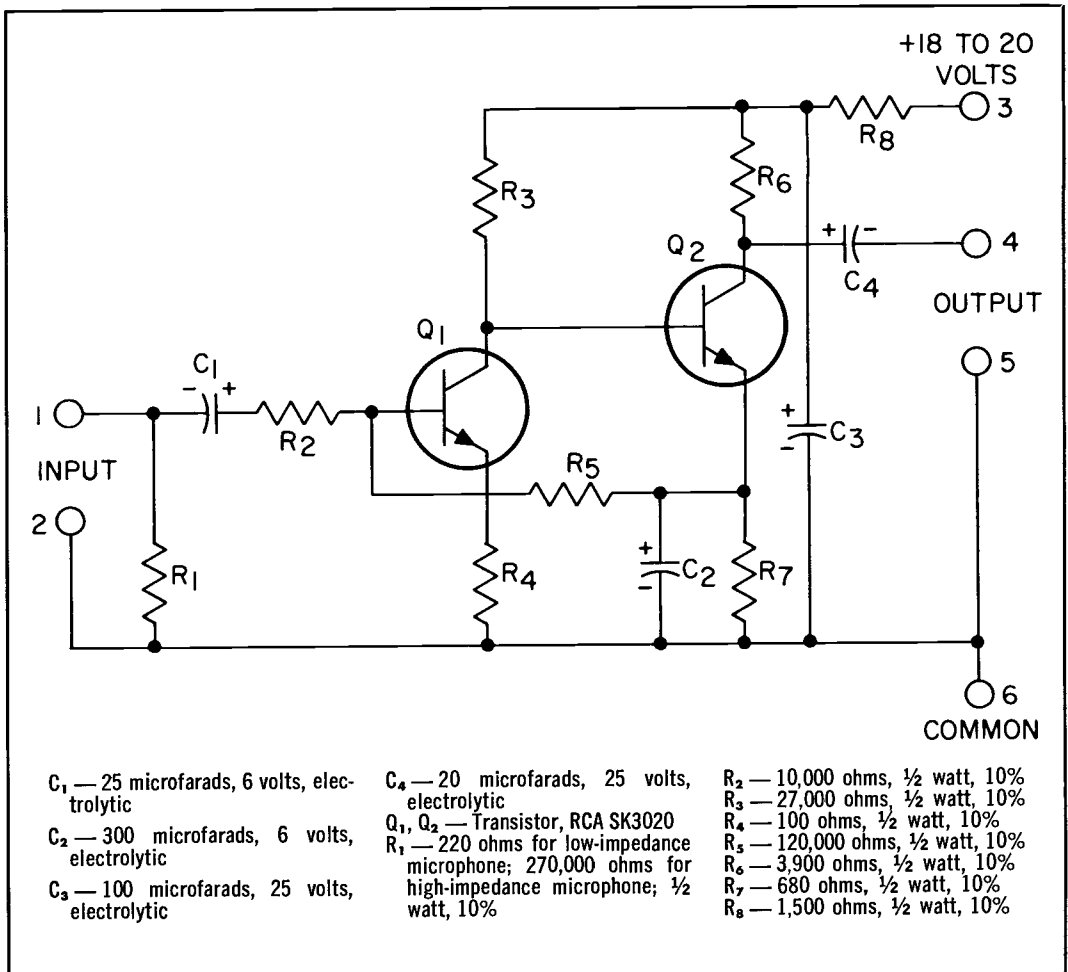

Figure 3: Schematic diagram and parts list for microphone preamplifier circuit.

The integrated-circuit code-practice oscillator is a simple but highly useful circuit that can be used in a code class.

The semi-automatic key generates a dot or a series of dots, depending on how long the paddle-key is held in the dot position; dashes must be made manually. The fully automatic electronic keyer, on the other hand, generates both dots and dashes automatically. The dot repetition rate of the semi-automatic keyer and the dot and dash repetition rate of the fully automatic keyer can be varied by means of a speed potentiometer. Both of these keyers make quality code-transmission easier.

The frequency-selective audio-frequency amplifier is designed to amplify signals at only one predetermined frequency; at this frequency, the voltage gain is about 20 to 30. At other frequencies, the gain is approximately unity. This circuit is very useful under conditions of heavy interference because it has the ability to eliminate the side noise and let the desired signal through.

The audio amplifier is a general-purpose, high-fidelity unit that can be used around the ham shack in any application that requires an amplifier with a power output up to 7½ watts. The amplifier is compatible with all of the audio circuits in the Manual that require amplification.

The dip/wave meter is an extremely useful tool for the radio amateur or the experimenter in electronics because it allows him to measure the resonant frequency and consequently the inductance and capacitance of both energized and unenergized radio-frequency circuits. The meter is battery-operated and hand-held.

Control of frequencies from 3.5 MHz through 148 MHz on the amateur band is possible with the variable-frequency oscillator circuit. The MOS field-effect transistor used in the circuit requires an operating potential of only 10 volts; this voltage can be obtained from an automobile or dry battery through a regulator, or from one of the low-voltage power supplies described in the Manual. Because the MOS transistor generates so little heat, the entire VFO can be enclosed in a box with its tuning coils and capacitors.

The VFO calibrator can be used by a ham operator to calibrate points on a VFO dial or on any signal generator. A separate 100-kHz output provided by the calibrator can also be used to align receivers and calibrate test equipment, such as grid-dip meters.

The most likely application of the audio-frequency-operated switch for the radio amateur is to control a radio transmitter. The AF switch eliminates the need for manual action and is designed with a slight delay action on turn-off so that pauses in speech will not cause the transmitter to turn off prematurely.

Four power supplies are described in the Manual. The voltages of two power supplies are predetermined and fixed; the voltages of the others are continuously variable within the rated values of the supplies. The output voltage of the fixed supplies is determined by fixed circuit components. The universal series power supply is designed to provide output voltages from 6 volts to 35 volts; the universal shunt supply provides 6 volts or less. The two continuously variable supplies are designed to deliver voltages in the ranges of 4.5 to 12 volts and zero to 12 volts, respectively. The 4.5- to 12-volt design is the simpler, more economical of the two. The maximum output current for any of these supplies is 1 ampere.

Audio Control System for SSB

The three circuits designed for joint use as a high-performance solid-state audio control system are particularly suited for SSB, but can also be used very effectively for high-quality tape recording systems and other high-fidelity audio applications.

Figure 1 shows the microphone preamplifier, audio oscillator, and audio mixer, compressor, and line driver assembled as a completed audio control system. Figure 2 shows a block diagram of these three circuits when used as an audio control system for SSB. The construction details for each of the three components of this system are given in the sections which follow.

Microphone Preamplifier

The microphone preamplifier is capable of boosting the output of a dynamic microphone to a 0.5- to 1.0-volt level. It is a two-stage, direct-coupled amplifier with enough feedback to maintain excellent frequency response and extremely low distortion. As with all solid-state preamplifiers, the operating impedance levels are such that this unit has a very low susceptibility to RF pickup and is therefore very stable. The preamplifier works equally well with low-impedance microphones (approximately 250 ohms) or with high-impedance dynamic

microphones (approximately 30,000 ohms).
Circuit Operation:

The schematic diagram and parts list for the microphone preamplifier are shown in Figure 3. When the circuit is in operation, base bias current for the input transistor, Q_1 , is obtained from the emitter of output transistor Q_2 through R_5 . Q_2 obtains its base bias current through the collector resistor of Q_1 , R_3 . This unique bias circuit provides DC feedback for stabilization of the operating points of the transistors. For example, if the operating current of Q_1 increases, the collector voltage of Q_1 decreases and reduces the voltage of the base of Q_2 . This lower voltage causes a reduction in the operating current of Q_2 . When the operating current of Q_2 decreases, the voltage at the emitter of Q_2 also decreases. This voltage

decrease is reflected back to the base of Q_1 , which undergoes a current reduction that offsets the initial increase.

This preamplifier circuit is designed to operate from an 18- to 20-volt source; voltage in this range can be obtained from batteries or from a power supply. The power circuit can be common to the power amplifier. The preamplifier circuit can tolerate voltages greater than 20 volts if R_8 is increased about 400 ohms for every volt above 20 volts. The current drain of the preamplifier is approximately 2.5 milliamperes; the voltage gain is 1,700.

Special Considerations:

When the preamplifier is used with a low-impedance dynamic microphone (such as the RCA-HK97 in the low-impedance mode), R_1 should be 220 ohms; when a microphone

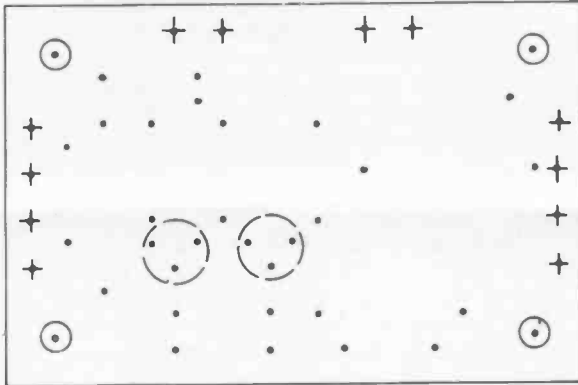

Figure 4: Drilling template for microphone preamplifier (scale 1 inch = 1 inch).

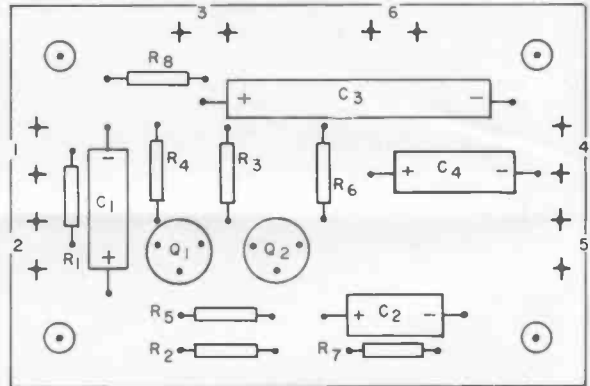

Figure 5: Component placement diagram for microphone preamplifier.

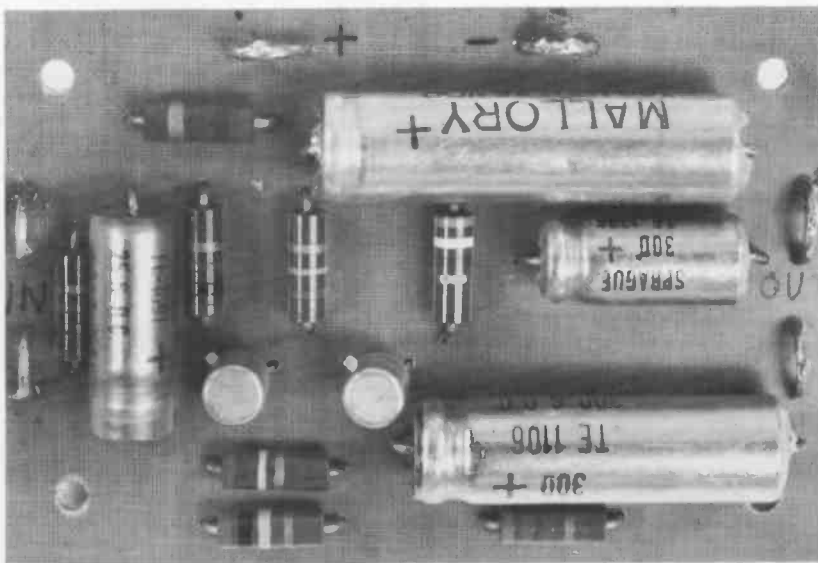

Figure 6: Components for microphone preamplifier mounted on circuit board.

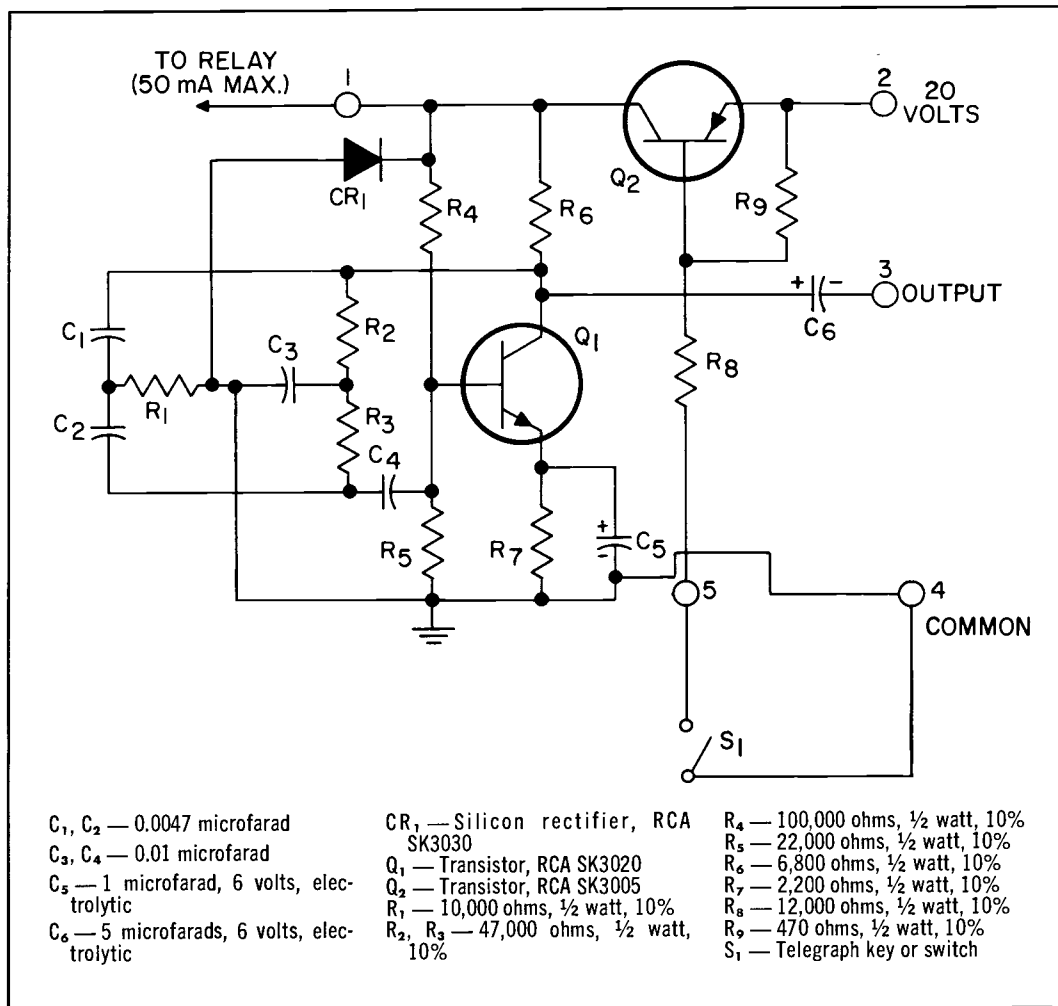

Figure 7: Schematic diagram and parts list for audio oscillator circuit.

with an impedance of about 30,000 ohms is used (such as the RCA-HK97 in the high-impedance mode), R_1 should be 270,000 ohms.

Construction:

The drilling template for the microphone preamplifier is shown in Figure 4. A component placement diagram and a photograph of the completed circuit board are shown in Figures 5 and 6, respectively. A single preamplifier circuit fits on a 3-by-2-inch circuit board; two can be built on a 3-by-4-inch board, and three on a 3-by-6-inch board. If the circuit is not constructed on a board, a ground bus should be used to ground the preamplifier to the circuits that follow it at one point only, preferably at the input to the circuits.

Functions and Circuit Operation of the Audio Oscillator

The audio oscillator, although designed originally for code practice, is excellently suited to provide a sine-wave signal for SSB transmitter tune-up.

The schematic diagram and parts list for the audio oscillator are shown in Figure 7. Transistor Q_1 , capacitors C_1 , C_2 , C_3 , and C_4 , and resistors R_1 , R_2 , and R_3 form a basic twin-T oscillator. Transistor Q_1 is an audio amplifier; its collector is connected to the twin-T network composed of C_1 , C_2 , and C_3 , and R_1 , R_2 , and R_3 . The output of this network is applied to the base of transistor Q_1 through capacitor C_4 , and supplies the feedback required for oscillation.

When the circuit is used to key a relay or

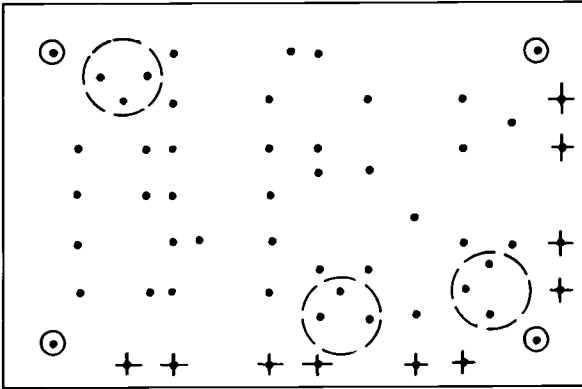

Figure 8: Drilling template for audio oscillator (scale 1 inch = 1 inch).

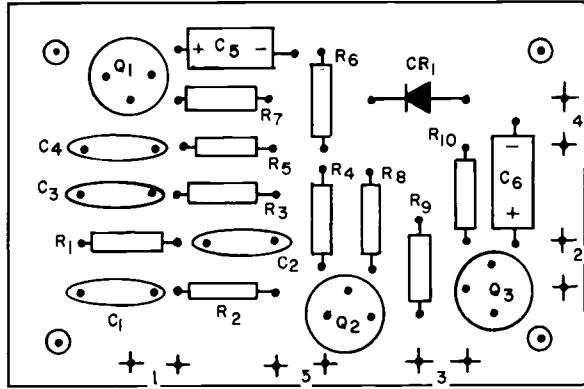
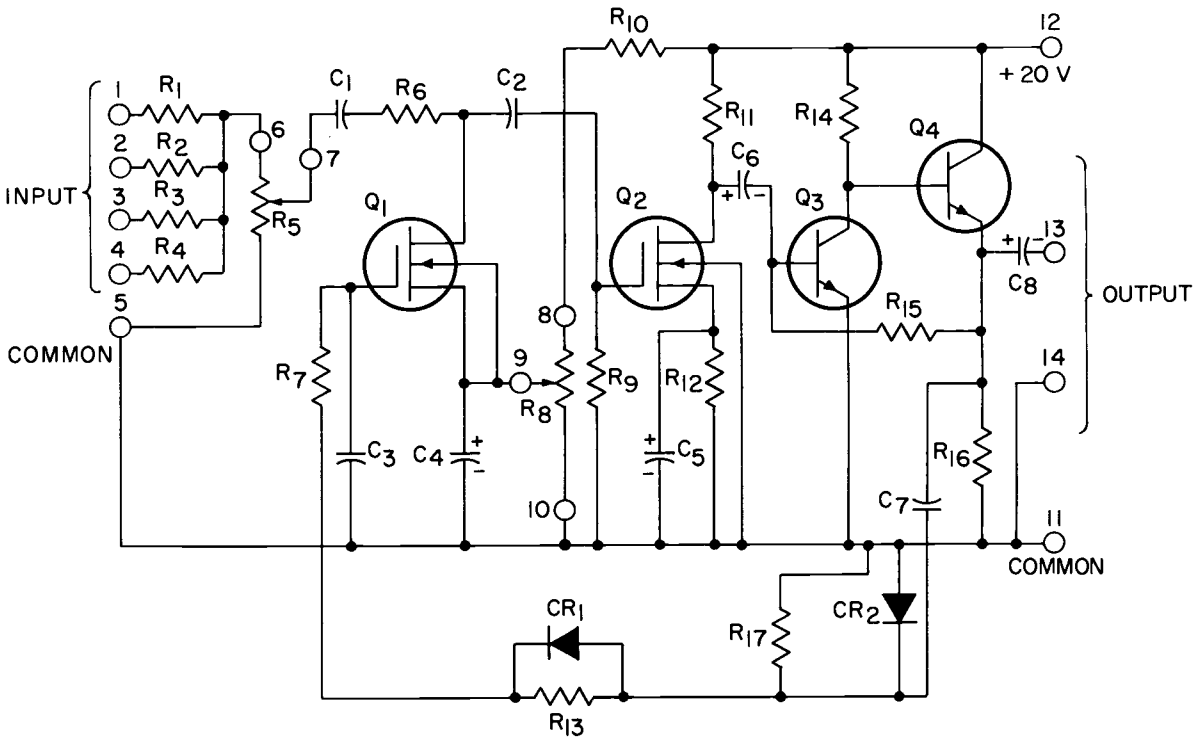

Figure 9: Component placement for audio oscillator. (Note that Q₃ and R₁₀ are omitted).



C₁, C₂, C₃, C₇ — 0.1 microfarad, paper
 C₄ — 10 microfarads, 12 volts, electrolytic
 C₅ — 15 microfarads, 6 volts, electrolytic
 C₆ — 5 microfarads, 25 volts, electrolytic
 C₈ — 50 microfarads, 25 volts, electrolytic
 CR₁, CR₂ — Germanium rectifier, type 1N270

Q₁, Q₂ — MOS field-effect transistor type 3N128
 Q₃, Q₄ — Transistor, RCA SK3020
 R₁, R₂, R₃, R₄, R₇ — 100,000 ohms, ½ watt, 10%
 R₅ — Potentiometer, 10,000 ohms, audio taper
 R₆ — 180,000 ohms, ½ watt, 10%
 R₈ — Potentiometer, 5,000 ohms, straight taper

R₉, R₁₃ — 1 megohm, ½ watt, 10%
 R₁₀ — 15,000 ohms, ½ watt, 10%
 R₁₁ — 10,000 ohms, ½ watt, 10%
 R₁₂ — 1,500 ohms, ½ watt, 10%
 R₁₄ — 1,200 ohms, ½ watt, 10%
 R₁₅ — 100,000 ohms, ½ watt, 10%
 R₁₆ — 470 ohms, ½ watt, 10%
 R₁₇ — 2 megohms, ½ watt, 10%

Figure 10: Schematic diagram and parts list for audio-mixer, compressor, and line-driver circuit.

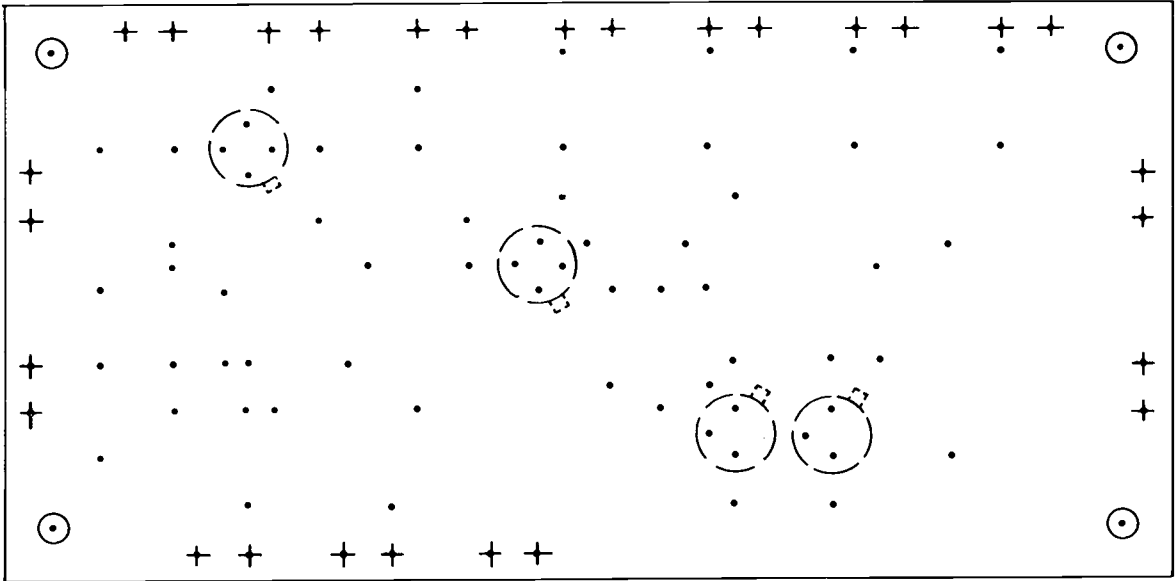

Figure 11: Drilling template for audio mixer, compressor, and line driver (scale 1 inch = 1 inch).

when it is desired to reduce the duty cycle of the transmitter, the supply voltage should be 20 volts. Transistor Q_2 switches power to Q_1 , as well as to the relay. Diode CR_1 protects Q_2 from the high inductive voltages that are present at the terminals of a relay when the relay-coil circuit is interrupted.

Construction:

The drilling template for the audio oscillator is shown in Figure 8 and a component-placement diagram in Figure 9. The template provides for the addition of an emitter-follower stage which is not needed when this circuit is used with the audio-mixer, compressor, and line-driver circuit.

Audio Mixer, Compressor, and Line Driver

The audio-mixer, compressor, and line-driver circuit is used to combine the outputs from the preamplifier and oscillator along with two additional inputs. The compressor portion of this circuit can be adjusted so that any input signal level between 50 millivolts and 1.0 volt will provide an output of approximately 1.0 volt. The line driver is designed for operation at 1-volt rms into a line of 250 ohms.

Circuit Operation:

The schematic diagram and parts list for the audio-mixer, compressor, and line-driver circuit are shown in Figure 10. The circuit consists of a four-channel resistive mixer; an MOS transistor (Q_1) that acts as a voltage-variable resistor; a high-impedance MOS transistor amplifier (Q_2); and a two-stage bipolar line driver.

The gain of each input can be controlled by use of a 50,000-ohm potentiometer between the output of the preamplifier or other source and the input of the mixer stage. Potentiometer R_5 is the master gain control; it controls all channels simultaneously.

The initial bias voltage for Q_1 is set by adjustment of potentiometer R_8 . When Q_1 is biased off, it has an effective drain-to-source resistance of several megohms. This high resistance allows nearly all of the signal voltage appearing at the potentiometer arm of R_5 to appear at the gate of Q_2 . The signal is amplified by Q_2 and passed to the output-amplifier and line-driver transistors, Q_3 and Q_4 . The output signal of Q_4 is rectified by CR_2 and the resultant DC signal is fed back to the gate of Q_1 . The rectified output signal is polarized in such a way that its application to Q_1 reduces the drain-to-source resistance of that transistor. The re-

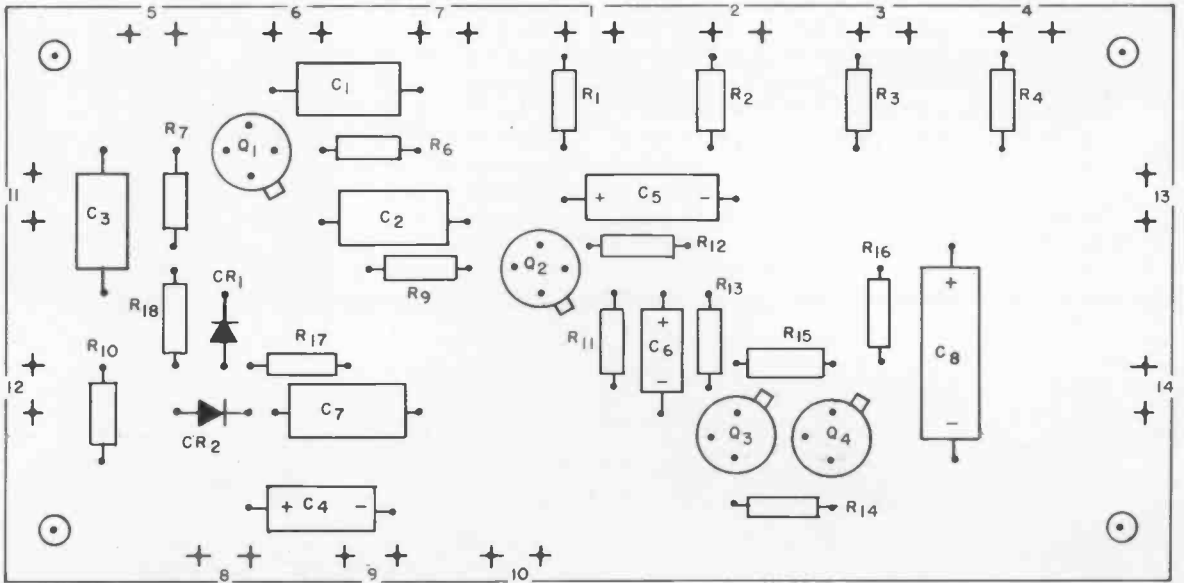

Figure 12: Component placement for audio-mixer, compressor, and line-driver circuit.

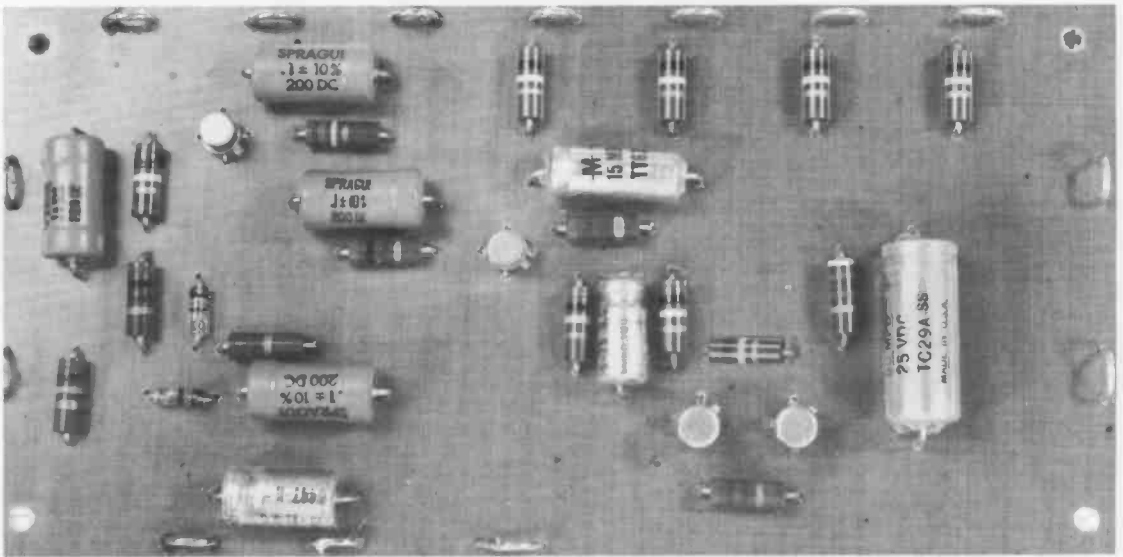

Figure 13: Components for audio-mixer, compressor, and line-driver circuit mounted on circuit board.

sult is a reduced input to Q₂ and an over-all reduction in amplifier gain. CR₁ is inserted in the feedback line so that the rectified DC signal can be applied very rapidly to the

gate of Q₁, and to C₅. During this application, C₃ is charged at a very fast rate. The discharge time of C₃ is slow because CR₁ forces the discharge current to flow

through R_{18} . The product of this arrangement of CR_1 , R_{18} , and C_3 is a circuit that has a fast attack time and a relatively slow release time. A fast attack time is a very desirable characteristic in a circuit of this type because it provides for immediate reduction in system gain and consequent prevention of the overload that could occur with loud speech. The delayed release time helps to maintain a constant level of output during small pauses in speech. Q_4 is connected as an emitter-follower to provide the amplifier with a low output impedance. Circuit current drain is about 23 milliamperes at 20 volts.

Construction:

The drilling template for the audio mixer, compressor, and line driver is shown in Figure 11. A component placement diagram and the completed circuit board appear in Figures 12 and 13, respectively.

Anxious to get started on this unit as soon as possible? If so, your reaction is typical of those being experienced by readers of the new "RCA Hobby Circuits Manual," throughout the country. The auto control system for SSB is but one of the exciting projects offered by this book to brighten your daily living. There are dozens more.

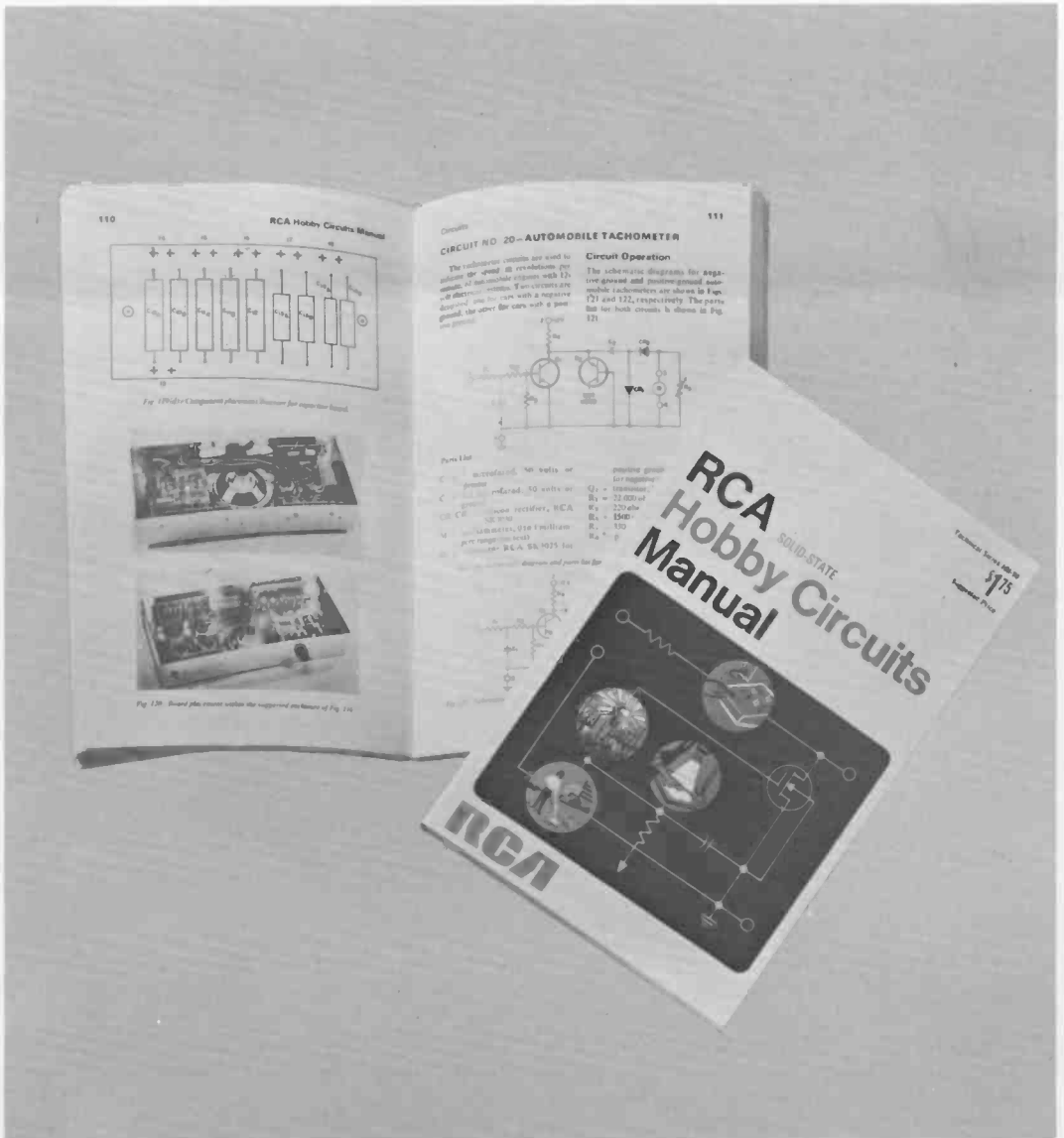

RCA HAM TIPS is published by the Electronic Components operation of RCA, Harrison, New Jersey. It is available free of charge from participating RCA Industrial Distributors. It is also available on a two-year subscription basis (\$1 for eight issues to cover costs of handling and mailing). Please make check or money order payable to RCA, and remit to "RCA, Section 882, Harrison, N. J. 07029."

DISTRIBUTED BY
 GEORGE D. BARBEY CO., INC.
 READING LEBANON
 LANCASTER POTTSTOWN

BLK RT
 ADL. 78¢ PD.



Information furnished by RCA is believed to be accurate and reliable. However, no responsibility is assumed by RCA for its use; nor for any infringements of patents or other rights

of third parties which may result from its use. No license is granted by implication or otherwise under any patent or patent rights of RCA.

Join the "big guns" on the bands...

On 'Phone, 9 of the top 10 DX'rs...on CW, 7 of the top 10 and...on VHF, 8 of the top 10...use **RCA Tubes**

Right across the ARRL "Honor Roll"—'Phone or CW, low band or VHF—the top scorers were checked by an independent research organization. The findings: the largest percentage of the "big guns" use RCA transmitting tubes! Whether they run commercial or

homebrew rigs! For dependable power that slices through QRM and QRN—lets you break through the pile-ups and take full advantage of band conditions—see your RCA Authorized Industrial Tube Distributor for power tubes—rated "tops" by the leaders.



Small Size—BIG POWER!

RCA-8122—paired for maximum legal input in CW and voice operations up to 500 MHz. See your RCA Distributor or write RCA Electronic Components, Commercial Engineering, Section 0000, Harrison, N. J. 07029, for data sheet giving full ICAS specs.

RCA

