

HAM TIPS

from



Published by RCA Manufacturing Company, Inc., Camden, N. J., U. S. A.

VOL. 2—No. 6

CAMDEN, N. J.

NOVEMBER, 1939

R-F TUBE COST OF 450-WATT RIG ONLY \$11.50

NEW RCA DUAL RATINGS MEET WIDE APPROVAL

Permit Increases of Power in Many Rigs

Judging by the comments we have already received regarding our new Dual Rating System, both directly and through our correspondence, it is evident that radio amateurs and many other users of RCA Transmitting Tubes welcome the new System with open arms. Unquestionably, the CCS and ICAS ratings for many of the most popular air-cooled transmitting tubes offer a high degree of flexibility in transmitter design which is almost equivalent to the introduction of many new tube types having

(Continued on page 4, column 3)

MINIATURE!



Four new miniature tubes that provide a complete complement for the design of compact, lightweight, portable equipment have just been announced by RCA. They are only two inches in length by three-quarters of an inch in diameter and give highly efficient operation from a 45-volt "B" supply.

RCA-812's DRIVEN BY RCA-807 MAKE EXCELLENT COMBINATION

Has 240 Watts Output on 'Phone and 340 Watts Output on CW

PICTURES?

We are still paying \$5.00 each for good photos of 100% RCA tubed transmitters. Final amplifier stages are O.K. Give us a brief description with important details. What have you?

(This offer good in Western Hemisphere, Hawaii, and the Philippine Islands.)

A transmitter employing a pair of the new RCA-812's or RCA-811's driven by a single RCA-807 may not be the last word in ham rigs, but it is a rig which you will find extremely hard to beat on a basis of tube cost versus performance. The final amplifier chassis of such a transmitter, including the 807 driver stage, is shown in the accompanying photographs and circuits.

This rig, using only three \$3.50 tubes, plus a \$1.00 "Tritet" crystal oscillator tube (RCA-6V6-G) for the exciter, has a total tube cost for the r-f section of only \$11.50. Since push-pull 812's, operating at the moderate plate voltage of 1500 volts, will take an input of 450 watts (class C telegraphy), the cost of the r-f tubes is unbelievably low. Expressed in terms of power amplifier watts input per dollar of total r-f tube cost, it is 450/11.50 or 39.2 watts input per dollar. Until the recent announcement of the new RCA-811 and RCA-812, this figure was excellent even for a single r-f amplifier stage! Facts and figures speak for themselves as regards the extreme economy of the push-pull 812 rig now to be described.

Uses Standard Parts

The various circuit components which are mentioned by manufacturer's trade name are the parts which were actually used in the construction of this transmitter. In many cases, equivalent parts of other manufacture can be substituted if desired.

The 807 driver and the push-pull 812's are mounted on an "Electralloy" chassis 10" x 17" x 3", a size suitable for relay rack mounting. The spacing between the various parts on top of the chassis is not particularly critical and can be seen in the top-view photograph. The split-stator

(Continued on page 2, column 1)

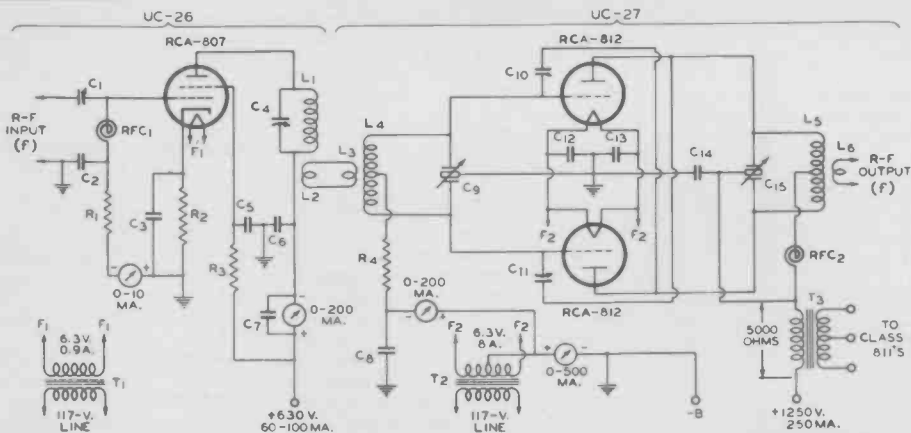

PUSH-PULL R-F POWER AMPLIFIER 812's† WITH 807 BEAM POWER DRIVER STAGE

Class C Telephony Power Output 240 Watts*

Class C Telegraphy Power Output 340 Watts††

- C₁ = 10-70 μf mica trimmer (ceramic-base type).
- C₂, C₃, C₄, C₅, C₆, C₇, C₈, C₉, C₁₀, C₁₁, C₁₂, C₁₃ = 0.005 μf mica.
- C₄ = 165 μf, 0.05" air gap (Cardwell Midway Type MO165BS).
- C₅ = 260 μf/section, 0.031" air gap (Cardwell Dual Midway Type MR260BD).
- C₁₀, C₁₁ = 4.7 μf, 0.140" air gap (Cardwell Type ZS7SS).
- C₁₄ = 0.002 μf mica, 5000 volts (Sangamo).
- C₁₅ = 100 μf/section, 0.070" air gap (Cardwell Dual Midway Type MT100GD).
- R₁ = 10,000 ohms, 1 watt.
- R₂ = 300 ohms, 10 watts.
- R₃ = 40,000 ohms, 10 watts.
- R₄ = 2500 ohms, 10 watts (photo shows 5000-ohm, 25-watt adjustable resistor).

- RFC₁, RFC₂ = 2½ millihenry r-f choke** (National Type R-100).
- L₁ = 9 turns ¼" copper tubing, 2" inside diameter, 4½" long (20 meters).
- L₂, L₃ = 2-turn coupling link, #18 insulated wire (or larger).
- L₄ = 14 turns #12 solid enamel, 1½" inside diameter, 1½" long, mounted on 5-pin tube base (20 meters).
- L₅ = 12 turns ¼" copper tubing, 2½" inside diameter, 4½" long (20 meters).
- L₆ = 2-turn output link, #12 solid wire, around center of L₅ (see text) and insulated for 3000 volts.
- T₁ = 6.3-volt, 1-ampere filament transformer (Thordarson T19F80).

- T₂ = 6.3-volt, 10-ampere filament transformer (Thordarson T19F99).
- T₃ = Modulation transformer, 150-175 watts; primary, plate-to-plate, 15,000 ohms; secondary, 5000 ohms. (Not shown.)
- † Or 811's—see text.
- ‡ Approximate.
- †† At 1500 plate volts and 300 ma. plate current.
- ** More inductance may be desirable at the lower frequencies.
- NOTE: Rotor shaft of C₁₅ is at high d-c plate potential. An insulated coupling shaft must be inserted between rotor shaft of C₁₅ and its control dial. Same applies to C₁.

Tube Cost of 450-Watt Rig Only \$11.50

(Continued from page 1, column 4)

grid condenser C_9 is mounted in the exact center (lengthwise) of the chassis. The other parts are then placed on the chassis so as to provide short grid and plate leads. The 807 plate tank L_1C_1 is at the left, L_2C_2 is in the center, and L_3C_3 is at the right. The neutralizing condensers C_{10} and C_{11} are mounted, by means of standard brackets supplied with the Cardwell AFU "100-watt" foundation unit, underneath the split-stator plate condenser C_{15} . This latter condenser, also a part of the AFU foundation unit, includes two type "M" base-mounting brackets which were shifted over to mount the grid condenser (C_9), type "MR260BD." The plate condenser, the frame of which can not be grounded to the chassis because it is tied to the +B lead (see circuit UC-27), is mounted on two sturdy metal-base ceramic pillars $\frac{1}{2}$ inch in diameter and $1\frac{1}{4}$ inches high. Standard right-angle brackets fasten the condenser frame to the ceramic insulators. If the +B connection to the rotor frame were omitted, C_{15} would have to have twice as much air gap between adjacent plates and would be much more bulky and expensive.

The two type "BW" yoke brackets supplied with the AFU foundation unit are not needed, because the 812 plate coils are mounted on home-made "Mycalex" jack-and-plug strips measuring $\frac{3}{4}$ " x $5\frac{1}{2}$ " x $\frac{1}{4}$ ". An outline drawing of these coil mountings is shown in Fig. 1.

The 807 plate-coil mounting is similar to that used in the final stage, except for the location and number of the plugs and jacks. Although the material used for the coil-mounting strips in this stage was not "Mycalex," it is preferable to use Mycalex (or other suitable low-loss material), at least for the jack strip and for the 10-meter-coil plug strip. Fig. 2 shows an outline drawing of the 807 coil mountings.

Individual Coupling Adjustments Easily Made

The aluminum brackets mounting the jack strip to condenser C_4 are designed to fit the front frame screw and the rear stator terminal of the condenser. The two plate-coil jacks go through both the insulating strip and the two mounting brackets, the latter forming the leads from coil to condenser. The two inner jacks are

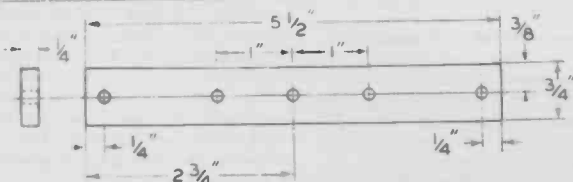
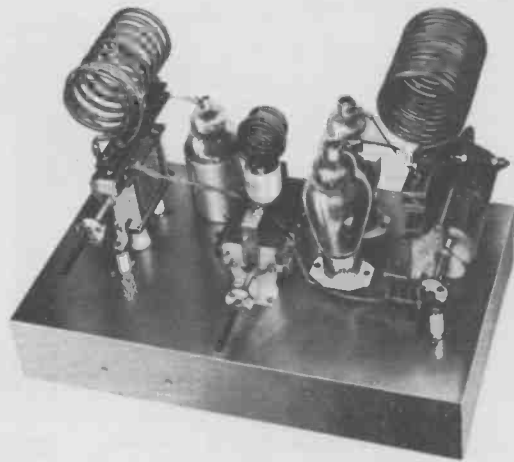

Figure 1—Outline drawing of Mycalex plug-and-jack strips used to mount the 812 plate coils. The jack strip is mounted directly on two opposite stator terminals of the condenser by two aluminum brackets. The end jacks go through both base strip and mounting brackets, thus forming the coil-condenser leads.



Clean, simple construction is a feature of this power amplifier using a pair of RCA-812's driven by an RCA-807. Maximum output is 340 Watts CW.

for the link circuit, the 2-turn link being an integral part of each plate coil. This arrangement allows individual coupling adjustments to be made once and then left alone, for each band. The tight coupling of the link as shown in the photograph was adequate to drive plate-modulated push-pull 811's, and overdrives two 812's. For the latter tubes, the link should be bent outward to loosen the coupling. As an incidental point, the neutralizing condensers did not have to be readjusted whether 811's or 812's were "plugged in" the final stage. The only change needed was in the grid excitation and in the value of grid leak R_4 .

Design data for the 20-meter coils (the ones shown in the photo) are given in the legend beneath circuit diagrams UC-26 and UC-27. Home-made coils are used because they readily permit the desired LC ratio to be obtained for each band. This point deserves an explanation. The 812 stage shown in circuit UC-27, being designed for plate-modulated telephony (changes for cw operation are covered further along), operates with the ICAS ratings of 1250 volts and 250 ma. Applying the ratio E_b/I_b (1250/250) to the capacitance chart on page 151 of the RCA TT-3 Manual, we find that a plate tuning capacitance (for a single-ended circuit) of $25 \mu\text{f}$ is indicated for a tank-circuit "Q" of 12, at 10 meters. For a split-tank circuit, this value becomes $\frac{1}{2}$ of 25, or $12.5 \mu\text{f}$ per condenser section for the 10-meter band. This is 12.5/10, or $1.25 \mu\text{f}$ per meter per section. At 20 meters, therefore, the

inductance of L_3 should be such that it resonates to the operating frequency with a capacitance per section of (20) (1.25), or $25 \mu\text{f}$. Thus, L_3 should be designed so that condenser C_{15} resonates, on 20 meters, when it is about $\frac{1}{8}$ meshed. Condenser C_{15} has a capacitance variation of $13 \mu\text{f}$ minimum to $100 \mu\text{f}$ maximum, or $87 \mu\text{f}$ total effective range. Therefore, $\frac{1}{8}$ of $87 \mu\text{f}$ plus the $13 \mu\text{f}$ minimum

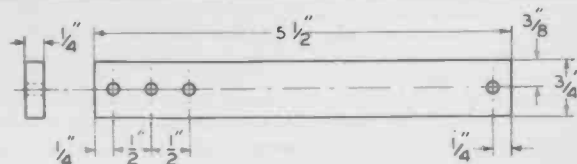

Figure 2—Outline drawing of plug-and-jack strips used to mount the 807 plate coil. The jack strip is mounted to the front frame screw and to the rear stator terminal of C_4 by means of aluminum brackets. The Mycalex strips come in 11-inch lengths and were obtained from the Allen D. Cardwell Co. Each length provides two coil strips.

value provides a total of about $25 \mu\text{f}$ per section, as desired.

Capacitance Not Critical

It should be remembered, of course, that the exact capacitance value used is not critical because there is nothing "sacred" about a "Q" of 12. The use of a slightly larger "Q" is quite good design for telephony. A smaller "Q" (less tuning capacitance) should be avoided, however, in the interest of better modulation linearity and in the reduction of harmonics. It is advisable, as a general rule, to determine the desired value of capacitance from the TT-3 chart and then to use this value as a design factor toward which to work in making coils for each band. For C_{15} , the capacitance chart values per condenser section for 5-band operation are as follows:

10 meters	$12.5 \mu\text{f}$ per section*
20 meters	$25 \mu\text{f}$ per section
40 meters	$50 \mu\text{f}$ per section
80 meters	$100 \mu\text{f}$ per section
160 meters	$200 \mu\text{f}$ per section

* More capacitance must actually be used because the minimum capacitance of C_{15} is $13 \mu\text{f}$.

It is apparent that, for this particular rig, the Cardwell plate condenser "MT100GD" ($100 \mu\text{f}$ per section) is just large enough for 80 meters with the plates fully meshed, and has a minimum capacitance just low enough for a satisfactory "Q" at 10 meters with the plates only slightly meshed. For 160-meter operation, it is advisable to add a $75\text{-}\mu\text{f}$ fixed air condenser of the plug-in type across the entire plate coil (L_3). This is the same as adding $150 \mu\text{f}$ per section to C_{15} as a minimum capacitance value. The fixed air condenser must have twice the air gap of C_{15} ; that is, an air gap of at least 0.14" is needed in order to withstand the peak-to-peak r-f voltage across L_3 . The r-f voltage at one end of the plate coil reaches a positive peak at the same instant the r-f voltage at the other end reaches a negative peak, and the peak-to-peak value is twice the peak value as measured to the center of the coil or to the rotor frame of C_{15} . A fixed air condenser such as Cardwell type JTT-75-OS or equivalent meets these specifications. Provision should be made for mounting it on the chassis at the right of C_{15} , if 160-meter operation is contemplated. Such provision was not made with the layout illustrated in the photograph, but a suitable re-arrangement of the parts is readily possible.

Capacitance Adequate For All Bands

The capacitance of either C_4 or C_9 , as specified in the legend, is adequate for all bands from 10 to 160 meters. In designing the coils for the 807 plate tank, one can again use the TT-3 capacitance chart. At 600 volts and 60 ma. (for the 807), a value of $1.25 \mu\text{f}$ per meter is again indicated, by co-incidence. Knowing the desired capacitance for each amateur band, one can readily design the various coils by using one of the well-known inductance formulas or charts as a guide, assisted by prior experience, along with a generous helping of "cut, try, squeeze, and pull."

Knowing the desired value of total effective tuning capacitance, one can obtain the value of the required inductance from the formula,

$$L = 25.33 \times 10^9 \text{ where "L" is in } \mu\text{H}$$

microhenries. "f" is in kilocycles per second, and "C" is in microfarads. In the case of the 20-meter final amplifier tank circuit, the total effective capacitance across the entire

R-F Tube Cost of 450-Watt Rig Only \$11.50

(Continued from page 2, column 4)

plate coil should be $12.5 \mu\text{f}$ —one-half of the $25 \mu\text{f}$ per section value previously mentioned. Inductance L_6 , as specified, is just a bit too small to resonate with this capacitance. Two more turns—14 instead of 12—may more nearly give the desired LC combination. Likewise, L_1 tunes to 14 Mc. with $58 \mu\text{f}$ of capacitance, and therefore should be slightly larger than the size specified in order to meet the theoretical design requirements previously outlined.

In none of these calculations have tube-output or circuit-wiring capacitances been mentioned. Wiring capacitances, in a well-designed transmitter layout, are usually negligible at frequencies up to 60 Mc. The effective output capacitance of two triodes in a push-pull stage is equal (approximately) to $\frac{1}{2}$ the plate-filament capacitance plus the grid-plate capacitance ($\frac{1}{2}C_{pf} + C_{gp}$). The two 812's, therefore, have a total effective output capacitance of $0.4 + 5.3$, or $5.7 \mu\text{f}$. Theoretically, in a push-pull stage, twice this value of capacitance ($11.4 \mu\text{f}$) should be subtracted from the per section condenser values obtained for each amateur band from the capacitance chart. At 30 Mc, the tube capacitance obviously represents the largest part of the total $12.5 \mu\text{f}$ per section required, even neglecting the minimum capacitance of C_{15} . The best procedure, therefore, is to design L_6 for 10 meters so that C_{15} tunes practically all the way out. These considerations show clearly why LC values become increasingly important at frequencies of 14 Mc and higher.

To return now to our description of the 812 rig, the top-view photograph does not show the two-turn output link coil (L_6) around the center of L_5 , although plug-and-jack connections are provided for it on the mounting strips. This link can be wound with #12 solid wire with a diameter about $\frac{1}{2}$ inch larger than the diameter of L_5 . The wire should either be insulated for 3000 volts with high-quality spaghetti tubing or separated from L_5 by ceramic spacers, so that it can in no case come in contact with the high d-c plate voltage on L_6 . The short +B lead from the center plug to the center tap of L_5 should be covered with heavy spaghetti tubing or else heavily taped.

The bottom-view photo of the chassis shows the location of the various filament transformers, resistors, by-pass condensers, and other parts. A separate filament transformer is used for the 812's so that the final stage can be keyed in the filament center-tap circuit, if desired. A keying relay can be placed under the chassis for this purpose, along with a key click filter, because plenty of extra space is available.

If the amplifier chassis is mounted in a rack, the meter connections to the 807 and 812 stages are simplified by mounting the four meters on the amplifier panel. If a separate meter panel is used, several meter leads

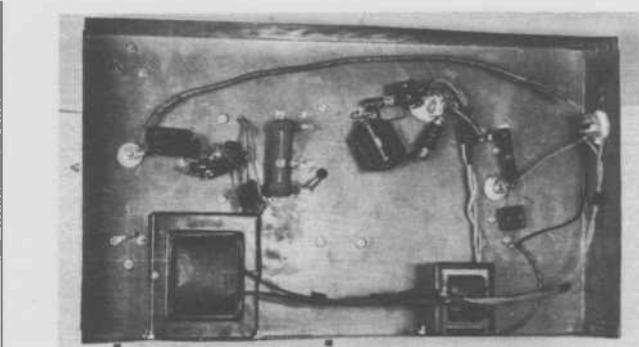

The under-chassis view also shows the remarkable simplicity of construction of this fine performing transmitter.

must be brought out by means of a terminal jack or strip. Of course, a single meter with a plug-cord can be used by placing closed-circuit meter jacks in place of the various meters. It is important, however, to leave the 500-ma. final-stage plate meter permanently wired in the cathode circuit at all times. This meter, connected as shown, will not include the grid current in its reading.

The r-f input to the 807 is fed through the 10-70- μf mica trimmer (C_1), which is located at the grid terminal of the 807 socket. The exciter unit, which can consist of a 6V6-G or 6L6-G "Tritet" crystal oscillator, should normally be located on a chassis immediately below the power amplifier. The 807 excitation lead can then be made quite short. A phone-tip plug-and-jack inserted in this lead will allow the two units to be readily disconnected for removal from the rack. A suitable "Tritet" oscillator is shown in circuit UC-1 in "Ham Tips" for September, 1938.

Tuning the Transmitter

In tuning up the rig for the first time, one should tune one stage at a time, beginning with the oscillator, and leaving the plate voltage off the 807 and the 812's. After the 807 grid-current meter shows that the oscillator is functioning properly (a d-c grid current of 3 to 5 ma. is proper for the 807), a 5000-ohm 200-watt protective resistor should be inserted in the 807 +B lead. The resonant point on C_4 can then be found without danger of overloading the 807 during the tuning procedure. The protective resistor should then be removed. Next, L_2 and C_3 should be adjusted for proper coupling and resonance, respectively, as indicated by the 812 grid meter.

With full plate voltage on the 807, the 812 grid meter should read somewhat higher than the desired operating value of 50 ma., because the amplifier grid current drops when the 812 plate voltage and plate load are applied. The next step, before the high voltage is placed on the final stage, is the neutralization of the 812's. A small neon bulb and a Bakelite-rod type of screw driver are handy tools for the proper adjustment of C_{10} and C_{11} . The shafts of these condensers are conveniently slotted for this purpose. The rear neutralizing condenser requires set-

ting at a slightly higher capacitance than the front one, due possibly to the fact that its lead to the grid of the rear 812 is just slightly longer (and has a little more capacitance to ground) than the corresponding front lead. This difference is of no practical importance in the operation of the amplifier, however. After an r-f voltage minimum (shown by the neon bulb) has been established at both ends of L_5 , the final amplifier grid meter should not "kick" perceptibly when C_{15} is tuned through resonance. It is essential, of course, constantly to retune C_4 , C_9 , and C_{15} as the neutralizing adjustments are being made, due to circuit interaction.

Protective Resistor in B+ Lead

The husky 5000-ohm protective resistor should next be placed in the +B lead to the 812's, and the resonant point on C_{15} located. The absence of a resonant point usually means that L_5 is either too big or too small for the tuning range of C_{15} . If a protective resistor is not used, the 500-ma. plate-current meter will bang off scale with a somewhat terrifying speed! "Spotting" of the zirconium-coated 812 plates, while not damaging to the tubes (see "Ham Tips," Oct., 1939), is undesirable and can be easily avoided by means of the protective resistor while the initial tuning is in progress. Once the resonant point is determined for a given band, the dial reading should be noted, so that the condenser can be pre-set in future "tunings up" after band changing. This also applies to the 807-stage dial setting.

All operating tests were made on 14 Mc. The final-stage plate current dips to about 30 ma. at no-load resonance. Pencil tests are not recommended to determine how large an r-f arc can be drawn from the final plate tank, because of safety considerations. Besides, the pencil catches on fire.

In the particular test made on this rig at the station of W2BRO, the 2-turn output link (L_6) was coupled to a half-wave "Zepp" antenna coil by means of a few feet of twisted pair terminated by another 2-turn link. The 812's loaded to 250 ma. very easily. Variation of the link coupling at the antenna tuned circuit was necessary because the coupling of L_6 was fixed. A swinging-link assembly at L_5L_6 would be more

convenient, if commercial plug-in coils were used.

May Be Modulated with Pair 811's

A logical, economical modulator for the 812's is a pair of RCA-811's in class B, driven in turn by a pair of 2A3's, or by a pair of 6L6's in class AB₁ with inverse feedback. A circuit of the latter type is shown on page 4 of Oct., 1939, "Ham Tips." With 1250 plate volts and zero bias, two 811's will deliver about 175 watts of a-f power. The push-pull 812's require only 155 watts of audio for 100% plate modulation, which means that some surplus modulating power is available from the class B 811's.

An oscillograph pattern of the r-f output, with a steady sine-wave signal, showed the modulation to be quite linear. No trouble was had with arc-overs or distortion at 100% modulation, even when an overload test was made with 1500 volts on the 812 plates.

CW Operation of 812's

For cw operation, the 812's can be run at the ICAS ratings of 1500 volts and 300 milliamperes. The grid leak (R_4) should be changed to 3500 ohms (20-watt size). The keying relay contacts can be placed in the lead coming from the center tap of filament transformer T_2 . However, because the filaments of the 812's assume the d-c plate potential when the key is up (the tubes act somewhat like an unloaded rectifier), filament by-pass condensers C_{12} and C_{13} must be changed to a high-voltage type—a rating of 2500 volts being adequate. An alternative by-passing arrangement is shown in circuit UC-23 in October, 1939 "Ham Tips," using one high- and two low-voltage condensers. A key-click filter will be found essential with this type of keying circuit.

Slightly more excitation is needed for cw operation of the 812's; this can be obtained by adjusting the coupling of L_2 and L_1 . Oscillator keying is not recommended for the circuits shown. For this type of keying, the 807 screen voltage would have to be obtained from a fixed, low-voltage source; in addition, partial fixed bias of near-cut-off value in conjunction with reduced values for grid leaks R_1 and R_4 would be required for both stages.

Substituting 811's

The only changes required in order to use plate-modulated push-pull 811's are in the grid excitation and in the value of the amplifier grid leak. The coupling of L_2 and L_1 must be tightened so as to increase the total amplifier d-c grid current from 50 ma. to 100 ma. The grid leak R_4 must be changed from 2500 ohms to 1250 ohms (20-watt size). The d-c plate current of the 807 driver should then be about 100 ma.—the maximum rated value for this tube. The 812's will load the 807 only to about 50 or 60 ma.

For cw operation with 811's, the grid leak R_4 should be made about 1700 ohms (20 watts). Partial fixed

(Continued on page 4, column 4)

FINE LOW-POWER RIG MADE WITH 6L6-G/809 TUBE COMBINATION

CM2AD Wins Tube for Circuit "Tip"

The excellent r-f amplifier characteristics of the RCA-809, together with its unusually low price, has made this tube one of the outstanding amateur favorites. The fact that the 809 requires relatively little driving power and operates at a moderate plate voltage makes it well suited for use in simple, low-power transmitters such as most beginning (and many old-time) amateurs take delight in constructing and operating.

The circuit of Fig. 3, submitted as a "ham tip" by Cuban CM2AD, shows a 6L6-G crystal oscillator-doubler driving an 809 final amplifier (CM2AD wins one 809 for this contribution). This rig is illustrated in the photo, with the 20-meter coils in place. A 40-meter crystal is employed with "straight-through" operation for that band. On 20 meters, the oscillator plate tank is tuned to the second harmonic of the crystal. The 809 is driven to a d-c grid current of 30 ma. on both 20 and 40 meters, with about the same d-c plate input (15 watts) to the oscillator in either case. CM2AD suggests that his inefficient 40-meter oscillator plate coil, wound on a tube base, may account for the fact that he does not get more drive on 40 than on 20 meters. In any event this arrangement is certainly good design, because he does not have to change the excitation to the 809 when changing bands. The 809 plate current at no-load resonance dips to 23 ma. on 40 meters and to 14 ma. on 20 meters, indicating that the amplifier plate-circuit efficiency is fairly high. The 809 loads to 100 ma. quite easily when the antenna load is coupled in by L_4 .

Uses Plate Modulation

CM2AD reports also having used plate modulation with this rig. He pushes the 809 grid current up to 35 ma. for 'phone, by increasing the oscillator plate voltage slightly. C_{11} should have a 2000-volt rating and C_9 a 3500-volt rating for plate-modulated operation.

The oscillator plate voltage is taken from a tap on a 25000-ohm, 200-watt bleeder across the 750-volt plate supply. Although CM2AD did not mention trouble from "chirps" when the 6L6-G is keyed, it is possible that a steadier note can be obtained by using a fixed tap on the voltage divider for the oscillator screen voltage, instead of a series screen resistor.

The oscillator circuit appears to be a "Tritet" without a tuning condenser across the cathode coil. The by-pass condenser shown in Fig. 3 in dotted lines was not included on CM2AD's original sketch. It may be required in some layouts, inasmuch as it furnishes the 6L6-G cathode

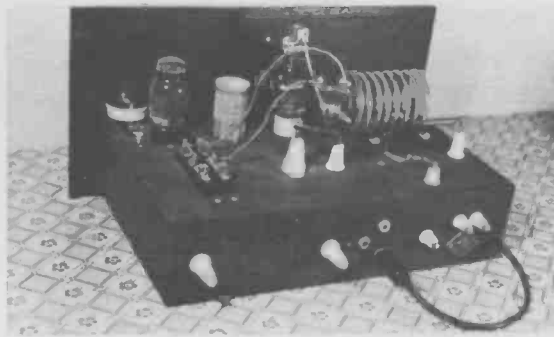

CM2AD takes in a 5-spot for this photo of his simple, two-tube rig using an RCA-6L6-G to drive an RCA-809 on 20 or 40 meters. Circuit is shown in Fig. 3. He reports having built three rigs of this type for friends—and that they all worked equally well. See accompanying story for more details.

circuit with a short r-f return path to ground. In this rig, however, the by-passing through C_7 and C_8 is adequate. The use of the extra condenser might require a slightly different value of inductance for cathode coil L_4 .

This little rig has given CM2AD real results. He lists his dx as 62 countries, WAC, and WAS. Many "kilowatt"ers have done less!

In a letter dated September 25, 1939, CM2AD reports that he is terribly disappointed over the Cuban Government's decision to cancel all Cuban amateur licenses. He believes, however, that new regulations permitting amateur operation are in the "offing." Along with him, we certainly hope so! In the meantime, our heartfelt sympathies to a silent neighbor.

NEW CHART

Your RCA Power Tube Distributor now has a large chart showing the superior values of RCA Power Tubes. Be sure and check this chart before making any power tube purchase.

New RCA Dual Ratings Meet Wide Approval

(Continued from page 1, column 1)

"in between" power ratings. That is, the gap in power capability between any tube and the next larger size has been materially reduced.

For those who missed the announcements carried in October "Ham Tips" and in November QST and RADIO, a brief description of the new RCA Dual Rating System is in order. Instead of one set of maximum ratings for each tube type, two sets of maximum ratings are given. These ratings are designated "Continuous Commercial Service (CCS)" and "Intermittent Commercial and Amateur Service" (ICAS).

CCS Same As Former Ratings

The CCS ratings are essentially the same as the former maximum ratings. The ICAS ratings, however, are considerably higher, permit the use of much greater power input, and provide a relatively large increase in useful power output. For example, the a-f power output of two 809's in class B is 100 watts at the old maxi-

imum plate-voltage rating of 750 volts. At the new ICAS rating of 1000 volts, the power output is 145 watts—an increase of 45 per cent. In plate-modulated telephony service, the r-f output of the 809 is 38 watts with the CCS ratings and 55 watts with the new ICAS ratings—also an increase of about 45 per cent.

The new system provides transmitting-tube ratings which recognize the diversified design requirements of modern transmitter applications. For example, there are numerous applications where the design factors of minimum size, light weight, low initial cost, and maximum power output are far more important than extremely long tube life. In such cases, the set designer may very properly decide that a small tube operated with ICAS ratings better meets his requirements than a larger tube operated with CCS ratings.

To meet the large demand for data on the new ICAS ratings, a 20-page booklet entitled INCREASED RATINGS, has been prepared and is available free on request from the Commercial Engineering Section, RCA Mfg. Co., Inc., Harrison, N. J.

R-F Tube Cost of 450-Watt Rig Only \$11.50

(Continued from page 3, column 4)

bias is not needed for the 811's when oscillator keying is employed, due to the zero-bias, high- μ design of this tube type. The 811 is, therefore, preferable to the 812 in this particular type of service. If center-tap keying of the final stage is to be used, there is little to choose from between the 811 and the 812.

A subsequent issue of "Ham Tips" will describe a class B modulator using two 811's, together with a circuit of a complete speech amplifier and driver. The subject of cathode modulation is being given special attention. More on this later.

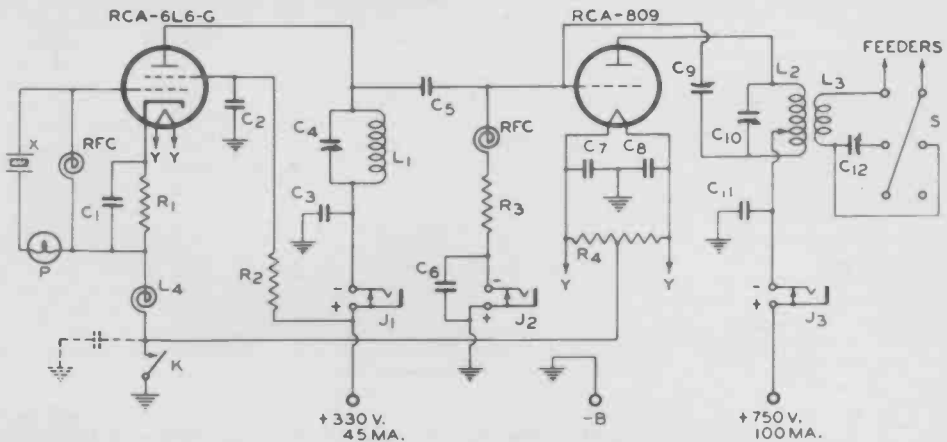

FIGURE 3—CW RIG FOR 40 AND 20 METERS

Power Output 55 Watts*

(Submitted by CM2AD, who gets one RCA-809 for this circuit suggestion)

- C_1 = 40 μ f mica
- $C_2, C_3, C_6, C_7, C_9, C_{11}$ = 0.002 μ f mica.
- C_4 = 150 μ f midget variable.
- C_5 = 50 μ f mica.
- C_8 = 18 μ f neutralizer.
- C_{10} = 100 μ f variable.
- C_{12} = 350 μ f receiver type.
- R_1 = 500 ohms, 5 watts.

- R_2 = 20,000 ohms, 5 watts.
- R_3 = 3000 ohms, 5 watts.
- R_4 = 40 ohms, c.t., wire-wound.
- K = Key.
- L_1, L_2 = Tune to 7 or 14 Mc.
- L_3 = Antenna coil—7 turns #14 enamel, 2" diameter.

- L_4 = 10 turns #20 D.C.C., 1" diam., 2" long (see text).
- RFC = 23 μ mh. r-f choke—small size.
- X = 40-meter crystal.
- P = 6-8 V., 150-ma. tan bead pilot bulb.
- S = D.P.D.T. feeder switch.
- J_1, J_2, J_3 = Single-closed-circuit jack.
- * Approximate.

The license extended to the purchaser of tubes appears in the License Notice accompanying them. Information contained herein is furnished without assuming any obligation.