

RCA Engineer

Vol. 30 No. 5 Sept. / Oct. 1985



COMPUTER GRAPHICS

RCA Engineer

A technical journal published by the
RCA Technical Excellence Center □ 13 Roszel Road □ P. O. Box 432 □ Princeton, NJ 08540-0432 □ Tacnet: 226-3090

RCA Engineer Staff

Tom King Editor

Mike Lynch Associate Editor

Louise Carr Art Editor

Rosemarie Cruz Editorial Assistant/Composition Specialist

Maria Pragliola Secretary

Editorial Advisory Board

Tony Bianculli Manager, Engineering Information, Technical Excellence Center □ **Jay Brandinger** Staff Vice-President, Systems Engineering, RCA Laboratories □ **Jim Carnes** Division Vice-President, Engineering, Consumer Electronics □ **John Christopher** Vice-President, Technical Operations, RCA Americom □ **Jim Feller** Division Vice-President, Engineering,

Aerospace and Defense □ **Mahlon Fisher** Division Vice-President, Engineering, Video Component & Display Division □ **Larry Gallace** Division Vice-President, Product Assurance and Environmental Engineering, Solid State Division □ **Arch Luther** Senior Staff Scientist, RCA Laboratories □ **Howie Rosenthal** Staff Vice-President, Engineering □ **Bill Underwood** Director, Technical Excellence Center □ **Bill Webster** Vice-President and Senior Technical Advisor, Electronic Products and Technology

Consulting Editors

Ed Burke Administrator, Marketing Information and Communications, Aerospace and Defense □ **Walt Dennen** Manager, Naval Systems Department Communications and Information, Missile and Surface Radar □ **John Phillips** Director, Business Development and Services, RCA Service Company

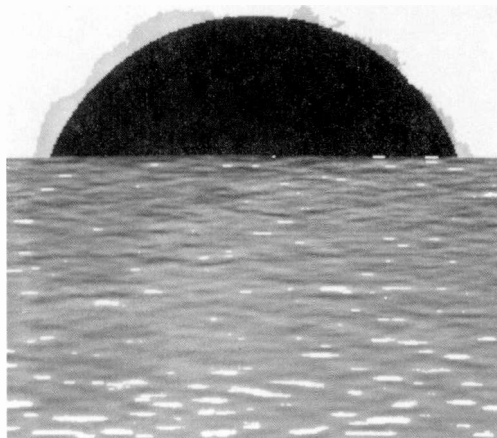

Our cover: This random fractal sunrise over a 'self-similar' sea was created by Joan Ogden using the multiresolution pyramid technique described in the article on page 4.

Cloud-like structures at four different scales ranging from fine to coarse were used to construct the sun and its corona. The shaded spherical shape was achieved by using different fuzzy circular masks at each scale. The sea and sky were added, and the whole scene was pseudo-colored. The red bar at the top of the cover is not part of Joan's graphic.

Cover illustration by Joan Ogden,
RCA Laboratories.

Cover design by RCA Engineer Staff.

□ To serve as a medium of interchange of technical information among various groups at RCA □ To create a community of engineering interest within the company by stressing the interrelated nature of all contributions □ To disseminate to RCA engineers technical information of professional value □ To publish in an appropriate manner important technical developments at RCA, and the role of the engineer □ To help publicize engineering achievements in a manner that will promote the interests and reputation of RCA in the engineering field □ To provide a convenient means by which the RCA engineer may review professional work before associates and engineering management □ To announce outstanding and unusual achievements of RCA engineers in a manner most likely to enhance their prestige and professional status.

now *million bytes*
A picture is worth a ~~thousand words~~

Complex designs, from submicroscopic molecular arrangements to very large assemblies such as the Space Station, can be achieved rapidly and accurately because of the capabilities of modern computer systems. Today an enormous amount of data can be assimilated and processed on a near real-time basis by computers linked by modern communications networks.

Advancement in computer graphics has provided a means for presenting these large amounts of data to our most efficient data transfer sensor, the eye. Displays have been designed to enhance the transfer of data, thus enabling us to rapidly perceive relationships, trends, and insights, thereby eliminating the need to view tens of thousands of data words.

Business units throughout RCA are finding more and more uses for computer graphics, from complex engineering drawings to ergonomically designed screens and displays. In Astro-Electronics Division, computer graphics has increased both productivity and quality of design,

manufacture, test, and operation of space systems. For instance, systems engineers use three-dimensional computer graphic displays to design the various modules of the Space Station that will be assembled in space. The microwave design engineer can view a complex combiner assembly in a three-dimensional display before transmitting the design data to a computer-controlled milling machine to make the part. And, as you will find in this issue, through color-coded displays of a spacecraft system, an operator can very quickly assess the status of a complex spacecraft system.

Tomorrow, through the application of artificial intelligence, we can look forward to even more efficient and productive systems to design, manufacture, and operate our products.

Robert Miller



Robert Miller
Division Vice-President, Engineering
Astro-Electronics Division

RCA Engineer

Vol. 30 | No. 5 Sept. | Oct. 1985

computer graphics

- 4** Pyramid-based computer graphics
J.M. Ogden | E.H. Adelson | J.R. Bergen | P.J. Burt
- 16** Graphics for the definition and visualization of physical systems—
some case studies
R.D. Scott

... as an engineering tool

- 24** Spooled-graphics laser printing from CMS
D.P. Barton
- 34** Accurate layouts for automatic component insertion
R.A. Monat
- 41** The operator display emulation facility
Using computers to design system display/control consoles
R.A. Faust, Jr. | W.L. Mays
- 47** An improved man/machine interface for spacecraft control
R.H. Harten | T. Crowe | A. Anton

... in RCA products and services

- 56** Graphics for election '84: An introduction
D. Rabinowitz
- 57** NBC election '84: Results by design
T.C. Alfieri
- 62** Innovative uses of computer graphics at NBC—Election day, 1984
C. Barton
- 67** Techniques for enhancement of interactive color graphics
for C³I systems
L. Arlan

general interest

- 75** Plasma etching for integrated circuit fabrication
M. Leahy
- 83** How to evaluate and shop for computer graphics software
J. Warner | J. Slitz

on the job/off the job

- 89** Engineering an electrically-powered automobile
S. Kreitzberg | J. Krupa

departments

News and Highlights, **93** | Erratum, **46**

Copyright © 1985 RCA Corporation
All rights reserved

in this issue . . .
computer graphics

- **Ogden et al.:** "In synthesizing and combining images, we would like to imitate the artist's ability to see an image on both large and small scales by representing the image mathematically on many different spatial scales."
- **Scott:** "... a primary goal is to reduce the drudgery of data entry, minimize errors, and allow the computer user to interact more and more in "natural" language, in conversational terms, or by menu."

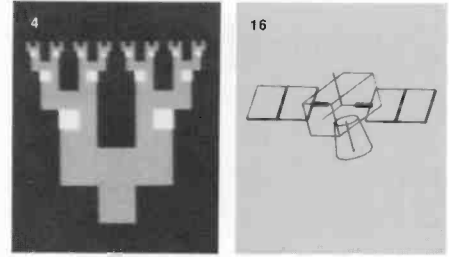

- **Barton:** "From a systems design viewpoint, our laser printer is not an end, but a beginning."
- **Monat:** "Rather than show the footprint, we chose to show the exclusion area. The exclusion area shows how much space is taken up by components already placed."
- **Faust/Mays:** "The mission of the ODEF team is to design, develop, and test operator interfaces for military systems under development at RCA."
- **Harten et al.:** "The main design concept we followed was that the operator should be made aware of the problem and led to it, not forced to find it."

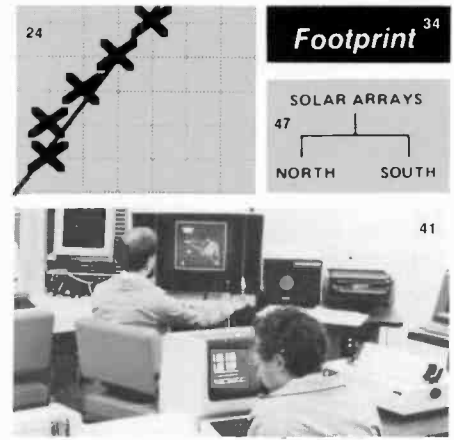

- **Alfieri:** "A graphic artist's ability to enhance our daily news productions with timely, unique, and innovative artwork was a quality we wanted in an automated system."
- **Barton:** "The system developed by NBC was greatly influenced by the requirements of the live production environment in which the system was finally going to be used."
- **Arlan:** "The analyst operating in today's tactical environment has a complex array of data resources that provide information regarding the enemy's movers, shooters, and emitters."



- **Leahy:** "Not only is this technology new, but we know it is absolutely essential to RCA's advanced circuit fabrication plans."
- **Warner/Slitz:** "Choosing a graphics software system for your application consists of more than finding software features that correspond to your discrete functional requirements."

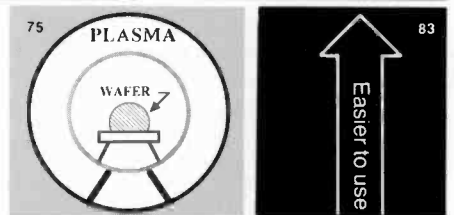

- **Kreitzberg/Krupa:** "This 75-pound monster came equipped with roller bearings on both sides of the armature, a series/parallel (compound) field, and the capability to accommodate a dc input . . ."

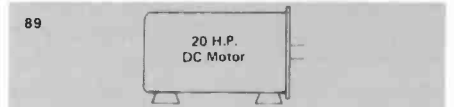

in future issues . . .
mechanical engineering
technology for the 1990s

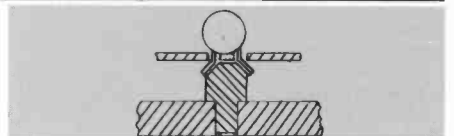

Pyramid-based computer graphics

Pyramid-based graphics techniques can provide realistic computer graphics on small systems without the complexities of physics simulations.

Human beings have an intuitive feel for graphics. Graphics problems such as blending two images smoothly, interpolating to fill in missing image data, or creating realistic looking images are routinely solved by artists using traditional media. It is much more difficult to perform these tasks mathematically. A major step in solving a computer graphics problem is choosing an appropriate numerical representation for the image, one which allows us to use our visual and artistic intuition in a natural way.

Artists often tend to separate the spatial scales of an image when creating or altering a picture. When an artist paints a landscape, the coarse scale (low spatial frequency) information is filled in first, as a wash of color in a large region. Intermediate-size details can be added next with a medium-size brush. As a last step, the artist draws the fine details with a small brush. The image can be considered a sum of overlays of increasingly fine detail. When an artist touches up a damaged picture, both the large and small scale variations are considered in filling in the missing pieces. In synthesizing and combining images, we would like to imitate the artist's ability to see an image on both large and small scales by representing the image mathematically on many different spatial scales simultaneously.

The simplest way to represent an image is to set the numerical value of each pixel proportional to the image intensity. This representation is useful when we want to paint or draw directly, one pixel at a time, or when simple manipulations of contrast or color are desired. But it becomes cumbersome when we want to look at an image at several spatial resolutions.

Abstract: *This paper describes pyramid solutions to graphics problems that have proven difficult in other image representations. The "physics simulation" approach grows more out of the physics and mathematical modelling traditions. Greater realism can be achieved by using the physics simulation approach, but the complexity and computation time are vastly increased over the multiresolution pyramid approaches described here.*

©1985 RCA Corporation.
 Final manuscript received October 21, 1985
 Reprint RE-30-5-1

A Fourier transform representation can be used to separate the various spatial scales of an image. Unfortunately, when we leave the familiar spatial domain for the spatial frequency domain our intuitive feel for the problem is lost. Operating on the Fourier transform of an image, we can no longer "see" local spatial features in a recognizable form. What is really needed is a representation that describes an image at multiple spatial resolutions, and also preserves the local spatial structure that allows us to "see" the picture at each scale. Pyramid representations are ideal for this class of problems.^{1,2,3}

The pyramid representation and computer graphics

The pyramid representation expresses an image as a sum of spatially bandpassed images while retaining local spatial information in each band. A pyramid is created by lowpass-filtering an image G_0 with a compact two-dimensional filter. The filtered image is then subsampled by removing every other pixel and every other row to obtain a reduced image G_1 . This process is repeated to form a Gaussian pyramid $G_0, G_1, G_2, G_3, \dots, G_n$ (Fig. 1).

$$G_k(i,j) = \sum_m \sum_n G_{k-1}(2i+m, 2j+n), k=1, N$$

Expanding G_1 to the same size as G_0 and subtracting yields the bandpassed image L_0 . A Laplacian pyramid $L_0, L_1, L_2, \dots, L_{n-1}$ can be built containing bandpassed images of decreasing size and spatial frequency.

$$L_k = G_k - G_{k+1}, k=0, N-1$$

where the expanded image $G_{k,1}$ is given by

$$G_{k,1}(i,j) = 4 \sum_m \sum_n G_{k,1-1}[(2i+m)/2, (2j+n)/2] f(m,n)$$

The original image can be reconstructed from the expanded bandpass images:

$$G_0 = L_0 + L_{1,1} + L_{2,2} + \dots + L_{N-1,N-1} + G_{N,N}$$

Figure 2 shows an image represented as a sum of several spatial frequency bands.

The Gaussian pyramid contains lowpassed versions of the original G_0 , at progressively lower spatial frequencies. This effect is clearly seen when the Gaussian pyramid “levels” are expanded to the same size as G_0 (Fig. 3a). The Laplacian pyramid consists of bandpassed copies of G_0 . Each Laplacian level contains the “edges” of a certain size, and spans approximately an octave in spatial frequency (Fig. 3b).

This pyramid representation is useful for two important classes of computer graphics problems. First, tasks that involve analysis of existing images, such as merging images or interpolating to fill in missing data smoothly, become much more intuitive when we can manipulate easily visible local image features at several spatial resolutions. And second, when we are synthesizing images, the pyramid becomes a multiresolution sketch pad. We can fill in the local spatial information at increasingly fine detail (as an artist does when painting) by specifying successive levels of a pyramid.

In this paper, we will describe pyramid solutions to some graphics problems that have proven difficult in other image representations:

1. Image analysis problems
 - (a) Interpolation to fill missing pieces of an image
 - (b) Smooth merging of several images to form mosaics
2. Creation of realistic looking images
 - (a) Shadows and shading
 - (b) Fast generation of natural looking textures and scenes using fractals
 - (c) Real-time animation of fractals.

Multiresolution interpolation and extrapolation

The problem

The need to interpolate missing image data in a smooth, natural way arises in a number of contexts. It can be used to remove spots and scratches from photographs, to fill in transmitted images that are incomplete, and to create interesting computer graphic effects.

A solution

Insight into the problem of interpolation is gained by considering the image as a sum of patterns of many scales. A typical photograph includes small scale fluctuations due to surface texture, superimposed on more gradual changes due to surface curvature or illumination variations. Similarly, a painting is a composite made up of features of many scales, rendered with



Fig. 2. The pyramid as a sum of spatial frequency bands.

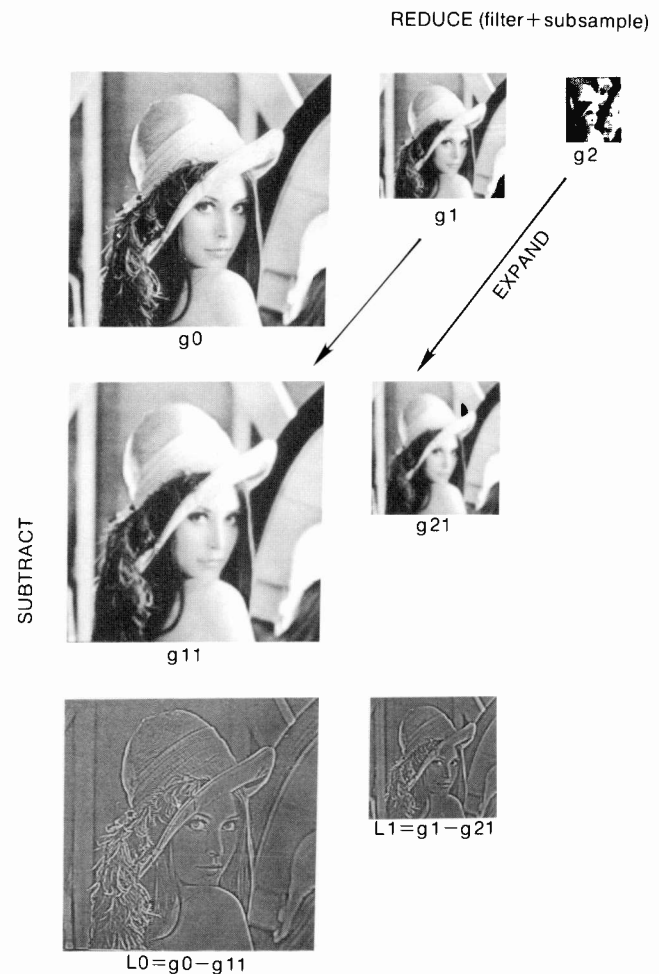

Fig. 1. Building the pyramid.

brushes of different sizes. In predicting the values of the missing pieces of an image, we need to consider intensity variations on both small and large scales.

Figure 4 shows a one-dimensional representation of an image G_0 that has some missing values. One method of interpolating to find the unknown region is to use a Taylor series expansion. If the size of the missing piece is comparable to the finest scale features of the image, a good estimate of the unknown value $x+dx$ can be obtained through a simple linear prediction based on the first derivative G_0' at the point x :

$$G_0(x+dx) = G_0(x) + dx G_0'(x).$$

If the missing piece is large compared to the fine scale features of



G_0



$G_{1,1}$



$G_{2,2}$



$L_{0,0}$



$L_{1,1}$



$L_{2,2}$

Fig. 3. Expanded Gaussian and Laplacian pyramids.

the image, we need to examine variations on larger scales as well. We can compute such an estimate by fitting the function $G_0(x)$ to a Taylor polynomial of higher degree. This involves taking higher order derivatives that represent the image variation over a larger number of pixels. One disadvantage of this approach for computer graphics is that it is computationally expensive. It is also difficult to adjust the degree of the interpolating polynomial to account for missing regions of different sizes.

An alternative way to look at the missing information on many scales is to build a Gaussian pyramid. This represents the image G_0 at different spatial resolutions ranging from fine (G_0) to coarse (G_n). The unknown piece of G_0 is also missing from G_1, G_2, \dots, G_n . Note that the size of the missing region is reduced in the reduced pyramid levels. Now, instead of fitting a Taylor polynomial of high degree at the finest spatial scale, we use linear interpolation at multiple spatial resolutions to fill in the missing information.

In the example shown, the size of the missing piece is large compared to the fine scale variations contained in G_0 and G_1 , but is comparable to the feature size in G_{n-1} and small compared to the coarse features of G_n . Starting with G_0 , we use linear extrapolation to predict the values of unknown points with two known neighbors.

$$G_0(i) = 2 G_0(i+1) - G_0(i+2)$$

For this example, most of the unknown values of G_0 are "left blank." A small border one pixel wide is extrapolated into the unknown region. Now we build G_1 and extrapolate again. At this reduced resolution, the extrapolated border corresponds to a larger proportion of the unknown region. When the extrapolated G_1 is expanded to full size, the border also expands in size from one pixel to several pixels. Continuing to lower spatial resolutions, we eventually reach a reduced pyramid level G_n , where the unknown region has shrunk to only one pixel. Extrapolation at G_n gives a pyramid level with all the values filled in.

An extrapolated image is built by reconstructing the extrapolated pyramid. Starting with G_n , we expand to form G_{n-1} . Where a pixel in the next highest frequency band G_{n-1} is missing, the value from G_{n-1} is used. Continuing this process, we form an extrapolated image G_0 , with all unknown points filled in.

Examples

Figure 5a shows a portrait that has had ink spilled on it. The locations of the ink spots are indicated in a mask image, Fig. 5b. When a two-dimensional multiresolution interpolation procedure is applied, the missing image points are filled in smoothly, as shown in Fig. 5c. In many cases, the result is so natural looking that the flaw would not be detected except on close

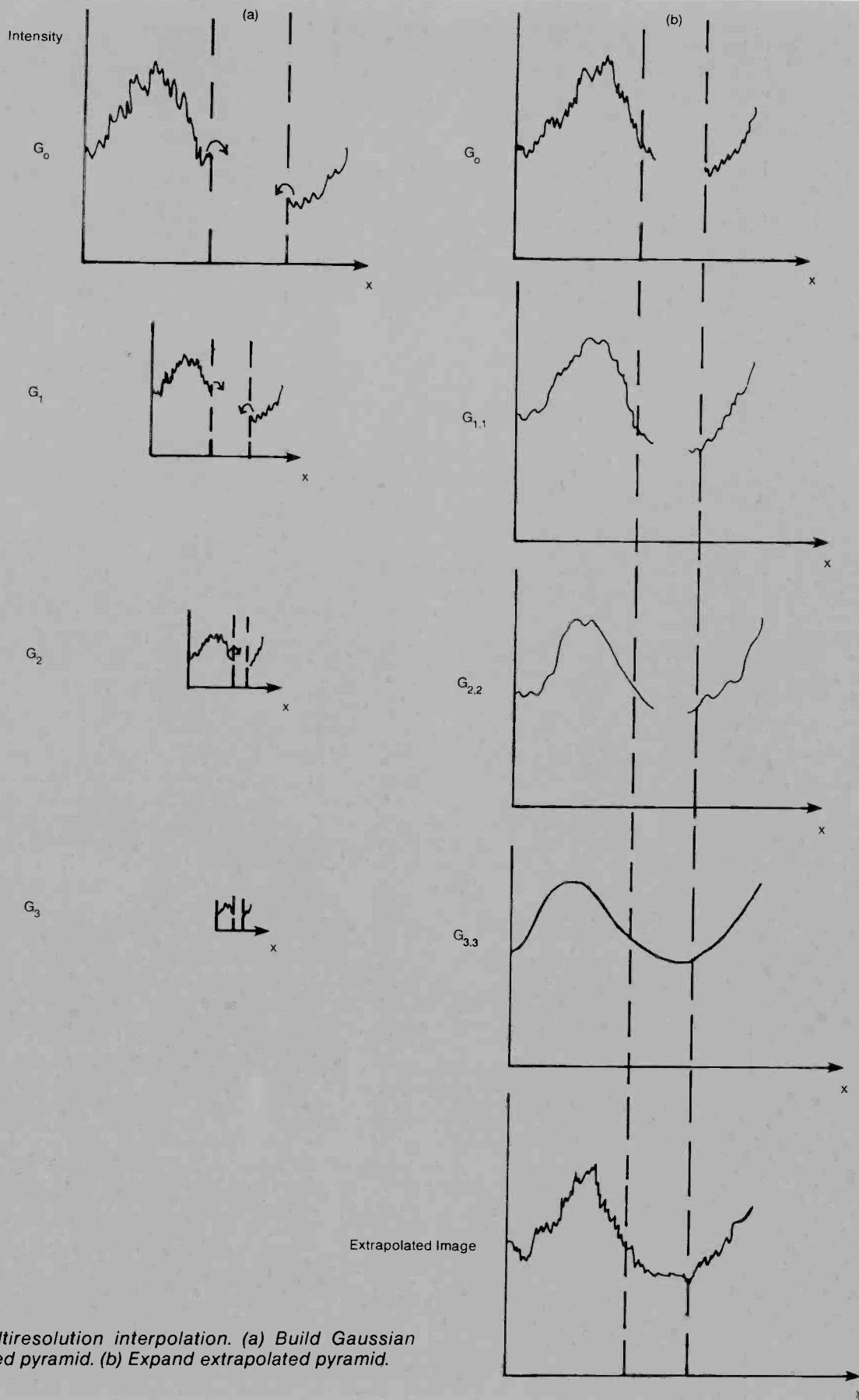

Fig. 4. Multiresolution interpolation. (a) Build Gaussian extrapolated pyramid. (b) Expand extrapolated pyramid.

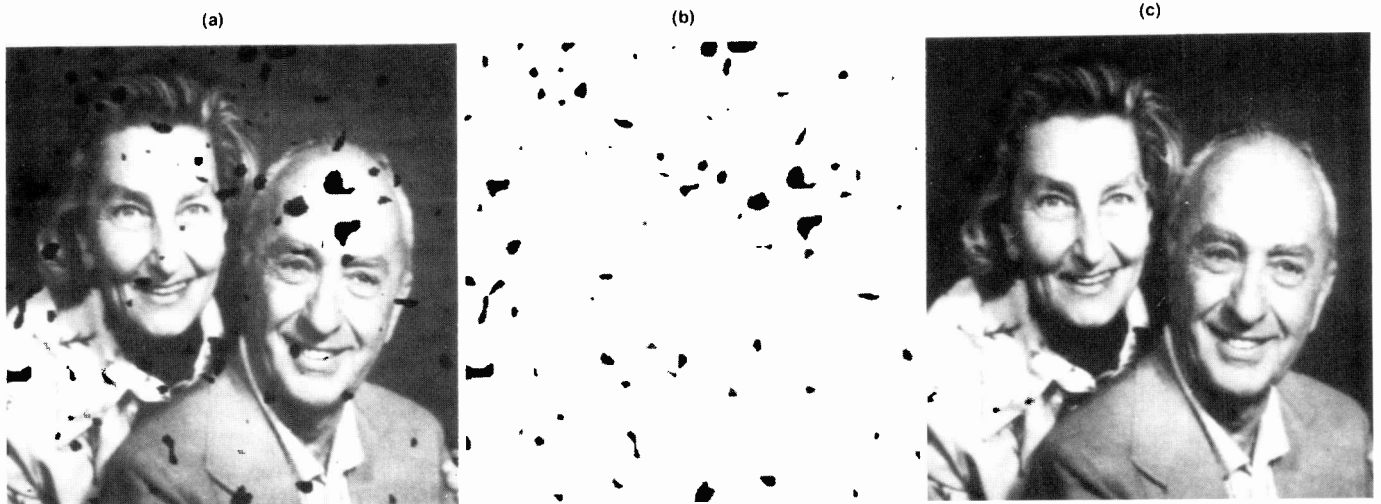

Fig. 5. Interpolation to fill missing points in an image.

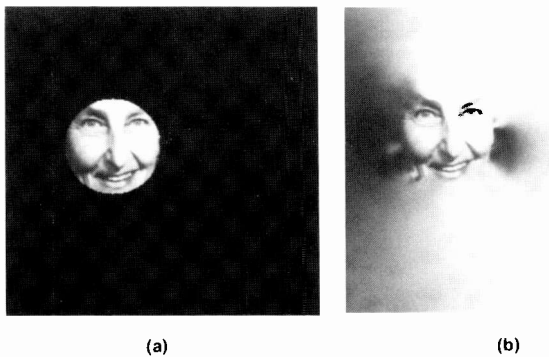

Fig. 6. Extrapolation example.

examination. Figure 6 illustrates extrapolation when known image points represent only a small island within the image domain.

Image merging

The problem

It is frequently desirable to combine several source images into a larger composite. Collages made up of multiple images are often found in art and advertising, as well as in science (for example, NASA's mosaic images of the planets). Images can even be combined to extend such properties as depth-of-field and dynamic range.

The essential problem in image merging may be stated as one of "pattern conservation." Important details of the component images must be preserved in the composite, while no spurious pattern elements are introduced by the merging process. Simple approaches to merging often create visible edge artifacts between regions taken from different source images.

To illustrate the problems encountered in image merging, suppose we wish to construct a mosaic consisting of the left half of an apple image, Fig. 7a, and the right half of an orange, Fig. 7b. The most direct procedure is to simply join these images along their center lines. However this results in a clearly visible step edge (Fig. 7c).

An alternative approach is to join image components smoothly by averaging pixel values within a transition zone centered on

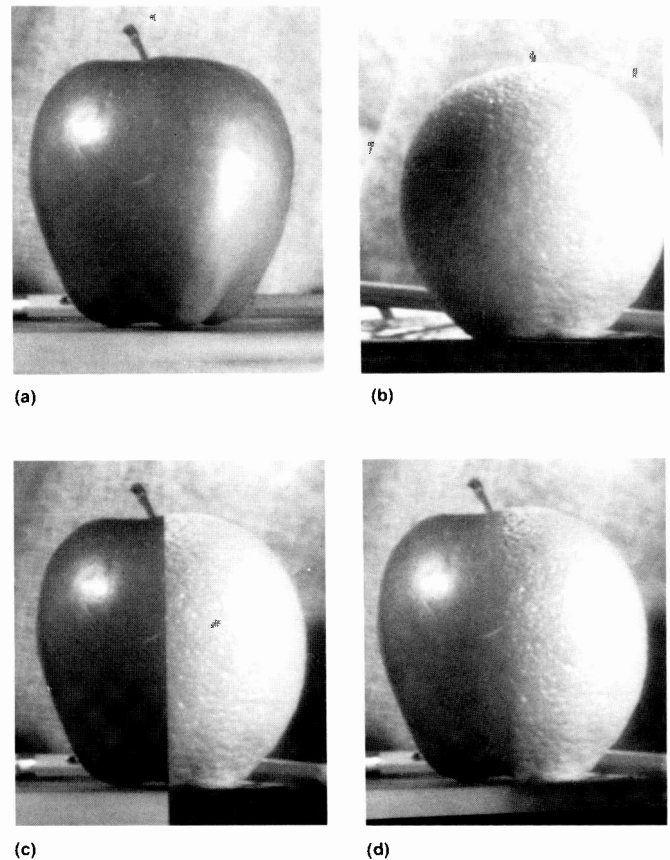

Fig. 7. Multi-resolution spline of apple and orange. (a) Apple, (b) orange, (c) cut and paste composite (d) multi-resolution pyramid mosaic.

the join line.^{3,4} The width of the transition zone is then a critical parameter of the merging process. If it is too narrow, the transition will still be visible as a somewhat blurred step. If it is too wide, features from both images will be visible within the transition zone as in a photographic double exposure. The blurred-edge effect is due to a mismatch of low frequencies along the mosaic boundary, while the double-exposure effect is due to a mismatch in high frequencies. In general there is no choice of transition zone width that can avoid both artifacts.

Multiresolution spline

We can resolve the transition zone dilemma if the images are decomposed into a set of bandpass components before they are merged. A wide transition zone can then be used for the low frequency components, while a narrow zone is used for the high frequency components. In order to have smooth blending, the width of the transition zone in a given band should be about one wavelength of the band's central frequency. The merged bandpass components are then recombined to obtain the final image mosaic.

Let $S_0, S_1, S_2, \dots, S_k$ be a set of K source images. A set of binary mask images $M_0, M_1, M_2, \dots, M_k$ determine how the source images should be combined. M_k is "1" where source image S_k is valid, and "0" elsewhere. Simply multiplying $S_k \times M_k$ and summing over k would give a "cut and paste" composite with step edges. Instead, we build a Laplacian pyramid L_{k1} for each source image, and a Gaussian pyramid M_{k1} for each mask image. A composite Laplacian pyramid L_{c1} is formed by "cutting and pasting" at each spatial scale by weighting each source pyramid level by its corresponding mask:

$$L_{c1}(i,j) = M_k(i,j) L_{k1}(i,j)$$

The final image is reconstructed from L_C by expanding each level and summing. Smooth blending is achieved because the transition zone in each pyramid level is comparable to a wavelength of the central frequency of that level. When this procedure is applied to the apple and orange images of Fig. 7, an "orple" is obtained with no visible seam (Fig. 7d).

Multifocus

When assembling information from multiple source images we need not always proceed region by region guided by mask images. Some types of information can be merged in the pyramid node by node and be guided by the node's own value. Here we show how this type of merging can be used to extend the depth-of-field of an image or increase its dynamic range.³

Figures 8a and 8b show two exposures of a circuit board taken with the camera focused at different depth planes. We wish to construct a composite image in which all the components and the board surface are in focus. Let L_A and L_B be Laplacian pyramids for the two source images. The low frequency levels of these pyramids should have nearly identical values, since changes in focus have little effect on the low frequency components of the image. On the other hand, changes in focus will affect node values in the pyramid levels where high spatial frequency information is encoded. However, corresponding nodes in the two images will generally represent the same feature of the scene, and will differ primarily in attenuation due to blur. The node with the largest amplitude will be in the image that is most nearly in focus. Thus, "in focus" image components can be selected node-by-node in the pyramids rather than region-by-region in the original images. A pyramid L_C is constructed for the composite image by setting each node equal to the corresponding node in L_A or L_B that has the larger absolute value:

$$\begin{aligned} \text{If} \quad & L_{A1}(i,j) > L_{B1}(i,j) \\ \text{then} \quad & L_{C1}(i,j) = L_{A1}(i,j) \end{aligned}$$

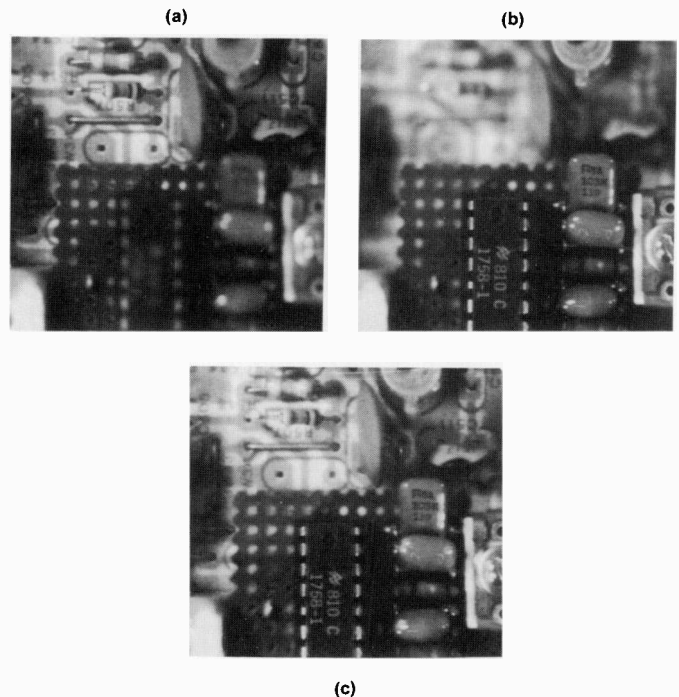

Fig. 8. Multi-focus composite. (a, b) Two images of the same scene taken with different focuses, and (c) composite with extended depth-of-field.

$$\text{else} \quad L_{C1}(i,j) = L_{B1}(i,j).$$

The composite image is then obtained simply by expanding and adding the levels of L_C . Figure 8c shows an extended depth-of-field image obtained in this way.

Creating realistic looking images: shadows and shading

The problem

We will consider three different approaches to the problem of creating a realistic looking image. The first approach is to use the computer as a paint box. No mathematical description of the scene is given. All the renderings, shading, shadows, and highlights are done "by hand," as though the artist were using a canvas. The advantage of "paint box" approach is complete artistic control. The disadvantage is that it is time consuming to create an image and difficult to make major changes without redrawing completely.

A second approach is to create a three-dimensional mathematical "universe." The artist specifies the location of objects in this new world, their shapes and physical properties, and the location of light sources. A two-dimensional, photograph-like image of the three-dimensional world is made by tracing a large number of light rays as they are reflected, refracted and absorbed. The advantage of this "physics simulation" approach is that very realistic looking images can be created. This approach is also flexible in that the viewing angle and properties of the component parts can be changed as input parameters. The disadvantage is that it requires a complex physical model and a lot of computation time.

There is a third, "multiresolution," approach that lies somewhere between the first two and combines some of the advantages

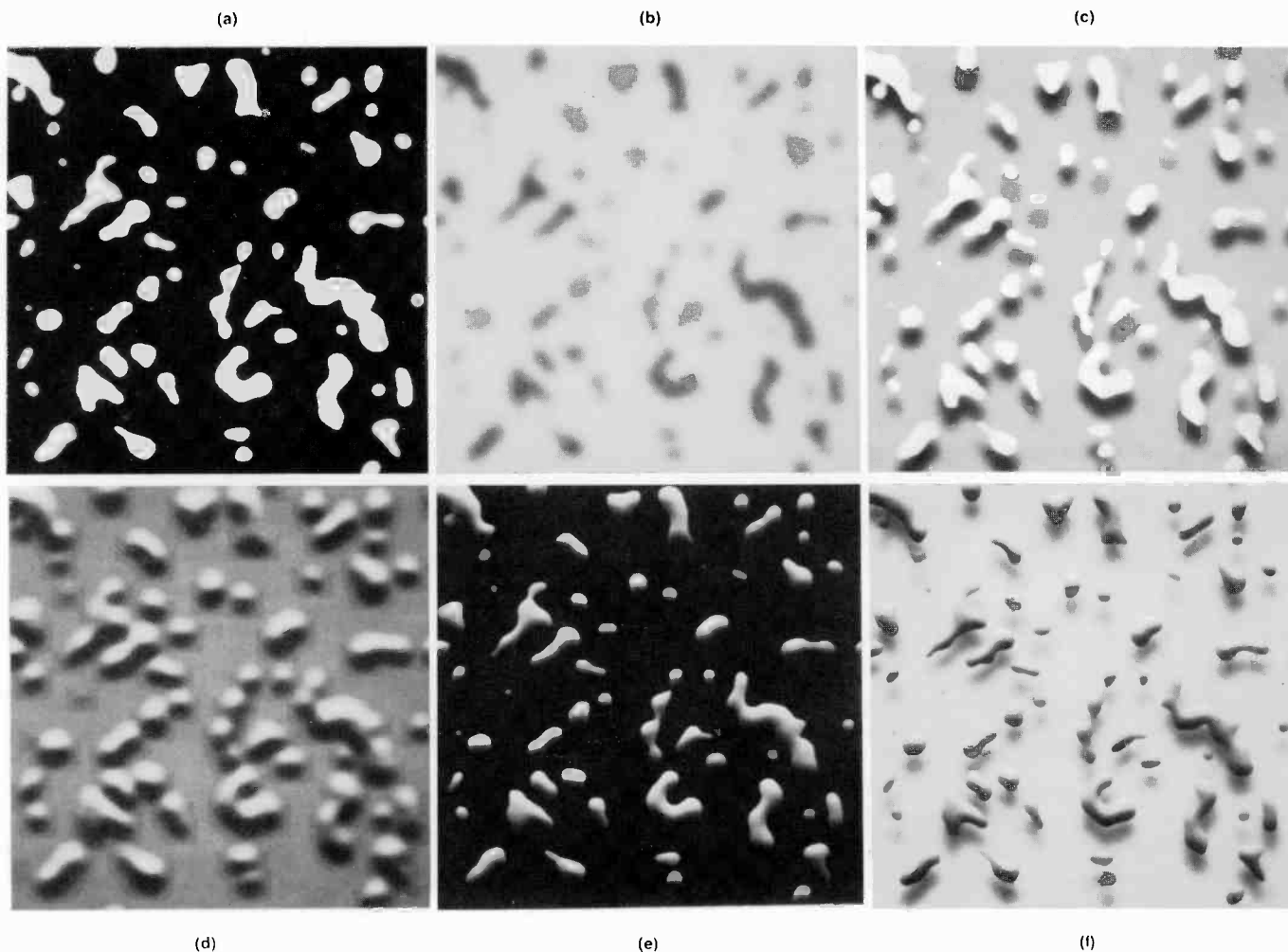

Fig. 9. *Multiresolution shadowing and shading of flat shapes.*

of each. As in the paint box approach, we are concerned primarily with painting the two-dimensional image. The difference lies in the type of information on the artist's palette. We usually think of a palette as an array of colors that can be blended and applied to an image. Using the pyramid we can extend the definition of palette to include multiresolution shape and edge information as well as color and intensity. Multiresolution lowpass and bandpass copies of image features are extremely useful in creating special effects and in adding realism to an artificially generated shape. The advantage of this approach is that natural looking images can be generated quickly without resorting to an elaborate physics simulation. Artistic decisions are made by viewing the two-dimensional image and the pyramid levels and combining desired elements of each.

An example

As an example of how an artist might use the pyramid as a spatial frequency palette, consider the problem of making flat shapes (Fig. 9a) appear three-dimensional by adding realistic looking shadows and shading. Both the shadows and shading resemble blurred copies of the original shape. Building a Gaussian pyramid of Fig. 9a, we select a lowpass copy that resembles soft shadows (Fig. 9b). Comparing Fig. 9a and a slightly displaced 9b pixel by pixel, and taking the maximum value at each point,

gives an image of shadowed paper cutouts floating or sitting on a glass-topped table (Fig. 9c). Now we need to add dimension to the white cutouts. It has long been known that filtering an image with a "gradient" filter $(1,-1)$ gives an effect of side illumination. When gradient filtering is done at multiple resolutions, there is a great improvement in this bas-relief effect. Performing a combination of gradient and lowpass filtering on Fig. 9a gives us the low-frequency relief 9d. If the minimum of Figs. 9d and 9a is taken, the result is an image of three-dimensional-looking droplets (Fig. 9e). Finally, we add Fig. 9e to 9c to form shadowed droplets in Fig. 9f.

Clearly, many other interesting graphic effects can be generated by imaginative use of the pyramid. It provides the artist with a convenient and efficient way of accessing certain important features of an image—shapes and edges—at multiple resolutions. For certain problems, especially when computation facilities are limited, the multiresolution approach offers considerable realism for little computation time.

Pyramid generation of fractals

The problem

The computer graphics community has adopted fractals as a remarkably effective way of synthesizing natural looking tex-

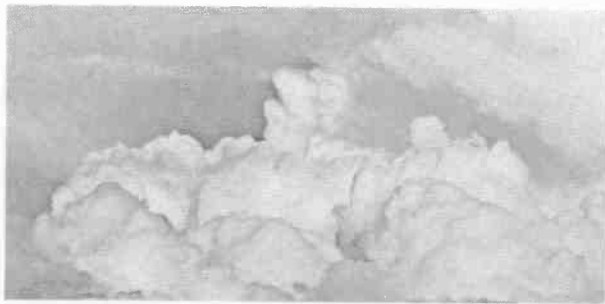

Fig. 10. Cloud as a sum of random circles.

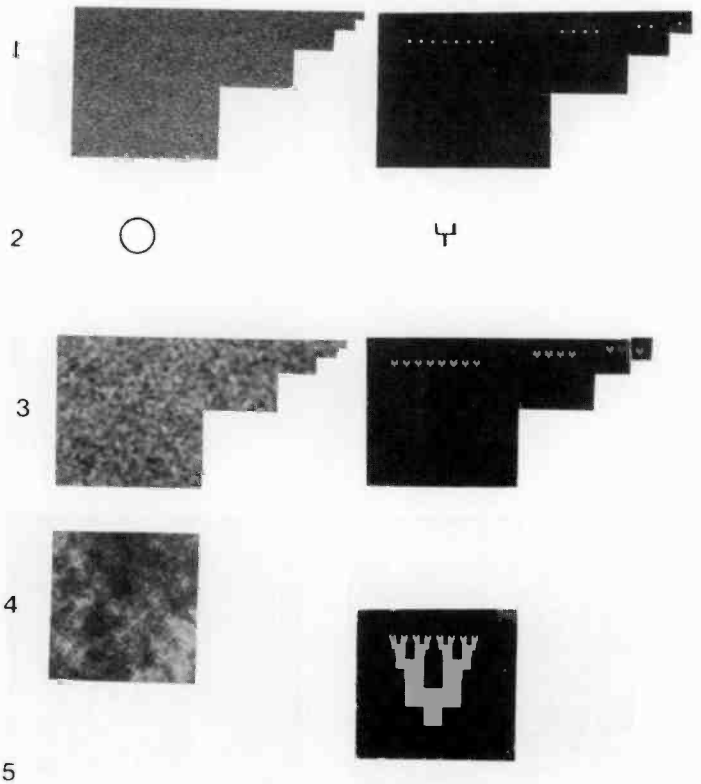

Fig. 12. Pyramid generation of fractals.

tures.^{5,6,7,8} The problem is to generate these textures quickly using multiresolution techniques.

Fractals and the pyramid

Traditional mathematics has relied on idealized models of the complicated and irregular forms of nature. Structures such as clouds, mountains, and coastlines are difficult to describe in terms of continuous, differentiable functions. Recently, Mandelbrot devised a new class of functions called "fractals" to express these complex natural forms.⁵

A fractal function includes both the basic form inherent in the object and its statistical or random properties. For example, a cloud can be visualized as a sum of random circles. The basic circle shape is seen at randomly distributed sizes and positions (Fig. 10).

Fractals have the property of self-similarity over many different geometric scales. A fractal appears similar as the spatial scale is changed over many orders of magnitude. As an example, consider a very jagged, rocky coastline. The coastline looks qualitatively similar when plotted on different spatial scales (see Fig. 11).

We have devised a fast fractal generation technique based on the pyramid algorithm, which takes advantage of the self-similarity of fractals. The pyramid breaks an image up into a sum of bandpassed images plus a lowpass filtered image. If an inherently self-similar fractal image is decomposed into pyramid form, one would expect the bandpassed images to look similar at each spatial frequency scale. Conversely, if similar patterns were entered into each spatial band of a pyramid, the reconstructed image should look like a fractal.

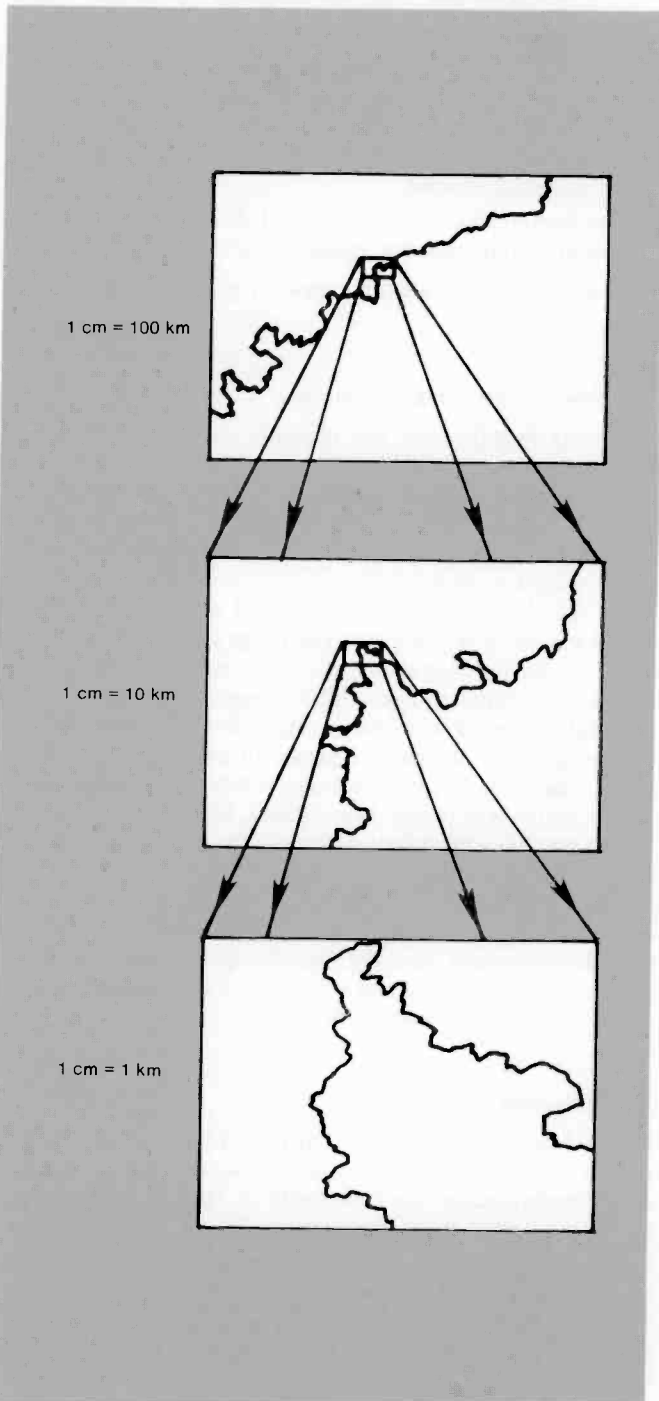

Fig. 11. Coastline on three different spatial scales.

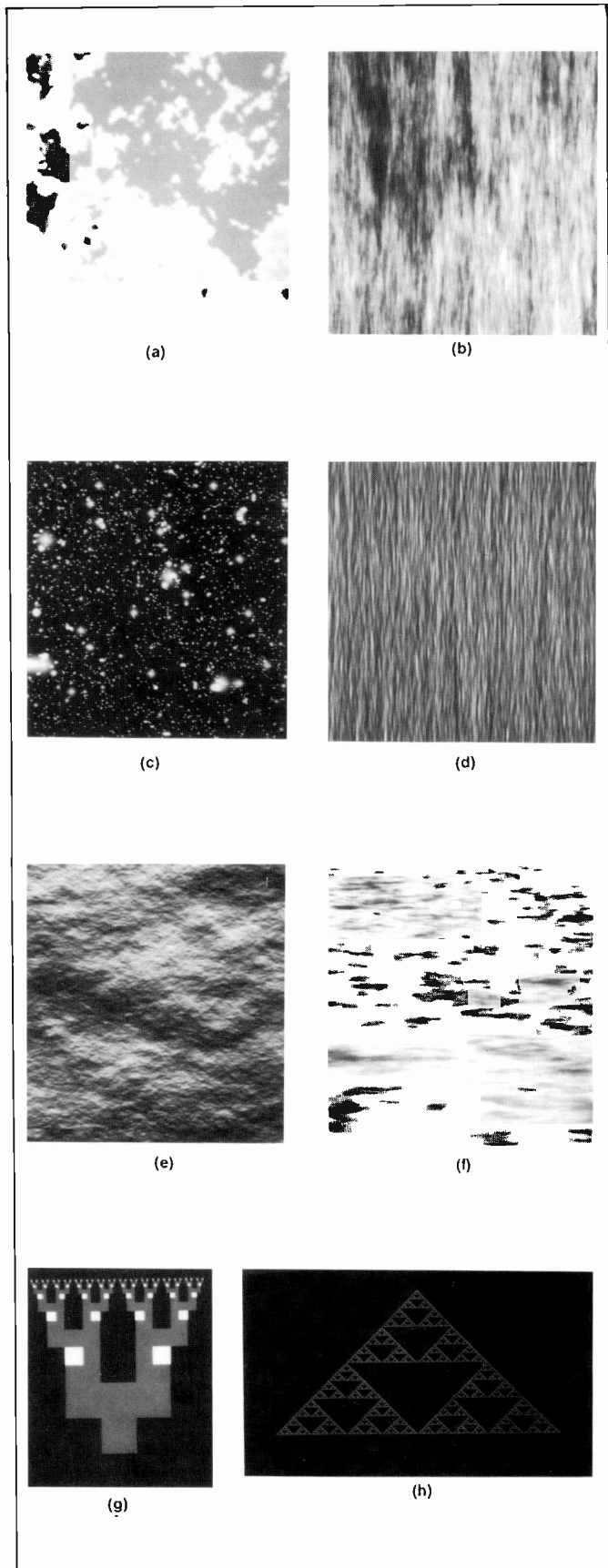

Fig. 13. Examples of fractals. (a) Clouds, (b) woodgrain, (c) galaxy, (d) papyrus, (e) granite, (f) waves, (g) fractal "tree," and (h) fractal gasket

Fractal generation method

The method used involves replicating a basic form, or "generator," at a succession of spatial scales, then summing to produce a fractal image (Fig. 12):

1. A "seed image" is set. This can be a regular array or a random pattern of dots.
2. A basic form, or "generator," is selected. This shape will appear at many spatial scales.
3. The seed image is convolved with a filter having the same shape as the generator. Each dot in the seed image will reproduce as an image of the generator. The result is a sum of generators with amplitude and position determined by the seed image. The convolved image is entered into the various levels of the pyramid.
4. The pyramid is reconstructed by expanding the various levels and adding. Because we have included generators over a wide range of spatial frequencies, the reconstructed image is a self-similar fractal.
5. The fractal image can be thresholded, colored, shaded, filtered, or otherwise manipulated to give pleasing effects.

Some examples of pyramid fractals are given in Table I and in Fig. 13.

Realtime fractal animation method

A moving fractal image (for example, clouds drifting by, or rippling waves) can be decomposed into a sum of spatial frequency bands. The different spatial frequency components move at different speeds. In an ocean wave, for example, low-frequency swells move more quickly than high-frequency ripples on the water's surface.

An initial fractal image is expressed as a sum of several spatial frequency components. The image is advanced one time frame by moving each spatial frequency component a specified amount and summing again. This creates a new fractal, which is slightly changed from the previous frame. Continuing this process gives an animated sequence of continuously evolving fractal images. Each spatial frequency component can be periodic with a fairly short repeat distance (say, half the image width), but the sum has a much longer period if the different components move at various speeds that are not multiples of each other. We have demonstrated this technique using our DeAnza 1P8500 image processor. Each new frame takes about 1/15th of a second to compute, and the overall repeat time was several minutes. Figure 14 shows an example of fractal animation for a beach scene (also see front cover).

Conclusions

Pyramid representations have much in common with the way people see the world. Human beings like to look at things on many spatial scales simultaneously. A strong analogy exists between an artist who paints images by adding progressively finer details, and a computer scientist who constructs images by adding together the spatial frequency bands of a pyramid. Representing an image on multiple spatial scales allows us to do things like blending apples and oranges naturally. When we express a picture as a sum of pyramid bands and operate on each band separately, we are taking an artistically familiar "painter's" approach. This contrasts with the "physics simulation"

Table I. Fractal examples

Figure	Seed Image	Generator Shape	Pyramid Parameters: Reconstruction filter levels	Enhancements
Clouds (13a)	Random noise	Circle	5×5 filter (a=0.45)* 6 levels	Threshold
Woodgrain (13b)	Random noise	Tapered line	3×3 filter (a=0.5)* 5 levels	Enhance Contrast
Galaxy (13c)	Sparse random noise	Dot	3×3 filter (a=0.5) 5 levels	
Papyrus (13d)	Random noise	Tapered line	3×3 filter (a=0.5)* 5 levels	Gradient filter
Granite (13e)	Random noise	V-shape convolved w/ gradient filter	3×3 filter (a=0.5)* 5 levels	
Waves (13f)	Random noise	Tapered line convolved w/ gradient filter	3×3 filter (a=0.5)* 5 levels	Pyramid levels multiplied by ramp to give perspective
Fractal Tree (13g)	Geometric series of dots	Ψ-shaped branch	2×2 "zoom filter" $\begin{pmatrix} 1 & 1 \\ 1 & 1 \end{pmatrix}$ 6 levels	
Fractal Gasket (13h)	Single dot		3×2 filter $\begin{pmatrix} 0 & 1 & 0 \\ 1 & 0 & 1 \end{pmatrix}$ 6 levels	

*These filters are separable with the form $f(x,y)=w(x) \times w(y)$ where $w(x)=(1/4-a/2, 1/4, a, 1/4, 1/4-a/2)$

approach, which grows more out of the physics and mathematical modelling traditions. Greater realism can be achieved by using the physics simulation approach, but the complexity and computation time are vastly increased over the multiresolution pyramid approaches described. Considering how well we can fake reality with the pyramid, it seems particularly well suited for making "realistic looking" computer graphic images on small systems.

References

1. P.J. Burt, "Fast Filter Transforms for Image Processing", *Computer Graphics and Image Processing*, 16, pp. 20-51 (1981).
2. P.J. Burt and E.H. Adelson, "The Laplacian Pyramid as a Compact Image Code", *IEEE Transactions on Communication COM-31*, pp. 532-540 (1983).
3. E.H. Adelson, C.H. Anderson, J.R. Bergen, P.J. Burt and J.M. Ogden, "Pyramid methods in image processing", *RCA Engineer*, Vol. 29, No. 6, pp. 33-41 (Nov./Dec. 1984).
4. P.J. Burt and E.H. Adelson, "A Multiresolution Spline with Application to Image Mosaics", *ACM Transactions on Graphics*, Vol. 2, pp. 217-236 (1983).
5. B. Mandelbrot, *The Fractal Geometry of Nature*, Freeman, San Francisco (1982).
6. A. Fournier, D. Fussell, and L. Carpenter, "Computer Rendering of Stochastic Models", *ACM Graphics and Image Processing*, Vol. 25, No. 6, p. 371 (1982).
7. A. Pentland, "Fractal-Based Description of Natural Scenes", *IEEE Transactions, SMC-13* (1983).
8. J.M. Ogden, "Generation of Fractals Using the Burt Pyramid," presented at the Optical Society of America meeting (October 1985).

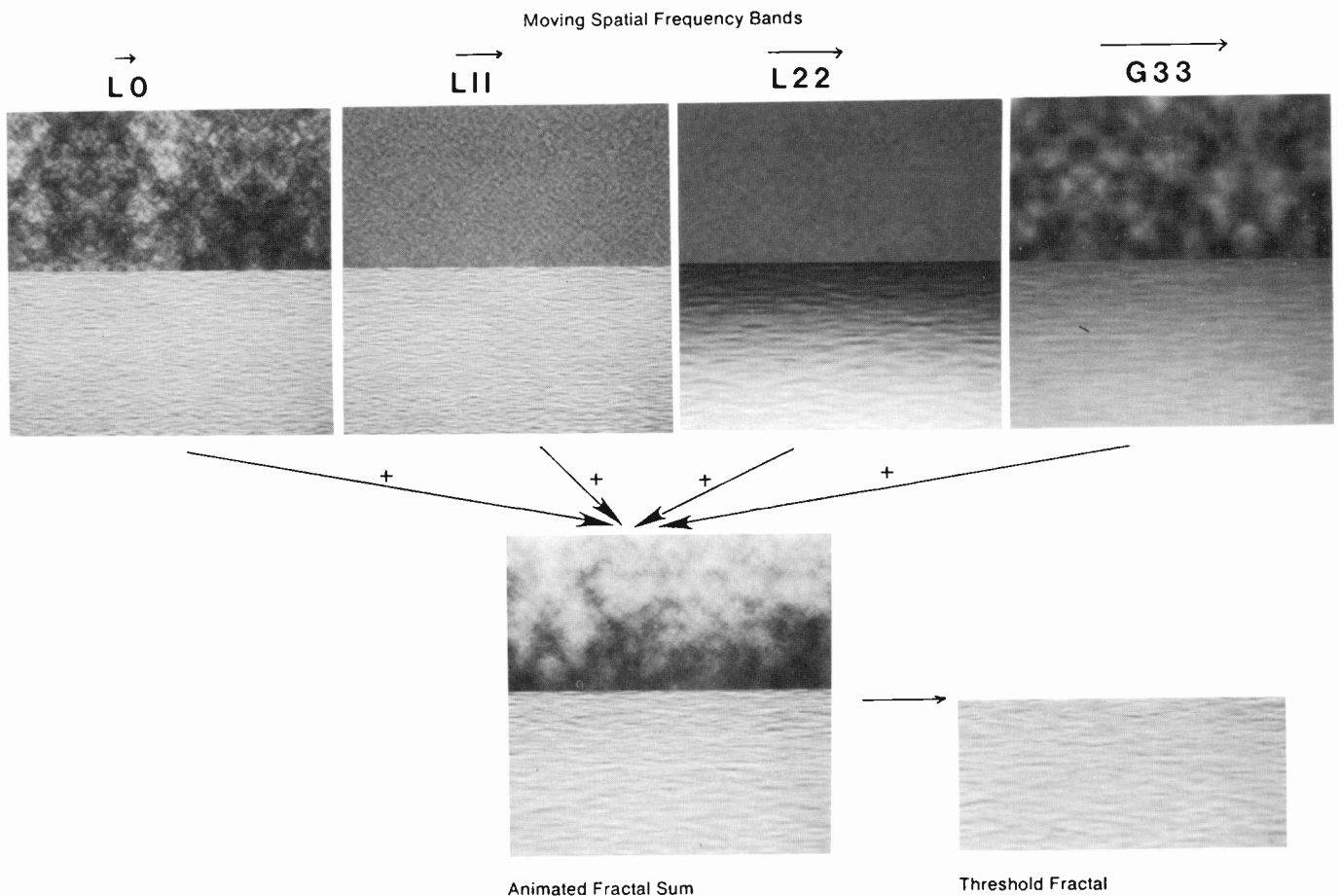

Fig. 14. *Fractal animation method*



Joan M. Ogden received a BS in Mathematics from the University of Illinois in 1970, and a PhD in Physics from the University of Maryland in 1977. After two years as a Postdoctoral research associate at Princeton Plasma Physics Laboratory, she started her own consulting company, working on a variety of applied physics problems.

In 1982 Dr. Ogden joined the Advanced Image Processing Research group at RCA Laboratories, first as a consultant and, in 1984, as a part-time Member of the Technical Staff. Her research interests at RCA include applications of the pyramid algorithm to noise reduction, data compression, and texture generation. She is the author or coauthor of more than 20 articles, has one patent pending, and is coinventor of an issued patent.

Dr. Ogden was awarded an National Science Foundation Visiting Professorship at Princeton University in 1985. She is on leave from RCA to teach at Princeton during the 1985 academic year.

Contact her at:
Princeton University
Princeton, N.J.
(609) 452-4966

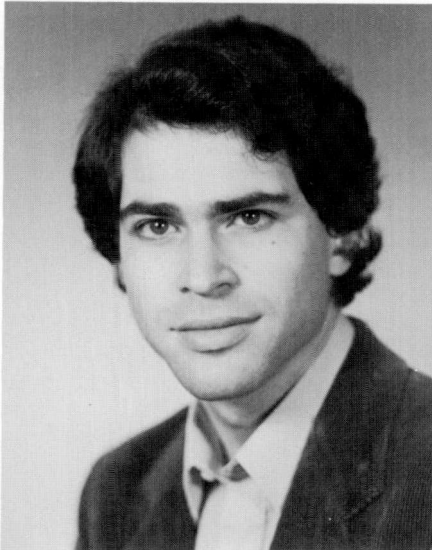

Edward H. Adelson received the BA degree, summa cum laude, in Physics and Philosophy from Yale University in 1974, and a PhD degree in Experimental Psychology from the University of Michigan in 1979. Dr. Adelson joined RCA Laboratories in 1981 as a Member of the Technical Staff. As part of the Advanced Image Processing group, in the Advanced Video Systems Research Laboratory, he has been involved in developing models of the human visual system, as well as image-processing algorithms for image enhancement and data compression.

Dr. Adelson holds two U.S. patents and has published a dozen papers on vision and image processing. His awards include the Optical Society of America's Adolph Lomb Medal (1984) and an RCA Laboratories Outstanding Achievement Award (1983). He is a member of the Association for Research in Vision and Ophthalmology, the Optical Society of America, and Phi Beta Kappa.

Contact him at:
RCA Laboratories
Princeton, N.J.
Tacnet: 226-3036

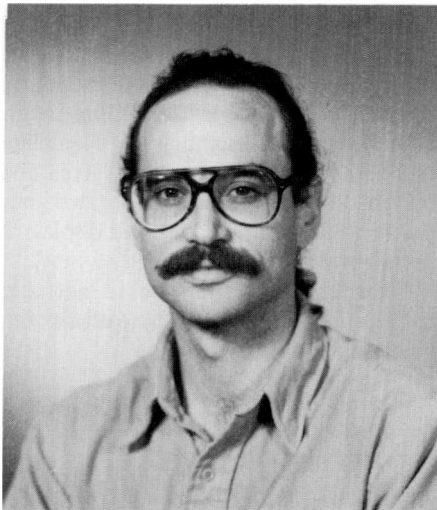

James R. Bergen received the BA degree in Mathematics and Psychology from the University of California, at Berkeley, in 1975, and the PhD degree in Biophysics and Theoretical Biology from the University of Chicago in 1981. His interests concern the quantitative analysis of information processing in the human visual systems, and the application of this analysis to problems in imaging system design and evaluation.

During 1981-82, Dr. Bergen was a Postdoctoral Member of Technical Staff at Bell Laboratories. In 1982 he joined RCA Laboratories as a Member, Technical Staff. His research activities at RCA include theoretical and experimental work on human vision, as well as perceptual aspects of HDTV systems and image processing techniques. In 1983, he shared an RCA Laboratories Outstanding Achievement Award.

Dr. Bergen has published many papers on visual psychophysics and perception, and is a frequent speaker at conferences on these subjects. He is a member of the Optical Society of America and the Association for Research in Vision and Ophthalmology.

Contact him at:
RCA Laboratories
Princeton, N.J.
Tacnet: 226-3003

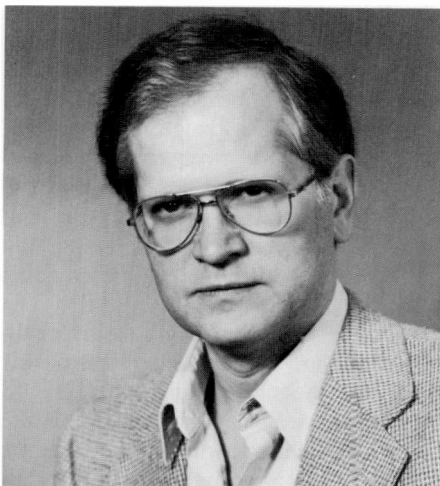

Peter J. Burt received the BA degree in Physics from Harvard University in 1968, and the MS and PhD degrees, both in Computer Science, from the University of Massachusetts, Amherst, in 1974 and 1976, respectively. From 1968 to 1972 he conducted research in sonar, particularly in acoustic imaging devices, at the U.S. Navy Underwater Systems Center, New London, Connecticut, and in London, England. As a Postdoctoral Fellow, he has studied both natural vision and computer image understanding at New York University (1976-78), Bell Laboratories (1978-79), and the University of Maryland (1979-80). He was a member of the engineering faculty at Rensselaer Polytechnic Institute from 1980 to 1983.

In 1983 Dr. Burt joined RCA Laboratories as a Member of the Technical Staff. He worked in the areas of computer vision, image data compression, and human perception, and in 1984 he became Head of the Advanced Image Processing group.

Dr. Burt has published more than 20 technical papers in his fields of expertise and is a member of the IEEE.

Contact him at:
RCA Laboratories
Princeton, N.J.
Tacnet: 226-2451

Graphics for the definition and visualization of physical systems—some case studies

PRSPEC: Computer graphics software that reduces the amount of engineering effort necessary to produce certain systems models and facilitates error checking.

The concept of graphics pre- and post-processors is well established. Among the earliest users were structural analysts, who previously struggled with hundreds of coordinate sets and connection lists in the process of describing the geometry of a physical system. They had to struggle again with a mountain of paper output to interpret stresses, displacements, and other parameters of interest in the analysis. Errors were frequent, and often discovered only when the answers made no sense.

The advent of two graphics processors, SUPERTAB from Structural Dynamics Research Corp. (SDRC), and PATRAN from PDA Engineering, Inc., reduced the analyst's problem to that of constructing an image, on the screen, of the critical

geometry of the structure (the process is now interactive, using menus and cursors). Even the problem of constructing grids and elements of a finite-element analysis has been software-automated for some classes of problems. Another class of problems is supported by SDRC's GEOMOD system and related products that model "solid" objects and can preserve kinematic coupling, both geometrically and graphically.

Within the industry, a primary goal is to reduce the drudgery of data entry, minimize errors, and allow the computer user to interact more and more in "natural" language, in conversational terms, or by menu.

As graphics packages are developed commercially, they tend to be specialized for particular disciplines. Thus, finite-element processors are broadly generalized to create models that look like finite-element models. With PATRAN and GEOMOD, solid images of complex bodies—such as automobiles, people, and the like—can be rendered even to the extent of providing shadows. The process is, however, one in which the user defines the object as a geometric entity, and the software system does the special rendering. While the commercial software systems do an outstanding job for their applications, one often finds it difficult to do specialized operations outside the original scope because no user software interfaces are provided.

Both the limitations of software flexibility and restricted individual access to some resources has led to the development of special applications of the graphics processor designated PRSPEC. This processor has a general user interface, allowing batch

and interactive input, and especially the ability to link user-written subroutines. A recent application was the demonstration of automatic boresighting of a satellite sensor model with respect to a given line of sight, involving rotation about two gimbal axes and automatic graphic display of boresight verification and field of view.

The processor software is portable between IBM/CMS and other systems with Fortran compilers.

Geometry visualization for radiation effects analysis

At Astro-Electronics, extensive use is made of the Modified Electron-Volt Dose Program (MEVDP) software, developed by the Kirtland Air Force Weapons Laboratory, for analysis of radiation damage of electronic components. The analysis consists of determining the equivalent amount of mass shielding between a radiation source and a given component and inferring the reduction of dosage afforded by that shielding. To specify the equivalent mass, a complete geometric description must be made of all material surrounding the object in question.

For the MEVDP program, the established method for providing input data is to divide the surrounding structure into solid primitive elements (prims), much like 3-D finite elements, whereby the elements consist of the predefined shapes of hexahedrons, spheres, cylinders, cones, hemispheres, and ellipsoids (see Fig. 1). Each shape must be described by certain key points and/or parameters. Thus, a cylinder primitive is defined by the two endpoints of its axis and a radius. More-

Abstract: *This article describes several applications of the graphics program PRSPEC, which include post-processing of data from mass properties and radiation shielding programs. PRSPEC is a graphics program that can be run in either batch or interactive mode. It can be used both as a pre- or post-processor of geometric data, and provides several user-defined interfaces, among which is the ability to execute user-written programs for additional generation and conditioning of data.*

The applications and software described herein, including PRSPEC, were developed by the author at RCA Astro-Electronics Division. They are graphics pre- and post-processors.

over, it must be located relative to the structure being analyzed by the absolute coordinates of the key points in a global frame of reference.

Finally, for each element of the structure, there are associated parameters including a sequence number, mass density, and possible relations with other elements. (The MEVDP admits Boolean operations, so that the combined mass of two shapes partially occupying the same volume will be treated as the mass of the union of the two shapes.)

The MEVDP makes no provision for the generation of data. Its input protocol requires that the data stream consist of a sequence of entries for each element, each subset consisting of a header entry (with sequence number and physical properties), and a set of entries listing the coordinates of the key points (see Table I). In the absence of supporting software the analyst was required to build the model essentially by hand, scaling the drawings as necessary, visualizing rotations and translations of the elemental shapes, and keeping track of the assembly by whatever means possible. One unique concern was the handling of "voids," wherein enclosed volumes are created by Boolean subtraction of one volume from a slightly larger one. Thus, the void elements as well as the "real" structure had to be kept in mind.

Building a mass model by manual calculations for a complex object buried inside a spacecraft (itself a complicated structure) is a formidable undertaking, and one fraught with errors. The question was posed to the author whether a way could be developed to at least verify the geometry of the model before running the MEVDP. Inasmuch as the users were committed to the use of the IBM/CMS system at the time, and it had no finite-element method (FEM) processors installed, the availability of the PRSPEC graphics program led to the implementation of a data stream interpreter that yields graphic displays of the structure. Subsequent refinements have provided a fully interactive facility.

Data stream interpreter

Because each sequential subset of data in the MEVDP input file describes a geometric entity, it is a fairly straightforward process to capture each subset and create a 3-D image of the entry. The PRSPEC processor was already equipped with the ability to draw circles and ellipses (as well as straight lines), so the task was to convert each MEVDP subset to a

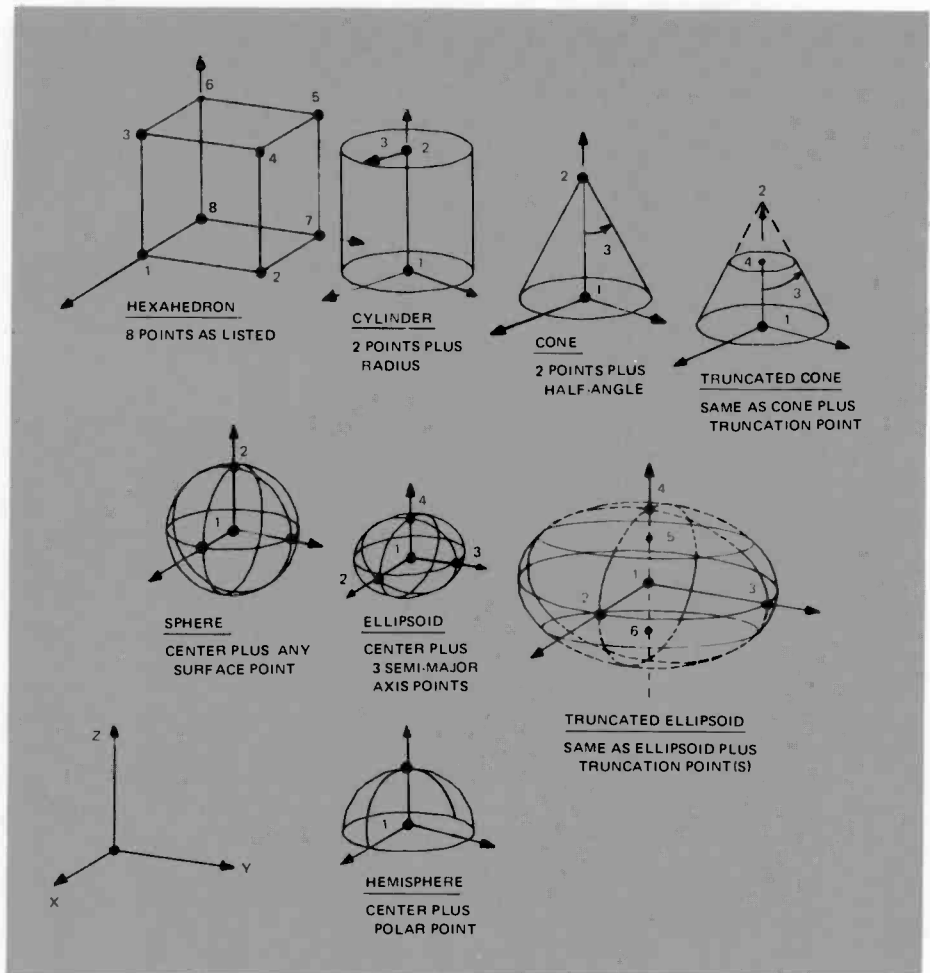

Fig. 1. MEVDP primitive geometry.

PRSPEC input data subset. It turns out that there is essentially a one-to-one correspondence between the two. For example, for a hexahedron the MEVDP requires the corner points to be specified in a particular order; therefore, a hexahedron can always be reformatted with a known topology.

Similar considerations follow for the other primitives, but here the analyst needs some options. The graphics program operates essentially in wireframe mode, but options have been developed that allow each primitive (by itself) to be displayed

in either wireframe caricature, or with hidden lines removed. In this way, a complex body can be displayed with all the primitives showing in their relative locations, but with a significant amount of clutter removed. The display is thus semi-transparent to the viewer. For the purpose of verifying the MEVDP input, this method works quite well, because errors in placement of the primitives are the primary concern, and the pictorial esthetics secondary.

As an example, consider the MEVDP representation of an ice cream cone (a

Table I. MEVDP source data format.

RADIATION BODY DATA STREAM (02/01/85)									
3.000E+01	2.500E-01	1.000E-01	ABFG	00	00	00	00	50	00
YES	YES	NO	NO						
2***									
STANDARD HEADER CARD: MEVDP DATA									
2000	9	1	0.2	0.0500	0	2	0		
	0.0		0.0	5.0	0.0		0.0		0.0
2001	7	1	1.0136	1.1000	0	2	0		
	0.0		0.0	5.0	0.0		0.0		6.0136
END									

cone plus a hemisphere, of course). The MEVDP data stream is shown in Table I, and the corresponding PRSPEC data stream in Table II.

The first five lines of Table I are control

data entries for the graphics translator (named "RADBOD"). Usually the data for an entire body are kept in a single reference file, and graphics for part or all of the body are generated under control

of a "sieve," represented by line 4. By this means, multiple runs can be made, with different graphic results, by selecting certain groups of primis via the sieve. The sieve consists of a list of serial numbers of the primis to be drawn, with "wild card" (*) options; for the above example all serial numbers in the range 2000 to 2999 are to be plotted.

Table II. PRSPEC data file generated from MEVDP data.

```

2WAY
YES NO      0 ONO  -02NO NO NO YES NO NO NO NO NO NO NO
                TEST SET
1.100E+01 8.500E+00
1.000E-01 1.000E-01 1.000E-01 1.000E-01 3 3 3 3
C: STANDARD HEADER CARD: MEVDP DATA
NEWP 71
PRIM
2000 9 1 0.2 0.0500 0 2 0
CART 51 0.0 0.0 5.000E+00 52 0.0 0.0 0.0
CART 53 1.014E+00 0.0 5.000E+00 54 -1.014E+00 0.0 5.000E+00
CART 55 0.0 1.014E+00 5.000E+00 56 0.0 -1.014E+00 5.000E+00
CART 57 0.0 0.0 -1.000E+00 58 0.0 0.0 1.000E+00
CIRC 51 1.014E+00 1.000E+01 0.0 51
B 51 51
JUMP
F 51 52
5.000E-01 3
A 53 52 0 54 52 0 55 52 0 56 52
JUMP
PRIM
2001 7 1 1.0136 1.1000 0 2 0
CART 61 0.0 0.0 5.000E+00 62 0.0 0.0 6.125E+00
CART 63 1.125E+00 0.0 5.000E+00 64 -1.125E+00 0.0 5.000E+00
CART 65 0.0 1.125E+00 5.000E+00 66 0.0 -1.125E+00 5.000E+00
CART 67 1.000E+00 0.0 0.0 68 0.0 1.000E+00 0.0
CIRC 61 1.125E+00 1.000E+01 0.0 61
B 61 61
CIRC 62 1.125E+00 1.000E+01 0.0 63
B 61 68
CIRC 64 1.125E+00 1.000E+01 0.0 62
B 61 68
CIRC 62 1.125E+00 1.000E+01 0.0 66
B 61 67
CIRC 65 1.125E+00 1.000E+01 0.0 62
B 61 67
PRIM
END
END
75000 0.0 0.0 2.500E+00 5.600E+00 8.000E+00 6.000E+00
1.100E+01 8.500E+00 0.0 1.100E+01 8.500E+00 +2 0 0 0 0 0
END

```

The first and second lines of the file are the file header and information controlling line styles. The third line of the file selects graphics options in terms of extra lines for visualization. A cylinder, for example, is easily visualized if a number of its generators are shown, as well as its envelope tangents. Spheres and ellipsoids are rendered by a set of great circles. These lines may be included or not, and hidden lines shown as dashed, or removed, at the discretion of the user. Envelope lines are determined by the program and shown, in any event.

Inspection shows that there is generally a one-to-one correspondence between the files represented by Tables I and II. Each subset of Table II starts with a control entry that defines the shape (PRIM). The next line echoes the MEVDP header entry and will be stored for reference. Entries labelled CART are coordinate sets for both key points and points generated for the artwork. Entries for various circles (CIRC) follow. Once coordinate information has been accounted for, entries are added to connect the various points with straight lines. Without going into details of the meaning of the entries, it is simply noted that sufficient information has been defined to generate cartoons of the shapes listed.

Figure 2 shows the several styles of output that would be available from this exercise. First, Fig. 2a is a simple wireframe model of the cone and hemisphere combined. The objects have been rendered using generators defined at four points equally spaced around the defining circles. The number of points chosen is, of course, arbitrary, but four are sufficient to give a workable picture. A significant improvement in the cartoon occurs when envelope lines are added (Fig. 2b). These flesh out the figures and help resolve ambiguities to some degree. The next improvement in rendering is shown in Fig. 2c, in which hidden lines have been removed and only the envelopes displayed. Fig. 2d restores the visible generators, and 2e shows hidden lines as dashed.

A more serious example of an actual working model is shown in Fig. 3. This

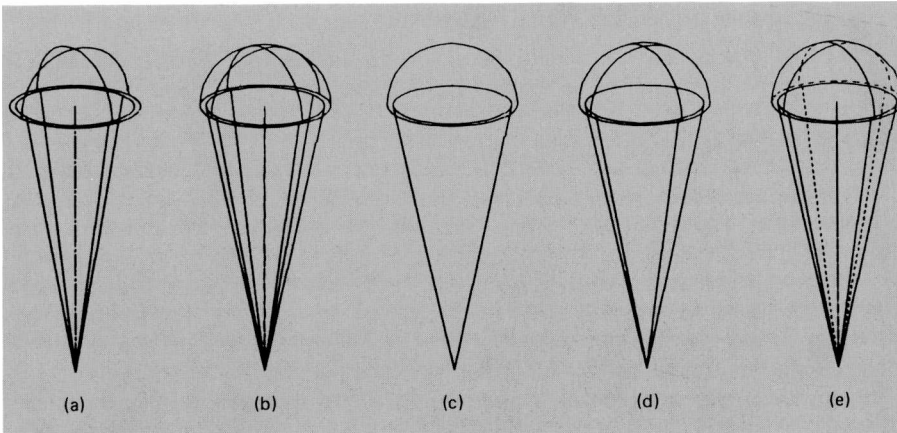

Fig. 2. Options for the ice cream cone.

figure represents a circuit board pack. The aim is to assess the effective shielding surrounding a chip on one of the boards. Three levels of detail are shown, all derived from a single database. Figure 3a models the physical bodies surrounding a device (PIP) that contains a set of circuit boards. The model for the PIP is shown in Fig. 3b, and the board level model (with chips) is shown in Figs. 3c and 3d.

Once the graphics data have been read from the input file, various views can be created interactively for inspection. Upon verification of the total database, the entire model may then be submitted to the MEVDP for dose analysis.

Geometry visualization for mass properties analysis

Subsequent to the creation of the radiation analysis interpreter, a similar consideration became apparent with respect to the analysis of spacecraft mass properties. A program had been developed, by a number of analysts at RCA Astro, for the determination of overall mass, center of mass, and moments of inertia of a spacecraft, based on the elemental mass properties of the components. Elemental mass properties are found by examination of parts lists, drawings, and data from previous calculations. Input data files are generated, by hand, for each subassembly on a spacecraft and considerations similar to the MEVDP input protocol are required: coordinates and rotations must be specified in a global coordinate frame, as well as elemental mass properties.

For the mass properties program, shapes are specified by type, length, width, radii (if appropriate), physical properties, and location of the center of mass, Table III shows a section of a typical input file, which may contain hundreds of shapes for an actual vehicle.

Note that there is at least as much difficulty, if not more, in mentally visualizing the shape and orientation of an elemental object (in the author's opinion) compared to the MEVDP situation, and the problems of verification are certainly as severe.

As before, a PRSPEC-compatible translator was written for graphic interpretation of the input data typified by Table III. The same set of prims used for MEVDP was incorporated and found adequate, and Fig. 4 shows a sample hardcopy plot from a mass properties run. It is interesting to discover that the cartoons of Fig. 4 look very much like a spacecraft, even though

close examination reveals the abstractions used to represent the components. Mass properties runs are not made interactively, although they could be. The size of the database and its impact on cost is the

principal restriction.

The mass properties program has been installed in the Prime computer at Astro-Electronics, which also supports the Medusa CAD system. As a point of

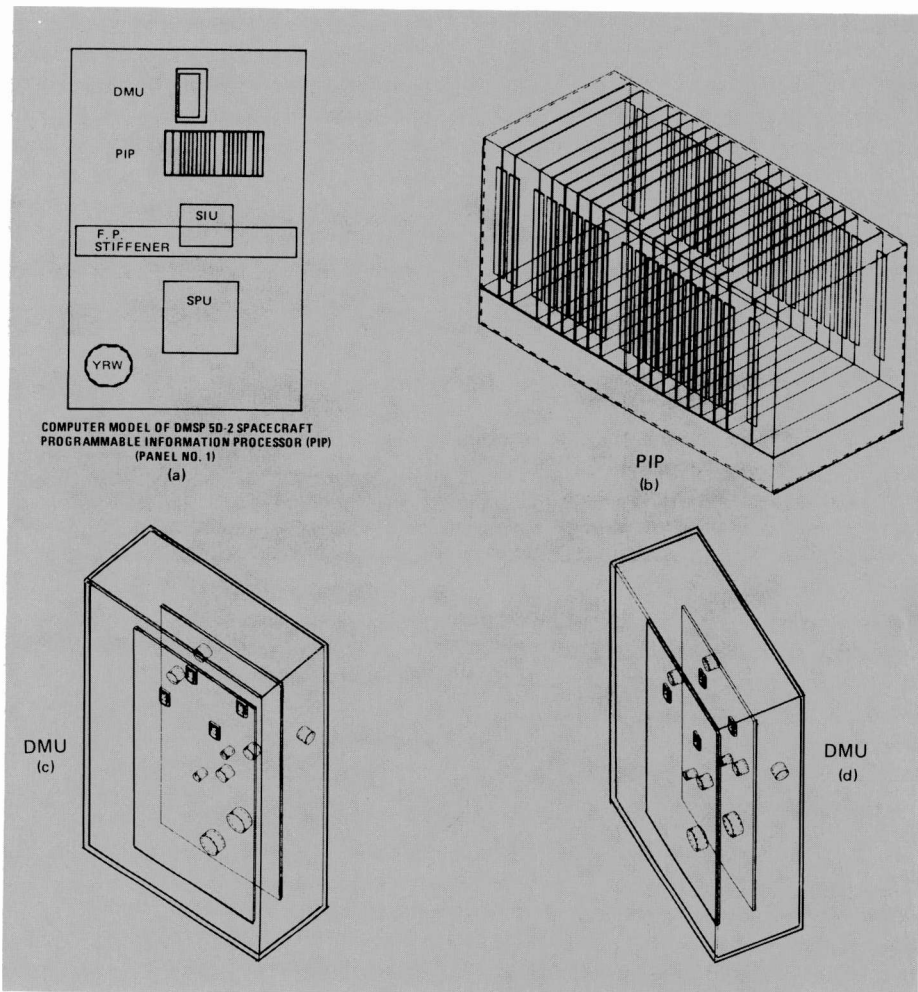

Fig. 3. Radiation analysis graphics for a circuit board pack.

Table III. Mass properties program input data stream.

...
101030100-44.75 -5.2 -17.8 14.3 1.9 1.9
101030100-44.75 -5.8 22.4 14.3 1.9 1.9
101030100-44.75 -35.1 -10.2 14.3 1.9 1.9
101030200-45.17 21.04 7.9 13.15 .38 .27
101030200-45.17 21.04 11.9 13.15 .38 .27
101030200-45.17 21.04 15.19 15.15 .38 .27
101030300-45.08526.996 6.641 15.56 7.84 3.44
101030300-45.08526.996 10.641 15.56 7.84 3.44
101030300-45.08526.996 14.641 15.56 7.84 3.44
101030400-44.75 16.0 12.5 14.0 1.9 1.9
101030400-44.75 19.0 10.0 14.0 1.9 1.9
101030400-44.75 19.0 14.0 14.0 1.9 1.9
101030600-33.3 0.474 2.91 133943.932756.412945.934.20 -190.817.85 49
101030700-44.06 26.44 -1.1 13191.7 104.5 291.2
101030800-14.13 -18.9 -13.7 16.25 10.53 7.75
1
2010308000. 90. 90. 112.5
101030800-14.13 -18.9 13.2 16.25 10.53 7.75
1
2010308000. 90. 90. 52.5
101031001-44.095-43.01524.548 13171.54 167.44 20.23
...

interest, the output from PRSPEC in this example was routed directly to a drawing file, from which Fig. 4 was then plotted. With this capability, the analysis results can become part of the formal CAD database.

Interactive modification of the database

While configuring the MEVDP interpreter, it was recognized that graphics support

would not alleviate the manual labor of initial preparation of data. Although PRSPEC provides the ability to copy and/or transform (step-and-repeat) input data subsets, it was decided that a dedicated manipulator would be more convenient for the analysis at that time. A processor (EXPAND) was created that does the following operations on a data subset representing a prim: copy, translate, rotate, and stretch. It also defines a set of prims as a block subset and performs copy,

rotations, and translations for that set. This provides a very convenient way to generate a data file that represents a complex body made of many similar parts, such as circuit boards and chips. The resulting data file is a standard MEVDP data file.

EXPAND is used in a batch mode, however, to aid in the preparation of the MEVDP data file. In a sense, it allows the analyst to make mistakes more easily. If the mistakes show up later on the graphics, the analyst must still go back to the source data file and correct them.

We decided that the most cost-effective way to resolve the issue would be the following:

- Create an initial MEVDP model with EXPAND using the traditional methods.
- Enter an interactive session with PRSPEC to visually examine the model for errors.
- Correct the errors in the same interactive session by modifying the position, orientation, and size of shapes.
- Add and/or delete certain prims if desired.
- Save the results of the interactive session (now in PRSPEC format) in an output file.
- Reinterpret the output file in terms of a final MEVDP model file for analysis.

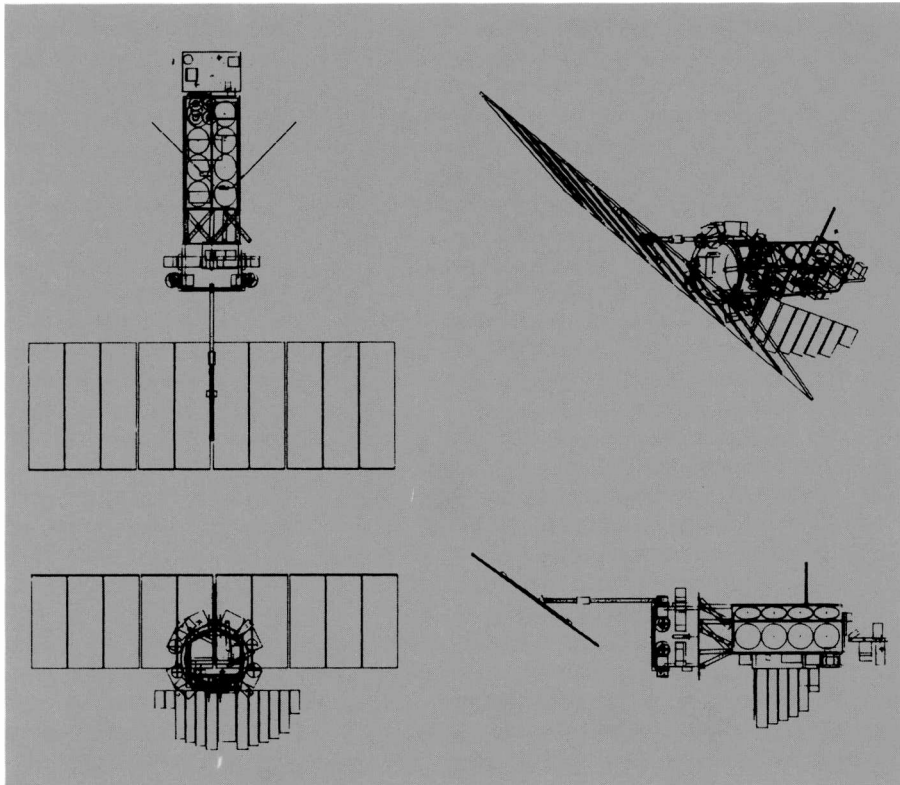

Fig. 4. Hardcopy output from mass-properties translator program.

Table IV. PRSPEC skeleton data file.

```

2WAY
YES NO      0 ONO  -02NO NO NO NO      NO NO NO NO YES
NO NO NO NO
                                TEST SET
 1.100E+01 8.500E+00 1.000E+00 1.000E+00
 2.500E-01 2.500E-01 2.500E-01 2.500E-01 3 3 3 3
C: X-Y-Z AXES:
CART 1 0.0 0.0 0.0 2 1.000E+00 0.0 0.0
CART 3 0.0 1.000E+00 0.0 4 0.0 0.0 1.000E+00
C: CONNECTIONS
JUMP
A 2 1 3 0 1 4
JUMP
C: VIEWS
END
END
75000 0.0 0.0 2.500E+00 5.600E+00 8.000E+00 6.000E+00
1.100E+01 8.500E+00 0.0 1.100E+01 8.500E+00 +2 0 0 0 0 0
END

```

The astute reader might point out that a single package could do the job by building the MEVDP model from scratch, interactively, and retaining the MEVDP data format throughout. This is quite true, but (a) scratch is hard to come by, (b) the model can indeed be built from scratch using PRSPEC (see the following example), and (c) the final MEVDP data file is usually generated as a one-shot operation after the model has been interactively refined. The current software set is the result of blending existing software with new, to address the needs of technique, schedule, and economics.

The MEVDP users were invited to define a command set for the interactive processing of the MEVDP model, and the set was then written into the PRSPEC software. The set allows the tracking of any shape designated as a prim, by number, and provides the same transformations as described above for the preprocessor.

With the interactive capability, one can start with a skeleton input file for PRSPEC and work the rest of a given exercise from there. Table IV shows a complete skeleton

Fig. 5a. The development of a simple cartoon for a spacecraft using the available command set. (Graphics are taken from a Tektronix 4014 terminal.) Starting at the top row and moving from left to right: A unit cube is added to the input axes set and scaled in the Z direction. Next, the scaled cube (solar panel) is shifted along the Y axis and then copied next to itself. A cylinder (array boom) is then added, scaled, and placed at the first panel. Note that the primes are labelled at their geometric centers, for identification. Starting at the second row: A group element is defined, consisting of elements 24, 25, and 26. The group is copied and rotated to become the set 20, 21, and 22. A box is then added to represent the spacecraft body, and a cone to represent the thrust motor.

The third row shows further group operations, wherein the six elements 2, 3, 4, 17, 18, 19 are rotated about the Y axis to suggest rotation of the complete solar array. Finally, the entire model is rotated about the (arbitrary) vector (1,0,1).

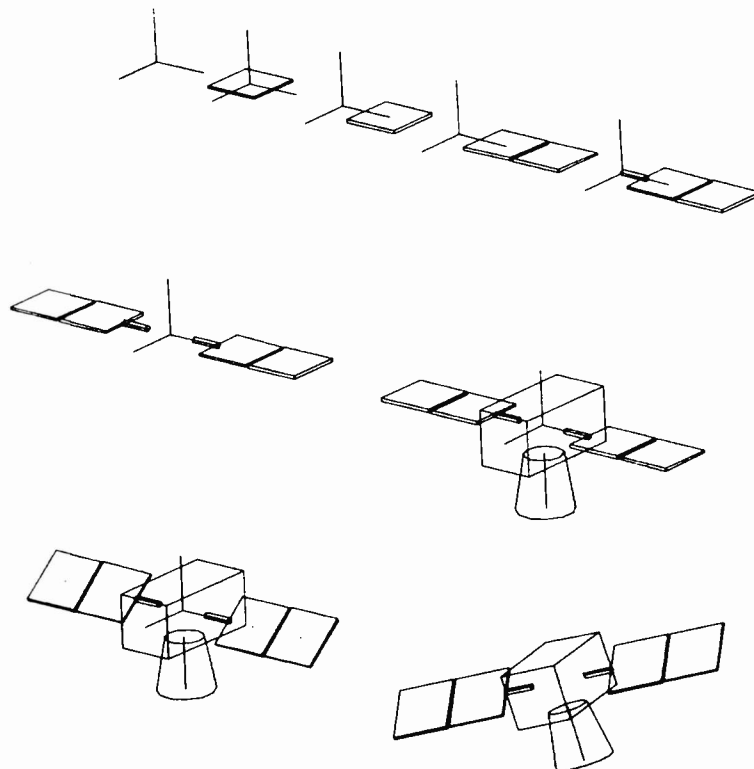
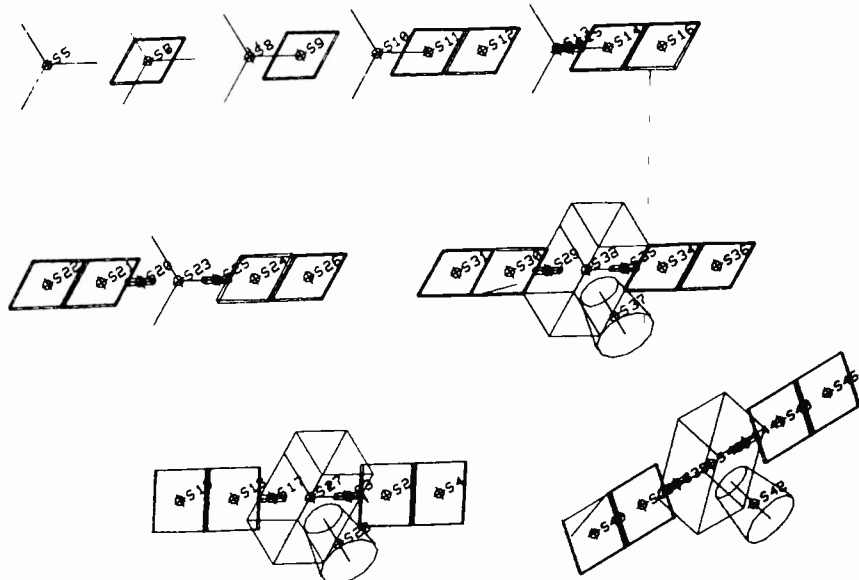

Fig. 5b. The same set of figures (at a slightly lower viewing angle) with the labels and hidden lines removed. Again, the hidden lines are processed at the element level, giving partial transparency.

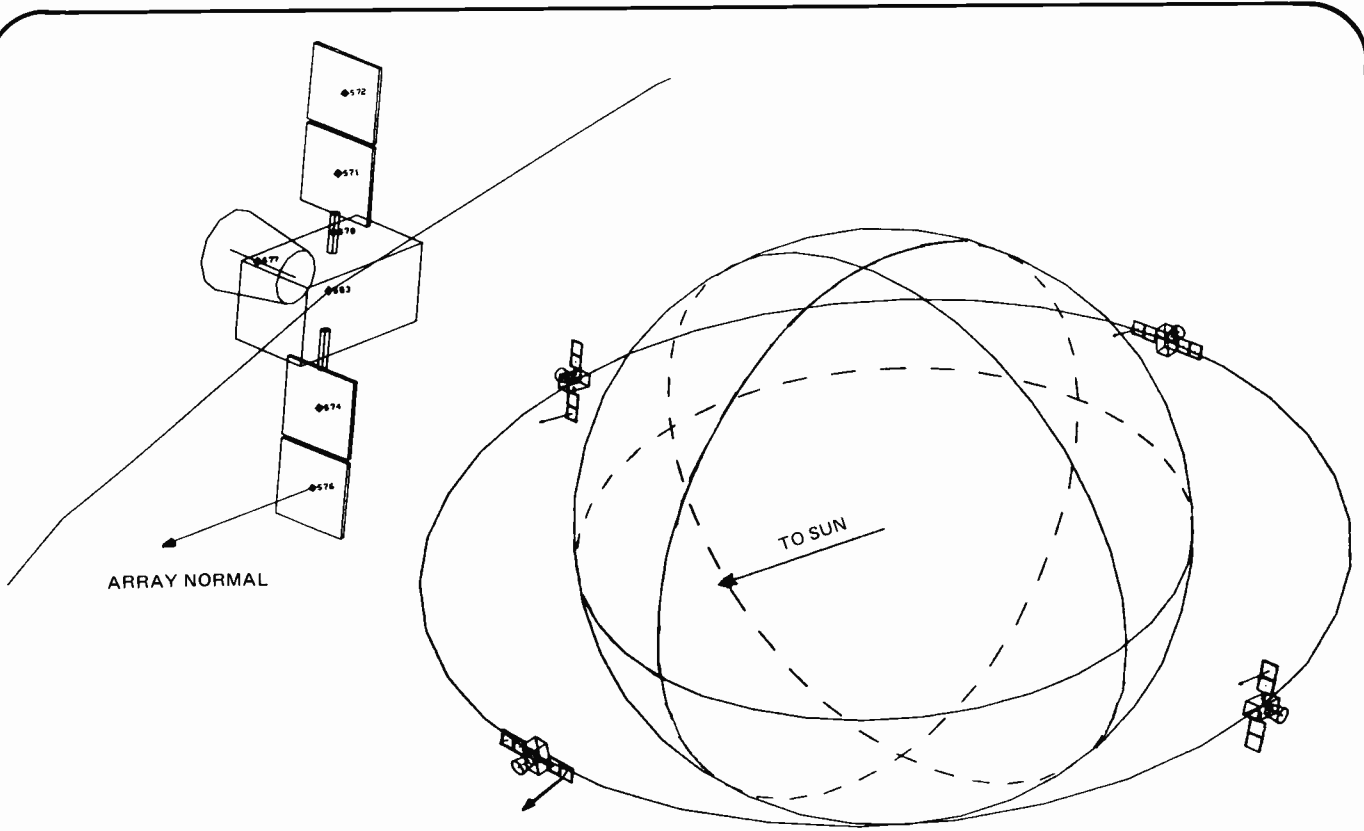
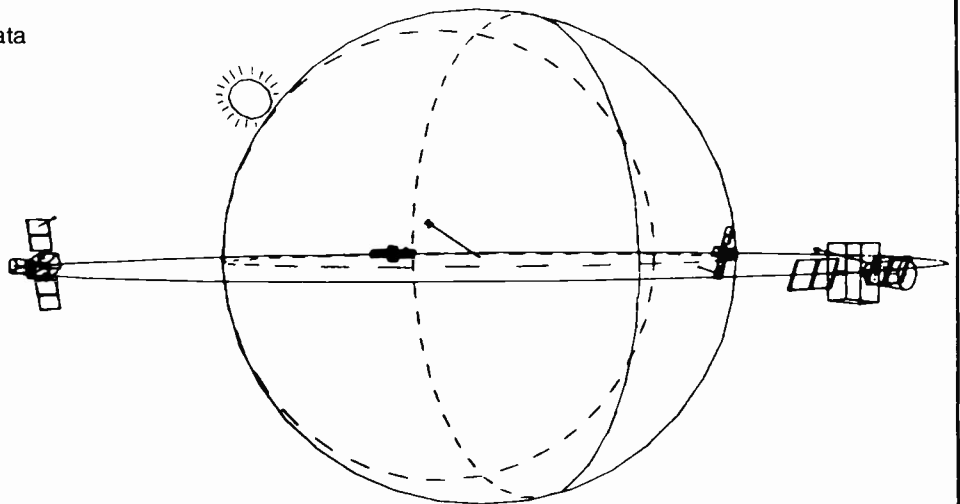

Fig. 6. The same cartoon as in Fig. 5 can be used for conceptual analysis of orientation of a spacecraft with respect to the earth and sun. The example is taken from a study of the TOPEX spacecraft, in which one issue is to be able to orient the spacecraft so that the solar array is always pointing normal to the sun. This technique is known as sun-nadir pointing, and involves rotations of

the spacecraft about the local normal to the earth and rotations of the array about its axis. Accurate graphics are indispensable for understanding the geometry of this exercise. Note that both the spacecraft body and the array are oriented in different ways in each position, to align the vector representing the array normal parallel to the vector pointing to the sun.

Fig. 7. A final example using the data of Fig. 6 to create the illusion of looking toward the sun from the spacecraft's reference, just at the beginning of an eclipse.



file that provides the system parameters and a set of X, Y, and Z axes. The file also defines the initial orientation of the viewpoint for the 3-D data set.

Summary

This paper has described several applications of the RCA general graphics program PRSPEC, in conjunction with dedicated translators, whereby previously established data streams are translated into a visual presentation of the physical model implied by the data. For established programs developed before the widespread availability of computer graphics, this technique is a means of enhancing those programs without costly rewrites or reformatting of the data protocols.

Also shown is the value of the ability to modify the model data while in an interactive graphics phase wherein errors are corrected, conceptual changes made, and an updated source data file is obtained on a round-trip basis.

Because PRSPEC was written as a general 3-D graphics package, with interfaces for user-written subroutines, it

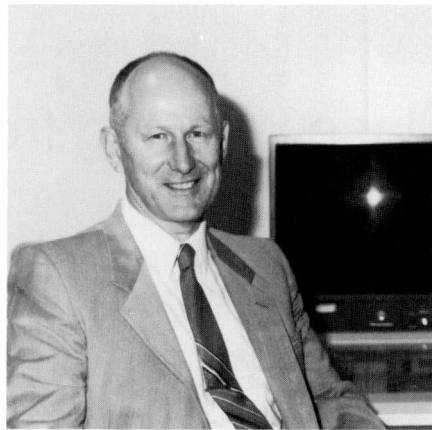

Richard D. Scott has been active in the engineering graphics discipline for a number of years. He participated in the setup of the Astro-Electronics CAD system (PRIME/MEDUSA), and wrote a number of supporting software routines for the system. His background is in mechanical engineering—in both design and analysis—at Astro-Electronics and RCA's Advanced Technology Laboratories. He is Associate Fellow of the AIAA and a member of the Interactive Graphics Committee.

Contact him at:
RCA Astro-Electronics Division
Princeton, N.J.
Tacnet: 229-2406

provides substantial flexibility for the manipulation and presentation of data, both physical and abstract. Applications have been made for vector maps and contour generation, kinematic studies, and thermal modeling.

Acknowledgments

The mass-properties preprocessor was written by Robert Lutz, RCA Astro-

Electronics Division, who also generated and provided the drawing of Fig. 4.

A post-processor (DERADBOD) was written by Amarjit Grewal, RCA Astro-Electronics Division, for the reconstruction of MEVDP data format from PRSPEC interactive sessions. He also created and provided the shielding model of Fig. 3.

Spooled-graphics laser printing from CMS

CMS users at RCA Laboratories can now "spool" graphics files to a laser printer, much as they would text or data files.

For some years, computer graphics has been an expensive tool, restricted to the privileged few whose applications demanded, and whose funds permitted, its use. Its hardware costs have been higher, and it has consumed large amounts of computing resources.

Now, because of the explosive growth in computer technology and the corresponding decrease in component costs, graphics hardware is becoming more and more affordable. As is common in the computer industry, the hardware precedes the software needed to use it. When computer users at RCA use the corporate mainframe or a local minicomputer to edit files or to run programs that produce data, they may indicate files or data to be

Abstract: *When computer users at RCA use the corporate mainframe or a local minicomputer to edit files or to run programs that produce data, they may indicate files or data to be printed, at some point in any session, either at their location or at the corporate computer center. This takes only a few simple commands (it is called "spooling"), and they can then proceed with their work. When the file or data is text, such an interruption takes a few seconds at most. Until recently, however, graphics has been a different story. This paper describes a system designed to provide spooling to a high-quality black and white graphics laser printer.*

printed, at some point in any session, either at their location or at the corporate computer center. This is called "spooling," and takes only a few simple commands (see the sidebar on spooling). They can then proceed with their work. When the file or data is text, such an interruption takes a few seconds at most. Until recently, however, graphics has been a different story. The user has required a locally-connected printer or plotter, and has had to tend it. There have been few choices:

- Pen plotter—medium- to high-quality, slow, minutes for a typical plot, still required for large-scale graphics output such as engineering drawings.
- Graphics copier or electrostatic printer—low- to high-quality, fast, seconds per plot, expensive.
- Dot-matrix impact or ink-jet printer: lowest quality, medium-speed, speed, seconds to minutes for a typical plot, jagged diagonal lines and curves.
- Laser printers: highest-quality black-and-white, fast, seconds per plot, expensive.

In essence, we have been faced with either great expense, low speed, or poor quality. A slow-speed pen plotter is not inexpensive to RCA because of the long periods of time an engineer or scientist spends waiting for it to finish a plot.

At the David Sarnoff Research Center, our users have long recognized the need for fast, convenient, high-quality, black-and-white hard copy graphics output devices used in the same way that we use our local and corporate computer center line printers. Recently, appropriately-priced

graphics laser printers appeared, and we elected to develop the software necessary to integrate them into our computing environment. Since the DSRC's business is supporting RCA's other divisions, we designed this software to be usable from other divisions.

From a systems design viewpoint, our laser printer is not an end, but a beginning.

Of course, we needed the spooled output capability possible with a shared printer, but while we can save the users time by tending the printer for them, we may negate that saving if they must spend minutes walking across a large complex to retrieve plots. As laser printers become less and less expensive, we hope to move them closer and closer to the user. It would be nice to have them as conveniently located as copy machines. Our "Labnet" Ungerman-Bass local area network can be the vehicle for this, but the software architecture must allow for it.

Just as black-and-white laser printers have declined in price, other devices will follow. Our software must allow for other possibilities, such as color slides, pen plots (for those users who must have them, so that babysitting can be by operator, rather than by engineer or scientist). The arrival of reasonably-priced, suitable-quality, color laser printers can be only a matter of time (if past experience dictates).

After we had considered the DSRC's users on the corporate mainframe, we still had users of local computers with similar needs to think about. Our software architecture had to be able to accommodate them as well. Again, Labnet could provide a data path.

Spooling

Different computer devices have always had different rates of data transfer and different capacities for storing information (with the two characteristics usually varying inversely). Smaller, faster devices have been placed closer to the actual computing (at the more abstract level), where the action is, and slower devices with larger capacities have been placed farther away at the input or output ends. The fastest devices with the least capacity are the registers in the CPU (central processing unit). Next are the RAM (random access memory) boards, some of which (called cache) are smaller and faster than others. After these are discs. After the disks are tapes. After the tapes are peripheral devices such as terminals (hard copy and video display), printers, and plotters. It may seem strange to think of these peripherals as having the greatest storage capacities, but you could type on a video display terminal until your fingers wore out without running out of virtual capacity, since it sends everything you type to the computer. Likewise,

as long as the system design allows for pausing to change paper, printers, plotters, and hard copy terminals are only limited by the amount of paper you can get your hands on.

For some time, computer systems have had distributed processors (called controllers) for the slower devices. This has meant that as results were produced by fast CPU computations, they could be passed to intermediate devices with greater capacities and lower speeds for buffering. Early in the game, programmers discovered that information could be sent off to tape (spooling to spools of tape), freeing the CPU for faster, more abstract computation, while an output controller transferred it out to a slow printer. As hardware has declined in price and increased in capacity and speed, spooling moved to disc (in larger systems) and special RAM buffers (for microcomputers). The principle remains the same: the waiter or waitress delivers the food to the table while the chef cooks.

Our corporate mainframe's timesharing operating system, IBM's CMS (Conversational Monitoring System¹), provides two paths from a user's account to remote job entry (RJE) devices: (1) the "virtual" printer, and (2) the "virtual" punch.

For several reasons, we chose to make the virtual punch our output path for graphics hard copy, and with that choice we had to consider the following:

(a) We would have to treat graphics hard copy a little differently from text, since RJE station translation tables to translate from EBCDIC to ASCII (see sidebar) were developed long before spooled graphics were even considered, and did not handle some "control" characters correctly for our laser printer. We could avoid conflicts with the needs of text printers by using the virtual punch (and doing our own translation).

(b) Not many people are using the virtual punch to punch Hollerith cards any more.

(c) The existence of a separate path for graphics would mean that a user could easily alternate between printing text and plotting graphics without needing to issue extra commands to redirect output from text printer to graphics printer.

Part of choosing a laser printer is choosing its graphics command set. All operate in a "native" mode (a language peculiar to each printer, and which takes maximum advantage of its features, such as multiple fonts (character styles), but which may be compatible with only a small portion of the graphics "packages" (see sidebar, page 27) in use. Most also operate in one or more "emulation" modes (imitating other older devices such as video terminals or pen

plotters, limited in features, but compatible with more software). An emulation mode would make our printer useful to the maximum possible number of users, while the native mode would make it more sophisticated for a few of our users. Emulation mode would also make it possible for our software to be used with more than one brand of printer, giving us some protection against a less than optimal choice of brand and model, and also giving us the flexibility to accommodate new product offerings in a very volatile laser printer market. We decided to start with emulation-mode compatible software for widest possible initial use, and to add native mode compatible software for more elaborate applications later. Two emulation modes are more popular than any others:

- (1) Tektronix PLOT10, emulating such graphics display terminals as the 4010 and 4014.² Tektronix made the first widely-used graphics display terminals.
- (2) Calcomp plotter compatibility (Calcomp made the first widely-used pen plotters).

More current brands of terminals can emulate the Tektronix 4010 than any other type. We chose 4010 emulation to give the most DSRC users the capability to view plots directly on their terminals before sending them on to the laser printer. This left us with a choice of four brands of laser printers with Tektronix emulation (this choice has since widened considerably and continues to do so). We chose the QMS Lasergrafix 1200, using an original equipment manufacturer's version of the Xerox 2700 "engine" (printer mechanism) with a controller (actually a rasterizing computer) by QMS. The controller added not only both native-mode and Tektronix 4010/4014 graphics, but also a variety of built-in fonts. In addition, the QMS controller rasterizes in the printer (see sidebar, page 28), removing that computing load from the host computer (CMS first, and later others). 4010 graphics, at 1024 dots by 768 dots, have "jaggeties" while 4014 and QMS graphics (which cost more to produce), do not. Here, there's no free lunch, but at least there's more than one menu selection.

While we were choosing our printer, we were also designing the software to send graphics to it from CMS (see Fig. 1). We had to do two things to plot on a remote graphics printer:

- (1) Direct the graphics into disk files.
- (2) "Spool" those files to the printer.

ASCII and EBCDIC

In computing's earlier days, industry members developed ASCII (American Standard Code for Information Interchange), a standard way of representing characters in computers. Some time later, IBM developed a larger code called EBCDIC (Extended Binary-Coded-Decimal Interchange Code), now used by IBM in its medium- and larger-sized computers (the smallest ones use ASCII). EBCDIC is naturally used by the "plug-compatible" manufacturers of IBM-like medium- and larger-sized computers. It is designed in such a way that even though the characters are represented by numbers in both sets, there is no formula that can be used to compute one from the other. Translation must be done by a table that relates one set, character by character, to the other. Our corporate mainframe's CMS operating system uses EBCDIC, and our QMS Lasergrafix printer uses ASCII.

Directing plots into files can be accomplished in one of two ways:

- (1) By using the CMS FILEDEF (file definition) command¹ to channel a program's output into a file, rather than to an output device such as a terminal.
- (2) By using the RCA CISS-supplied system enhancement ROUTERM (route terminal) command³ to fool the operating system into putting the output it thought was going to one's terminal into an output file instead.

Where possible, we used the former method, since it is a more straight-forward approach to the problem, and really involves specifying a procedure for the user to follow, rather than supplying custom software. There were cases, however, in which we were forced to resort to the latter. All involved using Tektronix emulation with the printer. Some graphics packages used IBM assembly language (for speed) to feed their output directly to the terminal, and could not be redirected with a FILEDEF. So far, three families of currently-installed packages can produce

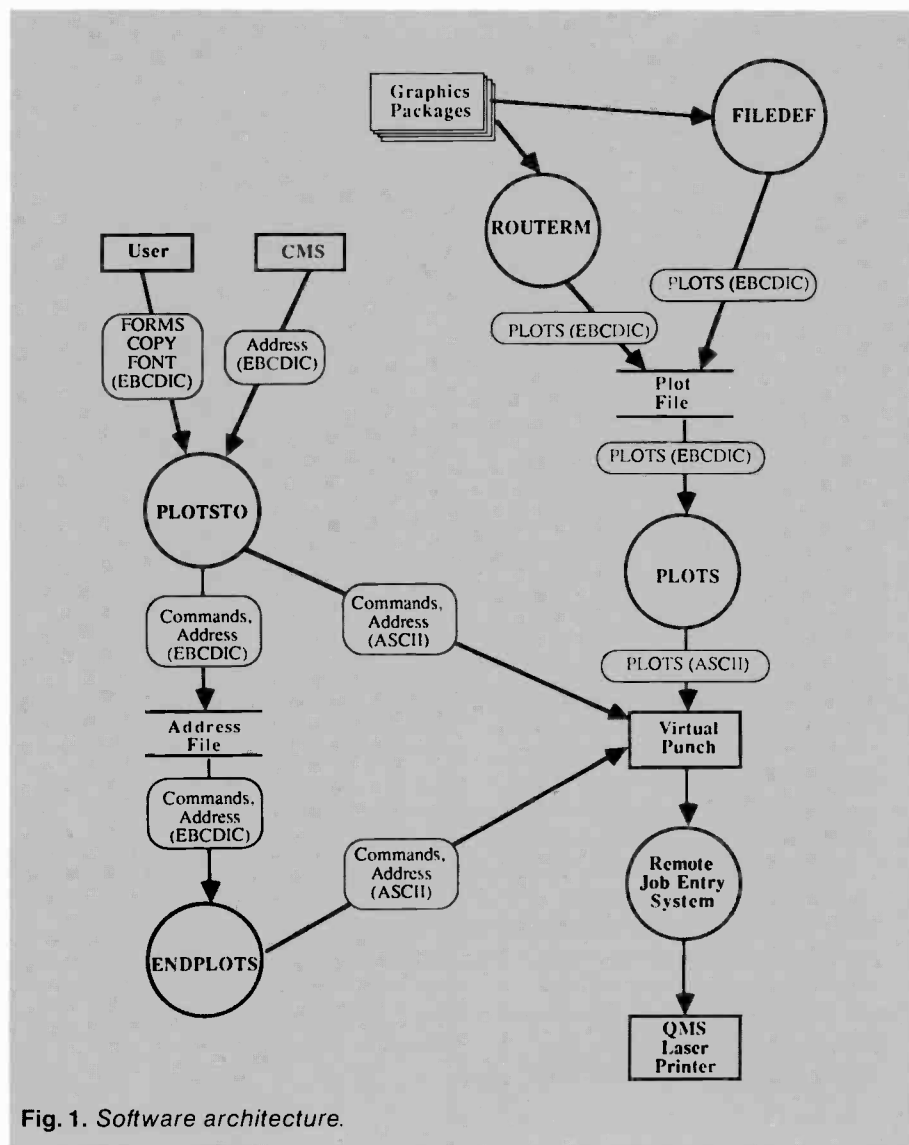

Fig. 1. Software architecture.

output in the native language of the QMS Lasergrafix. We FILEDEF with these.

Spooling files to an output device requires three steps:

- (1) Starting spooling. For text printers this is done by using the RCA CISS-supplied system enhancement ROUTE command,³ which identifies the destination and provides options for multiple copies, special forms, etc. We modeled our PLOTSTO command on ROUTE.
- (2) Spooling one or more files. For text printers the CMS PRINT command is used. We modeled our PLOTS command on PRINT. (We used the name PLOTS instead of PLOT because there was a program named PLOT already in use by DSRC users).
- (3) Stopping spooling. This step actually

causes the files to be sent to the device. Instead of requiring the user to issue a SPOOL⁴ command to the virtual punch, we provided the ENDPLOTS command.

Our approach was to try to extend the user's environment in a logical and consistent way to make it appear as if graphics had been a part of the spooling environment from the beginning.

PLOTSTO and ENDPLOTS also have a few "housekeeping" chores. When we spool the virtual punch to a remote destination, punch some files and close spooling, the remote operator sees the punch job identified on the remote station console, and with commands, directs the job to an appropriate device, such as an available card punch, which is not exactly what we had in mind. Normally, the FORMS option of the ROUTE command

Graphics packages

If there were no graphics "packages," graphics use would be limited to people actually trained in making computers draw pictures (a small group, indeed), which is the equivalent of limiting the use of cars to automotive design engineers. Packages are simply programs, collections of programs, or collections of pieces of programs. Graphics packages available to the corporate CMS user include:

- (1) **Tellagraf**: a program used to graph data (scientific or business) that uses English-like commands such as, "make the x-axis 6 inches long." Tellagraf can produce almost any type of 2-dimensional graph of data that one might want, including multiple graphs on a page, allowing the user to take advantage of laser printer resolution for comparison.
- (2) **Cuechart**: a program that lets the user select the graph he or she wants from a book of canned graphs, and which produces the file of commands that is used by Tellagraf to produce that graph. Cuechart is limited to certain subsets of graphs that can be produced by Tellagraf (although one familiar with Tellagraf can "doctor" a graph produced by Cuechart). A user familiar with Tellagraf is able to "can" other custom graph types for Cuechart users.
- (3) **Disspla**: a series of FORTRAN

subroutines to be called from within the user's program (written in FORTRAN, PL/I, COBOL, etc.) to produce graphs. Disspla can produce anything Tellagraf can produce, and can also be used for 3-dimensional graphs.

Tellagraf, Cuechart, and Disspla are products of ISSCO, Inc.

(4) **SAS/Graph**: a data-graphing package built in to the statistical package SAS. Between Tellagraf and Disspla in ease of use, it takes advantage of SAS' ability to manipulate the data statistically, and it graphs the results. It can produce 3-dimensional graphs, but not multiple graphs per page. SAS/Graph is a product of SAS Institute, Inc.

(5) **Focus**: part of the Focus database system, between Tellagraf and SAS/Graph in ease of use, with less richness than Cuechart, it benefits from its inclusion within the Focus database package (the user does not have to stop accessing data to graph it, and vice versa). Focus is a product of Information Builders, Inc.

(6) **DI-3000**: a series of FORTRAN subroutines to be called from within the user's program to produce graphical objects (lines, polygons, etc.). Unlike Disspla, DI-3000 permits the user to perform geometric modelling and graphic input.

(7) **Grafmaker**: a series of FORTRAN subroutines to be called from within the user's

program, which in turn call DI-3000 subroutines to produce graphs of data (including axes, tick marks, etc.). This package gives DI-3000 graphing capabilities similar to those of Disspla.

(8) **Contouring**: a series of FORTRAN subroutines to be called from within the user's program, which in turn call DI-3000 subroutines to produce graphs of 3-dimensional data. This package gives DI-3000 full 3-D data graphing capabilities.

(9) **DI-Textpro**: a series of FORTRAN subroutines to be called from within the user's program, which in turn call DI-3000 subroutines to provide text capabilities, including a variety of fonts with controls over their attributes. DI-3000, Grafmaker, Contouring, and DI-Textpro are products of Precision Visuals, Inc. These packages are currently installed on CMS on a trial basis.

Other programs on CMS include the ability to graph output: SUPRA and SUPREME, used for semiconductor process simulation, are only two examples of programs either acquired from outside sources or written by RCA users.

Tellagraf (and thus Cuechart), Disspla, SAS/Graph, DI-3000, Grafmaker, Contour, DI-Textpro, SUPRA, and SUPREME work with our laser printing software.

is our means of informing the operator that we want special paper in a printer, for example. Since this option can be any four characters, we chose "LASR" as the form for the QMS Lasergrafix. We anticipate using "SLID" for a film recorder and "PENS" for a plotter.

Once we had designed a software architecture capable of providing the necessities, we considered ways of taking advantage of the special features of the QMS Lasergrafix printer.⁵ This meant making PLOTSTO and ENDPLOTS more

sophisticated (if PLOTSTO turned on a special feature, ENDPLOTS should turn it off to avoid surprising the next user).

The ROUTE command allows a multiple copy option (the operating system actually sends the job to the remote device multiple times, which means that the copies are collated). We designed PLOTSTO to accept an optional argument pair, COPY *n*, where *n* is the number of copies, and pass it on (to ROUTE).

The ROUTE command also permits the use of an address distribution (the user

may create files containing different address blocks for distribution of output, assign each a four-character distribution code, and select the one desired with the code). We designed PLOTSTO to accept an optional argument pair, DIST *xxxx*, where *xxxx* is the distribution code, and pass it on (to ROUTE).

The QMS Lasergrafix printer has two modes, portrait (the long dimension of the paper is vertical, as in a portrait painting), and landscape (the long dimension of the paper is horizontal, as in a

Vectors, rasterization, and "jaggeties"

Rasterization

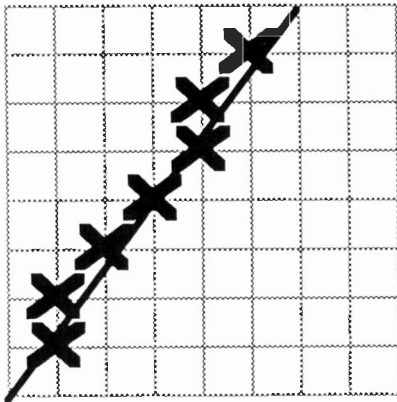

In the beginning, computer graphics was all done with vectors, or straight lines drawn between two points. The earliest graphics devices were CRT displays and pen plotters on which images were drawn as a series of straight lines, either by moving an electron beam around, turning it on for lines and off between them, or by moving a pen around, letting it draw on paper for lines and lifting it between them.

Note that a point can be represented by a line so short that we cannot tell it has any length at all. We can draw anything with straight lines if we can draw the lines short enough. We can draw almost anything if we can draw the lines almost short enough. If we give "addresses" for the horizontal (x) and vertical (y) distances of a point from the lower left-hand corner of our plotting surface (CRT screen or paper), the more addresses we have, the closer together we can put the points, and the shorter the lines we can make. Hence, more "addressable" points equals finer detail.

On high-quality vector CRT displays, the number of addressable points is high enough to make points or lines drawn on the screen overlap (because of "dot bloom"). There are actually two types of vector CRT displays:

Jaggeties

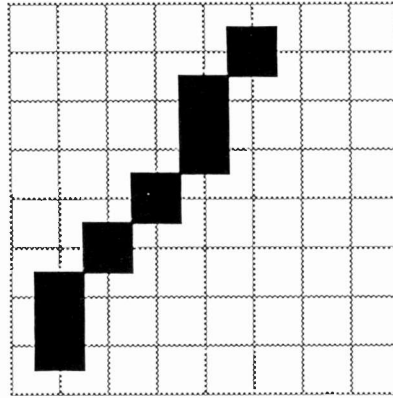

refresh, with short-persistence phosphors on which the image fades unless it is redrawn many times a second, and storage, on which the vector is drawn once, and the phosphors are kept energized by a "flood" gun which floods the whole screen with electrons of lower energy than the drawing beam (early Tektronix CRT display terminals such as the 4010 and 4014 used storage tube technology developed by Tektronix to retain waveforms on oscilloscopes).

On high-quality pen plotters the points are closer together than the width of the finest pen in order to produce the desired effect.

The Tektronix 4010 used 1024 points horizontally and 768 points vertically (it actually addressed 1024 points vertically, but since the screen was not square, one could only see or print 768). For a 7.5×10 inch plotting area on an 8.5×11 inch sheet of paper, this corresponds to approximately 100 points per inch. The later 4014 used 4096 points horizontally by 3072 points vertically for an equivalent addressability on paper of approximately 400 points per inch. The effect of low resolution on vector devices is the apparent use of a "broad brush" to draw the image.

Later (and generally less expensive) devices such as

Broad Brush

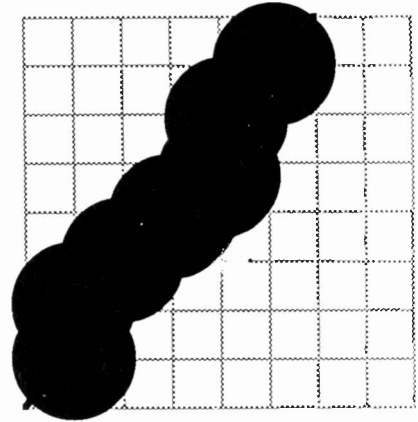

raster CRT displays, dot-matrix impact, thermal and ink-jet as well as laser (less expensive relative to its resolution capabilities) used "raster scanning" (just as a television does. Early raster-scan terminals were little more than TV sets with keyboards and some electronics added, which explains their much lower cost.

In a raster scan device, the plot area is scanned as a series of lines, usually from left to right, and line by line (usually from top to bottom). As each point on the plotting surface is scanned, if it is part of the image, it is "turned on", by brightening or darkening the electron beam (raster-scan CRT), firing a solenoid that slams an ink-impregnated ribbon into the paper (impact dot-matrix), spraying droplets of ink at the paper (ink-jet), or brightening or darkening a laser beam striking a "chargeable" drum. Depending on the particular device, the points (and raster-scan lines) might or might not overlap. The points are usually referred to as "pixels," or picture elements. If the points do not overlap, lines, especially those that are not strictly horizontal or vertical, have a stair-step effect known as the "jaggeties". Jaggeties are a product of low-cost, low-quality computer graphics, and brand the image as being "mechanical"

in appearance and generally inferior to that which could be produced by other means (manual drafting, for example). It is my experience that automation is much easier to sell to a client, particularly in view of its usual cost, if it does not produce a result that is judged inferior to that previously produced by other (usually manual) means. One would prefer then that points overlap to eliminate jaggedities, and that they be small enough to eliminate too much of a "broad brush" effect.

To express an image as a set of vectors, one may simply give the endpoints, coupled with "pen-up/pen-down" or "beam-off/beam-on" commands. To express it as a raster image, one must say whether each of the

dots is on or off (one might use a data compression code to say the next n dots are on or off). Images without large solid filled-in areas are generally expressed more compactly as vectors. The process of translating the vector commands for an image into a raster version is known as "rasterization." If one wishes to use a representation such as Tektronix vectors for an image to be displayed on a raster device such as a raster-scan CRT or laser printer, one must rasterize it first. For a complex image with high resolution (say the 300 dots per inch for a 7.5×10 inch plot area, which equals 6.75 million dots to be on or off), the computations for rasterization are not trivial! Depending upon the device, rasterization may be

done in the device itself in "hardware" (actually by a built-in computer designed for the purpose), or on the computer producing the graphics in software. In the former case, one pays the cost of rasterization at the time of purchase, and in the latter case, one pays it every time a graph is produced. Since the vector representation is generally more compact, and the connection between the device and the computer has a speed limit, graphs may be delivered to the device faster in vector form than in raster form, and may, in general, produce graphs more quickly. In sum, we are usually much better off paying the "up front" price of device or hardware rasterization.

landscape painting), and twelve character font (styles), nine portrait and three landscape. We designed the PLOTSTO command to accept the argument pair FONT xn , where x is either P or L (portrait or landscape) and n is the number of the font.

The system supplies leading and trailing banner pages, but these are in IBM's EBCDIC character set, not accessible to our software for translation to ASCII, and not translated by the RJE station, since we needed to suppress that translation and replace it with our own for proper graphics. Fortunately, the result is relatively benign, because each of these has no ASCII line feed or carriage return characters, and each comes out of the QMS Lasergrafix as a single line of typed-over jibberish. To correct for this, we made PLOTSTO create a banner page with the user's address block by accessing the RCA CISS-supplied ADDRESS command from within PLOTSTO, which sends the address block (correctly translated) and saves it in a disk file for ENDPLOTS to send as a trailing banner page. Before the banner page, we made PLOTSTO send commands selecting landscape mode, and a default character font, character spacing and line spacing, to make all banner pages look the same and to restore the printer to a known state. These are also stored in the file passed to ENDPLOTS for the trailing

banner page. After the banner page, if the user has requested a mode/font combination, PLOTSTO sends commands requesting the mode, the font, and appropriate character and line spacing for the latter (not all fonts are the same size; see sidebar, page 30).

We wrote PLOTSTO, PLOTS and ENDPLOTS in IBM's Pascal/VS,^{6,7} building on Kernighan and Plauger's *Software*

Tools in Pascal,⁸ after writing the necessary "primitives," or low-level modules to port those tools to CMS.

Now that we have provided a practical means of spooling high-quality hard copy graphics from the CMS environment, we will extend the capability to DSRC users of other computing environments, and to other shared graphics output devices. RCA Astro-Electronics Division now has a QMS

Prior to receiving his MS in Operations Research (with a minor in systems design) from Rutgers University, **Don Barton** worked for nine years as a field engineer on U.S. Air Force flight simulators, mostly in Japan. After receiving his degree, he worked as a hardware design engineer in data communications and computer peripherals, and later he worked for RCA Camden on a distributed computing system. He joined RCA Laboratories in 1980, where he developed a testing information system for VideoDisc research using a database and graphics on an IBM mainframe. He joined the Information Systems Planning and Computer Services Group in 1983, and now supports scientific computing for RCA Laboratories. His primary interests are computer graphics and the use of the computer as a tool for the researcher.

Contact him at:
RCA Laboratories
Princeton, N.J.
Tacnet: 226-2995

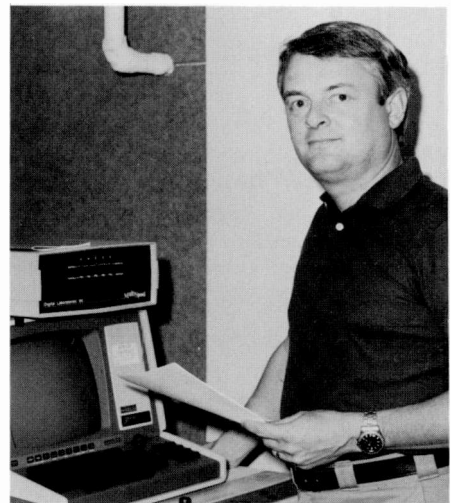

Landscape font, portrait font, and sample QMS bullet list

THIS IS FONT P328.
(PORTRAIT COMPLEX ROMAN BOLD 15 POINT)
ABCDEFGHIJKLMNOPQRSTUVWXYZ
abcdefghijklmnopqrstuvwxy
0123456789 !@#\$%&*()_+ -= {}[]\:"';<>?.,/

This is one of the nine portrait fonts available.

THIS IS FONT L328.
(LANDSCAPE COMPLEX ROMAN BOLD 15 POINT)
ABCDEFGHIJKLMNOPQRSTUVWXYZ
abcdefghijklmnopqrstuvwxy
0123456789 !@#\$%&*()_+ -= {}[]\:"';<>?.,/

This is one of the three landscape fonts available.

- Use this format to produce a bullet chart
- The 1 in column 1 of the first line says to start a new page.
- The 0 in column 1 of the second line says to skip a line (use a blank if you don't want to).
- You may simply copy this file (QMS BULLET) off Lablib and replace this text with yours.
- Your file may contain many such charts.
- When you are done, type:
PLOTSTO 21 (FONT L328
PLOTSCC filename filetype
ENDPLOTS
- where filename and filetype are for your chart file(s)
(you may use PLOTSCC between PLOTSTO and ENDPLOTS more than once for multiple chart files)

These characters are proportionally spaced, so columnar text will be a problem.

Example of QMS bullet list.

Satellite contour map

RCA Continental View

Bor Lat= 99.99 +
Bor Lon= 99.99 +
Sat Lon= 99.99W

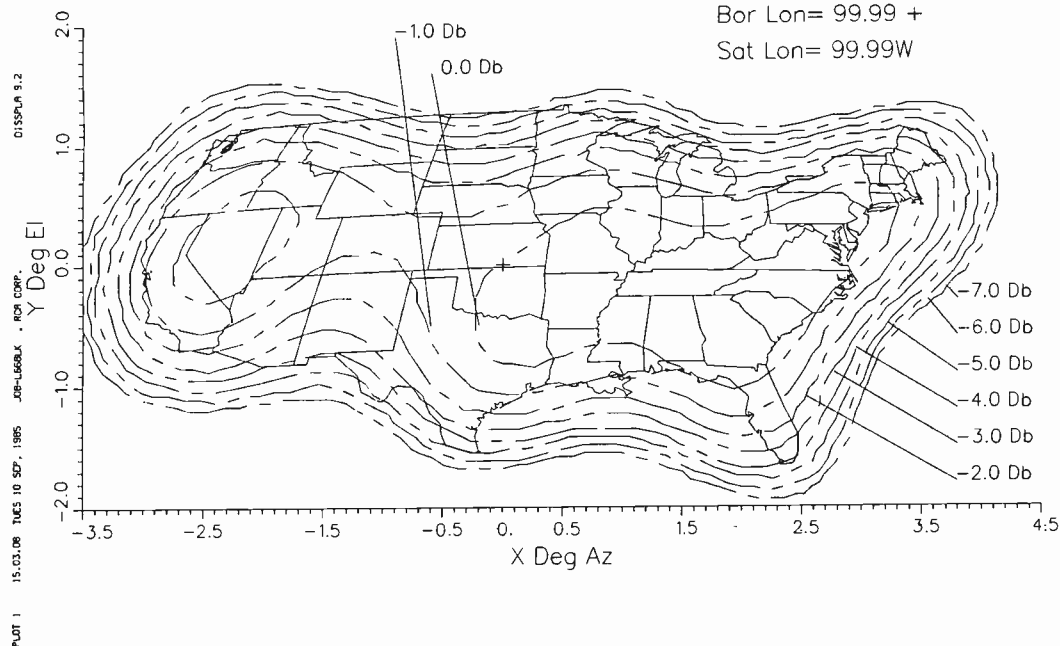

We obtained graphic documents from the Federal Communications Commission (FCC) and from the RCA Astro-Electronics Division showing contours of constant satellite-to-ground received-antenna power (EIRP), or the power density from the ground station needed to saturate the satellite amplifiers (SFD). We placed the contour information in data files by digitizing a large number of points on the contours, using a Tektronix 4954 digitizing tablet with a program written by K. W. Coffee and R. E. Enstrom.

In some cases, we recognized the maps as one of the standard

projections. In others, we could not recognize the projections. A program written by A. Guida converted all of the projections to mercator.

We produced the maps (with their associated contours and annotation) using a Disspla-based program written by L. Kihn, and directed them to the QMS laser printer.

The example plot shows:

1. A title containing the type of satellite, its position relative to the earth's surface, and the view of interest (not shown).

2. A projected map of the U.S. overlaid by the contours, with labels.
3. Information about the "boresight" or equivalent aim point of the center of the satellite's antenna beam axis on the earth's surface.

The QMS laser printer furnished plots with clear, readable text and well-delineated contours for analysis on standard-size plain paper for easy inclusion in reports.

—Les Kihn,
RCA Labs

Lasergrafix 1200 printer using our software for RJE printing.

Acknowledgments

I wish to thank John Lee of RCA Laboratories for his help with adapting our existing Remote Job Entry station to accommodate a laser printer; Sue Johnson

of CISS, Cherry Hill for her help with making a "new" IBM product, Pascal/VS, communicate with the CMS operating system; Frank Zonis and Linda Rusnak for modifying ROUTERM to enable us to direct Tektronix-compatible plots into a disk file; Ray Davis, CISS for help with ISSCO's products and the printer; Dr.

James Matey, RCA Laboratories for establishing the SAS/Graph approach to plotting on the printer; Dr. Ron Sverdlove and John Fields, both of RCA Laboratories, for configuring the ISSCO QMS driver; Dr. Russ Barton for the "windowpane" example plots in his sidebar; and Les Kihn for his plot of satellite coverage.

Windowpane plots

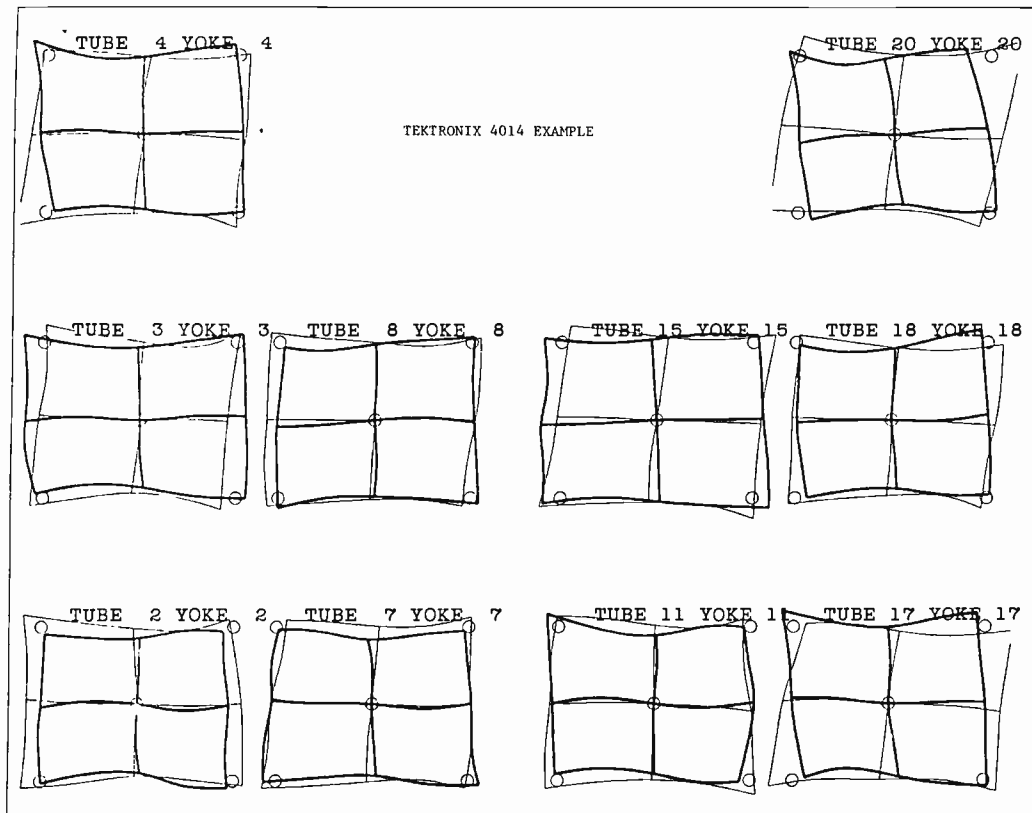

Ideally, the red, blue, and green beams of a color picture tube should coincide (converge) everywhere on the screen. This is so, for example, the image of a purple hat doesn't exhibit red or blue fringes around the edges. Practical requirements of design and manufacturing do result in small errors, however. By studying the nature of these errors, it is possible to identify their causes and make corrections that improve picture quality.

The nature of misconvergence errors for color picture tubes are easy to view using windowpane

plots. Each plot summarizes 100 measurements of misconvergence; 4 measures at each point of 25 points on the screen. Red-beam position relative to green, and blue-beam position relative to green are measured both in the horizontal and vertical directions. These errors are typically fractions of a millimeter, and are not easily detected in a plot that is to scale. Exaggerating the errors by about 50 times makes the pattern of misconvergence visible. The relative positions at each point on the screen are connected by smooth curves; a

thick line for blue and a thin line for red.

Because the information is reduced to shapes, it is possible to view a group of many plots together to look for common features. The usefulness of multiple windowpane plots depends on the availability of fast, high-resolution plotting hardware. The QMS laser printer provides the speed and resolution we need, as shown in this example of the QMS "QUIC mode."

—Russ Barton,
RCA Labs

References

1. *CMS Command and Macro Reference*, IBM Corp., Endicott, N.Y. (1983).
2. *4014 and 4014-1 Computer Display Terminal User's Manual*, Tektronix, Inc., Beaverton, Or. (1982).
3. *Computer Services User Guide*, Vol. 2, RCA Corp., Cherry Hill, N.J. (1984).
4. *CP Command Reference for General Users*, IBM Corp., Endicott, N.Y. (1983).
5. *QUIC Programming Manual*, Quality Micro Systems, Mobile, Ala. (1984).
6. *Pascal/VS Language Reference Manual*, IBM Corp., San Jose, Ca. (1981).
7. *Pascal/VS Programmer's Guide*, IBM Corp., San Jose, Ca. (1981).
8. Kernighan and Plauger, *Software Tools in Pascal*, Addison Wesley, Reading, Mass. (1981).

An information network with over 7500 ports and no passwords . . .

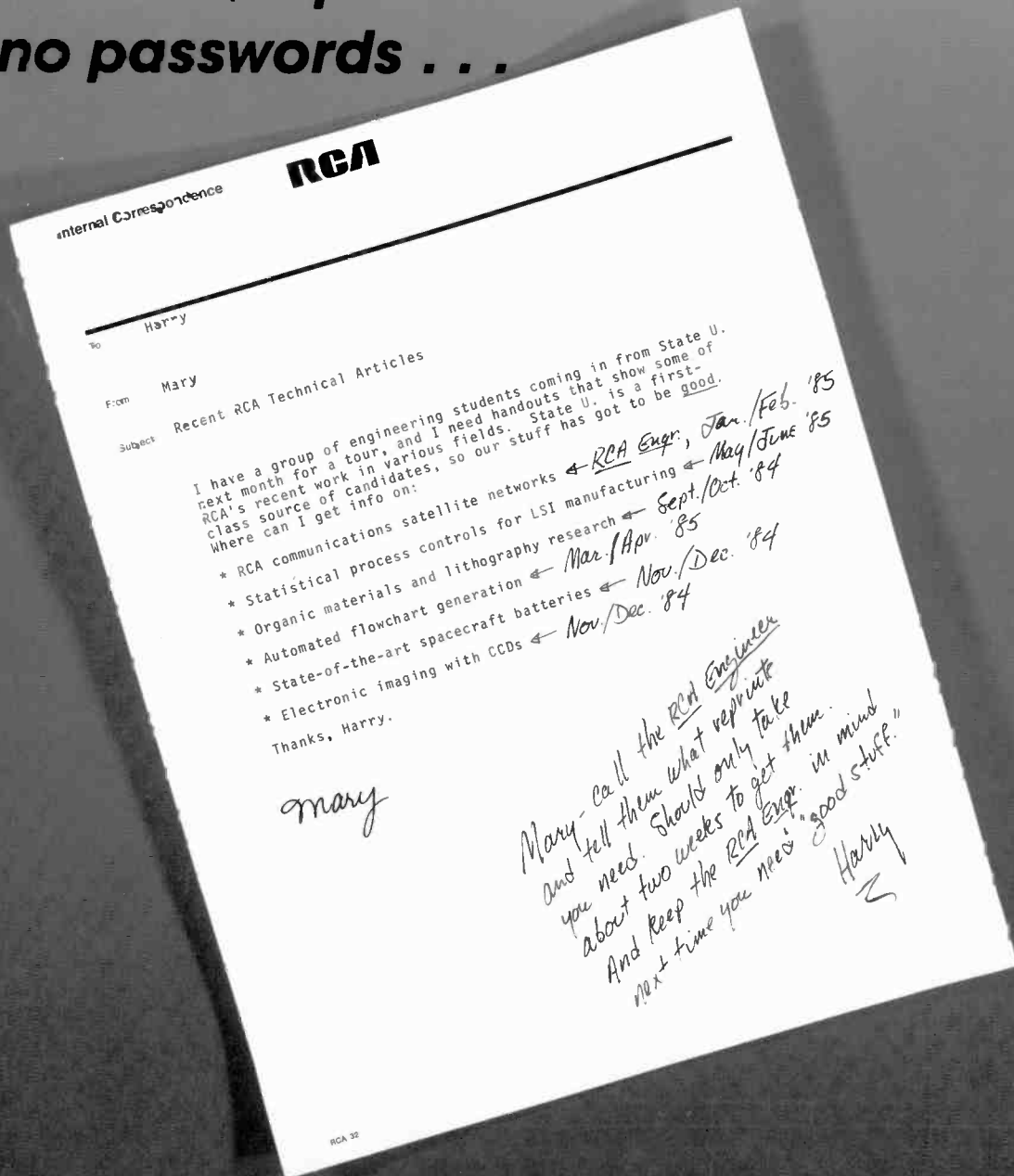

The *RCA Engineer* information network operates informally, but effectively. Memos, phone calls, and word-of-mouth are its protocols.

RCA Engineer articles are a reusable resource. Reprints are valuable tools for recruitment, marketing, seminars, and meetings with colleagues.

Reprints of single articles take about two weeks to make. If you want to put together a booklet of reprints from several issues, it

will take from four to eight weeks. We can, in fact, give you pretty much what you want, and the prices are lower than the original cost of printing the articles.

For more information and a complete price schedule, call or write to:

Louise Carr
RCA Engineer
M.S. RR 13
Princeton Labs
Tacnet: 226-3092

Accurate layouts for automatic component insertion

A unique program has been developed to show the spacing requirements for automatic insertion of axial and radial leaded components into printed circuit boards.

Many of today's printed circuit boards (PCBs) are dominated by digital integrated circuits. In contrast, the boards in a television receiver are still very much analog with many discrete components; a master board (see Fig. 1) may contain more than 400 components, of which about six are ICs. Production runs for typical digital boards may be much less than 100; runs for television boards may be several hundred thousand. The large volumes and cost pressures dictate that the boards be designed for automatic component insertion (ACI) when feasible.

The ACI design rules are a function of the insertion machine, the component being inserted, and the neighboring components. Conforming to these rules while designing the PCB is time-consuming and frustrating. Now, a program has been implemented on a computer aided design (CAD) system to graphically show the ACI constraints as exclusion areas.

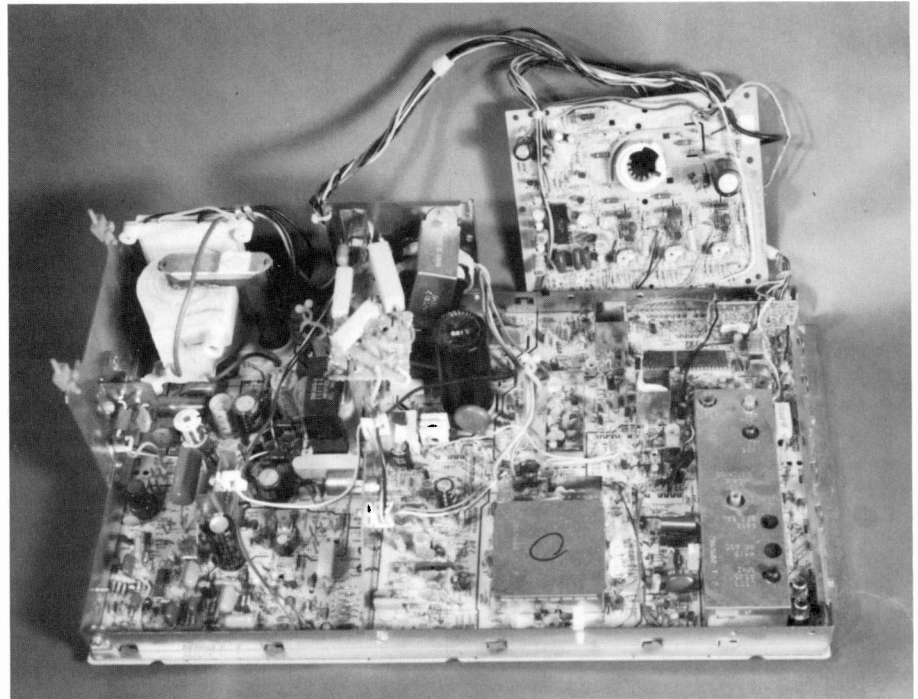

Fig. 1. The CTC-131 chassis was the first board designed using the "Footprint" program.

Abstract: *Layout of a printed circuit board for automatic component insertion can be a tedious and time-consuming task. For each insertion machine and component, up to 13 different clearances must be checked for each component. This paper describes a program that graphically displays the exclusion area associated with neighboring components. The major benefit achieved is a more compact and accurate layout designed in a shorter time.*

Background

PCB designers at Consumer Electronics create a layout based upon electrical, mechanical, and manufacturing constraints. These constraints often conflict with one another. The designer acts as a referee in creating a layout that is acceptable to all parties. Electrical and mechanical constraints are communicated to the designer on schematics, on drawings, and orally. Manufacturing constraints, for the most part, are published in a document titled

"Manufacturing Design Guidelines" (MDG).

One portion of the MDG describes ACI design rules for axial (e.g., resistor) and radial (e.g., transistor) leaded components. The ACI design rules attempt to reduce a three-dimensional dynamic problem to a two-dimensional static representation. These rules fill three 2-in. binders.

Most of the boards used in a television receiver are designed interactively using an Applicon AGS/870-I 2D CAD system.

Tools to further automate the layout process have therefore been developed for the Applicon system.

Using the ACI design guidelines

PCB designers have estimated that to check each pair of components can take up to three minutes. Of course, for commonly used parts the time required is much less. The complexity of the guidelines and the time required to follow them are best illustrated by the following typical example.

1. First, determine the insertion machines to be used to populate the board. Various manufacturing plants and production lines within a plant have different equipment complements. For this example, we will use a USM 5mm axial inserter. Data for each machine is in a different section of the MDG. USM 5mm axial data is in section 03-02.
2. Determine the automatic insertion method—axial or radial—based upon the part geometry.
3. Using the drawing part number on the schematic or Drawing List (DL), determine the part's classification. From Fig. 2, we see that a 1/4-watt resistor on drawing 99206 is assigned a classification of 1B2. The classification is based on the component type and geometry. Data for this component is in subsection 03-02-13, page 1B2 (see Fig. 3).
4. Assume that a 1/8-watt resistor on drawing 990697 is to be the neighboring component in the layout. It has already been placed in the layout and during manufacturing it is to be inserted before the 1/4-watt resistor. Again, use Fig. 2 to determine a classification of 1A1.
5. Figure 4 specifies the dimensions to be used from Fig. 3 based upon the relative component orientation. If the components are inserted parallel to each other, then dimensions P, A2, B2, C1, C3, D1, and D3 must be considered; otherwise A1, A3, B1, B3, C2, and D2 are used. Note that all dimensions are relative to the centers of the holes for the component leads. The actual dimensions to be used are in the first line of Fig. 3, since we are using a component classified as 1A1.
6. Apply the appropriate dimensions to the part to be placed in the layout at its proposed location. Figure 5 shows the dimensions for the example chosen. Determine if any rules have been violated. If not, consider the relationship between the component to be placed

SUBJECT		AUTOMATICALLY INSERTABLE RESISTORS		Minimum Insertion Span	
				Axial USM	Radial
1/8 Watt					
Classification	Drawing #	Part #	Axial Hole Size		
1A1	990697	ALL PARTS	F	.250	.200
1A2	2815583	ALL PARTS	H	.250	.200
1/5 Watt					
1A4	2874082	ALL PARTS	G	.250	.200
1/4 Watt					
**	181	2821551	ALL PARTS	K	.400 .200
		993218	ALL PARTS	K	.400 .200
		993272	" "	K	.400 .200
		993284	" "	K	.400 .200
		2816925	" "	K	.400 .200
		2874072	" "	-	- .200
	182	99206	" "	L	.350 .200
		99291	" "	L	.350 .200
		993152	" "	L	.350 .200
		727832	" "	L	.350 .200
		735729	" "	L	.350 .200
**		2819320	" "	L	.375 .200
*	183	2819434	ALL PARTS	H	.250 .200
	184	990401	ALL PARTS	K	.375 .200
		990413	" "	K	.375 .200
		993113	" "	K	.375 .200

Indicates Change. Addition or Deletion
 * ** ***

Supersedes 6/18/84

Fig. 2. A major use of this table is to determine the classification given the component's drawing/part number.

and other neighboring components. If a violation has occurred, move the proposed placement and perform this step again. Note that any move may create violations for components that were previously checked.

This example omitted mention of many problems routinely encountered during a layout. For example, the placement order during the layout is different than the insertion order. Three ACI passes are typically used: (1) axial parts parallel to the x-axis, (2) axial parts parallel to the y-axis, and (3) radial parts. Within each pass, the components are inserted in a snake-like pattern.

Designers initially attempted to ease the problem of designing to the ACI guidelines by building templates. Typically, one or more cells were used to convey the data. The cells contained data for the most frequently encountered situations, but they could not account for the dynamic insertion order. Some of the cells were difficult to read. Guideline cells were constantly being added to and deleted from the layout drawings.

Automating the ACI guidelines

A decision was made to implement a prototype program to provide the designers with some assistance in adhering to the

PRINTED IN U.S.A. **RCA** MANUFACTURING DESIGN GUIDELINES
 Manufacturing Technology
 Indianapolis, Indiana
 03-02-13
 Page 182
 SUBJECT AXIAL INSERTION COMPONENT AND TOOLING CLEARANCES TO RESISTORS Date NPT 9 1982

FOR USM 5MM EQUIPMENT

AXIAL RESISTOR BEING INSERTED

Classification	Drawing #	Part #	COMPONENT ON BOARD													
			P	A1	A2	A3	B1	B2	B3	C1	C2	C3	D1	D2	D3	
182	99206	" "	1A1	81	100	118	128	158	82	80	113	80	85	108	80	83
	99291	" "	1A2	85	104	118	128	164	84	82	117	84	100	113	84	100
	993152	" "	1A3	103	139	118	128	201	82	102	158	105	113	151	105	115
	727832	" "	1B1	108	117	118	128	176	87	93	130	87	103	128	87	105
	735729	" "	1B2	107	118	117	127	175	88	85	129	88	108	125	88	108
			1B3	85	104	121	130	184	84	91	117	84	100	113	84	100
			1B4	107	118	117	127	175	88	85	129	88	104	123	88	104
			1C1	141	178	117	127	210	82	103	188	101	110	159	101	110
			1C2	133	158	118	128	201	82	102	158	105	118	151	105	118
			1C3	133	159	117	127	201	81	101	158	101	110	151	101	110
			1C4	135	184	117	127	203	81	101	181	101	110	153	101	110
			1C5	133	159	117	128	201	82	102	158	105	118	151	105	118
			1C8	132	158	118	125	200	82	102	157	105	118	150	105	118
			1C9	158	204	117	127	226	88	107	192	88	108	176	88	108
			1C9	113	122	118	128	181	87	88	135	87	103	131	87	105
			1C10	127	138	118	128	185	88	88	151	87	105	145	87	105
			1C11	137	188	118	128	205	81	100	183	87	103	155	87	105
			1C12	121	130	117	127	189	85	88	144	101	110	138	101	110
			1C1	158	204	116	126	228	87	108	182	105	115	178	105	115
			1D2	132	158	114	124	200	82	102	157	104	113	150	104	113
			1D3	120	129	116	127	189	87	88	147	87	88	128	87	88
			2A1	71	80	115	128	158	88	85	83	87	105	88	87	105
			2B1	74	83	114	124	153	80	88	88	104	112	82	104	113
			2A1	85	88	118	128	157	84	82	111	84	100	107	84	100
			2A3	85	104	123	131	184	84	81	117	88	104	113	88	104
			3B2	103	112	120	128	171	88	83	123	84	100	113	84	100
			3B3	105	114	119	128	174	85	83	127	84	100	113	84	100
			3C2	110	118	118	128	178	85	84						
			3C3	110	118	118	128	178	85	84						
			3C4	110	118	118	128	178	85	84						
			3C5	110	118	118	128	178	85	84						
			3C6	110	118	118	128	178	85	84						
			3C7	110	118	118	128	178	85	84						
			3C8	110	118	118	128	178	85	84						
			3C9	110	118	118	128	178	85	84						
			3C10	110	118	118	128	178	85	84						
			3C11	110	118	118	128	178	85	84						
			3C12	110	118	118	128	178	85	84						
			3C13	110	118	118	128	178	85	84						
			3C14	110	118	118	128	178	85	84						
			3C15	110	118	118	128	178	85	84						
			3C16	110	118	118	128	178	85	84						
			3C17	110	118	118	128	178	85	84						
			3C18	110	118	118	128	178	85	84						
			3C19	110	118	118	128	178	85	84						
			3C20	110	118	118	128	178	85	84						
			3C21	110	118	118	128	178	85	84						
			3C22	110	118	118	128	178	85	84						
			3C23	110	118	118	128	178	85	84						
			3C24	110	118	118	128	178	85	84						
			3C25	110	118	118	128	178	85	84						
			3C26	110	118	118	128	178	85	84						
			3C27	110	118	118	128	178	85	84						
			3C28	110	118	118	128	178	85	84						
			3C29	110	118	118	128	178	85	84						
			3C30	110	118	118	128	178	85	84						
			3C31	110	118	118	128	178	85	84						
			3C32	110	118	118	128	178	85	84						
			3C33	110	118	118	128	178	85	84						
			3C34	110	118	118	128	178	85	84						
			3C35	110	118	118	128	178	85	84						
			3C36	110	118	118	128	178	85	84						
			3C37	110	118	118	128	178	85	84						
			3C38	110	118	118	128	178	85	84						
			3C39	110	118	118	128	178	85	84						
			3C40	110	118	118	128	178	85	84						
			3C41	110	118	118	128	178	85	84						
			3C42	110	118	118	128	178	85	84						
			3C43	110	118	118	128	178	85	84						
			3C44	110	118	118	128	178	85	84						
			3C45	110	118	118	128	178	85	84						
			3C46	110	118	118	128	178	85	84						
			3C47	110	118	118	128	178	85	84						
			3C48	110	118	118	128	178	85	84						
			3C49	110	118	118	128	178	85	84						
			3C50	110	118	118	128	178	85	84						

Indicates Change, Addition or Deletion

Supersedes

NOV 3 1982

Fig. 3. This chart specifies the clearances from parts of classification 1B2 to all other classifications which can be inserted earlier.

ACI guidelines. As mentioned above, PCB layout was being performed interactively using the Applicon CAD system. This environment dictated user interface and performance requirements. The user community named the main and supplemental programs "footprint" programs. The developers consider the version that has been used in production for more than two years a prototype.

Footprint vs. exclusion area

The traditional method of considering restrictions similar to the ACI guidelines is by looking at the footprint—how much space is taken up by the component to be inserted and its associated insertion machinery. From the example above, one can note that each time the subject component is moved, its footprint changes. This implies that the program would be executed each time the component is moved. Furthermore, it is difficult to assess the contribution of each neighboring component. This is an important consideration when a viola-

tion exists and the part must be moved. Which are the interfering parts? In what direction should the parts be moved? By how much?

Rather than show the footprint, we chose to show the exclusion area. The exclusion area shows how much space is taken up by components already placed. If a previously placed component is to be inserted after the subject component, the dimensions associated with the previously placed component determine the exclusion area.

There are several advantages to using the exclusion area instead of the footprint. A major benefit of drawing the exclusion area for each previously placed component is that the designer can see the effect of the neighboring components and then can decide how to move the subject component to remove violations or achieve a tighter layout.

Alternatively, the designer may choose to move a previously placed component. Once the exclusion area is calculated for a subject component, it remains constant no matter where the part is placed as long

as it is not rotated. The program to calculate the exclusion area is run once per subject component.

User interface

The design objectives for the user interface were to make it easy to use and to have it fit in with the Applicon supplied user interface. The steps involved are: (1) fit the neighboring components in the current window; (2) select the subject component; and (3) make a tablet stroke which in turn executes a user command that invokes the footprint program. Exclusion area data is then displayed on the graphics terminal. To eliminate the exclusion areas, just repaint the screen.

From the display of the exclusion areas, the designer decides if the current placement is correct. In general, the placement is acceptable if the line segment joining the subject component's holes is on or outside the composite exclusion area (see Fig. 6). In some instances it is acceptable to have either the holes or the body traverse the exclusion area; these two cases are indicated with arrows on the graphic display.

To provide the most help to the designer, the footprint must keep track of the insertion order and not the placement order. When a new component is placed, it is appended to the appropriate insertion order list. The designer can manipulate the component's position on the list.

Program design

The basic premise underlying the program design was that the execution time must be fast enough to make it an interactive tool. A 3-second response time on a single-user system was the design goal. Actual response times for this configuration are between 3 and 6 seconds.

The Applicon CAD system is implemented on a PDP-11/34 computer running the RSX-11 operating system. This computer has a 16-bit address, which means that programs must be less than 32k in length. The Applicon program is very heavily overlaid, leaving very little space for user-written programs and data. For this reason we decided to implement the program in a separate task, which allowed us to use the 32k as we saw fit.

When the Applicon system loads a file to be worked on interactively, it copies the data from an Applicon file structure into an RSX-11 file. Fortunately, RSX-11 allows a second task to open a file for

read access but not for write access. Our task reads the open drawing file to determine the selected component and those currently in the display window. A single read command reads two disk blocks (1 block = 512 bytes).

The amount of ACI guideline data demanded fast data retrieval. The file is organized in sections of six disk blocks; each read retrieves six blocks. The first section is an index for the remaining sections. For each classification and insertion method, the index contains the address of the data within the file. For many cases, only two disk accesses are necessary.

Data to draw the exclusion areas is placed in an RSX-11 dynamic storage area. After all of the exclusion areas are calculated, the user command running in the Applicon environment is resumed, and it then draws the exclusion areas directly to the graphic display, bypassing the database.

Additional performance is gained by extracting information contained in the Applicon cells pertaining to ACI when the program is first started. Extracted data are the hole locations, insertion method (axial, radial, etc.), and classification. Component body sizes are extracted from an auxiliary data file. This data is written to a small, well-organized RSX file.

Using the footprint program

Before reading the following example, it will be helpful to examine the display of a single component and its exclusion area shown in Fig. 6.

The following procedure illustrates how a designer might use the footprint program in an original design:

1. Components in the center of Fig. 7a have been placed correctly using the footprint program. The designer desires to place capacitor C982 above C981.
2. C982 is selected. Footprint is then called on to draw the exclusion areas as shown in Fig. 7b.
3. Using normal Applicon move commands, the designer moves C982 into its final position as in Fig. 7c.
4. A screen repaint is done showing the components in their final position (Fig. 7d).

Now suppose that an engineer decides C981 should be replaced with another capacitor with a larger body. The designer decides whether components must be moved by performing the following steps:

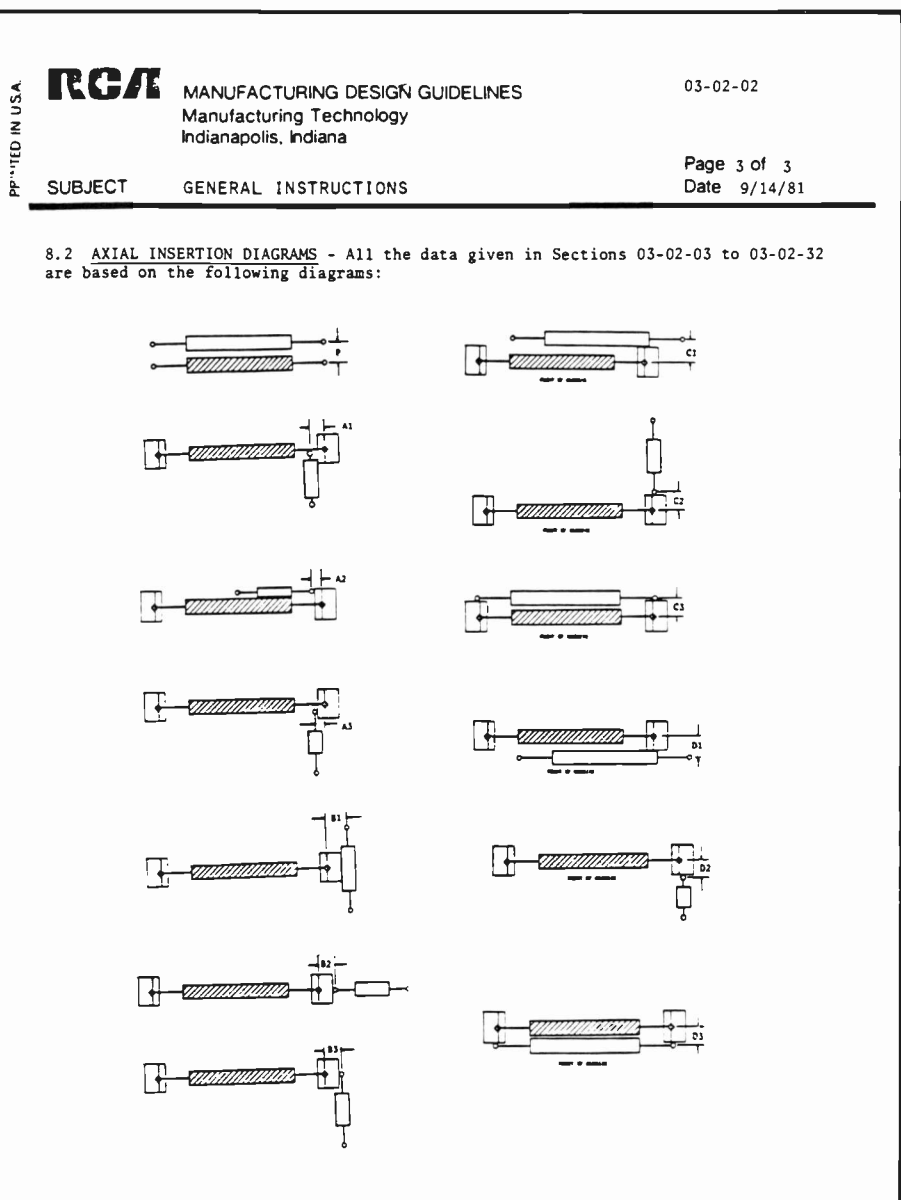

Fig. 4. Clearances between two axial parts are drawn in this figure. Similar figures exist for radial-axial and radial-radial components. The designer must determine which clearances are to be checked. The component being inserted is crosshatched. Rectangles at either end of the component represent the insertion machine.

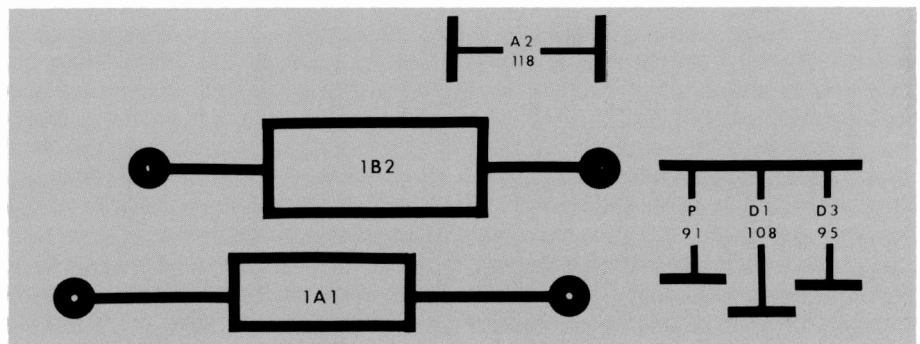

Fig. 5. Clearances are shown for the parts described in the example. The placement satisfies the P dimension (91 mils) but violates the D1 dimension (108 mils).

1. C981 is selected and footprint draws the exclusion areas (Fig. 8a). Note that C981 is inside the exclusion area associated with C982 by 25 mils. All other

component locations are still valid. The designer chooses to move C982 up. 2. The designer unselects C981, selects C982, repaints the screen and executes

footprint (Fig. 8b). This figure also shows the 25-mil overlap violation.

3. After C982 is moved up 25 mils, the exclusion areas are redrawn (Fig. 8c). No violations of ACI guidelines exist.

4. For a final check, the designer draws the exclusion areas now associated with C981 (Fig. 8d). Exclusion areas indicate that the placement is still valid.

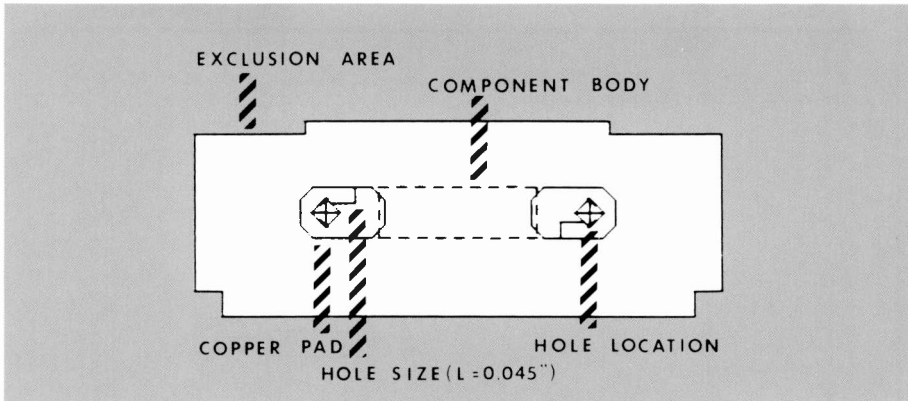

Fig. 6. The diagram is labelled to show the various elements of the component and the exclusion area as seen by the drafting designer while he is laying out the board at the Applicon terminal.

Conclusion

The project was successful because it demonstrated that the ACI guidelines could be automated. Some designers use the program whenever feasible. As mentioned previously, the current version is considered to be a prototype; it does not handle many special cases.

The program can be extended to perform interactive checking—it can tell the designer which components are producing

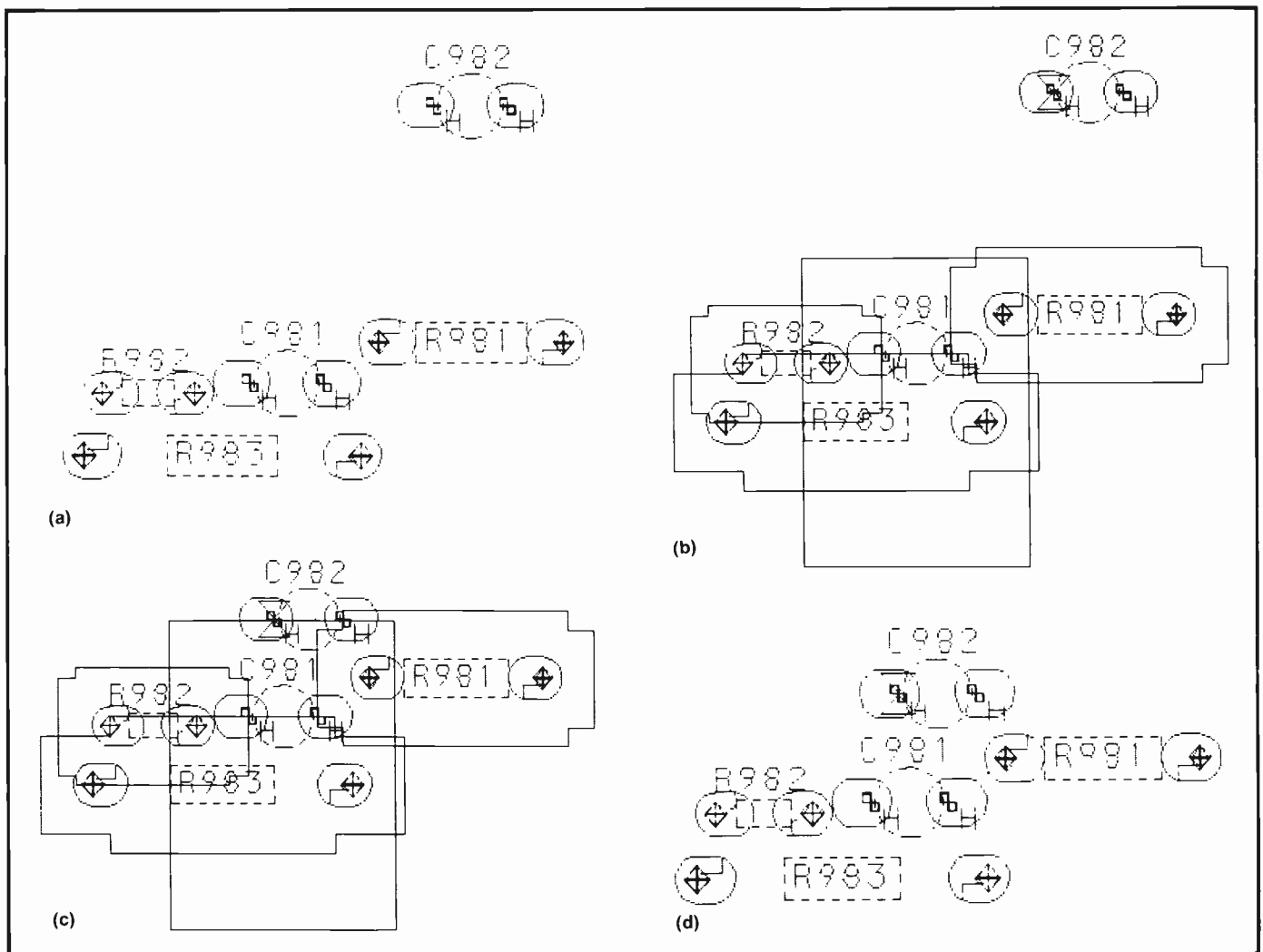

Fig. 7. A scenario of how the designer might use the "Footprint" program in an original design. The text describes the operations involved.

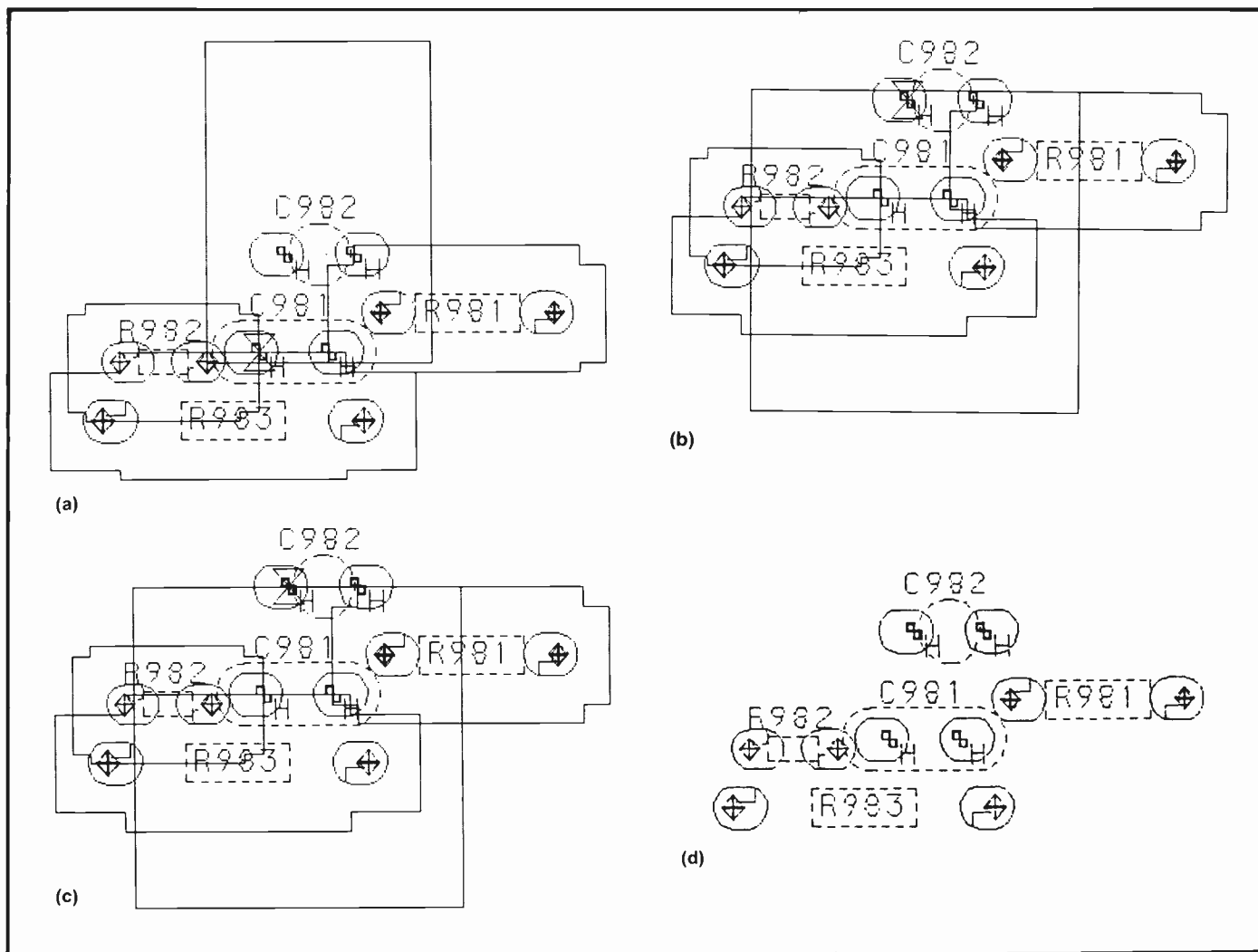

Fig. 8. An example of using "Footprint" for a component substitution. Note that the relative component insertion order is used to determine the exclusion areas by comparing 8a and 8b.

the violation. A further extension is to allow a batch check of the complete board. This would be useful as a final check before the design is signed off. Also, the impact of changing the insertion machines could be evaluated. Another extension is adding more insertion methods such as integrated circuits or surface-mount devices.

We achieved our goal of demonstrating that interactive layout aids are viable and can be used with complex rules.

Acknowledgments

I would like to thank William E. Davis for the time he spent explaining the operation of the ACI machines and the use of the Manufacturing Design Guidelines. He is also the author of the ACI portion of the MDG. Dr. Richard A. Sunshine provided the inspiration and guidance necessary to complete the project. The other

team members involved in the program implementation, Philip D. Deem and Iwen Kwo, deserve much credit for what was

accomplished. Al Riebe, our first user, spent many hours helping the implementation team in debugging the software.

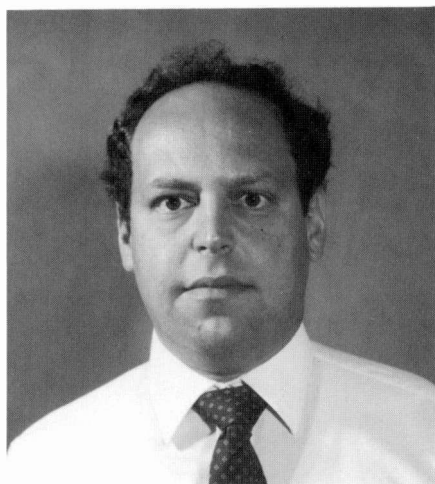

Bob Monat is Manager, Computer Integrated Manufacturing Systems in the Consumer Electronics Division. Bob received BSEE and M.Eng(EE) degrees from Rensselaer Polytechnic Institute in 1971, and he started his career at RCA after graduation. He has recently become responsible for the development of computer-based manufacturing systems. Upon transferring to Consumer Electronics, he had been involved with CAD/CAM in the procurement of systems and the development of custom software to satisfy unique CE business requirements. Previously he was at the Solid State Technology Center (Somerville N.J.) and Automated System Division (Burlington, Mass., and Washington, D.C.). Contact him at: **Consumer Electronics Operations Indianapolis, Ind.** Tacnet: 422-6682

To order your copies of RCA—A historical perspective . . .

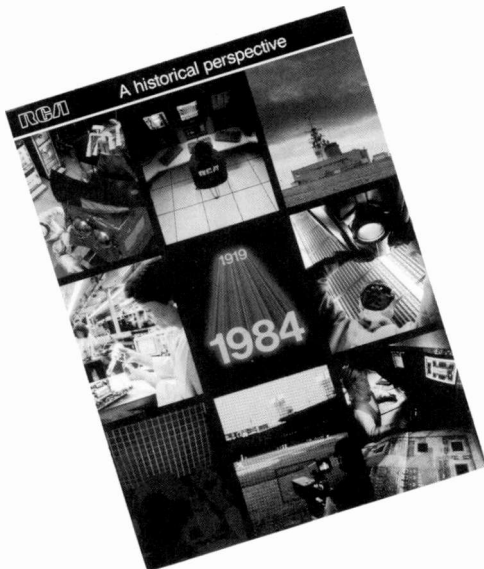

Color cover
88 pages

Single copies of the History are free.

Multiple copies are \$1.00 each,
and the minimum order is \$10.00.

Note: Distribution from the
Technical Excellence Center
is limited to RCA Corporation.

For single copies:

Simply fill in your name and address
on the right and mail it in.

For multiple-copy orders:

This order form must be accompanied
by a purchase order or a check
made out to RCA Corporation.
All the requested information must be
supplied for multiple-copy orders.

Mail completed order forms to:

Engineering Publication
RCA Technical Excellence Center
Mail Stop RR13, Princeton Labs.
Please do not telephone.

Billing information

(Purchase orders or checks must accompany multiple-copy orders.)

Name: _____

RCA Business Unit: _____

Dept. Number: _____

Billing Address: _____

Charge Number: _____

Quantity ordered: _____

Mailing information

(Use RCA internal mail for quantities up to 30 copies
and your organization's Shipping Address for larger quantities.)

Name: _____

Mail Stop: _____

Address: _____

The Operator Display Emulation Facility

Using computers to design system display/control consoles

The evaluation of operator display and control combinations early in the system design/development process contributes to performance optimization and avoids expensive modifications later.

The Operator Display Emulation Facility (ODEF) developed from a joint IR&D venture by two Missile and Surface Radar Division (MSRD) Engineering Department organizations: Man-Machine Systems and Display Design. Prior to the existence of this facility, the performance characteristics of a system's man-machine interface were tested only after design and prototype fabrication were completed. Revisions or modifications identified late in system

development were difficult and costly to make; this led to design compromises that would not have been necessary if the same information had been available earlier in the process. The ODEF allows evaluation of various display and control combinations by display designers and human factors specialists long before prototype equipment is fabricated and system software is finalized. Achievement of an earlier appraisal of the operator/machine interface and the related avoidance of late, expensive system modifications are the prime benefits offered by ODEF.

The mission of the ODEF team is to design, develop, and test operator interfaces for military systems under development at RCA. They produce innovative combina-

tions of equipment and software that permit the rapid evaluation of new display/control concepts via demonstration or man-in-the-loop experiments (Fig. 1). Two host computers, several high-resolution stroke-writing and raster-scan CRT displays, two flat-panel displays (plasma and electro-luminescent), and a number of control devices including touch screens, track balls, joy sticks, keyboards, and digital tablets, represent the major hardware components for testing applications. Several software packages have also been developed to assist in the design/evaluation process, including:

- SKETCH—allows the rapid construction and magnetic storage of static display formats.

Abstract: *The purpose, organization, and system development activities of the Operator Display Emulation Facility (ODEF) are discussed in relation to specified performance requirements. This computer laboratory facility focuses on the application of human factors engineering and display/control technology to the design, development, and evaluation of man-machine interfaces, commonly called consoles or workstations. The marriage of the human operator to the system workstation, achieved via data analysis, model demonstration, and testing, is described. When done early enough in the system development process, the effort results in better, more timely and less costly integration of an operator and machine system.*



Fig. 1. Some of the computer hardware resources of the ODEF.

- MOVEX—can easily create and present moving-target scenarios with which an operator can dynamically interact.
- SIGX and ANIMAX—permit interactive control and modification of selected display elements.

The workstation development process

A flow diagram of the ODEF activities involved in a display/control development and evaluation project is shown in Fig. 2. The starting points—and the source of the operating goals to be met—are the specified system performance requirements. While input from ODEF the personnel may be requested early in the system design process, Systems Engineering normally provides these requirements, which are derived from the system's mission objectives.

Operator role definition

System performance control functions are assigned to operators based on the skills and knowledge of the anticipated user group, as well as on the capabilities of the general human population. Human performance capabilities that influence operator role definition include visual, anthropometric, and information processing factors.

The ODEF workstation development process begins with a listing of statements that describe the various actions the human operator must take to enable the required system performance. Each statement identifies a major operator function, such as "configure instrumentation radar for mission," or "conduct system operability tests," and is supported with directions specifying the individual tasks that complete the function. A preliminary operations scenario is then constructed, providing time-frames for the functions and estimates of operator task loading.

Display/control device selection

The role definitions and operations scenario are the primary factors involved in the selection of display and control equipment for a workstation. The type of data to be displayed (graphic, alphanumeric, word text, etc.) and data update rates, together with the speed and accuracy requirements for the proper operation of the controls, are also important. In addition to these system-oriented factors, environmental variables may have to be considered. For example, if the system is for use by combat infantry, the light, noise, and temperature

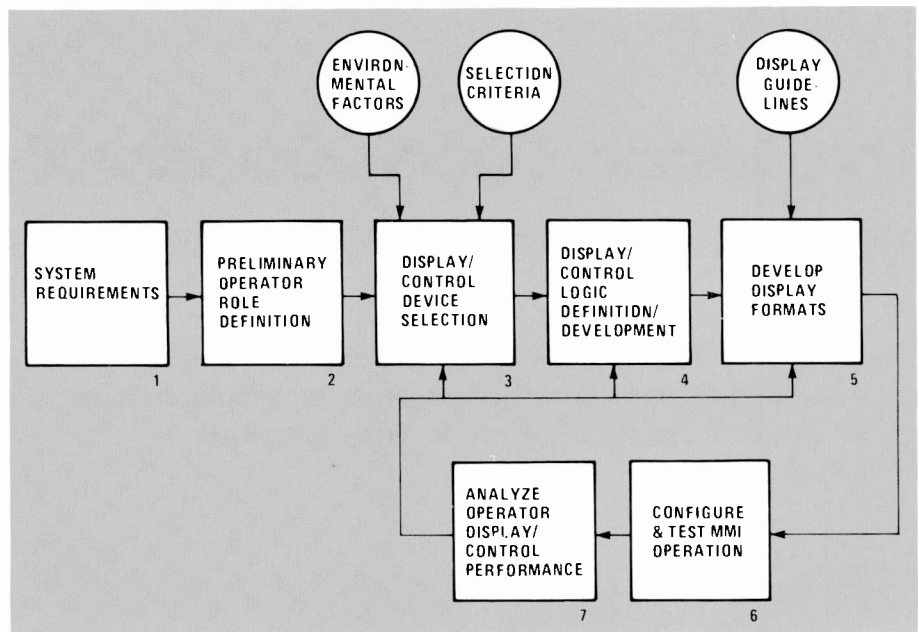

Fig. 2. The Operator Display Emulation Facility approach to the man-machine interface development process.

levels experienced by operators on the battlefield will vary considerably from those experienced in a remote command post. The portability of a battlefield system also introduces the anthropometric (human body measurement) variables of the soldier/operator. These variables narrow the range of display and control hardware suitable for use in this system's workstation in terms of display brightness, contrast ratio, size, weight, and reliability. Additional hardware selection factors may be: (1) technical data on the performance,

size, weight, cost, and reliability; (2) results of trade studies that balance system performance capabilities against the performance capabilities of other display/control devices on the market (Table I); and (3) results of laboratory experiments with high-resolution CRTs, LCDs, plasma and thin-film electroluminescent displays, and a variety of control devices from trackballs and joysticks to touch screens.

Once display and control devices that are generally suited for the system operator functions are selected, ODEF personnel

Table I. Display Characteristics determined by technology.

Display Technology	Characteristics					
	Sizes	Resolution	Brightness	Power	Weight	Bulk
Monochrome CRT	large-to-small	highest	high	medium	high	high
Shadow Mask CRT (Color)	large-to-small	high	medium	medium	high	high
AC Plasma Panel	very large-to-medium	medium	medium	low	medium	low
Thin-Film AC Electroluminescent	medium-to-small	medium	medium	low	low	low
Liquid Crystal	medium-to-small	medium	not emissive	minute	low	low
Light-Emitting Diode	small	low	high	highest	medium	low

work with project design team members to determine the specific configuration and number of these devices.

Display/control logic definition and development

ODEF Human Factors Engineers conduct an analysis to identify critical operator tasks requiring the implementation of supportive control logic. Tasks with little or no margin for error that can greatly affect mission performance, tasks that must be performed rapidly and accurately, and complex operator decision tasks typically qualify as critical. The "cause and effect" of every control action in the performance of a critical task must be identified. Flow diagrams, such as the one shown in Fig. 3, are used to communicate these interactions and serve as a basis for staff discussion prior to program coding.

Display format development

Information needed by a system workstation operator to complete the assigned functions is identified in the task analysis effort. The information, from simple go/no-go status to highly complex, multi-dimensional situation descriptions, is organized into a unified display format. Human factor guidelines are available to aid in this design process, but creativity and trial-and-error are still needed to produce an efficient display.

Factors to be considered include character size, text arrangement (headings, subheadings, indentation, etc.), symbols,

Table II. Color display guidelines

1. Use color for identifying or reinforcing relationships among spatially separated data or for alerting the operator.
2. Do not use color merely to make a display pretty; minimize the number of colors used.
3. Use no more than nine colors on a display.
4. Maintain maximum spectral separations between colors selected.
5. Do not use blue for small symbols or details.
6. Synchronize color usage with social/civil stereotypes (e.g., the traffic light pattern).
7. Display luminance, resolution, and/or symbol size must be increased as the number of colors is increased.
8. Test the developed display to assure that users perceive all the different kinds of data and data relationships present.

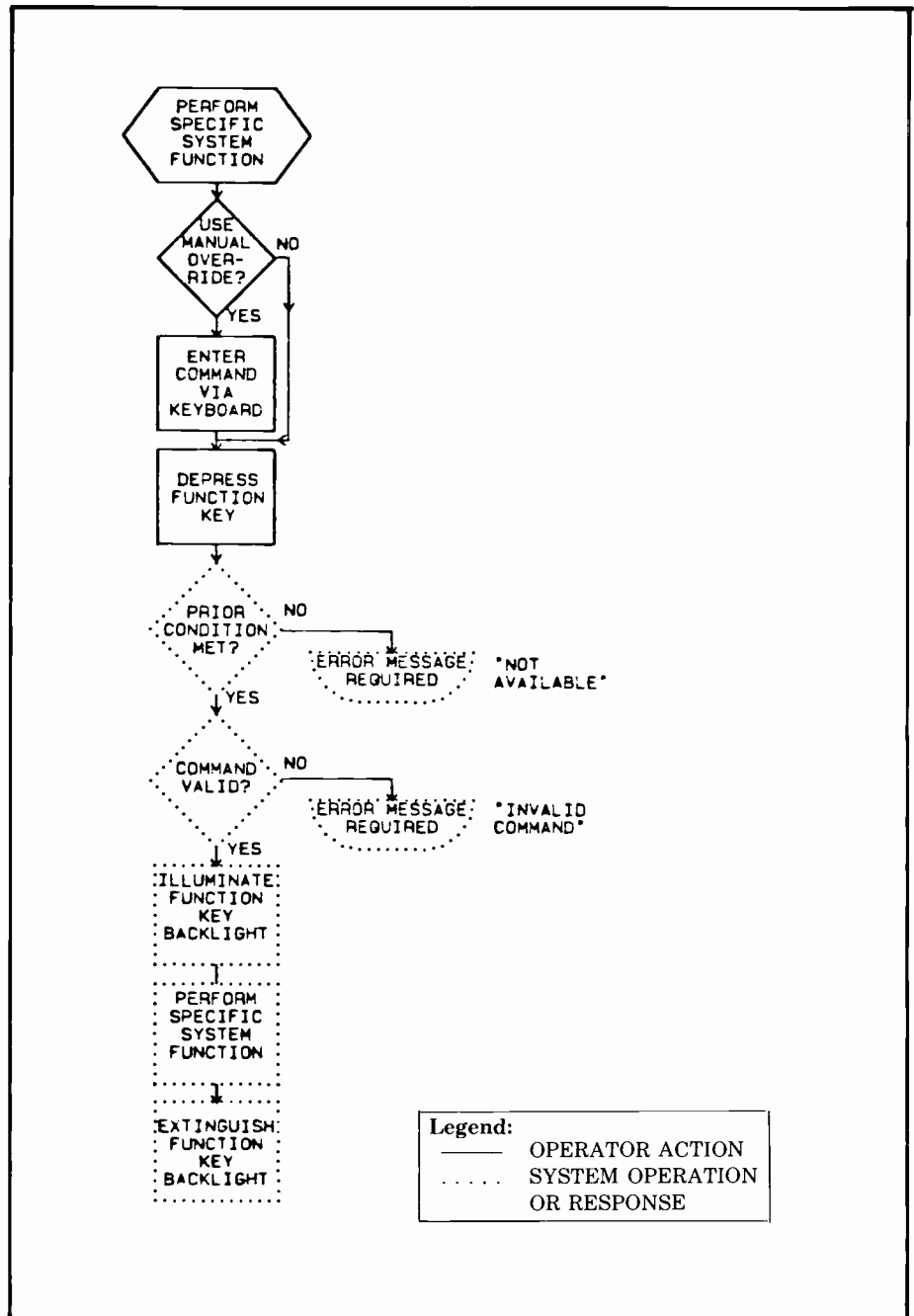

Fig. 3. A representative flow diagram used to communicate the control logic for critical operator tasks.

abbreviations, and proper use of color (Table II). Current CRT technology provides the display designer with a large color palette; this is particularly useful in presenting multi-dimensional information, overlays, target representations, and system-status levels. Once completed, the information display format is checked for coherence from an operator decision/action task perspective.

At this point in the workstation development process, the laboratory's emulation equipment can be used to allow an operator

to test the displays, controls, and software logic. Alternative designs are evaluated and compared, and the one or two best concepts are submitted to the final two processes: Configure and Test (Man-Machine Interface Operation, MMI), and Operator Display/Control Performance Analysis.

Configure and test

The selected display and control devices are arranged to stimulate the physical layout

Comparing operator performance on three input devices—an ODEF case study

The speed and accuracy of operator control responses to stimuli presented in two different scenarios were measured on three input devices: a CRT touch screen, a CRT and separate key pad, and a matrix of interactive key switches, each with a variable legend display. Twenty-four subjects, ranging in age from 23 to 63, participated in the experiment as operators. Their task was to "push a button" specified within a 4x4 matrix, presented either on the high-resolution (1024x1024 pixels) raster CRT used with touch screen or key pad, or on the interactive key-switch matrix.

Two operational scenarios were presented to each operator: a randomly generated alphabetic task to be performed on each device, and a simulated radar operations task to be performed on the touch screen and key pad. Time pressure was applied during certain trial runs to observe its effect on operator performance.

In forced trials fewer incorrect key hits were made with the interactive key-switch matrix than with the touch screen or key pad in the alphabetic scenario, but no significant differences were found

in either scenario in terms of the number of correct responses (see Experiment Definitions below).

In unforced trials the touch screen proved to be significantly faster (statistically speaking) than the other input devices in both operational scenarios. In the alphabetic scenario, the interactive key-switch matrix was more accurate than either the touch screen or key pad. In the radar operations scenario, the touch screen was more accurate than the key pad.

Experiment definitions

Trial—The response to the presentation of a single stimulus.

Forced trials—The operator was allowed 2.5 seconds in which to make a response.

Correct (forced trials)—The desired response was made within 2.5 seconds.

Incorrect (forced trials)—The desired response was not made within 2.5 seconds.

Unforced trials—The operator was allowed as much time as necessary for the response.

Error—The touch or depression of a wrong "button."

planned for the deployed system workstation. Here, careful attention is paid to anthropometric detail. Racks, tables, and chairs, as well as the control/display units, are arranged to achieve a "best fit" with respect to the spatial envelopes representing operator vision and reach. If an anthropometric problem is anticipated, a workstation mock-up is built to study the situation in greater detail and determine the best solution.

In the meantime, the interconnections for the display and control devices (CRTs, CPUs, keyboards, etc.) are completed, and preparations are made for the workstation demonstration or test. If a demonstration is required, a script containing the order of presentation of system-specific design features and benefits must be prepared. A formal test requires more detailed preparation. The experimental design for the test typically includes identification of performance data to be collected (e.g., operator response times), test subject type and number, the number and order of experimental tasks for the subject(s), and the

statistical methods for subsequent data analysis.

Applications software may have to be developed to provide control over test task introduction and/or to interact with the workstation operator.

Operator display/control performance analysis

A number of the statistical analysis packages for parametric and non-parametric data were developed by ODEF personnel. The subjective evaluations and observations of the test controllers and operators, together with the statistical data, are used to interpret the results, identify potential man-machine interface (MMI) design problems, develop proposed solutions, and identify areas for improvement.

Current developments

Personal computers are now commonly used by engineers in the performance of their day-to-day tasks. There is, con-

sequently, a much greater appreciation for the importance of keyboard layout, special function keys, CRT screen display contrast (and the eyestrain that you get if it is inadequate), and last but certainly not least, the interactive logic of the many different software packages available for every machine. To a growing extent, the control/display operator is the performance-limiting factor in today's high-speed, computer-controlled systems; the better the man-machine interfaces are designed, the better the systems will be able to accomplish their missions.

Current research efforts are directed at (1) achieving better physical and electrical integration of available display and control devices, and (2) developing better software to assist in the cost-effective design, development, and testing of man-machine interfaces.

References

1. McCormick, E.J., *Human Factors in Engineering and Design*, Fourth Edition, McGraw-Hill Book Company, New York, NY (1976).

When can the ODEF be involved in a system design and development project?

The facility is of value whenever the capabilities of man and machine are to be systematically combined to achieve a desired result. The table below provides a summary of the relative abilities of men and machines in performing system functions as a guideline for the development of man-machine interfaces.

The typical use of the ODEF during the system definition phase of a design project is the subject of this article. The computer-derived capability to generate display images and emulate control/display interactions—long before the development of system software or the production of component hardware—is useful for system design reviews and visual aid presentations. ODEF participates in IR&D projects, pre-proposal studies, proposal efforts, and software module testing (by providing a hardware testbed environment).

Relative capabilities of humans and machines¹

Humans are generally better at:

- Sensing very low levels of certain stimuli (visual, auditory, tactual, olfactory, and taste).
- Detecting stimuli against high “noise” level background (e.g., blips on a CRT display with poor reception).
- Recognizing patterns of complex stimuli which may vary from situation to situation (e.g., objects in aerial photographs; speech sounds).
- Sensing unusual and unexpected events in the environment.
- Storing large amounts of information over long periods of time (better at remembering principles and strategies than masses of detail).
- Retrieving (recalling) pertinent information from storage. (We frequently retrieve many related items of information, but the reliability of our recall is low.)
- Drawing upon varied experience in making decisions; adapting decisions to situational requirements; acting in emergencies (no previous “programming” required).
- Selecting alternative modes of operation when certain modes fail.
- Reasoning inductively, generalizing from observations.

- Applying principles to solutions of varied problems.
- Making subjective estimates and evaluations.
- Developing entirely new solutions.
- Concentrating on the most important activities when overload conditions exist (prioritizing).
- Adapting physical response to variations in operational requirements (within reason).

Machines are generally better at:

- Sensing stimuli that are outside the normal range of human sensitivity (e.g., x-rays, radar wavelengths, and ultrasonic vibrations).
- Applying deductive reasoning, such as recognizing stimuli as belonging to a general class (where the characteristics of the class can be specified).
- Monitoring for prespecified events, especially when infrequent (but machines cannot improvise in case of unanticipated events).
- Storing coded information quickly and in substantial quantity (e.g., large sets of numerical values).
- Retrieving coded information quickly and accurately on specific request (when specific instructions are provided for the information type).
- Processing quantitative information (following specified programs).
- Making rapid and consistent responses to input signals.
- Performing repetitive activities reliably.
- Exerting considerable physical force in a highly controlled manner.
- Maintaining performance over extended periods of time (i.e., machines do not need “coffee breaks”).
- Counting or measuring physical quantities.
- Performing several (programmed) activities simultaneously.
- Maintaining efficient operations under conditions of heavy load.
- Maintaining efficient operations despite environmental distractions.

Rick Faust is Unit Manager, Human Factors Engineering at the Missile and Surface Radar Division. Since joining RCA in 1968, he has conducted human factors engineering projects for a variety of military systems. Man-machine interface development and development is his principal area of technical interest. A member of the Human Factors Society and IEEE, Rick received a BS in Physics from Lafayette College and an MA in Sociology from the University of Maryland.

Contact him at:

**Missile and Surface Radar Division
Moorestown, N.J.
Tacnet: 253-6049**

Bill Mays is Unit Manager, Displays, in the Signal Processor and Computer Systems Section at the Missile and Surface Radar Division. He received the BSEE degree from the University of Texas (Austin), and joined RCA in 1966. Bill has worked on digital system design and logic design and verification, primarily in computer interface equipment for various radar systems such as the doppler tracker, laser range tracker, and dynamic target simulator. More recently, he has directed computer graphic display development projects, producing system software, firmware, hardware and test facilities, and conducted technological studies of flat panel displays for military applications.

Contact him at:

**Missile and Surface Radar Division
Moorestown, N.J.
Tacnet: 224-3448**

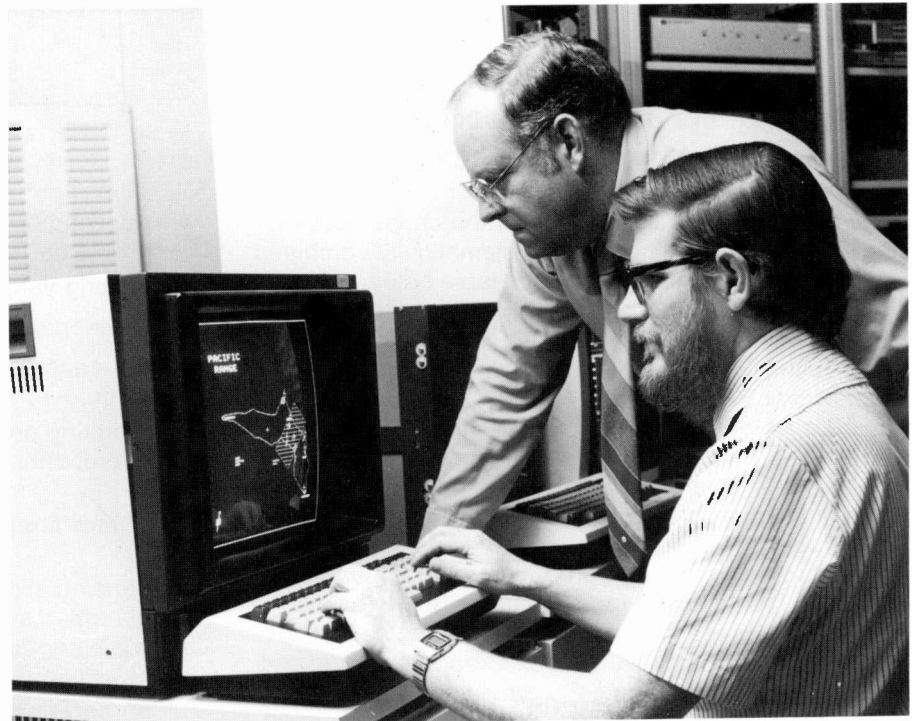

Authors, Faust, left and Mays.

Erratum

The following team received a David Sarnoff Award for Outstanding Achievement in Science, 1969:

**L. J. Berton
H. A. Freedman
J. A. Goodman
N. L. Gordon
J. T. O'Neil, Jr.
B. H. Sams
A. H. Simon
T. M. Stiller**

For the creation of a versatile, advanced, time-sharing system for the Spectra 70/45 computer.

Their names were inadvertently omitted from the list of past winners in our July/August issue.

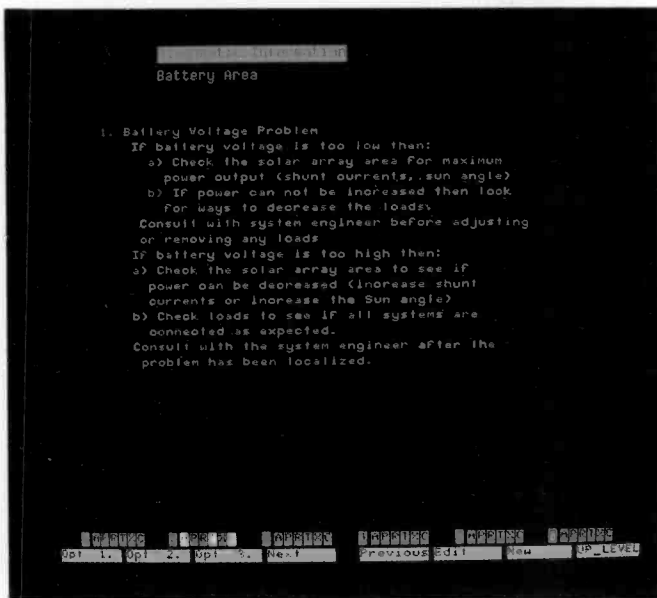

Fig. 16. Level 6, diagnostics screen.

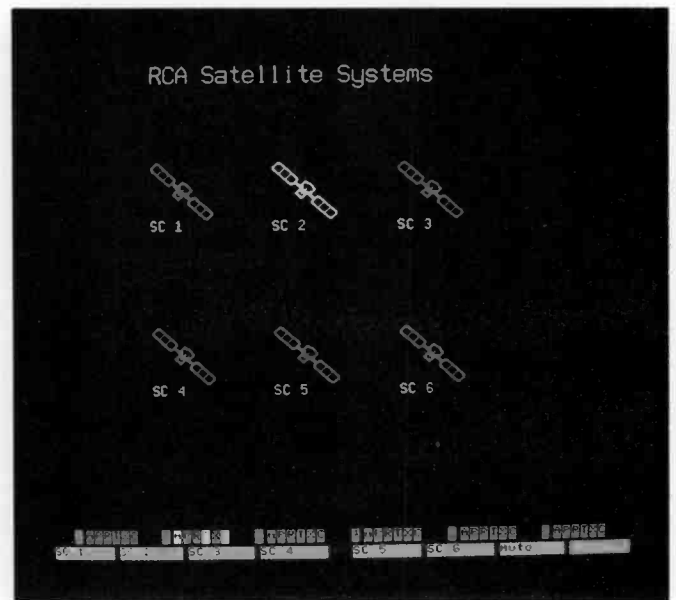

Fig. 17. Level 1, overview after the problem has been solved.

IMMI sample

To get an idea of how the IMMI system works, assume you are an operator. Figures 11 through 17 contain a series of photos of actual IMMI monitoring screens. Figure 11 contains an overview of an entire multi-spacecraft system. There is a satellite symbol representing each spacecraft. One of these symbols is red, one is yellow and the rest are green. Red indicates a serious problem, while yellow indicates a warning situation. At glance, you know that there are problems in two spacecraft and the rest are working normally. Associated with each symbol is an option at the bottom of the screen. You select option S/C2, since it is the spacecraft with the most serious problem.

Within a second, the screen shown in Fig. 12 appears. It contains an overview of the major subsystems of that particular spacecraft. There is a symbol associated with each major subsystem. The battery representing the power subsystem is red, indicating a problem in that subsystem. You select power option. This causes the screen shown in Fig. 13 to appear. It contains an overview of the power subsystem. There is a symbol representing each major component, from solar arrays and shunt to batteries. The battery box is red, indicating a problem with one of the batteries. Selecting option 5, associated with the batteries, causes the screen shown in Fig. 14 to appear.

This display contains a parallel design representing the two batteries in the spacecraft. Within each battery's design are boxes representing the main telemetry points such as voltage, current, and temperature. In addition are on/off status indicators for components like heaters and

chargers. These provide the viewer with additional information about the battery area. The parallel structure allows the user to locate similar information about the other batteries quickly and easily. The box associated with the voltage in battery 1 is red, indicating an abnormal battery voltage. The other battery sensors have normal readings. To obtain more detailed information, option 1 is selected. This causes the screen shown in Figure 15 to appear.

This screen contains a linear meter-like display of the actual telemetry values. Each telemetry point has a graph associated with it. Each graph contains a title, the actual value, the limit values, the units and a graphic representation of the value. The user can see at a glance how close a value is to a limit. These types of displays can be used to monitor values that may be approaching limit values. In addition, the name and bar are color-coded to represent the limit condition of the telemetry point. In this case the entry for battery 1 voltage is red.

The final step in the process is obtained by selecting option 1. This causes the screen shown in Fig. 16 to appear. This is a diagnostics screen. It contains some simple instructions to the operator concerning possible problems with the battery voltage. This forms the logical end to the operator's search. After the necessary information has been obtained, the system analyst can be called to help identify the problem. This entire search would take less than 10 seconds on the IMMI system. The reader may even have learned something about the satellite's structure just by looking at the screen designs. This is part of the goal of the IMMI design. Figure 17 shows the system status after the problem has been corrected through commanding external to IMMI.

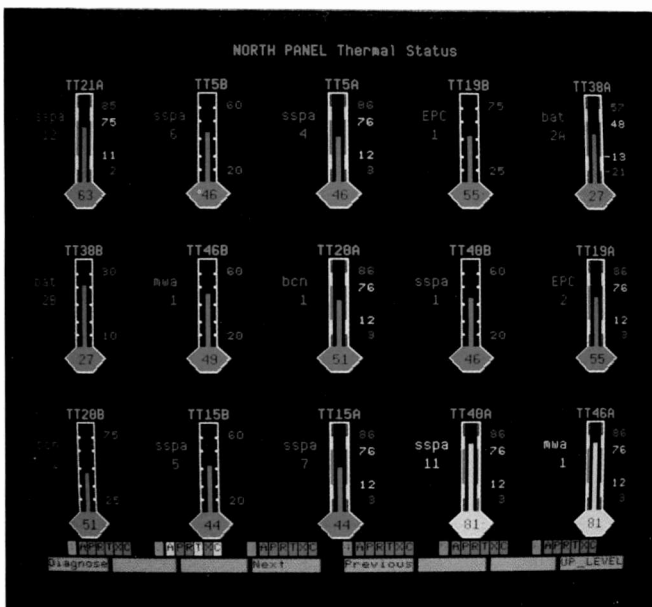

Fig. 18. Display of temperatures on the north panel using thermometers.

Screen drawing time

The screen drawing time was found to be a very important factor. Experiments were made in which the time it took to draw a screen was varied. The times ranged from under a second to approximately ten seconds. In a monitoring situation where a user wants to rapidly flip from one screen to the next, a screen drawing time of two seconds or more was found to be unacceptable. Users became annoyed while waiting for screens to appear. After some experimentation, a screen drawing time of about one second was found to be a reasonable compromise. The user is willing to accept the slight delay, while the time is long enough to prevent any severe restrictions on graphics complexity, resolution and hardware speed. A maximum of about two seconds was established as an upper limit on all but the most complex analyst support screens.

Graphics complexity

The level of complexity of the graphics was also investigated. A balance had to be struck between placing as much information as possible on a screen and user confusion. In a monitoring situation, a user should be able to glance at the screen and determine if there is a problem, and where. Typically, our screen designs limited the number of objects or items to between 10 and 20 per screen. This permitted rapid recognition and did not require the user to study the screen extensively.

The complexity varied somewhat with system structure level. At the top levels, the number of items per screen tended to be ten or less. These levels provide the controller with the basic overview of the system and its major components. A simpler design makes it easier for the user to assess the overall situation. The screens tended to be more complex at the lower levels. These screens contain the details of the different parts of the spacecraft subsystems. In many cases they contain parallel structures representing multiple or redundant components.

If there is a flow involved in the subsystem, such as power or communications payload, a left to right or top to bottom design is used. If there is any parallelism in the equipment functionality,

Graphics symbols

The screen designs used in the IMMI system make extensive use of symbols, or icons. In the monitoring screens, the symbols are basically simplified pictures that represent the different components. Figure 12 is a good example. It represents the overview of the subsystems of a single satellite. Little picture elements are used to represent each major subsystem in the spacecraft. Power is represented by something meant to look like a car battery. Thermal is represented by a thermometer. The basic idea was to keep it simple and easily recognizable. As the system matures, these symbols will probably be altered to reflect experience gained in different applications.

Figure 18 contains a display of temperatures on the north panel. The use of a thermometer-like representation quickly tells the user that the values being displayed are temperatures. Again, color-coding is used to show limit and warning status information.

The system analyst support screen designs contain more of the technical symbols found in technical drawings. Since the expert is familiar with these symbols it is unnecessary to use simplifications. The top-level analyst support screens still make use of the block diagrams, etc., necessary to display the functional information.

this is reflected in the graphical layout of the screen. These techniques were used to help convey the functionality and interrelationship of the different components.

Screen resolution

The screen resolution was determined by several factors. The main factor was speed. The more resolution, the longer it takes to fill the pixels on the screen. A 1024×1024 screen has four times as many pixels to fill as a 512×512 screen. If the graphics device is fast enough, this may not be a problem; however, in many devices it is.

Experiments showed that 512×512 point resolution is sufficient for the level of detail needed for monitoring displays. In many cases, less resolution would have been permissible, except for the text fonts. They were too large and coarse at the lower resolutions. The only area where higher resolution is useful is at the lower level subsystem displays or in the analyst support diagrams. There is a danger with the higher resolution, however, since a designer may be tempted to add too much detail and complexity in a screen design.

Additional factors were the display monitor characteristics. If one compares low- to high-resolution monitors, the problem of flicker can become quite noticeable. To minimize flicker, long-persistence phosphor screens or a non-interlaced display can be used. The long persistence phosphors are easier on the eye, but can leave ghost images of the previous screen. The non-interleaved displays require a higher refresh rate, are more expensive, and are less available at the higher resolutions. The 512×512 resolution was found to be satisfactory for monitoring displays.

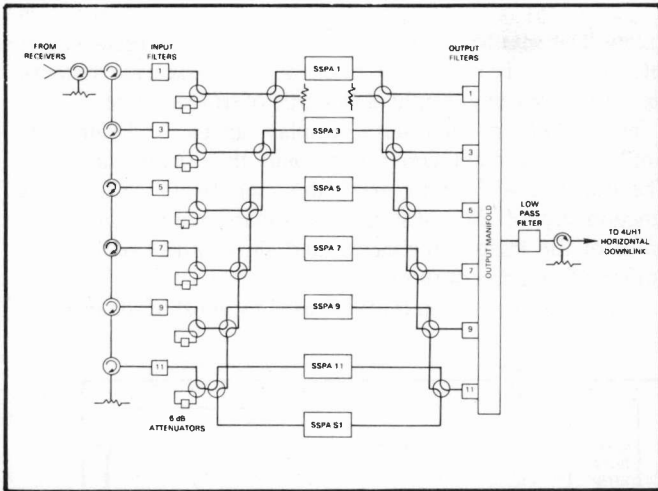

Fig. 2. Detailed functional diagram of part of a communications payload.

are currently operating multi-spacecraft systems, enhanced monitoring and control capabilities were needed. The Improved Man/Machine Interface (IMMI) project was begun in 1983 by Emil Dusio to investigate ways in which spacecraft monitoring and control and operator efficiency could be improved.

An initial analysis of existing satellite control systems showed four areas where improvements would have a noticeable impact on system performance:

- (1) The overall user interface to the system should be simplified.
- (2) The user interface must support the needs of the operator and the analyst.
- (3) An overview of the total system must be provided.
- (4) A structure should be provided for the analysis of spacecraft conditions.

The problem was how to make it easier for a spacecraft operator to control and monitor multi-spacecraft systems. The operator must be able to recognize problem conditions before they become serious. At the same time the system must provide improved support for the spacecraft analysts and engineers who are responsible for normal spacecraft operation and troubleshooting. The goal was to make these people more effective and to permit more complex systems to be controlled by fewer, less-skilled operators.

The main design concept we followed was that the operator should be made aware of the problem and led to it, not forced to find it. Also, the scope and complexity of the problem should be revealed to the user as it is identified and located. This approach could also be extended to the more detailed support required by the analyst studying normal and abnormal spacecraft conditions.

The implications of these goals were almost contradictory. To assist the operator, we wanted to provide a good overview and simple structures and screen designs. To aid the analyst, we had to provide detailed information and possibly complex screen designs. The key to solving these design requirements was to provide a structure that uses a top-down approach. The layered approach provides an overview at the upper levels and more details at the lower levels. This satisfies the requirements of both classes of users.

Several other requirements had to be considered in the IMMI design. The system must be able to interface with

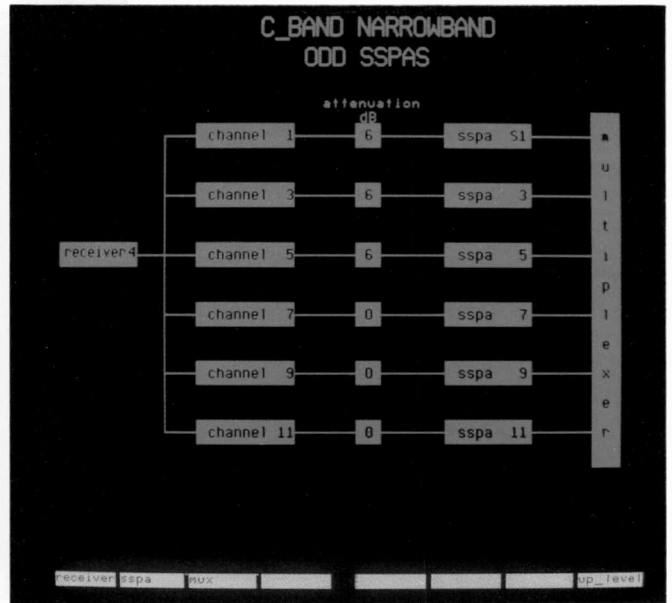

Fig. 3. IMMI diagram of the communications payload.

existing systems, making it attractive to existing customers. In addition, it should be able to evolve into a product that could be integrated into future ground system designs. Its use of high-speed color graphics and a structured approach make it a good basis for future system designs.

Structure

The approach adopted to satisfy various requirements was to set up a structure tree based on the subsystem functionality of the spacecraft. This structure defined the way the information would be organized, how it would be grouped, and provided a natural top-down approach. To satisfy the dual requirements of system monitoring by an operator and detailed problem analysis by a spacecraft engineer, a parallel structure was adopted. Both parts were based on the same spacecraft functionality. The monitoring function uses simpler graphics designs and is designed for easy recognition of problem situations. The analyst function provides more complex information. Both are part of the same system, and it is possible to move from one part to the other. To further enhance this capability, IMMI allows a user to select and rapidly flip between screens in both parts of the system. This permits the analyst to make full use of the monitoring and detailed information, and vice versa.

An example of the different levels of complexity between the monitoring and the analyst screens can be seen in Figs. 2 and 3. Figure 2 is an engineering diagram showing the part of a communications satellite's payload. It shows all the possible paths, switches, and key components. The circles with two curved lines are switches which, if set in the "other" position, would cause the circle to rotate 90 degrees and a different set of connections to be made. To figure out a route, a viewer must literally follow it with his finger. The numerous switches permit the systems engineer to reconfigure the components or reroute the signals around a faulty or substandard component.

Figure 3 is a sample IMMI screen design covering the same part of the payload. It does not show any of the complex switches. It only shows the resultant routes and the components involved. If there is a problem in channel 9, the operator

immediately knows that solid state parametric amplifier (SSPA) 9 is involved. It is much easier for the satellite controller to obtain the critical information using this screen. Figure 2 contains the type of information a systems engineer would require to switch out the faulty components. Figure 3 is better suited to determining which component is faulty. The IMMI structure must accommodate both types of information.

Status displays

The status displays are screen designs and a structure tree that provide the spacecraft monitoring function. The status displays are organized in a top-down, hierarchically-structured manner. The top-level display contains an overview of the entire system, with very little detail. The second level contains an overview of the main subsystems of a single satellite. At each successively lower level, the structure branches into the subsystems and subassemblies. At each level, the screen displays a more detailed

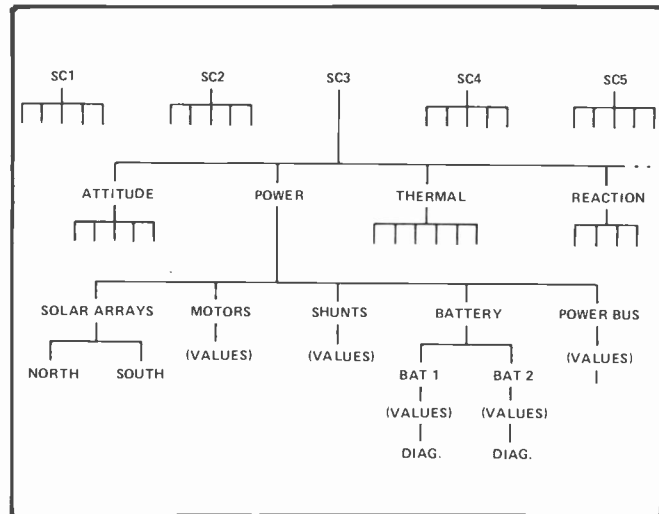

Fig. 4. Structure tree.

diagram of one of the components shown in the next-higher-level screen. The number of levels and the degree of branching is determined by the complexity of the different spacecraft systems. Figure 4 shows an example of this type of structure tree.

The layout of each status display screen is designed to emphasize the main components and their interrelationship. The design goals are to make the user aware of the basic functionality of the subsystem or subassembly, indicate the status of the main components, and show where to look for further information or more detail.

The same basic screen layout is used for most of the displays.

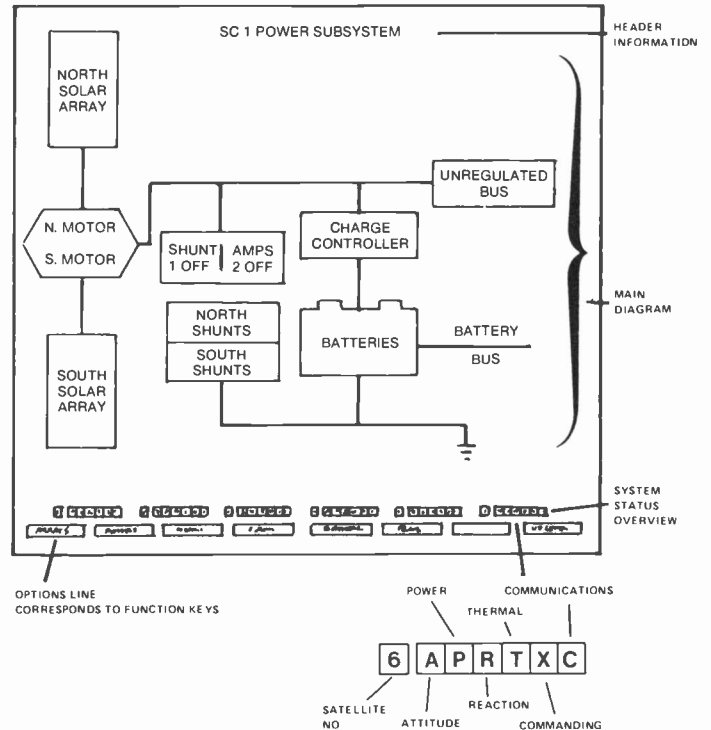

Fig. 5. Basic IMMI screen layout.

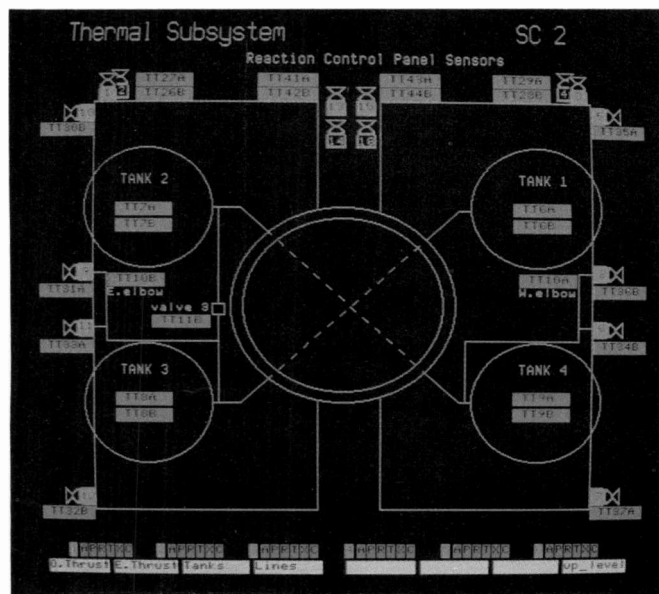

Fig. 6. Screen showing the thermal sensors in the reaction subsystem.

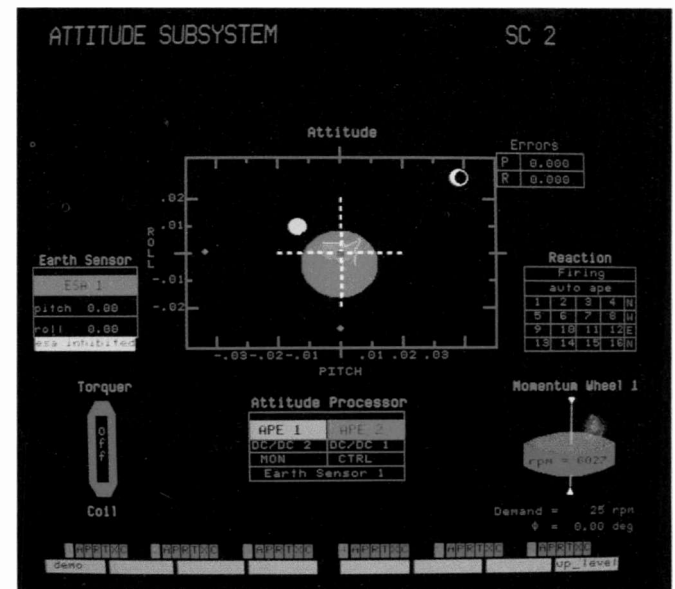

Fig. 7. Overview of the attitude subsystem.

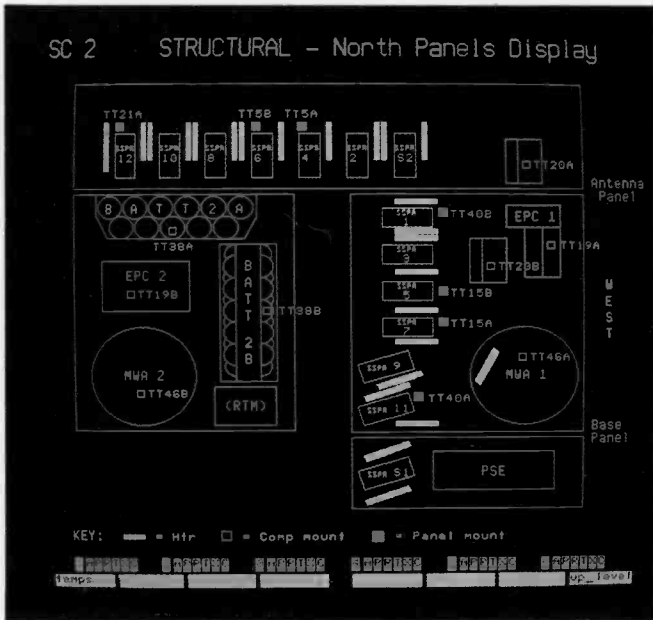

Fig. 8. Structural layout of components on the north panel of the spacecraft.

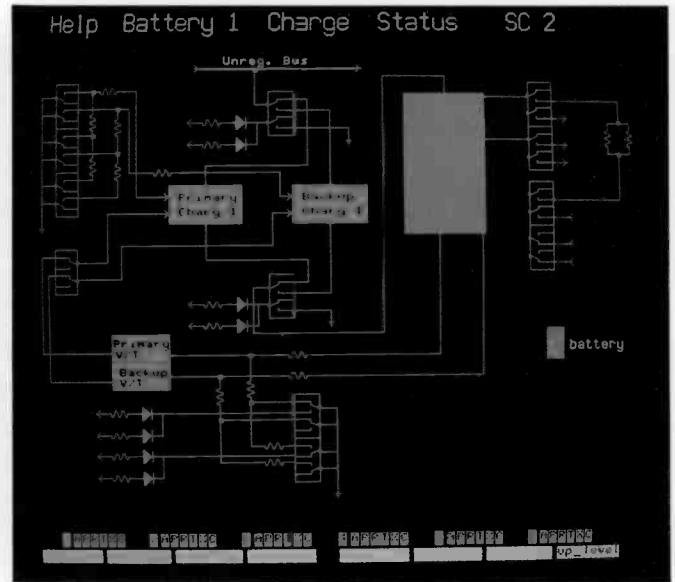

Fig. 9. Circuit of a battery charger.

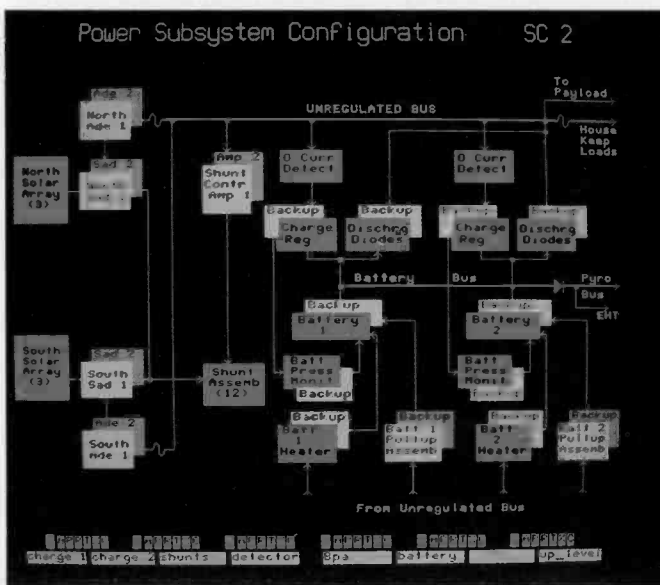

Fig. 10. Analyst overview of the power subsystem.

This layout is shown in Fig. 5. The top area contains a description of the information being displayed. The bottom contains the user options and prompt information. Slightly above the prompt information is the total system status information. The remainder of the screen is devoted to the status or analyst support information.

Figures 6 and 7 are sample IMMI screens. Figure 6 shows the main components of the reaction subsystem and their associated thermal sensors. The viewer can identify a sensor with a name and a component. At the same time an overview of the main components of the reaction subsystem is provided. The colors of the sensors indicate their status: green is normal, yellow is warning, red is serious error. Figure 7 is an overview of the attitude subsystem. The central display indicates the roll and pitch errors and the location of the Sun and Moon. The



Fig. 11. Level 1, overview of the total system.

status of the other parts of the attitude subsystem, as well as the thruster status of the reaction subsystem, is shown. Color codes indicate thruster status (enabled, armed, firing). If the Sun is near the Earth, the Earth sensor is disabled. These screens provide an overview of a particular area and make it easy for the operator to detect error conditions.

User options are indicated at the bottom of the screen. There is one associated with each major component shown on the screen. Selecting one of these options causes a new screen to appear. The new screen will contain more details about that component. This procedure is repeated at each level until it is unreasonable to go into more detail. The bottom level is usually determined by the actual telemetry sensor points on the spacecraft.

How does this structure aid the user? Starting at the top level, the user can quickly answer the basic question, "Are there any problems?". If one of the items is colored yellow or red, the

An improved man/machine interface for spacecraft control

A new top-down approach to spacecraft monitoring systems uses color graphics and a logical tree structure to improve the system capabilities and reduce the number of skilled operators necessary.

Current trends in communication and other spacecraft systems are toward more complex spacecraft, more telemetry per spacecraft, and more spacecraft being controlled from a single location. This trend places increased demands on the existing methods of spacecraft control and monitoring. The volume and complexity of the telemetry information make it increasingly difficult for satellite ground station controllers to notice and respond to abnormal spacecraft conditions.

Current systems typically use a series of telemetry limit checks and alarms to monitor and signal abnormal conditions. This works well for isolated or extreme conditions, but it is not as well suited for complex problems that may involve several subsystems. Nor is it particularly sensitive to spotting gradual trends or correlated problems. In current systems, the system performance is strongly dependent on the ability, experience, and skills of the satellite controllers involved.

A typical spacecraft monitoring system consists of an alarm system and screens full of telemetry data. A typical layout for a screen of telemetry data is shown in Fig. 1. The telemetry data comes from sensors on the spacecraft, which monitor the different functions. Limit checks are built into the ground station software

that monitors the telemetry information, and when a value goes outside of a predetermined range, an alarm is sounded. If there is an alarm condition, the alarm messages indicate the problem telemetry points and the displays are used to show the actual value(s) causing the alarm. In less critical situations, operators will monitor numerous telemetry points by placing them on the same display screen and examining them periodically to see if they are drifting or approaching critical values.

This method has worked successfully for many years, but its success has depended on skilled and experienced operators. As the complexity of the spacecraft payloads increases and the number of spacecraft grows, a larger number of these experienced operators will be required. Since the typical lifetime of the newer spacecraft can be as long as ten years, any means of reducing the number of required operators, while maintaining high operational standards, will have a significant impact on the operating costs of a multi-spacecraft system.

Since several of RCA Astro-Electronics Division's customers

Abstract: *The trend in communication and other spacecraft systems is towards more complex spacecraft, more telemetry per spacecraft, and more spacecraft being controlled from a single location. This trend places large demands on the existing methods of spacecraft control and monitoring. The volume and complexity of the telemetry information make it increasingly difficult for satellite ground station controllers to notice and respond to abnormal spacecraft conditions. This article discusses an improved man/machine interface for spacecraft monitoring and control, one that reduces the number of skilled operators needed while allowing improved control of multi-spacecraft systems.*

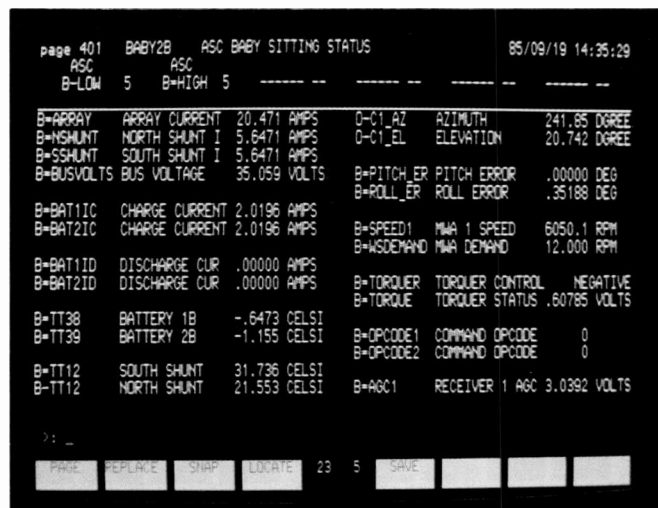

Fig. 1. Typical page display of telemetry data.

©1985 RCA Corporation.
Final manuscript received October 10, 1985
Reprint RE-30-5-6

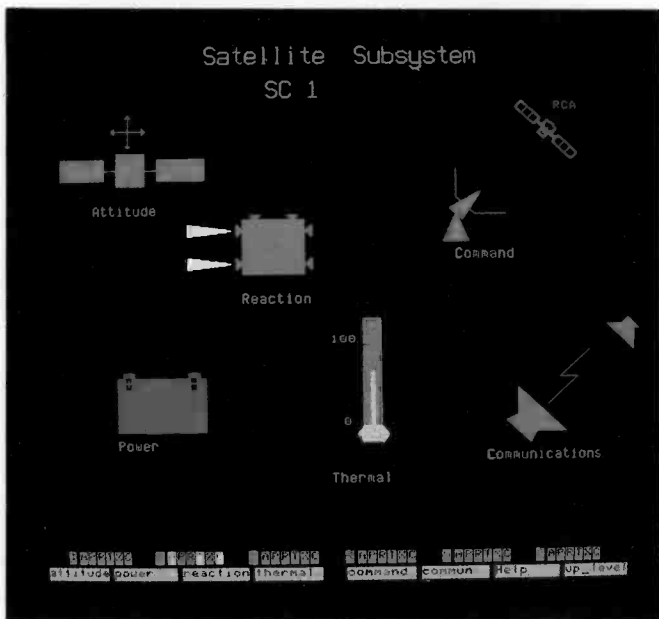

Fig. 12. Level 2, overview of a spacecraft's subsystems.

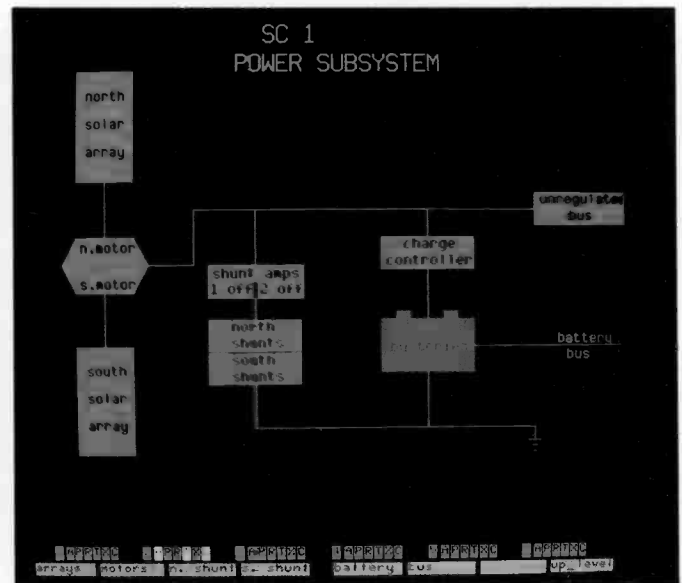

Fig. 13. Level 3, overview of the power subsystem.

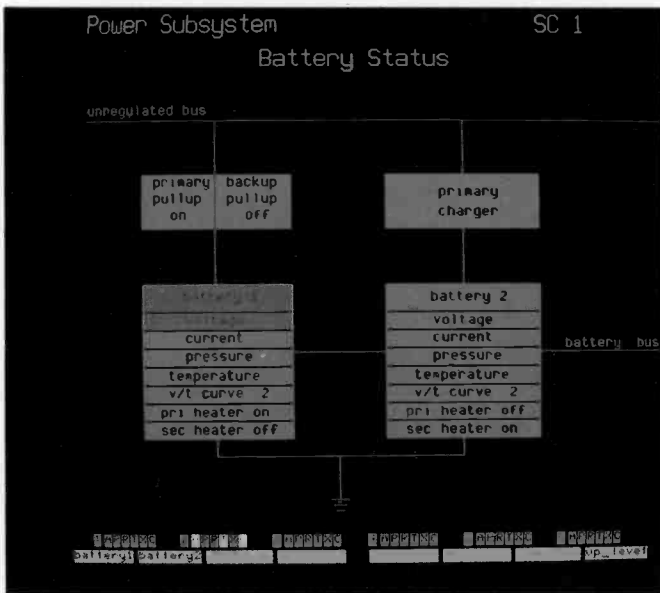

Fig. 14. Level 4, overview of the batteries.

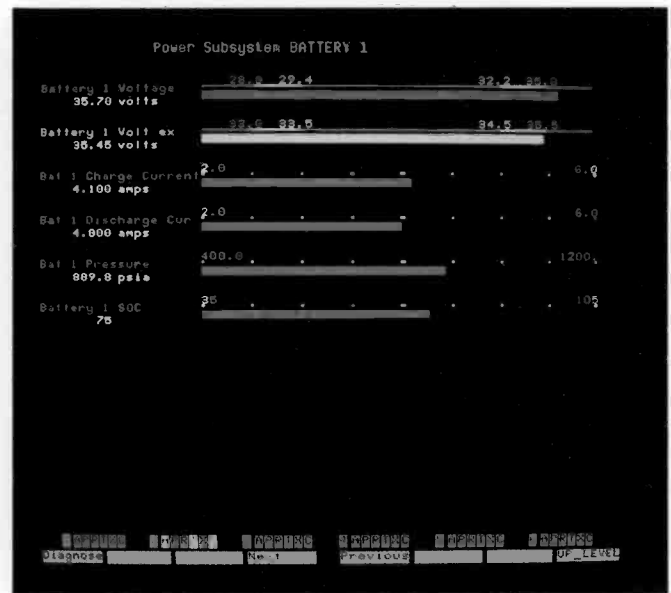

Fig. 15. Level 5, meter display of telemetry values and limits.

operator knows that there is a problem. The same screen also indicates any other problems. By following the colored indicators and selecting the appropriate options, the operator can localize a problem in a matter of seconds. The operator, in locating the problem, is gaining knowledge on the state of the rest of the system at the same time. Are there other problems? If so, are they related? This provides the operator with a better understanding of the nature and scope of the problem.

The accompanying sidebar provides an example of how the IMMI displays could be used in a spacecraft monitoring situation.

An interesting offshoot of the structured status screen system is that it can be used as an aid in familiarizing new engineers and managers with the system. By flipping through the screens, the viewer is presented with a visual display of the main components in the system, their complexity, and how they are organized. The status screens provide a basic description of the

system. The analyst screens can be used to provide detailed information. In no case would they replace standard documentation and manuals, but they could serve as a good introduction and aid.

Graphics

One of the basic assumptions of the Improved Man/Machine Interface (IMMI) project was that color graphics would be an important tool. It remained to establish how it should be used and what the requirements would be. Four main properties had to be evaluated: screen drawing time, graphics complexity, resolution, and effective use of colors. While many of these properties are interrelated, it is instructive to consider them separately.

The information transfer problem

One of the main problems encountered by the IMMI project was the transfer of information from the satellite subsystem experts into the IMMI design and software. Typically, this is done by project members talking to the experts, obtaining an understanding of each subsystem and integrating this into the software and graphics. This process is very time-consuming and open to errors. It is an art to be able to ask the proper questions to obtain the information and understanding needed to create the system. Yet one requires a degree of understanding before one can ask the proper questions. The experts are concerned with the design, fabrication, and functionality of the subsystem. It is not always easy for them to understand the type of information a software designer requires. In addition, it is sometimes difficult for the expert to be able to check the work of the software designer. A similar situation exists in many artificial intelligence and expert systems.

There does not appear to be an easy solution to

this problem. The success of many of the existing expert or AI systems has depended on the ability of the computer expert to learn the problem area in detail or for the engineer or applications expert to learn the computing techniques. Neither method is particularly efficient in manpower.

In an attempt to address this problem, future IMMI systems will contain design tools that will simplify the job of the engineer trying to "tell" the computer what he or she knows. Extensive use of graphics and simple editable lists will be used. The primary goal is to minimize the amount of computing an expert must learn. The key to the system will be a structured approach in which the experts will first define the basic structure tree and then fill in the details at the specific levels. The structural information will be used to guide and prompt the expert. Using a top-down approach should make it easier for the system to lead the experts to the area appropriate to their subsystem. It should also give them a feel for how their information fits into the system as a whole.

Colors

The use of colors in the graphics displays was a fundamental part of the IMMI approach. Three basic guidelines were followed:

- (1) Standardize the meaning and use of the colors in the designs.
- (2) Limit the number of colors to avoid confusion.
- (3) Use more subdued colors to avoid confusion and eye strain.

A maximum of 16 different colors were used in the screen designs. Approximately half of these were assigned to indicate subsystem and component status (green for normal, yellow for warning, red for severe error), ON/OFF, etc. The colors of the various boxes or symbols on a screen will change color depending on the status of the component or subsystem they represent. The remaining colors were used to denote and enhance features in the more complex designs. By standardizing the color usage, it is easy for a user to quickly pick out the critical elements on each screen. The number of colors was limited to prevent confusion and prevent the operator from having to remember too many color codes.

Although only 16 colors are used, each is custom-blended to suit our needs. In general, the primary colors and their simple mixes (cyan, magenta, etc.) are too bright for prolonged viewing. To overcome this we either added grey or decreased the intensity of the color. Shades of brown, gold, and blue were used in many of the more complex screen designs to delineate particular features. While the color choices are always biased by personal preferences, the more subdued shades are easier to view and seem to be quite effective, especially in low light situations.

Analyst support screens

In addition to the monitoring screen, the IMMI system also contains analyst support or help screens. These screens typically contain detailed diagrams, schematics and drawings of the space-

craft structure and its component subsystems. Typical examples are shown in Figs. 8 and 9. These screens are designed to aid the analyst. They can be quite complex and will be examined in detail by the analyst. There is a tendency to make these diagrams too complex, as the initial attempts to design these screens showed. Figure 10 is an example of such a screen, which may have to be redesigned. Some care must be taken to preserve the structured approach in which the highest level of detail is reserved for the lower level screens that cover a restricted part of a subassembly. Using this approach, we found a resolution of 512x512 was satisfactory, although additional resolution was justified in some diagrams. As with the operator monitoring screens, the size and readability of the descriptive text placed an effective limitation on the resolution that could be used. Even on the complex screens, the best guideline is to keep it as simple as possible.

Diagnostics

The bottom level of the IMMI structure tree is devoted to diagnostics. This was a logical outgrowth of the structured approach. Assuming a simple problem, the user has been led to the appropriate area of a spacecraft subsystem. This area typically deals with a few components and a limited number of telemetry points. Since the number of possibilities is limited, it becomes attractive to add a diagnostic capability. Information of the form, "If voltage x is low, check settings y and z . If they are normal, then do the following" becomes a possibility. The straightforward case is relatively easy to handle, but complex situations involving more than one subsystem can not be handled in this manner. This type of situation might better be handled by an expert system. Considerable experience will have to be gained before a true diagnostic system can be implemented.

A slightly different approach is to use the diagnostics as an operator aid. For a given problem it contains instructions for

collecting and preparing the necessary information for the systems engineer, who will have to analyze the problem. In this case the messages would be more of the nature: "If x is wrong, then obtain the following information." One could even have the computer obtain the information automatically at the operator's request. This approach is easier to implement and can be augmented with suggested actions as experience is gained. The diagnostic instructions could be updated by the systems engineer to reflect the current situation and previous experience. Future implementations of IMMI will adopt this latter approach. The use of knowledge-based and artificial intelligence systems is also being investigated for possible future applications.

Conclusions

The IMMI project has demonstrated that significant improvements in satellite monitoring can be achieved by using a highly-structured, top-down system that incorporates high-speed color graphics. The system is capable of supporting both the monitoring requirements of a satellite controller and the detailed information

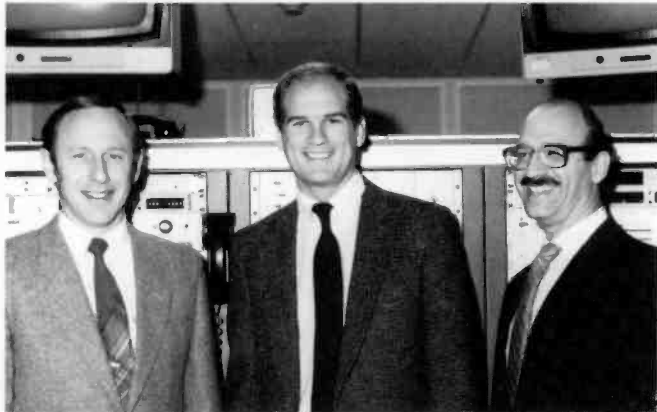

Authors, left to right: Harten, Crowe, and Anton.

Ronald Harten is a Principal Member of the Technical Staff, Astro-Electronics Division. He joined the Division in 1984, assuming the lead engineer role on the IMMI project. He is also involved in other aspects of ground system software. Prior to joining RCA, he worked as a research radio astronomer in the Netherlands for over 12 years. Ron earned his AB in Physics at Cornell University in 1966, and his PhD in Astrophysics at the University of Maryland in 1971. He is a member of the AAS and IAU.

Contact him at:
Astro-Electronics Division
Princeton, N.J.
Tacnet: 229-3551

needs of a system analyst. The effectiveness of the system is dependent on careful graphics design criteria and a proper top-down structure that forms the relationship between the graphics screens. This structure is based on the actual structure of the satellite and its subsystems. Rapid screen drawing times, simple screen designs, and standardization of layout, symbols, and colors were important factors in the success of IMMI. The system will inevitably evolve as more experience is gained.

Acknowledgments

The IMMI team also included Rhonda Adamson, who worked on the database, and Joan Hennessey and Tina Segal, who developed some of the subsystem and analyst support screens. We would also like to acknowledge the support of E. Dusio, S. Malyszka, R. Farag, R. Hrusovsky, W. Upson, E.C. Scholz, S. Fox, and J. Swale. The photographic work was done by Leo Cashel. We also appreciate the expert input from various members of the Spacecraft Systems and ASOC groups.

Tim Crowe is an Associate Member, Technical Staff at Astro-Electronics Division. Since joining RCA in 1983, Tim has been involved with various aspects of satellite ground station software and test equipment. His responsibilities on the IMMI project include telemetry analysis, database organization, and spacecraft subsystem display screens. Tim holds a BA degree in Computer Science from LaSalle University.

Contact him at:
Astro-Electronics Division
Princeton, N.J.
Tacnet: 229-2682

Art Anton is Manager, Aerospace Ground Equipment Software Development, Electronic Systems, at Astro-Electronics Division. His responsibilities include software design and development of spacecraft checkout stations and IR&D projects, such as IMMI and Artificial Intelligence Systems for Space Platforms. He joined RCA in 1977 at RCA Laboratories, and worked in advanced technology software systems. In 1979, he joined RCA Global Communications as Group Leader responsible for the development of software for various communications networks and store-and-forward SWITCH systems. Prior to RCA, his work included design of electrochemical and automated process-control systems. He holds a BA in chemistry from City University of New York, an MS in Physical Chemistry/Mathematics from Stevens Institute of Technology, and an MS in Computer Science from Rutgers University.

Contact him at:
Astro-Electronics Division
Princeton, N.J.
Tacnet: 229-3537

Graphics for Election '84: An introduction

One goal of any television production is the communication of information. At a sporting event, the camera can tell us who's on first, and an instant replay can provide insight into how a touchdown was scored. On a news program, the camera is pointed at a visiting dignitary or a burning building. In each of these cases, the camera provides visual information that emphasizes the importance of the event.

The Presidential Election is an especially rich source of visual information. The primary races leading up to election night, the issues, the locales, and the contrasting styles of the candidates are all interesting and important points of focus for news cameras. But the finale, Election Day, poses a difficult problem: Where do we point the cameras?

The story on Election Night is one of numbers. How much of the vote is in? Who won in which states? By what margin? What is the new composition of the House and Senate? Solving the problem of effectively communicating this information was the purpose of the NBC Election '84 Graphics Development Project, begun in mid-1983.

There were three teams involved in the project, which was under the overall direction of Tom Wolzien, NBC Network News. Roy Wetzel, Election Information Unit, Network News lead the statistical and data tabulation group. Bob Brandel, Network News Production and Design, headed the graphic design group. I headed the engineering development team, Computer Imaging, responsible for the technical implementation of the project.

Concepts of the types of displays were developed. We decided to use a new and unique approach that incorporated "real" images such as faces, buildings, and anti-aliased text. We also felt that animation was important, because it would create a dynamic sense of excitement. The key issue in the approach, however, was that the displays must visually convey the qualitative aspects of the data: How close

is the race? Who is ahead? How significant is a particular issue? Previous election coverage had done little more than display numbers. The drawback with that approach is that most of the significance is lost. The numbers are factually correct, but they are dismally poor at conveying information to the television audience.

Production constraints had to be addressed as well. Because the data was rapidly changing as votes were counted, the animation displays had to reflect the latest information. The Election Night show is live, so displays had to be available reliably and rapidly. Provisions had to be made for redundancy, error monitoring, and "disaster recovery." And the system had to be able to cover more than 500 races nationwide.

Once the design and production criteria were established, the search began for a total system approach to meet them. Computer-synthesized animations, using a high-speed computer and general-purpose frame buffer, could provide the needed image quality, but not the speed, flexibility, or usability necessary. Other, real-time animation systems were investigated, but they were expensive, hardware-intensive, and could not provide the image quality (complexity) that production design had requested.

At the time, we were starting to use a Quantel Paint Box in daily programming. While meeting the design criteria of realistic, anti-aliased images and text, it had neither the facility for animation, nor the ability to create an image as a function of external data. Several discussions followed with Quantel, and it seemed that software could be developed that satisfied the data-driven animation criteria. Essentially, we would create a dual-functionality for the machine. It would be an artist-operated graphic work station, and a data-driven real-time animation machine.

The following articles by Tom Alfieri and Christine Barton discuss the software and system development aspects of the project. Let me add that I think that

people issues were just as important to the overall successful outcome: By combining the talent and insight of programmers, engineers, system specialists, artists, and producers, we were able to do much more than any one person initially envisioned. Tradeoffs, such as whether to perform a particular function in hardware or software (which software?), or to have the artist create an image, became easier to resolve as we learned each other's capabilities. The design and engineering development teams learned to adjust the displays and the software to accommodate the time demands of a live television broadcast.

That's how our Election Night presentation used some of the most sophisticated graphic displays ever to appear live on the air.

David Rabinowitz
Director, Computer Imaging
NBC

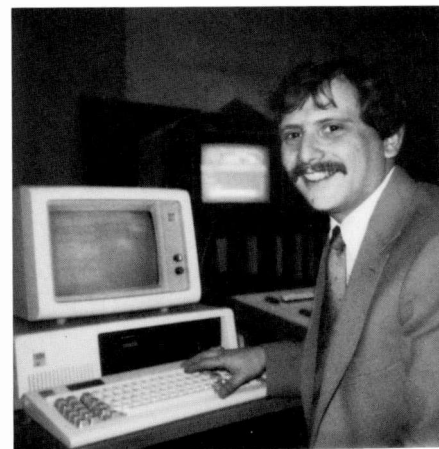

David Rabinowitz joined NBC as a Senior Staff Engineer in Technical Development in 1982. Prior to that, he was with Chyron Corporation as a design and project engineer. He holds one patent in digital video switching, and is a member of SMPTE, IEEE and ACM-Siggraph. Mr. Rabinowitz is an alumnus of (SUNY) Stony Brook.

He holds an Advanced Class Amateur Radio License (call sign: WA2CZ0).

NBC election '84: Results by design

NBC engineers, working against the clock, developed a digital graphics system that was a major contributor to the success of NBC's Election Night '84 broadcast.

Election '84: Results by Design was the title of NBC's commitment to present a new on-air look for its election night automatic display system. The system to be replaced had been in existence since the 1976 Presidential election. It utilized Chyron II character generators driven by special interfaces for the automatic display of numerical vote totals on a colored background (Fig. 1). This system had become cumbersome to maintain, but more importantly, it could not take advantage of the talents of graphic artists. A graphic artist's ability to enhance our daily news productions with timely, unique, and innovative artwork was a quality we wanted in an automated system. The Quantel Paint

Abstract: *This article describes the graphics system used by NBC during its broadcast of the 1984 Presidential election. The system it replaced had been in existence since the 1976 Presidential election. It utilized Chyron II character generators driven by special interfaces for the automatic display of numerical vote totals on a colored background. This system had become cumbersome to maintain, but more importantly, was incapable of utilizing the talents of graphic artists. The Quantel Paint Box, because it had shown itself to be a reliable and operationally useful tool, was selected as the graphic system. To meet the control and development requirements, a VAX computer system was selected.*

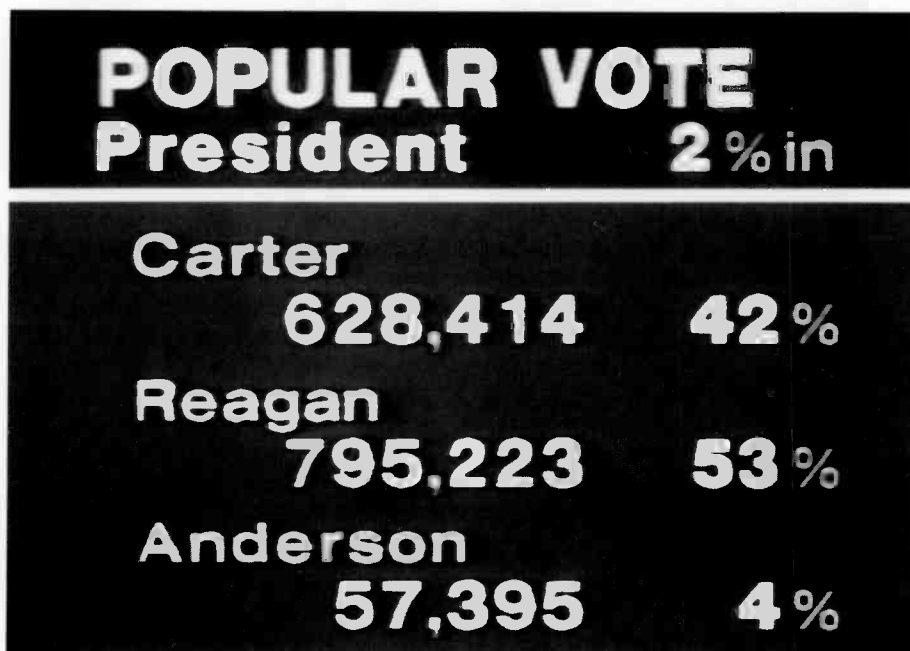

Fig. 1. Example of the type of display used in the 1980 Presidential election.

Box, because it had shown itself to be a reliable and operationally useful graphics tool, was selected as the graphic system. To meet the control and development requirements, a VAX computer system was selected.

Accomplishing our goal required the close working relationship of many and various talents. Programmers, graphic artists, and hardware engineers worked for nine months developing software, creating artwork, and implementing hardware. What follows is an overview of the system.

Scope of project

The project entailed the installation of eight Quantel DPB 7000 Paint Boxes in a temporary facility. These would be under the external control of two Digital Equipment Corporation VAX 11/750 computers. This facility would have to suffice as a software development laboratory, graphic artist design area, and a graphics playback area for the Election '84 broadcast.

Due to a tight time frame, the following criteria had to be met after the installation of the first three systems:

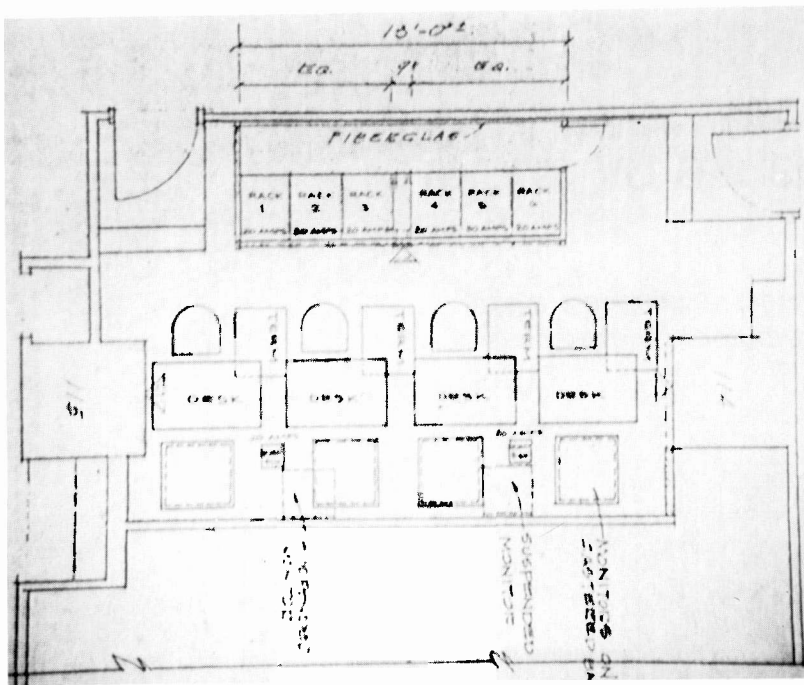

Fig. 2. Layout of the room that contained the first four Paint Box systems.

- The facility had to allow simultaneous use by programmer analysts and graphic design artists.
- All future equipment installations would not cause down time.
- Any system in the facility must be available for use by either a programmer analyst or graphic artist.
- The facility must be able to provide demonstration tapes for project status review.

With the facility eventually going to air, distribution of program video, monitoring feeds, timing feeds, control, and communication links was required. Control considerations were also needed for two additional Paint Box systems installed in the WNBC graphics area.

Facilities

Because a temporary facility would be used to house the Paint Boxes and their support equipment, all construction changes had to be minimized, so some compromises had to be made. Two considerations that could not be compromised, however, were power and air conditioning. A vacated office area adjacent to a computer room met these requirements. It was selected for installation of the first four systems (Fig. 2). This area afforded the additional benefits of a raised computer floor and a

clean air environment. The raised floor allowed for easy cable routing, thus minimizing cables on the floor and the need to construct costly overhead cable troughs. It must be noted that with existing fire laws only plenum cables can be placed in this type of raised floor. Also, cable bundle size was limited so as not to restrict the flow of air conditioning. To maintain a clean air environment, direct proper air flow, and eliminate the possibility of static electricity, all carpeting was removed. This 25x14-foot area eventually contained six racks for equipment, four design/development areas containing four Paint Box work stations, six DEC computer terminals, a U-matic videotape machine, and a color camera. Conditioned power was used for all technical equipment. To improve room lighting, a track light on a dimmer control was installed.

The room size was not sufficient to separate the people involved with software and graphic development from the noise generated by the twelve 330-megabyte disk drives. To minimize the ambient noise a removable, sectionalized enclosure was erected around the six racks of electronic equipment. The enclosure was constructed with acoustic wall cover mounted in aluminum channels and suspended from a ceiling track. The acoustic wall covering has an unfinished side that exposes the fiberglass interior. To safeguard against particles of fiberglass being rubbed loose,

a very fine nylon mesh was fastened over the exposed area. To allow the heat generated by the six racks of equipment to flow from the enclosure, openings were provided at the top and bottom of all panels.

An additional facility was needed to accommodate the installation of the remaining Paint Boxes. Using power and air conditioning once again as the primary considerations, an area called 9HC was selected. 9HC, which had housed the original Chyron II election graphics display system, overlooks the floor of Studio 8H, our election night studio. With only a minimal amount of development time remaining, acoustic enclosures were not installed. Existing technical power for equipment, air conditioning, and lighting were used without modification.

System requirements— development period

Graphic design requirements for Election '84 consisted of developing unique artwork for Presidential and Congressional contests. Original artwork was also required for depicting the responses obtained to the various poll and analysis questionnaires (Fig. 3). Included in this design task was defining the look of the animation display. Approximately 500 displays were prepared for use during the election night presentation.

Programmer analysts developed specialized software for use with the Paint Boxes and VAX 11/750 computers. The software development included writing programs for animation, creating new fonts, VAX control programs, system diagnostics, and PROM programming.

Four Paint Box systems were used for the software and graphic design requirements of Election '84. Each system contained a Paint Box, synchronizing generator, safe-area generator, RGB monitor, and five disk drives (see Fig. 4).

Video from each system, both encoded and RGB, was routed to a jackfield. The jackfield allowed for easy routing of video signals from one system's output to the input of any other system. The design of this facility and the equipment used allowed for all picture transfers from system to system to be accomplished in either a digital or RGB format. Maintaining picture transfers in these formats eliminated any concern of picture degradation due to NTSC encoding or decoding processes.

Included in the equipment was a high quality, inexpensive color television camera capable of producing both NTSC and RGB

video signals. This camera allowed the graphic artist to shoot either 35mm slides or 8×11 photographs of candidates from the numerous House and Senate contests. The video from the camera was then captured on a Paint Box system in the RGB format. To accommodate the requirement to shoot from a 35mm slide to an 8×11 photograph a no. 2 close-up adapter was used on the standard 10×1 zoom lens.

All encoded signals used within the room were for either comparison or recording purposes. The comparisons allowed graphic artists to evaluate the picture displayed on the RGB design monitor with an NTSC monitor reproduction. The recording of pictures and animation sequences allowed the review of design concepts and progress of the project.

The RGB signals were used for the transfer of analog video prior to recording onto a disk in a digital format. Once in digital form, picture information was transferred either by a floppy disk, removable storage drive (RSD), or 330-megabyte disk. An RSD, which holds approximately 70 pictures, was the main means of transferring new information onto systems.

When a Paint Box system was used for graphic design development, no operational changes were required from any manufacturer's specified procedures.

The hardware requirements for software development, in addition to the equipment previously mentioned, were two VAX 11/750 computers and six DEC computer terminals (Fig. 5). The six terminals were connected to the VAX via RS232 links running at 9600 baud. These terminals were used by the programmer analyst to develop and execute all necessary programs. During software development these programs were resident in the VAX 11/750. The Paint Boxes used with software development were connected to the VAX 11/750 via an RS232 link running at 19.2k baud. The program residing in the VAX was downloaded to the Paint Box by the programmer analyst, using one of the six terminals.

System requirements—night-of-air

The ten Paint Box systems used for night-of-air were divided into four configurations (Fig. 6). Each configuration was called a "user." The four users were National Vote, employing four systems, and Summary, Poll and Analysis, and WNBC, each using two systems. Each user was unique in the type of information it displayed. The



Fig. 3. Graphics produced as a result of vote totals and questionnaires.

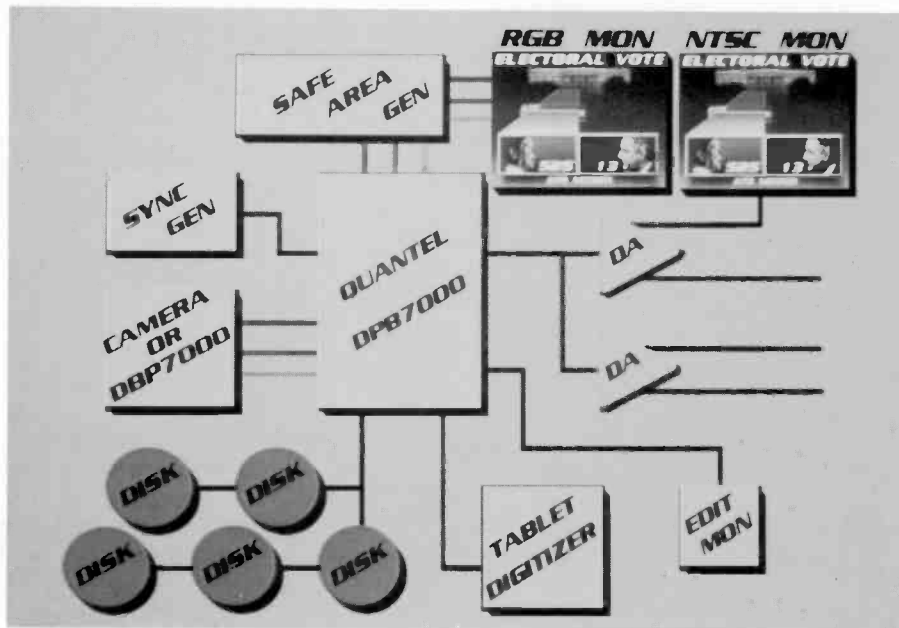

Fig. 4. Configuration of a Paint Box system.

hardware for each user system was identical.

Each system consisted of a Paint Box with a varying number of drives. National Vote had three on-line 330-megabyte disk drives, Summary had one, Poll and Analysis had two, and WNBC had one. Each system within each user's group was identical. The redundancy was required to allow for back-to-back displays and to accommodate the pace at which each user

was to be incorporated into the live air production.

With the exception of the Poll and Analysis systems, two VAX 11/750 computers, VAX A and VAX B, controlled the picture retrieval process of the eight Paint Boxes. The four National Vote Paint Boxes, referred to as Paint Boxes 1 through 4, were on VAX B. The two Summary Paint Boxes (5 and 6) and the WNBC systems (9 and 10) were on VAX A. A

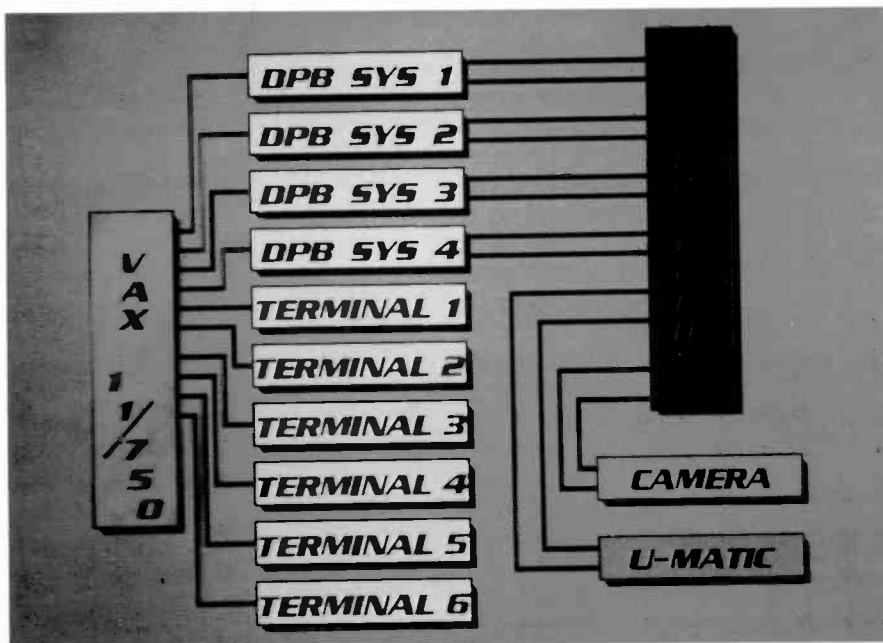

Fig. 5. Hardware requirements for software development.

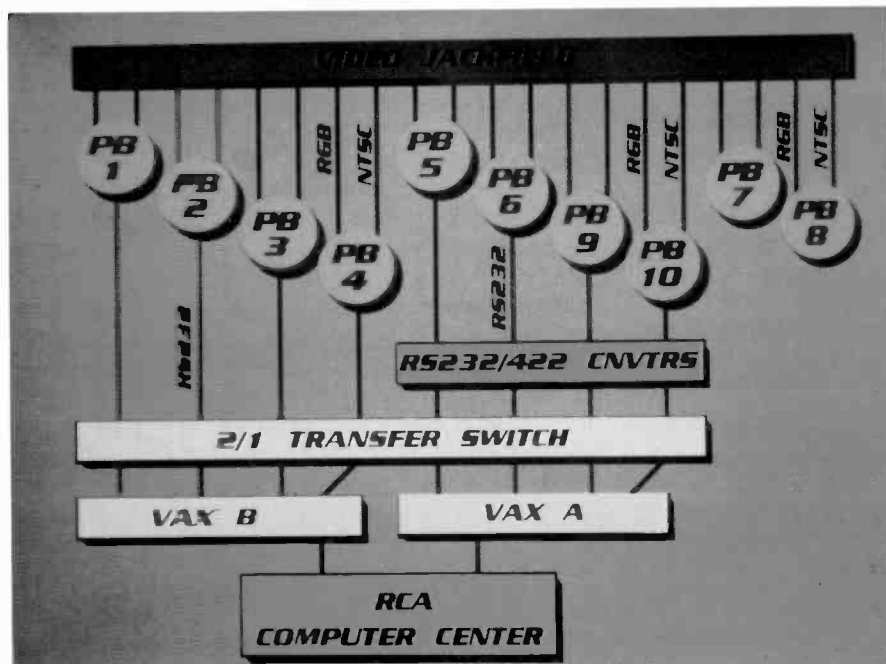

Fig. 6. Configuration of the ten Paint Box systems.

passive 2x1 switch at the inputs to VAX A and VAX B allowed the VAX System Manager to selectively redirect the control of any Paint Box to either VAX. Control data was transmitted at 19.2k baud between the VAX Paint Boxes via RS232 or RS422 EIA standards. The two standards were necessary to accommodate the various distances between Paint Boxes and VAX systems. RS232 should not be used at 19.2k baud beyond 50 feet. Since only

National Vote systems were within 50 feet, an RS232-to-RS422 converter was necessary. The converter is an in-line, self-powered device that was installed in the Paint Box racks.

On the night of air, all Paint Boxes under the control of the VAX had predetermined data written on their 330-megabyte disks. This data was either pictures of candidates, symbols, maps, or House and Senate layouts, depending on

the user. The VAX obtained current vote count statistical data of all races via dedicated telephone lines from the RCA Computer Center located in Cherry Hill, New Jersey. This data was used to update the various displays throughout the evening. The determination of which race was to be called and subsequently displayed involved four terminals. The terminals, referred to as List, Release, Control, and Animate, were connected to the VAX via RS232 communication links running at 4800 baud.

The List operator entered data that determined what races were to be aired. The Release operator released the races stored in the VAX on a first-in/first-out basis to the next available Paint Box, which brought up a static background. The Animate operator initiated a command that then modified the existing display with realtime-generated dynamic displays such as "towers" (Fig. 7), "sliding faces," or "mushrooms" (Fig. 8). If a Paint Box system failed, the Control operator's function was to eliminate that Paint Box from those available to the Release operator.

The two systems for Poll and Analysis, also referred to as Chancellor's Statistical Storyboard Package (CSSP), were VAX-independent. These systems were operated by graphic artists from the air studio during the election night telecast. For noise and aesthetic reasons the Paint Box mainframe and associated disk drives were located in room 9HC. The two artist work stations, safe-area generators, and ancillary computer terminals were on the studio floor. Each work station was connected to its Paint Box control input via an RS422 link. The computer terminals required for shifting between the CSSP and normal paint modes were connected to the Paint Box via RS232 links.

The encoded video output of each Paint Box was routed to distribution amplifiers. The two amplifiers per system supplied the required pre-equalized program and local monitoring feeds. Paint Box video for the eight network systems was routed to a central equipment area for appropriate distribution. To meet timing requirements, eight synchronization processors were used. The synchronization processors were installed in a rack on the floor of studio 8H. They sent a composite black-burst reference signal to each Paint Box. The Paint Boxes in turn sent their video to the synchronization processors for video processing. After the necessary initial level and timing adjustments were made at each Paint Box, all future rehearsal and night-of-air level and

timing corrections were made by a transmission engineer at the synchronization processor rack. With video from the Paint Box systems entering their appropriate production switchers, the air requirements for the project were satisfied.

The graphics displayed during the election night telecast had the primary function of disseminating information. The quality and manner of presentation, however, had the goal of capturing the viewer's attention. As with all visual effects, the wanted impact on an audience has only a limited duration. This project was developed around a concept that addresses this problem. We now have hardware that allows the imagination of talented people to be translated into dynamic, timely, and unique displays.

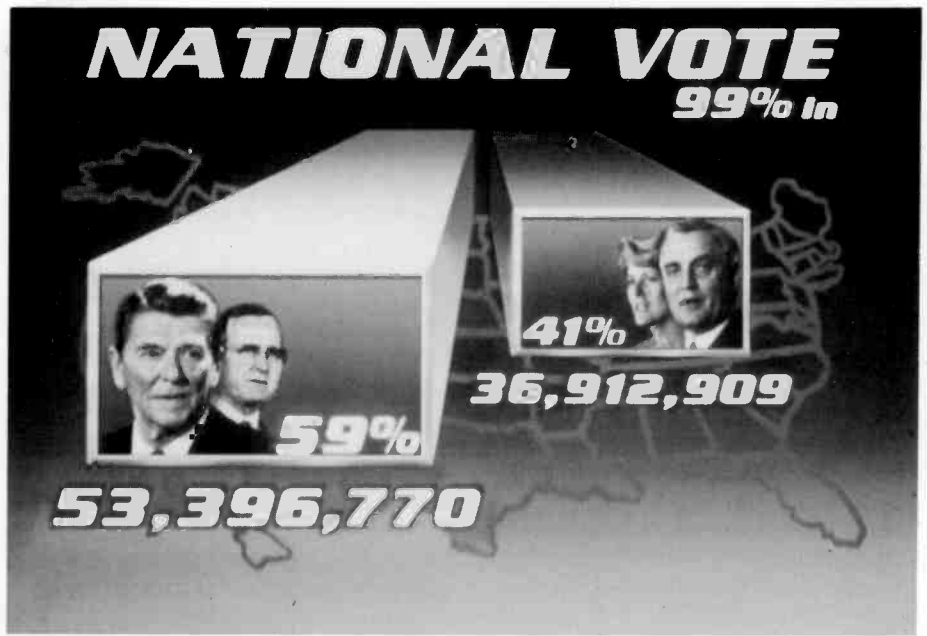

Fig. 7. Realtime-generated dynamic "tower" display.



Tom Alfieri began his NBC engineering career in 1964 as a television Electronic Maintenance Engineer. From 1972 to 1982 he worked on various assignments as a Development Engineer in the Technical Development Department. Since 1982 he has been with the Computer Imaging Department, working on the development of digital graphics systems. This article describes one such system. Contact him at:

NBC
New York, N.Y.
Tacnet: 324-2786



Fig. 8. Realtime-generated dynamic display nicknamed "mushrooms."

Innovative uses of computer graphics at NBC — Election Day, 1984

In this companion piece to Tom Alfieri's article, Christine Barton discusses NBC's Election '84 coverage from the perspective of the software developer.

NBC wanted to present its 1984 election night coverage in a way that would be more interesting and comprehensible than the traditional two-dimensional graphs or lists of candidates' names followed by vote totals. Graphic artists developed several initial storyboards that used color and graphic symbols in addition to the more common elements of candidate name and current vote to communicate the progress of a race. The artists also wanted to animate the graphics as a means of directing the viewer's attention to areas of the screen that contained the most important data.

Abstract: *An Election Graphics System was developed by NBC to display election results graphically in response to cues from a director during live television coverage of the election on November 6, 1984. The goals for the system were to convey information about the progress of 468 races on the ballot across the United States on that Election Day in an easily understood format. In order to meet these goals, NBC had to assemble a staff from several of its departments, configure new display devices with several computer processors, and develop computer software to control its prototype display system. This paper discusses issues confronted during this project and presents the solutions chosen.*

An additional consideration at this stage was the desire to have the graphics displayed in response to a few simple keyboard strokes.

Initial equipment selection

Following a survey of existing turnkey display systems in use within the broadcast industry, the artists selected Quantel Paint Boxes as display devices that would allow them to easily produce high-quality graphics, and which could incorporate sections of photographs and conventional art with computer generated artwork. This device's ability to include pictures of candidates in the election displays was viewed as an extremely useful method of communicating important election information, namely the candidates who were running. The device was also capable of animating the graphics by changing sections of the video frame within a vertical interval. Although the Paint Box hardware was capable of creating the sort of displays the artists and their producers desired, the turnkey software delivered with the Paint Boxes did not always allow access to the hardware features in a way required to produce the storyboarded displays. New software would have to be written to drive the Paint Box hardware.

In order to make the device display accurate vote totals for candidates in 468 races in response to an operator typing two or three keys, a Digital Equipment Corporation VAX 11/750 computer was

connected to the Paint Box using a serial interface.

The interfaced VAX also allowed the new software for the Paint Box to be written and compiled on the VAX and loaded into the Paint Box for testing.

System development

Although the original storyboards included drawn icons to represent candidates from each party, discussions with the hardware manufacturer made it clear that the system could provide an even better way of communicating the desired information: a photograph. Frequently during the project, a much better solution to a problem was found than had been expected by having artists work routinely with the technical staff.

Because this sort of interaction is limited when services are purchased from an outside vendor, NBC preferred to have its graphics system developed in-house. This arrangement was complicated by the departmental organization of NBC. The staff working on the development of the Election Graphics System included eight artists from Network News Graphics, six technical programmers and engineers from Engineering's Computer Imaging Department, seven programmers from the Network News Election Unit, and more than nine managers from all these departments. Although in-house development was viewed favorably on this project, the work was aided by a good working relationship

between Quantel and NBC. Just as the interaction of NBC artists with NBC programmers and engineers produced better results, the successful involvement of Quantel programmers and engineers with the NBC technical staff greatly enhanced the project.

The development work by artists and the technical staff produced seven storyboards that were used on the night of air. Using these storyboards, over 550 animated displays were prepared for possible use on the night of air. Each storyboard required Paint Box software subroutines to be written to display the desired animation. Each of the 550 displays using these storyboards required that files containing text fonts and pieces of artwork be available on disk drives connected to the Paint Box that was going to be used to construct the desired display. All Paint Boxes were not configured on the night of air to be able to produce any of the 550 displays. Each Paint Box was loaded with only a subset of the subroutines written for the storyboards, and had access to a set of disks that contained only a subset of the total number of artwork files. This was required because the total collection of artwork files was too large to be included on two hard disks, which was the disk configuration of some of the Paint Boxes.

The system developed by NBC was greatly influenced by the requirements of the live production environment in which the system was finally going to be used. The display devices obviously had to be quite reliable to prevent failures while they were displaying race results on the air. Since the displays were going to be controlled from a graphics control room staffed by 8 people, the displays had to be called up by simple commands. Control rooms are a very noisy environment; requests to each staff member in the control room are verbal, producing a cacophony of sound. Such an environment is not conducive to the concentration required for entering complex keyboard sequences. In addition to simple commands, the pressures of the control room suggested assigning each staff member in the control room only one function; on a cue from an associate director he need only type one short command on his keyboard, instead of selecting one command among many.

The graphics system on the night of air

The hardware configuration used for NBC's Paint Box graphics system on the night of

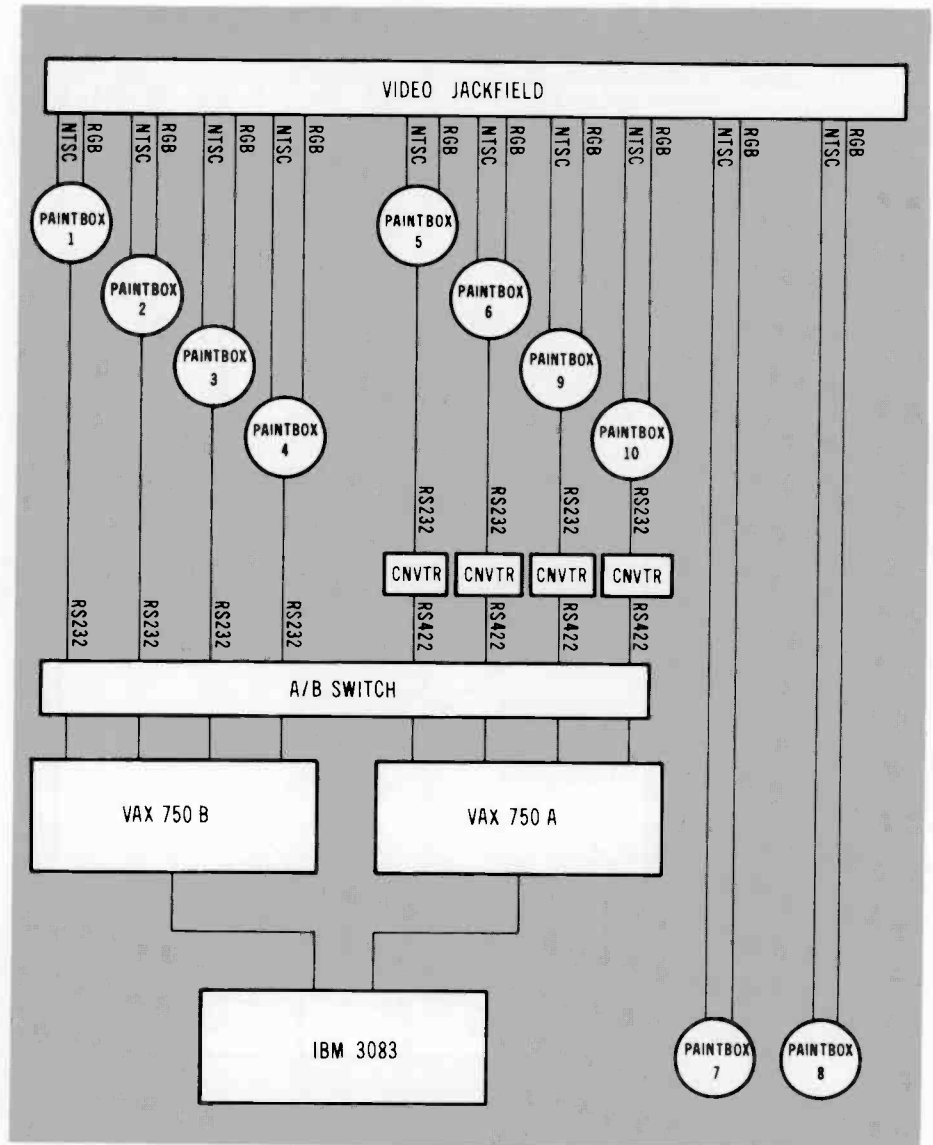

Fig. 1. Hardware block diagram.

air is shown in Fig. 1. Eight Paint Boxes were controlled by 2 VAX 11/750 processors. An IBM mainframe that collected election results was connected to both Vaxes to allow automatic updating of vote totals. In addition, two Paint Boxes operated on the night of air independently of VAX control, using software developed at NBC. This hardware configuration does not include conventional turnkey display devices used by NBC on election night; these devices included Paint Boxes, Dubner CBG boxes, ADDA still stores and tape machines that were run by conventional software and control methods.

The software used on election night is shown in Fig. 2. Four categories of software and disk files, also termed "users," were created for the night of air. Each user category consisted of 68000 software, Paint Box disk files, VAX software, and

VMS disk files. The 68000 software that controlled a Paint Box was written in Concurrent Pascal. The VAX software written under the VMS operating system in Pascal also consisted of a number of independently scheduled processes. Directories for disk files on both the Paint Box and the VAX were maintained on the VAX, so that the VAX processes had access to all information required for control of the Paint Box displays. The software and disk files were organized so that additions of new displays or modifications of artwork for existing displays impacted the disk files only; modifications to the motions defined by a storyboard were the only changes that required software changes. Data packets passed between the software processes running on the VAX and the 68000 carried parameters that fleshed out the generic storyboard into a display that

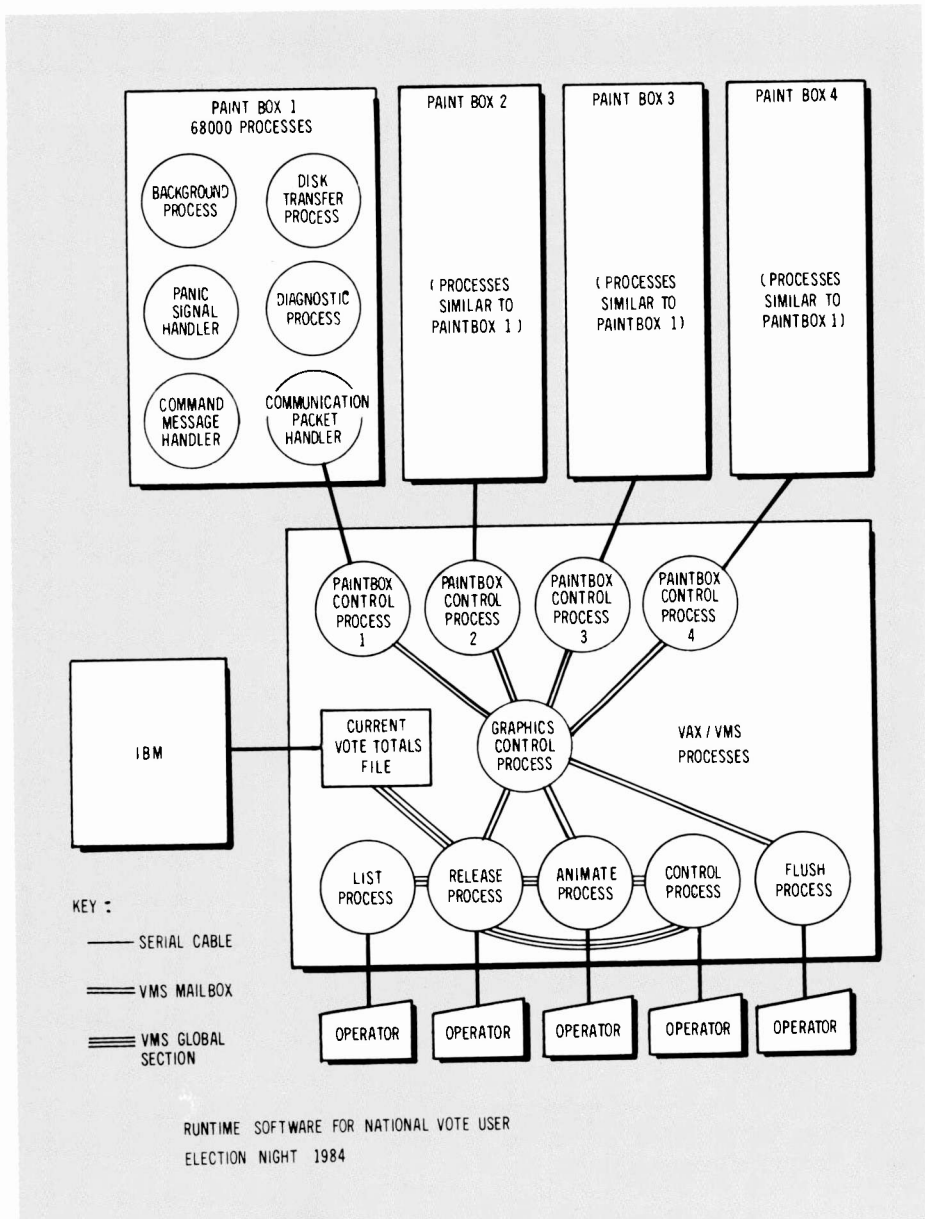

Fig. 2. Runtime software for national vote user, election night, 1984.

showed the results of a particular race. These data packets typically included current vote totals, disk file locations, and display-related coordinates. An emphasis in the software development was on general software that was data-driven whenever possible. This was required because the software coding, compilation, and load phase was time consuming, while changes to disk files were in general easier. Another emphasis in the software was its organization into independent processes and modules that implemented logically disjoint functions. Hence the VAX software in Fig. 2 for any user category consisted of at least 6 VAX processes and 6 Paint Box processes.

Within each user category the operator

interface to the display system used four processes: List, Release, Animate, and Control. The List operator entered three-or four-character codes on a VAX terminal for races that were considered newsworthy and would soon be discussed by the news staff. The Release operator released the next race code in the list just discussed to an idle Paint Box. The Control operator would remove a Paint Box that was failing from use until it had been repaired. The Animate operator would cause a Paint Box that had previously been prepared for use by a Release to be animated on the air.

The operational environment used on the night of air is shown in Figs. 3, 4, and 5. The control room for the network's

election coverage was located near the studio. Local news used a separate control room near their studio. A single graphics control room was located several floors away from both of these control rooms. The ten Paint Boxes, two Vaxes, and IBM data gathering equipment used in the system described here were located in five areas at NBC, including the network studio and four equipment rooms separated by several floors. The IBM mainframe was located in Cherry Hill, N.J. The director, several associate directors, and the List operator for network coverage worked in the main control room on the night of air; the Release, Animate and Control operators for network coverage worked in the graphics control room with another associate director. Cues for graphics were given using telephone lines between an associate director in the main control room and the associate director in the graphics control room; the graphics control room associate director then passed the cues verbally to the Release and Animate operators sitting next to her. The Control operator in the graphics control room was aided by two technical staff members, who were connected by phone lines to the equipment rooms. These technical support personnel coordinated repair procedures for failing equipment with staff in the equipment rooms; when a device was again operational, the support personnel informed the Control operator that it could be included for on-air use.

Precautions against failing displays on election night included redundant equipment and support personnel trained to remove and repair failing equipment while on air. Most of the hardware and software ran quite reliably in practice, however. The election day use of the displays included hours of rehearsal and test, as well as three broadcasts. During this 30-hour period there were about a half dozen minor failures, all of which were easily recoverable and did not produce undesirable on-air displays.

To aid in the general awareness of all the graphics control room staff of the progress of the show, two audio channels were broadcast over speakers in the graphics control room. One channel carried the audio from an open microphone in the main control room. This channel carried, among other voices, all cues from the show's director, and the executive producer's instructions to the production staff as to the desired content of upcoming program segments. The second audio channel carried the program as it was broadcast.

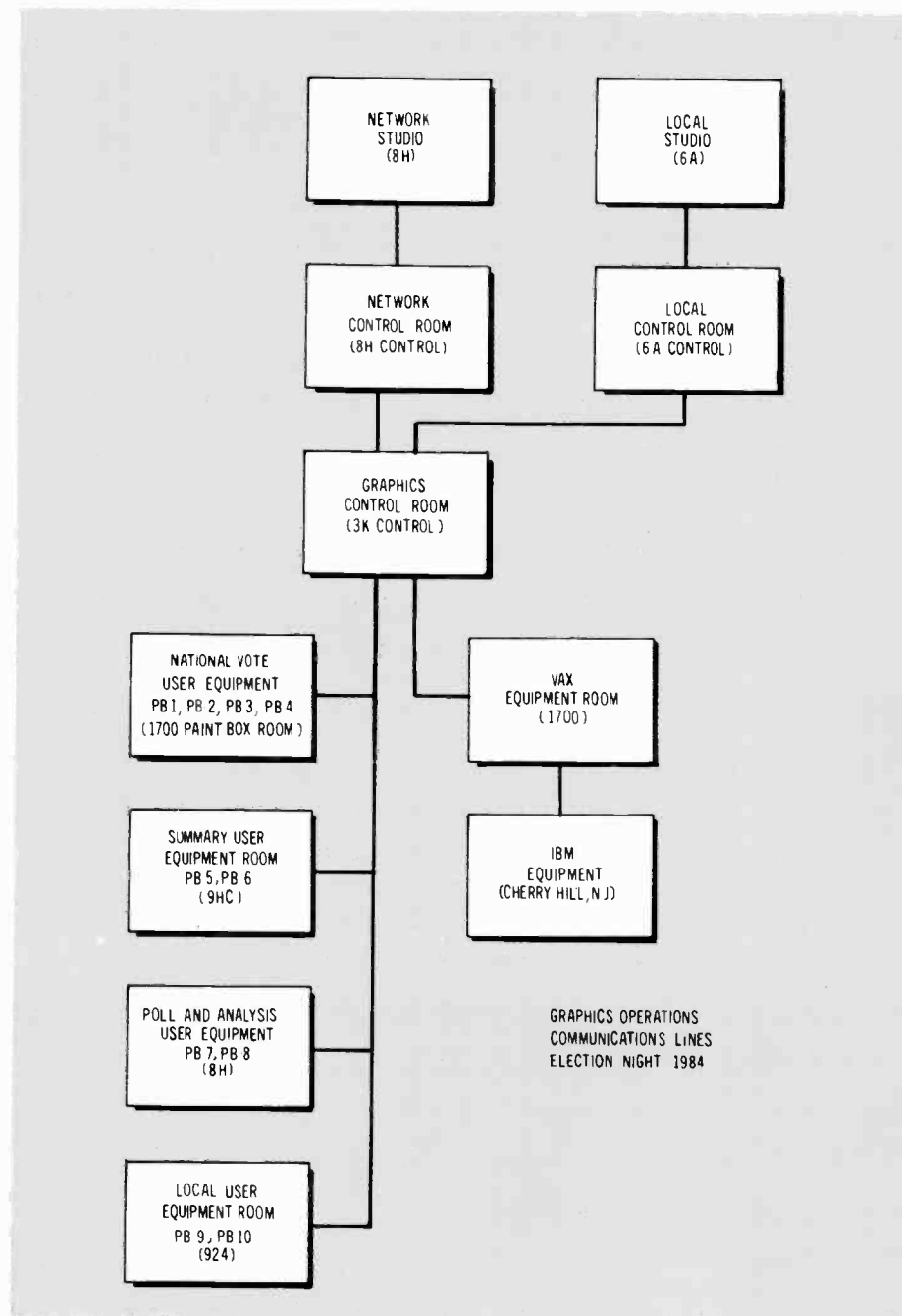

Fig. 3. Graphics operations communications lines, election night 1984.

Other monitoring equipment included video monitors for all ten paintboxes, two ADDA still stores, a Dubner CBG box, and three monitors carrying election coverage by other broadcasters.

Scheduling

The following are project milestones of The Election Graphics System:

- Project defined—April, 1983
- Equipment selected—July, 1983
- Development equipment and staff in place—November, 1983

- Initial software definition—December, 1983
- Initial software available for test—April, 1984
- Working storyboard definitions—June, 1984
- Initial Election Graphics System rehearsals—October, 1984
- Finalized storyboards, artwork, software, hardware—November 3, 1984
- Night of air—November 6, 1984

Several displays produced by NBC's Election Graphics System are shown in Figs.

6 and 7. The displays were used in NBC's coverage of the Presidential race on November 6, 1984.

Conclusions

The Election Graphics System was very effective for several reasons. There was an emphasis throughout the graphic design phases of the project on graphics that communicate specific election data, instead of on graphics intended only to grab attention or showcase graphics techniques. Production of some graphics storyboarded by designers could only have been done with the type of system we had. The success of the graphics produced was greatly enhanced by frequent communication between gra-



Christine Barton is a member of NBC's Computer Imaging Department, and was actively involved in software development as project manager for the 1984 election project. Prior to work at NBC, she worked as a systems and computer graphics programmer in several research groups, including the NASA/Ames ILLIAC IV parallel computer project, three Evans and Sutherland Computer Corporation computer-generated imagery projects, and New York Institute of Technology's Computer Graphics Laboratory.

Ms. Barton received a BS in Mathematics and Computer Science from the University of Illinois in 1971 and an MS in Mathematics from New York University in 1981. She is a member of ACM, IEEE, and ACM Siggraph.

Contact her at:

NBC
New York, N.Y.
Tacnet: 324-5390

phic designers and technical personnel, even when these groups worked in different corporate departments or for outside vendors. An additional consideration that contributed to the success of the night-of-air operation of the system was an emphasis on a simple operator interface appropriate for the election night operational environment.

Acknowledgments

The following people were involved on the Election Graphics System at NBC: Network News design artists were John Brainard, Anthony Franqueira, Steven Giangrasso, Kevin Hale, Michael Katz, Jeff Maltz, and Larry Wasserman; the Computer Imaging staff was David Rabinowitz, Christine Barton, Thomas Alfieri, Diane Pincinski, Andrew Siegel, and Maria Cantatore; the Network News Election Unit data collection staff was Joel High, William Niemi, Patricia King, Richard Ho, Nieba Jones, Ellen Mendelson, and Theresa Chan; Quantel programmers were Robert Long and Simon Carter; Management on the project included Joseph Alicastro, Joel Blumenthal, Joseph Branch, Robert Brandel, Ralph Famiglietta, Sheldon Hoffman, Richard Passentino, David Schmerler, Roy Wetzell, and Thomas Wolzien.

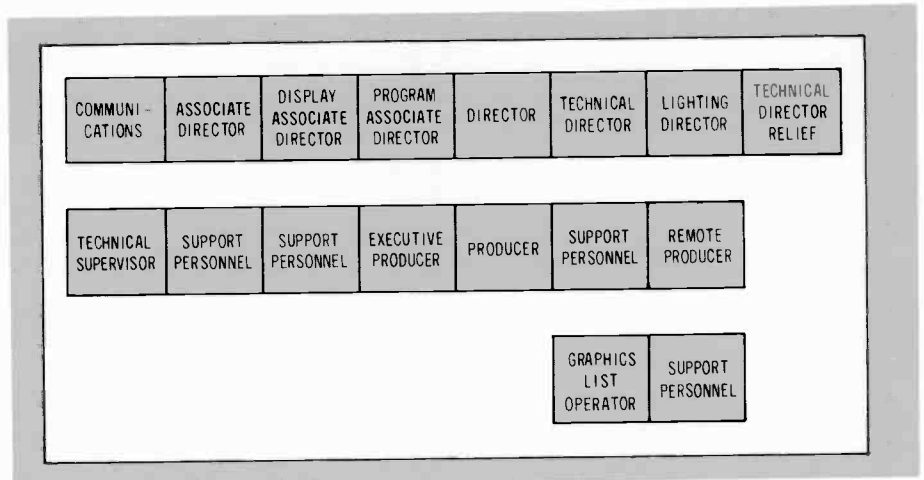

Fig. 4. Network control room seating, election night 1984.

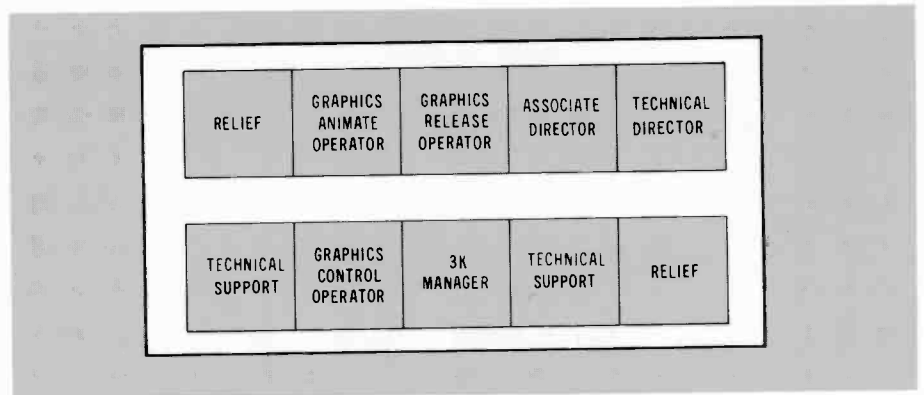

Fig. 5. Graphics control room seating, election night 1984.



Fig. 6. NBC national vote display 1984.



Fig. 7. NBC electoral vote display 1984.

Techniques for enhancement of interactive color graphics for C³I systems

Today's state-of-the-art battlefield intelligence gathering tools necessitate the use of recent developments in video processing to enhance the man/machine interface of colorgraphic workstations.

The battlefield of today contains an ever-increasing proliferation of sophisticated sensors and jammers. Old methods of handling and processing battlefield intelligence information—paper records and mapboard overlays with grease pencils—cannot cope with today's environment in which there

Abstract: *The use of automated support for command, control, and communications intelligence C³I systems is rapidly expanding with the increased use of computer technology, colorgraphic workstations, and electronic storage media. Newly emerging technologies provide practical solutions to support applications such as tactical intelligence analysis through the use of interactive colorgraphics and enhancement of the man/machine interface. This paper discusses tactical intelligence requirements, the overall analysis approach, and the new technologies available for enhanced operational support. The enhancement of the man/machine interface through effective high-definition display of color maps is also addressed.*

are thousands of sensor and human intelligence reports per hour. The command, control, and communications intelligence (C³I) system of today must provide a highly automated management system involving automatic data processing (ADP) to assist in processing highly dynamic tasks. The system must receive many types of sensor reports and assist the intelligence analyst in the correlation and fusion of real time data. It is vital that the analyst communicate with this system in a highly efficient manner through elective use of tools based on the feasible and practical application of emerging technologies.

In order to adequately define these tools and maximize the utilization of these technologies, it is first necessary to determine the intelligence requirements and understand the analysis approach.

System requirements

The principal requirement of a tactical C³I system is that it provide battlefield analysis in a timely and accurate manner by integrating all sources of intelligence. These sources include signal intelligence (SIGINT), which is the fusion of electronic and communication intelligence (ELINT and COMINT); image intelligence (IMINT), which includes

imagery from sources such as radar, photo, infrared (RADINT, PHOTINT, SLAR, IR); and human intelligence (HUMINT) from forward observers, reconnaissance, and prisoner interrogation. The function of the system is to provide tactical commanders with essential elements of information for mission planning by locating, identifying, and tracking the enemy as quickly and as accurately as possible. This information allows the intelligence team to analyze the enemy in the context of the battlefield with all its constraints such as weather, visibility, and surface conditions. It is then possible to estimate the enemy's capability and situation so that predictions can be made as to his intentions. Tactical reports are provided in near real time to the supported commander so that he can "see" the battlefield more effectively and respond appropriately with electronic warfare options. Intelligence analysis must also identify and warn of threats that require immediate response.

The use of highly-automated support in reporting, displaying, and disseminating specific location, time, and activity information from a large amount of data means that fewer people are in the loop, thereby providing useful intelligence in a more timely and accurate manner.



Fig. 1. RCA military colorgraphics workstation. This is an upgraded version of an AN/TSQ-130(V), showing alphanumeric database information on the right screen and electronically-stored maps with colorgraphic overlay displayed on the left screen.

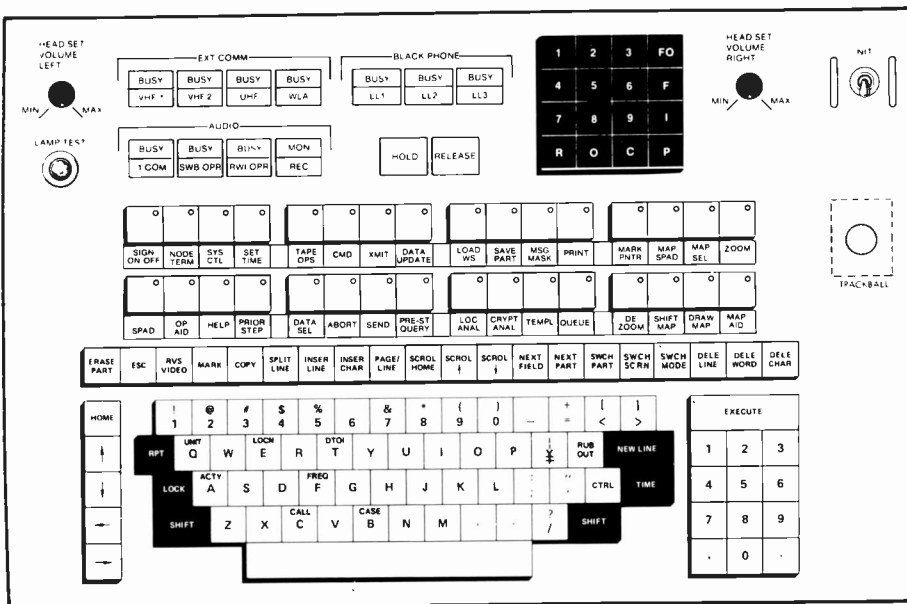

Fig. 2. RCA colorgraphics keyboard. Secure and non-secure communication controls are on the upper portion. Special function keys are in the middle two rows, and the standard keyboard is at the bottom, with commonly used word-select keys indicated.

Analysis approach

The analyst operating in today's tactical environment has a complex array of data resources that provide information regarding the enemy's movers, shooters, and emitters. Examples of these resources are TEAMPACK, TRAILBLAZER, AN/TRQ-32, QUICKFIX, and other direct support systems and sensors. It is the analyst's objective, through use of an automated system, to correlate the data

from this myriad of collection resources and present this data in a manner that depicts the battlefield situation. This can be best accomplished by plotting the enemy command and control nodes on a map so that a pattern can be formed from the enemy's electronic, infrared, acoustic, and other emissions. In addition, the analyst can quickly retrieve and review historical trends about the enemy from a database, which may help to predict the enemy's

intentions when compared to the present scenario. The commander and his staff can then plan an appropriate response and deal in a timely manner with immediate threats.

Colorgraphic workstation

The primary tools of the modern C³I analyst are communications, an automated database, and a military colorgraphic workstation.

The communication subsystem can typically provide the analyst with an array of voice, teletype, and data links in either a secure or nonsecure mode. Each of these facilities can be via wire or radio, and the analyst can communicate with other operators by voice or display screen.

The colorgraphic workstation typically contains a microcomputer that is loaded with the software necessary to support the type of functions required, a memory to buffer incoming and outgoing messages (and is linked to a host computer), and mass memory system containing the database. Figure 1 shows an adaptation of an AN/TSQ-130(V) workstation that has been upgraded with high-resolution color monitors and a color graphics generator. The operator has complete access to all communications, database, and algorithmic support through the control keyboard and associated headset. Color graphics are available on either or both monitors and electronically stored maps can be retrieved, displayed, and overlaid with color graphics.

The colorgraphic keyboard, shown in Fig. 2, illustrates the controls available to the intelligence analyst. The upper portion includes the selection and control of both secure and non-secure communications. A touch-tone dial set is shown on the right. The next two rows are the functional mode select pushbuttons with lights that indicate the selected mode. A trackball graphic cursor control is on the right and the cluster of eight controls next to it are those included for interactive colorgraphic functions. The lower portion is a standard ASCII control keyboard including numerical entry pad on the right, cursor controls on the left, and some unique word-select keys for frequently used words such as unit, location, date/time of intercept, activity, frequency, call sign, and case notation.

Figure 3 illustrates some typical military symbols that are used to overlay standard Army topographic maps. Under control of the operator or by graphic command from the host computer interface, a variety of

military symbols, alphanumeric annotations, and conic sections may be selected by menus from display lists and non-destructively overlaid on standard map backgrounds in a prioritized manner. Various attributes such as color, shape, size and blinking can be employed for rapid and accurate identification. The operator can typically draw a forward line of troops (FLOT) or place selected symbols using the cursor that is controlled by a trackball or other equivalent device such as a graphics tablet or mouse.

Map backgrounds

Two basic types of map backgrounds can be stored, retrieved, and displayed electronically to replace the old paper map with grease pencil overlays. One type is a digital-based decluttered map shown in Fig. 4, which can be used for navigation purposes and is useful for showing major roadways, rivers, and boundaries. The second type is the standard Army topographic map that contains a much higher level of information content for detailed C³I analysis. In addition, analysts are more accustomed to working with topographic paper maps. The information content of these maps, however, requires mass storage capacity and high-resolution display/processing for legibility. Figure 5 is a hypothetical example of a topographic map with simulated graphic overlay showing elements of the enemy's forces positioned along the Schmalkalden River, with key bridges indicated where river crossings are anticipated. Friendly forces are positioned on the high ground in the upper left corner of the map. Analysis has been accomplished through reception of enemy emanations and visual observation of the enemy force's key-element positional moves.

Map storage media

In order to select the appropriate map storage media using existing technology, it is first necessary to analyze the capacity requirements of standard topographic maps while considering the man-machine interface requirements of resolution and information transfer.

Figure 6a illustrates a typical 18-inch square map containing minimum line widths of .004 inch. If an approximation is made that at least one pixel is required to support and reproduce this minimum line width, then the entire map consists of 2×10^7 pixels. Secondly, if a high-resolution display is used that displays 480 active lines with a

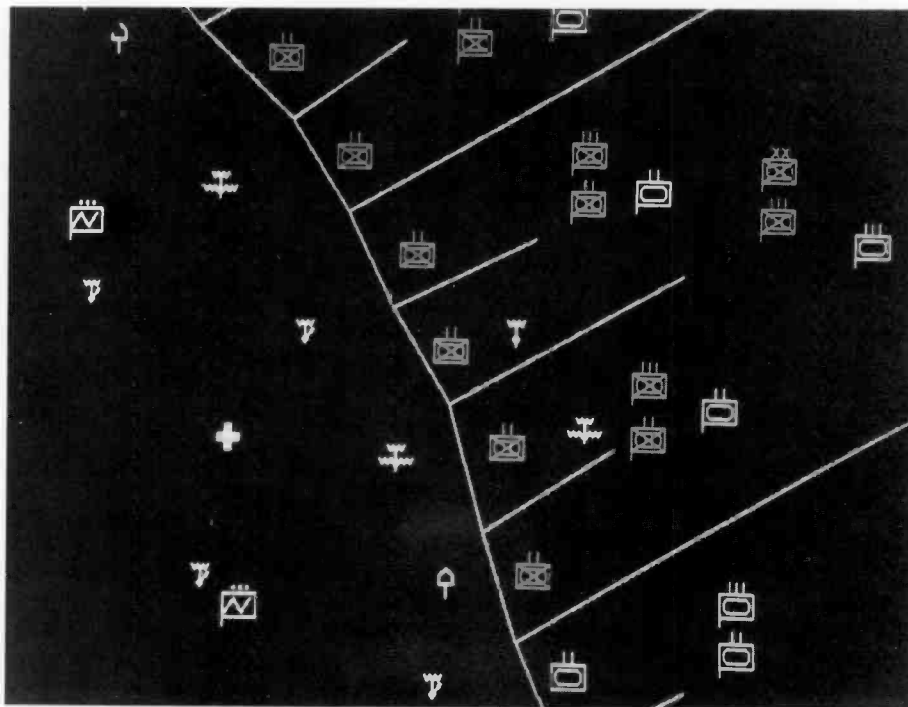

Fig. 3. Typical military symbols. These are used as graphic overlay elements on displayed maps to depict battlefield situations.

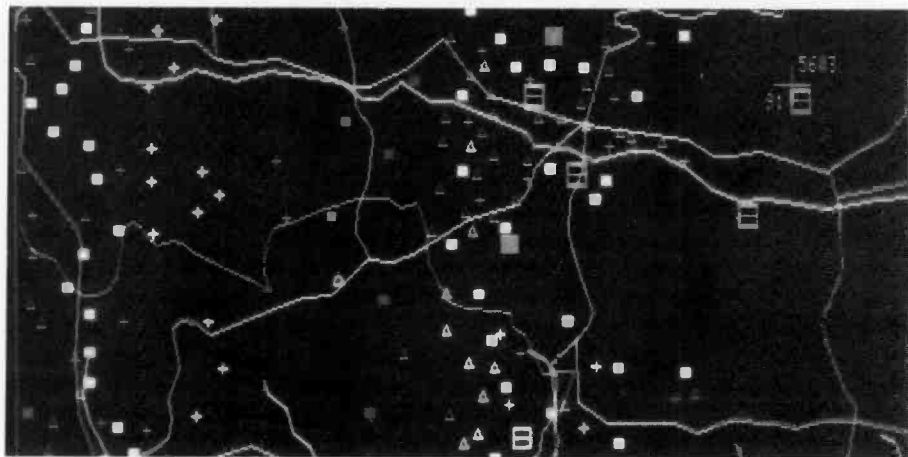

Fig. 4. Digital map. This is a sample of a digitized map stored in a standard computer memory and displayed on a CRT. Maps of this type are useful in depicting uncluttered scenes consisting of boundaries, roads, and rivers.

horizontal displayed-resolution of 640 pixels per line, a single displayed image will contain a maximum of 3×10^5 pixels, as illustrated in Fig. 6b. The total number of individual images required to represent the original map, then, is approximately 64. The optical magnification from paper map to displayed image is approximately 4:1 with full quality reproduction, and each map segment is presented to the operator with high legibility at a normal viewing distance of 18 inches from the display.

If a typical map with a scale of 1:50,000 is employed, the displayed map segment represents a tactical area of approximately

eight square kilometers based on the 4:1 optical magnification. In reality, a highly legible image covering an area of 3×4 kilometers, as shown in Fig. 5, is practical with enhanced video processing (optical magnification 3:1), which results in a map consisting of 37 map segments.

The storage requirements for a useful operational area can be illustrated by considering an area covering central Europe, which covers 696,000 square miles ($1,200 \times 580$ miles). Approximately 3,500 maps of 1:50,000 scale are required, resulting in a total storage requirement of 129,500 images. If a 50-percent overlap is required

to permit any point on the original map to be reasonably centered, the total requirement becomes 518,000 images, or approximately 1.6×10^{11} pixels. This represents a very high storage capacity requirement coupled with a requirement for rapid random access. A quick review of storage densities available in state-of-the-art technologies is shown in Table I. As illustrated, the only digital storage media that approaches the requirement of 1.6×10^{11} pixels is the newly emerging optical data disk. Assuming 8 bits/pixel for a digitized map in each of three primary colors, a total of 19 disks would be required. In comparison, an analog storage media of

either tape or laser videodisc containing NTSC encoded color imagery has a much higher capacity. Tape is not considered because of its long random access time. The laser videodisc is the obvious choice, and could supply the required capacity with six discs. In addition, any map can be recalled from a given disc within 5 seconds using commercially available, low-cost players employing a computer interface for automated control.

Enhanced video processing

To maximize the information transfer and functional efficiency of the intelligence

operation, it is important to consider the man-machine interface. One of the most vital workstation factors is the resolution presented to the operator by the display. A highly legible image can reduce fatigue, provide a high degree of information transfer to the analyst, and maximize the response time through rapid absorption and comprehension of information.

As previously described, the standard videodisc system provides a currently available source of rapid access cartographic information for the C³I analyst. The National Television Systems Committee (NTSC) format was defined nearly 30 years ago, but until recently has not been processed to extract all of the inherent color resolution.

New techniques involving comb filters can substantially improve the image quality and legibility of cartographic maps retrieved from videodisc storage and displayed at the colorgraphic workstation.

Table I. Recording densities of different media.

Digital

- Cassette— 10^6 to 10^7 bits
- Floppy disk— 2×10^7 bits
- High-density 9200-foot tape— 3×10^{10} bits
- Optical data disk— 2×10^{11} bits (two sides, 12-inch diameter)

Analog

- 9200-foot tape— 3×10^{11} pixels (8 bits/pixel)
- Laser video disk— 2.8×10^{10} pixels (8 bits/pixel)

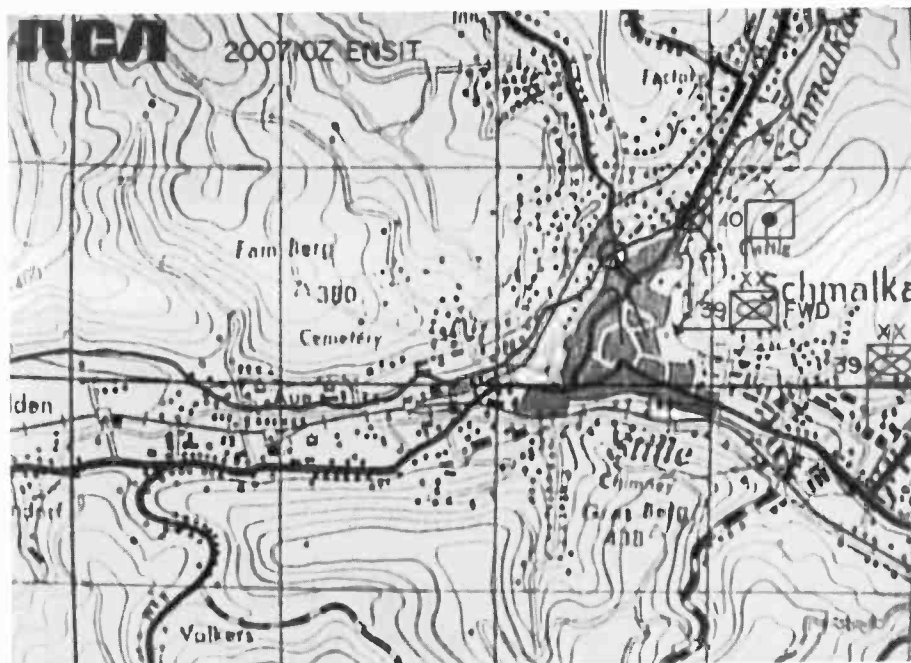

Fig. 5. Topographic map with graphic overlay. This is a photograph of a topographic map containing high information content and displayed on a high-resolution display. Graphic overlays are used to depict enemy elements and key positional forces.

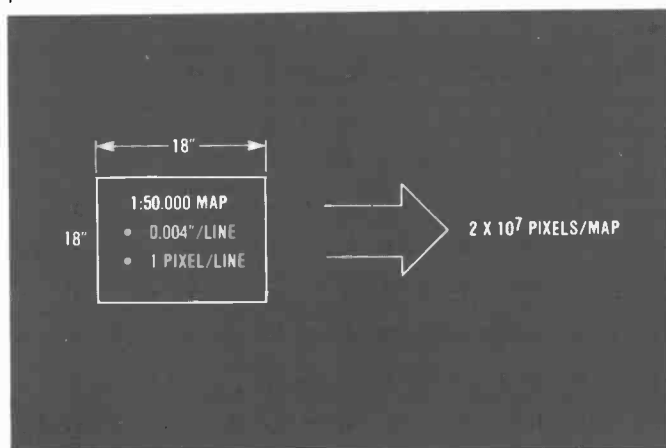

Fig. 6A. Map pixel density. This illustrates the total number of pixels required to produce a typical cartographic map of approximately 18x18 inches.

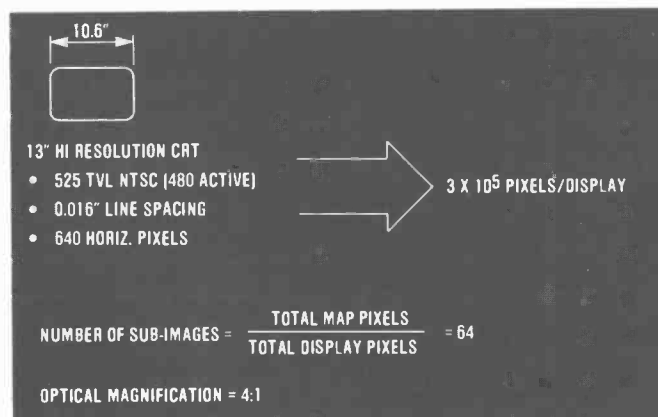

Fig. 6B. Displayed map pixel density. The number of pixels resolvable on a 13-inch diagonal display is shown here. This determines the number of sub-images required to legibly display the full map shown in Fig. 6a.

The fundamentals of color television signals are described in the literature,^{1,2} and will not be repeated here except for a few brief concepts that will help to describe the signal processing employed for enhanced map display. The NTSC encoded signal consists of two components; the luminance signal (Y) and the chrominance or color signal (C). The luminance signal represents the black-and-white content with full bandwidth information out to 4.5 MHz. The chrominance signal consists of two phase-modulated components; I (in-phase), and Q (quadrature), which are referenced to a color sub-carrier frequency. The color sub-carrier frequency (3.579545 MHz) was chosen to be an odd multiple of the half-line frequency (455xhalf-line). Since a line-scanned television system is a two-dimensional sampled system of an image, the luminance signal contains 60-Hz (vertical sample rate) power sidebands that are clustered at the horizontal line-rate sample and at all of the line-rate harmonics with an amplitude characteristic shown in Fig. 7. The chrominance portion of the composite signal also produces power clusters in the same fashion, but these are interleaved with the luminance clusters because the modulation reference frequency was chosen as an odd half harmonic of the horizontal rate. The relative amplitude and interlaced structure of the Y and C components are shown throughout the entire bandwidth, as illustrated in Fig. 7. The specific bandwidths allocated for Y, I, and Q in the NTSC standards are shown in Fig. 8. As can be seen, the luminance signal occupies the full 4.5-MHz bandwidth, but the I and Q components occupy limited bandwidths of approximately 1.5 MHz and 0.5 MHz, respectively, after demodulation.

Until recently, separation of the chrominance from the luminance signal was accomplished by bandwidth filtering. A 3.58-MHz trap is used to take the chrominance signal out of the composite signal, which leaves the luminance. The chrominance signal is developed by using a 1-MHz bandwidth filter that is bandpass-centered around 3.58 MHz. Unfortunately, this does not extract the interleaved luminance signal trapped in the bandpass chrominance signal and the chrominance in the bandrejected luminance. The result is the familiar dot crawl on vertical edges and color aliasing effects seen on home television receivers resulting from coherent high-frequency spatial patterns. In addition, bandrejection of the luminance signal substantially reduces the black-and-white picture resolution.

To more ideally separate the luminance

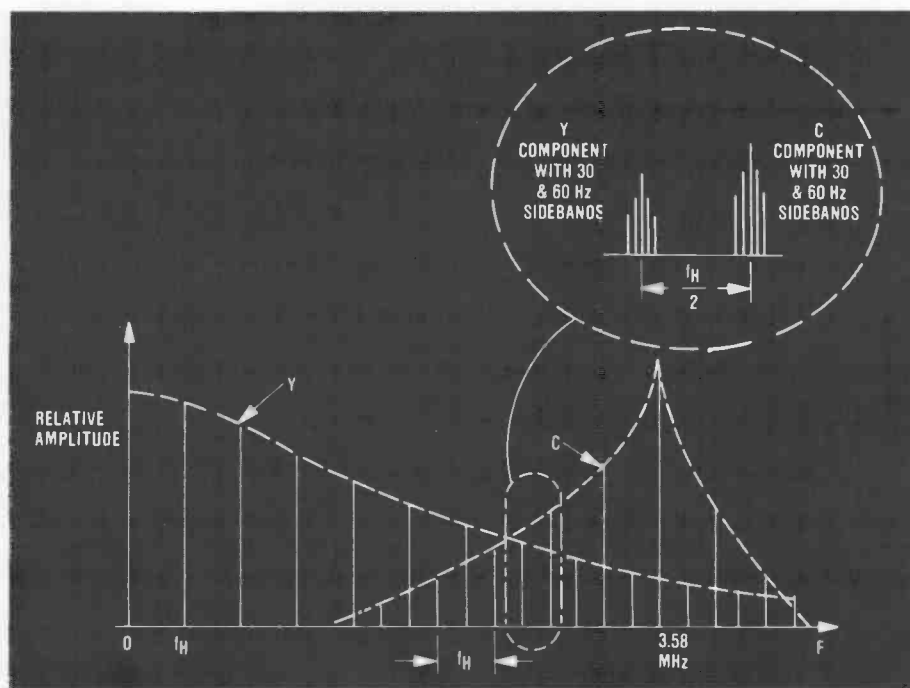

Fig. 7. Relative amplitudes of NTSC component signals. These are the relative amplitudes of the luminance and chrominance components of the NTSC signal. The exploded view illustrates the nature of the interleaved energy clusters of these components.

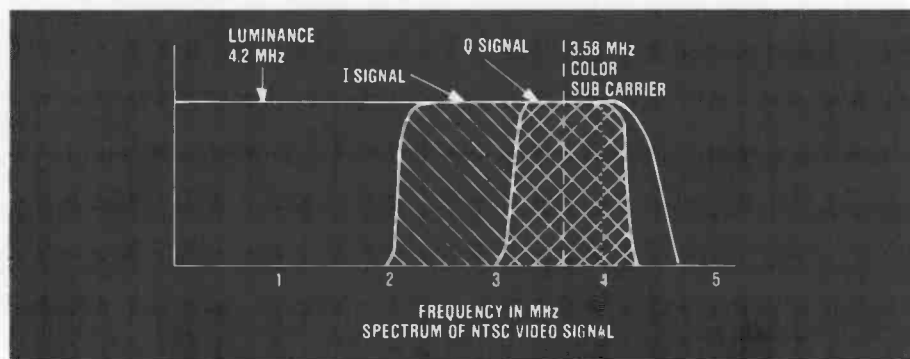

Fig. 8. NTSC Y, I, & Q bandwidths. This shows the allocated bandwidths of the luminance (Y), the in-phase (I), and the quadrature (Q) components of the chrominance signal. The cross-hatched areas illustrate the overlapping nature of the component spectra, which makes separation by simple bandwidth filtering undesirable.

and chrominance interleaved signals, a filter having peaks and nulls at the various energy clusters throughout the entire bandwidth and having a linear phase characteristic is required. The overall filter response has a "comb" shape, and is thus referred to as a comb filter. For the past several years it has been possible to make practical comb filters by implementing charge-coupled device (CCD) delay lines, and this has resulted in higher resolution and reduced cross-color effects. Figure 9 illustrates a practical filter circuit using a CCD delay line to achieve separation of the luminance and chrominance components through comb filtering. If the input to the circuit is

an applied unit-impulse function $\delta(t)$, it can be shown by Laplace transformation that the output of the luminance channel $H_1(\omega)$ and the output of the chrominance channel $H_2(\omega)$ can be expressed by

$$|H_1(\omega)| = 2|\cos T/2|$$

$$\text{and } |H_2(\omega)| = 2|\sin T/2|$$

where $T =$ the delay time

Therefore, $|H_1(\omega)|$ and $|H_2(\omega)|$ have the shape of full-wave-rectified sinusoids. If T is made equal to $1/f_H$, where f_H is the horizontal scanning frequency, the $|H_1(f)|$ has a maxima at the harmonics of f_H and

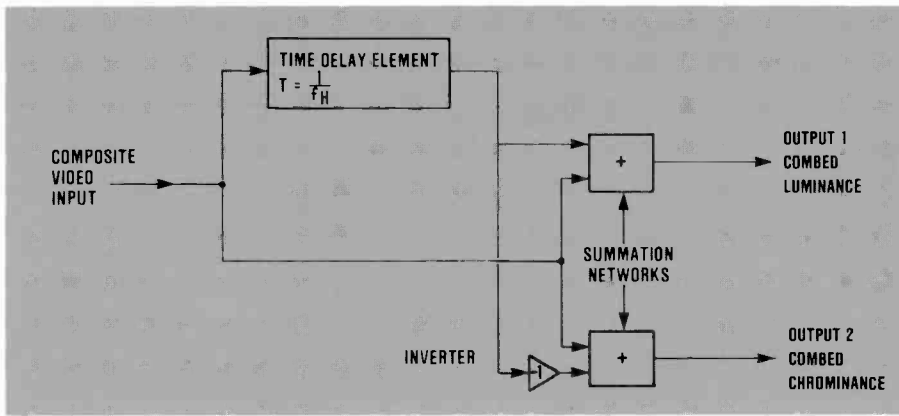

Fig. 9. Basic comb filter for separation of luminance and chrominance. This simplified functional diagram shows how a time delay element is used to implement comb filtering of the luminance and chrominance signals. Adding the in-phase luminance components separates the luminance from the composite signal by cancelling the chrominance signal. Inversion and addition separate the chrominance out by cancellation of the luminance component.

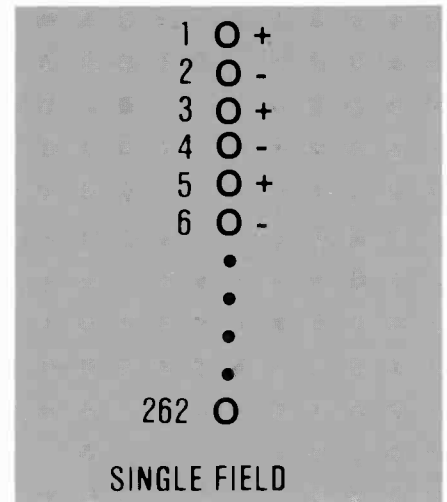

Fig. 10. Single-field phase relationship of scan lines. This diagram illustrates the relative phase relationship of the color subcarrier frequency in each scan line of a single NTSC field, and helps to explain the process of the line-comb filtering shown in Fig. 9 when the delay time is one line time.

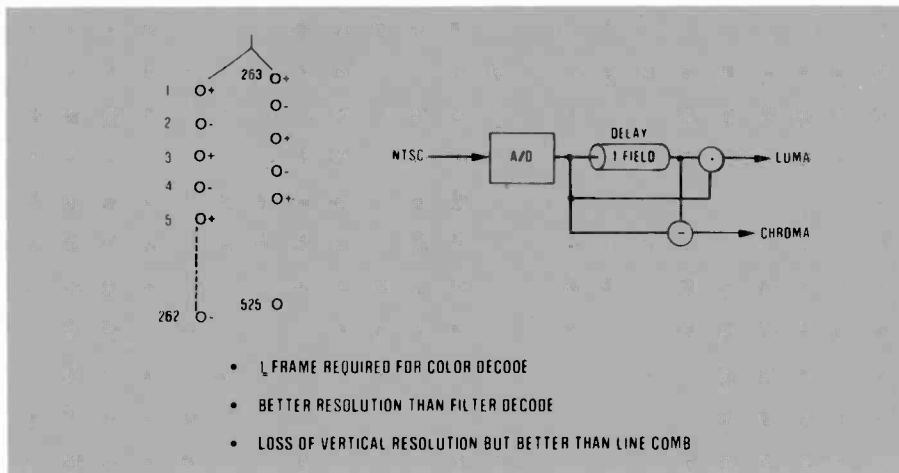

Fig. 11. Field combing. This shows the phase relationship of each scan line color subcarrier frequency in two corresponding interlace fields of a complete frame. Field combing of luminance and chrominance is achieved by using a full field delay.

$|H_2(f)|$ has maxima at harmonics between harmonics of f_h , thus forming the desired comb filter.

Another simplified way of graphically illustrating the line combing previously described is shown in Fig. 10. This diagram represents the scan lines in a single field as hypothetically viewed from the side edge of the scanned raster. The phase relationship of the subcarrier frequency is shown for each scan line. If each scan line is delayed by a full line time and then compared to the next line in real time according to the circuit in Fig. 9, one can see that combing will take place by cancellation—the components in one line are 180 degrees out of phase with components in the next line. If both scan lines have identical information, perfect combing takes place and full resolu-

tion with no cross-color components will be realized. This process of line-comb filtering has been employed in commercial TV receivers for several years.

Line-comb filtering is not ideal, however, when the two scan lines being compared have different information content. This results in imperfect combing and a loss in vertical color resolution. Techniques have been employed to partially restore the loss of vertical resolution, but averaging two lines from two different geometric locations of the image is not ideal.

A better approach, depicted in Fig. 11, is to perform field combing by using a full field delay and then comparing scan lines from two interlaced fields that are geographically close together. Finally, the ideal configuration is a full-frame comb that

now allows the combing process to use the same geographically-located lines with identical information content as shown in Fig. 12. Frame combing can be accomplished by digitizing a full frame of video, storing the frame in a memory, and then reading this frame out of memory in synchronization with the next frame being generated. If motion in the scene exists, then the full-frame delay will obviously produce undesirable effects by comparing two dissimilar frames. In this application, however, the maps stored on videodisc are stationary images, and two identical frames can be stored that will allow full-frame combing of the composite signal. In addition to full color resolution with no cross-color products, the signal-to-noise ratio is improved over that from a single frame, and defects in the videodisc such as localized dropouts are reduced.

Figure 13 is a photograph of an NTSC-encoded map that has been frame-combed and displayed on a 13-inch diagonal, fine-pitch-mask CRT. The color graphics depict the locations of elements of the 39th Motorized Rifle Battalion and the forward line of troops (FLOT). The graphics are overlaid on the map background in a prioritized, non-destructive manner. The direct-viewed quality of this high-resolution color image is much greater than can be represented by the reduced-size black-and-white photograph adjacent to it. This imagery was produced using a frame-comb system developed at RCA Laboratories.

Colorgraphic workstation

The full colorgraphic workstation for C³I analysis is illustrated by the simplified block diagram in Fig. 14. The dual-screen workstation can be utilized to present graphic-overlaid maps on either or both screens. A typical mode, shown in Fig. 1, employs a map with a tactical operational scenario overlay on one screen and alphanumeric information on the other screen that provide information from the database pertaining to operator-selected inquiries.

A particular map is accessed from the videodisc player by a given latitude/longitudinal coordinate and map scale factor command. The video signal is digitized by an 8-bit A/D converter sampling the NTSC video at a 14.3-MHz clock rate. The clock is derived from a circuit that phase locks to four times the 3.58-MHz color burst carrier, providing precise registration accuracy. It also provides approximately 750 samples per active line time to more than support the 4.5-MHz bandwidth, as well as quadrature sampling of the encoded chroma for ease in subsequent digital decoding. In addition, horizontal and vertical sync signals are stripped from the video and used by the address control logic for writing the digitized video into the two-frame (four-field) memory. Digital frame grabbing allows a single videodisc player to serve either a single or group of display processors, and provides the two frames required for frame combing. Once loaded, the memory readout is synchronized to the graphic display generator. Readout of the two frames requires two lines of video being clocked out in accordance with frame combing, as shown in Fig. 12. The readout can be selected to form a standard 525-line, 2:1-interlaced format with a 60-Hz field and 30-Hz frame rate, or a progressive scan can be performed, resulting in a 60-Hz non-interlaced frame rate.

Simple digital addition and differencing of the two frames provides luminance and chrominance signals, as described in the combing operation. Further decoding of the 3.58-MHz chrominance signal into its in-phase (I) and quadrature (Q) components is accomplished digitally. The I signal is obtained by selecting the chrominance samples with the 4x color subcarrier clock and low-pass filtering (2.5 MHz) the output. The Q signal is similarly obtained by selecting the chrominance samples with the same clock shifted by one cycle (corresponding to 90-degree phase shift for the 3.5-MHz color subcarrier), and low-pass filtering (2.0 MHz) the output. The signals are then converted to analog, and simple linear

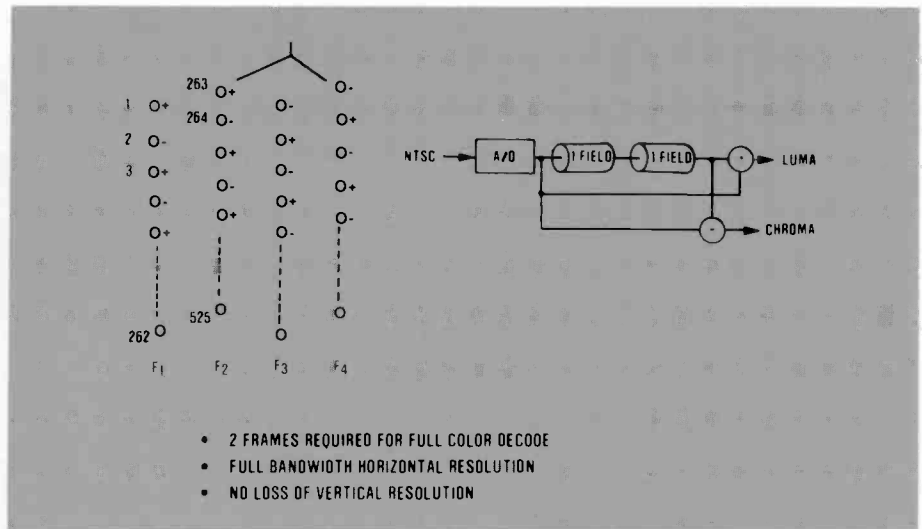

Fig. 12. Frame combing. The scan line phase relationship in four fields is shown here to illustrate the effectiveness of frame combing by comparison of scan lines from identical geometric locations of the image. Two full frames of the same image information are required for frame combing.

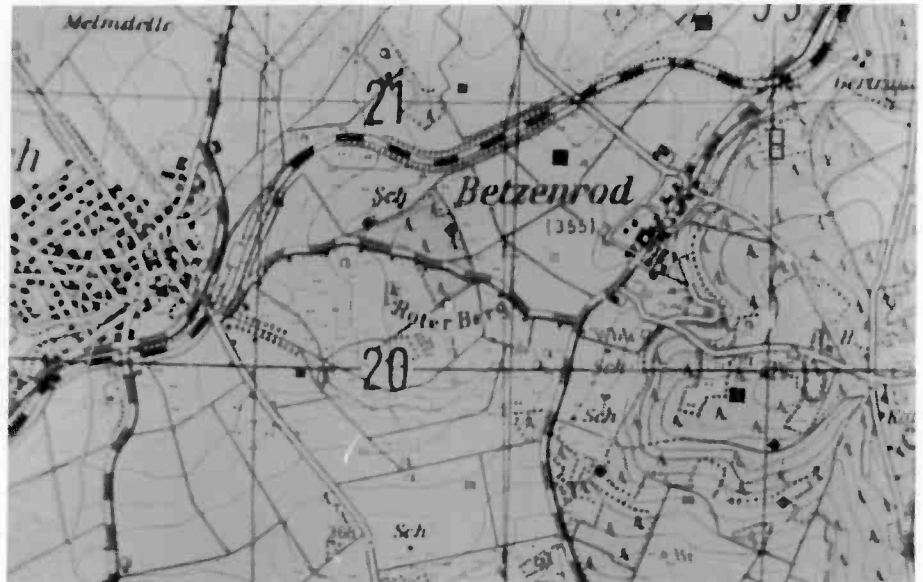

Fig. 13. Frame-combed map with graphic overlay. This photograph was taken from a high-resolution color display of a comb-processed map image that was retrieved from videodisc storage. Color resolution of high quality is achieved with no artifacts or dot crawl due to cross-color products. Graphic overlaid symbols are used to depict a military situation.

matrixing of the Y, I, and Q signals produces the required R, G, and B signals.

The output of the colorgraphic generator is synchronized to the readout from the frame-comb memory system, and is merged with the analog map video in the video keyer circuit. This circuit prioritizes the graphic overlay in a non-destructive manner so that changes can be made in the graphic overlay as required without having to recall the map from the videodisc each time a change is made.

Any one of many graphic generators

existing on the market today can be utilized, but it must be capable of gen-locking to external sync and providing a control I/O for the videodisc player. It must also contain software primitives for graphic generation such as circles and vectors, provide a display list of required graphic symbols, and be dual-ported for the left and right screen displays. Other features such as Graphic Kernel System (GKS) software implementation, resolution, processing speed, local memory, DMA, color palette, and architectural structure are application-dependent.

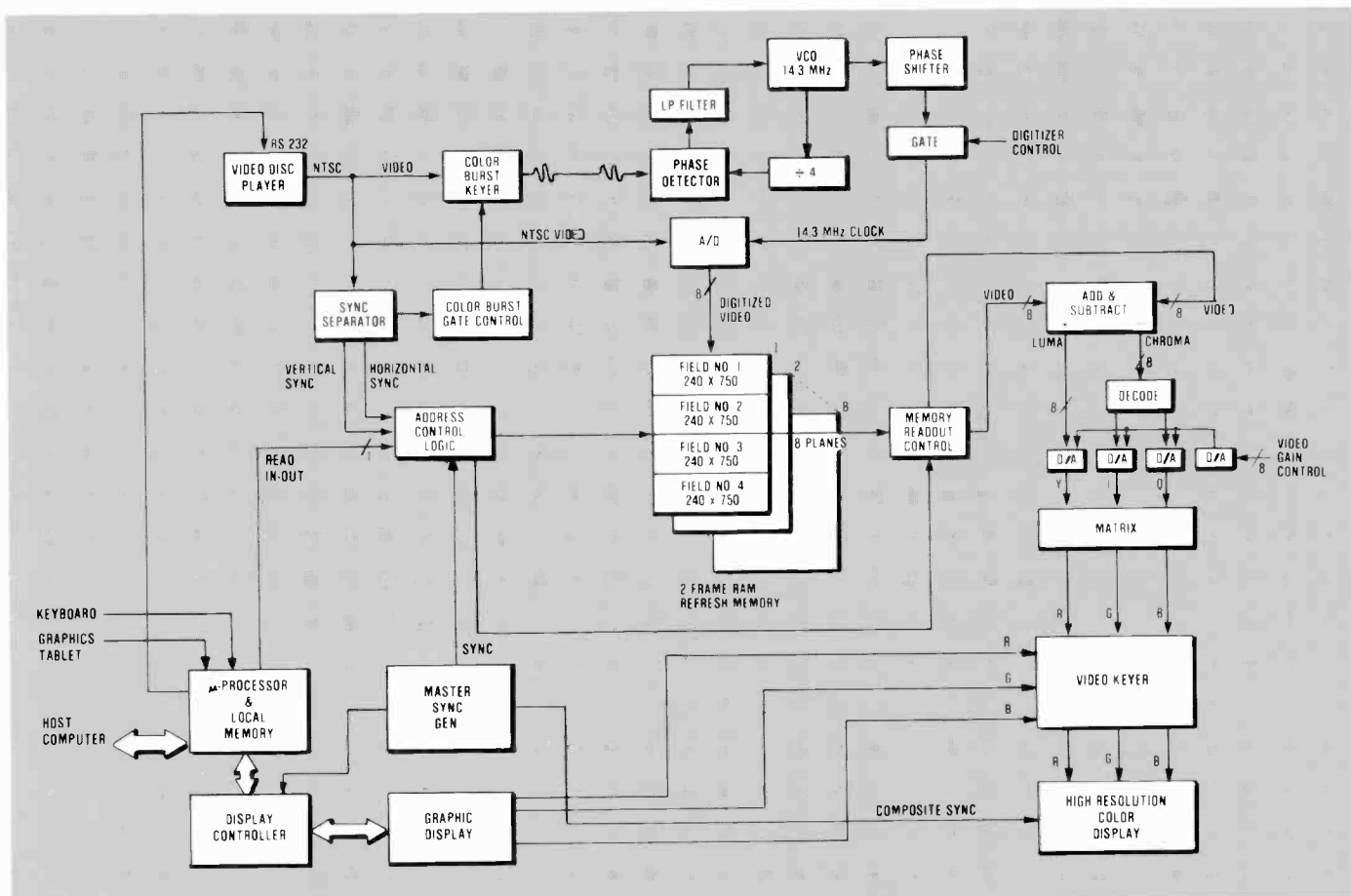

Fig. 14. Block diagram of colorgraphic workstation. This simplified block diagram of a colorgraphic workstation shows the techniques required to phase-lock video from a videodisc player for proper registration of the digitized video. Subsequent frame comb processing is achieved

from the memory, which refreshes the display in synchronism with the microprocessor-controlled colorgraphic generation. Non-destructive and prioritized graphic overlay is achieved via the video keys circuit.

Conclusion

The use of automated tools for C³I analysis is imperative in today's highly complex battlefield environment. Automation must be applied to the maximum extent possible, and is exemplified by the use of interactive graphics tools and automated databases. Techniques available to improve the man-machine interface have been described and are available with existing technology and off-the-shelf components. These tools, when supplemented with training, exercises, tests, and creative analysis utilizing artificial intelligence, can facilitate modern C³I systems for effective tactical intelligence operation.

References

1. D.H. Pritchard, "U.S. color television fundamentals—a review," *RCA Engineer*, Vol. 29, No. 6 (Nov./Dec. 1984).
2. R.T. Keen, "Encoding and decoding Wideband Ichroma signals," *RCA Engineer*, Vol. 29, No. 6 (Nov./Dec. 1984).



Lionel Arlan is Manager of Design Engineering, Command and Control Engineering at Automated Systems Division. He received his BEE from Clarkson College of Technology in 1954, and his MS in Electrical Engineering from Drexel Institute of Technology in 1961. Mr. Arlan has been involved with electro-optics and related weapon systems since joining RCA in 1954. His responsibilities have included design, development, and evaluation of special television camera application including slow-scan and low light level tv systems. For the past several years, Mr. Arlan has been responsible for development of techniques for enhancing colorgraphic display systems for retrieving and processing high-resolution cartographic maps from videodiscs.

Mr. Arlan is currently responsible for laser rangefinder programs, the Minuteman Drums program, and IR&D directed toward further enhancement of C³I colorgraphic display terminals.

Contact him at:
Automated Systems Division
Burlington, Mass.
Tacnet: 229-3729

Plasma etching for integrated circuit fabrication

The demand for smaller, more complex integrated circuits is spurring increased interest in dry etching, a process with much potential and an intriguing set of challenges.

A human hair is a huge object, if you are a microlithographer who prepares patterns of integrated circuits on semiconductor materials. A design as narrow as a 100-micrometer-wide human hair would be simply too bulky to be of practical use in a typical integrated circuit.

The semiconductor industry routinely produces patterns with features much smaller than the merely invisible. These objects, so far removed from everyday experience, must nevertheless be made in great volume to exacting specifications. To accomplish this, many techniques are brought to bear on a thin slice of silicon, in a hundred or more steps, to make the chips found in more and more of today's

Abstract: *One of the newest methods for making integrated-circuit chips is dry etching—exposing wafers to an excited-gas plasma to selectively remove material from the surface. Not only is this technology new, but we know it is absolutely essential to RCA's advanced circuit fabrication plans. Most market studies predict that over the next five years, dry etching equipment will account for 10 to 12 percent of the wafer processing equipment budgets of all semiconductor houses. This article discusses this new technology, and some of the reasons for the recent intense interest in it.*

products. One of the newest methods for making these chips is dry etching—exposing wafers to an excited-gas plasma to selectively remove material from the surface.

Not only is this technology new, but we know it is absolutely essential to RCA's advanced circuit fabrication plans. Most market studies predict that over the next five years, dry etching equipment will account for 10 to 12 percent of the wafer processing equipment budgets of all semiconductor houses. That percentage will amount to about 2.5 billion dollars from 1984 to 1988 inclusively, and points to major efforts in this technology by almost every manufacturer. What are the reasons for this intense activity in the field?

To answer that question, we should examine the history of the integrated circuit. New designs are created by increasing the number of devices on a chip and decreasing the sizes of the individual devices. Where the smallest object in a 1-kilobit random access memory (1k RAM) might have been 10 micrometers across, the latest generation of 1 megabit RAMs uses 1.25-micrometer features. As new discoveries in microlithography are made, the circuit designers are provided with new techniques for smaller, faster, and more complex devices.

Microlithography is a generic term for the fabrication of minute objects by forming patterns on surfaces. In simplest terms, a film is formed, certain areas of the film are covered with an etch-resistant material, and the uncovered sections are etched

away. As the size of the critical features in integrated circuits has decreased, the nature of the etching process has undergone a fundamental change away from a chemical treatment in some liquid etchant. The reason for this change is that a liquid etchant simply cannot produce the geometries necessary for advanced circuit designs. Before explaining why this is the case, a more basic question should be answered.

If circuits are becoming more complex, why is it necessary for the size of the individual features to decrease? Why not make the overall circuit larger? If the technology for making 10-micrometer devices is well developed, why not use it for making the newest circuits? The answer is two-fold. First, speed-of-operation is an important consideration in most circuit designs, especially in microprocessors. The propagation delays of signals within a circuit become longer as the circuit wiring becomes longer. The fastest devices must be optimized for minimum interconnection length.

The second factor is, however, the more important limit in circuit fabrication. In a typical IC, there may be ten masking and etching operations, as well as dozens of other fabrication steps. For a CMOS memory, 14 masking levels and well over 100 processing steps would be used. At each of these steps, contamination is present and some defect may be introduced, causing a failure when the circuit is tested. With random defects, the probability of a circuit having such a defect is proportional to its area. Reducing the area of the circuit

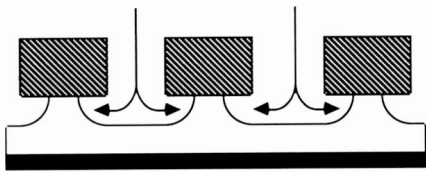

Fig. 1a. Isotropic Etching occurs in most wet etching solutions. Material is removed from under the edges of the mask.

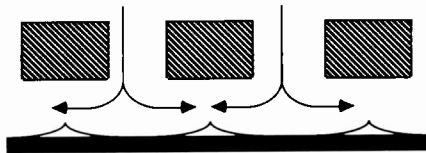

Fig. 1b. If the linewidth is less than twice the film thickness, the undercutting will destroy the pattern.

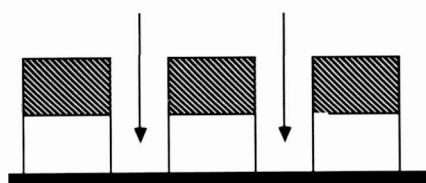

Fig. 1c. An anisotropic etch will not undercut, and the pattern will be preserved.

will reduce the number of circuits that will have a defect and will therefore increase the yield. Making the circuit elements smaller also allows the designer to add increased functionality and complexity to a device without paying a penalty in increased area and lower yield.

Characteristics of etching processes

There is a basic phenomenon that occurs in a liquid etchant that precludes its use in making small devices. Figure 1a illustrates the etching of a film that has been masked with some pattern. Liquid etching is isotropic, meaning that it has no preferred direction. Material is removed from under the edges of the mask. This is known as undercutting, and it becomes a problem when the mask is so narrow relative to the film thickness that the two undercuts meet and the line disappears. (Figure 1b) This occurs when the linewidth is less than twice the thickness of the etching film. Since the layer thickness is for the most part constrained by the electrical parameters of the devices, little can be gained by thinning the material. It is essential to minimize the loss in line size. If the undercutting can be eliminated com-

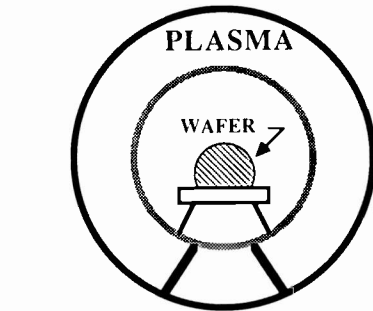

Fig. 2a. Barrel or Tubular Reactor. The wafers are placed in a holder and inserted into the chamber. There is often a shield to prevent the actual plasma glow from touching the wafer itself.

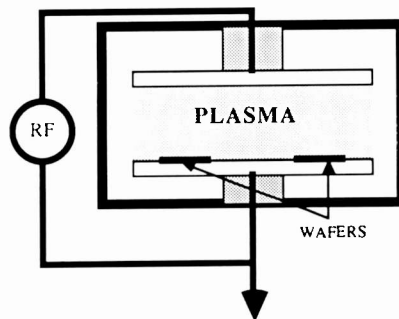

Fig. 2b. Parallel Plate Plasma Etcher. The wafers are placed on the grounded plate with the opposing plate powered by a radiofrequency (RF) source.

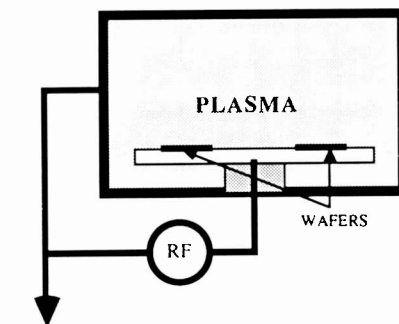

Fig. 2c. Relative Ion Etcher. The wafers are placed on the powered electrode. The chamber serves as the opposing, grounded electrode.

pletely, the constraint of line width versus line thickness is removed. (Fig. 1c) The methods for doing this will be discussed later.

Any etching process can be described by three characteristics: directionality, selectivity, and uniformity. Directionality, also known as anisotropy, is a measure of the etch rate perpendicular to a surface versus the etch rate parallel to that surface. As mentioned, liquid etchants usually do not have any directionality. (An exception to

this is the etching of single-crystal silicon where certain crystal planes etch much faster than others, leading to a directional etch.) Selectivity is the ability to etch one material faster than other materials. Liquid etchants are ideal in this characteristic since their action is simply chemical dissolution. By choosing the etch bath composition correctly, only the target material will dissolve, giving infinite selectivity. Uniformity can be expressed relative to any etch parameter, although the usual usage is that of an etch rate uniformity across a single wafer or batch of many wafers. Liquid etchants can be very uniform if correct techniques are used.

Dry processes have the same characteristics, but in most cases the balance is somewhat different. Directionality can be very good, leading to no undercutting. Selectivity is often not perfect, due to the energetic processes occurring in the plasma that tend to etch all materials to some degree. The control of uniformity is as much a function of the reactor design as it is related to the etching chemistry chosen.

One of the challenges of the technology is to balance the factors to fit a particular application, since in most cases, maximizing all three is not only difficult but often undesirable. Later, examples will be given that should illustrate why, for example, extreme selectivity or perfect directionality can lower yields.

Historical background

The development of dry processing tools began in the late 1960's with the use of oxygen plasmas to remove organic materials. This was known as plasma ashing. When it was found that silicon and silicon nitride could be removed in CF_4/O_2 plasmas, the semiconductor industry began to take notice. The equipment being used at that point was commonly known as the barrel or tubular reactor (Fig. 2a). A radio-frequency (rf) signal is applied to external electrodes surrounding a quartz tube that is filled with gas at a pressure of about 1 torr. (Metal chambers with different excitation schemes are also in use.) The discharge causes the dissociation of the gas into reactive species, which then etch the wafer. These tools etch isotropically and their advantage is not in the ability to etch smaller features, but to reduce the water consumption and chemical disposal problems associated with wet etching.

For many years it was known that materials could be removed in high vacuum

by accelerating non-reactive atoms (such as argon) in a dc or rf discharge. The impact of these atoms removes material ballistically, and is called sputtering. This process is highly directional, but suffers from many disadvantages. All materials are eroded to some degree and selectivity is very low. Materials tend to redeposit on the wafer surface, causing many undesirable effects.

It was recognized that by using a sputtering configuration with a gas that would etch the desired material rapidly, higher selectivity was possible. Directionality could still be obtained due to the bombardment of the wafer surface. This led to the development of two types of etching tools, the Parallel-Plate Reactor and the Reactive Ion Etcher.

The Parallel Plate reactor (Fig. 2b) contains two electrodes. The internal pressure may be an order of magnitude lower than in the tubular reactor (typically 50 to 500 millitorr). An rf signal is applied to the upper plate and the wafers are placed on the lower plate, which is grounded. This creates a potential difference between the wafer surface and the bulk of the plasma discharge. This potential drop of a few tens to a few hundreds of volts accelerates charged reactive species towards the wafer. The etching reactions can be enhanced where there is bombardment, leading to directional etching and decreased undercutting of the mask. This configuration is called plasma etching (PE).

The reactive ion etching (RIE) configuration is similar to the parallel plate reactor. The upper electrode is grounded, and usually made larger than the lower electrode. The rf power is applied to the lower electrode. In some cases, the upper plate is removed and the etching chamber itself becomes the opposing electrode (Fig. 2c). In this case the accelerating potentials can be very large, on the order of 500 volts. The etcher is operated at even lower pressures, 10 to 50 millitorr or so, and very high directionality can be obtained. Because this configuration does generate a substantial sputtering component, these tools are sometimes called reactive sputter etchers.

The number of variations on these basic themes is increasing rapidly. Many of the innovations are concerned with automation of the process, allowing humans to be removed from direct contact with the wafers. This can prevent some contamination and its associated yield loss. Computer control of all etching parameters is becoming available, as well as in-line integration of etching equipment with other processing

New techniques for dry processing technology

The basic principle used in dry etching is the enhancement of chemical reactions by the addition of energy. This energy breaks a molecule apart into active species, which then form compounds with the substrate. These compounds are volatile and evaporate, leaving an etched surface behind. The method used to add this energy to the chemical reaction is not limited to radio frequency excitation.

The dissociation of etch gas molecules occurs primarily by electron impact. If more electrons can be generated, etch rates can be increased. This can be done by magnetic confinement of the discharge. This technique is widely used in magnetron sputtering systems. The same technique can be used in reactive ion etching.

One of the difficulties with reactive ion etching (and high-power plasma etching) is the creation of both ions and electrons with very high kinetic energies. While this is useful for highly directional etching, it creates the possibility of damage to the wafer surface. The impact creates damage sites which, while necessary to the etching process, may destroy the electrical integrity of the integrated circuit. There are techniques that can minimize the damage or remove it, but avoiding its creation is more desirable. Lowering the input rf power will lower the bias voltage but will also lower the etch rates. Magnetic confinement can retain

high etch rates under these conditions by increasing the efficiency of the electron-impact ionization of the reactive gas. In fact, high input power can be used since the low impedance of these discharges leads to low bias potentials.

The use of magnetron-enhanced reactive ion etching was first reported by Horiike, and an etch tool is available commercially from Tylan/Tokuda. It contains a planar magnetron and moves the magnet assembly to achieve uniformity. Materials Research Corporation has changed the configuration of the magnets to achieve uniformity without motion. The MIE-720 is available as a cassette-to-cassette, automated etcher, and the MIE-710 is a research tool without the automation features.

Another development on the horizon of dry processing avoids the generation of bias voltages and plasmas completely. Silicon can be made to react with chlorine by focussing an ultraviolet laser on the wafer in the presence of the gas. This energy input serves to generate an etching reaction. Silicon tetrachloride is formed and evaporates from the surface. This technique has the intriguing property of not requiring a resist. The laser beam can be focussed only in the areas to be etched, yielding reasonably high resolution, good directionality, and very high selectivity. The first reports of this technique are appearing in the literature, and commercial development should be a few years away.

tools. However, there is still room for fundamental changes in the design of a dry processing machine. (See the sidebar.)

Sources of information

Because of the critical importance of this field to semiconductor fabrication, all IC manufacturers are involved in dry-process development to some degree. Not surpris-

ingly, many of the innovations in the field are considered proprietary and do not reach the scientific literature rapidly, if at all.

Most other semiconductor companies do not have RCA's advantage of a central research laboratory. In many cases, the advanced work is performed very close to the actual production line, with scientists and engineers responsible for both research and developmental functions. Only the

largest manufacturers can support central research facilities, and there are only a few universities that can fully address the rather complex issues of semiconductor fabrication. This means that crucial discoveries do not follow the usual path to publication, making it difficult to pinpoint where the important work is being done.

In a limited space, it is impossible to choose those contributions that can be considered most important to the field of dry processing. It would be better to list a few names that can serve as introductions to the literature. By using their papers as a starting point, you will come upon most of the important researchers in the field. (The reverse searching technique of finding those papers that refer to the early important work is very useful. Check with your RCA librarian for information about using the Citation Index.)

Richard Bersin at the International Plasma Corporation, Alan Reinberg at Texas Instruments (both now at Perkin Elmer), and Rudolf Heinecke at the Standard Telecommunications Laboratory (now at ASM) can certainly be considered pioneers, as well as Adir Jacob at the LFE Corporation. Dan Maydan and David Wang of Bell Laboratories (both now at Applied Materials) are best known for the development of useful etching machines. John Coburn and Harold Winters at IBM and Daniel Flamm and Vincent Donnelly at Bell Laboratories are well known for basic studies of reaction mechanisms and physical measurements of discharges. C. J. Mogab at Bell Laboratories and Geraldine Schwartz and Paul Schaible at IBM have made many contributions to the understanding of the physics and chemistry of dry processing.

RCA scientists have made important contributions in this field. The work of Hans Lehmann, Bernard Curtis, and Roland Widmer of the Zurich Laboratories, and John Vossen, Jer-Shen Maa, Bernard Halon, Michael Duffy, and Michael Leahy of RCA Laboratories has been presented at many international conferences and published in various journals. An even larger body of knowledge has been gained by RCA through the work of many process engineers in our factories and pilot lines, and those contributions are critical to RCA's future in the microelectronics industry.

Using the technology

The ability to use dry etching depends on many factors, but two areas are particularly

important. The first can be called Process Monitoring and Control. There are measurable quantities that can be used as monitors of the conditions within the etching tool. These can be used, for example, to detect the end of an etch step or the degradation of the etching characteristics. There are many methods used to accomplish this objective, and some will be reviewed in detail.

The second area of importance is closely related to the particular circuits being made. It is essentially the art of making intelligent tradeoffs between process characteristics and circuit designs. With geometries approaching 1 micrometer and critical film thicknesses of a few nanometers, the processing conditions and the three-dimensional design of the device are closely coupled, and failing to recognize this often means the difference between a successful product and disaster.

Before discussing some of the ways in which dry processes are controlled, the common features of all dry etching tools should be reviewed, as well as some details of the chemistry and physics of etching.

Design of an etcher

While the design of a reactor is still something of an art and many approaches are used, there are a few basic principles that are followed. A dry etcher requires a wafer handling mechanism, a gas handling system, vacuum pumping, and electrical control. The choices made in each of these categories interact with the other requirements.

Wafer handling may be fully manual. The earliest laboratory systems were sometimes placed in production lines without automated wafer transfer, and good yields could be obtained. However, due to particulate contamination caused by manual handling, the direction is toward fully-automated transfer of wafers in and out of the etcher. Currently, wafers are transported around processing lines in batches of 25 in clean carriers of one sort or another. (There have been some rather ambitious attempts in the industry at wafer handling across a whole production line, with tracking of individual wafers moving on air tracks. For the most part, batched handling is still the rule.) Wafers can be loaded into the etching chamber in two ways. Either the etching chamber is brought to atmospheric pressure, opened, loaded, and re-evacuated, or an intermediate vacuum load lock (as in an air lock) is used. There are advantages and disadvantages to each approach.

A vented-chamber system is simpler to design, which usually translates into increased reliability. However, it is usually loaded manually, adding to particulate contamination of the wafers. It is more susceptible to contamination from atmospheric water vapor and some etch processes (notably aluminum etching) are difficult to control under such conditions. The operator must also be protected from the etching chemistry, since an open chamber may emit noxious fumes. The pumping system must be capable of repeated cycling from room pressure to high vacuum and should pump rapidly to provide adequate throughput.

In a load-locked system, the main etching chamber remains at either high vacuum or at the processing pressure. In theory, it is never opened to the surroundings. Operator safety is easier to insure, and usually a relatively small load-lock is cycled in pressure. Most load-locked etchers are single-wafer tools, although some exist that hold full 25-wafer cassettes in the locks. The disadvantages are primarily mechanical. First, the handling must be automated and is usually complicated. Many sealing surfaces are used for the lock and chamber doors, leading to decreased vacuum integrity. There must be many sensors along the path of the wafers as they move in and out of the chambers, leading to complexity. This complexity, in a production environment, means decreased reliability and increased cost.

A reactive gas must be introduced into the etcher in some controlled fashion. This can be done simply by allowing gas to flow through a restriction. In some etchers, there is no other control of the pressure except by gas flow, leading to pressure instabilities as the etching proceeds. Further, it means that the pressure and mass flow are not independent of each other. This can be a problem when a pressure is chosen to provide a certain directionality, for example, and a gas flow must be chosen to provide uniformity. The ability to throttle the vacuum pumps to provide constant pressure over a wide range of input gas flows can be a distinct advantage. Closed-loop mass-flow controllers and throttle valves are now used on most commercially available systems.

The vacuum pumping method can take many forms, depending on the operating conditions. Plasma etch tools operate at relatively high pressures and mechanical pumps are sufficient in most cases, although gas flows may be very high and large pumps may be required. RIE systems

operating at a few millitorr use diffusion pumps, turbomolecular pumps, and cryopumps to achieve their low base pressures. For vented-chamber etchers it is desirable to have a low base pressure to minimize contamination, even though the pressure during the etch may be high. In the case of etching with toxic and corrosive gases such as chlorine (Cl_2), hydrogen chloride (HCl), or boron trichloride (BCl_3), extreme precautions must be taken with the vacuum pumps, especially when cryopumps are used. In almost all cases, special pump oils are required to prevent contamination of the etching chemistry and dangerous pump conditions.

Electrical control takes many forms. The rf generator should be stabilized with feedback control. It should be mated to the etching chamber to minimize losses and radiated power. The rf power level should be controlled accurately, and the option of regulating the power in response to the developed dc self-bias should be available. There must be interlocks to prevent the application of rf power when the chamber is open, as well as interlocks for operator safety. Full microprocessor control is now becoming the normal situation in most dry etch tools, to the degree that many systems only require specification of a simple recipe to etch wafers. The next generation of etchers will be integrated into a centralized wafer management computer, which will provide an even higher-level protocol to production line engineers.

Basics of the etching process

Using silicon as an example, etching is based on the formation of a volatile compound of silicon. Silicon tetrafluoride (SiF_4) and silicon tetrachloride (SiCl_4) both have high enough vapor pressures to be pumped away during the etch process. Taking the most studied case of carbon tetrafluoride/oxygen mixtures (CF_4/O_2), the rf discharge causes the release of free fluorine from the gas mixture. This fluorine will adsorb on the silicon surface, react with the silicon, and form SiF_4 , which then evaporates. The same process can occur using the chlorine analogue, carbon tetrachloride (CCl_4), to form SiCl_4 . In fact, the menu of choices of etchant materials is steadily increasing, although the end products remain the same.

The basic chemistry is simple, and if it were only chemistry that determined the etching characteristics, there would be little benefit in using dry processing. As mentioned above, liquids etch isotropically.

Explanation of dc self-bias formation in rf discharges.

When a dc potential is imposed across two electrodes in a low-pressure gas, a plasma can develop. This plasma will be composed of charged and neutral species. In the types of discharges used in semiconductor fabrication, the neutrals far outnumber the charged species, by three or four orders of magnitude. If an electrically-isolated disk is placed in the discharge, a flux of both positive and negative charges will arrive at the surface. The negative charges are carried by electrons, which move much faster than the ions carrying the positive charges. Since more electrons arrive per unit time than ions, the disk will become negatively charged. Electrons will begin to be repelled and positive ions will be attracted, forming a region of higher positive charge near the disk. The electron flux will be reduced due to the repulsion and will eventually balance the ion flux, leaving the disk charged to some negative potential. Positive ions are now accelerated to the disk and most of the electrons are repelled.

The potential developed at this disk in a dc discharge is rather small, a few tens of volts, and the acceleration of the ions is rather modest. While this added energy will enhance a chemical reaction somewhat, a few hundred volts of potential drop will do better. By

using an ac discharge with an excitation frequency greater than a few tens of kilohertz, the dc self-bias can be greater than 500 volts. This phenomenon is again related to the relative speeds of electrons versus ions and the capacitive coupling of the discharge.

Using a low-frequency ac excitation, the voltage measured across the blocking capacitor will follow the excitation voltage, with only small lags due to the fact that the insulator cannot charge instantaneously. At high frequencies, the effect of relative charge-carrier speed takes over. Because the positive ions move much more slowly than the electrons, the sample never fully reaches the full positive potential during its half-cycle. During the negative half-cycle, the sample charges rapidly. The resultant ac voltage waveform measured across the capacitor will be approximately equal to the excitation waveform but will be displaced negatively at some root-mean-square voltage. This is the self-bias voltage sometimes referred to as the dc bias. This bias governs the energy acquired by positive ions bombarding the sample, and can affect the directionality, selectivity, and etching rate of a particular plasma.

For a detailed discussion of this topic, see *Glow Discharge Processes*, Brian Chapman, Wiley-Interscience, New York (1980).

There are no accelerating fields. Barrel etchers do not produce any fields at the wafer surface, and also etch isotropically. The etching is primarily a chemical effect. In the geometry of a parallel-plate or RIE configuration, a dc self-bias due to the rf excitation develops (see sidebar), and a physical etching effect can be generated. The added energy can change the chemistry by increasing the reaction rate at the point of bombardment. This imparts a directionality with little undercutting, since the sidewalls are protected by the resist and cannot

"see" the impinging reactive species. Complications arise when there are sufficient uncharged reactive species in the plasma discharge. These can drift to the sidewalls and cause undercutting. In some cases, reactive species can migrate along the surface and accomplish the same effect.

A second mechanism for producing directional etching relies on a self-masking or passivating phenomenon. Many gases used in etching can also form polymers. These polymers can recombine with the active etchants, lowering the etch rate at

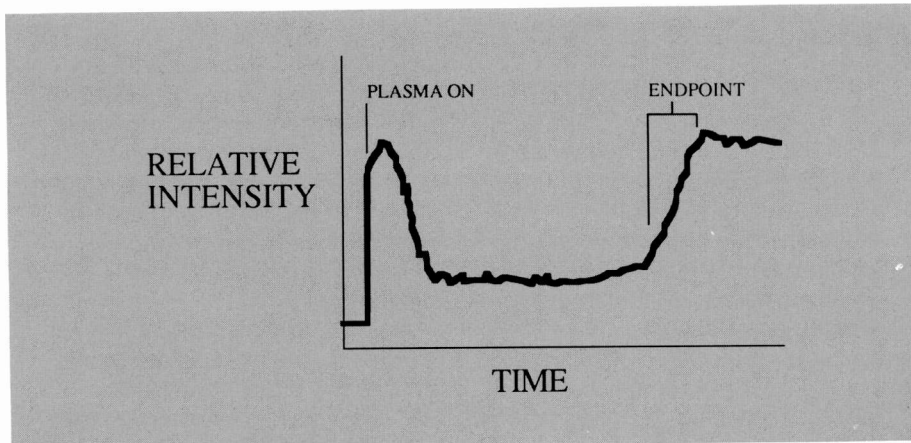

Fig. 3. Emission at 703.7 nanometers. Monitoring an etching process using optical emission. In this case, the emission at 703.7 nanometers is due to fluorine, which is consumed by the etching reactions. When the silicon film is etched through, the fluorine increases, and the etcher can be turned off.

the point of recombination, or can simply mask the etching by coating the surface. If competitive etching and masking reactions occur on the wafer surface, directional etching can be obtained. If the passivation is removed only where there is bombardment, the sidewalls of the defined features will be protected from the etching. In this way, an etching chemistry that would normally undercut can produce very directional etching. Aluminum can be etched in boron trichloride/chlorine mixtures and can be made to undercut severely. The addition of small amounts of chloroform, CHCl_3 , under otherwise identical conditions, will cause the sidewalls to be passivated, allowing vertical line profiles to be obtained.

Process monitoring and control

These examples hint at some of the techniques that can be used to monitor dry processes. The gas is dissociated into reactive species when the plasma discharge is initiated. These species usually emit radiation as they lose energy to their surroundings. The wavelengths and intensities of the emissions can be used to identify the nature and concentrations of the various components of the reactive gas mixture. Figure 3 depicts the emission intensity from fluorine atoms in a CF_4/O_2 plasma during a silicon etching process. As the plasma is ignited, the fluorine concentration increases. When the etching begins, the fluorine is consumed by the reaction, which forms silicon tetrafluoride. Its emission intensity will drop. At the completion of etching, the amount of exposed silicon drops rapidly (only the sidewalls may still be etching) and the fluorine emission

increases again. This is a method for endpoint detection, and has been in use for many years. Monitoring a reaction product, rather than a reactant, is also feasible. Etching of silicon dioxide in CF_4/H_2 can produce carbon dioxide, which will increase during the etch and then decrease at the endpoint. For some particularly difficult cases, multiple species may be monitored to provide an accurate endpoint.

This same technique can be used as a diagnostic tool to judge the health of an etcher. Hydrogen emissions are often the sign of a water leak, while nitrogen almost always means an air leak. In a highly automated etcher, a computer may obtain the optical emission signature and compare it to some known reference before allowing any wafers to be etched.

Similar monitoring of the chemical composition of plasma discharges can be done by mass spectrometry, infrared absorption, and laser-induced fluorescence, to name a few techniques. The details of these methods are documented in the literature.

There are also electrical parameters that are indicative of processes occurring in plasma discharge. The rf-induced dc self-bias can be a sensitive indicator. Most rf generators are capacitively-coupled to the etch electrodes, and the medium between the plates will affect the electrical characteristics. As the plasma chemistry changes, at endpoint for example, the dc bias will also change. Even if the dc bias is not used as an endpoint indicator, it should be monitored, and if possible, controlled directly. The magnitude of the bias will often be the controlling factor in the directionality of the etch.

Building an integrated circuit

The fabrication of an integrated circuit is a complex process. Many rather sophisticated procedures are used to make a working device out of silicon or some other semiconductor material. The role of dry processing in this sequence can be seen by examining the way in which a typical device is made.

By the time the process is complete, the wafer will have thin films of silicon, silicon dioxide, silicon nitride, and aluminum on it. There will be various amounts of dopants such as phosphorus and boron in both the silicon and in some of the silicon dioxide. The thickest films are 1 to 2 micrometers thick, while the thinnest may be only 5 nanometers (50 Angstroms). The dopants are introduced into very specific places in extremely small quantities to modify the electrical behavior. Aluminum is used as the "wires" that interconnect various elements of the circuits.

These thin films are deposited over the whole wafer surface and then removed in certain areas. In every case, the removal can be done with a dry etching procedure. The interactions that can occur during the process can be illustrated by looking at one particular step.

Consider the case of a polycrystalline silicon (polysilicon) film used as an interconnection. The structure is shown in Fig. 4. In many circuits, there are two or more levels of wiring. Usually one of these layers is aluminum, but there may be one or more levels of highly-doped silicon acting as connectors, much like a multi-layered circuit board. Some insulator, such as silicon dioxide, will be in place over the wafer surface, and holes will have been made in it to allow contact to the underlying levels. Contact will typically be made to the wafer surface itself and to a layer of polysilicon already formed.

The second polysilicon layer is deposited. It covers the first layer conformally, following the hills and valleys already present on the wafer surface from previous processing. It is now doped so that its conductivity is high enough to carry enough current. Photoresist is patterned over it, and it is ready to be etched.

There are a number of areas in the structure that can cause problems. At A, the polysilicon passes over a step formed by the layers below. Measured normal to the wafer surface, the polysilicon is substantially thicker. (It is approximately equal to the step height plus the thickness of the deposited film.) If the etching is highly

directional, this area will require a much longer time to clear. This means that the selectivity of the etchant must be very high, or the insulating oxide at B will be destroyed during this overetching time. Lowering the directionality will help the problem at A but will undercut the narrow line at C, causing high resistance or an open circuit. Raising the selectivity of the etch towards oxide is usually desirable but can cause second-order complications. Oxides form on top of the polysilicon naturally in air, and also during the doping step. If these oxides are not completely removed, the polysilicon will be unintentionally masked and short circuits will result.

These difficulties are related to the structure as it exists before etching. Similar problems may be created for subsequent operations at any etch step. Later in the process, aluminum is deposited over the wafer and it must cover the steps on the surface created by all the previous processing. If the sidewalls of the etched polysilicon are vertical and no smoothing occurs when the next insulator is deposited, the metal may not be able to pass over the steps without breaking.

Sometimes the problems that develop have even more pragmatic causes. A case in point was the early development of a large-area charge-coupled device at RCA Laboratories. This CCD was very large (about 0.5x0.8 inches) and contained a groove cut into a polysilicon layer. The groove was 3 micrometers wide and 10 meters long, and had to be made with no bridging across it. (That is the equivalent of building a sidewalk from New York to Las Vegas and keeping it free of fallen leaves.) When the process was changed from a wet etch to a dry etch, the yield went down. Examination revealed small bridges in the photoresist. Since the dry process did not undercut, these small bridges were resolved. In the wet etch, the undercutting etched away the silicon under the bridges and the CCD functioned properly.

It must be kept in mind that integrated circuits are three-dimensional structures. The structure affects the electrical parameters, and indiscriminate changes in the process can result in transistors that do not perform as the circuit designers intended. Speed requirements may not be met in a memory, timing may not be synchronized in a microprocessor, and in general, a working device will not be obtained. It takes a concerted effort by both processing engineers and circuit de-

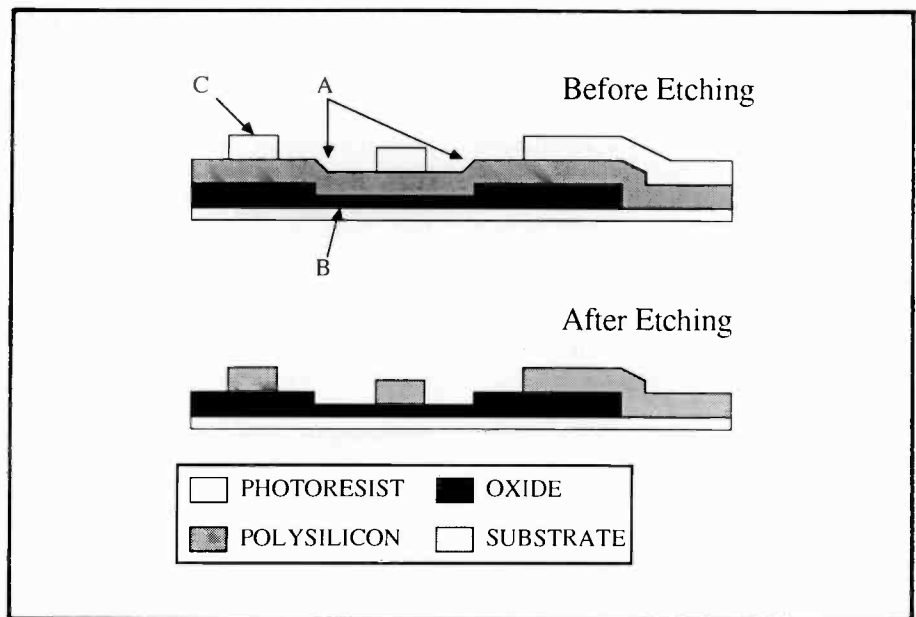

Fig. 4 Etch Problems in Real Circuits. (A) Areas where the vertical thickness of the silicon is greater due to an underlying step. (B) Thin oxide under the silicon, requiring highly selective etching. (C) Narrow photoresist lines that cannot be defined properly if excessive undercutting exists.

signers to reach a compromise that yields a product that can be manufactured at a profit.

Directions for the future

There are some developments that should attract attention in the next few years. Reactive Ion-Beam Etching (RIBE) and Magnetically-enhanced Ion Etching (MIE) are certainly noteworthy.

Reactive Ion-Beam Etching was developed to allow the separation of variables in a dry etch tool. The energies of the ions created in plasma etchers and reactive ion etchers are not easily controlled independently of other parameters, such as pressure and power. In a RIBE tool, these energies are electrically controlled by accelerating grids. In this way, an extra degree of control is possible, at least providing the opportunity for modifying the chemistry at the surface without changing the bombardment processes due to the ions. This technique will certainly be under intense development in the near term.

Magnetically-enhanced Ion Etching (MIE) is another technique under investigation by RCA Laboratories. It uses a magnetic field to increase the efficiency of the discharge, obtaining high directionality at low dc self-bias voltages. (See the sidebar.)

The longer-term development of this technology will likely proceed along two fronts. The first deals directly with the

basic requirements of future devices. The critical dimension of advanced circuits (such as the Very-High-Speed Integrated Circuit program of the Department of Defense) is now below 1 micrometer. A general rule of thumb is that dimensional control must be 10 percent of the designed size. If the smallest feature is 7500 Angstroms (0.75 micrometers), the tolerance is plus or minus 750 Angstroms. This degree of control was absolutely unthinkable a few years ago, and it is not clear if it is obtainable at all without major innovation. There will probably be design inventions that relax some of the size constraints, but the trend is still to smaller and smaller devices. Improvements in resist technology and the development of x-ray and electron beam lithographies must occur, or even a "perfect" dry etch process will be severely limited.

The second area will be in the application of these techniques to commercial etching tools. Dry etchers will become more intelligent by combining sophisticated sensors with computer processing that goes beyond simple process monitoring. Adaptive control of the etch process will become important so that, for example, if the etch computer determined that the etch was not proceeding uniformly, it would adjust the machine settings to obtain a better result.

An expert system will interrogate both the circuit designers and the processing engineers about the desired results. It will

determine the processing parameters and run the etchers. This implies a distinct lack of people in the processing line, and that is yet another area of application being addressed. The level of automation will most certainly increase to the point where no human interaction will be necessary. Wafers will be transported to and through the etch tool automatically. Process monitoring will be interfaced to centralized manufacturing control systems to record the detailed history of each wafer, as well as to alert engineers to problems.

Summary

Dry etching is an extremely useful technique in integrated circuit manufacture, and is essential for advanced devices. The interactions between the design goals and the processing steps are complex, and require great attention to detail. Dry etch tools are complicated systems that demand sophisticated monitoring and control. While the understanding of the processes occurring in a plasma is increasing, the field is still relatively young, and many problems remain unsolved.

Further reading

The best sources of information are the technical journals. The *Journal of the Electrochemical Society* devotes a majority of its pages to solid state science and technology. The Society has two divisions that address semiconductor issues, and it organizes symposia in plasma processing and other related areas. The *IEEE Transactions on Electronic Devices* is another good source of information, as is the *Journal of Vacuum Science and Technology*. There are many Japanese journals that contain useful information. Your RCA library has access to the computerized databases and a few keywords will obtain hundreds of references in this area in a short time.

One of the most useful ways to explore

the literature is by using the Citation Index. This source lists those papers that refer to a particular article, rather than the article itself. This procedure works forward in time rather than backward. If you have found an article by Smith that interests you, by searching Citation Index you can find those papers that cite Smith as a reference. Thus, by knowing just a few of the names mentioned in this article, you can find most of the important papers in the field.

There are few books in this field, since it is both moving too rapidly, and the technology is often considered proprietary. One source is *Glow Discharge Processes* by Brian Chapman (Wiley-Interscience, 1980), which contains many useful references and a wealth of basic information about discharges.

Bibliography

1. G.C. Schwartz and P.M. Schaible, *J. Vac. Sci. Technol.*, 16(2), p. 410 (1979). This is a short, simple discussion of reactive ion etching of silicon in chlorine-based plasmas. It illustrates many of the phenomena obtained in low-pressure discharges.
2. L.M. Ephrath, *IEEE Trans. Electron Dev.*, ED-28(11), p. 1315 (1981). This is a short, review-type paper on the uses of dry processing for VLSI. It concentrates on reactive ion etching, with examples of equipment and etching of typical device structures.
3. Brian Chapman, *Glow Discharge Processes*, Wiley-Interscience, New York (1980). This book, while somewhat short on practical dry processing information, does contain a useful list of references and a reasonably complete treatment of the physics of discharges.
4. M.F. Leahy, *Proc. 3rd Microelectronics Measurement Technology Seminar*, Benwill Publishing Corp., Boston (1981). Examples of optical endpoint detection for a number of important plasma processes are given. Silicon, silicon nitride, and aluminum etching discharges are presented.
5. H.W. Lehmann and R. Widmer, *J. Vac. Sci. Technol.*, 15, p. 319 (1978). This is an early silicon dioxide etching study showing profile control of sidewalls and sub-micron resolution of grating patterns.
6. D.L. Flamm and V.M. Donnelly, *Plasma Chemistry and Plasma Processing*, 1(4), p. 317 (1981). This review article gives 143 references up to about 1981. Concise treatments of a number of important areas are provided.



Dr. Michael F. Leahy is a Member of the Technical Staff at RCA Laboratories, Princeton, N.J. He received a BS in Chemistry from Long Island University, and an MS and PhD in Physical Chemistry from Rutgers University for thesis work in Mössbauer and Raman spectroscopy of organotin compounds. He spent two years at Princeton University as a Visiting Research Fellow studying the spectra of visual pigments, as well as directing the computerization of the Raman spectroscopy facilities. After joining RCA in 1978, he was involved in various aspects of integrated circuit fabrication, including wafer cleaning and contamination control. He is responsible for the development of dry processing technologies for advanced CMOS, CCD, and high-power MOS devices. He also chairs a Technology Committee of the Solid State Division, which is responsible for all technical evaluations of dry processing equipment. He received an RCA Laboratories Outstanding Achievement Award in 1983 (with M. Duffy and J.S. Maa) for the development of dry etching techniques. Dr. Leahy is the author of 9 papers and holds one U.S. Patent. He is a member of the Electrochemical Society. Contact him at:
**RCA Laboratories
Princeton, N.J.
Tacnet: 226-3037**

How to evaluate and shop for computer graphics software

Jim Warner is President of Precision Visuals, Inc., a vendor of device-independent computer graphics software, and John Slitz is Vice President of Marketing. Here they provide a "shopper's guide" to graphics software, offered from the perspective of the supplier.

For many years, scientists and engineers considered computer graphics as an application in and of itself, to be taken off the shelf and used when they needed to present information, such as summaries of research results. In the mid-1980s, graphics evolved into a necessary, integral component of many computer applications, as system users and developers discovered the effectiveness with which graphics can communicate complex technical data.

Parallel growth has taken place in the use of graphics at the interfaces between systems and their operators. Now, system designers are using graphics more often to increase human performance, as well as human understanding. In this context, graphic displays are becoming commonplace in control and simulation applications, while graphics-based systems are

Abstract: *In any computer application with a major graphics component, the keystone is the graphics software, which can greatly affect the cost and schedule of program development, as well as the productivity of the end user. We will present a methodology that can help ensure the selection of the optimal graphics software development strategy, both for a specific application and for the long-term needs of the organization.*

©1985 RCA Corporation.
Final manuscript received Sept. 18, 1985
Reprint RE-30-5-11

beginning to realize their extraordinary potential to increase productivity in design and manufacturing.

In a hardware/software system that employs graphics, the software is often the ingredient that has the most impact on system development time and cost, while being the most difficult item for which to plan. Over the life of the system, software will have a major impact on the productivity of the user. Also, the maintenance and upgrading of software may represent a large share of the system's operating cost.

In considering the software elements of systems incorporating graphics, it is useful to divide them into three separate levels: application software, tools packages, and device drivers.

For application software, developers have basically four choices: buy it as part of a turnkey system along with hardware, buy it ready to run, write their own code from scratch, or build each needed application using a software tools package.

All four approaches present tradeoffs between performance and flexibility. Turnkey systems and special-purpose application software both tend to be fast and efficient, because they are optimized for an application, specific hardware, or both. However, they are usually restricted to a small family of devices, are seldom portable to a different hardware environment, and are only designed to solve a specific kind of problem.

If a turnkey solution or off-the-shelf

application software can be found that very closely matches all of your requirements, then we would by all means recommend that you acquire it. Almost certainly, though, either of these approaches will entail compromises, because both are generalized for a class of users, not optimized for your specific situation.

With enough time and programming resources you might be able to develop compact, efficient application code without using a tools package by focusing only on the immediate needs of your end users and a small number of devices. On the other hand, the resulting application will not readily port to new devices in the future unless a considerable effort is made to design it to be device-independent. Without special graphics programming expertise and a strong need for graphics functionality that is not commercially available, it is difficult to justify writing original graphics application software without using a proven graphics tools package (see Fig. 1).

A tools package can be used to create many different applications, even on an ad hoc basis, and most of today's tools are based on standards that ensure a high degree of machine and device independence. Most tools vendors also offer extension packages that can get you part of the way toward a complete application, such as in mapping or presentation graphics.

Compared with turnkey systems and special-purpose application software, the tools approach offers much more flexibility.

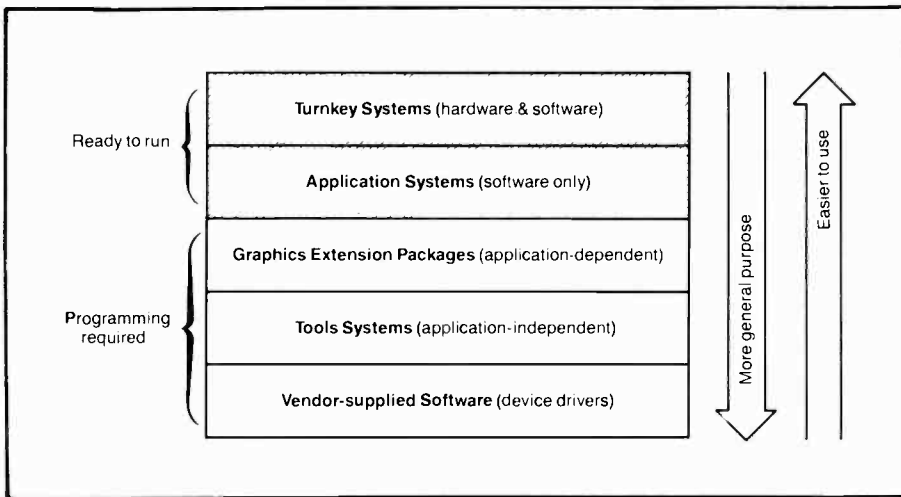

Fig 1. Generally speaking, the more specific the application, the easier a package is to use.

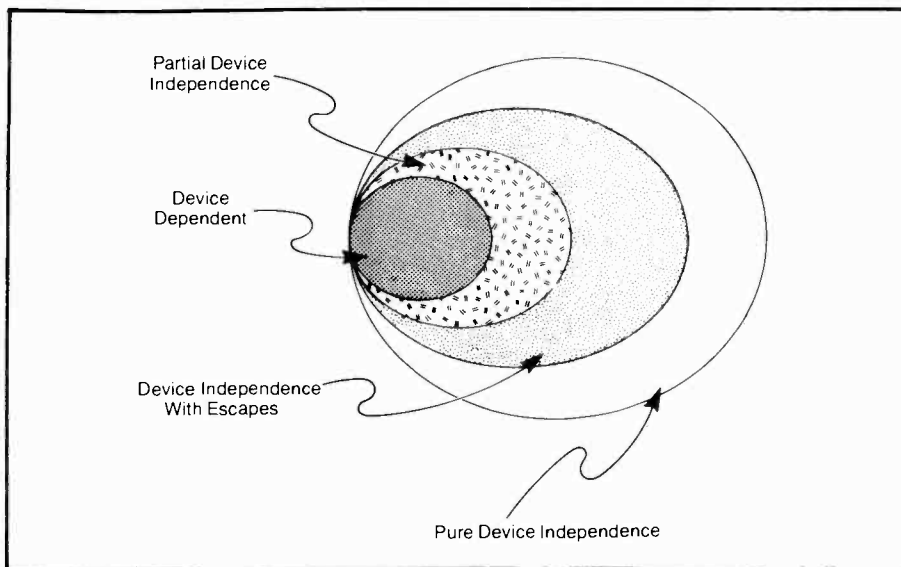

Fig 2. Machine independence is usually a matter of degree.

The application can run on many different machines and graphics devices, and can be tailored to your own particular needs. This flexibility, though, will be gained at the expense of some performance, because tools packages have to be large and sophisticated enough to address many machines, devices, and applications. Nevertheless, using standards-based tools may result in immediate, net performance gains, because they put you in control of selecting the hardware that meets your needs as you see them. Also, they will give you access to future advances in graphics devices and processing power and keep your hardware options open. As long as present trends continue, you should be able to move the application gradually to new devices with better performance and lower cost.

The third level of graphics software in

our scheme consists of device drivers, the programs you need to use a particular graphics device with a device-independent tools package. You will not have decisions to make about device drivers if you buy your hardware and software from the same source (e.g., Tektronix or a turnkey vendor), because the vendor will integrate them for you. In the more common case of mixing many different devices with device-independent software, the drivers will influence the overall performance of the system nearly as much as the application software and the design of the device itself.

The number and quality of device drivers offered by software tools vendors vary. The quality of a device driver is measured mainly in terms of the intelligence with which it can make use of hardware fea-

tures. For relatively simple devices you may be able to write a driver in-house, and in many instances hardware and software suppliers provide skeleton drivers to make this job easier. For high-performance devices, writing a driver is seldom feasible for the user, and the availability of a high-quality driver is crucial to the optimal use of the device.

General criteria for evaluating graphics software

Before comparing graphics software, it is important to define your problem succinctly and understand your needs completely. The importance of a patient, thorough approach to defining needs cannot be overemphasized.

This process requires gathering knowledge of your environment. You will have to develop a profile of the end users or operators who will use the application. Also, examine the blend of programmers and trainers who are available to support the application, because their skills determine the level of usability that you will require in the software you select. For example, a target user who is an engineer or electronics technician with solid computer skills will need less training, and will be able to deal with a more complex system interface (requiring less programmer time to create), than a casual computer user who needs a friendlier interface and more instruction.

Analyze the constraints and resources of your existing and planned computer systems, graphics devices, and any other applications that are planned or already in place. Graphics may place heavy demands on CPU time and communication links. Machine independence is usually a matter of degree—in any case, you should demand assurance that any software you obtain will install successfully and run efficiently on the available CPUs. Even on standalone workstations, some graphics software products will run much better than others (see Fig. 2).

Borrowed, shared, or inherited hardware may narrow your range of software choices. The best-quality devices tend to be the best-selling models and consequently the ones with the best available software support, but be skeptical of the quality of graphics software available for castoff hardware from little-known manufacturers. A small saving in hardware cost can vanish quickly if several weeks of programming support are needed to integrate a device into the system.

A shopping list for the graphics tools buyer

Device independence: Device drivers

- Most hardware features of the device supported by the driver
- Many devices supported—vendor actually has the devices in-house
- Vendor willing to develop quality drivers for new devices

System features:

- Does a given feature actually represent a solution to a potential problem, or is it merely excess baggage?

Debugging and error handling:

- Speaks English.
- Presents "snapshot" showing the subroutine called and parameters passed.
- Allows programmers to

specify the severity of an error that halts execution.

System architecture

- Device-independent routines and device drivers.
- Separate pipelines for two- and three-dimensional viewing.
- View them as guidelines, not gospel. Usability is more important than absolute fidelity.

Documentation

- Ask to see the manual before you purchase.
- In reference section, are all package capabilities illustrated and special contingencies covered?

In tutorial section—does it contain:

- An overview of textbook graphics concepts and how those concepts are implemented?

- A definition of technical terms?
- Frequent illustrations?
- Real-world examples with good annotation?
- Sample modules of frequently encountered graphics tasks?
- Device driver documentation?

Training

- A range of courses offered.
- Presented at the vendor's site—at your site—on a regional basis.
- User references: use them, but don't abuse them.

Your commitment

- Do you have sufficient human resources to: Design, code, document, and maintain your own custom application? Install new device drivers? Incorporate new features into the system as the need arises?

Defining needs

List your needs in your own terms, not in the language of graphics. For example, say "I need to generate pictures in the lab and display them later at several other facilities," not "I've got to have a metafile capability." Or, "I have to move objects around on the screen," not "I need a segmented data structure with pick input and image transformations."

Arrange your list of needs into a detailed hierarchy of "musts," "wants," and "don't cares" by assessing the task at hand and the environment you will be working in. Then, challenge the vendors to match their products' features to each item on your list. In this way, you will be concentrating on finding a software answer to each need, rather than wasting time trying to understand features that may not be relevant to your situation.

Conceptual model of a graphics system

Choosing a graphics software system for your application consists of more than finding software features that correspond to your discrete functional requirements. Tools packages—even those based on the same standards—are also differentiated by their architectures, which can influence

how well they run on a specific computer system. A modular design, for instance, allows device drivers to run on a workstation in a distributed processing environment. The structure of the tools system might also greatly affect the efficiency with which it accesses the special, advanced (that is, non-standard) features of high-performance hardware.

Tools packages are libraries of subroutines that can be called by an application program to perform basic graphics functions. Internally, the subroutines address an idealized "virtual" device that represents the combined functionality of many types of devices, such as plotters, CRT displays, joysticks, and image recorders. In actual operation, the subroutines must interface at some point to the individual personality of each device used. This takes place at the virtual device interface (VDI). For each device, a driver passes graphics input across the VDI to the device-independent layer of the tools package. Output commands from the device-independent layer pass through the VDI and are translated by the device driver into device-dependent commands that can be understood by the individual device. If an output command is inappropriate for the particular device, or if the driver is incapable of interpreting it, the system should ignore the command

or attempt to simulate the function in software. An intelligent device driver performs every possible function on the device, using software to simulate only what cannot be done by the device. Through simulation, a particular color on a raster display can appear as a crosshatching pattern when the image is drawn on a plotter.

A tools system might be designed to perform every graphics function (moving a plotter pen, drawing a line, forming polygons or markers, altering a viewing transformation, changing a color, etc.), always in the device-independent layer. At the other extreme, the package could be designed to handle only simple graphics functions at that level, letting the device driver, through user-selected parameters, decide whether more complex functions (such as drawing text characters or calculating a modeling transformation) will be carried out slowly in software or more rapidly on intelligent devices that have these capabilities built into hardware or firmware.

For high-performance applications using advanced devices, the system that works best will be the one with the most device intelligence, doing most of the work where it can be done most efficiently—in the hardware or firmware of the device. This architecture uses device drivers that are

Evaluation checklist for software vendors

- Products that solve your problem.
- Reliable service and timely answers.
- Updates and enhancements.
- Device drivers for newest graphics devices.
- Support for viable ANSI/ISO standards.
- Productivity enhancements beyond the standards.
- Documentation, training, and telephone support.
- Installation and on-site technical assistance.
- Market recognition and acceptance.
- Business staying power.

harder to design, but that give a device-independent system the ability to use device features to maximum advantage. Although some device drivers are bundled with tools packages or even offered free, you will ultimately get what you pay for, because highly capable drivers require a considerable engineering effort by the supplier. A package that supports sophisticated devices at the driver level will allow you to buy only what you need for each device, as well as providing better overall system performance.

Thus, in summary, the overall design of the tools system and the sophistication of its device drivers should be evaluated carefully in matching software tools to application requirements.

If a graphics application will be used on a large scale to amass a large graphical database (such as mechanical engineering drawings) over a long period, careful planning must be devoted to how the data will be stored and retrieved. A graphics software system that is dedicated to a specific application can manage graphical data in a simpler fashion than a system that has to be flexible enough to deal with many different kinds of graphical data. The application-independent system, for example, manipulates data in a virtual device coordinate system. The application-specific system can store information in terms of "world" coordinates that are appropriate to the application.

For each application database, program-

ming resources must be allocated to maintenance, because changes made at the virtual level must be preserved in the coordinates that are meaningful to the application. Software can perform the translations, but the programmer must ensure the integrity of the application database so if the hardware goes down, all pictures can be regenerated from that database. The graphics software system can thus remain free of any one application so it can be used in a standard way for many applications.

As graphics applications have grown, users are recognizing the need to handle their graphical data as valuable resources, using a metafile system for archival and active storage of pictures. A graphics metafile capability allows pictures to be generated at one time and place, stored somewhere else, and displayed at another time and place, all without re-executing the original application program that created them.

Metafiles can also be used to combine multiple pictures into one image, so they are useful for applications where some parts of a picture remain constant while other parts are updated. If a metafile capability is needed for an application, you can expect to have a significant investment in graphical data, so the issues to consider have to do with compatibility between software systems (see Fig. 3).

The role and reality of graphics standards

One of the criteria for comparing graphics software is adherence to either de facto or formally sanctioned standards. Standards conformance has different meaning and value to different users, but its implications can be profound for a buyer who is considering long-term investments in graphics systems.

In 1979, the first major attempt was made to standardize the use of graphics at the application level when the Association for Computing Machinery's Special Interest Group on Graphics proposed the Core standard to the American National Standards Institute (ANSI). Core achieved very widespread acceptance among software suppliers, hardware manufacturers, and thousands of users, but never became a formal standard. Its concepts, however, served as a foundation for the Graphical Kernel System (GKS) that only recently became the first true international graphics standard when it was formally adopted by the International Standards Organization (ISO) and ANSI.

Presently, Core and GKS are the only two standards that have any immediate impact on the buyer's software strategy decisions. Basically, the choices in tools packages are between those based on the well-proven Core model and the newer, but as-yet incomplete, GKS. Some users will have both, and will choose between them for each application the way they would choose between programming languages, because each system has its pros and cons for any one application. Core's 3-D capability gives it the edge in many situations, but GKS, which currently is only a 2-D system, is slowly gaining acceptance and is likely to be the basis for several standards that are now being considered.

One of these is PHIGS, the Programmer's Hierarchical Interactive Graphics System. PHIGS is a proposed standard for high-performance 3-D graphics. The Computer Graphics Interface (CGI) will attempt to establish standard ways for device-independent software subroutine packages to talk and listen directly and efficiently to advanced devices such as interactive workstations, in addition to the conventional hardware that presently requires device drivers.

The Computer Graphics Metafile (CGM) and Initial Graphics Exchange Specification (IGES) attempt to establish standards for storing, transmitting, and retrieving graphical data. If successful, these standards will simplify the exchange of pictures that were created or recorded by different sources.

Adherence to the standards has many benefits to any organization that has many users and applications. By standardizing on a few common graphics software tools, the organization can cut training costs and develop a pool of programmers with graphics experience who can help new graphics users get their applications into production faster. Application code based on a standard is much easier to maintain than highly customized programs.

But following the graphics standards offers no assurance of being able to take advantage of the best available graphics technology. Because of the process by which the standards are established, they evolve slowly through an arduous process of compromise and negotiation, lagging several years behind both hardware technology and market expectations. As current practice races ahead of the standards, software developers are facing increasing pressure to extend the functionality of their tools offerings beyond that mandated by

the standards. Some packages are marketed with claims of compliance to standards that have not yet been officially sanctioned. The risk to the buyer is that application software and graphical databases built with these products might not be compatible with the final versions of the standards.

Within the boundaries of the standards, there is significant room for tools developers to use their software engineering skills to make their packages easier to use than others. Some designers are better than others at making their packages easy to debug, test, and maintain. In the case of GKS, some of the first packages that have reached the market are only partial implementations of the standard, and may not have been designed for optimal growth into the higher levels, or into the 3-D extensions of GKS that are now being formulated by the standards-making bodies.

In the final analysis, consider the standards as guidelines, not gospel. If good graphics software offers you conformance to one or more of the official standards, so much the better, but remember that it is more important for the software to be effective and easy to use in your environment.

Key functionality to look for in graphics software tools

Above all, a tools package must solve your problem—it has to work, completely and reliably, in your application. The tools package must have proven compatibility with your CPUs, operating systems, and languages. It must also provide some way for you to acquire or produce device driver software for every device that you intend to use.

The process starts with honest evaluation of your needs. Then, look to a software vendor with a quality reputation, good history, and sound financial situation. The salespeople should know their software and be able to work with you on your application needs. Above all, be sure you get the names and phone numbers of people in your industry currently using the product you are evaluating. Call them. Check the documentation. Call the help line. Ask about training. The quicker you are up and running, the quicker you put graphics to work for you.

Documentation

Scrutinize the documentation as carefully as the package itself. While the quality of software manuals has steadily improved, vendors often presuppose too much knowl-

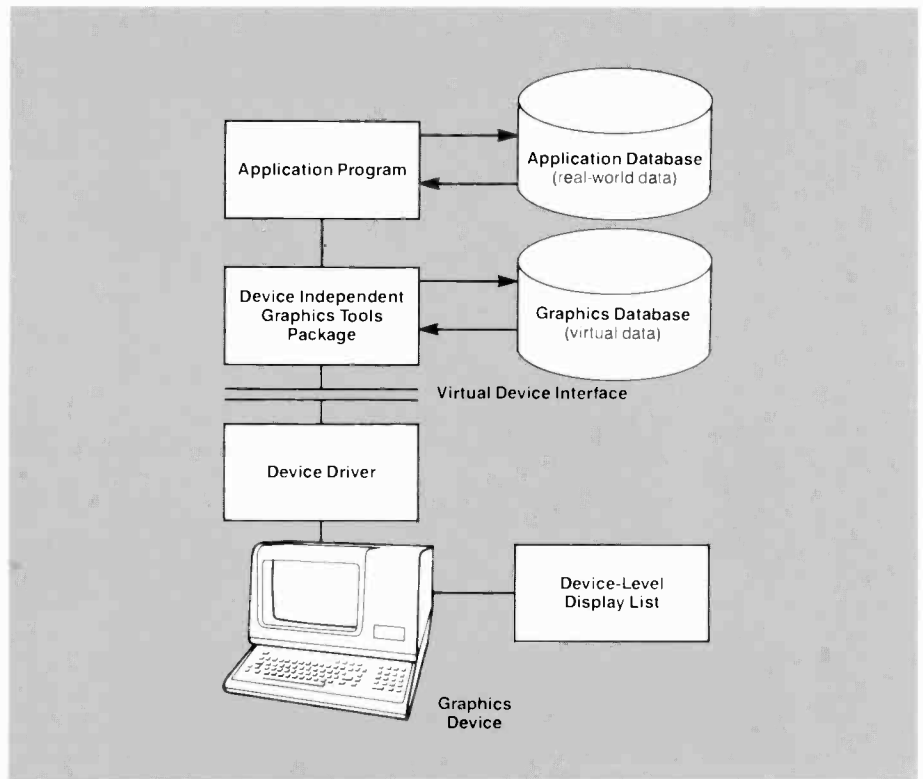

Fig. 3. System configuration with metafile capability.

edge on the part of the reader, particularly when he or she is a programmer. Therefore, demand a copy of the manual before you sign the contract, and look it over carefully.

You shouldn't have to be a "graphics programmer" to begin using a graphics package. The documentation should provide an overview of standard textbook graphics concepts. Just as important, the manual should show how those concepts are implemented by the software. Technical terms should be defined concisely, and whenever possible, abstract topics should be explained using real-world analogies. For example, the concept of "virtual camera" helps clarify three-dimensional transformations, while a metafile can be thought of as a picture library.

Documentation should include both a reference and a tutorial section. Reference documentation should not only explain all the capabilities of the package, but should account for special contingencies. What happens, for example, if the virtual camera is positioned coincident with the point it is viewing? If ten picture segments are stored, in what order are they displayed on the screen? If you are looking straight down on an object, which way is up? A few sentences describing the not-everyday occurrences can save hours of writing test programs.

How to evaluate graphics software documentation

- Overview of textbook graphic concepts.
- How concepts are implemented by the software.
- Reference and tutorial sections.
- Illustrations—the more the better.
- Programming examples—the more the better.
- Answers to "what if" and "how to" questions.
- Detailed documentation on each device driver.

Evaluate the documentation as carefully as you evaluate the software.

Tutorial documentation should walk the programmer through several programs, narrating each step of the way. For graphics material, of course, an abundance of illustrations is a must. Also highly useful are program modules that perform commonly used functions: rotating an object, menu selection using graphics input, and clearing

part of the screen. Such examples will save the programmer from having to create code that is already perfected.

Device driver documentation will also increase programmer productivity. High-performance devices do much of the work in firmware, and they all do it differently. Good driver documentation shows the programmer how the device-independent capabilities of a tools system relate to the specific features of a given device.

Training and user groups

Vendors take different approaches to customer training. Optimally, a variety of courses are offered—from basic ones designed for managers to advanced sessions tailored for experienced programmers. Inquire as to where the courses are held—at the vendor's headquarters, at your site, or either. Sometimes, classes are held on a regional level as well.

User groups are an excellent way to become familiar with the product, both before and after purchase, because they allow you to rub shoulders with system designer involved with a cross-section of applications.

Can you make the commitment?

The final question on your list should not be directed at your vendor, but at yourself—can you commit enough human resources to make a graphics tools package work? Like most worthwhile endeavors, graphics application programming takes

time and commitment—often a few months, sometimes in excess of a year.

Maintenance is also a factor. You should have the in-house expertise to install new device drivers when additional equipment is purchased, and to incorporate new features as the need arises.

James Warner is President and founder of Precision Visuals, a supplier of products that aid programmer and end-user productivity in scientific and engineering applications. He has been active in computer graphics as an educator, developer, vendor, and user for 14 years. Prior to forming Precision Visuals in 1980, Mr. Warner held positions at the Universities of Michigan and Colorado.

Mr. Warner is a regular contributor to computer graphics publications, writing articles and tutorials on graphics standardization, hardware implementation strategies, and the uses of graphics software tools. He is a frequent speaker at major computer conferences here and abroad.

John Slitz is Vice President of Marketing at Precision Visuals. Prior to that he held several positions at IBM. He has a BA in Economics from the State University of New York at Cortland, an MALS in Psychology/Sociology from the Graduate Faculty of the New School for Social Research, and an Executive MBA in Management from Fairleigh-Dickenson University.

Contact them at:
Precision Visuals
6260 Lookout Road
Boulder, Colorado 80301
(303)530-9000

S. Kreitzberg | J. Krupa

Engineering an electrically-powered automobile

Engineers are inveterate tinkerers, and as a result there is a Chevrolet Vega in Moorestown, N.J. that will never be the same . . .

After sitting in gas lines in the 1970s, we decided to answer an advertisement in a do-it-yourself magazine, headlined "Convert Your Car To Electric—Send for Our Plan." It looked like the perfect project for electrical engineers who loved to tinker with cars.

The plans were quickly obtained and just as quickly discarded. They were unclear and geared toward converting one particular model of car. We had to design our own conversion. To begin, we posted a notice on the RCA Moorestown bulletin board to enlist the aid of some co-workers. To our surprise, we received 43 positive responses, and an RCA electric car club was born.

Members ranged from people who had never opened the hood of a car to a man who had designed and built an electric tractor. Employee Relations, through the Moorestown Recreation Association, agreed to support us as a hobby club, and we were on our way. Plans started to take shape in regular meetings.

The car and its components

Finding a suitable car to convert, the number one problem, was solved when

Abstract: *Dozens of RCA Engineers have tried their hand at building an electric car. Two, driven to succeed, tell how they actually completed a roadworthy car and generated many new ideas in the process.*

the number one Kreitzberg son departed for college, leaving an old Chevrolet Vega behind. The club had its car. It was relatively light in weight, with a four-speed transmission and ample space in the engine compartment. The gasoline engine was removed and discarded (Fig. 1), but the four-speed transmission and clutch were left intact according to our planned approach.

Next, we had to locate a dc electric motor capable of moving a 2300-pound vehicle at a reasonable road speed. Investigation revealed that others were using old surplus aircraft starter/generator units which were made for continuous operation with forced-air cooling. After several calls to aircraft junkyards on the west coast, we found a 20-horsepower motor. This 75-pound monster came equipped with roller bearings on both ends of the armature, a series/parallel (compound) field, and the capability to accommodate a dc input ranging from 24 to 96 volts. Numerous other parts such as relays, voltage regulators, and motors were also obtained from aircraft sources. The batteries selected were heavy-duty marine Sears DieHards which were designed for repeated deep discharge.

Once the project got into full swing, it occupied every evening after work, weekends, and holidays. Family life became a thing of the past. We were redesigning a car! Considering that the original design cost millions of dollars and took thousands of man-hours, one can appreciate what it takes to redesign about a third of the vehicle. In addition to replacing everything in the engine compartment, the following had to be designed: a completely new

dashboard with voltage and current meters, a heating system for winter use (no more hot engine coolant available), an electrical pedal (formerly called the gas pedal) and associated motor controller, an on-board charging system, battery holders with provision for removing fumes emitted while charging, a 12-volt accessory system with its own on-board charger, and an adaptor to mate the clutch to the electric motor.

The effort was quite rewarding, however, since our hard work contributed to what will undoubtedly be the way of the future. Our club motto became "The future is now."

Coincidentally, the group learned of a similar student project at Cinnaminson High School. After speaking to the teacher in charge of the project, we invited them to join our club. From that day, our meetings were filled with students eager to discuss and learn about electric cars from RCA personnel. We helped them a great deal, but no less than their enthusiasm helped us to continue with this project. Many of these students went on to engineering colleges after graduation. We hope to see some of them back at RCA again as engineers.

Ready for the proving ground

Somehow, the big day finally arrived. The car, shown in Fig. 2, was finished and ready for testing. It had operated stationary (transmission in neutral) many times, but this was the ultimate test. Batteries were fully charged, and specific gravities were carefully checked. Tires were pumped to 36 pounds to minimize rolling friction. We all held our breath. Shift into first

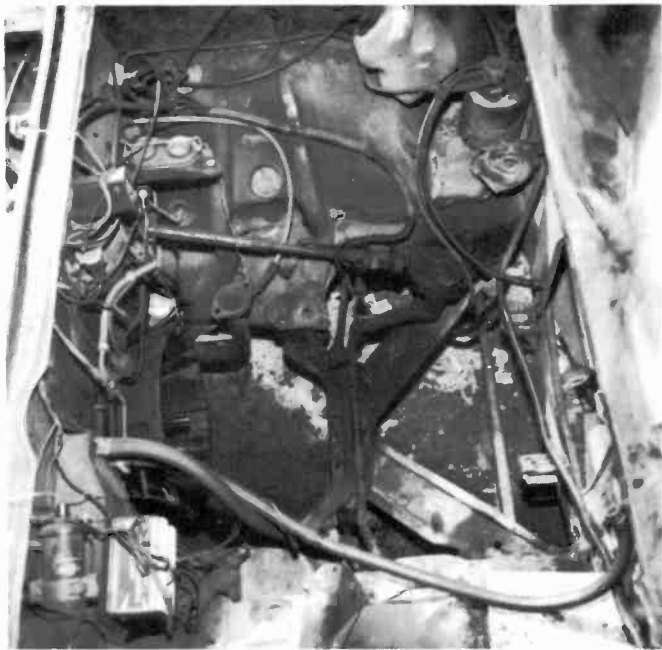

Fig. 1. With the gasoline engine removed, the Vega's engine compartment yields ample space for conversion.



Fig. 2. The first model produced by RCA's electric car club is ready for the road.

gear, step on the electric pedal, release the clutch, and away we go—it worked! The car rode beautifully. It had enough torque to get rolling up to about 30 miles per hour, but we soon ran out of power, so it was back to the drawing board. This problem was solved simply by going from a 48-volt to a 72-volt battery system.

Our top speed was then over 40 mph, a reasonable level for local driving. We began to use the car for daily commuting to and from work as part of the debugging process. The sound emitted by this vehicle is somewhat like a loud elevator whir, so needless to say, it generated a lot of attention wherever it went.

Our trip to the N.J. State Inspection Station was an especially memorable occasion. The first electric car under their inspection, a curiosity, was quickly surrounded by the entire inspection staff plus everyone who had been waiting in line. The car passed with flying colors on the first try.

Into the record books

It didn't take long for two newspapers and WPVI Action News to contact the club, via RCA. We also received a request from RCA Moorestown to exhibit the car for Open House. For this occasion, we upgraded the car (Fig. 3) by transferring the entire electric drive system to another Vega chassis of the same year but in better condition, with a newly painted body.

Moving from the outside upgrade to



Fig. 3. An improved car on display for the RCA Moorestown Open House. The entire electric drive system is emplaced in a better chassis.

the inside "nuts and bolts," the following paragraphs present the more detailed technical aspects of our design and discuss features planned for future models.

The technical details

When converting a conventional gasoline engine car to an electric drive, the standard transmission and differential are usually left intact. This greatly simplifies the conver-

sion process. Unfortunately, the speed-torque characteristics of the gasoline engine are not similar to those of the electric motor. Therefore, we had to match the electric motor characteristics to the existing transmission requirement. Calculations showed that a 3:1 speed reduction of the electric motor through a planetary gear system would be satisfactory. Accordingly, we obtained a 3:1 planetary gear reduction from a Ford automatic transmission, mod-

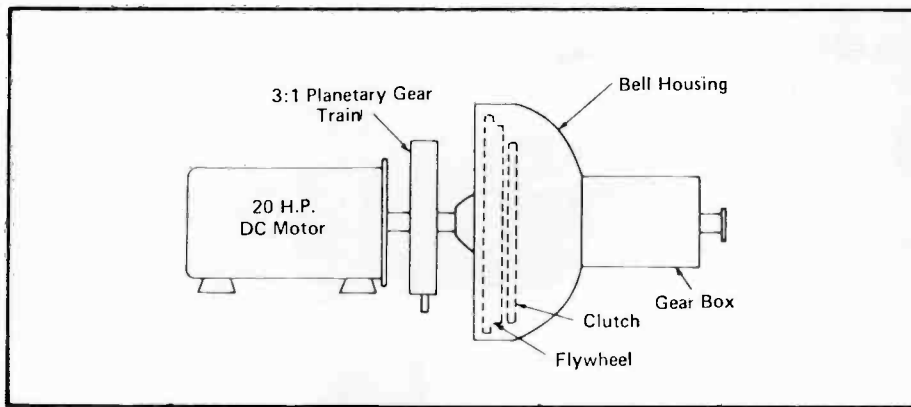

Fig. 4. A planetary gear system provides a fixed 3:1 speed reduction of the electric motor to match the transmission requirement. (Since this reduction is too high for normal highway use, a variable speed ratio system is now being developed.)

ified it, and connected it between the electric motor and the standard four-speed transmission. The electric motor is connected to the sun gear, the ring gear is held stationary, and the 3:1 speed reduction from the carrier is connected to the transmission. This is shown in Fig. 4. The planetary gears run in oil and provide a quiet, efficient speed reduction.

The car performs very well with this planetary gear. This speed reduction is, however, too high for normal highway use. We soon realized that a variable speed ratio would be preferable to a fixed ratio. To provide a variable speed, the planetary gear reduction is currently being replaced with a belt drive. The electric motor is now to be mounted on the fender wall, and the belt will drive a pulley mounted on the four-speed transmission. There are two sprockets on the electric motor shaft and two on the transmission box. Thus any one of four reduction ratios may be selected by simply lifting the belt tensioner arm and moving the belt to the desired sprocket.

This speed reduction system furnishes other advantages. The problem of aligning the electric motor to the four-speed transmission is eliminated, and the electric motor is now readily accessible for maintenance.

Ideally, the transmission for an electric drive automobile should consist of an infinitely variable speed ratio—the dc motor operates most efficiently when run within its nominal rating. The efficiency of the dc motor drops rapidly when it is overloaded, and this usually happens during acceleration. Unfortunately, such a transmission is not currently available; accordingly, several club members have undertaken the task of designing and building such a transmission. The system consists

of an integral package containing the electric motors and planetary gear trains.

An alternative to total conversion—the hybrid car

A small auxiliary gasoline engine may also be connected to the system, creating the popular hybrid electric car. With this arrangement, the car is powered on level roads by a small gasoline or diesel engine which drives a dc generator. For uphill climbs or acceleration the 72-volt batteries will automatically provide the extra power.

Many hybrid cars are in operation at the present time. The owners in many cases register more than 70 miles per gallon of fuel. With the integral package containing the dc motors and the matched transmission, conversion will be much easier and less expensive. The driving range of the hybrid car is almost limitless because, whenever the car does not require the full output from the engine, its power will automatically charge the batteries.

Related development projects

The following paragraphs describe some other development projects undertaken: an improved mechanical speed control, a new type of primary battery, and an entirely new approach to converting electrical energy into mechanical energy.

Speed control

We designed and built several different solid-state speed controllers using silicon-controlled rectifiers (SCRs) or high-current Darlington transistors. These units can switch in excess of 350 amps. They are reliable and provide very smooth speed

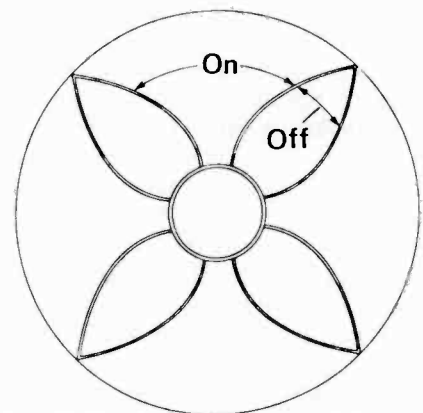

Fig. 5. Front view of a mechanical speed controller. The five-inch rotating disc provides a variable voltage control on only 15 watts of power.

control for the electric automobile. One drawback with the solid-state speed control is that the power dissipated by the switching elements can approach 200 watts when controlling 350 amps. A mechanical speed control was designed to provide a very simple, inexpensive, and efficient speed control using only 15 watts of power. The unit consists of a 5-inch copper disc with four isolating segments as shown in Fig. 5. The disc is rotated at 1000 rpm by a small permanent-magnet dc motor. A copper-composition brush is held against the disc. As the disc rotates, it will make or break the current depending on whether the brush is on the copper segment or the isolating segment. By moving the brush radially along the disc, the ON to OFF ratio is varied, providing a variable voltage control. Unlike other mechanical speed controls, the disc and brush are run entirely submerged in light oil. This eliminates arcing, reduces the brush wear, and provides cooling.

Primary battery

The greatest drawback of electric automobiles is the heavy, bulky, and relatively low capacity storage battery. With present storage battery systems the driving range between the charges is approximately 40 miles. The ideal battery would be one that did not require recharging but would simply be replaced, at a nominal cost, after perhaps 500 miles of service. This would approximate filling up the fuel tank on a gasoline-driven automobile.

A primary battery is very simple, consisting of plates of two dissimilar alloys in an electrolyte. The potential differences between the plates depends on the alloys used. If the plates are connected to an

external circuit, an electrical current is provided. This type of battery cannot be recharged, but it will supply current until the plates are dissipated. The current can be controlled by simply varying the depth of immersion in the electrolyte. The "current per pound" of alloy depends on the alloys that are used. One such alloy, which was originally manufactured as an aluminum solder, will provide approximately $3 \times 96,000$ coulomb per 30 grams, or about 1210 ampere-hours per pound. The voltage of this cell is 0.8 volt. Therefore, one pound will provide about one kilowatt hour. A typical electric automobile consumes about 6 kilowatts (100 amps at 60 volts) when traveling at 40 mph. Therefore, 6 pounds of alloy would be required to drive the car 40 miles. This type of battery has one serious drawback. As current is drawn from the plates they become coated with a chemical film that decreases the current density, eventually reducing it to zero. To prevent the chemical film from forming, an ultrasonic scrubber has been tried. The preliminary results were very encouraging. Presently, a method of directing the ultrasonic waves at all the plates from a single generator is being investigated.

New type of electric motor

The new alloy Nitinol, which has unusual characteristics, makes it possible to convert heat directly into mechanical energy. A piece of wire about 1/16 inch in diameter made from this alloy is very pliable and can be easily bent into a semicircle. If this semicircle is immersed in hot water (about 160°F), it will snap back into its original straight form with unusual force. The company that manufactures this alloy has designed a small wheel-motor that will rotate as long as part of the wheel is immersed in hot water.

The potential use of this alloy for a high-efficiency propulsion device for electric automobiles has been investigated. Instead of using hot water, the wire was heated by passing a pulse of current through it. The results were the same—the wire reverts to its original shape. To increase the mechanical force, thicker wires were used. However, the thicker wire required more force to bend and did not revert to the same original straight shape. To rectify this, many thin straps of the alloy were connected together at the ends, making the composite strap very pliable and easy to bend. A piece of this strap (approximately 1/4-inch square) exerts a force of over 10 pounds. Additionally, when the



Sid Kreitzberg joined RCA in 1962 and has worked in the Program Management Organization on the TALOS, BMEWS, and AEGIS programs. In 1979 he became interested in electric cars, and subsequently founded the RCA Electric Auto Association, of which he is President. The club has since become the Alternate Energy Club and is currently experimenting with such diverse items as fuel cells and super-high-mileage carburetors as well as electric cars. Mr. Kreitzberg, a Senior Member of the Engineering Staff, is currently engaged in project management activity on the AEGIS Operational Readiness Test System (ORTS) and the CG53 Underwater Shock Trails.

Contact him at:

**RCA Missile and Surface Radar Division
Moorestown, NJ
TACNET: 224-2842**

strap was inserted in a strong magnetic field, the response to the same current pulse was much faster, allowing more cycles per second. Development work with this unusual alloy is continuing. The goal is to develop a method of converting these impulses into smooth rotary motion.

The future electric automobile

The popularity of the electric car has fluctuated since its inception just before the turn of the century. Several years ago, during the gasoline shortage, there were thousands of these vehicles on the road. Many large manufacturers were preparing for full-scale electric automobile production. With the sudden abundance of gasoline and declining prices, many plans for electric car production have been put in limbo. However, strong interest and research in electric automobiles is continuing.

John E. Krupa joined RCA Montreal in 1953 and transferred to RCA Moorestown in 1959. He has been associated with most of Moorestown's projects as a Signal Processor Design Engineer. Currently, he is with the System Integration and Test activity. Mr. Krupa became interested in electric drives while serving with the Royal Air Force in World War II. More recently, he designed the dc motors and controls for a 140-hp diesel electric tractor. Now he is designing an integrated electric drive for a 300-hp electric tractor. His hobby—toy electric trains.

Contact him at:

**RCA Missile and Surface Radar Division
Moorestown, NJ
TACNET: 224-3024**

The future electric car will feature electric motors designed specifically for automobile use. The motor will be an integral part of the wheel, and independent four-wheel drives will be used. This principle has been successfully demonstrated on a large four-wheel drive tractor. The prime source of power will almost certainly be the low-temperature, hydrogen fusion generator. In general, nuclear physicists do not consider this generator a workable source of power because of its low output and efficiency. Nonetheless, in light of the fact that one gallon of sea or lake water contains enough deuterium to drive a car for 20 hours at 40 mph, this low-efficiency fusion generator looks very attractive. With on-board power no longer a problem, the size of the electric automobile will increase, and acceleration will be compatible with the present gasoline-driven car . . . and, oh yes, the electric models will be available in any color—except black.

Engineering News and Highlights

Hospodor named President of Americom



The election of **Andrew T. Hospodor** as President and Chief Executive Officer of RCA American Communications, Inc., has been announced by Eugene F. Murphy, RCA Executive Vice President of Communications and Electronic Services. Mr. Hospodor succeeds Dr. James J. Tietjen, who has become Vice President, RCA Laboratories. Since 1981, Mr. Hospodor has served as Division Vice President and General Manager of Automated Systems Division in Burlington, Massachusetts, where he had overall responsibility for the design and manufacturing of automatic test equipment, vehicle test equipment, and command and control systems.

Mr. Hospodor received his BS in Mechanical Engineering from Cornell University in 1960, and his MS in Mechanical Engineering and MBA from Lehigh University. In 1976, he completed the Harvard University Program for Management Development.

He is a member of the Association of the United States Army, the Armed Forces Communications and Electronics Association, the Air Force Association, the Association of Old Crows, the Army Aviation Association of America, and the Navy League of the United States. He is also a member of the American Defense Preparedness Association, the American Helicopter Association, Inc., the American Institute of Aeronautics and Astronautics, and the Security Affairs Support Association.

Stockton is new Division VP and GM at ASD



John D. Rittenhouse, RCA Executive Vice President, Aerospace and Defense, has appointed **Eugene M. Stockton** as Division Vice President and General Manager of RCA Automated Systems Division. Automated Systems Division designs and manufactures a wide range of automatic test equipment, vehicle test equipment and command and control systems. It was elevated to Division status earlier this year by RCA President and Chief Executive Officer Robert R. Frederick.

Prior to his appointment, Mr. Stockton was Division Vice President, Engineering, at ASD. He was responsible for engineering services and for C³I programs including the Remotely Monitored Battlefield Sensor System (REMBASS). Mr. Stockton's engineering organization also incorporated artificial intelligence techniques into command analysis functions. Since joining RCA Automated Systems in 1955 as an Associate Engineer, Mr. Stockton has served in a number of engineering management positions, including nine years as the Division's Chief Engineer.

Mr. Stockton holds a BS in Electrical Engineering from Michigan State University. He received an MSEE in electrical engineering from Drexel University in 1959, and an MBA from Western New England College in 1981. He also completed the Harvard Business School Advanced Management Program.

Webster named to new post



The appointment of **Dr. William M. Webster** as Vice President and Senior Technical Advisor has been announced by Roy H. Pollack, Executive Vice President, Electronic Products and Technology. Dr. Webster, who has served as Vice President, RCA Laboratories, since 1968, will now have responsibility for providing technical advice and counsel to all RCA activities.

He has been a leader in the field of solid state physics, and joined RCA Laboratories in 1946, making numerous contributions to tube and transistor developments. From 1954 to 1959, he was Manager of Advanced Development for the RCA Semiconductor and Materials Division. He returned to RCA Laboratories as Director of the Electronic Research Laboratory in 1959. He was appointed Staff Vice President, Materials and Device Research in 1966, and assumed responsibility for the management of RCA Laboratories in 1968. He was elected a Corporate Vice President in 1969.

Dr. Webster holds patents in such diverse fields as television, vacuum tubes, gas tubes, circuitry, and semiconductor devices. A member of the National Academy of Engineering, Dr. Webster was awarded the Frederik Philips Award by the Institute of Electrical and Electronics Engineers in 1980 "for sustained leadership in the management of research and development."

He received a BS in Physics from Union College in 1945, and a PhD in Electrical Engineering from Princeton University in 1954.

Tietjen to Head RCA Laboratories



Dr. James J. Tietjen, who has headed RCA American Communications, Inc., since 1983, has been appointed Vice President, RCA Laboratories by Roy H. Pollack, Executive Vice President, Electronic Products and Technology. He will be responsible for all of the research activities of RCA Laboratories, and will report to Mr. Pollack.

Dr. Tietjen is widely known for his work in materials and components research. A native of New York City, he received his BS, cum laude, in Chemistry from Iona College in 1956. He was awarded his MS and PhD degrees in Physical Chemistry in 1958 and 1963 from Pennsylvania State University.

After joining RCA Laboratories in 1963, Dr. Tietjen worked primarily on preparation of a broad range of semiconductors by chemical vapor transport reactions. This work led to the development of a series of new and improved electronic devices. He has published more than 30 technical papers in the area of materials and components research.

He was appointed a Research Group Head in 1969, and was named Director of the Materials Research Laboratory in 1970. In 1977 he was appointed Staff Vice President, Materials and Components Research, the position he held until being named President and Chief Operating Officer of RCA American Communications, Inc., in 1983. He became President and Chief Executive Officer in 1984.

Dr. Tietjen was twice a recipient of RCA's highest technical honor, the David Sarnoff Award for Outstanding Technical Achievement, in 1967 and 1970. He was also awarded RCA Laboratories Outstanding Achievement Awards in 1965 and 1969. In June of this year he was a recipient of the Pennsylvania State University Distinguished Alumnus Award, the university's highest honor.

Pate named SSD Ed Rep



Virginia Pate joined the Standards Group of RCA Solid State in 1978 as a Technical Writer, with responsibility for maintenance of Engineering Specifications. She later transferred to Engineering Publications, and was promoted to Technical Writer/Editor. Her initial duties involved the preparation of data sheets, catalogs, and Databooks covering Solid State products. Most recently she has been named Project Editor for publications concerning semicustom IC products, and has been given additional responsibilities in the preparation of promotional newsletters and brochures as well as application notes and technical manuals.

Ms. Pate received a BS in Chemistry (Honors), with a minor in Mathematics, from Morgan State University in 1963. She subsequently worked in the fields of analytical, research, and quality-control chemistry with companies such as Reed and Carnrick and CIBA Pharmaceutical, as well as with John Hopkins University.

Galton is named ASD TPA



Eugene B. Galton, Manager, Engineering Staff, has been appointed Technical Publications Administrator at RCA Automated Systems Division, Burlington, Mass. Mr. Galton joined RCA in 1956 as an Engineering Group Leader in Camden, New Jersey, and has held positions as Engineering Manager, Plant Manager, Marketing Manager, and PMO Manager with responsibilities in all of the product areas at RCA Burlington. Prior to joining RCA, Mr. Galton worked for Bell Laboratories and the Hazeltine Electronics Corporation as a design and development engineer on telephone headsets, IFF equipment, and airborne and shipboard electronics.

He is a graduate of Cornell University with an AB in Chemistry, and a BEE (with distinction). He also received an MEE from NYU and an MBA from Temple University. He is a member of Eta Kappa Nu, Tau Beta Pi, Phi Kappa Phi, Association of Old Crows, and a Senior Member of the IEEE.

Staff announcements

Aerospace and Defense

John D. Rittenhouse, Executive Vice President, Aerospace and Defense, announces his organization as follows: **William V. Goodwin**, Division Vice President and General Manager, Missile and Surface Radar Division; **Eugene M. Stockton**, Division Vice President and General Manager, Automated Systems Division; **Joseph Pane**, Division Vice President and General Manager, Government Volume Production; **Lawrence J. Schipper**, Division Vice President and General Manager, Communication and Information Systems Division; **Charles A. Schmidt**,

Division Vice President and General Manager, Astro-Electronics Division; **Joseph C. Volpe**, Division Vice President and General Manager, Broadcast Systems Division; **James B. Feller**, Staff Vice President, Technology; **James R. Foran**, Staff Vice President, Business Planning; **Leibard V. Fox**, Staff Vice President, Finance; **Donald L. Gilles**, Staff Vice President, Employee Relations; **Joseph B. Howe**, Staff Vice President, Systems and Manufacturing; and **Francis H. Stetter, Jr.**, Staff Vice President, Marketing.

James B. Feller, Staff Vice President, Technology, announces his organization as fol-

Kriesman is ASD Ed Rep



Linda Kriesman, Publications Engineer at RCA Automated Systems Division, Burlington Massachusetts, has been named Editorial Representative to the RCA Engineer. Ms. Kriesman joined RCA in 1984, and is responsible for the publication of proposals, technical reports, and conference papers. She is also strongly involved in writing and directing ASD video productions. Prior to joining RCA, Ms. Kriesman worked as a technical writer for a training firm in Washington state, where she wrote over 35 user manuals on such diverse subjects as chemical preparation, paper machine troubleshooting, and automatic control systems.

Ms. Kriesman served as an Intelligence Operations Specialist and Czech linguist for four years with the U.S. Army. She now serves as an Intelligence Specialist with the Naval Intelligence Reserve at South Weymouth Naval Air Station.

Ms. Kriesman graduated summa cum laude from Boston University with a BS in Broadcasting and Film. She is currently pursuing a Master's Degree in Technical and Professional Writing at Northeastern University.

lows: **Ronald A. Andrews**, Staff Vice President, Advanced Technology Laboratories; **John M. Herman**, Staff Vice President, Solid State Technology Center; **Thomas A. Martin**, Director, Technical Planning; and **Paul J. Nicholas**, Director, Special Programs.

Joseph B. Howe, Staff Vice President, Systems and Manufacturing, announces his organization as follows: **Joseph B. Howe**, Acting, Manufacturing Planning; and **Dennis J. Woywood**, Staff Vice President, Systems and Advanced Programs.

Dennis J. Woywood, Staff Vice President, Systems and Advanced Programs, announces his organization as follows: **Preston N. Shamer**, Manager, Advanced Program Development; and **Arthur R. Wentz**, Technical Director, Strategic Defense Initiative.

Americom

Eugene F. Murphy, RCA Executive Vice President of Communications and Electronic Services, announces the election of **Andrew T. Hospodor** as President and Chief Executive Officer.

A. L. Edwards, Manager, Program Management, announces the appointment of **R. A. Siddiqui** as Manager, Major Programs.

Murray Fruchter, Director, Terrestrial Systems, Technical Operations, announces the appointment of **G. D. Abernathy** as Manager, Equipment Engineering.

Muhammad Ashraf, Manager, Terrestrial Facilities Engineering, announces his organization as follows: **Frank W. De Mille**, Manager, Digital Systems; **Henry E. Foon**, Manager, Commercial Systems; and **Leonard Derkach**, Manager, Facilities and Construction.

Muhammad Ashraf, Manager, Terrestrial Facilities Engineering, announces the appointment of **Frank W. De Mille** as Manager, Digital Systems.

Astro-Electronics Division

Charles A. Schmidt, Division Vice President and General Manager, announces the appointment of **Frank A. Boyer** as Manager, Astro Quality Process Improvement and Planning.

Communication and Information Systems Division

Lawrence J. Schipper, Division Vice President and General Manager, announces the appointment of **Alfred C. Thompson** as Division Vice President, Business Development.

Lawrence J. Schipper, Division Vice President and General Manager, announces the appointment of **Bernard S. Sacks** as Director, Product Assurance.

John F. Serafin, Division Vice President, Program Operations, announces the appointment of **Edy J. Mozzi** as Director, Future Secure Voice Systems.

H. Andre Carron, Director, Manufacturing Operations, announces the appointment of **Vincent J. Mazzaglia** as Manager, Plant Engineering.

Consumer Electronics Operations

D. Joseph Donahue, Vice President, Consumer Electronics Operations, announces his organization as follows: **Robert C. Arnett**, Division Vice President, Manufacturing; **Bennie L. Borman**, Division Vice President, Manufacturing Engineering and Technology; **James E. Carnes**, Division Vice President, Engineering; **Keith U. Clary**, Division Vice President, Consumer Electronics Employee Relations; **Larry A. Cochran**, Director, Monitor Operations; **David E. Daly**, Division Vice President, Consumer Electronics Product Planning; **Michael B. Evans**, Division Vice President, Consumer Electronics Finance; **John P. Keating**, Division Vice President, Purchasing; **Harry Anderson**, Division Vice President, Program Management; and **James R. Smith**, Division Vice President, Product Assurance.

Robert C. Arnett, Division Vice President, Manufacturing, announces his organization as follows: **Terry J. Burns**, Director, Consumer Electronics-Mexican Operations and General Manager, RCA Componentes-S.A. de C.V.; **Robert E. Fein**, General Manager, Productos Electronicos de La Laguna-S.A. de C.V.; **G. Bruce Dilling**, Plant Manager, Bloomington Plant; **Dennis L. Dwyer**, Director, Production Planning, Transportation and Distribution; **David D. Eden**, Director, Crown Wood Products Operations; **Kenneth D. Lawson**, Director, Facilities Management; **James D. MacKay**, Plant Manager, RCA, Inc. (Canada); **J. B. Thomas**, Plant Manager, Indianapolis Plant; and **Kenneth S. Williams**, President and General Manager, RCA Taiwan Limited.

Kenneth S. Williams, President and General Manager, RCA Taiwan Limited, announces the appointment of **Glen E. Ernst** as Director, Manufacturing Operations, RCA Taiwan Limited.

Kenneth S. Williams, President and General Manager, RCA Taiwan Limited, announces the appointment of **Thomas A. Egold** as Manager, Materials, RCA Taiwan Limited.

Terry J. Burns, General Manager, RCA Componentes S.A. de C.V., announces the appointment of **David R. Crawford** as Manager, ACI Technology for RCA Componentes S.A. de C.V.

James E. Carnes, Division Vice President, Engineering, announces his organization as follows: **James A. McDonald**, Director, New Products Laboratory; **Eugene Lemke**, Staff Technical Coordinator; **George C. Waybright**, Director, Display Systems Engineering; **Robert P. Parker**, Director, Signal Systems; **Richard A. Sunshine**, Director, Mechanical Design Engineering; and **Willard N. Workman**, Director, Product Engineering.

Harry Anderson, Division Vice President, Program Management, announces the appointment of **Alfred L. Baker** as Manager, CTC140.

George C. Waybright, Director, Display Systems Engineering, announces his organization as follows: **Basab B. Dasgupta**, Manager, Magnetics Engineering; **William V. Fitzgerald, Jr.**, Manager, Deflection Subsystems; **Peter R. Knight**, Manager, Deflection and Power Supply; and **David E. Laux**, Manager, Advanced Yoke Development.

Stephen H. Morrall, Director, Television Product Planning and Development, announces the appointment of **Edward E. Thompson** as Manager, Television Product Line Development.

J. B. Thomas, Plant Manager, Indianapolis Plant, announces his organization as follows: **James R. Arvin**, Manager, Operations-Components; **Elliott N. Fuldauer**, Manager, Materials; **James P. Gallagher**, Manager, Plant Financial Operations; **Peter C. Hill**, Manager, Ferrite Operations; **Randall R. Mitchell, Jr.**, Manager, Plant Quality Control; **Richard E. Molyneux**, Manager, Operations-Plastics; **E. Rene' Parks**, Manager, Employee Relations, Consumer Electronics-Indianapolis; and **Walter E. Todd**, Manager, Facilities Services-Consumer Electronics-Indianapolis.

Larry A. Olson, Manager, Manufacturing Technology Center, announces the appointment of **Robert A. Monat** as Manager, Computer Integrated Manufacturing Systems.

Corporate Staff

Robert R. Frederick, President and Chief Executive Officer, announces the appointment of **George D. Prestwich** to the new position of Corporate Quality Executive.

Roy H. Pollack, Executive Vice President, Electronic Products and Technology, announces the appointment of **William M. Webster** as Vice President and Senior Technical Advisor.

Distributor and Special Products Division

E.A. Boschetti, Division Vice President and General Manager, announces the appointment of **Richard J. Klein** as Director, Engineering Quality Assurance.

Globcom

Anthony Longo, Manager, Central Office Engineering, announces that the Engineering Records activity is transferred from Construction and Installation to Central Office Engineer-

ing. **Anthony J. Fradella** will continue as Leader, Engineering Records.

John P. Shields, Director, Network Engineering, announces the appointment of **John A. Kruk** as Manager, Project Engineering.

William A. Klatt, Director, Network Operations, announces the appointment of **Joseph Cantelmo** as Manager, Gateway Operations.

Sharyn M. Yensko, Manager, Product Planning and Development, announces the appointment of **John P. Begley** as Program Manager.

Government Volume Production

Joseph Pane, Division Vice President and General Manager, Government Volume Production, announces his organization as follows: **William J. Bodo**, Director, Finance; **Joseph B. Christopher**, Director, Manufacturing Operations; **Robert M. Lisowski**, Manager, Technical Support; **Paul R. Morrison**, Manager, Contracts; **Fred Picus**, Manager, Special Programs; **William L. Reid**, Manager, Materials; **Nicholas B. Sher**, Manager, Product Assurance; **Bennie E. Tyree**, Director, SATCOM Programs; **James D. Wilson**, Manager, FSVS Programs; and **James C. Woolley**, Director, COMSEC Programs.

Robert M. Lisowski, Manager, Technical Support, announces the appointment of **William H. Turner** as Manager, Logistics Support.

Fred Picus, Manager, Special Programs, announces the appointment of **Norman Halem** as Deputy Manager, Programs.

NBC

Michael Sherlock, Executive Vice President, Operations and Technical Services, announces his organization as follows: **Arthur Timpani**, Director, Program Operation Services; **S. Merrill Weiss**, Director, Broadcast Systems Engineering; **Paul N. Beck**, Manager, Construction Contracts; **Kim L. Caster**, On-Air Technical Manager, Satellite Operations; **Ruediger Reinke**, Facilities Manager; **Doug Erb**, Manager, Election Communications; **Ferdinand Galli**, Technical Facilities Planning Manager; **Robert Martinez**, Manager, Electronic Maintenance; **Michael Mathews**, Technical Manager, Network News; **Robert E. Bartnik**, Technical Manager; **Lee Goldman**, Manager, Video Tape Operations; **Wayne Grennier**, Manager, Sports Technical Services; **Alexis Janaro**, Manager, Electronic Maintenance; and **Richard Post**, Technical Manager, Network News.

New Product Division

Erich Burlefinger, Division Vice President and General Manager, New Products Division, announces his organization as follows: **Don R. Carter**, Division Vice President, Tube Operations; **John H. Cook**, Director, Employee Relations; **Mark L. Frankel**, Division Vice President, Business Development; **Harold R. Krall**, Division Vice President, New Product Development; **Reginald R. Pattey**, Director, Strategic Planning and Services; **Ronald G. Power**, Vice President, Emitters and Detectors, RCA Inc. (Canada); **Carlton L. Rintz**, Division Vice President, Closed Circuit Video Equipment; **Randolph C. Rose**, Director, Finance; and **Eugene D. Savoye**, Director, CCD and Silicon Target Technology.

RCA Laboratories

Roy H. Pollack, Executive Vice President, Electronic Products and Technology, announces the appointment of **James J. Tietjen** as Vice President, RCA Laboratories.

Jon K. Clemens, Staff Vice President, Consumer Electronics Research, announces his organization as follows: **Curtis R. Carlson**, Director, Information Systems Research Laboratory; **Jack S. Fuhrer**, Director, Television Research Laboratory; **David D. Holmes**, Director, Advanced Television Technology Research; **Arthur Kaiman**, Director, Digital Products Research Laboratory; and **Arch C. Luther**, Senior Staff Scientist.

Bernard J. Lechner, Staff Vice President, Advanced Video Systems Research Laboratory, announces the appointment of **Walter H. Demmer** as Head, Digital Video Research.

RCA Service Company

Donald M. Cook, President, RCA Service Company, announces the appointment of **Leonard J. Schneider** to the newly created position of Division Vice President, Consumer and Business Services and Systems.

Donald M. Cook, President, RCA Service Company, announces the appointment of **John C. Phillips** as Director, Business Development and Services.

Leonard J. Schneider, Division Vice President, Consumer and Business Services and Systems, announces his organization as follows: **A. Gene Chumley**, Director, Operations—Business Communications Services; **Richard L. Layton**, Director, Engineering and Product Development; **Earle A. Malm II**, Division Vice President, Marketing and Sales; **J. William McGee**, Division Vice President, Field Operations—Consumer and Commercial Services; and **Leonard J. Schneider**, Acting, Planning and Administration.

J. William McGee, Division Vice President, Field Operations, announces the appointment of **Roy A. McFadden** as Director, Industrial Electronic Services and Operations Support.

Francis J. Hanson, Division Vice President, Contracting and Operations Analysis, announces his organization as follows: **James H. Stryker**, Manager, Operations Analysis; **William A. Comer**, Manager, Value and Quality Engineering; and **Philippe H. Melroy**, Manager, Contracting.

Richard L. Layton, Director, Engineering and Product Development, announces his organization as follows: **John W. Bakas**, Manager, Product Evaluation and Regulatory Affairs; **Paul R. Dickel**, Manager, Regulatory and Inter-Company Liaison; **John I. Matheus**, Manager, Future Secure Voice Systems; **George A. Drechen**, Manager, Field Engineering Services; **Joseph D. Kilpatrick**, Manager, Communications Systems Planning; **Montgomery C. Teague**, Administrator, Product Development—Healthcare; and **Walter F. Turley**, Manager, Product Development.

Solid State Division

Robert P. Jones, Division Vice President, Power Products and International Manufacturing, announces the following title changes: **Donald E. Burke**, Director, Engineering—Power Products, and **George W. Ianson**, Director, Product Marketing—Power Products.

John R. Steiner, Director, Environmental and Plant Engineering, announces the appointment of **F. Douglas Rue** as Manager, Plant Engineering—Somerville.

Professional activities

Parker receives Eta Kappa Nu award



The most recent RCA employee to receive an Eta Kappa Nu award is **Robert P. Parker**, Director of Signal Systems, Consumer Electronics Operations. He was one of three individuals selected for Honorable Mention in 1984. Mr. Parker was cited for "his contributions to the fields of color television technology and engineering management, and for his involvement in community activities." He is shown here receiving the award at a ceremony held in New York City. Also shown are (left to right) Cecelia Jankowski, Grumman Aerospace Corporation (Honorable Mention), Donald Christiansen, Publisher of *IEEE Spectrum*, (Master of Ceremonies), and Earl Steele, President of Eta Kappa Nu.

Inventor Recognition Program

The RCA Corporate Inventor Recognition Program was established in 1973, and each year recognizes those RCA inventors who are granted U.S. patents based on their RCA work. Milestone awards of jewelry, plaques, desk accessories, or crystal glass-

ware are made to inventors when they receive their 1st, 5th, 10th, 20th, 30th and 50th patents. The program provides for the informal presentation of a plaque in the form of a replica of an inventor's first U.S. patent upon the granting of that patent.

Awards for the other milestones are presented at award dinners held each year in Princeton, Lancaster, Indianapolis, Cherry Hill, Somerville, Burlington, and Zurich.

In 1984 there were 437 U.S. patents granted to 322 different RCA inventors. Of this number, 73 received their first patent, 33 their fifth, 21 their tenth, 5 their twentieth, and 4 their thirtieth. Those who received an award at one of the award dinners this year are shown in one of the group photographs. The numeral following each person's name indicates the milestone award received for 1984.

Those who received awards for five or more patents but are absent from the photographs include: **Alfonse A. Acampora (5)**, **John F. Corboy, Jr. (5)**, **Thomas J. Faith, Jr. (5)**, **Lubomir L. Jastrzebski (5)**, **Ronald W. Kipp (5)**, **George L. Schnable (10)**, **Minoru Toda (20)**, **Leon J. Vieland (5)**, and **George J. Whitley (5)**.



Zurich inventors: *Dr. Walter J. Merz, John R. Sandercock (5), Peter E. Haferl (30), and Ronald A. Mills.*



Cherry Hill inventors: Top Row—George S. Zorbalas (5); Charles W. Reno (5); Kevin J. Phillips (5); John D. Rittenhouse, Executive Vice President, RCA Aerospace and Defense; Charles E. Profera (5). Bottom Row—Alfred Schwarzmann (10); Kenneth C. Hudson (10); Leslie A. Torrington (20); Willard T. Patton (5).



Somerville inventors: Top Row—William C. Hittinger, Executive Vice President, Robert E. Wilson (10); Carl R. Turner, Division Vice President and General Manager, Solid State Division. Bottom Row—Joel R. Oberman (5); Robert H. Isham (5); Bhupendra P. Patel (5); Robert C. Shambelan (5).



Lancaster inventors: Top Row—Gilbert N. Butterwick (10); Larry M. Hughes (10); F. Carl Farmer, Jr. (5); Donald W. Bartch (10); Erich Burlefinger, Division Vice President and General Manager, New Products Division; Martin K. Brown (5). Bottom Row—Robert E. McHose (5); Charles M. Tomasetti (5); Stanley A. Harper (10); Paul P. Webb (5); Myron H. Wardell, Jr. (10).



Indianapolis inventors: Top Row—William V. Fitzgerald, Jr., (10); Thomas F. Kirschner (5); Billy W. Beyers, Jr. (10); Clyde F. Coleman (10); D. Joseph Donahue, Vice President, Consumer Electronics Operations. Bottom Row—Larry A. Cochran (10); Jack S. Fuhrer (10); Robert P. Parker (10); Robert L. Shanley, II (30); William A. Lagoni (10).



Princeton inventors: Seated—Edward A. James (5); Roger G. Stewart (30); Eugene S. Poliniak (20); Mahesh Kumar (5); Markus Nowogrodzki (5); Leonard Schiff (5); Frank W. Wendt (5). Standing—Steven A. Lipp (5); Howard G. Scheible (5); Peter A. Levine (20); Philip M. Heyman (10); Donald J. Sauer (10); Kenneth W. Hang (20); Terrence R. Smith (5); Ashok N. Prabhu (10); Allen L. Limberg (30); Brain W. Faughnan (5); Werner Kern (10); Christopher H. Srolle (5); William M. Webster, Vice President, RCA Laboratories; Thomas V. Bolger (10); William C. Hittinger, Executive Vice President.

Technical excellence



Second-quarter MSRDC TEC Awards



Best



DiCiurcio



Lampe



Mehling



Osterman



Pugh

William J. Best

For outstanding contributions to the integration and testing of the EDM-4 Signal Processor. Mr. Best came to the assignment as a junior team member with no

previous integration experience, and has become one of the team's most valued members after only 18 months. Of particular note are his expertise in microprocessor firmware analysis and his ability to troubleshoot all modes of the system.

John A. DiCiurcio

For extraordinary analytical and problem-solving accomplishments during the integration and testing phase of the EDM-4 Signal Processor development. His specific contributions ranged from resolution of high false-alarm rates and severe transient problems to optimization of range bias values for special functions. His analytical skills and innovative equipment modifications have been key factors in establishing the Signal Processor as a practical operating subsystem.

Ross W. Lampe

For major contributions to the IFF phased array antenna design for ADAR-M. He configured the antenna system, determined element spacing and array excitation, and verified the designs through simulation. Especially notable was his design of a printed circuit folded dipole radiating element. Dr. Lampe also coordinated related design activities to assure a workable system, and developed and maintained excellent working relationships with customer representatives.

John A. Mehling

For outstanding leadership in the software development for the PMTC AN/FPS-16 radar system upgrade. In MSRDC's first application of a VAX 11/780 for real-time

operations, Mr. Mehling led the team that overcame a variable and unpredictable interrupt response problem, developing the system without modifying the vendor's operating system. Their top-level system architecture and design has resulted in a highly modular, structured, and maintainable software system.

Dale M. Osterman

For technical leadership and application of his systems expertise to the EDM-4 Signal Processor integration and test effort. His intimate knowledge of the Signal Processor, down to the frame and module levels, contributed heavily to his extraordinary skill in troubleshooting. This ability, in combination with his personal dedication, has made him the key contributor to the integration and test of the EDM-4 Signal Processor.

Mikel Pugh

For conceiving, designing, and implementing a unique redundancy and reconfiguration control system for the AN/SPY-1B Waveform Generator. His innovative approach enables the off-line generator to be isolated from the on-line generator for repair and fault isolation testing. His creative approach to the timing control system made maximum use of PROMs to provide a highly flexible timing control system with major advantages over previous designs.

The award winners will be honored at a special function to be held early next year, and each will receive a commemorative plaque and a current text or reference book.

Mountaintop TEC winners



Neilson



VanHorn

John Neilson and Clyde VanHorn were recipients of the RCA Solid State Division Technical Excellence Annual Award. They were selected from nominees throughout the Solid State Division.

John Neilson is a 27-year RCA employee, and has a BS in Physics from Albright College, and an MS in Physics from the University of Pennsylvania. He is a Senior Member, Technical Staff in the Design and Product Engineering group. John presently holds thirteen patents and is a past recipient of the David Sarnoff Award and the Mountain-

top Technical Excellence Award. He was instrumental in the design of the high voltage silicon rectifier, stud rectifier, and high voltage stack rectifier devices. His design and implementation of the first triac gave RCA a two-year lead on the industry. Currently, John is active in the design and development of Power MOSFETS.

Clyde VanHorn, Senior Systems Analyst, has been the main architect for writing the software that allows the interconnecting of test equipment to the required inputs from

worldwide Marketing, Applications, Quality, and Sales. He has made numerous trips to Malaysia to assist in incorporating a computer database link to the U.S. A recipient of Mountaintop's Technical Excellence Award, Clyde is a 19-year RCA employee.

Palm Beach Gardens

Frank McCarty and **Chris Blauvelt** of RCA Solid State Division, Palm Beach Gardens, were awarded second-quarter individual

Technical Excellence Awards. Frank was selected for specifying and implementing a real-time Engineering Analysis Computer System utilizing HP3000, HP1000, and HP150 personal computers. This system reduced engineering analysis time from days to hours. Chris was selected for the development of a pseudo-automatic test-program generator for the Fairchild test systems. This development resulted in the Semicustom product line achieving a 24-hour turnaround time for design verification samples.

Marion TEC Award

Richard L. Gore received the Technician Award for the second quarter of 1985. Dick's efforts were directed toward solving particle-caused problems in the factory. He initiated and continues to use a mount cleanliness test, which has demonstrated a difference in cleanliness of mounts among mount vendors. A source of microspheres, which caused blocked apertures, was identified by this test.

MEP meeting at Skytop

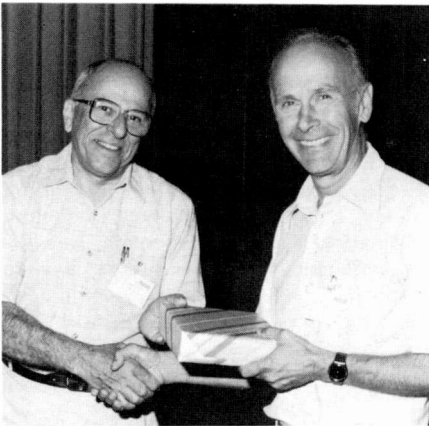

Anthony J. Bianculli, left, corporate coordinator for the MEP program, presents **Hans K. Jenny** with an award in recognition of his long service to the program. Mr. Jenny is one of the five "pioneers" who conceived or implemented the MEP program ten years ago. The other four pioneers are **William J. Underwood**, **Frank McClure**, **George R. Field**, and **Fred Dixon**.

The tenth annual meeting of the leaders of the RCA Minorities in Engineering Program (MEP) was held at Skytop Lodge, Pennsylvania on August 13-15. This year's speakers included **Roy H. Pollack**, Executive Vice President, Electronic Products and Technology, **William C. Hittinger**, Executive Vice President, and **Edward L. Scanlon**, Senior Vice President, Employee Relations.

MEP is a program to encourage minority high school students to consider technical careers. The program operates at 14 RCA locations and has, over the past decade, reached more than 2000 students. Technical coordinators at participating RCA locations are responsible for student engineering orientations, and an Employee Relations coordinator is responsible for liaison between RCA and the community and schools.

Americom TEC awards

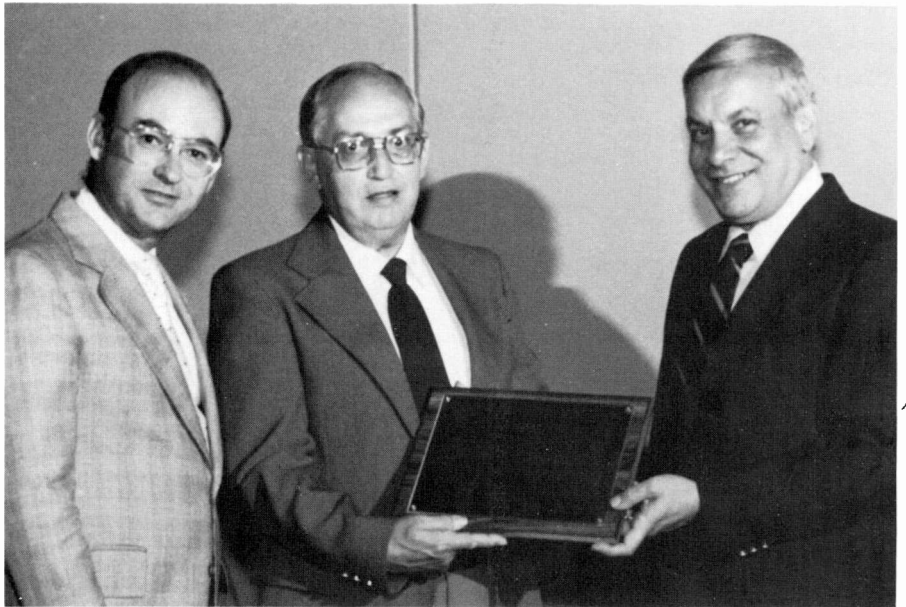

Cosmo Loguidice, Member, Engineering Staff, has been awarded the Technical Excellence Award for outstanding efforts in the complete reconfiguration of the multiple multiplex system at the Pt. Reyes California

Earth Station. This reconfiguration, with no interruption to our traffic, resulted in space savings capable of accommodating 28 additional racks in a location where no floor space was available for expansion.

Want article reprints?

Call Louise Carr, Tacnet: 226-3092

Want to write an article?

Call Tom King, Tacnet: 226-3090

Editorial Representatives and Technical Publications Administrators

Contact your Editorial Representative at the Tacnet numbers listed below to plan your *RCA Engineer* article and to announce your professional activities.

* Technical Publications Administrators, responsible for review and approval of papers and presentations, are indicated here with asterisks before their names.

Advanced Technology Laboratories Tacnet

*Merle Pietz Moorestown, New Jersey 253-6429
Ed Master Moorestown, New Jersey 253-6436

Aerospace & Defense Staff

*Theresa Law Cherry Hill, New Jersey 222-5833
(Approvals only)

American Communications

*Anita Labib Princeton, New Jersey 258-4346
(Approvals only)
Carolyn Powell Princeton, New Jersey 272-4194

Astro-Electronics Division

*Frank Yannotti Princeton, New Jersey 229-2544
Carol Coleman Princeton, New Jersey 229-2919

Automated Systems Division

*Gene Galton Burlington, Massachusetts 326-3775
Linda Kriesman Burlington, Massachusetts 326-3001

Broadcast Systems Division

*Harry Green Gibbsboro, New Jersey 266-3971

Consumer Electronics Operations

*Eugene Janson Indianapolis, Indiana 422-5208
John Hopkins Indianapolis, Indiana 422-5217
Larry Olson Indianapolis, Indiana 422-5117

Corporate Information Systems & Services

*Sue Handman Cherry Hill, New Jersey 222-6242

Global Communications

*Dorothy Unger Piscataway, New Jersey 335-4358

Communication and Information Systems Division

*Dan Tannenbaum Camden, New Jersey 222-3081
Bruce White Camden, New Jersey 222-3908

Solid State Technology Center

*Susan Suchy Somerville, New Jersey 325-7492

Missile and Surface Radar Division

*Don Higgs Moorestown, New Jersey 224-2836
Graham Boose Moorestown, New Jersey 253-6062
Jack Friedman Moorestown, New Jersey 224-2112

National Broadcasting Company Tacnet

*Bob Mausler New York, New York 324-4869

New Products Division

*Art Sweet Lancaster, Pennsylvania 227-6878
Bob McIntyre Ste Anne de Bellevue 514-457-9000

Network Services

*Bill Brown Princeton, New Jersey 272-7601

Patent Operations

George Haas Princeton, New Jersey 226-2888

RCA Cylix

Hank Coccozza Memphis, Tenn. 739-1177

RCA Laboratories

*Julie Dann (Approvals only) Princeton, New Jersey 226-2061
Eva Dukes Princeton, New Jersey 226-2882

RCA Records Division

*Greg Bogantz Indianapolis, Indiana 424-6141

RCA Service Company

*Murray Kaminsky Cherry Hill, New Jersey 222-6247
Dick Dombrosky Cherry Hill, New Jersey 222-4414
Ray MacWilliams Cherry Hill, New Jersey 222-5986

RCA Technical Excellence Center

*Tony Bianculli Princeton, New Jersey 226-2111
(for Corporate Approvals)

Solid State Division

*John Schoen Somerville, New Jersey 325-6467
Sy Silverstein Somerville, New Jersey 325-6168
Virginia Pate Somerville, New Jersey 325-6704
Harold Ronan Mountaintop, Pennsylvania 327-1473
or 327-1264

Dick Morey Palm Beach Gardens, Florida 722-1262
John Young Findlay, Ohio 425-1307

Video Component and Display Division

*Ed Madenford Lancaster, Pennsylvania 227-6444
Lou DiMattio Scranton, Pennsylvania 329-1435
Nick Meena Circleville, Ohio 432-1228
J.R. Reece Marion, Indiana 427-5566



Computer graphics is generally concerned with the construction of images from mathematical models. However digital methods can also be used to create realistic forgeries of real world scenes by merging pieces taken from actual photographs. This photograph was constructed from two source images, one of a head and shoulders, the second of an apple in front of the head and supported by a pole. Pyramid techniques were used to place a reduced version of the face on the apple and to remove the support. The result is a natural looking composite without seams or artifacts.

—Peter Burt
RCA Labs



A cloud can be thought of as a superposition of many circles of different sizes. Here, using a pyramid technique, six component images were made, each containing randomly positioned circles of a particular size. Summing the components gives a self-similar, fractal-like image. The "raw" fractal is then thresholded and pseudo-colored to give a cloud. If each component is moved at a different rate and summation is done repeatedly, realtime animation of random fractal scenes is possible.

—Joan Ogden
RCA Labs

RCA Engineer

A technical journal published by
the RCA Technical Excellence Center
"by and for the RCA engineer"

13 Roszel Road, P.O. Box 432, Princeton, N.J. 08540-0432
Address correction requested

BULK RATE
US Postage
PAID
Phila., Pa.
Permit No. 2906

EJ NOSSEN
203 ELKINS RD
CHERRY HILL
NJ 08034
GSDGC