

RCA Engineer

Vol. 27 No. 1 Jan./Feb. 1982

"SelectaVision" VideoDisc

The cover features a vibrant red background. In the upper right, there is a large, stylized shape in yellow and orange, resembling a jagged arrow or a stylized letter 'A'. The lower half of the cover is dominated by a complex, wavy pattern of blue and black lines, creating a sense of depth and movement, similar to a topographical map or a stylized landscape.

Cover design by Louise Carr



Small world. Our cover shows the stylus-disc interface of the Capacitance Electronic Disc system. The stylized color image, drawn from scanning electron micrographs with greater than 10,000-times magnification, shows the carbon-filled PVC VideoDisc surface and the diamond stylus with the thin metal electrode on one face.

Articles about the disc, by some of the interdisciplinary engineers and scientists responsible for making and protecting this pure and precise plastic part, reveal for us a physical landscape where electricity and chemistry form a partnership. General interest papers in this issue maintain the interdisciplinary flavor: microwaves for treating cancer; mathematical modeling "to debug debugging;" and a brief history of analog-to-digital conversion.

In the center of this issue, we are especially proud of the easy-to-follow, special tear-out insert giving the names, addresses, and photographs of our Editorial Representatives. Please store this four-page supplement nearby and call your Ed Rep frequently with ideas and comments. Because ideas—large and small—make this publication work for you.

—MRS

RCA Engineer

A technical journal published by
RCA Research and Engineering
Bldg. 204-2
Cherry Hill, NJ 08358
TACNET: 222-4254 (609-338-4254)

RCA Engineer Staff

Tom King	Editor
Mike Sweeny	Associate Editor
Louise Carr	Art Editor
Frank Strobl	Contributing Editor
Betty Gutchigian	Composition
Dorothy Berry	Editorial Secretary

Editorial Advisory Board

Jay Brandinger	Division Vice-President and General Manager, SelectaVision VideoDisc Operations
John Christopher	Vice-President, Technical Operations, RCA Americom
Bill Hartzell	Division Vice-President, Engineering, Picture Tube Division
Hans Jenny	Manager, Engineering Information
Arch Luther	Division Vice-President, Engineering and Product Assurance, Commercial Communications Systems Division
Howie Rosenthal	Staff Vice-President, Engineering
Ed Troy	Director, Operations Planning and Support, Solid State Division
Bill Underwood	Director, Engineering Professional Programs
Joe Volpe	Division Vice-President, Transmission Systems, Commercial Communications Systems Division
Bill Webster	Vice-President, Laboratories

Consulting Editors

Ed Burke	Administrator, Marketing Information and Communications, Government Systems Division
Walt Dennen	Manager, Naval Systems Department Communications and Information, Missile and Surface Radar
Charlie Foster	Manager, Systems and Procedures, RCA Laboratories
John Phillips	Manager, Business Development and Planning, RCA Service Company

• To disseminate to RCA engineers technical information of professional value • To publish in an appropriate manner important technical developments at RCA, and the role of the engineer • To serve as a medium of interchange of technical information between various groups at RCA • To create a community of engineering interest within the company by stressing the interrelated nature of all technical contributions • To help publicize engineering achievements in a manner that will promote the interests and reputation of RCA in the engineering field • To provide a convenient means by which the RCA engineer may review his professional work before associates and engineering management • To announce outstanding and unusual achievements of RCA engineers in a manner most likely to enhance their prestige and professional status.



H.S. Schlosser

QUALITY
DIVERSITY
+ AVAILABILITY

SUCCESS

One of the compelling factors in RCA's decision to introduce the VideoDisc was the conviction that an excellent supply of quality programs could be acquired to attract and hold consumer interest. A diverse and ever-growing selection of programs would be essential to the success of the new product.

A strong program-acquisition team was assembled and, with a great deal of effort, many hundreds of programs have been acquired over the last three years from 98 suppliers. When the VideoDisc came to market in March, 1981, RCA's initial catalog contained 100 titles. That number grew to 154 by year's end and will more than double in 1982. Every segment of the catalog will be expanded—with entertaining, informative and educational programs designed to please a wide variety of tastes and interests.

In launching the VideoDisc, RCA used existing audio/visual material. But as the VideoDisc player population expands, new productions will be released specifically "made for VideoDisc." Many projects are under way. *Complete Tennis from the Pros*, starring Arthur Ashe and 11 other tennis stars, is one example. The VideoDisc program staff is working closely with RCA Records to develop music VideoDiscs, a new type of programming with great possibilities for growth. While we're expanding the catalog, new players are in development that during 1982 will offer the consumer such features as stereo sound and remote control.

The VideoDisc system represents a significant RCA achievement — from research and development to production and marketing. Consumers can now afford a simple and reliable audio/visual playback system for the home. And they will be able to buy a wide variety of programs that will entertain and educate.

H. S. Schlosser
Executive Vice-President

RCA Engineer

Vol. 27 | No. 1 Jan. | Feb. 1982

4 "SelectaVision" VideoDisc Awards

- disc technology**
- 6** Manufacturing the VideoDiscs: An overview
H. Weisberg
 - 11** VideoDisc mastering: The software to hardware conversion
F.D. Kell | G. John | J. Stevens
 - 16** VideoDisc material compounding demands the right chemistry
B. Whipple | V.S. Dunn
 - 19** Micro-molding is a VideoDisc requirement
M. McNeely | M. Bock
 - 23** Design and manufacturing of the VideoDisc caddy
L.A. Torrington
-

- quality and reliability**
- 27** VideoDisc performance in the real world:
The role of VideoDisc Product Assurance
R.H. Huck
 - 30** Automatic VideoDisc and stylus test equipment
J.J. Kowalchik | A.P. Selwa
 - 35** Meet your Editorial Representatives
 - 39** The Chemical and Physical Laboratory supports VideoDisc
D. Hakala
-

- general interest**
- 43** Localized hyperthermia treatment of cancer
F. Sterzer
 - 53** Discovering how to ensure software reliability
M. Trachtenberg
 - 58** Linear integrated circuits are going digital
H.A. Wittlinger
-

- departments**
- 65** Patents
 - 68** Pen and Podium
 - 70** News and Highlights

in this issue ... disc technology

■ **Awards:** RCA recognizes engineers who showed outstanding technical excellence and achievement in meeting the challenge of VideoDisc.

■ **Weisberg:** "The disc, in addition to its chemical complexity, is a plastic precision part."

■ **Kell/John/Stevens:** "In the effort to improve our substrate quality at the beginning of VideoDisc mastering, maintaining the cutting-depth tolerances was our greatest technical problem."

■ **Whipple/Dunn:** "Most properties are obtained at the expense of others and every ingredient affects several critical parameters."

■ **McNeely/Bock:** "How do you mold a part one ten-thousandth of an inch wide and 12 miles long without any visual defects?"

■ **Torrington:** "In addition to protecting the disc during loading and unloading, the caddy performs mechanical functions within the player."

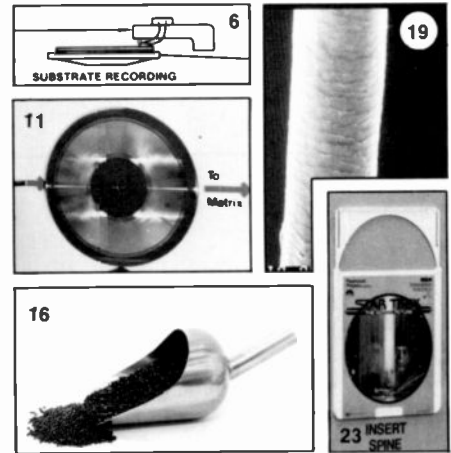

■ **Huck:** "This role involves a comprehensive overview of all product performance needs in the consumer environment."

■ **Kowalchik/Selwa:** "The ability to adapt both equipments to changes in system requirements is clearly a testimony to the power of micro-computers and the design skills of RCA engineers."

■ **Ed Reps:** A special pull-out section shows the people in your division who will get your engineering ideas published.

■ **Hakala:** "It is the challenge of the chemicals and materials analyst to be expert in the intricacies of the manufacturing process in order to be most effective."

27 Product Assurance

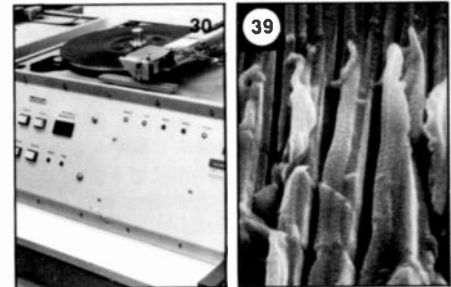

■ **Sterzer:** "In particular, a number of tumors that did not respond to conventional therapies responded well to combinations of localized hyperthermia and reduced amounts of radiation therapy."

■ **Trachtenberg:** "The model we wanted would ideally permit early cost and schedule trade-offs against all the functions that influence software-error content."

■ **Wittlinger:** "Even the human body converts analog stimuli and handles the signal in a digital manner."

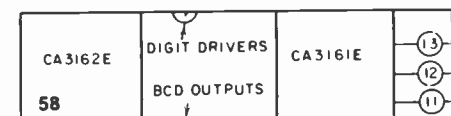
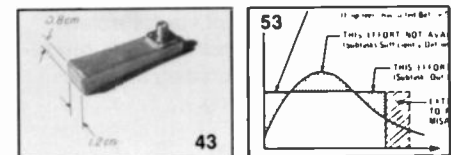

in future issues ... manufacturing engineering electro-optics anniversary issue



"SelectaVision" VideoDisc Awards

RCA Laboratories and "SelectaVision" VideoDisc Operations recognized these engineers and scientists, who worked on the VideoDisc project, for their technical excellence.

RCA Laboratories Achievement Awards

1965 - 1980

1967

Robert W. Jebens.

For ingenuity and versatility in the development of techniques for the generation of precision masking and high-density recording apparatus.

1970

Lucian A. Barton, Orville E. Dow, Leonard P. Fox, Dennis L. Matthies, and Richard W. Nosker.

For contributions to a team effort in devising and improving storage medium processes for high-density recording.

Jon K. Clemens, Marvin A. Leedom, and Richard C. Palmer.

For contributions to a team effort in the conception and development of signal systems and playback mechanisms for high-density recording systems.

Jerome B. Halter, Robert W. Jebens, Loren B. Johnston, and William H. Morewood.

For contributions to a team effort in the development and use of sophisticated techniques and apparatus for high-resolution electron-beam recording and electromechanical recording.

1973

David W. Fairbanks and Marvin A. Leedom.

For outstanding contributions to the technology of high-density recording mechanisms.

1974

Robert R. Demers, Joseph Guarracini, William H. Morewood, John H. Reisner, Jr., and George H.N. Riddle.

For a team effort resulting in improvements in the mechanisms and the optics of electron-beam recordings.

1975

Jeremiah Y. Avins, Arthur H. Firester, W. Ronald Roach, and Joseph P. Valentine.

For a team research effort resulting in the development of a VideoDisc defect detector.

1976

Richard W. Nosker.

For leadership and technical contributions, arising from a high order of scientific integrity, resulting in significant improvements in VideoDisc performance.

W. Ronald Roach.

For the invention and development of optical instrumentation suitable for the rapid analysis of VideoDisc groove and signal geometries.

Charles B. Carroll, Arthur H. Firester, Macy E. Heller, John P. Russell, and Wilber C. Stewart.

For the invention and development of optical recording and reading techniques compatible with the VideoDisc format.

1977

Jon K. Clemens, John H. Reisner, and Howard G. Scheible.

For contributions leading to a two-hour RCA VideoDisc.

Pabitra Datta, Leonard P. Fox, and Hirohisa Kawamoto.

For the development and implementation of a novel capacitive VideoDisc which eliminates the need for coatings.

1978

John C. Bleazey, Anil R. Dholakia, Richard C. Palmer, and Raymond L. Truesdell.

For contributions to a team effort in the conception and implementation of innovative approaches to improve the tracking performance of VideoDisc pickups.

1979

Charles B. Dieterich.

For the development of a novel information-management system for VideoDisc player control.

Bernard J. Yorkanis.

For the development of novel integrated circuits for VideoDisc.

Edward P. Cecelski, James J. Gibson, David L. Jose, Frank B. Lang, Karen A. Pitts, and Michael D. Ross.

For the development of advanced signal-processing circuits for VideoDisc.

Thomas Y. Chen, Arthur L. Greenberg, Jeremy D. Pollack, James J. Power, and Charles M. Wine.

For imaginative applications of micro-processor technology to VideoDisc.

Maurice D. Coutts, and Dennis L. Matthies.

For the development of analytical techniques and preparative procedures leading to superior surface quality of VideoDisc.

Robert R. Demers, David W. Fairbanks, William Z. Marder, and Bernardo E. Mesa.

For the design and development of equipment for automatically manufacturing VideoDisc player cartridges.

1980

Shiu-Shin Chio, David A. Furst, Rudolph H. Hedel, Michael J. Mindel, and Harry L. Pinch.

For contributions to the development of a mass-produced, durable VideoDisc stylus electrode.

Macy E. Heller, William C. Henderson, III, Grzegorz Kaganowicz, W. Ronald Roach, and John W. Robinson.

For contributions to micro-machining technology.

John H. Reisner, Robert E. Simms, John Valachovic, and Corris A. Whybark.

For contributions to the development of improved VideoDisc cutter heads.

David Sarnoff Awards for Outstanding Technical Achievement

The Selection Committee announced the following David Sarnoff Awards for Outstanding Technical Achievement which RCA Chairman Thornton F. Bradshaw presented on July 20, 1981 in New York, "for key contributions to the development of the CED VideoDisc System."

Todd J. Christopher
Jon K. Clemens
Pabitra Datta

Leonard P. Fox
Jerome B. Halter
Eugene O. Keizer
Marvin A. Leedom
Michael E. Miller
Fred R. Stave

In addition, Mr. Bradshaw presented a special award to *Thomas O. Stanley*, Staff Vice-President, Research Programs, RCA Laboratories, for his contributions to RCA's

VideoDisc developments. The plaque cited Mr. Stanley as "a visionary, who not only foresaw the CED VideoDisc system long before its time, but provided the technical encouragement and management support necessary to bring that vision to a reality." William M. Webster, Vice-President, RCA Laboratories, also attended the presentation.

"SelectaVision" VideoDisc Operations Technical Excellence Awards

The Criteria

The purpose of the Technical Excellence Award is to recognize outstanding creativity, resourcefulness, and proficiency in the application of technical disciplines. The selection criteria for the Technical Excellence Committee involve the following considerations: technical accomplishment, creativity, significance to VideoDisc, and discharge of responsibilities.

John W. Bowen and Timothy E. Farley



Bowen

Farley

John W. Bowen and Timothy E. Farley* received the first Technical Excellence Awards of "SelectaVision" VideoDisc Operations. On June 23, 1981, the awards were presented at a luncheon by Dr. Jay J. Brandinger, Division Vice-President and General Manager of "SelectaVision" VideoDisc Operations. Those attending the luncheon included the winners' management, members of Dr. Brandinger's staff and members of the Technical Excellence Committee.

Mr. Bowen and Mr. Farley were each recognized "by virtue of his outstanding creativity, resourcefulness, and proficiency in developing analytical techniques relating to disc performance and defect analysis."

Although prior efforts had been made to establish a defect analysis function, John and Tim were the first to develop the skills and methods to dissect defects, analyze them optically and chemically, and categorize them by sources. The methods John and Tim developed have been the key in the quantification of new carbons and other compound ingredients and process parameters in terms of micro-defect sizes and quantities. Such information has been extremely important in the VideoDisc Engineering and Manufacturing groups' achievement over the past two years of a significant reduction (by a factor of 20) in the quantities of disc surface defects.

The analytical techniques John and Tim have developed will become even more important in the near future. Stereo disc development and introduction impose stringent new requirements for low disc-defect levels, and the characterizations of disc defects will be an integral part of these development and introduction efforts.

* Timothy E. Farley, Engineering Assistant at RCA "SelectaVision" VideoDisc Operations, died as a result of a traffic accident on October 10, 1981. Tim, age 22, was a co-recipient of the first Technical Excellence Award at the Indianapolis Rockville Road facility. A native of Indianapolis, Indiana, he was an enthusiastic member of the technical team in "SelectaVision" VideoDisc. Tim started with RCA on February 14, 1979, as a Lab analyst and advanced to Engineering Assistant in the Engineering organization. He was an avid baseball participant and sports enthusiast. He will be greatly missed, but happily remembered.

—R. H. Huck



Torrington

Leslie A. Torrington, Member Engineering Staff, is the recipient of the September 1981, "SelectaVision" VideoDisc Technical Excellence Award by virtue of his outstanding creativity, resourcefulness, and proficiency in designing a VideoDisc Caddy

System which has been mass produced.

The award was presented at a luncheon on November 3, 1981, by Dr. Jay J. Brandinger, Division Vice-President and General Manager of "SelectaVision" VideoDisc Operations. Those attending the luncheon included Mr. Torrington's management, members of Dr. Brandinger's staff, and members of the Technical Excellence Committee.

The VideoDisc Caddy System serves as a transport mechanism for loading the disc into and out of the VideoDisc player, and it serves as a protection system for the ultra-sensitive disc. The caddy system prevents damage to the microscopic grooves of the VideoDisc by keeping dirt out and by providing protection from scratches, finger prints, and abrasion.

Although the caddy system was originally designed at the RCA David Sarnoff Research Center, Mr. Torrington has made a unique contribution by designing a caddy system which has been mass produced. The system of caddy, lip seal, spine, and label has performed effectively even when the external components have changed adversely. Les has been granted 16 U.S. patents since being with RCA; many of the patents pertain to the VideoDisc player and Caddy System.

—Produced by J.A. D'Arcy

Manufacturing the VideoDiscs: an overview

The RCA "CED" VideoDisc is the culmination of many years of research and represents a triumph of plastics technology.

Abstract: *The RCA "CED" VideoDisc involves advances in science, process technology, and manufacturing. This article describes the making of the disc including specifications, manufacturing processes, compound, material flow sequence and chemical treatments.*

The RCA "CED" VideoDisc can be considered only a distant cousin of the audio record. The technical and performance demands were far greater than that required for the highest quality audio record. New ground had to be broken in science, process technology, and manufacturing.

Some basic statistics will illustrate some of the demands the system puts on the disc. Grooves have a width of about $2.6\mu\text{m}$. The video signal is cut to a depth of about 850 angstroms, while the audio signal is cut to a depth of about 80 angstroms. One audio disc groove will accommodate 38 VideoDisc grooves—the VideoDisc holds about 10,000 grooves to the inch. One side of a 12-inch disc holds about 12 miles of groove length. The VideoDisc needs to be manufactured to exacting dimensions: the radius must be 5.922 in. to 5.962 in.; the thickness must be 0.073 in. to 0.086 in.; and the TIR is 0.006 in., maximum. The disc, in addition to its chemical complexity, is a plastic precision part.

©1982 RCA Corporation
Final manuscript received September 23, 1981.
Reprint RE-27-1-2

The manufacturing process

The recording process begins after information on a film is transferred to magnetic tape and the magnetic tape is edited and converted for compatibility with the VideoDisc system.

The key steps in VideoDisc manufacture are illustrated in Fig. 1. Audio and video are recorded onto a copper substrate

at half the real-time rate. The copper substrate containing the recorded information is used to "fan out," through the matrix process via nickel electroforming, to fabricate negative masters, positive mothers and, finally, negative stampers used in the final pressing operation to mold the discs (positive). This is done in order to generate many stampers from a single recorded substrate.

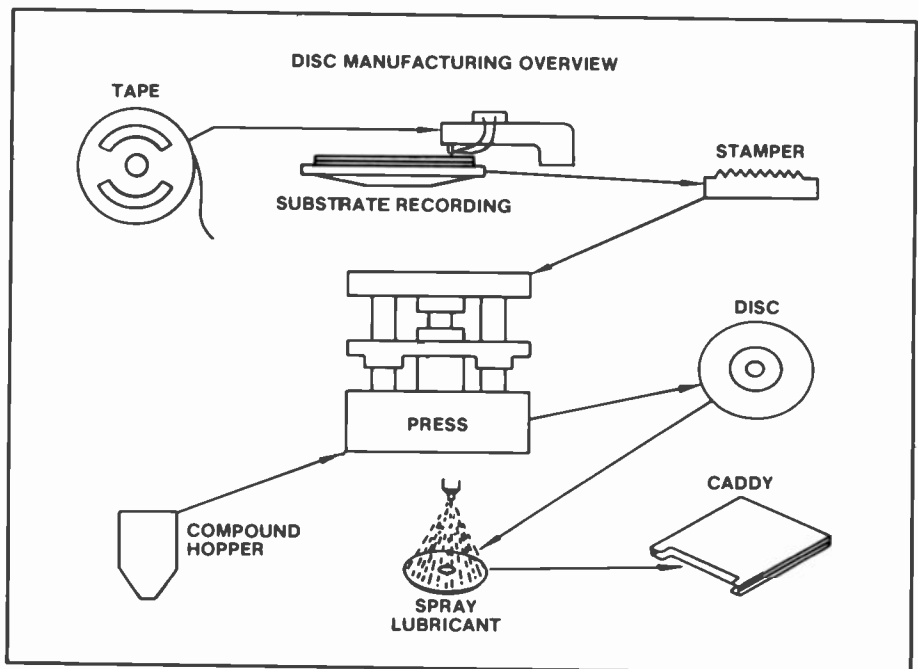

Fig. 1. Signals from magnetic tape are recorded onto a copper-plated substrate from which a nickel stamper is electroformed. The disc is pressed, chemically stabilized, lubricated, and inserted into a caddy.

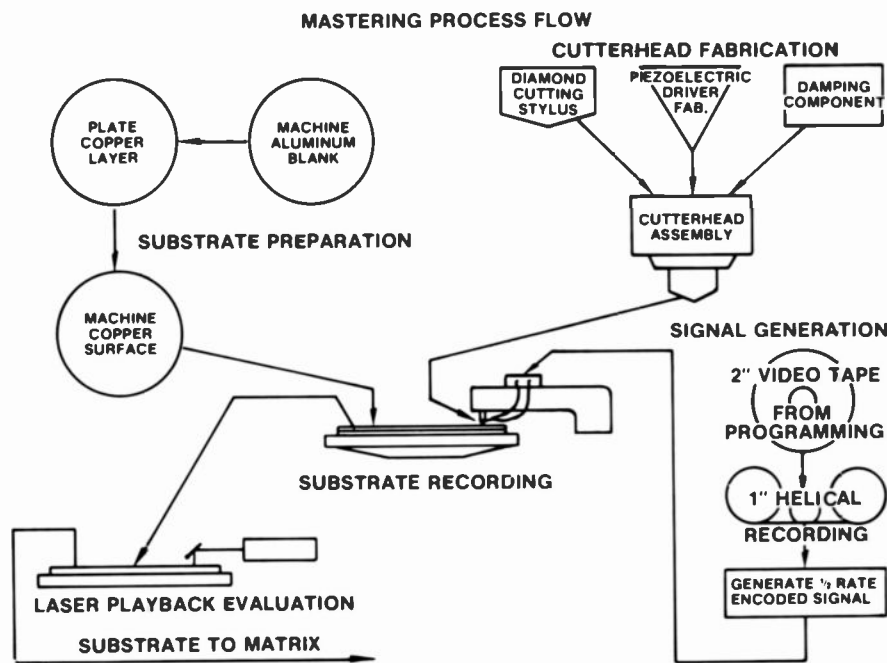

Fig. 2. A copper-plated aluminum substrate is used for recording by means of a diamond cutterhead. The quality of the recording is monitored with laser playback equipment.

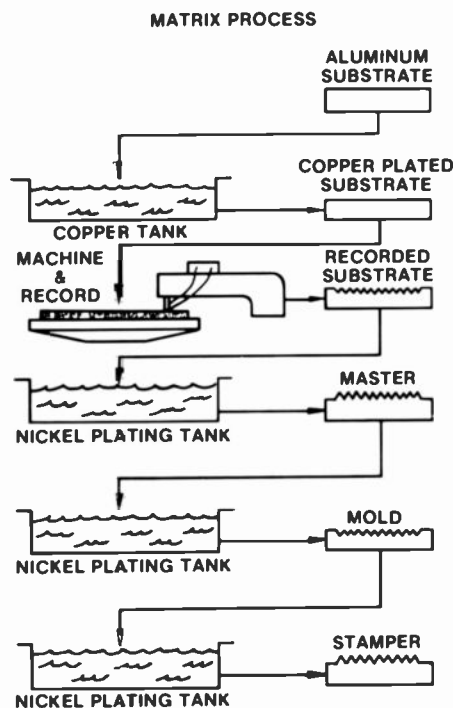

Fig. 3. Nickel masters are electroformed from the recorded substrate. These in turn are used to electroform molds (mothers) and stampers for use in pressing discs.

Molding material, which is separately compounded, is fed pneumatically to the automatic presses. The disc surfaces are then chemically stabilized, washed, dried, and lubricated by means of rather exacting chemical steps. The disc is then inserted into a caddy that serves as both a package and a protective envelope.

Figure 2 shows further details of the technology involved in the recording process. The program is dubbed onto a 1-in. helical-scan-format tape. The playback mechanism has been modified so that, in conjunction with a digital frame store, the

television signal can be recorded onto a substrate at half real-time rate.

The video signal from the slowed-down tape machine is encoded into a "buried-subcarrier" format, then the signal is FM modulated and fed to the Substrate Recording Lathe. The audio at half real-time rate is processed such that it will play back from a disc with optimum quality. The audio is FM modulated and added to the FM video going to the Substrate Recording Lathe.

A code (DAXI code) is added to the video signal to allow the disc player to

identify program start and finish, band number, playing time, and so on. Recording start and stop are controlled by a microprocessor. A diamond piezoelectric cutterhead assembly is separately manufactured for use in the recording process.

The first step in the matrix operation is to plate a copper surface onto an aluminum substrate. The aluminum substrate is machined flat for mastering, ultrasonically cleaned, and then dried. It is treated and then preplated to allow good adhesion of the copper plate.

MATERIAL FLOW SEQUENCE

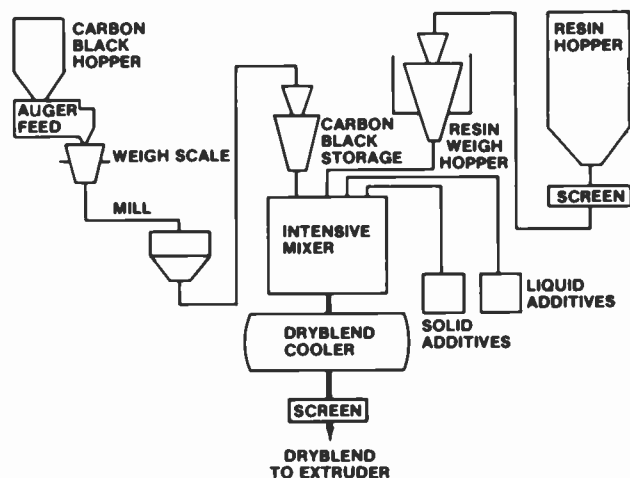

Fig. 4a. Sequence for manufacturing dry blend. PVC, carbon, and additives are blended. The blend is cooled and the dry blend is conveyed to the extruder hopper.

DRYBLEND FLOW SEQUENCE

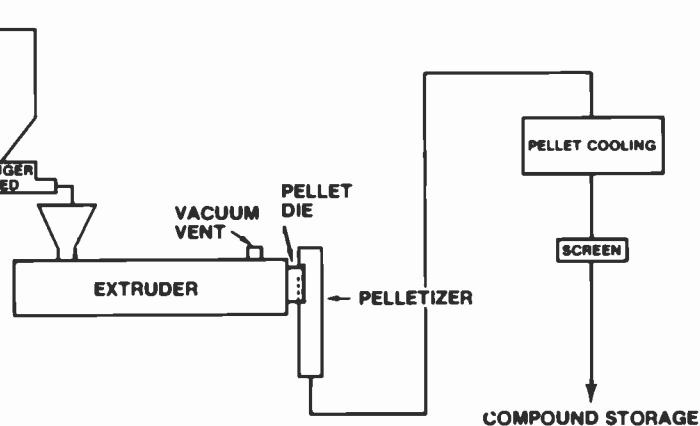

Fig. 4b. Final steps. The dry blend is extruded into a compound melt and chopped into pellets as the compound strands are forced through a die.

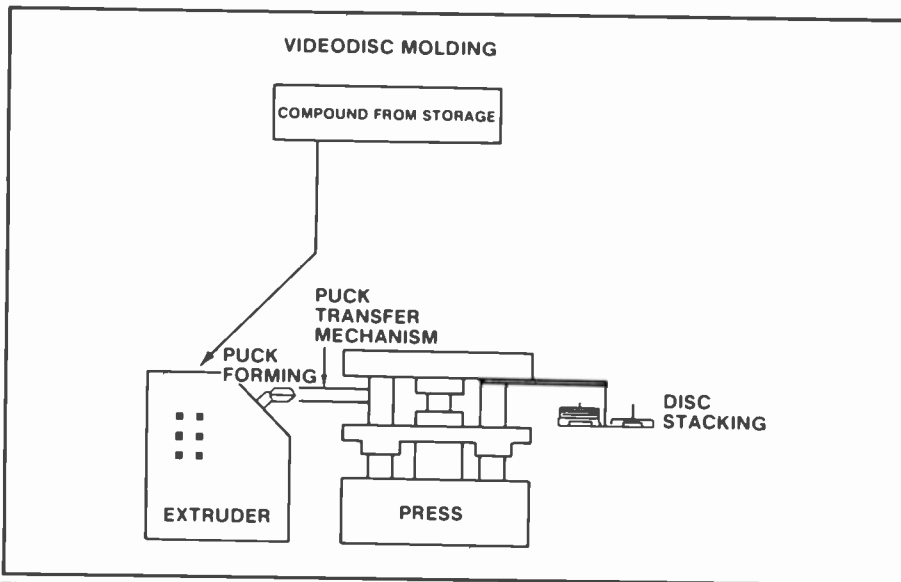

Fig. 5. Compound is fed to an automatic press through a small extruder into puck cavity. The puck is automatically transferred between the platens of a press from which the disc is pressed, flash is automatically trimmed, and the discs loaded onto spindles.

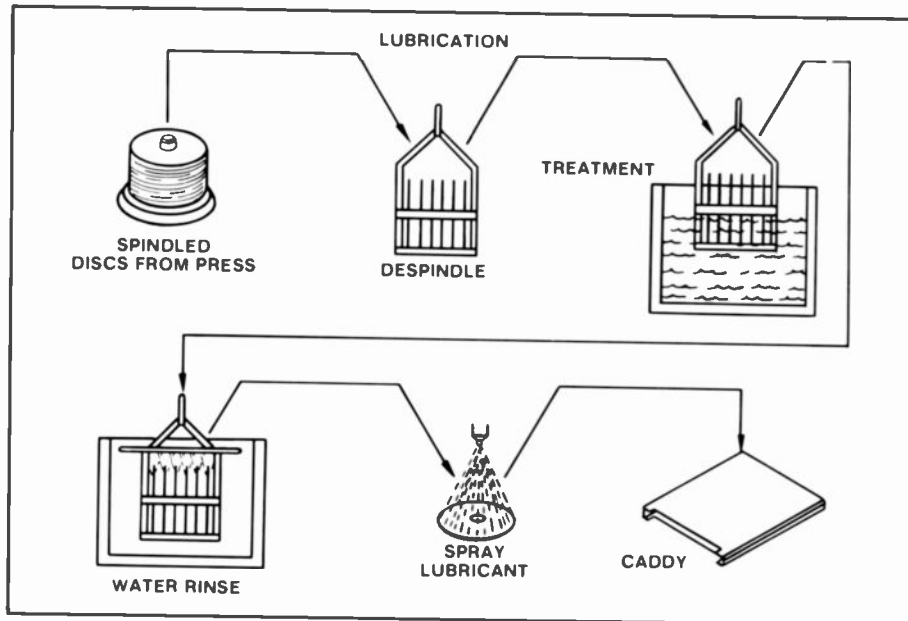

Fig. 6. Discs are chemically stabilized, rinsed, dried and lubricated and inserted into caddies.

The preplated part is mounted in a rotating bright copper bath and electroplated. This step is critical to a good electromechanical recording. By means of a closely controlled plating process, a hard copper surface about 15 mils thick is obtained. The properties must be such that a clean sharp groove can be cut into it without the cutting chip breaking or balling up.

Figure 3 illustrates the matrix operation, which includes copper electroplating for the substrate and nickel electroforming steps similar to those used in the record industry, but the details of the procedures

and the equipment used are significantly modified to provide the quality required for the Videodisc.

The compound

Basic and unique to the Videodisc process is the compound used. This formulation was specifically developed at RCA. It is a polyvinyl chloride (PVC) homopolymer matrix into which a high-conductivity carbon black has been dispersed. PVC content is about 75 percent and the carbon content is about 15 percent, with seven

other modifiers, stabilizers, process aids and internal lubricants added to produce a balanced blend of compound having the desired properties.

The compound must exactly replicate the recorded audio and video signals, achieve the exacting physical dimensions and stability required, and maintain resistivities of about 5-ohm-cm or less to achieve the required electrical characteristics.

Material flow sequence

The Videodisc material is compounded by a series of steps (Fig. 4a). The PVC flows from the storage hopper through a vibrating screen to a weighing hopper where a specific amount is metered into the mixer. The carbon black is also weighed and added to the mixer. Liquid and solid components are added and the materials are mixed until uniform. This batch of dry blended components is cooled and fed to the storage hopper of the extruder.

The dry blend (Fig. 4b) is continuously metered to a compounding extruder where it is melted and further mixed. A vacuum vent removes undesirable volatiles and the molten compound is forced through a die, cut into pellets, cooled, and stored or transported to the presses.

The carbon used to achieve the high level of conductivity required for the Videodisc had to be specifically developed. Never before had requirements for so exacting a carbon black existed. An active black having an area in excess of 800 square meters per gram and low volatile content had to be developed. Only traces of cations could be tolerated and low ash was required. Close cooperation with suppliers resulted in the production of this carbon specifically designed for use in formulating a "CED" Videodisc.

Purity and cleanliness of all major component additives for this system is higher than other commercial products and is on a par with that used by the semiconductor industry. Since the groove width is 2.5 μm , foreign undispersed particles of that magnitude or higher result in the formation of surface defects that will deflect the stylus and cause unwanted picture and sound disturbances.

There is no doubt that the Videodisc will spawn a series of raw materials manufactured to the highest purity levels not customary in the plastic compound-formulation industry. Suppliers of chemicals to the semiconductor industry responded

similarly during the early developmental stages of that technology.

The presses used are fully automatic, manufactured in Europe originally for audio discs, but significantly modified to RCA specifications to satisfy the exacting requirements of the VideoDisc.

The compound, in the form of pellets, is fed to the hopper and then to the short single-screw extruder attached to the press (Fig. 5). The extruder screw acts as an auger that conveys, compresses, and melts the pellets as they pass through the heated barrel. The feed section of the extruder screw is the bottom of the hopper. The molten extrudate is forced into the closed puck-shaped cup. The material fills this cup to a weight controlled by a timer. After the puck is formed and the extruder shuts off, the cup opens away from the puck. The mechanical arm then places the puck in the center area between the upper and lower molds of the press.

The stampers are clamped into the upper and lower mold bodies. The molds are heated by steam to about 370°F. Then the press closes and compresses the puck into a disc. The excess material is flashed out of the molds but is still connected to the disc. The hot plastic material remaining in the mold cavity is held under heat and pressure until a disc is formed with the stamper surfaces replicated in the hot plastic.

Steam is ejected from the molds, and water is introduced into the molds, cooling the stamper surface down to 80°F. Under these conditions the disc becomes hard and rigid. The press then opens and the disc is removed by grippers holding the flash. The entire molding procedure takes about forty seconds.

A process microcomputer ensures that each puck is molded with identical temperature conditions. The steam heating cycle is adjusted to a specific mold temperature and then the cooling cycle timer is further controlled to the final temperature. Each disc is therefore processed to the same maximum temperature and then cooled to the same molding temperature, regardless of fluctuations in steam pressure or water temperature.

Next, the disc is ejected from the grippers, the flash is trimmed off and the disc is dropped onto a spindle. A mechanical indexer automatically discharges an aluminum spacer every five discs to prevent warpage. The spindle is automatically discharged from its position and an empty spindle replaces it (Fig. 5).

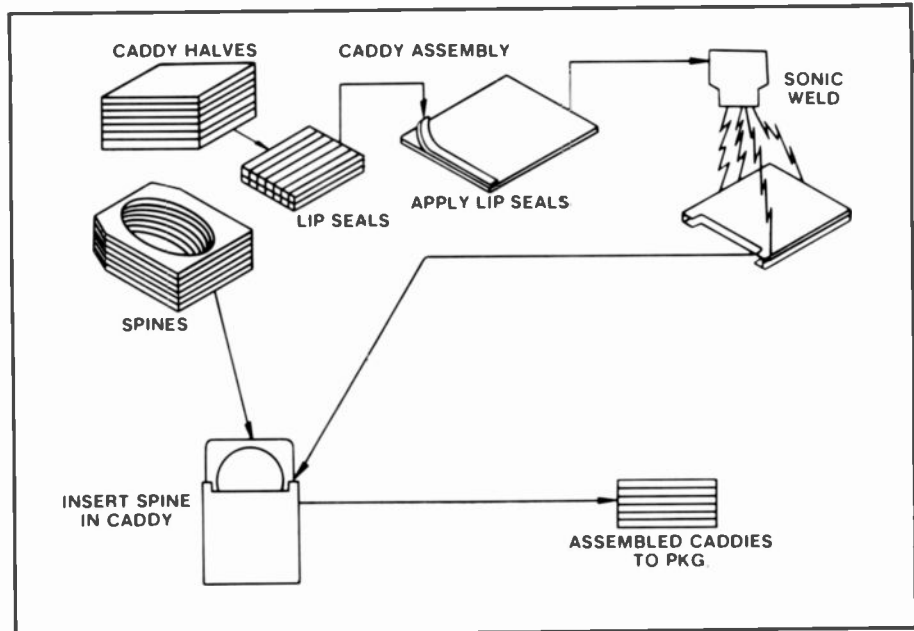

Fig. 7. Caddy assembly sequence. After lip seals are applied, plastic caddy halves are ultrasonically welded. The spine, which will hold the disc, is inserted into the caddy.

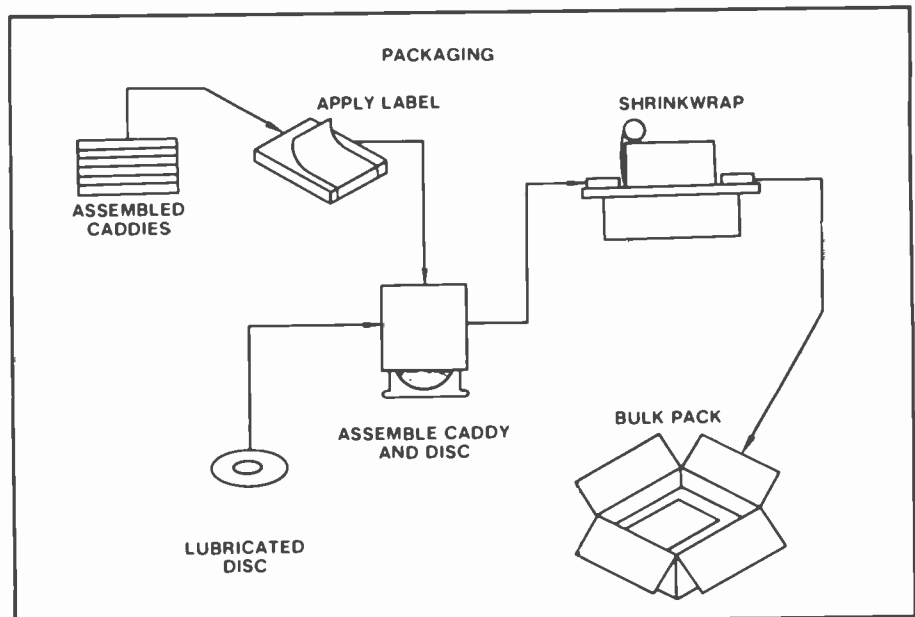

Fig. 8. A label identifying the program is glued onto the caddy and the disc is inserted. The assembly is shrink-wrapped and packed for shipment.

Chemical treatment

The final step before the disc is inserted into the caddy consists of a chemical surface treatment with a dilute solution of amines followed by hot water rinses and a final drying step (Fig. 6).

The discs are given a chemical surface treatment after pressing to minimize carrier-distress problems caused by moisture and age. Discs treated by this process show less carrier distress (loss of picture and sound) after moisture stress than untreated discs. The chemically treated discs

typically average a few tenths of a second carrier distress after moisture stress, compared with 20 to 30 seconds for the untreated discs.

After surface treatment, the discs are lubricated with a 250-angstrom film of specially developed silicone oil, using a spray process and equipment developed by RCA specifically for the VideoDisc. X-ray fluorescence measurements are used to control oil thickness. This lubricant provides wear protection for both the disc and stylus

The caddy

Molded caddy halves are separately assembled and automatically welded for supply to the disc operation (Fig. 7). The assembled caddies are labeled (Fig. 8) to denote the appropriate program material on the disc that is inserted to form the final package assembly.

Caddies are used to protect the disc from handling. This prevents the fingers from depositing on the disc salts and oils that would interfere with proper reproduction of the play material. The caddy is designed so that when it is inserted into the player, the disc is automatically transferred onto the spindle for play. In a similar way, reinsertion of the caddy will disengage the disc, allowing the caddy and disc to be removed as an assembly.

Extensive quality control tests are used during the manufacturing process. The final product is tested by Product Assurance to ensure that discs to be sold meet the highest quality standards.



Harry Weisberg received the B.S. degree in Chemical Engineering from City College of New York in 1944 and the M.S. degree in Polymer Chemistry from Brooklyn Polytechnic Institute in 1960. He studied electronics at the University of Scranton.

Mr. Weisberg joined RCA in 1958, where he has worked in various design and process-development areas. The RCA Thyristor and Power Rectifier Activity functioned under his design leadership from 1961 to 1965. During this time, he supervised and

participated in the design of RCA's thyristor line.

Mr. Weisberg was appointed Manager, Thyristor Product Development in 1965. In early 1969, he assumed responsibility for CMOS design and technology. In 1971, he advanced to Manager, MOS IC Products, and in 1973, he became the Director for this activity.

In June 1974, he advanced to Division Vice-President, Solid State MOS Integrated Circuits. In June of 1975, he assumed responsibility for all of RCA's solid state activities in Europe, Africa and the Middle East. From 1977 to 1979, he held a similar position with Harris.

He rejoined RCA in 1979 as a Division Vice-President for the newly-formed "SelectaVision" VideoDisc activity. The development of the disc and initiating of production was spearheaded by him at Indianapolis. Currently, Mr. Weisberg is responsible for Development Engineering for the VideoDisc.

Contact him at:
"SelectaVision" VideoDisc Operations
Indianapolis, Ind.
TACNET: 426-3104

VideoDisc mastering: The software to hardware conversion

With the program, Race For Your Life, Charlie Brown, the VideoDisc Mastering activity went into production in the second quarter of 1980, and the race to improve quality continues.

Abstract: *Following a brief overview of the operations performed during mastering for VideoDisc, this paper describes the efforts undertaken to enhance the quality of the end product, the VideoDisc, and to maximize yields.*

The display board shown in Fig. 1 illustrates the steps in mastering, the first operation performed in the creation of the VideoDisc at our "SelectaVision" VideoDisc plant. Program material is received on videotapes similar to the reel shown on the left side of the display. This reel is called a sub-master because the original copy or master is retained by our Hollywood operation, which performs the film-to-tape transfer. Each sub-master contains the program material for one side of a disc. In this form, the program material is referred to as software.

Shown in the upper left of Fig. 1, the initial step in the mastering operation is to copy the sub-master for a detailed review against our software standards. A copy tape is used in this review to minimize damage to the sub-master. This review may indicate the need for additional processing of the program material to attain the standards necessary for mastering. In Fig. 1, this operation is illustrated in the upper right, and includes such things as noise reduction, signal-level adjustments, and chroma-to-luminance timing corrections.

Either this enhanced copy or the ap-

proved sub-master is used in the final mastering operation. As shown, the approved tape is played on a special half-rate videotape system, which reduces the bandwidth, consistent with the cutting rates we are able to reliably achieve. The half-rate video signal is encoded into the special format developed for the "SelectaVision" VideoDisc system. This encoded video and the half-rate audio modulate separate FM carriers, which are added together to form a composite signal that is transferred to the groove of the VideoDisc.

The actual transfer of this composite signal into the groove pattern, which forms the master for one side of a VideoDisc, is accomplished in a Substrate Recording Lathe. This lathe provides a rotational drive for the substrate and a proportional translational drive for the diamond-tipped, groove-cutting assembly called the cutterhead. The rotational speed of the substrate and the translational motion of the cutterhead are "servoed" to a common reference so that the substrate makes one revolution for each eight TV fields, while the cutterhead translates about 100 millionths of an inch. These two motions create an involute with about 10,000 grooves per inch.

The nominal depth of the groove formed by the cutterhead is 20 microinches. This groove depth is modulated in proportion to the composite signal carrying video and audio through a piezoelectric element that supports the cutting diamond. In essence, the nominal groove-cutting depth of the diamond is modulated by electrically driving the piezoelectric element so that its

thickness changes with the composite signal. The change in the piezoelectric element's thickness, and thereby the change in the depth of the groove, is nominally 850 angstroms for the video carrier and 80 angstroms for the audio. Tolerances during this cutting operation are extremely tight and demand extreme precision.

Following recording, the substrate receives a microscopic examination to verify the integrity of the grooves and then is played at full rate on a laser player that simulates the action of the disc player, but without contact with the critical substrate surface. Those substrates which successfully complete the microscopic examination and the laser playback are delivered to the Matrix Department for further replication.

The need for high yield

As in the start up of every new production process, yields were not as high as one would like. This was particularly critical in the case of mastering because it is the first of several production processes in a series, and imperfect yields in subsequent parts of the disc manufacturing cycle—that is, matrix and pressing—reflect back ultimately to mastering with a multiplicative demand for greater output. To meet that demand, we have attempted to get our yield as high as possible and, although not yet to the levels that we would like, the mastering yield has substantially increased from the days of *Charlie Brown* and is continually getting

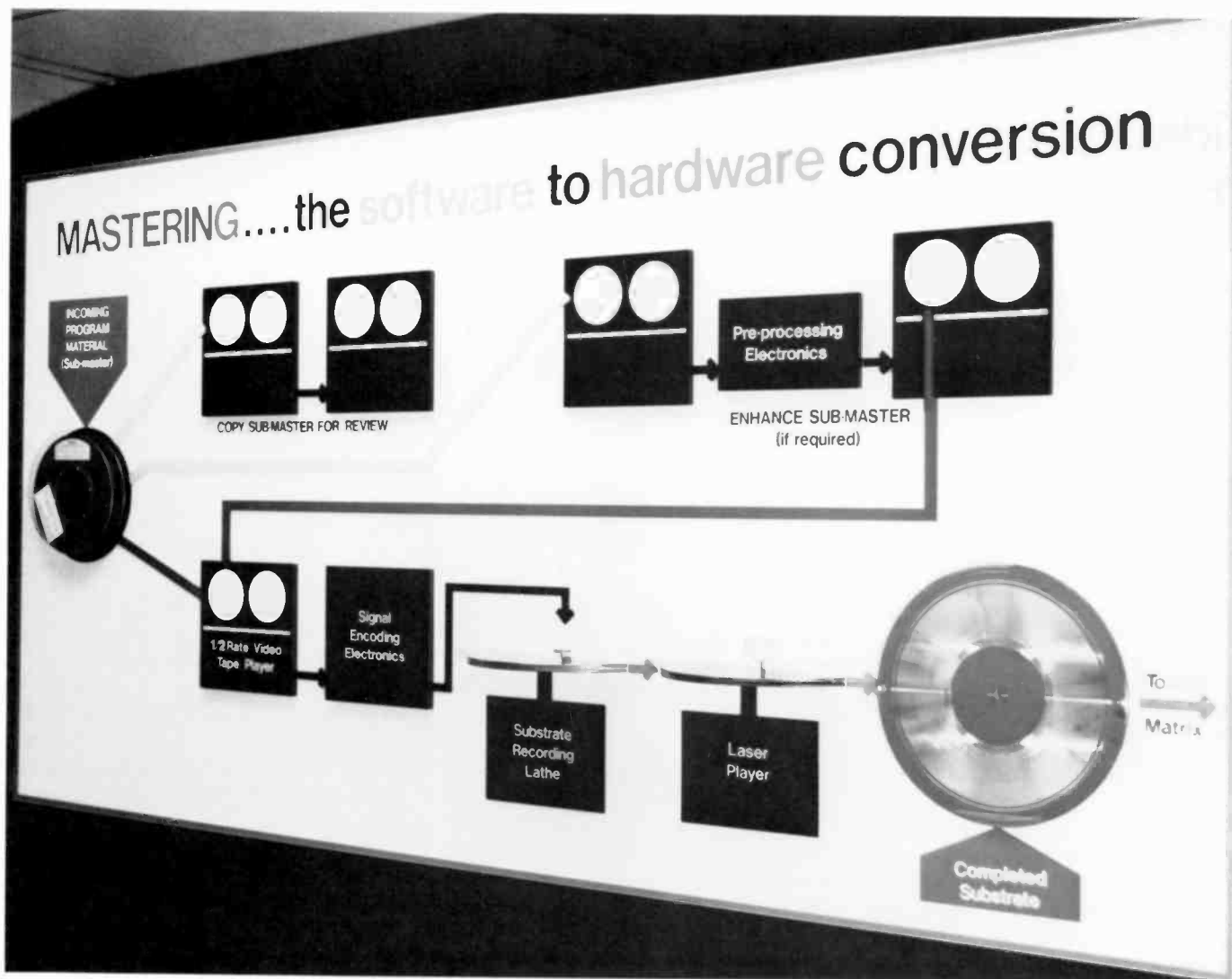

Fig. 1. A display board used at the "SelectaVision" VideoDisc Operation. It illustrates the basic functions performed in the creation of the master recording, the substrate, which is matrixed (the substrate makes many masters which make many mothers which make many stampers) to produce a multiplicity of the stampers used to press the disc. Separate substrates and stampers are obviously required for each side of the disc.

better. In this article, we will give insight into our mastering operation by sharing a few of our more interesting struggles to win the race with *Charlie Brown* and the ever-expanding group of program selections that followed.

The biggest problem: the smallest tolerances

As mentioned, the cutting depths for the video and audio are respectively 850 angstroms and 80 angstroms (80 angstroms is about 320 billionths of an inch). For good system performance these depths must be accurately controlled, and the tolerance one must impose to accurately repeat a dimension of 320 billionths of an inch is

very, very small. In the effort to improve our substrate quality at the beginning of VideoDisc mastering, maintaining these cutting-depth tolerances was our greatest technical problem. At that time, the video-carrier depth measurements were taken from SEM (scanning electron microscope) photographs of a thin nickel replica of the recorded substrate. The audio depth was inferred from the ratio of audio-carrier amplitude to the video-carrier amplitude as measured on the Laser Substrate Reader. These techniques of carrier measurements were time consuming, not very accurate, and always open for questioning. It generally took a week or more from the time a recording was made until the SEM measurements were available. Later on, audio-carrier measurements by means of SEM photomicrographs were

added to the recorded substrate inspection to verify and/or support playback measurements from the laser substrate reader.

In January 1980, we started using a laser diffraction spectrometer designed and built by the RCA Laboratories, Princeton, for measurement of the video carrier in lieu of the SEM photomicrographs. The diffraction spectrometer is a device designed to measure the diffraction spectrum produced when illuminating a recorded substrate by means of a laser beam. This instrument calculates, displays and plots the video-carrier signal depth and a squared error signal. The error signal indicates the difference between the groove shape of the substrate being measured and an "ideal" triangular groove cross section, thereby providing information on

the groove geometry of the substrate under investigation; for example, showing groove anomalies caused by worn or broken cutting styli or groove nonsymmetry caused by a tilted cutting stylus. The diffraction spectrometer, used for video-carrier measurements, improved the accuracy, resolution and repeatability of the measured values by at least one order of magnitude over the measurements taken from SEM photomicrographs.

The need for much tighter control of the audio-carrier depth to provide good audio performance without crosstalk of the audio signal into the video signal was met in May 1980 with the "Sound Carrier Amplitude Measurement System." This measuring system was built to specifications set forth in a disclosure by W.R. Roach of the Princeton Laboratories, and is based on measuring and analyzing the diffraction pattern of a laser beam when illuminating a relatively large area of a radially synchronized audio-carrier test band.

The use of the laser-diffraction-based measuring systems has brought about a major increase in mastering quality control. Use of these systems—for determination of the initial cutterhead response in the video and audio carrier regions, for measuring cutterhead response changes, and for evaluation of recorded substrates—has dropped the rejection rate of substrates for out-of-specification signal amplitudes to a very low and acceptable level.

The copper caper

The second major mastering problem was derived from a phenomenon known to us as chip ball-ups, a condition where some of the copper chips (shavings created during the substrate-recording operation) damage the grooves or weld into them. Extended correlations finally pinpointed the problem. Something was wrong with the plating baths used to deposit the copper surface on the substrate. These baths contain a special organic brightener used by the automotive industry to obtain a shiny, smooth copper underplating for chrome bumpers on cars. Thus, the standards on the brightener product had been controlled by the industry only to the extent that it produces a "bright" bumper underplating. The industry had shown little concern about the ability of the product to produce a copper plating into which 100-microinch-wide grooves could be machined without chip ball-ups.

To unravel mysteries in the plating process, additional instrumentation was obtained for the Matrix Department and frequent readings of critical bath parameters were embodied into the correlation with machining results. These efforts revealed a critical, nonlinear relationship between bath chloride and brightener concentrations that significantly affects the metallurgical, and hence machining properties of the copper deposit.

With this nominal understanding of the process, we started to develop process controls so that we could operate at the desired concentrations. This proved to be easier said than done because the consumption of both brightener and chloride during plating have separate nonlinear relationships dependent on the concentration of both. Reasonable control was finally attained through a strategy of an estimated add after each part, with daily adds based on a bath analysis to adjust the mixture to optimum concentrations.

Just as we were beginning to perfect bath control and hence reduce chip ball-ups during mastering, another correlation indicated a time-dependent deterioration of those substrates plated at the lower concentrations of chloride and brightener. Metallurgical tests subsequently verified that the extremely fine-grain copper produced in the bright copper acid bath does in fact recrystallize with time at the lower brightener concentrations. Since this condition significantly influenced the number of masters which could be matrixed from each substrate, a least cost trade-off favored less optimum copper for machining. Hence, we are currently "living" with a higher level of chip ball-ups in mastering until the copper process is further refined, but at least we know that the substrates we deliver will perform well in the Matrix Department.

Improving cutterhead quality

The foremost efforts in the cutterhead production area, since the start of production recording, were to improve cutterhead quality within the basic design constraints of our "standard" cutterhead. The first significant improvement came about in April 1980 when we modified the curing time/temperature of the diamond-to-PZT epoxy bond to produce a stronger and more reliable bond, which greatly reduced the failures that were due to loss of the diamond-cutting styli.

After some extensive testing, a change to thinner elements in the cutterhead trans-

ducer was adapted for the "standard" cutterhead in December 1980. The change to the smaller transducer resulted in an increased cutterhead resonant frequency, which eases equalization of the cutterhead and improves the differential gain characteristics markedly. In addition to these improvements, some increases in cutterhead quality were also achieved through upgraded assembly and testing fixtures, and procedures. Engineers at RCA Laboratories, Princeton, have been very instrumental in designing fixtures and establishing cutterhead assembly procedures, as well as initiating and/or proving out most of the improvements described above.

Diamonds aren't forever

As the volume of substrates delivered to the Matrix Department began to increase, we built a database on those substrates which had "matrixed" successfully. In other words, these substrates had supported the production of a large number of masters. In our terminology, they had "fanned" well. We analyzed this database seeking genetic reasons for their successful "fanning." (The copper recrystallization problem described earlier was revealed by correlation of parameters on those substrates that "fanned" poorly). Numerous parameters in the mastering and matrixing processes were considered in these correlations, including parameters in the copper baths, rake angle of the cutterhead diamond, diamond supplier, and cutting order of the diamond (that is, first cut with a new diamond, second cut with the diamond, and so on, through retirement of the cutterhead because the diamond had exceeded our limits for dimensional wear). These correlations proved highly informative, showing significant variations in "fanability" with both cutting order and supplier. One supplier's diamonds showed excellent "fanability" of substrates cut on the first three cuts of a new diamond, but then deteriorated rapidly, while the "fanability" of substrates cut with other major supplier's diamonds started at good and improved to excellent as the number of cuts increased. The difference in performance between the two suppliers' diamonds is assumed to result from a known difference in the diamond crystallographic orientation, however, this is still under investigation. In the interim, we have revised our diamond retirement strategy to optimize the substrate "fanability" in the matrix operations.



Gunter John joined Magnetic Products Division in 1966. In 1972, he transferred to "SelectaVision" VideoDisc Operations where he was responsible for the Indianapolis Electron Beam Recording and later the Electromechanical Recording effort. His present position is Manager of VideoDisc Mastering in "SelectaVision" VideoDisc Operations.

Contact him at:
"SelectaVision" VideoDisc Operations
Indianapolis, Ind.
TACNET: 426-3071

Don Kell is the Manager of Mastering Systems in "SelectaVision" VideoDisc Operations. He joined RCA in 1955 on a cooperative work assignment from Drexel Institute of Technology and has performed in a wide range of engineering and management assignments relating to wideband recording/processing for government and commercial systems. He has been a part of the drive to launch the VideoDisc and extend the catalog of available titles since February, 1980.

Contact him at:
"SelectaVision" VideoDisc Operations
Indianapolis, Ind.
TACNET: 426-3376

John Stevens joined RCA in 1966 from the B.B.C. in London. He has had technical and production experience with television systems worldwide. Recently, he was responsible for Telecine products (film and film to video) for Broadcast Systems Division. He is Manager of Signal Generation Operations at "SelectaVision" VideoDisc Operations.

Contact him at:
"SelectaVision" VideoDisc Operations
Indianapolis, Ind.
TACNET: 426-3378

The revision in our strategy had an apparent dramatic effect on the "fanability" of our substrates. In particular, the number of substrates rejected after the first use in electroforming a master dropped to nearly zero, reducing the demand on the Mastering Department and improving the efficiency in the Matrix Department.

A front-end realignment

The final picture quality of the VideoDisc depends to a great extent on the quality of the program material that we master. The old adage, "Garbage in, garbage out," holds true for VideoDisc. Program software supplied to our operation must meet very tight technical specifications. Sometimes material does not meet specifica-

tions because of limitations in the original software. For example, an old archive film starring Charlie Chaplin may not meet technical specifications but may have great public appeal. Obviously, experienced marketing and technical decisions have to be brought into play in the final approval of program material for mastering.

Before being scheduled for mastering, a software program is given a detailed review. This evaluation is conducted against a different set of standards than for broadcast television. The viewer at home watching VideoDisc will doubtless play the disc through many times and each time may notice the same defect. Defects in program material on broadcast television are largely forgotten because the opportunity for replay at the viewer's discretion does not exist. Thus, VideoDisc program material has to meet a higher standard. Poor

edits, frame jumps and other short-period defects can become irritants with multiple replays, so we have learned to look for and correct these imperfections with our pre-processing equipment.

Some of the parameters evaluated by Product Assurance and Mastering during software review can be graded by direct measurement of the video signal waveform. Others have to be graded by the experienced eye and ear of the reviewing technician. Table I lists some important parameters in software evaluation.

With the introductory VideoDisc catalog behind us, experience has taught us to distinguish software that will make a quality VideoDisc from software that will not. We have developed the capability to screen, and frequently correct the software at the front end, before mastering, thus ensuring the best possible program quality.

Summary and acknowledgment

The race to master the substrates required for the VideoDisc introductory catalog

Table I. Software evaluation parameters.

<i>Video parameter</i>
Picture white level <ul style="list-style-type: none">• Large area• Specular
Set-up level
Sync level
Luminance signal to noise ratio
Chroma/luminance delay
Colorimetry
Chroma level
Color shading
Photoconductive lag
Digital lag
Picture sharpness (acuity)
Edge transient response
Grey scale
Dark scene detail
Control track pulses
RS 170 A. sync standard
<i>Audio parameter</i>
Audio level
Distortion
Bandwidth and dynamic range
Balance of dialog to music
<i>Other</i>
Condition of tape reel
Poor program edits
Film scratches
Time code

was completed on schedule in January of 1981. This success resulted from significant improvement in our VideoDisc mastering operation across many areas, embodying a broad range of technology. These improvements would not have occurred without considerable support from organizational elements of RCA outside our Mastering activity. Improvements in software and signal processing were supported by activities headed by Al Malang in Hollywood, Jon Clemens in Princeton, and Jim Miller/Ed Freeman and Frank Levine/ Steve Godsey at Rockville Road; all with considerable consulting support from L.R. (Kirk) Kirkwood. Contributions in laser technology, particularly in the signal depth measurement techniques developed by Ron Roach, were spearheaded by the group led by Istvan Gorog in Princeton. Insight into copper process/metallurgical/machineability interactions were supported heavily by the Princeton activity under Len Fox, with support from consultant Carl Horsting, a long-term RCA employee retired in status but not in contributions. In cutterheads/copper machineability/diamond physics. John VanRaalte's group in Princeton set a rapid pace for developments and supplied good documentation packages. And finally many of the correlations of our databases, which proved again the value of statistics in refining a production process, were supported by Tom Strauss's group in our Rockville Product Assurance activity.

VideoDisc material compounding demands the right chemistry

The ingredients shown on this page were transformed into the pure, electrically conductive thermoplastic pellets (next page) with the right chemistry for RCA's VideoDiscs.

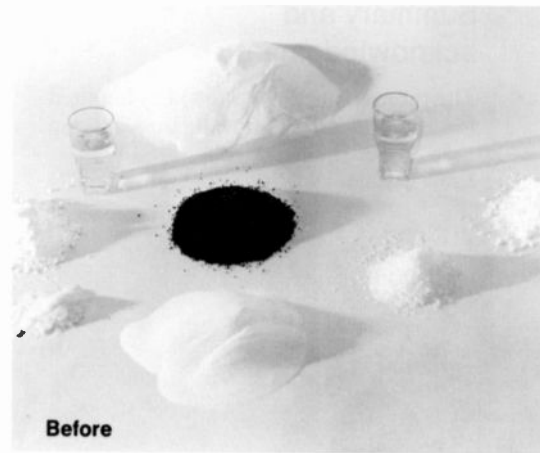

How do we make an electrically conductive thermoplastic that can replicate signal elements having dimensions about two or three times larger than the dimensions of the thermoplastic molecules and conductive carbon-black particles? How can we fill a thermoplastic so full of conductive carbon black that the particles touch and interlock while still allowing the mixture to flow readily for faithful replication? How can a thermoplastic composition be formulated to

be easily released from the mold surface without depositing at the interface a film that can obscure signal elements? What plasticization system can be chosen to enhance flow during processing without promoting shrinkage during the expected life of a VideoDisc? How can an inherently unstable thermoplastic, in a carbon-black-filled compound that promotes abnormally high shear heating, be processed through compounding, extruding and molding operations?

The ingredients

The above questions illustrate just a few of the parameters the VideoDisc compound must satisfy. Most properties are obtained at the expense of others and every ingredient affects several critical parameters. The list of properties that define a VideoDisc compound provide a narrow window for materials and usage levels, which must be methodically determined to achieve the best combination of VideoDisc properties and playback performance. The formulation consists of ingredients that are individually discussed below.

PVC

PVC (polyvinyl chloride) thermoplastic has a long history of use in audio records, however, the conductive VideoDisc com-

ound is more demanding. In the VideoDisc compound, the PVC is the major ingredient used as the matrix that surrounds the carbon black. This thermoplastic possesses a good balance of wear, scratch resistance, rigidity, and resilience. But it has poor thermal stability and degrades under heat and processing, liberating corrosive by-products.

Carbon black

Even though PVC is the major ingredient in the formulation, carbon black is the most important component. The carbon-black properties are not only critical but are variable from lot to lot. It is not yet possible to obtain carbon black with uniform structure and surface area. Therefore, the percentage of carbon black in the formulation is routinely adjusted to produce a compound with consistent electrical and flow properties.

The conductive carbon black in the VideoDisc has a surface area of approximately

1000 square meters per gram. The larger the surface area, the more conductive is the carbon black for a given weight percentage of carbon. The incorporation of carbon black decreases the flow of the compound, thus making processing difficult. The carbon black, as received, is a free-flowing granule. The granules must be easily dispersed with the PVC and other formulation components during high-intensity mixing.

The carbon black contains trace impurities, which can decrease the thermal stability of the compound and the playback performance of the VideoDisc. Thermal stability is monitored throughout the process.

Stabilizers

Stabilizers retard the rate of thermal degradation of the PVC thermoplastic, thereby allowing it to be processed at temperatures approaching 200°C. The most effective stabilizers in VideoDisc formulations are of the organo-tin type. A combination of stabilizers—both solid and liquid—has been found to provide the widest latitude of protection.

Plasticizers

Liquid plasticizers in the VideoDisc formula act as processing aids during dry blending, compounding and molding. Our "plasticizer" was chosen for its flow enhancement during molding and its compatibility with the PVC thermoplastic. Good compatibility ensures that plasticizers will



and after

not migrate to the surface during the life of the VideoDisc. Plasticizers with poor compatibility will adversely affect playback. The total concentration of liquid components in the formulation must be kept low to minimize shrinkage.

Lubricants

A lubrication system performs several indispensable functions in a VideoDisc formulation. The lubricants promote uniformity in the dry blend, reduce friction between the thermoplastic melt and the metal surfaces of the process equipment, lessen shear heating between polymer molecules, and aid release of the melt from the mold's metal surface.

An effective lubrication system is composed of several lubricants acting in such a manner that all the lubrication criteria are satisfied for each processing step. A balance between internal polymer-to-polymer interactions and external polymer-to-metal interactions must be struck to achieve optimum performance.

Our system was determined from the results of a great deal of testing and extensive trials. As the process was refined,

Abstract: *The chemical formulation for VideoDisc depends on the ingredients and on the process. Polyvinyl chloride is the thermoplastic matrix for a conductive carbon black with a large surface area. In addition, stabilizers, plasticizers, lubricants, and processing aids indispensably contribute to the formulation's success. The mixing process is unique because of the large amount of carbon put into a free-flowing, powdered, dry blend that is subsequently fused, melted and dispersed further in the extruding-compounding-pelletizing steps.*

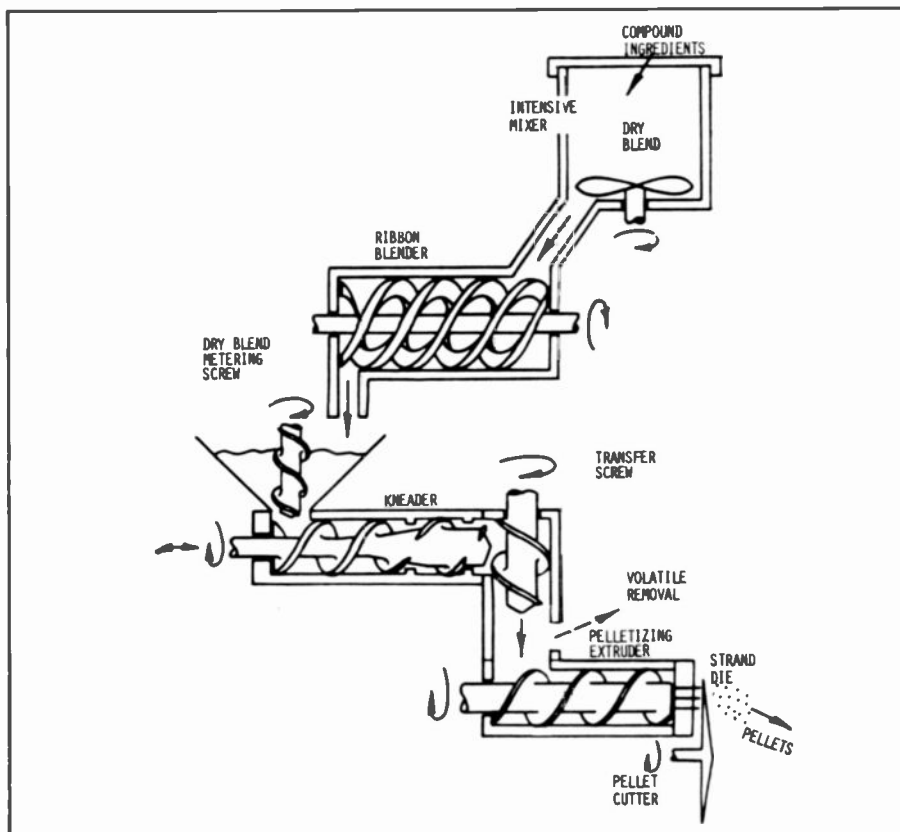

The ingredients are converted to dry blend in the mixer, then cooled in the ribbon blender. The dry blend is melted and dispersed in the mixer-kneader section, devolatilized and pelletized.

the lubricant levels were adjusted. The lubrication system consists of two fatty-acid-ester waxes and a metallic stearate.

Processing aids

Processing aids are used to promote fusion and melting of the PVC resin by fusing the particles together at an early stage in the compounding step. These ingredients increase the melt strength after fusion, and provide a controlled rate of fusion and uniform shear-heat generation. The processing aid is an effective external lubricant during processing, and it provides an excellent means for releasing the metal from the plastic at elevated temperatures.

Compound preparation

Our formulation consists of PVC, carbon black, liquid and solid tin stabilizers, powdered ester waxes, a powdered metallic stearate lubricant, a powdered processing aid, and a liquid plasticizer. These are all intensively mixed into a uniform and free-flowing, powdered dry blend. The dry blend is fused, melted, and dispersed further in

the extruding-compounding-pelletizing steps.

The mixing process is unique because of the large amount of carbon that is incorporated in the compound. The intensive mixer resembles a large Waring blender. When the carbon is first added to the vinyl in the mixer, the total volume increases considerably. As the intensive mixing continues, the carbon becomes dispersed with the PVC and other dry ingredients. The volume decreases with mixing as the carbon particles fill the voids between and become adsorbed on the vinyl particles.

After a batch is blended, it is dropped into a ribbon blender where it is cooled by contact with the walls of the cooler and the previously cooled batch of material. The cooling step is critical since the rate of cooling determines the final density of the dry blend. The extruder is fed dry blend on a volumetric basis and constant extrusion rates depend on constant cooling rates in the dry-blend step.

The heart of the pelletizing system is the compounding extruder. It is a single screw extruder that rotates and reciprocates in a combined motion. The flights (threads) of the screw are segmented and

the inside of the barrel has protruding pins that mesh with the segmented screw flights. The ends of the segmented screw flights pass close to the specially shaped pins, creating a localized intensive shearing action. The intensive shearing is followed by a gentler flow that interrupts the laminar flow in this region and shifts the sheared material away from the high-intensity mixing location. The rotational path of the screw-flight segments passes the pins first on one side and then the other for a front and rear wiping action and positive material exchange. The intensity of the shearing and mixing action is dependent upon the clearance between the rotating screw segments and the stationary pins.

The material is fed to the extruder as a dry blend. The dry blend is metered to the mixing section by a vertical feed screw in the hopper above the extruder barrel. The rate at which the dry blend is fed to the mixing section is one of the parameters that determine the location at which the dry blend fluxes into a melt inside the extruder. Another parameter that determines the flux point is the back pressure developed at the downstream end of the mixing extruder. This is mainly a function of the rotational speed of the transfer screw. The mixing section delivers melted, dispersed compound to the transfer section. The material, in molten form, passes through a vacuum port where moisture and other volatiles are removed. The devolatilized compound transfers to a single-screw pelletizing extruder, where the compound is forwarded and forced through small holds in the die plate. As the strands emerge from the die, a rotating knife cuts the strands and forms the pellets. The chopped molten pellet, relieved of stress after it is cut, changes from a cylindrical to a barrel-like shape. The hot pellets are cooled in a fluidized-bed counter-current unit and then screened for over- and under-sized pellets. The pelletized compound is packaged in stainless-steel containers. These containers are tumble-mixed and the container is tested as a lot.

Any particulate contaminant that becomes part of the compound can create serious problems. As the stylus rides along in the groove, the pressure created at the stylus-



Bruce Whipple is Manager of Compound and Plastic Development for "SelectaVision" VideoDisc Operations at Indianapolis. His group is responsible for compound formulation and process development of the compounding and pressing of discs. He joined the VideoDisc team in 1979. Contact him at:
"SelectaVision" VideoDisc Operations
Indianapolis, Ind.
TACNET: 426-3015

Victor Dunn joined RCA in 1979 as a Member Engineering Staff. His responsibilities include developing correlations between the physical properties of carbon black and VideoDisc playback performance, establishing a carbon-black source, assisting in the development of improved VideoDisc compounds, and selection of the compounding system used in production. Mr. Dunn has had over 16 years' experience in techniques related to the polymerization, stabilization, compounding, and processing of polyvinyl chloride resins. Contact him at:
"SelectaVision" VideoDisc Operations
Indianapolis, Ind.
TACNET: 426-3018

disc interface is quite high. If the local compliance of the disc varies abruptly, the stylus may loft and lose signal temporarily. If the lofting is relatively small and if the stylus lands in the same groove, electronic compensation will provide a substitute signal. If the stylus lofts forward or back, a noticeable flaw will be seen by the viewer. Buried particles as small as 20 micrometers can create serious viewing flaws. For this reason we filter and screen the ingredients in our plant, in addition to the special treatment they are given by the manufacturer. Highly filtered air is used to transport the materials everywhere in the processing up to the point that the compound is pressed into a disc.

Viscosity is a sensitive indication of the uniformity of the compound and is used

as the major control of processing properties. Since the viscosity of two-phase systems (carbon and PVC compound) is an indication of the volume of filler, viscosity is also a dependable predictor of the electrical behavior of the disc. After the lot of compound is tested and accepted, it is ready to be pressed into discs.

Conclusion

Formulating and processing the VideoDisc compound is complex. The system is now developed so that precision discs can be routinely manufactured. The formulation and process will further evolve with the optimization of the entire disc manufacturing system.

Micro-molding is a VideoDisc requirement

A human hair is as wide as 22 VideoDisc grooves in the scanning electron micrograph shown below (500X magnification). How do our VideoDisc engineers use materials and equipment to precisely mold all the signal elements within these microscopic grooves?

Abstract: For VideoDisc manufacturing, compression molding is used to successfully mold the high-percentage carbon-filled conductive compound into a precision disc with grooves one ten-thousandth of an inch wide and 12 miles long. The micro-molding process and equipment, together with pitfalls to be avoided, are described.

Molding the RCA "CED" VideoDisc presents a variety of unusual manufacturing opportunities. How do you mold a part one ten-thousandth of an inch wide and 12 miles long without any visual defects? The RCA VideoDisc contains such a groove on each side of the disc. This disc must be molded from a very stiff (by audio record standards), limited stability, carbon-filled material.

The grooves are so small that 38 of them will fit on the edge of a new dollar bill. The recorded video and audio information is contained in the bottom of these grooves. Figure 1 is a scanning electron micrograph of a human hair and a VideoDisc groove. Compression molding detail in the 10-angstrom (or 0.00000004-inch) range is required for the VideoDiscs. This article briefly covers the progress to date in the molding of the VideoDisc.

©1982 RCA Corporation
Final manuscript received Oct. 14, 1981.
Reprint RE-27-1-5

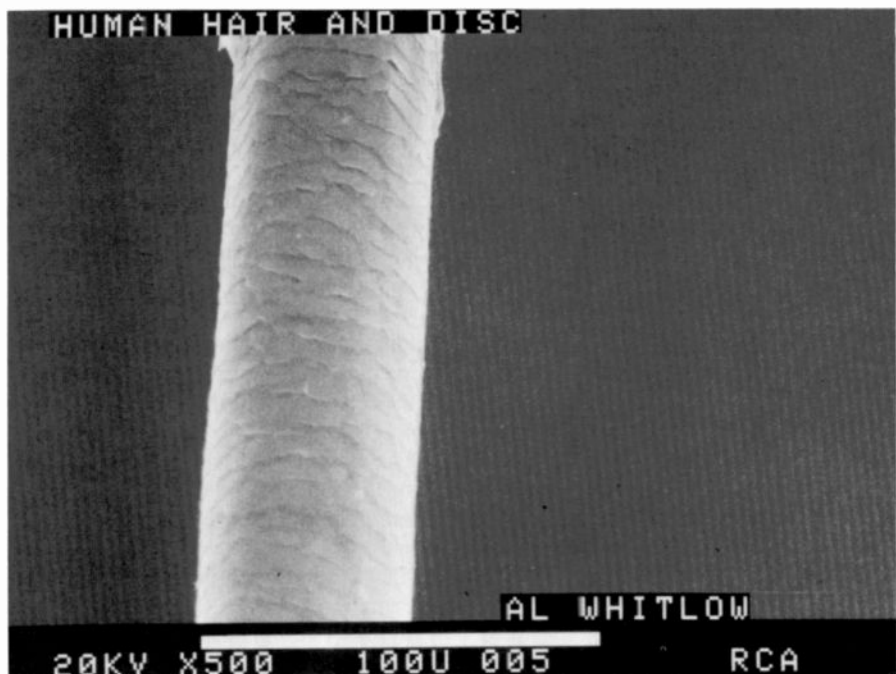

Fig. 1. This is a SEM photograph at 500X magnification showing a human hair and the RCA VideoDisc grooves. The signal elements (video and audio information) are the slots or holes horizontal to the vertical groove.

Molding equipment

The present RCA carbon-filled conductive VideoDisc became the system standard in mid-1977. Before then, the discs were injection molded from a non-filled PVC and then several coatings—metallic, insulating, and oil—were applied in a post-processing system. The carbon-filled

conductive compounds could not be molded by injection molding because of their high viscosity, limited heat stability, and unusual flow characteristics. As a result, the injection-molding equipment had to be abandoned.

Compression molding was selected as the only known process that could successfully mold the high-percentage carbon-

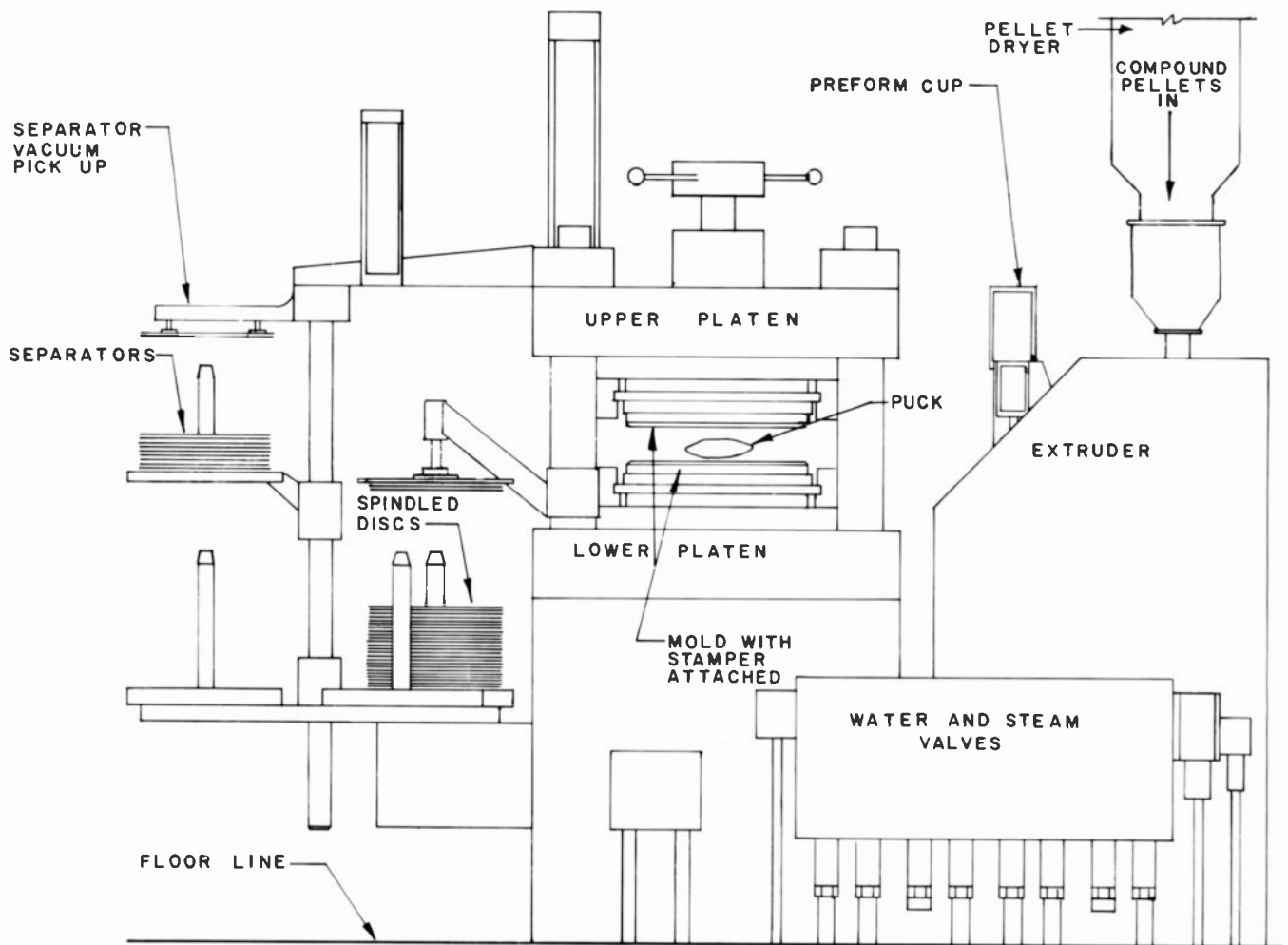

Fig. 2. The illustration shows the relative position of the various press components, except the disc edging station, which is located directly behind the press between the molding area and the spindled discs.

filled conductive compound. A worldwide study by RCA Records and Princeton determined that the best equipment for molding audio records was a compression press made in Europe. Initial contacts with the European company led to a joint development effort to provide an acceptable VideoDisc molding method. This joint effort was required because standard audio presses could not mold acceptable VideoDiscs. We are presently using the third configuration of the European press. The compression-molding press comprises four major sections, for extruding, molding, edging, and spindling. Figure 2 illustrates the various components of the molding system. The operation of the molding system is briefly described in this section.

Dried conductive-compound pellets are automatically loaded in the single-screw extruder. This unit uses electrical heat and a single extruder screw to form a specially shaped preform (or puck). Temperatures within the preform, at the time it is loaded into the press, are approximately 375°F.

Additional information about the manufacturing of the compound can be found in the article by Whipple and Dunn in this issue.

The molding section consists of a three-post, 112-ton, horizontal platen press with steam-heated and water-cooled molds. These molds hold the electroformed stampers that have the recorded video and audio information on them. The extruder's preform loader automatically inserts a hot preform between the steam-heated molds. When the mold temperature reaches the high-limit setting, the press's lower ram starts up and the disc is molded. A unique feature of the VideoDisc molding system is that a 1.3-in. disc-center hole is molded at the same time the disc is being formed. This feature is required because of the close tolerances needed for the disc side-to-side eccentricity. As the lower platen continues to close, the preform material flows across the mold face and through an outer diameter orifice into a disc removal ring. The mold steam shuts off and the

water starts cooling the mold. At about 80°F, the lower platen drops and the disc is removed from the mold. Next, the disc-removal ring carries the disc from the molding area to the edging station.

The disc compression-molding process uses the outer orifice of the mold and the heating and cooling cycle to build up pressure within the mold cavity. This process results in a ring of flash around the disc. Flash removal is accomplished during the edging operation. An upper and lower turntable, heated knife, and air router make up the edging station.

The edging cycle starts as the next disc is being molded. The disc-edge flash is cut by the heated knife before the closed turntable starts rotating. The knife removes the disc flash that leads to the thin section formed by the mold orifice. An air router machines the disc edge to the flatness required to allow interface with the caddy spline. Upon completion of the edging cycle, the upper turntable is raised and the

transferred to the spindle system, automatically.

At the spindling station, the discs are placed on a spindle, Fig. 2, with a separator every fifth disc. These separators are automatically placed on the spindle as specified to assure that the discs remain flat while on the spindle, and meet the system specifications for warp and acceleration. After 90 discs are placed on the spindle, the index table shifts and an empty spindle moves into the loading position. Full spindles of discs are moved from the pressing area for visual inspection, post-processing and packaging before shipment.

The various molding-system operations require close control of steam, water and hydraulic services, and a microprocessor controls the press functions.

Process requirements

Compression molding is a seemingly simple process used for decades to manufacture everything from toilet seats to audio records. The process itself is simple

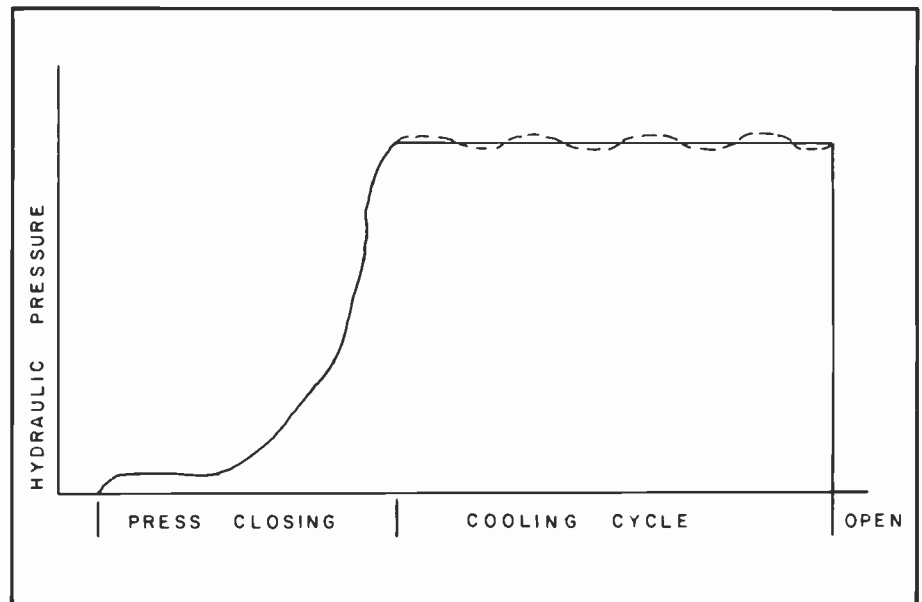

Fig. 3. Irregular hydraulic pressures, as represented by dotted line, induce stress into the molded disc. Warpage is the result of this stress. Controlled pressures, as represented by solid line, induce less stress, and therefore lead to a much flatter disc.

enough; it consists of an extruder to melt the compound and make it into a preform of desirable weight and shape. The preform is then placed between the two halves

of a heated mold whose configuration and detail one wishes to copy. The mold is then closed, using hydraulic pressure to form the semi-molten compound to the exact shape of the mold cavities. The compound then cools to a solid state, the mold is opened and the formed product is removed.

Adaptation of this simple process to the manufacture of the VideoDisc, with flatness specifications of less than 10 mils and microscopic groove replication requirements, presented some special problems. Two of the major problems are disc warpage and surface defects. Excessive disc warpage was overcome by the development of a new mold design, more effective control of cooling-water temperature and pressure, and better control of the press hydraulic system. Any high-pressure hydraulic fluctuation in the press has a pronounced effect upon the molded disc warpage. This effect was measured by installing pressure transducers in the press hydraulic system, recording the pressure signal, and observing the disc flatness. These measurements were made with good pressure control, and also while purposely causing the hydraulic pressure to fluctuate. Figure 3 is the hydraulic pressure curve under both constant and varying pressure conditions. Achieving the required control of the hydraulic system helped to eliminate disc warpage.

Other factors affecting disc warpage are mold-cooling rate (thermal shock) and press-closure speed (dynamic pressure). These factors have a less profound effect upon



Michael McNeely is Manager of Manufacturing Equipment Engineering for the "SelectaVision" VideoDisc Operation. He joined RCA Records Division at Indianapolis in 1967 as an Equipment Engineer in the Equipment Development section. From 1970 to 1972, he was involved in the Holographic Playback Project. His efforts on the VideoDisc Program have included various aspects of the equipment related to electroplating, finishing, compression and injection molding, compounding, post processing, and packaging.

Contact him at:
"SelectaVision" VideoDisc Operations
Indianapolis, Ind.
TACNET: 426-3083

Marvin Bock joined RCA in 1975 as a Molding Specialist and was promoted to Manufacturing Methods Engineer in 1977. His responsibilities include refinement of the molding process and trouble-shooting production problems. Mr. Bock had an extensive background in injection molding prior to joining RCA.

Contact him at:
"SelectaVision" VideoDisc Operations
Indianapolis, Ind.
TACNET: 426-3215

disc warpage than the peak hydraulic pressures; nevertheless, they had to be brought under control before we could achieve the disc flatness requirements.

Surface defects

Imperfections in the disc surface can cause stylus-tracking problems, increased noise, or signal loss. These defects are voids, blisters and stains.

Void: This is a hole in the disc surface caused by air entrapment during the molding process. This defect was eliminated by producing a dense preform, free of any air pockets, with a shape that flows radially during the pressing stage without trapping air.

Blister: This is a bubble on the disc surface, usually caused by gasses generated during the extrusion cycle, or moisture included with the compound. Close control of temperatures is necessary to prevent an overheating of the compound that

would result in the production of gas. To guard against possible moisture contamination, the compound is transported and stored in sealed tote bins before it is used on the Press Floor. As a final precaution, the compound is dried in the press hopper before the extrusion cycle begins.

Stain: This is a surface buildup or etching in the video groove area of the stamper. As a result, the molded disc has less signal depth or higher noise. Once the stampers become stained, the press run must be aborted and a new stamper setup must be installed. Oil and water vapor stains are minimized by careful maintenance of pipe connections. Also, the press is kept in a Class-100 clean area, an environment with a maximum of 100 particles bigger than $0.5 \mu\text{m}$ per cubic foot and a maximum of 10 particles bigger than $5.0 \mu\text{m}$ per cubic foot. Staining of the stampers at the press can also be the result of compound decomposition. Compound decomposition in the extruder is caused by low heat-stability material. Any compound in the extruder

during the heating-up period may be subjected to thermal degradation. Care must be used in the start-up procedures to make sure all degraded compound is purged prior to loading preforms into the mold.

Conclusion

The VideoDisc requires molding detail in the 10-angstrom range. To achieve this detail and minimize defects, the molding process parameters and equipment must be closely controlled. The development efforts by the RCA Rockville Road engineering groups has produced an acceptable process for molding the VideoDiscs.

Acknowledgments

We would like to thank those engineers, technicians, draftsmen and others who have made the successful molding of the VideoDisc possible.

Design and manufacturing of the VideoDisc caddy

Once the VideoDisc is made, the tough and elegantly engineered caddy protects it.

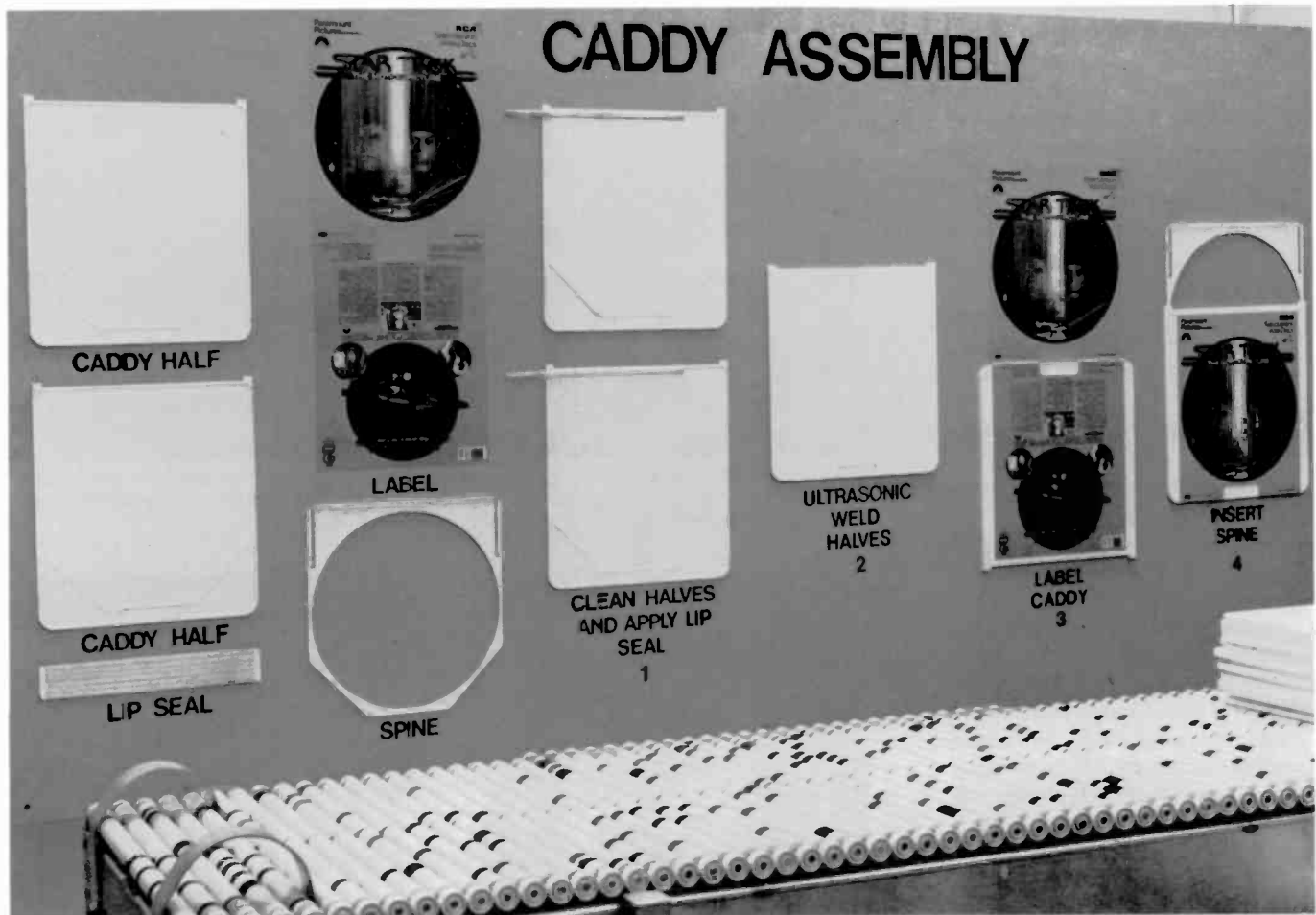

Abstract: *The details of the VideoDisc caddy's design and manufacture are given. The caddy adapts to a slot-leading concept for VideoDisc protection. The caddy also provides for side identification. Interfaces with the player and with the disc are covered, and a description of the caddy-and-spine molding process, assembly, testing and labeling is given.*

Since the need was recognized for a protective cover for the VideoDisc, the caddy has evolved as a combination of disc pro-

tection, handling convenience, and consumer appeal. The large billboard label presents an attractive image of a quality product to the customer. Shown above is the caddy assembly—parts and process.

Design considerations and approach

When enclosing the disc within a protective cover, the most important design aspect was that the device be adaptable to a player design that could use a slot-loading concept. This concept eliminated the inconvenience of opening the player lid to load and unload discs.

Earlier designs calling for the disc itself to be gripped by fingers inside the player were abandoned in favor of having the disc enclosed within a spine. The spine gave flexibility to the player's latching mechanism, because the leading edge of the spine could be shaped to a configuration that would lend itself to consistent latching.

Because the disc would always stay within the spine when being loaded and unloaded from the player, the *Side 1* and *2* correlation of disc to spine would be maintained, even if the caddy sleeve were reversed. The package design emphasized a balance of rigidity, impact resistance and thermal stability at low cost.

©1982 RCA Corporation
Final manuscript received August 10, 1981.
Reprint RE-27-1-6

“Is the correct disc in the correct caddy?”

Imagine a consumer's surprise if he bought a VideoDisc of a recent movie presentation, invited his friends home to watch, got settled in front of the TV with snacks and drinks, put the caddy into the player and found himself watching cooking lessons! What an embarrassment to everyone—especially RCA!

Can it happen? All systems are fallible, but the greatest care and the use of electronic detection methods are used to prevent this situation. The method used for ensuring that no mix-ups occur is a verification system that reads bar codes on the disc and label. When similar numbers are obtained, this allows the automatic loading machine to operate and insert the disc into the caddy.

On the back of the caddy label is a standard Universal Product code similar to that shown on many grocery items. This code is used by retailers at checkout counters to gain information; by distributors to simplify warehouse inventories, receiving, shipping and returns processing; and by the manufacturer to control production and manipulate a wide range of data. The most important VideoDisc production use, however, is that this bar code must correspond to a similar code molded into the disc.

The sequence of assembly starts with a labeled caddy into which the spine has previously been inserted, with the *Side 1* of the spine corresponding to the front pictorial side of the label. The caddy and spine are placed into a fixture that will the spine from the caddy only if the correct orientation is made. This will occur when the back side of the label is upwards so that the bar code can be scanned and the *Side 1* of the spine is downwards so that the unlocking mechanism can operate.

After unlocking, the scan is made and the numeric characters are shown on a display. The spine is now withdrawn to allow insertion of the disc. The disc is inserted into the open spine with its bar code downwards ready to be scanned from



Bar code verifier system. This system electronically scans the bar codes on the caddy label and the disc, allowing automatic loading of the disc into the caddy when similar readings are registered on the displays.



This view shows the molded-in bar code on the disc. It identifies Side One.

underneath. As the bar code on the disc is always molded on *Side 1*, this will establish the correct orientation for *Sides 1 and 2* of the disc corresponding to the correct sides of the spine.

After scanning the disc, and if the display corresponds (confirming the correct program matches the label),

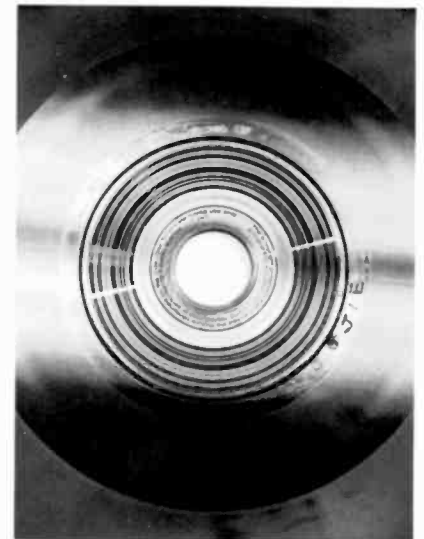

The label bar code is shown enlarged. It must match the disc before assembly is completed.

a mechanism is activated that closes the completed assembly.

When a two-disc album is produced, an extension is added to the label bar code to distinguish *Parts 1 and 2*. Similar information is molded into the disc bar code to recognize this difference and the same sequence is followed.

Function of individual components

Apart from the VideoDisc itself, the caddy assembly consists of two injection-molded caddy halves, two lip seals, the injection-molded spine, a label, and the final shrinkwrap. The lip seal is put into a recess at the front of each caddy half and is designed to fulfill three basic functions: to seal out dust and dirt when the disc and spine are in the caddy; to prevent the disc's recorded surfaces from sliding against the leading plastic edge of the caddy when being loaded and unloaded; and to clean the recorded surfaces of the disc during insertion and withdrawal from the player. After the assembly of the lip seal, the caddy halves are ultrasonically welded together to form a container for the disc and spine.

The main function of the spine is to provide a means for carrying the VideoDisc into and out of the player. At the leading edge of the spine, the side identification numbers are molded in for consumer recognition. These numbers are also molded with respect to a ramp. The ramp is detected by: mechanical logic that provides an electrical signal, and according to its orientation, the *Side 1* or *2* identification lamp is illuminated in the player, providing an early indication to the user of the side selected for playback.

The spine also includes molded locking fingers that are deflected into recesses in the caddy. Together, these fingers act as a locking device to prevent the disc from falling out during transit and to deter the consumer from indiscriminate access to the disc. The player mechanism defeats this locking feature, when the caddy is inserted and the spine is latched within the player, to allow the caddy sleeve to be withdrawn.

The label is a large one-piece wrap-around that gives maximum "billboard" effect while also providing an edge identification for caddies that are stored on shelves. The shrinkwrap is the final application—it has no structural function but it keeps the assembly clean.

Interface with the player

In addition to protecting the disc during loading and unloading, the caddy performs mechanical functions within the player. After playing a disc, the stylus will retract after reaching the end-of-play signal, but the player arm will not return to its start-

ing position. This is accomplished by inserting the caddy to retrieve the disc just played. Insertion of the caddy will push the player arm back to the start position, readying it for the next disc. No additional motors or mechanisms are needed.

Since the disc can still be spinning rapidly when the load/unload lever is activated, the player spindle stays in contact with the disc while the turntable is being lowered. This feature allows the disc to be restrained, when lowered to its position in line with the spine, ready for retrieval. Caddy insertion then causes the mechanical linkages to lower the turntable spindle from the disc, allowing disc removal from the player.

Interface with disc

The caddy internal clearance must be large enough so that there is no interference with the recorded surfaces of the disc and must permit low-force sliding contact when the disc is inserted and withdrawn. The maximum permissible internal clearance is that which does not allow overlap or jamming of the disc and spine. The flatness of the faces of the caddy are critical—they should not impart any tendency to warp the disc during storage. The internal surfaces must be smooth and be non-absorbent to the lubricant on the disc.

During the insertion of the caddy into the player for retrieval, the disc is pushed forward against the spine by the action of the lip seal. Since the disc has a rounded edge, it might be possible to jam the disc over or below the spine if the caddy were not properly aligned with the disc. But an entrapment is molded into the spine at this interface to catch the disc to prevent this occurrence.

Molding the caddy and spine

Molding the caddy halves to the flatness specification required for successful joining of the two halves into an acceptable assembly requires the precise control of many variables including molding machine, tooling, and material. The requirements of internal face flatness (no projections that could touch disc recorded surfaces) and external flat face (for attachment of label) means there is no possibility for strengthening ribs, runners, etc. that would aid molding control and stability.

The objective of the molding process is to produce a relatively large thin-wall part to the flatness specification with low mold-in stress for subsequent stability. To achieve maximum cost advantages, the injection-molding machines must run continuously and as automatically as possible. To obtain maximum yield of the welded assemblies, the individual caddy halves must be consistent with respect to flatness. Because the two halves are identical, parts from the same tool are welded together. No attempt is made for interchangeability from different tools, and shipments are received in skids from the single-cavity individual tools.

To achieve the required consistency per tool, the molding machines are equipped with process controllers. These controllers monitor and accurately control the critical molding parameters of injection pressure, velocity profile, shot size, melt temperature, and other variables. All tools are constructed with hot-runner plastic-feed systems so that no material is wasted per shot.

Of equal importance to the actual molding conditions are the subsequent handling and cooling approaches. Upon ejection from the mold, the caddy half is guided gently to a conveyor so that every part will fall in the same orientation. Since the specification for flatness does not allow any bow-in (for example, toward the disc), the part is placed on a frame and weight is applied at the center to bias the bow in an outward direction during cooling. Depending upon ambient conditions, the part takes approximately 15 minutes to stabilize. The part must be at room temperature before being packaged. The packaging containers hold approximately 50 parts each.

Assembly

After assembly of the lip seals, the caddy halves are nested together and ultrasonically welded. The weld area is in the form of staggered tongue-and-groove joints around three sides of the part. The staggered design permits parallel packaging of the part, from the vendor to the assembly area. At the top of each tongue section is a triangular-shaped energy director where the actual welding of the surfaces take place.

The welding machines are equipped with three full-length horns for the three sides to be welded. These horns are lowered simultaneously in a plunge-weld fashion. Adjustments are provided so that the flat



The ultrasonic welder machine. Three full-length horns are lowered simultaneously in a plunge-weld fashion.

faces of the horns may be tilted to compensate for the magnitude of the outward bow in the individual parts.

Testing parameters

Before welding, the individual halves are inspected for the bow profile, a characteristic that is important for initial setting of the welding machines. Heat tests determine molded-in stress levels that could affect the welded assembly.

After welding, the assembly is inspected for its critical dimensional parameters of thickness, width, twist, flatness and internal clearance. A pull test is performed to determine the strength of the weld joint, and selected samples are subjected to a heat test to assess the effects of any stress imposed by the welding process.

Labeling

The printed labels are applied with a wet-glue process on an automatic labeling machine. The labels have the glue applied by a roller and are fed flat onto a conveyor. The welded caddies are located by photoelectric detection and dropped down onto the label, into position. A station at the end of the machine folds the label over the caddy and wraps it into place. Tests are performed to ensure that the label is correctly positioned and that there has been no malformation of the welded caddy by over-wrapping or stretching.

Environmental tests are carried out to see if differences in expansion between the label and caddy affect the adhesion, cause bubbling, or affect any other dimensional parameters.

Final steps

The labeled caddies have the spine inserted in orientation with the label and are transported to the disc production line. After verification that the disc and caddy

combination is correct, the discs are loaded and the spine is snapped into place. The assemblies are then conveyed to the packaging area where the final shrinkwrap is applied, and the assemblies are boxed for shipment to the warehouse.



Leslie Torrington received the Higher National Certificate in Mechanical Engineering from the South-East Essex College of Technology in London, England in 1963. He joined RCA in Indianapolis in 1967 as a Design Engineer responsible for record-changer design. He was instrumental in the design of the industry's first all-plastic motorboard used in a fully automatic record player. In 1970, he joined the Advanced Development group in Indianapolis and worked on a cassette-type videotape recorder until 1973 when he joined the VideoDisc project. Mr. Torrington has been granted 15 U.S. patents for his work at RCA.

Contact him at:
"SelectaVision" VideoDisc Operations
Indianapolis, Ind.
TACNET: 426-3244



The label machine. The printed labels are applied, automatically, with a wet-glue process.

VideoDisc performance in the real world: The role of VideoDisc Product Assurance

Perceptions of product quality and performance, as judged by the consumer and by the manufacturer, may not always coincide. The challenge is to bring together these perceptions of quality and performance concerning the VideoDisc, in a cost-effective way, despite the risks inherent in a highly technical product in a new competitive market.

Abstract: *The Product Assurance organization within RCA "SelectaVision" VideoDisc Operations serves as a vital link in relaying the quality needs of the consumer back through the various RCA organizations involved in the development and production of VideoDiscs.*

Be it *Heaven Can Wait* or *The Godfather* or a myriad of other available programs, the choice of program material (commonly called software) is the ultimate key to consumer acceptance of the VideoDisc. Of equal importance, however, is the distinct need for the unquestioned quality and performance of the disc itself. It is in these areas that the Product Assurance organization places major emphasis.

Software assurance

Because high-quality primary program material is considered to be so important, RCA maintains a facility in Hollywood to obtain the best available film and videotape directly from originating studios. These original films and tapes are then converted to one-inch helical scan videotape. At Indianapolis, a review of these tapes is made to ensure that the tapes are of acceptable quality and to indicate the need for any additional processing to achieve good results on discs.

Product Assurance's review assesses all

incoming software for technical and subjective quality. A wide range of quality exists. In some older films, the technical and artistic quality is simply not up to today's standards. For example, the 1933 version of *King Kong* would be subjectively reviewed in a somewhat different manner than recent films. In the majority of newer films, however, the subjective analysis of the software is relatively uniform and consistent.

Quality of the recording also receives major attention. After a program recording has been made and the first metal parts (stampers) have been processed, a special evaluation is made of "proof" discs from the first press run of this program.

In this evaluation, the "proof" discs are carefully analyzed for video and audio quality. It is only after these critical steps are satisfactorily passed that multiple press runs are processed.

Product testing

A significant role of the Product Assurance organization involves the analysis of disc production press runs and the ultimate decisions on acceptance of discs for release to inventory. In addition to software acceptability, the basic inputs for these decisions include the following items:

Disc Visual Inspections

- Surface blemishes that could affect performance.

Disc Physical Properties

- Warp, concentricity of grooves and centerhole, and physical dimensions

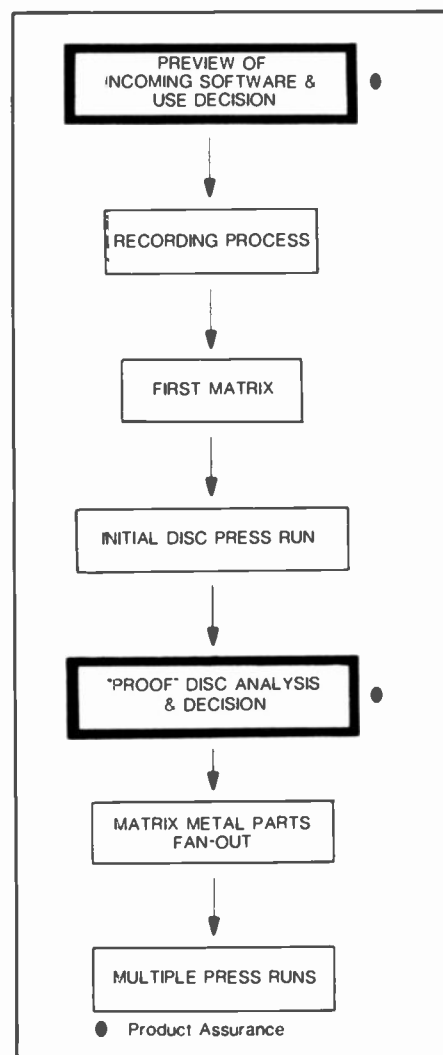

Fig. 1. Software qualification. Before mass production of the discs, the recorded program quality is controlled by critical inspections at the incoming software and "proof" disc stages.

Disc Playback

- Video signal-noise ratio
- Audio carrier-noise ratio
- Time-base stability (Jitter)
- Defect-gate activity
- Carrier distress (extended loss of playback signal)
- Tracking and dropouts

Final Product Audit

- Aesthetics of package, shrinkwrap, caddy, and label

Trend Audits of Final Product

- Playback parameters
- Environmental (stress) evaluations
- Simulated shipping, drop, vibration, and other tests
- Long-term storage
- Consumer Acceptance Laboratory (CAL) tests
- Field-returns analysis
- Systems performance

Development of in-house playback testing systems for video discs has spanned at least ten years. From the outset, it was apparent that massive volumes of discs would have to be accurately evaluated at minimum cost and in the shortest possible time. Given these constraints and the inherent 2-hour play time capability of the discs, it is literally impossible to evaluate each individual disc in any cost-effective way. Product Assurance now uses highly sophisticated sampling techniques and computer-controlled test hardware to assess, on a lot-by-lot basis, the technical and subjective quality levels of all outgoing discs.

Audit programs

Quality audits are extensively used by Product Assurance, in coordination with the Quality Control group, to rapidly assess the status of the product's compliance with standards.

The basic audit program uses a checklist for key processing areas and pays particular attention to cause-effect relationships. In addition to actual product performance requirements and conformance to specifications, audit programs are intended to monitor operator competence, work procedures, and standards of conformance to the total product quality program. In areas of nonconformance to specifications, a Material Review Board (MRB) assesses the effect of this nonconformance on disc quality, the anticipated consumer reaction, and the impact on production

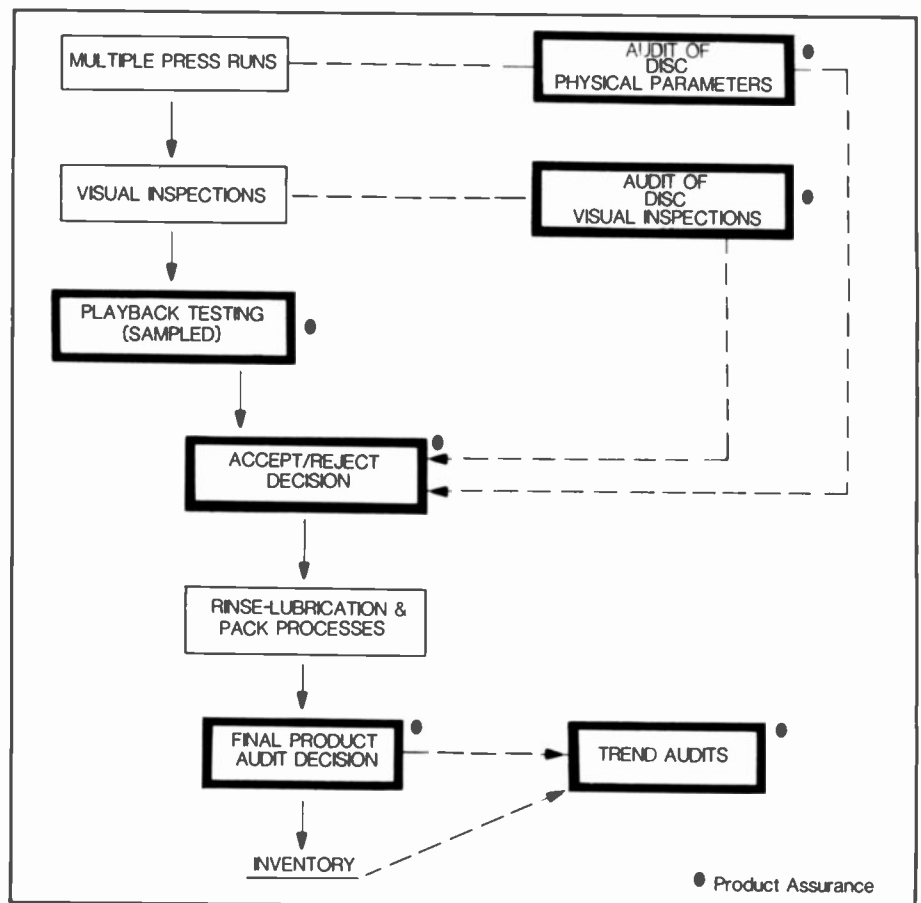

Fig. 2. Disc production. As shown in this simplified flowchart, Product Assurance provides decisions on lot acceptance at major disc production process points.

Environmental test services

Extensive tests have been developed to ensure that the VideoDisc and caddy will survive the range of temperature and humidity conditions that can be encountered in product storage, shipping, and in the consumer's home. These tests are conducted from random production discs and further ensure that discs will survive without damage, or adversely affect performance during play.

Typical environmental tests include:

- High-temperature cycling
- Low-temperature storage
- Moisture sensitivity (direct condensation on disc surface)
- Shipping simulation (vibration, shock, drop testing)
- Long-term storage simulations
- System tests under controlled environmental conditions

Components of the disc material must also be relatively unaffected by "aging" or changes in performance characteristics with time. Although the use of accelerated stress tests can give at least some indication, it

is also necessary to actually store discs for extended periods of time under controlled conditions. These tests normally range from six months to several years and involve comparisons of dimensional and playback stability.

To ensure that the VideoDisc system (disc, player, caddy, stylus and television receiver) performs reliably under all reasonable environmental conditions, it is also necessary to conduct "system" tests which, under well-designed statistical plans, are used to verify that the performance of the entire system is assured.

Vendor Assurance

Because many of the components in the disc are bought from other companies, control of product quality extends to vendor capabilities and responses. This area is significant because the variability in raw materials can significantly affect disc-defect levels and disc processing. Personnel in this activity also monitor processing materials and other product-related items, including packaging materials. Vendor Assurance serves as a technical liaison be-

tween the vendor and various RCA activities, such as Purchasing.

Product Assurance Engineering

Product Assurance Engineering provides the technical test support for a wide range of disc-related areas, including product support and new product and process development. As such, test services are provided to the various Engineering groups, and to Manufacturing, Quality Control, and others. It also serves as the technical arm of Product Assurance in the control of specifications and procedures.

As new processes and materials are developed, a series of designed experiments are established to validate the potential for further work or for introduction into the disc manufacturing process. Here, the Engineering staff conducts the tests and provides the final technical test data needed for the decision. In many cases, it is also necessary to evaluate the impact of process changes on the other parts of the system, such as the stylus or player. For these, joint tests may be conducted with other Engineering groups and the David Sarnoff Research Center technical staff. New products or product enhancements tend to impose more stringent demands upon materials and processing. For this reason, adequate tests are required to ensure quality levels consistent with the system demands.

One of the areas where Engineering has played a significant role is in the specific area of defect analysis. Defects on or in the disc surface can contribute to stylus skipping and dropouts. Special devices—known as microlocators—detect the coordinates of these defects, which are subsequently analyzed optically and by various analytical techniques to determine the elemental nature of the defect area.

Statistical assurance

The use of statistical techniques for product evaluation has become one of the primary tools of Product Assurance. Aided by the computer and advanced analysis techniques, data from multiple sources are used to optimize the actual number of production samples for the characterization of disc performance and to minimize actual testing time and costs. Programs are continuously being developed to better utilize data in product development, production, and analysis of product field



Fig. 3. Performance evaluation test system.

performance. Some significant examples include the following:

- Recognition of trend patterns
- Correlation of materials or processing conditions to disc performance parameters
- Statistical distribution analyses
- Field-performance modeling and correlations
- Manufacturing process-control support

Field performance analysis

One of the major hurdles to be crossed before the market introduction of the VideoDisc in March 1981, was to predict the level of consumer acceptance of the VideoDisc. Because no field response (in terms of sales or returns) was yet available, it was necessary to develop a statistical model of consumer response to VideoDisc performance. Through a series of field tests and "panel" tests, the subjective response of "typical" consumers was determined for all significant dimensional and play parameters. With some parameters more critical than others, a comprehensive response model that used a variables-weighting system for each tested parameter was developed. This algorithm was designed to determine the acceptability of disc production press runs for release to product inventory. This algorithm, with some modifications, has been in continuous use since the start of disc production at Indianapolis.

Since the market introduction of the VideoDisc, it has become feasible to verify the model by analyzing the actual rate and characteristics of discs returned for various reasons from consumers. By painstaking analysis of these discs, a composite profile of the likes and dislikes of consumers is being developed. This is an ongoing Product Assurance program that provides feedback to the Engineering and Manufacturing activities at Indianapolis.



Robert Huck is Manager of the VideoDisc Product Assurance and Test Organization. Prior to March 1981, he was Manager of the VideoDisc Engineering Test Group and had been involved with VideoDisc development at Indianapolis since 1972. He had previously managed engineering teams in the development of videotape, computer tape, and magnetic disc packs. He is a member of the IEEE, NSPE, and has served as the RCA Representative on several American National Standards Institute (ANSI) committees.

Contact him at:
"SelectaVision" VideoDisc Operations
Indianapolis, Ind.
TACNET: 426-3087

Automatic VideoDisc and stylus test equipment

The manufacture of VideoDisc and styli presents many chemical problems along the way, but the "acid tests" for product quality are electrical, not chemical.

Abstract: *The Performance Evaluation Test (PET) system collects electrical data that contributes to pass/fail decisions made on disc lots. The authors examine the main system controller and operator interface, the turntables, the test electronics, the electrical test parameters, and the software. In addition, the author covers the "how and what" of testing in a production environment.*

To meet the needs of a rapidly expanding VideoDisc business, several types of high-accuracy, automatic test equipment were required. This article describes two such systems, the Performance Evaluation Test (PET) system for VideoDiscs and the stylus parametric tester for VDC-3 cartridges.

Disc testing

Electrical VideoDisc testing is performed by the PET system (Performance Evaluation Test). The system—composed of a central calculator/controller, six precision turntables with microprocessor-based control and data-gathering electronics, a video signal-to-noise measuring rack, and a six-position television monitor rack—is shown in Fig. 1. Electrical data collected by PET equipment is used with other physical data to make pass/fail decisions on disc lots before shipment to the warehouse.

The main system controller and opera-



Fig. 1. A typical PET system showing television monitors, calculator, video signal-to-noise rack, and PET positions.

tor interface is a Hewlett-Packard 9825 desktop computer connected to the six PET positions via the IEEE-488 bus. A typical PET position is shown in Fig. 2. "Test programs," which determine what portions of the disc are to be tested, are compiled at the 9825 and downloaded to the positions by operator command. The positions can be given the same or different programs and they perform independently from one another.

After a position receives a test program, it must then be released to begin testing. At this time, the operator must enter—via the 9825—the disc number, press-run number, operator ID, and so on, which will be appended to the data file collected for a particular disc for identification of the data at a later time.

The test data from each of the PET positions is received by the 9825, where it is consolidated and a summary of the results is printed locally. The raw data is stored on a magnetic tape cassette which, when full, will be processed off line by another computer. Test results of several off-line electrical tests are entered by the operator via the keyboard and appended to the file in order that all electrical data be kept together. A real-time clock is installed in the 9825 to provide time and date information without operator intervention.

The PET positions are based on the Intel SBC series of 8080-based micro-computer boards and use an SBC-655 chassis. The processor board chosen was an SBC 80/20-4 because of its overall fit for both I/O and memory capacity. At the time of the design, no reasonably priced IEEE-488 interface boards were commercially available, so a multibus talker/listener board was designed to meet the need. The microcomputer performs all control functions, data collection, and communication for the position with the exception of the DAXI (Digital Auxiliary Information) detection and tracking error identification and statistics, which are performed by a Mostek 3874 single-chip microcomputer.

PET turntables are precision pieces designed for an industrial environment. They are tightly specified for flatness, runout, and balance. The turntable is driven, via a belt, by a DC motor/generator. The speed of the table is detected by a Hall-effect sensor, which monitors a multi-pole magnetic strip mounted under the turntable. A control circuit phase-locks the turntable to a crystal reference. A modified player arm is installed at each PET posi-



Fig. 2. A PET position showing precision turntable, front panel, and arm assembly.

tion to house a stylus that recovers the information from the disc via the "CED" (Capacitance Electronic Disc) system. The output from this arm is routed to the various test electronics and to a modified signal board, which converts it to NTSC video and audio. Other test electronics are connected to various points on the signal board and the video output is buffered and routed to video signal-to-noise measuring equipment in an external rack.

Test electronics are organized on a board-level basis and are installed in a card rack with a standard back plane. The back plane specification is extremely important in that it allows rapid response to change, an absolute necessity in a new manufacturing process like ours. Each board or group of boards in the test-board rack performs a specific function and is similar to test boards found in the SCOPE and GALT test equipment designed for testing power transistors.

The test boards resemble memory devices because they use a board-select pin that enables the I/O drivers to the microcomputer, function-select pins similar to address pins, and read/write lines that are exact parallels to those of memory devices. Two 8-bit data buses are implemented on the back plane—one for read data and one for write data. Boards needing immediate attention can direct interrupts to the microcomputer, but the majority are simply polled on a regular basis. Data collected from each board is preprocessed by the microcomputer and stored in RAM

until the completion of the test, when it is transmitted to the 9825.

Electrical test parameters include the following:

Carrier distress—a measure of the amount of time that the arm output falls below a fixed threshold (similar to dropouts in a magnetic tape system)

Tracking—a measure of the number and type of stylus-tracking errors due to defects on the disc surface

Time-base stability—a measure of physical disc deformations that result in picture "jitter" at various frequencies

Carrier level—a measurement of the arm's output level across the disc

Defect gate count—a second system for monitoring defect-correction circuit activity

Video signal-to-noise ratio—a manual measurement of video signal-to-noise.

Most of the test data is reported on an "interval" basis, where an "interval" is defined as 512 grooves of the disc. By this method, defects of interest can be located and examined to determine probable cause. Since the power of a microcomputer is somewhat limited in the area of mathematical calculations, a minimum amount of this activity is performed by the PET positions. The majority of mathematical calculation is deferred to the 9825, which is much more suited to the task.

PET system software is written in three

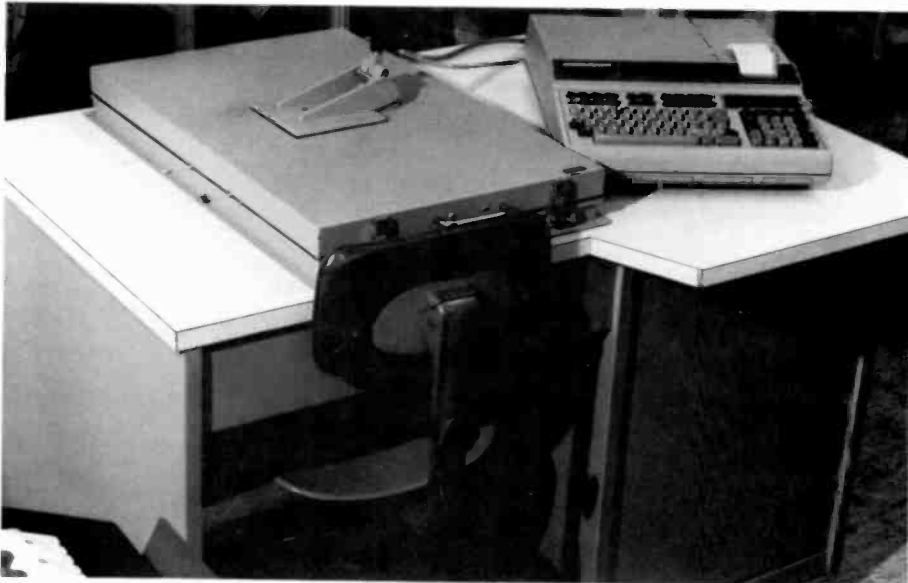

Fig. 3. The production stylus tester shown here places the operator in a comfortable position for changing cartridges and test discs, as well as for operating the HP9825 calculator.



Fig. 4. The RFI enclosure's lid, shown in the disc-changing position, does not block access to the calculator, nor to the equipment bay.

languages. The 9825 program is written in HPL, interfaces directly with the operator, and must be as fault tolerant as possible. This software is required to allocate tape files and manage the storage of data in addition to its other tasks. The SBC board software is written in PLM, chosen because of its ability for self-documentation and its structured nature. In this program, all software routines are located in modules, allowing relatively simple modification of program functions. The Mos-

tek 3874 microcomputer is programmed in assembler language primarily because of the similarity of this device to the one contained in the SFT-100 VideoDisc player.

Stylus testing

Before the scheduled start of stylus-cartridge production during the fourth quarter of 1979, stylus electrical testing was

performed on calibrated VideoDisc players. Because of the large quantity of styli to be manufactured, a system better suited to a production environment was required.

During the summer of 1979, Test Engineering at Rockville Road began to develop the prototype stylus electrical tester, with basic requirements of stability, precision, and especially, speed. The first portion of the stylus tester to be designed was the turntable, which had to have excellent vertical and horizontal runout characteristics. The stylus position relative to the turntable was controlled by a stepping motor that allowed accurate and rapid test-band locating.

Test Engineering developed a turntable interface controlled via a Hewlett Packard (HP) version of IEEE 488—HP-IB. The interface included positioning logic, a real-time clock, and circuitry for interfacing to the International Solid State Controller (ISSC), which drove the prototype micro-machining stylus-finishing line to which the stylus tester would be a peripheral unit. The actual measuring equipment used in the tester were an HP3585A spectrum analyzer and an HP3435A digital voltmeter, both controlled by an HP9825 calculator via HP-IB interfaces.

The controlling test program was developed by Test Engineering and included such features as a menu to select any grouping of tests devised by Stylus Engineering, statistics for the entire test run and a complete prompting program to aid the operator.

Figure 3 shows the tester in its operating configuration and Fig. 4 shows the RFI (Radio Frequency Interference) enclosure opened to provide access to the turntable components. By loosening one fastener, the hinged top of the RFI box can be opened to allow full "northern hemisphere" access to the interior of the turntable enclosure. The small door on the RFI box allows stylus changing. Figure 5 shows the equipment bay of the tester with the HP3585A at the top, the turntable-controlling interface below, it and the HP3435A DVM near the bottom. Power supplies and stepping-motor drive electronics are in the rear of this bay.

Stylus Production Engineering and Test Engineering collaborated on the design of a disc specifically for testing styli. This disc contains signals that allow the stylus tester to measure 11 stylus parameters between DC and 10 MHz. After Stylus Engineering analyzed early results, the number of parameters was reduced to six, which shortened the testing-cycle time considerably.

Software improvements further reduced the testing time, but Test Engineering personnel were limited by the response time of the HP3585A spectrum analyzer. It was clear that a faster spectrum analyzer was needed to increase throughput rather than further reducing the number of tested parameters.

During Spring 1981, construction of a replacement for the HP3585A spectrum analyzer was started in the Test Engineering department. This new analyzer was delivered to Stylus Production in October 1981 and incorporated into one of the stylus testers. The new spectrum analyzer system comprises two basic modules, as shown in Fig. 6. These are the spectrum-analyzer unit and the local oscillator synthesizer. Normally, a spectrum-analyzer module is required for each RF parameter to be measured. However, because of a special local oscillator (LO) port on the LO synthesizer all RF measurements can be done serially using only one of the analyzer slices, and remotely switching all the LOs through a single driver circuit. The trade-off is in speed since the parallel configuration allows simultaneous readings.

The analyzer module can be remotely controlled for RMS or peak measurements, for selecting internal references during self checking, for setting internal gain in 5-dB steps from 0 dB to 65 dB and for other features useful for maintenance and calibration.

In a normal configuration, the LOs are cabled separately to each analyzer unit and the units' addresses are set as required by the test program. A digital readback feature allows complete bus checking to be sure each unit can be controlled. The digital bus cable is compatible with the Intel 80/20-4 and the HP98032A.

To prevent creating a system locked into current needs, which would require time and money to reconfigure, the LOs are synthesized from a single 5-MHz VCXO by phase-lock-loop (PLL) synthesis. Measurement at a new RF frequency requires only that the PLL dividers be reprogrammed, that is, no additional oscillators are required.

The serial LO port mentioned earlier is controlled by the digital bus. The selected LO is also connected to an internal frequency counter of 1-kHz resolution so that the test program can check the actual frequency of any local oscillator. The manual switches on the LO module allow overrides to the remote capability and a sample of the selected LO is available at a

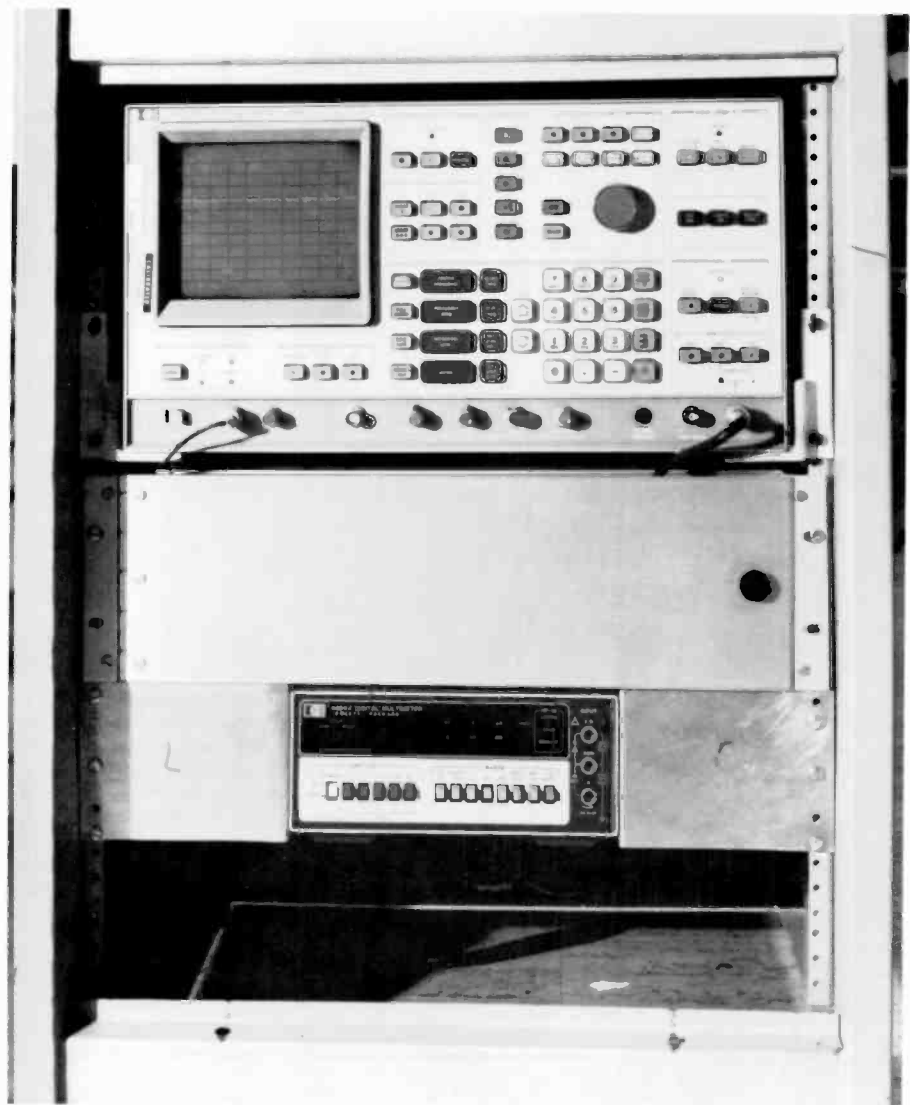

Fig. 5. The test equipment bay is located such that access to all internal units is possible during tester operation. Both the front (shown) and rear covers are removable.

BNC connector on the panel during remote and manual control. The RF line, which is daisy chained to all the analyzer modules, terminates at the panel of the LO module so an independent spectrum analyzer can be easily connected to verify readings. And finally, the address-selected storage (0-31) is inside the LO module. Its internal address is zero and 1-31 are available for spectrum-analyzer units and others.

Future expansion of this tester concept includes a possible calibration module based on the LO synthesis technique and a future change from HP-IB control of the turntable interface to the parallel bus technique. These two additions would allow further cost reduction because an Intel single-board computer could replace the HP9825A calculator.

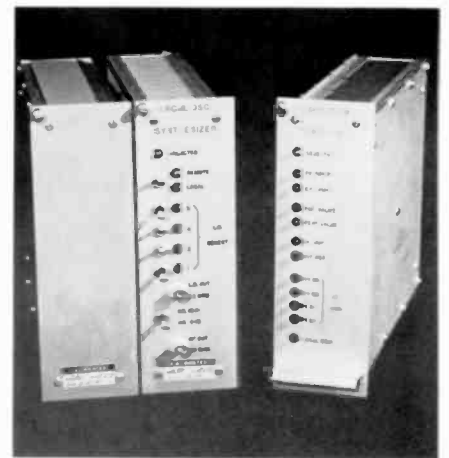

Fig. 6. In the current system, six spectrum analyzers units, one LO module, and the power supplies occupy no more space than does the HP3585A.



Paul Selwa joined RCA "SelectaVision" VideoDisc Operations in July 1979 as a Member of the Engineering Staff, assigned to Test Engineering. Since that time his primary work has been to develop stylus production testers, including the design of the equipment described in this paper. He is currently designing instrumentation for the presses used in disc production at RCA "SelectaVision" VideoDisc.

Contact him at:
"SelectaVision" VideoDisc Operations
Indianapolis, Ind.
TACNET: 426-3115

John Kowalchik, Senior Member of the Engineering Staff, joined RCA Solid State Division in 1974 and was involved in the testing of Power Transistor/Thyristor products at the Mountaintop, Pennsylvania location. In 1979, he transferred to "SelectaVision" VideoDisc where he worked on the design and development of disc test equipment and was project engineer for the PET test system.

Contact him at:
"SelectaVision" VideoDisc Operations
Indianapolis, Ind.
TACNET: 426-3212

Conclusion

The PET system in its present form has been working for two years. It has been and will continue to be an effective tool for the assessment of VideoDisc quality in a rapidly growing and constantly changing business. Stylus production testing has also been operational for the last two years but has undergone greater revision than the PET testers. Significant reduc-

tion in test time relative to that required by the initial testers has been realized by limiting the numbers of parameters tested and improving operating speed by the design of equipment specifically for the purpose. The ability to adapt both equipments to changes in system requirements is clearly a testimony to the fact that such equipment can be built using the power of microcomputers and the design skills of RCA engineers.

Meet your Editorial Representatives

The editorial contacts at your location are available to help you share the valuable information you have with the rest of the engineering community.

These Editorial Representatives (Ed Reps) can help you present that project or idea to a very important group—engineers and engineering management at RCA. Editorial representatives (for each major activity) are appointed, usually by the chief engineer. Basically, their objectives are to assist authors by stimulating,

planning, and coordinating appropriate papers for the *RCA Engineer* and to keep the editors informed of new developments. In addition, they inform the editors of professional activities, awards, publications, and promotions. On these four pages you will find a photo, location, and phone number of your Ed Rep. They are alphabetically listed by division for your convenience. Get to know your Ed Rep, and develop your own contribution to the professional literature.

Commercial Communications Systems Division (CCSD)



Bill Sepich*
Camden, N.J.
TACNET: 222-2156



Krishna Praba
Gibbsboro, N.J.
TACNET: 222-3605

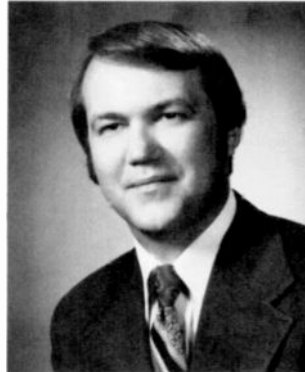

Andrew Billie
Meadowlands, Pa.
TACNET: 228-6231



John Ovnick*
Van Nuys, Calif.
TACNET: 534-3011

Consumer Electronics (CE)



Clyde Hoyt*
Indianapolis, Ind.
TACNET: 422-5208



Francis Holt
Indianapolis, Ind.
TACNET: 442-5217



Chuck Limberg
Indianapolis, Ind.
TACNET: 422-5117



Byron Taylor
Indianapolis, Ind.
TACNET: 426-3247



Don Willis
Indianapolis, Ind.
TACNET: 422-5883

*Technical Publications Administrators

Government Systems Division (GSD)



Merle Pietz*
Camden, N.J.
TACNET: 222-2161



Carol Klarmann
Princeton, N.J.
TACNET: 229-2919



Frank Yannotti*
Princeton, N.J.
TACNET: 229-2544



Paul Seeley*
Burlington, Mass.
TACNET: 326-3095



Dale Sherman
Burlington, Mass.
TACNET: 326-2985



Dan Tannenbaum*
Camden, N.J.
TACNET: 222-3081



Harry Ketcham
Camden, N.J.
TACNET: 222-3913



Ed Moore*
Cherry Hill, N.J.
TACNET: 222-5833

National Broadcasting Company (NBC)



Don Higgs*
Moorestown, N.J.
TACNET: 224-2836



Jack Friedman
Moorestown, N.J.
TACNET: 224-2112



Bob Mausler*
New York, N.Y.
TACNET: 324-4385



Joe Tripoli
Princeton, N.J.
TACNET: 226-2992

Patent Operations

*Technical Publications Administrators

Picture Tube Division (PTD)



Ed Madenford *
Lancaster, Pa.
TACNET: 227-3657



Nick Meena
Circleville, Ohio
TACNET: 432-1228



Jack Nubani
Scranton, Pa.
TACNET: 329-1499



J.R. Reece
Marion, Ind.
TACNET: 427-5566

RCA Communications



Murray Rosenthal*
Princeton, N.J.
TACNET: 258-4192



Carolyn Powell
Princeton, N.J.
TACNET: 258-4194



Dorothy Unger*
New York, N.Y.
TACNET: 323-7348



Bob McIntyre
Ste Anne de Bellevue
TACNET: 514-457-9000

RCA Records



Greg Bogantz*
Indianapolis, Ind.
TACNET: 424-6141



Joe Steoger*
Cherry Hill, N.J.
TACNET: 222-5547



Ray MacWilliams
Cherry Hill, N.J.
TACNET: 222-5986



Dick Dombrosky
Cherry Hill, N.J.
TACNET: 222-4414

*Technical Publications Administrators

Research and Engineering

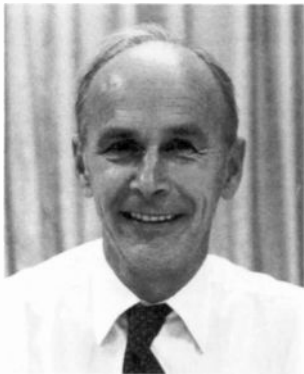

Hans Jenny *
Cherry Hill, N.J.
TACNET: 222-4251



Eva Dukes
Princeton, N.J.
TACNET: 226-2882



Nelson Crooks*
Indianapolis, Ind.
TACNET: 426-3164

Solid State Division (SSD)



John Schoen*
Somerville, N.J.
TACNET: 325-6467



Harold Ronan
Mountaintop, Pa.
TACNET: 327-1633 or 327-1827



Dick Morey
Palm Beach Gardens, Fla.
TACNET: 722-1262



Sy Silverstein
Somerville, N.J.
TACNET: 325-6168



John Young
Findlay, Ohio
TACNET: 425-1307



John Grosh
Lancaster, Pa.
TACNET: 227-2077



Judy Yeast
Somerville, N.J.
TACNET: 325-6248

***Technical Publications Administrators**

The Chemical and Physical Laboratory supports VideoDisc

Armed with some of the most sensitive equipment available, the scientists and engineers in this activity aim for better VideoDiscs...through space-age chemical and material analyses.

Abstract: *The Chemical and Physical Laboratory is a multifunctional department interacting with both the VideoDisc manufacturing and VideoDisc development activities to support and troubleshoot the manufacturing of the disc, using the most up-to-date chemical and material analyses.*

The Chemical and Physical Laboratory (C&P Lab) at the Rockville Road plant, where VideoDiscs are made, acts in several roles. These roles are discussed below.

Incoming materials inspection

The VideoDisc process uses a wide range of materials such as PVC resin, plastic additives (stabilizers, lubricants, processing aids), electroplating chemicals, disc-rinsing chemicals, disc lubricant, and adhesives. Each of these materials must be tested to meet the exacting specifications required to make a VideoDisc with high manufacturing yield.

In-process quality control (QC) support

The matrix, rinse-lubrication, and compounding activities require a variety of chemical and physical tests at a high frequency in order to maintain proper process control.

Manufacturing problem troubleshooting

Unfortunately, no manufacturing operation is trouble-free and occasions will arise where yield or quality will experience serious drops. In many cases, these problems are materials-related, and substantial efforts are required on the part of the lab to define the problem and isolate the cause. In this role the scientist, engineer, and technician act as detectives in solving the mystery. Indeed, many of the microanalytical techniques of forensic science are useful in detecting the small contaminants that can cause large problems in view of the disc geometries and dimensions.

Development project support

While a tremendous amount of effort and resources have been invested to develop the current manufacturing process and materials, optimization will continue for years to come. These projects require a materials characterization support. In addition, the C&P Lab itself must develop new and improved tests with better reliability and improved detection limits as well as tests for parameters yet unspecified.

The VideoDisc manufacturing operation is a high-technology materials- and process-oriented activity that requires a sophisticated approach to materials characterization and chemical analysis. Each of the above areas is essential in either maintaining or improving the manufac-

turing operation. The Chemical and Physical Laboratory currently services the VideoDisc operation, as well as provides support services to Stylus Manufacturing and Player Engineering.

Laboratory functions

The Chemical and Physical Laboratory can be divided into several functional subgroups that specialize in specific areas of responsibility.

The Chemical Analysis group (Table I lists major equipment) engages in the more classical aspects of chemical analysis. Typical examples include the following tests. The atomic absorption spectrometer is used for trace-metal analysis in resin and additives, for plating-bath compositional analysis, trace-metal analysis in sol-

Table I. Chemical analysis equipment.

Atomic Absorption Spectrometer (Varian).
High-Pressure Liquid Chromatograph (Waters).
Infrared Spectrometer (Perkin-Elmer).
UV/Visible Spectrometer (Beckman).
Particle Size/Distribution Analyzer (HIAC).
Gas Chromatograph (Varian).
Ion Chromatograph (Dionex).
pH/Specific Ion Electrode Meter (Orion).
Karl Fischer Autotitrator.
Sayboldt/Brookfield Viscometers.
Refractometer.

Table II. SEM/x-ray equipment.

Scanning Electron Microscopes (3).
a. AMR 1000 (1)
b. Cambridge Mark II (2)

Energy-Dispersive X-Ray Analyzer (PGT) for SEM.

Wavelength Dispersive X-Ray Fluorescence Spectrometer (Siemens).

Quadrupole Mass Spectrometer.

Microtome (for carbon-black dispersion).

Optical Microscope.

Table III. Compound testing equipment.

Capillary Rheometers (Instron).

Torque Rheometers (Brabender).

BET N₂ Surface Area Equipment.

Absorptometer.

Particle Size Classifiers (Rotap, Alpine).

Resistivity Measurement Device.

vents and environmental testing on wastewater analyses. The ultraviolet, visible and infrared spectrometers are used for both qualitative and quantitative analyses of solvents and contaminants in them, organic components in plating baths, and percentage additives in lubricants. The high-pressure liquid chromatograph (Fig. 1) is used for molecular-weight distribution of resins and disc lubricants.

The scanning electron microscope (SEM) and x-ray group (Table II lists equipment) is responsible for monitoring the cutterhead, disc, and stylus geometries. The critical dimensions involved in the VideoDisc system must be measured in microns and angstroms and can be measured accurately only under the SEM. Three SEMs are employed virtually full time, with the bulk of the workload being QC-type monitoring.

The energy-dispersive x-ray analyzer (EDXRA) (Fig. 2) is used in conjunction with an SEM for chemical analysis of microscopic defects in discs, metal parts, styli, as well as microcontamination in raw materials. The x-ray fluorescence spectrometer is used for QC monitoring of lubricant thickness as well as for routine examination of compound for stabilizer additive levels and contamination.

The primary function of the Compound Test Lab (Table III lists equipment) is in the routine monitoring of production compound material for melt viscosity, resistivity and heat stability; as well as characterization of resin, carbon

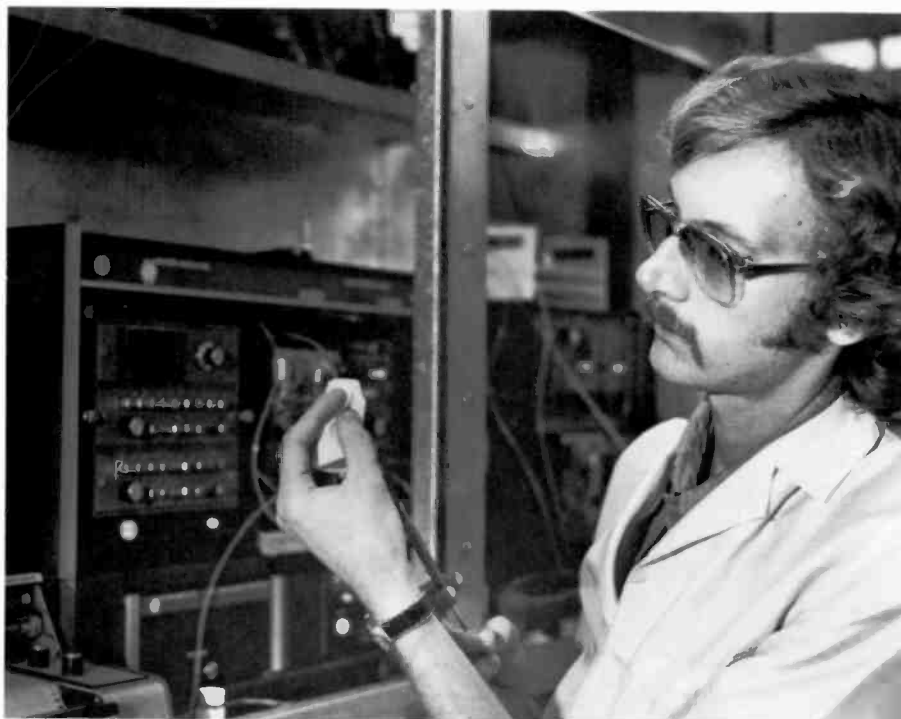

Fig. 1. The high-pressure liquid chromatograph (HPLC) provides an analytical separation technique used in mixture analysis and in determination of molecular weight distributions for resins and disc lubricants.

and other compound raw materials. This group provides manufacturing with real-time feedback.

The Physical/Thermal testing lab (Table IV lists equipment) is concerned with determination of melting points, heat capac-

ities, material degradation and weight loss through the use of the differential scanning calorimeter and the thermogravimetric analyzer (Fig. 3). Thermal mechanical analysis (TMA) is used for determination of glass transition temperatures and ther-

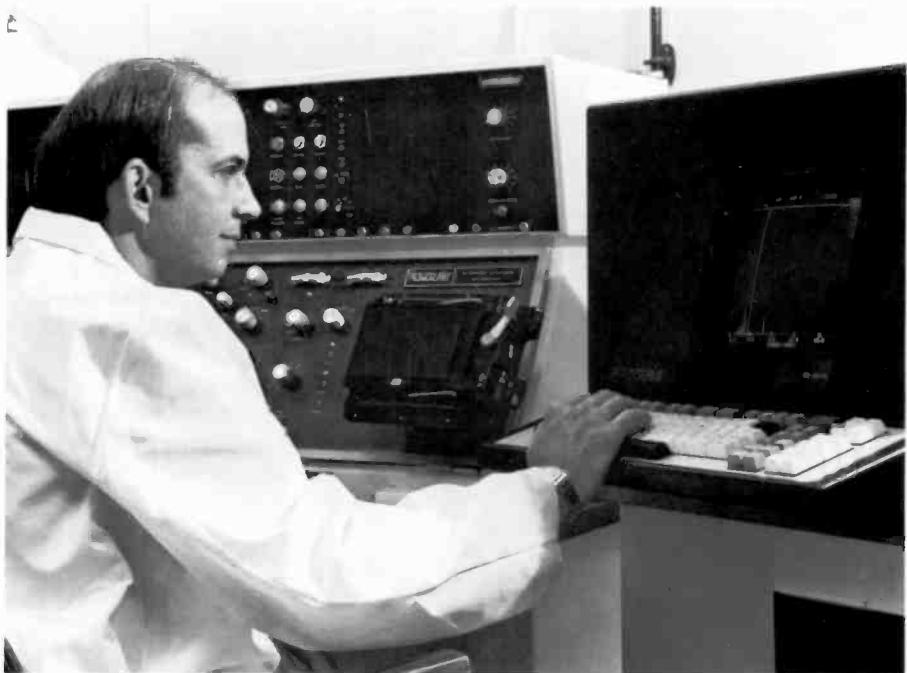

Fig. 2. The scanning electron microscope (SEM) is used in measurement and inspection of the microscopic geometries important to the disc, stamper, cutterhead, and stylus performance. The energy dispersive x-ray analysis (EDXRA) is used to provide chemical analysis of microscopic defects and microcontamination.



Fig. 3. The thermal analysis lab uses differential scanning calorimetry (DSC), thermogravimetric analysis (TGA), and thermomechanical analysis (TMA) to determine such parameters as melting point, heat capacity, glass transition temperature, expansion coefficients; and to monitor such phenomena as thermal degradation of polymers.

mal expansion coefficients. The Rheometrics mechanical spectrometer (Fig. 4) can be applied to studies of mechanical properties such as dynamic viscosity, and elastic modulus as a function of temperature.

Typical problems

As an example of a manufacturing problem encountered by the C&P Lab, we will discuss microcontamination, a specific case.



Fig. 4. The Rheometrics mechanical spectrometer is a versatile device that can subject the test sample to a variety of static and time-varying stresses at different temperatures, while monitoring mechanical response. Dynamic viscosity and elastic modulus are two parameters that can be measured.

See Table V for a general summary of some materials-related problems.

VideoDiscs that contain inhomogeneous particulate contaminants near the surface can exhibit undesirable playback effects when the stylus hits the defect. After electrical playback testing has located a defect on a disc, it is examined microscopically. The defect is opened using a surgical knife under an optical microscope and it can be examined by SEM for particle morphology and analyzed chemically by EDXRA (Figs. 5 and 6).

When a number of defects have been cataloged by chemical type, the real work starts. Is the contamination from a process fluid such as deionized water or a chemical rinse treatment? Is it from corroding process equipment? The answers to these questions are uncovered by the team of C&P Lab scientist and process engineer by identifying likely sources of contamination, performing the chemical analyses and matching results to our defect catalog (or fingerprint file). Successful completion of these tasks allows the process engineer to eliminate or reduce the contamination source.

In the case of raw materials, appropriate techniques need to be developed. For example, an appropriate separation technique (sieving, dissolution/filtration, etc.) must be determined for each raw material with analysis of the contamination separated out. After sufficient work

Table IV. Physical/Thermal testing equipment.

Differential Scanning Calorimeter (Perkin-Elmer).
Thermogravimetric Analyzer (Perkin-Elmer).
Mechanical Spectrometer (Rheometrics).
Thermomechanical Analyzer (Perkin-Elmer).
Environmental Ovens.

with the material vendor, an appropriate materials specification can be agreed upon, which will safeguard the disc product quality against contaminants in raw materials.

Additional problems might include such items as disc and stamper staining. This would involve analysis of the stained areas in both stamper and disc. Is it a compound-related stain? If so, is it due to low thermal stability and subsequent compound degradation, or is it due to bleed-out of lubricant or plasticizers due to incorrect weights in formulating the compound lot? If it is a stamper-related stain, what is the nature of the thin film on the metal surface and where did it originate in the matrix process? Again, the team of laboratory analyst and process engineer provides the answers to these questions, which ultimately lead to a solution of the problem.

Table V. Materials and chemicals process-related problems.

<i>Problem</i>	<i>Origin</i>
Tracking	Microcontamination (process or raw material).
Staining	Additive bleedout/ Compound degradation/ Stamper thin-film contaminant.
Warping	Compound rheological properties.
Audio/Video	Composite dependent on carbon properties and compound processing.
Carrier Distress	Surface contamination from process.
<i>Metal Parts</i>	
Substrate Machinability	Copper bath parameters/ Bath contamination.
Stress in Nickel Parts	Bath contamination.
Brittle Stamps	Bath contamination.

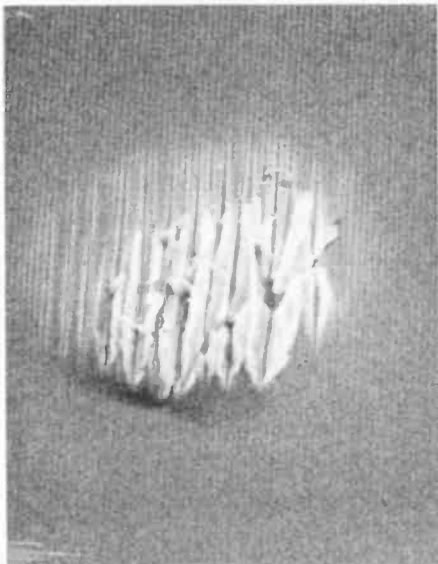
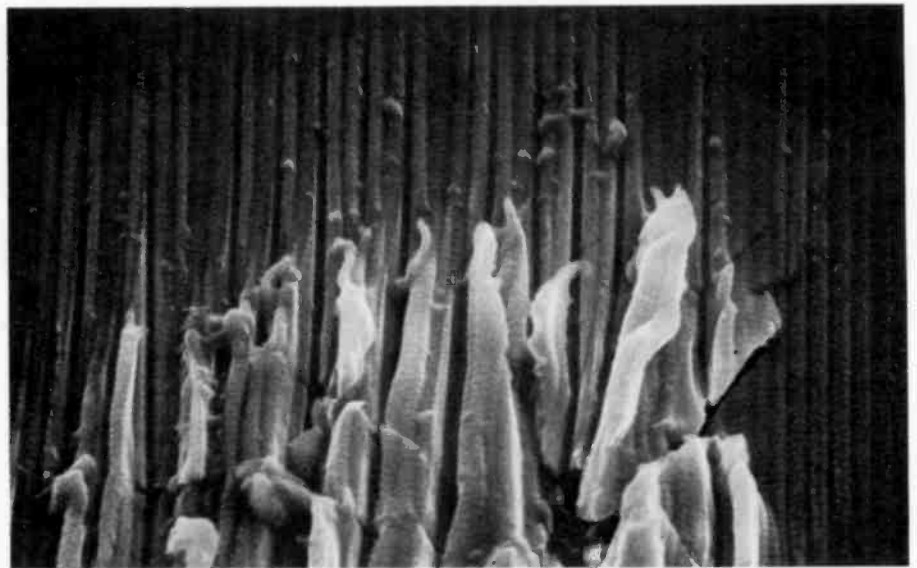

Fig. 5. The SEM can be used to examine carefully the morphology of disc surface defects and to discover what happens when the stylus interacts with such a defect.



Summary

As delineated above, the C&P Lab is a multifunctional department interacting with both the manufacturing and development activities to provide routine support and troubleshooting capabilities to maintain and advance the manufactura-

bility of the VideoDisc. It is the challenge of the chemicals and materials analyst to be expert in the techniques of analysis as well as to understand the intricacies of the

manufacturing process in order to be most effective. This challenge will be met by the C&P Lab personnel as the VideoDisc product continues to mature.



David Hakala joined RCA Picture Tube Division, as a process development engineer, after receiving his PhD in physical chemistry from R.P.I. in 1976. After serving as group leader of the Analytical Laboratory for two years, he joined VideoDisc Operations as Staff Scientist working on material problems. Currently, he is Manager of Chemical & Process Development and Acting Manager of Chemical & Physical Laboratory. He holds one patent and is the author of several publications.

Contact him at

"SelectaVision" VideoDisc Operations
Indianapolis, Ind.
TACNET: 426-3433

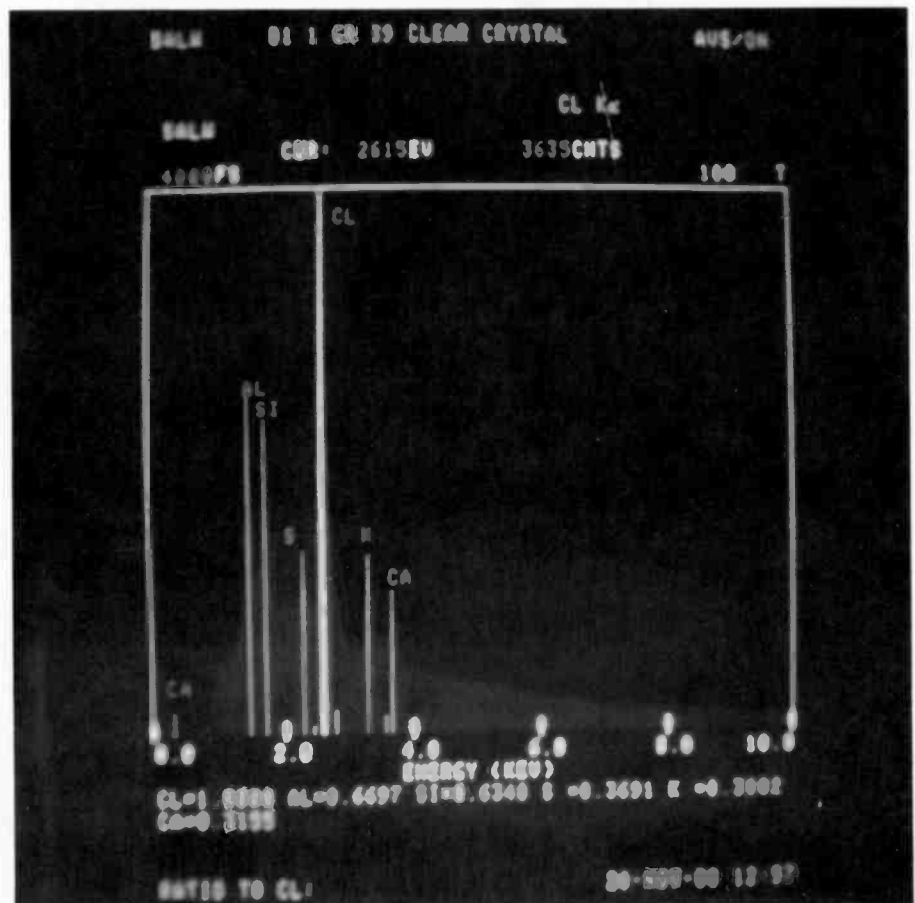

Fig. 6. The EDXRA is used to obtain a simultaneous analysis of chemical elements in a disc defect (Atomic Number 11 and higher). This serves as a fingerprint to be matched up with potential sources to identify and ultimately eliminate the problem.

Localized hyperthermia treatment of cancer

Cancer patients in many parts of the world are today being treated with equipment that can destroy malignant tumors with heat. RCA has developed radiofrequency and microwave equipment for this nonconventional method of treating cancer.

Abstract: *Localized hyperthermia (sustained heating of tissues to temperatures of about 42°C to 43.5°C) is one of a number of unconventional methods for treating cancer that are currently receiving increased attention from oncologists. This paper briefly reviews the effects of hyperthermia on malignant cells and tissues, and the methods for producing localized hyperthermia in animals and humans. Radiofrequency and microwave apparatus developed at RCA Laboratories for clinical applications of localized hyperthermia are described in some detail. Clinical results with a variety of cancers are encouraging.*

There are three major established methods for treating cancer: surgery, chemotherapy, and radiation therapy. In surgery, one tries to cut out the cancer, in chemotherapy one tries to poison it with chemicals, and in radiation therapy one tries to kill it with ionizing radiation such as X rays. Although impressive progress has been made and continues to be made in applying these methods either alone or in combination, the 5-year relative survival rate for cancer patients has improved little over the past 30 years.* In the United States the 5-year relative survival rate is currently about 41 percent, only about two percent better than it was in 1950. These statistics, as well as similar statistics on cancer mortality trends, indicate that surgery, chemotherapy and radiation therapy are beginning to assume the characteristics of mature technologies: advances tend to be evolutionary rather than revolutionary, and substantial improvements (such as,

for example, increasing the relative survival rates by a few percentage points) take a very long time and require high investments. It is for these reasons that a small but growing number of oncologists are taking a serious look at nonconventional methods for treating cancer. Prominent among these nonconventional methods is hyperthermia where one tries to destroy cancers with the help of heat.

This paper deals with one form of hyperthermia treatment of cancer, namely localized hyperthermia (as opposed to whole-body hyperthermia). The paper is organized into five parts: general background on cancer, the effect of hyperthermia on malignant cell cultures and on animal and human cancers, methods for inducing localized hyperthermia with emphasis on the radiofrequency (rf) and microwave apparatus developed at RCA Laboratories, clinical results obtained with localized hyperthermia, and conclusions and outlook for the future.

What is cancer?

Cancer or malignant neoplasm can be defined as a "relatively autonomous growth of tissue." The term "relatively autonomous" is used to indicate that the rate of growth of a cancer is, to a large extent, controlled by the cancer itself and not by the host organism. Cancers have the ability to metastasize, that is, they can establish secondary growth in the host at locations distant from the original or primary tumor. There are various routes through which cancer cells can be carried to new

locations, the most common being the blood circulation and the lymphatic system.

In humans, 75 percent of all cancers start in only ten anatomic sites (this statistic excludes cancer of the skin, which is the most common but also, except for melanoma, the most curable form of human cancer). These sites are colon and rectum, breast, lung and bronchus, prostate, uterus, lymph organs, bladder, stomach, blood and pancreas. Figure 1 shows the age-adjusted death rates from 1930 to 1977 for cancer at most of these sites in males and females in the United States.

Overall, cancer currently accounts for about 20 percent of all deaths in the United States. During 1981, approximately 400,000 persons, or about 180 persons per 100,000 population, will die of cancer here, making cancer the second most common cause of death in the country. The leading causes of death in the United States are diseases of the heart.

* The 5-year relative survival rate is the probability of a person remaining alive 5 years after having been diagnosed as having cancer, the rate being adjusted for the probability of death from other causes. The actual 5-year cancer survival rate (that is, the rate that is not adjusted for the probability of death from other causes) is currently about 33 percent in the United States. Both rates exclude skin cancers other than melanoma (melanoma is a highly dangerous form of skin cancer that is derived from cells containing pigments), and carcinoma diagnosed *in situ* (that is, diagnosed before the cancer has become invasive). See reference 1 for a detailed discussion of survival rates.

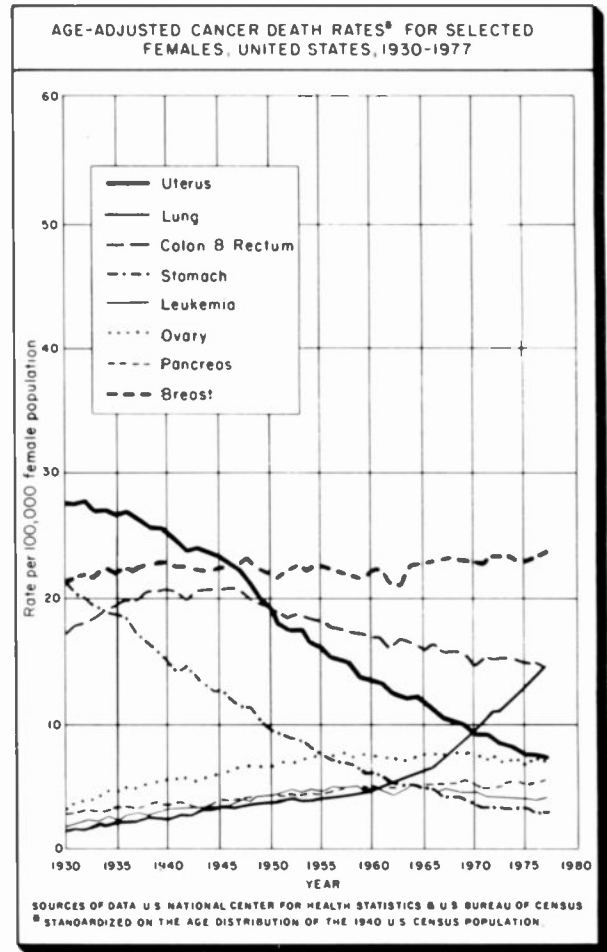
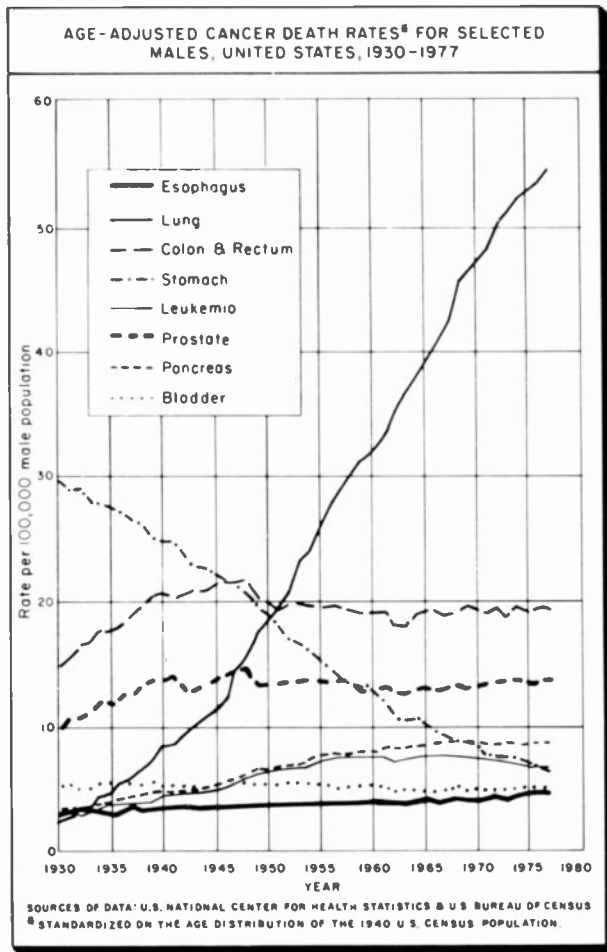

Fig. 1. Age-adjusted cancer death rates for selected sites in the United States, 1930 to 1977: (a) Males; (b) Females.

Why is hyperthermia effective in treating cancer?

The simple answer to the question posed in the heading of this section is that many malignant tumors are more sensitive to heat than normal tissues, that one can often selectively heat tumors to higher temperatures than surrounding healthy tissues, and that it is therefore often possible to selectively destroy cancers either by heat alone or by a combination of heat and radiation therapy or chemotherapy. A more complete answer is that there appear to be a variety of complex interrelated factors involved in the action of hyperthermia against cancer. These factors range from effects at the cellular level to effects caused by the sluggish blood flow common in large tumors. The biological phenomena underlying many of these factors are now only poorly understood.

Thermal effects in cell cultures

Cultures of malignant cells grown *in vitro* (grown in an artificial medium rather than

in a living organism) are often more sensitive to heat than are cultures of similar, but normal cells. This differential heat sensitivity is usually most pronounced when the temperature of the cultures is maintained at about 43°C for at least one hour. At temperatures below about 40°C, neither the malignant nor the normal cells are much affected by the heating, while at temperatures much above 45°C both types of cells are rapidly killed by the heat. A typical result obtained at 43°C for normal and malignant cells of the same type is shown in Fig. 2. Note that there is indeed a substantial difference in the surviving fractions between the two types of cells.

Studies of *in vitro* cell cultures also show that heat can increase the lethal effects of ionizing radiation and of certain chemotherapeutic agents. This is illustrated for the case of ionizing radiation in Fig. 3, which is a plot of surviving fraction for malignant cells *in vitro* as a function of radiation dose in rads.* The figure shows

* The rad is the unit of absorbed ionizing radiation dose. 1 rad equals 100 ergs/gm of absorbing material.

that for a dose of about 350 rads there is nearly a thousandfold increase in the lethal effect of the ionizing radiation when the temperature of the culture is increased from the normal human body temperature of 37°C (98.6°F) to 43°C (109.4°F).

What are the reasons for the dramatic increase in the lethal effects of ionizing radiation when cell cultures are heated to

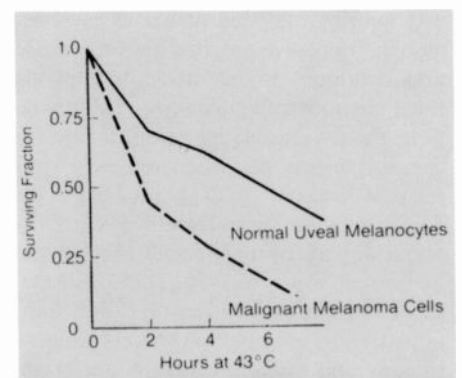

Fig. 2. Plot of surviving fraction of cells *in vitro* as a function of time for normal and for malignant melanoma cells. The cell cultures were maintained at 43°C. After reference 2.

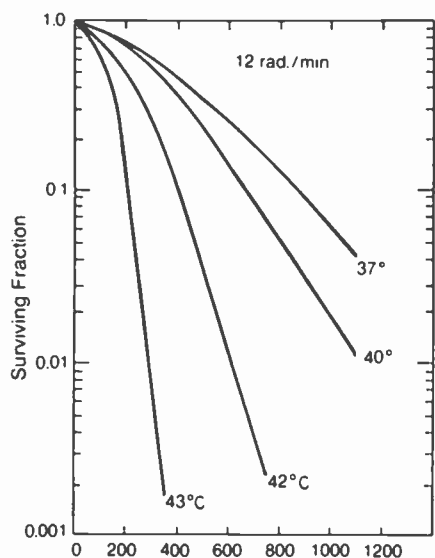

Fig. 3. Plot of surviving fraction of cells *in vitro* as a function of ionizing radiation dose for four different temperatures. After reference 2.

about 43°C? There are no definitive answers yet, but the following two effects that have been observed in experiments with cell cultures offer important clues.

- Hyperthermia (sustained heating to about 42°C to 43.5°C) apparently interferes with the repair of radiation-induced sublethal damage in cells.
- Cells in the middle-to-late S-phase of the cell cycle are most sensitive to hyperthermia.* This happens to be the part of the cell cycle where cells are most resistant to damage by ionizing radiation. Thus, the two therapies (or modalities) are complementary in their ability to damage cells. During the part of the cell cycle where ionizing radiation is most effective, hyperthermia is relatively ineffective, and vice versa.

Two other important thermal effects that have been observed in cell cultures need to be mentioned. First, hypoxic (poorly oxygenated) cells are more sensitive to hyperthermia than well-oxygenated cells. The significance of this observation to clinical treatment will become clear in the next subsection. Second, some malignant cell cultures develop a thermal tolerance to hyperthermia after having been exposed to sublethal hyperthermic doses. This suggests that tumors should be raised to hyperthermic temperatures as rapidly as can be tolerated by the patient.

* When cells divide they usually proceed through a characteristic cycle which consists of distinct phases designated as G1, S, G2, M, and D. In the S-phase, DNA is synthesized.

Thermal effects in tumors

The destructive effect of heat on malignant as well as on healthy tissues is a function of the temperature to which the tissues are raised, and the length of time the tissues are maintained at the temperature. This is illustrated in Fig. 4, which is based on *in vivo* (in living organisms) experiments with a particular mouse tumor. The figure shows three ranges of combinations of temperature and time. In the upper range (A), most healthy and malignant tissues are destroyed. In the intermediate range (B), most healthy tissues survive, but the tumor is eradicated with no subsequent regrowth. (This is the range of most interest for therapeutic use.) In the lowest range (C), there is little or no damage to healthy tissue, but the damage to the malignant tissues is insufficient for the complete destruction of the tumor and the prevention of its regrowth.

The differential heat sensitivity of malignant versus healthy tissues illustrated in Fig. 4 does not seem to be primarily due to any intrinsic cellular effects of the type shown in Fig. 2. Rather, effects at the tissue level, particularly those associated with the vascular system of malignancies, seem to play a major role. Malignant tumors commandeer blood supplies from adjacent healthy tissues, and distribute this blood to their own tissues by means of their own vascular system. The exact nature of the tumor's vascular system depends on the tumor type or even on the particular tumor itself. In general though, tumor vascular systems, particularly those of larger tumors, are not as efficient in moving blood as are typical normal vascular systems. Moreover, while the blood flow in most normal tissues increases as the temperature of the tissues is increased from normal body-core temperature ($\sim 37^\circ\text{C}$) to hyperthermic temperatures ($\sim 43^\circ\text{C}$)[†], the blood flow in many malignant tissues decreases with temperature above about 39°C, and prolonged exposure to hyperthermic temperatures often causes irreversible damage to the tumor capillaries.^{††}

† For example, in healthy human skin the local blood flow increases by almost a factor of ten when the temperature is raised from 37°C to 43°C.

†† When tumors are treated with both ionizing radiation and hyperthermia, tumor blood flow is further reduced because the ionizing radiation damages the tumor vascular system.

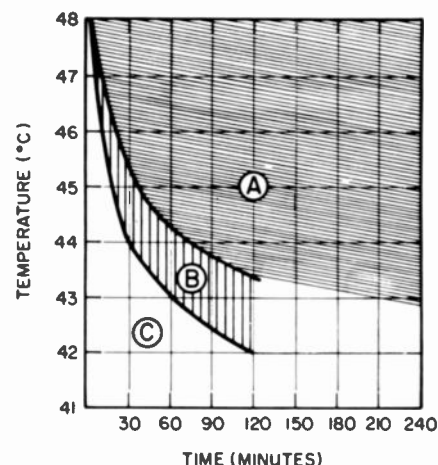

Fig. 4. Example of the effect of various temperature-time combinations on healthy versus malignant *in vivo* tissues. Range A causes destruction of both healthy and malignant tissues; range B allows most healthy tissues to survive, and kills the tumor with no subsequent regrowth; range C causes little or no damage to healthy tissue, and the tumor survives and regrows. After reference 2.

Impaired blood flow in tumors causes reduced blood supply to malignant tissues. This reduced blood supply in turn causes high extracellular pH in the malignant tissue, a factor known to enhance thermal injury. Furthermore, the low blood flow deprives the malignant cells of nutrients, and nutrient-deficient cells are particularly heat sensitive.

The impaired blood flow typical of many larger tumors often makes it possible to selectively heat tumors to temperatures substantially higher than those of healthy, well-vascularized tissues nearby. When tissues are heated with localized hyperthermia, most of the heat is carried away from the heated tissues by the blood flow. As a result, for the same constant heat input the temperature of tumors with impaired blood flow will reach equilibrium at a higher temperature than will well-vascularized normal tissues. If the localized hyperthermia is produced with radiofrequencies or microwaves, the differences between equilibrium temperatures of tumors and healthy tissues are often further increased, because there is typically about 50 percent more heating of tumor tissues (except for necrotic tissues) than of normal tissues for the same radiofrequency or microwave fields. This is because tumor tissues usually have a significantly higher water content than do normal tissues, and radiofrequencies and microwaves are absorbed at a faster rate in tissues with high water content than in tissues with low water content (see Table I).

Table I. Approximate useful depth for hyperthermia treatments with single radiating applicator.

Frequency (MHz)	Depth (cm)	
	H	L
30	10	>20
100	5	>20
1000	3	15
2500	2	10
5000	1	5

H = Tumor shielded from applicator by tissues with high water content, such as skin and muscle.

L = Tumor shielded from applicator by tissues with low water content, such as fat and bone.

Measurements on patients show that the differences in equilibrium temperature between tumors and healthy tissues when both are heated with rf or microwave radiation of the same power density can be

as high as several degrees Celsius, a difference of important biological significance (see Figs. 3 and 4). Figure 5 shows temperature-versus-time curves typical of cutaneous (affecting the skin) and subcutaneous tumors and of healthy tissues that are heated with microwaves. The curves were taken on a patient with an anaplastic (highly malignant) neck tumor. The dotted curve is the surface temperature of the tumor as a function of time when the tumor was heated with the waveguide applicator of Fig. 9a with 1 W of 2450-MHz microwave power. Note that the tumor temperature stabilized at about 41°C. The solid curve is the skin temperature versus time of healthy tissue on the opposite side of the neck when heated the same way as the tumor. In this case the temperature stabilized at a value only slightly higher than 39°C. Similar results are often obtained when tumors are heated with radiofrequencies. For example, when a subcutaneous melanoma in the groin of a patient was heated with

100-MHz radiation, the equilibrium tumor temperature was approximately 2°C higher than the temperature of surrounding normal tissues. In this instance, the temperatures of both the tumor and the normal tissues were measured with a radiometer operating at 2450 ± 100 MHz. Such a radiometer noninvasively measures average tissue temperatures to a depth of approximately 0.5 cm.

The synergism between ionizing radiation and hyperthermia that was illustrated in Fig. 2 for *in vitro* cell experiments also exists at the tissue level, and in fact forms the basis of much of the present use of hyperthermia in treating cancer patients. Figure 6 illustrates this synergism for the case of a mouse tumor that responded only partially to hyperthermia alone (Fig. 6a) or to radiation alone (two top curves of Fig. 6b). However, when the two modalities were combined (lower four curves of Fig. 6b), an excellent response was obtained.

One of the reasons for the synergism between ionizing radiation and hyperthermia can be explained with the aid of Fig. 7, which shows the morphology of a typical large tumor. The periphery of the tumor draws its blood supply from the neighboring healthy tissue, and its tissues are well oxygenated. The center of the tumor is necrotic (dead) because the tumor's vascular system failed to supply tissues in the center with sufficient nutrients to keep them alive. Between these two regions is a layer of malignant tissue that is anoxic (poorly oxygenated) but alive. These anoxic tissues are difficult to kill with ionizing radiation, since it usually takes 2.5 to 3 times greater doses of ionizing radiation to kill hypoxic cells than it does to kill fully-oxygenated cells. As a consequence, tumors that are treated only with ionizing radiation often shrink (malignant tissues in the well-oxygenated outer layer are killed), but the tumors often regrow after some time because too many malignant hypoxic cells survived the radiation therapy. Hyperthermia complements radiation therapy because, as mentioned above, hypoxic cells are more sensitive to heat than are well-oxygenated cells. In practice, this effect is often enhanced because anoxic tissues, due to their poor blood circulation, can often be heated to substantially higher temperatures than tissues with good blood circulation (because of the effects illustrated by Fig. 5).

A number of investigators have demonstrated synergism between chemotherapy and hyperthermia when treating animal

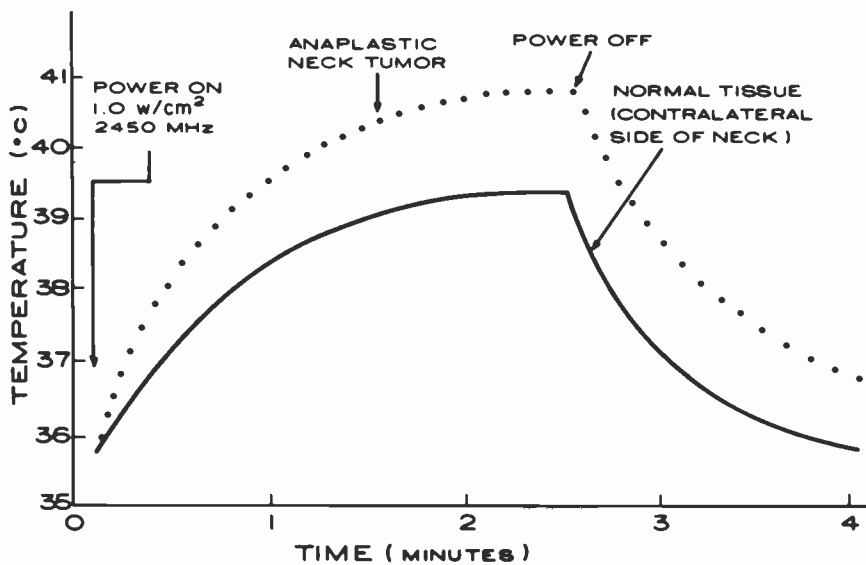

Fig. 5. Heating and cooling curves measured on a patient with an anaplastic neck tumor. Temperatures were measured with thermocouples placed at the center of the heated areas of the surface of the tumor and the surface of the contralateral side of the neck.

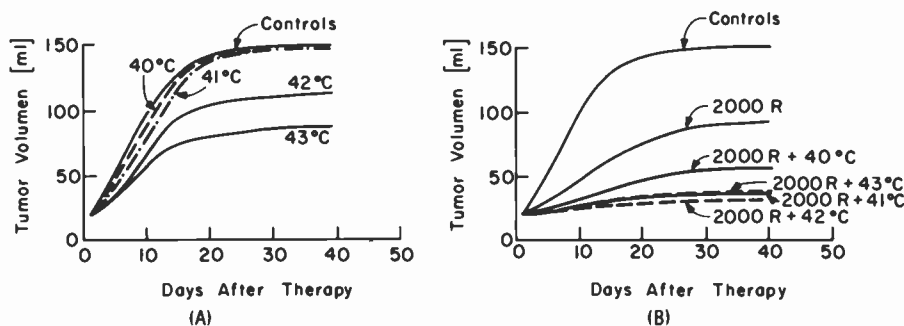

Fig. 6. Tumor volume versus days after treatment. (A) shows data for control animals and animals treated at four different temperatures with hyperthermia. (B) shows data for control animals and animals treated with 2000 rads of ionizing radiation with and without the addition of hyperthermia at four different temperatures. After reference 2.

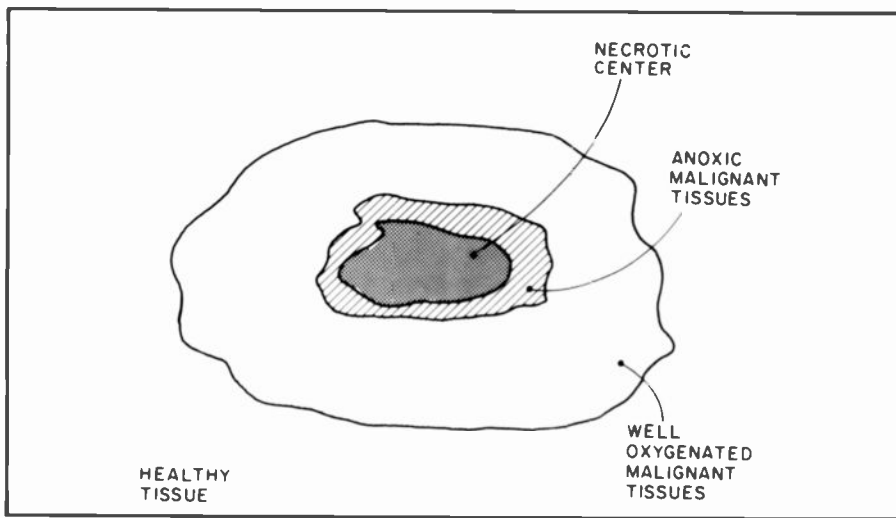

Fig. 7. Structure of a typical large tumor showing necrotic, poorly oxygenated and well-oxygenated tissues.

and human malignancies. The hyperthermia potentiates the cytotoxicity (cell-poisoning ability) of several important chemotherapeutic drugs because some of these drugs become more active at higher temperatures. Also, blood vessels and cell membranes in tumors allow easier penetration of drugs when heated, and hypoxic tumor cells, which tend to be resistant to chemotherapeutic drugs are, as was pointed out above, especially sensitive to hyperthermia.

A particularly intriguing feature of localized hyperthermia is that one sometimes observes anti-cancer action at a distance from the treated area. For example, it has been shown that when one of a bilateral (on both sides) pair of human colonic cancers growing in the cheek pouches of hamsters is treated with localized hyperthermia, the growth of the untreated contralateral (on the opposite side) tumor is inhibited. Similar effects are sometimes seen in patients treated with localized hyperthermia—untreated lesions at distant sites occasionally regress or change from being radiation resistant to radiation sensitive.³ There are also claims that metastases of certain tumors are less common in patients who are treated with localized hyperthermia followed, after some time, by surgery, than are metastases in patients who are treated only with surgery.

A possible explanation of these "action-at-a-distance" phenomena is that localized hyperthermia stimulates the immune response of the host, thus strengthening the ability of the host to fight cancer throughout his entire body. Indeed, it has been shown by direct microscopic observations that localized hyperthermia helps to activate some of the "policemen" of the im-

mune system (macrophages and T lymphocytes), causing them to infiltrate tumor sites. Another observation in support of the immunological theory is that the ability of localized hyperthermia to reduce or eliminate untreated metastatic lesions in animals is negated if the immunological response of the animal is artificially repressed.

Methods for producing localized hyperthermia

There are several methods currently in use for producing localized hyperthermia in cancer patients. The basis for these methods is either perfusion with externally heated blood or the direct heating of tis-

sues with ultrasound, radiofrequencies (rf), or microwaves.

In perfusion, blood is taken continuously from the patient, is heated, and is then reintroduced into the patient. Perfusion requires surgery (blood vessels of the patient must be connected to an external pump and heater). Also, because of the relatively poor blood circulation characteristic of many tumors, perfusion tends to heat healthy tissues faster than malignant tissues, which is a therapeutic disadvantage. Still, localized perfusion of limbs with melanoma lesions has yielded good results.

Ultrasound is useful for localized treatment of cutaneous and certain deep-seated tumors. With ultrasound it is easy to produce well-focused beams with relatively small apertures, since the wavelength of ultrasound in tissue is small. At a frequency of 1 MHz, for example, the wavelength in tissues is typically 1.5 mm. There is relatively little heating in fat as compared with muscle, which is usually an advantage in heating deep-seated tumors. Among the method's limitations: Large reflections from interfaces between various tissue types may result in hot spots from standing waves; the energy transfer from tissue to air is very poor (it is difficult to heat lungs); and there is very high absorption in bones.

Various methods have been devised to heat tumors with rf. In one method, the tumor to be heated is encircled by a number of implanted metallic needle-shaped electrodes, and rf voltages are applied across electrodes on opposite sides of the

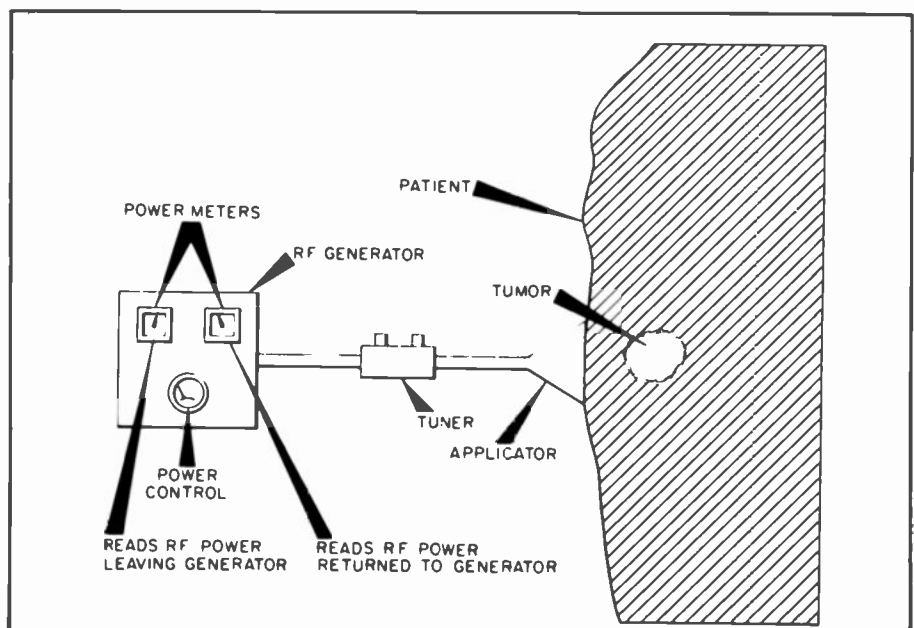

Fig. 8. Typical hyperthermia system.

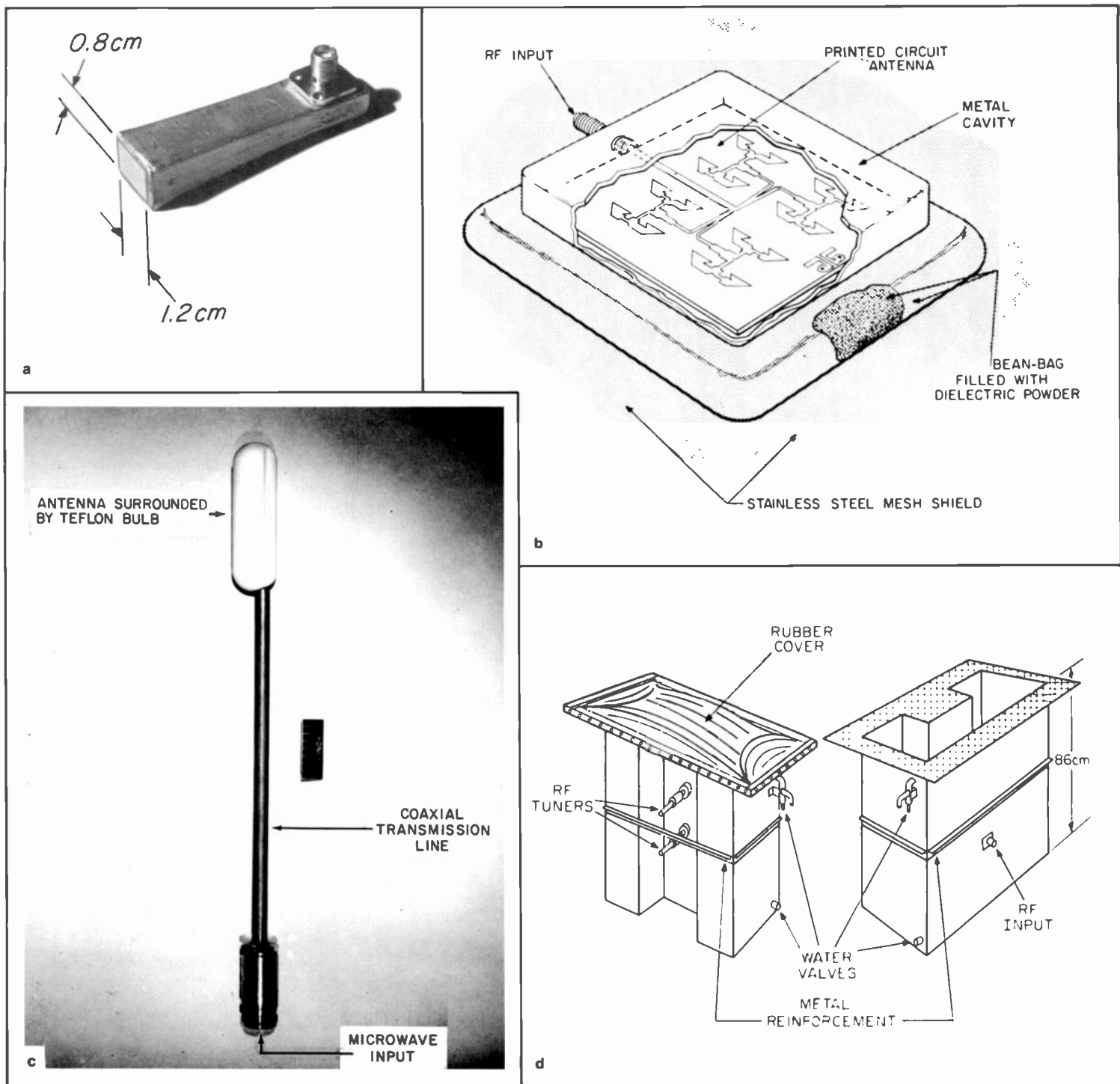

Fig. 9. Examples of rf and microwave-hyperthermia applicators that were developed at the Microwave Technology Center: (a) 2450-MHz waveguide applicator filled with solid dielectric (used for treating small, superficial lesions); (b) 2450-MHz "bean-bag" applicator with printed-circuit antenna (used for treating large superficial lesions and breast tumors); (c) 2450-MHz coaxial applicator (rectal applicator for treating prostate cancer); (d) 27-MHz water-filled waveguide applicator (used for treating deep-seated tumors).

tumor. This causes rf currents to flow through the tumor and heat it. Although well-localized heating can be produced with this method in many tumor sites, the method has the disadvantage of being invasive. Another rf method heats with rf currents that flow between capacitive elec-

trodes held against the surface of the body of the patient. This method is well suited for localized heating of protruding tumors. When deep-seated tumors are heated with capacitive electrodes, however, the heating patterns inside the body of the patient are often difficult to predict. Also, excessive

heating of skin and fat is often a problem unless multiple electrode configurations are used.

Localized and regional hyperthermia can also be produced by inductively inducing rf current flow in the tissues to be heated. Flat, pancake-shaped coils are useful for

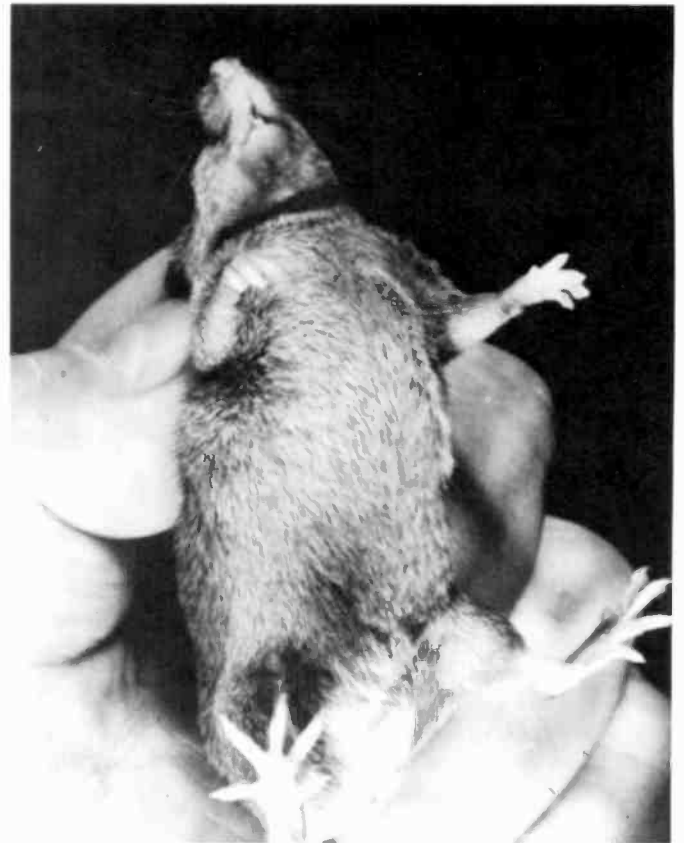
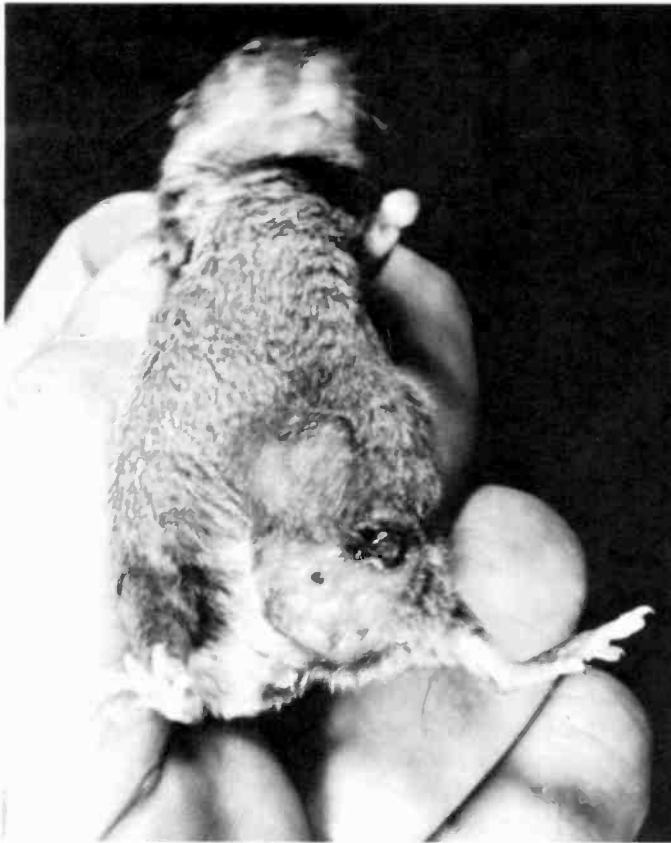

Fig. 10. C3H mice used to study the effects of localized hyperthermia on mouse breast cancer: (a) control mouse with advanced breast tumor; (b) mouse treated with localized hyperthermia.

local heating of tumors near the surface of the body. Regional hyperthermia can be induced by encircling part of the patient's body with one or more coils. In regional hyperthermia produced this way, however, the heating generally decreases toward the center of the body.

At the Microwave Technology Center of RCA Laboratories, we have developed apparatus for producing localized hyperthermia in cancer patients based on yet another method, namely the use of antennas or applicators to broadcast rf or micro-

wave energy into the tissues to be heated. The rf or microwaves travel through the tissues of the body in the form of exponentially decaying waves, giving up energy to the tissues via dielectric heating.

Figure 8 shows a block diagram of the

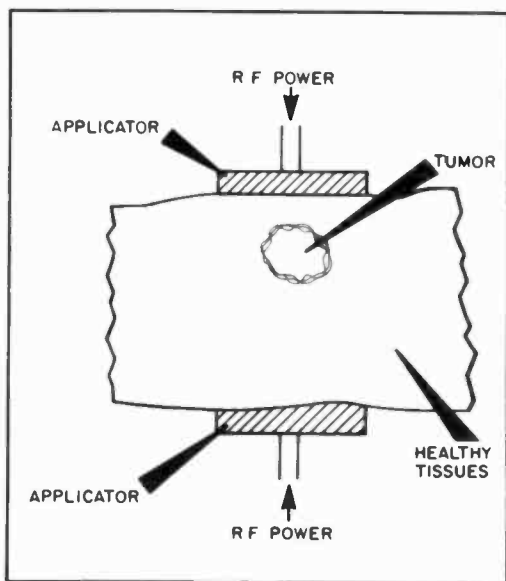

Fig. 11. "Cross-fire" arrangement for heating tumors with two applicators.

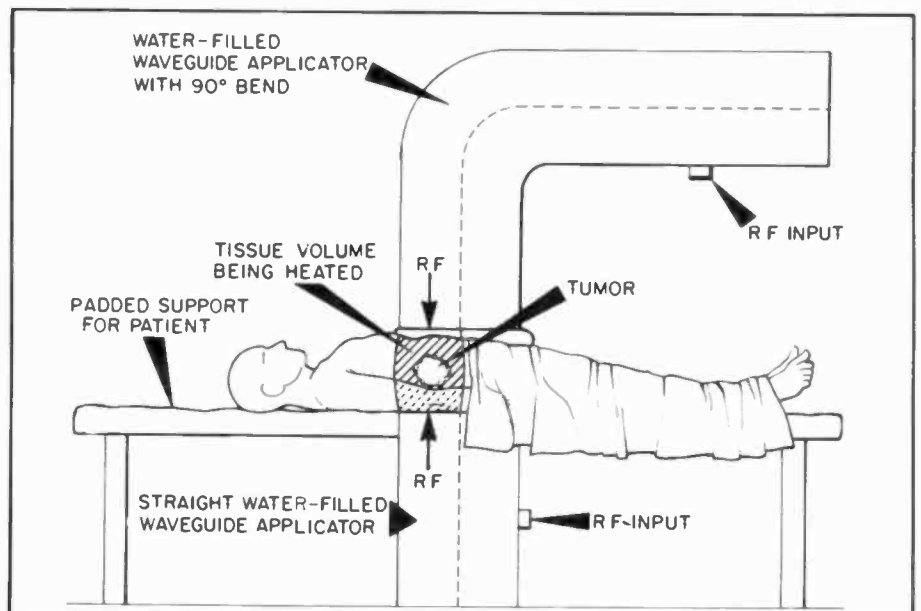

Fig. 12. Arrangement for producing localized hyperthermia in patient using two water-filled waveguide applicators.

apparatus used to induce localized hyperthermia with radiated rf or microwaves. Power produced by a generator is matched by means of a tuner into an applicator that radiates the power toward the tumor to be treated. Two power meters are provided, one for measuring the power leaving the generator, and a second one for measuring the power reflected back to the generator. The depth to which the rf or microwaves that are radiated by the applicator can penetrate into the patient and heat the tumor is primarily a function of the dielectric properties of the tissues shielding the tumor from the applicator and of the rf or microwave frequencies used. In general, the lower the water content of the shielding tissues, the deeper the penetration of a wave at a given frequency. Waves penetrate much deeper into fat (low water content) than into muscle (high water content). Also, at the frequencies of interest, the lower the frequency, the deeper the penetration into tissues with a given water content. The approximate useful depths for localized hyperthermia treatments using a single radiation applicator are listed in Table I (page 46).

Figure 9 shows four rf- and microwave-hyperthermia applicators that were developed at the Microwave Technology Center.³⁻⁶ The applicators shown in Fig. 9a-9c operate at a microwave frequency (2450 MHz); the applicator of Fig. 9d operates at a relatively low rf frequency (27 MHz).* The microwave applicators make it possible to accurately focus the microwave energy on the tumors to be treated, but their use is limited to treating cutaneous and subcutaneous tumors, tumors within or in the vicinity of natural body cavities, and tumors in the breasts. The rf applicator can be used to treat deep-seated tumors, but focusing is relatively poor (the wavelengths in tissues at 27 MHz are greater than 1 meter). The rf or microwave power levels required to raise tissues to hyperthermic temperature vary from about 1 W for the applicator of Fig. 9a to several hundred watts for the applicator of Fig. 9d.

All hyperthermia apparatus developed by us is first tried out on animals before any use on humans is attempted. The first study on animals carried out with our apparatus involved a group of 72 C3H

* 2450 MHz and 27.12 MHz are among frequencies set aside by the Federal Communications Commission for Industrial, Scientific and Medical applications. We have also built applicators that operate at 100 MHz, 300 MHz, 915 MHz, and 5800 MHz.

Q & A: Hyperthermia treatments and side effects

Q. What is a typical treatment plan for a patient undergoing localized hyperthermia using rf or microwave radiators?

A. *A minimum of about six to a maximum of about twenty hyperthermia sessions at the rate of two to three sessions per week. Each session lasts about forty-five minutes to one hour. During each session the temperature of the tumor or tumors to be treated is gradually raised to the hyperthermic range (about 42° C to 43.5° C), and is maintained in this temperature range for the remainder of the session. Ionizing radiation treatments are given either before or after the hyperthermia sessions.*

Q. Are localized rf- or microwave-hyperthermia treatments painful?

A. *Most patients tolerate localized hyperthermia treatments well, and feel comfortable during the treatments. Some patients, however, feel pain when the temperature of the treated area is raised for the first time to the hyperthermic range. In such patients, the technicians administering the hyperthermia treatment will reduce the temperatures of the treated areas to values that feel comfortable to the patients. The technicians will then gradually increase the temperatures, always staying below the threshold of pain of the patients. Eventually, even the most sensitive patients get used to the heating and learn to tolerate hyperthermic temperatures.*

Q. Can localized hyperthermia treatments be given on an outpatient basis?

A. *Yes. In fact, most of the patients being treated with the RCA-developed equipment are outpatients.*

Q. Does localized rf or microwave hyperthermia produce side effects in or near the treated area?

A. *When carefully applied, regional side effects associated with localized hyperthermia are, at most,*

mice.³ Breast cancer (mammary adenocarcinoma) was induced by implants in all 72 mice: 54 animals received four hyperthermia treatments localized to the tumor site (43°C, 45 minutes, every other day), with the applicator of Fig. 9a, while 18 served as nontreated controls. Complete eradication of tumors was achieved in all the treated animals and they showed no evidence of tumor recurrence over an obser-

vation period of 4 months, whereas all 18 controls died within 4 weeks post-inoculation. Figure 10a shows a control mouse with breast tumor; Fig. 10b shows a mouse treated with hyperthermia.

Deep-seated tumors are often best heated with two or more applicators whose radiations intersect at the tumor (also called a "cross-fire" arrangement). This is illustrated in Fig. 11 for the case of two

minor. Some patients develop skin blisters or superficial ulcerations on the treated areas, and in some cases there is subcutaneous fibrosis (replacement of normal tissue by fibrous tissue), but in general most healthy tissues tolerate hyperthermic temperatures well. In fact, some surface tumors heal so well after hyperthermia treatments that it is difficult to tell after the treatments where the tumors had originally been located. Healthy tissues can, of course, be damaged by heat, particularly if they are heated to temperatures above the hyperthermic range. Localized hyperthermia treatments must therefore be given only by well-trained technicians who are supervised by physicians familiar with the thermal tolerance limits of various tissues and organs.

Q. Does localized hyperthermia produce systemic side effects?

A. *The tissues that are destroyed by localized hyperthermia are usually removed from the tumor sites by the blood circulation, and the resulting waste products in the blood are removed by the kidneys. The kidneys of the patient may become overloaded if too much tumor tissue is destroyed too quickly by the localized hyperthermia.*

Q. Can localized hyperthermia treatments promote distant metastases?

A. *There are no indications now that localized hyperthermia treatments promote distant metastases. Many more years of careful record keeping and analysis will be needed, however, before the medical community can be absolutely certain of this. In the meantime, it is probably useful as a precaution to accompany the hyperthermia treatments by at least a small dose of radiation, and to be as certain as possible that the tumor temperature does get raised to the hyperthermic range.*

applicators facing each other. Cross-fire arrangements have proven useful for treating primary breast tumors. Here the breast is placed between two opposing bean-bag applicators of the type shown in Fig. 9b. Another important use of cross-fire arrangements is for treating deep-seated tumors in the trunk of the body. Figure 12 shows such an arrangement using two 27-MHz water-filled ridge waveguide applicators.

Clinical Results

Clinical experience in the United States with localized hyperthermia has been limited to date to a few hundred patients. All major types of cancers have been treated with localized hyperthermia including lung cancer, breast cancer, cancer of the colon, prostate cancer, head and neck cancer, skin cancers, and so on. Fairly typical of

the results obtained so far, covering a variety of tumors, are the following statistics from Thomas Jefferson University Hospital in Philadelphia and Montefiore Medical Center in New York City. Using reduced amounts of ionizing radiation together with localized rf and microwave hyperthermia resulted in total regression of about one-third of all tumors treated, with biopsies showing no histological evidence of any viable remaining tumor. Another one-third of the tumors regressed partially (>50 percent), and about one-third showed no response. Statistics from hospitals that treated only cutaneous tumors with ionizing radiation and localized rf or microwave hyperthermia are better: 78 percent complete response (Memorial Hospital, New York City) and 56 percent complete response, 28 percent partial response (Hershey Medical Center, Hershey, Pennsylvania).

While localized rf and microwave hyperthermia combined with reduced amounts of ionizing radiation has yielded encouraging results with many different types of malignancies, this type of therapy has been found to be particularly useful for treating breast cancers that have metastasized to the chest wall, tumors that regrow after having received close to the maximum tolerable dose of ionizing radiation, head and neck cancers, and malignant melanoma. Encouraging results have also been recently obtained using the applicator shown in Fig. 9c on 20 patients with prostate cancer at the Weizmann Institute of Science and the Kaplan Hospital in Rehovot, Israel, and with similar patients at Montefiore.

Patients who are candidates for hyperthermia treatment and their families and friends usually ask many questions about the treatments and their possible side effects. Some of the more commonly asked questions, and answers to them, are given in the sidebar, "Q&A: Hyperthermia treatments and side effects," page 50.

Conclusions and outlook for future

Localized hyperthermia has several features that make it an attractive modality for treating malignant tumors. The most important of these features are: the relative safety of localized hyperthermia compared to conventional methods of treating tumors; the selective destructive effect of heat above a threshold level of about 42.5°C on malignant versus normal tissues; the

sensitizing effect of heat when used in conjunction with ionizing radiation therapy, leading to reduced radiation doses and increased therapeutic ratio; the apparent stimulation of immune processes by hyperthermia leading to increased host defenses against tumor growth; and the sensitizing effects of hyperthermia when used in conjunction with chemotherapy.

A convenient way to produce localized hyperthermia is to use rf or microwave radiation. A variety of cutaneous, subcutaneous, and deep-seated tumors have been safely treated with this method. Therapeutic results have been encouraging. In particular, a number of tumors that did not respond to conventional therapies responded well to combinations of localized hyperthermia and reduced amounts of radiation therapy.

The number of cancer patients that are being treated with localized hyperthermia is likely to increase rapidly during the next few years. A growing number of oncologists are becoming familiar with the therapeutic possibilities of localized hyperthermia, and the equipments for producing localized hyperthermia are constantly being improved. Much emphasis will likely be placed on overcoming the present main limitation of localized hyperthermia, namely that one presently treats only local manifestations of cancer (that is, a particular tumor) rather than the systemic aspects of the disease. Promising approaches to treating the whole body of the patient include combining localized or regional hyperthermia with immunotherapy, chemotherapy, or tumor acidification⁷, scanning the whole body of the patient sequentially with regional hyperthermia, or using whole-body hyperthermia.

Acknowledgments

The apparatus for producing localized rf and microwave radiation described in this paper was developed over a period of several years in a cooperative program between the Radiotherapy Department of Montefiore Medical Center and the Microwave Technology Center of RCA Laboratories. The author wishes to express his deep appreciation to his colleagues on this program: Charles Botstein, Esther Friedenthal, Jozef Mendecki and Steve Weber of Montefiore and Elvira Beck, Markus Nowogrodzki, Robert Paglione and Frank Wozniak of RCA Laboratories, and also to the many patients who had the courage to participate in the initial clinical trials. The author also wishes to thank William Hittinger, Kerns Powers and William Webster for their continuing encouragement of this work.

References

1. J. E. Enstrom and D. F. Austin. "Interpreting Cancer Survival Rates." *Science* 195, No. 4281, pp. 847-851, Mar. 4, 1977.
2. F. Dietzel. "Tumor and Temperature." *Urban & Schwarzenberg*, Munchen-Berlin-Wien, 1975. pp. 101-110.
3. J. Mendecki *et al.*, "Microwave-Induced Hyperthermia in Cancer Treatment: Apparatus and Preliminary Results." *International Journal of Radiation Oncology, Biology and Physics*, Vol. 4, Nov./Dec. 1978, pp. 1095-1103.
4. F. Sterzer *et al.*, "Microwave Apparatus for the Treatment of Cancer by Hyperthermia." *Microwave Journal*, Vol. 23, Jan. 1980, pp. 39-44.
5. J. Mendecki *et al.*, "Microwave Applicators for Localized Hyperthermia Treatment of Cancer of the Prostate." *International Journal of Radiation Oncology, Biology & Physics*, Vol. 6, Nov. 1980, pp. 1583-1588.
6. R. Paglione *et al.*, "27 MHz Ridged Waveguide Applicators for Localized Hyperthermia Treatment of Deep-Seated Malignant Tumors." *Microwave Journal*, Vol. 24, pp. 72-80, Feb. 1981.
7. M. von Ardenne. "Hyperthermia and Cancer Therapy." *Cancer Chemother. Pharmacol.*, Vol. 4, No. 3, 1980, pp. 137-138.

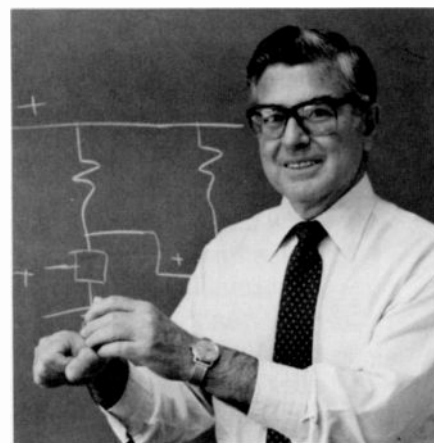

Fred Sterzer received the BS in Physics from the City College of New York in 1951, and the MS and PhD degrees in Physics from New York University in 1952 and 1955, respectively. He joined RCA Corporation in 1954 and has worked there on the development of traveling-wave tubes, optical components, high-speed logic, and microwave solid-state devices and circuits. His most recent work involves the application of microwave heating to the treatment of human cancers. Dr. Sterzer is currently Director of the Microwave Technology Center at RCA Laboratories, leading a group of approximately 85 scientists, engineers and technicians engaged in developing new microwave technologies. He is a member of the N.J. Commission on Radiation Protection and Chairman of its Advisory Committee on Non-ionizing Radiation.

Contact him at:
RCA Laboratories
Princeton, N.J.
TACNET: 226-2633

Discovering how to ensure software reliability

A mathematical model predicts the time and manpower needed to debug software to meet strict reliability requirements—before it's delivered to the user.

Abstract: *Ensuring software reliability is currently the most critical unsolved problem in software engineering. Efforts to find the solution are hampered by the absence of credible tools for predicting how much time and manpower are needed to test and debug a piece of software to a predetermined level of reliability. Our studies indicate that, during testing, changes in bug-detection rates generally follow a Rayleigh curve. The parameters that govern the shape of the Rayleigh curve can be accurately estimated using principles of M. Halstead's "software science" approach. Evidence to support these findings is briefly presented.*

The need

The process of developing computer and microcomputer programs, like any other engineering activity, is subject to various specification, design and implementation errors. Although modern software-development practices, such as structured programming and design reviews, have significantly reduced the number, many bugs still remain hidden in programs delivered to users. For example, to illustrate the magnitude of this problem, 198 critical bugs were detected in the first 9 months of field operations of a military command and control system despite over 20 man years of rigorous testing and checkout during development.¹ Furthermore, although subjected to one of the most thorough computer-testing programs ever conducted, the Apollo 14 encountered 18 software-based errors during its ten-day flight.²

Because developing totally reliable software seems generally impractical, one would expect that software and firmware would be developed like hardware, to meet specific reliability criteria, such as an acceptable mean time between failures. But this is not being done because software engineers have no credible tools to help them to predict how much a given program design or programming technique will impact a reliability requirement or to estimate how much testing will be needed to ensure that a program meets a reliability requirement. Work has been in progress within the Technical Assurance activity of Missile and Surface Radar, to develop these missing engineering tools. This effort increased recently in response to a request by the govern-

ment for RCA to assure that the software for a recent proposal would meet a very severe reliability requirement, expressed as a mean time between failures of at least 1500 operational hours.

This paper describes the development of a methodology that ensures that the time and manpower allocated for software testing are sufficient to make the software meet a specific operational reliability requirement.

Searching for a practical reliability model

In the hope of finding a currently available solution to the problem of predicting software reliability, we searched the technical literature for software reliability models.³ These models attempt to describe mathematically how the occurrences of software failures, or of software bugs, are distributed in time and program space, respectively. (A software failure is a test or operational malfunction caused by a software bug; that is, by a mistake in the program design or code.) We found over 25 different models, showing that there is avid interest but little agreement as to what determines software reliability.

Moreover, besides the lack of consensus, we were disappointed to find that the use of any of these models requires data known only after coding or testing begins, when it is often too late to influence the software-engineering process in a cost-effective manner. The model we wanted would ideally permit early cost and schedule trade-offs against all the factors that influence software-error content.

Reversing direction

All the models we examined were deductive models, based on general assumptions that determined their mathematical behavior. In every case, the evidence given to prove that the mathematics conform to experience was not convincing. We, therefore, thought that an inductive model based on actual error histories might be more successful. Inductive model development is opposite to deductive model development. Inductive model development proceeds from knowing how specific cases actually behave, to finding general explanations for the observed behavior. Max Planck's development of the Quantum Law of Black Body Radiation is an example of this approach. Planck worked out an excellent mathematical curve fit to pub-

©1982 RCA Corporation
Final manuscript received April 21, 1981.
Reprint RE-27-1-12

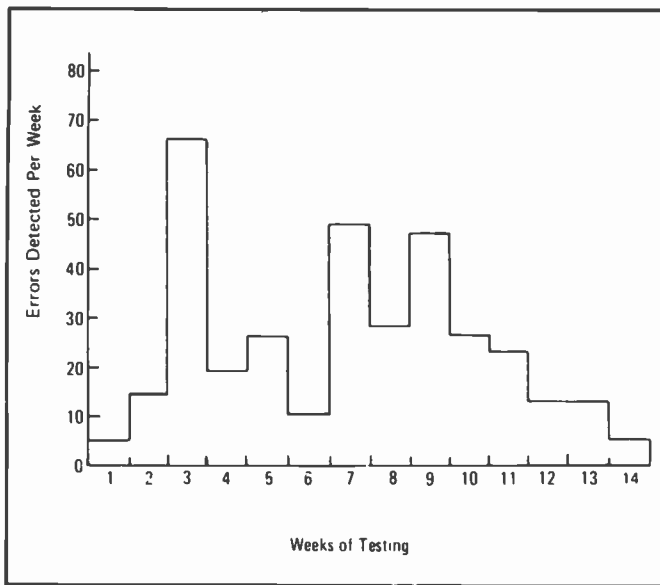

Fig. 1. A typical software error history during testing (from Thayer, *et al.*).

lished experimental data and then tried out alternative hypotheses until he found one that accounted for the fit.

The discovery

At first glance, a typical error history, as shown in Fig. 1, does not suggest that some "invisible hand" is shaping its behavior. It appears to be very "noisy" and if a repetitive pattern is hiding in the noise, something special must be done to bring it out.

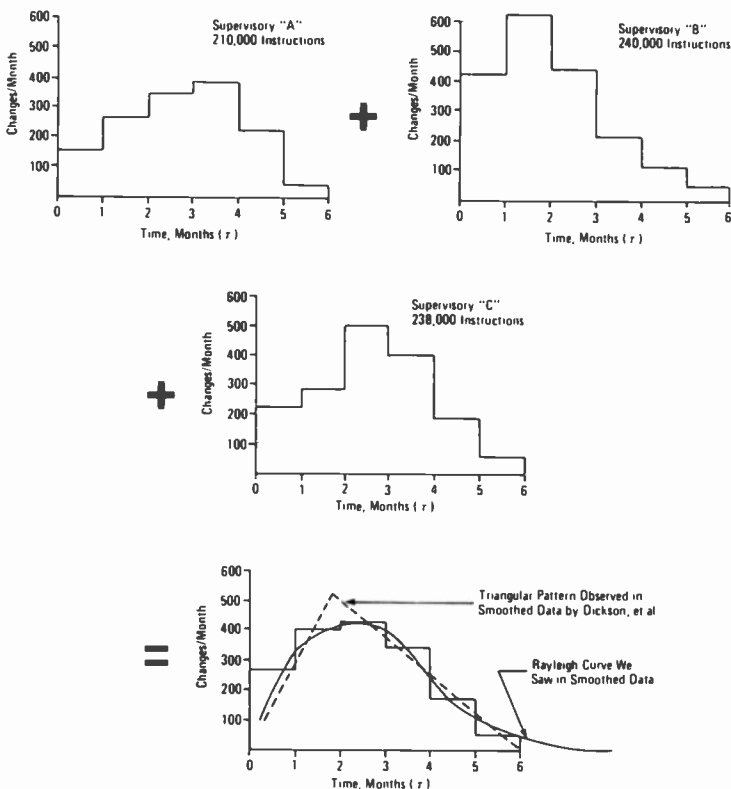

Fig. 2. Extracting a common pattern in error-rate data by normalizing and averaging data from many projects (after Dickson, *et al.*).

To solve this same problem, we found that J. Dickson, *et al.*, in a 1972 paper, had merged normalized error data from three projects into one composite histogram, as shown in Fig. 2.⁴ This approach tended to subtract out the differences and enhance the similarities among the separate error histories. To Dickson, the resulting profile seemed to confirm the hypothesis that error histories behaved in a triangular pattern. But, when we read the paper, the composite suggested to us the similar, but more complex, Rayleigh curve. We wondered if Rayleigh curves also fit other data, so we searched library documents and collected all the error histories we could find (ten of them).⁵ Then, using Dickson's method, we developed another composite. We found that the suggestion of a Rayleigh curve was again evident, as seen in Fig. 3.

Seeking the underlying cause

After tentatively verifying that a Rayleigh-like curve fits the average software-error history during testing, we sought an explanation. We found that Rayleigh functions are used in models for predicting bombing errors and for estimating software life-cycle manpower requirements. The bombing-error model (despite its suggestive title) proved unnoteworthy. The software-manpower model, fortunately, turned out otherwise.

In a 1963 paper, P.V. Norden of IBM showed that the manpower allocated for R&D projects normally follows the Rayleigh curve,⁶

$$m = \frac{M}{t_p^2} t e^{-t^2/2t_p^2} \quad (1)$$

where: m is the rate at which manpower is allocated at time t ; M is the total manpower allocated over the life-cycle of the project; and t_p is the time of peak project activity. He also found that the overall project curve was actually the envelope of the Rayleigh curves of all of the several project subcycles (for example, planning, design, and prototype development). In other words, each phase of an engineering project also followed a Rayleigh manning curve. Finally, he claimed that the Rayleigh curve resulted in the most cost-effective use of engineering personnel, as illustrated in Fig. 4. In a 1978 paper, L. Putnam of General Electric confirmed that the Norden-Rayleigh manpower model also held for software projects.⁷ Based on studies of over 200 systems, he derived the average relative amount of manpower involved at various times and in various phases of

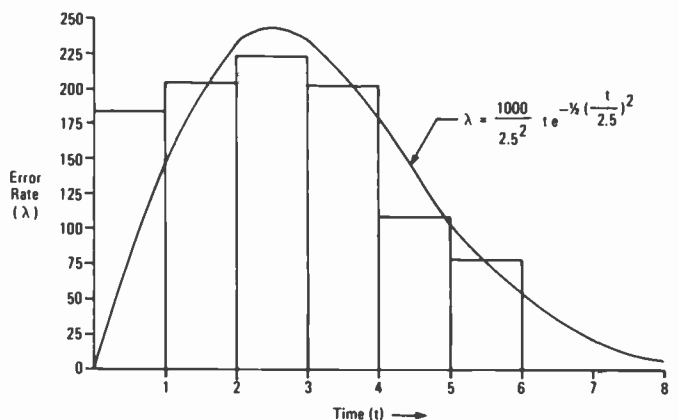

Fig. 3. Composite histogram and Rayleigh-fit of normalized error data from ten projects.

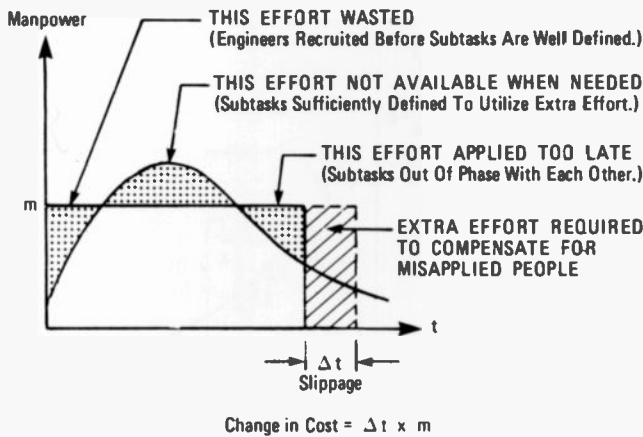

Fig. 4. Consequences of a non-Rayleigh scheme of manpower allocation (after Putnam⁷).

the overall life cycle of a software project, as shown in Fig. 5. The Rayleigh curve typical of the software-testing phase is shown in more detail in Fig. 6.

The connection

Manpower is the means by which the progress of an engineering activity is controlled. In software testing, progress is measured by the number of errors detected and corrected. These two variables are essentially related because, for reasons of efficiency, programmers do not usually seek to find new errors until they have corrected the old ones. A safe assumption is that this error rate is proportional to the rate at which manpower is applied to the testing activity, as long as new errors are detected at a rate sufficient to maintain a workload for correction and computer time is sufficient to cover error-correction needs. The fact that programmers are usually busy during testing indicates that these two requirements are generally met. The mathematical consequence of this argument is that

$$\lambda = Pm \quad (2)$$

where λ is the error rate during testing, P is a constant of proportionality equal to the project's average testing productivity (for example, average errors detected and corrected per man-month), and m is the rate at which manpower is applied during testing. Since Putnam showed that the manning of every phase of a software project tends to follow a Rayleigh curve, we can take m and substitute its Rayleigh expression as given in equation (1):

$$\lambda = Px \frac{M}{t_p^2} te^{-1/2} \left(\frac{t}{t_p}\right)^2 = \frac{B}{t_p^2} te^{-1/2} \left(\frac{t}{t_p}\right)^2 \quad (3)$$

where B is the number of bugs that can be detected and corrected given M manpower working at a P level of testing productivity, and t_p is the time of peak debugging activity.

Hence, we see that our Rayleigh-like error histograms are directly attributed to normally experienced Rayleigh-like allocations of manpower in the testing phase.

Before going too far

Norden claimed that allocating manpower according to a Rayleigh curve resulted in optimal usage of time and personnel. If

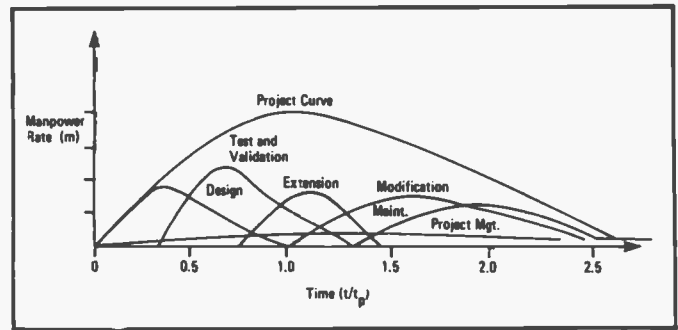

Fig. 5. The manpower requirements of a software life cycle and each of its phases follows a Rayleigh-like curve (after Putnam⁷).

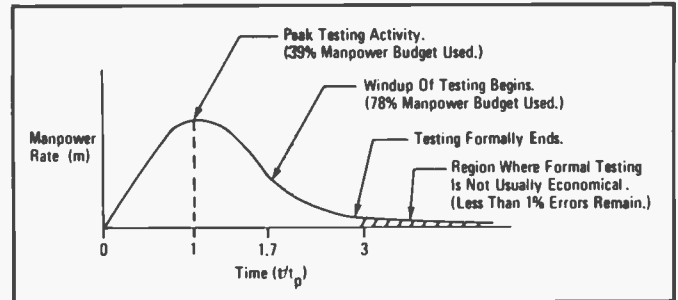

Fig. 6. Average manpower utilization curve during testing (after Putnam⁷).

this is true, then having a Rayleigh-like error-rate behavior would be desirable, since by equation (2) it would be indicative of optimal manpower usage. Before proceeding, we wanted to confirm Norden's claim. For this, we compared the programmer productivity of Putnam's Rayleigh-driven projects with comparable non-Rayleigh-biased projects from the Rome Air Development Center (RADC) productivity statistical database.⁸ As seen in Table I, we did find a tendency for significantly higher productivities in Rayleigh-driven projects.

The appearance of Rayleigh error rates resulted from merging the statistics from many projects. Perhaps this appearance was only a macro-statistic, valid for an aggregate but not for an individual case. Before continuing, we wanted to check this possibility. To this end, we fitted a Rayleigh curve to the testing-error data of "Project 3," the most comprehensive and accurate project-error statistics available.¹ As seen in Fig. 7, we found that it fit the data, especially after smoothing, well enough to justify continued study.

Finding the missing relations

Looking at equation (1), we see that the shape of the Rayleigh manning curve is governed by the parameters M (required manpower) and t_p (time of peak manning). As seen in equation (3), the shape of the corresponding testing-error-rate profile is controlled by the parameters B (total bug content) and the same t_p . If we knew the values of these parameters, we could allocate the software-testing manpower in the most efficient manner as well as predict when the number of bugs or the testing failure rate would be reduced to an acceptable level. Our next problem was to find ways to estimate these values from the information available during early project planning.

Evaluating t_p was no problem once we saw that it was the remaining unknown in equation (3) after B was determined and

Table I. Programmer productivity of Rayleigh-biased versus unbiased projects.

Rayleigh-biased projects			Unbiased projects		
Project ID	Lines of code (K)	Productivity*	Project ID	Lines of code (K)	Productivity*
ACS	168	928	N.A.	103	589
MPIS	132	328	N.A.	198	384
SAAS	165	255	N.A.	250	278
VTADS	485	218	N.A.	240	242
SIDPERS	630	164	N.A.	128	191
SAILS AB/X	954	146	N.A.	500	169
SAILS AB/C	699	124	N.A.	221	91
STANFINS	504	124	N.A.	487	41
—	—	—	N.A.	155	39
—	—	—	N.A.	136	32
Average		286			206
Weighted average (by lines of code)		198			175

*Lines of source code per man-month

λ and t were set to those values equivalent to the software-reliability requirement and software-delivery date, respectively.

For estimating M and B , the only techniques known to us were statistical ones based on correlating widely varying data, which would not have yielded very credible results. Fortunately, before we committed ourselves to a statistical approach, our local RCA technical library acquired and put on display a book, M. Halstead's *Elements of Software Science*, that addressed our very problems in theoretical terms.⁹ Halstead's theories explained the sources of observed statistical variation and thereby permitted us to develop accurate techniques for estimating the values of the parameters of the Rayleigh curve.

Based on Halstead's theory, we derived the following estimating formulas:

$$B = \sum_{i=1}^F B_i = \frac{2.9}{E_o} \sum_{i=1}^F (IS)^{1.13} \quad \text{and} \quad (4)$$

$$M = \sum_{i=1}^F M_i = \frac{5.0}{\bar{s}} \sum_{i=1}^F \frac{(IS)^{1.7}}{L^{1.5}} \quad (5)$$

where: B_i is the probable bug content of the i th software module;

M_i is the manpower needed to find and fix all the bugs in the i th module;

F is the estimated number of modules in the software system;

S is the estimated number of executable source statements in a module;

l is 7.5 or 2.7, depending on whether the module is written in high-order language (HOL) or assembly language, respectively;

L measures the economy of expression permitted

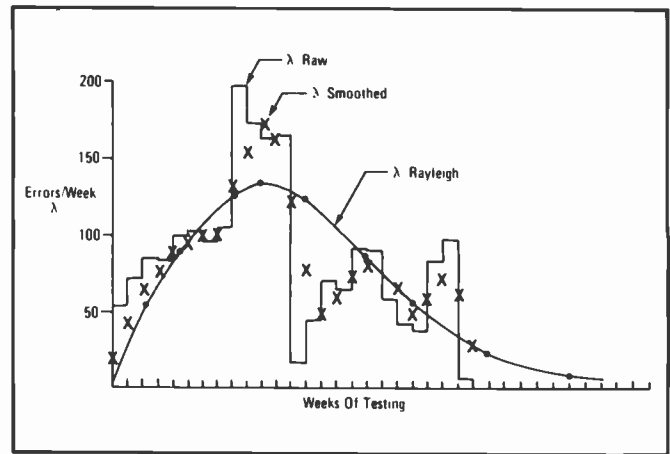

Fig. 7. Raw and smoothed data on errors detected while testing Project 3 and its Rayleigh curve fit (after Thayer¹).

by the specific language (for example, FORTRAN, BASIC) in which the module is written;

s is the effective discrimination rate or "speed" of the average programmer; and

E_o is the average programmer's "Poisson" constant of error making.

Values of L , s and E_o , appropriate for different conditions, have been empirically derived by Halstead, ourselves, and others to make the formulas adaptable for software developed and tested under various situations.

Yes, you can do something about it

Equations (4) and (5) suggest ways to reduce the generation of programming errors and the corresponding manpower needed for their detection and correction. Strategies can be employed to increase L , s , and E_o and thereby reduce probable bug content B and test effort M . For example, RADIC has shown that software using structured programming and HOL develops, on the average, half the errors per 1000 statements as software not using these techniques.¹¹ Furthermore, an IBM study showed that the use of independent design and code reviews prior to testing (which effectively increases E_o and s) resulted in the occurrence of 38-percent fewer errors during testing and a 25-percent reduction in total project manpower.¹²

But what about computer time?

Manpower is only one of the critical software-testing resource requirements. Computer time is equally important. How must it be allocated in order to ensure a Rayleigh debugging rate? In our literature search we found that J.D. Musa of Bell Labs already laid the groundwork to answer this question. In a 1975 IEEE paper, Musa theorized and empirically demonstrated that the number of bugs detected in software, b , is a function of the CPU time x used in its execution:¹³

$$b = B(1 - e^{-Ax}), \quad (6)$$

where B is the total number of undetected bugs at the start of testing, and A is a constant peculiar to each software system.

This implied that when the computer time used for testing, x ,

changes in each calendar period t , such that

$$\frac{dx}{dt} = Kt, \quad (7)$$

the result is a Rayleigh bug-detection rate. This can be seen by integrating (7)

$$x = \frac{Kt^2}{2} \quad (8)$$

and substituting the result in (6)

$$b = B(1 - e^{-AKt^2/2}) \quad (9)$$

and then differentiating this with respect to t

$$\frac{db}{dt} = \lambda = \frac{B}{AK} te^{-AKt^2/2} \quad (10)$$

Setting $AK = 1/t_p^2$ in (10) gives us a Rayleigh equation identical to the form shown earlier in equation (3).

What equation (7) means is that, to support Rayleigh and error-detection rates, the computer time needed for actual testing (exclusive of that needed for compilations, memory dumps, and so on) must be linearly incremented throughout testing. By modeling the typical testing activity, we determined that this condition normally occurs automatically during testing.¹⁴

Validating the model

Because our model integrates so many factors of software development (module size, language, profile, and amount of manpower) it has been difficult to find the necessary comprehensive data against which to check it; therefore, only a few tests have been made so far. The model has been confirmed in the following cases.

Prediction of bug content

The only available statistics on module size versus module bugs were collected by Thayer, *et. al.* They reported 2006 system-level bugs while testing 25 modules of a system called Project 3. Using equation (5) with the appropriate values¹⁰ of F , S , and l , led to an estimate of 2099 bugs (less than 5 percent off).

Estimate of required manpower

No manpower statistics are available for Project 3. In their absence, we checked our model against an RADC statistical model based specifically on Project 3 type (command and control) systems.¹⁵ The RADC model estimated that 474 man-months of testing were required for Project 3. Our formula (4) with appropriate values of F , S , l , L and s gave an estimate of 503 man-months (a difference of only 6 percent).

Conclusion

Partial answers to two related critical contemporary problems of software engineering—predicting and then ensuring software reliability—were found to be scattered throughout the technical literature. All that was needed for a comprehensive methodology for dealing with these problems was to interpret and selectively pull together these isolated findings.

The model resulting from this integration agrees closely with



Marty Trachtenberg is Manager in Technical Assurance RCA MSR, where he is primarily responsible for MSR Software Design Reviews. In 1960, with a background in scientific programming, he joined the RCA Computer Division. There he designed and managed the development of system software. He left RCA in 1968 to work for Auerbach Associates as a consultant specializing in the evaluation of computer software and hardware. He re-joined RCA in 1978.

Contact him at
**Missile and Surface Radar
 Moorestown, N.J.
 TACNET: 224-3182**

the few empirical tests that we have been able to make. It promises to provide a basis for the conscious employment of software-engineering-management strategies for optimal control of the software bug content before and after testing. We hope to start collecting comprehensive data from RCA's software and firmware projects to further test and, if necessary, improve the accuracy of this model.

References

1. Thayer, T. *et. al.*, *Software Reliability*, Elsevier North-Holland, N.Y. (1978).
2. DoD, *Defense Computer Resources Technology Plan* (June 1979).
3. IIT Research Institute, *Quantitative Software Models*, DACS, RADC, Griffis AFB, N.Y. (March 1979).
4. Dickson, J., Hesse, J., Kientz, A., and Shooman, M., "Quantitative Analysis of Software Reliability," 1972 IEEE *Proceedings of Annual Reliability and Maintainability Symposium*, pp. 148-157.
5. The data for five error histories can be found in Reference 1 and are identified as Projects 2.1A, 2.1B, 2.1BR, 2.2, and 3. The remaining five error histories are documented in Reference 4 and are identified as Applications A, B, C, D, and the composite of 3 supervisors.
6. Dean, B., Editor *Operations Research in Research and Development*, John Wiley & Sons, N.Y., Chapter 5 (1963).
7. Putnam, L., "A General Empirical Solution to the Macro Software Sizing and Estimating Problem," IEEE *Transactions on Software Engineering*, Vol. SE-4, No. 4, pp. 345-361 (July 1978).
8. Selected from the RADC Software Productivity Statistics, a listing of data from 400 software projects, available from Data and Analysis Center for Software (DACs), RADC/ISISI, Griffis AFB, N.Y., 13441.
9. Halstead, M., *Elements of Software Science*, Elsevier, N.Y. (1977).
10. Trachtenberg, M., "Estimating Software Debugging Requirements Based on a Rayleigh Error Rate Model: Part II," unpublished.
11. DACS Newsletter, RADC/ISISI, Vol. 1, No. 1.
12. Fagan, M.E., "Design and Code Inspections to Reduce Errors in Program Development," *IBM System Journal*, Vol. 15, No. 3, pp. 182-211 (1976).
13. Musa, J.D., "A Theory of Software Reliability and its Application," IEEE *Transactions on Software Engineering*, Vol. SE-1, No. 3, pp. 312-327 (Sept. 1975).
14. Trachtenberg, M., "Estimating Software Debugging Requirements Based on a Rayleigh Error Rate Model: Part I," unpublished.
15. Doty Associates, Inc., *Software Cost Estimation Study, Guidelines for Improved Software Cost Estimating*, Vol. III, RADC-TR-77-220 (August 1977).

Linear integrated circuits are going digital

The once sacred "maybe" world of linear integrated circuits has been invaded by the "yes-no... 1, 0" world of digital circuitry. This invasion has benefited both disciplines and, ultimately, the consumer.

Abstract: *Digital circuitry is being used in what were formerly linear circuit designs. Beginning with the RCA CA3090 FM-stereo decoder, introduced in 1971, the author traces the development of digital circuitry in various RCA circuits, particularly those, like the CA3162, that incorporate both linear and digital design techniques. The author concludes with a look at the areas where analog circuit designs still provide unparalleled advantages.*

During the last ten years, digital circuitry has slowly gained ground on electronics that once relied exclusively on linear design. We see digital design techniques invading this once sacred area of linear design, and superbly enhancing the performance of everything from home entertainment systems to the various electronic items we carry with us, like watches and calculators. This is only the beginning.

This article will trace the digital expansion into the domain of linear integrated circuits (ICs), show some of the applications considerations and flexibility of linear and digital ICs, and finally predict what will be available.

Historical background

One of the earliest linear designs to incorporate digital techniques was the RCA

CA3090, FM-stereo decoder introduced in 1971. This device has over 70 active transistors plus an assortment of diodes, resistors, and several capacitors. A 76-kHz voltage-controlled LC oscillator is counted down to 19 kHz where it is phase locked to the 19-kHz pilot carrier. A doubly balanced mixer demodulates the FM-detector output signals into left and right stereo signals. Even after ten years, this device is still being used in many current receivers.

Several years after the CA3090, RCA announced an industrial integrated-circuit comparator, the CA3099, shown in Fig. 1, which by virtue of an internal flip-flop eliminates one of the nuisances associated with Schmitt triggers and comparators—oscillation near the trip point. A single input connected to two different input-differential comparators (one is an NPN and the other a PNP) accommodates an input-signal range equal to the supply voltage applied to the integrated circuit. Effectively, the hysteresis band may be extended from a built-in 3-mV band to the total supply—an extremely flexible input structure. A simplified version of the original 14-pin multi-featured device was later introduced. This new 8-lead device, the CA3098, has enjoyed popularity in both industrial and consumer control systems.

Current products

Another device that represents a mix of both analog and digital signal-processing techniques is the alarm-system integrated circuit, the CA3164. As shown in Fig. 2,

one ultra-high input-impedance amplifier may be used to monitor the common lead to a differentially connected, ionization chamber used in smoke detectors.

Amplifier input-phase sense is such that smoke particles, entering the open ionization chamber, raise the resistance of that chamber and cause the potential on the input to the alarm's integrated circuit to be reduced. Once this potential falls below a predetermined calibration level, the comparator output is applied to the input of an OR gate. From this point on, the signal is digitally processed until it activates the alarm output stages, which in this integrated circuit are push-pull power amplifiers. Considerable logic is incorporated within this analog and digital integrated circuit to test the battery, warn the user of a low-battery condition, and allow for remote alarm units. This device is even programmable to either turn on the alarm continuously or pulse the alarm in the "beep" mode.

The CA1524 switching regulator IC uses a flip-flop to ensure precise duty-cycle control, with the elimination of the possibility of both push-pull outputs being turned on simultaneously. Analog circuitry within the device supplies a regulated 5-volt zener-referenced output, a sawtooth generator and a comparator controlled by an error amplifier to generate variable duty-cycle-output drive signals. Also included within this IC is a differential-type current-sense amplifier and an input terminal to shut down the device.

One of the more complex industrial integrated circuits that incorporates both linear and digital design techniques on a

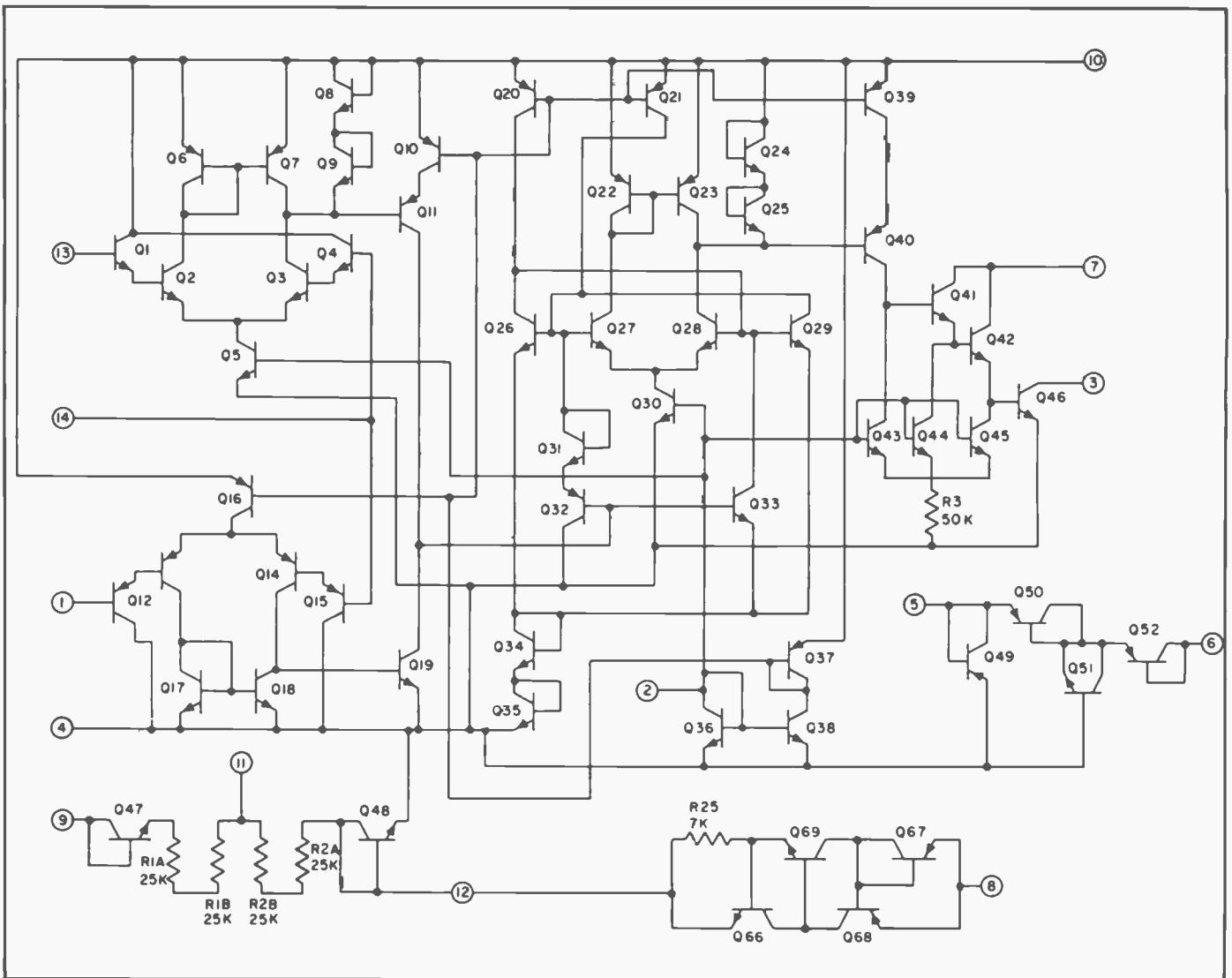

Fig. 1. The CA3099. Another industrial IC using digital techniques.

single chip to make a 3-digit analog-to-digital (A/D) converter is the CA3162. The digital section of this IC uses integrated injection logic (I²L) logic, while the integrating converter uses standard bipolar transistors. A single 5-volt supply powers this IC that has a bandgap reference voltage, differential signal input, and common-mode voltage range extending below the normal ground or substrate connection to the IC. This latter characteristic allows the meter to read from -99 mV to 999 mV. A binary-coded-decimal (BCD) to-seven-segment decoder IC with internal-segment current limiting complements the A/D converter. Three digit-drive transistors complete the digital panel meter circuit, Fig. 3.

The linear IC group did extensive work with the CMOS transistor array, the CD4007A. It was decided to add this device to the linear product line with characterization and specifications for linear

operation. From this effort, the CA3600 emerged. Each amplifier of this device has an open-loop voltage gain of approx-

imately 32 dB with 11-MHz unity-gain crossing. It has been used in conjunction with the CA3080, an operational transconduc-

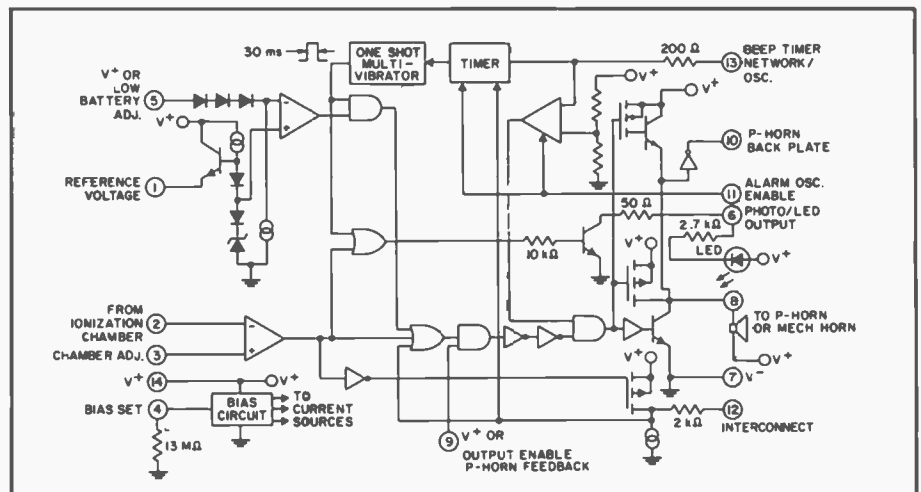

Fig. 2. The CA3164. An alarm system IC employing innovative BiMOS circuitry to achieve less than 1 pA input current with an MOS gate-protected input.

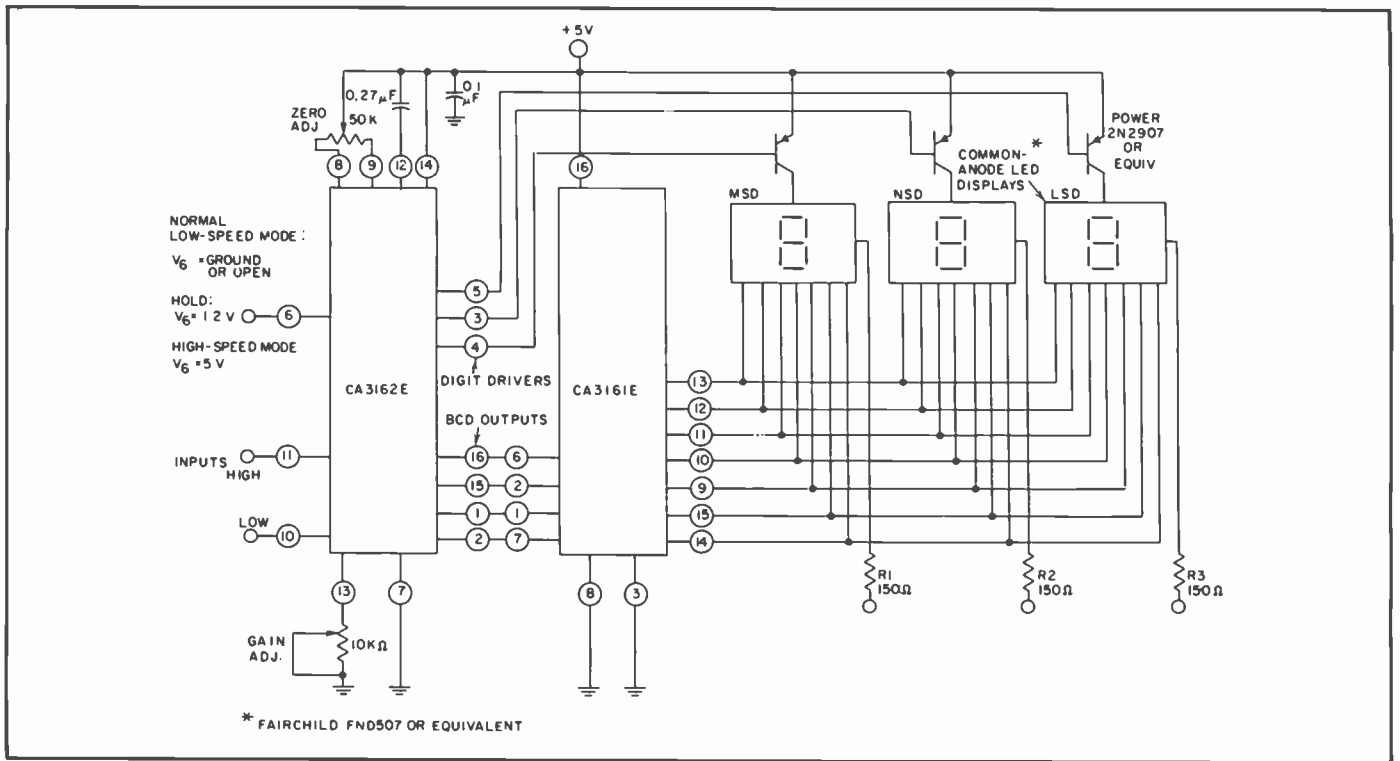

Fig. 3. The CA3162E basic digital meter using the CA3162E.

tance amplifier, as a precision-strobed micro-power comparator, as shown in Fig. 4, and by itself as a linear gain block in linear and digital systems. This latter circuit is shown in Figs. 5(a) and 5(b).

The concept of using CMOS devices fabricated on a sapphire substrate helped develop one of the more powerful CMOS components, a six-bit parallel or flash A/D converter. Figure 6 shows a functional block diagram of the industry's first 6-bit

CMOS/SOS flash A/D converter. Sixty-four high-speed CMOS inverters are used as strobeable, auto-balanced comparators. One complete conversion is made every 66 nanoseconds.

Several functions occur during each portion of the 15-MHz clock cycle. The first portion may be considered the auto-balance cycle when all the comparators are balanced by closing the switches, shorting the comparator input to the output. This

assumes, of course, that each PMOS and NMOS device making up the amplifier is similar. These devices are similar to the gain blocks shown on the CA3600 except that these devices are much smaller and diffused on a sapphire substrate to enhance the high-speed performance. When the input of each gain block is shorted to its output, each comparator output and input is at approximately half of the supply voltage. This operating point is also the highest current condition, resulting in the maximum comparator bandwidth.

Also during the auto-balance phase, each input-coupling capacitor is connected to its respective tap on the polysilicon reference ladder network on the chip. Each input capacitor is thus charged to the potential at its tap location on the ladder network.

During the next phase of the input-clock cycle, the switches shunting the comparators are opened and the input-coupling capacitor is switched to the unknown. At this time all the comparators either switch high or low depending upon where the sampled input is with respect to the ladder network. This data is stored, decoded and applied to the output latch and also applied to the three-state output stage.

The sapphire and high-speed CMOS devices give this device its high speed.

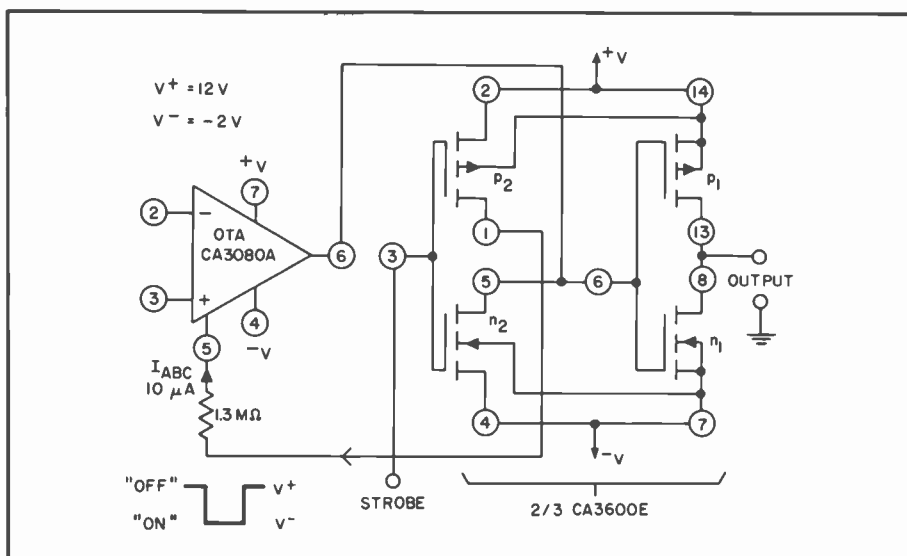

Fig. 4. The CA3600 is used in conjunction with the CA3080A as a strobeable micropower comparator.

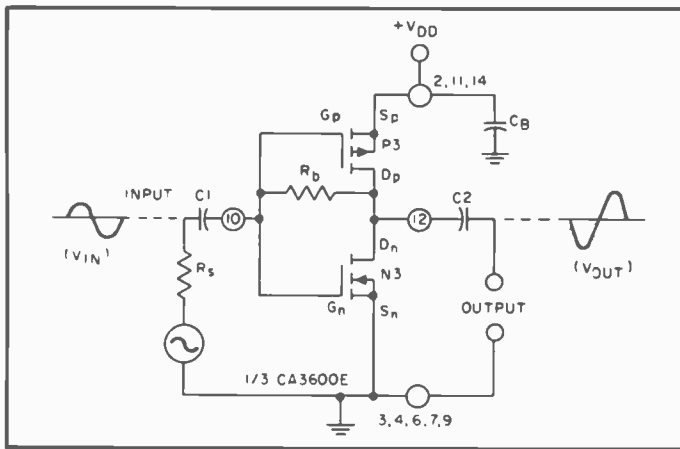

Fig. 5(a). The CA3600 is used as a feedback AC amplifier with its gain of approximately $-R_f/R_s$.

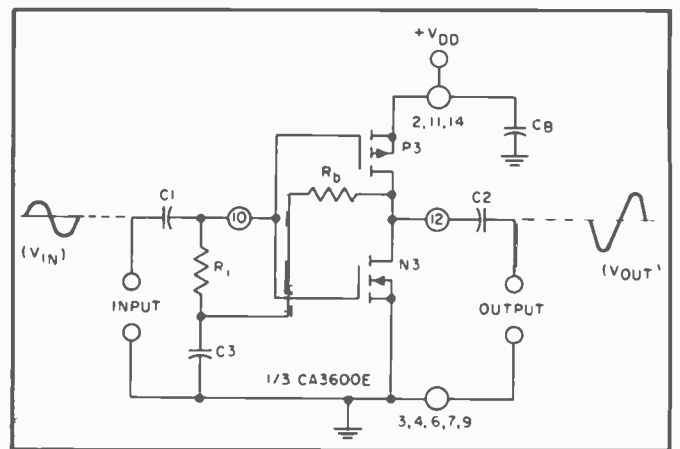

Fig. 5(b). The CA3600 is used as an open-loop AC amplifier. C_3 bypasses AC feedback.

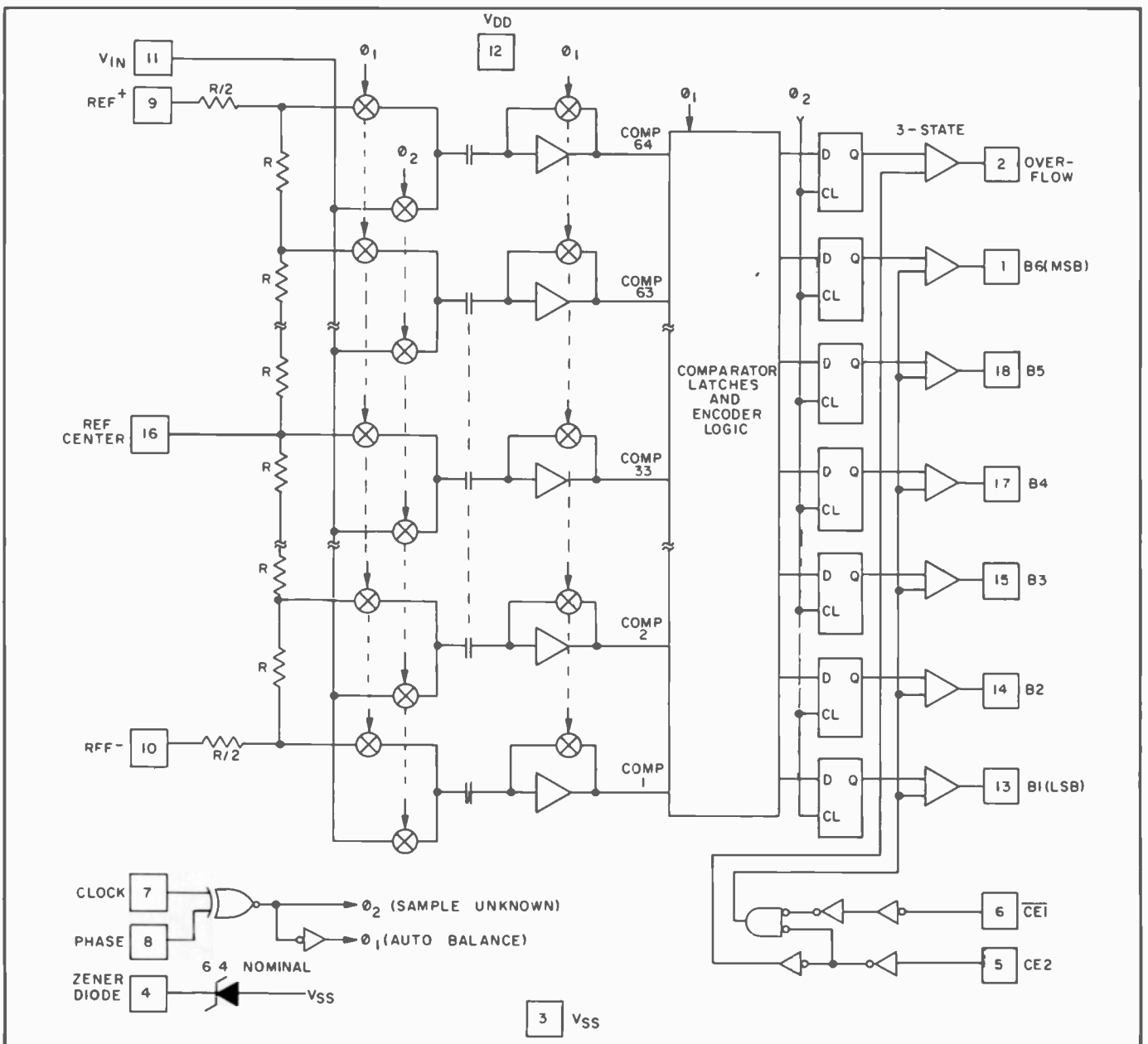

Fig. 6. Functional diagram of the 6-bit 15-MHz CMOS flat converter.

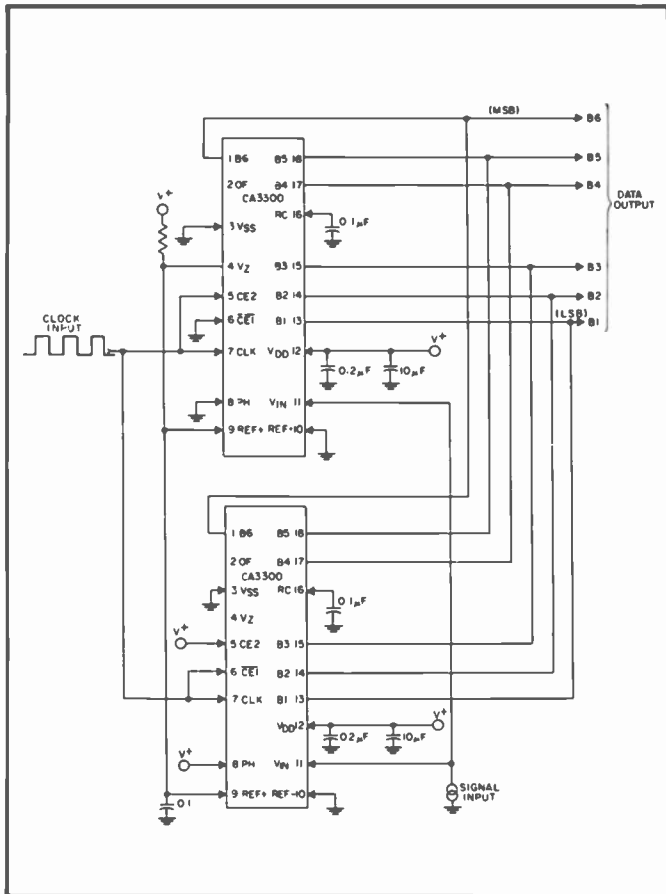

Fig. 7(a). Seven-bit circuit using two 16-bit flash converters.

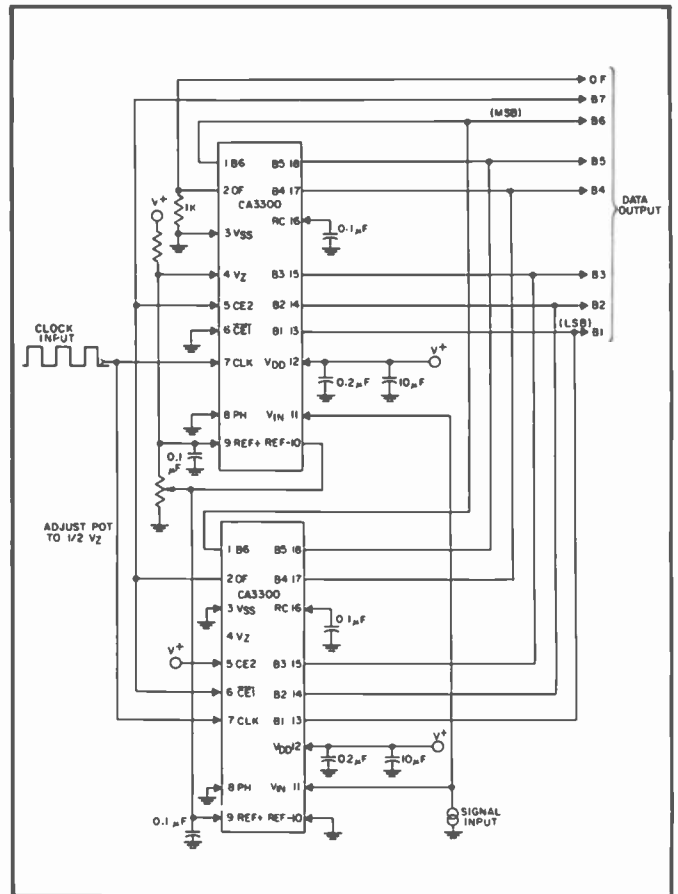

Fig. 7(b). Parallel, sequential 30-MHz operation with two 15-MHz, 6-bit flash converters.

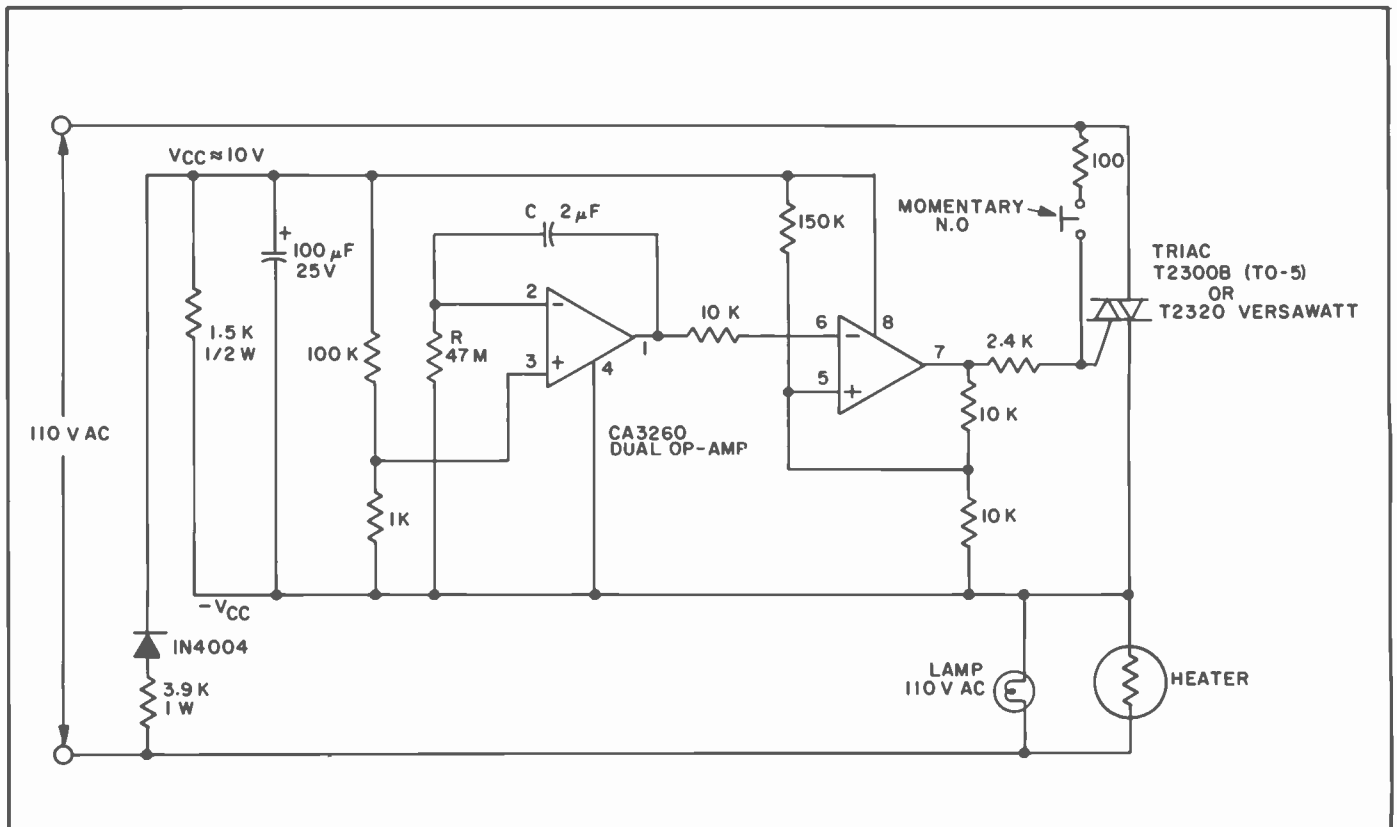

Fig. 8. A linear approach to a long-interval timer.

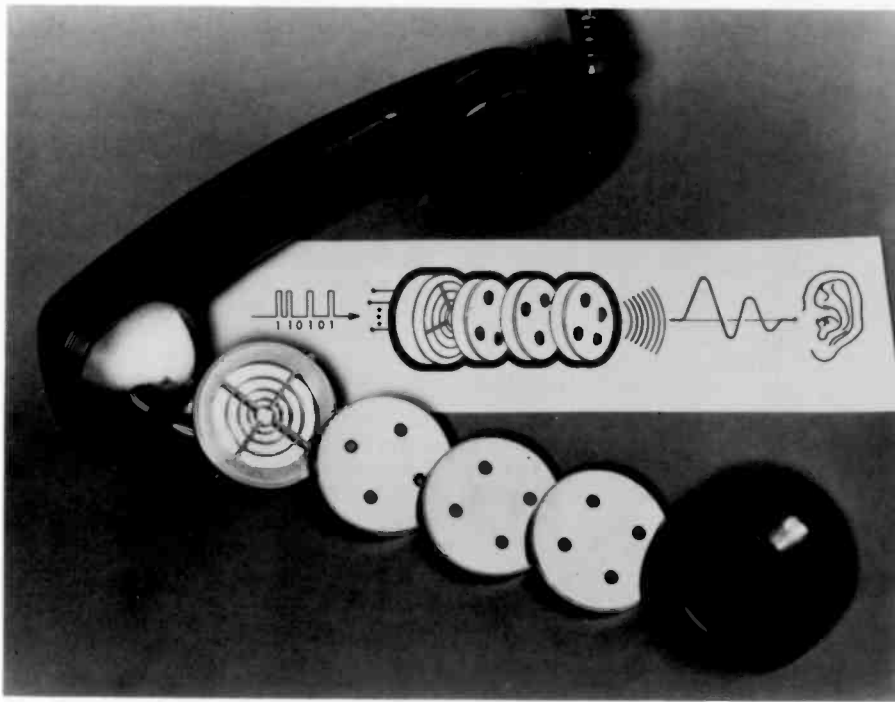

Fig. 9. Acoustical D/A converter developed by Bell Telephone Laboratories (Photo Courtesy Bell Labs).

Moreover, the CMOS circuitry helps conserve power so that this device consumes less than 50 mW when operating at 11 MHz with a 5-volt supply. Additional clock phasing control and the strobeable output latches permit connections of a second converter for 7-bit operation or an increase in the conversion rate to 30 MHz, with an 8-volt supply, as shown in Figs. 7(a) and 7(b). A new 8-bit converter, the CA3308, is to be announced during the first quarter of 1982.

An actual application problem will show the unusual turns a customer's design request can take and show some of the unusual advantages that our modern integrated circuits possess.

The customer required a 45 ± 5 minute timer. A push-to-start switch activates the timing cycle, which operates a triac. At the end of the cycle, the triac shuts down until the push-to-start button is again depressed. A CMOS 18-stage counter, clocking the power-line frequency, combined with a CMOS logic gate will perform the function. This would require two CMOS packages. A linear approach is also possible using a dual BiMOS operational amplifier, the CA3260. Figure 8 shows a schematic diagram of this approach. One amplifier operates as an ultra-low input-current integrator, while the other amplifier functions as a Schmitt comparator to reliably switch the drive to the triac at the end of the timing cycle.

Because the comparator trip points and the integrating current are a function almost exclusively of the supply voltage in these CMOS output stage amplifiers, the internal timing is independent of the supply voltage variations. Ultimately, cost considerations of all available approaches will determine the final system.

Two excellent examples of the introduction of digital techniques to consumer equipment are in the areas of color TV and digital audio. W.A. Lagoni described a baseband comb filter (in the April/May/June 1980 issue of the *RCA Engineer*) that is a prime example of product-performance enhancement. In this system, the accuracy of the charge-coupled-device (CCD) comb filter is determined by the precision of the clocking oscillator, which in this case is derived from a 3.58-MHz crystal-controlled subcarrier oscillator. Thus extremely precise, narrowband reject points are obtainable. This filtering technique results in better color pictures with reduced color beat patterns (normally associated with the narrow colored strips on conventional TV receivers). Additional linear circuitry also uses the output from the CCD device to further enhance the vertical resolution.

In the past, audio development has primarily centered on systems and accessories, such as the various cartridge recorders, and the stereo- and quadraphonics-reproduction systems. During the last five years, however, two major areas of signif-

icant improvement have been made. One is the introduction of digital recording and the other is digital control of turntable speeds.

Ideally the microphone would digitize the signal initially, but this has not happened—yet. Actually, the microphone is not one of the limiting factors in today's audio systems. Analog tape recorders are usually the limiting factor in both signal-to-noise ratio and, ultimately, dynamic range and distortion. New materials and fabrication techniques for both recording tape and tape recorder heads and material have made improvements to both these limiting factors in the last few years.

Digital recording techniques have shown that these limitations can be overcome and can extend the dynamic range to greater than 95 dB for a total range of 56,000-to-1, or 16 bits, which would represent one part out of 65,536. To a first order, dynamic range is only a function of system quantization. Greater dynamic range requires more discrete steps that result in additional digital bits.

An added bonus in using these techniques is the dramatic reduction in wow and flutter. Since a clock signal must be used in the digitizing process, this signal can also be used to control constant-speed capstan systems via analog servo systems. If this is not satisfactory, then speed correction can be accommodated with storage registers.

Similar techniques are used to make today's luxury audio turntables. Optical tachometer outputs phase lock the directly driven turntable motor speed to a crystal oscillator via an analog servo system.

Recently, an acoustical D/A converter for telephone receivers was described by J.L. Flanagan at Bell Telephone Laboratories. This receiver translates pulse-width-modulated information into fairly good fidelity audio. Figure 9 shows this device. Bell is also working on an A/D converter. CODEC circuits developed for telecommunication are other examples of a superb blend of analog and digital technologies.

All these products are new and eventually everyone will benefit from this introduction of digital techniques to our analog world. Despite the invasion of analog circuit designs by digital circuits, analog designs will remain where they can provide any of the following:

- Simple and rapid solution to a problem.
- Monitoring, conditioning and amplifying low-level signals, before application to an A/D converter.

- Differential line drivers and receivers, where the excellent common-mode rejection characteristics of the differential amplifier may be used even for digital signals.
- Signal-level translators when converting from one logic form to another.
- Aid in analog processing of signals from phase detectors and discriminators in phase-locked-loop systems.
- Convert digital outputs for D/A converter back to unusual analog signal levels, for example, provide unusual power, voltage, or current drives.

Conclusion

Man is most responsive to analog inputs. Large quantities of information are conveyed by the display of an analog watch or by the rate, deflection, and direction of an analog meter. More digital multimeter manufacturers are now offering instruments with both analog and digital displays. Watch manufacturers are also introducing timepieces with both displays. Even



Hal Wittlinger received the BSEE from Case Institute of Technology. In 1956, he joined the Tube Division of RCA and worked on horizontal deflection amplifiers and damper

diodes. Before joining the Solid State Division in 1966, he worked at Astro-Electronics. Here he designed television cameras for weather satellites and worked on video processing and regulating systems. In addition, he was responsible for the design of the synchronization system of the portable color TV camera used by NBC in the 1968 presidential conventions.

He is presently an Engineering Leader, working with advanced operational-type linear integrated circuits for use in a wide variety of applications ranging from instrumentation and control to consumer applications and computer interface systems.

Contact him at
Solid State Division
Somerville, N.J.
TACNET: 325-7028

the human body converts analog stimuli and handles the signal in a digital manner. Better understanding of man's digital nature, I am sure, will inevitably allow the blind to see and the deaf to hear. Recognition of the analog and digital aspects of

man will enhance his existence in this world. We must strive to better understand all aspects of these complex systems of nature so that we, as designers, can provide the complex systems needed in the future.

Patents

Advanced Technology Laboratories

Heagerty, W.F. | Pryor, R.L.
Folded-cascode amplifier arrangement with cascode load means—4284959

Pryor, R.L. | Heagerty, W.F.
Folded-cascode amplifier arrangement with current mirror amplifier—4284958

Siryj, B.W. | Gilson, A.P.
Optical disc changer apparatus—4286790

Siryj, B.W. | Horton, C.R. | Scott, R.D.
Thermal processor in an apparatus for developing photographic film—4293212

Siryj, B.W.
Solar tracking apparatus—4295621

Astro-Electronics

Auerbach, V.
Fault-tolerant interface circuit for parallel digital bus—4298982

Binge, D.S.
Hinge construction with positive locking means—4290168

Goldberg, E.A.
Degaussing arrangement for maser surrounded by magnetic shielding—4286304

Automated Systems

Thornhill, J., Jr. | Elder, R.B.
Earth self-orienting apparatus—4292861

Commercial Communications Systems

Herman, R.
Printed circuit board support structure—4301495

Johns, M.R.
Antenna array with impedance matching using mutual coupling—4301458

Matta, J.J. | Skalina, A.
Feed system for a circularly polarized tetra-coil antenna—4295144

Nikolayuk, N.
Circularly polarized slotted pylon antenna—4297706

Zorbalas, G.S.
Motor speed control circuit—4296446

Consumer Electronics

Carter, G.W.
Controlled local oscillator with apparatus for extending its frequency—4288875

Dodds, D.L.
Television display error correction—4296359

Fitzgerald, W.V., Jr.
Vertical deflection circuit—4293803

Hettiger, J.
Keyed noise filter in a television receiver—4295161

Hettiger, J.
Keying signal generator responsive to plural input signals—4295163

Knight, P.R.
Horizontal deflection generator and driver circuit—4298830

Laboni, W.A.
Signal processing circuit having a non-linear transfer function—4295160

Luz, D.W. | Willis, D.H.
Deflection and power supply circuit with reduced start-up drive—4282460

Naipally, S.V.
Luminance and chrominance signal separation network—4288811

Nicholson, J.E. | Wilmarth, P.C.
Television receiver chassis adapted to be compatible with different tuner and cabinet configurations—4297726

Shanley, R.L., II | Hettiger, J.
Failure compensated automatic kinescope beam current limiter—4295166

Shanley, R.L., II
Composite keying signal generator for a television receiver—4291336

Tulst, J.
Keyboard encoding arrangement—4282516

Wilmarth, P.C.
Color television receiver degaussing circuit—4295078

Coronet Industries

Silcox, D.R. | Doster, J.L.
Filament winding apparatus—4297095

Government Communications Systems

Clay, B.R.
Technique for recording a hologram suitable for use in optical retrieval system—4289372

Crowley, A.T.
Digitally adjustable phase shifting circuit—4295098

Nossen, E.J.
System and method for frequency discrimination—4291269

Nossen, E.J.
Frequency demodulation system—4291275

Laboratories

Avins, J.Y.
Incremental encoder—4300039

Balberg, I.
Silicon MOS inductor—4282537

Barnette, W.E. | Fox, E.C.
Compensation apparatus for a servo system with periodic command signals—4300226

Bell, A.E.
Replicable optical recording medium—4285056

Bell, A.E. | Bloom, A.
Bartolini, R.A. | Burke, W.J.
Thin protective overcoat layer for optical video disc—4300143

Bell, A.E.
Replicable optical recording medium—4300227

Bohringer, W.
Regulated deflection circuit with start-up and electronic circuit breaker control—4291257

Carroll, C.B. | Schaller, F.C. | Beres, E.A.
Automatic apparatus for molding a preform—4281816

Carroll, C.B. | Scheible, H.G.
Method for preparing stylus lapping discs—4297312

Comizzoli, R.B. | Vibratek, R.D.
Method of detecting a thin insulating film over a conductor—4296370

- Credelle, T.L. | Gange, R.A.
Beam clean up structure for flat panel display devices—4298819
- Datta, P.
Conductive molding composition and discs therefrom—4299736
- Demers, R.R.
Wafer and boule protection during the blade return stroke of a wafer saw—4287256
- Dinardo, J.R., Jr.
Method for fabricating flyleads for video disc styli—4282311
- Ettenberg, M. | Nuese, C.J.
III-V direct-bandgap semiconductor optical filter—4300811
- Faith, T.J., Jr.
Laminated conducting film on an integrated circuit substrate and method of forming the laminate—4302498
- Fisher, A.W.
Method for determining silicon content in layers of aluminum and silicon—4282266
- Gibson, W.G.
Signal separation networks—4283741
- Hanak, J.J.
Laser processing technique for fabricating series-connected and tandem junction series-connected solar cells into a solar battery—4292092
- Henderson, J.G. | Maturo, R.J.
Search type tuning system with direct address channel selection apparatus—4291413
- Hernqvist, K.G.
Method for coating a selected portion of the internal neck surface of a CRT—4285990
- Hernqvist, K.G.
CRT with means for suppressing arcing therein—4288719
- Heyman, P.M. | Bortfeld, D.P.
Apparatus and method for reading an identifying label on an information record—4292511
- Himics, R.J. | Kaplan, M. | Desai, N.V.
Method of exposing and developing a homopolymer resist—4286050
- Hsu, S.T.
Method of manufacturing bulk CMOS integrated circuits—4295266
- Hsu, S.T.
Electrically programmable control gate injected floating gate solid state memory transistor and method of making same—4297719
- Hung, L.K. | Bloom, A.
Water-based photoresists using stilbene compounds as crosslinking agents—4299910
- Ipri, A.C.
Input protection device for insulated gate field effect transistor—4282556
- James, E.A.
Fabrication of video disc flyleads—4284712
- Johnson, H.C.
Interrogating radar for use with tagged targets—4292637
- Keizer, E.O. | Alphonse, G.A.
System for measuring stylus shoe length—4296371
- Kiess, H.G. | Binggeli, B.K.
Readout of electrostatically stored information—4296478
- Maby, E.W. | Kawamoto, H. | Valembois, P.V.
Ion implanted stylus—4296144
- McCandless, H.E.
Electron gun—4298818
- Paglione, R.W.
Apparatus and method for application of radioactive and microwave energy to the body—4292960
- Perlow, S.M.
Impedance transformation network—4295107
- Priestley, E.B. | Call, P.J.
Method of depositing a silicon oxide dielectric layer—4282268
- Reitmeier, G.A.
Television image size altering apparatus—4282546
- Rhodes, R.N.
Checkerboard color filter providing tolerance—4286285
- Rhodes, R.N.
Color filter—4288812
- Rhodes, R.N. | Schroeder, A.C. | Moles, W.H.
Color encoding filter—4290671
- Rutishauser, E.A.
NTSC to PAL transcoder—4283738
- Sanford, R.F.
Automatic shutdown arrangement for stand-alone television modulator—4286336
- Scott, H.M.
Switching regulator with independent feedback path filter—4298892
- Simshauser, E.D. | Nosker, R.W.
Signal loss detector for video disc—4287587
- Southgate, P.D.
Apparatus for discerning the noticeable presence of spatial fluctuations of intensity within a two-dimensional visual field—4282510
- Southgate, P.D. | Crooks, H.N.
Apparatus for discerning the noticeable presence of spatial fluctuations of intensity within a two-dimensional visual field—4282511
- Southgate, P.D.
Inspection system for detecting defects in regular patterns—4292672
- Sterzer, F.
Ridge-waveguide applicator for treatment with electromagnetic energy—4282887
- Sterzer, F.
Serrodyning system employing an adjustable phase shifting circuit—4297641
- Truesdell, R.L. | Ross, M.D.
Apparatus for measuring the characteristics of a wideband electromechanical recording system having a transformer—4295216
- Vanraalte, J.A.
Modular tube shadow mask support system—4283654
- Warren, H.R.
Magnetic recording with reduced crosstalk and interchannel time displacement—4296430
- Weimer, P.K.
Architecture line-transfer CCD imagers—4291239
- ## Missile & Surface Radar
- Chressanthos, A.G.
Gaffney, B.P. | Halpern, H.M.
Digital CFAR signal processor for phase coded radars—4293856
- Kolc, R.F.
Nozzle for dispensing viscous fluid—4291642
- Schelhorn, R.L.
Composite substrate—4296272
- Stachejko, V.
U-shaped iris design exhibiting capacitive reactance in heavily loaded rectangular waveguide—4301430
- Young, W.C.
Assembly for positioning the coupling probe of a waveguide—4287496
- ## Picture Tube Division
- D'Amato, R.J.
Color picture tube having improved corrugated apertured mask—4293791

Godfrey, R.H. | Peck, J.O.
Cathode-ray tube screen border improvement—4300070

Harper, S.A.
Method for improving the adherence of a phosphor-photobinder layer to a glass support—4284694

Kuzminski, H.W.
Color picture tube having improved slit type shadow mask and method of making same—4296189

Maddox, W.J.
Light transmission measurement method—4289406

Nolan, R.A.
Color picture tube having improved slit type shadow mask and method of making same—4300069

Nubani, J.I.
Method for testing panel-to-funnel sealing layer of a cathode-ray tube—4302725

Ragland, F.R., Jr.
Method for determining the average width of luminescent stripes of a viewing screen—4286164

Ragland, F.R., Jr.
Mercury arc lamp having communicating mercury reservoir—4295074

Roberts, D.L.
Color picture tube having improved slit type shadow mask—4293792

Rudy, W.G.
Method for vaporizing getter material in a vacuum electron tube—4302063

Simon, P.B. | Barbin, P.L.
Television raster centering aid—4282461

RCA Records

Mattson, G.A.
Tape cartridge—4301976

"SelectaVision" VideoDisc Operations

Christopher, T.J. | Wilber, J.A.
Periodically biased video disc player servo system—4286282

Clemens, J.K.
Transcoder—4286283

Hughes, L.M. | George, K.L.
Stylus cleaning apparatus for video disc player—4285524

James, J.E.
Wide range drift compensated FM signal generator—4286237

McNeely, M.L.
Apparatus for molding recorded discs—4302175

Mindel, M.J. | Miller, M.E.
Rustman, J.C. | Palmer, R.C.
Method for improving the quality of low frequency output of a video disc pickup stylus—4287689

Pyles, G.D. | Wilber, J.A. | Christopher, T.J.
Fast recovery squelch circuit for a video disc player—4286290

Wilber, J.A. | Christopher, T.J.
VFO having plural feedback loops—4286235

Ziegel, D.H.
Work holder—4286414

Solid State Division

Ahmed, A.A.
Amplifier with cross-over current control—4297644

Ahmed, A.A.
Series voltage regulators for developing temperature-compensated voltages—4282477

Ahmed, A.A.
Current dividers using emitter-coupled transistor pairs—4284945

Assour, J.M. | Bates, T.I.
Bender, J.R. | Neilson, J.M.
Semiconductor thyristor device having integral ballast means—4292646

Balaban, A.R. | Steckler, S.A.
Pulse generator for a horizontal deflection system—4282549

Beelitz, H.R. | Preslar, D.R.
Method of integrating semiconductor components—4282538

Carter, D.R. | Doner, C.E.
Hammersand, F.G. | Tomcavage, J.R.
Circumferentially apertured cylindrical grid for electron tube—4295077

Delrio, E.H.
Means to orbit and rotate target wafers supported on planet member—4284033

Denning, R. | Spak, M.A. | Polhemus, B.
Method of applying thin metal deposits to a substrate—4297393

Dietz, W.F.
Horizontal deflection circuit and power supply with regulation by horizontal output transistor turn-off delay control—4301394

Dingwall, A.G.
Transition detector circuit—4286174

Harwood, L.A.
Transistor protection circuit—4302792

Heuner, R.C.
Starting circuit for low power oscillator circuit—4282496

Hoover, M.V.
Class AB push-pull FET amplifiers—4296382

Howard, T.B., Jr.
Etching tank in which the solution circulates by convection—4302273

Hsieh, P.K. | Vaccarella, R.M.
Level shift circuit—4295065

Kessler, S.W., Jr. | Olmstead, J.A.
Semiconductor power device having second breakdown protection—4291324

Koons, P.R. | Neilson, J.M.
Method of treating SIPOS passivated high voltage semiconductor device—4297149

Kucharewski, N. | Gillberg, J.E.
Gated oscillator—4286233

Leidich, A.J.
Reference current supply circuits—4282478

Leidich, A.J.
Amplifier with electrically controlled gain, with output suitable for direct coupling—4286226

Leidich, A.J.
Class AB push-pull quasi-linear amplifiers—4295101

Malchow, M.E.
Temperature-sensitive voltage divider—4295088

McKeon, E.F.
Switching network—4284911

Nyul, P. | Hughes, F.R.
Method of bonding two parts together and article produced thereby—4295151

Rodgers, R.L., III
Relaxation oscillators with electrical control of periodicities of oscillation—4292605

Schade, O.H., Jr.
Current regulating circuitry—4300091

Schade, O.H., Jr.
Reference potential generating circuits—4302718

Steckler, S.A. | Balaban, A.R.
Circuit arrangement for multiplexing an input function and an output function at a single terminal—4293870

Steckler, S.A. | Balaban, A.R.
Deflection system and switched-mode power supply using a common ramp generator—4292654

Wittlinger, H.A. | Salerno, C.P.
Position sensing and display means—4294321

Pen and Podium

Recent RCA technical papers and presentations

To obtain copies of papers, check your library or contact the author or his divisional Technical Publications Administrator (listed on back cover) for a reprint.

Americom

M.R. Freeling | L. Schiff

Technical Standards for Direct Broadcast Satellite Systems—*RCA Review*, Vol. 42, No. 3 (9/81)

Astro-Electronics

J. Badura | R. Gounder | S. Ino
Analytical (FEM) and Test Evaluation of Advanced Composite Antenna Reflectors for Communication Satellites—13th National SAMPE Tech. Conference, Mt. Pocono, Pa. (10/13-15/81)

J. Frohbieter

From Echo 1 to Entertainment Plus—28th Anniversary Conference American Astronautical Society, San Diego, Ca. (10/29/81)

L. Gomberg

Outlook for Meteorological Satellite and Related Technology—Tech. Marketing Society of America, Munich, Germany (10/19/81) London, England (10/22/81)

K.K. Oey | S. Teitelbaum

Highly Reliable Spaceborne Memory Subsystem—AIAA Computers in Aerospace II Conference, San Diego, Calif. (10/26/81)

K.K. Oey | S. Teitelbaum

SCP-050 The Next Generation CMOS SOS LSI Spaceborne Computer—AIAA Computers in Aerospace II Conference, San Diego, Calif. (10/26/81)

Automated Systems

F.F. Martin

Management of Design-to-Cost—Defense Systems Management College, Moorestown, N.J. (11/81)

M. Shilo | N.P. Veeder

A Portable Automated Cable Tester for U.S. Army Combat Vehicle Support—Electronic Connector Study Group, Inc., Philadelphia, Pa. (11/12/81)

L.B. Smith

Orientation of Cooperative Students into Industry—Panel Discussion at Northeastern Univ., Boston, Mass. (11/81)

Government

Communications Systems

D.G. Herzog | O.E. Bessette | A.A. Tapsony
An Example of a High Performance Optical Disc System Approach—Published: Conference Proceedings; Presented: 13th Electro-Optics Laser 81 Conference, Anaheim, Calif. (11/17/81)

A. Kaplan

Digital Signal Processing—Instructor at seminar given at SATCOM Agency, Ft. Monmouth, N.J. (9/16/81)

A. Kaplan

Digital Signal Processing—Instructor at seminar given to RCA Engineering and Management (9/9/81)

A.P. Moll

Protecting Against Failure in a Programmable Instrumentation System—*Mini-Micro Systems* (9/81)

Laboratories

R.S. Crandall

A Comparison of p-i-n and Schottky-Barrier Hydrogenated Amorphous Silicon, a-Si:H, Solar Cells—*RCA Review*, Vol. 42, No. 3 (9/81)

R.S. Crandall

Field Nonuniformity Due to Photogenerated Carriers in a p-i-n Solar Cell—*RCA Review*, Vol. 42, No. 3 (9/81)

R. Dube

A Fuzzy Sets Approach to Information Retrieval from A Criminal History Data Base—*AIEE Transactions*, Vol. 13, No. 3

M. Ettenberg | D. Botez

D.B. Gilbert | J.C. Connolly | H.V. Kowger
The Effect of Facet Mirror Reflectivity on the Spectrum of Single-Mode cw Constricted Double-Heterojunction Diode Lasers—*IEEE Journal of Quantum Electronics*, Vol. QE-17, No. 11 (11/81)

M. Ettenberg | I. Ladany

Metallization for Diode Lasers—*J. Vac. Sci. Technol.*, Vol. 19, No. 3 (10/11/81)

M. Ettenberg

On the Spatial Mode Stability of Oxide Stripe cw Lasers during Accelerated Aging at 70°C—*J. Appl. Phys.*, Vol. 52, No. 6 (6/81)

T.J. Faith | R.S. Irvén

J.J. O'Neill, Jr. | F.J. Tams, III
Oxygen Monitors for Aluminum and Al-O Thin Films—*J. Vac. Sci. Technol.*, Vol. 19, No. 3 (9/10/81)

S.T. Hsu

GIMOS—A Nonvolatile MOS Memory Transistor—*RCA Review*, Vol. 42, No. 3 (9/81)

S.T. Hsu

Observation of Electron and Hole Transport Through Thin SiO₂ Films—*RCA Review*, Vol. 42, No. 3 (9/81)

L. Jastrzebski | A.E. Bell | P. Wu (now with Exxon) | P.J. Zanzucchi

The Role of Plasma Diffusion in Heat Dissipation during Laser Annealing—*J. Appl. Phys.*, Vol. 52, No. 6 (6/81)

L. Jastrzebski

Deep Levels Study in Float Zone Si Used for Fabrication of CCD Imagers—*Journal of the Electrochemical Soc.*, Vol. 128, No. 9 (9/81)

M. Kumar | R.J. Menna | H. Huang

Planar Broad-Band 180° Hybrid Power Divider/Combiner Circuit—*IEEE Transactions on Microwave Theory and Techniques*, Vol. MTT-29, No. 11 (11/81)

M. Kumar | R.J. Menna | H. Huang

Broad-Band Active Phase Shifter Using Dual-Gate MESFET—*IEEE Transactions on Microwave Theory and Techniques*, Vol. MTT-29, No. 10 (10/81)

I. Ladany | R.T. Smith | C.W. Magee

Meltback and Pullover as Causes of Disturbances in Liquid-Phase Epitaxial Growth of InGaAsP/InP 1.3 μm Laser Material—*J. Appl. Phys.*, Vol. 52, No. 10 (10/81)

G.H. Olsen | F.Z. Hawrylo | D.J. Channin | D. Botez | M. Ettenberg

1.3 μm LPE- and VPE-Grown InGaAsP Edge-Emitting LEDs—*IEEE Journal of Quantum Electronics*, Vol. QE-17, No. 10 (10/81)

S.S. Perlman

Computer Simulation of Horizontal Transient Response of the NTSC Color-TV System—*RCA Review*, Vol. 42, No. 3 (9/81)

D.H. Pritchard | J.K. Clemens | M.D. Ross
The Principles and Quality of the Buried-

Subcarrier Encoding and Decoding System and Its Application to the RCA Video-Disc System—*RCA Review*, Vol. 42, No. 3 (9/81)

M.D. Ross | J.K. Clemens | R.C. Palmer
The Influence of Carrier-to-Noise Ratio and Stylus Life on the RCA VideoDisc System Parameters—*RCA Review*, Vol. 42, No. 3 (9/81)

L. Schiff | M.R. Freeling
Technical Standards for Direct Broadcast Satellite Systems—*RCA Review*, Vol. 42, No. 3 (9/81)

D.L. Staebler | R.S. Crandall | R. Williams
Stability of n-i-p Amorphous Silicon Solar Cells—*Appl. Phys. Lett.*, Vol. 39, No. 9 (11/1/81)

J.L. Vossen
VLSI Metallization: Some Problems and Trends—*J. Vac. Sci. Technol.*, Vol. 19, No. 3 (9-10/81)

Missile and Surface Radar

K. Abend
Spectral Estimation for Radar Imaging of Aircraft—IEEE Night, Philadelphia Section, University of Pennsylvania, Philadelphia, Pa. (10/20/81)

K. Abend
The Utility and Performance of Spectral Estimation in Radar Imaging—U.S. DOD Tri-Service Combat Identification System Conference, Ft. Monmouth, N.J. (10/81)

O.G. Allen
ASQC's Twenty-fifth Annual Symposium, King of Prussia, Pa. (11/19/81)

F.J. Buckley
Software Quality Assurance—Instructor, IEEE Software Quality Assurance Course, San Francisco, Calif. (10/14-16/81)

F.J. Buckley
Software Quality Assurance—Software Quality Assurance, Sacramento State University, Sacramento, Calif. (10/13/81)

F.J. Buckley
Software Quality Assurance—Instructor, IEEE Seminar on Software Quality Assurance, Washington, D.C. (11/18-20/81)

F.J. Buckley
IEEE Standard 730—A Standard for Software Quality Assurance Plans—(11/13/81)

C.L. Christianson
Next Generation Surface Radar Fire Control Meeting Multifunction Needs with Modular Evolution—AIAA Sensor Systems Conference, Los Angeles, Calif. (9/17-18/81) Palo Alto, Calif. (9/21-22/81)

R.I. Credon
Support Systems—Electrical Support Systems—Mechanical Room Arrangements—Combat Systems Engineering and Ship Design Seminar, MIT (8/81)

I.E. Goldstein
Background and Introduction and Topside Design—Combat Systems Engineering and Ship Design Seminar, MIT (8/81)

Two popular papers

Some landmark research papers show up as references in other authors' papers more often than others. An outside company that sells information on such developments recognized two RCA Laboratories authors this year for papers they wrote some time ago. Both papers were cited over 100 times, according to the Institute for Scientific Information. The authors, titles, and abstracts are listed below.

Goodman, A.M. Metal-semiconductor barrier height measurement by the differential capacitance method—one carrier system. *J. Appl. Phys.* 34:329-38, 1963. (RCA Laboratories, Princeton, N.J.)

Abstract: The differential-capacitance-measurement method for characterizing an ideal metal-semiconductor Schottky-barrier contact is based on assumptions which may or may not be valid. Some of these deviations from ideality were examined in order to determine their effects upon the interpretation and validity of measurements on real contacts.

Kressel, H., and Nelson H. Close-confinement gallium arsenide p-n junction lasers with reduced optical loss at room temperature. *RCA Rev.* 30:106-13, 1969.

Abstract: The first practical heterostructure room-temperature operation injection laser is reported. This new single heterojunction AlGaAs/GaAs structure has a threshold current density of 10,000 A/cm². This is a factor of five lower than previous typical GaAs homojunction lasers. An explanation for the improvement is presented.

L.J. Grantner
Anti-Submarine Warfare: Detect, Control, Engage and Anti-Submarine Warfare: Ship Impacts—Combat Systems Engineering and Ship Design Seminar, Naval Systems Department, MIT (8/81)

J. Haness | J. Friedman
Overcoming the Engineer's Fear of Communicating—Conference Proceedings, Frontiers in Education Conference, Rapid City, S. Dakota (10/19-21/81)

P.L. Kadakia | D.J. Herman
Core Resource Management of Large Real-Time Computer Program Development—AIAA Computers in Aerospace III Conference, San Diego, Calif. (10/26-28/81)

W. Keil
Engineering Aesthetics in Warship Design—*Naval Engineers Journal* (10/81)

R.F. Kolc
Attachment of Hermetic Chip Carriers to Various Substrate Materials—1st Annual International Electronics Packaging Conference, Cleveland, Ohio (11/10/81)

R.F. Kolc
High Density Packaging for an Artificial Pancreas—1st Annual International Electronics Packaging Conference, Cleveland, Ohio (11/9/81)

R.F. Kolc
High Density Packaging for an Artificial Pancreas—Rotary Club Meeting at MSR (9/81)

R.F. Kolc
Implemented Diabetic Insulin Pump—IEEE Philadelphia Section Meeting, Philadelphia, Pa. (9/22/81)

B.J. Matulis
From the Laboratory to Product Design—Conference Record, 1981 IEEE Engineering Management Conference, Dayton, Ohio (11/9-11/81)

F.E. Oliveto
Productivity through Reliability—Productivity and Technology Innovations Symposium, The Engineers' Club of Philadelphia (11/12/81)

M.H. Plofker
Combat System Availability—Combat Systems Engineering and Ship Design Seminar, MIT (8/81)

M. Rauchwerk
A Method for Digital Analysis of Radar Subsystem Performance—Conference Digest International Electrical, Electronic Conference and Exposition, Toronto (10/5-7/81)

F. Reifler
Optimal Orthogonal Control—Mathematics Colloquium, Georgetown Univ., Washington, D.C. (10/23/81)

R.J. Renfrow
Topside Design—Radar and Topside Design—Weapons—Combat Systems Engineering and Ship Design Seminar, MIT (8/81)

E.E. Roberts, Jr.
Error Budgeting Alignment and Ships' Flexure—Combat Systems Engineering and Ship Design Seminar, MIT (8/81)

R.L. Schelhorn
New Metal Core Substrate Materials for

Chip Carrier Circuit Applications—NEPCON Northwest, San Mateo, Calif. (11/3/81)

R.L. Schelhorn
Metal Core Materials for Thick Film Substrate Applications—ISHM 1981 *Proceedings*, ISHM '81, Chicago, Ill. (10/21-23/81)

R.L. Schelhorn
Thick Film Copper Multiple Applications—

NEPCON Northwest, San Mateo, Calif. (11/3-5/81)

J.T. Threston
System Functional Analysis and Functional Allocation; Performance Trade-off Analysis; Anti-Air Warfare—Detect/Control/Engage; Contemporary Combat System Designs; and Computers/Digital Technology—Combat Systems Engineering and Ship Design Seminar, MIT, 8/81

“SelectaVision”
VideoDisc Operations

J.J. Brandinger
The RCA CED VideoDisc System—An Overview—*RCA Review*, Vol. 42, No. 3 (9/81)

Engineering News and Highlights

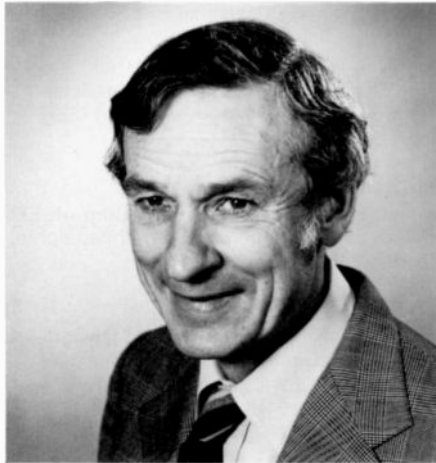

Seeley is new TPA

Paul E. Seeley, Manager of Technology Planning, has been appointed Technical Publications Administrator at RCA Automated Systems, Burlington, Massachusetts. Mr. Seeley joined RCA in 1955 as an engineering manager and became responsible for design and development of electro-optical equipments for aircraft, space and ground-based applications. He graduated from MIT with a B.S. degree in Physics, received a Certificate of PMD from the Harvard Business School, and obtained an M.S. in Engineering Management from Western New England College. He is currently responsible for the planning and application of current and future technologies at Automated Systems. Paul is a member of Sigma Xi; the American Institute of Physics Society; the National Society of Professional Engineers; and is a Senior Member of IEEE.

Contact him at:
Automated Systems
Burlington, Mass.
TACNET: 326-3095



Schoedler joins Corporate Engineering Education

James B. Schoedler joined Corporate Engineering Education as Administrator, Technical Education Programs in October 1981. In this position, he is principally responsible for the development of the Manufacturing Engineering Education Program.

Mr. Schoedler was trained as an electrical engineer, spent four years with the U.S. Air Force beginning in 1966, and also worked for Jetronic Industries in Philadelphia, a manufacturer of marine electronics equipment. Since 1974, he has been involved in the production of video-based training programs, most recently as Senior CMX Editor and Post-production Manager for Videosmith in Philadelphia. He has produced, directed or edited a variety of broadcast and non-broadcast television programs as well.

In 1978, Mr. Schoedler received the M.S. degree in Systems Engineering from the University of Pennsylvania with a concentration in communications systems.

Contact him at:
Corporate Engineering Education
Cherry Hill, N.J.
TACNET: 222-5141

Staff announcements

Commercial Communications Systems Division

Joseph C. Volpe, Division Vice-President, Broadcast Transmission Systems, announces the appointment of Bruno F. Melchionni, Manager, Transmission Systems Product Operations, and Albert T. Montemuro as Manager, Technical Services and Product Management.

Consumer Electronics

James E. Carnes, Director, New Products Laboratory, announces his organization as follows: Billy W. Beyers, Jr., Manager, Digital Products Development; Dal F. Griepentrog, Manager, Project Engineering; Scott A. Keneman, Manager, Television Digital Systems; James L. Newsome, Manager, Technology Applications; Richard A. Sunshine, Manager, Engineering Systems; Donald H. Willis, Manager, Deflection Systems Development; Craig S. Young, Manager, Advanced Mechanical Engineering; and James E. Carnes, Acting Manager, Signal Systems Development.

Laboratories

Carmen A. Catanese, Director, Picture Tube Systems Research Laboratory, announces the appointment of Curtis R. Carlson as Head, Image Quality and Human Perception Research.

Robert D. Lohman, Director, Display Processing and Manufacturing Research Laboratory, announces the appointment of Anthony S. Baran as Manager, Advanced Development—Manufacturing Technology. Mr. Baran will report to the Director, Display Processing and Manufacturing Research

Laboratory, and receive business guidance from the Division Vice-President, Engineering—Picture Tube Division.

RCA Global Communications

Valerian F. Podmolik, President and Chief Executive Officer, RCA Global Communications, Inc. announces the following appointments: **Joe T. Swaim**, Vice-President, Switched Services Engineering and Operations; and **Donald R. Stackhouse**, Vice-President, Leased Facilities and Systems Operations.

Solid State Division

John E. Mainzer, Director, Power Operations, announces his organization as fol-

lows: **Donald E. Burke**, Manager, Power Engineering; **Joseph V. Colarusso**, Manager, Planning; **George W. Ianson**, Manager, Wafer Fabrication; **Keith E. Loofbourrow**, Manager, Device Manufacturing—HiRel, Aerospace, Hybrid; **Vincent J. Lukach**, Manager, Quality and Reliability Assurance; **Joseph R. Spoon**, Manager, Industrial Relations at Mountaintop; and **Parker T. Valentine**, Manager, Product Marketing (Power).

Donald E. Burke, Manager, Power Engineering, announces his organization as follows: **Donald E. Burke**, Acting Manager, Bipolar Transistor Products (High Speed, Low Power, Hometax); **Eugene J. Chabak**, Manager, Hybrid Products; **Raymond T. Ford**, Manager, MOS Products; **F. Peter Jones**, Manager, Bipolar Transistor Products (Switch Max, High Voltage, Epi

Base); **Alan L. Sands**, Manager, Thyristor Products; **Robert J. Satriano**, Manager, Package Development; and **Wallace D. Williams**, Manager, Characterization and Test.

George W. Ianson, Manager, Wafer Fabrication, announces his organization as follows: **Michael A. Caravaggio**, Manager, Maintenance; **William B. Hall**, Manager, Process Engineering; and **George W. Ianson**, Acting Manager, Wafer Fabrication Manufacturing.

Keith E. Loofbourrow, Manager, Device Manufacturing, announces his organization as follows: **Eugene J. Chabak**, Acting Manager, Hybrid Manufacturing; and **Keith E. Loofbourrow**, Acting Manager, HiRel, Aerospace Manufacturing.

Professional activities

Eta Kappa Nu Jury of Award meets at RCA

The 1981 Eta Kappa Nu (Honorary Electrical Engineering Society) Jury of Award convened at RCA "SelectaVision" VideoDisc Operations on November 6, 1981, to select the Outstanding Young Electrical Engineer of the United States. The Jury Meeting was organized by **James A. D'Arcy** (RCA "SelectaVision" VideoDisc Operations), who is Chairman of the Eta Kappa Nu Awards Organization Committee, **Dr. Jay J. Brandinger**, Division Vice-President and General Manager of RCA "SelectaVision" VideoDisc Operations, was a member of the Jury. The other members of the Jury were:

- **Dr. Stacy V. Holmes**, Captain, USN Navy Electronics Systems Command
- **Dr. Robert W. Lucky** (Bell Laboratories) Executive Vice-President, Institute of Electrical and Electronics Engineers (IEEE).
- **Mr. Jack D. Kuehler**, IBM Corporate Vice-President and President, IBM General Technology Division
- **Mr. Darrell V. Menscer**, President, Public Service Indiana
- **Dr. Sydney R. Parker**, Professor of Electrical Engineering, Naval Postgraduate School (Past President, Eta Kappa Nu)

The purpose of the Eta Kappa Nu Recognition Award is to emphasize among Electrical Engineers that their service to mankind is manifested not only by achievements



The 1981 Jury of Award Meeting. Seated left to right, Dr. Stacy V. Holmes, Dr. Robert W. Lucky, and Dr. Jay J. Brandinger. Standing left to right, Mr. Jack D. Kuehler, Dr. Sydney R. Parker, Mr. James A. D'Arcy, and Mr. Darrell V. Menscer.

in purely technical affairs, but in a variety of other ways. Since 1936, forty-five young men who were less than 35 years of age and who had received their Baccalaureate degree less than 10 years before, have received the Award and 98 men of similar characteristics have received honorable mention. The most recent RCA employee to receive this Award is **John G.N. Hen-**

erson (RCA Labs) who was the 1977 winner. The Award is given on the basis not only of what success the young Electrical Engineers have had in their vocation, but also what they did to broaden themselves culturally and what they did for others. The 1981 winners will be honored at an award banquet on February 1, 1982, in New York City.

Hopkins elected Fellow of SMPTE



Dr. Robert Hopkins, Manager of Field Camera Engineering and Product Management for RCA Commercial Communications Systems Division, has been elected a Fellow of the Society of Motion Picture and Television Engineers.

SMPTE Fellowships are conferred on members of the Society who, because of their proficiency and contributions, are considered to have attained a superior rank among engineers or executives in the motion picture, television or related industries.

Over the past seven years, Dr. Hopkins has published articles on digital video in various journals, and he was responsible for the development of the RCA digital

frame-store synchronizer. He serves as the Chairman of the SMPTE Committee on New Technology, and his standards-committee work for the SMPTE has led to the development of world-wide digital video compatibility. Through his leadership the Society's international scope of activities has been expanded significantly.

Dr. Hopkins joined RCA in 1964 as Member of Technical Staff of the RCA David Sarnoff Research Laboratories, Princeton, N.J., a position he held until 1976. In that year, he joined RCA Broadcast Systems in Camden as Leader of Engineering Staff and served as an engineering unit manager before taking his present position.

Technical excellence

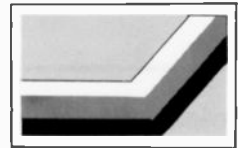

Technical excellence achievement Remote Automatic Weather Station (RAWS)



Left to right (front row) A. Frim, E. Wirtz, J. Looney. Left to right (back row) D. Priestley, Chief Engineer, R. Elder, J. Dong, R. Wilkins, J. McNamee, A. Hospodor, Vice-President and General Manager.

A team working on the Remote Automatic Weather Station (RAWS) has been selected by the Burlington Technical Excellence Committee for a Technical Excellence Award for their work on the Advanced Development Models.

The RAWS consists of a set of remote stations and a master station with a VHF data transmission link. The remote station automatically measures wind speed and direction, barometric pressure, temperature and relative humidity. The data transmitted from the remote station is received at the master station and displayed using a thermal printer. RAWS is a joint program with Automated Systems at Burlington responsible for the remote stations, and Government Communications Systems at Camden responsible for the master station. The remote station design group developed

power supplies, microprocessor control circuits, and data acquisition circuits that were integrated with purchased meteorological sensors and a GFE VHF digital data link.

The team members are:

J.W. Dong	Engineering Technician
A.H. Frim	Senior Project Member
J.A. Looney	Senior Member
J.A. McNamee	Senior Project Member
R.E. Wilkins	Engineering Technician
E.L. Wirtz	Senior Engineering Scientist

The team produced deliverable equipment that met all critical specifications for measurement accuracy, operating lifetime, and data-transmission performance. They

successfully solved a number of design problems, and efficiently coordinated with GCS on the data link and the meteorological equipment. The design assembly of two models was completed in only 10 months.

Mountaintop Technical Excellence Awards

The Mountaintop Technical Excellence Award is designed to recognize and reward members of the technical community who have consistently exhibited initiative, leadership, technical competence, attitude, and follow-up.



Bartholomay

Kubasik

The Technical Excellence Committee has reviewed candidates at the request and recommendation of fellow technical staff members and is proud to announce that **Walter Bartholomay** and **George Kubasik** are recipients of the Mountaintop Technical Excellence Award for November, 1981. The committee will honor these recipients at a luncheon and also at an annual dinner.

Editorial Representatives

Contact your Editorial Representative at the TACNET numbers listed here to schedule technical papers and announce your professional activities.

Commercial Communications Systems Division (CCSD)

TACNET

Broadcast Systems

* Bill Sepich Camden, New Jersey 222-2156
Krishna Praba Gibbsboro, New Jersey 222-3605
Andrew Billie Meadowlands, Pennsylvania 228-6231

Cablevision Systems

* John Ovnick Van Nuys, California 534-3011

Consumer Electronics (CE)

* Clyde Hoyt Indianapolis, Indiana 422-5208
Francis Holt Indianapolis, Indiana 422-5217
Chuck Limberg Indianapolis, Indiana 422-5117
Don Willis Indianapolis, Indiana 422-5883

Government Systems Division (GSD)

Advanced Technology Laboratories

* Merle Pietz Camden, New Jersey 222-2161

Astro-Electronics

* Frank Yannotti Princeton, New Jersey 229-2544
Carol Klarmann Princeton, New Jersey 229-2919

Automated Systems

* Paul Seeley Burlington, Massachusetts 326-3095
Dale Sherman Burlington, Massachusetts 326-2985

Government Communications Systems

* Dan Tannenbaum Camden, New Jersey 222-3081
Harry Ketcham Camden, New Jersey 222-3913

GSD Staff

* Ed Moore Cherry Hill, New Jersey 222-5833

Missile and Surface Radar

* Don Higgs Moorestown, New Jersey 224-2836
Jack Friedman Moorestown, New Jersey 224-2112

National Broadcasting Company (NBC)

* Bob Mausler New York, New York 324-4385

Patent Operations

Joseph Tripoli Princeton, New Jersey 226-2992

Picture Tube Division (PTD)

* Ed Madenford Lancaster, Pennsylvania 227-3657
Nick Meena Circleville, Ohio 432-1228
Jack Nubani Scranton, Pennsylvania 329-1499
J.R. Reece Marion, Indiana 427-5566

RCA Communications

TACNET

American Communications

* Murray Rosenthal Princeton, New Jersey 258-4192
Carolyn Powell Princeton, New Jersey 258-4194

Global Communications

* Dorothy Unger New York, New York 323-7348

RCA Limited (Canada)

Bob McIntyre Ste Anne de Bellevue 514-457-9000

RCA Records

* Greg Bogantz Indianapolis, Indiana 424-6141

RCA Service Company

* Joe Steoger Cherry Hill, New Jersey 222-5547
Ray MacWilliams Cherry Hill, New Jersey 222-5986
Dick Dombrosky Cherry Hill, New Jersey 222-4414

Research and Engineering

Corporate Engineering

* Hans Jenny Cherry Hill, New Jersey 222-4251

Laboratories

Eva Dukes Princeton, New Jersey 226-2882

SelectaVision® VideoDisc Operations

* Nelson Crooks Indianapolis, Indiana 426-3164

Solid State Division (SSD)

* John Schoen Somerville, New Jersey 325-6467

Power Devices

Harold Ronan Mountaintop, Pennsylvania 327-1633
or 327-1827

Integrated Circuits

Dick Morey Palm Beach Gardens, Florida 722-1262
Sy Silverstein Somerville, New Jersey 325-6168
John Young Findlay, Ohio 425-1307

Electro-Optics and Devices

John Grosh Lancaster, Pennsylvania 227-2077

Solid State Technology Center

Judy Yeast Somerville, New Jersey 325-6248

* Technical Publications Administrators, responsible for review and approval of papers and presentations, are indicated here with asterisks before their names.

RCA Engineer

A technical journal published by
Corporate Research and Engineering
"by and for the RCA engineer"

Bldg 204-2, Cherry Hill, NJ 08358
Forwarding and return postage guaranteed

BULK RATE
US Postage

PAID

Phila., Pa.
Permit No. 2906

EM MUSSELMANN
PO BOX 9
STRASBURG
PA 17579

LCTT