

RCA Engineer

Vol. 25/No. 1 June/July 1979

24th Anniversary Issue

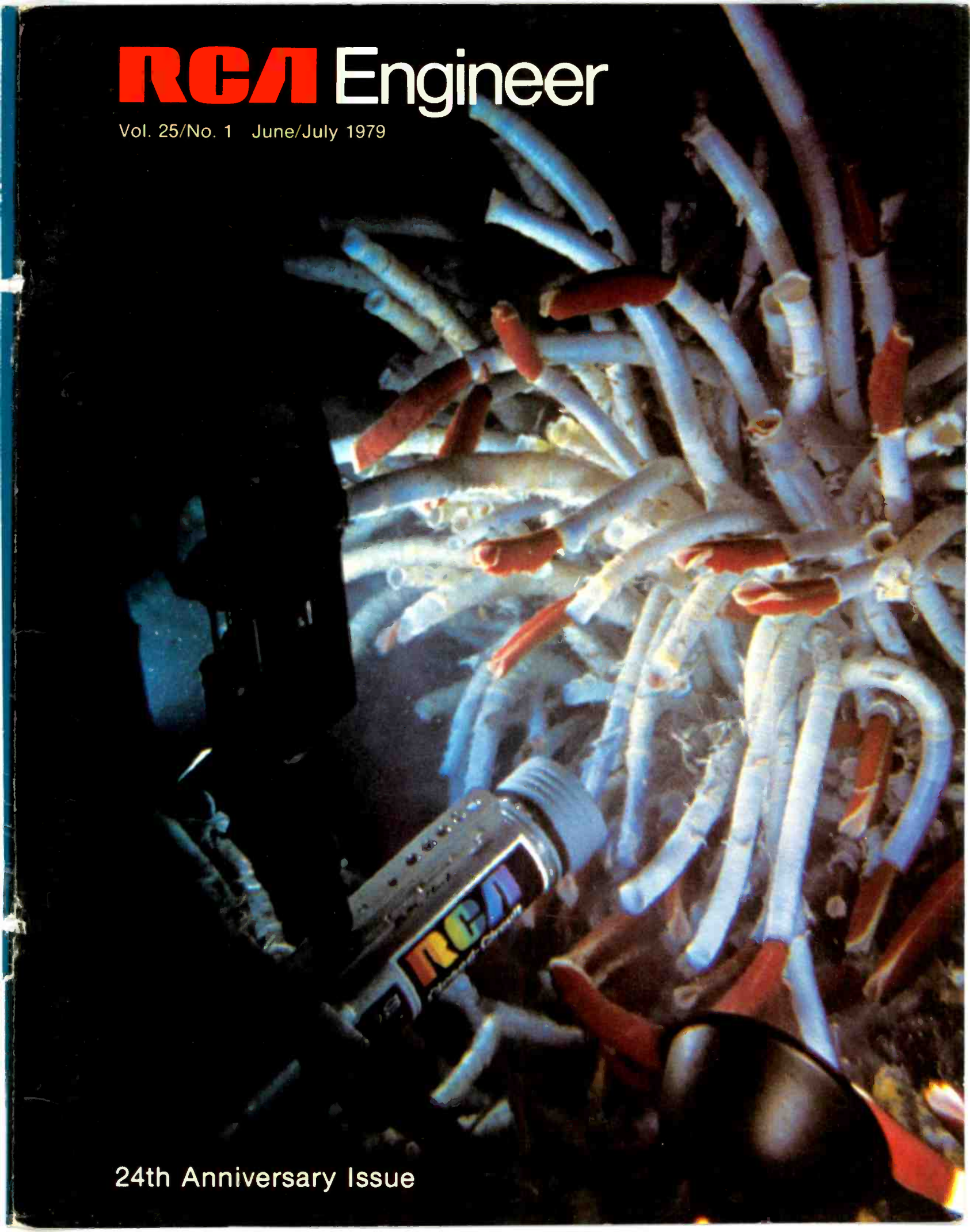

RCA Engineer

A technical journal published by
RCA Research and Engineering
Bldg. 204-2
Cherry Hill, N.J. 08358
Tel. 222-4254 (609-338-4254)
Indexed annually in the Apr/May issue.



Our cover shows a prototype RCA color television camera — all solid-state — used in an undersea exploration in the Galapagos Rift, off the coast of South America. To record the red, blue and green picture information, the camera employs three charge-coupled devices (CCDs) as image sensors.

The camera and a macro zoom lens were encased in a waterproof, pressurized housing which was mounted on a maneuverable arm outside the research submarine. The equipment gave the crew excellent close-up views of marine organisms. A sample frame from the CCD camera is pictured on the back cover of this issue.

Both photographs were made by Al Giddings, Sea Films, Inc., San Francisco. The photograph on the back cover was supplied courtesy of the National Geographic Society and is copyright © 1979 by the National Geographic Society.

RCA Engineer Staff

| | |
|-------------------------|---------------------|
| Tom King | Editor |
| Louise Carr | Art Editor |
| Frank Strobl | Contributing Editor |
| Betty Gutchigian | Composition |
| Dottie Snyder | Editorial Secretary |

Editorial Advisory Board

| | |
|-------------------------|---|
| Harry Anderson | Div. VP, Player Manufacturing, SelectaVision VideoDisc Operations |
| Jay Brandinger | Div. VP, SelectaVision VideoDisc Operations |
| John Christopher | VP, Tech. Operations, RCA Americom |
| Bill Hartzell | Div. VP, Engineering, Picture Tube Division |
| Jim Hepburn | VP, Advanced Programs RCA Globcom |
| Hans Jenny | Manager, Engineering Information Programs |
| Arch Luther | Chief Engineer, Commercial Communications Systems Div. |
| Howie Rosenthal | Staff VP, Engineering |
| Carl Turner | Div. VP, Systems, Services and Strategic Planning |
| Bill Underwood | Director, Engineering Professional Programs |
| Joe Volpe | Chief Engineer, Missile and Surface Radar |
| Bill Webster | VP, Laboratories |

Consulting Editors

| | |
|-----------------------|--|
| Ed Burke | Ldr., Presentation Services, Missile and Surface Radar |
| Walt Dennen | Director, Public Affairs, Solid State Division |
| Charlie Foster | Mgr., Scientific Publications, Laboratories |
| John Phillips | Mgr., Proposals and Publicity, Automated Systems |

•To disseminate to RCA engineers technical information of professional value •To publish in an appropriate manner important technical developments at RCA, and the role of the engineer • To serve as a medium of interchange of technical information between various groups at RCA • To create a community of engineering interest within the company by stressing the interrelated nature of all technical contributions • To help publicize engineering achievements in a manner that will promote the interests and reputation of RCA in the engineering field • To provide a convenient means by which the RCA engineer may review his professional work before associates and engineering management •To announce outstanding and unusual achievements of RCA engineers in a manner most likely to enhance their prestige and professional status.

Technical excellence for increased profitability



Charles C. Ellis

At the 60th Annual Meeting of Shareholders, Mr. Griffiths said, "We are spending a great deal of money in research. The amount in 1978 was approximately 25% to 30% higher than it was in '77, and in '79 we will spend about 29% more than we spent in '78. We are determined to place our electronics businesses in the forefront for all time to come, and we are taking a fair measure of our additional profits and putting them into research. The future of our electronics business lies in dedication to research and we will spend the money [necessary] to get the products of tomorrow." These remarks are positive indications of the continued support to research and engineering mentioned in Mr. Griffiths' earlier message to the engineers (*RCA Engineer*, 23/1, 1977).

Continuity and growth in this support can be expected, providing that the additional investment in research and engineering yields the appropriate return in profits (through new and better products, greater efficiency, expansion of present businesses, and entry into new ones).

To ensure that RCA's financial performance record of the past few years continues, we must be aware of the realities of our economy. The general crunch of inflation and the disproportionate rise of energy costs are forcing the consumer to be much more discriminating in his spending habits. He is placing increasing emphasis on the quality and useful lifespan of the products and services he purchases.

This challenges every member of the RCA technical team to:

- Provide innovation — not only in the design of products, but in their manufacture, maintenance and service, and
- Show an awareness of, and respect for, both domestic and foreign competition. Then turn out the most competitive product or service by recognizing and effectively using all our resources.

We, in RCA's financial community, are ready to work with you in this challenge to make this a corporation growing in profitability and reputation for excellence in its products and services.

A handwritten signature in black ink, appearing to read "Charles C. Ellis". The signature is fluid and cursive.

Charles C. Ellis
Senior Vice President, Finance
New York, New York

The Diversity of RCA's Electronics Businesses

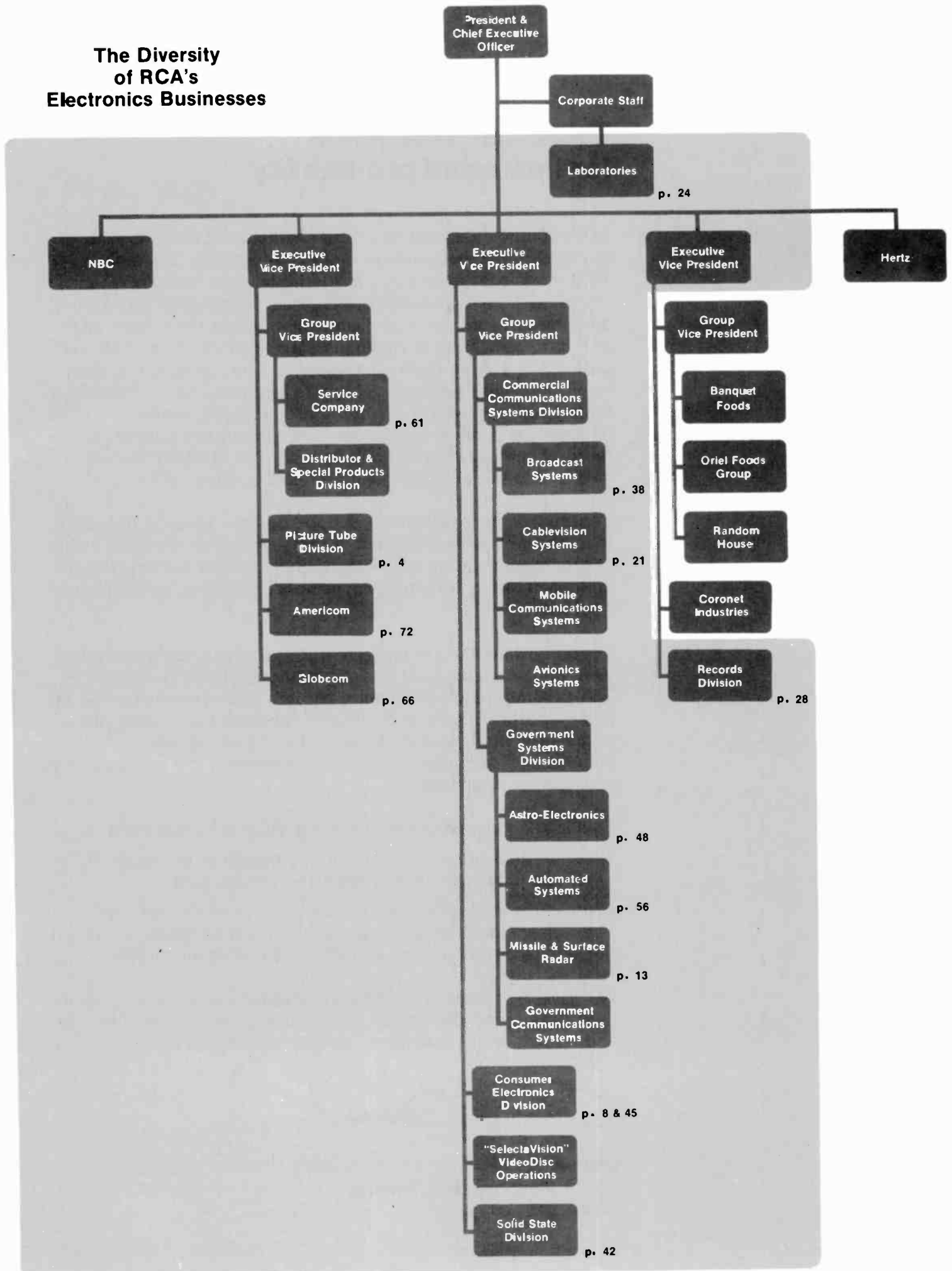

RCA Engineer

Vol 25|No. 1 June|July 79

- business profiles** 4 Color television picture tubes — worldwide
R.F. Dunn
- technology** 8 Frequency synthesis tuning systems with automatic offset tuning
B.W. Beyers|H. Blatter|J.B. George|J. Henderson|R. Rast|J. Tufts|C. Wine
- 13 Signal processing technology — a report on the state of the art
H.M. Halpern
- 21 Composite triple beat measurements
B. Arnold
- 24 A new electromotional device
M. Toda|S. Osaka|E.O. Johnson
- methods** 28 Automatic identification systems for operations control
D. Mishra
- equipment** 38 Quantum advances in television transmitter technology
R.M. Unetich|W.M. Boyd
- 42 Development and application of a prototype CCD color television camera
R.L. Rodgers, III
- 45 SelectaVision VCR — A VHS VideoCassette Recorder
T.C. Jobe
- systems** 48 Where are we? — a brief discussion of the Navy navigation satellite system
L.P. Yermack|N.U. Huffmaster
- 56 Total combat vehicle support with simplified test equipment
T.E. Fitzpatrick|R.E. Hanson
- 61 The RCA Springfield systems-engineering facility
F. Tarkington
- services** 66 Facsimile services at RCA Globcom
M.E. Logiadis
- 72 Echo control for RCA Americom satellite channels
R. Setzer
- departments** 77 Calls for Papers
- 77 Pen and Podium
- 79 Patents
- 80 Engineering News and Highlights

Color television picture tubes — worldwide

The growing international market for RCA's color television picture tubes makes it an interesting business for both marketing people and engineers.

Abstract: *The color TV picture tube market is growing. This paper documents present and projected future world markets for picture tubes and television sets, and lists major manufacturers, their plant locations and production capacities. RCA is named as one of the largest manufacturers. A brief history of color picture tube development is given.*

The marketplace for color picture tubes has expanded rapidly since RCA made the first color tubes in the Lancaster, Pa. plant in 1953. Today, in many parts of the world color tube sales are already big business; in others, demand is just beginning to grow, or has yet to start, but future prospects are bright.

As might be expected, the largest color tube markets are in the U.S., Japan and Western Europe. An interesting note is that all of the major color picture tube manufacturers are also major color TV set manufacturers. We have estimated that in 1978, more than 70 percent of all color sets produced were made by companies that also manufactured color picture tubes.

Color picture tube manufacturers

Table I lists present color tube manufacturers and their plant locations. Four of the tube manufacturers have capacities in excess of four million units, while the capacities of four others are in excess of two million units. RCA's domestic plants are located in Scranton, Pa., and Marion, Ind.

Five other U.S. manufacturers which were active during the U.S. color TV boom — Admiral, Motorola, National Video, Philco and Westinghouse — have since stopped making color TV tubes.

Looking into the future, new color tube manufacturing facilities are expected in the Far East and Eastern Europe with the help of RCA and Japanese technological support (Table II).

Table I. 1978 worldwide color tube manufacturers. Plant locations and number of plants are listed at the right.

| Home Base | U.S. | Canada | Mexico | Brazil | U.K. | W. Europe | E. Europe | Japan | Taiwan |
|---------------------------|------|--------|--------|--------|------|-----------|-----------|-------|--------|
| <i>United States</i> | | | | | | | | | |
| RCA* | 2 | 1 | 1 | 1 | | | | | |
| Sylvania** | 2 | | 1 | 1 | | 1 | | | |
| Rauland** | 1 | | | | | | | | |
| GE | 1 | | | | | | | | |
| <i>Japan</i> | | | | | | | | | |
| Hitachi* | | | | | | 1 | | 2 | |
| Toshiba* | | | | | | | | 2 | |
| Matsushita** | | | | | | | | 2 | |
| Sony** | 1 | | | | | | | 1 | |
| Mitsubishi | | | | | | | | 1 | |
| NEC | | | | | | | | 1 | |
| <i>W. Europe</i> | | | | | | | | | |
| Philips* | | | | 1 | 1 | 7 | | | 1 |
| RCA/Videocolor | | | | | | 2 | | | |
| Telefunken | | | | | | 1 | | | |
| SEL | | | | | | 1 | | | |
| <i>E. Europe and Asia</i> | | | | | | | | | |
| U.S.S.R | | | | | | | 2 | | |

* Plant capacity exceeds 4 million units.

** Plant capacity exceeds 2 million units.

Reprint RE-25-1-1

Final manuscript received Dec. 12, 1978.

Table II. Projected new color tube manufacturing facilities.

| Country | Startup | Plants | Technology Support |
|----------------|---------|----------------|---------------------|
| Poland | 1979 | 1 | RCA |
| U.S.S.R. | 1981 | 1 | RCA |
| E. Germany | 1983? | 1 | ? |
| Czechoslovakia | 1983? | 1 | Toshiba |
| Singapore | 1980 | 1 | Hitachi |
| S. Korea | 1982 | 3-5 plants (?) | Japanese - U.S. (?) |
| China | 1980? | 1 | Hitachi |

Table III. Color picture tube manufacturing capacities (Units in thousands).

| | 1978 | 1983 |
|----------------|--------------|--------------|
| North America | 10300 | 11000 |
| Latin America | 750 | 1250 |
| Western Europe | 8600 | 10800 |
| Eastern Europe | 1600 | 3400 |
| Japan | 16900 | 16900 |
| Far East | 100 | 4700 |
| Total | 38250 | 48050 |

Table IV. Color tube design factors.

A. Color Systems — Broadcasting

| | |
|--------------|--------------|
| U.S. & Japan | NTSC |
| Europe | PAL & SECAM |
| U.K. | Modified PAL |

Balance of world tracks the U.S. and European systems.

B. Current worldwide major basic color tube systems

| | |
|---------|---|
| RCA | Precision inline 90°-100°-110° standard & high-focus voltage bipot mounts |
| Zenith | 100° tripot mount |
| Philips | 20AX - 30AX 110° |

C. U.S. Color Tube Sizes

10V - 13V - 15V - 17V - 19V - 21V - 23V - 25V
Japanese down to 5V

D. Tube Design Variables

| | |
|--|--|
| Deflection angle | 90° - 100° - 110° |
| Gun design | { Tube design system Yoke designs Customer preferences |
| Neck diameter | |
| Neck length | |
| Funnel contour | |
| Tube lensing | |
| Integral implosion protection, with or without mounting lugs | { Customer preference Styling Local standards |
| Phosphors - Matrix | { Customer preferences |
| Panel glass transmission | |
| Mask | Optimize for moiré Super arch mask Transmission |
| Tube bases | Customer preferences |
| Second anode location | Customer preferences |

Table III summarizes our 1978 estimates and 1983 projections for five-day week, three-shift color tube manufacturing capacities.

Color tube history

Our country was the first with regular commercial color broadcasting. In the early days of color, RCA and the other U.S. tube manufacturers all made one color tube — a 21-inch, round 70 degree type. The picture changed by 1978. Because of product innovations, different broadcast standards, variations in screen size, cabinet styling and circuit design requirements, RCA, to support its worldwide commercial business, manufactured 52 different types.

Table IV lists some of the design

anomalies that have led to widespread color tube proliferation and a resultant decrease in industry color tube interchangeability. This has complicated manufacturing as well as marketing considerations. Europe has gone 110° for the larger size tubes but remains non-matrix. The U.S. uses 90° and 100° matrix. Europe employs push through for integral implosion protection; the U.S. and Japan use a different system. And so it goes, on and on.

Color TV set manufacturers

Currently, there are more than 70 color set manufacturers. Italian color broadcasting started in Jan. 1977 and, in its initial boom stage, is reported to support more than 30 TV set manufacturers. By comparison, in the early days of U.S. color, there were

more than 20 set manufacturers, all U.S. owned. Today there are 12: six are U.S. owned, five are Japanese, and one is Dutch. Some of today's large set manufacturers have yearly set production in the millions; some small set makers have outputs of less than 5,000 units. We project that the major set makers will grow while many of the small concerns will find it difficult to compete.

Table V lists the major color TV set manufacturers by home base and large volume areas of operation. Most of the set manufacturers are vertically integrated with regard to tubes and sets in their home base operations. Philips has very strong marketing positions in the U.K. and Western Europe. Most of the European set manufacturers listed have set plants in more than one country.

Table V. Major color TV set manufacturers. x = In-house tube source; o = Purchase tubes.

| Home Base | Volume Manufacturing Areas | | | | |
|-------------------------|----------------------------|-------------|------|-----------|-------|
| | U.S. | Latin Amer. | U.K. | W. Europe | Japan |
| <i>United States</i> | | | | | |
| RCA | x | | | | |
| Zenith | x | | | | |
| GE | x | | | | |
| Sylvania | x | | | | |
| Philco | | o | | | |
| <i>United Kingdom</i> | | | | | |
| Thorn | | | o | | |
| GEC | | | o | | |
| Rank | | | o | | |
| Rediffusion | | | o | | |
| <i>W. Europe</i> | | | | | |
| Philips | o | x-o | x | x | |
| Thompson/ Nordemende | | | | x | |
| ITT | | | o | x-o | |
| Grundig | | | | o | |
| Blaupunkt | | | | o | |
| Telefunken | | o | | x | |
| <i>Japan</i> | | | | | |
| Matsushita | o | o | | | x |
| Toshiba | o | o | | | x |
| Hitachi | o | o | o | o | x |
| Sony | x | | x | x | x |
| Sanyo | o | o | | o | o |
| Sharp | | o | | | o |
| Mitsubishi | o | | | | x |

In other parts of the world, the Japanese have interests in Taiwan, S. Korea, Singapore, and Australia, while the European set manufacturers are active in Africa and the Near East. It is projected that the East Europeans will have volume set facilities by the early 1980s.

Color tube markets

The color picture tube market is made up of the following:

1. Color TV set manufacturers (a very large market)
2. Replacement market/TV servicing (a small market)
3. Non TV market (an extremely small market)

While the statistics for items (2) and (3) are not good, we project that the total 1978 requirement for both of these markets is less than two million units. Most tubes used in the TV replacement market are rebuilt tubes.

Table VII. Color TV set percentage penetration levels.

| | 70+ | 40-70 | 20-39 | 1-19 | 0 |
|--------|-----|-------------|---------|-----------|-------|
| U.S. | | Netherlands | Belgium | Italy | Egypt |
| Japan | | W. Germany | France | Spain | India |
| U.K. | | Norway | Austria | S. Africa | China |
| Sweden | | Denmark | Taiwan | Mexico | Chile |
| Canada | | Finland | | Brazil | Korea |

Table VI. Projected color TV set sales.

| Area | 1978 | 1983 |
|-----------------------|-------|-------|
| U.S. | 10.25 | 10.50 |
| Canada | .85 | 1.00 |
| Latin America | 1.10 | 1.90 |
| Western Europe | 10.00 | 10.50 |
| Eastern Europe | 1.20 | 3.00 |
| Africa | .30 | .40 |
| Near East | .30 | .40 |
| Japan & Far East | 6.00 | 7.00 |
| Australia/New Zealand | .60 | .80 |
| <i>Total</i> | 30.6 | 35.3 |

Sales to set manufacturers comprise the major segment of the total color tube market. Table VI tabulates our worldwide projections for 1978 and 1983 color set sales. If we ignore inventory changes, these projections can also be used as color set productions, color tube requirements, and color tube productions. The largest color set markets now and for at least the next five years are the U.S., Western Europe, and Japan.

To analyze the present and future markets for color TV sets (and, therefore, color picture tubes), the following factors must be evaluated:

1. *Color broadcasting availability*—In many areas of the world such as parts of Asia, Africa, and Latin America, color broadcasting has not begun. It was only in January of 1977 that Italy officially began broadcasting. Within some countries with color broadcasting, there are remote areas that do not have useable signals.
2. *Electric Power availability*—This is self-evident and to a very large extent tracks Item 1.
3. *Economics/Consumer Purchasing Power*—This too is self-evident and to a large extent tracks Items 1 and 2. Low cost color TV sets have retail price levels of at least 3 to 4 times small low priced black and white sets.

Table VIII. Net status—imports and exports.

| | U.S. | Japan | W. Europe | Taiwan |
|--------------|---------|---------|-----------|---------|
| <i>Sets</i> | Imports | Exports | Imports | Exports |
| <i>Tubes</i> | Exports | Exports | Imports | Imports |

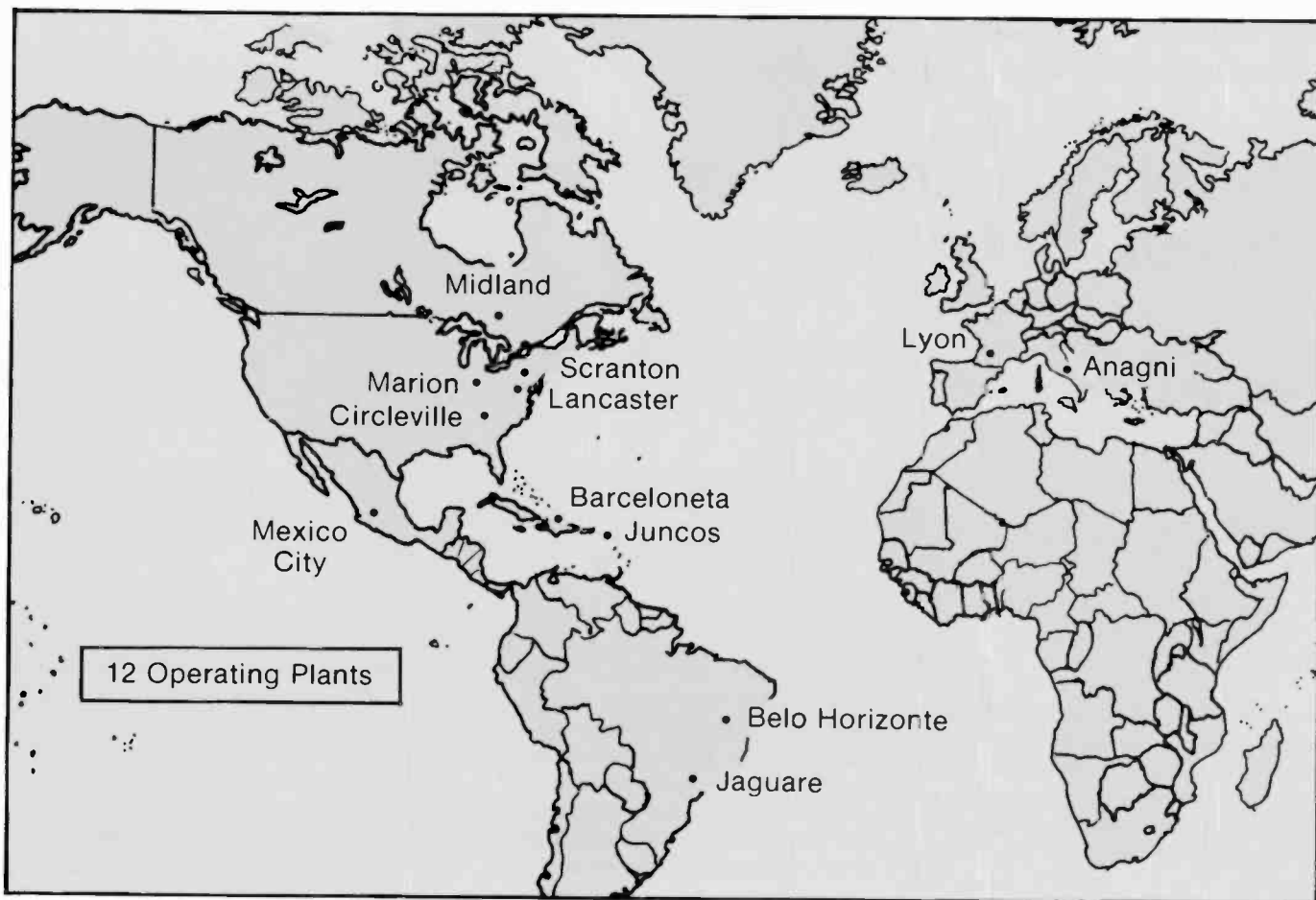

RCA picture tube division manufacturing locations.

4. *Color Set Household Penetration Levels* — Table VII is a snapshot of the different levels around the world. The penetration rate varies from none for many countries to 95 percent plus for Japan.

5. *New Household Formation Rates*

6. *Set Replacement Rates* — This is a difficult area to analyze. In the U.S. for vacuum tube and hybrid sets, 8 to 9 years average life expectancy has been projected. For solid state sets, 10 to 12 years plus are probably conservative life expectancy projections.

7. *Multiple Sets* — In the mature markets such as the U.S., this becomes a major factor.

NOTE: For 1978, we estimate the U.S. set sales were as follows: 24 percent first time buyers, 38 percent replacement, and 38 percent multiple sets.

8. *Institutional Set Market* — Consists of hotel, motel, hospital, and school sets. For 1978, we estimate that U.S. sales were 450,000 units.

Other factors which are important to color tube and set manufacturers are size mix, tube and set imports and exports. Japan is a large exporter of sets and tubes. For 1978, we estimate that Japan exported to Western Europe 600,000 sets and 2,500,000 tubes; to the U.S. 1,450,000 sets and 300,000 tubes. The U.S. exports sets to Canada but on an overall basis is a net importer of sets. The U.S. exports large quantities of tubes to Europe and on a net basis is a tube exporter. Table VIII briefly summarizes the major import — export flows for sets and tubes.

Conclusion

The worldwide color tube and set market is a growth business. The rate of growth varies in different parts of the world. The RCA Picture Tube Division is the major tube manufacturer in the U.S., Canada, and Mexico and is one of the largest worldwide tube manufacturers if not the largest. It is an interesting business for the marketing people as well as the technical profession.



Bob Dunn is Manager, Market Research and News and Information, Picture Tube Division. He has an extensive RCA background in engineering, sales, and marketing.

Contact him at:
RCA Picture Tube Division
Lancaster, PA 17604
Ext. 3249

Frequency synthesis tuning systems with automatic offset tuning

RCA ChanneLock electronic TV tuning systems find stations without any need for fine tuning.

Introduction

Since the advent of electronic television tuning systems in the late 1960s there has been a constant search for the best combination of technology and economics to yield an easily manufactured fully automatic tuning approach with simple user controls and a versatile variety of styling forms to meet application needs.

The present system is our answer to the automatic tuning problem. It was designed over a period of two years and uses almost every technology of the semiconductor industry. It is called a Frequency Synthesis Tuning System with Automatic Offset Tuning. The system is advertised as RCA ChanneLock.

Three systems — one design

The frequency synthesis tuning system can be manufactured on the same board with a variety of user controls and features. This is accomplished with a basic group of four integrated circuits and three optional ICs for additional features. The systems are *Keyboard*, *Scan Manual* and *Scan Remote*.

The keyboard system

The most basic frequency synthesizes tuning system is equipped with a 10 button keyboard for channel selection and a

Abstract: This paper describes a new closed-loop tuning system utilizing custom large scale integrated circuits to control the selection of the 82 U.S. television channels. The system is designed to minimize hardware but yet support multiple user features. No frequency adjustment or pre-alignment is needed for operation. A crystal frequency reference is continually used on each channel, but full

compatibility with automatic fine tuning is maintained to cope with transmitters operating off FCC-assigned frequencies. Channel selection is easily removed and is either by digital keyboard or by up-down scan of a user-selected list of channels stored in non-volatile digital memory. Channel number display is either on screen with time of day or off screen using a digital display.

digital LED channel display. To select a new channel two numbers are pressed, even for single number channels, providing total parity of tuning.

After the first button push, the display will show the number selected followed by a dash (-). The second button selection must be pushed within five seconds or the display will revert to the number of the previously tuned channel that is providing picture and sound through the retuning process.

The second button push, if within 5 seconds, results in an instant channel change to the new channel.

Selections of invalid channels result in tuning system turn off.

The scanning manual system

This version of frequency synthesis tuning is equipped with "channel UP/DOWN" selector buttons and a digital LED channel display. Channels are selected in numerical order using either the UP or DOWN channel selector button. Channel change occurs immediately as a button is pushed

and at half second intervals as a button is held.

The selection of a list of active channels for a local area is made possible using a non-volatile memory device. This device may be programmed by the user using a "Channel Program Select/Lock Switch" and two buttons to either "ADD" or "ERASE" channels.

In "Select", the programming mode, all channels can be obtained using the UP and

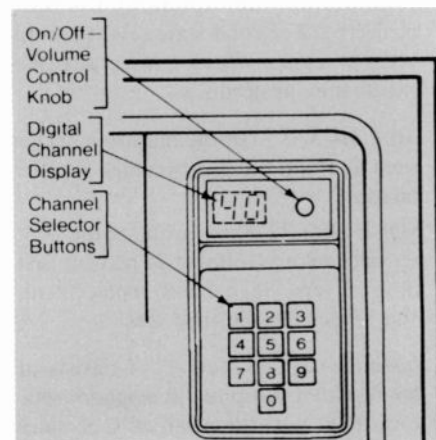

Fig. 1. Detail of keyboard user control.

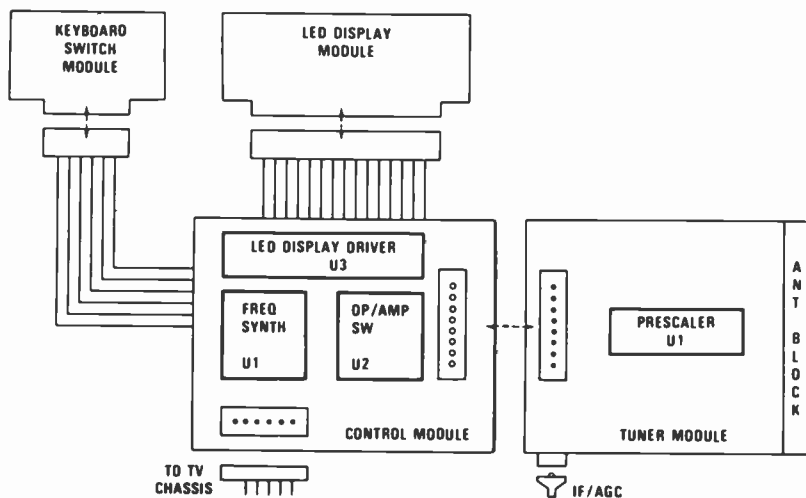

Fig. 2. Block diagram of keyboard system.

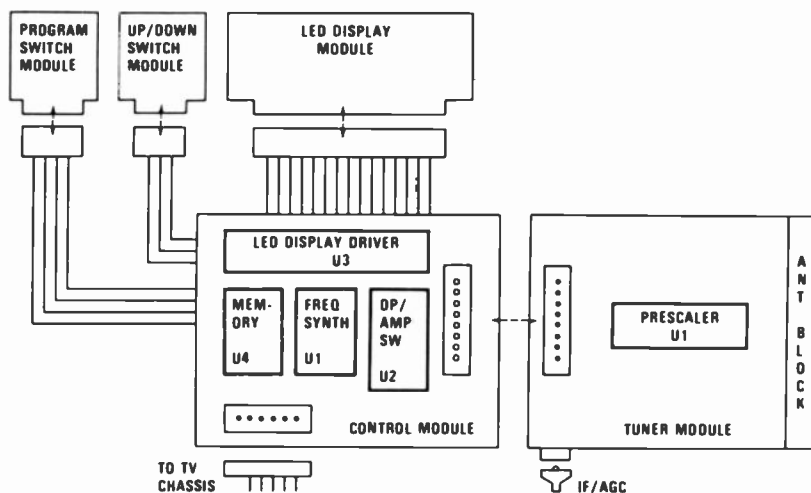

Fig. 4. Block diagram of scan manual system.

DOWN buttons. Channel change is immediate as a button is pushed and at a 10 channel per second rate after a half second delay if a button is held.

Active "ADD" channels will have sound. "ERASE" channels will not. "ADD" and "ERASE" work only in "SELECT" to prevent accidental memory changes.

The scanning remote system

The most complex frequency synthesis system has scan tuning in the manner of the manual scan system, but uses an on-screen channel display and an UP/DOWN push button volume on-off control.

The on screen channel display provides time of day and channel number using white figures edged with black for video visibility.

The display can be recalled to the screen for 5 seconds by tapping a volume control button or by selecting a new channel.

Clock setting is accomplished using time set buttons for MINUTES and HOURS. The buttons for channel and volume are duplicated on the remote hand unit and on the receiver.

Custom LSI features

The frequency synthesis system uses seven custom ICs consisting of four basic units and three optional ones for feature enhancement. The four basic ICs are: (1) prescaler, (2) synthesizer, (3) operational amplifier—band switch, and (4) LED decoder driver. The optional ICs are: (5) channel memory, (6) on-screen display clock, and (7) remote receiver decoder.

The prescaler

The prescaler function is to provide a digital divider for the tuner local oscillator

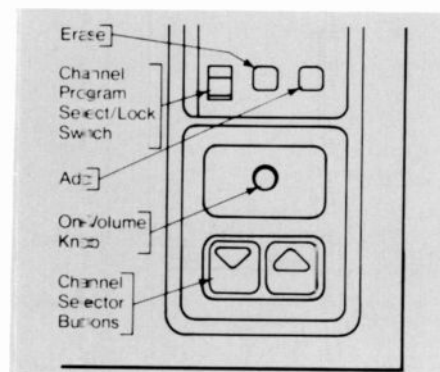

Fig. 3. Detail of scan manual user control.

signals. The IC uses emitter coupled logic technology that has been optimized for high sensitivity over a frequency range of 100 to 1,000 MHz. This makes possible minimum loading of the tuner oscillator and avoids the need for costly buffer amplifiers. The IC is internally structured to avoid feedback of harmonics from the logic counters to the tuner circuits to prevent interference. Further interference prevention is accomplished by minimizing the harmonic content of the output signal. Separate UHF and VHF inputs are used for optimum sensitivity.

The frequency spread of the output is minimized by using different divide factors for the VHF and UHF bands.

The synthesizer

The synthesizer integrated circuit uses NMOS technology and is the heart of the system. Its circuits include the crystal reference oscillator, timing counter, programmable divider, phase comparator, mode control, and user input control. The internal details of this IC are described in another paper entitled, "Frequency Synthesis Custom LSI: The Inside Story". In brief, the synthesizer receives frequency signals from the prescaler and processes them through a programmable divider that is programmed by the user's channel selection. The frequency of the divider's output is compared in a phase comparator to the frequency of a signal developed from an on-chip crystal oscillator and error signals are generated. Additionally, the synthesizer outputs the channel number selected in BCD code, controls tuner band selection, and generates commands that switch the system between synthesis coarse tuning and IF-derived automatic fine tuning. Automatic tuning of offset signals on VHF channels is also controlled by the synthesizer.

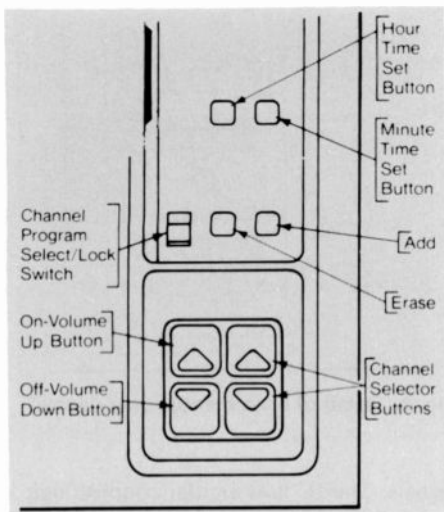

Fig. 5. Scan remote user controls.

The operational amplifier — band switch

This LSI uses a mix of bipolar and MOS technologies to optimize its multiple functions. The operational amplifier portion is used in the system to integrate the error signals from either the synthesizer or AFT to produce the tuning control voltage. The amplifier has MOS input devices to minimize bias current. The non-inverting amplifier input is tied to an on-chip voltage reference matched roughly to the mean voltage of the synthesizer output to provide for positive and negative error signals.

This chip also employs an MOS transmission gate for control of AFT signal switching. Its action is coordinated with the tristate output of the synthesizer for smooth AFT-synthesis switchover.

Lastly, bipolar emitter followers are used to drive the bandswitching circuits of the RF tuner. These devices operate as high current saturated switches selected by logic drives from the synthesizer.

LED decoder driver

This IC uses either low power Schottky or Isolated Integrated Injection Logic to statically decode the BCD channel number from the synthesizer and drive the cathodes of two seven segment LED displays.

The display drive outputs are open collectors to permit separate logic and segment drive power supplies.

Channel memory

The channel memory uses PMOS and MNOS technology to provide non-volatile memory of a user selected list of desired channels. The output is a skip or non-skip

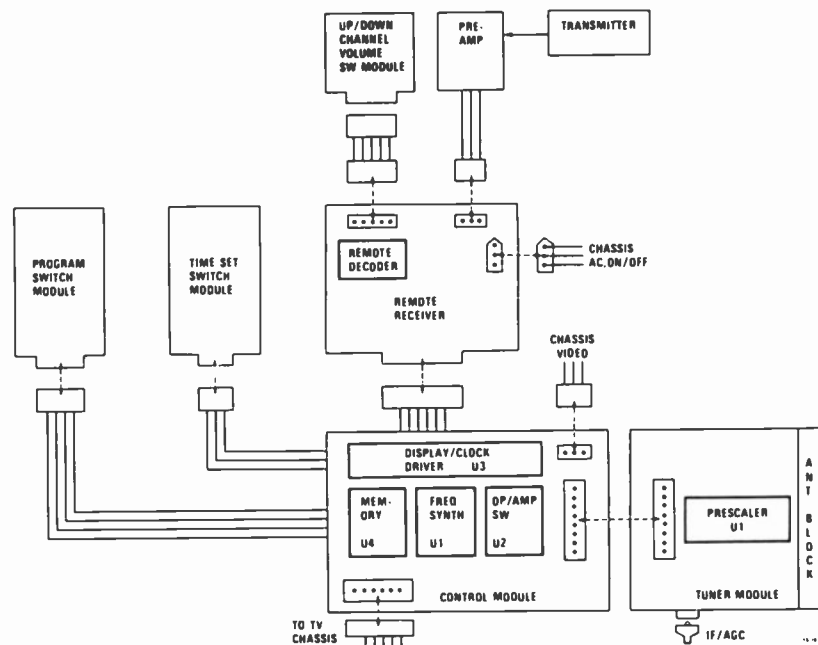

Fig. 6. Block diagram of scan remote system.

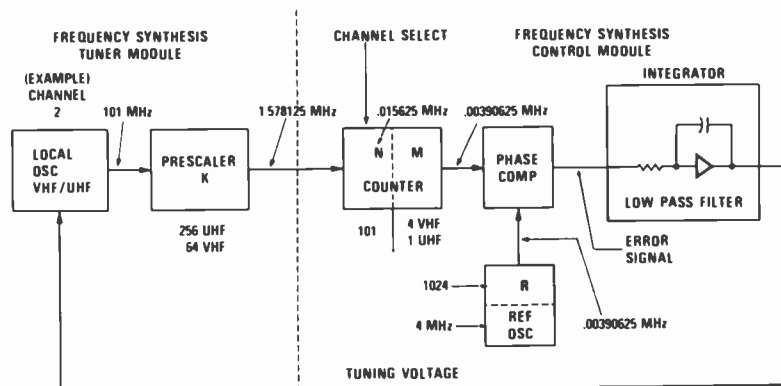

Fig. 7. Frequency synthesis—basic phase lock loop operation.

command to the synthesizer in response to the BCD channel number.

On-screen display clock

This IC uses NMOS technology and provides a video signal containing time of day and channel number information. This video is superimposed on the television picture and consists of white characters surrounded by a black edge. The chip has internal timers to control display duration. It receives 60-Hz line as a time reference and uses horizontal and vertical sync signals for display positioning.

Remote receiver decoder

The remote receiver uses integrated injection logic to count the frequency of the remote input signal. It has a digital-to-analog converter for volume control and

provides signals for channel change and receiver on-off. On-screen display recall is also provided. A ceramic resonator provides a frequency reference for the counter.

The basic phase lock loop

A portion of the signal developed by the tuner local oscillator (see Fig. 7) is fed to the prescaler IC and divided by either 256 for UHF or 64 for VHF. The resulting signal enters the synthesizer IC and is fed to the divide-by- N circuit directly. The divide by N counter then further divides the signal by the N factor where N is equal to the desired tuner oscillator frequency in megahertz. An additional M counter then divides the signal by 1 for (UHF) and 4 for (VHF). The result is a 3906.25 Hz signal if the tuner is correctly tuned or a frequency either higher or lower if tuning is incorrect.

Simultaneously, the 4-MHz crystal oscillator is divided by 1024 resulting in a reference signal of 3906.25 Hz.

The two signals are compared in a phase/frequency comparator and error signal is developed. The error signals from the synthesizer IC enter the operational amplifier section of the operational amplifier bandswitch IC which is connected as an active, operational integrator. The output of this integrator is the tuning control voltage that controls the local oscillator frequency, completing the loop.

What is automatic offset tuning?

The offset signals sometimes encountered with CATV converters, MATV systems, home video games, and video recorders fall in a range of ± 2 MHz around the FCC assigned VHF broadcast channel frequencies. These signals must be tuned by the receiver.

Conventional intermediate frequency referenced automatic fine tuning (AFT) has a pull-in range of about ± 1.5 MHz limited by the adjacent channel sound filter. This is obviously insufficient by itself to solve the ± 2 MHz requirement.

Pure frequency synthesis is inflexible in that the only frequencies that can be easily tuned are integral multiples of the reference frequency. This is defined as minimum step size and is equal to 1 MHz in our system. This approach is also obviously unusable alone for offset tuning.

Since neither method by itself is usable to solve the offset problem, let's see how a combination of the two provides a solution.

A new VHF channel is selected. The synthesis system tunes the FCC assigned frequency for that channel. When a phase lock has been completed, the system switches to AFT mode for signal searching within the AFT pull-in range of ± 1.5 MHz. The tuner either drifts toward a signal outside discriminator range or locks to a signal within the AFT range. During this process, the synthesizer counter circuits are used to determine the error between the FCC assigned frequency and the currently tuned frequency. The maximum tolerated error is ± 1.25 MHz. If, within a short time, the tuner drifts beyond ± 1.25 MHz, the system switches back to synthesizer mode and retunes at the FCC frequency plus 1 MHz. The AFT search procedure is repeated. If lock occurs, the system stabilizes in AFT mode. If no lock is obtained, due to drift exceeding ± 1.25 MHz, the system synthesizes the FCC frequency - 1 MHz and does another AFT search. A third failure to get an AFT lock will return the system back to the FCC nominal frequency. There, it will do alternate cycles of synthesis and AFT in search of a signal but with no further stepping. In lock mode, three seconds after tuning, all further stepping is prevented.

The choice of 1.25 MHz for the drift limit prevents lockout to the lower adjacent sound carrier (-1.5 MHz) during temporary dropout of the desired station's signal.

The physical structure

It was mentioned earlier that all FS systems use a common printed board for the tuning control functions. This board is about 13 cm square, uses single-sided copper, and contains all the ICs, power supply components, and filters needed for the system. The board is held in place in a wrap shell and is enclosed by radio-frequency radiation-suppressing shield covers. The RF tuner plugs directly into this control box to form a shielded modular assembly. The assembly includes the antenna connection terminal board and fits against the receiver back cover such that the terminals are accessible. The control buttons and LED assembly are connected to the tuning assembly by multiwire cables. An additional cable provides IF, AFT, AGC, power, sync, video, and audio control connections to the main receiver chassis. In remote versions additional subassemblies are used for standby power and remote signal processing.

There are no adjustments except for the usual RF tuner preselector and oscillator tracking in the keyboard and manual scan versions of the system. In the scan remote version one additional adjustment is used to set the channel and clock display width on the receiver screen.

The power supply

All power except remote standby power in a frequency synthesis receiver passes through the horizontal deflection oscillator and transformer. In doing so, it is series-

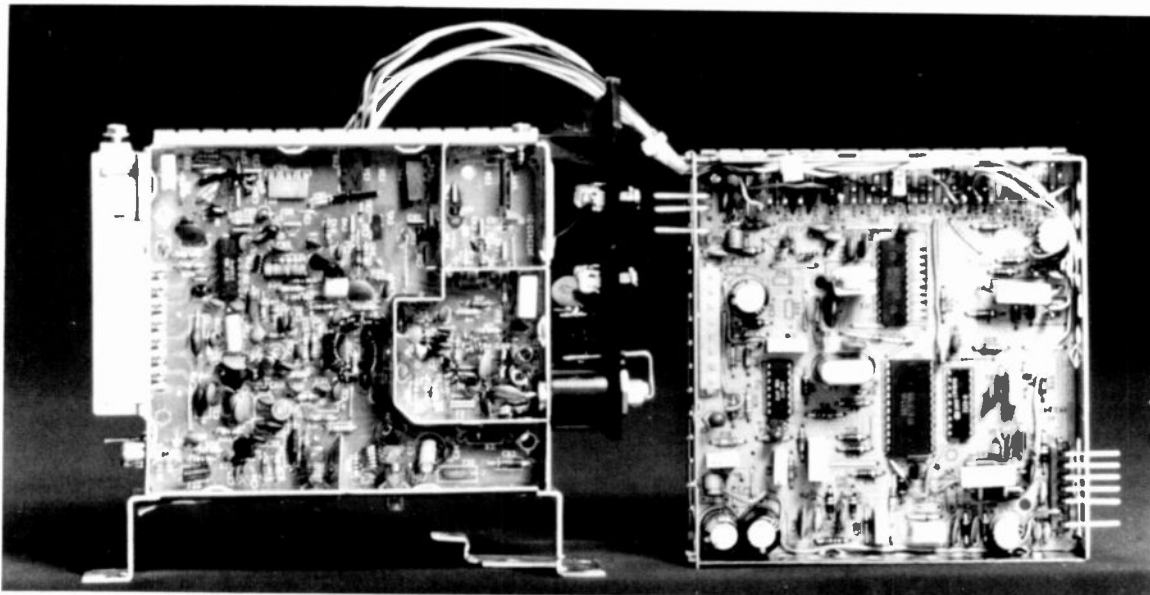

Fig. 8. Tuner and control modules.

regulated so as to be line-voltage independent. The tuning system makes use of two sources of power. One is a voltage derived from the main chassis DC voltage supply. This is used for the tuner bandswitching and RF circuits. In the second, the horizontal rate pulse signal is manipulated to provide all other needs. This horizontal pulse has a trace voltage of about 10 volts and a negative going retrace peak voltage of about -70 volts. The uses are as follows:

1. trace rectification for +8.5 volt LED anode supply and +5 volt logic;

2. peak to peak rectification for +33 volt operational amplifier tuning voltage supply;
3. negative peak rectification (scan versions) -30 volt for memory IC;
4. horizontal rate sync source for on screen display (remote versions).

Note: All supplies are shunt zener-regulated except the 8.5-volt LED supply, which uses the chassis series regulator to conserve power as the number of active LED segments varies with channel selection.

Acknowledgments

We wish to thank all the contributing personnel at RCA Laboratories, Princeton, N.J., RCA Consumer Electronics, Indianapolis, Ind., RCA Solid State Technology Center, Somerville, N.J.; and the various companies of the semiconductor industry whose efforts have made this system and this paper possible. A special thanks goes to Wayne W. Evans for his work in the system development.

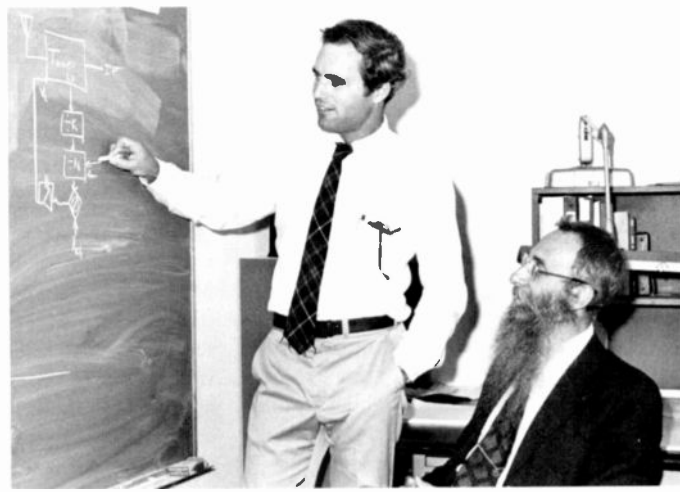

Standing (left to right) **B. Beyers, H. Blatter, J. George, and J. Tults.** Authors **J. Henderson and C. Wine.**
In the foreground, **R. Rast.**

B.W. Beyers joined RCA Consumer Electronics in 1965 where he worked as an advanced development engineer until 1974. In 1971 he was awarded the RCA Laboratories Outstanding Achievement Award for digital design related to TV. In 1974 he joined the TV tuning systems group.

Contact him at:
**RCA Consumer Electronics
Indianapolis, Ind.
Ext. 5906**

Harold Blatter is presently associated with the RCA Consumer Electronics, New Products Laboratory. Since joining RCA, in 1959, as a member of the technical staff at The David Sarnoff Research Center, he has been engaged in research in a variety of fields ranging from psychoacoustics to intelligent computer terminals.

Contact him at:
**RCA Consumer Electronics
Indianapolis, Ind.
Ext. 6866**

J. Barrett George, is currently Senior Engineer in the Digital Circuits Engineering Group, RCA Consumer Electronics, Indianapolis. He joined RCA Consumer Electronics in 1967 and has been involved with the development of tuners, tuning systems, and remote control. For the last three years, he has been involved in technical coordination of the RCA Consumer Electronics Frequency Synthesis project.

Contact him at:
**RCA Consumer Electronics
Indianapolis, Ind.
Ext. 5088**

John G.N. Henderson joined the RCA Laboratories in 1967, working in consumer electronics project areas, including IF filter design, surface acoustic wave filters, and television tuning systems.

Contact him at:
**RCA Consumer Electronics
Indianapolis, Ind.
Ext. 2531**

Robert M. Rast joined the staff of the RCA Laboratories in 1970, where he worked primarily in the consumer electronics areas of TV and CATV. He was appointed Head, TV Systems Technology Research in June, 1977. In November, 1977, he transferred to the New Products Laboratory located at the

Consumer Electronics Division, Indianapolis, and is Manager, New Products Development.

Contact him at:
**RCA Consumer Electronics
Indianapolis, Ind.
Ext. 6556**

Juri Tults was a member of the technical staff at RCA Laboratories in Princeton until November of 1977, before transferring to RCA Consumer Electronics in Indianapolis. In addition to projects related to TV receivers, his experience includes work on electroluminescent and liquid crystal displays, character recognition, and two-way CATV systems.

Contact him at:
**RCA Consumer Electronics
Indianapolis, Ind.
Ext. 6868**

Charles M. Wine joined the staff of RCA Laboratories in 1959, where he has worked in a variety of areas. He is now a Fellow of the Technical Staff, working in TV Microsystems Research.

Contact him at:
**RCA Consumer Electronics
Indianapolis, Ind.
Ext. 2296**

Signal processing technology — a report on the state of the art

The pressure for increased processing speeds and bandwidth has driven developers to order-of-magnitude improvements in device performance.

Abstract: *New components and advanced techniques have driven signal processing technology to remarkable performance levels over the past few years. This paper reviews some of the real-time requirements that have spurred these advances and examines the component technology and processing algorithms in use today.*

Analog, optical, and digital approaches are described, with emphasis on those techniques that are both currently popular and readily adaptable to the more complex processor architectures projected for the future.

The evolution of signal processing in recent years reflects the exponential growth of component technology generally — an explosion that astonishes even those directly involved. In the 1960s, signal processing was dominated by basic analog techniques which were adequate for the relatively modest processing rate requirements. Except for a few experimental digital systems and several optical approaches applied to sonar and synthetic-aperture radar, non-analog devices were limited to simple filtering tasks.

Today, the pressure for increased processing speeds and bandwidth has driven developers to order-of-magnitude improvements in device performance. Digital approaches now dominate the field, although both analog and optical techniques have shown notable advances. This paper reports on signal processing

technology today, with special emphasis on digital techniques and an indication of signal processing advances we may expect in the near future.

Signal processing needs

The requirements derive from a variety of areas, principally for military applications — radar, sonar, communications, image processing, pattern recognition, and intelligence gathering. The drivers are such factors as electromagnetic spectrum limitations; electronic countermeasures; multiple-mission processing requirements in a single system; rapid response; bandwidth conservation; high-speed multidimensional transformations; and the multiplexing of multiple users. Table I lists several areas of application and some typical signal processing functions — high-speed processes that must be performed between the sensor/receiver elements of a system and its computer. (Signal processing in this paper is distinguished from data processing by high throughput processing *prior* to any decisions or data selection, and by short response or integration times.)

Consider the application to radar. A number of major advances in the 1960s combined to establish a compelling need for high-speed digital signal processors. Among these was the phased-array radar with its ability to interleave multiple functions, to step the beam via inertialess electronic steering, and to transmit beams in rapid succession in many directions. This capability established new demands for flexibility and high-speed performance in the signal processor. For example,

antenna motion was no longer a limiting factor in the processing of clutter, a condition that led to markedly improved radar performance, but also imposed much more stringent requirements for processor stability and dynamic range. Further, the multiple function capability of the phased array radar brought requirements for greater processor flexibility and programmability, plus capability to store and process events which occur simultaneously or in very rapid sequence.

Although digital processing seemed desirable for programmability, memory, and performance, not even the largest digital computers could perform with the necessary speed the desired algorithms of matched filtering, convolution, spectrum analysis and correlation. For example, a matched filter for a relatively modest radar signal processing requirement (i.e., 1-MHz bandwidth and 10- μ s duration) would require 100 multiplications per microsecond over the entire receive interval, a taxing requirement for even the largest computers of the day.

Another area of major impact on signal processing requirements has been the effect of barrage jammers on the design of both radars and communication links. One of the key defenses against jammers is the coherent processing of wideband transmissions, with improvement in signal-to-jamming ratio by a factor equal to the ratio of transmission to information bandwidth. The result is that these so-called "spread spectrum" systems require large increases in bandwidth. Either the transmission bandwidth must be increased or the information bandwidth must be decreased.

Table I. Applications of high-speed signal processing.

| | |
|---|-----------------------------|
| Radar/Sonar | Image Processing |
| Prewhitening, filtering, integration | Image sharpening |
| Simultaneous beamforming | Motion compensation |
| Synthetic aperture formation | Spread function correction |
| Waveform processing | "N" dimensional tracking |
| Clutter/interference filtering | Turbulence filtering |
| Noise rejection | Correction for image motion |
| Threshold selection | Holographic transformation |
| Parameter estimation (position and derivatives of position, length, drag, shape, epoch) | Image formation |
| Identification | Object identification |
| ECCM | Coordinate transformation |
| Track error generation | Auto-regressive filtering |
| Motion compensation | Pattern Recognition |
| Frequency and time delay equalization | Attribute extraction |
| Multipath/dispersion correction | Parameter estimation |
| Fault tolerance | Filtering |
| Communications | Adaptive classification |
| Epoch synchronization | Decision processing |
| ECCM | Transformation |
| Encoding/decoding | Electronic Warfare |
| Error detection and correction | Signal demodulation |
| Multiplexing | Decoding |
| Equalization | Signal analysis |
| Multipath/dispersion correction | Direction finding |
| Bandwidth reduction | Signal filtering |
| | Association |

Technology to meet the needs

A truism in technology is that needs and feasibility grow hand in hand; every requirement evokes a series of responses until one or more are found to meet the need. Today, for example, digital VLSI (very large scale integration) technology may have more than 2000 gates per integrated circuit and easily support system throughput rates of 5 to 10 megasamples per second. Digital MSI (medium scale integration), having hundreds of gates per IC, supports throughput rates of 40 to 50 megasamples per second; individual modules have been constructed at RCA that operate at rates of 800 megasamples per second using MSI circuits. Recently, experimental digital circuits have been constructed using GaAs FETs, operating in the range of 3-8 gigasamples per second.

Analog circuitry has improved as well, with programmable surface acoustic wave (SAW) devices having time delay-bandwidth products of 5000 and bandwidths as high as 500 MHz. Charge-coupled devices (CCDs) are still relatively unreliable in analog applications, but in the next few years will probably support processor throughputs of up to 50

megasamples per second with time delay-bandwidth products of less than 1000. (Recent government contracts have been awarded to support sample rates ten times as great.)

Signal processing requirements are derived from three basic parameters: the signal bandwidth or required sampling rate, the waveform duration, and the time delay-bandwidth product which is equal to the number of samples to be processed to produce a single resultant sample at the processor output. Figure 1 illustrates the state of the art in both analog and digital component technology applicable to signal processing. Four major technologies are in use for signal processing: SAW, CCD, optical, and digital devices.

SAWs provide a highly efficient analog approach to performing matched filtering, spectrum analysis, convolution, and correlation. Programmability has been achieved, but with some difficulty. On the other hand, the use of the chirp Z transform algorithm (Appendix A) permits SAWs to perform these functions without programmability in the device. SAWs operate with carriers sufficiently high to support the signal bandwidth.

CCDs are the baseband analog of SAW devices. They can provide longer delays,

Brief glossary of signal processing terms

A few of the specialized technical terms used in this paper are included here for the convenience of the reader. A complete glossary may be found in Dr. L. Shapiro's paper "Digital Electronics, Part III - Digital Filter," *RCA Engineer*, Vol. 22, No. 4, p. 85-86, (Dec 1976/Jan 1977).

Aliasing: Signal distortion resulting from choice of a sample rate too close to the Nyquist interval for the signal (less than twice the highest frequency existing in the original signal). This phenomenon is due to the fact that bandwidth is shaped by filters with finite roll-off characteristics, resulting in some portion of the spectrum folding back into the passband.

Baseband: A low-pass signal represented as a real and imaginary

but at this time they encompass relatively low bandwidths. The same algorithms apply to both SAWs and CCDs, as do similar limitations (i.e., dynamic range, noise degradation).

Optical technologies make use of parallel access to data and the fact that the focal plane of a lens is the Fourier transform of the object plane. Despite their high computational rates, maintenance difficulties and poor data access have limited the application of optical processors to special designs, such as synthetic aperture radar (SAR).

Digital devices are operated at baseband. In the space of five years between 1970 and 1975, the cost to implement a digital function such as multiplication was reduced by two orders of magnitude through the use of increasing component integration. Digital processes allow the dynamic range to be a function determined by the implementation word size. Through

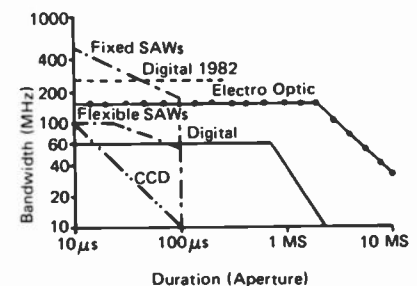

Fig. 1. Maximum signal duration and bandwidth define the capabilities of a signal processor. This chart compares surface acoustic wave devices, charge-coupled devices, and digital devices.

component about a zero frequency carrier. The quadrature (imaginary) component phase is fixed at 90° with respect to the in-phase (real) component for each frequency.

Convolution: An integral form representing the transient response of a signal through an electrical circuit, where the signal is represented by a time function and the circuit by its impulse response. Correlation is a special case of the same operator.

Finite Impulse Response (FIR) filters: Filters with paths that permit no feedback of data. Consequently transients die out in the time required for the first sample to completely traverse the filter.

Infinite Impulse Response (IIR) filters: In these filters, feedback theoretically permits transients to continue indefinitely.

the use of baseband in-phase and quadrature processing of complex arithmetic, digital devices can perform filter functions not realizable by analog means. Digital devices also permit indefinite temporary retention of data, since digital storage does not degrade with time as in the case of analog recirculating delay lines of CCDs. These factors make it possible to design digital signal processors to meet much more rigorous standards than have heretofore been possible—subject only to cost constraints.

The stability of digital processes is also higher than that of any other processing means. Further, digital approaches are much more amenable to precise mathematical description, thereby affording a design discipline in which computers can be used to provide and evaluate designs to precise performance requirements and cost. The ease with which programmable digital architectures can be developed is still another factor in favor of digital application. Perhaps the single most notable advantage of the digital approach, however, is its facility in applying the power of the Fast Fourier Transform (FFT), an algorithm that cuts so drastically into the number of arithmetic operations required for processing that its impact on signal processing technology is easily as important as that of any component advance.

These reasons explain in part the popularity of digital signal processing today. And the variety of digital approaches available makes it possible to select an architecture that is virtually tailor-made

Table II. Driving factors in signal processor architecture selection.

Available Component Technology

Tradeoffs exist between candidate component technologies with respect to: speed, cost, power dissipation, degree of integration, fan out, reliability, radiation hardness, maturity, size of the logic family, etc.

Allowable Throughput Delay

If the processor is an element of a control loop, delay between input and output may be a crucial factor.

Algorithms

The selection of algorithms is impacted by and impacts the architecture. For example, the FFT is easily partitioned for pipeline structures, but algorithms such as Winograd's and the prime factor are not.

Data Partitionability

Data is usually available as some time-ordered sequence. If effective use is to be made of parallel processing, this data stream must be partitionable without excessive overlap of data. As an example, two-dimensional Fourier transforms can be partitioned into multiple one-dimensional transforms. For radar, a single dwell can be distributed among an array of processors, with each processor processing the Doppler for each range cell it contains.

Control Complexity

The re-entrant or conventional computer permits great simplicity of control. The

advent of the programmable read-only memories and microcontrollers on a single IC has made complex control of arrays and pipelines possible.

Range of Utility

Various problems require various processor capabilities (e.g., program utility, word format, word notation).

Modularity

Logic partitioning can allow a restricted module set to be used in a variety of applications. Frequently the architecture is chosen to keep the number of module types small.

Reliability| Fault tolerance| Graceful degradation

Parallel architectures permit the use of identical configurations in parallel. Consequently, reliability, fault tolerance and/or graceful degradation can easily be achieved in the parallel elements (bus structures and multiplexers are the weak links). On the other hand, pipeline systems have fewer components.

Cost| Hardware effectiveness

Cost is usually the key. Reliability considerations frequently dictate component quality (class) required, which can be traded versus paralleling processors. Pipeline architectures are especially efficient in hardware, but may be less reliable.

for any signal processing problem. These architectures are summarized in the following paragraphs.

Digital signal processing architectures

Four classes of digital processors are commonly accepted:¹

1. *the re-entrant processor*, with a single data and a single instruction stream;
2. *the array processor*, with multiple data streams and a common instruction stream;
3. *the pipeline processor*, with a single data stream operated on sequentially by a string of processors, each with its own instruction stream; and
4. *the parallel processor*, consisting of multiple data streams operated-on by processors with independent instructions.

The choice of architecture is a function of whether high-speed or low-speed components are to be used, the degree of incorporation of fault tolerance (or "graceful degradation"), and the degree of programmability. Table II lists the key issues that apply in the selection of an architecture. A non-trivial discussion of the impact of these factors in the selection of processor architecture would require explanation beyond the scope of this paper.

The re-entrant processor

This type of processor is most like a computer; it offers programmability. Programs are run serially, and consequently throughput is low. Most micro-processors and commercially available signal processors are of this type. These machines, although re-entrant in structure, contain highly specialized

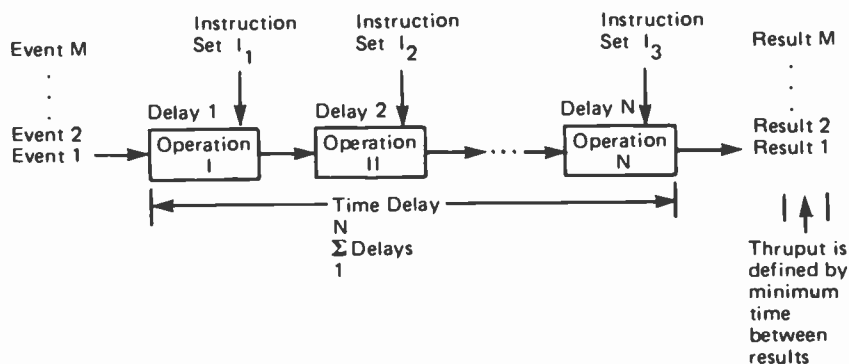

Fig. 2. General concept of a pipeline system. The signal events are presented sequentially at the input to a series of processors operating sequentially with independent instruction sets, providing sequential results.

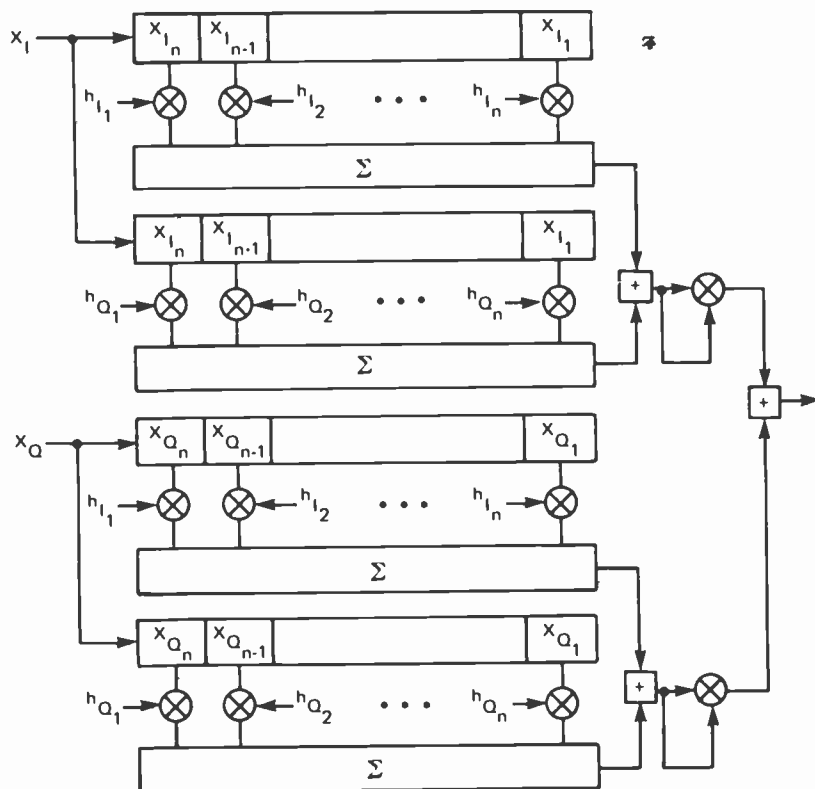

Fig. 3. Time-domain-sampled data convolver. The X_i (in-phase) and X_q (quadrature) samples of the signal are each processed through in-phase and quadrature matched filters.

arithmetic processors specifically suited for signal processor application, or they may include special-purpose hardware functions to perform frequent macro instructions in hardware. Signal processors of this type were discussed in an earlier issue of the *RCA Engineer* by Herold and Timken.² The advent of microprocessor/microcomputer implementations³ permits the embedding of re-entrant processors in parallel architectures.

The pipeline processor

The pipeline processor permits the designer to largely ignore the time required to

perform a computation and instead to concentrate on ensuring the desired data throughput. Figure 2 illustrates the principle. Although the total computational time may be long (i.e., microseconds), the system may be obtaining successive results at a high rate (i.e., tenths of microseconds). Since this processor property is frequently used by the designer both within the operational blocks and in the overall system as shown in the figure, the pipeline processor is most effectively used to perform finite impulse response processes (e.g., feed-forward filters) as opposed to recursive or infinite impulse response (IIR) functions requiring feedback (and attendant pipeline delays). Note, however, that

the only advantage of an IIR process—hardware savings—does not apply here, since efficient pipeline designs will be required to operate at full computational speed and capacity.

A continuous pipeline form of a time-domain processor is shown in Fig. 3. The complex multiplication requires four real products between the complex weights (h_j) and the complex samples of the signal (X_i) for each sample. M complex multiplies are performed in the passage of a sample through the filter, where M is the number of samples in the filter. $M \cdot N$ computations are performed to obtain N output samples. In a typical tactical phased array radar system the X_i are limited to a single bit and only two matched filters are required per channel because of the choice of biphasic code modulation. A single channel of this radar pulse compression system requires up to 408 modules. This single-bit processor is a relatively special case, and only now with new devices being developed by RCA and others can we consider fabricating a processor with substantial input dynamic range through multibit sampling words.

array radars are special-purpose devices, advantage is taken of the very special requirements of such systems. Greater generality and programmability and efficiency are realized when algorithms are chosen to minimize complexity, such as the fast Fourier transform and other fast transformations. The FFT is particularly useful, since it partitions into a regular pipeline structure, can be configured to perform most signal processing functions requiring high throughput, and accommodates programming with relatively simple control. The FFT algorithm also permits relatively simple methods of paralleling for higher throughput.

Parallel processors

Two types of parallel processing have been mentioned in this article: the array processor in which a large number of processors operate on different data in synchronism, using the same instruction set; and the multiprocessor in which each of the parallel processors operates on an independent data set with independent programs.

Each of the processing elements can in itself be a re-entrant, pipeline, or parallel processor of varying complexity. The main problem to be solved is efficient communications between processor elements. Signal processing, which normally consists

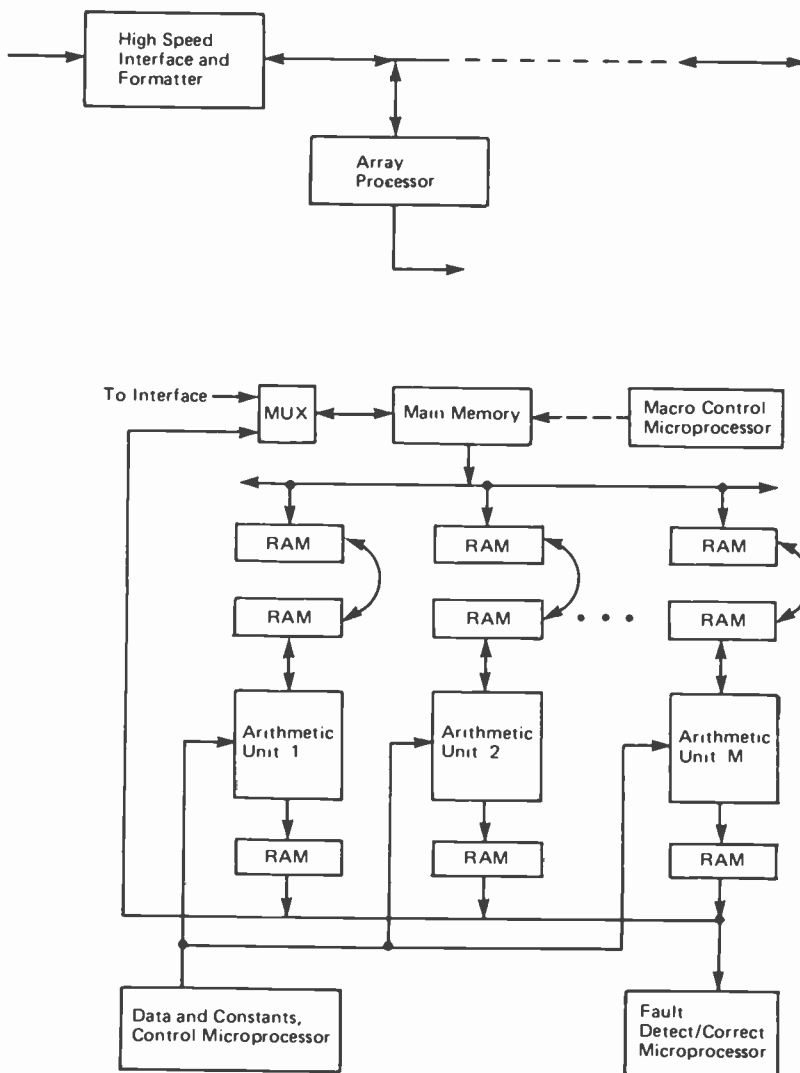

Fig. 4. Array processor concept supports high-speed processing while providing fault tolerance.

of long arrays of data, can also be configured for array processing.

Array processors have been built for more general-purpose processing, but the cost of components and the complexity of general-purpose control have made such machines costly and difficult to program. Application to signal processing in conjunction with distributed control allows simplicity in architecture. This type of processor is less efficient and slower than a pipeline processor of similar complexity. However, it combines high programmability with high throughput. Figure 4 illustrates the concept. For high throughput, double buffers are desired, permitting simultaneous processing within the array and loading of the array buffer. Interchangeability of input and output buffers would permit rapid transfer of data arrays. Control would be distributed. The highest level of control would distribute data to and from the main memory and

provide macro code instructions like "compute magnitude" or "compute three-point interpolation." Stored control data constants would be provided to each processing element from a common source, the control microprocessor.

The arithmetic unit can vary in complexity from a simple register arithmetic logic unit (RALU) to a multistage pipeline unit. The more specialized the arithmetic unit, the greater the throughput and the less the flexibility. The RALU accesses two arguments and performs rudimentary arithmetic (i.e., add, subtract, shift), while an "n" stage pipeline would transform 2^n points in a single Fourier transformation.

A third control processor could be included for self test and "fault tolerance." The processor could interrogate specific adder accumulation registers on each module for fault isolation via check sums, or by paralleling the data input into two processing elements and comparing the

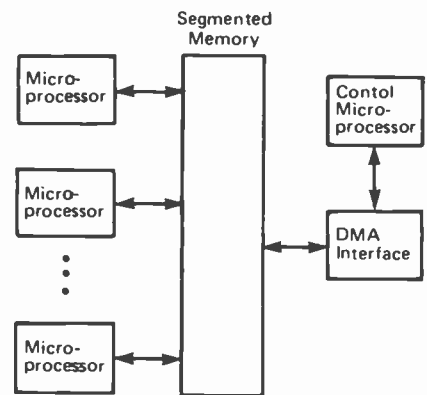

Fig. 5. Parallel processor for signal processing. The use of segmented memory reduces bus communications conflicts.

check sum results. Fault tolerance would be achieved by changing the address of a failed processor to a redundant parallel element. Multiple busses would provide bus protection.

Multi-processor or parallel processor architectures are designed to minimize bus and memory contention to maintain the desired high throughputs. Among the architectural contenders are the autonomous processors coupled to a control computer by means of memory, in which the control computer directs appropriate data to each processor (Fig. 5). Memory contentions between the data transfer and computation exist in each parallel processor and could be ameliorated by double buffering. Block transfer of data between parallel processors is the key problem, since each processor can access only a small portion of memory. Consequently, blocks of memory must be shifted infrequently and in synchronism. A common approach to block data transfer is the use of shared memory.

The ability to build complex arrays of processors at a cost acceptable for military applications has become available only since the advent of LSI. Commercial systems have not yet been marketed, but a number of military manufacturers are designing processors of this type for image processing and certain radar applications.

Future trends

Components

Continued progress in microprocessors, microcontrollers, and field-programmable read-only memories will result in increasingly more complex processor architectures, programmable through

selection among stored firmware programs. Control will be multilevel and distributed. The amount of hardware will be less a factor (at least in military applications), thereby easing the burden of complex multiplexed programs. The design costs associated with very large-scale integration (10,000 gates per integrated circuit) will preclude the extensive development of a logic family. Aside from the obvious memory developments, the emphasis will probably be on programmable logic and bit-slice integration. The complexity of the designs will result in more modular structures with fewer module types. Architectures will tend more to the array and pipeline structures. Figure 6 illustrates the packaging of a state-of-the-art 16-bit, bit-slice microprocessor using the AMD 2900 chip family.

Algorithms

Several approaches have been made to reduce the complexity of performing the Fourier transformation, with the objective of reducing computations below those



Hank Halpern has given innovative direction to RCA's advanced signal processing technology effort for more than 15 years. From 1962 to 1979 he worked with, and directed, the Signal Processing Synthesis section of MSR's Advanced Technology Programs Department. He was recently appointed Manager, Advanced Radar Programs, in the MSR Advanced Missions activity.

Contact him at:
Missile and Surface Radar
Moorestown, N.J.
Ext. 2723

required to perform the FFT. These include Winograd's algorithm,⁴ prime factor algorithm,⁵ number theoretic transforms,⁶ and polynomial transforms.⁷

Most of these algorithms show advantages over the FFT when they are performed on a conventional computer where "multiplies" are more time-consuming than "adds." Speed improvements of 40-100 percent were experienced on a PDP-11 computer. However, in most signal processors (and particularly so in the future) the time and cost to perform an addition will not differ significantly from that of a multiplication. Reduction of multiplies will be of little significance, especially since it is achieved with a loss of algorithm regularity.

A criterion for the algorithm of the future will be reduction in total number of operations, possibly trading against increasing the number of operations of a particular type or at the expense of regularity of sequence or algorithm structure, computational noise or word size. For small numbers of points, the Cook-Toom algorithm⁶ shows a reduction of total number of operations for fast convolution, proving that such algorithm improvements can be derived.

Fault detection and correction

The increasing number of gates per system presents a severe fault detection and maintenance problem. Today a single microprocessor integrated circuit can contain several thousand gates, while an entire system like an SPS-81 processor contains only 4×10^4 gates. Array processors provide the means for continuous on-line fault detection, and a failure may not be significant at all, or may be easily remedied through the use of redundant parallel-processing elements.

Testing down to the module level could be achieved by incorporating a built-in test chip on the module. This chip could perform a "check sum" on command and provide a serial output of the result. Self test could even be designed into the chip itself. Regardless of the specific solution, built-in testing will be a major requirement of those systems having increased complexity.

Conclusion

Each year since its inception, the integrated circuit has doubled in gate complexity. The current DoD initiative, VHSIC (very high

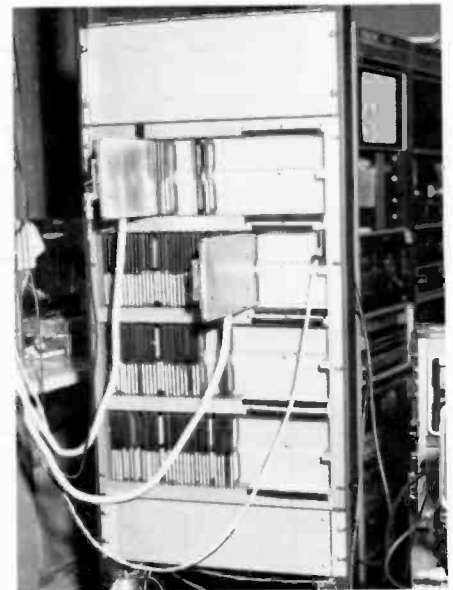

Fig. 6. Forward and inverse FFTs using LSI (built for U.S. Air Force Avionics Laboratory).

speed integrated circuits), is aimed at devices with gate-speed products in excess of 3×10^{12} circuits operating at 100 megasamples/sec with 30,000 gates. The component designer and the signal processor designer of the future will be required to work in close coordination and mutual understanding. The challenge will be the selection of circuits whose general utility can support the initial design costs and the design of systems that can be maintained or are inherently fault tolerant. There is no indication that the growth pattern is slowing.

References

1. Weinstock, W.W., "Radar Processing Architectures," *RCA Engineer*, Vol. 23, No. 5 (Feb/Mar 1978), pp. 32-37.
2. Herold, M.G., Timken, M.C., "Programmable Processors and Radar Signal Processing—An Applications Overview," *RCA Engineer*, Vol. 23, No. 5 (Feb/Mar 1978), pp. 76-81.
3. Buch, B.D., Clapper, S.L., Smith, R.J., "Microcomputers for Radar Systems" *RCA Engineer*, Vol. 23, No. 5 (Feb/Mar 1978), pp. 71-75.
4. Winograd, S., "On Computing the Discrete Fourier Transform," *Proceedings of the National Academy of Science*, Vol. 73, No. 4 (April 1976), pp. 1005-1006.
5. Kolba, D.P., Parks, T.W., "A Prime Factor FFT Algorithm Using High-Speed Convolution," *IEEE Transactions on Acoustics, Speech, Signal Processing*, Vol. ASSP-25, No. 4 (August 1977), pp. 281-294.
6. Agarwal, R.C., Burrus, C.S., "Number Theoretic Transforms to Implement Fast Digital Convolutions," *Proceedings IEEE*, Vol. 63 (April 1975), pp. 550-560.
7. Nussbaumer and Quandalle, "Computation of Convolutions and Discrete Fourier Transforms by Polynomial Transforms," *IBM Journal of Research and Development*, Vol. 22, No. 2 (March 1978), pp. 134-144.

Appendix A

The chirp Z transform

The chirp Z transform is a method of performing the Fourier transform utilizing a fixed matched filter for the kernel, $\exp(-j\pi y^2)$, commonly called "chirp." The Fourier integral can be manipulated to derive the chirp Z transform operation. Starting with the Fourier transformation integral

$$F(x) = \int f(y) \exp(j2\pi xy) dy \quad (A1)$$

we can rewrite Eq. A1 as

$$F(x) = \int f(y) \exp[\pi j(x+y)^2] \exp(-\pi jx^2) \exp(-\pi jy^2) dy \quad (A2)$$

$$= \exp(-\pi jx^2) \int [f(y) \exp(-j\pi y^2)] \exp[\pi j(x+y)^2] dy \quad (A3)$$

Interpreting Eq. A3 in terms of Eq. A1, the $f(y)$ is multiplied by a chirp function and convolved with the same chirp function. The result is multiplied by a chirp in the transformed variable to produce the Fourier transform. Expressed symbolically, $Z = \text{chirp function} = \exp(j\pi y^2)$

$$[f(y) \cdot Z] * Z = F(x)$$

Readers familiar with near-field focusing will notice the close relationship between the Z transform and the Fresnel transform or Fresnel focusing of an array.

Appendix B

The fast Fourier transform algorithm

The introduction of the fast Fourier transform algorithm (FFT) reduces the number of kernel operations in most signal processing

applications by the ratio $N/(\log_2 N)$, where N is the number of sample points being processed. Furthermore the FFT algorithm is easily partitioned for pipeline or parallel processing. The FFT and related new algorithms have had as great an impact as new components in making high-throughput digital processing possible.

Such signal processing functions as spectrum analysis, filtering, correlation and convolution require solutions of an integral of the type

$$f(\tau) = \int f(t) h(t-\tau) dt \quad (B1)$$

commonly called the convolution integral. This is the basic equation for the response of a linear time invariant system to a signal $f(t)$. It is well known that the Fourier transform dual of the convolution integral is the product of the Fourier transforms of $f(t)$ and $h(t)$, that is,

$$F(w) \cdot H(w) = G(w) \quad (B2)$$

where $F(w)$, $G(w)$ are the Fourier transforms of $f(t)$, $h(t)$, $g(t)$. A similar dual exists for the sampled data form, i.e.,

$$W_n = \sum X_m h_{n-m} \quad (B3)$$

and

$$W(Z) = X(Z) \cdot H(Z) \quad (B4)$$

In 1965, Cooley and Tukey published what was a rediscovery of the fast Fourier transform algorithm^{B1} which showed that the Fourier series could be calculated for N points by $N/\log_2 N$ operations instead of N^2 operations. Thus it became more efficient to solve equations of the form of Eq. B3 in the frequency domain using the duals shown in Eq. B4. The savings become substantial as the number of sample points to be transformed (N) increases. Figure B-1 illustrates some typical signal processing

| Function | Implementation | Frequency* Domain Computations | Time* Domain Computations |
|------------------------------------|--|---------------------------------------|---------------------------|
| Spectrum Analysis | Time Samples → FFT → Frequency Samples | $\frac{N}{2} \log_2 N$ | N^2 |
| Convolution and Generalized Filter | Time Samples → FFT → ⊗ → FFT → Time Samples Stored Filter Weights (Complex Frequency) | $N \log_2 N + \frac{N}{2}$ | N^2 |
| Correlation of Two Signals | Signal 1 → FFT → ⊗ → FFT → Correlation Function Signal 2 → FFT | $\frac{3N}{2} \log_2 N + \frac{N}{2}$ | N^2 |

* Number of computations assumes efficient pipeline operations without algorithm partitioning. Multiplications by 1, -1, j, and -j are counted in the number of operations

Fig. B-1. Performance of signal processes for a fixed aperture containing N samples.

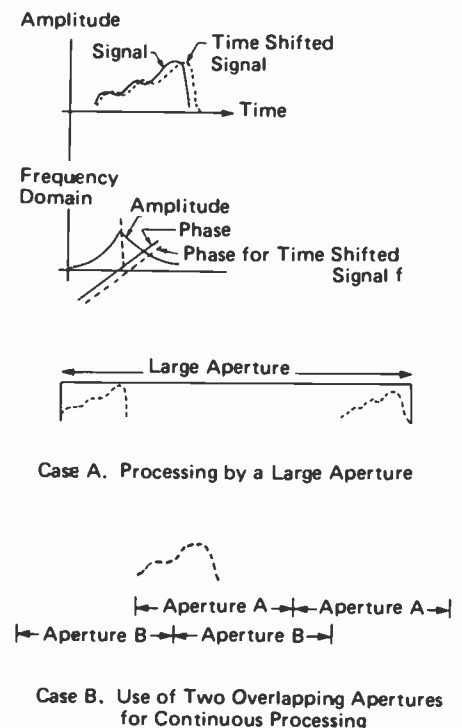

Fig. B-2. Application of the shifting theorem and appropriate aperture selection permits the continuous processing of data.

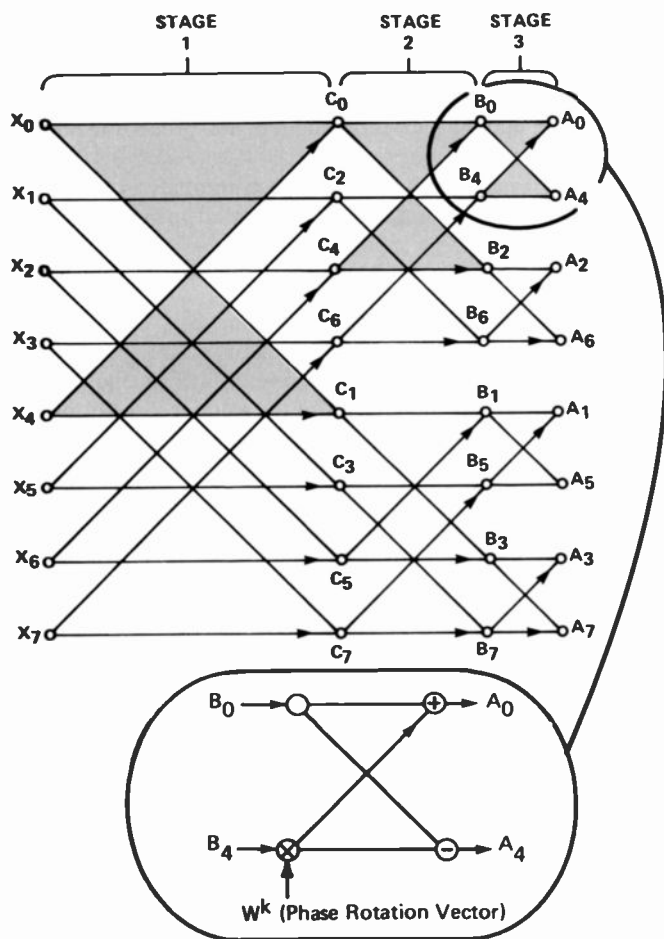

Fig. B3. Flow diagram of one form of the FFT algorithm for an 8-point transform.

applications and the number of operations in a frequency-domain solution versus a time-domain solution. In each case, the samples taken in time are transformed to Fourier series, multiplied together, and then an inverse Fourier transform is performed to return to a time function. The advantage of using the fast Fourier transform to perform the tabulated operations is evident from the reduction in the number of computations, approximately $(\log_2 N)/N$.

Handling continuous signals or signals with an unknown starting point

The Fourier series expansion obtains a fixed number of frequency coefficients based on a fixed number of input samples. The aperture over which the samples are taken determines the spacing of the Fourier coefficients in frequency; the sampling interval determines the aliasing or frequency foldover that can occur.

When a signal can arrive at an arbitrary time with respect to the sampling aperture of the processor, losses and sidelobes can occur due to incomplete processing of the signal. This problem can be solved either by using an aperture sufficiently long to capture the signal starting at any possible time, or, if the starting point is unconstrained, by continuously overlapped apertures. These modes of operation are possible because time shifting leaves the spectrum unchanged except for a fixed phase shift as shown in Fig. B2. The selection of a method is largely dependent on the range of

the epoch in which the signal can start. The continuous process requires four times the number of sample points for the signal than that required in a simple batch process, and the fixed aperture is dependent on the uncertainty in signal starting time. It can be shown that the overlapping of apertures can be achieved simply in a radix-2 computation FFT.

The required sampling rate

Shapiro^{B2} discussed the sampling rate required for minimum signal-to-noise ratio degradation. Complex sampling rates 10 percent greater than the signal bandwidth result in degradation in S/N due to aliasing of less than 0.1 dB. The sampling rate determines the number of samples to be processed and must be kept small for hardware efficiency.

Partitioning the FFT algorithm

The basic computational form of the FFT involves a series of "butterfly" computations (paired selection of data points followed by phase rotation and complex addition and subtraction) repeated for successive sample points in each processing stage. The flow diagram of Fig. B3 illustrates the computations and the sequence in which they are performed. The flow diagram can be decomposed into a fundamental computation, one of which is shaded in the diagram for each stage in the pipeline. The inset illustrates the arithmetic operation represented by the butterfly. The FFT flow shown represents one in which $N = 2^k$, where k is any integer and equal to the number of pipeline stages and N is the number of samples in the transformation. Further, the input is in natural order while the output is scrambled (the output is bit reversed, i.e., as if the natural order were expressed as a binary number and the order of the digits was reversed.)

Variants of the FFT can be applied to obtain efficient implementation and desired ordering. In a pipeline processor the data appears at the input in sequence. Then sample X_0 must be stored until X_4 arrives (four sample periods;) in Stage 2, each sample must be delayed for two sample periods, and in Stage 3, for one sample period. If the pipeline is to process a 16-point transform, then a stage would have to be added ahead of Stage 1. In this stage, the same butterfly operation is performed between samples eight delays apart.

The basic arithmetic operation consists of selecting two samples appropriately spaced, rotating the phase of one of the two samples, and then adding and subtracting the two samples. The phase rotation can be accomplished in many ways; for example, by multiplication of the real and imaginary components by the sine and cosine of the rotation angle, or by a chordic approximation method. Only a single rotation is required for every two points transformed by the butterfly operation. Since the rotation is usually the longest duration operation in the pipeline, processing could be performed at a sampling rate which is twice the time required for phase rotation.

References

- B1. Cooley, J.W., Tukey, J.W., "An Algorithm for the Machine Calculation of Complex Fourier Series," *Mathematics of Computation*, Vol. 19, No. 90, pp. 297-301.
- B2. Shapiro, L., "A Short Course in Digital Electronics — Concepts and Sampling Theory," *RCA Engineer*, Vol. 22, No. 2 (Aug/Sep 1972), pp. 56-63.

Composite triple beat measurements

In the CATV industry, controlling third-order intermodulation in a multi-channel system has long been a problem. The curves presented here allow the system operator, using readily available instruments, to obtain a correct measurement of system performance.

Introduction

How to measure triple beat (third order intermodulation) has been a problem in the CATV industry. One method is to measure a single triple beat and extrapolate to a 35-channel case. The problem with this method is that the single triple beat level will vary depending on the test frequencies used, resulting in poor correlation with the composite triple beat level produced when all channels are operated. Measurement of the composite triple beat per channel should be more practical since the composite triple beat produces the undesirable effects on a television screen. The problem with measuring the composite level is that it is below the system noise level in the trunk line. In the high level distribution, the composite level is above the system noise level, but the problem becomes one of instrumentation. Most signal level instrumentation available to the CATV operator is not capable of true power (rms) measurement of complex signal waveforms such as noise or multiple sine waves. Correction factors need to be established for typical signal level instrumentation used in the cable industry such as spectrum analyzers and signal level meters. The purpose of this paper is to present a set of curves which show the relative readings between a power meter (rms), signal level meter (peak) and a spectrum analyzer (peak or average).

Reprint RE-25-1-4
Final manuscript received Mar. 12, 1979.

Instrument comparison

Figure 1 shows the relative instrument measurement in decibels versus the total equivalent triple beat per channel for the worst case channel. The data was taken by measuring a single frequency signal with each of the instruments to obtain a reference point on the meter or CRT. Additional signals were added, then additional attenuation to return the readings to its reference point. The attenuator reading was used as the measured value. Individual signal generators were combined to form the composite beats when the number of measured beats was below 7. Amplifier distortion was used to generate beat combinations which were greater than 7. The test setup is shown in Fig. 4, Appendix A.

Curve 1 has $20 \log N$ slope and is shown for reference only. Curve 2 was plotted using the readings of the noise peaks measured on a spectrum analyzer in the log mode without the video filter. The analyzer used was a HP8554L/8552A. Curve 3 is the reading on a Jerrold 727 Signal Level

Meter; and curve 4 is the true rms reading mode with an HP 435A power meter.

Curve 5 was made with the spectrum analyzer in the linear mode and with the 100 Hz video averaging filter switched in. Curve 6 was made with the spectrum analyzer in the log mode and with the 100 Hz video averaging filter switched in.

One can see from the curves that the commonly used instruments can be calibrated to the power meter or to each other. The averaged readings on the spectrum analyzer parallel the power meter readings which would require a constant correction factor, whereas the signal level meter would require a variable correction factor depending on the number of channels.

Effects of modulation

The threshold of perceptibility of the composite triple beat on a TV receiver, based on subjective tests performed at RCA, was the same rms level for modulated carriers as it was for unmodulated carriers. The

Abstract: *This paper presents a set of curves which show the relative readings between a power meter, signal level meter and spectrum analyzer, when measuring the composite (summation) triple beat on a particular channel. The curves allow the CATV operator to obtain a correct measurement (rms) of composite triple*

beat for system performance when using common instruments such as the spectrum analyzer or signal level meter. A plot of a computer printout made at RCA is also given showing the total equivalent triple beats on the worst case channel versus the number of channels.

difference was that the output level of the amplifier could be increased approximately 5 dB when the carriers were modulated to obtain the same rms level for the composite triple beat.

The 5 dB change in level means that the modulation causes the average level to change 5 dB. This can be verified by calculating the average level of a modulated carrier, assuming that the distribution of gray level information is approximately uniform.

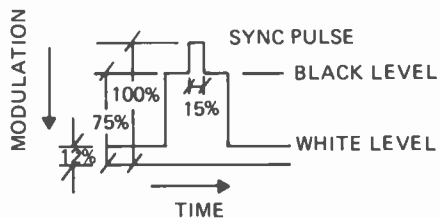

Block diagram of test setup.

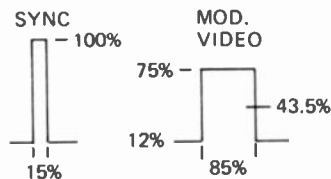

Modulated carrier waveform.

Total Average Level

$$\begin{aligned}
 &= \text{Average level in sync pulse} + \\
 &\quad \text{average level in modulated} \\
 &\quad \text{video} \\
 &= 100 \times .15 + \frac{(75 + 12)}{2} \times .85 \\
 &= 100 \times .15 + 43.5 \times .85 \\
 &= 51.98\% = 52\%
 \end{aligned}$$

The average level in a modulated carrier versus an unmodulated carrier is 52 percent or 5.6 dB from the peak carrier.

When measuring the composite triple beat with a power meter (true rms), the reference should be measured without modulation on the observed channel because the power meter will not measure the peak (which is the desired reference) with modulation.

Threshold of perceptibility

Figure 2 is a plot of two curves, Curve 1 being the required system level of an individual triple beat as a function of the total number of beats per channel. The measured points on Curve 1 were found by observing the threshold of perceptibility on a TV receiver of the total third order intermodulation (composite triple beat) on

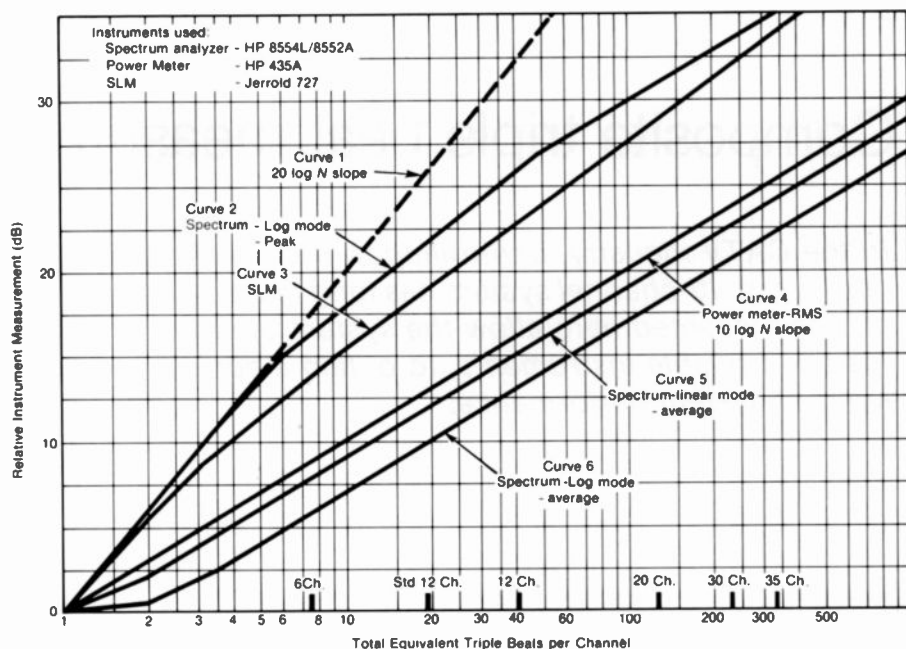

Fig. 1. Relative instrument measurement in dB vs total equivalent triple beat per channel (worst cast channel).

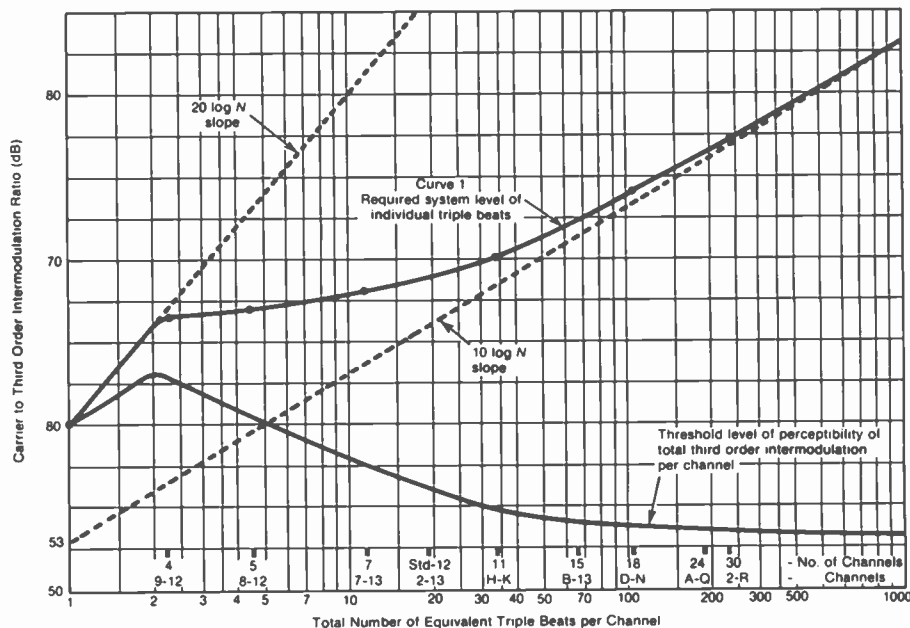

Fig. 2. Individual triple beat level & total third order intermodulation level vs total number of equivalent triple beats per channel.

one channel and then measuring the level of an individual triple beat.

Curve 2 is a plot of the threshold level of perceptibility of the total third order intermodulation (composite triple beat) per channel. Curve 2 was derived mathematically from Curve 1 by summing levels of the third order intermodulation products that fall on one channel and the curve was verified by measuring the composite triple beat with the power meter as indicated in this paper. A detailed analysis of Fig. 2 is given in a previous paper.¹

Number of triple beats

Figure 3 is a plot of a computer printout made at RCA showing the total equivalent triple beat on the worst case channel versus the number of channels. The worst case channel as shown in the computer run is the center channel in any group of channels. For this figure, channel 8 was used as the worst case channel and other channels were added evenly on each side of channel 8.

The lower curve was derived by adding channels, 6 MHz apart on each side of

channel 8. The discontinuity shown by the dotted lines is the point where the low band channels (2-6) were added, beginning with channel 6.

The upper curve began with the standard 12 channels adding the midband channels and then the superband channels.

Summary

The correction factor can be found from Fig. 1 for two common instruments used in CATV for measuring the composite triple beat.

The effect of modulation is to reduce the average level approximately 5 dB.

Figure 2 gives the threshold of perceptibility for third order intermodulation (triple beat) for a single triple beat and a composite triple beat.

Figure 3 gives total triple beat per channel versus the number of channels.

The curves in this paper give the CATV operator the tools to ensure that the system is within the output capabilities of the available equipment.

Reference

1. Arnold, B., "Required System Triple Beat Performance", RCA, North Hollywood, CA 91605 (1973).

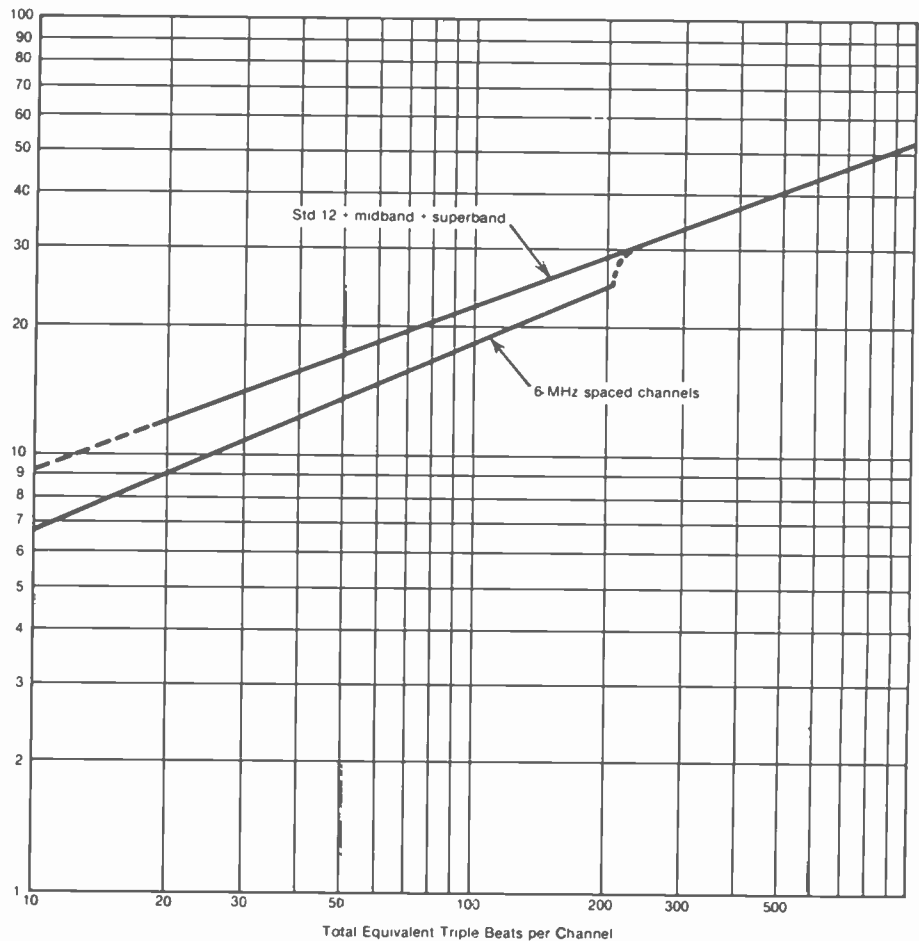
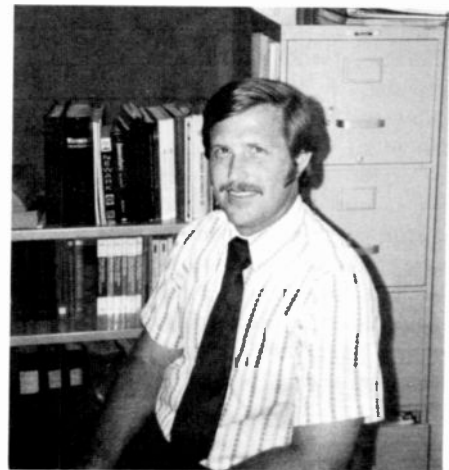

Fig. 3. Number of channels vs total equivalent triple beat per channel (worst case channel).

Appendix A

Table I. Test setup for triple beat measurement.

| Equipment | Manufacturer | Model |
|----------------------|-----------------|-------------|
| 30 ch. signal source | Theta Com | KTSS |
| Signal generators | Hewlett-Packard | 3200 |
| Attenuators | Texscan | SA-70 |
| Amplifier | TRW | 206 |
| Cascade | RCA | 150 |
| Filter | RCA | 150 |
| Filter | RCA | — |
| Signal level meters | Jerrold | 727 |
| Directional coupler | Dolphin | DC-10 |
| Power meter | Hewlett-Packard | 435A |
| Spectrum analyzer | Hewlett-Packard | 8554L/8552A |



Bert Arnold is Manager Distribution Systems, RCA, Cablevision Systems, North Hollywood, Calif. From 1961 to 1963, Bert worked as a broadcast engineer for KERO-TV in Bakersfield, California. His CATV experience includes three years with Anaconda Electronics and over ten years with RCA, CVS division. His present responsibilities include management of development of CATV distribution equipment and technical support for Marketing.

Contact him at:
Cablevision Systems
North Hollywood, Calif.
Ext. 208

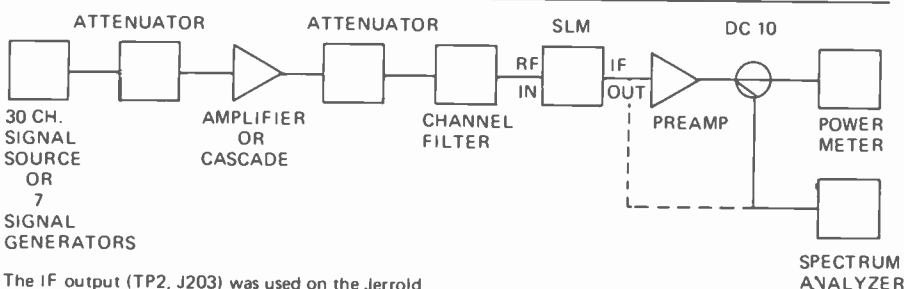

The IF output (TP2, J203) was used on the Jerrold 727 in order to provide selectivity for the power meter.

Test setup for triple beat measurement.

A new electromotional device

Polyvinylidene fluoride, PVF₂, a rugged and basically inexpensive piezoelectric polymer, is found to provide bimorph-type motion in a simple device with a great variety of future applications, all having unusual characteristics. Do you have any equipment requirements that such a device could fulfil?

Introduction

One major electronic device function is to convert electronic signals into mechanical motion. Devices that do this for example are: loudspeakers, motors, meters, and control solenoids. Most of these function on electromagnetic principles and contain inductances and structures of fairly substantial bulk compared to IC devices.

Inductances often cause circuit problems, such as uneven frequency response, build-up of relatively high voltages, and the requirement of energy-consuming currents.

Despite these disadvantages, there are few if any alternatives to the use of electromagnetic motion transducers if large physical force or high power is required. On the other hand, there are applications in electronics that do not require large force or power and could better be served with a more compact energy-conserving solid-state device.

The new device

Device action^{1,2} is based upon the excellent piezoelectric properties of PVF₂ (polyvinylidene fluoride) polymer film. This film is composed of long polymer molecular chains. Further processing with heat, pressure, and electrical fields causes the molecular chains to tend to become parallel to the film surface with a fairly

good degree of crystalline-like order. The molecules are then permanently polarized in the accordion-like structure shown in exaggerated scale in Fig. 1. During use a voltage is applied across the film via the metallized layers located on each side of the film. The resulting applied electric field inside the film either aids or bucks the electrical polarization already established in the film. The molecular chains respectively respond by either contracting or expanding slightly in length. Typically, ten volts applied across a 9 μ m-thick film causes it to expand or contract about 0.3 μ m for each centimeter of film length. Although very small, this displacement is sufficient for use in some commercial types of earphones and loudspeakers.

To amplify this small displacement to

larger values for other applications, the bimorph-type structure shown in Fig. 2 was adopted. This type of structure and its action is analogous to that in the bimetallic strip element widely used in thermostats. The device is built by cementing together two sheets of PVF₂ material of nominal 9 μ m thickness having the electrical polarization and connections arranged as noted in the figure. When a voltage V is applied to the device the internal electrical polarization is aided in one film layer and opposed in the other. The first film contracts in length and the other expands. This causes the bending motion indicated in the figure.

Ten volts applied across a 2-cm-long cantilever bimorph composed of two 9- μ m films causes a tip displacement ΔX of approximately 1 mm. Small displacements

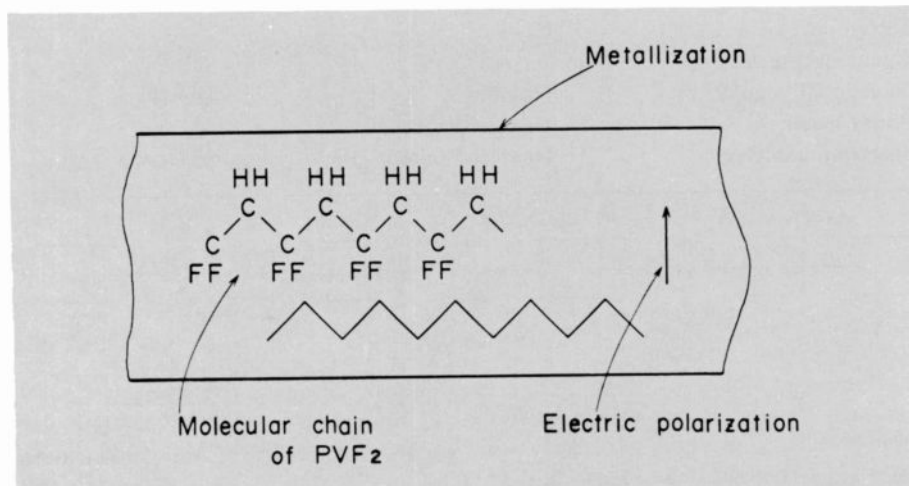

Fig. 1. Accordion-like molecular arrangement section of PVF₂ film. Greatly exaggerated scale.

Reprint RE-25-1-5
Final manuscript received Nov. 30, 1978.

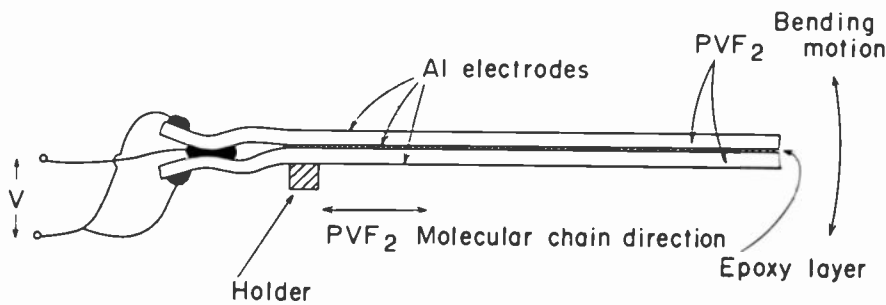

Fig. 2. Bimorph structure for amplifying electromechanical motion in PVF₂ films.

are linear with voltage and vary as the square of the cantilever length L and inversely as the square of the film thickness t . The radius of curvature R_0 of the cantilever varies inversely with V and directly with t^2 for both small and large tip displacements of the cantilever.

The generated tip force for such a device is 0.4 mg if the width w of the cantilever is 1 cm. To increase this force, multiple layer pairs can be used. Since the generated tip force increases as the square of the number N of layer-pairs, the force will be 10 mg if 5 layer-pairs are used. In general, the force varies directly as the film thickness t , the width w , the applied voltage V , and N^2 ; and inversely as the length L . Experiment and theory are in quite good agreement over a wide range of parameters.

The devices also show an inverse effect. If the cantilever is bent by an externally applied force, an output voltage is generated. Accordingly, the device can be used to sense mechanical movement or force. The output voltage varies directly as t^2 , the tip displacement ΔX , and inversely as L^2 . Typically, the output voltage is 60 mV for $t = 9 \mu\text{m}$, $\Delta X = 1 \text{ mm}$, and $L = 2 \text{ cm}$.

Temperature effects and life¹

Bimorph deflection sensitivity is relatively constant from -35°C to about 40°C . At lower temperatures deflection sensitivity falls off slowly with temperature. At temperatures above 40°C , the device starts to deform without any applied voltage. Only relatively minor changes in operating characteristics have been observed in preliminary life tests. The device seems relatively unaffected by moisture and humidity.

Applications

Piezoelectric bimorph devices are not new. However, previously available materials, PZT or quartz, for example, are rigid and brittle and cannot bend with a small radius of curvature. Furthermore, such materials are not convenient to handle in thin self-supporting films. The PVF₂ piezoelectric polymer is flexible, easily handled in thin films, and has good piezoelectric characteristics. Thus it seems to offer a whole new spectrum of applications denied

Abstract: This paper describes a method of utilizing the piezoelectric properties of polyvinylidene fluoride (PVF₂) to provide mechanical motion of sufficient magnitude (1) to generate volume air flow for ventilation; (2) to provide cantilever arm type voltage indication; and (3) to produce alphanumeric displays. Other applications are described. Bimorph characteristics such as sensitivity, temperature effects and life are given. The authors solicit reader suggestions for new applications.

older types of materials. A few possible applications are described below.

Ventilation fan

Analogy with the ancient hand fan ("uchiwa") suggests that a vibrating cantilever device (Fig. 3) might be useful in generating air flow. Anticipated advantages would be: light weight, low potential cost, small power consumption, elimination of maintenance, and possibility of use in unusual environments.

To demonstrate some of these, a vibrating 6-layer device 10-cm wide (w) and 1- to 9-cm in length (L) was driven at the cantilever mechanical resonance frequency f_0 ($\propto 1/L^2$) by a 150-volt ac square wave. Performance is shown in the curves of Fig. 4. For a 60-Hz driving frequency, mechanical resonance occurs when $L = 1.7 \text{ cm}$. The liters/second air flow rate was obtained from the wind beam cross-sectional area multiplied by the wind velocity. As seen in Fig. 4 this flow rate is notably quite independent of L and the corresponding resonant drive frequency. Analogy with

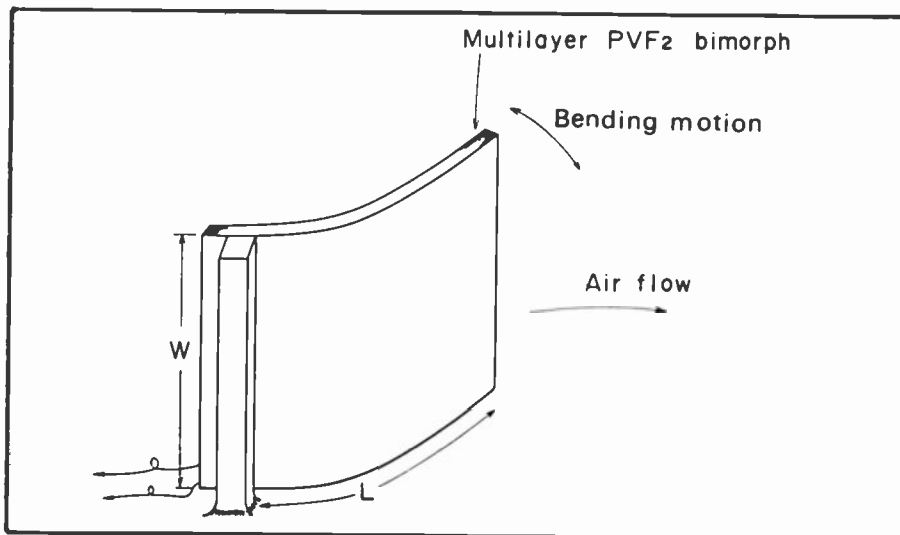

Fig. 3. Fan structure using PVF₂ bimorph.

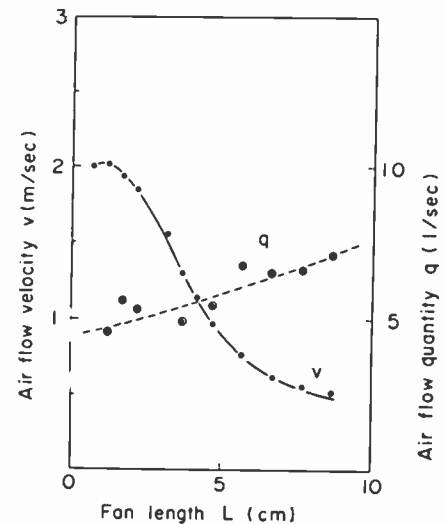

Fig. 4. Typical performance characteristics of PVF₂ fan.

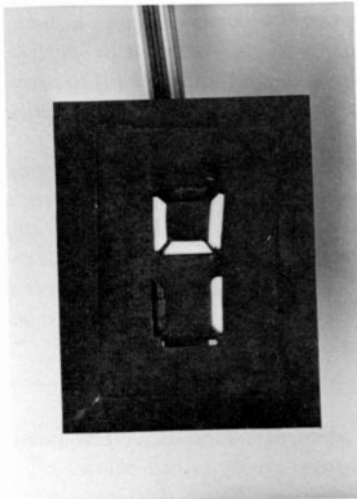

Fig. 5. Seven-segment slotted-mask display using PVF₂ bimorphs with white-colored tips.

conventional rotating fans suggested that the generated wind velocity should approximate the cantilever tip speed. Accordingly, the flow velocity should vary inversely as cantilever length L since the cantilever resonant frequency is inversely proportional to the square of the arm length L . Indeed, this tends to be the case as seen in Fig. 4. Detailed investigation of this novel vibrating fan shows that it is completely understandable in terms of an air-loaded elastic vibrator that drives air radially outwards by centrifugal force.³ The centrifugal aspects of the theory are similar to those involved in multi-blade centrifugal-type rotating fans.

Approximately 17 percent of the input electrical energy to a PVF₂ fan is converted into useful mechanical energy at atmospheric pressure. This efficiency performance is superior to that of very small-size

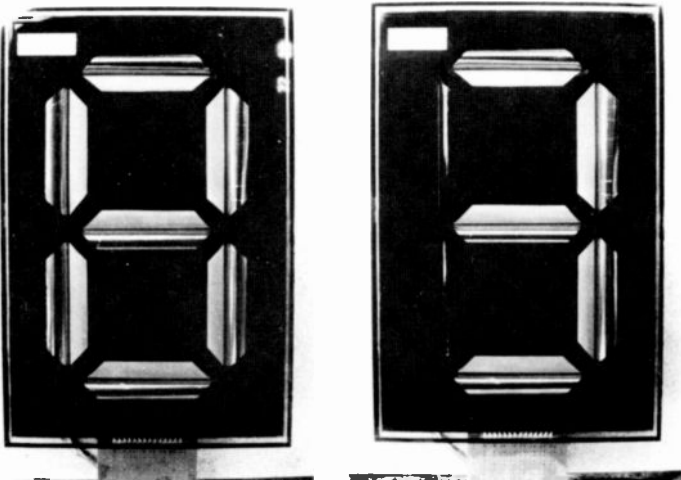

Fig. 6. Seven-segment large area display using PVF₂ bimorph elements with large amplitude mechanical displacements.

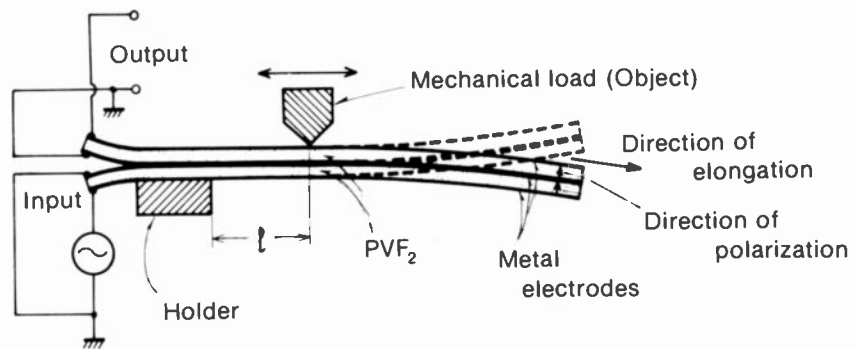

Fig. 7. Vibrating bimorph structure to detect adjacent objects and their relative position.

electric motor-driven fans. Most of the loss of input electric energy in the PVF₂ fan is caused by dielectric hysteresis.

To demonstrate that the air flows represented in Fig. 4 were of useful magnitude for equipment ventilation, two such fans, each 3.6 cm in length and 9.5 cm in width, and driven at 13 Hz, were mounted on opposite sides of the heat radiation panel in the cabinet of a piece of electronic equipment. The exit air was exhausted through a duct to prevent internal remixing. Before activating the fan the cabinet internal air temperature was 39°C, and that of the heat radiation panel, 66°C. After activation, these temperatures dropped to 34°C and 49°C, respectively.

Indicators and displays

An ability to convert an electric signal into mechanical motion with a low expenditure of energy, and with "plain-paper" viewability and format flexibility, suggests use for indicators and displays.⁴ The power consumption per square centimeter of

device area (9- μ m-thick layers) is about 10^{-9} watts when the applied dc voltage is 100 volts. For n square wave switching cycles per second the capacitive charging and discharging consumes $n \times 10^{-5}$ watts per cm² of bimorph device area with 9- μ m-thick material.

These features should make cantilever-arm type device use attractive for simple voltage indicators in equipment particularly where potentials are a few tens of volts or larger. In such applications the end of the cantilever would be colored to contrast with the area surrounding the bezel window through which the tip is viewed. Liberal use of such devices, in a radio transmitter for example, would allow critical voltages to be conveniently viewed without the need for costly conventional voltmeters, or the sometimes unsafe insertion of probe leads in the advent of servicing. Such indicators seem almost ideal for indicating the state of charge in electronic photoflash equipment.

Various alphanumeric-type displays have been demonstrated. In the seven-segment slotted-mask display (Fig. 5) the white-colored cantilever arm tips, about 3×15 mm² in area, came into view in a few tens of milliseconds when activated with 60 volts. In a novel large area display (Fig. 6) each segment was 4×10 cm² in area. Application of 120 volts causes each segment to flip over in about one-tenth second to either expose a characteristic color or one that merges with the surrounding areas.^{4,5}

Object sensor

One way to use PVF₂ devices for this purpose is to vibrate a bimorph cantilever structure with an ac voltage of low amplitude and frequency applied only to one layer (Fig. 7).⁶ A piezoelectrically generated voltage appears across the other layer. Its magnitude and frequency

Minoru Toda was engaged in the research of millimeter-wave circuit components at Shizuoka University from 1960 to 1962. He joined the RCA Research Laboratories, Inc., Tokyo, in 1962 as a Member of Technical Staff, and became a Manager of the Device Research Group in 1974, where he has been studying high-frequency phenomena of magnetoplasma in InSb, transport phenomena in ferromagnetic semiconductor chalcogenide spinels, surface acoustic wave devices and piezoelectric polymer devices. His present interest is device application of the piezoelectric polymer material.

Contact him at:
RCA Research Laboratories
 Tokyo, Japan

Susumu Osaka began working in the Technical Research Laboratories of the Japan Broadcasting Corporation (NHK) in 1964, where he was engaged in studies of spin re-orientation of RMO_3 . He joined the RCA Research Laboratories in Tokyo in 1970. Here he has been involved with optical absorption in ferromagnetic semiconductors, acoustic surface wave devices and, more recently, with piezoelectric polymer and PZT devices where his main activity has been with applications.

Contact him at:
RCA Research Laboratories
 Tokyo, Japan

Ed Johnson has been director of the RCA Research Laboratories in Tokyo since 1975. Previously, he was Manager of Technical Liaison for International Licensing. He has worked extensively in the fields of semiconductor devices, optoelectronics, and gas-discharge displays, and has received two RCA Outstanding Achievement awards for his research.

Contact him at:
RCA Research Laboratories, Inc.
 Tokyo, Japan

characteristics provide information on the presence and position of any object that interferes with the vibrations, either by direct or indirect contact. This device is simple and not easily damaged by objects



Authors **E. Johnson** (left), **S. Osaka** (center) and **M. Toda** (right).

that might strike the vibrating cantilever. The device seems particularly useful for detecting contact with very soft or light weight material such as paper or small particles.

A device 7.5 mm in length, 6 mm in width, with two 9- μm -thick layers generates an output signal of a few hundred millivolts when the frequency of the 18-volt driving signal was adjusted to the cantilever mechanical resonant frequency of 100 Hz.⁵ This output falls to about 100 mv depending upon where the object touches the cantilever. The point of contact can be sensed by the effect on the resonant frequency of the cantilever.

Conclusion

The PVF_2 piezoelectric polymer has unique electrical and mechanical properties useful for a new class of simple electromo-

tion devices with interesting promise for a variety of possible applications.

Reference

1. Toda, M., and Osaka, S., "Electromotional Device Using PVF₂ Multilayer Bimorph," *Trans. IECE Japan*, Vol. E61, No. 7, pp. 507-512 (1978).
2. Toda, M., "Design of Piezoelectric Polymer Motional Devices with Various Structures," *Trans. IECE Japan*, Vol. E61, No. 7, pp. 513-518 (1978).
3. Toda, M., "Theory of Airflow Generation by a Resonant-Type PVF₂ Bimorph Cantilever Vibrator," *Ferroelectrics*, Vol. 22 (1979, in press);
 Ioda, M., "High Field Dielectric Loss of PVF₂ and the Electromechanical Conversion Efficiency of a PVF₂ Fan," *Ferroelectrics*, Vol. 22 (1979, in press).
4. Toda, M., and Osaka, S., "Displays Using a Novel Piezoelectric Polymer Device Element," 1978 International Conference for Information Displays, San Francisco (April 18-20, 1978).
5. Ioda, M., and Osaka, S., "Application of PVF₂ Bimorph to Display Devices," *Proc. Conference of IECE Japan*, p. 346, Tokyo (March 1978).
6. Toda, M., "A PVF₂ Bimorph Device for Sensing the Presence and Position of Other Objects," *IEEE Trans. on Electron Devices*, Vol. ED-26, p. 815 (1979).

Automatic identification systems for operations control

A computerized system of coding and reading which can provide real-time control of production and materials handling.

Introduction

In recent decades, the broad disciplines of management and the knowledge and tools of human relations, work simplification, wage incentives, human engineering, value engineering and automation have met with varying degrees of success in enhancing productivity in manufacturing and distribution. We believe that in light of the maturity of known techniques, coupled with the growing sophistication of industry and the advent of cost-effective computer power, the tools will shift from classical work measurement and automation to information systems and scientific decision making.

Information resource and management control

Today management has become increasingly aware of its information resource through on-line computerized systems, improved new tools (such as materials requirements planning, MRP) and data base management. Four dimensions of this resource are significant: cost, accuracy, timeliness and the analytical conversion of data to information. The conventional transfer of data from a hard copy record to punched card and then to magnetic tape or disk is plagued with errors, delays and high cost. In addition, data base management has made the accuracy of multiple-use data critical because more than one user is affected by the incorrect information. A close examination of data processing

systems developed in the sixties confirms a belief that inaccuracy and considerable delay in data gathering often degraded the so-called management information systems to historical accounting systems. Several MRP system installations have failed because of inventory data inaccuracies.

Timeliness of data gathering is a vital element in providing information for management control and decision-making. Expanding the merits of operation feedback, Hill⁶ effectively states, "morning after production or shipping reports are historical not preventive... effective decision making is executed on the basis of events as or before they occur, not after... systems must provide discipline and controls based not only upon plans and performance goals, but also upon the dynamics of the actual operation."

Capturing of data is therefore important if management information systems are to yield their total value. The dramatic growth of automatic data gathering techniques using coded symbols has adequately begun to fulfill our requirements. Today, there is a growing application of automatic identification systems in manufacturing control.

Data gathering automation techniques

The data gathering needs of business can be enormous when it concerns a supplier, raw materials warehouse, production with all its states and departments, finished goods warehouse and distribution center, distributor and retailer. Consequently, the opportunity for automated data gathering is very significant. In addition, gathering of identical data by different segments of an

enterprise makes it imperative that product identification and data gathering systems be designed in the context of the total business system. Recognition of the information needs of the distributor and the retailer in the development of a data base for manufacturing operations control can be valuable because of the commonality in the data to be gathered and the information feedback required by the respective operations.

In view of the significance of data input methods, considerable advances have been made to meet the goals of economy, accuracy and timeliness. The techniques of magnetic ink character recognition (MICR), optical scanning of human readable information, mark sensing and on-line data gathering through terminals have produced dividends in data gathering efficiency. The advent of electronic speech recognition is making verbal data entry an economical possibility. A fast emerging new technique is that of bar coding and scanning where alphabetic characters and numeric digits are converted into an array of rectangular marks and spaces. Subsequently, a code scanner is used to read and identify the pattern of optically coded information. The Universal Product Code (UPC) symbol on grocery items is one example.

Abstract: *The current technology of automatic identification systems has been presented to provide a comprehensive basis for the design of such systems for operations control. The elements of the system, e.g., the code, scanner and system of controls, have been critically reviewed, along with a catalog of system applications.*

How automatic identification systems are used

Since 1967, when RCA demonstrated a laser scanner using the "bull's-eye" code at a Kroger store in Cincinnati, AIS has grown by leaps and bounds. The expanding acceptance of the Universal Product Code by the diverse American and foreign industries, has proved to be the greatest catalyst. "Rising from a relatively minor position as straightforward material handling control to near majority status as increasingly vital elements in a host of real-time information systems, automatic identification equipment can be found controlling machine tools, supporting piecework measurement, speeding up retail customer checkout, even in shoulder-slung use as a shelf inventory data collection tool."⁶ The diversity in applications is highlighted in the following:

Manufacturing control

At Levi Strauss in Little Rock, Ark., remote readers scan up to 9,000 cartons of men's slacks and tops received from ten different plants and shipped to customers throughout the country.¹⁴ Information gathered includes quantity, style, color and size.

RCA's plant in Marion, Ind., has achieved 100 percent accountability of finished products in color TV tubes.³ The remote scanners are engineered with split optics to read the bar-code labels on two stacked boxes.

A manufacturer of synthetic yarn¹⁴ employs 25 fixed-beam readers to monitor batches of yarn as they are moved by overhead conveyors, each carrying a license plate containing its number and sequential bar-code equivalent.

Production control

Scanners are used in a Volkswagen plant in West Germany to extend the lead time available for mating parts to automobile bodies at key points on the assembly line.¹⁴ Each body has its own number, and the conveyor hook it rides on carries a retroreflective label with its number. The computer stores the combination codes and tracks the location of the part for automobile bodies in an accumulator, waiting to be released to one of the assembly lines.

In a meat packing facility, a coded label identifies one of the hundreds of meat

products through all stages of production, storage and shipping, and provides real-time inventory control.¹⁴

At the Gillette Company in Andover, Mass., bar codes have been added by the carton manufacturer.¹⁴ The code is on the bottom of the case and is scanned from underneath (between conveyor rollers) by two readers at right angles to each other.

A pair of laser beam scanners alongside the automatic transmission line at GM's Buick Motor Div., Flint, Mich., identifies and keeps track of their production on a minute-to-minute basis.⁷

Product sorting

More scanners are used in this application than in any other for sortation of bar-coded products in manufacturing and distribution.

At the Chevrolet Motor Division, Buffalo, N.Y., randomly produced axles are sorted into batches on conveyors to be subsequently transferred to the shipping dock.¹²

The decision making systems department of American Cyanamid Company at Bound Brook, N.J., has developed a luminescent marking and reading system which permits printing an invisible code that does not interfere with package aesthetics.¹

An airlines baggage sortation system has been developed using bulls-eye coding.¹⁶

Warehousing & distribution

Zayre Corporation is reported to have designed an AIS for its five major distribution centers⁸ for identification of bar-coded cartons and contents for faster warehouse receiving and output at 203 discount department stores. Scanners on wheels are moved from conveyor to conveyor.

AIS is used widely in automated storage and retrieval systems. Typically, a crane has two parallel code readers, one for the base of the crane and the other for the shuttle carrier. The racks also carry license plates with retroreflective labels.

A cosmetic manufacturer uses a fixed-beam reader to monitor shipments for 50,000 specific customers at a rate of 16,000 per day. Shipping labels containing the bar code are generated on an impact printer.¹⁴

Inventory control

In a knitting mill, a preprinted bar-code label, indicating size, color and style, is

attached to each garment tag.¹⁴ After production, the labels are transferred from the tags to the garment boxes and remote scanners capture the information on magnetic tape. After the boxes are loaded onto a cart for transfer to the warehouse, inventory is updated by pen readers scanning the delivery merchandise.

In a replacement parts warehousing operation, in excess of 12,000 line items are reported to be processed daily and the material transported in 15,000 tote boxes with adjustable retroreflector code plates.¹⁴ Tote boxes are routed past 160 fixed-beam readers with associated diverters.

Many major retailers have coded their storage shelves and racks with product identification numbers. Stock replenishment requirements are recorded by using a wand which reads the shelf label and gathers the information on a cassette.

Automated inventory taking has proved popular with the advent of portable cassette recorders and wands.¹⁵

Transportation control

A commuter bar-code sticker valid for a fixed period and entitling the user to a reduced rate, is pasted to the side window of the car.¹⁴ At the toll booth, a remote scanner reads the label.

Terminal management systems have been designed at major rail and piggyback marshalling yards to incorporate computers, wheel sensors, weigh-in-motion scales and peripheral devices.¹³

The U.S. Postal Service took pioneering steps in 1968, by labeling postal vehicles and installing scanners at key facilities¹³. Subsequently, a model system of truck dispatch and routing control was installed for the network of bulk mail centers across the nation.

Scanners at marine terminal gates add dependability and speed to the collection of vessel arrivals and departures, and determine inventory of containers unloaded.¹³

In a hospital parking garage, scanners help control cash revenue, maintain precise records and keep track of parking space availability by reading the bar code stickers on automobile windows.¹⁴

Point-of-sale recording

Handheld code readers as well as fixed scanners are widely used in retail stores, particularly in grocery industry.^{18, 19, 21} The common codes being employed are UPC, OCR, Plessey and Codabar.

Circulating document & library control

A research hospital in Boston keeps track of X-ray folders using bar-codes and handheld wands.¹⁴

Barcoding of books has helped keeping track when they are charged out, returned or sent out for binding.

Automatic postage control

At Fingerhut Corp., St. Cloud, Minn., a computer-generated bar-code label is attached to each package.¹⁴ The label contains all the information needed to determine postage except weight. The package is scanned by a pen reader, and the data is stored in a computer memory. Subsequently, the package is conveyed to an automatic scale and the postage calculated by the computer.

What automatic identification systems consist of

The automatic identification manufacturers (AIM)* (see Table I) define AIS as "systems which combine machine-readable coding of goods-in-process for reading by strategically deployed code readers for purposes of accounting, tracking and movement control". The primary components of these systems include:

Product with an Identification. Examples are a tote box, an automotive axle, a crane, or a pack of chewing gum.

Code When applied to a product or made an integral part of it, can be read by a machine. Examples of codes are UPC, Bulls-eye, Plessey, etc.

Scanner. Reads the code and translates it into outputs acceptable to a control system. Examples are fixed beam or moving beam scanner, wands, etc.

System of Controls. Receives the information from scanners and actuates a device or reports (transmits) information. Examples are minicomputers, microprocessors, solenoids, relays, diverters, etc.

The secondary components of the

* Automatic identification manufacturers (AIM) have organized under the Material Handling Institute to publicize their expertise. Table I briefly outlines these manufacturers, their products and services, as presented by AIM. Several other manufacturers also offer technology in this field.

Table I. Manufacturers of automatic identification systems components (courtesy Materials Handling Institute).

A.B. Dick Co.
5700 W. Touhy Ave., Chicago, IL 60648
Bar code printers

Accu-Sort Systems, Inc.
601 Lawn Avenue, Sellersville, PA 18960
Management information and material management systems; interfaces, based on moving beam, fixed beam and pen scanners; self-contained logic to control machines for sortation; reflex, reflective and overhand scanners for material handling; bar code verifiers for packaging; scan all codes.

Apex Machine Co.
300 N. 12 Terrace, Ft. Lauderdale, Fla.
Bar code printers

Centronics Data Corp.
1 Wall St., Hudson, NH 03051
Bar code printers

Computer Identics
31 Dartmouth St., Westwood, MA 02090
Moving beam and handheld code readers; turnkey computer-based data collection systems for materials handling applications; production and inventory control.

Data Interface
4 W. Kenosha Ave., Danbury, CT 06810
Bar code printers

Datadyne Corp.
Valley Forge, PA 19481
Bar code printers

Dennison Mfg. Co.
300 Howard St., Framingham, MA 01701
Complete line of alpha/numeric/coded label generation, application, and verification systems for coded information identification.

Di/an Controls, Inc.
944 Dorchester Ave., Boston, MA 02125
Bar code printers

Electronics Corp. of America
1 Memorial Drive, Cambridge, MA 02142

Gould, Inc.
3631 Perkins Ave., Cleveland, OH 44114
Bar code printers

Identicon Corp.
1 Kenwood Circle, Franklin, MA 02038
Moving beam scanners; 2 of 5, Codabar, UPC codes; light pen (wand) systems, multiplexer option to support up to 16-pen station.

Markem Corp.
150 Congress St., Keene, NH 03431
Bar code printers accepting random, sequential or batch information; standard or custom bar coded labels.

Mekontrol, Inc.
56 Hudson St., Northboro, MA 01532
Fixed beam readers, incandescent and LED; code plates; retroreflective adjustable and fixed codes; code applicators, retroreflective materials; control systems.

Mohawkdata Sciences
3rd & Allendale Rd., King of Prussia, PA 19406
Bar code printers

Monarch Marking Systems, Inc.
P.O. Box 608, Dayton, OH 45401
Coding expertise; imprinting and applying equipment and related supplies; handheld and moving beam scanning product line.

3M Company
3M Center, St. Paul, MN 55101
Retroreflective tapes, liquids, chaulks, and sheets; automatic application equipment; parallel code readers and code plates.

Tally Corporation
8301 S. 180th St., Kent, WA 98031
Bar code printers

Versatec
10100 Bubb Rd., Cupertino, CA 95014
Bar code printers

Weber Marking Systems, Inc.
701 W. Algonquin Rd., Arlington Hts., IL 60005

Label printing equipment; in-plant shipment addressing, product identification and flow control labels; bar code labels; bar code printers.

system often include a printer, a verifier and an applicator for the coded label. AIM has published a glossary of terms pertaining to automatic identification technology which appears at the end of this paper.

Common codes and their characteristics

The push by manufacturers of automatic identification equipment has produced an explosion of codes, and the end is not in

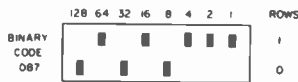

BINARY CODE - A code in which each bit has a weight of a power of two, according to its position.



DISTRIBUTION CODE (DC) - An eleven digit code compatible with the UPC.

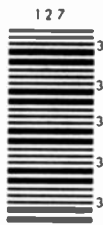

BINARY CODED DECIMAL (BCD) - a variation of the binary coding technique in which four bits are used to represent the digits 0 through 9.

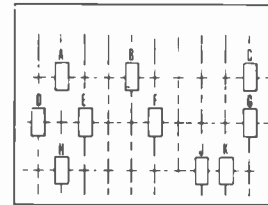

GEOMETRIC CODE - A code pattern which is based on the relative position of a code mark or marks in a grid of X-Y coordinates.

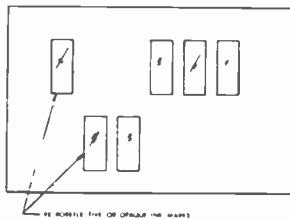

BI-LEVEL CODE - A coding technique in which data bits are presented in two parallel rows.



INTERLEAVED "TWO-OF-FIVE" CODE - A variation of the two-of-five code which uses space as well as bar-encodation.

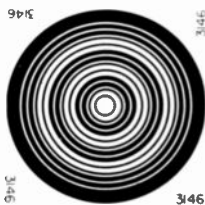

BULLSEYE CODE - An array of concentric rings and spaces in a pattern.

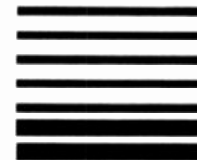

PERIODIC BINARY CODE - A binary format using the same amount of space for each bit — narrow bars being 0, and wide bars being 1.



CODABAR - A format in which 4 bars and 3 intervening light spaces are used to represent the digits 0-9 and certain alpha and special characters.



"THREE-OF-NINE" CODE - A code in which a combination of 3 out of 9 bits represent the digits 0-9, a 26 alpha character set, and special characters.



DECIMAL CODE - A format in which one uniquely shaped code bar represents one decimal digit.



"TWO-OF-FIVE" CODE - A code in which a combination of 2 bits out of 5 bits define the decimal digits 0-9.

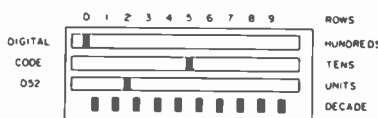

DIGITAL CODE - A direct decade code where each row represents a decimal digit encoded by the position of a code mark in each row.



UNIVERSAL PRODUCT CODE (UPC) - A ten digit bar code pattern adopted by U.S. grocery industry which identifies the product, (5 digits); and the manufacturer, (5 digits).

Fig. 1. A sampling of the many bar-codes produced by AIM for use in automatic identification systems. Selection of a proper code depends upon the several variables described.

AIS Glossary of Terms

bar code. Array of rectangular marks and spaces in a pre-determined pattern.

bit. Smallest code element which may possess information in either of two states.

bi directional code. A code format which permits reading in complementary directions.

calibration bars. A code bit(s) that provides the scanner with the contrast, speed, or code position information as required.

check digit. A calculated character included in a code which is used for error detection.

code. A mark or pattern of marks (bits) representing predetermined data.

code density. The number of code elements that can appear in a linear inch.

code label. A label which has been coded and is suitable for affixing to an article for code reading purposes.

code medium. The material used to construct a machine-readable code. Such materials may be retroreflective or opaque.

code medium gain. Value equal to the "background noise received" divided into the "code signal received."

code plate. A plate to which code marks are affixed in a fixed or adjustable code configuration or pattern.

code reader or scanner. A device used to read and identify a pattern of optically coded information.

clocking. A standard time reference against which code signal inputs are measured.

contact code reader or scanner. Requires contact with the code medium.

depth of field. The distance between the maximum and minimum plane in which the code can be read.

diffuse reflection. Reflection of lights from a surface where the reflection is scattered in all directions.

direct product coding. Where the code is marked or printed on the article.

edge error. Edge irregularities with respect to nominal bar edge.

expendable code. A code label which is disposed of after completion of designated use.

fixed beam code reader or scanner. A code reader using a stationary beam or beams to optically read and identify codes.

first read rate. The percentage of correct readings that will be obtained in one pass of a scanning device over a code.

gain. See "code medium gain."

handheld code reader or scanner. A pen-like, contact reader that is handheld.

horizontal bar code. A "picket fence" or horizontal array of vertical bars and spaces.

ink fill-in. Mark expansion beyond specified tolerances.

key mark or trigger. A code bit(s) that provides the scanner with the instruction that the code is in a position to be read.

lightpen. See "handheld code reader."

misalignment. Misorientation of the code from its "normal" position.

mis-read. When data at the device output does not agree with the coded data presented.

moving beam code reader or scanner. A code reader that dynamically searches for code marks by sweeping a moving optical beam through a field of view.

no-read. Absence of data at the device output due to no-code, defective code, or reader failure.

OCR. Optical character recognition.

omni-directional. Code format which can be read regardless of orientation on a given plane.

on-line coding. Creation and application of codes to the article in label form or directly on the article in process.

optical throw. The distance from the face of the code reader or scanner to the beginning of the depth field.

orientation bar(s). A code bar(s) that provides the scanner with start and stop reading instructions as well as code orientation.

parity marks(s) or bar(s). The addition

to a given code of one or more bits for purposes of code verification.

permanent code. A code which is reused in a system indefinitely.

pitch. Rotation about the X axis.

pre printed coding. Preparing a code in advance, either on a label or on the articles to be identified.

print contract. Comparison between mark reflectance and background reflectance.

resolution. The dimension of the smallest code element which can be identified by an optical scanner. Normally measured in thousandths of an inch.

retro. See "retroreflective."

retroreflective. Characteristic of material causing it to reflect light back to its source regardless of angle of incidence.

roll. See "pitch."

scanning curtain. A plane on the Y-Z axis in which the code can be read as defined by the scanning height and depth of field.

scanning height. With moving beam readers, the reading height in the Y axis. May vary through the depth of field.

scanning window. See "scanning beam readers."

skew. Rotation about the Y axis.

space encoding. The use of spaces between bars to carry encoded information.

specular reflection. Reflection of light from a surface at an equal but opposite angle to the angle of incidence.

start/stop bar(s). See "orientation bar(s)."

tilt. Rotation about the Z axis.

trigger mark. See "key mark."

unidirectional code. A code format which permits reading in one direction only.

vertical bar code. A "ladder-like" or vertical array of horizontal bars and spaces.

void(s). Missing ink coverage or white spots within bars.

wand. See "handheld code reader."

sight. Figure 1 presents some of the codes published by AIM. The Universal Product Code (UPC) has emerged as the standard for the U.S. grocery industry, with many other industries following suit. Table II lists the characteristics of three popular bar-codes — UPC, Codabar and Plessey — and compares bar-codes with optical character recognition. The breadth of spectrum can be appreciated by reviewing typical codes.

Binary Coded Digit (BCD) is a fundamental type of layout involving four fields — 1, 2, 4 and 8, where four bars represent one coded digit. The presence of a value in any of the four fields is designated by a wide line. The Arabic digit is obtained by adding these value bits. A revision in the above yields a 1, 2, 3, 7 BCD code in which only two wide bars are required to encode any value from 0 to 9. Use of octal numbers (0 to 7) changes the format to three bits per digit — 1, 2, and 4.

Two of Five is another variation of the BCD code. This uses five bits where two bits are always wide to represent a digit, rendering a high degree of reliability.

Decimal is a code in which a single horizontal or vertical bar represents one digit. The variation in the value is created by treating each half of the bar separately, removing from each half its right or left (upper or lower) portion, thus giving any one bar a shape unique to each digit from 0 to 9. This format is extremely compact.

Bulls-eye is a pattern consisting of concentric rings where the width of the rings may follow the BCD or 2 of 5 codes. The symbol is very large but it avoids all problems of orientation.

The *UPC* symbol consists of two sets of five digits each, separated by two tall center bars. The left series of five digits represents a number assigned to the manufacturer by the Distribution Number Bank, Washington, D.C. The five digits to the right of the center bars represent a number assigned by the manufacturer to the individual products. These ten digits uniquely identify item and do not include price. On both ends of the ten digit symbol other characters are included to facilitate and verify scanning. Normal UPC code uses a bidirectional scanning pattern.

The code system

The code system consists of three elements: the code media and content; methods of code generation; and means of application.

Code media (or substrates)

Code media have the intrinsic property of causing a difference in light intensity and a scanner senses variations in the reflectance of light from different surfaces. The amount of reflectance is determined by the principle that a black surface absorbs light and a white surface reflects it. Alternatives for causing differences in light intensities are to apply black opaque ink to a substrate or to a retroreflective material. Contrast is obtained by the ink absorbing the light and the white substrate reflecting or diffusing the light. The different substrates or background materials are discussed in the following.

Carrier Surface. One of the least expensive backing materials for the code mark is the carton used for packing products but there are many situations where it is not feasible.

The second type of background is paper. Three types of label paper are available. The white pressure-sensitive label is the most widely used. Normally, it is matte finished and has latex-impregnation for water resistance. Ultraviolet brightener is sometimes used to enhance the reflectivity of the background. A variety of adhesives are available which do not leave any deposit on the surface upon removal of the label. It's a sophisticated version of water activated paper with animal glue or other adhesive. The third type is retroreflective which carries a pressure-sensitive adhesive. It produces great reflectivity because the light from a scanner is reflected back into the scanner by small glass beads. This considerably enhances the depth of field of the scanner and permits some angularity of the product to the scanner. This material is expensive, costing \$8 to \$10 per thousand square inches, obviously it is warranted only when the application of the environment demands its use for permanent labels.

Label Type. There are three basic categories of labels used as background material for codes. The first category, permanent labels, assigns a coded label to a fixed carrier or storage unit and gets reused. Examples of such labels are vinyl, vinyl laminated with a clear mylar, retroreflective labels or tapes and ceramic tags. The second category—a reusable label, is a temporary assignment of a code to an item and the code is reassigned. The third category—an adjustable label, is a device attached to the side of a tote box which can be manually adjusted to indicate a certain code. The requirements of ruggedness and durability make this alternative expensive.

Code generation

Codes in a label form can be generated in a batch, sequential or random mode. These can also be preprinted by the corrugation or package supplier.

Batch. This is applicable where large quantities of the same coded label are required and generally produced ahead of requirement. Inexpensive offset printing devices are often used.

Sequential. The codes are consecutively numbered. These are commonly used for identical products that require individual identity. Resetting of printing elements for the codes can be achieved mechanically, electrically or by computer command.

Random. In this mode, the printing code format is independent of previous prints. The manual generation of random labels is relatively expensive. A computer-printed label is an economical solution if volume warrants it.

Printing and application

The design of the code, its chosen format, materials to be used for the background and mark, the mode of generation, are all optimized to give the least expensive and most reliable mark possible within the limits of the scanner. Provided these parameters are integrated properly, it is now up to the printing process to establish the quality mark necessary for assured system reliability¹⁰.

Methods of printing labels are: letterpress, flexographic, silk screen, gravure and dry ink transfer. The three basic approaches to code inprinting²⁰ are: on-line printing (part of the production process), off-line printing (preprinting at a non-production process location) and computer-line printers (either on or off-line). For reliable scanning, the marking medium should possess the property of absorbing as much light as possible in order to give little reflectance and provide a contrast with the background. Liquid inks of various kinds are used for this purpose. Finally, the application of labels can be manual or with a labeling machine.

Scanners

Three basic types of scanners are available: fixed beam or horizontal scan reader, moving beam or vertical scan reader and hand-held scanner.

Table II. Characteristics of the Codabar, Plessey and UPC bar-codes, and how they compare with optical character recognition devices. (Reproduced by courtesy of MSI Data Corp.).

A. Bar Codes

| <i>Characteristic</i> | <i>Codabar</i> | <i>Plessey</i> | <i>UPC</i> |
|-----------------------------|--|--|---|
| Possible printing methods | Press impact | Press | Press |
| Print quality tolerance | | | |
| Edge irregularity | Good | Good | Good |
| Ink growth | Excellent | Fair | Good |
| Intercharacter gap | Excellent | Poor | Poor |
| Acceleration tolerance | Excellent | Excellent | Good |
| Character error security | Excellent | Fair | Poor |
| Redundancy factor | 6:1 | 1.6:1 | 1:1 debatable |
| Character set | 16 data 4 start/stop | 10 data | 10 data |
| Illumination source | Infrared led | Infrared led | Helium-neon laser |
| Error detect scheme | Inherent | Check digit | Check digit |
| Independent fields | Yes | No | No |
| Nominal density, char/in | 10 | 6 | 10 |
| Graphics rejection | Excellent | Poor | Poor |
| Reader cost | Low | Low | High |
| Support equipment available | Complete spectrum of high/ low cost/performance printers and readers. Cash register wand. | Source or low speed printers. Portable wand only. | Source or low speed printers. Slot scanner. Wand reader. |

B. OCR vs Bar Codes

| <i>Characteristic</i> | <i>OCR—A (NRMA)</i> | <i>OCR—B</i> | <i>Bar Code</i> |
|---------------------------------------|---------------------|--------------|-----------------|
| Reader cost | High | High | Low |
| Character error security | Fair | Poor | Good |
| Print quality tolerance | Fair | Poor | Good |
| Human readable | Yes | Yes | No |
| Character set | 26 | 24 | 10-20 |
| Density (including human readable) | High | High | Low |

Fixed beam scanners

These scanners were the first and simplest. Using a fixed photocell, the area to be scanned is flooded with light from incandescent lamps or light emitting diodes, and the code is read. Of the two basic types, reflective readers have their light sources separated from the sensor, as shown in Fig. 2a. These are limited to code surface materials using opaque inks on a diffuse background. Retroreflective materials can't be used because the reflectance path is not directed back into the photo-sensor. In the case of reflex readers, the light source, the photo-sensor and the optics are integrated as shown in Fig. 2b. In the coaxial reader, as shown in Fig. 2c, the photosen-

sor is aligned so that it can receive reflection directly from the code.

Pros: Relatively inexpensive.

Cons: Depth of field is limited to 3 to 6 inches \pm one inch or less.

Moving beam scanners

These scanners incorporate a very narrow concentrated beam which sweeps through the vertical field at rates of 180-600 times per second. Consequently, the reader performs multiple scans of a code. A 360-scanner-second reader will look at a one-inch wide code 18 times as it passes on a conveyor at 100 feet per minute. The light source is usually a helium-neon laser or incandescent light source.

Most manufacturers insist upon a code which permits several scans, at least three or four before the code is validated.

Pros:(1) A code design can usually accommodate a wide variation in code alignment and orientation. (2) Most combinations of light background and dark code patterns can be read. (3) Codes printed on various backgrounds, from corrugated to retroreflective paper stock, can be scanned.

Con: Expensive

Hand held scanners

These scanners resemble a pen or wand that is stroked across the code. Its typical

application is for products which do not have a fixed path to follow, and the size of the code is very small. The scanner has to be moved at a prescribed rate (about 3 to 13 in./sec.) and it usually provides an audible signal to indicate a valid scan.

Pros: (1) Scans products which do not have a fixed path. (2) Reads codes of small size.

Cons: (1) Slow-speed scanner. (2) Requires precision in stroking.

Control systems

Control systems for AIS can range from very simple electromechanical devices to complex computer systems. Product sortation, for instance, can be achieved with electromechanical controls. Automation of production data gathering can be accomplished by integrating a magnetic tape unit with a scanner and interface. Microprocessor-based systems generate bar-coded labels with keyboard data entry. The usage of a computer to integrate scanning and code generation provides the maximum possibilities for operation control.

Considerations in the design of automatic identification systems

The recent proliferation of automatic identification equipment and systems has tended to confound the prospective designers and users of the system. In addition, considering the pervasive impact of such systems on various segments of manufacturing and distribution operations, it is imperative that a systematic approach be taken in its design and development.

The primary variables in the design of an automatic identification system are the product, the desired information characteristics and the nature of the product movement. The critical elements in the design procedure are to recognize the dynamic inter-relationships between the code and the scanner (Fig. 3), and the three-dimensional objectives of cost, benefit and reliability. The proper integration and compatibility of code, scanner and code printing (if required) may require several iterations in the design and selection process. Selection of codes and scanners requires a comprehensive evaluation of various factors, some of which are highlighted as follows:

Code design parameters

1. Information to be coded.
2. Code to be directly printed on product or applied as a label.
3. Space available on product for coding, product-shape and product surface characteristics.
4. Permanent or expendable code.
5. Speed of product movement.
6. Orientation of product movement, random, uni-directional and fixed path, or bidirectional and fixed path.
7. Need for built-in error detection.
8. Background color in case of code directly printed on product.
9. Depth of field.
10. Environment — humidity, dust, grease, etc.
11. Requirement for human-readable information.
12. Printing constraints — minimum bar thickness.
13. Scanning constraints.
14. Reliability standards.
15. Cost.

Scanner selection parameters

1. Type of code — ladder type, bulls-eye, etc.
2. Size of code.
3. Code media — paper or retroreflective.
4. Product speed.
5. Product orientation — fixed or random.
6. Product movement pattern — fixed (conveyor) or non-fixed, depth of field, skew, tilt, pitch, scan height and variation in code alignment and orientation.
7. Other operating characteristics.
8. Code constraints — code density, color, background, medium, medium gain.
9. Ambient light distraction.
10. Code printing constraint.
11. Code application constraint.
12. Environment — humidity, dust, grease, etc.
13. Reliability standards.
14. Cost.

Benefits from AIS in operations control

The beneficial impact of an automatic identification system is all pervasive in a manufacturing and distribution environment. Some of the expected benefits can be listed as follows:

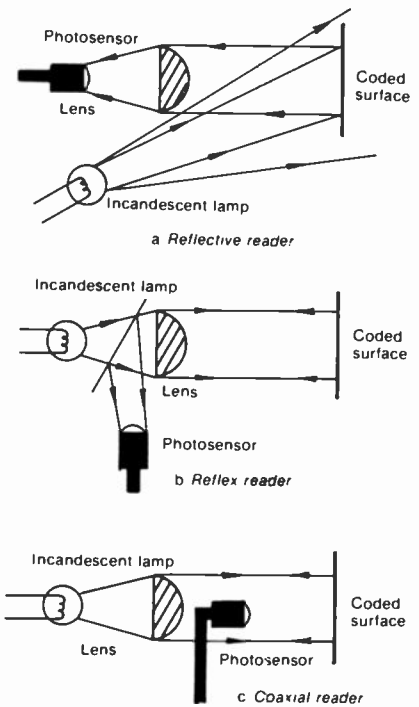

Fig. 2. Relative positions of coded surface, photosensor, and incandescent lamp for (a) reflective reader, (b) reflex reader, and (c) coaxial reader.

1. This form of automation of data gathering reduces data processing cost and significantly improves timeliness and accuracy of data acquired.
2. Management control and decision making are considerably enhanced because timely and adequate information is available from desired stages of production and distribution. Additional tracking mechanisms can be economically justified because of low costs of data gathering.
3. Reduction in data gathering cycle results in lower inventory levels of materials — raw, work-in-process and finished goods.
4. Utilization of plant resources is enhanced by improved operations scheduling derived from timely production feedback.
5. It enables the automation of material handling and quality control in the areas of product sortation, storage, retrieval and physical inventory taking.
6. Automated (computerized) printing and application of bar-coded stickers required for product identification reduces costs of identifying a product.

The emerging revolution

The various installations of AIS illustrate the tremendous economic benefits, but the total potential has yet to be exploited.

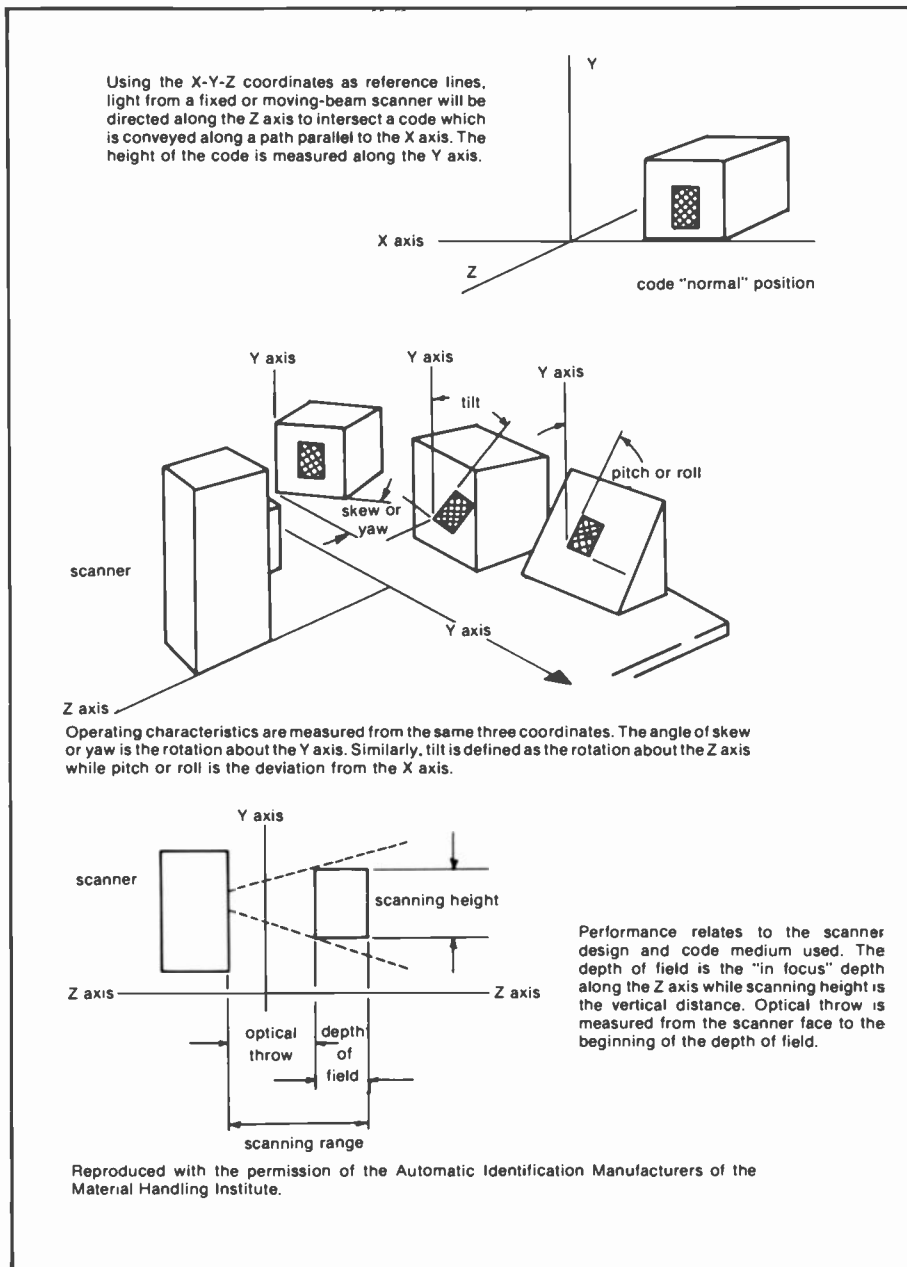

Fig. 3. Parameters for specifying operating characteristics for various positions of code and scanner.

Some of the pertinent developments are outlined below:

1. Impact of the timely and accurate visibility of information has been realized only superficially so far. The true awareness will be mind-boggling when management begins to take preventive actions rather than retroactive ones. The reduction in cost associated with false decisions based on obsolete data collection methods may justify implementation of automatic identification systems¹⁰.
2. The traditional MIS responsibility of data gathering has shifted to the

departments generating the data. Accuracy and timeliness of data entry have rightly become greater concerns for the manufacturing and warehousing personnel. The change is welcome, provided technical expertise in the realm of automated identification systems is cultivated among the users.

3. AIS was pioneered by material handling experts rather than by MIS. The result enhanced the skills of material handling, production and warehousing personnel. Industrial personnel are enriching their jobs in the process and entering the information systems age. Design of these systems, primarily by users, has made

them relevant, cost-effective and quickly acceptable.

4. Economical data gathering at different stages of production will enhance scheduling, quality control decisions and physical accounting of work in process.
5. Appreciable growth of on-line systems can be foreseen with AIS making data gathering economical and error-free.

Conclusion

It has been said that nothing is so irresistible as an idea whose time has come. No amount of opposition will succeed in mitigating the effects of such ideas, and to resist them is folly. Such is the probable case with the automatic identification system. However, it is an idea which has yet to spread through the entire fabric of all product (and some services) distribution, from manufacturing through retailing. This paper has attempted to provide a comprehensive background for prospective builders of such systems.

Acknowledgment

This paper is dedicated to Jim Parker, manager of production control, for his vision and courage to allow engineering to develop an automatic identification system, and to Peggy Frymire, senior industrial engineer, for her ability to develop the system.

Bibliography

1. Bowlen, R.W., "Random Input Printing of Scanning Marks," *Automation*, (Aug 1972), pp. 51-55.
2. Burke, M., "Shipping Containers Get A Code Of Their Own," *Material Handling Engineering*, (Feb 1976), pp. 53-55.
3. "Because Reliable Sorting Is A Must," *Modern Materials Handling*, (Oct 1974).
4. "Coding Applications Expand With New Optical Scanning Systems," *Purchasing*, (Jun 3, 1975), pp. 72-75.
5. "Eyes For Train Will Instantly Find Any Freight Car In America," *Modern Materials Handling*, (Dec 1967), p. 3.
6. "For Incoming Materials Flow: A Quantum Jump In Control," *Modern Materials Handling*, (Mar 1976), pp. 40-44.
7. Hill, J.M., "How To Read A Label That's Moving 17 M.P.H.," *Material Handling Engineering*, (1972 Special Issue), pp. 40-44.
8. "Laser Beam Scans Mini-Labels On Packages," *Modern Materials Handling*, (Mar 1970), pp. 50-52.
9. "No Alignment Problems In This Sorting System," *Modern Materials Handling*, (Jan 1974), p. 57.
10. "Optical Scanner and Computer Keep Accurate Figures," *Material Handling Engineering*, (Feb 1972), pp. 58-59.
11. "Push Button Coding Without An Operator," *Modern Materials Handling*, (Feb 1973), p. 71.

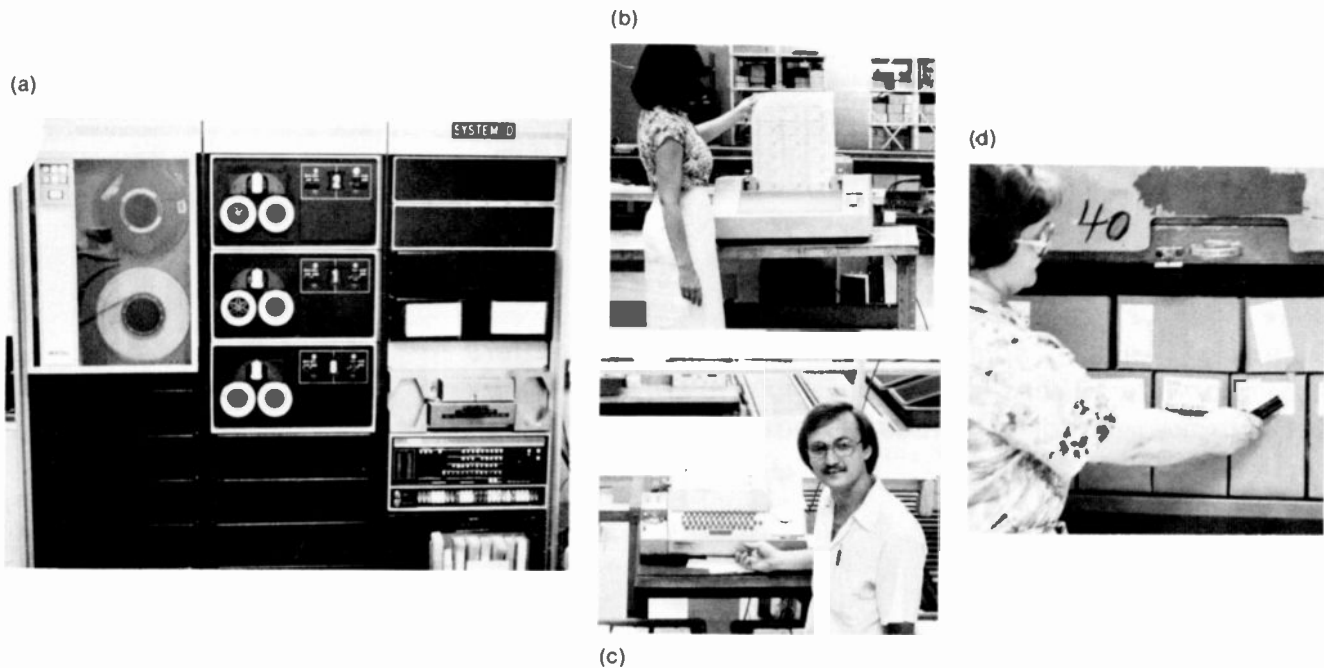

A typical automatic identification system: (a) minicomputer system, (b) bar code sticker printer, (c) terminal to activate sticker printer, (d) hand-held scanning of the finished product.

12. Revesz, G., "Coding: Key to Handling Control," *Automation*, (Feb 1970), pp. 51-56.
13. Scallen, R.P., "Labeling — Key To Remote Optical Scanning," *Automation*, (Jul 1971), pp. 42-46.
14. Stein, P., "What's A UPC?," *Computer Decisions*, (Aug 1975), p. 18.
15. "The Coming Battle At The Supermarket Counter," *Fortune*, (Sep 1975), pp. 105-182.
16. "The Supermarket Scanner That Failed," *Business Week*, (Mar 22, 1976).
17. "Universal Product Code, What Is It?," Published By Paperboard Packaging, 777 Third Ave., N.Y., NY 10017.
18. "What Hand-held Scanners Can Do For Automatic Data Gathering," *Modern Materials Handling*, (Oct 1975), pp. 73-74.
19. "What's The Best Way To Print Coded Labels," *Material Handling Engineering*, (Special Issue, Fall 1974), pp. 39-42.
20. Wilcox, R.S., "Coding Products With Retroreflective Materials," *Automation*, (Feb 1965), pp. 69-72.
21. Wurz, A., "Automatic Identification: A New Code Symbol For Shipping Containers," *Material Handling Engineering*, (Special Issue, Fall 1975), pp. 26-28.
22. Material Handling Institute, The Engineering Impact of Automatic Identification Systems on Material Handling. A report prepared by the A.I.M., (May 1974).
6. Hill, J.M., "Computer Based Code Reading Systems For Materials Management," *Proceedings of the NC/PDM Conference*, (Oct 1976), pp. 359-375.
7. "How Lasers Keep Tabs On Buick's Production," *Modern Materials Handling*, (Nov 1971), pp. 63-65.
8. "Keeping An Eye On Distribution With Mobile Scanners," *Modern Materials Handling*, (Jan 1972), pp. 56-58.
9. "Low Cost Code Reading," *Modern Materials Handling*, (Nov 1970), pp. 44-47.
10. Moodie, C.I. and Deisenroth, M.P., "An Introduction To Automatic Identification Systems In An Industrial Discrete-Part Manufacturing Environment." An unpublished teaching module being prepared under NSF sponsorship.
11. "New Dimensions In Code Reading High-Speed Optical Scanners," *Modern Materials Handling*, (Oct 1972), pp. 50-55.
12. "Scanner Sets Up Computer Conveyorized Sorting," *Modern Materials Handling*, (Nov 1975).
13. Technical Literature Provided By Computer Identities Corp., 31 Dartmouth Street, Westwood, MA 02090.
14. Technical Literature Provided by Identicon Corp., One Kenwood Circle, Franklin, MA 02038.
15. Technical Literature Provided By MSI Data Corp., 340 Fischer Ave., Costa Mesa, CA 92627.
16. "UPC Bar Code Printer," Industrial Tape Division, 3M Company, 3M Center, St. Paul MI 55101.
17. The Identicon Reader. (Winter 1973), Published by Identicon Corporation.
18. "Universal Product Code Carries A Message Of Price Reduction," *Material Handling Engineering*, (Oct 1972), pp. 55-59.
19. Walsh, D.C., "I.E.'s In The Supermarket," *Industrial Engineering*, (Feb 1976), pp. 14-19.
20. "What's The Best Way To Print Coded Labels," *Material Handling Engineering*, (Special Issue), (Fall 1974), pp. 39-42.
21. "When Product Codes Work," *Business Week*, (Feb 23, 1976).

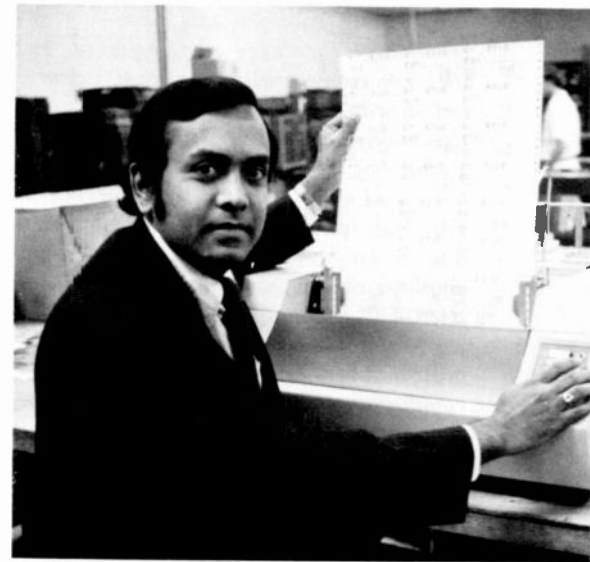

Dave Mishra is Manager, Engineering & Operations Services, RCA Records, Indianapolis. Upon the completion of his M.S. in Industrial Engineering and Operations Research at Purdue University in 1968, he joined RCA as an Industrial Engineer. Currently, he is responsible for the total Record Division Engineering and Plant Maintenance. His numerous technical publications have covered areas of scientific inventory management, manufacturing and warehousing productivity, automated data gathering, and manufacturing facility design.

Contact him at:
RCA Records
Indianapolis, Ind.
Ext. 6485

Quantum advances in television transmitter technology

RCA's new "G-line" of solid-state VHF television transmitters employs only two tubes, one visual and one aural, and they meet worldwide color broadcast standards.

Abstract: *Recent developments in component technology have been incorporated into a series of television transmitters featuring unusually high standards of performance, reliability and maintainability. The inter-relationship of these new components and their utilization in both classic and new circuit configurations is described. This paper covers a family of high-gain VHF tetrodes developed specifically for television broadcast service; the application of "heat pipe" technology in high-power solid-state amplifier cooling; developments in microstrip components for paralleling solid-state power amplifiers; surface acoustic wave filtering combined with new equalization circuit techniques; and the use of active broadband incidental phase correction in a low-level IF-modulated system. Various automatic features are also described which contribute to operator safety and on-air reliability of the transmitter.*

The design of a television transmitter is of necessity limited by the device technology available at the time of design. Moreover, it is difficult to utilize improved devices as they become available without extensive rework. Eventually, however, a complete redesign can be justified by predictable advances in operating economy, performance, reliability and maintainability. These are the results of this major new design program at RCA, truly a benchmark in television transmitter development.

Systems design

A new line of VHF transmitters, designed for the international market, has been introduced by RCA. It covers most power ranges with only one vacuum tube in the visual transmitter and one in the aural transmitter. The models presently available range from 10-kW to 30-kW visual rating, depending on the transmission system bandwidth. However, dual transmitters, with two units in parallel, can operate at power levels of 60-kW visual and 13.2-kW aural power output. Specific versions have been designed for CCIR systems B, M, D and K, for both Bands I and III. All of these units employ low level modulation and significantly improved surface acoustic wave (SAW) sideband filtering techniques. In addition, the systems include fully synthesized frequency generation including upconversion.

The driver system employs solid-state broadband amplification using transistors specifically developed for television signal amplification. The totally solid-state driver chain eliminates the need for tuned linear amplifier drivers and develops 1600 watts (peak of sync) drive for the power amplifier. Improvements in high-power VHF vacuum-tube technology have also been applied. The transmitters include an entirely new series of RCA Cermalox tetrodes and, when coupled with the all solid-state driver advances, result in state-of-the-art performance in television transmitters by achieving the maximum power outputs with single-tube designs.

The new TTG transmitter configuration

consists of three compact cabinets: a solid-state exciter/driver, power amplifier, and power supply/control.

Exciter/driver

The solid-state exciter is a self contained unit providing a conventional amplitude-modulated visual signal and frequency-modulated aural signal with outputs on the final transmission frequencies. The exciter operates at visual IF frequencies of 45.75 MHz for System M, and 38.9 MHz for Systems B,D and K. The aural IF frequencies are 41.25 MHz for System M, 33.4 MHz for System B, and 32.4 MHz for Systems D and K. A feedback control circuit maintains constant peak-of-sync output power and provides a single control for power adjustment.

Exciter/modulator

The exciter-modulator assembly consists of the aural IF exciter, visual modulator, local oscillator (LO) generator, precision oscillator, and visual synthesizer. The aural exciter (which is mechanically isolated) generates a frequency-modulated IF signal which is phase-locked to a stable reference oscillator. SCA input capabilities are provided. The synthesizer reference oscillator is a 10.0-MHz unit. A temperature-controlled crystal oscillator is standard, with the option of a proportional oven-

Reprint RE-25-1-7
Final manuscript received Feb. 12, 1979.

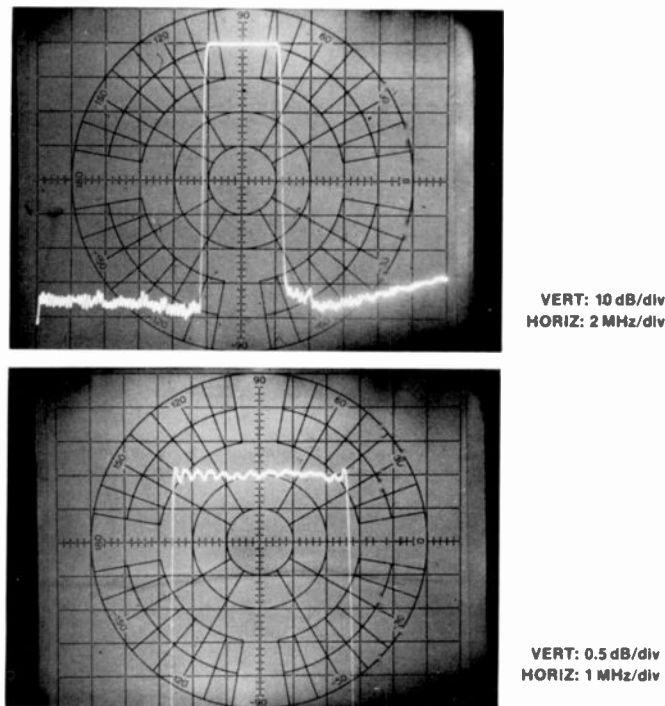

Fig. 1. Surface acoustic wave (SAW) filter performance data for CCIR System M.

controlled frequency standard for precise frequency control (PFC). No other crystal oscillators are required in the exciter. Visual IF voltage-controlled oscillators (VCO) of 45.75 and 38.9 MHz are phase-locked to the reference standard as are the visual frequency VCOs for Bands I and III.

The visual LO synthesizer provides programmable operation and closed-loop control of frequency and phase. The field effect transistor (FET) oscillator is buffered and divided by a high-speed divide-by-N circuit, set to produce an output signal at the 10-kHz phase-comparison frequency. The 10-MHz crystal oscillator is divided by 1000 to provide the stable reference input to the phase detector. The loop bandwidth and related loop filter design are selected to allow loop correction of low-frequency phase perturbations while highly attenuating the 10-kHz reference frequency. This results in a highly stable local oscillator signal for upconversion of the modulated IF to the output channel.

The amplitude-modulated IF signal is applied to the advanced SAW filter. The SAW filter for System M exhibits a band-pass frequency response, ripple variation, rapid delay excursions and skirt rejection specifications which surpass previous SAW vestigial sideband filter units (Fig. 1). Additionally, while temperature control for SAW filter designs is not always necessary to maintain transmitter system specifications, a proportional-controlled

chassis enclosure was designed to house the SAW plug-in module. This subassembly overcomes the normal temperature coefficient of the substrate material, maintaining the maximum possible level of performance.

Video circuitry

The video assembly includes the video input, video clamp, passive delay equalizers, differential phase corrector, and transversal equalizer (TE) sub-systems as required. Since the SAW filter, wide-band RF exciter circuits, and high power solid-state amplifiers are phase linear, no group delay correction is required. The last subsystem of the video assembly, the TE, corrects for waveform distortions (echoes) that may occur in certain SAW filter designs. This is accomplished by predistorting the video signal with appropriate polarity echoes of the same relative timing and magnitude as those present in the SAW filter.

RF processing

The RF processing assembly consists of a linearity corrector, incidental phase corrector, power control circuitry, visual/aural output mixers, and driver control sub-systems. The signal from the SAW filter is applied to the IF differential gain correc-

tors. Additionally, shaped phase-modulation correction is incorporated at the LO. The local oscillator signal is phase modulated by an adjustable, shaped video signal to compensate for incidental phase variation in the output amplifier stages. The incidental phase corrector comprises an IF video detector, video shaper and hybrid coupler phase modulator. The video shaper portion of the circuitry provides for both compression and expansion of any portion of the detected video signal. This feature allows accurate compensation for the phase vs amplitude characteristic of both the solid-state driver and vacuum-tube linear amplifiers. The broadband hybrid phase modulator provides precise phase correction of the LO signal without introducing amplitude modulation effects. Feedback circuits within the control subsystems provide for excellent output power stability over temperature and line variations. The IF signal is then routed to the output double-balanced mixer and converted to final carrier frequency.

Solid-state driver

A new and unique series of Band I and Band III solid-state drivers provides the peak-or-sync visual and CW aural power levels required to support a complete family of transmitters. Maximum use is made of the latest developments in ultra linear broadband TV amplifiers, wideband power combiners, modular packaging approaches, and advanced cooling techniques. The result is a highly reliable solid-state driver. The system (Fig. 2) employs a minimum number of output amplifier modules and combiners to achieve rated peak-of-sync power. This is made possible by the use of bipolar transistors and FET devices capable of producing the highest linear output power available today. The simplified combining tree utilizes only eight output amplifiers for Band I and twelve output amplifiers for Band III. The Band I and Band III 400 Watt modules are mechanically identical.

Driver design and cooling

The broadband 400 watt solid-state arrays presented two special design challenges: (1) a low distortion, but high peak-of-sync amplifier; and (2) an effective splitter/combiner.

The resulting power amplifier is an untuned microstrip circuit optimized for

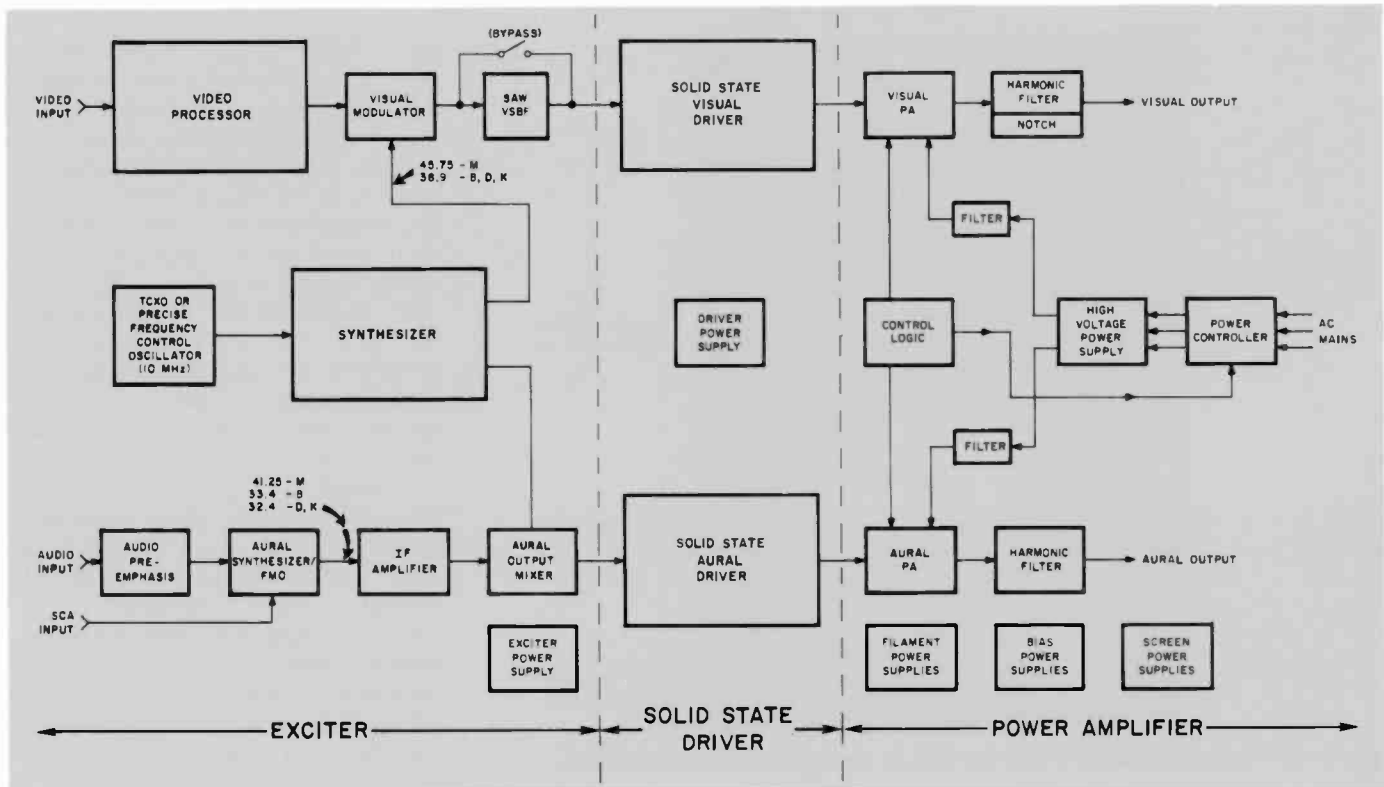

Fig. 2. Block diagram of TTV transmitter system.

minimum differential gain/phase characteristics. The design uses rugged high power devices in a low thermal resistance package. It is a high-power solid-state amplifier which can be easily paralleled in various combining schemes.

The splitter/combiner units utilize an innovative microstrip multi-section, N-Way design. A low loss substrate material used with this "wide-strip" design controls losses to values between 0.1 dB to 0.2 dB and in addition, provides high isolation, high power capability, wide bandwidth, minimum amplitude unbalance and low VSWR.

Necessary to the solid-state arrays which provide 1600 watts peak-of-sync power is cooling, since low junction temperatures are essential for high MTBF rates. To satisfy this requirement, RCA developed an "imbedded heat pipe module" utilizing a vapor chamber fluid to control transistor case temperatures. The 400 watt arrays and predriver amplifiers are mounted to a simplified ductwork and parallel-cooled with 100 CFM of air. Optimum circuit accessibility is provided by "front panel layout" of all solid-state modules, combiners, and related stripline loads.

Output combiner

An important requirement in the final combiner was minimum loss, broadband

characteristics, and a power handling capability in excess of 1600 watts peak-of-sync. The resulting small-volume, stripline combiner is a multi-element unit with insertion loss figures approaching those of the much larger coaxial-type combiners. The broadband characteristics of the driver are maintained over all international channels with high amplifier isolation and excellent bandwidth.

Single tube power amplifier

A better understanding of the relationship between tube parameters and video performance resulted in the design of tubes with inherently improved linearity. Thermal characteristics are also improved, reducing seal temperatures and increasing life. The new 9007 tube which is the same overall size and shape as its predecessor, the 8916 type, typifies these improvements. This new tube provides a peak visual power of 33 kW for System M.

Protection circuitry

A solid-state control-protection system developed by RCA guards solid-state power amplifiers employed as vacuum tube drivers against occasional high load VSWR and tube arcs, as well as input overdrive conditions, internal module

faults and temperature overloads. Thus, TV signal quality is maintained over the failure mode conditions. For personnel safety, a key interlock system turns off high voltage before access is gained to any circuitry.

Power supply and control

The power supply and control circuits supporting these new tube types also utilize the most advanced technologies, with full regulation of all necessary voltages (except the anode supply). SCR control of the AC input to the anode supply provides precisely controlled "soft" (solid-state) turn-on and "rapid" turn-off and, eliminates electromechanical AC contactors and their inherent deficiencies.

Conclusion

The application of new device technology and advanced circuit techniques in the new generation TTV television transmitter line provides state-of-the-art performance. This is accomplished with broadband circuitry and minimum tube count enhancing reliability and improving maintainability. The G-line has the operating economy as well as the power needed for circular polarization.

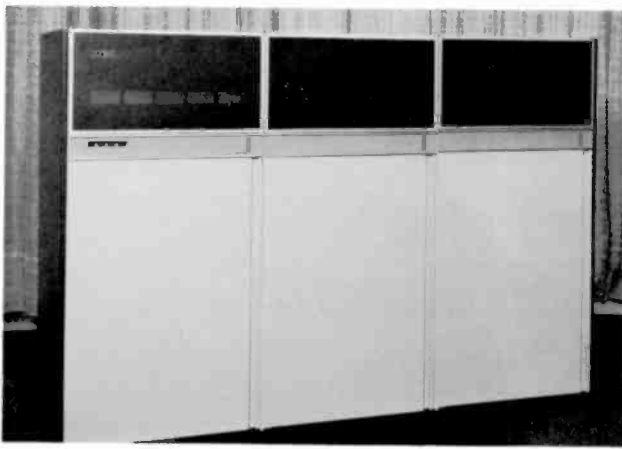

TTG-30L 30 kW channel 2 to 6 VHF television transmitter.

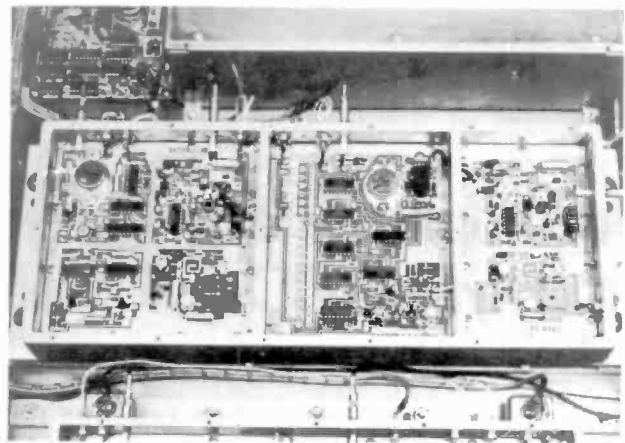

Programmable frequency synthesizer.



Electron gun structure of new tube design.



New 30 kW visual tube (left) and 7 kW aural tube.

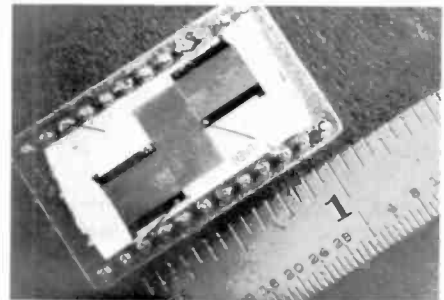

SAW filter lithium niobate substrate showing transducers and metallization.

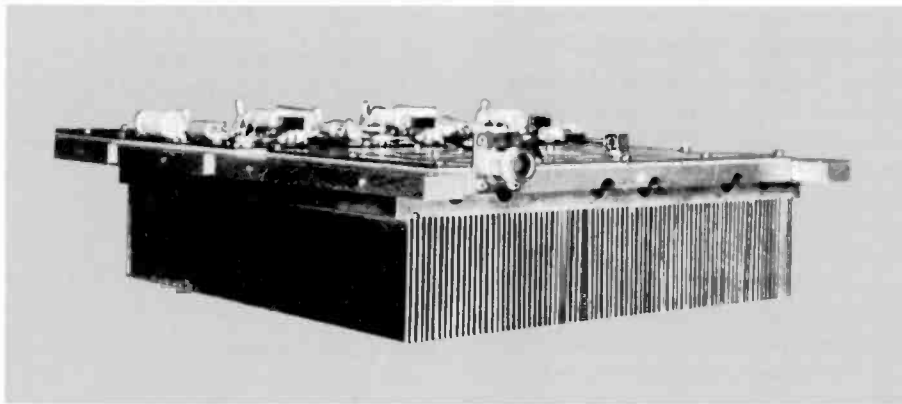

Side view of 400 watt array showing air fins and cut-outs where heat pipes are inserted.

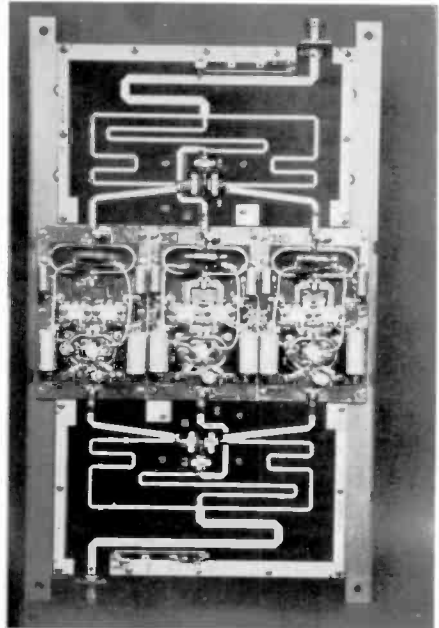

400 watt broadband solid state array.

Robert M. Unetich, Manager of Television Transmitter Engineering for RCA Broadcast Systems, Meadow Lands, Pa., is responsible for television transmitter design and development. Before joining RCA, he was involved in broadcast equipment development as manager of television transmitter engineering for Harris Corporation, Quincy, Ill. and vice president, engineering, EMCEE Broadcast Products, White Haven, Pa. Mr. Unetich is a co-author of the National Association of Broadcasters Engineering Handbook chapter on "Television Transmitters."

Contact him at:
Broadcast Systems
Meadow Lands, Pa.
Ext. 6244

William M. Boyd, an Engineering Leader in the Television Transmitter Engineering Section of RCA Broadcast Systems, Meadow Lands, Pa., is responsible for television transmitter subsystem design and development, including the new TTT-Line solid-state exciter and 1600-watt driver system. Mr. Boyd has been associated with television transmitter design since 1965 as a design engineer, project engineer and leader of various engineering projects related to VHF/UHF solid-state exciter and solid-state RF amplifier designs. He has a number of patents pending that are related to his recent design activities.

Contact him at:
Broadcast Systems
Meadow Lands, Pa.
Ext. 6254



R. Unetich



W. Boyd

Development and application of a prototype CCD color television camera

CCD color camera technology reaches to the bottom of the ocean and finds new life forms.

Abstract: *A brief summary is given of the system requirements for using a charge-coupled device (CCD) image sensor in a color television camera. Application of this technology has yielded a prototype camera which has been used in undersea exploration near the Galapagos Rift. Future prospects for CCD color cameras are suggested.*

At ocean depths of nearly 9,000 feet, the first detailed color pictures of unusual marine life forms were recorded with a prototype solid-state CCD color television camera. During a recent two-month expedition off the coast of Ecuador near the Galapagos Rift, the RCA camera and a 1-inch helical scan recorder were used aboard the research submarine, Alvin, operated by the Woods Hole Oceanographic Institution.

The research expedition, co-sponsored by the Office of Naval Research and the National Science Foundation, was initiated when geologists on a previous expedition to the Galapagos Islands to study volcanic activity on the sea floor, discovered dense colonies of organisms living in the warm water rising from volcanic vents in the ocean floor. In February and March 1979, a team of marine biologists returned to the Galapagos Rift. The team, led by Dr. J. Frederick Grassle of Woods Hole, included scientists from M.I.T., Scripps Institution of Oceanography, University of California at Santa Barbara, Harvard University, the University of Hawaii, University of Miami, Oregon State University, and Stanford University.

The National Geographic Society, who

had been part of the earlier expedition, was looking for ways to make a better photographic record. Choosing the prototype CCD color camera for its size and weight, they found it could be fitted into a 4-inch inside-diameter housing that was tested to a pressure of more than 20,000 pounds per square inch. The camera and lighting equipment were mounted on a remote-controlled hydraulic manipulator arm attached to the hull of the submarine.

The equipment, installed under a National Geographic Society grant, included additional quartz iodide lights that boosted the submarine's photographic lighting from 750 to 1500 watts. The exterior-mounted TV camera afforded researchers closer and clearer views of marine life and the sea floor (to within inches of a specimen) than they could have obtained with a camera filming from inside the submarine. Instead of peering through the Alvin's circular view ports, the three-man crew saw their subjects more clearly on television monitors and, when the trip ended, the researchers received duplicate video cassettes for further study in their laboratories.

The most interesting organisms found were giant "tube worms". Because of their novel anatomy, it is believed at this time, that they represent a new phylum, a major division of the animal kingdom. (They have no eyes, gut, or mouth, it is reported.) A report issued by the National Geographic Society said: The camera "obtained vivid color pictures of giant tube worms more than 8 feet long, fish, crabs, sea spiders, and foot-long clams thriving at depths of nearly 9,000 feet." The RCA developmental camera was praised for "the

Table I. Summary of system requirements for standard NTSC 525-line television (EIA RS-170).

Vertical parameters:

Frame time (1/30 second)
2 interlaced fields (1/60 second each)
Total number of lines per field (262.5)
Vertical blanking interval (.075 ± .005 V)
Active scan lines per field (nominal/243)

Required vertical cell count:
242-262 each field (repeated or interlaced)

Horizontal parameters:

Luminance electrical bandwidth (4.2 MHz)
Color receiver and VTR practice (3 MHz bandwidth)

Required cell count:
4.2 MHz (approx. 450 cells)
3 MHz (approx. 320 cells)

Format parameters:

Picture aspect ratio (4.3)

clarity of the pictures and bright colors revealed at ocean depths where no sunlight penetrated."

The cover of this issue shows a picture of the camera system in operation on the ocean bottom (The bright red tube worms live inside flexible white tubes that they build as they grow.) A sample video frame of the tube worms taken by the CCD camera is shown on the back cover of this issue.

Reprint RE-25-1-8
Final manuscript received May 24, 1979.

Table II. Available alternatives for the design of solid-state image sensors.

*Charge Transfer
(CCD & Bucket Brigade)*

- Vertical frame transfer
- Interline transfer

X, Y-Addressed

- Charge injection
- MOS photodiode

Performance Comparison Parameters

- Optical overload characteristics
- Blue sensitivity
- Fixed-pattern background and shading
- Optical aliasing and moire
- Cost

CCD color camera development

RCA introduced the world's first high-resolution, broadcast-compatible, black-and-white solid-state TV camera for sale in January, 1975. Since that time, a number of improvements in the sensor and camera have been made. Blue sensitivity of the sensor has been improved to allow high-performance color TV cameras to be made. The following will describe current color camera technology.

Color TV cameras are probably the best application for solid-state image sensors. The stability of image scan size and position obtainable with vidicon camera tubes is generally good enough for most black-and-white cameras. However, the slight variations in scan uniformity and geometry between tubes requires matched tubes and

precision components for a multiple-tube color camera. Single-tube color cameras generally require high uniformity of focus to generate good quality pictures. The precision imaging characteristics of solid-state sensors eliminate these problems.

The specifications for the U.S. standard 525-line NTSC television system are stated in the EIA RS-170 standard. Table I lists the vertical and horizontal parameters elaborated in RS-170; these factors led to the choice of the number of rows of sensors (which control vertical resolution) and the number of horizontal picture elements (pixels). A minimum of 320 horizontal pixels is required to meet the 3-MHz bandwidth typical of video cassette recorders and color TV receivers.¹

A number of approaches have been tried to create solid-state image sensors. Several of the most popular approaches are summarized in Table II. These approaches usually can be categorized as either charge transfer devices, where the images are transferred to the readout circuitry, or X, Y-addressed sensors which sample the stored charge at the coincidence of a row and a column address. The Table also shows some of the performance comparison parameters.

The solid-state sensor which has the best combination of performance parameters is the vertical frame transfer CCD imager. Figure 1 shows a block diagram of this type of sensor. The specific device described is a 512-element (vertical) x 320-element (horizontal) sensor. The image area of the sensor which is used to create the charge pattern is shown in the lower portion of Fig. 1. The charge pattern replicating the image is collected in the image area during the time taken to display one field of the picture on a TV receiver (approx. 16 msec). During the vertical blanking interval, the charge pattern is transferred to the storage area. This erases the image area and prepares it for the next exposure. The pattern in the storage area is loaded one line at a time into the horizontal readout register. The horizontal register is clocked at a 6.1-MHz rate to read out one line of information. The output circuitry located on the chip converts the charge pattern into a low-impedance output voltage which interfaces with the video processing circuitry (separate from the chip.) Figure 2 shows a photomicrograph of the upper right hand portion of Fig. 1.

Sensitivity to blue light is one of the important performance parameters for color cameras. The standard CCD image sensor (SID 52501) has a polysilicon gate structure. The charge pattern is formed in

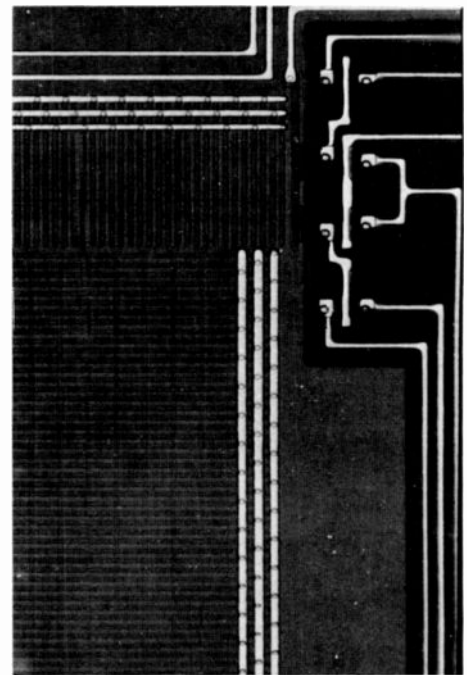

Fig. 2. Photomicrograph of 512 x 320 CCD image sensor.

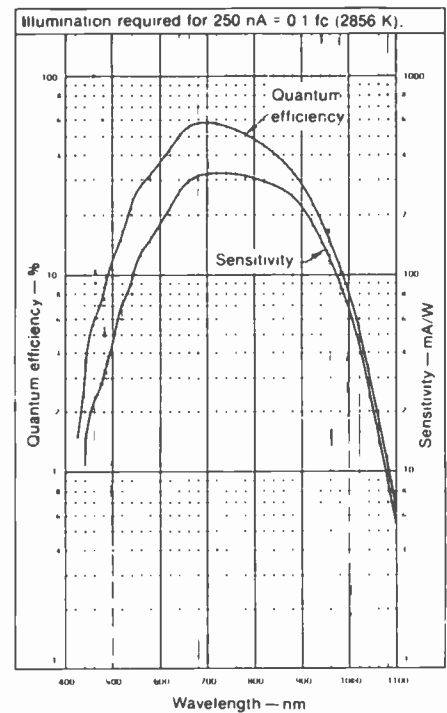

Fig. 3. Spectral response of SID 52501 image sensor.

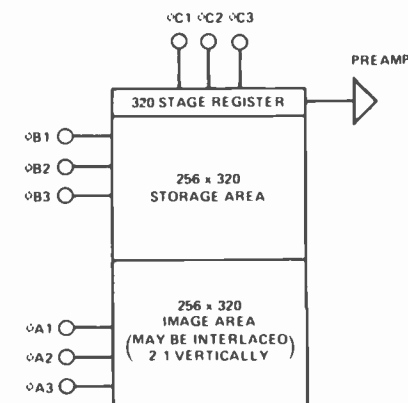

Fig. 1. Layout of 512 x 320 element CCD image sensor.

Table III. The trade-offs in CCD color TV camera design. One CCD vs. multiple CCDs.

- 512 x 320-element array has enough resolution for multiple device minimum color system.
- Single CCD color requires more resolution than 512 x 320 elements for minimum color system leading to higher cost for single chip than one chip of multiple-device system.
- Multiple-device CCD system does not have classic registration limitations of multiple-tube systems.
- Multiple-device system requires longer back focal length lens than single-device system does.
- Colorimetry and optical beat characteristics of multiple-device system superior to single-device system.

efficiency to drop severely in the blue portion (450 nm). New types of experimental CCDs have been developed which have high blue and green sensitivity. These new devices eliminate the polysilicon absorption problem and make color cameras feasible.

A color camera may be fabricated using one CCD or multiple CCDs. It was mentioned above that the stable, precise, image readout process from the CCD eliminates the registration stability problem of multiple-sensor-tube color cameras. Multiple-sensor devices (i.e. three CCDs) result in the highest performance cameras. The trade-offs involved in choosing between single CCDs and multiple CCDs to achieve a lower cost color camera are very complex issues. Table III highlights some of the trade-offs. A typical camera tube today has enough resolution to be the basis for either a one-tube or multiple-tube camera. This has resulted in a number of low-cost minimum-performance single-tube cameras to appear in the marketplace.

A single-chip color CCD camera will require a sensor having higher resolution than one of the sensors of a minimum-performance multiple-device CCD camera. The higher-resolution sensor will, therefore, cost more than one of the multiple-device lower-resolution sensors.

Figure 4 shows the optical arrangement of a three CCD color camera which is being developed by the Closed Circuit Video Equipment group in Lancaster, Pa. The figure shows the arrangement of a zoom

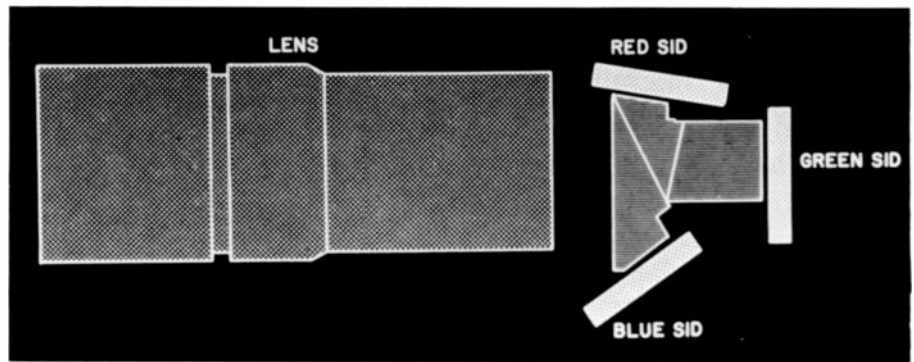

Fig. 4. Optical system of the prototype color TV camera.

lens on the left and a color separating prism with three SID sensors (RCA CCDs) on the right. The image of the scene passes through the prism on its way to the CCDs after being focused by the lens. The prism contains dichroic reflection layers which first reflect the blue image to the bottom position and then the red image to the top position. After subtracting the blue and red information, green is left to travel to the right hand sensor. The prism is very efficient in separating the light into the three primary colors and is similar to the prism separation methods that are used in broadcast TV cameras.

Future of the CCD color camera

The application of the first prototype CCD color camera in the National Geographic Society expedition described here is just a first step in what promises to be a very interesting and profitable future for the new type color camera. In addition to its

obvious advantages in size and weight, the CCD cameras also have the advantage of freedom from lag and highlight burn. Excellent life is predicted, so there should be minimum replacement cost of CCDs in these cameras.

In the future, there is a good possibility that CCD color cameras will play an important role in consumer and audio-visual applications. It also appears inevitable that the broadcast camera market will utilize CCD imagers for electronic journalism. The high resolution required for this market will be achieved by the introduction of CCDs with more resolution elements. Finally, because of the singular advantages of the CCD cameras, there will undoubtedly be numerous industrial, military, and space applications.

Reference

1. Rodgers, III, R.L., "Charge-coupled imager for 525-line television," *RCA Engineer*, Vol. 20, No. 1, pp. 79-82 (June/July 1974).

R.L. Rodgers III, Manager, Closed-Circuit Video Equipment Engineering, Systems and Equipment, Lancaster, Pa. received his training in physics and electrical engineering at the Polytechnic Institute of Brooklyn. Bob has been working on electro-optic imaging devices and systems since joining RCA at RCA Laboratories in 1964. He was instrumental in the conception and design of RCA's Silicon Vidicon and Silicon Intensifier Target (SIT) camera tubes. He transferred to the Electro-Optic Products Advanced Technology area in Lancaster in 1969 to continue work on silicon camera tubes and LLL TV cameras using these tubes, resulting in the development of a photoelectron noise-limited I-SIT camera. He was responsible for the development of RCA's 512 x 320 element CCD imager and CCD camera. In his current position, he is responsible for the engineering of all closed-circuit color and black and white cameras utilizing both CCDs and camera tubes. Mr. Rodgers has presented many



technical papers and received an RCA Laboratories Achievement Award in 1968.

Contact him at:
**Closed-Circuit Video
 Equipment Engineering
 Electro-Optics and Devices
 Lancaster, Pa.
 Ext. 3672**

SelectaVision VCR — A VHS VideoCassette Recorder

RCA Consumer Electronics introduced the videocassette recorder in the late summer of 1977. Now respected trade journals are crediting RCA with first place in consumer VCR sales.

SelectaVision VCR is by now a family of videocassette recorders (see list of models and features). The entire line is based upon a dual-time, helical scan video home system (VHS) format.

The VHS format identifies a class of VCR systems which have a high degree of compatibility and interchangeability. Any VHS cassette will fit into any VHS machine. Other common features of the VHS format are listed under "VHS Format Specifications," and described in the following paragraphs.

VHS FORMAT SPECIFICATIONS

Helical Scan Angle: 6°
Azimuth Angle: 6°
Writing Speed: 5.8 m/sec.
Head Wheel Diameter: 62mm
"Standard Play" Tape Speed:
33.33 mm/sec.
"Standard Play" Track Pitch: 58 μ m
Track Length: 97.1 mm
Video Width: 10.07 mm
Control Track Width: 0.75 mm
Audio Track Width: 1.0mm
Tape Path and Loading: "M" Loading
Luminance Signal: FM signal
Chroma Signal: Down-converted,
direct-recorded
Control Track Pulses: At vertical sync
rate, direct-recorded

Video heads

The video heads for the SelectaVision VCR are manufactured by precision processes and then carefully selected and matched

Reprint RE-25-1-9
Final manuscript received December 15, 1978.

before assembly into the upper cylinder. Core material is a special hot pressed ferrite (HPF) developed by Matsushita Electric Industrial Co., Ltd. This material is isotropic as compared with single-crystal ferrite, which is anisotropic. Consequently, it need not be as carefully oriented as single-crystal material. The width of the active portion of the video head is nominally 38 μ m. This is the track width of the recording at the Standard Play speed. The gap of the core is nominally 0.35 μ m, which will accommodate wavelengths down to approximately 0.75 μ m.

Tape

The tape used with the SelectaVision VCR is one-half inch (12.65 mm) wide. It consists of a magnetic powder coating 5 microns thick on a 15-micron thick polyester film. The oxide coating is Co γ -Fe₂O₃. The H_c is approximately 600 oersteds. Oxide uniformity and coating smoothness must be carefully controlled. The tape film must be resistant to dimensional changes caused by variations in temperature, humidity, or tension applied during machine operation. The system employs narrow track widths and short wavelengths.

Luminance signal

The luminance signal is recorded in an FM mode in order to accommodate the wide video bandwidth within the 6 db-per-octave characteristic of a magnetic recorder. The carrier frequency and deviation are such that the synctip of video produces a 3.4 MHz signal, and peak white produces 4.4 MHz.

The "Standard Play" mode of the VHS

system produces a very desirable characteristic in the recorded luminance pattern. This is because the locations of horizontal sync on adjacent tracks are aligned with each other; alignment reduces the visibility of signal pick-up from adjacent tracks. Thus, if the head picks up a signal from the adjacent track, any pattern produced during picture time will be random, not fixed in position, as would be horizontal sync.

The primary means of reducing crosstalk between tracks for the luminance signal is the azimuth recording technique. This provides a crosstalk attenuation of about 30 dB over the wavelength range covered by the 3.4 to 4.4 MHz frequency range.

Chrominance signal

The chrominance subcarrier of the television signal being processed is converted from 3.58 MHz to 629 kHz and then directly recorded onto the tape. The frequency reduction places the carrier and most sidebands below 900 kHz which is about the lowest frequency excursion of the FM luminance sidebands.

Because of the relatively large wavelength of the recorded chroma, azimuth recording has little effect in reducing chroma crosstalk between adjacent tracks. Instead, a line-by-line phase shift technique is used for the chroma signal.

On one set of tracks (that is, on one set of TV fields) the chroma signal is progressively shifted in an advancing phase direction by 90° per line. For example, if line 1 is 0°, line 2 will be +90°, line 3 +180°, etc. On the other set of fields (alternate tracks), the phase shift is in the phase lagging sense; 0°, -90°, -180°, etc.

In playback, the desired chroma signal is

returned to its proper phase by a reversal of the pre-recording phase shifting. However, an interesting thing has happened to any information which has been picked up from adjacent tracks. Because it was originally shifted in the opposite sense before recording, the phase shifting after playback to restore the phase of the desired signal, shifts the crosstalk signal in the opposite direction from the one needed to correct the phase. In addition, it leaves the phase of the crosstalk signal on each horizontal line 180° out-of-phase with that on the preceding line. With the crosstalk signal alternating phase 180° on each line, its removal by use of a I-H delay line, comb filter technique is simple. The direct and I-H delayed signals are added to give double the desired signal, along with virtual cancellation of crosstalk.

The 90° phase shift recording technique helps to reduce visibility of another picture disturbance. In the recording process, second harmonics of the color subcarrier are sometimes created. With the 90° phase shift for the fundamental, the second harmonics are shifted 180° and therefore are interlaced from line-to-line in the same manner that the color subcarrier is interlaced in the NTSC system.

Four-hour play/record time

One area in which VHS machines differ is in play time. In the first VHS machines, track width, head width, and track pitch were each 58 μm. This single speed system, for two-hour play time with 500 meters of tape, gave very good S/N ratio with creditable performance in dropout and crosstalk elimination.

When RCA opted for the VHS system, the consensus was that two hours of play/record time was insufficient. (The Sony/Zenith Beta format had already been

RCA SelectaVision VCR vs. Sony Betamax

| | <i>SelectaVision VCR</i> | <i>Betamax</i> |
|-------------------------|------------------------------------|------------------------|
| Tape Speeds: | 16.67 and 33.33 cm/sec. | 20.0 and 40.0 cm/sec. |
| Max. Tape in Cassette: | 250 meters | *150 meters |
| Magnetic Tape Coating: | Coγ-Fe ₂ O ₃ | CrO ₂ |
| Head Core Material: | Hot pressed ferrite | Single crystal ferrite |
| Tape Path: | M | Beta |
| Fast Forward/Rewind: | Unloaded | Loaded |
| Video Head Wheel Drive: | Direct drive motor | Belt drive from motor |
| Maximum Play Time: | 4 hours | *2 hours |

*Sony has released 13 μm thick tape cassettes in limited quantities. With these cassettes the tape amount increases to 225 m and play time to 3 hours.

up-graded from one to two hours.) Therefore, RCA insisted on four-hour capability.

A two-speed machine

The decision was also to provide selectable play times. These are called SP (for Standard Play) and LP (for Long Play) because the actual time chosen depends on the amount of tape in the cassette as well as on the tape speed.

The basic VHS machine had to be altered considerably to achieve the four-hour play/record time. Alterations were made by the Matsushita engineering staff to fit the rather stringent performance specifications from RCA engineering.

First, of course, the tape speed had to be halved. But, if that alone had been done, the track pitch would have been half the track width. This would have meant that each track, except the first and last, would have been completely overlapped by the preceding and succeeding tracks.

The solution was to narrow the head from 58 to 38 μm. Thus, in the SP mode, the track pitch is 58 μm, the track width is 38 μm, and there is a 20 μm guard band between tracks. In the LP mode, the pitch is 29 μm and there is no guard band; in fact, each succeeding track overlaps and partially erases 9 μm of the preceding one. Therefore, the effective track width is 29 μm with a 38 μm head. This makes crosstalk cancellation even more difficult.

Design advances

There were other consequences of making the VCR a two-speed machine. One is that audio performance differs somewhat at the two speeds. Wow, flutter, and audio bandwidth all suffer slightly at the slower speed.

A second consideration was the S/N degradation produced by the use of a narrower head and track. Three advancements were brought about by (1) improved formulation and better process control by the tape manufacturer, (2) higher quality video heads, and (3) a change in video signal processing. From the beginning, the VHS system employed a linear preemphasis/deemphasis processing for the luminance; a non-linear system is now used to further improve the S/N. Dropout immunity, which also suffered with reduction in track and head width, was offset by head and tape improvements.

The track overlap caused an additional interference problem. During the adjacent track horizontal sync interval, there was an interference pattern in the picture which was emphasized because it was fixed and stationary. This was virtually eliminated by



Fig. 1
VCT201 (left) and VCT400 videocassette recorders. These instruments are the foundation of the 1979 CE SelectaVision VCR product line.

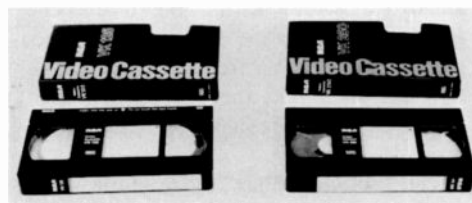

Fig. 2
The VK125 and VK250 cassettes are paperback book size, contain 125 and 250 meters of tape, and provide two and four hours of playing time respectively when used with any SelectaVision VCR.

FM interleaving. Interleaving is accomplished by shifting the FM carrier frequency on every other field by a frequency equal to one-half the horizontal line frequency; that is, by 7867 Hz. This interleaving signal allows for optical cancellation on the picture tube because the signal appearing on one of the interlaced vertical fields is 180° out of phase with that on the other field. The principle is the same as the chroma subcarrier interlace in NTSC.

The competition

This report is not intended as a competitive evaluation. However, since RCA and Sony are leading in VCR sales, and the systems will be compared, it seems appropriate to point out areas of significant similarity and difference.

The two machines are similar in the following features:

- Helical Scan
- FM Luminance
- Directly Recorded, Low-Frequency Chroma
- Azimuth Recording
- Half-Inch Tape
- Non-linear Pre-Emphasis for S/N Improvement
- Two Speed Operation (Sony also has one-speed models)
- Horizontal Sync Alignment at Standard Speed
- Chroma Phase Alteration (though different systems)
- Track Widths and Pitches

Tape path and thin tape

The Sony machine removes the tape from the cassette and wraps it around the head cylinder in a complex path which is roughly in the shape of a B or Beta. This reduces tape tension; however, because the tape threading requires so much time, Sony keeps the tape around the cylinder during fast forward and rewind operations.

The VHS "M" path describes the simple scheme of extracting the tape from the cassette with two pins and wrapping the tape half-way around the headwheel cylinder by moving the pins slightly past the center of the cylinder with one pin on each side. This is a fast, simple operation which allows the tape to be returned to the cassette, and out of contact with the cylinder during fast forward and rewind.

Thin tape is a feature improvement which Beta format proponents have been promising for almost a year. Its purpose is to narrow the play-time gap between Beta and VHS systems. At the time of this writing, relatively small amounts of the thinner tape have been available in retail outlets in the U.S. Of course, thinner (13 μm) tape could extend the SelectaVision VCR play time to six hours.

SelectaVision VCR features

The models introduced so far are the following:

- VBT200—Introduced in 1977. Has been replaced.
- VCT200—1978 replacement for VBT200. No longer available.
- VCT201—1979 step-up replacement for VCT200.
- VCT400—1979 deluxe instrument.

All have these features in common:

- *Dual Play Time Selector*—4-hour Maximum Play Time.
- *Digital Tape Location Counter With Automatic Memory.*
- *Audio Dub Capability*—Add Sound Track with Auxiliary Mic.
- *Video and Audio Out*—Play Into Monitor TV or Another VCR.
- *Video and Audio In*—For use with auxiliary camera.
- *Switchable (Chan. 3 or 4) Modulator*—Playback into TV RF input.
- *Pause and Remote Pause*—Eliminate unwanted material while recording. Stop machine when interrupted during playback.
- *TV/VCR Selector*—Record one program while watching another.

The following features appear only on the models indicated.

- *Digital Timer*—VBT200/VCT200. Includes a digital clock, can be set to turn VCR on at any time within 24 hours of the time it is set. The VCR turns itself off at end of tape.
- *Time Limited Timer*—VCT201. Similar to that in 200 series except can also be set to turn off at a specified time.
- *Mechanical V & U Tuners*—VBT200, VCT200, VCT201.
- *Program Indexing*—VCT400. This feature places a code on the tape at each recording start. In fast forward mode, machine will stop at each of these program start positions. To go from one index position to the next, FF must be pressed again.
- *Varactor Tuners*—VCT400. Fourteen customer-preselected channels can be addressed via push-buttons.



Thornley Jobe joined RCA in 1953 as a Liaison Engineer at the Bloomington, Indiana, Consumer Electronics (then Home Instruments Division) television receiver manufacturing plant. Over the years, he has held many positions in CE television engineering design and development. At present, his responsibilities include the technical administration of CE's video cassette recorder and video camera activities.

Contact him at:
Product Reliability Section
Consumer Electronics
Indianapolis, Ind.
Ext. 5223

- *Deluxe Programmable Timer*—VCT400. Includes a digital clock, can be programmed for four different events to occur during the next seven days. Each event consists of a day (numbered from the current day) and time of day for the VCR to turn on; the length of the event up to four hours; the channel to be selected. If "A" is selected instead of a numeral for the day, the event will occur each day until reprogrammed.

Conclusion

During the course of the development of the SelectaVision VCR, hundreds of evolutionary—and many somewhat radical—changes have been made to circuitry and mechanisms. These have enhanced performance and improved both manufacturing ease and reliability. Continuous liaison between engineering groups at CE and at Matsushita continues to contribute toward making SelectaVision the leading VCR in the field.

Where are we? — a brief discussion of the Navy navigation satellite system

Our involvement in the Navy's navigational satellite program, now in its fourteenth year, has produced a superb record of reliability.

Abstract: *This paper traces the progress of the design and construction of the Navy Navigation Satellite System (NNSS.) It describes the satellites and launching equipment, and documents the reliability performance of satellites presently in orbit. A new propulsion system is also described. Doppler frequency shift, the principle upon which NNSS operates, is treated in detail. The paper concludes with a look at the future of navigation satellite systems.*

Satellites Help Position Oil Drilling Rigs

"Winds and high seas stall drilling operations . . .

"Heavy seas and radio interference with five navigation satellites have slowed efforts to precisely position the 451-foot Glomar Pacific directly over a spot which geologists think most likely holds oil and gas deposits.

"Engineers say federal regulations require clear radio readings from at least 20 satellite passes to determine the location of the ship.

"Eight large deep water anchors planted in the sandy bottom 398 feet below will hold the ship steady on the sea's surface. . . ."

As reported in the Philadelphia Bulletin, March 26, 1978.

What does oil drilling have to do with Astro-Electronics, the center of RCA's space activity? Those navigation satellites for positioning the ship were produced at AE. They are part of the U.S. Navy navigation satellite system (NNSS). Originally, they were to provide two-dimensional (latitude and longitude) position information for the Polaris fleet of 40 submarines. Today, there are ap-

proximately 3,750 users (only 650 of which are military),¹ although the system is still owned, controlled and maintained by the Navy.

How did we get into navigation?

On October 4, 1957, the Soviet Union launched Sputnik I — the rest is history. In 1958, scientists at Johns Hopkins Applied Physics Laboratory, while tracking the satellite, discovered that the apparent doppler shift of the received signal could be used to determine the satellite's orbit. Conversely, they reasoned, if the orbit were known, the observer's position on earth could be determined. Hence, navigation by satellite was born. Actually, it was not that simple. It took several years of APL work to ready the "Transit" satellite system for production.

In 1965 RCA entered into a contract with the Strategic Systems Project Office (SSPO) to review the spacecraft baseline, redesign parts of the spacecraft, and produce test equipment. This was followed by several contracts which led to the production of 15 Transit spacecraft. During this time we operated as a prime contractor to SSPO. APL, also under contract to SSPO, acted as monitor of RCA's work, essentially having a technical

veto of proposed RCA changes. Figure 1 illustrates the relationship initiated in 1965 and still in force today.

A look at the record

Over the 13 years that RCA has worked with NNSS, there have been impressive results. As previously noted, RCA has produced 15 Transit spacecraft. APL has launched three and RCA three. Why so few? Certainly not because of poor performance (see Table I for the status of the polar-orbiting satellites). Outage time is essentially non-existent compared with in-service time. Our backlog led to what we at AE call the "long gray line" (Fig. 2), and are our best answer to the questions: "how reliable are your satellites?", or, "tell us how you implement system effectiveness, product assurance." In summary, these are the results of a good baseline design from APL and our attention to details of workmanship.

Meanwhile, SSPO and APL have proceeded with improvements to the satellite part of the Transit system. Two Transit improvement satellites (TIP) were launched in 1975 and 1976. After orbital checkout, RCA entered into a production

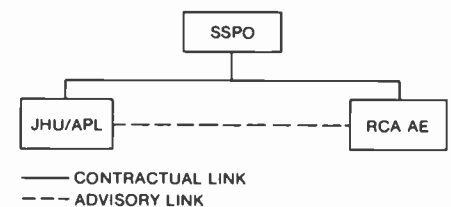

Fig. 1. Interrelationships among the Navy, RCA, and Johns Hopkins Applied Physics Laboratory.

Reprint RE-25-1-10
Final manuscript received June 20, 1978.

Table I. Performance record of NNSS constellation of satellites. Data as of Apr. 30, 1979.

| S/C | Built by | Launch date | In-service time | Out of service time | Percent reliability |
|-----------------------------|----------|----------------|-----------------|---------------------|---------------------|
| 012 | APL | April 14, 1967 | 12.0 years | 11.2 hours | 99.989 |
| 013 | APL | May 18, 1967 | 11.9 years | 34.6 hours | 99.967 |
| 014 | APL | Sept. 25, 1967 | 11.6 years | 52.1 hours | 99.949 |
| 018* | RCA | March 8, 1968 | 7.9 years | 1.8 hours | 99.997 |
| 019 | RCA | Aug. 27, 1970 | 8.6 years | 15.3 hours | 99.980 |
| 020 | RCA | Oct. 29, 1973 | 5.5 years | 9.0 hours | 99.981 |
| Totals: | | | | | |
| Total constellation time | | | 57.5 years | 123.9 hours | 99.975 |
| Currently active spacecraft | | | 49.6 years | 122.1 hours | 99.972 |
| RCA spacecraft only | | | 22.0 years | 26.1 hours | 99.986 |
| System reliability: | | | | | 99.93666 |

* Satellite 018 was taken out-of-service on March 1, 1976; the data for this satellite is not included in the totals.



Fig. 2. The "long gray line." This Navy inventory of NNSS satellites indicates the reliable on-orbit performance of the RCA-built version.

contract in 1977 for three additional satellites. The production TIPs are known as NOVA and are discussed later in this article; launch of the first of the series is planned for the spring of 1980.

NNSS — what it is and how it works³

The Navy navigation satellite system consists of a constellation of satellites, a network of tracking or injection stations that monitor and update satellite data, and the users of the NNSS, whose equipment is an integral part of the navigation system (Fig. 3).

The principle upon which the system operates is the Doppler frequency shift which occurs as the transmitting satellite passes overhead. The Doppler shift plus the information transmitted (satellite location) are processed by the user's equipment to determine latitude and longitude of the user.

Each NNSS satellite transmits on two

frequencies, 150 MHz and 400 MHz, developed from an ultrastable 5-MHz reference clock. The information transmitted consists of satellite ephemeris (location and time) data updated every two minutes.

Operation is analogous to an ordinary hyperbolic radio navigation system (such as Loran). However, the role of a fixed ground network of transmitting stations is replaced by a sequence of successive positions of a single orbiting satellite. By three successive determinations of hyperboloids, the intersection of each with the surface of the earth gives a line of position, and the lines of position intersect in the user's point of position. To improve the accuracy of determinations, a fourth readout of the satellite position is obtained. The technique is best described by the mathematics given in the following paragraphs.

Let t_1 , t_2 , t_3 , and t_4 be the four readout times and P_1 , P_2 , P_3 , and P_4 be the satellite orbit positions at each of the respective readouts in an earth-centered, but inertial-

ly oriented, coordinate system. The satellite and the user each have stable oscillators producing frequencies f_R and f_G for the received and ground frequencies, respectively. When beat against each other the difference frequency, $f_G - f_R$, is obtained. Note that the received frequency is not the satellite transmitted frequency f_T , but is modified by the doppler shift effect. The satellite emits recognizable time markers at the transmission times t_1 through t_4 . These times are recognized at times $t_1 + \Delta t_1$, $t_2 + \Delta t_2$, etc., where Δt 's are the travel times of the signal for each of the respective readout positions (see Fig. 4).

The receiving equipment is implemented to count the total number of beat cycles (cycles of $f_G - f_R$) between the time of receipt of the satellite time markers, or

$$N_{2-1} = \int_{t_1 + \Delta t_1}^{t_2 + \Delta t_2} (f_G - f_R) dt \quad (1)$$

where N_{2-1} is the number of beat cycles between times $t_2 + \Delta t_2$ and $t_1 + \Delta t_1$. Since f_G is stable and therefore a constant,

$$N_{2-1} = f_G (t_2 - t_1) + f_G (\Delta t_2 - \Delta t_1) - \int_{t_1 + \Delta t_1}^{t_2 + \Delta t_2} f_R dt \quad (2)$$

Note that the last term of Eq. 2 represents the total number of cycles received from the satellite between the t_1 marker and the t_2 marker. This is also the same number of cycles transmitted by the satellite between the time of transmitting each of the time markers. Therefore, it can be written

$$\int_{t_1 + \Delta t_1}^{t_2 + \Delta t_2} f_R dt = \int_{t_1}^{t_2} f_T dt \quad (3)$$

Since f_T is constant,

$$\int_{t_1}^{t_2} f_T dt = f_T (t_2 - t_1) \quad (4)$$

Substituting Eq. 4 into Eq. 2 gives:

$$N_{2-1} = (f_G - f_T) (t_2 - t_1) + f_G (\Delta t_2 - \Delta t_1) \quad (5)$$

Clearly, $\Delta t_2 - \Delta t_1$ is closely related to the differences in distance between the user's position and the satellite position, p_1 and P_1 . The user's point need not be stationary (as are the equations above) in an inertially

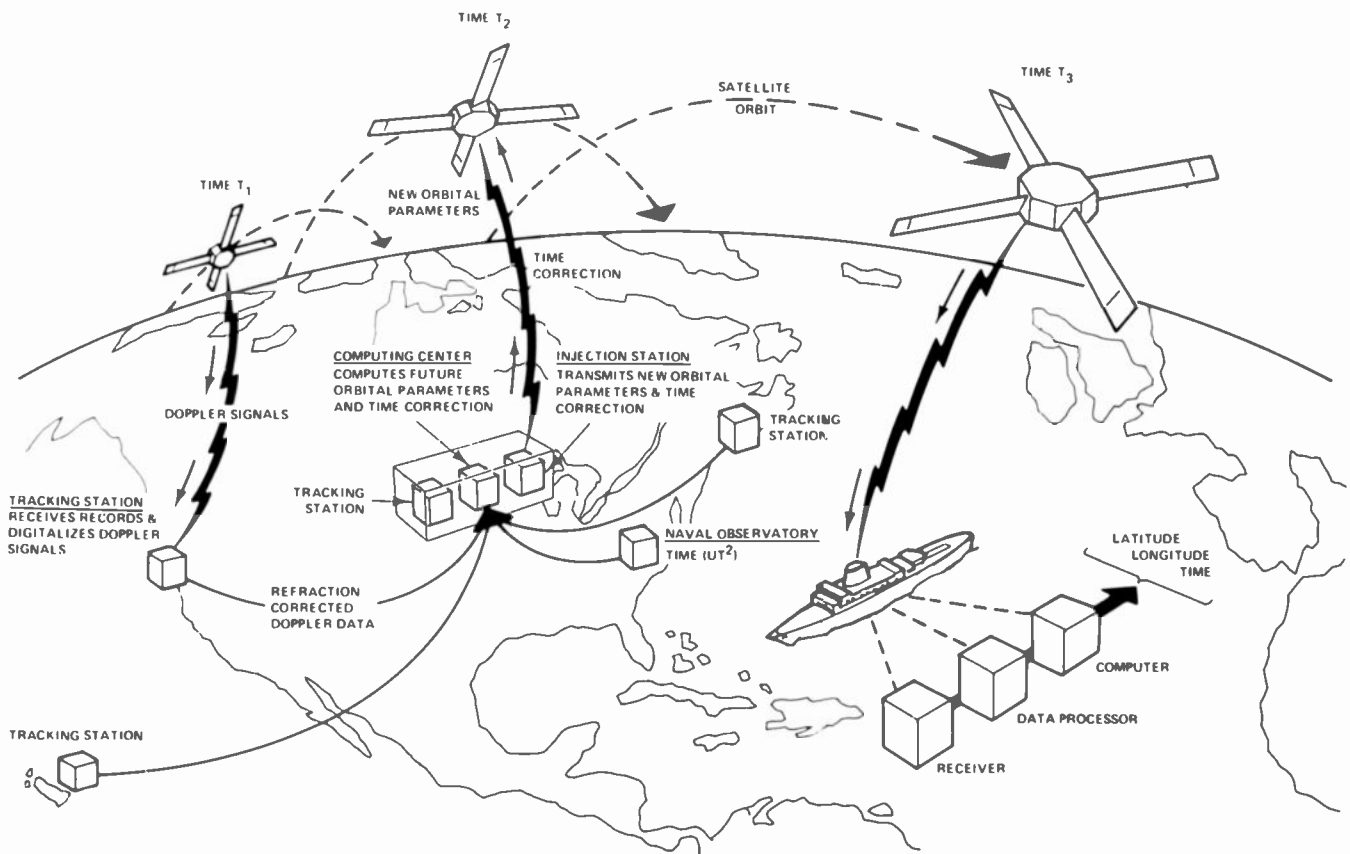

Fig. 3. Present and future operational uses of the Navy Navigation Satellite System.

oriented coordinate system. In fact, it is essential to include the motions of the user caused by earth rotations even if the user is stationary on the earth's surface.

Continuing with the development of the user's position, let $p_1, p_2, p_3,$ and p_4 be the user's position at times $t_1 + \Delta t_1 + t_2 + \Delta t_2$ etc., respectively. Additionally let ρ_1 be the distance P_1 to p_1 and C be the speed of light. Then

$$\Delta t_2 - \Delta t_1 = (1/C)(\rho_2 - \rho_1) \quad (6)$$

Equation 6 is substituted in Eq. 5 and solving for difference in distance between the satellite positions, ρ_2 and ρ_1 gives:

$$\rho_2 - \rho_1 = \frac{C}{f_G} N_{2,1} - C \left(1 - \frac{f_T}{f_G} \right) (t_2 - t_1) \quad (7)$$

Note that all of the terms to the right of Eq. 7 are known quantities. Combining Eq. 7 with the analogous equation involving P_2 and P_3 will yield two equations for the two unknown position coordinates of the user. However, due to the chance of a (relatively) inaccurate user frequency, these coordinates may be in error greater than 0.1 km (NNSS required accuracy).

This is best illustrated by examination of a special geometry case where the satellite

is just above the horizon at t_2 and is essentially retreating from the user. Then, $\rho_2 - \rho_1$ is very nearly the distance the

satellite moves during the interval (t_1, t_2) . Since this interval is two minutes, then the distance moved is of the order of 1000 km

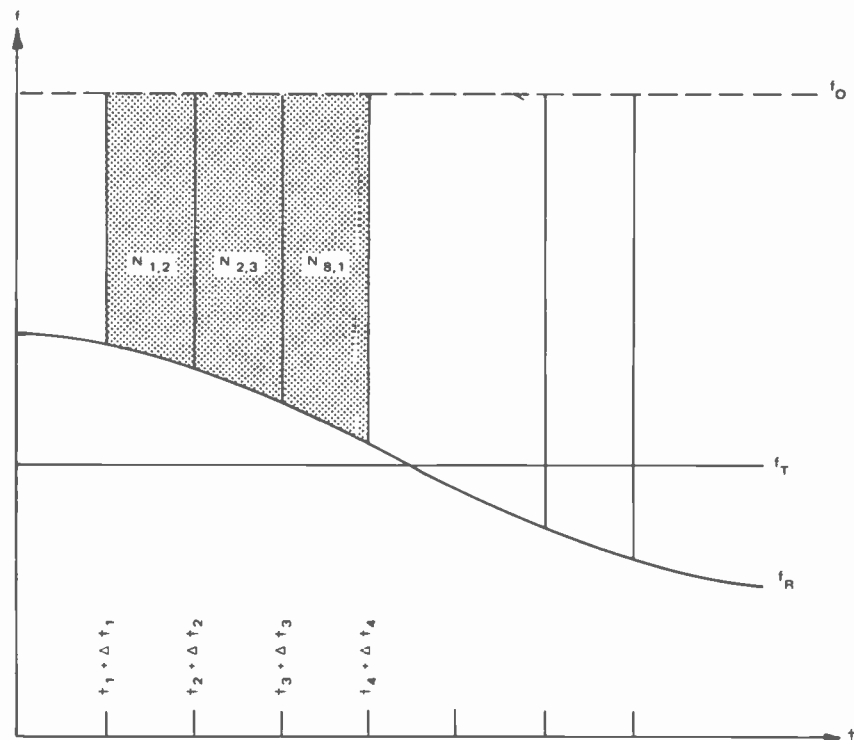

Fig. 4. Mathematical technique for measuring difference in distance between two points on satellite orbit.

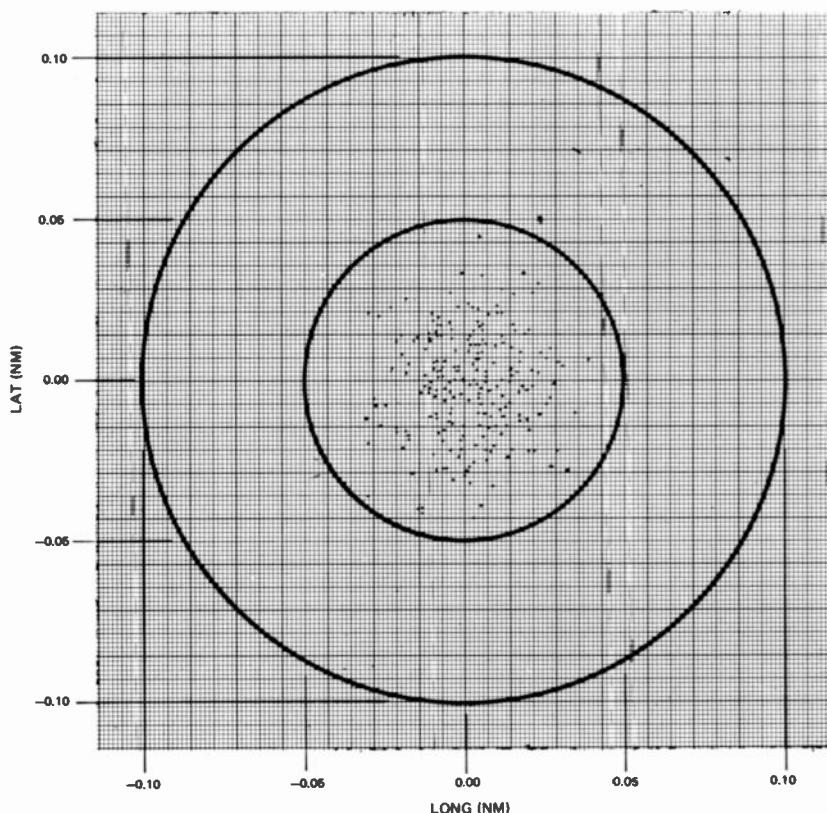

Fig. 5. Fix results illustrating a typical system accuracy.

(at 1100 km altitude, the satellite travels at about 8 km/sec). For an accuracy of 0.1 km, then an accuracy of 1 part in 10^4 is required. For the right hand term of Eq. 7 consider the special case that $f_T \approx f_R$, and write $f_G = f_T + \Delta f$ where Δf is small compared to f_G or f_T . From Eq. 7:

$$\rho_2 - \rho_1 = \frac{C}{f_G} N_{2-1} - \frac{C}{f_G} \Delta f (t_2 - t_1) \quad (8)$$

To make the last term small compared to 0.1 km, $\Delta f/f_G$ should be less than 10^{-9} . Although this is feasible with modern equipment, it is difficult to know the calibration with a comparable accuracy. The need for this stability has been eliminated through the use of a third baseline interval, $t_4 - t_3$. Using Eq. 8 together with the analogous equation based on the intervals (ρ_2, ρ_3) and (ρ_3, ρ_4) gives:

$$\rho_3 - \rho_2 = \frac{C}{f_G} N_{3-2} - \frac{C}{f_G} \Delta f (t_3 - t_2) \quad (9)$$

$$\rho_4 - \rho_3 = \frac{C}{f_G} N_{4-3} - \frac{C}{f_G} \Delta f (t_4 - t_3) \quad (10)$$

Since the satellite emits time marks at equal time intervals so that $t_2 - t_1 = t_3 - t_2 = t_4 - t_3 = 2$ minutes, Δf can be eliminated by

subtracting Eq. 9 from Eq. 8, and Eq. 10 from Eq. 9, giving:

$$-\rho_1 + 2\rho_2 - \rho_3 = \frac{C}{f_G} (N_{2-1} - N_{3-2}) \quad (11)$$

$$-\rho_2 + 2\rho_3 - \rho_4 = \frac{C}{f_G} (N_{3-2} - N_{4-3}) \quad (12)$$

Equations 11 and 12 are the equations of the unknown user position coordinates in terms of the known satellite positions at t_1, t_2, t_3 , and t_4 , the measured Doppler integrals $N_{2-1}, N_{3-2}, N_{4-3}$, and the ground reference frequency f_G . This requires a knowledge of f_G of one part in 10^5 , which is consistent with crude user equipment. Typically, the oscillators of the NNSS (both in the satellite and the users' equipment) have variations less than one part of 10^9 over the 6-minute time required to measure $N_{2-1}, N_{3-2}, N_{4-3}$. Therefore, neither oscillator is a significant factor in systems accuracy. Figure 5 is a typical set of results illustrating system accuracy.

Doppler vs. ionosphere effects

It should be noted that a fundamental but erroneous assumption in the derivation of

the equations above is that radio transmissions from the satellite are propagated on straight line paths at the velocity of light C . If the propagation medium were a vacuum, this would be true. However, since the medium is the ionosphere, a layer of ionized gas, the path and velocity of the transmitted signals are modified. The result is a transmitted signal not only modified by the Doppler shift $f_T + \Delta f_T$, but also by an apparent frequency variation caused by the ionosphere. The NNSS accounts for this variation by taking advantage of the fact that the effect of the ionosphere is frequency-dependent. Therefore, if two different frequencies are transmitted, then the Doppler effect is directly proportional to frequency, but the refraction effect is inversely proportional to frequency (to first-order accuracy). Since as stated previously, the NNSS transmits identical data on two frequencies, 150 MHz and 400 MHz, the ionosphere effect can be determined and a correction made to the Doppler shift to eliminate it from the position determination. The refraction correction in the current period is normally a few tenths of a kilometer and the error in this correction with the NNSS frequencies is less than a hundredth of a kilometer.

Who operates the satellites³

The basic navigation equations given in the previous section involve the satellite positions at four successive 2-minute intervals. These positions are transmitted to the user by a message that is a modulation on the two frequencies used to generate the Doppler shift. This message giving the satellite positions at each 2-minute interval is developed from data injected into the satellite approximately every 12 hours by one of the NAG (Naval Astronautics Group) injection stations located in Minnesota, California and Maine. The satellite orbit from which the message is derived is obtained from extrapolation of satellite tracking data from the three NAG injection/tracking stations, and the other NAG "tracking only" station.

The operational satellites^{2,3,4}

The present NNSS operational Transit satellites, OSCARs, (Fig. 6) are launched into polar orbits from Vandenberg Air Force Base. Standard Scout vehicles (four stage, solid fuel rockets) are used to boost

the satellites into circular polar orbits at an altitude of 600 nautical miles (nmi).

An OSCAR weighs 130 pounds and consists primarily of four parts: fourth stage adapter, main body, array, and gravity gradient boom with its end mass. The adapter is used to mate the satellite to the Scout fourth stage. The main body, which is approximately 19-in. (diameter) x 14-in. long, houses all of the electronics. The array consists of four blades with solar cells on both sides, and is deployed and fixed in place on orbit. The panel end-to-end measurement is 155 in. The gravity gradient boom deployed on orbit with its 3-lb. end mass extends to 100 ft.

The OSCAR satellite employs seven subsystems: Doppler, command, memory, telemetry, attitude control, thermal, and power. The Doppler subsystem consists of the electronics that provide the pair of ultrastable rf beacons necessary for Doppler measurements. These electronics include an ultrastable 5-MHz oscillator (good to 5 parts in 10^{10} for 20 minutes), two phase-modulated data transmitters (0.5-W at 150 MHz and 0.75 W at 400 MHz), and a deployable dual frequency (150-MHz and 400-MHz) antenna.

The command subsystem is used to control the operation of the spacecraft via an earth-to-spacecraft rf link. The rf link is also used to inject navigation message data into the memory subsystem. The command subsystem components consist of two half-wave dipole antennas, two receivers with 70-kHz if bandwidth and -120 -dBm sensitivity, and the digital command logic.

The memory subsystem contains the electronics that provide the data storage for the Doppler subsystem. The memory has the capability to store 18,720 bits of satellite ephemeris and 6,103 bits of systems data. The data format is organized into 39-bit words.

The telemetry subsystem provides the data necessary for monitoring the operation of the satellite. These data consist primarily of command and power subsystems' status information. In addition, diagnostic data are provided for analysis of spacecraft malfunctions. The telemetry data are in a PAM/FM/PM format; the PAM wave train consists of 35 serial pulses that modulate the FM subcarrier, which then bi-level shifts the rf carrier (PM). The commutator is a 35-channel, reed relay drive, free-running at 1 channel per second or synchronized with memory timing at approximately 1.5 channels per second.

The attitude control subsystem primarily consists of the 100-ft boom and its end

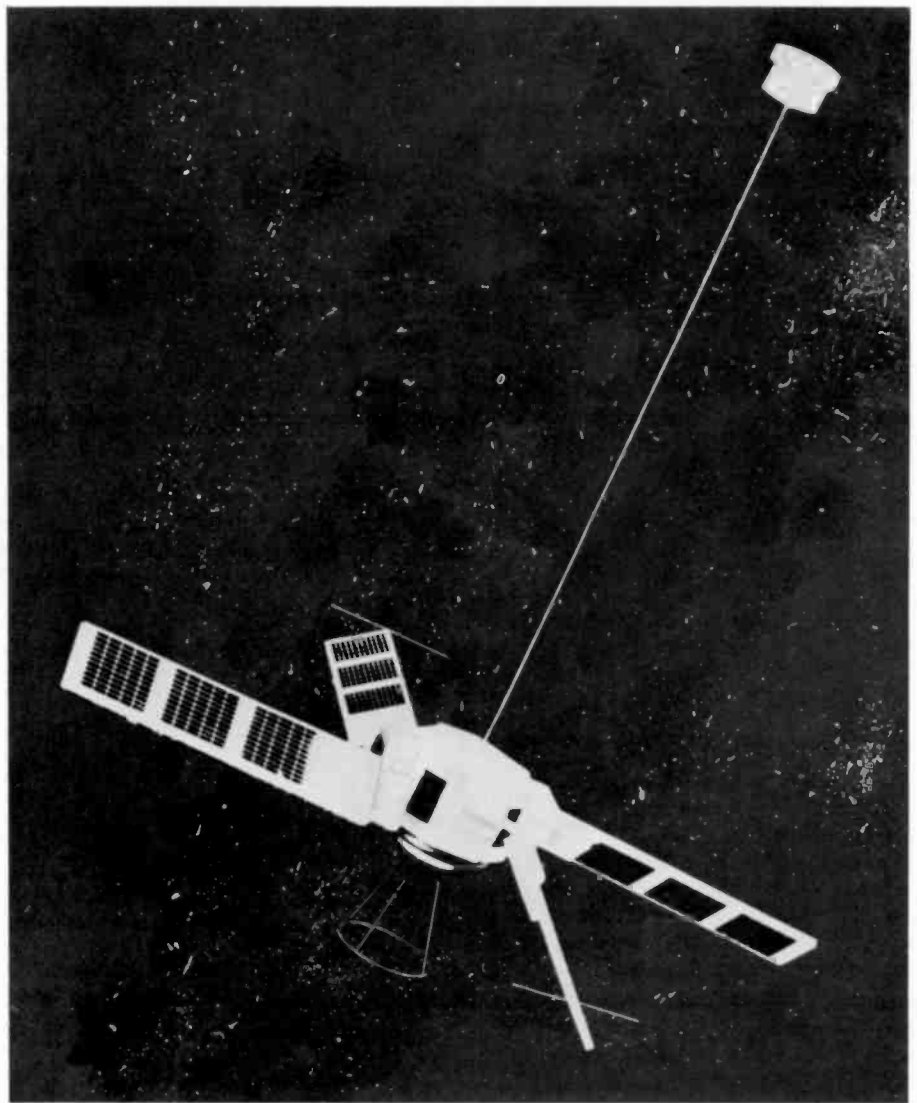

Fig. 6. Operational Transit satellite with extended gravity gradient boom in its orbit configuration.

mass to provide gravity gradient stabilization. This control orients the satellite to allow an earth-pointing antenna to be used for Doppler beacon transmissions. The components of the attitude control subsystem are its gravity gradient boom, a 30-ooersted electromagnet, and a three-axis magnetometer accurate to ± 5 millioersted.

The thermal subsystem controls the internal temperature of the satellite. Due to the large variation in sun angle (0° to 180°), an electrically powered heater system is needed to maintain spacecraft temperature. The thermal subsystem controls the box and battery temperatures to within a -5°C to $+35^\circ\text{C}$ range using an average heater power of 11 W.

The power subsystem converts solar power to electrical power and stores a portion of this power for use during eclipse portions of the orbit. The subsystem

supplies various regulated voltages to other subsystems on the spacecraft. The power subsystem components consist of voltage regulator, taking 9.9 Vdc to 11.6 Vdc and supplying $+9.7 \pm 0.2$ Vdc, the 12 amp hour battery, main and memory dc/dc converters taking an input voltage of +9.7 Vdc and providing -15.0 , $+4.1$, 5.0 , $+20.0$, ± 32.1 , $+21.4$, $+10.7$ Vdc, and the solar array which at a sun angle of 0 degree can provide 96 W of power.

The second phase of the NNSS operational satellite — NOVA^{5,6}

Although the Transit satellites have performed admirably exceeding all lifetime requirements, an improved NNSS satellite was designed to increase the system

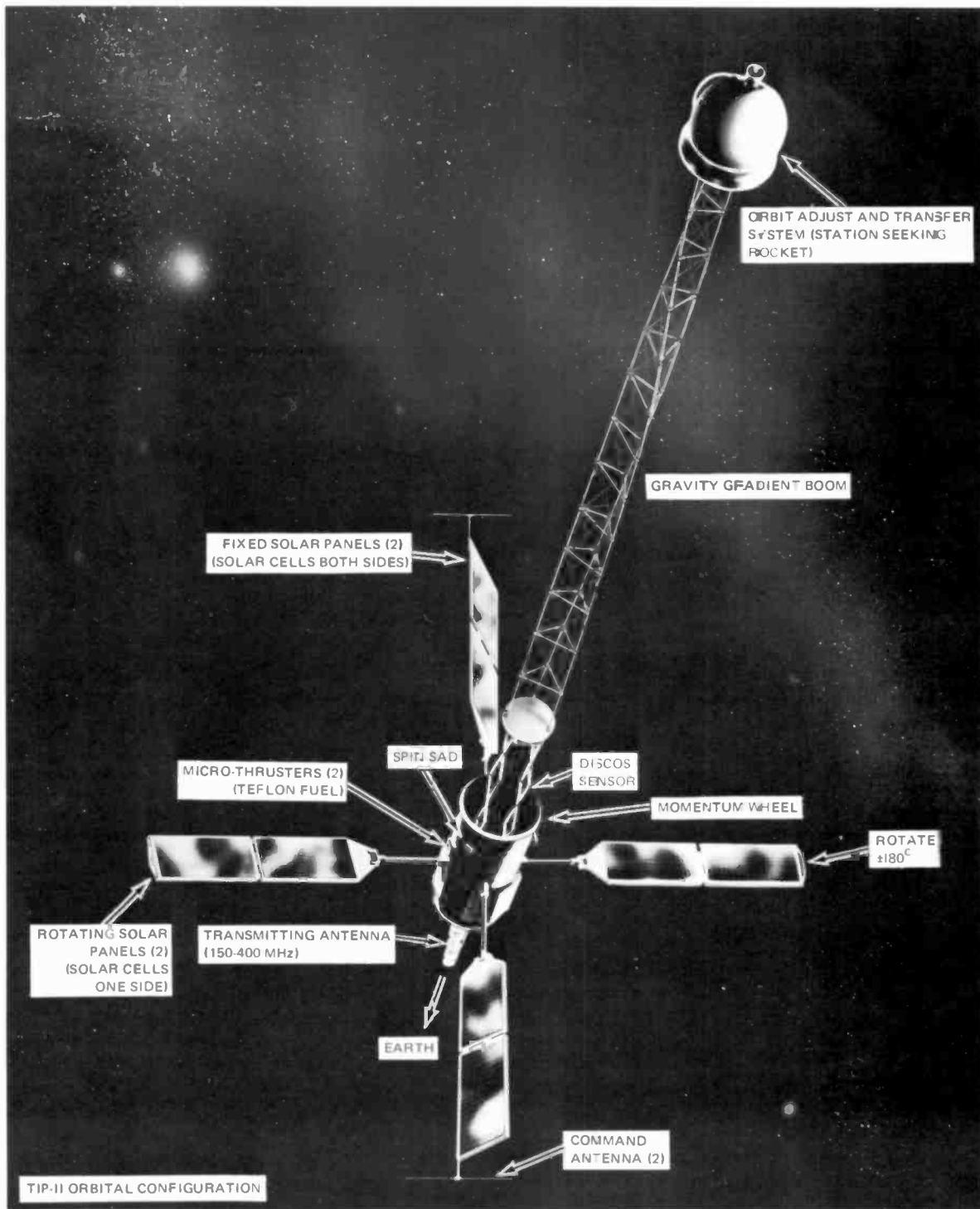

Fig. 7. The NOVA satellite in its orbit configuration. With its extended Astromast gravity gradient boom and the dual frequency bifilar antennas deployed, the satellite is approximately 33 feet, tip to tip.

capabilities. The improvements consist of an increased memory to provide eight days navigation message storage, orbit disturbance compensation, improved stability of the reference clock, increased transmitter outputs, and incorporation of a pseudo-random noise (PRN) modulation pattern for a new method of navigation-time pulse tracking (presently not planned for operational use).

The NOVA satellites (Fig. 7), the production version of the APL-designed TIP, are launched from Vandenberg Air Force Base with Scout-D (Altair IIIA fourth stage) vehicles. They are launched into an elliptical polar orbit at an altitude of 180 nmi x 400 nmi. The satellite then uses its orbit adjust and transfer system (OATS) to boost the satellite to a near perfect circular polar orbit. The OATS is

another increased capability designed into NOVA.

A NOVA satellite weighs 365 pounds and consists primarily of five parts: fourth stage adapter, main body, solar array, attitude cylinder, and gravity gradient boom. The adapter of the NOVA, used to mate the satellite to the Scout fourth stage, is approximately 18 in. (diameter) x 16 in. long. The main body houses most of the

satellite electronics. The attitude cylinder which is approximately 19 in. (diameter) x 24 in. long houses the attitude control equipment and the remaining electronics. The solar array consists of four blades with solar cells on both sides of two panels deployed and fixed into place on orbit and solar cells on one side of two panels deployed and rotatable on orbit. The panels' tip-to-tip measurements are 19-ft 2-in. The gravity gradient boom is a newly designed 26-ft Astromast boom with the empty 16-pound OATS propulsion tank as its end mass. With the boom extended and the dual frequency bifilar antenna deployed, the satellite is approximately 33-ft. long.

The NOVA satellite employs eight subsystems: Doppler, command, computer/memory, telemetry, attitude control, thermal, power, and DISCOS/propulsion. Each of the subsystems perform functions similar to that described for the Transit satellite with improvements in each and with the addition of the DISCOS/propulsion subsystem. The key characteristics are given in Table II. The improvements over the Transit satellite are described below.

The Doppler subsystem has an improved reference clock stability through the use of an improved dual 5-MHz oscillator and an incrementally programmable synthesizer (IPS). This combination provides exact offset frequencies of 5 MHz — 84.48 ppm (operational) and 5 MHz — 145.51 ppm (maintenance). The IPS precisely compensates for bias and aging of the 5-MHz oscillator. Another improvement to the doppler subsystem is the addition of the pseudo-random noise generator (PRN) providing a modulation pattern transmitted along with the navigational message. Appropriately modified receivers can recover the pattern with a precision of 10 to 20 nanoseconds. The pattern can be used to effect precise synchronization of remote clocks, shorten the exposure time required for a navigational fix, and allow navigation free of ionospheric refraction errors using a single rf transmission. Another Doppler system improvement is the increased rf output of the 150-MHz (1.5-W) and 400-MHz (3.5-W) transmitters.

The command subsystem improvements consist of redundant receivers and command logic units which are cross-strapped to provide double redundancy and, therefore, increased reliability.

The computer/memory has been improved to a storage capability of 32K individually addressable 16-bit words. The

Table II. Key characteristics of the TIP II satellite.

| | |
|--|--|
| <i>Polar Orbit</i> | |
| 600 nautical miles | |
| <i>Hardware systems</i> | |
| Power supply | Solar panel, 80 watt |
| Command system | Double redundant |
| Telemetry system | Digital 172 channels |
| Doppler transmitters | Dual frequency, NAVMSG/TLM |
| Attitude detection | Magnetometers, solar attitude detectors |
| Attitude control | Boom, momentum wheel, electromagnets |
| OATS/DISCOS | Station seeking/keeping |
| IPS/PRN | Time pulse tracking |
| <i>Flight computer</i> | |
| General purpose | Double redundant |
| Memory | 32K words (16 bit) |
| Cycle time | 4.8 microseconds |
| Duty cycle | 20 percent |
| <i>Frequency and clock</i> | |
| Master oscillator | 5 MHz |
| Nominal offsets | -84.48/-145.51 PPM |
| IPS offset control | $\Delta f = -f_o \left(1 + \frac{1}{A} \right) / B$ |
| Clock bits | ±2.4 microseconds |
| <i>Data links</i> | |
| Uplink (143 MHz) | 10/1000 bps |
| Downlinks (150, 400 MHz) | 50/325 bps |
| (325 bps subcarrier and 1300 bps fast dump modes are also possible.) | |

computer is a full-scale general-purpose digital computer with a standard central processor unit and a complete set of arithmetic and logical instructions working at a 4.8-microsecond cycle time. The computer is used to store the navigational message data (for up to 8 days) store telemetry data, store delayed commands, and send the delayed commands directly to the satellite hardware.

The telemetry subsystem has been completely redesigned. The improvements consist of an increased number of channels (172), addition of redundant modulation control for selecting and switching navigation data (50.8 bps) and telemetry data including computer dumps (325.5 bps or 1302 bps) to the satellite transmitters. The telemetry subsystem gathers, signal conditions and digitizes the satellite telemetry data to be transmitted to the ground, processed by the on-board computer, or stored in the computer memory.

The attitude control subsystem improvements consist of the addition of a

number of attitude detectors (sun sensors) for spinning and nonspinning satellite attitude determination. Additionally, the subsystem has incorporated a set of three orthogonal air core coils to precess the satellite spin axis and to increase or decrease the satellite spin rate. The extendable boom, used to gravity gradient control the satellite in a vertical position, is an improved, newly-designed Astromast 26-foot long, supporting the extended 16-pound OATS. To provide a third axis (yaw) of control a momentum wheel has been added to the subsystem. The momentum wheel is reversible and has two operational speeds. The addition of ball-in-tube nutation dampers and magnetic hysteresis rods provide for damping undesired satellite motion in the spinning and non-spinning phases, respectively.

The thermal subsystem has been changed to basically a passive thermal control subsystem with exception of heaters on the battery and on the OATS. The passive techniques used consist of

appropriate selection of surface finishes and incorporation of multilayer thermal blankets to maintain the equipment within the desired operating temperature range.

The power subsystem improvements include increased power from the solar array (136 watts at a 0° sun angle) utilizing two fixed panels with solar cells on both sides and two rotating panels with solar cells on one side. Additionally, the power subsystem has a battery charge regulator to process the solar array power for controlled delivery to the satellite battery and loads, maintaining the maximum charge state of the battery to within prescribed and selectable limits, and to remove all excessive array power in a non-dissipative (non-heat generating) manner.

DISCOS propulsion system

The propulsion subsystem is completely new. It contains an OATS and an orbital disturbance compensation subsystem (DISCOS) consisting of a sensor and two Teflon solid propellant propulsion (TSPPS) micro thrusters.

The OATS is used to boost the 365-lb satellite, parked by the Scout into a 180 nmi x 400 nmi elliptical orbit, to a 600 nmi circular polar orbit. The OATS uses hydrazine (N₂H₄) as its propellant and gaseous nitrogen (N₂) as its pressurant. The engine thrust is nominally 5.7 lb and the residual N₂H₄ is vented after the proper orbit is achieved.

The DISCOS subsystem was added to the satellite to provide the capability of maintaining the satellite in an orbit which can be predicted after three days of tracking to within ±85 meters after seven days. This is accomplished utilizing a sensor which is a drag-free proof mass (PM) placed at the satellite center of mass by means of a 45-cm extendable and adjustable boom. The PM, being drag-free, is kept in a perfect gravitational orbit by sensing when the satellite, which is not drag-free, "moves" in relation to the PM and firing the TSPPS micro-thruster to center the satellite at the PM null position. The DISCOS compensates for satellite disturbances of the order of 1.35×10^{-8} g down to a level of 1.6×10^{-11} g.

The TSPPS consists of two Teflon solid propellant engines placed fore and aft of the satellite velocity vector and the TSPPS electronics which accepts the fire signal from the DISCOS sensor and fires the engines up to a maximum rate of once per second. The TSPPS produces 87 micro-



Larry Yermack is responsible for the development and production of the new U.S. Navy navigation satellite, NOVA, the first of three satellites scheduled for launch in 1980. Since joining RCA in 1962, Larry has served as manager of various Navy and Department of Defense satellite programs. He is currently program manager for the Navy navigation satellite system.

Contact him at:
RCA Astro-Electronics
Princeton, N.J.
Ext. 2279



Norm Huffmaster has contributed to various attitude control and determination subsystems, including TIROS and DMSP spacecraft. He joined RCA in 1962 and has worked in both systems and project engineering positions in the Defense Meteorological Satellite Program. From 1975 through 1977, Norm managed the spacecraft integration and test group of DMSP. From 1977 through Jan. 1979 he was manager of the NNSS systems engineering group. He is presently manager of the DMSP 5D-1/5D-2 Program.

Contact him at:
RCA Astro-Electronics
Princeton, N.J.
Ext. 2446

pound-seconds of impulse with each firing which is produced by plasma generation and acceleration. The engine consists of a curved Teflon propellant stick, the propellant retainer, the discharge electrodes, the main energy storage capacitor, the discharge ignitors, and the nozzle. The firing sequence is: receive signal to fire, charge up of 600 V ignitor capacitor, charge up of 1600 V main energy storage capacitor, discharge of the ignitor, and discharge of the propellant electrodes which ablates a portion of the Teflon surface. This plasma is then accelerated out of the nozzle via a magnetic field.

The future

As noted earlier, RCA is now under contract for three NOVA spacecraft, with the first launch targeted for the spring of 1980. The Navy presently intends to procure two additional NOVA spacecraft after the first production unit is successfully launched and checked out in orbit.

The Government is, however, pursuing a three dimensional national navigation system known as the global positioning system, GPS. Rockwell International is the prime contractor for this system which is scheduled to be operational in the 1980s. Currently, the system is in an engineering development and evaluation phase.

References

1. Stansell, Thomas A., "The Many Faces of Transit," presented at the 33rd annual meeting of the Institute of Navigation, Costa Mesa, Ca. (Jun 1977), pg. 9.
2. Kershner, R.B., "The Operational Navy Navigational System," Applied Physics Laboratory, The Johns Hopkins University.
3. The Navy Navigational Satellite System, U.S. Navy Astronautics Group, Point Mugu, Ca., (Jan 1967).
4. Spacecraft Design Characteristics Manual for the Navy Navigation Satellite System (30180), RCA, Astro-Electronics, (Feb 16, 1970).
5. TIPCOM Program — DEC PDP-11, Computer Program, Applied Physics Laboratory, The Johns Hopkins University.
6. Braunstein, A.A., "Addendum for Spacecraft (30470) Design Characteristics," manual, (Baseline 30460) for the Transit Improvement Program (TIP III) Satellite, (Jul 1976).

Total combat vehicle support with simplified test equipment

Simplified "plug-in" test equipment has already eased the task of trouble-shooting Army vehicle power packs. Now the same approach is being extended to the whole combat vehicle.

Abstract: *This paper describes the application of a simplified test system to the infantry fighting vehicle XM-2 and the cavalry fighting vehicle XM-3, both under development by the Army. It outlines the first step toward providing the Army with a simple, cost effective, field portable, test set for forward support of major vehicle systems. The scope of the simplified test equipment concept has been expanded—to include test of the total vehicle, including turret power distribution, control, drive, stabilization and sighting systems as well as hull, engine, transmission and electrical systems. This will result in the ultimate speed and simplicity of providing forward maintenance support enabling increased battlefield availability, simplified training and reduced logistics costs.*

For several years now, considerable effort has been devoted to the task of developing compact, easy-to-use equipment for the diagnostic testing of internal combustion engines. Under contract to the U.S. Army, RCA developed the STE/ICE system (the letters standing for Simplified Test Equipment/Internal Combustion Engine) for power pack diagnostics in tactical and combat vehicles.

To meet the aims of the program, the system had to be portable, simple to apply, and yet include the sophisticated hardware and software necessary to make it comprehensive and reliable. It had to be suitable for use at the company level—the

farthest forward level of maintenance in a battlefield situation. These criteria have been satisfied in the RCA-designed test equipment set, the central feature of which is the VTM (Vehicle Test Meter). This microprocessor-based instrument replaces, in a single compact unit, a number of bulkier and much harder to use diagnostic equipments which the Army had been using previously. Combined with diagnostic connector assemblies (DCA) built right into the vehicles themselves, and transducer kits (TK) for measurements not connected through a DCA, the VTM greatly speeds the job of power pack diagnosis.

It was a natural next step, then, to extend this successful approach to diagnosis of other systems on the Army's family of combat vehicles. For the Army's new XM-2 and XM-3 for example, the aim is comprehensive—to cover the total vehicle, turret and hull as well as power pack, under the Simplified Test Equipment system.

Serial production of first-generation STE equipment was already well established at Burlington when, in January, 1978, the STE concept was expanded for the first time into the field of turret systems. This was an important technical breakthrough, and provided the springboard necessary for applying the system to the XM-1 battle tank—the Army's most advanced fighting vehicle system.

Two new fighting vehicles currently under development by the U.S. Army are the XM-2 Infantry Fighting Vehicle (IFV) and the XM-3 Cavalry Fighting Vehicle (CFV).

The IFV and CFV vehicles combine excellent mobility and high fire-power. Mobility is achieved by the combination of a 500 HP turbocharged diesel engine and a hydro-mechanical transmission. Firepower is provided by the following vehicle subsystems:

- all electric stabilized turret;
- 25 mm automatic cannon;
- 7.62 mm machine gun;
- two turret mounted TOW anti-tank missiles;
- a day/night integrated sighting system employing thermal imaging techniques; and
- six 5.56 mm firing port weapons (IFV only)

Early vehicle design stressed forward maintenance support and human factors associated with both the vehicle's operational crew and mechanic. Consistent with the goal of simplified vehicle maintenance, a single test system was designated for "on-vehicle" or organizational diagnosis of all hull and turret equipment problems.

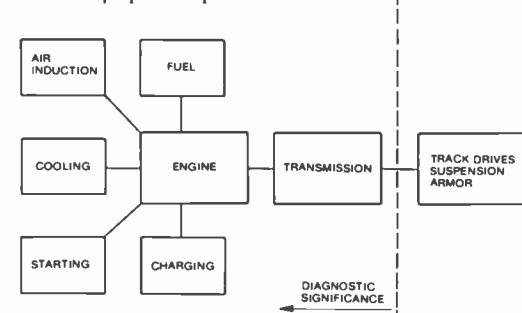

Fig. 1. Hull systems of the FVS fighting vehicle requiring diagnostic test equipment.

Reprint RE-25-1-11
Final manuscript received Oct. 10, 1978.

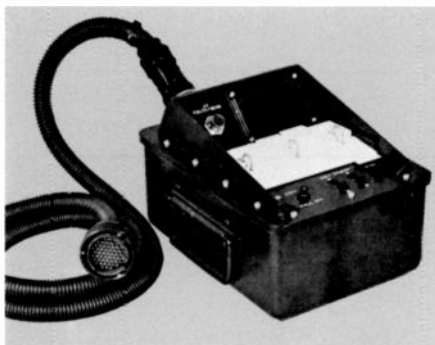

Fig. 2. Microprocessor-controlled vehicle test meter (VTM) provides digital readout of measurement parameters.

This system was the Simplified Test Equipment for Internal Combustion Engines (STE/ICE) developed by RCA for the U.S. Army. The extension of STE/ICE from its conventional role of power pack diagnosis to the mission of total vehicle test support is the principal focus of this paper. Extended test capability and its results afford an opportunity for examination of several aspects of this project:

1. The feasibility of total combat vehicle support via a single simplified test system has been demonstrated.

2. Clearly, the next step in simplifying the mechanic/test system interface is to define an optimized test system for combat vehicles.
3. The time phased progression of the STE/ICE FVS application program may serve as an example for other such applications. This project illustrates that it is beneficial for the test system to evolve in parallel with the development of the prime system.

FVS hull test capability

The FVS hull diagnostic problem is the same as that for all military land vehicles with the restricted accessibility characteristic of armored combat vehicles. Figure 1 illustrates the major systems and subsystems of the vehicle hull and indicates the main areas of diagnostic significance and test equipment requirements (faults in drive, suspension, and armor are more readily apparent and diagnosable without aids). It so happened that the STE/ICE system was developed to meet just those requirements for the Army Tank-Automotive Research and Development Command (TARADCOM).

STE/ICE — how it works

The heart of the STE/ICE system is the vehicle test meter (VTM) shown in Fig. 2. It is carefully designed to be simple to operate and understand. The man-machine interface is limited to a digital readout for displaying measurement results, two ten digit indexing switches used to select the desired test, a test initiation button and an on-off switch. This microprocessor controlled device measures parameters, and displays the results as either a pass/fail message or as digital values in appropriate units familiar to the mechanic (psi, rpm, volts, ohms, amps, etc.).

The VTM interfaces to the vehicle in two modes: built-in diagnostic connector assembly (DCA) and transducer kit (TK). The DCA is obviously the preferred mode of operation. However, practical limitations preclude prewiring of all possible measurement parameters. Therefore, a TK has been provided to make measurements not connected through a DCA or for testing the present vehicle fleet with no DCAs installed. Only the DCA capabilities of STE/ICE will be addressed in the rest of this paper since the FVS family of vehicles has been designed to take maximum advantage of this mode of operation.

Table 1. STE/ICE generic diagnostic connector assembly.

| <i>DCA type number</i> | <i>General class of vehicles</i> | <i>Engine types</i> |
|------------------------|---|--|
| 1 | Vehicles with medium sized diesel engines | Turbocharged and non-turbocharged engines with single plunger distributor type funnel systems and turbocharged engines with unit injector fuel systems |
| 2 | Vehicles with medium sized diesel engines | Non-turbocharged engines with unit injector fuel systems |
| 3 | Vehicles with medium sized diesel engines | Cummins engines with PT type of fuel system (turbocharged or not) |
| 4 | Vehicles with medium sized diesel engines | Caterpillar and Mack engines with multiple plunger type fuel systems (turbocharged or not) |
| 5 | Vehicles with large sized diesel engines | Turbocharged and non-turbocharged engines with single-plunger distributor type fuel systems and multiple air cleaners and turbochargers |
| • | • | • |
| • | • | • |
| • | • | • |
| 13 | Optional second DCA connector | Those vehicles with more test points than can be handled with one DCA connector, provides additional voltage temperature, and pressure test points |
| 14 | Special-purpose DCA | Not defined at this time |

DCA functions

Prototype DCAs were developed to be vehicle specific, that is, each vehicle type was assigned a code resistor and had a defined complement of sensors. By looking at the code resistor, the VTM would know what vehicle type was being tested, and would utilize read only memory (ROM) tables to identify the assigned transducer complement and appropriate scale factors. This concept would, however, necessitate updating all STE/ICE ROM sets every time a new vehicle DCA was introduced. With STE/ICE sets issued to troops all over the world, the logistics burden of such change programs would become impractical.

A generic DCA concept was, therefore, developed where 14 general DCA types (Table 1), each with its own code resistor, were defined by software tables programmed for each category. Each of these is really a "ceiling" DCA with a maximum test complement defined for it. The vehicle developer then has the flexibility to define the appropriate subset of measurements applicable to his vehicle. Special wiring conventions allow the VTM

to determine unused test functions so that appropriate operator messages can be displayed when a non-instrumented DCA test function is called for.

The FVS vehicles have been outfitted with two DCAs in the vehicle hull to maximize the benefit obtained through the use of STE/ICE for vehicle support. Table II lists all the test functions available through the two DCAs. The first DCA is the normal vehicle DCA (Generic DCA Number 3 from Table I) and the second is an optional DCA (Number 13 from Table I). Between the two connectors, the mechanic has extensive test capabilities in all the significant vehicle systems shown in Fig. 1. In many cases, he will be able to isolate system problems to an individual component through the available DCA functions and avoid unnecessary removal of parts restricting access to test points.

FVS turret test capability

The FVS Turret presented the vehicle developer with a different and more complex diagnostic problem. Figure 3 illustrates the complexity of the turret in terms of its electrical components. The initial parameter measurement requirements defined for maintenance support of this turret included 241 different test signals.

Complete turret testing by STE

The extension of the STE/ICE test and measurement capability to include complete turret testing is effected through changes internal and external to the standard STE/ICE set. Internal changes are primarily in microprocessor program memory. External changes are concentrated in a controllable interface box (CIB). The CIB expands the normal STE/ICE measurement capability to 291 channels with full scale capabilities ranging from ± 5 to ± 187 volts, some single ended, some differential, some shielded, and some with special overvoltage protection. The interface between the turret and the test equipment is through three standardized 128-pin test connectors and a power connector as shown in Fig. 4.

The simplicity of the system is best illustrated by its operational characteristics. Recommended procedure for use of the system is: connect all cables (P1, C1, C2, C3, DCA); turn system on with VTM power switch; select ap-

Table II. STE/ICE hull DCA test functions.

| <i>Function</i> | <i>DCA #1 (Type 3)</i> | <i>DCA #2 (Type 13)</i> |
|-------------------------------------|----------------------------|-----------------------------|
| <i>Engine tests</i> | | |
| Speed | x | x |
| Power | x | x |
| Compression balance | x | x |
| Oil pressure | x | |
| Oil temperature | x | |
| Coolant temperature | x | |
| Air cleaner pressure (switch) | x | |
| Fuel filter pressure (switch) | x | |
| Fuel rail pressure | x | |
| Turbocharger outlet pressure | x | |
| <i>Transmission tests</i> | | |
| Oil pressure | | x |
| Oil temperature | | x |
| <i>Electrical tests</i> | | |
| Battery voltage | x | |
| Battery current | x | |
| Battery/starter resistances | x | |
| Battery electrolyte level | | |
| Series Pair #1 | x | |
| Series Pair #2 | | x |
| Starter voltage | x | |
| Starter solenoid voltage | x | |
| Starter switch voltage | | x |
| Starter switch return voltage | | |
| Alternator output voltage | x | |
| Alternator field voltage | x | |
| Alternator field control voltage | | x |
| Fuel pump voltage | x | |
| Fan speed solenoid voltage | | x |

propriate test numbers; and observe displayed results. Once all cables have been connected, full turret test capability is available at the standard soldier tested (and accepted) VTM man-machine interface. The CIB has no control or display functions on it. Designing the system so that all test points can be connected simultaneously (3 cables) permits the mechanic to use the same set up procedure for turret testing regardless of fault symptoms.

The operation of the VTM in its Turret Test mode makes use of 600, 700, and 800 series test numbers. Normal vehicle testing uses test numbers less than 100 (only two digiswitches available for input). To use the

systems for turret testing, the mechanic must first enter a "number series indicator" (06 for 600, 07 for 700, 08 for 800) and then enter other test numbers within the series. The "number series indicator" need be entered only once for a whole group of tests within a series. Entering a "99" returns the VTM to its normal mode of operation where it is possible to enter another number series. All 600 Series test parameters come through a common test connector and the same is true for 700 and 800 Series parameters. Table III shows the distribution of turret system parameters within test and connector number series.

This distribution of systems within the number series permits much of the testing

Table III. Turret systems test points.

| Turret systems | Number of test points per test and connector Number Series | | |
|--|--|-----|-----|
| | 600 | 700 | 800 |
| Turret power control, and interlock distribution systems | 80 | 15 | |
| Turret electric drive and stabilization systems | | 69 | |
| Integrated sight and fire control electronic systems | | | 77 |

to be confined within a single number series. Thus, the mechanic is required to make only one entry for most tests.

The types of measurements called for are dc voltage, ac/RMS voltage, peak voltage, and peak-to-peak voltage. Table IV shows the distribution of these types of tests.

Standardization of the test connectors and their interface made several desirable features possible including operational simplicity, redundant parts, and a complete system self test. The turret test and self test connectors are all coded; the three test cables and three CIB multiplexing interfaces are all identical. Thus, it is possible to include a connector search routine in the software so that it does not matter how the mechanic connects the cables. The microprocessor determines

which turret test connector is connected to which CIB connector and then addresses the appropriate input channel. There is no wrong way to hook up the three cables.

CIB test functions

The CIB contains seven boards as shown in Fig. 5. All six of the input multiplexer boards are identical and completely interchangeable. In normal operation, there are three identical sets of hardware (cables, connectors, boards, and wires) connecting the three turret test connectors to the CIB receiver/interface board. Given this redundancy, the mechanic can have two faulty cables and four faulty MUX Boards but as long as one of the CIB Test

Table IV. STE/FVS test capability.

| Measurement type | Test number series | | | Total |
|--------------------|--------------------|-----|-----|------------|
| | 600 | 700 | 800 | |
| Volts dc | 79 | 82 | 58 | 219 |
| Volts ac/RMS | | | 15 | 15 |
| Volts peak | 1 | 2 | 1 | 4 |
| Volts peak-to-peak | | | 3 | 3 |
| Total | | | | 241 |

Connectors is fully operational, he can still perform all vehicle tests, the only penalty being the required movement of the remaining cable each time the number series is switched. Should he connect the one cable to the wrong connector, the VTM will so indicate by an error message.

The CIB self test is a fully compensated system test which includes a test of its own cables. Any one of the three test cables can be mated to the self test connector. The self-test then checks out all input channels and indicates either "pass" or how many bad channels were found and which ones they were. By simply interchanging cables, the mechanic can then fault-isolate to a single board or cable. If necessary, the same information will often allow isolation of the fault to a single chip or few chips. Thus, no new support equipment is required for the test system itself.

Conclusion

The results of the project described are most significant when viewed in concept. A

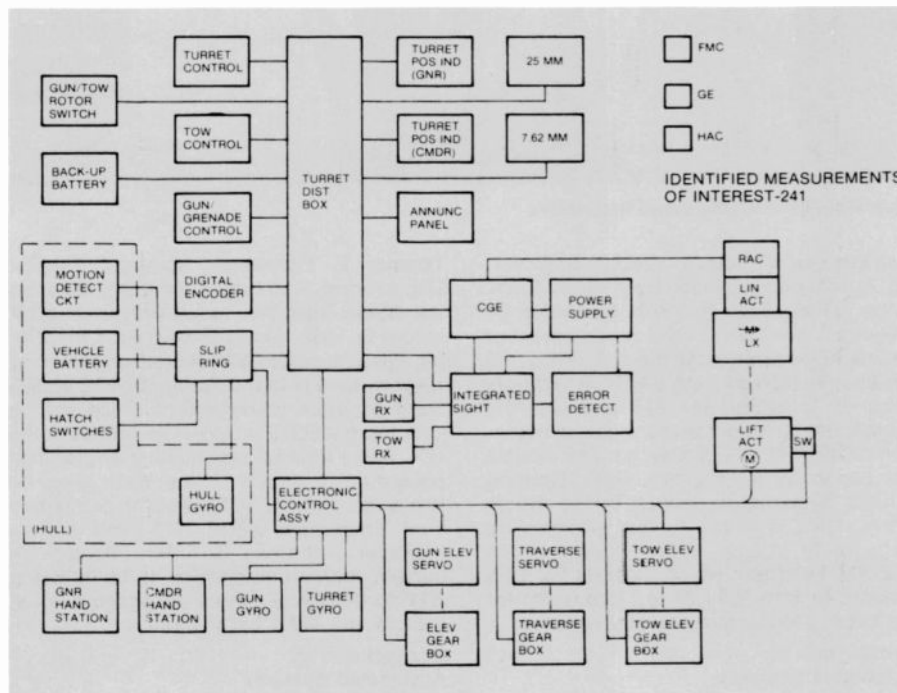

Fig. 3. Electrical components of the FVS turret require 241 different test signals.

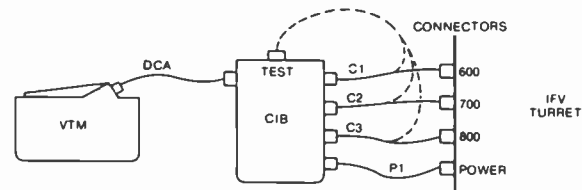

Fig. 4. FVS turret test connectors and controllable interface box (CIB).

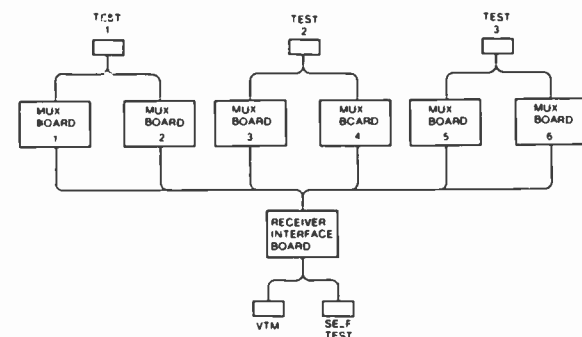

Fig. 5. Simplified block diagram showing multiplexer and interface boards of the CIB.

single simplified test system has been found capable of providing all required organizational or "on-vehicle" test capability for a modern, sophisticated combat vehicle. Among the benefits expected from the FVS test system approach are the following:

- Reduced vehicle logistics support costs from multiple use of a single organizational level test system.
- Hull systems mechanics will be trained in the use of STE/ICE in the course of normal MOS training. The FVS will impose no additional test equipment interface training on the Army mechanic.
- The interface between simplified test equipment and the mechanic initially designed for automotive mechanics will now be available to turret mechanics.
- The task of maintaining an inoperable vehicle in the field is made manageable by the ability to bring only one test system to the vehicle.

In the process of this demonstration, the STE/ICE application to FVS hull systems has confirmed the validity of the STE/ICE generic DCA concept. It is possible to field STE/ICE in support of the existing Army vehicle fleet while anticipating that future DCA equipped vehicles can be accommodated without change to the test system.

From the perspective afforded by this demonstration, it is possible to visualize additional characteristics of the test system that are desirable and achievable without significant additional test system complexity.

The next desirable test system feature is selective automation of turret diagnostics. The microprocessor built into the STE/ICE VTM provides the potential to automate turret test sequences to simplify the turret mechanic's task by making him less dependent on technical manuals. This automation should increase diagnostic accuracy while decreasing test time. The STE/ICE-CIB system now executes tests on a "one-at-a-time" basis. The turret mechanic depends on a technical manual diagnostic procedure to link test results to form diagnostic conclusions. One way to automate this diagnostic process is to validate the manual diagnostics contained in technical manuals, await the "frozen" production vehicle configurations and convert technical manual diagnostic procedures to test system program memory. In this way, a well validated diagnostic procedure can be obtained for the proper vehicle configuration while

minimizing the cost associated with software maintenance.

The test system described clearly may have use for other combat vehicles. If not directly applicable, it may be concluded that two project concepts apply:

1. A single simplified test system may perform all organizational level on-vehicle tests for a combat vehicle.
2. A test system may be applied in parallel with the development of the prime weapon system.

Given some standardization of diagnostic connector interfaces in turret systems (perhaps employing a generic interface concept) it seems practical to configure a single simplified test system for on-vehicle test of the entire combat vehicle fleet.

Acknowledgment

The authors wish to thank D.S. Sarna and J.W. Steyaert of the U.S. Army Tank-

Automotive Research and Development Command for their generous help in the work on which this article is based.

References

1. Sarna, D.S., and Steyaert, J.W., "Diagnostic Equipment Development for Military Vehicle Applications." Paper 780029 presented at SAE Automatic Engineering Congress, Detroit (Feb. 1978).
2. Hanson, R.E., and Fischer, H.L., "New Techniques for Automated Engine Diagnostics," presented at AUTOTESTCON, Hyannis (Nov. 1977).
3. Fischer, H.L., Fitzpatrick, T.E., "Simplified Automatic Test Equipment." Unpublished RCA paper presented at the Industry Joint Services Automatic Test Conference and Workshop, San Diego (Apr. 1978).
4. Muzi, A., "Sensor Selection for Automatic Diagnosis of Vehicles." Paper 770403 presented at SAE International Automotive Engineering Congress, Detroit (Mar. 1977).
5. Fineman, H.E., Fitzpatrick, I.E., and Fortin, A.H., "Simplifying Automotive Test Equipment through use of Advanced Electronics." Presented at IEEE NEREM, Boston (Nov. 1974).



Dick Hanson and Thomas Fitzpatrick.

Dick Hanson is Manager, Design Engineering, Automated Systems, Burlington, Mass. Since joining RCA in 1970, his major involvement has been in the development of vehicle test systems for the U.S. Army. He has been involved in the STE/ICE program since its inception in 1973 and was the engineering manager responsible for extension of the STE/ICE system to total vehicle test capability for the new FVS (Fighting Vehicle Systems) described in the article above. Dick is presently the engineering manager in charge of the design of the STE/XM-1 system, which extends the STE concept to total vehicle test capability for the XM-1, XM-2, XM-3 and ITV vehicles.

Contact him at:
Automated Systems
Burlington, Mass.
Ext. 2166

Thomas E. Fitzpatrick, Manager, Project Engineering, Automated Systems, received the BSME from Worcester Polytechnic Institute in 1968. Since joining RCA in 1970, Mr. Fitzpatrick has held project engineering responsibilities in the automatic test equipment program management office on the U.S. Navy AEGIS program as well as in the U.S. Army internal combustion engine test equipment program. In the latter area, he has been actively involved with Simplified Test Equipment since 1973, and project manager of it since 1975. Mr. Fitzpatrick's current major involvement is in applying STE to the Army's most advanced combat vehicle, the XM-1 battle tank.

Contact him at:
Automated Systems
Burlington, Mass.
Ext. 2629

The RCA Springfield systems - engineering facility

Headquarters for eight government-business-oriented service centers in the U.S. and Japan

Introduction

The programs discussed began with the desire of the United States Navy to utilize technology developed during World War II for modernization of the fleet. Attention at that time was focused on the electronic components of shipboard weapons, especially the control systems. Mechanical fire control computers were giving way to electronic analog equivalents. Sophisticated target-processing equipment was being developed to meet the threat of high-performance aircraft and guided missiles. All the while, tremendous advances were being made in sonar technology and in undersea warfare weapons and control systems.

A history of government service

RCA Service Company, a traditional supplier of field engineering services to the government, became involved in the installation and checkout of target designation and control equipment being produced for the Navy by RCA, Camden. Soon after, in 1951, RCA Government Services (then located in Gloucester, N.J.) began to acquire independent engineering support contracts from the Navy's technical bureaus. The contracts were, in the main, planning efforts supporting ship construction and modernization programs. Included were state-of-the-art

Abstract: *While the systems engineering programs of the Springfield center of the RCA Service Company entail a minimum of hardware design, the center, through its many activities, does have a significant impact on ship systems. It influences the selection of equipment, coordinates programs, defines support requirements,*

analyzes system interfaces, develops test procedures, and prepares supporting documentation for system operational use. This paper describes several RCA programs, all of which reflect the diversity of field operations and other technical support activities of the Government Services organization.

subsystems needed to satisfy mission requirements of the postwar Navy. Many of these new systems had not received formal acceptance by the Navy, since such acceptance for fleet use usually follows rigorous testing of prototype systems in the shipboard environment. Because of the crash nature of the ship programs, the ideal sequence of events from design to acceptance was frequently impractical for major subsystems; planning had to proceed on the assumption that these systems would receive ultimate approval for use. "Paper analyses" in effect modeled the new systems for their intended missions, and established reasonable confidence that they would perform as specified. Additionally, detailed studies of each system function and its electrical and mechanical compatibility with all interfaces were made and documented. A new approach to systems planning had been established, and a new discipline — systems integration and interface engineering — had been created.

RCA Service Company thus became more and more involved in ship systems planning, and in January 1954 the systems engineering center was established at Alexandria, Va.

The Springfield center

Today, RCA Service Company's systems engineering headquarters is in Springfield, Va., adjacent to the Washington Capitol beltway. There are satellite centers in Arlington and Norfolk; New London, Ct.; Newport, R.I.; San Diego, Ca.; and Warminster, Pa. Also, an office for technical liaison with the Naval weapons system engineering station at Port Hueneme is located in Oxnard, Ca. An overseas liaison office which supports the Springfield center's involvement with the Navy foreign military sales (FMS) programs for Japan is located in Tokyo, and a staging center for equipment being shipped to Japan is operated in the Oakland, Ca., area.

The role of RCA Service Company in systems engineering has been evolutionary. The Naval sea systems command (NAVSEA) and its ship design activities (successor agencies to the original Bureau of Ships and Bureau of Ordnance) are the current sponsors of the shipboard systems work contracted to RCA Service Company.

The Springfield center's undersea systems activities are in support of the

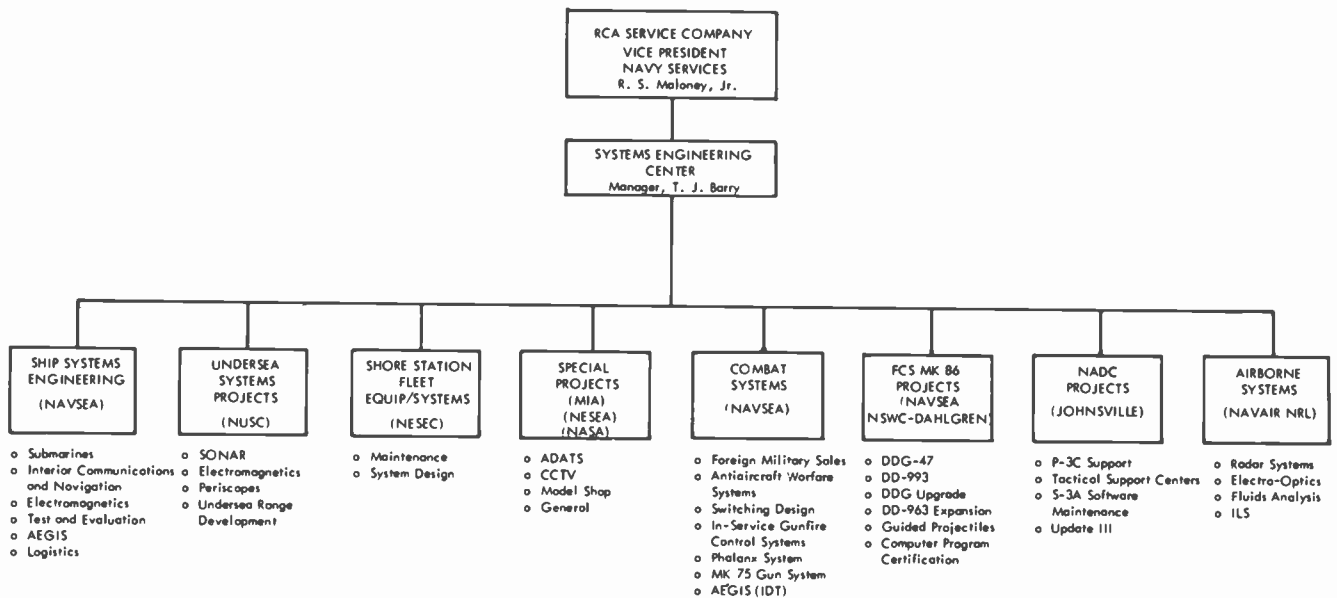

Fig. 1. Functional organization of the Systems Engineering Center.

Naval undersea centers in Newport and New London. Other Navy contract activities are largely shore-based functions and are sponsored by the air systems command (NAVAIR) and field activities of the electronics system command (NAVELEX), the electronic system engineering center (NESEC), and the electronics systems engineering activity (NESEA).

While systems engineering is the principal service of the Springfield complex, it is by no means the only activity of the center. The diversity of the systems engineering center is reflected in the functional organization chart depicted in Fig. 1, and Fig. 2 illustrates the major systems engineering functions. For example, in a major project associated with the Army missile intelligence agency (MIA), RCA systems engineering provides specialized technical services to that agency. Operating out of the special projects management office, the Springfield center is a source of technical support to the ADATS (Air Defense Artillery Threat Simulation) program. A cadre of RCA personnel, operating from the El Paso, Texas, area furnishes on-site operation and maintenance of the simulated enemy equipment employed in field exercises. Technicians, craftsmen, and support facilities of the model shop in the Springfield center furnish the resources utilized in the corollary support effort needed to overhaul or rebuild some of the nonstandard components of the simulation systems.

The special projects office at Springfield also furnishes installation and fabrication

services to NASA's Goddard Space Flight Center and to the International Communications Agency (formerly the U.S. Information Agency). Under a contract with NESEA at St. Inigoes, Maryland, on-site maintenance of closed circuit television (CCTV) systems is provided. These systems are comprised entirely of standard, commercially available equipment employing both color and black-and-white components, and are used for the collection of information from air operations, weather stations, and other briefing sources and for transmitting this information to selected monitoring receivers

located in Navy command and control areas.

Combat systems engineering

Combat systems engineering (CSE) is an organizational entity at Springfield supporting a number of ship programs involving six separate weapon systems. The CSE programs, under contracts with NAVSEA, include systems support to the Japanese maritime self defense force (JMSDF) and the U.S. Navy. Related CSE projects are provided under more limited

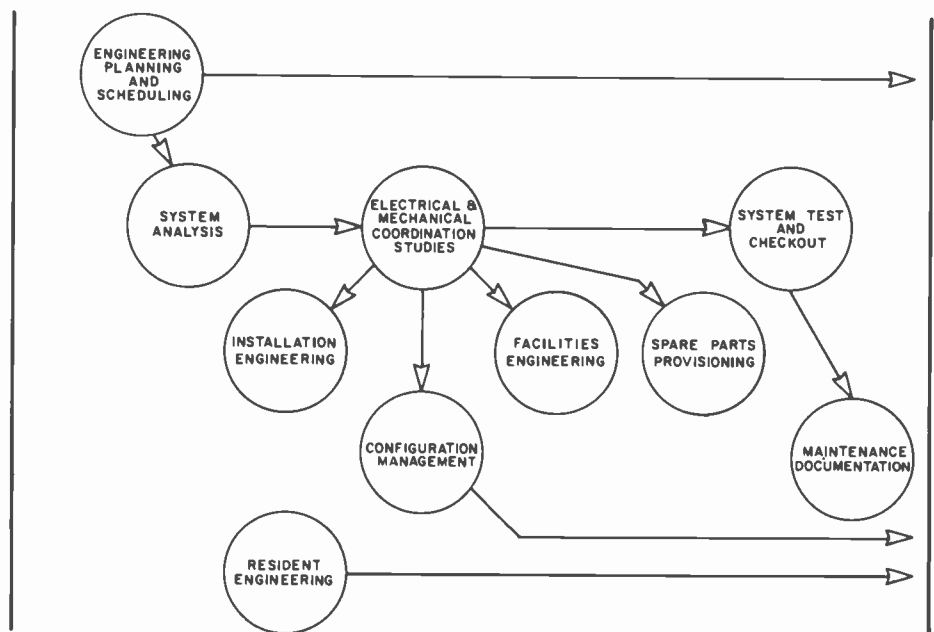

Fig. 2. Major system engineering functions.

support agreements with Navy field activities and by internal agreements with the RCA AEGIS project office in Moorestown, N.J. The CSE organization consists of three main subsections and a special section dealing with airborne systems maintenance programs and research test and evaluation.

International naval systems

The international naval systems project group (INSP) provides assistance to the FMS program office of NAVSEA, other Navy activities and various contractors, in providing technical support to JMSDF and other international maritime activities. While this applies primarily to shipboard combat systems, engineering services are also provided, as are logistics, software support, training, liaison, and other efforts related to the design, construction, test, and operation of ships, ordnance depots, land-based test sites, and training centers. The work of INSP began in 1960 with a Navy contract to provide a weapon systems engineering program to install a Tartar guided missile system in the French frigate DuPetit Thouars. Subsequent contracts provided the same support engineering for three additional French ships; all completed by the late 1960s. A similar program in behalf of JMSDF was initiated in 1961, resulting in Japan's first guided-missile-equipped destroyer (Fig. 3). The program has continued with other JMSDF ship programs.

The system engineering programs for JMSDF now involve several ship classes, entailing work with sonar sets, command and control equipment, combat operation centers, power generators, gun and guided missile systems, and the entire spectrum of radar and communication systems. Other on-going effort includes a wide range of documentation support, logistic processes, training, and configuration control.

Switchboard design

Switching systems design, a traditional activity at Springfield for over two decades, is an integral part of systems engineering, particularly combat systems. The products of this effort are the basis for Navy procurement of switching hardware. Switchboards (Fig. 4) provide the required interconnections between system components, including the ship interfaces. Remotely controlled switches effect the switching and distribution of data,



Fig. 3. Japanese Guided Missile Destroyer *Tachikaze* (DDG-168) underway.

reference voltages, control and indicating signals, scalar voltages, and navigational information.

Maintenance engineering

Maintenance engineering is provided for in-service Navy gun fire control systems including major and minor caliber gun mounts. The effort is directed toward increased operational effectiveness, improved maintenance, logistic support, and technical management. Engineering services are also provided for the Italian-developed Oto Melara Gun (U.S. Navy Mk 75) for compatibility and integration with U.S. Navy gun fire control systems. A separate effort by this section is devoted to engineering and technical services to the Navy's Phalanx System project office. Phalanx is an advanced "close in weapon system", an automatic, fully autonomous weapon for fast reaction and firing of special 20-mm ammunition.

Maintenance engineering services provided for the Naval air systems command includes the operation of a contamination control laboratory, where hydraulic fluids and special coolants are carefully analyzed for contaminants, using chemical methods and automatic particle counting equipment. The results of these laboratory tests are credited with a significant reduction in maintenance and in the number of accidents caused by aircraft control system malfunctioning due to contaminants. The airborne systems

maintenance group furnishes specialized engineering, analytical and technical support services to the Naval Research Laboratory. This effort is in support of laboratory and field testing of radar and electro-optic developmental systems.

CSE Mk 86 systems

Integration of the Mk 86 gun fire control system into the weapon systems of major combat ships is a separate and major Springfield center program. The Mk 86 gun weapon system is a state-of-the-art, digitally controlled system installed on the latest U.S. Navy ships for gun control. Some systems also provide for missile guidance (Fig. 5). The system is configured typically with ancillary equipment and associated systems including fire control switchboards, gun mounts, target designation transmitters (optics), a Naval tactical data system, Tartar guided-missile fire control systems, and ship's service and navigation systems. The RCA systems engineering program for the Mk 86 system provides system integration, coordination, liaison, and engineering to ensure proper installation and test and effective operation of the systems in the sea-going environment. The program encompasses:

- System development and analysis
- System interface design data development
- System installation engineering and documentation

- System test development and documentation
- System fleet engineering
- Direct engineering support
- Land-based test site coordination
- Field engineering
- Consulting services

Shipboard systems

Another major operating entity of the Springfield organization, shipboard systems, conducts specialized ship design support activities under an "omnibus" engineering services contract with NAVSEA and the Naval ship engineering center (NAVSEC). The activities of four of the subsections of shipboard systems are highlighted in the following paragraphs:

Submarine. An analysis and documentation group conducts feasibility studies of alterations proposed for submarines, and guidance plans are developed for the approved changes. In any proposed change, weight and moment are critical considerations that may require compensatory modification to other ship characteristics to ensure stability. New documentation then is often required to support changes to the equipment configurations. Prior to a change approval, power requirements, cost factors, and effects on habitability and operability all must be considered and carefully evaluated in the light of all possible trade-offs.

Electromagnetic (EM). The electromagnetic characteristics of each new and modified ship are actually measured and evaluated by a special RCA test team during sea trials. Tests are made of the electromagnetic compatibility of equipment with other fleet systems, and the rf radiation over a specified set of frequencies is carefully measured and analyzed for potential hazards to both personnel and ordnance items. The EM section so engaged provides a corollary supporting function in the maintenance of specifications, standards, and guidance documentation relating to the electromagnetic environment aboard ship.

Test and evaluation (T&E). In the ship acquisition process a critical factor in demonstrating operational readiness is the planning and execution of comprehensive test and evaluation programs. The planning of such tests for the ship subsystems as well as the total ship is one of the most important aspects of the ship design work at Springfield. The center has an enviable record in this work and is currently

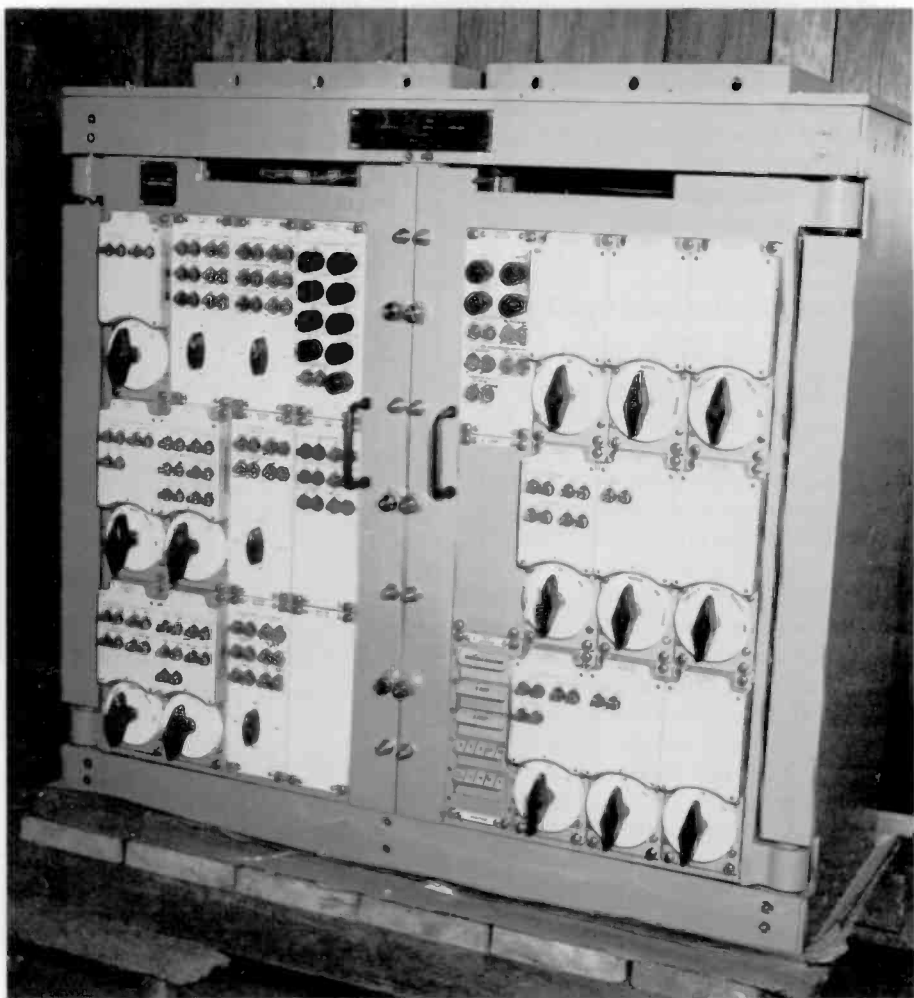

Fig. 4. Typical switchboard configuration for control and status data of a ship's navigation, fire control, and interface systems.



Fig. 5. USS Mississippi (CGN-40) underway. Radome of Gun Fire Control System Mk 86 Surface Search Radar, AN/SPQ-9, can be seen forward topside, Mk 45 gun mounts forward and aft, and dual-rail guided missile launchers forward and aft.

engaged in test and evaluation on a number of U.S. and foreign ship programs.

Interior Communications/Navigation (IC/NAV). Studies are conducted to aid in the determination and ultimate selection of shipboard interior communications, navigation, ship control, and alarm systems that are to be included in ships modernization or new construction. The studies include an analysis of the functional requirements and an evaluation of the capabilities and cost trade-offs of candidate systems satisfying the requirements.

Norfolk center

The Norfolk center was established in 1975 to provide logistical support and equipment staging for two of the major subsystems of the new 688 class of submarines, an effort sponsored under the shipboard systems engineering omnibus program with NAVSEA/NAVSEC. Under a separate contract support effort with the Naval electronics systems engineering center (NESEC) in nearby Portsmouth, Va., technicians and facilities are used to modify electronic equipment and to install new microwave communication equipment in Navy overseas communication stations. Personnel and facilities at the Norfolk center are also used to support the east coast equipment repair and overhaul responsibilities of the NESEC in San Diego.

Oakland-Oxnard

These two facilities are maintained for the concomitant support of the RCA Springfield center programs. At Oakland, Ca. (San Leandro), a depot is operated as a part of the Japanese ship program, being used to stage U.S.-manufactured ship systems equipment before its shipment overseas. The depot enables single shipments of entire systems in a coordinated effort which includes the careful inventory accounting of equipment and supporting documentation. At Oxnard, Ca., a technical liaison office is provided to facilitate communications between the Springfield center activities and the U.S. Naval weapon systems engineering station at Port Hueneme, Ca.

San Diego

The repair and overhaul responsibility for many types of shipboard electronic equipment used by the shore-based Naval training activities in the U.S. rests with the Naval electronics system engineering center (NESEC) at San Diego. The Springfield center has established a support facility in San Diego to provide NESEC with the manpower and facilities for this maintenance work. RCA technicians who are effectively on-call to the Naval training activities can respond to the requests of the respective sites fully prepared to provide maintenance. In most instances, however, the necessary repairs are extensive, tending toward overhaul needs, and arrangements are made to ship the equipment to either the RCA San Diego or the RCA Norfolk center. The Norfolk center is utilized to handle the repair and overhaul work for the Naval training centers located in the eastern part of the nation. Under a separate contract with NESEC, RCA provides the installation design effort and documentation to update and modernize the various Naval training activities sites. New equipment and systems planning encompasses electrical, electronic, and civil engineering skills as well as the technical skills used for installation and checkout.

Newport-New London

The RCA centers at Newport, R.I., and New London, Ct., furnish engineering and technical support services to the respective Navy undersea centers (NUSC). The scope of work is largely developmental support for underwater test ranges, sonar systems, underwater communications, and periscope systems. Conducted in such environments as submerged nuclear and conventional submarines and their sonar pods, tasks are wide ranging: optical surveys, earth probes, electromagnetic surveys, spectral analyses, mathematical modeling, digital logic design, psychological measurement associated with high-intensity underwater sound, etc.

Warminster

The RCA center at Warminster, Pa., serves the Naval Air Development Center



Frank Tarkington joined RCA in 1946 following a five year stint as a Navy Radioman in World War II. He began his RCA career with the Service Company as a television technician in New York City and was subsequently Factory Service Branch Manager, first in Baltimore, and later in Washington, D.C. In 1952 Mr. Tarkington joined the Government Service Department working in both technical and managerial capacities. He is presently a Program Manager for Government Services Marketing, concentrating on the development of Washington area Navy procurements.

Contact him at:
RCA Service Company
Systems Engineering Center
Springfield, Va.
Ext. 1109

(NADC) at Johnsville. It provides engineering support, specializing in prototype systems from concept to fully operational systems ready for evaluation. The Warminster capabilities include electrical and mechanical design and supporting documentation. An omnibus contract with NADC covers design assistance, fabrication, documentation, and maintenance services for P-3C aircraft software development facilities, carrier tactical support centers, S-3A aircraft, and the UPDATE III program (P-3C on-board tactical data processing).

Facsimile services at RCA Globcom

An innovative Global service to meet the present and future communications needs of the emerging "Electronic Office".

Abstract: *This paper describes the service and system characteristics of the recently introduced RCA Globcom international facsimile service — Q-Fax. It also presents RCA Globcom's future plans for a fully automatic switched facsimile service, as well as other message-oriented services to meet the communication demands of the emerging "electronic office."*

On March 1, 1978, RCA Globcom introduced the first commercial high-speed, high-quality facsimile service between the U.S. and Japan. This service, named Q-Fax, heralds a new era in international communications.

The Q-Fax network has been expanded in quick succession to include Hong Kong, Singapore, the Philippines, Switzerland, Argentina, Chile, Guam, Puerto Rico, Hawaii and Montreal, with several other countries planning to join by the end of this year.

To upgrade this service, RCA Globcom is currently working on a vigorous program for the development of a Q-Fax Store/Forward network which, among others, will automate system access, message routing and delivery, as well as provide accounting functions.

What Q-Fax is

The Q-Fax service, now operating between RCA Globcom's gateways and foreign points (Fig. 1), enables subscribers to send

documents, graphics and printed materials overseas in a matter of seconds via high-speed digital facsimile terminals.

Q-Fax service is accessed at the gateways by means of:

- facsimile terminals via the public switched telephone network (PSTN) or dedicated circuits,
- over-the-counter or messenger service.

The subscriber prepares documents for transmission by entering at the top margin of the first page, his account number, number of pages and addressee information. Optionally, he can enter this information on a Q-Fax sticker (Fig. 2) provided by RCA Globcom which he affixes on the top of the first page, or he can use an RCA Globcom Q-Fax form for addressing and message information. Other requirements are that certain page margins be maintained and that the print size not be smaller than Number 10.

Upon completion of document preparation the subscriber delivers to the nearest Q-Fax gateway, either by facsimile or over the counter. There an operator will affix a serial number and time/date on each page and transmit the pages to the overseas destination. The Q-Fax document is then delivered to the recipient.

In the U.S., RCA Globcom delivers facsimile documents by means of various types of facsimile terminals (representing almost 90 percent of the current subscriber installations) or via messenger service in the gateways. Overseas delivery, so far, is made by messenger or the postal service. However, it is expected that soon other

countries will also adopt delivery by local facsimile methods.

The quality of Q-Fax service has been very good. Since overseas transmission is carried out by high-speed, high-quality digital facsimile, with automatic error recovery, the received document is virtually identical to the original. As a result, once the service has been tried out, the subscriber usually becomes a repeat user.

Q-Fax system

The system supporting the Q-Fax service is shown in Fig. 3. Low-speed facsimile terminals constitute the most popular models in the U.S. At our gateways, groups of terminals are arranged in "hunt groups" over the PSTN so that if one terminal is busy, the next one responds to an incoming call. In this manner peak-hour traffic is not lost. These terminals can send and receive simultaneously in a full-duplex mode.

The high-speed, high-quality digital terminals utilized for transmission on the international circuits operate at 9600/4800 bps, with a resolution rate of 200 x 200 lines per inch (LPI) and error recovery through data block retransmission.

The transmission speed is approximately 26 seconds per average 8½ x 11-inch sheet at 200 x 200 L.P.I. resolution. These terminals employ a powerful two-

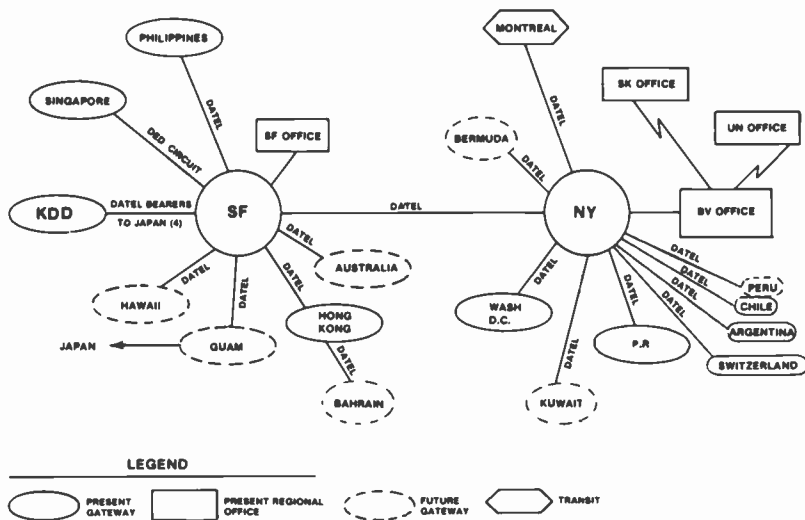

Fig. 1. RCA Q-Fax network now operating between Globcom Gateways and foreign points.

Q-Fax Message

RCA ACCOUNT NUMBER _____ NO OF PAGES _____ MESSAGE NO _____

Q | | | | | | | | _____

ADDRESS _____

Fig. 2. Q-Fax message sticker.

dimensional data compression scheme which on the average is twice as efficient as conventional one-dimension run-length-coding in the 200 x 200 L.P.I. resolution mode. Further details on this technique, and the algorithms used, are provided in later paragraphs.

The Q-Fax system presently utilizes satellite and cable voice-grade bearers. These facilities are shared with other services such as Dattel or Low-Speed Data in a time-division multiplex mode. This is possible, because facsimile traffic can be accumulated and transmitted when facilities are available. In addition, because of the digital nature of the high-speed

facsimile terminals, facsimile traffic can be time-division multiplexed with other data traffic on the same circuit.

This flexibility and the high-speed of these terminals contribute significantly towards maximizing the efficiency of the international facilities.

Development of a switched store-and-forward network

RCA Globcom is currently pursuing a vigorous program for the development of a switched Q-Fax store-and-forward (S/F)

network which will upgrade its existing Q-Fax service by fully automating system access, message routing and delivery, as well as by providing accounting functions.

Basically, the program aims at designing a computer-based S/F system, which will concentrate facsimile, word processing and other data terminal traffic at RCA Globcom gateway cities for subsequent transmission overseas at speeds of 9.6 to 56 kilobits/second.

The store-and-forward concept in the system architecture is of particular value to both RCA Globcom and its subscribers as it increases transmission-facility efficiency and smoothes out traffic peaks. Other important advantages of this concept are that it provides for message speed/format conversion, data compression through redundancy removal, and performs other signal processing deemed necessary for interfacing with high-speed transmission facilities. It also makes possible communication between otherwise-incompatible terminals.

Putting it another way, the system will be geared to meet the needs of the electronic office as it is expected to develop in the next decade or so. While it is quite early to accurately predict the traffic volume of a communicating electronic office, a case can be made for a tremendous demand for both domestic and international communications services linking such offices of the future.

To meet this demand, the RCA Globcom's Q-Fax S/F network underpinnings will be the distributed message processing centers in the gateways as shown in Fig. 4, which will facilitate traffic flow by decentralizing domestic and international communications facilities. Each Q-Fax S/F center is perceived as consisting of expandable minicomputer central processors, disk memories, interfaces with data terminals at various speeds, format and protocols, interfaces with public domestic and international packet and circuit-switching data networks, public switched telephone networks, international bearers, accounting/billing computers, and the like

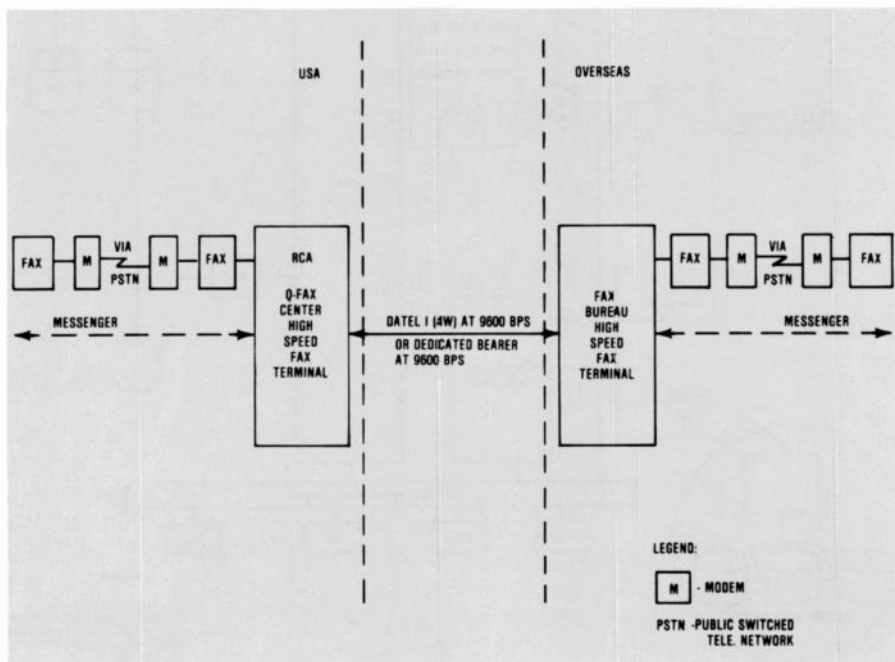

Fig. 3. The system behind Q-Fax.

(Fig. 5). Hardware will be under software control which lends itself to easy expansion or modification to meet future traffic demands.

Functional characteristics

One of the current RCA Globcom programs is the development of techniques enabling low-speed analog facsimile terminals (Group 1 = analog, 6 minutes/page; Group 2 = analog, 3 minutes/page) to communicate with each other, as well as with high-speed digital facsimile equipment (Group 3 = digital, 1 minute/page or less). Experimental models have been built and tested. They have proved the feasibility of the technique and have convinced us to use it in the program implementation phase which is now in progress.

This program achieved compatibility of various analog and digital facsimile terminals, for example, facsimile machines manufactured by Xerox Corp., and 3M Corp., were able to communicate via the S/F system with the same index of cooperation despite differences in resolution and scanning speed. (The index of cooperation is defined in terms of drum size and its rotation speed for Group 1 & 2 machines; the term is not applicable to Group 3 machines. Instead the horizontal and vertical resolution is used to determine cooperation between two machines.) Also, a slow analog machine (4-6 minutes per page) was able to communicate with a high-speed digital facsimile terminal despite significant differences, between the two machines, with respect to speed, resolution, format and protocol. In this instance, the fact that the high-speed machine is not slowed down, and its efficiency is not compromised, is of great importance.

A program is now underway (with work being jointly carried out by Globcom and the RCA Laboratories) to enable facsimile terminals of various makes to communicate on a switched basis.

One of the problems hindering facsimile communications is the incompatibility of facsimile terminals here and abroad. Although some progress has been made recently by U.S. manufacturers, as well as by the International Telegraph and Telephone Consultative Committee (CCITT), in standardizing communication protocols and formats of certain facsimile machines, most terminals are still unable to communicate with each other on either an international or national level. Even those which are able to "talk", produce copy

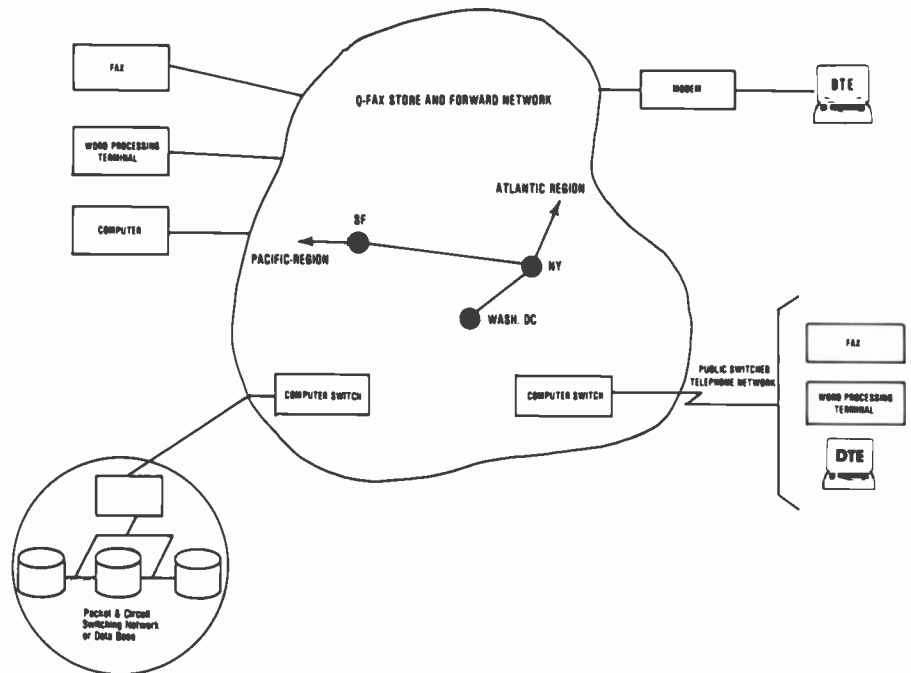

Fig. 4. Q-Fax S/F network distributed processing centers.

whose size of characters and graphics are not identical to that of the original, as their index of cooperation is not the same.

It is anticipated that this problem will be with us for many years, despite standardization efforts, as the state-of-the-art moves ahead producing more efficient

machines. RCA Globcom, however, is committed to the principle of developing international communications standards for the years ahead through active participation in CCITT meetings.

As mentioned earlier, the RCA Globcom Q-Fax S/F system will also enable

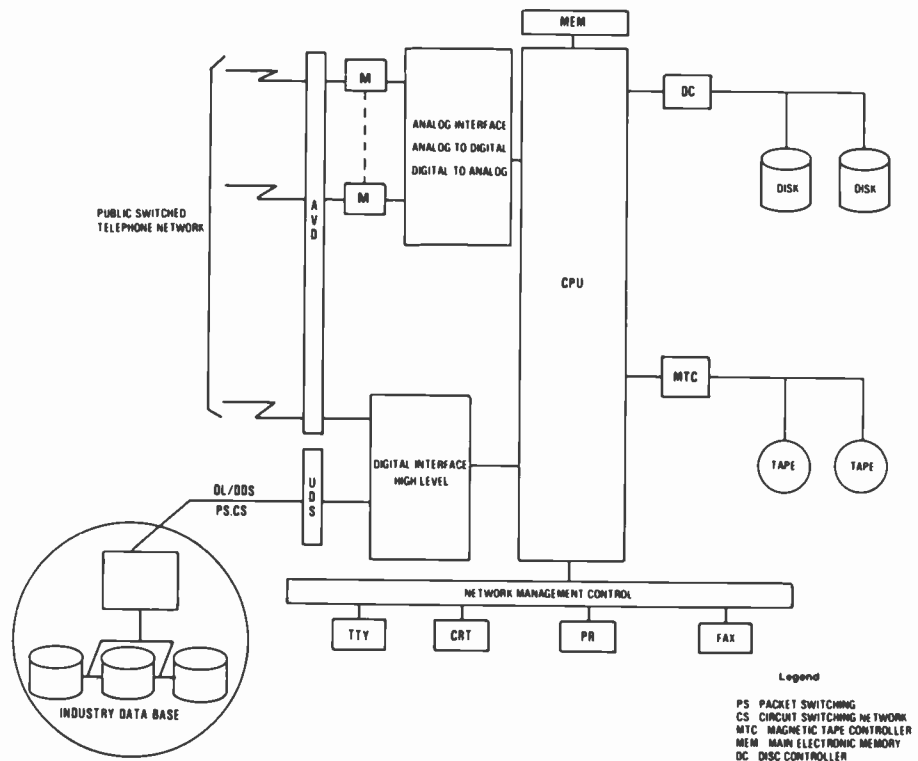

Fig. 5. Q-Fax S/F system configuration.

Legend
 PS PACKET SWITCHING
 CS CIRCUIT SWITCHING NETWORK
 MTC MAGNETIC TAPE CONTROLLER
 MEM MAIN ELECTRONIC MEMORY
 DC DISC CONTROLLER

Table I. Transmission time (seconds; in parentheses) and number of encoded bits for CCITT Test Charts.
Transmission speed is 9,600 bps. At the left side of the table, MH is the Modified Huffman one-dimensional code; READ is the Relative Element Address Designate two-dimensional code.

| document code | No. 1 | No. 2 | No. 3 | No. 4 | No. 5 | No. 6 | No. 7 | No. 8 | average | |
|---------------|---------------------|-------------------|--------------------|-------------------|-------------------|-------------------|-------------------|-------------------|-------------------|-------------------|
| 8 x | MH | 299 130 (31.2) | 268 279 (27.95) | 485 359 (50.6) | 804 239 (83.8) | 494 203 (51.5) | 358 853 (41.5) | 830 138 (86.5) | 47, 998 (49.8) | 507 274 (52.8) |
| | 7.7 K=∞ READ | 203 176 (21.2) | 128 018 (13.3) | 240 966 (25.1) | 529 896 (55.2) | 272 097 (28.3) | 159 948 (16.7) | 483 810 (50.4) | 167 521 (17.5) | 273 179 (28.4) |
| 8 x | MH | 150 720 (15.7) | 134 466 (14.0) | 242 573 (25.3) | 405 564 (42.2) | 249 785 (26.0) | 159 470 (20.8) | 415 475 (43.3) | 238 333 (24.8) | 254 548 (26.5) |
| | 3.85 K=∞ READ | 125 690 (13.1) | 74 636 (7.8) | 152 199 (15.9) | 353 851 (36.9) | 174 741 (18.2) | 94 473 (9.8) | 327 825 (34.1) | 109 378 (11.4) | 176 599 (18.4) |

Transmission speed : 9600 bps
() : transmission time in seconds

various kinds of terminals such as facsimile, word processors, computer printers and teleprinters to communicate with each other. For example, a word processing terminal or computer may transmit to a facsimile terminal; or a word processing unit can talk to another dissimilar terminal after format and protocol conversion by the store-and-forward system.

In an electronic office environment, this communication capability will greatly improve operating efficiency and satisfy the needs of these users.

The rapid proliferation of word processing (WP) units suggests that soon they may overtake facsimile in the number of operating systems in the field. We, therefore, anticipate a strong demand for international communication services for word processing systems as well as between computers and word processors. Although compatible word processors and computers can communicate directly in a circuit switch mode, we feel that the S/F system will offer a better service to the user in terms of quality, cost and other features.

A successful switched Q-Fax service is predicated on the existence of a thorough directory of facsimile, WP and other data terminals here and abroad. RCA Globcom is in the process of compiling this directory, and will publish it as soon as work is completed. A primary source of data for this compilation is our present Q-Fax service accessed by subscribers via facsimile terminals over the public switched telephone network.

The RCA Q-Fax S/F system will compress facsimile data using the relative

Table II. Algorithm for coding method.

| Mode | Elements to be coded | Notation | Code | |
|------------------|-----------------------------|-------------------------|----------------------------------|-------------------------|
| Pass mode | b_1, b_2 | P | 1110 | |
| Horizontal mode | $a_0 a_1, a_1 a_2$ | $H(a_0 a_1, a_1 a_2)$ | $1111 + M(a_0 a_1) + M(a_1 a_2)$ | |
| Vertical mode | a_1 just under b_1 | $a_1 b_1 = 0$ | $V(0)$ 0 | |
| | a_1 on the right of b_1 | $a_1 b_1 = 1$ | $V_R(a_1 b_1)$ | 100 |
| | | $a_1 b_1 \geq 2$ | | $1100 + D(a_1 b_1 - 1)$ |
| | a_1 on the left of b_1 | $a_1 b_1 = 1$ | $V_L(a_1 b_1)$ | 101 |
| $a_1 b_1 \geq 2$ | | $1101 + D(a_1 b_1 - 1)$ | | |

Legend: Transition elements, a_1, a_1, a_2, b_1, b_2 to be encoded are defined in the above figure.

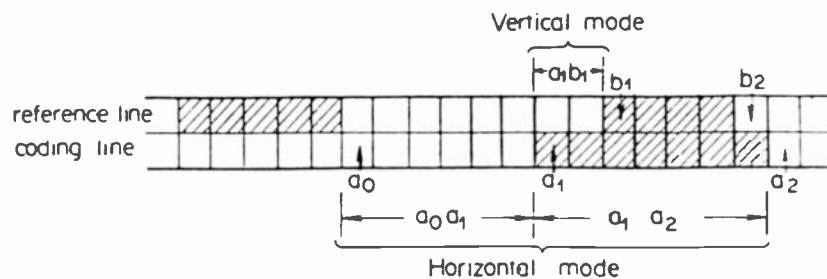

$D(n)$ represents the following n-bit code. $D(n)$: 00...0.1
└──────────┘
(n-1) bit
└──────────┘
n-bits

$M()$ represents horizontal codes defined by CCITT Recommendation T.4.

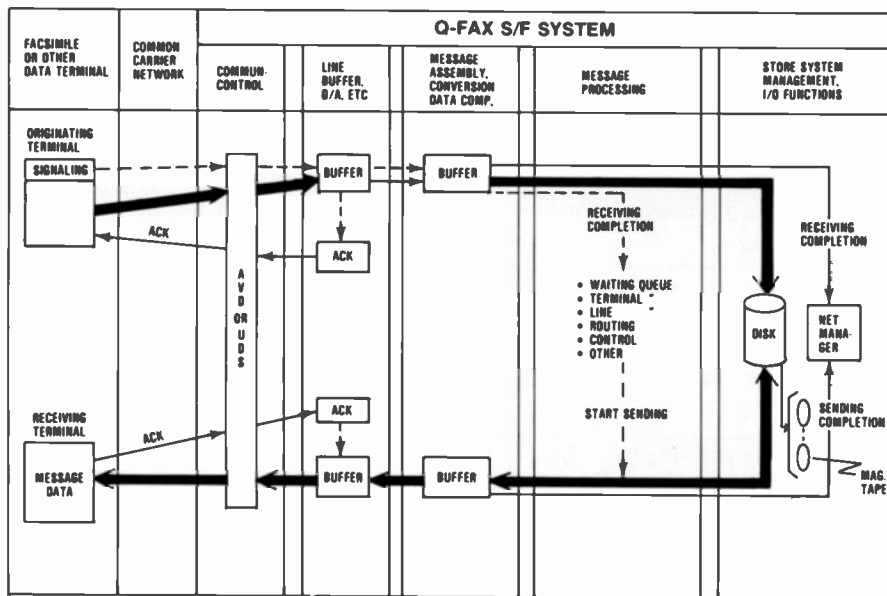

Fig. 6. Typical procedure for CCITT message flow.

element address designate (READ) or similar technique which eliminates redundancy and significantly reduces the data necessary for transmission overseas. Transmission time at 9600 bps and encoded bits for each CCITT digital facsimile test chart is shown in Table I. Based on the information content of the average 8 1/2 x 11-inch page, the data compression ratio is approximately 11:1 for the high-resolution rate of 200 x 200 LPI or about 300,000 bits per page. The READ data compression technique is two dimensional which encodes the bit length between black/white transitions, not only across a single line, but also with respect to transitions of the previous line. The shortest codes are

assigned to bit lengths between transitions with the highest frequency of occurrence. Table II shows the algorithm for this coding scheme.

As Table II indicates, the data compression ratio for the READ technique for the high-resolution mode is approximately 2:1 better than the modified Hoffman run-length coding of the one-dimensional technique.

Message processing

To implement the preceding functions, the following events take place. The subscriber signals the RCA alternate voice data (AVD) or unified digital switch (UDS) switching facilities via a touch-tone telephone or a key pad and provides information concerning his ID, message destination, priority, delivery method or other requirements for special service features. (RCA Globcom's AVD system will be made operational this summer and the UDS soon thereafter.) They will offer subscribers switching services on an analog and digital basis or a combination thereof.

Once a connection is established, a handshake procedure is enacted between the data terminal and the Q-Fax S/F system. This procedure differs from terminal to terminal. A typical handshake procedure for CCITT Group 3 digital facsimile terminals is shown in Fig. 6.

At the end of transmission the subscriber's data terminal requests a message acknowledgment (ACK) from the RCA system, which responds accordingly. If an

ACK is sent by RCA, the message is passed successively from the line buffer to the message assembly or data compression buffers, to the disk storage, according to the instructions of the operating program consisting of several subroutines.

The message remains in disk storage until a transmission facility and the receive terminal are available. At that point the message is taken out of the disk and sent simultaneously to magnetic-tape storage (for later retrieval, if necessary) and to the message assembly, or conversion buffer, thence to the line buffer, AVD/UDS, and finally to the receiving data terminal in a format it can accept.

Upon message receipt by the distant data terminal, it sends an ACK to the RCA system, which will pass it on to the sending terminal if so requested. This sequence of events is shown in Fig. 7.

The system capacity, or system throughput, is dependent primarily upon Central Processing Unit (CPU) processing capacity, main memory limit, and disk memory to line transfer capacity. While it is rather difficult to determine the traffic demand at this time, the initial system capacity will be approximately 3,000 pages per hour to meet the initially expected peak traffic demand. The hardware/software design will provide for modular expansion of the system to satisfy traffic volume increases, as well as new service requirements which will develop as the electronic office approaches reality. The optimum size of the information field in a data block will be selected on the basis of the quality of the line used and its absolute propagation delay.

For international satellite conditioned bearers, an optimum size is 2,048 bits. Terminal level control will be used to manage information flow during facsimile data transmission. Typical commands will be as follows:

- Network control command for communications between Q-Fax S/F systems or the Q-Fax S/F system and a packet switching network.
- Link control command for logical link setup and removal control.
- Flow control command for facsimile flow control.
- Data control for facsimile information control.

As mentioned earlier the Q-Fax S/F system will be under software control. An on-line operating system will supervise the on-line software, as well as execute task control, I/O control, program control,

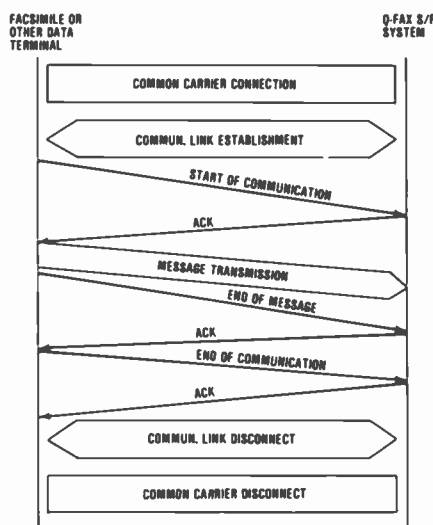
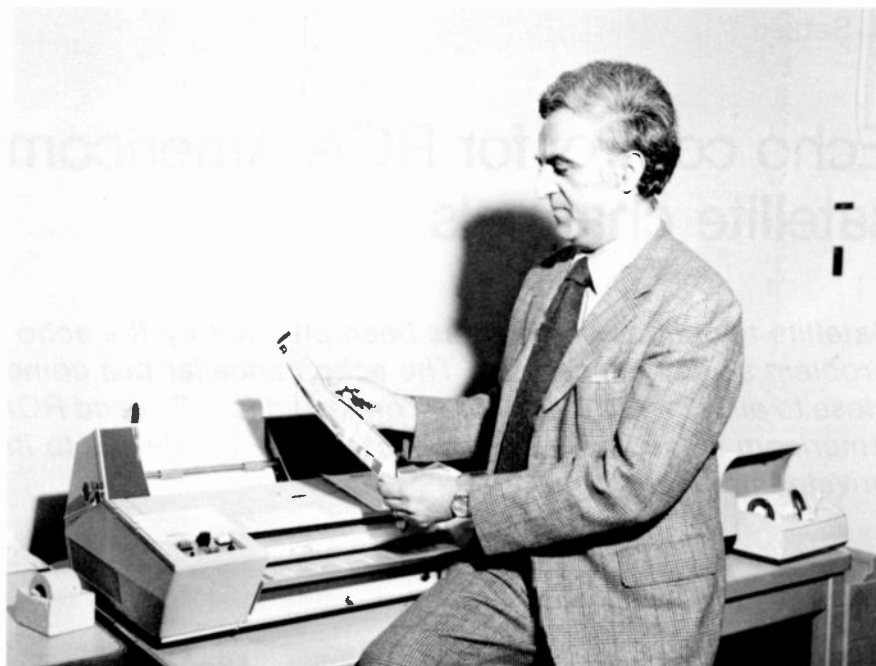

Fig. 7. Message receipt and acknowledgment sequence.

Minas E. Logiadis, Program Manager, Data & Facsimile Services Development, RCA Globcom, has been responsible for the design, development, and implementation of several communications equipment and systems. Recently, he engineered and implemented the U.S. computer communications network for the Society for Worldwide Interbank Financial Telecommunication (S.W.I.F.T.) which enables U.S. member banks to electronically transfer funds to and from other S.W.I.F.T. member banks worldwide. Currently he is responsible for the design and development of a Store & Forward global facsimile and word processing system (designated Q-Fax) to be inaugurated by RCA Globcom in the near future.

Contact him at:

**RCA Globcom
Data & Facsimile Services Development
New York, N.Y.
Ext. 3868**



interrupt control, etc. Following is a brief description of these programs.

The I/O control program will execute system management functions for various I/O devices, such as TTY and CRT.

A communications control program exercises link control of the terminal and transfers data to the line buffer.

The data compression program executes data compression using READ or equivalent techniques for facsimile data.

The compatibility program provides conversion to the format of the receiving facsimile terminal.

A facsimile data handling program provides terminal level processing for communications between facsimile terminals.

The message handling program comprises several subroutines executing control of various kinds over queues and buffer management.

The message processing program controls storage and retrieval in disk storage or magnetic-tape storage.

A management processing program administers system timing, command analysis and execution.

The diagnostic and fault processing program deals with network diagnostics and fault processing, detecting and localizing failures. It reconfigures the system using fall-back facilities, diagnoses equipment condition, initiates system start/stop, controls set-up/closing processing, and reports system status.

The statistics and accounting program will analyze traffic flow and volume, and provide accounting and billing information by location and department of subscribers who access the network.

Store-and-forward features

The enhanced Q-Fax S/F system will also offer the following special features, i.e.:

1. *Broadcast mode.* Subscribers will be able to request that RCA Globcom transmit their message to many stations at the same time. The receiving stations could be equipped with various types of facsimile terminals, WP systems or other data terminals which may or may not be compatible with the sending terminal.
2. *RCA Globcom Confirmation.* RCA Globcom, upon receiving a document/message, will notify the subscriber terminal if it was received satisfactorily.
3. *Delivery confirmation to a distant location.* RCA Globcom's system upon receiving an acknowledgment (ACK) or negative acknowledgment (NACK) from the receiving terminal will pass it on to the sending terminal, if so requested by sender.
4. *Message priority.* Two priority levels

will be offered, one aimed at fast transmission, the other at low efficiency.

5. *Polling.* A subscriber's station will be polled by the system at a specified time, if so requested.
6. *Message receive hold or forward.* This feature will be used by subscribers wishing to have the system hold their message until they request transmission, either to their own terminal or to another terminal they specify (confidential transmission).
7. *Message retrieval within a specified period.* The system will store messages already transmitted for a limited time to allow subscribers to retrieve them for correction, control and other purposes.
8. *Automatic billing by department and company location.* The Q-Fax S/F system will identify subscribers by department and company location, and pass this information on to them at the end of the month along with number of pages sent, addressee information, time, date, and other data.

Acknowledgment

The author wishes to express his sincere appreciation to Mr. R.J. Angliss, Executive Vice President, RCA Globcom Switched Services, for his valuable suggestions and comments.

Echo control for RCA Americom satellite channels

Satellite telephone service has been plagued by the echo problem since its inception. The echo canceller has come close to eliminating the problem once and for all — and RCA Americom is leading in the application of this device to its private line circuits.

Introduction

The introduction of satellites as a transmission facility for voice communications has added a new dimension to the problem of echo control in telephone circuits. Formerly, long line terrestrial transmission links used devices which were designed to provide an acceptable level of telephone circuit noise and echo for 99 percent of the population. However, the satellite link has rendered these devices unsatisfactory for a high percentage of the population, even when appropriate changes were made for the long delay of the satellite link. Therefore, objectionable results were obtained from early satellite telephone circuits because of the application of an outdated echo control technology. In fact, it has been determined from surveys that over 85 percent of potential satellite voice circuit users have been reluctant to use them because of the echo control problem. In the early 1970s, technological programs were introduced to solve the problem.

RCA Americom has been working jointly with industry to advance the state of the art, and currently is leading in the application of the latest device, called an echo canceller, to its private line circuits. The echo canceller will finally come very close to eliminating the echo problem once and for all.

The following article reviews the circuit parameters that cause echo and discusses

Abstract: *The fundamental problems caused by echo on telephone plant circuits and the circuit parameters are outlined. How these problems are solved and the efficiency of the solution is of major importance. The need for echo control on satellite channels is defined and two*

the operation of the echo suppressor and echo canceller in satellite telephony.

Fundamentals

An echo can be defined as a reflection of electric or acoustic energy. In many applications, reflection of electromagnetic waves is desirable, such as in radar or troposcopic communications, but reflection of speech is generally undesirable. Reflections occur at irregularities of transmission mediums and this is also true of telephone communication systems.

To determine the historical cause of communication circuit irregularities, it is interesting to reconstruct the development of the equipment leading to the present telephone plant. Consider first the telephone instrument itself. Naturally, a microphone is required to convert the speech to electrical energy and a speaker converts the electrical energy to acoustic energy. These devices each normally require a pair of leads.

methods of control are discussed and compared: echo suppressors and echo cancellers. The basic principles of echo suppressors are outlined. The conditions that cause the need for echo cancellers and how echo cancellers successfully solve the echo problem are also described.

Next, considering the objective of interconnecting subscribers great distances apart, it would be desirable to carry both the transmitted and received signals on the same pair of wires. This is indeed possible by using a simple transformer incorporated into the telephone set as shown in Fig. 1. Transmitter currents flow in opposite directions through windings A and B and cancel each other's effect in winding C to the same degree that impedances Z_{BAL} and Z_o match each other. These impedances are intentionally different so that a voltage is induced in winding C (called sidetone) and makes the instrument sound "alive". Also, received signals from the central office flow through windings A and B in series and provide the receive audio. The components providing this 2-wire to 4-wire signal separating function have come to be called the terminating set, or "term set."

Next, consider the interconnection of telephone sets which are carried on a 2-wire

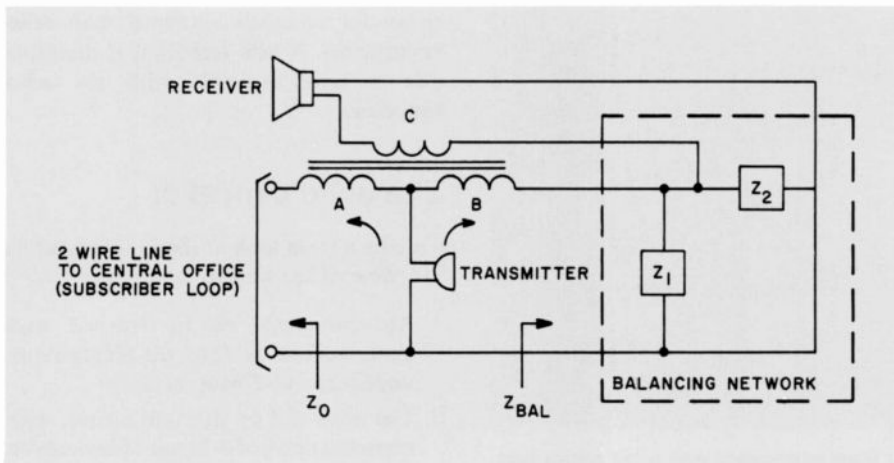

Fig. 1. The transformer in the typical telephone set permits the same pair of wires to carry both the transmitted and received signals.

basis to a switching office and then transmitted on a carrier facility (4-wire basis by nature) where many channels are multiplexed together. This is shown in Fig. 2. Note that the telephone set is shown as a 2-wire device but actually contains an integral term set. A term set is also required at each central office to separate the directions of transmission; but these term sets should be balanced as much as possible to accept the 4-wire receive (RX) from subscriber A, for example, at central office B and transmit it to the 2-wire facility toward subscriber B. This is shown as the direct speech path in Fig. 2. Leakage at the distant end from the 4-wire receive (RX) to the 4-wire transmit (TX) provides an undesirable echo path. The amount of leakage is called return loss (also echo return loss, or ERL) and can be expressed in decibels as:

$$ERL = 20 \log_{10} \left| \frac{Z_{BAL} + Z_{sub}}{Z_{BAL} - Z_{sub}} \right| \text{ dB}$$

Z_{sub} is determined primarily from the constants of the cable transmission line since the impedance of the telephone set can be controlled and the switching office is designed to provide negligible impedance transformation. However, each subscriber varies in distance from the central office and this causes a tremendous variation in Z_{sub} . Impedance compensation for each subscriber line is almost as economically prohibitive as providing 4-wire transmission for each line.

Z_{BAL} is selectable by circuit design but only a compromise value can be chosen to match the average value of Z_{sub} . The wide statistical variation in Z_{sub} is nevertheless well known and results in a distribution of ERL that has been shown to have a normal

probability density function. The distribution of subscriber loop impedance can be approximated by a normal probability density function, as shown in Fig. 3, but the approximation is not generally used. In any event, an average value of Z_{SUB} has been historically chosen as the "average subscriber loop."

Thus,

$$Z_{BAL} = \text{Average } [Z_{SUB}] = R + jX_c,$$

where $R = 900$ ohms, $C = 2.16 \mu F$.

Studies of the subjective reaction to echo over the range of expected ERL values have shown that the quality of the connection degrades as the echo is delayed in time. For short delays, the echo appears as additional sidetone and is no problem. For longer delays the same amount of echo is more objectionable and finally becomes intolerable. However, within limitations, it is possible to introduce direct loss in each direction of transmission to reduce the echo to an acceptable level. This loss should be introduced as a function of propagation delay (distance). The direct speech signal suffers the loss once but the echo path includes the loss twice.

This technique of introducing loss as a function of distance has been called the Via Net Loss plan (VNL)¹ and has been the basis of the Bell System terrestrial network design. Figure 4 shows the amount of loss required. Above 45 msec, the loss is excessive and an echo suppressor is required. Since the round trip delay of a satellite channel is approximately 600 msec, all satellite channels are equipped with echo suppressors.

Echo suppressors—how they work

The basic operating principle of an echo suppressor is to provide a direct speech path under some conditions and to interrupt the echo path under others. Note that the direct speech path used when one subscriber is talking becomes the echo path when the other subscriber is talking, as shown in Fig. 5. This is a split-type echo suppressor where one device is provided at each end. When only one person is talking, B, for example, B's TX PAD is set to 0 dB as is A's RX PAD. Therefore, no loss is encountered from B to A. Also A's TX PAD is set to 50 dB to prevent B from hearing his own echo, but this is no problem since A is not talking anyway. The circuit is symmetrical for single talker conversation in the reverse direction.

The problem is what to do when both parties talk at the same time. The design shown in Fig. 5 detects this double-talking condition and each suppressor switches in a 6 dB pad in the receive direction. (Actually the suppressor of the active speaker had switched in its 6 dB pad in anticipation of this state). These pads attenuate the direct speech of each talker by 6 dB and, as shown in the previous section, reduce the talker echo by 12 dB. The values chosen evidently represent a compromise. Also, the ERL distribution of $11\sigma 3$ dB (meaning normal

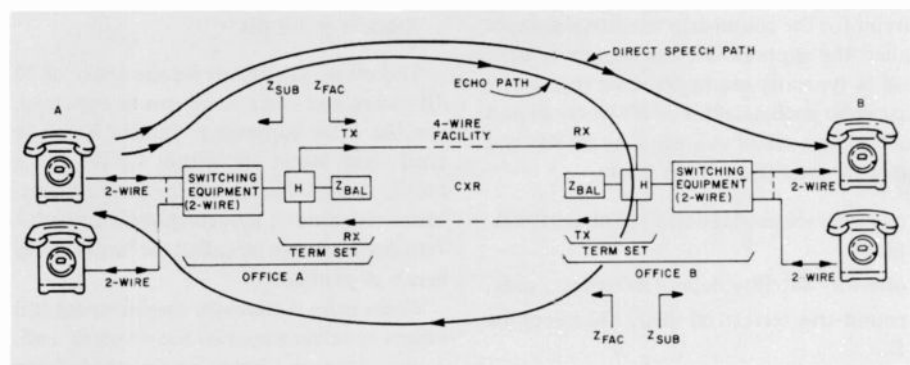

Fig. 2. Illustrating the use of "term sets" at each central office to provide 4-wire capability.

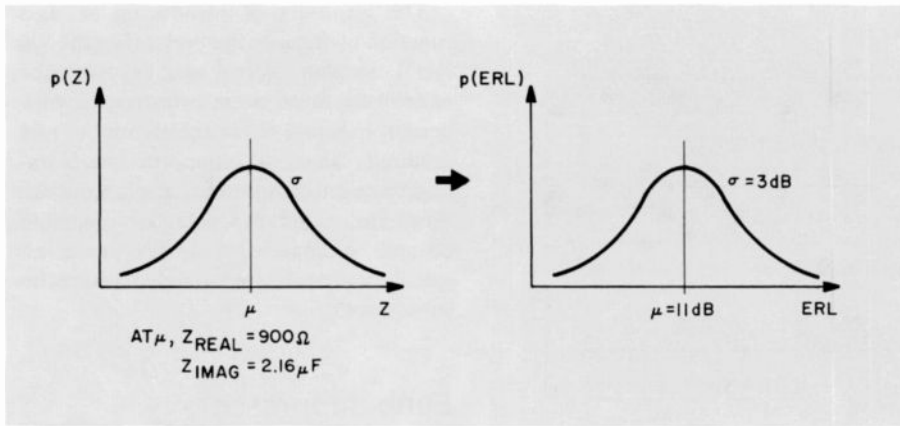

Fig. 3. Probability density functions of subscriber loop impedance and echo return loss.

distribution with mean of 11 dB and standard deviation of 3dB) is added to 12 dB to provide the overall level of echo protection. This approach does not satisfy VNL rules for echo protection but this is only true for the double-talk state.

Suppression loss hangover time

To gain further insight into echo suppressor operation, consider one of the timings involved in switching these pads in and out. The round-trip delay of the terrestrial link from the echo suppressor output through the hybrid and back to the echo suppressor input is called the echo path delay. This delay is a function of distance and, for domestic satellite circuits with both ends in the same country, the terrestrial delay typically ranges 0-30 msec. Now, consider a graceful transition from a single-talker state with A talking to a single-talker state with subscriber B talking, with a quiet interval in between. When A is talking, B's transmit pad is set to 50 dB but when A stops talking, B's pad should remain in the circuit for the echo path delay. The timing involved in holding the transmit pad (suppression pad) in the circuit for the round-trip terrestrial delay is called the suppression loss hangover time and is typically set to 60 msec (for worst case echo path delay). For B's transmit pad to suppress all of A's echo by 50 dB, the quiet interval must be at least:

- one-way terrestrial delay (15 msec) for A, plus
- one-way satellite delay (300 msec), plus
- round-trip terrestrial delay (30 msec) for B.

In other words, all echo can be sup-

pressed by 50 dB if the conversation is not more interactive than 345 msec. However, this is not likely and if B interrupts before this critical interval has expired, the suppression pad must be switched in to carry B's signal, and A's echo is returned (the suppressor loss hangover protection is lost).

The performance becomes even worse when one considers the detection threshold of the double-talker detectors of Fig. 5. Recall that the ERL distribution of the terrestrial link is 11 ± 3 dB. Using the 2σ low as the minimum ERL to be encountered, 5 dB can be expected. Now, the echo suppressor must be designed so that a constant echo of 5 dB does not create a double-talker or break-in condition, otherwise the unit would always be in double-talk and the performance would be very poor. Therefore, voice levels must be closer than 5 dB to cause break-in, and a comparative difference of +1.5 dB has been selected.

However, the following variations can be listed in the voice levels applied to the echo suppressor:

1. zero to seven decibel variation in subscriber loop losses,
2. zero to three decibel variation in carrier and cable gain stability,²
3. talker volume distribution with $\mu = -15$ dBm, $\sigma = 5.8$ dB.³

Therefore, variations on the order of 10 dB in average voice levels can be expected, but the echo suppressor cannot break-in until voice levels are within 1.5 dB. As a result, speech bursts can be lost entirely. More commonly, speech chopping results. This problem can be called the "equal-level break-in problem."

These echo suppressor impairments and others have been studied for 40 years³ and, while substantial improvements have been made, the basic impairments still remain

today for channels equipped with echo suppressors. A new technique is desirable and is now available with the echo canceller.

The echo canceller

To take a fresh look at the problem, let us list some of the known conditions.

1. An echo signal will be returned, with expected loss of 11 ± 3 dB (depends on impedance of 2-wire section).
2. The echo will be delayed in time, with expected delay of 0-30 msec (depends on length of 4-wire terrestrial section).
3. The signal which will become the echo is available in time before the actual echo is generated.

Therefore, if the signal which will become the echo is stored and the terrestrial level and delay are somehow determined, an estimate could be made of the expected echo. This estimate can then be subtracted from the actual circuit echo when it occurs. Furthermore, the estimate can be updated to further reduce the actual echo. A block diagram of such a circuit is shown in Fig. 6 and is called an echo canceller. This concept was basically developed by Comsat Labs.

The echo canceller, under a single talk condition, samples and stores the voice signal present at the satellite receive (SAT. RX) input and uses this as the first estimate of the echo (perhaps reduced by 11 dB). When the actual echo is received at the terrestrial transmit (TERR.TX), the es-

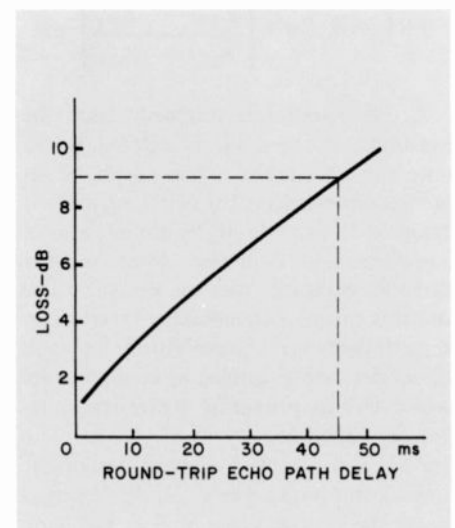

Fig. 4. The amount of loss required to reduce echo level increases with echo path delay.

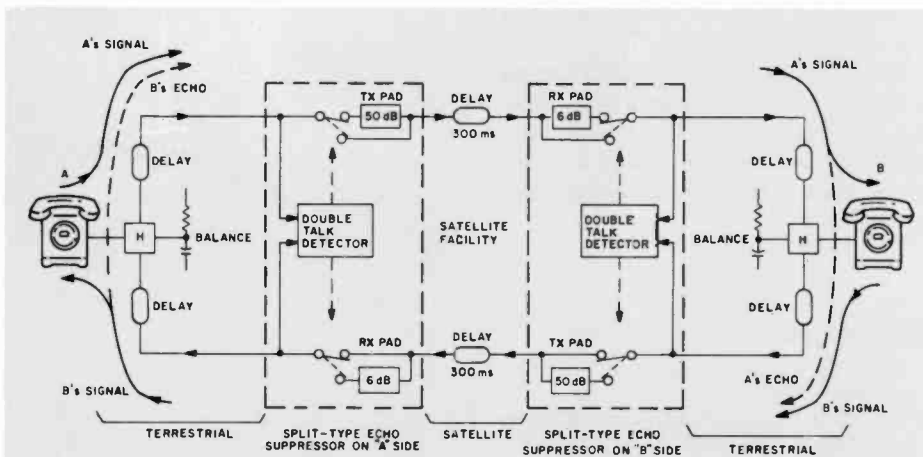

Fig. 5. A split echo suppressor connects the transmit speech path when one subscriber is talking but disconnects it when the other subscriber is talking (since this path is now the undesirable echo path)."

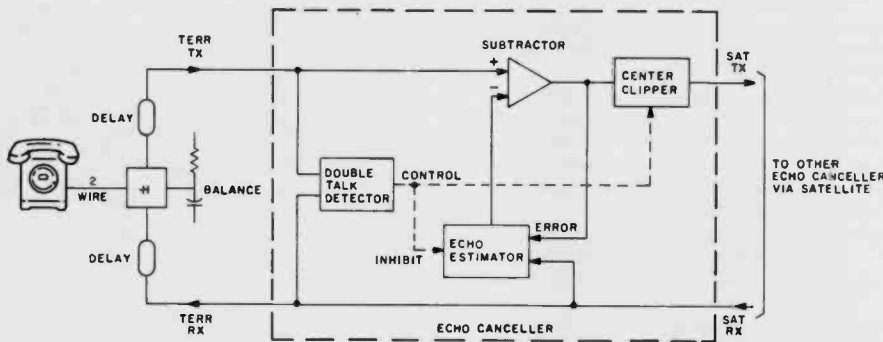

Fig. 6. The echo canceller estimates the expected echo level, then subtracts the estimate from the actual circuit echo when it occurs.

imate is subtracted from it and an error signal is generated. The error signal updates the echo estimate to reduce the error to a minimum. This process is called convergence, and generates a model of the echo path.⁶

Estimating the echo

The accuracy of the echo estimate, and thus the degree of cancellation is determined from several things. First, the actual error signal is contaminated with terrestrial noise. The echo canceller converges on the echo signal and also attempts to converge on the noise which continually changes the echo estimate to a small degree. Also, the structure of sampling, storing and correlating the actual and estimated echo signals limits the amount of resolution. Finally, the step size used in adjusting the echo estimate affects the residual echo left after cancellation, and results in an interesting tradeoff.⁵ If the step size is large, the speed of convergence will be fast but the

resolution will be limited. If the step size is small, convergence will be slower but the degree of cancellation will be better.

Considering these variables, the raw subtraction process is limited to about 30 dB of echo cancellation, with convergence in approximately 250 msec. It is desirable to achieve even further echo cancellation, for the single talker state, on the order of 45-50 dB. This is accomplished by removing all signals below a certain threshold, in the residual echo path (after subtraction). Signals above the threshold are not appreciably affected. This operation is called center clipping, and is also shown in Fig. 6. The center clipper rejects small signals (i.e., residual echo not cancelled by the subtractor plus terrestrial noise) but passes large signals (i.e., direct speech). The center clipper of an echo canceller is comparable to the suppression pad of an echo suppressor. In fact, an echo suppressor can be considered to be a center clipper with a very high threshold⁵; but it rejects all signals, wanted or unwanted.

The beauty of the echo canceller techni-

que is apparent during the double talk condition. Assuming that a period of single talking has occurred, the echo canceller will have converged on the line characteristics. Approximately 45 dB of echo cancellation is achieved after 250 msec with the center clipper "in" the circuit. Now, when double talk begins, the echo canceller must not be allowed to operate on the local signal and echo at the same time since this will adversely affect the echo estimate. The local direct speech signal would give a tremendous error in the echo estimate since it is not related to the distant signal. Therefore, the echo estimator must be inhibited from updating on the error signal as soon as double talk is detected. However, the echo estimator still maintains an accurate model of the echo path and continues to subtract the echo. The only possible problem occurs if the line characteristics change during the period of double talking but this is not very likely. Also, the center clipper is switched "out" of the circuit since it serves no useful function at this time and would only distort the near-end speech. Therefore, continuous double talking is possible with echo cancellation of 30 dB at each end. No speech bursts are lost since the process is continuous.

The processes involved in echo cancellation lend themselves to microprocessor control. First, the speech signal destined to become the unwanted echo signal must be sampled and stored for the maximum roundtrip terrestrial delay. For sampling at the Nyquist rate of $1/2f_{max}$ ($= 125 \mu\text{sec}$) and storing for 30 msec, 240 samples are required. Using a 12-bit speech sample and a 9-bit representation of the line impulse response,⁷ a minimum mean-square error algorithm used to converge the canceller would require 250 multiplications of 12 by 9 bits and 250 additions of these products during every sampling period. Another Comsat design⁷ uses logarithmic encoding to reduce hardware and calculation complexity and saves 28 percent of the memory space required for the previous Comsat design.⁸

Comparison of performance and conclusion

The quality of a satellite channel equipped with an echo suppressor is a function of many variables. In some cases, the quality is excellent and no practical improvement is possible with an echo canceller.⁸

For example, the performance of the

Table I. Performance ratings of circuits using echo suppressors and prototype echo cancellers, all operating under the same conditions (for domestic circuits).

| Type of circuit | Percentage of calls rated fair and poor |
|----------------------------------|---|
| Terrestrial with echo suppressor | 10 |
| Composite with echo suppressor | 21 |
| Satellite with echo suppressor | 34 |
| Satellite with echo cancellor | 12 |

channel equipped with an echo suppressor would no doubt be rated excellent if the following conditions exist:

1. the circuit ERL is 17 dB or greater (2σ high of 11σ dB distribution);
2. the terrestrial links exhibit little variation; and
3. the users adjust their talker volumes to overcome the "equal level break-in" problem and subconsciously limit the interactiveness of the conversation (become "polite").

However, as these variables deteriorate, so does the performance. The echo canceller, on the other hand, exhibits a more uniform range of excellent performance over the same range of variables. Some results of a comparison between echo suppressors and prototype echo cancellers operating under the same conditions (for domestic circuits) are given in Table I and include composite circuits (terrestrial channel in one direction and satellite channel in the other direction).⁹ Composite circuits have slightly more than one-half the roundtrip delay of a full satellite channel and thus would require less reduction of echo signals than a full satellite channel, for the same level of performance.

Thus the echo canceller makes the satellite channel perform as well as a terrestrial channel. Prototype Comsat Laboratories echo cancellers were used in this test.

RCA Laboratories also conducted comparative tests of echo cancellers and echo suppressors. Their results confirm the excellent performance of echo cancellers under a wide variety of circuit conditions. Then, RCA Americom field-tested several units on demonstration and customer

channels and the performance was well received by the customers.

As a result, RCA Americom is intending to apply echo cancellers on a large scale. This improved channel quality will assist RCA Americom in maintaining a strong market share of the private leased channel business.

References

1. "Notes on Distance Dialing," 1975 Edition, published at AT&T.
2. "Data Communications Using Voiceband Private Line Channels," Bell System Technical Reference, PUB 41004.
3. *Transmission Systems for Communications*, Bell Telephone Laboratories, Revised Fourth Ed., Chapter 9 (1971).
4. Brady, P.T., Helder, G.K., "Echo Suppressor Design in Telephone Communications," *Bell System Technical Journal*, Vol. 42 (1963).
5. Weinstein, Stephen, B., "Echo Cancellation in the Telephone Network," *IEEE Communications Society Magazine*.
6. Campanella, S.J., Suyderaud, H.G., Onufry, M., "Analysis of an Adaptive Impulse Response Echo Canceller," *Comsat Technical Review* (Spring 1972).
7. Horna, O.A., Dr., "Echo Canceller with Adaptive Transversal Filter Utilizing Pseudo-Logarithmic Coding," Comsat Laboratories.
8. Suyderaud, H.G., Campanella, S.J., Onuffy, M., "Results and Analysis of a Worldwide Echo Canceller Field Trial," *Comsat Technical Review* (Fall 1975).
9. Helder, G.K., Lopiparo, P.C., "Improving Transmission of Domestic Satellite Circuits," *Bell Laboratories Record* (Sept 1977).

Russ Setzer is a senior member of the engineering staff, and as a member of the advanced technology group he is engaged in research and development of satellite echo control and compandor programs.

Contact him at:
RCA Americom
Piscataway, N.J.
Ext. 4224

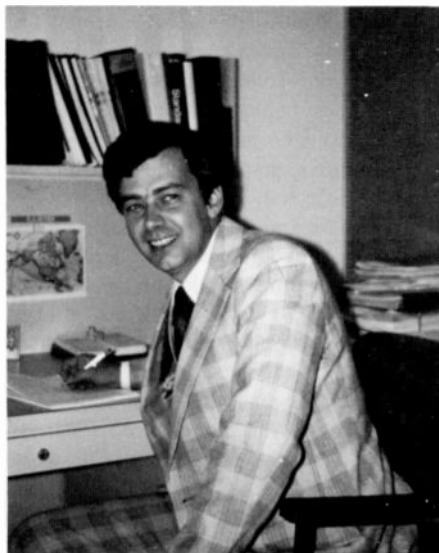

Calls for papers

Ed. Note: Calls are listed chronologically by meeting date. Listed after the meeting (in bold type) are the sponsor(s), the location, and deadline information for submittals.

SEP 16-19, 1979—**1979 Fall Meeting—Electronics Div.** (American Ceramics Soc.)

"Electronic Ceramics & Energy Conversion," Williamsburg, VA **Deadline Info:** David Hill, TI, Inc., 34 Forest St., MS-10-13, Attleboro, MA 02703 (617-222-2800 ext. 7338)

JAN 7-10, 1980—**14th IEEE Photovoltaic Specialists Conf.**, San Diego, CA **Deadline Info:** 7/15/79 300-word abstract to: Charles E. Backus, College of Engineering and

Applied Sciences, Arizona State University, Tempe, AZ 85281

FEB 26-28, 1980—**CLEOS/ICF 80** (IEEE) San Diego, CA **Deadline Info:** 10/1/79 35 word abstract/2-500 word summary to CLEOS, c/o Optical Society of America, Suite 620, 2000 L Street, N.W., Washington, DC 20036

Pen and Podium

Recent RCA technical papers and presentations

To obtain copies of papers, check your library or contact the author or his divisional Technical Publications Administrator (listed on back cover) for a reprint. For additional assistance in locating RCA technical literature, contact RCA Technical Communications, Bldg. 204-2, Cherry Hill, N.J., extension 4256.

Astro Electronics

K. Eng

Mathematical problems arising from passive intermodulation interference in communications satellites—Thesis: Columbia University, New York (3/9/79)

J.M. Goode

Hardware-software tradeoffs—IEEE Lecture Series on Software Engineering, Burlington, Mass. (4/79)

M.L. Johnson

Controlling the logistic support analysis—Society of Logistics Engineers, Boston Chapter, Billerica, Mass. (4/79)

R.M. Unetich|W.M. Boyd

Advances in television transmitter technology—International Television Symposium and Technical Exhibition, Montreux, Switzerland (5/28/79)

Advanced Technology Laboratories

G. Hunka|S. Damon

Engineering evaluation of an aided-track digitizing cursor system—1979 ASP-ACSM Annual Convention, Washington, D.C., *Proceedings* (3/18-24/79)

J.C. Willett

Solder problem elimination by design—Lowell University Continuing Education Printed Circuit Workshop, Lowell, Mass. (4/79)

Government Communications Systems

H. Barton, Jr.

Learning curve computations by computer—EIA G-47 Committee, Washington, D.C. (5/15/79)

E. Shecter

Report of quality and reliability assurance committee—NSIA ORAC Committee, Washington, D.C. (3/21/79)

Broadcast Systems

W.M. Boyd

Solid-state technology in television transmitters—WABE Conference, Edmonton, Alberta, Canada (5/8/79)

D. Hampel|K. Prost

Target activated munitions micro-signal processor for classification and ranging—1979 Fuze Section, Annual Mtg., Moline, Ill. (3/7/79)

R. Tarzaiski|C. Reno

Optical disc recording at 50 megabits/second—1979 SPIE Conference, Washington, D.C., *Proceedings* (4/17-20/79)

R.S. Hopkins

Digital signal origination and processing in the 525 line TV standard—Montreux Symp., Switzerland (5/27/79)

C. Humphries

The design of a digital time division multiplexed voice switching matrix—Thesis: University of Pennsylvania (5/4/79)

Automated Systems

H.L. Fischer

Microprocessing applications in non-electronic testing—IEEE Technical Mtg., Education & Computer Chapters, Cambridge, Mass. (4/79)

A.H. Lind

Comments on digital recording—Montreux Symp., Switzerland (5/27/79)

B.E. Tyree

Ground mobile force tactical satellite terminals—AFCEA (3/22/79)

L.J. Thorpe|R.A. Dischert

The microprocessor controlled TK-47 autocam camera—Montreux Symp., Switzerland (5/27/79)

D.M. Ward

A model for maximizing use of state-of-the-art technology in new communications systems—Cleveland Electronics Conference, Inc., Ohio, *Publ. Conf. Record* (6/6-7/79)

Laboratories

C.R. Carlson

Masking of spatial information — Modeling and Simulation Conf., Univ. of Pittsburgh, (4/79) *Proceedings*

C.R. Carlson | R.W. Cohen

Visibility of information on sampled/raster displays — SID Int. Symposium, Chicago, Ill., (5/79) *Digest of Technical Papers*

D.E. Carlson | C.W. Magee | A.R. Triano

The effect of hydrogen content on the photovoltaic properties of amorphous silicon — *J. of the Electrochemical Society*, Vol. 126, No. 4 (4/79)

C.R. Carlson | A. Pica

Invariance in sine-wave contrast discrimination — Assoc. for Res. in Vision & Ophthalmology, Sarasota, Fla. (4/79) *Supplement to Investigative Ophthalmology and Visual Science*, p. 61 (4/79)

R.L. Crane | R.W. Klopfenstein

Optimum weights in delay equalization — *IEEE Transactions on Circuits and Systems*, Vol. CAS-26, No. 1 (1/79)

D.A. deWolf

Operator and diagram techniques for solving intensity moment equations in random media: application to strong scattering — *Radio Science*, Vol. 14, No. 2, pp. 277-286 (Mar/Apr 1979)

D.A. deWolf

Optical propagation through turbulent air — *Optics and Laser Technology* (2/79)

J.I. Gittleman | E.K. Sichel | Y. Arie

Composite semiconductors: selective absorbers of solar energy — *Solar Energy Materials*, Vol. 1, Nos. 1, 2, pp. 93-104 (2/79)

I. Ladany | H.J. Wolkstein | D. Botez

R.S. Crandall | B.R. Dornan

D.R. Patterson | B.E. Tompkins

A 500 MHz driver for single-mode fiber-optic communication systems — *Proceedings*, 1978 IEEE International Electron Devices Meeting

G.H. Olsen | C.J. Nuese | M. Ettenberg

Low-threshold 1.25 μm vapor-grown InGaAsP CW lasers — *Applied Physics Letters*, Vol. 34, No. 4 (2/15/79)

D.O. North

Dielectric-waveguide-modal properties: a new analysis of the one-dimensional wave equation — *IEEE J. of Quantum Electronics*, Vol. QE-15, No. 1 (1/79)

E.S. Sabisky | H.A. Weakliem

An operating development model spacecraft hydrogen maser — *Proceedings* of the 1978 Annual Frequency Control Symposium U.S. Army Electronics Command, Ft. Monmouth, N.J.

H. Schade

Work functions and sublimation entropies of the elements — *Applied Physics* Vol. 18, pp. 339-344 (1979)

H.S. Sommers, Jr.

Current dependence of spontaneous emission and of junction resistance as a test of the internal dynamics of injection lasers — *Applied Physics Letters*, Vol. 34, No. 7 (4/1/79)

J.L. Vossen

The preparation of substrates for film deposition using glow discharge techniques — *J. Phys. E: Sci. Instrum.*, Vol. 12 (1979)

Missile and Surface Radar

J.A. Bauer

Advantages and applications of chip carriers to complex hybrids — ISHM, Metropolitan New York Chapter (5/3/79)

J.A. Bauer

Experience with chip carriers — International Electronics Packaging Society workshop, Philadelphia, Pa. (5/14/79)

M.W. Buckley

Project management — IEEE Central Indiana Section (3/79) The University of Washington, EE Dept., IEEE Seattle Section, Seattle, Wash. (3/30-31/79) Instructor, IEEE Continuing Education Prog., Billings, Mont. (5/9-10/79)

S. Fazzolari

Data structure design for large simulators — Tenth Annual Modeling and Simulation Conf., Pittsburgh, Pa. Published in *Proceedings*. (4/79)

F.R. Freiman | R.E. Park

The PRICE software cost model — *NAECON 79*, Vol. 1, p. 280, (5/79)

H.B. Gould | G.W. Suh

Managing change in large software projects — Tenth Annual Modeling and Simulation Conf., Pittsburgh, Pa. Published in *Proceedings* (4/79)

D.J. Herman

Computer programming skills in engineering — Rutgers University, Camden Campus (4/11/79)

T.G. Greene

How electronics is changing our lives — Woodbury High School, Woodbury, N.J. (4/4/79)

S.L. Hazen

Structural mode control in large aircraft — IEEE Control Systems Section, University of Pennsylvania (3/79)

R.A. Kasmar

Tradeoffs in real-time simulator design — Tenth Annual Modeling and Simulation Conference, Pittsburgh, Pa. Published in *Proceedings* (4/79)

R.D. Kemp

The user-oriented technical manuals for AEGIS — ADPA Technical Documentation Division Annual Meeting, Monterey, Cal. *Conference Digest* (5/22-25/79)

P. Levi

Radar panel report, Part A — Air Force/Industry ESD Manufacturing Cost Reduction Study, Vol. II, Panel Reports (12/78) - issued in April 1979

F.E. Oliveto

Configuration computer suites for system performance, reliability and availability - a systems approach — 10th Annual Reliability Technology Seminar, American Society for Quality Control, Philadelphia, Pa. (5/24/79)

W.T. Patton

Microwave design for reliability/availability - the AN/SPY-1A radar — *Microwave Journal* (3/79)

R.J. Rader

Real-time software development — N.Y. Academy of Sciences, New York City (2/79)

A. Schwarzmann

Performance of porcelain-metal substrate at microwaves — Electronic Component Conference, Cherry Hill, N.J. *Conference Digest* (5/14-16/79)

T.M. Shelton

A simplified fixture and reflow method for adhesion sample test preparation — International Society for Hybrid Microelectronics, Cherry Hill, N.J. (4/19/79)

H. Urkowitz

Indistinguishable signals — *Proceedings of the IEEE*, Vol. 67, pp. 694-695 (4/79)

H. Urkowitz

Reducing straddling losses in detection and estimation by digital interpolation — Electrical Engineering and Science Colloquium, University of Pennsylvania (2/79)

Solid State Division

M.N. Slater

Conflict and Cooperation: A Government-Industry Case History — 34th Annual Purdue Industrial Waste Conference (5/8-10/79)

Patents

Advanced Technology Laboratories

B.W. Siryj
Thermal processor—4148575

Commercial Communications Systems

L.J. Bazin
Automatic cable equalizer circuit—4151490

A.T. Crowley
Phase-locked loop with variable gain and bandwidth—4156855

P. Foldes
Helical antennas—4148030 (assigned to U.S. government)

P. Foldes
Subwavelength monopulse antenna—4148035 (assigned to U.S. government)

R.M. Kongelka|P.L. Buess
Switched microphone hang-up bracket—4151467 (assigned to U.S. government)

T.P. Ohrman
Magnetic tape position measuring system—4151566

Consumer Electronics

B.W. Beyers, Jr.
Display system for facilitating the setup of a tuning system—4156850

J.K. Kratz|E.W. Christensen, 2nd
Adjustable yoke mounting for in-line beam color television picture tube—4151561

D.W. Luz|J.C. Peer
Complementary latching disabling circuit—4147964

J. Stark, Jr.
Over-voltage amplitude prevention circuit for high voltage and deflection generating system—4149209

Laboratories

P.K. Baltzer
Parallel access memory system—4150364

A. Bloom|L.K. Hung
Liquid crystal dyestuffs and electro-optic devices incorporating same—4153343

T.L. Credelle|W.J. Hannan|F.W. Spong
Broadening the spatial frequency pass band of a thermoplastic layer—4148636

W.R. Curtice
Time displaced signal sorting apparatus—4147941

D.A. DeWolf|C.A. Catanese
Electron multiplier output electron optics—4149106

M.T. Gale|H.W. Lehmann|R.W. Widmer
Color diffractive subtractive filter master recording comprising a plurality of superposed two-level relief patterns on the surface of a substrate—4155627 (assigned to U.S. government)

J.M. Hammer
Optical waveguide with prism coupler for parallel light—4152045

L.A. Harwood|W.H. Groeneweg|A.V. Tuma
PAL switching control circuit—4148058

K.G. Hernqvist
Mercury arc lamps—4156826

R.J. Hollingsworth|C.S. Kim
Memory array with bias voltage generator—4156940

G.W. Hughes|H. Kawamoto
Method and apparatus for the determination of signal pickup qualities of a stylus of a capacitive disc video player—4152641

I. Ladany
Stripping of protective coatings from glass fibers—4149929

C.C. Lim
Self-regulating deflection circuit with resistive diode biasing—4153862

S.A. Lipp
Image display employing filter coated phosphor particles—30015

M. Nowogrodzki
Surface roughness measuring apparatus—4148027

K.D. Peters
Disc caddy and disc player system therefor—4149729

W. Phillips
Wave device having a reverse domain grating—4155055

E.S. Poliniak|N.V. Desai
Method for forming a surface relief pattern in a poly (olefin sulfone) layer—4153741

D.H. Pritchard
Time base error correction system—4150395

W.R. Roach|I. Gorog
Groove depth estimation system using diffractive groove effects—4155098

L.R. Rockett, Jr.
CCD gray-to-binary code generator—4155076

P.M. Russo
Color display having selectable off-on and background color control—4149152

W.W. Siekanowicz|T.L. Credelle
Proximity focused element scale image display device—4153856

C.R. Wronski|B. Abeles
Method of making camera tube target by modifying Schottky barrier heights—4149907

Licensing

J.J. Benavie
Corrective optical device for homonymous hemianopsia—4155633

Missile and Surface Radar

L.H. Yorinks|R.M. Scudder
Paraboloid reflector antenna—4156243

Picture Tube Division

B.G. Marks
Interlocking electron tube base and adapter—859857

J.H. Regnault, Jr.|R.E. Benway
Base assembly for an electron tube—4155618

E.S. Thall|J.J. Moscony
Method for blackening the surfaces of a body of ferrous metal—4149908

Records Division

S.K. Khanna
Molding composition—4151132

Solid State Division

S.S. Eaton, Jr.
Voltage boosting circuits—4149232

M. Glogolja
Thermal protection of amplifiers—4149124

M.V. Hoover
Frequency discriminators—4150338
(assigned to U.S. government)

M.V. Hoover
High power protection apparatus—4156264

J.M. Neilson
Gate turn-off semiconductor controlled
rectifier device with highly doped buffer
region portion—4156248

M.A. Polinsky|W.N. Lewis
Nonvolatile semiconductive memory device
and method of its manufacture—4151538

T.J. Robe
Folded-cascade amplifier stages—4151482

T.J. Robe
Radiation-hardened transistor amplifiers—
4151483

T.J. Robe
Radiation-hardened transistor amplifiers—
4151484

Engineering News and Highlights

Pepper to head Solid State Division



Dr. Robert S. Pepper has been named General Manager of the RCA Solid State Division. He will be proposed for election as a corporate vice president at the August 1 meeting of the RCA Board of Directors.

A graduate of the University of California at Berkeley, with a PhD degree in Electrical Engineering, Dr. Pepper joined the school's

faculty as an Assistant Professor in 1961. He was instrumental in establishing the first integrated circuit processing laboratory on a university campus in the United States.

He left the University in 1964 to join private industry, serving first as Manager, Linear Integrated Circuit Research and Development for the Sprague Electric Company, North Adams, Mass. The following year, Dr. Pepper was named Director, Integrated Circuit Development for the company. In 1967, he assumed the position of Associate Director, Research and Development, and the following year, added the responsibility for Integrated Circuit Engineering at Sprague.

Dr. Pepper moved to the company's Worcester, Mass., facility in 1970 as Corporate Manager, Functional Circuit Design and Technology. Here he was responsible on a profit and loss basis for three groups: Functional Monolithic Circuits, Hybrids, and Hermetic Seals. He was advanced to the special position of Technical Assistant to the Chairman of the Board of Sprague in 1973. In this role, Dr. Pepper advised cor-

porate staff members of new directions of electronic technologies leading to the selection of new product opportunities and the phasing out of declining product areas.

Dr. Pepper left Sprague in 1975, serving as a private consultant for six months before joining the Raytheon Missile Systems Division in Bedford, Mass., as Manager of Resource Development, Advanced Electronic Lab.

The following year he moved to the position of Director, Research and Development for Analog Devices' Semiconductor Division in Wilmington, Mass. In this position, he was instrumental in the development by Analog of the industry's first monolithic 10 bit D to A converter and monolithic RMS to dc converter. In August, 1976, he was promoted to Vice President and General Manager of Analog's Semiconductor Division.

As the new head of the RCA Solid State Division, he succeeds Bernard V. Vonderschmitt, and will report to Roy H. Pollack, Executive Vice President, RCA Corporation.

Cook appointed Division Vice President and General Manager, RCA Distributor and Special Products Division

Donald M. Cook has been appointed Division Vice President and General Manager, RCA Distributor and Special Products Division. This was announced by Julius Koppelman, Executive Vice President, RCA Corp. Mr. Cook succeeds James J. Badaracco, who was named President of RCA Service Company.

In 1960 Mr. Cook joined RCA as Administrator of Engineering Recruiting and later that year was named Manager,

College Relations, Corporate Staff. He became Director of College Relations in 1967 and then Director, Educational Planning and Programs. He was named Director, Education Services in 1973 and three years later was appointed Division Vice President of Government Services Marketing for RCA Service Company.

A native of Rochester, Pa., Mr. Cook holds a Bachelor of Science Degree and a Masters Degree from Pennsylvania State University.



Staff announcements

Consumer Electronics

Loren R. Wolter, President and General Manager, RCA Taiwan, Limited, announced the election of **Edward J. Byrum**, Vice President, Manufacturing and Manufacturing Engineering.

Promotions

Picture Tube Division

Leo Wootner from Senior Member, Technical Staff, to Leader, Technical Staff.

Broadcast Systems

Tom M. Gurley from Principal Member, Engineering Staff, to Unit Manager.

Larry J. Thorpe from Principal Member, Engineering Staff, to Unit Manager.

Laboratories

Brown F. Williams, Director, Semiconductor Devices and Energy Systems Research Laboratory announced the organization as follows: **David Carlson**, Head, Photovoltaic Devices Research; **Richard Williams**, Fellow, Technical staff; **Joseph J. Hanak**, Fellow, Technical Staff; **Richard Denning**, Manager, Advanced Power Engineering (Somerville); **Michael Ettenberg**, Head, Optoelectronic Devices and Systems Research; **Henry S. Sommers, Jr.**, Fellow, Technical Staff; **Arthur H. Firester**, Head, Process and Applications Research; **Bernard Hershonov**, Head, Energy Systems Analysis; **Charles J. Nuese**, Head, Silicon Device Research; and **Jacques I. Pankove**, Fellow, Technical Staff.

Robert D. Lohman, Director, Display Systems Research Laboratory, announced the organization as follows: **Jon K. Clemens**, Head, Signal Systems Research; **James J. Gibson**, Fellow, Technical Staff; **Eugene O. Keizer**, Staff Scientist; **John P. Russell**, Head, Display and Device Concepts Research; **Robert W. Shisler**, Manager, Advanced Development - Yokes (Lancaster); **Frans Van Hekken**, Manager, Advanced Development - Electron Guns (Lancaster); **John A. van Raalte**, Head, Video Recording Research; **Peter J. Wojtowicz**, Head, Electron Optics and Deflection Research; **P. Niel Yocom**, Head, Display Materials and

Process Research; **Karl G. Hernqvist**, Fellow, Technical Staff; and **Simon Larach**, Fellow, Technical Staff.

David Richman, Director, Materials and Processing Research Laboratory, announced the organization as follows: **Charles H. Anderson**, Head, Applied Mathematical and Physical Sciences; **Roger L. Crane**, Fellow, Technical Staff; **Ralph W. Klopfenstein**, Fellow, Technical Staff; **Vladimir S. Ban**, Head, VideoDisc Materials and Diagnostics Research; **Chih C. Wang**, Fellow, Technical Staff; **Glenn W. Cullen**, Head, Materials Synthesis Research; **Leonard P. Fox**, Head, VideoDisc Applied Process Research; and **Daniel L. Ross**, Head, Organic Materials and Devices Research.

Fred Sterzer, Director, Microwave Technology Center, announced the organization as follows: **Erwin F. Belohoubek**, Head, Microwave Circuits Technology; **Ho-Chung Huang**, Head, Microwave Process Technology; **S. Yegna Narayan**, Head, Microwave Materials Technology; **Markus Nowogrodzki**, Manager, Subsystems and Special Projects; **Fred Sterzer**, Acting, Optical Communications; and **Herbert J. Wolkstein**, Manager, Space and Countermeasure Programs.

David D. Holmes, Director, Consumer Electronics Research Laboratory, announced the organization as follows: **Robert H. Dawson**, Manager, New Technology Applications Research (Somerville); **Leopold A. Harwood**, Fellow, Technical Staff (Somerville); **David D. Holmes**, Acting, Product Assurance Research; **Stanley P. Knight**, Head, Signal Conversion Systems Research; **Dalton H. Pritchard**, Fellow, Technical Staff; **Lubomyr S. Onyshkevych**, Head, Electronic Packaging Research; **Werner F. Wedam**, Head, Television Receiver Systems Research; and **Kern K.N. Chang**, Fellow, Technical Staff.

Henry Kressel, Staff Vice President, Solid State Technology, announced the organization as follows: **Phillip K. Baltzer**, Head, LSI Systems and Applications; **Harold Borkan**, Manager, Special Projects and Products (SSTC); **Harry L. Cooke**, Manager, Administrative and Technical Operations (SSTC); **Larry J. French**, Director, LSI Systems, Design Laboratory and Photomask Technology (SSTC); **Israel H. Kalish**, Manager, Integrated Circuit Design and Process Development (SSTC); **Andrew G.F. Dingwall**, Fellow, Technical Staff (SSTC); **Louis S. Napoli**, Staff Scientist; and **Joseph H. Scott**, Director, Integrated Circuit Technology Research Laboratory.

Larry J. French, Director, LSI Systems and Design Research Laboratory (SSTC), has announced the appointment of **Lawrence M. Rosenberg** as Manager, Design Automation.

Marvin A. Leedom, Director, Manufacturing Systems and Technology, Research Laboratory, has announced the organiza-

tion as follows: **David P. Bortfeld**, Head, Manufacturing Systems and Process Control; **Charles B. Carroll**, Head, Electromechanical Systems; **Istvan Gorog**, Head, Manufacturing Research; **James P. Wittke**, Fellow, Technical Staff; **Marvin A. Leedom**, Acting, Advanced Control Systems; **William G. McGuffin**, Manager, Instrumentation Systems; **Chester J. Halgas**, Administrator, Prototype Development and Construction; and **Louis E. Potter**, Manager, Advanced Development Manufacturing Technology (Lancaster).

Alfred H. Teger, Director, Advanced Systems Research Laboratory, has announced the organization as follows: **Allen J. Korenjak**, Head, Automation Systems Research; **Thomas M. Stiller**, Fellow, Technical Staff; **Eduard Luedicke**, Staff Scientist; **D. Alex Ross**, Staff Engineer; **Richard H. Roth**, Head, System Architecture Research; **Allen H. Simon**, Fellow, Technical Staff; **Paul M. Russo**, Head, Microsystems Research; and **Charles M. Wine**, Fellow, Technical Staff.

Appointment of **Dr. David Richman** as Director, Materials and Processing Research Laboratory, has been announced by **Dr. James J. Tietjen**, Staff Vice President, Materials and Components Research, at RCA Laboratories in Princeton, N.J.

Solid State Division

Roy H. Pollack, Acting General Manager, Solid State Division, has announced the organization as follows: **Ben A. Jacoby** is appointed Division Vice President, Marketing, with responsibility for Sales and International Operations; **Joseph M. Cleary**, Division Vice President, Sales, and **Robert L. Klem**, Division Vice President, International Operations, will report to the Division Vice President, Marketing; **Carl R. Turner** is appointed Division Vice President, Systems, Services and Strategic Planning.

Edward M. Troy, Division Vice President, Solid State Power Devices, has announced the appointment of **Robert E. O'Brien** as Manager, Power Administration and Technology Projects.

Richard A. Santilli, Division Vice President, Integrated Circuits, has announced the appointment of **John P. McCarthy** as Director, Government and High Reliability Operations.

David S. Jacobson, Manager, Photomask Technology & Operations, announced the organization as follows: **Robert A. Geshner**, Manager, Advanced Mask Technology; **David S. Jacobson**, Acting Manager, Photomask Tooling Production, **Ronald M. Melewski**, Manager, Mask Manufacturing and Production Control; and **Robert L. Van Asselt**, Manager, Photomask Inspection and Quality Assurance.



Bannister



Corrado

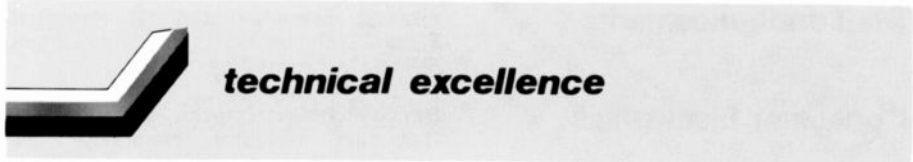

Moorestown lists third-quarter 1978 Technical Excellence Award Winners

A total of eleven Technical Excellence Awards were presented to Missile and Surface Radar personnel during the third quarter 1978. The award winners and brief summaries of the citations are given below.



Corso



Dempsey

R.J. Bannister — for analyzing and defining the AEGIS status structure, a necessary step toward developing the on-line automatic test system (IRTS) used in AEGIS to assess operational readiness and availability levels of equipment as well as identification and reporting of error conditions.

he designed the program and resolved unique NIDIR design problems. He completed the program a month early, and used it in resolving hardware and system problems.



Faul



Gagnon

J.S. Corrado — for developing and producing the Ship Combat System test documentation for the AEGIS destroyer and cruiser. This marked RCA's entry into the field of test documents to OPNAVINST 3960.10 and NAVMATINST 3960.7A. Enthusiastically accepted, the documents have since been embodied verbatim in Navy AEGIS documents.

A.J. Massey — for his participation in establishing the requirements for a Module Test Set as an item of AEGIS shipboard equipment. Using level-of-repair analyses, he accumulated and organized detailed logistics data in computerized life cycle cost models which enabled the choice of design for a new Module Test Set.



Hawkins



Massey

J.T. Corso — for defining an optimized rocket motor design for the Navy's new Standard Missile, SM-2, to be used in AEGIS. His work on evaluation criteria for missile trajectory solutions resulted in a set of recommendations that have been adopted by both the Navy and the missile contractor.

T. Murakami — for development of improved computer programs used for calibration of the TRADEX radar at Kwajalein. His new calibration programs embody the latest TRADEX system improvements, including the coherent signal processor. Moreover his automatic program is faster, easier, and more accurate than the test procedures used formerly.



Murakami



Reifler

D.J. Dempsey — for systems engineering leadership and innovative contributions to the system design concept for the Generic Threat Radar. The result was a winning proposal for a working array sensor that can simulate the behavior and electromagnetic signature of a variety of foreign radars.

F. Reifler — for developing the algorithms and analytical tools needed to optimize the rocket motor design for the Navy SM-2 Standard Missile intended for AEGIS. His work enabled simulated firings of a variety of motor designs. The outcome was an RCA-recommended motor design variant that was accepted by both the Navy and the missile contractor.

R.E. Faul — for outstanding performance in inaugurating the use of a new automatic (N/C) drilling system for printed wiring boards. He took responsibility for drill programming, set-up, and operation. He trained operators, generated innovative programs to drive the drill, and trained drafters to produce N/C tapes.

A.J. Stanchina — for leadership in the development of an automated Design Budget concept for the DDG-47 and combat system design. This concept, never before implemented in the ship design process, provides an automated mechanism for tracking and reporting changing needs for ship and combat system services with minimal cost and schedule impact.



Stanchina

A.J. Gagnon — for his level-of-repair analysis to determine requirements for the AEGIS Module Test Set. His analysis optimized troubleshooting and repair policies for AEGIS assemblies and printed wiring modules, providing substantiation for RCA proposals for a new Module Test Set to be part of each AEGIS ship.

Astro Electronics presents Technical Excellence Awards

The Engineering Excellence Committee at Astro Electronics, Princeton, has cited three engineers for their outstanding and innovative accomplishments. The award winners and brief summaries of their citations are given below:

J. Hawkins — for development of the computer programs in the first United Kingdom NIDIR instrumentation radar. Starting with available undocumented digital radar code,

Kai Y. Eng — for his outstanding engineering analysis which predicts the performance of communication satellite transponders and antennas. In less than five months, he developed a computer program which calculates the far field gain pattern



Eng



Phillips



Schmidt

produced from a multi-beam antenna of the type used on communication satellites like RCA Satcom.

Kevin Phillips and George Schmidt — for the design effort leading to the implementation of the Momentum Bias Attitude Control System for the DMSP Block 5D1F1 (F35) spacecraft. After the successful recovery of this spacecraft in March 1977, it became necessary to implement an attitude control system without resorting to gyros. The new system, developed by Phillips and Schmidt, was loaded in the spacecraft's computer and activated on May 20, 1977. Although the gyros failed shortly thereafter, the spacecraft is still performing its mission.

Corporate Microwave Symposium Held at DSRC, Princeton

On June 8, a corporate symposium on Microwave Technology was held at the David Sarnoff Research Center. The symposium covered all aspects of microwave work going on throughout RCA as well as future technology needs as perceived by the operating divisions. **Fred Sterzer** and **Mark Nowogrodzki** of the RCA Laboratories planned and organized the symposium which was attended by 90 people from many RCA locations.

The full-day symposium was divided basically into three parts: a morning session on microwave technology work in the Government Systems Division; an afternoon session on microwave projects at the Commercial Communications Systems Division; and a late-afternoon panel discussion. The panel discussion, moderated by **K.H. Powers**, RCA Laboratories, focused on "Microwave Technology in RCA's Future." Participants included **R.H. Aires**, Avionics

Systems; **J. Christopher**, Americom; **J.E. Kelgler**, Astro Electronics; **A.S. Robinson**, Missile and Surface Radar; and **D. Shore**, Government Systems Division. The following presentations made up the day's program:

Corporate Microwave Symposium

Morning Session —

Chairman: K.H. Powers (RCA Laboratories)

| | |
|--|---|
| "Recent Advances and Trends in Solid-State Microwave Devices and Circuits" | F. Sterzer RCA Laboratories |
| "Microwave Technology in GSD" | W.G. Anderson Government Systems Division |
| "C-Band FET Power Amplifier for TWT Replacement" | F. Drago Astro Electronics |
| "Spacecraft Microwave Requirements of the 80s" | P.E. Wright Astro Electronics |
| "Low Side-Lobe Phased Array Antennas for Tactical Radars" | W.T. Patton Missile and Surface Radar |
| "EW Systems and Needs" | R.J. Kampf Automated Systems |
| "Military SHF SATCOM Ground Terminal Microwave Development Needs" | G.V. Wild Government Communications Systems |
| "Millimeter Waves: An Overview of the State of the Art of Technology and Applications" | C.E. Profera Government Systems Division |

Afternoon Session —

Chairman: O. Ben Dov (CCSD)

| | |
|--|---|
| "Airborne Weather Radar Technology" | E.J. Denlinger RCA Laboratories G.A. Lucchi Avionics Systems |
| "Advanced Solid-State Radio at 800 MHz" | P. Buess Mobile Communications Systems H.J. Wolkstein RCA Laboratories |
| "A Large Active Satellite Antenna for Mobile Communications" | H. Staras RCA Laboratories |
| "Radar-Controlled Functions for Future Cars" | J.J. Risko RCA Laboratories |

For additional information:

Information is available by contacting the Chief Engineers and RCA Libraries, or by calling the speakers or the symposium organizers. (Copies of the Symposium proceedings have been made up which include the charts shown and some text.)

Professional Activities

GCS Authors and Inventors Reception

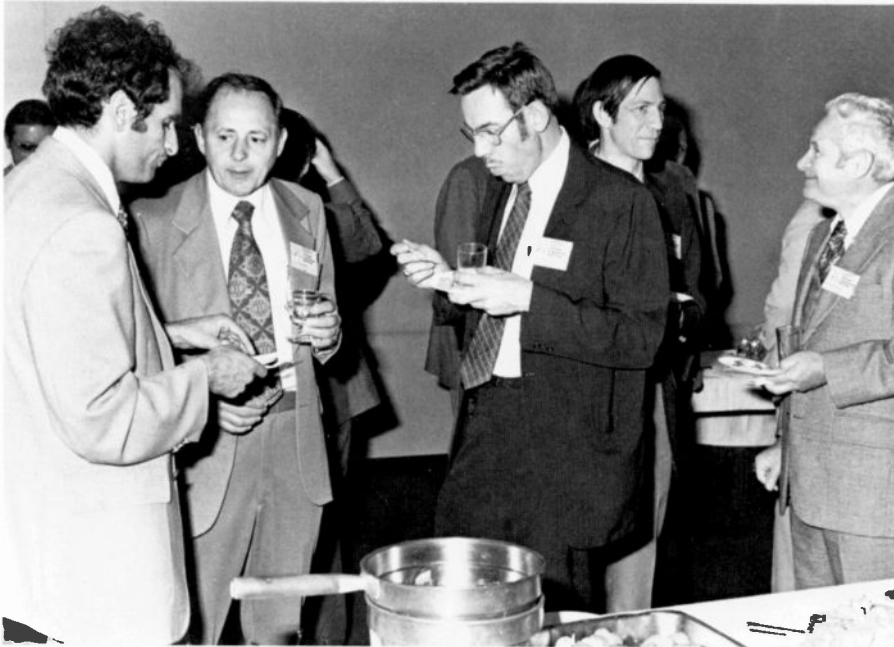

Don Kaplan (at the left), Jack Santoro, Gene Starner, Jim Daniel, and Bob Trachtenberg at the GCS Author and Inventor Reception on May 3, 1979.

GCS held its Authors and Inventors reception in Camden on May 3, hosted by J.B. Howe, Chief Engineer. The purpose of the reception was to honor 70 people who were

contributing authors and presenters of papers, as well as those who were disclosing inventors during 1978.

New Fellow of the SPIE

Burton R. Clay, a Senior Engineering Scientist at RCA Automated Systems, was elected Fellow of the Society of Photo-Optical Instrumentation Engineers. Since joining RCA in 1949, he has had nine years of electronic and magnetic circuit design in color television development and optical instrumentation, two years of computer peripheral equipment design, one year of fiber optics development, five years of laser system development and ten years in holographic system development. He has taken some thirteen state-of-the-art courses at Northeastern University. His current activities include full color holographic display development for aircraft using incoherent sources, correction of wavefront distortion by holographic means, stereo displays and laser rangefinder design. He received the RCA Technical Excellence Award for a laser obstacle detection system for the Department of Transportation.

Mr. Clay holds 23 U.S. patents. He is a

Member of the Society of Photo-Optical Instrumentation Engineers, Member of the Society of Photographic Scientists and Engineers, Senior Member of IEEE, and was Film Chairman of Electro 78 and past President of Sigma Xi RCA-AS Chapter. He is Short Communications Editor of *Optical Engineering*, past President of the Optical Society of America, New England Section. He has reviewed books for *Laser Focus* and he is a co-author of the *Handbook on Holography*, edited by H. John Caulfield, to be released by Academic Press in 1979. He has published several papers in the electro-optical field.

Vonderschmitt Awarded Honorary Doctorate

During the 101st commencement at Rose-Hulman Institute of Technology, Terre Haute, Indiana, **Bernard J. Vonderschmitt** was awarded an honorary doctor's degree for distinguished service in the field of

electronics. Mr. Vonderschmitt was graduated first in a class of 25 at Rose-Hulman Institute in 1944. He joined RCA in Camden as a design engineer the same year. After serving as a radar officer in the U.S. Navy, he returned as manager of applications and microelectronics. He subsequently held management positions of increasing responsibility and was appointed Vice President and General Manager of the RCA Solid State Division in January 1973.

Microcomputer club formed at RCA, Moorestown, N.J.

The Microcomputer Club of RCA, Moorestown, held its first meeting as an organization on July 11, 1979. The meeting featured a talk by Vic Stubbs on the use of a VIP microcomputer. The club was founded to exchange microsystems information, provide understanding of microsystems applications, provide training and assistance in microsystems technology, and foster the cooperative development of projects by the membership.

The membership is made up of hobbyists interested in microsystem hardware and software. The club has already defined areas of interest of the present membership and plans lectures, demonstrations, and workshops to communicate uses of microcomputer systems. Several members have already built their own microcomputers and ideas have been exchanged as to construction techniques, pitfalls of construction and programming, and how to keep construction project costs low.

The club presently meets once a month, during lunch hour, at the RCA Moorestown plant. RCA employees interested in the subject are welcome to attend meetings. Further information may be obtained from any of the club's officers (in Moorestown): Stan Goliaszewski, President, M.S. 127-308, Ext. 3951; Vic Stubbs, Vice President, M.S. 127-307, Ext. 2601; George Poletti, Secretary, M.S. 127-127, Ext. 3802; and Joe Corrado, Treasurer, M.S. 127-127, Ext. 3016.

Society of Packaging & Handling Engineers Honors Van Horn

John Van Horn, Missile and Surface Radar, Moorestown, was recently elected to the Sigma Pi Epsilon Fraternity of the Society of Packaging & Handling Engineers. The Society was developed to improve and promote the profession of packaging and material handling engineering. The Sigma Pi Epsilon is an honorary fraternity sponsored by the Society, to which a member is elected because of leadership and performance in the organization's field of interest.

Editorial Representatives

Contact your Editorial Representative, at the extensions listed here, to schedule technical papers and announce your professional activities.

Commercial Communications Systems Division

Broadcast Systems

BILL SEPICH* Camden, N.J. Ext. 2156
KRISHNA PRABA Gibbsboro, N.J. Ext. 3605
ANDREW BILLIE Meadow Lands, Pa. Ext. 6231

Mobile Communications Systems

KARL NEUMANN* Meadow Lands, Pa. Ext. 6444

Avionics Systems

STEWART METCHETTE* Van Nuys, Cal. Ext. 3806
JOHN McDONOUGH Van Nuys, Cal. Ext. 3353

Cablevision Systems

JOHN OVNICK* N. Hollywood, Cal. Ext. 241

Government Systems Division

Astro-Electronics

ED GOLDBERG* Princeton, N.J. Ext. 2544

Automated Systems

KEN PALM* Burlington, Mass. Ext. 3797
PETE DIACONOFF Burlington, Mass. Ext. 2975

Government Communications Systems

DAN TANNENBAUM* Camden, N.J. Ext. 3081
HARRY KETCHAM Camden, N.J. Ext. 3913

Government Engineering

MERLE PIETZ* Camden, N.J. Ext. 2161

Missile and Surface Radar

DON HIGGS* Moorestown, N.J. Ext. 2836
JACK FRIEDMAN Moorestown, N.J. Ext. 2112

Solid State Division

JOHN SCHOEN* Somerville, N.J. Ext. 6467

Power Devices

HAROLD RONAN Mountaintop, Pa. Ext. 633-827
SY SILVERSTEIN Somerville, N.J. Ext. 6168

Integrated Circuits

FRED FOERSTER Somerville, N.J. Ext. 7452
JOHN YOUNG Findlay, Ohio Ext. 307

Electro-Optics and Devices

RALPH ENGSTROM Lancaster, Pa. Ext. 2503

*Technical Publications Administrator, responsible for review and approval of papers and presentations.

Consumer Electronics

CLYDE HOYT* Indianapolis, Ind. Ext. 5208
FRANCIS HOLT Indianapolis, Ind. Ext. 5217
PAUL CROOKSHANKS Indianapolis, Ind. Ext. 5080
STEVE RACE Indianapolis, Ind. Ext. 5636
DON WILLIS Indianapolis, Ind. Ext. 5883

SelectaVision VideoDisc Operations

ROBERT MOORE Indianapolis, Ind. Ext. 3313

RCA Service Company

JOE STEOGER* Cherry Hill, N.J. Ext. 5547
RAY MacWILLIAMS Cherry Hill, N.J. Ext. 5986
DICK DOMBROSKY Cherry Hill, N.J. Ext. 4414

Distributor and Special Products Division

CHARLES REARICK* Deptford, N.J. Ext. 2513

Picture Tube Division

ED MADENFORD* Lancaster, Pa. Ext. 3657
NICK MEENA Circleville, Ohio Ext. 228
JACK NUBANI Scranton, Pa. Ext. 499
J.R. REECE Marion, Ind. Ext. 5566

Americom

MURRAY ROSENTHAL* Piscataway, N.J. Ext. 4363

Globcom

WALT LEIS* New York, N.Y. Ext. 7711

RCA Records

DAVE DEVARAJAN* Indianapolis, Ind. Ext. 6109

NBC

BOB MAUSLER* New York, N.Y. Ext. 3589

Patent Operations

JOSEPH TRIPOLI Princeton, N.J. Ext. 2992

Research and Engineering

Corporate Engineering

HANS JENNY* Cherry Hill, N.J. Ext. 4251

Laboratories

MAUCIE MILLER Princeton, N.J. Ext. 2322
LESLIE ADAMS Somerville, N.J. Ext. 7357

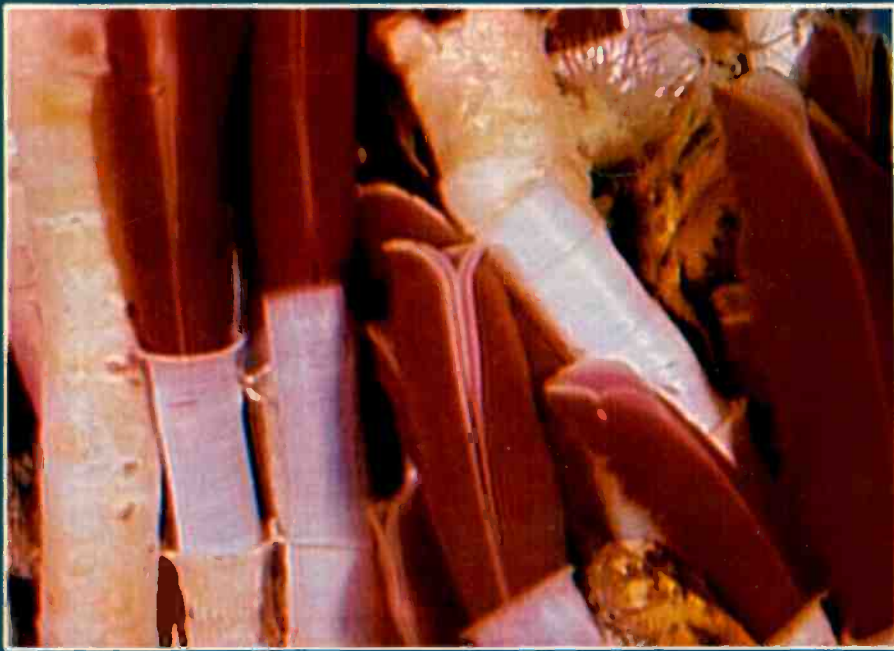

From the article, "Development and application of a prototype CCD color television camera," by R.L. Rodgers, III. A sample video frame from the prototype camera shows a view of giant tube worms found living on the Pacific Ocean floor near the Galapagos Rift.

The camera employs three charge-coupled devices as image sensors, each of which has 512 x 320 elements.

RCA Engineer

A technical journal published by
Corporate Technical Communications
"by and for the RCA engineer"